

december 1956
the
institute
of
radio
engineers

Proceedings of the IRE

Single Sideband
Issue

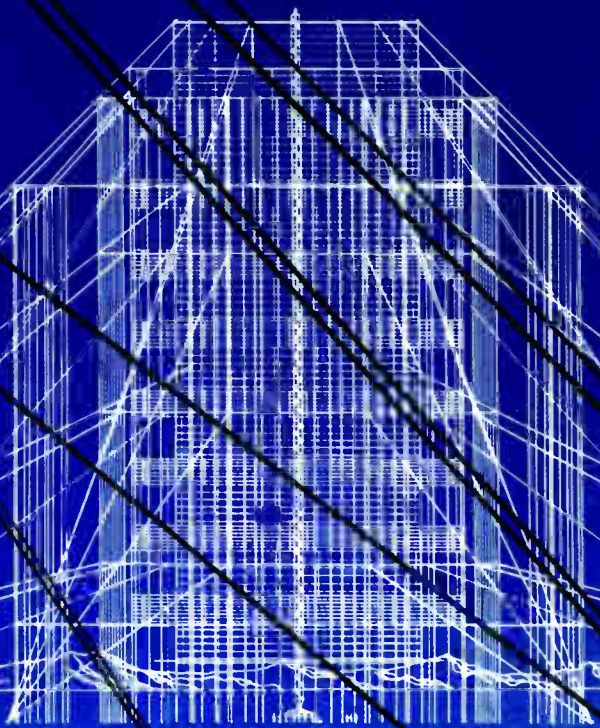

**LEADERS IN
MINIATURIZATION
FOR OVER
TWENTY YEARS...**



MINIATURIZED TRANSFORMER COMPONENTS **FROM STOCK**

Items below and 650 others in our catalog A.

HERMETIC SUB-MINIATURE AUDIO UNITS

These are the smallest hermetic audios made.

Dimensions... 1/2 x 11/16 x 29/32... Weight .8 oz.



TYPICAL ITEMS

Type No.	Application	MIL Type	Pri. Imp. Ohms	Sec. Imp. Ohms	DC in Pri MA	Response ± 2 db (Cyc.)	Max. level dbm
H-30	Input to grid	TF1A10YY	50*	62,500	0	150-10,000	+13
H-31	Single plate to single grid, 3:1	TF1A15YY	10,000	90,000	0	300-10,000	+13
H-32	Single plate to line	TF1A13YY	10,000*	200	3	300-10,000	+13
H-33	Single plate to low impedance	TF1A13YY	30,000	50	1	300-10,000	+15
H-34	Single plate to low impedance	TF1A13YY	100,000	60	.5	300-10,000	+6
H-35	Reactor	TF1A20YY	100 Henries-0 DC, 50 Henries-1 Ma. DC, 4,400 ohms.				
H-36	Transistor Interstage	TF1A15YY	25,000	1,000	.5	300-10,000	+10

*Can be used with higher source impedances, with corresponding reduction in frequency range and current

COMPACT HERMETIC AUDIO FILTERS



UTC standardized filters are for low pass, high pass, and band pass application in both inter-stage and line impedance designs. Thirty four stock values, others to order. Case 1-3/16 x 1-11/16 x 1-5/8 — 2-1/2 high... Weight 6-9 oz.

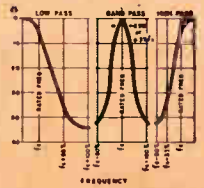

HERMETIC MINIATURE HI-Q TOROIDS

MQE units provide high Q, excellent stability and minimum hum pickup in a case only. 1/2 x 1-1/16 x 17/32... weight 1.5 oz.

TYPICAL ITEMS

Type No.	Inductance	DC Max.
MQE-1	7 mhy.	135
MQE-3	20 mhy.	80
MQE-5	50 mhy.	50
MQE-7	100 mhy.	35
MQE-10	4 hy.	17
MQE-12	9 hy.	12
MQE-15	2.8 hy.	7.2

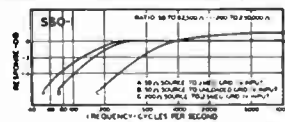
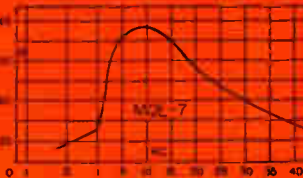

SUB-SUBOUNCER AUDIO UNITS

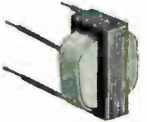

UTC Subouncer and sub-subouncer units provide exceptional efficiency and frequency range in miniature size. Constructional details assure maximum reliability. SSO units are 7/16 x 3/4 x 43/64... Weight 1/50 lb.

Type	Application	Level	Pri. Imp.	MA D.C. in Pri.	Sec. Imp.	Pri. Res.	Sec. Res.
*SSO-1	Input	+4 V.U.	200 50	0	250,000 62,500	13.5	3700
SSO-2	Interstage /3:1	+4 V.U.	10,000	0-.25	90,000	750	3250
*SSO-3	Plate to Line	+20 V.U.	10,000 25,000	3 1.5	200 500	2600	35
SSO-4	Output	+20 V.U.	30,000	1.0	50	2875	4.6
SSO-5	Reactor 50 HY at 1 mil. D.C.	4400 ohms D.C. Res.					
SSO-6	Output	+20 V.U.	100,000	.5	60	4700	3.3
*SSO-7	Transistor Interstage	+10 V.U.	20,000 30,000	.5 .5	800 1,200	850	125

* Impedance ratio is fixed, 1250:1 for SSO-1, 1:50 for SSO-3. Any impedance between the values shown may be employed.



SUB-SUBOUNCER (WIDE RANGE) AUDIO UNITS

Standard for the industry for 15 yrs., these units provide 30-20,000 cycle response in a case 7/8 dia. x 1-3/16 high. Weight 1 oz.

TYPICAL ITEMS

Type No.	Application	Pri. Imp.	Sec. Imp.
0-1	Mike, pickup or line to 1 grid	50, 200/250, 500/600	50,000
0-4	Single plate to 1 grid	15,000	60,000
0-7	Single plate to 2 grids, D.C. in Pri.	15,000	95,000
0-9	Single plate to line, D.C. in Pri.	15,000	50, 200/250, 500/600
0-10	Push pull plates to line	30,000 ohms plate to plate	50, 200/250, 500/600
0-12	Mixing and matching	50, 200/250	50, 200/250, 500/600
0-13	Reactor, 300 Hys.—no D.C.; 50 Hys.—3 MA. D.C., 6000 ohms		



HERMETIC VARIABLE INDUCTORS

These inductors provide high Q from 50 - 10,000 cycles with exceptional stability. Wide inductance range (10 - 1) in an extremely compact case 25/32 x 1-1/8 x 1-3/16... Weight 2 oz.

TYPICAL ITEMS

TYPE No.	Min. Hys.	Mean Hys.	Max. Hys.	DC Ma
HVC-1	.002	.006	.02	100
HVC-3	.011	.040	.11	40
HVC-5	.07	.25	.7	20
HVC-6	.2	.6	2	15
HVC-10	7.0	25	70	3.5
HVC-12	50	150	500	1.5

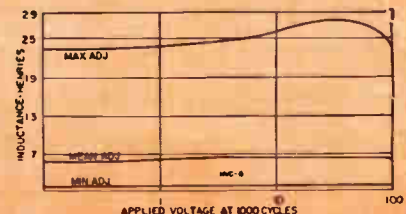
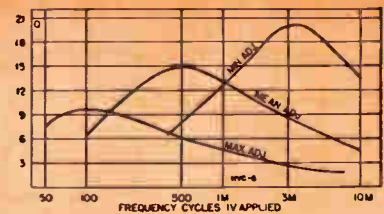

LET US MINIATURIZE YOUR GEAR.
SEND DETAILS OF YOUR NEEDS for SIZES and PRICES

UNITED TRANSFORMER CO.

150 Varick Street, New York 13, N. Y. • EXPORT DIVISION: 13 E. 40th St., New York 16, N. Y.

CABLES: "ARLAB"



miniaturized **CERA-MITE*** capacitors for transistor radios

TRIED AND PROVEN in thousands of transistor radios, Sprague's miniaturized line of Cera-Mite* disc capacitors is building an enviable record of trouble-free service in the field.

Mass production of a standardized line of the five popular capacitance values in the new smaller 50 volt d-c sizes assures continued high quality.

Two widely separated plants, one at Nashua, New Hampshire, and another at Grafton, Wisconsin, assure our customers of a dependable source of

supply to meet production schedules.

Complete technical data on Cera-Mite capacitors for transistor applications is given in Engineering Data Sheet 6121. Write (on your business letterhead, please) for your copy to the Technical Literature Section, Sprague Electric Company, 235 Marshall Street, North Adams, Mass.

• • •

Sprague on request will provide you with complete application engineering service for optimum results in the use of ceramic capacitors.

*Trademark

the mark of

SPRAGUE®

reliability

Export for the Americas: Sprague International Ltd., North Adams, Mass. CABLE: SPREXINT

PROCEEDINGS OF THE IRE December, 1956, Vol. 44, No. 12. Published monthly by the Institute of Radio Engineers, Inc., at 1 East 79 Street, New York 21, N.Y. Price per copy; members of the Institute of Radio Engineers, one additional copy, \$1.25; non-members \$3.00. Yearly subscription price: to members, one additional subscription, \$13.50; to non-members in United States, Canada and U.S. Possessions \$18.00; to non-members in foreign countries \$19.00. Entered as second class matter, October 26, 1927, at the post office at Menasha, Wisconsin, under the act of March 3, 1879. Acceptance for mailing at a special rate of postage is provided for in the act of February 28, 1925, embodied in Paragraph 4, Section 412, P. L. and R., authorized October 26, 1927.

Table of Contents will be found following page 96A



For this, the sixth of our 1956-57 series of "advertisements," we decided to ask a very good friend and neighbor of ours to contribute something interesting for this Single Sideband issue of the Proceedings because we believe he is one of the foremost workers in the field. So Murray Crosby of Crosby Laboratories has prepared this material.

Transformerless Single-Sideband Balanced Modulator

by Murray G. Crosby

Crosby Laboratories, Hicksville, New York

Some time ago we had a requirement for an AM modulator which would give low distortion and an AM output which would not change in percentage of modulation as the carrier input of the modulator was changed. This requirement appeared to be lacking in most of the available amplitude-modulation circuits. After experimentation with the circuit of Fig. 1, we found we had a circuit with the following advantages:

1. A balanced modulator for single-sideband operation which did not require impedance matching or balancing transformers and which could be easily adjusted for carrier-eliminated modulation.
2. A low distortion AM modulator for percentages of modulation up to 100%.
3. An AM modulator whose carrier input could be varied without changing the percentage of amplitude modulation in the output and without introducing distortion.

The three triodes of the circuit of Fig. 1 are connected in a manner the same as the triple-triode product detector.* Triodes T_1 and T_2 act as cathode followers to drive the cathode circuit of T_3 . These two triodes are adjusted for linear operation with respect to the output circuit Z_L . It will be noted that when the grid of either T_1 or T_2 is made positive, which also makes the cathode of T_3 positive, the resultant effect is to make the grid voltage of T_3 negative. Hence the phase of voltage appearing at Z_L from the grids of T_1 , or T_2 , is opposite to that from the grid of T_3 . This allows cancellation of the carrier in the output circuit by means of potentiometer P_1 . For complete

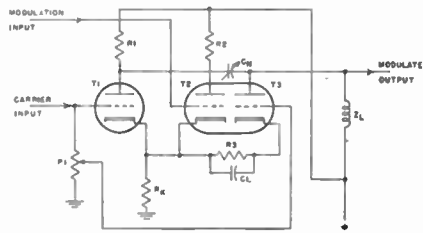

Fig. 1

carrier-eliminated amplitude modulation, P_1 is adjusted for a minimum of carrier output in Z_L , and C_n is adjusted to neutralize the capacity feed-through which may occur between T_1 and T_3 . In this way a carrier reduction of approximately 50 db may be maintained with stability.

If low distortion double-sideband AM is desired, the amplitude modulation percentage is adjusted to about 25% with the carrier neutralization from T_1 shut off, and then the carrier neutralization potentiometer P_1 is raised until the 25% modulation appears in the output as 100% modulation. In this way, low distortion AM may be produced with distortion of the order of less than 0.5%.

Using 6C4 or 12AU7 type tubes for the triodes, cathode resistor R_k is 1000 ohms. Resistor R_3 provides additional cathode bias for triode T_3 to provide the proper operation point. R_3 is 2700 ohms and C_1 is chosen to by-pass the

carrier frequency. If desired, R_3 and C_1 may be omitted so that all cathodes are tied together, and negative grid bias applied to the grid of T_3 through a resistance-capacity isolation for the bias. The use of a d-c grid bias on T_3 allows a more critical adjustment of linearity.

Resistors R_1 and R_2 may be approximately 470 ohms and C_n 0.25 μf for the 6C4-12AU7 type of triodes. P_1 may be 10,000 ohms and Z_L may be a choke which serves as a load and also prevents audio modulation input from passing directly through to the subsequent circuits. Z_L may be replaced by a resistance of 47,000 ohms if modulation feed-through is not a problem.

We have used this triple-triode modulator together with the corresponding triple-triode product detector in single-sideband transmitter and receiver combinations that have produced an overall distortion of transmitter and receiver of less than 0.5%. As a balanced modulator for single-sideband operation, circuit simplicity and ease of adjustment are obtained by the lack of the requirement of transformers and the small number of adjustments required to produce the carrier elimination balance. As a low distortion AM modulator, the circuit has the advantage that the percentage modulation is proportional to modulation input only and independent of carrier input. This feature allows use of the modulator in control circuits which apply the control to the carrier voltage to thereby eliminate distortion or other problems which might occur if the control were applied to the modulated wave.

* Murray G. Crosby, "Reception with Product Detectors," QST, May 1956.

Airborne Instruments Laboratory
INCORPORATED

160 OLD COUNTRY ROAD, MINEOLA, L. I., N. Y.
Phone Pioneer 2-0600

H+ THERE IS ONLY ONE MAGNET WIRE WITH AN EXTREMELY HIGH SPACE FACTOR CAPABLE OF SUCCESSFUL, CONTINUOUS OPERATION AT **250°C**

IT IS SPRAGUE'S...

Cerroc

CERAMIC INSULATED MAGNET WIRE



CEROC is an extremely thin and flexible ceramic insulation deposited on copper wire. This ceramic base insulation is unaffected by extremely high temperatures. Thus, in combination with silicone or Teflon overlays, Cerroc insulations permit much higher continuous operating temperatures than are possible with ordinary insulations.

There are three standard Cerroc Wires: Ceramic Single-Teflon and Ceramic Heavy-Teflon for operation at 250°C feature unique characteristics of flexibility, dielectric strength and resistance to moisture. They have been used successfully to 300°C in short time military applications. Ceramic Single-Silicone, for 200°C application, pairs the ceramic with a silicone reinforcement to facilitate winding.

All three Cerroc Wires have far superior cross-over characteristics to all-plastic insulated wire—all provide an extraordinarily high space factor that facilitates miniaturization with high-reliability standards.

ENLARGED CROSS-SECTIONS OF CERROC® COPPER MAGNET WIRE

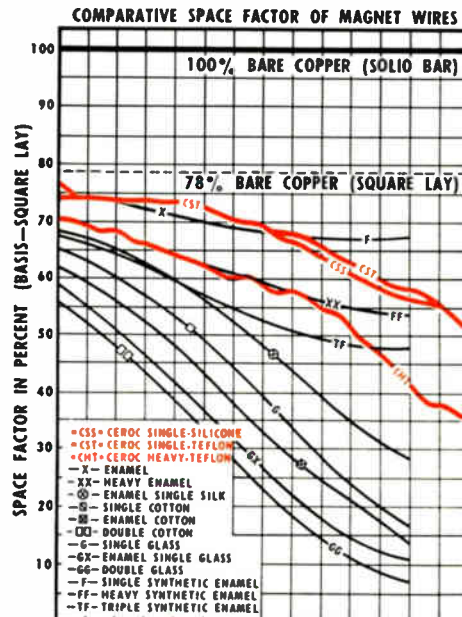

COMPARATIVE SPACE FACTOR OF MAGNET WIRES

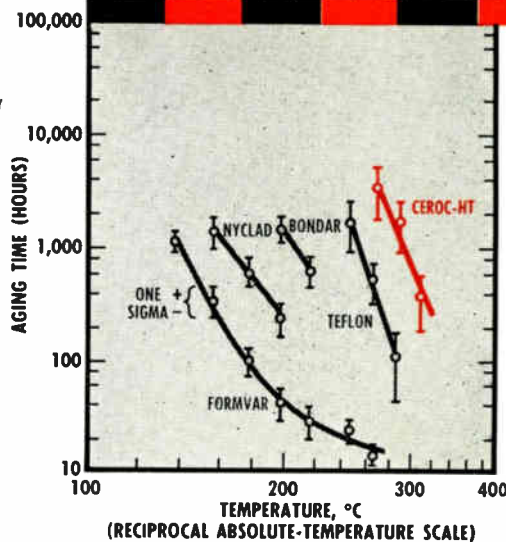

SPRAGUE

ELECTRIC COMPANY
235 MARSHALL ST. NORTH ADAMS, MASS.

THE HOW AND WHY OF THE WORLD'S PUREST SILICON

The purification of silicon by Bell Laboratories metallurgists has been richly rewarding. Their original research in this field revealed the chemical factors that control semiconductors; it was a major advance leading to Bell Laboratories' invention and development of transistors and the Bell Solar Battery. Now they have devised a simple but highly effective way to remove boron—one of the most difficult impurities to extract from silicon.

During refining, a stream of hydrogen and water vapor is kept flowing past the silicon. As the water vapor passes over the liquid silicon, it seizes boron atoms, forming boron oxide. The oxide is then pulled away to condense on the wall of the refining tube which is cooled by a water stream. Result of refining: boron and other harmful impurities are reduced to less than one part in 10,000,000,000.

The new silicon is being used to develop still better transistors and rectifiers for telephony. It is another example of how Bell Laboratories metallurgists help open the way to improved telephony.

BELL TELEPHONE LABORATORIES



World center of communications research and development

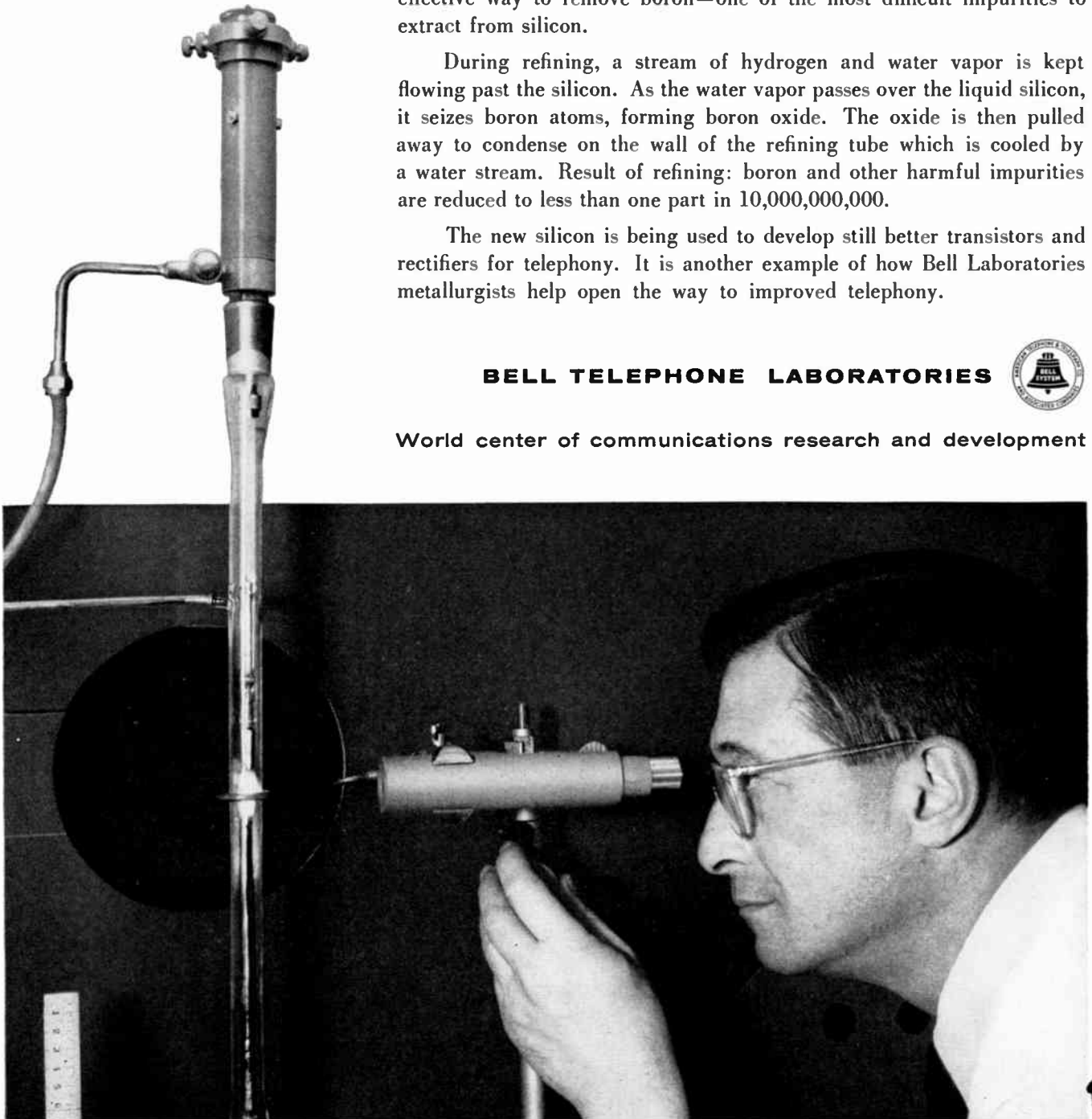

Metallurgist Henry C. Theuerer, M.A. in Chemistry, Columbia, watches a molten zone in a silicon rod under purification. Mr. Theuerer's most recent achievement was development of water-vapor treatment for removal of boron.

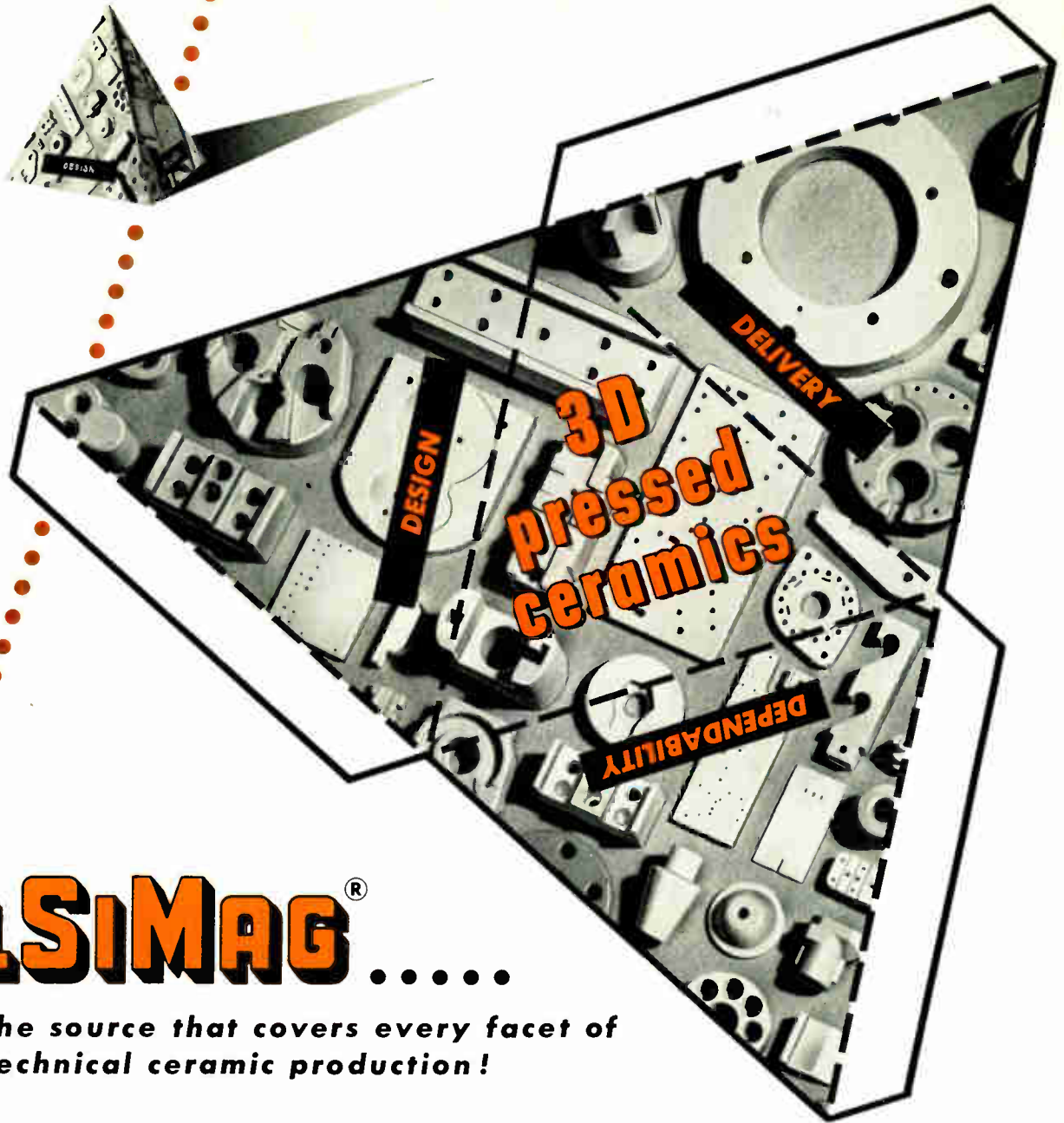

ALSiMAG®

the source that covers every facet of technical ceramic production!

DELIVERY—As promised. Facilities for any volume. Line-ups of modern, high-speed automatic presses—rotaries, single stroke types, domestic, imported. Specialized equipment for every operation. Dies produced in our own shop. Enormous kiln capacity. Staffed by experts dedicated to getting jobs done!

DEPENDABILITY—Widest choice of special characteristic materials in the industry. Compositions carefully matched to requirements. Proven production techniques. Quality Control throughout. Constant research and development. Over half a century of experience in supplying technical ceramics exact to specification.

DESIGN—Wider range—simplest to most intricate. Miniatures, multi-planes, wafer thins. Precision tolerances. Prototypes for test purposes. Free redesign service to improve efficiency, cut manufacturing costs. We produce parts others fear to try!

Your problems might be solved by ALSiMag Pressed Ceramics. Why not try them and see? Send blueprint or sketch with details of operating procedure for complete information.

AMERICAN LAVA

A Subsidiary of
Minnesota Mining and
Manufacturing Company



CORPORATION
CHATTANOOGA 5, TENN.
55TH YEAR OF CERAMIC LEADERSHIP

For service, contact Minnesota Mining & Manufacturing Co. Offices in these cities (see your local telephone directory): Atlanta, Ga. • Boston: Newton Center, Mass. • Buffalo, N. Y. • Chicago, Ill. • Cincinnati, O. • Cleveland, O. • Dallas, Texas • Detroit, Mich. • High Point, N. C. • Los Angeles, Calif. • New York: Ridgefield, N. J. • Philadelphia, Pa. • Pittsburgh, Pa. • St. Louis, Mo. • St. Paul, Minn. • So. San Francisco, Calif. • Seattle, Wash. Canada: Minnesota Mining & Manufacturing of Canada, Ltd., P. O. Box 757, London, Ont. All other export: Minnesota Mining & Manufacturing Co., International Division, 99 Park Ave., New York, N. Y.



TRANSPAC®
For Aircraft,
Guided Missiles,
And All
Miniaturized
Applications

MINIATURIZED POWER PACKS

**ACTUAL
SIZE
SHOWN**
Model TR20
Output 20vdc
at 200 MA

UNREGULATED TRANSPACS
Voltage ranges 5 through 2400 vdc output, currents up to 100 ma. For general tube and transistor applications.

**CONSTANT VOLTAGE
TRANSPACS**

Voltage ranges 75 through 900 vdc output, currents up to 40 ma. Line and load regulated. For general tube applications.

**CUSTOM DESIGNED
TRANSPACS**

ERA provides a complete service for special designs engineered in accordance with customer specifications. Write for quotation.

LOW VOLTAGE TRANSPACS

Available in voltage ranges 5 through 60 vdc output. Line and load regulated. Ideal for voltage reference, transistor and tube biases.

**TRANSISTORIZED
REGULATED TRANSPACS**

Available for DC outputs 5 through 300 vdc, currents up to 200 ma. Line and load regulated. For both tube and transistor applications.

**HIGH AMPERAGE
TRANSPACS**

Outputs 2.5 through 25 vdc, currents, up to 3 amperes. For DC filament, solenoid, and all high amperage applications.

**CONSTANT CURRENT
TRANSPACS**

Available in a full range of constant current regulated outputs. For electronic, electrical, chemical, and medical applications.

DUAL OUTPUT TRANSPACS

Constant current and constant voltage biases for AC operated transistor equipment.

TRANSPAC, a new concept in miniaturized, self contained AC operated DC power packs in 60 and 400 cycle models. Wired into circuits like other components, TRANSPAC supplies a rugged, reliable, stable source of DC power for all types of equipment. Over 60 stock models to choose from.

Write for TRANSPAC catalogue #IR-10 which lists detailed specifications.

*Trademark

Electronic Research Associates, Inc.

67 East Centre Street, Nutley 10, N.J.

Nutley 2-5410



Meetings with Exhibits

● As a service both to Members and the industry, we will endeavor to record in this column each month those meetings of IRE, its sections and professional groups which include exhibits.

△

Jan. 30, 1957

Electronics in Aviation Day, Sheraton-Astor Hotel, New York, N.Y.

Exhibits: Mr. R. R. Dexter, Institute of Aeronautical Sciences, Inc., 2 East 64th St., New York 21, N.Y.

Feb. 26-28, 1957

Western Joint Computer Conference, Statler Hotel, Los Angeles, Calif.

Exhibits: Mr. George P. West, Ramo-Wooldrige Corp., 5740 Arbor Vitae St., Los Angeles 45, Calif.

March 18-21, 1957

Radio Engineering Show and IRE National Convention, New York Coliseum, New York, N.Y.

Exhibits: Mr. William C. Copp, 1475 Broadway, New York 36, N.Y.

April 11-13, 1957

Ninth Southwestern IRE Conference and Electronic Show, Shamrock-Hilton Hotel, Houston, Tex.

Exhibits: Mr. Karl O. Heintz, P.O. Box 1234, Houston 1, Tex.

April 14-16, 1957

National Symposium on Telemetry, New Sheraton Hotel, Philadelphia, Pa.

Exhibits: Mr. L. P. Clark, Tele-Dynamics, Inc., 32nd & Walnut Sts., Philadelphia 4, Pa.

April 26-27, 1957

11th Annual Spring TV Conference, Engineering Society Building, Cincinnati, Ohio

Exhibits: Mr. Frank L. Wedig, Avco Mfg. Co., Cincinnati 25, Ohio

May 13-15, 1957

National Aeronautical & Navigational Conference, Dayton-Biltmore Hotel, Dayton, Ohio

Exhibits: Mr. R. W. Ittleson, 724 Golfview Drive, Dayton 6, Ohio

May 20-22, 1957

Armed Forces Communication & Electronics Association, Convention & Exhibits, Sheraton Park Hotel, Washington, 8, D.C.

Exhibits: Mr. William C. Copp, 1475 Broadway, New York 36, N.Y.

June 6-7, 1957

First National Symposium on Production Techniques, Willard Hotel, Washington, D.C.

Exhibits: Mr. Sidney Levine, 649 Monticello Drive, Falls Church, Va.

Note on Professional Group Meetings:

Some of the Professional Groups conduct meetings at which there are exhibits. Working committeemen on these groups are asked to send advance data to this column for publicity information. You may address these notices to the Advertising Department and of course listings are free to IRE Professional Groups.

WIDE RANGE
WIDE SWEEP-
Sweeping
OSCILLATOR

The
KAY
CALIBRATED
Mega-Sweep



- **Continuously Tunable Thru Video VHF and UHF Frequencies, 50KC-950MC Range**
- **Sweep Widths to 40 MC**
- **Single Dial Tuning**

Used with a standard cathode ray oscilloscope, the Kay Calibrated *Mega-Sweep* will display the response characteristic of wide band circuits over the frequency range of approximately 50 kc to 950 mc. It features a calibrated dial indication of the approximate output frequency. The center frequency of the sweeping output voltage may thus be set to an accuracy of about 10%. The calibrated *Mega-Sweep* is the ideal instrument for use in alignment of amplifiers and filters . . . also as an FM source of wide range for instructional and lab purposes.

SPECIFICATIONS

- Freq. Range:** 50 kc to 950 mc.
- Freq. Sweep:** Sawtooth, adjustable to 40 mc. Repetition rate, 50 to 100 c/s.
- RF Output:** *High*, approx. 100 mv max. into open circuit. *Low*, 5 mv into open circuit.
- RF Output Control:** Microwave attenuator continuously variable to 26 db.
- Output Waveform:** Less than 5% harmonic distortion at max. output.
- Meter:** Provides crystal detector current for peak output.
- Regulated Power Supply:** 105-125 v., 50 to 60 cps. Power Input, 100 watts.

Send for Catalog 110-A

\$495 f.o.b. factory

KAY
SWEEPING OSCILLATORS
for every application



KAY
Mega-Sweep

Widest range of the Kay line of sweeping oscillators. Provides continuous frequency coverage up through UHF-TV bands—50 kc to 1000 mc. Widely used in radar system development and in alignment and testing of TV and FM systems and components, as well as wide band IF and RF amplifiers and filters. Freq. range, 10 mc to 950 mc. Write for Catalog 100-A. Price, \$465 f.o.b. factory.



KAY
111-A CALIBRATED
Mega-Sweep

Higher output model calibrated *Mega-Sweep*, with zero level baseline. Higher output facilitates frequency response testing of UHF converters or tuners. Wider sweep width permits multi-channel response viewing. Zero level baseline is convenient means of measuring gain of test circuit.

Frequency Range	SPECIFICATIONS	
	Output Impedance	Output Voltage (Into Load)
1. 10 mc—950 mc	70 ohms unbalanced	0.15 Volts
2. 450 mc—900 mc	300 ohms balanced	0.3 Volts

Sweep Width: Continuously variable to approx. 40 mc max.
 Write for Catalog 111-A Price, \$575 f.o.b. factory

KAY 112-A CALIBRATED *Mega-Sweep*
 Same as 111-A, except total frequency range is 800 mc to 1200 mc. Catalog 112-A. Price, \$575 f.o.b. factory.

KAY ELECTRIC COMPANY Dept.
 14 MAPLE AVENUE PINE BROOK, N. J. 1-12
 CALdwell 6-4000

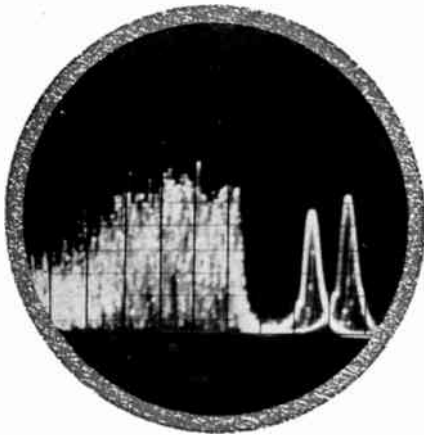

COMMUNICATIONS SYSTEMS ENGINEERS

The expanding scope of advanced communications projects has created several unique positions in fields related to VHF, UHF, microwave transmission and reception, forward scatter and single sideband applications at Hoffman. Electronics engineers with appropriate backgrounds will find these new assignments professionally stimulating and financially rewarding. Please address Vice President of Engineering:



Hoffman
LABORATORIES, INC.
3761 South Hill Street
Los Angeles 7, California
Telephone: RIchmond 9-4831

A SUBSIDIARY OF
HOFFMAN ELECTRONICS CORP.



Industrial Engineering Notes

INDUSTRY STATISTICS

Factory production of both radio and television receivers in August increased over the July level. Radio production increased over the August, 1955 level while TV showed a slight decline. Television output in August totaled 612,927 receivers compared with 336,931 produced in July. Television output in August, 1955 had totaled 647,903 units. Radio receiver production in August totaled 990,845 with 566,697 manufactured in July and 947,634 produced in August, 1955. Cumulative production figures for the first eight months of 1955 showed the production of 8,707,477 radios and 4,820,991 television receivers. TV sets manufactured with uhf tuning facilities totaled 90,419 compared with 41,803 produced in July, while 43 TV receivers containing fm circuits were manufactured in August compared with 273 produced in July. . . . The revised issue of the "Transistor Booklet," JETC Publication 6A, is now available. The booklet lists all transistors registered through September, 1956. Copies may be obtained from the RETMA Engineering Department, 11 West 42nd St., New York 36, N. Y., at \$2 each.

ENGINEER SHORTAGE

RETMA recently requested all of its member companies to submit answers to a recently distributed questionnaire pertaining to industry practices aimed at alleviating shortage of engineers, scientists and technical personnel. The purpose of the questionnaire is to fulfill a Department of Defense request of May 24, 1956, which asked the electronics industry to study the problem of technician shortages in the armed services and to propose means by which the situation might be alleviated. Guided by the RETMA Manpower Committee, under Chairman Grayson Swailes, of Hughes Aircraft Co., the two-stage survey is designed to (1) obtain in general terms a quantitative analysis of programs which are already in use in the electronics industry, and (2) submit any workable or proven practices which have been the most helpful in meeting the challenge of manpower shortages. The Manpower Committee believes that submission of the detailed information by member companies will enable RETMA to present to the Defense Department a comprehensive report on the qualitative aspects of programs which are in use in the electronics industry. At the same time, two other distinct services will be rendered through the survey, it is believed: (1) it will provide for the first time a library of comprehensive information on this vital subject, and (2) it will provide valuable guide lines to mem-

ber firms for the adoption and expansion of programs in this area, and will thus enable manufacturers to meet and solve the problem of manpower shortages in the vital areas of engineering, scientific and technical personnel.

MOBILIZATION

The Armed Services Electro-Standards Agency, Fort Monmouth, N. J., has announced the availability, in printed form, of the following documents and publications: MIL-R-11804B, Resistors, Fixed, Film (Power Type), MS91829, 16 Mar 56; MIL-R-11B, Resistors, Fixed, Composition (Insulated), Notice 1, 17 May 56; MIL-C-3883, Cord, Electrical (Audio Frequency), Amend-1, & 3 "SS," 20 Jun 56; MIL-C-3884, Cord, Electrical (Short Lay), Amend-1, 20 Jun 56; MIL-R-26C, Resistors, Fixed, Wirewound (Power Type), Notice 1, 28 Jun 56; MIL-C-62A, Capacitors, Fixed, Electrolytic (DC, Aluminum, Dry Electrolytic, Polarized), Amend-1, 26 Jul 56; and MIL-W-85C, Waveguide, Rigid, Rectangular, Amend-2, 9 Jul 56.

RESEARCH

The Office of Technical Services, U. S. Department of Commerce, has announced the availability of proceedings of the "First Joint Military-Industry Packaging and Materials Handling Symposium," compiled by the Navy. The 695-page illustrated volume (PB 121350) may be ordered from OTS, U. S. Department of Commerce, Washington 25, D. C., for \$6. A 102-page volume containing Navy-sponsored lectures on the philosophy and practical use of statistics in research and design has been made available to the public, the Office of Technical Services, U. S. Department of Commerce also announced. Order PB 121181, "Collection of Papers Presented at the Colloquium in Statistical Design of Laboratory Experiments," is available from OTS for \$2.75.

RETMA ACTIVITIES

The RETMA Engineering Department just announced that the following new standards were issued in August, 1956 and are available through the engineering office, 11 West 42nd St., New York 36, N. Y.: RS-161—Unit Standards for Ceram-

(Continued on page 12A)

* The data on which these NOTES are based were selected by permission from *Industry Reports*, issues of September 24, October 1, 8, 15 and 22, published by the Radio-Electronics-Television Manufacturers Association whose helpfulness is gratefully acknowledged.

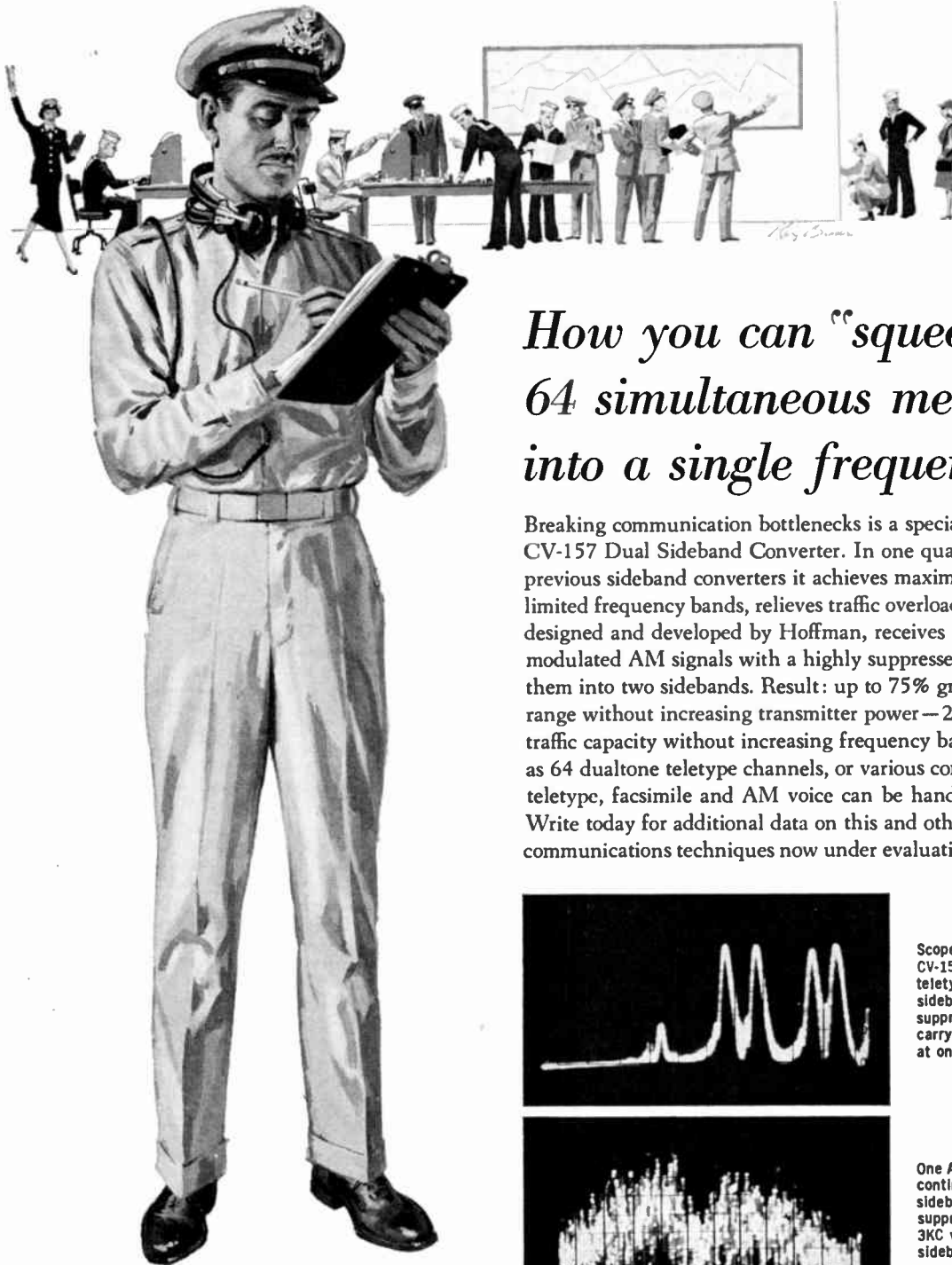

How you can "squeeze" 64 simultaneous messages into a single frequency

Breaking communication bottlenecks is a specialty of the Hoffman CV-157 Dual Sideband Converter. In one quarter the space of previous sideband converters it achieves maximum use of today's limited frequency bands, relieves traffic overloads. The CV-157, designed and developed by Hoffman, receives independently modulated AM signals with a highly suppressed carrier and splits them into two sidebands. Result: up to 75% greater effective range without increasing transmitter power—2 to 32 times more traffic capacity without increasing frequency bandwidths. As many as 64 dualtone teletype channels, or various combinations of teletype, facsimile and AM voice can be handled by the CV-157. Write today for additional data on this and other advanced communications techniques now under evaluation at Hoffman.

Electronics and Mechanical Engineers
Significant developments at Hoffman in the fields of VLF, HF, VHF, UHF, forward scatter and tropospheric communications, single sideband and advanced ECM techniques have created important positions for engineers of high calibre. Please address inquiries to Vice-President of Engineering.

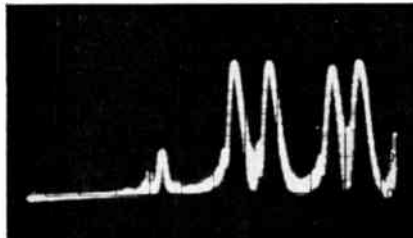

Scope pattern taken from Hoffman CV-157 showing two dualtone teletype channels on upper sideband, carrier partially suppressed. Each sideband can carry 32 teletype channels at one time.

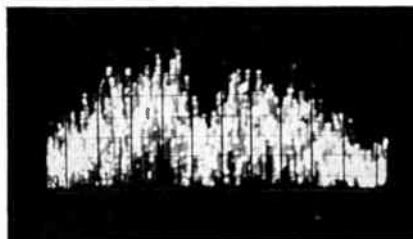

One AM voice channel (made by continuous vowel sound) on each sideband, carrier completely suppressed. CV-157 carries two 3KC voice channels on each sideband.

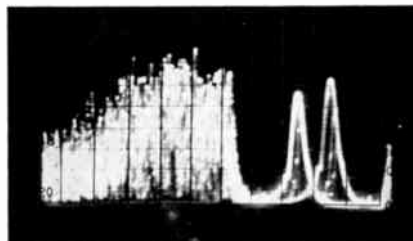

AM voice on lower sideband, dualtone teletype channel on upper. With suitable multiplexing equipment, the CV-157 handles 64 simultaneous dualtone teletype channels.

ALL PHOTOS UNRETOUCHED
FROM PANALYZOR MODEL SB-8

Hoffman LABORATORIES, INC.

A SUBSIDIARY OF HOFFMAN ELECTRONICS CORPORATION

3761 South Hill Street • Los Angeles 7, California

NEW **ULTRA-BROADBAND** **MICROWAVE** **SIGNAL** **GENERATOR**



POLARAD MSG-34

*Replaces 2 or more
present-day
signal generators
normally required
to cover
C and X bands
(4,200-11,000 mc)*

The new Polarad MSG-34 outperforms all existing signal generators both in frequency coverage and ease of operation. In all respects, it is the most efficient and economical instrument to generate frequencies between 4,200 and 11,000 mc at high power level.

By means of a unique design utilizing Polarad's exclusive UNI-DIAL control, Ultra-Broadband Frequency Coverage has been achieved in one completely integrated unit. Reflector voltages are automatically tracked while tuning continuously. Frequency is read direct from an expanded linear dial, eliminating the need for mode charts or slide rule interpolations.

Because of its operational simplicity and ultra broadband coverage, the MSG-34 will save valuable engineering and production-line man-hours.

AVAILABLE ON EQUIPMENT LEASE PLAN



ELECTRONICS CORPORATION
43-20 34th STREET, LONG ISLAND CITY 1, N. Y.

one continuous control 4,200-11,000mc

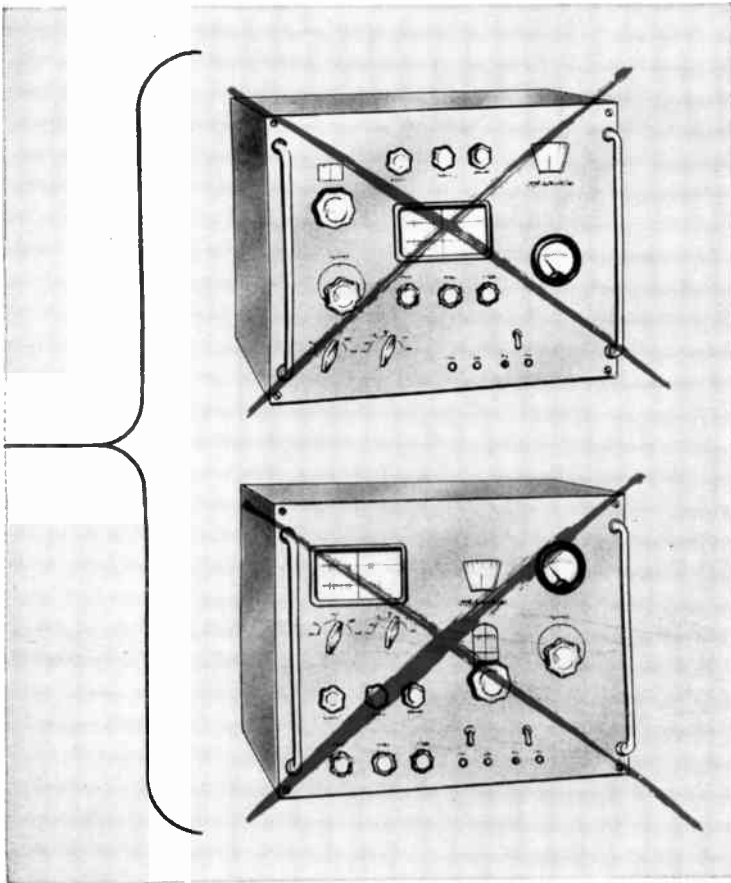

**Maintenance Available by
Field Service Specialists**

Features:

- Automatic power level control
- 1 milliwatt output
- UNI-DIAL tuning
- Internal pulse modulation: 10 to 10,000 pps.
- Internal square wave modulation: 10 to 10,000 pps.
- Pulse rise and decay time 0.1 μ sec.
- Non-contacting choke in oscillator
- Provision for external modulation, sine wave pulse, multiple pulse
- Unitized construction.

Specifications:

Frequency Range:
4,200 mc to 11,000 mc

Frequency Accuracy: $\pm 1\%$

Power Output:
1 milliwatt (0 dbm)
calibrated

Attenuator Output Range:
0 dbm to -127 dbm,
0.223 volts to 0.1
microvolt,
(directly calibrated).

**Attenuator Output
Accuracy:** ± 2 db from
0 to -127 dbm

Output Impedance:
50 ohms nominal.

Output VSWR: 2:1 maximum

Internal Pulse Modulation:
Width: 0.2 to 10 micro-
seconds.

Repetition Rate: 10 to
10,000 pps
Delay: 2 to 2,000 micro-
seconds.

Sync: internal, external-
pulse or sine wave.
Rise Time: 0.1 microsecond
as measured between
10% and 90% of maxi-
mum amplitude of the
initial rise.

Decay Time: 0.1 micro-
second as measured be-
tween 10% and 90% of
maximum amplitude of
the final decay.

Internal Square Wave:
Rate: 10 to 10,000 pps.
Symmetry: $\pm 5\%$
Sync: Internal

Internal FM:
Type: Linear sawtooth.
Frequency Deviation:
5 mc minimum.
Rate: 10 to 10,000 cps.
Synchronization: Internal
or external, pulse or
sine wave.

External Pulse Modulation:
Polarity: Positive or
negative.
Rate: 10 to 10,000 pps.
Pulse Width: 0.2 to 100
microseconds.
Amplitude: 10 to 40 volts
peak.

**Output Synchronization
Pulses:**
Polarity: Positive, delayed
and undelayed
Rate: 10 to 10,000 pps.
Amplitude: 15 volts peak
minimum.
Rise Time: Less than 0.25
microsecond.

External Sync:
Type of Input: Positive,
negative, or sine wave.
Amplitude: Pulse: 5 to 50
volts peak;
Sine wave: 5 to 40 volts
rms.

REPRESENTATIVES: Albuquerque, Atlanta, Baltimore, Boston, Buffalo, Chicago, Cleveland, Dayton, Denver; Fort Worth, Kansas City, Los Angeles, New York, Philadelphia, Portland, St. Louis, San Francisco, Schenectady, Syracuse, Washington, D. C., Winston-Salem, Canada; Arnprior, Ontario. Resident Representatives in Principal Foreign Cities

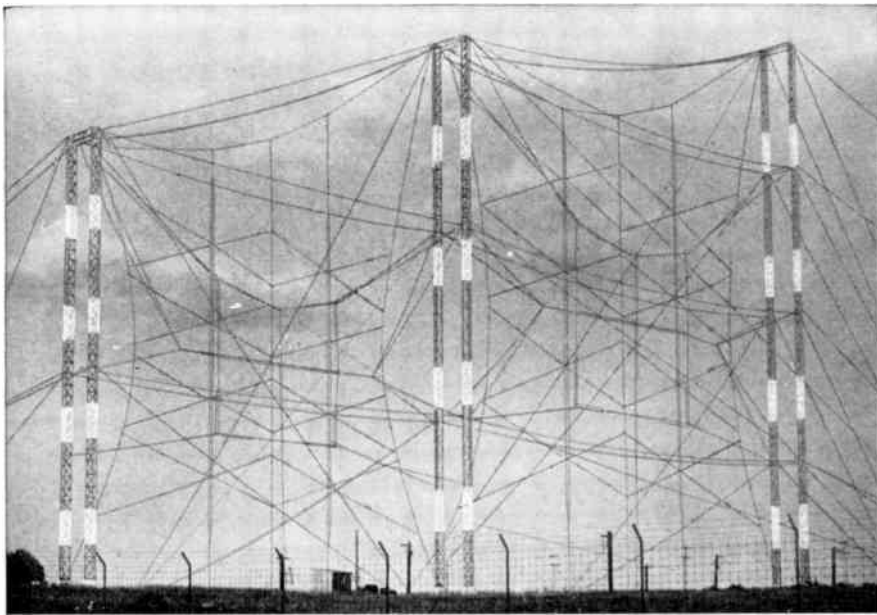

No Antenna Design Guesswork Here!

The difficult problem of "broadbanding" curtain antennas used for international broadcasting was mastered for the first time in this recent Trylon installation. Here, two curtain antennas were designed for bandwidths of $\pm 15\%$ of center frequencies (13.5 and 19.85 mc) with a maximum VSWR of only 1.5. Careful consideration of side lobes and back radiation was necessary to reduce interference as well as to achieve the hard-to-realize 5 to 10% improvement in readability compared with conventional rhombics of the same gain.

The experience of Trylon antenna specialists is no better demonstrated than by the actual "on the air" field measurements made after the completion of this complicated installation. Not only did the radiation pattern remain essentially as predicted in Trylon's initial calculations, but a gain of 18 db over a quarter-wave dipole was obtained.

Trylon welcomes the opportunity to apply the same sound engineering approach to every phase of your next antenna installation—whether for AM, FM, TV, Microwave, or long-distance communications.



**ANTENNA DESIGN, FABRICATION,
INSTALLATION**

GALVANIZED STEEL TOWERS

**ANTENNA SELECTOR, SHORTING,
and SLEWING SWITCHES**

HEAVY-DUTY ANTENNA ROTATORS

WIND TURBINE COMPANY, West Chester, Pa.

In Canada: The Wind Turbine Company of Canada, Ltd., Toronto 9, Ontario



Industrial Engineering Notes

(Continued from page 8A)

ic Based Printed Circuits; RS-162—Test Standards for Ceramic Based Printed Circuits; RS-163—RF Radiation Label; RS-164—Fixed Paper Dielectric Capacitors in Tubular Non-Metallic Cases (Rev. REC-118-A); and RS-165—Ceramic Dielectric Capacitors, 1000-7500 Volt Rating, Classes 1 and 2.

TECHNICAL

A collection of technical papers presented at a Symposium on the Application of Transistors in Military Electronics Equipment sponsored by the Department of Defense in 1953 is available for industry use from the Office of Technical Services, Commerce Department. The 32 papers contained in the 508-page illustrated volume are mainly concerned with fabrication of transistors by laboratory or pilot line techniques or combinations of both. The symposium was held at Yale University and featured speakers from both military and industrial laboratories. The publication, "Symposium on The Application of Transistors to Military Electronics Equipment" is number PB 111680, and can be ordered by the OTS, Commerce Department, Washington 25, D. C., for \$5. . . .

Development of two portable self-readers for the Navy's DT-60 personal dosimeter, which uses a silver-activated phosphate glass that reacts to gamma radiation, is described in two research reports just released by the Navy. Both reports can be obtained from the Office of Technical Services, Commerce Department, Washington 25, D. C., for 50 cents each. "A Portable Reader for DT-60 Dosimeters"—number PB 111887, states that operation of the dosimeter is by means of self-contained batteries and the reader is operable from an external source of either six volts DC or 115 volts AC. "A Pulsed-Light Reader for the DT-60 Glass Dosimeter"—number PB 111977, states that a storage capacitor, charged to a voltage proportional to the peak intensity of dosimeter fluorescence, is used to unbalance a vacuum-tube bridge circuit, and a meter reading bridge unbalance is calibrated directly in roentgens dosage. Power is supplied by five type-D flashlight batteries. . . . Thirty-five new technical problems for the attention of the nation's civilian inventors have been assigned by the Defense Department to the National Inventors Council, Commerce Department, the liaison agency between inventors and the armed services. These problems are published in a supplement to the Council's cumulative list, "Technical Problems Affecting National Defense." The supplement and the cumulative list may be obtained by writing to NIC, Department of Commerce, Washington 25, D. C. An inventor who has a proposed solution to any of the listed problems can submit ideas to the council for evaluation and, if the solution appears practicable, a presentation will be pre-

(Continued on page 14A)

International Silicon Diodes

Over 600 types

in full production!

PIV ratings up to 16,000 volts . . .

for high reliability

over a wide temperature range



Write on your letterhead for bulletins on any or all types illustrated. If you have a particular problem, our Application Advisory Group will be happy to submit a prompt evaluation and recommendation.

International Rectifier

C O R P O R A T I O N

EXECUTIVE OFFICES: EL SEGUNDO, CALIFORNIA • PHONE OREGON 8-6281

NEW YORK: 132 E. 70TH ST., TRAFALGAR 9-3330 • CHICAGO, 205 W. WACKER DR., FRANKLIN 2-3889

IN CANADA: ATLAS RADIO CORP., LTD., 50 WINGOLO AVE. W., TORONTO, ONTARIO, RU 1-6174

THE WORLD'S LARGEST SUPPLIER OF INDUSTRIAL METALLIC RECTIFIERS

AMONG IMPORTANT
ACTIVITIES AT HUGHES
IS A PROGRAM INVOLVING
COMPREHENSIVE
TESTING AND EVALUATION
IN CONNECTION WITH
HUGHES-DEVELOPED
RADAR FIRE CONTROL
AND NAVIGATION SYSTEMS
FOR LATEST TYPE
MILITARY ALL-WEATHER
INTERCEPTORS.



Convair F-102
all-weather interceptor.

System Test Engineers and Instrumentation Engineers

Scientific Staff Relations

HUGHES

There is need on our Staff for qualified engineers who thoroughly understand this field of operation, and who have sufficient analytical and theoretical ability to define needed tests; outline test specifications; assess data derived from such tests, and present an evaluation of performance in report form.

Engineers who qualify in this area should have 1 a basic interest in the system concept and over-all operation of test procedures; 2 experience in operation, maintenance, "debugging," development, and evaluation testing of electronic systems, and knowledge of laboratory and flight test procedures and equipment; 3 understanding of basic circuit applications at all frequencies; 4 initiative to secure supporting information from obscure sources.

Research and Development Laboratories
HUGHES AIRCRAFT COMPANY
Culver City, Los Angeles County, California



Industrial Engineering Notes

(Continued from page 12A)

pared for submission to the proper military agency. Problems in the supplement and cumulative list range through the fields of electronics, aeronautics, mechanics, plastics, chemistry, instrumentation, materials handling, metallurgy, and others. . . . A 215-225-mc converter to reduce noise in vhf receivers has been designed and developed by the Naval Research Laboratory and is described in a research report available to industry through the Office of Technical Services, Commerce Department. The publication, "A Low Noise 215-225-Mc Converter" states that the converter achieves a low noise figure in the receiver equipment that was unattainable with previous tubes. With the use of a General Electric GL 6299 triode the converter tunes the desired frequency range while the noise figure is due to low losses, low equivalent noise resistance, and low transit time conductance of the tubes. The GE tube is small in size, has low power requirements and excellent noise characteristics, according to the report. The report, number PB 121214, may be ordered from the OTS, Commerce Department, Washington 25, D. C., for 50 cents. . . . A new film, "Engineering—A Career for Tomorrow," is now being distributed by the Chicago Alumni Chapter of Eta Kappa Nu Association, the electrical engineering honor society. The 25-minute sound film, available in 16 mm color or black-and-white, outlines for youth audiences the work and opportunities available in the many fields of engineering, and the education and aptitudes necessary to carve a successful engineering career. The film has been cleared for television, and the Eta Kappa Nu Association will supply black-and-white copies on a loan basis free of charge for educational television station usage. Prices, postpaid, are: \$156.00 for color and \$81.00 for black-and-white, including reel, can and mailing carton. Inquiries regarding the film should be addressed to J. E. Farley, Illinois Bell Telephone Co., Room 301, 208 West Washington St., Chicago 6, Ill.

TELEVISION

The Federal Communications Commission now has under consideration the institution of a rule making proceeding for the purpose of adopting a standard test signal to be transmitted by television broadcast stations. The commission believes that it would be helpful in the meantime if television stations are authorized, without further specific authority, to transmit test signals during programming. Such test transmissions can be used for the purpose of developing and testing the feasibility of the method employed and will be of assistance in the preparation of comments and data in such rule making proceedings as may be instituted. Station licensees are cautioned, however, that the

(Continued on page 16A)

HUGHES PRODUCTS

proudly announces

TONOTRON

- Full circle persistence
- Displays complete spectrum of gray shades
- Controllable persistence
- Controllable rate of decay
- No hood needed, even in direct sunlight
- 5-inch screen

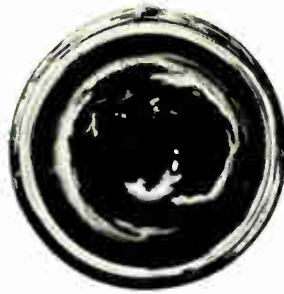

Weather radar with brilliant half-tone picture.



Narrow band, slow scan. Closed-circuit TV.



Freeze action until intentionally erased.



DIMENSIONS

- Over-all length: $11\frac{3}{8}$ inches, $\pm 3/8$ inch.
- Bulb diameter: $5\frac{3}{8}$ inches, maximum.
- Neck diameter: 1 inch, $\pm 1/16$ inch.



Single transient pulse, 20 micro-seconds wide with a one micro-second rise time, showing writing capabilities of one million inches per second. This photo was taken in full daylight without a hood.



MEMOTRON

Memotron gives instant and permanent display of one or successive transients.

HUGHES PRODUCTS

A DIVISION OF THE HUGHES AIRCRAFT COMPANY

ELECTRON TUBES

For descriptive literature write to
HUGHES PRODUCTS
ELECTRON TUBES
International Airport Station, Los Angeles 45, California

50 ohm Coax Terminations dc to 4 KMC!



8 new instruments! 1 to 500 watts coverage!

New Sierra 160 series Coaxial Terminations are ideal for use with directional couplers, or in other applications requiring wide frequency range and low VSWR. They provide extremely high stability, and will dissipate full rated power continuously up to an ambient temperature of 40°C. Derating permits operating at still greater ambient temperatures. Terminations are completely shielded, and may be used to adjust transmitters without radiation. They are also useful for converting Sierra Bi-Directional Power Monitors to a termination type wattmeter.

SPECIFICATIONS

Model	Power*	Connectors	VSWR
160-1F	1 watt	Type N fem.	Less than 1.06, dc to 2 KMC; } less than 1.08, dc to 4 KMC. }
160-1M	1 watt	Type N male	
160-5F	5 watts	Type N fem.	Less than 1.08, dc to 4 KMC.
160-5M	5 watts	Type N male	
160-20F	20 watts	Type N fem.	Less than 1.08, dc to 1 KMC; } less than 1.15, dc to 4 KMC. }
160-20M	20 watts	Type N male	
160-100F	100 watts	Type N fem.	Less than 1.2, dc to 3300 MC.
160-500F	500 watts	Type N fem.	

*Up to 40° C ambient.

New LOW PASS FILTERS

Sierra 184 series Low Pass Filters have an insertion loss not more than 0.4 db in pass band, sharp cut-off, 1.5 VSWR or less, and rejection greater than 60 db from 1.25 to 10 times cut-off frequency. Five models: for cut-off frequencies of 44, 76, 135, 230, 400 MC. Power range 250 watts in pass band, 25 watts in rejection band.

Write for Bulletin!

Sierra Electronic Corporation

San Carlos 2, California, U.S.A.
Canada: Atlas Radio Corporation, Ltd.
Toronto, Ontario

Manufacturers of Carrier Frequency Voltmeters, Directional Couplers, Wave Analyzers, Line Fault Analyzers, Wideband RF Transformers, Custom Radio Transmitters, VHF-UHF Detectors, Variable Impedance Wattmeters, Reflection Coefficient Meters, Calorimeters, Water Loads, Thermopiles, Ion Gauge and Ion Gauge Amplifiers, Phase Changers.

3663



sierra

Sales representatives in major cities



Industrial Engineering Notes

(Continued from page 14A)

specifications of any test signal which may be adopted will be determined after rule making, and equipment which may be used under this test authorization may be rendered obsolete as a result of the final specifications adopted, the FCC said. The transmission of test signals during program time pursuant to this Notice shall not interfere with synchronization nor degrade the quality of picture reception. Minor departures from signal specifications prescribed by the rules are permitted. Television broadcast stations are authorized to conduct test transmissions in accordance with the foregoing for the period ending January 15, 1957. Stations originating test signals under this experimental authorization are requested to notify the commission. . . . A notice appeared in the Federal Register of Oct. 10 which stated that all inquiry into the feasibility of transferring television broadcasting to the uhf band and comments pertaining thereto would be accepted by the Federal Communications Commission for an indefinite period. Though the date for filing comments in Docket 11532 ended Oct. 1, the commission said: "The comments filed by Oct. 1 will be carefully reviewed and evaluated by the commission, and it is expected that they will provide assistance to the commission in deciding what further steps should be taken in the long-range program for television. However, in view of the far-reaching, long-range character of the changes that would be involved in a transfer of all or a major part of television to the uhf and the time that would be required to make all of the necessary determinations as to its feasibility, it will be helpful if we continue to accept comments under this inquiry and, accordingly, no final date for the submission of such further comments is being designated at this time. As developments occur which shed new light on the problems which must be resolved before the commission decides whether to embark upon a specific, detailed change-over program, interested parties are requested to continue to file comments and supplementary comments on any aspects of the problem of converting television to uhf which may assist us in our continuing study of this subject." . . . The Federal Communications Commission has granted four more TV translator stations, bringing the total of such authorizations to ten. The grants went to: Eugene Strausser, to operate on Channel 80 in Center, Colo., and L. H. Faast, d/b as Faast TV to operate on Channel 70 in Doyleville, Colo., both to translate (rebroadcast) the programs of KCSJ-TV (Channel 5), Pueblo; City of Truth or Consequences, a municipal corporation to operate on Channel 70 in that city, N. Mex., to translate programs of KOB-TV (Channel 4), Albuquerque, N. Mex.; and Kittitas Valley T. V. Assn., Inc., to operate on Channel 71 in Ellensburg, Wash., to translate programs of KIMA-TV (Channel 29), Yakima.

Amperex[®] 4X150A...

...the **QUALITY**
4X150A

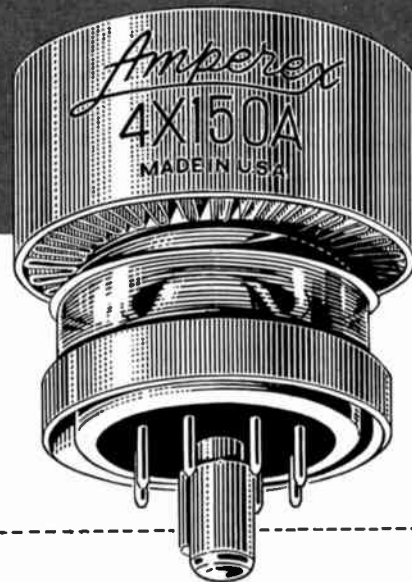

The reason why so many engineers are specifying AMPEREX 4X150A's for military equipment is not merely AMPEREX's reputation for extra-generous design and quality control. The AMPEREX 4X150A is outstanding in a number of specific qualitative details.

Most important of these is the use of exclusive metallurgical techniques and specially developed metal alloys in the construction of the tube elements. This insures freedom from deposits on the insulating materials, thereby eliminating electrical interelectrode leakage. Thus the AMPEREX 4X150A can be expected to retain its initial characteristics throughout its extended life.

The use of AMPEREX-developed automatic exhaust machine and other exclusive automation techniques are a further insurance of exceptionally uniform and stable 4X150A's... each, individually tested *beyond* JAN specifications.

OTHER OUTSTANDING FEATURES

- Exclusive all-molybdenum grid structure – for exceptional rigidity and mechanical strength.
- AMPEREX-pioneered powdered-glass stem – for high resistance to thermal and mechanical shock.
- Special-process corrosion resistant silver plating on all external metal surfaces.

Write for detailed data and/or applications-engineering information... convince yourself that the AMPEREX 4X150A is in a *quality class* by itself.



Amperex ELECTRONIC CORP.

230 Duffy Ave., Hicksville, Long Island, N. Y.

FREED

MIL-T-27A POWER, FILAMENT, PULSE & AUDIO TRANSFORMERS

FOR IMMEDIATE DELIVERY FROM STOCK

POWER TRANSFORMERS-STANDARD

All primaries 105/115/125 v., 60 c.p.s.

Cat. No.	Hi Volt Sec.	ct	DC Volts	DC Amps	Filament		MIL Case Size		
					Filament #1	Filament #2			
MGP1	400/200	✓	185	.070	6.3/5	2	6.3	3	HA
MGP2	650	✓	260	.070	6.3/5	2	6.3	4	JB
MGP3	650	✓	245	.150	6.3	5	5.0	3	KB
MGP4	800	✓	318	.175	5.0	3	6.3	8	LB
MGP5	900	✓	345	.250	5.0	3	6.3	8	MB
MGP6	700	✓	255	.250					KB
MGP7	1100	✓	419	.250					LB
MGP8	1600	✓	640	.250					NB

FILAMENT TRANSFORMERS-STANDARD

All primaries 105/115/125 v., 60 c.p.s.

Cat. No.	Secondary		Test VRMS	MIL Case
	Volt	Amp		
MGF1	2.5	3.0	2,500	EB
MGF2	2.5	10.0	2,500	GB
MGF3	5.0	3.0	2,500	FB
MGF4	5.0	10.0	2,500	HB
MGF5	6.3	2.0	2,500	FB
MGF6	6.3	5.0	2,500	GB
MGF7	6.3	10.0	2,500	JB
MGF8	6.3	20.0	2,500	KB
MGF9	2.5	10.0	10,000	JB
MGF10	5.0	10.0	10,000	KB

PULSE TRANSFORMERS

Cat. No.	Block & Dtc.	Int. Coupl'g	Low Pow. Out.	Pulse Voltage Kilovolts	Pulse Duration Microseconds	Duty Rate	No. of Wdgs.	Test Volt. KV RMS	Char. Imp. Ohms
MPT1	✓	✓	✓	0.25/0.25/0.25	0.2-1.0	.004	3	0.7	250
MPT2	✓	✓	✓	0.25/0.25	0.2-1.0	.004	2	0.7	250
MPT3	✓	✓	✓	0.5/0.5/0.5	0.2-1.5	.002	3	1.0	250
MPT4	✓	✓	✓	0.5/0.5	0.2-1.5	.002	2	1.0	250
MPT5	✓	✓	✓	0.5/0.5/0.5	0.5-2.0	.002	3	1.0	500
MPT6	✓	✓	✓	0.5/0.5	0.5-2.0	.002	2	1.0	500
MPT7	✓	✓	✓	0.7/0.7/0.7	0.5-1.5	.002	3	1.5	200
MPT8	✓	✓	✓	0.7/0.7	0.5-1.5	.002	2	1.5	200
MPT9	✓	✓	✓	1.0/1.0/1.0	0.7-3.5	.002	3	2.0	200
MPT10	✓	✓	✓	1.0/1.0	0.7-3.5	.002	2	2.0	200
MPT11	✓	✓	✓	1.0/1.0/1.0	1.0-5.0	.002	3	2.0	500
MPT12	✓	✓	✓	0.15/0.15/0.3/0.3	0.2-1.0	.004	4	0.7	700

AUDIO TRANSFORMERS

Catalog No.	Application	Impedance				P.P. Current	Min. Level
		Prim. Ohms	CL	Sec. Ohms	CL		
MGA1	Single or P.P. Plates to Single or P.P. Grids	10K	✓	90K Split	✓	10	15
MGA2	Line to Voice Coil	600 Split	✓	4, 8, 16	✓	0	33
MGA3	Line to Single or P.P. Grids	600 Split	✓	135K	✓	0	15
MGA4	Line to Line	600 Split	✓	600 Split	✓	0	15
MGA5	Single Plate to Line	7.6K 4.8T	✓	600 Split	✓	40	33
MGA6	Single Plate to Voice Coil	7.0K 4.8T	✓	4, 8, 16	✓	40	33
MGA7	Single or P.P. Plates to Line	15K	✓	600 Split	✓	10	33
MGA8	P.P. Plates to Line	24K	✓	600 Split	✓	10	33
MGA9	P.P. Plates to Line	60K	✓	600 Split	✓	10	27

Send for further information on these units, or special designs. Also ask for complete laboratory test instrument catalog.

FREED

TRANSFORMER CO., INC.

1720 Weirfield Street
Brooklyn (Kidgewood) 27, New York



J. E. W. Sterling, president of Stanford University and board chairman of Stanford Research Institute, has announced the appointment of **E. F. Carter** (A'23-F'36) as director of SRI. Mr. Carter has also been named to the Institute's board of directors.

The new chief executive of the applied research center joined SRI in 1954 as manager of research operations. Upon the resignation of J. E. Hobson, the Institute's head for eight years, last December, Mr. Carter was named associate director and since then has been responsible for overall direction of the Institute's activities.

A native of Elgin, Texas, Mr. Carter received a B.S. degree in engineering from Rice Institute in 1922. He began his career as a student engineer with the General Electric Co. at Schenectady, N. Y. Successively he became a section leader and a division engineer in the firm's radio department. In 1929 Mr. Carter joined the United Research Corporation, New York, where he was in charge of the radio division. Mr. Carter joined Sylvania Electric Products Co. in 1932, starting as a division engineer at Emporium, Pa. Moving to New York in 1941, he was named director of industrial relations, and in 1945 he became vice-president in charge of industrial relations.

He was appointed vice-president in charge of engineering at Sylvania in 1946 and advanced to the post of vice-president and technical director in 1952, a title he held until coming to SRI.

Mr. Carter has made twenty inventions in the field of electronics and holds patents on single frequency duplex transmission and reception, automatic volume control, certain control circuits and various improvements in radio receiver circuits.

A devoted "radio ham," Mr. Carter has long pursued the hobby

of radio contact with amateur operators around the world. He has been a licensed radio operator for thirty-five years and presently holds call letters K6GT.

SRI's new director is active in the American Institute of Electrical Engineers and the Illuminating Engineering Society. In addition he belongs to Tau Beta Pi and the American Radio Relay League.



M. P. WILDER

M. P. Wilder (A'28-SM'55), scientist in cathode-ray tube development over the past twenty-five years, has joined Allen B. Du Mont Laboratories, Inc. as staff engineer in charge of the company's storage tube development program. The announcement was made by Stanley J. Koch, director of Du Mont's Tube Research Division.

Immediately prior to joining Du Mont, Mr. Wilder was manager of the Photo-Forming Division of the Superior Tube Company, Norristown, Pennsylvania. From 1951 to 1954 he served as manager of the Stamford Division, Allen D. Cardwell Productions Corp., Stamford, Connecticut.

(Continued on page 22A)



**are you
killing
that still,
small
voice?**

When that voice prods your professional ego with, "You can do bigger and better things!" do you smother it with a wet blanket of doubt?

And when that same voice whispers to you of a gentle climate where the snow is yours just for the asking and sunshine is always yours for the basking, do you clobber it with the sledge hammer of self-denial?

Don't kill that voice! Its wisdom could lead you to a place where you'll find those bigger things, that better life—Firestone. If you've a mind that can matter in the guided missile field, Firestone needs you in its vital development program for the Army's "Corporal," first surface-to-surface guided ballistic missile. Here are just a few of our needs:

Flight Simulation
Electronics Systems
Missile Component Design
Systems Analysis
Structural Design
Field Engineering

Next time you hear that still, small voice, don't reach for your shotgun. Reach for your pen. Write—right now! Let that still, small voice guide you to big accomplishment for you, big happiness for your family!

Firestone

GUIDED MISSILE DIVISION
RESEARCH • DEVELOPMENT • MANUFACTURE

"Find your Future at Firestone"—Los Angeles • Monterey

WRITE: SCIENTIFIC STAFF DIRECTOR, LOS ANGELES 54, CALIF.

DESIGN PROBLEM:

More Rectifier Power per Dollar?

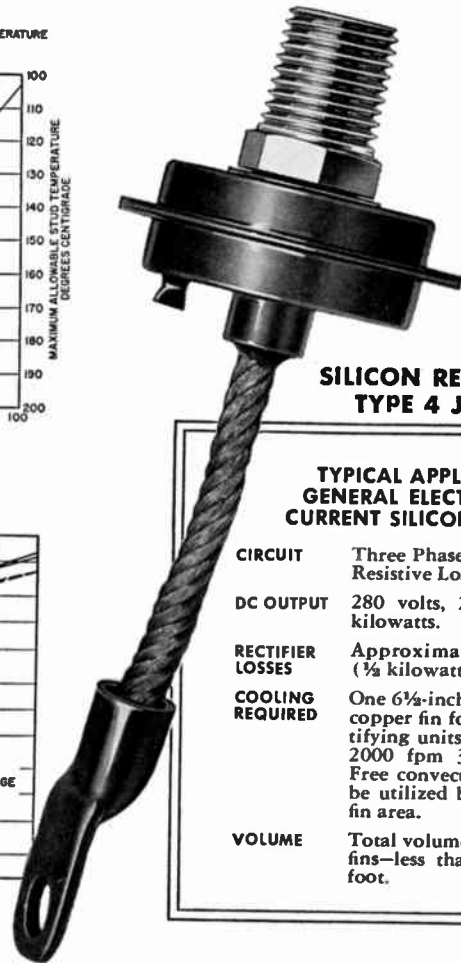
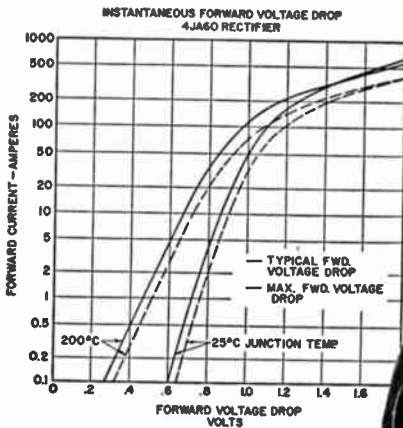
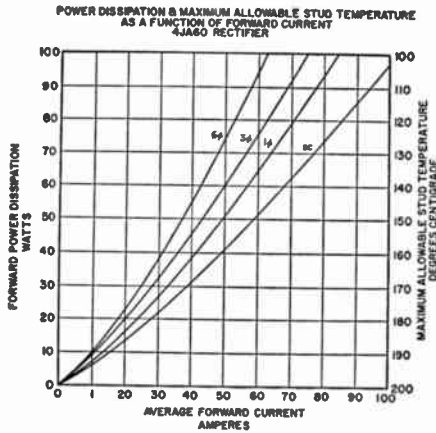

**SILICON RECTIFIER
TYPE 4 JA60**

TYPICAL APPLICATION GENERAL ELECTRIC HIGH CURRENT SILICON RECTIFIER

CIRCUIT	Three Phase Bridge Rectifier, Resistive Load.
DC OUTPUT	280 volts, 215 amperes, 60 kilowatts.
RECTIFIER LOSSES	Approximately one percent ($\frac{1}{2}$ kilowatt).
COOLING REQUIRED	One $6\frac{1}{2}$ -inch square $\frac{1}{8}$ " thick copper fin for each of six rectifying units when used with 2000 fpm 30°C forced air. Free convection cooling may be utilized by increasing the fin area.
VOLUME	Total volume of rectifiers and fins—less than $\frac{1}{2}$ of a cubic foot.

High Current SILICON RECTIFIERS, available now, cost less than other rectifying devices!



High Capacity Silicon Rectifiers—with rating up to 85 amps at 300 volt operating levels—now cost no more than other junction type rectifiers. These high-efficiency silicon rectifiers are produced using the alloy technique developed by General Electric research. Extended life tests show no deterioration in rectifier characteristics when operated at full rated condition.

All-Welded Seal for Trouble-Free Service. With the large area silicon element hermetically sealed within a steel housing, General Electric Silicon Rectifiers are immune to troubles caused by moisture, vibration, dust, or corrosion. They may be mounted in any position; and have a safe temperature range greater than any of the other junction-type units. Their "plumbing type" stud fitting assures fast cooling through heat sink connections.

Work Anywhere. General Electric Silicon Rectifiers can be

used in *any* rectifier application. They are being installed now in many applications including:

Arc Furnaces	Magnetic Devices
Cathodic Protection	Shop DC Supply
DC Motor Supply	Welding Equipment

All General Electric Silicon Rectifiers meet rigid military requirements. They are now available in four voltage ranges. For detailed application engineering information, consult your General Electric representative, or write to *General Electric Company, Semiconductor Products, Section X52126, Electronics Park, Syracuse, New York.*

Progress Is Our Most Important Product

GENERAL  ELECTRIC

Standardization saves you

TIME and MONEY

with

HUDSON
Precision Drawn
CASES-COVERS

3 MODERN PLANTS

Offering Precision Fabrication of:

STEEL
BRASS
ALUMINUM
COPPER
MU METAL

Including:

CERTIFIED
ALLOY WELDING
CERTIFIED
SPOT WELDING
SILVER SOLDERING
BRAZING

Call or write for prices on standard closures or send drawings for quotations on special parts or sub-assemblies.



Ask for your copy of the new Hudson Catalog



● PRECISION DRAWN CLOSURES

● QUALITY METAL STAMPINGS

● SHEET METAL WORK

Hudson Specialized Production Methods ...

Hudson standardized production makes it possible to solve even unusual closure problems quickly, with standard stock components. HUDSON offers the highest quality precision drawn closures at commercial prices. The standard line includes over a thousand types in sizes ranging from large to miniature, most available with a wide range of optional features. Check your closure requirements with HUDSON to assure maximum economy — fastest possible delivery!

HUDSON TOOL & DIE COMPANY • INC
18 MALVERN ST., NEWARK 5, N.J.
Telephone: Market 3-7584





**SO SENSITIVE
IT CAN MEASURE THE CHARGE
BETWEEN YOUR FINGERS**

CURTISS-WRIGHT DYNAMIC CAPACITOR ELECTROMETER

FOR STABLE AMPLIFICATION OF LOW-LEVEL DC SIGNALS

Measures currents as low as 10^{-16} amp. • Extremely high input impedance . . . 10^{15} ohms. • Low drift — less than ± 1 mv per 24 hours. • Uses dependable, durable dynamic capacitor. • Accuracy of $\pm \frac{1}{2}$ % full scale. • Only 14" x 10" x 9"

The Curtiss-Wright Dynamic Capacitor Electrometer is ideal for measuring minute currents or voltages from high impedance sources. There is no 60 cps interference since the Dynamic Capacitor Electrometer operates at 1,000 cps. The instrument can be used to measure static charges, potentials of floating grids, insulation leakage currents, capacitor dielectric leakages; and to study transistors and diodes. Its ruggedness, reliability, and high sensitivity make it especially suited for use in the nuclear field as a component in reactor control systems and in industrial control systems employing radioisotopes as energy sources. It can be used for pH determination, and in mass spectrometry. In biophysics and medicine it may be used to measure cell potentials, skin potentials, streaming potentials, injury potentials, and nerve impulses. Besides providing an indication on its own meter, it will operate any standard recorder. For details, write Nuclear Equipment Sales Dept., Curtiss-Wright Corporation, Electronics Division, Carlstadt, N. J.



(Continued from page 18A)

His experience in cathode-ray tube development began in 1932 when he joined Radio Inventions, Inc., New York City. Since that time he has served as a scientist with the Kenard Radio Tube Corp., the National Union Radio Tube Corp., the National Broadcasting Company, Remington Rand's Laboratory for Advanced Research, and the Columbia Broadcasting System's Laboratories.

He attended the Massachusetts Institute of Technology and the Stevens Institute of Technology. He is a member of the American Radio Relay League. Mr. Wilder has been issued fourteen United States' patents in television and allied fields.



A. R. Vallarino (S'43-A'44-M'55) has been appointed Director of Engineering, Development of Precision Technology, Inc., Livermore, California.

Precision Technology, Inc., a subsidiary of the General Precision Equipment Corporation, specializes in development and manufacture of scientific and control equipment for the Atomic Energy Commission, the Defense Department, their contractors and general industry.



The appointment of L. S. Preston (SM'56) to the post of Chief Engineer of the Electronic Engineering Company of California was announced by R. B. Bonney, Vice President of the company, recently.



L. S. PRESTON

Mr. Preston has a total of thirteen years' experience in engineering and engineering management. He joined the Electronic Engineering Company in 1949 as a radar design engineer; and later became technical staff engineer, supervising the activities of all engineers in the company's Point Mugu Division.

When the Florida Division of the company was opened in 1950, Preston was appointed division manager, and was charged with complete responsibility for all phases of the division's operations until 1955, when he returned to the Los Angeles Division of the Electronic Engineering Company as manager of the Engineering Department.

He received his B.S. degree in electrical engineering from the University of Texas in 1943.

(Continued on page 26A)

**Use your
IRE Directory
It's valuable!**

another **RAYTHEON** first!

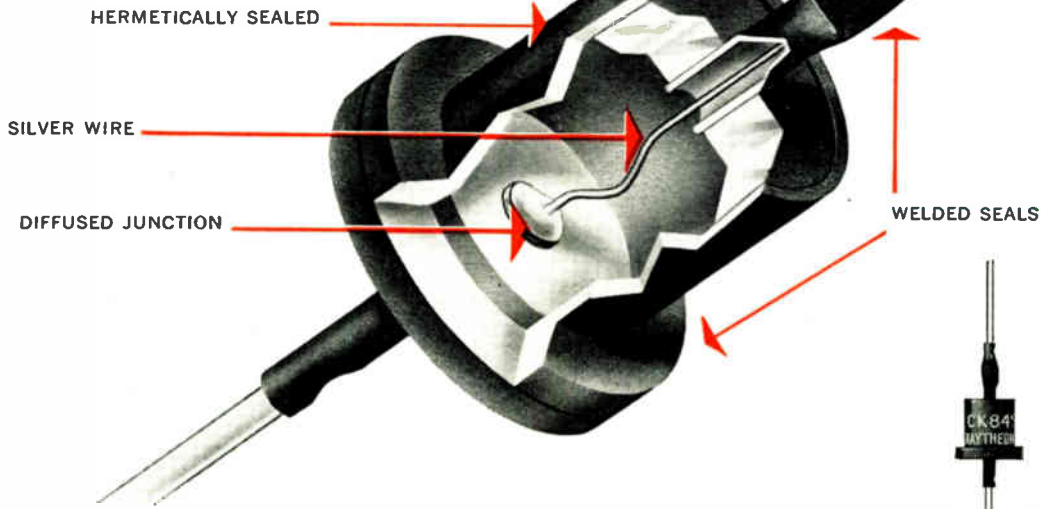

SOLID STATE DIFFUSED JUNCTION
SILICON RECTIFIERS
 now in **QUANTITY PRODUCTION**

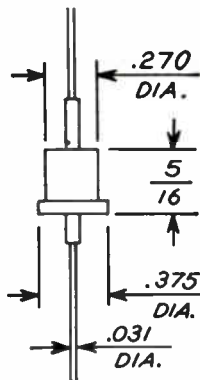

Uniform Characteristics — Uniformly High Quality

The Solid State Diffusion Process involves the formation of a junction by diffusing suitable gaseous materials into silicon at high temperatures. This process offers many advantages including:

1. Exact control of junction penetration.
2. Precise junction gradient for specific rectifier applications.
3. Flat junctions for uniformity and control of characteristics.

Operating Temperatures — minus 65°C to plus 150°C

Storage Temperature — up to 170°C

Hermetically Sealed — Welded

AVERAGE CHARACTERISTICS

Type	Peak Inverse Volts*	Forward Current**		Forward Volts*** at 350 mA 100°C	Reverse Current*** (max.) mA at rms volts 100°C
		milliamperes 100°C	150°C		
CK840	100	350	100	0.75	0.2 at 70
CK841	200	350	100	0.75	0.2 at 140
CK842	300	350	100	0.75	0.2 at 210
CK843	400	350	100	0.75	0.2 at 280
CK844	500	350	100	0.75	0.2 at 350
CK845	600	350	100	0.75	0.2 at 420

*PIV ratings apply from -65°C to +150°C

**Into inductive or resistive load

***Averaged over one complete cycle



SEMICONDUCTOR DIVISION

Silicon and Germanium Diodes and Transistors • Silicon Power Rectifiers

NEWTON, MASS.: 150 California St. • DEcatur 2-7177
 NEW YORK: 589 Fifth Ave. • PLaza 9-3900
 CHICAGO: 9501 Grand Ave., Franklin Park • TUxedo 9-5400
 LOS ANGELES: 5236 Santa Monica Blvd. • NOrmandy 5-4221

How to get reliability

Got the automation jitters?...worried about turning complex manufacturing operations over to an "electronic brain"?...worried about what can happen when one component in the control system fails?...

Reliability takes on a new and different meaning as American industry becomes more and more automated. Here are a few thoughts on the importance of reliability and how it can be controlled.



All of us are going to have to pay more attention to "reliability."

We'll have to pay more attention to individual "devices" within a system.

We'll have to guard ourselves carefully when we design the entire system.

The industrial pendulum is swinging more and more toward automatic controls, servo-mechanisms, computers, and automatic "watchers." As it does, the reliability factor becomes more and more important. Let's see why. For example, you probably have three radios at home. If one fails because a soldered joint comes apart, your home life is probably not disrupted to any alarming degree. But . . . consider the automatically controlled steel mill. One soldered joint failing, unless all controls are installed in duplicate (which is expensive) could tie up the entire production process for valuable minutes, if the maintenance crew has second sight. For hours, if automatic trouble-indicating and locating systems are not installed (and these are expensive, too). Last, but not least, lend a thought to the dependence of guided missiles and man-made satellites upon the reliability of electronic circuits and components. So . . . let's start to examine "reliability." Let's begin by looking at this definition which is currently popular in the technical field:

The reliability of a particular component or system of components is the probability that it will do what it is supposed to do under operating conditions for a specified operating time.

Now . . . this is a relatively well-accepted definition, and it offers the key to the problem of coping with failure control. Take the word "probability" in this definition. Let's discuss its implication.

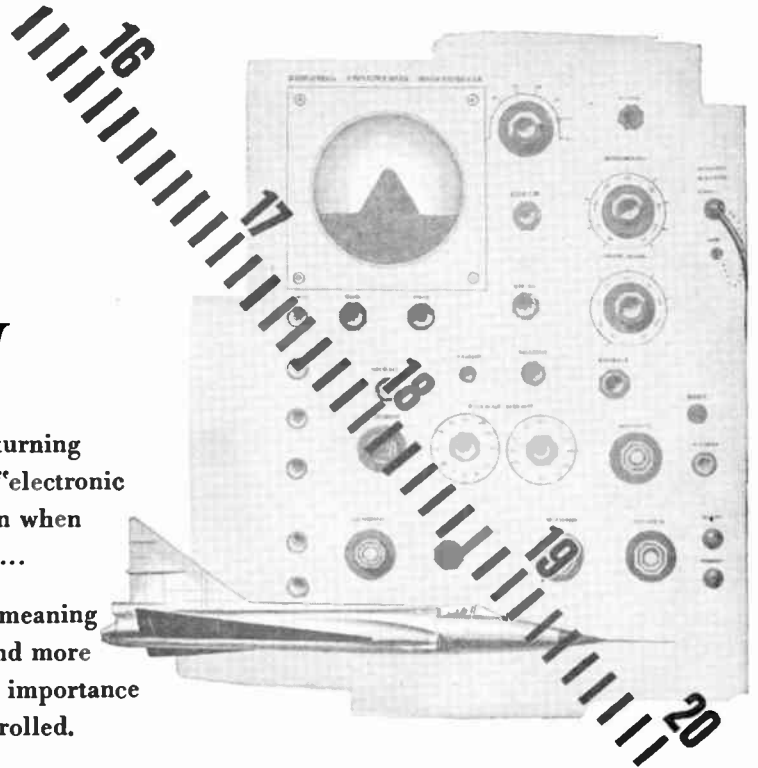

Many of today's systems, simple or complex, are a chain of components. So picture a system as a chain with its successive links. In the field of statistics the over-all reliability of the chain is the mathematical product of the reliabilities of the individual links . . .

$$\text{Overall Reliability, } R_o = r_1 \times r_2 \times r_3 \dots r_n$$

Now, let's consider a system made up of 100 different components, each of which has a reliability of 99%. In applying the formula, multiplication of .99 by itself 100 times gives an over-all reliability for the system of only 36.5%. Two out of three systems you have put together will probably fail!

Cannon becomes involved with this problem because our main business is making electric connectors. So, let's look at the following chart that covers contact reliabilities and reliability of the assembly in which they are mounted.

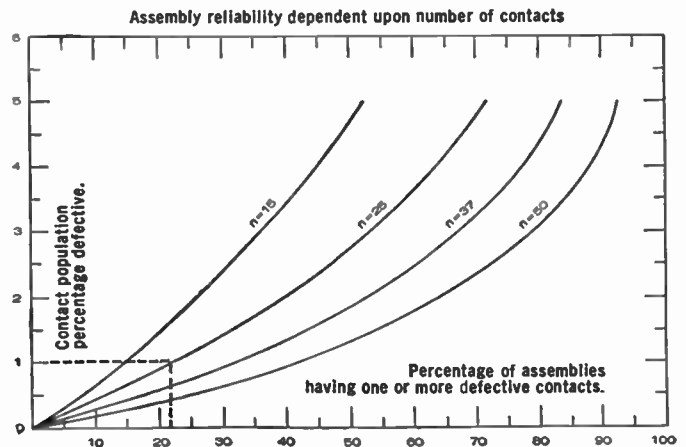

This chart illustrates the reliability of four connectors having 15, 25, 37 and 50 contacts respectively. As an example, assume that the contacts have a contact population of 1% defective (1 in 100 defective... this percentage is considered a fairly high standard in most fields). On the 15-contact assembly, we find from our chart that 14% of the connector assemblies would have one or more defective contacts! With 25 contacts, 22% would have one or more defective contacts. With 50 contacts, 41½%... is your hair starting to curl? Obviously, a 99% contact reliability standard for guided missile components is absolutely unacceptable. And, in between the simplest system and that of a guided missile, are hundreds of assemblies and systems whose reliability factors must be analyzed with utmost care.

But all is not lost! There's another side to the picture. With proper care, analysis, and control, our Cannon organization has actually achieved, in special "missile quality" contacts, a known level of only $2.85 \times 10^{-3}\%$ defective... only 1 part in 35,000! Naturally, we don't achieve that with all our contacts... but we do try to design and manufacture the utmost in reliability required for specific applications.

We have pictured this chart to show the direction we must all take, whether we're talking about connectors, other components, or systems. It boils down to two steps...

- * The number (n) of components must be kept low... *simplicity*.
- * The level of component reliability must constantly be improved... *hard work for all of us*.

Now...if we refer to our reliability definition on the previous page we note the phrase "do what it is supposed to do." So be sure *you* define these objectives for your component assembly, or system... failure to do so carefully can cause undue failure or the expenditure of unnecessary dollars for needless, excessively-reliable parts or design.

Further on in the same definition, we note the words "operating conditions." This brings up many new points for consideration. Here we are concerned with such things as temperature, pressure, humidity, corrosive atmosphere, stray electric and magnetic fields, low and high frequency noise, shock and vibration. Do your design standards need upgrading? Are your components designed and then tested to meet the operating conditions you specify... or are they designed to meet "average" conditions? Are you using adequate "safety factors"?

In a simple component, manufacturers have always looked for, recognized, and corrected faults when they occurred. We use component quality control to achieve and maintain Cannon's world famous product quality. But in complex systems such component quality control is not enough. Actually...

Reliability control over the system is needed. It should be all-encompassing. When you get right down to it, *reliability* is the product of procedures, equipment, and people... in

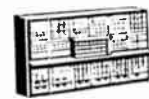
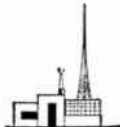

the design, manufacture, testing, control of quality, transportation, and use of products or systems.

Do you have a reliability control system?

Here are a few of the steps that are needed to get a reliability control system operating:

- 1. Determine Your Requirements.** Specify the environment, operating time, performance limits, and the percent of reliability required. Allow an adequate safety factor keeping in mind the end use of the finished product.
- 2. Collect Reliability Data.** Set up facilities for the continuous accumulation of data on component or system failures and their causes.
- 3. Establish quality control** and test procedures which show high degree of correlation with end-use conditions.
- 4. Analyze.** Determine if reliability requirements are being met. Establish the most important causes of failure by analyzing the data you collect.
- 5. Improve.** Take action to eliminate the most important defects or causes of failure. Reduce the failure rate to the required level.
- 6. Maintain Continuous Vigilance.** You have emphasized system design... you have used statistical analysis of failures... now exert continuous and critical control to be sure your "improvements" actually improve reliability. Examine new and unforeseen failure sources. Review and modify your requirements with changing conditions.

*

We at Cannon Electric are proud of our historical emphasis on quality and reliability. Since 1915 we have adhered to a design philosophy embracing the highest quality and reliability in each and every Cannon Plug for the specific application for which it is to be used. *If we can't design to that principle, we don't make it!* In manufacture, we are proud of our know-how in depth, proud of our fine quality control systems, proud of our personnel and proud of our reliability control group.

Whenever *you* have an electric connector reliability problem... in design, engineering, production, or prototype phases... we would appreciate the opportunity of discussing it with you.

Cordially,

Robert J. Cannon President

CANNON ELECTRIC COMPANY
3208 Humboldt St., Los Angeles 31, California



CANNON PLUGS

Eight plants around the seven seas!

Please Refer to Dept. 377

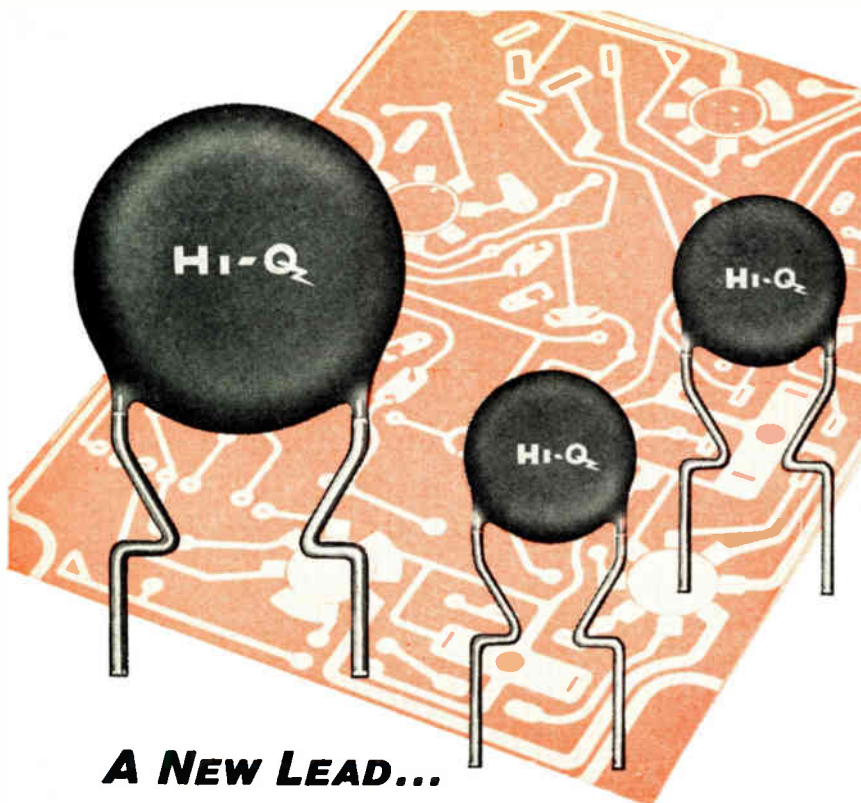

A NEW LEAD...

*to keep costs down
and quality up!*

HI-Q DISK CAPACITORS

MAINTEINING quality and at the same time reducing the cost of small components is a problem facing many manufacturers of radio-TV and other electronic equipment. Cut-and-formed, or "crimped" leads are another example of ingenuity leading to cost reductions.

"Crimped" leads on Hi-Q ceramic disk capacitors make possible completely coated or dipped units without the expense of cleaning leads. In addition, these new "crimped" leads insure good solderability as well as easier insertions for all printed-wiring assemblies.

Many Hi-Q customers have already experienced significant economies while maintaining or actually improving product quality, through the use of these new "crimped" lead ceramic capacitors.

Interested in more information? Write:

HI-Q
DIVISION

AEROVOX CORPORATION
OLEAN, N. Y.

In Canada: AEROVOX CANADA LTD., Hamilton, Ont.
Export: Ad Auriema, 89 Broad St., New York, N. Y., Cable: Auriema, N. Y.



(Continued from page 22A)

A. N. Goldsmith (A'12-F'15), electronics scientist and pioneer, has become consultant for *Electronic News*, the weekly industrial newspaper that Fairchild Publications, Inc., will publish in early 1957.



A. N. GOLDSMITH

As the newspaper's major consultant, he will advise as to correctness of data from the technical and industrial viewpoints and will analyze for the staff the significance of business trends.

Electronic News was conceived as an industrial newspaper that will provide management and engineers with information gathered from all over the world. Wade Fairchild is publisher of the new paper and A. D. Cook is the editor.

Though he is probably best known as the holder of over two hundred patents and as a consultant to Radio Corporation of America, National Broadcasting Company and Eastman Kodak Co., Dr. Goldsmith has long had an interest in publishing. He has been editor or editor emeritus of the *PROCEEDINGS OF THE IRE* every year since 1912 except 1929. In 1929 he was serving out his tenure as president of the IRE.

Dr. Goldsmith is also the author of several books. He was recipient of the IRE Medal of Honor in 1941 and the IRE Founder's Award in 1954.

Born in New York City on September 15, 1888, Dr. Goldsmith began his career as an instructor at the College of the City of New York in 1907, the same year he received his bachelor of science degree from that college. He remained with CCNY until 1919 and, in the meantime, obtained his doctorate of philosophy from Columbia University in 1911. CCNY appointed him associate professor of electrical engineering for life. He was granted an honorary doctor of science degree by Lawrence College in 1935.

He was elected President of the Society of Motion Picture and Television Engineers in 1932. He was chairman of several sectional committees of the American Standards Association.

In 1920 Dr. Goldsmith's work made possible the first commercial radio with only two control knobs and a built-in speaker. In 1940 he invented the first color television tube to find commercial use.

He was consulting engineer for General Electric Co. from 1915 to 1917 and director of research for Marconi Wireless Telegraph Co. of America from 1917 to 1919. That year, at the age of 31, he joined Radio Corporation of America as director of research, and then became vice-president and general engineer. He was with RCA until 1933 and acts as consultant to that firm to this day.

Besides the honors mentioned above, Dr. Goldsmith is an honorary member of the Radio Society of Great Britain, the International Committee of Radio Telegraphy (France), the Academy of Motion Picture Arts and Sciences, and the Institution of Radio Engineers (Australia). He is an Eminent Member of Eta Kappa Nu association. In addition, he is a member of the New York Medico-Surgical Society. He is also a Fellow of the American Institute of Electrical Engineers, the American Physical Society, the American Association for the Advancement of Science, the Acoustical Society of America, the Optical Society of America, and the International College of Surgeons.



Electronic Engineering Company of California has announced **D. R. Proctor** (SM'53) as Assistant Chief Engineer.

Mr. Proctor has a total of fifteen years' experience in engineering and engineering management. He joined the Electronic Engineering Company in 1951 as an electronic engineer; and later became a project engineer, responsible for the design and construction of highly complex timing, firing, and ground instrumentation equipment for missile ranges as well as other electronic developments. He was appointed Assistant Engineering Manager in 1955.



D. R. PROCTOR

Mr. Proctor received his B.A. degree in physics and mathematics in 1941 from the University of California, Berkeley. He is a registered professional engineer for the State of California, and a member of the Optical Society of America.



N. J. Dean (S'46-A'47-M'50-SM'53), formerly in charge of the applications group for the business machines program at the Laboratory for Electronics, has recently joined the management sciences department of the Ramo-Wooldrige Corporation, and has been appointed head of the data processing section of this department. This group is actively involved in various studies for business and government organizations for the application of electronic data processing systems to practical problems.



The appointment of **A. R. Hopkins** (A'27-M'32-SM'43) to the newly created post of Manager, Commercial Electronic Marketing Department, Radio Corporation of America, was announced recently.

Formerly Manager of the RCA broadcast and television equipment department, Mr. Hopkins now assumes broad administrative and functional responsibilities for the product planning and marketing of all RCA commercial electronic products.

Mr. Hopkins has been associated with RCA sales, merchandising, and engineering activities for more than twenty-seven years. He joined RCA as an engineer in

(Continued on page 28A)

It's **AEROVOX** for **HIGH VOLTAGE**

CAPACITORS FOR DC OR HIGH-CURRENT DISCHARGE APPLICATIONS



Type P-26 Capacitors . . . phenolic-tube case with metal end seals. Standard units available to 300,000 VDC. Higher voltages available with series-connected units.

No matter what the voltage requirements—you name them, **Aerovox** meets them. **Aerovox** is the industry's leading supplier of special high-voltage capacitors for radio-transmitters, betatrons, X-ray equipment, nuclear accelerators, radar, sonar and all military and pulse applications. Which accounts for such an experienced engineering staff with wide-scale knowledge of high-voltage equipment for high-current pulsing and minimum inductive reactance applications.

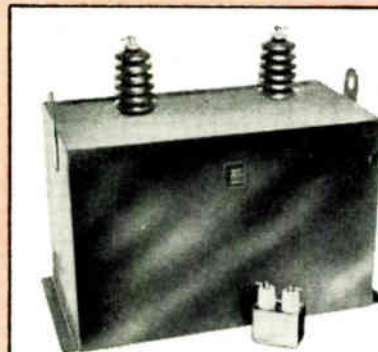

Type P-20 & Type P-09 Capacitors . . . standard high-voltage units to meet all military requirements. Voltage ratings to 150,000 VDC. Excellent for applications requiring heavy-duty DC service.

Special Capacitors . . . designed specifically for military and commercial applications, this toroidal-design, high-voltage capacitor is only one of many **Aerovox** manufactures in quantity to meet critical requirements.



Write

For complete information on how **Aerovox** can assist you with your capacitor needs.



AEROVOX CORPORATION

NEW BEDFORD, MASS.

In Canada: **AEROVOX CANADA, LTD.**, Hamilton, Ont.
Export: Ad, Auriema, 89 Broad St., New York, N. Y. • Cable: Auriema, N. Y.

HERE . . .

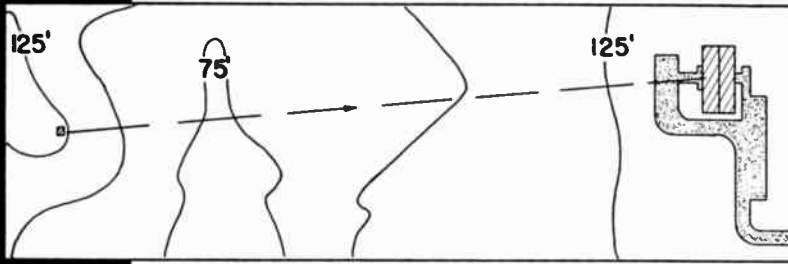

On a 12-acre plot near Smithtown, Long Island, Wheeler Laboratories is augmenting its microwave development facilities with an antenna range. As shown above, the transmitter building will look across a valley to the laboratory building now under construction. These new facilities will be equipped and staffed to solve unusual antenna problems.

Inquiries are invited; a brochure describing our services is available.

WHEELER LABORATORIES, INC.
122 Cutter Mill Road • Great Neck, N. Y.

HUnter 2-7876



(Continued from page 27A)

1929. In 1935, he transferred to RCA broadcast sales activities and shortly was advanced to manager of broadcast audio sales. In 1937, he was assigned to the company's Chicago office where for nine years he was broadcast district manager, then regional manager, for the former RCA Engineering Products Department.

In 1946, Mr. Hopkins was advanced to Sales Manager of the broadcast and industrial department, with headquarters in RCA's Camden, N. J., offices. Subsequently, he was advanced to general sales manager of the Engineering Products Department; manager of the Broadcast Marketing Department; and manager of the Broadcast and TV Equipment Department.

Mr. Hopkins was graduated in 1926 from Ohio State University with a degree in electrical engineering. He is a member of the National Association of Radio and Television Broadcasters, and serves on the executive committee of the Technical Products Division of the Radio-Electronics-Television Manufacturers Association.



A. M. Daily (M'56), hired in 1933 upon graduation from the University of Illinois, has been elected vice-president in charge of research and development at Chicago Telephone Supply Corporation, Elkhart, Indiana, variable resistor manufacturers.



A. M. DAILY

Mr. Daily started in the inspection department, then handled general engineering, sales engineering, and manufacturing assignments. He later served as director of the test laboratory, assistant plant superintendent, acting plant superintendent and chief research and development engineer. He has been on the firm's board of directors for six years.



Bernard Elbinger (S'49-A'50-M'55) has been Appointed Manager of the Special Products Section of Electronic Control Systems, Inc., an affiliate of Stromberg-Carlson and a subsidiary of General Dynamics Corporation.

In his new position, Mr. Elbinger will have charge of design and development of such special products as selective paging systems, automatic quality control devices, automatic test equipment and other special electronic systems.

A native of Detroit, Michigan, Mr. Elbinger served as a radar technician with

(Continued on page 30A)

d&r
dependable & reliable

WIDEBAND FLUTTER METER

The one and only instrument for measuring and evaluating wide band flutter



\$910.00
complete with cabinet as illustrated

with dust cover only
\$875.00

MODEL FL-4A

for manufacturers and users of high-speed tape recorders, who are engaged in instrumentation, telemetering and data transmission systems.

Features:

- Measures flutter frequencies dc to 5000 cps
- Internal 24 db/octave filters for analysis
- 3" oscilloscope for detailed flutter studies

Specifications:

Carrier frequency: 14.5kc from crystal oscillator
Indicators: $\pm 2\%$ drift and rms flutter meters
Range: 0.2, 0.6, and 2.0% rms full scale
Flutter filters: 0.5 to 30 cps; 30 to 300 cps;
300 to 5000 cps
Dimensions: 8 3/4" x 19" standard rack

Order Direct or write us for name of nearest representative

Manufacturers: Electronic and Electro-Mechanical Equipment & Components

d&r
LTD.

400 East Gutierrez Street
P. O. Box 1500, Santa Barbara, California
Telephone: WOODLAND 5-4511

FIRST silicon transistors meeting NAVY SPECS



For *reliability* under *extreme* conditions . . . design with TI's military silicon transistors . . . built to give you high gain in small signal applications at temperatures up to 150°C. Made to the stringent requirements of MIL-T-19112A (SHIPS) and MIL-T-19502 (SHIPS), these welded case, grown junction devices furnish the tremendous savings in weight, space and power you expect from transistorization . . . *plus* close parameter control

that permits you to design your circuits with confidence.

All 19 Texas Instruments silicon transistor types have proved themselves in military use. First and largest producer of silicon transistors, TI is the country's major supplier of high temperature transistors to industry for use in military and commercial equipment.

degradation rate tests for TI's USN-2N117 and USN-2N118 silicon transistors

test	condition	duration	end point at 25°C
lead fatigue	three 90-degree arcs	—	no broken leads $I_{CO} = 2\mu A$ maximum at 5V $h_{ob} = 2\mu mhos$ maximum $h_{fb} = -0.88$ minimum for 2N117 $h_{fb} = -0.94$ minimum for 2N118 no mechanical defects interfering with operation
vibration	100 to 1000 cps at 10 G	3 cycles, each x, y, and z plane	
vibration fatigue	60 cps at 10 G	32 hours, each x, y, and z plane	
shock	40 G, 11 milliseconds	3 shocks, each x, y, and z plane	
temperature cycle	-55°C to +150°C	10 cycles	
moisture resistance	MIL-STD-202	240 hours	
life, intermittent operation	$P_c = 150$ mW, $V_c = 30V$	1000 hours, accumulated operating time	
life, storage	150° C, ambient	1000 hours	
salt spray	MIL-STD-202	50 hours	

**LOOK TO TI FOR: SILICON HF, MEDIUM POWER, POWER, AND SMALL SIGNAL TRANSISTORS
SILICON DIODES AND RECTIFIERS • GERMANIUM VHF, POWER, RADIO, AND GENERAL PURPOSE TRANSISTORS**

**pioneer producer of
silicon transistors**



**TEXAS INSTRUMENTS
INCORPORATED**
6000 LEMMON AVENUE DALLAS 9, TEXAS

PROVEN Design Techniques
 make your
**COMPLEX AUDIO
 FILTER CONSTRUCTION**
 routine at
CHICAGO STANDARD

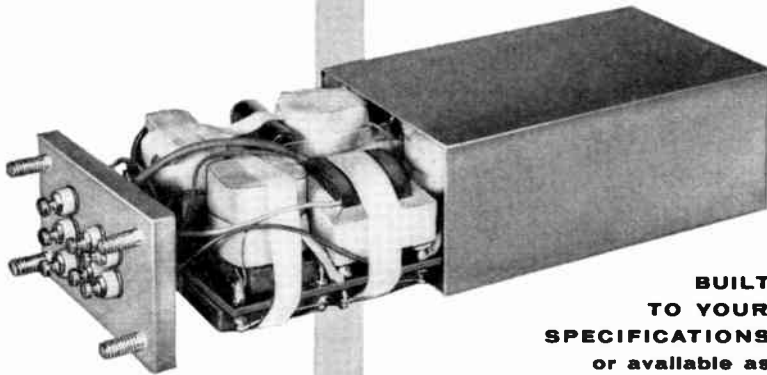

**BUILT
 TO YOUR
 SPECIFICATIONS**
 or available as
stock units.

Chicago Standard's years of experience in building thousands of filters have made possible a degree of skill in engineering and workmanship that can solve your difficult audio filter problems quickly . . . to your complete satisfaction.

Proven techniques of space utilization and mechanical design result in superior internal construction and efficient, compact, light-weight filters.

Proven design principles result in optimum coil and circuit performance. Reliable operation under extreme conditions is assured by:

1. High efficiency core materials.
2. Chicago's high strength ceramic terminals.
3. High dielectric strength insulation.

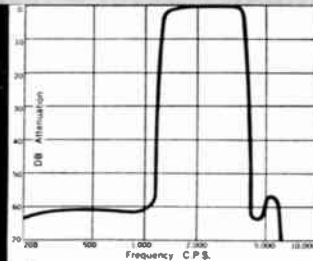

FREQUENCY RESPONSE
 Typical
 Band-Pass Filter



**CHICAGO STANDARD
 TRANSFORMER
 CORPORATION**



3501 Addison Street, Chicago 18, Illinois
 EXPORT SALES: Roburn Agencies, Inc.
 431 Greenwich Street, New York 13, New York

Write Today

outlining your filter requirements and for information on stock units.



(Continued from page 28A)

the air arm of the U. S. Marine Corps during World War II, and earned the rank of Master Technical Sergeant. Following the war he attended the University of Southern California, and received a bachelor's degree in electrical engineering after three years of study. He subsequently has taken graduate courses at the University of California, Los Angeles, in circuit analysis and servomechanisms.

After graduation, Mr. Elbinger served more than a year as an engineering aide with Gilfillan Brothers, Inc., working on the design of pulse circuits and associated equipment for automatic ground-controlled approach equipment. Later he joined Aerojet-General Corporation as an Electronic Development Engineer, and in that capacity developed electronic systems associated with infrared missile guidance, tracking and detection. He also had charge of a transistor study program at the time that transistors first appeared commercially.

Subsequently Mr. Elbinger became head of the Test Equipment Section at the Semi-Conductor Division of Hughes Aircraft Company. In that position he developed and fabricated automatic test and processing equipment for the manufacture and quality control of semi-conductors, as well as precision engineering test equipment for new products.



The appointment of E. L. Steele (A'55) as the chief development engineer of the Device Development Department in the Semiconductor Products Division, Motorola Inc. has been announced recently.



E. L. STEELE

In his new position, Dr. Steele will be located at the divisional headquarters in Phoenix, Arizona. There he will be responsible for the development of transistors, diodes, and other semiconductor devices.

Prior to his association with Motorola, Dr. Steele spent over four years as a research physicist with the General Electric Company in Syracuse, New York. His research projects included work in computer diodes, high frequency transistors, and physics of p-n junctions.

Dr. Steele received his bachelor of science degree from the University of Utah and his doctor of philosophy degree from Cornell University. He is a member of the American Physical Society. He is also the editor of the IRE TRANSACTIONS on Electron Devices.

(Continued on page 32A)



**FERRAMIC
CORES**



**FERRAMIC
MAGNETIC
CORES**

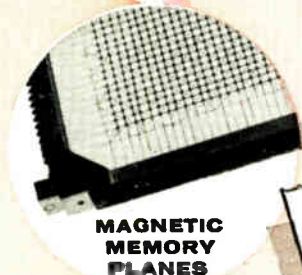

**MAGNETIC
MEMORY
PLANES**



**"ADVAC" HIGH
TEMPERATURE
SEALS**



STEATITES



**SOLDERSEAL
TERMINALS**

When
you
need

industrial ceramics

consult...



General Ceramics design and production facilities are geared to today's electronic and electrical requirements. In many cases, standardized designs and production methods can reduce costs and facilitate delivery. When specifications call for new designs and engineering, General Ceramics' half century of ceramic manufacturing experience is available to help solve your problem quickly, and economically!

*For complete information,
call or write Department P*

Headquarters for STEATITE, ALUMINA, ZIRCON, PORCELAIN SOLDERSEAL TERMINALS, "ADVAC" HIGH TEMPERATURE SEALS, CHEMICAL STONEWARE, IMPERVIOUS GRAPHITE, FERRAMIC MAGNETIC CORES, MAGNETIC MEMORY PLANES

*In response
to the trend
toward Single
Sideband*



A new Signal Generator (Crosby Model 160A) designed to meet the requirements of single-sideband receiver tests and also provide low-distortion double-sideband modulation for testing high-performance systems.

- ... Provides continuous coverage from audio frequencies to 1.5 mc
- ... Choice of five crystal controlled frequencies, 1.5-30 mc
- ... Is versatile-generates:
 - all forms of SSB including an ideal single-sideband signal, independent sideband modulation and inverted speech.
 - all forms of DSB including low-distortion AM, carrier eliminated AM or quadrature modulation.

For further information send for Technical Publication No. 258A.



CROSBY LABORATORIES, INC.

P. O. Box 233, Robbins Lane, Hicksville, L. I., New York
WELLS 1-3191



★ ULTRA LOW capacitance & attenuation

WE ARE SPECIALLY ORGANIZED
TO HANDLE DIRECT ORDERS OR
ENQUIRIES FROM OVERSEAS
SPOT DELIVERIES FOR U.S.
BILLED IN DOLLARS—
SETTLEMENT BY YOUR CHECK
CABLE OR AIRMAIL TODAY

TYPE	μm Fft	IMPED.Ω	O.D.
C 1	7.3	150	.36'
C 11	6.3	173	.36'
C 2	6.3	171	.44'
C 22	5.5	184	.44'
C 3	5.4	197	.64'
C 33	4.8	220	.64'
C 4	4.6	229	1.03'
C 44	4.1	252	1.03'



NEW 'MX and SM' SUBMINIATURE CONNECTORS
Constant 50Ω-63Ω-70Ω impedances

TRANSRADIO LTD. 138A Cromwell Rd. London SW7 ENGLAND CABLES: TRANSHAD, LONDON



(Continued from page 30A)

The appointment of C. L. Councilman (SM'54) as Chief Engineer of Air Associates, Inc., was announced recently.

In his new position, Mr. Councilman will direct the operation and administration of the Air Associates engineering departments responsible for all products developed and manufactured by the company. Prior to his advancement, he served for seven years as project engineer and as a section head within the company. Mr. Councilman has had fifteen years' experience in the electronics field.



C. L. COUNCILMAN

He is an active member of the Armed Forces Communications & Electronics Association, the American Ordnance Association, and the Air Force Association.

The appointment of M. C. Eliason (SM'52) as General Sales Manager of Air Associates, Inc., was announced recently.

In his new position, Mr. Eliason is responsible for all sales of engineered products for the Research & Development and Manufacturing Divisions of Air Associates.

In 1947, Eliason was affiliated with Air Associates as a project engineer. He left in 1949 to join the Research and Development Laboratories of the Hughes Aircraft Co., Culver City, California as a systems engineer. In 1954, Mr. Eliason rejoined Air Associates as its sales manager in the Electronic Equipment Division.



M. C. ELIASON

Early in his career, he was a technical engineer at California Institute of Technology doing applied research in the field of electronics. He attended Santa Monica Junior College, the University of California, and Loyola University at Los Angeles.

He is a member of the American Ordnance Association, Armed Forces Communications Association, Air Force Association, Society of Audio Engineers, and Aircraft Electrical Society.

(Continued on page 34A)

Use your
IRE DIRECTORY
It's valuable

A MP's NEW PULSE PACKETTE

Cat. No. 855007 Specifically designed to trigger modulator thyratrons, type VC-1257 or equivalent.

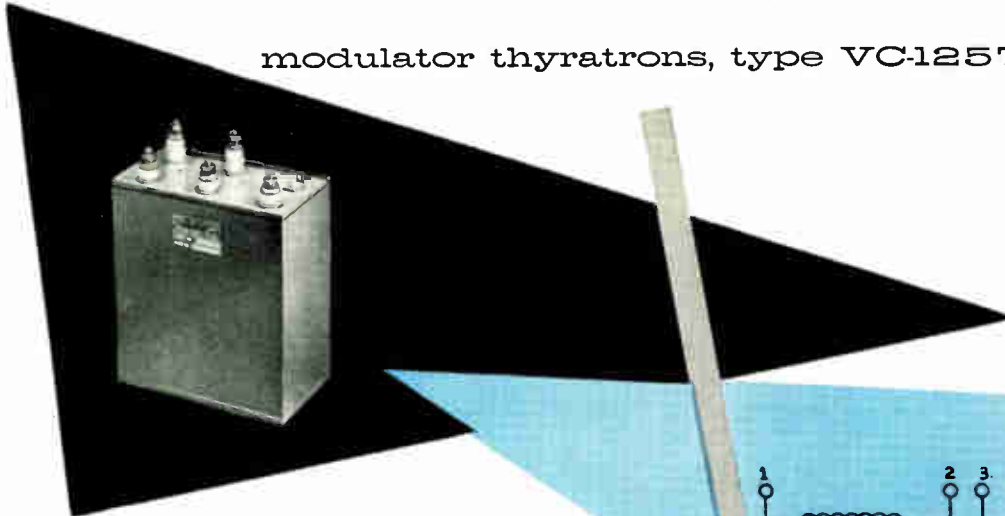

3-in-1 unit contains

1. Resonant charging choke
2. Pulse Forming Network
3. Pulse Transformer

This and similar designs now in production represent the culmination of A MP years of experience in high reliability pulse components.

Cuts procurement, stocking, testing and assembly problems by $\frac{2}{3}$. Saves time, design work, size and weight. Offers better performance, greater reliability.

Special designs available to meet individual requirements. Similar standard designs available on the shelf for other thyatron trigger applications.

Characteristics

1. Input: 2.8 KV DC MAX.
at 100 ma DC MAX.
2. Output +1.7 KV pulse amplitude
at 68 a peak
into 25 ohm resistive load.
 - (a) Pulse width at 70% amplitude
2.2 microsec. MIN.
 - (b) Rise time between 20% and
85% amplitude
.30 microsec. MAX.
 - (c) Allowable ripple on top wave +5%
3. Pulses per second 0 min. 1000 max.
4. Operating ambient temperature range
-55°C to +71°C.
5. Maximum operating altitude—10,000
ft.
6. Life expectancy 10,000 HRS.
7. Vibration and shock MIL-E-5400.

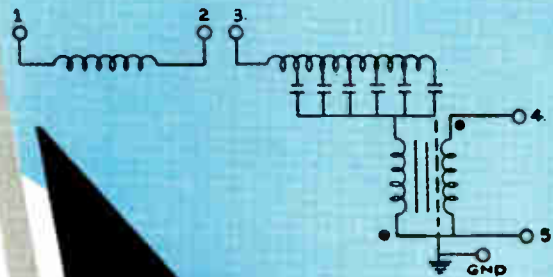

As a supplementary service A MP can supply grid filter networks to match these Pulse Packettes.



AMP Incorporated

Chemicals and Dielectric Division
155 Park Street, Elizabethtown, Penna.

A MP of Canada, Ltd
1764 Avenue Road
Toronto 12, Ontario, Canada

USE-FACTOR

Nucleonics
Video Laboratories
Computer Laboratories
Pulse Circuitry

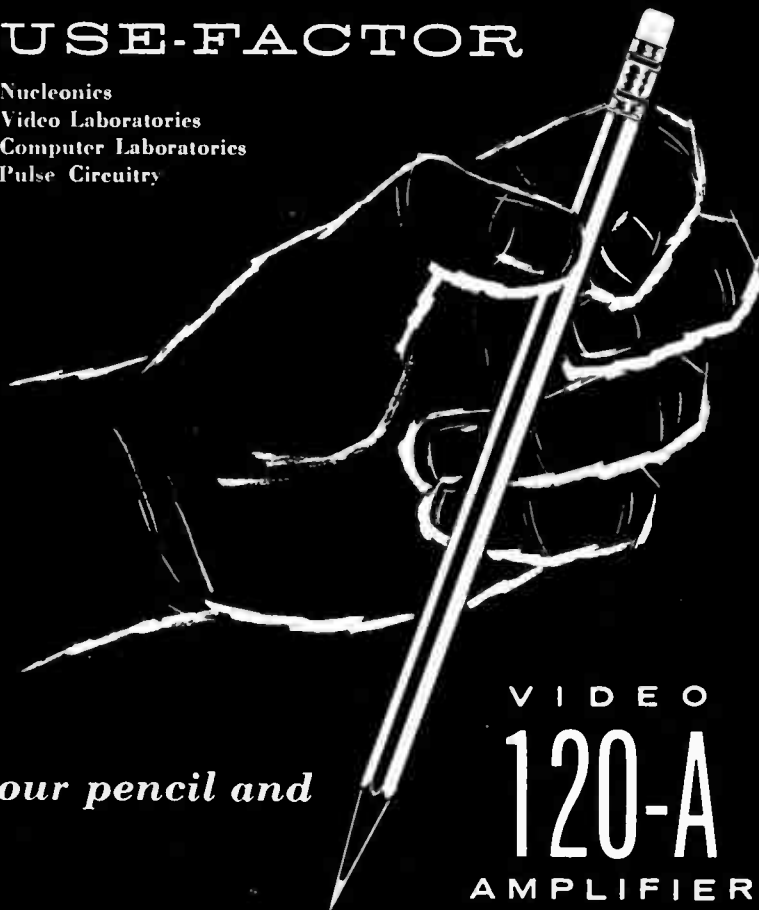

your pencil and

VIDEO
120-A
AMPLIFIER



RESPONSE: Within 3 db from 8 cps to 10 Mc/s
10% max. tilt for 15 cps square wave

INPUT IMPEDANCE: Selectable, HIGH: 4 Meg & 20 pfd; LOW: 0-1000 Ω

OUTPUT IMPEDANCE: Selectable, HIGH: 25 pfd load;
LOW: 75 Ω

GAIN: Continuously variable, High- z load: 48 db;
Low- z load 38 db

OUTPUT POLARITY REVERSIBLE-ELECTRONICALLY REG. SUPPLY 100 Volts pk-to-pk, hi- z load; 10 Volts pk-to-pk, LO- z load

AMERICAN ELECTRONIC LABORATORIES, INC.

641 ARCH STREET PHILA. 6, PENNA. LOMBARD 3-8780



(Continued from page 32A)

Leeds & Northrup Co. has announced the promotion of **G. M. Foley** (A'42-SM'53) to Head of the Nucleonics Section in the Research and Development Department. Foley joined L&N in 1946; he has been, successively, junior and senior research technologist, research scientist and now, section head.



G. M. FOLEY

Before coming to L&N, Foley was a research engineer with the Battelle Memorial Institute. He was graduated from the University of St. Andrews, Scotland, with a B.S. degree in chemistry and physics in 1938, and he has taken courses at the University of Pennsylvania. Mr. Foley is a member of the IRE Professional Group on Nuclear Science. He is also a member of the American Chemical Society. He has also published numerous papers and articles in the technical press.

He is a radio "ham" with the call W3UKI.

F. B. Llewellyn (A'23-F'38), a former president of the IRE and a member of the technical staff of Bell Telephone Laboratories for more than thirty years, has been appointed Assistant to President M. J. Kelly of Bell Telephone Laboratories. He succeeds T. C. Fry who retired on September 30.



F. B. LLEWELLYN

Dr. Llewellyn began his telephone career with the Western Electric Company's Engineering Department in 1923, and became a member of Bell Laboratories on its organization in 1925. His early work was in the field of radio research, including transatlantic radiotelephony, ship-to-shore radiotelephone service, and ultra-high frequency circuits and tubes. As circuit research engineer from 1936 to 1945, he was engaged in studies of broadband amplification, signal-to-noise relations, and equivalent circuits of high-frequency tubes. Since 1945 he has served in a consulting capacity, particularly in the areas of transoceanic and land repeated transmission systems. He has been granted 36 patents for his inventions in the communications field.

During World War II he served as a consultant to the Secretary of War, and until recently was a consultant to the Weapons Systems Evaluation Group of the Joint Chiefs of Staff. After the war he served as

(Continued on page 36A)

CP recommends...



Styroflex*
COAXIAL CABLE



Spirafil*
COAXIAL CABLE



Foamflex*
COAXIAL CABLE

**-for Superior Transmission
Line Performance in All Commercial
and Military Communications**

After two decades of rigid and semi-flexible transmission line production, CP as National Distributors for Phelps Dodge Copper Products Corporation, recommends Styroflex, Spirafil and Foamflex cables *exclusively!*

Service-proven in all segments of the industry, these superior high frequency cables are rapidly winning top-favor among engineers for AM, FM, TV, Pulse and many other services.

Let us tell you why we have changed to Styroflex, Spirafil and Foamflex cables. When you have the facts, as we have, you too will make the change.

*Products of the
Phelps Dodge
Copper Products
Corporation



Communication Products Company • Inc
Main Office and Plant: Marlboro, New Jersey—Tel. FReehold 8-1880

Pacific Coast Branch: 120 Santa Barbara Street, Santa Barbara, California—Telephones: WOODland 2-1712 and 1714

NEY'S SMALL PARTS PLAY A BIG PART IN PRECISION INSTRUMENTS • NEY'S SMALL PARTS

NEY'S SMALL PARTS PLAY A BIG PART IN PRECISION INSTRUMENTS • NEY'S SMALL PARTS

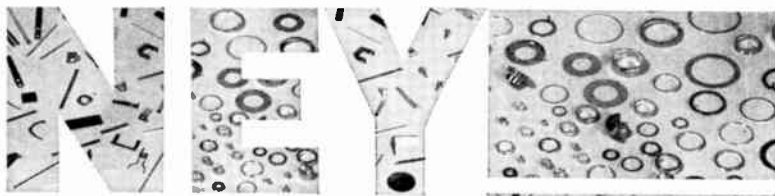

PRECIOUS METAL

ENGINEERED CONTACTS, SLIP RINGS & ALLOYS

Ney designs and makes to customers' specifications sliding contacts, slip rings and assemblies, commutator segments and assemblies, brush and brush holder assemblies, and precious metal resistance wire. Consult Ney's Engineering Dept. and find out how precious metals can improve your products.

THE J. M. NEY COMPANY, P.O. BOX 990, DEPT. 1, HARTFORD 1, CONN.
Specialists in Precious Metal Metallurgy since 1812



Ney has just built this modern new plant to give you even better products and better service.

NEY'S SMALL PARTS PLAY A BIG PART IN PRECISION INSTRUMENTS • NEY'S SMALL PARTS

TOP HAT FOR PLUG-IN UNITS

A widely used, dependable, improved clamp for electron tubes, relays and capacitors.



WRITE FOR NEW CATALOG

EASY TO APPLY
INSTANTLY RELEASED
POSITIVE LOCKING ACTION



TIMES FACSIMILE CORPORATION

540 West 58 St., New York 19, N. Y.
1523 L St., N. W. Washington 5, D. C.

CAPITOL RADIO ENGINEERING INSTITUTE

Pioneer in Radio Engineering Instruction Since 1927



ECPD Accredited
Technical Institute
Curricula

Advanced Home Study and Residence Courses in Practical Radio-Electronics and Television Engineering

Request your free Home Study or Resident School Catalog by writing to: Dept. 2612-C

3224 16th St., N. W. Washington 10, D. C.

Approved for Veteran Training



(Continued from page 34A)

Executive Secretary of the Science Advisory Committee with the Office of Defense Mobilization.

Dr. Llewellyn was graduated from Stevens Institute of Technology in 1922 and received the Ph.D. degree from Columbia in 1928. In 1949 he received the Stevens Honor Award from his alma mater. He was recently elected president of the Stevens Institute Alumni Association.

In 1935 he was awarded the Morris Liebman Memorial Prize of the IRE for his work in high-frequency electronics and on constant-frequency oscillators. He is a Fellow of the American Physical Society and the Operations Research Society of America.



E. R. Piore (A'38-M'42-SM'43-F'50) has joined International Business Machines Corporation, New York, N. Y., as director of research, it was announced recently by Thomas J. Watson, Jr. president.



E. R. PIORE

A distinguished physicist, Dr. Piore was formerly chief scientist of the Office of Naval Research. As top civilian in ONR, had a personal hand in instituting projects through which this organization gained general recognition as the leading research arm of the government. His most recent post was research vice-president for Avco Manufacturing Corporation where he was engaged mainly in the direction of scientific programs. He remains a consultant for that firm.

At IBM, Dr. Piore will head a company-wide research effort presently being carried on in laboratories located in New York and California and in Zurich, Switzerland.

Born in 1908 in Wilno, Russia, Dr. Piore came to this country at the age of nine. He received his A.B. from Wisconsin in 1930, and remained there as an instructor until 1935. In that year he earned his Ph.D. degree and joined RCA. Later, he moved to CBS as engineer-in-charge of the television laboratories. He is associated with some of the early work on color TV.

Dr. Piore is a consultant for the Science Advisory Committee and the Office of Defense Mobilization, and a Fellow of the American Physical Society. He also holds membership in the Society of Naval Engineers, Science Research Society of America and the Washington Academy of Sciences.



M. S. Feller (A'55), formerly a quality control engineer of I-T-E Circuit Breaker

(Continued on page 38A)

Direct readings of



New **hp** 523B
ELECTRONIC COUNTER

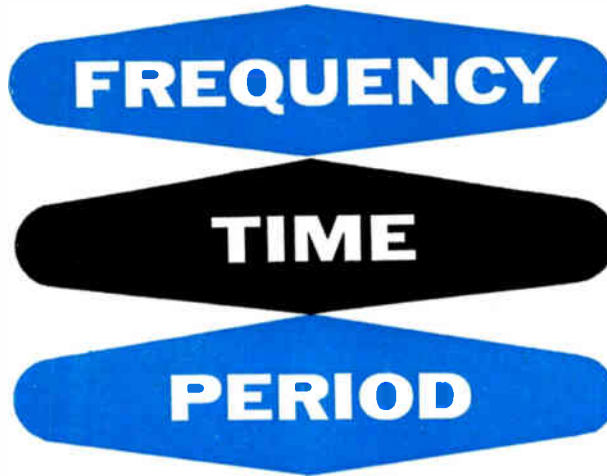

10 cps to 1.1 MC!

- ▲ **Extreme dependability**
- ▲ **Etched, untized circuits**
- ▲ **Permits viewing time-Interval start and stop points on oscilloscope**
- ▲ **High accuracy crystal oscillator circuit**
- ▲ **Trouble-localizer lights**
- ▲ **Counts pulses of selected voltage level**

Construction of the new *hp*- 523B is highest quality throughout. Etched circuits are rugged, ultra-dependable. Circuits are arranged for complete visibility. Trouble-localizer lights and plugs disconnecting circuit elements further simplify maintenance.

Exclusive features include a pulse output for oscilloscope Z-axis modulation permitting visual identification of the time-interval start and stop points on the input waveform measured. There is also a pulse count discriminator counting only pulses of voltage above a pre-determined level; and a high accuracy, high stability crystal controlled oscillator. Controls are color-coded, concentric, functionally arranged. Readings are direct in clear, bright numerals; decimal is automatic and illuminated.

The broad range and versatile usefulness of *hp*- 523B is indicated by the Specifications at right. Model 523B is designed for utmost speed and simplicity in measuring production quantities, rpm, nuclear pulses, power line frequencies, repetition rates, time intervals, pulse lengths, shutter speeds,

velocities, relay times, frequency ratios, phase delay, etc. With transducers, *hp*- 523B also provides local or remote measurement of weight, pressure, temperature, acceleration, etc.

BRIEF SPECIFICATIONS

FREQUENCY MEASUREMENT:

Range: 10 cps to 1.1 MC
Accuracy: ± 1 count \pm crystal stability
Input Minimum: 0.2 v RMS
Input Impedance: Approx. 1 megohm, 30 μ f shunt
Gate Time: 0.001, 0.01, 0.1, 1, 10 seconds
Reads Directly In: KC. Automatic decimal

PERIOD MEASUREMENT:

Range: 0.00001 cps to 10 KC
Accuracy: $\pm 0.3\%$ (1 period); $\pm 0.03\%$ (10 periods)
Input Minimum: 1 v RMS
Input Impedance: Approx. 1 megohm, 40 μ f shunt
Gate Time: 1 or 10 cycles of unknown
Standard Counting: 10 cps, 1 KC, 100 KC, 1 MC, External
Reads Directly In: Sec, msec, μ sec; automatic decimal

TIME INTERVAL MEASUREMENT:

Range: 3.0 μ sec to 100,000 sec (27.8 hrs)
Accuracy: $\pm 1/$ std. freq. counted \pm stability
Input Minimum: 1 v peak, dc coupled
Input Impedance: Approx. 1 megohm, 25 μ f shunt
Trigger Slope: Pos. or neg. on start/stop independent or common channels

Trigger Amplitude: -300 to +300 v adjustable
Standard Counting: 10 cps, 1 KC, 100 KC, 1 MC, External
Reads Directly In: Sec, msec, μ sec, automatic decimal

STABILITY:

DISPLAY TIME:

OUTPUTS:

PRICE:

2/1,000,000 per week. Also WWV
Variable 0.1 to 5 sec, or indefinite
Secondary standard: 10 cps, 1 KC
rectangular, 100 KC, 1 MC sine wave.
\$1,175.00

Data subject to change without notice. Price f.o.b. factory.



HEWLETT-PACKARD COMPANY

3695D Page Mill Road, Palo Alto, California, U.S.A.

Cable "HEWPACK" Davenport 5-4451

Field engineers in all principal areas



complete coverage in quality counters

Now Measure

TRUE RMS

**from 100 microvolts to 320 volts
REGARDLESS OF WAVEFORM
with the Ballantine Model 320 Voltmeter**

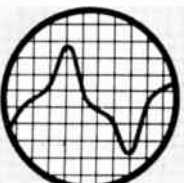
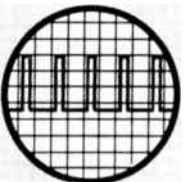
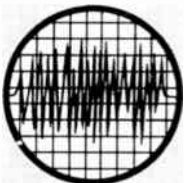
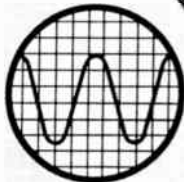

REPRESENTING:

A distinctly new departure in VTVM design.

FEATURING:

A built-in calibrator; — easily read 5-inch log meter; — immunity to severe overload; — useful auxiliary functions.

BRIEF SPECIFICATIONS:

- VOLTAGE RANGE:.....100 microvolts to 320 volts
- DECIBEL RANGE:..... — 80 dbv to +50 dbv
- FREQUENCY RANGE:.....5 to 500,000 cycles per second
- ACCURACY:.....3% from 15 cps to 150KC; 5% elsewhere
Figures apply to all meter readings
- MAXIMUM CREST FACTORS: 5 at full scale; 15 at bottom scale
- CALIBRATOR STABILITY: .05% for line variation 105-125 volts
- INPUT IMPEDANCE:....10 M Ω and 25 μ f, below 10 millivolts
10 M Ω and 8 μ f, above 10 millivolts
- POWER SUPPLY:..... 105-125 volts; 50-420 cps, 75 watt
Provision for 210-250 volt operation
- DIMENSIONS: (Portable Model).....14 3/8" wide, 10 1/2" high,
12 3/8" deep—Relay Rack Model is available
- WEIGHT:.....21 lbs., approximately
- PRICE: \$425

Write for the New Ballantine Catalog describing this and other instruments in greater details.

BALLANTINE LABORATORIES, INC. 
102 Fanny Road, Boonton, New Jersey



(Continued from page 36A)

Company's Special Products Division, has just been placed in charge of all sales and service of large waveguide and related test equipment, in order to more efficiently handle the firm's expanded activity in this field.



M. S. FELLER

Mr. Feller was also recently elected to the post of Secretary for the IRE Philadelphia Chapters of Professional Groups on Antenna and Propagation, and Microwave Theory and Techniques.

K. W. Marsh (M'47-SM'52) has been appointed Bendix Aviation Corporation's general project manager on a major guided missile project.

Mr. Marsh joined Bendix in February, 1956 and was recently transferred to the Pacific Division from the corporation's research laboratories in Detroit, Mich.



K. W. MARSH

Prior to joining Bendix, Mr. Marsh was senior project engineer for Fairchild Guided Missiles, Wyandanch, L. I., on a guided missile project for the Navy Bureau of Ordnance, in cooperation with the National Bureau of Standards. Previously, he was project administrator for Hazeltine Electronics Corporation, Little Neck, N. Y., on ground radar and IFF projects, and project engineer at Airadio Inc., Stamford, Conn.

During World War II he served as a major in the U. S. Army Signal Corps. He had been graduated from the Massachusetts Institute of Technology.

Salo Nachtigall, president of Fanon Electric Co., Brooklyn, N. Y., announced the appointment of J. P. Rice (M'52) as chief engineer. In addition to his regular duties Mr. Rice will also be in charge of new product development.

The firm manufactures intercom systems for home and industry, and phonographs. Mr. Rice, a member of the A.S.E., was formerly with Mark Simpson Manufacturing Co. as chief engineer for four years. He is also a member of the faculty at Eastern School of Radio and Television and a former instructor of Pierce School of Radio and Television.

(Continued on page 40A)

remote control circuits packaged to your specifications with **OAK rotary solenoids***

application-engineered and produced to meet your requirements

1. as simple solenoids



2. as rotary selectors

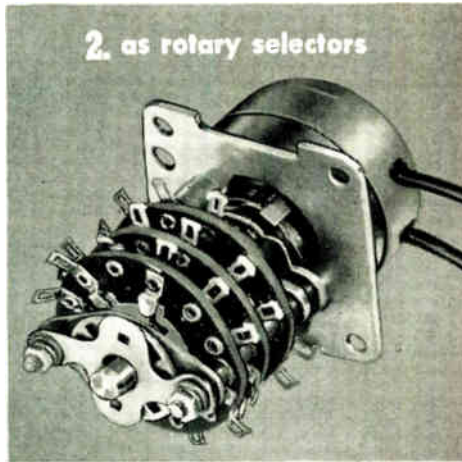

3. as complete remote control sub-chassis

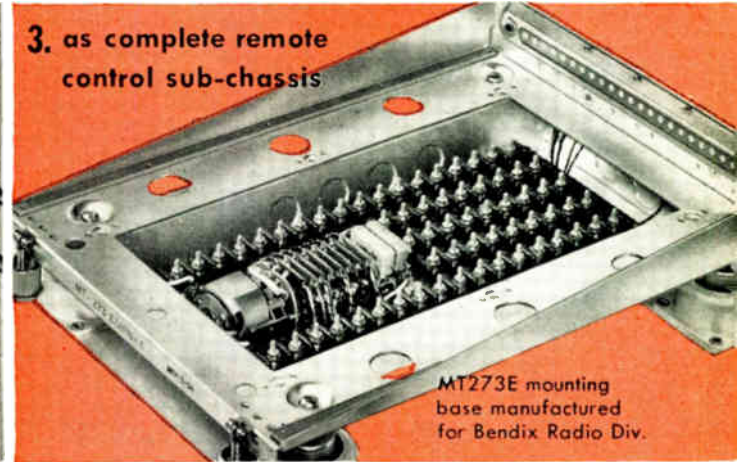

MT273E mounting base manufactured for Bendix Radio Div.

rugged, compact units that meet the most stringent MIL specs

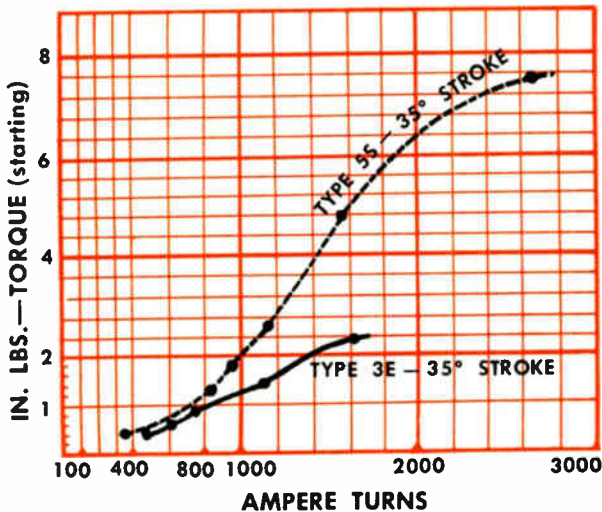

instant, positive HIGH TORQUE OUTPUT from LOW POWER INPUT

Oak rotary solenoids give you exceptionally high torque... instantly on application of power. Whether your installation requires a simple solenoid, rotary selectors with switch sections, or a complete remote control sub-chassis unit, OAK will completely engineer and manufacture to meet your individual requirements.



send for descriptive brochure with layout sheets

*Solenoids manufactured under license of G. H. Leland, Inc.



address depl. "O"

OAK MFG. CO.

1260 clybourn ave. • chicago 10, ill.

Four modern plants manufacturing switches, vibrators, tuners, choppers and rotary solenoids.

TUBELESS AUDIO COMPENSATION

*only 14 db
insertion loss!*

The Model 4201 Program Equalizer has been developed to provide utmost versatility for the compensation of sound recording and broadcast channels. High and low frequencies may be boosted or attenuated while the program is in progress with negligible effect on volume levels. It may be switched in or out instantaneously to permit compensation at predetermined portions of the program. This feature is especially useful in tape dubbing work.



Model 4201, Program Equalizer

FEATURES:

Equalization and attenuation in accurately calibrated 2 db. steps at 40, 100, 3000, 5000 and 10,000 cycles.
 Insertion Loss: Fixed at 14 db. with switch "in" or "out."
 Impedance: 500/600 ohms.
 Low Hum Pickup: May be used in moderately low-level channels.

send for Bulletin E for complete data
 Net Price \$195.00
 F. O. B. North Hollywood

Model 4201 Program Equalizer is also available for the custom builder in kit form with complete wiring instructions. Send for Bulletin TB-4.

Representatives in
 Principal Cities



Division of
 International Resistance Company
 12970 Bradley Avenue,
 Sylmar 6, Calif



(Continued from page 38A)

The association of H. L. Hull (SM'54) with Litton Industries as a Vice-President was announced today by Litton's president. Dr. Hull left his post as president of the Farnsworth Electronics Company, a division of the International Telephone and Telegraph Corporation, to move to Litton's corporate headquarters at Beverly Hills, California.



H. L. HULL

Active in various executive management positions for the Manhattan Project (Tennessee Eastman Corporation) and the Argonne National Laboratory in the field of atomic energy during the period 1943 to 1953, Dr. Hull was made a vice-president for research and development for the Capchert-Farnsworth Company in September, 1953. A year later he was elevated to the position of president of the Farnsworth Electronics Company.

Dr. Hull, a graduate of Nebraska Wesleyan University, received a Ph.D. in physics from Columbia University in 1933; following that he joined the Sperry Gyro-

scope Company to do research and development work in military and industrial electronics. He remained with Sperry until 1943 when he was named director of process improvement for the Tennessee Eastman Corporation at Oak Ridge, Tennessee.

For the past four years Dr. Hull has been an officer of the National Telemetering Conference, and in 1955 he was appointed chairman of the I. T. & T. Technical Committee on Nuclear Energy. He also attended the Geneva Conference on the Peacetime Uses of Atomic Energy as the representative of I. T. & T.

Lewis Balamuth (A'54-M'55), pioneer physicist in the field of ultrasonics and inventor of the Cavitron Ultrasonic Cutting Process has been named Vice-President for Research and Development of the Cavitron Equipment Corporation, Long Island City, New York.



LEWIS BALAMUTH

Major applications of the Cavitron Ultrasonic Cutting Process, which replaces conventional rotary grinding with a vibrationless and heatless action, have been in the production of intricate tools and dies cut from wear-resistant steels and alloys, the

(Continued on page 42A)

Electrically Conductive Cloth

**A New Engineering Material for
Many Applications in Electronics**

- SUGGESTED USES:
- RF SHIELDING
 - RADAR REFLECTION
 - MICROWAVE GASKETING
 - WARNING SYSTEMS
 - ATTENUATORS
 - STATIC DISCHARGE

Buy it by the yard and sew it to shape on any sewing machine. Or, have us sew it for you.

WRITE OR PHONE
Swift
 INDUSTRIES, INC.
 10 Love Lane, Hartford 1, Conn.
 Jackson 2-1181



★ **AIRCRAFT PUMPS**

Precision-built to rigid government specifications, a broad selection among Eastern pumps offers flexibility to your choice. Modifications can be made, or custom-made units designed to suit your project. Trim in size, light in weight, Eastern Aircraft Pumps give reliable long-term service.



★ **PRESSURIZATION**

Eastern pressurization units for airborne electronic equipment are available in many capacities to handle a broad range of requirements. Units consist of an air pump and motor assembly, pressure switch, check valve, tank valve, and terminal connectors. They meet government specifications and can be modified to your needs.



eliminate the "BUGS"

with Eastern aviation products

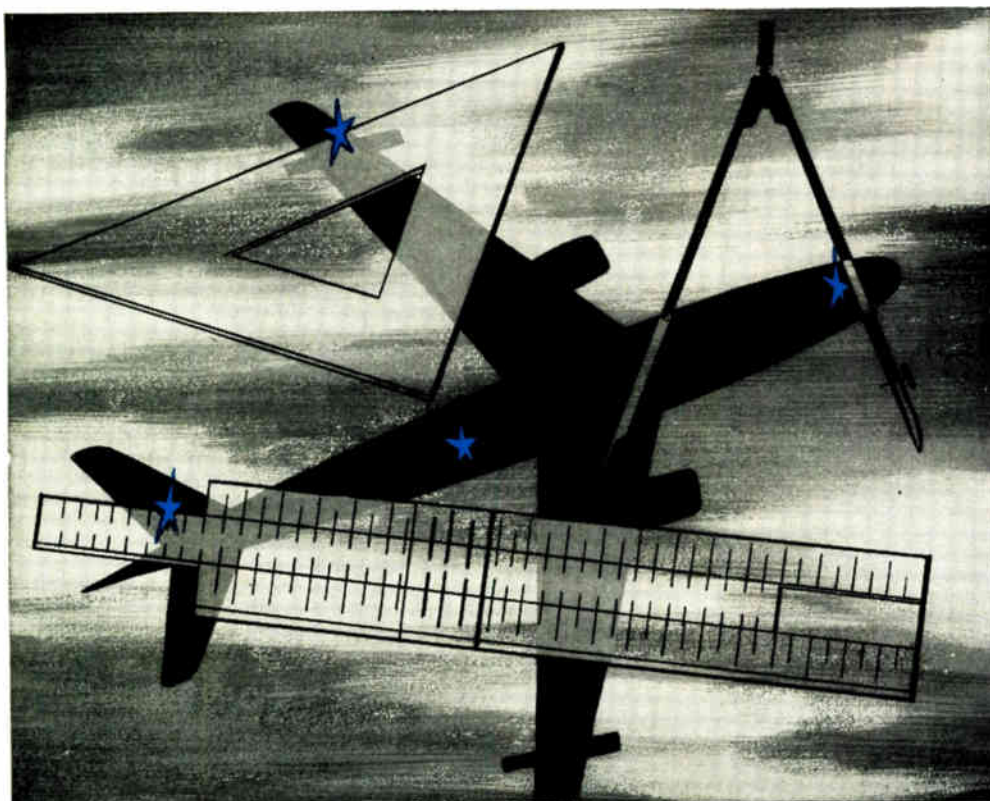
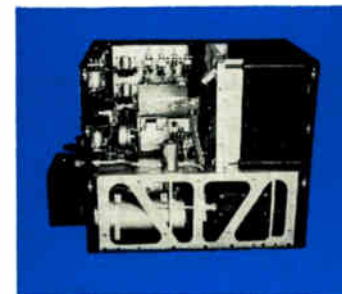
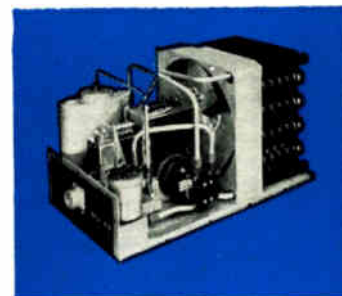

★ **COOLING UNITS**

Hold temperatures to safe operating limits in liquid cooled electronic tubes or similar devices. By virtue of long experience and using standard component parts, Eastern can suit your specific needs at a minimum cost for equipment.

★ **REFRIGERATION-TYPE**

Enable specified components to be held to fairly constant temperatures by use of various types of refrigeration units. Because of the variation in methods possible, Eastern units fill every requirement where the use of a refrigeration cycle is called for.

★ **SPECIAL UNITS**

Eastern's continual research and development program keeps pace with the growing aviation industry. As new problems occur with progress in aircraft development, Eastern units are constantly developed to fill their function as planes fly higher, or faster, or with greater load capacity.

Eastern welcomes the chance to help engineers "take out the bugs" with equipment that cools, pressurizes, or pumps. From the extensive line of existing units, new adaptations, or custom-made designs, Eastern is ready to meet every challenge for equipment that handles your needs *the best today . . . better tomorrow.*



Write for Aviation Products Catalog, Bulletin 330.

Kearfott FERRITE MICROWAVE COMPONENTS

KEARFOTT FERRITE DUPLEXERS

Improvements in recovery time, reduction in insertion loss and excellent magnetron isolation are performance benefits offered by Kearfott Ferrite Duplexers — designed to meet specific radar space requirements.



A Faraday rotation type unit is illustrated. A type and configuration is available for your requirements.

KEARFOTT FERRITE ISOLATORS

For superior performance KEARFOTT ISOLATORS custom designed to fit the exact combination of characteristics, available space and configuration for your radar system. For high or low power — for broad or narrow band use and with db ratios of isolation to insertion up to 150 to 1.

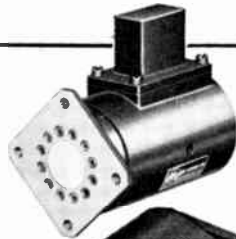

FARADAY ROTATION ISOLATOR



DIFFERENTIAL ABSORBER ISOLATOR



DIFFERENTIAL PHASE SHIFT ISOLATOR

Kearfott offers 3 types of Ferrite Isolators to assure the optimum performance of all microwave applications.

KEARFOTT FERRITE ATTENUATORS AND SWITCHES

Ferrites offer new circuit possibilities and product improvement for AGC and electronic switching of R.F. energy. Kearfott designs, precisely tailored to your most exacting requirements, assure maximum performance and reliability with minimum weight.



The 30 db variable attenuator illustrated, requires less than 3 watts control power.

Write for information on multi-purpose R.F. Test Sets. Available from stock — for X-Band, Ku Band and C Band

Kearfott's complete Microwave engineering and fabrication facilities are at your command. Inquiries on your Microwave problems will be treated in confidence.

Kearfott COMPANY, INC.

LITTLE FALLS, NEW JERSEY

WESTERN DIVISION
253 VINEDO AVE., PASADENA, CALIF.

EASTERN OFFICE
1378 Main Ave.
Clifton, N. J.

MIDWEST OFFICE
188 W. Randolph St.
Chicago, Ill.

SOUTH CENTRAL OFFICE
6115 Denton Drive
Dallas, Texas



(Continued from page 40A)

slicing and dicing of sapphire, quartz and ruby for the precision instrument field and the processing of germanium for the transistor industry.

Dr. Balamuth directed the development of the Ultrasonic Dental Unit, first introduced to the dental profession in 1954. The Ultrasonic Dental Unit, for the first time, provides a means for the virtual elimination of anesthesia in routine dentistry.

Cavatron's new vice-president received his doctorate in physics from Columbia University in 1934. He is a member of the American Physical Society, the Acoustical Society, and the American Ordnance Association. He is also a member of Sigma Xi and Epsilon Chi.

International Business Machines Corp. announces the appointment of H. T. Marcy (M'46) to Assistant Director of Product Development at IBM World Headquarters in New York City.



H. T. MARCY

Mr. Marcy began his employment with IBM in March, 1951 as a technical specialist assigned to the Airborne Computer Laboratory. In 1952 he was named development engineer and was also appointed consultant to the Air Force in the Technical Advisory Group of the Air Force Armament Center at Elgin Field. In 1954 he was transferred to Commercial Engineering and worked on technical policy planning, a staff assignment with the manager of the Endicott Laboratory. In December of that year he was transferred to World Headquarters on the staff of Director of Advance Machine Development and in March, 1955, he returned to Endicott to continue as senior engineer in Development Engineering. In April, 1956 he was appointed manager of Xerographic and Character Recognition Development in Development Engineering.

Mr. Marcy was born in Rochester, N. Y. In 1940 he received a bachelor of science degree in electrical engineering and in 1941 a master of science degree in the same field from the Massachusetts Institute of Technology.

He is a member of Eta Kappa Nu, Tau Beta Pi, and Sigma Xi. He is an Associate Member of the American Institute of Electrical Engineers and a member of the General Advisory Committee of the Broome County Technical Institute.

A radar and electronics specialist has been appointed supervisor in the electrical engineering research department at Armour Research Foundation of Illinois In-

(Continued on page 44A)

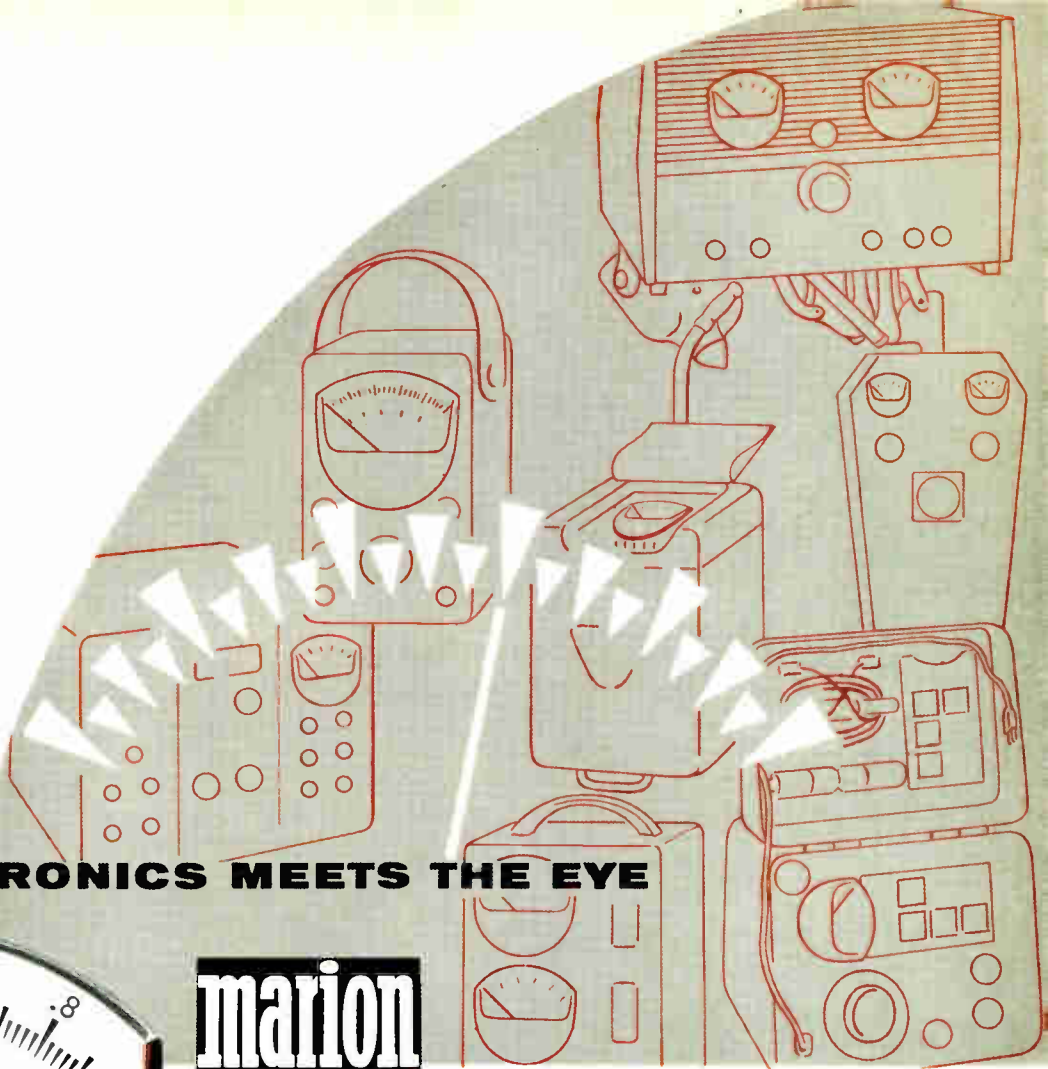

WHERE ELECTRONICS MEETS THE EYE



Modern equipment styling directs

attention to that critical area, the indicator — where electronics meets the eye of the user. Now, Marion Medalist* meters in your equipment will provide added eye appeal and sales appeal by successfully combining accuracy and reliability with color harmony and distinctive styling.

MARION MEDALIST METERS bring color harmony and functional beauty to panel design. Crystal clear, high temperature Plexiglas** fronts are available in many standard colors with harmonizing or contrasting dials. Custom case and dial colors can also be supplied.

Models include standard 1½, 2½ and 3½ inch sizes, interchangeable with ASA/MIL type mounting, and all standard DC ranges of microamperes, milliamperes, amperes, millivolts, volts, kilovolts, and AC rectifier types including VU and DB meters. The 1½" Medalists are also available as self-contained DC ammeters, rectifier-type AC voltmeters and VU meters.

Marion Medalists have another important advantage — increased readability. In the *same panel space*, a Medalist provides up to 50% more scale length — longer pointer — larger numerals — and *greater* natural dial illumination, than a *standard* round or square meter of the *same size*.

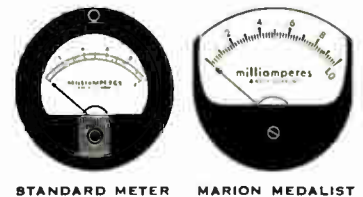

STANDARD METER MARION MEDALIST

These are the reasons that Marion Medalist Meters are setting new standards of appearance and readability, where electronics meets the eye.

*T.M. Reg. U. S. Pat. Off. U. S. & Foreign Patents
**Reg. T.M. Rohn & Hoos Co.

marion meters

MARION ELECTRICAL INSTRUMENT COMPANY
GRENIER FIELD, MANCHESTER, NEW HAMPSHIRE

MINIATURIZATION



with
*Increased
Reliability*

AMPHENOL *Micro* RIBBON CONNECTORS

Since their release in early 1956, thousands of AMPHENOL's miniature Micro-Ribbon connectors have been purchased for use in production and prototype electronic equipment. Engineers have been quick to realize the electrical and mechanical superiority of Micro-Ribbons—and are specifying these amazing connectors wherever *increased reliability* is as important as *miniaturization*.

In Micro-Ribbons there are no tiny pin contacts to bend or misalign, but self-wiping, self-cleaning sturdy *ribbon* contacts that provide easy, smooth insertion and extraction even in blind entrance locations. Both mating members are active, flexing members, assuring excellent double contact action at all times.

At 5 amperes, Micro-Ribbons are rated at 700 Volts D.C. at sea level and 200 Volts D.C. at 70,000 feet altitude. They are available in 14, 24 and 36 contacts. Dielectric is blue diallyl phthalate, contacts are gold-plated.



AMPHENOL ELECTRONICS CORPORATION
chicago 50, illinois
AMPHENOL CANADA LIMITED toronto 9, ontario



(Continued from page 42A)

stitute of Technology, Chicago, **J. E. McManus** (A'51-M'56) has been named supervisor of the communications and radio frequency section I.

Mr. McManus joined the Foundation in 1950 as an assistant engineer. During World War II, he worked on radar equipment for the Navy, specializing in jamming and anti-jamming equipment. At the Foundation, he has participated in research on the design of radar equipment, radar simulation, radar systems, telemetering, and doppler systems.

Mr. McManus received his B.S. degree in electrical engineering from the University of Detroit in 1949 and his M.S. degree from the University of Michigan in 1950.

He is a member of Eta Kapp Nu and Tau Beta Pi. He is also chairman of the Chicago chapter of the IRE Professional Group on Telemetry and Remote Control.



The appointment of **G. E. Pray** (M'41-SM'43) as General Manager of the Special Products Division has been announced

by Aerovox Corporation, New Bedford, Mass. He is in charge of all activities concerned with printed wiring, etched circuitry, pressed silver products, electronic sub-assemblies and electronic equipment.



G. E. PRAY

Mr. Pray comes to his new post with a wealth of radio-electronic engineering and management background. A graduate of Troy Conference Academy, of R.P.I. with a degree in electrical engineering, and of Rutgers with an M.S. degree in physics, his engineering and business career includes such past affiliations as research for R.C.A. Communications; co-operative work with Bell Laboratories in ship-to-shore radiophone including work in Europe and on radio stockbroker projects; and development of high-speed keying. His keying patents are now used on most high-speed transmitters all over the world. He supervised the design, production and testing of transmitters and high-gain receivers for the Signal Corps and acted as consultant for the Signal Corps at Washington and Wright Field. He worked on the development of Adcock direction finder for super frequencies, new vacuum tube types, and the first successful Navy radar receiver, with the Naval Research Laboratory before he became chief engineer and general manager of Airplane & Marine Instruments Inc., president of Radio Sonic Corporation, and president of General Electrosonics, which was later combined with Radio Sonic to become a wholly owned subsidiary of Mack Trucks. He then served as Mack

(Continued on page 46A)

-the heat's off!



This Electronic Reliability Engineer just discovered the IERC way to insure his chances of meeting equipment reliability specifications and military acceptance schedules.

Tubes failures (too often and too soon) caused by heat and vibration, the major causes of electron tube failures, were his problem.

With IERC Heat-dissipating Tube Shields, the "heat was off" both the suffering tubes and our man with the problem! Tube operating temperatures were lowered as much as 150°C and tubes are lasting 5 times longer. Schedules were met—time and money saved—highest tube reliability achieved!

Suspect and investigate the heat and vibration menace when tube failures plague you. Eliminate it with IERC Heat-dissipating Tube Shields — available in sizes for Miniature, Subminiature, Octal and Power types of electron tubes.

PATENTED OR PATS. PEND. IERC T-12 SHIELD AND BASE WITH 6080 TUBE ILLUSTRATED.
CROSS-LICENSED WITH NORTH AMERICAN AVIATION, INC.

IERC literature and latest Octal and Power tube shield Technical Bulletin

available now—FREE!

International
electronic research corporation
145 West Magnolia Boulevard, Burbank, Calif.



**NOW
for the
First
Time**



THE full authentic story of the man responsible for FM radio . . . the greatest American inventor since Edison, told in a book of extraordinary interest to every member of the Institute of Radio Engineers

MAN OF HIGH FIDELITY: Edwin Howard Armstrong

A BIOGRAPHY

By LAWRENCE LESSING. As a radio engineer, you are well aware of the matchless contributions Edwin Howard Armstrong made to the industry. Now, for the first time, you can read the full inside story of this amazing genius, written by an author equal to the challenge not only of depicting Armstrong's exciting personality but of describing and evaluating his inventions from a sound technical knowledge.

BASED ON ARMSTRONG'S PRIVATE PAPERS

Mr. Lessing, contributor to *Scientific American* and formerly an editor of *Fortune*, is a leading science journalist. In preparing this book, he has had access to a vast store of Armstrong's private papers and the help of Mrs. Armstrong and many of the inventor's closest friends. Much of the material in this book has never been revealed before!

CLARIFIES MAJOR ARMSTRONG'S PLACE IN THE INDUSTRY

MAN OF HIGH FIDELITY gives a careful, accurate account of all Armstrong's inventions (FM, the feedback system, the superheterodyne, etc.) and shows him as the last of the great individualistic inventors, a man who refused to be swallowed up by the great corporations. It makes the details of his legal battles vivid and dramatic and shows him exactly as he was throughout his fruitful, dedicated, tragic life.

MAN OF HIGH FIDELITY is a unique reading experience, a book you will want to own and an ideal gift for friends interested in the true story of American radio. It is copiously illustrated with photographs and drawings. We are so sure of its value to you that we offer it to you for ten days' free examination. Send no money. Mail the coupon NOW!

At your bookstore,
or mail the coupon for

[10 DAYS FREE-EXAMINATION]

J. B. LIPPINCOTT COMPANY
E. Washington Sq.
Philadelphia 5, Pa.

IRE-1

Please send me MAN OF HIGH FIDELITY: *Edwin Howard Armstrong* for examination and approval. Within ten days I will send you \$5.00 plus postage or will return the book postpaid.

Name

Address

City Zone State



(Continued from page 44A)

Trucks' vice-president and director of engineering and research for aircraft components and electronics subsidiary.

Mr. Pray is holder of numerous patents on radio-electronic devices, and author of papers, engineering reports, instruction books, and manuals for the Army and Navy. He is also a licensed professional engineer.

❖

The appointment of R. A. Burt (M'55) as Manager of the Systems Analysis Section of Electronic Control Systems, Inc. has been announced by A. F. Brewer, executive vice-president. Electronic Control Systems, Inc. is an affiliate of Stromberg-Carlson and a subsidiary of General Dynamics Corporation.

A native of LaGrange, Illinois, Mr. Burt is a graduate of the University of Chi-

cago, and holds a master's degree in applied mathematics from Purdue University. He has been a member of the Electronic Control Systems, Inc. technical staff since January, 1955.

During World War II Mr. Burt served as a naval aviator and air navigation instructor for the Naval Air Operational Training Command. While doing his graduate work he also was a member of the mathematics department at Purdue University.

Prior to joining Electronic Control Systems, Inc., Mr. Burt was for three years assistant manager of the automatic flight controls department of Lear, Inc., Santa Monica, Calif. In this capacity he was responsible for a number of development programs for automatic flight and missile control systems.

Previously Mr. Burt served as a mathematical analyst for the Rand Corporation, at Santa Monica, Calif., and as an aerodynamicist for the Bell Aircraft Corporation, Buffalo, N. Y. In these positions he worked on design analysis and performance estimates, using both analog and digital techniques.

Mr. Burt is a member of Sigma Xi.

THE 1956-1957 IRE DIRECTORY
contains more listings and more fact-filled advertisements
than ever before. Use it! It's valuable!

BIRD Model 43 *ThruLine* DIRECTIONAL WATTMETER

Reads Directly . . . WATTS FORWARD
WATTS REFLECTED... *In 50 Ohm Coaxial Lines*

Measures POWER into the antenna in the actual operating circuit. Continuous monitoring if desired.

Measures reflected power, direct reading. In antenna matching work, results show directly in lower reflected power.

Ideal for mobile equipment.

Tests 50 ohm r-f lines, antenna connectors, filters—quickly.

ACCURATE because of high directivity and small frequency error.

DIRECT READING—no calibration charts, no full scale meter adjustments needed. Meter scale reads directly for all ranges and is expanded for better down-scale reading.

CONVENIENT—does not require reversal of r-f connections. No auxiliary power required.

Negligible power loss and insertion VSWR.

Full scale power range and frequency range are determined by the selection of plug-in elements from the following list.

Frequency Range—25-1000 megacycles in five ranges vis. 25-60 (A), 50-125 (B), 100-250 (C), 200-500 (D), 400-1000 (E).

Power Range—10, 25, 50, 100, 250, and 500 watts full scale. Available in most frequency ranges.

Accuracy—5% of full scale.

Write for literature.



Model 43 with front element in operating position. Dimensions: 7" x 4" x 3" Weight, 4 pounds. SO239 jacks for PL259 plugs available.



BIRD
ELECTRONIC CORP.
1800 EAST 38TH ST., CLEVELAND 14, OHIO
TERMALINE Coaxial Line Instruments

**VAN GROOS
COMPANY**
Sherman Oaks, Cal.

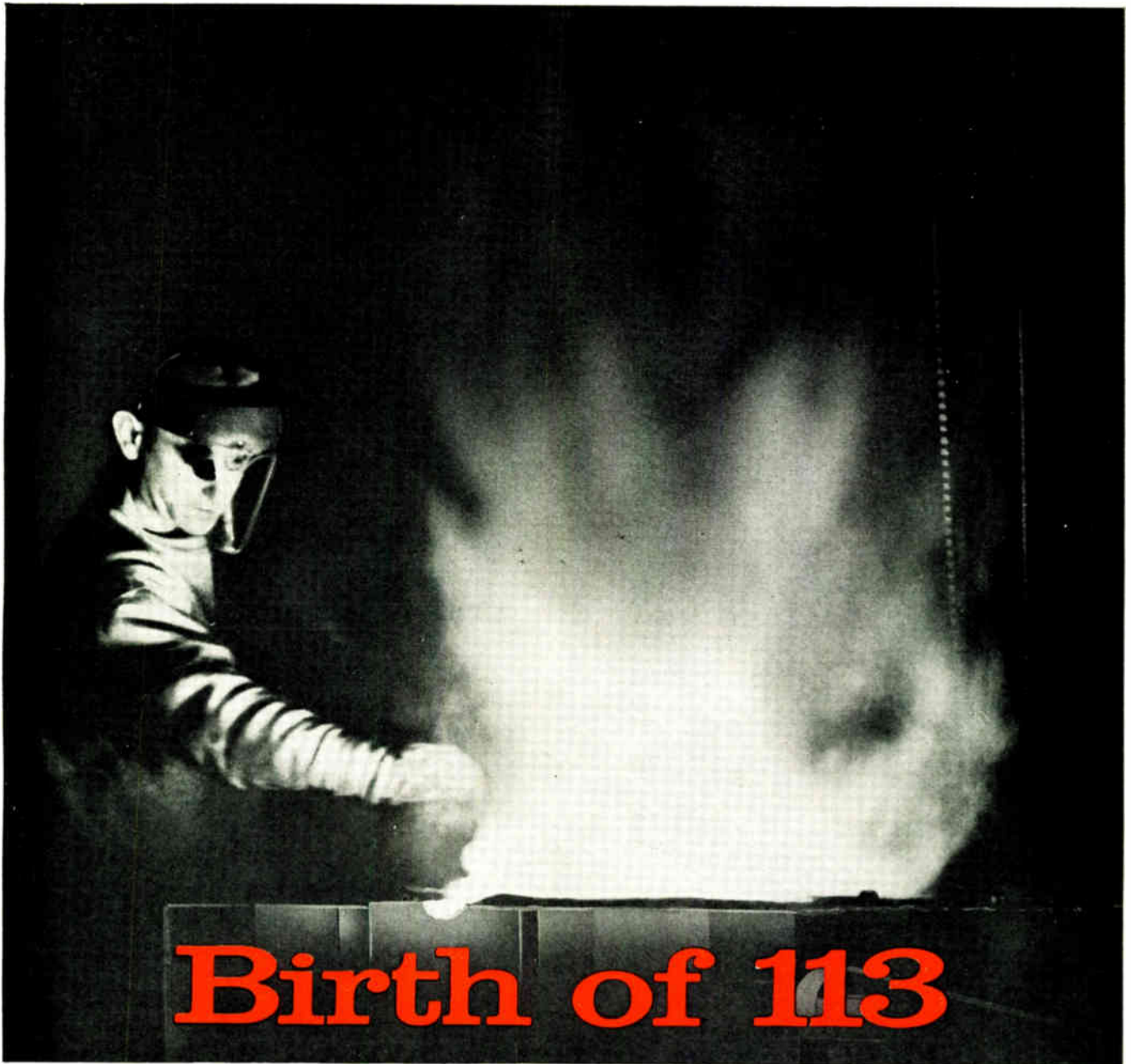

Birth of 113

At this stage, #113 is just a number. If all proceeds as planned, it will shortly acquire a name — the name of Driver-Harris's newest special-purpose alloy . . . made, as always, to meet the needs of a specific manufacturer.

When someone asks us for an alloy we do not have, we try to make it. Usually we succeed. To date we have succeeded 112 times. Many of our long line of electrical, electronic, and heat-resistant alloys — Nichrome*, Nichrome* V, Advance*, Karma*, Manganin, Nilvar*, and

the rest — are today famous names in industry the world over. And each of these was originally custom-made . . . produced exactly to the specifications of someone who needed it.

Are you in need of an alloy with special properties, not yet available? Put your specifications in our hands. You will gain the benefit of the 57 years of experience which has developed the largest variety of alloys ever made by any one company.

*T.M. Reg. U. S. Pat. Off.



Driver-Harris

HARRISON, NEW JERSEY

COMPANY

BRANCHES: Chicago, Detroit, Cleveland, Louisville, Los Angeles, San Francisco • In Canada: The B. GREENING WIRE COMPANY, Ltd., Hamilton, Ontario

MAKERS OF THE MOST COMPLETE LINE OF ELECTRIC HEATING, RESISTANCE, AND ELECTRONIC ALLOYS IN THE WORLD



Arithmetic Control Unit



Developed at **Philco Corp., Government & Industrial Div.**, 4700 Wissahickon Ave., Philadelphia, Pa., this computing unit occupies only one-third cubic foot and weighs 12 pounds. It operates on only 3 volts potential and employs Philco's direct-coupled circuitry thereby eliminating many components usually found in electronic computers. The unit contains nearly 1,000 transistors, 300 resistors and 12 capacitors permanently dip-soldered into plug-in, printed-circuit cards. Each card provides all the necessary functions for one binary digit including add, subtract, multiply, divide, square root, shift right, shift left, sign magnitude. Ten "math" cards and seven "control" cards are plugged into the 10 inch long unit to provide all arithmetic processing facilities between conventional input and output devices. Input-output connections are made by plugs. This TRANSAC unit adds two numbers in 1.5 microseconds; it multiplies in 15 microseconds. A row of indicator lights provides visual display of results. TRANSAC math-control units with larger digital capacities can be built in "building block" fashion by simply increasing the number of plug-in "cards."

Communications Receiver

Gonset Co., 901 So. Main St., Burbank, Calif., announces the G-66, a completely new communications receiver designed expressly for amateur mobile applications. This new receiver covers six bands, including standard broadcast, each amateur band being individually calibrated and spread across the easily read, slide-rule-type dial scale. Rotating drum exposes only

These manufacturers have invited PROCEEDINGS readers to write for literature and further technical information. Please mention your affiliation.

dial scale for band selected.

Bands: 0.54 to 2.0 mc, 3.5 to 4.0 mc, 7.0 to 7.3 mc, 14.0 to 14.35 mc, 21.0 to 21.45 mc, 28.0 to 29.7 mc.



Operating voltages: Separate, universal power supply/loudspeaker unit permits operation from 6 to 12 volts dc or 115 volts ac. Supplies are factory set for (specified) 6 or 12 volt operation.

Electrical features: AM, CW, SSB reception. Highly stable hf and bf oscillators with crystal controlled second conversation oscillator. High image rejection assured by double conversion with 2050 kc 1st if and 262 2nd if. Latter uses 8, high Q tuned circuits for flat-topped, steep shoulder selectivity curve. Bandwidth at 6 db down, 3.5 kc.

Package Industrial Controls

A diversified line of "package" industrial controls, providing automatic yet flexible monitoring and control of virtually any chemical or mechanical condition that can be measured electrically, is announced by the **Tipp Mfg. Co.**, Tipp City, Ohio.



Included among the functions that can be controlled by the instruments are voltage, current, torque, timing, pressure, temperature, liquid level, speed, depth, light, sound and deflection. The controls are effective over a variety of ranges for each function. Sensitivities begin with zero to 5 microamperes or zero to 5 millivolts. Normally the units operate on direct current, but they may be adapted to ac in most cases.

Either on-and-off or locking (shut-off) control action may be selected on most Tipp units. With on-off, the device takes control action when the signal reaches the preset limit, but it continues to test the signal periodically. If a permissible signal level is reached, the unit stops its control of auxiliary equipment but continues to indicate the signal. With locking control, the device must be reset manually each time the signal reaches the control point.

Tipp controls are available in either single or multi-meter models, depending on whether one or several signals must be monitored to provide complete control.

Commutation Switches

A standard motor-driven Mycalex Model TM-55 Series Commutation Switch with SUPRAMICA 555 ceramoplastic commutator plates, known as Type CP-299, has been announced by **Mycalex Electronics Corp.**, 125 Clifton Blvd., Clifton, N. J.



The unit has two rings of contacts and a maximum of 0.32 connector leads, brought out to a standard AN connector for easy installation. Brush size and type, duty cycle and general configuration are standard, but some modification of circuitry is possible.

(Continued on page 50A)

*Dick
Sounds like a real improvement
Jim*

BOST CHI DET LA NY PHILA OFC KLG
NEW RAYTHEON RECORDING STORAGE TUBE. CAN STORE A PICTURE
OR DATA IN LESS THAN 1/60 SECOND. READ OUT 30,000 TIMES.
NOW WITH OVER 600 LINES RESOLUTION AT HALF-AMPLITUDE
MODULATION. CAN BE USED FOR FREQUENCY OR SCAN CONVERSION.
A SUPERIOR TUBE IN WRITING-ERASING, STEEDXXXX SPEED,
DYNAMIC RANGE AND CAPACITY.

AMONG ITS USES ARE 1. DATA STORAGE FOR ANALOGUE COMPUTERS.
2. STOP MOTION OF TV SIGNALS. 3. STORAGE OF SIGNALS
TO BAND COMPRESS. 4. EXPANSION OF TV SIGNALS FOR NARROW
BAND TRANSMISSION. 5. STORAGE OF REPETITIVE SIGNALS TO
IMPROVE SIGNAL-TO-NOISE RATIO. MANY NEW PRODUCT USES
BEING DEVELOPED.

WRITE FOR YOURS NOW. NO OBLIGATION. TUBES ARE
AVAILABLE FOR IMMEDIATE DELIVERY ON
SMALL QUANTITY ORDERS.



Excellence in Electronics

RAYTHEON MANUFACTURING COMPANY

Microwave and Power Tube Operations, Section 27-67, Waltham 54, Mass.

Regional Sales Offices: 9501 W. Grand Avenue, Franklin Park, Illinois; 622 S. LaBrea Avenue, Los Angeles 36, California

Raytheon makes: Magnetrons and Klystrons, Backward Wave Oscillators, Traveling Wave Tubes, Storage Tubes, Power Tubes, Receiving Tubes, Picture Tubes, Transistors



*A new sealed,
shaft-driven precision
AC voltage divider
for accurate positioning
and calibration.*

Gertsch Rotary RatioTran*

100-turn or 1000-turn models available, both in anodized aluminum cases, sealed against dirt and moisture. Ratio is controlled by a single ball-bearing mounted shaft. An internal mechanical counter provides easy readout. Printed silver switches assure long life and reliability.

- High accuracy... as good as .005% linearity
- High resolution... as good as .0005%
- Low phase shift... less than 1'
- High input impedance... approx. 50 henrys (200 henrys in 1000-turn model)
- Continuous transient-free output

*TRADEMARK

FOR COMPLETE DATA SHEET, CONTACT YOUR NEAREST
GERTSCH ENGINEERING REPRESENTATIVE, OR

GERTSCH PRODUCTS, INC.

11846 MISSISSIPPI AVENUE
LOS ANGELES 25, CALIFORNIA



FOUR-CHANNEL CARRIER-TELEPHONE TERMINAL FOR RADIO LINKS

This is a miniaturized unit of advanced design which provides four voice channels on a frequency-division basis above a voice-frequency order-wire channel. Each of these five channels is provided with a 4-wire 2-wire termination and a voice-frequency ringing circuit for d-c or 20-cycle signals. Adjustable attenuators are provided in the 4-wire side of all channels, and a built-in test oscillator and meter permit complete line-up, maintenance and trouble-shooting checks to be made. Channel levels are from -9 to 0 dbm and line levels from -30 to 0 dbm. Channel width is 300 to 3500 cycles within 1 db.

This unit is only 5 1/4" high by 19" wide by 14" deep. It mounts on a standard rack and operates from 115 volts 50-60 cycles a.c.

RADIO ENGINEERING PRODUCTS
1080 UNIVERSITY ST., MONTREAL 3, CANADA
TELEPHONE UNIVERSITY 6-6887 CABLES RADENPRO, MONTREAL



News-New Products

(Continued from page 48A)

Power supply is 115 volts, 380 to 520 cps, single phase, and nominal speed at 400 cps is 5 rps. Noise level is below 50 millivolts.

Switches of this construction are operating successfully under adverse conditions, and have met specifications requiring -65 to 160° F ambient temperature range; 75,000 foot altitude; up to 500 cps and 10 g vibration; impact shocks of 15 g; and minimum life of 100 hours continuous operation without cleaning or adjustment.

Weight of the complete unit is less than 2 pounds.

Communications Receiver

Hammarlund Manufacturing Co., 460 W. 34th St., New York 1, N. Y., announces an addition to their line of communications receivers, the HQ-100. This receiver is a 10-tube superheterodyne with continuous tuning from 540 kc to 30 mc. List price is \$169.



A new audio output circuit features automatic frequency range control which permits optimum results on both communications and broadcast reception. Auto-Response also damps the speaker, eliminating "hangover" in the speaker itself.

A specially designed Q-Multiplier circuit provides continuously variable selectivity to meet all conditions encountered in tuning. Electrical bandspread tuning with direct calibration for the 80, 40, 20, 15 and 10 meter amateur bands is also provided. In addition to the electrical bandspread, a separate switch position permits optimum 20-meter bandspread.

Extra stability has been achieved through temperature compensation and voltage regulation of the high frequency oscillator circuit. Individually shielded rf and oscillator coils eliminate cross-talk between circuits.

(Continued on page 52A)

POTPOT

POTENTIOMETERS

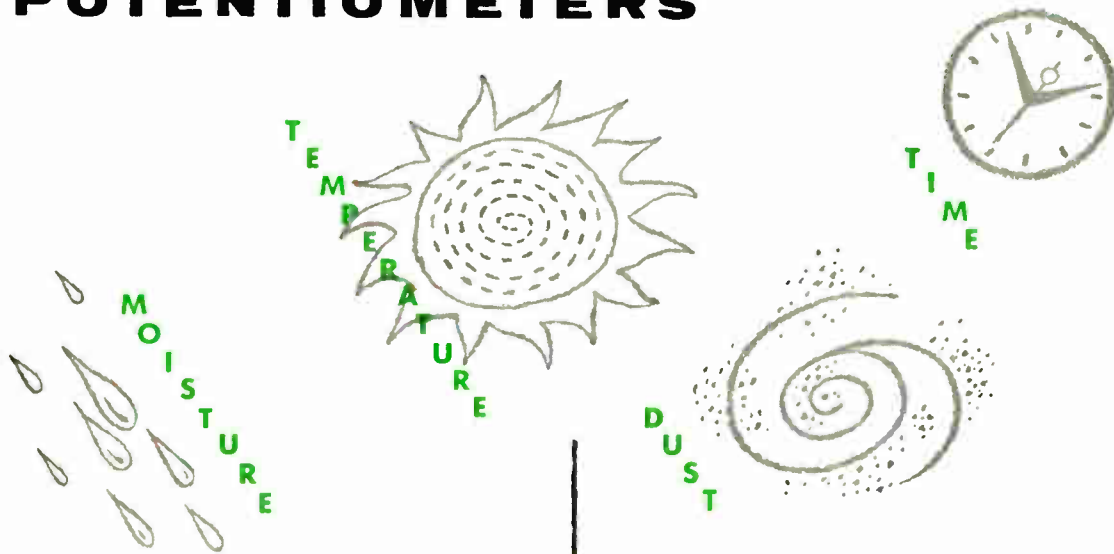

BUILT-IN PROTECTION

"Potpot" encapsulated potentiometers are available in either wire-wound or composition-element types, including Clarostat Series 48M and 49M miniatures, and in Series 43, 37, 51, 58 and 10 controls.

New encapsulating material provides water- and vapor-tight molded enclosure imbedding entire unit with exception of external shaft assembly and terminal tips. Special water-tight assembly for shaft bushing.

Designed to meet MIL-STD-202 Test Specification. Incorporating necessary salt-spray, humidity and temperature-cycling requirements of MIL-E-5272 climatic standards. Excellent shelf life.

Write for complete details.



CONTROLS AND RESISTORS

CLAROSTAT MFG. CO., INC.
DOVER, NEW HAMPSHIRE

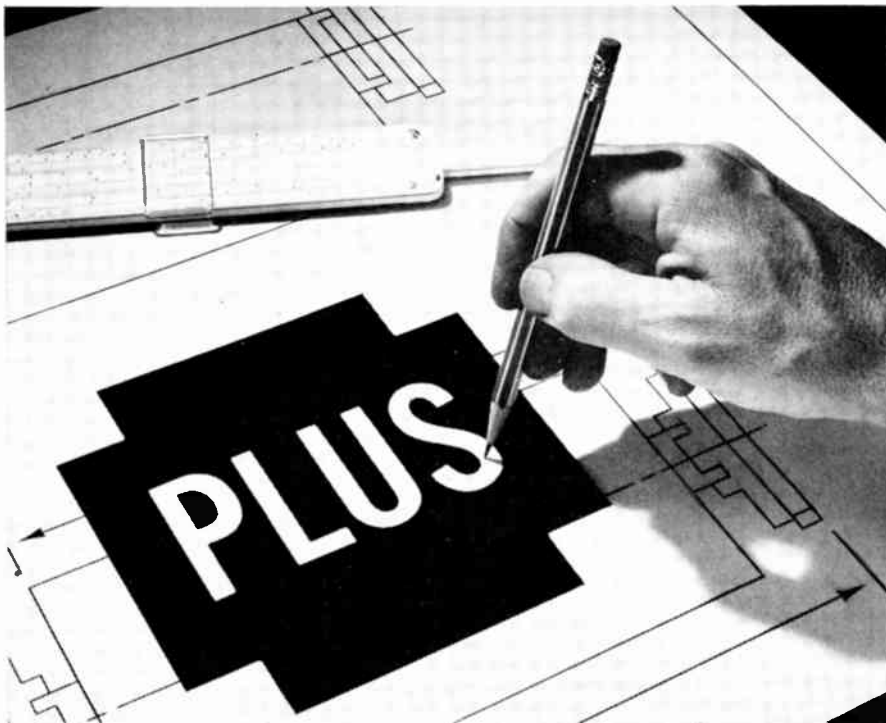

Put the PLUS in your microwave systems with AIRTRON *FERRITE* devices!

Airtron has stepped well beyond conventional designs through the use of remarkable non-reciprocal ferrite materials to give you microwave components with characteristics never before realized in the microwave design art!

Such vast improvements as isolating action, duplexing action, polarization diversity, electronic phase shift, remote attenuation and R.F. modulation are now possible with ferrite components.

These and Airtron's other great advancements are the *plus factors* that will minimize long line effects... provide rapid switching... improve AFC performance... permit rapid receiver recovery time... optimize magnetron operation... and eliminate mechanical mechanisms. Too, Airtron ferrite components will strengthen the reliability of your radar and microwave systems by increasing the operational life.

Airtron has successfully developed ferrite materials to a practical stage of application in a wide variety of designs, such as resonant absorption isolators, duplexers, switches, electrically variable attenuators and phase shifters, modulators, polarizers, beam switching antennas, single side band generators and similar devices that are unparalleled in comparison!

Add The Plus To Your Achievements with superior performing ferrite components by Airtron! For more detailed information and assistance in solving your specific microwave or ferrite component problems, contact Airtron immediately.

Airtron inc.

1107 West Elizabeth Avenue
Linden, New Jersey

Foreign Affiliates

AIRTRON CANADA, LTD.
Toronto, Canada

W. H. SANDERS (ELECTRONICS), LTD.
London, England

Engineers: Inquire about the unlimited career opportunities at our new ferrite center 317 Vassar St., Cambridge, Mass.

PERFECTION
in design

LONGER
life operation

UNPARRALLELED
comparison

SUPERIOR
performance



News-New Products

These manufacturers have invited PROCEEDINGS readers to write for literature and further technical information. Please mention your IRE affiliation.

(Continued from page 50A)

Supply for Transistor Circuits

A variable voltage, low cost supply especially designed for transistor circuit work has been introduced by Sorensen & Co., Inc., Stamford, Conn.



The new unit, known as a "T-Nobatron," Model T-50-1.5, features excellent line voltage regula-

(Continued on page 54A)

Midland Quality You Can See



Can YOUR Product Use CRYSTALS?

For many applications the glass holder developed by Midland is THE answer! Midland developed this advanced line of holders for the industry's requirements today and in the future.

Check with Midland for help on your plans or problems.

Midland

Manufacturing Company, Inc.
3155 Fiberglass Road Kansas City 15, Kansas
World's Largest Producer of Quartz Crystals.

For high-speed switching

CBS HIGH-FREQUENCY TRANSISTORS

2N182

2N183

2N184

These transistors are especially designed for high-speed switching . . . control . . . analog and digital computer applications. They are:

1. *NPV Symmetrical* . . . for better frequency response and reversible collector and emitter, permitting unusual applications.
2. *Alloy-Junction* . . . for greater uniformity, higher voltage and current, flatter gain, and more dependable performance.

Note the many desirable features. Write for Bulletin E-268 giving complete data and helpful application notes.



CHECK THESE FEATURES

1. High frequency response:
 - 2N182 2.5 to 5 mc.
 - 2N183 5 to 10 mc.
 - 2N184 10 to 20 mc.
2. High operating voltage . . . up to 30 volts.
3. High switching speed . . . below 0.2 μ sec.
4. High current amp. factor . . . up to 100.
5. High dissipation rating . . . up to 100 mw.
6. Low leakage current 3 μ amps av.
7. Low base resistance 150 ohms av.
8. Low collector capacitance 10 μ mf.

*Reliable products
through Advanced-Engineering.*



semiconductors

CBS-HYTRON

Semiconductor Operations, Lowell, Mass.

A DIVISION OF COLUMBIA BROADCASTING SYSTEM, INC.

0 CPS to 1 MC!
DIRECT READING



new
Computer-Measurements Model 226A

UNIVERSAL COUNTER-TIMER

OUTSTANDING FEATURES:

- ★ Three independent, adjustable trigger level controls permitting full rated sensitivity at any voltage level between -300 and +300 volts.
- ★ Small voltage increments ordinarily masked by attenuators are easily selected.
- ★ Simplified color-coded controls and direct read-out in kc, mc, sec, or millise, with automatic decimal point indication.
- ★ Oscilloscope marker signals facilitate start and stop trigger level adjustment for time interval measurement of complex waveforms.

A brand new, multi-purpose instrument provides precision measurement of frequency, frequency ratio, period (1/frequency) and time interval. Pressure, velocity, acceleration displacement, flow, RPS, RPM, etc., may also be measured with suitable transducers. The 226A may be used as a secondary frequency standard.

price: **\$1,100.00**

Long Term: 3 parts per million per week
 Display Time: Automatic: Continuously variable 0.1 to 10 seconds
 Manual: Until reset
 Input Impedance: 1 megohm and 50 mmf
 Trigger Level: Continuously adjustable from -300 to +300 volts
 Accuracy: ± 1 count \pm stability
 Secondary Frequency Standard: 1 mc; 100, 10, 1 kc; 100, 10, and 1 cps
 Dimensions: 17" W x 8 $\frac{3}{4}$ " H x 13 $\frac{1}{2}$ " D approx.
 Weight: 50 lbs. approx.



MODEL 225A 0 cps-100 kc
UNIVERSAL COUNTER-TIMER

Similar to the 226A in design. Featuring Oscilloscope Trigger Level Marker Signals; Three Direct-Coupled Inputs of 70 mv sensitivity; Direct Reading, Automatic Illuminated Decimal Point. Easily portable. Price: \$840.00

Data Subject to Change Without Notice - Prices F.O.B. Factory
 Write for complete specifications on the new 226A and the 225A models and the complete CMC line of electronic counting and controlling equipment.

Computer-Measurements Corporation
 5528 Vineland Avenue, North Hollywood, Calif. Dept. 86P

FREQUENCY

SPECIFICATIONS:

FREQUENCY MEASUREMENT

Frequency Range: 0-1,000,000 cycles per second
 Input Sensitivity: 0.2 volt rms. Direct-coupled input
 Time Bases: 0.00001, 0.0001, 0.001, 0.01, 0.1, 1 and 10 seconds. Also can use external 0-1 mc standard

PERIOD MEASUREMENT

Period Range: 10 microseconds to 1,000,000 seconds
 Frequency Range: 0.000001 cps to 100 kc
 Input Sensitivity: 0.2 volts rms. Direct-coupled input

Gate Times:

1 and 10 cycles of unknown frequency
 Standard Frequency Counted: 1 mc; 100, 10, 1 kc; 100, 10, 1 cps; external 0-1 mc.

TIME INTERVAL MEASUREMENT

Range: 3 microseconds to 1,000,000 seconds
 Start and Stop: Two independent or common channels Positive or negative slope
 Input Sensitivity: 0.2 volts rms. Direct-coupled input
 Standard Frequency Counted: 1 mc; 100, 10, 1 kc; 100, 10, 1 cps; external 0-1 mc.

GENERAL

Stability: Short Term: 1 part in 1,000,000 (temperature-regulated crystal)



News-New Products

These manufacturers have invited PROCEEDINGS readers to write for literature and further technical information. Please mention your IRE affiliation.

(Continued from page 52A)

tion and transient response for line and load pulses.

In-put range of the unit is 95-130 vac, 60 cps. Output voltage is 0-50 volts dc in 3 ranges, 0-10, 0-25, and 0-50 volts. Regulation for line changes is ± 1 per cent for 105-125 volts, ± 2 per cent for wider input. Ripple is 50 mv maximum.

Complete specifications, performance data and quotations are available.

Instrument Cases

Production of a new, standard line of drawn aluminum instrument cases is announced by Instrument Cases, Inc., 510 Garfield St., Glendale 4, Calif.



Complying with spec Mil-T-945A and Mil-STD-108c, they are available in transit, combination and instrument case types. Offered in a wide variety of sizes, the ICI cases provide savings in time and cost over the production of equivalent special or custom-built cases.

A descriptive engineering bulletin illustrating the various types and giving complete specifications and tables of sizes is available on request.

Special Surface Teflon Wire

Tensolite Insulated Wire Co., 198 Main St., Tarrytown, N. Y., and 1516 N. Gardner St., Los Angeles, Calif., announces a newly

(Continued on page 56A)

FREQUENCY • PERIOD • TIME INTERVAL • FREQUENCY • PERIOD • TIME INTERVAL • FREQUENCY • PERIOD • TIME INTERVAL • FREQUENCY



cc-30

Greatest Single Span

In building the Brooklyn Bridge, John Roebling fulfilled a creative engineering dream which stamped him as a master craftsman in his field. Completed by his son in 1883, it was at that time the longest single span ever erected and its record length of 1,595-1/2 feet was unsurpassed for twenty years.

FXR Precision MM Variable Attenuator gives *Greatest Range*

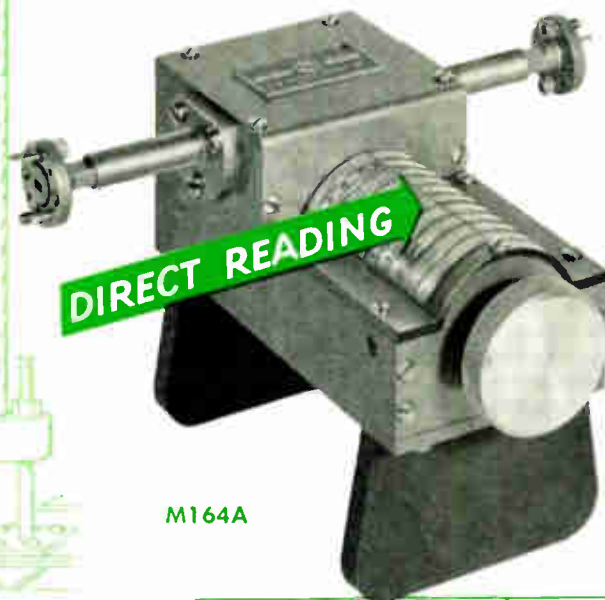

M164A

Here is an important step forward in the development of Microwave components, for measuring gain, coupling, and attenuation. Never before have direct attenuation readings been attainable with such speed and accuracy at millimeter wave lengths. Direct reading over a full waveguide bandwidth, this exceptionally convenient unit is calibrated to 50 DB of attenuation and features bilateral matching. The Precision Variable Attenuator is the latest in a growing line of Microwave Test Equipment, reflecting the outstanding craftsmanship for which FXR has become known throughout the microwave electronics industry.

Direct Reading Precision Variable Attenuator	Frequency Range (KMC/sec)	Waveguide Size	Calibrated Attenuation Range*	Maximum VSWR	Flange Type	Insertion Length
Type No. M164A	50-75	RG-98/U (0.148 x 0.074)	0-50db	1.15	UG-385/U	4-1/2"

*Maximum Calibration Error 0.1 db or 2% of reading, whichever is greater. Transmission loss is less than 1.0 db (not included in calibration).

EXPORT:

Szucs International Corp.
50 Broad Street,
New York 4, N. Y.
Cable: SUCANDEX

WEST COAST:

The Van Groos Company
14515 Dickens St.
Sherman Oaks, Calif.
STanley 7-9615

CHICAGO:

KoDell Sales Associates, Inc.
5875 No. Lincoln Ave.
Chicago 45, Ill.
LOng Beach 1-3042



FIRST BY FAR



Electronics & X-Ray Division

F-R MACHINE WORKS, Inc.

26-12 BOROUGHS PLACE, WOODSIDE 77, N. Y. • ASTORIA 8-2800



NOW AVAILABLE . . . the new FXR catalogue for 1956-57 showing a complete line of Precision Microwave Test Equipment.

REMEMBER!

SPECIFY

ERIE

TUBULAR CERAMICONS®

for

PRINTED WIRING APPLICATIONS

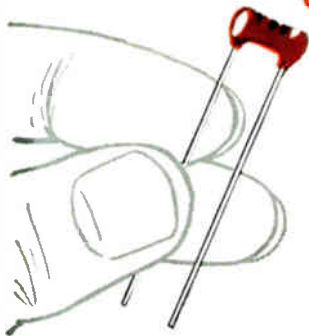

DIPPED PHENOLIC INSULATED

These Radial lead units are dipped in low-loss phenolic material which is baked and vacuum wax impregnated.

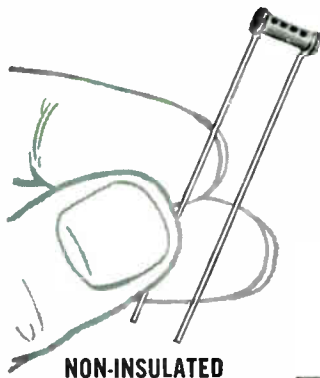

NON-INSULATED

Radial leads soldered to silver electrodes and sealed with moisture impervious coating to withstand humidity.

Write for 16 page Bulletin 313-2 for description of ERIE TUBULAR CERAMICONS. Also ask for our new 8 page Feed-Thru Ceramicon Bulletin 323.

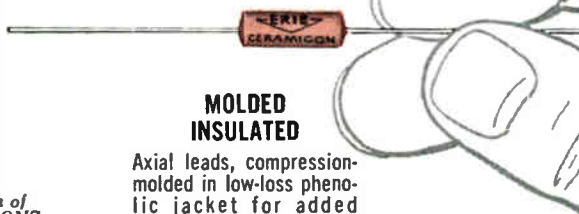

MOLDED INSULATED

Axial leads, compression-molded in low-loss phenolic jacket for added strength and protection against humidity.

- Leads are tin coated with a minimum of .001" heavy coating of solder to insure ease of solderability and to prolong shelf-life.
- ERIE TUBULAR CERAMICONS offer convenient form design, including 1/4" and 3/8" lead spacing, for printed wiring board applications where space is at a premium.
- Rugged construction of ERIE TUBULAR CERAMICONS features inherently strong dielectric design with leads wrapped around the dielectric and soldered to withstand stress and strain.
- Uniform case size of ERIE Molded Tubular Ceramicon is designed for automatic loading and is available packaged on tape called "Reel-Pack"—2000 to a reel.
- Temperature Compensating and General Purpose Ceramicon are available in a wide capacity range with tolerances as close as $\pm 1\%$ or $\pm .1$ mmf and in Hi-K types for by-pass and coupling applications.



These manufacturers have invited PROCEEDINGS readers to write for literature and further technical information. Please mention your IRE affiliation.

(Continued from page 54A)

developed Teflon insulated wire with a specially treated, readily "printable" surface. Wire treated in this manner is suited for leads on potted components, insuring complete moisture proofing of such products.

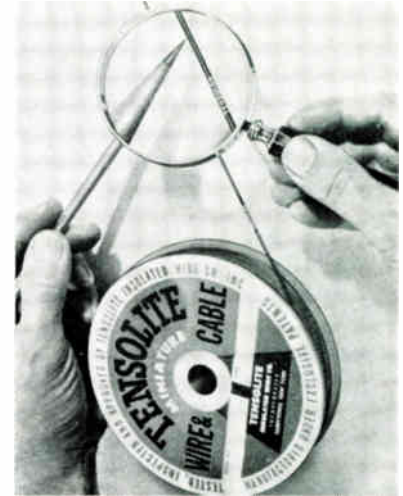

By this process, normally adhesion-resistant Teflon insulation is made receptive to standard adhesives and printing foils without materially affecting the other desirable physical and electrical properties of the insulation. Because potting compounds in use today will adhere to this type of lead wire, it is not necessary to use binding posts or hermetic seals to make outside connections.

Precision Phasemeter

Maxson Instruments Div., The W. L. Maxson Corp., 47-37 Austell Pl., Long Island City 1, N. Y., has developed a new Model 901 Phasemeter which permits direct reading of phase differences between sinusoidal voltages, from 0 to 360°, with provision for sense indication to avoid 180° ambiguity. Phase angle is measured to an absolute accuracy of 0.1°, with incremental accuracy of 0.01°, at all frequencies from 30 to 20,000 cps. The accuracy of measurement is not affected by even harmonics, or by third harmonics up to 1 per cent. A unique feature of this instrument renders measurement accuracy independent of secondary standards.

(Continued on page 58A)

ERIE ELECTRONICS DIVISION
ERIE RESISTOR CORPORATION
 Main Offices and Factories: ERIE, PA.
 Manufacturing Subsidiaries
 HOLLY SPRINGS, MISSISSIPPI • LONDON, ENGLAND • TRENTON, ONTARIO

The right people with the right facilities produce the right solutions



Observing measurement of circuit parameters in the Electronic Systems Division's Buffalo Engineering Laboratory. From left: H. S. Tittle, Manager—Buffalo Operations; M. C. Scott, Manager—Buffalo Engineering Laboratory; R. W. Ferry, Advanced Development Engineer; and A. W. Puttick, Engineering Manager.

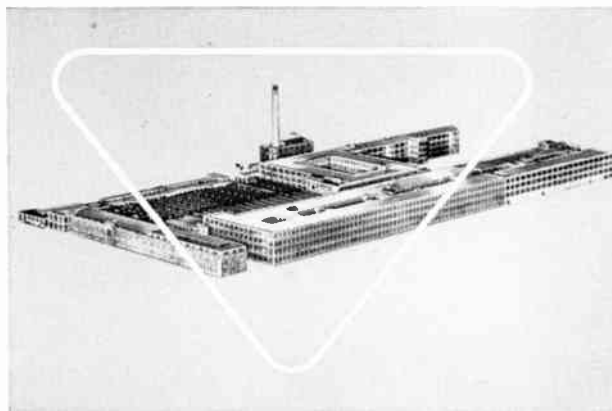

Buffalo Engineering Laboratory and manufacturing facilities occupy nearly 170,000 square feet of floor space in this industrial center at 175 Great Arrow Ave., Buffalo 7, New York.

Keeping electronic equipment cool with controlled air flow "Packaging"

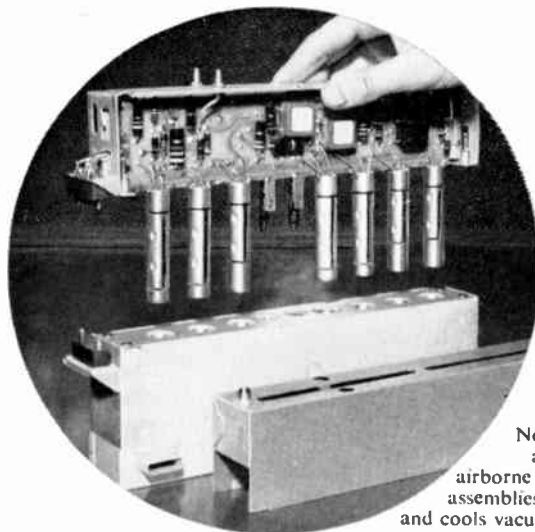

New "packaging" for airborne electronic assemblies insulates and cools vacuum tubes.

INTENSE HEAT generated by airborne electronic equipment and supersonic flight is posing new problems for the safety and performance both of crewmen and their planes.

An ingenious method for combating the heat menace was recently developed by Sylvania's Electronic Systems Division. Vacuum tubes are mounted in carefully sized ducts in light foam plastic material of the desired thermal properties. Accurately controlled air flow results in optimum cooling, while exhausting the air at high temperature.

Tests have proved that this is an ex-

remely effective method, giving cooling efficiencies of approximately 90 per cent. Through the use of such electronic "packaging" in supersonic aircraft, it is possible to reduce the amount of air-cooling equipment, with its accompanying weight penalties.

Problem solving, whether in research and development or in practical application, is the chief task of Sylvania's Electronic Systems Division. In all of its installations, the right people work with the right facilities, within a sound managerial environment. That is why they have produced right solutions to a vari-

ety of problems, and have made many important contributions in the fields of aviation electronics, guided missiles, countermeasures, communications, radar, computers, and control systems. Whether the problem is military or industrial, Sylvania's business is to come up with solutions that are producible.

The Electronic Systems Division has plant and laboratory facilities at Buffalo, N. Y., Mountain View, Calif., and Waltham, Mass. All are staffed with top-ranking scientists and engineers, backed with Sylvania's extensive resources in the electronics field.

SYLVANIA IS LOOKING FOR ENTERPRISING ENGINEERS

Sylvania has many opportunities in a wide range of defense projects. If you are not now engaged in defense work, you are invited to contact Edward W. Doty, Manager of Personnel, Electronic Systems Division, Sylvania Electric Products Inc., 100 First Avenue, Waltham 54, Mass.



SYLVANIA



SYLVANIA ELECTRIC PRODUCTS INC.

LIGHTING • RADIO • ELECTRONICS • TELEVISION • ATOMIC ENERGY • CHEMO-METALLURGY

For Single Side Band . . . Carrier Reinsertion

ULTRA STABLE OSCILLATOR

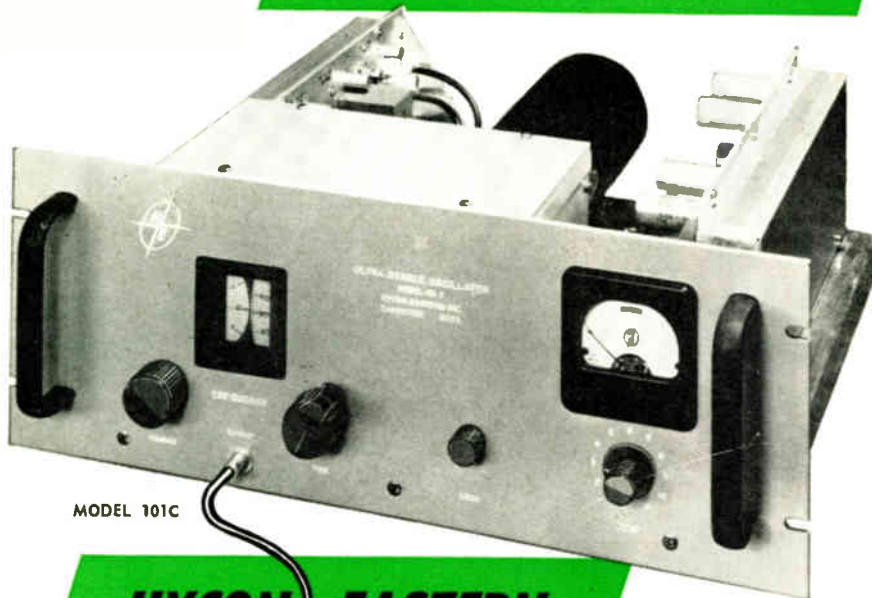

MODEL 101C

HYCON EASTERN

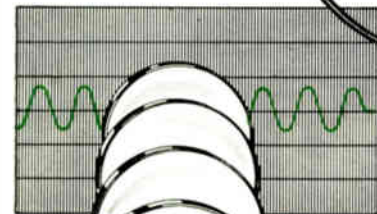

Hycon Eastern's new Ultra Stable Oscillator is a one megacycle signal source of exceptional stability. It is useful wherever precise time measurements or frequency control are required, as in reinsertion of carrier in suppressed carrier systems, telemetry, astronomical measurements, navigation systems, geophysics or other critical applications.

Write for Ultra Stable Oscillator Bulletin

STABILITY: 1 PART IN 10⁹

- **FREQUENCY STABILITY:** DRIFT RATE LESS THAN 1 PART IN 10⁹ PER DAY AFTER ONE MONTH'S OPERATION.
- **FREQUENCY:** 1 MEGACYCLE, VARIABLE OVER A RANGE OF 1 CYCLE. AVAILABLE AT OTHER FREQUENCIES ON SPECIAL ORDER.
- **CRYSTAL OVEN:** STABILIZED TO BETTER THAN 0.01°C BY TEMPERATURE-SENSITIVE RESISTANCE BRIDGE. OVEN CONTAINS NO MOVING PARTS.
- **DISSIPATION IN OSCILLATOR CRYSTAL:** STABILIZED AT A POWER LEVEL LESS THAN ONE MICROWATT.
- **2 OUTPUTS:** SINE WAVE—4 VOLTS RMS; PULSE—1 VOLT.
- **OUTPUT IMPEDANCE:** APPROXIMATELY 250 OHMS.
- **POWER REQUIRED:** 150 VOLTS, 100 MA, REGULATED DC, AND 6.3 VOLTS, 3 AMPERES, AC OR DC. (Matching Power Supply available)

HYCON EASTERN, INC.

75 Cambridge Parkway Dept. B-12 Cambridge 42, Mass.
 Affiliated with HYCON MFG. COMPANY, Pasadena, California



News-New Products

These manufacturers have invited PROCEEDINGS readers to write for literature and further technical information. Please mention your IRE affiliation.

(Continued from page 56A)

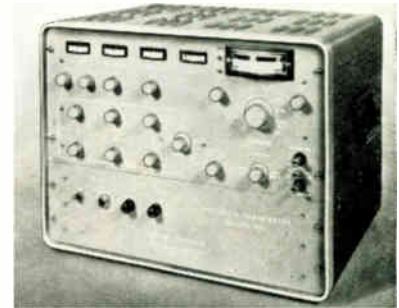

All controls and meters are located on the front panel. Phase angles are read directly from a calibrated two-degree, step control in combination with a 4 inch vernier indicator having a linear range of $\pm 1.0^\circ$.

Input impedance, for each channel, is 10 megohms shunted by 25 μf . Each input channel will handle signals from 0.5 to 5.0 volts rms. Higher levels may be handled with suitable attenuators. Besides the panel-control indication of output, the instrument provides an output signal for recording output on many types of commercial, strip-chart recorders.

Mercury Switch Pulser



Designed for calibration and stability measurements involving scintillation spectrometry circuits, the N-101 Mercury Switch Pulser features a continuously adjustable rise time (0.03–0.5 μs). Output delivers up to 10 ma maximum 22 volts, and is continuously variable with better than 0.1 per cent linearity. It has a battery pulse source and a stability better than 0.1 per cent per day after initial warm-up. Operates on 115 volts 60 cps, 18 watts. The N-101 is constructed on the Hamner Variflex Chassis for relay rack mounting or table top use. Literature is available. Developed by Hamner Electronics Co., Inc., Princeton, N. J.

(Continued on page 60A)

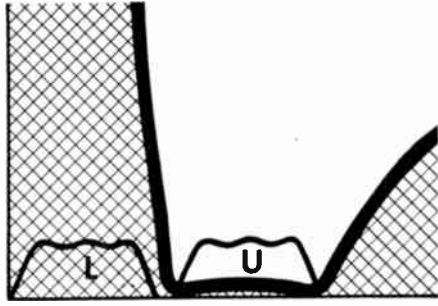

Crystal Filters for Single Sideband Communications

In no systems of modern communication are more stringent requirements placed on frequency selective networks than in single sideband transmission and reception. In SSB generation, for example, complete and accurate separation of sideband signals is necessary for optimum performance. Similarly, in the reception of SSB signals, the requirements for image rejection, pilot selection, and frequency control place exacting specifications upon the corresponding circuitry.

The use of the quartz resonator in providing reliable frequency control is well known throughout the industry. It is not surprising, therefore, that the quartz crystal should be called upon to provide stable, reliable, and compact frequency selection devices such as filters and discriminators.

The extremely low dissipation and excellent temperature stability which are characteristic of the quartz crystal provide SSB equipment utilizing crystal filters and crystal discriminators with many advantages:

Improved Sideband Rejection

Typical Hycon Eastern, Inc., SSB crystal filters permit the use of audio frequencies from 300 to 6000 cps while maintaining a sideband attenuation of at least 60 db. Filters with correspondingly sharp slopes are available with other bandwidths. At 16 Mc for instance, a 1 db bandwidth of 96 Kc has been achieved.

Frequency Range

Hycon Eastern, Inc., has produced filters for SSB application at frequencies from 80 Kc to 16 Mc.

Low Distortion

Passband uniformity within ± 1 db, negligible intermodulation distortion, and linear phase characteristics insure reproduction with utmost fidelity.

Stability

Systems employing crystal filters in conjunction with crystal oscillators enjoy both the stability inherent in crystal resonators and freedom from microphonic behavior.

Maintenance

All Hycon Eastern, Inc., frequency selective devices are hermetically sealed life-time components, requiring no realignment or readjustment.

Hycon Eastern, Inc., employing newly developed techniques for the *design* and *production* of crystal filters and associated components, is meeting the varied needs of SSB communications. The efforts of Hycon Eastern, Inc., in the field of sideband separation filters, pilot selection filters, and frequency discriminators employing quartz resonators have been concentrated at frequencies of 80, 100, and 500 Kc, and 3.2 and 16 Mc.

If the frequencies you contemplate using in your new SSB system fall between 10 Kc and 20 Mc, Hycon Eastern, Inc. can assist you in the selection of filter characteristics best suited to your needs. Address inquiries to: Mr. Austen Madeson,



HYCON EASTERN, INC.

75 Cambridge Parkway Dept. B-12 Cambridge 42, Mass.
Affiliated with HYCON MFG. COMPANY, Pasadena, California

MAGNETIC AMPLIFIERS • INC

AUTOMATIC UNIVERSAL
TRANSISTOR AND POWER
TRANSISTOR CURVE TRACERS

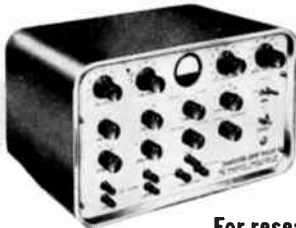

—For research,
circuit development and quality control
of transistors.

- High accuracy ($\pm 2.5\%$)
- Dynamic tracing of entire family of curves simultaneously, including—
- Internally generated calibration axes displayed at all times
- Retrace not blanked; anomalies clearly seen
- For all types of transistors and power transistors. Permits rapid determination of parameters. For selecting, matching and detecting anomalies and rejects.

Model 200A—Transistor Curve Tracer
Request Bulletin S393.
Model 300A—Power-Transistor Curve Tracer
Request Bulletin S667

and
PHASE ANALYZER
AND VACUUM TUBE
VOLTMETER



- Phase and Voltage of AC signals measured simultaneously and read directly from dial and meter scales.
- Useful frequency range from 20 cps. to 10 kc.
- AC signal under test need not be a pure sinusoid, but may be greatly distorted.
- Indispensable for alignment of servo systems, measurement of input requirements of non-linear loads and determination of amplifier input impedances even in the presence of noise feedback from the amplifier.
- Provision included for dynamic recording of internally demodulated AC transients.

Request Bulletin S675



Magnetic Amplifiers • Inc

632 TINTON AVENUE, NEW YORK 55, N.Y.—CYpress 2-6610
West Coast Division
136 WASHINGTON ST., EL SEGUNDO, CAL.—EAsgate 2-2056

for service and lab. work

Heathkit PRINTED CIRCUIT OSCILLOSCOPE KIT FOR COLOR TV!

① Check the outstanding engineering design of this modern *printed circuit* Scope. Designed for color TV work, ideal for critical Laboratory applications. Frequency response essentially flat from 5 cycles to 5 Mc down only $1\frac{1}{2}$ db at 3.58 Mc (TV color burst sync frequency). Down only 5 db at 5 Mc. New sweep generator 20-500,000 cycles, 5 times the range usually offered. Will sync wave form display up to 5 Mc and better. Printed circuit boards stabilize performance specifications and cut assembly time in half. Formerly available only in costly Lab type Scope. Features horizontal trace expansion for observation of pulse detail — retrace blanking amplifier — voltage regulated power supply — 3 step frequency compensated vertical input — low capacity nylon bushings on panel terminals — plus a host of other fine features. Combines peak performance and fine engineering features with low kit cost!

Heathkit TV SWEEP GENERATOR KIT ELECTRONIC SWEEP SYSTEM

② A new Heathkit sweep generator covering all frequencies encountered in TV service work (color or monochrome). FM frequencies too! 4 Mc — 220 Mc on fundamentals, harmonics up to 880 Mc. Smoothly controllable all-electronic sweep system. Nothing mechanical to vibrate or wear out. Crystal controlled 4.5 Mc fixed marker and separate variable marker 19-60 Mc on fundamentals and 57-180 Mc on calibrated harmonics. Plug-in crystal included. Blanking and phasing controls — automatic constant amplitude output circuit — efficient attenuation — maximum RF output well over .1 volt — vastly improved linearity. Easily your best buy in sweep generators.



MODEL
0-10
\$69⁵⁰
Shpg. Wt.
27 lbs.



MODEL
TS-4
\$49⁵⁰
Shpg. Wt.
16 lbs.

Heath
COMPANY
A SUBSIDIARY OF DAYSTROM, INC.
BENTON HARBOR 4, MICH.

WRITE FOR FREE CATALOG
...COMPLETE INFORMATION



News-New Products

These manufacturers have invited PROCEEDINGS readers to write for literature and further technical information. Please mention your IRE affiliation.

(Continued from page 58A)

Crystal Pulling Furnaces

Semiconductor manufacturers are offered two new low cost crystal pulling furnaces by NRC Equipment Corp., 160 Charlemont St., Newton Highlands 61, Mass. The compact NRC Model 2995 Vertical Crystal Pulling Furnace and NRC Model 2996 Horizontal Crystal Pulling Furnace can be used to grow either germanium or silicon crystals.

Selling for approximately half the price of custom-built crystal pullers, these new standard units are equally suited for production or research. Both models are easy to load, unload and clean. They offer excellent visibility of the melting surface. High quality crystals are assured by close temperature control and a vibration-free, precision pulling mechanism driven by a variable speed motor. Both units are readily adaptable to automatic operation.

Swing Racks

A new, light-weight, sturdy family of front-access swing racks is being offered by National Co., 61 Sherman St., Malden 48, Mass., in its new "blue chip" line of quality electronic components and hardware.

Available in three standard sizes, $8\frac{3}{4}$, 7 and $5\frac{1}{4}$ inches, these racks are available in hinged frame with open-back chassis where dust problems are at a minimum, and in hinged frame, with hinged-front chassis where enclosure of the under-chassis parts is desirable. Both types of construction provide for access to under-chassis elements from the front of the panel by simply swinging the rack out.

The combination of aluminum chassis and cold-rolled steel will support chassis weights up to 80 pounds. $17\frac{3}{4}$ inch minimum clearance is required for the swing racks.

Information will be furnished on request to the company.

Microwave Signal Sources

The Electronics & X-Ray Div., F-R Machine Works, Inc., 26-12 Borough Pl., Woodside 77, N. Y.,

(Continued on page 63A)

High reliability manufacturing of miniaturized paper tubular capacitors -- hermetically sealed in metal cans

To produce subminiature paper capacitors free from any possibility of latent defects, for use in the most critical applications, the Sangamo Electric Company has recently intensified its high reliability program of fabrication and inspection methods.

Incoming materials for these capacitors are rigidly inspected to meet stringent high reliability standards and are stored in areas where temperature, humidity and dust are controlled at all times.

Complete production histories are kept on the basis of small capacitor lots. X-raying of individual units, heat tests, vibration tests, altitude tests, and total destruction tests of a given percentage of all finished units assure components with an extremely low AQL. Testing facilities and resultant performance characteristics are far in excess of military specifications. Specify these high reliability capacitors for your critical applications.

Mail the coupon below for Sangamo's *NEW Engineering Catalog TS-105A*. It contains full information, including an easy-to-follow cross reference showing each variation listed in MIL-C-25 versus the comparable Sangamo unit.



SEPARATE FACILITIES are maintained for the exclusive processing and manufacture of high reliability capacitors. Only specially trained, highly skilled operators, who wear special clothing to prevent any possible source contamination, work here.



OIL-FILLED CAPACITORS are subjected to vacuum under elevated temperatures, then are individually examined to insure complete hermetic seal.

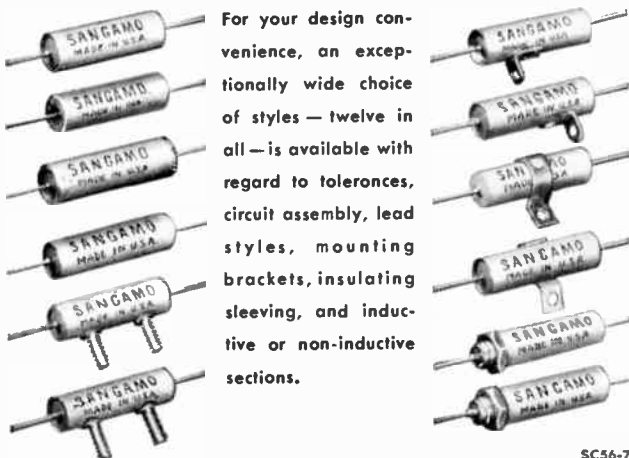

For your design convenience, an exceptionally wide choice of styles — twelve in all — is available with regard to tolerances, circuit assembly, lead styles, mounting brackets, insulating sleeving, and inductive or non-inductive sections.

SC56-7

SANGAMO ELECTRIC COMPANY

Capacitor Division
SPRINGFIELD, ILLINOIS

Please send me your **NEW Engineering Bulletin TS-105A**.

Name _____

Company _____

Address _____

City _____ Zone _____ State _____

Why are there **TWO SWEEP GENERATORS** in these oscilloscopes ?



The extra sweep generator makes an oscilloscope much more useful. With the Tektronix delaying sweep you can . . .

- 1 START THE OSCILLOSCOPE SWEEP WITH THE FIRST TRIGGER RECEIVED AFTER A CONTROLLABLE TIME-DELAY PERIOD.**
This is an important reason for the extra sweep generator and its associated pickoff circuit in Tektronix Type 535 and Type 545 Oscilloscopes. Triggering the delayed sweep by the observed signal guarantees a jitter-free display . . . ideal for examination of time-modulated pulses and signals with inherent jitter.
- 2 START THE OSCILLOSCOPE SWEEP AT THE END OF A CONTROLLABLE TIME-DELAY PERIOD . . .** convenient for observation of occurrences after an accurately determined time interval.
- 3 MAKE MORE ACCURATE TIME-INTERVAL MEASUREMENTS.**
A calibrated ten-turn time-delay control divides each of the twelve delay ranges into a thousand units. Range accuracy is within 1%, incremental accuracy on any range is within 0.2% of full scale.
- 4 TRANSFER PART OF A DISPLAY TO A FASTER SWEEP.**
By initially displaying a signal on the extra, delaying sweep, and then transferring it to the main oscilloscope sweep, a continuously adjustable horizontal expansion can be obtained. Degree of magnification is determined by the time/cm ratio between the two sweeps. The average jitter of 1 part in 25,000 permits practical use of very large magnifications. Further, the exact portion of the display on the delaying sweep that will appear on the faster main sweep is positively identified by trace brightening. Unblanking pulses for both sweeps are applied to the crt grid, causing the main sweep to show up as a brightened portion of the display on the delaying sweep.
- 5 ARM THE OSCILLOSCOPE SWEEP FOR TRIGGERED ONE-SHOT OPERATION.** A front-panel pushbutton or an electrical signal from a remote location can be used instead of the internal delayed trigger to arm the sweep. After the button is pressed, or the pulse received, the next trigger causes the main sweep to fire once and revert to the locked-out condition. Photographic recordings of a single transient made in this manner cannot be blurred by spurious signals following its occurrence. Because the single sweep can be triggered any time after the button is pressed or the pulse received, the time of occurrence need not be accurately predictable.

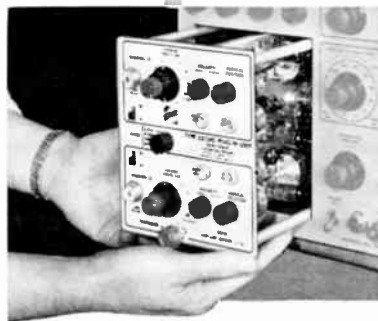

GREATER VERSATILITY PREFERRED

Customer preference for the Tektronix Oscilloscopes with a delaying sweep, Type 535 and Type 545, indicates that the increased utility is valued at much more than the small additional cost. Application possibilities of these versatile instruments make them worthy of your serious consideration.

TYPE 535 and TYPE 545 CHARACTERISTICS

Delay Specifications

A calibrated twelve-step range control and a ten-turn precision control provide for continuously-variable coverage of the full sweep-delay range—1 μ sec to 0.1 sec. Range accuracy is within 1%, incremental accuracy within 0.2% of full scale. Time jitter is less than 1 part in 20,000 in conventional sweep-delay operation. Display is completely jitter-free in triggered operation. The delaying sweep can be used as a rate generator, producing trigger rates from 10 cycles to 40 kc, continuously adjustable. The delayed trigger is available at a front-panel connector for external applications.

Other Specifications

Main-sweep range is 0.02 μ sec/cm to 12 sec/cm continuously variable, with 24 calibrated steps accurate within 3%. Accelerating potential is 10 kv. Vertical-amplifier response with Type 53/54K Fast-Rise Plug-in Unit. . . . Type 535, dc to 11 mc—Type 545, dc to 30 mc. Seven plug-in vertical preamplifiers are available for complete signal-handling versatility.

Type 535 (without plug-in units) **\$1300**

Type 545 (without plug-in units) **\$1450**

Prices f.o.b. Portland, Oregon

Your Tektronix Field Engineer or Representative will be happy to furnish complete specifications and arrange a demonstration at your convenience.

ENGINEERS — interested in furthering the advancement of the oscilloscope? We have openings for men with creative design ability. Please write Richard Ropiequet, Vice President, Engineering.

Tektronix, Inc.

P. O. Box 831 • Portland 7, Oregon

Phone CYpress 2-2611 • TWX-PD 265 • Cable: TEKTRONIX

(Continued from page 60A)

broad-band microwave signal sources, FXR Type No. A771A, packaged into one unit featuring a direct reading frequency dial that offers "one-knob control" from 950 to 2000 and 1900 to 4000 mc, are now being manufactured in production quantities by the Electronics & X-Ray Div., F-R Machine Works, Inc.

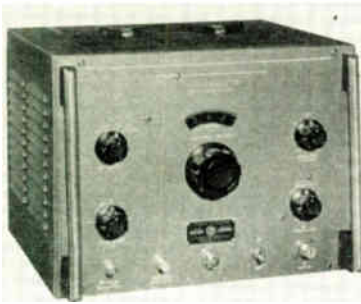

FXR's "all-in-one" Signal Sources combine a power supply, klystron, klystron cavity, modulator, variable rf attenuator and an automatic reflector voltage tracking system for efficient, versatile operation. Broad-band measurements now may be made with increased speed and ease. Output power across the band is high enough for most attenuation measurements. These FXR Signal Source units are packaged for simplicity of operation, maximum efficiency, improved stability and convenience.

A catalog sheet with complete specifications is available on request.

Oscillorecord Camera

Electronic Tube Corp., 1200 E. Mermaid Ave., Philadelphia 18, Pa., has introduced a new recording camera with film speed range from $\frac{1}{2}$ to 12,000 inches per minute in three overlapping continuous ranges.



(Continued on page 64A)

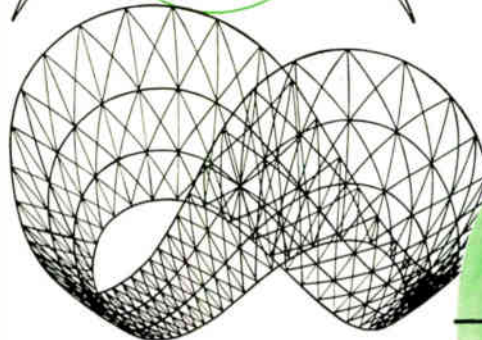
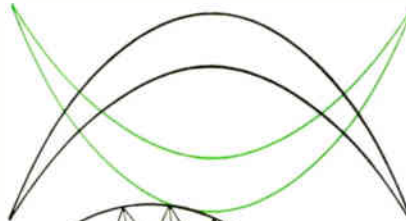
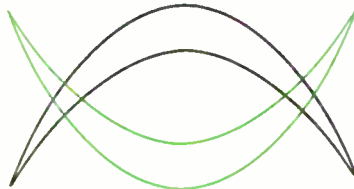
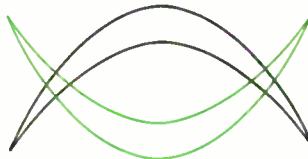
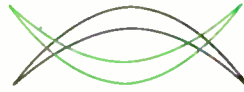

...ROUND TRIP TICKET

You can obtain the obvious advantages of a round trip ticket by bringing your radar component problems to Microwave Associates. We are equally concerned with both legs of the radar journey. Our products will not only help insure maximum transmission of energy to the target but will contribute to most efficient conversion of available return signals into useful data.

Microwave Associates offers the following design improvements to increase radar efficiency, sensitivity and reliability:

Recently developed super sensitive E Mixer series offers increased burn out resistance for longer life.

New, higher power designs, decreased spike leakage and insertion loss, faster recovery time and longer life.

Long life Philips cathode, high altitude designs, extra rugged construction for operation under extremes of shock and vibration.

SILICON DIODES

TR DUPLEXER TUBES

MAGNETRONS

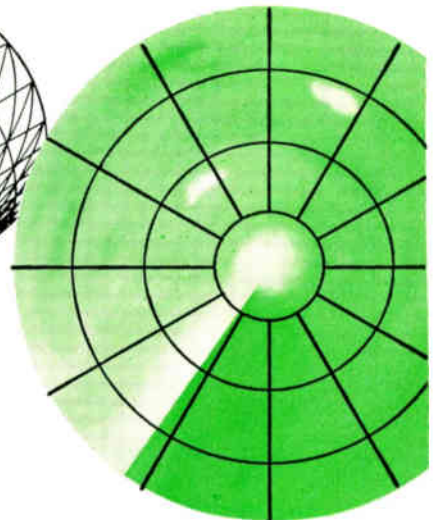

MICROWAVE ASSOCIATES INC.

22 Cummington St., Boston 15, Mass. CO pley 7-7577

Soon at our new plant: Northwest Industrial Park, Burlington, Mass.

**more for your
money from the
leader in the field!**

NEW

Berkeley

**MODEL
7360**

**1 mc UNIVERSAL COUNTER-
TIMER-EPUT* METER**

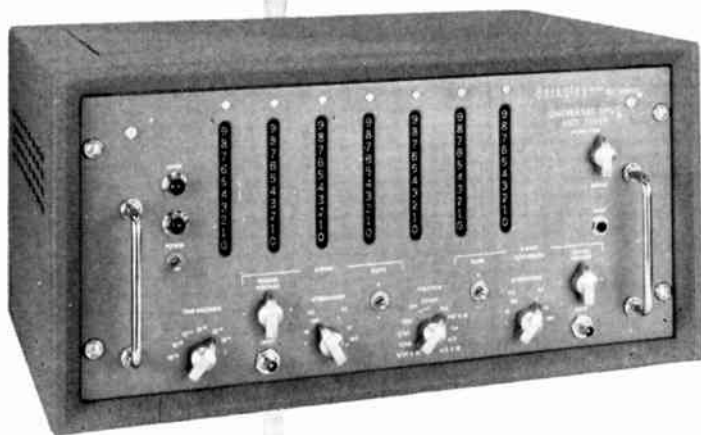

No other single instrument offers the wide range of usefulness of the truly universal Model 7360. It combines the functions of high-speed counter, time interval, EPUT*, frequency, frequency ratio and frequency period meters in one compact precision instrument.

No other instrument offers such outstanding value — 12 major improvements, at no increase in price:

- | | |
|---|---|
| <ul style="list-style-type: none"> 1 0.1 v rms sensitivity 2 Step attenuators 3 More stable frequency dividers 4 Electronic (not relay) reset 5 External frequency standard input connection 6 Ac or dc coupling of all input circuits 7 Accessory socket to power photocells, etc. 8 Direct connection to digital printers, data converters 9 Crystal-controlled time marker output 10 Unitized modular design | <ul style="list-style-type: none"> 11 Larger, brighter readout numbers 12 Modern-styled all-aluminum cabinets |
|---|---|

BRIEF SPECIFICATIONS

Freq. Range: 0 cps to 1 mc
 Time Int. Range: 1 μ sec to 10⁷ sec
 Period Range: 0 cps to 1 mc
 Time Base: 1 μ sec to 10⁷ sec
 Accuracy: \pm 1 count, \pm crystal stability
 Crystal stability: \pm 3 parts in 10⁷ per week
 Input Req.: 0.1 v rms, 10 megohm imp.,
 ac or dc-coupled
 Dimensions, cabinet: 10 $\frac{1}{4}$ "H x 20 $\frac{3}{4}$ "W x 16 $\frac{1}{2}$ "D
 (rack mount available)
 Price, f.o.b. factory: \$1,175.00
 (100 kc Model 7350, \$890.00)

If you want to get the most for your instrument dollar, investigate BERKELEY's outstanding new 7000 series Universal Counter-Timer-EPUT* meters now. Technical bulletin, complete data is yours for the asking; please address Dept. N12.

*Trademark

Berkeley *division*
 BECKMAN INSTRUMENTS INC.
 2200 Wright Avenue • Richmond 3, Calif.

93

64A

WHEN WRITING TO ADVERTISERS PLEASE MENTION—PROCEEDINGS OF THE IRE

December, 1956



News-New Products

These manufacturers have invited PROCEEDINGS readers to write for literature and further technical information. Please mention your IRE affiliation.

(Continued from page 62A)

Designated Model SM-100, this camera has been designed primarily for use with 5 inch oscilloscopes. It is capable of making either single frame or moving film recordings. The unit consists of 17x24x13 inch camera with supply and take-up magazines, a universal type mounting tripod, and a continuously variable motor speed control.

Camera lens is Wollensack f:1.5, 50 mm. coated, mounted in shutter with speeds from 1 to 1/100 second, diaphragm openings f:1.5 to f:8. Object to image ratio is 4.5:1.

Focusing is fixed for a standard mount, with housing arranged for access to lens and shutter for setting of aperture, and for single-frame exposure.

Provision has been made for illumination of a data card. A miniature glow lamp supplies timing marks on the edge of the film. Lamp is normally excited at line frequency using a pulse shaping circuit. Connections are available for external marker timing pulses.

Film magazines for both supply and takeup are individually removable with built-in light traps. Standard 400 foot capacity, with 1,000 foot supply available on special order at extra cost. Price \$885.00 fob Philadelphia.

**New Plant for Color
Television**



Color Television Inc., has moved the offices and plant from the present location at 973 E. San Carlos Ave., San Carlos, Calif., to 1421 Old County Rd., Belmont, Calif. All phases of this move will be completed and operations begun in the new plant on October 1, 1956. The new facility in Belmont will have a floor area of 30,100 square feet as compared with 10,400 square feet in San Carlos.

(Continued on page 67A)

Precision Instruments . . .

backed by the

RCA reputation

for engineering

excellence



VHF Signal Generator Type LG-22
(5 mc to 230 mc)

\$395.00*

VHF Signal Generator

Now . . . For The First Time . . . Precision Features in a Low Priced VHF Signal Generator . . . Ideal For Production Use!

This attractively priced RCA Signal Generator has laboratory precision features that make it highly desirable for production use. Excellent frequency accuracy and stability. Individually calibrated. Negligible RF leakage. Wave-guide below cut-off type attenuator normally found in more expensive instruments.

Valuable in designing and evaluating receivers, amplifiers, and other apparatus that operate at frequencies between 5 and 230 mc. Particularly useful in measuring

sensitivity and gain and for driving impedance bridges. Other signal generators available to meet your equipment and price requirements.

RCA Instruments of Laboratory Precision

PULSE GENERATOR ★ RF POWER METERS ★ NULL VOLT-METERS ★ IMPEDANCE BRIDGES ★ SIGNAL GENERATORS ★ VACUUM TUBE VOLTMETER ★ MULTIMETER ★ CRYSTAL MODULATOR AND OTHERS.

**Price in U.S.A., subject to change without notice.*



RADIO CORPORATION of AMERICA

CAMDEN, N. J.

In Canada: RCA VICTOR Company Limited, Montreal

USE COUPON BELOW FOR COMPLETE INFORMATION

Radio Corporation of America
Precision Electronic Instruments
Dept. M-94, Building 15-1, Camden, N. J.

Please send me complete information on the following instruments:

Send name of nearest representative

NAME _____ TITLE _____

COMPANY _____

ADDRESS _____

CITY _____ ZONE _____ STATE _____

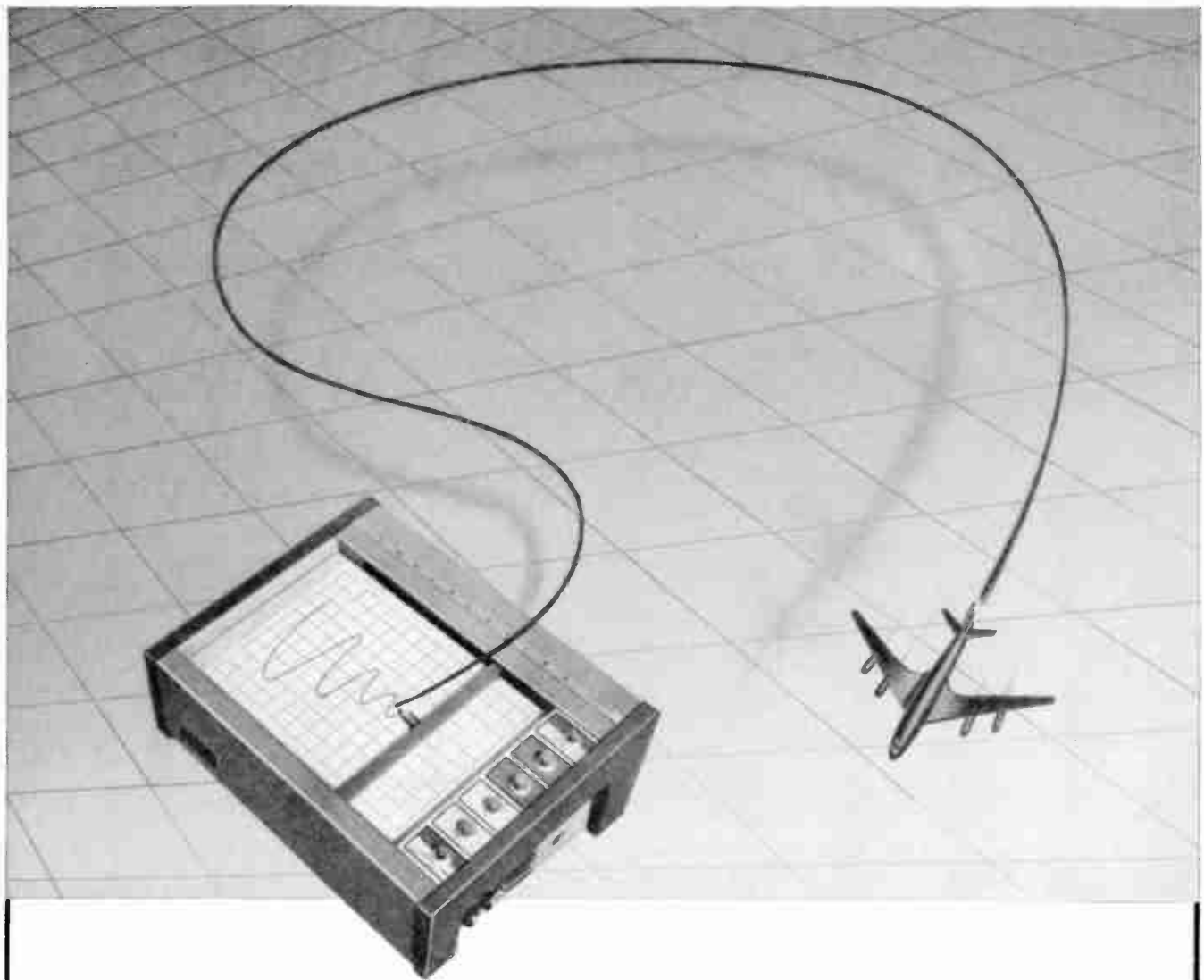

*Announcing a new member
in a proud family*

Once again, setting the PACE, Electronic Associates announces the newest addition to the royal family of recording equipment — the new Variplotter Model 1100D.

Another example of the PACE of Progress set by Electronic Associates, the new Model 1100D Variplotter offers 9 specific, built-in operational advantages, as well as 5 new integral convenience factors, to assure the ultimate in X-Y, table-top recording.

Complete specifications on these 9 operational advantages and 5 convenience factors will be forwarded to you on request.

For details on this and other Variplotter models, as well as information on Analog Computing Equipment, time rental at our Princeton Computation Center, or a visit with our skilled Sales Engineering staff, write Dept. IR-12, Electronic Associates, Inc., Long Branch, N. J.

**ELECTRONIC
ASSOCIATES**

Incorporated

• • • SETS THE

P A C E
PRECISION ANALOG COMPUTING EQUIPMENT

LONG BRANCH, NEW JERSEY • TELEPHONE LONG BRANCH 6-1100



These manufacturers have invited PROCEEDINGS readers to write for literature and further technical information. Please mention your IRE affiliation.

(Continued from page 64A)

Garvin Joins Thomas & Skinner

Appointment of Stefan J. Garvin as Manager of Operations in charge of all manufacturing, engineering and research activities has been announced by James C. Skinner, president of Thomas & Skinner, Inc., 1120 East 23rd St., Indianapolis, Ind.



Garvin brings to his new position a number of years of experience in this industry. He received a Master's Degree in Metallurgy from Cambridge University, Cambridge, England. After working for several years in the magnetic industry in England, Garvin came to the United States under a Mond Nickel Fellowship and studied at M.I.T., where he received his Master's Degree. Since 1950 he has been associated with the Arnold Engineering Co.

Knight Appointed by Air Associates

Frank W. Godsey, Jr., President of Air Associates, Inc., announced the appointment of Charles Knight as General Manager of the firm's Facsimile Equipment Division located at 511 Joyce Street, Orange, N. J.



Knight will now be responsible for all aspects of the company's facsimile program, which includes the planning of engineering programs, sales and sales promotion, production requirements, and service.

Knight, who has 17 years' experience in electronics and allied fields, has been with Air Associates for nine years, during which time he has served as Chief Design Engineer and Administrative Engineer.

(Continued on page 68A)



To users of ceramic parts...

is THERMAL SHOCK giving you trouble?

Stupakoff offers a number of ceramic bodies providing exceptional resistance to thermal shock, the most outstanding being STUPALITH, which has withstood over a hundred cycles from 2000° F to liquid air without harm.

are HIGH TEMPERATURES your problem?

Components formed of selected Stupakoff Ceramic Materials will withstand extremely high and prolonged temperatures, without deterioration, even in the presence of many corrosive gases and materials.

would PRECISION-MADE CERAMICS help speed your production?

Stupakoff specializes in the mass-production of precision-made ceramic parts and components. Tolerances of ± 0.001 in. are not unusual. Their use in assemblies of electrical and electronic equipment sharply reduces assembly costs, and assures correct functioning of the equipment in service. This precision is particularly valuable in miniaturized assemblies.

Write for the new Stupakoff Ceramic Data Chart

STUPAKOFF DIVISION OF
The CARBORUNDUM Company

WRITE DEPT. IRE LATROBE, PENNSYLVANIA





FILTERS BY TRIAD



The same brilliant design, expert workmanship and extensive facilities that make TRIAD transformers the "Symbol of Quality" is available to develop special wave filters for your particular requirements.

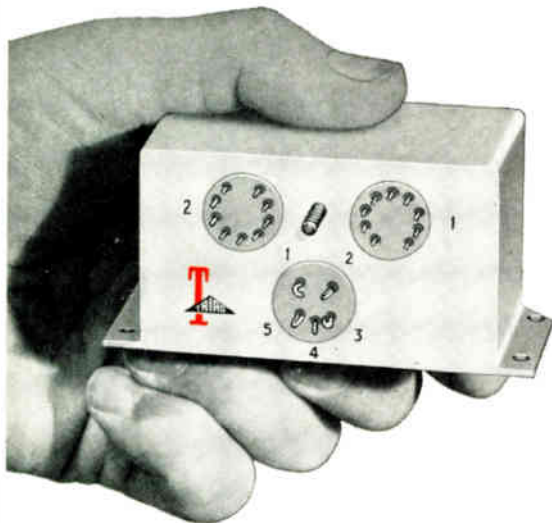

TOROIDS BY TRIAD



4055 REDWOOD AVE.
VENICE, CALIFORNIA

If your requirements are Reliability, Accuracy, Stability, with level temperature and humidity, specify TRIAD quality Toroids for your products. Special inductors, to your specifications, available from the factory.



News-New Products

These manufacturers have invited PROCEEDINGS readers to write for literature and further technical information. Please mention your IRE affiliation.

(Continued from page 67A)

WESGO Expands Facilities



With the tripling of plant facilities and purchase of additional land for future expansion, **Western Gold & Platinum Co.**, announces the move to new quarters in Belmont, Calif.

The 29-year old company presently is engaged in the manufacture of ultra high purity, low vapor pressure brazing alloys used in the manufacture of Klystron, Magnetron and conventional power vacuum tubes. The company also manufactures Gold, Silver and Platinum alloys and compounds for use in the electronic industry.

(Continued on page 71A)

NEW METER-RELAYS FROM 0-5 MICROAMPERES-UP Ruggedized - Sealed, Black Bakelite or Clear Plastic Cases

D'Arsonval meters with locking contacts for sensitive and accurate control or alarm.

TRIP POINT ADJUSTABLE to any point of scale arc. Sensitive to changes as little as 1%. One contact on moving pointer. The other on adjustable pointer. When pointers meet, contacts close and lock. Holding coil wound on moving coil. Locking is electro-magnetic. Manual or automatic reset. Spring action kicks contacts apart.

Ranges: From 0-5 microamperes, 0-5 millivolts or 0-300°F up.

Standard Contact Rating 5 to 25 milliamperes DC. Can be up to 100 milliamperes DC.

Ruggedized-Sealed metal cases, 2½", 3½" or 4½" round, shock-mounted movement, gasket-sealed.

Black Bakelite case, 4½" rectangular.

Clear Plastic cases, 2½", 3¾" or 4½" rectangular.

Panel meters and indicating pyrometers also in ruggedized-sealed, black bakelite or clear plastic cases. Write for new 40 page Catalog 4A on meter-relays, meters, pyrometers and automatic controls.

Model 255-C, 0-10 V DC \$42.50

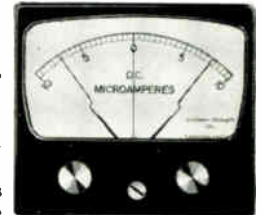

Model 461-C, 10-0-10 Ua DC \$83.25

Assembly Products, Inc., Chesterland 2, Ohio. HAmilton 3-4436 (West Coast: Desert Hot Springs 2, Calif. Phone: 4-3133 & 4-2453).

save panel space with **LAMBDA d.c. power supplies**

NEW COM-PAK* SERIES

*trademark

200-400-800 MA SERIES 0-200, 125-325 and 325-525 D.C. VOLTAGE RANGES



COM-PAK MODELS RANGES AND PRICES

Model ¹	Output Voltage ²	Output Current ³	Base Price ¹
C-280	0-200 VDC	0-200 MA	184.50
C-281	125-325 VDC	0-200 MA	159.50
C-282	325-525 VDC	0-200 MA	169.50
C-480	0-200 VDC	0-400 MA	259.50
C-481	125-325 VDC	0-400 MA	244.50
C-482	325-525 VDC	0-400 MA	259.50
C-880	0-200 VDC	0-800 MA	340.00
C-881	125-325 VDC	0-800 MA	315.00
C-882	325-525 VDC	0-800 MA	360.00

¹For metered models add suffix "M" to model and add \$30 to base price. (For example C-281M, \$189.50.)

DC OUTPUT (regulated for line and load):

Voltage Refer to chart above.
²Voltage range for any given model is completely covered in four continuously variable bands.

Current Refer to chart above.
³Current rating applies over entire voltage range.

Regulation (line) Better than 0.15% or 0.3 Volt (whichever is greater). For input variations from 105-125 VAC.

Regulation (load) Better than 0.25% or 0.5 Volt (whichever is greater). For load variations from 0 to full load.

Transient Response (line) Output voltage is constant within regulation specifications for step-function line voltage change of plus (+) 10 volts or minus (-) 10 volts rms within the limits of 105-125 VAC.

Prices and specifications effective November 1956, subject to change without notice.

Transient Response (load) Output voltage is constant within regulation specifications for step-function load change from 0 to full load or full load to 0.

Internal Impedance
 C-200 Series Less than 6 ohms.
 C-400 Series Less than 3 ohms.
 C-800 Series Less than 1.5 ohms.

Ripple and Noise Less than 3 millivolts rms.
 Polarity Either positive or negative may be grounded.

AMBIENT TEMPERATURE AND DUTY CYCLE Continuous duty at full load up to 50°C (122°F) ambient.

AC OUTPUT (unregulated) 6.5 VAC (at 115 VAC Input).⁴
 C-200 Series 10 AMP.
 C-400 Series 15 AMP.
 C-800 Series 20 AMP.

⁴Allows for voltage drop in connecting leads. Isolated and ungrounded.

AC INPUT 105-125 VAC, 50-400 CPS

OVERLOAD PROTECTION:

External Overload Protection AC and DC fuses, front panel, with built-in blown-fuse indicators.
 Internal Failure Protection Fuse, rear of chassis.

CONTROLS:

DC Output Controls Band-switches and screw-driver adjusting vernier-control, rear of chassis.
 AC and DC Switches Front panel.

GERMANIUM RECTIFIERS† · TRANSIENT-FREE OUTPUT · HERMETICALLY SEALED TRANSFORMERS

These new and compact power supplies occupy a minimum of space, deliver maximum performance. They are without qualification the finest power supplies in Lambda's long experience.

The 400 and 800 MA series include new, more efficient longer lasting germanium rectifiers. All Com-Pak models are constructed with hermetically sealed transformers and chokes. Completely † except in 200 MA series

protected from moisture, they can be depended on for long trouble free service.

These new Lambda power supplies represent a major advance in thermal and mechanical design, and in outstanding performance. Send in your first order now for priority in handling.

SEND FOR NEW CATALOG. Complete specifications for all Lambda Power Supplies.



LAMBDA Electronics Corp.

The First Name in Power Supplies

11-11 131ST STREET,
COLLEGE POINT 56, N. Y.

Cable Address: Lambdatron, New York



Rugged EIMAC 2C39B UHF Ceramic Triode Operates up to 250°C

TYPICAL OPERATION (RF Oscillator 2500mc)

D-C Plate Voltage	900v
D-C Grid Voltage	-22v
D-C Plate Current	90ma
D-C Grid Current	27ma
Useful Power Output	15w

Unilaterally interchangeable with the 2C39A, but designed with outstanding extras, Eimac's ceramic-and-metal 2C39B has proved its advantages in such UHF applications as missiles, air navigational systems and communications systems.

Because of its unique design and ceramic-metal construction, this air-cooled, planar-type, 100 watt triode has an envelope temperature rating of 250°C, and operates with minimum RF losses. All external terminal surfaces are silver plated. Sturdy, low-loss ceramic replaces glass, and the copper anode is fitted with light-weight fins for forced air cooling.

Used in systems up to 3000mc, the 2C39B has all the virtues of the 2C39A plus a longer life, more useful power output, and a greater immunity to damage by thermal and physical shock.

**For additional information,
contact our Application
Engineering Department.**

EITEL-McCULLOUGH, INC.
SAN BRUNO, CALIFORNIA
The World's Largest Manufacturer of Transmitting Tubes



News-New Products

These manufacturers have invited PROCEEDINGS readers to write for literature and further technical information. Please mention your IRE affiliation.

(Continued from page 68A)

Wesgo's Ceramic Division produces a pure aluminum oxide (AL-1009) and a 97.6 per cent aluminum oxide (AL-300) ceramic body in a large variety of shapes such as for electrical insulators, vacuum tube envelopes and output windows for Magnetron and Klystron vacuum tubes.

Haydu Brothers Re-establish Business

George and Zolton Haydu announce the formation of **Haydu Electronic Products, Inc.**, and the appointment of George Haydu as President. In organizing this company, the Haydu brothers purchased certain assets and manufacturing equipment, including complete Machine Products Division, Tool and Die Division, and Electronic Components Manufacturing Division, from Haydu Brothers of New Jersey, subsidiary of Burroughs Corporation.

The company will utilize its 24 years of specialized experience and will manufacture electronic components, as well as equipment, for the commercial and military fields. In addition, they will continue the production of precision burners for the electronics tube and glass working industries.

The new plant, located at 1426 W. Front St., Plainfield, N. J., has complete manufacturing facilities and many of the employees have been associated with the organization for over 18 years.

Frye Joins Lockheed

Dr. William E. Frye, a leading scientist in the missile guidance field, has joined the staff of the **Lockheed Missile Systems** division research laboratories in Palo Alto, Calif.

Director of Research Dr. Louis N. Ridenour announced that Frye has been assigned to one of Lockheed's major missile projects.

Frye received his Ph.D. in physics from the University of Chicago in 1941 and worked in the radio and electronics field at the Navy

(Continued on page 72A)



ACTUAL SIZE OF NEW BLILEY BG6A

A NEW CRYSTAL UNIT WITH PLUS FEATURES FOR PRECISION APPLICATIONS IN RANGE 3 mc TO 100 mc.



SMALL-BUTTON MINIATURE 7-PIN BASE



Bliley CRYSTALS

BLILEY ELECTRIC COMPANY
UNION STATION BUILDING
ERIE, PA.

WRITE FOR TECHNICAL BULLETIN #496

This all-glass vacuum mounted crystal unit offers *high reliability for applications which require minimum ageing*. When used with drive level less than one milliwatt, frequency shift due to ageing will not exceed .0002% during the first year of service.

Supplied for oven or non-oven operation. Specify Bliley type BG6A.

Crafted with Care



Torque as low as 0.003 ounce inches achieved by Giannini in MICROTORQUE® and MINITORQUE® Precision Potentiometers

For extremely sensitive instrument applications where minimum torque is essential, specify Giannini Microtorque and Minitorque precision potentiometers. Highly reliable performance under the most rugged operating conditions is assured by Giannini's care for detail and production crafting.

By using sapphire jewel bearings... and precision ball bearings in certain Minitorque models, these 1 inch diameter instruments effect an unusually low coefficient of friction.

Available in 12 standard linear wiring types, the potentiometer output can, on special order, be designed to perform to a wide range of natural or empirical functions. All models employ non-corrosive precious metal windings and contacts... thereby permitting light brush pressures and ensuring long noise-free life.

Dependability, reliability, and ten years proven application success are your benefits, when you use Giannini Microtorque and Minitorque potentiometers—precision instruments "crafted with care."

For additional information, please write for Bulletins 85111 and 85151.

SPECIFICATIONS:

- Torque 0.003 to 0.008 oz. in. depending on resistance and wiring type. (Sleeve bushing Minitorque 0.025 oz. in.)
- Resistance Range 100 to 100,000 ohms.
- Linearity ± 0.5% (± 0.25% on special order)
- Power Rating 1.63 watts @ 25°C.
- Shaft Diameter Microtorque, 0.031 in.,
Minitorque, 0.125 in.



G. M. GIANNINI & CO., INC., 918 EAST GREEN STREET, PASADENA, CALIFORNIA



These manufacturers have invited PROCEEDINGS readers to write for literature and further technical information. Please mention your IRE affiliation.

(Continued from page 71A)

Research laboratory in Washington, D. C. until 1946.

He then spent two and a half years on the Navajo missile project for North American Aviation, and has since been engaged in aircraft navigation and ballistic missile guidance research for the Rand Corp. in Santa Monica, Calif.

Linear Variable Differential Transformer

The Model 52 Four Channel LVDT (Linear Variable Differential Transformer) system manufactured by **Micro Gee Products, Inc.**, Dept. IRE, Box 1005, 6100 W. Slauson Ave., Culver City, Calif., is a standard 19 inch rack mounted chassis which can excite up to four LVDT transducers from zero to 10 volts RMS. The internal oscillator is a unitized plug-in unit which can operate at any frequency between 9 kc thru 22 kc. Other frequency ranges can be supplied from the factory.



The output of each channel is a proportional dc voltage of polarity and amplitude determined by the direction and displacement of the LVDT core from its null or center position. Each channel amplifier is also a plug-in unit for ease of servicing. A meter and selector switch on the front panel is used to monitor the LVDT excitation voltage and amplifier balance. Gain is variable from 1 to 10. Amplifier Input Impedance is 1 megohm or greater, Output Impedance is less than 2K at a gain of unity, and Output Saturation is ± 70 volts across 100K. Power Requirements are 6.3 volts at 4.4 amperes +300 volts at 40 ma, and -300 volts at 30 ma.

(Continued on page 74A)

RMC DISCAPS

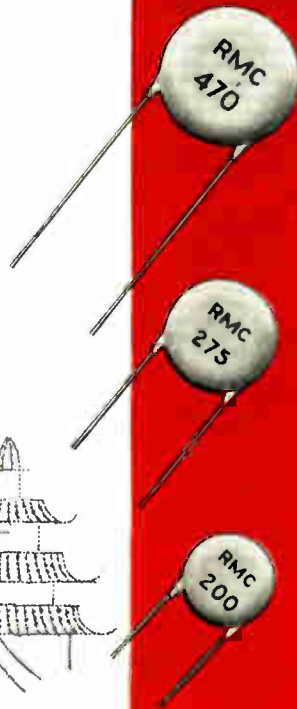

Modern research, manufacturing, and testing methods have made RMC DISCAPS the standard of performance throughout the entire electronics industry. Leading manufacturers of electrical and electronic products have established this standard by continuing to specify DISCAPS where specifications call for ceramic capacitors.

In a temperature compensating capacitor, RMC Type C DISCAPS have proved ideal for VHF and UHF applications because of smaller size and lower self-inductance. Available in a wide range of temperature coefficients and capacities, all type C DISCAPS are rated at 1000 working volts to provide a higher safety factor than other standard ceramic or mica capacitors.

Write today on your company letterhead for information on standard or special ceramic capacitors.

world-wide standard of quality

DISCAP
CERAMIC
CAPACITORS

RMC

RADIO MATERIALS CORPORATION
GENERAL OFFICE: 3325 N. California Ave., Chicago 18, Ill.
Two RMC Plants Devoted Exclusively to Ceramic Capacitors
FACTORIES AT CHICAGO, ILL. AND ATTICA, IND.

WHERE DO YOU BUY...



TELEPHONE INSTRUMENTS — Desk phones, in black and 7 color-tones. Wall phones. Units engineered to specifications.



TELEPHONE HANDSETS — Standard and "Push-to-talk" sets. Receiver and transmitter units. Cords, straight and coiled.

DIALS — Standard 10-impulse dial with spring combinations to fit most requirements.



RELAYS AND SWITCHES—Standard and miniature telephone type relays, Reed Armature relays and Matrix switches, Hermetically sealed shock and vibration resistant miniature and sub-miniature relays, Rotary and Crossbar switches, Mountings and frames for single and multiple configurations.



PLUS a wide range of: Keys, Terminal blocks, Lamp strips, Multi-terminal plugs and jacks, Coils, and allied components.

North is a manufacturer and prime supplier of these and many other communication components for original equipment manufacturers. All North equipment is backed by over 75 years' experience in the communications and electronics fields.

FOR A RELIABLE SOURCE OF SUPPLY YOU CAN DEPEND ON NORTH



INDUSTRIAL DIVISION

NORTH ELECTRIC COMPANY

552 S. MARKET ST., GALION, OHIO



News-New Products

These manufacturers have invited PROCEEDINGS readers to write for literature and further technical information. Please mention your IRE affiliation.

(Continued from page 72A)

Power Resistor

A new line of resistors for high-current, low-resistance applications has just been announced by the Ohmite Manufacturing Co., 3649 Howard St., Skokie, Ill.



The new units are known as Round-Wire Type, Powr-Rib® resistors. The units consist of ceramic insulators assembled on a metal bar and wound with resistance alloy wire. The construction is designed to provide flexibility and resistance to shock, plus efficient heat dissipation. Brackets and terminals are heavily plated to prevent oxidation.

The new Powr-Rib® resistors can be supplied in four lengths.

(Continued on page 76A)

how to
**complete
COAX
assemblies
successfully**



MICRODOT[®]
pioneer in micro-miniature circuitry, offers complete assemblies in any quantity. Write today and describe the coax solutions you require. With Microdot cables and over 300 Connectors, our engineers can quickly and economically supply guaranteed solutions giving you superior environmental performance and operating characteristics.

Actual Size!
Hermetic Seal
Insulated Feed-Through.

MICRODOT
1826 FREMONT ST.
SO. PASADENA, CALIF.

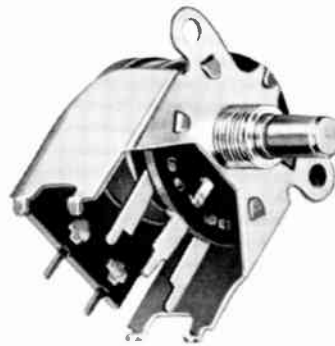

Especially designed for automatic assembly methods, this line of Mallory controls provides superior performance on printed circuit applications.

New Mallory Controls for Printed Circuits

ECONOMICAL STRIP TYPE CONTROLS FOR PRINTED CIRCUIT USE

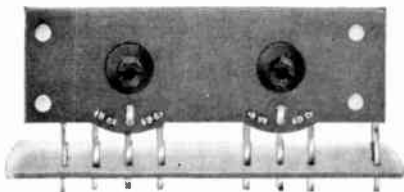

This simplified series of controls, a Mallory "first", consist of resistance wafers attached directly to a phenolic panel, in single, dual and triple units. You save in installation cost, for multiple units can be mounted as easily as a conventional single. You save in component cost, too . . . for these Mallory controls give you multiple units at substantially lower price than that of a corresponding number of individual controls. Resistance values cover the range from 250 ohms to 10 megohms. Numerous adaptations available. Write to Mallory for technical data.

Serving Industry with These Products:

Electromechanical—Resistors • Switches • Tuning Devices • Vibrators
Electrochemical—Capacitors • Rectifiers • Mercury Batteries
Metallurgical—Contacts • Special Metals • Welding Materials

Parts distributors in all major cities stock Mallory standard components for your convenience.

FOR your printed circuit designs, plan to take advantage of the simplified assembly and extra performance values offered by this new series of Mallory carbon controls.

A variety of designs is available. Included are self-supporting snap-in models for top of panel mounting . . . threaded bushing models . . . and types for mounting directly on the circuit panel. All are built with mounting lugs and terminals, precision-positioned for foolproof, fast assembly by automatic production machines. All incorporate these Mallory features:

High stability resistance element, made by special Mallory process, minimizes drift under severe humidity and temperature variations . . . gives long life.

Unusually low electrical noise.

New "floating ring" line switch, using a unique contact action, can be supplied on the new controls . . . far outlasts ordinary switches, gives clean, sharp make and break.

A complete selection of resistance values and tapers is available to match your circuit requirements. For complete data, write or call Mallory today.

Expect more . . . get more from

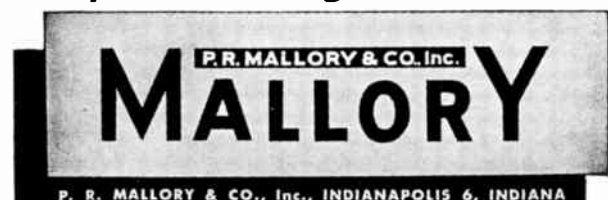

Lapp

TUBE SUPPORTS

for air-cooled power tubes

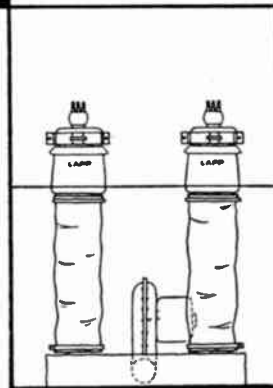

Since forced-air-cooled tubes were first introduced, equipment manufacturers have been designing their own supports, many of which

have been produced by Lapp. To standardize the great variety of tube support designs, Lapp set out to design a complete line which is now available and offers the equipment manufacturer a valuable service by way of more economical production, interchangeability and availability of replacement units. Lapp Tube Supports are compact, efficient and attractive in appearance. Their duty is threefold... they support the tubes, insulate, and furnish an air duct which channels air over tube fins for maximum cooling. Write for Bulletin 301, with complete description and specification data. Lapp Insulator Co., Inc., Radio Specialties Division, 929 Sumner Street, LeRoy, New York.



News-New Products

These manufacturers have invited PROCEEDINGS readers to write for literature and further technical information. Please mention your IRE affiliation.

(Continued from page 74A)

Resistance values range from 0.69 to 25 ohms; current ratings from 5.1 to 18.4 amperes. The longest unit, which is 16½ inches between mounting centers, is available from stock in 12 resistance values. Extra terminals are available to provide taps.

The new resistors supplement Ohmite's present lines of power type resistors—Corrib Vitreous Enameled Type and Powr-Rib Edgewound Ribbon Type. For more information ask for Bulletin 144.

Decade Scaler

The Model 414 Fast Decade Scale of 1,000 was designed by **Electrical and Physical Instrument Corp.**, 42-19 27th St., Long Island City 1, N. Y., to allow accurate high speed nuclear and other counting with a long term reliability previously approached.

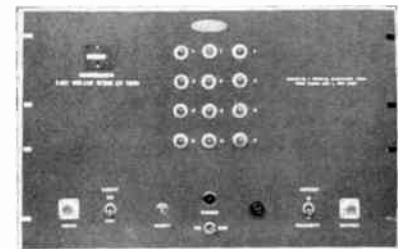

The gated decade system does not use feedback and makes possible a decade with a large bias range and an inherent reliability.

Diode input coupling to each flip-flip in the 10 mc and 1 mc sections and at the input of the slower decades further enhance reliability.

A high capacity forced air blower system keeps operating temperature and moisture content low.

A five digit electrical register which resets automatically with the scaling stages follows a scale of 1,000 which can be increased on special order up to a scale of 1,000,000.

The pulse resolution is 0.1 microsecond and continuous counting rates to 10,000,000 per second can be provided.

(Continued on page 78A)

SYSTEM DESIGNERS

now specify VA-800 series klystrons for
FORWARD SCATTER COMMUNICATION

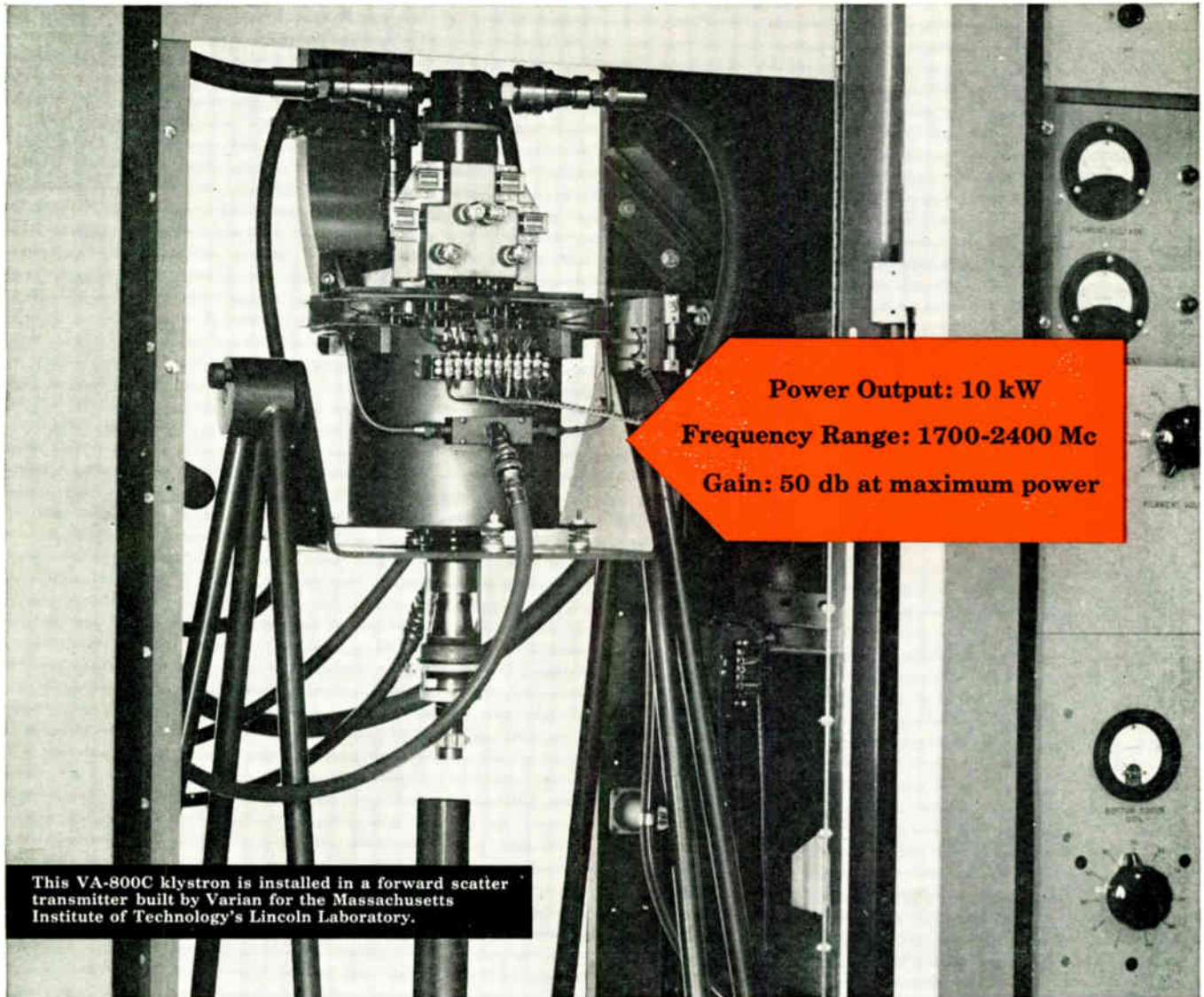

Power Output: 10 kW
Frequency Range: 1700-2400 Mc
Gain: 50 db at maximum power

This VA-800C klystron is installed in a forward scatter transmitter built by Varian for the Massachusetts Institute of Technology's Lincoln Laboratory.

First with 10 kW power in the important 2000 Mc range is the Varian VA-800 Klystron series. Two tubes cover the range 1700—2400 Mc, the VA-800C for higher frequencies . . . the VA-800A for lower frequencies. These klystrons offer reliability backed by a 1000-hour warranty, simplified design that permits easy installation without demounting any components and superior performance that extends microwave propagation far beyond previous limits.

VARIAN KLYSTRONS HELP SOLVE SYSTEM DESIGN PROBLEMS in long range microwave communication, cw radar and illuminator service. Why not write today for complete specifications and technical data on the VA-800 series and other Varian high-power klystrons? Contact your nearest Varian representative or address Applications Engineering Department -2

- **Career Opportunities at Varian** are well worth the consideration of engineers and scientists . . . a letter to our Personnel Director will bring full details.

THE
MARK OF
LEADERSHIP



VARIAN associates
PALO ALTO, CALIFORNIA

Representatives in principal cities

KLYSTRONS, TRAVELING WAVE TUBES, BACKWARD WAVE OSCILLATORS, LINEAR ACCELERATORS, MICROWAVE SYSTEM COMPONENTS, R. F. SPECTROMETERS, MAGNETS, MAGNETOMETERS, STALOS, POWER AMPLIFIERS, GRAPHIC RECORDERS, RESEARCH AND DEVELOPMENT SERVICES

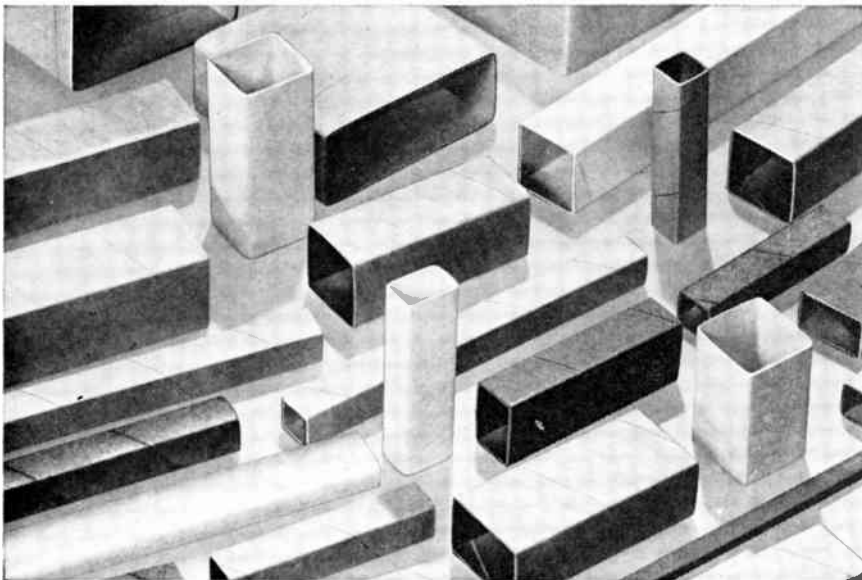

**If Dielectric or Corrosion Problems
Are Causing Coil Trouble...**

**PRECISION
CAN HELP
ELIMINATE
THEM!**

Precision specializes in the fabrication of square and rectangular, round and special shaped coil forms . . . acetate or mylar covered . . . silicone, phenolic or Resinite impregnated . . . to help you solve any dielectric or corrosion problem. Forms can be made to your exact specifications in all sizes from 1/16" square to 8" square, with wall thicknesses from .010 to .125.

Only the highest quality electrical grade kraft, quinterra, acetate or various combinations of

these materials are used. Precision Paper

Tubes are available in standard or exclusive patented DI-FORMED construction for greater crush resistance, high tensile strength and extreme dimensional stability.

Get immediate service. Call a Precision representative or contact our Chicago, Ill., or Hartford, Conn., plant.

sales offices in:

California, Oregon, Washington:
Covina, California, Edgewood 2-4693

Illinois, Indiana, Iowa, Wisconsin,
Missouri, Minnesota: Chicago, Illinois,
ARmitage 6-5200

Indiana, Ohio: Logansport, Indiana,
Logansport 2555

Northern Ohio: Cleveland, Ohio, Atlantic
1-1060

New England: Framingham, Massa-
chusetts, Trinity 3-7091

New Jersey, Delaware, Washington,
D.C., Maryland, Eastern Pennsylvania,

Virginia, Metropolitan New York:
Jersey City, New Jersey, Swathmore
5-2480

Upper New York: Syracuse, New York,
Syracuse 4-2141

CANADA: Montreal, Quebec, Canada,
Walnut 0337

MEXICO: Mexico 6, D. F., Telephone
35-06-18

**REQUEST
CATALOG**



PRECISION PAPER TUBE CO.

2D51 WEST CHARLESTON STREET • CHICAGO 47, ILLINOIS

Plant No. 2: 1 Flower Street, Hartford, Conn.



News-New Products

These manufacturers have invited PROCEEDINGS readers to write for literature and further technical information. Please mention your IRE affiliation.

(Continued from page 76A)

H-V Pulse Modulator

The Model PC 40 Pulse Modulator, developed by **Levinthal Electronic Products, Inc.**, 2979 Fair Oaks Ave., Redwood City, Calif., when used with an appropriate high-voltage dc supply, provides up to 50-kv positive output pulses. Pulse width is continuously variable from 5 to 200 microseconds at repetition rates up to 1 kc. Both pulse width and repetition rate are controlled continuously by knobs located at ground level. Pulse rise and pulse fall times are both 1 microsecond independent of pulse length. Sag on the flat top of the pulse is determined primarily by the size of the output filter-capacitor used in high-voltage power supply.



This pulse modulator was designed primarily to operate into a high-impedance load such as that represented by the modulating anode utilized in many of the high-power klystrons manufactured by Eitel-McCullough, Inc. Nominal load impedance is 1 megohm shunted by 25 μf . The equipment includes a floating deck which is tied to the modulating anode and switched to ground by an appropriate 50-kv tetrode. It also includes a buffer deck connected to the high-voltage supply and used to bring the pulse back down by a high-voltage tetrode which clamps the floating deck to the buffer deck.

(Continued on page 80A)

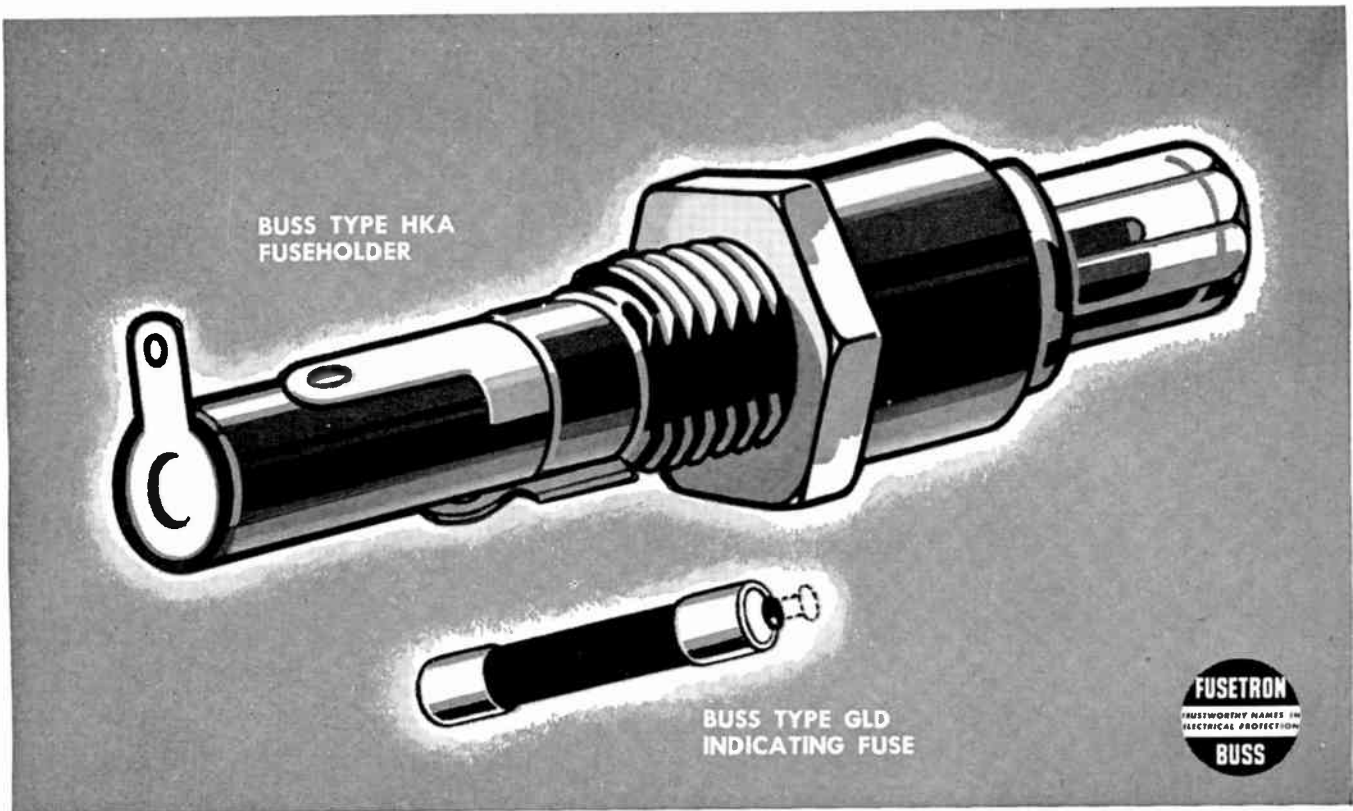

New! BUSS FUSEHOLDER and FUSE

Lamp Indicating • Signal Activating

**FLASHES A LIGHT • RINGS A BELL • TRIPS A RELAY
OR GIVES OTHER SIGNALS • TO TELL YOU WHEN
AND WHERE A FUSE BLOWS!**

Wide Application. Anywhere that it is desirable to have a visible or audible signal to indicate when a fuse blows, a practical answer is presented by the BUSS HKA fuseholder in combination with BUSS GLD fuses.

For example: When HKA holders are used on testing equipment they can give a remote signal if trouble develops in any part of the equipment . . . and the circuit in which trouble occurs is indicated by the glowing knob light.

On control circuits where the electrical fault must immediately be detected, the HKA holder can be used to give both an audible and visible signal—and a relay or other device can also be activated.

Control panels, switchboards and calculating or computing machines are but a few other examples of where it is advantageous to use HKA fuseholders to be warned of trouble on the circuit.

SPECIFICATIONS

BUSS Type HKA Fuseholder. Fuseholders are panel mounted for $\frac{1}{4}$ x $\frac{1}{4}$ inch BUSS GLD indicating fuses. Indicating lamp in transparent knob of fuseholder.

BUSS Type GLD Indicating Fuse: Indicating pin pops out when fuse is blown and activates signal or alarm.

For full information, write or phone for bulletin on HKA Fuseholders or . . . ask our Fuse Engineers to make recommendations for use of HKA Fuseholders. Send full details of proposed application.

If you prefer we will be glad to have a BUSS Sales Engineer call on you.

BUSSMANN MFG. CO. (Div. McGraw Electric Co.)
University of Jefferson St. Louis 7, Mo.

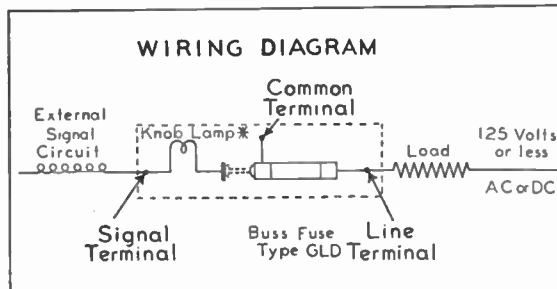

1256

is your problem here...



- Adjacent channel interference
- Relative side band level measurements
- RF cross modulation
- Keying transients
- Band occupancy studies
- Single side band investigations

solve it faster with

PANORAMIC PANALYZOR

SB-12 type T-100

featuring 10 cps resolution



Provides lightning-fast solutions to all problems requiring extremely high resolution. Automatic frequency control on narrow sweeps. Designed by Panoramic, this highly versatile, highly accurate instrument assures complete accuracy and speed for limitless laboratory and production test uses.

SPECIFICATIONS

- Dynamic range: 40 db
- Sweep rates: 30, 5, 1, and 0.1 cps
- Frequency range: 500 kc to 400 mc usable to 1000 mc
- Amplitude scale: linear or logarithmic
- Sweep width: 100 kc maximum, continuously reducible to 0 kc
- Cathode ray tube: flat face with edge lit screen and camera mount bezel

Write for complete details

Panoramic—for proven performance in plants and laboratories

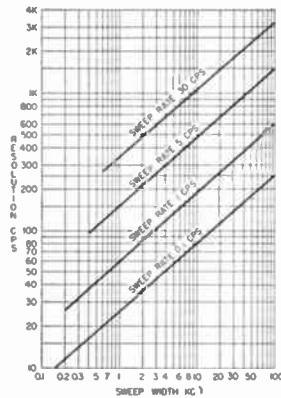

Resolution (in cps) vs sweep width (in kc)

Minimum frequency separation ΔF required to measure amplitude ratios E_2/E_1

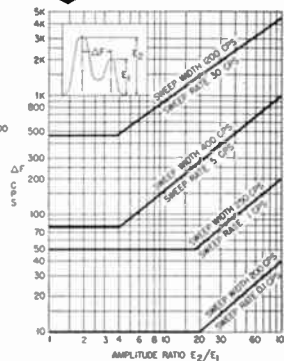

12 South Second Ave., Mount Vernon, N.Y. • Phone: MOUNT Vernon 4-3970
Cables: Panoramic, Mount Vernon, N.Y. State



These manufacturers have invited PROCEEDINGS readers to write for literature and further technical information. Please mention your IRE affiliation.

(Continued from page 78A)

Hermetically Sealed Thermostat

George Ulanet Co., 425 Market St., Newark 5, N. J., announces the introduction of the first hermetically sealed surface-sensing miniature thermostat available to industry in quantities. It meets aircraft military applications.

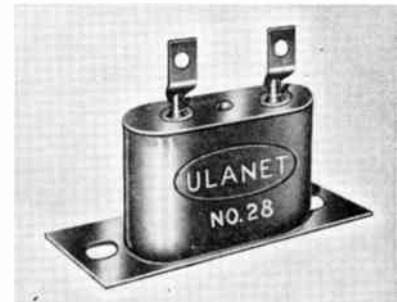

Pilot production units tested during the past few months by various aircraft and electronic manufacturers showed exceedingly high stability and rapid temperature response.

New design shortens the heat path between the mounting surface and thermal-sensing element thus decreasing the response time over 50 per cent.

Units are pre-calibrated to specified temperature and adjustment screw is sealed. Strain relief construction prevents calibration drift when unit is subjected to temperature variation between 50° C and +200° C. Size: 5/16 wide, 7/16 high exclusive of terminals, 3/4 inches long. Gold plated heat transfer bracket is 1 1/4 inches x 7/16 inches. Mounting Holes: 1 inch centers Rating 5 amperes 28 volts dc noninductive load 5 amperes 115 volts ac.

Slotted Lines

Six new portable slotted lines, Models 319 to 324, incorporating a carriage drive mechanism that is integral with the waveguide assembly, thus insuring minimum slope and eliminating the need for later adjustment, re-alignment or correction, have been developed by The Narda Corp., Mineola,

(Continued on page 82A)

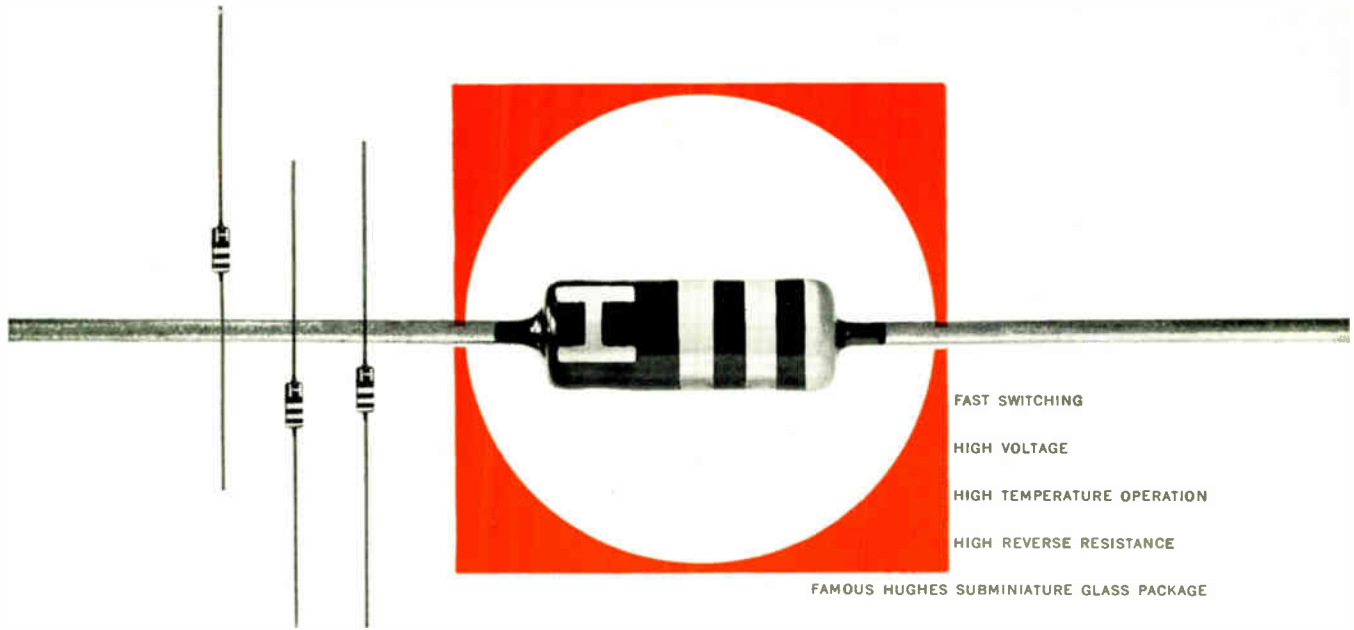

QUICK RECOVERY *Silicon Junction Diodes by Hughes*

DESIGN ENGINEERS—*Hughes Semiconductors now offers a new family of silicon junction diodes—especially designed to provide you with a device having significantly faster recovery characteristics than even germanium computer diodes and, in addition, capable of operating at high voltages and high temperatures. For the first time, this particular combination of characteristics—(high speed + high temperature + high voltage)—is available in a semiconductor.*

Excellent high-frequency characteristics of the new diodes enable you to use them instead of vacuum or germanium diodes in such applications as: FLIP-FLOP CIRCUITS . . . MODULATORS AND DEMODULATORS . . . DISCRIMINATOR CIRCUITS . . . CLAMPING AND GATING CIRCUITS . . . DETECTORS. So, whenever you need a diode for pulse or computer circuitry to perform under conditions that are marginal for vacuum or germanium diodes, use the new QUICK RECOVERY Silicon Junction Diodes—by HUGHES!

RECOVERY. All types recover to 400K ohms in one μ sec when switched from 30mA forward to 35V reverse. Special types with faster recovery are available if required.

WORKING INVERSE VOLTAGE. From 30 to 200 volts.

OPERATING TEMPERATURE RANGE. -55°C to $+135^{\circ}\text{C}$.

ACTUAL SIZE. Diode Glass Body. Length: 0.265-inch, max. Diameter: 0.105-inch, max.

TYPES NOW AVAILABLE. IN625, IN626, IN627, IN628, IN629.

With a wide variety of germanium and silicon diode types available for computer and other fast switching applications, we are in a position impartially to recommend the best type for your particular requirements. Our field sales engineers near you are ready to assist you in making the best possible selection. For further details, or for specifications covering the new Quick Recovery Silicon Junction Diodes, write: HUGHES PRODUCTS • SEMICONDUCTORS

International Airport Station, Los Angeles 45, California

HUGHES PRODUCTS

A DIVISION OF THE HUGHES AIRCRAFT COMPANY

HUGHES



SEMICONDUCTORS

© 1956, H. A. C.

Kearfott Components

**FOR EVERY SYSTEM
APPLICATION**



KEARFOTT offers the systems manufacturer the most complete line of precision made components available anywhere. Quantity production enables quick deliveries and reasonable prices.

SYNCHROS—Transmitters, Control Transformers, Resolvers, Repeaters, and Differentials in Bu Ord Sizes 8, 11 and 15. High Accuracy and environmental resistance.

SERVO MOTORS—High torque, low inertia Servo Motors, Inertial and Viscous damped Servo Motors, in Bu Ord Sizes 8, 11, 15, 18 and 23.

TACHOMETER GENERATORS—Available as damping generators, rate generators and integrators. They feature high output to null ratio and extremely linear outputs. Temperature stabilization may be provided.

GYROS—Directional, floated rate integrating, free, vertical, and spring restrained rate gyros for all airborne navigation, stabilization or fire control applications.

Bulletins giving physical and technical data of the various Kearfott Products will be sent on request. The Kearfott organization is available to assist in the development and manufacture of other precision components you may require.



KEARFOTT COMPANY, INC., LITTLE FALLS, N. J.

Sales and Engineering Offices: 1378 Main Avenue, Clifton, N. J.
Midwest Office: 188 W. Randolph Street, Chicago, Ill. South Central Office: 6115 Denton Drive, Dallas, Texas
West Coast Office: 253 N. Vineta Avenue, Pasadena, Calif.



News-New Products

These manufacturers have invited PROCEEDINGS readers to write for literature and further technical information. Please mention your IRE affiliation.

(Continued from page 80A)

L. I., N. Y. These impedance meters can be used to measure VSWR and impedances from 2,600 to 18,000 mc covering the waveguide sizes from $3 \times 1\frac{1}{2}$ inches to 0.702×0.391 inches.

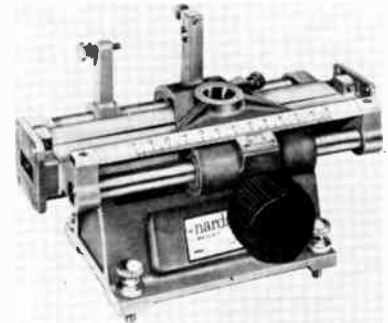

The complete impedance meter is supported by a removable pedestal casting, with the carriages riding on two stainless shafts supported by the waveguide casting. This type of integral assembly in-

(Continued on page 84A)

STAVOLT POWER RECTIFIERS

30
Standard
U.L. Approved
Models

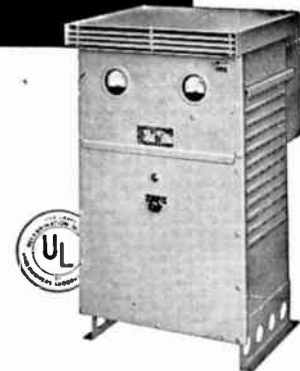

- Stationary or Mobile Types
- For Hangars, Air Fields, Missiles
- For Factories and Labs

Mag-Amp Control, Stable, Fast
15 to 1500 amps

Write for interesting
information to

CHRISTIE ELECTRIC CORP.
Formerly McCOLPIN-CHRISTIE CORP.
27th Year of Rectifier Manufacturing
3410 W. 67th St., Los Angeles 43, Calif.

KENNEDY ANTENNAS... *Probe the secrets of inter-stellar space*



*60' Radio Telescope Antenna by Kennedy at
Harvard University's Agassiz Station Observatory.*

Somewhere in the nearly empty reaches of outer space, two hydrogen atoms collide. After a 100-million year journey at the speed of light, the signal generated by that accidental collision reaches a super-sensitive radio telescope antenna in Massachusetts and is recorded — and so one grain more is added to man's knowledge of the universe.

Modern miracles like this happen every day at Harvard University's Agassiz Station Observatory, where a giant new radio telescope, with its 60' Kennedy antenna, is taking man further back in time . . . and further out into space . . . than he has ever been before.



ANTENNA EQUIPMENT

• **D. S. KENNEDY & CO.**

COHASSET, MASS. — TEL: CO4-1200

*Down-To-Earth SOLUTIONS to
Out-Of-This-World PROBLEMS*

**Tracking Antennas
Radio Telescopes
Radar Antennas
Tropospheric Scatter
Ionospheric Scatter**

decade counter

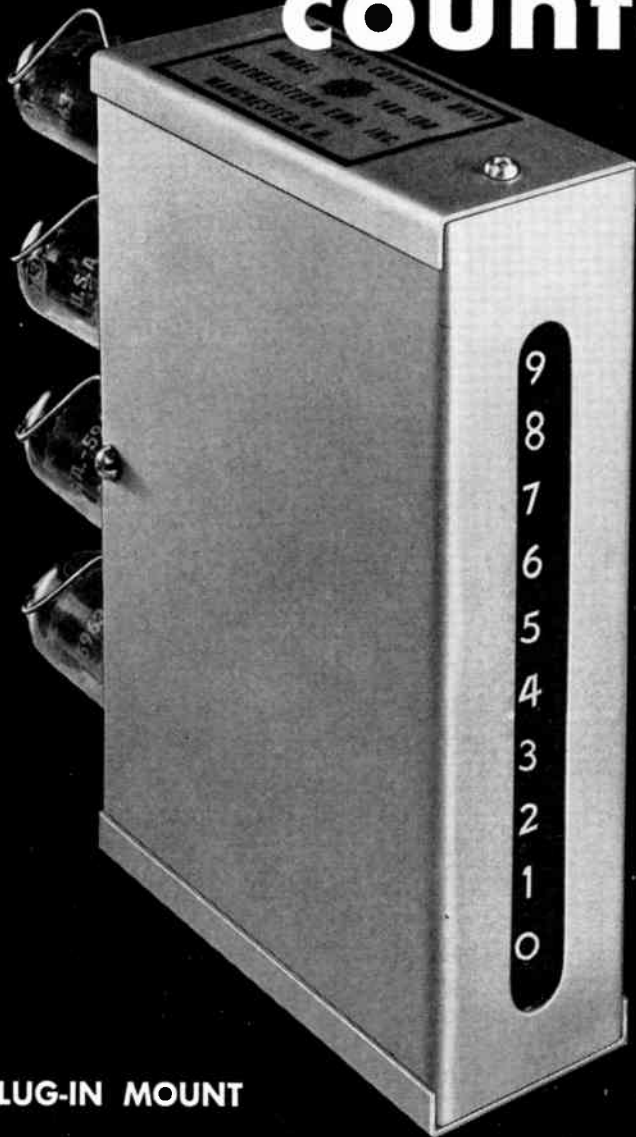

PLUG-IN MOUNT

**NEON LIGHT ILLUMINATED DIGIT FROM 0 TO 9.
AUTOMATIC RECYCLE BUT DISPLAYS REMAINDER
UNTIL RESET.**

MODEL

Max. (Counting) Rate	140-40	140-100
Resolution	40 Kc/sec	100 Kc/sec
Tubes	8 microseconds	4 microseconds
	4 - 5963	4 - 5963
Dimensions	1½" x 5½" x 5¼"	

northeastern engineering

Manchester

New Hampshire



News-New Products

These manufacturers have invited PROCEEDINGS readers to write for literature and further technical information. Please mention your IRE affiliation.

(Continued from page 82A)

sure the precision necessary to obtain minimum slope by original machining rather than by proper assembly of mating parts or a very critical adjustment at assembly. By the use of precision ball bushings the carriage is always symmetrically supported and provides rigid mounting for the probe regardless of position.

Since the entire mechanism is incorporated in the waveguide itself, Narda impedance meters can be used with pedestal removed where space is restricted. The precisely engraved scale and vernier are mounted at an angle for easy viewing even in poor illumination. The residual VSWR is under 1.01 and both slope and slot leakage are imperceptible. The carriage is provided with a mounting hole for use with all standard military and commercial probes and detectors including the Narda Model 229.

Signal Generator

A new Signal generator has been developed by the **Clough-Brengle Co.**, Dept. PIN, 6014 N. Broadway, Chicago 40, Ill., which, according to the manufacturer, combines a frequency coverage of 10 to 490 mc with high accuracy and frequency stability.

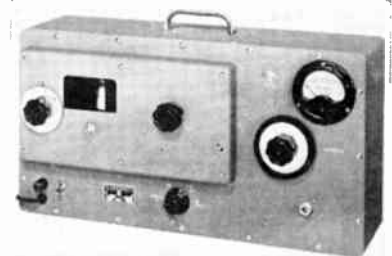

The generator, known as Model 555, is suitable for use in design and maintenance work where close tolerance must be had. It has 56 inches of scale in 8 equal ranges. Hand calibrated to ½ per cent dials are illuminated when in use, masked when idle. It is directly connected, with no gears to cause lost motion. Filament and plate supply are completely regulated, feature which provides increased high frequency stability.

(Continued on page 86A)

in **color** tv, too

CRUCIBLE PERMANENT **MAGNETS**

*for beam correctors, color purifiers and color equalizers
give maximum energy . . . minimum size*

Designers of electronic and control equipment can count on a *consistently higher* energy product with Crucible alnico magnets. *It means greater power from a minimum size magnet!*

And they're available in practically any size you want—from a fraction of an ounce to several hundred pounds. What's more, Crucible alnico permanent magnets can be sand cast, shell molded, or investment cast to your exact size, shape, or tolerance requirements.

Crucible has been a leading producer of these permanent magnets ever since alnico alloys were developed. And their manufacture is backed by over a half century of fine steelmaking experience. That's why so many magnet applications begin at Crucible.

*Crucible Steel Company of America,
The Oliver Building, Mellon Square,
Pittsburgh 22, Pa.*

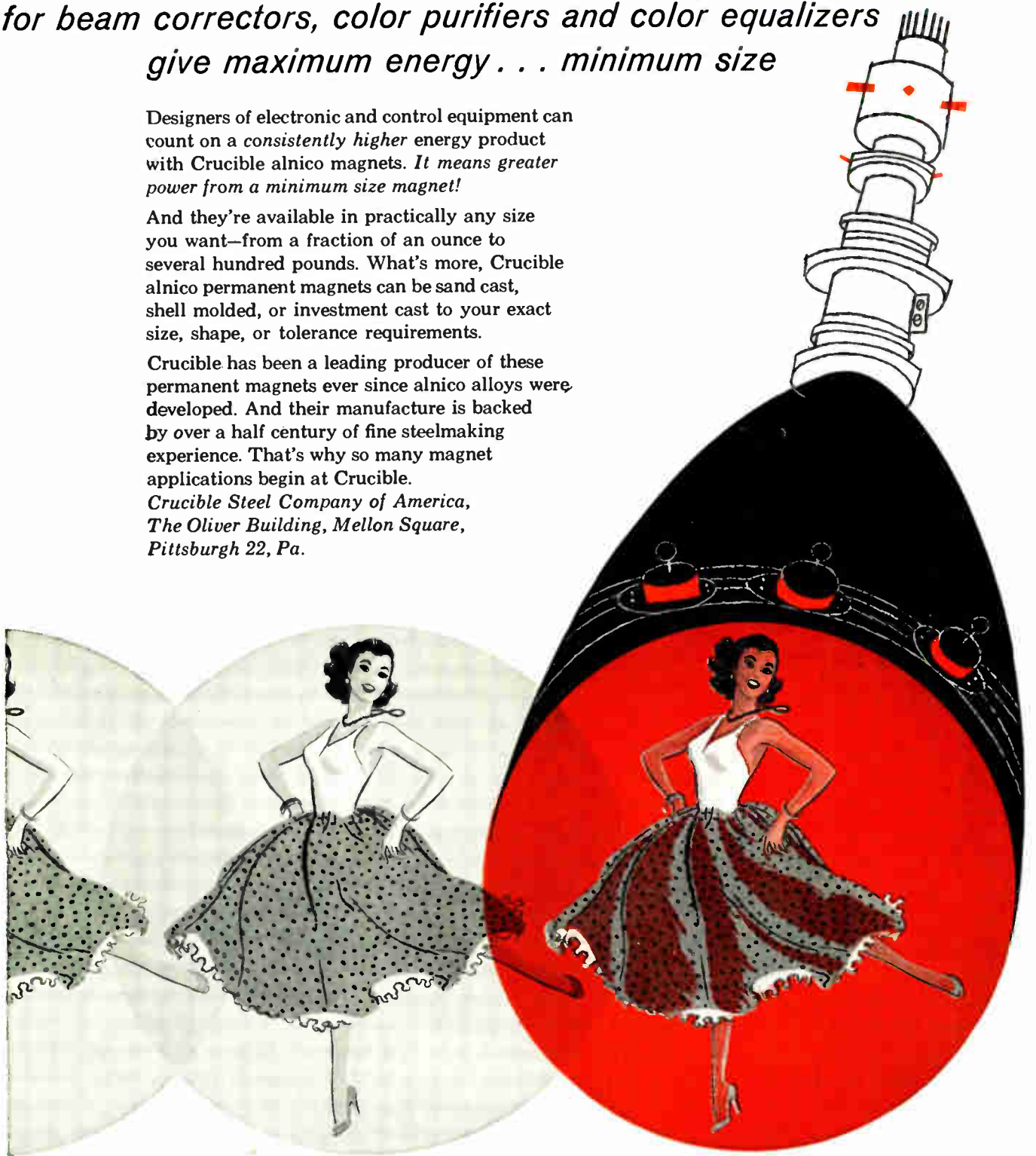

CRUCIBLE

first name in special purpose steels

Crucible Steel Company of America

INSURE *Proven Quality*

with

JONES PLUGS AND SOCKETS

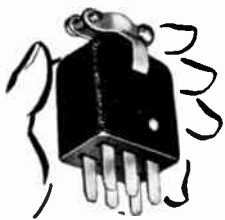

P-306-CCT
Plug, Cable
Clamp in Cap.

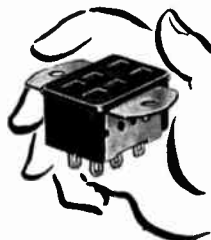

S-306-AB
Socket with
Angle Brackets.

Jones Series 300 illustrated. Small Plugs & Sockets for 1001 Uses. Cap or panel mounting.

- Knife-switch socket contacts phosphor bronze, cadmium plated.
- Bar type Plug contacts brass, cadmium plated, with cross section of 5/32" by 3/64".
- Insulation molded bakelite.
- All Plugs and Sockets polarized.
- Metal Caps, with formed fibre linings.
- Made in two to 33 contacts.
- For 45 volts, 5 amperes. Efficient at much higher ratings where circuit characteristics permit.

Ask for Jones Catalog No. 21 showing complete line of Electrical Connecting Devices, Plugs, Sockets, Terminal Strips. Write or wire today.



Jones

HOWARD B. JONES DIVISION
CINCH MANUFACTURING CORPORATION
CHICAGO 24, ILLINOIS
SUBSIDIARY OF UNITED-CARR FASTENER CORP.



News-New Products

These manufacturers have invited PROCEEDINGS readers to write for literature and further technical information. Please mention your IRE affiliation.

(Continued from page 84A)

Added features are a new piston attenuator of 0.2 microvolts to 0.2 volts, which operates without backlash, and a dc operated oscillator tube. Convenience modulation is CW, 400 cps, 1000 cps, with standby switch.

Output accuracy: 10 per cent at 0.2 volts. Power supply: 100 to 130 volts, 60 cps. Also available for other voltages and frequencies. Input 30 watts. Dimensions: 21×11×5½ inches. Weight 35 pounds.

Pushbutton Switch

A new pushbutton switch for computers, calculators, and similar electrical and electronic devices using whole banks of adding machine-type key switches has been announced by Hetherington, Inc., 1200 Elmwood Ave., Sharon Hill, Pa.

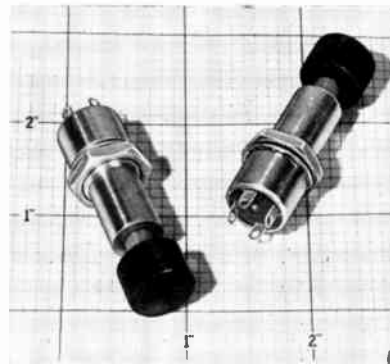

Known as the Type B5023, the new momentary contact switch responds to an operating pressure of ½ pound has a total button travel of ¼ inch. Contact arrangement is 2-circuit, break-before-make.

The entire switch mechanism is housed in a dust- and moisture-resistant anodized aluminum case 9/16 inch in diameter, the same diameter as the button so that switches may be grouped closely together. Total length, including button is 2 1/16 inches. Special key-type button caps are available in a variety of colors and styles, many engraved with a letter, numeral, or symbol. The switches are designed for a life of over 100,000 cycles at rated load of 28 volts, 3 amperes.

Specification available on request.

(Continued on page 160A)

Shasta

INSTRUMENTS

designed for the user!

MODEL 605 WIDE RANGE RESISTANCE BRIDGE

Features:

- ★ 10 ohm to 100 megohm range
- ★ Simple pushbutton operation
- ★ High accuracy
- ★ Negligible drift
- ★ Guard terminal for high-resistance measurements

Description:

Shasta model 605 provides a rapid, easy and highly-accurate means of measuring unknown resistances. Seven full-scale resistance value ranges are selectable by pushbuttons. Values are read directly on the linear scale of a precision multi-turn Helipot after "nulling" the unknown resistance on the 4" zero center galvanometer.



BRIEF SPECIFICATIONS:

Ranges: 100, 1k, 10k and 100k ohms, 1, 10 and 100 megohms
Lowest Meas: 5 ohms
Accuracy: ± (0.15% of res. meas., + .05% full scale)
Drift: Negligible after 30 min. warmup
Dimensions, weight: 9¾" H x 8" W x 9" D;
8 lbs.
Price (f.o.b. factory): \$170.00

Write today for Technical Bulletin 605; please address Dep't. SA-12

OTHER SHASTA QUALITY INSTRUMENTS

Expanded Scale Frequency Meters and Voltmeters
Audio Oscillators • AC Voltmeters • Power Supplies
Wide Band Amplifiers
Bridges • WWV Receivers
Decade Inductors.

Shasta

division

BECKMAN INSTRUMENTS INC.
P. O. Box 296, Station A, Richmond, California
Telephone LAandscape 6-7730

S-17

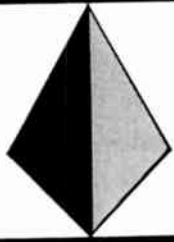

NO. 66

PYRAMID technical bulletin

SELENIUM RECTIFIERS

General:

The trend toward component miniaturization with attendant increase in equipment compactness has resulted in a steadily rising ambient operating temperature. Selenium rectifiers are particularly critical in this respect because much depends on their ability to maintain a high output voltage over extended periods of time. A major limiting factor in this respect has been the "Center-support" type of construction of conventional rectifiers and the tendency of this construction to concentrate the generated heat within a relatively small area. The Pyramid patented-type construction, known as the "Kool-sel," is a significant break-through of this heat barrier.

• An exploded view of a Pyramid rectifier is shown below. Note that the center support has been eliminated completely; instead, the individual selenium rectifier coils are supported at their outer edges. A molded phenolic yoke forms the main supporting member, with a mounting stud and locating boss molded into the yoke. In this way, they become integral parts of that yoke. The lugs of the rectifier are slotted to accommodate the two arms of the yoke and the rectifier cells and spacers are notched to fit snugly on the yoke arms. Clinching lips are provided on the top lug so that when it is pressed on the yoke, all components are locked together to form a rigid assembly. During assembly, the spacers are flexed slightly to insure that the unit remains tight under all normal environmental conditions.

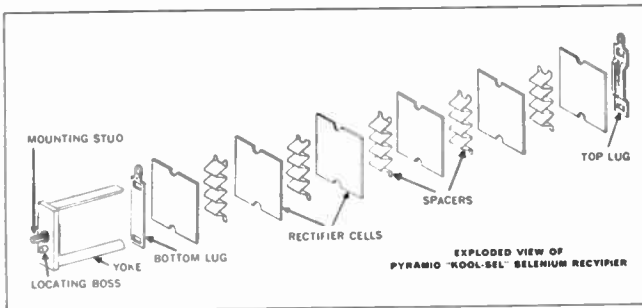

ADVANTAGES OF "Kool-sel" CONSTRUCTION:

Mechanical:

1. Cells and lugs are locked in place and cannot rotate.
2. Locking together of the components is accomplished without the current pickup contacts exerting excessive pressures on the cell counter electrode. Too much pressure may produce three detrimental effects: First, it may decrease the reverse resistance and thereby lower rectifier efficiency. Second, there is a cold flow of the counter electrode from under the pickup contacts. Third, fracture or damage to the counter electrode adjacent to the pickup contacts may occur.
3. The locating boss, being an integral part of the yoke, is always in the correct position.
4. Pulling on the locating lug cannot crack or break the alley (counter electrode) of the adjacent rectifier cell.
5. This particular mechanical construction results in fewer component parts.

Electrical:

1. There is a high dielectric strength between the "live" components (i.e., cells, spacers, and lugs) and the mounting stud. The normal insulation thickness over the mounting stud is 1/16".

2. There is high resistance to burnouts on current surges.
3. The current pickup points are distributed over the full width of the rectifier cell. This means that heat is dissipated rapidly and the temperature rise of the rectifier cells during the flow of current surges is relatively low.

CHARACTERISTICS:

Illustrated below is a typical aging Characteristics Chart, showing percentage change in output voltage vs hours of operation.

CATALOG NUMBER	KS-65	KS-75	KS-100	KS-150	KS-200	KS-250	KS-300	KS-350	KS-400	KS-500
Maximum RMS Input Voltage	130	130	130	130	130	130	130	130	130	130
Maximum Inverse Peak Voltage	380	380	380	380	380	380	380	380	380	380
Maximum Peak Current (MA)	650	750	1000	1500	2000	2500	3000	3500	4000	5000
Maximum RMS Current (MA)	162	187	250	375	500	625	750	875	1000	1250
Maximum DC Current (MA)	65	75	100	150	200	250	300	350	400	500
Approximate Rectifier Voltage Drop	5	5	5	5	5	5	5	5	5	5
Minimum Series Resistance	22	22	22	15	5	5	5	5	5	5
Maximum Operating Plate Temperature	85°C	85°C	85°C	85°C	85°C	85°C	85°C	85°C	85°C	85°C

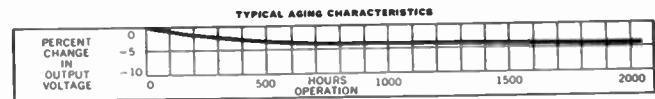

Voltage Regulation: The voltage regulation curves for a 300 ma selenium rectifier in a half-wave circuit with 117-volt rms input shown below. Suitable voltage regulation curves for all Pyramid "Kool-sel" selenium rectifiers are available upon request.

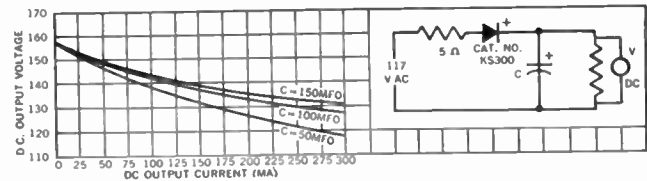

APPLICATIONS:

Radios and Radio-Phonographs: Low-cost, efficient rectifiers for radios and radio-phonograph combinations are "Kool-sel" KS-65, KS-75, and KS-150. The needs of most 5-tube chassis are met by the KS-65, while the KS-75 and KS-150 are used in sets with larger current requirements.

Television Receivers: High-voltage power supplies in television receivers—including color sets—use "Kool-sel" numbers KS-200, KS-250, KS-300, KS-350, KS-400, and KS-500. These rectifiers, used in voltage doubler or voltage tripler circuits provide the proper B-plus voltage, eliminating the size, cost, weight and hum problems of power transformers. "U" shaped brackets are available which permit the rectifiers to be mounted either in vertical or horizontal positions.

Radio Accessories: TV boosters, UHF converters, phonograph oscillators, inter-coms and the like can usually be powered suitably by a "Kool-sel" KS-65 rectifier.

Laboratory Instruments, Power Supplies, Amplifiers: Rectified high voltage through the use of voltage doubler and tripler circuits, for equipment where current requirements run as high as 500 ma, may be provided with "Kool-sel" rectifiers. Types KS-200 through KS-500 will be found useful for laboratory power supplies, DC filament supplies, motion picture projectors, amplifiers, test equipment and other specialized uses.

FOR COMPLETE DATA SEND FOR ENGINEERING BULLETIN—FORM KS-1

PYRAMID ELECTRIC CO. North Bergen, New Jersey



PYRAMID IS THE BIG NAME IN CAPACITORS AND SELENIUM RECTIFIERS TODAY!

a \$1,000,000 idea

Could stem from working
with the contents of these

Aladdin

inductor kits!

3 different kits are
now available, each
containing a different line of
Ferrite Cored Inductors

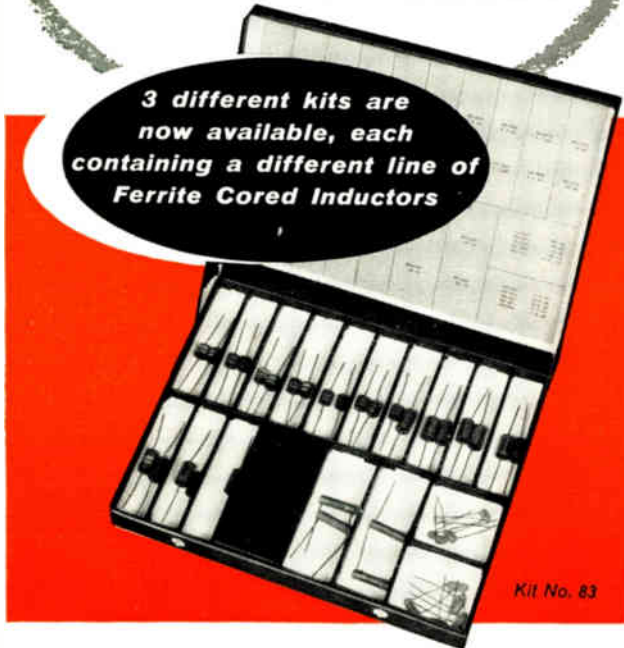

Kit No. 83

Every item in each Ferrite Core Inductor kit is a standard Aladdin component, available in mass production quantities

Kit No. 81—Contains 19 different Aladdin Green Line inductors with nominal values ranging from 1 millihenry to 1 henry, in RETMA increments, $\pm 20\%$. These are high-Q units wound on ferrite cores with a ferrite shield surrounding the coil and protected by a vitreous enamel finish. This line of inductors is used where highest quality and reliability, as well as small size, are required. They are used as low current chokes, in filters, in audio oscillators, and in impedance coupling circuits. They are ideally suited for use in compact transistorized circuits.

\$24.95

Kit No. 82—Contains 19 Aladdin Green Line SPECIAL units. These inductors are designed to have very high self-resonant frequencies. Like the regular Green Line units, they range from 1 millihenry to 1 henry.

\$24.95

Kit No. 83—Contains an assortment of Aladdin Brown Line and Tiny-L* inductors. 39 different ferrite-cored inductors, in RETMA increments from .22 microhenry through 100 millihenries, make up this assortment. The Tiny-L* Line (.22 μh to 6.8 μh) is particularly well suited for high current (2 amps) filament choke applications and in compensated video amplifier circuits. The Brown Line (10 μh to 100 mh) has been found very useful in general filtering applications as well as in compensated video amplifier circuits.

\$14.95

order
your kits
now

*T. M.

Shipped Postage Paid



Aladdin
radio industries, inc.

719 Murfreesboro Road, Nashville 2, Tennessee

limitless...

Poly-Scientific's newly perfected manufacturing processes permit limitless variation in design... every part custom made to your individual requirements.

Poly-Scientific is synonymous with versatility, precision, and performance. Every slip ring, commutator and brush assembly made by Poly-Scientific is the ultimate in quality.

The use of epoxy resins allows greater miniaturization without sacrifice of strength. Our perfected techniques permit the use of any of the noble metals and alloys, making possible the selection of the optimum material with the proper hardness for each specific application.

Dependable, long-life performance... minimum generated noise... freedom from tarnish... dimensional accuracy and stability... all of these are automatic when you specify Poly-Scientific. And best of all, prices are competitive.

slip ring assemblies
miniaturized brush assemblies
commutators
to fit any requirement



A 14 circuit slip ring assembly, highly miniaturized for a stabilized platform application. The rings are .020" wide of hard coin gold alloy with an O.D. of .099". The stainless steel backshaft diameter is .140". The leads are #30 AWG insulated with color coded teflon.

Brush block assembly for the above slip ring assembly. The precious metal alloy brushes are very accurately formed and located and are adjusted to exert a pressure to very tight tolerances. Also note similar color coded teflon leads.



Get the full story... write today for descriptive literature.

Poly-Scientific
CORPORATION
"Dept. P" BLACKSBURG, VIRGINIA

General Electric's

New

Water-

Activated

Batteries

Deliver up to

42 Watt Hours

Per Pound!

DRY G-E water-activated batteries are made dry, stored dry. Contain no electrolyte to leak or freeze. Demand no maintenance during storage other than normal precaution against moisture.

WET To activate, simply immerse in water. Batteries reach operating voltage as fast as 2 seconds . . . operate efficiently in extreme temperatures . . . are unaffected by external hydrostatic pressure.

POWER These silver-chloride/magnesium type batteries deliver up to 42 watt hours per pound and 3 watt hours per cubic inch, with nearly level power output over total operating life.

WHERE CAN YOU USE G-E WATER-ACTIVATED BATTERIES? Probably wherever you need a versatile source of d-c power, wrapped inside a small, light-weight package.

Delivering tremendous power for relative size and weight, these primary batteries can be used as "power packs" in any number of series, parallel, or series-parallel combinations you may need.

Though a wide range of ratings and

sizes is available, G-E water-activated batteries can be designed in nearly any combination of sizes, weights, and ratings to fit your specific application.

Examine your power needs now. If space, weight, and exceptional reliability are critical, phone your G-E Apparatus Sales Office, today. A representative will be glad to give you additional information on how G-E water-activated batteries can help solve these problems.

For descriptive bulletin GEA-6238A on G-E water-activated batteries, send coupon to:

General Electric Co., Section E223-5
Schenectady 5, N. Y.

for immediate project for reference only

Name

Position

Company

Street

City State

GENERAL  ELECTRIC

AN EXPOSITION OF Armed Forces Communications and Electronics

EVENT: AFCEA Annual National Convention
Armed Forces Communications & Electronics Association

TIME: May 20, 21, 22, 1957.
Monday, Tuesday, Wednesday.

PLACE: Washington, D. C. Sheraton-Park Hotel—All under one roof.

ATTENDANCE: Expected 3,500 Military & Business.
Boston Attendance in 1956 was 1,392.

EXHIBITS: 155 Units. American Manufacturers of Communications and
Electronics Equipment for Military Use.



This Program means business:

Monday, May 20th

8:30 AM—Sheraton Hall
Opening Breakfast
9:30 AM— Official Opening of Exhibits
10:00 AM—Caribar Room
Chapter Presidents Conference
10:00 AM-12:00 M—Sheraton Hall
Engineering Papers on Research
and Application
12:30 PM—Sheraton Hall
Keynote Luncheon
1:00 PM-5:00 PM—Adams Hamilton Room
Industrial Movies
2:30 PM-4:30 PM—Sheraton Hall
Monitored Panel on Scatter
Propagation
7:00 PM—Sheraton Hall
Buffet Supper

Exhibits: 9:30 AM—9:00 PM

Tuesday, May 21st

9:00 AM—Caribar Room
Council & Directors Meeting
10:00 AM-12:00 M—Sheraton Hall
Engineering Papers on Research
and Application
12:00 M—Box Lunch
Tour—Naval Research
Laboratory
1:00 PM-5:00 PM—Adams Hamilton Room
Industrial Movies
6:00 PM—Continental Room
Reception
7:30 PM—Sheraton Hall
Banquet

Exhibits: 9 AM—9 PM

Wednesday, May 22nd

8:00 AM—Caribar Room
Officers & Directors Breakfast
10:00 AM-12:00 M—Sheraton Hall
Engineering Papers on Research
and Application
12:30 PM—Sheraton Hall
Industrial Luncheon
1:00 PM-5:00 PM—Adams Hamilton Room
Industrial Movies
2:30 PM-4:30 PM—Sheraton Hall
Procurement Management
Forum

Exhibits: 9 AM—5 PM

For Information write or wire: **SIGNAL**

WILLIAM C. COPP & ASSOCIATES

1475 Broadway • New York 36, N. Y. • BRyant 9-7550

AFCEA at Boston 1956



MULTIPLE VARIABLE RESISTORS *designed specifically* for PRINTED CIRCUITS

SNAP INSTANTLY INTO PLACE—REMAIN FIRMLY LOCKED

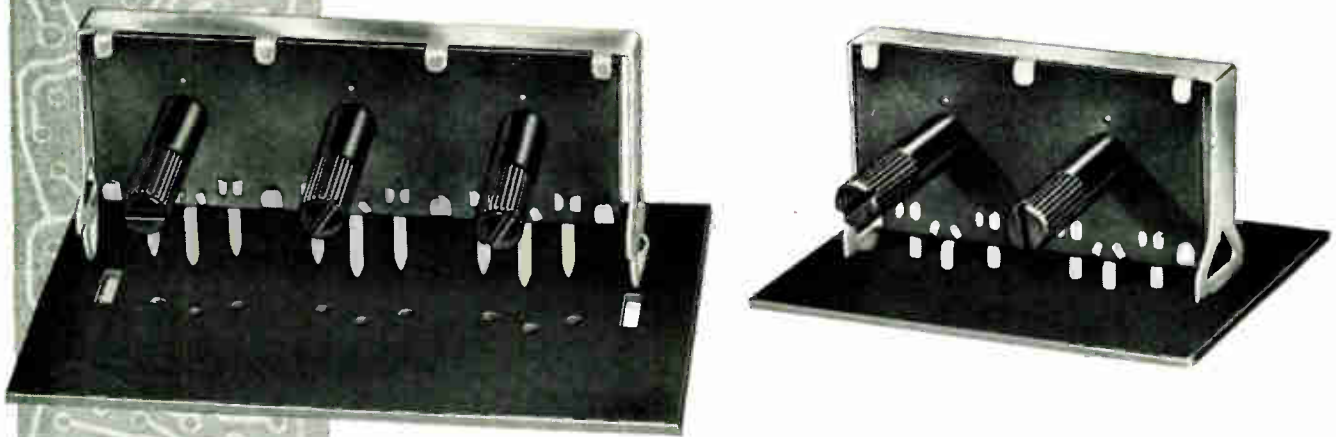

Illustrations are actual size—note compact multiple units

CONSERVES PANEL SPACE—REDUCES HANDLING COSTS

EAST COAST OFFICE
130 N. Broadway
Camden 2, New Jersey
Phone: Woodlawn 6-1668
TWX No. Camden NJ 380
Phila. Phone: Market 7-3129

WEST COAST SUBSIDIARY
Chicago Telephone of
California, Inc.
105 Pasadena Avenue
South Pasadena, Calif.
L.A. Phone: Clinton 5-7186
TWX LA 1105

SOUTHWESTERN U.S.A.
John A. Green Company
137 Parkhouse
Dallas 7, Texas
Phone: Riverside 3266

CANADIAN SUBSIDIARY
C. C. Meredith & Co., Ltd.
Streetsville, Ontario
Phone: 310

SOUTH AMERICA
Jose Luis Pontet
Buenos Aires, Argentina
Montevideo, Uruguay
Rio de Janeiro, Brazil
Sao Paulo, Brazil

OTHER EXPORT
Sylvan Ginsbury
8 West 40th Street
New York 18, New York
Phone: Pennsylvania 6-8239

A NEW TOTALLY FUNCTIONAL DESIGN CONCEPT

1. Snaps instantly into place with full length sturdy spring supports that lock control rigidly to printed panel.
Wide shoulders provide rugged support.
No mounting hardware, no separate support needed.
2. Compact multiple units conserve panel space, reduce handling costs and number of automatic assembly stations.
3. The only variable resistor with external contour designed specifically for mechanized handling and feeding into a printed panel.
4. Exclusive clip-off mounting supports and terminals for easy removal by service man without a solder pot.
5. Mounts upright with shafts parallel to printed panel, eliminating need for shaft protection during panel solder immersion.
6. Available in 2-control units (Series X52) or 3-control units (Series X53) as illustrated.

Many other types of controls available for your printed circuit and automation needs.

A CTS control can be tailored to your specific requirement. Let CTS SPECIALISTS help solve your current control problems. Write or phone today.



ELKHART • INDIANA

The Exclusive Specialists in Precision Mass Production of Variable Resistors

24 Fields of Special Interest -

The 24 Professional Groups are listed below, together with a brief definition of each, the name of

ACTIVITIES

The IRE Professional Group has the responsibility of providing the individual with the advantages of a small, select society in the field of his specialization, with its own magazine, just as IRE provides him with the advantages of a large, general society. The Group is concerned with the advancement of scientific engineering leading to increased professional standing in its field and serves to aid in promoting close cooperation and exchange of technical information among its members.

PUBLICATIONS

Every Group publishes a magazine which is called TRANSACTIONS of the Professional Group, generally on a regular quarterly schedule. The TRANSACTIONS serve to preserve and disseminate the body of knowledge that constitutes the fields of interest of the Groups. All editions are distributed without additional cost to members who have paid the annual assessment.

The CONVENTION RECORD covering the sessions presented at the IRE National Convention is furnished without further charge to the members of Groups who have paid assessments.

ORGANIZATION

The IRE Professional Group is established under a constitution within the framework of the IRE. The constitution defines the technical field of interest of the Group, establishes committee structures, describes broadly its functions and procedures, and fixes a minimum level of activity. The management of an IRE Professional Group is in the hands of its Administrative Committee, the officers and members of which are elected annually. The IRE provides financial assistance to the Groups in accordance with their activity and current needs.

MEMBERSHIP

IRE members of any grade are eligible for membership in the IRE Professional Groups and will receive all Group publications upon payment of the prescribed assessments. An IRE member may join as many Professional Groups as serve his interests and wishes.

To join IRE Professional Groups, indicate on the application coupon in the lower right-hand corner of the opposite page the Group or Groups you wish to join. Detach completed coupon and mail with your check for assessments to The Institute of Radio Engineers, 1 East 79th Street, New York 21, N.Y.

	<p>Aeronautical and Navigational Electronics</p> <p>Annual publications fee: \$2.</p> <p><i>The application of electronics to operation and traffic control of aircraft and to navigation of all craft.</i></p> <p>Mr. James L. Dennis, Chairman, 370 West First St., Dayton 2, Ohio</p> <p>19 Transactions, 5 Newsletters, *5, *6, *8, & *9, and *Vol. ANE-1, Nos. 1, 2, 3 and 4. Vol. 2, No. 1-4; Vol. 3, No. 1-2.</p>	<p>Antennas and Propagation</p> <p>Annual publications fee: \$4.</p> <p><i>Technical advances in antennas and wave propagation theory and the utilization of techniques or products of this field.</i></p> <p>Dr. Henry G. Booker, Chairman, School of EE, Cornell University, Ithaca, N.Y.</p> <p>15 Transactions, 1 Newsletter, *4, *Vol. AP-1, Nos. 1, 2; *Vol. AP-2, Nos. 1-4, AP-3, No. 1-3; AP-4, No. 1-2-3.</p>
<p>Audio</p> <p>Annual publications fee: \$2.</p> <p><i>Technology of communication at audio frequencies and of the audio portion of radio frequency systems, including acoustic terminations, recording and reproduction.</i></p> <p>Dr. D. W. Martin, Chairman, The Baldwin Piano Co., 1801 Gilbert Ave., Cincinnati, Ohio.</p> <p>32 Transactions, 4 Newsletters, *5, *7, *10, *Vol. AU-1, Nos. 1-6; *Vol. AU-2, Nos. 1-6; Vol. AU-3, Nos. 1-6; Vol. AU-4, No. 1-2-3-4.</p>	<p>Automatic Control</p> <p>Annual publications fee: \$2.</p> <p><i>The theory and application of automatic control techniques including feedback control systems.</i></p> <p>Mr. John C. Lozier, Chairman, Bell Telephone Labs., Whippany, N.J.</p> <p>1 Transactions PGAC-1.</p>	<p>Broadcast & Television Receivers</p> <p>Annual publications fee: \$2.</p> <p><i>The design and manufacture of broadcast and television receivers and components and activities related thereto.</i></p> <p>Dr. Lyman R. Fink, Chairman, Gen. Elec. Co., Schenectady, N.Y.</p> <p>14 Transactions, *1, *2, *3, *5, *6, *7, 8; BTR-1, No. 1-4, BTR-2, No. 1-2</p>
<p>Broadcasting Transmission Systems</p> <p>Annual publications fee: \$2.</p> <p><i>Broadcast transmission systems engineering, including the design and utilization of broadcast equipment.</i></p> <p>Mr. Oscar W. B. Reed, Jr., Chairman, Jansky & Bailey, 1735 DeSales St., N.W., Washington, D.C.</p> <p>5 Transactions, No. 1-5.</p>	<p>Circuit Theory</p> <p>Annual publications fee: \$3.</p> <p><i>Design and theory of operation of circuits for use in radio and electronic equipment.</i></p> <p>Dr. Herbert J. Carlin, Chairman, Microwave Research Institute, Polytechnic Institute of Brooklyn, 55 Johnson St., Brooklyn 1, N.Y.</p> <p>12 Transactions, *1, *2, *Vol. CT-1, Nos. 1-4; CT-2, No. 1-4; CS-3, Nos. 1-2.</p>	<p>Communications Systems</p> <p>Annual publications fee: \$2.</p> <p><i>Radio and wire telephone, telegraph and facsimile in marine, aeronautical, radio-relay, coaxial cable and fixed station services.</i></p> <p>Mr. F. M. Ryan, Chairman, AT&T Co., 195 Broadway, N.Y.</p> <p>6 Transactions, 5 Newsletters, *Vol. CS-1, No. 1; *Vol. CS-2, Nos. 1-2; CS-3, No. 1; CS-4, No. 1-2.</p>
<p>Component Parts</p> <p>Annual publications fee: \$2.</p> <p><i>The characteristics, limitation, applications, development, performance and reliability of component parts.</i></p> <p>Dr. R. M. Soria, Chairman, American Phenolic Corp., Chicago, Ill.</p> <p>5 Transactions. *PGCP-1-2-3-4. Vol. CP-3, No. 1.</p>	<p>Electron Devices</p> <p>Annual publications fee: \$2.</p> <p><i>Electron devices, including particularly electron tubes and solid state devices.</i></p> <p>Dr. Russell R. Law, Chairman, CBS-Hytron, Danvers, Mass.</p> <p>15 Transactions, 3 Newsletters, 2 Technical Bulletins, *1, *2, *4, *Vol. ED-1, Nos. 1-4; ED-2, No. 1-4, ED-3, No. 1-2-3.</p>	<p>Electronic Computers</p> <p>Annual publications fee: \$2.</p> <p><i>Design and operation of electronic computers.</i></p> <p>Dr. J. D. Noe, Chairman, Stanford Research Inst., Stanford, Calif.</p> <p>18 Transactions, 5 Newsletters, *Vol. EC-2, Nos. 2-4; *Vol. EC-3, Nos. 1-4, EC-4, No. 1-4; EC-5, No. 1-2.</p>

THE INSTITUTE OF RADIO

- IRE's 24 Professional Groups

the group chairman, and publications to date.

* Indicates publications still available

<p>Engineering Management Annual publications fee: \$1. <i>Engineering management and administration as applied to technical, industrial and educational activities in the field of electronics.</i> Rear-Adm. Chas. F. Horne, Jr., Chairman, Convair, Box 1011, Pomona, Calif. 6 Transactions, 8 Newsletters. *1, *2-3. EM-3, No. 1-2-3.</p>	<p>Industrial Electronics Annual publications fee: \$2. <i>Electronics pertaining to control, treatment and measurement, specifically, in industrial processes.</i> Mr. Carl E. Smith, Chairman, Carl E. Smith Consulting Engineers, 4900 Euclid Ave., Cleveland 3, Ohio. 3 Transactions, *PGIE-1-2-3.</p>	<p>Information Theory Annual publications fee: \$2. <i>Information theory and its application in radio circuitry and systems.</i> Dr. M. J. Di Toro, Chairman, Polytechnic Inst. of Brooklyn, Brooklyn, N.Y. 10 Transactions, 1 Newsletter. *2, *3, 4. IT-1, No. 1-2-3. IT-2, No. 1-3.</p>
<p>Instrumentation Annual publications fee: \$1. <i>Measurements and instrumentation utilizing electronic techniques.</i> Mr. F. G. Marble, Chairman, Boonton Radio Corp., Intervale Road, Boonton, N.J. 5 Transactions. *2, *3, 4, 5.</p>	<p>Medical Electronics Annual publications fee: \$2. <i>The application of electronics engineering to the problems of the medical profession.</i> Dr. Vladimir K. Zworykin, Chairman, RCA Laboratories, Princeton, N.J. 5 Transactions, 1-5 Newsletters, *1.</p>	<p>Microwave Theory and Techniques Annual publications fee: \$2. <i>Microwave theory, microwave circuitry and techniques, microwave measurements and the generation and amplification of microwaves.</i> Mr. H. F. Engelmann, Chairman, Federal Telecom Labs, Nutley, N.J. 14 Transactions. *Vol. MTT-1, No. 2; *Vol. MTT-2, Nos. 1-3; MTT-3, No. 1-6; MTT-4, No. 1-2-3.</p>
<p>Military Electronics Annual publications fee: \$1. <i>The electronics sciences, systems, activities and services germane to the requirements of the military. Aids other Professional Groups in liaison with the military.</i> Capt. Christian L. Engleman, Chairman, 2480 16th St., N.W., Washington 9, D.C.</p>	<p>Nuclear Science Annual publications fee: \$2. <i>Application of electronic techniques and devices to the nuclear field.</i> Dr. W. E. Shoupp, Chairman, Westinghouse Elec. Corp., Atomic Power Div., Pittsburgh 30, Pa. 5 Transactions, 3 Newsletters. NS-1, No. 1; NS-2, No. 1; NS-3, No. 1-3.</p>	<p>Production Techniques Annual publications fee: \$2. <i>New advances and materials applications for the improvement of production techniques, including automation techniques.</i> Mr. R. R. Batcher, Chairman, 240-02 42nd Ave., Douglaston, L.I., N.Y. 1 Transaction, No. 1.</p>
<p>Reliability and Quality Control Annual publications fee: \$2. <i>Techniques of determining and controlling the quality of electronic parts and equipment during their manufacture.</i> Dr. Victor Wouk, Chairman, Beta Electric Corp., 333 E. 103rd St., New York 29, N.Y. 8 Transactions, 1 Newsletter, *1, *2, *3, 4-5-6-7-8.</p>	<p>Telemetry and Remote Control Annual publications fee: \$1. <i>The control of devices and the measurement and recording of data from a remote point by radio.</i> Mr. Conrad H. Hoepfner, Chairman, Radiation, Inc., Melbourne, Fla. 6 Transactions, Newsletter. 1-2. TRC-1, No. 1-2-3; TRC-2, No. 1.</p>	<p>Ultrasonics Engineering Annual publications fee: \$2. <i>Ultrasonic measurements and communications, including underwater sound, ultrasonic delay lines, and various chemical and industrial ultrasonic devices.</i> Dr. J. F. Herrick, Chairman, Mayo Clinic, Rochester, Minn. 4 Transactions, 5 Newsletters. *1, 2-3.</p>
<p>Vehicular Communications Annual publications fee: \$2. <i>Communications problems in the field of land and mobile radio services, such as public safety, public utilities, railroads, commercial and transportation, etc.</i> Mr. Newton Monk, Chairman, Bell Telephone Labs., 463 West St., New York 14, N.Y. 6 Transactions, 3 Newsletters. *2, *3, *4, 5, 6.</p>	<p style="text-align: center;">USE THIS COUPON 12-56</p> <p>Miss Emily Sirjane IRE—1 East 79th St., New York 21, N.Y.</p> <p>Please enroll me for these IRE Professional Groups</p> <p>..... \$</p> <p>..... \$</p> <p>Name</p> <p>Address</p> <p>Place</p> <p>Please enclose remittance with this order.</p>	

ENGINEERS



1 East 79th Street, New York 21, N.Y.

Let DeMornay-Bonardi build your **COMPLETE MICROWAVE SYSTEMS**

-you'll save design time and testing time.

Cost is 25% to 50% less. Delivery months sooner!

Using "building-block" methods, D-B saves you time and money in special purpose system construction. We manufacture and stock 924 types of reliable components, from 2.60-90.0 KMc/SEC. This wide choice gives us the flexibility to build for any application, and allows better control over the elements in a complex system. It greatly simplifies design, saving weeks of trial-and-error methods.

Each D-B component selected from stock is already tested—hence the assembly needs no proving...

checks out as soon as it's put together... is guaranteed to work. With so many savings in engineering time, D-B can complete a system at a price 25% to 50% lower than your costs. Delivery time is cut by months.

All we need from you to construct a special purpose waveguide system are your electrical requirements and space allowance. We do the rest with building blocks, proved in use since 1941. Talk it over with a D-B representative, or write direct. New D-B catalog now ready—request a copy on your company letterhead.

Heterodyne System Designed for Beckman Instruments, Inc.

This system was designed to measure an unknown frequency anywhere between 10 KMc and 50 KMc by heterodyning it against a set of precisely known frequencies which are generated by multiplication from a low frequency primary standard. The system provides:

- a. Generation of standard reference frequencies by means of Klystron multiplier, a balanced sideband generator, crystal multipliers and band-pass filters.
- b. Coarse measurement and filtering of the unknown frequency by means of cavity wavemeters.
- c. Selection of the proper channel by means of three SPDT switches plus a special 3-way and 5-way switch for transitions from one waveguide size to another.
- d. Mixing of the unknown frequency with the properly selected reference frequency to provide an unambiguous beat frequency.

Except for the 3- and 5-way switches, all waveguide components used in this system are either stock D-B catalog items, or minor modifications of them—an important factor in quick delivery.

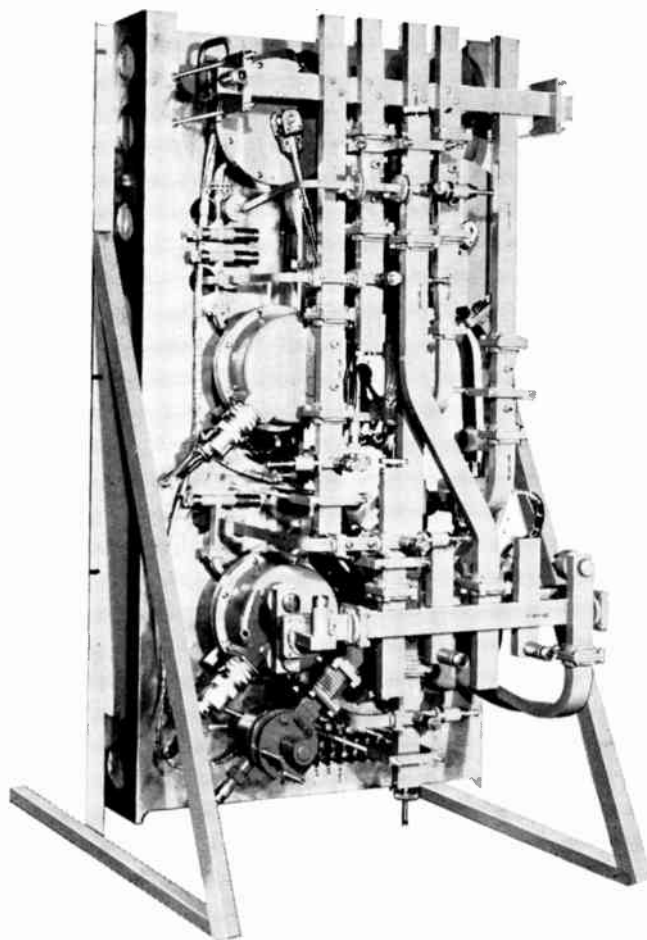

DEMORNAY BONARDI
780 SOUTH ARROYO PARKWAY,
PASADENA, CALIFORNIA

*for compactness
and light weight . . .*

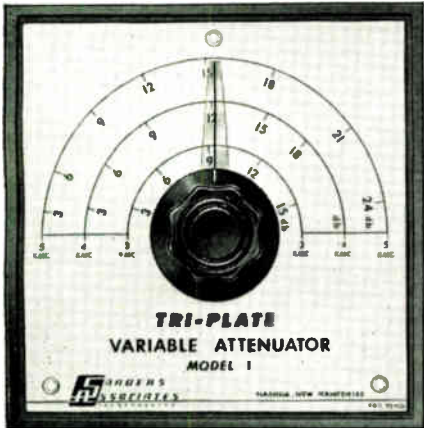

SANDERS TRI-PLATE[®] VARIABLE ATTENUATOR

*with a new type of printed
circuit transmission line
developed by Sanders Associates, Inc.*

This small, compact attenuator is used in the frequency range of 1000 to 6000 mc. Designed for use with a coaxial cable connection, it has low external leakage and gives broad-band performance.

Maximum Attenuation — linear function of frequency (20 db at 4,000 mc)

Insertion Loss — less than 1.5 db

Maximum VSWR — less than 1.25 at 4,000 mc.

Characteristic Impedance — 50 ohms

Average Power Rating — 2 watts

Dimensions — 5" x 5" x 1/4"

Weight — only 8 ounces

Other Tri-Plate products such as transitions, directional couplers, hybrid rings and special antennae can also be supplied.

Microwave systems will be engineered for conversion to TRI-PLATE and produced to your requirements.

**For detailed specifications,
write to Dept. IRE,**



©Sanders Associates

ENGINEERED CABLE SYSTEMS BY PACIFIC AUTOMATION ARE RELIABLE SYSTEMS



SYSTEM DESIGN

In your own plant our engineers can specify and design cable and cable components to meet your exact SYSTEM requirements.



SYSTEM FABRICATION

At this modern cable plant we build custom-made cable with facilities for fabricating and molding multi break-out harnesses and attaching and "potting" connectors so that a complete SYSTEM hook-up is provided.

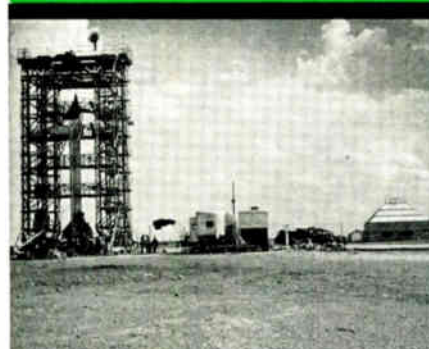

SYSTEM INSTALLATION

On-site installations in trailers and block houses of our custom-made cables and components are supervised by our field engineers to provide complete SYSTEM integration.



SYSTEM CHECK-OUT

Testing of on-site installations for circuitry by Pacific Automation Products engineers assures functional reliability of the electrical SYSTEM.



Write for Bulletin 157



Pacific Automation Products, Inc.
1000 AIR WAY, GLENDALE 1, CALIF.

Engineers and technicians will find a challenging and fascinating career with us. Your qualifications are welcomed.

for **SINGLE-SIDEBAND DESIGNS**

...from watts to hundreds of kilowatts...

SPECIFY RCA POWER TUBES

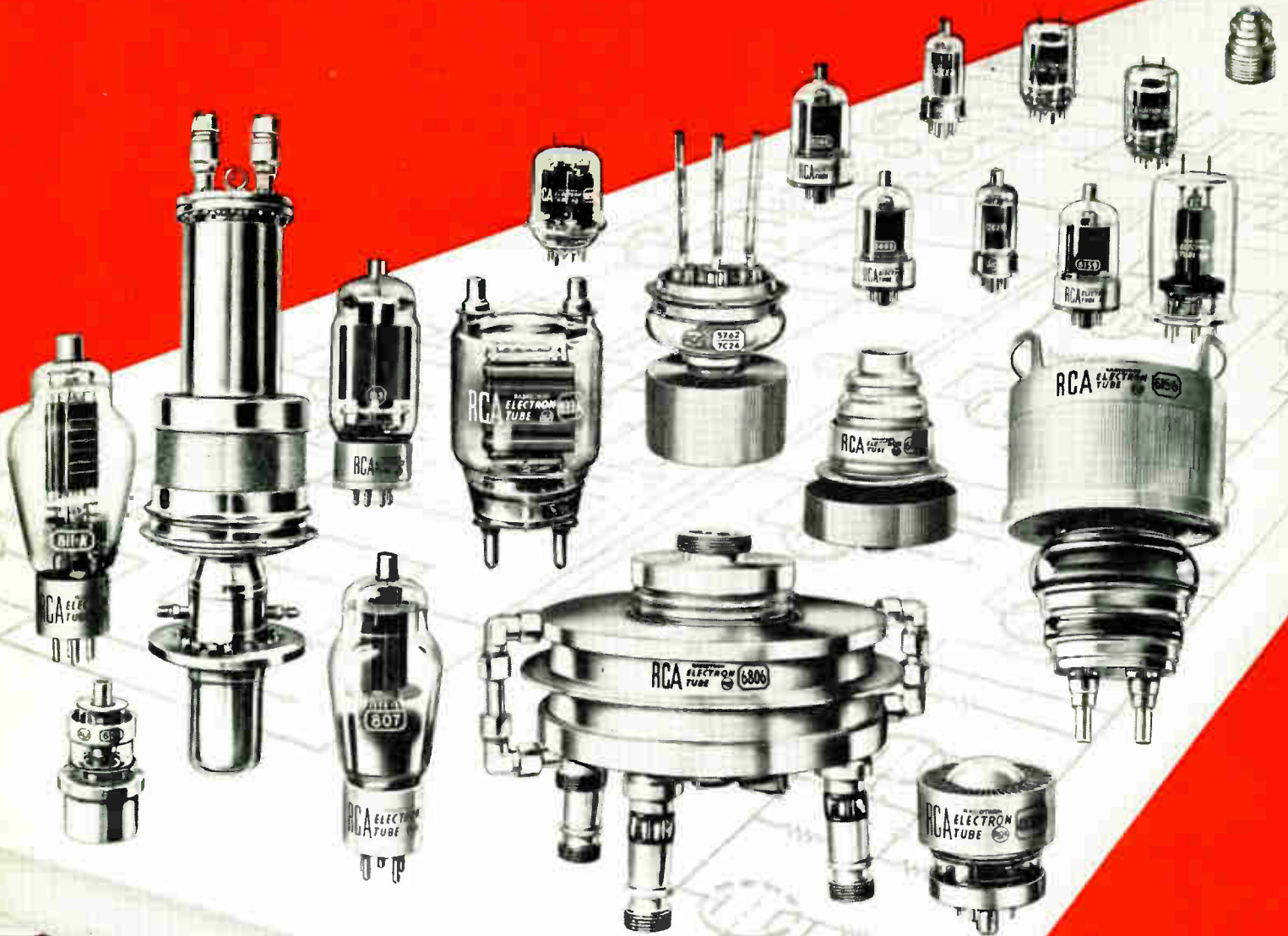

RCA offers a group of power tubes exhibiting performance characteristics that make possible the design of SSB transmitting equipment having excellent linearity, low modulation distortion, high power gain, wide band tunability, high efficiency, and reliable low-cost operation.

Outstanding power tube types offered by RCA for this important new field include: 2E24, 2E26, 807, 6524, 6850, 6146, 6883, 6159, 6816, 6884, 5894, 829-B, 811-A, 4X150-A, 4X150-D, 813, 6161, 833-A, 6181, 5762, 6166, 6806, and 6949.

Your RCA FIELD REPRESENTATIVE will be glad to discuss RCA POWER TUBES relative to your specific single-sideband designs. Contact him at the district office nearest you.

EAST: Humboldt 5-3900
744 Broad Street
Newark 2, N. J.

MIDWEST: Whitehall 4-2900
Suite 1181
Merchandise Mart Plaza
Chicago 54, Illinois

WEST: Raymond 3-8361
6355 East Washington Blvd.
Los Angeles 22, Calif.



RADIO CORPORATION OF AMERICA

Tube Division

Harrison, N. J.

PROCEEDINGS OF THE IRE®

Published Monthly by

The Institute of Radio Engineers, Inc.

VOLUME 44

December, 1956

NUMBER 12

EDITORIAL DEPARTMENT

Alfred N. Goldsmith,
Editor Emeritus

D. G. Fink, *Editor*

E. K. Gannett,
Managing Editor

Helene Samuels,
Assistant Editor

ADVERTISING DEPARTMENT

William C. Copp,
Advertising Manager

Lillian Petranek,
Assistant Advertising Manager

EDITORIAL BOARD

D. G. Fink, *Chairman*

W. N. Tuttle, *Vice-Chairman*

E. K. Gannett

Ferdinand Hamburger, Jr.

E. W. Herold

T. A. Hunter

J. D. Ryder

George W. Bailey,
Executive Secretary

John B. Buckley, *Chief Accountant*

Laurence G. Cumming,
Technical Secretary

Evelyn Benson, *Assistant to the
Executive Secretary*

Emily Sirjane, *Office Manager*

CONTENTS

Poles and Zeros.....	<i>The Editor</i>	1663
Tribute to Lee De Forest.....		1664
5896. Single-Sideband Techniques as Related to Spectrum Administration.....	<i>George C. McConaughy</i>	1665
5897. Introduction to Single-Sideband Issue.....	<i>I. J. Kaar</i>	1666
5898. An Introduction to Single-Sideband Communications.....	<i>J. F. Honey and D. K. Weaver, Jr.</i>	1667
5899. Early History of Single-Sideband Transmission.....	<i>Arthur A. Oswald</i>	1676
5900. Synthesizer Stabilized Single-Sideband Systems.....	<i>B. Fisk and C. L. Spencer</i>	1680
5901. A Suggestion for Spectrum Conservation.....	<i>R. T. Cox and E. W. Pappenfus</i>	1685
5902. Power and Economics of Single Sideband.....	<i>Ernest W. Pappenfus</i>	1689
5903. Application of Single-Sideband Technique to Frequency Shift Telegraph.....	<i>Christopher Buff</i>	1692
5904. Frequency Control Techniques for Single Sideband.....	<i>R. L. Craiglow and E. L. Martin</i>	1697
5905. A Third Method of Generation and Detection of Single-Sideband Signals.....	<i>Donald K. Weaver, Jr.</i>	1703
5906. Comparison of Linear Single-Sideband Transmitters with Envelope Elimination and Restoration Single-Sideband Transmitters.....	<i>Leonard R. Kahn</i>	1706
5907. Synchronous Communications.....	<i>John P. Costas</i>	1713
5908. The Phase-Shift Method of Single-Sideband Signal Generation.....	<i>Donald E. Norgaard</i>	1718
5909. The Phase-Shift Method of Single-Sideband Signal Reception.....	<i>Donald E. Norgaard</i>	1735
5910. Electromechanical Filters for Single-Sideband Applications.....	<i>Don L. Lundgren</i>	1744
5911. Factors Influencing Single-Sideband Receiver Design.....	<i>Luther W. Couillard</i>	1750
5912. Correction to "The Optimum Tapered Transmission Line Matching Section".....	<i>Robert E. Collin</i>	1753
5913. Linear Power Amplifier Design.....	<i>Warren B. Bruene</i>	1754
5914. Distortion Reducing Means for Single-Sideband Transmitters.....	<i>Warren B. Bruene</i>	1760
5915. Correction to "IRE Standards on Audio Systems and Components, Methods of Measurement of Gain, Amplification, Loss, Attenuation, and Amplitude-Frequency-Response".....		1765
5916. Automatic Tuning Techniques for Single-Sideband Equipment.....	<i>Vincent R. DeLong</i>	1766
5917. Linearity Testing Techniques for Sideband Equipment.....	<i>P. J. Icenbice, Jr. and H. E. Fellhauer</i>	1775
5918. Single-Sideband Operation for International Telegraph.....	<i>Eugene D. Becken</i>	1782
5919. SSB Receiving and Transmitting Equipment for Point-to-Point Service on HF Radio Circuits.....	<i>H. E. Goldstine, G. E. Hansell, and R. E. Schock</i>	1789
5920. Conversion of Airborne HF Receiver-Transmitter from Double Sideband to Single Sideband.....	<i>Harris A. Robinson</i>	1794
5921. Problems of Transition to Single-Sideband Operation.....	<i>N. H. Young</i>	1800
5922. The Problems of Transition to Single-Sideband Techniques in Aeronautical Communications.....	<i>John F. Honey</i>	1803
5923. The Application of SSB to High-Frequency Military Tactical Vehicular Radio Sets.....	<i>R. A. Kulinyi, R. H. Levine, and H. F. Meyer</i>	1810
5924. Single-Sideband Techniques Applied to Coordinated Mobile Communication Systems.....	<i>Adamant Brown</i>	1824

Contents continued on following page



Responsibility for the contents of papers published in the PROCEEDINGS of the IRE rests upon the authors. Statements made in papers are not binding on the IRE or its members.



THE COVER—Giant antennas, measuring from 140 to 200 feet high and 81 to 498 feet in diameter, will soon be placed in operation as a part of a 2-30 mc single-sideband communications system that the Collins Radio Company developed for the U. S. Air Force. On the cover is a steerable transmitting antenna consisting of four concentric nine-sided structures. The outer two structures make up a vertically polarized antenna and its reflecting screen, while the inner two comprise a horizontally polarized antenna and reflecting screen. The beam may be rotated a full 360° by energizing the proper sides. Receiving antennas will be of similar design but with eighteen sides instead of nine. The system will be used for point-to-point ground and air-ground communication at ranges up to 5000 miles or more. By using single-sideband techniques the number of channels will be at least doubled.

PROCEEDINGS OF THE IRE

Published Monthly by

The Institute of Radio Engineers, Inc.

BOARD OF DIRECTORS, 1956

A. V. Loughren, *President*
 Herre Rinia, *Vice-President*
 W. R. G. Baker, *Treasurer*
 Haradan Pratt, *Secretary*
 D. G. Fink, *Editor*
 W. R. Hewlett, *Senior Past President*
 J. D. Ryder, *Junior Past President*

1956

E. M. Boone (R4)
 J. N. Dyer (R2)
 A. N. Goldsmith
 J. T. Henderson (R8)
 T. A. Hunter
 A. G. Jensen
 J. W. McRae
 George Rappaport
 D. J. Tucker (R6)

1956-1957

J. G. Brainerd (R3)
 C. R. Burrows (R1)
 J. F. Byrne
 J. J. Gershon (R5)
 Ernst Weber
 C. F. Wolcott (R7)

1956-1958

E. W. Herold
 J. R. Whinnery



Change of address (with 15 days advance notice) and letters regarding subscriptions and payments should be mailed to the Secretary of the IRE, 1 East 79 Street, New York 21, N. Y. All rights of publication, including foreign language translations are reserved by the IRE. Abstracts of papers with mention of their source may be printed. Requests for republication should be addressed to The Institute of Radio Engineers.

(Continued)

5925. Single Sideband in the Amateur Service.....	George Grammer	1829
5926. Comparison of SSB and FM for VHF Mobile Service.....	H. Magnuski and W. Firestone	1834
5927. SSB Performance as a Function of Carrier Strength.....	William L. Firestone	1839
5928. Design of a High Power Single-Sideband VHF Communications System.....	John W. Smith	1848
5929. Single-Sideband Techniques in UHF Long-Range Communications.....	W. E. Morrow, Jr., C. L. Mack, Jr., B. E. Nichols, and J. Leonhard	1854

Correspondence:

5930. A Note on the Analog Computation of Small Quotients.....	Albert D. Bailey	1874
5931. Linear Programming and Optimal Telecommunication Networks.....	R. E. Kalaba and M. L. Juncosa	1874
5932. Microwave Semiconductor Switch.....	M. A. Armistead, E. G. Spencer, and R. D. Hatcher	1875
5933. Electrical Engineers Are Going Back to Science.....	Walter A. Knoop	1875
5934. Author's Comment.....	Frederick E. Ternan	1876
5935. The Dirac Delta Function.....	Philippe A. Clavier	1876
5936. Author's Comment.....	Richard A. Johnson	1877
5937. Letter from Mr. Lackey.....	R. B. Lackey	1877
5938. Author's Comment.....	Richard A. Johnson	1877
5939. RF Bandwidth of Frequency-Division Multiplex Systems Using Frequency Modulation.....	R. Hamer	1878
5940. Author's Comment.....	R. G. Medhurst	1878
5941. Pulse Narrowing by Filters.....	Richard K. Moore	1878
5942. Solar Temperature and Atmospheric Attenuation in the 7-8 MM Wavelength Range.....	R. N. Whitehurst and F. H. Mitchell	1879
5943. Minimizing Gain Variations with Temperature in RC Coupled Transistor Amplifiers.....	T. A. Prugh	1880
5944. Fast Switching with Junction Diodes.....	J. E. Scobey, W. A. White, and B. Salzberg	1880
Contributors		1882

IRE News and Radio Notes:

Calendar of Coming Events.....	1887
Activities of IRE Sections and Professional Groups.....	1888
TRANSACTIONS of the IRE Professional Groups.....	1889
Obituaries.....	1890
Technical Committee Notes.....	1891

Books:

5945. "Science and Information Theory," by Leon Brillouin.....	Reviewed by W. D. White	1892
5946. "Elements of Pulse Circuits," by F. J. M. Farley.....	Reviewed by G. B. Herzog	1892
5947. "Principles of Color Television," by the Hazeltine Laboratories Staff and ed. by Knox McIlwain and C. E. Dean.....	Reviewed by F. J. Bingley	1892
5948. "Vierpoltheorie und Frequenztransformation," by Torbern Laurent.....	Reviewed by H. Rothe	1893
5949. "Mathematics for Electronics with Applications," by H. M. Nodelman and F. W. Smith.....	Reviewed by Walter Kahn	1893
5950. Recent Books.....		1893
Programs.....		1894
5951. Abstracts of IRE TRANSACTIONS.....		1897
5952. Abstracts and References.....		1900
Annual Index to PROCEEDINGS OF THE IRE	Follows Page	1914
Annual Index to CONVENTION RECORD OF THE IRE	Follows PROCEEDINGS	Index

ADVERTISING SECTION

Meetings with Exhibits	6A	News—New Products.	48A	Membership.....	120A
Industrial Engineering		Professional Group		Positions Open.....	140A
Notes.....	8A	Meetings.....	101A	Positions Wanted.....	144A
IRE People.....	18A	Section Meetings.....	106A	Advertising Index.....	229A

Poles and Zeros

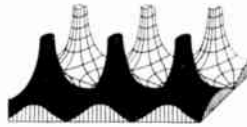

SSB and JTAC. In 1952, the Joint Technical Advisory Committee published a book "Radio Spectrum Conservation," which spelled out a great danger facing the radio industry—the creeping paralysis that infests frequency allocations. JTAC is sponsored jointly by IRE and RETMA. The latter organization underwrote the distribution of several thousand copies of the book to leading engineers, teachers and administrators throughout the world. Among the recipients were the members and staff of the Federal Communications Commission. Among the JTAC recommendations for combating the paralysis was "the use of the most efficient modulation methods, with respect to occupancy of the assigned channel."

Thereby hangs the tale of this special issue on Single Sideband Techniques. For in 1955, the FCC returned the favor by asking JTAC to undertake the collection of technical information, in preparation for rule making which would extend single sideband methods to services not now required to use this powerful tool of conservation. JTAC responded by querying technical organizations known to be active in this field, asking for papers on a variety of topics ranging from basic philosophy to specific techniques.

The response was overwhelming. No one, not even those working directly in the SSB field, realized how much was going on behind so many laboratory doors. Nine papers on as many different aspects came from one company alone. Ordinarily, a prudent editor would refrain from publishing this much, amounting to a quarter of the content of the issue, from one source. Under the circumstances, we congratulate that company for its outstanding activity in this important field. In all 34 papers were submitted. Of these, 30 were accepted for publication in this issue. IRE takes particular pleasure, as one of JTAC's sponsors, in publishing this material.

Chairman McConaughy of the FCC is preeminently qualified, as the principal administrator of the spectrum in the United States, to comment on the significance of these papers and to call attention to the tough technical and economic problems which presently block wider use of SSB. We urge all IRE members to read and weigh his comments, in the guest editorial that follows.

Particular credit is due seven individuals who read and organized the manuscripts, under great pressure of time. The FCC asked that these papers be committed to print at the earliest possible date, so as to permit reference to them during the current investigation and in the prospective hearings. So the issue date was moved up three months and the editorial work began before all of the papers were in hand. Our special thanks go, therefore, to I. J. Kaar, the member of JTAC to whom the SSB project was assigned and who did all the spade work, to J. F. Honey, who coordinated the material, read the abstracts and assigned the detailed reviews of particular papers, and to N. F. Schlaak, J. P. Costas, N. H. Young, Jr., E. A. LaPort, and A. M. Peterson, who reviewed them in detail. Their efforts in behalf of

JTAC, IRE, and the FCC will in due course extend far beyond professional bounds, as far in fact as the driver's seat of every radio-equipped taxicab.

Credit in full measure must also go to that good, gray organization, JTAC itself. This committee of eight senior statesmen has, since its creation in 1948, conducted its affairs with such singular wisdom that it has achieved, preeminently among engineering advisory bodies, the unquestioned confidence not only of the profession and the industry but of a not-always-friendly government. That lively observer of the scene, Martin Codel, once called the JTAC members "consulting engineers to the world." This standing has been achieved not by avoiding controversial issues, but by meeting them with pertinent technical data, carefully identified as to reliability, and by truly objective evaluation of their significance. The JTAC charter requires its members to serve wholly without instruction from their employers or any other organization, and the record shows wholehearted compliance with this necessary prerequisite to public and professional trust.

The JTAC reports contain much food for thought, even years after their original issue. One statement made in 1948, startling then but borne out today, is that a uhf television station, to compete with a vhf station, must radiate 5 to 20 megawatts. The FCC rules were recently amended to authorize 5 megawatts for uhf stations. In another area, JTAC stated its opinion in 1954 that narrower channels were technically feasible in the 152–162 mc mobile band, in response to an FCC request for information. In September, 1956, the Commission ruled that such narrower channels would be mandatory in this service, effective in 1963, and that new equipment must be designed for these channels after October, 1958.

Such advice must be based on engineering realities, and sound technical methods. These are originated, by and large, not by senior statesmen but by not-so-senior engineers-at-the-bench. For such engineers, we believe this issue of the PROCEEDINGS should serve not only as a source of information, but as a source of conviction that spectrum conservation can, and should, be advanced by technical methods.

Bulk. Those members who feel that the 1000-page IRE DIRECTORY should be shipped complete with reading stand, can sympathize with the postal workers in Menasha, Wisconsin, who are unfortunate enough to be required to take the output of our printer. The DIRECTORY loomed up in that post office as 116 tons of bound and wrapped paper, stacked to the ceiling. At 15 Directories to a mail sack, they filled over 3000 sacks, and it took two full days of back-breaking labor to clear the decks of this one issue alone. The fact that 158,000 copies of *Motor Service Magazine* were in the post office at the same time didn't help. So a tip of the hat to GPO, Menasha.—D.G.F.

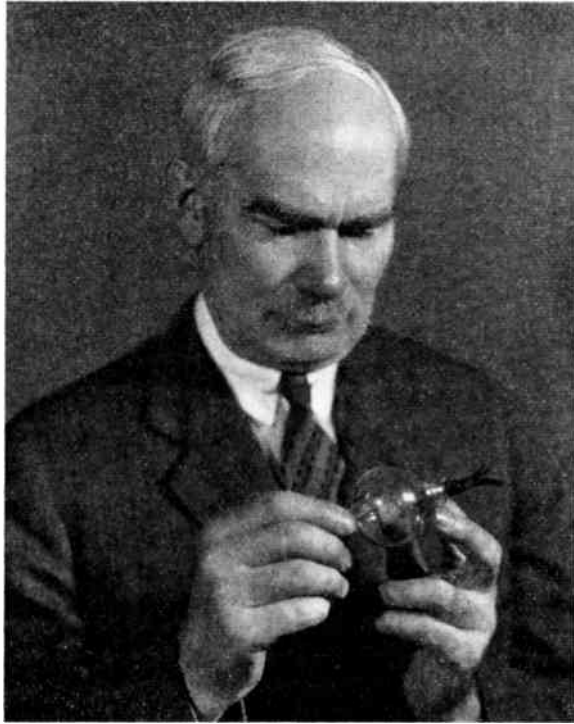

Tribute to Lee de Forest

On behalf of the Institute of Radio Engineers, its Directors, in meeting assembled, send greetings on this 50th anniversary of your momentous discovery. The grid electron tube has made possible the ramified developments in electricity that have now reached into every branch of technology and which are taking civilization across the threshold of a new era that is to bring revolutionary advances of untold magnitude for the uses of mankind.

For the Board of Directors,

A handwritten signature in cursive script, reading "A. V. Loughren". The signature is written in dark ink on a light background.

A. V. Loughren, President

November 14, 1956

Single-Sideband Techniques as Related to Spectrum Administration

GEORGE C. McCONNAUGHEY, *Chairman*
Federal Communications Commission

I am particularly pleased that this issue of the Institute's PROCEEDINGS is devoted to the subject of single sideband techniques. This subject is one of immediate and growing importance to the Federal Communications Commission. Our continual quest for practical methods of meeting the demands of an ever increasing, and in truth astounding, number of uses and users of the available spectrum space requires the help of the best engineering talent in the land. The Institute of Radio Engineers over the years has provided a real and most valuable contribution to the thinking of those of us engaged in administration and regulation of the radio spectrum. Spectrum-saving techniques of all kinds now must be given high priority in planning circles both in the government and industry. Indeed, today, in the enormous field of communications I believe the most fertile and productive ground for research and development lies in the area of new techniques for compressing more and more intelligence into narrower bandwidths, thus opening the way for more and better services of all types to the public.

During the years since World War II, tremendous progress has been made. In fact, the development of new electronic devices for both civilian and military use has far out-paced any orderly plans of spectrum allocation. The time for reappraisal is now. Fortunately, contemporary theoretical and technological advances are encouraging the more efficient use of the spectrum. Information theory gives us a yardstick for evaluating the various kinds of emission in terms which show their relative advantages.

The history and development of single sideband, as well as its inherent advantages, are well known to radio engineers. Some 90 per cent of our commercial overseas radiotelephone circuits are today utilizing this technique and efforts are being made to convert the remaining systems to this type of operation. Frequency control apparatus having precision adequate for use with single sideband has recently become available. Likewise, improved receiver components and designs are now available. Thus, contemporary developments in single sideband theory, engineering, and practice have now placed us in a position to utilize this technique in systems where its advantages are apparent.

It is the announced intent of the Federal Communications Commission to promulgate rules looking toward exclusive use of single sideband for radiotelephony on frequencies below 25 megacycles in the fixed and mobile radio services. Formal proceedings for this purpose have been commenced.

Implementation of single sideband transmission presents special problems in the various radio services. For example, in the maritime and aeronautical mobile services, international collaboration is necessary to assure communication between stations of different countries. Consideration must also be given to compatibility of AM and single sideband operations during the transition period. Additionally, conversion to single sideband must be so planned as to avoid unnecessary and premature obsolescence of existing installations. Special attention must, of course, be given to the specific problems in each radio service affected. These are but some of the matters which the Commission must consider. Consequently, the technical papers in this issue of the Institute's PROCEEDINGS are most timely contributions to knowledge of single sideband systems and equipment. In this connection, it is expected that the work of the IRE and the Joint Technical Advisory Committee will be of material assistance to the Commission in making provisions for single sideband utilization.

This issue of the PROCEEDINGS OF THE IRE constitutes a valuable contribution to the literature on single sideband theory and practice. Such published material is useful to the Commission in establishing technical standards. Also, constructive comments of interested parties furnished to the Commission in response to notices of proposed rule-making are of great help in formulating final rules. Therefore, I wish to encourage IRE members to submit comments regarding single sideband technical standards and other proposed, or to be proposed, rules affecting spectrum conservation.

On behalf of the Federal Communications Commission, I wish again to commend the Institute of Radio Engineers for its outstanding contributions toward advancement of the art of radio communications and for the whole-hearted cooperation it has always given all agencies of the government concerned with utilization and administration of the radio spectrum.

Introduction to Single-Sideband Issue

I. J. KAAR, *Chairman*
JTAC Subcommittee 56.1

On October 5, 1955, the FCC released its Public Notice No. 55-988 and its Notice of Proposed Rule Making No. 22939, thus breathing life again into an old and ever existing campaign to increase the usability of the communications channels. No one can deny that action in this direction is not only highly desirable but rapidly becoming mandatory if our communications systems are to be salvaged from chaos. If the rate at which the use of our communications channels is increasing were to be extrapolated, it would not be too difficult to predict the time at which the entire structure would collapse. It is quite obvious, therefore, that means must be found either to provide more spectrum space (which is not likely!) or to enhance the amount of information which can be transmitted through a given band in a given time. Single sideband may provide an answer and thus the FCC Public Notice.

Single Sideband is not new in the art. It has been known for many decades that the whole intelligence of an amplitude modulated signal resides in one of the sidebands. It is rather unusual, however, that so many years would pass before this technique would be fully recognized for its true worth.

At one time single sideband was actually considered for our national broadcasting system and it has been used for transoceanic telephony since the early 20's, as recounted in one of the papers of this issue, and it has been in use in wire communications, for economic reasons, since 1915. It is interesting to reflect upon the possible reasons why this technique was not exploited earlier and more widely. Some will say we were about ready for it when frequency modulation made its appearance and this is interesting because, in spite of the many advantages of fm, it can hardly be said to be a conservator of spectrum space. Others will contend that the alleged conservation of spectrum space afforded by SSB is to some extent a snare and a delusion. So as is usually the case, we do not have universal agreement.

To aid in resolving the problem, the FCC on October 6, 1955 wrote to the Joint Technical Ad-

visory Committee (which exists, in a large measure, to provide technical counsel to the FCC) and requested assistance. The JTAC agreed to undertake a study. A subcommittee was established on January 26, 1956 under the chairmanship of the writer who believes that the first action in any research should be a visit to the library. This has been done, in effect, by soliciting technical papers on all phases of single sideband operation from authorities in the field. These papers constitute this issue of the PROCEEDINGS.

This issue was intended to be a compendium on single sideband and it may seem odd to find included a single paper supporting a competitive scheme when, of course, many other papers of like nature could have been had. Let us say, then, that the Costas' paper was included to remind the reader that the optimum modulation scheme is still a controversial subject.

The papers lie in four domains: the first five papers contain historical and introductory material, the next eight deal with new techniques, the following five discuss design considerations, and the final group of twelve concern applications.

The material in the introductory section should provide the reader with a good over-all picture of the history and present status of SSB communications, its advantages and disadvantages, and the problems to be overcome in increasing its application. Following this, the techniques section includes a number of papers which provide detailed discussion of circuit and system problems unique to the SSB system. Problems involved in the design of SSB equipment and in the achievement of performance specifications such as linearity are discussed in the design section. The design of any communications system is largely determined by the application for which it is intended, and the papers which appear in the applications section of this issue discuss the requirements, restrictions, and approaches used in adapting the SSB system to a number of promising applications.

The grateful thanks of the JTAC goes out to the authors who responded, to the reviewers and to J. F. Honey who coordinated the reviews.

An Introduction to Single-Sideband Communications*

J. F. HONEY†, SENIOR MEMBER, IRE, AND D. K. WEAVER, JR.‡, ASSOCIATE MEMBER, IRE

Summary—The elements of the SSB communication system and its advantages over the AM system are discussed. These advantages include benefits to the individual user, generally in the form of reduced size and weight of equipment or more effective communication when conditions limit the size of the installation, and benefits to the radio environment which include spectrum conservation and reduction in the total radiated power required to accomplish a given communication function. Particular attention is devoted to the areas in which problems still remain in the use of SSB techniques in hf communication. Many of these problems arise from the necessity of having a suitable demodulating carrier at the receiver, and include the desirability of having highly accurate and stable frequency control of the transmitter and receiver, complex techniques for frequency synthesis, and techniques for carrier transmission and receiver afc. Other problems include compatibility between AM and SSB systems during the transition period, and standardization of SSB practices.

INTRODUCTION

THIS qualitative discussion of the over-all field of single-sideband communication is intended for the reader who does not necessarily specialize in the field but who, because of the increasing importance of SSB operation, desires a broad view of the elements and techniques, and the advantages and disadvantages involved. The advantages of SSB communication for the individual user accrue principally from the higher efficiency of sideband power generation in the SSB system, and take the form of reduced size and weight of equipment or more effective communication for a given size and weight. There are also advantages to the radio environment in which all users must operate that accrue from the reduced spectrum occupancy of the SSB signal and from the greatly-reduced total radiated power necessary to accomplish a given communication function. The hf portion of the spectrum between 2 and 25 mc is the only portion readily suited for long-range radio communication. In view of the increasing crowding of that portion of the spectrum, with consequent high levels of interference from other radio signals, these environmental advantages are major factors in the forthcoming widespread change to SSB service.

There are a number of areas of difficulty that still remain to be overcome if SSB techniques are to be widely used in the near future. The SSB system receives some very important advantages from the elimination of the high-power carrier signal used in amplitude-modulation communication; however, this elimination gives rise to a number of rather difficult problems at the receiver in providing a suitable demodulating carrier. These problems include the necessity of having highly-stable fre-

quency control of transmitter and receiver, the necessity for developing new carrier transmission techniques, and the use of complex receiver automatic frequency control techniques. Other system problems include the necessity for compatibility between AM and SSB systems in order to effect a transition both feasible and economical. There are also problems involved in the standardization of SSB techniques and practices.

THE NATURE OF THE SSB SIGNAL

SSB communication derives its name from the fact that the spectrum of the signal resembles one of the two sidebands that are created in the more familiar process of amplitude modulation. In the AM system a carrier $e_c(t)$, is varied in amplitude about a mean value in accordance with the modulating signal, $e_1(t)$. This operation is indicated in Fig. 1(a) and is described by (1), in which $e_2(t)$ denotes the resulting AM signal:

$$e_2(t) = [1 + ke_1(t)]e_c(t). \quad (1)$$

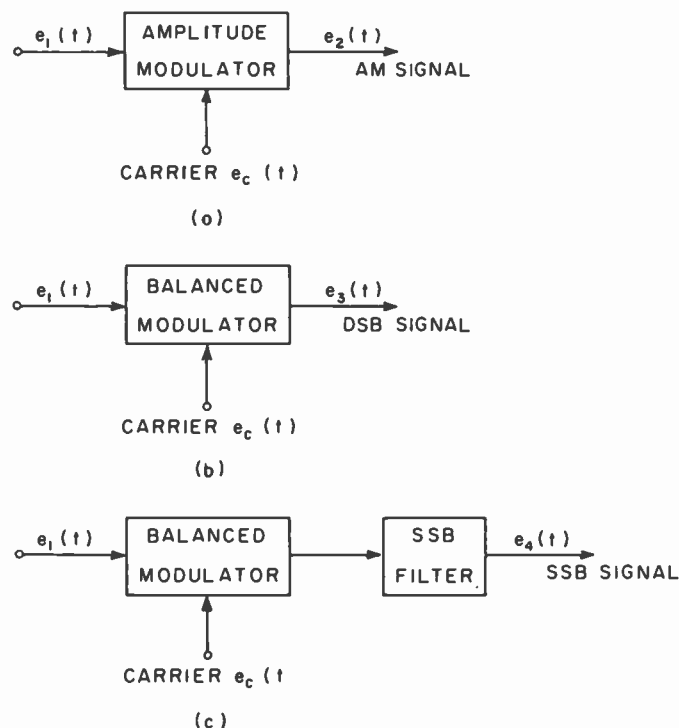

Fig. 1—Modulation systems.

Let the carrier, $e_c(t)$, be described as shown in (2) and the modulating signal, $e_1(t)$, be described as the sum of a large number of sinusoidal components as indicated by (3):

$$e_c(t) = \cos(\omega_c t + \phi_c) \quad (2)$$

* Original manuscript received by the IRE, August 24, 1956.

† Stanford Res. Inst., Menlo Park, Calif.

‡ Elec. Engrg. Dept., Montana State College, Bozeman, Mont.; formerly with Stanford Res. Inst., Menlo Park, Calif.

$$e_1(t) = \sum_{n=1}^N E_n \cos(\omega_n t + \phi_n). \quad (3)$$

We can substitute these expressions in (1) and rewrite the expression for the AM signal, $e_2(t)$, as

$$\begin{aligned} e_2(t) = & \cos(\omega_c t + \phi_c) \quad \text{carrier component} \\ & + \frac{k}{2} \sum_{n=1}^N E_n \cos[(\omega_c - \omega_n)t + \phi_c - \phi_n] \\ & \quad \text{lower sideband} \\ & + \frac{k}{2} \sum_{n=1}^N E_n \cos[(\omega_c + \omega_n)t + \phi_c + \phi_n] \\ & \quad \text{upper sideband.} \quad (4) \end{aligned}$$

This formulation clearly illustrates the existence of the original carrier component in the output signal with the upper and lower sidebands lying symmetrically on each side. The typical modulating signal as a function of time and of its frequency spectrum is illustrated in Fig. 2(a). The resulting AM signal and its spectrum, showing the two identical sidebands similar to the spectrum of the original modulating signal, are illustrated in Fig. 2(b).

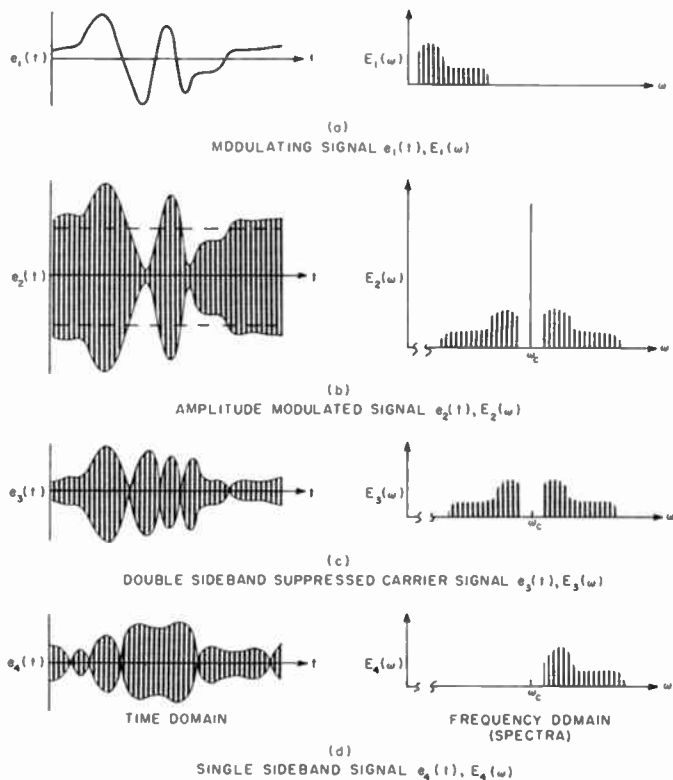

Fig. 2—Signal representations.

Instead of varying the amplitude of the carrier signal about a mean value in accordance with the modulating function, as was done in AM, we can multiply the carrier signal by the modulation function, $e_1(t)$, as indicated in (5) and in Fig. 1(b):

$$e_3(t) = e_c(t)e_1(t). \quad (5)$$

When we substitute (2) and (3) for the carrier and modulating signals into (5), it may be expanded in the form shown in (6):

$$\begin{aligned} e_3(t) = & \frac{1}{2} \sum_{n=1}^N E_N \cos[(\omega_c - \omega_n)t + \phi_c - \phi_n] \\ & \quad \text{lower sideband} \\ & + \frac{1}{2} \sum_{n=1}^N E_N \cos[(\omega_c + \omega_n)t + \phi_c + \phi_n] \\ & \quad \text{upper sideband.} \quad (6) \end{aligned}$$

The resulting signal, $e_3(t)$, is a double-sideband signal that is identical to the AM signal except that the strong carrier component is not present in the output. This type of signal is illustrated as a function of time and frequency in Fig. 2(c).

Perhaps the most familiar method of generating the SSB signal is that of generating a double-sideband signal similar to that just discussed and passing the resulting signal through a special SSB filter which passes one of the two sidebands and rejects the other, as indicated in Fig. 1(c). The expression for such an SSB signal, $e_4(t)$, is given in (7), and is illustrated as a function of time and frequency in Fig. 2(d):

$$e_4(t) = \frac{1}{2} \sum_{n=1}^N E_N \cos[(\omega_c + \omega_n)t + \phi_c + \phi_n]. \quad (7)$$

The lower sideband could have been selected instead of the upper sideband illustrated. Thus it appears that SSB modulation translates the spectrum of the modulating wave in frequency by a specified amount—either with or without inversion—and that the resulting signal occupies only half the total spectrum required for AM communication.

The AM signal is demodulated by rectifying the received signal, thereby recovering the envelope variations which contain the desired information. In another sense, the AM signal is applied to a nonlinear device. The difference frequencies, or intermodulation products, between the high-power carrier signal and the much-lower-power sideband components which result constitute the desired output signal.

The SSB suppressed-carrier signal does not include a high-power carrier signal to be used in the demodulation process, so this carrier must be supplied by the receiver itself. The sum of the signal and a high-power locally generated carrier can of course be rectified to produce difference frequencies between the carrier and the various components of the sideband. However, it is more common to use the locally-generated carrier to translate the SSB signal back to its original position in the audio-frequency band using conventional frequency conversion techniques. The block diagram of an SSB demodulator is shown in Fig. 3.

It is quite apparent that, if the demodulating carrier provided by the receiver is not of the correct frequency,

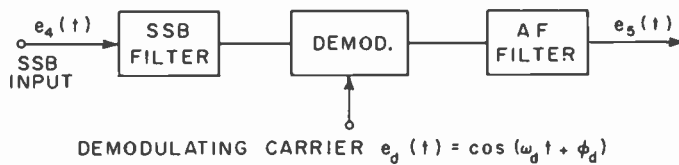

Fig. 3—Demodulation of SSB signal.

the demodulated SSB signal will be shifted up or down by a uniform amount from its original location in the spectrum. If the demodulating carrier $e_d(t)$, is described as shown in (8), the demodulated SSB signal, $e_s(t)$, will be given as shown in (9):

$$e_d(t) = \cos(\omega_d t + \phi_d) \quad (8)$$

$$e_s(t) = \sum_{n=1}^N E_n \cos[(\omega_c - \omega_d + \omega_n)t + \phi_c - \phi_d + \phi_n]. \quad (9)$$

It can be seen from inspection of (9) that if $e_d(t)$ is identical to the original carrier frequency, $e_c(t)$, used in the modulation process, the demodulated signal $e_s(t)$, will be identical to the original modulating signal, $e_1(t)$. If only the phase of the demodulating carrier is different from the phase of the original modulating carrier, all components of the output signal will have undergone a constant phase shift equal to the difference in phase of the modulating and demodulating carriers. If the frequency of the demodulating carrier differs from the frequency of the modulating carrier, the output signal, $e_s(t)$, will be shifted up or down by the difference frequency.

The problems involved in providing a demodulating carrier at the receiver of exactly the right frequency are formidable and will be discussed in substantially more detail later in this paper. These difficulties are a primary reason for the high cost and complexity of SSB equipment in comparison to AM equipment, and constitute the major reason why SSB techniques have not yet achieved widespread application in hf communications.

Relative Performance of AM and SSB Communications

Under ideal propagation conditions and under signal-to-noise ratio conditions that are better than those at which noise threshold effects appear in the AM detector, AM and SSB communication links provide identical performance if the total sideband power output of the two transmitters are the same. This includes the effect of the wider noise bandwidth of the AM receiver, and assumes coherent addition of the two sidebands of the AM signal. Under typical long-range propagation conditions, however, selective fading is likely to occur, and its effects are far more deleterious to the AM signal than to the SSB signal. Selective fading results from a combination of signals at the receiver arriving over two or

more propagation paths of differing lengths. These may result in partial cancellation of the carrier signal, or in a shift of the phase of the carrier signal relative to the phase of the sidebands. Phase distortion of the sidebands with respect to each other and to the carrier may also occur. Extensive tests have indicated that under excellent long-range propagation conditions involving point-to-point or air-ground communication, AM and SSB systems will perform identically if the power of the SSB transmission is equal to the power in one of the two sidebands of the AM transmission. This 3-db loss in the effective AM signal power is due to a combination of incoherent addition of the two sidebands of the AM signal due to a selective fading and to threshold effects in the AM detector. Under conditions in which severe fading has been observed, the effect on the AM signal has been much more severe than indicated above. Under such conditions, successful SSB communication has been established when the AM circuit of similar sideband power was completely out of service.

The SSB system is less subject to narrow-band man-made interference than is the AM system because it occupies only half the bandwidth of the AM system. It is correspondingly less likely, therefore, that an interfering signal will fall in the portion of the spectrum that is utilized. A study of the distribution in strength of the signals found in a normal hf radio environment indicates that the transmitter power equivalence of this advantage of the SSB system is as high as 6 db for narrow-band interference. The advantage is less for wider-bandwidth interfering signals, in which case the probabilities of an interfering signal appearing in two adjacent sidebands are no longer independent.

Advantages of the SSB System

The principal differences between SSB and AM communications that we have discussed so far include the reduction or elimination of the high-power carrier, a reduced spectrum requirement, and a more durable signal in the presence of selective fading and interference conditions. These points of comparison lead to substantial benefits both to the user of SSB equipment and to the radio environment as a whole.

The benefits to the individual user arise primarily from the higher over-all efficiency of generation and utilization of sideband power. If the performance of the SSB system is required to be equivalent to that of an existing AM system, the power of the SSB transmitter should be equivalent to the power of one of the two sidebands in the AM system. If equivalent performance is desired, the actual amount of saving in size and weight, or prime power requirement of the equipment, achieved by utilization of SSB techniques depends to a certain extent on the size of the installation. For purposes of rough estimation we can assume that 100-w AM and 125-w SSB equipments have approximately equal size, weight, and prime power requirements, and

that additional increments of power output in the SSB transmitter are approximately one-seventh as costly in terms of size, weight, and power requirement as equivalent increments in performance for the AM system. If equipment size and weight are the primary limiting factors for a given user, a 100-w AM transmitter can be replaced by a 125-w SSB transmitter. The SSB equipment will provide approximately the same performance that would be achieved using a 500-w AM transmitter; hence the system performance will be improved by approximately 7 db. The peak antenna voltage may be a limiting factor in situations in which electrically-small antennas or high-altitude operation in airborne communication is contemplated. Under this limiting condition a 100-w AM transmitter may be replaced by a 400-w SSB transmitter with a resulting improvement in system performance of approximately 12 db.

The benefit to the radio environment of widespread usage of SSB techniques is derived principally from the reduced spectrum occupancy and the reduction or elimination of the high-power carrier signal of AM communication. Because of the demodulating-carrier frequency-control problem, the SSB system requires a much higher order of frequency stability than present AM systems require, thereby reducing the guard-band requirement at the higher frequencies. This, plus the reduced spectrum requirement of the SSB signal, permits the assignment of at least twice as many SSB channels in a given portion of the spectrum as present AM practice permits.

In AM communication the total radiated power required to accomplish a given communication function is from 12 to 16 db greater than the total power required to accomplish the same function with SSB techniques. In a radio environment rapidly approaching the point at which additional communications will be limited by other radio signals rather than by natural noise, the importance of such a reduction in total radiated power can hardly be overestimated.

Disadvantages of the SSB System

The principal disadvantage of the SSB system is its cost and complexity. A slight degree of additional complexity is contributed by the SSB modulators and filters required, but the main source of the additional complexity is the problem of demodulating-carrier frequency control. The SSB system requires frequency control having accuracy and stability on the order of 0.2 to 2 parts per million in the hf spectrum, whereas present practice in fixed and mobile AM communication in the hf spectrum ranges from 50 to 200 parts per million. If multichannel operation is required, it becomes impractical to provide large banks of crystals having such high stability, and it becomes necessary to provide a very stable crystal oscillator using a highly complex frequency-synthesis technique for deriving any desired operating frequency from the one stable signal. These

disadvantages may be overshadowed in many applications by the advantages of reduced equipment size and weight or improved performance, as described above.

SSB TECHNIQUES

In the transmitter it is common practice to generate the SSB signal at a rather low fixed intermediate frequency and to translate it up to the final operating frequency in one or more steps. The SSB signal is then amplified to the desired power level using Class AB₁ or Class B linear power amplifiers. The SSB receiver performs similar functions in the inverse order and, with the exception of the demodulation stage, is not significantly different from the conventional superheterodyne communication receiver. A conventional tuned radio-frequency amplifier is used, and the signal is then heterodyned down to one or more fixed-frequency IF amplifiers which build up the signal power and achieve the necessary selectivity. The demodulation stage is actually a final stage of frequency conversion in which the SSB signal is heterodyned down to its original position in the af spectrum. The frequency of the signals used to effect the various frequency conversions in both the transmitter and receiver must be very accurately controlled. They must be supplied by highly stable crystal oscillators or, in the case of multichannel equipment, must be derived from a highly stable crystal oscillator by frequency-synthesis techniques.

In view of the fact that the various operations in the transmitter and receiver are so similar, it is often possible in the design of transceiver equipment to simplify by using some elements for both transmitting and receiving. The signals provided by the frequency synthesizer may, of course, be used for both purposes, and it may prove desirable to use a bilateral technique of SSB generation and demodulation.

There are a number of other techniques for SSB generation and demodulation in addition to the filter system previously discussed. These methods, together with further details on the filter method are discussed in the following.

SSB Modulation Techniques

The filter method of SSB generation has already been discussed in the second section, "The Nature of the SSB Signal," and is illustrated in Fig. 1(c). The filter system implies that the SSB signal is generated at a fixed IF at a moderately low power level. The IF to be used is determined to some extent by design considerations of the SSB filter itself and to some extent by the inherent stability considerations in the afc circuit of the receiver, if such is to be used. Suitable SSB filters can be constructed from LC elements for the frequency range of 20 to perhaps 100 kc for the single-channel voice signal. The recently-developed electromechanical filters have an advantage of small physical size, and have been built

for the frequency range of 100 to perhaps 600 kc. SSB filters using quartz crystals as the elements of the network have been used for many years at frequencies as low as 100 kc, and recent developments indicate that suitable filters can be constructed at frequencies as high as 10 mc.

The phasing technique of SSB generation is illustrated by the block diagram of Fig. 4. In this system two double-sideband signals are generated in balanced modulators and added together. Because the modulating signals and the carrier signals to each balanced modulator are phased in quadrature, the two resulting double-sideband signals add in such a way that one set of sidebands is canceled and the other set reinforced, producing the desired SSB output signal. It is obviously important in such a system that the quadrature phase relationship of the two carrier signals and of the two modulating signals be accurately maintained and that the transfer characteristics of the two balanced modulators be identical. Wide-band audio phase-difference networks have been constructed for bandwidths as large as 300 to 20,000 cps, providing quadrature phase relationship of the two output signals to within 0.2° in phase and 1 per cent in amplitude. Techniques for the synthesis and realization of this type of passive wide-band quadrature phase-difference network have been discussed in an article by Weaver.¹ This system is suitable for generating an SSB signal at fixed frequencies at any point in the IF or rf frequency range that may prove desirable. If a tunable or a wide-band 90° phase-difference network for the carrier signal is provided, the method can be used to generate an SSB signal at a variable frequency. This cannot be done with the filter method.

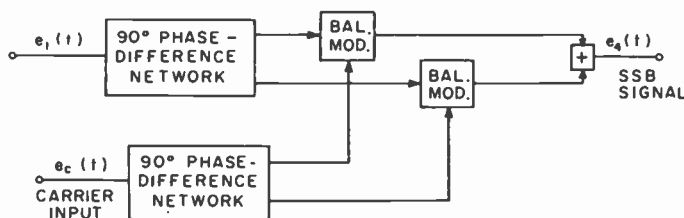

Fig. 4—Phasing method of SSB generation.

The phasing method of SSB generation has been used in the so-called high-level system of SSB generation. In this type of transmitter the two balanced modulators are actually the power output tubes, and the SSB signal is originally generated at the final power level and the desired output frequency. This technique has been demonstrated to perform satisfactorily, but it involves complex servo systems for the maintenance of the quad-

rature phase relationship of the variable-frequency carrier signal, and involves the accurate balance of the characteristics of the four power tubes in the double balanced modulator stage and accurate balance of the amplitude and phase characteristics of the four-channel modulator.

A third method of SSB generation, distinct from either the phasing or filter methods, has recently been suggested by Weaver and is described elsewhere.² This method is suitable, as is the phasing method, for generation of an SSB signal at any fixed or variable frequency in the IF or rf spectrum that may prove desirable. This method appears to be particularly well suited for future application in systems using an extremely wide bandwidth of modulation or systems which may require a constant-time-delay method of SSB generation.

In SSB transmission, the level of the undesired sideband that exists in the output signal is determined by the rejection characteristics of the SSB filter or phasing network used. The principal design objective to be achieved in this respect is that the level of the undesired sideband must be significantly smaller than the tolerable level of third-order intermodulation products (generated in the final amplifier) that occupy the undesired sideband.

In some applications it may be desirable to multiplex two channels of communication—one on the upper sideband and the other on the lower sideband. This can be accomplished quite readily in most types of SSB equipment simply by providing another set of SSB filters or by making certain simple modifications in the phasing technique, and providing the additional audio circuits necessary.

SSB Demodulation

All of the techniques discussed above for SSB generation are equally applicable in the demodulation of an SSB signal. As mentioned above, it may be desirable in transceiver equipment to use bilateral units in order to achieve additional circuit simplification. SSB demodulation does not, however, necessarily require the use of balanced modulators, and in some cases it may be desirable to use the more conventional type of receiver frequency converter circuit.

The requirement for undesired sideband rejection in the SSB receiver is entirely different from the corresponding requirement in the transmitter. SSB demodulation is essentially the last stage of frequency translation in which the IF signal is translated down to its appropriate position in the af spectrum. The unwanted sideband is the image of this last stage of frequency conversion, and the image rejection requirement in this stage is essentially the same as the image rejection

¹ D. K. Weaver, Jr., "Design of RC wide-band 90-degree phase-difference network," *Proc. IRE*, vol. 42, pp. 671-676; April, 1954.

² D. K. Weaver, "A third method of generation and detection of single-sideband signals," this issue, p. 1703.

tion requirement for any of the other stages of frequency translation that may be used in the receiver. The primary purpose is to reject interfering signals which may occur in the undersided sideband.

Linear Amplifiers

It is necessary that the amplifiers used to achieve the desired output power level for the SSB signal be linear in the sense that the output signal be as nearly identical as possible to the input signal. If nonlinear distortion of the SSB signal occurs in the final amplifier, third-order intermodulation products will be produced which fall within and near the desired sideband. If the SSB signal consists of two sinusoidal tones, f_1 and f_2 , the third-order distortion products of concern are of the form $2f_1 - f_2$, and $2f_2 - f_1$. If the SSB signal has a rectangular spectral distribution, the spectral distribution of the resulting third-order intermodulation products will be as shown in Fig. 5, and will extend one modulation bandwidth on either side of the assigned channel.

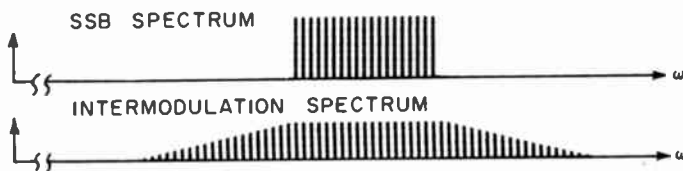

Fig. 5—Spectrum of intermodulation products.

In the case of multiplex channel operation, the permissible level of the third-order intermodulation products may be determined by the amount of cross-channel interference that can be tolerated. For single-channel communication it is difficult to specify a tolerable level of intermodulation distortion, but we can use as a guide the levels of distortion products lying outside the band that are achieved in typical AM service. The principal distortion products in AM service are not intermodulation terms, but result from modulation by harmonics of the various components of the modulating signal itself which are generated in the modulator stage and in the modulation characteristic of the power amplifier.

Demodulating Carrier Frequency Control

As has been mentioned in "The Nature of the SSB Signal" section of this paper, the demodulating carrier supplied in the receiver must be very close to the correct frequency in order to avoid undesirable shift of the spectrum of the demodulated signal. This may be accomplished by the use of highly stable crystal control of the transmitter and receiver. If sufficiently small demodulating carrier frequency error cannot be obtained by this method, it becomes necessary to transmit a certain amount of carrier power and to provide afc circuits in the receiver to correct the error of the demodulating carrier generated in the receiver. Present-day techniques

developed for long-range point-to-point application involve the continuous transmission of carrier power at a level of perhaps 10 to 15 db below the peak envelope power rating of the transmitter, and very narrow-band slow-acting receiver afc circuits are used to provide the final correction of the demodulating carrier frequency. The more recent requirements for fully automatic operation of the transmitting and receiving equipment and the desirability of rapid action of the receiver afc circuits, if any, place a great premium on high stability of the frequency control elements and on the design and performance characteristics of the carrier transmission and receiver afc techniques to be used. This constitutes perhaps the major problem in the realization of successful SSB communication in many modern applications, and it will be discussed in detail in the following parts of this paper.

AREAS IN WHICH PROBLEMS REMAIN

The following is a discussion of the principal problems that have restricted the use of SSB techniques until the present time. Most of these are concerned directly or indirectly with the demodulating-carrier frequency-control problem, and include the development of highly stable crystal oscillators and frequency synthesis techniques. There are also problems involved in achieving the compatibility of AM and SSB systems that will make an orderly transition possible, and in the determination of standard equipment specifications and operating procedures for SSB equipment in various applications.

Demodulating-Carrier Frequency Control

SSB communication derives several very important advantages from the reduction or elimination of the high-power carrier signal of AM, but a strong carrier component must, nevertheless, be supplied at the receiver in order to effect demodulation. It is often stated that the high-power carrier signal of AM communications carries no useful information, but this is not necessarily true. We have seen that information about both the carrier phase and frequency is necessary to demodulate the two sidebands of the AM signal. The use of the high-power carrier for the transmission of this information is only wasteful in that it is capable of a greater rate of transmission than is usually required. For voice communication over an SSB system, we do not need carrier phase information and can actually tolerate small frequency errors, so it follows that much less information need be provided at the receiver about the carrier than the AM system requires.

A certain amount of information about the proper carrier frequency may be provided at the receiver in advance of communication by providing extremely accurate and stable frequency control of both the transmitter and receiver. However, if this information is not

sufficient to describe the demodulating carrier frequency to the required degree of accuracy, we must transmit the additional information necessary in real time over the communication link. This is generally accomplished by transmitting a certain amount of carrier power either continuously or in bursts, and by providing afc circuits in the receiver to adjust the frequency of the demodulating carrier in accordance with the information obtained from the received carrier component.

The requirements for the accuracy of the demodulating carrier frequency may vary for different types of modulating signals. For voice communication, errors up to 10 cps are not noticeable under any conditions. In the absence of noise, errors as great as 50 cps detract considerably from the naturalness of the received speech signal but do not seriously impair its intelligibility. Errors over 50 cps result in rapidly increasing degradation of intelligibility. Under low signal-to-noise ratio or under marginal range conditions, however, frequency errors between 10 and 50 cps have been found to have a much more serious effect on intelligibility than they do in the absence of noise. A complete investigation of the effects of the smaller frequency errors on intelligibility under marginal noise conditions has yet to be conducted.

In air-ground communication, the Doppler shift of a transmitted or received signal due to motion of the aircraft toward or away from the communicating station is approximately 1 part per million per Mach number. The investigation of the effects of the smaller frequency errors on intelligibility under very noisy conditions suggested above will be of basic importance in determining whether or not independent frequency control of the SSB transmitter and receiver is acceptable for this application. There appears to be a possibility that the frequency errors due to Doppler shift alone in modern very-high-speed aircraft may be sufficient to seriously reduce performance of the system under maximum range conditions at the higher carrier frequencies.

If it is necessary to use carrier transmission and receiver afc, the primary design requirement will be that the performance of the carrier recovery system be such as not to degrade the performance of the communication link under the poorest usable signal-to-noise ratio conditions. The remaining design requirement is that the afc system must complete its function in a period of time short enough not to disrupt the operation of the communication link since such disruption causes unnecessary inconvenience to the operating personnel. Applications involving automatic operation of the equipment will, of course, require that the afc function be performed without aid from an operator in correcting the largest frequency errors that might occur.

When a carrier signal is received in the presence of noise, there is a minimum irreducible error in the ability to determine the frequency of the received carrier component in a given period of time. In other words, the

amount of carrier power which must be transmitted, relative to the sideband power output, is completely determined by the maximum tolerable residual frequency error, the response time required of the afc system, and the lowest signal-to-noise ratio useful in reception of the SSB signal. This irreducible error appears as frequency modulation of the demodulating carrier provided by the afc circuit, and must be held within limits of ± 10 cps peak deviation in order not to degrade a voice signal under low signal-to-noise conditions.

The so-called reconstituted-carrier method of providing a demodulating carrier utilizes a narrow-band filter to select the received carrier component. The received carrier is then amplified and used to demodulate the received SSB signal. This system has the disadvantage that its noise bandwidth is the same as the peak frequency-error correction that might be expected. The noise bandwidth of any afc system is basically determined by the response rate required and, in this case, the response rate will be far faster than necessary for most applications.

Discriminator circuits and synchronized oscillator circuits permit the noise bandwidth of the afc system to be separated completely from the peak-to-peak frequency error correction range desired and leave it to be determined only by the maximum response time permissible. Discriminators have the disadvantage that a noise threshold occurs when the noise power received in the entire correction range approaches the carrier power. Synchronized oscillators do not have such a noise threshold.

Frequency error due to Doppler shift or to drift of the transmitter or receiver crystals changes very slowly as a function of time. This slowness permits the use of afc circuits that makes corrections intermittently and permits the use of intermittent periods of carrier transmission. In the so-called controlled-carrier system of carrier transmission,³ the carrier is transmitted at about the same power level as the sideband signal for a short period at the beginning of each transmission and during subsequent pauses in speech modulation. Discriminator or synchronized-oscillator afc circuits can be arranged to make their correction during periods of high carrier reception and to hold the corrected frequency during periods when the carrier signal is not being received.

Certain applications may permit some manual tuning of the receiver during periods of reception. This may often permit the use of comparatively simple slow-acting afc circuits having narrow noise bandwidths and capable of satisfactory operation with carrier signal suppressed from 10 to 20 db below the peak envelope power of the transmitter. This type of system has been used for years in long-range point-to-point telephone

³ G. W. Barnes, "A Controlled-Carrier Single-Sideband System for Aircraft Communication," Royal Aircraft Establishment Tech Note RAD. 521; May, 1952.

communications. In other applications which require rapid and frequent correction of demodulating carrier frequency errors, one may be forced to the controlled carrier system in order to obtain sufficient carrier power to handle the information rate required.

Stable Oscillators

A great deal of progress has been made in the past few years in the development of stable quartz crystals for frequency control and associated ovens and oscillator circuits. The work by Warner and his associates at the Bell Telephone Laboratories⁴ indicates that there are certainly no fundamental obstacles in the way of achieving crystal oscillator stabilities far better than those considered acceptable in AM practice today. Crystal oscillators having long-term stabilities on the order of 0.2 to 2 parts per million are necessary in hf SSB communication, and crystal oscillators having stabilities as good as this or better are being developed for other applications, including frequency control of uhf links and navigation systems. A very considerable amount of progress is being made in the development of atomic frequency standards as well.

At the present time there appears no reason to doubt that crystal oscillators having stability sufficient for point-to-point SSB operation in hf applications and suitable for field application will be available within the next few years.

Frequency Synthesizers

In view of the high degree of crystal-oscillator stability required in SSB service, it is usually impracticable to provide a large number of crystals for multichannel operation and hence it becomes necessary to derive the various signals required for frequency conversion from one or a very small number of stable crystal oscillators. This is known as frequency synthesis. A large number of techniques of frequency synthesis have been developed and, while they differ substantially with regard to the methods used for obtaining the desired signals, they are all quite similar in that they require from 20 to 30 tube envelopes and are highly complex. This complexity is one of the principal disadvantages of SSB for multichannel applications, and it is to be hoped that simpler and more reliable synthesis techniques will be developed in the near future.

Phase Distortion

Filter and phasing techniques for SSB generation and reception are designed without regard to phase or time delay distortion of the modulating signals. While this is of little or no consequence in voice communications, it may become necessary in the future to develop

constant-time-delay filters to accommodate other types of modulating signals which will not tolerate phase distortion. The method of SSB generation suggested by Weaver elsewhere in this issue is applicable in this regard, since it can incorporate low-pass constant-time-delay filters that can be realized using presently available synthesis techniques.

Speech Processing

The SSB system, which has no noise threshold, is particularly well suited for the application of speech processing techniques. These techniques are intended to increase the average-to-peak ratio of the speech modulating signal, and greatly increase the signal power output of a transmitter having a given peak-power limitation. The technique of peak limiting, which has found considerable application in the past, results in undesirable distortion levels. It has been found that more sophisticated techniques involving the combination of spectrum tilting, automatic speech-amplifier gain control and speech clipping are far more effective in increasing the average level of modulation achievable without excessive distortion.

Compatibility of AM and SSB Systems

In order to effect an orderly and economically feasible transition from AM to SSB communication in many existing services, it appears necessary to design the new SSB equipment in such a way that it is compatible with existing AM equipment. Perhaps at a later stage in the transition period it will be desirable to modify the remaining AM equipment so that it is compatible with the SSB services. This question is discussed in detail in another paper⁵ and will not be investigated here. It will suffice to say that it is easy to equip an SSB receiver with an AM detector and to arrange an SSB transmitter to radiate a large carrier signal and one sideband at reduced power. Such a signal is readily detectable in a conventional AM receiver.

Standardization

There are many aspects of SSB communication for the different services in which careful thought will be required in the establishment of standardized design techniques and operating procedures before manufacturers can enter production with confidence that their equipment will not be rendered obsolete in a short period of time by some change in procedure. Typical of system characteristics requiring consideration of this kind are the choice of the upper or lower sideband, the definition of the assigned channel frequency, the frequency accuracy and stabilities required, and carrier transmission and receiver afc techniques. The picture is further complicated by the necessity of providing

⁴ A. W. Warner, "High-frequency crystal units for primary frequency standards," *PROC. IRE*, vol. 40, pp. 1030-1033; September, 1952.

⁵ N. Young, "Problems of transition to single-sideband operation," this issue, p. 1800.

operation compatible with AM systems during transition periods. A great deal of attention has been devoted to this problem during the past two years by the Radio Technical Commission for Aeronautics,⁶ the International Air Transport Association,⁷ and the Airlines Electronic Engineering Committee.⁸ These organizations are considering the problems involved in commercial airborne applications of SSB techniques for long-range air-ground communication, and have made a number of very significant recommendations for the standardization of airborne SSB equipment and the achievement of compatibility with AM systems during transition periods.

SSB APPLICATIONS

SSB techniques have been used for many years in lf and hf radiotelephony over long-range point-to-point links and for multiplexing a number of voice channels on wire lines. Until the present time, it has been more or less restricted to these applications by the cost and complexity of the equipment and by the difficulty of its operation, adjustment, and maintenance. Improvements in tubes, components, and SSB filter designs over the past few years have resulted in a widened field of practical application. The rapid increase in acceptance of SSB techniques in amateur radio communication graphically demonstrates the effect of these improvements. These advances have stimulated great interest in portable, mobile, and airborne applications, and a great deal of work has been done on the special problems discussed above which arise when fully automatic multichannel operation is required. It appears reasonable to expect that practical equipments suitable for these applications will be available in 2 to 5 years.

The Federal Communications Commission, in the interest of conservation of the hf spectrum, has released

⁶ Radio Technical Commission for Aeronautics, "The Application of Single Sideband Techniques to Aeronautical Communications," Paper 11-54/DO-53, prepared by RTCA SC-65; January 25, 1954.

⁷ International Air Transport Association, "Report of Single Sideband Compatibility Meeting, Montreal, Canada, November 14-18, 1955," DOC. GEN 1614. Address inquiries to IATA, International Aviation Bldg., Montreal 3, P.Q., Canada.

⁸ Aeronautical Radio, Inc., "Proposed ARINC Characteristic No. 533, Airborne HF SSB/AM System," AEEC Letter 56-3-26; September 10, 1956. This is a working paper prepared by ARINC for the Airlines Electronic Engineering Committee, and does not yet constitute policy approved by either organization.

"Notice of Proposed Rule Making FCC-55-987," which suggests amendments of Parts 6 and 9 of the Commission's *Rules and Regulations* to require the use of SSB transmission in fixed radiotelephone service below 25 mc within a period of from five to ten years. In "Notice of Proposal Making FCC-56-326," the Commission proposes an amendment of Part 9 of the *Rules and Regulations* to require the use of SSB transmission in the aeronautical mobile service for radio-telephony on frequencies below 25 mc.

The advantages of spectrum conservation and freedom from multipath propagation effects which recommend SSB communication so highly for hf applications are becoming just as important in vhf communication. The problems of SSB generation and demodulation in this frequency range are now no more difficult than for any other system, but the demodulating-carrier frequency-control problem is more difficult by an order of magnitude than in the hf case. We may nevertheless expect further increase in interest and activity in this field in the near future, particularly in applications requiring wide modulation bandwidths.

APOLOGIES

In preparing this paper, the authors have made every effort to present a complete outline of the field of SSB communication and to present the numerous problems therein in their proper perspective. However, they are unfortunately lacking in one important qualification for those who would prepare such a paper: omniscience. There are without question errors of omission and probably errors of commission. To those who may feel that some aspect has been slighted, the authors offer their apologies and express their confidence that the ensuing discussions will further the objectives of this paper and of this special issue of the PROCEEDINGS, as well as their own education.

ACKNOWLEDGMENT

This paper has been made possible through experience obtained in connection with Contract NOas 52-294c, between Stanford Research Institute and the Bureau of Aeronautics, Department of the Navy, on the development of AN/ARC-37(XN-) airborne SSB radio set.



Early History of Single-Sideband Transmission*

ARTHUR A. OSWALD†, FELLOW, IRE

Summary—This paper briefly reviews wire and radio art at the time of the invention of the single-sideband method of transmission. Recognition of sidebands, realization that either sideband contains the entire information and that the carrier wave conveys none, and the experimental discovery of homodyne reception, all preceded the invention.

The method was first employed commercially in carrier telephone systems.

Narrow resonance characteristics and limited transmitting power necessitated elimination of one sideband and carrier in the first transoceanic radio telephone system.

Successful application to hf radio systems and superior performance under fading conditions resulted in general adoption of single sideband for long-haul services.

THE SINGLE-SIDEBAND METHOD of transmission was conceived in the mind of John R. Carson in 1915 through pure analysis resulting from his mathematical studies related to modulation of a continuous-wave carrier by means of thermionic vacuum tubes.¹ Almost simultaneously, H. D. Arnold realized the possibility in connection with tests of the Arlington experimental radio telephone transmitter of that year. Like situations preceding some other great contributions to telephone communication, in this instance the high frequency wire and radio art was ripe for the invention.²

The first step was the recognition of sidebands *per se*. Until well after Carson's invention, there seems to have been no general, clear-cut recognition outside the Bell System, that modulation of a carrier by voice waves results in side frequencies above and below the carrier. LeBlanc, in describing his multiplex system,³ speaks of the modified high-frequency wave and calls for a channel spacing "high compared with the pitch of the sound waves." This might be construed as implying that a transmission band is involved but LeBlanc makes no comments in this direction. Fleming⁴ treats the modulated carrier as a wave of constant frequency but varying amplitude. Stone⁵ as late as 1912 says, "There is, in fact, in the transmission of a given message, (by carrier) but a single frequency of current involved."

The combining of two waves in a nonlinear element to produce sum and difference waves was an old phenomenon in acoustical physics. There appears to have been a certain carryover of that knowledge to the case

of electric-wave modulation by both Campbell and Colpitts whereby sidebands were tacitly assumed to exist although admittedly not very concretely visualized. The band spectrum of voice waves was well known. Campbell's electric wave filter⁶ had been invented. It is clear from correspondence that by 1913 Bell System engineers were assuming that speech, in being translated upward in frequency by modulation on a carrier, would still constitute a band of frequencies.

In the summer of 1914 a young physicist who was working on radio, in familiarizing himself with the subject, worked out a simple trigonometric analysis of an amplitude-modulated wave in his notebook. It showed three distinct components, the carrier and the upper and lower waves set off therefrom by the modulating frequency. The youthful analyst was Carl R. Englund; his notebook was dated August 19, 1914. Others may have done the same but this is the earliest known record. Nothing seems to have come directly from it. Those who knew apparently did not grasp the entire significance.

In October, 1914, R. A. Heising set up and tested a vacuum tube transmitting and receiving terminal, over an artificial line in the laboratory, which simulated two carrier telephone channels. This was the first putting together of an all-vacuum tube, high-frequency telephone system. It used separation coupled tuned circuits for frequency. Heising's report, dated December 18, 1914, recognized sidebands and mentioned the filter for realizing a "flat-topped transmission band."

The full blown appreciation came in mid-1915 during the radio-telephone experiments conducted at the U. S. Navy Radio Station at Arlington, Va. H. D. Arnold suggested that the antenna at Arlington be tuned to one side of the carrier frequency in order to pass one-sideband well, even though the other was attenuated. Here was recognition that one sideband contained all the signal elements necessary to reproduce the original speech. During this same period, John R. Carson independently set about analyzing vacuum-tube modulation, found the discrete components and recognized that one sideband and the carrier need not be transmitted. Kendall⁷ had just discovered that injection of a carrier at the receiver greatly enhanced detection. Carson knew of these homodyne experiments and, since they demonstrated the feasibility of reintroducing the carrier at the receiving end, they may have promoted his idea of eliminating the carrier at the transmitter. At any rate, Carson in addition to suppressing one sideband, did propose suppression of the carrier as well: a step beyond Arnold's

* Original manuscript received by the IRE, August 21, 1956.

† Retired from Bell Telephone Labs., New York, N. Y., 1956.

¹ J. R. Carson, U. S. Patents 1,449,382, 1,343,306, and 1,343,307.

² E. H. Colpitts and O. B. Blackwell, "Carrier current telephony and telegraphy," *AIEE Trans.*, vol. 40, pp. 205-300; February, 1921.

³ M. LeBlanc, U. S. Patent 857,079; 1907.

⁴ J. A. Fleming, "Electric Wave Telegraphy and Telephony," Longmans, Green and Co., London, Eng., 2nd ed., 1910.

⁵ J. S. Stone, "The practical aspects of the propagation of high-frequency electric waves among wires," *J. Franklin Inst.*, vol. 174, p. 353; October, 1912.

⁶ G. A. Campbell, U. S. Patent 1,227,113 and 1,227,114; 1917.

⁷ B. W. Kendall, U. S. Patent 1,330,471.

proposal. After several patent interferences Carson was granted in U. S. Patent 1,449,382, filed in 1915, claims both to suppression of one sideband and to suppression of the carrier with or without suppression of one sideband. (See Fig. 1.)

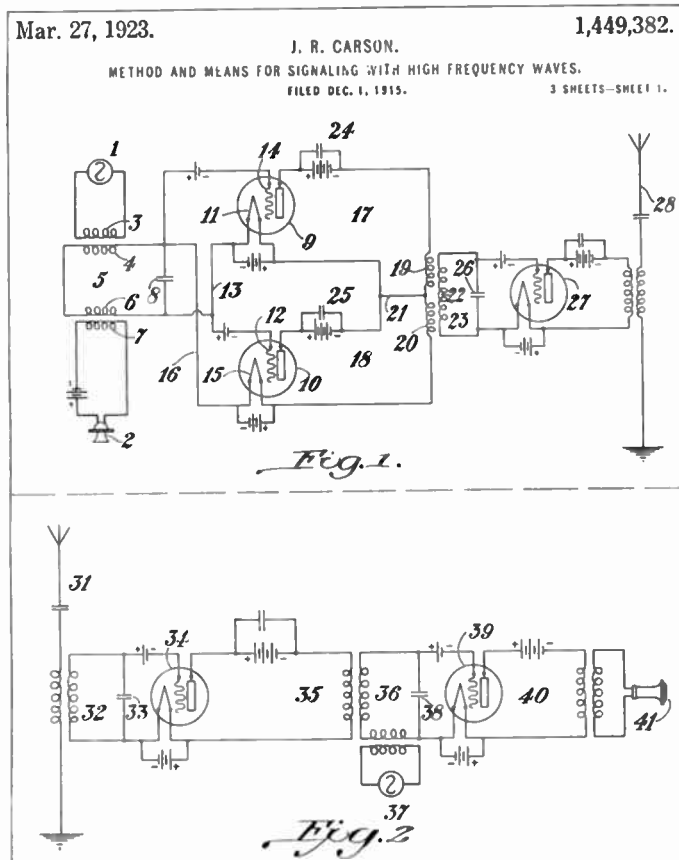

Fig. 1—Figs. 1 and 2 of J. R. Carson's patent.

It was from the modulation side of the laboratory work of 1913–1915 that the reality of sidebands and the possibility of single-sideband transmission were established. For more than a decade thereafter the physical reality of sidebands continued to be argued vigorously in some quarters; it was alleged that sidebands were merely a mathematical fiction. The establishment of the first transoceanic radio telephone system which employed single-sideband suppressed carrier transmission, provided an effective answer to radiomen.

Advantage was taken of single-sideband transmission in developing the first commercial wire carrier telephone system—Western Electric Company Type A—placed in service in 1918.⁸ Thus the first application of single-sideband transmission was for high-frequency wire telephony. Both time division and frequency division multiplex schemes had been invented much earlier. Single-sideband permitted obtaining twice as many channels in the very limited frequency spectrum then usable for

wire transmission. Since 1918 single-sideband transmission has been of unique value in carrier-telephone development; it is standard for many systems throughout the world. The first published mention concerning single-sideband applications to radio seems to have been made by Espenschied⁹ late in 1922.

The invention of the copper-to-glass seal by Housekeeper brought rapid development of water-cooled thermionic vacuum tubes following World War I. This opened the possibility of early realization of the Bell System's long quest for a transoceanic telephone service. During 1922 a powerful experimental single-sideband transmitter, operating at a midband frequency of 57 kc, was set up by their research engineers at Rocky Point, Long Island.¹⁰ (See Figs. 2 and 3, on the next page.) A receiving station was established at New South Gate, near London, England. Reliable one-way speech transmission was publicly demonstrated over this system in January, 1923. Thereafter the British Post Office worked hand-in-hand in establishing the first New York-London circuit which was opened for service in January, 1927. The limited transmitting power capacity and the narrow-resonance bands of efficient antennas at the low frequencies employed in this system, made imperative the adoption of single-sideband suppressed carrier methods. However, the frequencies were about three times higher than those used in existing carrier telephone systems. Hence, both the sideband generators¹¹ and the power amplifiers¹² involved pioneer development.

The first overseas system was followed in the next few years by so-called short-wave systems operating in the range now designated as high frequency (3–30 mc). Until about 1936 all the short-wave systems transmitted double sideband and carrier because the art in this frequency range did not permit practical single-sideband operation. However, the Bell System and British Post Office transmitters and possibly others were designed with low-level signal generators and power amplifiers so that the generators could be replaced by single-sideband generators when available.

In the late 1920's the Bell Telephone Laboratories constructed a special receiver with which to investigate the characteristics of shortwave single-sideband reception. This receiver occupied seven bays and used crystal filters. It was capable of receiving double-sideband transmissions and separating the sidebands and the carrier for experimental purposes. Provision was made for isolating, reconditioning, and re-inserting the transmitted carrier. Locally generated carrier and automatic frequency control were also provided, so that

⁹ L. Espenschied, "Applications to radio of wire transmission engineering," *Proc. IRE*, vol. 10, pp. 344–368, October, 1922; and *Bell Sys. Tech. J.*, vol. 1, pp. 117–141; November, 1922.

¹⁰ H. D. Arnold and L. Espenschied, "Transatlantic radio telephony," *J. AIEE*, vol. 42, August, 1923; and *Bell Sys. Tech. J.*, vol. 2, pp. 116–144; October, 1923.

¹¹ R. A. Heising, "Production of single-sideband for transatlantic radio telephony," *Proc. IRE*, vol. 13, pp. 291–312; June, 1925.

¹² A. A. Oswald and J. C. Schelling, "Power amplifiers in transatlantic radio telephony," *Proc. IRE*, vol. 13, pp. 313–361; June, 1925.

⁸ B. W. Kendall, "Carrier-current telephone systems," *Bell Labs. Rec.*, vol. 1, pp. 154–159; December, 1925.

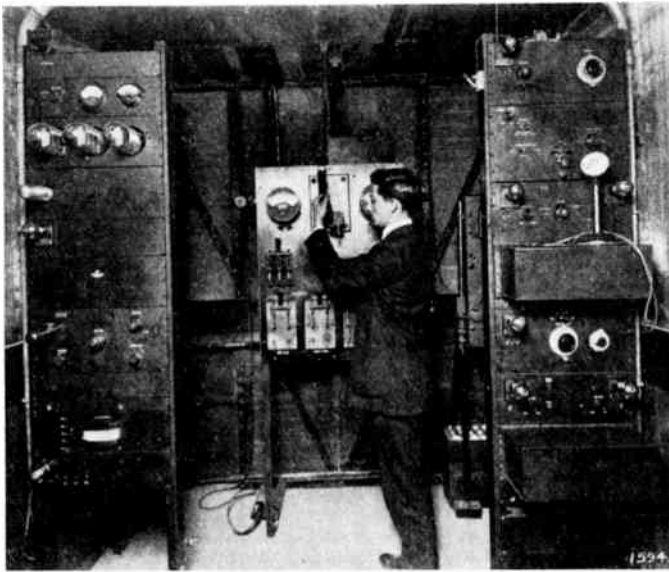

Fig. 2—Single sideband-generator installed at Rocky Point for 1922 Transatlantic experiments.

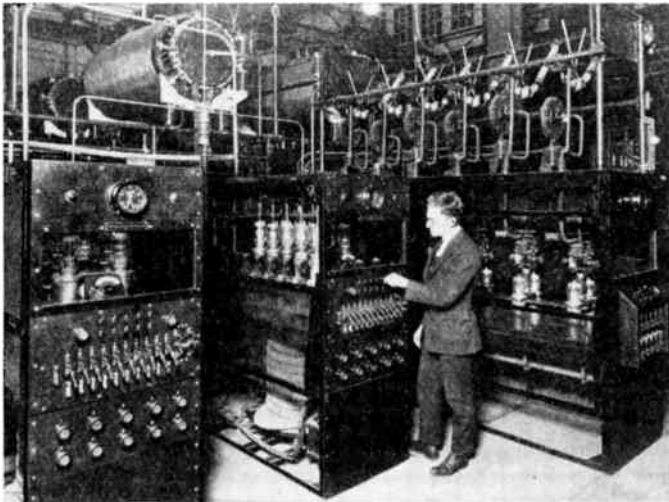

Fig. 3—Main rectifier (right) and two banks (left) of the power amplifier last stage as installed for single-sideband radio telephone experiments in 1922.

it was possible to simulate almost any kind of reception. The observations made with this equipment brought decisions to develop shortwave single-sideband transmitting and receiving units for a transoceanic trial.^{13,14} Upon completion, the transmitter was taken to England and with the cooperation of the British Post Office, set up in the station at Rugby. There followed extensive tests which confirmed that the theoretical advantages could be achieved in practice, in the presence of multiple path

¹³ F. A. Polkinghorn and N. F. Schlaack, "A single-sideband short-wave system for transatlantic telephony," *PROC. IRE*, vol. 23, pp. 701-718, July, 1935; and *Bell Sys. Tech. J.*, vol. 14, pp. 489-507; July, 1935.

¹⁴ G. Rodwin, "Single-sideband short-wave receiver," *Bell Labs. Rec.*, vol. 14, pp. 405-410; August, 1936.

transmission. This trial equipment was placed in commercial operation; in 1936 designs for production were initiated.¹⁵⁻¹⁸ During the next decade about 50 single-sideband circuits were established in all parts of the world using units of these designs; the applications increased thereafter.

During World War II single-sideband systems did valuable service in providing connections between continental United States and the armed forces in various parts of the globe. Many of these were multichannel teletypewriter systems using telephone circuits with speech channels used only for special purposes. The telegraph signal was two-tone (mark and space) with frequency diversity (4 tones per telegraph channel). After the war improved single-sideband equipments were developed in the Bell Telephone Laboratories and by several other companies in the United States and abroad. Today the single-sideband method is rather generally recognized as standard for long-haul point-to-point transmissions and is being seriously considered for other purposes such as communication with aircraft.¹⁹ Recently the Federal Communications Commission has proposed rules requiring single sideband for all point-to-point radio telephone transmission below 30 megacycles.

The first short-wave single-sideband equipment provided only a single speech channel on one side of the carrier, but it was quickly determined that a common power amplifier could be made sufficiently linear to permit adding a second channel on the opposite side of the carrier. At first, better performance was secured by spreading one channel from the carrier so that unwanted distortion products generated in the power amplifier by one channel would fall in the space between active bands and thus not create noise in the other channel. The urgent need for more telephone channels during the war years resulted in spreading both normal speech bands away from the carrier. A third circuit was then secured by splitting a speech channel and fitting the parts into the narrow-frequency space available adjacent to and on both sides of the carrier.

A single-sideband signal is generated by one of two basic methods: 1) modulating a carrier with a baseband signal and then suppressing all but one sideband with filters; or 2) balancing out the carrier and one sideband by an arrangement of double modulators in which the carrier and modulating signal applied to one modulator are shifted 90° with respect to those applied to the other modulator. The filtering method easily provides greater

¹⁵ A. A. Roetken, "A single-sideband receiver for short-wave telephone service," *PROC. IRE*, vol. 26, pp. 1455-1465; December, 1938.

¹⁶ A. A. Oswald, "A short-wave single-sideband radio telephone system," *PROC. IRE*, vol. 26, pp. 1431-1454; December, 1938.

¹⁷ J. C. Gabriel, "Single-sideband short-wave receiver," *Bell Labs. Rec.*, November, 1939.

¹⁸ K. L. King, "A twin-channel single-sideband radio transmitter," *Bell Labs. Rec.*, vol. 19, pp. 202-205; March, 1941.

¹⁹ Radio Technical Commission for Aeronautics, Rep. of Special Comm. 65, Paper 11-54/DO-53; January 25, 1954.

suppression and operating stability. The basic idea of the balancing scheme was invented by Hartley.²⁰ A scheme for transmitting independent intelligence on the two sides of the carrier is shown in a patent issued to Potter.²¹ Green²² suggested use of balancing methods for separating the two sidebands at the receiver. Balancing has been used in some short-haul carrier telephone systems where high suppression is not essential. In recent years balancing methods have received considerable attention in a number of laboratories as the search proceeds for economical ways to make various new single-sideband applications.

Once the feasibility of single-sideband transmission had been demonstrated, the Bell System was not alone in appreciating its advantages. The British Post Office supported a continuous program of development to establish improved systems. The Dutch, pioneer workers in the field, developed equipment and established multiplex circuits between the Netherlands and the Netherlands East Indies.²³ Reeves²⁴ of International Standard Electric Corporation did some major pioneer work. This paper makes no attempt to cover the expanded activity in the single-sideband field since World War II.

ACKNOWLEDGMENT

In closing the author wishes to acknowledge the valuable assistance given by L. Espenschied and F. A. Polkinghorn in making available material gathered in some of their historical studies.

BIBLIOGRAPHY

- [1] Deloraine, E. M. "Single Sideband Short Wave Telephone." *Société Française Electricité*, Bull. 2 (September, 1932), pp. 940-1009.
- [2] Kilesnikov, M. "Single Sideband Telephony." *L'Onde Electrique*, Vol. 12 (May, 1933), pp. 237-249.
- [3] Murphy, F. M. G. "A System for Single Sideband and Carrier Broadcast Transmission." *Marconi Review*, No. 50 (September-October, 1934), pp. 8-15.

²⁰ R. V. L. Hartley, U. S. Patent 1,666,206.

²¹ R. K. Potter, U. S. Patent 1,773,116.

²² E. I. Green, U. S. Patent 2,020,409.

²³ N. Koomans, "Single-sideband telephony applied to the radio link between the Netherlands and the Netherlands East Indies," *PROC. IRE*, vol. 26, pp. 182-206; February, 1938.

²⁴ A. H. Reeves, "The single-sideband system applied to short-wave telephone links," *J. IEE*, vol. 73, pp. 245-278; September, 1933.

- [4] Crosby, M. G. "Exhorted Carrier Amplitude and Phase Modulation Reception." *PROCEEDINGS OF THE IRE*, Vol. 33 (September, 1945), pp. 581-591.
- [5] Honnell, M. A. "Single Sideband Generator." *Electronics*, Vol. 18 (November, 1945), pp. 166-168.
- [6] Dome, R. B. "Wide-Band Phase Shift Network." *Electronics*, Vol. 19 (December, 1946), pp. 112-115.
- [7] Beranek, L. L. "The Design of Speech Communication Systems." *PROCEEDINGS OF THE IRE*, Vol. 35 (September, 1947), pp. 880-890.
- [8] Bray, W. J., Lillicrap, H. G., and Lowry, W. R. H. "The Design of Transmitter Drives and Receivers for Single Sideband." *Journal of Institution of Electrical Engineers*, Vol. 94 (December, 1947), pp. 298-312.
- [9] Goodman, B. "What is Single Sideband Telephony?" *Q.S.T.*, Vol. 32 (January, 1948), pp. 13-15.
- [10] Villard, O. G. "Simplified Single Sideband Reception." *Electronics*, Vol. 48 (May, 1948), pp. 82-85.
- [11] Dawley, R. L. "Single Sideband Suppressed-Carrier Transmitter Transmitter Adapter." *Q.S.T.*, Vol. 32 (July, 1948), pp. 40-49.
- [12] Norgaard, D. E. "What About Single Sideband?" *Q.S.T.*, Vol. 32 (May, 1948), pp. 13-19; (June, 1948), pp. 36-42; (July, 1948), pp. 11-15.
- [13] Van Der Wyck, C. T. F. "Modern Single Sideband Equipment of the Netherlands Postal Telephone and Telegraph." *PROCEEDINGS OF THE IRE*, Vol. 36 (August, 1948), pp. 970-980.
- [14] Curran, L. K. "Single Sideband Communication Systems." *PROCEEDINGS OF THE IRE*, (Australia) Vol. 9 (October, 1948), pp. 25.
- [15] Allen, J. F. "Single Sideband Communication Systems." *PROCEEDINGS OF THE IRE*, (Australia) Vol. 9 (October, 1948), pp. 25.
- [16] Villard, O. G. "A High-Level Single Sideband Transmitter." *PROCEEDINGS OF THE IRE*, Vol. 36 (November, 1948), pp. 1419-1425.
- [17] Polkinghorn, F. A. "Commercial SSB Radiotelephone Systems." *Communications*, Vol. 28 (December, 1948), pp. 24-27.
- [18] Kriby, H. D. B. "Single Sideband Radiotelephony." *Wireless World*, Vol. 55 (March, 1949), pp. 90-91.
- [19] Pembrose, G. "S.E.R. Single Sideband 2-kw and 20-kw Transmitters." *Annales de Radioelectricité* (In French), No. 4 (October, 1949), pp. 358-371.
- [20] Luck, D. G. C. "Wideband Phase Splitting Networks," *PROCEEDINGS OF THE IRE*, Vol. 37 (February, 1949), pp. 147-155.
- [21] Kirby, H. D. B. "The Single Sideband System of Radio-communication." *Electronic Engineering*, Vol. 22 (July, 1950), pp. 259-263.
- [22] Barnes, G. W. "A Controlled Carrier Single Sideband System for Aircraft Communication." *Royal Aircraft Establishment Technical Note RAD. 521* (May, 1952).
- [23] Klenk, L. M., Munn, A. J., and Nedelka, J. "A Multichannel Single Sideband Radio Transmitter." *PROCEEDINGS OF THE IRE*, Vol. 40 (July, 1952), pp. 783-790.
- [24] Lund, N., Rose, C. F. P., and Young, L. G. "Amplifiers for Multichannel Single Sideband Radio Transmitters." *PROCEEDINGS OF THE IRE*, Vol. 40 (July, 1952), pp. 790-796.
- [25] Kerwien, A. E. "Design of Modulation Equipment for Modern Single Sideband Transmitters." *PROCEEDINGS OF THE IRE*, Vol. 40 (July, 1952), pp. 797-803.
- [26] Kahn, Leonard R. "Single Sideband Transmission by Envelope Elimination and Restoration." *PROCEEDINGS OF THE IRE*, Vol. 40 (July, 1952), pp. 803-806.
- [27] Brown, A. and Levine, R. H. "Single Sideband for Mobile Communications." 1953 IRE CONVENTION RECORD, Part 2, pp. 123-128.
- [28] Honey, J. F. "Performance of AM and Single Sideband Communications." *Tele-Tech*. Vol. 12 (September, 1953), pp. 64-66.



Synthesizer Stabilized Single-Sideband Systems*

B. FISK† AND C. L. SPENCER†, MEMBER, IRE

Summary—Single-sideband high frequency communications systems have several advantages over AM, PM, and FM for long-range communications. These advantages include low harmonic and intermodulation distortion due to the behavior of the transmission medium, more efficient use of spectrum, and better power efficiency. Proposed precise frequency control would make it possible to employ single-sideband systems for a great many applications, including unlimited netting, that are currently outside the capabilities of conventional single sideband. It is anticipated that precise frequency-controlled single sideband can be employed to increase the reliability utility, and capacity of military and commercial hf radio communications.

INTRODUCTION

VECTOR representations afford one of the most direct and easily understood approaches to the fundamental concepts of the many different types of modulation and the relationships that exist between these different forms. For example, Fig. 1 is a vector

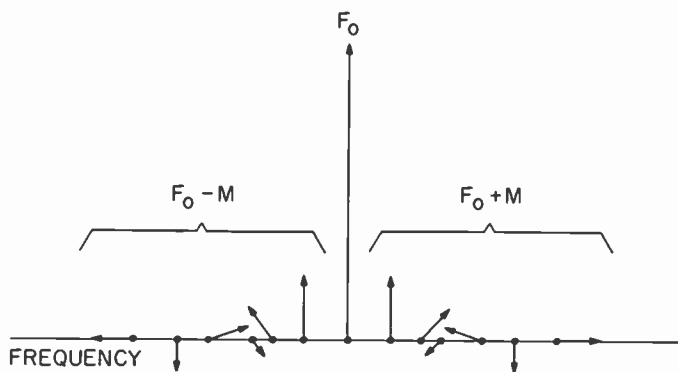

Fig. 1

representation of the general character of a complex amplitude-modulated signal at some particular instant in time. F_0 is the so-called carrier of this signal, $F_0 - M$ the lower sideband, and $F_0 + M$ the upper sideband. The amplitudes of individual components of the signal are represented by vector length, while vector direction indicates instantaneous phase with respect to the carrier. It will be readily recognized that the two sidebands are identically symmetrical to each other in both amplitude and phase about the carrier. If there is any variation from this symmetry, the signal represented is no longer a purely amplitude modulated signal. For example, if the carrier were shifted 90° with respect to the remaining components, then the signal would be primarily phase modulated and would carry almost no amplitude

variation. Disturbances in amplitudes, as well as phase, can also cause the nature of the modulation to be altered. In an amplitude-modulated signal the phase and amplitude relations between sideband components and the carrier are critical and any modification of these relationships changes the nature of the modulation rather radically.

An analysis of an amplitude-modulated signal shows that the carrier remains fixed and unchanging with time and therefore can be considered as conveying no direct information. Further examination of the complex amplitude-modulated signal illustrated in Fig. 1 points up the fact that the upper and lower sidebands contain duplicate information, therefore, as far as the transmission of information is concerned, it would be possible to transmit all the information contained in the signal of Fig. 1 by transmitting one of the sidebands without the carrier or the other sideband. When only one sideband of a conventional amplitude-modulated signal is employed for the transmission of information, the signal is described as being "single sideband."

The generation and detection of amplitude-modulated type signals are relatively simple and straightforward, consequently this form of radio communication has been employed extensively and will undoubtedly continue in widespread use for a great many years in the future. On the other hand, the generation and demodulation of single-sideband type signals are much more complex and exacting; consequently, single-sideband systems of radio communication have been employed only where there were distinct advantages to be gained through the use of such systems or where AM systems could not be made to function satisfactorily. Even though single-sideband radio communications systems have been used for 30 years for point-to-point radio communications, it has been only recently that interest has developed in more general applications of single sideband, such as general hf military communications.

ADVANTAGES OF SINGLE-SIDEBAND SYSTEMS OF COMMUNICATION

The most important advantage of single-sideband systems over amplitude, phase, or frequency modulation methods of communication becomes evident on medium and high frequency radio circuits that encounter ionospheric return transmission. In general, any signal that arrives at a receiving point, either partially or wholly by ionospheric return, is affected by so-called multipath and selective fading. In such a situation the phase relationships and relative amplitudes of the components of

* Original manuscript received by the IRE, August 15, 1956.
† Radio Division, Naval Research Lab., Washington 25, D. C.

a complex signal may be widely divergent at the receiving point from the signal that was originally transmitted. As pointed out previously, any change of the phase relations among the components of an amplitude-modulated signal results in a change of the nature of the modulation from purely amplitude modulation to a combination of AM and phase modulation, with the extreme case occurring when the carrier is shifted exactly 90° with respect to the sidebands, in which case there remains negligible amplitude variation in the total signal. In an AM system of communication, phase distortion of the signal components by the transmitting media can result in apparent reduction in index of modulation, or selective fading in complex signals, even though the rf field being received shows little change in average intensity.

If a selective fading situation occurred such that the carrier alone were erased from an amplitude-modulated signal, an amplitude-type detector would generate only harmonics and intermodulation products of the original modulation and none of the desired signal would be present in the output of the detector. Even a moderate selective fade of the carrier in an AM signal causes AM type detectors to generate excessive intermodulation and harmonic distortion. Not only does the fading of the carrier lead to difficulties, but the selective fading of individual components in either sideband can also cause an amplitude-type detector to generate excessive distortion. Voice communication over an amplitude-modulated circuit dependent upon ionospheric transmission is almost continually affected by excessive distortion and frequently the signals become completely unintelligible. This type distortion is so consistent and of such a magnitude on an AM circuit of this nature that high capacity communications systems, such as multiple-tone teletype equipments, will not function satisfactorily. The situation with phase and frequency modulation systems of communication is even more severe when these signals are subjected to phase and selective amplitude transmission distortion. The demodulation methods usually employed in systems of this type are generally more sensitive to transmission distortions than are AM systems.

The situation is very different when a properly designed and operated SSB system is employed on circuits subject to ionospheric transmission conditions. In a SSB system there is no phase or amplitude dependence within the transmitted signal between the various elements of the signal such as there is in amplitude, phase, or frequency modulation systems, consequently no harmonic distortion or intermodulation is caused by multipath phenomena. The fading or change of phase of one element of a SSB signal has no influence on the remainder of the signal. SSB signals are subject to selective fading as are other types of modulated signals, but this fading does not generate intelligence destroying harmonic dis-

ortion and intermodulation in the single-sideband demodulator. Selective fading produces what is known as amplitude vs frequency distortion in SSB systems, but this type of distortion only makes a voice signal sound peculiar and has little effect on intelligibility. In high-capacity multiple-tone communications systems used in conjunction with SSB, selective fading is compensated by employing either dual space diversity reception, or dual frequency diversity transmission and reception.

A second advantage of single-sideband systems over AM, pm, or fm systems is in the rf channel width requirements. Single-sideband systems of communication use only half the bandwidth of AM systems to transmit a given type of information. For example, an 8000-cycle wide channel is usually assigned for an AM voice circuit, whereas, two SSB voice circuits could be handled in this same channel assignment. Narrow-band phase and frequency modulation voice circuits usually require more than 8000 cycles because significant second- and third-order sidebands are produced as the modulation index approaches one; therefore SSB is considerably more economical of bandwidth than either of these. In the field of teletype communications it is common practice to assign 4000-cycle-wide channels for frequency shift transmission of either a single teletype circuit, or at most, four teletype circuits sequentially multiplexed. Through the use of SSB and multiple tone transmission systems it is possible to transmit at least sixteen teletype channels in a 4000-cycle assignment. Because of the extensive crowding and limited channels available in the hf spectrum, it is most important that any system employed at these frequencies give maximum communication for the bandwidth used. From this point of view SSB systems are far more efficient than any other system currently in use.

A third advantage which single-sideband systems show over AM and other systems of communication is in the transmitter power requirements and therefore in transmitter size and cost. For example, a 50-kw AM transmitter must be designed to deliver peak power output of 200 kw. A SSB transmitter capable of laying down an equivalent signal need have a peak power output of only approximately 12.5 kw. This means that the AM transmitter, its transmission-line system, and antenna system would need to be capable of handling four times as high rf voltages and currents as the SSB equipment capable of doing the same job. From the standpoint of ac input required to operate the two transmitters, the SSB transmitter should require only approximately one-sixth as much power as the AM transmitter.

SSB TRANSMITTER AND RECEIVER DESIGN

Fig. 2 is a simplified block diagram of a typical single-sideband transmitter of the type in general use at the present time. In amplitude-modulated transmitters the

actual modulation process is performed at the frequency of the transmitted signal and may be either at high level as is the case with a plate modulated final, or at a low level followed by several stages of linear amplification. The generation of a single-sideband signal is considerably more complex than is amplitude modulation, because of the fact that rather exacting filtering is part of the process of producing such a signal; therefore, in single-sideband transmitters, it is common practice to perform the modulation at a relatively low fixed frequency at which it is feasible to design and build satisfactory sideband filters. In the transmitter illustrated in Fig. 2 the modulation process is carried out at a frequency of 100 kc. The sideband filter employed would probably be a crystal lattice type with a moderately flat pass band and a very sharp cutoff at each side of the pass band, with especially high attenuation at the carrier frequency. Since in a transmitter of this nature the amount of carrier produced by the balanced modulator is 20 db or more below a normal AM carrier, and the sideband filter reduces this by another 30 to 40 db, a carrier bypass in the form of an adjustable attenuator is built in so that a pilot carrier of known amplitude can be transmitted. It is common practice to transmit the pilot carrier at a level that is 10 to 20 db below the level of a normal AM carrier. Two stages of conversion, one of them fixed frequency, are employed in this transmitter to insure that spurious signals and undesired products from conversions can be kept to a satisfactory low level at any operating frequency. All stages of the transmitter up to and including the second mixer operate at a very low power level. The linear power

double conversion in order to get the frequency of the sideband and carrier filters low enough to give the band-pass and rejection characteristics required and at the same time have a receiver with a very low image response. It will be recognized from Fig. 3 that there are several features in a SSB receiver that are not found in a standard communications receiver. These features include sideband and carrier filters, carrier amplifier and limiter, carrier discriminator, automatic tuning mechanisms, and a special audio demodulator. All of these features are necessary to separate sidebands from carrier, maintain the receiver in exact tune with the transmitted signal, and produce a signal that has a very low distortion and intermodulation level.

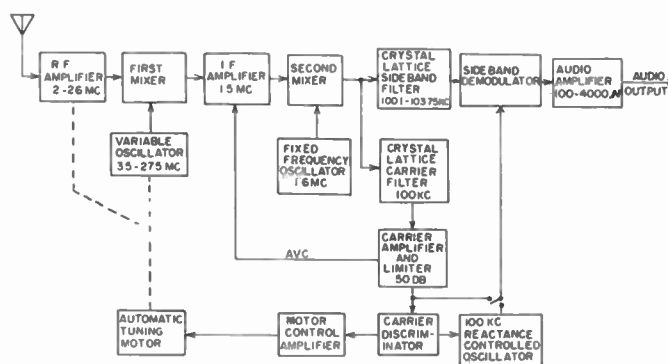

Fig. 3

PRECISION FREQUENCY-CONTROLLED SSB SYSTEMS

Up to the present time, single-sideband systems have been employed for rather limited and specialized applications in the hf region primarily because of the frequency tolerances that must be maintained in such systems and because of the nature of the equipment to maintain these tolerances. The proper functioning of any single-sideband system depends upon the accurate reinsertion of a suitable carrier into the demodulator of the SSB receiver. This reinserted carrier must be within a very few cycles of the original modulation frequency carrier if prohibitive frequency displacement is to be avoided, and since any instability of this carrier is reflected directly in the output, extreme care must be exercised to guarantee a stable and accurate insertion carrier. In present SSB systems, transmitter and receiver frequency stability and accuracy alone are not adequate to make it possible to establish and maintain a receiver in sufficiently accurate tune with a companion transmitter to give satisfactory communications. To get around this situation, all SSB receiving equipment has been designed to include some form of automatic transmitter tracking mechanism that is capable of maintaining the receiver in proper tune once the receiver is accurately manually tuned to the desired signal and as long as the received signal is "solid." Interference and

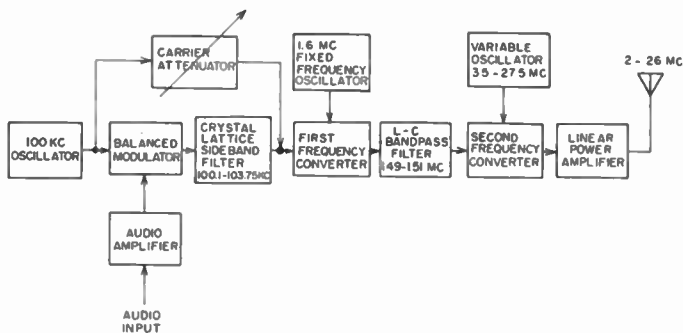

Fig. 2

amplifier requires a peak input of only approximately 0.1 watt to drive it to peak output. A high degree of linearity is required in all stages of a single-sideband transmitter if single-sideband systems are to perform satisfactorily. In general, over-all distortion and intermodulation products should be at least 40 db below one tone of a standard two-tone test signal in all single-sideband equipment.

Fig. 3 is an abbreviated block diagram of a single-sideband receiver that is typical of the ones in use at the present time. The majority of SSB receivers utilize

interruptions in the signal can cause such a receiver to become completely mistuned. In order for the receiver to be able to automatically track a transmitter, it is essential that some continuous signal in addition to the normal modulation be transmitted on which the receiver can automatically tune. The signal generally transmitted is a pilot carrier which in most instances is attenuated 10 to 30 db below normal AM carrier level. In the conventional SSB receiver, the carrier is removed from the remainder of the signal by means of a very sharp filter. The carrier is then amplified and limited and used for automatic tuning control, and either as a reinsertion carrier directly, or to lock the frequency of a local oscillator that furnishes a suitable insertion carrier. These characteristics limit the use of present single-sideband systems to special applications such as continuous duty point-to-point radio circuits. Services that require intermittent or net type operation are outside the capabilities of conventional SSB.

The fundamental limitation to the diversified application of SSB at the present time is based on the lack of precision frequency control of the transmitters and receivers utilized to implement SSB systems and not because of any fundamental SSB characteristic. The degree of precision frequency control required to guarantee maximum performance in the 2 to 30-mc frequency range is in the order of 1 part in 10^7 for both transmitters and receivers. This degree of frequency control can be readily attained for long periods of time through the use of precision frequency standards such as the 100-kc Loran Timing Oscillator along with properly designed frequency synthesizers.

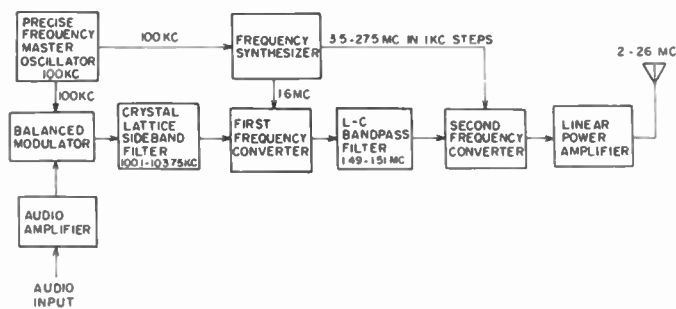

Fig. 4

Fig. 4 is an abbreviated block diagram of a precision frequency-controlled SSB transmitter of a type that could be employed for a wide variety of applications. It will be noted that the primary differences between this transmitter and the one of Fig. 2 are the frequency generation and control systems. Otherwise the two transmitters are identical in operation. The stability and accuracy of the final output frequency of the transmitter of Fig. 2 are directly dependent upon the stability and accuracy of the three separate oscillators

employed in its design, whereas the stability and accuracy of the output frequency of the transmitter of Fig. 4 are determined entirely by the characteristics of the 100-kc precision oscillator. The best frequency accuracy and stability that can be achieved with a transmitter such as the one illustrated in Fig. 2 are of the order of 1 part in 10^6 , which is entirely inadequate for SSB operation in the hf range except with automatic tracking receivers. With a transmitter of the type illustrated in Fig. 4, the frequency accuracy and stability are that of the master 100-kc standard. Currently there are standards in use that give frequency accuracy and stability good to 1 part in 10^8 per day but there are standards currently under development that are expected to be good to 1 part in 10^8 per month.

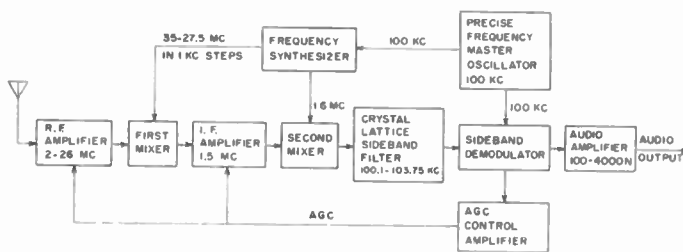

Fig. 5

Fig. 5 is a block diagram of a precision frequency-controlled SSB receiver designed to be a companion to the precision frequency transmitter of Fig. 4. A comparison of this receiver with the more or less conventional one of Fig. 3 shows that there are radical differences between the two other than the changes in frequency control methods. Since a SSB system with precision frequency control of both transmitters and receivers has no need for automatic tracking of receivers, the elements of a conventional SSB receiver that are employed for tracking have been left out in the receiver of Fig. 5. Therefore, a stabilized SSB receiver need not incorporate carrier filter, carrier amplifiers and limiters, discriminator, motor control amplifier, or tuning motor, gearing, clutches, etc. The actual signal processing in the two receivers is primarily identical, however. Tuning of a receiver of the type illustrated in Fig. 5 would be accomplished in a straightforward manner simply by setting the dials of the synthesizer to the required mixer frequency for the signal to be received and then tuning the rf input stages to the appropriate setting with perhaps a small amount of rf trimming to achieve maximum receiver sensitivity. Contrasted with the elaborate and painstaking procedure for tuning a conventional SSB receiver, the "setting" of a precision frequency-controlled receiver is far quicker, more direct and exact, with no signal-searching involved.

As indicated in Figs. 4 and 5, the precision frequency

control for SSB transmitters and receivers is derived through the use of precision master oscillators, followed by suitable frequency synthesizers. Oscillators, such as the famous 100-kc Loran standard are sufficiently accurate and stable to give the degree of precision necessary for SSB control; however, this standard is not capable of sustained high stability under conditions of shock and vibration such as would be expected in mobile applications. Currently there is a great deal of activity in the precise frequency standard field. Standards that will withstand rough usage and at the same time possess accuracy and stability at least one order better than the Loran standard should be ready for production within the next two years. In addition, work is under way on the transistorizing of precise standards, so that in the near future small, light-weight standards will be available for use with SSB equipment. In addition to the extensive work on quartz crystals standards, work is progressing on the production of practical atomic standards that may have frequency accuracies several orders better than expected from the most precise crystal standard, and that will not be subject to the frequency drift characteristic due to aging that is universal with crystal devices.

To date, precise frequency standards have been designed to operate at only a few frequencies such as 100 kc, 1 mc, 2.5 mc, 5 mc, or some other relatively low-fixed frequency. Consequently, to make available the great number of accurate frequencies required for a flexible SSB system it is necessary to employ some sort of frequency converting device in conjunction with a standard to produce the desired frequencies. These frequency converting devices are usually referred to as frequency synthesizers. Several different designs for synthesizers have been developed to date, ranging from multiple heterodyning devices to phase-locked disciplined oscillators. Some of the circuits developed would require as many as 80 tubes in a device such as would be needed for SSB applications. Other designs require 20 or even fewer tubes. In the design of synthesizers for hf SSB use it has been suggested that it is only necessary for these devices to be able to generate accurate output frequencies at the 1000-cycle points. This type of design results in considerable simplification over one that would be capable of delivering continuous accurate frequency control over the complete range.

APPLICATIONS FOR PRECISE FREQUENCY-CONTROLLED SSB SYSTEMS

Because of the critical, automatic tuning receivers employed and because of insufficiently accurate and stable frequency control in both transmitters and receivers, conventional SSB systems are primarily of value only on point-to-point, continuous duty circuits and therefore are not readily adaptable to more or less universal communication applications such as unlimited

net type operation or intermittent usage. Even with continual operator monitoring, conventional SSB net circuits would be so completely unreliable that they would be entirely useless for any military or commercial application. However, with precise frequency-controlled single-sideband equipment, net type operation represents no particular problem because it would be possible for operators to set transmitters and receivers to an exact assigned frequency and the equipment then could be operated from remote locations without further attention. Even unmanned nets that operated on the transponder principle would be entirely feasible. Precise frequency-controlled SSB would largely eliminate one of the more annoying features of nets that employ conventional AM or fm equipment, namely, the capture effect that occurs when two stations are transmitting simultaneously. Also, the carrier heterodynes and whistles and the cross modulation that occur under these circumstances would be reduced. With a precise frequency-controlled SSB net system, two or more simultaneous transmissions would not destroy or capture each other but instead all signals could be heard intelligibly much as with a telephone party line with two or more people talking at the same time.

A further application of precise frequency-controlled SSB could well be for situations and services that require brief intermittent transmissions with long periods of intervening radio silence. For example, precise frequency-controlled SSB could be used to implement a high-capacity flash-transmission system that would have a very high degree of reliability and at the same time require a minimum of transmission time.

HF radio channels suitable for point-to-point communications at any particular time of day are very limited and the ever increasing demand for frequency assignments far exceeds the available supply. It is current practice to assign 4000-cycle-wide channels for telegraph and teletype circuits, while voice circuits receive 8 to 12-kc channel assignments. From the standpoint of voice communications, it would be possible with stabilized SSB systems to utilize present 4-kc channel assignments for single voice circuits and 8-kc channels for two independent voice circuits. The situation could be improved even more drastically in the teletype situation since, through the use of stabilized SSB systems and techniques, it appears to be entirely practicable to operate individual independent 100-speed teletype circuits in a channel that need be only 250 cycles wide. On this basis it would be possible to provide 16 independent teletype circuits in the spectrum now frequently assigned to a single circuit, provided careful attention were given to geographic locations in making adjacent assignments.

In the application of precise frequency-control SSB equipment to aircraft communications the problem of Doppler frequency shift due to the speed of the plane

assumes importance. If the plane is flying toward the station with which it is communicating, the frequency shift is up, while if it is flying away, the shift is down. This Doppler shift due to motion is approximately one-cycle shift per megacycle of operating frequency at a speed of 600 knots. For example, if a plane were flying at a speed of 300 knots, and the operating frequency were 20 mc, the Doppler shift could be as much as ten cycles when the plane was flying either directly toward or directly away from the station with which it were communicating. With a voice signal, a total frequency difference that does not exceed 15 cycles causes negligible deterioration of the signal; therefore, in the example cited, no particular difficulty would be experienced because of the Doppler shift. However, if it were necessary to use precise frequency-control SSB for aircraft communications under circumstances where the Doppler shift exceeded 15 cycles, it would be advisable to incorporate in such equipment a form of very limited afc that could automatically tune a receiver over a range not to exceed 100 cycles. This would enable the receiver to remain accurately-enough tuned to its channel as not to get lost and at the same time be able to quickly tune to compensate for Doppler frequency shift as soon as a pilot carrier was received.

The applications listed are only a few of a great many possibilities in which communication reliability, capacity, and dependability can be substantially increased through the use of precise frequency-controlled single-sideband systems. Even though equipment complexity

will be increased appreciably and maintenance may require better trained technicians, equipment of this type will require far less skill and time to properly operate than conventional SSB or AM systems.

CONCLUSION

It has been pointed out that conventional SSB is superior to AM, pm, or fm for hf communications, either voice or multiple tone teletype. However, conventional SSB is limited in application to circuits that are continually in use and is not particularly adaptable to net type circuits or circuits where intermittent use is necessary. The addition of precise frequency control to SSB provides a system of hf communication that is readily adaptable to any communications situation, whether multiple station net, or point-to-point.

Even though precise frequency-controlled SSB equipment is somewhat more complex than conventional equipment, it will be able to handle a greater traffic load, unit-for-unit, than conventional equipment. Consequently, from a message capacity standpoint, it is anticipated that, in most instances, much less total equipment will be required to handle a given traffic load than with conventional systems.

To achieve the full benefits that are available from precise frequency-controlled SSB it is essential that distortion and intermodulation be maintained at such a low level that all unwanted distortion be at least 40 db below either tone, of a two-tone test signal, at all levels of modulation.

A Suggestion for Spectrum Conservation*

R. T. COX†, SENIOR MEMBER, IRE, AND E. W. PAPPENFUS†, SENIOR MEMBER, IRE

Summary—Frequency stability and reduced bandwidth of single sideband suppressed carrier transmissions are important factors which assist in easing the present crowding of the high frequency bands.

Present channel assignments are ordinarily predicated upon a frequency stability of 0.01 per cent and double sideband amplitude modulation. By making the transition to accurate frequency control and minimum bandwidth of transmission, many additional channels are made available. Typical examples are charted from the aeronautical mobile bands to illustrate this point. Factors affecting channel allocation are discussed.

* Original manuscript received by the IRE, September 10, 1956.
† Collins Radio Co., Cedar Rapids, Iowa.

OVER THE YEARS that radio communication has been known the need and use of radio has surpassed the development of new techniques and the opening of new frequency spectrum. This natural exploitation of a new and useful discovery has led to severe pressures on the frequency allocation agencies, and the need for channels has been felt in all parts of the spectrum. The effect of radio services on all classes of people has been great. To the public in general, radio means entertainment, social and business communications, and safety, as well as many other effects that influence the life of everyone. It is important that immedi-

ate consideration be given to all possible means for providing the necessary radio channels. Unless these channels are made available, industry, safety, services, transportation, and the Government, to name a few, will suffer.¹ The scarcity of radio channels and the need for more is evident particularly in the high frequency range from 2 to 30 mc. These are the frequencies best suited to long-range national and international communications. It is to be expected then that with all of the nations of the world making use of this one 28-mc range of frequencies severe congestion would occur. The International Telecommunications Union on a world-wide basis and the Federal Communications Commission in the United States regulate the allocation, use, and standards of operation for hf radio channels. The number and spacing of these channels are determined by the needs of each particular service and by the state of the radio art. The allocation and use of the spectrum is one of evolution. As new services show a need for radio channels, they compete with old services for the limited number of channels available, while new technological developments permit closer spacing. In addition to the need of the services and the state of the radio art, there are a number of operational factors which influence channel separation and total number of channels available. These factors are explained in paragraphs below.

SPURIOUS RADIATION

Spurious radiation can be generally defined as any output from a transmission system not required for the transmission of intelligence. It includes harmonics of the output frequency, undesired mixer products, broadband noise, and parasitic oscillations. Harmonics, mixer products, and noise can best be reduced by additional selectivity in transmitter circuits and band-pass or low-pass filters in the antenna lead. To accomplish the desired reduction of this class of spurious radiations it is necessary to add components and circuits to the transmitter over those which would be required to merely carry on communications without regard for interfering products. Parasitic oscillations must also be eliminated by proper design and operation. The reduction of all spurious products from a transmitter, or from a receiver for that matter, increase the cost of the unit, and, because of this, there is resistance on the part of the equipment manufacturer and on the part of the customer to include the new design features until forced to by operating rules promulgated by the licensing agency.

BANDWIDTH OF RECEIVER

The current trend of receiver design, which provides a very narrow steep-sided selectivity curve, permits

¹ Joint Technical Advisory Committee of IRE and RETMA, "Radio Spectrum Conservation," McGraw-Hill Book Co., Inc., New York, N. Y.; 1952.

closer spacing of transmitter channels without mutual interference. The use of low frequency IF amplifiers and improved filter techniques, such as the mechanical filter, permit the approach to the nearly ideal selectivity characteristic, allowing transmitters to be spaced more closely in the radio spectrum without causing interference in a receiver tuned to an adjacent channel. As receiver performance characteristics generally improve, the spectrum can be utilized more completely, with less need for a guard band between channels.

FREQUENCY STABILITY

It is perhaps obvious that frequency drift in either the transmitter or receiver will result in interference from the adjacent channel. In the transmitter, frequency instability is particularly dangerous since it may interfere with a large number of receivers; while in the receiver it merely degrades the performance of that particular receiving station. The aggregate frequency instability in both the transmitter and receiver dictates the guard band which must be allowed between channels; and thus it has a direct relationship to the number of channels which can be allocated in a given band. For example, a commonly assigned stability of 0.01 per cent will result in an allowable drift of ± 3000 cycles at 30 mc. This is equivalent to the loss of a band of frequency sufficient to accommodate two voice channels using single sideband transmission. Because of lack of policing, stations are frequently operated in which frequency drift is in excess of that allowable under the rules. Present frequency stability requirements must be increased to reduce the allowable drift of transmitters. It will then be possible to utilize the spectrum more fully.

BANDWIDTH OF TRANSMITTER

In many amplitude modulation transmitters the bandwidth occupied is determined only by the selectivity of rf circuits following the power amplifier. Over-modulation is all too common and audio bandwidth is not restricted by low-pass filters; thus, interfering signals can be generated, covering a band two or three times the normal modulating bandwidth. Attention should be given to early replacement of such transmitters with equipment utilizing minimum bandwidth for transmission. Single sideband suppressed carrier transmission suggests one means by which the bandwidth of the transmitter can be reduced as compared to amplitude modulation.

GEOGRAPHIC SPACING

To permit common usage of radio frequency channels, these channels are frequently allocated to many stations separated geographically so that interference between these stations is maintained below some predetermined minimum level. The nature of the transmission, power, frequency, and geographic spacing determines the

amount of mutual interference between transmitters on the same frequency channel. All too frequently, severe interference is permitted to exist because frequency channels are simply not available.

PERMISSIBLE INTERFERENCE LEVEL

In connection with the previous heading, Geographic Spacing, it is evident that the clear channel is a concept lost in the history of radio. Today there are very many stations operating on the same channel in many cases, and in the high frequency bands severe interference can exist even at great distances when propagation conditions are unusual. The assignment of station licenses must take the unusual condition into consideration and deal with the problem on the basis of maximum tolerable interference level. Here again single sideband transmission will alleviate the problem, as will be explained later.

The above discussion of problems and factors in the matter of frequency channel allocation indicates a great many limitations facing the FCC and similar agencies at the present time. There is, however, a good possibility of reduction in these problems through the conversion of voice circuits to single sideband transmission and reception. The bandwidth of transmission is, by the very nature of single sideband, reduced to at least one-half of that required for amplitude modulation. Frequently, due to spurious products from the transmitter, over-modulation and the like, bandwidth required by present transmitters is far in excess of that really required for effective communications. If a significant improvement is to be obtained in the matter of spectrum conservation by converting many of the radio frequency channels in the high frequency range to single sideband, then high-grade equipment of the very best design characteristics must be used. Good design characteristics include minimum bandwidth required for adequate voice communications, reduction of harmonic and spurious radiations and reduction of intermodulation distortion to the minimum, reduction of frequency drift and instability, and control of power to a level just sufficient to carry on adequate communications.

In the most foolproof single sideband network, good inherent frequency stability is required to obviate the necessity of providing automatic frequency control in the receiver. A frequency stability of one part per million to one part in ten million is entirely practical at the present time. This reduces a frequency error at 30 mc from an allowable 3000 cycles for 0.01 per cent to 3 to 30 cycles; thus, universal conversion to higher frequency stability will automatically make available a large number of additional channels.

Single sideband transmission and reception permits up to 9 db improvement in transmission capabilities; therefore, it is entirely practical to replace a 1-kw AM station with a 125-watt single sideband station. This

means that mutual interference between stations is greatly reduced. This is particularly true of AM systems when the carriers are offset due to frequency instability in which each AM circuit is plagued by a steady audible beat note between the two AM carriers. Single sideband suppressed carrier transmissions, of course, do not have a carrier to cause a steady, disagreeable beat note and single sideband voice interference does not degrade the transmission of speech to nearly the same degree as is true with interference between AM signals. The reception of single sideband signals from two or more transmitters is similar to listening to a number of independent conversations, all understandable, in a crowded room. While it is not intended to minimize the adverse effects of interference in a single sideband system, it should be understood that the degree of circuit degradation is much less than with amplitude modulation.

To indicate potential alleviation of the hf frequency spectrum channel crowding, reference is made to the chart of Fig. 1. Here the frequency allotment plan for

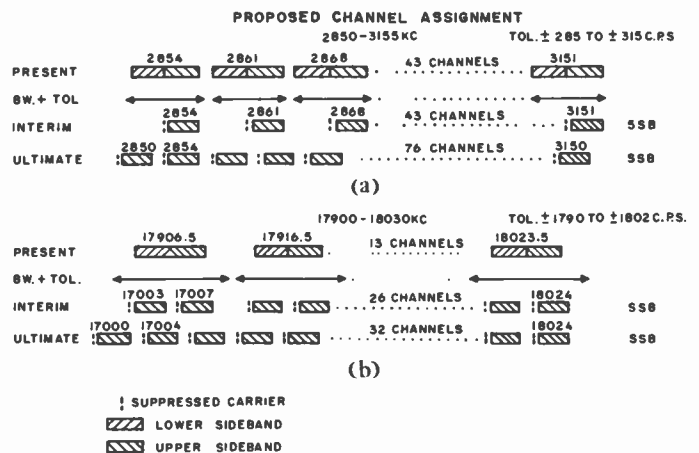

Fig. 1

the Aeronautical Mobile Service, as provided by the International Administrative Aeronautical Conference of the ITU, was taken as an example. In "A" the allotment plan for the low end of the spectrum is given; while in "B" comparable bar graphs show the frequency channels for the high end of the allotment plan. In the interim, single sideband channels must operate compatibly with existing AM channels and so may be centered with the suppressed carrier at the center of the allotted voice channel. At the low end of the band, for the first group of frequencies, 43 channels are available on an AM basis and 43 are available on the interim single sideband basis. Ultimately, with a 4-kc channel allocation plan allowing a 3-kc speech band and a 1-kc guard band, 76 channels are made available. At the high end of the range the additional frequency instability allowable under present rules (based on 0.01 per cent) makes possible the allocation of two single sideband channels for each AM channel; thus, the 13 channels in the fre-

quency range 17,900 to 18,030 kc increase to 26 channels for the interim plan and to 32 channels for the ultimate single sideband plan. A 4-kc channel allocation plan is suggested to provide a small guard band between channels and also to allow for possible supervisory and signaling functions which might be either within the voice band or above on an intermittent basis. It is interesting to note that the 4-kc channel coincides with each mc, 100-kc, and 20-kc interval. While this recurrence of channel frequency at fixed intervals is not of great importance, it is a potential convenience in channel assignment. A frequency generating system providing channels at each 1-kc interval in the hf range is adequate for the interim plan. A 4-kc exciter interval with attendant simplification of frequency control apparatus may be used ultimately if the suggested plan is adopted. It must be admitted that this frequency allocation plan is just a suggestion of the authors and has no support from any recognized frequency allocation organization. It is presented strictly as a proposal as to possible means for remedying a very serious limitation in the expansion of hf communications.

The analysis of channel allocation was based on a transmission band suitable for voice frequency operation. The same discussion applies with equal validity to multichannel telegraph or any frequency division transmission. The use of a single sideband transmitter may be viewed as simply a frequency translator in which the desired band of intelligence is converted to the assigned channel without the generation of distortion products or unwanted sidebands. Thus, if new transmission systems are developed requiring less bandwidth or possessing other advantages, a single sideband transmitter and receiver will accommodate these transmission systems.

It is obvious that an immediate and exclusive use of single sideband is not possible due to the reluctance of users to obsolete their present amplitude modulation equipment and write off a considerable investment in transmitters and receivers. There will, however, be certain users and potential users who will immediately shift to single sideband and this leads to a compatibility problem. The old and the new must be able to talk to each other. This dilemma is best solved by making the single sideband equipment suitable for both types of transmission. A single sideband suppressed carrier transmitter can provide a kind of amplitude modulation which has been termed full carrier single sideband. It consists of a carrier plus one sideband and may be received by a conventional AM receiver. This type of signal is usable in the above suggested frequency allocations but occupies the same bandwidth as single side-

band. It is much less effective because the carrier detracts from sideband power, but it does solve the problem of compatibility during the interim period when amplitude modulation and single sideband must exist at the same time.

The accomplishment of any significant improvement in the ground station of frequency allocations must come about through national and international policing by the cognizant organizations. The FCC has shown an awareness of this need through the request for comments on proposed rules governing conversion to single sideband in the hf spectrum.^{2,3} There has also been a continuing effort to impose higher standards of spurious rejection in transmitters to prevent undesired interference. Frequency stability is undergoing a constant evolution toward closer control, and with recent developments in frequency control in crystal oscillators and stabilized master oscillators, the closer frequency control is easily attainable.

It appears that the time is rapidly approaching when single sideband equipment of high quality will be readily available for use on existing circuits. It seems entirely practical to impose much tighter regulations on the transmission of radio signals in the hf band by 1960. These requirements might include frequency tolerance of ± 0.0001 per cent, voice bandwidth 3 kc, spurious and harmonic output not to exceed 50 microwatts, carrier suppression of 40 to 60 db, and intermodulation distortion -50 db. It might be well to standardize so that all transmissions use the upper sideband as shown in the proposed frequency allocation plan. By 1958 it might be desirable to specify that all new equipment being licensed must be capable of single sideband and that by 1960 all transmission should be converted to single sideband. These suggestions, if adopted by the FCC and ITU, will point to early relief in the matter of spectrum conservation. To insure that the maximum benefit is derived, very close policing and severe penalties for infractions would be necessary, and, inasmuch as even a doubling or quadrupling of existing hf channels would not take care of all necessary expansion in communications, a continuing evaluation of the needs of each service must be made. Increased use of other frequency bands such as the use of vhf scatter, where practical, may also assist in the long term spectrum conservation problem. It is seldom that a system for gaining a two to three-fold increase in spectrum usability is made available. Single sideband offers this great potential and thus is worthy of serious consideration. Indeed it *demand*s immediate further consideration.

² Docket 11513, October 5, 1955.

³ Docket 11678, April 12, 1956.

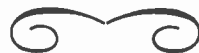

Power and Economics of Single Sideband*

ERNEST W. PAPPENFUS†, SENIOR MEMBER, IRE

Summary—Prime cost of equipment and continuing cost of operation are both important in the selection of communications apparatus. Listings are given for both transmitters and receivers on a comparable basis. Size, weight, floor area, and prime equipment costs are included to permit easy comparisons between single sideband and conventional equipment. Comparison of the equipments on all factors indicate the use of single sideband equipment in high frequency communications applications.

THE COST and economics of a new transmission means in radio are very important. Any new equipment concept must be justified on the basis of savings to the ultimate user, or by a more effective execution of the job to be done. There is a great reluctance on the part of every user of technical apparatus to adopt something new when the existing equipment is doing an even mediocre job. This is especially true in the vhf television bands. It is obvious that insufficient vhf television channels are available to provide adequate national coverage and that a shift to the uhf range would improve service to many television users. There has been, however, a universal reluctance of the TV set owner to buy even an inexpensive converter to make use of the additional channels in the uhf range. The large number of television receivers now in the hands of the public render a change in channel allocation in the TV band almost completely out of the question. The Federal Communications Commission would be faced by such a loud general clamor from the public upon announcing any change which would obsolete TV receivers that it will be difficult to initiate new rules even though technically desirable.

This pressure of existing users of radio to maintain a status quo is also evident in all other parts of the spectrum. The user must be forced into new and better equipment which will permit the allocation of additional radio channels by Federal regulation, or by an assurance that money will be saved in the long run by such a conversion. While recent publications by the FCC indicate a trend toward single sideband and forecast a change in the not too distant future to the use of single sideband for many services, it will be necessary for single sideband to justify its use in terms of cost factors and economics in operation if a willing transition is to occur.

Among the cost factors are those of initial cost of the single sideband transmitter and the single sideband receiver AM and SSB apparatus. Power output is normally considered to be one of the important considerations in analyzing transmitter specifications; therefore,

comparisons will be made from this standpoint. Another factor to be considered in the analysis of equipment is the operating economies which can be realized by changing to new, more advanced apparatus. This also will be discussed in more detail later.

Without question the low-power single sideband suppressed carrier transmitter will sell at a higher price than the comparable AM transmitter. This is brought about by the requirement for a larger number of circuits in the low level stages of the single sideband transmitter. In the higher power transmitters it is possible to achieve a very favorable cost comparison because the high level modulator and associated high voltage power supply of the AM transmitter can be eliminated which more than compensates for the low level modulator cost.

In the single sideband transmitter, linear amplifiers must be used throughout, from the very low level stages through the final linear power amplifier. If the full advantage of single sideband is to be realized in terms of spectrum conservation, then very close attention must be paid to the linearity of these amplifiers to insure that intermodulation distortion products are held to a very low level. To insure this linear operation, distortion compensating means must be used such as inverse radio frequency feedback, and operating levels throughout the amplifying string must be held to levels within the linear range. This means that more amplifying stages must be utilized than would be the case in a series of Class C amplifiers.

In a typical Class C amplitude modulation transmitter, multiplier stages and high gain amplifying stages are used. In a single sideband transmitter, frequency conversion of the single sideband signal must be used to maintain the character of the single sideband signal components.

In general, the rf portions of a single sideband transmitter bring about a moderate increase in number of components, stages, and vacuum tubes over that of an amplitude modulation transmitter of comparable power rating. The generation of single sideband, while requiring only relatively low power components, does require relatively precise control of components and a critically designed sideband separation filter. The generation of high-power single sideband signals is much more inexpensive, however, than would be the case in a high power modulator required in an amplitude modulation transmitter. Frequency control in an AM transmitter is relatively noncritical, while in a single sideband transmitter very precise frequency control is needed. For adequate reception of voice the frequency must

* Original manuscript received by the IRE, September 13, 1956.
† Collins Radio Company, Cedar Rapids, Iowa.

be controlled to within 50 cycles or less, although intelligibility does not suffer greatly until frequency errors in the order of 100 cycles are reached.

Since the single sideband transmitter is designed today instead of five or ten years in the past, it accumulates certain cost increasing features which should not be attributed to the generation of a single sideband signal. Typical of these features are servo automatic tuning and the attenuation of spurious and harmonic signals, which would be required in any newly designed amplitude modulation transmitter as well.

The single sideband receiver does not differ greatly from a well-designed communications receiver for amplitude modulation. It differs chiefly in the requirement for reduced bandwidth, which requires a relatively complex IF amplifier or the use of a crystal or mechanical filter. Only by the use of a high performance filter can the desired minimum bandwidth be achieved. Again in the single sideband receiver, as in the transmitter, greatly improved frequency stability is needed to insure high quality single sideband reception. Convenient frequency control on a multichannel basis in the receiver dictates the use of a frequency synthesizing or a stabilized master oscillator principle. This again is obviously more complex than a receiver designed for amplitude modulation in which a tunable low stability local oscillator is used. Single sideband reception is entirely possible using a standard communications receiver if an operator is manning the receiver with a relatively stable frequency injection system in both the hf oscillator and the beat frequency oscillator. To secure adequate frequency control careful attention by the operator is required at all times due to the normal frequency instability present in current communications receivers. For completely unattended operation a high degree of long term frequency stability and a convenient means of channel selection in the receiver are imperative. Frequency stability in the general order of one part per million is adequate up to the top of the hf range.

While a direct comparison of cost is impossible between AM and SSB equipment, a number of tabulations are shown below to serve as a guide. In the tabulation of transmitters, high level amplitude modulation units of a given carrier power level are compared with single sideband suppressed carrier equipments of the same peak envelope power rating. An AM transmitter must actually provide up to 9 db more carrier power than the peak envelope power rating of a single sideband transmitter. This means that a 125-watt SSB unit can replace a 1000-watt AM transmitter. Despite the legitimacy of such a comparison it was felt that such an approach might be open to question, hence the following tabulation was made. It will be noted that in the case of both transmitter and receiver comparisons, the advantages of single sideband suppressed carrier apparatus are noteworthy.

AMATEUR TRANSMITTER COMPARISON

	Amateur SSB	Amateur CW and AM
Floor Area	1.86 sq. feet	3.5 sq. feet
Volume	6.28 cu. feet	19.4 cu. feet
Weight	210 lbs.	675 lbs.
Power Consumption		
Average Speech	1000 watts	2850 watts
Number of Tubes	31	27
Selling Price	\$1995	\$3850

Frequency stability and coverage are the same for each transmitter. Each is rated at an amateur rating kilowatt. Frequency stability is not adequate to satisfy commercial standards.

RECEIVER COMPARISON

	Amateur AM-CW-SSB	Amateur CW and AM
Table Area	1.86 sq. feet	1.92 sq. feet
Volume	1.63 cu. feet	1.99 cu. feet
Weight	35 lbs.	50 lbs.
Power Consumption	100 watts	85 watts
Number of Tubes	22	19
Selling Price	\$595	\$530

Frequency stability and coverage are the same in the two receivers. The added components in the 75A-4 single sideband receiver are due to the separate detectors for AM and single sideband, an avc amplifier and a bias rectifier. Frequency stability is not adequate to satisfy commercial standards.

2-30 MC, 1 KW TRANSMITTER COMPARISON

	Crystal Controlled 1 KW PEP SSB	Crystal Controlled 1 KW AM
Floor Area	2.83 sq. feet	11.0 sq. feet
Volume	19.8 cu. feet	77.1 cu. feet
Weight	650 lbs.	1250 lbs.
Power Consumption		
Average Speech	2000 watts	3500 watts
Number of Tubes	32	28
Number of Transistors	35	
Selling Price	\$11,300	\$11,840

General characteristics are the same for both transmitters. Frequency stability however is better for the single sideband transmitter. Cost for the single sideband transmitter is based on a preliminary estimate.

COMPARISON OF HIGH POWER TRANSMITTERS

	45 KW PEP SSB, 2-30 MC	35 KW AM, 2-26 MC
Floor Area	30.2 sq. feet	106.5 sq. feet
Volume	167.5 cu. feet	687.3 cu. feet
Power Consumption		
Average Speech	35 kw	90.4 kw
Weight	5200 lbs.	17,653 lbs.
Number of Tubes	55	82
Number of Transistors	38	
Selling Price	\$45,000	\$98,000

General characteristics are the same for both transmitters. Each covers the hf band continuously and is automatically tuned. Frequency stability, however, is better for the 205J-1 SSB transmitter. The above selling price for the 205J-1 SSB transmitter including a crystal controlled exciter for single-sideband service is based on a preliminary estimate.

ADVANTAGE OF SSB TRANSMITTERS BASED ON PERCENTAGE OF SIZE, WEIGHT AND INPUT POWER REQUIRED FOR COMPARABLE AM POWER LEVEL

	40 KW	1 KW Commercial	1 KW Amateur
Volume	25 per cent	25 per cent	32 per cent
Weight	30 per cent	52 per cent	31 per cent
Input Power	39 per cent	57 per cent	35 per cent

The above tabulations show a striking advantage for the use of SSB equipment in transmission of hf signals. For receivers, the cost of a communications type receiver of adequate stability and general performance for single sideband service will cost several times as much as a comparable amplitude modulation unit. The chief cost factors are in the frequency control portions of the SSB receiver. Volume and weight increase in the SSB communications receiver also.

In addition to the advantage of reduced initial cost in the higher transmitter power ratings there are certain operating economies which can be achieved through the use of a single sideband transmitter. There is a significant factor of reduced primary power cost. A single sideband transmitter utilizing a linear amplifier in the high power range requires much less power from the power lines. This is due to the greatly increased effectiveness of single sideband communications which permits a lower power transmitter to do the job of a higher power AM unit. Another factor is the variation in input power depending upon signal level. During periods of high signal level full power is drawn from the primary power source, but during periods of low signal level the power drain is reduced to a great extent. Reference to

the previous comparisons between the equipments will indicate that the single sideband transmitter is economical of primary power drain.

The cost of transmitter buildings is increasing continuously so the matter of floor space is achieving increased attention from the radio user. The single sideband transmitter by eliminating the modulator requires much less floor space, and, hence, allows a smaller transmitter building. It must be admitted that some of the space saving in the single sideband equipment offered in comparison is due to improvement in components, an advantage which would be favorable to amplitude modulation also.

If transmitter utilization is important, multichannel operation with multiple teletype and voice channels on a single high power transmitter should not be overlooked. A minimum number of tuned circuits and maximum utilization of the spectrum result from this mode of operation. Great efficiencies can be realized through the use of multichannel operation of a single transmitter as contrasted to the use of a relatively larger number of lower power transmitters. The multichannel operation with any number of channels over four the power input is very similar to that of a voice channel.

Because of the improvement in signal-to-noise ratio made possible by single sideband transmission, it is possible for a given power rating to accommodate additional channels in the single sideband transmitter.

Because of the greater effectiveness of the single sideband transmitter, transmission line and antenna costs can be reduced because the peak voltages encountered are much less in the single sideband system.

As pointed out initially, new apparatus and new radio techniques must be justified on the basis of economy of operation or economies in the initial costs. This has been shown to be true in the instance of single sideband equipment. It can be expected that the use of single sideband transmitters and receivers will increase rapidly within the next few years.



Application of Single-Sideband Technique to Frequency Shift Telegraph*

CHRISTOPHER BUFF†, SENIOR MEMBER, IRE

Summary—Congestion of the 2 to 30 mc spectrum makes mandatory the reduction of bandwidths, on all types of transmissions, to the minimum technically required. This paper describes a method of economically utilizing the narrow-band plus high-stability techniques, normally associated with single-sideband systems, for frequency shift telegraph operation of one or more channels per transmitter. The frequency transposition type of fsk excitation is shown to have several advantages over present methods, whether for single channel operation with Class C transmitters or multichannel operation with linear transmitters. Tests made on a long-distance radio path indicate that frequency shifts as low as ± 30 cycles for single printer and ± 50 cycles for four-channel time-division multiplex are practicable, providing ultra-stable oscillators or afc is used.

INTRODUCTION

ABOUT a decade ago, in the record-communications field, the application of frequency shift keying to all forms of telegraph operation started to gain momentum. The situation then, in the radio-telegraph field, was somewhat analogous to that in the voice-communications field today, where single-sideband methods are spreading to many types of radio-telephone services.

FSK may itself be considered a form of single-sideband technique applied to telegraphy. The carrier, or assigned center frequency, is suppressed, mark and space sidebands are transmitted, and at the receiver a local carrier is injected which beats against the mark and space sidebands to produce low-frequency signals for final detection.

A closer look at the over-all situation, however, reveals that in the radiotelegraph field we may again turn to the single-sideband concept as applied to telephony and gain some desirable features to apply to frequency shift telegraphy.

Present fsk practices are, in many cases, wasteful of frequency spectrum. There is no longer much justification, for example, for the use of an 850 cycle shift for straight 60 wpm printer operation. Significant advances have been made through the use of four-channel multiplex operation with 400 cycles shift, and by the application of two synchronized four-channel multiplexes to a Twinplex circuit using 1200 cycles shift. The latter system is quite efficient, yielding one 60 wpm channel per 150 cycles of shift including guard bands. There will probably always be, however, a great number of low-traffic circuits on which the application of such complex systems is economically unjustified. At the present time, most of these single printer circuits occupy many

more cycles per channel than the high capacity trunk circuits which are time-division multiplexed.

Furthermore, even with the more efficient time-division systems mentioned, a four-to-one reduction in transmitted bandwidth, from 400 to 100 cycles overall, appears practical by using a transposition method of excitation and either a highly stable oscillator or some form of automatic frequency-control at the receivers.

In this paper a generalized approach to the application of single-sideband technique to frequency shift telegraphy, whether with Class C or linear transmitters, is discussed.

SSB/FSK SYSTEM

There is in use the so-called Polyplex system which allows for two or more equal amplitude carriers to be passed through a linear radio transmitter. The voice-frequency telegraph signals are first demodulated, however, before the rekeyed separate carriers are transposed to high frequency from a 200 kc level. This permits the use of any available control channel for keying and also allows the rf carrier shift to be adjusted to conform with the filters in existing fsk or Twinplex receiving equipment.

As the use of frequency-shifted voice-frequency control channels becomes more widespread it would be desirable to eliminate the demodulation step of the Polyplex system and evolve into a system of "single-sideband" frequency shift transmission as shown in Fig. 1.

Direct transposition of frequency shifted keying control tones to radio frequency would aid considerably in the conservation of frequency spectrum. In addition to less transmitted bandwidth, other advantages would be improved signal-to-noise ratio due to narrower receiving filters, high stability of shift values, reduction in possible keying bias and distortion due to elimination of demodulation ahead of transmitter, and a reduction in the number of shift adjustments.

There are a great many frequency shift circuits using either a single printer channel or a four-channel time-division multiplex. In such applications linear amplifiers are not required following the frequency transposition exciter. For this reason it is advantageous to separate the frequency transposition exciter from the transmitter proper. The exciter may then be connected either to a Class C or linear radio transmitter as required, resulting in an increase in operational flexibility (Figs. 2, 3, 4 on p. 1694).

Up to the present a single-sideband exciter and its

* Original manuscript received by the IRE, August 27, 1956.

† Mackay Radio and Telegraph Co., Inc., Brentwood, N. Y.

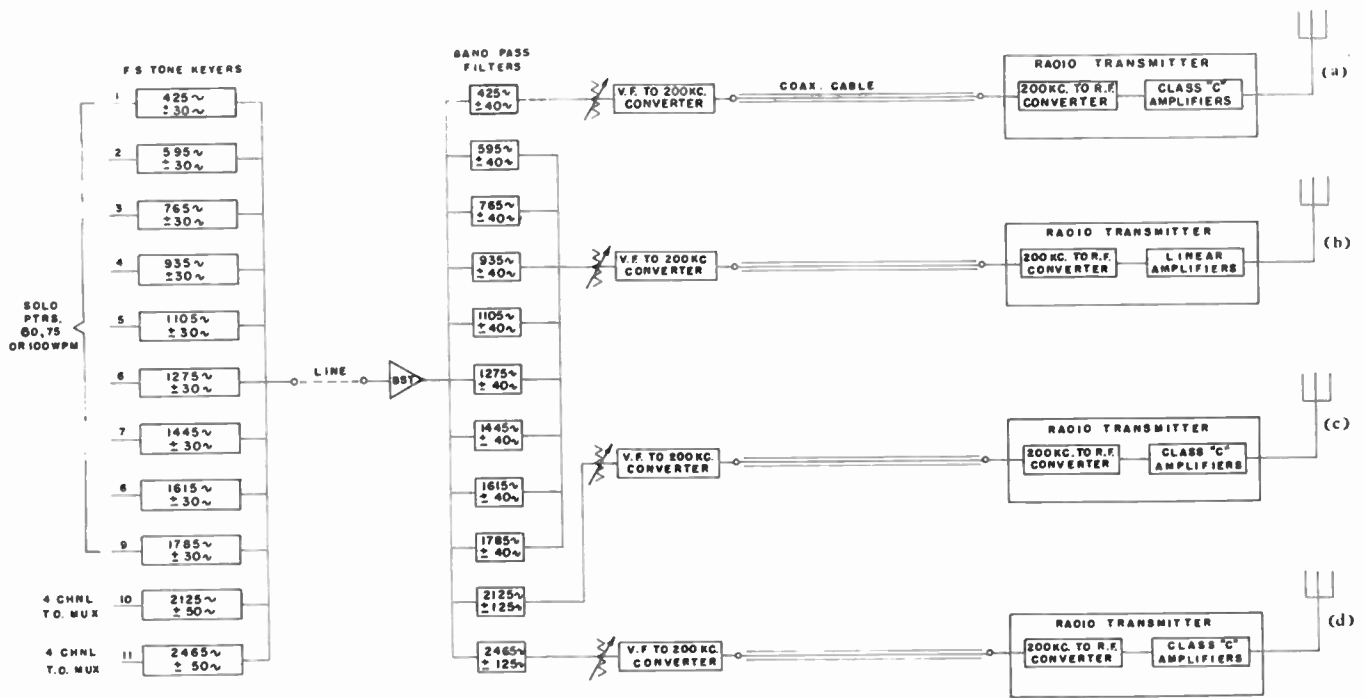

Fig. 1—Typical ssb/fsk transmitting system. VF facility shown provides nine single printer channels and two time-division multiplex channels. One possible grouping at transmitting station shows three Class C and one linear transmitter being driven from transposed keying tones. There is no interim demodulation in either case. (a) Single high-powered printer. (b) Group of eight mixed printers. (c) Four channel T.D. multiplex. (d) Four channel T.D. multiplex.

linear amplifiers following, have generally been considered as an entity. Such transmitters are, for economic reasons, not used for single channel fsk, but only on those circuits requiring a large number of channels to one point. In this case, power division may make circuit operation marginal with a given transmitter, requiring still higher power linear amplifiers to make the circuit workable.

With the ssb/fsk system, any one of the channels in a voice-frequency group could, if circuit operation requires it, drive an ordinary Class C transmitter to its full power output. A four-channel time-division multiplex, for example, using a frequency shift of ± 50 cycles on the control line facility, would consequently emit the identical frequency shift at the final radio frequency.

This signal, properly detected at the receivers through narrow-band filters, should render a gain of approximately 6 db over present 400 cycle shift operation.

Another advantage of this arrangement is that the narrow shift remains extremely stable at all radio frequencies and needs no readjustment from day to day. Also, since there is no demodulation ahead of the transmitter, keying bias and distortion factors are improved.

DISTORTION MEASUREMENT

One of the requirements of a large point-to-point radiotelegraph installation is flexibility in frequency assignments among a large number of transmitters and rapid frequency change capability in the individual transmitter.

As the number of multicarrier or single-sideband transmitters increases, this flexibility and speed of

change should not be lost. For this reason the distortion checking means should be rapid, though reliable, and preferably should indicate the complete spectrum of spurious radiations due to distortion products, rather than a specific order of sideband products. This is especially important in telegraph operation, where the spectrum is present continuously rather than sporadically as in the case of voice operation.

A panoramic measurement of total distortion products has been found to provide the desirable features of speed, accuracy, and completeness. An arrangement which has worked out well is to make the panoramic distortion measuring equipment mobile so that a single set-up may be used for checking a large number of transmitters. A sample of the transmitter output is picked up on a coaxial cable and fed to the panoramic equipment in front of the transmitter. Drive and loading adjustments may now be made while watching the over-all distortion picture and the best compromise between power output and distortion quickly arrived at.

Certain transmitters originally designed for Class C telegraph operation at 30 kilowatts output have been modified for linear operation and include an rf feedback arrangement from the final stage back to the low level 200 kc input stage. The power obtained under linear conditions with a two-tone test is approximately 15 kw, rms, for each of two carriers. From a telegraph standpoint it appears more logical to rate the transmitter in this way, in keeping with single signal ratings, rather than to refer to peak envelope power. In this way the effectiveness of each of the radiated carriers may be more readily compared to single signal conditions. With

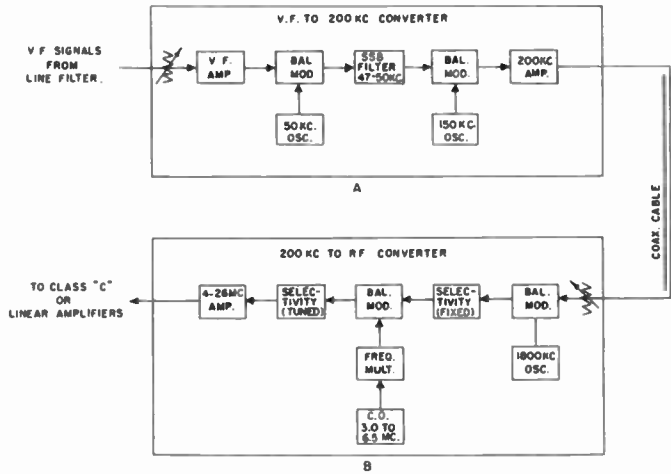

Fig. 2—VF to rf transposition exciter. Unit "A" takes the place of normal fsk exciter, while unit "B" takes the place of oscillator-multiplier section in transmitter. Considering that no vf to dc demodulators are used total circuitry is less than with conventional fsk system.

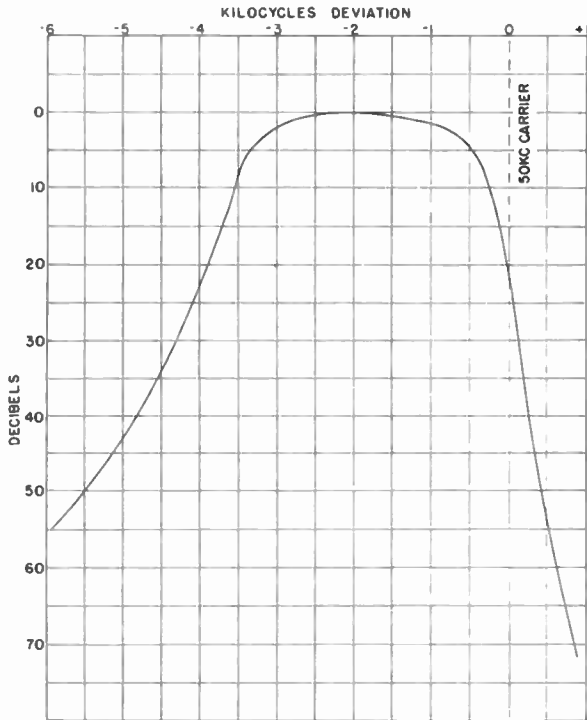

Fig. 3—Sideband filter used in ssb/fsk exciter.



Fig. 4—SSB/FSK exciter accepts frequency shifted tone keying signals in the range 425 to 2465 cycles and converts them to 200 kc range. The 200 kc signals are applied, over coaxial cable, to radio frequency converter in transmitter proper.

a two-tone test at 15 kw, rms, output per carrier, the maximum distortion products may be reduced to between 32 and 35 db below the main signal on the present transmitters (Figs. 5, 6).

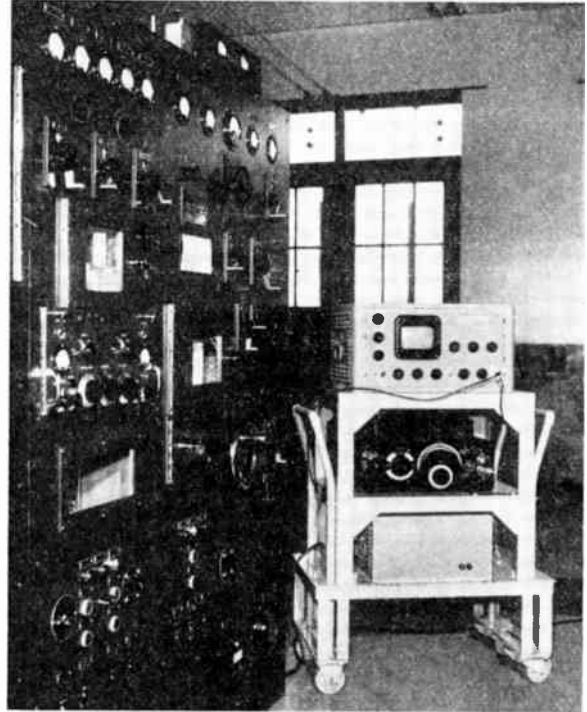

Fig. 5—Transmitter may be operated either linear or Class C using frequency transposition type of exciter. Panoramic equipment for distortion measurement at the right.

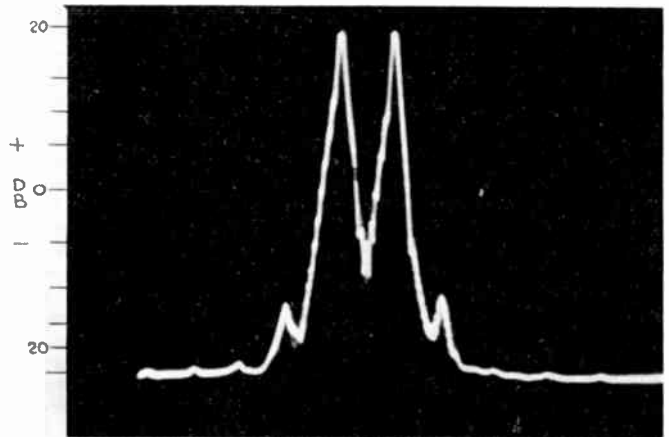

Fig. 6—Two-carrier test pattern at power output of approximately 10 kw, rms, per carrier. Third-order distortion products are about 32 db down. Separation of carriers is 2150 cycles.

BANDWIDTH AND FREQUENCY SHIFT CONSIDERATIONS

There appears to be some conflict in the literature and in practice as to the minimum frequency shift required for the successful passage of intelligence at a given speed on high frequency radio circuits. A rigorous application of wide band fm theory has resulted in the general impression that a high deviation ratio was a major factor in the performance of frequency shift circuits. It has

been stated that a deviation ratio of at least 4.7 was necessary for satisfactory fsk operation. Yet, we find improved circuit operation, all things including multipath phenomena considered, when 400 cycles shift, with an appropriately narrower filter band, is used for 150 baud multiplex operation, vs the former 800 cycles shift. The 400 cycle shift results in a deviation ratio of only 2.67. Furthermore, in single-sideband multichannel telegraphy, 85 cycles shift has been successfully used for 23 cycle printer speed, resulting in a deviation ratio of only 1.8. Recent tests have indicated that considerably lower ratios, properly utilized, are possible.

It is a matter of band-pass and low-pass filter bandwidths, discriminator sensitivity, and frequency stability, all combined. For very narrow band operation it has been found that a post-limiting linear discriminator permits the highest keying speed for a given pre-limiting filter band-pass. Discriminators having high output vs frequency change, *i.e.*, high sensitivity, will give the best over-all performance. The discriminators used in the ± 30 and ± 50 cycles frequency shift tests produce an output of approximately three-quarters of a volt per cycle, resulting in a voltage of several times cut-off, with ± 30 cycles shift or higher, for the keyed stage following the low-pass filter (Fig. 7).

Given adequate frequency stability, it appears advantageous for many reasons to design high frequency fsk systems which at least approach the following criteria:

$$1) \quad bw = \frac{3}{4} \cdot \frac{1}{P_t}$$

where P_t is the baud length in seconds.

$$2) \text{ total frequency shift} = 50 \text{ to } 60 \text{ per cent of } 1).$$

A simplified afc system for the receiver has been tested which will hold in a narrow band signal of this type for several hours, and more. The mark and space frequencies must be stable within ± 5 cycles over long periods in order to utilize such narrow shifts and bandwidth effectively.

If for no other reason than alleviating congestion of the high frequency spectrum, such criteria should be met.

Frequency shifted keying control channels in the Mackay System use 170 cycles spacing between low speed channels with ± 30 cycles shift and 340 cycles spacing between high speed channels with ± 50 cycles shift. Receiving filter bandwidths are ± 40 cycles and ± 125 cycles at 3-db points, respectively. These bandwidths were determined by the criterion for optimum signal-to-noise ratio; $bw = 3.0 \times \text{keying speed in cycles}$. It is important for minimum distortion that the low-pass, as well as the band-pass filters, use this same criterion, with careful attention being given to the waveshape at the output of the low-pass filter before peak

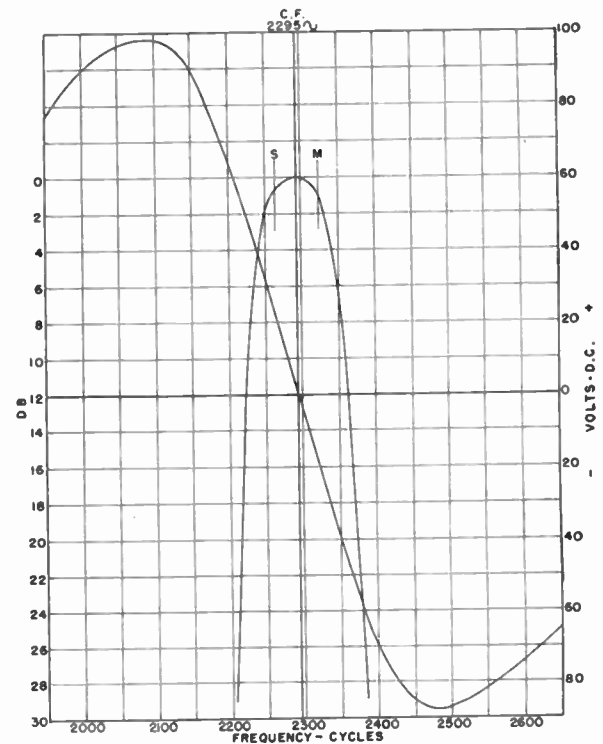

Fig. 7—Discriminator and receiving filter used in ± 30 cycles ssb/fsk test with 60 wpm printer keying.

clipping takes place. The low-pass filter, since it is asymmetrical, uses the factor 1.5 instead of 3.0. These factors may be derived from Goldman's analysis showing that the optimum bandwidth for pulse definition is equal to three-quarters the reciprocal of the pulse duration.

On other systems with 170 cycles spacing, it has been the practice to use ± 42.5 cycles shift. This is a rather poor choice as it puts the mark and space frequencies on the sharp slopes of the filters so that any slight change in frequency or in filter characteristics causes keying bias and distortion. It has been found that approximately ± 30 cycles shift produces a better keying waveshape and is more stable in operation.

The wide band channels with 340 cycles spacing, used for 150 to 170 baud multiplex signals, are of particular interest. Here a frequency shift of ± 50 cycles is used rather than ± 85 or ± 170 cycles as used in other systems. Total keying distortion after demodulation and using tone frequencies above 2.0 kc, is held to within 5 to 7 per cent. This makes possible the transmission of four-channel multiplex groups on center frequencies of 2125 cycles, 2465 and 2815 cycles, each with a filter bandwidth of ± 125 cycles.

While the above describes the situation on the keying line control facilities, where the frequency shifted tones are normally demodulated for rekeying of standard fsk excitors, tests have been made using the transposition method of excitation. The 2465 cycles channel, for example, may be picked off the receiving line filter output

and transposed to any radio frequency using the excitation scheme shown in Fig. 2.

The radio signal, as received on a dual diversity basis using input band-pass filters of ± 125 cycles bandwidth and discriminator detection after demodulation, averages about 7 per cent without multipath effects. With normally encountered multipath effects, the total distortion runs between 10 per cent and 25 per cent. The test converter with afc is shown in Fig. 8.

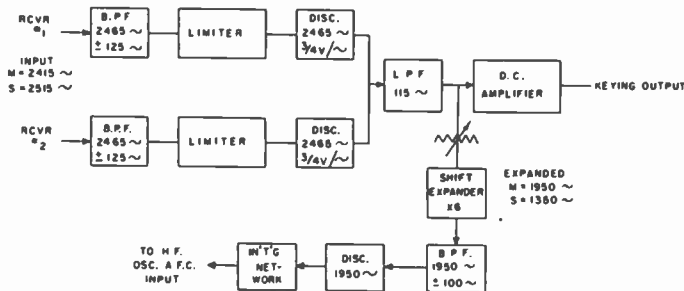

Fig. 8—Narrow-band converter with afc used in tests. 150 baud multiplex signals received at Brentwood, L. I. from San Francisco, Calif. averaged 20 per cent total distortion using bandwidths and frequency shifts shown.

Same converter with input band-pass filters reduced to ± 40 cycles and ± 30 cycles shift used with 44 baud printer keying averaged 10 to 15 per cent distortion.

We are guided in this pursuit by the fact that long distance Twinplex radio circuits using post-limiting filters of similar bandwidths for the mark-mark, mark-space, and space-mark frequencies have been operating very successfully at four-channel multiplex speeds. Outages due to all causes have been less than with the former wider band fsk equipment which had squared up low-pass filter output signals. The constant gain in s/n outweighs possible lost time due to severe multipath effects at infrequent times. This is the final criterion.

In the ssb/fsk system the narrow band filter is pre-limiting, further improving the s/n as compared to Twinplex which uses a 2.0 kc wide input filter and ± 125 cycle post-limiting filters.

The receiving high frequency oscillator will require a stability of ± 5 cycles at all usable frequencies. A drift of 5 cycles produces approximately a 5 per cent bias change. In lieu of this, afc may be used.

A master oscillator with afc has been constructed which will hold in the signal over long periods of time. This afc operates from the mark and/or space frequencies of a particular channel (Fig. 9).

Where linear transmitters are available, two or more time-division multiplex channels may be transmitted simultaneously. The afc scheme used in recent tests latches on to the keying signals of one of the channels, thereby holding all of them in control, since the tone frequencies remain very constant.

There is no pilot carrier transmitted in this system. The total number of channels may always be symmetrically placed with respect to the assigned carrier frequency.

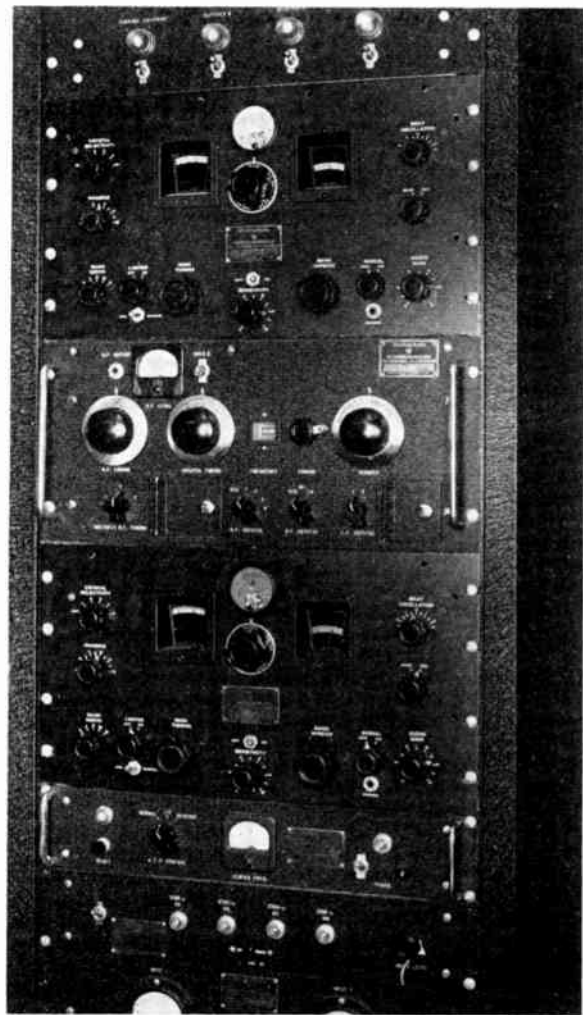

Fig. 9—Section of test receiving bay showing master variable oscillator (middle unit) which incorporates a linear reactance tube for applying afc voltage from external source.

NARROW-BAND SSB/FSK TESTS

Receiving tests were made at Brentwood, L. I. with narrow-band frequency shift keyed transmissions from Palo Alto, California on 15,675 kc. These tests were concerned mainly with oscilloscope observations of the keying waveshapes obtained with start-stop printer at 60 wpm speed, ± 30 cycles shift, and 150 baud four-channel multiplex with ± 50 cycles shift. The effects of normally encountered multipath phenomena with regard to over-all keying distortion, were found to be quite tolerable. The distortion, or "jitter" as it is called, averaged about 10–20 per cent most of the time. As the normal transition time for the radio frequency was approached, the "jitter" increased to the breaking point of around 40 per cent. It is realized that the over-all distortion at the frequency shift converter output is due to multipath plus noise and that each must be given a proper weighting factor. In a system in which the signals are shaped according to the criteria previously mentioned, the shortest bauds are essentially sine-wave shaped so that noise manifests itself mainly as pulse-edge distortion.

Another object of the tests was to determine the effectiveness and shortcomings of automatic frequency control derived from the signalling pulses themselves. Since the shifts were very narrow, discriminator detection was used for the signals and a so-called "shift-expander" for the afc derivation. With ± 50 cycle signals incoming shift, the expander puts out ± 300 cycles shift around a convenient audio frequency such as 1650 cycles. The marking and spacing frequencies may now be readily filtered out. One cycle change in the incoming ± 50 cycle signals then produces six cycles change in the expander output, allowing for precise frequency control. The associated variable master oscillator is very stable in itself, having a stability of approximately 1 cycle/mc/hour at normal room temperatures. The discriminator-reactance tube method of control, coupled with a time-constant relatively long with respect to the signalling pulses, was used. It was found that satisfactory frequency control could be obtained by using the marking frequency only, in dual diversity fashion. With start-stop printer, the transmission of continuous blanking signals, *i.e.*, all space elements except the stop pulse, affords the most crucial test of this type of automatic frequency control. Under this condition the afc held in satisfactorily, with fading signals, over periods of four hours, and more, without retune of any kind. Likewise, with multiplex signals, the afc could be made to hold in the ± 50 cycle shift signals over long periods without biasing effects or any noticeable loss of signal-to-noise ratio.

With the method of afc employed, the equipment could easily be adjusted to control on either ± 30 cycles, ± 50 cycles, or any other value of shift in the range ± 10 to ± 100 cycles.

Satisfactory start-stop printer copy was made over periods of three to four hours without retunes or loss of afc. Final evaluation tests on the basis of error counts have not yet been carried out.

From the results obtained thus far, it is evident that satisfactory operation will be possible at these low values of shift, and that the necessary afc can be provided without appreciable loss of s/n or other deleterious effects.

ACKNOWLEDGMENT

The author wishes to acknowledge the continuing efforts and contributions to this work made by his associates in the Brentwood Laboratory of Mackay Radio and Telegraph Company.

BIBLIOGRAPHY

- [1] Goldman, S. "Frequency Modulation, Analysis and Noise." New York: McGraw-Hill Book Co., Inc., 1948, pp. 99-100.
- [2] Davey, J. R., and Matte, A. N. "Frequency-Shift Telegraph Radio and Wire Applications." *Transactions of the AIEE*, Vol. 66 (1947), pp. 479-493.
- [3] Jordan, D. B., Greenberg, H., Eldredge, E. E., and Serniuk, W. "Multiple Frequency Shift Teletype Systems," *PROCEEDINGS OF THE IRE*, Vol. 43 (November, 1955), pp. 1647-1655.
- [4] Holland, J. D. "Design Considerations for a Radiotelegraph Receiving System." *Electrical Communication*, Vol. 29 (March, 1952), pp. 34-50.
- [5] Buff, C. "Twinplex and Twinmode Radiotelegraph Systems," *Electrical Communication*, Vol. 29 (March, 1952), pp. 20-30.

Frequency Control Techniques for Single Sideband*

R. L. CRAIGLOW†, ASSOCIATE MEMBER, IRE, AND E. L. MARTIN†, MEMBER, IRE

Summary—The virtual elimination of the carrier in single-sideband emission makes mandatory the accurate control of the frequencies used at the terminals of a single-sideband communications circuit. Independent, absolute frequency control of the receiver and transmitter provide immunity to propagation vagaries and interference which plague systems using partly-suppressed carrier and afc. Oscillators using high-frequency quartz resonators provide accurate and stable reference signals in small, rugged packages. A master oscillator, stabilized by phase comparison with signals derived from the reference oscillator, provide a multiplicity of accurate and stable channel frequencies.

IT IS of some interest to trace the development of frequency control circuits and the technical and economic forces that caused their evolution. In the early days of radio, the tunable LC oscillator provided

a simple and serviceable answer to the problem of generating channel frequencies. The lower-frequency end of the spectrum and amplitude modulation were in use and the spectrum was not unduly crowded.

Later crowding of the spectrum was alleviated by closer channel spacing and expansion into the higher-frequency regions. The increased frequency accuracy required was provided by crystal oscillators and a multiplicity of channels was provided by a like number of crystals. In World War II, the logistics of delivering the right crystal to the right place at the right time became untenable.

At the end of hostilities, those involved in multi-channel equipment design saw the virtual end of the simple MOPA circuit. A choice of one of hundreds of channels was required at the flick of a switch, guard bands were narrowed, vhf bands were pressed into more

* Original manuscript received by the IRE, September 10, 1956; revised manuscript received, September 28, 1956.

† Collins Radio Co., Cedar Rapids, Iowa.

extensive service, and under these forces the multiple crystal synthesizer soon evolved. The principle was simple: The output frequencies of several crystal oscillators were mixed together to produce the desired output frequencies. Each oscillator was provided with a means of selecting one of ten or more crystals so that a large number of channel frequencies may be synthesized. This principle is illustrated in Fig. 1.

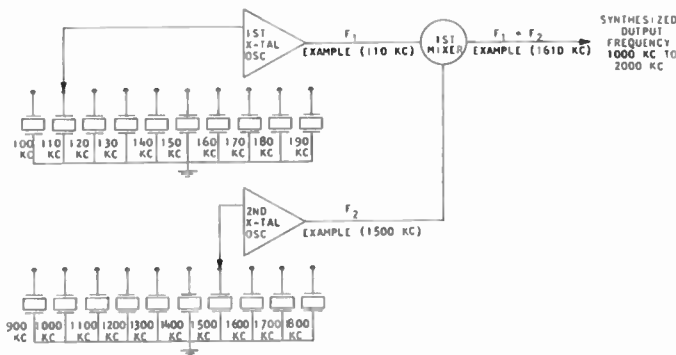

Fig. 1—Block diagram of a multiple crystal frequency synthesizer.

It now appears that we must turn to single sideband to further increase the number of available channels and this necessitates maintaining channel frequencies within a tolerance of $\pm \frac{1}{2}$ part per million. It would be technically and economically unfeasible to maintain all the crystals in a multiple crystal synthesizer to the required accuracy and therefore all the stability requirements must be concentrated in one or at most several highly-stable oscillators. From this challenge has emerged several operationally satisfactory types of single crystal synthesizers.

Basically, the single crystal frequency synthesizer is a circuit in which harmonics and subharmonics of a single-standard oscillator are combined to provide a multiplicity of output signals which are all harmonically related to a subharmonic of the standard oscillator.¹ A simple block diagram of such a synthesizer is shown in Fig. 2.

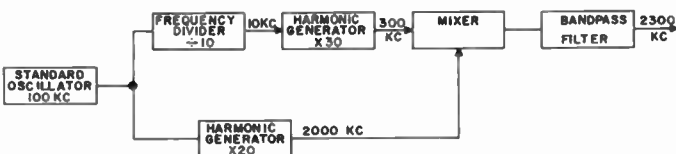

Fig. 2—Block diagram of a single crystal frequency synthesizer.

A great advantage of this circuit is that the accuracy and stability of the output signal is essentially equal to that of the standard oscillator. The problems involved in building a single frequency oscillator of extreme precision are much simpler than those associated with multifrequency oscillators. Furthermore, as techniques improve, the stability of the synthesizer is readily im-

¹ H. J. Finden, "The frequency synthesizer," *J. IEE*, vol. 90, part III, pp. 165-177; December, 1943.

proved as it is necessary only to replace the standard oscillator to obtain improved precision. The primary difficulty encountered in the design of the frequency synthesizer is the presence of spurious signals generated in the combining mixers. Extensive filtering and extremely careful selection of operating frequencies is required for even the simplest circuits. Spurious frequency problems increase rapidly as the output frequency range increases and the channel spacing decreases.

When the synthesizer is to be used in hf equipment, a considerable parts saving may be effected by interweaving the synthesizer and the equipment circuits. This is particularly easy to do with the superheterodyne circuits which are universally used in the hf frequency ranges as is shown in Fig. 3.

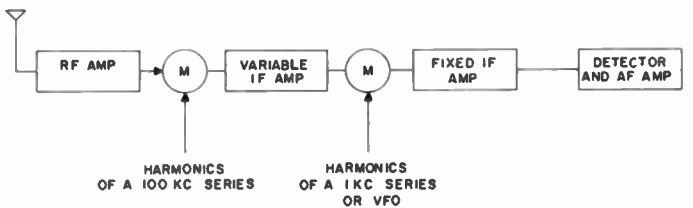

Fig. 3—Block diagram showing integration of a superheterodyne receiver and single crystal frequency synthesizer.

It is possible to retain the advantage of the frequency synthesizer and avoid many of the spurious frequency problems by using the synthesizer to provide a reference signal to control the frequency of a variable frequency master oscillator.^{2, 3} Such a circuit has come to be known as a stabilized master oscillator (frequently referred to by its initials SMO) and is shown in simplified block diagram form in Fig. 4.

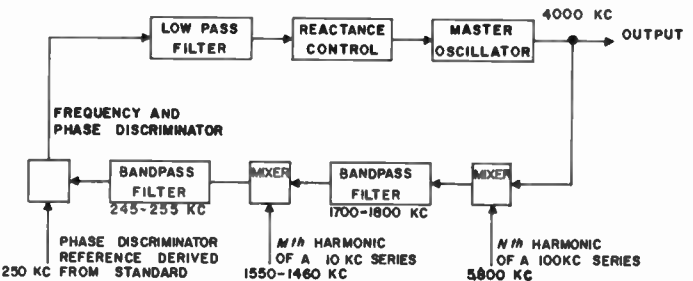

Fig. 4—Block diagram of a stabilized master oscillator frequency synthesizer.

TECHNICAL REQUIREMENTS

The frequency stabilities' requirements for single-sideband communications are quite severe when compared with most other communications systems. A frequency error in carrier reinjection of 20 cps or less will give good voice reproduction. Intelligibility is impaired

² E. W. Pappenfus, "Stabilized master oscillator for multichannel operation" *Electronics*, vol. 23, pp. 108-113; December, 1950.

³ G. J. Camfield, "A frequency generating system for vhf communication equipment," *J. IEE*, vol. 101, part III, pp. 85-90; April, 1954.

when the frequency error is 100 cps or greater and errors of only 50 cps result in noticeable distortion.

There are significant frequency errors introduced by the propagation medium and by Doppler shifts due to relative motion between transmitter and receiver in aircraft communications. In hf skywave transmission, the Doppler shifts caused by the motion of the ionosphere introduce frequency shifts of several cps. Doppler shift due to relative motion amounts to one part in 10^6 for every 670 miles per hour difference in velocity between the transmitting and receiving station. At a carrier frequency of 20 mc in communicating from a jet aircraft to ground, the frequency shift will be approximately 20 cps. Inasmuch as this represents approximately half of the desired maximum frequency error, the errors introduced by the transmitting and receiving equipment must be comparatively small. This dictates a design goal in the vicinity of $\pm \frac{1}{2}$ part in 10^6 in both ground and aircraft installations.

Present-day trends demand that communications be established on prearranged frequencies without searching a portion of the spectrum in order to obtain netting and therefore the figure of $\pm \frac{1}{2}$ part in 10^6 presents the required absolute accuracy over long periods of time rather than short-term stability. Further, most military and some commercial applications demand that operation be obtained on any one of the seven thousand or so SSB voice channels in the hf band. Summarizing, a channel frequency generator having an absolute accuracy of $\pm \frac{1}{2}$ part in 10^6 (± 0.00005 per cent) and providing either continuous coverage or channelized coverage in steps no greater than 4 kc is required in many SSB systems.

AFC VS ABSOLUTE FREQUENCY CONTROL

To meet the stringent frequency control requirements, early hf single-sideband systems utilized various methods of automatic control of the reinserted carrier at the receiver.^{4,5} Either a pilot tone or carrier was transmitted along with the sideband components and the receiver frequency was synchronized with the transmitter frequency. No stabilization of the transmitter frequency was used other than that obtained by using crystal controlled oscillators.

The first single-sideband radio-telephony system⁶ did not use automatic-frequency control and was able to accomplish its purpose because the operating frequency of about 60 kc was low enough that oscillators were then available with sufficient stability. Although oscillators have long been available with sufficient frequency stability and accuracy for use in high-frequency single-sideband equipment, these oscillators were bulky, frag-

ile, and limited in frequency channels. They were used principally as laboratory frequency standards. Improvements in the crystal art, development of circuit technique, and new components have made available the means to obtain hf receivers and transmitters capable of multichannel operation with sufficient frequency accuracy and stability for independent operation of the receiver.

The advantages obtained through the use of independent absolute frequency control are considerable. The bandwidth required for a communication channel is minimized as there need be no allotment for the synchronizing signal and the frequency tolerance. The relationship between transmitter and receiver carriers is absolute and indestructible and is, therefore, immune to any type or degree of interference, resulting in maximum fidelity of the received signal. Even in the extreme cases where Doppler effects introduce sufficient frequency shift to upset the system, making some form of automatic frequency correction necessary, the use of absolute frequency control assures that the bandwidth and, therefore, the interference susceptibility of the afc circuit will be minimized.

THE STABILIZED MASTER OSCILLATOR

The stabilized master oscillator consists of a variable frequency master oscillator capable of being locked to a reference signal derived from a standard oscillator of extremely high accuracy and stability.

The master oscillator is stabilized by means of a feedback servo system deriving its error signal from the comparison of the phase of the master oscillator and the phase of a signal derived from the standard reference oscillator. The master oscillator output is mixed with a spectrum of signals spaced 100 kc derived from the reference oscillator. The desired mixing product in the range 1.7 to 1.8 mc is selected with a bandpass filter and passed to the second mixer in which further translation is effected to shift the signal frequency to 250 kc. The desired signal is applied to a frequency and phase discriminator combination to obtain the correcting signal required to stabilize the master oscillator. The correcting signal may be used to control a saturable reactor, reactance tube or other frequency control device connected to the master oscillator, thus completing the servo loop (see block diagram, Fig. 4).

The manner in which frequency selection takes place can best be understood by considering independently the effect of frequency changes at each of the mixers included in the servo loop. Assuming that the injection frequencies at the second mixer remain fixed, it can be seen that as a master oscillator frequency is caused to vary, the servo loop circuit functions as a receiver with automatic frequency control. If the oscillator is tuned within ± 5 kc of 4000 kc, the received signal is within the passband determined by the bandpass filters and the master oscillator will lock to exactly 4000 kc. As the master oscillator tuning control is moved or if the fre-

⁴ F. A. Polkinghorn and N. F. Schlaack, "A single side-band short-wave system for transatlantic telephony," *Proc. IRE*, vol. 23, pp. 701-718; July, 1935.

⁵ N. Koomans, "Single-side-band telephony applied to the radio link between the Netherlands and the Netherlands East Indies," *Proc. IRE*, vol. 26, pp. 182-206; February, 1938.

⁶ R. A. Heising, "Production of single sideband for transatlantic radio telephony," *Proc. IRE*, vol. 13, pp. 291-312; June, 1925.

quency drifts, the servo loop will counteract the frequency change until the limit of the frequency control device is reached.

As long as the injection frequencies at the second mixer remain fixed, the servo loop will be able to control the master oscillator only at frequencies separated by 100-kc intervals.

The effect of varying the injection frequency at the second mixer will be considered now. This frequency can be adjusted to 10 different frequencies from 1550 to 1460 kc, spaced 10 kc apart. The IF and oscillator frequencies are chosen such that the 1550-kc frequency corresponds to the condition in which the master oscillator would be stabilized on frequencies that would be exact multiples of 100 kc. Now, if the frequency at the second mixer is increased by one 10-kc increment, the master oscillator will be stabilized on a frequency that will be 10 kc higher in frequency. By running through the range of this frequency, stabilization can be effected at 10-kc intervals between the 100-kc multiples.

Considering the complete loop it is possible to stabilize the master oscillator at 200 frequencies separated by 10-kc intervals. More channels can be synthesized by adding another mixer stage or by increasing the number of steps used at each mixer.

The accuracy of the stabilization obtained by the system described above depends on the accuracy of the frequencies used at the translating mixers. To obtain the greatest accuracy all of these frequencies are derived from a single source; a standard reference oscillator of extremely high accuracy and having great stability.

The use of a phase error signal in the control loop insures that the residual error of the stabilized oscillator will be measured in terms of degrees of phase angle between controlled and reference oscillators rather than cycles of frequency difference if only a frequency discriminator were used. However, a frequency discriminator is still a necessary part of the circuit, as the pull-in range of the phase discriminator is usually not large enough to cope with the initial frequency inaccuracy of the master oscillator.

STABILIZED MASTER OSCILLATOR DESIGN FACTORS

As in any feedback system, stability of operation of the correcting loop is an important consideration. Open loop gain-phase measurements in a phase-controlled stabilized master oscillator are practically impossible, owing to master oscillator instability. Considerable success has been achieved by measuring the closed-loop response and converting these data to open loop gain and phase data by means of a circle diagram. Stable operation can be obtained with loop bandwidths exceeding 400 cps, and enough gain to suppress microphonic disturbances arising from vibration and shock.

Although the stabilized master oscillator synthesizer avoids many spurious frequencies, careful attention to the frequencies used in the synthesizer mixer is still required. The low-pass filter between the discriminator

and the master oscillator reactance control controls the bandwidth of the system. Spurious products falling within a few kc of the desired frequency will phase modulate the master oscillator. However, those products falling outside this range will be effectively suppressed and will not appear in the master oscillator output.

Generally, the hold-in range of a controlled oscillator system exceeds the pull-in range. For this reason it is usually necessary to disable the control loop when shifting channels to insure lock-in on the desired channel and not one of the adjacent channels.

Owing to the fact that there are practical limitations on selectivity in the 100-kc frequency multiplier, steps must be taken to insure that the correct 100-kc harmonic is selected by the master oscillator. This can be done by limiting the pull-in range to slightly less than ± 50 kc and accurately tuning the master oscillator.

THE STANDARD REFERENCE OSCILLATOR

As the frequency accuracy and stability of the stabilized master oscillator are completely dependent upon the standard reference oscillator, it is very important to employ a reference oscillator of the greatest precision obtainable within the limitations of the over-all equipment specification. Using techniques now available it is possible to produce small and rugged oscillators capable of performing in the aircraft environment with precision equal to many laboratory frequency standards.

REFERENCE OSCILLATOR DESIGN FACTORS

In order to obtain reliable, low-distortion netting in single-sideband communication, great care must be exercised in the design of the reference crystal oscillator. The factors of primary importance in obtaining a high degree of frequency stability are listed below.

- 1) All components that form a part of the resonator circuit must be as stable with time and changes in environmental conditions as possible. This generally includes the quartz crystal resonator and a few capacitors and inductors immediately associated with it. The aging rate of the resonator may be minimized by maintaining a high degree of cleanliness in its construction. In order to maintain this cleanliness and eliminate atmospheric effects, the resonator should be sealed in an evacuated glass envelope. By careful orientation of the resonator plates with regard to the crystallographic axis the temperature coefficient of frequency may be made very small over a narrow range of temperature. Some immunity to the effects of mechanical shock and vibration can be obtained by proper mounting of the resonator plate.

- 2) Even though the components involved in the resonator circuit are relatively independent of environmental conditions, certain of these conditions require, in addition, careful regulation. Of particular importance is the temperature of the quartz crystal which must be extremely closely controlled. The resonant frequency of

quartz resonator is dependent on the rf power dissipated in it, especially at higher power. The crystal current must, therefore, be regulated at very low values. Reasonable steps should be taken to isolate the resonator from mechanical shock and vibration. The aging rate of quartz crystals increases markedly with ambient temperature, and therefore the temperature should be controlled at as low a value as possible. Consideration is being given to refrigeration of the crystal, and the National Bureau of Standards and Bell Telephone Laboratories are presently involved in investigations along these lines under Signal Corps sponsorship.

3) The coupling between the resonator and the active or amplifying portion of the circuit should be as small as possible while still maintaining sufficient coupling for sustained oscillations, so that the active portion cannot appreciably affect the natural frequency of resonator network. The Q of the resonance network should be as high as possible so as to allow very light coupling to the active network.

4) The ratio of the gain to the phase instabilities through the amplifying network must be maximized. Thus the coupling between the resonator and the amplifier portions of the circuit may be decreased by increasing the amplifier gain, but should this increase in gain be accompanied by a proportional increase in phase instability through the amplifier, no net improvement in stability would be obtained. Care in shielding is required between the oscillator stage and the following buffers so as to eliminate undesired feedback from these stages since this feedback generally has poor phase stability. Another source of phase instabilities is caused by the generation and mixing of harmonics in the amplifying portion of the oscillator circuit. Harmonics are generated by nonlinearities in the active network. Adjacent harmonics are mixed together in the same or other nonlinear portion of the circuit after having passed around the feedback network, thus producing a fundamental frequency component that is not, in general, phase stable. This cause of phase instability can be almost completely eliminated by use of an amplitude control system having a long time constant so as not to introduce appreciable harmonic components.

TYPICAL HIGH STABILITY OSCILLATOR DESIGN

An example of an oscillator suitable for use as a reference frequency generator is shown in Fig. 5. The operation can most readily be understood by reference to the block diagram shown in Fig. 6. The functions may be divided into the oscillator and oven control circuits. The oscillator consists of an amplitude-controlled Pierce type circuit. A highly-stable 1-mc quartz resonator is used. The temperature of this resonator and allied critical components are held constant to better than 0.01°C . during normal fixed station operation by means of an electronically-controlled oven shown in Fig. 7.

The 1-mc quartz resonator is a fundamental AT cut crystal, sealed in an evacuated glass envelope. This

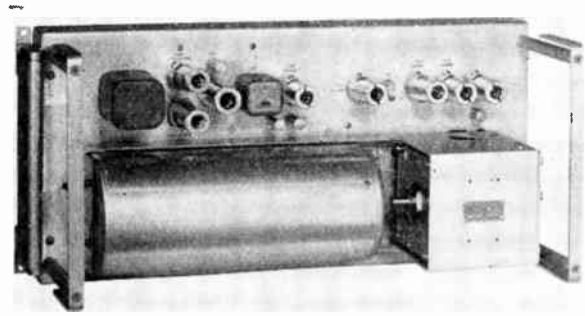

Fig. 5—Photograph of a typical reference frequency oscillator for ground station use.

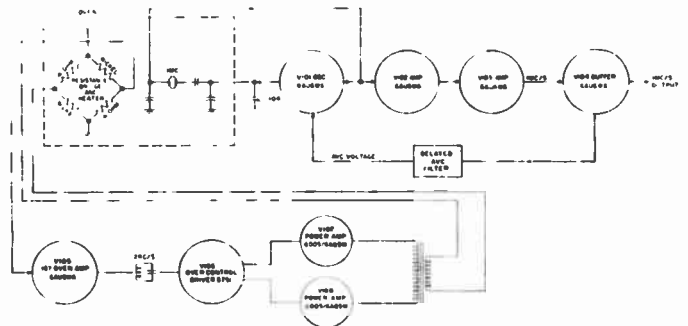

Fig. 6—Block diagram of a typical reference frequency oscillator.

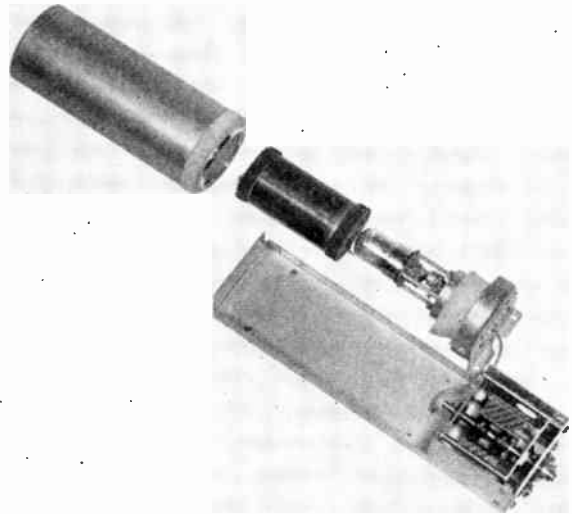

Fig. 7—Photograph showing the oven construction of a typical ground station reference frequency oscillator.

resonator has a minimum Q of one million and a temperature coefficient of only several parts in 10^7 per degree C. Small adjustments of the oscillator frequency are accomplished by means of a precision trimmer capacitor (C-104).

The amplitude of oscillation is controlled so that the resonator power dissipation is less than 0.1 microwatt, and so that no appreciable harmonics are present in this circuit.

This amplitude control is accomplished by amplifying the 1-mc oscillator output through two stages, rectifying

the output, and returning this bias voltage to the control grid of the oscillator tube in a fashion very similar to a delayed avc system. The two stages of amplification are followed by a third buffer, and these three stages provide adequate gain and isolation.

The oven is controlled at approximately 65°C., and is capable of delivering 8 w of heater power. There is no temperature cycling, inasmuch as the system is proportionally controlled. This oven maintains the resonator and other critical components at a constant temperature within very close limits.

The control circuit consists of a temperature-sensitive resistance bridge, which also acts as the heater and a tuned four-stage audio amplifier. Due to positive feedback through the bridge, the amplifier oscillates and delivers power to the heater. As the bridge heats up, it starts to come into balance until finally the attenuation of the bridge is just equal to the gain of the amplifier and stable, steady-state oscillations are produced. This maintains the oven at a temperature of a few hundredths of a degree C. below the true balance temperature of the bridge.

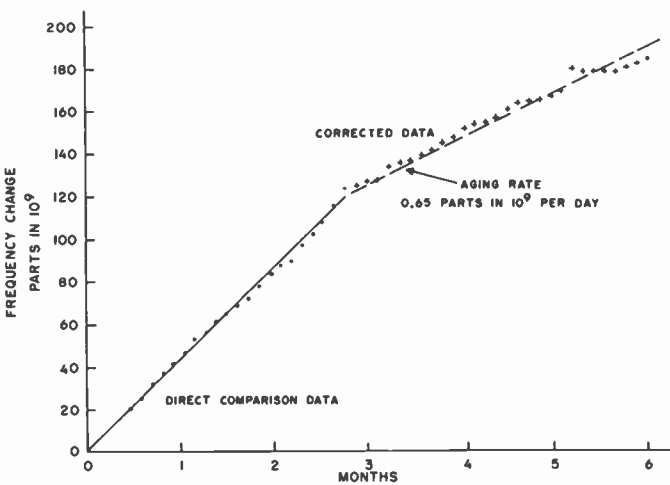

Fig. 8—Long-term frequency stability of a typical reference frequency oscillator. (Direct comparison data represents errors derived from time comparison with WWV. Corrected data represents errors derived from time comparison with WWV after having corrected data per WWV's time correction bulletin.)

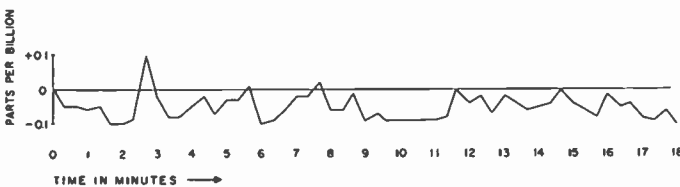

Fig. 9—Short-term frequency stability of a typical reference frequency oscillator.

Typical short-term and long-term frequency stability curves are shown above in Figs. 8 and 9 respectively. Shutdown of the equipment for a period of a day has little effect on the aging rate curve.

An example of what can be achieved toward miniatur-

ization and ruggedization for airborne applications is shown in Fig. 10. This oscillator is basically the same as the one previously described, except that the oven control circuit has here been transistorized and a crystal frequency of 3 mc was used to decrease the size of the crystal and oven and to increase the ruggedness of the resonator. The entire unit, including frequency dividers delivering 100-kc output, is housed in a $3 \times 4\frac{1}{2} \times 4\frac{1}{2}$ inch module. The long-term stability of this oscillator is approximately the same as that previously shown.

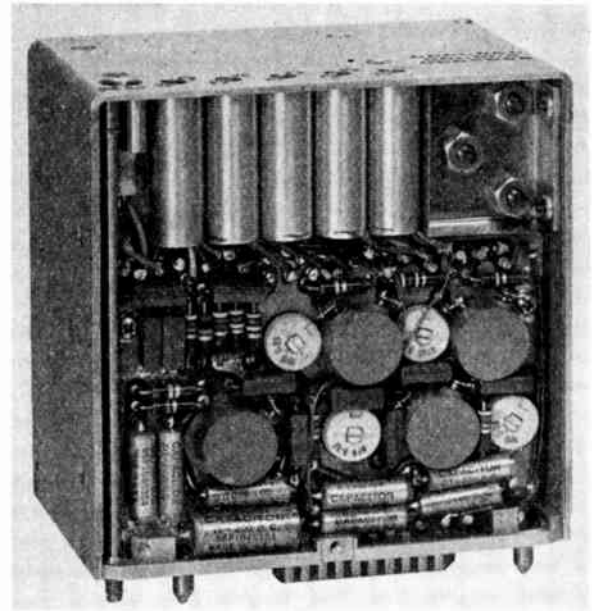

Fig. 10—Photograph of a typical airborne reference frequency oscillator.

CONCLUSION

The frequency control of a single-sideband equipment for the hf range must have the precision equal to that usually obtainable only in laboratory frequency standards. Although the use of pilot carrier and a/c permits some relaxation of oscillator requirements, susceptibility to fading and jamming make such a system undesirable. Using techniques now available, hf equipments can be economically produced to satisfy the operational requirement of multichannel capability with stability and accuracy sufficient for independent frequency control. The technique consists of using a stabilized master oscillator phase-locked to a reference signal generated by combining harmonics and subharmonics of a standard reference oscillator. The stability and accuracy of such a system are completely dependent upon the reference oscillator, and this can be made to have an error of less than 0.1 part per million per month, limited entirely by aging of the crystal resonator. With the attainment of this degree of equipment performance, the system performance has reached the point where the ionospheric effects and Doppler shifts resulting from high velocity movement of communicating stations become the limiting factors.

A Third Method of Generation and Detection of Single-Sideband Signals*

DONALD K. WEAVER, JR.†, ASSOCIATE MEMBER, IRE

Summary—This paper presents a third method of generation and detection of a single-sideband signal. The method is basically different from either the conventional filter or phasing method in that no sharp cutoff filters or wide-band 90° phase-difference networks are needed. This system is especially suited to keeping the signal energy confined to the desired bandwidth. Any unwanted sideband occupies the same band as the desired sideband, and the unwanted sideband in the usual sense is not present.

THE PURPOSE of this paper is to present a third basic method of generation and detection of single-sideband signals. Two methods are commonly used today. A block diagram of the first of these, the filter method, is shown in Fig. 1. The input signal (a speech waveform, for example) is applied to a balanced modulator along with the first translating or carrier frequency. The two normal sidebands appear in the output of the balanced modulation, but the carrier frequency is balanced out. The purpose of the filter is to select one sideband and reject the other. When the desired frequency location of the single-sideband signal is high compared with the original location of the input signal (e.g., translating speech to the hf region), it becomes very difficult to obtain filters that will pass one sideband and reject the other. To avoid this, the translation is done in several steps so as to ease the filter requirement.

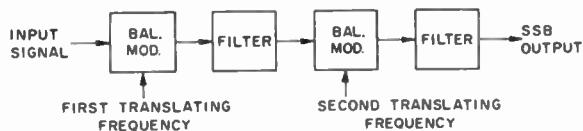

Fig. 1—Filter method of SSB generation.

Fig. 1 shows a system using two translational steps. In many radio transmission systems, three to five translational steps may be used. The detection problem is simply an inverse operation; that is, the arrows in Fig. 1 could be reversed. In detection, balanced modulators are not necessary, and ordinary converter circuits are satisfactory.

The second method, generally called the phasing method, is shown in Fig. 2. The input signal is applied to a wide-band 90° phase-difference network. This network passes all frequencies of the input signal uniformly in amplitude. However, the phase response is such that a sinusoidal input whose frequency falls anywhere within

the input signal frequency band will result in two equal amplitude sinusoidal signals whose phases differ by 90°. These quadrature signals are applied to a pair of balanced modulators. The translating carrier frequency is also divided into two 90° components. When the output signals from these two balanced modulators are added, one set of sidebands will add in phase, generating the desired signal, while the other sideband will cancel itself out. By subtracting instead of adding, it is possible to change sidebands.

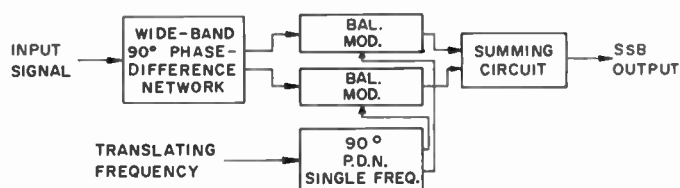

Fig. 2—Phasing method of SSB generation.

As this is a balancing method and does not require any sharp cutoff filters, it is possible to generate the desired sideband in a single translational step regardless of how high the final signal frequency may be. However, the degree to which the undesired sideband may be suppressed depends upon accurate balancing and requires very careful control of amplitudes and phases. As a practical matter it is quite easy to realize 20-db suppression, reasonable to expect 30 db, and quite difficult to go beyond 40 db. Suppression of 60 to 80 db or more can be realized using the filter method, but extreme care in maintaining low intermodulation in linear amplifiers is necessary if this degree of suppression is to exist in the final radiated signal.

The design and construction of a wide-band 90° phase-difference network is not a familiar art with most circuit designers, and this often acts as a roadblock to using the phasing method.

A block diagram showing the new method of single-sideband signal generation is shown in Fig. 3. The input signal e_i is confined to a bandwidth W with the lower band limit f_L as shown in Fig. 4. The band center is f_0 .

$$f_0 = f_L + W/2. \quad (1)$$

For convenience let the input signal be expressed as a summation of sinusoidal terms.

$$e_i(t) = \sum_{n=1}^N E_n \cos(\omega_n t + \phi_n). \quad (2)$$

* Original manuscript received by the IRE, June 25, 1956.

† Formerly with Stanford Res. Inst., Menlo Park, Calif., now with Elec. Eng. Dept., Montana State College, Bozeman, Mont.

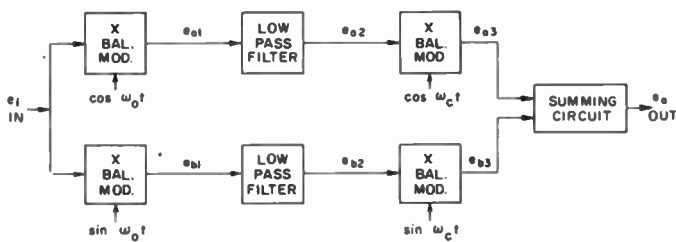

Fig. 3—Single-sideband generator.

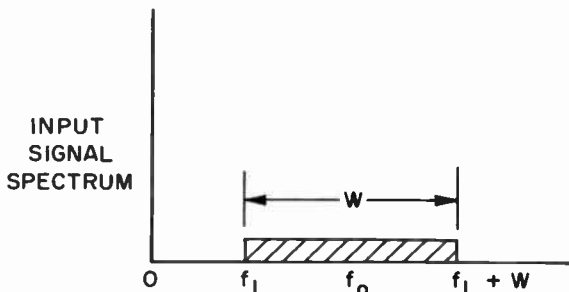

Fig. 4—Input signal spectrum.

Note that the modulating or carrier frequency of the first pair of balanced modulators is the center frequency of the input spectrum. The outputs of the first two balanced modulators are

$$e_{a1} = 2e_i(t) \cos \omega_0 t \tag{3}$$

$$e_{b1} = 2e_i(t) \sin \omega_0 t, \tag{4}$$

where

$$\omega_0 = 2\pi f_0. \tag{5}$$

The coefficient 2 is used for convenience and can be considered a property of the balanced modulators. Substituting (2) into (3) and (4) and expanding gives

$$e_{a1} = \sum_{n=1}^N E_n \cos [(\omega_n - \omega_0)t + \phi_n] + E_n \cos [(\omega_n + \omega_0)t + \phi_n] \tag{6}$$

$$e_{b1} = \sum_{n=1}^N -E_n \sin [(\omega_n - \omega_0)t + \phi_n] + E_n \sin [(\omega_n + \omega_0)t + \phi_n]. \tag{7}$$

The frequencies $f_n = \omega_n/2\pi$ are restricted to the original bandwidth W

$$f_L \leq f_n \leq f_L + W. \tag{8}$$

Hence the spectrum of the signals e_{a1} and e_{b1} is as shown in Fig. 5. The low-pass filter passes the frequencies from zero to $W/2$. From $W/2$ to $2f_0 - W/2$ there should be no signal energy which provides a convenient transition region for the filter. Above $2f_0 - W/2$ the filter should

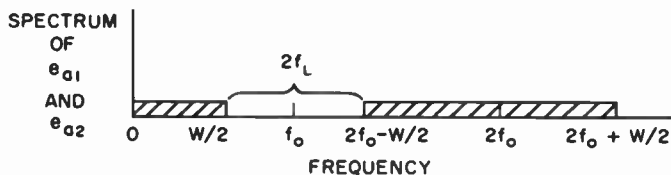

Fig. 5—Spectrum from first balanced modulators.

have adequate attenuation to eliminate the high-frequency components from the balanced modulators. Using such a filter the expressions for the filter output voltages are

$$e_{a2} = \sum_{n=1}^N E_n \cos [(\omega_n - \omega_0)t + \phi_n] \tag{9}$$

$$e_{b2} = \sum_{n=1}^N E_n \sin [(\omega_n - \omega_0)t + \phi_n]. \tag{10}$$

These two low-frequency functions are then applied to another pair of balanced modulators. However, in this case the translating frequency ω_c is the band center of the desired single-sideband signal. This is generally a high frequency compared with any of the frequencies of the original signal. The expressions for the outputs of this second pair of modulators are

$$e_{a3} = e_{a2} \cos \omega_c t \tag{11}$$

$$e_{b3} = e_{b2} \sin \omega_c t. \tag{12}$$

Substituting (9) and (10) into (11) and (12), and expanding gives

$$e_{a3} = \sum_{n=1}^N \frac{E_n}{2} \cos [(\omega_c + \omega_n - \omega_0)t + \phi_n] + \frac{E_n}{2} \cos [(\omega_c - \omega_n + \omega_0)t - \phi_n] \tag{13}$$

$$e_{b3} = \sum_{n=1}^N \frac{E_n}{2} \cos [(\omega_c + \omega_n - \omega_0)t + \phi_n] - \frac{E_n}{2} \cos [(\omega_c - \omega_n + \omega_0)t - \phi_n]. \tag{14}$$

Finally, adding (13) and (14) gives the desired single-sideband output.

$$e_0 = e_{a3} + e_{b3} \tag{15}$$

$$e_0 = \sum_{n=1}^N E_n \cos [(\omega_c + \omega_n - \omega_0)t + \phi_n]. \tag{16}$$

Note that the frequency normally referred to as the carrier corresponds to $\omega_c - \omega_0$ and that the frequency ω_c is the center of the single sideband. Fig. 6 shows the spectrum of e_0 .

This method of single-sideband generation does not need either sharp cutoff filters or wide-band 90° phase-

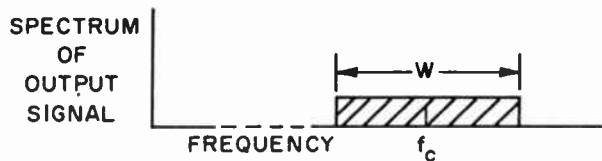

Fig. 6—Spectrum of output signal.

difference networks. Imperfections in the phasing or balancing do not result in the presence of the unwanted sideband in its usual location. Instead, the unwanted sideband occupies the same band of frequencies as the desired sideband, except that it is inverted. This is a very useful property of this system when channel conservation is an important reason for using single-sideband signals.

Fig. 7 shows the circuit of a single-sideband generator using this method. The input signal is a typical speech signal whose energy is confined to a band from 300 to 3300 cps. Care must be taken in the first pair of balanced modulators to keep the input signal component (linear term) from appearing in the output. The two low-pass filters pass all frequencies up to 1500 cps and provide adequate attenuation above 2100 cps. In the second pair of balanced modulators the rf oscillator signal must be accurately balanced out to keep it from appearing in the output.

Two tone tests indicated that undesired signal components were all more than 30 db below the desired signals. The input signal level was in the range 0.1 to 1.0 volt. Listening tests using speech and music indicated good quality. No difficulty was encountered in balancing the modulators or in phasing the translating signals. The balanced modulators, filters, and transformers can be packaged in a very small unit. As the circuit is bilateral, it can be used in demodulation as well as in generation of single-sideband signals. The lack of critical or expensive elements, combined with the ease of adjustment and the ruggedness and reliability of a passive circuit (such as the one shown in Fig. 7) makes this method attractive for application in future single-sideband systems.

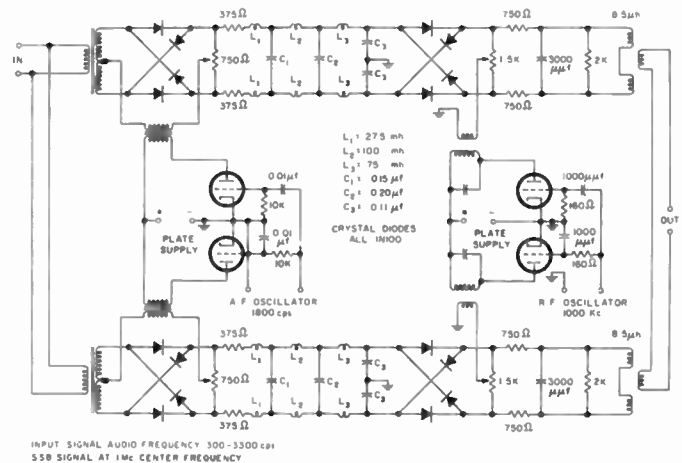

Fig. 7—Single-sideband generator.

BIBLIOGRAPHY

- [1] Polkinghorn, F. A., and Schlaack, N. F. "A Single Sideband Shortwave System for Transatlantic Radiotelephony." *Bell System Technical Journal*, Vol. 14 (July, 1935) and *PROCEEDINGS OF THE IRE*, Vol. 23 (July, 1935), pp. 701-718.
- [2] Oswald, A. A. "A Short-Wave Single-Sideband Radiotelephone System." *PROCEEDINGS OF THE IRE*, Vol. 26 (December, 1938), pp. 1431-1454.
- [3] Roetken, A. A. "A Single-Sideband Receiver for Short Wave Telephone Service." *PROCEEDINGS OF THE IRE*, Vol. 26 (December, 1938), pp. 1455-1465.
- [4] Dome, R. B. "Wide-Band Phase Shift Network." *Electronics*, Vol. 19 (December, 1946), pp. 122-115.
- [5] Bray, W. J., Lillcrap, H. G., and Lowry, W. R. H. "The Design of Transmitter Drives and Receivers for Single Sideband." *Journal of the Institution of Electrical Engineers*, Vol. 94, Part IIIA (December, 1947), pp. 298-312.
- [6] Villard, O. G. "Simplified Single Sideband Reception." *Electronics*, Vol. 21 (May, 1948), pp. 82-85.
- [7] Villard, O. G. "A High-Level Single Sideband Transmitter." *PROCEEDINGS OF THE IRE*, Vol. 36, (November 1948), pp. 1419-1425.
- [8] Polkinghorn, F. A. "Commercial SSB Radiotelephone Systems." *Communications*, Vol. 28 (December, 1948), pp. 24-27.
- [9] Kerwien, A. E. "Design of Modulation Equipment for Modern Single-Sideband Transmitters." *PROCEEDINGS OF THE IRE*, Vol. 40 (July, 1952), pp. 797-803.
- [10] Kahn, L. R. "Single-Sideband Transmission by Envelope Elimination and Restoration." *PROCEEDINGS OF THE IRE*, Vol. 40 (July, 1952), pp. 803-806.
- [11] Honey, J. F. "Performance of AM and Single Sideband Communications," *Tele-Tech.*, Vol. 12 (September, 1953), pp. 64-66, 147-149.
- [12] Weaver, D. K. Jr. "Design of RC Wide-Band 90-Degree Phase-Difference Network." *PROCEEDINGS OF THE IRE*, Vol. 42 (April, 1954), pp. 671-676.



Comparison of Linear Single-Sideband Transmitters with Envelope Elimination and Restoration Single-Sideband Transmitters*

LEONARD R. KAHN†, SENIOR MEMBER, IRE

Summary—The Elimination and Restoration System was originally described in 1952 [1]. The purpose of the following is to evaluate certain basic characteristics of the Envelope Elimination and Restoration System and to compare it with the Linear Amplifier System [2, 3].

BRIEF DESCRIPTION OF ENVELOPE ELIMINATION AND RESTORATION SYSTEM

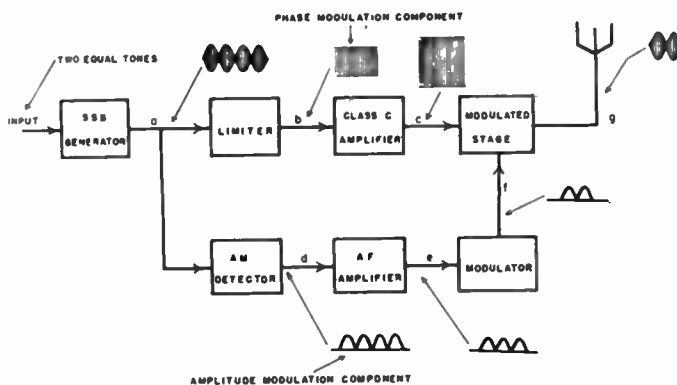

Fig. 1—Simplified block diagram of envelope elimination and restoration system.

PLEASE refer to Fig. 1, which is a simplified block diagram of the envelope elimination and restoration system. The waveshapes shown in this figure are for two equal amplitude tones with the carrier completely eliminated. The single-sideband generator used in practical equipment has been of the filter type but the phase shift techniques may also be used. The output of the single-sideband generator is fed to a limiter wherein the limiter removes the amplitude modulation component from the single-sideband wave producing a pure phase-modulated wave. Since a phase-modulated wave is not distorted by amplitude nonlinearities, this wave may be amplified in highly efficient Class C amplifiers. The Class C amplifier finally drives the modulated stage which may also be designed for Class C operation.

The amplitude modulation component of the single-sideband wave is isolated from the phase modulation component by the AM detector. The AM detector out-

put is identical to the envelope waveshape of the single-sideband wave at point *A*. This audio frequency wave is amplified and then fed to the modulator.

The modulator modulates the phase-modulated component by the envelope function in the modulated stage. If the time relationship between the phase and amplitude modulation components is properly maintained, the signal at point *G* will be a high powered replica of the single-sideband wave at point *A*. It should be stressed that Fig. 1 is a simplified block diagram and in itself is not a practical system. Such important elements as the equipment for equalizing time delays are missing but it is felt that the figure demonstrates the basic technique.

EFFICIENCY OF A LINEAR AMPLIFIER AND THE ENVELOPE ELIMINATION AND RESTORATION SYSTEM

In the analysis shown in Appendix I, the efficiency of the linear amplifier system is compared with that of the envelope elimination and restoration system. It might be assumed from a cursory examination of these two systems that the comparison is the same as that of a high-level modulated AM transmitter with a low-level modulated AM transmitter and therefore the high-level (envelope elimination and restoration system) would be slightly superior in efficiency to the linear amplifier low-level system. Actually the analysis is somewhat different because of the special waveshapes peculiar to single-sideband operation.

From the analysis shown in Appendix I, it is seen that, if it is assumed that the linear amplifier has a plate circuit efficiency of 60 per cent under conditions of full drive [4], its average efficiency will be 47.1 per cent for the two-tone case. In Appendix I, it is also shown that the plate circuit efficiency of the envelope elimination and restoration system is approximately 69 per cent.¹ Therefore, the ratio of power output from the envelope elimination and restoration system is 2.53 times that of the linear amplifier system assuming both systems utilize tubes having equal total plate dissipation. (That is, the summation of the plate dissipation capabilities of the tubes in the Class C amplifier, plus those in the Class B modulator, equals the plate dissipation capability of the final linear amplifier tubes.)

* Original manuscript received by the IRE, June 14, 1956; revised manuscript received, October 5, 1956.

† Kahn Research Laboratories, Freeport, N. Y.

¹ See Appendix I for the conditions assumed.

As pointed out in Appendix I, the above comparison is based upon an assumption of plate circuit efficiency for the Class C amplifier of 80 per cent. In both the linear and the envelope elimination and restoration transmitter calculations, we have not taken into consideration loss in the rf coupling networks but since both systems should have approximately the same loss in these circuits, the comparison would not require modification. If we had assumed that the Class C amplifier had a plate circuit efficiency of 75 per cent, the power output of the envelope elimination and restoration system would be 2.1 times as great as that from a linear amplifier system.

COMPARISON OF MEANS OF MODIFICATION OF HIGH LEVEL AM TRANSMITTERS TO SINGLE-SIDEBAND OPERATION

Many firms are reluctant to convert to single-sideband transmission because of the expense of completely replacing AM transmitting equipment. Therefore, there has been considerable interest in proposals for converting AM transmitters to single-sideband operation.

One method proposed is to use envelope elimination and restoration adapters. The second method proposed is to redesign the transmitter for Class B linear operation. This second technique would require appreciable engineering effort and in many cases additional stages would have to be added to make up for the decreased power gain of Class B linear amplifiers. Also, since frequency multipliers are not linear devices, further radical changes would be necessary.

It might be interesting to compare the power output from a high-level amplitude modulated transmitter converted to linear amplifier operation with the power output from the same transmitter utilizing an envelope elimination and restoration adapter.

In Appendix II, it is shown that a high-level amplitude modulated transmitter, if modified for Class B linear single-sideband operation, would have a peak envelope power rating of approximately two-thirds of the carrier rating of the transmitter. If such a transmitter was adapted by the envelope elimination and restoration system, the peak envelope power would be equal to approximately four times the carrier rating for single-sideband telephone operation. The rating of such a transmitter when transmitting multichannel teleprinter single-sideband signals varies between three to four times the carrier rating of the AM transmitter depending upon the number of tones transmitted and whether they are phase-locked. Thus we see that for telephone operation there is a power gain of approximately 6 and for a multichannel teleprinter a power gain of 4.5 to 6 over the power output from a high level modulated transmitter converted to Class B linear operation. If, in the above calculations, a figure of 75 per cent was assumed for the plate circuit efficiency of the final Class C

stage, the power gain of the envelope elimination and restoration system, over the linear amplifier system, would be 3.37 to 4.5 times.

It should be noted that the above comparison was based upon the assumption that a modulator for the transmitter was available. If a modulator is not available, it would be necessary to compare the cost of the modulator plus the envelope elimination and restoration adapter with the cost of engineering, labor, and the power disadvantage of converting the rf stages of the transmitter to Class B linear operation.

The above calculations are based upon the carrier rating of an AM transmitter. If the cw rating of the transmitter is used, the peak envelope power of the Class B linear is two-thirds the value above stated or approximately four-ninths of the cw rating of the transmitter. Similarly the peak envelope power of the envelope elimination and restoration adapter transmitter for single-sideband telephone operation is approximately 2.67 times the cw rating and from 2 to 2.67 times the cw rating for multichannel teleprinter operation.

REQUIRED MODULATOR RESPONSE

Table I is a tabulation of the required modulator frequency response for given spurious outputs from an envelope elimination and restoration transmitter.

TABLE I

Modulator equalized to pass up to	Worse spurious level for two equal tones
Fundamental of the difference frequency of the two equal tones	-25.3 db relative to 1 of the two tones
Second harmonic	-31.4 db
Third harmonic	-36.2 db
Fourth harmonic	-40.5 db

In the paper published in 1952 [1], a similar chart was furnished based upon the assumption that all the energy in the components not passed by the modulator added up to produce a single spurious component. That chart was therefore pessimistic as pointed out in that article. A new mathematical technique has since been developed [5] and the fact that the figures originally published were pessimistic was confirmed.

In Appendix III, this new technique is used to solve this problem. *However, it should be pointed out that these figures are still pessimistic because the analysis assumes that two equal amplitude tones are radiated and their frequencies are at the extreme ends of the transmitted band.* Of course, in practice, voice signals have most of their high energy components situated at relatively close spacing at the low-frequency end of the audio band. Another reason why these figures are pessimistic is that in most applications there are many components transmitted simultaneously rather than just the severe two-tone case. Multichannel telegraph single-sideband, and

of course voice systems, normally radiate more than two-tones simultaneously.

If, instead of two equal tones, tones of unequal amplitude are transmitted, the frequency response requirements of the modulator are eased.

Another important reason why these figures are quite conservative, is that the response of a conventional amplitude modulator does not suddenly go to zero above a certain frequency. If this effect is analyzed it is seen that the spurious is reduced by this vestigial frequency response because of two reasons. The first reason is that any energy at these higher frequencies assists in reducing the spurious. The second reason is that, for optimum spurious reduction, the highest frequency overtone which is passed by the modulator should have a smaller amplitude than indicated by the Fourier series expansion of the envelope. This may be seen by considering the analysis in Appendix III and examining the effect of reducing the percentage of modulation of the highest order overtone. This effect is considerably more important for high order harmonics.

It has been found, in practical installations, that for a signal bandwidth of up to 6 kc, a modulator, having a flat response or one equalized for a flat response of approximately 8 kc, can be used to produce signals having the worst spurious amplitude down 30 to 35 db relative to one of the two equal desired tones.

DISCUSSION OF PRACTICAL INSTALLATIONS OF ENVELOPE ELIMINATION AND RESTORATION SYSTEMS

Fig. 2 is a picture of a commercial single-sideband envelope elimination and restoration transmitting adapter. This adapter may be used to adapt an amplitude modulated transmitter to single-sideband service. The phase modulation component of the single-sideband wave is fed to a low level rf stage of the transmitter. The AM component of the single-sideband wave is fed from the adapter to the audio input of the transmitter. Aside from the installation of a connection for feeding the low level rf stage, no modification of the transmitter is necessary. This adapter may be used to produce independently modulated upper and lower sidebands and is being used in a number of transoceanic multichannel teletype circuits.

A similar model of the single-sideband transmitter adapter may be used for broadcast relay service. This adapter has been used in conjunction with a 100-kw AM transmitter to produce a 400-kw peak envelope single-sideband signal. We understand that this is the most powerful single-sideband transmitter in operation.

No attempt has been made to minimize the size of this equipment and certainly appreciable reduction in size and weight can be accomplished by use of conventional miniaturization techniques.

The average spurious output of systems using these adapters is from -32 to -35 db relative to the amplitude of one of the two equal tones. The best measure-

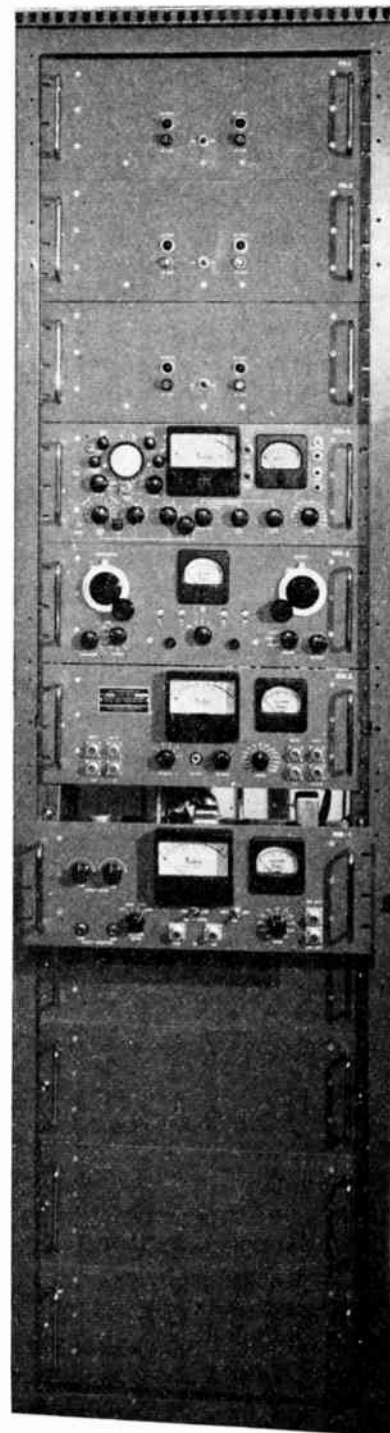

Fig. 2—SSB53-2A. Kahn Research Laboratories' twin sideband adapter.

ment of a practical 40-kw peak envelope power transmitter utilizing this system was slightly better than -40 db.

RÉSUMÉ OF ADVANTAGES OF ENVELOPE ELIMINATION AND RESTORATION SYSTEMS

The advantages of the envelope elimination and restoration system are as follows:

- 1) The envelope elimination and restoration system produces approximately 2.5 times the power output, as does the linear amplifier system, for a given total plate dissipation.
- 2) The envelope elimination and restoration system may be used to adapt existing high quality transmitters without any design change of these transmitters. The peak envelope rating of such a system is from 3 to 4 times the carrier rating. Of course, the system may also be used as a component part of new transmitters.
- 3) The envelope elimination and restoration system is relatively noncritical because Class C amplifiers may be used.
- 4) Frequency multiplication may be used in the envelope system simplifying design.
- 5) The envelope elimination and restoration system makes practical low-cost high-powered, 20-kw peak envelope power or more, single-sideband transmitters. In the linear system, each additional stage introduces distortion and this makes it very difficult to obtain satisfactory spurious figures from high-powered transmitters. Also, the high efficiency of envelope elimination and restoration type transmitters is of considerable economic importance.
- 6) At the present time there are no very high-powered linear amplifier type single-sideband transmitters available, and for such requirements, the envelope elimination and restoration system appears to be the only practical solution.

APPENDIX I

COMPARISON OF LINEAR AND ENVELOPE ELIMINATION AND RESTORATION SINGLE-SIDEBAND TRANSMITTER EFFICIENCIES

In order to compare the efficiency of the two systems, we will first derive an equation for efficiency of the linear amplifier. We will assume that the standard two equal tone signal is amplified by both systems because power and distortion ratings are generally based upon this specific waveshape.

The efficiency of a Class B linear amplifier is a linear function of the output voltage. (This functional relationship may be established by noting that output power is proportional to the square of the output voltage, yet the voltage from the plate power supply is constant and the current from the power supply is a linear function of the output wave of the amplifier. Therefore, since the output power varies as a square of the output voltage and the power input is merely a linear function, the efficiency must also be a linear function in order to establish the correct product function.)

Let us assume that the linear amplifier is used to amplify a signal composed of two equal amplitude tones and produces a 1-watt peak envelope power output. The

average power, P_0 , is therefore $\frac{1}{2}$ watt.² Since the envelope waveshape of a two equal tone wave is a full wave rectified sine wave and since the efficiency of a linear amplifier is a linear function of signal voltage, the efficiency as a function of time η_t is:

$$\eta_t = k \sin \omega t \quad (1)$$

where ω is the difference in angular velocity between the equal tones and k is the efficiency of the linear amplifier when delivering peak output.

The plate dissipation at any instant, t , is:

$$\begin{aligned} P_{dt} &= P_{it} - P_{ot} \\ &= \frac{P_{ot}}{\eta_t} - P_{ot} \end{aligned} \quad (2)$$

where

P_{it} = the power input fed to the amplifier from the power supply.

P_{ot} = the desired power output from the tube which is fed to the tank circuit.

($P_{ot} = \sin^2 \omega t \times 1$ watt for a two equal tone wave having a peak envelope power of 1 watt.)

Therefore,

$$P_{dt} = \frac{\sin^2 \omega t}{k \sin \omega t} - \sin^2 \omega t. \quad (3)$$

The average plate dissipation P_d is:

$$\begin{aligned} P_d &= \frac{1}{\pi} \int_0^{\pi/\omega} P_{dt} dt = \frac{1}{\pi} \int_0^{\pi/\omega} \left(\frac{\sin \omega t}{k} - \sin^2 \omega t \right) dt \\ P_d &= \frac{2}{\pi k} - \frac{1}{2}. \end{aligned} \quad (4)$$

Therefore, since the average power output in this case is $\frac{1}{2}$ watt, the efficiency of a linear amplifier when amplifying a two equal tone wave is

$$\eta = \frac{P_0}{P_0 + P_d} = \frac{1/2}{1/2 + 2/\pi k - 1/2} = \frac{\pi k}{4}. \quad (5)$$

We will assume that in the envelope elimination and restoration system the Class C modulated stage has a plate circuit efficiency of 80 per cent (coupling circuit losses are not considered in this comparison) and the Class B modulator stage has an efficiency of 55 per cent. The following calculations show an over-all efficiency of slightly over 69 per cent:

Let $P_0 = 0.5$ watt (1 watt peak envelope power)

² The fact that the peak envelope rating of a two equal tone wave is equal to two times the average power rating may be confirmed as follows: consider that each of the two equal amplitude tones has an rms amplitude of one-half volt developed across a one ohm resistance. Each of the tones would dissipate $\frac{1}{4}$ watt and the total power of the two tones would then be $\frac{1}{2}$ watt. The peak envelope power, however, occurs when the two tones are in phase and their combined amplitude would then be 1 volt rms so therefore their peak envelope power would be 1 watt.

$$P_d \text{ Class C stage} = \frac{0.5}{0.8} - 0.5 = 0.125 \text{ watt}$$

Since, for a 0.5 watt SSB signal (1w PEP) there is 0.095 watt in the AM component.

$$P_d \text{ Class B} = \frac{0.095}{0.8 \times 0.55} - \frac{0.095}{0.8} = 0.0971 \quad (6)$$

$$\text{Total } P_d = 0.125 + 0.097 = 0.222 \quad (7)$$

$$\eta = \frac{P_o}{P_o + P_d} = \frac{0.5}{0.5 + 0.222} = 69.2 \text{ per cent} \quad (8)$$

APPENDIX II

POWER OUTPUT OF A HIGH LEVEL MODULATED TRANSMITTER CONVERTED TO CLASS B LINEAR OPERATION

If we assume that the transmitter to be modified utilizes high-level modulation and that the modulated stage plate circuit efficiency is 80 per cent, then the plate dissipation, P_d , of the stage is:

$$\begin{aligned} P_d &= \frac{3}{2} P_{\text{carrier}} \frac{(1 - \eta)}{\eta} \\ &= \frac{3}{2} \frac{0.2}{0.8} P_{\text{carrier}} \\ &= 0.375 P_{\text{carrier}}. \end{aligned} \quad (9)$$

It was shown, in Appendix I, that a reasonable figure for the plate circuit efficiency of the linear single-sideband amplifier is 47.1 per cent. Therefore, the average power output, $P_{\text{SSB av}}$, of a transmitter altered to linear SSB operation is:

$$\begin{aligned} P_{\text{SSB av}} &= \frac{\eta}{1 - \eta} P_d = \frac{0.471}{1 - 0.471} \cdot 0.375 P_{\text{carrier}} \\ &= 0.334 P_{\text{carrier}}. \end{aligned} \quad (10)$$

For a two equal tone single-sideband wave, the peak envelope power is equal to two times the average power. Therefore, the peak envelope power output of a transmitter modified for linear amplifier operation is approximately 0.67 times the carrier power output rating of the unmodified transmitter.

APPENDIX III

MODULATOR FREQUENCY RESPONSE REQUIREMENT

The following analysis is accomplished in two segments. In the first part of the analysis the spectrum of the phase modulation component of the single-sideband wave is determined. This is the signal fed to the modulated stage in the envelope elimination and restoration system. In the second part of the analysis the phase-modulated wave is mathematically modulated by the components of the envelope of the two-tone single-

sideband wave that are within the frequency response of the modulator. In this manner it is possible to calculate the amount of spurious produced when the modulator can pass only a restricted number of overtones of the envelope function.

Part 1

The method to be used for determining the spectrum of the phase-modulated component of a two equal amplitude tone wave was described in 1953 [5]. This method is based upon the fact that a limiter is an amplitude modulator which modulates the input wave by the inverse function of the envelope of this input wave.

The method may be outlined in the following series of steps.

- 1) The signal wave fed to the limiter is fully described as to the amplitude, frequency, and relative phase of the spectrum components.
- 2) The envelope function, $F(t)$, of the input wave is determined.
- 3) The inverse function of the input envelope function, $1/F(t)$, is next calculated. This is the envelope-limiter gain function, $ELGF(t)$.
- 4) The Fourier series describing the envelope-limiter gain function determined in step 3 is calculated.³
- 5) Each individual input signal component described in step 1 is amplitude modulated (multiplied) by the Fourier series of the envelope-limiter gain function. The resulting spectrum is the desired output of an ideal limiter and therefore it is the phase-modulation component of the input wave described in step 1.

In accordance with the above procedure, the following calculations may be made.

Step 1: The frequency components of the input wave, to the limiter, are shown in Fig. 3, line 1. Besides these two equal tone components there is assumed to be a noise component which, in the analysis, is made to approach zero. It is assumed that at zero reference time the two tones are exactly out of phase.

Step 2: The amplitude modulation component of the input wave is shown in Fig. 4. In order to simplify the analysis, it is assumed that the bottom part of the wave is a straight line as shown in the figure. Actually the bottom of the wave is not perfectly flat but since this portion of the wave is made to approach a limit of zero this assumption does not affect the accuracy of the analysis. The envelope function may be defined as follows:

$$\begin{aligned} F(t) &\approx [N]_0^e + [S \sin \theta]_e^{\pi-e} + [N]_{\pi-e}^{\pi+e} \\ &\quad + [-S \sin \theta]_{\pi+e}^{2\pi-e} + [N]_{2\pi-e}^{2\pi}. \end{aligned} \quad (11)$$

Step 3: The envelope-limiter gain function, $ELGF(t)$, which is the inverse function of step 2, is determined.

³ In many cases, it will be less laborious to do step 4 before step 3.

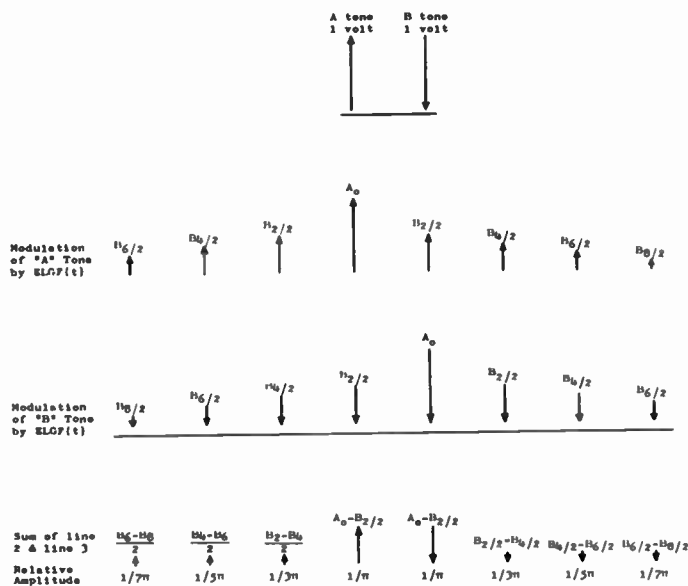

Fig. 3—Spectrum diagram showing calculation of two-tone phase modulation component.

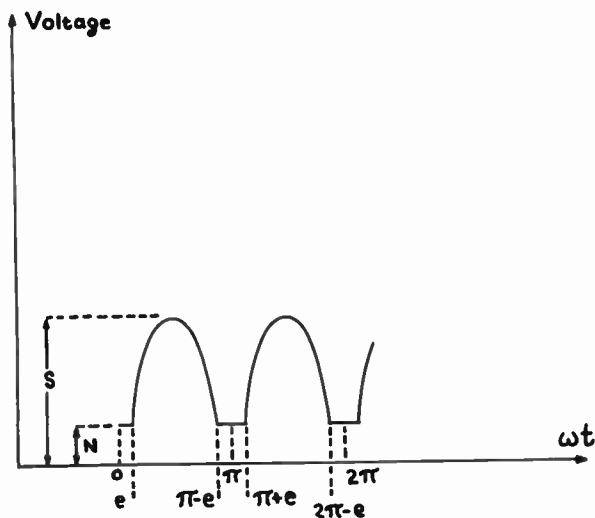

Fig. 4—Envelope wave shape of two tone wave plus noise.

This function may be defined as follows:

$$ELGF(t) = 1/F(t) \approx [1/N]_0^e + \left[\frac{1}{\sin \theta} \frac{1}{S} \right]_e^{\pi-e} + [1/N]_{\pi-e}^{\pi+e} + \left[\frac{-1}{\sin \theta} \frac{1}{S} \right]_{\pi+e}^{2\pi-e} + [1/N]_{2\pi-e}^{2\pi}$$

(12)

Step 4: Next, the Fourier series describing this wave is determined. The fundamental frequency of the Fourier series is assumed to be equal to one-half the frequency separation between the signal frequencies in order to simplify calculations. The dc component equals:

$$A_0 = \frac{1}{\pi} \int_0^\pi ELGF(t) d\theta = \frac{1}{\pi} \left[\int_0^e \frac{d\theta}{N} + \int_e^{\pi-e} \frac{d\theta}{S \sin \theta} + \int_{\pi-e}^\pi \frac{d\theta}{N} \right]$$

$$= \frac{1}{\pi} \left[\frac{2e}{N} + \frac{1}{S} \log \left\{ \frac{\sin \theta}{1 + \cos \theta} \right\}_e^{\pi-e} \right]$$

(13)

Due to the choice of fundamental frequency, all odd harmonics are equal to zero. The following equation defines the B_n Fourier series components where n is an even integer.

$$\frac{B_n}{2} = \frac{1}{\pi} \int_0^\pi ELGF(t) \cos n\theta d\theta$$

$$= \frac{1}{\pi} \left[\int_0^e \frac{\cos n\theta d\theta}{N} + \int_e^{\pi-e} \frac{\cos n\theta d\theta}{S \sin \theta} + \int_{\pi-e}^\pi \frac{\cos n\theta d\theta}{N} \right]$$

$$= \frac{1}{\pi} \left[\frac{2 \sin ne}{Nn} - 2 \int_e^{\pi-e} \frac{\sin(n-1)\theta d\theta}{S} + \int_e^{\pi-e} \frac{\cos(n-2)\theta d\theta}{S \sin \theta} \right]$$

(14)

but the next lower harmonic component, B_{n-2} , equals

$$\frac{B_{n-2}}{2} = \frac{1}{\pi} \int_0^\pi ELGF(t) \cos(n-2)\theta d\theta$$

$$= \frac{1}{\pi} \left[\frac{2 \sin(n-2)e}{N(n-2)} + \int_e^{\pi-e} \frac{\cos(n-2)\theta d\theta}{\sin \theta} \right]$$

(15)

For very small values of e , $\sin ne \approx ne$, where e is in radians. The error in this approximation vanishes as e approaches zero. Therefore, the first terms of B_n and B_{n-2} approach equality as e approaches zero. Therefore, the difference between B_n and B_{n-2} is

$$\frac{B_{n-2}}{2} - \frac{B_n}{2} = \frac{4}{S(n-1)\pi}$$

(16)

Similarly

$$A_0 = \frac{1}{\pi} \left[\frac{2e}{N} + \int_e^{\pi-e} \frac{d\theta}{S \sin \theta} \right]$$

$$\frac{B_2}{2} = \frac{1}{\pi} \left[\frac{2 \sin 2e}{N2} - 2 \int_e^{\pi-e} \frac{\sin \theta d\theta}{S} + \int_e^{\pi-e} \frac{d\theta}{S \sin \theta} \right]$$

(18)

Therefore (16) holds even for the difference between A_0 and $B_2/2$.

Step 5: Each of the two equal tone components is modulated by the various Fourier series components of

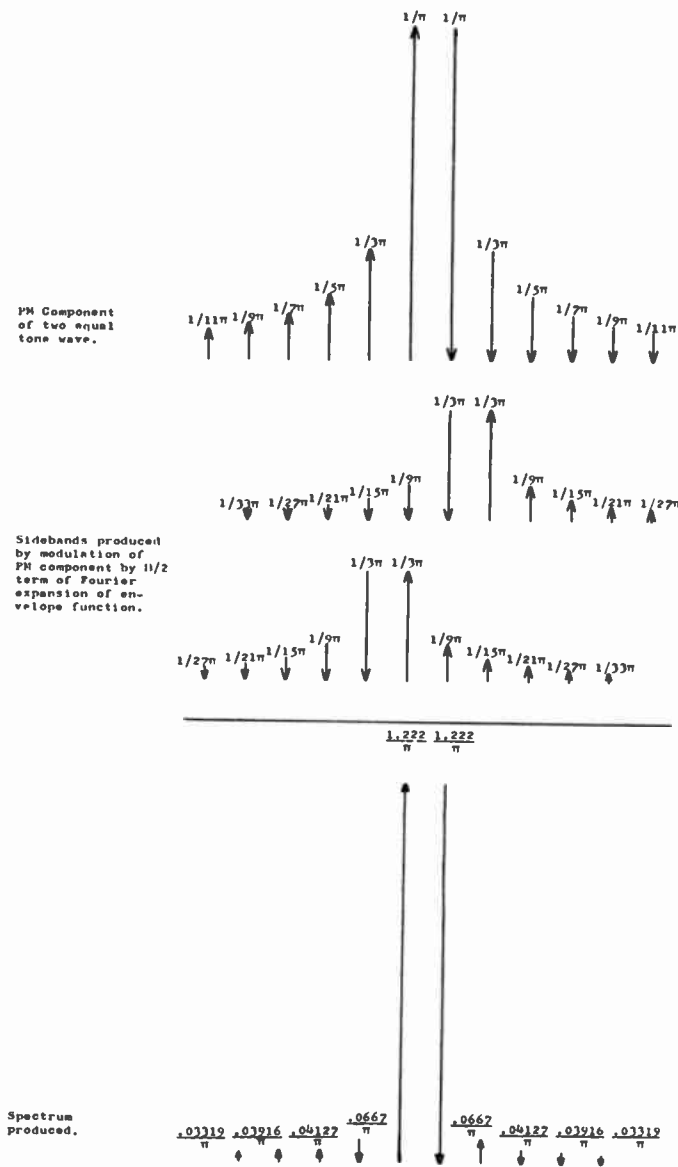

Fig. 5—Calculation of spectrum created when envelope elimination and restoration system is used with a low-fidelity modulator capable of passing only the fundamental beat note.

the envelope limiter gain functions, as shown in Fig. 3, lines 2 and 3. The result of this modulation process is then summated as shown in Fig. 3, line 4. It should be noted that, since the various sideband components are equal to a difference between B_n and B_{n-2} , the resulting spectrum may be readily determined to a very high order of precision by use of (16).

The result of this first part of the analysis is the phase-modulation component spectrum of a two equal

tone wave. In addition to its application to single-sideband analysis, this result is of interest to other fields of physics.

Part 2

As mentioned above, the second part of the analysis requires the calculation of the effect of amplitude modulation of the phase modulation spectrum by the Fourier series components of the envelope function of the two equal tone wave. The envelope function of the two equal tone wave is exactly equivalent to that of a full wave rectified sinewave and may be expanded into the following Fourier series:

$$e = \frac{2E}{\pi} \left[1 + \frac{2}{3} \cos 2\theta - \frac{2 \cos 4\theta}{15} + \frac{2}{35} \cos 6\theta \dots (-1)^{n/2+1} \frac{2 \cos n\theta}{n^2 - 1} \right] \quad (19)$$

where $n = \text{even integer}$.

The result of modulation by merely the fundamental component of the Fourier series is shown in Fig. 5. Thus, it is seen that the worse spurious component is 25.3 db down, relative to one of the two equal tone waves. The results of similar calculations for modulators with better frequency responses are shown in Table I.

ACKNOWLEDGMENT

The author wishes to gratefully acknowledge the advice and encouragement, in writing this paper, of James L. Finch and Walter Lyons of RCA Communications, Inc.; Julius Ross of the United States Information Agency; Edward Pierce and James Alden of Kaiser Aircraft and Electronics Corp.; Alfred W. Barber of Alfred W. Barber Laboratories, and Lloyd Ottenberg of Kahn Research Laboratories.

BIBLIOGRAPHY

- [1] Leonard R. Kahn. "Single-Sideband Transmission by Envelope Elimination and Restoration." PROCEEDINGS OF THE IRE, Vol. 40 (July, 1952), pp. 803-806.
- [2] A. H. Reeves. "Single-Sideband System Applied to Short Wave Telephone Links." *Journal of the Institution of Electrical Engineers* (London), Vol. 73 (September, 1933), pp. 245-279.
- [3] F. A. Polkinghorn and N. F. Schlaack. "A Single-Sideband Short Wave System for Transatlantic Telephony." PROCEEDINGS OF THE IRE, Vol. 23 (July, 1935), pp. 701-718.
- [4] N. Lund, C. F. P. Rose and L. G. Young. "Amplifiers for Multi-channel Single-Sideband Radio Transmitters." PROCEEDINGS OF THE IRE, Vol. 40 (July, 1952), pp. 790-796.
- [5] Leonard R. Kahn. "Analysis of a Limiter as a Variable-Gain Device," *Electrical Engineering*, Vol. 72 (December, 1953), pp. 1106-1109.
- [6] E. B. Moullin. "The Detection by a Straight Line Rectifier of Modulated and Heterodyne Signals." *Wireless Engineer* (London), Vol. 9 (July, 1932), pp. 378-383.

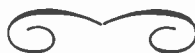

Synchronous Communications*

JOHN P. COSTAS†, ASSOCIATE MEMBER, IRE

Summary—It can be shown that present usage of amplitude modulation does not permit the inherent capabilities of the modulation process to be realized. In order to achieve the ultimate performance of which AM is capable synchronous or coherent detection techniques must be used at the receiver and carrier suppression must be employed at the transmitter.

When a performance comparison is made between a synchronous AM system and a single-sideband system it is shown that many of the advantages normally attributed to single sideband no longer exist. SSB has no power advantage over the synchronous AM (DSB) system and SSB is shown to be more susceptible to jamming. The performance of the two systems with regard to multipath or selective fading conditions is also discussed. The DSB system shows a decided advantage over SSB with regard to system complexity, especially at the transmitter. The bandwidth saving of SSB over DSB is considered and it is shown that factors other than signal bandwidth must be considered. The number of usable channels is not necessarily doubled by the use of SSB and in many practical situations no increase in the number of usable channels results from the use of SSB.

The transmitting and receiving equipment which has been developed under Air Force sponsorship is discussed. The receiving system design involves a local oscillator phase-control system which derives carrier phase information from the sidebands alone and does not require the use of a pilot carrier or synchronizing tone. The avoidance of superheterodyne techniques in this receiver is explained and the versatility of such a receiving system with regard to the reception of many different types of signals is pointed out.

System test results to date are presented and discussed.

INTRODUCTION

FOR A good many years, a very large percentage of all military and commercial communications systems have employed amplitude modulation for the transmission of information. In spite of certain well-known shortcomings of conventional AM, its use has been continued mainly due to the simplicity of this system as compared to other modulation methods which have been proposed. During the last few years, however, it has been felt by many responsible engineers that the increased demands being made on communications facilities could not be met by the use of conventional AM and that new modulation techniques would have to be employed in spite of the additional system complexity. Of these new techniques, single sideband has been singled out as the logical replacement for conventional AM and a great deal of publicity and financial support has been given SSB as a consequence.

Many technical reasons have been given to support the claim that SSB is better than AM and these points will be discussed in some detail later in this paper. In addition, many experiments have been performed which also indicate a superiority for SSB over AM. Some care must be taken, however, in drawing conclusions from the above statements. *We cannot conclude that SSB is superior to AM because we have no assurance*

whatever that conventional AM systems make efficient use of the modulation process employed. In other words, AM as a modulation process may be capable of far better performance than that which is obtained in conventional AM systems. If an analysis is made of AM and SSB systems, it will be found that existing SSB systems are very nearly optimum with respect to the modulation process employed whereas conventional AM systems fall far short of realizing the full potential of the modulation process employed. In fact, it could honestly be said that we have been misusing rather than using AM in the past. Realization of the above situation raises some immediate questions: What are the equipment requirements of the optimum AM system? How does the performance of the optimum AM system compare with that of SSB? Which shows the greater promise of fulfilling future military and commercial communications requirements, optimum AM or SSB? The remainder of this paper will be devoted mainly to answering these questions.

SYNCHRONOUS COMMUNICATIONS—THE OPTIMUM AM SYSTEM

Receiver

Conventional AM systems fail to obtain the full benefits of the modulation process for two main reasons: Inefficient use of generated power at the transmitter and inefficient detection methods at the receiver. Starting with the receiver it can be shown that if maximum receiver performance is to be obtained the detection process must involve the use of a phase-locked oscillator and a synchronous or coherent detector. The basic synchronous receiver is shown in Fig. 1. The incoming signal is

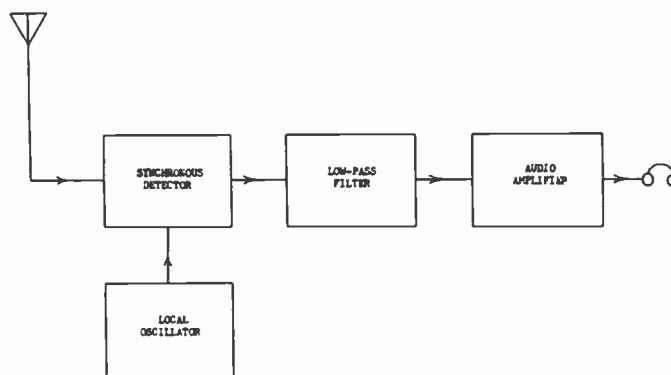

Fig. 1—Basic synchronous receiver.

mixed or multiplied with the coherent local oscillator signal in the detector and the demodulated audio output is thereby directly produced. The audio signal is then filtered and amplified. The local oscillator must be main-

* Original manuscript received by the IRE, August 31, 1956.

† General Electric Co., Syracuse, N. Y.

tained at proper phase so that the audio output contributions of the upper and lower sidebands reinforce one another. If the oscillator phase is 90° away from the optimum value a null in audio output will result which is typical of detectors of this type. The actual method of phase control will be explained shortly, but for the purpose of this discussion maintenance of correct oscillator phase shall be assumed.

In spite of the simplicity of this type of receiver, there are several important advantages worthy of note. To begin with, no IF system is employed which eliminates completely the problem of image responses. The opportunity to effectively use post-detector filtering allows extreme selectivity to be obtained without difficulty. The selectivity curve of such a receiver will be found to be the low-pass filter characteristic mirrored about the operating frequency. Not only is a high order of selectivity obtained in this manner, but the selectivity of the receiver may be easily changed by low-pass filter switching. The carrier component of the AM signal is not in any way involved in the demodulation process and need not be transmitted when using such a receiver. Furthermore, detection may be accomplished at very low level and consequently the bulk of total receiver gain may be at audio frequencies. This permits an obvious application of transistors but more important it allows the selectivity determining low-pass filter to be inserted at a low-level point in the receiver which aids immeasurably in protecting against spurious responses from very strong undesired signals.

Phase Control: To obtain a practical synchronous receiving system some additions to the basic receiver of Fig. 1 are required. A more complete synchronous receiver is shown in Fig. 2. The first thing to be noted

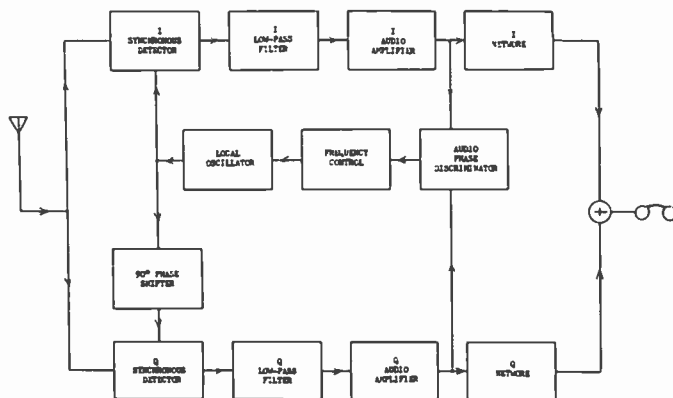

Fig. 2—Two-phase synchronous receiver.

about this diagram is that we have essentially two basic receivers with the same input signal but with local oscillator signals in phase quadrature to each other. To understand the operation of the phase-control circuit consider that the local oscillator signal is of the same phase as the carrier component of the incoming AM signal. Under these conditions, the in-phase or *I* audio

amplifier output will contain the demodulated audio signal while the quadrature or *Q* audio amplifier will have no output due to the quadrature null effect of the *Q* synchronous detector. If now the local oscillator phase drifts from its proper value by a few degrees the *I* audio will remain essentially unaffected but there will now appear some audio output from the *Q* channel. This *Q* channel audio will have the same polarity as the *I* channel audio for one direction of local oscillator phase drift and opposite polarity for the opposite direction of local oscillator phase drift. The *Q* audio level is proportional to the magnitude of the local oscillator phase angle error for small errors. Thus by simply combining the *I* and *Q* audio signals in the audio phase discriminator a dc control signal is obtained which automatically corrects for local oscillator phase errors. It should be noted that phase control information is derived entirely from the sideband components of the AM signal and that the carrier if present is not used in any way. Thus since both synchronization and demodulation are accomplished in complete independence of carrier, suppressed-carrier transmissions may be employed.

It is unfortunate that many engineers tend to avoid phase-locked systems. It is true that a certain amount of stability is a prerequisite but it has been determined by experiment that for this application the stability requirements of single-sideband voice are more than adequate. Once a certain degree of stability is obtained, the step to phase lock is a simple one. It is interesting to note that this phase-control system can be modified quite readily to correct for large frequency errors when receiving AM due to Doppler shift in air-to-air or ground-to-air links.

It is apparent that phase control ceases with modulation and that phase lock will have to be reestablished with the reappearance of modulation. This has not proved to be a serious problem since lock-up normally occurs so rapidly that no perceptible distortion results when receiving voice transmission. It should be further noted that such a phase control system is inherently immune to carrier capture or jamming. In addition it has been found that due to the narrow noise bandwidth of the phase-control loop, synchronization is maintained at noise levels which render the channel useless for voice communications.

Interference Suppression: The post-detector filters provide the sharp selectivity which, of course, contributes significantly to interference suppression. However, these filters cannot protect against interfering signal components which fall within the pass band of the receiver. Such interference can be reduced and sometimes eliminated by proper combination of the *I* and *Q* channel audio signals. To understand this process consider that the receiver is properly locked to a desired AM signal and that an undesired signal appears, some of whose components fall within the receiver pass band. Under these conditions the *I* channel will contain the desired audio signal plus an undesired component due

to the interference. The Q channel will contain only an interference component also arising from the presence of the interfering signal. In general the interference component in the I channel and the interference component in the Q channel are related to one another or they may be said to be correlated. Advantage may be taken of this correlation by treating the I and Q voltages with the I and Q networks and adding these network outputs. If properly done this process will reduce and sometimes eliminate the interfering signal from the receiver output as a result of destructive addition of the I and Q interference voltages.

The design of these networks is determined by the spectrum of the interfering signal and the details of network design may be found a report by the author.¹ Although such details cannot be given here it is interesting to consider one special interference case. If the interfering signal spectrum is confined entirely to one side of the desired signal carrier frequency the optimum I and Q networks become the familiar 90° phasing networks common in single-sideband work. Such operation does not however result in single-sideband reception of the desired signal since both desired signal sidebands contribute to receiver output at all times. This can be seen by noting that the Q channel contains no desired signal component so that network treatment and addition effects only the undesired audio signal components. The phasing networks are optimum only for the interference condition assumed above. If there is an overlap of the carrier frequency by the undesired signal spectrum the phasing networks are no longer optimum and a different network design is required for the greatest interference suppression.

This two-phase method of AM signal reception can aid materially in reducing interference. As a matter of fact it can be shown that the true anti-jam characteristics of AM cannot be realized unless a receiving system of the type discussed above is used. If we now compare the anti-jam characteristics of single sideband and suppressed-carrier AM properly received it will be found that intelligent jamming of each type of signal will result in a two-to-one power advantage for AM. The bandwidth reduction obtained with single sideband does not come without penalty. One of the penalties as we see here is that single sideband is more easily jammed than double sideband.

Transmitter

The synchronous receiver described above is capable of receiving suppressed-carrier AM transmissions. If a carrier is present as in standard AM this will cause no trouble but the receiver obviously makes no use whatever of the carrier component. The opportunity to employ carrier-suppressed AM transmissions can be used to good advantage in transmitter design. There are many ways in which to generate carrier-suppressed AM

signals and one of the more successful methods is shown in Fig. 3. A pair of class-C beam power amplifiers are screen modulated by a push-pull audio signal and are driven in push-pull from an rf exciter. The screens are returned to ground or to some negative bias value by means of the driver transformer center tap. Thus in the absence of modulation no rf output results and during modulation the tubes conduct alternately with audio polarity change. The circuit is extremely simple and a given pair of tubes used in such a transmitter can easily match the average rf power output of the same pair of tubes used in SSB linear amplifier service. The circuit is self-neutralizing and the tune-up procedure is very much the same as in any other class-C rf power amplifier. The excitation requirements are modest and as an example the order of 8 w of audio are required to produce a sideband power output equivalent to a standard AM carrier output of 1 kw. Modulation linearity is good and the circuit is amenable to various feedback techniques for obtaining very low distortion which may be required for multiplex transmissions.

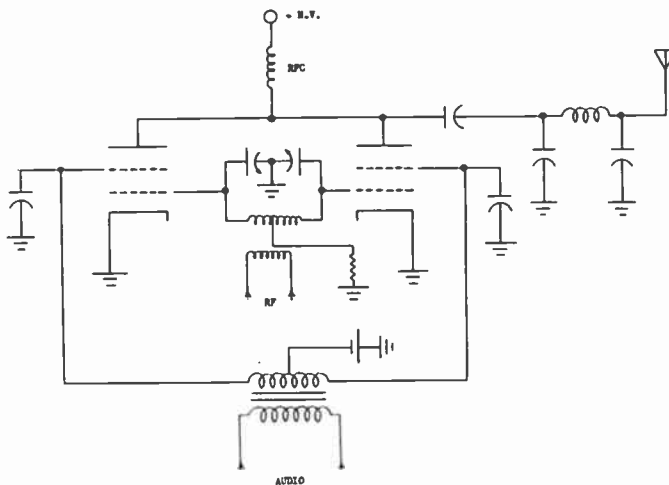

Fig. 3—Suppressed-carrier AM transmitter.

This transmitter circuit is by no means new. The information is presented here to indicate the equipment simplicity which can be realized by use of synchronous AM communications.

PROTOTYPE EQUIPMENT

A synchronous receiver covering the frequency range of 2–32 mc is shown in Fig. 4. The theory of operation of this receiver is essentially that of the two-phase synchronous receiver discussed earlier. This is a direct conversion receiver and the superheterodyne principle is not used. A rather unusual frequency synthesis system is employed to give high stability with very low spurious response. Only one crystal is used and this is a 100 kc oven-controlled unit.

This receiver will demodulate standard AM, suppressed-carrier AM, single sideband, narrow-band fm, phase modulation, and cw signals in an optimum man-

¹ J. P. Costas, "Interference Filtering," Mass. Inst. Tech. Res. Lab. of Elec., Tech. Rep. no. 185.



Fig. 4—The AN/FRR—48 (XW-1) synchronous receiver.



Fig. 5—The AN/FRT—29 (XW-1) suppressed-carrier AM transmitter.

ner. This versatility is a natural by-product of the synchronous detection system and no great effort is required to obtain this performance.

Fig. 5 shows a suppressed-carrier AM transmitter using a pair of 6146 tubes in the final. This unit is capable of 150-w peak sideband power output for continuous sine-wave modulation. The modulator is a single 12BH7 miniature double triode. Fig. 6 shows a transmitter capable of 1000-w peak sideband power output under continuous sine wave audio conditions. The final tubes are 4-250-A's and the modulator uses a pair of 6L6's. Both of these transmitters are continuously tunable over 2–30 mc.

A COMPARISON OF SYNCHRONOUS AM AND SINGLE SIDEBAND

It is interesting at this point to compare the relative advantages and disadvantages of synchronous AM and single-sideband systems. Although single sideband has a clear advantage over conventional AM this picture is radically changed when synchronous AM is considered.

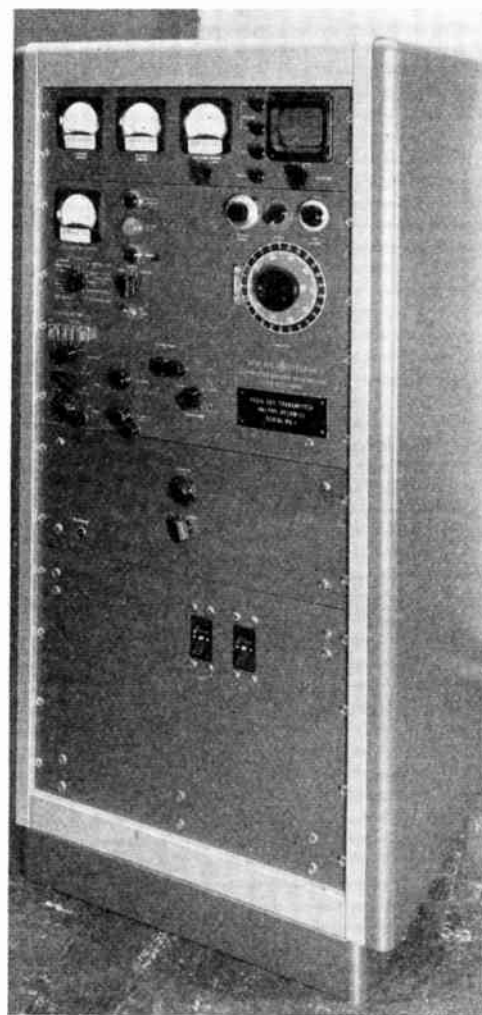

Fig. 6—The AN/FRT—30 (XW-1) suppressed-carrier AM transmitter.

Signal-to-Noise Ratio

If equal average powers are assumed for SSB and synchronous AM it can easily be shown that identical s/n ratios will result at the receiver. The additional noise involved from the reception of two sidebands is exactly compensated for by the coherent addition of these sidebands. The 9-db advantage often quoted for SSB is based on a full AM carrier and a peak power comparison. Since we have eliminated the carrier and since a given pair of tubes will give the same average power in suppressed-carrier AM or SSB service there is actually no advantage either way. If intelligent jamming rather than noise is considered there exists a clear advantage of two-to-one in average power in favor of synchronous AM.

System Complexity

Since the receiver described is also capable of SSB reception it would appear that synchronous AM and SSB systems involve roughly the same receiver complexity. This is not altogether true since much tighter design specifications must be imposed if high quality SSB reception is to be obtained. If AM reception only is con-

sidered these specifications may be relaxed considerably without materially affecting performance. The synchronous receiver described earlier may possess important advantages over conventional superheterodyne receivers but this point is not an issue here.

The suppressed-carrier AM transmitter is actually simpler than a conventional AM transmitter. It is of course far simpler than any SSB transmitter. There are no linear amplifiers, filters, phasing networks, or frequency translators involved. Personnel capable of operating or maintaining standard AM equipment will have no difficulty in adapting to suppressed-carrier AM. The military and commercial significance of this situation is rather obvious and further discussion of this point is not warranted.

Long-Range Communications

The selective fading and multipath conditions encountered in long-range circuits tend to vary the amplitude and phase of one sideband component relative to the other. This would perhaps tend to indicate an advantage for SSB but tests to date do not confirm this. Synchronous AM reception of standard AM signals over long paths has been consistently as good as SSB reception of the same signal. In some cases it was noted that the SSB receiver output contained a serious flutter which was only slightly discernible in the synchronous receiver output. Some attempt has been made to explain these results but as yet no complete explanation is available. One interesting fact about the synchronous receiver is that the local oscillator phase changes as the sidebands are modified by the medium since phase control is derived directly from the sidebands. In a study of special cases of signal distortion, it was found that the oscillator orients itself in phase in such a way as to attempt to compensate for the distortion caused by the medium. This may partially explain the good results which have been obtained. Perhaps another point of view would be that the synchronous receiver is taking advantage of the inherent diversity feature provided by the two AM sidebands.

Test results to date indicate that synchronous AM and single-sideband provide much the same performance for long-range communications. The AM system has been found on occasion to be better but since extensive tests have not been performed and a complete explanation of these results is not yet available it would be unfair to claim any advantage at this time for AM.

Spectrum Utilization

In theory, single-sideband transmissions require only half the bandwidth of equivalent AM transmissions and this fact has led to the popular belief that conversion to single sideband will result in an increase in usable channels by a factor of two. If a complete conversion to single sideband were made those who believe that twice the number of usable channels would be available might be in for a rather rude awakening. There are many factors

which determine frequency allocation besides modulation bandwidth. Under many conditions it actually turns out that modulation bandwidth is not a consideration. This is a complicated problem and only a few of the more pertinent points can be discussed briefly here.

To begin with the elimination of one sideband is a complicated and delicate business. Any one of several misadjustments of the SSB transmitter will result in an empty sideband which is not actually empty. We are not thinking here of a telephone company point-to-point system staffed by career personnel, but rather we have in mind the majority of military and commercial field installations. This is in no way meant to be a criticism, but the technical personnel problem faced by the military especially in time of war is a serious one and this simple fact of life cannot be ignored in future system planning. Thus we must concede that single-sideband transmissions will in practice not always be confined to one sideband and that those who allocate frequencies must take this into consideration.

There may be those who would argue that SSB transmitting equipment can be designed for simple operation. This is probably true but in general operational simplicity can only be obtained at the expense of additional complexity in manufacture and maintenance. This of course trades one set of problems for another but if we assume ideal SSB transmission we are still faced with an even more serious allocation problem. We refer here to the problem of receiver nonlinearity which becomes a dominant factor when trying to receive a weak signal in the presence of one or more near-frequency strong signals. Under such conditions the single-signal selectivity curves often shown by manufacturers are next to meaningless. This strong undesired-weak desired signal situation often arises in practice especially in the military where close physical spacing of equipment is mandatory as in the case of ships or aircraft and where the signal environment changes due to the changing locations of these vehicles. Because of this situation allocations to some extent must be made practically independent of modulation bandwidth and the theoretical spectrum conservation of single sideband cannot always be advantageously used.

The problem of receiver nonlinearity is especially serious in multiple conversion superheterodyne receivers for obvious reasons. This was the dominant factor in choosing a direct conversion scheme in the synchronous receiver described earlier. Although this approach has given good results and continued refinement has indicated that significant advances over prior art can be obtained, it cannot be said however that the receiver problem is solved. This problem will probably remain a serious one until new materials and components are made available. This is a relatively slow process and it is not at all absurd to consider that by the time this problem is eliminated new modulation processes will have appeared which will eclipse both of those now being considered.

In short, the spectrum economies of SSB which exist in theory cannot always be realized in practice as there exist many important military and commercial communications situations in which no increase in usable channels will result from the adoption of single sideband.

Jamming

The reduction of transmission bandwidth afforded by single sideband must be paid for in one form or another. A system has yet to be proposed which offers nothing but advantages. One of the prices paid for this reduction in bandwidth is greater susceptibility to jamming as was previously mentioned. There is an understandable tendency at times to ignore jamming since the systems with which we are usually concerned provide us with ample worries without any outside aid. Jamming of course cannot be ignored and from a military point of view this raises a very serious question. If we concede for the moment that by proper frequency allocation single sideband offers a normal channel capacity advantage over AM, what will happen to this advantage when we have the greatest need for communications? It is almost a certainty that at the time of greatest need jamming

will have to be reckoned with. Under these conditions any channel capacity advantage of SSB could easily vanish. A definite statement to this effect cannot be made of course without additional study but this is a factor well worth considering.

CONCLUSION

There is an undeniable need for improved communications and to date it appears that single sideband has been almost exclusively considered to supplant conventional AM. It has been the main purpose of this paper to point out that the improved performance needed can be obtained in another way. The synchronous AM system can compete more than favorably with single-sideband when all factors are taken into account.

ACKNOWLEDGMENT

Much of the work reported here was sponsored by the Rome Air Development Center of the Air Research and Development Command under Air Force contract AF 30(602) 584. The author wishes to acknowledge the support, cooperation, and encouragement which has been extended by the personnel of the Rome Air Development Center.

The Phase-Shift Method of Single-Sideband Signal Generation*

DONALD E. NORGAARD†, SENIOR MEMBER, IRE

Summary—A general expression is developed for sideband suppression obtained with the phase-shift method of single-sideband signal generation. The sideband suppression ratio is expressed in terms of four systems parameters, three of which are governed by the characteristics of wide-band phase-shift networks employed in such signal generators. Several typical phase-shift network configurations are analyzed and shown to be equivalent to a cascade of networks of "simplest" type. In addition, certain special network combinations are presented.

A simple dual-channel multiplex single-sideband generator of the phase-shift type is shown. Use of the phase-shift method in combination with band-pass filters to enhance system performance is discussed. The role of a modified phase-shift type of signal generator as a system-test signal source is outlined. The effects of intermodulation distortion on signal purity and the performance stability of the phase-shift method are discussed from the system viewpoint.

INTRODUCTION

THE PROBLEM of generating single-sideband signals having the required amounts of unwanted sideband suppression, channel bandwidth, and a

suitably low-modulation frequency cutoff presents a challenge to the designer of single-sideband apparatus. The phase-shift method of generating single-sideband signals provides a means for extending the useful bandwidth of single-sideband systems or for increasing unwanted sideband attenuation in systems where sharp cutoff filters are used. In conjunction with appropriately designed filters, either or both of these signal characteristics can be enhanced by use of the phase-shift method.

In addition, the phase-shift method permits economical simultaneous generation of a two-channel single-sideband signal in which upper and lower sidebands convey different intelligence. Since, fundamentally, no band-pass filters are required in the application of the method, frequency conversion to a specified operating band is not necessary, and certain advantages of cost, weight, simplicity, and reliability may be obtained in many cases.

It is the purpose of this paper to analyze the phase-shift method of single-sideband signal generation and to relate system performance to the parameters of the

* Original manuscript received by the IRE, September 26, 1956.
† General Electric Res. Lab., Schenectady, N. Y.

basic system elements. It is also intended that this paper serve as a stimulus to the serious-minded engineer for further development of useful design concepts which will aid in advancing the utility of single-sideband transmission systems.

THE PHASE-SHIFT METHOD

The fundamental concept involved in generation of a single-sideband signal by the phase-shift method is centered about two separate simultaneous modulation processes and subsequent combination of the modulation products. This method is shown in Fig. 1, which is a simplified representation of the practical embodiment of the principle. The output of modulator no. 1 contains "reference phase" sidebands symmetrically spaced about the carrier frequency, while the output of modulator no. 2 contains sidebands having identical frequencies and magnitudes as those of the first but of such relative phase that vector addition of the two outputs in the combining circuit results in cancellation of one set of sidebands and reinforcement of the other set.¹

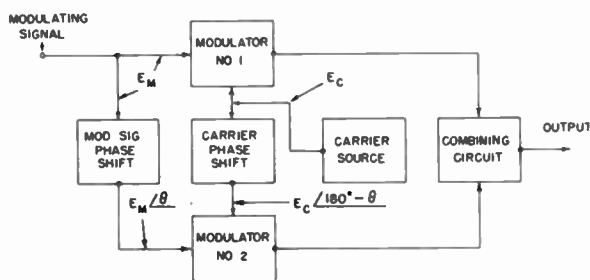

Fig. 1—Simplified block diagram of phase-shift method of single-sideband signal generation.

It can be shown that if the signal conditions indicated in Fig. 1 are maintained over a desired modulating-signal frequency range the action is to completely suppress one set of sidebands and to reinforce (double) the opposite set at the output. In addition, the carrier signal will not appear in the output if each modulator is a balanced modulator of the type which suppresses carrier.

In practice it is difficult to design a system such as that of Fig. 1 so that the indicated phase-shift, θ , is maintained over a wide enough modulating-signal frequency range to be useful for most applications. If, however, a phase-shifting network is included in each modulating signal path, the required differential phase-shift, in general, can be maintained within any desired tolerance over any desired frequency range. Such an arrangement is shown in Fig. 2, where the phase-shifting networks are identified by α and β . These will be referred to hereinafter as α and β networks, and the phase-shifts produced by each as α and β , respectively.

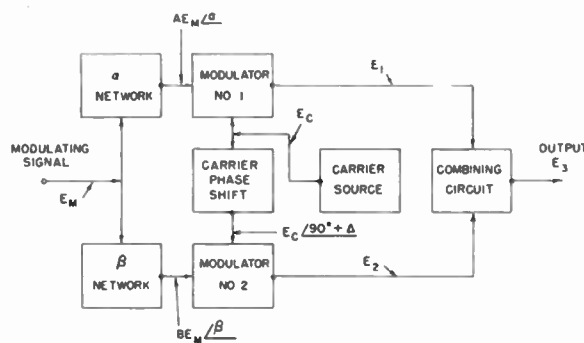

Fig. 2—Practical embodiment of phase-shift method.

ANALYSIS OF THE PHASE-SHIFT METHOD

The relationship between α and β may be expressed

$$\beta - \alpha = 90^\circ + \delta, \tag{1}$$

where β and α are, respectively, the phase shift of the β and α networks and δ is the angular deviation from 90° in the phase-shift difference. It follows that

$$\beta = \alpha + 90^\circ + \delta. \tag{2}$$

Similarly, in the carrier supply circuits to the modulators, an error angle Δ is permitted, as indicated in Fig. 2.

If a modulating signal component, $E_M \sin pt$, is applied simultaneously to the α and β networks and the signal output of the carrier source of Fig. 2 is expressed as $E_c \sin \omega_c t$, where E_M and E_c are, respectively, the peak magnitudes of the signals, p and ω_c are 2π times the respective frequencies, and t is time, then the four signals supplied to the two modulators may be written as follows:

To modulator 1 the carrier signal is

$$E_c \sin \omega_c t, \tag{3}$$

while the modulating signal is

$$AE_M \sin (pt + \alpha), \tag{4}$$

where A is a real constant of proportionality and α is the phase-shift of the α network.

To modulator 2 the carrier signal is

$$E_c \sin (\omega_c t + 90^\circ + \Delta), \tag{5}$$

while the modulating signal is

$$BE_M \sin (pt + \beta) = BE_M \sin (pt + \alpha + 90^\circ + \delta), \tag{6}$$

where B is a real constant of proportionality and β is the phase shift of the β network. Other terms are as defined previously.

Eqs. (4) and (6), of course, are written on the basis of but one sinusoidal component of modulating signal frequency, $p/2\pi$, for the sake of simplicity. Where complex waveforms are present in the modulating signal similar equations result for each Fourier component.

Assuming modulators 1 and 2 to be identical balanced modulators where the carrier term vanishes from the output, modulator 1 output may be written

¹ K. Henney, "The Radio Engineering Handbook," McGraw-Hill Book Co., Inc., New York, N. Y., 3rd ed., pp. 552-553; 1941.

$$E_1 = [E_c \sin(\omega_c t)] [AE_M \sin(pt + \alpha)], \quad (7)$$

which expands² to

$$E_1 = \frac{AE_c E_M}{2} \begin{bmatrix} \cos(\omega_c t - pt - \alpha) \\ -\cos(\omega_c t + pt + \alpha) \end{bmatrix}. \quad (8)$$

Similarly, modulator 2 output may be written

$$E_2 = [E_c \sin(\omega_c t + 90^\circ + \Delta)] \cdot [BE_M \sin(pt + \alpha + 90^\circ + \delta)], \quad (9)$$

which expands to

$$E_2 = \frac{BE_c E_M}{2} \begin{bmatrix} \cos(\omega_c t + 90^\circ + \Delta - pt - \alpha - 90^\circ - \delta) \\ -\cos(\omega_c t + 90^\circ + \Delta + pt + \alpha + 90^\circ + \delta) \end{bmatrix}, \quad (10)$$

which in turn reduces to

$$E_2 = \frac{BE_c E_M}{2} \begin{bmatrix} \cos(\omega_c t - pt - \alpha + \Delta - \delta) \\ +\cos(\omega_c t + pt + \Delta + \delta + \alpha) \end{bmatrix} \quad (11)$$

If the combining circuit adds the two modulator outputs, then the signal output may be expressed

$E_3 = E_1 + E_2$. Substituting,

$$E_3 = \frac{E_c E_M}{2} \begin{bmatrix} A \cos(\omega_c t - pt - \alpha) + B \cos(\omega_c t - pt - \alpha + \Delta - \delta) \\ -A \cos(\omega_c t + pt + \alpha) + B \cos(\omega_c t + pt + \alpha + \Delta + \delta) \end{bmatrix}. \quad (13)$$

Eq. (13) reduces to

$$E_3 = -\frac{E_c E_M}{2} \begin{bmatrix} \sqrt{A^2 + B^2 + 2AB \cos(\Delta - \delta)} \sin\left(\omega_c t - pt - \alpha - \tan^{-1} \frac{A + B \cos(\Delta - \delta)}{B \sin(\Delta - \delta)}\right) \\ \sqrt{A^2 + B^2 - 2AB \cos(\Delta + \delta)} \sin\left(\omega_c t + pt + \alpha + \tan^{-1} \frac{A - B \cos(\Delta + \delta)}{B \sin(\Delta + \delta)}\right) \end{bmatrix}. \quad (14)$$

The upper sideband term,

$$\sin\left[\omega_c t + pt + \alpha + \tan^{-1} \frac{A - B \cos(\Delta + \delta)}{B \sin(\Delta + \delta)}\right],$$

vanishes when its coefficient

$$\frac{E_c E_M}{2} \sqrt{A^2 + B^2 - 2AB \cos(\Delta + \delta)} = 0, \quad (15)$$

or when *both*

$$\Delta + \delta = 0 \quad (16)$$

and

$$A = B, \quad (17)$$

excluding the trivial cases where E_c or $E_M = 0$, or $A = 0$.

Alternatively, suppression of the lower sideband term can be accomplished by:

² The trigonometric identities involved in this and the following manipulations are taken from or derived from the tabulations appearing in R. G. Hudson, "The Engineer's Manual," John Wiley and Sons, Inc., New York, N. Y., 2nd ed.; 1947.

- 1) polarity reversal of either (but not both) modulating signal(s),
- 2) polarity reversal of either (but not both) carrier signal(s), or
- 3) subtraction of one modulator output from the other in the combining circuit.

The exact expression for E_3 [equivalent to that given by (14)] may be derived by substitution of appropriate algebraic sign in (3), (4), (5), (6), or (12) and carrying out the analysis in the manner indicated. In practice, polarity reversal of one of the modulating signals is the method generally used for "switching" sidebands.

A matter of primary interest is the ratio of the undesired sideband to the desired sideband. In this case,

$$\frac{\text{Undesired Sideband}}{\text{Desired Sideband}} = \sqrt{\frac{A^2 + B^2 - 2AB \cos(\Delta + \delta)}{A^2 + B^2 + 2AB \cos(\Delta - \delta)}}. \quad (18)$$

Eq. (18) is the fundamental expression for sideband suppression ratio obtained in generating single-sideband signals by the phase-shift method. Several corollary relationships may be derived from this equation, as follows:

When $A = B$, the magnitudes of the sideband components from the individual modulators (as seen at the output of the combining circuit) are equal, and

$$\frac{\text{Undesired Sideband}}{\text{Desired Sideband}} = \sqrt{\frac{1 - \cos(\Delta + \delta)}{1 + \cos(\Delta - \delta)}}. \quad (18a)$$

This ratio becomes zero when $(\Delta + \delta) = 0$ in accordance with (16) and (17).

When $A = B$ and $\Delta = 0$, then

$$\frac{\text{Undesired Sideband}}{\text{Desired Sideband}} = \sqrt{\frac{1 - \cos \delta}{1 + \cos \delta}} = \tan \frac{\delta}{2}. \quad (18b)$$

When $A = B$ and $\delta = 0$, then

$$\frac{\text{Undesired Sideband}}{\text{Desired Sideband}} = \sqrt{\frac{1 - \cos \Delta}{1 + \cos \Delta}} = \tan \frac{\Delta}{2}. \quad (18c)$$

When $(\Delta + \delta) = 0$, but $A \neq B$ and $\Delta \neq 0$, then

$$\frac{\text{Undesired Sideband}}{\text{Desired Sideband}} = \sqrt{\frac{A^2 + B^2 - 2AB}{A^2 + B^2 + 2AB \cos 2\Delta}}. \quad (18d)$$

When $(\Delta + \delta) = 0$, but $\Delta \neq 0$, and $A = B \neq 0$, then

$$\frac{\text{Undesired Sideband}}{\text{Desired Sideband}} = \sqrt{\frac{(A - B)^2}{A^2 + B^2 + 2AB \cos 2\Delta}} = 0. \quad (18e)$$

When $\Delta = \delta = 0$, but $A \neq B$ and $A \neq 0$, then

$$\frac{\text{Undesired Sideband}}{\text{Desired Sideband}} = \frac{A - B}{A + B}. \quad (18f)$$

The value of (18) through (18f) lies in the fact that the signal output characteristics arising from any degree of unbalance created by any one or a combination of causes can be determined in advance from system parameters. Conversely, certain system parameters can be determined from measurement of signal characteristics.

The foregoing analysis delineates the phase-shift method of generating single-sideband signals. The general treatment permits rather broad choice of methods for satisfying the particular functions indicated as essential to the system. As a practical matter, system performance is usually directly related to the performance of the α and β networks when a band of frequencies such as a voice channel, for example, serves as the modulating signal. Ideally, both the angle δ and the ratio of magnitudes, A/B , should remain constant over the entire modulating-signal frequency range. Optimum results dictate, in addition, that $\Delta = 0$.

As indicated by (18b) and (18c), the effect on sideband suppression of the phase error angle Δ is equal in importance to that of the angle δ . Since for any given carrier frequency of signal generation Δ is not a function of the modulating-signal frequency, the only significant requirement on Δ is that it be suitably chosen and maintained, a condition easily assured in most cases.

Although (8) and (10) would appear to place a premium on the relative amplitude stability of the carrier signal magnitudes supplied to each of the two modulators, this is not usually the case in practice. Many forms of balanced modulators exist in which the magnitude of the carrier excitation employed can be varied between relatively wide limits with negligible effect on the magnitudes of the sidebands produced. This type of modulator is implicitly assumed [despite (8) and (10)] in writing (13), where the product $E_c E_M$ can be taken as being virtually independent of the actual values of E_c indicated in (8) and (10).

It will be noted that no band-pass filters are indicated in Figs. 1 and 2, and none is required (in the usual sense) for successful operation of the phase-shift method. It is well to remember, however, that the operation of any modulator depends upon an inherent nonlinearity, so that circuits which follow the modulators should be designed for adequate harmonic suppression. Ordinary linear amplifier design is usually an entirely adequate precaution against trouble caused by harmonics of frequencies near the carrier frequency.

Since a sharp cutoff filter is not required for sideband separation there is essentially no restriction on the choice of carrier frequency $\omega_c/2\pi$. It is required, however, that the modulating devices be operable at the chosen frequency and that the carrier frequency phase shift introduced in the carrier supply path to one of the modulators be obtained and maintained within the limits necessary to assure adequate unwanted sideband suppression.

Likewise, no limit is placed on the power level at which signal generation is accomplished. Many factors, however, influence the choice of power level at this point in a complete system. In practice it is customary to generate the single-sideband signal at receiving-tube level (from a few microwatts to a few milliwatts) and to amplify the signals to the desired power level by linear amplifiers of appropriate characteristics.

Further, since no inherent restrictions appear in the choice of carrier frequency, selection of a sufficiently high fixed-frequency of signal generation can be made to simplify subsequent frequency conversion to a desired operating channel in cases where a single piece of apparatus must be used to serve a wide range of transmission channels.

MULTIPLEX SYSTEMS

The modulating signal, E_M , used in the foregoing analysis can comprise several individual channels of transmission. The ability of the phase-shift method to generate either lower- or upper-sideband signals selectively by choice of relative modulating signal polarity suggests an extremely simple and useful dual-channel single-sideband system. Each or either of the two channels so provided may, in turn, be multiplex channels. Fig. 3 illustrates such a dual-channel single-sideband signal generator.

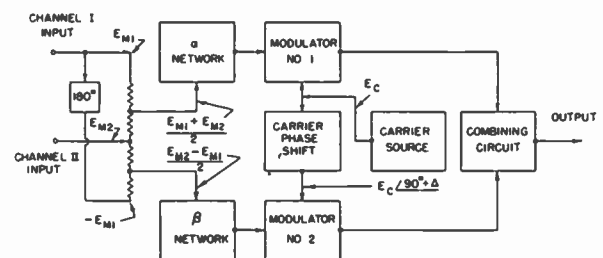

Fig. 3—Dual-channel single-sideband signal generator based on the phase-shift method. Channels I and II appear as opposite sidebands at output.

The modulators, α and β networks, combining circuit, etc. shown in Fig. 3 can be the same as indicated for the single-channel system of Fig. 2. The two separate channels are indicated at the left of the drawing by the legends E_{M1} and E_{M2} , respectively. A simple matrix which in effect adds E_{M1} to E_{M2} and delivers this sum signal to the α network, and which subtracts E_{M1} from E_{M2} and delivers this difference signal to the β network is the only additional equipment necessary to generate

a dual-channel signal. Alternative matrixing methods can be substituted for the resistive form illustrated. For example, a "T" connection of the secondaries of two transformers, each carrying its separate channel, would yield an equivalent result.

The analysis of the signal produced is similar to that employed in conjunction with the arrangement of Fig. 2. It will be apparent that the angle Δ should be zero in order to obtain the same sideband suppression characteristic for each channel. The suppression so obtained will then be optimum for each (if $A = B$) and will depend entirely upon the error angle, δ , introduced by the α and β networks.

CARRIER SUPPRESSION

In the preceding analysis the simplifying assumption was made that each modulator is perfectly balanced for carrier output. In practice such mathematical perfection is not generally attainable, nor is it required for most applications. It is not uncommon to obtain and maintain carrier suppressions of the order of 60 to 80 db in many modulator configurations. This attenuation is the amount by which the carrier component at the modulator output can be expected to be below the peak sideband output of such a modulator. Since the sideband signal outputs of the modulators necessary in the phase-shift method add numerically in the combining circuit when Δ and δ are approximately zero while the carrier outputs are added in approximate quadrature, the composite carrier balance (suppression) should be better than that of the individual modulators.

In many applications it is desirable to transmit a known amount of carrier signal along with the sideband channel(s) for agc and frequency control purposes at the receiving point. Such a carrier signal is called a pilot carrier and can be transmitted with negligible power loading of a final amplifier stage of a transmitter and with very slight loss of power devoted to transmission of sideband energy. For such a system it is common practice to introduce the required amount of carrier signal to some stage of a transmitter following the combining circuit rather than by deliberately disturbing the balance in either of the modulators. In simplified systems, however, carrier introduced by modulator unbalance can yield acceptable performance.

Again, in some applications the pilot signal may not be transmitted at "carrier" frequency but displaced from it by a predetermined amount. In this case the pilot carrier may be introduced to the system by modulation with an appropriate amount of signal mixed with a chosen channel signal to serve as the "offset pilot carrier." Suppression of the actual carrier signal is unaffected.

CHARACTERISTICS OF α AND β NETWORKS

It has been shown by (18) and its derivatives that the sideband suppression ratio obtained with the phase-shift method is directly dependent on the quantities A ,

B , δ , and Δ . In many respects A , B , and δ are directly related to the characteristics of the α and β networks of Figs. 2 and 3. The quantity Δ must also be chosen to be compatible with δ for optimum system performance, but there is no single value of Δ which will give ideal performance unless A , B , and δ are constant. The angle Δ is generally made equal and opposite to the average value of δ over a given band of modulation frequencies for which a system is designed.

The α and β networks, therefore, largely govern system performance in a manner quite analogous to the pass band and attenuation bands of filters which play an equivalent part in determining the sideband attenuation characteristics of single-sideband signal generating equipment of the filter type. It is entirely appropriate to devote some consideration to both the design and the practical aspects of the phase-shift networks themselves and to their use in the phase-shift method. The analogy between a filter and a set of phase-shift networks may be carried further by stating that it is intrinsically possible to design and construct phase-shifting networks with as close a tolerance on δ and on A and B as is necessary for any specified degree of sideband suppression over as broad a frequency range as desired. Generally speaking, the number of circuit branches or elements increases with diminishing tolerance, δ , and with increasing modulation frequency ratio. This is true of filter design also, where specification of skirt steepness, uniformity of response in the pass band, attenuation outside the pass band, and width of pass band dictates at least a minimum number of filter elements and maximum tolerances on terminating impedances and on reactance values of the filter elements themselves.

The ideal α and β networks for use in the phase-shift system should have the following characteristics:³

- 1) Each network should have constant attenuation at least over the band of modulating frequencies of interest.
- 2) The phase error angle, δ , should be constant over the band of modulating frequencies of interest. Preferably, δ , as expressed in (1) should be zero.

The first characteristic can be satisfied by use of "all-pass" network structures. The second characteristic fundamentally indicates a nonuniform time delay of signals as a function of frequency. Lattice (or semi-lattice) network structures can be designed to approximate these two requirements.

Perhaps the simplest phase-shifting structure which satisfies condition 1 is the "push-pull" excited series connected resistance and reactance as illustrated in Fig. 4. If balanced output signals are desired a second series connected resistance and reactance having the same time constant may be connected as indicated by the dashed lines. The phase shift vs frequency character-

³ Here we are concerned only with the electrical characteristics and not necessarily with feasibility, temperature, humidity, and time stabilities, cost, size, weight, etc., all of which are important.

istic of this structure is shown in Fig. 5. The magnitude of the output signal is independent of frequency with constant voltage excitation.

It will be noted that in Fig. 5 the frequency scale is expressed in terms of ω/ω_0 , where $\omega/2\pi$ is the frequency of the applied signal, and $\omega_0/2\pi$ is the frequency at which the absolute value of the reactance is equal to the resistance.

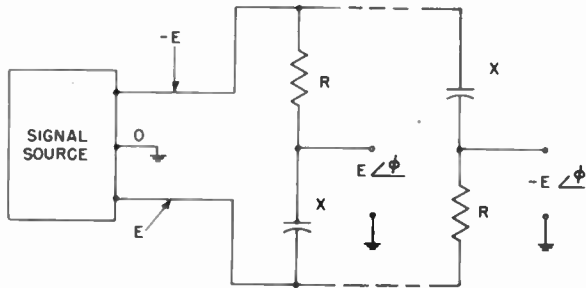

Fig. 4—Basic "simplest" phase-shifting network element.

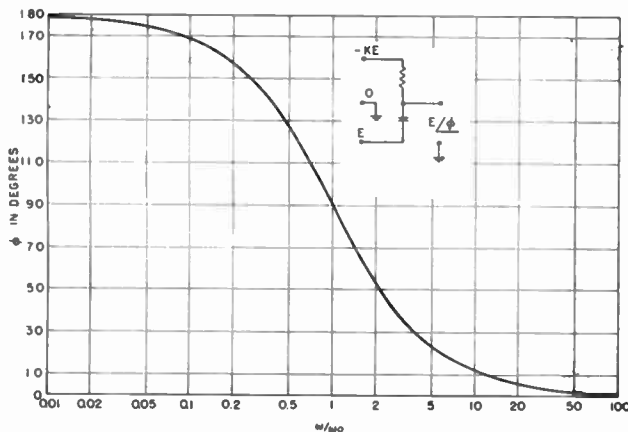

Fig. 5—Normalized phase-shift characteristic of basic phase-shift element.

Although the structure of Fig. 4 satisfies condition 1, it is clear that if such a network is taken to be a β network while the α network produces no phase shift (a condition similar to that indicated in Fig. 1) the angle δ is zero only at $\omega/\omega_0 = 1$, and varies between $+90^\circ$ and -90° at the extreme ends of the frequency domain. Furthermore, the greatest slope occurs at $\delta = 0$. If, however, an α network of identical structure is excited from the same terminals and its value of ω_0 made different from that of the β network, condition 1 will be satisfied by this network also, and the angle δ can be made zero at two values of ω/ω_0 by proper choice of the respective ω_0 's.

For systems having rather broad tolerance on sideband suppression (hence δ) and relatively small ratio of maximum to minimum modulation frequency, a pair of α and β networks of the design indicated in Fig. 4 might be satisfactory. Such a choice would, in most cases, represent a "minimum" system.

The symmetry and shape of the phase-shift curve of Fig. 5 suggest that the output signal, E/ϕ , of one phase-shifting stage be used as a source for another stage of

similar structure but of different ω_0 in order to extend the frequency ratio over which the phase curve (as plotted on semi-logarithmic coordinates) has a more nearly constant slope. Then, in turn, the output of the second stage can be used for a third stage, and so on as the need arises. The phase shift produced is then cumulative, and the amplitude response is still mathematically flat, if stray effects are not considered. If such a concatenation of n stages (or phase-shift elements) be taken as a β network, a similar group of n stages offset on the ω/ω_0 axis from the first group would provide a phase-shift curve having the same shape as that of the first group, and the phase difference as a function of ω/ω_0 will be the difference between the ordinates of the two phase curves. An obvious condition for a constant phase difference is for each curve of phase vs ω/ω_0 to be a straight line and for the slopes of the two to be identical. This, however, is not the only condition for a constant phase difference, since for any single-valued function of ω there exists another displaced vertically from the first by any chosen constant value. This displacement can be 90° so that δ would be zero over as great a range as desired with the result that such a set of networks could be considered as an ideal phase-shifting arrangement.

Can such a family be realized in practice? Probably not, if no restriction is placed on the frequency range over which δ is to be exactly zero. The fact is that networks can be designed to have a specified maximum value of δ over any specified frequency ratio if no restriction is placed on the number of elements used in meeting the specifications, and if no restriction is placed on the tolerance of the individual components. This condition is basically the parallel of that which governs the design of bandpass filters.

Many factors enter into the practical answer to the question stated above.

PRACTICAL PHASE-SHIFT NETWORK DESIGN⁴

There is almost a limitless number of combinations of network design and choice of δ which can yield satisfactory system performance as defined broadly in (18). In some cases better system performance might be obtained for a choice of δ not zero but, say 45° or 60° . Such a choice almost automatically rules out the dual-channel arrangement of Fig. 3 or else complicates other system features such as easy choice of sideband by reversal of one of the modulating signals. The design procedures, in any case, are similar.

The characteristics of certain phase-shift network structures are derived in Appendixes I and II where these fundamental building blocks useful in the design of phase-shift networks are described in considerable de-

⁴ The reader is referred to R. B. Dome, "Wide-band phase shift networks," *Electronics*, vol. 19, pp. 112-115; December, 1946.

D. G. C. Luck, "Properties of some wide-band phase-splitting networks," *Proc. IRE*, vol. 37, pp. 147-151; February, 1949.

S. Darlington, "Realization of a constant phase difference," *Bell Sys. Tech. J.*, vol. 24, pp. 94-104; January, 1950.

H. J. Orchard, "Synthesis of wide-band two-phase networks," *Wireless Engr.*, vol. 27, pp. 72-81; March, 1950.

tail. Such individual phase-shifting arrangements do not, in themselves, comprise suitable α and β combinations for use in the phase-shift method of generating single-sideband signals. As indicated previously, variations in the quantity δ exert a controlling influence on the sideband suppression obtainable with this method.

In general, suitable α and β networks which satisfy a specified tolerance on δ over a required frequency range will be two phase-shift networks which have the same number of identical structures and differ only in design-center frequencies. The number and type of elements, or stages, necessary will depend upon the tolerance placed on δ and the range of ω/ω_0 over which this tolerance must be maintained. The phase difference, $\beta - \alpha$, will be symmetrical about a frequency which is the geometric mean of the design-center frequencies of the α and β networks when these networks comprise an equal number of identical structures. The practical result of this fact is that it is necessary to compute $\beta - \alpha$ (or δ) for only half of the total range of ω/ω_0 of interest.

The enterprising designer will develop his own procedures of network pair design, so no effort will be made here to outline any particular method. The following general guides may prove to be helpful to the designer.

- 1) The shape of the individual α (or the β) vs ω/ω_0 characteristic is, in itself, of secondary importance. The primary objective is the phase difference characteristic, $\beta - \alpha$ vs ω/ω_0 , or its counterpart, δ vs ω/ω_0 .
- 2) In accordance with (18) it will be noted that the sideband suppression ratio is independent of the algebraic sign of $\Delta + \delta$, hence, with optimum value of Δ , dependent only on the absolute magnitude of δ .
- 3) An α, β phase-shift network pair is of optimum design when the peak excursions of δ as a function of ω/ω_0 are equal in magnitude and oscillate in algebraic sign. Optimum design networks invariably consist of an equal number of identical network structures in the α and β branches. Note that optimum design networks do not necessarily provide for $\delta = 0$ at all points of the δ vs ω/ω_0 characteristic between the limits of ω_{\min}/ω_0 and ω_{\max}/ω_0 , where ω_{\min} and ω_{\max} correspond to the limits of the band of modulation frequencies for which the design is made.⁵ In an optimum design network pair, the number of points where $\delta = 0$ will be twice the number of equivalent phase-shift elements of the basic class shown in Figs. 4, 10, and 11 used in the α or the β branch.⁶

- 4) The band-center is the geometric mean of the band-centers of the α and β networks, regardless of their individual complexity, provided the α and β networks have the same number of stages or equivalent elements.
- 5) The impedance levels of the phase-shifting elements must be established independently after determining the time constants necessary for a given design. Too high an impedance invites departure from theoretical performance due to stray capacitance and leakage resistance; too low an impedance can, in some cases, disturb the ratio, A/B , with a resulting degradation in sideband suppression.
- 6) Since the α and β networks operate as a team, it is best to consider provision of as nearly identical environment for each as possible.
- 7) In the application of optimum design phase-shift network pairs, the theoretical average attainable sideband suppression is, of course, greater than that occurring at the peak excursions of δ , but is not infinite (unless $\delta \equiv 0$) because the algebraic sign of δ plays no part in determining the amount of resultant sideband attenuation given by (18). The average sideband attenuation experienced with a "White Noise" modulating signal confined to the frequency limits $\omega_{\max}/\omega_{\min}$ would be approximately six decibels better than for specific modulation frequencies applied at points where δ has its maximum values within the stated frequency limits. Many signals useful in communications (voice, multichannel teletype, and, to a certain extent, music) approximate this condition.

PHASE-SHIFT NETWORK ARRAYS

In order to meet a required tolerance on δ over a certain frequency range, one or more of several special network combinations might be employed to advantage. One such combination is illustrated in Fig. 6, which is called a phase-shift network array.

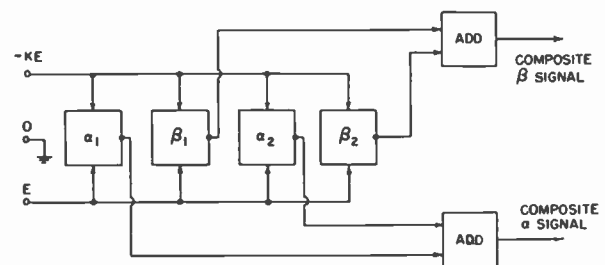

Fig. 6—A "shunt" phase-shift network array.

In the array of Fig. 6 the four phase-shifting networks, α_1 , α_2 , β_1 , and β_2 , are all driven from the same signal source, and, therefore, must be of such structure that a single value of K (see Appendixes I and II) can be applied to each. The principle of this array can be explained as follows:

⁵ The shape of the δ vs ω/ω_0 curve resembles the amplitude response curve of a multiple-tuned rf transformer. The designations ω_{\min} and ω_{\max} as used here correspond in a general way to the band limits typical of such a transformer.

⁶ An optimum design network pair may not necessarily be the best design for a specific system. It is conceivable, for example, that a certain portion of the modulating signal range carries a predominance of the signal power in some application. Best system performance might be obtained by departure from optimum design so that δ is small throughout the region of dominant signals even at the expense of greater values of δ in other portions of the operating band of frequencies.

The spacing between $\omega_{0\alpha_1}$ and $\omega_{0\beta_1}$ and the value of M (if applicable) is so chosen that δ_1 may have excursions considerably greater than the final tolerance on δ , but over a greater frequency range than is required for the system. Considered as an α , β pair the α_1 , β_1 networks should be of the optimum design class. The spacing between $\omega_{0\alpha_2}$ and $\omega_{0\beta_2}$ should be such that

$$\frac{\omega_{0\alpha_1}}{\omega_{0\beta_1}} = \frac{\omega_{0\alpha_2}}{\omega_{0\beta_2}} \quad (19)$$

with the result that the α_2 , β_2 pair will also be of the optimum design class.

By suitably positioning the α_2 , β_2 network pair on the ω/ω_0 axis relative to the α_1 , β_1 pair, an overlapping region where the algebraic signs of δ_1 (for the α_1 , β_1 pair) and δ_2 (for the other pair) are opposite can be obtained. The vector sum of the α_1 and β_2 voltages constitutes the composite α output signal, while the same operation with the β_1 and β_2 voltages results in the composite β output signal. These two composite output signals will exhibit greatly reduced excursions in composite δ and will also be characterized by amplitude variations when the operation is carried out properly. The sideband suppression characteristics for any configuration can be determined by appropriate substitution in (18).

The phase-shift array of Fig. 6 might be termed a "shunt" array, if a rigorous interpretation of the term is avoided.

A series array may be constructed in which the spacing of the α_1 and β_1 characteristics on the ω/ω_0 axis is such as to provide an average value of $\delta_1=45^\circ$. The spacing and positioning of the α_2 and β_2 characteristics are similar in principle to that described for the shunt array, except that the average $\delta_2=45^\circ$. If, then, the α_1 output be used as a signal source for the α_2 network and the method repeated for the β networks, the cumulative phase difference of this array can be made to average 90° with small excursion of δ and no amplitude variation as a function of frequency.

The series array can be shown to be the equivalent of a $2n$ -stage concatenation of basic phase-shift networks of the class shown in Fig. 4 (or the equivalent, per Appendix I), where n is the number of equivalent (or actual) stages of this same class incorporated in the α and β networks which comprise the series array. In the series array different values of K may be used for each stage, thus providing one more degree of freedom than offered by the shunt array. On the other hand, the shunt array method offers the possibility of certain economy in driving source facilities.

Still another phase-shift array is the method proposed by Villard,⁷ one form of which is shown in Fig. 7. Villard's array is an example of combined series and shunt methods. In this array, the minimum number of separate phase-shift networks required is 5; three identical α

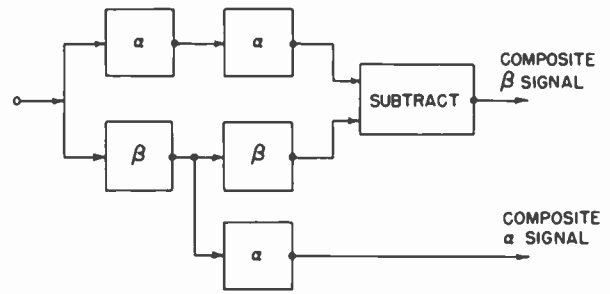

Fig. 7—A form of Villard's phase-shift network array.

networks and two identical β networks, or the converse.

The result of the cascading and matrixing operations indicated is to provide two output signals of exactly 90° phase difference (independent of δ for the generic pair of α , β networks) but of relative magnitudes dependent on δ in such a manner that the attainable sideband suppression is the square of that achievable by use of a single set of the α and β networks comprising the array.

Villard's array can be applied to:

- 1) provide greater system sideband suppression over a given $\omega_{\max}/\omega_{\min}$ range (as stated above),
- 2) relax the tolerances required of the elements of the phase-shift networks, or
- 3) extend the frequency range over which a given tolerance on sideband suppression can be attained.

Further extension of Villard's array is possible by pyramiding the system to any extent in order to enhance both or either the effective frequency range and/or attainable sideband suppression.

A "false" array will now be described. If the output signals of an α , β pair are added vectorially in one matrix to provide one composite output signal, while one of the same two signals is vectorially subtracted from the other in a second matrix⁸ to provide another composite output signal, the first composite output signal will be exactly 90° displaced from the second⁹ independent of the value of δ for the α , β pair, except in the trivial cases where $\delta = \pm 90^\circ$. While this may, at first consideration, appear to be an attractive solution to the problem of obtaining ideal system performance, the fact is that the magnitudes of the composite signals so obtained vary with δ in such a manner as to yield exactly the same system performance obtainable without use of the "array" just outlined. Such a matrix method cannot logically be termed an array since no increase in the number of phase shifting elements (or stages) is involved.

The inescapable consequence of employing network arrays to improve performance is that the number of basic elements equivalent to that of Fig. 4 increases.

Many other phase-shift arrays are, of course, possible. In applying network arrays, consideration should be

⁸ Each matrix is assumed to be free from phase and amplitude effects as a function of frequency.

⁹ The absolute magnitudes of the initial vector quantities must be equal in order to obtain this result.

⁷ O. G. Villard, Jr., "Cascade connection of 90-degree phase shift networks," *Proc. IRE*, vol. 40, pp. 334-337; March, 1952.

given to such factors as inter-element coupling methods (for instance, such as indicated in Fig. 12 and implied in Figs. 6 and 7) and the additional phase and amplitude tolerances so introduced by these methods when comparison is made between straightforward network designs and arrays of any variety. Although transmitting-system sideband attenuation can never be better than that afforded by the signal generating section of the apparatus, distortion of the signal in passing through other elements of the system sets practical limits on the signal quality necessary at the signal generation point. It must be pointed out that (18) was derived with classic disregard of the possibility of distortion anywhere in the system. Therefore, effort expended in improving sideband suppression capability without limit at the signal generator should be regarded as strictly academic exercise.

COMBINATION SYSTEMS

Throughout the foregoing treatment of phase-shift networks the bandwidth considered has been stated in terms of frequency ratio instead of in terms of $(\omega_{\max}/2\pi) - (\omega_{\min}/2\pi)$ as is common in band-pass filter practice. This basic fact suggests the use of the phase-shift method in combination with band-pass filters where improved or extended sideband suppression is required. This requirement may manifest itself in one or more of several forms. For example, a combination system may be indicated for:

- 1) better sideband suppression over a limited modulation frequency range than might be practical with either the phase-shift method or the filter method alone, or
- 2) lower minimum modulation frequency than that for which economical filter design can provide adequate sideband suppression, or
- 3) extended range systems, or
- 4) dual channel systems, or
- 5) combinations of 1, 2, 3, and 4, above.

The filtering burden is made lighter by application of a signal which already has much of the sideband energy removed from the stop-band of the filter. The sideband attenuation of a system where a phase-shift-generated single-sideband signal is passed through an appropriate sideband attenuating filter will be the product of the individual attenuations obtained. Expressed in logarithmic units (decibels), the over-all attenuation will be the sum of the individual attenuations. In view of the practical limits in performance dictated by possible amplifier distortion, the sideband suppression capabilities of either system (when both are used in tandem) can, in many cases, be relaxed without degradation of over-all performance, or the characteristics of the two methods can be used judiciously to supplement each other in one or more of the forms indicated in the above listing.

In the phase-shift method no inherent restriction is placed on the absolute value of ω so that with given limitations on sideband attenuation and $\omega_{\max}/\omega_{\min}$ (hence on phase-shift network complexity) a minimum modulation frequency as low as desired (but not including zero) can be accommodated as easily as any other. In combination systems where the phase-shift method is used to augment the useful modulation frequency range, the band-pass characteristics of the filter must be taken into account in determining over-all system response. In addition, a loss of sideband signal occurs at modulation frequencies where δ is large in the phase-shift portion of such a system. It is seen from (14) that the coefficient of the desired sideband at the output of the combining circuit is proportional to the quantity

$$\sqrt{A^2 + B^2 + 2AB \cos(\Delta - \delta)}.$$

If $A = B$ and $\Delta = 0$, the desired sideband has a magnitude dependent upon δ in accordance with the following expression:

$$\text{Desired Sideband} = A\sqrt{2(1 + \cos \delta)}. \quad (20)$$

Thus, where δ is small, the strength of the desired sideband is very closely proportional to $2A$. The curve shown in Fig. 8 indicates the loss in sideband magnitude as a function of δ . The quantity δ will be restricted to a range of values from $+90^\circ$ to -90° in most practical cases, so that the desired sideband output may be considered to have a maximum tolerance of ± 1.5 decibels over any range of modulation frequencies even in the absence of compensation for the effect indicated in Fig. 8.

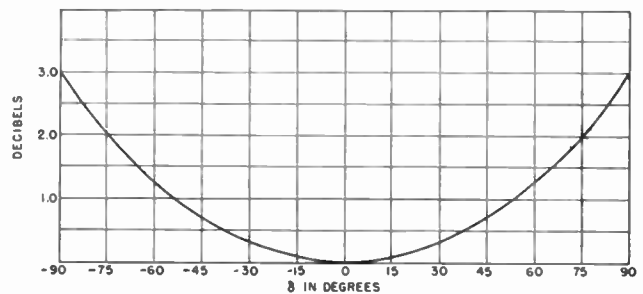

Fig. 8—Loss of desired output encountered when phase-shift error is great.

STABILITY

The performance of the phase-shift method of single-sideband signal generation is closely linked with both phase and amplitude of certain electrical quantities inherent in the process. Aside from the necessity of providing signals of a required precision initially the question of stability or of maintaining performance within specified tolerances under a variety of operating conditions is an important design consideration. Several categories of stability are of importance.

Carrier frequency stability is a direct function of the frequency control method used, and methods of obtaining any required stability are not basically different from accepted methods of frequency control in other apparatus. In general, carrier-frequency stability required in single-sideband systems is better than for amplitude modulation or frequency-modulation systems. The actual stability required depends upon the type of service to be rendered as well as the quality necessary. Carrier-frequency stability requirements that exist for a given service are in general dictated more by over-all system performance than by frequency stability of a certain order in the signal generation process, whatever method is used. In its own right, however, the phase-shift method can be classed as being quite tolerant with regard to carrier-frequency stability since no sharp-cutoff band-pass filters are inherently necessary.

Sideband-suppression stability relates to the degree of unwanted sideband suppression as a function of time under conditions of operational environment such as temperature, humidity, mechanical shock or vibration, and others.

In the phase-shift type of single-sideband signal generator the stability of sideband suppression is determined by the stability of the quantity $(\Delta + \delta)$ as well as the apparent ratio A/B as seen at the output of the combining circuit. [See (18) through (18f).] This then involves the stability of the two modulators as well as that of the α and β phase-shifting networks and any coupling devices. At first thought, this might be considered a substantial barrier to realization of stable or dependable performance of the phase-shift method until it is recalled that the modulators can be identical units of high intrinsic stability and that the phase-shift networks are of identical structure. Thus, the stability of A/B and the stability of the quantity δ can be made quite high.¹⁰ The stability of the remaining quantity, Δ , can be assured by a number of methods. For example, one such method is the principle of the "false" phase-shift network array in combination with modulators inherently insensitive to carrier level.

In many systems stability of amplitude of the output signal (more properly, signal conversion stability) is of importance. Since sideband-suppression stability obtained in the phase-shift method depends on amplitude stability in two branch circuits, over-all signal conversion stability is usually an intrinsic part of phase-shift signal generator system design. Many standard techniques for amplitude stabilization are applicable to the phase-shift method.

¹⁰ A shift of $\omega_{0\alpha}$ caused by temperature effects on the reactance and resistance elements comprising an α network will be accompanied by a similar shift of $\omega_{0\beta}$ if each portion of an α , β pair is subjected to the same motivating influence. The net effect on the magnitude of δ will be nil; only the frequency band will shift in proportion to the shift of $\omega_{0\alpha}$ or $\omega_{0\beta}$, a rather light casualty. It is assumed that the circuit elements used in the construction of the two networks have identical temperature coefficients and good "retrace" properties.

DISTORTION

Distortion of one type or another is the ever-present bugaboo of the electronic arts. One type of distortion which affects single-sideband systems adversely is intermodulation distortion. This form of distortion is a close relative of harmonic distortion, and both result from passage of signal through devices which have nonlinear output vs input characteristics.¹¹ We shall be concerned with the effects of distortion encountered in the process of generation of the desired single-sideband signal rather than in "post generation" distortion mentioned earlier.

In the phase-shift method, distortion products contributed by any element of the system shown in the block diagram of Fig. 2 can affect the purity of the output signal.¹² The distortion products of importance are those having frequencies in the same band as the desired signal as well as those very near it.

It is essential to provide modulator devices which have very little distortion within the signal level range of normal operation, since in the case of complex signals (more than one Fourier component) applied to the α and β networks, the waveforms presented to the modulators will be different not only from the original waveform but also different from one another due to unequal time delays in passing through the two phase-shifting networks. This implies, also, that any interstage coupling means (such as the vacuum tubes indicated in Fig. 12) be quite free from distortion within the normal signal level range. Distortion products originating within these portions of the system will not, in general, be suppressed in the manner indicated by the analysis of sideband suppression in conjunction with the arrangement of Fig. 2. In addition, the presence of distortion in these elements generally is accompanied by a change in magnitude of the original signal components so that the ratio, A/B , can be signal level dependent. The result of this is deterioration of the sideband-suppression ratio accompanied by intermodulation products which are produced.

Intermodulation-distortion products produced within the system of Fig. 2 can lie both within the desired signal range and adjacent to it, frequency-wise. Therefore, regardless of system distortion that can be tolerated, adjacent channel interference requirements frequently set an upper limit to the amount of intermodulation distortion allowable in the output of the signal-generating portion of a single-sideband system based on the phase-shift method. In practice, intermodulation distortion in amplifiers following the signal generating section of a

¹¹ Mere passage of signals through a device that is fundamentally nonlinear will not necessarily produce intermodulation distortion. Thus, for example, certain modulating devices need not introduce intermodulation distortion to signals although a modulating device is inherently nonlinear. Moreover, the term intermodulation distortion has no meaning if less than two signals of different frequency are involved simultaneously.

¹² An exception can be made in the cases of the carrier source and the rf phase-shifting device of Fig. 2, in general.

single-sideband system can (and generally does) introduce distortion products which affect signal purity in much the same manner as distortion products present in the output of the signal generator. Because of the desirability of high efficiency modes of amplifier operation at high power levels the amount of system distortion is governed almost entirely by post generation distortion in later stages of practical equipment regardless of the method of signal generation. While it is true that distortion products appearing in the output of the signal generator must be at or below the allowable system limit, this requirement is usually more easily satisfied than control of distortion products introduced by succeeding portions of a transmitting system.

Low distortion may be achieved in the modulators by operating each modulating element at a low percentage modulation. In the usual case, the modulators are balanced modulators, so this approach is limited mainly by considerations of noise level in the output signal and carrier balance stability.

Phase distortion (nonuniform time delay over the band of modulation frequencies) is usually severe in single-sideband systems. Although phase distortion does not introduce additional signal components to the output signal (in contrast to the effects of amplitude or intermodulation distortion) the waveform of a signal recovered in a properly designed receiver tuned to a single-sideband signal usually bears little resemblance to the waveform of the original modulating signal at the transmitter if other than single-tone modulation is used. Stated differently, the transient response of single-sideband systems is usually quite poor.

It will be noted that any information-bearing component of a modulating signal such as given by the expression $E_M \sin pt$ appears at the output of the system of Fig. 2 as a sideband represented by the expression

$$-\frac{E_c E_M}{2} \left[\sqrt{A^2 + B^2 + 2AB \cos(\Delta - \delta)} \cdot \sin \left(\omega_c t - pt - \alpha - \tan^{-1} \frac{A + B \cos(\Delta - \delta)}{B \sin(\Delta - \delta)} \right) \right]. \quad (21)$$

The above expression reduces to

$$-E_c E_M \sin(\omega_c t - pt - \alpha \pm 90^\circ) \quad (22)$$

if $A = B = 1$, and $\Delta = \delta = 0$. (Ideal conditions.)

Disregarding the fixed 90° phase-shift, it is seen that a phase-shift having a numerical value of α is encountered in the sideband component corresponding to the input signal component, $E_M \sin pt$. If α were zero no phase distortion would be present, or, if α increased *linearly* with modulation frequency, a fixed time delay would result and no phase distortion would exist. It can be seen from Fig. 14 that α will be approximately proportional to the *logarithm* of the modulating frequency. This type of

characteristic indicates that phase distortion is inherent in the process.

Conceivably, phase predistortion can be introduced to the modulating signal in the common path ahead of the phase-shifting networks to compensate for the effect just discussed when low signal generator phase distortion is important. The design of such compensation is beyond the scope of this paper.

It is well to remember that a signal-generating system is only part of a complete communication system, and that over-all phase distortion comprises that distortion attributable to the generating equipment, the transmission medium, and the receiving apparatus. In many cases the transmission medium exerts a controlling influence on system phase and amplitude response, and frequently this influence is neither predictable nor subject to control.

CONCLUSION

Certain characteristics of the phase-shift method offer unique possibilities in performance, utility, and system maintenance. The facility of generating either a lower-sideband or an upper-sideband signal by choice of a modulating-signal polarity has already been mentioned. The phase-shift method is unique for this purpose in that absolutely no disturbance in the carrier frequency of single-channel apparatus accompanies a "switch" of sideband. In addition, the simplicity of the means for providing dual-channel performance by use of the phase-shift method with very little additional equipment over a single-channel system constitutes an attractive feature of utility in comprehensive communication systems.

The inherent lack of restriction on channel low frequency cutoff and the several avenues of approach open to the designer in providing virtually unrestricted channel bandwidth with the phase-shift method provide a favorable climate for application of single-sideband transmission to a variety of uses. The several alternatives available to the designer in systems which combine the features of the filter method with the phase-shift method to enhance system performance are worthy of consideration.

Generation of a single-sideband signal directly at the final frequency of transmission by means of the phase-shift method offers the possibility of economy in space, complexity, cost, and weight and of improved reliability for fixed-frequency services. The insensitivity of the phase-shift method to carrier frequency offers additional features in heterodyne type of transmission systems.

A phase-shift type of single-sideband signal generator used as a source of test signals for transmission systems becomes a valuable tool for test and maintenance. It will be noted that the signal output of one of the balanced modulators of Fig. 2 inherently consists of two sidebands of exactly equal magnitude spaced from one another by twice the modulation frequency. Thus, if the modulation signal path to one of the balanced modula-

tors is blocked, a sine-wave modulating signal applied to the system generates a two-tone test signal having a combined peak magnitude numerically equal to the peak value of a single-sideband signal that would result in normal operation. The use of such a test signal¹³ is beyond the scope of this paper, but the advantage of a "built-in" source of test signal of this type at substantially no cost should not be overlooked.

Use of the basic phase-shift type of signal generator for test purposes is still further exploited with the arrangement of Fig. 9. As indicated, a signal presented to one of the modulators is used as horizontal deflection of an oscilloscope while the vertical deflection for the oscilloscope is a resulting high frequency signal obtained from any following portion of the transmitting system.

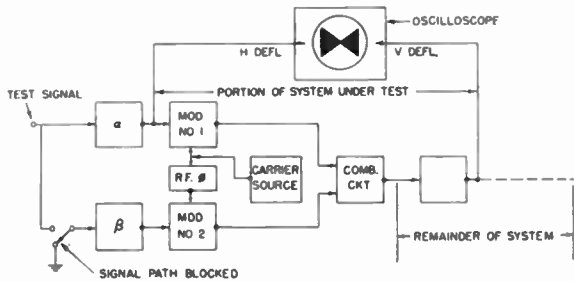

Fig. 9—System linearity test method utilizing a modification of the phase-shift method as a double-sideband signal source.

The remaining modulator is maintained in an active condition but its modulating signal path is blocked. The display on the face of the oscilloscope is a "bow-tie" display which allows immediate inspection of the overall transfer characteristic of the portion of the apparatus between the two monitoring points. The important feature of this method is that modulating signals of any waveform or frequency within the limits imposed by coupling circuits and bandwidth of the portion of the apparatus under test¹⁴ will yield the same type of display. For example, the test signal source can be obtained from unfiltered commercial power mains, or, of course, any other available signal including voice, music, or teletype normally transmitted by the system is satisfactory for the purpose. Alternatively, the same test method can be made to include the second modulator by disabling the first modulator instead of the second and obtaining the horizontal deflection signal from the input of the active modulator.

¹³ R. W. Ehrlich, "How to test and align a linear amplifier," *QST*, vol. 36, pp. 39-43; May, 1952.

S. G. Reque, "Linear rf amplifiers," *QST*, vol. 33, pp. 15-20; May, 1949.

¹⁴ These limits, in general, will be much broader than those set by the operating range of the phase-shift networks within which δ is made approximately zero. Amplitude linearity tests of the nature described by S. I. Kramer, "A sensitive method for the measurement of amplitude linearity," *Proc. IRE*, vol. 44, pp. 1059-1060; August, 1956, are feasible if the sawtooth test waveform is applied directly to the appropriate modulator.

Unfortunately these test methods are not directly applicable to combination systems because of the attenuation and phase-shift characteristics associated with sharp cutoff filters.

Throughout the foregoing an effort has been made to delineate the major building blocks of the phase-shift method of single-sideband signal generation with sufficient detail and objectivity to serve as a useful guide to the equipment designer as well as the analyst. Although the treatment has been piecemeal in some respects, too much emphasis cannot be placed upon the fact that the phase-shift method is an aggregation of a few relatively simple processes with very clearly defined interrelation. Thus, instead of being a haphazard combination, the phase-shift method should be considered as a single unit which, nevertheless, allows a wide choice of design parameters. Comment has been confined to the phase-shift method alone, except insofar as certain broad analogies serve to aid in the presentation or discussion of factors directly involved in the specific subject matter of this paper.

APPENDIX I

ANALYSIS OF THE BASIC PHASE-SHIFT ELEMENT

The numerical value of the phase-shift obtained with the arrangement of Fig. 4 may be derived as follows:

A current I flows from the terminal $-E$ to the terminal E through the circuit components of the network. Thus,

$$I = \frac{-2E}{R - jX_c}, \tag{23}$$

where $j = \sqrt{-1}$. The open circuit output voltage of the network is

$$E_0 = -E - IR. \tag{24}$$

Substituting for I ,

$$E_0 = -E - \frac{2ER}{R - jX_c} = E \frac{(R + jX_c)}{R - jX_c}. \tag{25}$$

$$E_0 = E \frac{\sqrt{R^2 + X_c^2} / \tan^{-1} \frac{X_c}{R}}{\sqrt{R^2 + X_c^2} / -\tan^{-1} \frac{X_c}{R}}, \tag{26}$$

so

$$E_0 = E / 2 \tan^{-1} \frac{X_c}{R}. \tag{27}$$

$$X_c = 1/\omega C, \text{ so} \tag{28}$$

$$E_0 = E / 2 \tan^{-1} \frac{1}{\omega CR}. \tag{29}$$

Also, X_{c0} may be defined

$$X_{c0} = \frac{1}{\omega_0 C} = R, \quad (30)$$

or

$$\frac{1}{RC} = \omega_0 \quad (31)$$

Substituting in (29),

$$E_0 = E / \left[2 \tan^{-1} \frac{\omega_0}{\omega} \right] = E / \left[2 \cot^{-1} \frac{\omega}{\omega_0} \right]. \quad (32)$$

A resistance shunting the reactive arm of the network may be accommodated by adjustment of the driving signal conditions. The network then is altered to the form shown in Fig. 10. As before, a current I flows

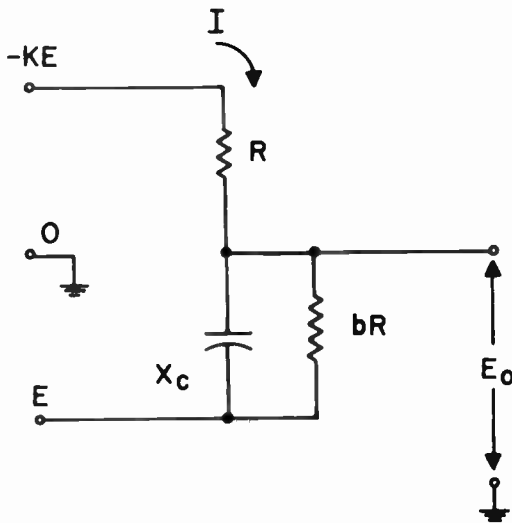

Fig. 10—A modified "basic" phase-shift network.

through the resistor R of the network. This current then divides in its flow through the shunt combination of X_c and bR and returns to the other terminal of the driving source.

$$I = \frac{-(E + KE)}{R - \frac{jbRX_c}{bR - jX_c}} = \frac{-E(K + 1)(bR - jX_c)}{bR^2 - jRX_c(1 + b)}. \quad (33)$$

The output voltage may be written

$$E_0 = -KE - IR. \quad (34)$$

Substituting the value for I ,

$$E_0 = -KE + \frac{E(K + 1)(bR - jX_c)}{bR - jX_c(1 + b)}. \quad (35)$$

After manipulation, (35) becomes

$$E_0 = E \left[\frac{bR + jX_c(bK - 1)}{bR - jX_c(1 + b)} \right]. \quad (36)$$

The absolute magnitude of E_0 is independent of X_c if

$$bK - 1 = 1 + b, \quad (37)$$

or if

$$K = \frac{b + 2}{b}. \quad (38)$$

Thus,

$$E_0 = E \left[\frac{bR + jX_c(1 + b)}{bR - jX_c(1 + b)} \right]. \quad (39)$$

Eq. (39) may be written

$$E_0 = E / \left[2 \tan^{-1} \left(\frac{1 + b}{b} \right) \frac{X_c}{R} \right]. \quad (40)$$

As before,

$$X_c/R = \frac{\omega_0}{\omega}. \quad (41)$$

Thus,

$$\begin{aligned} E_0 &= E / \left[2 \tan^{-1} \left(\frac{1 + b}{b} \right) \frac{\omega_0}{\omega} \right] \\ &= E / \left[2 \cot^{-1} \left(\frac{b}{1 + b} \right) \frac{\omega}{\omega_0} \right]. \end{aligned} \quad (42)$$

The phase-shift curve is identical in shape to that of Fig. 5, but is shifted horizontally from it by an amount $b/(1 + b)$.

A shunt combination of resistance and reactance across the output terminals of the network of Fig. 4 may also be accommodated. The network then becomes that of Fig. 11. The current I_1 flowing from the input termi-

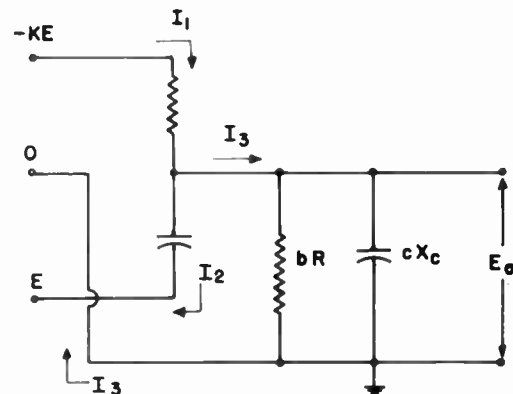

Fig. 11—Another modification of the "basic" phase-shift network.

nal $-KE$ divides into two paths; one of these is to the other input terminal of the network, while the other path is through the impedance shunting the output terminals. In effect this last current flows back into a

tap on the exciting source. The three currents may be written

$$I_1 = \frac{-(KE + E_0)}{R}, \quad (43)$$

$$I_2 = \frac{E_0 - E}{-jX_c}, \quad (44)$$

and

$$I_3 = \frac{E_0(bR - icX_c)}{-jbcRX_c}. \quad (45)$$

According to Kirchhoff's laws,

$$I_1 = I_2 + I_3. \quad (46)$$

Substituting,

$$-\frac{(KE + E_0)}{R} = \frac{E_0 - E}{-jX_c} + \frac{E_0(bR - jcX_c)}{-jbcRX_c}. \quad (47)$$

Solving (47) for E_0 ,

$$E_0 = \frac{bcE(R + iKX_c)}{(bc + b)\left(R - j\frac{bc + c}{bc + b}X_c\right)}, \quad (48)$$

which may be written

$$E_0 = \frac{cE[R + jKX_c]}{(1 + c)\left[R - j\frac{c(b + 1)}{b(c + 1)}X_c\right]}. \quad (49)$$

The output magnitude is independent of X_c if

$$K = \frac{c(b + 1)}{b(c + 1)}, \quad (50)$$

so that

$$E_0 = \frac{c}{(c + 1)} E \left[\frac{R + j\frac{c(b + 1)}{b(c + 1)}X_c}{R - j\frac{c(b + 1)}{b(c + 1)}X_c} \right]. \quad (51)$$

Eq. (51) may be written

$$E_0 = \frac{c}{(c + 1)} E \left/ 2 \cot^{-1} \left(\frac{b(c + 1)\omega}{c(b + 1)\omega_0} \right) \right. \quad (52)$$

The shape of the phase-shift curve is identical to that of Fig. 5, but displaced horizontally from it if

$$\frac{b(c + 1)}{c(b + 1)} \neq 1.$$

A fixed attenuation $c/(c + 1)$ occurs in this case.

If $b \rightarrow \infty$, the essential impedance shunting the output of the network is the reactance cX_c , and

$$E_0 = \frac{c}{(c + 1)} E \left/ 2 \cot^{-1} \left(\frac{c + 1}{c} \right) \frac{\omega}{\omega_0} \right., \quad (53)$$

where

$$K = \frac{c}{c + 1}. \quad (54)$$

If $c \rightarrow \infty$, the essential impedance shunting the output of the network is the resistance bR , and

$$E_0 = E \left/ 2 \cot^{-1} \left(\frac{b}{b + 1} \right) \frac{\omega}{\omega_0} \right., \quad (55)$$

where

$$K = \frac{b + 1}{b}. \quad (56)$$

If $b = c$, the time constant of the shunting impedance is the same as that of the primary elements, and

$$E_0 = \frac{c}{(c + 1)} E \left/ 2 \cot^{-1} \frac{\omega}{\omega_0} \right., \quad (57)$$

where

$$K = 1. \quad (58)$$

If $b = c = \infty$, the shunting impedance is absent and the output voltage is in accordance with (32), in which $K = 1$ is implicit.

The effect of the current I_3 on the voltages E and $-KE$ due to internal impedance of the source must be taken into account in the design of the source.

The arrangement of Fig. 11 is useful when resistive loading of the phase-shift network is unavoidable, such as in the case where a transistor is driven by the signal output of the network, or where the equivalent input impedance of a load such as a modulator can be represented by a shunt R, C combination at modulation frequencies.

APPENDIX II

COMPOSITE PHASE-SHIFT NETWORK DESIGN

An important concept in the design of phase-shifting systems is the cumulative phase-shift obtained from several stages of phase-shifting elements. It has been shown that circuit arrangements such as Figs. 4, 10, and 11 have phase-shift curves of identical shape, differing only in position along the ω/ω_0 axis. Where the driving signal for a phase-shifting stage is obtained from the output of a previous phase-shifting stage the total phase shift is the algebraic sum of the individual phase-shifts. Thus if

$$\phi_1 = 2 \cot^{-1} \frac{\omega}{\omega_{01}}, \quad (59)$$

where ϕ_1 is the phase-shift produced in the first stage, ω is 2π times frequency, and ω_{01} is 2π times the frequency

at which the phase-shift ϕ_1 is 90° , and if

$$\phi_2 = 2 \cot^{-1} \frac{\omega}{\omega_{0_2}}, \quad (60)$$

where ϕ_2 is the phase-shift produced in the second stage, ω is 2π times frequency, and ω_{0_2} is 2π times the frequency at which the phase-shift ϕ_2 is 90° , then

$$\phi_a = \phi_1 + \phi_2 = 2 \left(\cot^{-1} \frac{\omega}{\omega_{0_1}} + \cot^{-1} \frac{\omega}{\omega_{0_2}} \right), \quad (61)$$

where ϕ_a is the total phase-shift produced in the two stages.

Eq. (61) may be expressed

$$\phi_a = 2 \cot^{-1} \left[\frac{1 - \frac{\omega^2}{\omega_{0_1}\omega_{0_2}}}{\omega/\omega_{0_1} + \omega/\omega_{0_2}} \right]. \quad (62)$$

If

$$P = \omega_{0_2}/\omega_{0_1}, \quad (63)$$

then

$$\phi_a = 2 \cot^{-1} \left[\frac{1 + \frac{\omega^2}{P(\omega_{0_1})^2}}{\frac{\omega}{\omega_{0_1}} + \frac{\omega}{P\omega_{0_1}}} \right]. \quad (64)$$

Eq. (64) reduces to

$$\phi_a = 2 \cot^{-1} \left[\frac{P \frac{\omega_{0_1}}{\omega} - \frac{\omega}{\omega_{0_1}}}{P + 1} \right]. \quad (65)$$

If

$$\omega_{0_a} = Q\omega_{0_1}, \quad (66)$$

then (65) becomes

$$\phi_a = 2 \cot^{-1} \left[\frac{P \frac{\omega_{0_a}}{\omega} - \frac{Q\omega}{\omega_{0_a}}}{P + 1} \right]. \quad (67)$$

If

$$P = Q^2, \quad (68)$$

then (67) becomes

$$\phi_a = 2 \cot^{-1} \left[\frac{Q \left(\frac{\omega_{0_a}}{\omega} - \frac{\omega}{\omega_{0_a}} \right)}{Q^2 + 1} \right]. \quad (69)$$

If

$$M = Q + 1/Q, \quad (70)$$

then (69) becomes

$$\phi_a = 2 \cot^{-1} \left[\frac{\frac{\omega_{0_a}}{\omega} - \frac{\omega}{\omega_{0_a}}}{M} \right]. \quad (71)$$

It follows from (63), (66), and (68) that

$$\omega_{0_a} = \sqrt{\omega_{0_1}\omega_{0_2}}, \quad (72)$$

or that ω_{0_a} is the geometric mean of ω_{0_1} and ω_{0_2} . Therefore,

$$\omega_{0_a} = Q\omega_{0_1} = \frac{\omega_{0_2}}{Q}. \quad (73)$$

The total phase shift realized from such a pair of phase-shift stages is symmetrical about the frequency $\omega_{0_a}/2\pi$, at which frequency the phase shift is 180° .

The total phase-shift realized at any frequency, $\omega/2\pi$, from two stages of the type illustrated in Figs. 4, 10, and/or 11 may be determined from (71). Care must be taken to compute the correct values of the center frequencies, $\omega_{0_1}/2\pi$, and $\omega_{0_2}/2\pi$, in cases where the network design equation indicates a multiplying factor other than unity before the term ω/ω_0 of the phase-shift angle. For example, if a phase-shifting stage of the structure of Fig. 11 is used, the phase angle

$$\phi_1 = 2 \cot^{-1} \frac{b(c+1)}{c(b+1)} \left(\frac{\omega}{\omega_0} \right), \quad (74)$$

in accordance with (52). Thus, from (59)

$$\phi_1 = 2 \cot^{-1} \frac{\omega}{\omega_{0_1}} = 2 \cot^{-1} \frac{b(c+1)}{c(b+1)} \left(\frac{\omega}{\omega_0} \right), \quad (75)$$

from which

$$\frac{\omega}{\omega_{0_1}} = \frac{b(c+1)}{c(b+1)} \left(\frac{\omega}{\omega_0} \right), \quad (76)$$

with the result that

$$\omega_{0_1} = \frac{c(b+1)}{b(c+1)} \omega_0. \quad (77)$$

Any number of phase-shift stages may be combined by the method just outlined. Since the phase-shift and voltage transfer characteristic of any one stage depend upon the load impedance into which the stage works, care should be taken in the choice of coupling means employed between individual stages. A convenient method of providing such coupling is in the use of vacuum tubes as unilateral coupling devices in the manner illustrated in Fig. 12.

In Fig. 12 advantage is taken of the fact that the capacitor element of each stage is an open circuit at zero frequency, so that the effective bias supply for any given vacuum tube stage (except the first) is equal to

the cathode voltage of the preceding stage. The final stage illustrated in Fig. 12 can serve as a source for additional stages or as a source for either polarity of phase-shifted signal output. The amplitude vs frequency characteristic of a properly designed concatenation of phase-shifting stages can be made uniform from zero to almost any desired upper frequency limit. The values of K_a, K_b , etc. in Fig. 12 are unity in the practical case where the shunt impedance at points such as A, B , etc. can be considered to have negligible effect on the amplitude response and phase-shift characteristics. In cases where the effects of shunt impedances are not negligible, suitable values of K can be chosen in accordance with (50) of Appendix I.

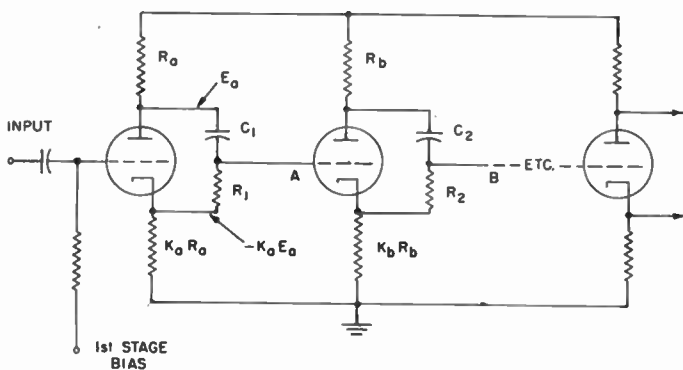

Fig. 12—Concatenation of phase-shift network elements. Vacuum tubes are used as unilateral coupling devices between elements.

The loading effects of the individual RC circuits on the voltage source should be considered for any design such as shown in Fig. 12. The effective internal impedance of the first stage of Fig. 12 at low frequencies is the sum of the parallel combination of the plate resistance of the first vacuum tube and plate load resistor R_o and the cathode resistor $K_o R_a$. Thus,

$$Z_{s1} = \frac{R_a(K_a + 1)R_p}{R_o(K_o + 1) + R_p}, \quad (78)$$

where Z_{s1} is the total effective source impedance of the first stage, and R_p is the plate resistance of the first tube under its operating conditions. Similar relations hold for succeeding stages. Current flow through the phase-shift elements R_1, C_1 causes voltage drop (which is a function of frequency) due to the internal impedance of the source with a resulting departure from completely uniform amplitude vs frequency response. Such departures from "flat" response which are not matched by identical departures in the other network of an α, β pair will cause degradation of the sideband attenuation due to unequal variation in the quantities A and B of (18). A properly matched α, β pair will have identical amplitude response in each network for optimum system performance.

Another network structure which is of considerable importance as a phase-shifting circuit is shown in Fig. 13. The analysis of this network is similar to that of the network of Fig. 11, although somewhat more involved. The three currents shown in Fig. 13 may be written as follows:

$$I_1 = \frac{-(E_o + KE)}{a(R - jX_c)}, \quad (79)$$

$$I_2 = \frac{(E - E_o)(R - jX_c)}{jRX_c}, \quad (80)$$

and

$$I_3 = \frac{-E_o(R - jX_c)}{jbRX_c}. \quad (81)$$

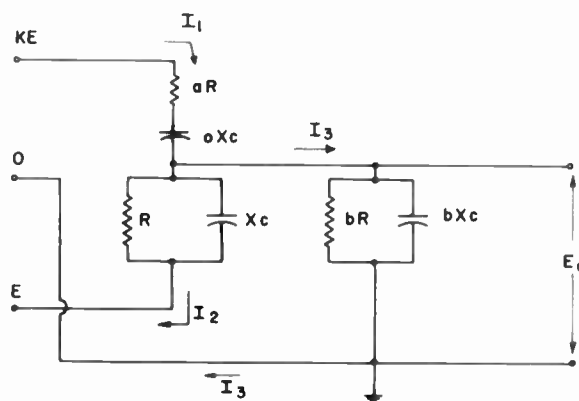

Fig. 13—The "M-Derived" phase-shift network.

As before,

$$I_1 = I_2 + I_3. \quad (46a)$$

Substituting for I_1, I_2 , and I_3 ,

$$\frac{-(E_o + KE)}{a(R - jX_c)} = \frac{(E - E_o)(R - jX_c)}{jRX_c} - \frac{E_o(R - jX_c)}{jbRX_c}. \quad (82)$$

Eq. (82) may be solved for E_o , the output signal. Thus

$$E_o = \frac{b}{(b+1)} E \frac{[a(R^2 - X_c^2) + jRX_c(K - 2a)]}{\left[a(R^2 - X_c^2) - jRX_c \frac{(b+2a+2ab)}{(b+1)} \right]}. \quad (83)$$

The magnitude of E_o is independent of X_c when

$$K = \frac{b + 2a + 2ab}{b + 1} + 2a. \quad (84)$$

Therefore, with K chosen as in (84),

$$E_o = \frac{b}{(b+1)} E \frac{1}{2 \tan^{-1} \left[\frac{b+2a+2ab}{a(b+1)} \right]} \frac{RX_c}{R^2 - X_c^2}, \quad (85)$$

which may be written

$$E_0 = \frac{1}{(1 + 1/b)}$$

$$\cdot E / 2 \cot^{-1} \left[\frac{a(1 + 1/b)}{(1 + 2a/b + 2a)} \left(\frac{R}{X_c} - \frac{X_c}{R} \right) \right]. \quad (86)$$

In accordance with (27) through (31)

$$\frac{X_c}{R} = \frac{\omega_{0M}}{\omega}, \quad (87)$$

where ω_{0M} is 2π times the design-center frequency of the network. Substituting in (86),

$$E_0 = \frac{1}{(1 + 1/b)}$$

$$\cdot E / 2 \cot^{-1} \left[\frac{a(1 + 1/b)}{1 + 2a/b + 2a} \left(\frac{\omega}{\omega_M} - \frac{\omega_{0M}}{\omega} \right) \right]. \quad (88)$$

The parallel between this expression and that of (71) is immediately apparent if (88) is written

$$E_0 = - \frac{1}{(1 + 1/b)}$$

$$\cdot E / 2 \cot^{-1} \left[\frac{a(1 + 1/b)}{1 + 2a/b + 2a} \left(\frac{\omega_{0M}}{\omega} - \frac{\omega}{\omega_{0M}} \right) \right] \quad (88a)$$

and the phase-shift,

$$\phi_M = 2 \cot^{-1} \left[\frac{a(1 + 1/b)}{1 + 2a/b + 2a} \left(\frac{\omega_{0M}}{\omega} - \frac{\omega}{\omega_{0M}} \right) \right], \quad (89)$$

compared with ϕ_a as given by (71). In this comparison, substitution of

$$\omega_{0M} = \omega_{0a} \quad (90)$$

and

$$\frac{1 + 2a/b + 2a}{a(1 + 1/b)} = M \quad (91)$$

completes the picture.

Thus, the *single* structure of the form illustrated in Fig. 13 duplicates the phase-shift obtainable from a *two-stage* phase-shifting arrangement of the form illustrated in Fig. 12 except for a polarity reversal which cannot be interpreted as a phase-shift in the strict meaning of the term.

Substitution of

$$aM = \frac{1 + 2a/b + 2a}{(1 + 1/b)} \quad (92)$$

in (84) yields

$$K = a(M + 2), \quad (93)$$

from which

$$M = \frac{K - 2a}{a}. \quad (94)$$

It follows, also, that

$$a = \frac{K}{M + 2} = \frac{1}{(M - 2)(1 + 1/b)}. \quad (95)$$

An important variation of the structure of Fig. 13 is obtained when the constant $b \rightarrow \infty$. In this case the branch "b" is missing, and, of course, $I_3 = 0$, in accordance with (81). Then

$$E_0 = - E / 2 \cot^{-1} \left(\frac{a}{1 + 2a} \right) \left(\frac{\omega_{0M}}{\omega} - \frac{\omega}{\omega_{0M}} \right). \quad (96)$$

It follows from (84) when $1/b = 0$ that

$$K = 1 + 4a, \quad (97)$$

and from (93) that

$$M = \frac{1 + 2a}{a}. \quad (98)$$

It follows, also, that

$$a = \frac{K - 1}{4} = \frac{1}{M - 2}, \quad (99)$$

and that

$$M = \frac{2(K + 1)}{K - 1} = \frac{4}{K - 1} + 2. \quad (100)$$

Frequently in the application of the structure of Fig. 13 it is desired to make $K = 1$ so that a balanced source may be used. In this case,

$$a(M + 2) = 1, \quad (101)$$

from which

$$a = \frac{1}{M + 2}. \quad (102)$$

Substitution of $K = 1$ and $a = 1/(M + 2)$ in (84) yields the value

$$b = \frac{M - 2}{4} \quad (103)$$

necessary to satisfy (88a). Eq. (88a) becomes

$$E_0 = - \left(\frac{M - 2}{M + 2} \right) E / 2 \cot^{-1} \frac{\left(\frac{\omega_{0M}}{\omega} - \frac{\omega}{\omega_{0M}} \right)}{M}. \quad (104)$$

when $K = 1$.

As with the network structures of Figs. 4, 10, and 11, due account must be taken of the load impedance into which the network of Fig. 13 works, and the effect of I_3 on the voltages E and $-KE$ must also be considered.

It will be noted that the time constant is the same in each branch of the network of Fig. 13. It is not necessary to maintain this relationship in order to realize a useful phase-shifting network. The effect of using different time constants is to shift the phase angle ϕ_M along the ω/ω_0 axis without changing the shape of the phase-shift curve for any given value of M .

The phase-shifting structure of Fig. 13 might well be called an " M -Derived" phase-shifting network.

It is possible to construct a composite (multistage) network of the sort indicated in Fig. 12, where the individual stages are of the " M -Derived" type, or to use a combination of any of the types of network structure described in Appendixes I and II. Because of the equivalence of one M -Derived network to two of the types indicated in Figs. 4, 10, and 11, certain economy of apparatus can be realized by the use of the M -Derived structure in as many of the stages of a composite network as possible. The number of combinations possible is very large, which situation provides a favorable atmosphere for ingenuity.

Fig. 14 illustrates several phase vs ω/ω_0 characteristics obtainable with the single M -Derived network of Fig. 13. The family of phase-shift curves is obtained by variation of the parameter M over the range indicated.

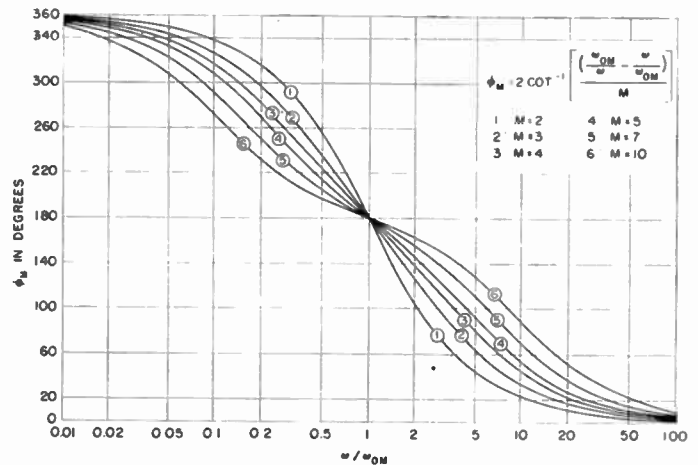

Fig. 14—Normalized phase-shift characteristics obtainable with " M -Derived" phase-shift networks.

ACKNOWLEDGMENT

The author is indebted to R. L. Watters of the General Electric Research Laboratory, and G. M. Rein-smith of the Electronics Division of the General Electric Company, for their suggestions and help in analysis and design of phase-shift networks, to Dr. A. W. Hull of the General Electric Research Laboratory for his whole-hearted support of the research effort associated with the study of the phase-shift method, and to W. N. Coffey of the General Electric Research Laboratory for his many helpful suggestions in the preparation of this paper.

The Phase-Shift Method of Single-Sideband Signal Reception*

DONALD E. NORGAARD†, SENIOR MEMBER, IRE

Summary—The phase-shift method of single-sideband signal reception exhibits characteristics determined by four principal design parameters. The expression developed for the ratio of sideband rejection to sideband acceptance is similar to that which expresses the sideband suppression ratio obtainable with the phase-shift method single-sideband signal generation.

Zero frequency output signals derived by demodulators from a transmitted pilot carrier may be used for gain control and frequency control in a receiver designed for this mode of operation. Dual channel operation is obtained with a minimum of equipment added to that necessary for single channel use. Use of the phase-shift method in combination with band-pass filters to enhance performance is discussed.

* Original manuscript received by the IRE, October 8, 1956.

† General Electric Res. Labs., Schenectady, N. Y.

INTRODUCTION

A COMPLETE communication system involves the processing of an input stimulus to a form suitable for transmission by means of a selected medium to one or more receiving locations where the received energy is converted back into the form of the original stimulus or to an acceptable analog. Utilization of the signal available at a receiving point calls for receiving apparatus particularly suited for the characteristics of the signaling (transmission) mode. This, of course, broadly defines a single-sideband receiver when the signaling mode is that known as single sideband.

The problem of reception of single-sideband signals

can be reduced to one of providing sufficient bandwidth and uniformity of response over this bandwidth to be consistent with system requirements, and to restrict response of the receiving system to signals necessary for compliance with these requirements. In addition, the receiving method should introduce minimum amounts of noise and distortion to the signals it is called upon to convey.

The phase-shift method of single-sideband reception is a logical and compatible extension of the phase-shift method of generating single-sideband signals.¹ As such it shares many of the characteristics of this signal generating method. It is the purpose of this paper to analyze the phase-shift method of signal reception and to relate performance to the parameters of its composite elements.

ACTION OF EXALTED CARRIER DEMODULATORS

The phase-shift method of signal reception is made possible by certain properties of exalted carrier demodulators. An exalted carrier demodulator is one in which two signals are combined nonlinearly to produce an output signal at a frequency (or frequencies) different from those of the two input signals.² Specifically, low-frequency beats or heterodynes are the output signals of interest in this discussion. An understanding of the action of such demodulators is an almost necessary prelude to comprehension of the phase-shift receiving method.

If an input signal is applied simultaneously to two identical demodulators together with separate carrier signals in the manner indicated in Fig. 1, the separate

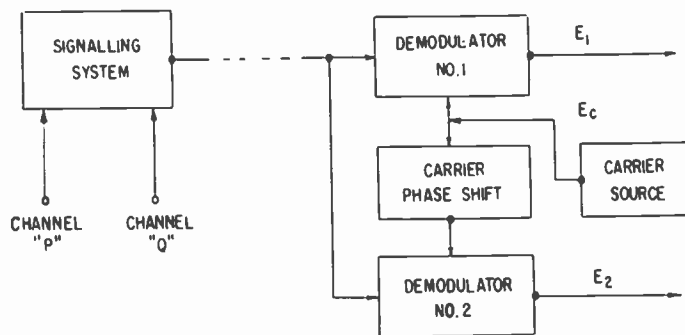

Fig. 1—Use of two exalted carrier demodulators supplied with reference carrier signals at a fixed phase difference to provide signals suitable for resolution by the phase-shift method of signal reception.

output signals of the two demodulators exhibit characteristics dependent upon the phase relationship between the two applied carrier signals. By way of explanation, let it be assumed that the signaling system in

the left-hand portion of Fig. 1 is a dual-channel single-sideband signal generator in which two channels, P and Q , are converted to upper and lower sideband signals, respectively, about a carrier frequency $\omega_c/2\pi$. Let it be assumed, further, that the carrier source in the right-hand portion of Fig. 1 operates at the same carrier frequency as that of the signaling system.³

The input signal (from the signaling system) to the two demodulators may be expressed

$$\text{Input Signal} = P \sin(\omega_c t + pt) + Q \sin(\omega_c t - qt), \quad (1)$$

where P and Q are, respectively, the peak magnitudes of the two sideband signals, ω_c is 2π times the frequency of the signalling system carrier, p and q are, respectively, 2π times the modulating frequencies of the two channels, and t is time.

It will be appreciated that (1) is an expression of the character of the signal when a single tone comprises the signal supplied to each of the separate channel inputs and is limited in this manner for purposes of clarity. Complex waveforms may be transmitted, of course, but a complete specification of the signal would consist of a summation of all the Fourier components of each complex waveform. Since p and q can represent any of a series of single tones actually applied, no loss of generality results from this method of notation.

The carrier signal supplied to Demodulator No. 1 may be expressed

$$\text{Carrier No. 1} = E_c(\sin \omega_c t + \gamma), \quad (2)$$

where E_c is the peak magnitude of the carrier signal, γ is an arbitrary phase angle, and the other symbols are as defined previously.

Similarly, the carrier signal supplied to Demodulator No. 2 may be expressed

$$\text{Carrier No. 2} = E_c \sin(\omega_c t + \gamma + 90^\circ + \Delta), \quad (3)$$

where Δ is the angular error in maintaining quadrature relationship between Carrier No. 1 and Carrier No. 2. The other symbols are as defined previously.

Eq. (3) may be written

$$\text{Carrier No. 2} = E_c \cos(\omega_c t + \gamma + \Delta). \quad (4)$$

If each modulator acts to perform a normalized multiplication of its two input signals, the output signals of the two demodulators may be expressed

$$E_1 = 2[\sin(\omega_c t + \gamma)][P \sin(\omega_c t + pt) + Q \sin(\omega_c t - qt)] \quad (5)$$

for the output of Demodulator No. 1, and

$$E_2 = 2[\cos(\omega_c t + \gamma + \Delta)][P \sin(\omega_c t + pt) + Q \sin(\omega_c t - qt)] \quad (6)$$

for the output of Demodulator No. 2.

³ This statement, if accepted at face value, precludes frequency conversion at any point in the system. It will be understood that this is a simplification intended to aid the process of explanation.

¹ D. E. Norgaard, "The phase-shift method of single-sideband signal generation," this issue, p. 1718.

² The distinction between a demodulator and a modulator is mainly one of relative numerical values applied to the input and output frequencies. The term demodulator is generally applied to a device which produces low-frequency output signals from high-frequency input signals, essentially the reverse of the action of a modulator.

Eq. (5) expands⁴ to

$$E_1 = \left\{ \begin{aligned} &P[\cos(pt - \gamma) - \cos(2\omega_c t + pt + \gamma)] \\ &+ Q[\cos(-qt - \gamma) - \cos(2\omega_c t - qt + \gamma)] \end{aligned} \right\}, \quad (7)$$

while (6) expands to

$$E_2 = \left\{ \begin{aligned} &P[\sin(pt - \gamma - \Delta) + \sin(2\omega_c t + pt + \gamma + \Delta)] \\ &+ Q[\sin(-qt - \gamma - \Delta) + \sin(2\omega_c t - qt + \gamma + \Delta)] \end{aligned} \right\}. \quad (8)$$

After filtering,⁵ the demodulator outputs may be expressed

$$E_1 = P \cos(pt - \gamma) + Q \cos(qt + \gamma) \quad (9)$$

for the output of Demodulator No. 1, and

$$\begin{aligned} E_2 &= P \sin(pt - \gamma - \Delta) - Q \sin(qt + \gamma + \Delta) \\ &= P \sin(pt - \gamma - \Delta) + Q \sin(qt + \gamma + \Delta + 180^\circ) \end{aligned} \quad (10)$$

for the output of Demodulator No. 2.

Eq. (9) may be written

$$E_1 = P \sin(pt - \gamma + 90^\circ) + Q \sin(qt + \gamma + 90^\circ). \quad (11)$$

Terms appearing in (10) and (11) may now be compared. It will be noted that the "P" channel appears in both demodulator outputs at the same magnitude and with a phase difference of $(90^\circ + \Delta)$, while the "Q" channel appears in both outputs with the same magnitude but with a phase difference of $-(90^\circ + \Delta)$. Note, also, that the arbitrary angle γ does not affect these phase differences.

ANALYSIS OF THE PHASE-SHIFT METHOD OF RECEPTION

The phase differences inherent in the signal outputs of the two demodulators are indicative of whether a given component of the input signal has a frequency higher or lower than the carrier signal supplied to the demodulators. This information may be utilized to separate lower sideband signals from upper sideband signals, thus accomplishing a result which is the equivalent of use of two sharp cutoff filters. Fig. 2 illustrates a method for resolving upper and lower sideband regions into separate channels.

Let it be assumed that the signaling system, the demodulators, the carrier source, and the carrier phase-shift network of Fig. 2 are the same as illustrated in Fig. 1. The output signals⁶ of the two demodulators are supplied separately to phase-shift networks which have the property of producing a relatively constant differential phase-shift in signals passing through them. The two phase-shifted signal outputs are then simultaneously

added and subtracted in the combining circuit to provide separate output signals in response to input signals in the two respective sideband regions. The phase-shift networks are identified by the symbols α and β . These will be referred to hereinafter as α and β networks, and the phase shifts produced by each as α and β , respectively.

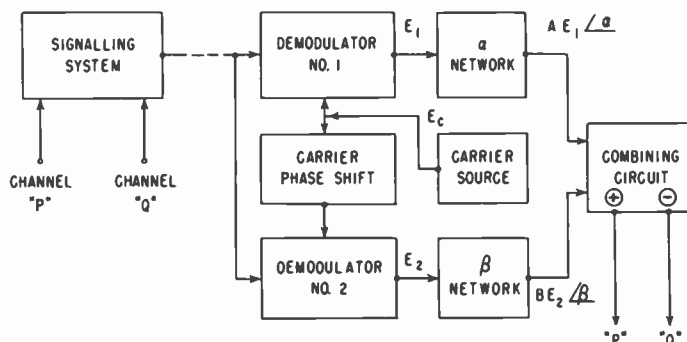

Fig. 2—Elements of the phase-shift method of single-sideband signal reception. Channels "P" and "Q" are transmitted on opposite sidebands and are resolved into separate output channels without use of band-pass filters.

The relationship between α and β may be expressed

$$\beta - \alpha = 90^\circ + \delta, \quad (12)$$

where β and α are, respectively, the phase shift of the β and α networks, and δ is the angular deviation from 90° in the phase-shift difference. It follows that

$$\beta = \alpha + 90^\circ + \delta. \quad (13)$$

In accordance with Fig. 2, the output of Demodulator No. 1 serves as a signal source for the α network. The output signal of the α network is then

$$\alpha \text{ network output} = A E_1 \angle \alpha \quad (14)$$

where A is a real constant of proportionality, E_1 is the output of Demodulator No. 1, and the symbol $\angle \alpha$ indicates a phase-shift of α .

In accordance with (11) and (14)

$$\alpha \text{ Network Output} = A \left\{ \begin{aligned} &P \sin(pt - \gamma + 90^\circ + \alpha) \\ &+ Q \sin(qt + \gamma + 90^\circ + \alpha) \end{aligned} \right\}. \quad (15)$$

Similarly, the output of the β network may be expressed

$$\beta \text{ Network Output} = B E_2 \angle \beta \quad (16)$$

where B is a real constant of proportionality, E_2 is the output of Demodulator No. 2, and the $\angle \beta$ indicates a phase shift of β .

In accordance with (10) and (13), (16) becomes

$$\begin{aligned} \beta \text{ network output} \\ = B \left\{ \begin{aligned} &P \sin(pt - \gamma - \Delta + \alpha + 90^\circ + \delta) \\ &+ Q \sin(qt + \gamma + \Delta + \alpha - 90^\circ + \delta) \end{aligned} \right\}. \end{aligned} \quad (17)$$

⁴ The trigonometric identities involved in this and the following manipulations are taken from or derived from the tabulations appearing in R. G. Hudson, "The Engineer's Manual," John Wiley and Sons, Inc., New York, N. Y., 2nd ed.; 1947.

⁵ The filtering indicated is to remove signals having frequencies of the order of $\omega_c/2\pi$ and greater from the output of each demodulator. It is assumed that the filter introduces no phase or amplitude effects at the frequencies $p/2\pi$ and $q/2\pi$.

⁶ The filtering action to remove high-frequency products from the outputs of the demodulators is assumed to be an inherent function of each demodulator.

The vector sum of the α and β network output voltages appears at the (+) terminal of the combining circuit. This sum may be expressed

Sum Signal

$$= \left\{ \begin{array}{l} P[A \sin (pt + \alpha - \gamma + 90^\circ) \\ + B \sin (pt + \alpha - \gamma + 90^\circ + \delta - \Delta)] \\ + Q[A \sin (qt + \alpha + \gamma + 90^\circ) \\ + B \sin (qt + \alpha + \gamma - 90^\circ + \delta + \Delta)] \end{array} \right\}. \quad (18)$$

$$\text{Difference Signal} = \left\{ \begin{array}{l} P\sqrt{A^2 + B^2 - 2AB \cos (\Delta - \delta)} \sin \left(pt + \alpha - \gamma - \tan^{-1} \frac{A - B \cos (\Delta - \delta)}{B \sin (\Delta - \delta)} \right) \\ - Q\sqrt{A^2 + B^2 + 2AB \cos (\Delta + \delta)} \sin \left(qt + \alpha + \gamma - \tan^{-1} \frac{A + B \cos (\Delta + \delta)}{B \sin (\Delta + \delta)} \right) \end{array} \right\}. \quad (28)$$

Eq. (18) may be written

Sum Signal

$$= \left\{ \begin{array}{l} P[A \cos (pt + \alpha - \gamma) + B \cos (pt + \alpha - \gamma + \delta - \Delta)] \\ + Q[A \cos (qt + \alpha + \gamma) - B \cos (qt + \alpha + \gamma + \delta + \Delta)] \end{array} \right\}. \quad (19)$$

Equation (19) may be expressed

$$\text{Sum Signal} = \left\{ \begin{array}{l} -P\sqrt{A^2 + B^2 + 2AB \cos (\Delta - \delta)} \sin \left(pt + \alpha - \gamma + \tan^{-1} \frac{A + B \cos (\Delta - \delta)}{B \sin (\Delta - \delta)} \right) \\ + Q\sqrt{A^2 + B^2 - 2AB \cos (\Delta + \delta)} \sin \left(qt + \alpha + \gamma + \tan^{-1} \frac{A - B \cos (\Delta + \delta)}{B \sin (\Delta + \delta)} \right) \end{array} \right\}. \quad (20)$$

The voltage recovered from the lower sideband signal, $Q \sin (\omega_c t - qt)$, is

$$Q\sqrt{A^2 + B^2 - 2AB \cos (\Delta + \delta)}. \quad (21)$$

This voltage vanishes when both

$$A = B \quad (22)$$

and

$$\Delta + \delta = 0. \quad (23)$$

The voltage recovered from the upper sideband signal, $P \sin (\omega_c t - pt)$, is

$$-P\sqrt{A^2 + B^2 + 2AB \cos (\Delta - \delta)}. \quad (24)$$

This coefficient becomes $-2AP$ when both

$$A = B \quad (25)$$

and

$$\Delta - \delta = 0. \quad (26)$$

Similarly, the vector difference of the α and β output voltages appears at the (-) terminal of the combining circuit. This difference may be expressed

Difference Signal

$$= \left\{ \begin{array}{l} P[A \sin (pt + \alpha - \gamma + 90^\circ) \\ - B \sin (pt + \alpha - \gamma - 90^\circ + \delta - \Delta)] \\ + Q[A \sin (qt + \alpha + \gamma + 90^\circ) \\ - B \sin (qt + \alpha + \gamma - 90^\circ + \delta + \Delta)] \end{array} \right\}. \quad (27)$$

Eq. (27) may be expressed

The voltage recovered from the upper sideband signal, $P \sin (\omega_c t + pt)$, is

$$P\sqrt{A^2 + B^2 - 2AB \cos (\Delta - \delta)}. \quad (29)$$

This voltage vanishes when both

$$A = B \quad (30)$$

and

$$\Delta - \delta = 0. \quad (31)$$

The voltage recovered from the lower sideband signal, $Q \sin (\omega_c t - qt)$ is

$$-Q\sqrt{A^2 + B^2 + 2AB \cos (\Delta + \delta)}. \quad (32)$$

This coefficient becomes $-2AQ$ when both

$$A = B \quad (33)$$

and

$$\Delta + \delta = 0. \quad (34)$$

Interest is centered about the ratio of the rejected sideband response to the accepted sideband response. At the sum signal output of the combining circuit of Fig. 2 the ratio may be expressed

$$\frac{\text{Rejected Sideband Response}}{\text{Accepted Sideband Response}} = \sqrt{\frac{A^2 + B^2 - 2AB \cos (\Delta + \delta)}{A^2 + B^2 + 2AB \cos (\Delta - \delta)}}. \quad (35)$$

At the difference signal output, the ratio may be expressed

Rejected Sideband Response
Accepted Sideband Response

$$= \sqrt{\frac{A^2 + B^2 - 2AB \cos(\Delta - \delta)}{A^2 + B^2 + 2AB \cos(\Delta + \delta)}} \quad (36)$$

Neither of the above ratios can become zero except when $A = B$, since both A and B are real numbers. The sideband rejection ratio obtained for the sum signal output becomes zero when $A = B$ and $(\Delta + \delta) = 0$, while the sideband rejection ratio obtained for the difference signal output becomes zero when $A = B$ and $(\Delta - \delta) = 0$. Thus, if ideal channel separation is to be achieved simultaneously in each output, it follows in addition to $A = B$, that

$$\Delta = 0 \quad (37)$$

and

$$\delta = 0. \quad (38)$$

When $A = B$ and $\Delta = 0$, (35) and (36) reduce to

$$\frac{\text{Rejected Sideband Response}}{\text{Accepted Sideband Response}} = \tan\left(\frac{\delta}{2}\right). \quad (39)$$

Eq. (39) may be taken as defining the signal rejection characteristic of the phase-shift method of single-sideband signal reception since the error angle δ is not independent of signal frequency in the general case, while the quantities A , B , and Δ can be controlled sufficiently well so that a major portion of the degradation of the sideband rejection ratio [as expressed by (35) and (36)] is almost entirely due to departures of δ from zero.

Eqs. (35) and (36) are the fundamental expressions for sideband rejection obtainable with the phase-shift method of single-sideband signal reception. These equations are similar to the equation developed for sideband suppression obtainable with the phase-shift method of single-sideband signal generation.¹

The foregoing analysis delineates the phase-shift method of single-sideband signal reception. The treatment has been sufficiently general to serve as an outline which permits rather broad choice of means for satisfying the particular functions indicated as essential to the method. In the practical case the angle Δ is made zero in the interest of providing equivalent sideband rejection in both channels as well as optimum performance in the case of single-channel equipment. It can be appreciated that when $\Delta = 0$ the performance is determined by the three remaining parameters, A , B , and δ , which are dependent upon the characteristics of the α and β networks required for implementation of the method. These phase-shift networks may be designed to provide any desired tolerance on A , B , and δ over any desired modulation frequency range excluding zero cycles per

second. Many such networks and network arrays are described elsewhere.^{1,7-11}

Since channel separation (selectivity) is obtained at modulation frequencies by use of the phase-shift method, no restriction of carrier frequency is inherent in the method. Thus, operation can be successful at the same frequency as that of the transmitting system, as indicated in Fig. 2, if the angle Δ is suitably chosen and maintained. The usual application of the phase-shift method, however, is in conjunction with superheterodyne types of equipment where incoming signals are converted to a fixed intermediate frequency at which the demodulators are designed to operate. Design of receiving equipment with a sufficiently high value of intermediate frequency to permit adequate image selectivity to be obtained with a single frequency conversion does not require sacrifice of channel selectivity when the phase-shift method is used.

The application of the phase-shift method to generalized reception is shown in Fig. 3. In this case the

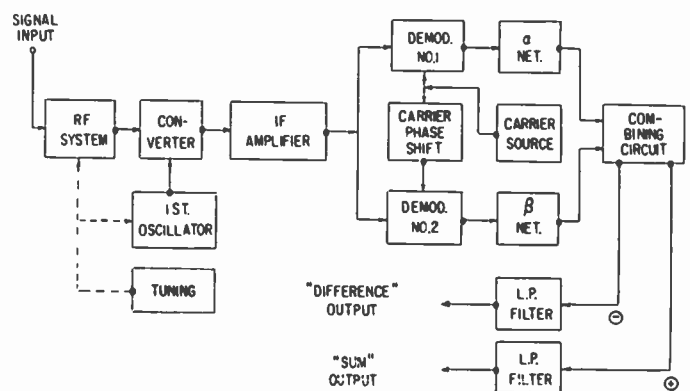

Fig. 3—Typical application of the phase-shift method in a superheterodyne type of receiver. The low-pass filters in output channels define effective bandwidth of each channel.

carrier signal required by the demodulators is at the center frequency of the intermediate frequency (IF) amplifier so that the phase error angle Δ may be maintained at zero by simple means. The apparatus of Fig. 3 may be of conventional superheterodyne design up to the output of the intermediate frequency amplifier. The remainder of the apparatus is identical to that shown in Fig. 2 except for the addition of a low-pass filter in each channel output. The band-pass characteristics of the signal path as far as the output of the IF amplifier must be such that adequate system response is maintained in each channel. In general, the bandwidth of this portion of the receiver is made sufficiently great to provide sub-

⁷ R. B. Dome, "Wide-band phase shift networks," *Electronics*, vol. 19, pp. 112-115; December, 1946.

⁸ David G. C. Luck, "Properties of some wide-band phase-splitting networks," *Proc. IRE*, vol. 37, pp. 147-151; February, 1949.

⁹ S. Darlington, "Realization of a constant phase difference," *Bell Sys. Tech. J.*, vol. 24, pp. 94-104; January, 1950.

¹⁰ H. J. Orchard, "Synthesis of wideband two-phase networks," *Wireless Engr.*, vol. 27, pp. 72-81; March, 1950.

¹¹ O. G. Villard, Jr., "Cascade connection of 90-degree phase shift networks," *Proc. IRE*, vol. 40, pp. 334-337; March, 1952.

stantially no limitation to recovered signal bandwidth. The low-pass filter in each channel output can provide necessary attenuation outside the high frequency response limits necessary for the channel.

Fig. 4 illustrates the effective band-pass characteristic obtainable with the phase shift method in combination with a 3 kc low-pass filter in one channel. It will be noted that the IF bandwidth (assumed to be 8 kc) does not affect the over-all characteristic at recovered signal frequencies below 4 kc and plays no part in determining channel separation between upper and lower sideband. For purposes of clarity the response characteristic of only one channel is shown in Fig. 4, the response characteristic of the other channel being a mirror image (about zero recovered frequency) of the one shown. The minimum attenuation of 60 db in the rejected sideband region requires a maximum value of approximately $1/10^\circ$ for δ . The approach to idealized band-pass response indicated by Fig. 4 is phenomenal when it is realized that this type of performance is obtainable at any center frequency where the demodulators are capable of operating and where Δ can be maintained at a value of approximately zero.

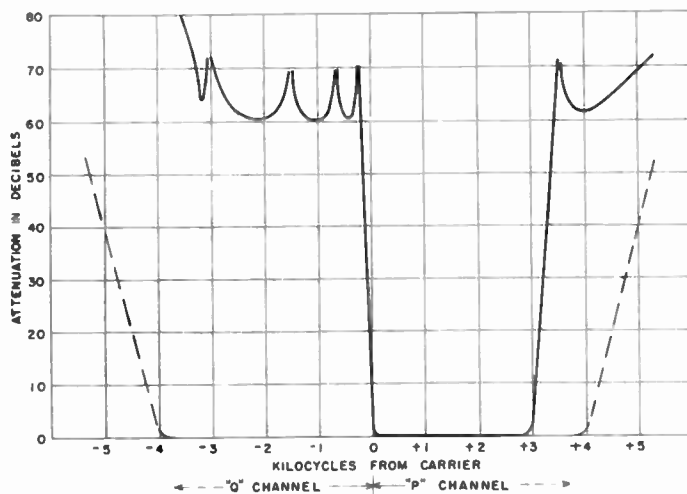

Fig. 4—Equivalent selectivity of system of the type shown in Fig. 3. A "mirror image" characteristic for the "Q" channel is also obtained simultaneously. Dashed lines indicate an assumed selectivity characteristic of circuits preceding the demodulators. Slope of the attenuation characteristic near zero frequency is governed by phase-shift network design, while slope of the characteristic above 3 kilocycles is governed by cutoff characteristic of low-pass filter.

It will be noted that the channel "P" attenuation is 3 db greater than minimum at a recovered frequency of zero cps. The attenuation increases as the characteristic is extended into the channel "Q" band. The response to channel "Q" signals drops very rapidly to the design rejection value of 60 db. This indicates a value of $\delta = \pm 90^\circ$ at zero frequency and a value of $\delta = 0$ at about 200 cps in this example. The error angle δ then oscillates¹²

¹² This behavior is typical of optimum design α and β network pairs described in footnote 1.

about zero degrees *average* value as the recovered signal frequency increases until it crosses through zero for the last time at about 3 kc, the nominal band limit. The channel "P" low-pass filter is effective in reducing response to signals in the channel "Q" region beyond its cutoff frequency. Separation between two channels such as P and Q of the system under discussion within the band-pass of the channel low-pass filters is governed solely by the characteristics of the phase-shift method alone since no channel selectivity precedes the phase-shift portion of the system.

COMBINATION SYSTEMS

The phase-shift reception method lends itself to operation in systems which provide selectivity ahead of the demodulators. Such a combination system may be used to increase attenuation of unwanted signals beyond the amount that may be provided economically by either the phase-shift method or the filter method alone. Combination methods may be used also to exploit the band-pass and band rejection properties typical of each method. A combination system is especially advantageous in single-channel systems. The over-all unwanted signal attenuation in combination systems is the product of the attenuations of each method where these attenuations are expressed in arithmetic (linear) ratios.

OPERATION WITH PILOT CARRIER TRANSMISSION SYSTEMS

In order to reduce the rather stringent requirements placed on carrier frequency stability of both transmitter and receiver where a given quality of service would indicate almost impossibly small tolerance, a pilot carrier is transmitted along with the intelligence-bearing sidebands such as channels P and Q indicated previously. In single-sideband communication systems the pilot carrier usually is transmitted at a level considerably below that of the sidebands and serves as a reference for both frequency and gain control in receivers.

The two demodulators necessary for implementation of the phase-shift receiving method can serve as convenient devices for extracting information conveyed by the pilot carrier and making this information available for both frequency control and gain control purposes in the receiver. It will be understood that the *average* frequency of the carrier as seen at the receiving point will be that of the transmitter and that the *average* magnitude of the carrier at the receiver input will be indicative of the amount of amplification required at the receiver to maintain recovered signal output (s) at a level proportional to the modulating signal input(s) at the transmitter.

The phase-shift receiving method calls for two demodulators supplied with locally generated carrier signals maintained in quadrature phase relationship. If a pilot carrier is transmitted at carrier frequency $(\omega_c/2\pi)$ and applied to the two demodulators at a finite signal level along with the P and Q channel signals, then (1)

can be modified to specify the complete signal. Thus,

$$\text{Input Signal} = E_s \sin \omega_c t + P \sin (\omega_c t + p)t + Q \sin (\omega_c t + q)t \quad (40)$$

where E_s is the peak magnitude of the pilot carrier. Other terms are as defined previously.

The locally generated carrier signals applied to the demodulators are described by (2) and (4). The output of Demodulator No. 1 may now be expressed

$$E_1 = 2 \sin (\omega_c t + \gamma) [E_s \sin \omega_c t + P \sin (\omega_c t + p)t + Q \sin (\omega_c t + q)t] \quad (41)$$

which expands to

$$E_1 = \left\{ \begin{array}{l} E_s \cos \gamma - E_s \cos (2\omega_c t + \gamma) \\ + P [\cos (pt - \gamma) - \cos (2\omega_c t + pt + \gamma)] \\ + Q [\cos (qt + \gamma) - \cos (2\omega_c t - qt + \gamma)] \end{array} \right\}. \quad (42)$$

After high-frequency filtering, Demodulator No. 1 output may be written

$$E_1 = E_s \cos \gamma + P \cos (pt - \gamma) + Q \cos (qt + \gamma). \quad (43)$$

It will be noted that the recovered signals, P and Q , are unaffected by transmission of carrier, but that a new term, $E_s \cos \gamma$, appears when (43) is compared with (9). If γ is assumed to be constant, this new term represents a unipotential output signal recovered by Demodulator No. 1. This direct current component is proportional to the carrier signal applied at the received signal input of this demodulator.

Similarly, the signal recovered from Demodulator No. 2 may be shown to contain a unipotential term,

$$E_s \sin (-\gamma - \Delta) = -E_s \sin (\gamma + \Delta), \quad (44)$$

which is also proportional to the carrier signal applied. In the case of interest, $\Delta = 0$, so the unipotential output of Demodulator No. 2 is

$$\text{DC component of } E_2 = -E_s \sin \gamma \quad (45)$$

when $\Delta = 0$.

Since the angle γ was initially of arbitrary value it may be allowed to have any value convenient for the purpose at hand. Suppose γ is allowed to have a nominal value of 180° . Eq. (43) may then be written

$$E_1 = E_s \cos \gamma = -E_s \quad (43a)$$

for extremely low frequencies (below those of channels P and Q).

Similarly, (45) may be written

$$E_2 = -E_s \sin \gamma \quad (45a)$$

for low frequencies only.

The direct current component of E_1 may be used as a signal-controlled source of bias or gain control voltage for one or more of the stages comprising the signal path

preceding the demodulators if γ is approximately 180° .¹³ The appearance of this direct current component related to the pilot carrier is limited to the case of synchronous operation of the local carrier source E_s with the input signal carrier E_s . Its magnitude is independent of sidebands P and Q .

When γ is 180° the direct current component delivered by Demodulator No. 2 responds in magnitude and polarity to variations in γ as indicated in (45a). This output signal may serve as a source of voltage for use in controlling the frequency of one of the local oscillators which comprise a portion of a typical receiver such as shown in Fig. 3. The magnitude of the control source is dependent upon the magnitude of the carrier component E_s , as well as upon the value of γ . Thus, for a fixed value of E_s , a frequency control voltage proportional to $\sin \gamma$ is available for actuation of a frequency control device in response to the relative phase angle. Various types of servomechanisms responsive to the control voltage may be used for the purpose.

In combination, the two unipotential signals appearing in the outputs of the respective demodulators may be used to regulate both the average value of E_s by automatic gain control means and the average value of γ by reactance variation of a frequency determining element of an oscillator within the receiver. The detailed design of such servomechanisms is beyond the scope of this paper. It should be emphasized, however, that these servomechanisms will seek to reduce the variation of the magnitudes of both E_s and γ when designed for stable operation. The following may serve as helpful guides in the design of suitable gain and frequency regulation systems:

- 1) Selective fading action can, in effect, modulate both the magnitude of E_s and its apparent phase. Under these conditions the average magnitude of E_s is a measure of the average strength of the intelligence channels P and Q . Similarly, the average phase angle γ is a measure of synchronism. At any instant the strength of the carrier may *not* be a measure of circuit attenuation, so considerable averaging (or integration) of the "direct current" output of Demodulator No. 1 is required in processing this control signal for automatic gain control purposes. For example, time constants in excess of 10 seconds are not uncommon in agc systems for this service. Similarly, the "direct current" output of Demodulator No. 2 is not necessarily instantaneously a measure of synchronism. Consequently, integration of this frequency control component is necessary in order to obtain an averaging effect. In either case, the result of the integration process is to reduce the response speed of the servomechanism.

¹³ Since the cosine function has an absolute magnitude of approximately unity near zero degrees and 180° , the magnitude of the voltage component will not depend critically upon γ .

- 2) Both the maximum excursion of carrier frequency and the rate of change of frequency must be consistent with the servomechanism design for satisfactory operation. This includes the frequency control means employed at the transmitter as well as that of the receiver. Under conditions of severe selective fading the maximum apparent rate of change of frequency may exceed the ability of the servomechanism to "follow" the signal although the average rate of change of frequency may be well within the limits of the system.
- 3) Initial tuning operations are generally accomplished manually. Provision should be made for either completely or partially disabling the automatic features and resetting to midrange during the manual tuning operation. This is especially desirable in the frequency control circuits. Automatic operation may be restored after initial tuning is completed.
- 4) Completely manual frequency control is desirable for use with systems which transmit no pilot carrier or where intermittent transmissions are commonplace. Fast-acting, slow-recovery automatic gain control arrangements can be employed to prevent more than momentary overloads with intermittent transmissions having wide variations in signal strength. Such gain control action is based on the strength of the intelligence bearing sideband(s) and seeks to regulate the recovered channel output amplitude independent of the input strength at the transmitter.
- 5) Operation with signals which utilize "offset" pilot carrier does not affect the general method of gain control or frequency control already described. Additional signal processing is generally necessary in systems of this nature.
- 6) The effective bandwidth of the frequency control signal after integration is generally very small, sometimes as little as 1/10 cps or less. The resulting noise bandwidth of such a "filter" is correspondingly small, so that adequate frequency control can be maintained with very little coherent signal (pilot carrier) energy at signal levels where the degradation of the channels P and Q due to noise generally establishes practical threshold conditions before disturbance of the frequency control system due to noise occurs. In the limit, however, random (white) noise will affect the frequency control system unless the frequency control function is disabled at a threshold point where the noise disturbs the tuning system. The nature of the control signal developed by

Demodulator No. 2 is such that disappearance of coherent signal at the input of the demodulator disables the control system automatically.

DEMODULATORS

The foregoing analysis of the phase-shift method of reception has assumed that the demodulators required by the method operate as perfect signal multiplying devices in order to provide output signals suitable for subsequent processing by the remainder of the system. Many demodulator configurations which approximate the theoretical performance postulated may be devised. Certain departures from this unqualified ideal are allowable, if these departures are of identical nature in each of the two demodulators. In particular, departures from absolutely uniform frequency response throughout the range of recovered signal bandwidth will not degrade the signal rejection properties of the method if these departures are the same in each demodulator. On the other hand, distortion which appears in the output of either (or both) demodulator(s) will degrade performance.

Demodulators suited for use in the phase-shift method of reception must be capable of providing zero frequency output signals if frequency control and gain control functions are to be derived from a pilot carrier in the manner explained previously. In general, some form of balanced demodulator is desirable in order to prevent unwanted mutual coupling between the two demodulators and to reduce distortion in the recovered signal output.

One form of demodulator particularly well suited for use in the phase-shift method is shown in Fig. 5. This is

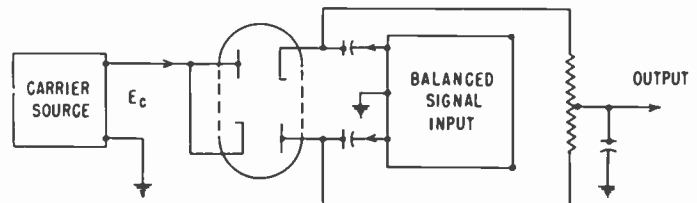

Fig. 5—Example of exalted carrier demodulator suitable for use in the phase-shift method. The two signal sources may be interchanged provided suitable voltage ratios are maintained.

a balanced demodulator of the peak conduction type. Operating conditions are established by maintaining a large ratio of carrier signal to received signal with the result that the effective percentage modulation apparent at each diode of the demodulator is small. Ratios in excess of 100 are not unreasonable provided the locally applied carrier signal level is at least several volts. Semiconductor diodes are not suited for operation in the circuit of Fig. 5 since excessive noise is developed by reverse current flow through such devices. Thermionic

diodes such as the type 6AL5 operate quite satisfactorily with a peak value of approximately 200 volts applied by the source E_c . Signal input and carrier input points may be interchanged, if desired, provided suitable signal level ratios are maintained.

DISTORTION

In receiving apparatus as well as transmitting apparatus, distortion occurring in various sections of the equipment can degrade performance from the idealized values predicted on the basis of distortionless amplifying and converting processes. Intermodulation distortion can add spurious signals to each of the recovered channel output signals represented by P and Q of Fig. 3. Signal components of each intelligence channel engage in a "mixing" process which generates intermodulation products that affect each channel adversely when distortion occurs anywhere in the signal path ahead of the demodulators. This process is identical to that which exists in transmitting equipment.

An additional problem exists in receiving equipment where signals totally unrelated to the desired signals may be applied to the system. These undesired signals may be of much greater magnitude than the desired signals and may lie entirely outside the frequency band of the desired signals. To the author's knowledge, no completely adequate method has ever been devised for prevention of intermodulation effects arising from this condition. Operation of receiving circuits well below overload levels on the desired signals affords some protection against such intermodulation from strong adjacent signals. The degree to which this may be done is limited by noise considerations as well as by effective band-pass configurations applicable to receiving apparatus in the signal path ahead of active circuit elements such as vacuum tubes, transistors, etc. Conventional receiver design combines the selectivity function with the amplification function so that as the input signal is built up in level in its progress through the receiver the relative response to signals outside the necessary pass band is reduced. This represents a reasonable compromise between perfection and reality, and, of course, has its limitations.

The requirement for low distortion particularly applicable to the phase-shift method extends through the demodulators, the phase-shift networks, and the combining circuit. Distortion products produced in portions of the receiving circuits preceding the demodulators will be acted upon by the equivalent selectivity characteristics of the type indicated in Fig. 4. Distortion products generated in the demodulators, however, will not be subject to this "filtering" action. Similarly, distortion products produced in the phase-shift networks and the combining circuit will, in general, appear in the channel outputs. Thus, control of intermod-

ulation distortion should be such that the amplifying and signal processing circuits preceding the demodulators generate almost all of the system intermodulation distortion products observable in the complete apparatus.¹⁴

CONCLUSION

The phase-shift method of single-sideband signal reception permits design of receiving apparatus without recourse to band-pass filter techniques. In effect, the band-pass and band rejection characteristics are the result of operations performed at demodulated signal frequencies. The selectivity properties inherent to the method can be applied to provide broad uniform response in an "acceptance" band with sharp transition to a "rejection" band. The attenuation obtainable in the rejection band as well as its width are determined by the characteristics of phase-shift networks of the "all-pass" variety.

The adjacent bands of acceptance and rejection may be interchanged readily, and separate channel outputs may be obtained simultaneously from signals appearing in each of these frequency bands. Used in conjunction with band-pass filters, certain characteristics of the filter method can be combined in a number of ways with the characteristics of the phase-shift method for improvement or extension of receiving system performance. When used as a portion of communication systems which employ a pilot carrier, "zero" frequency output signals available from the two signal demodulators required by the method may be used for frequency and gain control purposes in the receiving apparatus.

As with most electronic equipment, performance is affected by distortion occurring within certain non-linear amplifying and coupling devices. Such distortion serves to degrade performance characteristics otherwise attainable.

The phase-shift method may be applied readily to receiving equipment not initially designed for single-sideband service. Channel separation characteristics are quite independent of the carrier frequency about which demodulation takes place.

Many of the performance characteristics of the phase-shift method of single-sideband signal reception are governed by the same parameters which determine equivalent characteristics of transmission systems based on the phase-shift method. The parallel of phase-shift methods applied to transmission and reception is so close that a single expression delineating performance of transmitting equipment can be used substantially interchangeably for delineation of receiver performance.

¹⁴ It is assumed that intermodulation distortion will occur under certain signal conditions regardless of design. Any receiving system free from such possibilities would be an extremely desirable one if it duplicated the desirable features of conventional equipment.

Electromechanical Filters for Single-Sideband Applications*

DON L. LUNDGREN†, ASSOCIATE MEMBER, IRE

Summary—In discussing some of the basic properties of electromechanical filters, both longitudinal and torsional modes of vibration are considered. The torsional mode has advantages which make it superior to the longitudinal mode in most applications. The limits of the frequency range, at the present state of the art, are from approximately 50 to 600 kc. From a production standpoint, however, the preferred frequencies are from 200 to 250 kc.

The high Q and inherent thermal stability of electromechanical filters make them ideally suited for filter type single-sideband equipments. In view of their size, weight, rugged construction, and reduced spurious responses, torsional mode filters designed to operate at a carrier frequency of 250 kc are an excellent choice for this application.

A typical 250 kc 9-resonant section torsional sideband filter provides 300 cycles of audio cutoff, carrier rejection of 27 db, and a 60 to 6 db shape factor of 1.56. A 7-resonant section filter of the same type provides 20 db of carrier rejection and a shape factor of 1.85.

Carrier filters of 250 kc have been built having a bandwidth of 200 cycles and a shape factor of 3.

INTRODUCTION

FILTER systems used in single-sideband equipments must exhibit a high degree of selectivity, in order that the carrier and undesired sideband frequencies be sufficiently attenuated. Furthermore, they must be designed such that the characteristics are relatively constant with variations in time and temperature. In the past, filters used in sideband filter systems have usually been of the LC or quartz-crystal type. However, with improvements in the newer electromechanical filters, such as lower cost and smaller size, combined with a high degree of stability, equipment designers are rapidly adopting this new type of filter.

It is rather difficult to compare the LC, quartz-crystal, and electromechanical filters without discussing specific applications. Each has its own advantages and disadvantages depending upon the operating frequency, bandwidth, etc. For example, LC filters have been used in single-sideband equipments at an IF of 25 kc. These have provided excellent selectivity near the carrier frequency. On the other hand, at 25 kc, an extra stage of frequency conversion is required, frequency-temperature stability of the filter is relatively poor; and the insertion loss, high. Also, the large physical size and weight of this unit is definitely not desirable with the ever increasing trend toward miniaturization.

Quartz-crystal filters have been used in single-sideband equipments at an IF of 100 kc. Selectivity and stability are excellent. However, these filters are very large physically and will not withstand appreciable

shock or vibration. Furthermore, the cost is quite high.

Electromechanical filters at 250 kc are very small and light-weight. Rejection characteristics are excellent although not necessarily superior to the quartz-crystal filter. The voltage insertion loss is less than 1 db in the torsional mode of vibration, and frequency stability is better than 2 PPM/°C. in a properly designed filter. Production quantities of 200 kc torsional mode filters have been built to withstand shock and vibration tests under MIL-T-17113. These filters lend themselves to shock mounting techniques where many other modes of vibration do not.

Although the commercial use of electromechanical filters is relatively new, the basic principles have been fairly well established and a reasonable amount of information is available in the literature.¹⁻⁸

FILTER TYPES

Present electromechanical filters are of the band-pass type that cover the frequency range of 50 to 600 kc with bandwidths up to approximately 10 per cent. These figures are by no means theoretical bounds but represent the region of present interest and experience. A multitude of mechanical configurations and modes of vibration are possible which would provide filters having certain band-pass characteristics. However, not all configurations are economically feasible. Furthermore, when such characteristics as spurious responses, insertion loss, and ability to withstand shock and vibration are taken into account, the desirable modes of vibration and mechanical configurations are narrowed down considerably.

The results of theoretical and practical investigations have produced two filter types which are not only simple in design but lend themselves to quantity production. These are referred to as the slug-coupled longitudinal filter and the neck-coupled torsional filter.

¹ H. H. Hall, "A magnetostriction filter," *Proc. IRE*, vol. 21, pp. 1328-1338; September, 1933.

² R. Adler, "Compact electromechanical filter," *Electronics*, vol. 20, pp. 100-105; April, 1947.

³ W. van B. Roberts and L. L. Burns, "Mechanical filters for radio frequencies," *RCA Rev.*, vol. 10, pp. 348-365; September, 1949.

⁴ L. L. Burns, "A band-pass mechanical filter for 100 kc," *RCA Rev.*, vol. 13, pp. 34-46; March, 1952.

⁵ M. L. Doelz and J. C. Hathaway, "How to use mechanical filters," *Electronics*, vol. 26, pp. 138-142; March, 1953.

⁶ W. van B. Roberts, "Some applications of permanently magnetized ferrite magnetostrictive resonators," *RCA Rev.*, vol. 14, pp. 3-16; March, 1953.

⁷ S. P. Lapin, "Electromechanical filters," *Proc. NEC*, vol. 9, pp. 353-362; February, 1954.

⁸ R. W. George, "Electromechanical filters for 100 kc carrier and sideband selection," *Proc. IRE*, vol. 44, pp. 14-18; January, 1956.

* Original manuscript received by the IRE, September 27, 1956.

† Radio Corp. of America, Camden, N. J.

MECHANICAL CONFIGURATIONS AND MODES OF VIBRATION

The slug-coupled filter consists of small diameter resonators and large diameter couplers as shown in Fig. 1(a). It is designed to operate in the longitudinal mode. The thin resonators are equivalent to tuned circuits whereas the heavier slugs are equivalent to mutual inductances. Thus, the entire filter acts as a chain of mutually coupled resonant circuits in cascade.

Fig. 1(b) shows a neck-coupled filter. In this case, large diameter resonators and small diameter couplers are used. This configuration is designed to operate in the torsional mode. The large resonators or tuned circuits are coupled by thin necks or springs. The necks can be thought of as capacitors. We then have a filter which acts as a chain of capacitively coupled resonant circuits in cascade.

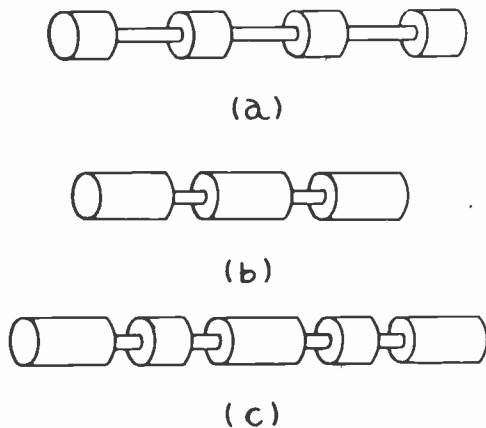

Fig. 1—(a) Slug-coupled filter, normally operated in the longitudinal mode of vibration. (b) Neck-coupled filter, normally operated in the torsional mode of vibration. (c) Neck-coupled filter with multiple couplers, normally used for narrow-band torsional mode filters.

It should be understood that both of these configurations could be designed to operate in either the longitudinal or torsional mode of vibration. But for practical reasons, they are designed to operate as indicated. The resonators of either configuration are usually $\lambda/2$ in length, whereas the couplers are usually $\lambda/4$ long, where λ is the wavelength.

In the case of narrow-band filters, where very low coupling coefficients are required, the multiple coupler is often used. This filter, as shown in Fig. 1(c) has three resonators and two multiple couplers. The large diameter $\lambda/4$ elements inserted between two $\lambda/4$ necks act as the decoupling elements. In some cases, multiple couplers can also be used to suppress spurious responses by breaking up the regular periodic structure of a filter.

The coupling coefficient between resonant sections, which determines the bandwidth, depends upon the ratio of coupler to resonator diameters. In the longitudinal mode, this ratio varies as the square root of the kinetic energy ratios while in the torsional mode it

varies as the fourth root.³

The most significant improvement in the filter types described lies in the method of fabrication. Not only has the cost been reduced, but many of the response characteristics have been vastly improved. In the past, these filters were constructed by means of a jig which spaced the larger diameter components along a thin rod or tube, after which they were soft-soldered in place. Many serious problems arose from this type of construction, such as uncertain uniformity of the soldered joints and detuning effects due to varying amounts of solder. This resulted in poor frequency-temperature characteristics and aging of the filter which often caused a change in center frequency, peak-to-valley response and insertion loss. Present methods of construction are quite simple by comparison. The entire filter is centerless ground from one piece of stock after which the resonators are tuned to frequency. Filters thus constructed are free of aging effects, spurious responses are reduced, and frequency-temperature characteristics are vastly improved. Furthermore, the rejects in quantity production are reduced to almost zero.

PRINCIPLES OF OPERATION

Regardless of the mode of vibration, all electromechanical filters operate basically in the same manner. To utilize them at radio frequencies requires a double conversion of energy. First, electrical energy is supplied to the input circuit. It is then converted to mechanical energy by means of a transducer, passed through the mechanical filter elements, and reconverted back to electrical energy by means of an output transducer. In the process of traversing the length of the filter, the energy takes on the response characteristics dictated by the geometry of the mechanical elements.

The input and output circuits consist of coils which are tuned to resonance at the center frequency of the pass band. Located within these coils and attached to the ends of the mechanical filter are the magnetostrictive electromechanical transducers. A magnetic field is required to provide bias for the transducers and is usually accomplished by means of small, permanent magnets. To properly terminate a filter, mechanical damping must be supplied to the end resonators. This is obtained from the attached transducers, which in turn receive their damping from the electrical tuned circuits. Unless the tuned circuits are designed to act as the end resonators, they should have relatively low Q 's to provide the required broad-band electrical termination. Since filters are normally used as a coupling means between two amplifier stages, the impedances of the stages must be high compared to the filter impedances in order that further damping of the electrical end circuits does not occur.

These principles are embodied in the schematic diagram of a neck-coupled filter having nine mechanical resonators as shown in Fig. 2. Balanced electromechani-

cal transducers⁸ are used as a means of exciting the filter in the torsional mode of vibration. The transducers are $\lambda/2$ long and operate in the longitudinal mode. The magnetic field required for the transducers is supplied by the permanent magnets as shown. Quarter-wave sections are included on the ends of the filter rod for mounting purposes.

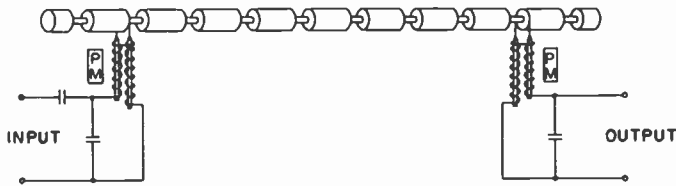

Fig. 2—Schematic diagram of a neck-coupled torsional mode electromechanical filter having 9 resonators.

DESIGN OF ELECTROMECHANICAL FILTERS

The performance characteristics of a filter can be specified in terms of the coupling coefficients between adjacent resonators and the damping of these resonators. In a mechanical filter, the coupler diameters depend upon the coupling coefficients that are chosen. Therefore, in order that the mechanical configuration remains simple to construct, it is desirable to have all coupling coefficients, and consequently the coupler diameters, alike.

The Tchebycheff design^{9,10} gives n peaks of equal amplitude and $(n-1)$ valleys of equal depth. This filter gives the best possible attenuation outside the pass band for a given peak-to-valley ratio of any filter composed of a given number of simple coupled circuits. It is strikingly superior in selectivity to the Butterworth (max-flat) design⁹ even when the allowed ripple is too small to be easily measured. As a mechanical filter, it is composed of identical resonators but with couplers of unequal diameters. Although this design would be desirable from the standpoint of selectivity, it is not economically feasible in production due to the very tight tolerances required on physical dimensions.

The Campbell design⁸ is a compromise filter having all coupling coefficients alike except for the end sections which are increased by $\sqrt{2}$. A comparison of actual response curves shows that the selectivity of the Tchebycheff filter is only slightly better than the Campbell. Thus, in designing the filter to give a Campbell response, we obtain excellent selectivity plus simplicity of fabrication. Simplified design equations for the Campbell response are available in the literature^{8,9} and are used to design both the longitudinal and torsional mode filters herein described.

⁸ M. Dishal, "Design of dissipative band-pass filters producing desired exact amplitude-frequency characteristics," *PROC. IRE*, vol. 37, pp. 1050-1069; September, 1949.

¹⁰ P. E. Richards, "Universal optimum response curves for arbitrarily coupled resonators," *PROC. IRE*, vol. 34, pp. 624-629, September, 1956.

LONGITUDINAL VS TORSIONAL MODES

Several factors must be given consideration when choosing the best mode for a particular application. The most important of these are listed below.

Thermal Stability

The resonators of a torsional filter are tuned to frequency by removing a small amount of material from either the ends or the center, depending upon the direction of frequency change. This has no effect on the frequency-temperature characteristics of the resonator material. In the longitudinal mode, a small bead of soft solder is placed over the center of the thin resonators. Part of this solder is then carefully removed until the resonator approaches the proper frequency. Although the amount of solder that remains on each resonator is small, it does effect the over-all frequency-temperature characteristics. Consequently, the thermal stability of the longitudinal filter is inferior to the torsional. There are means of overcoming this difficulty, however. For example, the filter could be fabricated with a small increase in diameter at its center. The filter rod would then be tuned by grinding away some of the excess material until it reached resonance. Of course, this would require great care unless it were done by automation. If too much material were removed, it could not be replaced as is the case with solder. Another solution to the problem is to heat treat the filter rod material such that it has a positive temperature coefficient. This would tend to cancel the effects of the solder which is negative. The method is rather difficult to control in production, however, due to the varying amounts of solder from section to section.

Shock and Vibration

For most commercial applications, either the longitudinal or torsional mode filter is satisfactory. But for military applications, where shock and vibration must be considered, the heavier construction of the torsional mode makes it more suitable. Furthermore, it lends itself to shock mounting techniques far better than the longitudinal mode.

Spurious Responses

Spurious responses arise in filters as a result of the presence of some natural frequency of the resonators occurring near the desired frequency. This undesired frequency can then be excited quite easily, and the excitation is usually produced by some microscopic mechanical defect in the filter. By way of example, a bending vibration might be induced in a thin rod undergoing longitudinal vibration by virtue of a bend in the rod, a slight dissymmetry in the cross section at some point, or an inhomogeneity in the material. Spurious responses also arise from certain methods used in mounting the filter rod.

The two filter types under consideration have relatively few spurious responses and can be controlled so

that they are reasonably low in amplitude and well outside the pass band. The only spurious responses above 60 db that arise in the slug-coupled longitudinal mode are nearly always due to a large fillet at the point where the resonator joins the coupler. By keeping the fillet to a radius of less than 0.010 inches, all spurious responses due to this cause are usually eliminated. In the torsional mode, spurious responses often arise due to other modes of vibration, but normally they are of low amplitude and several kc away from the pass band. Their amplitude and location depend somewhat on the resonator length to diameter ratio and are best determined by experimental means. Bending modes, which are easily excited in a torsional filter, are reduced by using a pair of transducers in a balanced arrangement.⁸

Input-Output Coupling

The effects of stray input-output coupling is to cause a flaring of the skirts with a subsequent loss in selectivity. External coupling is eliminated by proper shielding of the input and output terminals. Internal coupling is more difficult to overcome, especially in a higher frequency filter where the length is short. Although the coils in a longitudinal filter are farther apart, coupling can take place through the filter rod, unless adequate shielding of the coils is provided. In the torsional filter, a pair of coils is used at each end. Each pair is connected to produce opposing fields. The stray fields are then so small that no special shielding is required.

Physical Size

The velocity of sound in the torsional mode is approximately 35 per cent less than it is in the longitudinal mode. Since the length of the filter varies directly as the velocity, a torsional filter with equivalent selectivity is shorter. However, it is slightly larger in height and width due to the larger coil assemblies and twin transducers. The relative dimensions depend to some extent on the operating frequency also. For example, at 300 kc a 7-resonant section longitudinal filter or a 9-resonant section torsional filter can be assembled in a package $\frac{3}{4} \times \frac{3}{4} \times 3\frac{1}{4}$ inches long. Thus, greater selectivity is obtained in the same space from a torsional filter.

Fabrication

The neck-coupled filter as compared to the slug-coupled filter is more desirable from a production viewpoint for several reasons:

- 1) Less grinding is required to fabricate the rod.
- 2) Dimensional tolerances are easier to maintain.
- 3) Larger fillets are not objectionable. A small fillet requires frequent redressing of the grinding wheel.
- 4) The heavier construction allows greater ease of handling.
- 5) Tuning of the resonators is simplified.
- 6) Greater accuracy of tuning can be maintained.

From the foregoing, it can be seen that the neck-coupled torsional filter is the preferred type. This is

especially true of sideband filters since placement frequency and bandwidth must be maintained to fairly close tolerances. Selection of the operating frequency is determined largely by the dimensional tolerances that are physically realizable. As the frequency increases, the tolerances become more difficult to maintain. At the lower frequencies, the filter becomes rather large. For example, a nine resonant section torsional filter at 100 kc is approximately 9 inches long. As a compromise, the frequency range from 200 to 250 kc is preferred.

TORSIONAL FILTERS AT 250 KC

A production unit of a 250 kc torsional filter, having seven resonant sections, is shown in Fig. 3. The case is designed to accept any one of three filters, namely: an upper sideband, lower sideband, or carrier. Quarter-wave end sections, securely clamped in place, are used as a means for mounting the filter rod. These are attached to the end resonators via quarter-wave necks.

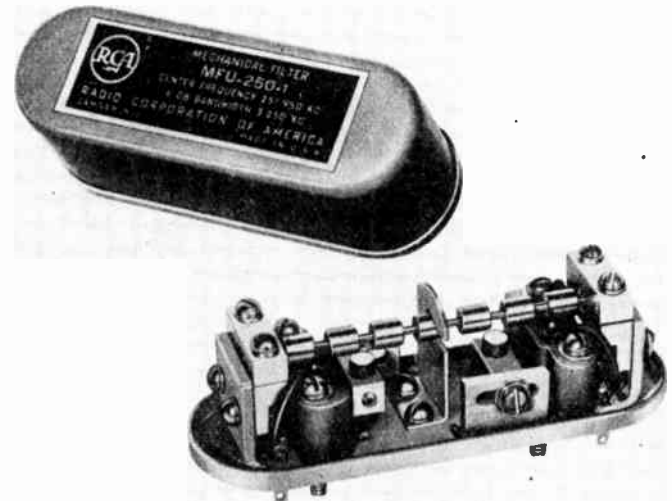

Fig. 3—Typical production unit of a 250 kc torsional filter having 7 resonators.

Encircling the center section is a "snubber" bracket that prevents the rod from exceeding its elastic limit while undergoing shock. Steel is used for the case material in order to isolate the unit from external magnetic fields. The housing is filled with a dry inert gas and hermetically sealed.

Fig. 4 shows the response curve of a 250 kc carrier filter with a 6 db bandwidth of 200 cycles. The 7-resonant sections provide a shape factor of 2.8 to 1. A coupling coefficient of 0.04 per cent was used, based on the design equations⁸ for a Campbell response. The filter rod was made from Ni-Span C¹¹ which had been heat treated to give a temperature coefficient of less than 2 PPM/°C. Each resonator is tuned to ± 5 cycles of center frequency. Ferrite transducers attached to $\frac{1}{8}$ -inch long Ni-Span C wires are spot welded to the inboard

¹¹ Ni-Span C, registered trade-mark of the International Nickel Co., can be obtained from the H. A. Wilson Co., Union, N. J.

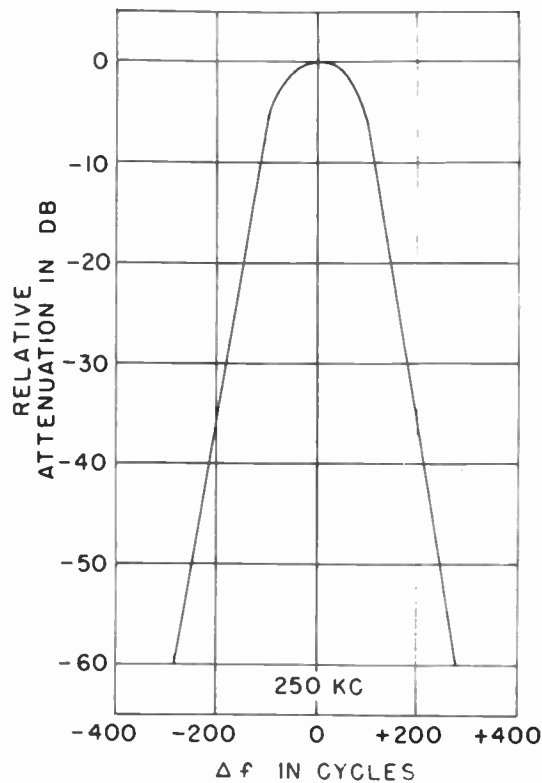

Fig. 4—Response of a 250 kc carrier filter with 200-cycle bandwidth.

side of the end resonators. The transducers operate in the longitudinal mode and are supplied with a dc flux from small adjustable alnico magnets. Coils having an inductance of 500 microhenries and a Q of 35 are used for the input and output circuits. Dimensions of the filter rod are given in Table I. It will be noted that the dimensions were held to very close tolerances. This is necessary in order to maintain the desired bandwidth and also to minimize the tuning of each resonator.

TABLE I

Length of Resonators, $\lambda/2$	0.2270 inch \pm 0.0005 inch
Length of Couplers, $\lambda/4$	0.1135 inch \pm 0.0005 inch
Diameter of Resonators	0.2500 inch \pm 0.0002 inch
Diameter of Interior Couplers	0.0420 inch \pm 0.0002 inch
Diameter of End Couplers	0.0460 inch \pm 0.0002 inch

The performance characteristics of some typical 250 kc sideband filters having seven resonators are given in Table II. It will be noted that the temperature coefficient is less than 2 PPM/ $^{\circ}$ C. over the temperature range of -40° C. to $+85^{\circ}$ C. This amounts to a maximum shift in the response curve of approximately ± 25 cycles measured from room temperature to the temperature extremes. Needless to say, this small shift causes very little change in the rejection of the carrier and adjacent sidebands.

An item of interest, not shown in Table II, is the termination stability vs temperature. Good termination stability is obtained by maintaining a constant im-

pedance over the temperature range. This is achieved through the use of broad band electrical circuits and ferrite transducers whose coupling coefficients remain constant with temperature. Measured values indicate that the ripple in the pass band changes by less than 1 db and the output voltage varies by approximately ± 1 db at the temperature extremes.

TABLE II

Characteristics	Lower Sideband	Upper Sideband
Carrier Frequency	250 kc	250 kc
Peak-to-Valley Ratio	1 db	1 db
-3 db Audio Cutoff	350 cycles	330 cycles
Carrier Rejection	22 db	21 db
Adjacent Sideband Rejection (400 cycles)	38 db	37 db
-6 db BW	3.4 kc	3.4 kc
-60 db BW	6.3 kc	6.3 kc
Shape Factor	1.85	1.85
Insertion Loss*	<1 db	<1 db
$Z_{in} = Z_{out}$	30 k ohms	30 k ohms
Temperature Coefficient (-40° C. to $+85^{\circ}$ C.)	<2 PPM/ $^{\circ}$ C.	<2 PPM/ $^{\circ}$ C.

* Insertion loss in db = $20 \log \frac{E_{out}}{E_{in}}$.

The low value of insertion loss is possible through the use of high efficiency ferrite transducers.¹² Electro-mechanical coupling coefficients on the order of 10 to 20 per cent are necessary for sideband filters. To obtain this requires a transducer with low mechanical and eddy current losses and high magnetostrictive properties.

The selectivity of a filter increases as the number of resonators. However, beyond seven, it increases at a very slow rate and the improvement is obtained at the expense of increased filter length. This is borne out by Table III which gives the shape factor for Campbell type filters having various numbers of resonators. These figures are valid for bandwidths of 1 per cent or more and assume a material Q of infinity. Measured values indicate the error on shape factor to be about 5 per cent when using Ni-Span C which has a Q on the order of 15,000. Included in Table III are the various lengths of 250 kc neck-coupled torsional rods corresponding to the number of resonators used.

TABLE III

Resonators	Shape Factor	Total Length of 250 kc Rod in Inches
2	72.90	1.02
3	34.00	1.36
4	3.62	1.70
5	2.81	2.00
6	2.18	2.38
7	1.84	2.71
8	1.60	3.05
9	1.48	3.39
10	1.37	3.73
11	1.29	4.07

¹² R. L. Harvey, "Ferrites and their properties at radio frequencies," *Proc. NEC*, vol. 9, pp. 287-298; February, 1954.

The response curves of both upper and lower sideband filters, having nine resonators each and operating at 250 kc are shown in Fig. 5. They are assembled in the same manner as those shown in Fig. 3 except that the case is approximately 0.75 inch longer. The characteristics are the same as those given in Table II with the following exceptions:

- 1) The -3 db audio cutoff is 300 cycles.
- 2) Carrier rejection is 27 db.
- 3) Adjacent sideband rejection (400 cycles) is 50 db.
- 4) The -6 db bandwidth is 3.2 kc.
- 5) The shape factor is 1.56.

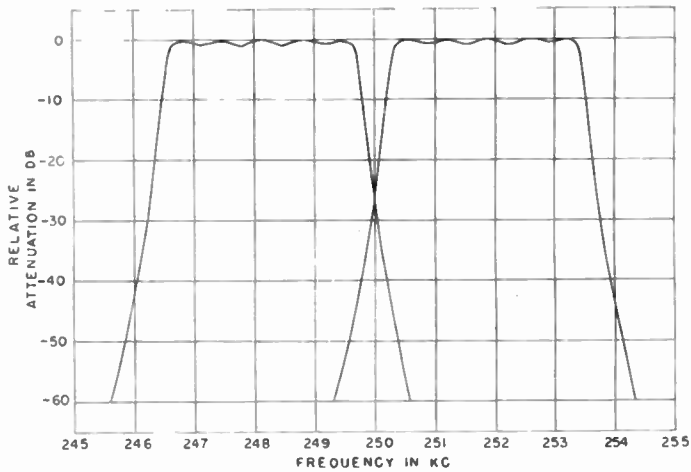

Fig. 5—Response curves of 250 kc upper- and lower-sideband filters having 9 mechanical resonators.

200 KC SLUG-COUPLED LONGITUDINAL FILTER

As an illustration of the slug-coupled longitudinal mode, the characteristics of a 200 kc band-pass filter are presented in Fig. 6 and Table IV. This unit has six mechanical resonators as shown by the schematic diagram. The filter rod was centerless ground from Ni-Span C and contains four resonators and five couplers $\lambda/2$ and $\lambda/4$ long, respectively. The end resonators are quarter-wave long ferrites and also serve as the electro-mechanical transducers. Coupling coefficients were

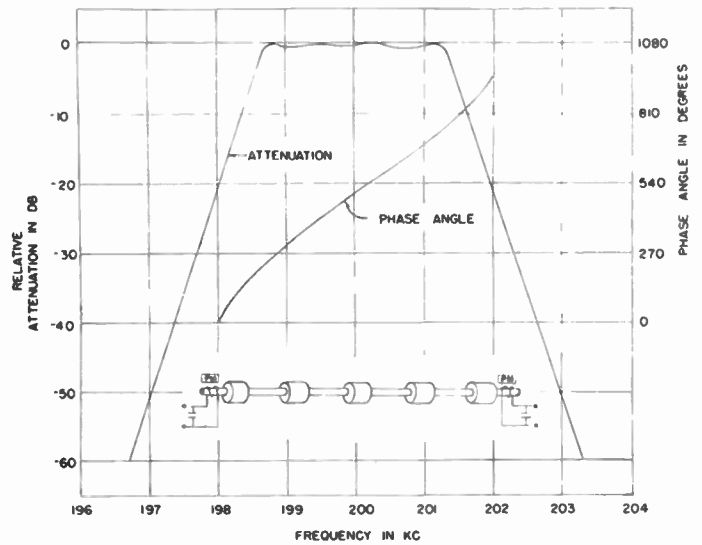

Fig. 6—200-kc Slug-coupled longitudinal band-pass filter.

TABLE IV

Center Frequency	200 kc
Peak-to-Valley Ratio	<1 db
-6 db BW	3 kc
Shape Factor	2.2
Insertion Loss	-1.5 db
$Z_{in} = Z_{out}$	24 k ohms
Temperature Coefficient (-40°C. to +85°C.)	-2 PPM/°C.

chosen to give a Campbell response. The phase-angle curve included in Fig. 6 merely indicates the total number of degrees of phase shift over the pass band region and was obtained by comparing the unmodulated rf input and output signals.

ACKNOWLEDGMENT

The author wishes to acknowledge the guidance and encouragement received from J. E. Eiselein and the helpful suggestions received from R. W. George. Special thanks should go to Dr. A. H. Benner, R. E. Jenkinson, and C. C. Osgood for advanced development work done by them that was useful in the preparation of this paper.



Factors Influencing Single Sideband Receiver Design*

LUTHER W. COUILLARD†

Summary—This paper presents a brief discussion of some of the problems which confront the designer of single sideband receiving equipment. Among the items considered are frequency stability, cross modulation, gain distribution and diversity combining. Some of the presently used techniques for single sideband receivers are also presented.

THE RECENT emphasis on the use of single sideband for high frequency communications has been brought about by several things—the most important among these being the better use of the radio frequency spectrum. It has also been brought about by the better propagation characteristics of single sideband since the serious effects of selective fading are eliminated. There have also been several new design techniques recently which have provided practical solutions to some of the more difficult problems associated with single sideband. It is these new design techniques and their influence on single-sideband receiver design which will be briefly discussed in this paper.

To achieve the maximum reduction in bandwidth required for single sideband transmission, only one sideband should be transmitted, and both the carrier and opposite sideband must be suppressed as much as is practical (usually 40 to 60 db). The most difficult problem when receiving such a signal is the reinsertion of a carrier sufficiently close to the correct frequency to yield proper demodulation. In most applications the accuracy needed for voice communication is 50 cycles or better. It is true that strong signals can still be understood with frequency errors as high as 100 to 200 cycles but with weak signals and noisy circuits, frequency error as small as 20 cycles will have a slight affect on the intelligibility. There are a number of modulation schemes which send this carrier frequency information along with the single sideband transmission in the form of partially suppressed carriers (–20 db) or pilot tones. There is also a fluctuating carrier system which allows the carrier to come up during pauses in the regular messages often enough for afc systems to “hang on” with sufficient accuracy.

These afc systems use more of the rf spectrum and require additional time for the locking on or correction periods. The basic reason for using these systems has been to allow more error in the receivers and transmitters, but it should also be remembered that a system which relies on some form of carrier or pilot tone for afc

is especially susceptible to interference from strong signals or noise. In some cases the desired signal might not only be lost but the receiver may lock on the wrong signal.

For fixed station use both receivers and transmitters can be stabilized sufficiently with crystals for single sideband voice circuits without afc systems; however, oven control and periodic frequency adjustments are usually necessary. Multichannel teletype and high density signal systems are more critical and may be limited by inadequate crystal frequency stability unless afc is used. There are methods using high grade crystals and elaborate oven control circuits which give high quality single sideband circuits without the use of afc. When several frequencies are required with rapid switching of frequencies, then these systems become impractical.

In recent years there has been considerable work done on the idea of producing a number of frequencies which are referenced to or derived from a single standard oscillator. Such a system can justify a lot of cost and design effort in developing a high-grade single frequency standard since only one is required. This standard is then used in systems which multiply, divide, add, and subtract from the basic frequency. Such systems are not continuously tunable unless an additional variable oscillator, or variations in the standard are used which invariably introduce frequency error and lower the overall accuracy and stability. This leads to the logical use of a channelized system which has only discreet frequencies of high stability and accuracy. These channels might be based on voice bandwidths which would be about every four kilocycles, or even closer, but more difficult steps of one kilocycle each.

Because of the importance of the frequency accuracy and stability in single sideband equipment, it may be pertinent to describe briefly the technique to be used in a new mobile (airborne) single sideband transceiver. Stabilization of the oscillator is secured in a stabilized master oscillator (SMO) circuit. In the stabilized master oscillator a moderately stable permeability tuned oscillator is controlled by a selected signal from a radio frequency spectrum. The rf spectrum is derived through regenerative dividers from a frequency standard of high accuracy. Because of recent developments a mobile frequency standard can be made with sufficiently accurate control of oven temperature, circuit voltages, and constants to hold within approximately one part in 100 million per day. Each spectrum point is then very stable

* Original manuscript received by the IRE, September 10, 1956.

† Collins Radio Company, Cedar Rapids, Iowa.

and in automatic frequency control arrangement serves to slave the master oscillator to the selected spectrum point, with the result that each selected frequency channel possesses the same stability as that of the frequency standard. The selection of the desired spectrum point is accomplished by using a triple conversion heterodyne circuit in which spectra of signals spaced from 100 kc down to 1 kc are used as injection signals. This circuit translates the master oscillator signal to a fixed intermediate frequency at which a phase discriminator provides the correcting signal. Channels spaced 1 kc apart, as accurate and stable as the frequency standard itself, are provided throughout the range 2 to 30 mc. Such a stabilized master oscillator is being developed for airborne use and is also adaptable for fixed station use. Similar stabilized master oscillator circuits have been used in the vhf range with ten kilocycle channel spacing.

Sometime ago the use of double conversion superheterodyne circuits became popular for continuously tunable receivers. The main advantage of such receivers is the extra image rejection obtained, however, it is also possible to get a decided improvement in frequency stability. This can be achieved by using crystals in the high frequency conversion and injecting the tunable oscillator at a lower frequency conversion where its error has less effect. Such receivers are more complicated, having more crystals and switches than conventional types, but resulting in a decided improvement in frequency stability, dial presentation, and ease of tuning. In such a receiver it is also advisable to use a tunable oscillator of rather high accuracy and stability in this second conversion since its error will still be the limiting stability factor. Several designs presently use hermetic sealing, permeability tuning, and oven control on these oscillators to achieve maximum stability. This type receiver has had wide acceptance for attended operation in single sideband amateur use, and several of the latest hf military receivers use this same principle. They have also been used for experimental mobile single sideband communication, both on the ground and in the air with good results. The double superheterodyne circuit is also useful in that it makes possible a constant tuning rate for all frequency bands. This is especially important on single sideband signals where a low tuning rate is essential for easy operation. Tuning rates as low as 25 kc per turn of the tuning knob have proven quite successful, providing some method of spinning the knob rapidly is also available. This problem of frequency control is covered rather carefully by other authors.¹

Another factor to be considered rather carefully in single-sideband receiver design is the use of automatic gain control. Conventional AM systems are usually not usable since they operate on the level of the carrier which is suppressed in single sideband. Automatic gain

control systems must be used which obtain their information directly from the modulation envelope. This can be done with conventional diode rectifiers that usually require some type of amplification. This may be a dc amplifier or an ac amplifier using the IF frequency. Special care must be taken to isolate the agc system from the reinserted carrier since it will probably be a rather large signal of the same frequency as the IF signals. Developing the agc voltage from the audio signal will help solve this problem and also give extra gain. In either case, the time constant of the system is very important. The control must be rapid enough to prevent strong signals from coming through too loud at first and yet be slow enough not to follow the syllabic variation of normal speech. One solution to this time constant problem is to use a fast charge, slow discharge type of circuit. Circuits having a charge time of 50 milliseconds and discharge time of 5 seconds have proven successful. Consideration should also be given to dual time constant circuits having a ratio of about 100 to 1. Such a circuit allows the rapid signal changes to develop a control voltage across one rc network and the slow signal variation to develop a control voltage across another rc circuit. These two voltages can then be applied in series or to different stages to give the desired control characteristics. Such a dual time constant circuit is similar to a rapid agc system used in conjunction with a manual gain control.

If multiple channel signals are being received such that they have separate output channels, then there must be additional consideration given as to how the separate agc voltages should be combined to control the common rf stages. One system is to use bias gates on the individual channel agc voltages and allow only the strongest channel to control the rf stages while each individual channel controls its own IF amplifiers. This may cause some loss in the weakest signal channel but will give protection to the rf stages against overloading. Such a system would also be necessary if the upper and lower sidebands were used as independent channels.

The problems of cross modulation and adjacent channel interference have long been ones which have plagued receiver designers. These problems have grown more serious with the increasing power and number of stations, until they have become the limiting factor in many instances such as on board ships and in vehicles where separation of transmitting and receiving antennas is not possible. Since single sideband is looked upon as a way to still further increase the number of available frequencies, an extra burden is placed on the single sideband receiver designer to provide receivers which are capable of satisfactory operation with still closer channel spacings.

Since most cross modulation troubles occur in the front end of a receiver, special consideration should be given the rf tube, the mixer tubes, and the amount of rf

¹ R. L. Craiglow and E. L. Martin, "Frequency control techniques for SSB," this issue, p. 1697.

gain. This is the section of the receiver where a compromise must be made between strong signal or weak signal operation. Since many applications do not require the maximum in sensitivity from hf receivers due to good antennas and atmospheric noise, it is usually sufficient to limit the noise figures to between 6 and 10 db. This will then help determine the tube types and rf gain required. In choosing a mixer tube, consideration should be given to getting a large ratio between the tube noise level and its cross modulating point. This means that a mixer with low noise and a low cross modulation point would not be as good as one with higher noise and proportionally higher cross modulation point. The extra gain required for the latter tube can be easily made up in the rf stages.

The choice of rf tubes is not quite so flexible since the amount of signal voltage ahead of the first stage is limited. However, tubes with reasonably good noise figures and strong signal handling capabilities are available. The recently developed 6BZ6 and 6DC6 tubes should be considered since they have good noise figures and large signal handling capabilities.

The amount of gain designed into each rf stage should be just enough to insure that the desired signal-to-noise ratio is maintained. Extra gain will cause quicker overload and poor cross modulation characteristics. The gain can be adjusted by tapping down on the rf coils and by adjusting their tuned impedance. The selectivity of the rf stages should be maintained as high as practical to give as much rejection to "off-resonant" signals as possible. Again, a compromise with sensitivity must be made since additional coils ahead of the first rf tube will cause some loss of even the desired signal so that the signal-to-noise ratio at the first tube will be lowered. In many applications an extra coil ahead of the first tube is worth the loss in sensitivity to obtain the extra rejection to undesired signals. Some consideration might also be given to providing switching facilities so extra coils could be added if needed or switched out for maximum sensitivity.

The problem of distortion and intermodulation in the rf stages of a single sideband receiver also deserves special consideration since there are resulting frequency products which can easily fall within the desired bandwidth being received. This is especially troublesome on multichannel signals where distortion or intermodulation of one or more channels would cause errors in other channels. This trouble occurs when signal levels are high and is not as much of a problem in receivers as in single sideband exciters. However, careful design of the receivers agc system and proper distribution of the control voltages is necessary to prevent overload trouble. The use of tubes which can handle large signals and control biases is also necessary.

The choice of a demodulator is also very important since this can also be a source of intermodulation. Ord-

nary diode detectors are satisfactory for voice, providing they are operated with several volts of reinserted carrier and about one-tenth volt of signal. This will give third-order products about 20 db down. Better performance can be obtained from multigrad detectors which are operated like conventional mixers. Double and triple triode circuits are also used and have certain advantages, as do more complicated balanced and ring demodulators using diodes.

The consideration of what bandwidth to use for the single sideband receiver is another problem and involves several things. For single sideband voice signals about a 3-kc bandwidth should be used. The pass band should be reasonably flat and the skirts as steep as possible. Crystal lattice and mechanical filters are often used to get these optimum results. If the receiver is also to be used for conventional AM, the 3-kc bandwidth may be used to select one sideband and the carrier with good results. Some extra precaution must be taken when receiving AM signals since AM stations do not have the rigid frequency stability requirements that single sideband transmitters do and, consequently, may require a wider receiver bandwidth. This is especially true in "channelized" or "step-tuned" single sideband receivers which cannot be tuned exactly to received frequencies.

In single sideband receiver design the problem of which sideband to use and how to select sidebands must also be considered. It seems likely that for commercial communication a standard will be set up using only upper sidebands. In the meantime and for the military receivers, provisions should be provided for the selection of either upper or lower sidebands. In a receiver the problem is to reinsert the carrier on the proper side of the signal. In stabilized step-tuned systems, it is usually easier to move the signal to the proper side of the carrier by switching the IF selectivity. This is especially easy if the IF filter is simple and compact like a mechanical filter. However, if the carrier is tunable as with a simple beat frequency oscillator (bfo), then it would be easier and more economical to move the carrier to the opposite side of the IF filter. A rather unique method of selecting sidebands used in a new amateur receiver is referred to as "pass band" tuning. In this system the bfo may be mechanically coupled to a trimmer on the main tuning oscillator so they track together, moving cycle for cycle. This means that a cw beat note will not change as the bfo is tuned but will move around in the pass band of the receiver. This allows the bfo to be set on the carrier frequency of a station and either sideband to be received by simply rotating the bfo from one side of the pass band to the other. This is also useful for single sideband and cw for orienting the signal to a position in the pass band with minimum interference.

It is quite a common practice to use two AM receivers with widely spaced antennas for diversity reception. By adding or combining the received signals, protection

against selective fading is achieved. Selective fading does not cause severe distortion of single sideband signals like it does with AM since there is no carrier to be lost. However, there can be a variation or loss in signal due to multipath cancellation which will also be helped by space diversity systems. The use of polarization diversity and frequency diversity might also be considered. In each of these single sideband systems the combining of received signals becomes a problem since phase differences will not allow simple addition. These phase differences are due to variation in signal levels and path lengths and have been observed to be often greater than 360 degrees. In order to add such signals, certain variable phase correcting methods can be used. One system is to feed a phase discriminator with the two received signals and use the output to drive a phase correcting circuit to hold the phase of one signal so it could be added with the other. Another method of phase correction would be to correct the phase of the reinserted

carrier in one of the receivers. Another way to obtain some of the advantages of single sideband diversity would be to use a switch which is actuated by the strongest signal. Some problem with switching transients may result, but such a system may be made quite simple.

In conclusion it should be noted that much of the material presented in this paper is not new to the receiver designer actively engaged in single sideband work. However, it is believed that the rapid move toward more single sideband communication will necessarily bring additional engineers into this field who may benefit by such a review of single sideband receiver techniques. It also points out that the single sideband receiver designer must do a better job in reducing the usual receiver problems, especially those dealing with adjacent channel interference. It also indicates some of the presently used techniques which are being used in recent single sideband receiver designs.

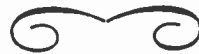

CORRECTION

The following correction to "The Optimum Tapered Transmission Line Matching Section," by Robert E. Collin, which appeared on pages 539-548 of the April, 1956 issue of PROCEEDINGS has been brought to the attention of the author by Dr. E. Folke Bolinder.

On page 545 in the second column, directly under the subtitle "Gaussian Taper" the following sentence appears: "The Gaussian taper is obtained when the number of sections in the binomial transformer is increased without limit while the total length of the transformer is kept constant."

The terminology "Gaussian" is used in this paper to refer to a taper having a characteristic impedance varying as a Gaussian function [see (38)]. This taper is not obtained as a limiting case of the binomial transformer but rather as a limiting case of a transformer having a triangular distribution of reflections.¹

¹ E. F. Bolinder, "Fourier transforms in the theory of inhomogeneous transmission lines," *Trans. Roy. Inst. Tech.*, Stockholm, Sweden, no. 48, p. 34; 1951.

The limiting case of the binomial transformer results in a taper which has a Gaussian distribution of reflections and is called a "Gaussian" taper by Bolinder.² This is the taper referred to by Southworth³ and does not correspond to the taper having a Gaussian characteristic impedance variation as stated in a later correspondence⁴ by the author. The derivation of the results for the limiting case of the binomial transformer may be found in lecture notes by W. W. Hansen.⁵

The confusion in this case has arisen because of the different terminology used by various authors.

² *Ibid.*, p. 43.

³ G. C. Southworth, "Principles and Applications of Waveguide Transmission," D. Van Nostrand Co., Inc., New York, N. Y., sec. 9.1, 1950.

⁴ R. E. Collin, "Rebuttal," *Proc. IRE*, vol. 44, p. 1056; August, 1956.

⁵ S. Seely and E. C. Pollard, notes on microwaves based upon a series of lectures by W. W. Hansen, PB 6851 and 6852; 1941.

Linear Power Amplifier Design*

WARREN B. BRUENE, SENIOR MEMBER, IRE†

Summary—The principal requirements of linear power amplifiers for single-sideband and frequency multiplexing service are low distortion and reliability. The nature of distortion generation is discussed and a theoretical tube characteristic for zero distortion in class AB operation is presented. Simple expressions for quickly estimating tube operating conditions and a more detailed presentation of the Chaffee 11-point analysis for accurate computation is made. High gain stages minimize the number of stages required and enhance reliability. An illustration shows the circuit of a high gain, high performance three-stage amplifier suitable for linear amplifier service and automatic tuning.

WITH THE acceptance of single sideband by the communications industry and the increasing use of multiplexing and data transmission, attention has turned to the development of linear power amplifiers for communication transmitters. One principal requirement is low intermodulation distortion, for reasons outlined in a companion paper.¹ A second important requirement is reliability because of the dependence placed on reliable communication and the increased amount of traffic passing through a given transmitter. A basic means of achieving reliability is through simplicity and the circuits described will follow this pattern.

Efficiency of power conversion in linear transmitters is a consideration which has engendered numerous attempts to develop linear amplifiers for single sideband that have higher efficiency. To the writer's knowledge, all of these schemes have higher distortion than that obtainable from simple class AB linear amplifiers and, in general, are more complex. Actually, plate efficiency is not as important in single sideband service as it is with amplitude modulation. Zero signal plate dissipation is more important, however, and this can best be reduced by improved tube characteristics and by proper choice of tube operating conditions. For these reasons this paper will limit its area to that of linear amplifiers operating class AB.

NATURE OF LINEAR RF AMPLIFIER DISTORTION

Since the main sources of distortion are the nonlinear characteristics of the rf power amplifier tubes, the nature of single-sideband distortion and tube operating characteristics will be discussed.

First consider the plate characteristics of a tube as an rf amplifier with tuned input and output circuits so the rf voltages can be considered sine wave for the duration of each cycle. A load line can be established which will then be a straight line on a set of constant current plate

characteristic curves for the tube. Plotting the values of plate current on this line against grid voltage gives a curve as shown in Fig. 1.

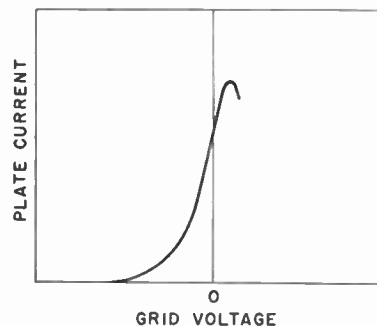

Fig. 1—Typical tube transfer characteristic.

The shape of this curve and the choice of zero signal operating point determines the distortion which will be produced. A power series expressing this curve (written around the zero signal operating point) contains the coefficients of each order of curvature.

$$i_p = k_0 + k_1e_g + k_2e_g^2 + k_3e_g^3 + k_4e_g^4 + k_5e_g^5 + \dots + k_n e_g^n$$

where i_p represents instantaneous plate current, k_1 , k_2 , etc., the coefficients of their respective terms, and e_g is the input grid voltage signal. An input signal consisting of two equal amplitude frequencies with a small percentage frequency separation can be applied to this expression to obtain the distortion products that are of concern in linear amplifiers.

Fig. 2 shows the spectrum distribution of the stronger products. It will be observed that tuned circuits can filter out all products except those which lie adjacent to the input frequencies. The products generated by the even-order components are all far removed from the desired output frequency so that adequate selectivity of the output tank circuits and filters will attenuate them to nearly any desired level. For example, a tube with a pure square law curve can be operated in a class A rf amplifier with undistorted output.

The odd order components each produce products which fall close to the original frequencies and cannot be removed in practice by selective circuits in the usual application. See Fig. 3 for a two-frequency signal.

The inside pair of distortion products are third-order products. The next are fifth, seventh, etc. All other odd order products, such as third harmonics, etc., are removed by the selective tank circuits.

* Original manuscript received by the IRE, September 10, 1956.

† Collins Radio Co., Cedar Rapids, Iowa.

¹ W. B. Bruene, "Distortion reducing means for single-sideband transmitters," this issue, p. 1760.

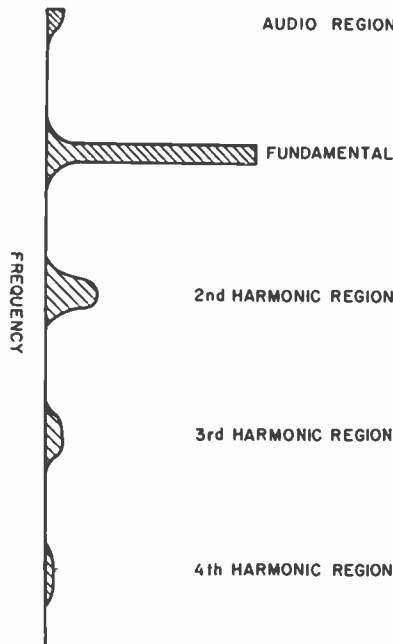

Fig. 2—Spectrum distribution of products generated.

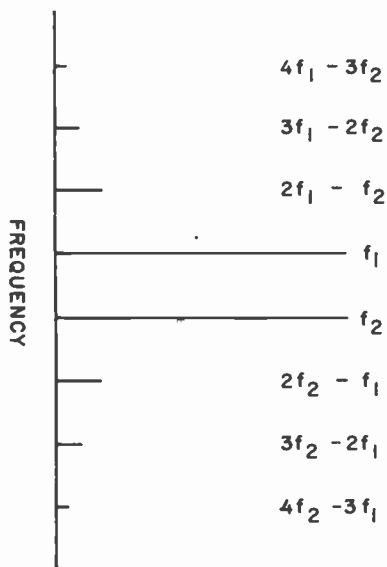

Fig. 3—Single-sideband distortion products.

The first and most important means of reducing distortion in a single-sideband linear power amplifier is to choose a tube with a good plate characteristic and choose the operating condition for low odd order curvatures.

IDEAL TUBE PLATE CHARACTERISTIC

Fig. 4 shows a plate characteristic and the operating point that will allow class AB operation with no odd order distortion products.

From point *A* to *B* the curvature is second order, or a simple ($i_p = ke_g^2$) curve. From point *B* the curve continues at the same slope in a straight line to point *C*. The zero signal operating point, *Q*, is located midway

horizontally between *A* and *B*. It is also located directly above the point of “projected cutoff,” point *P*, where an extension of *CB* crosses the zero plate current line.

Small signals whose peak-to-peak amplitude is less than the horizontal distance between *A* and *B* operate on a pure second-order curve, resulting in no single-sideband distortion. When the input signal becomes greater than *AB* it enters a linear region on both peaks at the same time and since the slope of *BC* is correct there is no change in gain of the fundamental components and no single-sideband distortion will result at large signals either.

The plate current at point *Q* determines the static plate current I_{BS} of the tube and, when multiplied by the dc plate voltage, determines the static plate dissipation. A very sharp cutoff characteristic will give lowest static plate dissipation but it does cause greater generation of higher-order harmonics which need careful attenuation. An ideal tube plate characteristic then is that shown in Fig. 4 with the peak plate current at *C* in the region of 10 to 20 times the static plate current at point *Q*.

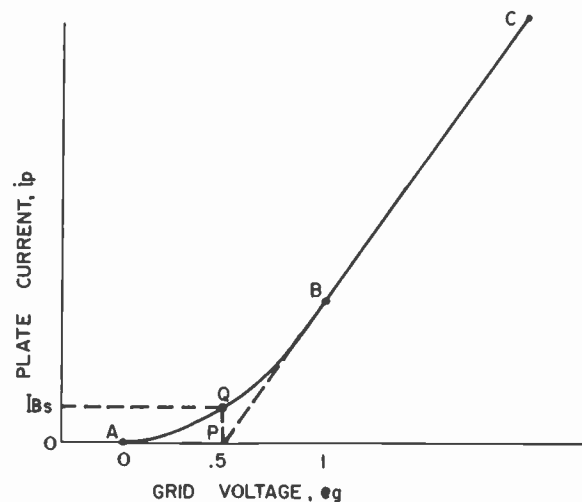

Fig. 4—Ideal tube characteristic for class AB operation.

CHOICE OF OPERATING POINT

It is emphasized that even with this ideal characteristic there is only one zero signal point, *Q*, that will yield zero distortion. A power series for this curve based on any other point will contain odd order components, in addition to the even order ones. Fig. 5 shows the distortion that will be obtained by operating at other bias points.

Fig. 6 shows distortion vs bias point for a theoretical curve similar to Fig. 4 except that a three-halves power curve is used from *A* to *B*. It is noted that minimum distortion occurs approximately at the point of projected cutoff, also.

Most tubes have a characteristic similar to Fig. 4, although *AB* is not pure square law and the region from *B* to *C* is rather limited and seldom straight. The static

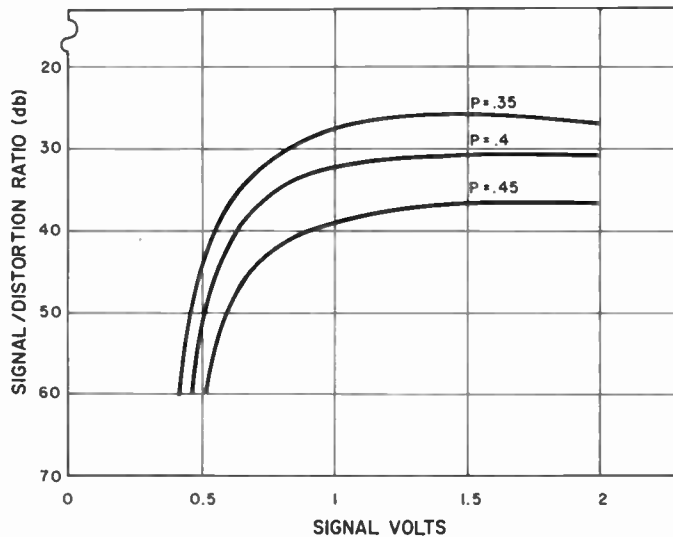

Fig. 5—Distortion vs signal level for other bias points.

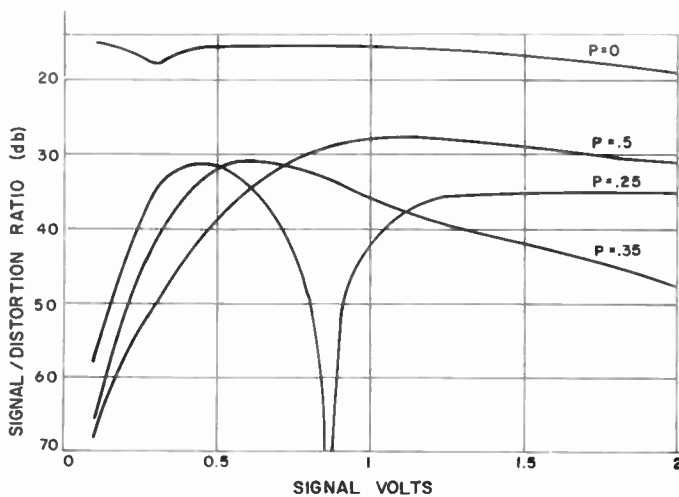

Fig. 6—Distortion using 3/2 power curve.

plate current for minimum distortion is usually so high that plate dissipation is near or beyond the maximum rating of the tube when using desired dc plate voltage. For example, one of the better medium power triodes for linear amplifier service is the 3X2500A3 which requires approximately 0.5-ampere plate current for minimum distortion. A desirable plate voltage is 5000 volts, which results in a static plate dissipation of 2500 watts which is the maximum plate dissipation rating of the tube. Transmitting type tetrodes and pentodes have similar characteristics, except that the optimum plate current is a function of screen voltage. The high screen voltages required for class AB₁ operation usually require an excessive amount of plate current for minimum distortion. As a consequence, the designer has the choice of accepting the higher distortion by operating at a lower than optimum static plate current or using a lower screen voltage and driving the tube into the positive grid region, which is the second principal cause of distortion in linear power amplifiers.

Fig. 7 shows typical grid current characteristics along a tube load line. This grid current loads the input circuit in a nonlinear manner and the only way to minimize distortion from this cause is to use a driver stage with very good regulation. A brute force method of accomplishing this is to simply load the grid circuit heavily with fixed resistance. This has a practical limitation but it is usually possible to realize better over-all distortion in the larger tetrode power tubes by using a lower screen voltage to gain a better plate current characteristic and accepting some distortion caused by operating in the grid current region. Actually, a fair compromise can be reached and signal-to-distortion ratios of 30 to 35 db can be achieved with existing tubes, including triode, tetrode, and pentode types.

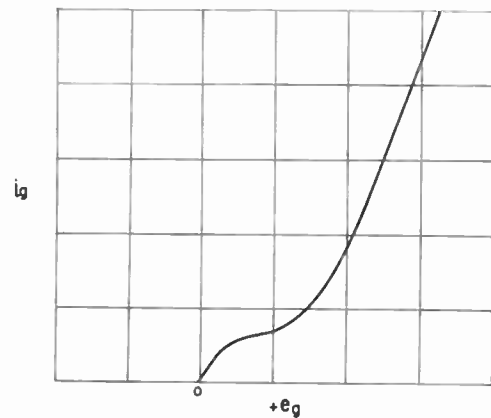

Fig. 7—Grid current vs grid voltage along load line.

ESTIMATING TUBE OPERATING CONDITIONS

As a first approximation, the tube plate dissipation rating required is about one-half the useful peak envelope power output desired from the stage. The operating conditions of a tube operating in a linear rf amplifier operating class AB can be estimated quickly using the simple equations for a theoretical class B tube shown in Fig. 8. From the end point of the load line which establishes the instantaneous peak plate current, i_p , and the peak plate voltage swing, e_p , the principal plate characteristics can be estimated using the following relationship for a single-frequency signal.

$$I_B = \frac{i_p}{\pi} \quad \text{dc plate current,}$$

$$P_{in} = \frac{i_p E_B}{\pi} \quad \text{watts plate input,}$$

$$P_o = \frac{i_p e_p}{4} \quad \text{watts rf power output,}$$

$$\text{Eff} = \frac{\pi e_p}{4 E_B} \quad \text{plate efficiency.}$$

For a standard two-frequency test signal the relationships become

$$I_B = \frac{2}{\pi^2} i_p,$$

$$P_{in} = \frac{2}{\pi^2} i_p E_B,$$

$$P_o = \frac{i_p e_p}{8},$$

$$\text{Eff} = \left(\frac{\pi}{4}\right)^2 \frac{e_p}{E_B}.$$

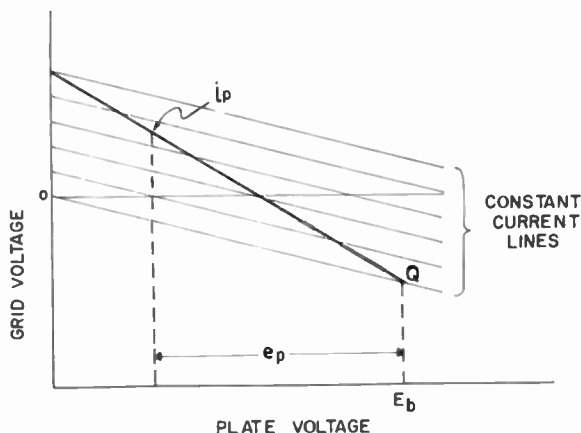

Fig. 8—Theoretical class B tube characteristic.

A plot of plate dissipation and plate efficiency for both signals vs signal level is shown in Fig. 9. This theoretical tube is linear to cutoff so there is zero static plate dissipation. An actual tube with a moderate static plate dissipation requirement for low distortion as previously discussed would have characteristics more like that shown in Fig. 10. It is noted that the plate dissipation and efficiency at maximum signal level are not affected much by even rather high values of static plate dissipation. In practice, the peak plate swing is limited to something less than the dc plate voltage in order to avoid excessive grid drive, excessive screen current or operation in the nonlinear plate current region. Most tubes operate with an efficiency in the region of 65 to 70 per cent, at peak signal level.

CALCULATION OF TUBE OPERATING CONDITIONS (SINGLE TONE)

The operating conditions for a power amplifier can be calculated quite accurately by selecting a load line and using the 11-point analysis originated by Chaffee.² Sarbacher devised a mechanical aid for the Chaffee method and published an article on its use.³ More recently, Eitel-McCullough, Inc., made available another aid and a well-written procedure of its use.⁴ Both of the

² E. L. Chaffee, "A simplified harmonic analysis," *Rev. Sci. Instr.*, vol. 17, pp. 384-389; October, 1936.
³ R. I. Sarbacher, "Graphical determination of pa performance," *Electronics*, vol. 17, pp. 52-58; December, 1942.
⁴ "Tube Performance Computer," Application Bulletin, Eitel-McCullough, Inc., no. 5.

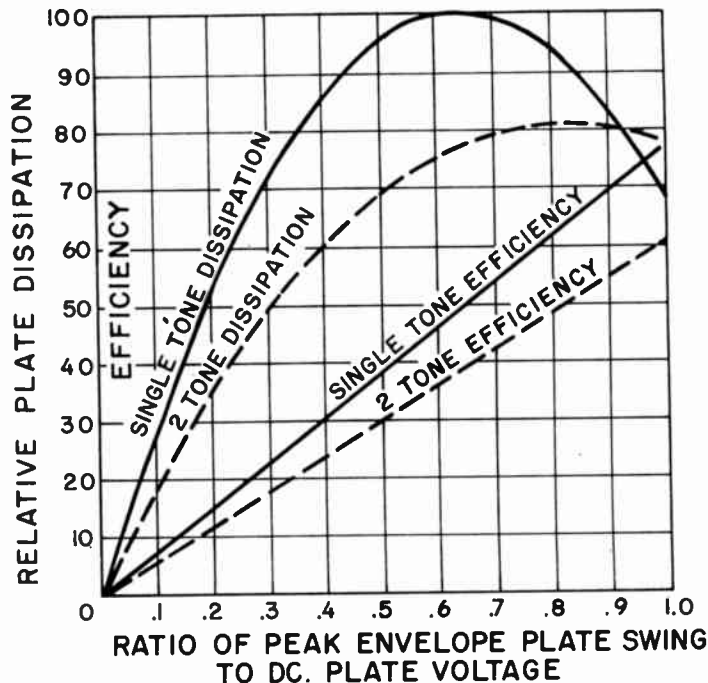

Fig. 9— P_d vs signal level of theoretical class B tube.

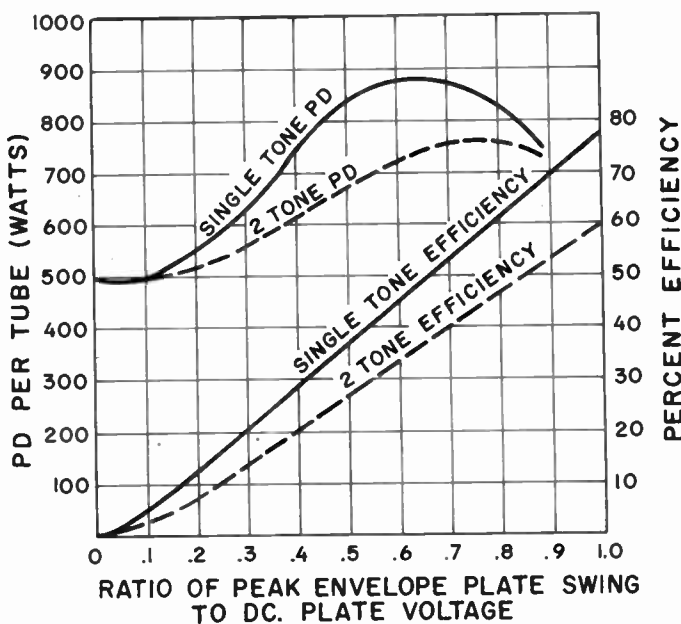

Fig. 10— P_d and Eff for class AB operation.

latter references were written for class C amplifiers, but a slight extension allows their use on class AB operation, also.

Basically, this method assumes sine wave voltages which are 180° out of phase on the grid and plate. Points along the load line each 15° over the cycle are found with the aid of the mechanical devices which simply have lines spaced according to the sine function. The currents read at these points along the load line are put into the equations given to determine the dc component of current and the fundamental ac component.

Knowing these values of plate, grid, and screen currents, all values of input, output, and dissipation are readily computed.

This method of calculation will now be given in more detail. Calculations are made on a selected load line and, if it turns out that the desired operating conditions are not realized, it is necessary to try other load lines until either the desired or optimum conditions are found. Plotting a curve similar to that shown in Fig. 4 using points obtained along the selected load line will indicate the static plate current required for minimum distortion and should be compromised as necessary with screen voltage, driving power, and static plate dissipation considerations.

Fig. 11 shows a load line drawn on a set of constant current curves. Below is a sine wave representing the rf plate voltage. Projecting upward from the 15° points on the sine wave establishes points A, B, C, etc. on the load line. Each of these points except point A is used to represent the average plate current over a 15° interval extending $7\frac{1}{2}^\circ$ each side of the point. Since only half of the cycle is analyzed, point A represents only half a 15° interval, or $7\frac{1}{2}^\circ$. The average dc plate current is found by simply averaging these readings. This is done by using:

$$I_{av} = \frac{1}{12} \left(\frac{A}{2} + B + C + D + E + F + Q + F' + E' + D' + C' + B' + \frac{A'}{2} \right).$$

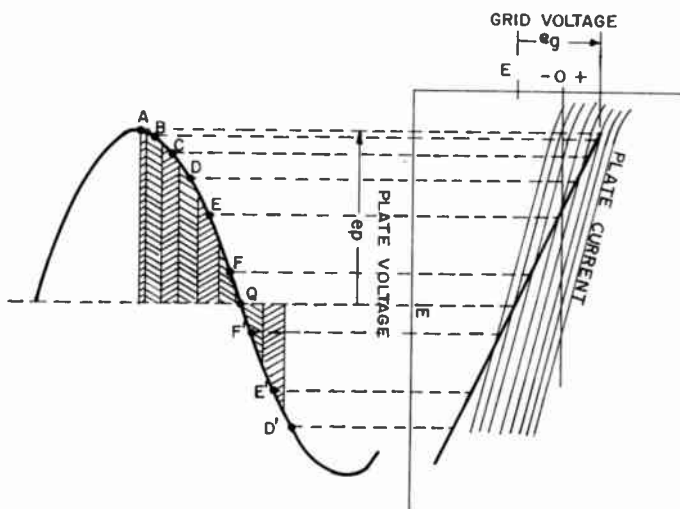

Fig. 11—Principle of graphical analysis.

The $1/12$ term comes from using only one-half the cycle since it is symmetrical and there are twelve 15° intervals over one-half a cycle. This equation includes all the terms for class A operation but normally for class AB operation, those beyond F' or E' are zero. The references cited^{3,4} are only concerned with class C operation and they have dropped the Q and all following terms since they are always zero in class C operation.

The fundamental ac component of current is obtained by using:

$$I_1 = \frac{1}{12} [(A - A') + 1.93(B - B') + 1.73(C - C') + 1.41(D - D') + (E - E') + 0.52(F - F')].$$

It is noted that the coefficients of the various terms are twice the cosine of the angle except the $(A - A')$ term where the coefficient is one-half twice the cosine of 0° or unity.

If the second, third, or fourth harmonic components of current are required, the following are used:

$$I_2 = \frac{1}{12} [(A + A' + C + C' - E - E') + 1.93(B + B' - F - F') - Q],$$

$$I_3 = \frac{1}{12} [(A - A') + 1.41(B + D' + F' - B' - D - F) - 2(E - E')],$$

$$I_4 = \frac{1}{12} [(A + B + F + F' + B' + A' - C - E - E' - C') + 2(Q - D - D')].$$

These equations for harmonic current are only approximate and apply only to tetrode and pentode tubes.

This method of computing the dc and ac components applies to grid and screen current, also. All values of dc and fundamental ac components of the plate, grid, and screen, if any, should be calculated except the ac component of screen current is only of interest in cathode driven tetrode amplifiers. The ac components calculated using the above equations are peak values and not rms values.

The following equations are used to calculate the various operating conditions:

$$I_p(\text{av}) = \text{dc plate current,}$$

$$P_{in} = E_B I_p(\text{av}) \text{ watts input,}$$

$$\text{P.O.} = \frac{i_p e_p}{2} \text{ watts output,}$$

$$\text{Eff} = \frac{P_o}{P_{in}} \text{ 100 per cent plate efficiency,}$$

$$P_{pd} = P_{in} - P_o = \text{plate dissipation,}$$

$$I_g(\text{av}) = \text{dc grid current,}$$

$$P_{dr} = \frac{i_g e_g}{2} = \text{watts grid driving power,}$$

$$P_c = I_g(\text{av}) E_c = \text{drive consumed by bias supply,}$$

$$P_{gd} = P_{dr} - P_c = \text{watts grid dissipation,}$$

$$I_s(\text{av}) = \text{dc screen current,}$$

$P_{s,d} = I_s(av)E_s =$ screen dissipation, and

$$R_L = \frac{e_p}{i_p} = \text{rf plate load resistance.}$$

The above calculations are for conventional grid driven circuits. When using triodes, the screen current is absent, of course, but all other calculations are the same for triodes and tetrodes.

Very often it is desirable to operate tetrodes with screen voltages other than those for which the curves are available. Since the currents vary approximately as the three-halves power of the screen voltage, it is not too difficult to assign new values to the grid and plate voltage coordinates and to the constant current lines. For example, if it is desired to operate with a screen voltage of 500 v and the curves are for 300 v, all voltage values on the curves must be multiplied by the voltage factor of 500/300 or 1.67. The current values are all multiplied by the three-halves power of the voltage factor, *e.g.*, $(1.67)^{3/2} = 2.15$, which is the current factor. Using these new values on the curves, the operating conditions can be calculated as in the previous section.

AMPLIFIER DESIGN CONSIDERATIONS

There are many advantages in separating the power amplifier from the exciter in order to provide a flexible and more universal type of transmitter installation. It has been found that about 0.1 w is a practical value of exciter output as this allows use of receiving type tubes in the exciter stage with a signal-to-distortion ratio exceeding 50 db.

By using modern high gain tetrodes it is practical to raise the 0.1 w power level to as high as 40 kw in just three stages. In fact, over 10 db of gain is left over for rf feedback. Three stages with a gain of over 1,000,000 in a compact layout require very clean design and excellent shielding. Enclosing each stage in a separate compartment and using feedthrough type capacitors for lead filtering will provide on the order of 80-db isolation between the power amplifier and input. The use of 50-ohm coaxial line input and output is an important aid in realizing very high isolation. Confining all rf power within the transmitter building to shielded enclosures and coaxial transmission lines is very effective in keeping stray rf out of control circuits and the audio and radio telegraph terminal equipment and it also aids in minimizing stray harmonic radiation. Actually, the Radio Amateurs have adopted this concept of station design more quickly than commercial users, although it is expected that commercial use will increase rapidly when antenna feeds systems for matching 50-ohm transmitter output become more widely known.

In addition to good shielding, each stage should be accurately neutralized to obtain better tuning characteristics and more uniform stage gain across the frequency range with a moderate amount of interstage circuit swamping. In order to eliminate all screen by-

passing problems in the high power tetrode stage the writer has successfully used the simple expedient of operating the screen at ground potential. Making contact between the chassis deck and the entire periphery of the ring screen terminal on tubes such as the 6166 and 4X5000A provides the best possible grid to plate isolation. The filament is operated below ground potential by the amount of the screen voltage which complicates the power supply a little but this is a modest price to pay for the excellent circuit stability and freedom from vhf parasites which has been experienced.

Fig. 12 shows the basic circuit of a three-stage amplifier incorporating these features. By giving careful attention to design details, a high performance linear power amplifier with low distortion has resulted.

It is noted that there are only 4 tuning controls, one for each of the 3 tuned circuits and 1 for the power amplifier loading adjustment. Automatic tuning has been successfully adapted to this circuit and it is relatively economical because of the small number of servo-mechanisms required.

The small number of stages, tuned circuits, and components inherently has an advantage with regard to reliability and ease of maintenance.

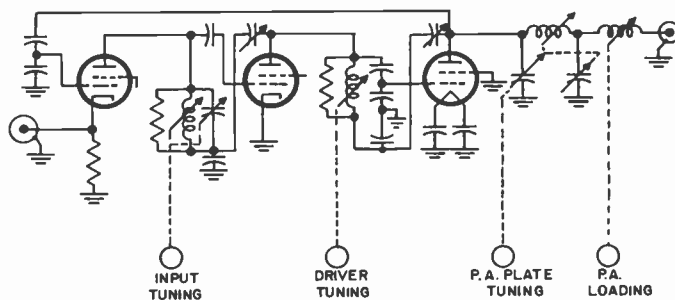

Fig. 12—High performance three-stage linear power amplifier.

CONCLUSION

The transfer characteristic of a tube and the choice of its operating condition determines the intermodulation distortion of a linear rf amplifier. The theoretical tube transfer characteristic presented may serve as a guide for tube manufacturers in the development of tubes with lower distortion. The optimum zero signal point of operation for low intermodulation can be estimated from published tube characteristic curves and Chaffee's method of analysis provides a useful and quite accurate method of computing the operating conditions of a class AB rf power amplifier.

The increasing use of single sideband and multiplexing to realize increased traffic density per transmitter channel requires the use of linear power amplifiers. Future requirements will call for ever increasing performance with regard to low distortion, low spurious output, and reliability. It is hoped that this paper will provide an incentive for further contributions to the state of the art.

Distortion Reducing Means for Single-Sideband Transmitters*

WARREN B. BRUENE†, SENIOR MEMBER, IRE

Summary—The need for reduced levels of intermodulation distortion products from linear rf power amplifiers is increasing as the state of the art advances. Two basic means of reducing distortion to levels better than is obtainable from available tubes are shown. One is direct rf feedback and the other is envelope distortion cancelling modulation. Some of the problems and limitations as well as advantages and performance characteristics are presented to aid the reader in evaluating these methods. RF feedback is a superior method, although useful amounts of distortion reduction can be achieved using envelope distortion cancelling modulation. A circuit of an amplifier combining both methods is shown which produces better performance than using either alone.

THE RAPID development of single-sideband techniques during the past few years has advanced the art to the point where it is accepted by the hf communication industry. In fact, it makes possible a better communication circuit at lower cost for the same standards of equipment performance. Single-sideband techniques also offer a great increase in channel capacity; first, because a channel requires half the previous bandwidth, and secondly, because several channels can be multiplexed which minimizes the guard band required between channels. To obtain the maximum use of the frequency spectrum we must use the minimum bandwidth practical per channel, minimize or eliminate guard bands for frequency drift and limited receiver selectivity, and confine all transmitter radiation to the assigned channel. This means that all spurious output due to harmonics and cross modulation distortion products must be kept as low as advances in the state of the art make possible.

It is these new higher standards and circuits for making more channels available that makes single-sideband so valuable, although seemingly more complex.

Some of the early single-sideband transmitters¹ realized the advantages of single-sideband transmission, but the power amplifier distortion was so great (25-db signal-to-distortion ratio) that voice channels were spaced a full channel apart to avoid excessive interference from noise due to distortion products. A more recent equipment² has low enough distortion (35 db) so that the quality of adjacent voice channels was acceptable. Still lower distortion is desirable, however, to yield higher quality voice circuits. Perhaps even more important are the distortion products that fall outside

the assigned channels which may interfere with another service receiving a weak signal on an adjacent channel.

The main source of distortion, of course, are the non-linear characteristics of rf power amplifier tubes. The best means of achieving low distortion is proper choice of the power amplifier tubes and their operating conditions. A companion paper³ outlines desirable tube characteristics and operating conditions for low distortion.

Another very desirable characteristic of a linear amplifier stage is high gain. Each stage generates distortion and the distortion products add approximately vectorially, so, for a given distortion per stage, fewer stages will yield lower over-all distortion.

The design objectives for transmitters in current development are minimum signal-to-distortion ratios of 35 to 40 db, using a two-frequency test signal. This represents an advancement in the state of the art but it takes no stretch of the imagination to realize that a signal-to-distortion ratio of 50 db would increase the utility of single sideband in the communications industry still more.

If the distortion of available tubes operated at practical operating conditions does not yield as low a distortion figure as desired, then some means of distortion cancelling must be used. There are two general types of distortion cancelling means used. One is direct rf feedback⁴ and the other is envelope modulation which may be accomplished in any of several ways.

RF FEEDBACK

RF feedback is a very effective means of reducing distortion. Ten db of rf feedback will produce nearly 10 db of distortion reduction and this is realized at all signal levels. A modest amount of feedback can be obtained very simply in a two or three-stage amplifier. Fig. 1 shows a typical two-stage amplifier and Fig. 2 shows an amplifier with feedback around three stages.

The amount of feedback that can be safely used depends upon the phase-gain characteristics around the feedback loop just as in any other type of feedback circuit. The principal contributions to the phase-gain characteristic are those of the tuned circuits which are within the feedback loop. In Fig. 1 these are the interstage tank circuit and the input characteristic of the output tank circuit. In Fig. 2 the two interstage tuned circuits plus the input characteristic of the output net-

* Original manuscript received by the IRE, September 10, 1956.

† Collins Radio Co., Cedar Rapids, Iowa.

¹ A. A. Oswald, "A short-wave single sideband radio telephone system," *PROC. IRE*, vol. 26, pp. 1431-1454; December, 1938.

² L. M. Klenk, A. J. Munn, and J. Nedelka, "A multichannel single sideband transmitter," *PROC. IRE*, vol. 40, pp. 783-790; July, 1952.

³ Bruene, "Linear power amplifier design," this issue, p. 1754.

⁴ W. B. Bruene, "Linear power amplifiers for SSB transmitters," *Electronics*, vol. 28, pp. 124-125; August, 1955.

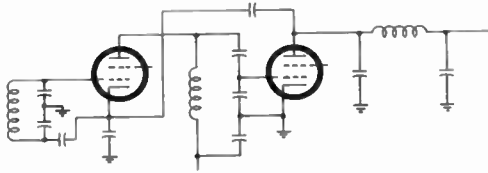

Fig. 1—Two-stage rf power amplifier with feedback.

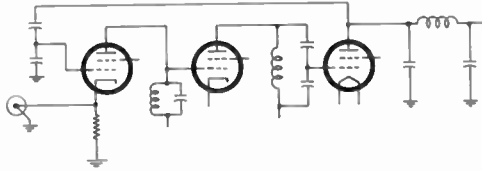

Fig. 2—RF feedback around three stages.

work appear within the feedback loop. It must also be recognized that the Q 's of the circuits may vary widely and that any degree of mistuning must be considered.

The phase-gain characteristic of the interstage circuits is very nearly that of the infinite Q characteristic if the Q is high or if the resistance in the circuit is in parallel with it and not in one leg only. The finite source resistance of the preceding tube's plate characteristic will not change the phase-gain curve but it does have the effect of lowering the apparent Q of the circuit.

If each of the three tuned circuits of a three-stage rf feedback amplifier can be assumed to have the characteristics of Fig. 3, the maximum amount of feedback that will allow a 30° phase margin can be found. This is represented by the minimum loss when the total phase shift is $180^\circ - 30^\circ$ or 150° . A few experimental checks showed that this minimum loss occurs when the phase shift in each circuit was the same, *i.e.*, 50° in each. The loss is then $3.8 + 3.8 + 3.8 = 11.4$ db. (Note that 11.4 db gain around the feedback loop corresponds to 13.4 db of feedback from a distortion reduction standpoint or relative amplifier gain with and without feedback. $11.4 \text{ db} = 3.4$ voltage gain around loop. $3.4 + 1 = \text{total feedback} = 4.4$ or 13.4 db.) It is also noted that the loss is 18 db total for 180° phase shift which gives a corresponding gain margin or $18 - 11.4 = 6.6$ db.

The above observation also applies to the case where the Q 's of the tuned circuits are not equal. The minimum loss still occurs where the circuits are tuned so that at some frequency the phase shift in each is 50° . Fig. 4 shows the superimposed resonance curves of three circuits of unequal Q for this condition. Any other tuning condition will have greater loss at 150° total phase shift and, hence, a greater margin of stability. If this worst possible tuning condition is not allowed to exist, the amount of feedback can be increased. This can be accomplished by using circuit Q 's that are widely different and tuning each exactly to resonance. Use of one Q twice the other two allows 15.4 db of feedback and if the one Q is 10 times the other two up to 20.8 db of feedback can be used.

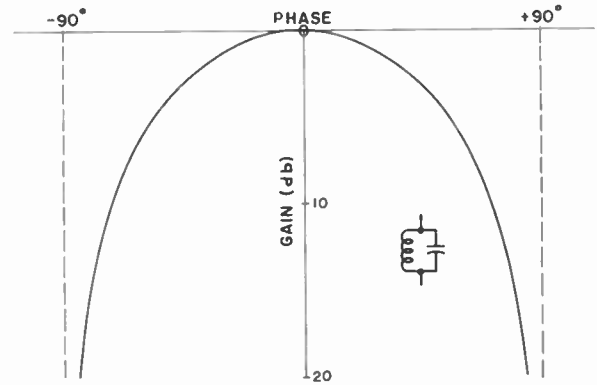

Fig. 3—Phase-gain of infinite Q -tuned circuits.

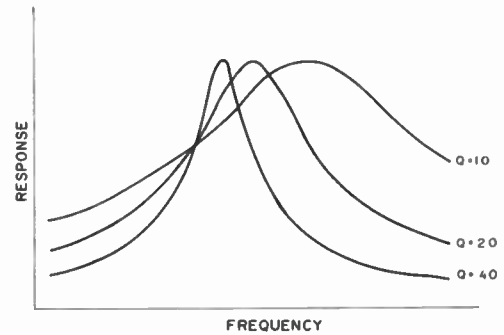

Fig. 4—Relative tuning position for minimum loss at 30° phase margin.

In the above example the phase-gain characteristic of all three tuned circuits was assumed to be that shown in Fig. 3. The input characteristic of a Pi-L output network with a Q of 10 (*i.e.*, input $Xc = 0.1 R_L$) is not symmetrical and is shown in Fig. 5.

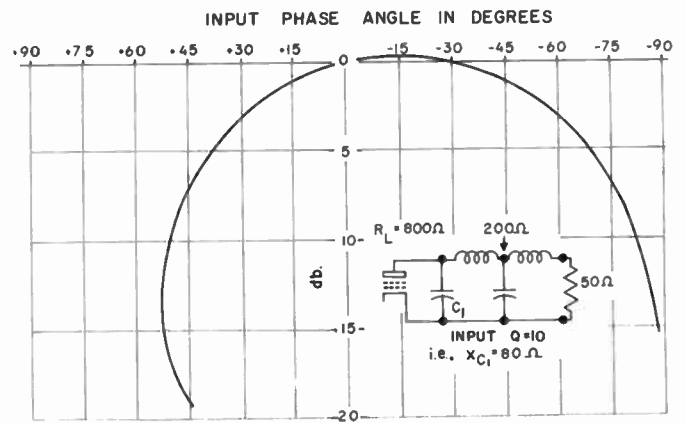

Fig. 5—Phase-gain plot of input of a Pi-L network.

Consider an example using this Pi-L network in a three-stage feedback amplifier. Any degree of mistuning allows only 10.8 db of feedback for the minimum phase margin of 30° . For comparison a two-stage feedback amplifier with the same Pi-L network can use up to 18.7 db of feedback for the same phase margin. Use of a higher Q Pi-L output network and some means of avoid-

ing the worst possible mistuning condition allows very useful amounts of rf feedback to be used. In practice, 10 db of feedback in a three-stage feedback amplifier has been used with good results, and, although 18 db can be used in a two-stage amplifier, it has been found more practical for other reasons to use only 12 to 15 db, which gives a very wide stability margin.

ENVELOPE DISTORTION CANCELLING MODULATION

The second general type of single-sideband distortion reduction uses some form of amplitude modulation to restore the shape of a distorted single-sideband envelope. When a two-frequency signal passes through a nonlinear amplifier the distortion products cause the shape of the rf output envelope to be different from the input signal and using amplitude modulation to restore the envelope shape can produce a useful amount of distortion cancelling.

One method uses envelope feedback which is a carry-over from AM practice.⁵ Fig. 6 shows a block diagram

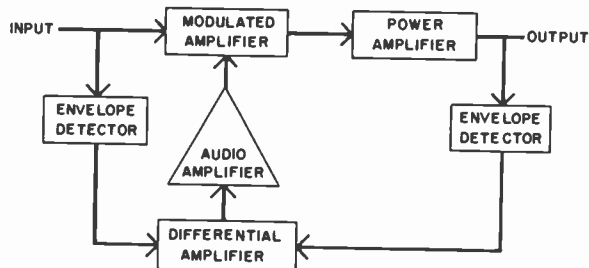

Fig. 6—Envelope feedback circuit for AM.

of this circuit. This circuit has been successful in reducing distortion in linear amplifiers in AM broadcast transmitters because a carrier of constant amplitude was always present which could be modulated, and it is the *envelope* which is detected in an AM system. Single-sideband is different in that there may be no carrier present and in single sideband it is the frequencies which make up the envelope rather than the envelope itself which are detected by the demodulator in the receiver. A study of the mathematics of the circuit of Fig. 6 shows that the gain of the audio amplifier should vary in an inverse manner to the instantaneous amplitude of the input signal envelope. To the writer's knowledge, this function has not been incorporated in existing single-sideband amplifier envelope feedback circuits and undoubtedly accounts for the fact that distortion reduction decreases with decreasing signal amplitude in these equipments. Fig. 7 shows typical performance of conventional envelope feedback circuits and the dotted line shows what would be expected if the gain of the audio amplifier were varied inversely with the amplitude of the input signal envelope. A circuit for

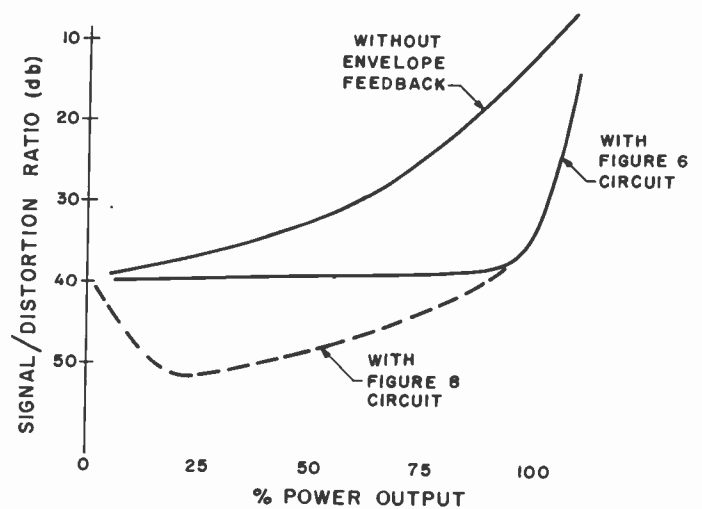

Fig. 7—Distortion reduction by envelope feedback.

accomplishing this is shown in Fig. 8. It is impractical for the audio amplifier gain to become infinite at zero amplitude so the finite gain limit causes the dotted curve of Fig. 7 to coincide with the no feedback curve at zero signal amplitude.

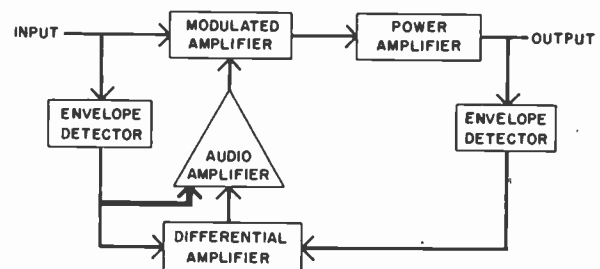

Fig. 8—Envelope feedback circuit for single sideband.

Envelope feedback circuits present some rather difficult design requirements. If these are not met adequately this circuit will cause distortion to be generated in an otherwise low distortion amplifier. The most important and most difficult problem is overcoming the apparent envelope time lead inherent in rf tank circuits. This causes the envelope of continuous tones at the output envelope detector to be leading in time from that at the input envelope detector as shown in Fig. 9. For example, a signal of two frequencies 10 kc apart passing through four tuned circuits each with a Q of 20 at an operating frequency of 4 mc will have an apparent envelope lead of approximately $\frac{1}{2}$ microsecond. Another way of stating this is that the higher frequency is leading by 20° the relative phase of the lower frequency as shown by this example in Fig. 9. In order to get a proper balance in the differential amplifier a delay network must be inserted in the rf amplifier or in the output envelope detector circuit. There is a fallacy in this reasoning which assumes a continuous wave signal with the envelope repeating in a cyclic manner, however.

⁵ F. E. Terman and R. R. Buss, "Some notes on linear and grid-modulated radio frequency amplifiers," Proc. IRE, vol. 29, pp. 104-107; March, 1941.

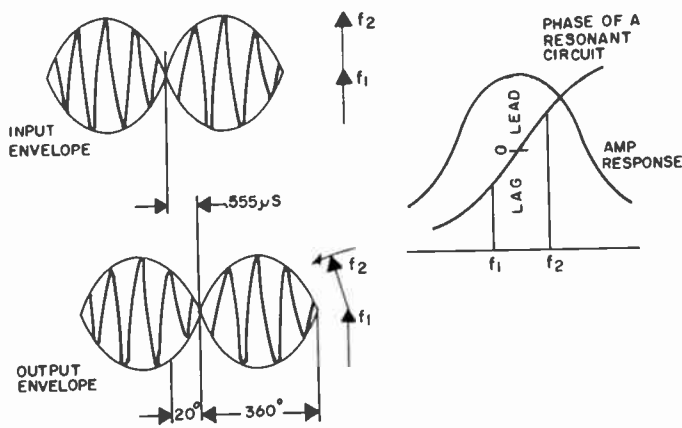

Fig. 9—Envelope lead due to tank circuits.

Actually, the intended purpose of the envelope modulator is to keep the output envelope shape the same as that of the input envelope. The only way this can be accomplished perfectly is on an instantaneous basis. There is some delay inherent in the envelope detectors which usually can be kept relatively small, but it is apparent that any time delay around the feedback loop will cause the distortion cancelling modulation to come late. How late relative to the rate at which the envelope is changing places a limit on the effectiveness of this circuit. Excessive time delay can cause a very serious amount of uncancelled distortion to be generated which would destroy that circuit's usefulness. This discussion also serves to show that the standard two-frequency test signal may give optimistic readings for performance of equipment using envelope feedback.

Another limitation of envelope feedback is that the bandwidth of the feedback circuit should be theoretically infinite because frequency components of the amplitude-detected envelope are not the same as the components which produce the envelope, and are not limited to the same frequency range. For example, the envelope of two equal amplitude rf frequencies is the same as that of a full wave rectified sine wave which theoretically contains an infinite number of components. It can be shown, however, that by considering the probable frequencies and their amplitudes of random signals an envelope feedback frequency response of three times the rf channel width will realize a large percentage of the possible usefulness of envelope feedback.

Another envelope feedback circuit requirement is that the phase-gain characteristic around the feedback loop must be carefully controlled to maintain stability of the circuit and this must be compatible with the previously discussed time-delay and frequency response requirements.

A proper amplitude balance must be maintained from the envelope detectors at the differential amplifier in order that only the distortion components of the output envelope are used to modulate the input envelope. If the gain of the power amplifier stages changes when tuning to a new frequency, the level from the output envelope

detector must be changed a corresponding amount to maintain the proper balance at the differential amplifier. An unbalance will cause generation of distortion in Fig. 8, unless dc circuits are maintained from the envelope detector through to the modulated amplifier. In Fig. 6 an unbalance will always generate distortion whether or not the audio circuits pass dc. In some cases this generated distortion can be useful if it happens to cancel distortion produced in the rf amplifiers.

There have been numerous attempts to obtain a modulating audio signal for distortion cancellation in different ways. Nonlinear circuit loading has also been used as a distortion cancelling means. In general, the capabilities of most of these schemes are quite limited but in some cases a useful amount of distortion cancellation can be achieved.

COMBINED ENVELOPE MODULATION DISTORTION CANCELLING AND RF FEEDBACK

The writer has successfully combined one type of envelope modulation with rf feedback and Fig. 10 shows

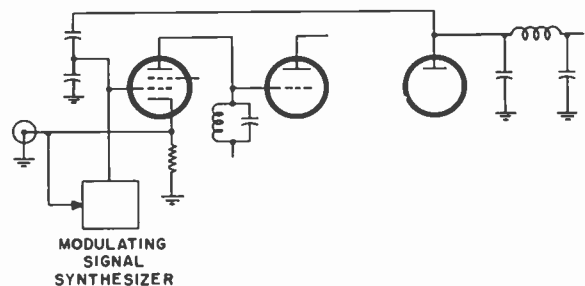

Fig. 10—Combined envelope modulation and rf feedback.

a simplified schematic of this circuit. Three high gain stages with 10 db of rf feedback around all three stages are used. A modulating signal is synthesized from the input envelope and used to grid modulate the first stage. The envelope distortion cancelling modulation is effectively within the rf feedback loop so when the rf feedback reduces the residual distortion by 10 db a total distortion reduction on the order of 20 db can be readily achieved. This circuit adapted to a 20-kw transmitter in the laboratory demonstrated a signal-to-distortion ratio of better than 50 db for all distortion products at any signal level up to 20-kw peak envelope power using a two-frequency test signal.

The modulating signal synthesizing circuit was very simple and only did a crude job of generating a signal approximating the ideal. It was capable of substantial distortion reduction for rf signals greater than one-tenth of rated peak power output, however. Fig. 11 shows the improvement of the 20-kw transmitter distortion by addition of the envelope distortion-cancelling modulator. RF feedback was not used during these measurements but when it was added the 50-db signal-to-distortion ratio was achieved using a standard two-frequency test signal.

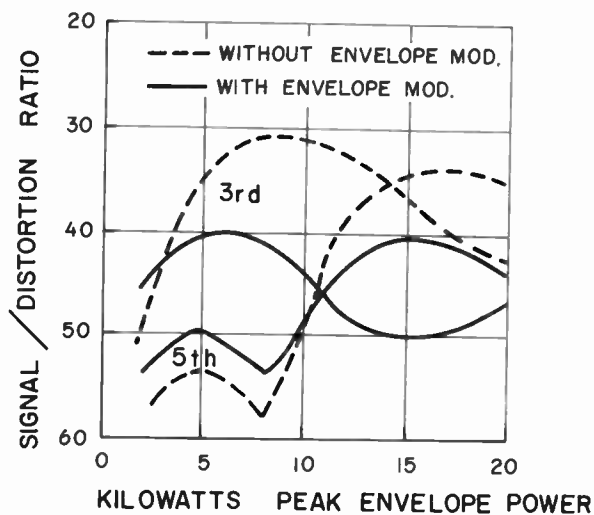

Fig. 11—Envelope distortion cancellation in 20-kw transmitter.

PERFORMANCE MEASUREMENTS

There was reason to doubt the value of this envelope modulation with other types of signals because of the unpredictableness of nonlinear element characteristics. Tests were made using three frequencies and four frequencies for the test signal and the improvement was still almost as good. A 3-kc band of white noise was then used for the test signal and the spectrum was again analyzed using an analyzer with a 150-cps bandwidth and sweeping at a rate of 200 cps. Many charts were made using a pen recorder on the output of the spectrum analyzer for various signal levels with and without envelope modulation, with and without rf feedback and with both rf feedback and envelope modulation.

The envelope modulation yielded the most distortion reduction when the rms power level was 7 db below 20-kw peak envelope power. At higher levels the distortion from limiting on noise peaks increased rapidly and at a lower noise signal level much of the signal was in the low level region where this particular circuit was less effective as indicated by Fig. 11. The improvement of the envelope modulator is shown in Fig. 12 for this signal level. It is noted that the greatest reduction lies near the passband where the third-order products are predominant. Beyond 6 kc from the band edge there is no improvement as only seventh and higher-order products lie in this region and this envelope modulator did not reduce them as previously determined from two-frequency test measurements.

RF feedback, on the other hand, is effective on the higher-order products, also, and Fig. 13 shows the improvement by rf feedback at the same noise signal level. The additional improvement of using both envelope modulation and rf feedback is also shown in the same figure. The value of using the envelope modulation rapidly diminished at lower signal levels and vanished at a noise signal level about 6 db below the -7 db level.

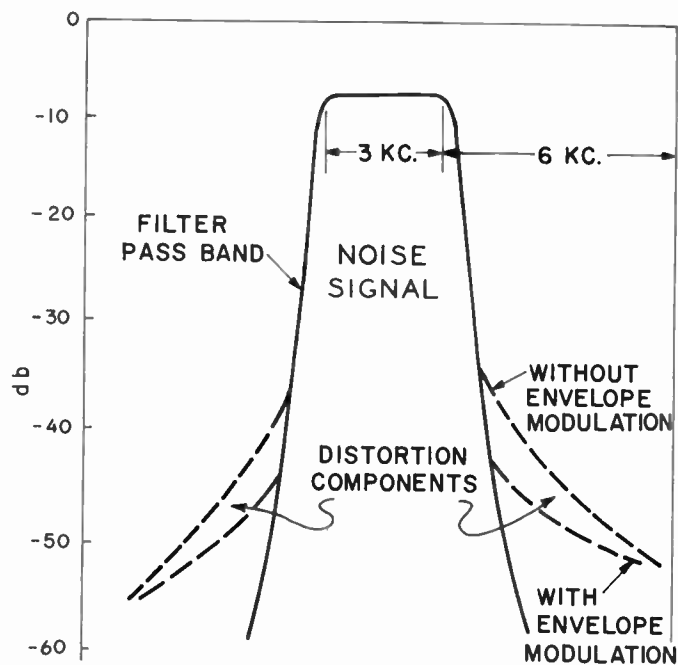

Fig. 12—Distortion components with and without envelope modulation.

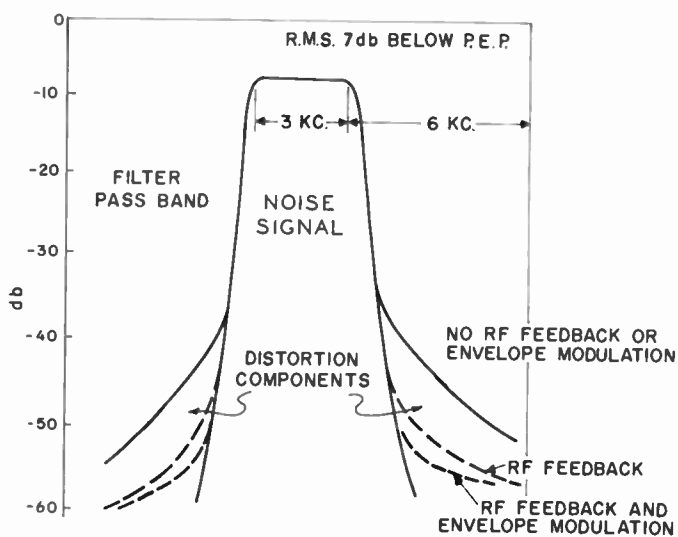

Fig. 13—Improvement using both envelope modulation and rf feedback.

CONCLUSION

These tests indicate that rf feedback is a superior method of reducing distortion. It is fully effective on any type of signal at any signal level up to the peak power limit of the amplifier. It is effective on all orders of distortion components with the only limit being the bandwidth of the interstage tank circuits which are ordinarily many times wider than the communication channel.

Envelope modulation can be used to achieve a useful amount of distortion reduction but it is basically an indirect method and difficult to apply to full advantage.

It is expected that an improvement over the performance shown here can be achieved by obtaining a better envelope modulating signal. The frequency response of the envelope modulation circuits must be several times the bandwidth of the transmitter channel width. It appears that inherent practical limitations make it a less useful means of distortion reduction, particularly for the higher order products that lie beyond the immediately adjacent channels.

A simple method has been shown using both rf feedback and envelope modulation that yielded a 50-db

signal to distortion ratio with a two-frequency test signal. The addition of envelope modulation distortion cancellation to an rf feedback amplifier appears to be useful, although not as much as might be expected.

The complexity and limitations of linear amplifier designs requiring these distortion reducing means show the need for the development of rf power amplifier tubes with lower distortion. Future requirements will restrict adjacent channel undesired output more than at present and better tubes will allow this to be achieved with less complexity and more reliability.

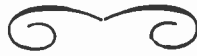

CORRECTION

The Audio Techniques Committee has requested that the following correction be made to "IRE Standards on Audio Systems and Components, Methods of Measurement of Gain, Amplification, Loss, Attenuation, and Amplitude-Frequency-Response," which appeared in the May, 1956 issue of *PROCEEDINGS*. The second paragraph of Section 1.2, on page 674 should read as follows:

In audio practice, the term "amplification" is employed for, and should be limited to, the expression of a current or voltage ratio between any two points in a transmission system. When expressing a power ratio it is recommended that the term "gain" be used instead of amplification. Conversely the use of the term gain (or the inverse term "loss") to express a current or voltage ratio is deprecated.

Automatic Tuning Techniques for Single-Sideband Equipment*

VINCENT R. DeLONG†, MEMBER, IRE

Summary—Methods of automatically positioning tuned circuits for rapid frequency changes are discussed. Equipment ranging from low level single-sideband exciter-receivers to high power linear rf amplifiers are considered with attention given to the correlation of positioning accuracy, tuning change time, and ultimate cost of equipment. The merits and limitations of mechanical positioning, follow-up potentiometer servo systems, and phase servo systems, are noted.

Special emphasis is placed upon the adjustment of tank circuits in linear power amplifiers. The problem of obtaining phase information for the servo systems is presented and several improved circuits for tuning and loading detection are explained.

The paper is concluded with a general discussion of gain control, sequencing of control circuits, and protection of tubes during tuning cycles.

INTRODUCTION

WITH the growing impetus for practical methods of utilizing the advantages of single sideband for hf communication, developments are rapidly progressing to design equipment whose operation is as simple or even more simple than operation of present double-sideband systems. A technique which promises to aid in this endeavor is automatic tuning. Automatic tuning is a term which has been overworked in describing nearly every invention that caused a circuit to resonate without outside aid. For purposes of this discussion, automatic tuning will refer to the technique of adjusting radio communications equipment in such a manner that its operation may be virtually unattended.

Automatic tuning of a single-sideband transmitter presents a problem which requires a study of the system as a whole from the operator to the antenna. The automatic consideration breaks down into five distinct fields: tuning the single-sideband exciter, tuning the linear amplifiers, loading the final amplifier and the antenna, adjusting the circuit gains, and operating the control circuits. When each one of these functions is properly performed without the aid of a human being, it may be said that the system is truly automatically tuned.

TUNING THE EXCITER

Automatic tuning of transmitting equipment infers the ability to be able to switch to new operating frequencies in rather rapid succession. This requires switching capabilities in the basic frequency generating device. In view of the great frequency stability necessary for single-sideband communication, two methods of frequency control are in general use. These are the crystal oscillator and the stabilized master oscillator

(SMO). Of these two choices, the SMO is by far the most versatile, the most stable, and unfortunately the most costly. In systems where slightly reduced stability can be tolerated, and where only a few predetermined channels are necessary to maintain communications, the crystal oscillator offers the most economical solution for generating the basic frequency.

With crystal controlled oscillators, frequency selection is a fairly simple matter. Various channels may be chosen by merely switching the proper crystals into the circuit or by selecting the proper crystal oscillator. If remote control of the transmitting equipment is necessary for system operation, it is an easy matter to obtain mechanical assemblies that will position the channel switch from remote electrical information. The only shortcomings of this arrangement are limited channel selections and only medium-frequency stability.

Use of a stabilized master oscillator frequency-generating scheme allows the generation of an almost super stable signal whose stability may be only limited by the excellence with which a frequency standard may be built as a reference unit. Depending upon the application, two degrees of stability may be obtained with a SMO circuit. If the communications system can tolerate discreet channels with spacings up to as close as 1 kc, thousands of channels may be made available with each frequency in its turn being phase locked to the frequency standard. On the other hand, if complete frequency coverage is needed in the application, frequencies between the phase locked channels may be supplied with a not too distressing reduction in SMO stability.

Frequency selection with a stabilized master oscillator may be done in a variety of ways. With local operation, a calibrated dial may manually be used to select the frequency. Remotely this same dial may be channeled to a number of "pre-set" frequencies by mechanical memory schemes. A recently employed arrangement uses a follow-up potentiometer servo system to select thousands of channels either locally or remotely by merely selecting the proper precision resistance. By employing a special switch design to select the resistances, a direct reading frequency indication dial may be provided. It appears that the technique in this field is continually changing and improving, with present developments allowing nearly infinite frequency channel control with local operation, but limiting channels to a finite number with remote selection.

Once the basic frequency has been selected, it must be operated on by additional equipment to generate the final single-sideband signal. To encompass an entire sys-

* Original manuscript received by the IRE, September 10, 1956.

† Collins Radio Company, Cedar Rapids, Ia.

tem of automatic tuning, consideration must be given to the method by which the sideband is to be obtained. Of the several ways of generating a single-sideband signal, by far the most popular is the low level method employing filters. In practical frequency schemes this infers operation of a balanced modulator in the 100-kc to 500-kc region, filtering at the balanced modulator frequency to remove the unwanted sideband, and either single or multiple conversion to the operating frequency. Early designs by the Bell Telephone Laboratories used balanced modulators at 100 kc mostly because this was a favorable region for the construction of a crystal lattice filter.¹ The Collins Radio Company has been employing 300 kc partly because this 300 kc works well in the frequency conversion scheme used to reach the final operating frequency, and partly because a good mechanical filter can be constructed in this region. The local oscillator chosen to go with the 300-kc intermediate frequency is in the range of 2 to 4 mc. Reasons for the choice of this range are many and complex, but in general this frequency ratio and range are practical values for the construction of an extremely stable permeability-tuned oscillator with linearized tuning. Utilizing this intermediate frequency together with the 2 to 4 mc oscillator, it is possible to obtain sideband output on any frequency in the hf range with a minimum of spurious outputs. It is thus apparent that the crystal oscillator or the stabilized master oscillator whose use as basic frequency devices has already been discussed should have their outputs some place between 2 and 4 mc, depending upon the output frequency desired if this frequency conversion plan is used.

Inasmuch as the only circuits of great interest from the automatic operation standpoint are those which need readjustment with frequency, the carrier generator which generates the intermediate frequency, the balanced modulators, and sideband filters, may be dispensed with as they are of fixed frequency for a given installation. Speculation has already been given to ways and means of controlling the tuning of the oscillator. The next tuned circuits to need attention are the mixer tank circuits and the tank circuits of the following low level amplifiers, necessary either for amplification or for selectivity to reject mixer spurious responses. If more than a single conversion is necessary there are also multiplier tank circuits to be positioned which are used to step up the local oscillator frequency for subsequent injections. Starting at the 300-kc generation point and using a basic frequency between 2 and 4 mc, more than ten tuned circuits may be necessary before a power level of 0.1 watt on the operating frequency is attained. About 0.1-watt level is chosen as the power level at which receiver type techniques are reaching their limitation giving way to the more elaborate tank circuits necessary to handle appreciable power. This is also the

arbitrary dividing line between a single-sideband "exciter" and a single-sideband power amplifier unit.

With as many as ten circuits in use on one frequency and the possibility of thirty circuits necessary to cover only the high-frequency spectrum in a band-switched exciter, it is obviously impossible to consider individual positioning of each tank circuit for every frequency change. For the design of a crystal-controlled exciter with a very limited number of channels, it might be quite practical to have pretuned sets of coils that could be switched into the various circuits or, for that matter, complete pre-tuned individual mixer-multiplier stages could be switched. For the design of a versatile automatically-tuned transmitter such an arrangement would be quite limited. One practical solution is to employ permeability-tuned coils for each circuit whose inductance variation has been tapered such that the tuning shaft travel has been linearized with respect to frequency. These then may all be ganged together to provide one tuning control for all the mixer-multiplier circuits.

Once the mixer-multiplier tank circuits are tracked, it is necessary to worry about the positioning of only one control instead of a possible thirty. Because the coils in the mixer-multiplier circuits have drives linearized with respect to frequency, it is entirely possible to mechanically connect their positioning shaft to a SMO whose mechanical operation is also linearized in the same manner. By means of quite complex mechanical linkages, high stability exciters have been built with all the tuned circuits ganged to a master control. The same problem may be solved with electrical coupling, by supplying the mixer-multiplier with a very accurate follow-up potentiometer servo system which has the master potentiometer located on the SMO. Such a scheme, although possibly slightly higher in initial cost, is extremely flexible in its application and has numerous advantages that become more evident when the concept is studied in relation to entire systems. Fig. 1 (next page) shows the two approaches for comparison. A common design of the servo controlled mixer-multiplier assembly may be used with many different oscillators. For example, a multiple channel exciter with a switched crystal oscillator may employ the servo mixer-multiplier by merely switching in the proper master resistance for each channel. By the addition of a few tubes, the same tank circuits of the mixer-multiplier may be employed as a receiver. Thus a whole family of exciters, receivers, and transceivers may be generated using the same master building block, the servo controlled mixer-multiplier unit.

Exactly which plan is chosen to select the exciter frequency depends mostly upon analysis of the communication problem to determine what frequencies must be made available and by what manner they must be selected. Solutions have been offered not only for tuning exciters but also for automatically tuning receivers. Whatever is determined as the proper choice of exciter for the application, it is bound to influence the planning of the tuning techniques of the amplifiers to follow.

¹ A. E. Kerwien, "Design of modulation equipment for modern single-sideband transmitters," *Proc. IRE*, vol. 40, pp. 797-803; July, 1952.



Fig. 1—(a) Aircraft SSB exciter with servo coupled mixer-multiplier. All units are plug-in module construction. (b) SSB ground station exciter drawer. All mixer-multipliers and oscillators are mechanically ganged to front gear plate.

TUNING THE LINEAR AMPLIFIER

In a single-sideband transmitter a series of linear amplifiers all on the operating frequency are employed to boost the exciter power level to the desired power output. Because of the relatively high power level in these amplifiers, it becomes difficult to track more than a minor number of tank circuits. As each tank circuit or set of tracked tank circuits will require one servomotor to tune the circuit to resonance, it behooves the designer to consider carefully the use of an unnecessary stage of amplification. A design most conservative of tuned circuits employs the modern high gain tetrode or pentode. Using these modern tubes with 0.1-watt exciter output, power levels to 1 kw may be obtained with two stages of amplification, to 50 kw with three stages, and to 300 kw in four stages. In order to get satisfactory linearity with these types of tubes rf feedback may be employed. With feedback, additional restrictions and precautions must be placed upon the design of the automatic tuning system. The exact number of stages of amplification and the resulting servo tuning units to be employed depend entirely upon the tube types available and the discretion of the designer. In any event, the final product must be a compromise that will satisfy both the gain and linearity requirements and yet employ no more than a graceful complement of motor tuned circuits. Experience has shown that the best designs are realized when the rf circuits, and the automatic tuning arrangements are conceived simultaneously with easy interchange of com-

promise between the two considerations.

Of fundamental importance in the design of an automatic tuning system is the choice of the tune-up time. It is clear that no objection could arise to a nearly instantaneous response; however, it is apparent that the shorter the time allowed for tuning, the greater must be the power of the servo motors used to move a given friction load and the more exact will be the precision of the system. In the past, equipment users have been satisfied with a frequency change time of a few seconds to about 60 seconds. In general, it is found that the shorter the tuning time required, the higher powered the output stage desired, and the greater the frequency spectrum to be serviced, the greater will be the cost of the servo equipment. In the struggle for improvement every effort should be made to arrive at a design that will hold the tuning time to a minimum for any group of components of a given cost.

Two varieties of servo systems are available to position transmitter components, the nonlinear relay operated servo and the full proportional control servo. Each of these may employ either a dc motor or an ac motor for the driving mechanism. Although many successful designs have employed dc motors, they are not to be preferred because of the commutator problem. The nonlinear relay system is very economical but is rather crude for the present state of the art. The amount of tuning accuracy that may be obtained is limited and its use is not satisfactory except where a low grade servo system can be tolerated. On the other hand the proportional control system will give excellent performance and in the past few years has seen rapid advances both in the availability of excellent components and in the gain of engineering know-how in the application of servo mechanism theory. There are currently on the market many high performance two phase ac servo motors with low inertia and extremely compact design. In the 400-cycle frequency range the units are capable of amazing performance and the variety is almost unlimited. Motors may be obtained with attached rate generators of excellent quality for servo system stabilization or with integral mechanical damping devices. The servo pre-amplifiers may now be transistorized to give increased reliability, and great strides in the magnetic amplifier field offer a valuable tool for the control of power to the servo motor. Whole organizations of engineers specializing only in the design of servo mechanisms are available throughout the country, and the application of their efforts can add almost unlimited improvement to the quality of an automatically-tuned transmitter.

Choice of the servo system depends not only upon the tuning time but also upon the components to be positioned and the degree of accuracy required. The components and the position accuracy are a function of the rf circuit design. There are two broad design choices, that is, either band-switched or continuous coverage tank circuits for the amplifiers. Band-switching has the

advantage of using a cheaper motor driven switch for large frequency changes and hence may possibly cause a reduction in the size of the more costly tuning motor required, since the tuning motor then operates as a vernier device to tune in between the larger frequency jumps. This arrangement might roughly be classed as a two-speed servo system. If band-switching is employed, care must be taken to maintain some sort of compatibility between the amplifier switching points and the frequencies at which the exciter switches; otherwise, it will be difficult to obtain information to position properly the amplifier band switches. Band-switching may also be done with lost motion devices connected to the tuning servo motor. These arrangements are true two-speed servo systems and are entirely practical, but great finesse must be used to avoid more complication than might be caused by doing the job by more conventional methods. Continuously-tuned amplifiers employing a ganged L and C combination for the tank circuit enjoy the advantage of yielding a more theoretically perfect rf circuit over a range of frequency. It is usually easier to keep the operating conditions more nearly optimum at all frequencies and to keep the design freer from clutter and complication. There is, of course, no need for the extra motor driven band-switch gear. For the usual case more precise servo-control equipment is required for a continuous tuning arrangement than for the band-switched design for a given tune up time.

Whether the choice be band-switched or continuous tuning, suitable components must be procured for the tank circuits. Obviously there can be only two kinds of variable elements, the capacitor and the inductor. Either one or both of these elements may be varied to effect resonance in the tank circuits. While in manually-tuned transmitters the prime consideration is whether or not the component will handle the voltage and current in the circuit, in automatically-tuned transmitters the type of mechanical load that the element will present to the servomotor becomes almost as important a facet. The ideal component will present little friction, practically no "wind-up" or "spring-back," low break-free torque or "sticktion," and very low inertia to the servo motor. Among the best available tuning elements for servo-control are small variable air capacitors with good bearings. While they require considerably larger servos for the same tuning accuracy, the next best mechanical load is the variable vacuum capacitor. There are virtually no commercial inductors on the market which will fill the circuit requirements of a given design and still have reasonable mechanical aptitudes. Nearly always the most difficult single task of building a high power automatically-tuned amplifier is the design of a variable inductor that will have long trouble free life and yet meet all the requirements of a good servo driven element. Unquestionably, any time expended to improve the mechanical design of the element is better spent than time trying to beef up the servo system to handle the unfavorable mechanical load.

The mechanical linkage from the motor to the active elements ideally consists of a well-designed spur gear train. Proper caution must be exercised to keep the backlash to a low value, the amount of which may be tolerated depending upon the precision of the positioning required. The first stages of reduction from the motor require special attention to avoid adding too much inertia to the system. Certain gearing steps and gear thickness will yield better results. These may be determined by procedures already in the literature.² Other acceptable gearing include well-planned chain or belt linkages and line shafts. Worm gears or screws are not to be preferred because of their inherent low efficiency and resulting requirement for needless servo power. The gear train should also be fitted with some sort of stop mechanism to avoid damage to the tuning element in the event of over-travel. If possible, the driven element should be built into a unified electromechanical assembly. This arrangement is much preferred because of the greater ease of disassembly for servicing and the decreased possibility of the various electrical elements, the over-travel stops, and the motor getting out of synchronism. An example of each method of assembly is shown in Fig. 2 (next page). In small transmitters unified construction can usually be attained while in high power equipment it is often necessary to divorce the motor and gearing assembly from the driven elements.

Before selection of the correct servo system can be completed an estimate of the required servo positioning accuracy must be prepared. After the mechanical travel of the components is known, together with the circuit in which they are used, it is possible to estimate the needed precision of positioning. A plot of inductance and capacity variation vs turns of their operating shaft is prepared for each element. The operating frequency at which the smallest variation in mechanical setting would cause the greatest degree of departure from resonance is estimated. In the normal design this occurs at the highest output frequency where the highest loaded Q in the tank circuits usually exists. Next, the number of degrees of electrical phase shift from resonance that can be tolerated is estimated. This value is used and worked back through the tuning curves to be expressed in terms of mechanical displacement that will cause that error. This mechanical displacement is then doubled to take care of the fact that this displacement may occur in either direction from resonance, and expressed as a ratio of the total travel required. Practical accuracies range from one part in 500 to one part in 10,000. As an example, a servo with accuracy requirement of one part in 1000 would be the case where if the total tuning travel were divided into 1000 equal parts, the servo system must be capable of stopping the elements within the limits of any one of these 1000 slots as desired. This statement of accuracy together with the

² D. P. Petersen, "Predicting minimum-inertia power gear trains," *Machine Design*, vol. 26, pp. 161-167; June, 1954.

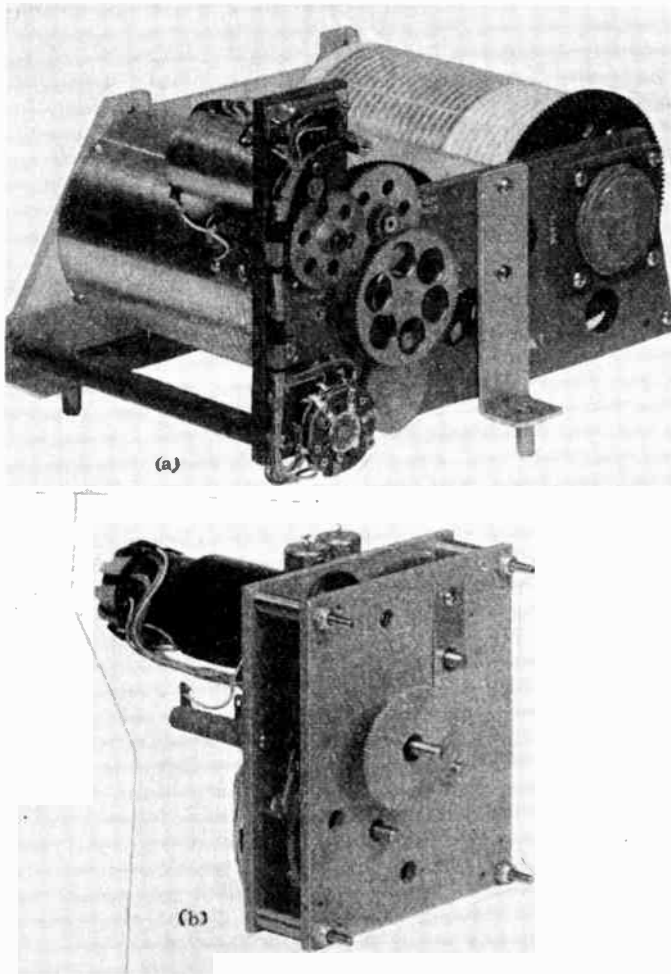

Fig. 2—(a) Roller coil showing example of unitized gear drive and component design. (b) Independent type gear drive unit.

mechanical load description and the tuning time fully describe what grade of servo system must be provided.

To complete the servo system a source of positioning error signal has to be found. Information may be obtained as to the degree of electrical mistuning by a phase discriminator or as to the degree of mechanical misplacement by a follow-up potentiometer geared to the tuning elements. The follow-up potentiometer servo has long been used to reposition tank circuits in transmitters to previously selected resonances. Banks of master potentiometers are adjusted for various frequencies and then switched to instigate a frequency change. For a ground station transmitter having available an antenna system with a fairly constant input impedance and an operating procedure which can tolerate the limited number of channels and other shortcomings, the follow-up system may be a satisfactory solution. On the other hand, in mobile transmitter equipments where variations in antenna impedance are the rule and where the availability of many channels is a necessity, a phase operated servo system is a must. Furthermore, the trend toward the use of high gain tetrodes and rf feedback in the linear amplifiers points toward the far superior adjustment provided by the constant phase surveillance

for all types of automatic transmitters. Shown in Fig. 3 is the phase discriminator which has often been employed to determine any deviation of the plate tank circuit from resonance. A balanced voltage $E_b + E_c$ is obtained from either the plate or grid circuits by a link-coupled coil that is shielded to prevent incidental capacity coupling. From the remaining tank circuit a reference voltage is obtained through a 90° phase-shifting network to yield voltage E_a . Any deviation from resonance causes E_a and $E_b + E_c$ to be at some relationship other than 90° . Net result of such a phase shift is unbalancing of the dc voltage outputs from the two diode rectifiers. An error signal is consequently delivered from

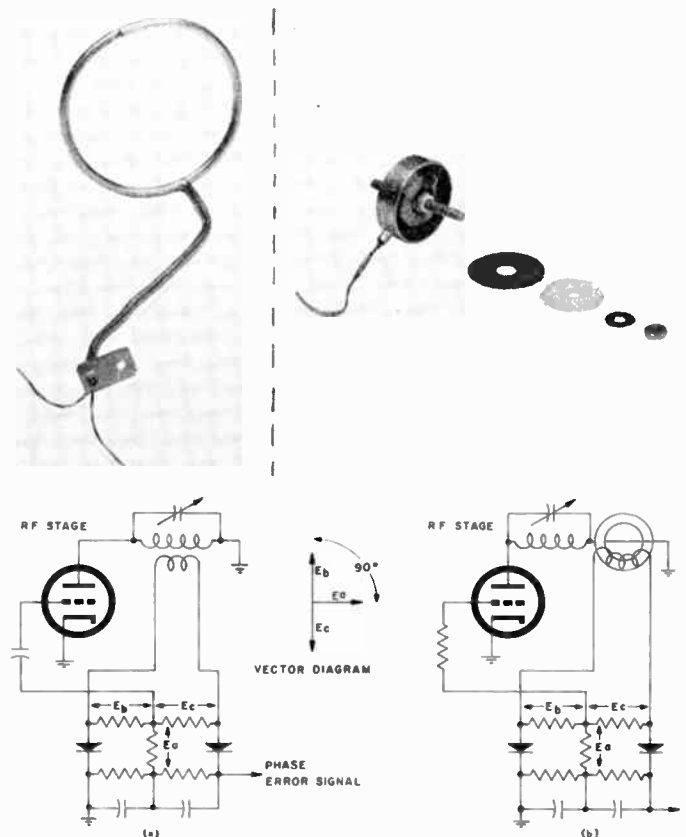

Fig. 3—(a) Circuit diagram of phase discriminator, with shield link pictured above. (b) Circuit diagram of phase discriminator, with photograph of current transformer construction above.

the circuit which may be used to motivate the servo system and return the balance to normal with proper resonating of the tank circuit involved. For most satisfactory operation all three vectors E_a , E_b , and E_c should all be nearly equal. It is apparent that E_a will vary with frequency due to the type of phase-shift network employed. This leads to wide variations in the output level of the discriminator and also to possible errors if the voltage unbalance becomes too great. Hence, for any sort of frequency spectrum coverage, the components of the phase shift network must either be switched or continuously varied. To avoid this difficulty the second discriminator of Fig. 3 has been developed. This circuit uses a shielded toroidal current transformer that pro-

vides an inherent 90° phase shift because the voltage output is in phase with the 90° phase shifted current of the tank circuit coil. The reference voltage may be obtained by either a resistance, capacitance, or inductance divider as long as no phase shift is allowed. The resulting circuit performs exactly like the first described except that the gain variations are minimized due to the elimination of the frequency sensitive phase shift circuit. Gain variations are kept especially small if the loaded Q of the tank circuit in which the current transformer is inserted is held fairly constant. The phase discriminator is usually applied individually to each stage that is in need of tuning information. However, it may be used just as conveniently around two or more stages. Such an arrangement may be used in a circuit with rf feedback to maintain zero phase shift inside the rf feedback loop. This will give added assurance that the feedback is working most effectively to correct the nonlinearities of the amplifier stages.

The phase discriminator is a well-behaved circuit in the vicinity of resonance. Unfortunately the discriminator responds to harmonic tuning points and signals of undeterminate nature lie between the harmonic responses. To insure that the amplifier will pull into the correct frequency, some sort of coarse tuning information must be provided. If each motor driven circuit is equipped with a potentiometer, coarse follow-up potentiometer information may be obtained from the exciter stages. It is necessary to provide some type of sequencing control that will initiate the coarse signal when a frequency change is made and turn off the coarse when the amplifier is nearing resonance. Except for the difficulties of getting the coarse information from the master potentiometer in the exciter to track adequately with the tuning curves of the amplifier tank circuits and the problems of making the sequencing function happen in proper order, such a coarse scheme will effectively supply pre-information. Pretuning information may also be derived from the exciter output signal.³ The circuit shown in Fig. 4 samples the amplifier input signal and puts out various ratios of positive to negative voltage depending upon the frequency. The two-output leads are connected across a follow-up potentiometer on the tank circuit gear train to be positioned. A null is arrived at by the servo system which roughly positions the tuning elements. The tuning curve of the tank circuit is tracked by proper choice of the frequency sensitive elements in the coarse comparator. Location of the phase discriminator response can also be reached by searching. The tank circuits are all returned to the low frequency end with each frequency selection, and then allowed to progress in the increase frequency direction until the first response is reached. This method is not considered too good because of the increased tuning time and the additional wear on the components. A final

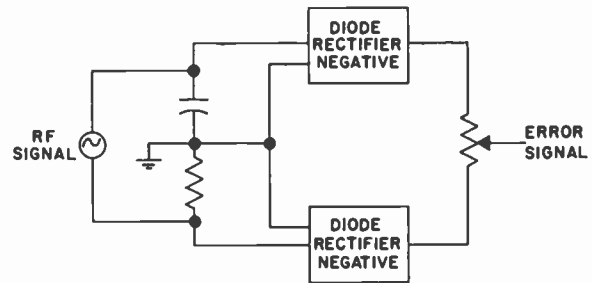

Fig. 4—Frequency comparator block diagram.

method is to break the tuning of the tank circuits into band-switched frequency segments that are so small that the circuit can never be tuned outside the signal skirts of the phase discriminator. Any of those varieties of coarse positioning schemes may be used, with the right choice being that which best fits the over-all system planning.

Final analysis of the servo tuning system is made by testing for a comfortable margin of stability. At all frequencies and under all operating conditions the servo should be free of hunting and jitter. If instability occurs it may indicate an error in the original estimation of the grade of servo required. The accuracy of a system already constructed may be improved by the addition of electrical stabilizing networks such as the lead and integrating networks, or by adding a rate generator or inertia drag cup damper to the motor providing, of course, that these aids are not already used. If the problem is persistent, complete or partial redesign of either or both the electrical and mechanical system may be required. A marginal system will most surely lead to difficulties in subsequent models of the same equipment.

LOADING THE FINAL AMPLIFIER

In order for a linear power amplifier to function properly its plate impedance must be closely controlled. This implies that rf coupling networks must be designed to transform the antenna impedance to a value that is compatible with the output stage. Design of these networks must be such that good efficiency and harmonic reduction is obtained in addition to being capable of automatic control. There must be a minimum number of variable elements in the network, the positioning of the elements must not be ambiguous, and the elements must be so arranged that it is possible to obtain electrical information for their phasing.

The most important single design consideration is the antenna which is to be matched. There are two general divisions in this respect. First, there are the carefully designed fixed antenna systems which normally are fed with a transmission line with a relatively low voltage standing wave ratio. Secondly, there are the short usually inadequate antennas with extremely unwieldy input impedances which are often encountered in mobile installations. Typical methods of attacking each of these types are shown in Fig. 5. A convenient solution to the

³ V. R. DeLong, "Automatic tuning for high-power transmitter," *Electronics*, vol. 29, pp. 134-137; July, 1956.

ground station equipment is some sort of a pi-L network as shown. The network, which is either band-switched or continuously tuned, is ganged in some manner such that only two control shafts are necessary. One of these controls must have a more marked effect upon the phasing of the network while the other should have more control over the impedance looking into the network.

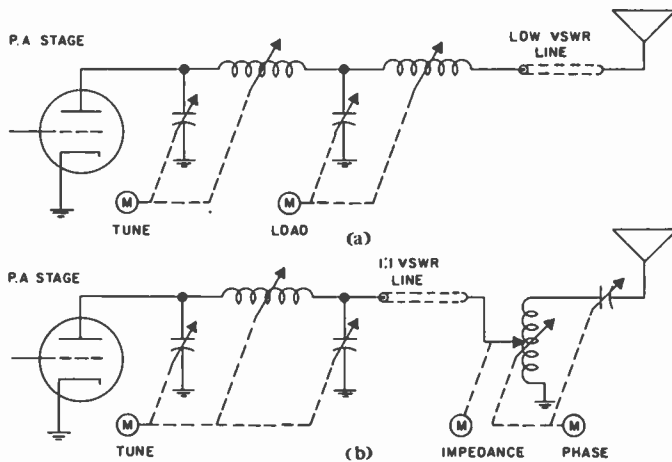

Fig. 5—(a) Pi-L output network. (b) Pi network with external antenna coupler.

The values of the circuit are chosen such that manipulation of the two controls will resonate and match the final amplifier into the transmission line at all frequencies and line vswr expected in the application. Exactly which elements are mechanically connected to which shafts depends upon the design and may vary with the application. The network shown in Fig. 5 for the second type of antenna systems may reasonably be separated into two parts, the plate tank circuit and the antenna coupler. The coupler may be an integral unit of the transmitter, but in the most frequent application it is located at the base of the antenna in a separate enclosure to provide minimum losses in connecting the antenna and the transmitter. In its simplest case, the coupler will have two control shafts. One control has the most effect over phasing, the other most effect over input impedance. Once again the components are chosen such that over the specified frequency range the two controls have adequate travel to tune the antenna to resonance and cause the input impedance to be some chosen value. This impedance is selected to be a coaxial line value, and thus after coupler tuning, the transmitter is presented with a flat line. With proper design of the pi network in the final amplifier, a uniform impedance step up may be maintained at all frequencies, and an additional control is not necessary to realize the proper plate load impedance.

Loading signals for the loading control of the pi-L network system must be generated. As it is known that the gain of a tetrode or pentode is dependent upon the load resistance, a loading comparator circuit such as indicated in Fig. 6 may be constructed. Basically, if the

loading control is adjusted by the servo system until a given ratio of positively rectified grid signal voltage and negatively rectified plate signal voltage yield a null, the loading impedance will then be a predetermined value. However, if the class B stage is inadvertently driven into the class C region either by signal peaks or during the tuning cycle, the grid voltage will continue to rise while the plate signal voltage will remain about constant. Net result of such a condition will be a change in the positioning signal delivered to the loading servo. To prevent this a clamping diode *D* is added. This diode circuit is adjusted to clamp the grid signal at the threshold of grid cut off to a plate current sample obtained across a cathode resistor. Hence, the loading is determined by the ratio of the plate current to plate voltage swing in the class C operation region. Proper compromise of the magnitude of the plate, grid, and clamping signal voltages result in a loading comparator that yields proper loading information regardless of the operating conditions, provided that the plate circuit is held at resonance.

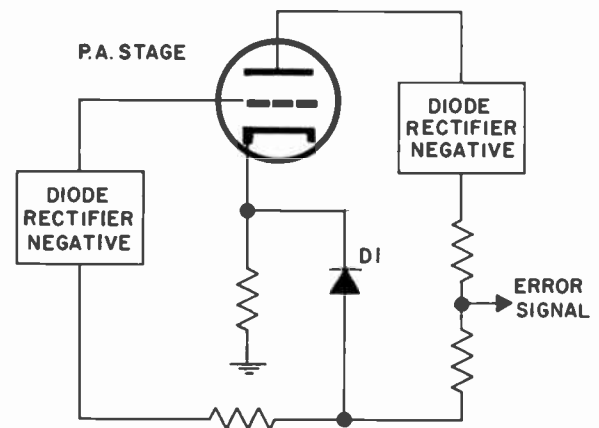

Fig. 6—SSB final amplifier loading comparator.

The antenna coupler method employs a phase discriminator not too unlike the shielded toroidal current transformer plate discriminator already described.⁴ The center conductor of the coaxial line to the final amplifier is fed through the current transformer and the resultant sample of current is compared with the coaxial voltage to ground for proper phase relationship. This phase sensitive signal is used to operate the phasing control and hold the line input to pure resistance. Comparison of the current and voltage samples for proper magnitude yields impedance information from simple ohms law consideration. The resultant information operates the impedance adjusting control to provide a proper value for coaxial line termination. These circuits together with some one of the coarse positioning schemes earlier described, manage to present automatically a flat line to the final amplifier.

⁴ E. W. Schwittek, "Servocoupler matches aircraft antennas," *Electronics*, vol. 27, pp. 188-192; October, 1954.

GAIN ADJUSTING

For distortion-free operation of a single-sideband transmitter, proper gain adjustment must be maintained in many circuits. Fig. 7 shows six circuit points that must have correct signal level for the most satisfactory operation of a typical SSB system. With a manually-controlled transmitter the operator can make it his concern to see that the levels at each one of these points are optimally adjusted. When a system is automatically tuned, many of these gains will change from channel-to-channel due to tracking errors, changes in circuit load impedance caused by varying QX product, and amplifier gain variations caused by tube aging and voltage fluctuation. The gain variations allowable for each point must be investigated, and a method of keeping the gain within these limits must be found for automatic operation.

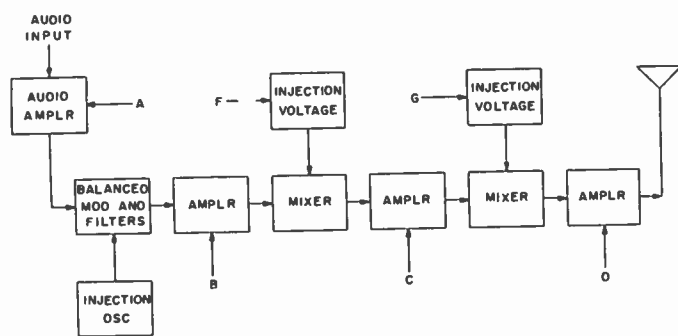

Fig. 7—SSB system gain block diagram.

It is found that if the audio level at point *A* is not kept within certain limits of the oscillator injection voltage the balanced modulator may deliver the sidebands with the carrier not reduced by the desired amount, may produce high noise levels, or may cause excessive distortion. At points *B* and *C* the gain must be controlled such that the signal to injection voltage ratio is of the value to produce linear mixer operation, lowest spurious signal output, and low noise level. At point *D*, levels must be arranged so that each linear amplifier is operating in its linear range to avoid undue intermodulation distortion. Injection voltages at *F* and *G* must be of proper level. Although these injection levels are obtained through tuned stages, they are nonlinear stages and fairly constant injection voltages may be obtained at all frequencies of operation by operating the amplifiers into saturation. Hence, the control of levels *F* and *G* is not too great a concern and will not be given further attention.

Any of the gains to be considered may be adjusted dynamically, statically, or by a combination of both. Static adjustment is defined as a relatively fixed adjustment that is done either directly with a potentiometer or similar device, or indirectly by varying the bias on a variable gain amplifier stage with a potentiometer. Dynamic adjustment is a gain adjustment made on the

basis of the signal level present, and the amplifier gain is caused to vary accordingly. Examples of such a method are the compressor and limiter amplifiers used in audio control.

Control of the audio line gain at point *A* may or may not be a problem depending upon the application. If the input happens to be a multichannel telegraph signal, it may be possible to design the amplifiers for a single initial installation adjustment. If the input signal is a voice channel or is arriving from various telephone lines, some gain adjusting may be needed at *A* for optimum performance. Use of a compression amplifier or a low distortion limiter may be used for correction of some of the variation. With the audio gain properly handled the gain at point *B* can most often be fixed in the initial exciter design with no further concern needed. The amplifiers of points *C* and *D* invariably show gain variation with changes in frequency as they employ tuned circuits requiring repositioning with frequency. With every precaution in the design to equalize the gain, there still may exist a 20 to 30-db variation. Known gain deviations following tuning patterns may be statically corrected by potentiometers ganged to the tank circuits and wound with resistance tapers that will place proper corrective voltage variations on the grids of the variable gain amplifiers located at points *C* and *D*. Although much improvement can be gained by such arrangements, tracking errors and gain changes due to voltage fluctuation cannot be corrected by these means. Further improvement can be attained by using a motor driven potentiometer to supply gain control voltage to points *C* and *D*. By sampling the balanced modulator output and the power amplifier output and employing a servo system to maintain the ratio of the two values constant through the motor operated potentiometer, an almost constant static gain adjustment can be attained under all conditions.

Even after almost perfect static gain control is attained, gain problems still exist. If the input signal is adjusted so that the average levels are driving the final amplifier stage near its maximum power rating, trouble may be experienced with peak signals driving the amplifier into distortion and, hence, causing interference on adjacent channels. This problem is especially bad with voice traffic. If gain is reduced to prevent overloading of the final amplifier, then the power rating of the transmitter is poorly utilized. An improvement can be obtained by a circuit described in the literature as automatic load control.⁵ A delay biased diode detector samples the rf output from the final and is adjusted to conduct when output peaks reach rated power. The dc voltage generated by rectification is fed back to reduce the gain dynamically at point *B*. It is evident that the control could also be accomplished at points *A*, *C*, or *D* with slightly different results possible. In reality the

⁵ N. Lund, C. F. P. Rose, and L. G. Young, "Amplifiers for multichannel single-sideband radio transmitters," *Proc. IRE*, vol. 40, pp. 790-796; July, 1952.

alc circuit is merely a limiter type circuit with a fast attack, slow release time, and a compression ratio of about 10 to 1. The merit of having the limiting threshold circuit on the output stage is apparent. This allows very precise location of the threshold right at rated power output. Were the limiter installed on earlier stages, some margin would have to be allowed for gain variations between the limiter stage and the final amplifier.

Besides the combination static and dynamic control system just explained, full dynamic control can be achieved with a dual time constant method. The control voltage returning on the alc bus from the power amplifier may be fed through very long time constant circuits to points *C* and *D* and through the usual time constant circuit to point *B*. The long release time on the control fed to the variable gain amplifiers at points *C* and *D* can be made to perform roughly the same function as static control done with motor driven potentiometers. Dynamic control is very simple and economical but must be used with caution. In multichannel service the dynamic gain control may cause one channel to modulate another through the gain adjusting circuit. Then too, with large degrees of control, no signal conditions for any period of time may cause the gain of the amplifiers to rise so high that random noise will drive the transmitter to full power. An aid in this matter may be a signal-operated transmitting relay that will disable the transmitter when no signal is present. Characteristics of the relay circuit must be such that its release time is shorter than the release time of the gain adjusting circuit. It is interesting to note that the gain problems encountered in automatic transmitters are very similar to those solved by the vogad in telephone-radio circuits, a device well described in the literature.⁶ The net effect of properly applied gain control to a single-sideband transmitter is to radiate a stronger signal with less interference for a transmitter of a given power.

CONTROL CIRCUITS

Final phase of the technique of automatically tuning a single-sideband transmitter is the operation of the control circuits. To give an idea of the intermeshing of functions between all units, a typical transmitter control block diagram is given in Fig. 8. Following the diagram, a recycle is started by a frequency change initiated by

⁶ S. B. Wright, S. Doba, and A. C. Dickieson, "A vogad for radio-telephone circuits," *PROC. IRE*, vol. 27, pp. 254-257; April, 1939. R. A. Heising, "Radio extension links to telephone system," *Bell Sys. Tech. J.*, vol. 19, pp. 611-646; October, 1940.

the operator. In turn, the exciter signals the power amplifier unit of the change and switches the antenna. The power amplifier, hearing of the recycle, signals the operator to hold up traffic, the power supply to reduce voltage for tuning protection, and the exciter to supply coarse tuning information. Coarse information is used by the power amplifiers as needed and then disabled. The exciter is signaled to reinsert a carrier for fine tuning purposes and finally the power supply is asked to deliver full power. All functions completed, the carrier is turned off and the operator receives a signal to resume full traffic.

The generation of control information to perform these functions may be obtained either from a pure time-sequence arrangement employing time delay relays or from indicating devices that monitor the circuit gains, rf output, servo error signal levels, or other such circuit qualities. Ordinarily, both timing-sequence and circuit monitoring are employed to give the desired results.

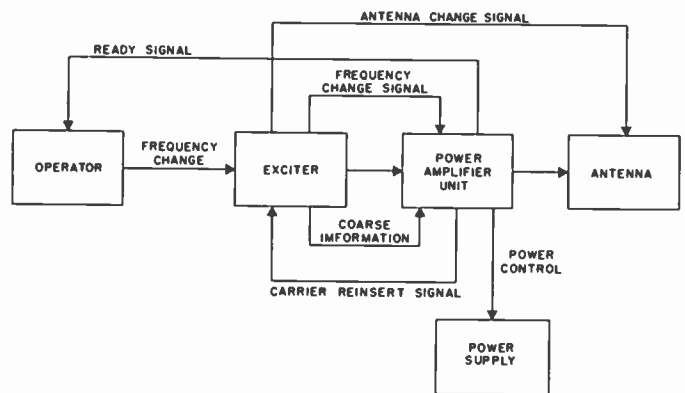
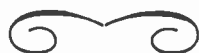

Fig. 8—Automatic tuning control block diagram.

CONCLUSION

Using the techniques described, successful modern automatically-tuned sideband equipment has been designed. Although the initial equipment cost is greater due to the automatic features, it is felt that the increased ease of operation together with the greater probability that the transmitter will be adjusted for minimum interference with other communications channels easily justifies the larger investment. Quick frequency change, facilitated by automatic tuning, coupled with the spectrum conservation effected by single-sideband operation, should aid greatly in expanding the utility of the crowded high frequency region.



Linearity Testing Techniques for Sideband Equipment*

P. J. ICENBICE, JR.†, SENIOR MEMBER, IRE, AND H. E. FELLHAUER†, ASSOCIATE MEMBER, IRE

Summary—The linear rf amplifier is a vital segment of all sideband equipments and measurement of its degree of nonlinearity is therefore of paramount importance. The basis for using the two-tone method of measurement is described by showing the types of nonlinear distortion products generated by the different orders of transfer characteristic curvature. Measurements by noise loading are described and it is shown that the results are essentially independent of the delay distortion characteristics of an amplifier. Descriptions of two basic types of distortion-measuring equipments, one using noise and the other using two tones, are given. Brief descriptions, photographs, and block diagrams are shown for audio-video and high-frequency spectrum measuring instruments.

OBJECTIVES

THE OBJECTIVES of this paper are to examine the state of the art in the field of sideband equipment linearity testing, to discuss some recent applications of specialized techniques, to present a foundation of basic mathematics, and to justify the choice of multiple tone and noise loading in conjunction with spectrum analysis of the output signals.

INTRODUCTION

The purpose of a communication system is to deliver a signal which is a replica of the input information. The accuracy of reproduction (system linearity) is therefore of prime importance. Communication systems often can tolerate 25 per cent or more total harmonic distortion and remain usable on a specific channel. However, the generation of new frequencies results in interference with other channels and lowers the maximum information rate or intelligibility. Since an important advantage of single sideband is that of spectrum conservation, considerable attention must be given to the production or generation of frequencies falling outside as well as inside the desired channel limits. The evaluation of system linearity can be conducted by measuring the relative amplitudes of the unwanted frequencies in the output of the loaded system.

The input test signal used to simulate a loaded condition can be a single-frequency tone, two or more simultaneous tones, or random noise. If a single-frequency tone is used to load the system under test, the percentage of rms total harmonic voltage is normally measured. This type of measurement is of some value for audio amplifiers but is entirely inadequate for suppressed carrier and linear rf amplifiers with band-pass circuits, since a single audio tone is converted to a single rf frequency with the harmonic output depending to a greater degree upon the band-pass circuits of the ampli-

fiers than upon the degree of nonlinearity that exists in the band-pass of the system. The band-pass distortion is all that will be detected by a receiver tuned to a signal frequency. Since this is true a useful distortion test must utilize at least two tones so that distortion products fall within and near the band-pass of the system.

In all instances over-all system linearity is of paramount importance, however, the basic element of any system is considered to be an amplifier. The following discussion of linearity testing is in terms of measurements of this basic element although it may in actuality take the form of a mixer or of a complex network.

AMPLIFIER WITH SECOND-ORDER CURVATURE

An amplifier, Fig. 1(a) may be considered a device in which the output current is some function of the input voltage, or $i=f(e)$. If the amplifier is linear, $i=ke$, where k is a constant, at least over some definite range of e . In general, an amplifier is not linear, and the transfer function represented by the curve in Fig. 1(b) can be written

$$i = k_0 + k_1e + k_2e^2 + k_3e^3 + \dots, \quad (1)$$

where k_0, k_1 , etc., are constants. If the transfer function curve passes through the origin, as shown; *i.e.*, the amplifier output is zero when the input signal is zero, k_0 will disappear. If all terms above the second order can be neglected, then

$$i = k_1e + k_2e^2. \quad (2)$$

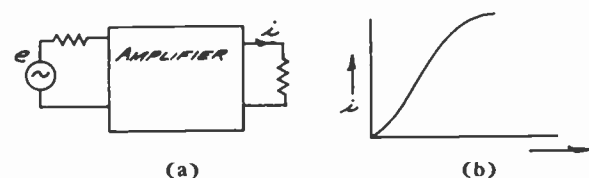

Fig. 1

If the input signal is a sine wave ($e=E \sin wt$), then

$$i = k_1E \sin wt + k_2(E \sin wt)^2,$$

and using the trigonometric identity

$$\sin^2 a = 1/2 (1 - \cos 2a):$$

$$i = k_1E \sin wt + \frac{k_2E^2}{2} - \frac{k_2E^2}{2} \cos (2wt). \quad (3)$$

Eq. (3) shows in a simple way the well-known presence of a second-harmonic frequency in the output of

* Original manuscript received by the IRE, September 10, 1956.
† Collins Radio Co., Cedar Rapids, Iowa.

an amplifier whose transfer function contains second-order curvature.

Let (2) hold, and consider the application of several simultaneous sine wave signals, of different frequencies, to the input. Then

$$e = E_1 \sin w_1 t + E_2 \sin w_2 t + E_3 \sin w_3 t + \dots + E_n \sin w_n t$$

and

$$i = k_1(E_1 \sin w_1 t + E_2 \sin w_2 t + E_3 \sin w_3 t + \dots + E_n \sin w_n t) + [k_2(E_1 \sin w_1 t + E_2 \sin w_2 t + E_3 \sin w_3 t + \dots + E_n \sin w_n t)^2]. \quad (4)$$

Expansion of the squared term above yields the expression

$$[k_2(E_1^2 \sin^2 w_1 t + E_2^2 \sin^2 w_2 t + E_3^2 \sin^2 w_3 t \dots + E_n^2 \sin^2 w_n t + 2E_1 E_2 \sin w_1 t \sin w_2 t + 2E_1 E_3 \sin w_1 t \sin w_3 t + \dots + 2E_1 E_n \sin w_1 t \sin w_n t + \dots + 2E_{n-1} E_n \sin w_{n-1} t \sin w_n t)].$$

It is seen that this expression contains terms of the form $\sin^2 a$ and $\sin a \sin b$ only. Each of the \sin^2 terms yields a second harmonic. Noting the trigonometric identity,

$$\sin a \sin b = 1/2[\cos(a - b) - \cos(a + b)]$$

it is evident that each of the terms of the form $\sin a \sin b$ yield frequencies equal to the sum and difference of the a and b frequencies.

To summarize, if a number of different frequencies are simultaneously applied to the input of an amplifier which exhibits only second-order curvature in its transfer characteristic, output frequencies will be of four kinds: 1) Zero frequency (direct current); 2) frequencies equal to those impressed; 3) second harmonics of those impressed, and 4) sum and difference frequencies of all combinations of signals, taken two at a time.

If the group of simultaneous frequencies occupies a band which is narrow in comparison to the mid-band frequency, and if the amplifier is frequency selective (the usual condition in an amplifier handling single sideband), the first, third, and fourth kinds of frequencies described above will be negligibly small at the amplifier output. Fig. 2 graphically illustrates this condition.

Furthermore, as can be seen by inspection of (4), all output currents having frequencies of the second kind; *i.e.*, having the same frequencies as those impressed, will have amplitudes proportional to the input signal voltages, the proportionality constant being k_1 . Thus, a selective amplifier under the above conditions will exhibit the properties of a linear amplifier even though its transfer characteristic shows second order curvature. It then follows that measurement of the magnitudes of second-

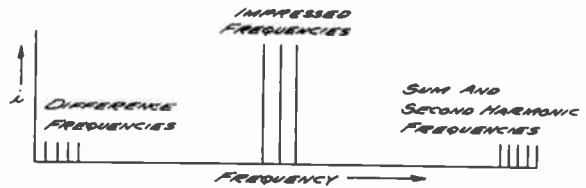

Fig. 2

harmonic currents or sum and difference frequency currents has little or no bearing on the determination of linearity of such an amplifier.

AMPLIFIER WITH THIRD-ORDER CURVATURE

It is usually found that at least the third-order term in (1) must be included to represent adequately the transfer characteristic of an amplifier. Again, if a number of voltages of different frequencies are simultaneously applied to the input of such an amplifier, the output current will be

$$i = k_1(E_1 \sin w_1 t + E_2 \sin w_2 t + E_3 \sin w_3 t + \dots + E_n \sin w_n t) + k_2(E_1 \sin w_1 t + E_2 \sin w_2 t + E_3 \sin w_3 t + \dots + E_n \sin w_n t)^2 + k_3(E_1 \sin w_1 t + E_2 \sin w_2 t + E_3 \sin w_3 t + \dots + E_n \sin w_n t)^3. \quad (5)$$

We are now interested in only the third-order term in this equation, and we obtain, by expanding and collecting, the expression

$$\begin{aligned} & E_1^3 \sin^3 w_1 t + E_2^3 \sin^3 w_2 t + E_3^3 \sin^3 w_3 t \\ & + \dots + E_n^3 \sin^3 w_n t \\ & + 3E_1^2 E_2 \sin^2 w_1 t \sin w_2 t + 3E_1^2 E_3 \sin^2 w_1 t \sin w_3 t \\ & + \dots + 3E_1^2 E_n \sin^2 w_1 t \sin w_n t \\ & + 3E_1 E_2^2 \sin w_1 t \sin^2 w_2 t + 3E_2^2 E_3 \sin^2 w_2 t \sin w_3 t \\ & + \dots + 3E_2^2 E_n \sin^2 w_2 t \sin w_n t \\ & + 3E_1 E_3^2 \sin w_1 t \sin^2 w_3 t + 3E_2 E_3^2 \sin w_2 t \sin^2 w_3 t \\ & + \dots + 3E_3^2 E_n \sin^2 w_3 t \sin w_n t \\ & + \dots + 3E_{n-1} E_n^2 \sin w_{n-1} t \sin^2 w_n t \\ & + 6E_1 E_2 E_3 \sin w_1 t \sin w_2 t \sin w_3 t \\ & + \dots + 6E_1 E_2 E_n \sin w_1 t \sin w_2 t \sin w_n t \\ & + \dots + 6E_1 E_3 E_n \sin w_1 t \sin w_3 t \sin w_n t \\ & + \dots + 6E_1 E_{n-1} E_n \sin w_1 t \sin w_{n-1} t \sin w_n t \\ & + \dots + 6E_{n-2} E_{n-1} E_n \sin w_{n-2} t \sin w_{n-1} t \sin w_n t. \quad (6) \end{aligned}$$

This expansion shows that the third-order term of (5) contains terms of only three types: 1) Terms of the type $\sin^3 a$, $\sin^3 b$, etc.; 2) terms of the type $(\sin^2 a \sin b)$, $(\sin^2 b \sin a)$, etc., and 3) terms of the type $(\sin a \sin b \sin c)$, $(\sin a \sin b \sin d)$, etc. By trigonometric identities

$$\sin^3 a = \frac{3 \sin a - \sin 3a}{4},$$

$$\sin^2 a \sin b = \frac{\sin b}{2} - \frac{\sin(2a+b)}{4} + \frac{\sin(2a-b)}{4}, \text{ and}$$

$$\sin a \sin b \sin c = \frac{\sin(a+b-c) + \sin(a-b+c) - \sin(a+b+c) - \sin(a-b-c)}{4}.$$

If these identities are introduced in (6) it is seen that output currents of the following frequencies will be present, in addition to those caused by the first and second-order terms of (5).

- 1) Having the same frequencies as the input signal, but with amplitudes proportional to the cube of the input voltage of the corresponding frequency.
- 2) Having the same frequencies as the input signal, but with amplitudes proportional to the product of the first power of the corresponding frequency and the square of another frequency, taken in all combinations.
- 3) Having frequencies equal to three times those of the input signal.
- 4) Having frequencies of the type $2w_{m1} + w_{n1}$, taken in all combinations.
- 5) Having frequencies of the type $2w_{m1} - w_{n1}$, taken in all combinations.
- 6) Having frequencies of the type $w_{i1} \pm w_{m1} \pm w_{n1}$, taken in all combinations.

Again, if the band-pass of the amplifier is narrow with respect to the band-pass center frequency, harmonics of the input signal and signals of the types $2w_{m1} + w_{n1}$ and $w_{i1} + w_{m1} + w_{n1}$ will not appear at the output. However, signals of the types $2w_{m1} - w_{n1}$ and $w_{i1} + w_{m1} - w_{n1}$ have frequencies nearly the same as those of the input signals themselves and may appear in the output.

Let a number of signals whose frequencies lie in a narrow channel be applied to the amplifier, and let the band-pass of the amplifier be several times wider than the signal channel. Let f_a be the lowest and f_b the highest frequency of the group of signals. Then the highest possible frequency of the type $2w_{m1} - w_{n1}$ will be $2f_b - f_a$. If $f_b = f_a + \Delta f$, then

$$\begin{aligned} 2f_b - f_a &= 2f_b - f_b + \Delta f \\ 2f_b - f_a &= f_b + \Delta f. \end{aligned} \quad (7)$$

Similarly, the lowest possible frequency of this type is

$$2f_a - f_b = f_a - \Delta f. \quad (8)$$

It is apparent that frequencies of the type $w_{i1} + w_{m1} - w_{n1}$ can never be greater than $f_b + \Delta f$ nor less than $f_a - \Delta f$, for the highest possible frequency of this type exists when w_{i1} and w_{m1} become equal to f_b and w_{n1} equals f_a . Also the lowest possible frequency of this type exists when w_{i1} and w_{m1} become equal to f_a and w_{n1} equals f_b .

Therefore, third-order curvature of the transfer characteristic will cause the appearance of new frequencies which

will, in general, extend over a frequency range exactly three times the width of the frequency range of the input signals, and whose center frequency is the same as the center frequency of the input signals.

Furthermore, it is seen that the total output current at the frequency of an input voltage is not proportional to the input voltage, due to the presence of components described in (1) and (2) above.

AMPLIFIER WITH CURVATURE ABOVE THE THIRD ORDER

It can be shown that all even-order terms of (1), when expanded, result only in signals of zero frequency, even harmonics the highest of which is the same as the order of the term, and sum and difference frequencies whose combinations lie near zero or near even harmonics.

Also, all odd-order terms result in output signals whose frequencies are the same as the input signals, but not proportional in amplitude; are odd harmonics of the input signals, the highest harmonic corresponding to the order of the term; are sum combinations centered at the odd harmonics, and are difference combinations centered at the input signal frequencies and covering a bandwidth n times the bandwidth of the input signals, where n is equal to the order of the term.

INTEGRATED TEST SET FOR SPECTRUM ANALYSIS

The preceding study indicates that a frequency spectrum analysis is an ideal approach to the measurement of frequencies generated by signals passing through an amplifier or system with an unknown amplitude transfer characteristic. Fig. 3 is a photograph of such a complete test ensemble and Fig. 4 is the block diagram.

The basic circuit of this equipment is that of a wave analyzer. Additional features permit accurate and simultaneous measurements of hum, distortion, noise, and other spurious products, in the form of a direct plot of db level vs frequency. Two variable frequency audio oscillators produce test signals for single-sideband intermodulation distortion measurements. Intermodulation distortion between the two audio oscillators is prevented by the use of low-pass filters and the maximum practical degree of isolation in the network which combines the two audio signals. The mixer circuits have been carefully designed to permit measurement of intermodulation distortion products 70 db down on one scale plus or minus 1 db. Appropriate mixer injection level controls and continuous metering circuits are provided on the front panel to insure linearity through a 70-db dynamic range under all conditions.

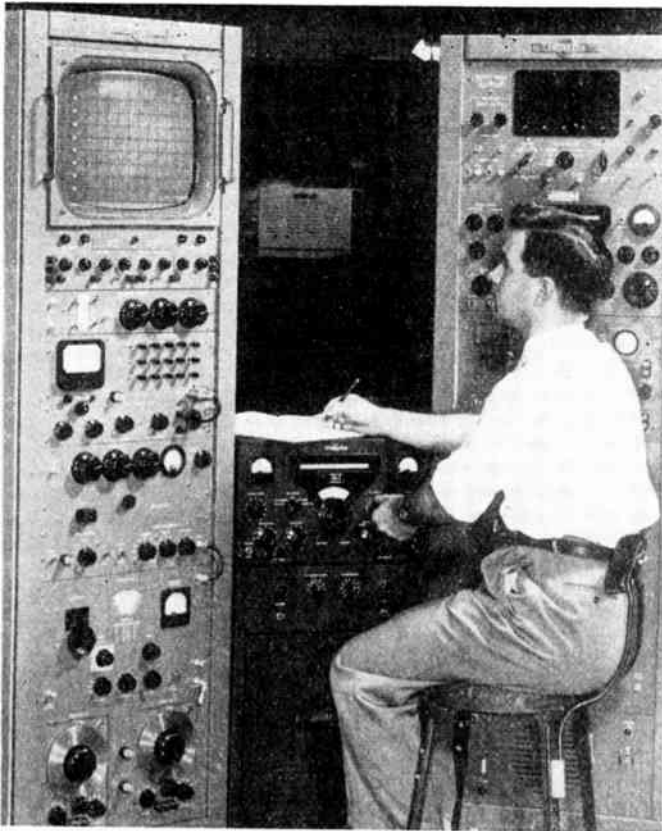

Fig. 3—Spectrum analyzer.

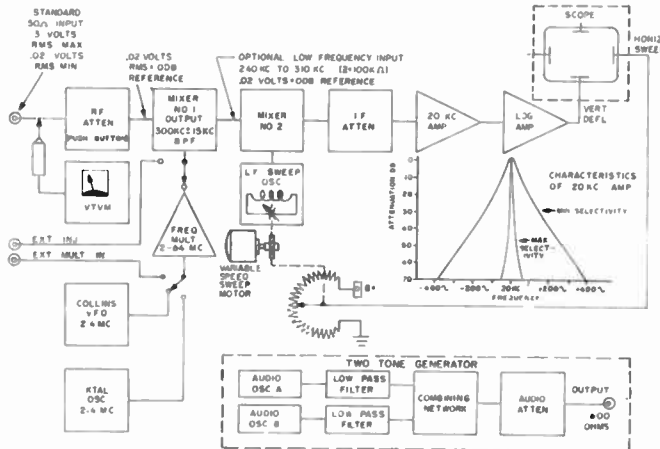

Fig. 4—Block diagram of spectrum analyzer.

This test set is designed to accept a frequency spectrum with a center frequency from 1.7 mc to 64.3 mc, and from 240 kc to 310 kc without additional coils or test equipment. A cathode-ray tube with a long persistence 17-inch screen is used to display the output signals. The signal to be analyzed is fed into the precision attenuator panel and adjusted to the proper level. The internal vtvm can be connected to monitor the input signal. The signal is then applied to mixer number one and converted to the first IF of 300 ± 15 kc. The output of mixer number one is applied to mixer number two where the signal is heterodyned to 20 kc. The second

mixer can accept any frequency between 240 kc and 310 kc, permitting measurements to be made within this common IF range. A variable speed motor drives the sweep oscillator to provide the injection signal for the second mixer. Sweep widths of 4 kc, 8 kc, and 16 kc are available.

The output of the second mixer is applied to a precision attenuator with one-tenth db steps and amplified in a variable selectivity 20-kc IF strip. The signal is then fed into an amplifier having an output which is a logarithmic function of the input over a 70-db dynamic range. The final tube in the selective amplifier rectifies the 20-kc signal producing a direct current which drives the vertical deflection circuit of the oscilloscope or external recorder. A precision wire-wound potentiometer, driven by the sweep oscillator motor, provides a synchronized horizontal sweep voltage.

The capabilities and limitations of the test equipment for any measurement must be fully understood. Therefore it seems desirable to first analyze the simple case of a single-frequency carrier without modulation. This ideal carrier then appears as one exact plot of the selectivity of the measuring equipment. If the bandwidth of the selective amplifier is changed, the displayed shape of the same carrier under test must change to the new selectivity of the test equipment. Since all signals are composed of discrete frequencies, each with its own amplitude, each individual response is basically the shape of the test equipment selectivity curve. However, when discrete frequencies are spaced less than a few cps apart, their corresponding deflections tend to merge into each other. The ability to separate discrete frequencies is known as the resolving powers of the equipment. Maximum resolving powers result when minimum sweep width, minimum sweep speed, and maximum selectivity are used.

SINGLE-SIDEBAND PATTERNS

Single-sideband signals are normally transmitted with a reduced or suppressed carrier. This vestigial carrier is usually measured with reference to one of two audio tones used to measure the intermodulation distortion products. Any reference may be selected in a particular equipment specification; however, it is usually desirable to measure with respect to one of the two test tones for simplicity. The signal-to-distortion ratio can be converted, if required, to another reference. Definite bench marks must be defined or considerable confusion may result. Peak envelope power (PEP) is the average power of the highest amplitude signal measured over one rf cycle. Therefore, when two equal tones not synchronized in phase are applied to a system the PEP will be 6 db greater than when either tone is applied alone. When a test signal composed of two tones with equal amplitude is used, the average power dissipated by the load is one-half the PEP. This neglects the vestigial carrier power which is very small. (Twenty db of suppression represents only 1 per cent of the

average power in one tone.) The standard two-tone signal, therefore, produces a pattern which has two discrete frequencies (f_{m1} and f_{m2}) of zero db reference. Thus, a perfect composite pattern consists of three discrete frequencies, f_{m1} and f_{m2} of equal amplitude and f_c , the carrier, which should be suppressed to the required level. Practical circuits always have some degree of intermodulation distortion, which appears in the form of new discrete frequencies above and below the two test tones. The frequency of these new distortion products can be predicted using the preceding analysis. The order of a distortion product is the sum of the coefficients in the frequency expression. An example of a fifth-order product is $(3)f_c + (2)f_{m1}$. The odd-order products are the most undesirable because they are in or near the desired transmission band as shown above. A signal-to-distortion ratio (s/d) of 40 db is usually acceptable for a high-frequency communications system when the equipment is tested on a two-tone basis.

COINCIDENTAL FREQUENCY AND AMPLITUDE MODULATION

Any of the oscillators in the SSB system, or in the test equipment, may have incidental frequency and amplitude modulation caused by such deficiencies as power supply ripple or alternating currents in tube heaters. This causes new sidebands which can be seen on the visual display spectrum analyzer as responses symmetrically located on either side of each original tone and distortion product responses. Because of the simultaneous angle and amplitude modulation, these sidebands will be unequal in amplitude. An analysis of this phenomenon has been made and the results are summarized below.¹

$$\sin \phi = \frac{S_1 - S_2}{E_c}$$

$$S_1 = \frac{E_c}{2} (M + \Delta\theta \sin \phi)$$

$$S_2 = \frac{E_c}{2} (M - \Delta\theta \sin \phi),$$

where M = AM modulation factor.

The following is a summary of the mathematical analysis illustrated in Fig. 5:

- 1) The angle ϕ measures the phase lead of the PM signal with respect to the AM signal.
- 2) The PM produces an extra pair of sidebands, $f_c \pm 2f_m$ and amplitudes $E_c M \Delta\theta / 4$.
- 3) The phase of the carrier is modified by the addition of a quadrature component of amplitude $E_c M \Delta\theta \cos \phi / 2$.
- 4) The phases of the dominant sidebands ($f_c \pm f_m$) are modified by quadrature components of amplitudes $E_c \Delta\theta \cos \phi / 2$.

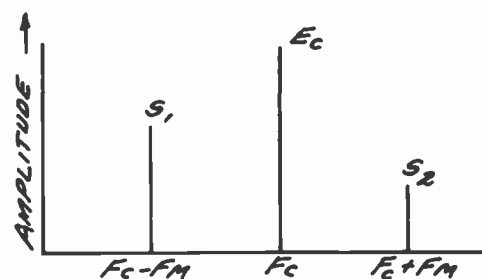

Fig. 5

- 5) The PM distorts the symmetry of the two dominant sidebands by subtracting $E_c \Delta\theta \sin \phi / 2$ from the amplitude of the upper dominant sideband and adding it to the amplitude of the lower dominant sideband.

NOISE-LOADED INTERMODULATION DISTORTION TEST SETS

The two-tone test set is an extremely versatile instrument when the two frequencies can be varied over a wide range. However, much data must be collected if it is desirable to measure distortion using a considerable number of tone combinations. The transfer function of a system normally varies with the absolute frequencies of the test tones as well as their frequency difference and may be multiple valued when the effects of power supply characteristics are considered. Under certain conditions, then, it may be more desirable to use a test signal which more nearly represents the typical complex signal actually transmitted.

In many respects white Gaussian noise is an ideal test signal. It can be easily reproduced and measured and, in addition, it is ideally complex. If band-limited noise is introduced into the system under test, the linearity can be described in terms of the noise outside the original band limits.

Fig. 6 shows a block diagram and Fig. 7 a photograph of a typical fixed frequency noise-loaded linearity test set. Although this particular equipment was designed to measure characteristics of uhf systems having a base band from 12 to 112 kc, the method is directly applicable to SSB in the hf and vhf spectrums by proper selection of filters.

The output of a random noise generator is fed into a band-pass filter which equally passes all noise frequencies in the base band to be tested, except for the low and high channel. The noise, therefore, can equally load all but a few kilocycles of the transmission band to any degree of modulation or deviation desired. Three band-pass filters, with equal bandwidth and insertion loss, are used at the receiving end of the system. One band-pass filter is chosen near the center of the transmitted noise pass band for the reference signal and a true rms noise voltage across a load resistor is measured. Once the reference voltage is established, the other two filters are switched separately into a true rms voltmeter-load circuit and their levels in db below the reference meas-

¹ V. W. Bolie, "Analysis of P.M. Distortion of A.M. Sidebands," Collins Tech. Rep., Collins Radio Co., Cedar Rapids, Iowa.

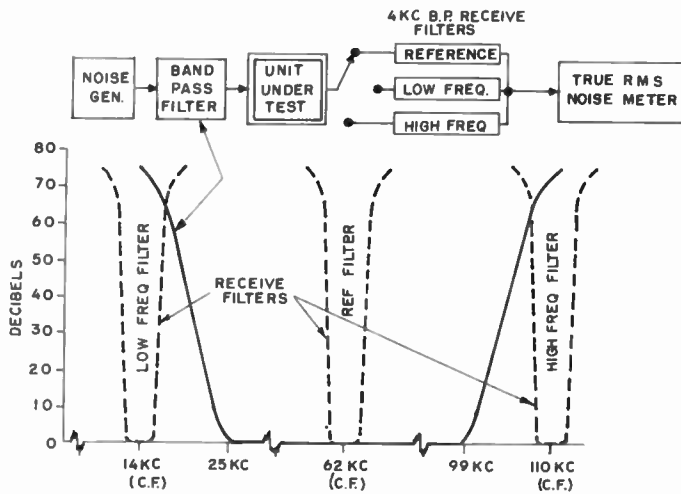

Fig. 6—Fixed frequency noise-loaded intermodulation distortion test set; block diagram and selectivity curves.

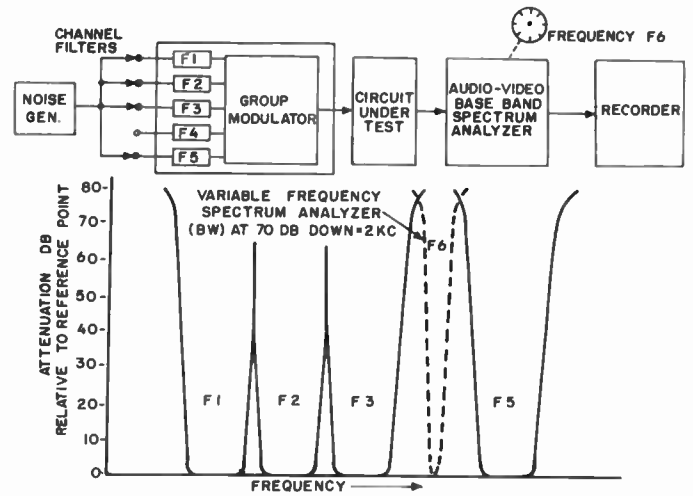

Fig. 8—Variable frequency noise-loaded intermodulation distortion test set; block diagram and selective curves.



Fig. 7—Fixed frequency noise-loaded intermodulation distortion test set.

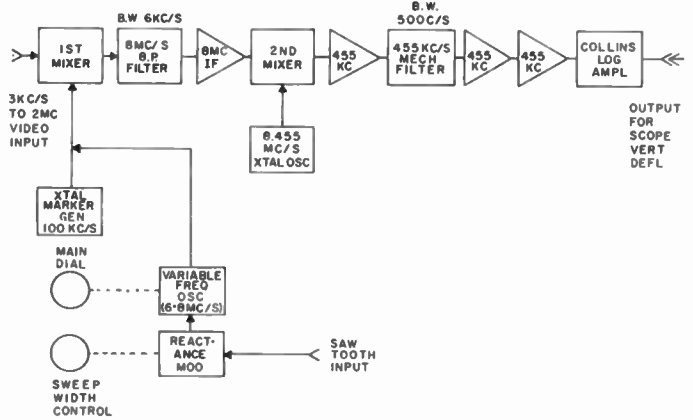

Fig. 9—Base-band (audio-video) spectrum analyzer; block diagram.

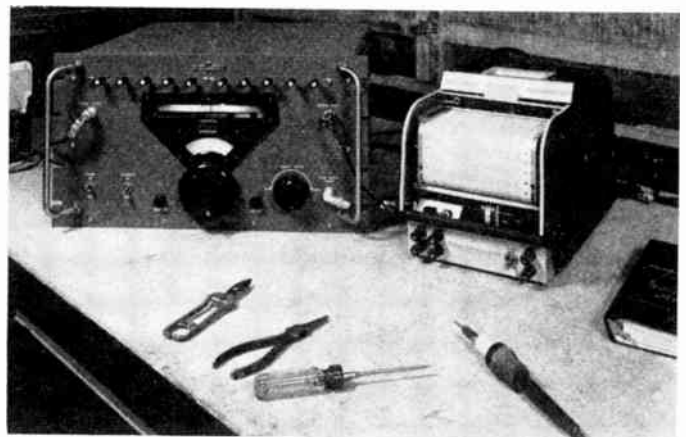

Fig. 10—Base-band (audio-video) spectrum analyzer and rectilinear recorder.

ured. Therefore, the two levels in db below the reference represent the low-frequency and high-frequency intermodulation distortion generated in the loaded system. It is possible to test one-way or unilateral systems with this type of test equipment.

BASE-BAND (AUDIO-VIDEO) SPECTRUM ANALYZER

A more universal test set employing noise or discrete frequencies is shown in Figs. 8, 9, and 10.

This test set is designed to permit simultaneous observance of a range of audio and video signals from 3 kc to 2000 kc. A means of measuring "Y" axis amplitude directly in decibels and "X" axis frequency directly in kilocycles of any signal or signals from 3 kc to 2000 kc is provided.

This analyzer is basically a double-frequency conversion superheterodyne receiver with the first selective IF circuits centered at 8000 kc. The second IF circuits contain a 500-cycle bandwidth mechanical filter ($\frac{1}{2}$ bandwidth equals 1 kc at 70 db down), which is centered at 455 kc; this selectivity essentially determines the resolving powers of the equipment. Other mechanical filters may be easily inserted for increased or decreased selectivity.

The 455-kc IF output is coupled to a logarithmic amplifier with an accurate 70-db dynamic range. The dc output of the logarithmic amplifier drives the vertical deflection amplifiers of the oscilloscope or rectilinear recorder. A frequency marker generator is coupled into the first mixer to provide accurate 50-kc calibration markers on the "X" axis sweep.

Horizontal sweep synchronization is accomplished by utilizing the horizontal saw tooth output of the oscilloscope to drive the reactance modulator. An internal frequency modulated oscillator provides a signal which sweeps a nominal range of 50 kc. The sweep width is adjustable from 0 kc to 70 kc by a panel control.

A special electronic reactance modulator circuit varies the permeability-tuned oscillator frequency over a constant excursion regardless of the main tuning dial frequency. The frequency-modulated injection signal and unknown input signal are mixed in the first balanced mixer. The mixer plate circuit consists of a selective double quartz crystal bridge band-pass filter that provides a path for the 8000-kc signals to the 8000-kc amplifier and into the second mixer. A crystal controlled signal at 8455 kc is mixed in the second mixer with the incoming 8000-kc signals to provide a second IF frequency of 455 kc for increased selectivity and gain.

The main dial controls the variable frequency oscillator from 6000 kc to 8000 kc, which corresponds to a dial or input signal frequency of 2000 kc to 0 kc. The main tuning dial mechanism is equipped with a detent mechanism to position the dial at 50-kc intervals so that the complete frequency range can be examined accurately and rapidly in 50-kc increments. Each 180° of knob rotation represents 50 kc; each dial division equals 4 kc.

The equipment is particularly suited for portable and field use if used with a portable rectilinear recorder.

EFFECT OF DELAY DISTORTION ON LINEARITY MEASUREMENTS

A network which has delay distortion, but negligible nonlinear distortion, will not cause the production of new output frequencies. This is shown for a noise signal, in the following, and can easily be shown for other signals in a similar manner.

A noise signal may be approximated by considering it to be a current varying in a random manner, but repeating itself at equal and long intervals of time. For example, noise can be recorded on a tape, the tape made endless, and then played back. A Fourier analysis of this noise-like signal can then be made, taking the funda-

mental tone as the one corresponding to the repetition rate of the endless tape. This signal can be written

$$i_1 = I_0 + I_1 \sin(\omega_1 t + \phi_1) + I_2 \sin(\omega_2 t + \phi_2) + \dots + I_n \sin(\omega_n t + \phi_n) \quad (9)$$

where I_0 is the dc component and ϕ_n is an angle representing the phase of each harmonic current. This approximate equation for a noise signal can be made to approach white Gaussian noise to any degree desired by increasing the period of the lowest frequency.

If the signal of (9) is introduced into a network which has delay distortion, but no nonlinear distortion, the output will be

$$i_2 = I_0' + I_1' \sin(\omega_1 t + \phi_1') + I_2' \sin(\omega_2 t + \phi_2') + \dots + I_n' \sin(\omega_n t + \phi_n') \quad (10)$$

The new coefficients for the sine terms allow for possible frequency distortion in the network, and the new phase angle terms are the result of the delay distortion. The only limitation placed on the values of ϕ_n' is that they be invariant with time.

$$\sin(\omega_n t + \phi_n') \text{ can be written as} \\ \sin \omega_n t \cos \phi_n' + \cos \omega_n t \sin \phi_n'$$

ϕ_n' is a constant for any one harmonic, therefore, $\cos \phi_n'$ and $\sin \phi_n'$ are constants. Then $\sin(\omega_n t + \phi_n')$ can be rewritten as

$$a_n \sin \omega_n t + b_n \cos \omega_n t, \quad (11)$$

where a_n and b_n are constants. This expression does not contain new frequencies.

It is also apparent from (11) that the amplitudes of the output components are not affected by delay distortion. Therefore, the existence of delay distortion within a network will not influence the results of measuring nonlinear distortion by the noise or other multi-signal loading methods if the delay distortion does not vary with time.

MEASUREMENT OF DELAY DISTORTION

Current and future requirements for measuring time of transmission and delay distortion are important when transmitting information at a rate approaching the theoretical maximum. Even our present-day complex signals undergo considerable degradation when passed through as many as 20 repeaters if special design techniques are not employed to compensate or equalize variations in the velocity of propagation across the band-pass of the system. It should be noted that phase always varies with frequency in a reactive network but phase distortion is not necessarily produced. The direct measurement of phase is possible at audio frequencies by means of several commercially available instruments. If a graph of the phase measurements is plotted against frequency, the resulting curve may then be differentiated with respect to frequency. This derivative is known as envelope delay $d\beta/d\omega$. Phase delay is defined as β/ω

and approaches the value of the envelope delay expression $d\beta/d\omega$, when the phase-frequency plot approaches a straight line. The perfect system is never available in practice, so the phase delay is never exactly equal to the envelope delay.

Delay distortion measurements are usually conducted by passing a modulated signal through a network and measuring the resultant modulation envelope phase shift caused by the network under test. Time delay is then computed by using $T_d = \theta/360f_m$ where T_d is the delay in seconds, θ is the phase shift of the modulation envelope in degrees, and f_m the frequency of modulation in cps. Error sources in this type of measurement are well documented.²⁻⁴

² W. D. Cannon, "An Envelope Delay Measuring Instrument in the Audio-Frequency Range," AIEE Fall Meeting, October 5, 1955.

³ L. E. Hunt and W. J. Albersheim, "A scanner for rapid measurement of envelope delay distortion," Proc. IRE, vol. 40, pp. 454-459; April, 1952.

⁴ A. van Weel, "Error Sources in Group-Delay Measurements on Electric Network," Philips Res. Repts.; April, 1956.

CONCLUSION

It has been shown that odd-order distortion in a selective amplifier causes the appearance of currents having new frequencies, many of which fall in and near the pass band of the device. System linearity is degraded and interference results. In contrast, even order distortion results only in new frequencies which fall outside the band pass region.

Measuring equipment generating either two tones or noise as the input signal may be used to evaluate the linearity of an amplifier or system, the former being more versatile and the latter having the advantage that the test signal more nearly simulates certain actual signals. In either case, delay distortion does not affect the measurements.

Systems in which delay distortion can seriously change or completely destroy the useful characteristics of the signal must be tested using equipment designed for this particular purpose, a common method being the measurement of envelope phase shift.

Single-Sideband Operation for International Telegraph*

EUGENE D. BECKEN†, MEMBER, IRE

Summary—The increased demands for multiple and direct international radiotelegraph channels between the nations of the world and the shortage of usable high-frequency spectrum has greatly increased the importance of the single-sideband radio system for this purpose. The world's requirements for high frequencies, 4 mc to 30 mc, are so large that they are assigned over and over again to various services on the basis of geographical and time sharing. Single-sideband operation with multiple subcarriers and automatic-frequency control permit a high order of frequency utilization efficiency.

Single-sideband operation offers a high degree of flexibility in meeting the various requirements of international communications. The number of its subcarriers can be changed to meet varying load conditions; they can be shifted to avoid temporary interference; and they can be used to operate with more than one point in the same geographical area. Codes with various numbers of signal elements either equal or unequal in length, and different types of modulation, and speeds can be carried on any or all subcarriers.

INTRODUCTION

SINGLE-SIDEBAND operation is assuming considerably greater importance in commercial international telegraph service. The reasons for this are that it provides for improved utilization of the radio communication spectrum and it permits desirable operating flexibility, thus assisting appreciably in meeting the demands for this service. In order to secure an un-

derstanding of the significance of the role of single-sideband operations, it is necessary on the one hand to recognize the growth and changes in the service requirements and, on the other hand, to examine the technical problems inherent in this growth and the ability of single-sideband operation to meet these problems.

TECHNICAL OPERATIONS

Growth of International Communication

The world's requirements for international communication services are changing and growing with increased vigor. Economic and political advancement, with ever increasing industrialization, sets the pace, demanding improvements in both quality and quantity of international communications. The world of business and trade is poised on the age of jet transportation with its great demands for fast and extensive communication channels. Direct communication between each country regardless of boundaries and distances is actively sought.

High Frequency Spectrum

What does this mean then in a technical sense for international telegraph communications? It will be necessary to examine the world-wide frequency story. Almost all long distance transoceanic radio communications require utilization of the 4-mc to 30-mc frequency spectrum.

* Original manuscript received by the IRE, September 18, 1956.

† RCA Communications, Inc., New York 4, N. Y.

If this 4-mc to 30-mc frequency spectrum were divided into 3-kc channels, it would result in the apparent availability of 8,666 channels. Further, if by the use of tone telegraph channeling equipment each of these were divided into twelve telegraph channels, it would seem that 103,992 telegraph channels were available. There are, however, several factors which materially reduce the number of usable channels and there are others which add to the world's potential storehouse of telegraph channels.

The optimum frequency requirements for a long distance radio circuit are subject to day and night, seasonal, and eleven-year sunspot cycle variations. At any given time there may be only a comparatively small range of frequencies that could support reliable communications. In the north Atlantic area under present normal conditions, this usable frequency spread amounts to about 4 mc of frequency space in the daytime and 2 mc at night. Middle Atlantic transoceanic circuits have a somewhat higher normal-frequency spread now being about 6 mc in the daytime and 4 mc at night while circuits between the United States and South America experience a normal-frequency spread of around 8 mc in the daytime and 4 mc at nighttime. Very long radio circuits such as those across the Pacific Ocean have even a narrower normal-frequency spread being about 3 mc in the daytime and 1 mc to 2 mc at night.

The usable frequency spread tends to narrow under disturbed radio propagation conditions for all circuits along with a decrease in the usable frequency. The spread may then often be only 1 mc or 2 mc wide.¹ As a general rule, the usable frequency spread decreases with the lower frequencies which are optimum for nighttime and low sunspot cycle conditions. Circuits operated across sunrise or sunset conditions are more critical and the nighttime conditions at one end of the circuit with its requirement for a lower optimum working frequency are controlling. The earth is nearest the sun during winter conditions in the northern hemisphere and consequently the optimum working frequencies at this time during daylight hours are higher for both the northern and southern hemispheres. When the earth is furthest from the sun, which occurs during the summer season in the northern hemisphere, the daytime optimum working frequencies are lower.

These frequency characteristics also change with the seasons, the latitudes, and to some degree with the longitudes on the earth's surface. Atmospheric noise which varies over the globe has a relative influence on the usable frequency spread since a high-noise area does not provide much leeway on signal strength. Another point to be recognized is that insofar as daily frequency requirement fluctuations are concerned, one part of the world is under daylight or high frequency conditions while the other part is subject to nighttime or lower frequency conditions.

¹ J. H. Nelson, "Observed diurnal variations in frequencies and signal qualities between New York and Central Europe," *RCA Rev.*, vol. XV, pp. 602-606; December, 1954.

While these variations in usable frequencies reduce the number of potential world-wide communication channels substantially, they have a value on the positive side as well. Part of the world can be operating on day frequencies while the rest of the world is on night frequencies. This geographical and time sharing enhances the world's frequency pool even though the same factors making this enhancement possible also reduce the total useful frequencies for any and all circuits because of the limited spread of usable frequencies at any one time. The extent of time and geographical sharing is determined by the cyclical variations of the ionosphere, atmospheric absorption, atmospheric and man-made noises, antenna gain and directivity, radio receiver and transmitter performance characteristics, the type of service involved, and by the bandwidth required. Much more will be said about bandwidth.

The high-frequency radio spectrum from about 3 mc to 30 mc is allocated to several different services which includes the fixed point-to-point, mobile, and broadcasting services. In addition, the allocation pattern varies with the three regions of the world as established by the International Telecommunication and Radio Conferences held in Atlantic City in 1947. The effect of these regulatory limitations for the 3-mc to 27.5-mc band for locations under the jurisdiction of the United States Government's Federal Communications Commission is that 12,780 kc rather than 24,500 kc of spectrum space is available to international fixed point-to-point communication carriers for radio telegraphy, radiotelephony, radiophoto, and program service. This is equivalent to 4,260 channels of 3-kc bandwidth. Since the present state of developments indicate that from 8 to 12 telegraph channels—each operated at 60 wpm—might be carried in each 3-kc bandwidth, there seems to be a maximum of 51,120 telegraph channels that might become available for telegraph service if other factors did not enter and the spectrum was not also required for other services. However, the limited-frequency spread of the ionosphere discussed above and transmitter and receiver bandwidth characteristics decreases the channel availability while geographical and time sharing increases it.

If all of the frequency performance factors outlined above were completely consistent in wholly foreseeable cyclical variation, much more usable frequency time could be secured. Instead, the ionosphere is an emotional creature subject to influences and bombardment from outer space which cause behavior patterns varying substantially from the norm. The usable frequency pattern is often altered during radio disturbances which causes a change in the world's interference potential and can result in a temporary decrease in over-all frequency utilization efficiency.

Each country throughout the world has listed frequencies of various bandwidths in the fixed high-frequency band for radiotelegraphy, radiotelephony, program, and radiophoto with the International Frequency Registration Board in Switzerland. Each new circuit requirement has to be considered for harmful

interference potential to existing circuits. Each frequency has had to be assigned over and over again throughout the world on the basis of geographical and time sharing. Extensive frequency usage in many areas, and particularly in the lower portions of the frequency spectrum, has made it very difficult to add new circuits without causing harmful interference to existing services.

All of this emphasizes two things; first, the importance of conservation of bandwidth and second, the need for flexibility of operations. The need for improved techniques designed to increase the amount of communications per kilocycle of space is urgent.

Frequency Utilization

Single-sideband techniques lend themselves admirably well to meet these needs of frequency conservation and operational flexibility. Frequency spectrum conservation with single-sideband operation has been extensively used in the telephone field but has not had equal application in the telegraph services.^{2,3} When one and up to four 60 wpm telegraph channels are required between two points, frequency shift keying using standard transmitters and receivers, has met the requirements. It has not been until more than four channels have been required between two points that single-sideband systems have been generally used for international telegraph communications. A typical arrangement of three single-sideband subcarriers, each carrying four Time Division Multiplex channels of 60 wpm teleprinter signals, is shown in Fig. 1.⁴ A similar arrangement showing several subcarriers, each capable of carrying two-channel Time Division Multiplex keying is shown in Fig. 2. Normally this latter arrangement would be limited to four subcarriers or a total of eight 60 wpm teleprinter signals. These audio frequencies were chosen because they gave a good ratio between total frequency shift and keying speed and because standard audio filters were available for them. Since these filters do not go below 425 cycles the lowest subcarrier has been limited to the 425/595 cycle filter combination.

The two-channel Time Division system shown in Fig. 2 will be used under conditions of severe multipath on the radio path with delays of 3 to 4 milliseconds or more. The 11.7 millisecond signal element length of two-channel keying is free of multipath degradation while the 5.86 millisecond signal element length of four-channel Time Division Multiplex keying is effected if subjected to multipath elongation in the order of about 2 or 3 milliseconds.

For the purposes of determining the bandwidth of emission, the solo channel speed of 60 wpm is considered equivalent to $22\frac{1}{2}$ cycle keying while two-channel and four-channel Time Division Multiplex is considered

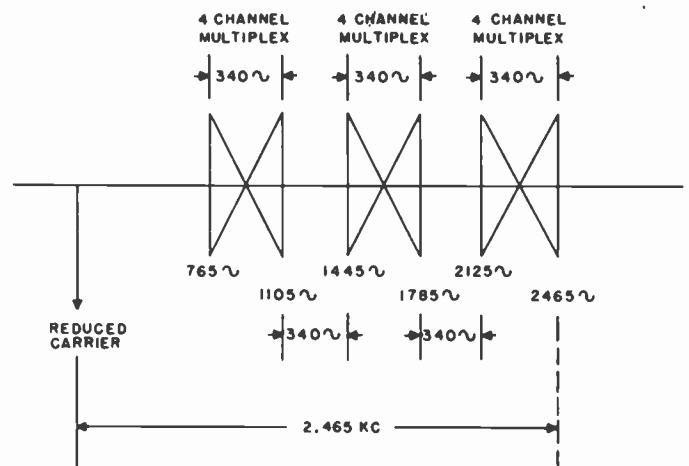

Fig. 1—Single-sideband subcarrier system with four-channel time division multiplex on each.

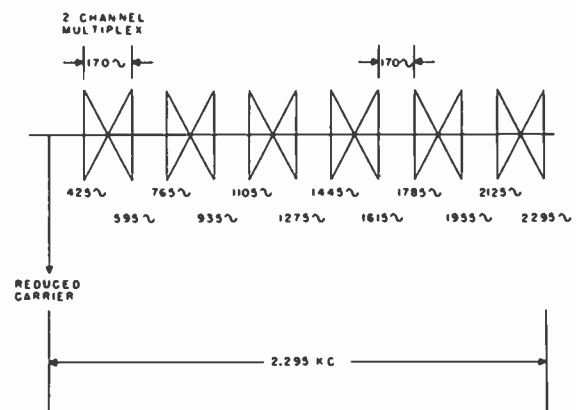

Fig. 2—Single-sideband subcarrier system with two-channel time division multiplex.

equivalent to about $42\frac{1}{2}$ and 85 cycles keying speed respectively. Emission bandwidth distribution is then determined theoretically from the index of modulation $\Delta F/f$ (where ΔF equals one-half total shift and f is the keying frequency) and the corresponding Bessel functions. The ratio $\Delta F/f$ for both two-channel and four-channel keying with subcarrier shifts, as shown in Figs. 1 and 2, gives a modulation index of 2. If all discrete frequencies having a voltage value of two percent or greater of the value of the unmodulated subcarrier are considered included in the emission bandwidth this gives a theoretical bandwidth of 340 cycles for each subcarrier shifted a total of 170 cycles and carrying two-channel Time Division Multiplex and a theoretical bandwidth of 680 cycles for each subcarrier shifted a total of 340 cycles and carrying four-channel Time Division Multiplex.

Obviously, this bandwidth must be restricted to insure proper operation of the subcarrier. Accordingly, transmission bandwidth for the subcarriers is restricted to include only the fundamental of the keying frequency. For keying speed of $171\frac{3}{4}$ bauds, corresponding to four-channel Time Division Multiplex operation, only the two approximately 85 cps side frequencies lying outside the mark and space frequencies are passed and

² F. A. Polkinghorn and N. F. Schlaack, "A single-sideband short-wave system for transatlantic telephony," *PROC. IRE*, vol. 23, pp. 701-718; July, 1935.

³ A. A. Oswald, "A short-wave single-sideband radiotelephone system," *PROC. IRE*, vol. 26, pp. 1431-1454; December, 1938.

⁴ I. K. Given, "Recent advances in international radio communications," *IRE TRANS.*, vol. CS-2, pp. 86-92; November, 1954.

higher side frequencies are very largely eliminated. One method is to use audio shift keyers with the single-sideband subcarriers which have internal circuits for generating either the marking frequencies or the spacing frequencies and which are arranged so that they shift suddenly from one of these frequencies to the other. At the instant this shift is made there is no change in the phase of the frequency generated. This can be accomplished by employing a frequency determining element which is manipulated with the key to provide either a marking frequency or a spacing frequency as demanded by the controlling signal. A band-pass filter is required in the output of this unit. This band-pass filter, when the keyer is used for four-channel Time Division signals (171 $\frac{3}{4}$ bauds) with the frequency shift of plus and minus 170 cycles per second, has characteristics as shown in Table I below.

TABLE I

Frequency, cps, either side of center frequency	Attenuation above that of center frequency attenuation db.
170	1.5+or -0.5
340	6.0+or -0.5
510	13.5+or -1.0
680	24.0+2.0-4
above 680	maximum practicable

For single-channel speed or two-channel speed (42 $\frac{3}{4}$ bauds or 85 $\frac{3}{4}$ bauds) with a total shift of 170 cps, the filters required are just half as wide as the ones listed above. It will be noted, for example, that the fifth harmonic of the signals, when transmitting reversals of minimum length elements, will be attenuated about 9 db by these filters while higher harmonics are attenuated to a greater degree. The strength of these harmonics is fundamentally quite low. When they are further attenuated by the filters, their strength is so low that they do not cause objectionable intermodulation in adjacent channels. The specifications require that the second harmonic of the shifted subcarrier be reduced down to at least 20 db below the fundamental and that the higher harmonics are reduced at least as much when they fall into the band of one of the neighboring subcarriers.

Single-sideband telegraph transmission operates with the carrier reduced to a level 20 db below a standard reference. This standard reference level is that level of one of two equal sinewave monotones which will produce the rated peak effective power in the transmitter output.

A method of determining bandwidth necessarily occupied is given in The International Radio Consultative Committee's Recommendation No. 87 which, although pertaining to frequency shift carrier operation, is also applicable in principle to single-sideband subcarrier operation.⁵ Thus according to these recommendations the necessary bandwidth is given by

$$2.5D + 0.5B \text{ for } 2.5 < m \leq 8,$$

where

D = deviation or one-half frequency shift,

B = keying speed in bauds, and

m = modulation index.

Although not completely applicable in this case since the modulation index is 2, it is interesting to note the results. This formula gives a bandwidth of 234 cycles for each subcarrier with 2-channel Time Division Multiplex and 467 $\frac{1}{2}$ cycles bandwidth for each subcarrier with four-channel Time Division Multiplex. On this basis twelve 60 wpm channel operation, as shown in Fig. 1, occupies a necessary bandwidth of 2465 cycles plus the keying sideband of the extreme end of the top subcarrier or plus 64 cycles and, if the same value of 64 cycles is assumed for guard-band clearance on the low side of the reduced carrier, it gives a total of 2593 cycles as the necessarily-occupied bandwidth.

The necessary bandwidth of transmissions is only part of the story however since interference occurs at the receiving location and is determined partly by the bandwidths of reception. The utilization of automatic-frequency control in single-sideband systems makes it possible to reduce the bandwidths in the receiver which reduces the possibility of harmful interference and consequently increases the opportunities for more efficient frequency utilization. The receiver filters used to separate the lowest subcarrier frequency channel from other channels have the characteristics shown in Table II.

TABLE II

Attenuation in db relative to midband	Frequency—cps			
	For 170 cps shift		For 340 cps shift	
40	1560	2030	1710	2610
30	1580	2020	1850	2580
20	1600	1995	1800	2510
10	1720	1960	1840	2470
5	1640	1930	1870	2430
2.5	1670	1905	1910	2390
0	1735	1835	2030	2220

The automatic-frequency control employed on single-sideband receivers makes these closely-spaced subcarriers possible. The future may see further reduction in the amount of shift on the subcarriers with even a higher-frequency utilization efficiency.

Operating Flexibility

The second basic advantage of single-sideband operation is its flexibility. Single-sideband equipment such as the new RCA SSB-3 system, as described in another paper in this issue,⁶ is capable of operation with the telegraph subcarriers either all above, below or on both sides of the reduced carrier. In addition, the keying of any one subcarrier can easily be shifted to any other subcarrier. This flexibility can be of considerable advantage when interference which is localized in only part of the received spectrum suddenly arises. In addi-

⁵ CCIR International Radio Consultative Committee, Documents of the VIIth Plenary Assembly, London, 1953, vol. I, pp. 75-81; International Telecommunication Union, Geneva, 1953.

⁶ H. E. Goldstine, G. E. Hansell, and R. E. Schock, "SSB receiving and transmitting equipment for point-to-point service on hf radio circuits," this issue, p. 1789.

tion, interference to any one subcarrier will affect that keying only. Systems employing four frequency or signaling positions to secure two channels will be subject to interference to both channels even though the actual interference is limited to only one of the frequencies.

As has been indicated above, interference occurs at the receiving station and under certain conditions it is possible that quadrupling of the power will just make the difference between a workable and unworkable signal. If eight 60 wpm teleprinter channels are being carried on two single-sideband subcarriers, then a reduction to one subcarrier will permit a quadrupling in the power of the remaining subcarrier which could provide the required signal-to-interference ratio or signal-to-noise ratio at the receiving station to maintain a working circuit.

The international telegraph industry has seen a remarkable growth in direct customer to customer services in recent years and the greatest volume is secured during coincident business hours at each end of the circuit. This calls for a maximum number of channels during daylight conditions when the optimum working frequencies are highest and less subject to atmospheric noise. At night when the communication load is lighter and fewer channels are needed, the optimum working frequencies are lower and more subjected to atmospheric noise, and the single-sideband system permits an easy reduction in the number of subcarriers with a consequent increase in power for the remaining. This characteristic of single-sideband operation affords an opportunity for maximizing daytime and nighttime performance with a given capital investment.

Another advantage of single-sideband flexibility is the ability to "fork" circuits. Suppose it is necessary to work two countries located in the same geographical area, but neither one has sufficient traffic to warrant eight or twelve channels. With single-sideband reception in both countries, each can make use of the subcarrier carrying its traffic only. Thus one transmission facility can be used simultaneously to work two or more neighboring countries in what is referred to as "forked" operation.

The last few years have seen an enormous growth in data processing with computers and business machines expanding into many new fields and applications. Many of these new installations are generally very expensive and will be limited in number with the associated requirement that the "data" must be communicated long distances to the machines. This communication may be by means of the standard 5-unit stop-start code system as used in almost all of the telegraph systems. As such the communications can be handled on a single-sideband subcarrier with Time Division Multiplex in the same manner that message traffic is processed. However, this method of communications may not be satisfactory for data transmission. It may not be fast enough or it may require the use of special codes. Six-unit and eight-unit codes, both start-stop and synchronous, are in use. The frequency division system of single sideband lends itself admirably well to these various requirements.

It can be used, for example, with an IBM transceiver

which employs an eight-unit start-stop code, 10.5 elements, for reading and transmitting information over long distances from punched card to a receiving machine which punches a new card.⁷ The IBM data transmission machine referred to is capable of operating at various speeds. The frequency division system of single sideband can easily provide the desired channel bandwidth by the simple expedient of supplying the necessary channel filters.

Another example of special communication would be the transmission of Teletypesetter signals at high speeds.⁸ While tests have been made at 600 wpm on landline systems, using a start-stop six-unit code, it should be possible to send about half that speed on a single-sideband radio system. The limiting factor would not be the single-sideband system but the multipath that might occur on the radio path. The single-sideband system is easily capable of handling unequal length code such as the Morse code. It can handle different codes and different speeds on the various subcarriers simultaneously. One aggregate can carry a four-channel Time Division Multiplex/ARQ system employing the ARQ seven-unit Moore code, a second subcarrier can carry a solo eight-unit start-stop code, and a third subcarrier a 100 wpm Morse signal.

This versatility gives the single-sideband system a decided advantage over the frequency shift duplex system where four alternate frequencies are transmitted to give two channels. This latter system must be operated on a synchronized basis if its bandwidth utilization is to be efficient and deterioration under multipath conditions is to be avoided. Such synchronous operation prohibits the use of unequal length codes, codes with stop elements of greater duration than the signal elements, and different kinds of codes on the two channels. In addition, the necessity of transmission synchronization means that the keying devices should be either near each other or, if they are not, it requires an auxiliary system for synchronization control.

No one can foresee for certain what the data transmission requirements of tomorrow will be but the single-sideband system will undoubtedly be in a preferred position to meet all developments.

There are other services which require maintenance of center hole count, *i.e.*, for each character or function entering a communication system the same number of characters or functions must be received. Other services require a circuit in which there is no character storage. Single-sideband systems lend themselves to these special applications, as well as being able to handle telephone, broadcast, and radiophoto signals.

Power

The peak envelope power of the single-sideband transmitter divided by the square of the number of sub-

⁷ C. R. Doty and L. A. Tate, "A data transmission machine," *AIEE Transaction Paper*, no. 56-985, p. 3; August 7, 1956.

⁸ H. A. Rhodes, "Tests of intercity transmission of teletypesetter signals at 600 words per minute," *AIEE Conference Paper*, no. 56-397, pp. 1-9; January, 1956.

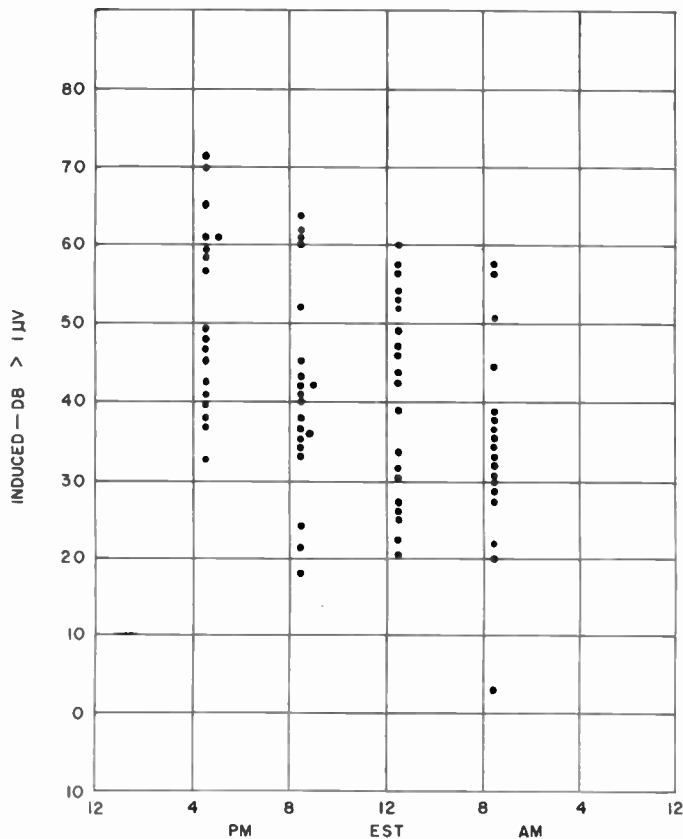

Fig. 3—Reception GLK, 8005 kc, London transmission at Riverhead, N. Y., for the month of November, 1951.

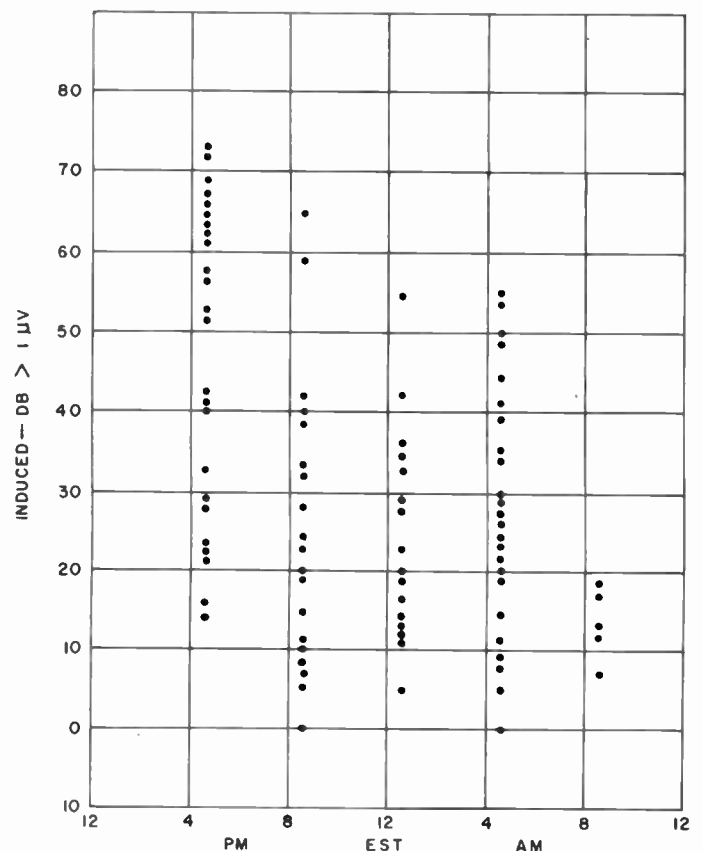

Fig. 4—Reception GLK, 8005 kc, London transmission at Riverhead, N. Y., for the month of January, 1953.

carriers gives the minimum power per subcarrier. Limiting increases the possible power per subcarrier although the exact amount of the increase must be determined in each individual case. With a peak envelope power of 20 kw and four subcarriers, it is anticipated that the subcarrier power will be 2 kw.

The amount of power required per subcarrier and the total peak envelope power of a single-sideband transmitting system varies considerably between circuits and over cyclical propagation changes. It is believed that once medium power has been obtained, say 20 or 25-kw PEP, further power gains must be at least in the order of 3-db or more to be significant. Anything less than about a 3-db step would hardly be warranted. It is usually more practical to double the effectiveness of the antenna systems by employing end-fire or two-bay rhombic antennas. End-fire rhombic antenna construction consists of placing a second rhombic a proper distance ahead and below the first rhombic such that they physically overlap in the direction of transmission. The relative phase of the feed lines to the two rhombics is also important.

The reason for considering power steps of at least 3-db is that received signals vary a great deal more than this and anything less would have inconsequential effect on improving circuit continuity. Examples of this large variability in signal intensity are given in Figs. 3 and 4 which show the hourly median values of signals level received from GLK 8005 kc, London, at Riverhead, N. Y. On these plots each dot represents the median

level recorded during that hour of one day. The induced microvolts shown are about 6 db greater than the microvolts which would appear across a 200-ohm receiver input impedance. These graphs are typical of the wide range of received signal intensity and lend support to the contention that db gains of less than about 3-db will probably not be noticed.

It is to be noted here that systems with four signaling or frequency positions for channeling have the advantage that maximum peak power is available at all times on each channel. However, since the received bandwidth has to be sufficient to cover the entire spectrum the total received noise and consequently the signal-to-noise ratio for each channel is probably no better than for the single-sideband system.

The availability of ARQ, automatic error correction, on transoceanic circuits has also made it possible to operate with considerably less power than would otherwise be required. Usually when the ionosphere fails to support a frequency the addition of power would be completely unproductive and a frequency change is in order. It is believed that single-sideband transmitter powers in the order of 50 to 60 kw will be required for only a few of the most difficult of the world's international telegraph communication circuits.

Operating Standardization

Fig. 5 shows the preferred method of channel designation for Time Division Multiplex on subcarriers of a single-sideband system. The marking and spacing fre-

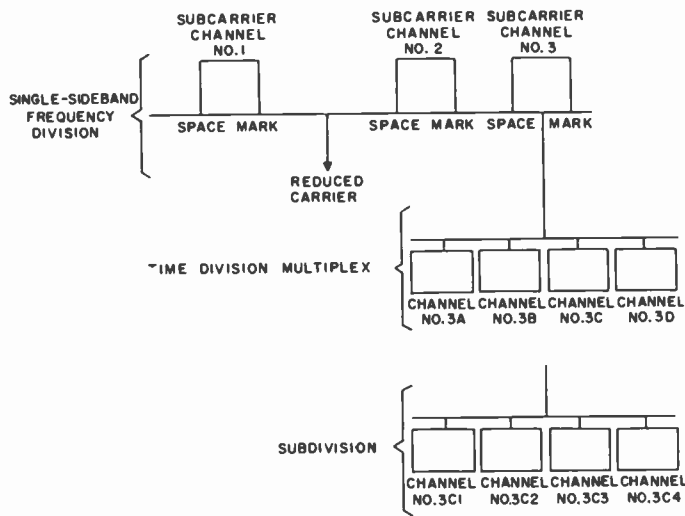

Fig. 5—Standard designations for time-division multiplex with subdivision of one channel all on a single-sideband system.

quencies are also indicated. It is to be noted that the spacing frequency is the lowest in the spectrum regardless of whether the subcarrier is above or below the reduced carrier. This means that in shifting a subcarrier from the upper sideband to the lower sideband the keying will have to be reversed in order to maintain this standardization. Insofar as the telegraph terminal equipment is concerned, marking corresponds to rest condition on the five-unit start-stop system while marking corresponds to key down or active condition on Morse keying. These system standardizations have not yet had world-wide acceptance and are being considered further by the CCIR, International Radio Consultative Committee, of the International Telecommunications Union.

These matters of standardization of single-sideband technical operations require coordination with foreign administrations. Considerable progress has been made in arriving at the standards of channeling and designation, as outlined above.

Transmitter and Receiver

Finally, mention must be made of the two basic methods of providing single-sideband transmissions. One of these is referred to as the linear single-sideband system of which the RCA new SSB-3 system is an example. Photographs of the transmitter and receiver appear in another paper in this issue.⁸

The second method involves utilization of a standard broadcast-type transmitter equipped with a high level audio modulator and an adaptor which splits the keying into a phase modulation component and an amplitude component.⁹ The phase modulation component is amplified by means of the Class-C amplifier and the amplitude envelope is restored at the final amplifier through the high level audio modulator. Fig. 6 shows a photograph of this Kahn single-sideband adaptor.

⁸ L. R. Kahn, "Single-sideband transmission by envelope elimination and restoration," Proc. IRE, vol. 40, pp. 803-806; July, 1952.

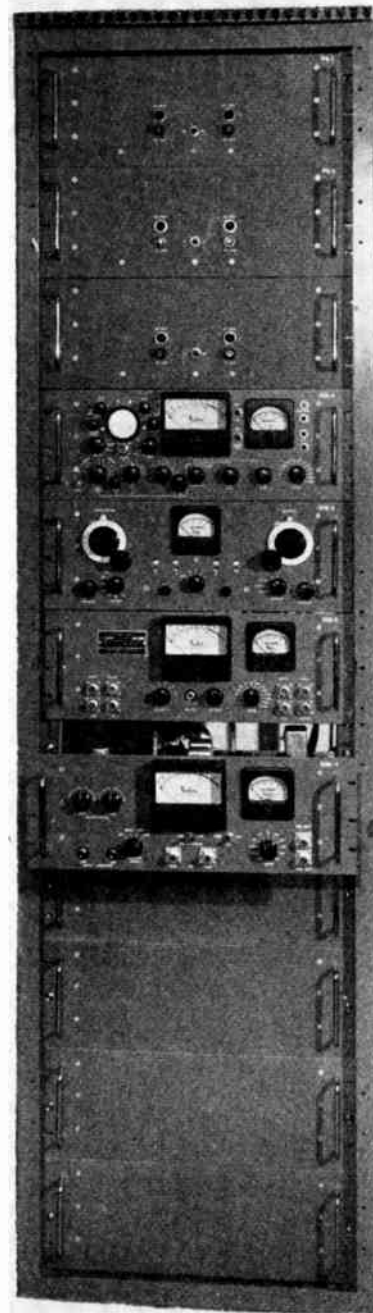

Fig. 6—Kahn single-sideband adaptor for use with standard telephone-type transmitters.

CONCLUSION

All of the technical factors outlined above must be considered carefully along with cost factors in choosing between the different communication systems. When more than four channels are needed between two points requiring long distance radio communications, the single-sideband system is preferred because of its frequency spectrum utilization efficiency and because of its flexibility for so many kinds and types of communication services.

ACKNOWLEDGMENT

The author is particularly indebted to J. L. Finch for his guidance and assistance in the preparation of this paper.

SSB Receiving and Transmitting Equipment for Point-to-Point Service on HF Radio Circuits*

H. E. GOLDSTINE†, MEMBER, IRE, G. E. HANSELL‡, MEMBER, IRE, AND R. E. SCHOCK‡, MEMBER, IRE

Summary—The single-sideband receiving equipment, described in this paper, operates in the frequency range from 2.8 to 28 megacycles. The receiver provides for dual space-diversity reception of single sideband, independent sideband, double sideband, amplitude modulation, or phase modulation signals. The first heterodyne oscillator and the second heterodyne oscillator are common to both receiver circuits. The first heterodyne oscillator is a highly stabilized oscillator of the "captive" type. Diversified carrier from the two receivers is used in a comparator-type afc system. A noise-operated squelch disables the afc during poor-signal intervals. The agc voltage may be supplied from a choice of the signal carrier, the aggregate energy of either sideband, or (in the case of phone reception) from a combination of carrier and sideband energy. A diversity combiner is provided for the reception of phone signals. The telegraph diversity combiner uses a relatively simple limiter-combiner system. The receiver has a noise figure of 6 db and a minimum image ratio of 100 db.

The companion transmitter is comprised of single-sideband modulating equipment, heterodyne frequency converters, and a linear amplifier system having a peak power output of 20 kw. The amplifier features continuous tuning throughout the operating range of 4 to 30 mc. The entire transmitter is designed to meet modern requirements of low distortion and low spurious radiation. It is intended to meet telephone, multichannel telegraph, and facsimile service requirements. Provision is made for operation with two independent sidebands, either or both of which may be transmitted, and with various amounts of carrier reduction. Double sideband AM may also be transmitted. This transmitter is believed to provide an optimum compromise between power level and equipment cost.

INTRODUCTION

CERTAIN rather special qualifications are desirable in today's receiving and transmitting equipment used for point-to-point commercial radio service. The advantages of single sideband and the advantages of diversity reception are well established. The crowded frequency spectrum requires of the receiver a maximum of selectivity and high image ratio. If the receiver is used as one of many in a particular receiving location, such things as low-back radiation of the first oscillator become of prime importance. A receiver with continuous tuning is desirable in many cases, and this without sacrificing greatly in stability and resetability. Available choice of bandwidth, to accommodate the spectrum of the particular service being used, is a desirable feature in the receiver. As with the receiver, continuous tuning of the transmitter is often desirable. Where single-sideband transmitters run with a number of intelligence channels on either or both sidebands, a high transmitter power output is essential to a satisfactory power level of each intelligence channel. To achieve this, while maintaining linearity, compactness, and ease of operation, is the transmitter-design goal. Mechanical design and arrangement which make for easy testing and maintenance are of prime importance

for both receivers and transmitters. It is the purpose of this paper to describe the RCA dual diversity single-sideband receiver, SSB-R3, and the companion transmitter, SSB-T3, in which the above requirements are attained to a considerable degree.

THE RECEIVER

Dual Diversity

The receiver is designed for two-receiver space-diversity reception. However the two signals pass from the two spaced-antenna inputs to the two audio outputs without combination of the intelligence signals. The receiver from input to output, is essentially two individual receivers but with common heterodyne oscillators, common agc, common afc, common packaging, and common rf tuning controls. All diversity combining of the intelligence signals is done in adaptors fed from the receiver audio outputs and especially designed for combining the particular type of intelligence signal being received. A simplified block diagram, which will be referred to in describing the receiver, is shown in Fig. 1 (next page). It does not indicate the manner of packaging the receiver units.

The RF Amplifiers

The rf tuning range from 2.8 to 28 mc is covered in four bands. Band-switching is accomplished by switching the tube heaters. The rf amplifier for each receiver has four permeability tuned circuits for each band. The two receiver tunings are ganged together, requiring only one tuning for both receivers. Input impedance of the amplifiers is normally 200 ohms balanced, but this may be converted to 50 ohms unbalanced by connecting one of the input leads, on each output, to the center tap of its respective input coil. The use of four tuned circuits in each amplifier chain results in a first-heterodyne-oscillator back radiation at the rf inputs of less than 1 μ v under all tuning conditions.

The IIF Oscillator

The hf oscillator is of the captive type and is common to both receivers. It has four bands, calibrated in signal frequency, covering the same ranges in each band as the rf amplifiers. The oscillator may best be described by referring to its block diagram, Fig. 2. In operation, a selected harmonic of the crystal oscillator is mixed with the output of the slave oscillator to produce a frequency in the 2 to 3 mc range. This is fed through selectivity to a phase comparator. Signal from a highly stabilized, permeability tuned, 2 to 3 mc oscillator is also fed to the phase comparator. The output of the phase comparator operates, through a reactance tube, upon the

* Original manuscript received by the IRE, September 17, 1956.

† RCA Labs., Div. Transmission Lab., Rockv Pt., N. Y.

‡ RCA Labs., Div. Radio Reception Lab., Riverhead, N. Y.

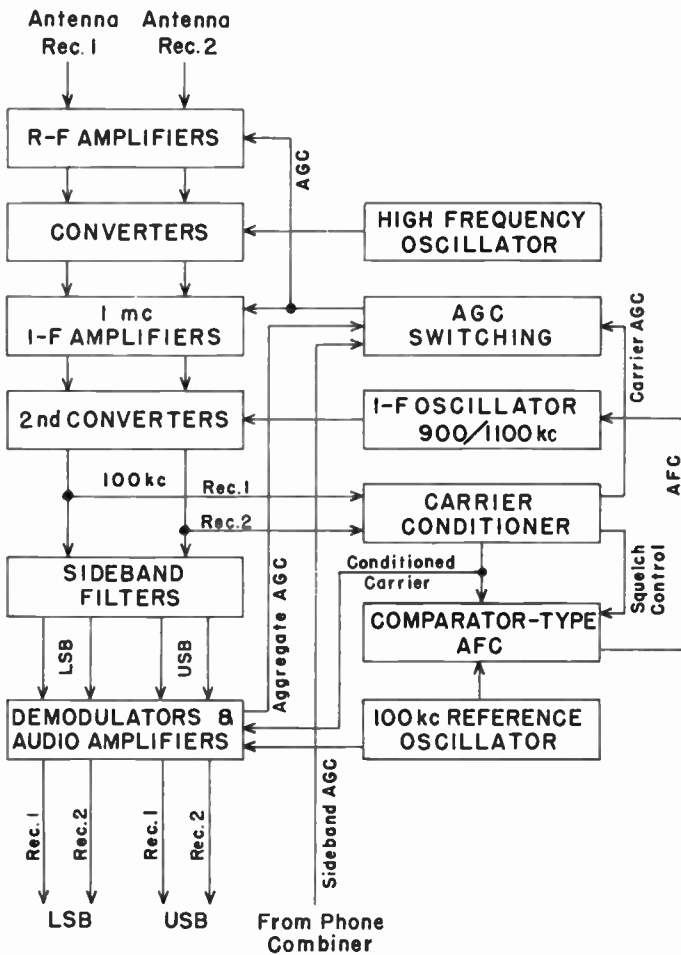

Fig. 1—Simplified block diagram of dual-diversity SSB-R3 receiver.

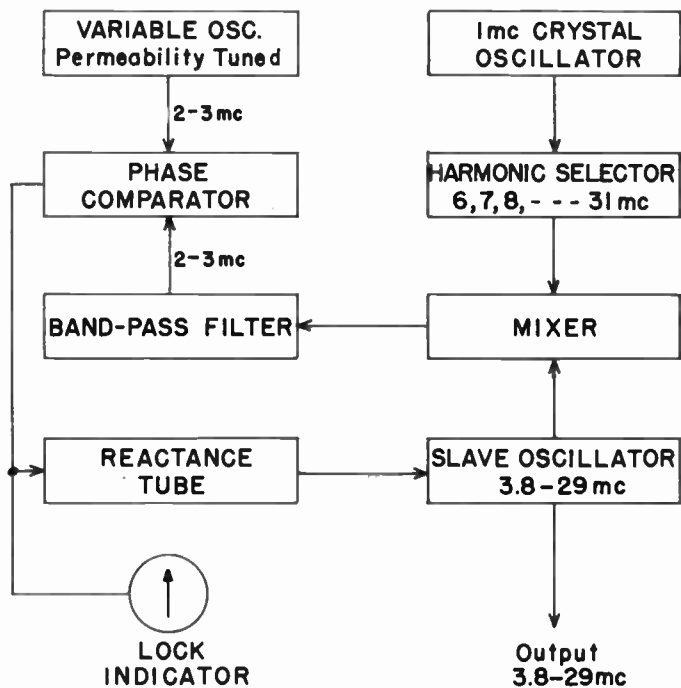

Fig. 2—Block diagram of the hf oscillator.

slave oscillator to hold the output of the mixer in phase with the output of the 2 to 3 mc variable oscillator. This in effect locks the slave oscillator in phase. The tuning calibration accuracy is ± 750 cycles. The over-all stability is approximately 50 cycles for a 12 hour period after the initial warmup. In operation the oscillator output is fed to the first converter at a frequency 1 mc higher than the incoming signal frequency, thus converting it to a 1 mc IF frequency. The image ratio resulting is approximately 100 db at 28 mc.

The IF Amplifiers

The IF amplifier chains consist of four double-tuned transformers and two pentodes in tuned transformer stages. The 1 mc intermediate frequency is converted to 100 kc in the converters following the IF chains. The four double-tuned transformers in each IF amplifier chain, plus a double-tuned transformer in the output of each converter, results in an over-all bandwidth at this point of 18 kc.

The IF Oscillator

This oscillator, for converting from 1 mc to 100 kc, is highly stable with respect to changes in supply voltage or changes in tube gain. Provision is made for switching the frequency from 900 kc to 1100 kc or *vice versa*, for the purpose of interchanging sidebands at the sideband filter inputs. The afc operates on this oscillator as will be described later.

The Carrier Conditioner

As indicated in Fig. 1, the outputs of the second converters feed to the "sideband filters" and also to the "carrier conditioner." Several operations take place in the carrier conditioner and these are shown in Fig. 3. Here the receiver no. 1 and receiver no. 2 signals, from their respective second converters, feed into their respective carrier filters. The carrier filters are 35 cycles wide centered on 100 kc. Their outputs feed to the "carrier combiner," and also to the "carrier rectifiers." These carrier rectifiers have a common load, and the dc voltage developed across this load is used for agc. The combiner serves to select the stronger of the two carrier signals fed to it. The output of the carrier combiner is fed to a limiter having a limiting range of 45 db. The limiter output feeds to a noise rectifier circuit. In the noise rectifier circuit any noise which appears on the carrier is amplified and rectified to obtain a voltage which disables the action of the afc during noisy-signal intervals. The filtered, amplified, and limited carrier at the output of the limiter is designated as a "conditioned" carrier. Beside feeding to the noise rectifier circuit, it is used in the afc circuit, and is made available to the final demodulators for demodulation of the signal.

The Sideband Filters

The fidelity of the receiver up to the output of the second converters is essentially flat for 6 kc either side

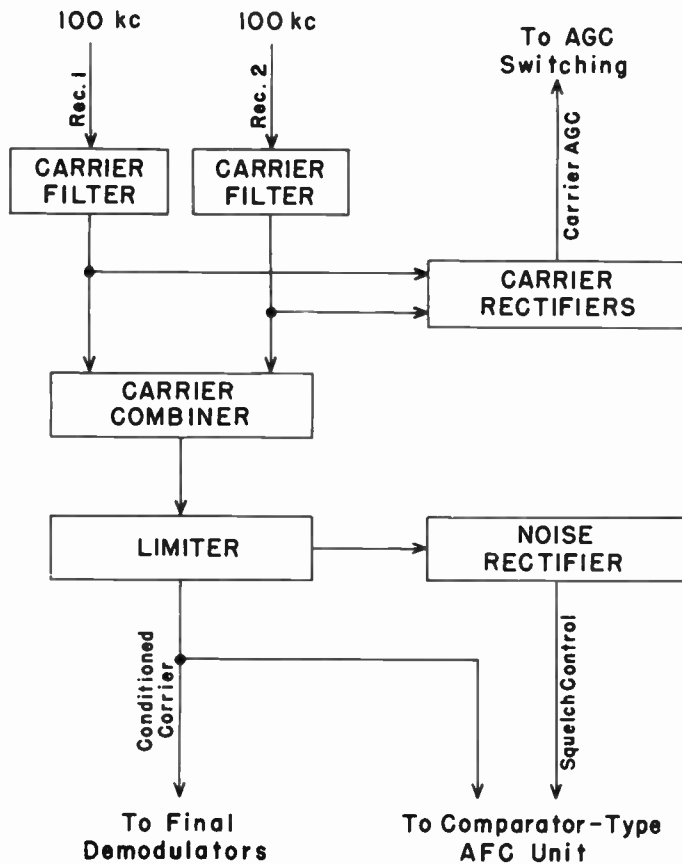

Fig. 3—Block diagram of the carrier conditioner.

of the carrier. By using upper and lower sideband filters with 6 kc fidelity, a full 6 kc fidelity output can be had at each side band demodulator output. Packaging of the sideband filters in this receiver is such that if the receiver is not to be used for a service requiring full 6 kc fidelity, filters may be obtained with the receiver which are less expensive, and which will select that portion of the sideband spectrum used by this particular service. Furthermore if the receiver is always to be used on signals using one sideband only (either upper or lower), the receiver may be obtained with filters for one sideband only. As has been pointed out, the IF oscillator may be operated at either 900 kc or at 1100 kc for the purpose of interchanging the sidebands at the sideband filter inputs when desired, so that either sideband may be placed in the particular sideband filters used.

The 100 KC Reference Oscillator

The 100 kc reference oscillator indicated in Fig. 1 is a stabilized crystal oscillator. It provides a reference to which the conditioned carrier may be compared for afc purposes. It is also supplied to the demodulators as one demodulating-carrier choice.

The Demodulators

Signals from the sideband filters pass to the demodulators for conversion to audio. Packaging of the receiver is such that one demodulator-unit package provides

demodulation for one sideband output (lower or upper) for one receiver and the same sideband output for the other receiver. Thus if the receiver is to be used entirely on signals with one sideband only working, then only one demodulator unit need be provided with that receiver. If the receiver is to be used on signals with two sidebands working independently, then one demodulator unit must be provided for the lower sideband and a second demodulator unit for the upper sideband.

The demodulator circuit used is of the product-detector type. Levels are purposely held to a relatively low level throughout the receiver, down to the final detector, in order to avoid intermodulation products. Intermodulation products at the demodulator output are down 50 db or more.

Each demodulator unit provides a choice of carriers for insertion at the detector. The conditioned carrier is provided as one choice, and the 100 kc reference oscillator signal as another. When the receiver is to be followed by a telegraph combiner, for the reception of telegraph signals, a third carrier choice is provided. In this case the carrier choice provided for each detector is offset from 100 kc, and by a different amount for each detector, for reasons to be discussed under the heading of "The Telegraph Combiner."

The Automatic Frequency Control

The automatic frequency control operates through a synchronous inductor motor connected to a variable capacitor in the IF oscillator tuned circuit. This afc is of the comparator type, which compares the frequencies of the conditioned carrier and the reference oscillator and operates the motor in a sense to make correction when these frequencies are not in agreement. The afc normally holds the carrier to within one cycle of the 100 kc reference oscillator frequency.

The Automatic Gain Control

Automatic gain control is applied to all the rf and IF amplifier tubes. Several agc voltage sources are provided, and provision is made for selecting the source desired. This is indicated in Fig. 1 where the various agc voltage sources are shown feeding into an agc switching unit. It has been customary practice to use rectified carrier as the agc voltage source. However, in telegraph signal reception, better results have been obtained when the aggregate telegraph sideband energy is rectified to supply the agc voltage source. This is referred to in Fig. 1 as "aggregate agc."

In the phone combiner, used with this receiver for phone reception, there is provided an audio rectifier which may be connected across the same load used by the carrier rectifiers. The voltage resulting across this common load is used for agc. It is designated in Fig. 1 as "sideband agc." Choice of agc supply voltage is made at the block in Fig. 1 designated as "agc switching."

Here also, switching is provided for an agc time constant choice of 0.72, 7.2, and 57 seconds.

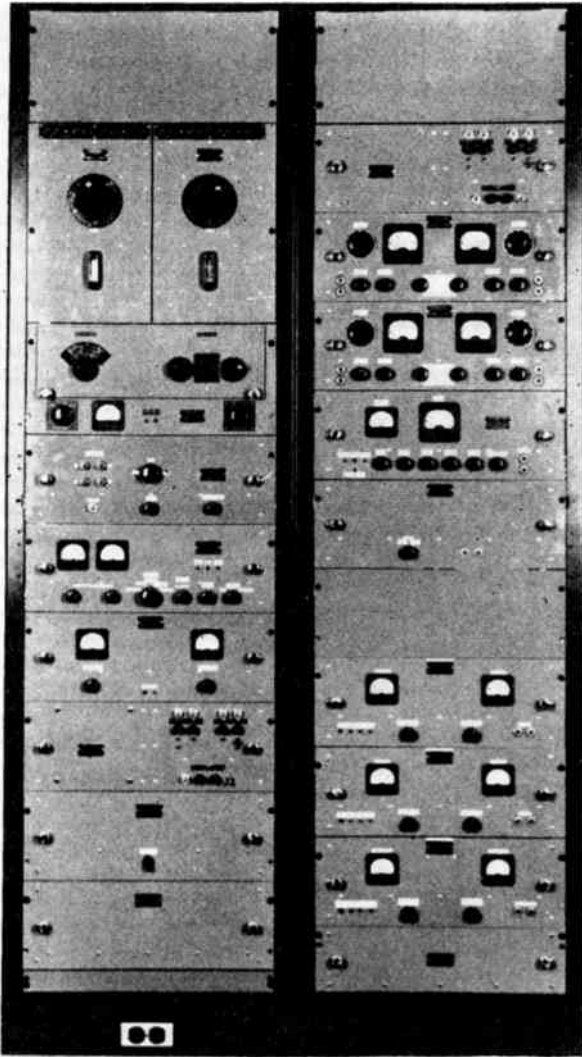

Fig. 4—Photograph of the SSB-R3 receiver.

Mechanical and Power Features

A photograph of the receiver is shown in Fig. 4. The dual diversity receiver itself occupies one full rack and about $\frac{1}{3}$ to $\frac{1}{2}$ the space in a second rack, depending on the type of service for which the receiver is to be used. The lower section of the right-hand rack, in the photograph, contains a phone combiner unit and also telegraph combining equipment for three tone channels.

The various units of the receiver and combining equipment are roll-out mounted to provide ready access for test and service. All power and signal cabling remains connected when the roll-out is used.

Each rack has its own regulated dc power supply and its own power control unit. The power supply frequency range is from $47\frac{1}{2}$ to 63 cycles. Provision is made for operating in a power voltage range from 100 to 130 volts ac or in a range from 200 to 260 volts ac as desired.

DIVERSITY COMBINING EQUIPMENT

The Phone Combiner

As was previously stated, signals pass through the dual diversity receiver from the two spaced-antenna in-

puts to the demodulator outputs without diversity combination, and that such combination is accomplished in combining equipment following the demodulators. When the receiver is to be used for phone signal reception, a "phone combiner" unit is provided. This combiner uses a diversity gating circuit with a characteristic such that two signals entering the combiner with a 1 db amplitude differential will have a 25 db differential at the combined output.

The Telegraph Combiner

The telegraph combining equipment provides dual-diversity single sideband reception of telegraph radio signal over the range of the receiver described above. The telegraph combining system can best be described by reference to Fig. 5. The telegraph sideband is demod-

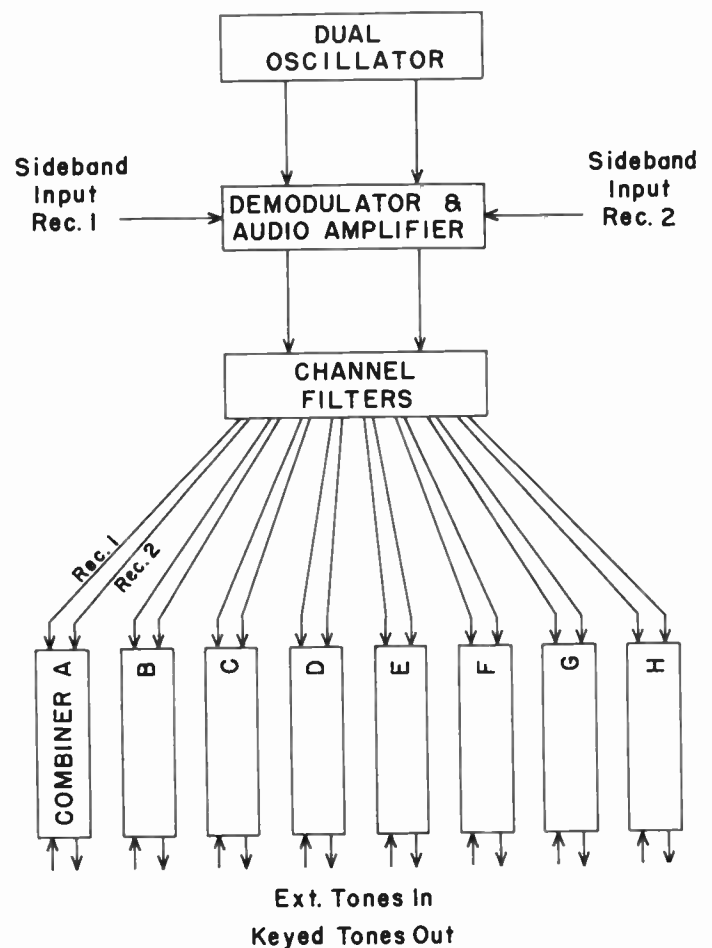

Fig. 5—Block diagram of the telegraph combining system.

ulated using a dual oscillator unit with a separate offset crystal for each receiver such that the tone channels are reproduced at a higher audio frequency than the original transmitted tones. The tones from the two receivers are offset by different amounts making it possible to use a common limiter combining system. Following the demodulator unit, the audio telegraph channels for each receiver are separated by filters and connected to a

combining unit for each tone telegraph channel being transmitted. The individual channel combiner units can best be described by reference to Fig. 6. The frequencies passed by the filter unit for receiver 1 and receiver 2 for a given channel are individually amplified and connected to a common limiting system. The limiting system is designed to accommodate a large fading range making it unnecessary to provide an individual agc system for each tone telegraph channel. Following the limiting system the frequencies for the two receivers are separated by filters and passed to a discriminator for each receiver. The discriminators are followed by detectors having a common load. The detected output is then passed through a low-pass keying filter to a trigger keyer system. The output of the keyer is an on-off keyed tone. The tone source can be either internal to the unit or from an external tone source.

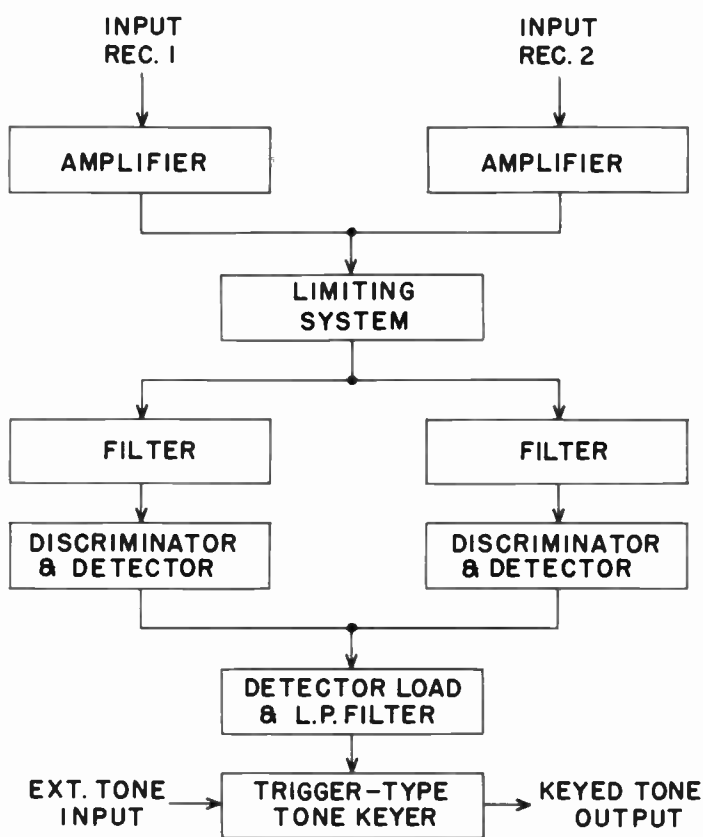

Fig. 6—Block diagram of the individual-channel telegraph combiner.

The diversity action is made possible by virtue of the fact that the frequencies from the two receivers are offset with respect to each other such that phase cancellation is not a problem. The total diversity action is due to the capture effect in the limiting system plus the effect of the common detector load. Measurements have shown that if the two signals differ by 1.3 db or more the weaker signal will not contribute to the output. An advantage gained by this type of diversity system is the simplicity of the circuitry in the telegraph combiner

unit. This is rather important since a combiner unit is required for each tone telegraph channel in use.

Two systems for two different speeds have been worked out. The first system uses three tone channels with 340 cycles total frequency shift and 680 cycles channel separation. The present plan is to use each of these tone channels for four telegraph circuits operating in time division multiplex at 60 words per minute for each telegraph circuit or 240 words per minute for each tone channel. The over-all system is capable of 12 telegraph circuits at 60 words per minute each. Table I shows the center of each transmitted tone channel and the center of each receiver tone channel at the input to the channel combiner unit.

TABLE I
QUADRUPLIX SPEED SYSTEM—3 CHANNELS 340 CYCLES SHIFT—
680 CYCLES SEPARATION

Channel	Transmitted	Receiver 1	Receiver 2
A	935	2125	3485
B	1615	2805	4165
C	2295	3485	4845

The second system uses eight tone channels with 170 cycles total frequency shift and 340 cycles channel separation. The present plan is to use each of these tone channels for two telegraph circuits in diplex operation at 60 words per minute for each telegraph circuit. The over-all system is capable of 16 telegraph circuits operating at 60 words per minute each. Table II shows the center of each transmitted tone channel and the center of each receiver tone channel at the input to the channel combiner unit.

TABLE II
DIPLEX SPEED SYSTEM—8 CHANNELS 170 CYCLES SHIFT
—340 CYCLES SEPARATION

Channel	Transmitted	Receiver 1	Receiver 2
A	510	1785	2465
B	850	2125	2805
C	1190	2465	3145
D	1530	2805	3485
E	1870	3145	3825
F	2210	3485	4165
G	2550	3825	4505
H	2890	4165	4845

Obviously the same general system could be adapted to other shifts, keying speed, or channel separations. In this connection it should be pointed out that all channel units are identical except for the filters and discriminators. This particular equipment has been arranged to have all of the filters in a common unit for each system and uses a plug-in dual discriminator to fit the channel and system in use.

THE TRANSMITTER

The transmitter is designed to cover a frequency range of 4–30 mc, with peak power output of 20 kw. The fre-

frequency range meets service requirements for long distance, high frequency, ionospheric communication.

Manual tuning is provided so that the transmitter can be easily tuned to the desired frequency in this band with self-contained tuning components. The transmitter is designed to provide commercial service for either multitone telegraphy or telephony. To simplify the adjustment and tuning of the transmitter, a number of rf stages are gang tuned and the tank coil and condensers are ganged together to provide a nearly constant LC ratio over the required frequency band.

Either or both of the independent sidebands can be used for transmission of intelligence. Audio bandwidths of 200 to 3500 cycles per second or 100 to 6000 cycles can be obtained, depending upon choice of the single-sideband generators.

The transmitter uses air cooled type tubes and is self-contained, with the exception of the high voltage rectifier transformer, in a unit approximately 88 inches wide by 89 inches high by 48 inches deep. A photograph of the research model transmitter is shown in Fig. 7. Tetrode tubes are used for the high frequency linear amplifiers and the output stage uses a pair of high power tetrodes to produce the 20 kw peak output level. When greater power is desired, a power amplifier may be added. The peak power rating is believed to represent nearly optimum compromise between the desire for high signal power and the desire for moderate cost.

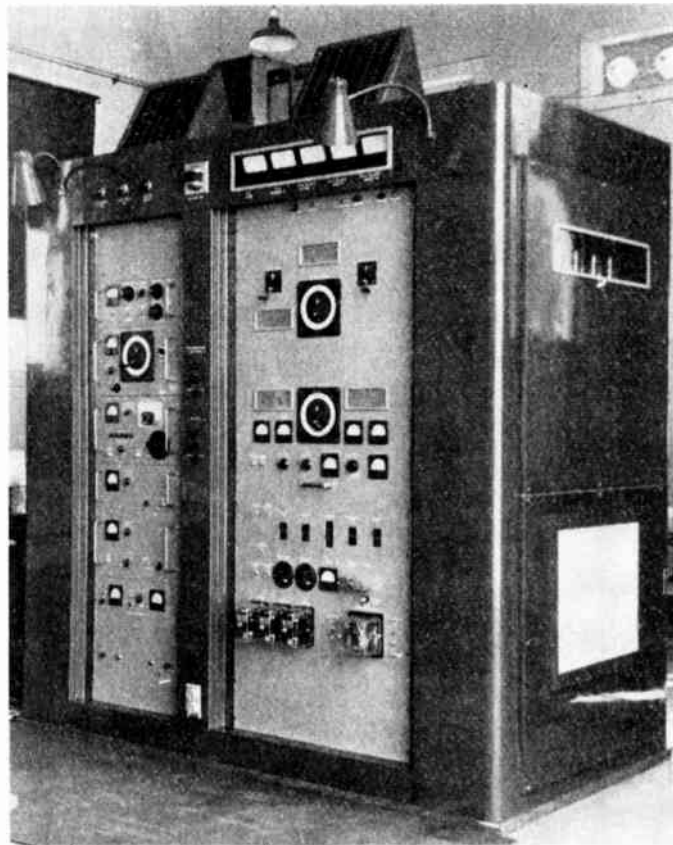

Fig. 7—Photograph for the SSB-T3 transmitter.

Conversion of Airborne HF Receiver-Transmitter from Double Sideband to Single Sideband*

HARRIS A. ROBINSON†, SENIOR MEMBER, IRE

Summary—In the past, the problem of frequency accuracy and stability has been the major deterrent in the effective utilization of single sideband, suppressed carrier techniques for hf air-ground communications. This paper describes briefly the AN/ARC-21 airborne hf, double sideband, communication equipment, and the frequency-control system which permits the remote selection and accurate automatic tuning to any selected frequency channel of the 44,000 available at intervals of 0.5 kc in the 2 to 24 mc spectrum. The improvement in the stability of this frequency-control system and the modifications of the several major subassemblies, essential to the conversion of this equipment to the single-sideband mode, are described. The provision for reception and transmission of an equivalent amplitude modulated signal during the transition period is discussed. Block diagrams, performance characteristics, and photographs are presented showing the original DSB equipment and the SSB conversion.

INTRODUCTION

TWO-WAY RADIO communication between aircraft and ground, over distances in excess of 200 miles is dependent upon the effective utilization of the available frequencies. Frequency bands in the high-frequency portion of the spectrum from 2 to 24 megacycles per second have been utilized in order to take full advantage of ionospheric propagation. Since the earliest days of airborne communication, radio telephone transmission and reception have been entirely by amplitude modulation of a nominally stable carrier frequency, with the resultant double sideband symmetrically displaced either side of the carrier frequency. The outstanding advantages of long-distance voice communication in the high-frequency spectrum obtainable by concentrating the available power in a

* Original manuscript received by the IRE, September 24, 1956.
† Airborne Systems Dept., RCA, Camden, N. J.

single sideband with suppressed carrier have long been recognized and will not be repeated here.^{1,2} Until relatively recently, the problem of frequency accuracy and stability in the system comprising a group of airborne transmitters and receivers has been the major obstacle in the path of effective utilization of SSBSC techniques for air-ground communications. This problem of frequency stability in hf airborne communication has been particularly challenging in view of the extremes of environmental conditions encountered, *i.e.*, temperature, humidity, condensation, vibration, shock, altitude, etc., and with complete recognition of the necessity of rapid, remote selection of any desired frequency channel from the hundreds of channels available in the hf spectrum. In the case of airborne military communication equipment, requiring the utmost flexibility and freedom in selecting and utilizing any frequency which may become available, the selectable frequency channels required number in tens of thousands.

PRESENT EQUIPMENT

The AN/ARC-21 equipment designed and manufactured for the United States Air Force by the Radio Corporation of America represents the latest advance in military airborne hf communication equipment. Voice communication is provided by high level amplitude modulation. Other transmission modes include telegraph keying of the unmodulated carrier (cw) and frequency shift keying (fsk). A total of 44,000 frequency channels are available at intervals of 0.5 kc covering the frequency spectrum 2 to 23.9995 mc. Any frequency channel is selectable from a remotely located master control position reading directly in frequency. Further provision has been made for presetting any desired combination of twenty frequency channels, the latter being selectable at any one of a maximum of five remote sub-control positions.

The selection of a frequency channel at any control position initiates an automatic cycle which tunes the receiver and transmitter exciter. The automatic tuning and loading of the power amplifier and the remote antenna coupler is initiated by closure of the microphone control or keying circuit preceding the first transmission on any frequency channel.

A brief summary of the AN/ARC-21 performance characteristics is listed in Table I. The transmitter is nominally rated at 100 watts of carrier power with a modulation capability of 90 to 100 per cent with clipped speech input. The pressurized case permits operation at full power at altitudes up to 70,000 feet, (50,000 feet with nonpressurized power supply). Before discussing the conversion of the AN/ARC-21 to the single-sideband mode it is desirable for the reader to become

¹ G. W. Barnes, "A single-sideband system for aircraft communication," *J. I.E.E.*, vol. 101, p. 121-130; May, 1954.

² J. F. Honey, "Performance of amplitude modulation and single-sideband communication," *Tele-Tech*, vol. 12, pp. 64-66; September 1953.

TABLE I
SUMMARY OF PERFORMANCE CHARACTERISTICS

Characteristic	AN/ARC-21	SSB Conversion
Frequency Range	2,000 to 23.9995 mc	Same
Available Freq. Channels	Total 44,000	Same
Frequency Channel Spacing	500 cps	Same
Modes of Transmission		
Voice	AM-DSB	SSBSC
Telegraphy	CW	CW
Teletype	FSK	FSK
Voice	—	AM Equiv.
Altitude Range	0 to 70,000 feet*	Same
Temperature Range	-55 to +55° C.	Same
Automatic Tuning	Receiver & Transmitter	Same
Power Output		
Carrier	100 watts	Suppressed
Voice Modulation	90 to 100 per cent	250 watts peak envelope power
Band Width (voice emission)	8 kc	4 kc
Frequency Stability		
at 10 mc	± 150 cps	± 17 cps
at 20 mc	± 300 cps	± 22 cps
Receiver Selectivity	8 kc	4 kc
Receiver Sensitivity for 10 db signal/noise	3 to 5 microvolts	1 to 1.5 microvolts

* 50,000 ft with nonpressurized power supply.

familiar with the basic design and construction of the receiver-transmitter unit. The photograph of Fig. 1 shows the external appearance of the rt unit in its pressurized heat exchanger case. This photograph also shows the master control and one of the subcontrol units, as well as the separate power unit. The receiver-

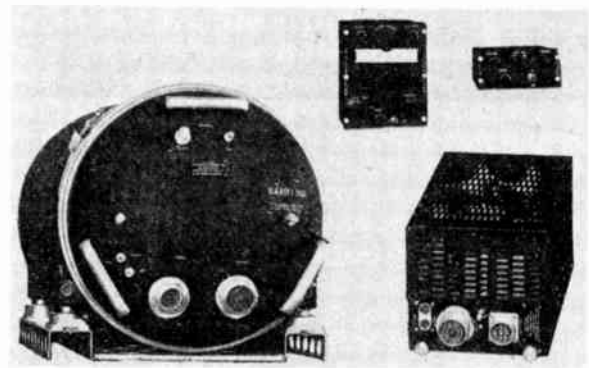

Fig. 1—External view showing receiver-transmitter in the pressurized case, master control; subcontrol and power unit.

transmitter comprises nine major subassembly units designed for separable plug-in assembly, to permit the attainment of compactness while retaining ease of servicing and maintenance. The side view of the rt unit is shown in the photograph of Fig. 2 and a bottom view in the photograph of Fig. 3.

The block diagram of Fig. 4 shows the basic interrelation of the major portions of the receiver and transmitter. The receiver is basically a dual superheterodyne comprising an rf amplifier, mixer, first IF amplifier at

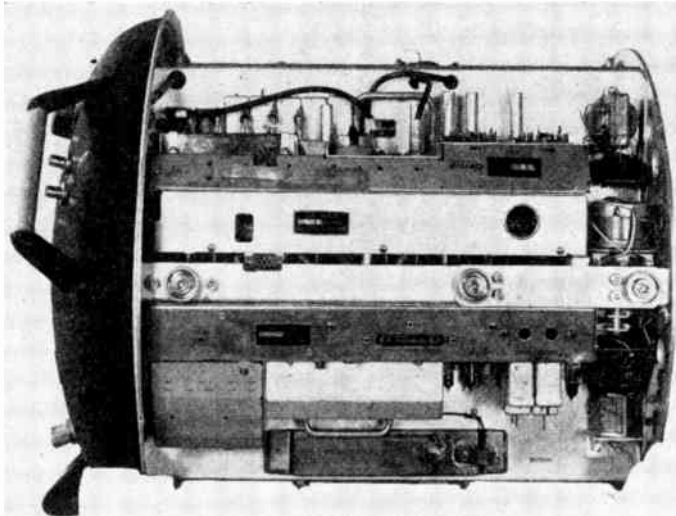

Fig. 2—Internal view from side showing plug-in subassemblies of the frequency-control units.

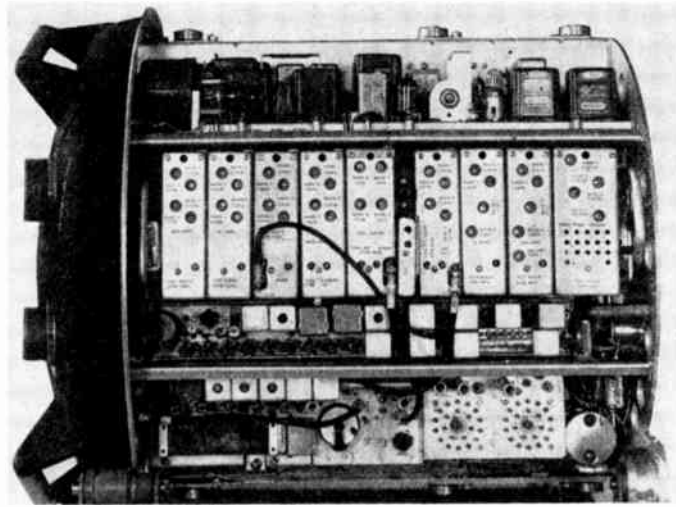

Fig. 3—Internal view from beneath showing plug-in assemblies. The central unit is the rf tuner-exciter unit with the IF-AF unit immediately below.

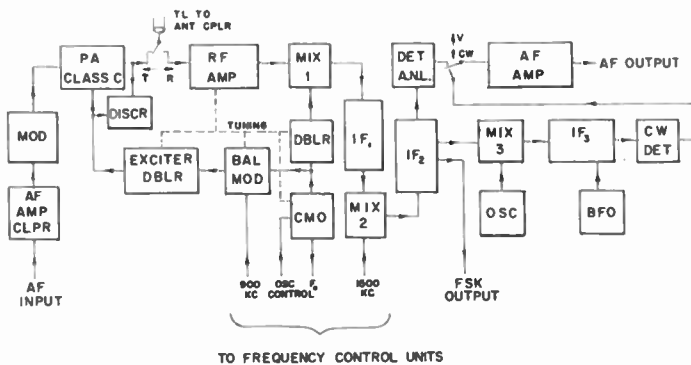

Fig. 4—Block diagram of the present AN/ARC-21 double-sideband receiver-transmitter.

1800 kc, second mixer, and the second IF amplifier at 300 kc. For voice reception the latter is coupled to an envelope detector and automatic noise limiter followed by the audio-frequency amplifier. For cw reception a

third mixer and third IF amplifier at 105 kc couples into a cw detector along with the beat-frequency oscillator.

A controlled master oscillator (cmo) feeds the required injection frequency to the first mixer through a frequency doubler. Output from the cmo is also furnished to a balanced modulator where it is combined with a 900-kc input (representing one half the first IF) to produce the transmitter drive at one-half the signal frequency.

The transmitter exciter amplifies the signal level and terminates in a frequency doubler which provides the grid drive to the class "C" power amplifier. The modulating audio signal input is clipped to provide peak limiting, and after passage through a low-pass filter is amplified to drive the class "B" stage. The latter modulates the power amplifier for amplitude modulation.

The tuning of the receiver rf amplifier, balanced modulator, and low-level exciter stages for the transmitter are ganged with the tuning of the controlled master oscillator (cmo). This tuning assembly consists of a motor-driven platform positioning the permeability tuning cores of the ganged-tuned circuits. A portion of the output frequency (F_0) from the cmo is supplied to the frequency-control units shown in the block diagram of Fig. 5. The frequency-control system comprises a

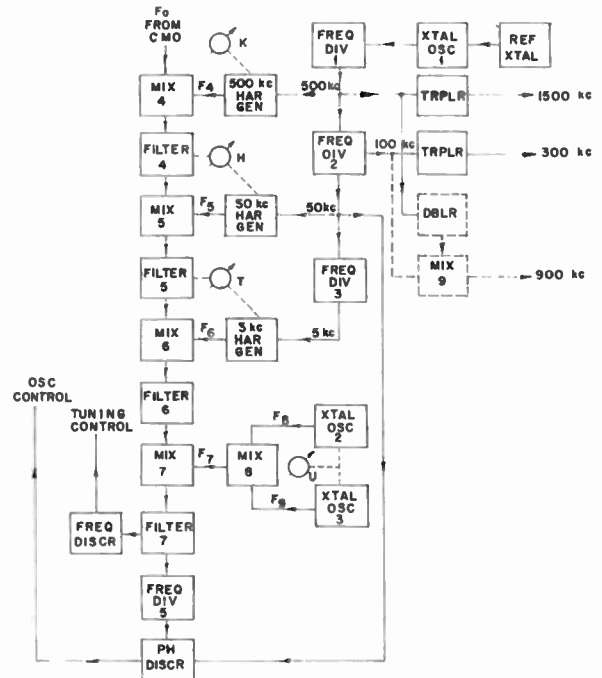

Fig. 5—Block diagram of the frequency-control units.

series of mixer stages each excited by a harmonic generator. The output of each mixer stage couples to the successive mixer through a selective filter network as shown. The heart of the frequency-control system is the reference crystal oscillator; the accuracy and stability of all of the available 44,000 frequency channels is primarily determined by this crystal. This unit includes a hermetically sealed, thermostatically controlled stabilized crystal and associated oscillator cir-

cuit elements. The reference crystal feeds the first harmonic generator at 500 kc. Through a series of frequency multipliers and dividers, output frequencies at 1500, 900, 300, 100, 50, and 5 kc are generated from the reference crystal. The frequency channel setting selected at the remote control position is reproduced at the rt unit by a series of four-bridge type, servoselector followers driving appropriate switches.

The "thousands" or megacycle servoselector (*K*) has twenty-two positions each corresponding to a 1-megacycle segment of the 2 to 24 mc frequency spectrum. This servo selects the required harmonic of the 500 kc harmonic generator, injected into mixer 4. Similarly the "hundreds" servoselector (*H*) having 10 positions, selects the required harmonic output of the 50-kc harmonic generator for mixer 5 as well as switching the resonant frequency of the selective filter 4. The "tens" servoselector (*T*) selects the harmonic output from the 5 kc harmonic generator for mixer 6 and switches the resonant selective filter 5. The "units" servoselector (*U*) has 20 positions to select the 0.5-kc-channel increments and functions to select a combination of output frequencies from crystal oscillators 2 and 3. The former has 4 frequencies and the latter 5 frequencies. By utilizing the combinations of these two oscillators the resultant output of mixer 8 is a total of 20 frequencies spaced at increments of 250 cps from 265 to 269.75 kc. This output (F_7) feeds mixer 7 producing a nominal output frequency in the vicinity of 500 kc.

During the automatic tuning cycle of the receiver, the master oscillator (cno) is tuned from the low-frequency or reference end of the tuning range or band. As it approaches the tuning position corresponding to the selected frequency the output through the series of mixers and filters (4 to 7 inclusive) approximates 500 kc as the master oscillator approaches and passes through the correct tuning point. A frequency discriminator is connected to filter 7 with cross over at 500 kc. This discriminator produces a dc voltage which activates the tuning control.

As the correct tuning point is passed, the tuning is shifted from a high speed to slow speed and the direction reversed allowing the master oscillator to return to the correct frequency. As the resultant output from the master oscillator and the series of mixers again passes the 500-kc point, the output of filter 7 through the frequency divider 5, produces a 50-kc input to the phase discriminator. Here oscillator control voltage is developed by a phase comparison with the 50-kc output derived from the reference crystal oscillator. The resultant dc voltage provides the oscillator control necessary to maintain this phase synchronization.

The related portions of the frequency selection and automatic tuning cycle are shown as a time sequence in the diagram of Fig. 6. The receiver tuning cycle of 7 seconds starts with positioning of the servoselector units (*K*, *H*, *T*, and *U*). During this time the master oscillator tuning goes to the low frequency "Home" or reference position. After the band-switch setting, dependent upon

the "thousands" or megacycles servoposition, is completed, the master oscillator scans the band at high speed (approximately 1 inch per second movement of the permeability tuning cores). The control voltage developed by the resultant frequency output of filter 7 passing through the 500-kc frequency discriminator reverses the tuning and reduces the speed to 0.01 inch per second during the final phase synchronization portion of the receiver tuning cycle.

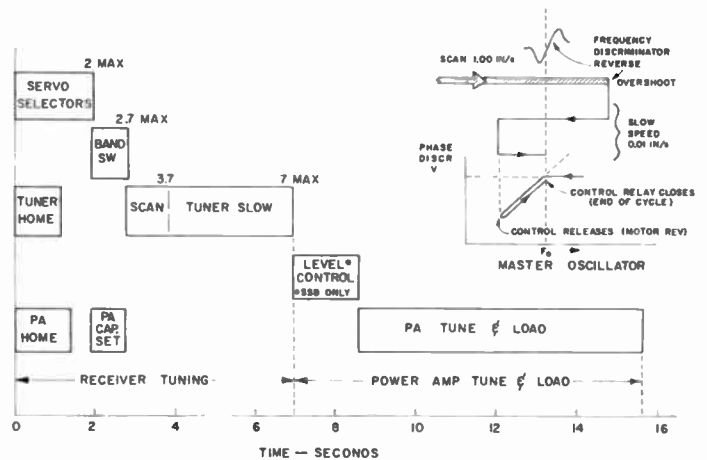

Fig. 6—Diagram of the automatic tuning sequence.

As shown in the tuning cycle diagram of Fig. 6, the total elapsed time from the remote selection of the desired frequency to the completion of the tuning of the receiver-exciter approximates 7 seconds. During the early portions of this cycle the power amplifier tuning and loading components "home" to their reference positions. The first closure of the microphone control circuit, following the new frequency selection, initiates the power amplifier automatic tuning and loading cycle which requires approximately ten seconds to complete.

To further illustrate the relationship of the master oscillator frequency and the several mixer, filter, and harmonic generator outputs of the frequency-control units, the frequencies at the various points in the system of Fig. 5 are listed in Table II for a typical frequency-channel selection.

TABLE II

TYPICAL FREQUENCY INTER-RELATIONS IN THE FREQUENCY CONTROL UNITS FOR CHANNEL FREQUENCY OF 2,999.5 KC. REFERENCE FIGS. 4 AND 5

Frequency	Kilocycles
Selected Channel	2,999.5
F_0 Controlled Master Osc.	2,399.75
F_4 Output 500 KC Har. Gen.	3,000.00
Output Mixer & Filter 4	600.25
F_5 Output 50 KC Har. Gen.	450.00
Output Mixer & Filter 5	150.25
F_6 Output 5 KC Har. Gen.	80.00
Output Mixer & Filter 6	230.25
F_7 Output Mixer 8	269.75
F_8 Output Crystal Osc. 2	120.75
F_9 Output Crystal Osc. 3	149.00
Output Mixer & Filter 7	500.00
Output Freq. Div. 5	50.00

CONVERSION TO SINGLE SIDEBAND

In view of the extensive usage of the AN/ARC-21 equipment and in order to take full advantage of the operational training and maintenance "know-how" that has developed over a period of several years, it appeared desirable to consider an SSB conversion. The objective was the minimum modifications necessary to obtain the recognized improvements of SSB while still retaining, as far as possible, the basic advantages of the present equipment.

The conversion of the AN/ARC-21 to the single-sideband mode has been facilitated by two major factors:

- 1) The mechanical design of the receiver-transmitter allowing modification or replacement of several of the major subassembly units.
- 2) The frequency-control system with its inherently high order of frequency stability and potential for further increase in frequency stability within the system parameters.

During the transition period from the present amplitude-modulated, double-sideband mode to the single sideband, suppressed carrier mode of voice communication there exists the further requirements that the newer SSB equipment be capable of communicating with stations equipped only for the present AM or double sideband mode. Provision has been made to transmit an equivalent AM signal by radiating the carrier at approximately half-amplitude together with the single sideband at half-amplitude. Such a signal can be received on a conventional AM receiver with the usual envelope detector. Reception of an AM signal is provided in the SSB equipment by switching to an auxiliary diode, envelope detector.

The block diagram of Fig. 7 shows the SSB conversion and the extent of the revisions are evident by comparison with the previous diagram of Fig. 4. The basic dual superheterodyne receiver is unchanged through the second mixer. The band-pass of the 300-kc second IF was reduced approximately one-half by a new mechanical filter of 4-kc bandwidth. The selective third IF and detector for cw reception have been deleted for further simplification. The audio amplifier connects for SSB reception to a mixer-type demodulator supplied with 300 kc from the frequency-control unit or to the auxiliary diode detector and noise limiter for equivalent AM reception (ame). The controlled master oscillator (cmo) and doubler supplies the required injection frequency to the first mixer as before; however, the doubler output is now applied to the balanced modulator (Bal. Mod. 1) for transmission.

The input audio signal after passage through the clipper and low-pass filter modulates the 300-kc carrier in a second-balanced modulator (Bal. Mod. 2). An

electromechanical filter³ selects the desired sideband and after amplification this sideband-signal modulates the 1500-kc carrier from the frequency-control unit, producing the desired sideband signal at 1800 kc for injection into the first-balanced modulator. The SSB output of this balanced modulator, is amplified by the tuned linear exciter stages to furnish drive for the two parallel 4X150D tubes in the class A₁B final power amplifier.

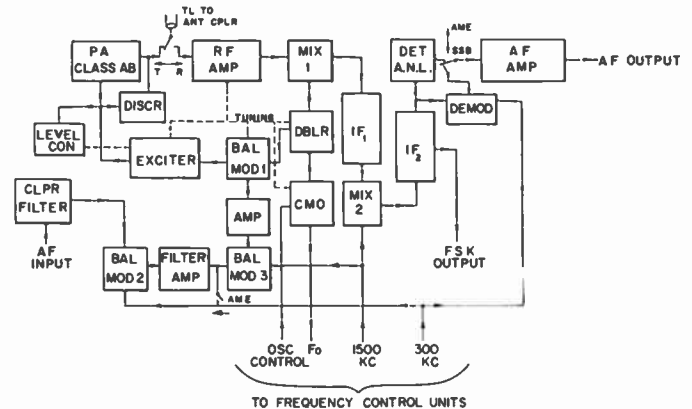

Fig. 7—Block diagram of the SSB conversion.

As before, a phase discriminator coupled to the input and output of the power amplifier is utilized to furnish a control signal to the PA tuning servo for automatic tuning of the output tank circuit. To insure the proper drive level at the final amplifier, despite variation in the gain of the exciter stages over the frequency range and from band-to-band, the 300-kc carrier is resupplied at a predetermined level during the transmitter tuning cycle. Operating on this carrier a level-control servo adjusts the gain of the exciter stages to obtain the requisite final drive. When the equivalent AM mode is selected the 300-kc carrier at half-amplitude is resupplied following the sideband filter, as shown in the diagram (Fig. 7). The frequency-control units outlined in the block diagram of Fig. 5 are basically unchanged except for the deletion of the doubler and mixer (shown dotted) which previously furnished the 900-kc carrier. In order to obtain the higher order of frequency accuracy and stability required for a suppressed carrier, single-sideband system, an improved stabilized reference crystal has been utilized. Since a crystal having frequency stability of the order of 1 part in 10^7 was limited to one megacycle, a two-to-one frequency divider stage (Freq. Div. 1) was required in the SSB conversion together with the tripler for the 300-kc carrier supply. With this frequency-control system all the available frequency channels are directly derived from the reference crystal and reflect the improved stability and accuracy of the latter. There is further a slight frequency deviation

³ D. L. Lundgren, "Electromechanical filters for single-sideband applications," this issue, p. 1744.

which may arise from the group of 9 low-frequency crystals selected by the "Units" selector (U). This group of crystals is thermally controlled and contributes a maximum deviation of 10.8 cps at the output signal frequency.

Since the basic frequency-control system is unchanged, the automatic receiver tuning cycle, initiated by a remote frequency selection remains unchanged (See Fig. 6). The transmitter tuning cycle requires an additional 1.5 seconds at the start to permit the level control servo to adjust the exciter gain.

In the diagram of Fig. 8, the relative positions of the several carrier frequencies and the selected sidebands are shown for this arrangement of modulators as described. It should be noted that in order to transmit and receive the nominal upper sideband of the suppressed carrier frequency F_c , the lower sideband is selected in the receiver second IF and in the output of the 300-kc balanced modulator of the SSB generator.

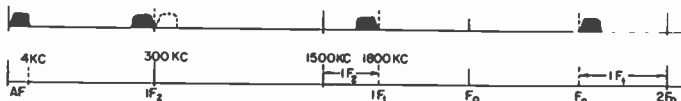

Fig. 8—Diagram showing relationship of carrier frequencies and sidebands.

Of outstanding importance in the accomplishment of this conversion of the AN/ARC-21 to SSB is the fact that all modifications are confined to the rt unit and its subassemblies. Thus there is no necessity for costly aircraft rewiring, revised power unit, and control boxes.

Typical of the more extensive modifications of the several subassembly units is the modulator shown in the photographs of Fig. 9. Conversion includes the removal of the class B modulator and the addition of the second and third balanced modulators, sideband filter, and associated amplifier. The photographs of Fig. 10 likewise shows the power amplifier unit before and after conversion. In Table I a summary of the performance characteristics of the SSB conversion are listed to permit ease of comparison with the original AN/ARC-21 data.

An extensive program of laboratory and flight testing has verified in a striking manner the anticipated theoretical improvements in communication. The voice signals on SSB have the ability to get through particularly when propagation conditions make the conventional double-sideband transmission submarginal.

ACKNOWLEDGMENT

The hf communication equipment described, both the original DSB and the conversion to SSB, is the product of the hf communication group of design and development engineers of the RCA Airborne System Department. The author is grateful to these engineering associates and to our managers John Woodward, Robert Trachtenberg, and Harry Ruben for their active interest and support in this work.

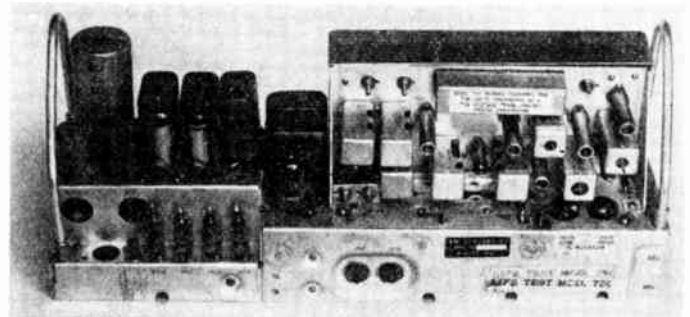
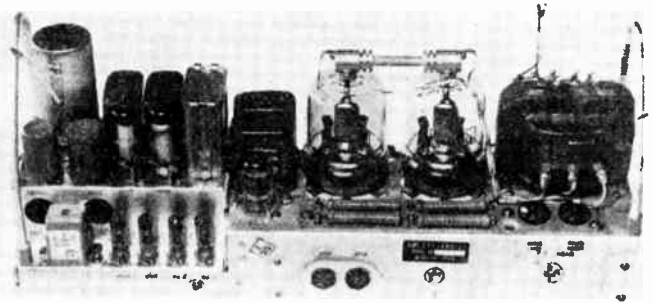

Fig. 9—Modulator unit before and after conversion showing replacement of class B modulator by SSB generator in lower view.

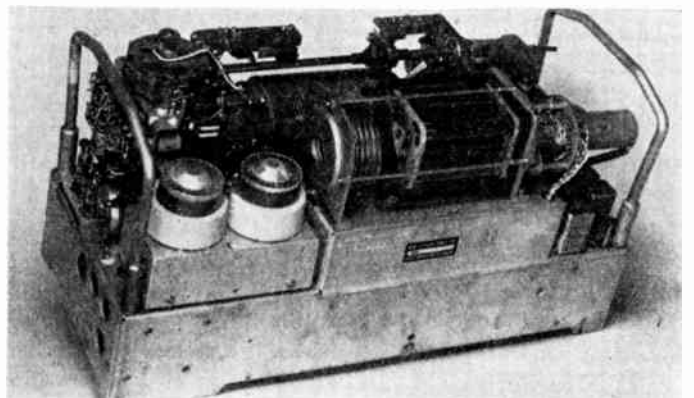
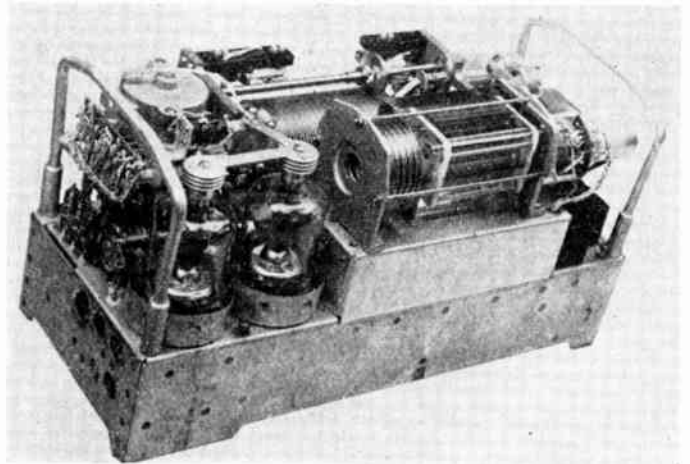

Fig. 10—Power amplifier unit before and after conversion. SSB linear amplifier in lower view.

Problems of Transition to Single-Sideband Operation*

NORMAN H. YOUNG, JR.,† SENIOR MEMBER, IRE

Summary—Single-sideband operation, in its most advanced forms, is not compatible with transmitting and receiving equipment presently in use for voice circuits throughout the world. Changing to a new system of modulation presents problems during the transition period. These problems include questions of technical standards, frequency allocation, compromise modulation systems to permit compatible communication with unconverted stations, and in changes in operating customs and procedures that may become desirable as a result of the other modifications. Some of these problems are outlined and discussed in this paper.

INTRODUCTION

THE TECHNICAL advantages of single-sideband operation for voice communications have been known for more than twenty years. In the past few years the rising pressure for channel allocations and the technical progress that permits more advanced equipment design have combined to make these advantages more important, until it now appears that they may cease to be luxuries and are becoming necessities.

Since it is not possible to choose a wholly new system for all high-frequency voice communication and effect a grand shift to this system on a designated day, means must be foreseen for the transition from the present equipment and practises to the newer systems that offer so much promise after the transition period has been completed.

The changeover is more complicated since the signals emitted by the old and new systems are not inherently compatible. Special means for overcoming this problem will be discussed in the review of technical problems.

TECHNICAL PROBLEMS

For international telephone service, using fixed stations (and to some degree for ship-to-shore radiotelephone) the technical problems have been solved for many years. Equipment using pilot carrier techniques is readily available from many makers in many countries. Such apparatus is capable of excellent performance and reliability. Ability to transmit two or three telephone conversations simultaneously through the same radio circuit is provided where the traffic density warrants this complexity. Circuit quality sufficient for all purposes, including the use of privacy equipment, is normally provided.

There are many applications for radio telephone service where the high cost and equipment complexity of the long-haul equipment cannot be justified. Single and party-line services to outlying posts in undeveloped country, or linking small islands having low traffic

density, might be examples of this requirement. The principal technical problem in providing equipment for this service lies in furnishing a carrier of sufficient accuracy for demodulation at the receiver. The elaborate filters and motor controlled oscillators used in the long-haul equipment are too complex and costly, and cannot be switched from channel to channel without technical attention. Conventional crystal oscillators have not been able to provide sufficient frequency accuracy to insure effective communication.

Recent refinements of design of crystal oscillators and studies of the effects of such inaccuracy on the resulting speech signal have led to the conclusion that effective service can be rendered by a simple equipment in which the carrier is fully suppressed at the transmitter and is restored at the receiver under the direct control of crystal oscillators of accuracy sufficient for the purpose.

The speech quality provided in this manner is completely understandable, but in the worst cases of accumulated tolerances the resulting sounds may not be entirely natural. To permit the user to correct for this effect, at least one equipment provides a "speech clarifier" consisting of a fine adjustment for the frequency of the receiver first oscillator. When the range of this adjustment is restricted to a few cycles, natural sounding speech can be provided by adjustment, yet even severe maladjustment will not prevent intelligibility as signals from other stations are received.

Equipment of the type described is suitable for either the short-haul service mentioned, or for use in marine radiotelephone service, since the power requirements and simplicity of control required are comparable. With suitable flexible choice of primary power source converters, a common equipment design can serve both applications. Equipment of this type has been described and is available in small quantities, although applications to date have been largely outside the United States.¹

One major application that cannot be served by equipment of the type described is air-to-ground communications for international aircraft operations. The requirements of this service include the provision of single-sideband transmission and reception on a large number of channels, selectable rapidly under control of an operator. This operator is unskilled in technical matters and not free to provide any extended attention to tuning procedures, so that complete automatic channel selection is essential. Natural speech without further adjustment is required, so that "clarifier" con-

* Original manuscript received by the IRE, September 13, 1956.
† Federal Telecommun. Labs., Belleville, N. J.

¹ E. A. LaPort and K. L. Neumann, "A new low-power single-sideband communication system," *RCA Rev.*, vol. 16, pp. 635-647; December, 1955.

trols are not permissible to simplify the design. In addition to the limitations imposed on the design by the requirements for light weight and small size, it is impractical to carry a second equipment for communication with those ground stations that have not yet made the transition to single-sideband operation; so the equipment must provide in itself a signal that can be received by conventional amplitude-modulation receivers without adjustment, and must be capable of receiving AM signals from the ground when required. Equipment having such properties has been called "bi-mode" equipment.^{2,3}

In connection with airborne applications of single-sideband modulation, it must be noted that restoration of the carrier at the receiver, purely on the basis of frequency accuracy, is not necessarily applicable as aircraft speeds increase. At an airspeed of 635 knots, Doppler effect is approximately one part per million. At the higher frequencies used for air-to-ground communication this factor alone begins to be significant at the airspeeds that will be used in the near future for commercial operation. (For military purposes these speeds are already an operational accomplishment.) For this reason attention has been directed to systems using a pilot carrier. For power conservation and most effective utilization of transmitter tube capability, it has been suggested that this carrier might vary with the speech signal, being greatest when the speech is smallest. Designs of equipment using such controlled carrier equipment have been completed and flight tested.⁴ Decision to use pilot carriers or to rely on frequency accuracy alone must be taken before standards can be set.

It should also be noted that much of the impetus toward the wider use of single sideband has come from the successful application of this technique by radio amateurs. Successful communication is a daily occurrence, not only between pairs of stations, but in nets of many stations on the same frequency, and the use of automatic voice control for switching between transmitting and receiving conditions gives these nets a close approximation to the operational freedom of a party-line telephone circuit.

Extrapolating this achievement to commercial standards of performance, however, requires substantial equipment development. The circuits used by amateurs function as they do largely because the demodulated speech quality is useful at a substantially lower standard of performance than is demanded of commercial equipment, and because the equipment adjustments (especially the receiver tuning) are made with

unusual care and repeated throughout the communication period as necessary.

One major technical problem facing equipment designers is the lack of equipment for testing the designs in process. Satisfactory apparatus for generating a low power signal is not available in sufficient quantity or quality for many development programs. Recent information indicates that certain laboratory instruments developed for specific programs may be made available commercially, but today's instrument catalogs fail to indicate either signal generators or receivers of known performance suitable for use in the development of equipment to commercial standards of performance.

LEGAL PROBLEMS

The widespread application of single-sideband modulation will pose legal problems. While most regulatory agencies are receptive to proposals to solve these problems, since the increased channel space provided is most attractive, this willingness to act must be translated into regulations and interpretations of existing regulations as the application of single sideband is extended.

Examples of legal action that are required include the following:

Permission to radiate a single-sideband signal must be extended. At first this may be on an experimental basis, then on a working basis, as each service applies the net method.

A firm requirement must be established to change to single-sideband modulation by a particular future date. Implementation of such orders is essential if the advantages of spectrum conservation are to be achieved. The desire of a small number of users to continue with amplitude modulation cannot be permitted to block progress to more effective utilization of our limited natural resource, the frequency spectrum. Regulations leading toward such a change distributed over a ten year period have been proposed by the Federal Communications Commission.⁵

Technical performance requirements for the new equipment must be established to insure that radiation lying outside the newly set limits is effectively controlled. A program for qualification testing and type approval of equipment must be undertaken.

To apply sound allocation principles to the new equipment will require reconsideration of the entire high-frequency spectrum, presumably at an international conference, before full advantages will be gained from the transition. As more channels are made available, questions will arise as to whether the nations or services using a given section of the spectrum, having cooperated to make more channels available in that band, should be allowed to increase their utilization of the band, or whether the band should be narrowed and the channels made available to other users.

² "Report of Single Sideband Compatibility Meeting," Int. Air Transport Assn., Montreal, Canada, p. 7, sec. 2, November 14-18, 1955.

³ "Proposed ARINC Characteristic No. 533, Airborne HF SSB/AM System Draft No. 2," Aeronautical Radio Inc., Washington, D. C., June, 1956.

⁴ G. W. Barnes, "A Controlled Carried Single-Sideband System for Aircraft Communication," A.M.I.E.E. paper of Royal Aircraft Establishment, Farnborough, England.

⁵ "Notice of Proposed Rule Making, Docket No. 11513," Federal Communications Comm., Washington, D. C., October, 1955.

These and other legal problems will be the subject of debate throughout the transition period, as the application of single sideband is increased.

ECONOMIC PROBLEMS

The transition to single-sideband operation will be reasonably prompt and complete only if the economic questions are resolved in a manner to show the profitable nature of the change. In this field the fact that radio is more economical for some purposes than other forms of communication may be a sufficient incentive, since certain radio channels may be available on the basis of single-sideband operation only.

Where this is not the case the increased circuit quality available from equipment of a given power may be a controlling factor. The freedom from selective fading may make for greater circuit utility.

The natural obsolescence of equipment will also be a factor. It is probable that the new equipment, just by being of better speech quality or of better reliability than the old, would have replaced existing installations, regardless of the need for a change in the radiated signal.

Since the economic situation will vary widely between users, the creation of "bi-mode" equipment capable of communicating with either type of equipment during the transition period will allow a free play of the above factors in determining the schedule for replacement of equipment.

PROCEDURAL AND OPERATIONAL PROBLEMS

The application of single-sideband equipment on a general basis may be expected to have important effects on the operational techniques used. The greater frequency accuracy and the precise channelling required to make single sideband intelligible will provide clear channels that can be seized and used by all parties with the assurance that any station within range is already accurately tuned to the signal. Extended calling, transmission of "Test" signals, and the like can be discontinued or greatly restricted, freeing a given channel for more useful communications. (In this connection surveys have shown that it is not unusual for more than half of all messages on a radio circuit to be concerned with the effectiveness of the circuit itself, rather than carrying useful information supplied to the circuit for its intended communication function.)

With the elimination of the carrier, the undesirable consequences of two transmissions appearing in one channel at the same time are reduced. In the case of two amplitude modulated signals the strong beat between their carriers drowns out the modulation, and neither transmission is intelligible. In the case of single-sideband signals there is no beat, and the stronger of the two signals is almost always intelligible. In many cases where the amplitude difference is not too great either of the transmissions may be understood by an effort of atten-

tion, just as conversations in a single room may be selected at will by an attentive listener.

For this reason the application of voice control to the transmit-receive function is reasonable. When a number of stations so equipped are operating as a net on a common frequency the signals available to the listener are similar to those heard on a party-line telephone system. Each speaker is heard as he speaks, and when two or more speak at one time the loudest is heard. Extensive use of this system of operation by radio amateurs has provided experience indicating the flexibility and general usefulness of this method. It is particularly useful where the users are not technically or operationally trained, since the use of the equipment is natural and conforms with past experience of telephone users.

Equipment of this type may naturally be used with remote handsets, and provision of suitable control circuitry for operation from incoming telephone lines is relatively simple.

As a slight disadvantage, it should be noted that early installations may produce some translation of the speech frequencies. This is a form of distortion to which most users are unaccustomed. Some experience in listening to voices under this form of transmission may be required to insure best possible understanding in cases of serious distortion.

Selective calling and signalling devices are also affected by any translation of signal frequencies. Because previous types of transmission have not produced this effect, certain devices now in commercial service impose severe limitations on the single-sideband system. It is probable that this problem will be solved in time by increased frequency accuracy, but during the transition period it may be necessary to provide simple adapters for such signalling devices to permit them a greater flexibility, or to modify the means of transmission of the signals so that accurate tones (possibly produced by beating two frequencies, both of which are transmitted) are available to actuate existing selector mechanisms.

PERSONNEL PROBLEMS

The need for specially trained operating personnel may well be reduced, as the service provided by radio systems approaches ever closer to that used by all classes of personnel as standard telephone procedure. The more effective use of channels, however, will require effective discipline to avoid unnecessary messages and other forms of interference. Experience in densely populated channels, as is a regular occurrence in taxi radio systems, has shown that a reasonable indoctrination of the users results in general cooperation for common advantage.

In the field of maintenance personnel we find that the situation will be little changed from its present status. While training will be required to teach the present maintenance technicians the details of the new equipment, the present personnel will undoubtedly be able to maintain the apparatus after such training. In

general, the equipment will be less complex, and less filled with new devices and principles, than airborne radar and other devices now coming into use.

The limited availability of satisfactory test equipment, already noted in this article, will make it necessary for the equipment manufacturers to give more than customary attention to the maintenance problem. Specialized test sets and checking devices will be required to insure effective operation and prompt repair. Such equipment may be made available directly to larger users of equipment, while the establishment of repair centers at suitable field locations may provide the service required by smaller users. Systems of main-

tenance and repair bases already established for other equipment can readily add the facilities required, as economic pressures make such investment justifiable.

CONCLUSION

The considerations outlined indicate the scope of problems arising in the transition of high-frequency voice communications to single-sideband modulation. It is possible that the transition will never be complete, but to the extent that the problems are discussed, refined, and solved by the cooperation of all those concerned, the art of high-frequency communication will be advanced during the coming years.

The Problems of Transition to Single-Sideband Techniques in Aeronautical Communications*

JOHN F. HONEY†, SENIOR MEMBER, IRE

Summary—The use of SSB techniques in air-ground communications appears highly desirable because of the spectrum conservation and because of the improved performance which can be achieved under the limitations on size and weight or peak antenna voltage. An orderly and economically sound procedure of transition from AM to SSB techniques requires that a degree of compatibility between the two systems be achieved. Early SSB equipments must be capable of operating in an AM system, and eventually AM equipments will have to be modified to perform in an SSB system. Various techniques for effecting both types of modifications are reviewed. It is suggested that new SSB equipment provide an AM detector and means for transmitting a full-carrier SSB signal which can be received on an AM receiver.

SINGLE sideband radio communication has been lurking on the horizon ever since 1915, when it was first conceived by a mathematician named Carson and—independently—by an engineer named Arnold. Someone once remarked that single sideband has been invented regularly every five years since that time. The truth of the matter probably lies in the fact that the techniques involved have been far enough ahead of the state of the art to restrict its use to a limited number of fixed station point-to-point applications.

Inevitably, this situation is changing. Recent developments in improved frequency stability, filter design, and modern vacuum tubes head the list of key factors. There is every reason to believe that practical, easy to operate single-sideband (SSB) equipment suitable for airborne application will appear on the market at competitive prices within the next few years.

SSB techniques offer several very important ad-

vantages to both civil and military users of long-distance radio communications. Perhaps the most important single advantage is spectrum economy. The transmission of one sideband instead of two, plus the improved frequency stability required by the system in order to permit reduction or elimination of transmitted carrier, make it possible to assign at least twice as many channels per band as present AM practice permits. In addition, the SSB system offers a very substantial power advantage which results not only from the elimination of the high power carrier of AM but from reduced susceptibility to poor propagation conditions, noise, and interference. The actual amount of this power advantage which can be realized in a given application has been shown to depend largely on limiting factors such as size and weight, prime power requirements or peak allowable antenna voltage which may apply in that application [1], but it has been demonstrated that an SSB system using a transmitter rated at 100 watts peak power¹ will perform about the same as an AM system using a 400-watt transmitter under typical long-distance propagation conditions.

Unfortunately, present-day AM systems are by and large not compatible with what we consider to be the ultimate SSB communication system. There are, however, certain compromises that can be made in the design of the SSB equipment and certain modifications that can be made in existing AM equipment which will

¹ Peak power of a radio transmitter: the mean power supplied to the antenna during one radio frequency cycle at the highest crest of the modulation envelope, taken under conditions of normal operation (ch. I, art. 1, par. 61, Radio Regulations [2]). The term "peak envelope power (pep)" has found common usage, and is identically defined.

* Reprinted from IRE TRANS., vol. ANE-3, pp. 10-16; March, 1955.

† Stanford Research Institute, Menlo Park, Calif.

provide a degree of compatibility. It is the purpose of this paper to discuss these changes and various other factors involved in the transition problem.

THE TRANSITION PROBLEM

The basic problem confronting the user of an AM communication system who wishes to obtain the additional benefits of the SSB system may be stated simply. How should the transition from AM to SSB best be implemented? What should be the specifications of the new SSB equipment introduced into the system, and what modifications might be made to existing AM equipment to extend its useful life in the transition period?

The user will have certain requirements which should be met by an acceptable transition procedure. Some typical requirements are listed in the following; however, it should be pointed out that each individual application may not have all these requirements and some may have others not listed here.

1) There should be no interruption to normally required service during the period of transition arising from incompatibility between new SSB equipment, existing AM equipment as it may be modified, or unmodified AM equipment remaining in service.

2) There should be no concentrated expenditures required in the mobile equipment. It should be possible therefore to effect the transition on a basis of normal equipment replacement, with minor modification to existing equipment, over a period of time.

3) Modification of existing AM equipment should be minimized. In cases involving large numbers of mobile or airborne AM installations which communicate with relatively few central station installations, little or no modification should be required. Some modification may be justifiable in central station AM equipment before it is replaced if improved performance is obtained with new airborne equipment, provided that the modified equipment remains compatible with existing AM airborne equipment.

4) Maximum advantage of the spectrum and power economy of the SSB system should be obtained during each stage of the transition insofar as this is consistent with the requirements listed above.

There is one comment that should be made before proceeding with the details of AM and SSB compatibility. There is no doubt whatsoever that AM communication is with us to stay. AM techniques are familiar and comparatively simple, and they are very well suited for many applications. For this reason, transition for one user may merely involve replacing a portion of the total equipment in use. For another it may involve eventual replacement of all equipment. It follows that our "transition period" for one user may be a relatively permanent situation, while for others it may only be temporary. Compatibility factors will be discussed in sufficient detail so that those who are interested will be able to treat the case of partial transition as well as the case of complete transition.

REVIEW OF AM AND SSB COMMUNICATION SYSTEMS

In the AM system the level of a radio-frequency carrier is varied about a mean value in accordance with an audio modulating voltage. This results in two sidebands arranged symmetrically around a high-power rf carrier signal. In AM receivers the signal is amplified to a mean level in the neighborhood of 10 volts before detection, in order to obtain linear detector action. The detector then rectifies the vector sum of the carrier and the two sidebands and recovers an audio voltage corresponding to the variations in the amplitude of the resultant rf signal.

The SSB signal, as its name implies, consists of just one sideband which is identical to one of the two found in the AM signal.² There may or may not be a significant amount of carrier power transmitted with the signal; this depends on the receiver frequency control problem, and several methods of treating the carrier will be discussed shortly. The SSB receiver accepts that portion of the spectrum occupied by the SSB signal and provides the carrier signal necessary for detection. The detection process in most SSB receivers may be considered a last step of frequency conversion in which the SSB signal at the output of the last IF stage is simply heterodyned down to the correct position in the audio spectrum. It is not truly detection, but a linear reversible process of frequency translation such as that used in the frequency converter stages of any AM superheterodyne receiver, and it can be accomplished at any desired signal level. The carrier supplied by the receiver is the conversion signal for this last stage of frequency translation, and its frequency must be very close to the correct value in order that the output signal occupies the correct position in the audio spectrum.

A demodulating carrier frequency error of 10 cycles per second is unnoticeable in speech communication. An error of 25 cycles per second causes just noticeable loss of naturalness or loss in the ability to recognize the voice of the speaker in conditions of high signal-to-noise ratio. It does not noticeably affect intelligibility except under conditions of low signal-to-noise ratio. A frequency error of 50 cycles per second causes considerable loss of naturalness and a slight reduction of intelligibility under high signal-to-noise ratio conditions. The loss of intelligibility under low signal-to-noise ratio conditions is greater. Higher frequency errors cause rapidly decreasing intelligibility under noise-free conditions and would not be considered acceptable in a communications system because of the severe loss of intelligibility under low signal-to-noise ratio conditions.

This requirement for very precise frequency control in the receiver and transmitter of the SSB system has been and still is one of the primary technical obstacles in the achievement of a practical airborne equipment, and it is

² The IATA and RTCA conferences have recommended standardization on upper sideband operation for single-channel voice communication in aeromobile service [3 and 4].

an important consideration in the selection of an acceptable transition procedure. Frequency stabilities in SSB equipment should be on the order of from 0.5 to 5 parts per million (ppm) for successful operation in the 2 to 30 mc range. AM stabilities required in this range at the present time run between 50 and 200 ppm [2], depending upon the type of equipment.

We are really concerned only with the frequency error of the demodulating carrier in the SSB receiver rather than the absolute accuracy and stability of the system. We can transmit a carrier signal along with the single sideband and provide an AFC system in the receiver to reduce the error between the receiver and demodulating carriers to an acceptable degree. This approach is by no means a panacea for all the ills of accurate frequency control. The AFC circuits must operate correctly under signal-to-noise ratios so low as to render the voice signal marginally useful. They must complete the correction in a reasonably short interval of time, and the residual errors plus those due to the effects of noise on the circuit must be acceptably small.

Several SSB systems differing in the treatment of carrier transmission and demodulating carrier-frequency control have been developed. These are briefly reviewed in the following:

1) Suppressed-carrier SSB transmission. The carrier component of the transmitted signal is suppressed as far as practicable at the transmitter—perhaps 30 to 50 db below peak power output. The transmitter and receiver are independently controlled to an accuracy commensurate with the requirements of the SSB system, and no receiver AFC circuits are used.

2) Reduced-carrier SSB transmission. The carrier is transmitted at a power level from 10 to 20 db below the peak power of the transmitter. The receiver provides a slow-acting AFC system to reduce demodulating carrier frequency error. This system has seen many years of service on a number of transoceanic point-to-point links.

3) Controlled-carrier SSB transmission. Carrier is transmitted for a short initial interval of each transmission and during intersyllable and interword pauses in modulation. The carrier is transmitted at such power level as will maintain the average power output of the transmitter approximately constant with or without modulation, and may have a maximum value from 3 to 6 db below the peak power rating of the transmitter. The receiver provides AFC circuits which are activated by the bursts of carrier and which may provide a memory function to hold frequency during periods of modulation. See [5] for further discussion of this system.

4) Full-carrier SSB transmission. In this system, sufficient carrier power is transmitted at all times to effect demodulation of the single-sideband signal in a linear or square-law detector, and no demodulating carrier source or AFC system is required at the receiver. A receiver AFC system may however be used to control the frequency of a locally generated demodulating carrier if desired. The carrier is transmitted at a level from

3.5 to 6 db below the peak power rating of the transmitter, and the remaining transmitter capacity is devoted to the SSB signal.

Before leaving the discussion of frequency control, we should mention the Doppler shift which will occur when an airborne station is moving toward or away from the ground station with which it is communicating. The amount of shift is equal to the rate at which the propagation path length is changing in wavelengths per second, and is proportional to the operating frequency and the velocity of the aircraft toward or away from the station. For an aircraft traveling at 670 mph toward the ground station, and transmitting on 20 mc, the received signals will be shifted upward in frequency by 20 cps. Doppler shift may eventually become severe enough to require carrier transmission and receiver AFC for that reason alone, but for the immediate future at least we will use it only if we cannot provide sufficiently good frequency control for the SSB equipment.

Let us consider for a moment the relative performance of the 100-watt SSB suppressed-carrier transmitter and a 200-watt AM transmitter. Both are assumed to be transmitting to appropriate AM and SSB receivers. For 50 per cent average modulation index, the AM transmitter develops two sidebands of 12.5 watts each and the SSB transmitter delivers 25 watts in one sideband. The AM receiver will accept the noise occurring in both sidebands, and the two noise components add incoherently in the output of the receiver. The signals in the two sidebands, however, add coherently, which results in the same signal-to-noise ratio in the output of the receiver as will be obtained in the case of the SSB receiver. However, experience has shown that coherent addition of the two sidebands of the AM signal is not fully achieved under typical long-distance communication paths because of multipath transmission or selective fading effects. In addition, the carrier may fade or be shifted in phase from the correct value. Under good long distance conditions we will expect a 100-watt SSB transmitter to provide about the same performance that we achieve with a 400-watt AM transmitter. As propagation conditions become poorer, in the sense of more severe selective fading, we find that the signal at the output of the AM receiver suffers much more serious degradation, and we are then better advised to use an SSB receiver to receive only one of the two sidebands of the AM transmission.

EQUIPMENT MODIFICATIONS FOR IMPROVED COMPATIBILITY

We have reviewed the performance of all-AM and all-SSB systems, and we can now proceed to the treatment of composite systems and the modifications required to permit their successful operation. The following two sections of the discussion concern the modifications which might be made in SSB transmitters and receivers to permit them to function in an essentially unmodified AM system. The next two sections of the discussion are

concerned with the modifications which might be made in AM receivers and transmitters to permit operation of the equipment in an essentially unmodified SSB system.

There are also a great number of composite systems which might involve some modification of both AM and SSB equipment. A discussion of all such possible cases would become undesirably lengthy and involved. The following discussion of the four cases listed above will attempt to cover the factors of importance in such intermediate systems.

SSB Receiver Modifications for AM Signals

An SSB receiver may readily be designed to include a conventional AM detector. Since AM detection is ordinarily accomplished at a significantly higher signal level than SSB detection, this will probably require an extra stage of IF amplification. The bandwidth of the IF amplifiers prior to AM detection should be wide enough to pass either both sidebands or one sideband plus the carrier, with an extra allowance for the frequency stability of the AM transmitters involved.

An SSB receiver equipped with locally generated demodulating carrier will receive one sideband of the double-sideband AM signal provided that is correctly tuned. The high-power carrier of the AM signal provides an excellent control reference for the demodulating carrier generated in the receiver, and AFC circuits can be provided to correct frequency errors between the received carrier and the demodulating carrier up to approximately ± 300 cps. If the frequency errors due to the AM transmitter are substantially larger than this, it will be necessary to provide manual tuning adjustment of the SSB receiver in order to bring the received signal within the correction range of the AFC circuit.

Many SSB receivers using a locally generated carrier and an AFC system have a carrier filter before the AFC circuit which is as broad as the frequency correction range desired. When the receiver is tuned to an AM signal the carrier-to-noise ratio at the output of such a filter is sufficiently good for demodulation of the weakest usable sideband signal, and the filtered AM carrier may be used directly, with the AFC system and the local carrier source disabled. This modification may offer a slight advantage in terms of easier tuning and a larger tolerance for error in AM transmitter frequency control.

SSB Transmitter Modifications for AM Reception

The principal requirement to be met by a modified SSB transmitter is that sufficient carrier power be radiated to effect detection in an unmodified AM receiver. There are a number of ways in which this may be accomplished and they can be compared on the basis of relative efficiency and the complexity or cost of the modification. In the following, we will assume that we start with a 100-watt SSB transmitter which uses a linear-amplifier power stage, and we will compute the relative effectiveness achieved through several different types of modifications.

Low Level AM Conversion of SSB Transmitter: Simple and inexpensive additions to the low level circuits of the SSB transmitter will provide for the generation of an AM signal instead of a SSB signal. The AM signal is then heterodyned to the final desired frequency and amplified to the desired power level in exactly the same manner as was the SSB signal, and no modifications of these circuits are required. The peak power rating of the transmitter is still 100 watts, which means that the transmitter modified for AM would be rated at 25 watts carrier power output. At 50 per cent average modulation index, each of the two sidebands will represent about 1.5 watts as compared with 6.25 watts for a 100-watt AM transmitter and 25 watts total power for a 100-watt SSB transmitter. We will, of course, retain the improved frequency stability of the SSB equipment, but we will have sacrificed both the spectrum economy and efficiency of the SSB system.

High Level AM Conversion: It is possible to modify the power stages of the SSB transmitter so that the equipment operates as a straightforward AM plate-modulated transmitter. This is not a simple or inexpensive modification; it almost amounts to building two transmitters in one box. The speech amplifier and the carrier generating circuits of the SSB equipment are retained, but we must completely change the operating conditions of the final stage, including bias and screen voltages and plate load impedance. We may need to change the L/C ratio of the output circuit in order to obtain better harmonic rejection for Class C operation, and this requires a wider range of the variable circuit elements used. We need a modulator, including modulation transformer, and we need a considerable amount of switching and control mechanism to effect the change from AM to SSB.

If we assume that the total amount of high voltage power delivered to the power stage of the transmitter shall be held constant for either AM or SSB transmission, simple calculations indicate the AM transmitter will be rated at approximately 50 watts carrier power output. At 50 per cent average modulation index each of two sidebands will represent about 3.1 watts of power.

Full Carrier Conversion: It is not necessary that the transmitter radiate both sidebands in order that the signal be detectable on an AM receiver. It is only necessary that the transmitter radiate sufficient carrier power to effect demodulation of the single-sideband signal in the linear detector of an AM receiver. The SSB transmitter can be modified to transmit a relatively high power carrier and one sideband at reduced power by very simple provisions in the low level modulation circuitry. No other changes to the power stages or power supply are necessary. The size and weight of the equipment is not changed and the cost of the modification is very small. A 100-watt SSB transmitter so modified might transmit a 25-watt carrier signal. Fifty per cent average voice modulation of the remaining transmitter capacity would result in 6.2 watts in the transmitted

sideband. This transmitter would provide about the same signal-to-noise ratio at the output of an unmodified AM receiver as would be obtained from an AM transmitter rated at 50-watts carrier power output under typical long range communication conditions.

When a carrier and one sideband are demodulated in a linear detector a certain amount of distortion takes place. For the operating conditions proposed above, the second harmonic content at the output of a linear detector would be 12 per cent at 50 per cent sine wave modulation and 20 at 100 per cent sine wave modulation. These distortion levels are regarded as acceptable for speech communications because of the masking effect. This type of distortion will not occur if the detector used has a square-law-characteristic.

AM Receiver Modifications for SSB Signals

The SSB suppressed-carrier signal does not provide sufficient carrier to effect demodulation in a conventional AM receiver, and it is therefore necessary that the AM receiver be modified to provide the demodulating carrier at the correct frequency.

Most modern AM communications receivers having a beat frequency oscillator (BFO) can be used to detect an SSB suppressed-carrier signal. The receiver is set to accept the single sideband, and the receiver BFO is very carefully adjusted to the correct frequency so that it can act as the demodulating carrier in the linear detector. The tuning operation is exceedingly difficult and time-consuming and requires a highly skilled operator. This method of operation is mentioned for the sake of completeness, but it is not considered a practical approach to the problem for military or commercial operations because of the tuning difficulty.

AM receivers can be fitted with SSB adapters that permit satisfactory reception of SSB signals. The adapter connects to the output of the receiver's IF amplifier and provides the necessary SSB selectivity, the source of demodulating carrier with AFC, and the proper type of demodulator circuit. The adapter's AFC circuits greatly reduce the difficulty of tuning, but if the receiver's frequency stability is not sufficiently good it may still be necessary to use manual tuning to bring the signal within the range of control of the AFC circuit.

If the SSB signal received contains sufficient carrier power for demodulation, as will be the case with the full-carrier SSB signal, the only modification desirable in an AM receiver is a reduction in IF bandwidth commensurate with the bandwidth of the SSB signal and the combined frequency stability of the transmitter and receiver. The AM receiver AGC and squelch circuits will function as normal for AM reception. No special carrier recovery circuits or detector circuits are required.

We have pointed out that it will be desirable to minimize modification of existing AM facilities during the early stages of transition from AM to SSB communications. While it may be permissible to use SSB receiver adapters in central station facilities, it is quite

doubtful that they could or should be used with each mobile or airborne AM receiver. Among other reasons, the adapters represent an investment which would be lost at the time the mobile equipment was replaced with SSB equipment.

AM Transmitter Modifications for SSB Reception

As has been pointed out in the first section, the AM signal can usually be received on SSB receivers with little difficulty. There are, however, several modifications which can be made in the AM transmitter to improve the performance of the system. These modifications, which will be discussed in detail, deal with improved frequency stability, the elimination of residual fm or pm, and the conversion of the AM transmitter to SSB full-carrier transmission.

Frequency Stability: Earlier discussions have indicated the requirement for better frequency stability in the SSB system than is presently achieved in AM communications systems. In order to avoid the necessity for manual tuning of SSB equipment used to receive AM transmissions and to retain the benefits of automatic tuning or channel selection, it is desirable that the frequency tolerance of the AM transmitters be improved so that the carrier frequency will lie within the correction range of AFC systems provided in the SSB receiver. Practical AFC or carrier recovery systems will provide a correction range on the order of ± 300 cycles per second. If the SSB receiver frequency control tolerance is 5 ppm, this implies AM transmitter tolerance of 5 ppm at 30 mc, 25 ppm at 10 mc, or 100 ppm at 3 mc and below. Present regulations require AM frequency tolerances of 200 ppm for mobile stations and from 50 to 100 ppm—depending on power—for ground-based stations [2].

While it may be impractical to improve significantly the stability of existing airborne AM equipment, it should be possible to improve the ground station equipment to the point where it will serve adequately with either airborne AM or SSB equipment. Better frequency control may be obtained at first by improved frequency measurement techniques and more careful maintenance. Later, more elaborate steps may be taken to improve the stability of the transmitting equipment. If a limited number of channels are needed it may be possible to achieve better stability through the substitution of modern temperature-controlled crystals and improved oscillator circuits. If a large number of channels are required, it may be desirable to replace the old exciter unit with a stabilized master oscillator or frequency synthesizer which will produce any desired frequency with the stability of a highly stable crystal oscillator. These frequency determining elements may be used later with ground SSB equipment which will replace the AM transmitters, so the investment need not be lost.

Residual FM or PM: Some AM transmitters have been observed to have a considerable amount of carrier fm or pm at line or modulation frequencies. While this

may not cause trouble in AM reception, the carrier circuits of an SSB receiver may not be able to follow the rapid frequency variations. This results in frequency modulation of the entire audio output spectrum. In the author's experience this effect is occasionally encountered in AM transmitters using VFO frequency control; it has not yet been found in a crystal controlled transmitter. The same effects may of course be produced by residual FM of the conversion signal oscillators in a superheterodyne receiver. The peak frequency deviation permissible is 10 cycles per second from zero to 200 cycles per second modulation frequency. At higher modulation frequencies the peak phase deviation should not exceed 10° .

Conversion of AM Transmitters to SSB Full-Carrier Operation: Kahn has suggested a system by means of which it appears possible to convert an AM transmitter into an SSB transmitter by the use of a special adaptor [6]. An SSB signal carrying the desired modulation is first generated at a low-power level by any suitable technique. The rf phase information contained in the SSB signal is then separated by limiting techniques, and the resulting constant-amplitude phase-modulated signal is used as the excitation for a conventional AM transmitter. The amplitude variations of the low-level SSB signal are separated by a detection process, and the resulting rf envelope amplitude information is used to drive the modulator of the AM transmitter. The phase and amplitude components of the SSB signal are then recombined in the modulation of the high-power output stage of the transmitter. If this is done correctly, the resulting signal will be a high-power version of the original low-level SSB signal.

The system poses several technical obstacles. The AM transmitter modulator is theoretically required to respond down to zero frequency in order to carry all possible difference frequencies in the modulation spectrum, including the varying average level of modulation, and it is required to respond up to several times the highest modulation frequency because the envelope of the SSB signal is not an analytic function of time. Furthermore, the time delay of the rf channel should be the same as the time delay of the modulating signal channel, and the latter should have constant time delay over the extended response range. These problems are treated in somewhat more detail in [6].

The author wishes to suggest a possible modification to the Kahn system which may minimize some of the difficulties mentioned above. The objective of the proposed system is the elimination of one sideband only, from the output of an AM transmitter, leaving the full carrier and the other sideband. Such a signal may be received on either AM or SSB receivers, and as such may be desirable during a transition period. Furthermore, the system makes available the important spectrum conservation advantage of full SSB operation.

A low-level SSB signal is generated as before, with the exception that carrier is inserted at from 1.5 to 2 times the peak envelope voltage level of the SSB signal. The

amplitude and phase characteristics of this signal are then separated as described above, and the resulting signals are used for the excitation and modulation of a conventional AM telephone transmitter.

The advantages of this mode of operation arise from the facts that the average level of the signal remains very nearly constant with or without modulation and that the modulating signal is always an analytic function with greatly reduced harmonic content. In other words, the spurious output signals near the desired sideband which may result from a normal AM transmitter modulation bandwidth instead of the extended response from dc to several times the highest modulating frequency are very much less than would have been obtained for SSB suppressed-carrier operation. It still remains necessary to equalize the time-delay characteristics of the rf and af channels.

A 100-watt AM transmitter modified in this way may be received on either AM or SSB receivers. Performance obtained with an SSB receiver will duplicate that obtainable with a 25-watt SSB suppressed-carrier transmitter. Performance obtained with an AM receiver should be significantly better than that which would have been obtained with the same AM transmitter before modification under severe fading conditions.

It should be pointed out that this variation on the Kahn system has not, to the author's knowledge, been thoroughly investigated. Further work will be necessary before this system can be seriously considered as a step in the transition procedure.

A SAMPLE TRANSITION PROCEDURE

We have discussed a number of different modifications to AM and SSB equipment that may be of value in a transition period. There is in general more than one way in which each aspect of the transition problem—such as SSB reception of signals from an AM transmitter—may be approached, and there are different types of communications systems. Clearly, the techniques to be used in effecting transition from AM to SSB will depend on the individual requirements of each case.

In the following, an attempt has been made to illustrate how suitable techniques might be coordinated. We will consider a problem similar to that of the commercial airlines, in which one or more central stations must communicate with a larger number of airborne installations. We will assume that single-channel voice communication is required. The objectives to be achieved in the transition procedure are essentially those discussed earlier: uninterrupted operation, minimized modification to mobile AM equipment, and transition costs distributed over a period of time in which SSB equipment is incorporated into the system on a routine equipment-replacement basis.

Airborne Equipment

Existing airborne AM transmitter/receiver equipment is not modified. When existing equipment is required, both transmitter and receiver portions are re-

placed by SSB transmitter/receiver equipment. The new SSB transmitters would be capable of full-carrier operation in addition to normal suppressed-carrier transmission, and would have the best frequency stability it is possible to achieve. Frequency stabilities on the order of 0.5 ppm are desirable. The new single-sideband receivers shall provide a separate channel for the demodulation of an AM signal. Both the transmitter and receiver modifications are relatively inexpensive and do not contribute appreciably to the cost or complexity of the equipment. They enable the new equipment to transmit to, and receive from, existing unmodified ground AM equipment. If frequency stability no better than 5 ppm can be achieved, the receiver shall incorporate an AFC circuit capable of correcting frequency errors up to 300 cycles.

Central Station Equipment

Central station receiving and transmitting equipment is considered to be replaceable separately rather than as a combination R/T unit assumed in the mobile installation.

Ground stations are equipped with new SSB receivers having high frequency stability as soon as convenient. These receivers may be operated in parallel with existing AM receivers or they may incorporate the parallel AM detection channel. The frequency stability of ground-based AM transmitters is improved at first by better maintenance and frequency-measurement techniques and later by the substitution of better exciters. If the SSB full-carrier adapter units for AM transmitters are found to be practical, these are incorporated as convenient. Eventually, ground AM transmitting equipment will be replaced by SSB transmitters capable of suppressed-carrier or full-carrier operation and having frequency stability on the order of 0.5 ppm or better.

System Characteristics

The transition procedure discussed here provides for new ground equipment which will communicate with either new or old airborne equipment. Similarly, the new airborne equipment will communicate with either new or old ground installations. This transition period com-

patibility is achieved through the use of full-carrier SSB transmission. In addition to providing SSB spectrum economy and being suitable for either AM or SSB reception, this type of signal is chosen for the simplicity and efficiency of the modifications required in new airborne SSB equipment. SSB full-carrier transmission does not achieve the power advantage of the SSB suppressed-carrier system. This is not a matter of prime importance at the ground installation. It appears to represent a reasonable compromise for the airborne stations.

It will not be possible to assign narrower channels for the exclusive use of SSB equipment until the transition is completed in the entire system or in isolable portions thereof. During the early stages of transition most of the traffic will be handled by AM equipment, and the SSB equipment will operate in the established AM channels. The equipment will use the upper sideband only, with the carrier at the center or assigned frequency of the channel. As the transition on portions of the system approaches completion, the wider band AM channel assignments may be replaced by two SSB channel assignments, and it would appear reasonable that the interference from an occasional AM transmission may be tolerated. Both SSB channels would use upper sideband only. The carrier of the upper SSB channel would be at or near the center or assigned frequency of the AM channel. The carrier of the lower channel would be near the lower edge of the assigned channel. Some geographical separation between adjacent SSB channels would be desirable just as it is in present-day AM practice.

BIBLIOGRAPHY

- [1] Honey, J. F., "Performance of AM and Single-Sideband Communications," *Tele-Tech and Elect. Ind.* (September, 1953), p. 64.
- [2] Telecommunications Convention Final Protocol, and Radio Regulations, Atlantic City, October 2, 1947, Department of State publication 3509, U. S. Govt. Printing Office, Washington, D. C. (1950).
- [3] Radio Technical Commission for Aeronautics, *The Application of Single Sideband Techniques to Aeronautical Communications*. Paper 11-54/DO-53 prepared by RTCA SC-65, January 25, 1954.
- [4] International Air Transport Association, *Report of Single Sideband Compatibility Meeting*, Montreal, Canada, November 14-18, 1955. DOC. GEN/1614. Address inquiries to IATA, International Aviation Building, Montreal 3, Canada.
- [5] Barnes, G. W., "A Controlled Carrier Single Sideband System for Aircraft Communication," Royal Aircraft Establishment Tech. Note RAD. 521 (May, 1952).
- [6] Kahn, L. R., "Single-Sideband Transmission by Envelope Elimination and Restoration," *PROCEEDINGS OF THE IRE*, Vol. 40 (July, 1952), p. 830.



The Application of SSB to High-Frequency Military Tactical Vehicular Radio Sets*

R. A. KULINYI†, MEMBER, IRE, R. H. LEVINE†, SENIOR MEMBER, IRE, AND H. F. MEYER†, SENIOR MEMBER, IRE

Summary—The application, characteristics, and limitations of hf radio sets for military vehicular communication are tabulated and discussed. By the use of SSB, transistorization, and electric tuning it is shown that a s/n improvement of 16 db over the most modern existing DSB set of equal size and power drain is possible. A conservative s/n improvement of 7 db is shown theoretically and experimentally to provide up to twice the distance range and up to 170 per cent better word recognition than DSB. Additional advantages of interference reduction, spectrum utilization, quasi-duplex operation, heat reduction, equipment reliability, and reduction of maintenance problems are discussed. The problems of compatibility with DSB, frequency control, voltage breakdown, space, and reduction of mechanical moving parts together with suggested solutions are presented.

THIS PAPER is concerned with the improvement of tactical, vehicular radio sets. New military concepts, such as dispersion in the face of atomic warfare and the attendant need for high mobility and flexibility in the employment of forces have badly strained all existing communications systems of the Army.

One area in which this is especially true is that of tactical, vehicular radio sets. By a tactical radio set is meant a set which is to be employed under field conditions in a combat army. Such equipment is characterized by ruggedness, minimum complexity in operation, and principal use by personnel who are primarily concerned with other duties, nontechnical in nature. Truck drivers, artillery spotters, tank commanders, and similar nontechnically trained personnel are the principal users. The equipment must be designed to fit their requirements and level of technical training.

A vehicular set is one which is mounted, operated, and powered in a moving tactical vehicle, over poor or non-existent roads. Further, it must withstand the environmental conditions of being fully exposed to the weather 24 hours a day. An additional requirement of not compromising the tactical mission of the vehicle is normally included. A radio set mounted in a tank understandably cannot be allowed to interfere with the combat effectiveness of that tank.

Several classes of vehicular sets find application in the military. Sets operating in the uhf spectrum have been used for air-ground communications in support of troops. VHF/FM sets have formed the backbone of vehicular communications. While vhf/fm sets are obviously well suited to vehicular communications, counterbalancing their advantages are the handicaps of

limited distance range and wide variations in range caused by siting locations. To achieve greatest reliable vhf range often leads to the most exposed and dangerous site. Despite these disadvantages there has been and will continue to be a major application for these sets.

The hf vehicular radio set has a long history and its ancestor was the cavalry set. For many years it was the only vehicular set until the advent of vhf/fm. In modern times these sets have been used to cover the longer distance requirements such as communication with other service arms using hf nets, the frequent necessity for point-to-point communications between such units as reconnaissance vehicles, and base stations over a wide range of distances. These requirements result in the operation of vehicular sets in nets and on a point-to-point basis both mobile and fixed.

Now modern warfare concepts have introduced extensive geographical communications requirements down to low echelons. The basic "spreading out" of units imposes communication problems that can only be met by the extended ground wave and sky-wave transmission characteristics of hf radio.

STATE OF THE ART FOR VEHICULAR HF SETS

For many years, in the interest of aviation and radar agencies, electronic and mechanical development of receiver and transmitter circuitry was concentrated upon solving problems in higher frequency ranges to the apparent neglect of hf. Today, however, many of these developments have been applied with benefit in other than their original applications.

Transmitter tubes of great compactness and high-power gain provide the key to more rf power in less space. External anodes, comparatively low anode and screen voltages, beamed tetrode configurations and the consequent low signal drive power requirements are benefits at hf from solutions to vhf and uhf problems.

Frequency control today is just assuming its rightful place as a determinant of progress in communications. With current refinements in both variable and crystal oscillator design as well as in their mechanical engineering, the former can be restricted to little more than an interpolator between the highly stable heterodyne frequencies of the latter. Calibration and stability of today's hf radio equipment has provided the vehicular operator with an unfailing means to occupy his assigned channel and no other.

From the stringent requirements of airborne radio has come the ability to make a transmitter tune itself.

* Original manuscript received by the IRE, September 4, 1956.
† Signal Corp. Eng. Labs., Ft. Monmouth, N. J.

This achievement is more difficult to apply to hf vehicular radio because of inherently poorer radiating facilities. Tanks and jeeps are smaller than fighter planes and radiating structures must sustain contact with trees and bridges at normal vehicle speeds without being damaged or demounted for the occasion. The standard fifteen-foot whip antenna meets these mechanical requirements but at 1.5 mc presents a complex impedance of about $2-j1000$ ohms. Despite such drastic resonating problems, present hf equipment is capable of resonating within seconds.

Considering power consumed and radiated, current mechanical design for sets of this class makes very efficient use of available space. Product design has provided smaller and extremely rugged components such as transformers, vacuum-sealed control relays and multicontact connectors. "You can't miniaturize heat!" is an undeniable truism but better internal heat distribution and forced ventilation have provided a conservatively rated 100-watt hf AM set in essentially the same space that its predecessor produced 20 watts.

Major subassemblies have become separate mechanical entities, tied together by a main frame and front panel. Thus maintenance is expedited to the point of reactivating the faulty set in minimum time. A subassembly at fault, however, can be worked on at lower echelons, in most cases, and many components replaced by field service men.

Electromechanical design is an important key to improved performance in today's equipment. Servomotors and dc positioners are reliable substitutes for the transmitter operator's fickle fingers. Gear trains and cams in the receiver become computers to provide octave tuning at rf while operating all frequency dependent settings and driving a cyclometer-counter decade presentation. This mechanism shows frequency down to one kilocycle with an over-all accuracy of better than 300 cps over an operating range of from 0.5 to 32 mc when calibrated to the nearest 100 kc point, using an internal standard. This frequency setting is done with only two knobs.

Power drain on vehicular electrical systems, like all electrical demand situations, has consistently climbed over recent years. An hf transmitter which requires up to 40 amp or more, regularly, and nearly 100 amps at peak load presented an impossible requirement for most 24-volt equipped military vehicles a few years ago. One solution was found in civilian police radio practice where use was made of an alternator-rectifier-exciter-regulator combination which could power this set at low engine speeds for long periods of time without fouling the spark plugs or draining the battery. Tactical military hf radio vehicles are specially equipped with such a generating system floated across the battery.

To sum up this account of where we stand today, Fig. 1 shows a set which conforms to the preceding description. Radio set AN/GRC-19 is a 100-w 1.5-20-mc vehicular receiver-transmitter combination, developed

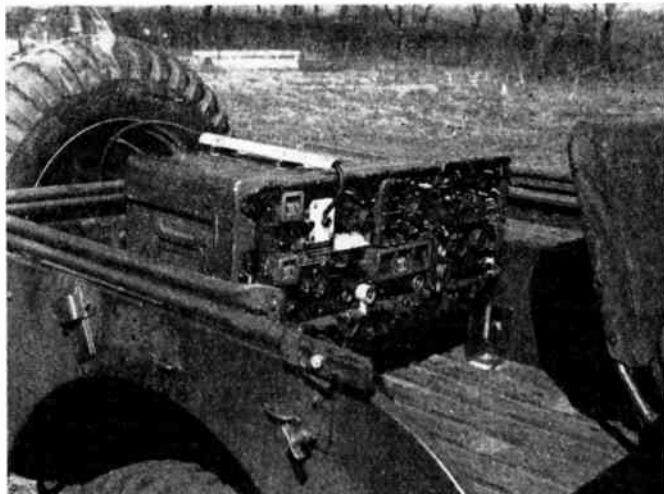

Fig. 1—Modern military 100-watt high-frequency double-sideband vehicular radio set AN/GRC-19 installed in "jeep." Standard of comparison for proposed new SSB equipment.

by Collins Radio Company to SCEL specifications and currently in successful field use.

GENERAL

The important characteristics required for an hf vehicular radio set are tabulated in Table I (next page) which is self-explanatory. Table I also shows in a qualitative fashion how well the most modern hf vehicular radio set, AN/GRC-19, fulfills these requirements. For a new hf vehicular set to be worth its salt, it should effect major improvements over the AN/GRC-19. The features and techniques incorporated in the AN/GRC-19 which evolved over a number of earlier designs or were first placed in the AN/GRC-19 and which result in excellent standards of performance should be retained. The new design should emphasize these areas where current equipment is deficient. While all such areas are of great importance they may be listed in descending order of importance; circuit reliability, operating reliability, maintenance training, maintenance time, power input, speak-to-talk, radio-wire integration, type-to-write, acoustic-noise generation.

Consideration of available techniques indicates that large improvements in the needed areas can be best obtained by the adoption of SSB modulation and detection; maximum use of semiconductors in lieu of vacuum tubes and rotating machinery; incorporation of electric tuning in lieu of mechanical gears, shafts, couplings, cams, etc.; installation of additional faultfinding features; extension of the removable subassembly principle; and improvement in accessibility of subassemblies for rapid exchange.

SSB promises a significant improvement in circuit reliability, particularly over the longer distances and for the increasingly difficult communication needs imposed by modern warfare. SSB offers the most adaptable system for incorporation of speak-to-talk facilities which will greatly assist in furnishing the needed increase in

TABLE I
REQUIRED CHARACTERISTICS FOR LONG-RANGE VEHICULAR RADIO SETS

Subject	Requirement	Remarks	Standing of AN/GRC-19
Communication range	50 miles 100 miles 1000 miles	Predominantly Frequently Occasionally	Yes Yes Yes
Service	Single channel voice Radioteletype CW telegraph	Predominantly Frequently Emergency	Yes With Applique Yes
Application	Mobile or stationary Local or remote control Net Point to Point	Predominantly Frequently	Yes Yes Yes Yes
System	Voice speak to talk (desirable) Voice push to talk (tolerable) Voice radio-wire integration Voice full duplex RTTY type to write (desirable) RTTY push to write (tolerable) RTTY full duplex	Predominantly Occasionally Infrequently Predominantly Frequently	No Yes Fair Yes No With Applique With Applique
Installation	Open Vehicle Mobile Shelter Closed Vehicle Building Indoors	Predominantly Frequently Frequently Occasionally	Yes Yes Yes Yes
Circuit reliability	Maximize 100% day or night regardless of terrain, interference, etc., desired	Prime Requirement	Fair (See text)
Operating reliability	Maximize 100% freedom from failure desired	Prime Requirement	Good
Operator Training and Attention	Minimize for non-technical personnel	Prime Requirement	Excellent
Maintenance Training	Minimize	Prime Requirement	Poor
Maintenance Time	Minimize for fault finding and repair	Prime Requirement	Fair
Power Source	Vehicular Engine Generator (dc) Fixed ac Engine Generator (ac)	Predominantly Frequently Infrequently Occasionally	Yes Yes Requires Converter Requires Converter
Antenna	15' Vehicular Whip Long Wire End Fed $\frac{1}{2}$ Wave Doublet	Predominantly Improvisation Frequently	Yes Yes Yes
Size	14" x 12" x 33" maximum due to vehicle space	Prime Requirement	Yes
Weight	Minimize	Secondary Requirement	Fair
Acoustic Noise Generation	Minimize	Primary Requirement	Poor
Operating Environment	Climate World-Wide Temperature -40 to 65°C. Shock-Combat Vehicle Vibration-Combat Vehicle	Primary Requirement	Excellent
Average Power Input	Minimize not to exceed 1 kw during transmission	Primary Requirement	Meets Maximum
Frequency Control	Rapid and accurate selection of any frequency within its range	Primary Requirement	Excellent for DSB
Frequency Range	1.5-30 mc Desirable 1.5-20 mc Tolerable	Primary Requirement	Transmitter 1.5-20 mc Receiver 1.5-32 mc

traffic handling capacity for vehicular voice communications. Semiconductors can result in space saving making it possible to incorporate the greater circuitry required for SSB in the available space. Operating reliability can be improved by the use of semiconductors not only from the standpoint of the inherent long life of such devices but by reducing the heat losses in the equipment. Input power conservation can be effected with semiconductors due to lower power requirements and higher

efficiencies when employed to replace dynamotors. The gain in input power conservation can be utilized to reduce standby drain and make available more talking power and hence greater circuit reliability. Replacement of rotating machinery with semiconductors will effect substantial reduction in acoustic noise generation which is often a serious problem in making the position of the radio set known to a closeby enemy.

The automatic tuning features of the AN/GRC-19

as applied to the power handling stages of the transmitter have not only drastically reduced operator training but have made possible the design of these portions of the set independent of restrictive layout required by mechanical linkages to the front panel. The reliability of these circuits has been excellent. Supplementing these features with electric tuning of low-power stages (receiver as well as transmitter) will greatly increase the flexibility of possible layouts of the equipment thereby conserving much-needed space and facilitating sub-assembly arrangement for ease of maintenance. The remaining recommended improvements are obviously pertinent to maintenance training and required maintenance time.

Over a period of nearly ten years, while developing and producing the current hf vehicular radio set, AN/GRC-19, an explicit and practical research program of studies and tests has been under way, at the Signal Corps Engineering Laboratories, which measured the performance of all methods of voice communications at hf except SSB. Conclusions drawn from this work, together with the classic studies of Bell Telephone Laboratories on their overseas radio telephone service in the mid-1930's, showed us nearly five years ago that only through use of SSB could any marked improvement in circuit reliability be achieved in tactical hf voice radio. At that time we lacked techniques to realize this objective in the military environment and demands of the Korean action precluded necessary development. In the last two years this program of internal effort has been directed to achieve first, the detailed specification of practical performance and, second, construction of working equipment for user tests which conforms to these requirements.

EXPECTED ADVANTAGES FROM SSB

In order to obtain substantial improvement in circuit reliability, the primary concern is to achieve a better signal-to-noise ratio at the receiver. The term "noise" in this sense refers to receiver noise, atmospheric, distortion (as due to multipath), interference, etc. The "talking power" of the transmitter is the foundation for the received signal-to-noise ratio.

Increased Talking Power

One of the principal anticipated gains to be realized in new equipment for this service is increased "talking power." By "talking power" is meant that portion of transmitter output power which carries intelligence, in contrast to static output such as the carrier of an AM transmitter. Thus, while a 200-watt AM transmitter and a 200-watt SSB transmitter have ratings which sound similar, the maximum sideband intelligence power output of the AM set is 100 watts, while the corresponding output of the SSB set is 200 watts, a 3-db difference. Factors relating to bandwidth, method of detection, mode of propagation (ground wave or sky wave) enter into a complete analysis of s/n at the

receiver, and must therefore be considered in the computation of full system performance. These factors, together with spectrum utilization and vulnerability to interference, will be considered in later portions of this paper.

In this discussion only filter-derived^{1,2} SSB is considered. A thorough consideration was given to other SSB systems before concluding that this method was the only one which satisfied the requirements. For brevity, no detailed comparisons of methods of SSB generation are included in this paper. The reader is referred to the literature for a discussion of the various methods.

Also, voice clipping and/or pre-emphasis do not appear in these calculations, although one or both are certain to be used in the proposed equipment. The effects of speech processing upon the following calculations should be slight, inasmuch as the peak factors would remain large even with both types of processing.

The fixed parameter of prime concern in comparing the talking power of AM and SSB army vehicular sets is the input power of the equipment. It is necessary to supplement the standard vehicular power system with a special heavy current alternator-rectifier unit in order to supply adequate power to the present-day radio equipment. This power system is now loaded to full capacity. Any replacement for the current radio equipment must not require more power from the vehicle, as replacement of the electrical units with a higher capacity system is not considered feasible, for both practical and economic reasons. Therefore, a study of what improvement in talking power might be offered by SSB in replacing AM vehicular equipment, with total input power as the fixed parameter, must be considered an important comparison basis. While such a study might well include some thought of what might be done in improving AM equipment design to reflect the type of SSB equipment being considered, no such consideration of new AM equipment is included in this discussion due to the multifold advantages of SSB.

These advantages, such as reduction in spectrum congestion and reduced vulnerability to interference, weigh heavily in favor of directing new development in this direction. This would probably be true even if SSB only "broke even" with conceivable AM equipment. Therefore, the following comparison is based upon replacement of radio set AN/GRC-19 with SSB equipment which appears to be presently within the state of the art. The main comparison is confined to the SSB final amplifier and the AM final amplifier and modulator, as it is felt that extensive transistorization of preceding stages should make their power drain negligible in comparison. This is not wholly true, in view of the more extensive circuits required in presently en-

¹ A. Brown and R. Levine, "SSB for mobile communication," 1953 IRE CONVENTION RECORD, part 2, p. 123.

² The American Radio Relay League, "SSB for the Radio Amateur," Rumson Press, Concord, N. H., 1954.

visioned SSB equipment. It would seem, however, to be a close approximation.

The calculations that follow do not include heater, screen, or control grid dissipations, inasmuch as they are minor items and are to a large extent offset between the AM modulator and the SSB amplifier.

AN/GRC-19 DSB—Calculation of Amplifier Performance

Power input to AN/GRC-19 PA, 1000 volts, 200 ma³
 $= 1000 \text{ v} \times 200 \text{ ma} = 200 \text{ w}$.

Plate efficiency = 0.70 average = n_p .

So PA output = $200 \text{ w} \times 0.7 = 140 \text{ w}$.

Average output to antenna = 100 w .³

So losses in matching circuit = 40 w .

Matching ckt efficiency = $100/400 = 0.715$.

Modulator input at no signal³ = $1000 \text{ v} \times 40 \text{ ma} = 40 \text{ w}$.

Modulator input at 100 per cent mod = $1000 \text{ v} \times 210 \text{ ma} = 210 \text{ w}$.³

Therefore, when speech having 18 db peak factor⁴ is spoken continuously, long term power input (average power) can be estimated.

PA input (constant) = 200 w .

Modulator input = $40 + (1/31.6) (210 - 40) = 45 \text{ w}$
 (assuming constant apportionment of loss and output).

Total = 245 w .

AN/GRC-19 max sideband-output power (at 100 per cent mod) = $\frac{1}{2}$ carrier power = 50 w .

Ratio of long term power/max. SB power = $245/50 = 4.9$.

Calculation of Linear Amplifier Performance

The following calculations are based upon the Eimac type 4X250B tube, inasmuch as it appears at this time to be the most likely tube type to be applied to this service.

While the manufacturer's typical operating data for this tube shows high static dissipation in SSB service, tests have indicated that for single-channel voice operation this static drain may be safely reduced to less than 25 per cent of the recommended value with no serious degradation in performance. Under these conditions tests have shown that available circuitry with feedback will provide reduction in third order distortion greater than 35 db. With this consideration, the following calculations are based upon 2000-v operation of two parallel type 4X250B tubes, with a total static dissipation of 100 watts.

Linear Amplifier Calculation—Case I: SSB Service

Zero signal input = 100 watts .

Maximum output = 650 watts .

Maximum signal losses = output $((1/n_p) - 1) = 435 \text{ watts}$
 (assuming $n_p = 0.60$, reasonable in view of the low static drain).

Maximum signal input = output + losses = 1085 watts .

Assuming a linear variation of loss with signal output, the long term power input with a talker, 18-db peak factor = static loss + maximum output/31.6 + (maximum loss - static loss)/31.6 = $100 + 650/31.6 + (435 - 100)/31.6 = 131 \text{ watts}$.

Maximum output through antenna network = maximum output \times antenna matching ckt efficiency = $650 \times 0.715 = 464 \text{ watts}$.

Ratio of long term power input/maximum output = $131/464 = 0.28$.

Talking power improvement, for equal average input power, SSB/DSB = DSB long term/average out \div SSB long term/average out = $4.9/0.28 = 17.3$, or approximately 12 db.

If suitable semiconductor power supplies are considered for the high voltage source, with an efficiency of almost double that of rotating machines, this figure might well be increased to almost 16 db, based upon a comparison of actual power drain from the vehicle. This, of course, is the true criteria of comparison.

Linear Amplifier Calculation—Case II: Compatible Emission for DSB Reception

As explained in detail in the section of this paper on compatibility, it is proposed to transmit a carrier plus one sideband for communication to a double-sideband receiver. The following calculations apply in this case:

Carrier = 100 watts output = max sideband power.

Static loss remains = 100 watts .

Output = 100 watts on carrier alone.

Amp output for carrier = 100 watts /matching ckt eff = 140 w .

If a linear variation is assumed, with maximum loss of 435 watts, then power loss at 100 watts output carrier = static loss + (carrier/max out).

(max loss - static loss) = $100 + (140/650)(435 - 100) = 172 \text{ watts}$.

So input power for carrier only = output + loss = $140 + 172 = 312 \text{ watts}$.

Additional input for speech = amp output + loss = $140 + 72 = 212 \text{ watts}$.

Input due to speech with 18 db peak factor = $212/31.6 = 7 \text{ watts}$.

Long term input for compatible AM transmission = carrier input + speech input = $312 + 7 = 319 \text{ watts}$.

It is noted that this long-term power input is quite close to the value found for the AN/GRC-19. Further, the use of semiconductor power supplies, as discussed elsewhere in this paper, should greatly decrease the actual drain from the vehicle power system as compared to AN/GRC-19. Therefore, the SSB equipment radiating a compatible DSB type signal should be capable of delivering approximately twice the AN/GRC-19 sideband power. Under normal ground wave conditions, as dis-

³ From measured data on AN/GRC-19.

⁴ B. D. Holbrook and J. T. Dixon, "Load rating theory for multichannel amplifiers," *Bell Sys. Tech. J.*, vol. 18, p. 635; October, 1939. Ratio of peak/average speech power which has a 0.1 per cent probability of being exceeded = 18 db. The ratio of rms of the peak-to-average power is 15 db = $10 \log 31.6$.

cussed in a later portion of the paper, this gives the desired performance when received on a DSB receiver. Under sky wave conditions, performance is superior to DSB.

The preceding calculations, while approximate, should give conservative estimates of new SSB equipment performance.

When the Case I calculations (full SSB) are done on the basis of the manufacturer's ratings for static drain, the additional fixed power input required reduces the SSB to AN/GRC-19 ratio to slightly over 7 db.

Circuit Reliability

"Increased talking power" is a useful term, but the improvement in communication that can be obtained with the greater talking power is of primary concern. Qualitatively, this higher talking power for SSB should result in the successful transmission of the same intelligence at a greater range, or greater intelligence at the same range. Quantitatively, these improvements may be estimated on the basis of the probability of successful recognition of words in standard word lists. Such a procedure may be checked by experimental methods and provide an answer to the basic question: What does the increased talking power buy in terms of better communication? The theoretical computations are quite straightforward for the case of ground wave communication which fits the majority of applications for the hf vehicular set. Based upon the previous discussion of talking power, it would appear that a 7 db advantage for SSB represents a highly conservative assumption that can readily be met in practice regardless of the success or failure of blue-sky dreaming. This value was selected in the theoretical and experimental work to be discussed.

To predict the improvement in intelligibility at equal range for SSB over DSB, it is necessary to calculate the per cent word recognition vs the received signal-to-noise ratio. Using the method described by Beranek⁵ the articulation index was calculated for a flat system passing an audio band 330- to 3650-cps and, assuming Gaussian noise, the articulation index was plotted vs signal-to-noise ratio. This curve, together with the empirically determined curve of per cent recognition of the Harvard PB phonetically balanced word lists vs articulation index, permitted the computation and plot of per cent word recognition vs s/n. In the case under discussion, the s/n at a given location should be 7 db greater for SSB than DSB. Therefore, at any given s/n assumed for DSB giving a certain per cent word recognition, the per cent word recognition for SSB can be read off at a s/n 7 db greater. Curve no. 1, Fig. 2, is a plot obtained in this manner of per cent SSB word recognition vs per cent DSB word recognition. The gain in intelligibility for SSB is significant, particularly at the lower values of DSB per cent word recognition.

Personnel of RCA and SCEL⁶ jointly instituted a series of field tests simulating tactical conditions to measure the improvement provided by SSB under the conditions described previously. DSB and SSB transmissions were radiated alternately from the same 15-foot whip antenna mounted on a standard military vehicle. The power was adjusted to provide the same radiated field for DSB as produced by the AN/GRC-19 (approximately 100 watts carrier 100 per cent modulated on the voice peaks). The SSB power radiated (approximately 250 w) was 7 db above the average double-sideband power. For ground wave reception in the presence of Gaussian noise this results in a 7 db s/n improvement for SSB over DSB. Since, under these conditions the two sidebands of DSB are phase coherent while the SSB receiver accepts half the noise power, the noise gain of the SSB receiver is cancelled by the enhancement of the DSB signal due to phase coherence.

PB word lists prerecorded on tape were transmitted over the system having a bandwidth of 3300 cps employing DSB for every other word and SSB for the interleaved words. The transmitting facility was fixed at the Signal Corps Engineering Laboratories. A receiving van with whip antenna was used to receive and record the transmission at many different locations and the recorded tapes were subsequently evaluated by a trained crew at the University of Delaware.

Tests were made over distances of 5 to 100 miles. Ground conditions varied including sandy soil, good soil, sea water, and composites thereof. Transmissions were made at various hours of the day and night at a frequency of 4035 mc. Fifty word PB lists were transmitted to a total of twelve different locations involving a total of 116 lists and 5800 words transmitted.

The small circles plotted on Fig. 2 show the results of these tests. It may be seen that there is a high degree of scatter which is not to be unexpected since the tests were conducted as in practice under highly varying conditions of interference, electrical equipment noise, atmospheric, and, in some cases, multipath of ground and sky wave. Of greater importance is the fact that the theoretical curve is too optimistic. A more detailed analysis indicates that the curve is even more optimistic than shown because most of the points which are close to the line or above it at DSB percentages less than 70 per cent were conditions where either sky wave or a combination of sky wave and ground wave conditions were present. Under these latter conditions, it would be expected SSB would be even better than predicted. Measurements of signal-to-noise (including interference) on the received tapes showed that the average of the lists at each location ranged from a 5 db to 8.8 db improvement for SSB over DSB, with the higher values under deep fading conditions. A selection of those tests which were free of the extraneous effects shows a substantial departure below the idealized curve.

⁵ Leo L. Beranek, "The design of speech communication systems," *PROC. IRE*, vol. 35, pp. 880-890; September, 1947.

⁶ Contract No. DA36-039 sc-64683.

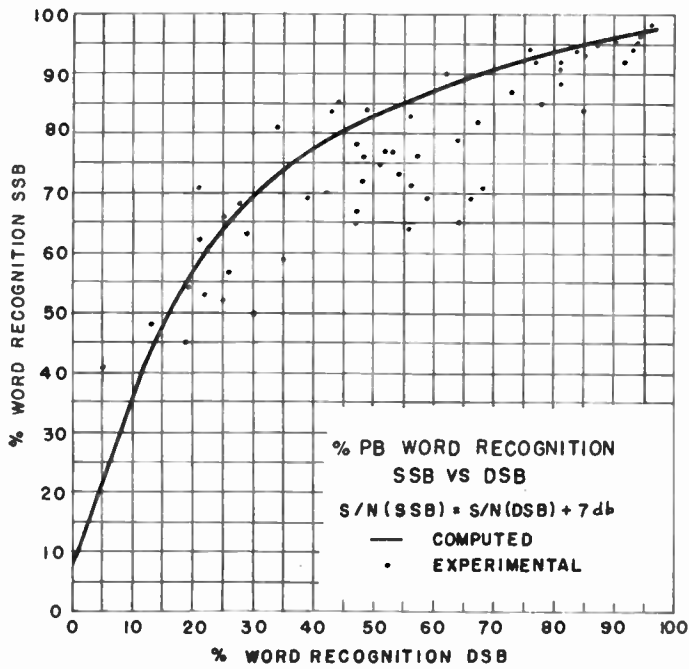

Fig. 2

It is recognized, of course, that the relationship of articulation index to word intelligibility varies from listening crew to crew and for particular systems.

Despite the reduction in expected improvement as determined by these tests, there remains a substantial benefit from SSB. This may best be shown by Fig. 3,

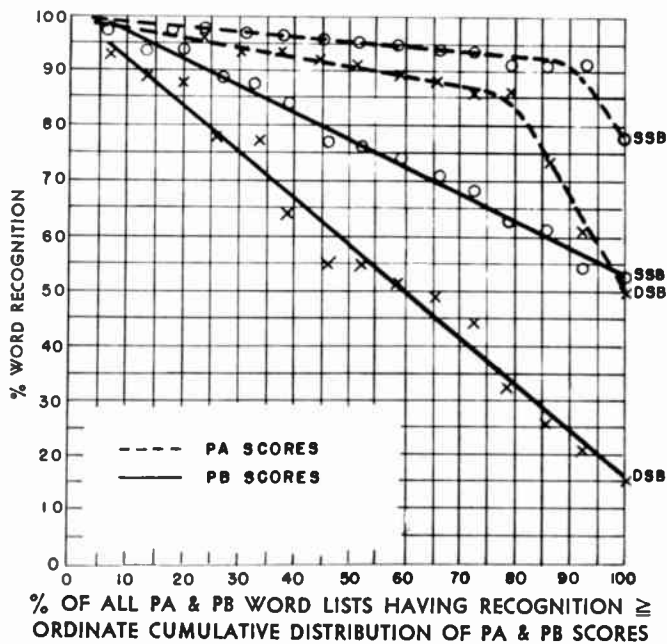

Fig. 3

a cumulative plot of all the tests. It may be seen that in no case did the per cent word recognition fall below 53 per cent for SSB, while 45 per cent of the DSB results were below this value. Previous measurements of sentence intelligibility (*i.e.*, communication of ideas) indicate that a word recognition of 70 per cent or greater

will provide sentence intelligibility of 95 per cent or higher. Under these conditions, it may be assumed that SSB gave satisfactory sentence intelligibility 65 per cent of the time, while DSB gave equivalent results only 35 per cent of the time. Those latter results should not be taken as the capability of the systems to communicate because of the use of a single test frequency assignment for all ranges and all times. In practice, two or more frequencies are made available for such application.

When communication conditions are adverse and the message must go through, it is common practice to resort to the phonetic alphabet of 26 words and the 10 numerals. Using this restricted vocabulary, 50 word lists (designated as PA lists) were prepared and transmitted at the same locations and in the same manner as described for the PB lists. The cumulative results are shown by the dotted curves of Fig. 3. The curves are closer together than for the PB lists but there is a significant improvement under the conditions where the phonetic alphabet would be commonly used, that is, the right-hand side of the plot. Using SSB 92 per cent of the time the word was correctly recognized 9 times out of 10 or better, while on DSB the word was correctly recognized 55 per cent of the time 9 times out of 10 or better. Fig. 4 is a plot of PB scores vs PA scores for both

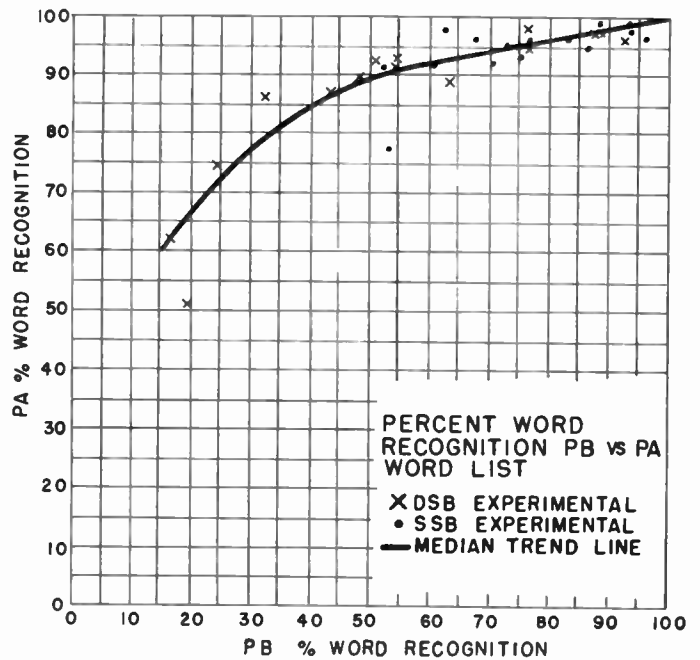

Fig. 4

DSB and SSB. The scattering of the data did not permit the determination of any significant differences between SSB and DSB on the PA/PB relationship for individual tests.

Assuming constant noise at any range, the range at which the SSB should give equivalent word recognition to DSB at a shorter range will be given by the SSB range at which the s/n at the receiver is equal to the s/n at the DSB receiver. Therefore, it is merely necessary to consider the relationship of attenuation vs

distance. Considering the attenuation at the given distance for DSB, the distance is extended until the additional attenuation is equal to the SSB increased talking power gain plus half-bandwidth receiver gain. The attenuation vs distance is a function of frequency and ground constants.

Fig. 5 is a plot of ground wave SSB range vs DSB range for several frequencies and ground conditions. Fig. 5 shows that the SSB to DSB range should vary from about 1.3 to 2 over limits included in Fig. 5.

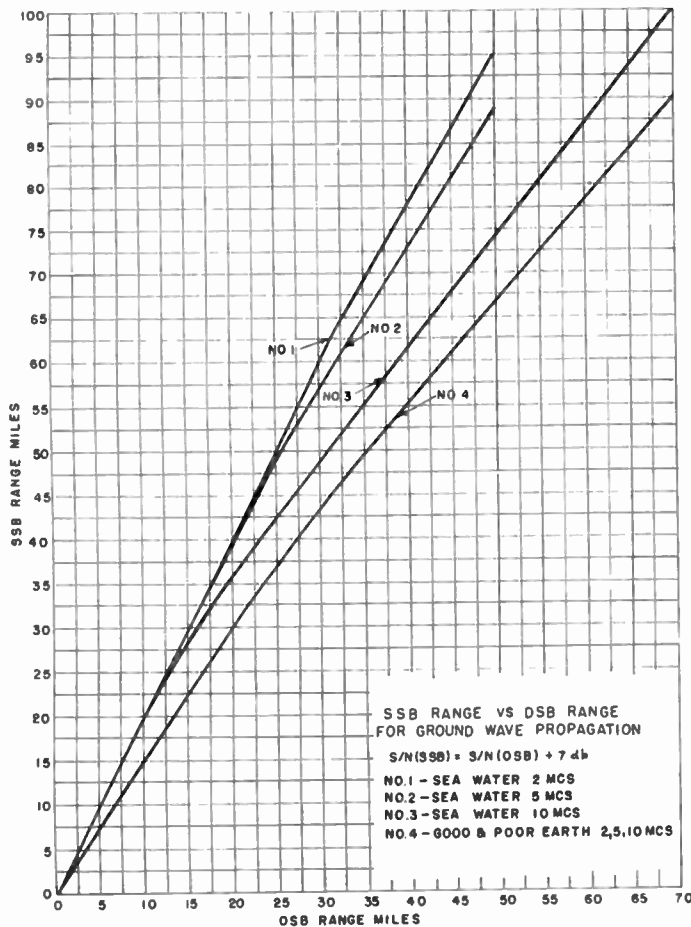

Fig. 5

The test results referred to previously cannot be readily interpreted to compare the range of SSB vs DSB for equal intelligibility since the data at different ranges were taken at different times with different extraneous conditions. Considering this limitation, the data still show a striking advantage for SSB which may be stated in the following manner:

- 1) At equal distances SSB gave higher PB scores 96 per cent of the time.
- 2) At a distance 10 miles greater than DSB, SSB gave higher PB scores 90 per cent of the time.
- 3) At a distance of 20 miles greater than DSB, SSB gave higher PB scores 100 per cent of the time.
- 4) At a distance of 30 miles greater than DSB, SSB gave higher PB scores 86 per cent of the time.

Multipath transmission via sky wave or both sky wave and ground wave is an important factor in the applica-

tion of an hf vehicular radio set. At the longer distances in the day time and even at distances of the order of 30 miles during the night, this effect seriously degrades DSB. SSB is, of course, immune to the distortion produced in DSB receivers due to selective fading resulting from multipath. In addition to the distortion, the multipath tends to upset the phase correlation between sidebands in DSB transmission. Assuming completely random phase between sidebands, DSB suffers another 3 db disadvantage compared to SSB. As previously mentioned, the maximum gain for SSB shown by the dots on Fig. 2 can be traced to the tests that showed evidence of multipath transmission. Taking only those tests so affected, the average PB SSB/DSB scored ratio is 1.7 compared to 1.2 for the nonmultipath cases. Furthermore, the lowest DSB scores were obtained under multipath conditions.

Quasi-Duplex Operation

Present tactical voice radio usage is mainly the familiar netted operation of a number of sets on a common frequency with "push-to-talk" carrier control from a button on the microphone. Increasing demands are heard, however, for duplex operation in which both parties to a conversation can break in on each other almost at will. With normal double-sideband radio this requires a separate frequency assignment for each direction of traffic, and precludes netted operation. Recent amateur band exploitation of SSB has led to application of voice-operated control circuitry which may solve both the SSB duplex and the break-in netting problems. For this mode of operation, the SSB set is quiescent in the receiving condition. Turning the microphone on will not normally radiate any signal but as soon as the operator begins to talk the set switches to the transmitting condition. As the speaker pauses for breath or between words, the set returns to the receiving condition. Once the proper frequency is attained, any number of sets may converse in this manner, greatly expediting the handling of traffic.

This automatic switching function would eliminate extended dc push-to-talk control as now used, as well as avoid the effects of hybrid unbalance in connection with 2-wire lines.

Receiver protection in this quasi-duplex mode is one problem area. The receiver and transmitter must operate from one antenna over a wide-frequency range, with protection against receiver burnout or high-level audio transients. While the problem is similar to that encountered by the amateurs,⁷ reliable operation with the extreme range of voltages encountered on a whip antenna requires further consideration. Another problem arises in combatting the high ambient noise levels which are to be found in tactical vehicles, lest false switching occur at the automatic voice control. Improved noise cancelling microphones and speech recognition

⁷ E. L. Campbell, "Variations in T-R switch performance," *QST*, vol. 60, p. 23; May, 1956.

circuits for the control unit appear necessary for practical quasi-duplex operation.

Interference Reduction and Vulnerability

SSB offers several advantages in the area of radio interference. First, less interference is created by SSB transmitters due to the reduced bandwidth occupancy and elimination of the carrier component. Second, the receiving equipment is less susceptible to interfering signals by virtue of its narrow IF bandwidth compared to an AM receiver. Third, the absence of strong carrier signals in areas where SSB equipment is predominant lessens the problems of receiver front end blocking. Together, these factors clearly indicate the desirability of SSB from an interference reduction and vulnerability standpoint.

At the risk of seeming obvious, improved spectrum economy through the use of SSB must be discussed. There are hazards and limitations to channel saving by SSB which are not ordinarily considered. Suppression of the carrier and unwanted sideband from a double-sideband signal does not automatically guarantee that "linear" amplifier stages and power supplies will produce negligible adjacent channel distortion. Only with care in equipment design can distortion products be so controlled as to approach the theoretical spectrum savings. Also, the mere introduction of some SSB equipment in bands occupied by AM and other services cannot be expected to yield much improvement in spectrum utilization. Only when definite slices of spectrum are allocated exclusively to SSB can important gains be realized. While at first glance it would appear a straightforward doubling of channels might be expected with SSB, important gains other than halving bandwidth may be realized. Possibly the inherent high stability of such SSB equipment can result in the reduction of guardband allowances. Much remains to be considered, and on the whole, detailed study should precede the issuance of any channel allocation scheme.

PROBLEMS IN APPLICATION OF SSB

Compatibility

The huge investment in military vehicular DSB equipment precludes the adoption of SSB equipment all at one time. For a number of years, it will be necessary to interoperate SSB equipment with DSB equipment. Reception of DSB transmissions on SSB receivers by detecting one sideband is theoretically feasible. Unfortunately, the frequency stability of most DSB vehicular transmitters is insufficient to permit this form of reception without AFC at the receiver. AFC, while employed successfully for many years on fixed plant SSB systems, is not considered desirable for this class of service because of its vulnerability to interference. Even the more modern DSB vehicular transmitters, such as AN/GRC-19 transmitter, while having short-term stability sufficient for SSB, do not have the long-term accuracy required. It is necessary that the receiver correctly receive the first transmission from a trans-

mitter although there has been no previous transmission on the channel, or many hours have elapsed since the last transmission. It would appear possible to turn off the receiver carrier oscillator, and linearly detect the incoming carrier and one sideband, accepting the distortion produced by this method. The high selectivity of the SSB receiver would negate this method for receiving the older DSB equipment of poor stability. It appears best to incorporate another IF filter bandwidth in the receiver capable of accepting both sidebands, and then detect the DSB signal in the usual fashion.

For transmission from the SSB transmitter to a DSB receiver it would be possible to arrange the transmitter for a choice of DSB/SSB transmission but this appears to unduly complicate the transmitter. A more promising method would be to arrange the SSB transmitter in such a manner that one sideband and a large carrier are transmitted to the DSB receiver. This can be received on the envelope detector and the distortion is tolerable from a speech intelligibility standpoint. The distortion produced by envelope detection for two frequencies having equal amplitudes is approximately 20 per cent and predominantly second harmonic. If the SSB transmitter is adjusted so the voice peaks ($\frac{1}{3}$ sec) are equal to the carrier amplitude, then the average value of speech is 12 db below the peak and the ratio of average sideband amplitude to carrier is 0.25. Under these conditions the average distortion on a two-tone basis is approximately 6 per cent. A sacrifice in talking power must be made in order to transmit the carrier without increased battery drain, as discussed earlier. The talking power available, however, is equivalent to the talking power of the AN/GRC-19 and hence the range and reliability of a DSB-SSB circuit should be equivalent to the best current vehicular DSB circuit.

Since the SSB radio set must talk with other SSB sets or DSB sets on voice, RTTY, or cw, there must be compatibility of dial readings vs frequency assignments. For DSB radio sets the carrier frequency is set at the frequency assignment. For RTTY, using DSB sets, assignment is either the mark frequency or symmetrically located between the mark and space frequencies. Since the shift is small (850 or less) there is no great problem in dial calibration vs frequency assignment. Frequency shift radioteletype applied to an SSB transmitter is most simply and economically arranged by use of audio frequencies introduced into the normal speech input of the transmitter. Using this technique, the mark and space frequencies may be readily placed symmetrically about the center of the transmitter audio band. Similarly, cw can easily be applied by means of an audio tone at the center of the audio band. For DSB/SSB voice compatibility, it should not be necessary to retune either the SSB or DSB receiver when switching from one mode of operation to the other on the same frequency assignment. While there has been a trend toward defining the position of the nonexistent carrier in SSB as the assigned frequency, this does not offer the best in operation from a compatibility standpoint. Another approach

would be to specify the assigned frequency as the center of the intelligence band radiated which should insure dial compatibility for the various classes of service and for both DSB and SSB.

A detailed analysis of the fine points of assignment and operating philosophy disclose pros and cons for each method, but, in the opinion of the authors, the pros have it for the latter arrangement. Fig. 6 (next page) shows the relationships for both methods under various operating conditions. It should be noted that this arrangement is the only one complying with the Atlantic City agreements.⁸

Standardization of either upper or lower sideband for single-channel SSB is of great importance. Until such standardization is agreed upon, it will be necessary to provide choice of upper or lower sideband in both receiver and transmitter. If the philosophy discussed above, of centering the band radiated about the assignment is adopted, the choice at the receiver may be accomplished by providing a choice of local oscillator injection on either side of the IF pass band. If the transmitter is similarly designed so that upper and lower sideband occupy the same rf channel and merely represent an inversion, greater compatibility is obtained. Under this latter condition an error in the choice of sideband at the transmitter does not result in transmission in the wrong rf channel and the distant receiver at least has an opportunity to hear the signal.

Frequency Stability and Accuracy Requirements

Modern military problems require vehicular radio sets capable of netting without prior reference to a radiated signal. A transmitter may be quiet for hours and then come on the air with a short transmission which must be received at the distant location. The stability to accomplish this type of operation on DSB is inherent in the AN/GRC-19.

The stability and calibration accuracy needed to accomplish this with SSB is much more stringent because the received sideband must match up with the local carrier injection at the receiver to a degree that will give useful intelligibility. Fletcher,⁹ reports tests made on telephone carrier systems relating frequency error to articulation, and shows that shifts as great as -175 or $+400$ result in short sentence intelligibility higher than 90 per cent. Such data represent a system having a high initial s/n. In his revised work Fletcher¹⁰ shows that the effect on the articulation index operates as a multiplying factor less than unity and tabulates a number of values for this factor vs frequency error. The articulation index is also a function of the signal-to-noise ratio. The slope of word recognition/articulation index is much smaller for values of word recognition above 80 per cent than for below 80 per cent. It would be expected then that the deleterious effect of a given frequency error would

be greater for lower values of word recognition corresponding to the lower range of the articulation index. These conditions will obtain under poor s/n conditions and therefore the problem at hand is to determine the maximum permissible frequency error at the s/n corresponding to the lowest useful percentage of word recognition. However, since the per cent word recognition/articulations index slope is practically uniform from 20 to 70 per cent word recognition, we may arbitrarily allow for a maximum of 10 per cent degradation in word recognition due to frequency error.

It is unlikely that less than 20 per cent word recognition will be useful in any application of the radio set and the degradation will be less than 10 per cent above word recognition scores exceeding 70 per cent. Applying Fletcher's data, it would appear that a frequency error of -30 $+75$ cps would satisfy this requirement. Supplementing the joint RCA/SCEL field tests, a series of word recognition-frequency error tests at various signal-to-noise ratios was carried out under the contract, and the recorded tapes evaluated by the same listening crew. At a s/n ratio of 6 db (vu meter reading corresponding to $\frac{1}{8}$ sec peak average noise 13 db), the per cent word recognition averaged 59 per cent at zero frequency error and dropped to approximately 55 per cent at ± 30 cps. At a s/n ratio of 10 db (17 db corrected) the average word recognition at zero frequency error was 70 per cent and was essentially flat ± 100 cps.

It is to be noted that there was appreciable scatter in the results and the data were quite symmetrical for plus and minus errors at all s/n tested and a maximum of ± 150 cps error which is contrary to expectations. It would appear reasonable from the data to set a total maximum system error of the order of 40 to 60 cps.

To achieve this order of accuracy over a wide-frequency range in a vehicular radio set subject to extreme environmental conditions is a tall order. While in many commercial applications it would be permissible to utilize a crystal specifically ground for each frequency assignment, this is not possible in tactical military applications where the assignments are subject to rapid change. Consideration of the problem with relation to the current state of the art rules out continuously tunable variable frequency oscillator control and requires dependence upon crystal control to furnish discrete frequency steps throughout the spectrum. In this form of crystal control all the discrete frequencies are derived or controlled by one or more standard frequency crystals. There are many available methods for obtaining discrete frequency steps from crystals. In general, the circuit complexity becomes greater the smaller the interval between discrete frequency steps. Therefore, to obtain the desired accuracy in minimum space with maximum simplicity, reliability, and economy, the interval should be chosen as large as practicable. Analysis of the various applications of the vehicular radio set points to a maximum interval of 500 cps as desirable and an interval of 1000 cps as tolerable.

Selection of discrete frequency steps alone is satis-

⁸ "Final Acts of the Interntl. Telecommun. and Radio Conf.," Atlantic City, N. J., Radio Regulations, p. 6; 1947.

⁹ Harvey Fletcher, "Speech and Hearing 1929," D. Van Nostrand Co., New York, N. Y.; 1929.

¹⁰ Harvey, Fletcher, "Speech and Hearing in Communication 1953," D. Van Nostrand Co., New York, N. Y.; 1953.

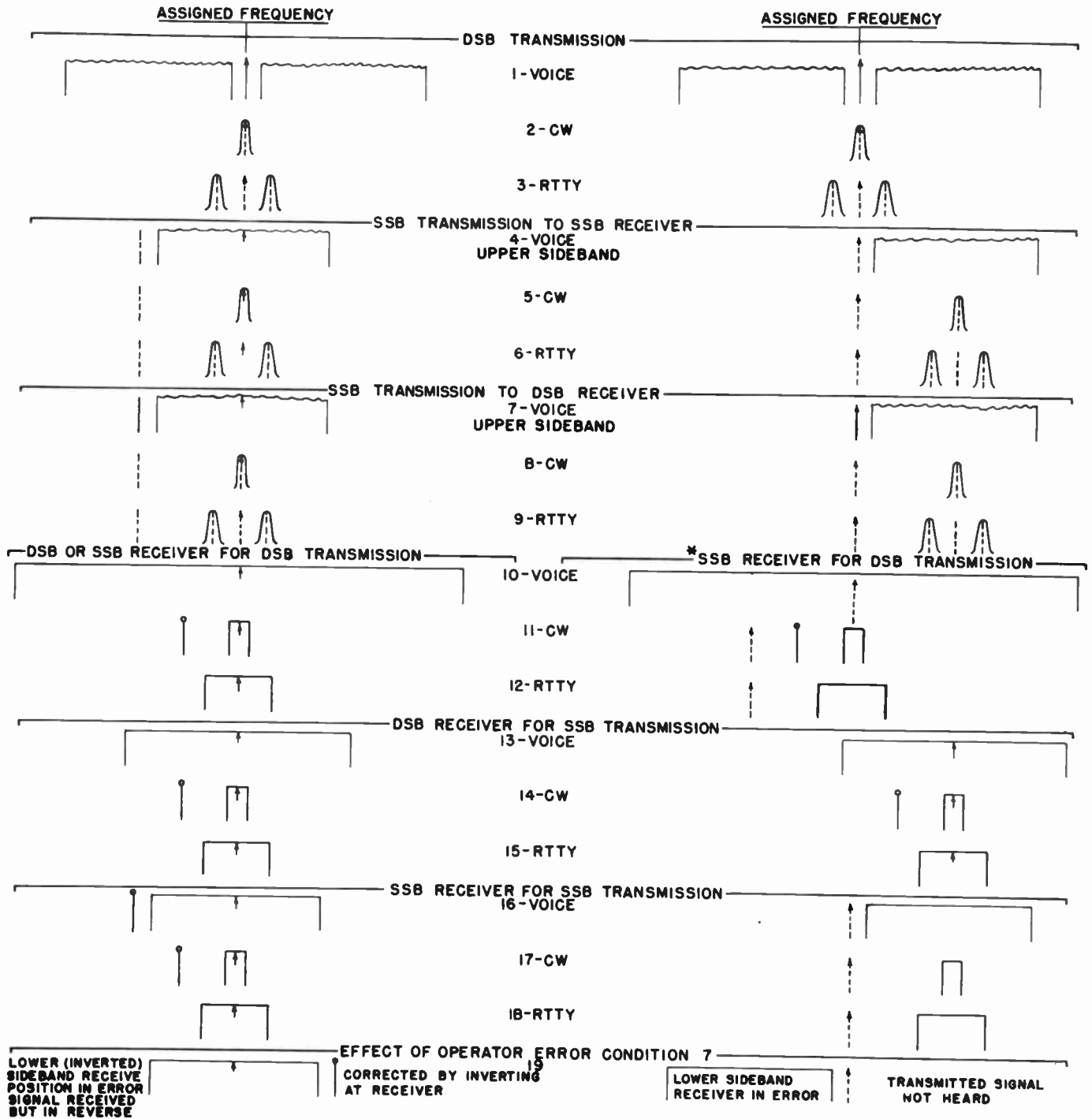

SYSTEM A

IDENTICAL DIAL READING ALL TRANSMITTERS & RECEIVERS.
 FREQUENCY ASSIGNMENT CENTER OF RADIATED BAND.
 LOWER OR UPPER SIDEBAND IN SSB OCCUPY SAME RF CHANNEL INVERTED.
 IF RECEIVER CENTERED AT SAME FREQUENCY ALL BANDWIDTHS.

LEGEND

- ↑-DIAL SETTING OF RECEIVER OR TRANSMITTER
- |-FICTICIOUS COMPONENT
- ↑-LOCAL OSCILLATOR INJECTION AT RECEIVER (ACTUAL FREQUENCY TRANSLATED TO IF REGION)
- TRANSMITTED - SOLID LINES
- RECEIVER BANDWIDTH-SOLID LINES

SYSTEM B

DIAL READINGS VARY WITH SERVICE. FREQUENCY ASSIGNMENT AT REAL OR FICTICIOUS CARRIER.
 LOWER AND UPPER SSB SIDEBANDS OCCUPY DIFFERENT CHANNELS.
 IF RECEIVER CENTERED AT SAME FREQUENCY ALL BANDWIDTHS.

* DSB RECEIVER FOR DSB TRANSMISSION SAME AS 10,11,12 SYSTEM A

Fig. 6

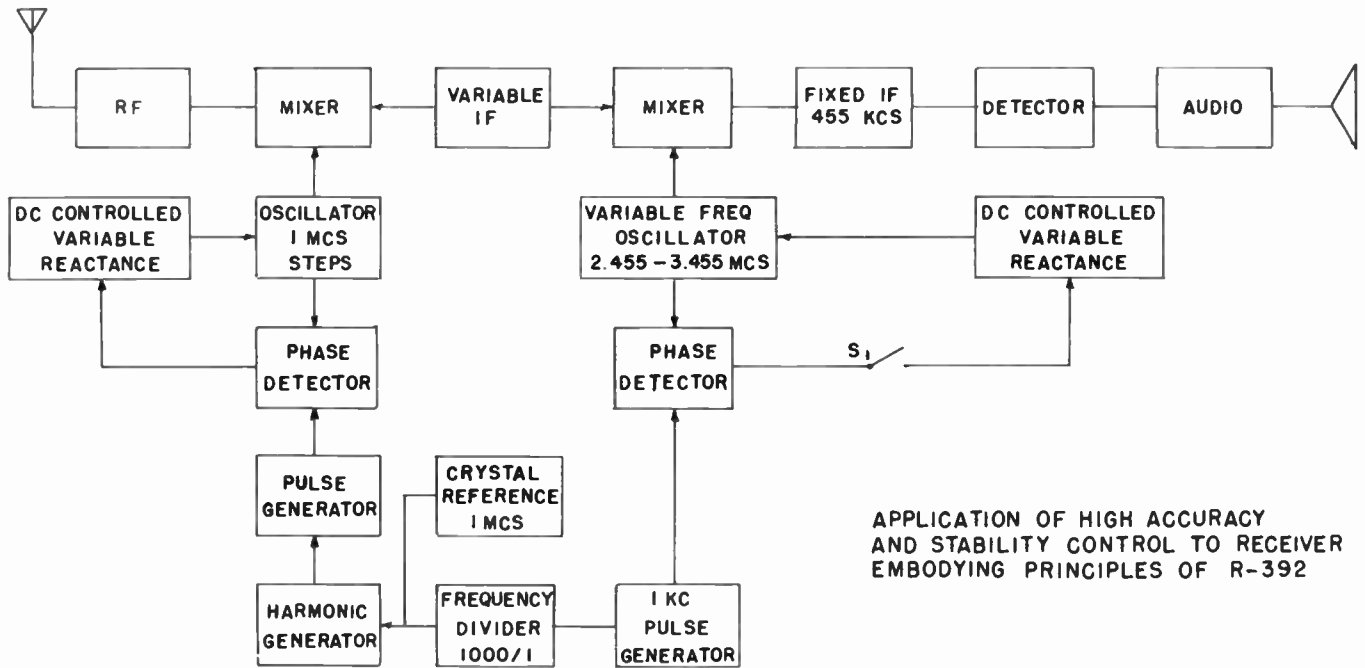

(a)

APPLICATION OF HIGH ACCURACY
AND STABILITY CONTROL TO RECEIVER
EMBODYING PRINCIPLES OF R-392

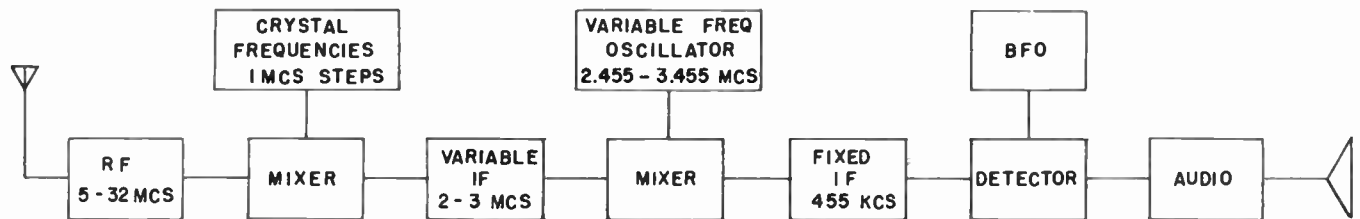

HIGHLY SIMPLIFIED BLOCK DIAGRAM R-392 URR/AN/GRC-19

(b)

Fig. 7

factory for transmitting purposes but provision should be made in the receiver to interpolate between the steps for special applications. The interpolation does not require the accuracy or stability necessary for the discrete steps and the requirement can be met by the performance obtained in the AN/GRC-19 receiver.

The AN/GRC-19 receiver (R-392), tuning from 1.5 to 32 mc, possesses a high order of accuracy and stability for a DSB receiver. When calibrated to the nearest 100-kc point with the internal calibrator, the accuracy is plus or minus 300 cps or better, and the short time stability is in the order of 100 cps over wide environmental conditions. A highly simplified block diagram, Fig. 7(a), illustrates the principles of this receiver.

A rather simple method for obtaining the accuracy and stability needed for SSB in a receiver utilizing the R-392 technique is shown in Fig. 7(b). A crystal reference good to 1 part in 10^6 is used to lock the 1-mc step oscillator to obtain the correct megacycle tuning step and to lock the vfo to any desired 1-kc step in the

megacycle range. Since the inherent accuracy of the unlocked receiver is better than one-half the 1-kc spacing, there is no ambiguity as to the frequency to which the receiver is locked. Figure 7(b) shows only one technique for locking the receiver oscillators to a reference. Several experimental systems employing transistors have been developed at the Signal Corps Engineering Laboratories for experimental purposes. RCA developed an experimental controllable reactance consisting of a semiconductor operating in the nonconduction region which permits control of the variable oscillator simply and without degrading the inherent oscillator stability. One complete experimental system developed at the Signal Corps Engineering Laboratories for applying frequency stabilization to a receiver using R-392 principles requires circuitry involving 10 semiconductors and 1 vacuum tube to achieve stabilization.

Similar techniques applied to locking relatively stable variable frequency oscillators to a crystal reference spectrum appear to offer promise for a simple trans-

mitter frequency generation scheme. While stable frequency generation is one of the critical portions of a wide coverage SSB transmitter, the over-all equipment presents other frequency control problems. A complete transmitter must provide for introducing modulation at a fixed frequency, and without multiplication converting and amplifying the output to cover the desired range without serious spurious emission and with an essentially linear dial system. Various systems of heterodyning and filtering have been used in other SSB transmitters, but none covering the required frequency range have been simple enough to receive serious consideration in this application. The problem is very much akin to running a receiver "backwards," with introduction of modulation occurring at the final IF frequency. Considerable study remains necessary before a definite system of conversion is adopted for vehicular application.

Heat Dissipation

In view of the increased output expected to SSB for a limited power input, it is immediately evident that heat dissipation will not be as much of a problem as in the AN/GRC-19. However, in the case of compatible AM transmission in which a steady carrier signal must be radiated, the losses would exceed AN/GRC-19 values if dynamotors were used. Concentration of the losses in the final amplifier tubes should allow a simplified cooling design. Here, the efficiency improvement of semiconductor power supplies will be of great value in keeping the over-all equipment power loss at a minimum. The power losses for SSB and AN/GRC-19 are shown in Table II below. Only PA plate loss, antenna network losses, and power supply losses are included.

TABLE II
POWER LOSSES—COMPARISON

AN/GRC-19	385 watts
SSB:	
with dynamotor supply*	223
with semiconductor supply†	137
SSB Compatible DSB:	
with dynamotor supply*	529
with semiconductor supply†	293

* Dynamotor efficiency 50 per cent.

† Semiconductor supply assumed efficiency 80 per cent.

Voltage Breakdown Considerations

It is a well-known virtue of SSB transmitters that a considerably higher sideband power may be delivered without exceeding peak voltages encountered in AM equipment. A 400-watt SSB transmitter has a peak output voltage equal to that of a 100-watt AM transmitter. Increasing the SSB output to a level of 12 db greater than the AN/GRC-19 would result in a sideband output of approximately 790 watts. The peak voltage at this output would be $\sqrt{790/400} = 1.41$ per cent of that encountered in the AN/GRC-19. Fig. 8 shows the relationship between SSB transmitter talking power improvement, relative to AN/GRC-19 vs per cent AN/GRC-19 output circuit voltage. Thus, for the same output volt-

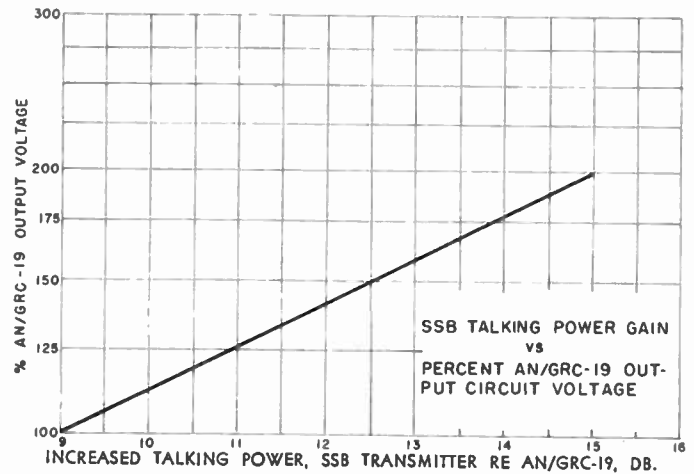

Fig. 8

age a 9-db improvement can be realized with SSB.

For the power level of interest, 790 watts, the AN/GRC-19 output circuit components must be increased in rating to safely handle the 41 per cent increase in voltage. However, the average power output will not exceed that of the AN/GRC-19, even when compatible AM is transmitted. Therefore, no additional provision for heat dissipation in the output circuit need be considered.

Space Problems

While it appears that voltage breakdown problems relating to the proposed SSB transmitter are not major, some additional space above that occupied by corresponding AN/GRC-19 components may be required. This is not clearly the case, but certainly appears reasonable. Both the SSB transmitter and receiver are, however, being called upon to perform functions that obviously require considerably more circuitry than now contained in the AN/GRC-19. It is probable that the frequency-control circuits alone will require nearly as many stages as the entire present equipment comprises. To solve this problem, transistorization, as discussed below, is a first order solution. It is hoped that another major space saving may be effected by the use of electrically-tuned circuit elements. The slug racks, pinion drives, and assorted machinery for the transmission of dial manipulation to the slug racks are in themselves bulky, expensive, and complex. In addition, the mechanical clearances which must be provided for the slug racks are considerable, and coils must be proportioned to permit proper slug insertion. The application of electric tuning is discussed in the following section.

APPLICATION OF ASSOCIATED TECHNIQUES

Transistorization

Transistorization of all receiver stages except rf stages and vfo has already been achieved in an experimental model of radio receiver R-392. The use of transistors for the rf stages depends upon the availability of low-noise transistors and their performance in the presence of strong interfering signals. To match the tube per-

formance the transistors must not degrade the signal-to-noise ratio due to equivalent input resistance by more than 1 db. In a vehicular set the problem of operating a number of sets in close proximity to one another becomes serious, causing blocking and cross-modulation of nearby receivers. The R-392 receiver uses tubes employing 26 volts on all elements which makes the front end interference problems more difficult than in a conventional receiver, however, by dint of much engineering, a usable characteristic has been obtained. The allied problems when using transistors are not yet known. Additional progress in the state of the art of circuitry, and probably of transistors, is necessary before a transistor vfo can be built with as high a stability as has been achieved with tubes. Neglecting these two trouble areas, a successful transistorized version of the R-392 has been built which gave equal or higher performance than the tube version.

In the transmitter no particular problems are envisioned for applying transistors to speech amplifier circuits, servoamplifiers, etc. Their use in frequency-control circuitry has already been demonstrated and with the advent of higher-frequency transistors there appears to be no reason why transistors cannot be used throughout the sideband generator and exciter up to the grid of the driver tube. A fascinating possibility exists in the use of transistors to replace the dynamotors in the transmitter. Transistors of sufficient power handling capacity are now available to permit replacement of the dynamotor for the low B voltage, PA grid bias, and ac servo input requirements. It is even feasible at the current state of the art to use a multiple number of transistors of high-power capacity to supply the PA plate and screen requirements, but the problem is to do this in the available space and over the temperature range. One feels that this technique is "just around the corner" with the advances being made in transistors.

Electric Tuning

Developments, during recent years, of materials and techniques for obtaining reactances controllable in magnitude by the application of dc control voltage, offer an attractive mechanism for realizing electric tuning of circuits without the need for mechanical motion. Stemming from the saturable reactor and magnetic amplifiers, controllable rf inductors depending upon the variation of core permeability with degree of saturation have become available. Considerable work has been accomplished in the development of controllable capacitors dependent upon the variation of dielectric constant of certain materials with dielectric stress. These devices have been employed to a limited extent in electric tuning problems. The variable inductor is essentially a low-voltage significant current device while the variable capacitor is a high-voltage negligible current device. Both of these components suffer from a lack of temperature stability, aging effects, and lack of retraceability of the reactance vs control voltage characteristic. At the present time the variable inductor appears to offer the

most attractive characteristic for the problem at hand.

The lack of retraceability of the variable inductor is the most serious problem in applying this technique to the tuned circuits of the exciter and sideband generator of the vehicular radio set, and is caused by hysteresis effects in the core material. In special applications, as for example a search receiver, this has been overcome by always tuning in one direction. Feedback techniques have appeared in the literature.¹¹ Experimental work at SCCEL has indicated that rather precise control may be obtained by degaussing the core with ac prior to tuning to a desired point and then applying the correct control voltage for the frequency. This offers no particular problem in tuning a transmitter or receiver to a desired frequency. When the receiver is used free wheeling, that is, tuning back and forth looking for a signal rather than tuning to a specified frequency, a problem is raised. One approach that seems to be possible would periodically degauss the inductors at a sufficiently high rate that sufficient accuracy would be obtained to meet the speed of manual tuning back and forth. If a high enough degaussing frequency can be used and the degaussing time can be made sufficiently short and the degaussing duty cycle can be shortened it appears that the circuits can be tuned without operator annoyance. The periodic degaussing would only take effect during actual tuning. There is no intention at the current state of the art of applying electric tuning to the precision variable oscillator but rather to the tuned selective circuits which can stand a mistracking error of the order of 1 db.

The mechanical control to the front panel is then envisioned as direct drive of the oscillator and ganged potentiometers. Two other problems are of importance in applying electric tuning, namely accuracy of the applied control voltage and calibration correction means for obtaining straight-line frequency tuning of the variable inductors.

CONCLUSION

The need for improvements in hf vehicular radio sets and the areas where these improvements can be obtained have been shown. The adoption of SSB in this class of set promises worthwhile improvements, particularly in the area of increased circuit reliability. Adoption of other techniques such as transistorization and electric tuning are shown to offer substantial improvements in themselves as well as contributing toward the adoption of SSB in the class of equipment. The state of the art appears ripe for exploitation in the design of a new hf vehicular set to meet the needs of the Army.

ACKNOWLEDGMENT

It is desired to acknowledge the many contributions of the following Radio Corporation of America personnel who participated extensively in the program under Contract No. DA36-039 sc-64683: B. A. Trevor, E. O. Selby, K. G. MacLean, H. E. Goldstine, and J. Kilgore.

¹¹ A. L. Kaufman, "Circuit design with controllable inductors—II," *Electronic Design*, vol. 2, p. 24; May, 1954.

Single-Sideband Techniques Applied to Coordinated Mobile Communication Systems*

ADAMANT BROWN†, SENIOR MEMBER, IRE

Summary—There has been increasingly widespread use of radio to replace wire and cable in telephone communications systems. Most of it, however, has been applied to telephone trunks between switchboards or for private line application. Use of it on a large scale for subscriber lines into a switchboard has never been considered economically acceptable due to the extravagance of the frequency spectrum requirements, cost of equipment, and numerous undesirable technical problems. The radio central system described in this paper promises to provide radio subscriber lines with sufficient bandwidth economy to make them worthwhile for mobile subscribers.

The requirements of such a mobile communications system are discussed with particular attention being given to their effects on the choice of a modulation technique. It is shown that single-sideband techniques are well suited for application to coordinated mobile communication systems, and overcome many of the technical difficulties associated with other methods of modulation.

Problems of interference, automatic frequency control, and systems stability are discussed. Methods of reducing the effects of the intermodulation distortion and resulting cross-channel interference that occur in the input stages of a broad-band radio receiver are given. One solution is suggested to selective calling on a single-sideband coordinated communications system having relatively poor frequency stability.

INTRODUCTION

IN GENERAL, the advantages of single-sideband techniques are associated mainly with the high-frequency spectrum, where its properties are used to alleviate the effects of sky wave propagation, increase intelligence power and provide reductions in bandwidth requirements. By combining single-sideband techniques with a coordinated communications system,¹ a communications system suitable for mobile-to-mobile and mobile-to-fixed stations operating in the vhf and uhf portions of the spectrum can be realized. Such a system might be termed a "radio central system." A radio central system would provide service to a number of subscribers within a given geographical area, both for radio communications between the subscribers, and for access to a local and long distance communications network consisting of various radio relay and wire communications circuits. Such a system might well serve for mobile telephone service, taxicab systems, or police radio systems, or may serve all services simultaneously.

SYSTEM REQUIREMENTS

The radio central system should be a true radio equivalent of a local exchange as used in the wire telephone system and, therefore, each radio subchannel, whether serving as a loop or trunk circuit, must operate

as nearly as possible in the manner normally associated with wire communications.

As in telephone communications planning, great consideration should be given to the traffic load that will be imposed upon the system. This is related to the number of subscribers who are simultaneously connected to the system and to the peak load of all subchannels during the busy-hour operation of the system.

Following usual telephone practice, a further requirement is that of duplex transmission. This is important in any system intended to be used by subscribers who are in the habit of using wire line telephone procedures rather than the usual push-to-talk operation normally associated with radio communications. Recent studies have indicated that the rate of exchange of information is considerably greater when duplex transmission is provided.

Perhaps a more important reason for requiring duplex transmission is the difficulty of carrying push-to-talk control signals for a radio line throughout a wire network. Radio lines must therefore behave as nearly as possible in the same manner as wire lines.

Since it is economically unsound, both from a frequency and an equipment standpoint, to provide individual circuits for each and every subscriber, a system incorporating selective calling and an indication of a busy circuit to the various parties who share the same channel must be provided.

An additional requirement which will be imposed upon the system is a means for handling reverting call circuits. A reverting call circuit is a call from one subscriber to another subscriber on the same party line, that is, who share the same subchannel frequency.

Other requirements are subscribers of the radio central must be capable of complete mobility at all times; conservation of frequency spectrum must be a primary consideration; and in the case of subscribers who operate an emergency type service, provision must be made to continue communications on a direct subscriber-to-subscriber basis during times when the radio central, for any of various reasons, may be out of operation.

EQUIPMENT FACILITIES REQUIRED

Mutual access must be given to subscribers of the radio central and to other subscribers in other areas who may be on wire lines, radio relay circuits, or other types of voice facility. This essentially means that the facilities at the radio central must include a switchboard, either manual or automatic, with provision for signalling the switchboard, provision for indicating busy circuits, and the use of alternate circuits in the

* Original manuscript received by the IRE, September 4, 1956.

† U. S. Signal Corps Engrg. Labs., Fort Monmouth, N. J.

¹ Charles F. Hobbs, "Techniques for close channel spacing at vhf and higher frequencies," *Proc. IRE*, vol. 40, pp. 329-334; March, 1952.

case of urgent calls. All this must approach as nearly as possible the normal facilities and procedures associated with wire line telephone circuits.

Communications must be duplex rather than push-to-talk. This requirement implies that both transmitting and receiving equipment must be in operation at the same location simultaneously. This would present a formidable problem if it were attempted to use the usual techniques such as single channel am and fm circuits as presently used in the vhf and uhf bands. Some degree of workability could be achieved, however, by assigning an entirely different widely separated block of frequencies for transmission and for reception. Considering the guard bands required, in order to eliminate various intermodulation products and spurious interferences, and the number of antennas and receivers required at the central, the use of individual separately-assigned frequencies would tend to use a quantity of spectrum far out of proportion to the service provided, as well as to produce an almost insoluble engineering problem. In ordinary single-channel use of the vhf and uhf spectrums, even with channel splitting, about 20 times as much spectrum is used as is needed to provide communications.

The number of subscribers and the number of subchannels available in a radio central must be consistent with the traffic loading capability. Affecting this is a situation in which a subscriber desires communication with another subscriber sharing the same subchannel, *i.e.*, a reverting call. One way of providing this service is to give each subscriber two alternate subchannels. This normally increases traffic handling capabilities for a given number of circuits. During a reverting call condition, however, two of the channels would be occupied rather than one.

It is possible to provide a "simulated" duplex operation on one subchannel. This involves the additional complication of voice controlled gain adjusting circuits at the radio central.² For purposes of this paper it will be considered that the alternate channel provision is adequate.

COORDINATED COMMUNICATION

By coordinating the communication of a particular area, service or group of persons with a common interest, spectrum use can be made more nearly consistent with communications requirements. Guard bands would only be required between systems. These guard bands could actually be smaller, since only one adjustment is required in each radio central system to correct the frequency of the entire group. There have been numerous proposals in recent years for coordination of radio systems.^{1,3,4}

² G. W. Barnes, "A single-sideband controlled-carrier system for aircraft communication," *Proc. IEE, (London)*, Part III, vol. 101, pp. 121-135; May, 1954.

³ "FCC Hearing on Possible Use of Frequencies 470-500 mcs for Mobile Telephone Service," FCC Docket No. 8976.

⁴ "Hearing Before Federal Communications Commission on Allocation of Radio Frequencies," FCC Docket No. 8658.

ADVANTAGES OF SINGLE SIDEBAND

The primary object of this paper is to show that single-sideband techniques of modulation are the most suitable for radio central application. A brief review of some of the advantages of single sideband is in order. While these points have been recounted in numerous articles and publications, they are reviewed here for the benefit of those who are not fully conversant with the technicalities of single sideband.

Single sideband offers the equivalency of higher transmitted power when compared to double-sideband systems. Various ways may be used in expressing the equivalent power gain, depending upon which transmitter parameter is considered to be fixed. The most commonly used figure is 9 db, which is arrived at by eliminating the carrier and adding the carrier power to the intelligence power. This is equivalent to a 6 db improvement. Three more db are added for the equivalent reduction in noise bandwidth. In all, a total of 9 db improvement is realized. On a primary power input basis, this figure is even greater, approaching 18 db, since very little power is required during periods between syllables and words of a transmission.

There is also an improvement in transmission characteristics during various multipath propagation conditions, which is not included in the 9 db figure. This improvement may be explained in several ways, such as elimination of harmonic distortion caused by carrier fading, and elimination of frequency distortion caused by the two sidebands phasing one another. The latter advantage, however, is not particularly noticed in the vhf and uhf bands.

In all, a single-sideband system may be considered as much as ten or more times as powerful as a conventional double-sideband system with the same transmitter power output.

Since we are discussing mobile applications, a very important point which cannot be overlooked is the reduction of antenna and antenna feeder voltages, and the reduction of power source requirements which may be obtained with no loss in effectiveness of communications.⁵

Spectrum economy is automatically realized by the use of single sideband. In view of the fundamental limitations of the radio frequency spectrum, reductions of bandwidth are a necessity in order to avoid hopeless overcrowding. This is an immediate need, inasmuch as the portion of the radio frequency usable for communication is very nearly approaching the hopeless classification today.

As opposed to frequency modulation techniques, single-sideband modulation signals are always heard in direct proportion to the strength received when two or more signals are being received simultaneously. Certainly the capture effect available in fm has advantages in certain situations. For example, in high-fidelity fm

⁵ A. Brown and R. H. Levine, "Single sideband for mobile communications," 1953 IRE CONVENTION RECORD, Part II, p. 123.

broadcasting it is desired that all signals except the strongest one be suppressed. The same phenomenon, however, can work to great disadvantage. For example, an interfering signal only a little stronger than the desired signal will almost completely exclude the desired signal.

Although the signal-to-noise ratio when using fm techniques may be somewhat better when signals are well above the noise level, as soon as the desired signal strength becomes weak, the signal-to-noise ratio of frequency modulation rapidly deteriorates. Beyond this maximum fm range, however, single-sideband techniques still provide sufficiently good signal-to-noise ratios to effect an adequate exchange of communication.

Single-sideband signals with suppressed carrier, when received simultaneously, will not produce heterodyne whistles, which psychologically tend to reduce the rate of exchange of information. The desired signal may still be heard even though the interfering one is stronger.

RECENT ADVANCES IN SINGLE-SIDEBAND EQUIPMENT

The application of single sideband to mobile communications, even in the hf spectrum, would have seemed extremely dubious and visionary only a few years ago. Since that time rapid advances have been made in the techniques necessary for single-sideband operation. These include: simplification in the design of linear amplifiers, improved tubes, the development of small mechanical filters with required ruggedness and stability, improved frequency control methods, improved crystals and crystal ovens. All of these techniques are covered adequately by papers in their respective fields.

A TYPICAL RADIO CENTRAL SYSTEM

In order to describe the operation of a radio central system which will meet the requirements previously stated, a somewhat hypothetical system has been chosen. The system consists of a multiplex single-sideband system with eight voice subchannels and a reference carrier, used for frequency correction and signaling, spaced some 75 kc from the voice channels. Signals from the subscribers are single-sideband, reduced carrier, and are assigned in a band 10 mc above the central transmitter frequency. All frequencies in the following discussion are for purposes of explanation only.

Fig. 1 is a block diagram of both the transmitting and receiving portions of the equipment at the radio central. The upper part of the figure is the transmitter portion of the radio central and the lower part is the receiver portion of the radio central. It can be seen by studying the diagram of the transmitter portion that the voice frequencies modulate crystal-controlled subcarrier frequencies at 425 kc for channel 1, and thence at 5 kc intervals through 460 kc for channel 8. The subcarrier and lower sidebands are removed by means of

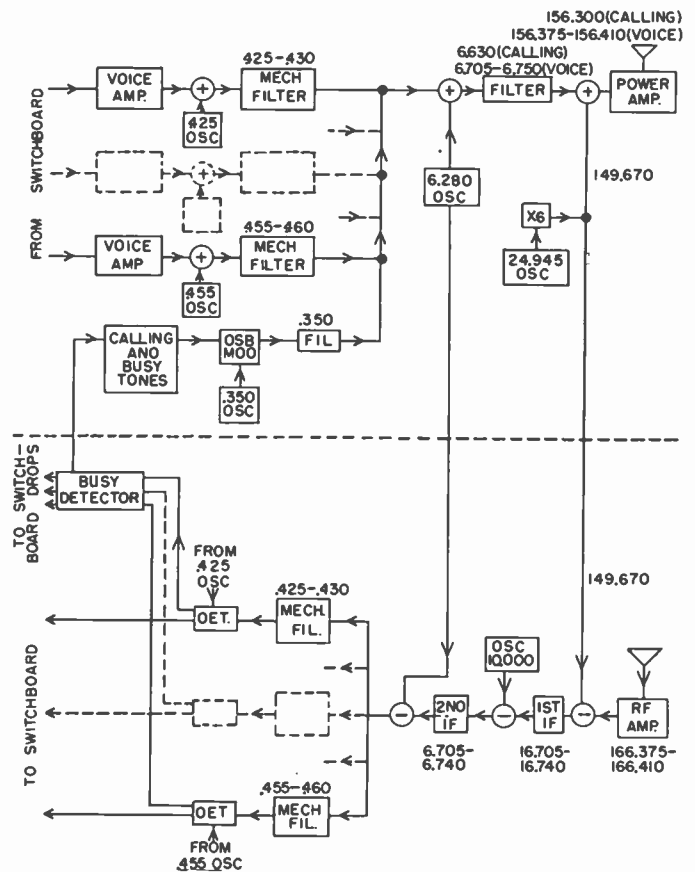

Fig. 1—Radio central transmitter and receiver block diagram.

a balanced modulator and a mechanical filter with approximately 3 kc band-pass. Each channel has its own mechanical filter.

A reference frequency is generated by the 350 kc crystal-controlled oscillator. This is combined with the upper sidebands of the voice channels, converted in two heterodyning steps to the vhf band, and transmitted as shown in the spectrum diagram of Fig. 2(A).

The reference frequency which is shown in the spectrum diagram as F_0 serves two functions. It is used to correct the frequencies of received sidebands in the subscriber's receiver so that the subcarrier can be reinserted with negligible frequency error; and it is amplitude modulated by selective calling tones, thus acting as a carrier for them.

The subscriber's receiver, Fig. 3, accepts the spectrum as transmitted from the central and, after converting it to a lower frequency, selects the particular channel or channels associated with it and separates out the reference frequency from the intelligence channels by a different band-pass amplifier.

It can be seen by following through the block diagram how frequency errors are cancelled by adding and subtracting two frequencies which contain the same errors. The diagram also shows how the errors are cancelled out in the subscriber's transmitter. With respect to the local oscillator in the central station receiver, there is left only the negligible error between the 350-kc and

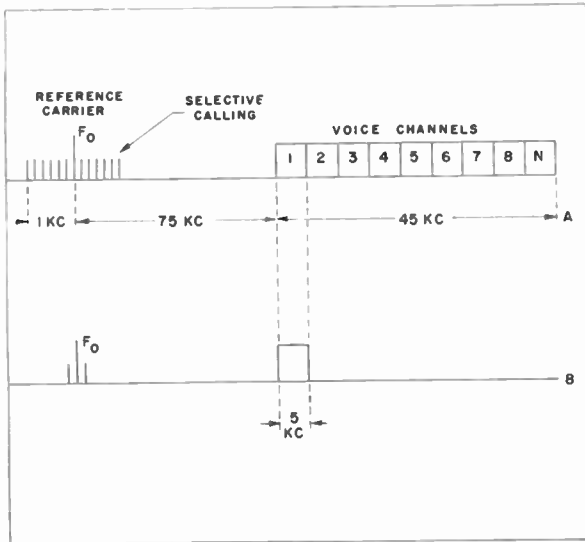

Fig. 2—Radio central transmitter spectrum. (a)—Entire spectrum transmitted by the central; (b)—Portion of spectrum selected by subscriber no. 1.

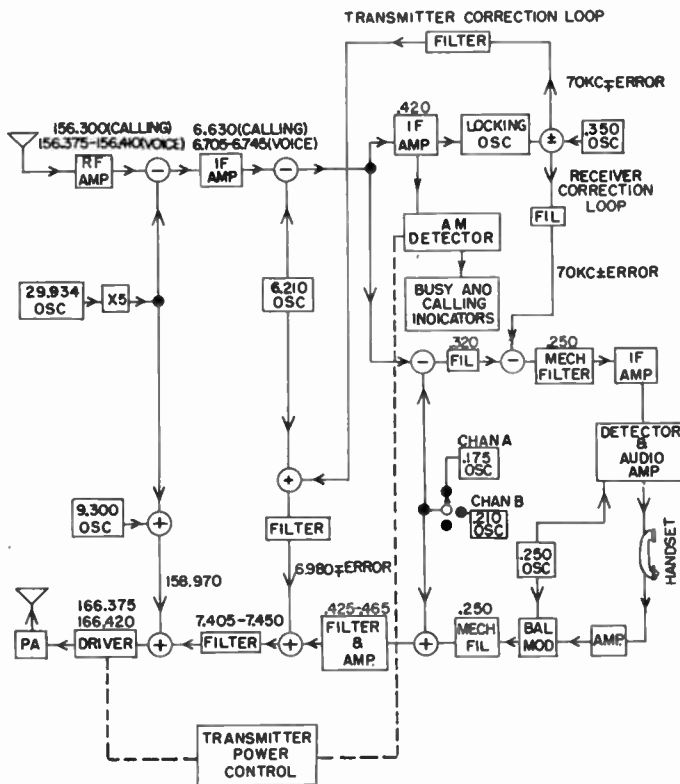

Fig. 3—Subscriber transmitter and receiver block diagram.

425-kc oscillators, plus an additional error, which can easily be kept within tolerable limits, caused by the offset oscillators, respectively, the 9.3-mc oscillator in the subscriber's transmitter, and the 10-mc oscillator in the central receiver. With 0.0002 per cent stability of the offset oscillators, a total frequency error of approximately 40 cycles would be expected due to drift of the offset oscillators. Articulation tests indicate that with signal-to-noise ratios as low as 6 db, an error of 50 cycles produces practically no loss in intelligi-

bility. With better signal-to-noise ratios, considerably greater frequency errors may be tolerated.

The spectrum transmitted from the subscriber's transmitter is shown in Fig. 4. These transmissions from the subscribers to the central station consist of single sidebands with partially suppressed carrier for each channel. This partially suppressed carrier is not necessary from a frequency controlling standpoint, but is required in order to actuate signals on the switchboard associated with the central and for assistance in the adjustment of gain of the individual channels of the radio central receiver.

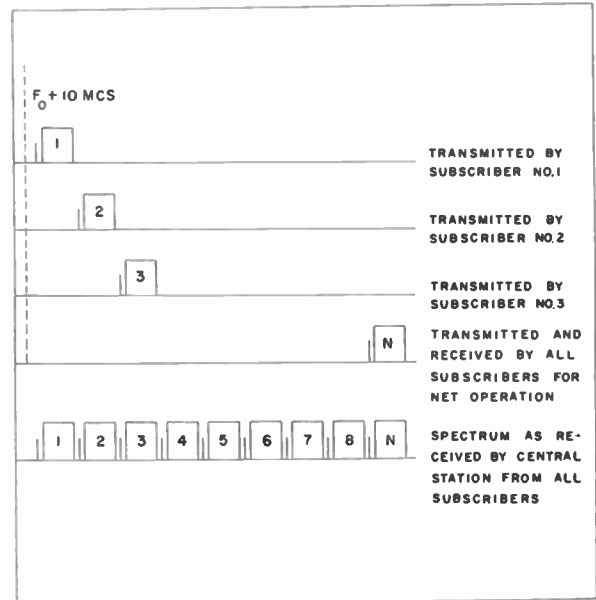

Fig. 4—Radio central receiver spectrum.

In order to make most efficient use of the radio frequency spectrum, the frequencies transmitted by different radio centrals would be interleaved with each other as shown in Fig. 5 on the following page. By so interleaving the intelligence and carrier channels of a number of radio centrals, some 15 radio centrals with 8 channels each could be accommodated in approximately 1 mc. This is not done, however, without geographical assignment of frequencies.

RECEIVER DYNAMIC RANGE

Probably one of the most difficult problems lies with the radio receiver associated with the central. This receiver is required to accept signals from subscribers which are close to the radio central and to subscribers who are near the fringe distance or in poor locations. These signal strengths may vary as much as 100 db in level and be on adjacent voice channels. The best dynamic range that one would expect of a broad-band input receiver is in the order of 55 to 60 db. There are, however, a number of things that can be done to improve the situation.

The use of single sideband from the subscriber's transmitter effectively increases the dynamic range of

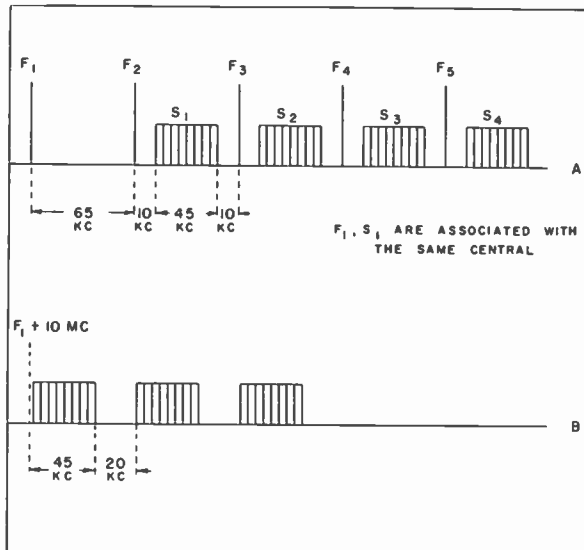

Fig. 5—Frequency assignment spectrum for radio central systems. A: Central station transmitters. B: Subscriber station transmitters.

the receiver. This improvement is approximately in proportion to the reduction in strength of the subscriber's subcarrier. It appears that an increase in effective dynamic range, approaching as high as 20 to 25 db, can be achieved with complete suppression of the subcarrier. Much of this improvement can be explained on the basis of comparing a continuous tone, the carrier, with the rather small and fortuitous time a voice signal is at peak amplitude.⁶ It is easily seen that this technique can only be used with some form of single-sideband modulation. Frequency and amplitude modulation in general require the use of full carrier.

Referring again to Fig. 3, it will be noted that there is a box labeled "transmitter power control" which is connected between the receiver reference carrier detector and the power output stages of the transmitter. This device is used to reduce the subscriber transmitter power as the subscriber approaches within close range of the radio central receiver. It is not necessary that this control be proportional, but can simply insert a fixed attenuation in the power output of the subscriber's transmitter. This attenuation may be on the order of 20 to 40 db. The radio central receiver individual sub-channel gain controls compensate for the reduction in subscriber power. This procedure results in an additional margin against overload of the system of from 20 to 40 db.

An additional device which may be employed to effectively increase the dynamic range of the radio central receiver is to employ a technique known as sideband spreading.⁷ The limited dynamic range of the receiver is due to the generation of odd (predominate 3rd order) distortion products produced in the mixer and rf stages. By simply leaving certain channels vacant it is possible

to have all the third order products which are generated directly by a voice channel fall in unused portions of the spectrum. By leaving a few more blank channels on third order products, both those directly generated and those generated by two or more channels can be eliminated. Even with full sideband spreading only approximately 8 kc average is required per voice channel. This is still a manifold improvement over the present single-channel techniques.

The use of all of the foregoing techniques can result in an improvement of from 60 to perhaps 85 db, thus making possible a radio central system dynamic range in the order of 115–145 db, which is far more than necessary for reliable radio central type of operation. It is not expected that the use of sideband spreading would be necessary.

SELECTIVE CALLING ON A SINGLE-SIDEBAND SYSTEM

In general, the frequency stability for the selective calling portion of the system exceeds that required or available for voice communication. It is desirable that the selective calling portion of the system function even though for some reason the system is not in perfect synchronization. This is done in the scheme discussed in this paper by making the selective calling portion of the subscriber's receivers independent of the automatic frequency control and carrier reinsertion used for voice reception. The selective calling signals are modulated on the pilot or synchronizing carrier on a double-sideband basis. Only a low percentage of modulation is necessary for this service since reception of the selective calling tones is done by extremely narrow filters.

CONCLUSION

The evolution of mobile communications, using present-day techniques, to the degree of performance and service considered standard for modern wire telephone service, is far from realization. Such performance and service are required, however, if full exploitation of mobile communications potentialities is to be realized.

The use of single-sideband techniques in combination with the radio central concept promises sufficient economy of bandwidth, increased signal-to-noise ratios, and convenience of operation to make possible the large scale use of mobile radio telephone service where present techniques are not economically feasible.

Concepts of radio-wire integration, and certain equipment design problems require further study. However, it appears that a workable system is now within the state of the art.

ACKNOWLEDGMENT

The author is indebted to R. S. Boykin, D. H. Hamsher, and E. A. Stega for valuable suggestions and assistance in the preparation of this paper. Portions of this paper are based upon work done under Signal Corps contract with Motorola, Incorporated. Appreciation is due Dr. W. L. Firestone and H. Magnuski for use of some of their material.

⁶ B. D. Holbrook and J. T. Dickson, "Load rating theory for multichannel amplifiers," *Bell Sys. Tech. J.*, vol. 18, p. 524; October, 1939.

⁷ E. H. Ullrich, "Ultra-shortwave communications," *Elect. Commun. (London)*, vol. 16, pp. 64–86; July, 1937.

Single Sideband in the Amateur Service*

GEORGE GRAMMER†, ASSOCIATE MEMBER, IRE

Summary—Single-sideband techniques are in wide use in the amateur hf bands allotted for radiotelephony, and the number of amateur stations equipped for SSB is growing rapidly. This paper touches briefly on the historical background of SSB in the amateur service, and outlines the operating characteristics that have proved to be most advantageous in meeting the special requirements of amateur communication. The broad categories of equipment in current use are described, and some of the problems peculiar to a service in which several modes of radiotelephony are used simultaneously in a frequency band, without channelization, are discussed.

BACKGROUND

ALTHOUGH single-sideband transmitters had been built and used by a handful of experimenters in the early 1930's, the present widespread use of SSB in amateur radiotelephone communication can be said to have had its origin in the development of the wideband 90° differential audio phase-shift network. The phase-shift method of generating a single-sideband signal, with its prospect of less over-all complexity and lower cost than the filter techniques then in use, excited considerable interest in the amateur world. This in turn stimulated development of filter-type equipment suitable for amateur use, an undertaking in which the availability of usable quartz crystals at very low cost from war surplus was an important factor.

In actual practice, the seemingly greater complexity of the filter method has turned out to be more apparent than real. Equipment for amateur use must be capable of operating at any frequency within several bands lying between 1.5 and 30 mc, and consideration of rf circuit behavior leads to the conclusion that the optimum design for a phasing-type transmitter is one in which the SSB signal is generated at a fixed frequency, just as in the case of the filter system. The end result is that there is little difference between the two systems in respect to number of tubes and circuits involved, when equal flexibility is stipulated. The recent availability of high-performance filters at reasonable cost has tended to reduce the cost differential.

Several factors have contributed importantly to the increasing popularity of SSB in the amateur service. The system has proved to give greater range and more consistent communication through noise and interference than amplitude modulation. It has also provided a more *natural* means of communication, since with voice-controlled transmitters and receivers, which are in universal use, it is possible to have "back-and-forth" communication similar to conversation over an ordinary wire telephone circuit. This is in contrast with the "monologue" type of communication generally em-

ployed when a carrier is transmitted. (In amateur operation, the carrierless SSB system lends itself more readily to satisfactory "voice break-in" than does AM, particularly when carrier-operated agc is used in AM reception.) These operating advantages are available to those unable to undertake design and construction, since manufacturers catering to the amateur market offer a wide variety of SSB equipment. Single sideband is now a well-established mode of communication in the amateur service.

CURRENT OPERATING PRACTICES

In the amateur service, communication is largely of a personal nature and is unscheduled. There are no assigned channel frequencies in the frequency bands allotted to amateurs, but simply subbands in which various modes of radiotelephony are permitted. Operation may take place on any frequency within such an assignment.

Operating methods, developed by experience, have reduced to the following:

1) All stations engaged in intercommunication, including more than two operating as a net, transmit on the same (eliminated or virtual) carrier frequency. This permits each station in a net to use a single receiver without retuning, for receiving each of the other stations.

2) The same sideband, *i.e.*, upper or lower, is used by all stations in a net. At times a pair of stations wishing to leave a net temporarily will do so by retaining the same virtual carrier frequency and switching to the sideband not being used by the net.

3) A form of rapid break-in closely simulating duplex operation is used. The switching may be done manually but in practically all cases is accomplished by using voice-controlled circuits. These circuits are adjusted for rapid "make" operation so that the transmitter is switched on practically instantaneously when the microphone is actuated. The release time of the holding circuit is adjusted so that the transmitter continues in operation during the intervals between words in ordinary speaking, but is shut off after a slightly greater pause—a time interval of perhaps one-half second, on the average.

The system usually includes an antitrip circuit enabling the use of a loud-speaker for reception; the sound from the speaker is balanced out, in the transmitting speech amplifier circuits, in such a way as to prevent its causing the transmitter to go on the air. The switching arrangement usually also includes a means for silencing the receiver during transmission.

4) Carrier elimination is as complete as possible. The use of a pilot carrier for automatic locking of the re-

* Original manuscript received by the IRE, June 29, 1956.

† Tech. Dir., Amer. Radio Relay League, West Hartford, Conn.

ceiver local oscillator is considered to be precluded by the conditions of operation in an amateur band. Since it is not unusual for two SSB nets to be working on nominal carrier frequencies separated only by a kilocycle or so, the presence of more or less continuous heterodyne interference from pilot carriers would be undesirable and sometimes destructive. Also, since both SSB and AM are operated in the same frequency assignments, there would be numerous occasions when an AM carrier would assume control of the receiver.

Operation is not on "spot" frequencies, but on a frequency selected to minimize interference from and to other stations operating at the time. Additional stations wishing to join the net must be able to adjust their transmitting frequencies to within a relatively small number of cycles of the frequency on which operation is already under way.

PERFORMANCE OBJECTIVES

Amateurs are fairly well skilled in the operation of their equipment, so that to some extent the burden of system performance can be shifted from the equipment to the operator. There are no formal performance standards for amateur SSB equipment, but the operating practices outlined above dictate certain requirements.

Frequency Stability

Long-term stability is not of primary importance since operation is on randomly-chosen frequencies within an assigned band. A high order of short-term stability (of the order of 100 cycles or less over a period of a few hours) is desirable because a frequency drift on the part of one or more stations in a net eventually will cause the demodulated signals from those stations to become unintelligible, unless all receivers in the net are manually retuned. This in turn requires either that all transmitting frequencies be readjusted to coincide, or that all receivers be manually retuned to each station as it transmits. The latter is impracticable when individual transmissions are short.

In this connection, it has been found that the tolerable error in the carrier frequency locally inserted for demodulation is of the order of 100–200 cycles, which is considerably greater than the generally-used figure of 50 cycles. Although speech does not sound natural with an error of this magnitude, it is intelligible after a little experience on the part of the receiving operator.

Frequency modulation and similar rapid variations in carrier frequency, usually associated with voltage changes in the oscillator circuit or changes in oscillator loading resulting from the operation of the modulator, tend to be destructive of intelligibility. Since the oscillator can be stabilized by voltage regulation and by adequate isolation from succeeding stages, no serious design problem is involved.

Carrier Suppression

Carrier suppression of the order of 40 db or more be-

low peak envelope output is readily possible. To maintain this, continuous monitoring of modulator balance is required, with manual readjustment as necessary.

Unwanted Sideband Suppression

The unwanted sideband can be attenuated 60 db or more in a properly-constructed filter-type generator using a mechanical filter or lattice-type quartz-crystal filter at 450 kc. Thirty to 40 db is more representative of simpler crystal filters. The theoretical attenuation of the commonly-used type of 90-degree audio phase-shift network is 39 db or more in the 200–2700 cycle range. The over-all system performance is usually degraded somewhat because of component tolerances and inaccuracy of adjustment of the 90-degree rf network.

Although the filter method is inherently capable of higher performance than the phasing method in this respect, in practice the difference is not marked because, assuming that the full capabilities of the phasing system are realized, the remnant sideband is masked by spurious products arising in subsequent frequency converters and linear amplifiers.

Suppression of Spurious Emissions

The most important of these are intermodulation products falling near the desired sideband. They arise principally in the linear power amplifiers, and to a lesser extent in frequency converters. With the phasing method there is in addition the possibility of somewhat similar spurious products resulting from distortion in the balanced modulators. While no accurate figures are available because of the difficulty of measurement under operating conditions, there appears to be no doubt that spurious emissions are of appreciably higher amplitude than the undesired sideband, in a properly-operated transmitter of good design. It is estimated that 30-db average suppression of unwanted emissions of all types, including the undesired sideband, represents good performance at the present time. Suppression of this order is sufficient (as compared with double-sideband transmissions) to effect a substantial reduction in interference in the amateur bands.

EQUIPMENT

In the United States there are five bands of frequencies allotted for exclusive amateur use in the hf part of the spectrum. These are of various widths, with their low-frequency edges in harmonic relationship—3.5, 7, 14, 21, and 28 mc. There are in addition frequencies available near 1800 kc and 27 mc on a shared basis with other services. In each of the exclusive bands there is a suballocation for radiotelephony, but these subbands are not in strict harmonic relationship. It is customary to provide for operation in all the exclusive hf bands in a given amateur equipment (vhf operation is not generally included in such a design). Based on this and the previously discussed considerations the over-all requirements for SSB equipment may be stated as follows:

1) Output in all of the exclusive hf bands, and preferably also in the two shared allocations.

2) Continuously-variable frequency control within each band (or subband, in the case of equipment designed exclusively for SSB telephony; *i.e.*, not including provision for cw telegraphy).

3) Selection of either the upper or lower sideband.

4) System performance in accordance with the objectives discussed in the preceding section.

Transmitting circuits designed to meet these requirements usually employ a single-sideband generator operating at a fixed frequency. The final operating frequency is achieved (ordinarily at a very low power level) by one or more frequency conversions. The number of conversions required is determined by the initial generating frequency and the necessity for achieving adequate selectivity to prevent radiation of spurious signals—images, harmonics of stages operating at frequencies lower than the final output frequency, and beats between such undesired responses—arising in the frequency-conversion process.

In both the filter system and the phasing system the audio bandwidth is approximately 3 kc, voice communication being the only objective.

Filter Method

A block diagram of a typical transmitting arrangement using a sideband filter at approximately 450 kc is shown in Fig. 1.

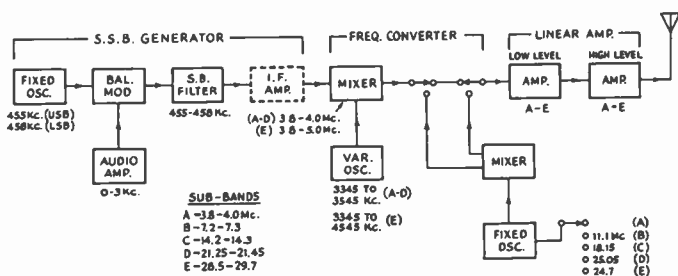

Fig. 1—Representative block layout of a filter-type single-sideband transmitter designed for use in the high-frequency bands assigned to the amateur service.

The SSB generating system is conventional (although there may be considerable variation in circuit details in different equipments) except possibly in the provision of two fixed-oscillator frequencies—455 and 458 kc in the example—for selection of either the upper or lower sideband. In the frequency converter the nominal 455-kc input is heterodyned up to the subband 3.8–4.0 mc. using a variable-frequency oscillator covering a 200-kc tuning range. This range is large enough to permit working throughout all subbands assigned for radiotelephony below 28 mc. The mixer drives one or more linear amplifiers directly, for final output in the 3.8–4.0 mc band. For the higher frequency bands its output is again heterodyned up, using fixed frequencies as indicated for the various subbands. This arrangement is

used to provide greater separation between the desired signal and its image than would be available with a single heterodyning step, more separation being desirable because of the lower selectivity per tuned circuit at the higher frequencies.

The assignment at 28 mc requires special consideration, since the subband in this region is wider in terms of kilocycles. It can be handled by changing the vfo circuit to cover a 1.2-mc range, 3345–4545 kc. in the example. The fixed-frequency oscillator in the frequency-converter system usually is crystal-controlled. Note that in some cases the sidebands are inverted in the frequency-conversion process.

The sideband-selecting arrangement places the initial carrier frequencies at suitable spots on the upper and lower skirts of the sideband-filter selectivity curve, in order to make use of the same filter for both upper and lower sideband. This is somewhat inconvenient since switching between sidebands requires readjustment of the variable-frequency oscillator in the frequency converter to compensate for the frequency change in the initial oscillator. This could be overcome, at additional cost, by using a single carrier frequency with a separate filter for each sideband. An inexpensive method is to change the vfo frequency discretely by the appropriate amount, simultaneously with the change in fixed-oscillator frequency. There is usually a small error in this method because of the difficulty of getting exactly the same frequency change at all parts of the vfo tuning range.

In equipment using inductance-capacitance filters the filter usually operates in the range 10–25 kc. Because of image considerations such systems have a first frequency conversion to the 450-kc region, after which the remainder of the transmitter is designed along the lines discussed above. The extra conversion in this case offers the opportunity for sideband selection without the disadvantage just mentioned, in that two beating-oscillator frequencies can be used in the process of converting to 450 kc. This is shown in Fig. 2.

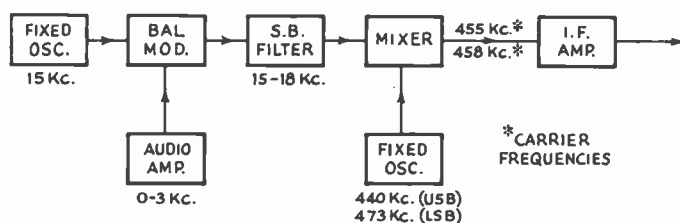

Fig. 2—Filter-type single-sideband generator using low-frequency LC filter with frequency converter to 455 kc. This circuit can be used as a substitute for the generator shown in Fig. 1.

Phasing Method

A transmitter using the phase-shift method of SSB generation can be designed along lines almost identical with the filter system, merely by replacing the balanced modulator and sideband filter in Fig. 1 by the appropri-

ate phasing-system circuits. A single fixed-oscillator frequency is sufficient since sideband selection can be accomplished by reversing the phase of the audio signal in one branch of the modulator system.

With the phasing method there is considerably more freedom in the selection of an initial frequency for SSB generation, since the phase-shift circuits will give practically identical performance at any frequency in the range discussed. The SSB signal can, in fact, be generated at the final operating frequency. However, the balanced modulators and rf phase-shift networks usually require some readjustment when the frequency is varied within a band, if peak performance is to be maintained. To avoid the necessity for this readjustment it has become common practice to use a fixed frequency for SSB generation and employ heterodyne methods with a variable-frequency beating oscillator for output frequency selection.

A particular combination that has had wide use is shown in Fig. 3. This provides output in either of two

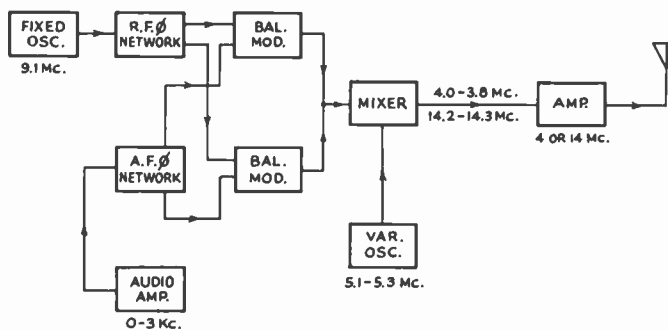

Fig. 3—Phasing-type generator and associated equipment for output at either 4 or 14 mc.

sub-allocations, 3.8–4.0 mc or 14.2–14.3 mc. (the bulk of SSB communication is carried on in these two sub-bands at the present time). The fixed SSB generating frequency is 9.1 mc. The two output frequencies are obtained from the upper and lower rf beats between 9.1 mc and the output of a variable-frequency oscillator covering 5.1–5.3 mc. Band-changing requires changing only the output tuned circuits of the mixer and succeeding amplifiers. For work in other suballocations there are available the alternatives of frequency conversion from either 4 or 14 mc, along the lines discussed in connection with the filter method, or substitution of appropriate vfo ranges for the 5.1–5.3 mc range shown in the figure.

Another method of band-changing, used in recently-introduced manufactured equipment designed for amateur use, is shown in block form in Fig. 4. In this case the SSB signal is generated at a series of fixed frequencies, one for each frequency band, and is beat against a variable-frequency oscillator to give output in the various sub-bands allotted for radiotelephony. This method has the advantage of requiring only one frequency conversion while using a vfo that operates over

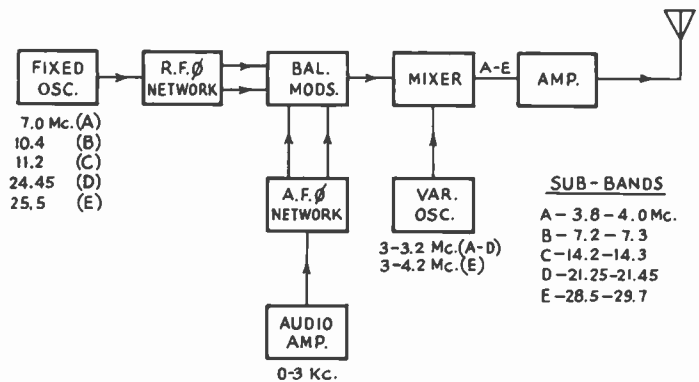

Fig. 4—Method of band changing based on using a single-range variable-frequency oscillator (for frequency adjustment within a band) and several fixed sideband-generating frequencies.

the same frequency range for any output frequency (except that the range is extended in the case of the widest band, 28.5–29.7 mc). It also has the advantage that either the sum or difference of the radio frequencies can be chosen at will without inverting the sideband relationship.

Linear Amplifiers

Circuits used in linear amplifiers conform more or less to standard practice, with increasing use being made of the grounded-grid type circuit because of its relatively constant grid-input impedance at different driving-voltage levels. Although the regulations governing the amateur service permit a maximum dc input of 1000 watts¹ the average power level is considerably less—probably in the vicinity of 200–300 watts.

Class AB1 operation of tetrode power amplifiers is much favored because of the very low driving-power requirements and the elimination of the grid-circuit regulation problems that accompany Class AB2 operation. Also to minimize such regulation problems, considerable use has been made of high- μ triodes of the type capable of being operated at zero grid bias with normal plate voltage, so that grid current flows at all modulation levels.

In one transmitter manufactured for amateur use a feed-back circuit has been incorporated to reduce distortion and spurious output, the suppression for this unit being rated at 35 db. However, such circuit modifications have not as yet come into general use.

Dynamic regulation of the plate-supply voltage of a linear amplifier has been given considerable attention, and the use of large values of output capacitance in the plate power supply filter has become common.

Receiving Equipment

A great deal of SSB work is carried on with communications receivers designed for AM and cw telegraph heterodyne reception, with no special features for single-sideband reception. The better receivers of this type

¹ As measured by the dc plate voltage and current, using a plate ammeter having a time constant not exceeding 0.25 second.

have for many years included quartz-crystal filters or means for obtaining comparable selectivity at the intermediate frequency (approximately 450 kc). Such selectivity characteristics are adequate for realizing the receiving advantages of SSB. Since pilot carriers are not used in the amateur service, the absence of automatic frequency control for the local hf oscillator is not a handicap. The local carrier for signal demodulation is supplied by the cw beat-frequency oscillator. In conventional receivers of this type the agc system is carrier-operated and becomes inoperative when the beat-frequency oscillator is used. Hence automatic gain control is not available and the rf gain must be controlled manually in order to keep the signal level at the demodulator below the limit at which distortion becomes objectionable.

Although the better-grade communications receivers of standard design meet many of the requirements for reception of SSB signals, a more favorable type of selectivity (flat-topped band with steep skirts) can be obtained and a more satisfactory demodulator employed by making use of an "adapter" circuit designed to operate from the signal as it exists in the IF system of the communications receiver. A representative adapter arrangement is shown in block form in Fig. 5. In prac-

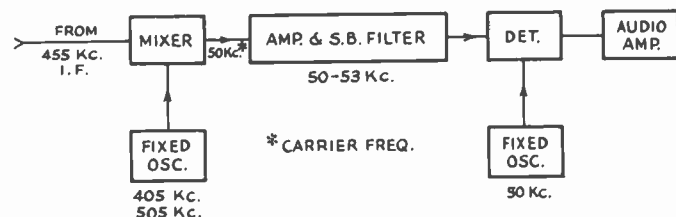

Fig. 5—Filter-type adapter circuit for use with conventional communications receivers.

tice, the additional IF amplifier (50–53 kc in this example) may lie anywhere in the frequency range 10–100 kc. The first fixed-frequency oscillator has two selectable frequencies so that the signal may be inverted, thereby providing for reception of either sideband.

Another type of adapter, shown in Fig. 6, utilizes the properties of 90-degree rf and af phase-shift networks to select one sideband and reject the other. As in the transmitting case, either sideband may be selected by reversing phase in one branch of the af network. For sideband selection, the system is used with a receiver having an effective bandwidth of approximately 6 kc.

A number of receivers incorporating the basic features of the circuit of Fig. 5 are now commercially available. In such receivers the first intermediate frequency usually is in the 1500–2000 kc region, with the second conversion to the low-frequency IF. This may be 50–100 kc in the case of receivers using LC filters, or 250–500 kc in the case of receivers using mechanical filters. Some recent models also incorporate agc systems that operate on carrierless signals and are not affected by the output of the demodulating oscillator.

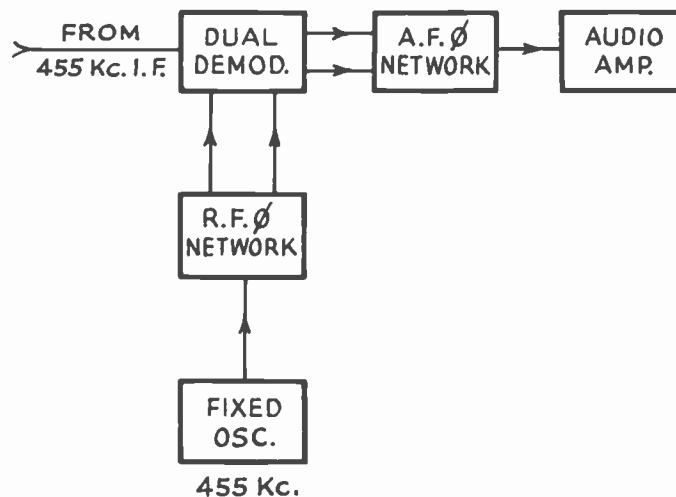

Fig. 6—Phasing-type single-sideband adapter for receivers.

CONCLUSION

There are now several thousand amateur stations equipped for single-sideband operation despite the fact that the use of SSB imposes, for the average amateur, comparatively severe technical requirements. Also, the technique of SSB operating under the conditions outlined requires skill and continuous attention to both receiver and transmitter adjustment. Partly because of these reasons and partly because of the overload characteristics of AM receivers with carrier-operated agc,² there has been continuing opposition to the use of SSB on the part of numbers of operators of AM equipment. Nevertheless, the use of SSB continues to increase at a healthy rate, attesting to its inherent superiority as a communication method in the amateur service.

The 2-to-1 reduction in bandwidth as compared with amplitude modulation has not been the dominant factor in the adoption of SSB by amateurs, although its importance is not to be minimized. In view of amateur operating conditions, the elimination of the carrier has proved to be even more beneficial. The most serious interference in an amateur telephony allocation is that caused by heterodynes between carriers, and by the demodulating effect of a strong carrier on a weak one, along with capture of the agc system of the receiver by the strongest of several carriers present in the receiver pass band. Eliminating this interference, together with the appreciable increase in sideband power possible with the same tube equipment as compared with amplitude modulation, not only has increased the reliability of communication many-fold but has provided opportunities for low-power operation that were practically nonexistent with conventional AM in the crowded amateur bands.

² In the presence of a carrierless signal, the receiver tends to overload at relatively low signal levels. The SSB signal has the appearance of being "broad" under this condition, effectively masking the fact that the actual bandwidth is less than that of a corresponding AM signal. With both AM and SSB operation in the same frequency assignment, the condition occurs frequently when conventional methods of AM reception are used.

Comparison of SSB and FM for VHF Mobile Service*

H. MAGNUSKI† AND W. FIRESTONE‡, SENIOR MEMBER, IRE

Summary—Mobile SSB and fm systems are compared on the basis of the same equipment size. The influence of the speech processing on the comparative results is discussed. It is concluded that SSB may provide a somewhat better range of operation with considerable spectrum saving but the signal-to-noise ratio in strong signal areas will be poorer.

INTRODUCTION

IN THE PAST, much consideration has been given to the use of SSB for fixed station communication at the low, medium, and high frequencies. In addition, SSB has often been compared to AM on the basis of equal total radiated power. The use of SSB for mobile service at vhf frequencies has been considered impractical because of the difficulty in obtaining the required frequency stability with this type of operation.

It is apparent that due to the expected improvement in spectrum utilization by the use of SSB, its application to mobile vhf service would be desirable if it could be achieved. In the past decade, significant strides have been made in building oscillators of greater and greater stability, and improved methods of selecting out and regenerating a carrier immersed in noise are now available. These two factors have made it possible to consider and build SSB for vhf mobile applications.

For the above reasons, it has been apparent that an expected performance comparison between SSB and fm in short range mobile applications is required.

BASIS FOR COMPARISON

Since the two systems (SSB and fm) are quite different, one must first agree what system features we are after and what equipments we are about to compare. For mobile operation, only voice modulation will be considered and the range of operation will be of primary importance to us. A curve predicting the signal-to-noise ratio vs attenuation inserted between the transmitter and the receiver would tell us the relative range of both systems. It is well known¹ from propagation theory that 12 db or more of additional attenuation inserted will result in doubling of the range in miles. It may also be mentioned that for range determination, threshold conditions and small s/n, approaching unity, will be of interest, and further, the results will not be the same as in strong signal areas, where the fm, due to the so called improvement factor, will, as a rule, provide a somewhat better s/n.

In comparing the equipment, the same operating frequency and the same receiver noise figure is assumed, but not the same bandwidth. Otherwise the receivers will not differ much in size, cost and complexity. A more difficult task is the transmitter comparison. In mobile applications, the size, cost and power drain are most important, hence, it is felt that the most logical assumption would be to have the same size equipments. It is further assumed that the size of the transmitter is a function of power dissipated in it, and furthermore, that most of the power is dissipated in the final rf power amplifier. Thus to simplify the assumptions, the following comparisons will be based on the same dissipated power in final rf amplifier tubes during the normal speech loading of the transmitter or to say it differently, the same output tubes will be used to their full capability in both transmitters. Fig. 1 shows the two transmitters built using this assumption and one may see that they look substantially the same and offhand no one could tell that the top one is a SSB transmitter.

We may add that this is perhaps the most disadvantageous assumption for SSB because the SSB transmitter operates in Class AB or B and is less efficient than a Class C fm transmitter, therefore the average output power and also the drain from the battery or other primary source will be lower. A comparison based on equal drain would be more advantageous for SSB by some 2 or 3 db, depending on assumed or measured efficiencies.

TRANSMITTER POWER LIMITATIONS

There is no problem in measuring transmitter power in fm systems and the power output, dissipation, and efficiency of the transmitter are substantially independent of modulation. Unfortunately, the same cannot be said of SSB, where both the power output and efficiency, and as a result the dissipation, are a complex function of the modulating signal. In general, little power is drawn and dissipated with no modulating signal applied, and, as the signal increases, the dissipation increases, as does the efficiency. The efficiency rises up to a maximum value at which distortion of the signal peaks usually occurs. This consideration is further complicated if a partially suppressed carrier is continuously transmitted as it is necessary to do in vhf SSB systems because of insufficient frequency stability. For a more detailed consideration of carrier reduction, the reader is referred to Firestone's paper.² For the purpose of the following comparison it is assumed that the carrier is reduced by

* Original manuscript received by the IRE, October 1, 1956.

† Motorola, Inc. Chicago, Ill.

¹ C. R. Burrows and M. C. Gray, "The effect of the earth's curvature on ground-wave propagation," *Proc. IRE*, vol. 29, pp. 16-24; January, 1941.

² W. L. Firestone, "SSB performance as a function of carrier strength," p. 1839.

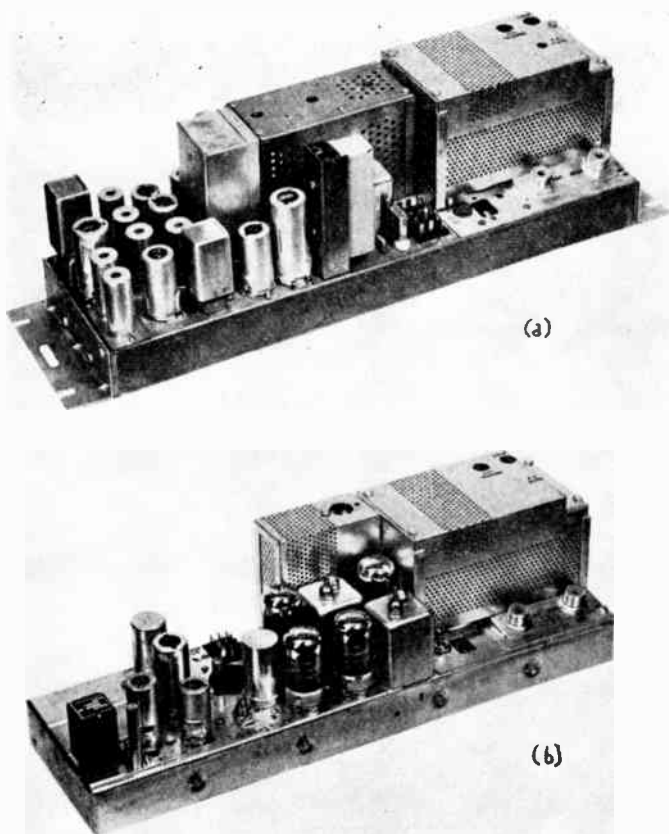

Fig. 1—(a) Single-sideband transmitter. (b) FM transmitter.

more than 13 db below the peak value of the sideband, thus having small effect on the total amount of transmitted sideband power, and that the receiver circuitry is fully capable of restoring such a reduced carrier for detection needs. Thus, to estimate the power output of a SSB transmitter, first it is necessary to describe the character of the modulating signal.

Fig. 2 represents typical power distribution in human speech vs time, as derived by the authors, as an extension of Davenport.³ We can see that the power peaks exceed the average power by some 20 db for short periods of time. On the other hand, for some 25 per cent of time there is no power at all. Obviously, to transmit such unmodified speech, the equipment would have to have a very high peak power capability vs average power. This would greatly decrease the transmitter efficiency and received s/n and therefore is never done. In an fm system, the maximum deviation is limited by the receiver bandwidth and cannot be exceeded without serious distortion and introduction of noise into the receiver. Thus, fm systems are very definitely peak limited. If we would have to transmit the modulating signal with high peak-to-average power ratio, through an fm system, then the average deviation would be very

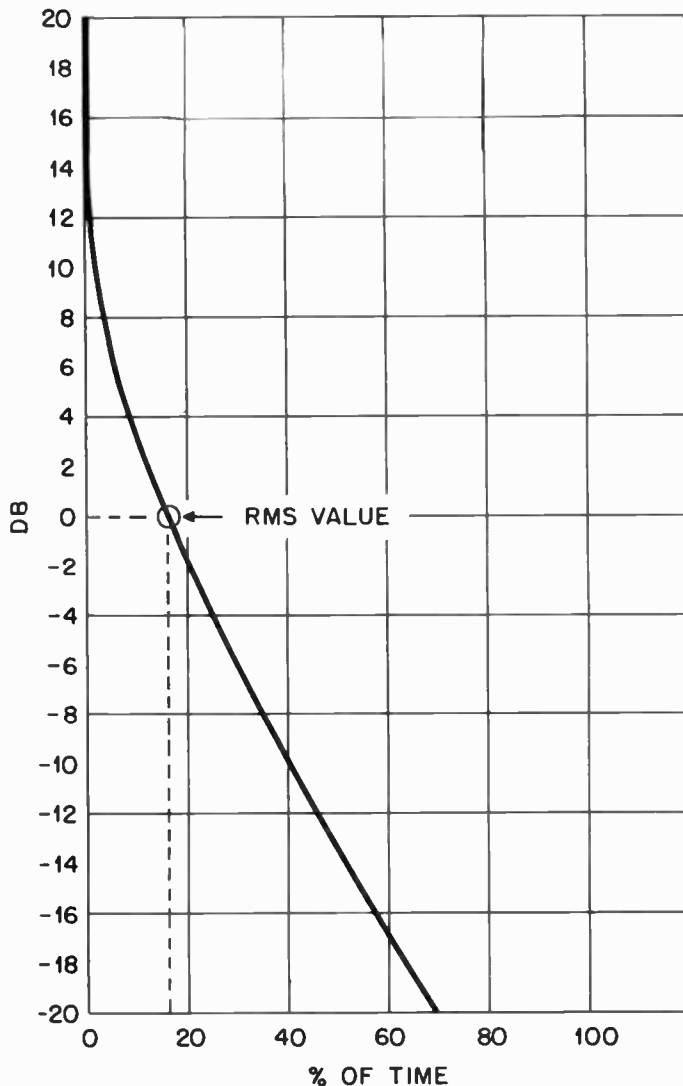

Fig. 2—Percentage of time voice spends above a given level.

low and the recovered s/n would also decrease in proportion. Such an fm system would look very bad indeed.

In a SSB system, there is not a definite peak power limitation and one can select the transmitter operating point and supply voltage in such a way that high peaks can be transmitted with relatively low average power. However, such a set up leads to a low average efficiency of the transmitter resulting in high dissipation and a small average output power gain. Therefore, all practical mobile systems do not transmit undistorted speech with unlimited peak to rms ratios and some kind of speech processing is always used to improve the received snr. The speech wave form distortions we refer to are not to be confused with the audible distortions as experienced by the human ear. Considerable waveform distortion can be tolerated by the ear before it senses any distortion.

SPEECH PROCESSING

By speech processing it is meant any scheme which distorts the original speech, including changing the ratio

³ W. B. Davenport, "A Study of Speech Probability Distributions," Res. Lab. of Electronics, Tech. Rep. no. 148; August, 1950.

of peak to average power and changing the amplitude vs frequency distribution. Speech can be processed in any number of ways and to any degree desirable and there are practically as many processes as there are engineers designing the equipment. Usually the processing consists first of clipping the peaks, second, emphasizing high frequencies and third, filtering the high frequency components (either existing in the speech or created by the clipping process), as well as low-frequency components which are difficult to transmit and deemed unnecessary to preserve the intelligibility of the speech. Deviation limiters, speech clippers, compressors, and other gain control amplifiers as well as preemphasis will all fall under these general categories of speech processing. It is not within the scope of this paper to discuss the relative merits of all the different methods of speech processing, and only two general statements will be made.

First, the more the speech is clipped or otherwise processed, the stronger the average speech power detected will be at the receiver and therefore the better the snr. This obviously helps legibility in high noise conditions. On the other hand, the more speech is processed the more distortion is introduced, which has the opposite effect. In general, a compromise has to be reached between these two factors in order to obtain the maximum possible intelligibility. In comparing fm and SSB systems, one can see that in an fm system a higher degree of speech processing will be desirable for best intelligibility than in single sideband, because the average deviation increases in proportion to the clipping of the peaks, while in SSB the average power usually changes only slightly with clipping, mainly due to the changes in transmitter efficiency. This is true only if the SSB transmitter design is optimized in each case for the particular processed speech it is expected to transmit. We can conclude that in the optimized systems, speech transmitted through the SSB system would be less distorted than in an fm system, in which a high degree of processing with attendant distortions are the accepted standard as anybody familiar with fm mobile reception can testify.

The second statement is that because of the differences in speech processing between different systems, the results of the comparison between fm and single sideband which are to be discussed, are only as good as the assumption made as to the speech processing. Practical systems, when compared, may differ a few db one way or the other depending on what kind of speech processing was included in them. Therefore, the answer to the question regarding which system will provide a better range and better s/n is relative and no complete agreement is expected between engineers, even after reading this paper.

In an fm system, we assume an intensive clipping or instantaneous deviation limiting giving a peak-to-average value of about 6 db (3 db more than undistorted sine wave). This assumption will also mean that

in fm the average detected speech power will be 3 db below the power of the test signal causing full deviation. For SSB operation, a statistical experiment on a small scale was performed in order to decide how much to process the speech for best intelligibility.⁴ The result of this experiment is shown on Fig. 3. This table shows the readability in signal-to-noise ratios of unity, -3 and -6 db and for different amounts of clipping. By s/n it is meant the average speech power (after it was clipped and filtered by a band-pass filter) to the average white noise power. One can see that one can clip the speech so that after filtering, the peak to rms ratio is reduced to only 9.5 db and still the readability (in noise, which is twice as strong as the average speech power) is 56 per cent, or almost as good as with unclipped speech which was 63 per cent. This condition was selected for comparison of the SSB and fm systems.

S/N db \ P _k /RMS db	PERCENTAGE READABILITY			
	0	-3	-6	-9
15.1	100	63	20	0
12.2	100	63	20	0
9.5	100	56	10	0
7.6	100	43	0	0

Fig. 3—Percentage readability for voice at various clipping levels.

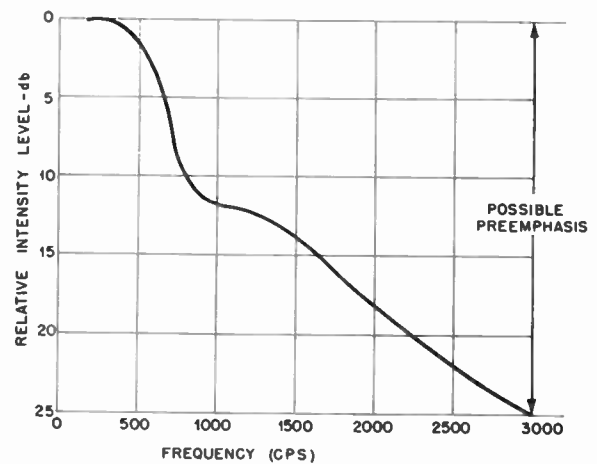

Fig. 4—Power vs frequency, distribution of speech.

Another processing assumed was preemphasis of high frequencies. Fig. 4 shows a typical power vs frequency distribution in human speech from Fletcher.⁵ One can see that high frequencies can be considerably preemphasized (up to 25 db at 3000 cps) to make the energy distribution uniform at all frequencies. The assumed preemphasis was 16 db at 3000 cycles for both systems. At the receiving end complementary deemphasis was

⁴ Lloyd Engelbrecht, "Clip Speech Study," unpublished Motorola Rep.; July 20, 1956.

⁵ H. Fletcher, "Speech and Hearing in Communication," D. Van Nostrand Co., New York, N. Y., p. 78; 1953.

assumed. It is to be noted here that in strong signal areas the deemphasis circuit benefits the fm receiver much more than SSB receiver because of parabolic noise power distribution in fm receivers. By deemphasizing the high-frequency response of the receiver, we also cut down the high-frequency noise and in fm systems most of the noise power is at the higher frequencies. The resulting noise spectra are presented in Fig. 5.

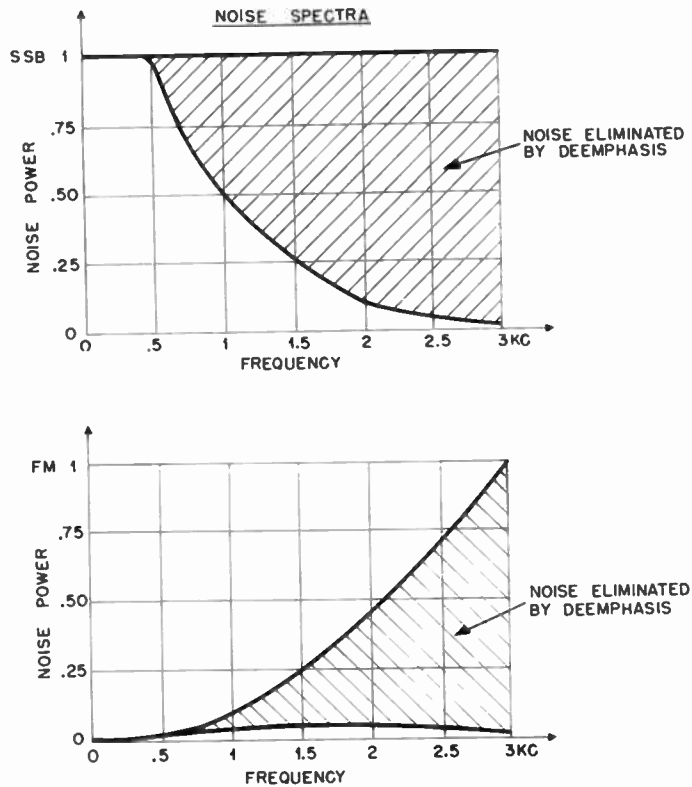

Fig. 5—Improvement in s/n ratio due to deemphasis.

FM—10.7 db
AM and SSB—6.8 db } relative advantage to fm 3.9 db.

These factors were evaluated⁶ and were found to be, for an fm system, 10.7 db advantage, and for a single-sideband system, 6.8 db advantage, over the systems not using preemphasis. However, this factor will not influence the range of the fm system as it will in the case of SSB, since it effectively narrows the bandpass of the receiver and thus decreases the noise power. This can be seen on Fig. 9, which will be discussed later, and shows that SSB has no breaking point as does fm (hence range is increased). Its importance in SSB should not be overlooked.

TRANSMITTER POWER

After one has decided on processing the modulating signal to be used with the SSB transmitter, an optimum transmitter design has to be considered. For a given output tube with a given maximum dissipation and a given plate voltage, the modulating signal (consisting of clipped speech) can be increased to a certain value

⁶ W. L. Firestone, "Noise Output from F.M. and S.S.B. Receivers," unpublished Motorola Rep.; February 24, 1956.

before one of two things occurs, 1) full tube dissipation may be reached, 2) the peaks may exceed the peak power capability of the transmitter and additional distortions and/or peak clipping may occur before the full dissipation is reached. To optimize the design of the transmitter, the selection of the supply voltage and tube operating point should be such that these two things, namely the full power dissipation and peak clipping, should occur at the same time. In this case, a maximum, average output power for a given processed speech input will be reached. One can see that a different transmitter design will be necessary for different assumed speech processing. Also, obviously some means has to be included to protect the transmitter from overloading in case the input signal is different from the one which was assumed for the design. Fig. 6 presents the com-

	F M	SSB
DC PLATE VOLTAGE	560V	625V
TOTAL INPUT TO RF AMPL.	120 WATTS	80 WATTS
DISSIPATION IN FINAL RF AMPL.	60 WATTS	60 WATTS
RF OUTPUT AVERAGE	60 WATTS	20 WATTS
RF OUTPUT PEAK	60 WATTS	178 WATTS
EFFICIENCY	50 %	25 %
RELATIVE OUTPUT	0 db	-4.7db
DRAIN FROM 12V POWER SUPPLY	27.8 AMPS 334 WATTS	17.4 AMPS 209 WATTS
RELATIVE DRAIN	0 db	-2db

Fig. 6—Comparison of transmitters.

parison of transmitter output powers for the experimental fm and SSB transmitters which were shown on Fig. 1 and were built, based on the above assumptions. One can see that the average power in the antenna of an SSB transmitter will be lower by 4.7 db. However, the consumption of supply power by the SSB transmitter is also lower by 2 db. The dc power supplies for both fm and SSB will be different but approximately of the same size. The fm supply will deliver more average power but the SSB will have a higher voltage and has to have a large peak power capability which is not required of the fm supply.

EXPECTED DETECTED SIGNAL-TO-NOISE RATIO CURVES

In calculating the s/n, first the bandwidth of the receiver has to be assumed in order that the relative noise powers can be calculated. It is assumed that the single-sideband receiver will have a noise bandwidth of 4.5 kc. This is somewhat larger than the 3.5 kc necessary for speech transmission because a margin of approximately ± 0.5 kc has to be allowed for carrier instability. In narrow band fm, a deviation of ± 5 -kc and a 12-kc bandwidth is assumed. In wide-band fm, a 15-kc deviation and a 35-kc bandwidth is assumed. Based on these assumptions, the noise power of each of the three receivers under consideration is tabulated in Fig. 7. The

	SSB	NARROW FM	WIDE FM	AM
DEVIATION KC	—	± 5	± 15	—
BANDWIDTH KC	4.5	12	35	8
(ASSUMING NF = 10 db) NOISE POWER WATTS - dbw RELATIVE	1.8 × 10 ⁻¹⁶ 157.4 0 db	4.8 × 10 ⁻¹⁶ 153.2 +4.2	14. × 10 ⁻¹⁶ 148.5 +8.9	3.2 × 10 ⁻¹⁶ 154.9 +2.5 db

Fig. 7—Receiver bandwidths and noise.

s/n in fm systems, as a function of carrier-to-noise ratio, is well known⁷ and curves of Fig. 8 show the expected s/n calculated for assumed deviations. Now combining the results of Fig. 6 (transmitted power), Fig. 5 (pre-emphasis), Fig. 7 (receiver noise) and Fig. 8, we obtain

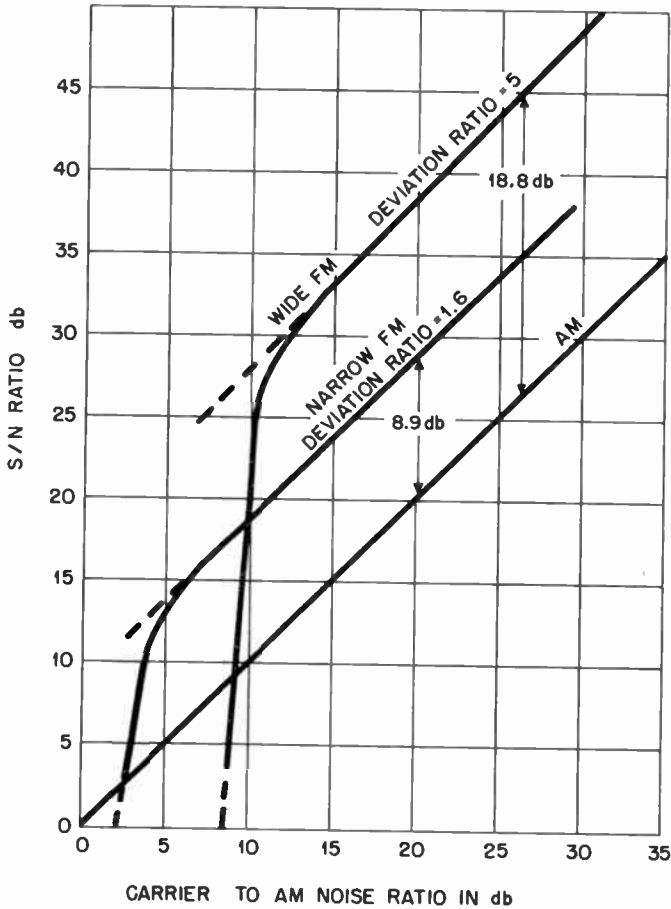

Fig. 8.

an over-all comparison presented on Fig. 9 which shows the s/n as a function of attenuation in db inserted between the transmitter and receiver. From this figure, one can see that the SSB system will give a somewhat larger range than both fm systems, but, on

⁷ F. E. Terman, "Radio Engineers Handbook," McGraw-Hill Book Co., Inc., New York, N. Y., p. 672; 1943.

	AM	SSB	FM NARROW	FM WIDE
CARRIER POWER WATTS dbw	20 ^① +13	20 +13	60 +17.7	60 +17.7
NOISE POWER dbw	-154.9	-157.4	-153.2	-148.5
ATTENUATION OF CARRIER TO MAKE IT EQUAL TO RECEIVER NOISE db	167.9	170.4	170.9	166.2
RELATIVE RATIO OF DETECTED SIGNAL TO CARRIER POWER db	-3 ^②	0	-3	-3

	SSB & AM	FM (NARROW)	FM (WIDE)
PRE-EMPHASIS db	6.8	10.7	10.7
FM IMPROVEMENT db	0	8.9	18.8
TOTAL	6.8	19.6	29.5

- ① BASED ON SAME SIZE EQUIPMENT AND EQUAL TOTAL DISSIPATIONS.
- ② AM IS PEAK MODULATION LIMITED SAME AS FM.

(a)

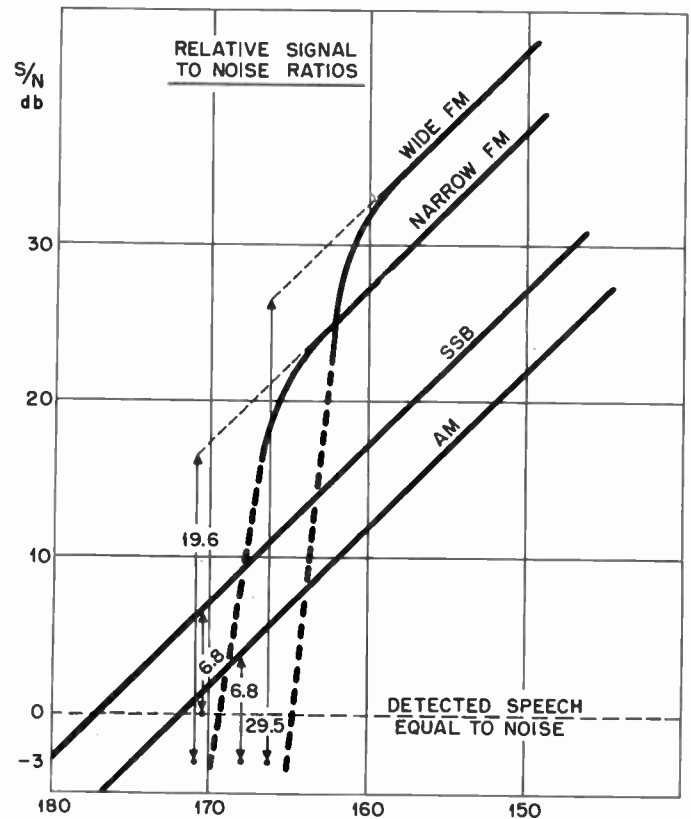

(b)

Fig. 9—(a) Detected signal power vs noise. Improvement factors allowed. (b) Attenuation between transmitter and receiver db.

the other hand, in the strong signal area will not provide as good a s/n as the narrower band fm and particularly the wideband fm system.

CONCLUSION

In comparing fm and SSB equipments for the vhf mobile service and assuming equal equipment size, we can draw the following conclusions:

1) The relative performance of single-sideband and fm systems depends considerably on the amount of speech processing and whether one or the other is better as far as range is concerned depends on what amount of speech distortion and what minimum s/n can be tolerated.

2) SSB provides approximately three times the savings in the occupied bandwidth as compared to narrow fm system and more than that as compared to wide band fm system.

3) It is expected that speech transmission through a SSB system should in average be somewhat less distorted than in an fm system, due to the smaller degree of processing which is necessary to obtain the best intelligibility in noise.

4) Consumption of primary power will be less in a

SSB system than in fm system of equivalent performance.

5) In strong signal areas fm systems will provide a better s/n than SSB systems. However, this fm advantage in mobile service may be disputed, since once we have a good signal, exceptionally good s/n is not necessary for intelligibility.

To sum it up, SSB equipment has a good chance of competing in the future with fm in mobile service and will provide as good or possibly better range with substantial frequency spectrum saving; however, its advantages in practical voice communication systems are not as great as one would suspect from some superficial comparisons of both systems as done in the past. Also, it is realized that there are quite a few problems to be solved before good, practical, and stable SSB equipment can be developed and produced. There are also other practical problems, for example, ignition noise which seems to be more severe in narrow band SSB system and which has to be eliminated by shielding of the ignition system or by additional impulse noise elimination circuitry in the receiver.

ACKNOWLEDGMENT

The many helpful suggestions by R. Richardson are gratefully acknowledged.

SSB Performance as a Function of Carrier Strength*

WILLIAM L. FIRESTONE†, SENIOR MEMBER, IRE

Summary—This paper shows the important part that the carrier plays in over-all system performance and in particular compares the various systems using full carrier, reduced carrier, suppressed carrier and controlled carrier. It is concluded that as the carrier is reduced, the factors of modulation splatter, transmitter efficiency, available peak sideband power, desensitization, and intermodulation all tend to improve. It is also pointed out that due to system stability requirements, complete suppression at the higher radio-frequencies is not feasible. Because there are many types of SSB receiving systems, each requiring a different amount of carrier for synchronizing purposes, it is necessary to consider all values of transmitted carrier to compare the resulting systems and to gain a better understanding of the system characteristics considered. The characteristics of the controlled carrier system are discussed for completeness.

INTRODUCTION

THE USE OF single sideband in transoceanic radiotelephone service and more recently in amateur radiotelephony and aeronautical com-

munication is well known [1-3]. Because the amount of transmitted carrier plays an important role in regard to modulation splatter, transmitter efficiency, power output, receiver desensitization, and intermodulation, as well as over-all system design, the question of "how much carrier to send" is a vital one.

When working at the lower radio-frequencies, it is possible to reinsert the carrier locally with sufficient accuracy so as not to require the transmitter to send a carrier for locking purposes. However, at the higher radio-frequencies, such as 150 mc, this is not feasible. Even if carrier stabilities of a crystal oscillator approach 0.0002 per cent, an error of 300 cycles can occur at the transmitter as well as the receiver. Consequently a total of 600 cycles of error is possible. Because an error of 50 cycles results in considerable distortion, an error up to 600 cycles is hardly acceptable. It is for this reason that at the higher radio-frequencies it is absolutely mandatory to send some amount of carrier for receiver lock-

* Original manuscript received by the IRE, October 19, 1956.

† Motorola, Inc., Chicago, Ill.

ing purposes. A completely suppressed carrier system therefore becomes impractical at most vhf frequencies.

It is the purpose of this paper to consider what effect the carrier amplitude has on the quantities of splatter, efficiency, etc., and to compare the following systems using, 1) a full carrier, 2) a reduced carrier, 3) a suppressed carrier, and 4) a controlled carrier.

MODULATION SPLATTER

In determining the quantitative effects of reducing the carrier on the splatter spectrum, it is first necessary to attempt a mathematical description of the linearity curve of the transmitter. For the purposes of analysis, such a typical curve is shown in Fig. 1 along with its

$$e_o = e_i - 0.05e_i^2 + 0.33e_i^3 - 0.15e_i^4 - 0.69e_i^5 - 0.5e_i^6 + e_i^7 - 0.10e_i^9$$

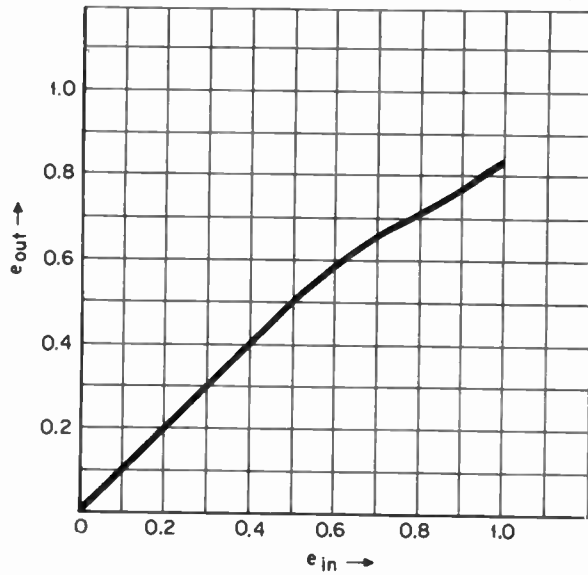

Fig. 1—Linearity curve of transmitter.

power series description.

$$e_o = e_i - 0.05e_i^2 + 0.33e_i^3 - 0.15e_i^4 - 0.69e_i^5 - 0.5e_i^6 + e_i^7 - 0.10e_i^9 \tag{1}$$

If we consider that the output of the transmitter consists of two signals of amplitude, *b* and *c* respectively, we may compute the spectrum generated by inserting for *e_i* the quantity

$$e_i = b \sin \omega_1 t + c \sin \omega_2 t, \tag{2}$$

and expanding appropriately.

Those spectrum components which fall back into the original band are of interest and are seen to be due only to the odd order type terms. Furthermore, care must be exercised in expanding (1) insofar as higher order terms generate lower order spectral lines in the band.

A graphic portrayal of the results of this analysis is shown in Fig. 2. It is clear that the radiated spectrum is a function of the nonlinearities (*a_n*) and the signal amplitudes (*b* and *c*). For convenience, let *b* sin *ω₁t* represent the carrier, while *c* sin *ω₂t* represents the side-

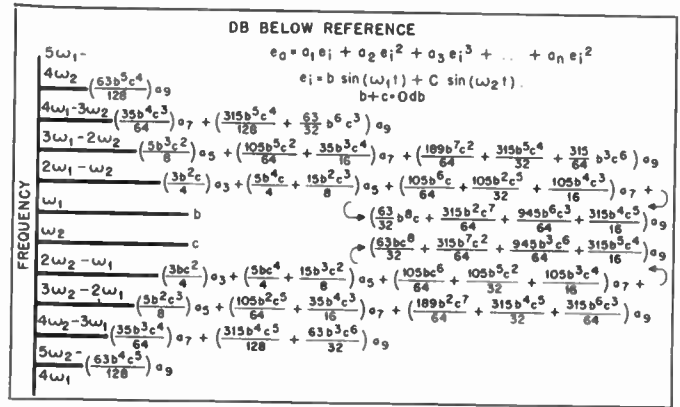

Fig. 2—Single-sideband splatter spectra due to nonlinearities.

band to be transmitted. While the ratio of *b* to *c* may vary as desired, unless otherwise stated it is always to be understood that the amplitude *b* + *c* = 0 db. This relation permits a fair comparison by assuring a peak signal limitation. This is necessary in order that the signal does not go into nonlinear regions not shown in Fig. 1. Fig. 3 shows a plot of the amplitude of the various side-

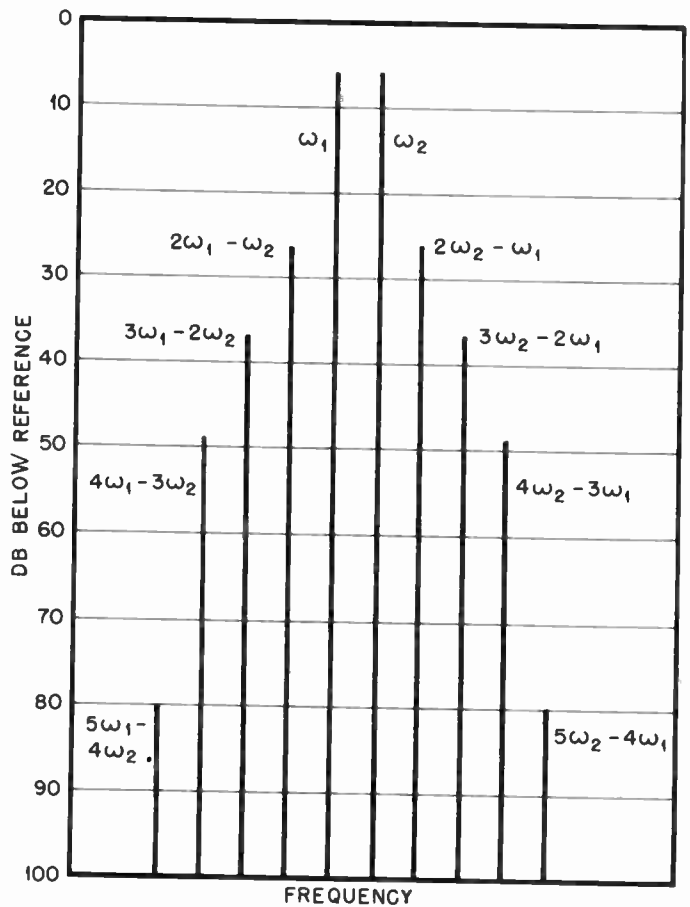

Fig. 3—Spectra from two equal signals.

bands when the carrier and sideband are of equal amplitude. Fig. 4 shows a photograph of a typical spectrum resulting from a SSB transmitter when *b* equals *c*.

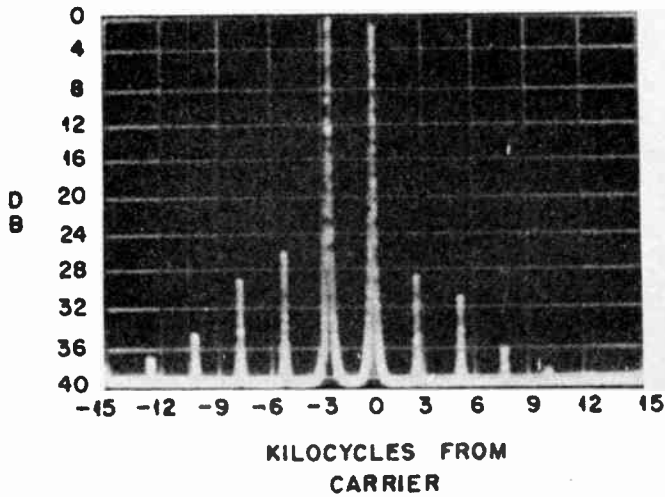

Fig. 4—Two-tone spectrum.

Fig. 5 shows the case where the carrier is nonsuppressed and the sideband is reduced by 12 db, while Fig. 6 shows the case where the carrier is reduced by 20 db and the sideband has its maximum value. By comparison

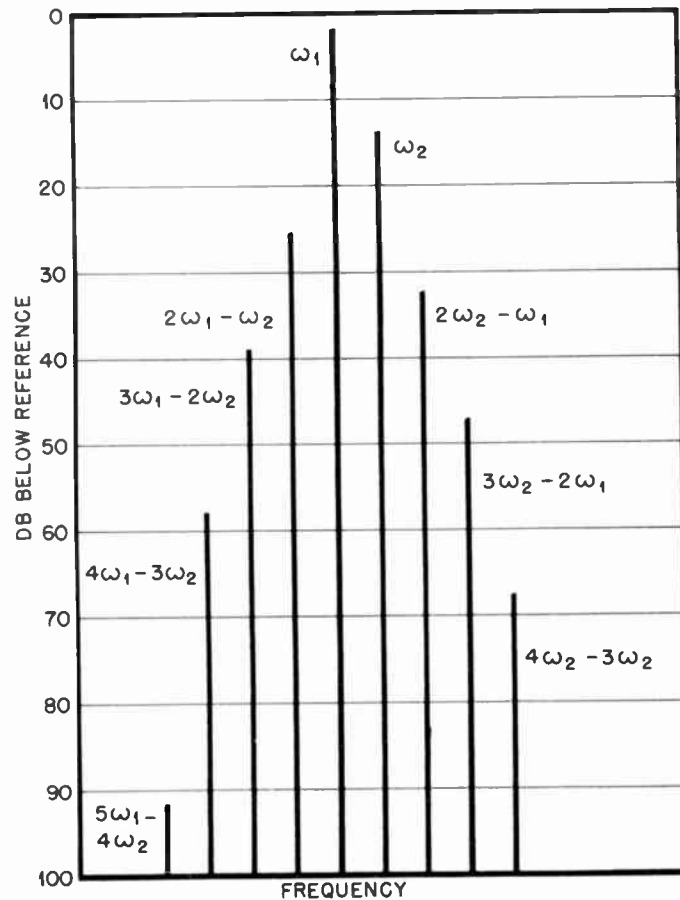

Fig. 5—Single-sideband spectra nonsuppressed carrier.

of Figs. 5 and 6 with Fig. 3, it becomes clear that the splatter (terms other than w_1 and w_2) is nonsymmetrical. This is also clear from Fig. 2, where it can be seen that the coefficients to the right of w_2 are always associated

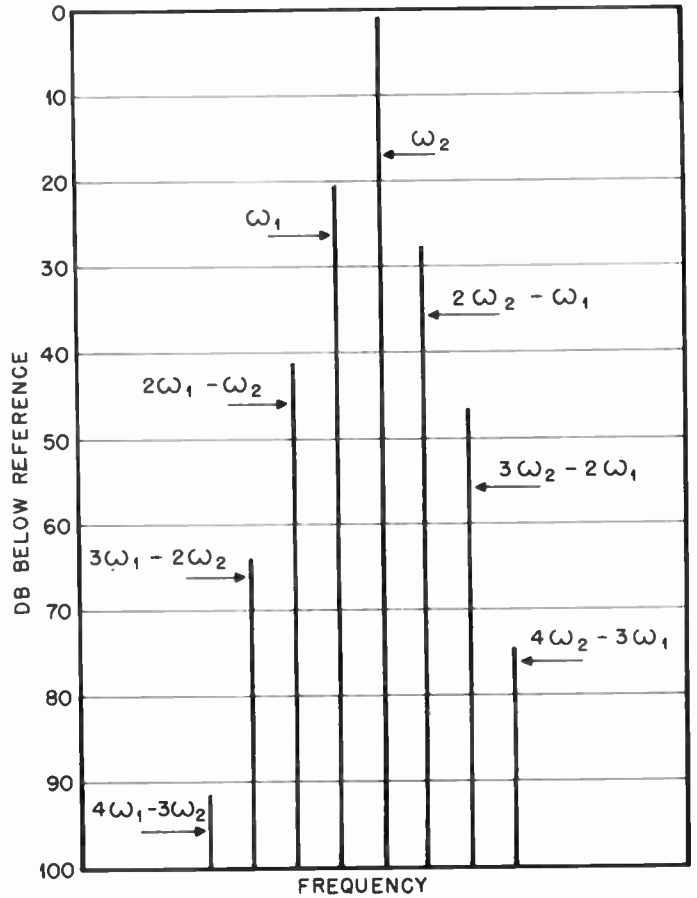

Fig. 6—Single-sideband spectra carrier 20 db down.

with a higher order of the amplitude c while the coefficients to the left of w_1 are always associated with a higher order of the amplitude b .

By progressively going from Fig. 3 to Figs. 5 and 6, it can be seen even though the peak signal swing is held constant, the reducing of either the carrier or the sideband results in considerably less splatter. The drop-off in splatter goes at a faster rate (due to the nature of its generation) than the reduction of either of the signals. The physical reason for the improvement is due to the fact that the resultant envelope variations caused by the two signals in question decreases as the ratio between the signals increases, hence this variation is over a smaller portion of the nonlinear curve with the attendant result that less nonlinear mixing of the signals results.

In Fig. 7 we have the special case of a 26-db reduced carrier and 6-db reduced sideband (hence, here $b+c = -3$ db). The result is a drastic reduction of splatter. Once again the over-all amplitude variations are reduced and the center point of operation is on a more linear portion of the dynamic characteristic, hence a great reduction in mixing action.

If we were using the case where $b=c$ [equivalent to the frequently used 2-tone test for SSB (Fig. 3)] and both b and c were reduced identically, we would expect from the above that the tone-to-splatter ratio would improve due to the expected rapid reduction in splatter.

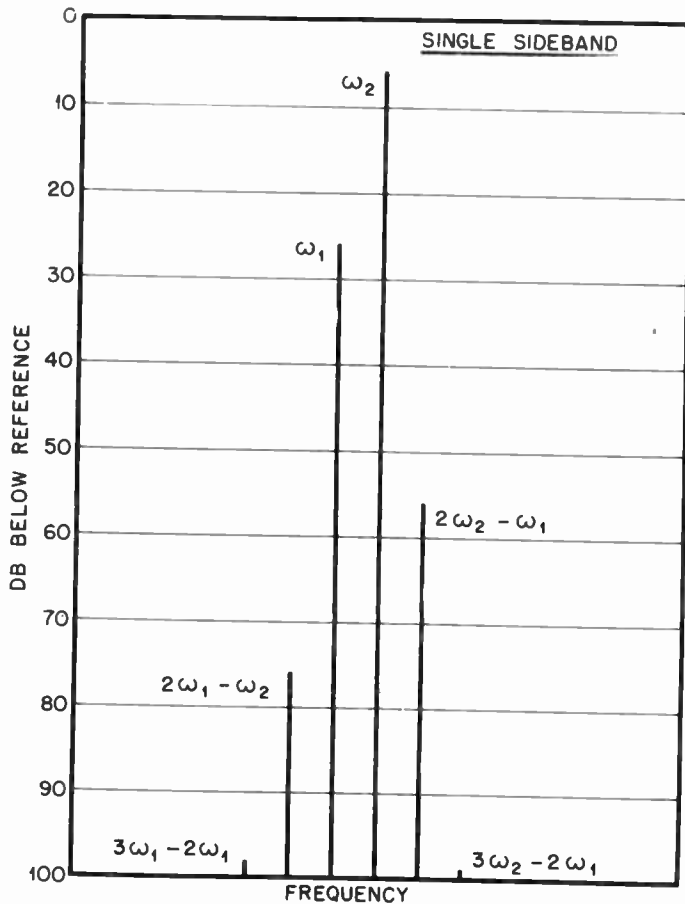

Fig. 7—Single-sideband spectra carrier—26 db.

Experimental evidence showing the decrease of splatter with a reduction of 2-tone input signal has been made and is shown in Fig. 8. As is clearly indicated, the amount of tone-to-splatter ratio is a function of the particular transmitter used. Insofar as the third-order splatter energy is much greater than any higher order splatter, showing only third-order splatter (distortion) indicates the type of reduction expected.

At this time, we might conclude the following: 1) a large ratio between the various tones being transmitted means less splatter than when the tones are more equal in amplitude; 2) reducing the input tones so the peak output power is not reached results in a considerably improved tone-to-splatter ratio; 3) the amount of sideband splatter would be small if our transfer characteristic could be made fairly linear. This all means that as the carrier is reduced, less splatter is to be expected. Hence, the suppressed carrier system is the best from this point of view, while the full carrier system is the worst, with reduced carrier and controlled carrier fitting in between. A controlled carrier system refers to a system in which the carrier increases as the speech energy decreases and vice versa.

If we consider Figs. 3, 5, and 6 in the light of speech communication, we would expect some additional improvement in splatter because the average voice energy is some 16 db below its peak value and hence voice

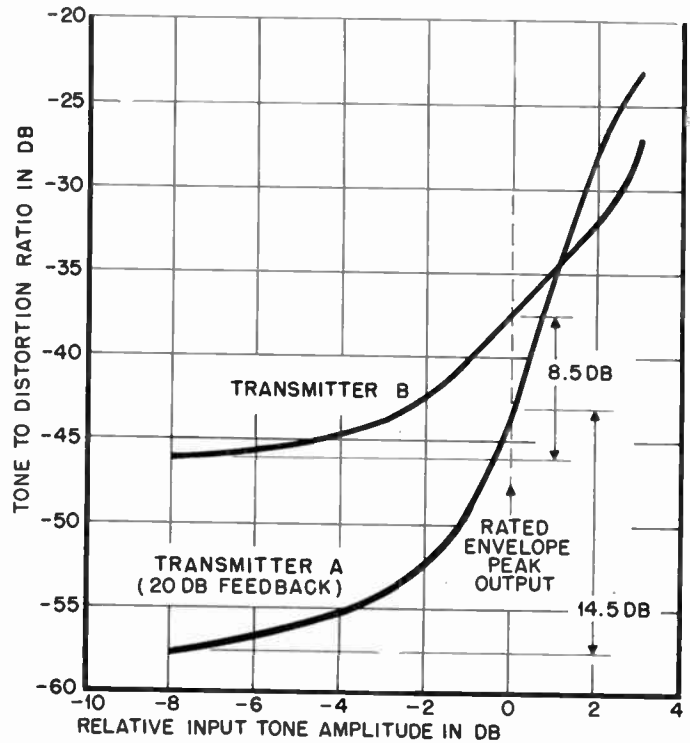

Fig. 8—Typical measured variation of third-order distortion ratios [6].

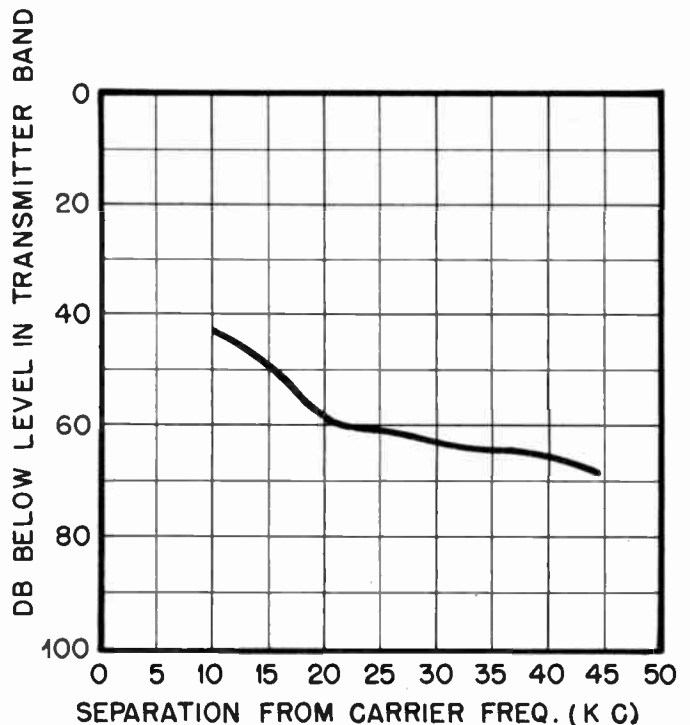

Fig. 9—Measurements on a SSB suppressed carrier transmitter modulated with voice [5].

would operate over a more linear portion of the curve more of the time. While the above statement is true, measurements have shown that achieving a 60-db signal-to-splatter ratio with voice modulation, at 20 kc from the carrier is actually rather good (see Fig. 9). The reason for this goes back to the fact that the nonlineari-

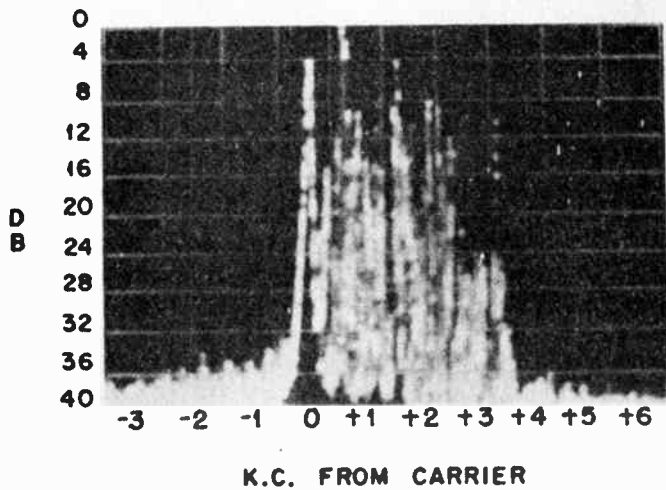

Fig. 10—SSB spectrum input to driver.

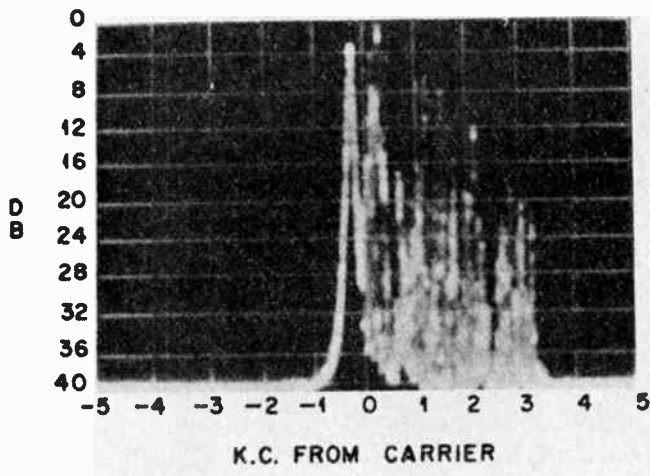

Fig. 11—SSB spectrum output of final amplifier.

ties of a SSB transmitter are often more complicated than those shown in Fig. 1. While Fig. 1 might be reasonably accurate for some particular stage, it may not adequately represent a complex transmitter. Some of the reasons for nonlinearities in SSB transmitters are:

- 1) Grid current (changing the loading),
- 2) Secondary emission,
- 3) Overload of output stage,
- 4) Linearity of tube characteristics,
- 5) Regulation of power supply,
- 6) RF feedback.

The dynamic characteristics of each stage add to that of the following in such a manner that the over-all distortion may decrease or increase. In multistage transmitters such effects may be quite complex if many stages are operated near overload. If it is possible, at most the last two stages only should contribute appreciably to the over-all distortion. Figures of 60 db or better can be expected only when the transmitter is well-designed, not overloaded, possibly has some feedback incorporated to control the distortion characteristic, or in short, is very linear.

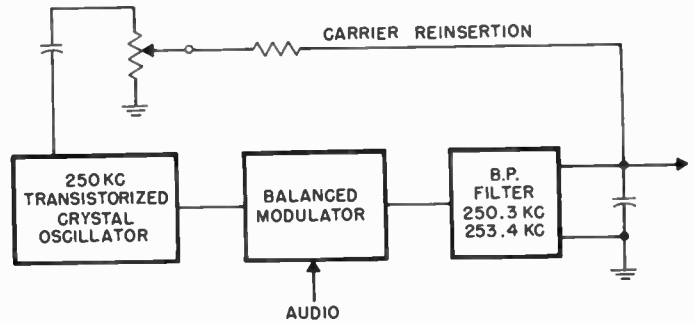

Fig. 12—Method of controlling amount of carrier transmitted.

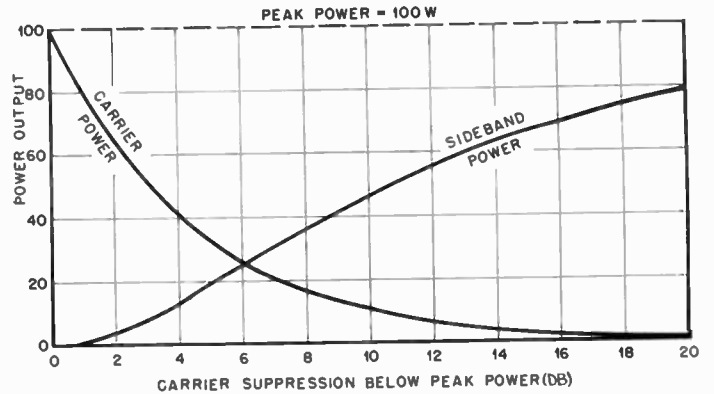

Fig. 13—Variation of sideband power with carrier suppression. (Linear final-peak power limited.)

Fig. 10 is presented to show the SSB rf spectrum input to the driver stage of an experimental transmitter, while Fig. 11 shows the spectrum out of the final amplifier. It is clear from these photographs that the driver and final amplifier stage can cause a great increase in sideband splatter unless steps are taken to carefully control the linearity of the last two stages.

Fig. 12 shows the method now in use in our laboratory for controlling the amount of carrier reduction. By completely suppressing the carrier initially and then reinserting the desired amount by a voltage divider circuit it is easy to control the amount of carrier reduction accurately.

POWER OUTPUT VS SUPPRESSED CARRIER

Fig. 13 shows how reducing the carrier increases the available sideband power for a peak power limited transmitter. If V_1 is the carrier voltage and V_2 the sideband voltage, then V_1^2 is proportional to the carrier power and V_2^2 is proportional to the sideband power, while $(V_1 + V_2)^2$ is made to equal the peak power capability of the transmitter.

It is therefore very clear that the more the carrier power is reduced, the greater is the available sideband power. Hence, reducing the carrier is desirable from this point of view. If the carrier is reduced by 16 db, then the peak sideband power approaches 70 per cent of the total peak power available, while a carrier power reduction of 20 db results in 80 per cent of the total peak power available for the sidebands. Complete suppression,

of course, will yield 100 per cent of the energy as sideband power.

In the special case of a controlled carrier, where the carrier power is an inverse function of the audio signal input, most of the power during heavy modulation periods is available as sideband power, hence this system may well be the equivalent of a reduced carrier system depending on the exact manner and degree that the carrier is controlled. However, because the carrier power is at or near full value in a controlled carrier system when the modulation is not present, full plate dissipation will be occurring. For this reason, average power dissipation will be higher in a controlled carrier system, and we may run into the additional limitation of average power dissipation. A reduced carrier system with a stated peak power limitation will therefore have less average power dissipation over a long period of time.

Fig. 14 shows the power output and plate dissipation

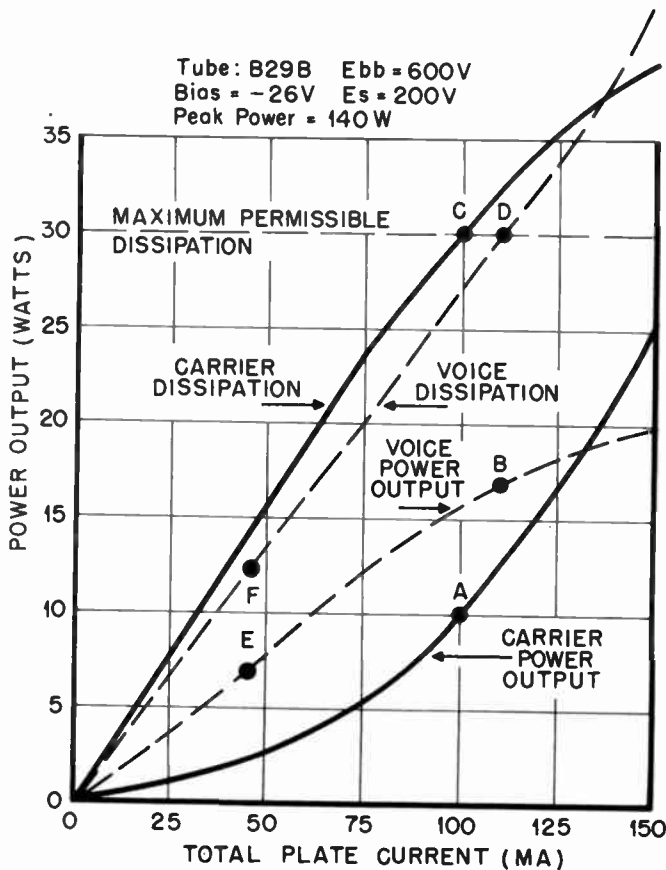

Fig. 14—Power output and dissipation of SSB power amplifier. Tube: 829 B. Ebb=600 v. Bias=-26 v. Es=200 v. Peak power=140 w.

of the final amplifier of an experimental SSB transmitter. The solid curves are for carrier power output and carrier dissipation, while the dashed lines are for the power output under voice conditions. In the carrier case, only the carrier was being transmitted and for the voice curves, only the voice sidebands were being transmitted. The curves are shown together for comparison.

The carrier power output curve is seen to be parabolic or square law as it should be since $P_0 = I^2 R_L$ where R_L is fixed during the test. The voice power output curve on the other hand is not parabolic due to the fact that the transmitter is peak power limited.

For example, if the average power output with voice is 7 watts, then any peak powers in excess of 13 db (140 watts) will tend to be clipped since 140 watts is the maximum peak output capacity. This clipping will occur even though the dissipation of the tube is not exceeded as can readily be seen by picking off the 7 watt point (E) on the voice power output (Fig. 14) and by going vertically upward to point F. At point F, we see that the plate dissipation is only 12.5 watts, which is well under the rated tube dissipation.

While it is true that limiting the peaks will result in splatter, we can get some idea of how serious such splatter might be by the following method. The formula derived to fit the average voice distribution has been given by W. E. Davenport [4], and is:

$$P(i) = \frac{0.36}{0.118\sqrt{2\pi}} e^{-1/2(i/0.118)^2} + 0.316e^{-1.15i} \quad (3)$$

which reduces to

$$P(i) = 1.22e^{-36i^2} + 0.316e^{-1.15i} \quad (4)$$

where $P(i)di$ is the probability of the voice being between the amplitude i and $i+di$.

The area under this voice probability curve is equal to one and the curve is so normalized that the current value of one is equal to the rms value of current.

Since we are concerned with clipping levels above the rms value or $i > 1$, the formula may be reduced to $P(i) = 0.316e^{-1.15i}$ without introducing appreciable errors. To find the per cent of time the voice spends at the clipping level, we must integrate the probability curve as follows:

$$T = 2 \int_{i_1}^{\infty} P(i)di. \quad (5)$$

The factor 2 is needed because the voice spends as much time in the negative current direction as it does in the positive direction. The upper limit of infinity is taken because we wish to know the total time spent above the i_1 level and not between two levels such as i_1 and i_2 (where $i_2 > i_1$).

After substituting for $P(i)$ from (4) and integrating, we get

$$T = \frac{0.632}{1.15} e^{-1.15i(\text{clip})}. \quad (6)$$

Table I shows the results presented in tabulated form. We can now see that 13 db of clip results in being at the clip level 0.32 per cent of the time. The exact amount of splatter power that the period of Table I corresponds

TABLE I
PERCENTAGE OF TIME ABOVE CLIP LEVEL

Clip Level Above RMS	Tau in Per Cent
+3	10.8
+6	5.5
+9	2.1
+12	0.5
+13	0.32
+15	—

to is a function of the exact nature of the transmitter limiting and represents a fairly involved analysis. However, the small percentage time is indicative of the amount of splatter and when one considers that this splatter is over a rather large spectrum it is clear that the splatter energy per cycle is not great. Also, it is clear that when the period T becomes large, a considerable amount of splatter will be present.

In order to keep this splatter to a minimum, the peak power to average radiated power should be increased so that peak limiting will not occur; or the voice has to be processed. By processing it is meant that the peak to rms value of the voice itself is limited before being amplified in the high-frequency rf portions of the transmitter. Tests have been run which show that voice may be very heavily clipped and filtered without significantly reducing the readability. This of course means the peak to rms capability of the transmitter itself need not be as large as with unprocessed speech.

In any case, if only a single tone (or carrier) is transmitted, the point of operation on the power output curve (Fig. 14) is at A , while the carrier dissipation is at point C . In transmitting only speech power, the point of operation on voice power output will shift to point B while the dissipation (still the max permissible) will shift to point D . The end result is a 70 per cent increase in transmitted power when we go from carrier to voice sidebands while operating at a maximum dissipation rating. The increase indicated is not limited to 70 per cent and a differently designed final may well show a much greater voice power improvement. The reason for this improvement is discussed below.

FINAL AMPLIFIER EFFICIENCY

Fig. 15 shows a plot of the percentage of efficiency vs total amplifier plate current for both carrier and voice transmissions. The efficiency curve for carrier only being transmitted is seen to be practically a straight line. This is as expected because the efficiency of a linear class B amplifier may be expressed as

$$N_p = \frac{\pi}{4} \frac{\sqrt{2}E_p}{E_{bb}} \tag{7}$$

where E_p is the rms value of the rf plate voltage. If the amplifier is linear, then E_p will rise linearly with E_o (rms

grid voltage) and hence the efficiency will rise linearly.

The curve for voice efficiency starts rising linearly but with a much steeper slope. The steeper slope is due to the different basic nature of voice compared with a constant carrier. For the same total plate current, the character of voice is such that it has many peaks which rise often and significantly beyond the average value. These voice peaks momentarily operate in higher efficiency regions (and at higher power outputs) and hence raise the average efficiency for a given average current.

Tube: 829B $E_s = 200V$
Bias = -26V Peak Power = 140W

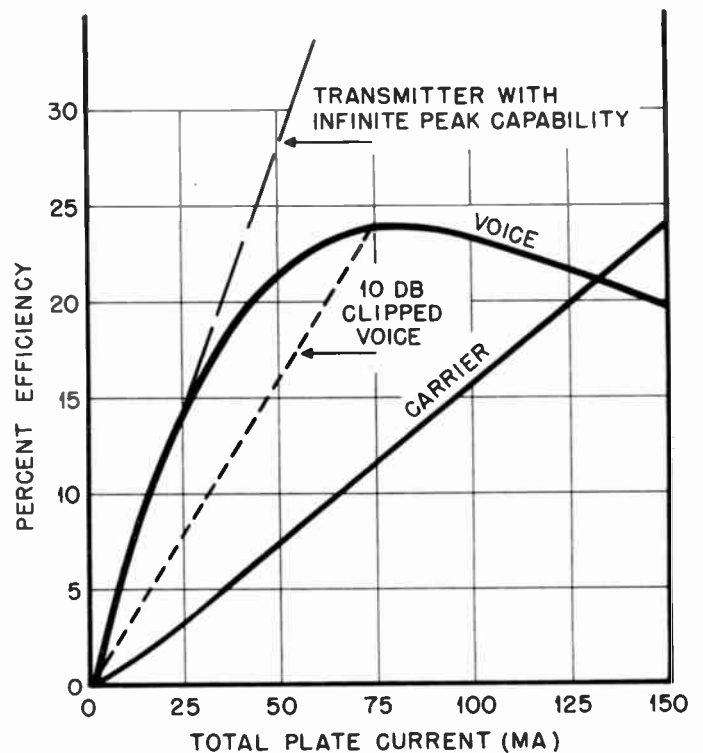

Fig. 15—SSB power amplifier efficiency. Tube: 829 B. $E_s = 200$ v. Bias = -26 v. Peak power = 140 w.

If the transmitter were capable of handling infinite peak powers, the efficiency curve would continue along the steep-slope long-dashed line shown in Fig. 15. In practice, however, infinite peak capability is not practical and the voice curve shown is for a peak limited transmitter. As the peaks of voice become limited to a specific maximum efficiency, the over-all efficiency on voice will continue to rise, but at an increasingly slower rate. The maximum efficiency for the particular test set is seen to be 24 per cent. It is to be remembered (from Fig. 14) that the maximum dissipation is exceeded at 110 ma for voice and 100 ma for carrier.

As the amplifier is driven harder, more and more speech limiting in the final occurs, and now the situation reverses. At 135 ma of plate current, the voice is very heavily limited and the voice dissipation curve (Fig. 14)

rises above the carrier dissipation curve. Hence, the voice power output curve drops below the carrier power output curve and the voice efficiency curve falls below the carrier efficiency curve. All of this happens beyond the normal maximum permissible dissipation and is only presented for completeness.

If it is desired to operate the transmitter without limiting in the final, but one does not wish to raise its peak power capability, the speech may be processed so that its peak to rms ratio is decreased. If we clip our speech for a 10 db peak to rms ratio, the efficiency will follow the short dotted line up to the voice curve at 75 ma, at which point the final itself will limit and we will then continue along the voice curve. Should the voice be processed in the audio circuits such that it has only a 6-db peak to rms ratio, we would naturally add a straight line at a slope somewhere between that of the carrier and that of 10-db clipped voice. This line would terminate as before on the voice curve and the transmitter itself would only limit at very high plate currents.

RECEIVER DESENSITIZATION

The strongest unwanted signal which needs to be rejected by a receiver depends greatly on the desensitization and intermodulation characteristics of the receiver. By desensitization we mean the phenomenon occurring when a strong signal decreases the total receiver gain. This is generally caused by the grid voltage on one or more tubes swinging into the positive grid region and thus building up additional bias or loading the grid-tuned circuits by grid current.

Situations frequently arise where a mobile receiver is in close proximity (perhaps within a few hundred feet) of a powerful vhf transmitter working on an adjacent channel. At the same time, the desired station may be far away and the receiver may be attempting to receive a very weak signal. Under such conditions, the receiver in question may be completely desensitized or blocked by this high level signal.

If, however, the interfering signal is generated by an SSB transmitter, the amount and nature of the desensitization change. To begin with, when no speech is being transmitted, the amount of desensitization is strictly a function of the amount of carrier radiated. Hence, reducing the carrier will decrease the desensitization effect and the number of db the carrier is reduced is a direct measure of the added protection obtained.

Next, we need to consider the case where speech is being transmitted. Under speech conditions the average power transmitted will be an indication of the average desensitization level expected but its nature will be quite different than that of, say, an fm signal whose output power is constant.

During the modulation period the radiated power changes radically and the worst desensitization naturally will occur on voice peaks, while practically no desensitization occurs during the voice valleys. In other

words, the desensitization tends to follow the instantaneous amount of radiated power. The receiver itself will not lengthen the intermodulation periods because the time constants in every rf circuit of practically all commercial receivers are on the order of a few microseconds while the voice peaks and valleys are of the order of many milliseconds.

Hence, even with voice, the desensitization will be somewhat sporadic, occurring at voice energy rates. The result is that this type of interference may still permit communication on a channel which would normally be completely blocked.

We may conclude at this point that a SSB system using a reduced carrier will cause considerably less desensitization than a standard AM or fm signal for at least two reasons. First, because the carrier is reduced (or even suppressed) and is all that is transmitted under no modulation conditions; second, the large sideband power that does occur is of a temporary nature. We might add that for a given communication range we would expect to use less sideband power in average than the carrier power of an fm station.

INTERMODULATION

Another problem resulting from spectrum crowding is intermodulation. If there are two strong signals on frequency $f \pm \Delta f$, and $f \pm 2\Delta f$, where f is the receiver frequency and Δf is the channel spacing (or some multiple thereof), then the second harmonic of the first signal beating with the second signal can create a beat note of frequency f . These harmonics and beating occur due to nonlinearities in the amplifying tubes and mixer stage.

$$2(f \pm \Delta f) - (f \pm 2\Delta f) = f.$$

If A is the amplitude of $f \pm \Delta f$ and B is the amplitude of $f \pm 2\Delta f$, it can easily be seen that the amplitude of the resulting "on frequency" signal f is proportional to $3A^2B$. Hence, reducing the amplitude of A and B by, say, 16 db results in the intermodulation term decreasing by 48 db which is a tremendous improvement. This type of improvement is achieved in a reduced or suppressed carrier system but is not realized in a controlled carrier system since such a system usually sends a full carrier under no modulation conditions. It is true that under modulation conditions the intermodulation will increase in proportion to the instantaneous sideband power but if the peak to rms ratio is 16 db then the peak modulation power will merely approach that of an unreduced carrier system. Hence, only under peak conditions will the intermodulation approach that of a comparable full carrier system. From Table I we can surmise that the percentage of time that this happens is considerably less than one per cent. We may therefore conclude that reducing the carrier will greatly improve intermodulation even under modulation conditions. Furthermore, a controlled carrier system may be expected to show very little improvement because as the carrier is re-

TABLE II
SUMMARY OF SYSTEM CHARACTERISTICS

Characteristic	Nature of Characteristic	Full Carrier	Reduced Carrier	Suppressed Carrier	Controlled Carrier
Modulation Splatter	Result of transmitter nonlinearities	For the same nonlinearity modulation splatter decreases to the right. Due to voice using more linear portion of curve in average →			Approaches the improvement of a reduced carrier system
Peak Sideband Power	Increases as carrier is decreased	Greater peak sidebands possible →			Can be made equal to a reduced carrier system
Transmitter Efficiency	Efficiency increases with drive	Efficiency increases as a full carrier is replaced with voice. Due to peak to rms. characteristics of voice improvement →			Similar to that of a reduced carrier system
Receiver Desensitization	Average adjacent channel power overpowering a receiver	Approximately proportional to average power transmitted over a long period of time →			Not much improvement over full carrier system due to almost constant total output power
Intermodulation	A function of two interfering signals producing an on frequency signal	Proportional to A^2B . Hence reducing A and B by x db results in $3x$ db improvement →			Not much improvement over full carrier system due to almost constant total output power
System Stability	A function of crystal oscillator stability	Requires a lock-in oscillator	Cannot be achieved at higher radio frequencies		Requires a lock-in oscillator

Note: A = amplitude of interfering signal. B = amplitude of interfering signal. Arrows show direction of improvement.

duced, the sideband power is increased, thus tending to hold the total radiated power constant.

SYSTEM STABILITY

When working at the lower radio-frequencies, it is possible to reinsert the carrier locally with sufficient accuracy so as not to require the transmitter to send a carrier for locking purposes. However, at the higher radio-frequencies such as 150 mc, this is not feasible. Even if carrier stabilities of a crystal oscillator approach 0.0002 per cent an error of 300 cycles can occur both at the transmitter as well as the receiver. Consequently, a total of 600 cycles of error is possible. Insofar as an error of 50 cycles results in considerable distortion, an error up to 600 cycles is hardly acceptable. It is for this reason that it is absolutely mandatory to send some amount of carrier for receiver locking purposes.

A suppressed carrier system, therefore, becomes impractical at most vhf frequencies. A reduced carrier system may use any of several types of lock-in oscillators or even a motor driven system for error correction.

CONCLUSION

From the preceding analysis and discussion, we can conclude that as the carrier is reduced, the factors of modulation splatter, transmitter efficiency, peak sideband power, desensitization, and intermodulation all tend to improve. While these factors alone would dictate complete carrier suppression, it is not feasible to do so because of the system frequency stability requirements. Hence, a pilot carrier is normally required. The amount of carrier reduction permissible is a function of

the type of receiving system, such as: 1) AFC controls. 2) Lock-in oscillator. 3) Phase lock system. 4) Active filter system. 5) Narrow band amplifier and limiter system. 6) Locally injected oscillator when system stability justifies it. As a consequence, a specific carrier value cannot be arrived at from this general discussion. Once the receiving system is decided upon, the amount of carrier needed will follow and the results of this paper can then be used to compare the system arrived at with SSB systems using different amounts of carrier. Comparison with fm and AM systems can also be made. It is also clear that considerable thought should go into the receiver design since the amount of carrier to lock the receiver has such a large influence on the transmitter design and the resulting system characteristics.

The controlled carrier system has some advantages as regards locking the receiver due to the large carrier transmitted during nonspeech conditions. However, while an improvement in splatter, efficiency, and peak sideband power is expected because for these factors the controlled carrier system acts like a reduced carrier system, the amount of receiver desensitization and intermodulation will not be significantly better than a full carrier system due to the high average power always being transmitted. Hence, this type of system will not show the over-all gains of a reduced carrier system.

Shown in Table II is an over-all comparative summary of SSB performance as a function of carrier strength. This table is presented only to form a comparative basis between the systems and is not meant to be complete. The text itself covers the various points in greater detail.

ACKNOWLEDGMENT

The author wishes to acknowledge the contributions of R. Dronsuth, O. Eness, and L. Englebrecht, who supplied the photographs and other experimental data, and of R. Richardson, who made many valuable comments.

BIBLIOGRAPHY

- [1] F. A. Polkinghorn and N. F. Schlaack. "A Single Sideband Shortwave System for Transatlantic Radiotelephony." *Bell System Technical Journal*, Vol. 14 (July, 1935), pp. 489-508.
- [2] American Radio Relay League Staff. *Single Sideband for the Radio Amateur*. The Rumford Press, Concord, N. H., 1954.
- [3] George E. Brenette. "An Air Force Single Sideband System." *Symposium on Aeronautical Communications* (November 21, 1955), p. 85.
- [4] W. B. Davenport. "A Study of Speech Probability Distributions." Massachusetts Institute of Technology Research Laboratory of Electronics Technical Report No. 148, August, 1950.
- [5] L. M. Klenk, A. V. Munn, and J. Nedelka. "A Multichannel Single Sideband Radio Transmitter." *PROCEEDINGS OF THE IRE*, Vol. 40 (July, 1952), pp. 783-790.
- [6] N. Lund, C. F. P. Rose, and L. G. Young. "Amplifiers for Multichannel Single Sideband Radio Transmitters." *PROCEEDINGS OF THE IRE*, Vol. 40 (July, 1952), pp. 790-796.
- [7] A. E. Kerwien. "Design of Modulation Equipment for Modern Single Sideband Transmitters." *PROCEEDINGS OF THE IRE*, Vol. 40 (July, 1952), pp. 797-803.
- [8] L. R. Kahn. "SSB Transmission by Envelope Elimination and Restoration." *PROCEEDINGS OF THE IRE*, Vol. 40 (July, 1952), pp. 803-805.
- [9] Frank B. Gunther. "A High Power Linear Amplifier for Single Sideband Applications." *Symposium on Aeronautical Communications* (November 21, 1955), p. 98.
- [10] W. L. Firestone, Angus Macdonald, and Henry Magnuski. "Modulation Splatter of VHF and UHF Transmitters." *Proceedings of the National Electronics Conference*, Vol. 10 (February, 1955), pp. 264-273.
- [11] W. L. Firestone. "Evaluation of Sideband Noise and Modulation Splatter." 1955 IRE CONVENTION RECORD, Part 8, pp. 22-28.
- [12] A. Brown and R. H. Levine. "Single Sideband for Mobile Communications." 1953 IRE CONVENTION RECORD, Part 2, pp. 123-128.
- [13] Radio Technical Commission for Aeronautics, Special Committee 65, "The Application of Single Sideband Techniques to Aeronautical Communications." 11-54/DO-53, January, 1954.
- [14] J. F. Honey. "Performance of AM and Single Sideband Communications." *Tele-Tech*, Vol. 12 (September, 1953), pp. 64-66, 147-149.
- [15] F. A. Polkinghorn. "Commercial Single Sideband Radiotelephone Systems." *Communications*, Vol. 28 (December, 1948), pp. 24-27.

Design of a High Power Single-Sideband VHF Communications System*

JOHN W. SMITH†, SENIOR MEMBER, IRE

Summary—When high-power transmission is considered in the vhf region, it is implied that ionospheric scatter propagation is contemplated. The type of modulation that best fits the propagation mode is considered—especially fm and SSB. This discussion shows that SSB is a logical choice for this type of circuit and that adequate frequency stability is the only requirement necessary to insure improved communications at vhf using this method of modulation. Some of the factors influencing the design of a 40-kw, dupliex, vhf system are presented.

IT HAS BEEN established^{1,2} that vhf transhorizon radio signals, because of their persistency, are suitable for highly reliable, long distant communication circuits. To overcome the basic transmission loss and to provide an adequate fade margin, relatively high power transmission is required. To support a single voice channel at 30 mc with at least a 10-db signal-to-noise ratio for 99.5 per cent of the time over a 900-mile path, at least 40 kw of transmitter power, 20-db antennas and dual diversity reception are required. The same equipment would similarly support four voice channels with

a path length of 475 miles or 16 time division multiplexed, synchronous teletypewriter channels with 99.99 per cent reliability on a 900-mile circuit.³

One of the major problems associated with vhf transhorizon propagation is multipath effects. The most severe of these is back scatter during periods of *F*-layer propagation. Multipath delays up to 50 milliseconds may be encountered during conditions of back scatter. However, good antenna design should minimize such multipath effects. Under normal conditions of scatter propagation, the multipath delay within the medium should not exceed 20 μ sec.

Since the propagation mode is subject to multipath delays, a broad-band modulation system would have drawbacks. Also, ionospheric scatter propagation is more effective in the 25 to 50-mc range. This portion of the spectrum is already crowded. It is then necessary to employ a method of modulation means that utilizes a minimum bandwidth and is little affected by delay distortion.

For voice transmission, single sideband (SSB) and frequency modulation (fm) must both be considered.⁴

³ R. M. Ringoen and J. W. Smith, "VHF transhorizon communication techniques." *Electronics*, pp. 154-159; May, 1956.

⁴ G. L. Millen, W. E. Morrow, A. J. Poté, W. H. Radford, and J. B. Wiesner, "UHF long-range communication systems," *PROC. IRE*, vol. 43, pp. 1269-1281; October, 1955.

* Original manuscript received by the IRE, September 10, 1956.

† Collins Radio Co., Cedar Rapids, Iowa.

¹ D. K. Bailey, R. Bateman, and R. C. Kirby, "Radio transmission at VHF by scattering and other processes in the lower ionosphere," *Proc. IRE*, vol. 43, pp. 1181-1230; October, 1955.

² W. G. Abel, J. T. DeBettencourt, J. H. Chisholm, and J. F. Roche, "Investigations of scattering and multipath properties of ionospheric propagation at radio frequencies exceeding the MUF," *PROC. IRE*, vol. 43, pp. 1255-1268; October, 1955.

Fig. 1 shows a comparison of SSB and narrow-band fm for systems employing one and four voice channels. The effective channel test tone-to-noise ratio is plotted as a function of transmission loss for both SSB and fm with system parameters as indicated. Also shown is the transmission loss that will be exceeded 50, 10, and 1 per cent of the time on a typical circuit.

Although fm does not make the most efficient use of bandwidth (6 times modulation frequency for a deviation ratio of one) and has definite threshold effects as indicated in Fig. 1, it does have certain characteristics which are desirable for scatter applications. The most notable are insensitivity to rapid fading as long as the received signal exceeds the threshold level and relative freedom from distortion.

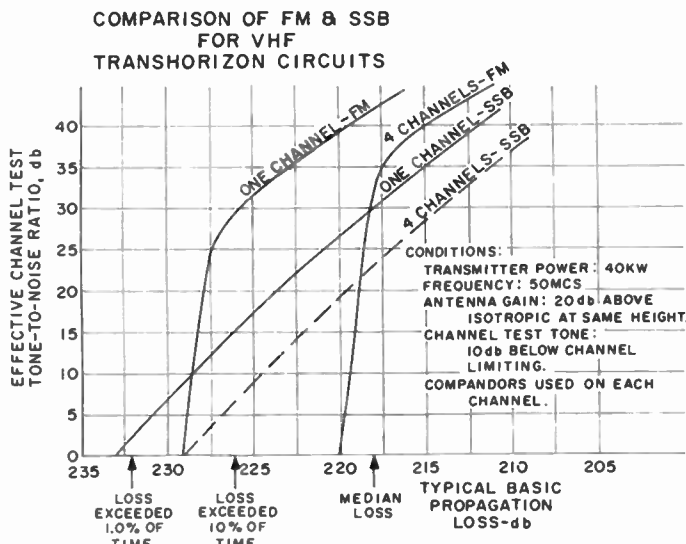

Fig. 1—Comparison of fm and SSB for vhf transhorizon circuits indicating the superiority of SSB at low signal levels.

SSB modulation also has several advantages which make it attractive for scatter circuits. Among these advantages are the minimum use of band width, no threshold effects, considerably lower average power requirement compared to fm and considerable tolerance to delay distortion within the medium. On the other hand, SSB equipment requires high-linearity power amplifiers and good frequency stability.

From Fig. 1 it can be seen that the signal on a typical circuit will be below the fm receiver threshold for one-voice channel circuit 10 per cent of the time. For four-voice channels, the fm threshold is about at the median signal level. This means in the latter case that most of the time the channels would be unuseable and that for a single voice channel the reliability would be poor.

Teletypewriter systems should be designed to operate with a signal-to-noise ratio, as measured in a 3-kc band, well below 10 db if high reliability is to be achieved. This completely eliminates the possibility of placing teletypewriter information in a voice channel, which in turn frequency modulates the transmitter, since then the fm threshold would determine the minimum usable

signal level. During the low-signal level conditions SSB would be superior to fm for both voice and teletypewriter transmission. It is, therefore, concluded from bandwidth, flexibility, delay distortion, and signal-to-noise standpoints that SSB is sufficiently superior to fm for vhf scatter circuits to offset the advantages of fm equipment simplicity.

The choice of SSB modulation in the vhf range in turn presents frequency stability requirements which not long ago were considered unattainable. For SSB voice demodulation there is no strict frequency tolerance that can be applied to the demodulating carrier. It is known that SSB voice signals can be understood with the demodulating carrier offset from the correct value by as much as 150 cycles. However, there may be a psychoacoustic phenomenon which increases the intelligibility in the presence of noise, due to improved transient response or phase coherence, when the demodulation carrier frequency is correct. Until such time as this information is available, an arbitrary tolerance for the demodulation carrier frequency for good quality circuits has been established at about ± 20 cycles. Allowing 10 cycles for Doppler shifts due to the medium, 5 cycles for the transmitter, and 5 cycles for the receiver for a 50-mc circuit results in a frequency stability requirement of one part in ten.

Synchronous transmission of multiplexed teletypewriter data⁶ using 2.5 to 22 millisecond pulses imposes a far more stringent timing requirement and consequently a greater frequency tolerance than SSB voice in the vhf range. It is advantageous to have sufficient frequency stability so the oscillators may be used as time references at both the transmitting and receiving terminals, eliminating the need for continuous transmission of synchronizing information. Present-day oscillators are capable of frequency stabilities exceeding one part in 10^8 per day. In terms of time, this stability would produce an error of one millisecond in a period of 28 hours. This stability is adequate for synchronous transmission of teletypewriter data with pulse characteristics previously mentioned and for transmission of SSB voice.

It is not required that the vhf transhorizon system be capable of rapid shifts in operating frequency. It would be feasible to engineer a vhf transhorizon system utilizing a crystal oscillator, the frequency of which is chosen for each operating frequency. Development of crystal oscillators has not advanced to the point, however, where it is relatively easy and economical to obtain one part in 10^8 stability over a wide range of oscillator frequencies. Considerable development has been expended on crystals operating in a narrow frequency range around either 100 kc or 1 mc.

For this reason, it appears logical to use a stabilized master oscillator in conjunction with a frequency standard at each terminal to provide injection frequencies to the excitors and receivers so they may be set up at any

⁶ M. L. Doelz, E. T. Heald, and D. L. Martin, "Binary data transmission techniques for linear systems," submitted for publication in *Proc. IRE*.

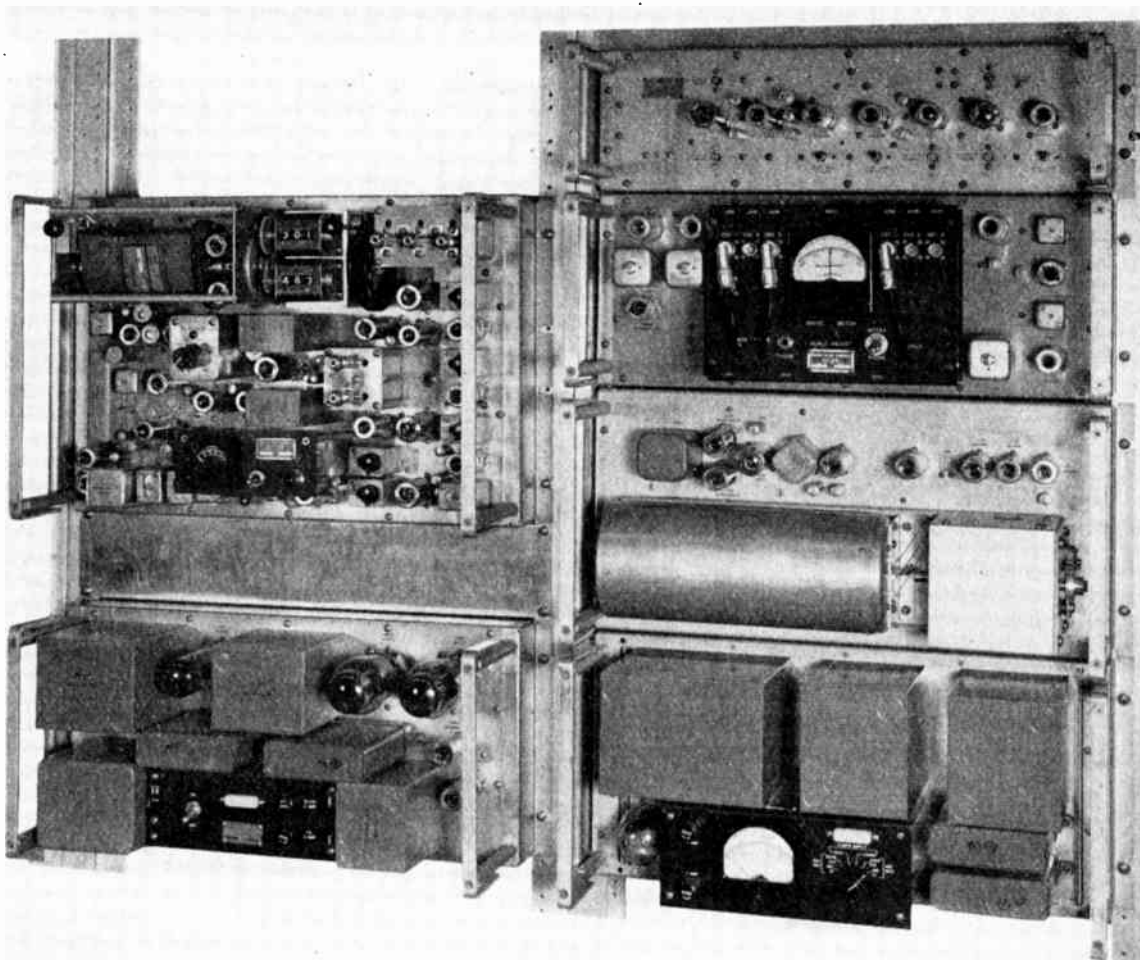

Fig. 2—Frequency generating equipment.

one of a number of frequencies separated by a distinct increment. Basically, a stabilized master oscillator functions to generate a spectrum of closely spaced frequencies, the stability of each being determined by the frequency standard. A variable frequency oscillator is then phase locked to one of these spectrum points. By taking a 1-mc oscillator and dividing its frequency to 100 kc and to 10 kc and in turn providing these two frequencies to a stabilized master oscillator, it is possible to obtain outputs from the stabilized master oscillator spaced sufficiently close together to provide the injection frequencies required for operation with 10-kc channel spacing. When the bandwidth required for a typical vhf circuit is considered along with the interference that may be encountered as a result of meteor Doppler shifts, it is not logical to space channels any closer than 10 kc. Fig. 2 is a photograph of typical frequency generating equipment. This photograph shows a stabilized master oscillator and its associated power supply mounted on the left-hand rack together with a frequency divider, frequency comparator, high stability 1-mc oscillator and associated power supply on the right-hand rack.

Since the most outstanding characteristic of vhf scatter propagation is its persistence, it is important that the reliability of the equipment used in vhf trans-horizon systems be extremely high; otherwise, the main system feature will be compromised. From a propagation standpoint, it is feasible to provide a teleprinter transmission reliability in excess of 99.9 per cent. To achieve a similar equipment reliability requires the utilization of several special techniques.

The transmitter is generally considered to be the least reliable component in the system. For vhf SSB systems it is required that the transmitter or power amplifier linearity be such that the intermodulation distortion as measured with two tones be at least 30 db below one tone of the two-tone test signal. The utilization of rf feedback not only improves the transmitter linearity but also stabilizes the transmitter power output and stabilizes the amplifier⁶ phase characteristics.

The reliability of a 40-kw vhf transmitter will be less

⁶ W. B. Bruene, "Linear power amplifier for SSB transmitters," *Electronics*, vol. 28, pp. 124-125; August, 1955.

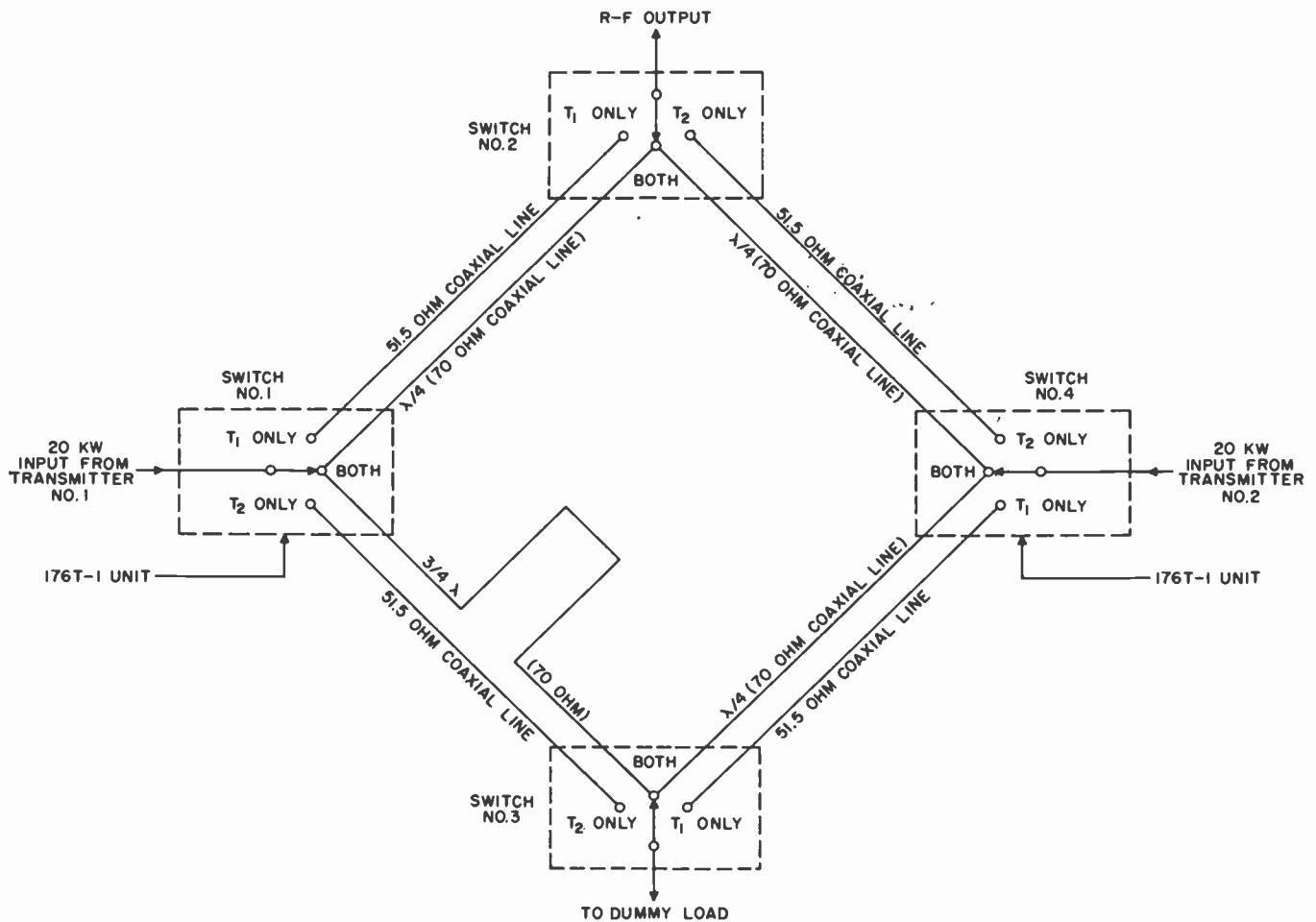

Fig. 3—Hybrid ring transmitter paralleling network. This network isolates the two transmitters and adds the transmitter outputs at the antenna.

than the reliability of a lower power transmitter. This points up the need for providing standby transmitters at each vhf terminal and incorporating methods for rapidly switching a standby unit into service. Not only is this a costly solution in terms of primary-power requirements, space and investment, it is also costly from the standpoint of switch-over time.

It appears more logical to utilize two completely independent lower power transmitters in parallel to provide 40-kw power for vhf transhorizon systems. In this manner, each transmitter serves as a standby for the other. However, some method of paralleling these units must be utilized to couple them into the same antenna. It has been found that the coaxial hybrid ring shown in Fig. 3 is ideal for this purpose.

By tracing the signal routes through this circuit, it is found there is little coupling between the two transmitters. With both transmitters operating at the same power and phase output, all the power from each transmitter will be coupled to the antenna and none to the load. If one transmitter fails, half of the power from the other transmitter goes into the hybrid load, and half into the antenna. This means that a complete failure of

one of the transmitters results in a 6-db decrease in transmitted power. No switch-over time is involved.

A hybrid ring circuit developed for paralleling two 20-kw transmitters over part of the vhf range is shown in Fig. 4. The coaxial switches on the network are provided for switching one transmitter directly to the load and the other transmitter directly to the antenna. This would normally be done within two or three seconds if one of the two parallel transmitters failed.

Using two transmitters in parallel, a large savings in primary power is also realized. During some times of the year, propagation will be much better than at other times. Often 20 kw of transmitter power will be adequate. Under these conditions, one transmitter may be shut down—unless the protection against failure is required—netting a large reduction in primary power consumption. A transmitter developed for this application employs a single $4 \times 150A$ input amplifier, two $4 \times 150A$'s as drivers and a pair of 6166's as output amplifiers. Twelve db of rf feedback is used around the last two stages. The transmitter requires approximately a half-watt of input power for 20 kw of peak envelope output power. The plate efficiency of the final stage is

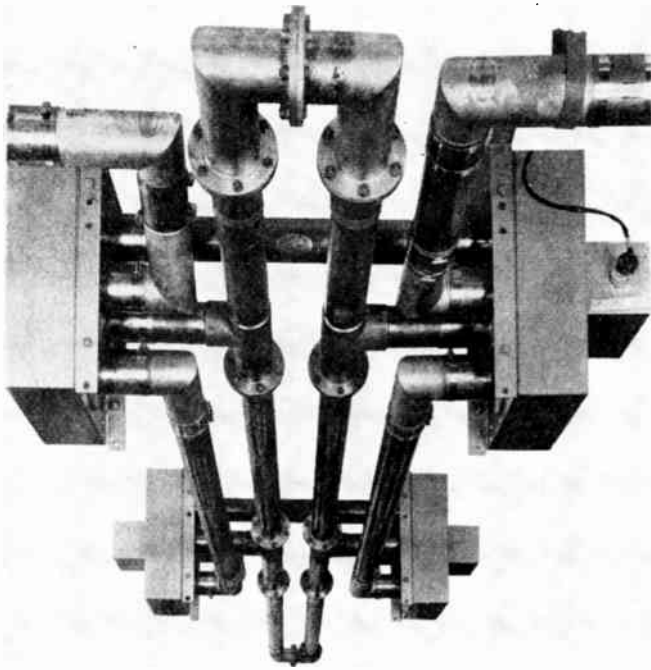

Fig. 4—Transmitter paralleling hybrid ring for a portion of vhf range.

56 per cent at full output and the over-all efficiency of the transmitter is 45 per cent for 20 kw of peak envelope output power. The power consumption of the transmitter is 13 kw when there is no input signal applied. The third-order distortion products are at least 30 db below one tone of a two-tone test signal at full peak envelope power.

As described in the literature,¹ large antennas are required for use in vhf transhorizon systems. The use of 2000 feet rhombics or antennas with apertures in excess of 10,000 square feet are common. For the minimum number of antennas to be utilized in any vhf system, it becomes desirable to transmit and receive on a common antenna and utilize a second antenna at the terminal for diversity reception and transmitting standby antenna.

Several problems are associated with duplex operation on a common antenna at the 40-kw level in the vhf range. The equipment itself must be well shielded so that radiation from the power amplifier units does not interfere with the operation of the receivers located in the same area.

High-performance filters must be used in the transmitting and receiving antenna lines so the receivers and transmitters are effectively isolated. In one system it has been found that noise in the output of the transmitter at a frequency removed 10 per cent is -176 dbw per cycle bandwidth. The minimum receiver noise is approximately -200 dbw per cycle bandwidth. Therefore, the transmitter output noise must be attenuated at least 30 db if it is not to contribute to the receiver noise.

Measurements on typical receivers indicate that at a frequency removed 10 per cent an interfering signal must be below a -37 dbw level if it is to result in negligible distortion, desensitization and cross modulation in the receiver. Since the transmitter power output is $+46$ dbw this means that for 10 per cent frequency spacing, the filters in the receiving antenna line must attenuate the transmitter frequency by 83 db or more.

A rejection notch filter in the transmitter line is most practical to reject the noise in the transmitter output at the receiver frequency. Such a filter is shown in Fig. 5. This filter design was chosen because it required the use of coaxial line no greater than $3\frac{1}{8}$ inches. The attenuation of a filter to the transmitter frequencies is negligible, being less than 0.1 db.

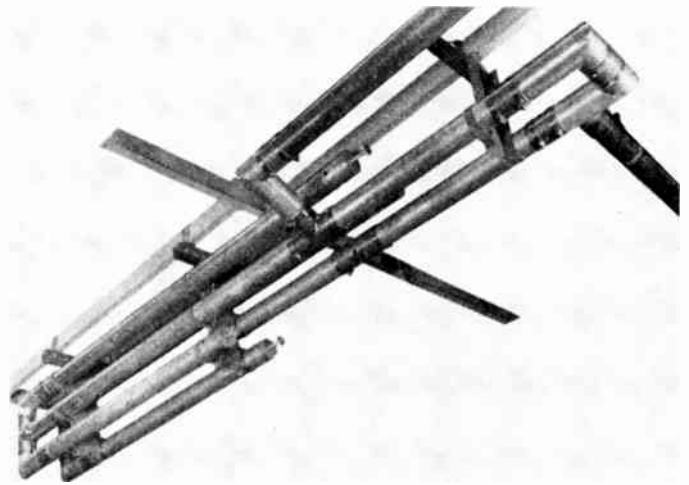

Fig. 5—Transmitting, rejection notch filter.

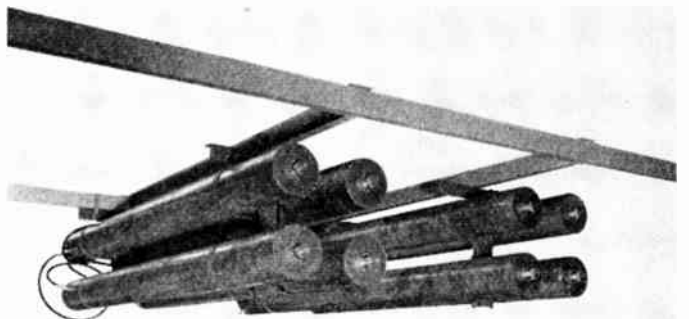

Fig. 6—Two receiving band-pass filters.

A band-pass receiver filter shown in Fig. 6 developed for a vhf transhorizon system consists of four coaxial resonators in cascade. It has an insertion loss of 1.2 db and is more than adequate for attenuating the 40-kw transmitter power sufficiently that duplex operation with a transmitter-receiver frequency spacing of 10 per cent is feasible. By modifying the filter arrangement slightly, it should be possible to provide duplex operation at frequencies spaced as little as 4 per cent for a

system requiring a bandwidth of not more than 20 kc.

Voice multiplexing can be accomplished by using the techniques normally employed in telephone carrier or microwave systems. However, Doppler shifts due to reflections from meteor trails can cause errors in teletypewriter data by shifting the received frequency an amount equal to the mark-space shift. The maximum Doppler shifts that have been observed over ionospheric scatter circuits are less than 6 kc. If the teletypewriter system employs a shift from mark to space of 6 kc or greater, it should be impossible to experience teletypewriter interference due to reflections from meteor trails. However, if all tones in a frequency division multiplex system had to be spaced at least 6 kc apart, a very large bandwidth would be required. Because of this fact and because of the 6-db loss due to peak-to-average ratio of a frequency division system, a time division multiplex teletypewriter equipment is recommended.

Diversity reception of long-range high-frequency AM circuits has been common practice where a high degree of reliability was necessary. Combining the outputs of diversity receivers is accomplished by paralleling the audio outputs of the two receivers using a common detector load resistor, and cross connecting the agc circuits of each receiver. However, with the development of scatter techniques utilizing fm or pm, the process of optimum combining of the receiver outputs has been more thoroughly investigated.⁷

The two most used methods of diversity selection are the diversity switch where the audio from the receiver with the better signal-to-noise ratio is used, and the diversity combiner in which both receivers contribute to the output at all times. The degree of contribution is determined by the signal-to-noise ratio of each receiver. The combiner technique gives the more desirable results because it is free from switching transients, and if properly designed, makes it possible to obtain a better signal-to-noise ratio output than that of either receiver.

If a diversity combiner is used to provide improved signal-to-noise ratio, the following conditions must exist:

- 1) The base band output from the receivers must be in phase.
- 2) The net system gain from the transmitter through the medium and each receiver must be held equal and constant.

⁷ C. L. Mack, "Diversity reception in uhf long-range communications," *Proc. IRE*, vol. 43, pp. 1281-1289; October, 1955.

- 3) The combining curve must have the proper characteristic.⁸

With an fm system the first two requirements are easily met, and the third can be met with proper design of the combiner. With AM systems, the requirement is more stringent with respect to constant system gain; *i.e.*, a very tight agc system must be employed. With SSB systems both items 1) and 2) must be considered—particularly item 1).

In double sideband AM or fm systems the base band output is the result of detecting the carrier and its sidebands; therefore, the base band phase to a first order approximation is unaffected by time delays encountered by the rf signal in the medium. In SSB the output phase of the base band is directly dependent upon the phase of the received rf signal; therefore, during any path length changes the base band output phase will change.

To overcome these problems, a reference signal is transmitted at reduced level and is received by both receivers. Since the frequency separation between the reference signal and the intelligence signals is very small compared to the radiated frequency, the reference signal will undergo approximately the same time delays in the transmission medium as the intelligence signals that are to be combined. With only one sideband, the delay differences do not cause serious distortion in demodulation, and are usually insignificant compared to the period of a component of the demodulated base band. Consequently, if the reference signal is used in one of the heterodyne translation processes, any phase shifts caused by time delays in the medium may be made to cancel out. Thus, to a first-degree approximation, the output phase of the SSB system is now independent of path length variations in the medium. The reference signal also provides a good reference level from which any changes in the net system gain can be determined and, when properly applied, the net system gain may be held essentially constant.

From the foregoing discussion it is seen that SSB techniques may logically be applied to vhf circuits. Adequate frequency stability is the only requirement necessary to insure improved communications by the use of SSB as the radiated frequency is increased. Careful consideration must be given to teletypewriter multiplexing and to diversity reception techniques if the maximum communications reliability is to be achieved.

⁸ D. G. Brennan, "On the maximum signal-to-noise ratio realizable from several noisy signals," *Proc. IRE*, vol. 43, p. 1530; October, 1955.



Single-Sideband Techniques in UHF Long-Range Communications*

W. E. MORROW, JR.†, C. L. MACK, JR.†, B. E. NICHOLS†, AND J. LEONHARD†

Summary—Several factors relevant to the design of uhf long-range communication systems are analyzed. In particular, single-sideband amplitude modulation is evaluated and compared to frequency modulation, with special regard to: a) spectrum conservation; b) performance in the presence of multipath; and c) realized channel signal-to-noise ratio vs total transmitted rf power. It is shown that:

- 1) SSB requires one-sixth to one-tenth of the spectrum width required by fm.
- 2) The useful bandwidth of the transmission medium in the presence of multipath is at least four times as great for SSB as for fm.
- 3) The average power required for a twenty-four channel SSB system is about 20 decibels less than that required for an equivalent fm system, providing equal usable communications.

System design considerations are discussed for uhf single sideband, as well as the design parameters of a particular set of equipment operating in the 300 to 400-megacycle band.

The linearity of high-power klystrons is discussed, and a promising technique for achieving highly efficient operation of such devices is described.

INTRODUCTION

IN RECENT YEARS, it has been learned that uhf signals of useful strength can be transmitted consistently to several hundred miles beyond the horizon. Antennas of up to 60 feet in diameter and transmitters of 10 or more kilowatts output power are employed in order to overcome the propagation losses which can approach values of 100 db in excess of free space attenuation at distances of 300 miles. Under these circumstances, it is important to employ modulation techniques which permit most efficient utilization of the received energy.

In the following paper, it is shown that single-sideband modulation has significant advantages for long-range uhf communication systems. In addition, the design features of equipment for transmitting and receiving uhf-SSB signals are described.

PROPAGATION EFFECTS

Knowledge of the propagation peculiarities of uhf beyond-the-horizon transmissions is necessary in any comparison of modulation techniques. Considerable information has been published on uhf beyond-the-

horizon (tropospheric scatter) propagation;¹⁻⁷ unfortunately, most of this information concerns the characteristics of narrow bandwidth transmissions. Some data have been published on the multipath distortion and frequency selective fading effects important in wide bandwidth transmissions.⁸⁻¹⁰ The theory of this type of propagation is not yet well understood; however, experiments indicate that the observed effects are due to inhomogeneities in the troposphere, and reflections from aircraft in the transmission path.

Measurements show that the hourly median signal strengths typically vary over a range as great as 80 db. In addition, Rayleigh-distributed rapid variations in signal strength occur at rates from about 1.0 to 50.0 per second; the faster fading rates occur in the presence of aircraft. It is found that signals received on widely-separated ($>50\lambda$) antennas have uncorrelated rapid variations.

The multipath delays produced by tropospheric transmissions are typically of the order of a few tenths of a microsecond; however, much longer delays can occur from transmission paths due to reflections from aircraft. In this latter case, the maximum multipath delay is determined principally by the antenna beamwidths and the length of the circuit. For circuits with antennas of equal horizontal and vertical beamwidths, it can be shown that the greater variations in delay occur for paths along the upper and lower edges of the antenna beams. Fig. 1 shows a vertical cross section of a typical circuit with the two antennas aimed at the hori-

¹ T.I.D. Report 2.4.5., "Summary of Tropospheric Propagation Measurements and the Development of Empirical Propagation Charts," Federal Communications Commission (27989); October 20, 1948.

² J. W. Herbstreit, K. A. Norton, D. L. Rice, and G. E. Schafer, "Radio wave scattering in tropospheric propagation," 1953 IRE Conv. Rec., Part 2, pp. 85-93. NBS Report 2459 of April 15, 1953.

³ I. H. Gerks, "Propagation at 412 mc from a high-powered transmitter," Proc. IRE, vol. 39, pp. 1374-1382; November, 1951.

⁴ K. Bullington, "Radio propagation variations at vhf and uhf," Proc. IRE, vol. 38, pp. 27-32; January, 1950.

⁵ E. C. S. Megaw, "The scattering of short radio waves by tropospheric turbulence," *Nature*, vol. 166, pp. 1100-1104; December, 1950.

⁶ K. Bullington, "Radio transmission beyond the horizon in the 40 to 4,000 mc band," Proc. IRE, vol. 41, pp. 132-135; January, 1953.

⁷ Scatter Propagation Issue, Proc. IRE, vol. 43; October, 1955.

⁸ J. H. Chisholm, *et al.*, "Investigations of angular scattering and multipath properties of tropospheric propagation of short radio waves beyond the horizon," Proc. IRE, vol. 43, pp. 1317-1335; October, 1955.

⁹ W. H. Tidd, "Demonstration of bandwidth capabilities of beyond-horizon tropospheric radio propagation," Proc. IRE, vol. 43, pp. 1297-1299; October, 1955.

¹⁰ G. L. Mellen, *et al.*, "UHF long-range communication systems," Proc. IRE, vol. 43, pp. 1269-1281; October, 1955.

* Original manuscript received by the IRE, September 24, 1956. The research in this document was supported jointly by the U. S. Army, Navy, and Air Force under contract with Mass. Inst. Tech., Cambridge, Mass.

† M.I.T. Lincoln Lab., Lexington, Mass.

zons. If it is assumed that transmissions can take place by a path tangent to the horizons at the transmitter and receiver (path TAR) and by a path at an angle α above the horizons (path TBR), then the difference in transmission delay between these two paths can be calculated as:

$$\Delta T \cong \frac{l}{c} \left(\frac{l}{2r} \alpha + \alpha^2 \right) \quad (1)$$

where

- l is the path length,
- r is the earth's radius,
- c is the velocity of light,
- α is the angle above the horizon of the TBR path in radius.

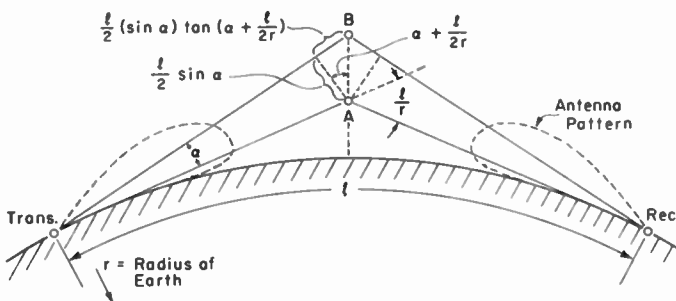

Fig. 1—Vertical cross section of path.

It is evident that the amplitude of the delayed signal (path TBR) will decrease as α increases. Assuming equal scattering cross sections at A and B , the delayed signal will be 6 db lower than the signal received over the path TAR when α equals one-half the 3-db antenna beamwidth (identical antennas assumed). As α is further increased the delayed signal level will decrease rapidly. In the following discussion it will be assumed that the maximum multipath delay is that calculated for the paths (a) along the horizons (TAR) and (b) at an angle to the horizontal equal to one-half the 3-db antenna beamwidth. Fig. 2 has been prepared on this basis. The delays shown in Fig. 2 agree within 20 per cent of values measured on 150–200 mile circuits with 0.6°, 2.5°, and 6.0° antenna beams.

Multipath propagation will produce distortion of transmitted signals in both the time and frequency domain. The effects in the time domain are most noticeable in the case of pulsed signals which are lengthened in time (smeared) by approximately the multipath differential time delay. In addition, various other forms of distortion in the pulse shape may occur. In the frequency domain, the multipath propagation can produce variations in the levels of signals received at different frequencies (frequency selective fading).

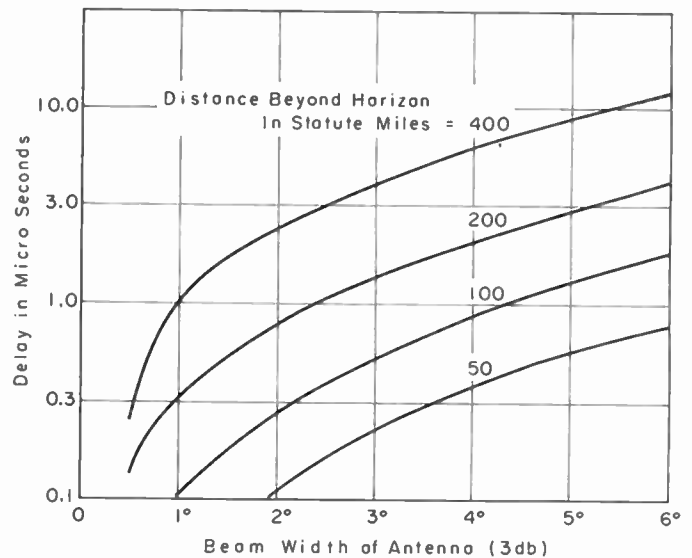

Fig. 2—Delay differences of various paths.

For the case of two paths of equal attenuation with a delay difference of ΔT seconds, the received signal will have the following well-known form:

$$e_r = \cos \frac{2\pi f \Delta T}{2} \sin 2\pi f t. \quad (2)$$

Fig. 3 in accordance with (2) shows that the amplitude of the received signal varies from zero to a maximum with a frequency separation between maxima and minima of $1/2\Delta T$. In the case of an actual circuit, the attenuation of the two paths would vary considerably in an independent fashion and produce frequency selective fading typical of the other curve in Fig. 3.

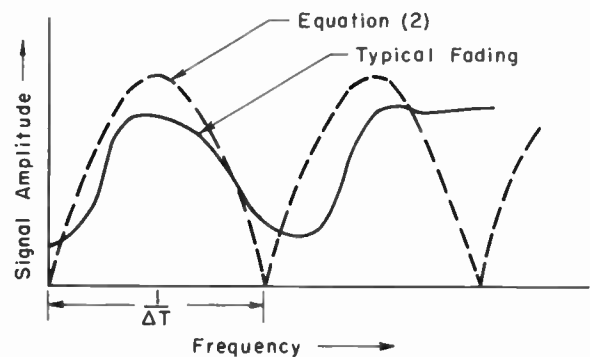

Fig. 3—Fading due to signal arriving over two paths.

The frequency selective fading effects of uhf multipath propagation can be approximately determined as follows:

Assume that signals at frequencies f and $f + \Delta f$ are received by two paths of differential delay ΔT , with uncorrelated varying amplitudes A_1 and A_2 , which are

Rayleigh distributed and have identical means. Further assume that ΔT is varying randomly over several rf cycles.

At any instant the received signals will be:

$$e_1 = A_1 \sin 2\pi f t + A_2 \sin 2\pi f (t + \Delta T). \quad (3)$$

$$e_2 = A_1 \sin 2\pi (f + \Delta f) t + A_2 \sin 2\pi [(f + \Delta f)(t + \Delta T)]. \quad (4)$$

A_1 and A_2 are the instantaneous amplitudes.

Δf is the frequency separation of the two signals.

ΔT is the multipath delay.

We may write from (3) and (4) the ratio of the mean squared signal amplitudes:

$$\frac{\overline{e_2^2}}{\overline{e_1^2}} = \frac{A_1^2 + A_2^2 + 2A_1A_2[\cos(2\pi f\Delta T)\cos(2\pi\Delta f\Delta T) - \sin(2\pi f\Delta T)\sin(2\pi\Delta f\Delta T)]}{A_1^2 + A_2^2 + 2A_1A_2\cos 2\pi f\Delta T}. \quad (5)$$

The distribution of $\overline{e_2^2}/\overline{e_1^2}$ is desired, as a function of the product of ΔT . Evaluation of this distribution in a closed form is difficult; however, the distribution of (5) has been evaluated by approximate numerical techniques. The results are plotted in Fig. 4 which shows the per cent of time various ratios of the two signals are exceeded as a function of the nondimensional parameter $\Delta f\Delta T$. Measurements made at $\Delta f\Delta T$ of 0.025, 0.05, and 0.1 on a 400-mc, 200-mile circuit agree with Fig. 4 to within about 2 db.

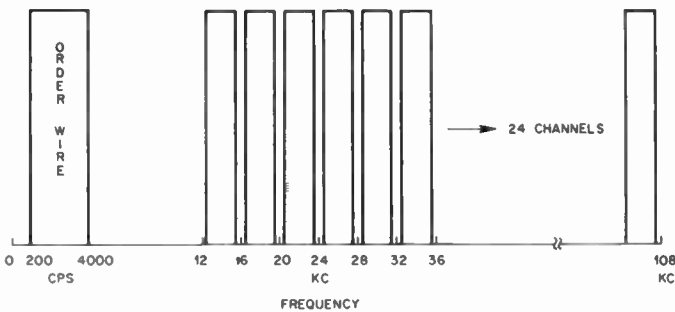

Fig. 4—Typical spectrum allocation—frequency division multiplex voice channels. CCIF channel allocation for twenty-four-channel system.

In multipath situations where one component of the received signal is produced by reflection from a fast-moving aircraft, very rapid fluctuations will occur in received signal amplitude and phase. Maximum fading rates and Doppler frequency shifts of from 20 to 40 cps have been observed on typical circuits.

MODULATION TECHNIQUES

At the present time, long-range uhf communications systems usually employ frequency modulation with frequency-division single-sideband multiplex for multi-channel operation. A typical spectrum allocation is

shown in Fig. 4. In the discussion that follows, direct single-sideband modulation and pulse-code modulation will be compared with a typical fm system. Among the criteria that can be used for comparison of these modulation techniques are the factors of: 1) rf bandwidth required, 2) maximum channel capacity due to limitations set by multipath propagation, and 3) channel signal-to-noise ratio for a given rf signal power.

RF Bandwidth Required

The bandwidths required per voice channel for each of these systems are noted in Table I.

It is obvious that the SSB modulation has a signifi-

TABLE I

	Bandwidth per Voice Channel
SSB	4 kc (which includes channel guard band)
FM (deviation ratio 2.0)	24 to 40 kc (depending on intermodulation requirements)
PCM-AM 8000 samples per second 8 bits per sample 64000 bits per second	64 to 100 kc

cant advantage from the spectrum conservation point of view.

Capacity Limitations Due to Multipath

In any discussion of propagation-bandwidth limitations of the various modulation techniques, it should be recognized that the attenuation and delay of the various possible propagation paths are variables dependent upon such factors as the number of aircraft in the circuit, etc. Therefore, the comparison in this discussion will be on the basis of the rather severe case of two paths with nominally fixed delay and with Rayleigh-distributed attenuations of equal means (Fig. 5).

In the case of SSB modulation, the frequency selective effects shown in Fig. 5 will produce variations of received signal level for the various channels; however, intermodulation will not be produced since the propagation has the characteristics of a quasi-stationary passive network and does not contain any nonlinear elements which are necessary for the production of interchannel cross-modulation noise in an SSB system. The frequency selective fading effects can be overcome by the use of multiple-pilot amplitude regulators. Fig. 5 shows that a single pilot amplitude regulator is effective over

a limited range of $\Delta f \Delta T$ of perhaps 0.01 to 0.02. However, two pilot amplitude regulators can be arranged for proportional amplitude control of the frequencies lying between them. With this arrangement the selective fading can be reduced to a very few db over a range as great as $\Delta f \Delta T = 0.1$ to 0.2. This is possible since over a range of $\Delta f \Delta T \leq 0.2$ the variation in attenuation at two frequencies has been measured to be very nearly proportional to the frequency separation. If necessary, additional pilots can be used to obtain even greater bandwidths.

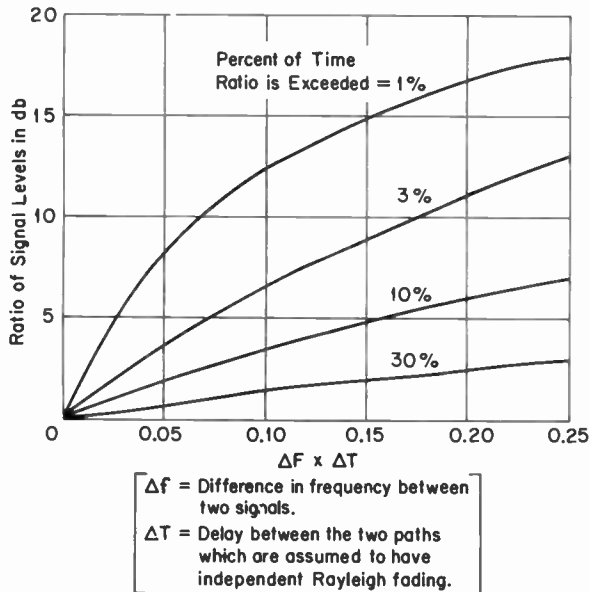

Fig. 5—Ratios of signal levels at separated frequencies.

With frequency modulation, the effects of frequency selective fading are complex. Both intermodulation noise and channel level instabilities can be produced. Pilot regulator techniques can, of course, be used to overcome these level variations. Of more serious consequence is the intermodulation noise produced by the multipath propagation which results in nonuniform phase and amplitude transmission of the various sidebands of a frequency-modulation signal. In order to maintain a sufficiently low intermodulation noise level (40 db below signal level), operation with $\Delta f \Delta T$ equal to 0.05 or less is usually desirable.¹¹

In the case of pcm, operation at a pulse rate of less than $1/2\Delta T$ is required for reliable separation of successive pulses. Under these conditions there is, of course, no channel level instability and a fixed quantization noise level. The effective modulation bandwidth is set by the fact that a 4-kc band requires about 60,000 bits per second or approximately 16 bits per cycle of bandwidth. Thus

¹¹ W. J. Albersheim and J. P. Schafer, "Echo distortion in the fm transmission of frequency-division multiplex," Proc. IRE, vol. 40, pp. 316-328; March, 1952.

$$\Delta f_{\text{mod.}} \leq \frac{1}{2\Delta T} \cdot \frac{1}{16} = \frac{1}{32\Delta T}$$

or

$$\Delta f \Delta T \leq 0.03.$$

The bandwidth limitations of the three modulation techniques under multipath propagation conditions are summarized in Table II.

TABLE II

Modulation	Max. Bandwidth for Multichannel Service With Multipath Delay ΔT	
SSB	0.02/ ΔT 0.2/ ΔT very large	1 pilot 2 pilots multiple pilots
FM	0.05/ ΔT	
PCM	0.03/ ΔT	

It is seen that SSB has significant advantages in regard to capacity limitations imposed by multipath propagation.

Signal-to-Noise Comparisons

Under the conditions of single voice channel operation with a constant rf received signal, a comparison of the modulation techniques is relatively simple. Actual systems operate with a number of voice channels most of which are *not* energized at any given time. In addition the rf signal strength typically undergoes rapid variations in level (fading). Thus, for valid comparisons, it is necessary to determine for the various modulation systems, the probability distribution of channel signal-to-noise ratios given a definite median rf signal.

Sources of noise include: transmitting equipment, propagation (incidental noise picked up by the antenna), and the receiver front end. Transmitting equipment noise, as discussed below, can be held to quite acceptable limits, 55 db below the signal level being readily achieved through the power amplifier. The frequency region of importance in tropospheric communication systems, roughly 200 mc to 5000 mc, is characterized by very low levels of cosmic noise, generally corresponding to a noise temperature in the range 25°K to 100°K. On the other hand, radio-frequency preamplifiers and mixers currently available for use in uhf receivers have effective noise temperatures in the range 600°K to 3000°K, some 8 to 20 db above antenna noise.

Single-Sideband Modulation

In order to compute the probability distribution of channel signal-to-noise ratio, it is necessary to determine the following: 1) receiver transfer function; 2) distribution (in time) of transmitted power per channel; and 3) distribution (in time) of path attenuation.

The receiver transfer function relates input rf signal power to demodulated signal-to-noise ratio. At 293°K, the noise power per cycle of bandwidth is 204 db below 1 w. Assuming, for the time being a standard noise figure of 6 db for a uhf front end, the noise power in a 3200-cycle channel bandwidth is minus 163 dbw. Since each channel occupies its own rf bandwidth and utilizes the facilities of the receiver independently, we can speak with complete generality of the receiver characteristics of a single channel. This is shown in Fig. 6, where the average radio-frequency power per channel is plotted against the resultant channel signal-to-noise ratio in the baseband.

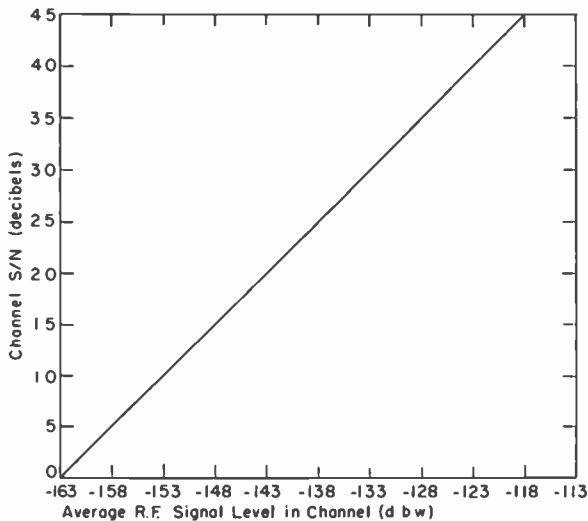

Fig. 6—Single-sideband receiver transfer function (6 db N.F.).

The relationship between rf signal level and channel s/n ratio having been established, we might next investigate the factors determining rf signal level expectations on a per channel basis. Consider the multichannel telephone system depicted in Fig. 7 (opposite); each voice channel equipped with its own transmitter, antennas, and receiver. The rf signal level at the receiver terminals of any particular channel, *assuming that the channel is in use*, would depend upon the power capability of its transmitter, the gain of the antenna system, and the path attenuation at the time the transmission is taking place. In view of the fact that the frequencies of transmission are all contained in a small contiguous band, it would be foolish to use one antenna for each channel; one large antenna would give each channel a better system margin than several small antennas. It is also obvious that one uhf receiver can be used to convert from the transmission frequencies down to the individual channel frequencies. At this point each channel receiver can select its 3200-cycle portion of the common output for ultimate demodulation.

When considering the transmitters, however, a very important fact arises. Each individual uhf transmitter will emit a signal only when a "voice" signal energizes its baseband channel transmitter. No rf power will be

required of the uhf transmitter when that channel is not in use. If all of the baseband channel transmitters were connected to one large uhf transmitter and automatic equipment were provided to keep the large transmitter at maximum power output, each channel would enjoy the full transmitter output so long as no other channel is active coincidentally. In general, with independent use of each channel, this can be considered a random time-sharing process. This situation is shown in Fig. 8.

A realistic basis upon which to compute channel-loading statistics is afforded by the Bernoulli (Binomial) distribution employed by commercial telephone companies. These statistics are appropriate to the problem of total power capability required of a line amplifier system in which all channels are available for immediate use. The situation, therefore, is entirely analogous to a radio system in which every line is a "hot" line, *i.e.*, connected at all times to telephones (or data equipment) at each end.

The binomial probability distribution can be stated generally as follows:

If the probability of an event E in any single trial is p , $0 \leq p \leq 1$, so that the probability of nonoccurrence of E is $q = 1 - p$, then the probability of *exactly* r occurrences of E in n independent trials is given by

$$b(r) = \binom{n}{r} p^r q^{n-r} = \frac{n!}{r!(n-r)!} p^r q^{n-r}. \quad (6)$$

In order to make use of existing Bell Telephone Laboratories data, it will be necessary to employ entirely different symbols than the standard ones shown above. These shall now be defined:

Let

Event E = transmission of energy.

N = total number of channels in the system.

This corresponds to the small n in the normal usage, *i.e.*, the number of independent trials available is just the total number of channels available.

n = number of channels putting energy into line. This corresponds to r in the normal sense.

τ = average fraction of the time that a channel is transmitting. This figure, called the *activity factor*, is the actual measure of how busy a multichannel circuit has been and can be expected to be. τ corresponds to p in the normal usage.

$b(n)$ = probability that n channels are transmitting at any given time.

We shall rewrite the equation to conform to commercial usage as

$$b(n) = \binom{N}{n} \tau^n (1 - \tau)^{N-n}. \quad (7)$$

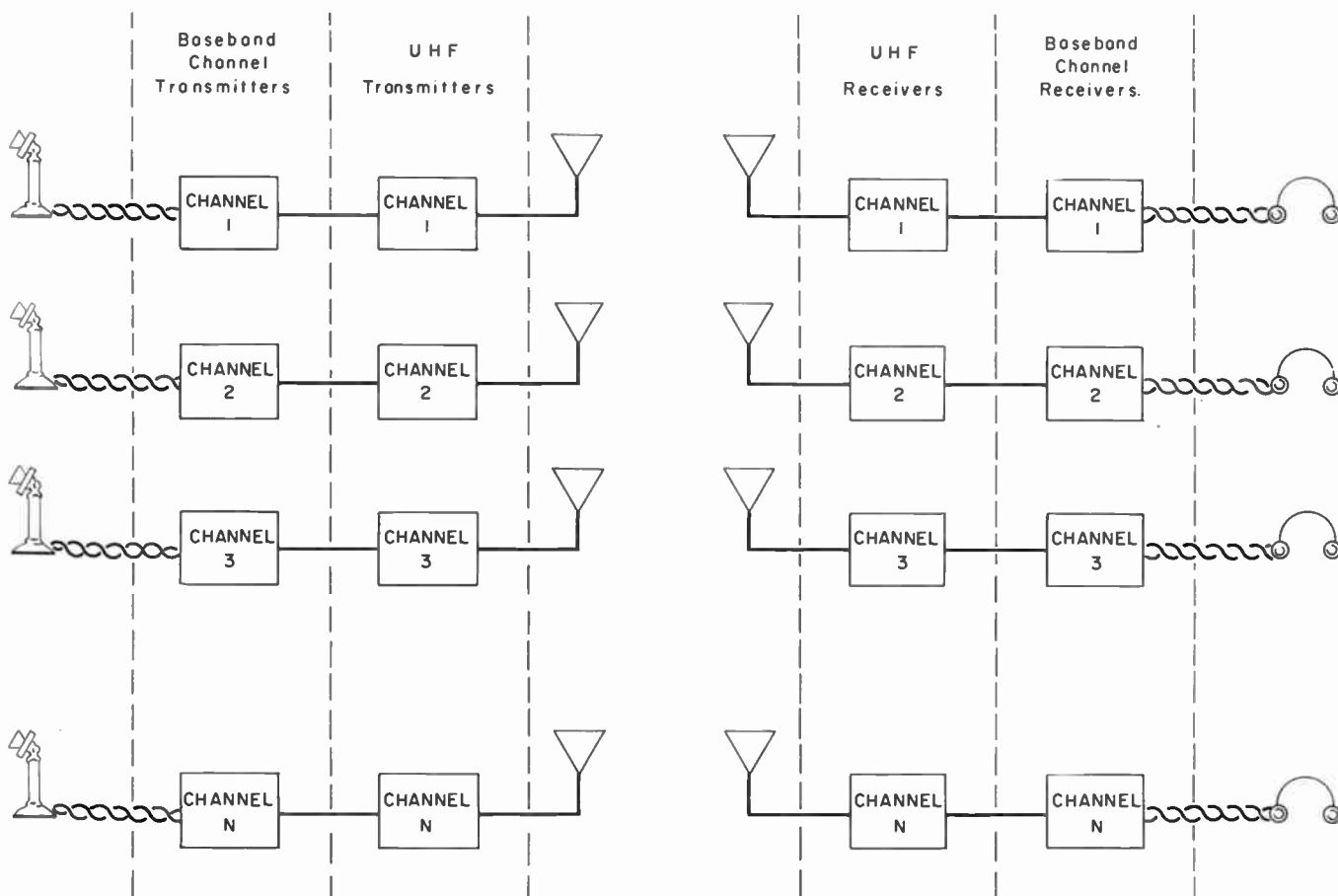

Fig. 7—"Exploded" view of multichannel SSB system.

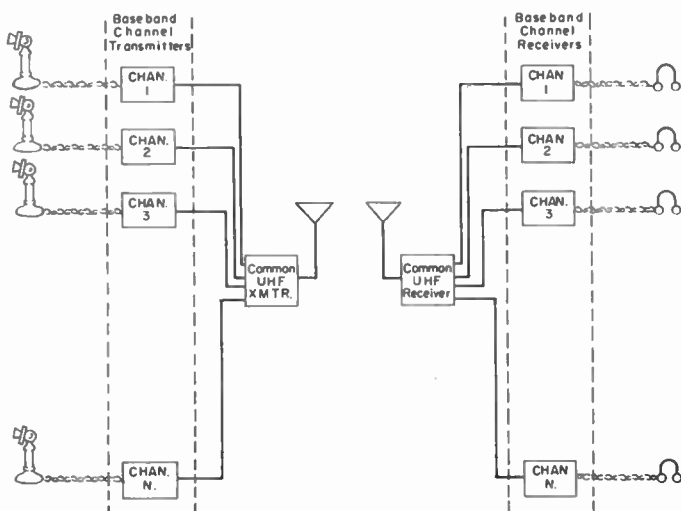

Fig. 8—"Shared" uhf system configuration.

The Bell System employs the figure $\tau = 0.25$ as representative of the *busiest hour* load on an intercity trunk line.¹² Their line amplifiers are designed accordingly. In actual practice, however, the largest τ ever measured during the "busy" hour on such a trunk was 0.095 by

¹² B. D. Holbrook and J. T. Dixon, "Load rating theory for multichannel amplifiers," *Bell Sys. Tech. J.*, vol. 18, pp. 624-644; October, 1939.

Brooks in 1940. The trunk involved was an outgoing long distance line from New York City. It must be kept in mind that we are dealing with the statistics of the *busy hour* and that these are not at all representative of the kind of channel activity that would be expected on a *sustained* basis in a commercial system. However, in the interests of conservatism, we shall be employing these "busy-hour" statistics as if they were sustained *twenty-four hours a day throughout the entire year*.

Considering a twenty-four-channel system for the moment, and using a value of 0.10 for τ , we arrive at the busy-hour channel-loading distributing given in Table III (next page). The fact that such an activity factor is the largest measured to date is understandable when one considers the characteristics of speech. A large part of the intelligence of speech is contained in its intermittent nature: the pauses between syllables, words, and sentences, and the natural pauses incidental to the average speaker. In addition, the normal adult must inhale about sixteen times a minute—a time-consuming process that is physiologically noncoincident with speech sounds. Add to this the requirements of signaling, reference to written material, and bidirectional flow of information, and it soon becomes clear that an activity factor of 10 per cent on every channel of a high capacity system is representative of a "busy" hour indeed.

TABLE III

Number of Channels Coincidentally Using the Transmitter	Per Cent of Time During Busy Hours ($\tau=0.10$)
0	7.98
1	21.27
2	27.18
3	22.15
4	12.91
5	5.74
6	2.02
7	0.58
8	0.14
9	0.03
10	0.00
⋮	⋮
⋮	⋮
24	0.00

Since equally appropriate data are not available for teletype or data links, similar measurements will have to be made on systems involving these types of transmission. It will be seen, however, that a transmission technique which characteristically uses transmitter power when no information is being conveyed is intolerably inefficient—when viewed in the present frame of reference.

The next question is: What fraction of the transmitter's power output is available to any given channel in the system? We predicate our discussion on a scheme wherein the transmitter is kept fully loaded, independently of the number of channels simultaneously using it. A definition of "fully loaded" is required.

The usual fixed limitation of a single-sideband transmitter is its peak power capability. This may be the saturation level of the final tube in the transmitter, or the allowable limitation from the standpoint of distortion. In a random signal of the type resulting from a single voice or a multiplexed combination of voices, an agreement must be reached as to what is the peak power level of the distribution. The figure used as a basis for the work reported on in this paper is that power exceeded one per cent of the time in a "continuous" speech wave. (That is, without the loading factors discussed above.) It is found that the ratio of this power level to the average power level is 11 db. After conversion of the speech wave in a multiplex voice channel, the same ratio obtains. If clipping or pre-emphasis is applied before multiplex conversion, the peak-to-average ratio of the distribution after conversion is still 11 db.¹³ When two or more multiplexed voice channels are added together, the resultant peak-to-average ratio is as given in Table IV. (The leveling off at 8.2 db is merely an expression of the factors involved in the central-limit theorem as they apply to this case.) We define: A transmitter is fully loaded when its peak power capability is being

TABLE IV¹³

Number of Voice Channels Contributing to Distribution	Peak-to-Average Ratio of Resultant Distribution	Average Power in Each Channel (Referred to Combined Peak)
1	11.0 db	-11.0 db
2	9.5	-12.5
3	8.5	-13.4
4	8.2	-14.2
5	8.2	-15.2
6	8.2	-16.0
7	8.2	-16.7
8	8.2	-17.2
9	8.2	-17.7

exceeded one per cent of the time. Its average power output can be inferred from the data of Table IV. The average power in each channel is also tabulated.

It would at first sight appear that the question as to the power available for each channel is answered by a comparison of Tables III and IV, e.g., with an activity factor of one-tenth there will be two channels coincidentally active 27 per cent of the time and they will each have an average power 12.5 db below the transmitter's peak capability. An example will show that this is not the distribution of primary interest in our particular problem.

Consider a two-channel system with an activity factor of one-fourth; Fig. 9 indicates channel activity as dashes

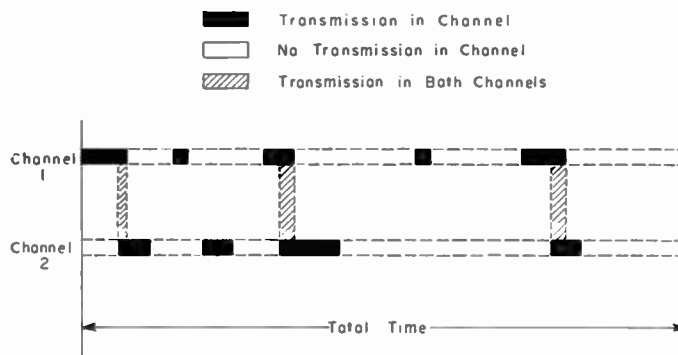

Fig. 9—Example of channel activity—two-channel system.

along the time axis. As might be expected on a random basis, the fraction of the total time during which two channels are transmitting is one-sixteenth. The fraction of the time during which neither channel is transmitting is

$$1 - (1/4 + 1/4 - 1/16) = 9/16 = (3/4)^2. \quad (8)$$

However, it is of little importance to the individual using channel 2 that he could have had the entire transmitter to himself, if he had used it when he didn't. What is important in any given channel is the distribution of the transmitter power available to that channel when it is

¹³ These data originate from studies made by D. Karp at M.I.T. Lincoln Laboratory.

in use. Consequently, we must modify our calculations to make use of the conditional probability, $b(n)$, ($n \geq 1$) rather than the normal channel-loading expression of (7). Since we have merely reduced the number of allowed alternatives by one while maintaining the same activity factor, it is not surprising to find that the conditional probability is given by the Bernoulli distribution of $N - 1$ channels, where n now becomes the number of other channels sharing the transmitter power at any instant of time. The resultant distribution of channel power for the case of a twenty-four-channel system during the "busy hour" is given in Table V.

TABLE V

Number of Other Users	Average Power in Each Channel (Referred to Transmitter Peak)	Per Cent of the Time a Given Channel Is in Use	Average Power in Channel Referred to Upper Bound (db re. -11 db)
0	-11.0 db	8.9	0.0 db
1	-12.5	22.6	-1.5
2	-13.4	27.7	-2.4
3	-14.2	21.5	-3.2
4	-15.2	12.0	-4.2
5	-16.0	5.0	-5.0
6	-16.7	1.7	-5.7
7	-17.2	0.6	-6.2

It is seen that any given channel will have the full transmitter exclusively to itself approximately 9 per cent of the time, giving a channel average power 11 db below peak transmitter power, but that the channel power will be 4.2 db below this figure during 12 per cent of its use and so on. The fourth column is referred to the maximum power available to a channel, while the third column gives the per cent of time during which this implicit "loss of power" occurs.

Given the transfer function of the receiver as it pertains to any given channel, the statistics governing net path attenuation between antenna terminals, and the distribution of the transmitter power in a channel during a period of peak system utilization, we are ready to calculate the net distribution of channel signal-to-noise ratio. There remains one additional aspect of the problem, however, which should be treated as a separate matter.

The usual procedure in the design of these long-range systems has been to decide what short-term signal quality is considered acceptable, e.g., what s/n ratio should be exceeded 99 per cent of the time during any one hour, and then to express the reliability (or performance) of the system as the percentage of the annual hourly medium signal levels which will provide such short-term signal quality. It is a characteristic of the propagation that low signal levels are accompanied by rapid fading having an essentially Rayleigh distribution of amplitude, and it is just these low hourly medians that are of prime importance in determining system reliability. During such an hour, the effective path at-

tenuation varies over a range of 26 db between the first percentile and the ninety-ninth percentile, and it does so with a time constant ranging from a fraction of a second to many seconds—just the sort of time scale with which the channel power might be expected to vary. The point arises: given that the distributions of transmitted power and path attenuation are independent, what is the net distribution of received power within the hour? Since all operational circuits employ diversity reception, the distribution of effective path attenuation used in the calculation should be one describing a diversified system. A very significant advantage of a single-sideband receiver is the fact that, having a linear transfer function down to the bitter end, it makes full use of the type of combiner diversity described in a previous report.¹⁴ As to the order of diversity, many factors lead us to the choice of fourth order, not the least of which is the system-sparing philosophy expressed in a later section of this paper. Following the nomenclature suggested by Brennan,¹⁵ we shall call this particular type of diversity "maximal-ratio combination" to distinguish it from the type discussed later on. The general form of the distribution has been given by Sichak¹⁶ and others,^{16,17} we shall use the density function

$$g_m(p_c) = \frac{1}{(m-1)!} p_c^{m-1} e^{-p_c} \quad (0 \leq p_c \leq \infty) \quad (9)$$

where p_c = power signal-to-noise ratio after combination, and m = order of diversity.

In order to make use of (9) for our present purposes, we must recall that p_c is the effective received signal-to-noise ratio given a constant transmitted power and, since the noise injected into the system is effectively a constant, that $g_m(p_c)$ is equally well the density function describing the effective received power. The tabulated variable given in the fourth column of Table V, call it p_t , is the ratio of the transmitted average power in each channel to the maximum average power available in the transmitter (11 db below its peak power capability). If the maximum average channel power is employed in the calculation of the hourly median, then the sum (in db) of p_t and p_c will be the effective received power within the hour. A knowledge of the distribution of $p_t + p_c$ will then permit us to calculate a combined "fading margin" plus "channel-competition margin" for this particular system. The distribution of $p_t + p_c$ for twenty-four channels has been evaluated by machine calculation and appears, in the form of the cumulative

¹⁴ C. L. Mack, "Diversity reception in uhf long-range communications," Proc. IRE, vol. 43, pp. 1281-1289; October, 1955.

¹⁵ Studies performed by D. G. Brennan at M.I.T. Lincoln Lab.

¹⁶ F. J. Altman and W. Sichak, "A simplified diversity communication system for beyond-the-horizon links," IRE TRANS., vol. CS-4, pp. 50-56; March, 1956.

¹⁷ H. Staras, "The statistics of combiner diversity," Proc. IRE, vol. 44, pp. 1057-1058; August, 1956.

function, in Fig. 10. A plot of the fourth-order diversity distribution is included for purposes of comparison. The ordinate scale has been plotted in db relative to the median of the nondiversified received signal since this is the median resulting from system calculations employing the long-term path loss. Noting in particular the ninety-ninth percentile, we see that the short-term fading allowance that must be made in system design calculations, contingent on the coincidence of a high activity factor and a low hourly median, has gone up 3.5 db. When more precise data are available from operational systems in existence, it may be possible to generalize the treatment to include the long term distribution of activity factor vs the annual distribution of hourly medians. Until such time, however, the "busy hour" must be applied against the lowest medians and the resultant "fading allowance" considered an additional margin of safety.

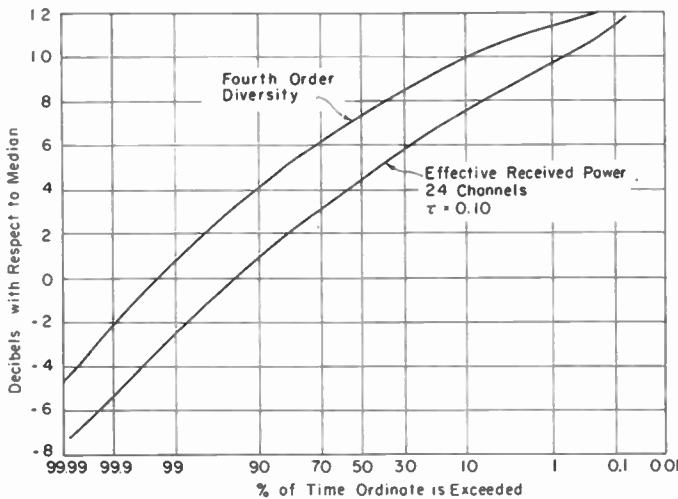

Fig. 10—Single-sideband s/n distribution. Upper curve: Fourth-order maximal-ratio diversity distribution. Lower curve: combined distribution—twenty-four channels, $\tau=0.10$, fourth-order diversity.

Additional curves involving the parameters τ and N have been plotted in Fig. 11.

It remains to compute the value of median received signal power required to provide "acceptable" short-term signal quality for the twenty-four-channel example. What is acceptable signal quality will obviously depend on the type of signaling being employed in the system. In the case of speech, the situation is represented in Fig. 12 in terms of the per cent of errors made in the reception of unrelated words; the standard articulation test. In the case of teletype tone converters presently available as commercial equipment, a 13 to 15-db signal-to-noise ratio is generally required for very good copy, a signal which is fluctuating with occasional excursions as low as 10 db above noise will print errors. Consequently, when the hourly median signal level has fallen to the point that the distribution function given in Fig. 10 corresponds to a 10-db signal-to-noise ratio

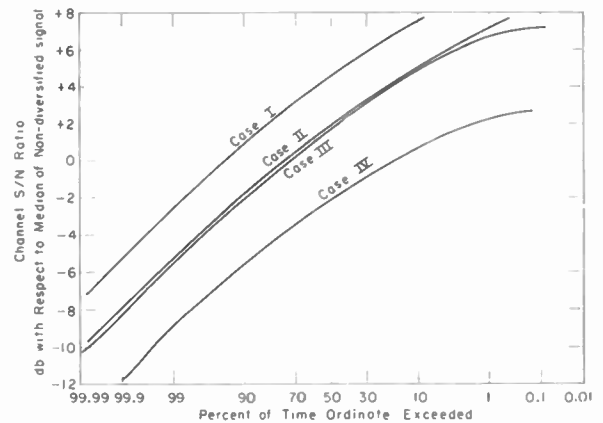

Fig. 11—Combined distributions for various cases. Case I: Twenty-four channels, $\tau=0.10$, fourth-order maximal-ratio diversity. Case II: Twenty-four channels, $\tau=0.25$, fourth-order maximal-ratio diversity. Case III: Sixty channels, $\tau=0.10$, fourth-order maximal-ratio diversity. Case IV: Sixty channels, $\tau=0.25$, fourth-order maximal-ratio diversity.

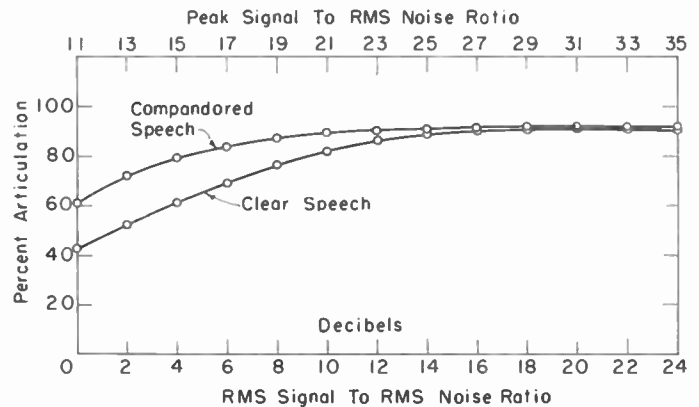

Fig. 12—Articulation intelligibility. Upper curve: With compandor. Lower curve: "Clear" speech.

one per cent of the time during an hour, we say a minimum acceptable signal quality obtains. A lower median is considered system failure. The performance at a minimum median signal level of a twenty-four-channel single-sideband system is shown in Fig. 13. Note that the median rf signal level required for such a distribution is approximately minus 150 dbw.

In the preceding analysis, no use has been made of speech compression techniques. Compandors (see Fig. 12) provide at least two notable advantages: 1) They suppress additive noise *in the presence of speech*, and 2) they reduce the wide disparity in talker levels, tending to give everyone a fairer share of the transmitter power. It should be pointed out that these techniques are useful whenever one is dealing with a linear system, *i.e.*, a system employing a demodulation technique that converts the rf signal-to-noise ratio directly to baseband signal-to-noise ratio. In the case of bandwidth exchange systems, a baseband s/n improvement is realized for strong signals but a completely useless post detection signal results from weak rf signals. As far as compandors are

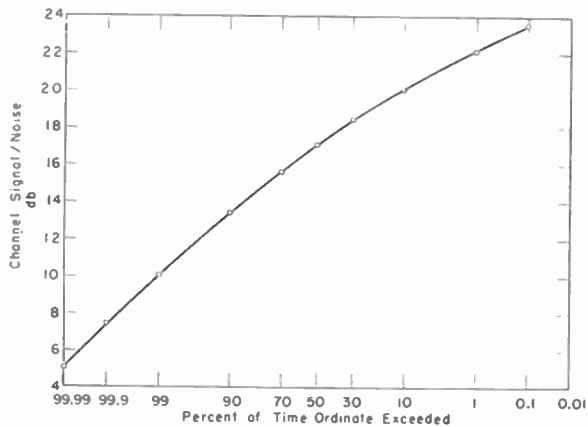

Fig. 13—Minimum "acceptable" channel quality (channel $s/n \geq 10$ db during 99 per cent of hour).

concerned, the experience in the field has been that they actually deteriorate the performance of an fm system—the noise bursts occurring during fades are accentuated by the expander at the expense of the speech (or data) wave.

Frequency Modulation

In view of its convenience at the time and with regard to its apparent advantages of signal-to-noise enhancement, frequency modulation was the preferred modulation technique in the early days of uhf long-range systems development. Since all operational systems in existence today employ fm, and with virtually identical modulation parameters, it would be well to include—for the sake of comparison—the essential performance characteristics of an fm system.

Consider, for example, a twenty-four channel system whose baseband, as in the SSB case, goes up to 108 kilocycles. In deciding on a deviation ratio for an fm system whose performance is to be judged at low rf signal-to-noise ratios, one is led to a low deviation ratio from considerations of minimizing noise bandwidth and to a high deviation ratio from considerations of noise suppression characteristics.^{18,19} The optimum is approximately one and one-half, although systems in use today employ a slightly higher ratio. Since distortion must be held within acceptable limits, at least the second-order sidebands of the resultant signal must be transmitted and received, giving a net rf bandwidth of 648 kc. The total rf (actually IF) noise present in such a bandwidth after a front end with a 6-db noise figure is minus 140 dbw.

The channel activity factors discussed above are pertinent in a slightly different way to the fm system as well. Since each multiplexed channel will contribute to a baseband signal having a resultant amplitude distribution whose peak values must not excessively deviate the

frequency being transmitted, the Holbrook²⁰ loading statistics are applied to determine the allowable (fixed) level in each channel. For twenty-four channels the allowance is 16.7 db below the maximum deviation capability of the system. The resultant channel signal-to-noise ratio as a function of received rf signal level is given in curve A of Fig. 14. If automatic loading techniques were applied to this case, an average 5-db advantage might be expected, and this is reflected in curve B of Fig. 14. Note that these considerations apply to the demodulated signal-to-noise ratio only *above* threshold; a circumstance fundamentally different from that described in the case of single sideband.

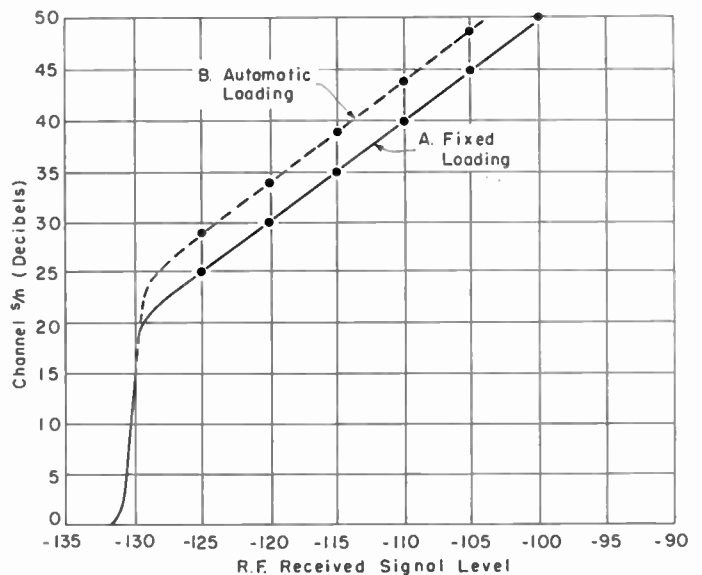

Fig. 14—FM receiver transfer function (6 db N.F., twenty-four channels). Curve A: Fixed Holbrook loading allowance. Curve B: With automatic load control, assuming $\tau=0.10$.

To see what distribution of channel signal-to-noise ratios might result from any particular hourly median rf signal level, it is again necessary to combine the receiver transfer function with the appropriate diversity distribution. Considering diversity systems presently developed and demonstrated, the technique affording the best near-threshold performance in an fm system is that called "linear adder,"¹⁶ later called "equal-gain combiner" in the frame of reference developed by Brennan. Fig. 15 shows the fourth-order distribution of predetection signal-to-noise ratio and, through reference to curve B of Fig. 14, the distribution of post-detection channel signal-to-noise ratio at a time when the lowest acceptable level is exceeded 99 per cent of the time during an hourly median. In this case, the minimum required hourly median of received rf signal level is minus 130 dbw; some 20.5 db above that required in the SSB case. For purposes of comparison, the

¹⁸ H. S. Black, "Modulation Theory," D. Van Nostrand Co., Inc., New York, N. Y., ch. 14; 1953.

¹⁹ F. L. H. M. Stumpers, "Theory of frequency-modulation noise," Proc. IRE, vol. 36, pp. 1081-1092; September, 1948.

²⁰ B. D. Holbrook and J. T. Dixon, "Load rating theory for multichannel amplifiers," Bell Sys. Tech. J., vol. 18, pp. 624-644; October, 1939.

channel s/n ratio distribution given in Fig. 15 for the fm case is repeated in Fig. 16 with the channel s/n ratio distribution of the equivalent SSB system. By "equivalent" is meant: the same number of channels, activity factor (0.10), average transmitter power, antenna system, length of path, order of diversity (although the more advantageous type of diversity has been employed in each case), and receiver noise figure. It might be argued that the same average transmitter power should not be used in each case since the efficiency of an SSB power amplifier is less than that of an fm power amplifier. This may not be the case very much longer as will be seen in a later section of the paper.

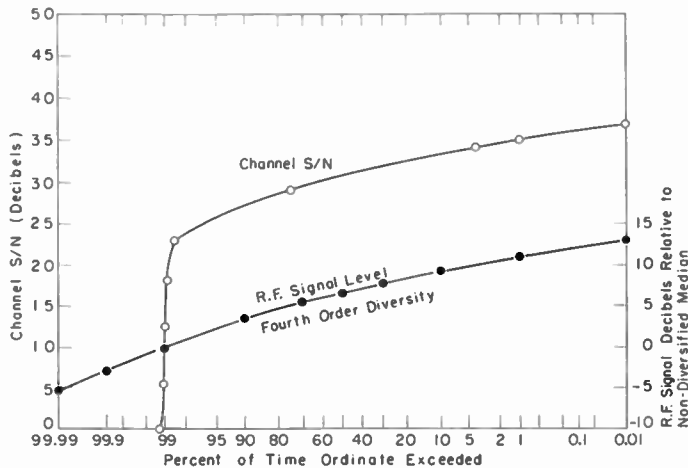

Fig. 15—FM s/n distribution when received median is minus 130 dbw. Lower curve: Received rf signal distribution (fourth-order equal-gain diversity). Upper curve: Joint distribution—twenty-four channels, $\tau=0.10$, fourth-order diversity.

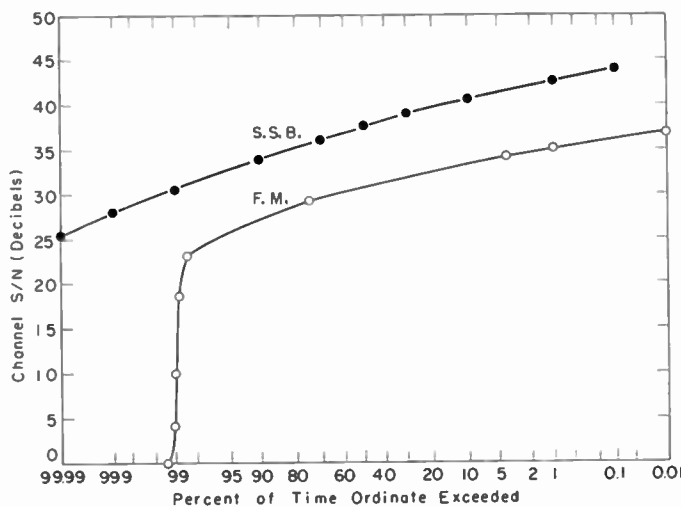

Fig. 16—System comparison: FM vs equivalent SSB.

The advantages of SSB can be partially summarized as follows: 1) spectrum conservation, 2) superior performance against multipath, and 3) less power required for a given channel signal-to-noise ratio.

UHF-SSB SYSTEM DESIGN

Among the design problems of a multichannel uhf-SSB tropospheric radio system are: frequency conversion of the telephone multiplex signals to uhf; efficient generation of high-power uhf-SSB signals with a minimum of distortion, and transmission and reception of SSB signals through a medium having frequency selective fading and Doppler frequency shifts described in the section above on propagation.

Frequency Conversion

There are two basic techniques for the conversion of multiplex signals to higher frequencies: the filter method, and the phase shift method in one of its variations.²¹ With either technique, the multiplex signals are converted to a higher frequency by mixing with a carrier signal in a balanced modulator which provides for rejection of the carrier. With the phase shift techniques, one of the two sideband outputs generated by the mixing process is cancelled by adding the outputs of two balanced modulators whose input signals have been suitably shifted in phase. In order to obtain 40 db of sideband rejection with this technique, it is necessary to maintain the signal amplitudes to within 1 per cent and the phase angles to within less than 1.0° . This requires the use of extremely accurate and highly stable components. The one advantage of this technique is that it is possible to convert the signals directly to the desired frequency. With the filter technique, the desired sideband is selected by an appropriate band-pass filter which can reduce the other sideband to an arbitrarily low level. The filter technique usually requires two or more frequency conversions and filtering processes because of restrictions on the realizability of the uhf band-pass filters required for a single conversion. For the case of two conversions, it is possible with present uhf filter techniques to reject sidebands and image responses as close as 1 or 2 per cent. This permits a first conversion frequency of 10 to 20 mc. With recent developments in crystal filters, it is possible to achieve band-pass filters at 10 to 20 mc which pass a desired sideband of 10 to 100 or more kc from carrier frequency while rejecting the other sideband by 40 db or more.

Generation of High-Power UHF-SSB Signals

High-power uhf-SSB signals can be generated by either uhf triode-tetrode linear power amplifiers or by klystron power amplifiers. The choice of amplifier type is governed by the efficiency that can be achieved while maintaining intermodulation distortion at a desired level. The linearity requirements of typical systems are that with uniform noise loading of the transmission band the third-order intermodulation products be at least 40 db down from signal power as measured in identical

²¹ Black, *op. cit.*, ch. 11.

bandwidths. To achieve the required linearity with triode or tetrode power amplifiers, operation in class A_1 or AB_1 is necessary with resulting poor efficiency. For this reason, the use of high efficiency klystron power amplifiers of the type described below is very attractive.

Transmission and Reception of SSB Signals

A single frequency called the pilot, derived from the carrier used in the first conversion, is transmitted along with the upper sideband signals. This pilot is used in the receiver for mixing with the sideband signals to produce the original multiplex signal. The relationship between the pilot and sideband is preserved in the frequency conversion process in the exciter and during transmission through a medium where signals are subject to Doppler frequency shift. Thus, it is possible in the receiver to reconstruct the multiplex signals with their original frequency and phase. With diversity reception, the output signals from each receiver are added together; coherent phase relationships are therefore essential between these signals to realize the maximum advantage of diversity combination at the multiplex level. With a transmitted pilot, the frequency and phase of the receiver output signals are not dependent directly on the frequency stability of the first conversion oscillator, the uhf carrier frequency in the exciter, or the uhf LO signal in the receiver.

In order to provide information to the receiver as to the effect propagation and multipath have on the transmitted signals, a reference tone of constant amplitude must be transmitted along with the multiplex signals. In the receiver, a wide range high-speed agc circuit to correct for the fading is controlled by this reference tone. The transmitted pilot may be used as the reference tone, but only the pilot end of the multiplex band will be kept constant in amplitude by the agc action if frequency selective fading is present across the band. A slope equalizer circuit is therefore required to correct for the proportional frequency response distortion across the band caused by frequency selective fading. A tone inserted at the opposite end of the band from the pilot is transmitted along with the pilot and the multiplex signals. In the receiver, a filter extracts and detects this tone to develop a voltage to operate the slope equalizer which varies the frequency response of an amplifier stage linearly from no correction at the pilot end of the band to maximum correction at the tone end of the band.

The frequency stability of the exciter oscillators and the receiver oscillator must be such that the received pilot signal will remain centered within the bandpass of a pilot extraction filter. This is required for the agc system to maintain constant IF amplifier output but, more important, the phase of the pilot must not shift in relation to the multiplex signals in order that the phase of the output signals shall be coherent with those of

other receivers and thus provide for maximum diversity combiner effectiveness. The width of the filter must be such that frequency shift caused by oscillator drift and the Doppler effect will not exceed the phase shift limits of the pilot. For efficient utilization of transmitter power, it is desirable that the level of the transmitted pilot be low relative to the sideband signals. However, the signal-to-noise ratio for the pilot should be greater than the signal-to-noise ratio of a multiplex channel in the receiver. The relative level of transmitted pilot to sideband signals depends upon the width of the pilot extraction filter which, in turn, depends upon the amount of Doppler frequency shift encountered, the stability of the exciter and receiver oscillators, and the tolerable loss in combiner effectiveness.

DESIGN OF A 300-400 MC SSB SYSTEM

Following is a description of a single-sideband communication system for twenty-four-voice channel operation at 300-400 mc. Such a system consists of an SSB multiplex equipment for translating the twenty-four-voice channels into the band 12 to 112 kc, an exciter equipment for translating this signal band to uhf and amplifying it to a power level sufficient to drive the power amplifier, a linear power amplifier, a transmitting and receiving antenna system, and a diversity receiving system which translates the received uhf-SSB signals back to the original signal band. The design of the multiplex equipment and antenna system is omitted from the following discussion since their design is similar to that presently employed in fm systems.

Exciter

General Features: Fig. 17 is a block diagram of the exciter and transmitter. Upper and lower sideband signals are generated by the 16-mc balanced modulator with suppression of the 16-mc carrier originating from a

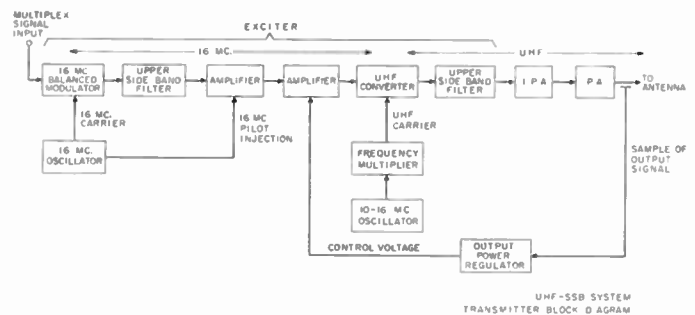

Fig. 17—Transmitter block diagram.

stable 16-mc oscillator. Signals from the upper-sideband filter and an added pilot at 16 mc are amplified by a stage whose gain is controlled by the output power regulator and are then mixed with the uhf carrier in the uhf converter. The uhf carrier is derived from a stable oscillator and frequency multiplier. Upper-sideband

signals of the modulated uhf carrier are selected by a filter and the signal appears at a low power level as a uhf pilot with the signal channels between 12 and 112 kc higher in frequency than the pilot. This low-level uhf signal is raised in level by the IPA which drives the klystron power amplifier. The output power regulator keeps the power amplifier operating at the maximum peak power output consistent with distortion requirements.

Sixteen-MC Oscillator:²² The 16-mc oscillator may be similar to the 10–16-mc oscillator described below but it need not be quite as stable. However, the frequency should not drift so as to become a significant part of the frequency variations within the pilot extraction filter.

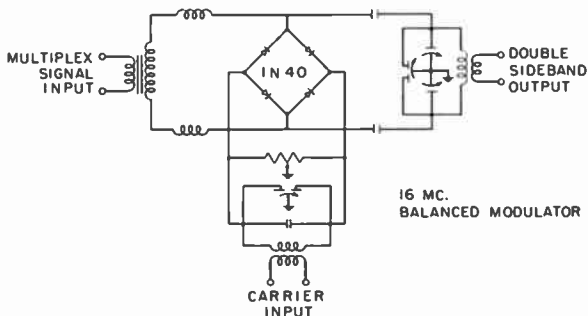

Fig. 18—Sixteen-mc balanced modulator diagram.

Sixteen-MC Balanced Modulator: Fig. 18 is a diagram of the balanced modulator circuit using a type IN40 modulator, a matched quad of germanium diodes. Resistive and capacitive balance controls are provided for the 16-mc carrier input and a capacitive balance control is provided for the output circuit. RF chokes isolate the transformer from the bridge output and series capacitors isolate the output circuit from the signal transformer. Peak output level of the modulator is -20 dbm, pilot suppression is 40 db, and intermodulation distortion is 50 db below the peak channel signal level.

Sideband Filter: The 16-mc sideband filter is a dual section half-lattice crystal type and has a band-pass of 16.012 to 16.112 mc flat within 1 db and has at least a 40-db attenuation below 15.988 mc and above 16.300 mc. Following the filter is an amplifier which makes up for the filter insertion loss and adds the 16-mc pilot at a level of 10 db below the peak level in one multiplex channel. A second amplifier follows with a variable gain controlled by the output power regulator.

UHF Converter: The uhf converter is a IN21B crystal mixer mounted in a tuned coaxial line resonator. Upper sideband peak output level of the mixer is -20 dbm with an intermodulation distortion 50 db down. Tuned coaxial line resonators form the uhf filter which passes the upper sideband resulting from the uhf con-

version and rejects the carrier and lower sideband by a factor of 40 db. Additional filtering is provided in the IPA and PA.

Ten to Sixteen-MC Oscillator: This oscillator is based on a circuit described by Felch and Israel.²² Crystals at specified frequencies in the 10–16-mc range mounted in individual plug-in ovens are utilized and the oscillator-tuned circuits are tunable over the band to accommodate any crystal. The stability requirement of this oscillator depends on the receiver pilot extraction filter bandwidth, the relative level of pilot and side-band signals, and the tolerable combiner loss. In this system, the pilot filter was chosen to be 300 cycles wide to permit the pilot level to be 10 db below the peak level in a multiplex channel of 3-kc bandwidth. An 80-cycle variation in a 300-cycle-wide filter causes a 28° phase shift of the pilot and therefore a 28° phase shift of multiplex signal producing a loss of about 0.3 db in combiner effectiveness, an acceptable amount. Doppler frequency shifts as high as 40 cycles have been measured; therefore the oscillators should not introduce more than another 40-cycle shift. Individually the exciter or receiver oscillators must each have a short-term stability of 20 cycles at 400 mc or a stability of five parts in 10^8 . Short-term frequency drift is caused mostly by the cycling of the crystal oven. Long-term drift is caused mostly by aging of the crystal and the oven and by changing of parameters with age and temperature of components associated with the crystal such as the tube and frequency pulling capacitors and inductors. An afc system is included in the receiver that does not respond to short-term frequency changes but will correct the long-term drift.

Frequency multiplication of 27, producing frequencies in the 270 to 430 mc range, is achieved by three triplers using type 6J6 twin triodes operating in push-pull. A buffer stage is provided after the first tripler with high Q -tuned circuits to filter out the fundamental. The final filtering is achieved in a tuned coaxial line resonator at the uhf carrier frequency. Incidental amplitude modulation, phase jitter, and spurious outputs must be kept low in the oscillator and multiplier to insure that resulting modulation products do not impair the quality of the multiplex channels.

IPA: Signals from the uhf converter must be raised from a peak power level of approximately -20 dbm to about $+20$ dbm in order to drive the klystron power amplifier to saturation. An extremely linear intermediate power amplifier is necessary in order that the total distortion of the signal shall be held within the over-all system requirements. This requires that the distortion products of the amplifier be about 50 db down, thus forcing one to the choice of an output tube which is capable of peak saturation power output 5 to 10 db greater than the peak signal power output desired. In this case, a tube capable of 3 to 10 w peak saturation power output is needed. The requirement of 50 db of linear gain at 1 w peak power output in the frequency range 300–400 mc could theoretically be met by a beam-

²² E. P. Felch and J. O. Israel, "A simple circuit for frequency standards employing overtone crystals," *Proc. IRE*, vol. 43, pp. 596–603; May, 1955.

modulated amplifier such as a traveling-wave tube amplifier. However, no satisfactory amplifier of this type is known to exist for this frequency range. The amplifier chosen for this system consisted of four cascaded synchronously-tuned class A_1 stages employing 4X150A tetrodes. This tube was selected since it was able to produce 100 milliwatts of average power output at a gain of 15 db per stage with distortion 50 db down.

Output Power Regulator: The output power regulator is a device which automatically adjusts the input signal level of the power amplifier to produce the maximum power output consistent with a given amount of distortion of the output signal. The method which will be described here has been chosen to minimize the complexity of the circuit. The distortion is not measured directly; instead advantage is taken of the fact that the amount of distortion produced in the output of the power amplifier is determined by the percentage of time the power amplifier is driven into its nonlinear region of operation, namely, the saturation region of the particular klystron involved.

A block diagram of the output power regulator is shown in Fig. 19. A diode power detector reproduces

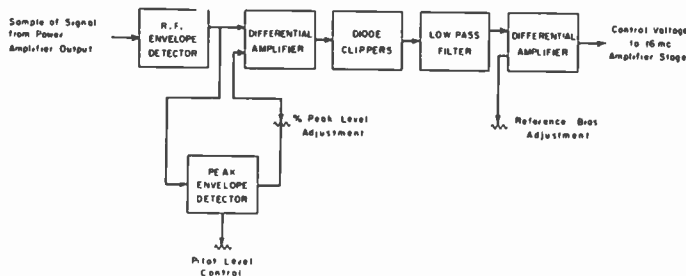

Fig. 19—Output power regulator block diagram.

the envelope of a sample of the rf output of the power amplifier. The peak value of the envelope is measured by a peak detector. If the level of the input signal to the power amplifier initially is sufficient to drive some of the output signal peaks to the saturation region of the amplifier, the peak of the envelope will have a fixed maximum value. A certain fraction of this peak value provides a reference voltage to one input of a differential amplifier, while the entire envelope is fed to the other input. The diode clippers and low-pass filter network develop a voltage that is proportional to the per cent time the envelope exceeds a certain fraction of peak envelope. The cut-off frequency of the filter determines the speed of response of the regulator. The output of the filter is amplified by another differential amplifier which has a reference voltage on one input. The output of this amplifier is a negative voltage which controls the gain of a variable gain 16-mc stage in the exciter. The pilot level control circuit allows the power amplifier output to be held at any desired level when no message channels are in use.

Other schemes for obtaining an indication of the distortion of the output signal which have been considered,

but not yet fully investigated, include measurement of the beam loss current of the klystron, and measurement of the second harmonic distortion content of the output signal.

Power Amplifier

The uhf-SSB signal from the exciter must be amplified from a peak power level of approximately -10 dbw to a level of $+40$ dbw. The power amplifier which accomplishes this must be linear in order that the distortion of the signal shall not exceed the tolerances set by the system requirements. In addition, high efficiency operation is desirable. Velocity modulation tubes have been found to excel in satisfying the requirements of linearity, efficiency, and gain.

Linearity: The linearity requirements imposed on the power amplifier, for satisfactory operation of a multiplexed SSB system, are fairly stringent. It is necessary that the *intermodulation* distortion produced by the amplifier be sufficiently low to prevent signals in some of the multiplex channels from generating interfering noise in other multiplex channels. To achieve this, it is not sufficient that the quasi-static relation of the average input power to the average output power be linear. What is essential is that the amplifier be linear with respect to the *instantaneous* input and output signal waveforms. However, it has been shown²³ that neither a "flat" frequency response nor a linear phase response is essential to the purpose of reducing intermodulation distortion.

A standard measurement technique has been adopted for measuring the linearity of amplifiers for this class of service. The test input signal has the characteristics of random noise over essentially the entire bandwidth of the amplifier with the exception of a narrow portion of the band which is left free of the input signal. The intermodulation distortion figure is defined as the ratio of the output noise power per cycle in the "nonloaded" portion of the passband to the noise power per cycle in the "loaded" part of the passband.

Although this "noise-loading" technique is equivalent to simultaneous transmission of $n-1$ channels of an n -channel system, and the statistical probability of such an occurrence vanishes as n becomes large, the convenience of performing the measurement and the conservativeness of the results make this a very attractive method of checking the linearity of frequency-division multiplexed SSB systems.

Multiple cavity power klystrons and traveling-wave tubes have remarkable linearity, even when driven to "saturation" power levels on the peaks of modulation. These tubes are already in use as uhf-tv linear amplifiers and as uhf amplifiers for fm beyond-the-horizon radio systems. In these applications, power gains up to 55 db have been realized with power outputs up to 50 kw at

²³ E. Oger, "Utilisation de la contre-réaction sur les émetteurs à bandes latérales indépendantes et à double bande," *Annales de Radio-électricité*, no. 38, vol. 9, pp. 327-341; October, 1954.

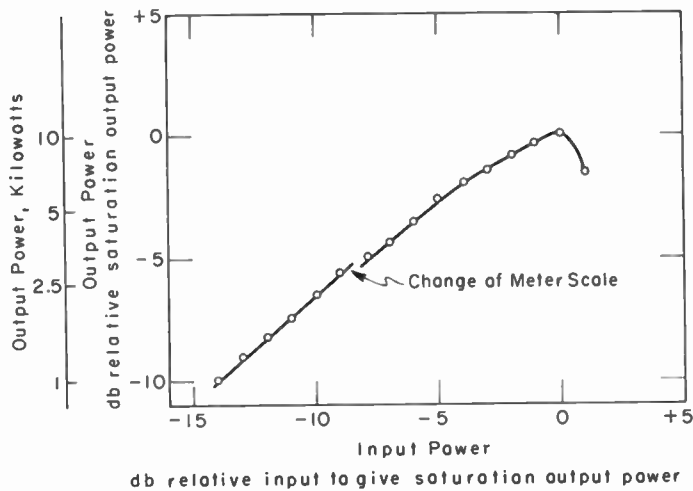

Fig. 20—Power transfer characteristic curve of Varian VA800 klystron.

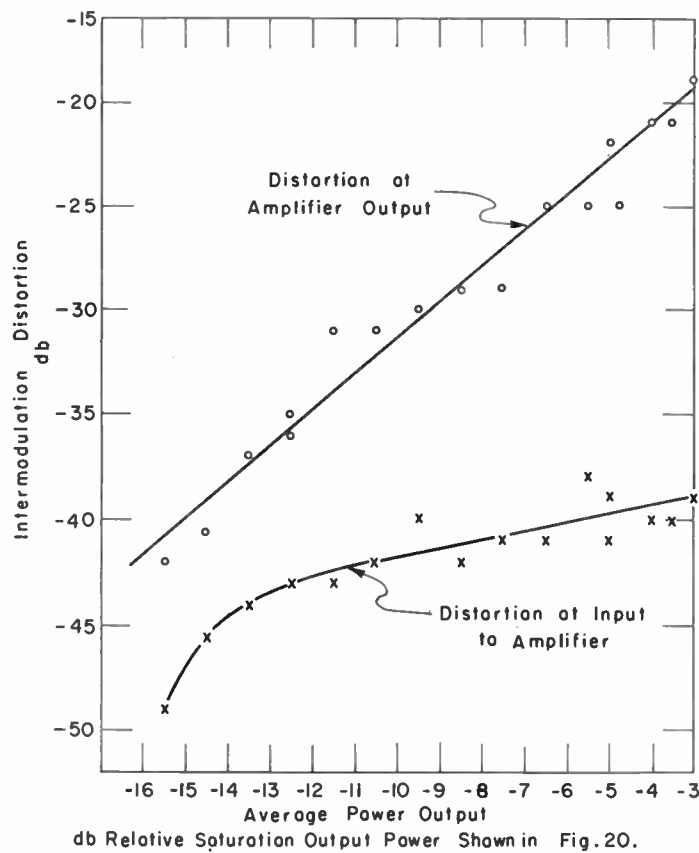

Fig. 21—Intermodulation distortion vs average power output curve for Varian VA800 klystron.

the lower uhf frequencies and up to 10 kw at the higher uhf frequencies.

Fig. 20 and Fig. 21 show the power transfer characteristics and intermodulation distortion measured on a 10-kw klystron amplifier at 2200 mc. The klystron was detuned (broad banded), so that the small signal gain was 6 db below the synchronously-tuned gain in order to improve the stability and linearity of the amplifier. Measurements made on other klystron amplifiers oper-

ating in the 300 to 400-mc region indicate that these results are typical for this type of amplifier.

The measurement of intermodulation distortion (Fig. 21) was made with a double-sideband, suppressed-carrier, noise-modulated input signal to the klystron. The modulation had the characteristics of random noise in the band 20 kc to 140 kc as illustrated in Fig. 22. The ratio between the peak power level which is exceeded one per cent of the time and the average power level of the signal was then 8.2 db. A sample of the amplifier output was demodulated and the average power was measured in a 2-kc band centered first at the center of the noise band, 80 kc from the carrier, and then (with the same filter) in a 2-kc band centered 240 kc from the carrier. The intermodulation products measured here were due to the second harmonics of one sideband mixing with the fundamental frequencies of the other sideband. The bandwidth of the amplifier and associated equipment was in excess of 10 mc. The noise in the measuring equipment was 3 to 5 db below the smallest noise signals being measured. Measurements on the same amplifiers using variations of this noise technique have yielded the same results.

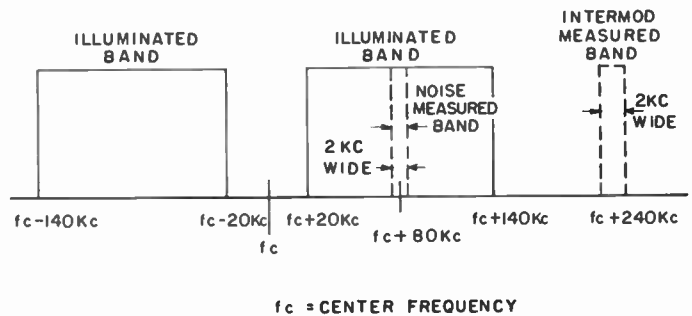

Fig. 22—Noise modulated signal for intermodulation distortion measurement.

Various feedback techniques may be used to improve the linearity of the uhf klystron amplifier. Two methods have been briefly investigated: direct rf feedback and balanced envelope feedback. The results of this investigation are by no means complete, but will be mentioned here to indicate some of the problems which are encountered when applying these techniques to uhf single-sideband amplifiers.

A moderate amount (up to 10 db) of direct rf feedback has been successfully applied to a 10 kw, 3-cavity klystron operating in the 400-mc region. A sample of the amplifier output signal was combined, through rf phase shifters and attenuators, with the input signal with an rf phase such as to produce negative feedback. The feedback voltage is delayed a few rf cycles, thus some phase distortion is introduced in the output signal; but, since changes in the modulation envelope occur at a relatively slow rate, the feedback is effective in reducing envelope distortion. With this arrangement (see Fig. 23) the amount of feedback which can be applied is dependent on the phase shift characteristics of the klystron in the

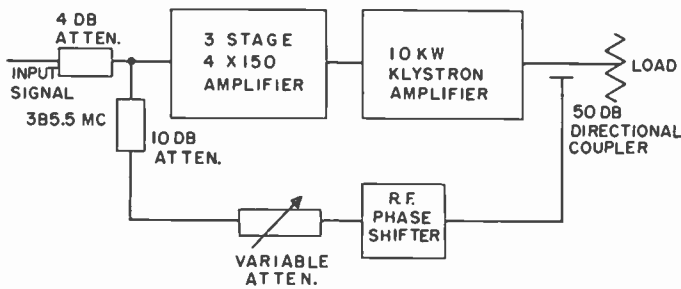

Fig. 23—Direct rf feedback arrangement.

vicinity of operating frequency, as determined by the bandwidth of the various cavity resonators. For maximum feedback without oscillation, it is necessary that the phase shift be controlled principally by one resonator. Usually the input cavity of the klystron is employed for this purpose. If the input resonator is not suitable an external resonator may be used. In preliminary tests of this technique, under nonoptimum conditions, up to 6 db reduction of intermodulation distortion was obtained.

Envelope feedback is a technique in which the modulation envelopes of the input and output signals of an amplifier are compared and the difference between them is remodulated on the input signal in such a way as to reduce the difference between them (and thus the distortion). This technique has been used to good advantage in reducing intermodulation distortion related to a distorted modulation envelope.²³

When applying this feedback technique to a klystron amplifier which is to amplify a single sideband having sideband frequencies which extend to 112 kc from the carrier (or pilot) frequency (see Fig. 24), one encounters many difficulties which tend to limit the amount of feedback which can be effectively applied.

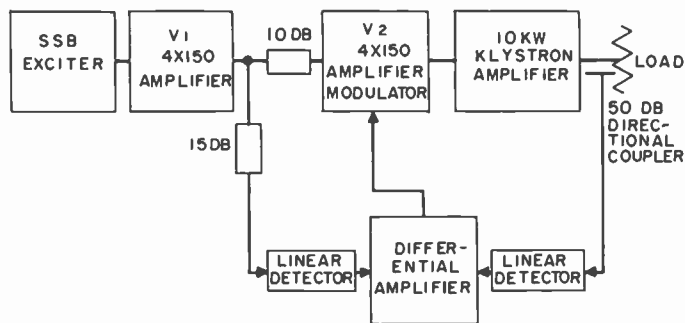

Fig. 24—Balanced envelope feedback arrangement.

It is assumed that the feedback network, including the demodulators and the remodulator must pass a band of frequencies from dc up to at least twice the highest fundamental frequency of the modulation envelope (in this case 200 kc) in order to achieve sufficient reduction of distortion. It is necessary that the phase shift around the feedback loop be constant over this frequency range. Furthermore, it is required that the gain of the feedback loop be reduced below a gain margin of safety at some

frequency at which the phase shift around the loop has exceeded a phase margin of safety, in order that the loop be unconditionally stable. When this technique was used, less than 10 db of stable feedback could be applied to the 400-mc klystron amplifier. The envelope delay through the klystron at the modulation frequencies tended to become the limiting factor in the amount of stable feedback which could be applied, thus, phase correction networks could not be used to extend the range over which feedback could be applied. In addition, this delay severely limited the effectiveness of the feedback at the higher modulating frequencies (40 kc and above), in that the higher-order distortion products were increased in amplitude while the lower-order were decreased.

Efficiency: The use of triodes and tetrodes in low-power stages confronts the designer with a not intolerable compromise between linearity and efficiency. The theoretical peak power efficiency of a class A₁ tetrode amplifier is about 50 per cent; that of a carefully managed push-pull class B₁ amplifier is 78 per cent. With a single-sideband signal having a peak-to-average power ratio of 8 db, the over-all average efficiencies would be 7.5 per cent for Class A, and only slightly greater for Class B. This is tolerable in the case of low-power operation, but when these figures are applied to an amplifier whose average power output is 10 kw, they are no longer tolerable. It is then necessary to make judicious use of nonlinear operation (class B and class C) in the final power stage with feedback employed over several stages to exchange gain for efficiency at an additional cost in complexity.

A very different picture is emerging in the case of velocity-modulated-beam amplifiers. Inasmuch as an intrinsic separation exists between rf functions and dc functions in such devices, the factors governing linearity and efficiency can be dealt with independently.

The average beam energy of a klystron operating at a single-tone saturation power output level is shown in Fig. 25 in various regions of the tube environment. The saturation conversion efficiency, rf out/dc in, has been assumed to be 50 per cent. The upper curve depicts potential and average kinetic energy relationships in a "grounded" collector amplifier. In this scheme, half of the beam energy (represented as the product of charge, Q , and accelerating voltage, V_A) is converted into rf energy at the output gap, and the other half is converted into heat at the collector. The lower curve represents the same relationships in an "ideal" depressed collector amplifier. Half of the beam energy is again converted into rf at the output gap, a process which decelerates the rms beam velocity by a factor of $1/\sqrt{2}$. The voltage of the beam power supply, V_B , is set at a level substantially less than that of the accelerating supply, V_A . A retarding potential gradient now exists in the collector region. Those electrons having kinetic energies in excess of $e(V_A - V_B)$, where e is the magnitude of the electronic charge, will be collected, and those

having energies equal to or less than this will be turned back to the body of the klystron. If we denote the collector current as i_B and the body current as i_A , the total power requirement of the klystron will be $i_A V_A + i_B V_B$.

An attempt to accomplish an increase in efficiency by this technique was made by Winkler²⁴ in 1953, but in a more elegant manner than that indicated in Fig. 25. Unfortunately the results were disappointing.

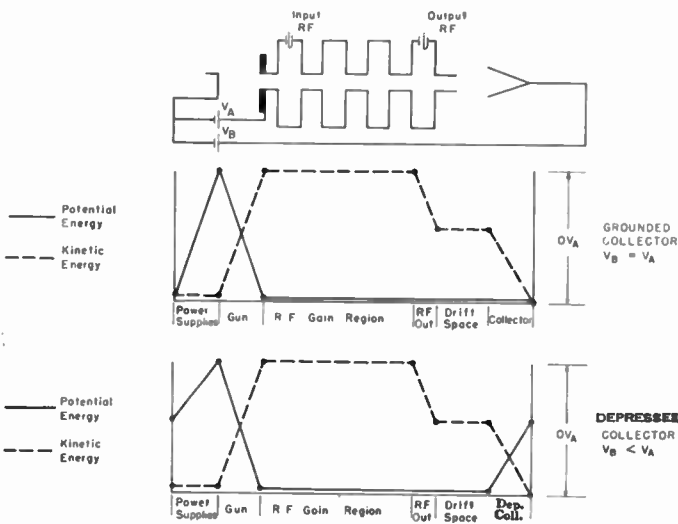

Fig. 25—Average energy diagrams—graphs refer to related position in klystron circuit directly above.

The authors, after reading Winkler's excellent paper on the subject, made a new attempt, with the cooperation of the Eitel-McCullough Corp., on a standard 1-kw klystron in 1955. The results were equally disappointing at first. The "normal collector" curve in Fig. 26 is typical of the behavior of the collector current when the collector is elevated toward the cathode potential with no rf output from the tube. Since the kinetic energy of the beam is uniformly much greater than the potential energy of the collector under the conditions illustrated in this curve, there is no question of "reflecting" electrons from the opposing field between collector and body. The most satisfactory explanation is that the primary electrons are indeed collected but that the emitted secondaries are accelerated back up the tube by the collector field and result in a net loss of collector current.

One method of solving the problem of secondary emission is to make use of the almost single-valued unit vector of primary electron velocity as contrasted with the widely dispersive nature of secondary electron trajectories. The classical model of a "black body" can be stated as: Allow radiant energy to fall on an orifice in a hollow cavity whose dimensions are large compared to those of the orifice. "Secondary" emission from any place on the inside of the cavity has a distribution of

²⁴ R. H. Winkler, "A Method of Improving the Efficiency of Klystrons," Microwave Laboratory Report No. 235 (Stanford Univ.), May, 1954.

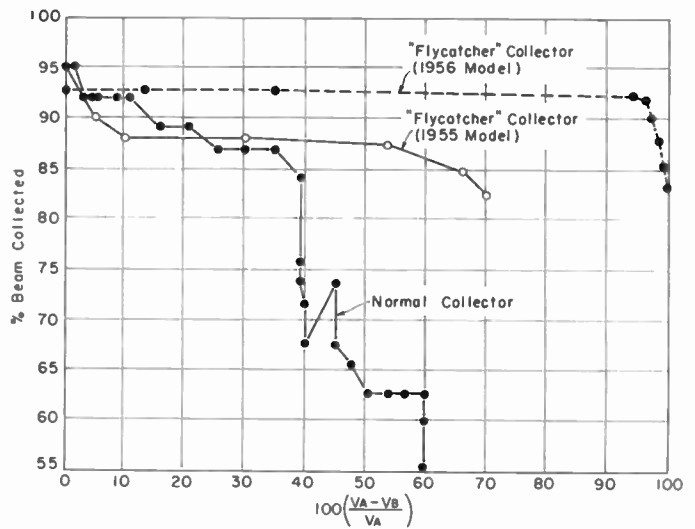

Fig. 26—DC depression characteristics of three collector configurations.

initial velocities over essentially 2π steradians. The solid angle subtended by the orifice being small, the percentage of escape trajectories is small.

A collector using this principle has been given the nickname, "flycatcher collector." The principle was immediately put to the test in the 1955 experiments (results shown in Fig. 26). A sophisticated version was then designed by Eimac and incorporated in a 1-kw klystron for operation in the 2000-mc band. The dc performance of this latter collector is shown in the top curve of Fig. 26 (1956 model). Parametric curves of the rf characteristics of this tube are given in Fig. 27 in which a single-

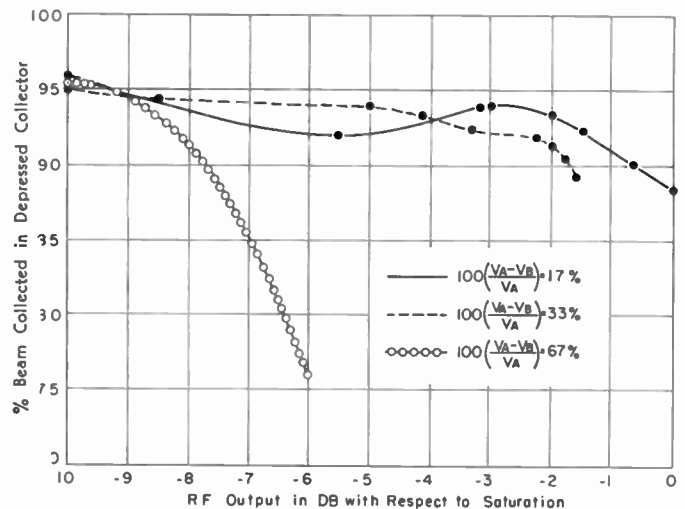

Fig. 27—Depression characteristics (1956 model flycatcher) under single-tone rf conditions.

frequency rf drive was varied to provide an rf output ranging up to a saturation level of 400 w while the collector was held at various levels of depression.

If the flycatcher collector were perfect, all of the curves in Fig. 27 would be monotonic. To know how far

short of "ideal" this particular collector design is would require a knowledge of the distribution of electron velocities after the beam has coupled various amounts of rf power into the output. Such data will presumably be available in a few months. It is certain, however, that the spread of the distribution will increase as the output power increases. If the output power is made to fluctuate between zero and saturation level, as is the case in single sideband, the most efficient operation can be expected to involve a very low value of V_B . When the tube employed in the measurements shown in Fig. 27 is noise modulated, the data shown in Fig. 28 are obtained. Note that the value of $i_A V_A + i_B V_B$ has not been minimized even at the maximum level of depression shown. The upper curve is for an underloaded case and the lower curve is obtained when the tube is driven to saturation on peaks.

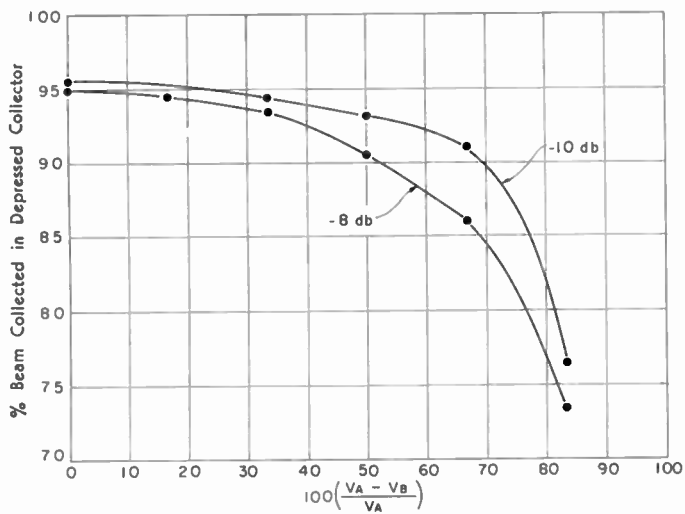

Fig. 28—Depression characteristics (1956 model flycatcher) under noise-modulated rf conditions. Upper curve: Average output power 10 db below saturation. Lower curve: Average output power 8 db below saturation.

To improve the over-all efficiency still further, additional collector elements can be built into the tube and set at a variety of voltages. The sorting process should take place automatically in view of the space charge force and the time during which it acts on a decelerated electron. However, if this fails in any particular instance, an adaptation of the "stop band" properties of periodic field focusing²⁶ should do the trick. A far more attractive alternative would be available if some method were found to cause the electron beam to interact on itself in the velocity analog of self inductance. If the velocity of the beam could be "smoothed" in some manner, efficiencies approaching 100 per cent could be achieved with a single depressed collector element.

Meanwhile it is expected that single-sideband power

amplifiers realizing 25 per cent over-all tube efficiency can be built to operate in any frequency band for which a velocity-modulated beam tube exists.

Receiver

General Features: Fig. 29 is a block diagram of the receiver which converts the uhf signals from the antenna to the 12 to 112-kc multiplex equipment frequency range. The preselector filter in the antenna system is a band-pass filter rejecting the receiver image frequency and any nearby or associated transmitter frequency. A crystal mixer converts the received signal to the 16-mc IF by mixing with the LO signal originating from the 10 to 16-mc oscillator and frequency multiplier.

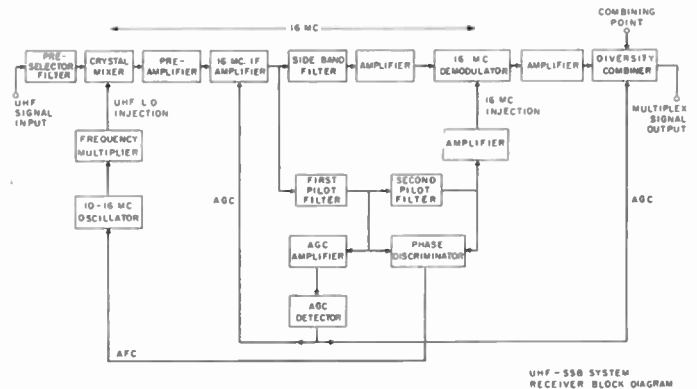

Fig. 29—Receiver block diagram.

A low-noise preamplifier delivers the 16-mc signals to the IF amplifier having a wide dynamic range, high-speed agc circuit. Image frequency rejection for the 16-mc demodulator is achieved in the sideband filter. The signal is further amplified and fed to the 16-mc demodulator along with the output from the second pilot extraction filter, a clean 16-mc signal. Original multiplex signals are recovered and amplified and then combined with signals from other diversity receivers. The pilot filters and phase discriminator produce an afc signal that corrects the receiver LO frequency to keep the pilot centered within the filters. Output of the first pilot filter is amplified and detected and returned to the IF amplifier as the agc voltage.

UHF Front End: Fig. 30 is a simplified diagram of the uhf front end. The noise figure using a IN21D crystal and preselector filter to reject the image frequency is not greater than 6 db. Type 417A and 6AN4 triodes form a cascode preamplifier at 16 mc. Input uhf tuned circuits are lumped constants, a strap brass helical coil, and a piston type capacitor. The IF transformer coupling the crystal mixer to the 417A grid has a nine to thirty-two turn transformation to match the crystal output impedance to the tube input impedance to give lowest noise figure. Local oscillator signal derived from a 10 to 16-mc oscillator and frequency multiplier similar to that of the exciter is injected through magnetic

²⁶ J. T. Mendel, C. F. Quate, and W. H. Yocom, "Electron beam focusing with periodic permanent magnets," Proc. IRE, vol. 42, pp. 800-810; May, 1954.

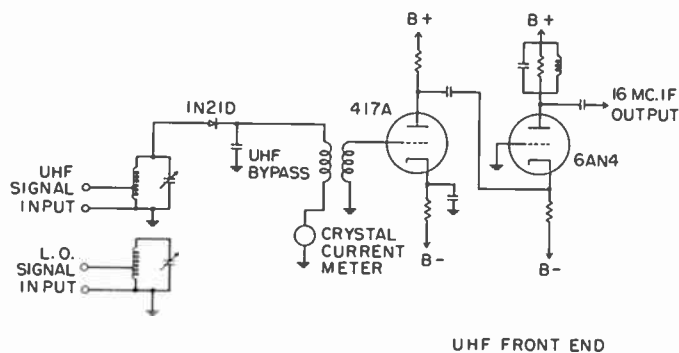

Fig. 30—Receiver front end diagram.

coupling to the uhf signal input tank circuit. Minimum peak channel signal level of -123 dbm gives a 10-db signal-to-noise ratio in the 3-kc-wide channel at the receiver output.

IF Amplifier: Sixteen-mc IF amplification with an input signal level variation of 80 db is accomplished utilizing 6BA6 pentode tubes with agc voltage returned to the grids. A flat passband with good rejection to strong signals in adjacent channels is provided. Differential phase shift is minimized between pilot and all multiplex band frequencies throughout the gain range of the amplifier in order that the demodulated multiplex signals have equal phase with other receiver outputs for maximum combiner effectiveness. Use of cathode followers between amplifier stages adequately reduces the detuning of tank circuits by Miller effect capacitance change as the tube gain is varied.

Sixteen-MC Demodulator: Fig. 31 (opposite) is a simplified diagram of the 16-mc demodulator, afc, agc, and diversity combiner circuits. Demodulation of the multiplex signal is achieved in the tube that mixes the extracted pilot with the sideband signal. The sideband filter, similar to that of the exciter, rejects the image frequency band. Amplification of the signals in a feedback amplifier and addition with signals from other receivers in the diversity combiner complete the signal channel. Bandwidth of each pilot filter is 425 cycles and when connected in cascade gives an effective bandwidth of 300 cycles. The pilot is further amplified to a level such that the demodulator is effectively insensitive to pilot amplitude variations.

AGC Circuit: Output from the first pilot filter is amplified and detected to produce an agc voltage that is fed to the IF strip through a cathode follower. A delay voltage of about 80 volts is provided by the second vacuum diode section and a silicon junction diode used as a constant voltage source which adds the agc voltage to the delay voltage. With this circuit, the input level to the IF amplifier may vary 80 db from -133 dbm to -53 dbm pilot level and the pilot output level of the IF strip will vary only $\frac{1}{2}$ db.

Diversity Combiner: Since the agc voltage is proportional to the signal level, this voltage is used to control

the action of the maximal-ratio diversity combiner. A stable dc amplifier drives the combiner. Operation of the combiner has been described elsewhere.¹³ Another control on the combiner to correct for long-term changes in receiver noise and gain is provided (not shown). The noise level in an unused channel below 12 kc is sampled, integrated, and subtracted from the agc voltage.

AFC Circuit: The outputs from the first and second pilot filters have different phase responses. These outputs are amplified and fed to the phase discriminator which compares their phase to determine whether the pilot is centered in the filters. If the pilot is centered, the phases of the output signals will be equal and the discriminator output will be zero. If the pilot is not centered, the phase discriminator produces a positive or negative dc voltage that is amplified to drive a small dc motor which turns a piston-type trimmer capacitor on the receiver local oscillator to change its frequency a small amount until the pilot is centered in the filters. The RC integrator preceding the amplifier has a long time constant to make the afc insensitive to short-term frequency fluctuations but will respond to long-term frequency drift of the associated oscillators.

Field Tests

Field testing over a 188-mile path was initiated in October, 1955. The equipment, similar in most respects to that developed subsequently and described above, involved three conversions to the 375-mc to 425-mc band. The antennas employed were 28-foot parabolas and the transmitter was a 10-kw klystron operating without collector depression.

Data relating to the multipath problem discussed above were obtained by simultaneous recording of the signal levels of five frequencies at intervals of 25 kc.

Reciprocal transmissions were employed—fm one way and SSB the other—with receivers capable of twenty-four-channel operation in each instance but employing only twelve. The results were in good agreement with—indeed, led to an appreciation of the factors involved in—the analysis presented above.

Testing of diversity equipment was carried out on a 70-mile path.

It might be remarked that equipment reliability must keep pace with propagation reliability if the system performance discussed in the third section is to be realized. It has been convincingly demonstrated in the field that the most important adjunct to system design for reliability is complete redundancy in *operating* equipment. The most favorable method of implementation is that in which two complete radio sets operate independently, *i.e.*, such that an equipment failure in one set does not substantially impair the operational status of its parallel "twin." Nine months' operating experience with a seventy-two-channel system employing such parallel "sparing" has provided only one instance in which both halves of the system failed coincidentally—

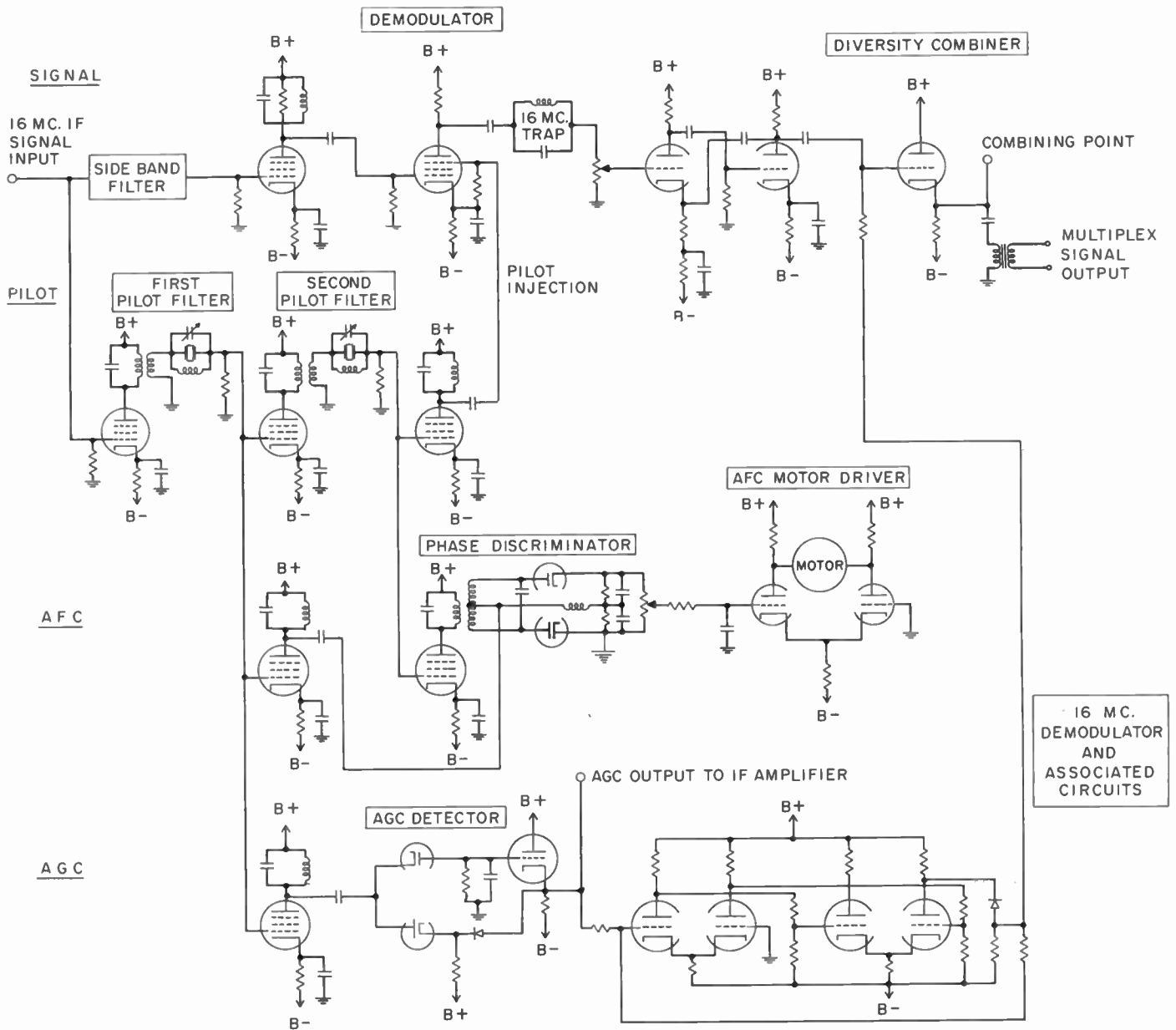

Fig. 31—Receiver 16-mc demodulator and associated circuits.

and that for a duration of two minutes. Since all this can be accomplished with just two antennas at each terminal (by means of dual polarization horns)¹⁶ while at the same time providing fourth-order diversity reception, the use of fourth-order diversity has become the preferred technique. A failure of either system "twin," whether it be due to transmitter or antenna, merely

causes a temporary drop to dual diversity operation until repairs can be effected.

ACKNOWLEDGMENT

The authors are indebted to D. G. Brennan who contributed substantially to this paper by critical review and numerous helpful suggestions.



Correspondence

A Note on the Analog Computation of Small Quotients*

Electrical circuits that effect division of one voltage by another are generally involved and additional complexity enters if one requires the instantaneous quotient of two rapidly fluctuating voltages. Several electrical analog computer techniques are available, and of these the method of electrically obtaining the antilogarithm of the difference of the logarithms of a the two voltage is possibly attractive because it is straight forward and instantaneous. The logarithmic analog is particularly attractive for ratios in the neighborhood of unity. However, if the range of quotients or ratios is in the neighborhood of zero, the system is seen to fail because of the physical nonrealizability of the logarithm of a vanishingly small voltage.

The computation of small quotients by logarithmic analog methods may be made possible and practicable to a reasonable approximation by means of appropriate linear operations upon the electrical data before the logarithmic operations. These operations permit circumvention of the "log-zero impasse."

It is not difficult to show by series expansions that if $(e_1/e_2)^2 < 1$,

$$\begin{aligned} \log\left(e_2 + \frac{e_1}{2}\right) - \log\left(e_2 - \frac{e_1}{2}\right) \\ = \frac{e_1}{e_2} + 2\frac{\left(\frac{e_1}{2e_2}\right)^3}{3} + 2\frac{\left(\frac{e_1}{2e_2}\right)^5}{5} + \dots \\ = \frac{e_1}{e_2} [1 + \epsilon]. \end{aligned}$$

The series converges rapidly for all ratios of e_1 to e_2 less than 0.5. Table I shows the per cent error as a function of the voltage ratio.

TABLE I
PER CENT ERROR OF PERTINENT ANALOG
COMPUTATION OF A QUOTIENT AS A
FUNCTION OF THE RATIO

Ratio (e_1/e_2)	Per Cent Error of Quotient (100%)
0.0	0.0
0.1	0.083
0.2	0.335
0.3	0.760
0.4	1.363
0.5	2.162

It is interesting to observe that the desired quotient is obtained directly as the difference of the outputs of the two logarithmic circuits. An antilogarithm circuit is not required! Thus the analog computation of small quotients or ratios is effected through the electrical simulation of the operations on the left-hand side of the equation given above. Although the procedure as it stands is limited to small ratios, depending upon the goodness of the desired quotient, the method

is more general than may first appear. As an example, for larger ratios one can first replace e_1 by ke_1 where k is a sufficiently small number less than unity and calculate the ratio of ke_1 to e_2 by the above analog procedure. Subsequent multiplication of the quotient so determined by $1/k$ will yield the desired results. Fluctuation noise sets the practical lower limit on the smallness of e_1 , of course.

ALBERT D. BAILEY
Elec. Eng. Res. Lab.
University of Illinois
Urbana, Ill.

Linear Programming and Optimal Telecommunication Networks*

Certain notions from the theory of graphs, a branch of topology, find application in telecommunication system problems. For example, a paper by J. B. Kruskal¹ contains a technique which may be used in solving a significant minimal cost network problem. Other examples appear in Prihar.²

Here, however, we wish to call attention to the fact that the field of *linear programming*, developed in recent years, holds great promise for providing solutions to a number of important telecommunication system optimization problems.³ It provides a general system approach for resolving the complex interactions among system-switching and transmission capacities, users' demands, and economic factors.

In this short note we indicate the method by treating a simplified optimal routing problem in which, for brevity, switching constraints are neglected. Consider a telecommunication network consisting of stations, each of which may originate, relay and receive messages. During the time interval τ , chosen so that relatively steady-state conditions prevail, let c_{ij} be the number of messages which may be sent over a direct link from i to j (the capacity of the link), and let a_{ij} be the number of messages originated at i and destined for another station j . The routing doctrine is given by prescribing the number of messages, ultimately destined for k , to be sent from i over a direct link to j during the time τ . Thus we define x_{ijk} ($i \neq j$, $i \neq k$) to be the number of messages to be sent during the interval τ over a direct link from i to j and ultimately

destined for k . For given system capacities, c_{ij} , and given users' demands, a_{ij} , we seek an optimal routing doctrine, *i.e.*, a set of x 's which will maximize the number of messages delivered throughout the system.

Mathematically, the problem is to maximize

$$\sum_{i,j} x_{ijj} \quad (1)$$

subject to the conditions

$$x_{ijk} \geq 0, \quad (2)$$

$$\sum_k x_{ijk} \leq c_{ij}, \quad (3)$$

$$\sum_k x_{ikj} - \sum_k x_{kij} \leq a_{ij}. \quad (4)$$

The sum in (1) is the number of delivered messages, since x_{ijj} is the number of messages sent during time τ from i to j and ultimately destined for j . Condition (2) states that the x 's are non-negative, and (3) provides that the individual link capacities are not to be exceeded. Condition (4) expresses the fact that the number of messages sent out from i , ultimately destined for j , minus the number of messages sent into i , destined for j , is no greater than the number of messages originated at i and destined for j . The difference is the number of messages backlogged at i and destined for j . The problem is readily solved using the simplex method of George Dantzig,⁴ though large problems require the use of high speed digital computers. A central traffic control unit, so equipped, could expedite traffic flow by making use of periodic demand and system capacity reports.

Great flexibility characterizes this approach to telecommunication system problems. Thus switching considerations are easily introduced into the optimal routing problem, and dynamic aspects of behavior over a sequence of intervals may be investigated. Even the broader field of design of telecommunication networks can be so treated. For example, a problem of the following type can be handled: Given a) an existing telecommunication system, b) unit costs for expanding switching and transmission facilities, c) predicted increases in future traffic demands, and d) a specified future grade of service, show how to augment the existing system so that at minimal cost one may provide the specified grade of service to meet the increased future demands. Various stochastic elements may be introduced into the models. Finally, we note that various questions involving plant modernization and plant expansion over a period of years may be similarly considered.

R. E. KALABA AND M. L. JUNCOSA
The RAND Corporation
Santa Monica, Calif.

* Received by the IRE, July 30, 1956.

¹ J. B. Kruskal, "On the shortest spanning subtree of a graph and the traveling salesman problem," *Proc. Amer. Math. Soc.*, vol. 7, pp. 48-50; February, 1956.

² Z. Prihar, "Topological properties of telecommunication networks," *Proc. IRE*, vol. 44, pp. 927-933; July, 1956.

³ R. E. Kalaba and M. L. Juncosa, Res. Memo. RM-1687. The RAND Corporation, Santa Monica, Calif.; 1956.

⁴ G. Dantzig, A. Orden, and P. Wolf, "The generalized simplex method for minimizing a linear form under linear inequality restraints," *Pacific J. Math.*, vol. 5, pp. 183-195; June, 1955.

Microwave Semiconductor Switch*

The potentialities of using semiconductors for modulating and switching rf energy have been recognized since the first uses of semiconductors as detectors. As examples of recent work other laboratories^{1,2} have reported the development of coaxial line filter switches for use at 700 and 3000 mc. Semiconductor diodes are employed as terminations of the branch arms of the filter. By changing the bias on the diodes the rf impedance is changed, which causes a change in the effective lengths of branch arms. This action gives rise to the switching function.

In the Pound³ rf stabilized microwave system, which is in general use at both 10,000 and 24,000 mc, a small amount of modulation results from applying a 30-mc voltage to a silicon crystal diode placed directly in the waveguide.

Efforts at this laboratory have resulted in the development of a high-speed X-band semiconductor switch which employs an *n*-type germanium crystal diode. Although the switch was tested in many forms, that which has the best characteristics is obtained with the diode placed in a well-designed crystal mount in the center of the waveguide. The solid line in Fig. 1 shows the isolation (insertion loss in the OFF condition) as a function of dc bias for a 1N263, *n*-type germanium diode. For comparison a similar curve is shown for a 1N23B, *p*-type silicon diode. The crystal currents are shown by dashed lines. For the highest currents, the dc resistances approach 10 ohms for the 1N263 and 30 ohms for the 1N23B diodes.

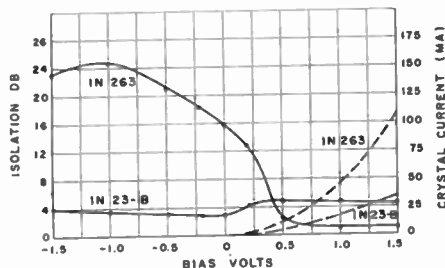

Fig. 1—The solid lines show the switching function of the *n*-type germanium 1N263 crystal diode and of the *p*-type silicon 1N23B. The dashed lines indicate the crystal current. The data were taken at 9200 mc and at 0.1 milliwatt incident power.

The data shown are for incident microwave powers of one milliwatt or less. Using two diodes, a switching isolation as high as 10 db is obtained at powers of 50 milliwatts.⁴

* Received by the IRE, September 26, 1956.

¹ D. J. Grace, "A Microwave Switch Employing Germanium Diodes," Tech. Rep. No. 26, Appl. Electronics Lab., Stanford Univ., Stanford, Calif., January 17, 1955.

² Franklin S. Coale, "A switch detector circuit," IRE TRANS., vol. MTT-3, pp. 59-61; December, 1955

³ R. V. Pound, "Electronic frequency stabilization of microwave oscillators," *Rev. Sci. Instr.*, vol. 17, p. 490; November, 1946.

⁴ High-speed ferrite switches, capable of handling large rf power, were reported by R. C. LeCraw, "High-speed magnetic pulsing of ferrites," *J. Appl. Phys.*, vol. 25, pp. 678-679; May, 1954, and by R. C. LeCraw and H. B. Bruns, "Time delay in high-speed ferrite microwave switches," *J. Appl. Phys.*, vol. 26, p. 124; January, 1955. One of the major advantages of the semi-conductor switch is the relatively insignificant switching power required, even at high repetition rates.

Isolations of 25 db with insertion losses of one db are obtained with the germanium diode. In comparison extensive work⁴ with silicon diodes has resulted in isolations of only 6 db with insertion losses of about 3 db. The curves of Fig. 1 may be considered typical of the two types of available diodes.

A plausible explanation of the difference in the switching action in the two semiconductors can be made on the basis that the effective masses of the silicon holes are larger than the effective masses of the germanium electrons. Because of this, the carrier mobility is about three times smaller for *p*-type silicon than for the *n*-type germanium. The microwave resistance of the semiconductor is dependent on the in-phase rf electric currents and is a function of the scattering of the holes in silicon and electrons in germanium. The microwave reactance is a function of the storage of charges in the semiconductor and thus also depends on the inertia of the holes and electrons.

Additional understanding of the X-band microwave characteristics of the switch is obtained from the data of Fig. 2. The solid lines are the normalized microwave resistances and the dashed lines are the normalized reactances. Comparing Figs. 1 and 2, it is seen that for the germanium 1N263 for the condition of minimum insertion loss the normalized resistance is near unity, while the reactance is low. The greatest isolation is obtained when the resistive and reactive components are near zero. In this condition 80 per cent of the microwave energy is reflected, 0.3 per cent is transmitted past the diode and the remainder is absorbed by the diode. The curves given are for data taken at 9200 mc to show the appearance of a resonance at this frequency for the 1N23B.

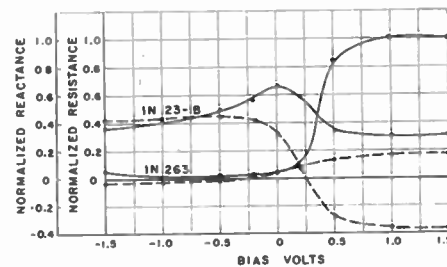

Fig. 2—The microwave normalized resistances, shown by solid lines, and the normalized reactances, shown by dashed lines, are given for the same conditions as Fig. 1. The resonance for the 1N23B appears only at this frequency.

At 5000 to 6500 mc the shapes of the reactance and resistance curves of the 1N23B are similar to those of the 1N263. The isolation characteristics become comparable at these frequencies. The switching characteristics of both diodes deteriorate at 18,000 mc. As this frequency is approached the variation in resistance with changes in bias decreases greatly. At 18,000 mc the resistance curve is reversed and the change in amplitude is small.

⁴ E. G. Spencer and M. A. Armistead, "De-champs Analysis of a Crystal Modulator," unpublished DOFL Tech. Memo, September 21, 1954.

A further important characteristic is seen in the measurements from 20°C. to 150°C. for the 1N263. These data, for a typical crystal, are given in Fig. 3. Only a small deterioration of switching characteristics is indicated. Repeating the heating and cooling cycle produced no measurable temperature hysteresis effects.

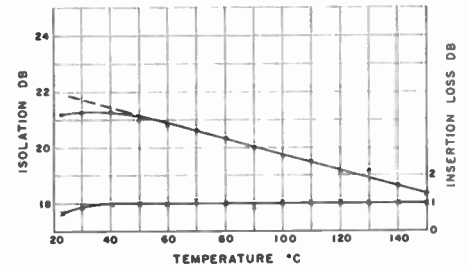

Fig. 3—Switching action is given as a function of temperature for the 1N263. The isolation is shown by the curve using solid dots and the insertion loss is shown by the curve using crosses.

In application these switches have been used with $\frac{1}{2}$ microsecond pulses. Complete data are not yet available on the ultimate switching speeds attainable.

M. A. ARMISTEAD, E. G. SPENCER, AND
R. D. HATCHER
Diamond Ordnance Fuze Labs.
Washington 25, D. C.

Electrical Engineers Are Going Back to Science*

(Letter from Mr. Knoop)

The publication of the above article¹ could not help but evoke serious comment from one electronic engineer who feels that perhaps Professor Terman has been unduly restrictive in his reference of "creative engineering." Let it first be said that anyone who has made the contributions to electronic engineering as a teacher, author, and pillar of IRE strength as has Professor Terman must command important and immediate attention. That a sound, fundamental curriculum in the basic sciences and mathematics is important and needs greater emphasis in our educational process goes without question. The writer has encouraged many young men bent upon inventive careers, and about to enter college, to seek courses leading to degrees in physics for just this reason.

However, a number of statements in Professor Terman's article seem extremely unrealistic. Specifically, "creative engineering" does not exclude a broad field of endeavor concerned with other than circuit invention and basic communication system theory. The writer submits that one great

* Received by the IRE, August 30, 1956.

¹ F. E. Terman, *Proc. IRE*, vol. 44, pp. 738-740; June, 1956.

industry failing today has little direct bearing on the proficiency of the engineer to deal with his mathematical tools or storage of basic science information. It is one thing to create a new circuit in the laboratory, and quite another to reproduce it, describe it, manufacture and test it, and render it capable of dependable field operation for a period of one one-hundredth that of the lowly 60-cycle alternator or one one-thousandth that of the 60-cycle transformer.

One of the most important things Professor Terman can do to improve his curriculum is to teach his students to think *rationaly and deal with their fellow man* in an honest, forthright and mutually respectable manner, and to *express their views* and convictions understandably, simply, and fairly.

It is suggested that many electronic engineers concerned with industrial applications of electronics have continual occasion to deal with shopmen, accountants, test foremen, maintenance supervisors, purchasing agents, engineering managers, and plant supervisors when their performance is measured by comparison with men who have learned the fundamentals described above and not by being specialists having master's and doctor's degrees.

Frequently he is expected to have a working knowledge of beam deflections, stresses and strains, spring constants, metallurgical practice, machine tool operations, and thermodynamic problems. The fact that 40 per cent of the authors who wrote papers for PROCEEDINGS OF THE IRE were majors in other than electrical engineering, such as physics and mathematics, only reflects the editorial policy of PROCEEDINGS, and does not in any way reflect the proportion of those who have chosen other areas of "creative electronic engineering."

The heavy emphasis on science "that is characteristic of electronics" is no different than the vagaries of "boundary conditions of fluid flow" or "statically indeterminate mechanical structures" or "dynamic stresses in a chemical plant piping system" currently under study in other branches of engineering in which electronics may play a significant part.

Let us not forget one definition of a creative engineer as being a man who can design and build something for a dollar that any damn fool can make for five.

Please let us not move electrical engineering away from engineering and back toward the sciences. Teach us to be rational men with a fundamental understanding of the behaviors of nature and provide us the ability to describe effectively the interrelationship of men, machines, and economics.

WALTER A. KNOOP
Gawler-Knoop Co.,
Roseland, N. J.

(Author's Comment)²

Mr. Knoop and I are closer together than might be realized at first glance. I agree that creative engineering has many forms, even though I cannot subscribe to the view that this necessarily means that scien-

tific tools have little direct relation with such matters as dependable operation. For example, the theory of probability, and statistical methods of quality control, are very important in obtaining reliability. Again, with respect to design, consider the lowly 60-cycle transformer. Today the man who has access to an electronic computer and knows how to put his problem on it, can do for \$0.90 what it takes \$1.00 for an old style designer to accomplish, and what "any damn fool can do for \$5.00."

I am in full agreement with Mr. Knoop's view that many areas of engineering outside of electronics are also going back to science. In some of these the movement toward science is almost as rapid as in electronics; in others, it is present in a significant although lesser degree. In fact, almost everywhere in engineering this trend is present to at least some extent. I did not dwell on this in my paper, however, because I was writing about electronics and electrical engineering, and not about other fields of engineering.

The importance of a good working knowledge of beam deflections, spring constants, etc., to a man in electronics varies with circumstances, and is in any event, a matter of opinion. It is still my belief, however, that when one is dealing with averages, a working knowledge of stresses, strains, and deflections equivalent to that obtained in typical undergraduate courses taken by all engineers, is less important in electronics than knowledge of some other topics, as for example, solid-state physics, electromagnetic theory, or the scientific background of metallurgy.

Every engineering educator agrees fully with the view that it is desirable that a student think rationally, deal effectively with his fellow man, and be able to express his views both orally and in writing. Although my paper did not make any attempt to discuss general education in the engineering curriculum, my own views are indicated by the fact that at Stanford the percentage of general education included in the undergraduate curriculum is one of the highest among the four-year undergraduate engineering curricula in the country. In addition, we require of our engineers more work in written and spoken English than the University requires of all students in its general education program.

With respect to Mr. Knoop's fourth paragraph, I do not believe that a man who has a good undergraduate training, and then goes on for the master's or doctor's degree, is any less qualified as a result of his advanced training to deal with shopmen, accountants, engineering managers, or plant supervisors, than men with the same undergraduate training and no advanced training. In fact, it is not even necessary to have an engineering training to deal with the people in the shop; I know some physicists and chemists who are superb in this regard.

One point on which Mr. Knoop and I are not in agreement is the implication of the last sentence of his first paragraph, that when a young man is bent upon an inventive career, he should be encouraged to seek

courses leading to degrees in physics. I do not feel that physics is the only road to inventiveness.

Finally, I am in full agreement with Mr. Knoop's last sentence, in which he emphasizes the importance of the interrelationship of men, machines, and economics. When this subject is tackled quantitatively, it leads one into linear programming, which is a basic technique of operations research, and here we are right back to where I came in, with engineers going back to science.

FREDERICK E. TERMAN
Dean and Provost, School of Engrg.
Stanford Univ.
Stanford, Calif.

The Dirac Delta Function*

(Letter from Mr. Clavier)

Prof. Johnson's little note on Dirac Delta function¹ revives the controversy between mathematicians and physicists on the "mathematically correct" or "usefully incorrect" definition of the Delta function. One thing however is certain: one cannot keep the same name for two entities which are not equivalent and for instance have not the same Laplace transform. None of the four definitions of the Delta function given by Johnson are "mathematically correct" because they are limits, the uniqueness or existence of which can be doubted. For instance the Laplace transform of definition (a) is, following Johnson's argument, truly:

$$L[\delta(t)] = \lim_{\tau \rightarrow 0} \lim_{a \rightarrow 0} [\exp(-a/\tau)]$$

and not one which is obtained only if one assumes that the limit of a is used first. There is, however, a "mathematically correct" definition of the Dirac Delta function one should stick to for two reasons. First, because it is correct, and never ambiguous; second, it keeps all the useful properties ever derived from any of the incorrect definitions and increases even that wealth of properties considerably.

Any integrable function can be represented by its value in function of the value of the variable (the extension to many variables is obvious) which one represents by $f(t)$, but can also be represented by its projection on a class of particular functions, the class D of functions. It is then represented by

$$f(\phi) = f \cdot \phi = \int_{-\infty}^{+\infty} f(t)\phi(t)dt \quad (1)$$

in which ϕ is any function of the class D. The Dirac Delta function, which has no correct representation of the type $f(t)$ be-

* Received by the IRE, September 10, 1956.

¹ R. A. Johnson, "A note concerning the Dirac Delta function," Proc. IRE, vol. 44, p. 1058; August, 1956.

² Received by the IRE, October 1, 1956.

cause it is not really a function, has however a perfectly correct representation of the second type. It is:

$$\delta(t - t_0) \cdot \phi = \phi(t_0). \quad (2)$$

The projection of integrable functions on the ϕ space which may seem cumbersome at first is on the contrary in many cases very useful.

There is for instance no difficulty in finding the derivatives of the Dirac Delta function, the n th derivative being given by:

$$\delta^N(t - t_0) \cdot \phi = (-1)^N \phi^N(t_0) \quad (3)$$

in which the index represents the order of differentiation, from the simple identity:

$$f'(\phi) = -f(\phi'). \quad (4)$$

That the algebra of the ϕ space is not different in essence or complexity from common algebra stems from (2). If the projection of the Dirac Delta function on ϕ is $\phi(t_0)$ then the projection of ϕ on the Dirac Delta function is also $\phi(t_0)$. Replacing ϕ by any integrable function one obtains:

$$f \cdot \delta(t - t_0) = f(t_0). \quad (5)$$

Thus common algebra in which the representation $f(t)$ is used is none else but the algebra of the projections of the integrable functions on the Dirac Delta function.

It happens that not all integrable functions can be projected fully on the Dirac Delta space while all integrable functions can be projected on the ϕ space (for instance $\delta(t) \cdot \delta(t)$ or for that matter $U(t) \cdot \delta(t)$ have no meaning). Because of this the algebra of integrable functions represented by their projections on the ϕ space is considerably simpler than common algebra. For instance, in this algebra all integrable functions are differentiable an infinite number of times.

Not wishing to lengthen this note, let me refer any interested reader to the appended bibliography and conclude by an example. The convolution product of two functions when it exists is an integrable function which one can naturally project on the ϕ space. Thus:

$$(f * F) \cdot \phi = \int_{-\infty}^{+\infty} \int_{-\infty}^{+\infty} f(u)F(v)\phi(u+v)dudv \quad (6)$$

or simply:

$$(f * F) \cdot \phi = F(v) \cdot (f(u) \cdot \tau_v \phi) \quad (7)$$

in which τ_v is for the translation of $\phi(u)$ on the u axis by an amount v .

Replacing f by the first derivative of the Dirac Delta function, one obtains at once:

$$\begin{aligned} (\delta^I(t) * F) \cdot \phi &= F(v) \cdot (\delta^I(u) \cdot \tau_v \phi) \\ &= -F(v) \cdot \phi(v)' = F^I \cdot \phi \end{aligned}$$

which means that the convolution product of the first derivative of the Dirac Delta function placed at the origin with any function is equal to the first derivative of that

function or that the derivative of a function is none else but the convolution product of that function by the first derivative of the Dirac Delta function placed at the origin, . . . etc.

PHILIPPE A. CLAVIER
Zenith Radio Corp.
Chicago, Ill.

BIBLIOGRAPHY

- [1] Schwartz, Laurent. *Theorie des Distributions*. 2 vols. Paris: Hermann and Co., 1950.
- [2] Halperin, Israel. *Introduction to the Theory of Distributions*. Toronto: University of Toronto Press, 1952.
- [3] Clavier, P. A. "Some Applications of the Laurent Schwartz Distribution Theory to Network Problems." *Proceedings of the Symposium on Modern Network Theory*, Polytechnic Institute of Brooklyn, Vol. 5 (April, 1955).

(Author's Comment)²

Mr. Clavier's development of the δ function in terms of the Theory of Distributions is well put. It is true that in this domain properties of the function are readily derived. However, I have two criticisms to make.

First of all, I feel that invoking the high-powered Theory of Distributions which, in itself, entails most difficult concepts to explain certain difficulties in the δ function which is, as everyone agrees, another highly difficult concept is venturing into the field of "mathematically correct" definitions which due to their complexities are of little value in a practical sense.

Secondly, even though the δ function exists and is well behaved in the functional representation, it still does not actually exist in the point function representation even in a Lebesgue or a Stieltjes sense.

I feel that the δ function should be treated only as a convenient method of expressing otherwise mathematically inexpressible concepts, for example, the derivative of the Heaviside unit step function, in a formal manner only, since it is a physically as well as a mathematically impossible phenomenon and is only a limiting case.

RICHARD A. JOHNSON
Dept. of Elec. Engrg.
University of Manitoba
Winnipeg, Canada

¹Received by the IRE, October 3, 1956.

(Letter from Mr. Lackey)³

In the August, 1956 PROCEEDINGS,¹ Johnson writes that several different definitions of the Dirac Delta function are not equivalent because their respective Laplace Transforms are not identical. It should be noted that the three cases which Mr. Johnson claims do not conform, are defined for both positive and negative values of t while his transformation integral is defined only for positive values of t , effectively changing the delta function definition. If, however, one uses the two-sided Laplace Integral⁴ in determining the transform; namely,

³ Received by the IRE, August 23, 1956.

⁴ Van der Pol and Bremmer, "Operational Calculus based upon the Two-sided Laplace Integral," Cambridge University Press, Cambridge, England, 1950.

$$F(s) = \int_{-\infty}^{+\infty} f(t)e^{-st}dt,$$

one finds that the three cases mentioned do in fact have Laplace transforms equal to unity. This may be shown as follows:

In the general case,

$$\delta(t) = \lim_{\tau \rightarrow \infty} \frac{U[t + (1 - \rho)\tau] - U(t - \rho\tau]}{\tau}$$

where $0 \leq \rho \leq 1$.

The two-sided Laplace transform may then be written

$$\begin{aligned} L[\delta(t)] &= \lim_{\tau \rightarrow \infty} \frac{1}{\tau} \int_{-\infty}^{+\infty} \{U[t + (1 - \rho)\tau] \\ &\quad - U(t - \rho\tau)\} e^{-st} dt \\ &= \lim_{\tau \rightarrow \infty} \frac{1}{\tau} \left\{ \int_{(\rho-1)\tau}^{\infty} e^{-st} dt - \int_{\rho\tau}^{\infty} e^{-st} dt \right\}, \end{aligned}$$

since $U[t + (1 - \rho)\tau] = 0$ for $t < (\rho - 1)\tau$ and $U(t - \rho\tau) = 0$ for $t < \rho\tau$.

We may then write

$$\begin{aligned} L[\delta(t)] &= \lim_{\tau \rightarrow \infty} \frac{1}{\tau} \int_{(\rho-1)\tau}^{\rho\tau} e^{-st} dt \\ &= \lim_{\tau \rightarrow \infty} \frac{1}{-s\tau} [e^{-s\rho\tau} - e^{-s(\rho-1)\tau}]. \end{aligned}$$

Expanding both terms in a power series, we find

$$\begin{aligned} L[\delta(t)] &= \lim_{\tau \rightarrow \infty} \frac{1}{-s\tau} [1 - s\rho\tau + s^2\rho^2\tau^2 - \dots \\ &\quad - 1 + s(\rho - 1)\tau - s^2(\rho - 1)^2\tau^2 + \dots]. \end{aligned}$$

Collecting terms and dividing gives

$$L[\delta(t)] = \lim_{\tau \rightarrow \infty} \left[\rho - s\rho^2\tau - (\rho - 1) + s(\rho - 1)^2\tau + \dots \right],$$

and finally,

$$L[\delta(t)] = 1.$$

R. B. LACKEY
Ohio State Univ.
Columbus 10, Ohio

(Author's Comment)⁵

I fully agree with Mr. Lackey's note which is in essence the same as that which I recently received from J. W. Craig of M.I.T. My reason for using the single-ended transform was to illustrate that the common definitions of the delta functions are not equivalent in that sense. Most authors treating the transform method use the single-ended type (for example, Goldman) without illustrating the fact that the t function must be zero for negative t . I felt that an illustration of this fact was more valuable than just repeating the condition.

Further to the study of the unit impulse and step functions, I refer the reader to the consideration of such functions as $U(x)$ and $\delta(x)$ where x itself is either $U(t)$ or $\delta(t)$ or combinations of these. The results are curious and interesting when taken in a strictly formal sense.

RICHARD A. JOHNSON

⁵ Received by the IRE, September 17, 1956.

RF Bandwidth of Frequency-Division Multiplex Systems Using Frequency Modulation*

(Letter from Mr. Hamer)

An investigation of the fm and pm noise power spectra has been carried out in the British Post Office. Measurements have been compared with the theoretical results of Stewart¹ and Bosse² and general fm and pm noise spectra curves have been derived. Some comments on the above article³ may therefore be of interest.

First, it is not clear why an arbitrary 11 db should be introduced to define some vague "peak deviation." When simulating a multiplex signal by a band of noise, the magnitude of this signal can only be defined by its rms value, and only this value can be measured in an actual experiment. It may readily be shown that in the large deviation case, for example, the power density of the fm noise spectrum is

$$f_m W(x) = \frac{1}{\sqrt{2\pi m}} \exp. - \frac{x^2}{2m^2} \quad (1)$$

where f_m is the highest modulating frequency, x is the normalized relative frequency ($=f/f_m$), and m is the rms modulation index, $\Delta f/f_m$. It is unnecessary to introduce any quasi-peak deviation. Also, Stewart's approximation for the low-deviation case, with the lowest modulating frequency, f_0 , tending to zero, is

$$f_m W(x) = \frac{2m^2}{\pi^2 m^4 + 4x^2} \quad (2)$$

where the symbols are as before. Again, there is no need to introduce a "peak deviation."

A second point arises here. In practice, f_0 is never quite zero, and to a first approximation the spectrum is then confined to the range $x_0 \leq |x| \leq 1$ and is given by

$$f_m W(x) = \frac{m^2}{2x^2(1-x_0)} \quad (3)$$

where

$$x_0 = f_0/f_m.$$

It does not follow, however, that (2) has no practical significance. It is our conclusion that the spectrum approximates to (2) or to (3) as m^2/x_0 is greater than or less than unity. When m is small, but m^2/x_0 is not very large or very small, the spectrum corresponds to neither equation, and there is no clearly defined step at $x = \pm 1$. We find, however, that when $m=0.08$ and $m^2/x_0=0.11$, corresponding to Medhurst's Fig. 1, the sharp step in the spectrum is clearly evident.

Third, it is worth noting that our measurements indicate that the spectrum is Gaussian within less than 1.0 db down to normalized power densities of -40 db when $m > 2$. When $m=0.86$, corresponding to Medhurst's criterion $s/p_m=3$, the divergence from the Gaussian curve at power

densities of -40 db is greater than 10 db.

These minor criticisms in no way lessen the value of Mr. Medhurst's work, and his application of the noise spectra to the problem of defining the operating bandwidth is a major contribution to the work in this field. It is interesting to note that we have also arrived at an operating bandwidth of 12 mc for a similar 600-channel system by somewhat less elegant methods.

R. HAMER
P. O. Engrg. Dept.
Radio Lab.
Castleton, Cardiff, Wales

(Author's Comment)⁴

It is interesting to find that so much independent work has been put into this problem. Besides the paper under discussion and the report⁵ (which I understand is to be published in *Wireless Engineer*) of Mr. Hamer and his colleagues, a further contribution⁶ has appeared very recently, and there may well be more in the press. It is fortunate that differences in theoretical approach and range of measurement make the various sets of results to a considerable extent complementary.

The 11-db peak factor was introduced to conform with previous usage.⁷ It is a purely "engineering" figure, and may well date back to the period before Landon's clarifying paper,⁸ when it seems to have been thought that a definite peak of random noise existed, attempts being actually made to measure it. It may well now be preferable to express all results in terms of rms level. Of course, the introduction of a peak factor makes no difference to the final results, provided that the constants in the various expressions for spectrum shape and distortion are properly adjusted.

I am indebted to Mr. Hamer for illuminating private discussion which has clarified, to some extent, the question whether conditions exist under which Stewart's expression applies. It appears certain that in all small deviation cases so far measured Stewart's expression is not appropriate. It is also theoretically plausible that for a particular m (in Hamer's notation), some very small f_0 should exist for which the sharp discontinuity at the upper end of the spectrum will smooth out in conformity with Stewart's prediction. However, it seems safe to infer from the trend of measurements that the order of smallness of f_0 required would be such as to be quite irrelevant to practical considerations, at least in the frequency-division-multiplex telephony case.

There does not appear to be any sub-

stantial discrepancy between the measured results of White, Hamer, and Wilkinson⁴ and those in the paper under discussion, bearing in mind somewhat different modulating conditions. Both sets of measurements seem to suggest that the Gaussian curve is approached closely when m exceeds a value somewhere between 1.0 and 1.5. Certain differences in detailed shape for similar m values are probably due to differences in minimum modulating frequency and in sharpness of cutoff at the lower end of the band.

R. G. MEDHURST
Research Labs.
The General Electric Co. Ltd.
Wembley, England

Pulse Narrowing by Filters*

It is well known that passing a pulse-type signal through a filter has the effect of stretching out the base of the pulse. Many engineers interpret this to mean that the pulse is also stretched at its half-power points. It is the purpose of this note to show that such is frequently not the case.

Extremely short pulses are always stretched somewhat by filters. However, the duration of a square pulse need be only a little over half the time constant of a low-pass filter before the half-power width of the pulse is actually reduced by passing through the filter. Fig. 1 illustrates this phenomenon by showing a pulse-stretching factor which is the ratio of the length of a square pulse (at the half-power points) after passing through the filter to the original duration of the pulse. It should be noted that the output pulse is shorter at the half-power points for all pulse durations in excess of 0.56 times the time constant of the filter. A minimum length for a square pulse and a simple low-pass filter is reached at about 0.7 times the original length. For very long pulses, of course, the percentage change is small, and the pulse stretching factor approaches unity from below as the duration of the pulse is increased without bound.

The example chosen to carry out the calculations associated with Fig. 1 is that of a simple square pulse of duration T passing through a filter whose impulse response (memory function) is a decreasing exponential. The pulse shortening effect is not restricted to such a simple class of pulses, however, but can be observed with many other classes. It should be noted, of course, that the pulse is always stretched at its base even though it may be shortened at the half-power points by passing through the filter.

For the example chosen the impulse response is given by

$$m(t) = e^{-t/T_0} \quad (1)$$

The square pulse is represented by

$$F(t) = 0 \quad t < 0 \\ = 1 \quad 0 < t < T \\ = 0 \quad T < t \quad (2)$$

* Received by the IRE, August 17, 1956. Work for this paper was performed while the author was employed as a consultant to Sandia Corporation.

⁴ Received by the IRE, October 1, 1956.

⁵ R. W. White, R. Hamer, and R. G. Wilkinson, "The power spectrum of a carrier modulated in phase or frequency by uniform Gaussian noise," P. O. Eng. Dept., Radio Rep. No. 2414; October, 1955.

⁶ J. R. W. Smith and J. L. Slow, "Energy distribution in a wave frequency modulated by a multichannel telephone signal," *ATE J.*, vol. 12, pp. 182-202; July, 1956.

⁷ W. J. Albersheim and J. P. Schafer, "Echo distortion in the fm transmission of frequency-division multiplex," *Proc. IRE*, vol. 40, pp. 316-328; March, 1952.

⁸ V. D. Landon, "The distribution of amplitude with time in fluctuation noise," *Proc. IRE*, vol. 29, pp. 50-55; February, 1941.

* Received by the IRE, August 24, 1956.

¹ J. L. Stewart, "The power spectrum of a carrier frequency-modulated by Gaussian noise," *Proc. IRE*, vol. 42, pp. 1539-1542; October, 1954.

² G. Bosse, "Die berechnung des spektrums bei vielkanal-richtfunkverbindungen mit frequenzmodulation," *Frequenz*, vol. 7, p. 239; August, 1953.

³ R. G. Medhurst, *Proc. IRE*, vol. 44, pp. 189-199; February, 1956.

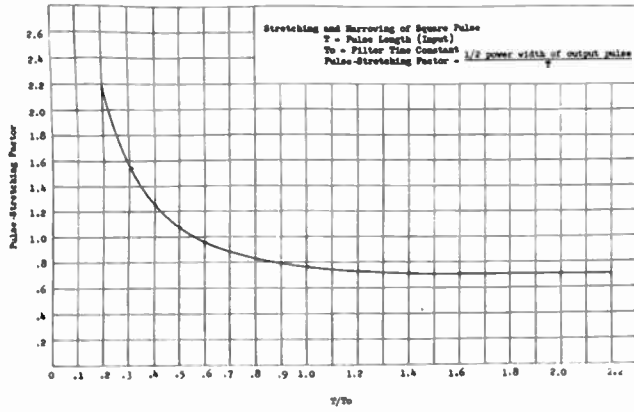

Fig. 1

The filter output is given by the superposition integral as $G(t)$:

$$G(t) = \int_0^\infty F(t)m(t-\tau)d\tau. \quad (3)$$

Substituting into the convolution integral we obtain

$$\begin{aligned} G(t) &= 0 \quad t < 0 \\ &= \int_0^t e^{-(t-\tau)/T_0} d\tau \quad 0 < t < T \\ &= \int_0^T e^{-(t-\tau)/T_0} d\tau \quad T < t \end{aligned} \quad (4)$$

which integrates to

$$\begin{aligned} G(t) &= 0 \quad t < 0 \\ &= T_0(1 - e^{-t/T_0}) \quad 0 < t < T \\ &= T_0 e^{-t/T_0} (e^{T/T_0} - 1) \quad T < t. \end{aligned} \quad (5)$$

The maximum value of the output occurs just at the end of the input pulse at which time the energy storage in the filter reactances is a maximum. The output at this time is given by

$$G_{max} = T_0(1 - e^{-T/T_0}). \quad (6)$$

The half-power width of the output pulse is given by $(t_1 - t_2)$. These are defined by

$$\begin{aligned} T_0(1 - e^{-t_1/T_0}) &= \frac{\sqrt{2}}{2} T_0(1 - e^{-T/T_0}) \\ T_0 e^{-t_2/T_0} [e^{T/T_0} - 1] &= \frac{\sqrt{2}}{2} T_0(1 - e^{-T/T_0}). \end{aligned} \quad (7)$$

From this it can be seen that

$$\begin{aligned} (t_2 - t_1)/T_0 &= \ln \frac{\left(1 - \frac{1}{\sqrt{2}}\right) e^{T/T_0} - \frac{1}{\sqrt{2}} e^{-T/T_0} + (\sqrt{2}-1)}{\frac{1}{\sqrt{2}} (1 - e^{-T/T_0})}. \end{aligned} \quad (8)$$

Note that the output pulse width approaches the input pulse width as the input pulse length approaches infinity.

It is the ratio of the output pulse width from (8) to the input pulse width which has been plotted in Fig. 1 as a function of the ratio of pulse duration to time constant of the filter.

It is hoped that this note will help some of the readers keep from falling into the trap

of assuming that the pulse width is stretched at all amplitude levels by passing through a filter when, in fact, it is always stretched only at the lowest amplitude level and may in fact be shortened at higher amplitude levels such as the half-power point.

RICHARD K. MOORE
Dept. of Elec. Eng.
University of New Mexico
Albuquerque, N. M.

Solar Temperature and Atmospheric Attenuation in the 7-8 MM Wavelength Range*

Measurements of the effective temperature of the sun and the total vertical attenuation in the earth's atmosphere have been made with a Dicke-type radiometer.¹ The instrument has an 18-inch paraboloidal antenna and is carried by an equatorial mounting with a clock drive. The local oscillator, a Raytheon QK-293 klystron, feeds a bal-

with a center frequency of 45 mc and a gain of 100 db. The second detector is followed by a conventional audio-frequency amplifier, 30 cps filter, and phase comparison detector.

Integration time constants of 1, 5, and 20 seconds are available. The rms noise fluctuation of the output is about 20°K with the 1-second integration time. The noise figure of the receiver, as estimated from the noise fluctuation, is about 20 db.

A typical transit of the sun through the antenna beam is shown in Fig. 1 (below). The duration of this record is about 14 minutes, and the time constant is 5 seconds. The calibration point at the left-hand side is the deflection produced by a piece of microwave absorber held in front of the antenna so as to fill the antenna beam. This gives a scale reading corresponding to ambient temperature. The antenna temperature in this example is about 720°K when the sun is in the beam.

The experiments consist of measurement of the antenna temperature with the antenna pointing first at the sun, then at the sky at the same altitude as the sun. A series of such measurements at different altitudes of the sun, plus knowledge of the antenna pattern, determines the sun's effective temperature and the total vertical attenuation in the earth's atmosphere, under the assumption that the atmosphere is horizontally stratified.² Results indicate a solar temperature at 7.5 mm of $6000 \pm 500^\circ\text{K}$ and values of total vertical attenuation between 0.3 and 0.6 db for types of weather ranging from clear to completely overcast with moderate rain. Cloud cover appears to have little effect on attenuation in this wavelength range.

The values quoted above are in good agreement with the expected results based on extrapolation of published data on solar temperature at longer wavelengths,³ and the attenuation is in good agreement with the predictions of the Van Vleck theory,⁴

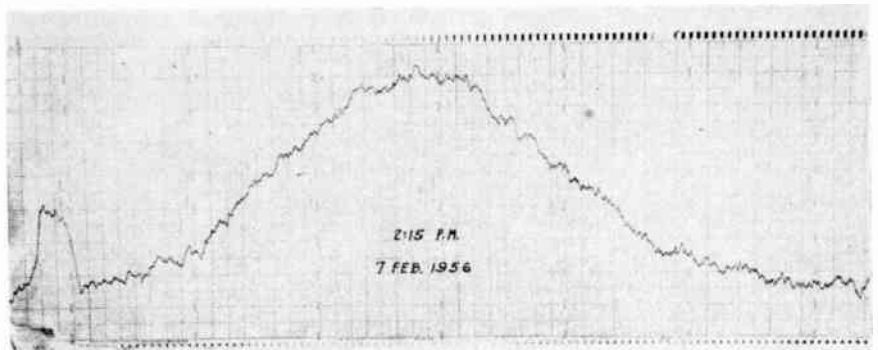

Fig. 1—Transit of sun through antenna beam of 7.5 mm radiometer. One division on time scale equals one-quarter minute.

anced mixer which uses Sylvania 1N53 crystals. The intermediate-frequency amplifier consists of a Wallman cascode preamplifier followed by a nine-stage amplifier. The intermediate-frequency bandwidth is 14 mc,

* Received by the IRE, June 29, 1956. A summary of this work was presented at the American Astronomical Society meeting in Columbus, Ohio, March, 1956.

¹ R. H. Dicke, "Measurement of thermal radiation at microwave frequencies," *Rev. Sci. Instr.*, vol. 17, pp. 268-275; July, 1946.

² G. R. Nicoll and F. L. Warner, "Atmospheric Attenuation Measurements at 8 mm Wavelength," T.R.E. Memo 471; 1951.

³ J. L. Pawsey and R. N. Bracewell, "Radio Astronomy," Oxford Univ. Press, New York, N. Y., p. 159; 1955.

Gene R. Marnet, "Atmospheric Attenuation of Microwave Radiation," Collins Radio Co. Rep. CTR-136; 1955.

J. P. Hagen, "Temperature gradient in the sun's atmosphere measured at radio frequencies," *Astrophys. J.*, vol. 113, pp. 547-566; May, 1951.

⁴ J. H. Van Vleck, E. M. Purcell, and H. Goldstein, "Propagation of Short Radio Waves," M.I.T. Rad. Lab. Ser., McGraw-Hill Book Co., Inc., New York, N. Y., vol. 13, ch. 8; 1951.

although attenuation in cloudy and rainy weather is somewhat smaller than anticipated. It is planned to investigate possible long-range variations in solar temperature and atmospheric attenuation in a wider wavelength region.

This work has been supported by a grant from the Research Committee of the University of Alabama. Jack Copeland designed and built most of the electronic units and helped greatly in obtaining the data.

R. N. WHITEHURST AND
F. H. MITCHELL
Physics Dept.
University of Alabama
University, Ala.

Minimizing Gain Variations with Temperature in RC Coupled Transistor Amplifiers*

A number of techniques for stabilizing the gain of an RC coupled transistor amplifier with temperature have been described in the literature.^{1,2} An additional method has been developed which may be of aid to the circuit designer either in combination with these previous techniques or by itself.

The basic circuit utilized is the cascaded RC coupled common emitter amplifier shown in Fig. 1. The voltage gain of one

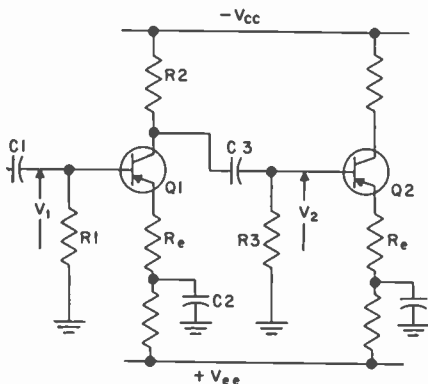

Fig. 1—Schematic of typical circuit.

stage (from the base of the first transistor to the base of the second) as developed from approximate expressions³ for stage voltage gain and input resistance of the following stage can be expressed as

$$A_v \approx \frac{h_{fb}}{(h_{ib} + R_s)g_e + (1 + h_{fb})} \quad (1)$$

where g_e is the total external interstage load

* Received by the IRE, August 6, 1956.

¹ R. B. Hurley, "A temperature stabilized transistor amplifier," IRE TRANS., vol. PGCP-2, pp. 93-103; September, 1954.

² W. Greatbatch and W. Hirtreiter, "Germanium transistor amplifiers stable to 95°C," Proc. IRE, vol. 43, p. 1974; December, 1955.

³ A. E. Hayes, Jr. and W. W. Wells, "A simplified procedure for the design of transistor audio amplifiers," 1956 IRE CONVENTION RECORD, Part 7, pp. 45-61.

conductance made up of resistors R_2 and R_3 , the h parameters are common base, and R_s is the external emitter circuit resistance.

The two transistor parameters h_{fb} and h_{ib} enter into (1). The variations in the magnitude of h_{fb} with temperature have a negligible effect on the numerator of (1). The denominator has the principal temperature sensitivity. The two factors h_{ib} and $(1 + h_{fb})$ have a temperature variation that cannot be ignored. For presently available alloy and grown junction triode transistors these two factors vary in opposite directions with temperature, i.e., h_{ib} increases and $(1 + h_{fb})$ decreases as temperature increases.

The opposing changes in the two factors in the denominator permit the temperature variation of voltage gain to be minimized by proper choice of external circuit conductance, g_e . This value of circuit conductance is given by

$$g_e^* = - \frac{\partial(1 + h_{fb})}{\partial T} / \frac{\partial h_{ib}}{\partial T} \quad (2)$$

Typical values of the temperature coefficients for alloy junction germanium transistors operated at 1 ma emitter current are 8.2×10^{-2} ohms per degree centigrade for h_{ib} and -9.1×10^{-6} units per degree centigrade for $(1 + h_{fb})$. The resulting optimum circuit conductance g_e^* from (2) is 1.11 millimhos or a resistance of 900 ohms.

Germanium and silicon transistor amplifiers have been designed using this technique. Fig. 2 shows the results for a four-

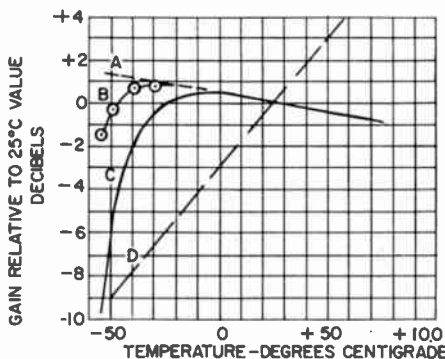

Fig. 2—Effect of ambient temperature on the gain of a four-stage transistor amplifier.

stage amplifier incorporating alloy junction germanium transistors. Curve C shows the performance of the over-all amplifier. Curve A is a linear extrapolation of the high temperature response to the low temperature region. Curve D is an estimated response of an uncompensated amplifier. Curve B shows the response obtained when the effect of poor emitter capacitor bypass action at low temperatures is eliminated. The variation from -50°C . to $+75^\circ\text{C}$. is ± 1 db out of a total gain of 80 db. This compares with the uncompensated design which would give a 15 db change over the same temperature range.

It should be stressed that the success of the balancing scheme depends to a large

measure on maintaining a stable operating point.

It has come to the author's attention since the completion of the above work that the Bell Telephone Laboratories independently developed the temperature balancing technique.

The author wishes to thank Charles W. Durieux and Robert C. Carter for helpful discussions, and James Dyson for taking much of the experimental data.

T. A. PRUGH
Diamond Ordnance Fuze Labs.
Washington 25, D. C.

Fast Switching with Junction Diodes*

When a junction diode which is conducting in the forward direction is suddenly biased in the reverse direction, the current does not immediately drop to its normally low steady-state reverse value. Instead, it overshoots to a relatively high negative value, limited by the applied reverse voltage and the total series resistance, and then gradually decays to its low steady-state value.¹ This reverse transient current is due to stored minority carriers which are injected during the forward part of the cycle and diffuse back when the voltage is reversed. The time required for "recovery" in typical commercial diodes is of the order of one-tenth to ten microseconds; this sets a limit to the speed with which a diode can be switched, and to its upper frequency limit of rectification.

This limit to fast operation of junction diodes can be circumvented by abandoning operation about zero voltage and utilizing, instead, operation about the reverse voltage at which "avalanche breakdown" takes place. The avalanche process in semiconductor junction diodes is generally similar to the cumulative collision ionization which occurs in a gas discharge. A moderate reverse voltage establishes a strong electric field in the very thin depletion region which exists on the high-resistivity side of the junction. Thermally-generated carriers which traverse the region of high electric field gain sufficient energy to ionize neutral atoms. The electron-hole products of ionization also cause ionization in turn, and thus the initial small thermally-generated current is greatly multiplied.²⁻⁵ In the method to be described the diode is operated in the third quadrant of its I-V characteristic. The applied signal is superposed on a steady

* Received by the IRE, August 29, 1956.

¹ L. A. Meacham and S. E. Michaels, "Observations of the rapid withdrawal of stored holes from germanium transistors and varistors," Phys. Rev., vol. 78, pp. 175-176; April 15, 1950.

² K. G. McKay and K. B. McAfee, "Electron multiplication in silicon and germanium," Phys. Rev., vol. 91, pp. 1079-1084; September 1, 1953.

³ K. G. McKay, "Avalanche breakdown in silicon," Phys. Rev., vol. 94, pp. 877-884; May 15, 1954.

⁴ P. A. Wolff, "Theory of electron multiplication in silicon and germanium," Phys. Rev., vol. 95, pp. 1415-1420; September 15, 1954.

⁵ S. L. Miller, "Avalanche breakdown in germanium," Phys. Rev., vol. 99, pp. 1234-1241; August 15, 1955.

bias, somewhat less than the breakdown voltage. When the polarity of the signal voltage is such as to increase the reverse voltage beyond the breakdown point, high current is obtained as a result of the avalanche process. When the signal voltage changes sign, the current is reduced to its low reverse steady-state value. The time required for switching from high current to low current is determined by the time required to sweep the electron and hole products of the avalanche out of the depletion region and be absorbed in the *n* and *p* regions, respectively. There is no storage of minority carriers. Since the diode voltage is never reversed, and a strong electric field in the depletion region therefore can be maintained, the traversal time can be short, perhaps as low as 10^{-12} second. The time required for the electrons and holes to be absorbed in the *n* and *p* regions, respectively, is the relaxation time; for 1 ohm-cm material, this is of the order of 10^{-12} second. The reverse transient current should thus be insignificant.

Although the phrase "avalanche breakdown" may have a catastrophic connotation, this mode of operation is perfectly stable and reliable. Provided that the maximum power dissipation is not exceeded, no physical or chemical change in the semiconductor takes place.

An experimental comparison of the transient current obtained in normal operation and in operation about the avalanche breakdown point is depicted in Figs. 1 and 2,

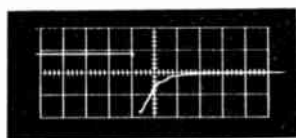

Fig. 1—Recovery characteristic of type S-6 silicon diode under normal operation in circuit for measuring reverse current transient.
Scale: Vert = 1.0 v/cm
Horiz = 0.1 μsec/cm.

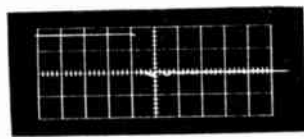

Fig. 2—Recovery characteristic of type S-6 silicon diode operated at avalanche breakdown.
Scale: Vert = 0.5 v/cm
Horiz = 0.1 μsec/cm.

respectively. These oscillograms of current vs time show the relative speeds with which a diode can be switched from high current to low current in the two modes of operation. In Fig. 1 the duration of the switching transient is about 0.25 microsecond. In Fig. 2 there is no observable transient, although the resolving power of the oscilloscope is of the order of 10^{-8} second. The circuit used for this comparison was similar to one now commonly employed to obtain recovery characteristics.⁶ The diode was of the bonded silicon variety, Transiron type S-6, chosen

for its suitability for both modes of operation.

If a diode is to be used for a fast switch, as described above, it is desirable that its breakdown voltage be as low as possible to keep power dissipation down, but high enough so that the applied signal does not drive the diode into forward conduction during the off part of the cycle. The diode capacitance should be low to minimize *C-R* "spikes." In addition, the reverse current should be very low until the breakdown voltage is reached, and thereafter should rise as steeply as possible. Finally, the reverse *I-V* characteristic should be free of "scintillation beads." The latter are unstable regions which occur in the neighborhood of the breakdown voltage, usually at quite low currents.⁷ They appear on a dynamic *I-V* presentation as many superposed scintillating traces of negative slope; between such regions the oscilloscope trace is well-defined and has a positive slope. When a diode which exhibits these "beads" is biased at a point of instability, the diode current is found to consist of random pulses which have a thermal origin, the diode acting in effect as a solid-state Geiger counter. The random pulse count is very high at room temperature, but can be reduced by operating the diode at low temperature. The reverse *I-V* characteristic of commercial diodes often exhibits such "beads," which are undesirable if a diode is to be used for a fast switch. For example, type 1N138 silicon junction diodes almost always display these "beads."⁸

To obtain some practical experience and to provide further comparison of both modes of operation, the three-input diode logical AND circuit shown in Fig. 3 was set up.⁹

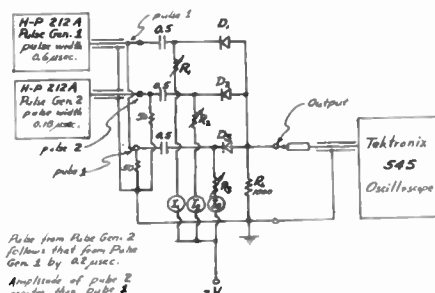

Fig. 3—Three-input diode logical AND circuit.

Fig. 4(a) shows the output voltage of the circuit when 1N138 diodes are used in normal fashion, at the zero voltage point. Note the overshoot, a result of minority carrier storage, at the leading edge of the wide pulse during anticoincidence. Fig. 4(b) shows the output voltage when the diodes were operated at the same currents, but biased at the reverse breakdown point. Although the pedestal during anticoincidence is of greater amplitude, no overshoot appears at

⁷ K. G. McKay, "Avalanche breakdown in silicon," *Phys. Rev.*, vol. 94, pp. 877-884; May 15, 1954.
⁸ Unpublished work of K. Bewig and B. Salzberg. The authors wish to thank Mr. Bewig for permission to describe some of these findings on the "bead" phenomena.

⁹ Tung Chang Chen, "Diode coincidence and mixing circuits in digital computers," *Proc. IRE*, vol. 38, pp. 511-514; May, 1950.

its leading edge. The smearing of the trace which is to be observed at the top of the pulse during coincidence, and following the period of coincidence, is caused by the undesirable "scintillation beads" which are contained in the reverse *I-V* characteristic of these diodes.

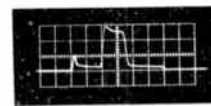

(a)



(b)

Fig. 4—Output of circuit of Fig. 3 for (a) normal, and (b) avalanche-breakdown operation of *D*₁, *D*₂, and *D*₃, each a type 1N138 silicon diode. Branch bias current $I_1 = I_2 = I_3 = 3.0$ ma.
Scale: Vert = 2.0 v/cm
Horiz = 0.1 μsec/cm.

Results obtained with the circuit of Fig. 3, when type S-6 bonded silicon diodes were employed, are shown in Fig. 5(a) and (b). Fig. 5(a) shows the output voltage of the circuit when the diodes were used in the normal manner. Fig. 5(b) shows the output voltage when the diodes were operated at the reverse breakdown point; again, there is no overshoot due to minority carrier storage. In Fig. 5(b), furthermore, there is no evidence of smeared traces caused by "beads," such as appear in Fig. 4(b). The pedestal during anticoincidence in Fig. 5(b) is greater in relative amplitude, however, than that in Fig. 4(b); this is the result of a relatively slow rise in avalanche current beyond the breakdown voltage in the characteristic of the type S-6 diodes.

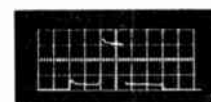

(a)

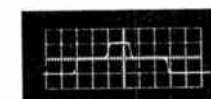

(b)

Fig. 5—Output of circuit of Fig. 3 for (a) normal, and (b) avalanche-breakdown operation of *D*₁, *D*₂, and *D*₃, each a type S-6 silicon (bonded) diode. Branch bias current $I_1 = I_2 = I_3 = 3.0$ ma.
Scale: Vert = 1.0 v/cm
Horiz = 0.1 μsec/cm.

Thus, by utilizing operation about the reverse breakdown voltage, fast switching is possible and practicable. We wish to point out, however, that for such operation selection-testing is necessary at present since diodes are now neither manufactured nor factory-tested for the requisite properties.

J. E. SCOBAY, W. A. WHITE, AND
B. SALZBERG
Naval Res. Lab.
Washington 25, D. C.

⁶ T. E. Firlie, M. E. McMahon, and J. F. Roach, "Recovery-time measurements on point-contact germanium diodes," *Proc. IRE*, vol. 43, pp. 603-607; May, 1955.

Contributors

Eugene D. Becken (S'32-A'35-M'46) was born on April 29, 1911 in Minnesota. He received the degree of B.S.E.E. from the University of North Dakota in 1932. He received the degree of M.S.E.E. from the University of Minnesota in 1933.



E. D. BECKEN

He has since been employed in various operating and engineering capacities by RCA Communications, Inc. He was awarded a Sloan Fellowship at the Massachusetts Institute of Technology in 1951 for a year's study of industrial management, which culminated in the degree of M.S. in business and engineering administration.

His present position with RCA Communications, Inc. in New York is assistant vice-president and plant operations engineer.

Mr. Becken is a registered professional engineer in New York State and a member of the American Institute of Electrical Engineers and Sigma Tau, and an associate member of Sigma Xi.



Warren B. Bruene (A'45-M'45-SM'49) was born on November 1, 1916 at Beaman, Iowa. He received the B.S. degree in electrical engineering from Iowa State College in 1938. In 1939 he joined the Collins Radio Company in Cedar Rapids, Iowa, and engaged in the development of numerous types of radiotransmitting equipment.



W. B. BRUENE

During the past four years he has been almost exclusively engaged in the development of single-sideband high-frequency transmitters. He has been granted several patents. At present, Mr. Bruene heads an engineering development group at the Collins Radio Company.



Adamant Brown (SM'52) was born in Savannah, Ga., on July 29, 1920. He studied at Jacksonville Junior College and with the University of Chicago, and was awarded the B.S. in E.E. in 1948 by McKinley Roosevelt. At present he is studying at Monmouth College.



A. BROWN

From 1939 to 1942 he was connected with broadcasting stations WMFJ and WJAX, and with the City of Jacksonville, Fla., as a radio engineer. He

has been employed by the Signal Corps since 1943 and has been actively engaged in the exploitation of single-sideband techniques since 1946. He is presently employed as an electronic scientist with the Office of Technical Plans, Signal Corps Engineering Laboratories.

Mr. Brown is chairman of IRE Technical Subcommittee 15.5, Single-Sideband Transmitters, and is co-editor of the *Scanner*, the publication of the Monmouth subsection. He is also a member of the American Institute of Electrical Engineers.



Christopher Buff (A'45-M'48-SM'55) was born at Camden, N. J. on January 6, 1917. He took engineering courses at Union County (N. J.) Junior College and at Hofstra College. Since 1931, he has been an active licensed radio amateur.



C. BUFF

From 1941 through 1946, he was employed in various engineering capacities by Press Wireless, Inc., and was instrumental in the development of some of the early fsk keying equipment.

Since 1946, he has been with Mackay Radio and Telegraph Company working mainly on fsk, Twinplex, and terminal equipment design. Some time was spent in South America arranging for Twinplex operation of the Rio de Janeiro and Buenos Aires radiotelegraph circuits. He is at present a supervising engineer in the company.



John P. Costas (S'46-A'51) was born on September 16, 1923, in Wabash, Ind. He received the degree of Bachelor of Science in electrical engineering from Purdue University, Lafayette, Ind., in 1944. He then served with the U. S. Navy as radar officer, during which time he attended the Harvard and M.I.T. Radar Schools.



J. P. COSTAS

In 1946, he returned to Purdue, and was conferred the degree of Master of Science in electrical engineering in 1947. He then entered Massachusetts Institute of Technology, Cambridge, Mass., and in 1951 obtained the degree of Doctor of Science.

Dr. Costas has been employed by the General Electric Company since 1951 and is presently a consulting engineer in the Heavy Military Electronic Equipment Department of the Defense Electronics Division at Syracuse, N. Y.

Luther W. Couillard (M'45-SM'55) was born in Minneapolis, Minn., on October 1, 1916. He received the B.E.E. degree from the University of Minnesota in June, 1938.



L. W. COUILLARD

He was employed in the engineering department of the Northern States Power Company until 1940, and has since been a member of the staff in the engineering department of the Collins Radio Company. His work has been primarily in the high-frequency communication field with emphasis on high frequency receiver design. Mr. Couillard is a member of Eta Kappa Nu.



Robert T. Cox (A'45-SM'46) was born November 22, 1917 at Port Arthur, Canada. He received the B.S. degree in electrical engineering in 1939 and the M.S. degree in electrical engineering in 1940 from Rensselaer Polytechnic Institute, Troy, N. Y. In 1940 and 1941, he did graduate work at Ohio State University in Columbus.



R. T. COX

In June, 1941, Mr. Cox joined Collins Radio Company, Cedar Rapids, Iowa, as a development engineer. He was promoted to director of engineering in 1946, and in April, 1954 was made vice-president of research and development.

Mr. Cox is a member of Sigma Xi and Eta Kappa Nu, and is on the Technical Advisory Panel on Electronics, Department of Defense.



Robert L. Craiglow (A'50) was born in Columbus, Ohio, on May 11, 1923. In 1941, he became a student in the College of Engineering of Ohio State University at Columbus. He interrupted his schooling during World War II to serve three years in the U. S. Army Signal Corps. He then returned to Ohio State and received the B.S. degree in electrical engineering in 1946. From that time, he has been employed by Collins Radio Company, Cedar Rapids, Iowa, in work involving frequency generating means.



R. L. CRAIGLOW

Vincent R. DeLong (S'49-A'50-M'56) was born on November 16, 1926, at Rochester, Minn. He received the B.E.E. degree



V. R. DELONG

from the University of Minnesota in 1950. In June of 1950 he joined the Research and Development Department of the Collins Radio Company, where he has been employed for the past six years.

Mr. DeLong has been engaged in the designing, developing, and testing of high frequency communications equipment for government and commercial applications.

He is a member of Tau Beta Pi, Eta Kappa Nu, and Triangle fraternities.



Harold E. Fellhauer (A'53) was born in Clinton, Mo., on December 29, 1911. He received the B.S.E.E. degree from the University of Kansas in 1934.



H. E. FELLHAUER

He has been associated with Trans-World Airlines and Wilcox Electric Company, primarily in the field of fixed station transmitters.

Mr. Fellhauer served as a radar technical officer in the U. S. Navy from 1943 to 1946, specializing in fire control. He has been employed since 1953 at Collins Radio Company, Cedar Rapids, Iowa, where he has been engaged in single-sideband transmitter development.



William L. Firestone (M'49-SM'53) was born in Chicago, Ill., on June 20, 1921. Before World War II he worked at Motorola, Inc., and attended the RCA Institute.



W. L. FIRESTONE

During World War II he graduated from the Navy Radio Materiel School at Treasure Island, Calif., where he also taught Navy radio.

He attended the University of California, and later the University of Colorado, receiving the B.S. degree in electrical engineering in 1946.

After working on the Manhattan Project for six months, he returned to Motorola as a microwave engineer. He received the M.S.E.E. degree from the Illinois Institute of Technology in 1949 and the Ph.D. degree in 1952 from Northwestern University. Since 1951 he has been engaged in vhf research and is currently the Assistant Chief Engineer of the Applied Research Department at Motorola.

Dr. Firestone is a member of Sigma Xi, Tau Beta Pi, HKN, Pi Mu Epsilon and AIEE, and is currently a lecturer at Northwestern University.

Bert Fisk was born November 8, 1909 in Orofino, Idaho. He received the B.S. degree in 1933 and the M.S. degree in 1936



B. FISK

from the University of Idaho, and taught science and mathematics in Idaho high schools until 1941 when he was called to active military service with the Navy. In the Navy he taught electronics at the preradar school at Bowdoin College for eighteen months and then was ordered

to sea duty with the amphibious fleet where he served as radar, electronics, and communications officer aboard the USS *Arcturus*.

He was discharged to inactive duty in 1945 and immediately went to work at the U. S. Naval Research Laboratory where he currently holds the position of head of the Communications Security Section of the Radio Division.

Mr. Fisk is a member of RESA and recently was awarded the Navy's Distinguished Civilian Service award.



Hallan E. Goldstine (A'29-SM'47) was born on September 2, 1907 in Paris, Ky. He received the B.S. degree in mechanical engineering from the University of Kentucky, Lexington, Ky., in 1928 and in the same year joined the Transmitter Research and Development Laboratory of RCA Communications, Inc., New York, N. Y.



H. E. GOLDSTINE

Since 1942, Mr. Goldstine has been a member of the Communications Research Section of RCA Laboratories.

❖

George Grammer (A'49) was born in Philadelphia, Pa., in 1905. He studied electrical engineering at Drexel Institute of Technology in Philadelphia during the years 1923 to 1926.



G. GRAMMER

Three years later, in 1929, he joined the staff of the American Radio Relay League. For one year thereafter, Mr. Grammer was associated with the Technical Information Service. From 1930 to 1938 he was assistant technical

editor of the magazine *QST*, and in 1938 became technical editor, a position he holds at the present time. Since 1942, Mr. Grammer has been technical director of the American Radio Relay League.

Grant E. Hansell (A'41-SM'46) was born on June 17, 1909 in Indiana. He received the B.S. degree in electrical engineering from Purdue University, Lafayette, Ind., in 1931.



G. E. HANSELL

In the same year, Mr. Hansell joined the Receiver Research and Development Laboratory of RCA Communications, Inc., New York, N. Y. He has been a member of the Communications Research Section of

RCA Laboratories.



John F. Honey (S'43-A'49-SM'53) was born in Portland, Ore., on August 29, 1921. During World War II, he served with the Air Force and the Signal Corps, working in long-range point-to-point communications in the Pacific Theatre. He attend Reed College in Portland, Ore., in 1941 and 1942, and after the war studied at Stanford University. He received the B.S. degree in 1947 and the



J. F. HONEY

degree of electrical engineer in 1948. He worked as a research assistant at Stanford University in 1947 and 1948.

Mr. Honey joined the staff of the Stanford Research Institute in December, 1948, and was made head of the Communications Group of the Radio Systems Laboratory in 1953. He has directed the Institute's research in radio communications, and has specialized in applied research and development in the field of single-sideband communications.

Mr. Honey is a member of Sigma Xi, the Scientific Research Society of America, and the Armed Forces Communications and Electronics Association.



Phineas J. Icenbice, Jr. (SM'56) was born May 14, 1922, in Deep River, Iowa. He attended Iowa State College for several



P. J. ICENBICE

years, as well as other technical colleges, during active duty with the U. S. Navy. In 1944, he became technically qualified as an engineering radar officer.

After completing a Northwestern University teachers training course, he was assigned to the post of electronics theory instructor.

Mr. Icenbice has been employed by the Collins Radio Company, Cedar Rapids, Iowa, for the past 14½ years as a design

engineer and manager of the final test and type test departments.

Since 1938, he has been an active radio amateur WØNKZ, and he has been issued a number of patents in the electronic field.

❖

Leonard R. Kahn (S'46-M'51-SM'54) was born on June 16, 1926, in New York, N. Y. He received the B.E.E. degree from the Polytechnic Institute of Brooklyn in 1951. He also studied at the Engineering School of Syracuse University and New York University Law School. Since 1953, Mr. Kahn has been a member of the associated teaching staff of the Electrical Engineering Department of Polytechnic



L. R. KAHN

Institute of Brooklyn.

From 1944 to 1946, Mr. Kahn served in the United States Army Signal Corps and from 1947 to 1950 he was employed by RCA Communications, Inc. During the last year of his employment by RCA Communications he was on part-time loan to RCA Laboratories. From 1950 to 1952, Mr. Kahn was employed by Crosby Laboratories. In 1952, he organized the Kahn Research Laboratories where he is now owner and research director. He has supervised research and development on single-sideband transmitters, tone converters, and other communications and television equipment. He has also served as Consultant to the Voice of America, Kaiser Aircraft and Electronics, as well as other commercial organizations. Mr. Kahn has a number of inventions in the communications field, including the ratio squarer diversity system and television and communications transmitters.

Mr. Kahn is an associate member of the AIEE, and a member of Tau Beta Pi, Eta Kappa Nu, and Sigma Xi and the American Association for the Advancement of Science. He is also a member of the IRE Single-Sideband Transmitter Sub-Committee, and Chairman of RETMA Communications Transmitter Group TR6.1.

❖

Robert A. Kulinyi (A'49-M'49) was born on May 22, 1919 in New York, N. Y. He graduated from Virginia Polytechnic Institute in 1941 as Bachelor of Science in electrical engineering.



R. A. KULINYI

After a short period as instructor at that institution he joined the Signal Corps Laboratories as junior engineer working in the field of vehicular radio installation and suppression of vehicular radio noise.

From mid-1943 to 1946 Mr. Kulinyi served with the U. S. Marine Corps as Radar and Air Warning Officer. Upon separation from military serv-

ice, he resumed work at the Signal Corps Engineering Laboratories in the field of radio countermeasures and antijamming. From 1947 to the present he has been working on Long Range Radio Communications problems including development of very high power transmitters, mobile high-frequency radio sets, reliable communications systems for normal and scatter propagation modes and SSB systems for fixed plant and tactical service.

❖

Julius Leonhard (S'50-A'52) was born in New York, N. Y., on June 18, 1919. From 1940 to 1942, he was on the engineering staff of radio station WBRK, Pittsfield, Mass.



J. LEONHARD

During World War II, he was a radio technician in the U. S. Navy. He graduated from Massachusetts Institute of Technology, Cambridge, Mass., in 1951, with the B.S. degree in electrical engineering. He was a staff mem-

ber of the Research Laboratory of Electronics, M.I.T., from 1951 to 1953.

Since 1953 he has been a staff member of M.I.T. Lincoln Laboratory.

He is a member of Tau Beta Pi, Eta Kappa Nu, and Sigma Xi.

❖

Robert H. Levine (S'48-A'49-M'54-SM'56) was born on September 11, 1928, in Albany, N. Y. He received the B.S. degree



R. H. LEVINE

in electrical engineering from Purdue University, Lafayette, Ind., in 1949. He served on active duty with the U. S. Army Signal Corps following graduation, and has been with the Signal Corps Engineering Laboratories, Fort Monmouth, N. J., since 1950. His work has been prin-

cipally in the field of single-sideband communications.

❖

Don L. Lundgren (A'52) was born in Deer Lodge, Mont., on June 3, 1917. After serving in the U. S. Army Air Corps during World War II, he was honorably discharged in 1945. In 1949, he received his engineering degree and spent



D. L. LUNDGREN

the following two years as an instructor in electrical engineering at American Institute of Technology. In June, 1956, he received the M.S. degree in elec-

trical engineering from Drexel Institute of Technology, Philadelphia, Pa.

In 1951, he joined the Commercial Electronic Products Division of RCA, Camden, N. J. where he was engaged in the design and development of visual alignment equipment for fm mobile communications receivers, special purpose oscilloscopes, multiplex channelling equipment, and various test equipments. For the past two years, his activities have been concentrated on the design of electromechanical filters.

❖

Charles L. Mack, Jr. (A'55) was born in Cleveland, Ohio, on July 20, 1926. He received the B.S. in physics from Harvard University in 1948. From 1948 to 1953, while a graduate student in physics at the University of Pennsylvania, he was engaged in research work.



C. L. MACK, JR.

Mr. Mack also taught in the physics department, the Johnson Foundation, the electrical engineering department, and the medical school of the

University of Pennsylvania.

In 1953, he joined the staff of the system engineering group in communications of Lincoln Laboratory at Massachusetts Institute of Technology, Cambridge, Mass.

❖

Henry Magnuski (A'40-SM'46) was born in Warsaw, Poland, on January 30, 1909. He received the Diploma of Electrical Engineer



H. MAGNUSKI

in 1934 from the Technical University of Warsaw. He was a senior engineer in charge of military communication equipment for the Polish State Radio and Telephone Works before coming to the U.S.A. in 1939.

Mr. Magnuski joined Motorola Inc., in 1940, and was en-

gaged in the design of communication equipment and radar beacons, for which he was rewarded the U. S. Navy Certificate of Commendation for outstanding service.

After the war he specialized in microwave relay systems and mobile communication equipment research and design.

His present position is that of Associate Director of Research. He is a registered professional engineer in the State of Illinois and a member of the AIEE.

❖

Emil L. Martin (A'49-M'54) was born in Minneapolis, Minn., on August 15, 1922. He enrolled at the University of Minnesota in 1941, joined the U. S. Coast Guard in 1942, serving four years as a radio operator, and then returned to the university following his release from the Coast Guard in 1946.

He received the B.S. degree in electrical engineering in 1948 and joined Collins Radio Company, Cedar Rapids, Iowa.



E. L. MARTIN

Mr. Martin has specialized in uhf communications equipment development, and contributed important design functions to the Collins ARC-27, CU-355(XN-1), and ARC-46(XN-1) projects.

He is currently assigned to single-sideband development in Engineering and Research Department III.

Mr. Martin is a member of the American Radio Relay League and has been a licensed amateur operator on W0NCS since 1938.



Harold F. Meyer (SM'50) was born in New York, N. Y. on September 2, 1916. He studied at Boston and Columbia Universities. For many years he was active as a radio experimenter, amateur, member of the Naval Communication Reserve and in the radio business. In 1940 he became Technical Research Editor for the Encyclopedia Americana.



H. F. MEYER

Entering Government Service in the Signal Corps Plant

Engineering Agency in 1942, Mr. Meyer became chairman and technical secretary of the Technical Coordination Committee and Chief of the Engineering Coordination Section. In 1945 he transferred to the Signal Corps Engineering Laboratories, Ft. Monmouth, N. J. and became chief engineer of the Long Range Equipment Section. In 1955 he was made chief of the Long Range Radio Branch. In these capacities since 1946 he has been responsible for research and development of the Army long distance radio communication equipment and systems.



Walter E. Morrow, Jr. (S'48-A'41) was born in Springfield, Mass., on July 24, 1928. He received the S.B. degree from Massachusetts Institute of Technology, Cambridge, Mass., in 1949 and the S.M. degree from the same institution in 1951.



W. E. MORROW, JR.

Since that time he has been associated with M.I.T. Lincoln Laboratory, first, as a staff engineer and more recently as a group leader.

While at Lincoln Laboratory he has done research and development on transistor circuit design, vhf ionospheric scatter communication systems, and uhf tropospheric scatter communication systems

Burt E. Nichols was born in Newton, Mass., on January 2, 1923. He is a graduate of Cornell University with the degree of B.S.



B. E. NICHOLS

in electrical engineering in 1944. Mr. Nichols was a USNR electronics officer following his attendance at the M.I.T. Radar School in 1945. In 1951, Mr. Nichols went to Rome, Italy, as an RCA field engineer attached to the Air Force Military Assistance Advisory Group, at the American Embassy. Working with the Italian Air Force, he assisted setting up an electronics school for training with American radar and radio equipment given the Italian Air Force under the mutual aid program.

In 1954, he returned to this country and joined the staff of M.I.T. Lincoln Laboratory in the communications systems engineering group and has worked with the development of the SSB system for the uhf tropospheric scatter communications systems.



Donald E. Norgaard (S'36-A'38-SM'52) was born June 11, 1914, in Council Bluffs, Iowa. After receiving the Bachelor of Science



D. E. NORGAARD

degree in electrical engineering from the Rice Institute in 1936 he joined the staff of the General Engineering Laboratory of the General Electric Company in Schenectady, N. Y. In 1938 he joined the Transmitter Engineering Department of the General Electric Company and

was engaged in the development of television studio equipment. From 1940 until the end of World War II he was engaged in development of naval gunfire control radar systems. In 1946 he joined the Research Laboratory of the General Electric Company as a research associate, where his activities included work on communication systems and devices.

Mr. Norgaard participated in field tests on television synchronization conducted in behalf of the NTSC in 1939 and was a member of the RTPB Committee on Synchronization Standards and Video Modulation in 1944. He also served as vice-chairman of the RMA Sub-Committee on Television Studio Facilities in 1945 and 1946.

Licensed as a professional engineer in the State of New York in 1947, Mr. Norgaard also is licensed as an amateur radio operator. He is a member of Phi Beta Kappa and Tau Beta Pi.



Arthur A. Oswald (A'19-M'25-F'28) was born in Lake Linden, Mich., on March 3, 1891. He received the B.S. and E.E. degrees

from Armour Institute of Technology in 1916 and 1927, respectively. He joined the Radio Research Section of the Western Electric Company's Engineering Department in 1916 and remained in this organization when it became a part of the Bell Telephone Laboratories, which was formed in 1925.



A. A. OSWALD

During World War I he helped develop radio telephones for airplanes and was directly responsible for the development of a radio system for the guidance of unmanned airplanes. During World War II he supervised groups engaged in radio communication and radar projects.

During his Bell System career Mr. Oswald was responsible for ship-to-shore and transoceanic telephone systems, radio guidance of drone planes, ultra-high-frequency short-haul point-to-point links, and relay systems. After developing the experimental radio telephone system at Rocky Point, Long Island, during 1922-23, he spent two years in England engineering the first circuit from New York to London and is one of the two persons who held the first conversation across the Atlantic Ocean.

Groups under his supervision have developed the single-sideband systems and equipments for Bell System overseas services. At the time of his retirement from the Bell Telephone Laboratories, Mr. Oswald was Transmission Systems Development Engineer in charge of activities concerning Overseas Radio, Mobile Systems, and some of the light-route, short-haul, point-to-point systems including microwave relay.

Mr. Oswald is a Fellow of the AIEE, a member of Tau Beta Pi and Eta Kappa Nu.



Ernest W. Pappenfus (M'45-SM'50) was born in Raymond, Mont., on September 23, 1917. He received the B.E.E. degree from the University of Minnesota in 1941. After part-time broadcast operator work in Minneapolis radio stations during his college years, Mr. Pappenfus joined the Collins Radio Company, Cedar Rapids, Iowa, in July, 1941.



E. W. PAPPENFUS

In the Collins organization, he has served as test engineer, patent engineer, design engineer, project engineer, and is now assistant director of engineering. His present duties include the direction of all hf equipment development with particular emphasis on single-sideband.

Mr. Pappenfus is a member of ARRL, the Cedar Rapids Engineers Club, and Tau Beta Pi.

Harris A. Robinson (J'27-A'29-M'36-SM'43) was born in Philadelphia, Pa., on November 13, 1907. He was employed during the summer of 1928 by the Radio-marine Corp. of America as a ship-board radio operator.



H. A. ROBINSON

After graduating from the University of Pennsylvania in 1929, with the B.S. degree in electrical engineering, he was employed by the General Electric Company at Schemmady on their Radio Test Course. During this period he took part-time graduate work at Union College, returning to the University of Pennsylvania in 1930 on a full-time graduate fellowship.

After receiving the M.S. degree in electrical engineering in 1931, Mr. Robinson entered the Special Receiver Engineering group with RCA at Camden. Design and development work in military and aircraft receivers led to his appointment in 1939 as leader of the Aircraft Receiver Group. With the formation of the Aviation Section in 1944, Mr. Robinson has continued actively in airborne communication engineering design as a group leader.

Mr. Robinson has received thirteen U. S. patents in communications. He is a member of Sigma Xi and Eta Kappa Nu.



Robert E. Schock (A'30-SM'46) was born on June 17, 1906 in Nebraska. In 1929, he received the B.S. degree in electrical engineering from Colorado A. and M. College. Mr. Schock joined the Radio Corporation of America in July, 1929, as a student engineer and in January, 1930, he became affiliated with the Receiver Research and Development Laboratory of RCA Communications, Inc., New York, N. Y. He has been a member of the Communications Research Section of RCA Laboratories since 1942.



R. E. SCHOCK

York, N. Y. He has been a member of the Communications Research Section of RCA Laboratories since 1942.

John W. Smith (A'45-M'46-SM'49) was born in Duluth, Minn. on February 28, 1918. He received the B.E.E. degree from the University of Minnesota in 1940 and the degree of professional electrical engineer from the same university in June, 1955.



J. W. SMITH

Since June, 1940 he has been associated with Collins Radio Company as a staff engineer, group head, and more recently, as the senior staff member to the assistant director of research and development, specializing in the research and development of vhf scatter systems and single-sideband transmission.

While at Collins Radio, Mr. Smith has also been associated with research and development of high-frequency and broadcast transmitters, frequency control equipment, distance measuring equipment, autopilots, missile guidance, and telemetering.

He has served as the secretary-treasurer, vice-chairman and chairman of the Cedar Rapids Section of the IRE.



Charles L. Spencer (M'54) was born in Terre Haute, Ind., May 3, 1917. He received the B.S. degree from the University of Arkansas in 1940.



C. L. SPENCER

This was followed by five years of military experience in the Army's Armored Force. Some 600 days of this was spent under combat conditions as a communications officer. In 1945 he joined the Communication Branch of the U. S. Naval Research Laboratory where he has designed new communication systems and equipment, instructed military personnel, and helped put into operation these advanced systems of communication. He also serves in the capacity of technical consultant to the Bureau of Ships on matters pertaining to SSB communication equipments.

He is member of RESA and has received the Navy's Distinguished Civilian Service Award.

Donald K. Weaver, Jr. (S'48-A'51) was born in Great Falls, Mont., on July 18, 1924. He attended Stanford University receiving the B.S. degree in 1948, the M.S. degree in 1949 and the degree of Electrical Engineer in 1950. From 1948 to 1950, he was employed as a research assistant in the department of electrical engineering at Stanford University. From 1950 to 1956, Mr. Weaver was a member of the engineering staff at Stanford Research Institute where he held the position of senior research engineer. At present, he is an associate professor of electrical engineering at Montana State College.



D. K. WEAVER, JR.

Mr. Weaver is a member of Tau Beta Pi and Sigma Xi.



Norman H. Young (A'37-SM'45) was born in Philadelphia, Pa., September 10, 1913. He attended Pennsylvania State College, receiving the degree of Bachelor of Science in 1934 and Master of Science in 1935. He joined the Laboratories of the Philco Radio and Television Corporation, working on the development of television transmitting equipment until 1941.



N. H. YOUNG, JR.

In early 1942 he joined the Laboratories of the International Telephone and Telegraph System, and has continued in this organization to the present, where he is now a Division Head in the Air Navigation Laboratory of Federal Telecommunication Laboratories.

His activities have included the design of transmitters for color television, microwave links for multichannel voice communication, pulse modulation systems, and presently the design of communication and air navigation equipment for commercial and military applications.

Mr. Young has served on many committees of the IRE, the NTSC and CCIR. He is the author of numerous papers in the field of radio communication and navigation aids.



IRE News and Radio Notes

IRE FOUNDER A. N. GOLDSMITH WINS SMPTE PROGRESS MEDAL

A. N. Goldsmith, motion picture and television consultant, has been selected by the Society of Motion Picture and Television Engineers as the 1956 recipient of its highest award, the Progress Medal. Dr. Goldsmith received this award during the Society's 80th convention at Los Angeles's Ambassador Hotel, October 9.



A. N. GOLDSMITH

The Progress Medal was established in 1935 to honor outstanding achievement in motion picture and television technology. Dr. Goldsmith was selected as this year's recipient "for his many contributions to the progress of sound motion picture and television engineering, particularly his early recognition of the importance of a tricolor kinescope and his concept of the means for its accomplishment." Dr. Goldsmith holds the patent on the aperture mask phosphor triad color kinescope tube.

Dr. Goldsmith has been active in research since he joined the General Electric Company in 1915. He was director of research of the Marconi Wireless Telegraph Company of America and of the Radio Corporation of America, of which he later became vice-president and general engineer. He presently serves as consultant to such companies as RCA, the National Broadcasting Company, and Eastman Kodak Co.

Dr. Goldsmith has received many honors for his research and inventions, including the Medal of Honor and Founders Award of the IRE, the Modern Pioneer Award, and the Townsend Harris Medal. He is a Fellow of the SMPTE and from 1932 to 1934 he was president of the SMPTE.

A founder, Fellow and Editor Emeritus of the IRE, he was IRE President in 1927. He served as Editor of the IRE for forty-one years and has been a Director since the formation of IRE in 1912.

HANSON ACCEPTS POTTS AWARD

The Audio Engineering Society recently presented its John H. Potts Memorial Award of 1956 to O. B. Hanson, Vice-President of Engineering Services, Radio Corporation of America, in "recognition of his contributions to better broadcasting systems and facilities."

The presentation was made at the annual banquet of the Audio Engineering Society held at the New York Trade Show Building, New York, on September 27.

Mr. Hanson, formerly vice-president and chief engineer of the National Broadcasting Company and a pioneer of nearly thirty-five years in radio and television, is an IRE Fellow. He was an IRE Director from 1938 to 1943.

ARRL AWARDS G. W. BAILEY SINGLE SIDEBAND CERTIFICATE

George W. Bailey, an IRE Fellow and Executive Secretary, whose call letters are W2KH, has been awarded WAS-SSB Certificate #1 for being the first amateur radio operator to present proof of contact by single sideband with all forty-eight states.

Mr. Bailey has long been active in amateur radio and is a former president of the American Radio Relay League and International Amateur Radio Union.

THREE SUBSECTIONS ENTER IRE

The IRE Executive Committee, at its meeting of September 25, approved the establishment of three Subsections. They are as follows: the New Hampshire Subsection of the Boston Section, the Shreveport Subsection of the Dallas Section, and the Panama City Subsection of the Northwest Florida Section.

AIEE MEMBER-FOR-LIFE FUND AWARD GOES TO F. E. TERMAN

The first Member-for-Life Fund Medal of the American Institute of Electrical Engineers was awarded to F. E. Terman, Provost and Dean of the School of Engineering, Stanford University. It was presented October 2, during the AIEE Fall General Meeting at Chicago.



F. E. TERMAN

The medal provided by the Member-for-Life Medal Fund, is to be awarded annually to a teacher of electrical engineering for "excellence in teaching, ability to inspire students to higher achievements, contributions to the teaching of electrical engineering in textbooks and in writings on engineering education, active participation in the work of the profession and educational societies, and contributions to teaching and the profession through research, engineering achievements and technical papers."

Dr. Terman, a native of English, Ind., received a bachelor of arts degree and a degree in electrical engineering from Stanford, and a doctorate in science from Massachusetts Institute of Technology. Dr. Terman joined the staff of Stanford in 1925, where he has been dean of the school of engineering since 1945 and provost since 1955. He has received honorary degrees from Harvard, Syracuse University, and the University of British Columbia.

During World War II, Dr. Terman was on leave of absence to direct the Radio Research Laboratory at Harvard, where countermeasures against enemy radar were being developed.

Dr. Terman is the author of several books, and a Fellow of the IRE and AIEE.

Calendar of Coming Events

- Midwest Symposium on Circuit Theory, Michigan State University, E. Lansing, Mich., Dec. 3-4
- Second Instrumentation Conference & Exhibit, Biltmore Hotel, Atlanta, Ga., Dec. 5-7
- IRE-AIEE-ACM Eastern Joint Computer Conference, Hotel New Yorker, New York, Dec. 10-12
- Winter Meeting of Amer. Nuclear Society, Sheraton-Park Hotel, Washington, D. C., Dec. 10-12
- RETMA Symposium on Applied Reliability, Bovard Hall, Univ. of So. Calif., Los Angeles, Calif., Dec. 19-20
- Symposium on Communication Theory and Antenna Design, Hillel House, Boston Univ., Boston, Mass., Jan. 9-11
- Symposium on Reliability & Quality Control in Elec., Statler Hotel, Wash., D. C., Jan. 14-15, 1957
- Symposium on VLF Waves, Boulder Labs., Boulder, Colo., Jan. 23-25
- Symposium on Microwave Ferrite Devices & Applications, Engrg. Society Auditorium, New York City, Jan. 28-29
- Electronics in Aviation Day, New York City, Jan. 30
- Operations Research Symposium, U. of Pa., Philadelphia Pa., Feb. 7
- PGME Symposium on Recording of Heart Sounds, Univ. of Buffalo Medical School, Buffalo, N. Y., Feb. 14
- Conference on Transistor Circuits, Philadelphia, Pa., Feb. 14-15
- Western Joint Computer Conference, Statler Hotel, Los Angeles, Calif., Feb. 26-28
- National Biophysics Conference, Columbus, Ohio, March 4-6
- EJC Second Annual Nuclear Science and Engineering Congress, Philadelphia, Pa., March 11-14
- IRE National Convention, Waldorf-Astoria and New York Coliseum, New York City, March 18-21
- Industrial Electronics Educational Conference, Ill., Inst. of Tech., Chicago, Ill., April 9-10
- Ninth Southwestern Regional Conference & Show, Shamrock-Hilton Hotel, Houston, Tex., April 11-13
- National Simulation Conference, Shamrock-Hilton Hotel, Houston, Tex., April 11-13
- PGTRC National Telemetering Symposium, Philadelphia, Pa., April 14-16
- Symposium on Role of Solid State Devices in Electric Circuits Engrg. Society Bldg., New York City, April 23-25
- Region Seven Technical Conference & Trade Show, San Diego, Calif., April 24-26

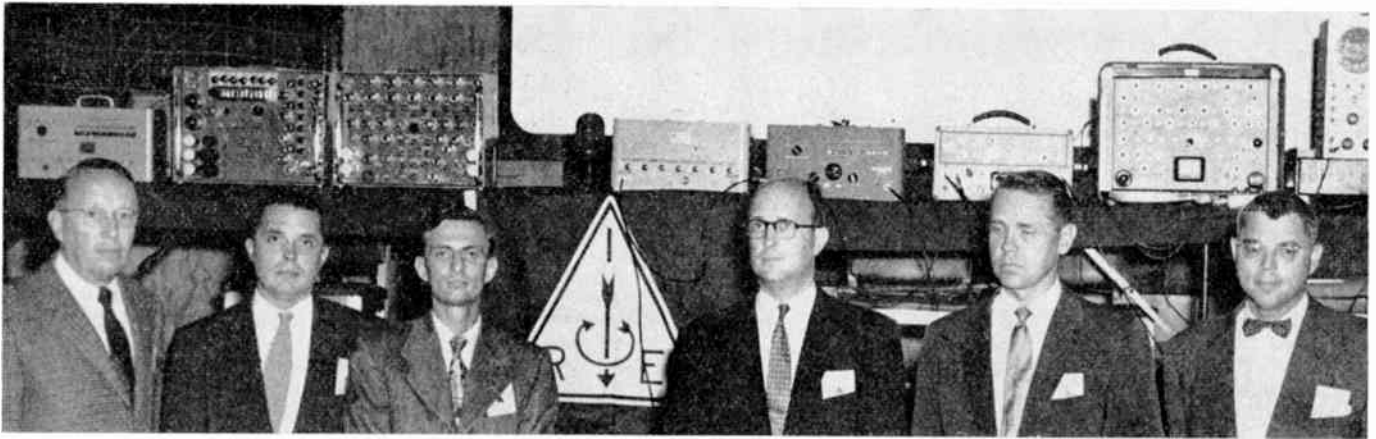

The first afternoon session of the recent PGBTS Sixth Fall Symposium in Pittsburgh featured papers by (left to right): A. E. Cullum, Jr., moderator; R. S. Kirby,

National Bureau of Standards; Robert Crotinger, WHIO-TV; C. H. Evans, Eastman Kodak; R. Snyder, Ampex; and J. R. Popkin-Curman, Telechrome, Inc.

ACTIVITIES OF IRE SECTIONS AND PROFESSIONAL GROUPS



Dignitaries at the 1956 WESCON included (left to right): J. S. McCullough, San Francisco IRE Section Chairman; V. J. Braun, Los Angeles IRE Section Chairman; E. P. Gertsch, WESCON Show Vice-Chairman; B. S. Angwin, WESCON Convention Vice-Chairman; C. F. Wolcott, WESCON Board Chairman; and T. P. Walker, WCEMA Pres. 1956 WESCON was held at Los Angeles; San Francisco will be 1957 host.



T. L. Martin, Jr. (left), University of Arizona, was presented with the Region Seven Electronic Achievement Award by IRE President A. V. Loughren at WESCON. WESCON exhibited a TV-telephone and solar energy devices.



J. S. Ryder, former IRE President, congratulates W. B. Kouwenhoven (center), Johns Hopkins University, and J. H. Dellinger (right), consultant, upon their induction into Eta Kappa Nu. W. H. Huggins and David Middleton also received the first annual National Electronics Conference papers award for their paper, "A Comparison of the Phase and Amplitude Principles in Signal Detection," given at the 1955 NEC.



The Alamogordo-Holloman Section recently honored 1956 IRE President A. V. Loughren at a dinner. Seated left to right, starting at lower left are: John Rolland, Mayor of Alamogordo; Mrs. Davis; Mr. Loughren; Lt. O. W. Fix, Section Chairman; Brig. Gen. L. I. Davis, Commanding General of Holloman Air Development Center; Mrs. Loughren; B. Holder, Editor of the Alamogordo Daily News; Mrs. Rolland; O. A. Steele, Section Vice-Chairman; Mrs. Hall; Mrs. Steele; Mrs. Holder; Lt. T. F. Hall, Section Secretary; and Mrs. Fix.

TRANSACTIONS OF THE IRE PROFESSIONAL GROUPS

The following issues of TRANSACTIONS are available from the Institute of Radio Engineers, Inc., 1 East 79 Street, New York 21, New York, at the prices listed below:

Sponsoring Group	Publications	Group Members	IRE Members	Non-Members*	
Aeronautical and Navigational Electronics	PGAE-5 (6 pages)	\$.30	\$.45	\$.90	
	PGAE-6 (10 pages)	.30	.45	.90	
	PGAE-8, June 1953 (23 pages)	.65	.95	1.95	
	PGAE-9, September 1953 (27 pages)	.70	1.05	2.10	
	Vol. ANE-1, No. 2, June 1954 (22 pages)	.95	1.40	2.85	
	Vol. ANE-1, No. 3, September 1954 (27 pages)	1.00	1.50	3.00	
	Vol. ANE-1, No. 4, December 1954 (27 pages)	1.00	1.50	3.00	
	Vol. ANE-2, No. 1, March 1955 (41 pages)	1.40	2.10	4.20	
	Vol. ANE-2, No. 2, June 1955 (49 pages)	1.55	2.30	4.65	
	Vol. ANE-2, No. 3, September 1955 (27 pages)	.95	1.45	2.85	
	Vol. ANE-2, No. 4, December 1955 (47 pages)	1.40	2.10	4.20	
	Vol. ANE-3, No. 1, March 1956 (42 pages)	1.30	1.95	3.90	
	Vol. ANE-3, No. 2, June 1956 (54 pages)	1.40	2.10	4.20	
	Antennas and Propagation	PGAP-4 (136 pages)	2.20	3.30	6.60
Vol. AP-1, No. 1, July 1953 (30 pages)		1.20	1.80	3.60	
Vol. AP-1, No. 2, October 1953 (31 pages)		1.20	1.80	3.60	
Vol. AP-2, No. 1, January 1954 (39 pages)		1.35	2.00	4.05	
Vol. AP-2, No. 2, April 1954 (41 pages)		2.00	3.00	6.00	
Vol. AP-2, No. 3, July 1954 (36 pages)		1.50	2.25	4.50	
Vol. AP-3, No. 4, October 1954 (36 pages)		1.50	2.25	4.50	
Vol. AP-3, No. 1, January 1955 (43 pages)		1.60	2.40	4.80	
Vol. AP-3, No. 2, April 1955 (47 pages)		1.60	2.40	4.80	
Vol. AP-3, No. 3, July 1955 (66 pages)		2.05	3.10	6.15	
Vol. AP-4, No. 1, January 1956 (100 pages)		2.65	3.95	7.95	
Vol. AP-4, No. 2, April 1956 (83 pages)		2.20	3.30	6.60	
Audio		PGA-7 (47 pages)	.90	1.35	2.70
		PGA-10, November-December 1952 (27 pages)	.70	1.05	2.10
	Vol. AU-1, No. 2, March-April 1953 (34 pages)	.80	1.20	2.40	
	Vol. AU-1, No. 6, November-December 1953 (27 pages)	.90	1.35	2.70	
	Vol. AU-2, No. 1, January-February 1954 (38 pages)	1.20	1.80	3.60	
	Vol. AU-2, No. 2, March-April 1954 (31 pages)	.95	1.40	2.85	
	Vol. AU-2, No. 3, May-June 1954 (27 pages)	.95	1.40	2.85	
	Vol. AU-2, No. 4, July-August 1954 (27 pages)	.95	1.40	2.85	
	Vol. AU-2, No. 5, September-October 1954 (22 pages)	.95	1.40	2.85	
	Vol. AU-2, No. 6, November-December 1954 (24 pages)	.80	1.20	2.40	
	Vol. AU-3, No. 1, January-February 1955 (20 pages)	.60	.90	1.80	
	Vol. AU-3, No. 2, March-April 1955 (32 pages)	.95	1.40	2.85	
	Vol. AU-3, No. 3, May-June 1955 (30 pages)	.85	1.25	2.55	
	Vol. AU-3, No. 4, July-August 1955 (46 pages)	1.15	1.75	3.45	
	Vol. AU-3, No. 5, September-October 1955 (33 pages)	.90	1.35	2.70	
	Vol. AU-3, No. 6, November-December 1955 (36 pages)	.95	1.40	2.85	
	Vol. AU-4, No. 1, January-February 1956 (27 pages)	.75	1.10	2.25	
	Vol. AU-4, No. 2, March-April 1956 (17 pages)	.55	.80	1.65	
	Vol. AU-4, No. 3, May-June 1956 (34 pages)	.80	1.20	2.40	
Vol. AU-4, No. 4, July-August 1956 (23 pages)	.60	.90	1.80		
Automatic Control	PGAC-1: May 1956 (97 pages)	1.95	2.90	5.85	
Broadcast Transmission Systems	PGBTS-2: December 1955 (54 pages)	1.20	1.80	3.60	
	PGBTS-4: March 1956 (21 pages)	.75	1.10	2.25	
Broadcast and Television Receivers	PGBTR-1: (12 pages)	.50	.75	1.50	
	PGBTR-5: January 1954 (96 pages)	1.80	2.70	5.40	
	PGBTR-7: July 1954 (58 pages)	1.15	1.70	3.45	
	PGBTR-8: October 1954 (20 pages)	.90	1.35	2.70	
	Vol. BTR-1, No. 1, January 1955 (68 pages)	1.25	1.85	3.75	
	Vol. BTR-1, No. 2, April 1955 (40 pages)	.95	1.45	2.85	
	Vol. BTR-1, No. 3, July 1955 (51 pages)	.95	1.45	2.85	
	Vol. BTR-1, No. 4, October 1955 (19 pages)	.95	1.40	2.85	
	Vol. BTR-1, No. 1, April 1956 (30 pages)	1.10	1.65	3.30	
	Vol. BTR-2, No. 2, July 1956 (21 pages)	.85	1.25	2.55	

* Public libraries, colleges and subscription agencies may purchase at IRE member rate.
(Continued on page 1890)

CIRCUIT THEORY TRANSACTIONS WILL COVER ACTIVE NETWORKS

The September, 1957 issue of the IRE TRANSACTIONS on Circuit Theory will emphasize the subject of active networks. For the purposes of this issue, the term *active networks* will be interpreted to include not only those networks in which the terminal characteristics actually place the activity in evidence, but also passive structures in which active elements (such as tubes or transistors) play a key role in the realization of the specified characteristics.

It is desired to direct emphasis toward: (1) basic properties of active networks; (2) analysis techniques to evidence basic characteristics of active networks; (3) design techniques; and (4) synthesis techniques. Here (1) includes such considerations as realizability criteria with specified types of stability and representation in terms of gyrators and negative resistances, or other basic elements. (2) includes general methods of analysis, interpretations and manipulations of such descriptive characterizations as the sensitivity function, and techniques for stability analysis of multi-loop systems. (3) includes techniques for the logical design of tube and transistor circuits based on appropriate incremental models, and the significance of these models in terms of realizable network characteristics. Finally, (4) embraces attempts to extend passive-network-theory concepts and techniques to the synthesis of active networks, synthesis techniques based on block-diagram or signal-flow-diagram manipulations, etc.

Primary emphasis will be placed on the properties and design of active networks which are linear and time-invariant, or which can be analyzed or designed by quasi-linearization methods.

Information concerning possible contributions for the issue should be forwarded to the guest editor, J. G. Truxal, Polytechnic Institute of Brooklyn, 55 Johnson Street, Brooklyn 1, New York. Although the deadline for the acceptance of papers is May 15, 1957, prospective authors are urged to contact the guest editor at an earlier date so as to assist in the planning of the issue.

EXPANDED ASESQA QUALIFICATION TESTING PROGRAM IS ANNOUNCED

To supplement government testing laboratories, the Armed Services Electro-Standards Agency (ASESA), Fort Monmouth, N. J., recently inaugurated a program providing for qualification testing of electronic and electric parts in commercial testing laboratories and in plants of parts manufacturers. This program has been so effective that its scope is being enlarged to permit qualification testing in the plants of electronic-equipment manufacturers. Many equipment manufacturers have facilities for qualification testing in accordance with the ASESA specifications already, and frequently perform such tests.

Equipment manufacturers who feel that their facilities are adequate for such testing and who desire additional information on this program, are encouraged to contact the Director, Armed Services Electro-Standards Agency (ASESA), Fort Monmouth, N. J.

RUSSIAN SCIENTISTS SPEAK AT INFORMATION THEORY MEETING

The 1956 Information Theory Symposium was held at the Kresge Auditorium of the Massachusetts Institute of Technology on September 10-12. The meeting, like the preceding symposium in 1954, was organized by the IRE Professional Group on Information Theory and the Research Laboratory of Electronics of M.I.T., and was co-sponsored by the Office of Naval Research, the Air Research and Development Command, the Signal Corps Engineering Laboratories and the International Scientific Radio Union (URSI). About three hundred attended the meeting, including two scientists from France, two from Germany and three from the USSR.

One highlight of the meeting was a banquet for over two hundred at the M.I.T. Faculty Club, with an after-dinner speech by Professor Norbert Wiener on information theory and physics. Another feature of the symposium was the presentation of two papers not originally on the program: one by A. N. Kolmogorov, one of the greatest living Russian mathematicians; and one by V. I. Siforov, the chairman of the Russian equivalent of the IRE. These papers arrived Sunday, September 9, and were translated by M. D. Friedman and duplicated by Electronics Translations so that they could be distributed to the participants the morning of Tuesday, September 11.

The nineteen scheduled papers have already appeared in a preprint issue of the PGIT TRANSACTIONS. The two Russian papers will appear in a forthcoming issue of TRANSACTIONS.

OBITUARIES

Bruce Bailey (A'46-M'55) recently died as the result of an automobile accident at the age of 29. He was a partner in the firm of B. and B. Engineering Associates, Concord, N. H. at the time of his death.

His studies at the Massachusetts Institute of Technology, interrupted briefly by service in the U. S. Army, culminated in a bachelor's degree in communications engineering in 1949. After summer employment as a junior engineer in the research division of the National Union Radio Corporation, Mr. Bailey turned to study again, this time at Cornell University Graduate School for a year. Up until the time of his death he had continued with graduate studies at Columbia and M.I.T. Following 1950 he worked for A. B. Dumont Laboratories, Sonotone Corporation of Elmsford, N. Y., and Northeast Electronics Corporation of Concord, N. H. before he organized his own firm, B. and B. Engineering Associates. His firm developed the transistor thermometer and other electronic products.

Mr. Bailey was a member of several IRE Professional Groups, and a registered professional engineer of the State of New Hampshire.



F. H. Trimmer (M'54), who helped establish the Voice of America transmitters, died recently. He had resided in Arlington, Va.

TRANSACTIONS OF THE IRE PROFESSIONAL GROUPS (Continued)

Sponsoring Group	Publications	Group Mem- bers	IRE Mem- bers	Non- Mem- bers*
Circuit Theory	Vol. CT-1, No. 4, December 1954 (42 pages)	\$1.00	\$1.50	\$3.00
	Vol. CT-2, No. 1, March 1955 (106 pages)	2.70	4.05	8.10
	Vol. CT-2, No. 3, September 1955 (62 pages)	1.40	2.10	4.20
	Vol. CT-2, No. 4, December 1955 (88 pages)	1.85	2.75	5.55
	Vol. CT-3, No. 2, June 1956 (74 pages)	1.60	2.40	4.80
Communications Systems	Vol. CS-2, No. 1, January 1954 (83 pages)	1.65	2.50	4.95
	Vol. CS-2, No. 2, July 1954 (132 pages)	2.25	3.35	6.75
	Vol. CS-2, No. 3, November 1954 (181 pages)	3.00	4.50	9.00
	Vol. CS-3, No. 1, March 1955 (72 pages)	1.00	1.50	3.00
	Vol. CS-4, No. 1, March 1956 (122 pages)	2.15	3.20	6.45
	Vol. CS-4, No. 2, May 1956 (182 pages)	2.90	4.35	8.70
Component Parts	PGCP-1: March 1954 (46 pages)	1.20	1.80	3.60
	PGCP-2: September 1954 (119 pages)	2.25	3.35	6.75
	PGCP-3: April 1955 (44 pages)	1.00	1.50	3.00
	PGCP-4: November 1955 (92 pages)	2.00	3.00	6.00
	Vol. CP-3, No. 1, March 1956 (35 pages)	1.70	2.55	5.10
Electronic Computers	Vol. EC-3, No. 3, September 1954 (54 pages)	1.80	2.70	5.40
	Vol. EC-4, No. 3, September 1955 (45 pages)	1.00	1.50	3.00
	Vol. EC-4, No. 4, December 1955 (40 pages)	.90	1.35	2.70
	Vol. EC-5, No. 2, June 1956 (46 pages)	.90	1.35	2.70
	Electron Devices	PGED-4: December 1953 (62 pages)	1.30	1.95
Vol. ED-1, No. 2, April 1954 (75 pages)		1.40	2.10	4.20
Vol. ED-1, No. 3, August 1954 (77 pages)		1.40	2.10	4.20
Vol. ED-1, No. 4, December 1954 (280 pages)		3.20	4.80	9.60
Vol. ED-2, No. 2, April 1955 (53 pages)		2.10	3.15	6.30
Vol. ED-2, No. 3, July 1955 (27 pages)		1.10	1.65	3.30
Vol. ED-2, No. 4, October 1955 (42 pages)		1.50	2.25	4.50
Vol. ED-3, No. 1, January 1956 (74 pages)		2.10	3.15	6.30
Vol. ED-3, No. 2, April 1956 (40 pages)		1.10	1.65	3.30
Vol. ED-3, No. 3, July 1956 (45 pages)		1.35	2.00	4.05
Engineering Management	PGEM-1: February 1954 (55 pages)	1.15	1.70	3.45
	Vol. EM-3, No. 1, January 1956 (29 pages)	.95	1.40	2.85
	Vol. EM-3, No. 2, April 1956 (15 pages)	.55	.80	1.65
	Vol. EM-3, No. 3, July 1956 (37 pages)	.90	1.35	2.70
Industrial Electronics	PGIE-1: August 1953 (40 pages)	1.00	1.50	3.00
	PGIE-2: March 1955 (81 pages)	1.90	2.85	5.70
	PGIE-3: March 1956 (110 pages)	1.70	2.55	5.10
Information Theory	PGIT-3: March 1954 (159 pages)	2.60	3.90	7.80
	PGIT-4: September 1954 (234 pages)	3.35	5.00	10.00
	Vol. IT-1, No. 1, March 1955 (76 pages)	2.40	3.60	7.20
	Vol. IT-1, No. 2, September 1955 (50 pages)	1.90	2.85	5.70
	Vol. IT-1, No. 3, December 1955 (44 pages)	1.55	2.30	4.65
	Vol. IT-2, No. 1, March 1956 (45 pages)	1.60	2.40	4.80
Instrumentation	PGI-3: April 1954 (55 pages)	1.05	1.55	3.15
	PGI-4: October 1955 (182 pages)	2.70	4.05	8.10
Medical Electronics	PGME-2: October 1955 (39 pages)	.85	1.25	2.55
	PGME-3: November 1955 (55 pages)	1.10	1.65	3.30
	PGME-4: February 1956 (51 pages)	1.95	2.90	5.85
	PGME-5: July 1956 (62 pages)	1.75	2.60	5.25
	Microwave Theory and Techniques	Vol. MTT-2, No. 3, September 1954 (54 pages)	1.10	1.65
Vol. MTT-3, No. 1, January 1955 (47 pages)		1.50	2.25	4.50
Vol. MTT-3, No. 4, July 1955 (54 pages)		1.60	2.40	4.80
Vol. MTT-3, No. 5, October 1955 (59 pages)		1.70	2.55	5.10
Vol. MTT-3, No. 6, December 1955 (64 pages)		1.75	2.60	5.25
Vol. MTT-4, No. 1, January 1956 (63 pages)		1.65	2.45	4.95
Vol. MTT-4, No. 2, April 1956 (69 pages)		1.70	2.55	5.10
Nuclear Science	Vol. NS-1, No. 1, September 1954 (42 pages)	.70	1.00	2.00
	Vol. NS-2, No. 1, June 1955 (15 pages)	.55	.85	1.65
	Vol. NS-3, No. 1, February 1956 (40 pages)	.90	1.35	2.70
	Vol. NS-3, No. 2, March 1956 (31 pages)	1.40	2.10	4.20
	Vol. NS-3, No. 3, June 1956 (24 pages)	1.00	1.50	3.00
	Production Techniques	PGPT-1: September 1956 (57 pages)	1.20	1.80

* Public libraries, colleges and subscription agencies may purchase at IRE member rate.
(Continued on page 1891)

TRANSACTIONS OF THE IRE PROFESSIONAL GROUPS (Continued)

Sponsoring Group	Publications	Group Mem- bers	IRE Mem- bers	Non- Mem- bers*
Reliability and Quality Control	PGQC-2: March 1953 (51 pages)	\$1.30	\$1.95	\$3.90
	PGQC-3: February 1954 (39 pages)	1.15	1.70	3.45
	PGQC-4: December 1954 (56 pages)	1.20	1.80	3.60
	PGRQC-5: April 1955 (56 pages)	1.15	1.75	3.45
	PGRQC-6: February 1956 (66 pages)	1.50	2.25	4.50
	PGRQC-7: April 1956 (52 pages)	1.10	1.65	3.30
	PGRQC-8: September 1956 (58 pages)	1.10	1.65	3.30
	Telemetry and Remote Control	PGRTRC-1: August 1954 (16 pages)	.85	1.25
PGRTRC-2: November 1954 (24 pages)		.95	1.40	2.85
Vol. TRC-1, No. 1, February 1955 (24 pages)		.95	1.40	2.85
Vol. TRC-1, No. 2, May 1955 (24 pages)		.95	1.40	2.85
Vol. TRC-1, No. 3, August 1955 (12 pages)		.70	1.05	2.10
Vol. TRC-2, No. 1, March 1956 (22 pages)		1.00	1.50	3.00
Ultrasonics Engineering	PGUE-1: June 1954 (62 pages)	1.55	2.30	4.65
	PGUE-3: May 1955 (70 pages)	1.45	2.20	4.35
	PGUE-4: August 1956 (75 pages)	1.50	2.25	4.50
Vehicular Communications	PGVC-4: June 1954 (98 pages)	2.40	3.60	7.20
	PGVC-5: June 1955 (76 pages)	1.50	2.25	4.50
	PGVC-6: July 1956 (82 pages)	1.55	2.30	4.65

* Public libraries, colleges and subscription agencies may purchase at IRE member rate.

Mr. Trimmer joined the Office of War Information in 1942 and aided in the construction of twenty-two large radio transmitters for the VOA in the United States and several overseas. His work for VOA included development of the five most powerful short wave radio transmitters in the world.

Mr. Trimmer, who was telecommunications adviser to the United States Information Agency, was a native of Lancaster, Ohio. He graduated with an electrical engineering degree from Ohio State University in 1933, and the Harvard Business School in 1938.

He was a cost accountant for the Anchor-Hocking Glass Corp. from 1939 to 1941 and operations officer for the Office of Emergency Management from 1941 to 1942.

In 1942 Mr. Trimmer was employed by the Office of War Information. He transferred to the State Department in 1945 as assistant to the chief of communications facilities. He was named chief of the facilities planning branch in 1946. He was vice-chairman of the United States delegations to International Communication Conferences in Mexico City in 1949 and in Rapallo, Italy, in 1950.

TECHNICAL COMMITTEE NOTES

The Audio Techniques Committee met at IRE Headquarters on September 25 with

Chairman Iden Kerney presiding. R. E. Yaeger submitted his resignation as Chairman of Subcommittee 3.1 on Audio Definitions, and D. S. Dewire was appointed as his successor. The major portion of the meeting was devoted to the review of the Proposed Standard on Audio Definitions.

Chairman P. A. Redhead presided at a meeting of the Electron Tubes Committee held at IRE Headquarters on October 10. It was reported that Rolf Peter has accepted the chairmanship of the 1957 Electron Tube Research Conference. The committee discussed, amended and unanimously approved the following sections of the Proposed Standard on Methods of Test: Phase of Frequency Sink Measurements, Methods of Measurement of Frequency, Methods of Power Measurement, and Method of Measurement of Local Oscillator Noise.

The Facsimile Committee held a meeting at the Times Building on September 14 with Chairman K. R. McConnell presiding. The entire meeting was devoted to preliminary work on the Proposed Facsimile Test Standards.

Chairman J. E. Eiselein presided at a meeting of the Industrial Electronics Committee held at IRE Headquarters on September 12. A suggestion that "covat" be standardized as the name of a continuously variable autotransformer was discussed and it was decided that there is no basic need for it. It was reported that E. A. Keller and R. D. Chipp have been appointed to the committee.

Mr. Eiselein announced that there will be an education conference on Industrial Electronics at the Illinois Institute of Technology. Program and dates will be revealed later.

The committee reviewed a list of definitions of terms submitted by Subcommittee 10.1 on Definitions.

The Information Theory and Modulation Systems Committee met at IRE Headquarters on September 28 with Chairman J. G. Kreer presiding. The entire meeting was devoted to discussion of the Proposed Definitions of Terms Standard now in preparation in the committee.

Chairman R. M. Showers of the Radio Frequency Interference Committee and Chairman D. E. Harnett of the Radio Receivers Committee presided at a joint meeting of the two committees held at IRE Headquarters on October 10. The purpose of this meeting was to review the International Electrotechnical Commission document, "Recommended Methods of Radiation Measurements on -Receivers for Amplitude Modulation Broadcast Transmissions, -Receivers for Frequency Modulation Broadcast Transmissions, -Receivers for Television Broadcast Transmission." Earl Anderson, former U. S. delegate to IEC Committee 12 on Radio Communication, was present at this meeting, and advised the committee of the preliminary work on which this new document was based. After considerable discussion it was decided that a task group would be formed with J. A. Hansen as chairman to prepare comments on this document for transmittal to the IEC.

The Radio Frequency Interference Committee held a meeting at IRE Headquarters on October 10 with Chairman R. M. Showers presiding.

M. S. Corrington, Chairman of Subcommittee 27.1 on Basic Measurements, distributed for the information of the committee members the following reports prepared by his subcommittee: "Radio Frequency Absorbers for Frequencies above 50 MC," and "Baluns for VHF and UHF Measurements."

The committee reviewed and discussed the recent FCC ruling on community antennas, amendment No. 15-3. (FCC 56-691, Docket 9288.)

M. W. Baldwin presided at a meeting of the Standards Committee on October 11 at IRE Headquarters. The Proposed Standard on Electron Tubes: Camera Tube and Phototube Definitions was discussed, amended, and unanimously approved on motion by P. A. Redhead and seconded by J. G. Kreer.

The Proposed Standard on Piezoelectric Crystals: The Piezoelectric Vibrator: Definitions and Methods of Measurement was discussed and amended, and will be returned for final approval at the next meeting.

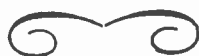

Books

Science and Information Theory by Leon Brillouin

Published (1956) by Academic Press Inc., 111 Fifth Ave., N. Y. 3, N. Y. 301 pages+18 index pages +xvii pages. Illus. 9½×6½. \$6.80.

This book is written by an adjunct professor of physics at Columbia University and presents the subject of information theory from a physicist's point of view. This influence is reflected in the chapter headings which include such topics as "Summary of Thermodynamics" (Chapter 9), "Maxwell's Demon and the Negentropy Principle of Information" (Chapter 13), and "Information Theory, the Uncertainty Principle, and Physical Limits of Observation" (Chapter 16). This does not mean to say the communications aspects of information theory are slighted. On the contrary, there are several chapters on various aspects of coding, a chapter on the English language, and one on Fourier analysis and sampling procedure. Even in these chapters, however, it is apparent that the author's background is in physics rather than in mathematics or engineering.

There is no question that a better understanding of the physical principles of thermodynamics and quantum theory including the uncertainty principle would be of great value to most engineers. It is also believed that the outstanding work of such people as Wiener,^{1,2} Shannon,³ and Woodward⁴ should be of value to physicists. The reviewer would therefore welcome a good book which bridged the gap between information theory and physics. However, the reviewer does not feel he can recommend this book for this purpose. It may prove stimulating and provocative to advanced workers in the field but it contains so many statements that are either erroneous or highly ambiguous that unless the reader is already well grounded in the subject, he is likely to be led astray. The following examples will serve to illustrate what the reviewer means.

On page 148, speaking of a circuit containing a resistor, an inductor, and a rectifier, all in series, he says "The rectifier cannot rectify the random currents induced by the emf's because a rectified current could be used to do work in contradiction to the second law of thermodynamics. . . . There may, however, be a rectified voltage, and this is what we wish to compute." Nowhere in this section does he explain why, if a rectified current is a violation of the second principle, a rectified voltage is not. Neither does he explain how a rectified voltage can appear without a rectified current.

On page 207, he discusses a waveguide having "thickness d equal to Δx . This waveguide has a low-frequency cut-off corre-

sponding to $\lambda/2=d$ and can only transmit frequencies above this limit." He neglects to mention that in common microwave practice, the thickness of the waveguide is usually substantially less than $\lambda/2$ and that the cut-off frequency is normally a function of the width. Partly as a result of this mistake, he states on page 235, "In order to measure a length L with an error ΔL , we must use radiation of wavelength $\lambda \leq 2\Delta L$." Apparently, he is unaware of cw phase comparison navigation systems such as Decca which far exceed the accuracies which this statement implies.

On page 114 he states "High grade energy is mechanical or electric energy. Medium grade energy is chemical energy. Low grade energy is heat. . . . Grade of energy can be exactly defined as corresponding to negative entropy ($-s$)." He does not explain, however, how the concept of thermodynamic entropy defined in terms of heat only can be used to determine the relative grade of, say, electrical energy and chemical energy. Neither does he explain how, if electrical energy and chemical energy are of different grade, we can have a reversible electrochemical reaction as in a storage battery.

The rather extensive discussion of the uncertainty principle was apparently written without the author having read Woodward's excellent book. This is unfortunate since the somewhat cumbersome treatment could have been greatly improved and placed on a much firmer foundation had he used Woodward's techniques. Another criticism that might be made is that the author apparently has no clear conception of the difference between accuracy and resolution. For example, a fire control radar having a beamwidth of 3 degrees may be able to track targets to an accuracy of 1/10 of a degree. If we were to accept the discussion on page 207, however, we would call this radar accurate to 3 degrees.

Despite the above criticisms, the author does present some provocative and challenging thoughts and it is to be hoped that someday we will have a more careful and precise treatment of these same ideas.

W. D. WHITE
Airborne Instruments Laboratory, Inc.
Mineola, N. Y.

Elements of Pulse Circuits by F. J. M. Farley

Published (1956) by John Wiley & Sons, Inc., 440 Fourth Ave., N. Y. 16, N. Y. 138 pages+3 index pages +viii pages. 74 figures. 6½×4½. \$2.00.

This monograph on pulse circuits is intended for the physicist and research worker who desire a qualitative understanding of basic pulse circuitry. As a compendium of commonly used pulse circuits it may serve as a guide to further study for the tyro in pulse circuitry. It cannot be considered as a pulse circuit design handbook. The circuits are described in a qualitative fashion, with some practical applications of the circuits shown, but little quantitative data on the operation provided. With the increased use of radar-type circuitry in commercial equipment, the technician faced with servicing

this equipment may find this book to be on an appropriate level to satisfy his need of an elementary explanation of circuit operation.

The book opens with a consideration of square waves and sawtooth waves. After developing the concept of integration and differentiation by RC circuits, the effect of these circuits on square and sawtooth waves is analyzed physically. Throughout the remainder of the book, loss of highs or lows is considered a process of integration or differentiation. The use of diodes for clipping and clamping is explained, but no mention is made of the common and useful driven diode clamp. The gain expression gR is given for a pentode without mentioning that it is an approximation of the exact equation, though sufficiently accurate for all wideband amplifiers. Use of g for tube transconductance (gm) and R_0 for plate resistance (r_p) may be a little confusing to the American reader.

The basic multivibrator circuits are covered, but although the phantatron circuit is mentioned no explanation or circuit diagram of this important family of timing circuits is included. The distributed amplifier is explained as an extension of series and shunt peaking to a single stage and removes some of the mystery often associated with distributed amplifiers.

The concluding chapter on applications deals almost exclusively with time base generators and counter type circuitry. Computer circuitry is notably missing. Also missing is any reference to functionally equivalent transistor circuits, a serious omission for any up-to-date book.

Conclusion: a good book for the technician and beginner, definitely not for electronic engineers.

G. B. HERZOG
RCA Lab.
Princeton, N. J.

Principles of Color Television by the Hazeltine Laboratories Staff and ed. by Knox McIlwain and C. E. Dean

Published (1956) by John Wiley & Sons, Inc., 440 Fourth Ave., N. Y. 16, N. Y. 547 pages+32 index pages+13 pages of appendix+xvii pages. Illus. 9½×6½. \$13.00.

The book is a substantial volume, including a total of eighteen chapters. Starting with a discussion of basic principles of light and photometry, the book proceeds logically to a thorough treatise on color perception and colorimetry. This material occupies the first five chapters. The relation between the colorimetric information to be transmitted, the characteristics of the eye, and the available television bandwidth is discussed in three further chapters. Thus, the first eight chapters are devoted to the basic discussion of the fundamentals of system theory and design.

The next three chapters consider production of the composite color signal, synchronization (both deflection and color reference), and gamma correction. This is followed by a chapter on the FCC color television standards—which might with advantage have been placed earlier in the book.

¹ Norbert Wiener, "The Extrapolation, Interpolation, and Smoothing of Stationary Time Series with Engineering Applications," Technology Press of the Massachusetts Institute of Technology, Cambridge, Mass.; 1949.

² Norbert Wiener, "Cybernetics," Technology Press of the Massachusetts Institute of Technology, Cambridge, Mass.; 1948.

³ C. E. Shannon, "A Mathematical Theory of Communication," *Bell System Technical Journal*, Vol. 27, No. 3; July, 1948.

⁴ P. M. Woodward, "Probability and Information Theory with Application to Radar," McGraw-Hill, New York; 1953.

There is a chapter on transmitting equipment, and one on color television receivers. This latter is followed by two chapters on decoders for three gun and single gun displays respectively. The book concludes with a chapter on test and measuring methods, a glossary of color television terms, and three appendices including one on principal formulas for-components of the color signal.

The book is definitely a most valuable addition to the literature. It is written by engineers for engineers, and not only has the advantage of capable editing by Mr. McIlwain and Dr. Dean, but also that of contributions by authors who cover a wide field of experience in television engineering. The result is a volume which speaks with authority. In short, this reviewer liked the book and heartily recommends it.

F. J. BINGLEY
Philco Corporation
Philadelphia, Pa.

Vierpoltheorie und Frequenztransformation by Torbern Laurent

Published (1956) by Springer-Verlag OHG., Berlin, Germany. 291 pages+3 index pages+5 pages of bibliography+xii pages. 176 figures. 9 1/2 x 6 1/2. 34.50 DM.

During the past years many different methods have been developed for the mathematical treatment of the behavior of electrical networks. In Torbern Laurent's very interesting book these problems are described and solved with the help of the four-pole-theory together with the special method of frequency-transformation developed by the author for the study and verification of impedance networks. The book starts with necessary symbols and mathematical methods (Chapter 1, p. 1-45) and the principles of the well-known four-pole-theory (Chapter 2, p. 46-95). The third chapter gives the fundamental principles of frequency-transformation. In the next chapter methods for using it are discussed. Chapter 4 (p. 145-190) covers filter-networks; Chapter 5 (p. 191-236), homogeneous cables and lines; Chapter 6 (p. 237-263), amplifiers; Chapter 7 (p. 264-277), inhomogeneous cables and lines; and Chapter 8 (p. 278-292), problems of electromagnetic radiation.

By the author's method of frequency-transformation either the angular frequency ω in each impedance-expression of any impedance-element of the network is substituted for by a new frequency-function $W(\omega)$ (frequency-substitution), or each impedance

expression is multiplied with a dimensionless factor $\psi(\omega)$ (impedance-multiplication). Important to note is that, here by the frequency-substitution all expressions defining the behavior of the network are transposed by the same frequency-substitution. All the expressions which are functions of a ratio between currents or voltages as the network-damping are not changed by the impedance-multiplication on the other side.

Therefore, the frequency-transformation is a universal method for studying the frequency-behavior of given networks for calculating the parameters of an impedance-network with given frequency-functions.

The author, who is professor of telegraphy and telephony at the Institute of Technology, Stockholm, Sweden, has discussed these methods and their handling in a very clear and understandable manner. To everyone—scientist, engineer or student—interested in network-synthesis, therefore, the book may be well recommended. It will bring to the reader many interesting principles and possibilities for handling problems.

H. ROTHE
Institute of Technology
Karlsruhe, W. Germany

Mathematics for Electronics with Applications by H. M. Nodelman and F. W. Smith

Published (1956) by McGraw-Hill Book Co., Inc., 330 W. 42 St., N. Y. 36, N. Y. 360 pages+14 index pages+14 appendix pages+viii pages. Illus. 9 1/2 x 6 1/2. \$7.00.

This book is "intended for those readers who have a background of elementary calculus, physics, and elementary electric network theory, and is designed for use in industry and undergraduate technical institutes . . ." such as, for example, the RCA Institute in which Mr. Nodelman is head of the mathematics and physics department. It presents the mathematical manipulations required for the solution of a large number of problems arising in electrical engineering, particularly electronics. The range of topics includes: dimensional analysis, determinants and matrices, (power) series, differential equations including solution via the Laplace transform, and boolean algebra, in that order.

The format, attractive in view of the book's expressed intent, is to motivate a new subject by citing an application or working out a simple example with tools already available. Then the required results are stated and explained, a (numerical) example taking the place of proof. The book contains many convenient tables of formulas, numeri-

cal constants, and e.g., transient response curves, most of which have been adapted from the literature.

However, several serious defects in the text were noted. Treatment of Fourier series is nearly omitted regardless of the high rank (7th) (Laplace transforms rank 9th) the authors assign it in their "Study Plan in Mathematics for Specialists in Electronics"; the general expansion formulas are not given. The plethora of references to the mathematical and technical literature have not been graded in any way. The usefulness of most of these to a student at the level for which this book is written is highly questionable. Then the "extension" of Theorem 5-7B Eq. 5-45 on addition of determinants is false. In Section 6-8 the authors do not hold the concepts of a passive network and a reciprocal network distinct.

The above cited deficiencies considerably detract from the book as a whole.

WALTER KAHN
Microwave Research Institute
Brooklyn, N. Y.

RECENT BOOKS

- Garner, R. H., *Mechanical Design for Electronic Engineers*. D. Van Nostrand Company, Inc., 250 Fourth Ave., N. Y. 3, N. Y. \$5.00.
- Hellman, C. I., *Elements of Radio*. D. Van Nostrand Company, Inc., 250 Fourth Ave., N. Y. 3, N. Y. \$4.95.
- Mandl, Matthew, *Mandl's Television Servicing*, rev. ed. The Macmillan Company, 60 Fifth Ave., N. Y. 11, N. Y. \$6.50.
- Mark, David, *Basics of Phototubes and Photocells*. John F. Rider, Inc., 480 Canal St., N. Y. 13, N. Y. \$2.90.
- Most-Often-Needed 1957 Television Servicing Information, Volume TV-12*. Compiled by M. N. Beitman. Supreme Publications, 1760 Balsam Road, Highland Park, Ill. \$3.00.
- Proceedings of the 1956 Electronic Components Symposium*. Engineering Publishers, GPO Box 1151, N. Y. 1, N. Y. Paper bound, \$5.00; cloth bound, \$9.50.
- Swiggett, R. L., *Introduction to Printed Circuits*. John F. Rider, Inc., 480 Canal St., N. Y. 13, N. Y. \$2.70.
- The International Dictionary of Physics and Electronics*. D. Van Nostrand Company, 250 Fourth Ave., N. Y. 3, N. Y. \$20.00.
- Warburton-Brown, D., *Induction Heating Practice*. Philosophical Library, 50 E. 40 St., N. Y. 16, N. Y. \$10.00.



Eastern Joint Computer Conference

DECEMBER 10-12, 1956

MANHATTAN CENTER, NEW YORK CITY

Monday morning

J. W. Leas, Session Chairman.
Welcome, J. R. Weiner, Conference Chairman.
Introduction and Keynote Speech, H. T. Engstrom.
New Computer Developments Around the World, E. S. Calhoun.
Evaluation of New Computer Components, Equipments, and Systems for Naval Use, L. D. Whitelock.

Afternoon

NEW SYSTEMS

Norman Scott, Session Chairman.
The TRANSAC S-1000 Computer, J. L. Maddox, J. B. O'Toole, and S. Y. Young.
A Transistor Computer with a 256×256 Memory, J. L. Mitchell and K. H. Olsen.
Design Objectives for the IBM STRETCH Computer, S. W. Dunwell.
A New Large Scale Data Handling System—DATAMATIC 1000, R. M. Bloch, W. C. Carter, E. J. Dieterich and J. E. Smith.
The TRADIC LEPRECHAUN Computer, J. A. Githens.
Functional Description of the NCR 304 Data Processing System for Business Applications, M. S. Shiohitz and A. A. Cherin, and M. J. Mendelson.

Tuesday morning

CIRCUITS AND COMPONENTS

T. A. Kalin, Session Chairman.
Ambient Approach to Solid-State Computer Components, J. K. Hawkins.
A Magnetically-Controlled Gating Element, D. A. Buck.
A 2.5 Megacycle Ferractor Accumulator, T. H. Bonn and R. D. Torrey.
High-Temperature Silicon-Transistor Computer Circuits, J. B. Angell.
A Saturable-Transformer Digital Amplifier with Diode Switching, E. W. Hogue.

Luncheon, speaker to be announced.

Afternoon

INPUT-OUTPUT DEVICES

W. H. Burkhart, Session Chairman.
An Automatic Input for Business Data Processing Systems, K. R. Eldredge, F. J. Kamphoefner and P. H. Wendt.
The Burroughs Electrographic Printer-Plotter for Ordnance Computing, Herman Epstein and Paul Kintner.
A Transistorized Transcribing Card Punch, C. T. Cole, K. L. Chien, and C. H. Propster.
Apparatus for Magnetic Storage on Three-Inch Wide Tape, by R. B. Lawrance, R. E. Wilkins, and R. A. Pendleton.
Synchronization of a Magnetic Computer, J. Keilsohn and G. Smoliar.

Wednesday morning

HIGH-SPEED MEMORIES

Morris Rubinoff, Session Chairman.
A Technique for Using Memory Cores as Logical Elements, L. Andrews.
Recent Developments in Very High-Speed Magnetic Storage Techniques, W. W. Lawrence.
A Low-Cost Megabit Memory, R. A. Tracy.
A New Magnetic Memory, J. A. Rajchman.
A Compact Coincident-Current Memory, A. V. Pohn and S. Rubens.
A Cryotron Catalog Memory System, A. E. Slade.

Afternoon

RANDOM ACCESS MEMORY FILES AND CONFERENCE SUMMARY

John Howard, Session Chairman.
The Datafile—A New Tool for Extensive File Storage, D. N. MacDonald and C. L. Ricker.
Engineering Design of a Multiple Access Storage System (MASS), M. L. Greenfield.
A Large-Capacity Drum File, V. J. Porter and H. F. Welsh.
System Organization of the IBM 305, M. L. Lesser and J. W. Haanstra.
Conference Summary, J. W. Carr, III.

Symposium on Communication Theory and Antenna Design

CO-SPONSORED BY THE AIR FORCE RESEARCH CENTER AND BOSTON UNIVERSITY, HILLEL HOUSE, BOSTON UNIVERSITY, BOSTON, MASS., JANUARY 9-11, 1957

The Air Force Cambridge Research Center and the Physical Research Laboratories of Boston University are co-sponsoring a tutorial symposium on communication theory and antenna design, to be held at Hillel House, Boston University, Boston, Mass., January 9-11, 1957. Aimed at antenna designers, the symposium will feature unclassified papers of 45-60 minute length, discussion periods, a special meeting in which classified material will be presented and discussed, and a banquet.

Advance registrations at \$1.50 each are required for admission, and banquet tickets are also available at \$3.50 apiece. All correspondence should be addressed to Miss Alice Cahill, CRRD, Air Force Cambridge Research Center, Air Research and Development Command, Laurence G. Hanscom Field, Bedford, Mass., and checks should be made payable to Miss E. T. Ahern.

The symposium committee consists of: Lt. G. B. Parrent, Jr., AFCRC; Edward O'Neil, Boston University; Charles Drane,

AFCRC; and R. C. Gunter, Jr., AFCRC—Clark University.

WEDNESDAY MORNING, JANUARY 9

Registration: 9:00-9:30 A.M.

Opening Address: Duncan MacDonald, Boston University, and L. W. Hollingsworth, AFCRC.

Keynote Talk, R. C. Gunter, Jr., AFCRC—Clark University.

Mathematical Introduction I, Charles Bumer, Clark University.

Mathematical Introduction II, F. S. Holt, AFCRC—Tufts University.

LUNCH

WEDNESDAY AFTERNOON,
JANUARY 9

Application to Electronics I, Arthur Kohlenberg, Melpar, Inc.

Application to Electronics II, Peter Elias, Massachusetts Institute of Technology.

WEDNESDAY EVENING,
JANUARY 9

Symposium Banquet at Laurence G. Hanscom Field, Bedford, Mass., 7:30 P.M.

Speaker: Col. G. T. Gould, Jr., Director, Communications & Electronics Division, Hq. Air Research and Development Command.

THURSDAY MORNING,
JANUARY 10

Application to Optics I, Edward O'Neil, Boston University.

Application to Optics III, Lt. G. B. Parent, Jr., Air Force Cambridge Research Center.

LUNCH

THURSDAY AFTERNOON,
JANUARY 10

Electro-Optical Systems in Cascade, Otto Schade, Radio Corp. of America.

Application to Radio Astronomy I, R. N. Bracewell, Div. of Radio Physics, Commonwealth Scientific and Industrial Research Organization, Australia.

Application to Radio Astronomy II, Harold Ewen, Ewen-Knight, Inc.

THURSDAY EVENING,
JANUARY 10

Discussion Group on the Application to Antenna Problems.

Group Leader: R. C. Spencer, Sylvania Electric Products Corp.

FRIDAY MORNING, JANUARY 11

Antennas I, John Ruze, AFCRC—Radiation Engineering Laboratory.

Antennas II, W. H. Steel, Div. of Physics, Commonwealth Scientific and Industrial Research Organization, Australia.

Antennas III, speaker to be announced.

LUNCH

FRIDAY AFTERNOON, JANUARY 11

Classified contributed papers on special antenna problems.

Third National Symposium on Reliability and Quality Control in Electronics

SPONSORED BY IRE, AIEE, ASQC AND RETMA, HOTEL STATLER, WASHINGTON, D. C., JANUARY 14-16, 1957



Left to right—Some members of the committee planning the Third National Symposium on Reliability and Quality Control in Electronics: (front row) M. E. King, Finance; A. B. Mundel, ASQC Representative; M. M. Tall, General Chairman; Victor Wouk, PGRQC Representative; (back row) R. M. Jacobs, Publicity; Robert Murrell, Registration; J. E. Culbertson, Facilities Co-Chairman; J. W. Greer, General Co-Chairman, and I. W. Schoeninger, Facilities Co-Chairman. C. M. Ryerson, Program Chairman, is absent from the picture.

The Third National Symposium on Reliability and Quality Control in Electronics will be held at Hotel Statler, Washington, D. C. on January 14-16. Arrangements will be adequate for only 1500 attendees so advance registration is urged. Fees, which include admission to the banquet and a copy of TRANSACTIONS, are scaled as follows: advance registration for members of PGRQC and ASQC, \$15.00; advance registration for all others, \$17.00; door registration, \$20.00; extra banquet tickets, \$9.00; extra copies of TRANSACTIONS, \$5.00; and tour tickets (maximum, two), \$1.50. Advance registra-

tions should be made with R. G. Murrell, Registration Chairman, Melpar, Inc., Falls Church, Virginia.

Committee chairmen handling the details of the symposium are: M. M. Tall, General Chairman; J. W. Greer, Co-Chairman; C. M. Ryerson, Program; M. E. King, Finance; P. K. McElroy, TRANSACTIONS; A. Warsher, Speakers and Hospitality; I. W. Schoeninger, Facilities; R. M. Jacobs, Publicity.

For security reasons, tour tickets are available only to advance registrants and are adequate for only forty persons on each

tour. In order to qualify for tickets, persons must furnish their full names, home addresses, company affiliations and addresses, and a statement of U. S. citizenship. All tours will start and end at the Statler Hotel.

MONDAY, JANUARY 14

9:15 A.M.

Presidential Room

Keynote Address: *Review and Prediction in Reliability*, J. M. Bridges, Office of the Assistant Secretary of Defense.

10:00 A.M.

PRINCIPLES FOR DESIGN AND MANAGEMENT OF RELIABILITY PROGRAMS

Presidential Room

L. W. Ball, United Geophysical Labs., moderator.

Organizing for Reliability, Ralph Kuehn, IBM.

Communication Channels for Reliability Operations, Royal Weller, Naval Air Missile Test Center.

Quality Assurance and Reliability in Production, E. G. D. Paterson, Bell Telephone Labs.

Steps Supplier Should Take to Manufacture Reliable Products, L. J. Paddison, Sandia Corporation.

MATHEMATICAL AND ADVANCED THEORY

Congressional Room

C. R. Knight, Aeronautical Radio Inc., moderator.

Optimum Network Syntheses, Louis Weinberg, Hughes Aircraft Company.

Reliability for Parallel Redundant Systems, T. L. Burnett, IBM.

Statistical Developments in Life Testing, Benjamin Epstein, Wayne State Univ.

Estimation of Reliability Functions, G. R. Herd, Aeronautical Radio Inc.

2:00 P.M.

Congressional Room

Trends in Airborne Equipment Reliability, moderated by R. Seldon, Chance Vought Aircraft Inc.

Panel discussion with the following panelists: H. D. Voegtlen, Hughes Aircraft Co.; H. R. Powell, Sperry Gyroscope Company; E. R. Linne, General Electric Company; E. F. Dertinger, American Bosch Arma Corp.; G. G. Brown, Inland Testing Labs.; and C. L. McCabe, Convair.

Presidential Room

System Reliability Analysis, moderated by G. Armour, General Electric Company. Panel discussion with the following panelists: C. E. Beams, General Electric Company; R. H. Briggs, Westinghouse Elec. Corp.; J. W. Dunifon, General Dynamics Corp.; R. R. Carhart, Lockheed Aircraft Corp.; C. R. Knight and G. R. Herd, Aeronautical Radio Inc.; A. T. Pollock, Philco Corp.; Philip Reiter, Signal Corps Supply Co.; C. M. Ryerson and M. M. Tall, RCA; S. M. Truex, Office of the Secretary of Defense; Dean Voegtlen, Hughes Aircraft Co.; and H. A. Voorhees and J. E. Culbertson, Western Electric Co.

7:30 P.M.

Movie: "Environmental Factors in Reliability of Electronic Equipment."

8:00 P.M.

QUALITY ACCEPTANCE PRACTICES

Congressional Room

L. J. Jacobson, International Resistance Co., moderator.

Introduction to Quality Acceptance Practices, L. J. Jacobson.

Qualification Acceptance Practices in Specifications, M. A. Acheson, Sylvania Electric Co.

Qualification Acceptance Practices in Complex Mechanisms, G. Bowler and W. Kauffman, Hughes Aircraft and Radio Corporation of America.

Qualification Testing, A. Warsher, Bendix Aviation Corp.

RELIABILITY REPORTS

Presidential Room

R. H. DeWitt, Office of the Assistant Secretary of Defense, moderator.

Numerical Reliability Requirements, D. H. Wagner, Burroughs Corp.

Quantitative Reliability Acceptance Testing, W. T. Sumerlin, Philco Corp.

Guided Missile Program Management, E. A. Bender, OASD.

Military Reliable Tube Program, M. Landis, Secretariat of the Advisory Group on Electron Tubes.

TUESDAY, JANUARY 15

9:00 A.M.

COMMERCIAL ELECTRONIC RELIABILITY

Congressional Room

J. W. McRae, Sandia Corp., moderator.

Mobile Commercial Communications Reliability, A. A. McDonald, Motorola, Inc.

Commercial Airborne Reliability, W. A. MacCrehan, Bendix Radio Co.

Microwave Reliability, R. Lukens, Philco Corp.

An Evaluation of Transistor Life Data, J. D. Johnson and B. Van Swearingen, IBM.

Airborne Communication Malfunction Evaluation, A. Hull, United Airlines, Inc.

RELIABILITY OF COMPONENT PARTS

Presidential Room

L. Podolsky, Sprague Electric Co., moderator.

Specification and Measurement of Component Reliability, I. K. Munsen, Radio Corporation of America.

Reliability of Metallized Paper Capacitors, W. Lamphier, Sprague Electric Co.

Reliability in Capacitor Manufacture, H. S. Herrick, Eric Resistor Corp.

Resistor Reliability Prediction, D. S. Gilbert, WCRE-WADC.

Nuclear Radiation Effects on Parts, R. J. Milliron, WCRE-WADC.

2:00 P.M.

QUALITY CONTROL IN PRODUCTION

Congressional Room

A. E. Mundel, Sonotone Corp., moderator.

Simulation Techniques to Verify Reliability, S. J. Callabro, Federal Telephone and Radio Co.

Cause-and-Effect Studies with Many Variables, D. Shainin, Rath & Strong, Inc.

Time Samples Measure Equipment Performance, D. Hill, D. Voegtlen and R. H. Meyers, Hughes Aircraft Co.

A Low-Cost Sequential Sampling Method, R. M. Jacobs, RCA.

TECHNIQUES FOR RELIABLE DESIGN

Presidential Room

R. M. Sewell, NAESU, moderator.
Standard Parts Can Be Versatile, G. Neuschaefer, NYSN Material Lab.

Reliability and Maintenance Design Considerations, J. R. Smith, NEL.

Design Standardization and Reliability, J. Muncy, National Bureau of Standards.

A Method of Circuit Standardization, G. T. Ross, RCA.

A Summary of Reliability Literature, C. J. Moore, NAESU.

6:00 P.M.

Presidential Room

Banquet.
Master Formulations and the Professor Factor, D. E. Noble, Motorola, Inc.

8:00 P.M.

Congressional Room

Panel on *Basic Definitions Used in Reliability*, moderated by C. M. Ryerson, RCA.

Panelists: J. H. Allen, Bendix Pacific; L. W. Ball, United Geophysical; E. V. Bersinger, Minneapolis-Honeywell; R. R. Carhart, Lockheed; L. M. Clement, Crosley Avco Div.; E. F. Dertinger, Arma; R. H. DeWitt, OASD; J. Dorfman, Raytheon; D. A. Hill, Hughes Aircraft; C. E. McLaughlin, WADC; E. J. Nucci, Bureau of Ships; and L. J. Paddison, Sandia Corp.

WEDNESDAY, JANUARY 16

8 A.M. AND 1:00 P.M.

Tours of Andrew Air Force Base Headquarters Airways and Communications Service, Naval Ordnance Laboratory, and the David Taylor Model Basin.

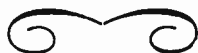

Abstracts of IRE Transactions

Aeronautical & Navigational Electronics

VOL. ANE-3, No. 3
SEPTEMBER, 1956

Editorial—J. V. N. Granger

Impact of Guided Missiles on the Military
Future—M. F. Schoeffel

An Improved Medium-Range Navigation
System for Aircraft—C. G. McMullen

Most navigation systems proposed have been so radical as to require a revolution for their implementation. The system described herein would employ existing ground and airborne equipment with the addition of a small, new unit in the aircraft. This unit would employ only well-known circuits and techniques. The working of the system is explained, and data are presented on the accuracy to be expected.

Design Features of the ASN-7 Navigational
Computer—S. I. Frangoulis

ATC Transponder—The Design and Appli-
cation of a Magnetostriction Delay Line for
Coding Purposes—V. L. Johnson

In order to meet operational requirements high pulse position accuracy is required for the reply-code pulses transmitted by the ATC Transponder. The use of a magnetostriction delay line as the primary delay element for positioning the constituent pulses of the reply code groups is discussed. The design of a magnetostriction delay line for this purpose is discussed and a method for remote selection of the reply codes is presented.

The Role of the Design Engineer in the
Field Support of Complex Airborne Electronic
Equipment—H. W. Brown, Jr.

The success of a complex airborne electronic equipment is highly dependent upon a well-planned and timely implemented field support program. The design engineer, however, plays a very fundamental and basic role and the fulfillment of his responsibilities is of major importance. In following good engineering design practice he must consider the requirements imposed by the field. Among these are packaging, the incorporation of self-testing circuitry and test points, and accessibility of adjustments and components, all of which contribute to ease of maintenance, thus reducing the turn around time of nonoperating equipment. Of equal importance is his analysis of field failure reports, reflecting where necessary any improvements into the design of the equipment.

The Probe Excited Airframe as a High Fre-
quency Antenna—W. L. Curtis, T. G. Dalby,
and F. S. Holman

An electrically isolated probe mounted on an airframe extremity has been investigated as a means of exciting the airframe as a high-frequency antenna. The probe maintains most of the advantages of isolated structure or "cap" type antennas over fixed wires, and it does not require a break in basic airframe structure. Measurements have been made of radiation patterns and impedance of such a probe mounted at a number of positions on a B-47 airplane. Impedance characteristics at low frequencies depend strongly on the length of the probe and its location on the airframe, but not to any great degree on the shape of the airframe itself. At higher frequencies, however, the impedance indicates clearly the effects of various resonant modes of the airframe. Radiation pattern characteristics of these antennas are due primarily to excitation of the airframe and are modified

The following issues of "Transactions" have recently been published, and are now available from the Institute of Radio Engineers, Inc., 1 East 79th Street, New York 21, N. Y. at the following prices. The contents of each issue and, where available, abstracts of technical papers are given below.

Sponsoring Group	Publication	Group Members	IRE Members	Non- Members*
Aeronautical & Navigational Electronics	Vol. ANE-3, No. 3	\$1.05	\$1.55	\$3.15
Audio	Vol. AU-4, No. 5	.60	.90	1.80
Broadcast Trans- mission Systems	PGBTS-5	1.05	1.55	3.15
Medical Electronics	PGME-6	1.25	1.85	3.75
Microwave Theory & Techniques	Vol. MTT-4, No. 3	1.25	1.85	3.75

* Public libraries and colleges may purchase copies at IRE Member rates.

by the probe itself only to the extent that the probe location influences the airframe modes which are excited.

The Radar Display as a Linear Filter—
Daniel Levine

When an intensity-modulated cathode ray tube is fed by an electronic gamma-correction circuit to compensate for the tube power law, the over-all system may be interpreted as a linear filter. It is shown that if the electron distribution within the beam is Gaussian, then (for at least some applications) the corresponding equivalent filter has a Gaussian amplitude characteristic and zero phase shift. Thus, a recent radar tube, the 5FP14A, has a frequency response given by $\exp[-7.07f^2]$ when used on a range of 30 nautical miles. (Here f is expressed in megacycles.) A similar result applies to this tube when used as a flying-spot scanner.

If the radar video amplifier is to produce no degradation of this display it must be flat to a frequency $1.2v/w$, where v is the sweep velocity and w the spot size. The desirable pulse duration is equal to the time required to sweep past a spot. Simple modifications of these relations are necessary if ground-range sweeps are used.

Engineering Techniques in the Simulator
Evaluation of Flight Information Displays—
Frank Klimowski, Jr.

Display evaluation by simulator methods is analyzed from the point of view of reducing the operational delays in producing an experimental display, providing an experimental system, and obtaining performance data. The techniques recommended to relieve the problem are: display synthesis, programmable facilities, automatic processing of syllabuses, flexible function generation and function sequencing, and the use of dc analog computers for real time performance measurements.

Correspondence
Contributors
PGANE News

Audio

VOL. AU-4, No. 5, SEPTEMBER-
OCTOBER, 1956

Musical Audio Engineering and Research
Today—D. W. Martin
PGA News
Engineers and Music—C. H. Chandler
Engineers working in the field of audio, especially if they deal directly with musicians,

may find themselves at a serious disadvantage because of a lack of musical knowledge. The acquisition of such knowledge, on the other hand, can increase their professional prestige, improve the quality of their work, and open new horizons for personal enjoyment. The author of this paper, a musician of varied experience as well as an engineer, shows that a very useful background in music is not hard to obtain. This article specifies in concrete terms the information which should be acquired for basic musical understanding, and gives suggestions as to how this information may be obtained.

Energy Distribution in Music—J. P. Over-
ley

A knowledge of the manner in which the acoustic power encountered in music varies with respect to frequency can be a useful tool in the design of components to be used in audio reinforcement or reproduction systems. This paper deals with the amplitude of fractional-second energy peaks, without reference to the rate of their occurrence. It is these peaks which must be considered when distortion is of primary consideration; average power is useful only in predicting temperature rise (where applicable) of single-handling components. Throughout the discussion emphasis is placed upon the difference between average and peak energy consideration.

The source material from which the distribution analysis is drawn consisted of recent commercial vinyl recordings played on a carefully equalized reproducing system. Ten various types of music are classified and a distribution curve for each is drawn. The methods used in arriving at a typical curve are shown by breaking the spectrum into octaves with a band pass filter.

The distribution information mentioned above is applied to the design of a three-channel loudspeaker system as an example of use. Other possible applications are mentioned.

An Audio Flutter-Weighting Network—
F. A. Comerchi and E. Oliveros

Listener preference rankings of selected samples of programs containing many types of flutter will be compared to measurements of the same flutter using a meter weighted with respect to flutter rate in accordance with the threshold of perceptibility. It will be shown that the correct weighting curve varies with the level of flutter, and modification should be made to the flutter meter in order to obtain objective rankings of program containing the same type of flutter.

Learning, A Major Factor Influencing Preferences for High-Fidelity Reproducing Systems—R. E. Kirk

Frequency range preference of 210 college students for monaurally reproduced music and speech was determined by an A-B-A preference test. Two groups of subjects then listened to music reproduced over a restricted frequency range and a relatively unrestricted frequency range respectively for six and one-half weeks. The results of a post-frequency range preference test indicate that: 1) learning plays an important role in determining preferences for sound reproducing systems; 2) continued contact with a particular system produces shifts in preference for this system; and 3) the average college student prefers music and speech reproduced over a restricted frequency range rather than an unrestricted frequency range.

Contributors

Broadcast Transmission Systems

PGBTS-5, SEPTEMBER, 1956

(Seventh Region Technical Conference, Salt Lake City, Utah, April 11-13, 1956)

Modern Techniques for the Determination of Service Areas of Television Broadcast Stations—A. E. Cullum, Jr.

Propagation conditions at frequencies allocated to television broadcasting require a statistical analysis of field intensity measurements in order to determine the coverage of a television broadcast station. Methods have been developed for the sampling of the field intensity at a height of 30 feet above ground along a true radial. Method of analysis of the field data and interpretation of the results are presented. Results of several surveys are shown. Good correlation is obtained between predicted field intensity contours and measured field intensity contours.

Community Television Systems—A. S. Taylor and Bruce Hamilton

Part of the genius of modern technological society is the dynamic ingenuity with which solutions are found to problems thought to be impossible. When the FCC Table of Television allocations was released to the public, there was much cynical scoffing at the television assignments in communities of less than 2500 persons. Yet, today there is a rapidly growing and soundly financed industry providing excellent television service to communities of but a few thousand persons. The explosive and belligerent development of re-radiator systems operating without FCC approval is a phenomenon involving towns of less than 2500 persons, for the most part. Low population density is no longer an excuse for the failure to provide either the luxuries or necessities of modern living.

A Cordless Microphone System—A. B. Chamberlain

A cordless (radio) microphone system, successfully used by CBS Television, consisting of a small microphone, miniature FM transmitter, special receivers, and a diversity antenna system is described. The need for continued development work to produce smaller, more rugged and reliable components, having as an objective a system with performance and dependability equal to that obtained from standard studio microphones, is stressed. A system of this type could materially lessen the need for microphone booms in television and motion picture studios.

Also emphasized is the fact that even more important than improved performance and relief from microphone boom problems, is the freedom of movement given the performer, made possible by the cordless microphone, a new latitude without which programs such as Ed Murrow's *Person to Person* show could not be successfully produced.

(Tenth Annual Spring Television Conference, Cincinnati, Ohio, April 13-14, 1956).

Technical Standards for Color Television—J. W. Wentworth

A Transistor Video Amplifier Having 80 Volts Output—V. H. Grinich

A transistor video amplifier which has sufficient output signal, swing, and bandwidth to drive a standard picture tube is described. The amplifier consists of three junction transistors in the following configurations (starting at the input end): grounded-collector, grounded-emitter, and common-base. A resistive feedback path is provided from the output of the grounded-emitter stage to the amplifier input. Adequate dynamic range is obtained by means of the common-base stage which gives an output voltage swing that is twice the breakdown voltage of the transistor. The feedback employed not only improves the linearity and high-frequency response but also aids in obtaining dc restoration. Because of the current and voltage variable reactance effects in junction transistors, the frequency response of the amplifier is a function of the operating point. Circuit models that are used in the analysis and design of such amplifiers are discussed.

Standardized Transmitting Aerials for Medium-Frequency Broadcasting—S. F. Brownless

The Postmaster-General's Department has developed a range of aerial systems suitable for National Broadcasting Service transmitting stations of powers from 200 watts to 50 kilowatts in the frequency range 540-1600 kc/s. The aerial systems fall into two classes: "high" aerials having special anti-fading properties, usually near half-a-wavelength in height, and "low" aerials less than a quarter-wavelength in height. This paper traces the development of the designs, with special emphasis on low aerial systems suitable for construction by Departmental staff. Here the application of practices well-established at vhf leads to structures believed to be novel for M.F. broadcasting. Charts and diagrams are given from which aerial structures suitable for any particular application may be readily selected.

Medical Electronics

PGME-6, OCTOBER, 1956

Foreword

Dynamic Negative Admittance Components in Statically Stable Membranes—O. H. Schmitt

Electro-Ionics of Nerve Action—K. S. Cole Viruses and Macromolecules Studied with the Electron Microscope and Ultracentrifuge—R. W. G. Wyckoff

The Use of Ionizing Radiation to Study Virus Structure—Ernest Pollard

Microwave Theory & Techniques

VOL. MTT-4, NO. 3, JULY, 1956

Foreword

Tables of Constants for Rectangular Waveguides (In Decimal Frequencies)—Sperry Gyroscope Company

E. L. Ginzton

Microwaves—Present and Future—E. L. Ginzton

Rapid Measurement of Dielectric Constant and Loss Tangent—D. M. Bowie and K. S. Kelleher

The problem of evaluating dielectric constant and loss tangent by the short-circuited-waveguide technique has been encountered continually in recent years in the study of artificial dielectric media and radome materials. In general, practical measurements have involved materials with low loss and dielectric constants less than 10. The analytical method normally applied to data on such materials

requires laborious computation. The available graphical methods have not completely eliminated computation and have provided answers of unsatisfactory accuracy.

The present paper describes rapid graphical techniques for evaluating dielectric constant and loss tangent from the quantities normally measured with the slotted line, using samples of arbitrarily chosen length. It begins with equations previously derived for the case of low-loss media. By use of a new parameter, the relationship between dielectric constant and the measured shift in standing-wave minimum is plotted in such a way that all possible values of dielectric constant within any predetermined range are read directly from the graph with no computation whatsoever. A graph can be readily prepared to apply over a full range of frequency to all sizes of rectangular waveguide.

With the dielectric constant known, a simplification in determining the loss tangent is possible, using half-wavelength samples. The loss tangent is obtained by direct recourse to a graph of loss tangent as a function of the standing wave ratio.

Propagation in Ferrite-Filled Transversely Magnetized Waveguide—P. H. Vartanian and E. T. Jaynes

A solution to the problem of propagation of higher modes in a transversely magnetized ferrite-filled rectangular waveguide has been found. The solutions to the problem are expressed in the form of four rigorous nonlinear algebraic equations which characterize the problem and are ready for numerical solution. Dependence of the fields in the direction of magnetization is the same as for classical modes.

Currents Excited on a Conducting Surface of Large Radius of Curvature—J. R. Wait

The nature of the electromagnetic field of an antenna in the vicinity of a surface of large radius of curvature is discussed. Assuming a spherical surface, the solution for a dipole source in the form of the Watson residue series is transformed to a more rapidly converging series which is preferable at short distances. Using this result, numerical data is presented in graphical form for the currents induced on the spherical surface. The curves are applicable to both a stub and slot antenna mounted on the conducting surface.

A Note on Noise Temperature—P. D. Strum

The effective noise temperature of the output impedance of a lossy passive network at an arbitrary noise temperature connected to one or more resistive loads at arbitrary noise temperature lies between the highest and the lowest of these noise temperatures, as determined by the losses between the output terminals and the loads. The determination of the effective noise temperature of a gas-discharge noise generator over a wide frequency range is simplified by the substitution of a loss measurement for the more difficult noise temperature measurement. For minimum-noise radar applications care must be used in considering the excess noise of crystal mixers and gas-discharge duplexers. The influence of galactic radiation on a receiving system is such that there is an optimum frequency in the region of 200 to 600 mc for minimum "operating noise figure." Typical examples of radio-astronomy measurements are amenable to analysis of the type given. Finally, several corrections to measured noise figure are analyzed.

Compact Microwave Single-Sideband Modulator Using Ferrites—J. C. Cacheris and H. A. Dropkin

This paper describes a single-sideband modulator for shifting the frequency of an x -band signal by means of a rotating magnetic field transverse to a ferrite differential half-wave section. The device is one of the first practical applications of the double-refraction properties of ferrites.

Improvements over an earlier model include reduction in size and continuous operation without drift. An efficient and compact magnetic structure has been designed for producing the rotating magnetic field. Excessive heating of the ferrite and voltage breakdown of the coils is eliminated by a forced-air cooling system.

The modulator shifts the microwave-carrier frequency of 9375 mc by plus or minus 20 kc. With a rotating field of approximately 200 oersteds the microwave insertion loss is 1.0 db. The undesired sideband suppression is above 40 db while the carrier suppression is 23 db. For a frequency bandwidth of 500 mc, the insertion loss remains below 5 db.

A Semi-Infinite Array of Parallel Metallic Plates of Finite Thickness for Microwave Systems—R. I. Primich

An array of parallel metallic plates of finite thickness are useful in microwave lenses. The effect of finite thickness in the idealized situation of a semi-infinite array of perfect conductivity, is treated theoretically and experimentally for normal incidence of a uniform plane wave on the plane interface separating the medium from free space. The theoretical discussion involves the approximate variational method and a procedure is given for estimating the order of magnitude of the error in the final result. It is shown that it can be advantageous to use plates of finite thickness since the reflection from the interface can be reduced from that existing for infinitely thin plates.

The Characteristic Impedance of Trough and Slab Lines—R. M. Chisholm

A variational method is used to develop an expression for the characteristic impedance of a "trough line" consisting of a circular cylinder mounted inside and parallel to the walls of a semi-infinite rectangular trough. The "slab line"

consisting of a circular cylinder between infinite, parallel plates is treated as a special case of the trough line in which the bottom of the trough is taken to be infinitely remote from the circular cylinder. The solution has not been restricted to cylinders that are mounted exactly half way between the parallel walls of the trough; a simple formula is presented for calculating the tolerances which must be placed on the "centering" of the center conductor for a given allowable error in the characteristic impedance.

The expression for the characteristic impedance is presented as the sum of three terms. The first is a "zero order" logarithmic term, the second a "second order" correction term which vanishes as the center conductor becomes infinitely small, and the third is an "off-center" correction term which arises when the cylinder is not exactly half way between the parallel walls of the trough. The second order correction term amounts to about 0.3 ohms when the characteristic impedance is of the order of 50 ohms. A fourth order approximation using the same method changes this by about 0.001 ohm.

A Simplified Calibration of Two-Port Transmission Line Devices—F. L. Wentworth and D. R. Barthel

During the evaluation measurements of several two-port junction devices over a wide band of frequencies the authors found that the method of shorts as described in three previous papers was too laborious to be practical. By reinterpreting and combining the ideas of earlier authors a valuable simplification was obtained. Since this paper is based upon the previous articles, no fundamental proofs will be given except to show the necessary extensions involved.

Impedance and Polarization-Ratio Trans-

formations by a Graphical Method Using the Isometric Circles—E. F. Bolinder

The isometric circles for the direct and inverse linear fractional transformations can be used for transformations of impedances and polarization ratios. In the loxodromic case an inversion is performed in the isometric circle of the direct transformation, followed by a reflection in the symmetry line of the two circles, and a rotation around the origin of the isometric circle of the inverse transformation. In the nonloxodromic case only the first two operations have to be applied. Three illustrative examples are given: the first shows the transformation of the right half of the complex impedance plane into the unit circle (Smith Chart); the second gives a circular geometric proof of the Weissfloch transformer theorem; the third shows an example of cascading, lossless, two terminal-pair networks.

A Broad-Band Dual-Mode Circular Waveguide Transducer—R. D. Tompkins

This paper describes a broad-band dual-mode waveguide transducer designed to couple two orthogonal TE_{11} circular waveguide modes in separate rectangular waveguide ports. A compact, rugged, economical junction was developed to operate 8600 mc–9600 mc with a vswr of less than 1.15 at the rectangular port and a mode isolation of 50 db or greater.

Developmental models are described to indicate the evolution from theory to the final model. Some problems encountered in attaining a small physical size are discussed in detail. The new junction has application to mode multiflexing, circular waveguide ferrite devices, circular polarization, and as a circular waveguide magic-T.

Correction
Correspondence
Contributors



Abstracts and References

Compiled by the Radio Research Organization of the Department of Scientific and Industrial Research, London, England, and Published by Arrangement with that Department and the *Wireless Engineer*, London, England

NOTE: The Institute of Radio Engineers does not have available copies of the publications mentioned in these pages, nor does it have reprints of the articles abstracted. Correspondence regarding these articles and requests for their procurement should be addressed to the individual publications, not to the IRE.

Acoustics and Audio Frequencies.....	1900
Antennas and Transmission Lines.....	1900
Automatic Computers.....	1901
Circuits and Circuit Elements.....	1901
General Physics.....	1902
Geophysical and Extraterrestrial Phenomena.....	1903
Location and Aids to Navigation.....	1905
Materials and Subsidiary Techniques..	1905
Mathematics.....	1908
Measurements and Test Gear.....	1909
Other Applications of Radio and Electronics.....	1910
Propagation of Waves.....	1910
Reception.....	1911
Stations and Communication Systems..	1912
Subsidiary Apparatus.....	1912
Television and Phototelegraphy.....	1912
Transmission.....	1913
Tubes and Thermionics.....	1913
Miscellaneous.....	1914

The number in heavy type at the upper left of each Abstract is its Universal Decimal Classification number and is not to be confused with the Decimal Classification used by the United States National Bureau of Standards. The number in heavy type at the top right is the serial number of the Abstract, DC numbers marked with a dagger (†) must be regarded as provisional.

ACOUSTICS AND AUDIO FREQUENCIES

- 534.232 3266
Emission of Sound by a Rotating Dipole—L. N. Sretenski. (*Akust. Zh.*, vol. 2, pp. 93-98, January/March, 1956.) A theoretical paper.
- 534.232:621.395.623.7 3267
The Generation of Sound Pulses for Acoustic Measurements by means of Loudspeakers—H. Niese. (*Hochfrequenztech. u. Elektroakust.*, vol. 64, pp. 84-90; November, 1955.) The production of pulses with desired waveforms is discussed. A special loudspeaker with a spherical radiation pattern has been developed to simulate the sound from an orchestra.
- 534.24:534.861 3268
Wobbling of an Audio Note due to a Rotating Target—M. V. J. Row and S. R. Rao. (*J. Inst. Telecommun. Engrs., India*, vol. 2, pp. 100-102; March, 1956.) Analysis is presented of the frequency rise and fall of an initially-steady tone after reflection of the sound wave from a rotating target. The theory is relevant to effects which might be produced by a fan operating in a studio.
- 534.26 3269
Diffraction by a Cylinder of Finite Length—W. E. Williams. (*Proc. Camb. Phil. Soc.*, vol. 52, part 2, pp. 322-335; April, 1956.) The diffraction of a plane sound wave by a hollow cylinder is considered. Laplace transforms are used, and the problem is reduced to the solution of two complex integral equations. The solution is finite for all values of the cylinder length, including those corresponding to resonance conditions.

- 534.31 3270
The Transient State resulting from the Excitation of a String by a Bow—B. Bladier. (*C.R. Acad. Sci., Paris*, vol. 242, pp. 2704-2707; June 4, 1956.)

- 534.79 3271
A Re-determination of the Equal-Loudness Relations for Pure Tones—D. W. Robinson and R. S. Dadson. (*Brit. J. Appl. Phys.*, vol. 7, pp. 166-181; May, 1956.) Report of an investigation carried out at the National Physical Laboratory. Subjective measurements were made at frequencies in the range 25 cps-15 kc and at sound pressure levels up to about 130 db above 0.0002 dyn/cm². A new determination was made of the normal threshold of hearing in free field; the results are highly consistent with the equal-loudness contours. Discrepancies between results obtained previously by various workers are to some extent explained.

- 534.844 3272
Note on the Statistical Treatment of the Reverberation Process—W. Kraak. (*Hochfrequenztech. u. Elektroakust.*, vol. 64, pp. 90-93; November, 1955.) The validity of formulas derived by Eyring (*J. Acoust. Soc. Amer.*, vol. 1, pp. 217-241; January, 1930) for a nonuniform distribution of absorptive material is confirmed.

- 534.86:621.375.4.029.3 3273
Transistor Preamps—Starke. (See 3323.)

- 534.862.6 3274
Calculation of the Audibility of Nonlinear Distortion originating in an Electroacoustic System—A. V. Rimski-Korsakov. (*Akust. Zh.*, vol. 2, pp. 51-61; January/March, 1956.) The probability is calculated of the products of nonlinear distortion in a sound-reproducing channel exceeding the masking level due to the fundamental signal and the threshold of audibility in the auditorium. In the particular case of a signal with a flat frequency spectrum distorted by a square-law nonlinearity, the threshold of perceptibility of the distortion corresponds to a harmonic coefficient of between 2 and 3 per cent.

- 621.395.614:546.431.824-31 3275
Nondirectional Ceramic Sound Receivers—A. A. Anan'eva. (*Akust. Zh.*, vol. 2, pp. 10-27; January/March, 1956.) The characteristics of cylindrical and spherical BaTiO₃ microphones were investigated experimentally at frequencies up to several hundred kc. Experimental results are presented graphically, in tabular form and in 78 oscillograms of the polar characteristics.

ANTENNAS AND TRANSMISSION LINES

- 621.372.2 3276
Propagation of Waves along an Infinitely Long Helix—N. N. Smirnov. (*C.R. Acad. Sci. U.R.S.S.*, vol. 108, pp. 243-246; May 11, 1956. In Russian.) The dispersion equation is discussed theoretically.

- 621.372.22:621.372.51 3277
Impedance Transformers—J. Willis and N. K. Sinha. (*Wireless Engr.*, vol. 33, pp. 204-208; September, 1956.) Experimental work is reported on nonuniform-transmission-line devices previously discussed theoretically (1614 of 1956). A compensated coaxial-line-resistor termination designed to give negligible reflection over a wide band is described. Observed and calculated reflection patterns for two types of tapered line are compared. Attenuation effects are negligible in practical cases.

- 621.372.43 3278
The Optimum Tapered Transmission-Line Matching Section—R. W. Klopfenstein, E. F. Bolinder, and R. E. Collin. (*Proc. IRE*, vol. 44, pp. 1055-1056; August, 1956.) Comments on 1953 of 1956 and author's reply.

- 621.372.8 3279
Production of Slow Electromagnetic Waves by means of Cylindrical Current Sheets—F. Berstein and W. Chahid. (*C.R. Acad. Sci., Paris*, vol. 242, pp. 2918-2920; June 18, 1956.) Brief discussion of possible modes with waves slowed by complex helix structures: the mathematical analysis assumes a continuous conducting surface.

- 621.372.8 3280
Propagation of Electromagnetic Waves between Two Circular Cylindrical Surfaces in the Presence of Longitudinal, Periodically Spaced Diaphragms—E. G. Solov'ev. (*Radioelekhnika, Moscow*, vol. 11, pp. 57-60; January, 1956.) Analysis is given for an E wave traveling circumferentially between a pair of coaxial cylindrical sheets with diaphragms spaced along the coaxial midsurface. Comparison of the results with those obtained earlier (978 of 1956) indicates that for wavelengths very much longer than the diaphragm space period, the phase velocity is reduced by the diaphragm system and a large number of space harmonics are produced; the higher their number the lower their phase velocity. This suggests use of systems of this type for delay lines.

- 621.396.676:621.396.933 3281
TACAN Radio Bearing and Distance System for Aerial Navigation—(See 3386.)

- 621.396.677:621.396.97 3282
Vertical Radiation and Tropical Broadcasting—Dickinson. (See 3536.)

The Index to the Abstracts and References published in the PROC. IRE from February, 1955 through January, 1956 is published by the PROC. IRE, June, 1956, Part II. It is also published by *Wireless Engineer* and included in the March, 1956 issue of that journal. Included with the Index is a selected list of journals scanned for abstracting with publishers' addresses.

621.396.677.8:621.396.65.029.63 3283
A Decimetre-Wavelength Radio-Link Network providing High-Quality Program Channels using Pulse Phase Modulation: Part 2—Aerial Installations—E. Schüttlöffel. (*Telefunken Ztg.*, vol. 29, pp. 12–20; English summary, p. 63; March, 1956.) Parabolic reflector antennas with dipole exciters are used, with auxiliary deviating reflectors at one point. Part 1: 3534 below.

AUTOMATIC COMPUTERS

016:681.142 3284
Bibliography of Literature on Mathematical Simulation (Analogue Computers) (1947–1954)—(*Automatika i Telemekhanika*, vol. 17, pp. 279–288, 268–383; March/April, 1956.) About 500 items are listed, including books, conference reports, and papers. About 70 references are to Russian literature.

681.142 3285
Electronic Differential Analyser of the G.M. Krzhizhanovski Energetics Institute of the U.S.S.R. Academy of Sciences—I. S. Bruk and N. N. Lenov. (*Automatika i Telemekhanika*, vol. 17, pp. 217–227; March, 1956.) The analyzer comprises 38 operational amplifiers, 4 multipliers, and 4 function transformers with a harmonics generator. The basic circuits are described. Differential equations up to the 19th order have been solved; equations up to the 25th order could be handled.

681.142 3286
Magnetic Shift-Register Correlator—R. C. Kelner and M. H. Glauber. (*Electronics*, vol. 29, pp. 172–175; August, 1956.) "Printed decimal digits 0 to 9 are easily recognized by a magnetic-shift register using digital-to-analog converters at each stage. Recognition is obtained using a waveform-fitting function instrumented with the shift-register for correlation."

681.142 3287
Triangular-Wave Analog Multiplier—R. A. Meyers and H. B. Davis. (*Electronics*, vol. 29, pp. 182–185; August, 1956.)

681.142 3288
High-Density Williams Storage—S. Y. Wong. (*IRE TRANS.*, vol. EC-4, pp. 156–158; December, 1955. Abstract, *Proc. IRE*, vol. 44, p. 580; April, 1956.)

681.142:621.383.2 3289
Bit Storage via Electro-optical Feedback—A. Milch. (*IRE TRANS.*, vol. EC-4, pp. 136–144; December, 1955.) The use of a device including a photoemissive cathode and a luminescent anode as a computer component is discussed.

CIRCUITS AND CIRCUIT ELEMENTS

621.3-71 3290
Review of Industrial Applications of Heat Transfer to Electronics—J. Kaye. (*Proc. IRE*, vol. 44, pp. 977–991; August, 1956.) Techniques for controlling the temperature conditions of operation of electronic equipment are reviewed with particular reference to conditions in fast aircraft and missiles. Particular examples discussed are 1) an air-cooled 25-kw tube (*IRE TRANS.*, vol. ED-1, pp. 9–26; April, 1954), 2) cold-plate techniques for cooling miniature and subminiature equipment, 3) valves designed for operation at surface temperatures near 500° C., and 4) evaporation cooling of miniature transformers by means of fluorochromicals. The importance of the subject of heat transfer to designers of electronic equipment is stressed, and training programs at the Massachusetts Institute of Technology are mentioned.

621.316.546:621.3.018.756 3291
Fast-Rise Pulse Generator with High

Pulse Repetition Frequency—C. G. Dorn. (*Rev. Sci. Instrum.*, vol. 27, pp. 283–284; May, 1956.) Description of a single-pole multi-position switch in which mercury is ejected through a rotating nozzle on to a series of contact pins, thus generating pulses having a rise time <0.002 μ s, at repetition rates >10 kc, with peak pulse power of 50 w.

621.316.82 3292
On Concavity of Resistance Functions—H. M. Melvin. (*J. Appl. Phys.*, vol. 27, pp. 658–659; June, 1956.) A short proof is given of a theorem presented by Shannon and Hagebarger (1635 of 1956).

621.318.424 3293
Ferromagnetic Coupling between Crossed Coils—U. F. Gianola and D. B. James. (*J. Appl. Phys.*, vol. 27, pp. 608–609; June, 1956.) Discussion of the operation of devices comprising e.g., a toroidal and a solenoidal coil wound on a common cylindrical saturated ferromagnetic core; gating, coincidence, and signal storage applications are mentioned.

621.319.4 3294
Self-Healing in Metallized Paper Capacitors—C. B. Charlton. (*TMC Tech. J.*, vol. 6, pp. 27–41; March, 1955.) The physical and manufacturing techniques involved in the production of truly self-healing single-layer metallized-paper capacitors are described.

621.372.4 3295
Decomposition of the Derivative of the Impedance of a Two-Terminal Network—L. Lunelli. (*Alta Frequenza*, vol. 25, pp. 152–159; April, 1956.) Extension of theory presented previously (3183 of 1955).

621.372.54 3296
Design Data for Ladder Networks—E. Green. (*Marconi Rev.*, vol. 19, pp. 78–88; 2nd Quarter, 1956.) Design data for networks with up to nine branches and attenuation curves for networks with up to eleven branches are presented in expansion of previous work (1267 of 1953 and 2563 of 1955).

621.372.54.029.6 3297
Directional Channel-Separation Filters—S. B. Cohn and F. S. Coale. (*Proc. IRE*, vol. 44, pp. 1018–1024; August, 1956.) Networks are discussed which combine the properties of directional couplers with those of conventional filters; such networks are useful for channel combining and separating in microwave communication systems and in installations where a single antenna is shared by several systems. Designs using waveguides, coaxial and strip lines and lumped-constant circuits are indicated; the performance of some experimental filters is described.

621.372.542.21 3298
Low-Pass Filters for Metre Waves—O. Guarracino. (*Alta Frequenza*, vol. 25, pp. 161–168; April, 1956.) Filters intended for suppression of harmonics in m- λ measurements, and having cutoff frequencies of about 100–300 mc, comprise three LC II sections with lumped-constant components. The construction and method of adjustment are described.

621.372.543.2 3299
A Low-Pass/Band-Pass Frequency Transformation—K. B. Irani. (*Commun. News*, vol. 16, pp. 99–104; April, 1956.) A simple transformation is presented for converting a low-pass insertion-power ratio into a band-pass ratio; the technique facilitates the design of band-pass filters when the attenuation curves on either side of the pass band are required to be asymmetrical.

621.372.56.029.6:621.318.134 3300
A Unidirectional Attenuator with Delay

Line and Ferrite Element for the 4-Gc/s Frequency Band—W. Eichin. (*Nachrichtentechn. Z.*, vol. 9, pp. 168–172; April, 1956.) The attenuation afforded by various devices comprising ferrite tubes surrounding helical lines and in turn surrounded by tubular magnets was investigated experimentally; results are presented graphically. The attenuation obtained with the final design was about 1 db in the forward direction and 20 db in the blocking direction.

621.372.6:621.318.134 3301
Frequency Doubling and Mixing in Ferrites—J. E. Pippin. (*Proc. IRE*, vol. 44, pp. 1054–1055; August, 1956.) Analysis is presented indicating the particular polarization and frequency conditions under which frequency doubling and mixing will occur in ferrite devices of the type discussed by Ayres *et al.* (2138 of 1956).

621.372.6.012 3302
The Derivation of the Six-Terminal-Network Curve, its Graphical Interpretation and its Application in determining the Transformation Properties of Loss-Free Six-Terminal and Eight-Terminal Networks—H. Lucg. (*Arch. elektr. Übertragung*, vol. 10, pp. 151–162; April, 1956.)

621.373 3303
Tuned Circuits containing Negative Resistance—J. Gross. (*J. Appl. Phys.*, vol. 27, pp. 603–607; June, 1956.) Analysis indicates that the combination of a current-controlled negative resistance with a parallel-tuned circuit, or of a voltage-controlled negative conductance with a series-tuned circuit yields a bistable circuit rather than a self-sustaining oscillator.

621.373.42:621.396.61:621.376.32 3304
The Gain Characteristic inside the Pull-In Range particularly in F.M. Transmitters and Wobblers—Woschni. (See 3560.)

621.373.42.016.35 3305
Oscillator Frequency Stability—A. S. Gladwin. (*Wireless Engr.*, vol. 33, pp. 209–220; September, 1956.) The case of an oscillator connected to a mismatched load by a long feeder is considered. In addition to hysteresis effects, with resonant loads a type of instability occurs which takes the form of a periodic modulation of the oscillation frequency (see also 54 of 1956). Stability criteria appropriate to both effects are derived for various circuit arrangements. Results of experiments with a triode oscillator operating at 10 mc are reasonably consistent with the theory. In general, the hysteresis type of instability predominates.

621.373.421.11 3306
Novel Circuit for a Stable Variable-Frequency Oscillator—D. Makow. (*Proc. IRE*, vol. 44, pp. 1031–1036; August, 1956.) A circuit designed to reduce the effect of resonator frequency drift uses a multiloop feedback arrangement with three oscillators maintained at frequencies such that one is the sum of the other two, the sum frequency being controlled by a quartz crystal while the other two are controlled by variable LC resonators. The circuit and frequency-drift/temperature characteristics of an experimental oscillator are shown.

621.373.431.2:621.396.96 3307
'Hard-Tube' Pulsers for Radar—H. A. Reise. (*Bell Lab. Rec.*, vol. 34, pp. 153–156; April, 1956.) Developments in design of high-vacuum tubes make possible the construction of blocking-oscillator pulse modulators comparable in size and efficiency with line-type thyatron modulators, with advantages in stability resulting from the pulse shape.

- 621.373.5:621.314.7 3308
Current-Derived Resistance-Capacitance Oscillators using Junction Transistors—D. E. Hooper and A. E. Jackets. (*Electronic Engng.*, vol. 28, pp. 333-337; August, 1956.) Two circuits using 180° phase-shift networks, suitable for use at very low frequencies, and one with a 0° phase-shift network, giving a maximum frequency of 30 kc are described.
- 621.374 3309
Pulse Scaler Circuit with High Resolving Power—U. Pellegrini. (*Alta Frequenza*, vol. 25, pp. 130-139; April, 1956.) A circuit with a resolving time of 5×10^{-8} is based on a step-by-step capacitor charge and a rapid discharge process. The scaling factor can be varied from 2 to 10 without loss of stability. As a frequency divider, the circuit is limited to the range 200 kc-20 mc. Input pulses must be at least 2 v peak-to-peak.
- 621.374.3/4 3310
High-Frequency Electronic Counter—A. V. Lord and S. J. Lent. (*Wireless Engr.*, vol. 33, pp. 220-226; September, 1956.) A circuit suitable for the frequency divider following the 2-4-mc subcarrier generator in a color-television receiver is based on a triggered binary cascade with feedback. The high counting rate is achieved by incorporating a gating arrangement.
- 621.374.3:621.375.2 3311
An Input Amplifier for a Pulse-Height Analyser—A. Folkierski. (*J. Sci. Instru.*, vol. 33, pp. 187-191; May, 1956.) The analyzer described can be gated by pulses coincident with the pulses to be measured, the error introduced being <1 per cent of the maximum output pulse height. Variation of the input amplification enables the scale to be expanded for detailed examination of part of a spectrum.
- 621.374.32:621.318.57 3312
A Nine's Complement Decade Counter with Recorder—J. A. Phillips. (*Electronic Engng.*, vol. 28, pp. 344-349; August, 1956.) "A brief outline of decimal counting using weighted binary digits is given with special reference to systems giving complements of nine. A binary decade electronic counter arranged so as to allow the reading of nine's complements, which may be used to represent negative numbers is then described. In the circuit arrangement used in this counter the maximum counting rate remains the same as that of a simple binary counter. Recording of the number counted is made on 'Teledeltos' paper, the record and counter reset being carried out simultaneously."
- 621.374.33 3313
Gate selects Pulses for Spectrum Analysis—A. Ross and L. Simon. (*Electronics*, vol. 29, pp. 179-181; August, 1956.) A circuit permitting isolation of pulses from 0.2 to 150 μ s wide, at repetition rates up to 10,000 per sec., is described.
- 621.375.2 3314
Nonlinear Distortion and Stability of Reflex Circuits—Yu. A. Chernov. (*Radio-tekhnika, Moscow*, vol. 11, pp. 17-31; January, 1956.) Two single-tube and three two-tube hf-crystal-detector-lf reflex amplifier circuits are discussed. The coefficient of nonlinear distortion, k_f , is calculated for the various circuits and the results are plotted (Fig. 5) as a function of the parameter αA , the relative change of slope of the I_A/V_0 curve from the value at the working point, due to the applied lf signal; k_f can theoretically be made zero by using a pair of identical tubes in the circuit shown in Fig. 4. The stability criteria are also discussed.
- 621.375.2.024 3315
D.C. Decade Amplifier—W. G. Royce and W. D. Mathews. (*Tele-Tech and Electronic Ind.* vol. 15, pp. 90-91, 157; April, 1956.) The circuit incorporates RC and direct-coupled stages and a chopper stabilizing amplifier, giving a bandwidth of 0-100 kc, with a gain of 0-60 db in 20-db steps. The equivalent input dc drift is $\approx 10 \mu$ v; output is up to ± 35 v and ± 20 ma.
- 621.375.2.024:621.376.332 3316
Isolating Direct-Current Amplifiers—A. Chevallier and B. Prokocimer. (*Rev. Gén. Élect.*, vol. 65, pp. 199-203; April, 1956.) A circuit providing an output direct current or voltage proportional to an input direct voltage, and having no common point between input and output, uses a fixed-frequency crystal-controlled oscillator in conjunction with a discriminator whose phase is varied by means of an electromechanical modulator which converts the input signal into a capacitance variation. Several applications are mentioned.
- 621.375.221.029.5 3317
Wide-Band Linear R.F. Amplifier—B. F. Davies. (*Wireless World*, vol. 62, pp. 374-378; 446-449; August/September, 1956.) The amplifier described is designed for use with a common antenna to provide a distribution system for a ship. Frequency coverage is 150 kc-25 mc with suppression in the 400-535-kc and 1.6-3.8-mc bands; nominal gain is 15 db. Performance figures are given; the level of intermodulation and cross-modulation products is low.
- 621.375.226 3318
Synthesis of Amplifiers with Triple-Tuned Coupled Circuits—A. Smolinski. (*Archiwum Elektrotech.*, vol. 4, pp. 35-64. English summary, pp. 63-64; 1955.)
- 621.375.23.024:621.317.725 3319
Unity-Gain Voltmeter Amplifier—Hyder. (See 3485.)
- 621.375.3:621.318.435 3320
Behaviour of Saturable Reactors in Magnetic Amplifiers—P. N. Das. (*Indian J. Phys.*, vol. 39, pp. 129-142; March, 1956.) A detailed analysis is presented of the behavior of a magnetic amplifier in which the core material is assumed to have a square BH characteristic. Systems with single cores, two series-connected cores and two parallel-connected cores are considered, with dc sources of 1) infinite and 2) low impedance. Results are presented graphically; supporting experimental evidence is mentioned briefly.
- 621.375.4:621.314.7 3321
Measurement Considerations in High-Frequency Power Gain of Junction Transistors—Pritchard. (See 3566.)
- 621.375.4:621.396.96 3322
Transistor Amplifier for Radar Video—R. Leslie. (*Electronics*, vol. 29, pp. 142-145; August, 1956.) The design of a video amplifier using Si transistors, suitable for airborne radar systems, is discussed. High-frequency compensation is obtained by RC degenerative feedback in a grounded-emitter circuit with temperature stabilization of emitter-current bias.
- 621.375.4.029.3:534.86 3323
Transistor Preamps—H. F. Starke. (*Audio*, vol. 40, pp. 31-32; 73; April, 1956.) Discussion of practical design considerations for preamplifiers for use 1) with gramophones with a boosted low-frequency response and a flat-response main amplifier, and 2) with microphones, the preamplifier in this case having a flat response.
- 621.375.4.029.3:621.314.7 3324
A 200-mw Amplifier employing Transistors—(Mullard Tech. Commun., vol. 2, pp. 210-216; April, 1956.) The af amplifier described comprises an input stage, a driver, and a Class-B stage, with over-all feedback; the maximum output is 215 mw, measured at 400 cps, with 10 per cent total harmonic distortion, mainly third harmonic. The sensitivity at the 2.5-k Ω input terminal is about 6 mv. Minimum total distortion is 1.7 per cent, at an output of about 15 mw.
- 621.376.332 3325
Design of a Single Linear Frequency Discriminator—K. G. Fancourt and J. K. Skwirzynski. (*Marconi Rev.*, vol. 9, pp. 61-77; 2nd Quarter, 1956.) The discriminator described consists essentially of two tuned circuits with the parameters chosen to minimize second and third harmonics. Design information is presented in graphs.

GENERAL PHYSICS

- 534.01:519.2 3326
Statistical Properties of a Moving Waveform—M. S. Longuet-Higgins. (*Proc. Camb. Phil. Soc.*, vol. 52, pp. 234-245; April, 1956.)
- 537/538].081 3327
The Giorgi System of Units and the Rationalization of the Equations of Electricity—A. Ilivici. (*Rev. Gén. Élect.*, vol. 65, pp. 245-251; April, 1956.)
- 537.2:621.3.011.1 3328
New Theorems on the Electrostatic Field—B. Konorski. (*Archiwum Elektrotech.*, vol. 4, pp. 65-157. German summary, pp. 155-157; 1955.) The "law of least capacitance" is discussed; the concept of the "intermediate electrode" is introduced to facilitate the formulation. A system of two cylinders with parallel axes is considered, and an examination is made of the variation of the total capacitance of the system on displacing the imaginary intermediate electrode constituted by an infinitely thin metal sheet shaped to coincide with one of the equipotential surfaces. The analysis is extended to systems of spheres and other geometrical forms. Formulas giving attractive and repulsive forces for numerous particular cases are tabulated.
- 537.29:537.56:621.385.833 3329
Field Ionization of Gases at a Metal Surface and the Resolution of the Field Ion Microscope—E. W. Müller and K. Bahadur. (*Phys. Rev.*, vol. 102, pp. 624-631; May, 1956.)
- 537.29:539.233:621.385.833 3330
Field Desorption—E. W. Müller. (*Phys. Rev.*, vol. 102, pp. 618-624; May, 1956.) Report of a study of the action of strong electric fields in removing adsorbed films of Ba, Th, etc., from a w surface, using a field-emission microscope and maintaining the metal surface positive.
- 537.311.1 3331
Electronic Conduction in Solids with Spherically Symmetric Band Structure—R. Barrie. (*Proc. Phys. Soc.*, vol. 69, pp. 553-561; May, 1956.) Elastic scattering of electrons by ionized impurities, and inelastic scattering by the nonacoustical modes of the lattice vibrations in a homopolar crystal, are discussed for electrons whose energy is a nonquadratic function of the wave number vector.
- 537.311.1 3332
Acceleration of Electrons by an External Force Field—E. N. Adams and P. N. Argyres. (*Phys. Rev.*, vol. 102, pp. 605-606; May, 1956.) "The usual proof that an electron in an energy band reacts to an external force as though it had an effective mass is shown to be invalid. It is shown, however, that for static externally applied fields, modified (field-dependent) energy bands can be found for which the acceleration theorem is rigorously correct."
- 537.311.62:537.312.62 3333
The Penetration Depth in Impure Superconducting Tin—R. G. Chambers. (*Proc.*

Camb. Phil. Soc., vol. 52, pp. 363-375; April, 1956.) "A new method is described for measuring the surface impedance of metals at low temperatures and at radio-frequencies. Using this method, the surface impedance of normal tin and the penetration depth λ in superconducting tin have been studied at about 9 mc frequency as a function of impurity content. The measured surface impedances agree well with the values expected, and the penetration depths increase with impurity content, in confirmation of Pippard's observations [*Proc. Roy. Soc. A.* vol. 216, pp. 547-568; February 24, 1953] at 9400 mc."

537.311.62:538.569.4 3334

Cyclotron Resonance under Anomalous Skin-Effect Conditions—R. G. Chambers. (*Phil. Mag.*, vol. 1, pp. 459-465; May, 1956.) Results to be expected from attempts to observe cyclotron resonance in metals are discussed.

537.5 3335

Mobility and Space Charge of Ions in Nonuniform Field—Yu. M. Kagan and V. I. Perel'. (*C.R. Acad. Sci. U.R.S.S.*, vol. 108, pp. 222-225; In Russian, May 11, 1956.) The equations developed lead to a generalization of the Child-Langmuir 3/2-power law to cover the case of arbitrary pressures.

537.5 3336

The Carrier Density in a Plasma and its Determination by means of the Pulse Probe—D. Kamke and H. J. Rose. (*Z. Phys.*, vol. 145, pp. 83-115; April 9, 1956.) The pulse method discussed does not depend on particular assumptions regarding the transition layer between the unipolar (Langmuir) layer and the undisturbed plasma. Theory, apparatus, and experimental results are described. Over 40 references.

537.52 3337

Statistical Study of Electron Avalanches in Gaseous Discharge—S. Kojima and K. Kato. (*J. Phys. Soc. Japan*, vol. 11, pp. 322-326; March, 1956.) For low pressures the pulse size distribution at potentials below the breakdown value agreed with that given by the Townsend theory, assuming the absence of space charge. At atmospheric pressure the discharge was modified, probably by space charge, and pulse size tended to become uniform.

537.525 3338

Starting of an Electrical Gas Discharge in a Uniform Alternating Field—W. Fucks, L. Graf, G. Mues, and H. G. Müller. (*Z. Phys.*, vol. 145, pp. 1-19; April 9, 1956.) In the subcritical range, i.e., when the half-period of the alternating field is greater than the duration of an ionization step, the number of ionization steps in a half-period varies with frequency and with field strength. Over this range, the breakdown-voltage/frequency characteristic is positive, but beyond a certain value of frequency it becomes negative, later undergoing a further inflection, so that at a frequency of 2×10^8 cps it is again positive. Comprehensive experimental results illustrating these phases and the influence of pressure and electrode separation on them are presented.

537.525.92:537.56 3339

'Contact' Phenomena in Plasma—L. A. Sena and N. S. Taube. (*Zh. eksp. teor. Fiz.*, vol. 30, pp. 287-290; February, 1956.) Discontinuities of potential between parts of a plasma which differ in electron concentration and temperature are considered theoretically by the classical contact-potential theory of metals. The validity of this treatment is confirmed experimentally.

537.533:537.312.62 3340

Investigation of Electron Emission from Superconductors—F. Bedard, H. Meissner,

and G. E. Owen. (*Phys. Rev.*, vol. 102, pp. 667-670; May 1, 1956.)

537.533:537.534.8 3341

Secondary Electron Emission from Metals under the Action of Ions and Neutral Particles—V. G. Tel'kovski. (*C.R. Acad. Sci. U.R.S.S.*, vol. 108, pp. 444-446; In Russian; May 21, 1956.) Experimental results obtained by bombardment of clean metals with ions of H, He, N, Ne, Ar, and Mo and neutral atoms of the inert gases show that the coefficient of secondary emission increases linearly at particle velocities up to 2×10^8 cm; for proton bombardment a maximum occurs at a velocity of 2.5×10^8 cm.

537.533.7 3342

Investigation of Characteristic Energy Losses by the Retarding-Field Method—G. Haberstroh. (*Z. Phys.*, vol. 145, pp. 20-43; April 9, 1956.) The energy distribution of electrons and the angular distribution of their paths after passage through thin foils of Al, Ag, Ge, and Al_2O_3 are studied.

537.533.8 3343

Dependence of Secondary Electron Emission upon Angle of Incidence of 1.3-MeV Primaries—R. A. Shatas, J. F. Marshall, and M. A. Pomerantz. (*Phys. Rev.*, vol. 102, pp. 682-686; May 1, 1956.)

537.533.8:537.226 3344

Secondary Electron Emission from Dielectrics—A. R. Shul'man. (*Zh. Tekh. Fiz.*, vol. 25, pp. 2150-2156; October, 1955.) Experiments are described in which, in order to avoid changes in the structure of the target due to electron bombardment, the primary beam was switched on for only 10-30 μ s, so that there was one incident electron for about 10^8 atoms of the emitter surface, and the destruction of the target could therefore be neglected. The results obtained are different from those usually quoted; a new interpretation of the phenomenon is given.

537.56:538.56 3345

Model for Collision Processes in Gases: Small-Amplitude Oscillations of Charged Two-Component Systems—E. P. Gross and M. Krook. (*Phys. Rev.*, vol. 102, pp. 593-604; May 1, 1956.) Continuation of work reported previously [2633 of 1954 (Bhatnagar et al.)].

537.562:538.561:523.16 3346

Large-Amplitude Plasma Streaming and Charge Segregation—R. W. Lenz. (*Z. Naturf.*, vol. 10a, pp. 766-776; September/October, 1955.) See 1015 of 1955; see also *ibid.*, pp. 761-765.

538.311:538.65 3347

The Magnetostatic Force on Two Circular Cylindrical Conductors carrying Uniform Steady Currents—E. E. Jones. (*J. Franklin Inst.*, vol. 261, pp. 397-408; April, 1956.) The magnetic field due to two parallel conductors in a nonuniform magnetic field is determined for the case when the conductor material is magnetic. General expressions are deduced for the magnetostatic force and are investigated for particular examples.

538.5:621.313 3348

Fluid Self-Excited Dynamo—L. Davis, Jr. (*Phys. Rev.*, vol. 102, pp. 939-940; May 15, 1956.) "The possibility that a simply connected perfectly conducting fluid body could generate an increasing external magnetic field by acting as a self-excited dynamo is demonstrated by exhibiting a cycle of motions that doubles the external field each cycle. The essential feature of the motion is that interior points become surface points."

538.56:544.68:535.33 3349

Analysis of Traces of Impurities in Rare Gases by Ultra-high-Frequency Excitation of

Optical Radiation—M. Servigne, P. Guérin de Montgareuil, and D. Dominé. (*C.R. Acad. Sci., Paris*, vol. 242, pp. 2827-2830; June 11, 1956.) Technique is discussed in which a cell, filled at low pressure with the gas to be analyzed, is arranged in the field of a continuous microwave oscillation generated by a magnetron.

538.561:537.533 3350

Čerenkov Radiation from Extended Electron Beams near a Medium of Complex Index of Refraction—H. Lashinsky. (*J. Appl. Phys.*, vol. 27, pp. 631-635; June, 1956.) Extension of the theory presented by Danos (1628 of 1955). If ferrites are used in place of simple dielectric media, the radiated power can, under suitable conditions, be increased.

538.566:537.562 3351

Variation with Electron Energy of the Collision Cross Section of Helium for Slow Electrons—J. M. Anderson and L. Goldstein. (*Phys. Rev.*, vol. 102, pp. 933-938; May 15, 1956.) Continuation of previous work on the interaction of microwaves in gas-discharge plasmas (1383 of May and back references). Momentum transfer between He atoms and electrons with energies between 0.04 and 0.4 eV is investigated, the electron density being not less than about 10^{19} /cm³. Experimental results appear to indicate a slight variation of momentum transfer with electron energy.

538.6 3352

Motion of a Sphere through a Conducting Fluid in the Presence of a Strong Magnetic Field—K. Stewartson. (*Proc. Camb. Phil. Soc.*, vol. 52, pp. 301-316; April, 1956.)

537.5 3353

Basic Processes of Gaseous Electronics [Book Review]—L. B. Loeb. Publishers: University of California Press, Berkeley and Los Angeles; Cambridge University Press, London, 1012 pp., 1955. (*Brit. Commun. Electronics*, vol. 3, p. 214; April, 1956.) A comprehensive review.

538.566:535.4 3354

Scattering and Diffraction of Radio Waves [Book Review]—J. R. Mentzer. Publishers: Pergamon Press, London, and New York, vol. 2, p. 301; May, 1955.) One of a series of monographs on *Electronics and Waves*; mathematical methods are indicated for solving problems encountered in the study of radar performance and antenna systems.

GEOPHYSICAL AND EXTRATERRESTRIAL PHENOMENA

523:538.3:550.38 3355

Hydromagnetic Dynamo Theory—W. M. Elsasser. (*Rev. Mod. Phys.*, vol. 28, pp. 135-163; April, 1956.) The equations of magnetohydrodynamics are used to study the mechanism whereby cosmic magnetic fields such as those of the earth, of sunspots and the sun, and of magnetic stars are generated and maintained.

523.16 3356

The Nature of Radiation from Radiogalaxy NGC 4486—I. S. Shklovski. (*Astronom. Zh.*, vol. 32, pp. 215-225; English summary. May/June, 1955.) The continuous optical radiation from the "jet" in the core of the galaxy is explained quantitatively by the presence of relativistic electrons with energies of 10^{11} - 10^{13} eV moving in a magnetic field of approximately 10^{-4} g; relativistic electrons with energies of 10^8 - 10^9 eV diffusing into the galaxy are probably the source of rf emission.

523.16:523.42 3357

Impulsive Radio Signals from the Planet Venus—J. D. Kraus. (*Nature, Lond.*, vol. 178, p. 33; July 7, 1956.) Report of reception at the Ohio State University of radiation at a

- wavelength of 11 m. The observations were made using an interferometer array of horizontal $\lambda/2$ elements with reflectors. The peak power in a burst is estimated to be about 40 w per cps of bandwidth; this is about 0.003 of the value estimated for a burst from Jupiter. On the basis of power considerations, the mechanism involved could be of lightning-discharge type. A record obtained on May 30, 1956 is reproduced and discussed *ibid.*, vol. 178, pp. 103-104; July 14, 1956.
- 523.16:523.42 3358
Class II Radio Signals from Venus at a Wave-length of 11 Metres—J. D. Kraus. (*Nature, Lond.*, vol. 178, pp. 159-160; July 21, 1956.) Reception of radiation with a different waveform from that discussed previously (3357 above) is reported; this radiation, designated class II, is of a more sustained nature, lasting for a second or longer and varying at an af rate, e.g., 125 cps. A record of a series of pulses observed on June 4, 1956 is shown. The radiation appears to have a bandwidth of at least 2 mc. On studying tape recordings, signals resembling echoes were noted; these may be due to reflection from the moon.
- 523.16:537.562:538.561 3359
Large-Amplitude Plasma Streaming and Charge Segregation—Larenz. (See 3346.)
- 523.16:621.396.11:551.510.535 3360
On the Propagation of Radio Waves through the Upper Ionosphere—Ellis. (See 3514.)
- 523.16+528.5+551.594.5]:551.510.535:621.396.11.0.029.6 3361
Review of Ionospheric Effects at V.H.F. and U.H.F.—Little, Rayton, and Roof. (See 3519.)
- 523.5:537.56 3362
Inadequacy of Recombination as the Source of Light from Enduring Meteor Trains—G. S. Hawkins and A. F. Cook. (*Nature, Lond.*, vol. 178, pp. 161-162; July 21, 1956.) Critical discussion of the suggestion made by Öpik (3592 of 1955) that the column of light produced by a meteor is due to recombination of the meteoric ions and free electrons.
- 523.72:523.78 3363
Observations of Solar Radio Radiation during the Eclipse of June 30th, 1954: Part I—O. Czyżewski, J. de Mezer, and A. Strzalkowski. (*Acta Geophys. Polon.*, vol. 3, pp. 155-160; 1955. In English.) Observations made at Cracow, using apparatus operating at about 1 m λ with a parabolic aerial of diameter 5 m, are reported. Records for July 12th and 13th are shown for comparison with those for the eclipse day.
- 550.385:523.7 3364
A Note on the Annual Variation of Geomagnetic Activity and M-Regions—J. N. Tandon. (*J. Geophys. Res.*, vol. 61, pp. 211-213; June, 1956.) "Results of an investigation are given associating recurrent 27-day geomagnetic activity with M-regions of the sun, around years of sunspot minima. The association of M-sequences with various solar features of the disk and corona is also indicated." For a longer account of related work, see *Indian J. Phys.*, vol. 30, pp. 153-168; April, 1956.
- 551.51 3365
Charge Transfer in the Upper Atmosphere—S. N. Ghosh. (*J. Geophys. Res.*, vol. 61, pp. 193-200; June, 1956.) Collision processes involving charged solar particles entering the upper atmosphere are discussed. Charge-transfer reactions involving solar H^+ and Ca^+ ions are likely to excite spectrum lines of these elements and of the atmospheric gases; in the case of H^+ , at auroral levels. The ratio of the density of O^+ to O_2^+ ions and the effective recombination coefficient for the F layer are derived.
- 551.510.3 3366
On a Pitot-Tube Method of Upper-Atmosphere Measurements—Vi-Cheng Liu. (*J. Geophys. Res.*, vol. 61, pp. 171-178; June, 1956.) A method is presented for deducing atmospheric density, pressure, and temperature at heights up to 80 km.
- 551.510.3:535.325 3367
Thermodynamic Method for Measurement of the Refractive Index of the Atmosphere. Description of the Radiosonde MD1—P. Misme. (*Ann. télécommun.*, vol. 11, pp. 81-84; April, 1956.) Apparatus is described which is capable of determining the distribution of temperature, pressure, and humidity variations with a fineness sufficient for radio-propagation calculations.
- 551.510.5:551.593.9 3368
The Altitude of the (OI) 5577A Line in the Night Airglow measured from a Rocket—O. E. Berg, M. Koomen, L. Meredith, and R. Scolnik. (*J. Geophys. Res.*, vol. 61, pp. 302-303; June, 1956.) Measurements using rocket-borne photometers show that the layer from which the λ 5577 line originates lies between 70 and 105 km, with peak luminosity between 90 and 95 km.
- 551.510.5:551.593.9 3369
Distribution of the Night Airglow (OI) 5577A and Na D Layers measured from a Rocket—M. Koomen, R. Scolnik and R. Tousey. (*J. Geophys. Res.*, vol. 61, pp. 304-306; June, 1956.) An experiment similar to that described by Berg *et al.* (3368 above) confirms the results for the λ 5577 line and shows that the sodium D lines are excited in a layer of altitude between 70 and 95 km.
- 551.510.52 3370
Determination of the Alpha-Ray Emission of Materials constituting the Earth's Surface—V. F. Hess, V. J. Kisselbach, and H. A. Miranda, Jr. (*J. Geophys. Res.*, vol. 61, pp. 265-271; June, 1956.) It is concluded, from measurements, that α -ray emission is not an important factor in the ionization balance of the lower atmosphere.
- 551.510.535+523 3371
Influence of Magnetic Field on Convective Instability in the Atmospheres of Stars and in the Ionosphere of the Earth—B. N. Gershman and V. L. Ginzburg. (*Astronom. Zh.*, vol. 32, pp. 201-208; May/June, 1955.) The case of a medium with anisotropic electrical and thermal conductivities is considered. In a plasma which does not contain a large number of neutral particles the calculated influence of the magnetic field on convection is essentially different from that predicted by the magnetohydrodynamic approximation; in the ionosphere the influence of the magnetic field is small owing to the presence of a large number of molecules. See also 2290 of 1955.
- 551.510.535 3372
Electron Resonance in Ionospheric Waves—C. O. Hines. (*J. Atmos. Terr. Phys.*, vol. 9, pp. 56-70; July, 1956.) Certain features of large-scale traveling disturbances in the F layer are explained as electron-resonance effects, whereby small initial disturbances are amplified. Estimates of ionospheric parameters based on this interpretation are in good agreement with values to be expected.
- 551.510.535 3373
Two Types of Development of the E₂ Layer at Ahmedabad—R. G. Rastogi. (*J. Atmos. Terr. Phys.*, vol. 9, pp. 71-72 and plates; July, 1956.) The sequence of phenomena leading to the separation of E₂ and E₁ layers after high-level sunrise is summarized and illustrated by photographic records. The existence of a layer which is photoionized by solar radiation at a height of about 150 km is indicated.
- 551.510.535 3374
World-Wide Spread F—G. Reber. (*J. Geophys. Res.*, vol. 61, pp. 157-164; June, 1956.) Records from widely distributed ionosphere stations for the period of the last complete sunspot cycle show that the spread-F equator is roughly parallel to the geomagnetic equator, swinging $\pm 25^\circ$ of latitude over the cycle.
- 551.510.535:523.72 3375
The Solar X-Ray Spectrum and the Density of the Upper Atmosphere—E. T. Byram, T. A. Chubb, and H. Friednan. (*J. Geophys. Res.*, vol. 61, pp. 251-263; June, 1956.) Data derived from rocket experiments give a measure of the flux density of solar X rays incident on the E layer. From the rate of X-ray absorption at heights between 128 and 110 km the atmospheric density is computed to be about one-third of the current Rocket Panel average values.
- 551.510.535+550.385]:523.75 3376
Ionospheric Effects produced by Solar Flare Radiation—V. Agy. (*Phys. Rev.*, vol. 102, pp. 917; May 1, 1956.) Comment of 423 of 1956 (Sedra and Hazzaa).
- 551.510.535:523.78 3377
The Effective Recombination Coefficients in the E and F₁ Layers during the Solar Eclipse of 25 February 1952—C. M. Minnis. (*J. Atmos. Terr. Phys.*, vol. 9, pp. 36-44; July, 1956.) The contribution to the E layer ionization of each of two isolated sources of radiation assumed to exist near the east and west limbs of the sun is derived and expressed as a linear function of $1/\alpha'$, where α' is the effective recombination coefficient during the eclipse. On equating the corresponding functions for Khartoum and Ibadan it is found that for both places $\alpha'_E = 1.2 \times 10^{-6} \text{cm}^3 \text{s}^{-1}$ as against the value $1.5 \times 10^{-6} \text{cm}^3 \text{s}^{-1}$ obtained for Khartoum on assuming that the intensity of ionizing radiation fell to zero at second contact (2298 of 1955). For the F₁ layer it is concluded that $\alpha'_{F_1} = 0.65 \times 10^{-6} \text{cm}^3 \text{s}^{-1}$.
- 551.510.535:523.78 3378
Interpretation of Ionospheric Measurements made during Solar Eclipses—C. M. Minnis. (*Nature, Lond.*, vol. 178, pp. 33-34; July 7, 1956.) By combining observational data obtained at Khartoum and Ibadan during the eclipse of 1952, a determination is made of the recombination coefficient in the E layer; the most probable value is 1.2. This result is at variance with the conclusions reached by Hunaerts and Nicolet (1412 of 1956), and implies absence of radiation from the corona. See also 3377 above.
- 551.510.535:523.78 3379
Ionospheric Observations during the Solar Eclipse of 30th June 1954—B. Landmark, F. Lied, T. Orhaug, and S. Skribeland. (*Geophys. Publ.*, vol. 19, pp. 1-39; 1956) Records of hf were obtained in Norway at Tromsya (100 per cent obscuration), Kjeller (96 per cent) and Tromsø (66 per cent). Strong E_s ionization prevented the accurate observation of f_0E , but f_0F_1 was reliable and, assuming complete cutoff of the ionizing radiation at totality, gave $\alpha_E = 1.7 \times 10^{-6} \text{cm}^3 \text{s}^{-1}$ at Tromsya. The F₁-layer data are consistent with a solar model in which 14 per cent and 5 per cent of the radiation was emitted from areas near the west and east limbs respectively; 10 per cent originated in an undefined area which may cover the greater part of the sun's disk. The changes in f_0F_2 indicate a marked solar control of the F₂ layer and, assuming a recombination law, give $\alpha_{F_2} \approx 3 \times 10^{-6} \text{cm}^3 \text{s}^{-1}$. Measurements of D-region absorption are consistent with the solar model deduced from the F₁-layer data, and give $\alpha_D N_0 = 13 \times 10^{-4} \text{s}^{-1}$. A theoretical treatment is given of the eclipse changes in the D region.

551.510.535:550.385 3380

Systematic Investigations of the Influence of Geomagnetic Activity on the Nocturnal Critical Frequencies of the F_2 Layer—G. Lange-Hesse. (*Arch. Elekt. Übertragung*, vol. 10, pp. 139–144; April, 1956.) Results of a statistical analysis of data covering a period of $6\frac{1}{2}$ years are presented graphically. The probability that a geomagnetic activity index C_k of magnitude $1.2 \leq C_k \leq 2.0$ determined over a 24-hour period 1800–1800, is followed by an ionospheric storm is 80 per cent in the summer of a sunspot maximum year and 60 per cent in winter; the corresponding figures for a 0600–0600 C_k index in a sunspot minimum year are 75 per cent and 55 per cent respectively. See also 2942 of 1954.

551.510.535:621.396.11 3381

Ionospheric Absorption at Dakar—Delobau and Suchy. (See 3513.)

551.510.535:621.396.11 3382

Calculation of Charge Density Distribution of Multilayers from Transit-Time Data—J. Shmoys and S. N. Karp. (*J. Geophys. Res.*, vol. 61, pp. 183–191; June, 1956.) A method is discussed for calculating the electron-density distribution in the ionosphere from data obtained using a rocket-borne variable-frequency transmitter, or pulse reflections from higher layers. It is not possible to obtain a solution free from ambiguity.

551.594.5 3383

Characteristics of Auroras caused by Angular Dispersed Protons—A. Omholt. (*J. Atmos. Terr. Phys.*, vol. 9, pp. 18–27; July, 1956.)

551.594.5:551.510.535 3384

Secondary Processes due to Absorption of the Lyman Lines emitted from Aurorae—A. Omholt. (*J. Atmos. Terr. Phys.*, vol. 9, pp. 28–35; July, 1956.) Discussion indicates that the α line of the hydrogen Lyman series emitted from auroras may be effective in ionizing NO in the lower atmosphere, but not to the extent required for polar blackouts. Absorption of the Lyman β line by oxygen atoms is not significant in ordinary auroras.

551.594.6 3385

On the Waveform of a Radio Atmospheric at Short Ranges—J. R. Wait. (*Proc. IRE*, vol. 44, p. 1052; August, 1956.) Calculated values for the waveform at various distances up to 200 km from the discharge are shown graphically; the ionospherically reflected wave is not taken into account, and the discharge producing the atmospheric is represented by an idealized function.

LOCATION AND AIDS TO NAVIGATION

621.396.933:621.396.676 3386

TACAN Radio Bearing and Distance System for Aerial Navigation—(*Elect. Commun.*, vol. 33, pp. 2–100; March, 1956.) A symposium comprising the following papers:

Development of TACAN at Federal Telecommunication Laboratories—P. C. Sandretto (pp. 4–10).

Principles of TACAN—R. I. Colin and S. H. Dodington (pp. 11–25).

TACAN Ground Beacon AN/URN-3—II. B. Scarborough (pp. 26–34).

Antenna for the AN/URN-3 TACAN Beacon—A. M. Casabona (pp. 35–59).

Airborne TACAN Equipment AN/ARN-21—S. H. Dodington (pp. 60–64).

British TACAN Equipment (pp. 65–66).

Experimental Determination of TACAN Bearing and Distance Accuracy—E. De-Faymoreau (pp. 67–73).

Coordinated-System Concept of Air Navigation—P. C. Sandretto (pp. 74–79).

Quartz-Crystal Control at 1000 Mc/s—S. H. Dodington (pp. 80–84).

Error Reduction in TACAN Bearing-Indication Facility—M. Masonson (pp. 85–100).

For a short description of TACAN, see 125 of 1956.

621.396.962.3 3387

Marconi Coherent M.T.I. Radar on 50 cm—E. Eastwood, T. R. Blakemore, and B. J. Witt. (*Marconi Rev.*, vol. 19, pp. 53–60; 2nd Quarter, 1956.) The Type-S.232 equipment for airport terminal work is described. The pulse length is 2 or 4 μ s, and the repetition rate 500–800 s.

621.396.962.38 3388

Some Problems of Secondary Surveillance Radar Systems—K. E. Harris. (*J. Brit. IRE*, vol. 16, pp. 355–382; July, 1956.) Systems comprising a ground interrogator and airborne transponders, for air-traffic control, are discussed. The choice of operating frequency is governed by international allocations, availability of components, and required horizontal definition. Systems are classified as dependent or independent according as they do or do not use the primary radar transmitter as interrogator. The scanning and display arrangements may also be either associated or dissociated. Side-lobe effects can be eliminated by either responder or interrogator suppression. Other problems considered include transponder saturation and methods of count-down, the "capture" of airborne units by one ground station to the exclusion of others, second-time-round signals, unlocked responses due to remote ground stations, and coding.

621.396.969.3 3389

Automatic Tracking Radar Systems—P. Bouvier. (*Onde Elect.*, vol. 36, pp. 336–347; April, 1956.) The operating principles of the system are explained and French equipment in large-scale production is briefly described; the wavelength used is 10 cm.

621.396.969.3 3390

Some Limiting Cases of Radar Sea Clutter Noise—A. H. Schooley. (*Proc. IRE*, vol. 44, pp. 1043–1047; August, 1956.) Analysis is presented yielding limiting values of the effective radar scattering area per unit area of the sea surface, as a function of the radar depression angle, for perfectly smooth and for rough surfaces. Some experimental data supporting the theory are also presented.

MATERIALS AND SUBSIDIARY TECHNIQUES

531.788.7 3391

Absolute Determination of Pressure using the Ionization Gauge—R. P. Henry. (*Le Vide*, vol. 11, pp. 54–63; March/April, 1956.)

533.5:546.49 3392

Technology and Application of Mercury in Vacuum Technique—W. Espe. (*Nachr. Tech.*, vol. 6, pp. 155–161; April, 1956.) A survey with 59 references.

533.56 3393

Diffusion Pump using Freon 12—J. Delcher, R. Geller, G. Mongodin, and F. Prévot. (*Le Vide*, vol. 11, pp. 78–80; March/April, 1956.)

535.215 3394

Infrared Response of Pyrolyzed Organic Films—J. F. Andrew. (*J. Opt. Soc. Amer.*, vol. 46, pp. 209–214; March, 1956.) Report of an experimental investigation of photoconduction in films prepared by pyrolysis of cellophane and orlon.

535.215:538.569 3395

Study of Crystallized P_2Zn_3 at Low Temperatures—J. Lagrenaudie. (*J. Phys. Radium*, vol. 17, pp. 359–362; April, 1956.) An experimental investigation of photoconduction and photomagnetolectric effect in this material is reported. The existence of traps at several

levels is demonstrated. The results are compared with those for TE.

535.215:546.811-3 3396

Relaxation of Photoconductivity of Stannic Oxide—A. I. Andrievski and V. A. Zhuravlev. (*C.R. Acad. Sci. U.R.S.S.*, vol. 108, pp. 43–46; May 1, 1956. In Russian.) Relaxation times of 20–3000 s were observed in different specimens; each specimen possessed several relaxation times, the magnitudes and numbers of which varied with the intensity of illumination. These results are discussed.

535.37 3397

Contribution to the Problem of Non-stoichiometry in Oxygen-Dominated Phosphors—J. L. Ouweltjes and W. L. Wanmaker. (*J. Electrochem. Soc.*, vol. 103, pp. 160–165; March, 1956.)

535.376 3398

Field-Induced Color Shift in Electroluminescent Zinc Sulfide—J. F. Waymouth and F. Bitter. (*Phys. Rev.*, vol. 102, pp. 686–689; May 1, 1956.)

537.226/.228.1:546.431.824-31 3399

Preparation of Barium Titanyl Oxalate Tetrahydrate for Conversion to Barium Titanate of High Purity—W. S. Clabaugh, E. M. Swiggard, and R. Gilchrist. (*J. Res. Nat. Bur. Stand.*, vol. 56, pp. 289–291; May, 1956.)

537.226/.228.1:546.431.824-31 3400

Anomalous Polarization in Undiluted Ceramic $BaTiO_3$ —H. L. Blood, S. Levine, and N. H. Roberts. (*J. Appl. Phys.*, vol. 27, pp. 660–661; June, 1956.) Experimental results are presented and briefly discussed; observed deviations from normal ferroelectric behavior may be related to those discussed by Känzig (e.g. 2988 of 1955).

537.226/.227 3401

Structure and Phase Transitions of Ferroelectric Sodium-Cadmium Niobates—B. Lewis and E. A. D. White. (*J. Electronics*, vol. 1, pp. 646–664; May, 1956.) Report of a detailed experimental investigation. Sodium-cadmium niobates form single-phase solid solutions of perovskite type, the cadmium niobate entering as $CdNb_2O_6$ rather than $Cd_2Nb_2O_7$. The ferroelectric properties are associated with a doubled unit cell, whereas antiferroelectric sodium niobate has a quadrupled cell. Over a range of composition and temperature the ferroelectric and antiferroelectric structures coexist. See also 2087 of 1956.

537.226/.227:537.227 3402

High Permittivity of Niobates and Tantalates of Divalent Metals—G. A. Smolenski, V. A. Isupov, and A. I. Agranovskaya. (*C.R. Acad. Sci. U.R.S.S.*, vol. 108, pp. 232–235; May 11, 1956. In Russian.) The dielectric constant at 1 kc and its temperature coefficient, and the loss tangent at 1 kc and temperature 20° C. are tabulated for niobates, metaniobates, tantalates, and metatantalates of Ca, Cd, Sr, Pb, and Ba. The curves presented show that $Sr_2Ta_2O_7$ is ferroelectric; the maxima of the ϵ and $\tan \delta$ temperature curves for $CdNb_2O_6$ are due not to a ferroelectric phase transition but to electronic processes.

537.227 3403

Spontaneous Polarization of Guanidine Aluminum Sulfate Hexahydrate at Low Temperatures—A. G. Chynoweth. (*Phys. Rev.*, vol. 102, pp. 1021–1023; May 15, 1956.) The spontaneous polarization of this material [2415 of 1956 (Holden *et al.*)] was investigated by observing the pyroelectric effect, using the method described in 1745 of 1956. The results indicate that the spontaneous polarization and the specific heat are smooth functions of temperature over the range from room temperature down to -180° C.; there is no evidence of a phase transition or Curie point.

- 537.227 3404
Ferroelectricity in the Alums—R. Pepinsky, F. Jona, and G. Shirane. (*Phys. Rev.*, vol. 102, pp. 1181–1182; May 15, 1956.) Measurements on a large number of alums indicate that some are ferroelectric, others antiferroelectric. The dielectric-constant/temperature curve and hysteresis loops are presented for methylammonium aluminium sulphate dodecahydrate (MASD), which is typical of the ferroelectric alums.
- 537.227 3405
Ferroelectric Properties of Solid Solutions of (Pb,Ba)SnO₃, Pb(Ti,Sn)O₃ and Pb(Zr,Sn)O₃—G. A. Smolenski, A. I. Agronovskaya, A. M. Kalinina, and T. M. Fedotova. (*Zh. Tekh. Fiz.*, vol. 25, pp. 2134–2142; October, 1955.) A report is presented on an experimental investigation. The main conclusions reached are: 1) solid solutions of (Ba,Pb)SnO₃ possess ferroelectric properties; as distinct from other ferroelectrics, their central ions do not possess the electron structure of the atom of a noble gas; 2) the transition temperature of these solid solutions is displaced towards lower temperatures as the BaSnO₃ content increases; 3) solid solutions of Pb(Ti,Sn)O₃ and Pb(Zr,Sn)O₃ are characterized by high transition temperatures even for a high content of PbSnO₃; 4) two phase transitions are observed in solid solutions of Pb(Zr,Sn)O₃.
- 537.227:546.431.824-31 3406
Surface Space-Charge Layers in Barium Titanate—A. G. Chynoweth. (*Phys. Rev.*, vol. 102, pp. 705–714; May 1, 1956.) Effects of the type discussed by Känzig (2988 of 1955) are investigated experimentally using technique described previously (1745 of 1956). From the waveforms of the pyroelectric current signals, it is tentatively concluded that space-charge layers up to 10⁻⁸ cm thick exist at the surface of single crystals, and that these space charges also produce a field through the bulk of the crystal. Corroboratory evidence is provided by an associated photovoltaic effect and asymmetry of the hysteresis loops. Various effects due to these space-charge fields are mentioned.
- 537.228.1:546.431.824-31 3407
Dielectric and Piezoelectric Properties of the Solid Solutions (Ba,Sr)TiO₃, (Ba,Pb)TiO₃, Ba(Ti,Sn)O₃ and Ba(Ti,Zr)O₃—N. A. Roi. (*Akust. Zh.*, vol. 2, pp. 62–70; January/March, 1956.) Measurements are presented graphically of the following characteristics: 1) ϵ/T , 2) d_{33}/E_0 , 3) coercive-force/composition, where ϵ is the permittivity, T the temperature, d_{33} the piezoelectric modulus and E_0 the polarizing field strength.
- 537.311.31:538.63:546.47 3408
The Interrelation of the Anisotropy of the Hall Effect and the Change of Resistance in Metals in a Magnetic Field: Part 1—Investigation of Zinc—E. S. Borovik. (*Zh. Eksp. Teor. Fiz.*, vol. 30, pp. 262–271; February, 1956. English summary, *ibid.*, Supplement, p.4.)
- 537.311.33+621.315.6 3409
Ionization Interaction between Impurities in Semiconductors and Insulators—R. L. Longini and R. F. Greene. (*Phys. Rev.*, vol. 102, pp. 992–999; May 15, 1956.) The free energy of an imperfect crystal includes components which arise from the ionizability of these imperfections and which represent chemical interactions between them. These ionization terms, which involve the Fermi level and the parameters of the energy-band model, are used to explain systematic differences between n - and p -type semiconductors in respect of lattice-vacancy concentration, substitutional-atom diffusion coefficients and amphoteric-impurity behavior, as well as the variation of solid/liquid impurity distribution coefficients of some semiconductors with the rate of crystal growth, and the "charge-balance" effect in insulators.
- 537.311.33 3410
Surface Barriers at Semiconductor Contacts—R. Stratton. (*Proc. Phys. Soc.*, vol. 69, pp. 513–527; May 1, 1956.) Current flow across a surface of discontinuity is treated according to the diode and the diffusion theories of barrier rectifiers and the results are applied to measurements on SiC point contacts and a grain boundary in Ge, respectively. The contact resistance found is consistent with a barrier caused by donor and acceptor surface states, whose density on SiC is about 10¹³/cm² and on Ge about 5×10¹¹/cm².
- 537.311.33 3411
High-Frequency Conductivity in Semiconductors—B. Donovan and N. H. March. (*Proc. Phys. Soc.*, vol. 69, pp. 528–538; May 1, 1956.) Theory is developed for nondegenerate semiconductors with spherical energy surfaces, the cases of single- and two-band models with lattice and impurity scattering being considered. Divergencies from available experimental results are discussed.
- 537.311.33 3412
The Stoichiometry of Intermetallic Semiconductors—R. J. Hodgkinson. (*J. Electronics*, vol. 1, pp. 612–624; May, 1956.) The effects of small concentrations of point defects on the free energy of a crystal of formula AB are discussed. The maximum melting point of the compound does not occur at the composition corresponding exactly to the formula AB. The type of phase diagram arising from this fact is derived. Published experimental evidence is quoted in support of the theory. A crystal which is heat-treated in presence of its vapor will not necessarily have the same concentration of defects as one of the same composition grown from the melt at the same temperature.
- 537.311.33 3413
Negative Magnetoresistance Effect in Semiconductors—C. Rigaux and J. M. Thuillier. (*C.R. Acad. Sci., Paris*, vol. 242, pp. 2710–2712; June 4, 1956.) An interpretation of the effect different from that of Mackintosh (2805 of 1956) or Stevens (2806 of 1956) is presented.
- 537.311.33 3414
Characteristic Times of Electronic Processes in Semiconductors—E. I. Adirovich and G. M. Guro. (*C.R. Acad. Sci. U.R.S.S.*, vol. 108, pp. 417–420; May 21, 1956. In Russian.) Characteristic times are calculated, assuming the presence of recombination centres (traps) of one type and of fully ionized acceptors and donors. Two of the calculated characteristic times correspond to the electron and hole lifetimes calculated by Shockley and Read (420 of 1953), two others are decay times.
- 537.311.33 3415
Some Problems of the Multi-electron Theory of Semiconductors—S. V. Vonsovski. (*Zh. Tekh. Fiz.*, vol. 25, pp. 20222–2029; October, 1955.) The various stages in the development of the multielectron theory are briefly reviewed and its advantages pointed out. The limitations of the theory are then considered, arising from 1) the use of the "adiabatic" approximation in which there is no allowance for the active dynamic participation of the system of ions, and 2) the exaggerated importance attached to the ordered disposition of ions. The possibilities of overcoming these limitations are indicated and a generalized multielectron model of atomic semiconductors is discussed.
- 537.311.33 3416
Theory of Semiconductors with An Impurity Band—A. G. Samoilovich and M. I. Klinger. (*Zh. Tekh. Fiz.*, vol. 25, pp. 2050–2060; October, 1955.) The properties of an electron gas are considered for the following two cases: 1) a metal with a narrow conduction band, and 2) a semiconductor with an impurity band. The chemical potential is calculated for both cases and the electrical conductivity and thermo-emf are also determined, in the first case from the degree of filling of the narrow band, and in the second case from the temperature. The results are compared with experimental data.
- 537.311.33 3417
Properties and Structure of Ternary Semiconducting Systems (Part 2—Electrical Properties and Structure of Materials of the System comprising Thallium, Antimony and Arsenic Selenides)—N. A. Goryunova and B. T. Kolomiets. (*Zh. Tekh. Fiz.*, vol. 25, pp. 2069–2078; October, 1955.) In continuation of work reported previously [1751 of 1956 (Kolomiets and Goryunova) an investigation was made of the variation of the properties of intermediate mixtures at the transition between the crystalline and amorphous compounds. Seven melts with gradual replacement of Sb by As were synthesized and numerous experiments carried out.
- 537.311.33 3418
Correlation between the Heat of Formation of a Semiconductor and the Electron Mobility—V. P. Zhuze. (*Zh. Tekh. Fiz.*, vol. 25, pp. 2079–2092; October, 1955.) The insufficiency of the existing theory of electron mobility is pointed out; it would be of interest to determine experimentally the dependence of mobility on some macroscopic parameter of the substance. Reference is made to a previous investigation by Blum and Regel' (*ibid.*, vol. 21, pp. 316–327; March, 1951.), where fairly close correlation was established between electron mobility and the heat of formation of binary semiconducting compounds. Much new information has since been accumulated; this is summarized in a table giving data on 39 compounds. The various factors underlying the observed correlation are discussed.
- 537.311.33 3419
The Temperature Dependence of the Density and Electrical Conductivity of Liquid Solutions of the System Te-Se—N. P. Mokrovski and A. R. Regel'. (*Zh. Tekh. Fiz.*, vol. 25, pp. 2093–2096; October, 1955.)
- 537.311.33:537.226 3420
The Present State of some Problems of the Theory of Semiconductors and Dielectrics, and Directions of Further Development of the Theory—S. I. Pekar. (*Zh. Tekh. Fiz.*, vol. 25, pp. 2030–2043; October, 1955.) Shortened version of a paper read at a conference on semiconductors held in Leningrad in February, 1955. The headings are: 1) phenomenological theory of semiconductors; 2) kinetics of electrons in the conduction band; 3) thermal (radiationless) electron transitions; 4) photo-transitions of electrons; 5) methods of calculating the quantum stationary states of a crystal.
- 537.311.33:538.569.4 3421
Quantum Theory of Cyclotron Resonance in Semiconductors: General Theory—J. M. Luttinger. (*Phys. Rev.*, vol. 102, pp. 1030–1041; May 15, 1956.)
- 537.311.33:541.57 3422
The Chemical Bond in Semiconductors—E. Mooser and W. B. Pearson. (*J. Electronics*, vol. 1, pp. 629–645; May, 1956.) Discussion presented previously (2781 of 1956) is treated more fully.

- 537.311.33:546.23 3423
The Absorption Edge of Amorphous Selenium and its Change with Temperature—C. Hilsum. (*Proc. Phys. Soc.*, vol. 69, pp. 506-512; May 1, 1956.) Experimental results showing the variation of absorption coefficient with λ over the range 0.58-0.66 μ are presented. The absorption edge shifts with temperature by 2.7 Å/deg, equivalent to a change in the energy gap of 9.7×10^{-4} ev/deg.
- 537.311.33:546.26-1:539.1 3424
Effect of Fast Neutron Bombardment on Physical Properties of Graphite: a Review of Early Work at the Metallurgical Laboratory—M. Burton and T. J. Neubert. (*J. Appl. Phys.*, vol. 27, pp. 557-567; June, 1956.) Variations of the elastic modulus and the thermal and electrical resistance are related to the displacement of the carbon atoms for their normal positions in the crystal lattice. Hall-effect measurements indicate that the neutron-induced disturbances are electron traps. Abstracts of papers by various workers dealing with the particular aspects are presented on pp. 568-572, following the main paper.
- 537.311.33:546.28 3425
Paramagnetic Resonance in As-Doped Silicon—A. Honig and J. Combrisson. (*Phys. Rev.*, vol. 102, pp. 917-918; May 1, 1956.) As a result of studies further to those described previously [753 of 1955 (Honig)] a new interpretation of the observed effects is advanced.
- 537.311.33:546.28+549.514.5]:539.2 3426
Adsorption of Ammonia on Silicon—L. Miller. (*Z. Naturf.*, vol. 10a, pp. 801-802; September/October, 1955.) It has been found that the adsorption of NH_3 is a useful criterion in the investigation of the surface properties of quartz and other forms of SiO_2 . The presence of water on a quartz surface is known to increase the adsorption of NH_3 . Methods based on these effects are used to indicate the presence of SiO_2 layers on Si. Attempts to produce an oxide-free Si surface by hf technique were unsuccessful.
- 537.311.33:546.289 3427
A Note on the Theory of Dislocation in Germanium—T. Shindo. (*J. Phys. Soc. Japan*, vol. 11, pp. 331-332; March, 1956.) Following on the work of Read (457 of 1955), a more general expression is found for the fraction of dislocation acceptor sites occupied, which reduces to that given by Read for the case when the number of trapped electrons is small compared with the number of donor centres.
- 537.311.33:546.289 3428
The Electrical Properties of Dislocations in Germanium—J. W. Allen. (*J. Electronics*, vol. 1, pp. 580-588; May, 1956.) Different experimental results can be reduced to consistency by considering the effects of impurity-atmosphere formation at the dislocations. Experiments to test this theory are suggested.
- 537.311.33:546.289 3429
Self-Diffusion in Germanium—H. Letaw, Jr. W. M. Portnoy, and L. Slifkin. (*Phys. Rev.*, vol. 102, pp. 636-639; May 1, 1956.) "An accurate determination of the self-diffusion coefficient in germanium has been obtained. In the temperature range 766°-928° C., it is represented by $D = 7.8 \exp(-68,500/RT)$ cm^2/sec . The probably errors in the frequency factor and activation energy are $\pm 3.4 \text{ cm}^2$ and $\pm 0.96 \text{ kcal/mol}$, respectively."
- 537.311.33:546.289 3430
Scattering of Carriers from Doubly Charged Impurity Sites in Germanium—W. W. Tyler and H. H. Woodbury. (*Phys. Rev.*, vol. 102, pp. 647-655; May 1, 1956.) Measurements are reported which indicate that Zn is a double-acceptor impurity in Ge, the acceptor levels lying 0.03 and 0.05 ev from the valence band. Hall-effect measurements show that scattering from doubly charged Zn sites is about four times that from singly charged Ga sites. Photoconductivity measurements on *n*-type Ge specimens containing Fe or Mn impurities indicate that at high levels of illumination the steady-state increase in free-electron concentration is roughly equal to the known concentrations of double-acceptor impurities. The accompanying mobility increases provide additional confirmation of the assumption that holes trapped at doubly charged impurity sites are responsible for the photosensitivity.
- 537.311.33:546.289 3431
Measurements of Surface Electrical Properties of Bombardment-Cleaned Germanium—J. T. Law and C. G. B. Garrett. (*J. Appl. Phys.*, vol. 27, p. 656; June, 1956.) Measurements were made of the surface recombination velocity and surface conductivity of a *p*-type bombardment-cleaned Ge specimen 1) in vacuum, 2) after admission of oxygen, and 3) after subsequent heating at about 400° C. The effects of step 2) are annulled by step 3). This result is interpreted as indicating that a bombardment-cleaned surface has already at least one layer of oxygen on it before any measurements can be made.
- 537.311.33:546.289 3432
Trap Activation Energies in N-Type Germanium—P. Ransom and F. W. G. Rose. (*J. Electronics*, vol. 1, pp. 625-628; May, 1956.) Discussion indicates that it should be possible to determine from measurements by the Morton-Haynes method [741 of 1953 (Valdes)], in darkness and with various intensities of background illumination, both the activation energy and the concentration of different traps in a single sample.
- 537.311.33:546.289 3433
Observations on the Growth of Excess Current in Germanium *p-n* Junctions—A. R. F. Plummer. (*Proc. Phys. Soc.*, vol. 69, pp. 539-547; May 1, 1956.) The excess current induced by water vapor has been resolved experimentally into two components having linear and saturation relations with the applied voltage; the possibility of identifying these components with channel and surface leakage currents is discussed but not established.
- 537.311.33:546.289 3434
The Possibility of obtaining a *p-n* Junction in Germanium by Pulse Heating—M. M. Bredov. (*Zh. Tekh. Fiz.*, vol. 25, pp. 2104-2111; October, 1955.) The method proposed is based on the known fact that if *n*-type Ge is heated to a temperature of 800°-900° and then rapidly cooled, the sign of its conduction changes (thermal conversion). If a short pulse of heat is applied to the specimen, conversion should take place in the surface layer and a *p-n* junction should be formed at a depth corresponding to the transition between the converted layer and the unaffected bulk of the specimen. The necessary pulse heating can be obtained by irradiating the specimen with a pulsed electron beam. The theory of the method is discussed; the results have been confirmed experimentally.
- 537.311.33:546.289:535.215 3435
Photoconductivity in Manganese-Doped Germanium—R. Newman and H. H. Tyler. (*Phys. Rev.*, vol. 102, pp. 613-617; May 1, 1956.) "Impurity photoconduction has been observed in *n*- and *p*-type Mn-doped germanium at low temperatures. The spectra are consistent with the published ionization energy values determined from conductivity data. High-resistivity *n*-type samples show high intrinsic photosensitivity and long response times at low temperatures. In such samples of the intrinsic photocurrent could be quenched by a factor of $\sim 10^4$ with light in the 0.3 to 0.7 ev range. Intrinsic photoconductivity was found to vary more rapidly than linearly with a light intensity over a limited range."
- 537.311.33:[546.289+546.681]:535.33/34 3436
L-Spectra of Gallium and Germanium—A. Lemasson-Lucasson. (*C.R. Acad. Sci., Paris*, vol. 242, pp. 3059-3061; June 25, 1956.)
- 537.311.33:546.289:538.63 3437
An Investigation of the Nernst Effect in Germanium—T. V. Krylova and I. V. Mochan. (*Zh. Tekh. Fiz.*, vol. 25, pp. 2119-2121; October, 1955.) A report is presented on an experimental investigation. One of the conclusions reached is that the mobility of holes varies as $T^{-1/2}$.
- 537.311.33:546.289:539.16 3438
Effects of Gamma Radiation on Germanium—J. W. Cleland, J. H. Crawford, Jr, and D. K. Holmes. (*Phys. Rev.*, vol. 102, pp. 722-724; May 1, 1956.) Experiments with high-purity *n*- and *p*-type specimens are reported. The extrinsic electron concentration of *n*-type material decreased at a rate only about 10^{-3} of that for fast-neutron irradiation. Extended exposure converts *n*-type material to *p*-type. For *p*-type material the rate of removal of carriers is much lower than for *n*-type. The value deduced for the cross section for atomic displacements is about $1.5 \times 10^{-24} \text{ cm}^2$.
- 537.311.33:546.47.241 3439
Electrical Properties of Zinc Telluride—B. I. Boltaks, O. A. Matveev, and V. P. Savinov. (*Zh. Tekh. Fiz.*, vol. 25, pp. 2097-2103; October, 1955.) An experimental investigation is reported; the main conclusions are as follows: ZnTe is a semiconductor of *p*-type, with an energy gap of 0.65 ± 0.03 ev. Its electrical properties are greatly effected by atmospheric oxygen. There is a peculiar temperature dependence of the coefficient of thermo-emf for specimens with a composition close to the stoichiometric value. The mobility of holes is 30-50 cm per v/cm, and varies with temperature in proportion to $T^{-1/2}$. The effective mass of a hole is about 0.2 of the mass of a free electron.
- 537.311.33:546.48.241.1:535.215:535.37 3440
Luminescence, Transmission, and Width of the Energy Gap of CdTe Single Crystals—C. Z. van Doorn and D. de Nobel. (*Physica*, vol. 22, pp. 338-342; April, 1956.) Luminescence with a maximum at about 8880 Å was obtained on illuminating a CdTe single crystal and on biasing a CdTe *p-n* junction in the forward direction. Possible mechanisms giving rise to the luminescence are indicated. The width of the energy gap determined from measurements of the spectral transmission of a single crystal is 1.51 ev at room temperature.
- 537.311.33:546.561-31 3441
Resistance of Metal/Semiconductor Contact at High Contact-Potential Differences—N. A. Gozhenko and Yu. M. Altaiski. (*Zh. Eksp. Teor. Fiz.*, vol. 30, pp. 401-402; February, 1956.) Measurements of the contact resistance of 1) $\text{Cu}_2\text{O}/\text{Al}$ and 2) $\text{Cu}_2\text{O}/\text{Cu}$, show that as the air pressure is increased from zero to about 20 mm Hg the resistance in case 1) first decreases and then increases, and in case 2) increases monotonically. The contact potential in case 1) is 1.18 v, in case 2) 0.22 v. The anomalous behavior of the contact resistance in case 1) is discussed.
- 537.311.33:546.561-31:548.25 3442
The Intergrowth of Cu and Cu_2O after Oxidation and Reduction—G. Jelinek, E. Menzel, and C. Menzel-Koppf. (*Z. Naturf.*, vol. 10a, pp. 802-803; September/October, 1955.)
- 537.311.33:546.682.86 3443
Contribution to the Study of Carrier Mobility in InSb—J. Tavernier. (*C.R. Acad. Sci.*,

- Paris, vol. 242, pp. 2707-2710; June 4, 1956.) Measurements were made of the temperature variation of resistance and Hall constant for a *p*-type specimen in which the temperature of inversion of the Hall effect was not much below room temperature. Results are shown graphically. An approximate formula is derived giving the variation with applied magnetic field of the ratio of electron mobility to hole mobility; a value of 15.5 kg is hence calculated for the magnetic field strength at which the Hall effect disappears at room temperature. The observed value is 14 kg.
- 537.311.33:621.317.799 3444
Apparatus for Measurement of Hall Effect and Magnetoresistance in Semiconductors—G. Della Pergola and D. Sette. (*Alta Frequenza*, vol. 25, pp. 140-151; April, 1956.) The apparatus described permits measurements at values of magnetic induction up to about 1.3 wb/m². Measurements on an *n*-type Ge specimen are reported.
- 537.311.33:669.046.54/.55 3445
Zone-Melting Processes for Compounds AB with a Measurable Vapour Pressure under Influence of the Atmosphere—J. van den Boomgaard. (*Philips Res. Rep.*, vol. 11, pp. 91-102; April, 1956.) Conditions under which purification by zone melting is possible are investigated. The relation between the deviation from stoichiometric composition and the position along the rod of material is derived. See also 2810 of 1956.
- 537.312.62:538.222 3446
Paramagnetic Effect in Superconducting Tin, Indium, and Thallium—J. C. Thompson. (*Phys. Rev.*, vol. 102, pp. 1004-1008; May 15, 1956.) "Measurements have been carried out on the longitudinal magnetization of pure rods in the intermediate state between normal and super-conduction. The observed 'paramagnetic' flux increase is dependent on the externally sustained current, external magnetic field, and temperature only."
- 538.22 3447
Superexchange Interactions and Magnetic Lattices of the Rhombohedral Sesquioxides of the Transition Elements and their Solid Solutions—Yin-Yuan Li. (*Phys. Rev.*, vol. 102, pp. 1015-1020; May 15, 1956.)
- 538.221 3448
Magnetic Dispersion and Absorption of Iron between 0 and 7000 Mc/s—E. Naschke. (*J. Phys. Radium*, vol. 17, pp. 330-337; April, 1956.) The variation of initial permeability with frequency was studied by measurements on wire specimens in which the size of the individual domains had been increased by heat treatment so as to shift the ferromagnetic dispersion due to wall movements to a frequency range lower than that associated with electron-spin rotation. The results are discussed in relation to various theories on magnetic dispersion due to wall movements.
- 538.221 3449
Magnetization of a Magnetite Single Crystal near the Curie Point—D. O. Smith. (*Phys. Rev.*, vol. 102, pp. 959-963; May 15, 1956.) Experimental technique is described which enables an unambiguous indication to be obtained of spontaneous and induced magnetization of a single domain at temperatures around the Curie point. The magnetization/magnetizing-field (*M/H*) curves in this temperature region are highly nonlinear; replotting in the form of *H/T* curves shows that the magnetic energy is proportional to *M*².
- 538.221:538.24 3450
Magnetization Curves and Domain Structure—L. F. Bates and A. Hart. (*Proc. Phys. Soc.*, vol. 69, pp. 497-505; May 1, 1956.) The theoretical work of Lee (117 of 1954) on domain structure has been supplemented by an experimental study of the changes in domain patterns in a Néel-cut crystal of Si-iron occurring when the crystal dimensions are changed. Calculated magnetization curves based on the results show better agreement with experimental curves than has been obtained previously, particularly for low field strengths. A substantial hysteresis loss occurs in strong fields with crystals of finite size.
- 538.221:621.318.12 3451
The Effect of substituting Al³⁺ Ions for Fe³⁺ Ions on the Magnetic Properties of the Compounds (6Fe₂O₃, BaO), (6Fe₂O₃, SrO), (6Fe₂O₃, PbO)—C. Guillaud and G. Villers. (*C.R. Acad. Sci., Paris*, vol. 242, pp. 2817-2820; June 11, 1956.) Experimental results indicate that the effect of the substitution is to increase the coercive force, to reduce the saturation moment, and to modify the shape of the magnetization curve. Crystals with grain dimensions <0.5 μ are obtained by appropriate heat treatment.
- 538.221:621.318.124 3452
Neutron Diffraction Observation of Heat Treatment in Cobalt Ferrite—E. Prince. (*Phys. Rev.*, vol. 102, pp. 674-676; May 11, 1956.) Results of experiments indicate that, when heat treatment is applied in a magnetic field, the magnetic moments are in general displaced from the directions which would be expected from considerations of crystal anisotropy alone.
- 538.221:621.318.134 3453
The Metallography of Ferrites—P. Levesque and L. Gerlach. (*J. Amer. Ceram. Soc.*, vol. 39, pp. 119-120; March 1, 1956.) A note on the preparation and etching of ferrite specimens for displaying grain size, grain orientation, and porosity.
- 538.221:621.318.134 3454
Ordering and Antiferromagnetism in Ferrites—P. W. Anderson. (*Phys. Rev.*, vol. 102, pp. 1008-1013; May 15, 1956.) "The octahedral sites in the spinel structure form one of the anomalous lattices in which it is possible to achieve essentially perfect short-range order while maintaining a finite entropy. In such a lattice nearest-neighbor forces alone can never lead to long-range order, while calculations indicate that even the long-range Coulomb forces are only 5 per cent effective in creating long-range order. This is shown to have many possible consequences both for antiferromagnetism in 'normal' ferrites and for ordering in 'reverse' ferrites."
- 538.221:621.318.134 3455
Magnetic Measurements on Individual Microscopic Ferrite Particles near the Single-Domain Size—A. H. Morrish and S. P. Yu. (*Phys. Rev.*, vol. 102, pp. 670-673; May 1, 1956.) Measurements made with the quartz-fibre torsion balance described previously [2155 of 1956 (Yu and Morrish)] provide evidence confirming the existence of single-domain particles; the critical size is in agreement with that found from theory (170 of 1956).
- 538.221:621.318.134 3456
The Temperature-Dependent Resistivity of certain Iron-Deficient Magnesium Manganese Ferrites—W. P. Osmond. (*J. Electronics*, vol. 1, pp. 665-666; May, 1956.) Results reported by Blackman and Sherry (1468 of 1956) are interpreted as indicating that the firing temperature was high enough to ensure complete oxygen compensation for the reduced Fe₂O₃ content.
- 538.221:621.318.134 3457
The Reduction of Eddy-Current Losses in Manganese-Zinc Ferrites by Addition of Calcium—C. Guillaud, M. Paulus, and P. Vautier. (*C.R. Acad. Sci., Paris*, vol. 242, pp. 2712-2715; June 4, 1956.) An experimental investigation has been made of the effect of introducing a small proportion of Ca, using a radioactive isotope to facilitate study of the diffusion. The Ca apparently diffuses preferentially in the joints between the crystal grains, thus increasing the resistance of the ferrites and reducing the eddy-current losses.
- 538.221:621.318.134:538.652 3458
Influence of Magnetostriction on the Initial Permeability of Manganese-Zinc Ferrites—R. Vautier. (*C.R. Acad. Sci., Paris*, vol. 242, pp. 2814-2817; June 11, 1956.) Theoretical considerations and experimental results indicate that it is not possible to predict the initial permeability of polycrystalline Mn-Zn ferrites from measurements of the longitudinal magnetostriction. Measurements on single crystals, parallel to the crystal axes, may be more conclusive.
- 538.221.023 3459
Approximate Representation of Magnetization Curves by Simple Algebraic or Transcendental Functions—J. Fischer and H. Moser. (*Arch. Elektrotech.*, vol. 42, pp. 286-299; April 17, 1956.) Fifteen different functions used as approximations to the experimentally determined *BH* curves are discussed, and conclusions are tabulated regarding the range of conditions over which these approximations are useful.
- 549.514.5:531:535.21-31 3460
The Effect of U. V. and X-Ray Radiation on Silicate Glasses, Fused Silica and Quartz Crystals—A. Kats and J. M. Stevels. (*Philips Res. Rep.*, vol. 11, pp. 115-156; April, 1956.) The results of an experimental investigation into the effect of irradiation on the structure of these SiO₂ compounds are given and discussed in terms of nomenclature introduced previously [*ibid.*, pp. 103-114; (Stevels and Kats)]. A table indicates absorption bands associated with certain of the imperfections noted.
- 621.318.134:546.3:669.05 3461
Preparation of Alkali Ferrites, Nickelites and Cobaltites by Fusion Electrolysis—M. Dodero and C. Déportes. (*C.R. Acad. Sci., Paris*, vol. 242, pp. 2939-2941; June 18, 1956.)
- 6661.037 3462
Solder Glass Sealing—R. H. Dalton. (*J. Amer. Ceram. Soc.*, vol. 39, pp. 109-112; March 1, 1956.) The development of low-melting-point glasses suitable for soldering ordinary glasses is described, together with some techniques used in making such seals.

MATHEMATICS

- 517.5 3463
Convenient Calculation Procedure for the Harmonic Analysis and Synthesis of Periodic Waves—R. Chocholle. (*Rev. Sci., Paris*, vol. 92, pp. 3-14; January-March, 1954.) Simplification is effected by breaking down some operations and by grouping together identical operations.
- 517.9 3464
A Critical-Value Problem relative to a Non-linear Differential Equation of Practical Importance—A. Giger. (*Z. Angew. Math. Phys.*, vol. 7, pp. 121-129; March 25, 1956.) Discussion of the equation $d^2\theta/dr^2 + \alpha d\theta/dr + \sin \theta = \beta$, which arises, e.g., in the analysis of the synchronization of oscillations. For every value of β within the range $0 < |\beta| < 1$ there exists a critical value α_0 of α such that for $\alpha > \alpha_0$ there is no periodic solution; the values of α_0 are calculated.
- 517.9 3465
A Solution of Tranter's Dual-Integral-Equations Problem—J. C. Cooke. (*Quart. J. Mech. Appl. Math.*, vol. 9, pp. 103-110; March, 1956.) The solution of a pair of integral equa-

tions occurring in potential problems and previously studied by Tranter (695 of 1955) is given as an integral containing an unknown function which is determined by means of an integral equation of Fredholm's type.

517.9 3466

Round-Off Errors in Implicit-Finite-Difference Methods—A. R. Mitchell. (*Quart. J. Mech. Appl. Math.*, vol. 9, pp. 111-121; March, 1956.) "Symmetrical and asymmetrical implicit finite difference replacements involving a variable parameter a and a variable mesh ratio s are considered for the heat conduction and wave equations, and expressions obtained for the round-off errors. It is found that the stable backward difference replacements, four-point for the heat conduction equation and five-point for the wave equation, give rise to minimum round-off errors."

519.21:621.396.621 3467

Notes on some Properties of Stationary Random Functions entering into Problems of Frequency Changing—A. Blanc-Lapierre, P. Dumontet, and M. Savelli. (*C.R. Acad. Sci., Paris*, vol. 242, pp. 2799-2800; June 11, 1956.)

MEASUREMENTS AND TEST GEAR

529.78 3468

Construction and Performance of New Quartz Clocks at the Physikalisch-Technische Bundesanstalt—A. Scheibe, U. Adelsberger, G. Becker, G. Ohl, and R. Süß. (*Z. angew. Phys.*, vol. 8, pp. 175-183; April, 1956.) Frequency stability has been improved as a result of modifications in the method of supporting the quartz rod, the arrangement of electrodes, the internal thermostat, the master-oscillator circuit, and the frequency-divider circuit. In clocks P1 and P3 the frequency variation associated with aging is <1 part in 10^8 in a month.

531.761+529.7 3469

Atomic Time and the Definition of the Second—L. Essen. (*Nature, Lond.*, vol. 178, pp. 34-35; July 1, 1956.) Difficulties inherent in the establishment of a single unit of time, as advocated by Pérard (2834 of 1956), are discussed. Tentative proposals are advanced, implementation of which would make the atomic standard immediately available while preserving a single unit of time closely linked with, although not defined by, that given by astronomical observations.

621.317.3.029.6:621.317.7.029.6 3470

The Technique of Microwave Measurements—(*J. Brit. IRE*, vol. 16, pp. 385-400; July, 1956.) Report of a discussion dealing with the measurement of power, attenuation, impedance, frequency, and dielectric properties.

621.317.328:621.396.823:621.3.013.78 3471

A Method of making Screen-Room Measurements—K. E. Mortenson and C. J. Truax. (*Elect. Engng.*, vol. 75, p. 326; April, 1956.) Digest of paper published in *Trans. Amer. Inst. Elect. Engrs.*, Part I, *Communication and Electronics*, vol. 74, pp. 746-750; January, 1956.) A method is described for determining the "free-space" interference field strengths of electrical equipment from measurements made in a screen room. The limitations of the method are: 1) the size of the equipment must be less than one third of the room size and the linear dimensions must be less than one tenth of the wavelength used, and 2) the frequency used should be about half the lowest resonant mode of the room.

621.317.328.029.62/.63:621.396.621.54 3472

A.V.H.F./U.H.F. Field-Strength Recording Receiver using Post-Detector Selectivity—Harvey, (See 3528.)

621.317.33 3473

A Slide-Wire Cylinder for the Townsend

Circuit as a Simple Adjunct in the Precision Measurement of Very High Resistances—H. Mette. (*Z. Angew. Phys.*, vol. 8, pp. 191-193; April, 1956.)

621.317.33:621.375.4:621.314.7 3474

Measurement of the Input Resistance and Reactance of a Transistor Amplifier by Varying the Impedance of an Oscillator—A. P. Teplova, V. M. Tuchkevich, and A. I. Uvarov. (*Zh. Tekh. Fiz.*, vol. 25, pp. 2112-2118; October, 1955.) A simple method is described which involves connecting an oscillator to the transistor input and varying the impedance of the oscillator. The theory of the method is discussed and measurements at frequencies up to 10 mc are reported.

621.317.335.2:621.318.42 3475

Measurement of the Self-Capacitance of an Inductor at High Frequencies—J. P. Newsome. (*Electronic Engng.*, vol. 28, pp. 350-352; August, 1956.) The methods of measurement discussed include one based on the determination of the self-resonance frequency of the inductor by use of a Q meter; this is particularly useful for small values of self-capacitance

621.317.337:621.372.41 3476

Measurement of the Electrical Equivalent—Circuit Constants of High-Q Resonators—E. Frisch. (*Nachrichtentech. Z.*, vol. 9, pp. 182-185; April, 1956.) A method of determining the equivalent LCR values of ferrite-rod and piezoelectric resonators is described, involving frequency, and impedance measurements. Other methods are reviewed.

621.317.34.018.782.4 3477

Error Sources in Group-Delay Measurements on Electric Networks—A. van Weel. (*Philips Res. Rep.*, vol. 11, pp. 81-90; April, 1956.) "Errors in group-delay measurements can be caused by spurious phase modulation in the amplitude modulator or in the network under test, by a varying carrier-frequency level on the detector, and by overloading the network under test. These effects are discussed and counter measures are indicated."

621.317.35:621.372.5.012 3478

A Sensitive Method for the Measurement of Amplitude Linearity—S. I. Kramer. (*Proc. IRE*, vol. 44, pp. 1059-1060; August, 1956.) The method outlined is based on applying a linear sawtooth waveform to the input terminals of the device under test and passing the output through a differentiator; the differentiated waveform is observed oscillographically, departure from linearity being indicated by departure of the cro trace from the horizontal.

621.317.373 3479

A Simple Method of Accurate Phase Measurement of a Four-Terminal Network—B. Chatterjee. (*J. Inst. Telecommun. Engrs., India*, vol. 2, pp. 93-95; March, 1956.) Brief description of a method in which the change of phase produced by a quadripole is measured by inserting the quadripole in the feedback loop of an oscillating circuit and noting the resulting frequency change.

621.317.4:539.152.1:538.569.4 3480

A Nuclear-Resonance Meter for Magnetic Flux—V. Andresiani and D. Sette. (*Ricerca Sci.*, vol. 26, pp. 1101-1115; April, 1956.) An instrument for measurement of flux values between 0.15 and 1.2 Wb/m² is described; a transitron oscillator is used.

621.317.42:538.632 3481

Measurements on Magnetically Soft Materials by means of the Hall Generator—F. Assmus and R. Boll. (*Elektrotech. Z., Edn A*, vol. 77, pp. 234-236; April 11, 1956.) Small Hall generators made of Group III-V alloys were used in several applications involving the measurement of magnetic field strengths in the

range 0.1-10 oersted. The applications briefly described include measurement of the field strength in individual crystals of a silicon-iron rectangular-frame specimen, the magnetization of strips of metal, etc. The technique is particularly useful for indicating local variations.

621.317.443.029.5/.62 3482

Advances in the Design and Application of the Radio-Frequency Permeameter—A. L. Rasmussen, A. W. Enfield, and A. Hess. (*J. Res. Nat. Bur. Stand.*, vol. 56, pp. 261-267; May, 1956.) The instrument described previously [1857 of 1954 (Haas)] has been further developed. The frequency range covered is 0.05-50 mc. In the range 0.1-35 mc the accuracy of permeability determinations obtained from reference to a primary standard is within ± 2 per cent.

621.317.444 3483

Development of a Vibrating-Coil Magnetometer—D. O. Smith. (*Rev. Sci. Instrum.*, vol. 27, pp. 261-268; May, 1956.) An alternating voltage proportional to the magnetic field of a dipole created by inserting a small sample of magnetic material into a magnetizing field is derived by means of a coil vibrating along the axis of the dipole at a distance up to 2 cm from the sample. Measurements are continuous and recordable; accuracy is within 1 per cent for a dipole moment of 8.56×10^{-4} A.M.².

621.317.7:537.54:621.396.822.029.6 3484

The Gas-Discharge Tube as a Device for Noise Measurement in the Centimetre Waveband—W. Klein and W. Friz. (*J. Electronics*, vol. 1, pp. 589-600; May, 1956. In German.) The production of white noise in the electron plasma of the selfsupporting gas discharge is explained on the basis of thermodynamic theory. The available noise power for a discharge with purely electronic absorption corresponds to the full energy value of the electron temperature.

621.317.725:621.375.23.024 3485

Unity-Gain Voltmeter Amplifier—H. R. Hyder. (*Tele-Tech. and Electronic Ind.*, vol. 15, pp. 84-85; April, 1956.) Circuit details are given of a highly stable three-stage dc amplifier incorporating differential first stage and cathode-follower output, suitable as a coupling unit between a high-impedance source and a low-impedance load; with a 0-1-v voltmeter connected across the output, ranges of 1 to 1000 v are obtainable.

621.317.725:621.385 3486

Improved Slide-Back Valve Voltmeter—O. E. Dzierzynski. (*Wireless World*, vol. 62, pp. 441-445; September, 1956.)

621.317.727 3487

A Switch-Dial Potential Divider—W. K. Clothier. (*J. Sci. Instrum.*, vol. 33, pp. 196-198; May, 1956.) Variants of a general class of divider network are described in which the errors due to switch contacts are small, making them specially suitable for low-resistance applications.

621.317.729:621.396.823 3488

Equipment for recording R.F. Interference due to High-Voltage Power Transmission Lines—J. Carteron, E. Fromy, and B. Prokocimer. (*Rev. Gén. Élect.*, vol. 65, pp. 203-208; April, 1956.) Equipment for ground measurements of the field strength due to corona effects comprises 1) a small vertical antenna fixed directly to the metal case enclosing 2) an amplifier with a small number of circuits tuned to the fixed operating frequency, 3) a quasi-peak detector, and 4) a continuous electromechanical recorder actuated by a dc amplifier of the type described by Chevallier and Prokocimer (3316 above) in which stable

operation is achieved by using a high degree of feedback distributed between the stages.

621.317.742 3489

A New Technique for the Measurement of Microwave Standing-Wave Ratios—A. C. MacPherson and D. M. Kerns. (Proc. IRE, vol. 44, pp. 1024-1030; August 1956.) A high-precision method using a stationary detector and sliding load is described. Generator, detector, and load are connected respectively to the arms of a three-arm waveguide junction. The variation of the detector response as the phase of the load is varied yields a curve similar to a standing-wave pattern, from which the unknown load can be determined using the procedure indicated. The technique is amenable to rigorous theoretical analysis.

621.317.755 3490

Increasing the Accuracy of C.R.O. Measurements—T. H. Bonn. (Proc. IRE, vol. 44, p. 1062; August, 1956.) Techniques in which the cro is used as a null detector yield accuracies within ± 0.1 per cent.

621.317.755 3491

An Automatic Cathode-Ray-Oscilloscope Beam-Brightening Device for Transient Recordings—O. H. Davie; J. Wood. (*J. Sci. Instru.*, vol. 33, p. 203; May, 1956.) Comment on 860 of 1956 and author's reply. Modifications to the original device are suggested.

621.317.755:537.52 3492

The Production of a Short-Duration Pulse of High Velocity Electrons—D. H. Le Croissette. (*Electronic Engng.*, vol. 28, pp. 356-358; August, 1956.) A pulse of duration 0.2 μ s, used for initiating ionization in a gas-filled system, is obtained by making an electron beam traverse a hole in a steel plate; the operation is synchronized with an oscillograph timebase, thus permitting the simultaneous display of the ionizing pulse and the resulting discharge build-up.

621.317.761 3493

The "Frequency Microscope," a Recording Frequency-Measuring Instrument with Very High Sensitivity—G. Ohl. (*Arch. Elekt. Übertragung*, vol. 10, pp. 145-150; April, 1956.) A precision method of using a drum-type chronograph is described. The beat produced by two signals with nearly equal frequencies is used to trace a sequence of marks on the drum, the rate of rotation of which is controlled by a quartz crystal and is adjustable in discrete steps. The heterodyne frequency can be accurately determined by the graphical method described.

621.317.761:621.314.7 3494

Transistor Frequency Meters—L. R. Blake and A. R. Eames. (*Electronic Engng.*, vol. 28, pp. 322-327; August, 1956.) Based on the switched-capacitor method, using a transistor switch, the meter described covers the range 0.3-100 kc in six subranges, giving an accuracy within 0.5-1 per cent. The indication is independent of signal level or waveform.

621.317.763.029.6 3495

The Generation of Multiple TE_{m0} and TM_{m0} Modes between Parallel Plates and in Rectangular Waveguides by Interference, and its Application to the Measurement of Wavelength—J. I. Caicoya. (*Rev. Telecomunicación, Madrid*, vol. 11, pp. 2-30; March, 1956. In Spanish and English.) Detailed analysis is presented for the reflection of microwaves at plane surfaces and the generation of multiple modes by interference. The basic experimental system comprises a pair of parallel rectangular plates with variable separation, arranged symmetrically with respect to a reference plane, and a third parallel rectangular plate whose position is adjusted independently to effect the auxiliary reflection required to produce interference.

Horns with variable angular position are used as signal source and detector. Wavelength is determined from the settings for zero detected energy. The instrument has a wide operating frequency band.

621.317.784.029.3 3496

Electronic Wattmeter with Wide Frequency Range—T. J. Schultz. (*Rev. Sci. Instru.*, vol. 27, pp. 278-279; May, 1956.) A dynamometer movement is employed, the input to the two coils being supplied by independent power amplifiers using voltage and current negative feedback. Frequency response is level to within ± 0.17 db between 20 cps and 20 kc.

621.317.799:537.311.33 3497

Apparatus for Measurement of Hall Effect and Magnetoresistance in Semiconductors—Della Pergola and Sette. (See 3444.)

621.317.799:621.385.029.6:621.396.96 3498

Magnetron Tester detects Lost Pulses—P. Koustas and D. D. Mawhinney. (*Electronics*, vol. 29, pp. 164-168; August, 1956.) Radar magnetron output pulses of incorrect frequency, or inadequate amplitude or width, are detected by a coincidence meter in which the output is sampled and analyzed, and are compared with a signal derived from the magnetron modulator circuit.

621.319.4(083.74) 3499

New Variable Capacitors with Zero Initial Capacitance—G. Zickner. (*Z. Angew. Phys.*, vol. 8, pp. 187-191; April, 1956.) Two types of standard capacitor are described in which the capacitance between two fixed plate systems is varied by means of a rotatable screen. These capacitors have three terminals, and are hence only suitable for use in certain types of circuit, such as bridges. The time stability is equal to that of fixed standard air capacitors, and the capacitance is more precisely defined than in capacitors with only one set of plates connected to the case.

OTHER APPLICATIONS OF RADIO AND ELECTRONICS

531.768:534.86 3500

Calibration of Vibration Pickups at High Frequencies using a Michelson Interferometer—S. M. Davies. (*Nature, Lond.*, vol. 178, p. 161; July 21, 1956.)

621.316.825:621.317.39 3501

The Use of Semiconductors in Investigating Natural Phenomena—A. F. Chudnovski. (*Zh. Tekh. Fiz.*, vol. 25, pp. 2122-2133; October, 1955.) Brief descriptions are given of the following measuring instruments based on the use of thermistors: 1) probe for measuring the temperature distribution in soil; 2) electropysychrometer for remote measurements; 3) "thermospider" for measuring the average temperature of the soil surface; 4) thermomanometer; 5) instrument for determining the absolute air humidity; 6) instrument for direct measurements of small temperature differences and absolute humidity of the air; 7) microelectrometer for measuring the surface temperature of leaves and stalks of plants. General considerations underlying the operation of these instruments are discussed.

621.383.2:621.385.832:531.76 3502

Physical Bases of Electron-Optical Chronography—E. K. Zavoiski and S. D. Franchenko. (*C.R. Acad. Sci. URSS.*, vol. 108, pp. 218-221; May 11, 1956. In Russian.) Very short flashes of light can be measured by means of an electronoptical image converter in which the electron beam is deflected by a rapidly rotating electric or magnetic field. In the limiting case a circle of radius 5 cm is traced in 10^{-10} s; assuming a resolution of 300 lines/cm the shortest measurable time interval is 10^{-14} s.

621.384.611 3503

Cyclotron with Sectional Magnet—E. M. Moroz. (*C.R. Acad. Sci. URSS*, vol. 108, pp. 436-439; May 21, 1956. In Russian.) The principles of operation of a cyclotron using a magnet comprised of wedge-shaped sectors are discussed.

621.384.612 3504

Influence of Radiation on Synchrotron Oscillations of Electrons in Systems with Strong [alternating-gradient] Focusing—A. N. Matveev. (*C.R. Acad. Sci. URSS*, vol. 108, pp. 432-435; May 21, 1956. In Russian.)

621.387.424 3505

An Oxygen-Quenched Geiger-Müller Counter—D. Srdoč. (*J. Sci. Instru.*, vol. 33, pp. 185-186; May, 1956.)

621.398 3506

Determination of Visual Interpolation Errors in the Plotting of Curves from Commutated Data—L. Katz. (IRE TRANS., vol. TRC-1, pp. 15-24; February, 1955.) The frequency and sampling-rate requirements of telemetering systems are discussed, in relation to the errors to be expected in interpolating between the measured points.

621.385.833 3507

Optique électronique I : Lentilles électroniques [Book Review]—P. Grivet, M. Y. Bernard, and A. Septier. Bordas, Paris, 1955, pp. 184 (*Proc. Phys. Soc.*, vol. 69, p. 587; May 1, 1956.) A research monograph in which the theoretical exposition is supplemented by practical detail. "... the best short account of electron lenses that has yet appeared."

PROPAGATION OF WAVES

621.396.11 3508

On the Lateral Deviation of Radio Waves coming from Europe—K. Miya and S. Kanaya. (*Rep. Ionosphere Res. Japan*, vol. 10, pp. 1-8; March, 1956.) Measurements of reception in Japan with antennas pointing in various directions indicate that propagation often takes place along paths deviating from the great circle. The observations support the theory advanced previously (235 of 1956) that forward scattering at the earth's surface is involved.

621.396.11:523.5 3509

Some Properties of Oblique Radio Reflections from Meteor Ionization Trails—O. G. Villard, Jr., A. M. Peterson, L. A. Manning, and V. R. Eshleman. (*J. Geophys. Res.*, vol. 61, pp. 233-249; June, 1956.) Observations were made over a 960-km path using one transmitter on frequencies of 23.2, 46.4 and 92.8 mc and a second transmitter located at various distances along and offset from the main propagation path and operating on adjacent frequencies. The percentage of the total time during which reflections were received was in accordance with theoretical expectations. Re-radiation from low-density trails was highly directional; the relatively infrequent high-density trails gave long-duration echoes which were much less directional and were subject to fading. Contours of constant correlation were highly elongated in the direction of the propagation path. See also 236 of 1956.

621.396.11:551.510.535 3510

Reflection of Radio Signals by the Ionosphere—P. Poincelot. (*Ann. Télécommun.*, vol. 11, pp. 70-80; April, 1956.) The propagation of plane waves in a stratified medium is analyzed 1) for linear variation of ionization with height, and 2) for an exponential variation. Results for continuous waves are obtained first, and pulse propagation is then studied, using group-velocity theory; numerical examples are given. The influence of the longitudinal component of the earth's magnetic field is discussed. See also e.g., 3725 of 1955.

- 621.396.11:551.510.535 3511
Orientation of Aerial of Ionospheric Station—Z. Ts. Rapoport. (*Zh. Eksp. Teor. Fiz.*, vol. 30, pp. 407-408; February, 1956.) The effect is calculated of the orientation relative to the magnetic meridian of the electric vector of the wave incident normally on the ionosphere (angle β) on the ratio of the average energy flux of the reflected ordinary wave (S_2) to that of the extraordinary wave (S_1). The curves showing (S_2/S_1) as a function of β are plotted with $|K_2|$, the polarization index of the ordinary wave, as parameter.
- 621.396.11:551.510.535 3512
Ionospheric Focussing and Image Zones—B. D. Khurana. (*J. Inst. Telecommun. Engrs., India*, vol. 2, pp. 96-99; March, 1956.) "The desired target region of reception in short-wave broadcasting is covered by firing the radio waves from a suitably designed transmitting antenna, into the ionosphere, at predetermined angles. Analysis shows that in addition to the target region, some extra zones on the earth's surface also come to receive an appreciably enhanced signal strength. This so-called 'focussing' results from the curvature of the reflecting layers. The 'first order image zones' have been determined for the regional short-wave transmitters of AIR [All India Radio], and plotted on the great-circle map, as an illustration."
- 621.396.11:551.510.535 3513
Ionospheric Absorption at Dakar—F. Delo-beau and K. Suchy. (*J. Atmos. Terr. Phys.*, vol. 9, pp. 45-50; July, 1956. In French.) Selective and nonselective absorption characteristics have been determined from measurements at Dakar. Nonselective absorption is proportional to D-layer electron density and follows the density variations with sunspot number. Variations of selective absorption are related to the observation that the collision frequency at mid-height of the E layer varies inversely as the sunspot number.
- 621.396.11:551.510.535:523.16 3514
On the Propagation of Radio Waves through the Upper Ionosphere—G. R. Ellis. (*J. Atmos. Terr. Phys.*, vol. 9, pp. 51-55; July, 1956.) "The low-frequency limit for the propagation of radio waves through the ionosphere is discussed. It is shown that reflection and absorption of extraordinary waves can occur well above the F region near the level where $f = f_H$, if the wave frequency is less than $f_H F_2$, and if the electron density near this level is not negligible. In these circumstances the low-frequency limit will be determined by $f_0 F_2$, and observations of cosmic radio emission at frequencies much below 1 mc are unlikely."
- 621.396.11:621.396.91 3515
Time Signals for the Determination of Longitude—W. H. Ward. (*Proc. IRE*, vol. 44, pp. 1064-1065; August, 1956.) In connection with determinations of longitude to be made during the International Geophysical Year, radio propagation velocities are required to be known with high accuracy. A method for determining this velocity is outlined, involving two pairs of transmitting and receiving stations and one land-line link.
- 621.396.11.029.45/.5 3516
Amplitude and Phase Curves for Ground-Wave Propagation in the Band 200 c/s to 500 kc/s—J. R. Wait and H. H. Howe. (*Nat. Bur. Stand. Circulars*, pp. 17; May 21, 1956.) Values of the field strength and phase at distances from 1 to 1500 miles are computed, assuming a very short vertical radiator and ground conductivity values of 4, 0.01, and 0.001 mho/m.
- 621.396.11.029.6 3517
Marconi's Last Paper, "On the Propagation of Microwaves over Considerable Distances"—T. J. Carroll. (*Proc. IRE*, vol. 44, pp. 1056-1057; August, 1956.) An English translation is given of this paper, which was written in 1933 and describes experiments on the reception of 500-mc signals at distances up to 258 km, almost nine times the optical distance.
- 621.396.11.029.6 3518
Reflection of Ultra-short Waves at Layer Inhomogeneities of the Troposphere—V. N. Troitski. (*Radiotekhnika, Moscow*, vol. 11, pp. 7-16; January, 1956.) Reflection at oblique incidence is considered for a layer in which permittivity $\epsilon(z)$ varies with height in accordance with the formula $\epsilon(z) = \epsilon_0 N e^{a z} (1 + e^{a z})^{-1} - M e^{a z} (1 + e^{a z})^{-2}$, where ϵ_0 is the permittivity at the boundary and M , N , and a are characteristic parameters of the layer. The variation of the reflection coefficient with layer thickness is investigated. See also *ibid.*, vol. 11, pp. 3-20; May, 1956.
- 621.396.11.029.6:551.510.535:[523.16 + 523.5 + 551.594.5] 3519
Review of Ionospheric Effects at V.H.F. and U.H.F.—C. G. Little, W. M. Rayton, and R. B. Roof. (*Proc. IRE*, vol. 44, pp. 992-1018; August, 1956.) The present state of knowledge on the following effects is summarized: radar echoes from aurora, radar echoes from meteors, the Faraday effect and radar echoes from the moon, radio noise of auroral origin, absorption of radio waves by the ionosphere, refraction of radio waves by the ionosphere, and the scintillation of radio stars. 182 references.
- 621.396.11.029.62 3520
V.H.F. Diffraction by Mountains of the Alaska Range—(*Proc. IRE*, vol. 44, pp. 1049-1050; August, 1956.) Report of reception at Lake Minchumina of 200-mc television signals from Anchorage, 200 miles away on the far side of the mountain ridge. Measurements of field-strength distribution made from an airplane established a fine-structure diffraction pattern. Time variations of field strength and direction of arrival can be explained by changes in meteorological conditions over the paths of signal components scattered and/or diffracted by widely separated peaks. The results give substantial support to knife-edge theory.
- 621.396.11.029.62:551.510.535 3521
Oblique-Incidence Measurements of the Heights at which Ionospheric Scattering of V.H.F. Radio Waves occurs—V. C. Pineo. (*J. Geophys. Res.*, vol. 61, pp. 165-169; June, 1956.) From the differences in propagation times for pulses propagated along tropospheric and ionospheric paths between stations 810 km apart it is tentatively concluded that the operative scattering layers are at heights of 86 km and 70 km for the night-time and mid-day hours respectively.
- 621.396.11.029.63 3522
Propagation Tests at a Frequency of 1000 Mc/s over Various Paths—F. Vecchiacchi. (*Alla Frequenza*, vol. 25, pp. 100-129; April, 1956.) Detailed report of tests made in northern and central Italy during the period 1951-1954. All the paths tested afforded optical visibility; the two longest were 189 km and 196 km respectively. The results indicate that wide-band communication can be maintained for a high percentage of the time. Field-strength fluctuations were much greater in summer than in winter, but on almost every day in summer there was a period of a few hours during which the amplitude of the fluctuations was reduced. Winter periods relatively free from fluctuations are associated with rainy weather.
- 621.396.812.029.62 + 621.397.62 3523
Long-Distance Television Reception in the USSR—W. Sorokine. (*Tel'vision*, pp. 85-88; March/April, 1956.) Long digest of reports of amateur band-1 reception published in *Radio, Moscow*, November-December, 1955. Details and diagrams are given of one of the receivers and antennas used.
- RECEPTION
- 621.376.23:621.396.822 3524
Some Points in the Theory of Square-Law Detection of Background Noise—A. Blanc-Lapierre, P. Dumontet, and M. Savelli. (*C.R. Acad. Sci., Paris*, vol. 242, pp. 2911-2913; June 18, 1956.) The spectrum $X^2(t) + S^2(t)$ is studied, $X(t)$ being a stationary random Laplace function and $S(t)$ its transform in certain linear filters.
- 621.396.62:621.396.812.3 3525
The Statistics of Combiner Diversity—H. Staras. (*Proc. IRE*, vol. 44, pp. 1057-1058; August, 1956.) An analytic method for evaluating the combined statistical distribution in terms of a tabulated function is discussed; results are presented graphically for the combined signal up to ten-fold diversity.
- 621.396.62.029.62:621.376.33 3526
Switched-Tuned F.M. Unit—J. M. Beukers. (*Wireless World*, vol. 62, pp. 427-434; September, 1956.) A modified form of the receiver described by Amos and Johnstone (2096 of 1955) incorporates a reactance tube controlled by the error voltage from the ratio detector and in turn controlling the oscillator so as to provide afc. Constructional details are given.
- 621.396.621.54 3527
Communications Receiver Type-BX 925A—J. H. van Wageningen. (*Commun. News*, vol. 16, pp. 92-98; April, 1956.) A single-heterodyne receiver for telegraphy or telephony is described; it has two stages of rf and two stages of IF amplification. Special features include the combination of mechanical band-spread with high-speed tuning by motor, and the provision of a crystal-controlled calibration oscillator.
- 621.396.621.54:621.317.328.029.62/.63 3528
A V.H.F./U.H.F. Field-Strength Recording Receiver using Post-Detector Selectivity—R. V. Harvey, G. F. Newell, and J. G. Spencer. (*B.E.C. Engng. Div. Monographs*, pp. 1-26; April, 1956.) Design and performance details for a pretuned receiver for bands III and IV are discussed. A separate signal-frequency unit is used for each band, followed by a common IF unit working at 10.7 mc. The output signal-noise ratio has been increased by restricting the bandwidth of the circuits following the detector, enabling a higher sensitivity to be obtained. The receiver has been designed for unattended operation over periods up to one month with a calibration stability within ± 1 db.
- 621.396.621.54:621.385.5 3529
The Presentation and Application of the Characteristics of the Pentagrid Converter Valve—Wilshire. (See 3590.)
- 621.396.621.54.029.45/.51:621.375.234 3530
A Very-Low-Frequency Receiver with High Selectivity—C. S. Fowler. (*J. Brit. IRE*, vol. 16, pp. 401-404; July, 1956.) A superheterodyne receiver for the frequency band 6-36 kc is described. High selectivity is obtained by using mixed positive and negative feedback to control the Q factor of the IF tuned circuits.
- 621.396.82:621.397.62(083.74) 3531
IRE Standards on Methods of Measurement of the Conducted Interference Output of Broadcast and Television Receivers in the Range of 300 kc/s to 25 Mc/s, 1956—(*Proc. IRE*, vol. 44, pp. 1040-1043; August, 1956.) Standard 56 IRE 27.S1, supplement to 54 IRE 17.S1.
- 621.396.823:621.317.729 3532
Equipment for recording R.F. Interference

due to High-Voltage Power Transmission Lines—Carteron, Fromy, and Prokocimer. (See 3488.)

STATIONS AND COMMUNICATION SYSTEMS

621.396.3:621.396.43:523.5 3533

Janet [communication system]—W. T. Cocking. (*Wireless Engr.*, vol. 33, p. 203; September, 1956.) Brief note on a long-range radiotelegraphy system developed by the Canadian Defence Research Board, in which the propagation path is provided by ionized meteor trails. Frequencies between 30 and 60 mc are used, and transmitters with a power output of about 800 w are used with Yagi antenna systems having a gain of about 10 db. Messages for transmission are recorded in readiness, and the actual transmission starts automatically when ionization occurs at the appropriate reflection point relative to transmitter and receiver. For another account, see *Wireless World*, vol. 62, pp. 404-405; September, 1956.

621.396.41:621.396.65.029.63 3534

A Decimetre-Wavelength Radio-Link Network providing High-Quality Program Channels using Pulse Phase Modulation (Part I—Transmission Requirements, Planning and Results—G. Brühl. (*Telefunken Ztg.*, vol. 29, pp. 5-12; March, 1956. English summary pp. 62-63.) Description of the 500-mile Austrian network, which comprises 25 stations in six main sections. Carrier frequencies between 2.06 and 2.3 mc are used; three 15-kc program channels and six 3.2-kc speech channels are accommodated. The over-all signal/noise ratio is >66 db.

621.396.71.029.55(43) 3535

Federal German Post Office Overseas Radio Transmitting Station at Elmshorn—E. Meinel. (*Nachrichtentech. Z.*, vol. 9, pp. 115-158; April, 1956.) The station comprises 16 sw transmitters, including four 20-kw ssb and two 50-kw dsb telephony transmitters and ten 20-kw transmitters for telegraphy; 21 rhombic antennas and several horizontal dipole arrays are used. The equipment and services are briefly described.

621.396.97:621.396.677 3536

Vertical Radiation and Tropical Broadcasting—A. H. Dickinson. (*J. Brit. IRE*, vol. 16, pp. 405-411; July, 1956.) An estimate, based on five years' operating experience, is presented of the requirements in respect of antenna design, transmitter power and operating frequencies for sw broadcasting stations in the tropics to serve the large areas outside the main population centres. Antennas comprising 16-element binomial arrays [2335 of 1952 (Adorian and Dickinson)] used in conjunction with 5-kw transmitters should be able to serve areas of 90,000 miles.² Co-channel stations should be separated by 1500 miles. Each station requires two or three frequencies in the 2.5-, 3.5-, 5- and 9-mc bands, in order to cope with ionosphere variations, but the number of frequency changes should be kept to a minimum for the convenience of listeners.

SUBSIDIARY APPARATUS

621.311.6 3537

A Balanced, Unregulated, Dual Power Supply—K. N. Hemmenway. (*Proc. IRE*, vol. 44, p. 1053; August, 1956.) A circuit is described for simultaneously providing positive and negative voltages which remain equal in face of line voltage variations; practical details are given for a unit supplying ± 300 v at 38.9 ma. A graph shows the performance of the unit used with a dc amplifier providing a balanced load.

621.311.6:621.314.63:537.311.33:535.215

3538

Semiconductor Solar-Energy Converters—A. Hähnlein. (*Nachrichtentech. Z.*, vol. 9, pp. 145-150; April, 1956.) A concise review of the physical fundamentals includes brief discussions of radiant-energy absorption in semiconductors, the effect of *p-n* junctions and the energy conversion efficiency.

621.311.61:621.314.1:621.314.7 3539

Efficient and Reliable Transistor High-Voltage Power Supply—G. E. Driver. (*Nucleonics*, vol. 14, pp. 74, 76; March, 1956.) The system comprises a 9-v battery, a transistor oscillator, crystal rectifier, and corona-type regulator; the output is about 20 μ a at 900 v.

621.314.634 3540

Life-Test Results on Selenium Rectifiers—G. C. Chernish. (*Tele.-Tech. and Electronic Ind.*, vol. 15, pp. 68-69, 169; April, 1956.) Tests on a representative selection of Se rectifiers for radio and television equipment show variations in shelf life, useful life, and temperature characteristics; the need for drastic derating is suggested.

TELEVISION AND PHOTOTELEGRAPHY

621.397.242:621.397.743 3541

A 21-Mc/s Local Television Network—H. J. Schmidt. (*Nachrichtentech. Z.*, vol. 9, pp. 173-177; April, 1956.) The modulators, amplifiers, and demodulators used in the coaxial-line network linking the studios, control rooms, and transmitters located in various parts of Hamburg are discussed. A dsb system with positive AM is used.

621.397.5:535.623 3542

Notes on a Colour-Television System with Two Amplitude-Modulated [sub]-Carriers—J. Wolf. (*Elektronische Rundschau*, vol. 10, pp. 101-104; April, 1956.) Factors relevant to the choice of color subcarriers for a European system are discussed; it is shown that frequency interlace is not an essential prerequisite for the transmission of color information within the luminance band. A simple method of fixing the ratio between color subcarrier and line frequency in the two-subcarrier system described by Haantjes and Teer (1224 of 1956) is indicated with reference to a suitable circuit.

621.397.5(083.74) 3543

Television in the World Today—C. J. Hirsch. (*Elect. Engng.*, vol. 75, pp. 321-325; April, 1956.) The various television standards in use are tabulated and briefly discussed.

621.397.6:621.397.7:535.623 3544

Pedestal Processing Amplifier for Television Studio Operation—R. C. Kennedy. (*RCA Rev.*, vol. 17, pp. 297-302; June, 1956.) "The pedestal processing amplifier is a device capable of removing the synchronizing pulses from either a color or monochrome television signal so as to permit simultaneous presentation of pictures from separate locations. It utilizes a new type of sync separator which provides a sync signal having constant amplitude for input signal variations of ± 14 decibels."

621.397.61 3545

A Flat-Bed Facsimile Telegraph Transmitter—W. D. Buckingham. (*Elect. Engng.*, vol. 75, pp. 356-359; April, 1956.) Experimental equipment is described in which the message sheet may be of any desired length, and is advanced slowly while scanning is effected by the forward sweep across the sheet of a light spot of diameter 0.01 inch. The light is produced by a special type of tungsten arc lamp. A cylindrical reflector is used for concentrating the light reflected from the message sheet on the photo-

621.397.61:535.623 3546

Colorimetry, Film Requirements and Masking Techniques for Color Television—H. N. Kozanowski and S. L. Bendell. (*J. Soc. Mot. Pict. Telev. Engrs.*, vol. 65, pp. 201-204; April, 1956.) Basic requirements for transmission of color films are discussed and improved equipment for electronic masking and hue control is described.

621.397.611.2:621.397.8 3547

The Possibility of a "Normal" Resolution by Television Transmitting Tubes with Energy Storage—Ya. A. Ryftin. (*Zh. Tekh. Fiz.*, vol. 25, pp. 2214-2232; October, 1955.) "Normal" or maximum attainable, resolution is defined and an analysis is made of the causes which lower the operational quality of storage tubes. The possibility of obtaining "normal" resolution with this type of tube is discussed and some practical suggestions are made. A rough estimate is given of the extent to which existing storage tubes fail to provide full quality service with 625-line scanning.

621.397.62+621.396.812.029.62+621.396.677.3 3548

Long-Distance Television Reception in the USSR—Sorokine. (See 3523.)

621.397.62:535.623 3549

Color Purity in Ungated Sequential Displays—G. S. Ley. (*IRE TRANS.*, vol. BTR-1, pp. 36-43; January, 1955. Abstract, *Proc.* vol. 43, p. 383; March, 1955.)

621.397.62:535.623 3550

The Practical Aspects of the Color Subcarrier Synchronization Problem—W. J. Gruen. (*IRE TRANS.*, vol. BTR-1, pp. 44-51; January, 1955. Abstract, *Proc. IRE*, vol. 43, p. 383; March, 1955.)

621.397.62:621.376.33 3551

Sampling Detector for Intercarrier TV Sound—K. Schlesinger. (*Electronics*, vol. 29, pp. 138-141; August, 1956.) One half of a double triode is connected as a feedback oscillator, locked through the inductance of its tank circuit to a driver stage fed by the 4.5-mc fm sound carrier. It is coupled through a common cathode connection to the sampling triode, which is arranged to function at zero passage of the carrier voltage, thus yielding maximum fm detection while ignoring residual AM.

621.397.62:621.396.82(083.74) 3552

IRE Standards on Methods of Measurement of the Conducted Interference Output of Broadcast and Television Receivers in the Range of 300 kc/s to 25 mc/s 1956. (*Proc. IRE*, vol. 44, pp. 1040-1043; August, 1956.) Standard 56 IRE 27.S1, supplement to 54 IRE 17.S1.

621.397.621.2:535.623:621.385.832 3553

Effect of Magnetic Deflection on Electron Beam Convergence [in colour-television tubes]—P. E. Kaus. (*RCA Rev.*, vol. 17, pp. 168-189; June, 1956.) "The image curvatures of deflection yokes are calculated and minimized using third-order perturbation theory. It is found that the mean image curvature is too large to dispense with dynamic convergence when a point focus is needed. Proper field shaping, however, can produce a good line focus over the whole screen without dynamic convergence."

621.397.621.2:535.623:621.385.832 3554

Recent Improvements in the 21AXP22 Color Kinescope—R. B. Janes, L. B. Headrick, and J. Evans. (*RCA Rev.*, vol. 17, pp. 143-167; June, 1956.) The location and formation of the phosphor dots on the face-plate of this three-gun tube [2771 of 1955 (Seelen *et al.*)] are effected in a special optical device called a "lighthouse." Modifications of this device

leading to improved color performance of the tube are described.

621.397.621.2:535.623:621.385.832 3555
Kinescope Electron Guns for producing Noncircular Spots—Knechtli and Beam. (See 3593.)

621.397.7:621.397.6 3556
Standardization of Television Equipment at Radiodiffusion-Television Française—L. Gousot. (*Onde Élect.*, vol. 36, pp. 352-368; April, 1956.) Video-frequency equipment is considered to have reached a stable state of development; present practice is described. Component specifications and characteristics are detailed in an appendix.

621.397.5:535.623 3557
Color Television Engineering [Book Review]—J. W. Wentworth. McGraw-Hill Book Co., Inc., New York and London. (*Engineering, Lond.*, vol. 181, p. 208; April 13, 1956.) "The outstanding value of the book is its clear presentation of fundamental color theory and the marriage of this theory with that of television engineering."

TRANSMISSION

621.376.32:621.396.61:621.396.41 3558
Exciters multiplex F.M. Carriers—H. G. Stratman. (*Electronics*, vol. 29, pp. 148-150; August, 1956.) The equipment consists of a fm exciter which provides a main carrier of frequency 100 mc, using a serrasoid modulator circuit [342 of 1949 (Day)], and a similar unit generating an audio-modulated subcarrier of frequency 32.5 kc to perform the multiplexing operation. The total audio distortion is <0.2 per cent, with a crosstalk figure of about $\times 55$ db.

621.396.61:621.375.232.4 3559
Linear 15-kW Amplifier with Grounded-Grid Stage—A. Di Marco. (*Rev. Electr. Electronica, Buenos Aires*, vol. 44, pp. 125-128; March, 1956.) A description is given of a two-stage amplifier for a transmitter. The second stage is cathode-excited, while the first stage is designed for class-AB1 operation. The gain is 50 db. A vertical-panel construction system is used, giving good accessibility.

621.396.61:621.376.32:621.373.42 3560
The Gain Characteristic inside the Pull-In Range particularly in F.M. Transmitters and Wobblers—E. G. Woschni. (*Hochfrequenztech. u. Elektroakust.*, vol. 64, pp. 63-73; November, 1955.) Continuation of earlier work on the occurrence of pull-in ranges in fm transmitters and wobblers controlled by reactance tubes (*ibid.*, vol. 63, pp. 119-125; December, 1954). The dependence of the pull-in range on the residual attenuation is analysed. A formula is derived expressing the gain variation in terms of the maximum gain at the middle of the pull-in range and of the fractional detuning. Values of lock-in range and gain obtained experimentally are in some cases substantially higher than calculated values; the discrepancies are attributed to distortion introduced during the frequency-modulation process.

TUBES AND THERMIONICS

621.3-71 3561
Review of Industrial Applications of Heat Transfer to Electronics—Kaye. (See 3290.)

621.314.63:621.314.7 3562
Low-Frequency Circuit Theory of the Double-Base Diode—J. J. Suran. (*IRE TRANS*, vol. ED-2, pp. 40-48; April, 1955.) A study is made of the operating mechanism of the single-junction semiconductor device with two ohmic contacts; large-signal operation is treated by applying small-signal theory to successive restricted regions of the characteristic, part of which exhibits negative resistance. Circuit pa-

rameters are related to the physical constants of the device.

621.314.7 3563
The Four-Terminal-Network Parameters of the Junction Transistor in the Three Basic Circuit Arrangements—G. Meyer-Brötz. (*Telefunken Ztg.*, vol. 29, pp. 21-28; March, 1956. English summary, pp. 63-64.)

621.314.7 3564
Experimental Study of Point-Contact Transistor—S. Iwase. (*Rep. Elect. Commun. Lab., Japan*, vol. 3, pp. 27-33; November, 1955.) An account is given of the Ge surface treatment, and of experiments on the electrical forming of the transistor with different point-contact materials. Best characteristics are obtained with a collector containing 0.25 per cent-1 per cent of a Group-V impurity; the emitter substance should not be the same as the collector.

621.314.7 3565
A Junction Transistor with High Current Gain—J. W. Granville. (*J. Electronics*, vol. 1, pp. 565-579; May, 1956.) The production and performance of a new transistor with a $p-n$ -junction emitter and an $n-n^+$ -junction collector are described and compared with the corresponding aspects of point-contact transistors. The $n-n^+$ junction is made by alloying a Sn-Sb alloy to the Ge, while the $p-n$ junction is made by alloying In to the Ge. High noise factors, of the order of 60 db, were observed in experimental $p-n-p^+$ transistors; possible methods of eliminating this and other drawbacks are mentioned. Use of Si instead of Ge could lead to improved performance.

621.314.7:621.375.4 3566
Measurement Considerations in High-Frequency Power Gain of Junction Transistors—R. L. Pritchard. (*Proc. IRE*, vol. 44, pp. 1050-1051; August, 1956.) Reasons are given for the particular choice of methods used in the work described previously (3774 of 1955); the theory is extended to two types of neutralization used in common-emitter transistor amplifiers.

621.383.2 3567
The Time Lag and other Undesirable Phenomena observed in Vacuum Photo-tubes at Weak Illumination: Part 2—M. Sugawara. (*J. Phys. Soc. Japan*, vol. 11, pp. 271-278; March, 1956.) A specially constructed cell, having a second, semitransparent cathode which can be insulated, is used to show that abnormal response characteristics in standard photocells can be explained by the adherence of photoemissive material to the inner surfaces of the cell. Part 1: 2905 of 1956.

621.383.2:535.215.08 3568
Apparatus for the Study of Spectral Response of Photoelectric Surface—H. Mitsuhashi and T. Nakayama. (*J. Phys. Soc. Japan*, vol. 11, pp. 308-311; March, 1956.) Constancy of the test source intensity is secured by a servomechanism controlled by comparison with a standard source. The photoelectric response is also recorded automatically.

621.383.2:621.396.822 3569
Flicker Noise in Vacuum Photoelectric Diodes—R. J. J. Zijlstra and C. T. J. Alkemade. (*J. Appl. Phys.*, vol. 27, pp. 656-657; June, 1956.) Noise in photocells with $Cs-Cs_2O-Ag$ and with Cs_2-Sb photocathodes was measured over the frequency range 1 cps-1 kc. Results are presented graphically; they are consistent with the assumption that the frequency-dependent flicker noise superimposed on the shot noise is generated in a cathode layer whose resistance fluctuates with time.

621.383.2:681.142 3570
Bit Storage via Electro-optical Feedback—Milch. (See 3289.)

21.385:621.3.015.3 3571
Theory of Transient Processes in Electronic Devices and in Circuits containing such Devices—G. A. Grinberg. (*Zh. Tekh. Fiz.*, vol. 26, pp. 2183-2192; October, 1955.) A mathematical analysis is given of the rise of the current in an electronic device on application of a pulse voltage. The case of a plane diode with a direct voltage suddenly applied is considered in detail.

621.385.002.2 3572
Techniques for the Manufacture and Inspection of Reliable Electronic Valves—J. Brasier. (*Le Vide*, vol. 11, pp. 66-77; March/April, 1956.) U.S.A. procedure for preparing specifications for reliable valves is indicated; the distinction between specifications applicable during actual manufacture and those applicable during a subsequent inspection is emphasized. French official specifications and the manufacturing steps taken to satisfy them are described and illustrated.

621.385.029.6 3573
Plasma-Frequency Reduction Factors in Electron Beams—G. M. Branch and T. G. Mihran. (*IRE TRANS*, vol. ED-2, pp.3-11; April, 1955.) Long-beam microwave tubes are discussed. The plasma-frequency reduction factor due to the presence of the drift-tube walls is calculated for a variety of beam and drift-tube cross sections, and the results are presented in a series of graphs. One particular result is that for an annular beam the reduction factor depends primarily on the width of the annulus.

621.385.029.6 3574
Modern Reflex Klystrons—R. Hechtel. (*Arch. Elekt. Übertragung*, vol. 10, pp. 133-138; April, 1956.) The construction and performance characteristics of an experimental klystron with an output of 4-5 w in the 3.6-4.2-kmc frequency band are compared with those of the U.S.A. types RK 5976 and 431A.

621.385.029.6 3575
Travelling-Wave Valves for 4-cm Waves: Research and Development at the Centre National d'Études des Télécommunications—A. Bobenrieth and O. Cahen. (*Onde Élect.*, vol. 36, pp. 307-317; April, 1956.) The design and production of tubes to the specifications of the French Post Office are described. Characteristics of an experimental model are given; saturation power is >1 w at 7.0-7.5 kmc, varying only slightly with frequency, for inputs of about 0.3 mw.

621.385.029.6 3576
Recent Developments of O-Type Carcinotrons—P. Palluel. (*Onde Élect.*, vol. 36, pp. 318-335; April, 1956.) A range of six models developed by the Compagnie Générale de TSF covers the range 1-15 kmc; details are given of construction and performance. See also 1904 of 1956 (Palluel and Goldberger).

621.385.029.6 3577
When is a Backward Wave not a Backward Wave?—J. E. Rowe and G. Hok. (*Proc. IRE*, vol. 44, pp. 1060-1061; August, 1956.) A critical discussion of some methods of analyzing the large-signal operation of traveling-wave tubes.

621.385.029.6:621.396.822 3578
Noise in Traveling-Wave Tubes—A. G. Mungall. (*IRE TRANS*, vol. ED-2, pp. 12-17; April, 1955.) Noise measurements on tubes for operation at 3.2 cm λ are reported. The effects of anode-to-helix separation, space charge, field distribution, and gas pressure are studied. A modified theory of space-charge smoothing of microwave shot noise is suggested. Possible improvement of noise figure by use of a triode gun in place of a diode is discussed.

- 621.385.029.6:621.396.822 3579
The Noise Factor of Traveling-Wave Tubes—G. Hok. (PROC. IRE, vol. 44, p. 1061; August, 1956.) Discussion indicates that no theoretical lower limit for the noise factor is found when a simple mathematical model with appropriate means for shaping the beam is chosen.
- 621.385.032.2 3580
Effect of Cathode Roughness on the Maximum Current Density in an Electron Beam—G. W. Preston. (*J. Appl. Phys.*, vol. 27, pp. 627-630; June, 1956.) Analysis indicates that the current density in a focused beam may be greatly reduced due to roughness of the cathode surface; the minimum beam diameter attainable is unaffected by change of cathode temperature or proportional changes in the potentials of all electrodes.
- 621.385.032.21:537.5 3581
High-Frequency Oscillations in the Space Charge of some Electron Emission Systems—K. T. Dolder and O. Klemperer. (*J. Electronics*, vol. 1, pp. 601-611; May, 1956.) "The occurrence of multiple electron sources in electron emission systems was investigated for thermionic filamentary cathodes in the form of a straight wire, of a hairpin, and of a helical spiral. The experimental results are all consistent with the view that the occurrence of multiple sources is the result of standing electron space charge oscillations close to the cathode surface. The frequencies of these oscillations are believed to be between 10^4 and 10^8 cps."
- 621.385.032.212:621.396.822 3582
Electron-Beam Noisiness and Equivalent Thermal Temperature for High-Field Emission from a Low-Temperature Cathode—R. W. DeGrasse and G. Wade. (PROC. IRE, vol. 44, pp. 1048-1049; August, 1956.) Analysis indicates that the noise-equivalent temperature of a field-emission cathode at 0°K is directly proportional to the strength of the field at the cathode, E , and inversely proportional to the square root of the work function ϕ . For a tungsten cathode with $\phi = 4.5$ eV and $E = 3.5 \times 10^8$ V/m the equivalent temperature is 2640°K . A small change in either E or ϕ has a very large effect on the emission.
- 621.385.032.216 3583
Electrolytic Transport Phenomena in the Oxide Cathode—R. H. Plumlee. (*RCA Rev.*, vol. 17, pp. 190-230; June, 1956.) Experiments are described in which chemical changes were detected in BaO cathodes following emission of electrons. The evaporation of H_2 , H_2O , O_2 , CO, and CO_2 from the cathode was found to depend on field strength, temperature, state of cathode activity, lapse of time, and previous duty period. Some correlation was also found between residual gas pressures and cathode activity. It is deduced that the cathode coating contains impurities incorporated as anions in labile equilibrium with their molecular dissociation fragments present in the vacuum at low partial pressures.
- 621.385.032.216 3584
Emission and Conduction Measurements Oxide Cathodes—A. Kestelyn-Loebenstein. (*Appl. Sci. Res.*, vol. B6, pp. 105-116; 1956.) An experimental investigation of cathodes with Ni base is reported; the observed characteristics are fundamentally different from those for W-base cathodes (*Le Vide*, vol. 9, pp. 148-154; July/September, 1954.) The shape of the characteristics is not consistent with a pore-conduction mechanism, but a second conduction mechanism whose onset depends on field strength is indicated; this is thought to have its seat in the Ni/coating interface.
- 621.385.032.216 3585
Capillary Cathodes produced by Compression and Sintering—G. Mesnard and R. Uzan. (*Le Vide*, vol. 11, pp. 44-53; March/April, 1956.) Cathodes with a porous nickel or tungsten surface, containing mixed Ba and Sr carbonates, are discussed and their performance is compared with that of cathodes in which the alkaline earth carbonates are mixed homogeneously with nickel or tungsten powder. See also 1842 of 1955 (Uzan and Mesnard).
- 621.385.032.216:537.311.33 3586
The Electron Donor Centers in the Oxide Cathode—R. H. Plumlee. (*RCA Rev.*, vol. 17, pp. 231-274; June, 1956.) The chemistry of the oxide cathode, and of electronically active solids in general, is considered in terms of the electronic chemical potential, which is determined by the Fermi level of the material. A particular impurity group is identified as the important donor-centre type. For a brief note on this work, see *J. Appl. Phys.*, vol. 27, pp. 659-660; June, 1956.
- 621.385.15+621.383.27]:621.396.822 3587
Flicker Noise in Secondary-Emission Tubes and Multiplier Phototubes—R. C. Schwantes, H. J. Hannam, and A. van der Ziel. (*J. Appl. Phys.*, vol. 27, pp. 573-577; June, 1956.) Noise measurements on Type-EFP60 secondary-emission tubes and Type-5819 photomultipliers are reported; the existence of a flicker-noise component varying as $1/f$ at frequencies up to 10^4 cps was established for the tubes but not for the photomultipliers. The results are discussed in terms of fluctuations of the work function of the emitting surfaces.
- 621.385.33.026.446 3588
Technology of the 120-kw Transmitting Triode Type-RS 526—E. Uredat. (*Telefunken Ztg.*, vol. 29, pp. 47-54; March, 1956. English summary, p. 65.) The construction of this water-cooled triode is described and compared with that of the 80-kw air-cooled triode Type-RS 726 and the 120-kw triode Type-RS 826 cooled by evaporation of water. The characteristics of the three triodes are tabulated.
- 621.385.5 3589
Current Partition in Electron Valves with More than One Positive Electrode, for Low Current Densities—H. Göllnitz. (*Hochfrequenztech. u. Elektroakust.*, vol. 64, pp. 95-102; January, 1956.) Current partition in pentodes is examined by calculating the electron trajectory for the limiting case dividing electrons passing through the suppressor grid from those reflected by it, for an arbitrary angle of incidence of the electrons. The calculation is facilitated by considering only paths through the saddle points of the suppressor-grid field.
- 621.385.5:621.396.621.54 3590
The Presentation and Application of the Characteristics of the Pentagrid Converter Valve—H. R. Wilshire. (PROC. IRE, Aust., vol. 17, pp. 113-122; April, 1956.) "The conversion transconductance (g_c) of pentagrid converter tubes (1R5 and 6BE6) is a function of the signal grid bias, direct screen voltage, screen grid oscillator voltage, oscillator grid current and, in some circuits, the oscillator voltage at the cathode. This paper discusses the measurement and display of the variation of g_c with these five parameters with the object of obtaining optimum performance in the converter stage of radio receivers."
- 621.385.832 3591
Theory of Deflection—A. M. Strashkevich. (*Radio-tekhnika, Moscow*, vol. 11, pp. 64-69; February, 1956.) The general properties of axially antisymmetric fields which can be used in the deflector [3290 of 1952 (Schlesinger)] are considered. The condition is derived for equal sensitivity of deflection of an electron beam in two mutually perpendicular directions and an example of a system satisfying this condition is given.
- 621.385.832:535.376.07 3592
Variations of the Properties of Luminescent Screens under Electron Bombardment in Cathode-Ray Tubes—K. H. J. Rottgardt and W. Berthold. (*Z. Naturf.*, vol. 10a, pp. 736-740; September/October, 1955.) The luminescence decay curves and the dependence of luminescence intensity on anode voltage are compared for Al-coated ZnS:Ag screens 1) before and 2) after bombardment by 16-kv electrons. The results indicate that the observed reduction of luminescence is associated with disturbance of the crystal lattice. See also 2485 of 1955.
- 621.385.832:621.397.621.2:535.623 3593
Kinescope Electron Guns for producing Noncircular Spots—R. C. Knechtli and W. R. Beam. (*RCA Rev.*, vol. 17, pp. 275-296; June, 1956.) Designs are described in which either the electron crossover or an interposed aperture is shaped so as to produce a spot of desired non-circular form. One example is a line-crossover gun suitable for the parallel-line-screen color kinescope discussed by Bond *et al.* (848 of 1952).
- 621.387:621.318.57(083.74) 3594
IRE Standards on Electron Tubes; TR and ATR Tube Definitions, 1956—(Proc. IRE, vol. 44, pp. 1037-1039; August, 1956.) Standard 56 IRE 7. S3.

MISCELLANEOUS

061.4:621.37/39 3595

Radio Show Review—(*Wireless World*, vol. 62, pp. 468-480; October, 1956.) Report of design trends observed at the 1956 National Radio Exhibition. Greater standardization of television receivers is noted; transistors are used in portable broadcast receivers and sound-reproducing equipment. Band-III and dual-band antennas were featured. Transistors with cutoff frequencies up to 10 mc were shown. For another account see *Wireless Engrg.*, vol. 33, pp. 229-234; October, 1956.

061.6:621.396 3596

Physics at the Radar Research Establishment, Malvern—R. A. Smith. (*Proc. Roy. Soc. A*, vol. 235, pp. 1-10; April 10, 1956.) An account of the organization and research program.

621.3:378.9 3597

B.B.C. Engineering Training Centre—(*Engineer, Lond.*, vol. 201, pp. 609-610; June, 1956.) A brief description of the organization, equipment, and curriculum of the Centre at Wood Norton Hall.

621.3.002.2:551.58 3598

Consideration of Climatic Influences in the Development and Construction of Electronic Equipment—E. Ganz and K. Michel. (*Bull. Schweiz. Elektrotech. Ver.*, vol. 47, pp. 441-458; May 12, 1956. In French.) Factors discussed include temperature, pressure, humidity, icing, air pollution and ultraviolet radiation; both large-scale geographic and local environmental variations are considered. No simple tropicalization process is universally satisfactory; the particular conditions must be studied in each case. Climatological knowledge should be more systematically disseminated.

Index to
PROCEEDINGS OF THE IRE

Volume 44, 1956



The Institute of Radio Engineers, Inc.
1 East 79 Street, New York 21, N.Y.

TABLE OF CONTENTS

	Page
Contents	
Volume 44, chronologically listed	3
Authors	
Listed alphabetically	8
Book Reviews	
Listed alphabetically	10
Subjects	
Listed alphabetically	11
Nontechnical Index	
Abstracts and References	15
Abstracts of TRANSACTIONS	15
Awards	15
Board of Directors	15
Calendar of Coming Events	15
Committees	15
Conventions and Meetings	16
Editorials	17
Front Covers	17
Frontispieces	17
IRE People	17
Miscellaneous	18
Notices	18
Obituaries	18
Photographs	18
Poles and Zeros	19
Professional Groups	20
Report of Secretary	20
Scanning the Issue	20
Sections and Subsections	20

PROCEEDINGS OF THE IRE

CONTENTS OF VOLUME 44—1956

Volume 44, Number 1, January, 1956

Volume 44, Number 2, February, 1956 (Cont'd)

Cumulative Index Number	Page
Arthur V. Loughren, President, 1956.....	2
The State of Radio and Electronics in Egypt, <i>Professor H. M. Mahmoud</i>	3
5598. A Survey of Application of Ferrites to Inductor Design, <i>R. S. Duncan, H. A. Stone, Jr.</i>	4
5599. Electromechanical Filters for 100-KC Carrier and Sideband Selection, <i>R. W. George</i>	14
5600. New Microwave Repeater System Using Traveling-Wave Tubes, <i>N. Sawazaki and T. Honma</i>	19
5601. Geophysical Prospection of Underground Water in the Desert by Means of Electromagnetic Interference Fringes, <i>M. A. H. El-Said</i>	24
5602. A Transmission Line Taper of Improved Design, <i>R. W. Klopfenstein</i>	31
5603. A Precision Resonance Method for Measuring Dielectric Properties of Low-Loss Solid Materials in the Microwave Region, <i>S. Saito and K. Kurokawa</i>	35
5604. Transistor Amplifiers for Use in a Digital Computer, <i>Q. W. Simkins and J. H. Vogelsong</i>	43
5605. A Developmental Wide-Band, 100-Watt, 20 DB, S-Band Traveling-Wave Amplifier Utilizing Periodic Permanent Magnets, <i>W. W. Siekanowicz and F. Sterzer</i>	55
5606. Spurious Modulation of Electron Beams, <i>C. C. Culler</i>	61
5607. Negative Resistance Regions in the Collector Characteristics of the Point-Contact Transistor, <i>L. E. Miller</i>	65
5608. The Dependence of Transistor Parameters on the Distribution of Base Layer Resistivity, <i>J. L. Moll and I. M. Ross</i>	72
5609. Surface Resistance and Reactance of Metals at Infrared Frequencies, <i>J. R. Beattie and G. K. T. Conn</i>	78
5610. Transverse-Field Traveling-Wave Tubes with Periodic Electrostatic Focusing, <i>R. Adler, O. M. Kromhout, and P. A. Clavier</i>	82
5611. A Simplified Method of Solving Linear and Nonlinear Systems, <i>R. Boxer and S. Thaler</i>	89
5612. Multi-Beam Velocity-Type Frequency Multiplier, <i>Yukito Matsuo</i>	101
5613. IRE Standards on Terminology for Feedback Control Systems.....	107
Correction to "Temperature Coefficient of AT Cut Quartz Crystals," by E. A. Gerber.....	109
Correspondence:	
5614. Scattering Matrix Measurements on Nonreciprocal Microwave Devices, <i>J. E. Pippin</i>	110
5615. A New Treatment for Parabolic Reflector Problems, <i>B. Chatterjee</i>	110
5616. A Method of Launching Surface Waves, <i>J. D. Lawson</i>	111
5617. Noise Reduction in CW Magnetrons, <i>R. L. Krulee and J. A. Mullen</i>	111
5618. Russian Vacuum-Tube Terminology, <i>G. F. Schultz</i>	112
Contributors	112
IRE News and Radio Notes	115-126
5619. Abstracts of IRE TRANSACTIONS.....	130
5620. Abstracts and References.....	134
Annual Index to CONVENTION RECORD OF THE IRE	Follows Page 148

Volume 44, Number 2, February, 1956

Scanning the Issue, <i>The Managing Editor</i>	150
Poles and Zeros, <i>The Editor</i>	151
Herre Rinia, Vice-President 1956.....	152
The New IRE Professional Group on Military Electronics, <i>C. L. Engleman</i>	153
5621. Magnetic Core Circuits for Digital Data-Processing Systems, <i>D. Loev, W. Miehle, J. Paivinen, and J. Wylen</i>	154
5622. Long-Range Propagation of Low-Frequency Radio Waves between the Earth and the Ionosphere, <i>J. Shmoys</i>	163
5623. Artificial Dielectrics Utilizing Cylindrical and Spherical Voids, <i>H. T. Ward, W. O. Puro, and D. M. Bowie</i>	171
5624. Broadband Microwave Frequency Meter, <i>P. H. Vartanian and J. L. Melchor</i>	175

Cumulative Index Number	Page
5625. The Frequency Response of Bipolar Transistors with Drift Fields, <i>L. B. Valdes</i>	178
5626. Transistor Fabrication by the Melt-Quench Process, <i>J. I. Pankove</i>	185
5627. RF Bandwidth of Frequency-Division Multiplex Systems Using Frequency Modulation, <i>R. G. Medhurst</i>	189
5628. Design Information on Large-Signal Traveling-Wave Amplifiers, <i>J. E. Rowe</i>	200
5629. The Polarguide—A Constant Resistance Waveguide Filter, <i>R. W. Klopfenstein and J. Epstein</i>	210
5630. Frequency Stability of Point-Contact Transistor Oscillators, <i>C. C. Cheng</i>	219
5631. Prediction of Pulse Radar Performance, <i>W. M. Hall</i>	224
5632. Methods of Sampling Band-Limited Functions, <i>R. S. Berkowitz</i>	231
5633. The Rubber Membrane and Resistance Paper Analogies, <i>J. H. Owen Harries</i>	236
5634. Radar Polarization Power Scattering Matrix, <i>C. D. Graves</i>	248
5635. Statistical Design and Evaluation of Filters for the Restoration of Sampled Data, <i>R. M. Stewart</i>	253
Correspondence:	
5636. Comment on "Echo Distortion in the FM Transmission of Frequency-Division Multiplex," <i>R. G. Medhurst</i>	258
5637. Rebuttal, <i>W. J. Albersheim and J. P. Schafer</i>	258
5638. On Network Determinants, <i>I. Cedarbaum</i>	258
5639. Nonlinearity of Propagation in Ferrite Media, <i>Alvin Clavin</i>	259
5640. A Note on the Small Amplitude Transient Response of P-N Junctions, <i>B. R. Gossick</i>	259
5641. Some Thoughts on Technical Meetings, <i>R. M. Fano</i>	260
5642. The Unit for Frequency, <i>J. Hers</i>	260
5643. E and C Type Traveling-Wave Devices, <i>P. Guenard and O. Doehler</i>	261
5644. Transistor Power Converter Capable of 250 Watts DC Output, <i>G. C. Uchirin</i>	261
5645. Optimum Gain of Amplifiers, <i>H. A. Haus</i>	263
Contributors	264
IRE News and Radio Notes:	
Seventh Regional Conference Set for April 11-13, 1956.....	267
IRE Activities Along the Eastern Seaboard.....	269
Professional Group News.....	271
Technical Committee Notes.....	271
Books:	
5646. "Static and Dynamic Electron Optics," by <i>P. A. Sturrock</i> . (Reviewed by <i>R. G. E. Hutter</i>).....	272
5647. "Electronic Transformers and Circuits," second edition, by <i>Reuben Lee</i> (Reviewed by <i>Knox McIlwain</i>).....	272
1956 Transistor Circuits Conference.....	272
5648. Abstracts of IRE TRANSACTIONS.....	273
5649. Abstracts and References.....	278

Volume 44, Number 3, March, 1956

Scanning the Issue, <i>The Managing Editor</i>	294
Poles and Zeros, <i>The Editor</i>	295
J. V. L. Hogan, 1956 Medal of Honor Winner.....	296
5650. Color Television Receiver Design—A Review of Current Practice, <i>R. G. Clapp, E. G. Clark, George Howitt, H. E. Beste, E. E. Sanford, M. O. Pyle, and R. J. Farber</i>	297
5651. The Transfluxor, <i>J. A. Rajchman and A. W. Lo</i>	321
5652. The O-Type Carcinotron Tube, <i>P. Palluel and A. K. Goldberger</i>	333
5653. IRE Standards on Electron Devices: Definitions of Terms Related to Microwave Tubes (Klystrons, Magnetrons, and Traveling Wave Tubes), 1956.....	346
5654. A New Pressed Dispenser Cathode, <i>P. P. Coppola and R. C. Hughes</i>	351
5655. Junction Transistors with Alpha Greater than Unity, <i>H. Schenkel and H. Stutz</i>	360
5656. Frequency Modulation Noise in Oscillators, <i>J. L. Stewart</i>	372

Volume 44, Number 3, March, 1956 (Cont'd)

Cumulative Index Number	Page
Correspondence:	
5657. Russian Ionosphere Terminology, <i>G. F. Schults</i>	376
5658. Variation with Temperature of Quartz Resonator Characteristics, <i>Rudolf Bechmann and Vera Durana</i>	377
5659. Transfer Ratios of Resistance and RLC Networks, <i>A. Talbot</i>	377
5660. Signal-Seeking Devices, <i>M. W. P. Strandberg</i>	378
5661. On Passive and Active Networks and Generalized Norton's and Thevenin's Theorems, <i>L. A. Zadeh</i>	378
5662. A Note on Local Feedback, <i>A. Fuchs</i>	379
Contributors.....	380
IRE News and Radio Notes:	
National Convention Committees.....	382
Convention Technical Sessions Schedule.....	383
Summaries of Technical Papers.....	384
Calendar of Events.....	418
Transactions of the IRE Professional Groups.....	419
Professional Group News.....	425
Technical Committee Notes.....	425
Books:	
5663. "Color Television Receiver Practices," by the <i>Hazeltine Corp. Laboratories Staff</i> (Reviewed by <i>W. P. Boothroyd</i>)	426
5664. "Instrument Engineering: Vol. III, Applications of the Instrument Engineering Method; Part One, Measurement Systems," by <i>C. S. Draper, Walter McKay, and Sidney Lees</i> (Reviewed by <i>J. G. Truxal</i>).....	426
5665. "Fundamentals of Television Engineering," by <i>G. M. Glasford</i> (Reviewed by <i>Scott Helt</i>).....	426
5666. "Transistor Electronics," by <i>A. W. Lo, et al.</i> (Reviewed by <i>A. J. Grossman and F. H. Blecher</i>).....	426
5667. "Principles of Electromagnetism," third edition, by <i>E. B. Moullin</i> (Reviewed by <i>J. R. Whinnery</i>).....	427
5668. "Color Television Engineering," by <i>J. W. Wentworth</i> (Reviewed by <i>R. P. Burr</i>).....	427
5669. "Electrons, Waves and Messages," by <i>J. R. Piercc</i> (Reviewed by <i>F. E. Terman</i>).....	427
Professional Groups.....	431
Sections and Subsections.....	431
5670. Abstracts of IRE TRANSACTIONS.....	433
5671. Abstracts and References.....	438

Volume 44, Number 4, April, 1956

Scanning the Issue, <i>The Managing Editor</i>	454
Poles and Zeros, <i>The Editor</i>	455
Donald G. Fink, Editor, 1956.....	456
5672. Electronic Music, <i>Hugh Le Caine</i>	457
5673. Transistors versus Vacuum Tubes, <i>D. G. Fink</i>	479
5674. The Cryotron—A Superconductive Computer Component, <i>D. A. Buck</i>	482
5675. Factors Affecting Reliability of Alloy Junction Transistors, <i>A. J. Wahl and J. J. Kleimack</i>	494
5676. Microwave Detector, <i>J. T. Mendel</i>	503
5677. Increasing the Reliability of Electronic Equipment by the Use of Redundant Circuits, <i>C. J. Creveling</i>	509
5678. Transformer "Miniaturization" Using Fluorochemical Liquids and Conduction Techniques, <i>L. F. Kilham, Jr. and R. R. Ursch</i>	515
5679. IRE Standards on Electron Devices: Definitions of Terms Related to Storage Tubes, 1956.....	521
5680. A Systems Approach to Electronic Reliability, <i>W. F. Lucbbert</i>	523
5681. A Magnetic Thyatron Grid Control Circuit, <i>J. H. Burnett</i>	529
5682. Analysis of a Regenerative Amplifier with Distributed Amplification, <i>B. S. Golosman</i>	533
5683. Keep-Alive Instabilities in a TR Switch, <i>T. J. Bridges, P. O. Hawkins, and D. Walsh</i>	535
5684. The Optimum Tapered Transmission Line Matching Section, <i>R. E. Collin</i>	539
5685. A New Annular Waveguide Rotary Joint, <i>Kiyo Tomiyasu</i>	548
5686. A Double-Slab Ferrite Field Displacement Isolator at 11 KMC, <i>S. Weisbaum and H. Boyet</i>	554
Correspondence:	
5687. A Note on Sidebands Produced by Ferrite Modulators, <i>P. A. Rizzi and D. J. Rich</i>	556
5687A. Principles of Communications Systems, <i>W. D. Hersberger</i>	556
5688. The Equivalent Characteristics of the Cascode Amplifier, <i>F. Langford-Smith</i>	556
5689. Fourier Transforms and Tapered Transmission Lines, <i>E. F. Bolinder</i>	557

Volume 44, Number 4, April, 1956 (Cont'd)

Cumulative Index Number	Page
5690. High-Frequency Shot Noise in P-N Junctions, <i>A. Uhlir, Jr.</i>	557
Contributors.....	558
IRE News and Radio Notes:	
IRE Awards, 1956.....	561
New Fellows.....	562
Calendar of Coming Events.....	571
Professional Group News.....	575
Technical Committee Notes.....	575
Books:	
5691. "Electronic Motion Pictures," by <i>Albert Abramson</i> (Reviewed by <i>J. H. Battison</i>).....	576
5692. "Principles of Guided Missile Design: Guidance," by <i>A. S. Locke, et al.</i> (Reviewed by <i>C. H. Hoepfner</i>)....	576
5693. "Basic Processes of Gaseous Electronics," by <i>L. B. Loeb</i> (Reviewed by <i>W. G. Dow</i>).....	576
5694. "Transistors and Other Crystal Valves," by <i>T. R. Scott</i> (Reviewed by <i>I. A. Getling</i>).....	577
5695. "Noise," by <i>Albert van der Ziel</i> (Reviewed by <i>W. E. Fromm</i>).....	577
5696. Recent Books.....	578
1956 IRE CONVENTION RECORD.....	578
5697. Abstracts of IRE TRANSACTIONS.....	579
5698. Abstracts and References.....	582

Volume 44, Number 5, May, 1956

Scanning the Issue, <i>The Managing Editor</i>	598
Poles and Zeros, <i>The Editor</i>	599
E. Milton Boone, Director, 1955-1956.....	600
5699. Physical Sources of Noise, <i>J. R. Pierce</i>	601
5700. Methods of Solving Noise Problems, <i>W. R. Bennett</i>	609
5701. Video Measurements Employing Transient Techniques, <i>H. A. Samulon</i>	638
5702. The Design of High-Power Traveling-Wave Tubes, <i>M. Chodorow and E. J. Nalos</i>	649
5703. Progress in the Development of Post-Acceleration and Electrostatic Deflection, <i>Kurt Schlesinger</i>	659
5704. IRE Standards on Audio Systems and Components: Methods of Measurement of Gain, Amplification, Loss, Attenuation, and Amplitude-Frequency-Response, 1956.....	668
5705. Cascaded Feedthrough Capacitors, <i>H. M. Schlicke</i>	686
Correspondence:	
5706. Estimating the Ratio of Steady Sinusoidal Signal to Random Noise from Experimental Data, <i>M. L. Phillips</i> ..	692
5707. Russian Antenna Terminology, <i>G. F. Schults</i>	692
5708. Spurious Modulation of Electron Beams, <i>Theodore Moreno</i>	693
5709. A Note on the Root Locus Method, <i>Harry Lass</i>	693
5710. The Radiation Pattern of an Antenna Mounted on a Surface of Large Radius of Curvature, <i>J. R. Wait</i>	694
5711. Comment on "Radar Polarization Power Scattering Matrix," <i>E. M. Kennaugh</i>	695
5712. Rebuttal, <i>C. D. Graves</i>	695
5713. Oral Examination Procedure, <i>S. J. Mason</i>	696
5714. Phase Stabilization of Microwave Oscillators, <i>M. W. P. Strandberg</i>	696
5715. Observations of Electroluminescence Excited by AC and DC Fields in Surface-Treated Phosphors, <i>J. N. Bowtell and H. C. Bate</i>	697
Contributors.....	697
IRE News and Radio Notes:	
Convention News Picture Section.....	699
National Telemetry Conference Is Slated for August 20-21 at Los Angeles.....	702
Calendar of Events.....	702
Obituary.....	706
Professional Group News.....	706
Technical Committee Notes.....	706
National Conference on Aeronautical Electronics.....	707
Symposium on Reliable Applications of Electron Tubes.....	709
Professional Groups.....	710
Sections.....	710
Books:	
5716. "Fundamentals of Electroacoustics," by <i>F. A. Fischer</i> (Reviewed by <i>B. B. Bauer</i>).....	712
5717. "Electric Network Synthesis: Image Parameter Method," by <i>M. B. Reed</i> (Reviewed by <i>A. B. Giordano</i>)....	712
5718. "Introduction to Electronic Analogue Computers," by <i>C. A. A. Wass</i> (Reviewed by <i>Stanley Rogers</i>).....	712

<i>Cumulative Index Number</i>	<i>Page</i>
5719. "Nuclear Radiation Detectors," by <i>J. Sharpe</i> (Reviewed by <i>J. W. Coltman</i>).....	712
5720. "Network Analysis," by <i>M. E. Van Valkenburg</i> (Reviewed by <i>P. F. Ordnung</i>).....	713
5721. Recent Books.....	713
5722. Abstracts of IRE TRANSACTIONS.....	714
5723. Abstracts and References.....	719
Annual Index to 1955 IRE TRANSACTIONS. Follows Page	732

Volume 44, Number 6, June, 1956

Scanning the Issue, <i>The Managing Editor</i>	734
John R. Whinnery, Director, 1956-1958.....	736
Poles and Zeros, <i>The Editor</i>	737
5724. Electrical Engineers Are Going Back to Science!, <i>F. E. Terman</i>	738
5725. The IGY Program, <i>Joseph Kaplan</i>	741
5726. The Exploration of Outer Space with an Earth Satellite, <i>J. P. Hagen</i>	744
5727. Placing the Satellite in Its Orbit, <i>M. W. Rosen</i>	748
5728. Telemetering and Propagation Problems of Placing the Earth Satellite in Its Orbit, <i>D. G. Masur</i>	752
5729. Tracking the Earth Satellite, and Data Transmission, by Radio, <i>J. T. Mengel</i>	755
5730. A Research Program Based on the Optical Tracking of Artificial Earth Satellites, <i>F. L. Whipple and J. A. Hynek</i>	760
5731. The Scientific Value of the Earth Satellite Program, <i>J. A. Van Allen</i>	764
5732. Television Sweep Generation with Resonant Networks and Lines, <i>Kurt Schlesinger</i>	768
5733. IRE Standards on Facsimile: Definitions of Terms, 1956	776
5734. Docile Behavior of Feedback Amplifiers, <i>S. J. Mason</i> ..	781
5735. A Note on Bandwidth, <i>Amos Nathan</i>	788
5736. Measurement of Microwave Dielectric Constants and Tensor Permeabilities of Ferrite Spheres, <i>E. G. Spencer, R. C. LeCraw, and F. Reggia</i>	790
5737. The Effect of AGC on Radar Tracking Noise, <i>R. H. DeLano and I. Pfeffer</i>	801
5738. Theory of Noisy Fourpoles, <i>H. Rothe and W. Dalhke</i> ...	811
5739. Correction to "Design Information on Large-Signal Traveling-Wave Amplifiers," <i>J. E. Rowe</i>	818
Correspondence:	
5740. Some Applications of Fourier Transforms in Electrical Engineering and Their Interrelationships, <i>E. F. Bolinder</i>	820
Contributors	821
IRE News and Radio Notes:	
Calendar of Events.....	824
Transactions of the IRE Professional Groups.....	825
Professional Group News.....	826
Obituary.....	827
Technical Committee Notes.....	828
Books:	
5741. "Nachrichtenübertragung Mittels Sehr Höher Frequenzen," by <i>Gerhard Megla</i> (Reviewed by <i>W. J. Albersheim</i>).....	828
5742. "Advances in Electronics and Electron Physics: Vol. VII," edited by <i>L. Marton</i> (Reviewed by <i>G. C. Dacey</i>)	828
5743. "Vacuum Valves in Pulse Techniques," by <i>P. A. Neelson</i> (Reviewed by <i>W. H. Lapham</i>).....	829
5744. "Modern Physics," by <i>R. L. Sproull</i> (Reviewed by <i>Frank Herman</i>).....	829
5745. "Proceedings of the Symposium on Electromagnetic Wave Theory" (Reviewed by <i>Martin Katsin</i>).....	829
5746. Abstracts of IRE TRANSACTIONS.....	830
Report of the Secretary—1955.....	834
IRE Committees—1956.....	838
IRE Representatives in Colleges.....	844
IRE Representatives on Other Bodies.....	845
5747. Abstracts and References.....	846

Volume 44, Number 7, July, 1956

Scanning the Issue, <i>The Managing Editor</i>	862
Edward W. Herold, Director, 1956-1958.....	864
Poles and Zeros, <i>The Editor</i>	865
5748. International Cooperation in Radio Research—URSI and IRE, <i>J. H. Dellinger</i>	866
5749. Tantalum Solid Electrolytic Capacitors, <i>D. A. McLean and F. S. Power</i>	872

<i>Cumulative Index Number</i>	<i>Page</i>
5750. Theory of the Transverse-Current Traveling-Wave Tube, <i>D. A. Dunn, W. A. Harman, L. M. Field, and G. S. Kino</i>	879
5751. An Experimental Transverse-Current Traveling-Wave Tube, <i>D. A. Dunn and W. A. Harman</i>	888
5752. Some Effects of Magnetic Field Strength on Space-Charge-Wave Propagation, <i>George R. Brewer</i>	896
5753. Some General Properties of Nonlinear Elements—Part I. General Energy Relations, <i>J. M. Manley and H. E. Rowe</i>	904
5754. A Solution to the Approximation Problem for RC Low-Pass Filters, <i>K. L. Su and B. J. Dasher</i>	914
5755. Feedback Theory—Further Properties of Signal Flow Graphs, <i>S. J. Mason</i>	920
5756. Correction to "The Radiation Pattern of an Antenna Mounted on a Surface of Large Radius of Curvature," <i>James R. Wait</i>	926
5757. Topological Properties of Telecommunication Networks, <i>Z. Prihar</i>	927
5758. IRE Standards on Letter Symbols for Semiconductor Devices, 1956.....	934
Correspondence:	
5759. A Dip in the Minimum Noise Figure of Beam-Type Microwave Amplifiers, <i>P. K. Tien</i>	938
5760. Microphonism Due to Transistor Leads, <i>C. W. Durieux and T. A. Prugh</i>	938
5761. On the Effective Noise Temperature of Gas Discharge Noise Generators, <i>W. D. White and J. G. Greene</i>	939
5762. "Geophysical Prospection of Underground Water in the Desert by Means of Electromagnetic Interference Fringes," <i>G. L. Brown</i>	940
5763. Rebuttal, <i>M. A. H. El-Said</i>	940
5764. Maximum Efficiency of Four-Terminal Networks, <i>E. F. Bolinder</i>	941
Contributors	942
IRE News and Radio Notes:	
Calendar of Coming Events.....	944
The Newest Foreign IRE Section: Tokyo, Japan.....	944
Professional Group News.....	947
Technical Committee Notes.....	948
Professional Groups.....	949
Sections.....	949
Books:	
5765. "Ultrasonic Engineering," by <i>A. E. Crawford</i> (Reviewed by <i>O. E. Mattiat</i>).....	951
5766. "Scattering and Diffraction of Radio Waves," by <i>J. R. Mentzer</i> (Reviewed by <i>Nathan Marcuvitz</i>).....	951
5767. "Spheroidal Wave Functions," by <i>J. A. Stratton, et al.</i> (Reviewed by <i>E. T. Jaynes</i>).....	951
5768. "Atlas of Ground-Wave Propagation Curves for Frequencies Between 30 MC and 300 MC," by <i>Balth. van der Pol</i> (Reviewed by <i>H. G. Booker</i>).....	952
5769. Abstracts of IRE TRANSACTIONS.....	952
5770. Abstracts and References.....	958

Volume 44, Number 8, August, 1956

Scanning the Issue, <i>The Managing Editor</i>	974
C. Frederick Wolcott, Director, 1956-1957.....	975
Poles and Zeros, <i>The Editor</i>	976
5771. Review of Industrial Applications of Heat Transfer to Electronics, <i>Joseph Kaye</i>	977
5772. Review of Ionospheric Effects at VHF and UHF, <i>C. G. Little, W. M. Rayton, and R. B. Roof</i>	992
5773. Directional Channel-Separation Filters, <i>S. B. Cohn and F. S. Coale</i>	1018
5774. A New Technique for the Measurement of Microwave Standing-Wave Ratios, <i>A. C. Macpherson and D. M. Kerns</i>	1024
5775. Novel Circuit for a Stable Variable Frequency Oscillator, <i>David M. Makow</i>	1031
5776. IRE Standards on Electron Devices: TR and ATR Tube Definitions, 1956.....	1037
5777. IRE Standards on Methods of Measurement of the Conducted Interference Output of Broadcast and Television Receivers in the Range of 300 KC to 25 MC, 1956.....	1040
5778. Some Limiting Cases of Radar Sea Clutter Noise, <i>Allen H. Schooley</i>	1043
5779. Correction to "Transistor Amplifiers for Use in a Digital Computer," <i>Q. W. Simkins and J. H. Vogelsong</i> ..	1047

Volume 44, Number 8, August, 1956 (Cont'd)

<i>Cumulative Index Number</i>	<i>Page</i>
Correspondence:	
5780. Electron Beam Noisiness and Equivalent Thermal Temperature for High-Field Emission from a Low-Temperature Cathode, <i>R. W. DeGrasse and G. Wade</i>	1048
5781. VHF Diffraction by Mountains of the Alaska Range, <i>George W. Swenson, Jr.</i>	1049
5782. Measurement Considerations in High-Frequency Power Gain of Junction Transistors, <i>R. L. Pritchard</i>	1050
5783. On the Waveform of a Radio Atmospheric at Short Ranges, <i>J. R. Wait</i>	1052
5784. A Balanced, Unregulated, Dual Power Supply, <i>K. N. Hemmenway</i>	1053
5785. Systemic Learning, <i>Robert R. McPherson</i>	1054
5786. On the Use of a Special Word for the Quantity "Angular Velocity," <i>Robert R. Buss</i>	1054
5787. Frequency Doubling and Mixing in Ferrites, <i>John E. Pippin</i>	1054
5788. The Optimum Tapered Line Matching Section, <i>R. W. Klopfenstein and E. Folke Bolinder</i>	1055
5789. Rebuttal, <i>R. E. Collin</i>	1056
5790. Marconi's Last Paper, "On the Propagation of Microwaves over Considerable Distances," <i>Thomas J. Carroll</i>	1056
5791. The Statistics of Combiner Diversity, <i>Harold Staras</i>	1057
5792. A Note Concerning the Dirac Delta Function, <i>R. A. Johnson</i>	1058
5793. A Sensitive Method for the Measurement of Amplitude Linearity, <i>Stanley I. Kramer</i>	1059
5794. When Is a Backward Wave Not a Backward Wave?, <i>J. E. Rowe and G. Hok</i>	1060
5795. The Noise Factor of Traveling-Wave Tubes, <i>Gunnar Hok</i>	1061
5796. Geophysical Prospection of Underground Water in the Desert by Means of Electromagnetic Interference Fringes, <i>H. Löwy</i>	1062
5797. Increasing the Accuracy of CRO Measurements, <i>Theodore H. Bonn</i>	1062
5798. Optimum Slicing Level in a Noisy Binary Channel, <i>R. M. Hollis</i>	1062
5799. Power Transfer in Double-Tuned Coupling Networks, <i>Arthur P. Stern</i>	1063
5800. Time Signals for the Determination of Longitude, <i>W. H. Ward</i>	1064
5801. Application of Equipartition Theory to Electric Circuits, <i>D. A. Bell</i>	1065
5802. Russian Condenser Terminology, <i>George F. Schullz</i>	1066
Contributors	1067
IRE News and Radio Notes	1069
5803-5804. Books	1073
1956 Programs	1075
1956 IRE CONVENTION RECORD	1081
5805. Abstracts of IRE TRANSACTIONS	1082
5806. Abstracts and References	1085

Volume 44, Number 9, September, 1956

Scanning the Issue, <i>The Managing Editor</i>	1102
Charles R. Burrows, Director, 1956-1957	1104
Poles and Zeros, <i>The Editor</i>	1105
5807. Nikola Tesla, 1856-1954, <i>Haraden Pratt</i>	1106
5808. A New Beam-Indexing Color Television Display System, <i>R. G. Clapp, E. M. Creamer, S. W. Moulton, M. E. Partin, and J. S. Bryan</i>	1108
5809. A Beam-Indexing Color Picture Tube—The Apple Tube, <i>G. F. Barnett, F. J. Bingley, S. L. Parsons, G. W. Pratt, and M. Sadowsky</i>	1115
5810. Current Status of Apple Receiver Circuits and Components, <i>R. A. Bloomsburgh, W. P. Boothroyd, G. A. Fedde, and R. C. Moore</i>	1120
5811. Directions of Improvement in NTSC Color Television Systems, <i>Donald Richman</i>	1125
5812. A Precise New System of FM Radar, <i>Mohamed A. W. Ismail</i>	1140
5813. Maximum Angular Accuracy of a Pulsed Search Radar, <i>Peter Swerling</i>	1146
5814. An 8-mm Klystron Power Oscillator, <i>R. L. Bell and M. Hillier</i>	1155
5815. Restrictions on the Shape Factors of the Step Response of Positive Real System Functions, <i>Armen H. Zemanian</i>	1160
5816. Correction to "Generalized Equations for RC Phase-Shift Oscillators," <i>Sol Sherr</i>	1165

Volume 44, Number 9, September, 1956 (Cont'd)

<i>Cumulative Index Number</i>	<i>Page</i>
5817. IRE Standards on Electronic Computers: Definitions of Terms, 1956	1166
5818. <i>P-N-P-N</i> Transistor Switches, <i>J. L. Moll, M. Tanenbaum, J. M. Goldey, and N. Holonyak</i>	1174
5819. Two-Terminal <i>P-N</i> Junction Devices for Frequency Conversion and Computation, <i>Arthur Uhlir, Jr.</i>	1183
Correspondence:	
5820. Radar Echoes from Meteor Trails Under Conditions of Severe Diffusion, <i>Gerald S. Hawkins</i>	1192
Contributors	1193
IRE News and Radio Notes:	
Calendar of Coming Events	1198
TRANSACTIONS of IRE Professional Groups	1198
Professional Group News	1200
Obituary	1201
Technical Committee Notes	1201
Books:	
5821. "An Introduction to Stochastic Processes," by <i>M. S. Bartlett</i> (Reviewed by <i>E. E. David, Jr.</i>)	1201
5822. "Transistors Handbook," by <i>W. D. Beville</i> (Reviewed by <i>R. P. Burr</i>)	1202
5823. "Color Television Standards," by <i>D. G. Fink</i> (Reviewed by <i>W. T. Wintringham</i>)	1202
5824. "Principles of Nuclear Reactor Engineering," by <i>S. Glasstone</i> (Reviewed by <i>J. W. Coltman</i>)	1202
5825. "Closed-Circuit and Industrial Television," by <i>E. M. Moll</i> (Reviewed by <i>R. D. Chipp</i>)	1202
5826. "Frequency Response," ed. by <i>Rufus Oldenburger</i> (Reviewed by <i>L. J. Giacoletto</i>)	1203
5827. Recent Books	1203
Professional Groups	1203
Sections	1204
Programs	1206
5828. Abstracts of IRE TRANSACTIONS	1210
5829. Abstracts and References	1214

Volume 44, Number 10, October, 1956

Joseph J. Gershon, Director, 1956-1957	1231
Poles and Zeros, <i>The Editor</i>	1232
5830. Introduction to the Ferrites Issue, <i>C. Lester Hogan</i>	1233
5831. A Survey of the Properties and Applications of Ferrites Below Microwave Frequencies, <i>C. Dale Owens</i>	1234
5832. Fundamental Theory of Ferro- and Ferri-magnetism, <i>J. H. Van Vleck</i>	1248
5833. Magnetic Resonance in Ferrites, <i>N. Bloembergen</i>	1259
5834. The Nonlinear Behavior of Ferrites at High Microwave Signal Levels, <i>Harry Suhl</i>	1270
5835. Microwave Resonance Relations in Anisotropic Single Crystal Ferrites, <i>Joseph O. Artman</i>	1284
5836. Dielectric Properties of and Conductivity in Ferrites, <i>LeGrand G. Van Uitert</i>	1294
5837. Methods of Preparation and Crystal Chemistry of Ferrites, <i>Donald L. Fresh</i>	1303
5838. Intrinsic Tensor Permeabilities on Ferrite Rods, Spheres, and Disks, <i>E. G. Spencer, L. A. Ault, and R. C. LeCraw</i>	1311
5839. Permeability Tensor Values from Waveguide Measurements, <i>E. B. Mullen and E. R. Carlson</i>	1318
5840. Resonance Loss Properties of Ferrites in 9 KMC Region, <i>Samuel Sensiper</i>	1323
5841. Anisotropy of Cobalt-Substituted Mn Ferrite Single Crystals, <i>P. E. Tannenwald and M. H. Seavey</i>	1343
5842. The Elements of Nonreciprocal Microwave Devices, <i>C. Lester Hogan</i>	1345
5843. Frequency and Loss Characteristics of Microwave Ferrite Devices, <i>Benjamin Lax</i>	1368
5844. Ferrites as Microwave Circuit Elements, <i>Gerald S. Heller</i>	1386
5845. Network Properties of Circulators Based on the Scattering Concept, <i>Milton A. Treuhaft</i>	1394
5846. Topics in Guided-Wave Propagation in Magnetized Ferrites, <i>Morris L. Kales</i>	1403
5847. Anomalous Propagation in Ferrite-Loaded Waveguide, <i>Harold Seidel</i>	1410
5848. Birefringence of Ferrites in Circular Waveguide, <i>N. Karayianis and J. C. Cacheris</i>	1414
5849. A New Ferrite Isolator, <i>Bengt N. Enander</i>	1421
5850. Magnetic Tuning of Resonant Cavities and Wideband Frequency Modulation of Klystrons, <i>G. R. Jones, J. C. Cacheris, and C. A. Morrison</i>	1431
5851. Ferrite Directional Couplers, <i>A. D. Berk and E. Strumwasser</i>	1439
5852. Ferrite-Tuned Resonant Cavities, <i>Clifford E. Fay</i>	1446

Volume 44, Number 10, October, 1956 (Cont'd)

<i>Cumulative Index Number</i>	<i>Page</i>
5853. Ferrite-Tunable Microwave Cavities and the Introduction of a New Reflectionless, Tunable Microwave Filter, <i>Conrad E. Nelson</i>	1449
5854. Three New Ferrite Phase Shifters, <i>Howard Scharfman</i>	1456
5855. Ferrite-Tunable Filter for Use in S Band, <i>James H. Burgess</i>	1460
5856. Radiation from Ferrite-Filled Apertures, <i>D. J. Angelakos and M. M. Korman</i>	1463
5857. Correction to "Some Aspects of Mixer Crystal Performance," <i>Peter D. Strum</i>	1468
Correspondence:	
5858. The Radiation Patterns and Conductances of Slots Cut on Rectangular Metal Plates, <i>J. R. Wait and D. G. Frood</i>	1469
5859. Standard Frequencies and Time Signals WWV and WWVH, <i>National Bureau of Standards</i>	1470
5860. Analog Computer Amplifier Circuits, <i>Hiroshi Amemiya</i>	1473
5861. Spurious Modulation in Q-Band Magnetrons, <i>T. M. Goss and P. A. Lindsay</i>	1474
5862. Inductive AC Admittance of Junction Transistor, <i>M. Onoe and A. Ushirokawa</i>	1475
5863. Note on "The Variation of Junction Transistor Current Amplification Factor with Emitter Current," <i>N. H. Fletcher</i>	1475
Contributors	
IRE News and Radio Notes:	
Final Call for IRE National Convention Papers.....	1481
Miscellaneous Publications of the IRE.....	1483
Obituaries.....	1484
Technical Committee Notes.....	1485
Books:	
5864. "Electronics and Electron Devices," by <i>A. L. Albert</i> (Reviewed by <i>Samuel Seely</i>).....	1486
5865. "A Study of the Double Modulated FM Radar," by <i>Mohamed Ismail</i> (Reviewed by <i>R. M. Page</i>).....	1486
5866. "Electronic Computers and Management Control," by <i>George Kozmetsky and Paul Kircher</i> (Reviewed by <i>J. R. Weiner</i>).....	1486
5867. "Random Processes in Automatic Control," by <i>J. H. Laning, Jr. and R. H. Battin</i> (Reviewed by <i>W. R. Bennett</i>).....	1487
5868. "Transistors I," by <i>RCA Laboratories</i> (Reviewed by <i>A. P. Stern</i>).....	1487
5869. "Electronic Engineering," by <i>Samuel Seely</i> (Reviewed by <i>J. G. Brainerd</i>).....	1488
5870. "Radio Electronics," by <i>Samuel Seely</i> (Reviewed by <i>A. V. Eastman</i>).....	1488
5871. "Solid State Physics, Vol. I," ed. by <i>Frederick Seitz and David Turnbull</i> (Reviewed by <i>G. C. Dacey</i>).....	1489
5872. Recent Books.....	1489
5873. Abstracts of IRE TRANSACTIONS.....	1491
IRE Committees—1956.....	1493
IRE Representatives on Other Bodies.....	1499
IRE Representatives in Colleges.....	1500
5874. Abstracts and References.....	1502

Volume 44, Number 11, November, 1956

Ernst Weber, Director, 1955–1957.....	1518
Poles and Zeros, <i>The Editor</i>	1519
Scanning the Issue, <i>The Managing Editor</i>	1520
5875. Quality Control in Electronics, <i>Mary N. Torrey</i>	1521
5876. Frequency Control in the 300–1200 MC Region, <i>D. W. Fraser and E. G. Holmes</i>	1531
5877. Correction to "High-Frequency Shot Noise in P-N Junctions," <i>Arthur Uhlir, Jr.</i>	1541
5878. IRE Standards on Solid-State Devices: Methods of Testing Transistors, 1956.....	1542
5879. Common-Emitter Transistor Video Amplifiers, <i>Georg Bruun</i>	1561
5880. Hazards Due to Total Body Irradiation by Radar, <i>H. P. Schwann and K. Li</i>	1572
5881. An Analysis of Pulse-Synchronized Oscillators, <i>Gaston Salme</i>	1582
5882. A Sideband-Mixing Superheterodyne Receiver, <i>M. Cohn and W. C. King</i>	1595
5883. Frequency-Temperature-Angle Characteristics of AT-Type Resonators Made of Natural and Synthetic Quartz, <i>Rudolf Bechmann</i>	1600

Volume 44, Number 11, November, 1956 (Cont'd)

<i>Cumulative Index Number</i>	<i>Page</i>
5884. Distortion in Frequency-Modulation Systems Due to Small Sinusoidal Variations of Transmission Characteristics, <i>R. G. Medhurst and G. F. Small</i>	1608
5885. Precision Electronic Switching with Feedback Amplifiers, <i>Charles M. Edwards</i>	1613
Correspondence:	
5886. Special Case of a Bridge Equivalent of Brune Networks, <i>M. E. Van Valkenburg</i>	1621
5887. Useful Bandwidth in Scatter Transmission, <i>J. P. Vogel</i>	1621
5888. Russian Resistance and Resistor Terminology, <i>G. F. Schultz</i>	1622
Contributors	
IRE News and Radio Notes:	
VLP Symposium.....	1626
Calendar of Coming Events.....	1627
Professional Group News.....	1628
Technical Committee Notes.....	1629
Books:	
5889. "Automatic Digital Calculators," by <i>A. D. Booth and K. H. V. Booth</i> (Reviewed by <i>Werner Buchholz</i>).....	1629
5890. "Electromagnetic Waves," by <i>G. T. DiFranca</i> (Reviewed by <i>S. B. Cohn</i>).....	1630
5891. "Studien über einkreisige Schwingungs-systeme mit zeitlich veränderlichen Elementen," by <i>B. R. Gloor</i> (Reviewed by <i>W. J. Albersheim</i>).....	1630
5892. "Transistors in Radio and Television," by <i>M. S. Kiver</i> (Reviewed by <i>R. P. Burr</i>).....	1630
5893. "Linear Transient Analysis," by <i>Ernst Weber</i> (Reviewed by <i>L. A. Zadeh</i>).....	1630
Professional Groups.....	1631
Sections.....	1632
Subsections.....	1633
Programs.....	1634
5894. Abstracts of IRE TRANSACTIONS.....	1637
5895. Abstracts and References.....	1646

Volume 44, Number 12, December, 1956

Poles and Zeros, <i>The Editor</i>	1663
Tribute to Lee De Forest.....	1664
5896. Single-Sideband Techniques as Related to Spectrum Administration, <i>George C. McConaughy</i>	1665
5897. Introduction to Single-Sideband Issue, <i>I. J. Kaar</i>	1666
5898. An Introduction to Single-Sideband Communications, <i>J. F. Honey and D. K. Weaver, Jr.</i>	1667
5899. Early History of Single-Sideband Transmission, <i>Arthur A. Oswald</i>	1676
5900. Synthesizer Stabilized Single-Sideband Systems, <i>B. Fisk and C. L. Spencer</i>	1680
5901. A Suggestion for Spectrum Conservation, <i>R. T. Cox and E. W. Pappenfus</i>	1685
5902. Power and Economics of Single Sideband, <i>Ernest W. Pappenfus</i>	1689
5903. Application of Single-Sideband Technique to Frequency Shift Telegraph, <i>Christopher Buff</i>	1692
5904. Frequency Control Techniques for Single Sideband, <i>R. L. Craiglow and E. L. Martin</i>	1697
5905. A Third Method of Generation and Detection of Single-Sideband Signals, <i>Donald K. Weaver, Jr.</i>	1703
5906. Comparison of Linear Single-Sideband Transmitters with Envelope Elimination and Restoration Single-Sideband Transmitters, <i>Leonard R. Kahn</i>	1706
5907. Synchronous Communications, <i>John P. Costas</i>	1713
5908. The Phase-Shift Method of Single-Sideband Signal Generation, <i>Donald E. Norgaard</i>	1718
5909. The Phase-Shift Method of Single-Sideband Signal Reception, <i>Donald E. Norgaard</i>	1735
5910. Electromechanical Filters for Single-Sideband Applications, <i>Don L. Lundgren</i>	1744
5911. Factors Influencing Single-Sideband Receiver Design, <i>Luther W. Couillard</i>	1750
5912. Correction to "The Optimum Tapered Transmission Line Matching Section," <i>Robert E. Collin</i>	1753
5913. Linear Power Amplifier Design, <i>Warren B. Bruene</i>	1754
5914. Distortion Reducing Means for Single-Sideband Transmitters, <i>Warren B. Bruene</i>	1760
5915. Correction to "IRE Standards on Audio Systems and Components, Methods of Measurement of Gain, Amplification, Loss, Attenuation, and Amplitude-Frequency-Response".....	1765

<i>Cumulative Index Number</i>	<i>Page</i>
5916. Automatic Tuning Techniques for Single-Sideband Equipment, <i>Vincent R. DeLong</i>	1766
5917. Linearity Testing Techniques for Sideband Equipment, <i>P. J. Icenbice, Jr. and H. E. Fellhauer</i>	1775
5918. Single-Sideband Operation for International Telegraph, <i>Eugene D. Becken</i>	1782
5919. SSB Receiving and Transmitting Equipment for Point-to-Point Service on HF Radio Circuits, <i>H. E. Goldstine, G. E. Hansell, and R. E. Schock</i>	1789
5920. Conversion of Airborne HF Receiver-Transmitter from Double Sideband to Single Sideband, <i>Harris A. Robinson</i>	1794
5921. Problems of Transition to Single-Sideband Operation, <i>N. H. Young</i>	1800
5922. The Problems of Transition to Single-Sideband Techniques in Aeronautical Communications, <i>John F. Honey</i>	1803
5923. The Application of SSB to High-Frequency Military Tactical Vehicular Radio Sets, <i>R. A. Kulinyi, R. H. Levine, and H. F. Meyer</i>	1810
5924. Single-Sideband Techniques Applied to Coordinated Mobile Communication Systems, <i>Adamant Brown</i> ..	1824
5925. Single Sideband in the Amateur Service, <i>George Grammer</i>	1829
5926. Comparison of SSB and FM for VHF Mobile Service, <i>H. Magnuski and W. Firestone</i>	1834
5927. SSB Performance as a Function of Carrier Strength, <i>William L. Firestone</i>	1839
5928. Design of a High Power Single-Sideband VHF Communications System, <i>John W. Smith</i>	1848
5929. Single-Sideband Techniques in UHF Long-Range Communications, <i>W. E. Morrow, Jr., C. L. Mack, Jr., B. E. Nichols, and J. Leonhard</i>	1854
<i>Correspondence:</i>	
5930. A Note on the Analog Computation of Small Quotients, <i>Albert D. Bailey</i>	1874
5931. Linear Programming and Optimal Telecommunication Networks, <i>R. E. Kalaba and M. L. Juncosa</i>	1874
5932. Microwave Semiconductor Switch, <i>M. A. Armistead, E. G. Spencer, and R. D. Haicher</i>	1875
5933. Electrical Engineers Are Going Back to Science, <i>Walter A. Knoop</i>	1875
5934. Author's Comment, <i>Frederick E. Terman</i>	1876
5935. The Dirac Delta Function, <i>Philippe A. Clavier</i>	1876

<i>Cumulative Index Number</i>	<i>Page</i>
5936. Author's Comment, <i>Richard A. Johnson</i>	1877
5937. Letter from Mr. Lackey, <i>R. B. Lackey</i>	1877
5938. Author's Comment, <i>Richard A. Johnson</i>	1877
5939. RF Bandwidth of Frequency-Division Multiplex Systems Using Frequency Modulation, <i>R. Hamer</i>	1878
5940. Author's Comment, <i>R. G. Medhurst</i>	1878
5941. Pulse Narrowing by Filters, <i>Richard K. Moore</i>	1878
5942. Solar Temperature and Atmospheric Attenuation in the 7-8 MM Wavelength Range, <i>R. N. Whitehurst and F. H. Mitchell</i>	1879
5943. Minimizing Gain Variations with Temperature in RC Coupled Transistor Amplifiers, <i>T. A. Prugh</i>	1880
5944. Fast Switching with Junction Diodes, <i>J. E. Scobey, W. A. White, and B. Salzberg</i>	1880
<i>Contributors</i>	
<i>IRE News and Radio Notes:</i>	
Calendar of Coming Events.....	1887
Activities of IRE Sections and Professional Groups...	1888
TRANSACTIONS of the IRE Professional Groups.....	1889
Obituaries.....	1890
Technical Committee Notes.....	1891
<i>Books:</i>	
5945. "Science and Information Theory," by <i>Leon Brillouin</i> (Reviewed by <i>W. D. White</i>).....	1892
5946. "Elements of Pulse Circuits," by <i>F. J. M. Farley</i> (Reviewed by <i>G. B. Herzog</i>).....	1892
5947. "Principles of Color Television," by the <i>Hazeltine Laboratories Staff</i> and ed. by <i>Knox McIlwain and C. E. Dean</i> (Reviewed by <i>F. J. Bingley</i>).....	1892
5948. "Vierpoltheorie und Frequenztransformation," by <i>Torbern Laurent</i> (Reviewed by <i>H. Rothe</i>).....	1893
5949. "Mathematics for Electronics with Applications," by <i>H. M. Nodelman and F. W. Smith</i> (Reviewed by <i>Walter Kahn</i>).....	1893
5950. Recent Books.....	1893
Programs.....	1894
5951. Abstracts of IRE TRANSACTIONS.....	1897
5952. Abstracts and References.....	1900
Annual Index to PROCEEDINGS OF THE IRE.....	Follows Page 1914
Annual Index to CONVENTION RECORD OF THE IRE.....	Follows PROCEEDINGS Index

INDEX TO AUTHORS

Numbers refer to chronological list. Light-face type indicates papers, bold-face type indicates discussions, and *italics refer to books and book reviews.*

A	Bell, D. A.: 5801	Brewer, G. R.: 5752	Chatterjee, B.: 5615
Adler, R.: 5610	Bell, R. L.: 5814	Bridges, T. J.: 5683	Cheng, C. C.: 5630
Albersheim, W. J.: 5637, 5741, 5891	Bennett, W. R.: 5700, 5867	Brown, A.: 5924	Chipp, R. D.: 5825
Amemiya, H.: 5860	Berk, A. D.: 5851	Brown, G. L.: 5762	Chodorow, M.: 5702
Angelakos, D. J.: 5856	Berkowitz, R. S.: 5632	Bruene, W. B.: 5913, 5914	Clapp, R. G.: 5650, 5808
Armistead, M. A.: 5932	Beste, H. E.: 5650	Bruun, G.: 5879	Clark, E. G.: 5650
Artman, J. O.: 5835	Bingley, F. J.: 5809	Bryan, J. S.: 5808	Clavier, P. A.: 5610, 5935
Ault, L. A.: 5838	Blecher, F. H.: 5666	Buchholz, W.: 5889	Clavin, A.: 5639
B	Bloembergen, N.: 5833	Buck, D. A.: 5674	Coale, F. S.: 5773
Bailey, A. D.: 5930	Bloomsburgh, R. A.: 5810	Buff, C.: 5903	Cohn, M.: 5882
Barnett, G. F.: 5809	Bolinder, E. F.: 5689, 5740, 5764, 5788	Burgess, J. H.: 5855	Cohn, S. B.: 5773, 5890
Bate, H. C.: 5715	Bonn, T. H.: 5797	Burnett, J. H.: 5681	Collin, R. E.: 5684, 5789, 5912
Battison, J. H.: 5691	Booker, H. G.: 5768	Burr, R. P.: 5668, 5822, 5892	Coltman, J. W.: 5719, 5824
Bauer, B. B.: 5716	Boothroyd, W. P.: 5663, 5810	Buss, R. R.: 5786	Conn, G. K. T.: 5609
Beattie, J. R.: 5609	Bowie, D. M.: 5623	C	Coppola, P. P.: 5654
Bechmann, R.: 5658, 5883	Bowtell, J. N.: 5715	Cacheris, J. C.: 5848, 5850	Costas, J. P.: 5906
Becken, E. D.: 5918	Boxer, R.: 5611	Carlson, E. R.: 5839	Couillard, L. W.: 5911
	Boyet, H.: 5686	Carroll, T. J.: 5790	Cox, R. T.: 5901
	Brainerd, J. G.: 5869	Cedarbaum, I.: 5638	Craiglow, R. L.: 5904
			Creamer, E. M.: 5808

Creveling, C. J.: 5677
Cutler, C. C.: 5606

D

Dacey, G. C.: 5742, 5871
Dahlke, W.: 5738
Dasher, B. J.: 5754
David, E. E., Jr.: 5821
DeGrasse, R. W.: 5780
DeLano, R. H.: 5737
Dellinger, J. H.: 5748
DeLong, V. R.: 5916
Doehler, O.: 5643
Dow, W. G.: 5693
Duncan, R. S.: 5598
Dunn, D. A.: 5750, 5751
Durana, V.: 5658
Durieux, C. W.: 5760

E

Eastman, A. V.: 5870
Edwards, C. M.: 5885
El-Said, M. A. H.: 5601, 5763
Enander, B. N.: 5849
Epstein, J.: 5629

F

Fano, R. M.: 5641
Farber, R. J.: 5650
Fay, C. E.: 5852
Fedde, G. A.: 5810
Fellhauer, H. E.: 5917
Field, L. M.: 5750
Fink, D. G.: 5673
Firestone, W.: 5926, 5927
Fisk, B.: 5900
Fletcher, N. H.: 5863
Frazier, D. W.: 5876
Fresh, D. L.: 5837
Fromm, W. E.: 5695
Frood, D. G.: 5858
Fuchs, A.: 5662

G

George, R. W.: 5599
Gerber, E. A.: 5613A
Getting, I. A.: 5694
Giacoletto, L. J.: 5826
Giordano, A. B.: 5717
Goldberger, A. K.: 5652
Goldey, J. M.: 5818
Goldstine, H. E.: 5919
Golosman, B. S.: 5682
Goss, T. M.: 5861
Gossick, B. R.: 5640
Grammer, G.: 5925
Graves, C. D.: 5634, 5712
Greene, J. G.: 5761
Grossman, A. J.: 5666
Guenard, P.: 5643

H

Hagen, J. P.: 5726
Hall, W. M.: 5631
Hamer, R.: 5939
Hansell, G. E.: 5919
Harman, W. A.: 5750, 5751
Harries, J. H.: 5633
Hatcher, R. D.: 5932
Haus, H. A.: 5645
Hawkins, G. S.: 5820
Hawkins, P. O.: 5683
Heller, G. S.: 5844
Helt, S.: 5665
Hemmenway, K. N.: 5784
Herman, F.: 5744
Hers, J.: 5642
Hershberger, W. D.: 5687
Herzog, G. B.: 5946
Hillier, M.: 5814
Hoepfner, C. H.: 5692
Hogan, C. L.: 5830, 5842
Hok, G.: 5794, 5795
Hollis, R. M.: 5798

Holmes, E. G.: 5876
Holonyak, N.: 5818
Honey, J. F.: 5898, 5922
Honma, T.: 5600
Howitt, G.: 5650
Hughes, R. C.: 5654
Hutter, R. G. E.: 5646
Hynek, J. A.: 5730

I

Icenbice, P. J., Jr.: 5917
Ismail, M. A. W.: 5812

J

Jaynes, E. T.: 5767
Johnson, R. A.: 5792, 5936, 5938
Jones, G. R.: 5850
Juncosa, M. L.: 5931

K

Kaar, I. J.: 5897
Kabala, R. E.: 5931
Kahn, L. R.: 5906
Kahn, W.: 5949
Kales, M. L.: 5846
Kaplan, J.: 5725
Karayianis, N.: 5848
Katzin, M.: 5745
Kaye, J.: 5771
Kennaugh, E. M.: 5711
Kerns, D. M.: 5774
Kilham, L. F., Jr.: 5678
King, W. C.: 5882
Kino, G. S.: 5750
Kleimack, J. J.: 5675
Klopfenstein, R. W.: 5602, 5629, 5788
Knight, C. R.: 5803
Knoop, W. A.: 5933
Korman, M. M.: 5856
Kramer, S. I.: 5793
Kromhout, O. M.: 5610
Krulce, R. L.: 5617
Kulinyi, R. A.: 5923
Kurokawa, K.: 5603

L

Lackey, R. B.: 5937
Langford-Smith, F.: 5688
Lapham, W. H.: 5743
Lass, H.: 5709
Lawson, J. D.: 5616
Lax, B.: 5843
Le Caine, H.: 5672
LeCraw, R. C.: 5736, 5838
Levine, R. H.: 5923
Li, K.: 5880
Lindsay, P. A.: 5861
Little, C. G.: 5772
Lo, A. W.: 5651
Loev, D.: 5621
Lowy, H.: 5796
Luebbert, W. F.: 5680
Lundgren, D. L.: 5910

M

Macpherson, A. C.: 5774
Magnuski, H.: 5926
Makow, D. M.: 5775
Manley, J. M.: 5753
Marcuvitz, N.: 5766
Martin, E. L.: 5904
Mason, S. J.: 5713, 5734, 5755
Matsuo, Y.: 5612
Mattiat, O. E.: 5765
Mazur, D. G.: 5728
McConaughy, G. C.: 5896
McIlwain, K.: 5647
McLean, D. A.: 5749
McPherson, R. R.: 5785
Medhurst, R. G.: 5627, 5636, 5884, 5940
Melchor, J. L.: 5624

Mendel, J. T.: 5676
Mengel, J. T.: 5729
Meyer, H. F.: 5923
Miehle, W.: 5621
Miller, L. E.: 5607
Mitchell, F. H.: 5942
Moll, J. L.: 5608, 5818
Moore, R. C.: 5810
Moore, R. K.: 5941
Moreno, T.: 5708
Morrison, C. A.: 5850
Moulton, S. W.: 5808
Mullen, E. B.: 5839
Mullen, J. A.: 5617

N

Nalos, E. J.: 5702
Nathan, A.: 5735
Nelson, C. E.: 5853
Norgaard, D. E.: 5908, 5909

O

Onoe, M.: 5862
Ordung, P. F.: 5720
Oswald, A. A.: 5899
Owens, C. D.: 5831

P

Page, R. M.: 5865
Paivinen, J.: 5621
Palluel, P.: 5652
Pankove, J. I.: 5626
Pappenfus, E. W.: 5901, 5902
Parsons, S. L.: 5809
Partin, M. E.: 5808
Pfeffer, I.: 5737
Phillips, M. L.: 5706
Pierce, J. R.: 5699
Pippin, J. E.: 5614, 5787
Power, F. S.: 5749
Pratt, G. W.: 5809
Pratt, H.: 5807
Prihar, Z.: 5757
Pritchard, R. L.: 5782
Prugh, T. A.: 5760, 5943
Puro, W. O.: 5623
Pyle, M. O.: 5650

R

Rajchman, J. A.: 5651
Rayton, W. M.: 5772
Reggia, F.: 5736
Rich, D. J.: 5686A
Richman, D.: 5811
Rizzi, P. A.: 5686A
Robinson, H. A.: 5920
Rogers, S.: 5718
Roof, R. B.: 5772
Rosen, M. W.: 5727
Ross, I. M.: 5608
Rothe, H.: 5738
Rowe, H. E.: 5753
Rowe, J. E.: 5628, 5739, 5794

S

Sadowsky, M.: 5809
Saito, S.: 5603
Salmet, G.: 5881
Salzberg, B.: 5944
Samulon, H. A.: 5701
Sanford, E. E.: 5650
Sawazaki, N.: 5600
Schafer, J. P.: 5637
Scharfman, H.: 5854
Schenkel, H.: 5655
Schlesinger, K.: 5703, 5732
Schlicke, H. M.: 5705
Schock, R. E.: 5919
Schooley, A. H.: 5778
Schultz, G. F.: 5618, 5657, 5707, 5802, 5888
Schwan, H. P.: 5880

Scobey, J. E.: 5944
Seavey, M. H.: 5841
Seely, S.: 5864
Seidel, H.: 5847
Sensiper, S.: 5840
Sherr, S.: 5816
Shmoys, J.: 5622
Siekaniowicz, W. W.: 5605
Simkins, Q. W.: 5604, 5779
Small, G. F.: 5884
Smith, J. W.: 5928
Spencer, C. L.: 5900
Spencer, E. G.: 5736 5838, 5932
Staras, H.: 5791
Statz, H.: 5655
Stern, A. P.: 5868, 5799
Sterzer, F.: 5605
Stewart, J. L.: 5656
Stewart, R. M.: 5635
Stone, H. A., Jr.: 5598
Strandberg, M. W. P.: 5660, 5714
Strum, P. D.: 5857
Strumwasser, E.: 5851
Su, K. L.: 5754
Suhl, H.: 5834
Swenson, G. W., Jr.: 5781
Swerling, P.: 5813

T

Talbot, A.: 5659
Tannenbaum, M.: 5818
Tannenwald, P. E.: 5841
Terman, F. E.: 5669, 5724, 5934
Thaler, S.: 5611
Tien, P. K.: 5759
Toniyaasu, K.: 5685
Torrey, M. N.: 5875
Treuhaft, M. A.: 5845
Truxal, J. G.: 5664

U

Uchirin, G. C.: 5664
Uhlir, A., Jr.: 5819, 5690, 5877
Ursch, R. R.: 5678
Ushirokawa, A.: 5862

V

Valdes, L. B.: 5625
Van Allen, J. A.: 5731
Van Uiter, L. G.: 5836
Van Valkenburg, M. E.: 5886
Van Vleck, J. H.: 5832
Vartanian, P. H.: 5624
Voge, J. P.: 5887
Vogelsong, J. H.: 5604, 5779

W

Wade, G.: 5780
Wahl, A. J.: 5675
Wait, J. R.: 5710, 5756, 5858, 5783
Walsh, D.: 5683
Ward, H. T.: 5623
Ward, W. H.: 5800
Weaver, D. K., Jr.: 5898, 5905
Weiner, R.: 5866
Weisbaum, S.: 5686
Whinnery, J. R.: 5667
Whipple, F. L.: 5730
White, W. A.: 5944
White, W. D.: 5761
Whitehurst, R. N.: 5942
Wintringham, W. T.: 5823
Wylen, J.: 5621

Y

Young, N. H.: 5921

Z

Zadeh, L. A.: 5661, 5893
Zemanian, A. H.: 5815

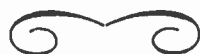

INDEX TO BOOK REVIEWS

Numbers refer to chronological list.

- Abacs or Nomograms, by A. Giet (Title only): 5872D
- Abstracts of Literature on Semiconduction and Luminescent Materials and Their Applications, compiled by Battello Memorial Institute: 5827B
- Advances in Electronics and Electron Physics: Vol. VII, edited by L. Marton (Reviewed by G. C. Dacey): 5742
- A-M Detectors, by Alexander Schure (Title only): 5696F
- Atlas of Ground-Wave Propagation Curves for Frequencies Between 30 MC and 300 MC, by Balth. van der Pol (Reviewed by H. G. Booker): 5768
- Attenuators, Equalizers and Filters, by H. M. Tremaine and G. K. Tefteau (Title only): 5721I
- Automatic Digital Calculators, by A. D. Booth and K. H. V. Booth (Reviewed by Werner Buchholz): 5889
- Basic Mathematics for Science and Engineering, by P. G. Andres, H. J. Miser and H. Reingold (Title only): 5827C
- Basic Processes of Gaseous Electronics, by L. B. Loeb (Reviewed by W. G. Dow): 5693
- Basics of Phototubes and Photocells, by D. Mark (Title only): 5950D
- Closed Circuit and Industrial Television, by E. M. Noll (Reviewed by R. D. Chipp): 5825
- Color Television Engineering, by J. W. Wentworth (Reviewed by R. P. Burr): 5668
- Color Television Receiver Practices, by the Hazeltine Corp. Laboratories Staff (Reviewed by W. P. Boothroyd): 5663
- Color Television Standards, by D. G. Fink (Reviewed by W. T. Wintringham): 5823
- Control of Nuclear Reactors and Power Plants, by M. A. Schultz (Title only): 5827I
- Criteria for Professional Employment of Engineers, published by National Society of Professional Engineers (Title only): 5872B
- Crystal Oscillators, by A. Schure (Title only): 5827J
- Digital Differential Analyzers: Part One, The Elements, by G. F. Forbes (Title only): 5827E
- Education as a Profession, by Myron Lieberman (Title only): 5872E
- Electric Network Synthesis: Image Parameter Method, by N. B. Reed (Reviewed by A. B. Giordano): 5717
- Electromagnetic Waves, by G. T. DiFrancia (Reviewed by S. B. Cohn): 5890
- Electronic Computers and Management Control, by George Kozmetsky and Paul Kircher (Reviewed by J. R. Weiner): 5866
- Electronic Data Processing for Business and Industry, by R. G. Canning (Title only): 5721A
- Electronic Engineering, by Samuel Seely (Reviewed by J. G. Brainerd): 5869
- Electronic Motion Pictures, by Albert Abramson (Reviewed by J. H. Battison): 5691
- Electronic Transformers and Circuits, by Reuben Lee (Reviewed by Knox McIlwain): 5647
- Electronics and Electron Devices, by A. L. Albert (Reviewed by Samuel Seely): 5864
- Electronics, the Science of Electronics in Action, by A. W. Keen (Title only): 5804B
- Electrons, Waves and Messages, by J. R. Pierce (Reviewed by F. E. Terman): 5669
- Elements of Pulse Circuits, by F. J. M. Farley (Reviewed by G. B. Herzog): 5946
- Elements of Radio, by C. I. Hellman (Title only): 5950B
- Engineering Drawing and Geometry, by R. P. Hoelscher and C. H. Springer (Title only): 5696A
- Faster, Faster, by W. J. Eckert and R. Jones (Title only): 5721D
- Four Hundred American Standards in the Electrical Field (Title only): 5696I
- Frequency Response, edited by Rufus Oldenburger (Reviewed by J. J. Giocolletto): 5826
- Fundamentals of Electroacoustics, by F. A. Fischer (Reviewed by B. B. Bauer): 5716
- Fundamentals of Television Engineering, by G. M. Glasford (Reviewed by Scott Helt): 5665
- Hi-Fi Loudspeakers and Enclosures, by A. B. Cohen (Title only): 5721B
- High Vacuum Technique, third ed. revised (Title only): 5827M
- Induction Heating Practice, by D. Warburton-Brown (Title only): 5950I
- Industrial Research Laboratories of the United States (Title only): 5804A
- Instrument Engineering: Vol. III, Applications of the Instrument Engineering Method; Part One, Measurement Systems, by C. S. Draper, Walter McKay, and Sidney Lees (Reviewed by J. G. Truxal): 5664
- Integral Transforms in Mathematical Physics, by C. J. Tranter, 2nd ed. (Title only): 5872H
- International Dictionary of Physics and Electronics (Title only): 5950H
- Introduction to Color TV, by M. Kaufman and H. Thomas (Title only): 5721E
- Introduction to Electronic Analogue Computers, by C. A. A. Wass (Reviewed by Stanley Rogers): 5718
- Introduction to Printed Circuits, by R. L. Swiggett (Title only): 5950G
- Introduction to Stochastic Processes, by M. S. Bartlett (Reviewed by E. E. David, Jr.): 5821
- Introduction to TV Servicing (For 525 and 625 Line Receivers), by H. L. Swaluw and J. van der Woerd (Title only): 5696H
- Inverse Feedback, by A. Schure (Title only): 5872F
- Legal Problems in Engineering, by Melvin Nord (Title only): 5804C
- Limiters and Clippers, by Alexander Schure (Title only): 5696G
- Linear Transient Analysis, Vol. II by Ernst Weber (Reviewed by L. A. Zadeh): 5893
- Mandl's Television Servicing, by M. Mandl (Title only): 5950C
- Mathematics for Electronics with Applications, by H. M. Nodelman and F. W. Smith (Reviewed by W. Kahn): 5949
- Mechanical Design for Electronic Engineers, by R. H. Garner (Title only): 5950A
- Modern College Physics, by H. E. White (Title only): 5696L
- Modern Physics, by R. L. Sproull (Reviewed by Frank Herman): 5744
- Molecular Beams, by K. F. Smith (Title only): 5827K
- Most-Often-Needed 1957 Television Servicing Information, Vol. TV-12, compiled by M. N. Beitman (Title only): 5950E
- Multivibrators, by Alexander Schure (Title only): 5721H
- Nachrichtenubertagung Mittels Sehr Hoher Frequenzen, by Gerhard Megla (Reviewed by W. J. Albersheim): 5741
- Network Analysis, by M. E. Van Valkenburg (Reviewed by P. F. Ordnung): 5720
- Noise, by Albert van der Ziel (Reviewed by W. E. Fromm): 5695
- Nomograms of Complex Hyperbolic Functions, by Jorgen Rybner (Title only): 5721G
- Nuclear Radiation Detectors, by J. Sharpe (Reviewed by J. W. Coltman): 5719
- Numerical Analysis, by Zdenek Kopal (Title only): 5696C
- Operations Research for Management, Vol. II, edited by J. F. McCloskey and J. M. Copping (Title only): 5804D
- Principles of Color Television, by Hazeltine Laboratories Staff, edited by J. McIlwain and C. E. Dean (Reviewed by F. J. Bingley): 5947
- Principles of Electromagnetism, by E. B. Moullin (Reviewed by J. R. Whinnery): 5667
- Principles of Guided Missile Design: Guidance by A. A. Locke, *et al.* (Reviewed by C. H. Hoepfner): 5692
- Principles of Nuclear Reactor Engineering, by S. Glasstone (Reviewed by J. W. Coltman): 5824
- Proceedings of 1956 Electronic Components Symposium (Title only): 5950F
- Proceedings of RETMA Symposium on Automation (Title only): 5696E
- Proceedings of the Symposium on Electromagnetic Wave Theory (Reviewed by Martin Katzin): 5745
- Quality Control and Applied Statistics, Abstracts, Vol. 1, Issue 1, edited by R. S. Titchen, A. J. Rosenthal, Bruce Boller-man and Frank Nistico (Title only): 5804F
- Radio Electronics, by Samuel Seely (Reviewed by A. V. Eastman): 5870
- Radio Handbook, edited by W. I. Orr (Title only): 5721F
- Random Processes in Automatic Control, by J. H. Laning, Jr. and R. H. Battin (Reviewed by W. R. Bennett): 5867
- Reliability Factors for Ground Electronic Equipment, edited by Keith Henney (Reviewed by C. R. Knight): 5803
- Review of Current Research and Directory of Member Institutions, edited by Renato Contini (Title only): 5827G
- Rider's Specialized Hi-Fi AM-FM Tuner Manual, compiled by J. F. Rider Lab. Staff (Title only): 5827H
- Science and Information Theory, by L. Brillouin (Reviewed by W. D. White): 5945
- Spheroidal Wave Functions, by J. A. Stratton, *et al.* (Reviewed by E. T. Jaynes): 5767
- Static and Dynamic Electron Optics, by P. A. Sturrock (Reviewed by R. G. E. Hutter): 5646
- Studien uber einkreisige Schwingungs-sys-

teme mit zeitlich veränderlichen Elementen, by B. R. Gloor (Reviewed by W. J. Albersheim): 5891
 Study of the Double Modulated FM Radar, by Mohamed Ismail (Reviewed by R. M. Page): 5865
 Switching Relay Design, by R. L. Peek, Jr. and H. N. Wagar (Title only): 5827F
 Symposium on Monte Carlo Methods, edited by H. A. Meyer (Title only): 5804
 Technical Publications: Their Purpose, Preparation and Production, by C. Baker (Title only): 5827D
 Television Factbook, 23rd ed., published by Television Digest (Title only): 5872G
 Television, How It Works, by J. R. Johnson (Title only): 5696B
 Theory of Sound, Vols. I and II, by Lord Rayleigh, *Reprint* (Title only): 5804G
 Time-Saving Network Calculations, by Harry Stockman, 2nd ed. (Title only): 5804H
 Transistor Electronics, by A. W. Lo, *et al.* (Reviewed by A. J. Grossman and F. H. Blecher): 5666

Transistors I., by RCA Laboratories (Reviewed by A. P. Stern): 5868
 Transistors Handbook, by W. D. Bevirt (Reviewed by R. P. Burr): 5822
 Transistors and Other Crystal Valves, by T. R. Scott (Reviewed by I. A. Getting): 5694
 Transistors in Radio and Television, by M. S. Kiver (Reviewed by R. P. Burr): 5892
 TV Repair Questions and Answers—Deflection and H-V Circuits, by Sidney Platt (Title only): 5696D
 TV Servicing Guide, by L. D. Deane and C. C. Young, Jr. (Title only): 5872C
 Ultrasonic Engineering, by A. E. Crawford (Reviewed by O. E. Mattiat): 5765
 U.R.S.I. Proceedings of the XI General Assembly, Vol. Ten, Part Two (Title only): 5804J
 U.R.S.I. Proceedings of the XI General Assembly: Vol. Ten, Part Three, Commission III on Ionospheric Radio (Title only): 5827L
 U.R.S.I. Proceedings of the XI General As-

sembly: Vol. Ten, Part Five (Title only): 5696J
 U.R.S.I. Proceedings of the XI General Assembly: Vol. Ten, Part Six (Title only): 5696K
 Vacuum Symposium Transactions, 1954, compiled by Committee on Vacuum Techniques, Inc. (Title only): 5827A
 Vacuum Symposium Transactions, 1955, compiled by the Committee on Vacuum Techniques (Title only): 5872A
 Vacuum Valves in Pulse Techniques, by P. A. Neeteson (Reviewed by W. H. Lapham): 5843
 Vierpoltheorie und Frequenztransformation, by T. Laurent (Reviewed by H. Rothe): 5948
 Who's Who in Electronics, 1956, edited by R. A. Harris (Title only): 5804E
 Worldwide Radio Noise Levels Expected in the Frequency Band 10 Kilocycles to 100 Megacycles, by W. Q. Crichlow, D. F. Smith, R. N. Morton, and W. R. Corliss (Title only): 5721C

INDEX TO SUBJECTS

Numbers refer to chronological list.

A

Aeronautical Communications, Transition to Single Sideband, Problems: 5922
 Airborne HF Transmitters, Conversion to Single Sideband: 5920
 Amplifiers: 5604, 5605, 5628, 5645, 5682, 5688, 5734, 5739, 5759, 5779, 5794, 5860, 5879, 5885, 5913
 Beam-Type, Microwave, Dip in Minimum Noise Figure: 5759
 Cascode, Equivalent Characteristics of: 5688
 Circuits, for Analog Computers: 5860
 Feedback: 5734, 5885
 for Precision Electronic Switching: 5885
 Stability of: 5734
 Linear Power: 5913
 Optimum Gain: 5645
 Regenerative, with Distributed Amplification: 5682
 Single Sideband: 5906, 5917
 Linear Transmitters, and Envelope Elimination and Restoration Transmitters: 5906
 Linearity Testing: 5917
 Transistor: 5604, 5779, 5879, 5913
 Common-Emitter, for Television: 5879
 for Digital Computers: 5604, 5779
 RC Coupled, Minimizing Gain Variations with Temperature: 5913
 Traveling-Wave: 5605, 5628, 5739, 5794
 Backward Waves: 5794
 Large-Signal, Design Information: 5628, 5739
 with Periodic Permanent Magnets: 5605
 Amplitude Linearity, Sensitive Method for Measurement: 5793
 Amplitude Modulation, Synchronous Communications: 5907
 Analog Computation of Small Quotients: 5930
 Angular Accuracy of Pulsed Search Radar: 5813

Angular Velocity, Special Word for: 5786
 Anisotropy of Cobalt-Substituted Mn Ferrite Single Crystals: 5841
 Antennas: 5707, 5710, 5756, 5856, 5858
 Ferrite-Filled Apertures: 5856
 Mounted on Curved Surface: 5710
 Russian Terminology: 5707
 Slots in Metal Plates: 5858
 Apple Receiver Circuits and Components: 5810
 Apple Tube: 5809
 Approximation Problem, Solution for RC Low-Pass Filters: 5754
 Atmospheric Attenuation and Solar Temperature in 7-8 MM Wavelength Range: 5942
 Atmospheric, Waveforms at Short Ranges: 5783
 Audio Measurements, Standards on: 5704, 5915
 Correction: 5915
 Aurora, Radar Echoes and Radio Noise from: 5772
 Automatic Gain Control, Effect on Radar Tracking Noise: 5737

B

Backward Waves, Criterion for: 5794
 Bandwidth: 5627, 5735, 5887, 5939, 5940
 of FM Multiplex Systems: 5627, 5939, 5940
 of Networks with Arbitrary Transfer Characteristics: 5735
 for Scatter Transmission: 5887
 Beam-Indexing Color Picture Tube: 5809
 Beam-Indexing Color Television Display System: 5808
 Binary Signals, Optimum Slicing Level in Noisy Channel: 5798
 Bipolar Transistor Frequency Response: 5625
 Birefringence of Ferrites in Circular Waveguide: 5858
 Bridge Equivalent of Brune Networks: 5886

C

Capacitors: 5705, 5749, 5802
 Cascaded Feedthrough: 5705
 Russian Terminology: 5802
 Tantalum Solid Electrolytic: 5749
 Carcinotron, O Type: 5652
 Carrier and Sideband Selection, Electromechanical Filters for: 5599
 Carrier Strength Single Sideband Performance: 5927
 Cascode Amplifier, Equivalent Characteristics of: 5688
 Cathodes: 5654, 5780
 Low Temperature, Noise from: 5780
 Pressed Dispenser: 5654
 Cathode Ray Oscillograph: 5797
 Cavities, Ferrite Tunable Microwave: 5850, 5852, 5853
 Circuits: 5621, 5677, 5801, 5844
 Equipartition Theory Applied to: 5801
 Redundant, to Increase Equipment Reliability: 5677
 Circulators Network Properties of: 5845
 Cobalt-Substituted Mn Ferrites Single Crystals, Anisotropy of: 5841
 Color Television: 5650, 5808, 5809, 5810, 5811
 Apple Receiver Circuits and Components: 5810
 Beam-Indexing Display System: 5808
 Beam-Indexing Picture Tube: 5809
 NTSC, Directions of Improvement: 5811
 Receiver Design: 5650
 Combiner Diversity Statistics: 5791
 Communications Systems: 5687A, 5928, 5929
 Single Sideband UHF: 5928, 5929
 Long-Range: 5929
 Computers: 5604, 5674, 5860
 Analog, Amplifier Circuits: 5860
 Cryotron: 5674
 Digital, Transistor Amplifiers for: 5604, 5779
 Condenser, Russian Terminology: 5802
 Cryotron: 5674

D

Data Handling Systems: 5621, 5635
 Filters for Restoration of Sampled Data: 5635
 Magnetic Core Circuits: 5621
 Deflection, Electrostatic: 5703
 Delta Function, Dirac: 5692, 5935, 5936, 5937, 5938
 Detection and Generation of Single-Sideband Signals, Third Method of: 5905
 Detector, Microwave Electron Beam: 5676
 Dielectrics: 5693, 5623, 5736, 5837
 Artificial, using Cylindrical and Spherical Voids: 5623
 Constants of Ferrite Spheres Measured: 5736
 Measurement at Microwaves: 5603
 Properties and Conductivity of Ferrites: 5837
 Diffraction, VHF, by Alaska Range Mountains: 5781
 Diffusion; Radar Echocs from Meteor Trails: 5820
 Diodes, Junction, Fast Switching: 5944
 Dirac Delta Function: 5792, 5935, 5936, 5937, 5938
 Directional Channel-Separation Filters: 5773
 Directional Couplers, Ferrite: 5851
 Distortion Reduction for Single-Sideband Transmitters: 5914
 Distributed Amplification, Regenerative Amplifier: 5682
 Diversity, Combiner, Statistics of: 5791
 Double-Sideband Airborne HF Receiver-Transmitter, Conversion to Single-Sideband: 5920

E

Earth Satellite: 5725-5731
 Exploration of Outer Space: 5726
 IGY Program: 5725
 Optical Tracking of: 5730
 Placing in Orbit: 5727, 5728
 Telemetry Problem: 5728
 Scientific Value of: 5731
 Tracking and Telemetry: 5729
 Echo Distortion in FM Transmission of Frequency-Division Multiplex: 5636, 5637
 Educational Requirements of Electrical Engineers: 5724, 5933, 5934
 Electrical Engineers Are Going Back to Science: 5724, 5933, 5934
 Electroluminescence of Phosphors: 5715
 Electrolytic Tantalum Solid Capacitors: 5749
 Electromagnetic Interference Fringes Used in Geophysical Prospection of Underground Water: 5601, 5762, 5763, 5796
 Electromagnetic Radiation, Hazard to Body: 5880
 Electromechanical Filters: 5599, 5910
 Carrier and Sideband Selection, 100-KC: 5599
 Single-Sideband Applications: 5910
 Electron Beams: 5606, 5676, 5708, 5780
 Microwave Detector: 5676
 Noise from Low-Temperature Cathode Emission: 5780
 Spurious Modulation of: 5606, 5708
 Electron Devices; Standards on Terms: 5653, 5679
 Microwave Tube Terms: 5653
 Storage Tube Terms: 5679
 Electron Tubes: 5600, 5610, 5618, 5654, 5702, 5750, 5751, 5776, 5795
 Pressed Dispenser Cathode: 5654
 Russian Terminology: 5618
 Standards, TR and ATR Tube Definitions: 5776
 Traveling-Wave: 5600, 5610, 5702, 5750, 5751, 5795
 High Power, Design of: 5702
 in Microwave Repeater System: 5600
 Noise Factor: 5795

Transverse-Current: 5750, 5751
 Transverse, with Periodic Electrostatic Focusing: 5610
 Electronic Computers, Standards on Terms: 5816
 Electronic Music: 5672
 Electrostatic Deflection: 5702
 Envelope Elimination and Restoration System Compared with Linear Amplifier System: 5906
 Equipartition Theory Applied to Electric Circuits: 5801

F

Facsimile, Standards on Terms: 5733
 Feedback: 5613, 5662, 5734, 5755, 5885
 Amplifiers: 5734, 5885
 for Precision Electronic Switching: 5885
 Stability of: 5734
 Control Systems: 5613, 5734
 Standards on Terminology: 5613
 Local Negative: 5662
 Theory, Signal Flow Graphs: 5755
 Ferrites: 5598, 5639, 5686, 5687, 5736, 5787, 5830, 5831, 5832, 5833, 5834, 5835, 5836, 5837, 5838, 5839, 5940, 5841, 5842, 5843, 5844, 5845, 5846, 5847, 5848, 5849, 5850, 5851, 5852, 5853, 5854, 5855, 5856
 Anomalous Propagation in Ferrite-Loaded Waveguide: 5847
 Birefringence, in Circular Waveguide: 5848
 Cobalt-Substituted Mn Ferrite Single Crystals, Anisotropy: 5841
 Crystal Chemistry: 5837
 Dielectric Properties and Conductivity: 5836
 Directional Couplers: 5851
 Ferro- and Ferri-Magnetism: 5832
 Field Displacement Isolator: 5686
 Frequency and Loss Characteristics of Microwave Devices: 5843
 Frequency Doubling and Mixing in: 5787
 Inductor Design: 5598
 Introduction to Ferrites Issue of Proceedings: 5830
 Isolator: 5849
 Magnetic Resonance in: 5833
 Magnetic Tuning of Resonant Cavities: 5850
 Magnetized, Guide Wave Propagation in: 5846
 Methods of Preparation: 5837
 as Microwave Circuit Elements: 5844
 below Microwave Frequencies: 5831
 Modulators, Sidebands of: 5687
 Network Properties of Circulators Based on Scattering Concept: 5845
 Nonlinear Behavior at High Microwave Signal Levels: 5834
 Nonlinearity of Propagation: 5639
 Nonreciprocal Microwave Devices: 5842
 Permeability Tensor Values from Waveguide Measurements: 5839
 Permeabilities of Rods, Spheres and Disks: 5838
 Phase Shifters: 5854
 Radiation from Apertures: 5856
 Resonance Loss Properties in 9 KMC Region: 5840
 Single Crystal, Microwave Resonance Relations: 5835
 Spheres, Dielectric Constants of: 5736
 Tunable Filter for Use in S Band: 5855
 Tunable Cavities: 5852, 5853
 Ferromagnetism and Ferrimagnetism: 5832
 Filters: 5599, 5629, 5635, 5754, 5773, 5853, 5855, 5910, 5941
 Directional Channel-Separation: 5773
 Electromechanical: 5599, 5910
 for Carrier and Sideband Selection, 100-KC: 5599
 Single-Sideband Applications: 5910
 Ferrite-Tunable, for Use in S Band: 5855

Pulse Narrowing: 5941
 RC Low-Pass, Solution to Approximation Problem: 5754
 Reflectionless, for Ferrite Tunable Microwave Cavities: 5853
 for Restoration of Sampled Data: 5635
 Waveguide, Polarguide Type: 5629
 Fluorochemicals for Transformer Miniaturization: 5678
 Four-Poles: 5614, 5738
 Microwave, Measurement: 5614
 Noisy: 5738
 Fourier Transforms: 5689, 5740
 Applications in Electrical Engineering: 5740
 and Tapered Transmission Lines: 5680
 Frequency: 5612, 5624, 5625, 5627, 5636, 5637, 5642, 5656, 5787, 5812, 5819, 5859, 5876, 5884, 5903, 5904, 5926, 5939, 5940
 Control in 300-1200 MC Region: 5876
 Control Techniques for Single-Sideband: 5904
 Conversion, Junction Devices for: 5819
 Doubling and Mixing in Ferrites: 5787
 Meter, Broadband Microwave: 5624
 Modulation: 5627, 5636, 5637, 5656, 5812, 5884, 5939, 5940
 Bandwidth of Multiplex Systems: 5627, 5939, 5940
 Distortion Due to Small Sinusoidal Variations of Transmission: 5884
 Echo Distortion in Transmission of Frequency-Division Multiplex: 5636, 5637
 Noise in Oscillators: 5656
 Radar, Precise New System: 5812
 and Single-Sideband Mobile Service: 5926
 Multipliers; Multi-Beam, Velocity-Type: 5612
 Response of Bipolar Transistor: 5625
 Shift Telegraph Single-Sideband Technique Applied to: 5903
 Standard WWV and WWVH: 5859
 Unit: 5642

G

Gas Discharge Noise Generators: 5761
 Geophysical Prospection of Underground Water by Means of Electromagnetic Interference Fringes: 5601, 5762, 5763, 5796
 Grids, Magnetic Thyatron: 5681

H

Heat Transfer, Industrial Applications to Electronics: 5771

I

Inductors, Applications of Ferrites to Design: 5598
 Infrared Frequency, Surface Resistance and Reactance of Metals: 5609
 Institute of Radio Engineers and URSI: 5748
 Interference Patterns, Use in Water Prospecting: 5601, 5762, 5763, 5796
 International Geophysical Year Program: 5725
 International Scientific Radio Union (URSI) and IRE: 5748
 Ionosphere: 5622, 5657, 5772
 Effects at VHF and UHF: 5772
 Long-Range, Low-Frequency Propagation: 5622
 Russian Terminology: 5657
 Isolator, Ferrite: 5686, 5849
 Field Displacement: 5686

J

Junctions: 5640, 5690, 5819, 5944
 Devices for Frequency Conversion: 5819
 Diodes, Fast Switching: 5944
 P-N: 5640, 5690
 High-Frequency Shot Noise in: 5690
 Transient Response of: 5640

K

Keep-Alive Instabilities in TR Switch: 5683
 Klystrons: 5653, 5834, 5850
 Magnetic Tuning of Resonant Cavities: 5850
 Power Oscillator, 8 Mm: 5814
 Standards on Terms: 5653
 Wideband Frequency Modulation of: 5850

L

Learning, Systemic: 5785
 Linear Amplifier Single-Sideband System and Envelope Elimination and Restoration System: 5906
 Linear Programming and Optimal Telecommunication Networks: 5931
 Linearity Testing Techniques for Single-Sideband Equipment: 5917
 Long-Range Communications System, Single Sideband: 5929
 Longitude Determination by Time Signals: 5800

M

Magnetic Cores: 5621, 5651
 in Digital Data-Processing Systems: 5621
 Transfluxor: 5651
 Magnetic Field Strength, Effect on Space-Charge-Wave Propagation: 5752
 Magnetic Resonance in Ferrites: 5833
 Magnetic Tuning of Resonant Cavities: 5850
 Magnetrons: 5617, 5653, 5861
 Noise Reduction: 5617
 Q-Band, Spurious Modulation in: 5861
 Standards on Terms: 5653
 Marconi's Last Paper on Microwave Propagation: 5790
 Measurements: 5603, 5614, 5701, 5704, 5774, 5782, 5793, 5797, 5839, 5915
 of Amplitude Linearity: 5793
 CRO: 5797
 Dielectric, at Microwaves: 5603
 of High Frequency Power Gain of Junction Transistors: 5782
 of Microwave Standing Wave Ratios: 5774
 Scattering Matrix, on Nonreciprocal Microwave Devices: 5614
 Standards on Methods of, for Audio Systems and Components: 5704, 5915
 Correction: 5915
 Video, Employing Transient Techniques: 5701
 Waveguide, Ferrite Permeability Tensor Values from: 5839
 Melt-Quench Process of Transistor Fabrication: 5626
 Meteor Trails, Radar Echoes from: 5820
 Microphonism Due to Transistor Leads: 5760
 Microwave Detector: 5676
 Microwave Repeater System Using Traveling-Wave Tubes: 5600
 Miniaturization of Transformers: 5678
 Minitrack System for Tracking Earth Satellite: 5729
 Mobile Communications, Single-Sideband: 5924, 5926
 and FM Systems: 5926
 Modulators, Ferrite, Sidebands of: 5687
 Multiplex Systems: 5627, 5636, 5637, 5939, 5940
 Echo Distortion in FM Transmission: 5636, 5637
 Frequency Division, RF Bandwidth: 5627, 5939, 5940
 Music, Electronic: 5672

N

Networks: 5611, 5638, 5659, 5661, 5709, 5735, 5738, 5757, 5764, 5799, 5815, 5845, 5886, 5931
 "Active" Defined: 5661
 with Arbitrary Transfer Characteristics, Bandwidth of: 5735

Bridge Equivalent of Brune Network: 5886
 Closed Loop, Root Locus Method: 5709
 Determinants: 5638
 Double-Tuned Coupling; Power Transfer in: 5799
 Four-Terminal, Maximum Efficiency: 5764
 Noisy Four-Poles: 5738
 "Passive" Defined: 5661
 Properties of Circulators Based on Scattering Concept: 5845
 Shape Factors of the Step Response: 5815
 Simplified Method of Solving: 5611
 Telecommunication: 5757, 5931
 and Linear Programming: 5931
 Topological Properties: 5757
 Transfer Ratios of Resistance and RLC: 5659
 Noise: 5617, 5656, 5690, 5699, 5700, 5706, 5737, 5738, 5759, 5760, 5761, 5772, 5795
 Beam-Type Microwave Amplifiers, Dip in Minimum: 5759
 Factor in Traveling-Wave Tubes: 5795
 FM, in Oscillators: 5656
 in Four-Poles: 5738
 Generators, Gas Discharge: 5761
 High Frequency Shot, in P-N Junctions: 5690
 Methods of Solving Problems: 5700
 Microphonism Due to Transistor Leads: 5760
 Physical Sources of: 5699
 Radar Tracking, Effect of AGC: 5737
 Radio, of Auroral Origin: 5772
 Ratio of Steady Sinusoidal Signal to: 5706
 Reduction in Magnetrons: 5617
 Scintillation of Radio Stars: 5772
 Nonlinear Elements, General Energy Relations: 5753
 Nonreciprocal Microwave Ferrite Devices: 5842
 Norton's and Thevenin's Theorems Generalized: 5661
 NTSC Color Television Systems, Directions of Improvement: 5811

O

Optical Tracking of Artificial Earth Satellite: 5730
 Oral Examination Procedure: 5713
 Oscillators: 5630, 5652, 5656, 5714, 5775, 5814, 5876, 5881
 Backward-Wave: 5652
 Frequency Control in 300-1200 MC Region: 5876
 Frequency Modulation Noise: 5656
 Klystron Power, 8 mm: 5814
 Microwave, Phase Stabilization of: 5714
 Pulse-Synchronized, Analysis of: 5881
 Stable Variable Frequency: 5775
 Transistor, Frequency Stability of: 5630
 Oscillograph, Cathode Ray, Measurements: 5797

P

Parabolic Reflectors, Treatment of Problems: 5615
 Permeability, Ferrite: 5838, 5839
 Rods, Spheres and Disks: 5838
 Waveguide, Measurement of: 5839
 Phase Comparison Method of Tracking Earth Satellite: 5729
 Phase Shift Method: 5908, 5909
 of Single-Sideband Signal Generation: 5908
 of Single-Sideband Signal Reception: 5909
 Phase Shifters, Ferrite: 5854
 Phase Stabilization of Microwave Oscillators: 5714
 Phosphors, Electroluminescence of: 5715
 Polarguide: 5629
 Polarization, Radar, Power Scattering Matrix: 5634, 5711, 5712
 Positive Real System Functions, Shape Factors of Step Response: 5815

Power Converter, Transistor: 5644
 Power Scattering, Radar: 5634, 5711, 5712
 Power Supply, Balanced, Unregulated, Dual: 5784
 Programming, Linear, and Optimal Telecommunication Networks: 5931
 Pulse Narrowing by Filters: 5941
 Pulse Radar, Prediction of Performance: 5631
 Pulse-Synchronized Oscillators, Analysis of: 5881
 Pulsed Search Radar, Maximum Angular Accuracy: 5813

Q

Quartz: 5613A, 5658, 5883
 AT-Type Resonators: 5883
 Temperature Coefficient: 5613A
 Variation with Temperature of Resonator Characteristics: 5658
 Quality Control in Electronics: 5875

R

Radar: 5631, 5634, 5711, 5712, 5737, 5772, 5778, 5812, 5813, 5820, 5880
 Echoes: 5772, 5820
 from Aurora: 5772
 from Meteors: 5772, 5820
 FM, Precise New System: 5812
 Hazards Due to Total Body Irradiation: 5880
 Power Scattering: 5634, 5711, 5712
 Pulse, Prediction of Performance: 5631
 Pulsed Search, Maximum Angular Accuracy: 5813
 Sea Clutter Noise: 5778
 Tracking Noise, Effect of AGC: 5737
 Radiation: 5858, 5880
 Hazards to Body: 5880
 from Slots in Metal Plates: 5858
 Radio Stars, Scintillation of: 5772
 Receivers: 5650, 5777, 5882, 5911, 5919, 5920
 Airborne HF, Conversion to Single-Sideband: 5920
 for Color Television: 5650
 Microwave, Sideband-Mixing Superheterodyne: 5882
 Single-Sideband: 5911, 5919
 Factors Influencing Design: 5911
 for HF Radio Circuits, Point-to-Point Service: 5919
 Standards on Interference Measurement: 5777
 Redundant Circuits: 5677
 Reflection Coefficient, Microwave, Measurement Technique: 5774
 Reflectors, Parabolic, Treatment of Problems: 5615
 Regenerative Amplifier with Distributed Amplification: 5682
 Reliability: 5675, 5677, 5680
 Alloy Junction, Transistor: 5675
 Electronic, Increased by Use of Redundant Circuits: 5677
 Systems Approach to: 5680
 Repeater System, Microwave, Use of Traveling-Wave Tubes: 5600
 Resistance Paper Analogy: 5633
 Resistors, Russian Terminology: 5888
 Resonance: 5603, 5835, 5840
 Loss Properties of Ferrites in 9 KMC Region: 5840
 Method for Measuring Dielectric Properties of Low-Loss Solid Materials in Microwave Region: 5603
 Relations in Single Crystal Ferrites: 5835
 Resonators, Quartz: 5658, 5883
 AT-Type, Frequency-Temperature-Angle Characteristics: 5883
 Variation with Temperature: 5658
 Root Locus Method: 5709
 Rotary Joints, Annular, Waveguide: 5685
 Rubber Membrane Analogy: 5633
 Russian Terminology: 5618, 5651, 5707, 5802, 5888
 for Antennas: 5707
 for Condensers: 5802

for Ionosphere: 5657
for Resistance and Resistors: 5888
for Vacuum Tubes: 5618

S

Sampling Band-Limited Functions: 5632
Scattering: 5614, 5634, 5711, 5712, 5845, 5887
Concept in Circulators: 5845
Measurements on Nonreciprocal Devices: 5614
Power, of Radar: 5634, 5711, 5712
Tropospheric, Useful Bandwidth for Transmission: 5887
Scintillation of Radio Stars: 5772
Semiconductor Devices, Standards on Letter Symbols: 5758
Shape Factors of the Step Response: 5815
Sideband and Carrier Selection, Electromechanical Filters for: 5599
Sideband-Mixing, Superheterodyne Receiver: 5882
Sidebands Produced by Ferrite Modulators: 5687
Signal-Seeking Radio, Trigger Circuit: 5660
Signals: 5632, 5706, 5755, 5800
Flow Graphs: 5755
Sampling Band-Limited Functions: 5632
Sinusoidal, Ratio to Noise: 5706
Time, for Determination of Longitude: 5800
Single-Sideband: 5896, 5897, 5899, 5900, 5901, 5902, 5903, 5904, 5905, 5906, 5907, 5908, 5909, 5910, 5911, 5913, 5914, 5916, 5917, 5918, 5919, 5920, 5921, 5922, 5923, 5924, 5925, 5926, 5927, 5928, 5929
Airborne HF Receiver-Transmitter, Conversion to: 5920
in Amateur Service: 5925
Amplifiers, Linear Power: 5913
Automatic Tuning Techniques for Equipment: 5916
Carrier Strength: 5927
Communications, Introduction to Problems: 5898
Economics and Power: 5902
Electromechanical Filters for: 5910
Equipment for Point-to-Point Service on HF Radio Circuits: 5919
Frequency Control Techniques for: 5904 and FM Mobile Service: 5926
for International Telegraph: 5918
Introduction to Special Issue on: 5897
Linearity Testing Techniques for Equipment: 5917
for Military Vehicular Radio Sets: 5923
for Mobile Communications Systems: 5924
Power and Economics: 5902
Problems of Transition: 5921, 5922
in Aeronautical Communications: 5922
in Operation: 5921
Receivers, Factors Influencing Design: 5911
Signals: 5905, 5908, 5909
Phase Shift Method of Generation: 5908
Phase Shift Method of Reception: 5909
Third Method of Generation and Detection: 5905
Spectrum Conservation 5901
and Synchronous AM System Compared: 5907
Synthesizer Stabilized Systems: 5900
Technique: 5896, 5903
and Frequency Shift Telegraph: 5903
and Spectrum Administration: 5896
Transmission, Early History of: 5899
Transmitters: 5906, 5914
Distortion Reduction: 5914
Linear System Compared with Envelope Elimination and Restoration System: 5906
UHF: 5928, 5929
Long Range: 5929
Solar Temperature and Atmospheric Attenuation in 7-8 MM Wavelength

Range: 5942

Solid State Devices, Standards on Methods of Testing Transistors: 5878
Space-Charge-Wave Propagation, Effect of Magnetic Field Strength: 5752
Spectrum: 5896, 5901
Administration, Related to Single-Sideband Techniques: 5896
Conservation Single-Sideband: 5901
Spurious Modulation in Magnetrans: 5861
Stable Variable Frequency Oscillator: 5775
Standards: 5613, 5653, 5679, 5704, 5733, 5758, 5776, 5777, 5816, 5878, 5915
on Audio Systems and Components, Methods of Measurement: 5704, 5915
Correction: 5915
on Electron Devices: 5653, 5679
Microwave Tube Terms: 5653
Storage Tube Terms: 5679
on Electron Tubes, TR and ATR Tube Definitions: 5776
on Electronic Computer Terms: 5816
on Facsimile Terms: 5773
on Feedback Control Systems Terminology: 5613
on Receiver Interference Measurements: 5777
on Semiconductor Devices, Letter Symbols: 5758
on Solid State Devices, Transistor Testing: 5878
Standing-Wave Ratios, Measurement of: 5774
Stars as Noise Source: 5772
Statistical Techniques in Quality Control: 5875
Step Response, Shape Factors: 5815
Storage Tubes, Standards on Terms: 5679
Superconductivity, Cryotron: 5674
Surface Resistance at Infrared Frequency: 5609
Surface Waves, Method of Launching: 5616
Sweep Circuits for Television Receivers: 5732
Switches: 5818, 5885
P-N-P-N Transistor: 5818
Precision Electronic, with Feedback Amplifier: 5885
Switching with Junction Diodes: 5944
Synchronous Communications: 5907
Synthesizer Stabilized Single-Sideband Systems: 5900
Systemic Learning: 5785

T

Tantalum Electrolytic Capacitors: 5749
Tapered Transmission Lines: 5602, 5684, 5689, 5788, 5789, 5912
Design of: 5602
and Fourier Transforms: 5689
Matching Section: 5684, 5788, 5789, 5912
Correction: 5912
Technical Meetings: 5641
Telecommunication Networks: 5757, 5931
and Linear Programming: 5931
Topological Properties: 5757
Telegraph: 5903, 5918
Frequency Shift, Single-Sideband Technique Applied to: 5903
International, Single Sideband Operation for: 5918
Telemetry: 5728, 5729
of Earth Satellite: 5729
of Satellite Launching Vehicle: 5728
Television: 5650, 5701, 5703, 5732, 5808, 5809, 5810, 5811, 5879
Common-Emitter Transistor Amplifiers: 5879
Color: 5650, 5701, 5703, 5732, 5808, 5809, 5810, 5811, 5879
Apple Receiver Circuits and Components: 5810
Beam-Indexing Display System: 5808
Beam-Indexing Picture Tube: 5809
NTSC, Directions of Improvement: 5811
Receiver Design: 5650

Measurements Employing Transient Techniques: 5701
Sweep Circuit: 5732
Tubes, Post-Acceleration: 5703
Tesla, Nikola: 5807
Thevenin's and Norton's Theorems Generalized: 5661
Third Method of Generation and Detection of Single-Sideband Signals: 5905
Thyratron, Magnetic Grid Control Circuit: 5681
Time Signals: 5800, 5859
for Determination of Longitude: 5800
Standard WWV and WWVH: 5859
Topological Properties of Telecommunication Networks: 5757
TR Switch, Keep-Alive Instabilities: 5683
Transfluxor: 5651
Transformers, Miniaturization, Using Fluorochemicals: 5678
Transient Measurement Techniques for Video: 5701
Transient Response of P-N Junctions: 5640
Transistors: 5604, 5607, 5608, 5625, 5626, 5630, 5644, 5655, 5673, 5675, 5760, 5779, 5782, 5818, 5862, 5863, 5878, 5879, 5943
Amplifiers: 5604, 5779, 5943
for Digital Computers: 5604, 5779
RC Coupled, Minimizing Gain Variations with Temperature: 5943
Base Layer Resistivity: 5608
Bipolar, Frequency Response: 5625
Common Emitter Video Amplifiers: 5879
Fabrication by Melt-Quench Process: 5626
Junction: 5655, 5675, 5787, 5862, 5863
with Alpha Greater than Unity: 5655
Factors Affecting Reliability: 5675
Inductive AC Admittance: 5862
Measurement Considerations in High Frequency Power Gain: 5782
Variation of Current Amplification Factor with Emitter Current: 5863
Microphonism Due to Leads: 5760
Oscillators, Frequency Stability of: 5630
Point Contact, Negative Resistance Regions: 5607
Power Converter: 5644
Standards on Methods of Testing: 5878
Switches, P-N-P-N: 5818
vs Vacuum Tubes: 5673
Transmission Lines, Tapered: 5602, 5684, 5689, 5788, 5789
Design of: 5602
and Fourier Transforms: 5689
Matching Section: 5684, 5788, 5789, 5912
Correction: 5912
Transmitters, Single-Sideband: 5906, 5914, 5919, 5920
Conversion of Airborne HF: 5920
Distortion Reduction: 5914
for HF Radio Circuit, Point-to-Point Service: 5919
Linear System Compared with Envelope Elimination and Restoration System: 5906
Traveling Wave: 5600, 5605, 5610, 5628, 5643, 5652, 5653, 5702, 5739, 5750, 5751, 5794, 5795
Amplifiers: 5605, 5628, 5739, 5794
Backward-Waves: 5794
Large Signal, Design Information: 5628, 5739
with Periodic Permanent Magnets: 5605
Tubes: 5600, 5610, 5643, 5652, 5653, 5702, 5750, 5751, 5795
High Power, Design of: 5702
in Microwave Repeater System: 5600
Noise Factor: 5795
O-Type Carcinotron: 5652
Standards on Terms: 5653
Transverse-Current: 5750, 5751
Transverse-Field, with Periodic Electrostatic Focusing: 5610

Types E, C, M, O: 5643
Tropospheric Scattering, Useful Bandwidth
for Transmission by: 5887
Tuning, Automatic, for Single-Sideband
Equipment: 5916

U
Underground Water Prospecting: 5601,
5762, 5763, 5796
URSI and IRE: 5748

V
Vacuum Tubes vs Transistors: 5673
Vanguard Earth Satellite Program: 5725,
5726, 5727, 5728, 5729, 5730, 5731
Vehicular Radio Sets, Single-Sideband Military: 5923
Velocity-Type Frequency Multiplier: 5612

W
Water Prospecting by Means of Electro-
magnetic Interference Fringes: 5601,
5762, 5763, 5796
Wave Propagation: 5622, 5639, 5752, 5772,
5781, 5790, 5846, 5847, 5887
Anomalous, in Ferrite-Loaded Wave-
guide: 5847
Bandwidth Useful in Scatter Transmis-
sion: 5887
Ionospheric Effects at VHF and UHF:
5772
Long-Range, Low-Frequency: 5622
in Magnetized Ferrites: 5846
Marconi's Last Paper: 5790
Nonlinearity in Ferrites: 5639
Space-Charge-Wave, Effects of Magnetic
Field Strength: 5752

VHF Diffraction by Alaska Range Moun-
tains: 5781
Waveform of a Radio Atmospheric at Short
Ranges: 5783
Waveguides: 5685, 5839, 5847, 5848, 5856
Annular Rotary Joint: 5685
Circular, Birefringence of Ferrites: 5848
Ferrite-Loaded, Anomalous Propagation
in: 5847
Measurements of Ferrite Permeability
Tensor Values: 5839
Radiation from Ferrite-Filled Apertures:
5756
WWV and WWVH: 5859

Y
Yokes, Electrostatic: 5703

NONTECHNICAL INDEX

Abstracts and References

Monthly Listings:
January, pp. 134-148
February, pp. 278-292
March, pp. 438-452
April, pp. 582-596
May, pp. 719-732
June, pp. 846-860
July, pp. 958-972
August, pp. 1085-1100
September, pp. 1214-1228
October, pp. 1502-1516
November, pp. 1646-1660
December, pp. 1900-1914

Abstracts of TRANSACTIONS

Monthly Listings:
January, pp. 130-133
February, pp. 273-277
March, pp. 433-435
April, pp. 579-581
May, pp. 714-718
June, pp. 830-833
July, pp. 952-957
August, pp. 1082-1084
September, pp. 1210-1213
October, pp. 1491-1493
November, pp. 1637-1645
December, pp. 1897-1899

Awards

DIAMOND, HARRY, MEMORIAL AWARD
1956: Hinman, W. S., Jr.; April, p. 561

FELLOW AWARDS:

Alexander, S. N.; April, p. 562
Anton, N. G.; April, p. 562
Bachman, W. S.; April, p. 562
Bailey, G. W.; April, p. 562
Barkley, W. J.; April, p. 562
Barlow, H. E. M.; April, p. 562
Barton, L. E.; April, p. 562
Beam, R. E.; April, p. 562
Beggs, J. E.; April, p. 562
Beltz, W. H.; April, p. 563
Bennett, W. R.; April, p. 563
Boone, E. M.; April, p. 563
Boothroyd, W. P.; April, p. 563
Bossart, P. N.; April, p. 563
Bronwell, A. B.; April, p. 563
Brown, A. S.; April, p. 563
Budenbom, H. T.; April, p. 563
Cahoon, R. D.; April, p. 563
Carlin, H. J.; April, p. 564

Clark, A. B.; April, p. 564
Corcoran, G. F.; April, p. 564
Davis, T. M.; April, p. 564
Dingley, E. N., Jr.; April, p. 564
Duffendack, O. S.; April, p. 564
Eckert, J. P., Jr.; April, p. 564
Edgerton, H. E.; April, p. 564
Espersen, G. A.; April, p. 564
Fay, C. E.; April, p. 565
Finch, W. G. H.; April, p. 565
Fox, A. G.; April, p. 565
Glover, A. M.; April, p. 565
Goldman, S.; April, p. 565
Goldstein, L.; April, p. 565
Granger, J. V. N.; April, p. 565
Hall, N. I.; April, p. 565
Harris, D. B.; April, p. 565
Hergenrother, R. C.; April, p. 566
Hobson, J. E.; April, p. 566
Jensen, J. C.; April, p. 566
Jesty, L. C.; April, p. 566
Kalmus, H. P.; April, p. 566
Kennedy, M. E.; April, p. 566
Koehler, G.; April, p. 566
Korman, N. I.; April, p. 566
Lehovec, K.; April, p. 566
Leverenz, H. W.; April, p. 567
Mayer, H. F.; April, p. 567
McElrath, G.; April, p. 567
McFarlane, M. D.; April, p. 567
Millar, J. Z.; April, p. 567
Miller, B. F.; April, p. 567
Moller, R.; April, p. 567
Newhouse, R. C.; April, p. 567
Nottingham, W. B.; April, p. 567
Page, C. H.; April, p. 568
Palmer, W.; April, p. 568
Petrillo, S. E.; April, p. 568
Poch, W. J.; April, p. 568
Rabinow, J.; April, p. 568
Rappaport, F.; April, p. 568
Richardson, A. G.; April, p. 568
Rhode, L.; April, p. 568
Scholz, C. E.; April, p. 568
Sheldon, J. L.; April, p. 569
Skellett, A. M.; April, p. 569
Slattery, J. J.; April, p. 569
Smyth, J. B.; April, p. 569
Snow, H. A.; April, p. 569
Spitzer, E. E.; April, p. 569
Strutt, M. J. O.; April, p. 569
Suits, C. G.; April, p. 569
Teal, G. K.; April, p. 569
Tolson, W. A.; April, p. 570
Wallace, R. L., Jr.; April, p. 570
Ziel, A. van der; April, p. 570

FOUNDERS AWARD

Heising, R. A.; November, p. 1628

LIEBMANN, MORRIS, MEMORIAL PRIZE
1956: Bullington, K.; April, p. 561

MEDAL OF HONOR

1956: Hogan, J. V. L.; April, p. 561

1957: Stratton, J. A.; November, p. 1628

THOMPSON, BROWDER J., MEMORIAL PRIZE

Announced: January, p. 115

1956: Bridges, J. E.; April, p. 561

ZWORYKIN, VLADIMIR K., TELEVISION PRIZE

Announced: January, p. 115

1956: Bingley, F. J.; April, p. 561

Board of Directors

Announcement of 1956 Officers and Direc-
tors; January, p. 115

Nominations for 1957 Officers and Direc-
tors; July, p. 944

Calendar of Coming Events

Monthly Listings:

January, p. 115
February, p. 267
March, p. 418
April, p. 571
May, p. 702
June, p. 824
July, p. 944
August, p. 1069
September, p. 1198
October, p. 1481
November, p. 1627
December, p. 1887

Committees

MEMBERSHIP LISTS:

June, p. 838
October, p. 1493

REPRESENTATIVES IN COLLEGES:

June, p. 844
October, p. 1500

REPRESENTATIVES ON OTHER BODIES:

June, p. 845
October, p. 1499

TECHNICAL COMMITTEE NOTES:

Antennas and Waveguides: February, p.
271; April, p. 575; August, p. 1073;
September, p. 1201; October, p.
1485

Audio Techniques: May, p. 706; June, p.
828; Oct, p. 1485; Dec., p. 1891

- Circuits: January, p. 125; February, p. 271; May, p. 706; June, p. 828; October, p. 1485
- Electron Tubes: March, p. 425; April, p. 575; August, p. 1073; October, p. 1485; November, p. 1629; December, p. 1891
- Electronic Computers: January, p. 125
- Facsimile: February, p. 271; March, p. 425; April, p. 575; May, p. 706; August, p. 1073; October, p. 1485; December, p. 1891
- Industrial Electronics: October, p. 1485; November, p. 1629; December, p. 1891
- Information Theory and Modulation Systems: August, p. 1073; October, p. 1485; December, p. 1891
- Measurements and Instrumentation: October, p. 1485
- Navigation Aids: January, p. 125; February, p. 271; October, p. 1485
- Nuclear Techniques: October, p. 1485
- Piezoelectric Crystals: March, p. 425; October, p. 1485
- Radio Frequency Interference: January, p. 125; February, p. 271; April, p. 575; June, p. 828; September, p. 1201; October, p. 1485; December, p. 1891
- Radio Receivers: June, p. 828; October, p. 1485; December, 1891
- Radio Transmitters: April, p. 575; June, p. 828; August, p. 1073; September, p. 1201; October, p. 1486
- Recording and Reproducing: May, p. 706; October, p. 1486
- Solid State Devices: February, p. 271; October, p. 1486
- Standards: February, p. 271; March, p. 425; April, p. 576; June, p. 828; August, p. 1073; September, p. 1201; November, p. 1629; December, p. 1891
- Symbols: May, p. 706; October, p. 1486
- Television Systems: October, p. 1486
- Video Techniques: March, p. 425; October, p. 1486
- Buenos Aires Ninth Annual Convention, Buenos Aires Section, November 21-25, 1955, Buenos Aires, Argentina: March, p. 423
- Canadian IRE Convention and Exposition, October 1-3, 1956, Toronto, Canada: January, p. 124; September, p. 1206
- Circuit Theory Second Midwest Symposium, December 3-4, 1956, East Lansing, Mich.: November, p. 1635
- Communications Theory and Antenna Design Symposium, Air Force Cambridge Research Center-Boston Univ., January 9-11, 1957, Boston, Mass.: October, p. 1484; December, p. 1894
- Computer Applications Symposium, Armour Research Foundation, October 9-10, 1956, Chicago, Ill.: October, p. 1482
- Creative Engineering Symposium, Philadelphia Section of IRE and AIEE, beginning October 11, 1956, Philadelphia, Pa.: October, p. 1482
- Eastern Joint Computer Conference, November 7-9, 1955, Boston, Mass.: January, p. 124
- Eastern Joint Computer Conference, December 10-12, 1956, New York City: June, p. 824; December, p. 1894
- Electrical Techniques in Medicine and Biology, Ninth Annual Conference, November 7-9, 1956, New York City: June, p. 824; October, p. 1490
- Electron Devices, First Annual Technical Meeting, PGED, October 24-25, 1955, Washington, D. C.: January, p. 122
- Electron Devices, Second Annual Technical Meeting, October 25-26, Washington, D. C.: May, p. 702; August, p. 1072; October, p. 1482
- Electronic Components Symposium, May 1-3, 1956, Washington, D. C.: March, p. 423
- Electronics Conference, Kansas City Section, November 3-4, 1955, Kansas City, Kan.: January, p. 117
- Ferrites Convention, Institute of Electrical Engineers, October 29, 1956, London, England: April, p. 573
- Ferrites Symposium, Harvard Univ., April 2-4, 1956, Cambridge, Mass.: March, p. 419
- Human Engineering Conference, Third International Automation Exposition, November 26-30, 1956, New York City: October, p. 1482
- Industrial Electronics Educational Conference, First Annual, PGIE-Armour Research Foundation, April 9-10, 1957, Chicago, Ill.: November, p. 1628
- Industrial Electronics Symposium, Fifth Annual, September 24-25, 1956, Cleveland, Ohio: August, p. 1080
- Industrial Research Conference, Armour Research Foundation, April 18-19, 1956, Chicago, Ill.: March, p. 418
- Information Theory Symposium, September 12-16, 1955, London, England: April, p. 574-575
- Information Theory Symposium, Sept. 10-12, 1956, Cambridge, Mass.: May, p. 704; August, p. 1069; December, p. 1890
- IRE National Convention, March 19-22, 1956, New York City: January, p. 115; March, p. 382; April, p. 578; May, p. 699
- Israel National Electronics Convention, May 9-10, 1956, Haifa, Israel: October, p. 1483
- Instrument-Automation Conference, Eleventh Annual, September 17-21, 1956, New York City: July, p. 945
- Instrumentation Conference, First Annual, PGI, November 28-30, 1955, Atlanta, Ga.: February, p. 269
- Instrumentation Conference, Second Annual, PGI, December 5-7, 1956, Atlanta, Ga.: May, p. 705; August, p. 1070; November, p. 1636
- Kansas City IRE Section Technical Conference, November 8-9, 1956, Kansas City, Kan.: September, p. 1196; October, p. 1491
- Magnetic Amplifiers Technical Conference and Exhibit, April 5-6, 1956, Syracuse, N. Y.: February, p. 270; March, p. 428
- Magnetism and Magnetic Materials Conference and Exhibit, October 16-18, 1956, Boston, Mass.: May, p. 705; September, p. 1199
- Microwave Techniques National Symposium, February, 2-3, 1956, Philadelphia, Pa.: January, p. 129
- Microwave Tubes, International Congress, May 29-June 2, 1956, Paris, France: January, p. 125
- National Electronics Conference, October 3-5, 1955, Chicago, Ill.: Jan., p. 123
- National Electronics Conference, October 1-3, 1956, Chicago, Ill.: June, p. 826; August, p. 1070; October, p. 1484
- National Electronics Conference, 1957-63 Meeting Dates: August, p. 1069
- New England Radio Engineering Meeting, April 23-24, 1956, Boston, Mass.: March, p. 424
- New England Radio Engineering Meeting Boston and Connecticut Valley Sections, November 15-16, 1956, Boston, Mass.: November, p. 1628
- Nonlinear Circuit Analysis Symposium, April 25-27, 1956, New York City: March, p. 429; July, p. 947
- Nuclear Science, Third Annual Meeting, PGNS, Sept. 20-22, 1956, Pittsburgh, Pa.: August, p. 1072; September, p. 1206
- Office Automation Conference, International Automation Exposition, November 26-27, 1956, New York City: October, p. 1482
- Optics-Microwave Symposium, November 14-16, 1956, Washington, D. C.: September, p. 1200; November, p. 1634
- Propagation Symposium, September 17-22, 1956, Paris, France: June, p. 826
- Radio Fall Meeting, October 15-17, 1956, Syracuse, N. Y.: October, p. 1489
- Reliable Applications of Electron Tubes Symposium, May 21-22, 1956, Philadelphia, Pa.: May, p. 709
- Reliability and Quality Control, Second National Symposium, January 9-10, 1956, Washington, D. C.: Jan., p. 124
- Reliability and Quality Control, Third National Symposium, January 14-16, 1957, Washington, D. C.: July, p. 947; November, p. 1628; December, p. 1895
- Scatter Techniques Symposium, PGAP-PGCS, Washington, D. C.: April, p. 571
- Semiconductor Symposium, April 29-May 3, 1956, San Francisco, Calif.: March, p. 430
- Semiconductor Symposium, October 1-4, 1956, Cleveland, Ohio: Aug., p. 1069
- Seventh Region Technical Conference, April 11-13, 1956, Salt Lake City, Utah: February, p. 267, July, p. 945
- Southwestern Conference and Electronics Show, Eighth Annual, February 9-11, 1956, Oklahoma City, Okla.: January, p. 116
- Southwestern Conference and Electronics Show, Ninth Annual, April 11-13, 1957, Houston, Texas: Oct., p. 1482
- Simulation Conference, National, PGEC, January 19-21, 1956, Dallas, Texas: January, p. 128
- Telemetry Conference, National, August 20-21, Los Angeles, Calif.: May, p. 702, August, p. 1075

Television Conference, Tenth Annual, April 13-14, 1956, Cincinnati, Ohio: January, p. 116; July, p. 947

Transistor Circuits Conference, February, 16-17, 1956, Philadelphia, Pa.: February, p. 272; May, p. 705

URSI Fall Meeting, October 11-12, 1956, Berkeley, Calif.: September, p. 1199

URSI Spring Meeting, April 30-May 3, 1956, Washington, D. C.: April, p. 572

URSI Twelfth General Assembly, August 22-September 5, 1957, Boulder, Colo.: April, p. 572

Vacuum Technology, Third National Symposium, October 10-12, 1956, Chicago, Ill.: October, p. 1484

Vehicular Communications, Seventh Annual National Conference, November 29-30, 1956, Detroit, Mich.: September, p. 1200; November, p. 1634

Very Low Frequency Symposium, January 23-25, 1957, Boulder, Colo.: September, p. 1200; November, p. 1626

Western Electronic Show and Convention, August 21-25, 1956, Los Angeles, Calif.: August, p. 1075; December, p. 1888

Western Joint Computer Conference and Exhibit, February 7-9, 1956, San Francisco, Calif.: May, p. 706

Editorials

Engleman, C. L.
New IRE Professional Group on Military Electronics; February, p. 153

Mahmoud, H. M.
State of Radio and Electronics in Egypt; January, p. 3

Tuttle, W. N., and Bennett, W. R.
Two Tutorial Papers on Noise; May, p. 601

Front Covers

Iron Oxide Particles Form Pattern on Magnetic Surface; January

IF Transformers; February

IRE National Convention and Engineering Show; March

Stator of an Electrostatic Generator of an Electronic Organ; April

Waveform of Broad-Band Thermal Noise; May

U. S. Earth Satellite; June

Redesigned Components for Printed Circuits; July

Probing the Aurora with Radar; August

Poles and Zeros in Three Dimensions; September

Ferrite Isolator; October

Quality Control Techniques; November

Single Sideband Antenna; December

Frontispieces

Boone, E. Milton; May, p. 600

Burrows, Charles R.; September, p. 1104

De Forest, Lee; December, p. 1664

Fink, Donald G.; April, p. 456

Gershon, Joseph J.; October, p. 1231

Herold, Edward W.; July, p. 864

Hogan, John V. L.; March, p. 296

Loughren, Arthur V.; January, p. 2

Rinia, Herre; February, p. 152

Weber, Ernst; November, p. 1518

Whinnery, John R.; June, p. 736

Wolcott, C. Frederick; August, p. 975

IRE People

Anton, Nicholas; October, p. 52A

Arn, S. F.; April, p. 82A

Atherton, C. A.; March, p. 36A

Baker, W. R. G.; September, p. 74A

Barrow, W. L.; January, p. 44A

Beatty, R. W.; January, p. 50A

Beer, A. C.; November, p. 66A

Bennett, Rawson; March, p. 36A

Benson, R. W.; August, p. 69A

Birnbaum, George; January, p. 58A

Blakely, R. T.; August, p. 69A

Bown, Ralph; May, p. 48A

Boyers, J. S.; October, p. 80A

Bracco, D. J.; June, p. 32A

Bradburn, J. R.; September, p. 66A

Braun, V. J.; September, p. 75A

Brenner, J. C.; April, p. 76A

Brooks, R. W.; April, p. 25A

Budd, W. H.; November, p. 40A

Bull, R. W.; June, p. 36A

Burmeister, M. A.; August, p. 48A

Burr, R. P.; August, p. 64A

Burrows, C. R.; August, p. 58A

Burt, R. A.; December, p. 46A

Busignies, H. G.; August, p. 52A

Butts, R. S.; August, p. 70A

Cameron, Emmet; October, p. 62A

Campbell, V. H.; June, p. 36A

Cantwell, R. J.; March, p. 40A

Caplan, N.; June, p. 24A

Carter, E. F.; December, p. 18A

Casey, K. T.; May, p. 47A

Chaffee, M. A.; March, p. 40A

Christensen, Bert; October, p. 93A

Clavier, A. G.; March, p. 34A

Cohen, S. B.; April, p. 59A

Condon, E. U.; September, p. 44A

Cooper, A. E.; February, p. 36A

Cooper, J. V.; March, p. 42A

Costas, J. P.; July, p. 30A

Councilman, C. L.; December, p. 32A

Daily, A. M.; December, p. 28A

Dalke, J. L.; May, p. 76A

Davidson, W. F.; January, p. 48A

Davis, L. B.; September, p. 74A

Dean, N. J.; December, p. 27A

Dean, W. B.; September, p. 64A

deButtencourt, J. T.; February, p. 42A

DeBolt, H. E.; January, p. 58A

Dickinson, H. B.; November, p. 40A

Diederichs, J. K.; May, p. 80A

Dilks, U. C. S.; November, p. 54A

Dodds, Wellesley; April, p. 72A

Dunning, O. M.; February, p. 38A

Edson, W. A.; April, p. 26A

Elbinger, B.; December, p. 28A

Eliason, M. C.; December, p. 32A

Ellefson, B. S.; July, p. 34A

Evan-Jones, W.; September, p. 54A

Ewing, D. H.; April, p. 44A

Fannin, B. M.; October, p. 91A

Farley, J. L.; July, p. 40A

Feller, M. S.; December, p. 36A

Foley, G. M.; December, p. 34A

Forrester, J. W.; August, p. 46A

Furth, F. R.; March, p. 42A

Gaither, L. E.; April, p. 44A

Garr, D. E.; August, p. 62A

Geffe, P. R.; May, p. 72A

Glauber, L.; September, p. 76A

Glover, A. M.; February, p. 32A

Goetz, J. A., Jr.; April, p. 60A; November, p. 44A

Goldsmith, A. N.; December, p. 26A

Goldsmith, T. T., Jr.; May, p. 47A

Gordon, J. P.; October, p. 74A

Graf, A. W.; August, p. 48A

Grahant, B.; April, p. 74A

Green, E. I.; August, p. 54A

Greer, W. R.; January, p. 54A

Gurewitsch, A. M.; August, p. 52A

Guterman, H. C.; May, p. 74A

Haagens, D.; November, p. 46A

Hall, N. I.; August, p. 46A

Hammerschmidt, A. L.; August, p. 58A

Harries, Wolfgang; April, p. 32A

Hawthorne, E. I.; October, p. 93A

Haynes, M. K.; April, p. 76A

Hazen, H. L.; April, p. 40A

Heflin, W. H.; February, p. 36A

Hermelin, L. S.; May, p. 80A

Herrick, M. P.; November, p. 48A

Hodgson, A. R., Jr.; July, p. 40A

Hopkins, A. R.; December, p. 27A

Howard, J. H.; March, p. 34A

Hull, H. L.; December, p. 40A

Humphreys, T. I.; April, p. 30A

Huntley, H. R.; March, p. 44A

Jarmie, T. W.; August, p. 72A

Jenkins, E. W. Jr.; February, p. 38A

Jepsen, R. L.; October, p. 62A

Johnson, J. D.; October, p. 58A

Johnson, R. R.; September, p. 76A

Julian, R. S.; June, p. 32A

Kaar, I. J.; March, p. 44A

Kalbfell, D. C.; April, p. 71A

Kane, R. W.; October, p. 62A

Katzin, Martin; October, p. 52A

Keller, E. A.; April, p. 48A

Kendall, H. C.; July, p. 45A

Ketay, M. F.; April, p. 25A

Kirby, R. C.; January, p. 52A

Kiriloff, A. A.; October, p. 58A

Kline, M. B.; May, p. 58A

Krueger, R. E.; April, p. 44A

Krutter, Harry; April, p. 36A

Lance, H. W.; November, p. 40A

Laurent, G. J.; July, p. 38A

LeCraw, R. C.; March, p. 48A

LeGrand, C. C.; June, p. 32A

Leng, R. B.; January, p. 54A

Levine, Sol; November, p. 52A

Llewellyn, F. B.; September, p. 66A; December, p. 34A

Lin, Hung C.; September, p. 75A

Lohse, E.; June, p. 24A

Loughridge, D. H.; August, p. 54A

Lovejoy, R. E.; February, p. 40A

Lovoff, Adolph; April, p. 71A

MacManus, J. E.; December, p. 42A

Maginnis, W. P.; January, p. 48A

Main, R. C.; August, p. 70A

Mankin, A. H.; April, p. 36A

Marcy, H. T.; December, p. 42A

Marsh, K. W.; December, p. 38A

Marvin, H. B.; October, p. 62A

Mayo-Wells, W. J.; May, p. 58A

McCaul, J. N.; October, p. 72A

McCormack, R. L.; April, p. 74A

McDonald, J. J.; September, p. 64A

Meek, T. J.; April, p. 59A

Meisling, T. H.; October, p. 69A

Melloh, A. W.; October, p. 91A

Mezger, G. R.; November, p. 48A

Mieher, W. W.; April, p. 64A

Miller, F. G.; November, p. 44A

Mobley, Mal, Jr.; July, p. 30A

Moore, R. K.; October, p. 89A

Moreno, Theodore; October, p. 62A

Morgan, A. H.; January, p. 56A

Myers, V. V. Jr.; October, p. 93A

Nelson, J. W., Jr.; April, p. 32A

Nierman, L. G.; August, p. 48A

O'Bryant, H. M.; March, p. 50A

Ogilvie, A. R.; October, p. 84A

Oldfield, H. R. Jr.; April, p. 30A

Orman, L. M., Col.; October, p. 74A

Parode, L. C.; June, p. 36A

Patterson, H. R.; May, p. 47A

Patterson, Howard; October, p. 62A

Patton, H. W.; April, p. 66A

Pedersen, I. C.; February, p. 40A

Peterson, C. A.; October, p. 80A

Piore, E. R.; December, p. 36A

Post, E. A.; April, p. 25A

Post, F. L.; October, p. 56A

Pratt, R. E.; March, p. 50A

Pray, G. E.; December, p. 44A

Preston, L. S.; December, p. 22A

Proctor, D. R.; December, p. 27A

Rappaport, George; August, p. 64A

Raymond, R. C.; October, p. 76A

Read, Oliver; August, p. 60A

Renne, H. S.; July, p. 30A

Rice, C. I.; April, p. 80A

Rice, J. R.; December, p. 38A

Rice, R. B.; June, p. 28A

Roberts, A. S.; September, p. 50A

Robertson, T. E., Jr.; May, p. 76A

Roehm, F. J.; January, p. 56A

Rogers, M. D.; April, p. 25A
 Roney, R. K.; November, p. 44A
 Rosen, Leo; April, p. 76A
 Russell, J. B.; October, p. 100A
 Sackman, Robert; September, p. 80A
 Sandretto, P. C.; March, p. 56A
 Sattlem, I.; June, p. 28A
 Schenk, P. J.; November, p. 50A
 Schooley, A. H.; July, p. 42A
 Selby, M. C.; January, p. 44A
 Sell, W. B.; July, p. 30A
 Selsted, W. T.; October, p. 56A
 Senf, H. R.; September, p. 74A
 Shannon, C. E.; April, p. 78A
 Sheingold, L. S.; July, p. 32A
 Shepherd, M., Jr.; March, p. 58A
 Shockley, William; August, p. 52A
 Simpson, Murray; July, p. 34A
 Sink, R. L.; April, p. 48A
 Slattery, J. J.; May, p. 68A
 Spenser, R. C.; March, p. 60A
 Spinks, A. W.; October, p. 69A
 Staras, Harold; October, p. 66A
 Stearns, H. M.; October, p. 62A
 Steel, E. L.; December, p. 30A
 Steen, J. R.; September, p. 44A
 Steinberg, B. D.; July, p. 38A
 Steinkamp, W. H.; February, p. 44A
 Stratton, J. A.; March, p. 61A
 Stratton, J. A.; August, p. 58A
 Stratton, J. A.; September, p. 66A
 Sunstein, D. E.; July, p. 38A
 Swanson, J. P.; September, p. 50A
 Terman, F. E.; May, p. 66A
 Thalner, R. R.; October, p. 93A
 Thayer, G. N.; February, p. 42A
 Tinkham, R. J.; September, p. 48A
 Travis, I.; November, p. 66A
 Tulchin, H.; July, p. 45A
 Van Duyne, J. P.; May, p. 80A
 Van Rensselaer, C.; April, p. 52A
 Venaglia, E. J.; August, p. 67A
 Wagener, Winfield; April, p. 66A
 Wagner, S.; January, p. 60A
 Walker, E. A.; January, p. 54A
 Walker, E. A.; September, p. 54A
 Weedfall, W. W.; November, p. 50A
 White, E. S.; September, p. 80A
 Whitehead, J. R.; January, p. 46A
 Wilder, M. W.; December, p. 18A
 Winn, O. H.; October, p. 72A
 Winter, N. L.; March, p. 61A
 Youdin, Myron; April, p. 71A
 Zarem, A. M.; February, p. 32A

Miscellaneous

Bailey, G. W., Awarded ARRL Single Sideband Certificate; December, p. 1887
 Baker, W. R. G., Elected Head of RETMA; August, p. 1070
 Brookhaven Opens Second School for Nuclear Training; October, p. 1482
 deRosa, L. A., Receives PIB Certificate of Achievement; August, p. 1070
 Dingley, E. N., Jr., Wins Defense Department Award; March, p. 421
 Dubilier, William, Wins French Medal; June, p. 824
 Earth Satellite Program Technical Panel Named; March, p. 419
 Engstrom, E. W., Wins Ericsson Medal; April, p. 575
 Everitt, W. L., Elected President of American Society for Engineering Education; September, p. 1196
 Ferrite Specifications Group Recently Formed; October, p. 1484
 FCC Rules Governing Restricted Radiation Devices; March, p. 436
 Fink, D. G., Receives SMPTE Award; November, p. 1628
 Goldsmith, A. N., IRE Founder, Wins SMPTE Progress Medal; December, p. 1887
 Granger, J. V. N., Wins 1955 Regional Award; January, p. 116

Guy, R. F., Honored with Marconi Memorial Gold Medal; June, p. 824
 Hanson, O. B., Accepts Potts Award; December, p. 1887
 Institute of Mathematical Sciences Temporary Memberships Available; May, p. 705
 Ionospheric Research Group Wins Commerce Dept. Award; September, p. 1200
 Kelly, Mervin J., Elected as Foreign Member of Swedish Royal Academy of Sciences; February, p. 270
 M. I. T. Establishes School for Advanced Study; March, p. 420
 M.I.T. and IBM Cooperate on Computation Center Project; November, p. 1627
 Mettler, R. F., Cited by U. S. Junior Chamber of Commerce; March, p. 424
 National Bureau of Standards to Relocate in Maryland; October, p. 1481
 National Science Foundation Announces Colloquia Speakers; November, p. 1627
 Olson, H. F., Receives John Scott Award; March, p. 421
 Purdue Offers July Courses in Systems Engineering; May, p. 705
 Radio Club of America, Inc., Elects New Officers; April, p. 572
 Rosenberg, P., Wins Abrams Award for Paper on Photogrammetry; July, p. 944
 Soviet Automation Journal Now Available in English; October, p. 1481
 Stanford Announces 1956-57 Fellowships in Electronics; February, p. 267
 Stickroth, G. J., Honored by Aeronautical Institute; March, p. 420
 Terman, F. E., Receives AIEE Member-for-Life Award; December, p. 1887
 Wayne University Offers Summer Courses; May, p. 704
 Zenneck, J. A. W., Greeted by IRE on His 85th Birthday; July, p. 944

Notices

ASESA Expanded Qualification Testing Program Announced; December, p. 1889
 Broadcast Transmission Systems Symposium Papers Deadline Announced; June, p. 825
 Circuit Theory Professional Group Invites Papers on Signal Theory; January, p. 124
 Computer Applications Symposium Proceedings Now Available; March, p. 423
 Electron Devices Professional Group Calls For Technical Meeting Papers; April, p. 572; May, p. 702
 Engineers Joint Council Nuclear Congress Invites Papers; October, p. 1484
 Information Theory Symposium Papers Invited; May, p. 704
 Instrumentation Conference Invites Papers; May, p. 705
 IRE 1957 National Convention Papers Deadline; July, p. 947; August, p. 1070; September, p. 1196; October, p. 1481
 IRE 1956 NATIONAL CONVENTION RECORD Available; August, p. 1081
 IRE Standards Available in Complete Set; February, p. 270
 IRE TRANSACTIONS Available; March, p. 419; June, p. 825; September, p. 1198
 Magnetic Conference Invites Papers; May, p. 705
 Miscellaneous IRE Publications Available; October, p. 1483
 Nonlinear Circuit Analysis Symposium Proceedings To Be Available; July, p. 947
 Nuclear Science Professional Group Invites Papers for Annual Meeting; March, p. 419

Radome Symposium Papers Called for; May, p. 704
 Solid State Circuits Symposium Papers Solicited; November, p. 1629
 WESCON Papers Deadline; March, p. 419; April, p. 573

Obituaries

Bagnall, Vernon B.; June, p. 827
 Bailey, Bruce; December, p. 1890
 Barkhausen, Heinrich G.; May, p. 706
 Beltz, W. H.; March, p. 425
 Carlton, M. Barry; October, p. 1484
 Clark, A. B.; January, p. 125
 Clark, George H.; August, p. 1072
 Dixon, G. P.; September, p. 1201
 Ehret, Cornelius D.; April, p. 575
 Englund, C. R.; October, p. 1485
 Foster, Arnot P.; January, p. 125
 Helt, Scott; October, p. 1485
 Hollenberg, Arthur V.; August, p. 1072
 MacDonald, A. S.; July, p. 948
 Nelson, James R.; August, p. 1072
 Pickard, Greenleaf Whittier; March, p. 425
 Reiskind, Hillel I.; August, p. 1072
 Reoch, Alexander E.; March, p. 425
 Schlesman, Carleton H.; February, p. 271
 Shanklin, John P.; October, p. 1485
 Shelby, R. E.; February, p. 271
 Trimmer, F. H.; December, p. 1890

Photographs

Alexander, S. N.; April, p. 562
 Allaben, Stanton De Forest, Builds First Amateur Receiver; May, p. 703
 Anton, N. G.; April, p. 562
 Bachman, W. S.; April, p. 562
 Bailey, G. W.; April, p. 562
 Baker, K. D., and Shelton, W.; September, p. 1197
 Baker, W. R. G.; August, p. 1070
 Barkhausen, H. G.; May, p. 706
 Barkley, W. J.; April, p. 562
 Barlow, H. E. M.; April, p. 562
 Barnes, A. S., Shows Transistors at Philadelphia Section Student Forum; March, p. 422
 Barton, L. E.; April, p. 562
 Batcher, R. R., Receives Certificate of Appreciation from A. C. Beck; August, p. 1071
 Beam, R. E.; April, p. 562
 Bean, C. P., Van Vleck, J. H., Hogan, C. L., and Weiss, M. T., at Symposium on Microwave Properties and Applications of Ferrites; July, p. 946
 Beer, A. C.; July, p. 945
 Beggs, J. E.; April, p. 562
 Beltz, W. H.; March, p. 425; April, p. 563
 Bennett, W. R.; April, p. 563
 Beverage, H. H., Honored at National Electronics Conference; January, p. 123
 Bingley, F. J.; April, p. 561
 Boone, E. M.; April, p. 563
 Boothroyd, W. P.; April, p. 563
 Bossart, P. N.; April, p. 563
 Bridges, J. E.; April, p. 561
 Bronwell, A. B.; April, p. 563
 Brown, A. S.; April, p. 563
 Budenbom, H. T.; April, p. 563
 Buenos Aires Section Ninth Annual Convention; March, p. 423
 Buffalo-Niagara Section-Hamilton Section Joint Session at Niagara Falls, N. Y.; March, p. 418
 Bullington, Kenneth; April, p. 561
 Cahoon, R. D.; April, p. 563
 Canadian IRE Convention Committee Chairman for 1956; March, p. 421
 Carlin, H. J.; April, p. 564
 Carlton, M. B.; October, p. 1485
 Cedar Rapids Section Officers, 1956; July, p. 946
 Chicago Section Publicity Committee; April, p. 574

- Clark, A. B.; January, p. 125; April, p. 564
- Clement, L. M., 1955 RETMA Award Recipient, Congratulated by Loughren; January, p. 118
- Cole, R. I., and Metz, Henry; September, p. 1197
- Computers Conference, Boston, Mass.; January, p. 124
- Corcoran, G. F.; April, p. 564
- Dallas Section 1956 Officers; September, p. 1197
- Davis, T. M.; April, p. 564
- deRosa, L. A.; August, p. 1070
- Dingley, E. N., Jr.; March, p. 421; April, p. 564
- Dixon, G. P.; September, p. 1201
- Duffendack, O. S.; April, p. 564
- East Coast Conference on Aeronautical and Navigational Electronics Steering Committee with Baltimore Mayor Thomas D'Alesandro, Jr.; August, p. 1071
- Eckert, J. P., Jr.; April, p. 564
- Edgerton, H. E.; April, p. 564
- Electronic Sortation System for Mail, Artist's View at Canadian IRE Convention; November, p. 1626
- Englund, C. R.; October, p. 1485
- Espersen, G. A.; April, p. 564
- Everitt, W. L.; September, p. 1196
- Faust, J. W., Jr.; July, p. 945
- Fay, C. E.; April, p. 565
- Field, L. M., Addresses PGED Technical Meeting; January, p. 122
- Finch, W. G. H.; April, p. 565
- Fink, D. G., Addresses PGED Technical Meeting; January, p. 122
- Forster, W. H., Shows Vidicon Camera Tube at Philadelphia Student Forum; March, p. 422
- Fort Huachuca Subsection Fall Meeting; January, p. 118
- Fox, A. G.; April, p. 565
- Friend, A. W., Recipient of Second National Electronics Award; January, p. 123
- Gardner, Trevor; January, p. 124
- George Banta Company, Inc., Receives IRE Plaque; February, p. 268
- Glover, A. M.; April, p. 565
- Goldman, S.; April, p. 565
- Goldsmith, A. N.; December, p. 1887
- Goldstein, L.; April, p. 565
- Granger, J. V. N.; April, p. 565
- Gunther, F. A.; April, p. 572
- Gut, R. F.; June, p. 824
- Hall, N. I.; April, p. 565
- Harris, D. B.; April, p. 565
- Haycock, Loughren, Wolcott, and Pettit, at Region Seven Conference, Salt Lake City, Utah; July, p. 945
- Heising, R. A.; November, p. 1628
- Hergenrother, R. C.; April, p. 566
- Hinman, W. S., Jr.; April, p. 561
- Hobson, J. E.; April, p. 566
- Hogan, J. V. L.; April, p. 561
- Hoyler, C. N., Demonstrates Electronic Analog Computer at Philadelphia Section Student Forum; March, p. 422
- Industrial Electronics Symposium Planning Committee; September, p. 1197
- IRE National Convention, 1956; May, p. 699
- IRE Southwestern Conference; April, p. 573
- Israel National Electronics Convention; October, p. 1483
- Instrumentation Conference, Atlanta, Ga., Visited by Ryder; February, p. 269
- Jenness, R. R.; October, p. 1484
- Jensen, J. C.; April, p. 566
- Jesty, L. C.; April, p. 566
- Joint Meeting of Boston Section and PGA, February, p. 269
- Kalmus, H. P.; April, p. 566
- Kansas City Section IRE Conference; January, p. 117
- Kennedy, M. E.; April, p. 566
- Koehler, G.; April, p. 566
- Korman, N. I.; April, p. 566
- Kraus Introduces Speaker at Joint Meeting of Philadelphia Section and PGA; February, p. 270
- Kresge Auditorium, M. I. T.; February, p. 269
- Lehovec, K.; April, p. 566
- Leverenz, H. W.; April, p. 567
- London, Fred, Presenting Paper at Emporium IRE Section Summer Seminar; November, p. 1627
- Loughren, A. V., honored by Alamogordo-Holloman Section; December, p. 1888
- Loughren with Iowa Student Members; May, p. 704
- Loughren and Personnel of U. S. Navy Mine Defense Laboratory; September, p. 1197
- Loughren and Teal at Southwestern Regional Conference; May, p. 703
- Loughren Visits Dallas Section; May, p. 705
- Martin, T. L., Jr., and Loughren, A. V., at WESCON; December, p. 1888
- Mayer, H. F.; April, p. 567
- Mayer, H. F., Feted by Rome-Utica Section; April, p. 571
- McClellan, L. N., Honored at National Electronics Conference; January, p. 123
- McDonald, A. S.; July, p. 948
- McElrath, G.; April, p. 567
- McFarlane, M. D.; April, p. 567
- Middleton, A. E.; July, p. 945
- Millar, J. Z.; April, p. 567
- Miller, B. F.; April, p. 567
- Miller, B. F., Receives Fellow Award from W. E. Peterson at Los Angeles Section Dinner; July, p. 946
- Moller, Rolf; April, p. 567
- Morton, J. A., Addresses PGED Technical Meeting; January, p. 122
- National Aeronautical Symposium, Utica, N. Y.; February, p. 268
- Nelson, Sir George, with A. V. Loughren and M. D. Hoven; August, p. 1069
- Nergaard, L. S., Addresses PGED Technical Meeting; January, p. 122
- New England Radio-Electronics Meeting, 1955; March, p. 424
- New York Section Dinner Honors Members; August, p. 1071
- Newfoundland-Labrador Section Greets Ryder; January, p. 121
- Newhouse, R. C.; April, p. 567
- NIKE Installation Toured by Professional Groups; May, p. 703
- North, H. Q.; July, p. 945
- Northwest Florida Section Visited by Ryder; February, p. 269
- Nottingham, W. B.; April, p. 567
- Olson Explains Principles of Music Synthesizer to Philadelphia Audience; February, p. 270
- Olson, H. F.; March, p. 421
- Operations Research Symposium Banquet, University of Pennsylvania; May, p. 703
- Page, C. H.; April, p. 568
- Palmer, W.; April, p. 568
- Petrillo, S. E.; April, p. 568
- Pettit, J. M., Congratulates J. V. N. Granger, Award Recipient; January, p. 116
- PGANE Annual Conference, Baltimore, Md.; January, p. 119
- PGBTS Sixth Fall Symposium, Pittsburgh, Pa.; December, p. 1888
- PGED Technical Meeting, Washington, D. C.; January, p. 122
- Philadelphia Section Sponsors Student Forum on Electronic Careers; March, p. 422
- Pickard, G. W.; March, p. 425
- Piedmont Subsection (North Carolina-Virginia Section) Officers; January, p. 118
- Poch, W. J.; April, p. 568
- Rabinow, J.; April, p. 568
- Radio Interference Reduction Conference Speakers; June, p. 827
- Ramo, S.; February, p. 267
- Rappaport, G.; April, p. 568
- Redstone Arsenal Plays Host to IRE Visitors; May, p. 703
- Reliability-Quality Control Symposium Speakers; March, p. 423
- Richardson, A. G.; April, p. 568
- Rinia, H., Dyer, J. N., and Loughren, A. V., at Fellow Award Meeting and Cocktail Party of Long Island Section; July, p. 946
- Rohde, Lothar; April, p. 568
- Rosenberg, P.; July, p. 944
- Ryder, J. S., Congratulates Kouwenhoven, W. B., and Dellinger, J. H., upon Induction Into Eta Kappa Nu; December, p. 1888
- Ryder Examines L-3 GEDA Computer at Goodyear Aircraft, Akron, Ohio; January, p. 118
- Ryder, J. D., Visits IRE Sections, U. S. and Canada; January, p. 120
- Scatter Techniques Technical Symposium; April, p. 571
- Scholz, C. E.; April, p. 568
- Shanklin, J. P.; October, p. 1485
- Shelby, R. E.; February, p. 271
- Sheldon, J. L.; April, p. 569
- Skellett, A. M.; April, p. 569
- Slattery, J. J.; April, p. 569
- Smyth, J. B.; April, p. 569
- Snow, H. A.; April, p. 569
- Southwestern Conference, Oklahoma City, Okla; May, p. 702
- Spitzer, E. E.; April, p. 569
- Stern, Thielman, Kikuchi, Cook, and Weber, at Nonlinear Circuit Symposium; July, p. 947
- Stratton, J. A.; November, p. 1628
- Strutt, M. J. O.; April, p. 569
- Suits, C. G.; April, p. 596
- Symposium on Radio Astronomy, National Electronics Conference, Chicago, Ill.; January, p. 118
- Tartaglia, Dante, Speaks at Buenos Aires Section Ninth Annual Convention; March, p. 423
- Teal, G. K.; April, p. 569
- Teal, G. K.; July, p. 945
- Termer, F. E.; December, p. 1887
- Thompson, O. I., President of National Electronics Conference; January, p. 123
- Tokyo IRE Section Meeting; July, p. 944
- Tolson, W. A.; April, p. 570
- Transistor Conference Committee; May, p. 705
- Webster, E. M.; April, p. 573
- Wallace, R. L., Jr.; April, p. 570
- WESCON Board of Directors, 1956; August, p. 1076
- WESCON, Dignitaries, 1956; December, p. 1888
- WESCON Officers, 1956; August, p. 1076
- World's Largest Open Pit Copper Mine, Bingham, Utah; February, p. 267
- Young, B. B., and Chapp, S., Examine AC Network Calculator; July, p. 946
- Ziel, A. Van Der; April, p. 570

Poles and Zeros

- Editor, The Aids in Preparation and Utilization of IRE Publications; August, p. 976
- Automatic Library Access System; March, p. 455
- Correspondence Section of PROCEEDINGS; November, p. 1519
- Editorial Balance for IRE Publications; June, p. 737
- Electromagnetic Wave Theory Symposium Proceedings; May, p. 599
- Geographical Shift in IRE Membership; March, p. 455

IRE Committee on History of Electronics; September, p. 1105
 IRE Financial Surplus; July, p. 865
 IRE Membership Growth; August, p. 976; November, p. 1519
 Language; February, p. 151
 Lawful Standards; March, p. 295
 Mathematics in IRE Technical Papers; May, p. 599
 Preparation of Special Ferrites Issue: October, p. 1232
 PROCEEDINGS vs TRANSACTIONS—I; March, p. 295
 PROCEEDINGS vs TRANSACTIONS—II; April, p. 455
 PROCEEDINGS vs TRANSACTIONS—III; May, p. 599
 Publication Time Required for PROCEEDINGS Papers; September, p. 1105
 Special Issues of PROCEEDINGS; July, p. 865
 Technology of Ferrites; October, p. 1232
 Why P & Z?; February, p. 151
 Ryder, J. D.
 Evolution of Electrical Engineering Education; June, p. 737

Professional Groups

CHAIRMEN

January, p. 126
 March, p. 431
 May, p. 710
 July, p. 949
 September, p. 1203
 November, p. 1631

News

Aeronautical and Navigational Electronics: January, p. 119; March, p. 425; April, p. 575; August, p. 1072
 Antennas and Propagation: April, p. 571, p. 706; September, p. 1200
 Audio: January, p. 116; February, p. 269, p. 270; May, p. 706
 Broadcast Transmission Systems: July, p. 947; August, p. 1080
 Circuit Theory: January, p. 124; July, p. 947; August, p. 1072; December, p. 1889
 Communications Systems: April, p. 575; June, p. 824; September, p. 1209
 Component Parts: August, p. 1072
 Electron Devices: January, p. 122; May, 702; August, p. 1072; October, p. 1482
 Electronic Computers: July, p. 946, p. 948
 Engineering Management: November, p. 1628
 Industrial Electronics: February, p. 270; November, p. 1628
 Information Theory: December, p. 1890
 Medical Electronics: April, p. 575; May, p. 706

Microwave Theory and Technique: May, p. 706
 Military Electronics: January, p. 115; March, p. 425; May, p. 706; June, p. 827; August, p. 1072
 New Chapters Announced: June, p. 826; July, p. 948; November, p. 1628
 Nuclear Science: May, p. 706; August, p. 1072; September, p. 1206
 Production Techniques: August, p. 1072
 Reliability and Quality Control: July, p. 947; November, p. 1628
 Ultrasonics Engineering: September, p. 1200
 Vehicular Communications: February, p. 271; June, p. 827; August, p. 1072; September, p. 1200

TRANSACTIONS

Available Issues: December, p. 1889

Report of Secretary

Letter to Board of Directors—1955; June, p. 834

Scanning the Issue

Monthly Notes

February, p. 150
 March, p. 294
 April, p. 454
 May, p. 598
 June, p. 734
 July, p. 862
 August, p. 974
 September, p. 1102
 November, p. 1520

Sections and Subsections

Chairmen and Secretaries

January, p. 126
 March, p. 431
 May, p. 710
 July, p. 949
 September, p. 1204
 November, p. 1632

Alamogordo-Holloman Section Established; August, p. 1069
 Alamogordo-Holloman Section Honors Loughren; December, p. 1888
 Boston and Connecticut Valley Sections Sponsor Tenth Anniversary NEREM; March, p. 424
 Boston Section Inaugurates Transistor Lecture Series; March, p. 418
 Boston Section-PGA Joint Meeting, M. I. T.; February, p. 269
 Buenos Aires Section Holds Ninth Annual Convention; March, p. 423
 Cedar Rapids Section Holds Automation Symposium; February, p. 270

Cedar Rapids Section Officers, 1956; July, p. 946
 Dallas Section 1956 Officers; September, p. 1197
 Fort Worth Section Approved; March, p. 418
 Hampton Roads Subsection (North Carolina-Virginia Section) Formed; October, p. 1481
 Houston Section To Hold Ninth Southwestern IRE Conference; October, p. 1482
 Israel Sections Co-Sponsors First National Electronics Convention in Israel; October, p. 1483
 Japan Establishes IRE Section; February, p. 267
 Kansas City Section Annual Technical Conference; September, p. 1196; October, p. 1491
 Long Island Section Fellow Award Meeting and Cocktail Party; July, p. 946
 Los Angeles Section Dinner Features Presentation of Fellow Awards; July, p. 946
 Los Angeles Section Meeting Attended by Students From Five Colleges; June, p. 825
 Memphis Subsection Established; August, p. 1069
 Newfoundland-Labrador Section Greets Ryder; January, p. 121
 New Hampshire Subsection Established; December, p. 1887
 Northwest Florida Section Meeting in Panama City, Fla.; November, p. 1627
 Panama City Subsection Established; December, p. 1887
 Philadelphia Section Holds Joint Meeting with PGA; February, p. 270
 Philadelphia Section Sponsors Student Forum on Electronic Careers; March, p. 422
 Philadelphia Sections of IRE and AIEE and PG on Electronic Computers Hold Joint Meeting; July, p. 946
 Philadelphia Sections of IRE and AIEE Set Creative Engineering Sessions; October, p. 1482
 Regina Section Established; August, p. 1069
 Rio de Janeiro, Brazil, Section Established; November, p. 1626
 San Fernando Valley Subsection Established; August, p. 1069
 Shreveport Subsection Established; December, p. 1887
 Southern Alberta Section Established; August, p. 1069
 Tucson Section Established; August, p. 1069
 Washington, D. C., Section Annual Banquet; April, p. 573
 Washington, D. C., Section Officers Elected; September, p. 1197
 Western North Carolina Subsection Established; August, p. 1069



Index to
IRE CONVENTION RECORD

Volume IV, 1956



The Institute of Radio Engineers, Inc.
1 East 79 Street, New York 21, N.Y.

TABLE OF CONTENTS

	Page
Part 1	
Telemetry, Antennas and Propagation.....	3
Part 2	
Circuit Theory.....	3
Part 3	
Electron Devices and Receivers.....	4
Part 4	
Computers, Information Theory, Automatic Control.....	4
Part 5	
Microwave and Instrumentation.....	5
Part 6	
Manufacturing Electronics.....	5
Part 7	
Audio and Broadcast.....	6
Part 8	
Aeronautical, Communication and Military Electronics.....	6
Part 9	
Ultrasonics, Medical and Nuclear Electronics.....	7
Index to Authors.....	8
Index to Subjects.....	9
1956 IRE CONVENTION RECORD PRICES.....	14

IRE CONVENTION RECORD

CONTENTS OF VOLUME IV—1956

Part 1—Telemetry, Antennas and Propagation

Cumulative Index Number	Page
SESSION 5: Antennas and Propagation I—Propagation (Sponsored by the Professional Group on Antennas and Propagation.)	
729. Wave Propagation over a 350 Mile Path at 960 MC, <i>I. H. Gerks and A. J. Svien</i>	3
730. Ionospheric Cross Modulation from a 1000 KW Long Wave Broadcast Transmitter, <i>E. T. Martin and G. Jacobs</i>	9
731. Atmospheric Refraction of 8.7 mm Radiation, <i>G. R. Marnier and R. M. Ringoen</i>	14
732. Recent Developments in the Theory of Sea Clutter, <i>M. Katzin</i>	19
733. Radar-Type Propagation Survey Experiments for Communication Systems, <i>R. E. Lacy and C. E. Sharp</i>	20
SESSION 14: Antennas and Propagation II (Sponsored by the Professional Group on Antennas and Propagation.)	
734. A Theory of Scattering by Nonisotropic Irregularities with Application to Radar Reflections from the Aurora (Abstract), <i>H. G. Booker</i>	28
735. The Correlation of Radar Sea Clutter on Vertical and Horizontal Polarization with Wave Height and Slope, <i>F. C. Macdonald</i>	29
736. Precipitation Particle Impact Noise in Aircraft Antennas, <i>R. L. Tanner</i>	33
737. An Analysis of Conical Scan Antennas for Tracking, <i>J. B. Damonte and D. J. Stoddard</i>	39
738. Corrections to Current Distributions on Curved Reflectors, <i>R. Plonsey</i>	48
SESSION 22: Telemetry Components (Sponsored by the Professional Group on Telemetry and Remote Control.)	
739. A Report on Wire Strain Transducer System Calibration, <i>G. W. Harrison</i>	54
740. Precision Subcarrier Discriminator for FM Telemetry, <i>W. H. Duerig</i>	70
741. Automatic Tracking Antenna Array for the 217 MC Telemetry Band (APOTA), <i>H. G. Oltman, Jr. and B. J. Bittner</i>	83
742. Sub-Miniature Telemetry Transmitter, <i>L. R. Hender-shot</i>	87
743. A Bi-Directional Pulse Totalizer for Control and Telemetry, <i>H. D. Wright</i>	92
SESSION 24: The IGY Program (Sponsored jointly by the Professional Groups on Antennas and Propagation, Telemetry and Remote Control, and Military Electronics.)	
744. The IGY Program, <i>J. Kaplan</i>	96
745. The Exploration of Outer Space with an Earth Satellite, <i>J. P. Hagen</i>	99
746. Placing the Satellite in Its Orbit, <i>M. W. Rosen</i>	103
747. Telemetry and Propagation Problems of Placing the Earth Satellite in Its Orbit, <i>D. G. Mazur</i>	108
748. Tracking the Earth Satellite and Data Transmission by Radio, <i>J. T. Mengel</i>	112
749. A Research Program Based on the Optical Tracking of Artificial Earth Satellites (Abstract), <i>F. L. Whipple and J. Allen Hymek</i>	119
750. The Scientific Value of the Earth Satellite Program, <i>J. A. Van Allen</i>	124
SESSION 28: Flight Data Reduction Systems (Sponsored by the Professional Group on Telemetry and Remote Control.)	
751. An Improved System for Collecting and Processing Flight Test Data, <i>H. W. Royce</i>	129
752. Airborne Data Acquisition System, <i>W. H. Foster</i>	133
753. Requirements of a High Speed, All Electronic, Fully Automatic Data Handling System, <i>F. K. Williams</i>	140
754. Techniques for a High Speed, High Quantity, Data Processing System; Idiot II, <i>M. L. Klein and R. B. Rush</i>	143

Part 1—Telemetry, Antennas and Propagation (Cont'd)

Cumulative Index Number	Page
SESSION 33: Antennas and Propagation III—Antennas (Sponsored by the Professional Group on Antennas and Propagation.)	
755. Cross Polarization Effects on Antenna Radiation Patterns, <i>K. S. Kelleher and W. G. Scott</i>	153
756. A Vertical Antenna Made of Transposed Sections of Coaxial Cable, <i>H. A. Wheeler</i>	160
757. Electrically Small, Ferrite-Loaded Loop Antennas, <i>V. H. Rumsey and W. L. Weeks</i>	165
758. A Wide Band Coaxial Hybrid, <i>A. Alford and C. B. Watts, Jr.</i>	171
759. Dielectric Bifocal Lenses, <i>R. M. Brown</i>	180
SESSION 38: Telemetry Systems (Sponsored by the Professional Group on Telemetry and Remote Control.)	
760. Automatic Remote Control and Telemetry by Telephone, <i>C. H. Doersam, Jr.</i>	188
761. Noise and Crosstalk in Multiplexed FM Systems, <i>R. A. Runyan</i>	194
762. High Capacity Pulse Code Telemeter and Data Reduction System, <i>G. S. Shaw</i>	199
763. The Development of a High-Speed Electronic Multiplexer and Coder for Use with a PCM Telemeter, <i>R. P. Bishop and R. E. Marquand</i>	203
SESSION 40: Antennas and Propagation IV—Microwave Antennas (Sponsored by the Professional Group on Antennas and Propagation.)	
764. High Efficiency Microwave Lens, <i>R. L. Smedes</i>	208
765. Ferrod Radiator Systems, <i>F. Reggia, E. G. Spencer, R. D. Hatcher, and J. E. Tompkins</i>	213
766. A Design Method for Very Long Linear Arrays, <i>M. G. Chernin and R. W. Bickmore</i>	225
767. Some New Microwave Antenna Designs Based on the Trough Waveguide, <i>R. Karas and W. Rotman</i>	230
768. Future Trends in Radomes for Ground Electronic Equipment, <i>M. V. Ratynski</i>	236
769. A Toroidal Microwave Reflector, <i>G. D. M. Peeler and D. H. Archer</i>	242

Part 2—Circuit Theory

SESSION 30: Circuits I—Symposium on Application of Recent Network Ideas to Feedback System Problems (Sponsored by the Professional Group on Circuit Theory.)	
770. Network Theory in the Practical Design of Control Systems, <i>J. G. Truxal</i>	3
771. Some Theorems Applicable to the Problem of Stability in Linear Systems, <i>J. L. Bower</i>	8
772. Feedback System Synthesis by the Inverse Root-Locus Method, <i>J. A. Aseltine</i>	13
773. Modulated Control Systems, <i>R. E. Graham</i>	18
SESSION 41: Circuits II—Design and Application of Active Networks (Sponsored by the Professional Group on Circuit Theory.)	
774. Driving-Point Impedance Functions of Active Networks, <i>N. DeClaris</i>	26
775. Active Network Synthesis, <i>I. M. Horowitz</i>	38
776. Considerations on the Stability of Active Elements and Applications to Transistors, <i>A. P. Stern</i>	46
777. Invariants of Linear Noisy Networks, <i>H. A. Haus and R. B. Adler</i>	53
778. Graphical Analysis of Transistor Circuits by Separation of Variables, <i>D. L. Finn and B. J. Dasher</i>	68
SESSION 49: Circuits III—Network Synthesis Techniques (Sponsored by the Professional Group on Circuit Theory.)	

Part 2—Circuit Theory (Cont'd)

<i>Cumulative Index Number</i>	<i>Page</i>
779. Simple and Double Alternation in Network Synthesis, <i>F. M. Reza</i>	72
780. Synthesis of Tchebycheff RC Band Pass Filters, <i>D. Helman</i>	77
781. Pulsed RC Networks for Sampled-Data Systems, <i>J. Sklansky</i>	81
782. An Operational Calculus for Numerical Analysis, <i>S. Thaler and R. Boxer</i>	100
783. Linear Complementary Smoothing Compensated for Sampled Data Lags, <i>J. L. Ryerson</i>	106

Part 3—Electron Devices and Receivers

SESSION 16: Microwave Tubes (Sponsored by the Professional Group on Electron Devices.)	
784. Investigation of a Traveling Wave Tube with Interchangeable External Slow-Wave Structures, <i>A. R. Mathews, C. T. Suh, and K. R. Spangenberg</i>	3
785. Hollow Beams in Electrostatic Fields, <i>L. A. Harris</i>	11
786. Microwave Transmitter Tuning by Rapid-Interchange, Fixed-Frequency Klystrons, <i>R. A. La Plante</i>	19
787. Design and Performance of Low Noise Guns for Traveling-Wave Tubes, <i>R. C. Knechtli and W. R. Beam</i>	23
788. Backward Wave Oscillator Tubes, <i>W. W. Menke</i>	30
789. Backward Wave Oscillators for Low Voltage Operation, <i>W. L. Beaver</i>	35
SESSION 23: Electron Tubes (Sponsored by the Professional Group on Electron Devices.)	
790. Image Orthicon for Pickup at Low Light Levels, <i>A. A. Rolow</i>	41
791. Heat-Flow Considerations in the Design of High-Dissipation Receiving Tubes, <i>O. H. Schade, Jr.</i>	50
792. The Hy-Tramp, A Grid Controlled High Transconductance Electron Multiplier, <i>W. E. Hosteller</i>	55
793. A Long-Life Cathode for High Power UHF Transmitting Tubes, <i>M. J. Sivka and R. E. Manfredi</i>	58
794. A Method of Measuring Cathode Interface Impedance, <i>W. U. Shipley</i>	64
SESSION 29: Broadcast and Television Receivers (Sponsored by the Professional Group on Broadcast and Television Receivers.)	
795. Stability Considerations in Transistor IF Amplifiers, <i>D. D. Holmes and T. O. Stanley</i>	67
796. Application of Transistors to Battery-Powered Portable Receivers, <i>J. W. Englund</i>	68
797. Design of Double Tuned IF Transformers for Transistor Amplifiers, <i>M. J. Hellstrom</i>	69
798. Transient Response Versus Chrominance Bandwidth of Simultaneous Color Television Receivers, <i>C. W. Baugh and H. E. Sweeney</i>	77
799. A Deflection and Convergence System for Use with the Color Picture Tubes, <i>R. B. Gethmann</i>	84
SESSION 37: Color Television Receivers (Sponsored by the Professional Group on Broadcast and Television Receivers.)	
800. The "Chromatron" as the Basis for Low-Cost Television Receivers, <i>R. D'Amato, R. Dressler, and A. Jacobs</i>	89
801. The Optimum Relative Phosphor Efficiencies, <i>S. K. Alles</i>	90
802. A New Color Television Display—The Apple System, <i>J. S. Bryan, R. G. Clapp, E. M. Creamer, S. W. Moulton, and M. E. Partin</i>	94
803. A Beam Indexing Color Picture Tube—The Apple Tube, <i>G. F. Barnett, F. J. Bingley, S. L. Parsons, G. W. Pratt, and M. Sadowsky</i>	101
804. Current Status of Apple Receiver Circuits and Components, <i>R. A. Bloomsburgh, W. P. Boothroyd, G. A. Fedde, and R. C. Moore</i>	107
SESSION 43: Color Television (Sponsored by Professional Groups on Broadcast and Television Receivers and Electron Devices.)	
805. Recent Improvements in the 21AXP22 Color Kinescope, <i>R. B. Janes, L. B. Headrick, and J. Evans</i>	113
806. General Electric Post Acceleration Color Tube, <i>C. G. Lob</i>	114
807. Correct Prints of Color Tube Screens, <i>H. Heil</i>	118
808. The Unipotential Mask-Focusing Colortron, <i>N. Fyler, C. Cain, and P. Hambleton</i>	122

Part 3—Electron Devices and Receivers (Cont'd)

<i>Cumulative Index Number</i>	<i>Page</i>
809. Focusing Grill Color Kinescopes, <i>E. G. Ramberg, H. B. Law, H. S. Allwine, D. C. Darling, C. W. Henderson, and H. Rosenthal</i>	128
SESSION 50: Solid State Devices (Sponsored by Professional Group on Electron Devices.)	
810. Electrets, <i>E. G. Linden</i>	135
811. High Frequency Germanium NPN Tetrode, <i>D. W. Baker</i>	143
812. Optimum Design of Power Output Transistors, <i>M. A. Clark</i>	151
813. Investigation of Power Gain and Transistor Parameters as Functions of Temperature and Frequency, <i>A. B. Glenn and I. Joffe</i>	157
814. High Frequency Tetrodes, <i>R. F. Stewart, B. Cornelison, and W. A. Adcock</i>	166
815. Semiconductor Capacitance Amplifier, <i>F. Dill, Jr. and L. Depian</i>	172

Part 4—Computers, Information Theory, Automatic Control

SESSION 7: Information Theory I (Sponsored by the Professional Group on Information Theory.)	
816. Information Theory and Quality Control, <i>J. Rothstein</i> ..	3
817. Coherent Detection of Sinusoidal Signals in Gaussian Noise, <i>K. S. Müller and R. Bernstein</i>	12
818. Piecewise Quadratic Detector, <i>R. Deutsch</i>	15
819. A Theory for the Experimental Determination of Optimum Nonlinear Systems, <i>A. G. Bose</i>	21
820. Evaluation of Complex Statistical Functions by an Analog Computer, <i>R. R. Favreau, H. Low, and I. Pfeffer</i> ..	31
SESSION 10: Automatic Control (Sponsored by the Professional Group on Automatic Control.)	
821. Feedback-Control of a Length-Modulated Pulse Generator, <i>J. E. Shea and P. F. Ordnung</i>	38
822. A Non-Linear Noise Suppression Network, <i>R. L. Gordon</i>	46
823. Measurement and Stabilization of Nonlinear Feedback Systems, <i>G. Casserly and J. G. Truxal</i>	52
824. Optimum Switching Criteria for Discontinuous Automatic Controls, <i>N. J. Rose</i>	61
825. The Reasonableness Check in Automation, <i>C. H. Doersam, Jr.</i>	67
SESSION 32: Electronic Computers I (Sponsored by the Professional Group on Electronic Computers.)	
826. A Multiple Input Analog Multiplier (Abstract), <i>D. D. Porter and A. S. Robinson</i>	73
827. Analogue Multiplying Circuits Using Switching Transistors, <i>K. Chen and R. O. Decker</i>	74
828. Logic Design of the RCA BIZMAC Computer, <i>A. D. Beard, L. S. Bensky, D. L. Neulleton, and G. E. Poorie</i> ..	81
829. Input and Output Devices of the RCA BIZMAC System, <i>J. A. Brustman, K. L. Chien, and D. Flechtner</i>	88
830. Burroughs G-101 High Speed Printer, <i>E. M. DiGiulio</i> ..	94
SESSION 39: Electronic Computers II (Sponsored by the Professional Group on Electronic Computers.)	
831. A Magnetic-Drum Sorting System, <i>B. Cox and J. Goldberg</i>	101
832. A Magnetic Drum Extension to the Gamma 3 Computer, <i>P. L. Dreyfus, H. G. Feissel, and B. M. Leclerc</i>	105
833. The Univac Magnetic Computer—Part I. Logical Design and Specifications (Abstract), <i>A. J. Gehring, L. W. Stowe, and L. D. Wilson</i>	109
834. The Univac Magnetic Computer—Part II. Megacycle Magnetic Modules (Abstract), <i>B. K. Smith</i>	110
835. The Univac Magnetic Computer—Part III. Drum Memory (Abstract), <i>V. J. Porter, S. E. Smith, and M. Naiman</i>	111
836. SESSION 42: Electronic Computers III—Symposium on the Impact of Computers on Science and Society (Sponsored by the Professional Group on Electronic Computers.)	112
SESSION 46: Information Theory II (Sponsored by the Professional Group on Information Theory.)	
837. Certain Aspects of Coherence, Modulation and Selectivity in Information Transmission Systems, <i>S. Goldman</i> ...	113

Part 4—Computers, Information Theory,
Automatic Control (Cont'd)

<i>Cumulative Index Number</i>	<i>Page</i>
838. Some Results in Coding Theory (Title only), <i>C. Shannon</i>	126
839. Session Commentary, <i>P. Elias</i>	127
840. Limits on Nerve Impulse Transmission, <i>P. D. Wall, J. Y. Lettvin, W. H. Pitts, and W. S. McCulloch</i>	128
SESSION 53: Information Theory III (Sponsored by the Professional Group on Information Theory.)	
841. A Prediction Theory Approach to Information Rates, <i>K. H. Powers</i>	132
842. Reduced-Alphabet Representation of Television Signals, <i>E. R. Kretzmer</i>	140
843. A Bit-Squeezing Technique Applied to Speech Signals, <i>E. E. David, Jr. and H. S. McDonald</i>	148
844. Communication Through Noisy, Random-Multipath Channels, <i>G. L. Turin</i>	154
845. Multipath Distortion of TV Signals and the Design of a Corrective Filter, <i>A. V. Balakrishnan</i>	167

Part 5—Microwave and Instrumentation

SESSION 1: Instrumentation I (Sponsored by the Professional Group on Instrumentation.)	
846. A Transadmittance Meter for VHF-UHF Measurements, <i>W. R. Thurston</i>	3
847. Measurement of Electron Tube Admittance Matrix Parameters at Ultra-High Frequencies, <i>M. M. Zimet and S. Friedman</i>	8
848. Transistor Measurements at High Power Levels, <i>S. I. Kramer and R. F. Wheeler</i>	15
849. A Transistorized Events-Per-Unit-Time Meter, <i>H. Chisholm</i>	19
850. The Application of Magnetic Techniques to a Reliable 40 KC Eput Meter Design, <i>D. A. Weinstein</i>	25
SESSION 26: Microwaves I—General (Sponsored by the Professional Group on Microwave Theory and Techniques.)	
851. Leakage Radiation from a Braided Coaxial Cable, <i>E. R. Schatz, M. E. Taylor, R. F. Robl, and K. L. Konnerth</i>	32
852. A Trimode Turnstile Waveguide Junction, <i>R. S. Potter</i>	36
853. The H-Guide, A Waveguide for Microwaves, <i>F. J. Tischer</i>	44
854. Microwave Spectrum Synthesis with the Traveling-Wave Tube, <i>P. D. Lacy</i>	48
855. An Orthogonal Mode Transducer, <i>R. L. Fogel</i>	53
SESSION 34: Microwaves II—Ferrites (Sponsored by the Professional Group on Microwave Theory and Techniques.)	
856. The Design of Non-Reciprocal Phase Shift Sections, <i>H. N. Chait and N. G. Sakiotis</i>	58
857. Tensor Permeabilities of Ferrites below Magnetic Saturation, <i>R. C. LeCraw and E. G. Spencer</i>	66
858. A Miniaturized High Temperature Isolator, <i>R. F. Sullivan and R. C. LeCraw</i>	75
859. Broadbanding Ferrite Microwave Isolators, <i>P. H. Vartanian, J. L. Melchor, and W. P. Ayres</i>	79
860. Ferrite Microwave Phaseshifters, <i>R. F. Soohoo</i>	84
861. A Balanced-Stripline Isolator, <i>O. W. Fix</i>	99
SESSION 47: Microwaves III—Filters (Sponsored by the Professional Group on Microwave Theory and Techniques.)	
862. Directional Channel-Separation Filters, <i>S. B. Cohn and F. S. Coale</i>	106
863. A Resonant Cavity Frequency Duplexer, <i>E. O. Bowers and C. W. Curtis</i>	113
864. Synthesis of Wide-Band Microwave Filters to Have Prescribed Insertion Loss, <i>E. M. T. Jones</i>	119
865. Crossed-Mode Tunable Selector for Microwaves, <i>N. A. Spencer</i>	129
866. The Susceptance of a Circular Iris to the Dominant TE ₁₁ Mode in Circular Waveguide, <i>M. Handelsman</i>	133
SESSION 48: Instrumentation II (Sponsored by the Professional Group on Instrumentation.)	
867. A Method of Repetitive Examination of Transient Phenomena, <i>J. W. Dorsett</i>	141
868. A Magnetic Head for the Megacycle Range, <i>O. Kornei</i>	145
869. Extending the Versatility of a Laboratory Magnetic Tape Data Storage Device, <i>A. V. Gangnes</i>	150

Part 5—Microwave and Instrumentation (Cont'd)

<i>Cumulative Index Number</i>	<i>Page</i>
870. A Time Bridge, <i>M. Kline and C. E. Webb</i>	155
871. A Versatile Quadrature Time Base Comparator for Automatic Frequency Measurement, <i>J. J. Weber</i>	158
SESSION 54: Microwave Instrumentation (Sponsored jointly by the Professional Groups on Instrumentation and on Microwave Theory and Techniques.)	
872. An Amplitude Regulator for Microwave Signal Sources, <i>P. Fire and P. H. Vartanian</i>	166
873. Measurement of the Complex Dielectric Constant of Materials from 100 to 1200 Mc over a Wide Range of Temperature, <i>I. Bady</i>	172
874. The Z-Scope, An Automatic Impedance Plotter, <i>J. P. Vinding</i>	178
875. A Swept, Broad Band, Microwave, Double Detection System with Automatic Synchronization, <i>D. L. Favin</i>	184
876. Coaxial Components Employing Gaseous Discharges at Microwave Frequencies, <i>R. H. Geiger and P. E. Dorney</i>	193
877. High Power Breakdown of Microwave Structures, <i>G. K. Hart, F. R. Stevenson, and M. S. Tenenbaum</i>	199

Part 6—Manufacturing Electronics

SESSION 6: Assuring Our Engineering Future (Sponsored by the Professional Group on Engineering Management.)	
878. Industrial Research of the Future, <i>E. D. Reeves</i>	3
879. Human Relations Responsibilities of Engineers, <i>P. E. Hemke</i>	7
880. The Challenge to the Engineering Manager, <i>C. H. Linder</i>	10
SESSION 8: The Effects of Environmental and Operating Conditions on the Reliability of "Reliable" Electron Tubes (Sponsored by the Professional Group on Reliability and Quality Control.)	
881. A Basic Study of the Effects of Operating and Environmental Factors on Electron Tubes, <i>W. S. Bowie</i>	15
882. The Effects of Mechanical Excitation, <i>F. Warnock</i>	17
883. The Effects of Heater Cycling and Heater Voltage, <i>W. S. Bowie</i>	21
884. The Effects of Ambient Temperature, <i>P. F. Barnett</i>	26
885. The Effects of Plate Voltage, Plate Current and Plate Dissipation, <i>D. E. Lammers</i>	30
886. The Effects of Pulse Operation, <i>W. U. Shipley</i>	37
SESSION 17: Quality Control and Reliability Studies of Electronic Equipments (Sponsored by the Professional Group on Reliability and Quality Control.)	
887. Achieving Operational Effectiveness and Reliability with Unreliable Components and Equipment, <i>W. F. Luebbert</i>	41
888. Some Reliability Aspects of Systems Design, <i>F. Moskowitz and J. McLean</i>	50
889. Training for Quality Control, <i>C. J. Quirk</i>	60
890. A Bombing System Reliability Program, <i>R. L. Wendt and M. H. Smith</i>	68
891. A Reliability Department Operation for Production Missiles, <i>E. F. Dertinger</i>	75
SESSION 27: Engineering Management Techniques (Sponsored by the Professional Group on Engineering Management.)	
892. Words Needn't Fail (Abstract), <i>P. R. Beall</i>	83
893. How Teamwork Brainstorming Solves Problems (Abstract), <i>W. A. Pleuthner</i>	84
894. Strengthening the Recognition of Engineering, <i>G. W. Griffin, Jr.</i>	85
895. The Motivation of Technical People (Abstract), <i>L. M. Spencer</i>	89
SESSION 35: Design Approaches with Printed Wiring (Sponsored by the Professional Group on Production Techniques.)	
896. Engineering of Printed Circuits to Facilitate Production, <i>R. C. Calcut and C. A. Arts</i>	90
897. Principles of Circuit Design for Automation, <i>H. S. Dordick</i>	94
898. Modular Construction—Its Implications to the Design Engineer, <i>R. E. Bauer</i>	104
899. A New Automation Technique for Soldering Components to Foil-Wire Boards, <i>A. A. Lawson, P. R. Ritt, and H. K. Hazel</i>	111

Part 6—Manufacturing Electronics (Cont'd)

Cumulative Index Number	Page
900. Printed Circuits Via Xerography, <i>F. A. Schwartz and E. M. Van Wagner</i>	115
901. Cupric Oxidized Foil for Printed Circuit Laminates, <i>L. W. McGinnis, G. H. Mains, and J. S. Tatnall</i>	121
SESSION 44: Component Parts I (Sponsored by the Professional Group on Component Parts.)	
902. The Power Supply in Military Equipment, <i>S. Perlman</i> ...	126
903. The Silver-Zinc Rechargeable Battery, <i>P. L. Howard</i> ...	132
904. The Wafer Coil Pulse Transformer, <i>A. Babcock and A. Zack</i>	137
905. Magnetic Component Encapsulation for Military Airborne Application, <i>A. Lucic</i>	140
906. A Compact High-voltage Power Supply Using a Transistor Inverter Circuit, <i>M. S. Chester</i>	146
SESSION 45: Industrial Electronics (Sponsored by the Professional Group on Industrial Electronics.)	
907. High Frequency Shields, <i>R. E. Lafferty</i>	151
908. Field Intensity Measurements on Induction-Heating Equipment, <i>T. E. Nash</i>	159
909. Basic Considerations in the Design of Electronic Power Supplies for Electrodynamical Shakers, <i>D. J. Fritch</i>	161
910. Magnetic Amplifier Industrial Control Techniques for Improved Accuracy and Reliability, <i>H. W. Patton</i>	167
SESSION 52: Component Parts II (Sponsored by the Professional Group on Component Parts.)	
911. Preparation of Standards and Test Procedures for Printed Circuits, <i>E. R. Gamson and A. Henesian</i>	172
912. Cascaded Feedthrough Capacitors, <i>H. M. Schlicke</i>	184
913. Performance of Continuous and Discontinuous Tube Feedthrough Capacitors at VHF and Higher Frequencies, <i>E. M. Williams and J. H. Foster</i>	188
914. Piezoelectric Ceramic I-F Band Pass Filters, <i>O. E. Mattiat</i>	192
915. Tantalum Solid Electrolytic Capacitors, <i>D. A. McLean and F. S. Power</i>	200

Part 7—Audio and Broadcast

SESSION 12: Trends in TV Equipment (Sponsored by the Professional Group on Broadcast Transmission Systems.)	
916. High Stability Television Synchronization Generator, <i>F. T. Thompson</i>	3
917. Pedestal Processing Amplifier for Television, <i>R. C. Kennedy</i>	10
918. A New Electronic Masker for Color Television, <i>J. H. Haines</i>	19
919. Reworking the Network or Remote Video Signal, <i>R. R. Embree</i>	31
920. A 3-Vidicon Color Television Camera for Live Pickup, <i>L. E. Anderson</i>	39
SESSION 13: Audio Techniques (Sponsored by the Professional Group on Audio.)	
921. A Simplified Procedure for the Design of Transistor Audio Amplifiers, <i>A. E. Hayes, Jr., and W. W. Wells</i>	45
922. An Audio Flutter Weighting Network, <i>F. A. Comerci and E. Oliveros</i>	62
923. A Flutter Meter Incorporating Subjective Weightings (Abstract), <i>M. A. Cotter</i>	74
924. A Simplified Method for the Performance Measurement of Magnetic Tape Recorders, <i>J. B. Hull</i>	75
925. A 3000 Watt Audio Power Amplifier, <i>A. B. Bereskin</i>	80
SESSION 20: TV Transmitting Equipment and Techniques (Sponsored by the Professional Group on Broadcast Transmission Systems.)	
926. High Gain Antenna Arrays for Television Broadcast Transmission Using a Slotted Ring Antenna, <i>A. Alford and H. H. Leach</i>	87
927. Self-Diplexing T-V Antenna, <i>C. B. Mayer and P. M. Pan</i>	95
928. Television Field Strength Measurements—A Tool in Transmitting Antenna Planning, <i>R. E. Rohrer and O. Reed, Jr.</i>	108
929. A New Monitor for Television Transmitters, <i>C. A. Cady</i> ..	117
930. A Pack Type Television System, <i>W. B. Harris</i>	128
SESSION 21: High Quality Sound Reproduction (Sponsored by the Professional Group on Broadcast Transmission Systems.)	

Part 7—Audio and Broadcast (Cont'd)

Cumulative Index Number	Page
931. Equalization Considerations in Direct Magnetic Recording for Audio Purposes, <i>R. H. Snyder and J. W. Havstad</i>	134
932. Design of a High Fidelity 10 Watt Transistor Audio Amplifier, <i>R. P. Crow and R. D. Mohler</i>	142
933. Performance of the "Distributed Port" Loudspeaker Enclosure, <i>A. F. Petrie</i>	151
934. A Phonograph System for the Automobile, <i>P. C. Goldmark</i>	159
SESSION 25: Color Television Tape Recording (Sponsored jointly by the Professional Groups on Audio and on Broadcast Transmission Systems.)	
935. A Magnetic Tape System for Recording and Reproducing Standard FCC Color Television Signals—General Considerations (Abstract), <i>H. F. Olson</i>	166
936. A Magnetic Tape System for Recording and Reproducing Standard FCC Color Television Signals—Electronic System (Abstract), <i>W. D. Houghton</i>	167
937. A Magnetic Tape System for Recording and Reproducing Standard FCC Color Television Signals—The Magnetic Head (Abstract), <i>J. A. Zenel</i>	168
938. A Magnetic Tape System for Recording and Reproducing Standard FCC Color Television Signals—The Tape Transport Mechanism (Abstract), <i>A. R. Morgan and M. Artzt</i>	169
939. A Magnetic Tape System for Recording and Reproducing Standard FCC Color Television Signals—Audio Systems (Abstract), <i>J. G. Woodward</i>	170
SESSION 55: Broadcast Transmission Systems—New Horizons (Sponsored by the Professional Group on Broadcast Transmission Systems.)	
940. The Technical Boundary Conditions of Subscription Television, <i>A. Ellett and R. Adler</i>	171
941. An Integrated System of Coded Picture Transmission, <i>E. M. Roschke, W. S. Druz, C. Eilers, and J. Pulles</i> ...	173
942. Chromaticity Coordinate-Plotting Photometer, <i>W. H. Highleyman, M. J. Cantella, and V. A. Babits</i>	174
943. Recent Improvements in Black-and-White Film Recording for Color Television Use, <i>W. L. Hughes</i>	180
944. Design Considerations for a High Quality Transistorized Program Amplifier for Remote Broadcast Use, <i>J. K. Birch</i>	189

Part 8—Aeronautical, Communication and Military Electronics

SESSION 3: Vehicular Communications: "New Horizons for Vehicular Communications" (Sponsored by the Professional Group on Vehicular Communications.)	
945. Miniaturization Techniques Utilized in a Multichannel Crystal Controlled VHF Oscillator, <i>E. M. Stryker, Jr.</i>	3
946. A New Concept for Communication Vibrator Design, <i>A. B. Tollefsen, Jr.</i>	8
947. More Words Per Minute Per Kilocycle, <i>C. B. Plummer</i> ..	14
948. A Vehicular User Looks at the Future, <i>D. E. York</i>	17
949. Is 960 MC. Suitable for Mobile Operation?, <i>C. J. Schultz</i>	20
SESSION 4: General Communications Systems (Sponsored by the Professional Group on Communications Systems.)	
950. The Place of Communications in Integrated Data Processing, <i>A. O. Mann</i>	24
951. A Means for Analysis of Communication Equipment and System Performance Using Log-Log Selectivity Curves, <i>E. Toth</i>	28
952. Sixteen Channel Time Division Multiplex System Employing Transistors and Magnetic Core Memory Circuits, <i>J. C. Myrick</i>	36
953. Transmitting Tubes for Linear Amplifier Service, <i>R. L. Norton</i>	41
954. Methods of Reducing Frequency Variations in Crystals Over a Wide Temperature Range, <i>L. F. Koerner</i>	48
SESSION 11: Air Traffic Control (Sponsored by the Professional Group on Aeronautical and Navigational Electronics.)	
955. Symbolic Display System for Air Traffic Control, <i>L. T. Harris</i>	55
956. A New Look at Requirements for Electronic Systems in Air Traffic Control, <i>R. S. Grubmeyer</i>	60

Part 8—Aeronautical, Communication and
Military Electronics (Cont'd)

Cumulative Index Number	Page
957. Traffic Control Electronics Research Goes Modern, <i>E. Storrs and J. Ryerson</i>	64
958. An Analysis for Human Flight Control, <i>L. J. Fogel</i>	69
959. Enhancement of Aircraft Radar Return by Use of Airborne Reflectors and Circular Polarization, <i>J. J. Panasiwicz</i>	89
960. A Three-Dimensional Aircraft Visibility Diagram, <i>A. Feiner and F. I. Diamond</i>	97
SESSION 15: Symposium on Air Force Communications and Electronics Problems and Philosophies (Sponsored by the Professional Group on Military Electronics.)	
961. Opening Remarks by the Moderator, <i>J. E. Kelo</i>	101
962. Air Force Operational Problems, <i>G. A. Blake</i>	102
963. Communications in Air Defense, <i>H. E. Neal</i>	105
964. Mobility Requirements for Tactical Operations, <i>R. F. Frost</i>	108
965. Requirements for Data Transmission and Graphics, <i>J. B. Bestic</i>	111
966. U. S. Air Force Communications Systems Problems, <i>F. W. Donkin</i>	113
967. Research and Exploratory Needs (Electronics), <i>G. T. Gould, Jr.</i>	116
968. Communications in Air Navigation & Traffic Control, <i>H. Davis</i>	119
969. Atmospheric and Propagation, <i>L. M. Hollingsworth</i>	127
970. Communications in Its Military Aircraft Environment, <i>J. E. Kelo</i>	131
971. The Need for Closer Relations, <i>G. A. Blake</i>	136
972. Panel Summary by Moderator.....	138
SESSION 19: Navigation (Sponsored by the Professional Group on Aeronautical and Navigational Electronics.)	
973. A Radiometric Inertial Reference System, <i>V. W. Bolie</i>	139
974. Analytical Prediction of Missile Guidance Accuracy, <i>W. E. Mathews</i>	150
975. Considerations Affecting the Choice of a Long-Range Navigation System, <i>S. Rosenberg</i>	154
976. Doppler Type High Frequency Radio Direction Finder, <i>J. A. Fantoni and R. C. Benoit, Jr.</i>	165
977. USAF UHF Direction Finding Facility, <i>R. C. Benoit, Jr., and J. A. Fantoni</i>	172
978. Co-Location of Tacan VOR-DME Systems, <i>P. E. Ricketts</i>	178
SESSION 31: Nuclear Effects on Electronic Systems (Sponsored by the Professional Group on Military Electronics.)	
979. Effects of Nuclear Radiation on Electronic Components (Title only), <i>T. Baldwin</i>	181
980. The Effects of an Air Burst Atomic Bomb on a Tactical Communication System, <i>J. Eggert</i>	182
981. Dose Rate Dependence of Dosimeters at Dose Rates up to Two Million Roentgen Per Hour, <i>M. N. Stein</i>	192
982. Techniques of Measurement at High Rates, <i>P. Brown</i>	197
983. Radiological Instrumentation, <i>G. Carp</i>	199
SESSION 36: Over-The-Horizon Systems (Sponsored by the Professional Group on Communications Systems.)	
984. VLF Transhorizon Communication System Design, <i>R. M. Ringo</i>	203
985. Report on the Over-The-Horizon Radio Transmission Tests Between Florida and Cuba, <i>K. P. Stiles</i>	212
986. A Broad-Band Over-The-Horizon Link for Florida to Cuba, <i>R. T. Adams, H. Havstad, L. Pollack, and W. Sichak</i>	216

Part 8—Aeronautical, Communication and
Military Electronics (Cont'd)

Cumulative Index Number	Page
987. An Over-The-Horizon Radio Link Between Puerto Rico and the Dominican Republic, <i>R. E. Gray and R. A. Felsenfeld</i>	217
988. Relative Interference Produced by UHF Scatter and Line-Of-Sight Systems, <i>R. M. Ringo</i>	219

Part 9—Ultrasonics, Medical and Nuclear
Electronics

SESSION 2: Medical Electronics I (Sponsored by the Professional Group on Medical Electronics.)	
989. The Perception of Direction as a Function of Binaural Temporal and Amplitude Disparity, <i>R. J. Christman</i>	3
990. An Apparatus for Brain Tumor Localization Using Positron Emitting Radioactive Isotopes, <i>S. Aronow and G. L. Brownell</i>	8
991. The Application of Automatic, High-Speed Measurement Techniques to Cytology, <i>W. E. Tolles, R. C. Bostrom, and H. S. Sawyer</i>	17
992. An Intercommunication System for the Surgical Operating Room, <i>M. M. Davis, Jr., and M. Baldwin</i>	24
993. The Physiograph: A New Instrument for Teaching Physiology, <i>L. A. Geddes</i>	29
SESSION 9: Ultrasonics (Sponsored by the Professional Group on Ultrasonics Engineering.)	
994. Ultrasonic Stroboscope, <i>E. Hiedemann</i>	38
995. Surface Resonances of Bubbles and Biological Cells, <i>E. Ackerman and T. F. Proctor</i>	45
996. Electronic Design Considerations in the Application of Piezoelectric Transducers, <i>W. Bradley, Jr.</i>	51
997. Propagation of Elastic Pulses Near the Stressed End of a Cylindrical Bar, <i>A. H. Mitzler</i>	55
998. Transient and Steady-State Response of Ultrasonic Piezoelectric Transducers, <i>E. G. Cook</i>	61
999. Some Resonator Properties of Synthetic and Doped Synthetic Quartz, <i>A. R. Chi</i>	70
SESSION 18: Nuclear Instrumentation (Sponsored by the Professional Group on Nuclear Science.)	
1000. Some Transistor Circuits Used in a Magnetic Core Type Kickserter, <i>F. S. Goulding</i>	76
1001. Punch Card Recording and Multiple Counting Data (Abstract), <i>H. D. Le Vine and H. Sadowski</i>	82
1002. Instrument Opportunities in Nuclear Systems, <i>V. Parsegian</i>	83
1003. Control Aspects of the Experimental Boiling Water Reactor Power Plant, <i>W. C. Lipinski</i>	84
1004. Control and Automatic Startup of the Geneva Conference Reactor, <i>E. P. Epler and S. H. Ilanauer</i>	90
SESSION 51: Where is Medical Electronics Going? A Symposium in Prediction (Sponsored by the Professional Group on Medical Electronics.)	
1005. Medical Electronics Will Provide Technical Facilities with Which Life Scientists Will Implement Their Work, <i>V. K. Zworykin</i>	99
1006. Where Is Medical Electronics Going? Part II. (Title only), <i>C. L. Taylor</i>	103
1007. Medical Electronics and Fundamental Biophysics, <i>A. C. Burton</i>	104
1008. Where is Medical Electronics Going? Part IV, <i>O. H. Schmitt</i>	107



INDEX TO AUTHORS

- A**
- Ackerman, E.: 995
 Adams, R. T.: 986
 Adcock, W. A.: 814
 Adler, R. B.: 777
 Adler, R.: 940
 Alford, A.: 758, 926
 Allwine, H. S.: 809
 Altes, S. K.: 801
 Anderson, L. E.: 920
 Archer, D. H.: 769
 Aronow, S.: 990
 Artz, C. A.: 896
 Artzt, M.: 938
 Aselftine, J. A.: 772
 Ayres, W. P.: 859
- B**
- Babcock, A.: 904
 Babits, V. A.: 942
 Bady, I.: 873
 Baker, D. W.: 811
 Balakrishnan, A. V.: 845
 Baldwin, M.: 992
 Baldwin, T.: 979
 Barnett, G. F.: 803
 Barnett, P. F.: 884
 Bauer, R. E.: 898
 Baugh, C. W.: 798
 Beall, P. R.: 892
 Beam, W. R.: 787
 Beard, A. D.: 828
 Beaver, W. L.: 789
 Benoit, R. C., Jr.: 976, 977
 Bensky, L. S.: 828
 Bereskin, A. B.: 925
 Bernstein, R.: 817
 Bestic, J. B.: 965
 Bickmore, R. W.: 766
 Bingley, F. J.: 803
 Birch, J. K.: 944
 Bishop, R. P.: 763
 Bittner, B. J.: 741
 Blake, G. A.: 962, 971
 Bloomsburgh, R. A.: 804
 Bolie, V. W.: 973
 Booker, H. G.: 734
 Boothroyd, W. P.: 804
 Bose, A. G.: 819
 Bostrom, R. C.: 991
 Bower, J. L.: 771
 Bowers, E. O.: 863
 Bowie, W. S.: 881, 883
 Boxer, R.: 782
 Bradley, W., Jr.: 996
 Brown, Peter: 982
 Brown, R. M.: 759
 Brownell, G. L.: 990
 Brustman, J. A.: 829
 Bryan, J. S.: 802
 Burton, A. C.: 1007
- C**
- Cain, C.: 808
 Calcut, R. C.: 896
 Cady, C. A.: 929
 Cantella, M. J.: 942
 Carp, G.: 983
 Casserly, G.: 823
 Chait, H. N.: 856
 Chen, K.: 827
 Chernin, M. G.: 766
 Chester, M. S.: 906
 Chi, A. R.: 999
 Chien, K. L.: 829
 Chisholm, H.: 849
 Christman, R. J.: 989
 Clark, M. A.: 812
 Clapp, R. G.: 802
 Coale, F. S.: 862
- Cohn, S. B.: 862
 Comerci, F. A.: 922
 Cook, E. G.: 998
 Cornelison, B.: 814
 Cotter, M. A.: 923
 Cox, B.: 831
 Creamer, E. M.: 802
 Crow, R. P.: 932
 Curtis, C. W.: 863
- D**
- D'Amato, R.: 800
 Damonte, J. B.: 737
 Darling, D. C.: 809
 Dasher, B. J.: 778
 David, E. E., Jr.: 843
 Davis, H.: 968
 Davis, M. M., Jr.: 992
 DeClariss, N.: 774
 Decker, R. O.: 827
 Depian, Louis: 815
 Dertinger, E. F.: 891
 Deutsch, R.: 818
 Diamond, F. I.: 960
 DiGiulio, E. M.: 830
 Dill, F., Jr.: 815
 Doersam, C. H., Jr.: 760
 Donkin, F. W.: 966
 Dordick, H. S.: 897
 Dorney, P. E.: 876
 Dorsett, J. W.: 867
 Dressler, R.: 800
 Dreyfus, P. L.: 832
 Druz, W. S.: 941
 Duerig, W. H.: 740
- E**
- Eggert, J.: 980
 Eilers, C.: 941
 Elias, P.: 839
 Ellett, A.: 940
 Embree, R. R.: 919
 Englund, J. W.: 796
 Epler, E. P.: 1004
 Evans, J.: 805
- F**
- Fantoni, J. A.: 976, 977
 Favin, D. L.: 875
 Favreau, R. R.: 820
 Fedde, G. A.: 804
 Feiner, A.: 960
 Feissel, H. G.: 832
 Felsenheld, R. A.: 987
 Finn, D. L.: 778
 Fire, P.: 872
 Fix, O. W.: 861
 Flechtner, D.:
 Fogel, L. J.: 958
 Fogel, R. L.: 855
 Foster, J. H.: 913
 Foster, W. H.: 752
 Friedman, S.: 847
 Fritch, D. J.: 909
 Frost, R. F.: 964
 Fyler, N.: 808
- G**
- Gamson, E. R.: 911
 Gangnes, A. V.: 869
 Geddes, L. A.: 993
 Gehring, A. J.: 833
 Geiger, R. H.: 876
 Gerks, I. H.: 729
 Gethmann, R. B.: 799
 Glenn, A. B.: 813
 Goldberg, J.: 831
 Goldman, S.: 837
 Goldmark, P. C.: 934
 Gordon, R. L.: 822
- Gould, G. T., Jr.: 967
 Goulding, F. S.: 1000
 Graham, R. E.: 773
 Gray, R. E.: 987
 Griffin, G. W., Jr.: 894
 Cox, B.: 831
 Creamer, E. M.: 802
 Crow, R. P.: 932
 Curtis, C. W.: 863
- H**
- Hagen, J. P.: 745
 Haines, J. H.: 918
 Hambleton, P.: 808
 Hanauer, S. H.: 1004
 Handelsman, M.: 866
 Harris, L. A.: 785
 Harris, L. T.: 955
 Harris, W. B.: 930
 Harrison, W. G.: 739
 Hart, G. K.: 877
 Hatcher, R. D.: 765
 Haus, H. A.: 777
 Havstad, J. W.: 931
 Havstad, H.: 986
 Hayes, A. E., Jr.: 921
 Hazel, H. K.: 899
 Headrick, L. B.: 805
 Heil, H.: 807
 Hellstrom, M. J.: 797
 Helman, D.: 780
 Hemke, P. E.: 879
 Henderson, C. W.: 809
 Hendershot, L. R.: 742
 Henesian, A.: 911
 Hiedemann, E.: 994
 Highleyman, W. H.: 942
 Hollingsworth, L. M.: 969
 Holmes, D. D.: 795
 Horowitz, I. M.: 775
 Hostetler, W. E.: 792
 Houghton, W. D.: 936
 Howard, P. L.: 903
 Hughes, W. L.: 943
 Hull, J. B.: 924
 Hynek, J. A.: 749
- J**
- Jacobs, A.: 800
 Jacobs, G.: 730
 James, R. B.: 805
 Joffe, I.: 813
 Jones, E. M. T.: 864
- K**
- Kaplan, J.: 744
 Karas, N.: 767
 Katzin, M.: 732
 Kelleher, K. S.: 755
 Kennedy, R. C.: 917
 Keto, J. E.: 961, 970
 Klein, M. L.: 754
 Kline, M.: 870
 Knechtli, R. C.: 787
 Koerner, L. F.: 954
 Konnerth, K. L.: 851
 Kornei, O.: 868
 Kramer, S. I.: 848
 Kretzmer, E. R.: 842
- L**
- Lacy, P. D.: 854
 Lacy, R. E.: 733
 Lafferty, R. E.: 907
 Lammers, D. E.: 885
 La Plante, R. A.: 786
 Law, H. B.: 809
 Lawson, A. A.: 899
 Leach, H. H.: 926
 Leclerc, B. M.: 832
 LeCraw, R. C.: 857, 858
 Lettvin, J. Y.: 840
 LeVine, H. D.: 1001
- Linden, E. G.: 810
 Linder, C. H.: 880
 Lipinski, W. C.: 1003
 Lob, C. G.: 806
 Low, H.: 820
 Lucic, A.: 905
 Luebbert, W. F.: 887
- M**
- Macdonald, F. C.: 735
 Mains, G. H.: 901
 Manfredi, R. E.: 793
 Mann, A. O.: 950
 Marner, G. R.: 731
 Marquand, R. E.: 763
 Martin, E. T.: 730
 Mathews, A. R.: 784
 Mathews, W. E.: 974
 Mayer, C. B.: 927
 Mattiat, O. E.: 914
 Mazur, D. G.: 747
 McCulloch, W. S.: 840
 McDonald, H. S.: 843
 McGinnis, L. W.: 901
 McLean, D. A.: 915
 McLean, J.: 888
 Meitzler, A. H.: 997
 Melchor, J. L.: 859
 Mengel, J. T.: 748
 Menke, W. W.: 788
 Miller, K. S.: 817
 Mohler, R. D.: 932
 Moore, R. C.: 804
 Morgan, A. R.: 938
 Moskowitz, F.: 888
 Moulton, S. W.: 802
 Myrick, J. C.: 952
- N**
- Naiman, M.: 835
 Nash, T. E.: 908
 Neal, H. E.: 963
 Nettleton, D. L.: 828
 Norton, R. L.: 953
- O**
- Oliveros, E.: 922
 Olson, H. F.: 935
 Oltman, H. G., Jr.: 741
 Ordnung, P. F.: 821
- P**
- Pan, P. M.: 927
 Panasiewicz, J. J.: 959
 Parsegian, V.: 1002
 Parsons, S. L.: 803
 Partin, M. E.: 802
 Patton, H. W.: 910
 Peeler, G. D. M.: 769
 Perlman, S.: 902
 Petrie, A. F.: 933
 Pfeffer, I.: 820
 Pitts, W. H.: 840
 Pleuthner, W. A.: 893
 Plonsey, R.: 738
 Plummer, C. B.: 947
 Pollack, L.: 986
 Poorte, G. E.: 828
 Porter, D. D.: 826
 Porter, V. J.: 835
 Potter, R. S.: 852
 Power, F. S.: 915
 Powers, K. H.: 841
 Pratt, G. W.: 803
 Proctor, T. F.: 995
 Pulles, J.: 941
- Q**
- Quirk, C. J.: 889

R
 Ramberg, E. G.: 809
 Ratynski, M. V.: 768
 Reed, O., Jr.: 928
 Reeves, E. D.: 878
 Reggia, F.: 765
 Reza, F. M.: 779
 Ricketts, P. E.: 978
 Ringoen, R. M.: 731, 984, 988
 Ritt, P. R.: 899
 Rohrer, R. E.: 928
 Robinson, A. S.: 826
 Robl, R. F.: 851
 Roschke, E. M.: 941
 Rose, N. J.: 824
 Rosen, M. W.: 746
 Rosenberg, S.: 975
 Rosenthal, H.: 809
 Rothstein, J.: 816
 Rotman, W.: 767
 Rotow, A. A.: 790
 Royce, H. W.: 751
 Rumsey, V. H.: 757
 Runyan, R. A.: 761
 Rush, R. B.: 754
 Ryerson, J. L.: 783, 957

S
 Sadowski, H.: 1001
 Sadowsky, M.: 803

Sah, T. C.: 784
 Sakiotis, N. G.: 856
 Sawyer, H. S.: 991
 Schade, O. H., Jr.: 791
 Schatz, E. R.: 851
 Schlicke, H. M.: 912
 Schmitt, O. H.: 1008
 Schultz, C. J.: 949
 Schwertz, F. A.: 900
 Scott, W. G.: 755
 Shannon, C.: 838
 Sharp, C. E.: 733
 Shaw, G. S.: 762
 Shea, J. E.: 821
 Shipley, W. U.: 794, 886
 Sichak, W.: 986
 Slivka, M. J.: 793
 Sklansky, J.: 781
 Smedes, R. L.: 764
 Smith, B. K.: 834
 Smith, S. E.: 835
 Smith, M. H.: 890
 Snyder, R. H.: 931
 Soohoo, R. F.: 860
 Spangenberg, K. R.: 784
 Spencer, E. G.: 765, 857
 Spencer, L. M.: 895
 Spencer, N. A.: 865
 Stanley, T. O.: 795
 Stein, M. N.: 981
 Stern, A. P.: 776

Stevenson, F. R.: 877
 Stewart, R. F.: 814
 Stiles, K. P.: 985
 Stoddard, D. J.: 737
 Storrs, E.: 957
 Stowe, L. W.: 833
 Stryker, E. M., Jr.: 944
 Sullivan, R. F.: 858
 Svien, A. J.: 729
 Sweeney, H. E.: 789

T
 Tanenbaum, M. S.: 877
 Tanner, R. L.: 736
 Tatnall, J. S.: 901
 Taylor, C. L.: 1006
 Taylor, M. E.: 851
 Thaler, S.: 782
 Thompson, F. T.: 916
 Thurston, W. R.: 846
 Tischer, F. J.: 853
 Tollefsen, A. B., Jr.: 946
 Tolles, W. E.: 991
 Tompkins, J. E.: 765
 Toth, E.: 951
 Truxal, J. G.: 770, 823
 Turin, G. L.: 844

V
 Van Allen, J. A.: 750
 Van Wagner, E. M.: 776

Vartanian, P. H.: 859, 872
 Vinding, J. P.: 874

W
 Wall, P. D.: 840
 Warnock, F.: 882
 Watts, C. B., Jr.: 758
 Webb, C. E.: 871
 Weber, I. J.: 871
 Weeks, W. L.: 757
 Weinstein, D. A.: 850
 Wells, W. W.: 921
 Wendt, R. L.: 890
 Wheeler, H. A.: 756
 Wheeler, R. F.: 848
 Whipple, F. L.: 749
 Williams, E. M.: 913
 Williams, F. K.: 753
 Wilson, L. D.: 833
 Woodward, J. G.: 939
 Wright, H. D.: 743

Y
 York, D. E.: 948

Z
 Zack, A.: 904
 Zenel, J. A.: 937
 Zimet, M. M.: 847
 Zworykin, V. K.: 1005

INDEX TO SUBJECTS

A
 Admittance, Electron Tube, Matrix Parameters at UHF: 847
 Air Force Communications and Electronics Problems: 961, 962, 963, 964, 965, 966, 967, 968, 969, 970, 971, 972
 Air Navigation and Traffic Control: 968
 Atmospheric and Propagation: 969
 Closer Relations between Equipment Users and Engineers: 971
 Communications in Air Defense: 963
 Data Transmission and Graphics: 965
 Military Aircraft Environment: 970
 Mobility Requirements for Tactical Operations: 964
 Opening Remarks by Moderator: 961
 Operational Problems: 962
 Research and Exploratory Needs: 967
 Summary of Symposium: 972
 U. S. Air Force Communications Systems Problems: 966
 Air Traffic Control: 955, 956, 957, 968 and Air Force Communications: 968
 Electronics Research Goes Modern: 957
 Electronics Systems Requirements: 956
 Symbolic Display System for: 955
 Airborne Data Acquisition System: 752
 Airborne Electronics Systems, Encapsulation of Magnetic Components: 905
 Airborne Reflectors and Circular Polarization for Aircraft Radar Return: 959
 Aircraft Visibility Diagram, Three Dimensional: 960
 Amplifiers: 795, 797, 815, 910, 917, 921, 925, 932, 944, 953
 Audio: 921, 925, 932
 Power, 3000 Watt: 925
 Transistor: 921
 Transistor, High Fidelity, 10 Watt: 932

Linear, Transmitting Tubes for: 953
 Magnetic, Industrial Control Techniques for Accuracy and Reliability: 910
 Pedestal Processing for Television: 917
 Semiconductor Capacitance: 815
 Transistor: 795, 797, 944
 Double-Tuned IF Transformers for: 797
 IF, Stability Considerations: 795
 for Remote Broadcast Use: 944
 Amplitude Regulator for Microwave Signal Sources: 872
 Analog Multipliers: 826, 827
 Multiple Input: 826
 Using Switching Circuits: 827
 Antennas: 736, 737, 741, 755, 756, 757, 767, 768, 926, 927, 928
 Aircraft, Precipitation Static in: 736
 Automatic Tracking, for Telemetering: 741
 Conical Scan, for Tracking: 737
 Cross Polarization Effects on Radiation Patterns: 755
 Ferrite Loop: 757
 Microwave, Based on Trough Waveguide: 767
 Radomes for Ground Electronic Equipment: 768
 Slotted Ring, in High Gain TV Arrays: 926
 Television: 927, 928
 Self Duplexing: 927
 Transmitting, and Field Strength Measurements: 928
 Vertical, Made of Transposed Sections of Coaxial Cable: 756
 APOTA Tracking Antennas: 741
 Arrays: 741, 756, 766, 926
 Automatic Tracking, for Telemetering: 741

High-Gain TV, Slotted Ring: 926
 Long Linear, Design of: 766
 Vertical, Made of Transposed Sections of Coaxial Cable: 756
 Atmospherics, Air Force Communications Problem: 969
 Atomic Bomb, Air Burst, Effects on Tactical Communication System: 980
 Attenuator, Microwave, Amplitude Regulator for Signal Sources: 872
 Audio Flutter Weighting Network: 922
 Aurora, Radar Reflections from: 734
 Automatic Controls: 773, 824
 Modulated: 773
 Optimum Switching Criteria: 824
 Automatic Remote Control and Telemetering by Telephone: 760
 Automatic Tracking Antennas for Telemetering: 741
 Automation: 825, 897, 899
 Circuit Design for: 897
 Reasonableness Check: 825
 Technique for Soldering Components: 899
 Automobile Phonograph System: 934

B
 Backward-Wave Oscillators: 788, 789
 for Low-Voltage Operation: 789
 Tubes: 788
 Battery, Silver-Zinc, Rechargeable: 903
 Bi-Directional Pulse Totalizer for Control and Telemetry: 743
 Binaural Temporal and Amplitude Disparity and Human Direction Perception: 989
 Biological Cells, Surface Resonances of: 995
 Biophysics and Medical Electronics: 1007
 Bit-Squeezing Technique Applied to Speech Signals: 843

BIZMAC: 828, 829
 Input and Output Devices: 829
 Logic Design of: 828
 Boiling Water Reactor Power Plant, Control Aspects of: 1003
 Bombing System Reliability Program: 890
 Brain Tumor Localization Using Positron-Emitting Radioactive Isotopes: 990
 Brainstorm Panels: 893
 Breakdown, High Power, of Microwave Structures: 877
 Briefing Laymen on Engineering Information: 892
 Broadcasting: 926, 944
 Remote, Transistorized Program Amplifier for: 944
 Television, High-Gain, Slotted-Ring Arrays: 926

C

Cameras, Color Television, Vidicon: 920
 Cancer Detection by Cytoanalyzer: 991
 Capacitors: 912, 913, 915
 Cascaded Feedthrough: 912
 Tantalum Solid Electrolytic: 915
 Tube Feedthrough, Performance Above VHF: 913
 Cascaded Feedthrough Capacitors: 912
 Cathodes: 793, 794
 Interface Impedance, Measurement of: 794
 Long-Life, for UHF Transmitting Tubes: 793
 Cavities, Resonant, Frequency Duplexer: 863
 Chromatron Television Receiver: 800
 Circuits: 778, 896, 897, 898, 900, 901, 911, 1000
 Designs for Automation: 897
 Modular Construction, Implications to Design Engineer: 898
 Printed: 896, 900, 901, 911
 Cupric Oxidized Foil for Laminates: 901
 Engineering to Facilitate Production: 896
 Standards and Test Procedures: 911
 Xerography: 900
 Transistor: 778, 1000
 Graphical Analysis by Separation of Variables: 778
 in Magnetic Core Type Kicksorter: 1000
 Circular Polarization for Aircraft Radar Return: 959
 Coaxial Cables, Leakage Radiation: 851
 Coaxial Components Employing Gaseous Discharges at Microwave Frequencies: 876
 Coded Picture Transmission: 941
 Coders, High Speed, Electronic, for Telemetering: 763
 Coding Theory, Results in: 838
 Color Television: 798, 799, 800, 801, 802, 803, 805, 806, 807, 808, 809, 918, 920, 935, 936, 937, 938, 939, 942
 Cameras, Vidicon: 920
 Chromacity Coordinate-Plotting Photometer: 942
 Color Purity: 807
 Kinescopes: 805, 809
 Focusing Grill, Color: 809
 Improvements: 805
 Magnetic Tape Recording: 935, 936, 937, 938, 939
 Audio Systems: 939
 Electronic System: 936
 Magnetic Head: 937
 Transport Mechanism: 938
 Mask-Focusing Colortron: 808
 Masker: 918
 Post Acceleration Color Tube, GE: 806
 Receivers: 798, 800, 802, 803, 804
 Apple Beam Indexing System: 802, 803, 804
 Chromatron: 800
 Transient Response vs. Chrominance Bandwidth: 798

Tubes: 799, 801
 Deflection and Convergence System: 799
 Phosphor Efficiencies: 801
 Colortron, Unipotential Mask-Focusing: 808
 Communication through Noisy Random-Multipath Channels: 844
 Communication Systems: 733, 980, 984, 985, 986, 987, 988
 Interference Produced by UHF Scatter and Line-of-Sight Systems: 988
 Over-the-Horizon Radio Link: 985, 986, 987
 Broadband, between Florida and Cuba: 986
 between Puerto Rico and Dominican Republic: 987
 Transmission Tests between Florida and Cuba: 985
 Radar-Type Propagation Survey Experiments for: 733
 Tactical Effects of Air Burst Bomb on: 980
 VHF Transhorizon: 984
 Comparators, Quadrature Time Base, for Automatic Frequency Measurement: 871
 Computers: 820, 826, 828, 829, 830, 831, 832, 833, 834, 835, 836
 Analog: 820, 826
 Multiplier, Multiple Input: 826
 Statistical Functions Evaluated by: 820
 Impact on Science and Society: 836
 Magnetic Drum: 831, 832
 Extension to Gamma 3 Computer: 832
 Sorting System: 831
 in Univac: 835
 Printers, Burroughs G-101 High Speed: 830
 RCA BIZMAC: 828, 829
 Input and Output Devices: 829
 Logic Design of: 828
 Univac Magnetic: 833, 834, 835
 Drum Memory: 835
 Logical Design and Specifications: 833
 Megacycle Magnetic Modules: 834
 Cross Polarization Effects on Antenna Radiation Patterns: 755
 Crosstalk in Multiplexed FM Systems: 761
 Crystals, Reducing Frequency Variations over Wide Temperature Range: 954
 Cupric Oxidized Foil for Printed Circuit Laminates: 901
 Current Distribution on Curved Reflectors: 738
 Cytology, Automatic High-Speed Measurement Techniques for: 991

D

Data Handling Systems: 751, 752, 753, 754, 762, 950, 1001
 Airborne Acquisition System: 752
 Flight Data Collecting and Processing: 751
 High Speed, All Electronic, Fully Automatic: 753
 High Speed, High Quantity, Data Processing Techniques: 754
 Place of Communications in: 950
 Punch Card Recording and Multiple Counting Data: 1001
 Telemeter, High Capacity Pulse Code: 762
 Data Processing, Integrated, Place of Communications in: 950
 Data Transmission and Graphics in Air Force Communications: 965
 Delay Lines, Time Bridge: 870
 Detection: 817, 875
 of Sinusoidal Signals in Gaussian Noise: 817
 Swept, with Automatic Synchronization: 875
 Detectors, Piecewise Quadratic: 818
 Dielectrics: 759, 810, 873
 Bifocal Lenses: 759

Constant, Measurement of, from 100-1200 MC: 873
 Electrets: 810
 Diffraction, Current Distributions on Curved Reflectors: 738
 Direction Finders: 976, 977
 Doppler Type High Frequency: 976
 UHF, USAF: 977
 Direction Perception as Binaural Function of Hearing: 989
 Discontinuous Automatic Controls, Switching Criteria: 824
 Discriminators, Precision Subcarrier, for FM Telemetering: 740
 Doppler Type High Frequency Radio Direction Finders: 976
 Dosimeter, Sensitivity Measurements: 981
 Driving-Point Impedance Functions of Active Networks: 774

E

Earth Satellite: 744, 745, 746, 747, 748, 749, 750
 Exploration of Outer Space: 745
 IGY Program: 744
 Optical Tracking of: 749
 Placing in Orbit: 746, 747
 Telemetering Problem: 747
 Scientific Value of: 750
 Tracking and Telemetering: 748
 Elastic Pulses, Propagation in Cylindrical Bars: 997
 Electrets: 810
 Electrolytic Capacitors, Tantalum Solid: 915
 Electron Beams, Hollow, in Electrostatic Fields: 785
 Electron Guns, Low Noise, for Traveling-Wave Tubes: 787
 Electron Multiplier, Grid Controlled, High Transconductance: 792
 Electron Tubes: 784, 787, 793, 847, 881, 882, 883, 884, 885, 886
 Admittance Matrix Parameters at UHF: 847
 Ambient Temperature, Effects of: 884
 Heater Cycling and Heater Voltage: Effects of: 883
 High-Dissipation Receiving, Heat-Flow Considerations: 791
 Mechanical Excitation, Effects of: 882
 Operating and Environmental Factors: 881
 Plate Voltage, Plate Current and Plate Dissipation, Effects of: 885
 Pulse Operation, Effects of: 886
 Traveling-Wave: 784, 787
 Low Noise Guns: 787
 with Slow-Wave Structures: 784
 UHF Transmitting, Long-Life Cathode for: 793

Electronic Components, Effect of Nuclear Radiation: 979
 Encapsulation, Magnetic Component, for Military Airborne Application: 905
 Engineering Management: 880, 893, 894, 895
 Brainstorm Panels: 893
 Challenges to Manager: 880
 Motivation of Technical People: 895
 Strengthening the Recognition of Engineering: 894
 Equalization Considerations in Direct Magnetic Recording for Audio Purposes: 931
 Events-Per-Unit-Time Meter: 849, 850
 Forty KC, Magnetic Techniques: 850
 Transistorized: 849

F

Feedbacks: 770, 771, 772, 821, 823
 Control of Length-Modulated Pulse Generator: 821
 Control Systems, 770, 771
 Design of: 770
 Problem of Stability: 771
 Nonlinear, Measurement and Stabilization of: 823

Systems, Synthesis by Inverse Root-Locus Method: 772
 Feedthrough Capacitors: 912, 913
 Cascaded: 912
 Tubular, Continuous and Discontinuous, Performance at VHF Range: 913
 Ferrites: 757, 856, 857, 858, 859, 860, 861, 868, 872
 Amplitude Regulator for Microwave Signal Sources: 872
 Balanced Strip Line Isolator: 861
 Broadbanding Microwave Isolators: 859
 Loop Antennas: 757
 Magnetic Head for Megacycle Range: 868
 Microwave Phaseshifters: 860
 Miniaturized High Temperature Isolator: 858
 Non-Reciprocal Phase Shift Sections: 856
 Tensor Permeabilities below Magnetic Saturation: 857
 Ferrod Radiation Systems: 765
 Field Intensity Measurements on Induction-Heating Equipment: 908
 Filters: 780, 819, 845, 862, 863, 864, 865, 914 to Correct Multipath Distortion of TV Signals: 845
 Crossed-Mode Tunable Selector for Microwaves: 865
 Directional Channel-Separation: 862
 Nonlinear, Experimental Determination of Optimum: 819
 Piezoelectric Ceramic IF Band-Pass: 914
 RC, Tchebycheff Band-Pass: 780
 Resonant Cavity Frequency Duplexer: 863
 Wide-Band Microwave, Synthesis for Prescribed Insertion Loss: 864
 Flight Control, Human Operator Characteristics: 958
 Flight Data: 751, 752, 753, 754
 Airborne Acquisition System: 752
 Collecting and Processing of Test Flight Data: 751
 High Speed, All-Electronic, Fully Automatic Handling System: 753
 High Speed, High Quantity Processing Techniques: 754
 Flutter: 922, 923
 Audio, Weighting Network: 922
 Meter, with Subjective Weightings: 923
 Frequency Measurements, Automatic, by Quadrature Time Base Comparator: 871
 Frequency Modulation: 740, 761
 Multiplexed Systems, Noise and Crosstalk: 761
 Telemetry, Precision Subcarrier Discriminator for: 740
 Future of Vehicular Communication: 948

G

Gas Discharge Plasma in Microwave Coaxial Components: 876
 Generators, Television Synchronization, High Stability: 916
 Geneva Conference Reactor, Control and Automatic Startup: 1004
 Graphics and Data Transmission in Air Force Communications: 965

H

Hearing Mechanism, Direction Perception as a Binaural Function: 989
 Heat-Flow Considerations in the Design of High-Dissipation Receiving Tubes: 791
 Heating Equipment, Induction, Field Intensity Measurements: 908
 High Fidelity, Transistor Audio Amplifier: 932
 High Frequency Shields: 907
 Hollow Beams in Electrostatic Fields: 785
 Human Flight Control, Analysis for: 958
 Human Relations Responsibilities of Engineers: 879
 Hy-Tramp Electron Multiplier: 792

I

Idiot II Data Processing Techniques: 754
 Image Orthicon for Pickup at Low Light Levels: 790
 Impedance: 774, 794, 874
 Cathode Interface, Measurement of: 794
 Driving Point, of Active Networks: 774
 Plotter, Automatic, Z-Scope of: 874
 Induction Heating Equipment, Field Intensity Measurements: 908
 Industrial Research of the Future: 878
 Information Theory: 816, 839, 841
 Prediction Theory Approach to Information Rates: 841
 and Quality Control: 816
 Session Commentary: 839
 Information Transmission Systems, Coherence, Modulation and Selectivity: 837
 Instrument Opportunities in Nuclear Systems: 1002
 Instrumentation, Radiological: 983
 Intercommunication System for Operating Room: 992
 Interference from Over-the-Horizon UHF and Line-of-Sight Systems: 988
 International Geophysical Year Program: 744
 Ionospheric Cross Modulation from 1000 KW Transmitter: 730
 Iris, Susceptance of: 866
 Isolators: 858, 859, 861
 Balanced-Stripline: 861
 Broadbanding Ferrite Microwave: 859
 Miniaturized High Temperature: 858
 Isotopes, Positron-Emitting, for Brain Tumor Localization: 990

K

Kicksorter, Magnetic Core Type, Transistor Circuits in: 1000
 Kinescopes, Color: 805, 809
 Focusing Grill: 809
 Improvements in: 805
 Klystrons, Rapid-Interchange for Transmitter Tuning: 785

L

Laminates, Cupric Oxidized Foil for: 901
 Lenses: 759, 764
 Dielectric Bifocal: 759
 Microwave, High Efficiency: 764
 Line-of-Sight Systems, Interference Relative to Over-The-Horizon UHF Systems: 988
 Loudspeakers, Enclosures, Distributed Port Performance: 933

M

Magnetic Component Encapsulation for Military Airborne Application: 905
 Magnetic Core: 952, 1000
 Kicksorter, Transistor Circuits in: 1000
 Memory Circuits in 16 Channel Multiplex System: 952
 Magnetic Drum: 831, 832, 835
 Extension to Gamma 3 Computer: 832
 Memory: 835
 Sorting System: 831
 Magnetic Recordings, Audio Direct, Equalization Considerations: 931
 Magnetic Tape: 867, 869, 924, 935, 936, 937, 938, 939
 Color TV Recordings: 935, 936, 937, 938, 939
 Audio System: 939
 Electronic System: 936
 Magnetic Head: 937
 Transport Mechanism: 938
 Data Storage Considerations: 869
 Performance Measurement: 924
 for Repetitive Examination of Transient Phenomena: 867
 Masker for Color Television: 918

Measurements: 794, 846, 847, 848, 871, 873, 875, 908, 924, 928, 981, 982, 991
 of Cathode Interface Impedance: 794
 to Classify Cytological Smears: 991
 of Dielectric Constant from 100-1200 MC: 873
 Dosimeter Sensitivity to Radiation: 981
 of Electron Tube Admittance Matrix Parameters at UHF: 847
 Field Intensity, on Induction-Heating Equipment: 908
 Frequency, Automatic, by Quadrature Time Base Comparator: 871
 of High Gamma Exposure Rates: 982
 of Magnetic Tape Recorder Performance: 924
 Swept, Double Detection System with Automatic Synchronization: 875
 Television Field Strength: 928
 Transistor, at High Power Levels: 848
 VHF-UHF, Transadmittance Meter for: 846
 Medical Electronics: 1005, 1006, 1007, 1008 as Aid to Medical Progress: 1005
 and Biophysics: 1007
 Where Is It Going?: 1006, 1008
 Memories, Magnetic Drum, for Univac: 835
 Memory Circuits for 16 Channel Multiplex System: 952
 Microwave Reflector, Toroidal: 769
 Microwave Spectrum Synthesis with the Traveling-Wave Tube: 854
 Microwave Structures, High Power Breakdown of: 877
 Military Equipment, Power Supply in: 902
 Miniaturization of VHF Oscillator: 945
 Minitrack System for Tracking Earth Satellites: 748
 Missiles: 891, 974
 Guidance Accuracy, Analytic Prediction of: 974
 Reliability in Production: 891
 Mobile Communications: 947, 948, 949
 Future of: 948
 More Words Per Minute Per Kilocycle: 947
 Operation at 960 Mc: 949
 Modular Construction, Implications to Design Engineer: 898
 Modulated Control Systems: 773
 Modulation, Ionospheric Cross, from Long Wave Transmitter: 730
 Modules, Megacycle Magnetic, for Univac: 834
 Motivation of Technical People: 895
 Multipath Distortion of TV Signals and Design of Corrective Filter: 845
 Multiplex Systems: 761, 952
 FM, Noise and Crosstalk: 761
 Sixteen Channel, with Transistors and Magnetic Core Memory Circuits: 952
 Multiplexer, High-Speed Electronic, for Telemetry: 763
 Multipliers, Analog: 826, 827
 Multiple Input: 826
 Using Switching Transistors: 827

N

Navigation Systems: 975, 978
 Long Range, Considerations Affecting Choice: 975
 TACAN VOR-DME Systems, Co-location of: 978
 Nerve Impulse Transmission, Limits on: 840
 Networks: 770, 774, 775, 776, 777, 779, 781, 822, 922
 Active: 774, 775, 776
 Driving Point Impedance Functions of: 774
 Synthesis: 775
 Transistor Stability: 776
 Audio Flutter Weighting: 922
 Noisy, Invariants: 777
 Nonlinear Noise Suppression: 822
 RC Pulsed, for Sampled-Data Systems: 781

Synthesis, Simple and Double Alternation in: 779
 Theory, and Feedback Control System Design: 770
 Nonlinear Systems: 819, 822, 823
 Experimental Determination of Optimum: 819
 Feedbacks, Measurement and Stabilization of: 823
 Noise Suppression: 822
 Nonreciprocal Phase Shift Sections: 856
 Noise: 736, 761, 777, 817, 818, 822, 844, 969
 as Air Force Communications Problem: 969
 Detectors, Piecewise Quadratic: 818
 Gaussian, Detection of Sinusoidal Signals: 817
 Invariants of Linear Noisy Networks: 777
 in Multiplexing FM Systems: 761
 Precipitation Static in Aircraft Antennas: 736
 in Random Multipath Channels: 844
 Suppression in Nonlinear Systems: 822
 Nuclear Power Plant, Experimental Boiling Water Reactor Type, Control Aspects of: 1003
 Nuclear Radiation: 979, 980, 981, 982, 983
 from Air Burst Bomb, Effects on Tactical Communication System: 980
 Effects on Electronic Components: 979
 Measurements of: 981, 982, 983
 Dosimeter Sensitivity: 981
 Field, Instrumentation for: 983
 at High Rates: 982
 Nuclear Reactor, Geneva Conference, Control and Automatic Startup: 1004
 Nuclear Systems, Instrument Opportunities in: 1002
 Numerical Analysis, Operational Calculus for: 782

O

Operating Room Intercommunication System: 992
 Operational Calculus for Numerical Analysis: 782
 Optical Tracking of Earth Satellite: 749
 Orthogonal Mode Transducer: 855
 Oscillators: 788, 789, 945, 954
 Backward-Wave: 788, 789
 for Low Voltage Operation: 789
 Tubes: 788
 Crystal, Reducing Frequency Variation over Wide Temperature Range: 954
 VHF, Miniaturization of: 945
 Over-the-Horizon Systems: 984, 985, 986, 987, 988
 Broadband Link for Florida and Cuba: 986
 Radio Link between Puerto Rico and Dominican Republic: 987
 Radio Transmission Tests between Florida and Cuba: 985
 UHF, Interference Relative to Line-of-Sight Systems: 988
 VHF, Design of: 984

P

Phase Comparison Method for Tracking Earth Satellite: 748
 Phaseshifters: 856, 860
 Ferrite Microwave: 860
 Nonreciprocal Sections: 856
 Phonograph System for Automobiles: 934
 Phosphor Efficiencies in Color Television Tubes: 801
 Photometer for Chromacity Coordinate-Plotting: 942
 Physiograph: 993
 Piezoelectricity: 914, 996, 998
 Filters, Ceramic IF Band Pass: 914
 Transducers: 996, 998
 Electronic Design Considerations: 996
 Ultrasonic, Transient and Steady-State Response: 998

Plotters, Automatic Impedance, Z-Scope of: 874
 Polarization, Circular, for Aircraft Radar Return: 959
 Positron Scanner for Brain Tumor Localization: 990
 Power Plant, Nuclear, Experimental Boiling Water Type: 1003
 Power Supply: 902, 906, 909
 for Electrodynamical Shakers: 909
 Transistor Inverter Circuit for: 906
 in Military Equipment: 902
 Precipitation Particle Impact Noise in Aircraft Antennas: 736
 Prediction Theory Approach to Information Rates: 841
 Printed Circuits: 896, 900, 901, 911
 Cupric Oxidized Foil for Laminates: 901
 Engineering to Facilitate Production: 896
 Standards and Test Procedures: 911
 Xerography: 900
 Pulses: 743, 821, 904, 997
 Elastic, Propagation in Cylindrical Bars: 997
 Generators, Length-Modulated, Feedback Control of: 821
 Totalizer, Bi-Directional, for Control and Telemetry: 743
 Transformer, Wafer Type: 904
 Punch Card Recording and Multiple Counting Data: 1001

Q

Quadrature Time Base Comparator for Automatic Frequency Measurements: 871
 Quality Control: 816, 889
 and Information Theory: 816
 Training for: 889
 Quantizing: 842, 843
 Bit-Squeezing Technique Applied to Speech Signals: 843
 Reduced Alphabet Representation of TV Signals: 842
 Quartz, Synthetic, Resonator Properties of: 999

R

Radar: 733, 734, 735, 955, 959, 960
 Air Traffic Control Symbolic Display System: 955
 Airborne Reflectors and Circular Polarization: 959
 Aircraft Visibility Diagram, Three Dimensional: 960
 Propagation Survey Experiments for Communications Systems: 733
 Reflections from Aurora: 734
 Sea Clutter, Correlation on Measurements: 735
 Radiac Systems, Dosimeter Sensitivity Measurements: 981
 Radiation: 755, 765, 851, 979, 980, 981, 982, 983
 from Air Burst Bomb, Effects on Tactical Communication System: 980
 from Antennas, Effects of Cross Polarization: 755
 Leakage from Braided Coaxial Cable: 851
 Measurements: 981, 982, 983
 Dosimeter Sensitivity: 981
 Field, Instrumentation for: 983
 at High Rates: 982
 Nuclear, Effects on Electronic Components: 979
 Radiators, Ferrod: 765
 Radioactive Isotopes, Positron-Emitting, for Brain Tumor Localization: 990
 Radiological Instrumentation: 983
 Radiometric Inertial Reference System: 973
 Radomes for Ground Electronic Equipment: 768
 Random-Multipath Channels, Noisy, Communication through: 844
 Receivers: 796, 798, 802, 803, 804

Battery-Powered, Transistors for: 796
 Color Television: 798, 802, 803, 804
 Apple Beam Indexing System: 802, 803, 804
 Transient Response vs. Chrominance Bandwidth: 798
 Receiving Tubes, High Dissipation, Heat-Flow Considerations: 791
 Recorders, Magnetic Tape, Performance Measurements: 924
 Recordings, Magnetic, Audio Direct, Equalization Considerations: 931
 Reflectors: 738, 769, 959
 Airborne, for Aircraft Radar Return: 959
 Curved, Current Distributions on: 738
 Toroidal, Microwave: 769
 Refraction, Atmospheric, of 8.7 MM Radiation: 731
 Regulator, Amplitude, for Microwave Signal Sources: 872
 Reliability: 887, 888, 889, 890, 891, 910
 Bombing System Program: 890
 in Magnetic Amplifier Production: 910
 for Missiles, in Production Phase: 891
 in Systems Design: 888
 Training for Quality Control: 889
 with Unreliable Components and Equipment: 887
 Remote Broadcasting Transistor Amplifier: 944
 Remote Control by Telephone: 760
 Resonances, Surface, of Bubbles and Biological Cells: 995
 Resonators, Synthetic and Doped Synthetic Quartz: 999

S

Sampled Data Systems, Pulsed RC Networks: 781
 Sampling: 783, 843
 Bit-Squeezing Technique Applied to Speech Signals: 843
 Lags, Compensation for: 783
 Scattering: 732, 734
 by Nonisotropic Irregularities: 734
 Sea Clutter: 732
 Sea Clutter: 732, 735
 Radar, Correlation of Measurements: 735
 Recent Developments in Theory: 732
 Selectivity Curves for Analysis of Communication Equipment and System Performance: 951
 Selectors, Microwave, Crossed-Mode Tunable: 865
 Semiconductors, Capacitance Amplifier: 815
 Shakers, Electrodynamical, Power Supply Considerations: 909
 Shields, High Frequency: 907
 Signals, Sinusoidal, Detection in Gaussian Noise: 818
 Silver-Zinc Rechargeable Battery: 903
 Soldering of Components, Automation Technique: 899
 Spectrum Synthesis, Microwave, with Traveling-Wave Tube: 854
 Speech Signals, Bit-Squeezing Technique Applied to: 843
 Standards for Printed Circuits: 911
 Statistical Functions, Evaluation by Analog Computer: 820
 Strengthening the Recognition of Engineering: 894
 Strip Lines, Isolator: 861
 Stroboscope, Ultrasonic: 994
 Subscription Television, Technical Boundary Conditions: 940
 Surface Resonances of Bubbles and Biological Cells: 995
 Switching: 824, 827
 Discontinuous Automatic Controls: 824
 Transistors for Analog Multipliers: 827

T

TACAN VOR-DME Systems, Co-location of: 978
 Tantalum Solid Electrolytic Capacitors: 915

Tape Recorders, Magnetic, Performance Measurements: 924
 Tape Recordings, Magnetic: 867, 935, 936, 937, 938, 939
 for Color Television: 935, 936, 937, 938, 939
 Audio System: 939
 Electronic System: 936
 Magnetic Head: 937
 Transport Mechanism: 938
 Repetitive Examination of Transient Phenomena: 867
 Tchebycheff RC Band-Pass Filters, Synthesis of: 780
 Teamwork Brainstorming Solves Problems: 893
 Telemetering: 740, 741, 742, 743, 747, 748, 760, 762, 763
 Automatic Tracking Antennas for: 741
 Bi-Directional Pulse Totalizer: 743
 of Earth Satellite: 748
 of Earth Satellite Launching Vehicle: 747
 FM, Precision Subcarrier Discriminator: 740
 High Capacity Pulse Code Telemeter: 762
 High Speed Electronic Multiplexer and Coder: 763
 by Telephone: 760
 Transmitter, Sub-Miniature: 742
 Telephone for Automatic Remote Control and Telemetering: 760
 Television: 790, 798, 799, 800, 801, 802, 803, 804, 805, 806, 807, 808, 809, 842, 845, 916, 917, 918, 919, 920, 926, 927, 928, 929, 930, 935, 936, 937, 938, 939, 940, 941, 942, 943
 Amplifiers, Pedestal Processing: 917
 Antennas: 926, 927
 Arrays, High-Gain, Slotted Ring: 926
 Self-Diplexing: 927
 Coded Picture Transmission: 941
 Color: 798, 799, 800, 801, 802, 803, 804, 805, 806, 807, 808, 809, 918, 920, 935, 936, 937, 938, 939, 942, 943
 Black and White Film Improvements for Use in: 943
 Cameras, Vidicon: 920
 Chromacity Coordinate-Plotting Photometer: 942
 Color Purity: 807
 Kinescope, Focusing Grill: 809
 Kinescope Improvements: 805
 Magnetic Tape Recording: 935
 Magnetic Tape Recording Audio System: 939
 Magnetic Tape Recording Electronic System: 936
 Magnetic Tape Recording Magnetic Head: 937
 Magnetic Tape Recording Transport Mechanism: 938
 Mask-Focusing Colortron: 808
 Masker: 918
 Receivers, Apple Beam-Indexing System: 802, 803, 804
 Receivers, Chromatron: 800
 Receivers, Transient Response vs. Chrominance Bandwidth in: 798
 Tubes, Deflection and Convergence System: 799
 Tubes, Phosphor Efficiencies: 801
 Tubes, Post Acceleration Color: 806
 Field Strength Measurements: 928

Image Orthicons at Low Light Levels: 790
 Multipath Distortion of Signals and Design of Corrective Filter: 845
 Pack Type System: 930
 Picture Signals, Reworking of: 919
 Reduced-Alphabet Representation of Signals: 842
 Subscription, Technical Boundary Conditions: 940
 Synchronization Generator, High Stability: 916
 Transmitters, Monitor for: 929
 Testing of Printed Circuits: 911
 Tetrodes, High Frequency: 811, 814
 NPN Germanium: 811
 Toroidal Microwave Reflector: 769
 Totalizer, Bi-Directional Pulse, for Control and Telemetry: 743
 Tracking: 737, 741, 973
 Automatic, Antenna Arrays for Telemetering: 741
 Conical Scan Antennas for: 737
 Radiometric Inertial Reference System: 973
 Transadmittance Meter for VHF-UHF Measurements: 846
 Transducers: 739, 855, 868, 996, 998
 Magnetic Head for Megacycle Range: 868
 Orthogonal Mode: 855
 Piezoelectric: 996, 998
 Electronic Design Considerations: 996
 Ultrasonic, Transient and Steady-State Response: 998
 Wire Strain System Calibration: 739
 Transformers: 797, 904
 Double-Tuned IF, for Transistor Amplifiers: 797
 Wafer Coil Pulse: 904
 Transient Response: 798, 867
 vs. Chrominance Bandwidth in Receivers: 798
 Repetitive Examination by Magnetic Tape: 867
 Transmission Lines: 758, 861, 870
 Bridges, Wide Band Coaxial Hybrid: 758
 Strip, Isolator: 861
 Time Bridge: 870
 Transmitters: 730, 742, 785, 929
 Ionospheric Cross Modulation: 730
 Sub-Miniature, for Telemetering: 742
 Television, Monitor for: 929
 Tuning by Rapid-Interchange Klystrons: 785
 Transmitting Tubes for Linear Amplifier Service: 953
 Transistors: 776, 778, 795, 796, 797, 811, 812, 813, 814, 827, 848, 849, 906, 921, 932, 944, 952, 1000
 Amplifiers: 795, 797, 921, 932, 944
 Audio: 921
 Audio, High Fidelity, 10 Watts: 932
 Double-Tuned IF Transformers for: 797
 IF, Stability Considerations: 795
 for Remote Broadcasting: 944
 for Battery-Powered Portable Receivers: 796
 Circuits, in Magnetic Core Type Kick-sorter: 1000
 Events-Per-Unit-Time Meter: 849
 Graphical Analysis by Separation of Variables: 778

Inverter Circuit for Power Supply: 906
 Measurements at High Power Levels: 848
 Power Gain and Parameters as Functions of Temperature and Frequency: 813
 Power, Optimum Design: 812
 for Sixteen Channel Multiplex System: 952
 Stability: 772
 Switching for Analog Multipliers: 827
 Tetrodes, High Frequency: 811, 814
 NPN: 811
 Traveling-Wave Tubes: 784, 787, 854
 Low Noise Guns: 787
 Microwave Spectrum Synthesis: 854
 with Slow-Wave Structures: 784
 Tube Feedthrough Capacitors, Continuous and Discontinuous, Performance above VHF: 913

U

Ultrasonics: 994, 995, 996, 997, 998, 999
 Piezoelectric Transducers: 996, 998
 in Electronic Design: 996
 Transient and Steady-State Response: 998
 Propagation of Pulses in Cylindrical Bars: 997
 Resonator Properties of Synthetic and Doped Synthetic Quartz: 999
 Stroboscope: 994
 Surface Resonances of Bubble and Biological Cells: 995
 Univac Magnetic Computer: 833, 834, 835
 Drum Memory: 835
 Logical Design and Specifications: 833
 Megacycle Magnetic Modules: 834

V

Vanguard Earth Satellite Program: 744, 745, 746, 747, 748, 749
 Vibrators, Communication, New Design Concept: 946
 VOR-DME TACAN Systems, Co-location of: 978

W

Wafer Coil Pulse Transformer: 904
 Wave Propagation: 729, 730, 731, 733, 969, 997
 and Air Force Communications: 969
 Atmospheric Refraction of 8.7 MM Radiation: 731
 Ionospheric Cross Modulation from 1000 KW Transmitter: 730
 of Pulses in Cylindrical Bars: 997
 Radar Type, for Communications Systems: 733
 Tropospheric, over 350 Mile Path at 960 MC: 729
 Waveguides: 739, 767, 852, 853, 856, 866
 Circular, Susceptance of a Circular Iris: 866
 H-Guide, for Microwaves: 853
 Junction, Trimode, Turnstile: 852
 Non-Reciprocal Phase Shift Sections: 856
 Trough, for Microwave Antennas: 767
 Wire Strain Transducer System Calibration: 739
 Words Needn't Fail: 892

X

Xerography for Printing Circuits: 900



1956 IRE CONVENTION RECORD PRICES

Part	Title	Sponsored by the Following IRE Professional Groups	Prices for Members (M) Colleges and Public Libraries (L) Non-Members (NM)		
			M	L	NM
1	Telemetry, Antennas and Propagation	Antennas and Propagation Telemetry and Remote Control	\$3.00	\$7.20	\$9.00
2	Circuit Theory	Circuit Theory	1.25	3.00	3.75
3	Electron Devices and Receivers	Broadcast and Television Receivers Electron Devices	2.50	6.00	7.50
4	Computers, Information Theory, Automatic Control	Automatic Control Electronic Computers Information Theory	3.50	8.40	10.50
5	Microwave and Instrumentation	Instrumentation Microwave Theory and Techniques	2.75	6.60	8.25
6	Manufacturing Electronics	Component Parts Engineering Management Industrial Electronics Production Techniques Reliability and Quality Control	3.25	7.80	9.75
7	Audio and Broadcast	Audio Broadcast Transmission Systems	2.25	5.40	6.75
8	Aeronautical, Communication and Military Electronics	Aeronautical and Navigational Electronics Communications Systems Military Electronics Vehicular Communications	2.75	6.60	8.25
9	Ultrasonics, Medical and Nuclear Electron- ics	Medical Electronics Nuclear Science Ultrasonic Engineering	1.50	3.60	4.50
	Complete Convention Record (All Nine Parts)		\$22.75	\$54.60	\$68.25



How to get reliability from a *whisker*

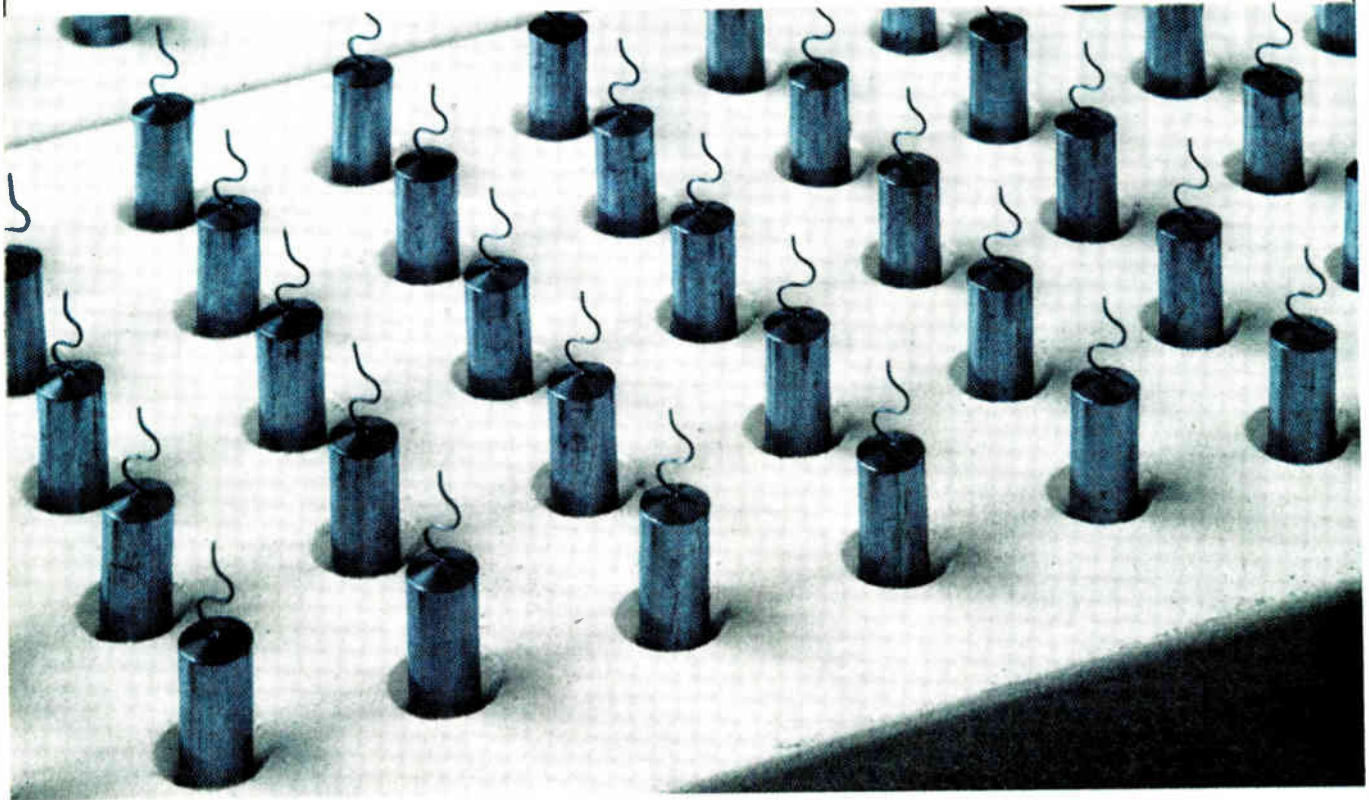

Reliability of germanium and silicon diodes at PSI is achieved through careful development and control of production processes. Reliability can't be added to a diode after its construction; it results from the consistent performance of operations which are specifically developed to yield reliable diodes.

PSI has thoroughly analyzed each operation to determine the interrelation between process variability and end-product reliability. Precise standards have been established, and each operation is constantly monitored.

PSI STANDARDS FOR WHISKERS ARE RIGIDLY MAINTAINED

The whisker-pin assembly must be mechanically strong, within nine controlled dimensional limits, and clean. Whisker point concentricity is maintained within .005". Whisker axis must be within 5° of the pin axis. Whisker

wire must not be pinched at any point. When the whisker is pulled, it must break before the weld tears loose. Finished assemblies are carefully checked to assure freedom from contamination.

PSI applies equal care in the process control of all other parts as well as the final assembly. This consistent policy of determining the relationships between processes of manufacture and product reliability plus continuous process control results in a high degree of built-in reliability that exceeds the exacting standards generally accepted on the market today.



PSI offers new standards of reliability in fusion-sealed germanium and silicon diodes with four basic lead arrangements.

Pacific Semiconductors, Inc.

10451 WEST JEFFERSON BOULEVARD, CULVER CITY, CALIFORNIA



NO TRIMMING NECESSARY WITH BORG ABSOLUTE LINEARITY 900 SERIES MICROPOTS

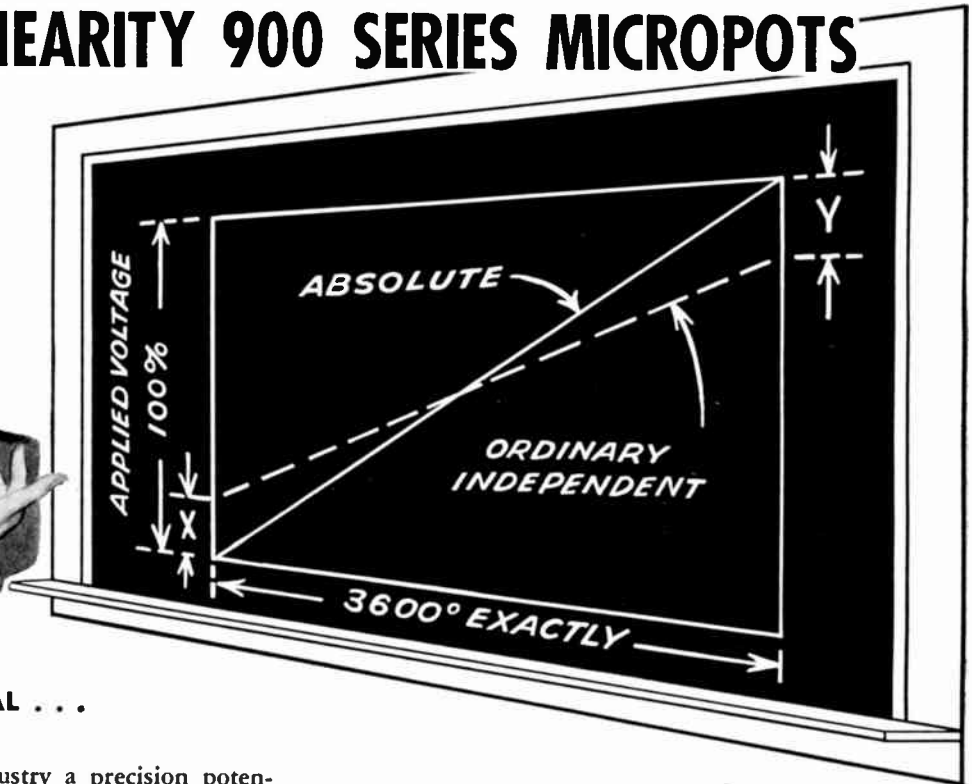

BORG ACHIEVES THE IDEAL . . . ABSOLUTE LINEARITY

Borg offers the electronics industry a precision potentiometer with Absolute Linearity inherent in the pot itself. It requires no trimming of any kind!

THE END OF UNCERTAINTY

Embodied in Borg's new 900 Series 10-turn and 3-turn Precision Potentiometers are exclusive advantages that provide this high degree of accuracy. You get from zero to 100% of applied voltage over exactly 3600° (or 1080°) of shaft rotation.

This means no such parameters as electrical rotation tolerances, end resistance or jump-off resistance need be considered error in output. Many doors, formerly closed to electronic design engineers, are now opened by Borg Absolute Linearity.

ORDINARY INDEPENDENT LINEARITY

Note the line marked "Ordinary Independent" on the blackboard diagram. This line is unable to go to zero and 100% of applied voltage because of X and Y known as end resistances. Therefore, trimming is required to compensate for the potentiometer errors of end resistances X and Y.

Now, note that the line marked "Absolute" goes through zero applied voltage output at zero shaft rotation and through 100% applied voltage output at 3600° of shaft

rotation. This is the reference line for absolute linearity and is inherent in the Borg 900 Series potentiometer. Thus Borg achieves absolute linearity without trimming of any kind.

SIMPLICITY ASSURES RELIABILITY AND ACCURACY

Simplicity of the Borg 900 Series Micropot affords greater accuracy and reliability. It eliminates such possible sources of error as trimming errors, unstable trimming, resistances, etc. Another Borg advantage simplifies assembly and reduces possibility of error. The Borg CCW mechanical stop is set up to provide a phasing point. This exclusive advantage reduces field replacement to the purely mechanical process of attaching leads and phasing from the present stop.

ABSOLUTE LINEARITY REDUCES COST

The accuracy and reliability of your equipment is improved with a Borg 900 Series potentiometer which also effects a savings in time and money. Your cost is lowered by eliminating trimming resistors and the technically trained labor competent to install them.

Many other advantages of the Borg 900 Series can help solve your potentiometer problems as they are now doing in all types of equipment from jet engines to steel mills.

Write for Complete Engineering Data • CATALOG BED-A56

BORG EQUIPMENT DIVISION
THE GEORGE W. BORG CORPORATION
JANESVILLE, WISCONSIN



Built by Borg



TRAIL BLAZER

Unlike companies offering stock equipment, REL specializes in solving problems: radio problems. For thirty-four years, REL's design and manufacturing skill and facilities have been devoted to blazing new trails.

Brilliant and unrivaled success is being achieved by REL in these and related applications:

- Tropospheric scatter systems*
- Point-to-point communications (long & short range)*
- Guided missile control gear*
- Thin route telephone toll service*
- Wave propagation research equipment*

Your specialized radio problems deserve solution by REL.



Radio Engineering Laboratories, Inc.

36-40 37th St • Long Island City 1, N Y

Stillwell 6-2100 • Teletype: NY 4-2816

Canadian representative: AHEARN & SOPER CO • BOX 715 • OTTAWA

*Creative careers at REL await a few exceptional engineers.
Address resumes to James W. Kelly, Personnel Director.*

New

Allen-Bradley developments

GREATER COLOR PURITY—BETTER CONVERGENCE

1.

FULL ROUND YOKE CORES

FOR COLOR TV

ALSO BLACK AND WHITE

Allen-Bradley has developed a method of producing ferrite deflection yoke cores as a full 360° ring! Unlike cores made from quarter rounds, the new full round cores are perfectly concentric and have parallel inner surfaces. They require no grinding. The round rings are "cracked" into halves and taped for shipment. Assembly is quick and economical. The tape is rolled back, the core is slipped over the coils, and the tape put back in place. The core's concentricity assures better convergence and greater color purity.



These ferrite yoke cores are produced as full rounds, and are "cracked" into halves and taped, as shown, for easy assembly.

2.

FLARED YOKE FERRITE CORES

FOR NEW 110° TUBE . . . SAVES WEIGHT

For the new 110° picture tube, Allen-Bradley has developed a flared yoke ferrite core whose outer surface is also shaped to reduce the amount of material required. This makes possible a weight reduction of approximately 30% over conventional cylindrical cores.

The new flared yoke is produced as a solid piece but, with the Allen-Bradley method, the yoke is "cracked" into halves, yet a perfect ring is maintained. Available in Allen-Bradley Class WO-1 ferrites which are to be preferred because of their uniform magnetic characteristics.

Allen-Bradley Co.
114 W. Greenfield Ave.
Milwaukee 4, Wis.

In Canada—
Allen-Bradley Canada Ltd., Galt, Ont.

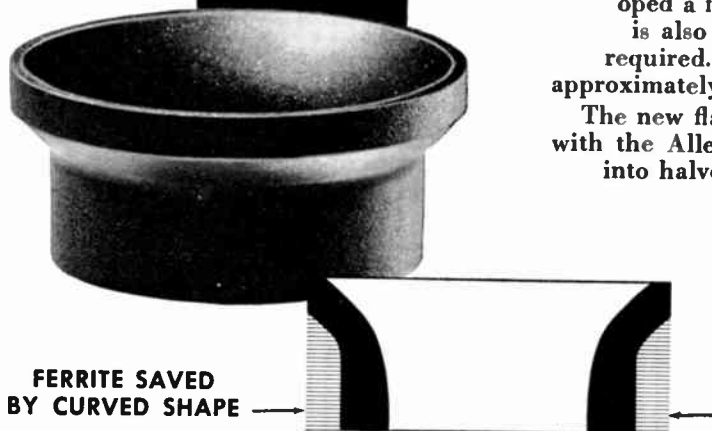

FERRITE SAVED
BY CURVED SHAPE



ALLEN - BRADLEY

RADIO, ELECTRONIC, AND TELEVISION COMPONENTS

QUALITY



Professional Group Meetings

ANTENNAS & PROPAGATION— MICROWAVE THEORY & TECHNIQUES

Albuquerque—Los Alamos—
September 19

"Antennas in Radio Astronomy,"
B. M. Fannon, University of New Mexico.

San Diego—October 9

"New Developments in Automation,"
E. M. Grabbe, Ramo-Wooldridge Corp.

AUDIO

Syracuse—September 12

"Recent Developments in Recording
and Reproduction of Music," J. B. Mint-
er, Components Corporation.

BROADCAST & TELEVISION RECEIVERS

Los Angeles—September 27

"Projected Outlook for Radio and Tel-
evision Receivers," C. A. Nichols, Hoff-
man Radio and Television.; "Significance
of Patent System Pertaining to the Tech-
nological Field," B. L. Birchard, Hoffman
Laboratories, Inc.

COMMUNICATIONS SYSTEMS

Rome—Utica—April 3

"DEW Line," K. B. Clarke, Western
Electric Company.

COMPONENT PARTS

Los Angeles—September 10

"The Electrolytic Film," John Burn-
ham, Engineering Consultant; "Mercury
Wetted Contact Relays—a Film on High
Speed Operation," Reginald Thatcher,
C. P. Clare Co.

Washington—September 12

"Statistical Concepts in Life Testing,"
Marvin Zelen, Statistical Engineering
Section of the National Bureau of Stand-
ards.

ELECTRONIC COMPUTERS

Los Angeles—September 20

"DIANA Data Processing System,"
by N. J. Dean, Ramo-Wooldridge.

ELECTRON DEVICES

New York—September 27

"Miniature Ceramic Tubes," J. E.
Beggs, General Electric.

San Francisco—September 19

"Induced Recrystallization in Molyb-
denum and Tungsten Filaments," E. A.
Coomes, Notre Dame University.

(Continued on page 104A)

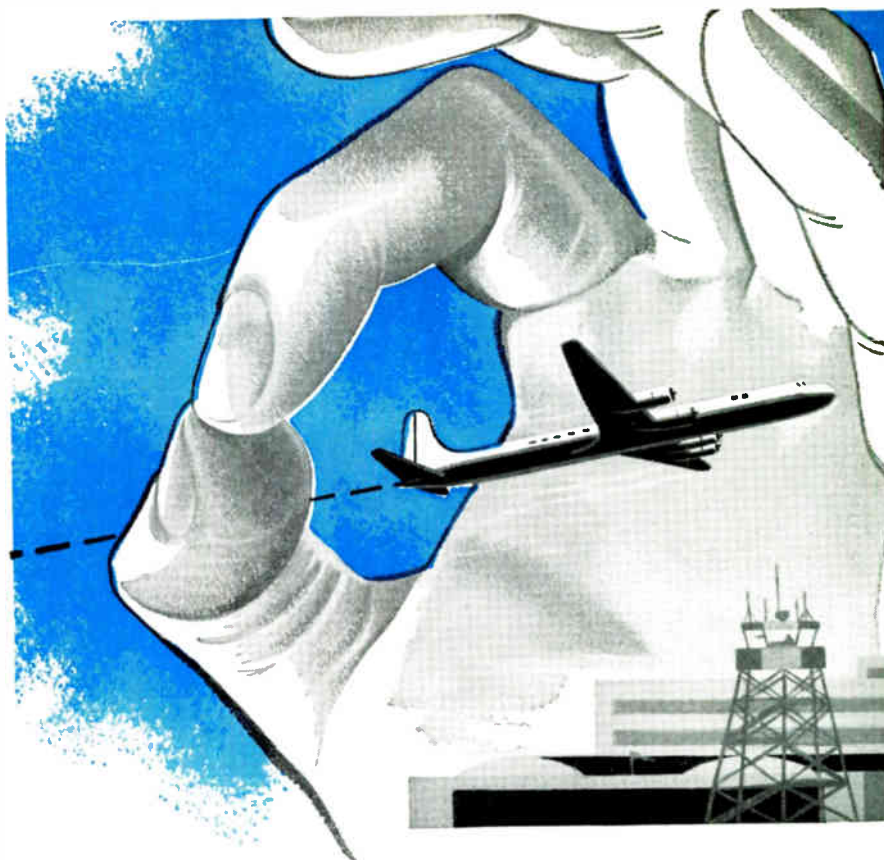

Test with **ARC Precision** ... Fly with **ACCURACY**

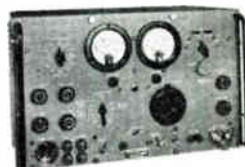

Type H-14A
Signal Generator



Type H-16
Standard Course Checker



Type H-12
UHF Signal Generator

Radio technicians and pilots trust ARC test equipment to keep airborne instruments in tune for precision navigation and communication.

The Type H-14A Signal Generator has two uses: (1) It provides a sure and simple means to check omnirange and localizer receivers in aircraft on the field, by sending out a continuous test identifying signal on hangar antenna. Tuned to this signal, individual pilots or whole squadrons can test their own equipment. The instrument permits voice transmission simultaneously with radio signal. (2) It is widely used for making quantitative measurements on the bench during receiver equipment maintenance.

The H-16 Standard Course Checker measures the accuracy of the indicated omni course in ARC's H-14A or other omni signal generator to better than 1/2 degree. It has a built-in method of checking its own precision.

Type H-12 Signal Generator (900-2100 mc) is equal to military TS-419/U, and provides a reliable source of CW or pulsed rf. Internal circuits provide control of width, rate and delay of internally-generated pulses. Complete specifications on request.

Dependable Airborne Electronic Equipment Since 1928

Aircraft Radio Corporation

BOONTON, NEW JERSEY

Omni/ILS Receivers • Course Directors • UHF and VHF Receivers and Transmitters • LF Receivers and Loop Direction Finders • 10-Channel Isolation Amplifiers • 8-Watt Audio Amplifiers • Interphone Amplifiers • Omnirange Signal Generators and Standard Course Checkers • 900-2100 Mc Signal Generators



Sylvania

NPN transistor

complements

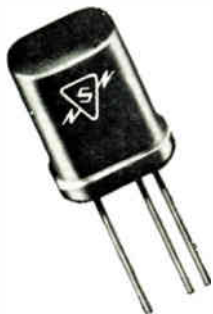

*—offer stage-by-stage
flexibility for every
basic portable
radio design*

A full line of NPN transistors for portable radio

—offers uniformly high quality, highest gain, and a stage-by-stage choice for desired power supply, sensitivity and output



LEADING manufacturers who insist on the highest quality components for their transistorized portable radio designs are choosing Sylvania All-NPN transistor complements for good reasons.

Sylvania's experience in volume manufacture of NPN alloy junction transistors assures uniformly high quality—amazingly few line rejects.

And, whatever the power supply requirements, sensitivity, or output, Sylvania offers the designer complete flexibility in a line of transistors which can be interchangeable with PNP types.

Check this block diagram. It outlines the stage-by-stage choice which is afforded the designer. Mixer-oscillator or converter stage is a matter of desired balance between sensitivity and signal-to-noise ratio. There's a choice of IF for most economical design based bandwidth, power supply, and required output.

For complete details write on your company letterhead. Address Dept. M32R.

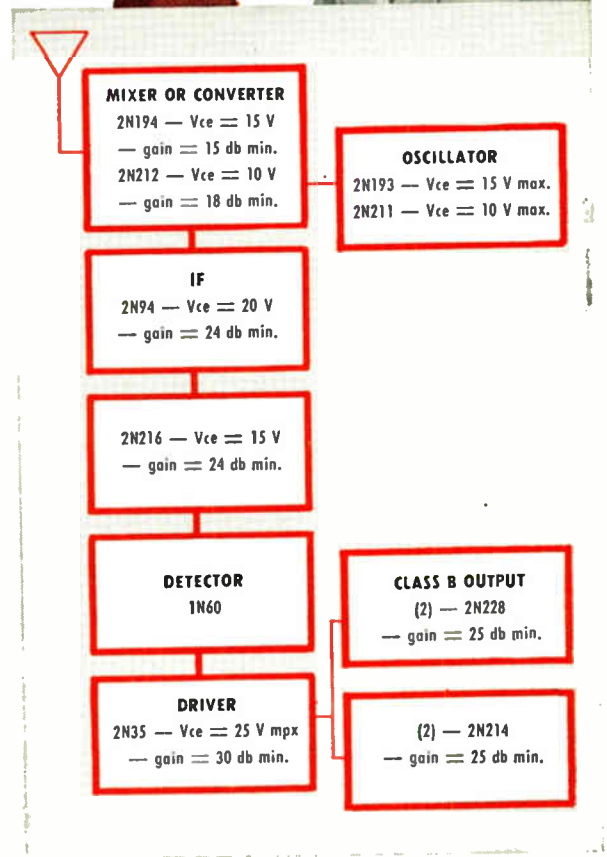

SYLVANIA

SYLVANIA ELECTRIC PRODUCTS INC.
1740 Broadway, New York 19, N. Y.
In Canada: Sylvania Electric (Canada) Ltd.
Shell Tower Building, Montreal

LIGHTING • RADIO • TELEVISION • ELECTRONICS • ATOMIC ENERGY

THE **NEW** ARTOS AUTOMATIC wire-stripping and TERMINAL-ATTACHING MACHINE

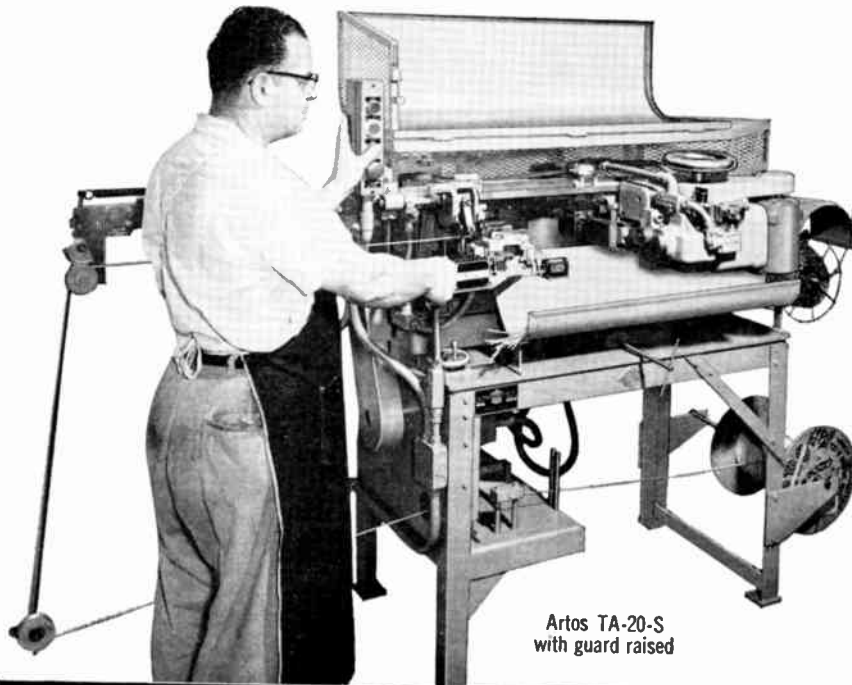

Artos TA-20-S
with guard raised

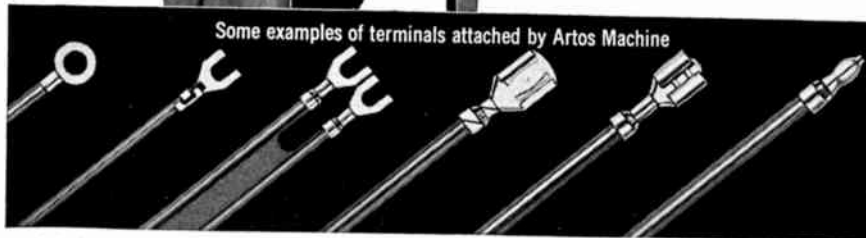

Some examples of terminals attached by Artos Machine

This new Artos TA-20-S brings still greater speed and production economy to large-quantity users of wire leads with terminals attached. It *automatically* performs the following services *all in one operation*:

1. Measures and cuts wire to predetermined lengths.
2. Strips one or both ends of wire.
3. Attaches practically any prefabricated terminal in strip form, to one end of wire.
4. Marks finished wire leads with code numbers and letters. (Optional attachment not standard part of machine.)

ALL OPERATIONS ARE AUTOMATIC. Machine can be operated by unskilled labor. It is easily set up and adjusted for different lengths of wire and stripping. Die units for different type terminals simply and quickly changed. Production speeds up to 3,000 finished pieces per hour.

ARTOS MACHINES ARE USED by electric appliance, automotive, aircraft, electronics and other industries that want automation in the production of wire leads in quantity. Agents throughout the world.

Engineering consultation and recommendations given without obligation.

WRITE FOR
BULLETIN

No. 655 on the
Artos TA-20-S



ARTOS ENGINEERING CO.

2735 South 28th Street • Milwaukee 46, Wisconsin



(Continued from page 101A)

Washington, D. C.—September 17

"Principles of Storage Tubes and Future Trends," S. T. Smith, Naval Research Laboratory.

ENGINEERING MANAGEMENT

Rome-Utica—September 5

"Personnel Selection and Training for Engineering Management," W. R. G. Baker, General Electric.

INFORMATION THEORY

Albuquerque-Los Alamos—
September 13

"The Vocabulary of Information Theory, Part I," B. L. Basore.

Albuquerque-Los Alamos—October 11

"The Vocabulary of Information Theory, Part II," by B. L. Basore.

MEDICAL ELECTRONICS

Buffalo-Niagara—September 11

"Electrophysiology of the Eye: Phenomena and Instrumentation," W. Noell, Roswell Park Memorial Institute.

(Continued on page 106A)

SINGLE-SIDEBAND TRANSMITTER ADAPTER

Adapts AM transmitters to single-sideband operation

- Provides extra channels
- Improves signal-to-noise and signal-ta-jamming
- Reduces fading problems
- Uses most efficient 5SB system
- Allows the use of Class-C amplifiers & multipliers
- Low initial & operating cost



**KAHN
RESEARCH LABORATORIES**
22 Pine St.
Freeport, L.I., New York
Freeport 9-8800

Another product *surprise* from Helipot!

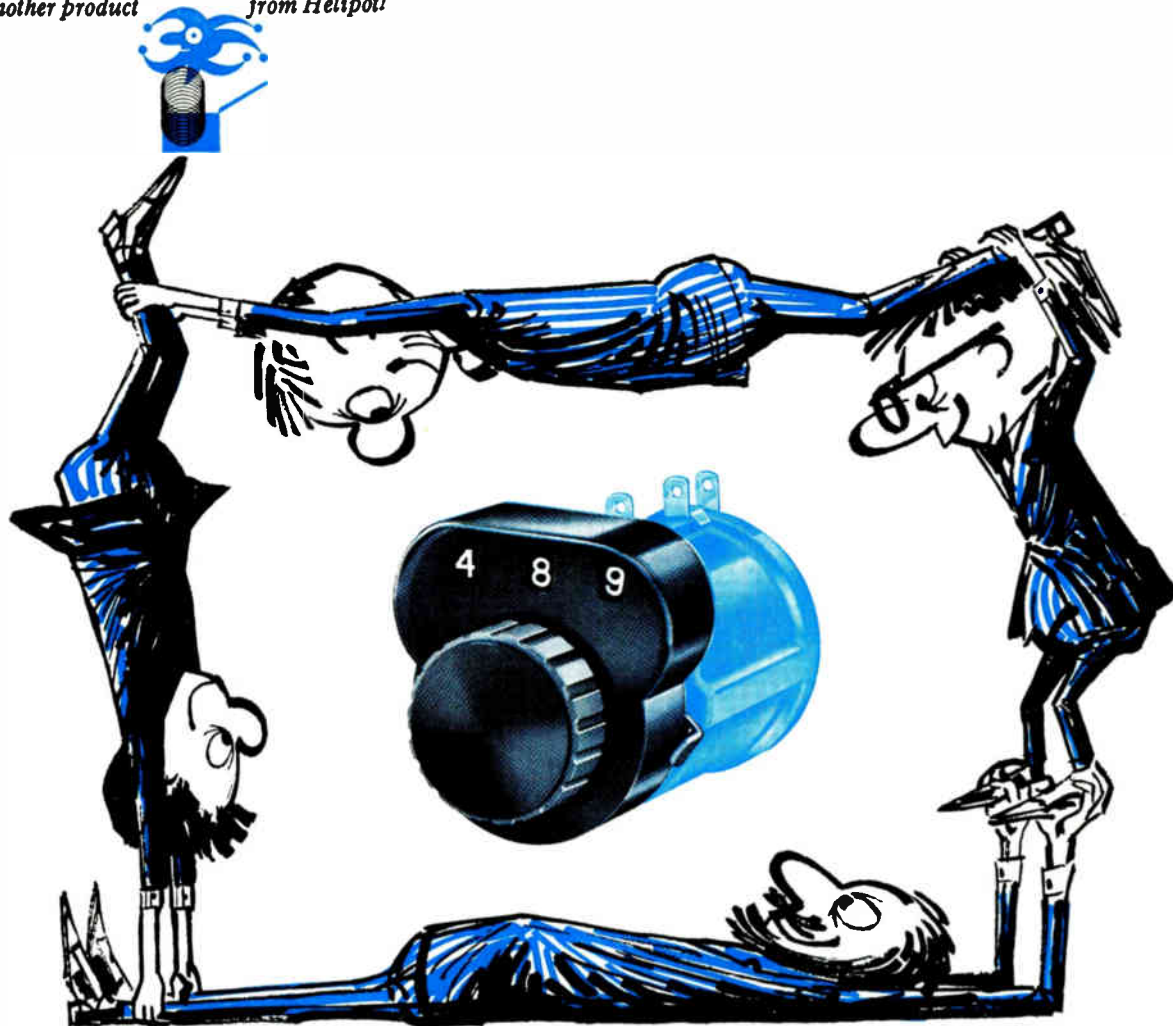

A Dial to reckon with

When position is everything, you can count on the new DIGIDIAL* ten-turn decimal-counting dial... for indicating shaft position from 0° to $3,600^\circ$... with reading resolution of 0.05% of full scale or better.

The DIGIDIAL reads by the numbers. This means farewell to interpolations and operator errors... hail and hello to fast, accurate reading from as far as six feet away... from just about any angle except behind the panel. You'll welcome its compact construction, light weight, simple installation and smooth operation. You'll utter gleeful greetings to the positive, non-distorting locking mechanism.

If position is important to you, you'll want to know more about the DIGIDIAL... to get the whole story, write for data file 1223.

Beckman®

Helipot Corporation: Newport Beach, California

a division of Beckman Instruments, Inc.

Engineering representatives in principal cities

Better Coils begin with PARAFORMED PAPER TUBES

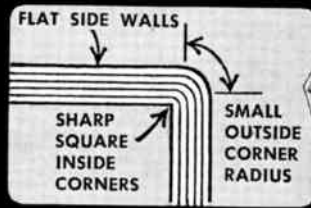

- No sharp outside edges to cut wire
- No need for wedges to tighten wire
- Permits winding coils to closer tolerances
- Allows faster stacking of wound coils
- Has full rigidity and physical strength

ANY SIZE—SQUARE OR RECTANGULAR

PARAFORMED paper tubes simplify coil winding operations and speed production, yet cost no more. In the exclusive PARAFORM method of tube making, no artificial heat or pressure is used—*Paraforming* takes place at the time of spiral winding. Hi-Dielectric. Hi-Strength. Kraft, Fish Paper, Acetate, Red Rope or any combination wound on automatic machines. *Produced from stock arbors or special sizes engineered for you.* Can also be supplied in regular or with slight bow.

PARAMOUNT PAPER TUBE CORP.

618 LAFAYETTE STREET, FORT WAYNE 2, INDIANA
Manufacturers of Paper Tubing for the Electrical Industry Since 1931

SPIRAL WOUND
Not Die Formed

Write on company
letterhead for
**STOCK
ARBOR LIST**
of over 2000 sizes



Professional Group Meetings

(Continued from page 104A)

MICROWAVE THEORY & TECHNIQUES

Los Angeles—September 11

"Application of Ionized Gases in Microwave Circuitry," H. Ozaki, Hughes Aircraft Company.

Northern New Jersey—September 19

"A New Faraday Rotation Phenomenon and the Application to Microwave Switching," J. A. Weiss, Bell Telephone Laboratories.

MILITARY ELECTRONICS

Los Angeles—September 25

"Weapons System Organization and Implementation," Major J. J. Mahoney, Edwards Air Force Base.

NUCLEAR SCIENCE

Albuquerque—Los Alamos—
September 14

"Nuclear Reactors," S. Glastone, Los Alamos Scientific Laboratory.

Connecticut Valley—September 27

"Human Engineering," A. E. Hickey, Jr., Human Factors Section, Electric Boat.

PRODUCTION TECHNIQUES

Washington—September 27

"A Survey of European vs. American Production Technics," by H. E. Ruehlmann, Elco Corporation.

TELEMETRY & REMOTE CONTROL

Los Angeles—September 18

"Transistors in Telemetry" by W. P. Klemens, Bendix—Pacific Div.; "Application of the Phase Locked Loop to Telemetry," by C. E. Gilchrist, Jet Propulsion Labs.

VEHICULAR COMMUNICATIONS

Los Angeles—June 14

"A Comparison of Split Channel and Single Sideband for Land Mobile Services," A. A. Macdonald, Motorola Communications & Electronics, Inc.



Section Meetings

AKRON

"Consideration Leading to Development of Color Television Standards," by A. V. Loughren, President, IRE; September 18, 1956.

(Continued on page 108A)

ONE MEGACYCLE PULSE GENERATOR

SIMPLIFIES YOUR NON-LINEAR CIRCUIT DESIGN



MODEL B-3
PULSE GENERATOR...\$1,750.00

- Pulse Widths from .08 to 10,000 μ s
- Duty Factor: 25%
- Adjustable Rise Time from .02 to 1 μ s
- Positive or Negative pulses
- Repetition Rates through 1 megacycle
- Internal Delay to 10,000 μ s

The B-3 series is adaptable for multiple pulse outputs

Write for complete data: our Bulletin I-B-3

Rutherford ELECTRONICS CO. Telephone: TEXAS 0-4362
3707 S. ROBERTSON BLVD.
CULVER CITY, CALIFORNIA

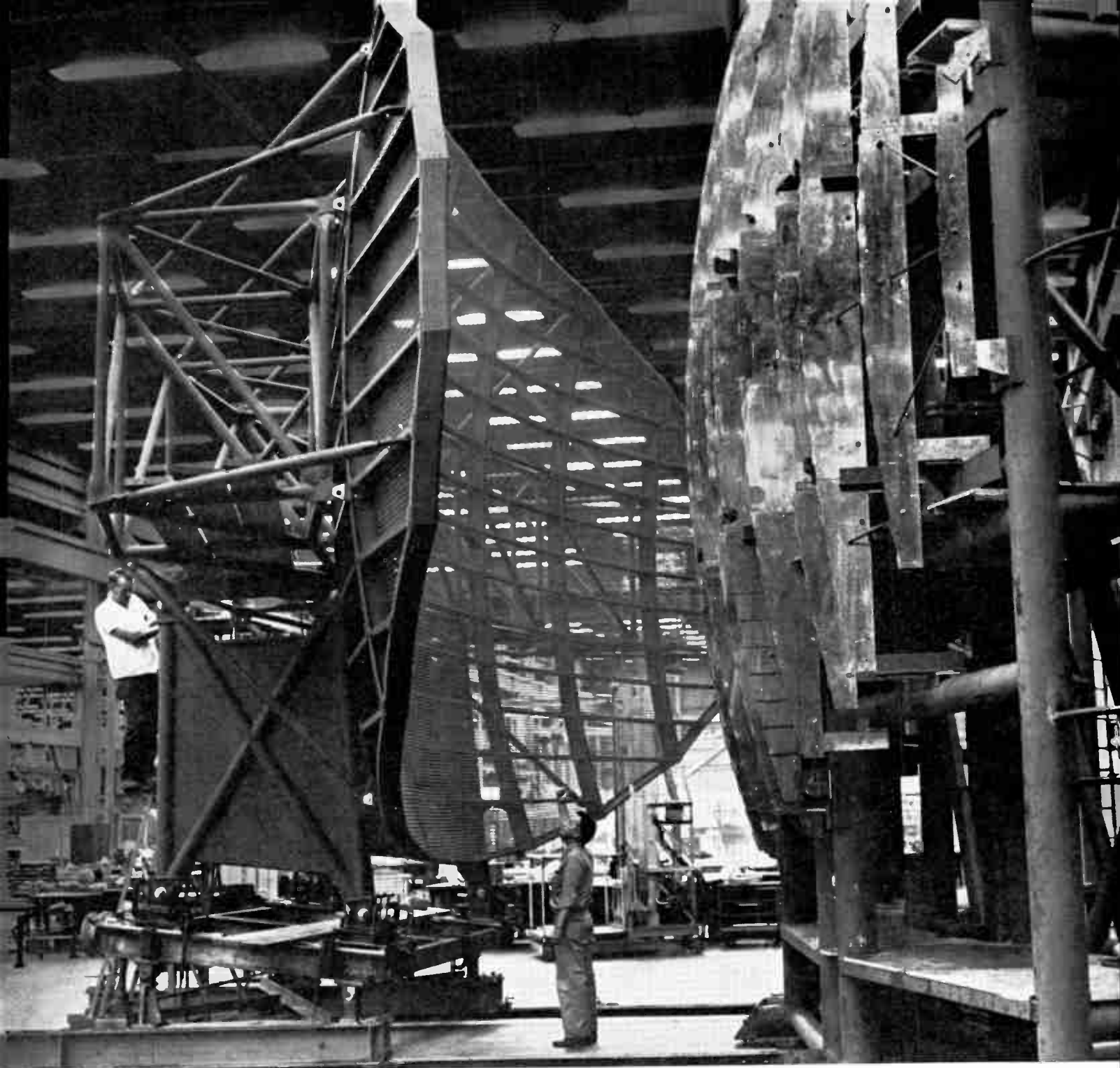

PRECISION JIG (RIGHT) GAGES ACCURACY OF HUGE ANTENNA SURFACE TO 1/100 OF AN INCH—PROOF THAT LARGE OR SMALL . . .

General Electric Antennas Are Engineered to Give Your Radar System Top Reliability and Accuracy

Backed by more than two decades of experience and proven reliability, General Electric antennas are thoroughly engineered to your specific needs.

Whether your radar system calls for extensive research and development—for component manufacturing—or simply for production of your antenna design, G.E.'s advanced facilities and intensive engineering programs are your assurance of the finest antenna work available!

Examine *your* antenna needs, now. Large or small, simple or complex—General Electric engineering can answer them. Simply contact your local G-E Ap-

paratus Sales Office. An antenna specialist will be glad to give you specific information. General Electric Co., Section 223-6, Schenectady, N. Y.

Progress Is Our Most Important Product

GENERAL  **ELECTRIC**

TRANSCO COAXIAL SWITCHES

**-the complete line
for broad-band,
high efficiency
RF switching**

You'll find TRANSCO switches reliable under all conditions described in existing military specifications. Reliability—plus minimum insertion loss, low V S W R, and high isolation between channels—make TRANSCO the most specified coaxial switches in the industry.

Send your coaxial switching problems to TRANSCO. Technical data on any unit or the complete line sent on request.



1460
series

MOTOR OPERATED
—SP2T to SP6T; also DP transfer and DPDT. Frequencies to 11,000 MC.



M1460
series

MANUALLY OPERATED
— same contact arrangement and RF head as the 1460 Series.



11000
series

MINIATURE—SPDT
— remote-control unit, excellent RF characteristics over wide frequency range.



14000
series

MINIATURE—SP4T
— for wide application flexibility. Weight only 0.75 lbs. Frequencies to 10,000 MC.

TRANSCO

PRODUCTS, INC.
Always the Finest in Avionics
12210 NEBRASKA AVE.,
LOS ANGELES 25, CALIF.

REPRESENTATIVES IN MAJOR AREAS



Section Meetings

(Continued from page 106A)

ALAMOGORDO-HOLLOMAN

"Computer Applications," by M. C. Green, Holloman AFB; September 19, 1956.

ATLANTA

"Engineering the New WGST Studios Building and Facilities," by Ben Akerman, Radio Station WGST; September 27, 1956.

BALTIMORE

"Applications of the Cryotron," by Dudley A. Buck, Massachusetts Institute of Technology, Cambridge; October 10, 1956.

BEAUMONT-PORT ARTHUR

"Engineering Outlook For the Coming Year," by Dean R. V. Andrews, Lamar State College of Technology; "Resume of Experiences at Boeing," by Lloyd B. Cherry, Lamar State College of Technology; September 26, 1956.

BUFFALO NIAGARA

"Color Television Standards of the USA," by A. V. Loughren, President, IRE; September 19, 1956.

"Professional Aspects of Engineering," by Gerry Morse, Minneapolis Honeywell Regulator Company; October 17, 1956.

CEDAR RAPIDS

"Aircraft Proximity Warning and Collision Avoidance," by Frank C. White, Air Transport Association; and Dr. D. O. McCoy, Collins Radio Company; October 17, 1956.

CHINA LAKE

"Nonlinear Methods in Circuit Analysis," by Dr. Louis Pipes, University of California at Los Angeles; October 2, 1956.

CONNECTICUT VALLEY

"Recent Developments in Computers—Their Design and Application," by George V. Hawkins, I.B.M. Corporation; September 20, 1956.

DALLAS

"A Commercial 'C' Band Weather Radar," by John F. Beckerich, Collins Radio Company; September 25, 1956.

DAYTON

"The Air Force Nuclear Test Facility," by Col. John Hood, Jr., USAF, and Lt. W. O. Douggett, USAF; September 6, 1956.

DENVER

"National Bureau of Standards Calibration Center," by Harvey W. Lance, National Bureau of Standards; September 28, 1956.

EGYPT

"A Review of Electrical Digital Computers," by Dr. Y. El Hakim, Alexandria University; October 3, 1956.

ELMIRA-CORNING

"Light Amplification," by Joseph Lempert, Westinghouse Corp; September 17, 1956.

(Continued on page 110A)

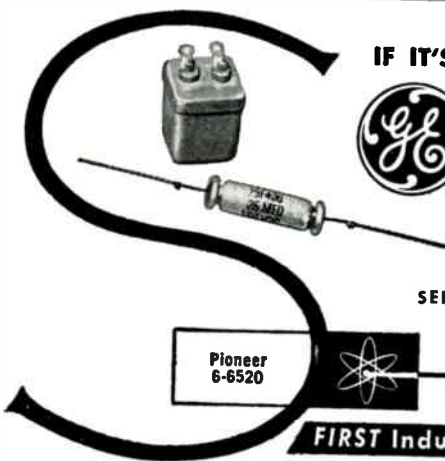

IF IT'S **NEW** —

Schweber stocks it!
tantalytic capacitors

NOW, available from Schweber stock, over 250 different ratings in the 85°C and the NEW 125°C, polar and non-polar types.

SEND for "Tantalytic Engineering Bulletin."

Schweber ELECTRONICS

122 Herricks Road Mineola, L. I., New York

FIRST Industrial Component SPECIALIST

TANTALYTIC IS A REG. G.E. TRADE NAME



FOR MORE QUALITY-PER-DOLLAR, BUY RECONDITIONED TEST EQUIPMENT

We will quote on new and used top-quality commercial brands and select military surplus items in our choice stock to your needs.

AN/APR-4 LABORATORY RECEIVERS

Complete with all five Tuning Units, covering the range 38 to 4,000 Mc.; wideband discone and other antennas, wavetraps, mobile accessories, 100 page technical manual, etc. Versatile, accurate, compact—the aristocrat of lab receivers in this range. Write for data sheet and quotations.

We have a large variety of hard-to-get equipment including choice military test sets, microwave, airborne, communications, radar, telemetering, nucleonics, and laboratory electronics of all kinds. Quality standards maintained. State your general requirements and we will suggest suitable items.

ENGINEERING ASSOCIATES

434 PATTERSON ROAD

DAYTON 9, OHIO

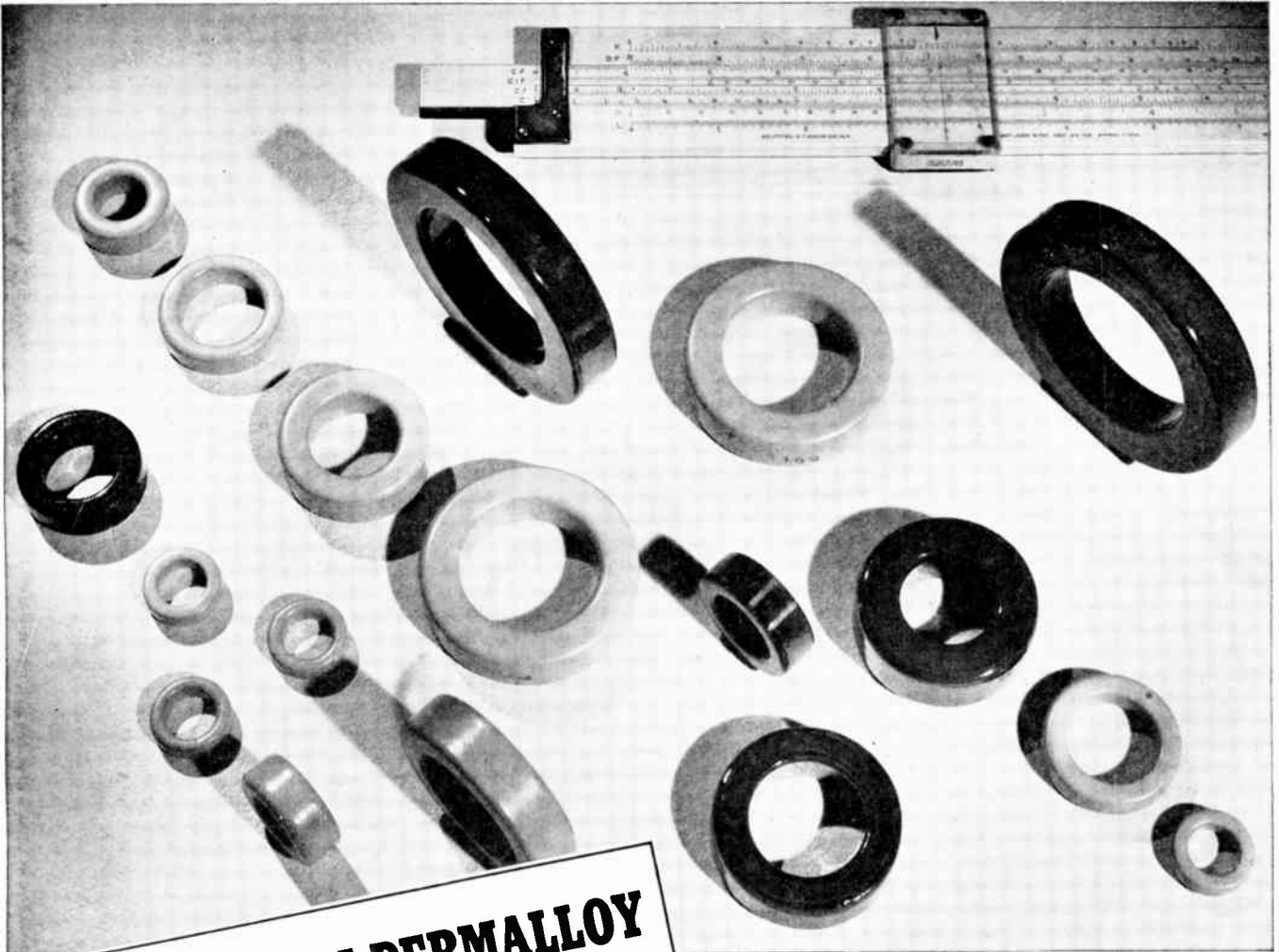

MOLYBDENUM PERMALLOY POWDER CORES

(New technical data now available)
Write for Bulletin PC-104B, dated October, 1956

**HIGH Q TOROIDS for use in
Loading Coils, Filters, Broadband
Carrier Systems and Networks—
for frequencies up to 200 K C**

COMPLETE LINE OF CORES TO MEET YOUR NEEDS

- ★ Manufactured in a full range of sizes—from 0.500" diameter to 5.218" in all permeabilities.
- ★ Furnished temperature stabilized, including wide range stabilization (-65°F to $+185^{\circ}\text{F}$), for many types.
- ★ Available from stock in most popular types due to additional manufacturing facilities.

For high Q in a small volume, characterized by low eddy current and hysteresis losses, ARNOLD Moly Permalloy Powder Toroidal Cores are commercially available to meet high standards of physical and electrical requirements. They provide constant permeability over a wide range of flux density. The 125 Mu cores are recommended for use up to 15 kc, 60 Mu at 10 to 50 kc, 26 Mu at 30 to 75 kc, and 14 Mu at 50 to 200 kc. Many of these cores may be furnished stabilized to provide constant permeability ($\pm 0.1\%$) over a specific temperature range.

For Bulletin—ADDRESS DEPT. P-612

WSW 6328

THE ARNOLD ENGINEERING COMPANY

SUBSIDIARY OF ALLEGHENY LUDLUM STEEL CORPORATION

Main Office & Plant: Marengo, Illinois

Repath Pacific Division Plant: 641 East 61st Street, Los Angeles, Calif.

District Sales Offices:

New York: 350 Fifth Ave. Los Angeles: 3450 Wilshire Blvd. Boston: 200 Berkeley St.

SPECTROL

Precision

Potentiometers

MODEL 100



Precision 1 3/8" dia. single-turn potentiometer. Standard Resistance Range—10 Ω to 30 K Ω \pm 3.0%. Standard linearity \pm 0.5%. May be ganged—2 to 15 sections. Up to 14 extra taps per section.

MODEL 200



Precision 1 3/4" dia. single-turn potentiometer. Standard Resistance Range—5 Ω to 65 K Ω \pm 3.0%. Standard linearity \pm 0.3%. May be ganged—2 to 15 sections. Up to 21 extra taps per section.

MODEL 300



Precision 2" dia. single-turn potentiometer. Standard Resistance Range—20 Ω to 75 K Ω \pm 3.0%. Standard linearity \pm 0.3%. May be ganged—2 to 15 sections. Up to 21 extra taps per section.

MODEL 400

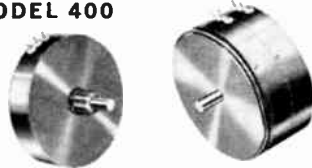

Precision 3" dia. single-turn potentiometer. Standard Resistance Range—100 Ω to 100 K Ω \pm 3.0%. Standard linearity \pm 0.3%. May be ganged—2 to 15 sections. Up to 33 extra taps per section.

MODEL 500



Precision 7/8" dia. miniature 10-turn potentiometer. Standard Resistance Range—25 Ω to 120 K Ω \pm 3.0%. Standard linearity \pm 0.3%. Up to 38 extra taps per section.

MODEL 700



Precision 7/8" dia. miniature single-turn potentiometer. Standard Resistance Range—10 Ω to 20 K Ω \pm 3.0%. Standard linearity \pm 0.5%. May be ganged—2 to 6 sections. Up to 9 extra taps per section.

MODEL 800

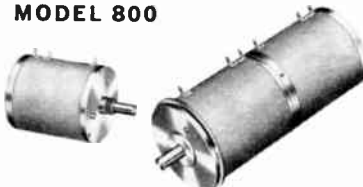

Precision 1 3/8" dia. 10-turn potentiometer. Standard Resistance Range—50 Ω to 400 K Ω \pm 3.0%. Standard linearity \pm 0.3%. May be ganged—2 to 3 sections. Up to 48 extra taps per section.

MODEL 850



Precision 1 3/8" dia. 3-turn potentiometer. Standard Resistance Range—20 Ω to 120 K Ω \pm 3.0%. Standard linearity \pm 0.3%. May be ganged—2 to 3 sections. Up to 18 extra taps per section.

Spectrol potentiometers may be tailored to comply with a wide variety of electrical and mechanical requirements.

Write for complete details

SPECTROL

**SPECTROL ELECTRONICS
DIVISION OF
CARRIER CORPORATION**

1704 South Del Mar, San Gabriel, California



(Continued from page 108A)

EVANSVILLE-OWENSBORO

"Light Amplifiers," by Dr. Walter Grattidge, General Electric Company, September 12, 1956.

"The Philco Color Tube," by G. W. Pratt, Lansdale Tube Company; October 10, 1956.

FORT WAYNE

"Guided Missile Test Equipment," by Donald L. Ackworth, Farnsworth Electronics Company; October 4, 1956.

HOUSTON

"Nature of Aircraft Control Problems," by Dr. C. W. Jiles, Convair Company; and "Use of Analog Computers in A-Craft Control Problems," by S. T. Abraham, Convair Company; September 11, 1956.

HUNTSVILLE

"Survey of Recent Developments in Transistors," by Abraham Coblenz, Clevite Transistor Products; September 11, 1956.

INDIANAPOLIS

"Electronic Simulation of Air Traffic," by T. K. Vickers, C.A.A. Test Center; September 28, 1956.

LITTLE ROCK

General Electric Motion Picture "This Is Automation" and IRE Tapescript "Germanium—The Magic Metal," September 25, 1956.

LONG ISLAND

"Speech, Music and Hearing," by Dr. Winston E. Kock; Bell Telephone Labs.; September 12, 1956.

LOS ANGELES

"A Practical Application of Phase Measuring Techniques to Precision and Distance Measuring Equipments," by W. J. Thompson, Cubic Corporation and "Propagation Effects for UHF-VHF Radar Design," by Dr. L. C. Van Atta, Hughes Aircraft Company. Dinner Speaker; "Highlights of a Year in Holland," by Dr. W. D. Hershberger, University of California; October 2, 1956.

LUBBOCK

General meeting; September 13, 1956.
"Electronic Computers," by Charles E. Houston, Texas Technological College; October 4, 1956.

MIAMI

"Measurements of Television Broadcast Transmission Systems," by Clemens X. Castle; September 21, 1956.

MONTREAL

"Unusual Electron Tube Effects of Concern to Circuit Designers" by W. E. Babcock, R.C.A.; September 19, 1956.

"Color Television," by A. V. Loughren, President, IRE; October 17, 1956.

NEWFOUNDLAND

"Forward Propagation by Ionosphere Scatter," by J. B. Austin, USAF, September 19, 1956.

NEW YORK

"The Gyrotor and Its Applications," by Dr. H. J. Carlin, Polytechnic Institute of Brooklyn; October 3, 1956.

(Continued on page 112A)

Industry's Highest Power Transistors

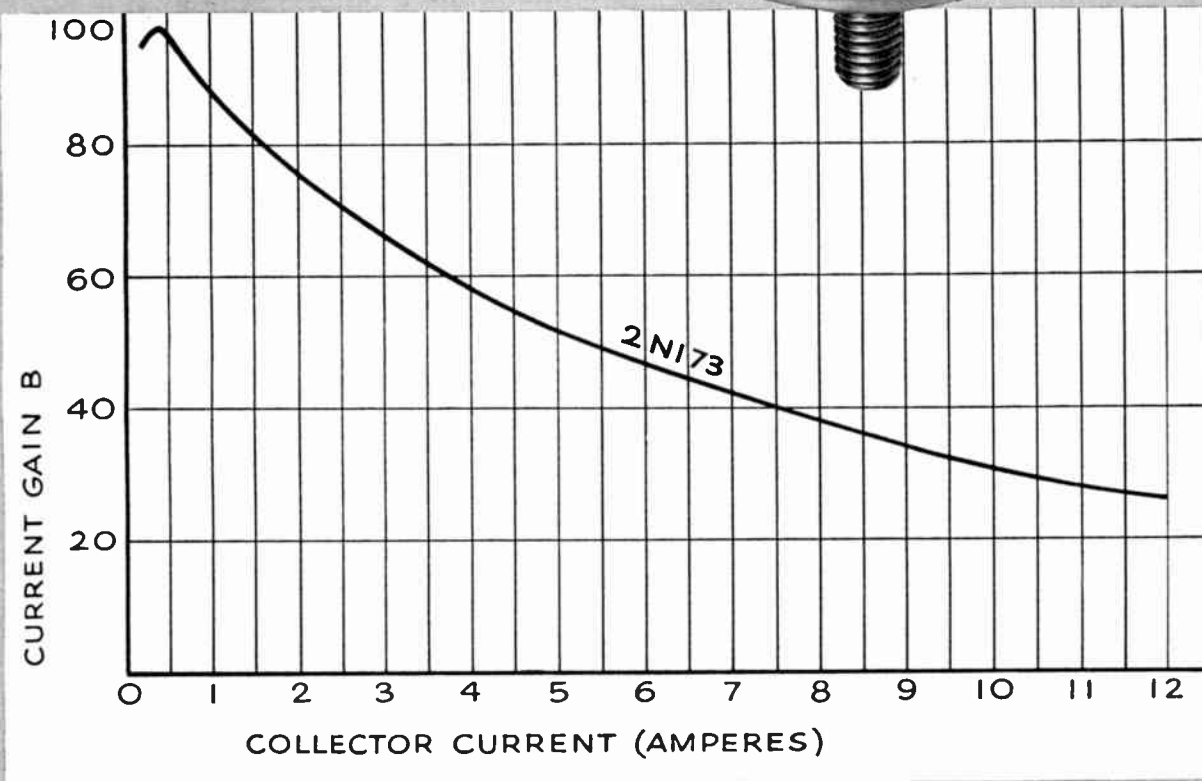

Delco Radio "High-Power" Transistors set a new industry standard of performance —
Produced by the thousands each day!

Delco Radio alloy junction germanium PNP power transistors 2N173 and 2N174, now in volume production, are characterized by high output power, high gain and low distortion. Stabilizing processes eliminate the effect of time on performance characteristics.

The high power handling ability does not exclude applications for low and medium power levels. Performance at low levels exceeds that of many low power transistors and will provide a higher degree of safety and stability to equipment design.

TYPICAL CHARACTERISTICS		
	2N173	2N174
Properties (25°C)	12 Volts	28 Volts
Maximum current	12	12 amps
Maximum collector voltage	60	80 volts
Saturation voltage (12 amp.)	0.7	0.7 volts
Power gain (Class A, 10 watts)	38	38 db
Alpha cutoff frequency	0.4	0.4 Mc
Power dissipation	55	55 watts
Thermal gradient from junction to mounting base	1.2°	1.2° °C/watt
Distortion (Class A, 10 watts)	5%	5%

DELCO RADIO

**DIVISION OF GENERAL MOTORS
KOKOMO, INDIANA**



NOW... A BETTER, SAFER WAY TO SHIP SPARE PARTS

in custom-engineered cabinets by **CRAIG**

A well-known electronics manufacturer recently came to CRAIG with a severe "spare parts" headache. His problem: to make completely transportable hundreds of spare parts for field equipment — and at the same time provide quick and easy access to each individual part in order to avoid delays in making repairs.

CRAIG's answer: lightweight, rugged, waterproof aluminum cabinets with sturdy, removable drawers, indexed and compartmented to make each component easy to find . . . including provisions for such "spares" as complete receivers and transmitters shockmounted in special slide-out frames.

Result: spare parts now travel first class in complete safety — and at surprisingly low cost, because CRAIG has the men and the means to do a big job economically . . . and fast.

For more detailed information and descriptive specifications, write CRAIG today.

Craig
SYSTEMS, INC.
Dept. D-12 Danvers, Mass.
Phone: SPring 4-1870

COMPLETE SYSTEM SPARE PARTS
PACKAGING — Cabinets by
CRAIG, installed in the
TACAN ground station, make
finding spare parts for the
complete system easy and
quick. This installation in-
cludes work bench with tool
drawers.

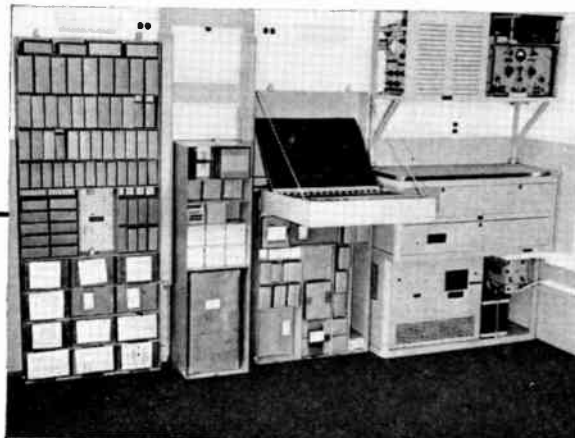

Section Meetings

(Continued from page 110A)

NORTHERN ALBERTA

"New Ideas, Materials and Techniques in Radio Electronics," by Samuel Freedman; Chemaiboy Products Corporation; October 9, 1956.

NORTHERN NEW JERSEY

"Single Sideband System Communications: SSBI Equipment," by Niles L. Barlow, Radiomarine Corp. of America; "Comparison of Single and Double Sideband Systems," by H. F. Meyer and Robert Kulinyi, U. S. Army Signal Corps.; October 10, 1956.

NORTHWEST FLORIDA

"Recent Developments in Magnetic Tape Recording," by Lawrence Bell, Air Force Armament Center; October 8, 1956.

OKLAHOMA CITY

Presentation of OCAMA Mission Briefing and Inspection Tour of IBM 702; October 9, 1956.

PHOENIX

"Strain Gage Applications—Imagination Unlimited," by Peter K. Stein, Air Research Manufacturing Company of Arizona; September 21, 1956.

PITTSBURGH

"Applications of Linear Filter Theory," by Dr. W. C. Dean, Gulf Research and Development; October 8, 1956.

(Continued on page 116A)

**CABLE
CLIPS**

★
of all Nylon
for severe conditions

★
*of Ethyl
Cellulose*
for maximum
economy

WECKESSER

*molded
Black Nylon*

**SCREWS
and NUTS**

★
Acid resistant

★
Need no insulation

★
Can't rust

★
Can't corrode

WECKESSER COMPANY
5715-17 Northwest Highway • Chicago 30, Ill.

WARNER ELECTRIC BRAKE & CLUTCH CO.

*"puts the finger" on
automatic rug machinery
with the aid of*

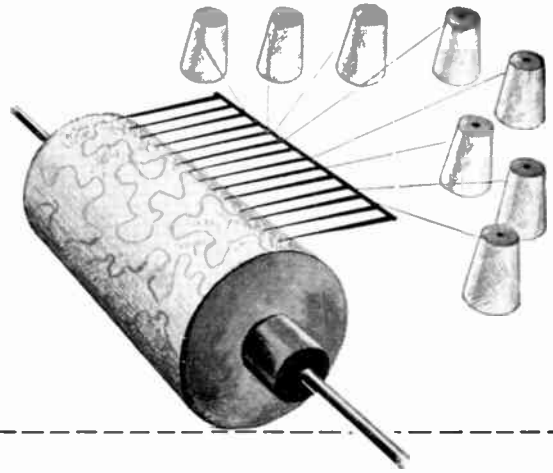

RADIO RECEPTOR SELENIUM RECTIFIERS

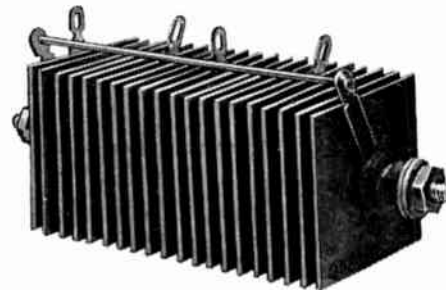
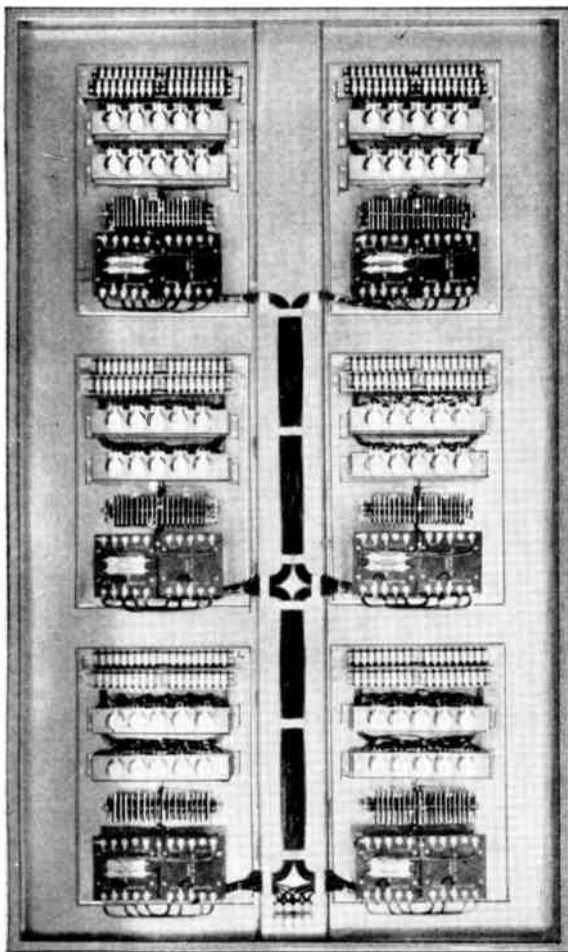

Guiding the 120 electric clutches that act as automated fingers in a new rug tufting machine is a Warner control panel whose key components are six Radio Receptor rectifiers. These fingers "feel" the rug pattern on a revolving roll, send information to the control station from which actuating impulses are relayed to clutches controlling yarn feed.

A Radio Receptor customer for many years, Warner Electric Brake & Clutch Co. utilizes RRco. selenium rectifiers in this application and many others because long experience has proved they can depend upon them for continuous and heavy duty, without fear of costly breakdowns.

If you have a problem in rectification, do as many fine companies do in the United States and throughout the world — Specify RRco. selenium rectifiers. Millions are in service in almost every possible type of circuit. Would you like our most recent literature? Please write section P-18.



Semiconductor Division
RADIO RECEPTOR COMPANY, INC.

Radio and Electronic Products Since 1922

240 WYTHE AVENUE, BROOKLYN 11, N. Y. EVERgreen 8-6000

OTHER PRODUCTS OF RADIO RECEPTOR: Germanium and Silicon Diodes, Dielectric Heating Generators and Presses, Communications, Radar and Navigation Equipment.



COLLINS LEADS IN SSB DEVELOPMENT

An entire new line with **20** variations of kilowatt and up Airborne and



AIRBORNE KILOWATT

An SSB airborne communication system utilizing transceiver techniques delivers 1 kilowatt PEP. Automatic tuning by servos enables accurate selection by remote control of any of the 28,000 available channels in 1 kc increments.



From an integrated design concept, Collins has developed a line of 2-30 mc single sideband systems with a flexibility to fill the requirements of any installation. Fully compatible with AM, the systems were designed expressly to take advantage of SSB's narrower bandwidth, greater effective talking power and relative immunity from degradation through selective fading. The equipment includes ground 1-kilowatt transmitters and transceivers, 5-, 20- and 45-kilowatt transmitters, receivers, exciters and airborne 1-kilowatt transceivers. Back of these systems is over a decade of foresighted research which produced distortion reducing features, extreme frequency stability, the Mechanical Filter, improved low spurious circuitry, non-critical neutralization and amplifier stability, and easily operated servo tuning. Use of common module "building blocks" enhances the system flexibility and simplifies maintenance and stocking.

Collins

CREATIVE LEADER IN COMMUNICATION



COLLINS RADIO COMPANY

CEDAR RAPIDS, IOWA • DALLAS • BURBANK • NEW YORK
WASHINGTON, D.C. • MIAMI • SEATTLE

COLLINS RADIO COMPANY OF CANADA, LTD., TORONTO
COLLINS RADIO COMPANY OF ENGLAND, LTD., LONDON

Ground High-Frequency, Point-to-Point Communication Systems

GROUND KILOWATT

This HF SSB series includes 1 kw transceivers and transmitters; receivers, and exciters for higher power amplifiers. Incorporated are such advances as multiplex voice and teletype operation and independent, absolute frequency control techniques. Channels 1 kc spaced are obtained from a stabilized master oscillator referenced to a frequency standard with stability of one part in 10^8 per day.

GROUND 5-, 20-, 45-KW

High power linear amplifiers in this series have been designed for power outputs of 5, 20, or 45 kilowatts PEP with input from exciters of the other series. Improved linear operation results from such distortion reducing means as RF feedback and envelope modulation. A non-critical neutralization scheme is employed.

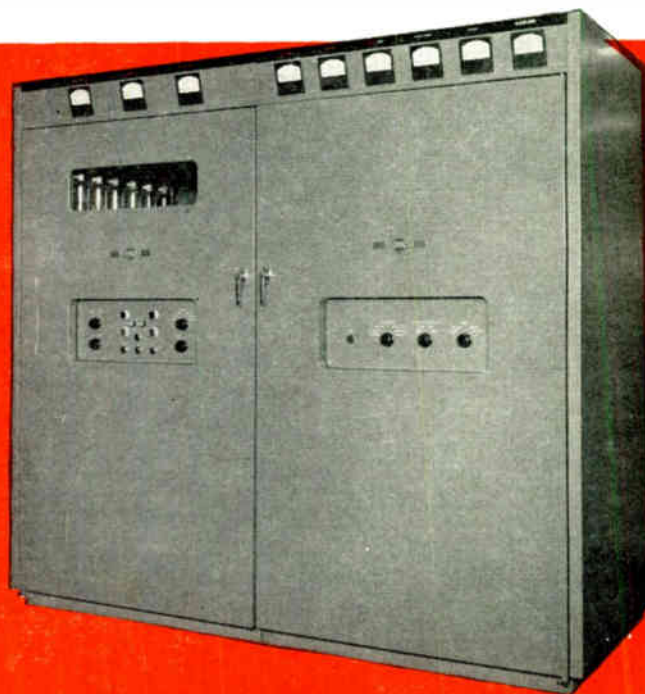

Accent on **VERSATILITY!**

TDI MINIATURE CHECKOUT STATIONS

Field Use

airborne
ground
marine

Application

missile checkout
aircraft tracking
missile tracking
general remote
instrumentation

Installation

aircraft
jeeps
autos
trailers
ships

Operational with

pen recorders
tape recorders
oscillographs
photographic equipment

Accurate • Stable • Simplified • Ruggedized



TDI Type 2201A Miniature Subcarrier Discriminator—compact, twin-tee feedback type designed for separation of all subcarrier signals in the RDB band. Basic chassis accommodates any frequency. Features outstanding stability, linearity and sensitivity. Width 5 3/4", Depth 11 1/2", Height 3 3/4", Weight 7 1/2 lbs.

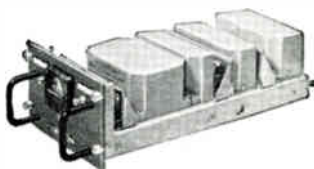

TDI Type 2201C Miniature Subcarrier Discriminator—same design features as 2201A with meter on front panel, connector in rear, plug-in subminiature tubes, no dust cover. Width 5 3/4", Depth 15", Height 3 3/4", Weight 7 1/2 lbs.

TELE-DYNAMICS INC.

Formerly, Raymond Rosen Engineering Products, Inc.
32nd & Walnut Streets, Philadelphia 4, Pennsylvania
15016 Ventura Boulevard, Sherman Oaks, California

QUALITY knight-kits FOR LAB, SERVICE & INDUSTRIAL USE

fine electronic equipment in easy-to-build form



Only \$1275

knight-kit VOLTAGE CALIBRATOR KIT

Permits use of any scope as a precision peak-to-peak AC voltmeter. Puts a true square-wave voltage on scope screen. Range switch and calibrated potentiometer selects any voltage between .01 and 100 volts in 4 ranges. Fifth position feeds external signal to scope for comparison. Has voltage regulator tube—output voltage stays constant with line variation from 80-135 volts. Accuracy, $\pm 6\%$ on all ranges. Shunt capacitance only 15 mmf. Includes control for providing precision initial setting. Direct coupling of output provides ground reference for DC scopes. Complete kit includes all parts; case, full instructions. Shpg. wt., 5 lbs.

Model 83 Y 136. Voltage Calibrator Kit. Net \$12.75



knight-kit 5" WIDE BAND OSCILLOSCOPE KIT

- + 2 Printed Circuit Boards
- + 5 Mc Width for Color TV
- + Hor. Sweep to 600 Kc
- + 25 mv-inch Sensitivity
- + DC Positioning Controls
- + Z-Axis Input

Only \$6900

Outstanding value in a quality scope, ideal for Color TV work and high-frequency lab applications: Wide-sweep range from 15 to 600,000 cps. Locks in at frequencies as high as 9 mc. Only 1 db down at 3.58 color burst frequency. Vertical response: ± 3 db, 5 cycles to 5 mc. Vertical sensitivity, 25 rms mv/inch. 20 mmf input capacity. Special features: cathode-follower vertical and horizontal inputs; 2nd anode of 1400 volts for high intensity trace; p-p vertical and horizontal amplifiers; faithful square wave response; positive and negative locking for excellent synch on complex waveforms; frequency-compensated input attenuator; Z-axis input, 1-volt peak-to-peak calibrating voltage; internal astigmatism control; blanking circuit to eliminate retrace lines, etc. Complete with all tubes (including CRT), parts, punched chassis, case, full assembly instructions. Shpg. wt., 40 lbs.

Model 83 YZ 144. Wide-Band Oscilloscope Kit. Net \$69.00

FREE 356-PAGE CATALOG

ALLIED'S 1957 Catalog lists dozens of other low-cost quality Knight-Kit test instruments, as well as the world's largest stocks of electron tubes, transistors, parts, audio equipment—everything in Electronics for Industry. Write for FREE copy today.

All Prices Net F.O.B. Chicago

ORDER FROM ALLIED RADIO

Dept. 35-M-6, 100 N. Western Ave.
Chicago 80, Illinois

Our 35th year



Section Meetings

(Continued from page 112A)

REGINA

"New Ideas, Materials and Techniques in Electronics," by Samuel Freedman, Chemalloy Products; October 5, 1956.

SACRAMENTO

"Transistors," by Earl G. Marshall, Pacific Telephone and Telegraph Company; October 4, 1956.

SAN DIEGO

"New Developments in Automation," by Dr. Eugene M. Grabbe, Ramo-Wooldrige Corporation; October 9 1956.

TORONTO

"Telecommunications," by The Hon. George C. Marler, Minister of Transport; October 1, 1956.

TUCSON

"Highlights of Amateur Radio Activity in Tucson Area," by G. A. Sinclair, Hughes Aircraft Company; and "Scatter Propagation Characteristics and System Considerations," by A. Svien, Collins Radio Company; September 28, 1956.

WASHINGTON, D. C.

"Radio Astronomy: A New Window in the Sky," by Edward F. McClain, Naval Research Laboratory; September 10, 1956.

WINNIPEG

"New Ideas, Materials and Techniques in Radio Electronics," by Samuel Freedman, Chemalloy Electronics Corporation; October 4, 1956.

SUBSECTIONS

BERKSHIRE COUNTY

"The Challenges and Opportunities of Professional Societies," by Charles F. Savage, General Electric Company; September 21, 1956.

BUENAVENTURA

"Typical Problems of the New Engineer Manager," by T. Jarmie, Electronic Engineering Company; September 13, 1956.

"Brain Wave Potentials and Correlates of Behavior," by Dr. Harold F. Burks, San Gabriel School System; October 11, 1956.

CHARLESTON

Tapescript: "The Physics of Music and Hearing" and "High Fidelity Demonstration," by Lt. Cdr. John G. Cormack, U. S. Navy; October 8, 1956.

ERIE

"Modular Construction," by Richard Anderson, Erie Resistor Corporation; October 4, 1956.

LANCASTER

"Transistorized Television Cameras Using the Miniature Vidicon," by W. S. Pike RCA Labs.; October 10, 1956.

MONMOUTH

"Electron Tubes at the Frequency Frontier," by Arthur Karp, Bell Telephone Labs.; October 17, 1956.

(Continued on page 120A)

B.F. Goodrich

For duplicating free space conditions

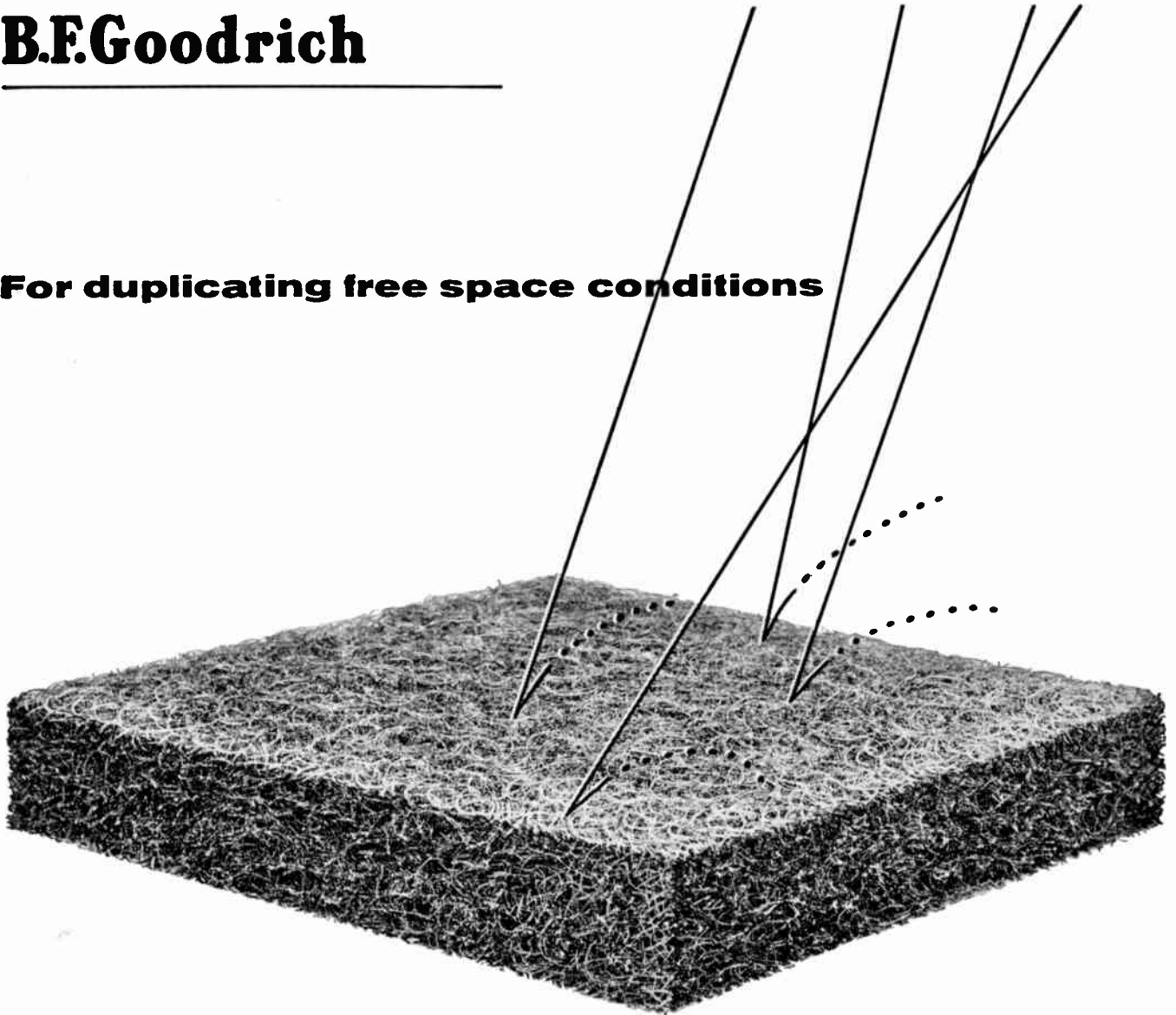

Spongex[®] Microwave Absorbent

absorbs 99% incident energy
... 4% to 5% more
than any other
microwave absorbent.

*Write today for samples and booklet on this durable,
economical and easy-to-install absorbent.*

SPONGE PRODUCTS DIVISION



264 DERBY PLACE, SHELTON, CONNECTICUT

FAST • ACCURATE AUTOMATIC DATA PROCESSING

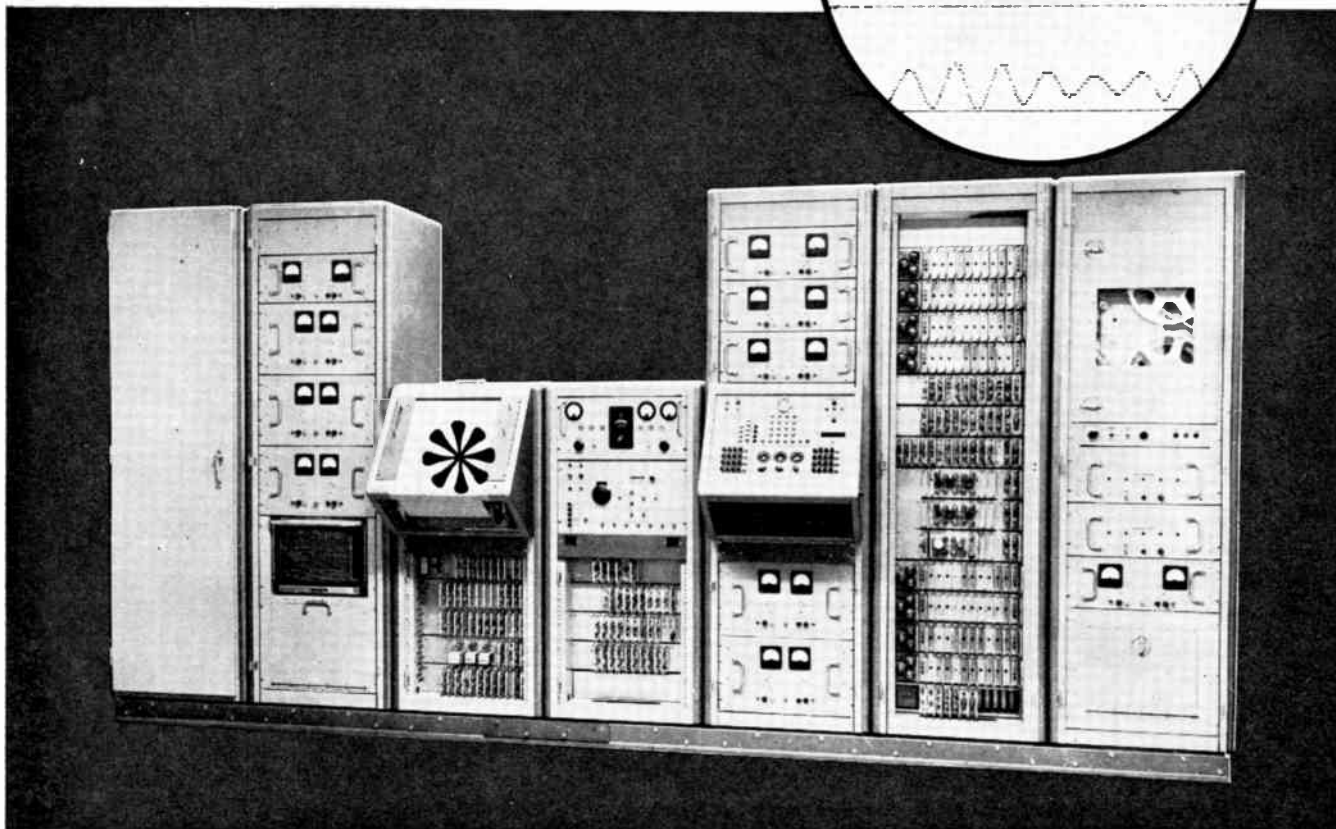
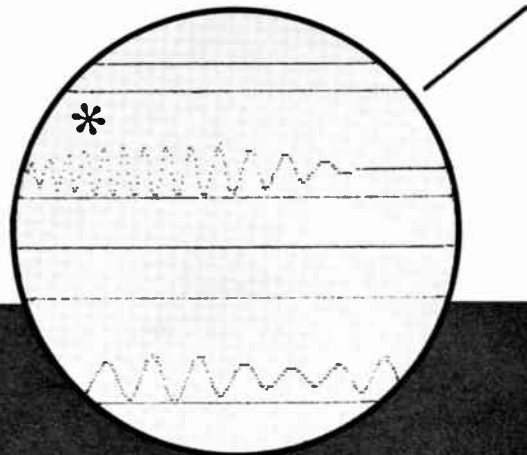

FEATURING INSTANTANEOUS QUICK-LOOK RECORDING

THE RADIATION, INC. DATA PROCESSING SYSTEM bridges the gap between data collection and data reduction. It accepts analog or digital inputs and converts the data to a form acceptable by high-speed digital computers. Information is handled in digital form throughout, maintaining extremely high accuracy. A quick-Look analog plot of all information being processed is simultaneously available.

This plot, in real time, is especially valuable for editing out unnecessary information and reducing computer load. The system features automatic programming and eliminates normal manual procedures necessary to prepare the collected data for computer input. Thus, much valuable time is saved between test and evaluation — allowing results of previous tests to be incorporated in changes in design and procedure with little delay.

This equipment can be fitted to your particular data handling problem. Write for complete information to Dept. F

Personnel Inquiries Invited



RADIATION Inc.

Melbourne, Fla.
Orlando, Fla.

Electronics • Avionics • Instrumentation

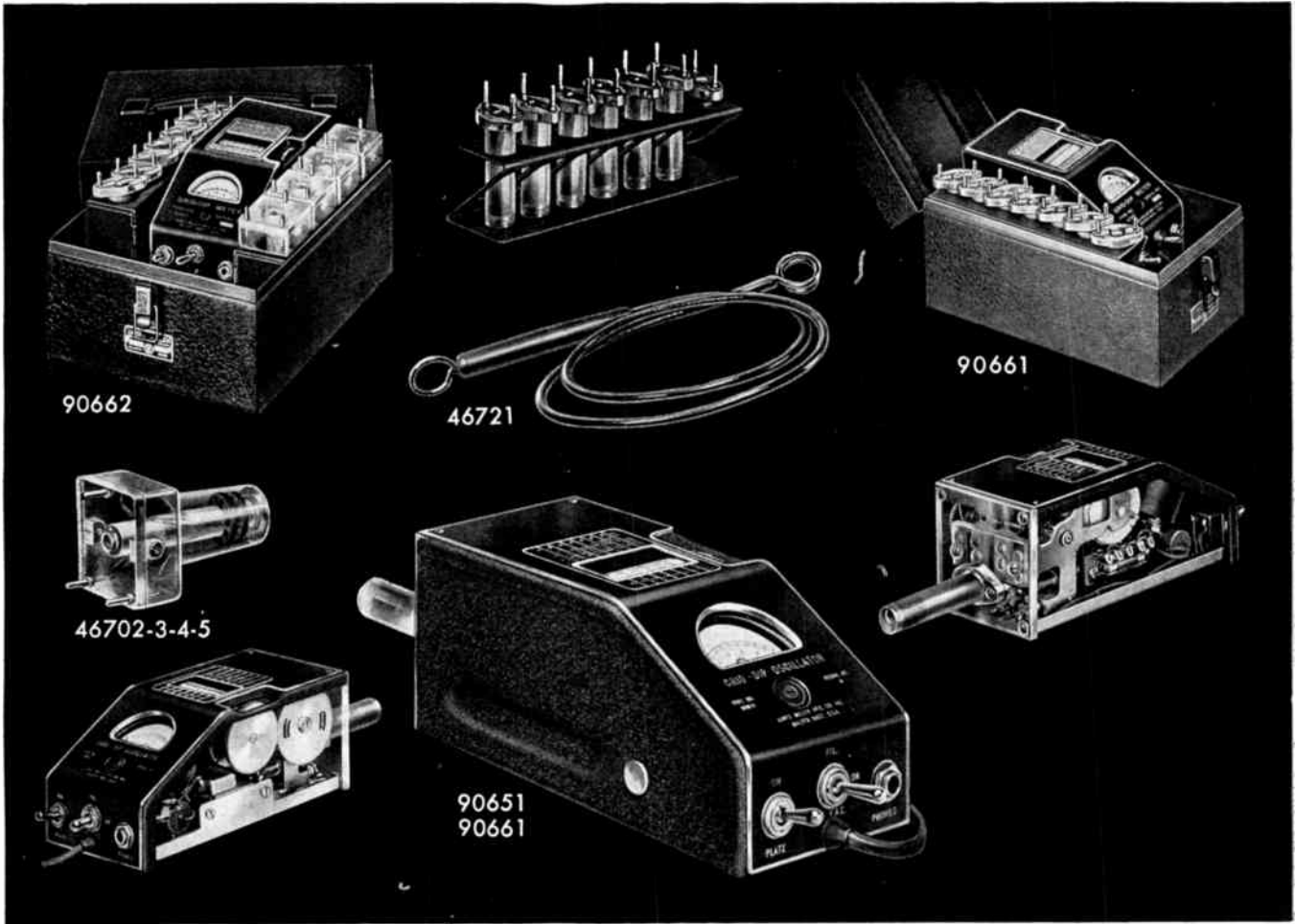

Designed for Application

Grid Dip Meters

Millen Grid Dip Meters are available to meet all various laboratory and servicing requirements.

The 90662 Industrial Grid Dip Meter completely calibrated for laboratory use with a range from 225 kc. to 300 mc. incorporates features desired for both industrial and laboratory application, including three wire grounding type power cord and suitable carrying case.

The 90661 Industrial Grid Dip Meter is similar to the 90662 except for a reduced range of 1.7 to 300 mc. It likewise incorporates the three wire grounding type cord and metal carrying case.

The 90651 Standard Grid Dip Meter is a somewhat less expensive version of the grid dip meter. The calibration while adequate for general usage is not as complete as in the case of the industrial model. It is supplied without grounding lead and without carrying case. The range is 1.7 to 300 mc. Extra inductors available extends range to 220 kc.

The Millen Grid Dip Meter is a calibrated stable RF oscillator unit with a meter to read grid current. The frequency determining coil is plugged into the unit so that it may be used as a probe.

These instruments are complete with a built-in transformer type A.C. power supply and internal terminal board to provide connections for battery operation where it is desirable to use the unit on antenna measurements and other usages where A.C. power is not available. Compactness

has been achieved without loss of performance or convenience of usage. The incorporation of the power supply, oscillator and probe into a single unit provides a convenient device for checking all types of circuits. The indicating instrument is a standard 2 inch General Electric instrument with an easy to read scale. The calibrated dial is a large 205° drum dial which provides seven direct reading scales, plus an additional universal scale, all with the same length and readability. Each range has its individual plug-in probe completely enclosed in a contour fitting polystyrene case for assurance of permanence of calibration as well as to prevent any possibility of mechanical damage or of unintentional contact with the components of the circuit being tested.

The Grid Dip Meters may be used as:

1. A Grid Dip Oscillator
2. An Oscillating Detector
3. A Signal Generator
4. An Indicating Absorption Wavemeter

The most common usage of the Grid Dip Meter is as an oscillating frequency meter to determine the resonant frequencies of de-energized tuned circuits.

Size of Grid Dip Meter only (less probe): 7 in. x 3 $\frac{1}{2}$ in. x 3 $\frac{3}{8}$ in.

JAMES MILLEN

MAIN OFFICE



MFG. CO., INC.

AND FACTORY

MALDEN, MASSACHUSETTS, U. S. A.

Electro-Pulse presents a New

FAST PULSE GENERATOR

- Output Flexibility
- Advanced/Delayed Operation
- Direct Coupled Pos. or Neg. Pulses

ECONOMICAL...

...FAST RISE TIME

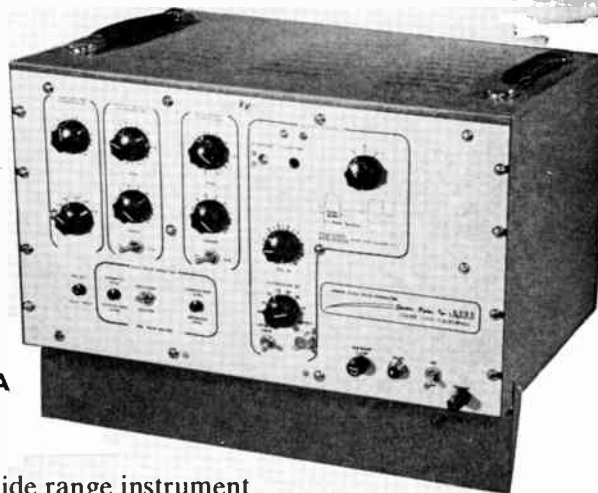

Model 2125A

A wide range instrument designed for the economical generation of fast rise time pulses at low impedance. Direct coupled output at ground potential minimizes waveform problems, and optional use of internal load allows provision of full power to low impedance loads and optimum waveform to higher loads.

- 90 V Amplitude Open Circuit, 50 V into 50 Ohm Load
- .02 μ s Rise Time
- 10 CPS to 100 KC Rep. Rate
- 0 to 100 μ s Delay or Advance
- .1 to 100 μ s Pulse Width
- 60 DB Attenuator.

Write for Complete Data: Our Bulletin 2125A/1

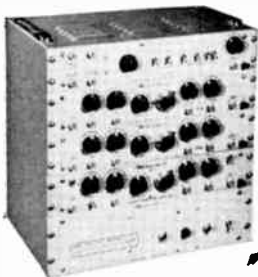

Model 2120A PRECISION PULSE GENERATOR

The Model 2125A Pulse Generator is the latest addition to the Electro-Pulse line of electronic instrumentation which includes Precision, Variable, and Megacycle Pulse Generators, Pulse Code Generators, Pulse Oscillators, Time Delay Generators, and Electronic Counting Equipment.

Representatives in Major Cities

Electro-Pulse, Inc.

11861 TEALE STREET, CULVER CITY, CALIFORNIA
Telephones: EXmont 8-6764 and TEXas 0-8006



(Continued from page 116A)

NEW HAMPSHIRE

"Problems in Making Synchronized Sound Movies in Africa," by Daniel Blitz, Sanders Associates, Inc.; September 25, 1956.

PIEDMONT

"High Fidelity Amplifiers and Associated Equipment," by F. H. McIntosh, McIntosh Laboratory, Inc.; September 14, 1956.

WESTCHESTER

"Magnetic Amplifiers and Diode Shaping Networks for Analogue Computers," by Joseph Schwartz, ACF Industries; September 19, 1956.

"A General Treatment of Analog Computer Operation and Use," by Peter L. Richman, Reeves Instrument Corporation; October 17, 1956.



The following admissions and transfers were approved and are now effective:

Transfer to Senior Member

Bernstein, S., Schenectady, N. Y.
Brown, T. G., Paramus, N. J.
Buranich, G. F., Lewiston, N. Y.
Culler, D. M., Hicksville, Ohio
Davis, J. K., Corning, N. Y.
Eldridge, A. J., Albuquerque, N. Mex.
Fink, A., Plainview, L. I., N. Y.
Fong, S. G., Fort Wayne, Ind.
Garber, J. F., Jr., Wright-Patterson AFB, Ohio
Glantz, L. M., Brooklyn, N. Y.
Gould, L. M., East Meadow, L. I., N. Y.
Hartig, E. O., Phoenix, Ariz.
Hauser, P. D., Dayton, Ohio
Helland, J. C., Beverly Hills, Calif.
Heller, H. H., Cleveland, Ohio
Hessler, J., Jr., Fort Wayne, Ind.
Hitt, W. R., Phoenix, Ariz.
Hoberg, G. G., Berwyn, Pa.
Holder, F. P., Atlanta, Ga.
Hollander, G. L., Cleveland, Ohio
King, L. E., Dallas, Tex.
LaPointe, J. C., West Hyattsville, Md.
Lumsden, R. B., Ville St. Laurent, Montreal, Que., Canada
Mansur, F., San Bruno, Calif.
McDonald, T. K., Midwest City, Okla.
Miller, H. G., New York, N. Y.
Mooney, D. H., Glen Burnie, Md.
Nichols, W. R., Seattle, Wash.
Nuttall, E. D., Shreveport, La.
Price, E. L., Jr., Tonawanda, N. Y.
Rapaport, H., New York, N. Y.
Rutstein, I., Rockville Centre, L. I., N. Y.
Sandison, T. A., Toronto, Ont., Canada
Tufro, A. J., Banfield, Argentina, S. A.
Williams, C. S., Dallas, Tex.
Worcester, W. G., Boulder, Colo.
Zurcher, L. A., North Canton, Ohio

Admission to Senior Member

Baccus, I. B., East Lansing, Mich.
Berk, A. D., Culver City, Calif.
Brock, E. G., McMinnville, Ore.
Cooper, D. I., Morristown, N. J.
Driscoll, W. G., Framingham Center, Mass.
Eggert, J., New York, N. Y.
Good, D. C., Arlington, Va.

(Continued on page 124A)

New Grant 3400

*thin*slide

*mounts standard 17" chassis
in standard 18" rack or cabinets*

REQUIRES ONLY 19/64" SPACE PER SIDE—

YET HAS

FULL ROLLER ACTION

(fits RETMA rack hole spacing)

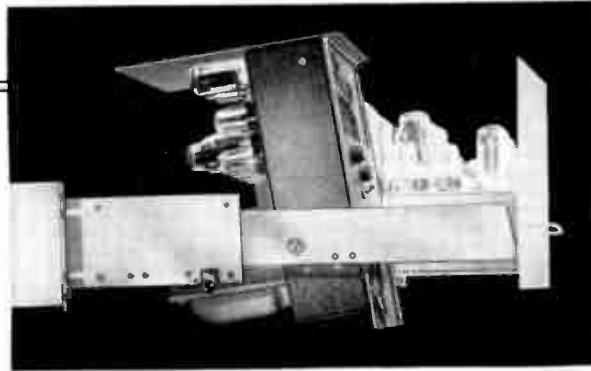

The Grant 3400 Thin slide requires only 19/64" space per side—installs readily in standard racks and cabinets. Allows instant access to chassis measuring from 10" to 16" deep. Tilts through 100° for under-chassis servicing. Positive lock in "out" position. Lock has finger-tip release for instant return or removal of chassis. Eight hardened steel rollers carry the rated load of 100 lbs. smoothly and easily—durability insures frictionless rolling for thousands of cycles of use.

Slide mounting not only provides for quick access—it usually eliminates need for rear access doors and rear aisles—a very important saving of space.

The Grant 3400 is a versatile slide, suited for use in your *product*, in *plant equipment*, *prototype* and *breadboard* work, and in *production line* or *field test equipment*. Very moderate cost allows a wide range of applications in original equipment.

Write today for Grant 3400
Thin slide Technical Bulletin—contains
full data and specifications.

Grant INDUSTRIAL SLIDES

Grant Pulley and Hardware Corporation
factories: 31-87 Whitestone Parkway, Flushing 54, N. Y.
944 Long Beach Avenue, Los Angeles 21, Calif.

Direct Reading Spectrum Analyzer

- for
- Visual frequency calibration — high resolution
 - Leakage and interference measurements
 - Standing wave measurements
 - Pulse modulation analysis
 - Sensitive receiver

The **BASIC SCOPE** for **VISUAL** **MICROWAVE**



SPECIFICATIONS

Model No.	Equipment
Model DU.....	Spectrum Display and Power Unit
Model STU-1...	RF Tuning Unit 10-1,000 mc.
Model STU-2A.	RF Tuning Unit 910-4, 560 mc.
Model STU-3A.	RF Tuning Unit 4,370-22,000 mc.
Model STU-4...	RF Tuning Unit 21,000-33,000 mc.
Model STU-5...	RF Tuning Unit 33,000-44,000 mc.
	Frequency Range: 10 mc to 44,000 mc.
	Frequency Accuracy: $\pm 1\%$
	Resolution: 25 kc.
	Frequency Dispersion: Electronically controlled, continually adjustable from 400 kc to 25 mc per one screen diameter (horizontal expansion to 20 kc per inch)

Frequency differences as small as 40 kc measurable by means of variable frequency marker with adjustable amplitude. Portable and completely self-contained.

Input Impedance: 50 ohms—nominal
Overall Gain: 120 db
Input Power: 400 Watts
Sensitivity: (minimum discernible signal)
STU-1: 10-400 mcs—89 dbm
400-1,000 mcs—84 dbm
STU-2A: 910-2,200 mcs—87 dbm
1,980-4,560 mcs—77 dbm
STU-3A: 4,370-10,920 mcs—75 dbm
8,900-22,000 mcs—60 dbm
STU-4: 21,000-33,000 mcs—55 dbm
STU-5: 33,000-44,000 mcs—45 dbm
Attenuation:
RF internal 100 db continuously variable
(STU-1, STU-2A, STU-3A)
IF 60 db continuously variable

Broadband 10-44,000 mc

Now, the Polarad Model TSA Spectrum Analyzer provides the same visual advantages for microwave testing as the standard oscilloscope accomplishes for low frequency signals. This is a "must" instrument for microwave work! It displays with high sensitivity on a bright easily defined CRT, pulse modulation components, frequency differences, attenuation and band width characteristics, leakage detection, radiation and interference signals, and VSWR information.

This is visual instrumentation—it provides immediate and complete information because of the high resolution obtainable.

Frequencies are read directly on the linear dial with 1% accuracy as the set is tuned. Maximum reliability and long life are assured through use of non-contacting oscillator plungers. A variable frequency marker with both frequency and amplitude adjustable is provided.



ANALYSIS

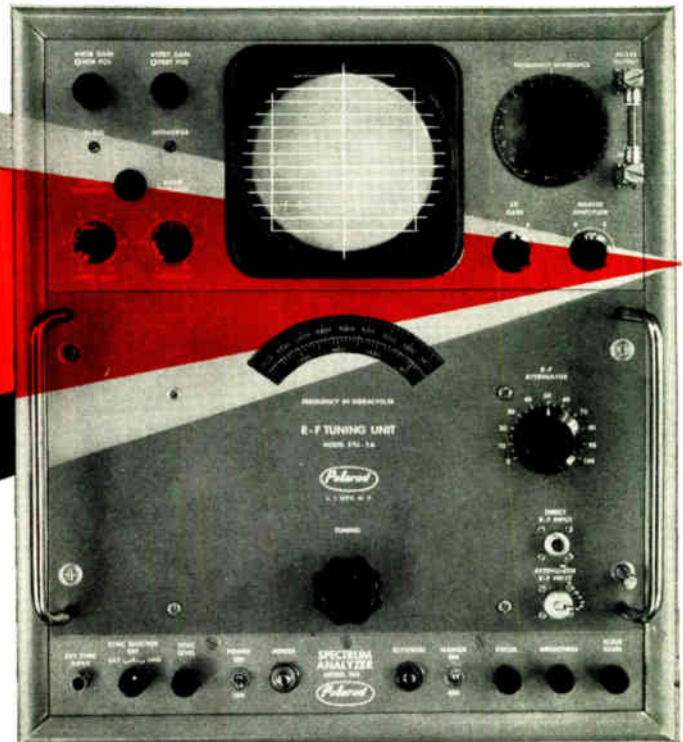

Write today—directly to Polarad, or your nearest Polarad representative—to find out how the Model TSA Spectrum Analyzer can speed your research and solve your microwave measurement and testing problems.

Write for your copy of the Polarad "Handbook of Spectrum Analyzer Techniques". 50c per copy. Includes discussion of Spectrum Analyzer operation, applications and formulae for analysis techniques.

AVAILABLE ON EQUIPMENT LEASE PLAN

FIELD MAINTENANCE SERVICE AVAILABLE
THROUGHOUT THE COUNTRY

Phone Polarad Collect for
information regarding the
Spectrum Analyzer, Model TSA.
EXeter 2-4500



ELECTRONICS CORPORATION
43-20 34th Street, Long Island City 1, N. Y.

REPRESENTATIVES: Albuquerque, Atlanta, Baltimore, Boston, Buffalo, Chicago, Cleveland, Dayton, Denver, Fort Worth, Kansas City, Los Angeles, New York, Philadelphia, Portland, St. Louis, San Francisco, Schenectady, Syracuse, Washington, D. C., Winston-Salem, Canada; Arnprior, Ontario. Resident Representatives in Principal Foreign Cities

**True Hermetic Sealing
assures Maximum Stability**

in **AMPERITE** **RELAYS and REGULATORS**

Simplest • Most Compact • Most Economical



STANDARD

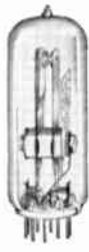

MINIATURE

Thermostatic **DELAY RELAYS** **2 to 180 Seconds**

- Actuated by a heater, they operate on A.C., D.C., or Pulsating Current.
- *Hermetically sealed.* Not affected by altitude, moisture, or other climate changes.
- *SPST only* — normally open or normally closed.

Amperite Thermostatic Delay Relays are compensated for ambient temperature changes from -55° to $+70^{\circ}$ C. Heaters consume approximately 2 W. and may be operated continuously. The units are most compact, rugged, explosion-proof, long-lived, and — *inexpensive!*

TYPES: Standard Radio Octal, and 9-Pin Miniature

**PROBLEM? Send for
Bulletin No. TR-81**

Also — Amperite Differential Relays: Used for automatic overload, under-voltage or under-current protection.

BALLAST REGULATORS

Amperite Regulators are designed to keep the current in a circuit automatically regulated at a definite value (for example, 0.5 amp.) ... For currents of 60 ma. to 5 amps. Operate on A.C., D.C., Pulsating Current.

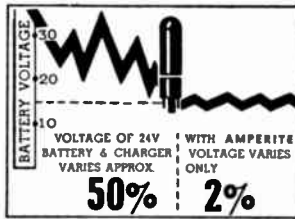
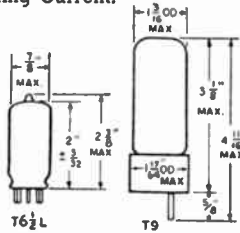

T9 BULB



Hermetically sealed, they are not affected by changes in altitude, ambient temperature (-55° to $+90^{\circ}$ C.), or humidity ... Rugged, light, compact, most inexpensive.

Write for 4-page Technical Bulletin No. AB-51

AMPERITE CO., Inc.

561 Broadway, New York 12, N. Y.

Telephone: CAnal 6-1446

In Canada: Atlas Radio Corp., Ltd.

50 Wingold Avenue, Toronto 10, Ontario

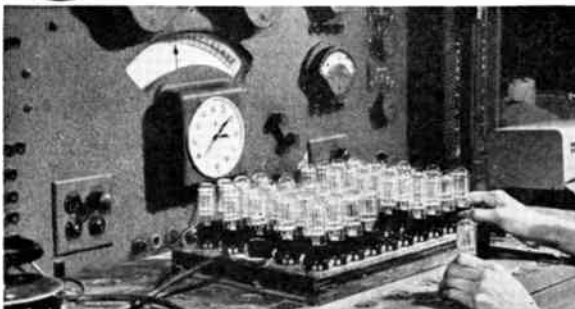

Individual inspection and double-checking assures top quality of Amperite products.



Membership

(Continued from page 120A)

- Grigsby, J. L., Stanford, Calif.
 Grubb, W. C., Jr., Wickatunk, N. J.
 Hepperle, C. M., Encino, Calif.
 Johnson, J. G., Falls Church, Va.
 Kaeburn, L. K., Studio City, Calif.
 Kimp, H. D., Bryn Mawr, Pa.
 Leister, R. E., Ellicott City, Md.
 Leverton, W. F., Waltham, Mass.
 MacIill, J., Skaneateles, N. Y.
 Metzger, J. E., Closter, N. J.
 Moore, J. W., Bethesda, Md.
 Moore, W. P., Tampa, Fla.
 Neal, P. L., Chevy Chase, Md.
 Nyden, R. C., Mountain View, Calif.
 Peters, C. W., Washington, D. C.
 Richardson, J. M., Boulder, Colo.
 Ries, C. A., New Hyde Park, L. I., N. Y.
 Roberts, L. W., Boston, Mass.
 Schwarz, E. G., Binghamton, N. Y.
 Seaman, E. F., Washington, D. C.
 Shephard, R. W., Albuquerque, N. Mex.
 Stellmacher, D. D., Los Angeles, Calif.
 Sures, A. H., Silver Spring, Md.
 Wiegand, E. P., Berlin, (British Sector), Germany
 Woo, W. G., West Newton, Mass.

Transfer to Member

- Alexander, E. J., Madison, N. J.
 Ambrosio, A., Los Angeles, Calif.
 Andersen, V. O., Oakland, Calif.
 Anderson, E. M., Fargo, N. Dak.
 Anderson, J. B., Harper Woods, Mich.
 Anderson, J. D., Livermore, Calif.
 Arrington, A. C., Roy, Utah
 Badger, G. M. W., Berkeley, Calif.
 Baldwin, G. L., Murray Hill, N. J.
 Baloga, J. J., Wilkes-Barre, Pa.
 Barker, R. C., North Haven, Conn.
 Bassett, D. M., Pacoima, Calif.
 Bekker, D. I., Tiv'on, Haifa, Israel
 Beneke, E. H., Chicago, Ill.
 Bennion, D. R., Menlo Park, Calif.
 Bissett, E. B., Potomac Heights, Md.
 Bleisch, G. W., Murray Hill, N. J.
 Blickstein, M. J., Bayside, L. I., N. Y.
 Bogora, G. F., Toronto, Ont., Calif.
 Bohl, L. H., Jr., Harrison, N. Y.
 Borner, R. C., New York, N. Y.
 Bouquet, F. L., Jr., San Fernando, Calif.
 Boyles, J. O., Kansas City, Mo.
 Brandes, P. D., Schenectady, N. Y.
 Bravo, A., Los Angeles, Calif.
 Broder, A., Glen Oaks, L. I., N. Y.
 Bryan, W. C., Monterey, Calif.
 Buehrle, C. D., Grand Prairie, Tex.
 Burkhalter, R. M., McComb, Miss.
 Byrne, W. C., Jr., Lake Forest, Ill.
 Carignan, R. J., Erlton, N. J.
 Carrington, W. A., Grand Rapids, Mich.
 Cassidy, J. J., Jr., Old Greenwich, Conn.
 Chimera, A. J., Buffalo, N. Y.
 Christensen, A. G., Scarborough, Ont., Canada
 Chu, G. Y., Ipswich, Mass.
 Claar, D. E., Los Angeles, Calif.
 Clark, H. R., Whippany, N. J.
 Clauer, C. K., Deerfield, Ill.
 Cleary, C. J., Jr., Schenectady, N. Y.
 Clifton, J. L., Oklahoma City, Okla.
 Colangelo, L. P., Rome, N. Y.
 Compton, M. E., Jr., Alexandria, Va.
 Coogan, E. A., Quaker Hill, Conn.
 Cook, G. W., Pasadena, Calif.
 Cook, M., La Jolla, Calif.
 Corwin, G., Lexington, Mass.
 Cosgrave, S. J., Seal Beach, Calif.
 Cotterill, M. J., San Mateo, Calif.
 Cox, C. W., Winston-Salem, N. C.
 Cox, G. L., Horseheads, N. Y.
 Crane, R. B., Baltimore, Md.

(Continued on page 126A)

**FAST...PRECISE...AUTOMATIC
RESISTANCE MEASUREMENTS
FOR LABORATORY OR INDUSTRY**

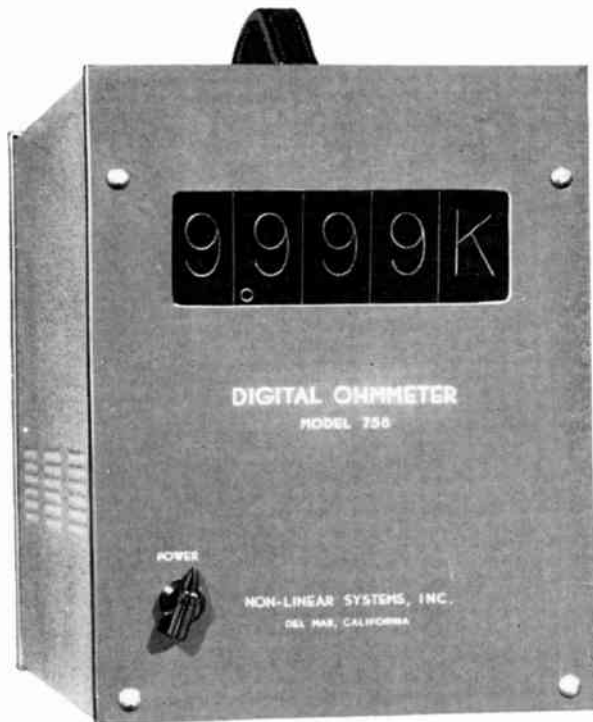

Models 758 and 759 available in either rack mount or portable. Portable model is pictured above.



FAST, AUTOMATIC MEASUREMENT of a wide range of resistance values, with an exceptionally high degree of accuracy, now is available in Non-Linear Systems Digital Ohmmeters. Resistance values are displayed in a horizontal line on one-inch-high luminous numerals clearly legible at distances to 30 feet. The readout decimal point location and range selection are automatic. And these instruments feature the exclusive NLS *oil-sealed stepping switches*, specifically re-designed for NLS digital equipment. This feature has been time-tested in the widely accepted NLS Model 451 Digital Voltmeter; it guarantees maximum maintenance-free life of stepping switches even in the presence of dust and humidity. Accuracy, ruggedness, high-speed automatic operation, reliability and economy adapt NLS Digital Ohmmeters to a wide variety of applications in laboratory, production, inspection and field testing...even with unskilled personnel. Ask your nearest NLS representative about these instruments...or mail the coupon below for full details.

CHARACTERISTICS

Model 758 (4-Digit Display)
 RANGES: .0001K to .9999K 100.0K to 999.9K
 1.000K to 9.999K 1000K to 9999K
 10.00K to 99.99K

ACCURACY: $\pm 0.1\%$ of value read or 1 digit, whichever quantity is greater.

Model 759 (5-Digit Display)
 RANGES: ACCURACY: *
 0.0001K to 9.9999K $\pm (0.01\% + 1 \text{ digit})$
 10.000K to 99.999K $\pm (0.01\% + 1 \text{ digit})$
 100.00K to 999.99K $\pm (0.03\% + 1 \text{ digit})$
 1000.0K to 9999.9K $\pm (0.05\% + 1 \text{ digit})$ to 5 meg.
 $\pm (0.1\% + 1 \text{ digit})$ to 10 meg.

*Percentages are expressed as % of value measured

BOTH MODELS

RANGE SELECTION & DECIMAL LOCATION: *Automatic*
 SIZES: *Rack Mount*—5 1/4" H, 19" W, 15 1/4" D.
Bench Top (Portable)—11" H, 8 1/4" W, 15 1/4" D.
 WEIGHT: 33 lbs

PRIMARY POWER: 115 \pm 10v, 60 cycles, 75 watts.

ACCESSORIES: *Data printing provision with automatic print control and Clary Printer or Electric Typewriter.*

*Connection and automatic control for card or paper tape punching equipment.
 Multi-channel input scanners.*



non-linear systems, inc.
 Del Mar, Calif. • Phone: SKyline 5-1134

ORIGINATORS OF THE
 DIGITAL VOLTMETER

Digital Ohmmeters • AC-DC Converters • Data Reduction Systems • Digital Readouts • Peak Reader Systems • Binary Decimal Converters • Digital Recording Systems

NON-LINEAR SYSTEMS, INC.

Dept. A-126, Del Mar Airport, Del Mar, Calif.
 Send new Technical Bulletin 1256 with full information on NLS Digital Ohmmeters—Models 758 and 759.

NAME _____
 COMPANY _____
 ADDRESS _____
 CITY _____ STATE _____

tomorrow's resistor is here today!

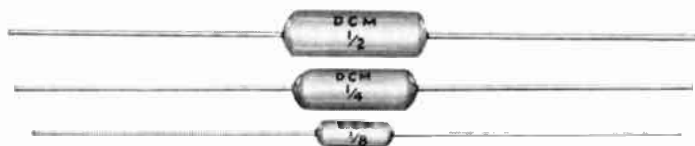
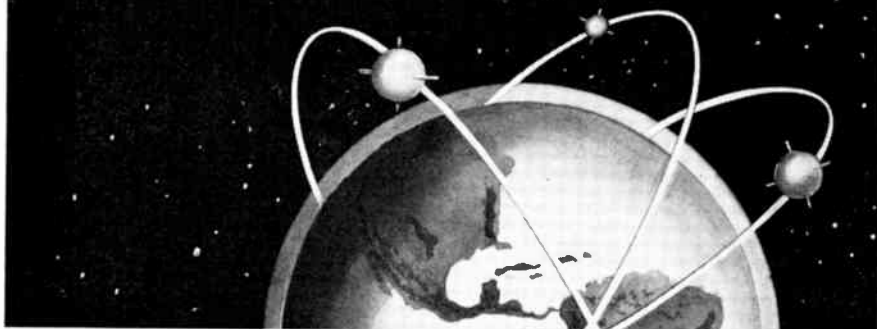

NEW . . . and now available in three sizes, 1/8, 1/4, 1/2 watt

ELECTRA Molded (plastic encapsulated) deposited carbon resistors

Performance to meet, not just today's most exacting requirements, but the needs of the future for higher and still higher limits of reliability! That's what you get in Electra's new doubly-insulated molded resistors. Yes, doubly-insulated . . . to give you extra mechanical protection, longer load life, better electrical insulation, greater resistance to heat and moisture. And look at these truly "miniature" sizes:

	Resistance Range	Length	Diameter	Lead Dia.	Lead Length
DCM 1/8	10 Ohms to 1 Meg.	13/32"	.136"	.026"	1 1/2"
DCM 1/4	10 Ohms to 1 Meg.	19/32"	.219"	.026"	1 1/2"
DCM 1/2	10 Ohms to 2.5 Meg.	3/4"	.25"	.032"	1 1/2"

Made to meet or exceed New MIL-R-10509B

Electra also offers you a complete line of Standard and Ceramic Hermetically Sealed deposited carbon resistors. Write today for full details.

WRITE FOR FREE SAMPLES* OF NEW W-BLADE SEALED SWITCH

Snap-action; sealed against water, dirt, dust, chemicals; exceptional life expectancy; positive, precise calibration; high capacity compared to size. AND AMAZINGLY LOW COST!



1/2 actual size

One sample assembled, sealed, ready for testing; another that you can take apart for inspection. Write today . . . no cost, no obligation.

ELECTRA MANUFACTURING COMPANY
4051 Broadway Kansas City, Mo.



(Continued from page 124A)

- Crapo, S. T., Belmont, Mass.
- Crenshaw, D. M., Raleigh, N. C.
- Cronin, C. E., Manchester, Conn.
- Curtis, G. D., Irving, Tex.
- Da Roza, F. G., Detroit, Mich.
- Dean, M. A., West Hempstead, L. I., N. Y.
- Deml, A. J., Glassboro, N. J.
- De Rose, R. A., Chicago, Ill.
- Dewey, G. C., New York, N. Y.
- Deyoe, D. C., China Lake, Calif.
- Doroshaw, S. R., Baltimore, Md.
- Dougherty, J. G., Jr., Bethesda, Md.
- Dreifke, G. E., St. Louis, Mo.
- Duffy, J. J., New York, N. Y.
- Du Vall, W. E., Gardena, Calif.
- Efting, H. J., Sunnyvale, Calif.
- Enemark, R. B., West Acton, Mass.
- Enzler, A. J., Richmond, Calif.
- Evans, N. L., Jr., Paterson, N. J.
- Fanelli, F. A., Norwich, Conn.
- Farber, B., East Meadow, L. I., N. Y.
- Fedde, G. A., Hatboro, Pa.
- Feldman, S., Brooklyn, N. Y.
- Fow, B. F., Philadelphia, Pa.
- Frankiewicz, C., Long Beach, Calif.
- Fredrick, R. E., Jr., Rowayton, Conn.
- Fredricks, I., Flushing, L. I., N. Y.
- Frei, J., Las Cruces, N. Mex.
- Freiman, M. J., Syosset, L. I., N. Y.
- French, R. W., Liverpool, N. Y.
- Friedman, S., Fort Wayne, Ind.
- Frost, R. R., Syracuse, N. Y.
- Funk, R. E., York, Pa.
- Goldberg, S. R., Fort Lee, N. J.
- Graf, E. A., San Francisco, Calif.
- Gravel, J. P. J., Schenectady, N. Y.
- Greatbatch, W., Clarence, N. Y.
- Greene, R. M., Washington, D. C.
- Griffin, L. L., Arlington, Va.
- Hall, J. R., Collingswood, N. J.
- Hammill, C. W., Euclid, Ohio
- Hart, J. W., Winnetka, Ill.
- Hartzell, J. W., Madison, N. J.
- Hatton, W. L., Wellesley Hills, Mass.
- Hautaniemi, B. W., Wellesley, Mass.
- Herman, F., Princeton, N. J.
- Heywood, J. E., Palo Alto, Calif.
- Hildreth, A. E., Jr., Southampton, L. I., N. Y.
- Hoberman, M. J., Fair Lawn, N. J.
- Hoffman, C. P., Baltimore, Md.
- Holly, J. A., San Fernando, Calif.
- Holup, A. C., Richmond, Va.
- Horst, W. R., Spring Valley, Ohio
- Howes, R. E., Inglewood, Calif.
- Hutton, J. E., Midwest City, Okla.
- Hval, H. N., Clifton, N. J.
- Hyde, W. E., Jr., Syracuse, N. Y.
- Johnston, J. B., Cincinnati, Ohio
- Joyce, M. V., Jr., Brooklyn, N. Y.
- Kail, W. F., Columbus, Ohio
- Kalish, H. M., Parsippany, N. J.
- Kalson, N. H., Encino, Calif.
- Kazules, A. J., East Lynn, Mass.
- Kellough, S. H., Columbus, Ohio
- Kerfoot, J. H., Toronto, Ont., Canada
- Kiessling, G. A., Camden, N. J.
- Kiessling, R. C., San Carlos, Calif.
- Kimble, C. B., East Greenwich, R. I.
- Kingan, J., Bridgeton, N. J.
- Kleinman, J. M., Loveland, Ohio
- Klingler, D. E., Allen Park, Mich.
- Knox, R. W., Floral Park, L. I., N. Y.
- Kolts, R. C., Springfield, N. J.
- Krason, H. C., University Park, Md.
- Kruger, F. W., Glendale, Calif.
- Kruse, O. E., Kingsville, Tex.
- Kurner, C. J., Washington, D. C.
- Kuss, P. W., West Englewood, N. J.

(Continued on page 128A)

1957 1958 1959 1960 1961

DEPENDABILITY

Guaranteed for **5** years



The best guarantee in the business!
 The 401 is so dependable, we're backing it with a *five year guarantee* on all printed wiring and power transformers . . . and, all other components, including the cathode-ray tube, carry a full one-year guarantee.

DU MONT 401

- **IDENTICAL X- AND Y- AMPLIFIERS:** Sensitivity, 10 mv/cm. Sinewave response extends flat from dc to 150 kc. Calibration standards built-in for both amplifiers.
- **SWEEPS:** 18 calibrated ranges extending from 50 ms/cm to 4 us/cm. 3 times sweep expansion available.
- **RELATIVE PHASE SHIFT BETWEEN AMPLIFIERS:** Easily set for less than 1° at frequencies below 150 kc.
- **CATHODE-RAY TUBE:** Tight tolerance Type 5ADP, operated at 3000 volts acceleration.
- **STABLE OPERATION:** Regulation of all power supply potentials, including heaters, provides complete stability.

Best buy in the medium price range—a general-purpose, low-frequency oscillograph for complete, high-quality quantitative measurement. The 401 offers a new high in precision, ease of operation and convenience as a result of “human engineering”—an exclusive of the Du Mont 400 philosophy of instrument design.

WRITE FOR DETAILS.

\$420.00

(slightly higher for 50-cycle areas)

DU MONT® One of the  Series

TECHNICAL SALES DEPARTMENT, ALLEN B. DU MONT LABORATORIES, INC. • CLIFTON, N. J.



ALL Eimac Air System Sockets are Thermo-Electrically Designed for Optimum Cooling

To perform a specific function in a specific manner calls for custom design. To cool a tube efficiently, keeping airflow and circuit losses at a minimum, calls for a thermo-electrically designed air socket.

Eimac's line of 16 air sockets provides these advantages for nearly all Eimac multi-grid and klystron tube types.

Pictured above is the SK-100, for the 3K3000L-series klystrons. Below it the SK-400, for the 4-400A. Next is the SK-600, for the 4X250B. And finally the SK-300, for the 4X5000A. Each is the best for its own specific function. And each is an original Eimac custom design. There are 12 others, every one as outstanding.

Among these 12 is the SK-630. Developed for use with Eimac's 4X150A, 4X150D, 4X250B, 4X250F, and 4W300B in tropical atmospheres, it employs an encapsulated screen-to-cathode bypass capacitor which, in combination with shielded circuits, permits stable high gain operation up to the tube's highest useful frequency.

Eimac air system sockets chimneys are also available.

For further information, write our Application Engineering Department.



EITEL-McCULLOUGH, INC.
SAN BRUNO, CALIFORNIA
The World's Largest Manufacturer of Transmitting Tubes



(Continued from page 126A)

- Laisk, E., Armidale, N. S. W., Australia
- Landsyshev, A. N., San Luis Obispo, Calif.
- Larkins, G. L., Miami, Fla.
- Leeds, M. F., San Diego, Calif.
- Leeking, A. M., Los Angeles, Calif.
- Lefkowitz, H., Hyattsville, Md.
- Leichner, G. H., Champaign, Ill.
- Leoutsakos, G. N., Hampton, N. H.
- Levy, E., Jr., Norwalk, Conn.
- Lezan, G. R. E., Marblehead, Mass.
- Linsenhardt, A. E., Baltimore, Md.
- Lippel, B., Poughkeepsie, N. Y.
- Loebl, W. W., Yonkers, N. Y.
- Loveman, B. D., Flushing, L. I., N. Y.
- Lyman, R. C., Monroeville, Pa.
- Lynch, T. G., North Vancouver, B. C., Canada
- Lyon, T. J., Milwaukee, Wis.
- Mages, L. J., Westchester, Maywood, Ill.
- Mainland, R., South San Francisco, Calif.
- Mallison, R. E., Livonia, Mich.
- Marsh, D. S., Silver Spring, Md.
- Martin, W. C., Bossier City, La.
- Mason, D. F., Cuyahoga Falls, Ohio
- McBirney, H. R., Bethesda, Md.
- McBride, W. J., Flint, Mich.
- McDermitt, E. L., Fort Wayne, Ind.
- McMurray, D. D., Oelwein, Iowa
- Medla, E., Wappingers Falls, N. Y.
- Merrill, R. E., Baltimore, Md.
- Meyer, W. H., Willowdale, Ont., Canada
- Michie, C. G., Edmonton, Alta., Canada
- Miller, W. A., Brooklyn, N. Y.
- Mills, N. B., Wantagh, L. I., N. Y.
- Mishra, S., Kirkee, Poona, India
- Montagnon, N. B., Arnprior, Ont., Canada
- Morrison, G. E., Alameda, Calif.
- Mundo, C. J., Jr., Westbury, L. I., N. Y.
- Nelson, L., Vienna, Va.
- Nemchuk, W. J., Jackson Heights, L. I., N. Y.
- Nethken, R. T., Fort Worth, Tex.
- Newell, C. J., Detroit, Mich.
- Newell, R. A., Boonton, N. J.
- Nicholson, C. L., West Asheville, N. C.
- Nissim, S., Jackson, Mich.
- Nourse, R. B., Los Angeles, Calif.
- Noyes, J. E., Deming, N. Mex.
- O'Connor, J. F., Glen Head, L. I., N. Y.
- Ogasawara, T. B., Seattle, Wash.
- Olewine, W. P., Rockville, Md.
- Oliver, G. A., Ardmore, Pa.
- Olsefsky, C. C., Van Nuys, Calif.
- Olson, C. L., Collingswood, N. J.
- O'Neill, J. R., Mountain View, Calif.
- Pascoe, D., Tucson, Ariz.
- Paul, C. E., Whippany, N. J.
- Paulos, L. B., Northridge, Calif.
- Paulson, C. T., Pittsburgh, Pa.
- Pawkett, L. E., Seattle, Wash.
- Peck, J. L., Montclair, N. J.
- Peterson, R. H., Solana Beach, Calif.
- Pelner, N., Brooklyn, N. Y.
- Perkins, H. A., Jr., Pittsburgh, Pa.
- Person, L. B., Stockholm, Sweden
- Petranek, D. J., Janesville, Wis.
- Pfeiffer, D. A., Cocoa, Fla.
- Phillips, T. H., Graybill, Ind.
- Pierson, V. F., Morristown, N. J.
- Pinol, D. G., Redondo Beach, Calif.
- Pitlik, H., New York, N. Y.
- Piwonka, W. G., Cleveland, Ohio
- Poznanski, Z., Montreal, Que., Canada
- Prosser, T. F., Hayward, Calif.
- Rabinowitz, J., Carlstadt, N. J.
- Racker, J., Brooklyn, N. Y.
- Read, E. F., Cedar Rapids, Iowa
- Reibert, F. A., North Syracuse, N. Y.
- Reich, M. L., Winston-Salem, N. C.
- Remley, F. M., Jr., Ann Arbor, Mich.
- Renk, B. J., Minneapolis, Minn.
- Rhodes, H. G., West Salem, Wis.

(Continued on page 130A)

LARGE

WAVEGUIDE COMPONENTS

WR 770 to WR 2100 and larger if required

To complement the waveguide presently being supplied for major military and commercial applications we now offer a complete line of components and test equipment. All items are currently in production and are available on short term delivery.

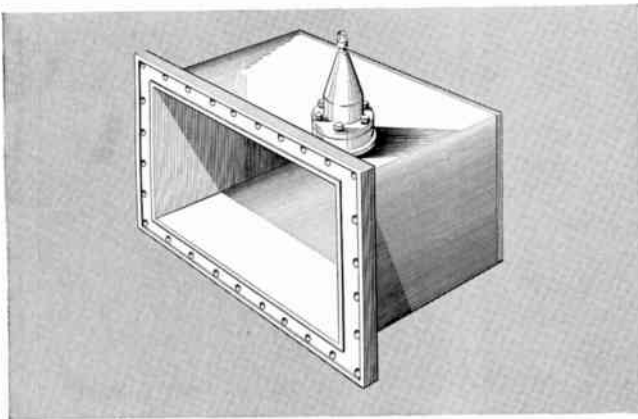

● Waveguide to Coaxial Transitions

High-strength, lightweight aluminum construction. Supplied as standard with 3 1/4 in. coaxial connector-adapters to other sizes available. All transitions designed for high power handling capacity.

● Terminations

Aluminum construction. Engineered to absorb virtually all incident power. Load is adjustable with locking device to secure it in any position.

● Attenuators

Vane type designed to provide 20 db of attenuation with a minimum of mismatch. Calibration curves available.

● Directional Couplers

Bolted and doweled aluminum construction. Power split to customer requirements.

● Special Components

Including Waveguide Switches, Duplexers, Diplexters, Series and Shunt Tees, Rotary Joints, and Special Shapes.

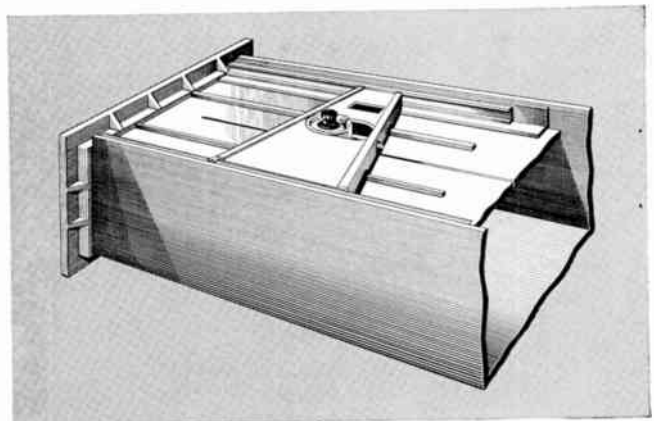

● Slotted Lines

Fully engineered, aluminum bolted, and doweled construction. Probes tunable over entire frequency band.

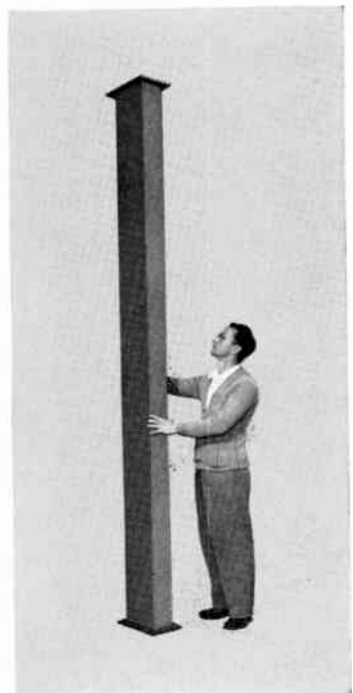

For more information on above components and waveguide, write I-T-E Circuit Breaker Company, Dept. 45, Special Products Division, 601 East Erie Avenue, Philadelphia 34, Pa.

I-T-E CIRCUIT BREAKER COMPANY

Special Products Division

DALOHM... miniature but mighty!

announces the new "MIL-E-TRIZED"
**A10-W-TRIMMER
 POTENTIOMETER**



**Wire Wound
 High Temperature
 Humidity Proof—Ruggedized**



Designed to meet increased demands of MIL. specifications, DALOHM A10-W-Trimmer potentiometer provides precision adjustment in critical electronic circuits under extreme environmental conditions. The A10-W-Trimmer has an extended winding surface and assures high precision resolution without sacrificing sub-miniature design.

- Unique new safety clutch prevents damage from over-exursion of the trimmer adjustment screw.
- Holds set resistance values—internal units have nearly identical coefficients of expansion.
- Housing has heat resistance of 200° C continuous.
- Resistance values 10 ohms to 50,000 ohms; tolerance 5% standard; power rating .8 watt.
- Size .220 x .312 x 1.250; weight 2.25 grams.

Write for Bulletin R-32

DALE PRODUCTS, INC.
 Phone 2139

1302 28th Ave., Columbus, Nebraska, U.S.A.

Export Dept.: Pan-Mar Corp.
 1270 Broadway, New York 1, N.Y.
 In Canada: Charles W. Painton,
 Ltd., 6 Alcina Ave., Toronto



Membership

(Continued from page 128A)

- Riedel, J. C., Altadena, Calif.
 Robinson, D. L., Albertson, L. I., N. Y.
 Robinson, M. P., Jr., West Concord, Mass.
 Roeder, J. R., Severna Park, Md.
 Romano, G. F., Baltimore, Md.
 Rooney, W. V., New York, N. Y.
 Rosenthal, C. W., Murray Hill, N. J.
 Rubin, J., New York, N. Y.
 Sacco, V., Oradell, N. J.
 Salzer, R. M., Clifton, N. J.
 Sass, L. J., Rochester, N. Y.
 Snoddy, R. E., San Bruno, Calif.
 Sommer, J. G., Jr., Bethesda, Md.
 Spector, A., Farmingdale, L. I., N. Y.
 Stauffer, R. L., Hamilton, Ont., Canada
 Strauss, D. J., Woodland Hills, Calif.
 Strauss, G. M., Nanuet, N. Y.
 Schafer, G. E., Indianapolis, Ind.
 Schwab, B. B., Downey, Calif.
 Schwartz, H., Burbank, Calif.
 Sedik, J. J., Waltham, Mass.
 Senger, F. A., Towson, Md.
 Siegal, A., New York, N. Y.
 Smith, E. L., Wilmette, Ill.
 Smith, R. H., Brooklyn, N. Y.
 Solomon, C., Levittown, L. I., N. Y.
 Soma, R., Chicago, Ill.
 Stearns, H. F., Syracuse, N. Y.
 Stein, V. J., Peekskill, N. Y.
 Stelzer, R. B., Bellaire, Tex.
 Stevens, C. R., Phoenix, Ariz.
 Stone, O. L., Lexington, Mass.
 Stover, H. A., Cedar Rapids, Iowa
 Swanson, H. E., Palmerton, Pa.
 Taira, W. C., Syracuse, N. Y.
 Tait, R. B., Milwaukee, Wis.
 Tate, W. R., Culver City, Calif.
 Taylor, F. E., Buffalo, N. Y.
 Taylor, L. L., Granville, Ohio
 Terrell, R. L., Levittown, Pa.
 Thomas, J. J., San Diego, Calif.
 Thomas, J. K., II, Norristown, Pa.
 Thomasson, L. T., Seattle, Wash.
 Thunder, L. C., Patuxent River, Md.
 Thurman, E. J., Norwalk, Calif.
 Titus, R. W., Muroc, Calif.
 Toense, E. R., Silver Spring, Md.
 Tornheim, H., Santa Barbara, Calif.
 Torrey, R. D., Philadelphia, Pa.
 Tressler, J. B., Hudson, Ind.
 Triplett, M. M., Bluffton, Ohio
 Tu, J. C., Memphis, Tenn.
 Twist, G. A., Hatboro, Pa.
 Urban, C., Briarcliff Manor, N. Y.
 Valentine, F. C., Fort Wayne, Ind.
 Van Dyck, E. A., Antwerp, Belgium
 Van Horne, T. B., Culver City, Calif.
 Van Winkle, H. W., Jr., Poughkeepsie, N. Y.
 Vaughan, T. J., Wadsworth, Ohio
 Vidro, E. F., Jr., St. Paul, Minn.
 Viles, F. L., San Diego, Calif.
 Waas, G. J., Brooklyn, N. Y.
 Walding, E. C., Chicago, Ill.
 Walker, R. V., Fort Walton Beach, Fla.
 Walter, C. H., Columbus, Ohio
 Ward, J. C., Pleasantville, N. Y.
 Weaver, J. H., Eldorado, Sask., Canada
 Weber, I. J., Kew Gardens Hills, L. I., N. Y.
 Weber, G. L., Miami, Fla.
 Weindorf, D. R., Culver City, Calif.
 Weinstein, I., Long Beach, L. I., N. Y.
 Weiss, F., Santa Monica, Calif.
 Weiss, G. D., New York, N. Y.
 Weiss, H., Louisville, Ky.
 Weiss, M., Wantagh, L. I., N. Y.
 White, J. R., Devon, Conn.
 Whitmore, D. C., Poughkeepsie, N. Y.
 Wild, H. K., Wappingers Falls, N. Y.

(Continued on page 132A)

NOISE MASKING



**HANDLE BOTH PROBLEMS WITH
 SKL VARIABLE FILTERS**

HELPFUL

SKL Electronic Filters are used constantly in acoustic, speech and psychology laboratories to shape bands of noise over a wide spectrum for measurements of masking effect in research on annoyance threshold judgments, loudness adaptation, sonar audibility, etc.

HARMFUL

SKL Electronic Filters are widely used in vibration, telemetering, underwater sound and cardiography studies to eliminate interfering hash and unwanted frequencies in the outputs of all kinds of transducers such as microphones, accelerometers, hot wire anemometers, hydrophones, etc.

Why not let SKL Series 300 Variable Electronic Filters solve your problem too?
 Write for data sheets.

SKL

SPENCER-KENNEDY LABORATORIES, INC.
 1320 SOLDIERS FIELD ROAD, BOSTON 35, MASS.

Rate
Tach
Reference
Power
Damping

GENERATORS

to your precise specifications.

MANUFACTURED UNDER CLOSE QUALITY CONTROL INCLUDING 100% ELECTRICAL INSPECTION.



TYPE GENERATOR	SIZE	OSTER TYPE	MOUNTING	LENGTH INCHES	MOTOR						GENERATOR					
					Power Supply	Min. Stall Torque oz-in	No Load RPM	Total Watts Input at Stall	Rated Voltage			Output Voltage Gradient Volts 1000 RPM No Load	Linear Up To RPM	Excitation Voltage	Null Voltage Millivolts	Phase Shift
									Fired Phase	Control Phase	12.5 200~ at 6000RPM					
A.C. Tachometer	10	10-MTG 6227-01	Face	2-9/16	400~	.1	9,500	10	115	115	12.5 200~ at 6000RPM	-	-	-	-	
Rate	10	10-MTG 6226-02	Synchro	2-9/64	400~	.3	6,500	-	26	26	.24	4500	26V 400~	23	-	
Rate	10	10 6677-01	Face	1-3/8	Mech. Driven	-	-	-	-	-	.41	8000	18V 400~	50	-	
Rate	10	10-MTG 6231-01	Synchro	2-3/16	400~	.26	19,400	14	26	26	.34	8000	26V 400~	23	7°	
Rate	10	10-MTG 6226-04	Synchro	2-15/16	400~	.3	6,500	6.2	26	26	.45	4000	18V 400~	50	-	
Rate	10	6229-03	Synchro	2-1/8	400~	.25	10,500	6.0	26	26	.3	4000	18V 400~	12	-	
Rate	10	6229-02	Synchro	1-5/8	400~	.25	10,000	6.0	26	26	01-5.5 ø2 .115	4000	18V 400~	12	0+5°	
Rate	10	6229-05	Face	2-1/8	400~	-	10,000	6.0	26	26	.3	4000	18V 400~	12	-	
Tachometer Squirrel Cage Rotor	10	10-TG 6676-01	Synchro	1-1/16	Mech. Driven	-	-	-	-	-	.3	4500	6.3V 100~	-	-	
Tachometer Squirrel Cage Rotor	15	15 5151-01	Synchro	1-13/64	Mech. Driven	-	-	-	-	-	1.3	4500	115V 400~	50	-	
A.C. Tachometer D.C. Motor	15	15-MTG 6276-01	Synchro	3-7/16	D.C.	2	11,000	-	28 D.C.	-	.25	5000	115V 400-1200~	25	15°	
Damping	21	D 5851-01	Face	2-11/16	400~	3.5	7,500	40	115	115	.022	6500	26V 400~	-	-	
D.C. Tachometer	12	12-D 8301-02	Face	2-1/4	Mech. Driven	-	-	-	-	-	2.7	8000	P.M.	-	-	
							Phase 1 Output Voltage	Phase 1 Output Current	Phase 2 Output Voltage	Phase 2 Output Current	Output Frequency	Speed At Rated Output	Type Rotor	Torque Input		
Dual Output	10	6702-01	Synchro	1-5/8	Mech. Driven	67	.011 A	1.4	.150 A	400~	12,000	P. M.	-	-		
A.C. Power	17	6951-03	Synchro Spec.	1-9/16	Mech. Driven	24	.85 A	24	.85 A	420~	12,600	P. M.	3.5 oz.in.	-		
Reference	25	23-TG 6776-01	Synchro	4	Mech. Driven	40	.0375 A	40	.0375 A	35~	2,100	P. M.	-	-		

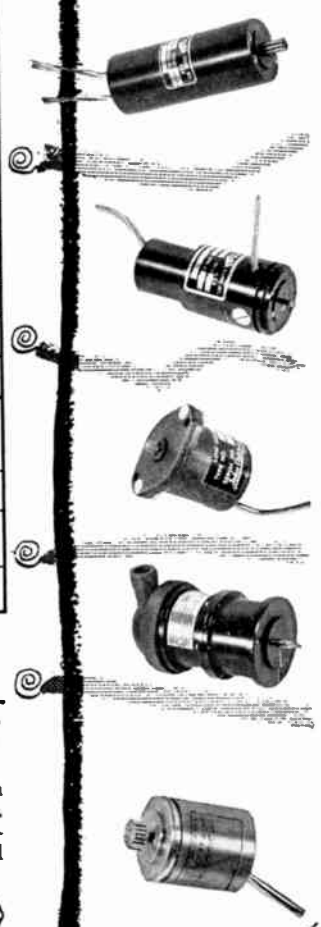

Many other variations available. Your detailed spec governs:



- EXCITATION VOLTAGE • OPERATING TEMPERATURE RANGE • INPUT AND OUTPUT • IMPEDANCE • PHASE SHIFT • HUMIDITY RESISTANT • FUNGUS RESISTANT • MIL SPEC TO BE MET • GEAR TRAIN AVAILABLE • BRAKE AVAILABLE •

Consult Oster specialists on your generator problems. Write today for further information, stating your detailed requirements.

Other products include Actuators, Servos, AC Drive Motors, Servo Mechanism Assemblies, DC Motors, Motor-Gear-Trains, Fast Response Resolvers, Servo Torque Units, Synchros, Motor Driven Blower and Fan Assemblies and Synchro Indicators.

John Oster
MANUFACTURING CO.
Your Rotating Equipment Specialist
Avionic Division Racine, Wisconsin

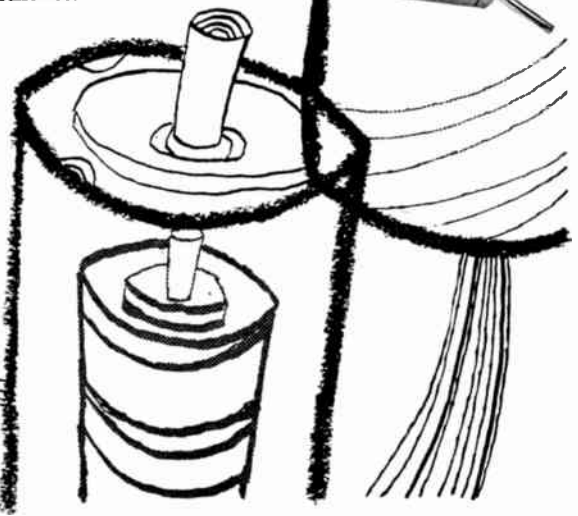
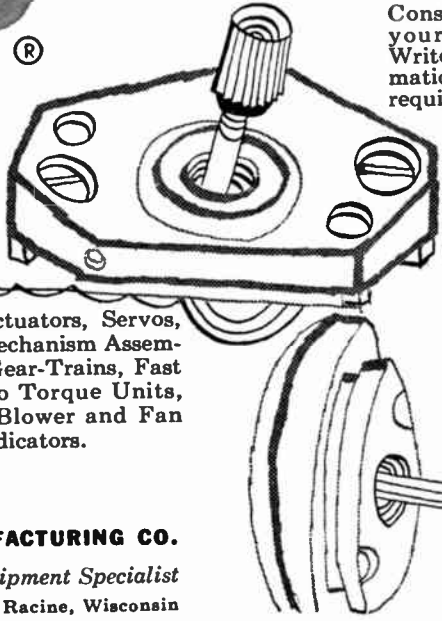

MEASURE NOISE AND FIELD INTENSITY FROM 150 KC TO 1000 MC— WITH ONE METER!

Quickly • Accurately • Reliably



Noise and Field Intensity Meter
Model NF-105
(Commercial Equivalent of AN/URM-7)



TA/NF-105:
150 KC-20MC



T1/NF-105:
20-200MC



T2/NF-105:
200-400MC



T3/NF-105:
400-1000MC

Empire Devices Noise and Field Intensity Meter Model NF-105 permits measurements of RF interference and field intensity over the entire frequency range from 150 kilocycles to 1000 megacycles. It is merely necessary to select one of four individual plug-in tuning units, depending on the frequency range desired. Tuning units are readily interchangeable... can be used with all Empire Devices Noise and Field Intensity Meters Model NF-105 now in the field.

Each of the four separate tuning units employs at least one RF amplifier stage with tuned input. Calibration for noise measurements is easily accomplished by means of the built-in impulse noise calibrator. With this instrument costly repetition of components common to all frequency ranges is eliminated because only the tuners need be changed. The same components... indicating circuits, calibrators, RF attenuators, detectors and audio amplifier... and power supplies... are used at all times.

Noise and Field Intensity Meter Model NF-105 is accurate and versatile, it may be used for measuring field intensity, RF interference, or as an ultra-sensitive VTVM. A complete line of accessories is available.

For complete performance data, send for Catalog No. N-356

NEW YORK—Digby 9-1240 • SYRACUSE—Syracuse 2-6253 • PHILA-
DELPHIA—Sherwood 7-9080 • PITTSBURGH—Atlantic 1-9248 • BOS-
TON—Twinbrook 4-1955 • WASHINGTON, D. C.—DEcatur 2-8000 •
ATLANTA—Exchange 7801 • VALPARAISO, FLA.—5937 • DETROIT
—B Roadway 3-2900 • CLEVELAND—Evergreen 2-4114 • DAYTON—
Fulton 8794 • CHICAGO—ESlebrook 9-2700 • ST. LOUIS—Evergreen
5-7728 • DENVER—MAIn 3-0343 • FORT WORTH—WAlnut 3-8811 •
ALBUQUERQUE—ALbuquerque 5-9632 • LOS ANGELES—REpublic 2-
8103 • PALO ALTO—DAvenport 3-4455 • PORTLAND—CApital 7-3830 •
SPITTSVILLE, ONT., CAN.—HAzeldean-56 • EXPORT: NEW YORK—
Murray Hill 2-3760

EMPIRE DEVICES
PRODUCTS CORPORATION

38-15 BELL BOULEVARD • BAYSIDE 61 • NEW YORK

manufacturers of

FIELD INTENSITY METERS • DISTORTION ANALYZERS • IMPULSE GENERATORS • COAXIAL ATTENUATORS • CRYSTAL MIXERS



Membership

(Continued from page 130A)

Williams, J. C., Columbus, Ohio
Williams, T. G., San Francisco, Calif.
Wilsker, O., Philadelphia, Pa.
Winn, W. F., West Long Branch, N. J.
Winters, W. D., Fairborn, Ohio
Wischnia, H. F., Stanford, Conn.
Wood, P. E., Chicago, Ill.
Wooster, A. F., St. Clair Shores, Mich.
Wulfe, R. F., Fullerton, Calif.
Yates, C. R., Montclair, N. J.
Zabetakis, S. G., Pittsburgh, Pa.
Zacharia, H., Baltimore, Md.
Zanichkowsky, M., Richmond Hill, L. I., N. Y.
Zeitew, H., North Hollywood, Calif.
Zitelli, L. T., Palo Alto, Calif.

The following elections have been approved and are now effective:

Transfer to Member

Dickson, A. R. K., Buenos Aires, Argentina, S. A.
Dillon, R. S., Los Angeles, Calif.
Dinzik, D. J., Bound Brook, N. J.
Doctor, B., Cincinnati, Ohio
Eckel, C. C., Runnemed, N. J.
Elfvig, A. L., Stockholm, Sweden
Elices, F. J., Montevideo, Uruguay, S. A.
Feldman, J., Sunnyside, L. I., N. Y.
Francini, G., Roma, Italy
Gado, L. G., China Lake, Calif.
Gladson, G. G., Tulsa, Okla.
Gouin, P. L., Addis Ababa, Ethiopia
Grant, D. A., Ottawa, Ont., Canada
Grauberger, W. E., North Syracuse, N. Y.
Gregson, J. H., Scarborough, Ont., Canada
Guba, R. F., Waltham, Mass.
Gudmandsen, P. E., Kongensvej, Denmark
Haas, M. L., Cleveland, Ohio
Hagger, H. J., Basle, Switzerland
Harmegnies, P. A., Mons, Belgium
Hughes, J. M., San Francisco, Calif.
Jackson, C. H., Bellmore, L. I., N. Y.
Jackson, N. B., London, Ont., Canada
Jensen, S. E., Struer, Denmark
Johnston, H., IV., Thornwood, N. Y.
Jones, T. J., Miami, Fla.
Jones, W. F., Burbank, Calif.
Kalt, C. G., Port Chester, N. Y.
Kardos, M., Denver, Colo.
Kelley, W. C., Ballinger, Tex.
Kennedy, E. D., West Hyattsville, Md.
Kennedy, W. A., Seattle, Wash.
Kern, G. A., Mountain View, N. J.
Kriger, L. V., Dorchester, Mass.
Kruesi, G. G., Dayton, Ohio
Martin, M. M., Oklahoma City, Okla.
McCully, G. R., Ottawa, Ont., Canada
Menefee, H. R., Dover, N. H.
Moore, R. T., Los Angeles, Calif.
Muller, J. S., Corning, N. Y.
Nelson, W. F., Brooklyn, N. Y.
Nishio, H., Yokohama, Japan
Norton, J. A., Ottawa, Ont., Canada
Oakes, R. E., Yaphank, L. I., N. Y.

Admission to Member

Abbott, C. C., San Pedro, Calif.
Abou-Taleb, N. M., Newark, N. J.
Adams, T. E., Hyattsville, Md.
Ahalt, C. A., Dayton, Ohio
Ake, T. E., Redondo Beach, Calif.
Albicocco, S. P., Long Island City, L. I., N. Y.
Allen, F. W., North Hollywood, Calif.
Allison, G. D., Tucson, Ariz.
Anaya, F. J., New York, N. Y.
Andelin, D. R., White Sands Proving Ground, N. Mex.

(Continued on page 134A)

edp

2

IRE remembers the man



JOHN V. L. HOGAN
recipient of the
IRE Medal of Honor, 1956



FRANK J. BINGLEY,
recipient of the
IRE Television Award, 1956



KENNETH BULLINGTON,
recipient of the
IRE Liebman Prize, 1956.



WILBUR S. HINMAN, Jr.
recipient of the
IRE Diamond Award, 1956



JACK E. BRIDGES,
recipient of the
IRE Thompson Award, 1956.

for he is the creative force in a dynamic, growing industry!

Earth satellites, FM, TV, radar, transistors, scatter propagation, solid state electronics point the way to the markets of tomorrow. In radio-electronics, the radio-engineer builds these markets as he builds idea upon idea. His ever widening knowledge makes this an industry of rapid obsolescence. Progress is spelled in newness — printed circuits, computers with memory feed-back control, telemeters that reduce radio signals to understandable data, completely automatic factories.

Radio-engineers have made radio-electronics a giant. This comparatively young field will reach a 12 billion dollar volume this year and promises, within half a decade, to rival the automotive field as our nation's largest industry! IRE always remembers the men responsible for this growth.

The Institute of Radio Engineers is a professional Society of 50,000 radio-electronic engineers devoted to the advancement of their field of specialization. Their official publication, *Proceedings of the IRE*, is concerned solely with these men and their accomplishments. And *Proceedings of the IRE* is the only engineering journal in the radio-electronic industry exclusively edited *by and for* radio-electronic engineers.

Yes, IRE remembers the man . . . then is it any wonder that the men remember IRE? Best way to get products remembered, if they are sold in the radio-electronics field, is through advertising in the pages of *Proceedings of the IRE* for . . . *if you want to sell the radio industry, you've got to tell the radio engineer!*



THE INSTITUTE OF RADIO ENGINEERS
Proceedings of the IRE



Adv. Dept., 1475 Broadway, New York 36, New York
Chicago • Cleveland • San Francisco • Los Angeles



you don't need an Elephant
to pull a Wagon...

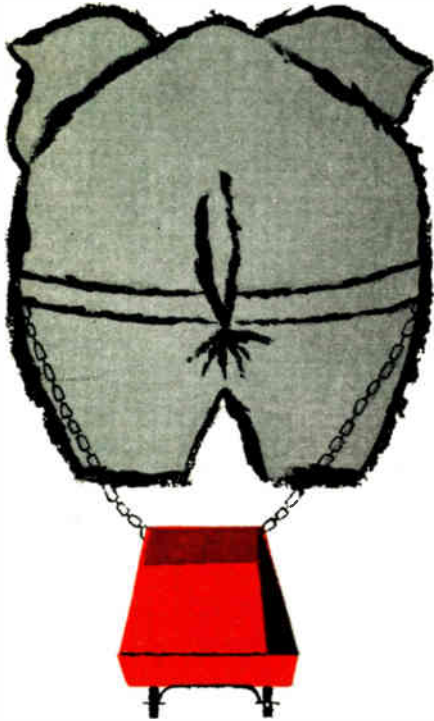

in delay lines, too,
you waste money
when you
"over-specify"

To avoid the costly pitfalls of over-specification of custom designed delay lines, take advantage of the engineering service and lab reports offered by ESC. As pioneer manufacturers and specialists in this field, ESC offers complete follow-through on the equipment applications of fixed and variable delay lines. "You tell us the problem... we'll recommend the realistic and economical specifications for your delay line requirements." The well-rounded equipment background of the ESC Engineering Staff makes this possible.

A lab report, submitted with the ESC prototype, will include your submitted electrical requirements, photo-oscillograms, which indicate input and output pulse shape and output rise-time; the test equipment used, and evaluation of the electrical characteristics of the prototype.

Write ESC for an informative catalog and complete information.



ESC

CORPORATION

538 BERGEN BOULEVARD, PALISADES PARK, N. J.



(Continued from page 132A)

Andersen, A. H., Roslyn Heights, L. I., N. Y.
Anderson, P. G., Philadelphia, Pa.
ap Rhys, T. L., Linthicum Heights, Md.
Ares, M., Syracuse, N. Y.
Athas, A. P., Utica, N. Y.
Bachman, W. S., Jr., Kenmore, N. Y.
Baker, W. F., Cambridge, Mass.
Baeumler, H. W., Columbus, Ohio
Barnett, M. L., Dallas, Tex.
Bateman, C. D., Belleville, Ont., Canada
Beaudrie, J. C., Pasadena, Calif.
Bennett, K., San Mateo, Calif.
Bensimon, J. C., Camden, N. J.
Bergmann, S. M., Brookline, Mass.
Biagiotti, R. V., Uniondale, L. I., N. Y.
Black, H., Albuquerque, N. Mex.
Blodgett, A. R., Baldwinville, N. Y.
Bosquez, R. D., Jr., Fort Worth, Tex.
Bouton, D. M., Schenectady, N. Y.
Bouyoucos, J. V., Cambridge, Mass.
Brink, D. K., Kansas City, Mo.
Britton, J. R., Honolulu, Hawaii
Browning, R. A., Ventura, Calif.
Burns, S. S., Wausau, Wis.
Chadwick, R. T., Royal Oak, Mich.
Chafin, R. L., Pasadena, Calif.
Cole, I. L., Albuquerque, N. Mex.
Coling, F. L., Torrance, Calif.
Crawford, R. A., Indianapolis, Ind.
da Cruz, A. M., New Bedford, Mass.
Daily, A. M., Elkhart, Ind.
Danahy, R. T., Arlington, Mass.
Day, J. W. B., Ottawa, Ont., Canada
Delano, A. B., Waltham, Mass.
Delbridge, W. A., Malton, Ont., Canada

Devine, J. H., Jr., Kew Garden Hills, L. I., N. Y.
Dimmick, R. R., El Cerrito, Calif.
Elliott, R. G., Glen Oaks, L. I., N. Y.
Emerick, L. C., Brookville, Pa.
Ericson, C. W., Jr., Van Nuys, Calif.
Farrall, G. A., Groton, Mass.
Ferrantino, S. J., Richmond Hill, L. I., N. Y.
Frederick, J. A., Oxnard, Calif.
French, R. L., Los Angeles, Calif.
Gambino, F. S., Long Island City, L. I., N. Y.
Gardner, R. S., New York, N. Y.
Gatterer, L. E., Boulder, Colo.
Gebhardt, H. W., Jr., Los Angeles, Calif.
Gibson, J. D. S., Dayton, Ohio
Girvin, R. A., Hawthorne, Calif.
Godfrey, P., Brooklyn, N. Y.
Greene, G. F., New Hyde Park, L. I., N. Y.
Greene, H. R., Cuyahoga Falls, Ohio
Gregg, R. C., Fry, Ariz.
Hamjian, R. V., Corning, N. Y.
Hansard, H. H., Montreal, Que., Canada
Haque, S. A., Washington, D. C.
Hatzikyriakos, P. P., Lancaster, Pa.
Hermach, F. L., Silver Spring, Md.
Herrick, H. S., Erie, Pa.
Higgins, R. N., Levittown, L. I., N. Y.
Hight, W. C., Regina, Sask., Canada
Hill, L. E., Fort Monmouth, N. J.
Hitchcock, R. W., Upland, Calif.
Holly, R., North Hollywood, Calif.
Homa, R. M., Jamaica, L. I., N. Y.
Horowitz, M., Brooklyn, N. Y.
Howe, L. H., Big Flats, N. Y.
Howell, M., Somerdale, N. J.
Huff, J. F., Jr., Dayton, Ohio
Humphrey, W. M., Cambridge, Mass.
Jachlewski, R. H., Lewiston, N. Y.
Jocoy, E. H., Buffalo, N. Y.
Joerg, E. A., New York, N. Y.
Johnson, W. R., Utica, N. Y.

(Continued on page 136A)

**Precision-Produced
MATERIALS for
TRANSISTORS
and DIODES**

**Specialists in
the Unusual**

GOLD doped with N-type or P-type elements —
supplied in the form of wire, sheet or ribbon and
cut or stamped pieces.

INDIUM electroplated base or precious
metal wires.

WELDED RIBBONS — Dissimilar metal ribbons of
the same width can be continuously welded
together, within close overlap tolerances.

Write for List of Products

SIGMUND COHN CORP.
121 SOUTH COLUMBUS AVE., MOUNT VERNON, N. Y.

ARE YOU, LIKE SYLVANIA,

*Pushing to Higher
Frequencies?*



Dr. R. G. Hutter, manager of Sylvania's Physics Research Laboratories, under whose direction basic research in traveling wave tubes is carried on, discussing problems with engineer R. I. Harrison. Dr. Hutter is holding a Sylvania low level 2000-4000 mc amplifier tube in his hands.

When Sylvania started out on a traveling wave tube program, their research engineers specified PRD test equipment. High quality was an important factor in their choice. In addition, they wanted a line of test equipment covering a wide frequency range to take care of future developments in higher frequencies.

If you, like Sylvania, are pushing to higher frequencies, you will be interested in PRD's full coverage and especially in the —

PRD MILLIMETER WAVEGUIDE TEST EQUIPMENT

- Why? Because:
1. Precision really counts with millimeter equipment
 2. PRD has pioneering experience in this field
 3. The equipment is available now.



Write for
PRD Reports
Vol. 4, No. 3

Polytechnic **RESEARCH
& DEVELOPMENT CO., INC.**

202 TILLARY STREET
BROOKLYN 1, N. Y.
Telephone: ULster 2-6800



Midwest Sales Office:
1 SOUTH NORTHWEST HIGHWAY, PARK RIDGE, ILLINOIS — TALcott 3-3174
Western Sales Office:
737-41, SUITE 7, NO. SEWARD STREET, HOLLYWOOD 38, CAL. — HO 5-5287

2 "NEW" SWITCHCRAFT® MICROPHONE CONNECTORS



**FEATURING—
NO SOLDERING FOR ATTACHMENT
OF LEADS OR CABLE**

Wide terminals with broad headed screws (similar to those used in Phone Plugs) make it convenient and fast to attach leads *without soldering.*

Fits standard single contact Microphone Connectors such as Switchcraft 2501-MP.

**AVAILABLE AT ALL LEADING
RADIO PARTS JOBBERS**

2 TYPES

2501 FL—has long nickel plated handle with built-in cable clamp in the end cap. U.S.A. List \$2.25.

2501 FS—has short nickel plated handle. U.S.A. List \$1.65.

**SWITCHCRAFT
INC.**

1332 N. Halsted St., Chicago 22, Ill.

Canadian Representative:
Atlas Radio Corp. Ltd., 50 Wingold Ave.,
Toronto, Canada



Fastest Voltage Regulator Available THE CURTISS-WRIGHT LINE REGULATOR

The Curtiss-Wright Model EE 100 Distortion Eliminating Voltage Regulator provides faster recovery time than any other regular on the market—less than 1/50th cycle, or 330 microseconds. It also reduces typical power line distortion to less than 0.3%. Capacity is 1.4 KVA.

Now being installed in a rapidly growing number of laboratories and production test departments, it provides simpler, more accurate calibration of meters, better design of transformers, synchros and motors . . . easier testing with fewer rejects, more accurate measurement of magnetic properties and receiver sensitivity . . . better a.c. computer performance, elimination of fast line transient effects. Write for details.

Electronic Component & Instrument Sales Department



Simultaneous recordings of response to step change in 60 cps voltage.

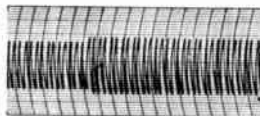

Typical electromechanical regulator output. Recovery time over 4 seconds.

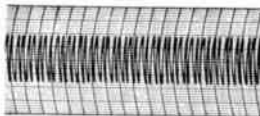

Curtiss-Wright DEVR output. Full recovery 330 microseconds.



(Continued from page 134A)

- Jutila, S. T., Syracuse, N. Y.
- Kane, J. F., Palo Alto, Calif.
- Kelley, G. J., Utica, N. Y.
- Kersch, C. J., Los Angeles, Calif.
- King, C. G., Jr., Culver City, Calif.
- Knauf, G. M., Griffiss AFB, N. Y.
- Kosso, E. V., Syracuse, N. Y.
- Kotowski, J. P., Woodstock, N. Y.
- Lafferty, V. C., Bellwood, Ill.
- Latham, W. S., Groton, Conn.
- Lee, L., State College, Pa.
- Leffler, R., San Diego, Calif.
- LeLacheur, R. M., Allentown, Pa.
- Lemaster, S. W., Owensboro, Ky.
- Levy, E. C., Los Angeles, Calif.
- Lewis, F. W., Fayetteville, Ark.
- Lewis, H. W., Vallejo, Calif.
- Lieberman, D., New York, N. Y.
- Litton, J., Jr., Great Neck, L. I., N. Y.
- Livingstone, J. K., Rome, N. Y.
- Long, E. D., Sumter, S. C.
- Lytel, A., Syracuse, N. Y.
- MacDonald, H. J., Holloman AFB, N. Mex.
- MacEwan, A., Jr., South Braintree, Mass.
- Magagnos, W. F., Glen Cove, L. I., N. Y.
- Martello, A. S., Saugerties, N. Y.
- Martin, M. B., Bethpage, L. I., N. Y.
- Masuda, H. B., Los Angeles, Calif.
- Mayer, F. N., Huntington, L. I., N. Y.
- McAlister, C. L., Midland, Mich.
- McDowell, J. K., Albuquerque, N. Mex.
- McMullen, A. L., Tucson, Ariz.
- Miller, R. B., South Bend, Ind.
- Millett, M. R., Bridgeport, Pa.
- Minkiewicz, M. D. K., Montreal, Que., Canada
- Mobille, G. J., Levittown, L. I., N. Y.
- Morris, V. B., Jr., Baltimore, Md.
- Mueller, R. W., Chicago, Ill.
- Nehama, I. D., Whippany, N. J.
- Netherwood, D. B., Dayton, Ohio
- Nurmi, L. O., Euclid, Ohio
- O'Connor, M. A., Jr., Dayton, Ohio
- Ogar, G. W., Dayton, Ohio
- Oleson, D. R., Elmira, N. Y.
- Orford, R. J., Huntington Station, L. I., N. Y.
- Otto, F. B., Woburn, Mass.
- Parish, M. L., San Diego, Calif.
- Pauloski, S. H., Pompton Plains, N. J.
- Pierce, E. P., Jr., Fort Huachuca, Ariz.
- Pinto, R. C., Elizabeth, N. J.
- Porter, J. B., San Diego, Calif.
- Porter, J. H., Rochester, N. Y.
- Punshon, R. L., Regina, Sask., Canada
- Raillard, H., Syracuse, N. Y.
- Rawnsley, J. A., Melbourne, Fla.
- Reagh, W. L., Smyrna, Ga.
- Reddan, E. D., Wellesley Hills, Mass.
- Redmond, K. P., New York, N. Y.
- Reiter, A. M., West Los Angeles, Calif.
- Rich, L. C., Long Island City, L. I., N. Y.
- Riddell, R. S., Montreal, Que., Canada
- Riel, R. W., Westfield, Mass.
- Risk, W. P., Jr., Albuquerque, N. Mex.
- Romano, A. J., Redondo Beach, Calif.
- Rowe, S., Cincinnati, Ohio
- Roy, F. J., Longview, Tex.
- Roy, L. B., Arlington, Va.
- Rubenstein, H., Philadelphia, Pa.
- Rusch, W. T., Paterson, N. J.
- Rush, C. J., New York, N. Y.
- Samp, T. A., Rivera, Calif.
- Sanford, R. S., Potsdam, N. Y.
- Sartain, A., Birmingham, Ala.
- Savage, J. W., Washington, D. C.
- Schaefer, F. J., Jr., Whippany, N. J.
- Schneider, I., Brooklyn, N. Y.
- Schreyer, H. T., Rio de Janeiro, Tijuca, Brazil
- Schulz, E. R., Liverpool, N. Y.
- Seferian, R. K., Reseda, Calif.
- Shedd, I. A., Hawthorne, Calif.

(Continued on page 138A)

HEARD EVERYWHERE
Lowell
 ®

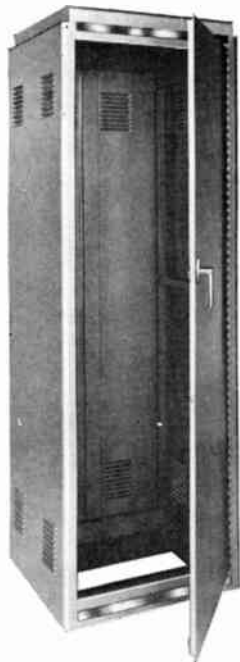

1

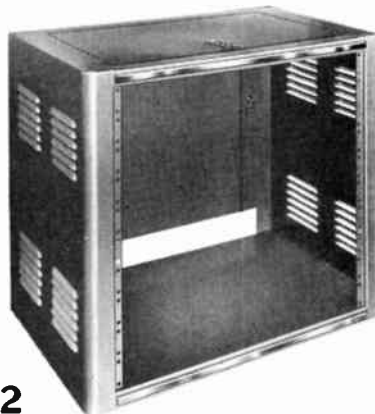

2

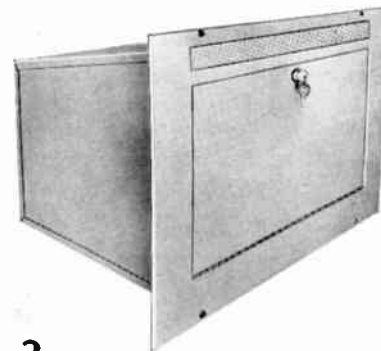

3

Electronic Housing Equipment...

Maximum Versatility and Flexibility in Every Application

For Industry . . . Schools . . . Airports

For Broadcasting . . . Recording . . . Testing Apparatus

Lowell-designed electronic housings and equipment offer you every advantage. It is a *complete* line that offers maximum versatility and flexibility to meet your needs. Advanced mass production techniques hold prices to the lowest practicable levels. *Prompt delivery from stock.*

1. Transmitter Racks for 19", 24" and 30" panels—18½" and 24" deep. Standard and deluxe models. All models are furnished with front and rear doors which are fitted with a lock-type catch and handle. Each rack is constructed of heavy 16-gauge steel with extra heavy No. 12 gauge steel bottom. Heavy mounting angles are drilled to standard 1¼"-½" spacing. Mounting angles are adjustable from front to back by means of channel slides. There is a 4½" wide rectangular hole in the bottom for leads. Mounting hardware furnished with each unit. Silver gray hammertone finish with bright metal trim on top and bottom.

2. Deluxe Desk Cabinet Racks for standard 19" Rack Panels—15" deep. Made of heavy gauge cold rolled steel, completely welded together.

Panel mounting angles are drilled to standard 1¼"-½" spacings. Enough No. 10/24 speed clips and machine screws are furnished to mount several rack panels. Door at top permits easy access to equipment; choice of hinged door or solid back.

3. Amplifier Cabinet for recessed applications. Made of 16-gauge steel with a grille cover of ⅛" thick sheet steel. Grille has door with lock and piano hinge and hot air vent opening in top to let hot air escape. Adequate knockouts for all wiring purposes. Back is finished in a protective zinc chromate.

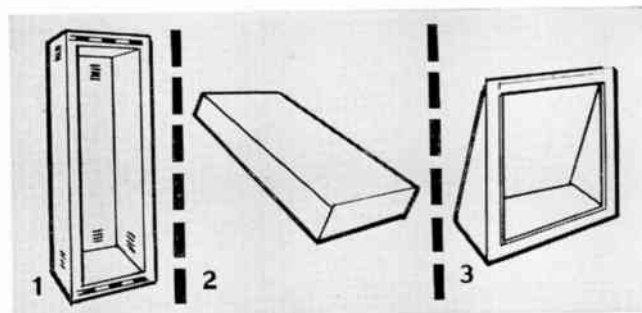

1. Cabinet Relay Racks for standard 19" Rack Panels
 2. Standard Steel and Aluminum Blank Chassis
 3. Relay Racks—TR Desk Type

HEARD EVERYWHERE
Lowell
 ®

For complete information and specifications, write:
MANUFACTURING COMPANY

3030 LaClede Station Road, St. Louis 17, Missouri
 In Canada: Atlas Radio Corp., Ltd., 50 Wingold Ave., Toronto 10, Ontario

MANUFACTURERS OF FAMOUS LOWELL "EAR LEVEL" SOUND SPEAKER BAFFLES, PROTECTIVE ENCLOSURES, INTERCOM EQUIPMENT.

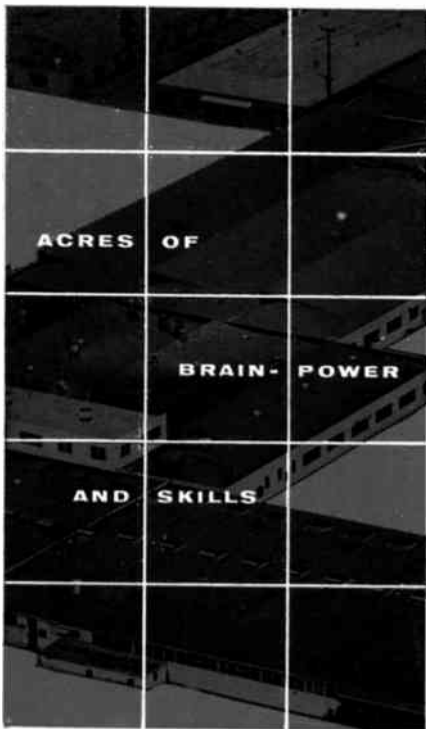

ACRES OF

BRAIN-POWER

AND SKILLS

IT TAKES BIG FACILITIES

to get the job done fast and right

and Packard-Bell has 12½ acres of plant space at your service... plus... the brainpower and skills to create, produce and develop quality electronic equipment... and make on-time deliveries.



RESEARCH DEVELOPMENT PRODUCTION

Now Producing Communication, navigation, radar, identification, sonar, missile guidance and missile handling equipment, etc., delay lines, pulse transformers, pulse-forming networks, filters, low-voltage coils, printed wiring boards, assemblies, slip rings, commutators and printed wiring switch plates.

We Invite you to inspect Packard-Bell facilities... oldest and largest completely integrated electronics facility in the West. Write for brochure to: Dept. P-12, Packard-Bell Electronics Corporation, 12333 W. Olympic Blvd., Los Angeles 64, California.

Packard-Bell
ELECTRONICS

LEADERSHIP IN ELECTRONICS
FOR OVER 30 YEARS



(Continued from page 136A)

Shibata, K., Houston, Tex.
Silver, R., Cambridge, Mass.
Sinclair, A. L., III, Towson, Md.
Sinha, N. K., Bihars, India
Skudrzyk, E. J., State College, Pa.
Small, C. R., Woodbury Heights, N. J.
Smeltzer, V. J., Kansas City, Mo.
Soleta, G. S., South Bend, Ind.
Soule, W. J., Horseheads, N. Y.
Sprengeler, J. H., Cedar Rapids, Iowa
Steinhoff, R., Livingston, N. J.
Strohm, R. B., Granada Hills, Calif.
Sutton, J. S., Reseda, Calif.
Tash, M., St. Louis, Mo.
Taylor, H. V., Alamogordo, N. Mex.
Taylor, N. J., Montreal, Que., Canada
Tennant, H. R., Arlington, Va.
Tobin, F. H., Jr., Lexington, Mass.
Townsend, H. D., Warren, Ill.
Tucker, S. L., Novelty, Ohio
Turhan, M., Istanbul, Turkey
Turke, B. A., Western Springs, Ill.
Uebele, G. S., Long Beach, Calif.
Usim, W., Sherman Oaks, Calif.
Valette, H. C., Venice, Calif.
Van Deloo, P. A., Rochester, N. Y.
Vieth, R. V., Jennings, Mo.
Walker, E. S., Culver City, Calif.
Wall, R. B., Littleton Common, Mass.
Wallace, R. A., Glen Oaks Village, L. I., N. Y.
Walsh, G. J., Willowdale, Ont., Canada
Wappler, F. C., New York, N. Y.
Warren, F. H., Kenmore, N. Y.
Watkins, P. E., Kimberly, Idaho

Webb, J. K., Utica, N. Y.
Whaley, W. W., Mineola, L. I., N. Y.
Whitestine, P. W., Washington, D. C.
Whitley, G. E., Holloman AFB, N. Mex.
Whitmore, J. H., Wilmington, Del.
Wilson, J. T. R., Sacramento, Calif.
Wong, K. L., Culver City, Calif.
Wood, C. R., Adelphi, Md.
Woodsum, S. P., Groton, Mass.
Wright, E. B., Irwin, Pa.
Young, R. W., Ashaway, R. I.

The following elections to the Associate grade were approved and are now effective:

Abremski, M. C., Tampa, Fla.
Aldrich, J. L., West Hyattsville, Md.
Alltree, R. C., Vancouver, B.C., Canada
Andersson, K. N., Stockholm, Sweden
Ansell, R. E., Washington, D. C.
Arnold, H. N., San Antonio, Tex.
Bach, R. G., Old Bethpage, L. I., N. Y.
Baron, H. D., Trail, B.C., Canada
Bartholomew, R. J., Northbridge, Calif.
Beatty, D. R., Sun Valley, Calif.
Belinsky, O. A., Chicago, Ill.
Benson, W. J., Patuxent, Md.
Bent, J. E., Jr., Long Beach, Calif.
Bergman, R. L., Darlington, Md.
Boehly, M. A., Rochester, N. Y.
Boose, W. H., Hespeler, Ont., Canada
Bordelon, C. J., Fort Worth, Tex.
Brown, B. L., Portland, Ore.
Burns, D. C., Pine Hill, N. J.
Burton, F. E., Cincinnati, Ohio
Carmack, W. J., San Antonio, Tex.
Christensen, O., Hillerod, Denmark
Clark, C. E., Bellefontaine, Ohio
Clark, O. J., Pico, Calif.
Clark, W. G., Memphis, Tenn.
Cohen, M., Los Angeles, Calif.

(Continued on page 154A)

no "ghosts" with CUSIL decarbonized brazing alloy

a Silver-Copper Eutectic brazing alloy by

WESGO

... producers of
Nicoro, Nioro, In-
cosil and Incoro

high purity, low vapor pressure
brazing alloys for high vacuum
systems.

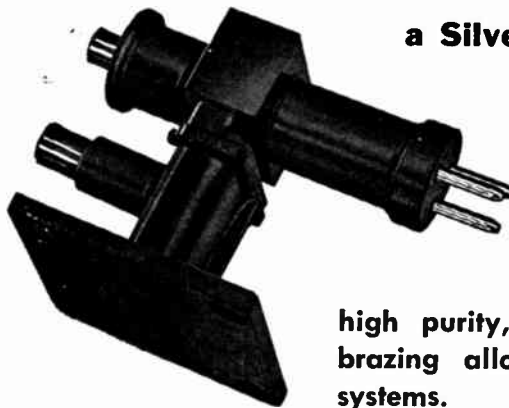

Decarbonization... an exclusive process for elimination of carbon and "dirt" ever present in silver brazing alloy wires. No "leakers" due to non-wetting characteristics of carbon. No free carbon particles in electron beam.

Write for additional information

WESTERN GOLD & PLATINUM COMPANY
OUR NEW ADDRESS—BELMONT, CALIF.

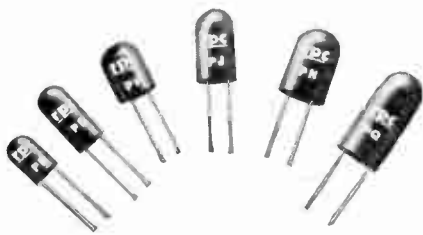

NEW Printed Circuit Precision Resistors

To meet the requirements for printed circuitry, RPC has developed Type P Encapsulated Wire Wound Precision Resistors. Miniature, single ended units designed for easy rapid mounting on printed circuit panels with no support other than the wire leads. Many newly developed techniques are employed in the manufacture of Type P Resistors. These units can be operated in ambient temperatures up to 125°C. and will withstand all applicable tests of MIL-R-93A, Amdt. 3. Available in 6 sizes, rated from 1/10 watt to .4 watt. $\frac{1}{4}$ " diameter by $\frac{3}{16}$ " long to $\frac{3}{8}$ " diameter by $\frac{3}{4}$ " long. Resistance values to 3 megohms. Tolerances from 1% to 0.05%.

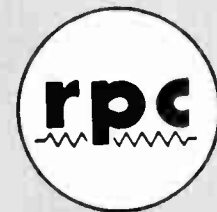

HIGH QUALITY RESISTORS FOR ELECTRONICS

RPC is a widely recognized supplier of high quality resistors to industry, Government Agencies and the Armed Forces. Advanced production methods, modern equipment and scientific skill enables RPC to manufacture resistors of highest quality in large quantities at reasonable cost. Modern manufacturing plant is completely air conditioned and equipped with electronic dust precipitators to insure highest production accuracy. RPC resistors are specified for use in instruments, electronic computers, radiation equipment and scientific instruments.

Test equipment and standards for checking and calibrating are equalled by only a few of this country's outstanding laboratories. Our ability to produce resistors of highest quality coupled with prompt delivery have established RPC as a leading manufacturer of resistors. Small or large orders are promptly filled.

Representatives in principal cities. For full information send for latest catalog.



Wire Wound Precision Meter Multiplier Resistors

Type MFA and MFB High Voltage Wire Wound Resistors are Hermetically Sealed in glazed steatite tubes with ferrule ends for maximum protection against all adverse environmental conditions. Fully meet all requirements of JAN-R-29. Special multi-section winding insures greatest safety factor due to low voltage gradient between sections. Standard resistors up to 6 megohms, 6 KV, 0.5% tolerance. Higher resistance and closer tolerances available. MFA 9-25/32 inches long x $1\frac{1}{32}$ inches diameter. MFB $5\frac{1}{32}$ inches long x $1\frac{1}{2}$ inches diameter.

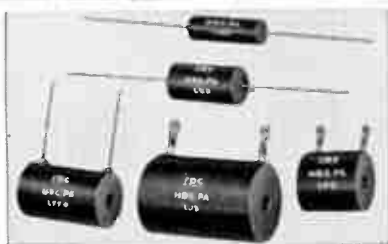

Encapsulated Precision Wire Wound Resistors

RPC Type L Encapsulated Resistors will withstand temperature and humidity cycling, salt water immersion and extremes of altitude, humidity, corrosion and shock without electrical or mechanical deterioration. Type L resistors are available in many sizes and styles ranging from sub-miniature to standard with lug terminals, axial or radial wire leads. Available for operation at 105° C. or 125° C. ambient temperatures. These resistors will meet all applicable requirements of MIL-R-93A, Amdt. 3. Type L can be furnished with all resistance alloys and resistance tolerances from 1% to .02%.



High Voltage Resistors

Type B Resistors are stable compact units for use up to 40 KV. These resistors are used for VT voltmeter multipliers, high resistance voltage dividers, bleeders, high resistance standards and in radiation equipment. They can be furnished in resistance to 100,000 megohms. Available as tapped resistors and matched pairs. Sizes range from a 1 watt resistor 1 inch long x $\frac{3}{16}$ inch diameter rated at 3500 volts, to a 10 watt resistor $6\frac{1}{2}$ inches long x $\frac{1}{16}$ inch diameter rated at 40 KV. Low temperature and voltage coefficients. Standard resistance tolerance 15%. Tolerances of 10%, 5% and 3% available. Tolerance of 2% available in matched pairs.



Wire Wound Precision Resistors

Type A Precision Resistors are widely used for all general requirements. They are available in a wide variety of sizes, styles and terminal types. They can be furnished with all resistance alloys in tolerances from 1% to .02%. Type A will meet the requirements of MIL-R-93A, Amdt. 2, Characteristic B. Special winding techniques, impregnation and thermal aging result in resistors of exceptional stability. Matched resistors, networks and special assemblies can be supplied.



High Megohm Resistors

Type H Resistors are used in electrometer circuits, radiation equipment and as high resistance standards. Resistance available to 100 million megohms. (10^{14} ohms). For utmost stability under adverse conditions Type HSD and HSK Hermetically Sealed are recommended. Eight sizes from $\frac{3}{4}$ inch to 3 inches long are available. Voltage rating to 15,000 volts. Low temperature and voltage coefficients. Standard resistance tolerance 10%. Tolerance of 5% and 3% available. Also matched pairs 2% tolerance.

RESISTANCE PRODUCTS CO.

914 S. 13th Street
HARRISBURG, PA.

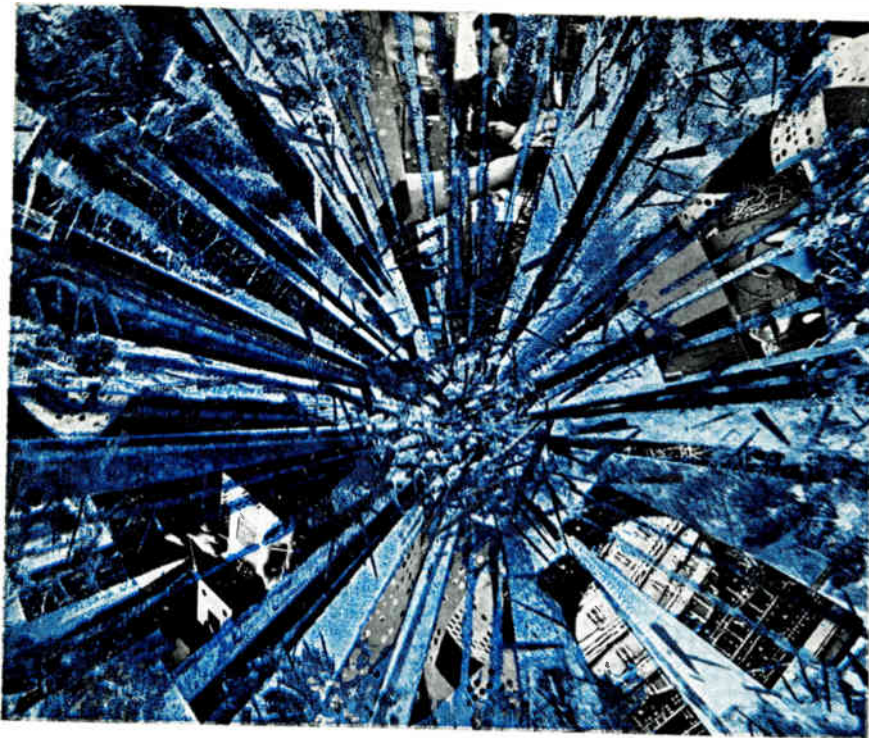

OPPORTUNITY IN SOUTHERN CALIFORNIA

stable, high-paying careers for
**CREATIVE DIGITAL
 COMPUTER ENGINEERS**
*experienced in advanced data-processing
 systems design*

Here, in one of America's leading companies in the development of digital computers and electronic systems, you'll have full opportunity to make design contributions at the most advanced level. You'll enjoy the broad working freedom of a small, select research-design group and the vast technical resources of a parent company of international stature. The program is a continuing one with constant creative challenges. Because most activity is in development of equipment for worldwide commercial markets, stability is assured. Related projects are also undertaken for government and industry. New, ultra-modern, air-conditioned facility in a pleasant suburb of Los Angeles—the nation's fast-growing electronics capital. Broad benefits.



<p>Senior Electronic Engineer With experience in drum memories for digital computer systems. Excellent opportunity to form and head project in this work.</p>	<p>Senior Computer Circuitry Engineer With transistor experience in digital computer applications. Core circuitry experience desirable.</p>
<p>Senior Systems Logician Must be a strongly creative man with demonstrated ability in digital computer logical design.</p>	<p>Senior Mechanical Engineer Advanced degree, broad experience in digital computer design, drum design, tape-handling systems, input-output equipment.</p>

Excellent openings for engineers with experience in: logical design • ferroelectrics • magnetic cores • computer systems • transistor circuits • input-output devices • applications of physics • computer systems specifications • definition of system requirements.

For 16-page brochure describing activities and career potential at the NCR Electronics Division, write or contact D. P. Gillespie, Director of Industrial Relations

*National**
THE NATIONAL CASH REGISTER COMPANY
 Electronics Division
 1401 East El Segundo Boulevard, Hawthorne, Calif.

*Trademark Reg. U. S. Pat. Off.



The following positions of interest to IRE members have been reported as open. Apply in writing, addressing reply to company mentioned or to Box No.

The Institute reserves the right to refuse any announcement without giving a reason for the refusal.

Proceedings of the IRE
 1 East 79th St., New York 21, N.Y.

SENIOR SYSTEMS ENGINEER

For a key position in our Communication Engineering Dept. Must have a minimum of 5 years in planning microwave and telephone carrier systems. Interesting work in research on advanced commercial communication systems and product planning. Apply Employment Mgr., Lenkurt Electric Company, 1105 Old Country Road, San Carlos, Calif.

ENGINEERS—PHYSICISTS

MICROWAVE PHYSICIST or ENGINEER for research and development projects dealing with microwave tubes. Some travelling wave tube experience desirable. BS. or MS. with some experience.

PHYSICIST for transistor research and development. Knowledge of basic transistor phenomena necessary. BS. or MS. with some experience. Excellent working conditions in suburban Westchester laboratory. Many company benefits. Salaries commensurate with experience. Please send resume to Philips Laboratories, Irvington-on-Hudson, New York, Att: Exec. Ass't.

INSTRUCTOR AND PROFESSORIAL RANK TEACHERS

Instructor and professorial rank teachers needed in electrical engineering starting February 1, 1957. Extensive graduate program and research activities. Location: Pennsylvania. Box 995.

COMMUNICATIONS SYSTEMS ENGINEER SECTION CHIEF

An opening exists for a top level engineer to head a group working on special and standard two-way communications systems. This is an excellent opportunity for a man of energy and accomplishment to join one of the major electronics companies in the country. Location: east coast. Reply in confidence giving full details. All replies will be answered, Box 996.

ELECTRICAL ENGINEERS

Several positions open for Electrical Engineers in the development engineering group of a small growing engineering and manufacturing company. Circuit design experience is essential. Experience with any phases of the following systems will be helpful: Radar, simulators, computers, cathode ray displays, industrial automatic controls. Located in Allentown-Reading area. Send resume to Penn-East Engineering Corp., Box 240, Kutztown, Pa.



**Use your
 IRE DIRECTORY
 It's valuable**



SALES ENGINEER

Sales Engineer—New York area for national manufacturer of tubeless magnetic amplifier power supplies. Excellent pay, benefits and advancement. All resumes held in confidence. Send to Millard Leff, Perkin Engineering Corporation, 1060 Broad Street, Newark 2, New Jersey.

SALES ENGINEERS (2)

Exceptional opportunity with rapidly expanding, progressive sales organization engaged in electronic, nuclear, automation and high vacuum fields. Requirements: Age 26 to 35, E.E. or physics degree, above average scholastic record; plus enthusiasm, good personality, technical competence and ability to work with minimum supervision. Car required. Training at Long Island, New York headquarters. Permanent location: Schenectady, New York and Hartford, Conn. Salary, commission and bonus. Reply in detail with resume. Box 1003.

ELECTRONIC ENGINEER OR PHYSICIST

A position is open on the research and development staff of Paul Rosenberg Associates for an engineer or physicist with strong electronic experience. A broad background in general physics is desirable. PRA is an 11 year old firm of consulting physicists (not manufacturers) engaged in unusually interesting and challenging projects of research and development for government and industry. Ideal working conditions. Located in a suburb 25 minutes from the heart of New York City. U.S. citizenship required. Applications will be kept in strict confidence. Paul Rosenberg Associates, 100 Stevens Ave., Mt. Vernon, New York.

INSTRUCTOR

To teach electricity and electronics in a technical institute operating under the supervision of the State University of New York. Minimum requirements are a BS. in EE. and industrial experience. Teaching experience desirable but not necessary. For further information write William R. Pulhamus, Head, Electrical Dept., Mohawk Valley Technical Institute, 751 State Street, Utica, New York.

ELECTRICAL, MECHANICAL ENGINEERS AND PHYSICISTS

Acoustic Research—Excellent opportunities exist for electrical or mechanical engineers and physicists who are interested in applied acoustic research and development. Currently over 30 diversified projects are in operation offering excellent opportunity for professional development. Tuition free graduate study and relocation allowance offered. Write A. J. Paneral, Armour Research Foundation, 10 West 35th St., Chicago 16, Illinois.

ELECTRICAL ENGINEERS AND PHYSICISTS

Electrons, Incorporated, a leader in the high current industrial thyatron and pool tube field, has excellent openings for interested design engineers, or physicists in important new developments. Prior experience in tube engineering not required. Write for an interview appointment. Electrons Incorporated, 127 Sussex Ave., Newark 3, New Jersey.

APPLICATION AND SALES ENGINEER—INDUSTRIAL CONTROL

Nationally known manufacturer of industrial power control tubes, offers excellent opportunity for graduate Electrical Engineer with some engineering experience and an interest in industrial electronics and automatic control. Moderate travel requirements. Electrons, Incorporated, 127 Sussex Ave., Newark 3, New Jersey.

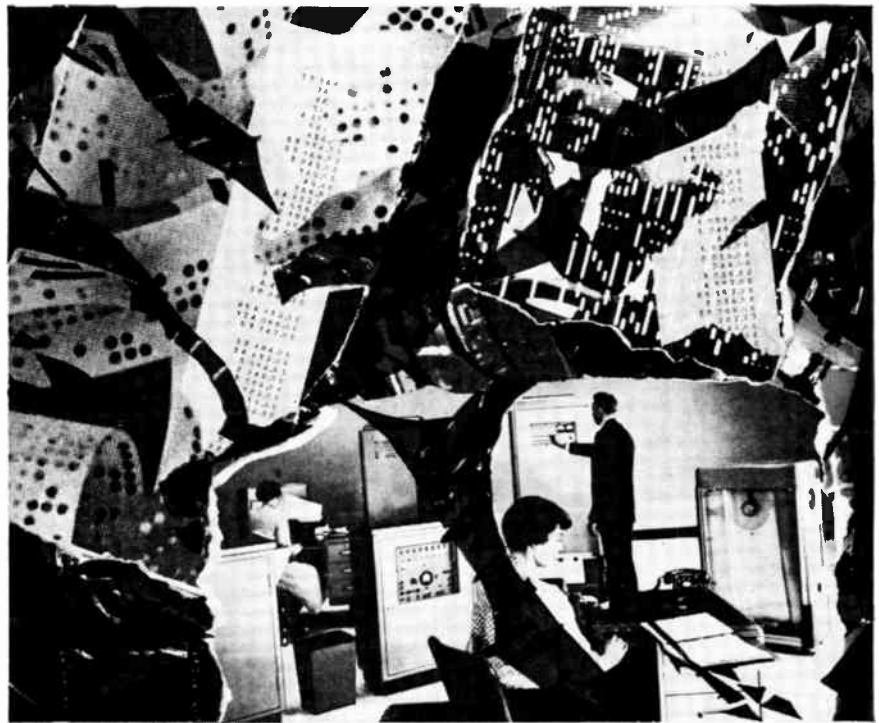

OPPORTUNITY IN SOUTHERN CALIFORNIA

DATA-PROCESSING SYSTEMS SPECIALISTS

long-range program in business systems
—unusual creative freedom

Here's opportunity to do advanced creative work with a leading company in the development of digital computer systems. Activity includes systems analysis of present customer requirements and future computer applications, with special emphasis on practical applications of new concepts. You'll be well rewarded, both in salary and advancement, for your creativeness. You'll enjoy the broad working freedom of a select research-design group—and the stability afforded by a parent company of international stature. You'll help develop data-processing systems for worldwide commercial markets—in a continuing program. Ultra-modern laboratory in a pleasant Los Angeles suburb. Broad benefits, relocation expenses.



Operations research specialist

With advanced degree in mathematics. Experienced in mathematical formulation of business and management problems, and familiar with the functions of electronic equipment in operations research techniques.

Senior computer systems engineer

Advanced degree preferred, although not required, either in engineering or mathematics. Broad background in logical and systems design and ability to do independent research in computer structures and computer logic.

Senior data-processing systems designer

With technical degree and extensive background in formulating computer systems for business data-processing. Should have experience in application of equipment as well as in design.

Computer applications specialist

With technical degree. Should have solid experience in programming, systems analysis and applications studies. Work is adaptation of computer characteristics to business data-processing requirements.

For 16-page brochure describing activities and career potential at the NCR Electronics Division, write or contact D. P. Gillespie, Director of Industrial Relations

National*

*Trademark Reg. U. S. Pat. Off.

THE NATIONAL CASH REGISTER COMPANY
Electronics Division
1401 East El Segundo Boulevard, Hawthorne, Calif.

THIS
is the kind of

ENGINEERING
HELP

we need!

Electronic Engineering in telemetering, guidance, radar and particularly circuit designing.

Hydraulic and Servo Engineering in control and auto-pilots.

Mechanical Engineering in packaging and structures.

Please write us or mail coupon
for full information.

W. C. Walker, Engineering Employment Mgr.
Pacifo Division, Bendix Aviation Corp.
11610 Sherman Way, North Hollywood, Calif.

I am interested in this engineering field _____
I am a graduate engineer with _____ degree.
I am not a graduate engineer but have _____
years experience.

Name _____
Address _____
City _____
Zone _____ State _____

OPPORTUNITIES

IN DESIGN & ENGINEERING FOR PROJECT OR SYSTEMS
ENGINEERS • ELECTRONIC ENGINEERS • DESIGN ENGINEERS
ELECTRICAL ENGINEERS • FIELD ENGINEERS

Kollsman's expansion in the airborne equipment field has created openings for additional engineers and electromechanical designers, and offers unusual scope to alert, capable and enthusiastic professional men. For engineers, a degree in Mechanical Engineering, Electronic Engineering or Physics is necessary, plus experience or a strong interest in airborne instrumentation or allied fields.

The congeniality at Kollsman, plus the modern facilities and top professional men provide an atmosphere conducive to creative effort and achievement. Here are designed America's finest aircraft instruments.

Please submit resumes to T. A. DeLuca
Confidential interviews will be arranged.



kollsman INSTRUMENT CORPORATION

60-09 40th AVENUE, ELMHURST, NEW YORK • SUBSIDIARY OF Standard COIL PRODUCTS CO. INC.

Testing vs Fundamentals

Employment ads that put their emphasis on extra-curricular and fringe benefits can make enticing reading.

But here at GPL we're convinced that what the serious-minded engineer is primarily interested in is *fundamentals*. After all, when you're looking for a new job, aren't you, first of all, interested in the straightforward answers to a few, simple questions? Is the work interesting? How will it help me advance—professionally and monetarily? What is the company's record? Is it an engineer-minded company?

We know that when you check the fundamentals at GPL—and the secondary benefits, too, for that matter—you'll be interested.

It takes more than a column of type to tell you about the achievements and opportunities at a company as active and successful as General Precision Laboratory. We suggest that you send us your resumé so we can get better acquainted. Write to Richard R. Hoffman, Employment Manager. Expense-paid interviews can be arranged in advance for any time, including weekends.

Currently, GPL seeks engineers interested in:

RADAR NAVIGATION and BOMBING SYSTEMS (Poppler & Inertial)

Research • Development • Applications • Systems Analysis • Systems Test
Administrative Engineering • Mechanical Design • Mechanical Packaging • Field
Engineering • Technical Writing • Component Specification and Test • Production Follow-up

Computers • Magnetic Amplifiers • Servos • Microwave Techniques
Pulse Circuitry • Transistorization



GENERAL PRECISION LABORATORY
INCORPORATED

63 Bedford Road, Pleasantville, N. Y.

in the heart of Westchester County.

A SUBSIDIARY OF



**These are the surroundings
of Leadership**

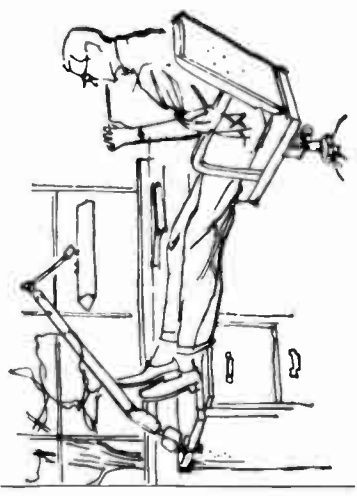
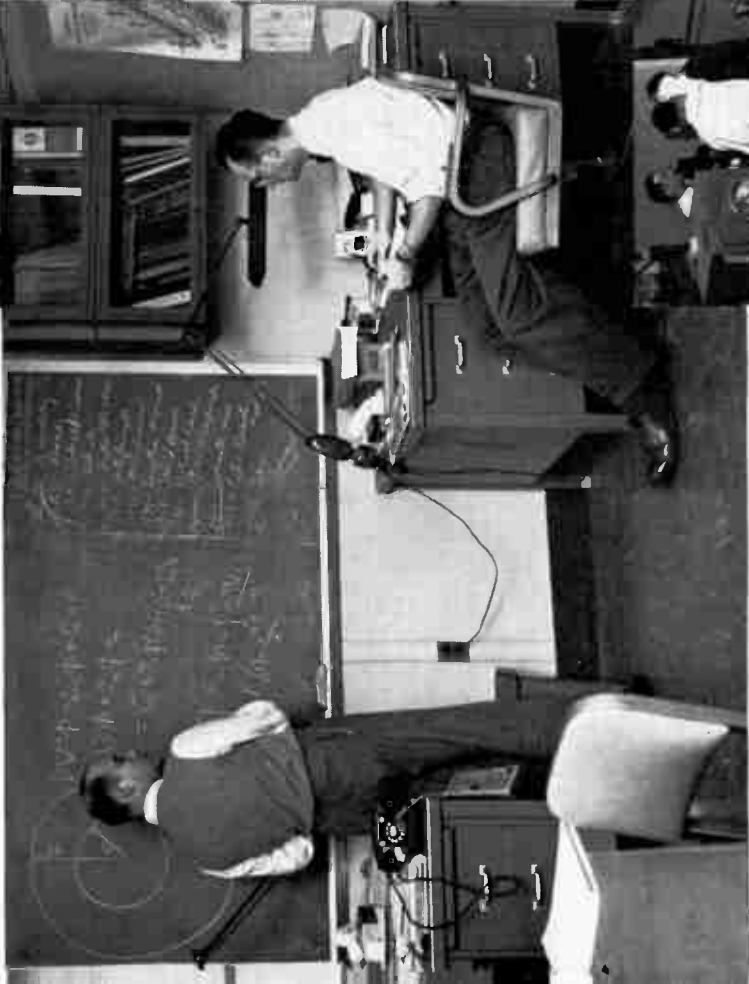
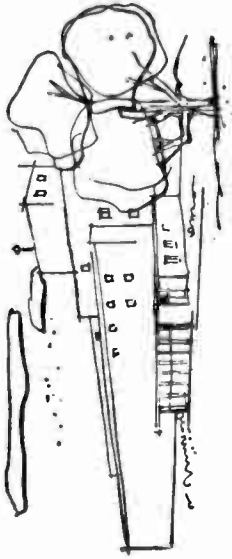

Argonne
NATIONAL LABORATORY

INQUIRIES INVITED: Professional Personnel Office
P.O. Box 299 • Lemont, Illinois

ENGINEERS, BS, MS, PhD

COMPUTER ENGINEERING POSITIONS

Now open at **General Electric's**

New Computer Department
at Palo Alto, Calif., Schenectady, N.Y. and Phoenix, Ariz.

Immediate Opportunities on **ERMA COMPUTER**
(Electronic Recording Machine Accounting)
**and many other general purpose and
special application computers, both digital and analog**

Openings for
**PHYSICISTS • ELECTRONIC ENGINEERS • MECHANICAL ENGINEERS
ELECTROMECHANICAL ENGINEERS • NUMERICAL ANALYSTS**

ERMA IS REVOLUTIONARY IN CONCEPT AND EXECUTION
...First industrial data processing system designed to solve entire checking account bookkeeping.
...Originally conceived by Bank of America and developed to the bank's specifications by Stanford Research Institute.
...Now being product-designed for manufacture, by General Electric, making optimum use of transistors.

Please send your resume to **C. E. Irwin COMPUTER DEPARTMENT**

GENERAL  ELECTRIC

Building 32, Schenectady, N. Y.

ARIZONA

Famous for Its Climate and for Western Living

GOODYEAR AIRCRAFT CORPORATION

ELECTRONIC LABORATORY

Arizona Division

Litchfield Park, Arizona

Modern schools and housing available. Outdoor recreation the year 'round.

This modern laboratory is the Western Division of the well-established Aerophysics Department of the Goodyear Aircraft Corporation of Akron, Ohio.

**A Subsidiary of the
GOODYEAR TIRE AND RUBBER CO.**

Openings at all levels of experience in the branches of engineering listed below and other related fields. We urge you, especially the young engineers to investigate opportunities at Goodyear Aircraft. We think you would like the friendly, informal atmosphere of our laboratory, the challenging nature of our projects and the stimulating association with engineers and scientists at the top of their profession. Whatever may be your specialty in microwave, servomechanisms, circuit design or packaging, you will grow with Goodyear Aircraft. We think, also that you and your family will enjoy western living in Phoenix.

**Complete Missile and Electronic Systems
Microwaves, Servomechanisms,
Radars and Stabilized Antennas.**

**TRANSISTOR APPLICATION
ELECTRONIC PACKAGING
ELECTRONIC GROUND
SUPPORT EQUIPMENT**

Long-range research and development projects.
University of Arizona graduate studies available under the Goodyear Fellowship Program, or company-financed evening courses.

**WESTERN LIVING AT ITS BEST
"IN THE VALLEY OF THE SUN"**

Modern Inexpensive Housing

Send resume to:

**A. E. Manning
Engineering and Scientific Personnel**

GOODYEAR AIRCRAFT

LITCHFIELD PARK, PHOENIX, ARIZONA

Similar opportunities available in our Akron, Ohio Laboratory



Positions Wanted

By Armed Forces Veterans

In order to give a reasonably equal opportunity to all applicants and to avoid overcrowding of the corresponding column, the following rules have been adopted:

The IRE publishes free of charge notices of positions wanted by IRE members who are now in the Service or have received an honorable discharge. Such notices should not have more than five lines. They may be inserted only after a lapse of one month or more following a previous insertion and the maximum number or insertions is three per year. The IRE necessarily reserves the right to decline any announcement without assignment of reason.

Address replies to box number indicated, c/o IRE, 1 East 79th St., New York 21, N.Y.

ELECTRONIC ENGINEER

BEE. 1954, working on MEE. Age 26: married. Desires position in medical electronics. 5 years experience in electronics, 1 year design and development, including TV, frequency control systems, microwave test equipment, radar indicator circuitry, microwave relay system maintenance. Box 950 W.

(Continued on page 146A)

ENGINEERS and SCIENTISTS

Very attractive career opportunities in beautiful
**LANCASTER COUNTY
PENNSYLVANIA**
with major special purpose tube manufacturer.

OPENINGS FOR

**ME's Machine Designers,
EE's, Ch.E.'s. and Physicists,
BS thru PhD. degrees.**

**Junior and Senior draftsmen
Electronic Technicians**

Send Detailed resume to **BOX #999
Institute of Radio Engineers
1 East 79th St.
New York 21, N.Y.**

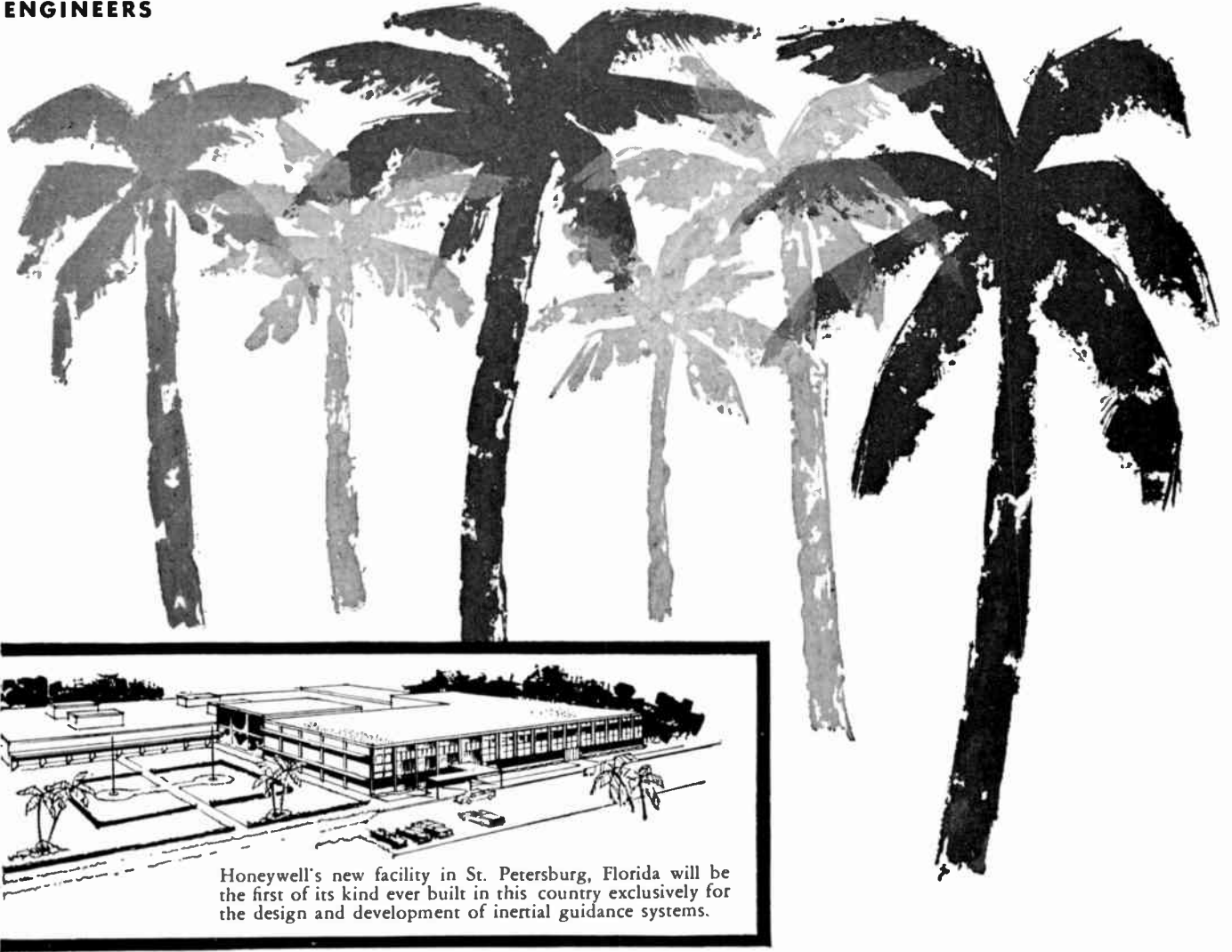

Honeywell's new facility in St. Petersburg, Florida will be the first of its kind ever built in this country exclusively for the design and development of inertial guidance systems.

HONEYWELL GOES TO FLORIDA:

200 OUTSTANDING SCIENTISTS AND ENGINEERS ARE NEEDED FOR HONEYWELL'S NEW INERTIAL GUIDANCE PROGRAM!

Right now Honeywell is selecting, for the engineering staff of its new Florida facility, creative, forward-looking men with the scientific knowledge and ability to qualify for this advanced work.

These men will receive first-rate salaries, have unusual opportunities for advancement and be supplied with the finest in equipment and facilities.

They will work in small design and development groups where individual ability and contributions are quickly recognized and rewarded.

This Florida location affords ideal living. Nearby St. Petersburg has many cultural and educational advantages, and the entire area is noted for its climate and recreational facilities. Housing is plentiful, cost-of-living lower than the national average.

MINNEAPOLIS
Honeywell



Aeronautical Division

Immediate Design and Development Openings in Inertial Guidance:

Systems Analysts • Product Designers • Product Managers
Special Needs for Trained Personnel in the Following or Related Fields:

Inertial Guidance	Digital Computers
Systems Engineering	Computer Logic
Mathematical Analysis	Mathematical Analysis and Programming
Platform Design	Transistor Pulse Circuitry
Floated Gyro and Accelerometer Design	Magnetic Memory Design
Precision Analog Computer Design	Panel Instrument Design
Transistor and Magnetic Circuits	Electronic Packaging
Optic and Ground Handling Equipment	

SEND RÉSUMÉ TODAY if your interests and experience are related to the fields listed above. Mail immediately a résumé of your education and experience to Bruce D. Wood, Technical Director, Dept. TF-1, 1433 Stinson Blvd., N.E., Minneapolis 13, Minnesota.



AN UP-TO-EARTH VIEW OF THE FUTURE IN SERVO CONTROLS AND INSTRUMENTATION

The Martin launching vehicle of the first man-made Earth satellite will be the opening gun of a new and endless age of exploration into space.

There are many exciting new opportunities at Martin in the fields of servo controls development and instrumentation engineering.

If you are doing some down-to-earth thinking on this fabulous future you'd do well to contact J. M. Hollyday, Dept. P-12, The Glenn L. Martin Company, Baltimore 3, Maryland.

MARTIN
BALTIMORE



Positions Wanted

By Armed Forces Veterans

(Continued from page 144A)

ELECTRICAL ENGINEER

BEE. Cornell 1953. Experience in transistor circuitry, electronic test equipment design and fabrication, and technical writing. Military experience includes teaching and technical intelligence. F.C.C. 1st class commercial radiotelephony license. Some knowledge of written and spoken Japanese. Desires commercial or field engineer position in Japan requiring professional competence. Box 952 W.

SALES ENGINEER

Electronic Engineer—MSEE. 6 years of diversified experience in research, development, production, administration and sales. Desires sales position with a future. Married; age 30. Will relocate if necessary. Box 954 W.

CHIEF ENGINEER

BEE., MEE. Tau Beta Pi, Eta Kappa Nu; age 39, married, 3 children. 10 years broad experience in electronics, computers, power supplies, transistor circuits, printed circuits. Ingenuity and ability offered for responsible challenging position. Box 956 W.

ANALOG COMPUTER PROJECT ENGINEER

MSEE., 8 years experience, mostly design and development of analog computers for airborne and missile system applications. Age 37, married, family. Desires to locate in small mountain west or Pacific coast community. Box 957 W.

(Continued on page 150A)

opportunities in OPERATIONS RESEARCH

THE OPERATIONS RESEARCH OFFICE OF THE JOHNS HOPKINS UNIVERSITY offers exceptional opportunities for scientists who prefer the challenge of operational problems of unusual scope and diversity to routine design and development work. Our current research program has openings for men qualified in electronics and physics who are particularly interested in:

- Mathematical analysis
- Determining applications of known photographic, acoustic, infrared and radar techniques to military problems
- Military communications systems planning, analysis and evaluation
- Electronic countermeasures analysis

Please send your resume to
Research Personnel Officer

THE OPERATIONS RESEARCH OFFICE
THE JOHNS HOPKINS
UNIVERSITY

7100 Connecticut Avenue
Chevy Chase, Md.

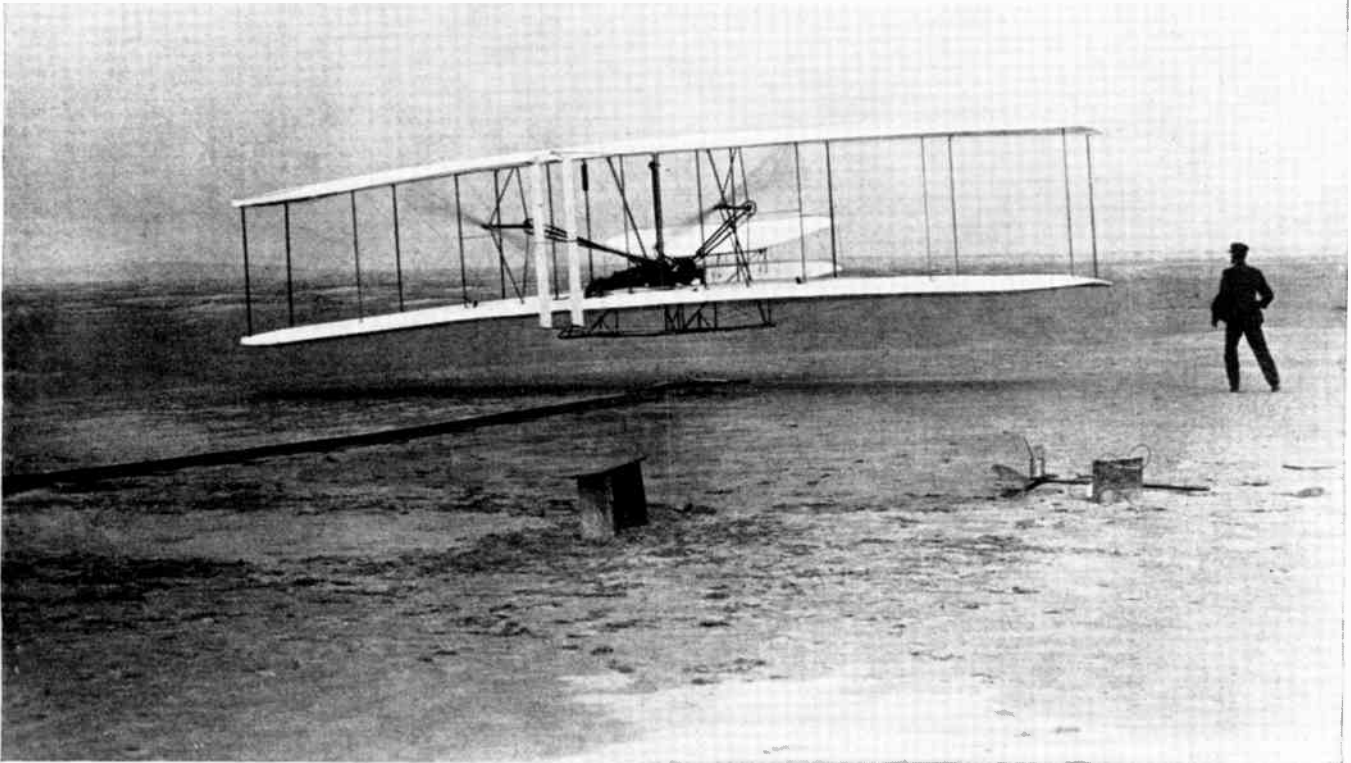

Experiment by two bicycle mechanics, Kitty Hawk, 1903

BETTMANN ARCHIVE

Ever wished you had the same chance as the Wright Brothers? You have—in missile engineering!

The Wright Brothers found existing aerodynamics concepts to be unreliable—so they formulated their own. By this ability to see further than accepted doctrine they started the mainstream of aviation development on its way. It is this power to reach beyond standard ideas that has led through every major advance in aeronautical science right up to

the remarkable progress now going on in missile engineering.

If you have this desire to 'reach beyond' you should be with us right now. You'll find no better place to master the problems of very high speed, global-range flight.

Here at North American, we are pioneers in this new era of flight. A supersonic test vehicle, the X-10, is already flying. As a leader in ad-

vanced weapons systems, we have the prime responsibility for the SM-64 Navaho Intercontinental Missile. This program is unique because it is *fully integrated*; it covers every aspect of Missile Engineering—including the most advanced developments in supersonic airframe design and manufacture, guidance and control systems, jet and rocket engines, and flight testing.

IF YOUR SPECIALTY IS LISTED HERE, WRITE TODAY FOR OUR FREE BROCHURE:

Instrumentation Design, Development & Application Standards, Drawings Checking, Specifications Writing
High Temperature Materials Engineering Structures, Stress, Flutter and Aeroelasticity Missile Airframe Design
Component and System Reliability Engineering Aerodynamics Thermodynamics Hydraulic, Pneumatic and Servo Engineering
Guidance and Flight Control Systems Evaluation Systems and Components Testing Missile and Ground Power
Engineering Flight Test Launching Equipment Field Service and Technical Training

THE ADDRESS: Mr. M. Brunetti, Engineering Personnel Dept. 91-121RE
Missile Development Division, 12214 Lakewood Blvd., Downey, California

NORTH AMERICAN AVIATION, INC.





Electronic Systems Specialists

SYLVANIA'S

rapid growth is almost twice that of the electronics industry as a whole... think what this can mean to *you* in opportunity and rapid advancement. And Sylvania helps underwrite your advanced studies in leading universities in both locations ...because we want you to assume greater responsibility and leadership. Here are some typical problems being solved by Sylvania engineers and physicists in our Buffalo, N. Y. and Waltham, Mass. laboratories.

AT BUFFALO:

1. How do you design 10 similar microsecond timing circuits whose delay times can be varied over a range of 100 times by analog control voltage maintaining a tracking accuracy of $\pm 0.1\%$ in an environment of -65°C to $+125^{\circ}\text{C}$ at sea level to 100,000 feet?
2. If you know which bits of a code group are in error, can you modify the hamming code to use these data to provide maximum information capacity in a noisy channel?
3. Can you design a crystal mixer to operate with latest production type crystals and having a noise figure less than 12db above KTB operating in the "S"-band?

If you believe that you can assist us in the solving of these problems, please write:

BUFFALO LABORATORY

E. F. Culverhouse
175 Great Arrow Ave.
Buffalo 7, N. Y.

AT WALTHAM:

4. What are the statistical factors to be considered in calculating the detection probability of a search radar?
5. What is the effect of atmosphere turbulence on high gain antenna performance?
6. How is the sidelobe level of a radar antenna effected by random perturbations of phase and amplitude over the aperture?
7. How does the AGC bandwidth effect the accuracy of angle-tracking?

WALTHAM LABORATORIES

Erling Mostue
100 First Ave.
Waltham, Mass.

Your inquiries
will be answered
within 2 weeks.



*If you want an unusually
interesting career in
communications engineering*

we're sure that

WE HAVE THE JOB FOR YOU

Whether you are completing your professional education, are a recent engineering graduate, an experienced field engineer, a design specialist, or a qualified analyst of communications and associated equipments or systems—

Whether your field is mechanical or electronic—

Whether your prime interest is in laboratory research, field engineering or in communications-electronics project work that will offer you the opportunity to follow an idea from drawing board to production line—

THERE'S A PLACE FOR YOU AS:

- * **ENGINEERING AIDE**
- ** **JUNIOR ENGINEER**
- *** **PROJECT ENGINEER**
- **** **SENIOR ENGINEER**

Starting at:

\$4000-\$9000, based on your professional education, training and experience

With the Opportunity

- FOR further training at our expense
- FOR varied and interesting work in the Washington, D.C. area or overseas (housing or housing allowance provided in overseas positions)
- FOR building a rewarding career

If You Are Interested—

Tell us something about yourself: age, education, marital status, previous military service, (U.S. citizenship necessary), business experience, state of health, interest in Washington or overseas positions, salary requirements, in a letter to:

Mr. Jerome E. Tramble
P.O. Box 1644
Central Station
Arlington, Va.

ELECTRONIC ENGINEERS

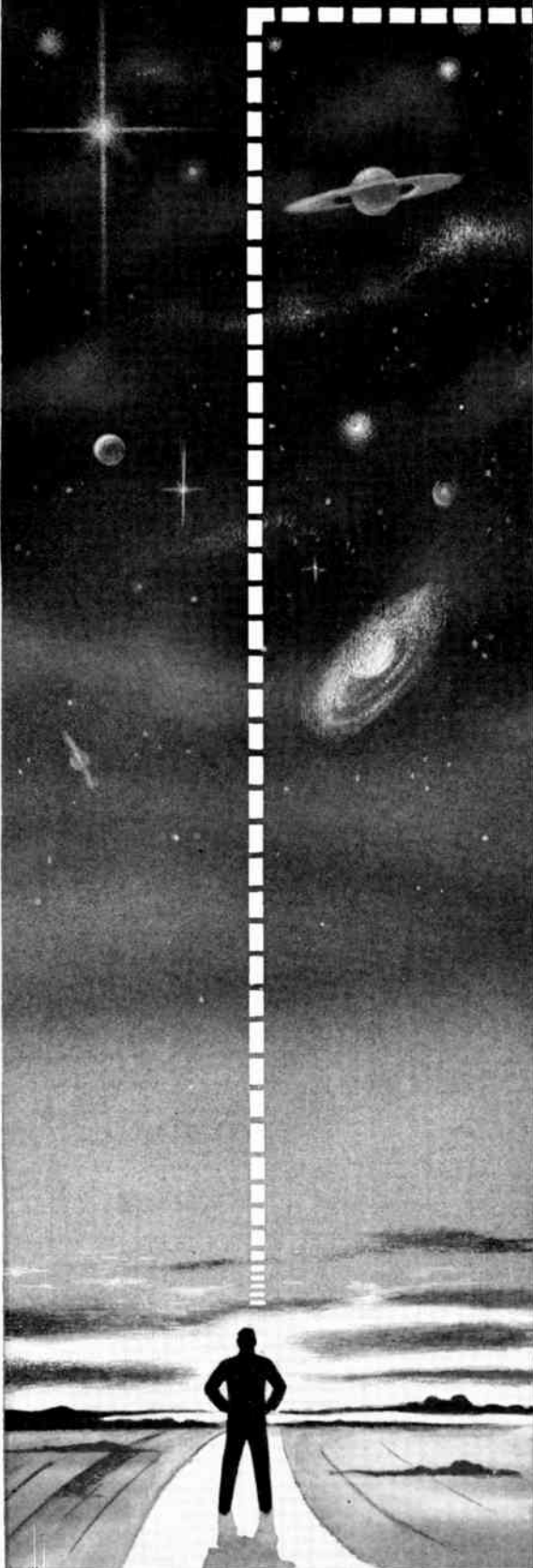

Consider the significance of your profession!

The shape of things to come is being designed by electronic engineers of professional stature, the exceptional engineers who—by education and experience—are qualified to fulfill an important destiny. Such men are needed at Bendix Radio to do research and development on the most advanced electronic systems in both military and commercial fields.

Nowhere are the professional aspects of the engineer's career held in higher regard than they are at Bendix Radio!

At Bendix you will be given the opportunity for important accomplishment while working on the most advanced electronic systems. These include:

- MISSILE GUIDANCE & TRACKING SYSTEMS
- RADAR WARNING SYSTEMS
- MILITARY ELECTRONICS
- RESEARCH & DEVELOPMENT
- AUTOMOTIVE ELECTRONIC RESEARCH
- AIRBORNE ELECTRONICS SYSTEMS
- MOBILE COMMUNICATIONS SYSTEMS

At Bendix Radio, the importance of *your* career is fully recognized. You are given the opportunity for rapid professional growth while working with leading engineers who are pioneers in their fields. You are backed up by skilled sub-professional people and kept well-informed as to the status of company work and project developments. You work in a modern plant with the latest equipment and will receive an excellent salary, periodic merit reviews and complete company benefits, including assistance in graduate education.

The attitude, the way of life and the vision of the future is designed for the man of professional stature at Bendix Radio. We invite you to take up this way of life in our beautiful residential area and look upward toward a bright future.

*Drop us a postal card,
briefly stating your education
and experience. We'll act fast
... and confidentially!*

Address: Employment Supervisor, Dept. M



Bendix

DIVISION OF BENDIX AVIATION CORP., BALTIMORE 4, MD.

Radio

Mr. ENGINEER Why Not Consider FIELD ENGINEERING

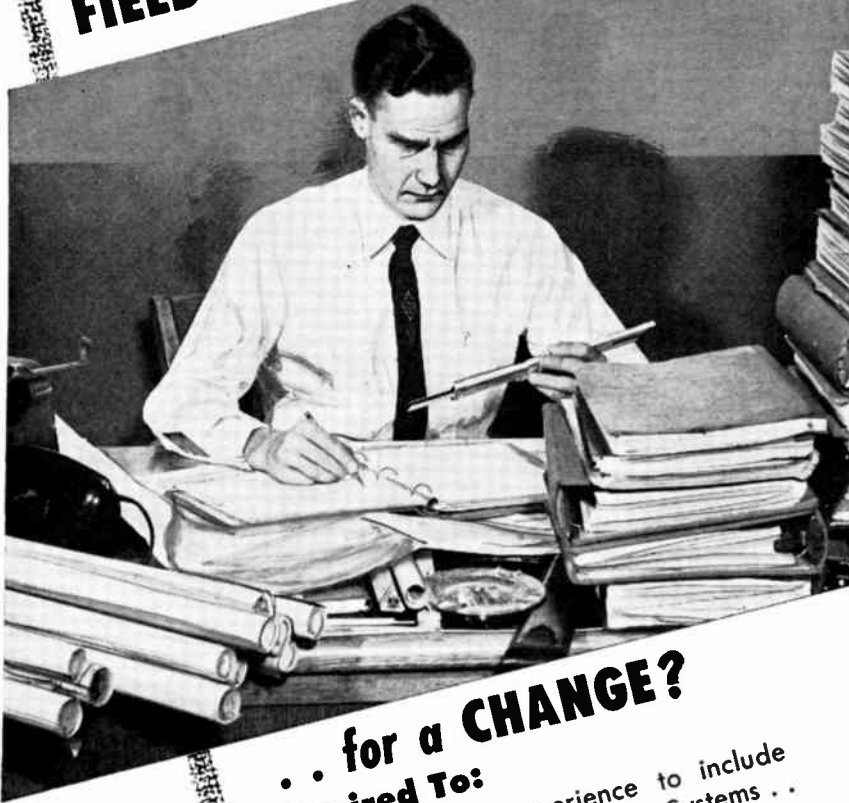

Have YOU Ever Desired To:

- EXPAND your experience to include World Wide Communications Systems . .
- BECOME fully experienced in the world's most advanced electronic systems and equipment . .
- ENJOY the freedom of locating anywhere in the world . .
- INCREASE your earning potential and provide greater security for your family . .

• If you find yourself answering yes to any of these questions, let us send you our new, full color, illustrated employment brochure which explains the challenge as well as the positions now open for PHILCO Field Engineers. Write NOW . . . get the facts on . . .

"PHILCO . . . First IN EMPLOYMENT OPPORTUNITIES"

PHILCO TECHREP DIVISION

DEPT. 20, 22nd & Lehigh Avenue,
Philadelphia, Pa.



Positions Wanted

By Armed Forces Veterans

(Continued from page 146A)

ELECTRONIC ENGINEER

Former Signal Corps officer; age 28, married. BEE. 1952, MEE. 1955. 1 year radar design experience plus teaching, administration and good technical background. Versatile and ambitious. Desires position providing diversified engineering and management opportunities, near eastern seaboard. Box 967 W.

ENGINEER

BEE. 1954. Short but varied experience in electronics. Presently Air Force Squadron Operations Officer. Have been in charge of engineering and managing large scale communications systems. Desires responsible position leading to management level. Box 968 W.

ENGINEER

BEE. January 1950. MEE. 1953. 5½ years diversified experience in development and testing of control systems, including 1 year in gun fire control; 3 years in guided missiles, part as group leader; 1½ years aircraft controls and hydraulic components. Past year active as sales engineer for large eastern manufacturers' representative of electronic components. Box 969 W.

ENGINEERING MANAGER

BSEE. 20 years broad diversified electronics experience as officer and civilian, Navy and AF, including laboratory R&D, field and reliability engineering, design engineering administration, R&D Staff Officer, management of priority defense projects. Past and recent experience in engineering proposal evaluation, development planning, programming and supervision of ground passive detection and electromagnetic intercept systems. Box 970 W.

AUDIO AND COMMUNICATIONS DEVELOPMENT ENGINEER

Electronics engineer leaving service in March, desires position as development engineer in field of audio or radio communications. Has BSEE. degree, 4 years civilian, and 1½ years military engineering experience. Prefers mid-west or east location and position that can grow to management level. Age 27, married. Prepared resume available. Box 971 W.

ENGINEER

BEE. 1951, and MEE. 1954. 3½ years experience in industry and 2 years service experience in pulse techniques, digital computer circuitry and logic, CRT display circuitry and systems design. Desires position in east coast company in systems design. Available at beginning of 1957. Box 975 W.

ELECTRONIC PRODUCT DESIGN

BSEE. near BS. in management; 6 years as Project and Group Engineer in product and packaging design on ground, airborne and missile guidance equipments. Seeking responsible position with eastern firm; salary \$9000. Box 976 W.

ENGINEER

Applied physicist, MS., age 33. 5 years research experience in the fields of instrumentation and opto-electronic devices. Desires responsible position in a research institute. Fluent in German, fair in French and Spanish. Box 977 W.

(Continued on page 151A)

MERRY CHRISTMAS

by Dahl

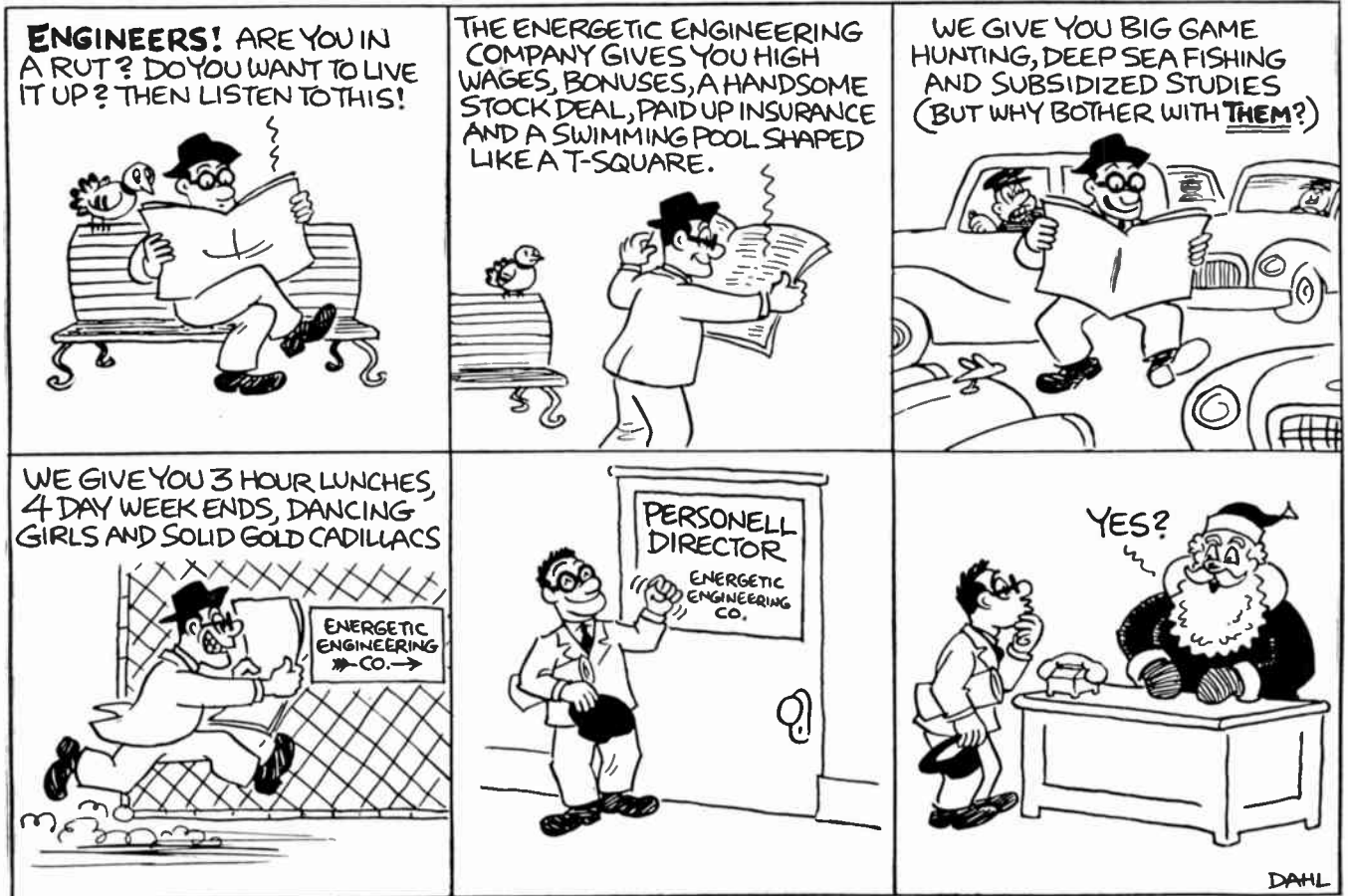

For information regarding
Engineering Positions
in the
Microwave and Power Tube Operations
Write D. Hamant

RAYTHEON MANUFACTURING COMPANY

Waltham 54, Massachusetts



Excellence in Electronics

ENGINEERING UNLIMITED

...an established concept at Convair-Pomona where your opportunities in the career of your choice are virtually unlimited. Work in the finest engineering facility in the country at America's first exclusive Guided Missile plant. Ultra-modern surroundings, completely air-conditioned, in beautiful Pomona only minutes from Los Angeles, the mountains, the seashore or desert recreation. Here is country living near the city at its best:

Excellent opportunities available now in:

**ELECTRONICS
DYNAMICS
AERODYNAMICS
THERMODYNAMICS
OPERATIONS RESEARCH
HYDRAULICS
MECHANICAL DESIGN
LABORATORY TEST ENGINEERING**

Generous travel allowance to Engineers who are accepted.

Write now enclosing a complete resume to:

**Employment
Dept. 3-E**

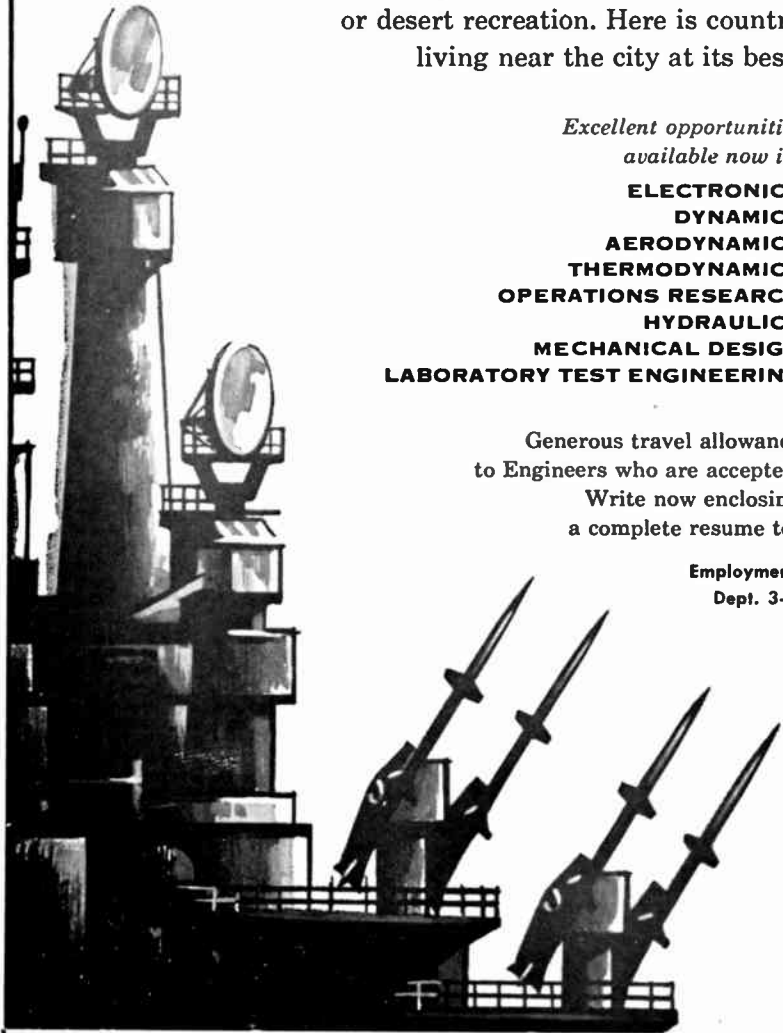

CONVAIR

A DIVISION OF
GENERAL DYNAMICS
CORPORATION

**POMONA
CALIFORNIA**



electrical
engineers

who are interested in working on new, exploratory technical developments are reading the Lincoln Laboratory folder. It describes some of our activities in:

SAGE
semi-automatic ground environment
AEW
air-borne early warning
SCATTER COMMUNICATIONS
WHIRLWIND COMPUTER
TRANSISTORIZED DIGITAL COMPUTERS
MEMORY DEVICES
HEAVY RADARS
SOLID STATE

If you would like a copy for yourself, or perhaps for some young man with related experience, write:

RESEARCH AND DEVELOPMENT

**MIT
LINCOLN
LABORATORY**
Box 16
Lexington, Mass.



ENGINEERS ...

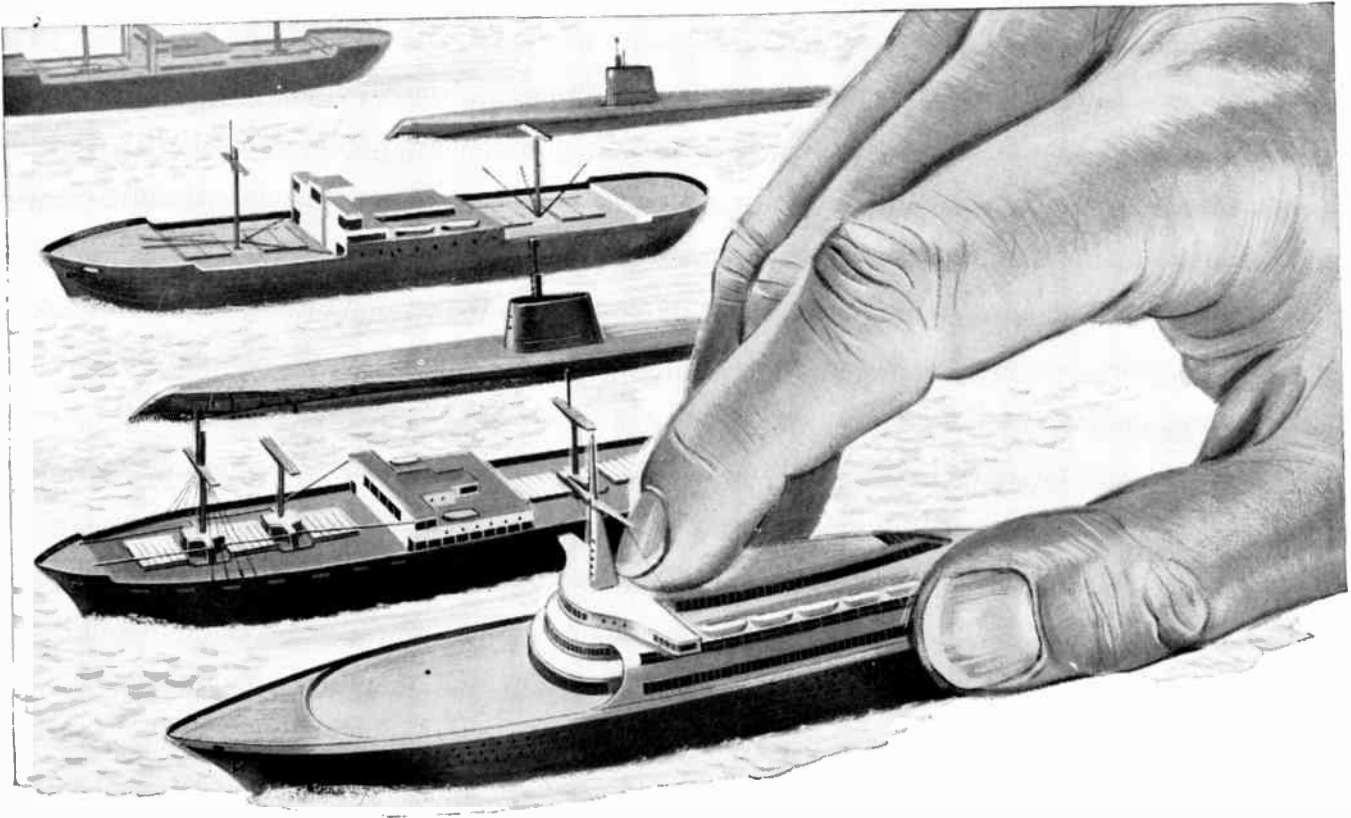

Help develop the world's first nuclear powered fleet

Nuclear power offers tremendous advantage for naval vessels. From the fuel standpoint, cruising ranges are virtually unlimited—even at new high speeds. No refueling facilities will be required to replenish nuclear propulsion fuel. Therefore, the physical design of the fleet can be streamlined for greater efficiency and safety.

At the country's largest design-engineering center for nuclear power reactors, Bettis Plant in Pittsburgh, operated for the Atomic Energy Commission by Westinghouse, the application of nuclear power has progressed rapidly. However, the nuclear power plants already in operation today represent only the beginning of a new technological era. *Major advances in many areas are necessary.*

Electrical engineers are concerned with the circuitry that controls the actions of the reactor mechanisms as well as some of the instrumentation that reports what is going on inside the nuclear reactor.

To do this, Bettis Plant needs farsighted men. Regardless of your interest, you can choose a place in the varied operations at Bettis Plant.

Atomic experience is not necessary.

What's more, Bettis Plant is in Pittsburgh's South Hills. Here you can enjoy good living in pleasant suburbs near the plant, and still be convenient to one of the nation's most progressive metropolitan areas.

Educational opportunities are exceptional. Westinghouse helps you continue your studies at any one of three Pittsburgh universities.

Write for descriptive brochure on opportunities in your field. Be sure to specify your interests. Address Mr. A. M. Johnston, Westinghouse Bettis Plant, Dept. A93, P.O. Box 1468, Pittsburgh 30, Pa.



BETTIS PLANT Westinghouse



JOSEPH D. SCHANTZ
Chief Electronics Engineer
is interviewing
qualified . . .

RADAR SPECIALISTS

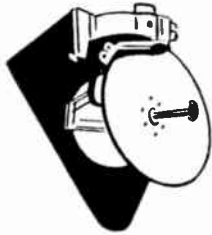

for Research and Development
at Millimeter Wavelengths

Responsibilities will include :

- All phases of radar development for shipborne tracking radar.
- Shipboard stabilization techniques.
- Antenna and feed mechanisms.
- Development of microwave and modular circuitry.
- Synchronizer and tracking circuitry.

Knowledge of computers, servomechanisms, etc. desirable.

Salary commensurate with background and experience.

Bell's fast moving research and development program offers many other challenging openings for engineers and technicians in all fields. There is an interesting and secure future for you at Bell, with opportunities limited only by your own capability for accomplishment.

Write to Manager, Engineering Personnel, Dept. T

BELL AIRCRAFT CORPORATION

P.O. Box 1, Buffalo 5, N. Y. or
call Mr. H. Ackerman collect at
Niagara Falls 7851, Ext. 7216
for a personal interview.



Positions Wanted

By Armed Forces Veterans

(Continued from page 150A)

ENGINEER

BSEE, 1953, MSEE. Presently serving as Project Officer at Air Force R&D lab. Will have 3 years experience in UHF and microwave equipment when separated from Air Force next spring. Have also worked on counters and pulsing circuits. Desires foreign assignment in manufacturing, research or field engineering. Box 978 W.



Membership

(Continued from page 138A)

- Cupp, J. C., San Fernando, Calif.
DeCristoforo, E. J., Hollywood, Calif.
Douglas, D. R., Lakemore, Ohio
Dryden, T. W. R., Belleville, Ont., Canada
Feile, R. H., Tarrytown, N. Y.
Feldhusen, R. L., St. Petersburg, Fla.
Fines, W. W., Ancaster, Ont., Canada
Frankel, S. K., Elgin, Ill.
Freeman, S., Philadelphia, Pa.
Garrish, G. G., New York, N. Y.
Glenn, H. L., Winston-Salem, N. C.
Goldstrohm, W. J., Peekskill, N. Y.
Golz, H. C., Aurora, Ill.
Gould, S., Montreal, Que., Canada
Hack, W. L., Belmont, Calif.
Haglund, H. H., Roslyn, L. I., N. Y.
Hansen, D. R., Ottawa, Ont., Canada
Harris, O. E., Hamilton, Ont., Canada
Harris, T. R., Arlington Heights, Ill.
Hart, P. C., Winslow, Ariz.
Haynes, W. S., New York, N. Y.
Heflich, G. B., North Bergen, N. J.
Higgins, R. W., White Plains, N. Y.
Hill, R. F., Calgary, Alta., Canada
Himes, S. F., Chicago, Ill.
Hoffman, T. S., Alhambra, Calif.
Hollingsworth, V. N., Stittville, N. Y.
Hooper, J. L., Parkstone, Dorset, England
Hopkinson, E. A., North Las Vegas, Nev.
Jochim, M. W., New York, N. Y.
Johnson, A. W., Warrentown, Va.
Johnson, N. C. M., Jr., Annapolis, Md.
Kanzanjian, H. A., Redwood City, Calif.
Kasser, H. N., Baltimore, Md.
Keon, R. H., St. Petersburg, Fla.
Kilbrith, D. W., Cocoa Beach, Fla.
Kloster, D. E., Bridgeport, Conn.
Kohout, R. J., Elgin, Ill.
Kowalewski, J. C., San Diego, Calif.
Krausz, C., Erie, Pa.
Kuklin, H. S., Omaha, Neb.
Lawson, A. C., Jr., Milwaukee, Wis.
Ledford, R. E., Jr., Dallas, Tex.
Lee, R. E., Lakewood, Calif.
Leonard, D. A., Jermyn, Pa.
Lindtner, E. G., St. Petersburg, Fla.
Lindtner, J., Gulfport, Fla.
Lowney, S. W., Schenectady, N. Y.
McFarland, J. H., Texarkana, Tex.
Manser, J. E., Philadelphia, Pa.
Matyas, J. A., Chicago, Ill.
Meinken, K. C., Philadelphia, Pa.
Miller, E. R., Milwaukee, Wis.
Miller, M. P., St. Petersburg, Fla.
Mueller, E. A., Afton, Mo.
Murthy, K. N., Vuyyuru, South India
Nichols, R. P., Melrose, Mass.
Norris, P. S., Calgary, Alta., Canada

(Continued on page 158A)

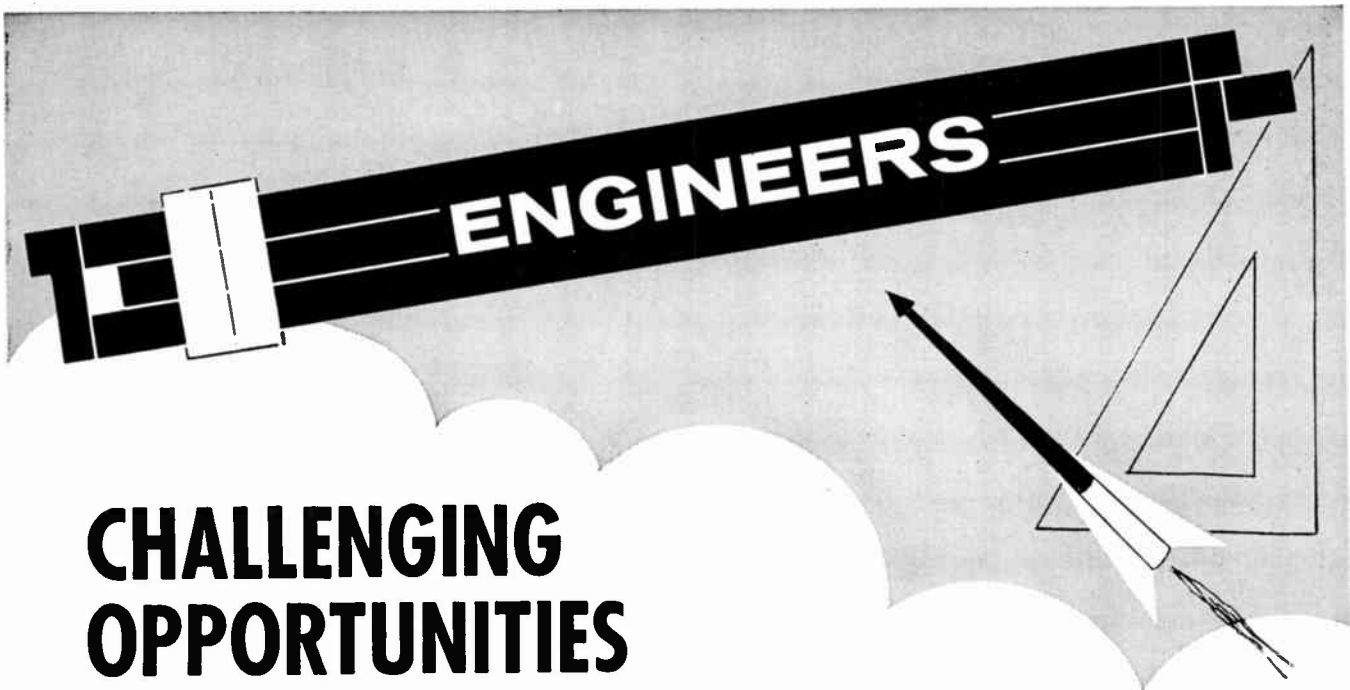

CHALLENGING OPPORTUNITIES

- Avionics
- Computers
- Jet Engine Fuel Controls
- Inertial Systems
- Missile Guidance

WITH **AC** THE ELECTRONICS DIVISION OF

General Motors

ALL GRADUATE ENGINEERS are offered permanent job opportunities. We extend a cordial invitation to every deserving Engineer and Designer to write us their wants. We may be able to supply the square hole for the square peg!

YOUR FUTURE depends on your making the right connection with the right firm as quickly as possible.

The men hired will enjoy working with some of the top men in the field and with the finest test, research and development facilities. GM's long-standing policy of decentralization creates individual opportunity and recognition.

Why not send us full facts about your education, work background, etc. We will do all we can to treat your application with the fullest confidence.

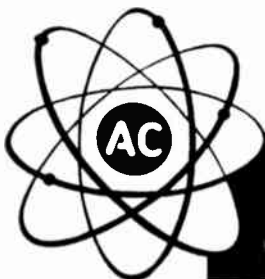

AC SPARK PLUG

GENERAL MOTORS CORPORATION
MILWAUKEE 2, WIS.

THE ELECTRONICS DIVISION

GENERAL MOTORS CORPORATION
FLINT 2, MICH.

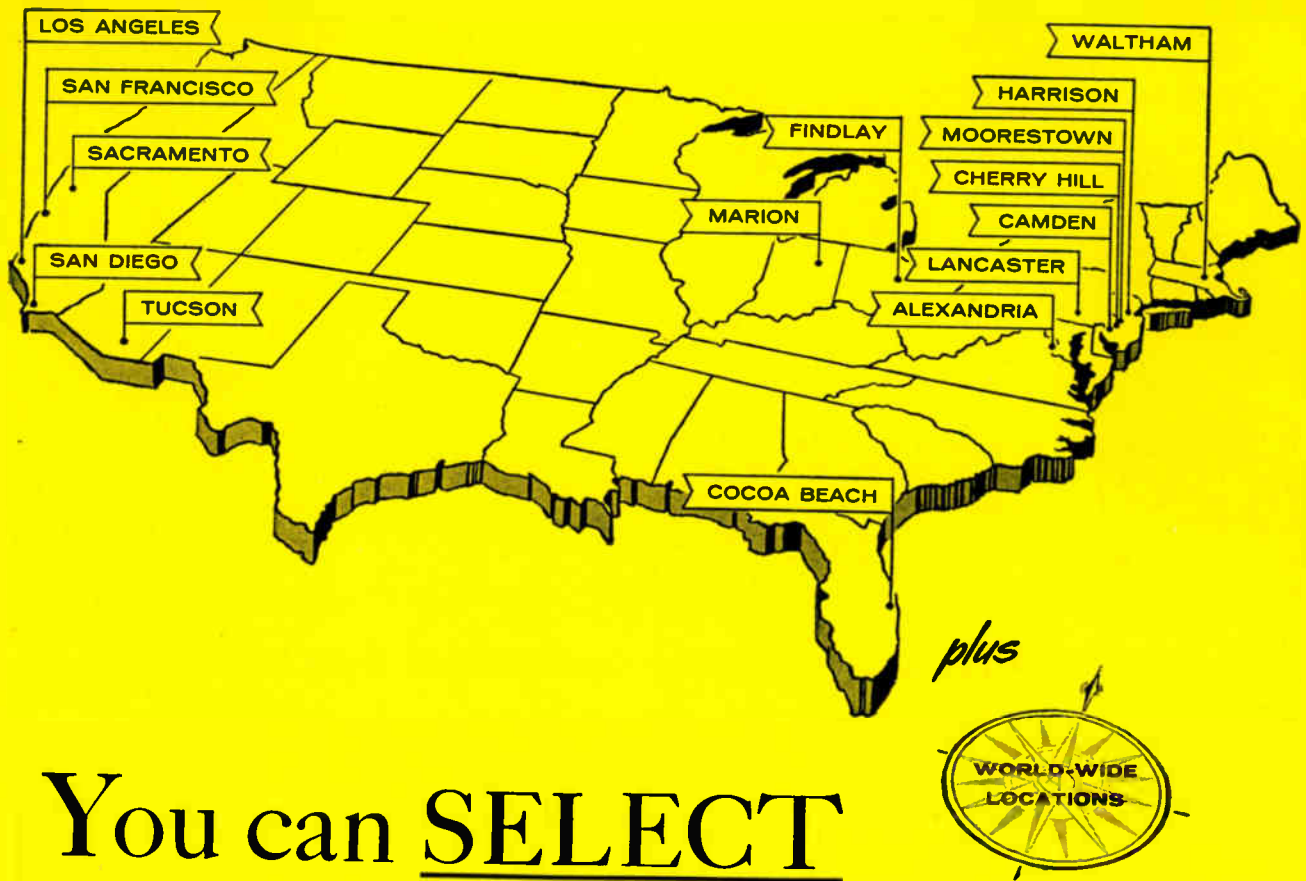

You can SELECT at RCA!

... New Opportunities ... 17 + Locations ... One Best For You And Your Family

**Can anyone but RCA offer you
a choice of locations like this?**

At Camden, Moorestown or Cherry Hill, you enjoy cultural advantages of Greater Philadelphia, live at moderate cost in pleasant suburban communities. Waltham offers at-home opportunities for New England engineers. Four ideal West Coast locations. Harrison borders on Greater New York. Lancaster, Marion and Findlay have small-town advantages. There's pleasant year-round outdoor living in Cocoa Beach, on Florida's central east coast. RCA Service Company and International Division assignments include ideal locations in the United States, and wherever RCA electronic equipments are installed and serviced throughout the world.

Individual Recognition—

RCA organizes engineering activities into groups small enough to allow broadest scope for your individual accomplishment. The average group has just 11 engineers. Yet, in all activities, you are supported by the entire facilities and engineering resources of RCA.

Salaries—

RCA engineering salaries average measurably higher than other companies' in the field. Intermediate engineers, \$5000-\$8500; senior engineers, \$8500-\$15,000; staff and supervisory salaries open.

Advancement—

Scheduled, objective appraisal of your work speeds promotion. Professional and financial progress is just as sure as your achievements make it.

Professional Status—

RCA bases world leadership in electronics on the abilities of exceptional men at every organizational level. Many have notable engineering and scientific reputations. You work in day-by-day association with men of this caliber.

Benefits—

There's a complete program at RCA. A very liberal Tuition Refund Plan. Company-paid life, sickness and accident, hospital-surgical insurance for you and your family. Modern retirement plan. Relocation expenses paid. Suggestion and patent awards.

Now, Pinpoint Your Future

...Here are the Opportunities!

...Here are the Locations!

FIELDS OF ENGINEERING ACTIVITY		MANAGERS	TYPE OF DEGREE AND YEARS OF EXPERIENCE PREFERRED											
			Electrical Engineers			Mechanical Engineers			Physical Science			Ceramics Glass Technology Metallurgy		
			0-2	2-3	4-15	0-2	2-3	4-15	1-2	2-3	4-15	1-2	2-3	4-15
• SYSTEMS <i>(Integration of theory, equipments and environment to create and optimize major electronic concepts.)</i>	AVIATION ELECTRONICS • CONTROLS		W	W	W	W	W	W	W	W	W			
	DIGITAL DATA HANDLING DEVICES	M		M	M		C	C		C	C			
	MISSILE ELECTRONICS • RADAR	M	W	M	M	W	M	M	W	M	M			
	INERTIAL NAVIGATION			W	W		W	W		W	W			
	COMMUNICATIONS			C	C								C	N
• DESIGN • DEVELOPMENT														
MISSILE WEAPONS SYSTEMS —Planning and Design—Radar—Fire Control—Servo Mechanisms—Computers		M	M	M	M	M	M	M	M	M	M			
AVIATION ELECTRONICS —Radar—Computers—Servo Mechanisms—Shock and Vibration—Circuitry—Remote Control—Heat Transfer—Sub-Miniaturization—Automatic Flight—Automation—Transistorization		W	W	W	W	W	W	W	W	W	W			
RADAR —Circuitry—Antenna Design—Servo Systems—Gear Trains—Intricate Mechanisms—Fire Control—Information Handling—Displays		M	C	C	C	C	C	C	C	C	C			
COMPUTERS —Systems—Advanced Development—Circuitry—Assembly Design—Mechanisms—Programming—Digital Data Handling Devices			C	C	C	C	C	C	C	C	C			
KINESCOPIES (B & W and Color), OSCILLOSCOPES —Electron Optics—Instrumental Analysis—Solid States (Phosphors, High Temperature Phenomena, Photosensitive Materials and Glass to Metal Sealing)			L	L	L	L	L	L	L	L	L	L	L	L
RECEIVING TUBES —Tube Design—Test and Application Engineering—Chemical and Physical Development—Methods and Process Engineering—Advanced Development			H	H	H		H	H		H	H		H	H
SEMICONDUCTORS —Transistors—Semiconductor Devices—Materials			V	V	V	V	V	V	V	V	V	V	V	V
MICROWAVE TUBES —Tube Development and Manufacture (Traveling Wave—Backward Wave—Magnetron)		H		H	H		H	H		H	H		H	H
GAS, POWER AND PHOTO TUBES —Photosensitive Devices—Glass to Metal Sealing—UHF and VHF—Power			L	L	L	L	L	L	L	L	L	L	L	
COMMUNICATIONS —Specialized Systems—Microwave—Mobile—Aviation—Audio—Propagation Studies—Acoustics—Transducers			C	C	C		C	C	C	C	C			
BROADCAST AND TV —Monochrome and Color Studio Equipment—Cameras—Monitors—High Power Transmitters			C	C	C	C	C	C	C	C	C			
• SYSTEMS APPLICATION <i>(Evaluation and Planning—Design and Development—Modification—Specification)</i>														
MISSILE TEST INSTRUMENTATION (Data Acquisition and Processing)—Radar—Telemetry—Timing—Communications—Optics—Computers		F	F	F	F	F	F	F	F	F	F			
RADAR —Airborne—Surface—Shipboard—Sonar—Fire Control		F	F	F	F	F	F	F	F	F	F			
COMMUNICATIONS —Radio—HF—VHF—UHF—Microwave—Telephone—Teletype—Telegraph Terminal Equipment—Wave Propagation		F	F	F	F	F	F	F	F	F	F			
• MACHINE DESIGN			L	L		L	L		C		L	L		
Mechanical and Electrical—Automatic or Semi-Automatic Machines							H	H						

Locations: C—Camden, N.J. F—Cocoa Beach, Fla. H—Harrison, N.J. I—Clark, N.J. (periodic foreign assignments). L—Lancaster, Pa. M—Moorestown, N.J. N—New York, N.Y. S—RCA Service Co. (Cherry Hill, N.J.; Alexandria, Va.; Tucson, Ariz.; San Diego, Sacramento, San Francisco, Calif., Foreign Assignments). V—Somerville, N.J. W—Waltham, Mass. X—West Los Angeles, Calif. Y—Marion, Ind.

Please send resume of education and experience, with location preferred, to:

Mr. John R. Weld, Employment Manager
 Dept. A-13M, Radio Corporation of America
 30 Rockefeller Plaza, New York 20, N.Y.



RADIO CORPORATION of AMERICA

Copyright 1956 Radio Corporation of America

electronic engineers

SENIOR and JUNIOR

*Continued Expansion
Opens Up New Opportunities with*



Greenwich, Connecticut

Excellent positions are available with the General Engineering Laboratories of American Machine & Foundry Company, a recognized leader in the design, development and manufacture of atomic, electronic and mechanical equipment for the consumer, industry and defense.

If you qualify in any of the fields listed below, investigate these opportunities now:

- High power radar system development
- Tropospheric scatter systems
- Microwave theory & component design
- Electronic packaging
- Missile control and handling systems
- Antenna design
- Electronic countermeasures
- Telemetry
- Data handling
- Circuit theory
- Navigation systems
- Instruments

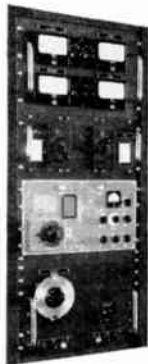

Good opportunities for advancement through advanced education on the premises as well as at nearby graduate schools in addition to a liberal tuition reimbursement plan, excellent employee benefits and an ideal location in Connecticut, surrounded by fine suburban communities. Relocation expenses paid.

Advanced electronic equipment recently designed by AMF

Please send your resume to Mr. J. F. Weigandt
OR for additional technical information,
contact Mr. D. R. Barker or Mr. H. R. Holloway
NOrmandy 1-7400

General Engineering Laboratories

American Machine & Foundry Company

Fawcett Bldg. • Fawcett Place
Greenwich, Connecticut



Membership

(Continued from page 151A)

Page, A. E., Elmhurst, L. I., N. Y.
Paul, S., Samastipur, Bihar, India
Petti, U. A., Hackensack, N. J.
Pope, R. L., Tampa, Fla.
Porter, D. D., Tallmadge, Ohio
Poveda, H., St. Paul, Minn.
Prendes, J. R., Tampa, Fla.
Ragland, R. M., New York, N. Y.
Raphael, H. S., North Hollywood, Calif.
Rausa, F. C., Hartselle, Ala.
Rea, J. K., St. Petersburg, Fla.
Reagh, D. M., Burnaby, B. C., Canada
Rich, J. C., Tampa, Fla.
Rubin, A. R., Brooklyn, N. Y.
Sanford, R. S., Potsdam, N. Y.
Sawvelle, E. V., Oelwein, Iowa
Schnabel, C. P. J., Amsterdam, Netherlands
Seale, E. G., Terenure, Dublin, Ireland
Segal, C. M., Sun Valley, Calif.
Shak, H. K. Y., Honolulu, Hawaii
Shamban, W. S., Culver City, Calif.
Shigemoto, J. M., Los Angeles, Calif.
Skelly, P. G., Atlanta, Ga.
Smith, W. J., Laurel Springs, N. J.
Snyder, J. S., Ottawa, Ont., Canada
Solie, A. J., South Gate, Calif.
Sommermeyer, O. R., Passaic, N. J.
Sparks, J. F., Baltimore, Md.
Spearman, J. C., St. Petersburg, Fla.
Steckler, I., New York, N. Y.
Stornaio, P. U., Passaic, N. J.
Taagepera, A., Kitchener, Ont., Canada
Tait, W. F., Abington, Pa.
Todd, H. F. E., Hamilton, Ont., Canada
Townsend, R., Manchester, Mass.

(Continued on page 160A)

OPPORTUNITIES for Electrical Engineers and Physicists in Automation

FMC Central Engineering's current expansion into automatic measurement and control field provides unusual opportunities for technical accomplishment on important company sponsored programs. There is need for both systems engineers and specialists.

Qualified technical specialists who desire to participate in this activity, write:

Manager of Central Engineering

**FOOD MACHINERY AND
CHEMICAL CORPORATION**

San Jose, California
1105 Coleman Ave.
Phone CYpress 4-8124



DESTINATION:

PEACE!

Heat of a new weapon system in America's inventory of counter-measures that guard the peace is an IBM airborne computer — specially designed to guide America's most powerful bombers with unbelievable precision.

To build *complete systems reliability* into this airborne computer, IBM submits the finest available components to tests of torturing extremes. Only those that survive are used. But, from this test data, IBM electronic computers figure ways to improve the failures and make those selected even better. In this way, IBM helps strengthen the general reliability of all electronic systems, and give to America's airborne defenders a mighty—and dependable — weapon for guarding the peace.

ENGINEERS:

IBM offers exciting opportunities to work on computers, control systems, inertial guidance, and microwave circuitry.

In addition to excellent starting salaries and on-the-job training with pay, IBM offers a chance for rapid promotion through its individual merit system. You'll work in some of the choicest locations in all America and enjoy the advantages of IBM's industry-famous employee-benefit policies.

WRITE, giving details of background and interests, to: R. A. Whitehorne, Room 2712, International Business Machines Corporation, 590 Madison Avenue, New York 22, N.Y.

Positions available in Owego and Kingston, N. Y. IBM Laboratories and Manufacturing Plants also located in: Poughkeepsie and Endicott, N. Y.; San Jose, Calif.; Rochester, Minn.; and Lexington, Ky.

IBM[®]

**MILITARY
PRODUCTS**

MILITARY PRODUCTS • DATA PROCESSING • ELECTRIC TYPEWRITERS • TIME EQUIPMENT

ENGINEERS:

- *air-borne system engineers*
- *project engineers on small rotating equipment*
- *instrument designers*

Work with a recognized industry leader . . . expanding Avionic Division creates opportunities . . . complete engineering, laboratory and production facilities.

We need men who want to get ahead on their own merits . . . who are willing to do a job . . . and be rewarded accordingly.

You'll like Racine . . . our plant overlooks beautiful Lake Michigan . . . it's just one hour to Chicago . . . and convenient to Wisconsin's famous North Woods lakes and resorts.

Let's get acquainted. You are invited to write the Director of Industrial Relations today. All communications are strictly confidential.

John Oster

MANUFACTURING CO.
avionic division
RACINE, WISCONSIN

MICROWAVE AND GUIDANCE ENGINEERS

The Mechanical Division of General Mills, Inc., offers excellent employment opportunities for electronics engineers in its Microwave Development Laboratory and its Guidance Laboratory located in Minneapolis. These are part of our well-equipped Research and Development facilities which are engaged in advanced equipment development and military study programs. You can work closely with prominent scientists on extremely interesting projects where you will be recognized for your contributions. Congenial associates and atmosphere. Alert, progressive, stable, permanent organization. Openings for bachelor, master and doctor degrees.

Microwave Laboratory

Design of low-noise figure superheterodyne receivers and video circuits. There is emphasis on special-purpose precision microwave RF components and circuits with some broad banding requirements. Work is being done on micro-second and millimicrosecond pulse techniques. Propagation studies at centimeter and meter wave lengths are being made in connection with radar sea clutter, optimizing radar ranges, and MTI synthesis. Electronic systems engineers do theoretical and experimental analysis of electronic counter-measures techniques and equipment, radar system synthesis and development, and system feasibility analysis based upon application of information theory. Activities in antenna development include utilizing well-equipped antenna pattern test ranges in the design of high-gain antennas both for ground-based and airborne use, for radome analysis, and in design of VHF-UHF antennas.

Tear off and mail to:

Peter D. Burgess, Director of Personnel
Mechanical Division of General Mills, Inc.
1620 Central Avenue N.E.
Minneapolis 13, Minnesota

Guidance Laboratory

Equipped to do experimental, analytical, design and development work in servomechanisms, electronic equipment, analog computers, precision electromechanical and mechanical equipment. Using these facilities, studies and development work are carried on in inertial guidance systems, fire control systems, equipment for radio guided missiles, and bombing systems. Magnetic amplifiers and special purpose transformers are also developed. A Reeves analog computer equipped with an XY plotter and Sanborn recorder is available for mathematical analysis of problems.

You are invited to mail in the coupon below, and we will send you in complete confidence, technical material that will describe our activities.

MECHANICAL DIVISION OF General Mills

NAME

College Degree Year

Address

City Zone State



(Continued from page 158A)

Valo, H. L., Milwaukee, Wis.
van Tuyen, N., Washington, D. C.
Vena, A. C., Stratford, Conn.
Vogel, S., New York, N. Y.
Vokoun, R. C., Berwyn, Ill.
Wade, G. L., Santa Monica, Calif.
Whitehead, E. H., Los Angeles, Calif.
Wilber, L. E., San Mateo, Calif.
Wilensky, H. B., Detroit, Mich.
Willert, A. F., St. Petersburg, Fla.
Win, U. S., Rangoon, Burma
Wolff, A. F., Los Angeles, Calif.
Wunsch, P. G., Jr., Clifton, N. J.
Wylie, L., Sepulveda, Calif.



(Continued from page 86A)

These manufacturers have invited PROCEEDINGS readers to write for literature and further technical information. Please mention your IRE affiliation.

Matching Unit for Audio Oscillator

Waveforms, Inc., 333 Sixth Ave., New York 14, N.Y., announces a new applique for use with the 510B Audio Oscillator.

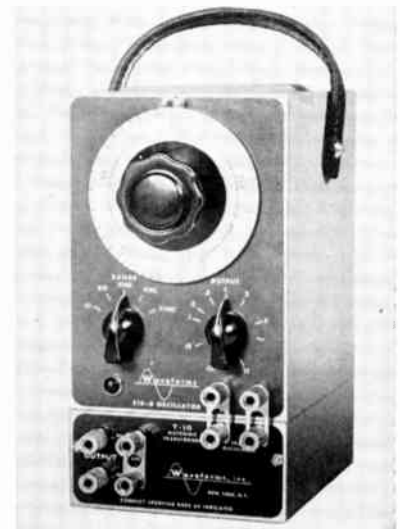

The T-10 Matching Unit consists of a repeat coil and resistive network designed to furnish a balanced signal of up to +8 dbm. Impedances of 150 or 600 ohms ± 5 per cent over the range 19 cps to 50 kc are selected by means of straps at the binding posts.

The unit is housed in a sheet metal enclosure which forms a permanent part of the oscillator assembly. Price is \$40.

(Continued on page 162A)

Henry Rempt (second from left), head of the Electronics and Armament Systems Division, discusses problems inherent in the application of large electronic sensing devices to aircraft with David Morrissey, A.E.W. Systems Specialist, Harold Held, Data Links Specialist in the Advanced Techniques Group, and Nelson Harnois, head of the Electronics and Armament Systems Engineering Department.



Lockheed expands electronics division

■ To keep pace with its ever-increasing emphasis on electronics, Lockheed has expanded and centralized research and development activities under the Electronics and Armament Systems Division. The Division is under the direction of Henry Rempt.

Responsibilities of the Division include originating and developing complex electronics and armament systems for all new Lockheed aircraft.

A number of technical management positions for Electronics Systems Engineers has been created. The positions will appeal particularly to those who seek an extremely wide range of assignments.

Technical management positions are open in fields of:

Fire control, countermeasures, inertial systems, weapons, communications, infra-red, optics, sonics, magnetics, antennas and micro-waves.

Under Lockheed's philosophy of operation, Electronics Systems Engineers supervise and participate in conceiving advanced systems and then performing research, development and evaluation up to production stages on all Lockheed aircraft — radar search planes, high-speed fighters, cargo and passenger transports, bombers, jet trainers.

*Electronics Engineers possessing experience or keen interest in systems activities are invited to write E. W. Des Lauriers.
Dept. ED-8-12.*

California Division

LOCKHEED

AIRCRAFT CORPORATION • BURBANK

CALIFORNIA



Does your family count?

One of the major reasons why Raytheon is attracting so many engineers is because Massachusetts, where most of Raytheon's plants are located, is an exceptionally fine place to live and bring up a family. A stimulating four season climate, above average schools and colleges, good and abundant water, the medical, cultural and research center of the world and nearness to all year 'round recreational advantages make it ideal. Your choice of urban or suburban living.

Raytheon as prime contractor for the Army, Navy and Air Force in guided missiles, and pioneer in the field of Doppler Radar Aircraft Navigation and Control Systems offers vital, interesting work, excellent salary and advancement prospects, modern facilities, company assistance in advanced engineering courses, relocation expenses, liberal vacations, group life & health insurance.

If you are interested in the design and development of guided missile or aircraft radar systems and have experience in these fields:

Circuit Design	Microwave
Electronic Packaging	Specifications
Test Equipment Design	Radar Systems
Analog Computer Design	Tube Applications

Come in or send brief resume to:

G. P. O'NEIL



**MISSILE
SYSTEMS
DIVISION**

—————▶—————
B E D F O R D , M A S S .



These manufacturers have invited PROCEEDINGS readers to write for literature and further technical information. Please mention your IRE affiliation.

(Continued from page 160A)

Test Probe

An improved test probe for Amateurs, Experimenters and technicians, equipped with a new and different type of selfholding connector is announced by E-Z Hook Test Products, 1536 Woodburn Ave., Covington, Ky.



This test probe features a special built-in terminal board which makes it easier to build special test probe assemblies, such as detectors, isolation networks, low capacity probes, and so forth. They speed servicing, make troubleshooting easier, and testing safer. Available in five colors for easier lead identification. Uses: On all types of test equipment where safe, fast connections are desired, such as: scopes, meters, substitution boxes, test and jumper leads.

(Continued on page 166A)

MANAGER AIRBORNE FIRE CONTROL DESIGN AND DEVELOPMENT

This position calls for engineering leadership. You'll be responsible for technical and administrative management of a group of airborne fire control supervisors and engineers.

You should have a degree in EE or Engineering Physics, with post graduate study desirable. A minimum of 10 years' radar design and development experience, plus accomplishments in the fields of pulse radar transmitters, microwave techniques, timing and display circuits or servomechanisms.

Complete facilities. Modern benefit program for you and your family.

For confidential interview, write to Box #1011, Institute of Radio Engineers, 1 East 79th St., New York 21, N.Y.

electronic tube engineers

THERE'S SOMETHING NEW UNDER THE SOUTHERN SUN!

New Opportunity At A New Plant
With An Old And Honored Name . . .

SPERRY ELECTRONIC TUBE DIVISION

OF SPERRY RAND CORP.
Gainesville, Florida
"THE UNIVERSITY CITY"

You rarely run into a happier combination of opportunity, stability and geography. Here is your chance to make a fresh start with a new, expanding division of an old, established company in a location noted for excellent year-round climate. Your outlook, your approach, your creative efficiency all will benefit from this ideal situation. The potential of this new division is tremendous . . . and so is your potential here. You'll get an excellent salary, full employee benefits . . . a chance to study at the nearby University of Florida under Sperry's tuition refund program.

EXCEPTIONALLY FINE LIVING CONDITIONS

Imagine living in a year-round vacation land! Thanks to Florida's celebrated climate, you'll be able to enjoy fishing, boating, swimming practically every day at picturesque lakes and uncrowded Gulf beaches. Minutes from your work are comfortable homes of every size and description. Gainesville is a cultured university city offering typical Southern graciousness and hospitality. You'll feel at home from the start.

POSITION REQUIREMENTS

Your experience should include microwave tube design, development or production, microwave theory, electro-mechanical assembly techniques. Your work will be in Magnetrons, Klystrons, Traveling Wave Tubes.

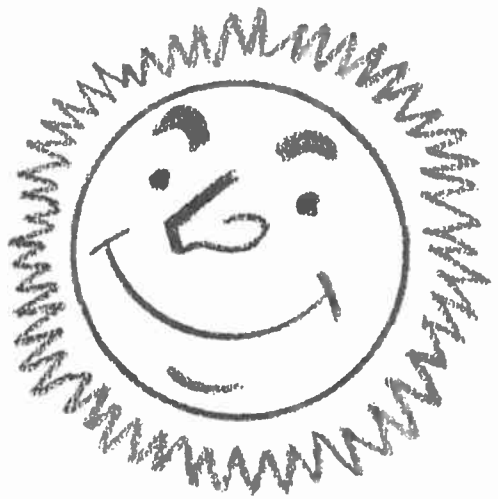

*Please Send Resume To:
Employment Dept.*

SPERRY
ELECTRONIC
TUBE DIVISION
OF SPERRY RAND CORP.
Gainesville, Florida

ENGINEERING GRADS

are you
interested in
joining the
electronic
industry's
leading staffs

in these
development
areas?

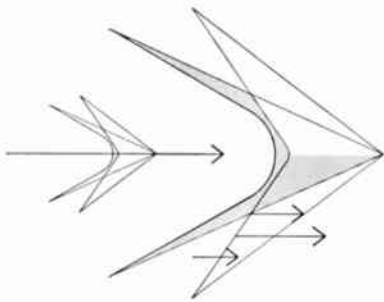

Send resume' to:

L. R. Nuss
Collins Radio Company
Cedar Rapids, Iowa

FRED AIKEN
Collins Radio Company
2700 W. Olive,
Burbank, California

HAROLD MCDANIEL
Collins Radio Company
1930 Hi-Line Drive
Dallas, Texas

COLLINS RADIO COMPANY
CEDAR RAPIDS • BURBANK • DALLAS



Single Sideband — The most advanced development in SSB for complete air and ground communication systems for commercial, military, and amateur applications. *Example:* Collins SSB HF program for intercontinental air/air, air/ground, ground/air, and ground/ground for USAF.

Scatter Propagation — Pioneering development in complete point-to-point Transhorizon systems employing UHF tropospheric or VHF ionospheric scatter propagation. Systems engineering integrates this new type of transmission with existing equipment or entirely new designs. *Example:* Collins Transhorizon communication systems for DEW-Line.

Microwave, Multiplex — Collins is now the leading designer and manufacturer of complete communication and control microwave systems. New orders are underway for the petroleum, broadcast and telephone industries. *Example:* Collins 85,000 channel-mile microwave system for Continental and Sinclair pipe line companies.

Aviation Electronics — Already supplying 80 percent of the airline electronics, Collins is now engineering an entire new airborne electronic system for airline and business aircraft. Developments underway for complete communication, navigation, flight instrumentation and flight control system. *Example:* first radar anti-collision system now in development.

Military Electronics — Many basic development airborne and ground equipment programs are underway for the Air Force, Navy and Signal Corps. *Example:* Collins new integrated electronics package, CNI (Communication, Navigation and Identification) for new jet aircraft.

Predicted Wave Radio Signalling — Linearity and highly stable frequency characteristics of Collins advanced SSB equipments make possible great improvements in the frequency spectrum utilization and performance of binary data transmission systems. *Example:* Land line and HF experimental circuits in operation between Cedar Rapids and Burbank.

Whether you choose one of these development areas or one of many others equally stimulating, at Collins you'll join a small close-knit engineering group. This tight-group approach has helped make Collins the leader in the electronics field. And it helps you as an individual, by making you an important member of a top-flight engineering task force. Join a team at Collins, in the climate of your choice: research and development laboratories located in Cedar Rapids, Iowa; Burbank, California; Dallas, Texas. U.S. citizenship a requirement.

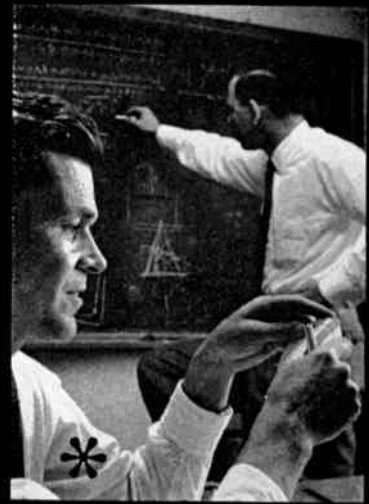

Cold Calculation

Technical Operations scientists calculate... as F. Everett Reed is doing above, in his quest for high energy fuels, for example. But they also work in integrated groups, bringing to bear on any problem the force of many varied disciplines... for results.

Inquiry about Technical Operations' working methods can lead you to cold calculation...

about your career as a

Electronics Engineer or Physicist

But you'll respond warmly to Technical Operations'

- simple, sensible salary policies
- management by scientists themselves
- small groups for individual recognition
- growth plans for long-range security

You'll find limitless opportunity in experimental research and development work in chemistry, physics, nucleonics, and electronic instrumentation. Challenging positions are available in theoretical work in operations research, reactor design, digital computing and other fields.

address: Robert L. Koller

TECHNICAL OPERATIONS

INCORPORATED

6 Schouler Court
Arlington 74, Massachusetts

* F. Everett Reed and Robert L. Koller

ENGINEERS and PHYSICISTS



The Valley of Decision

Here in Great Valley, George Washington, our first president and a great engineering strategist, made many decisions vital to the defense of our nation. His basic thinking then . . . in the winter of 1777-78, when his army was encamped on the now historic site of Valley Forge . . . was not much different than ours today. For here in the four Burroughs research facilities, located almost within the very shadow of these hallowed grounds, dedicated men are still searching for better ways to preserve our great country and the heritage which our founding fathers ensured for us.

To such men, stimulating and challenging assignments in advanced computer techniques are the order of the day at Burroughs. And, if you have initiative and creative imagination with degrees or background in Electrical Engineering, Mechanical Engineering, Electromechanical Engineering, Mechanical Design Engineering, Mathematics or Physics, why not put it to the fullest possible use at one of our laboratories?



Write or Telephone

M. E. JENKINS, PLACEMENT MANAGER • Paoli 4700



BURROUGHS CORPORATION

Research Center

PAOLI, PA., NEAR HISTORIC VALLEY FORGE

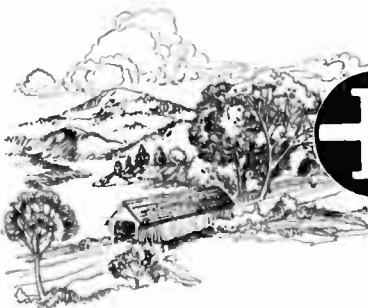

CUBIC RESEARCH AIDS IN AIR WEAPONS DEVELOPMENT

- Provides accurate test data
- Accelerates Weapon Evaluation



CUBIC RESEARCH IN ELECTRONIC PROBLEMS—IN FREQUENCIES FROM D.C. TO MICROWAVE—AIDS GOVERNMENT AIRCRAFT AND AIR ARMAMENT TESTING

MASTER STATION—
MULTIPLE OR SINGLE

Attention!

A Relaxed Life for You and Your Family in Vacation-land. Interested?

CUBIC CORPORATION of San Diego offers this and more to Engineers who are anxious to advance themselves and get more out of life at the same time. Note these advantages:

- Long-range, challenging programs
- Chance to grow with a rapidly growing company
- Extremely diverging problems
- Management by engineers
- In an area where there's plentiful housing and at reasonable costs

THIS CAN ALL BE YOURS! Write Dept. 918 today for details.

CUBIC CORPORATION
ELECTRONIC EQUIPMENT . . . RESEARCH . . . DEVELOPMENT
5575 Kearny Villa Road, San Diego 11, Calif.



News-New Products

These manufacturers have invited PROCEEDINGS readers to write for literature and further technical information. Please mention your IRE affiliation.

(Continued from page 162A)

Wilson Of Servomechanisms Moves To West Coast

The Advertising and Public Relations Department of Servomechanisms, Inc., headed up by Warren C. Wilson, Advertising and Public Relations Manager, has moved to Western Division headquarters in Hawthorne, Calif. it was announced today by Harold R. Larsen, V.P. and G.M. for Servomechanisms, Inc. This change is effective immediately.



Formerly the Department was located at Westbury, New York.

The new address will be: Servomechanisms, Inc., Executive Staff, 12500 Aviation Blvd., Hawthorne, Calif.

(Continued on page 168A)

THERE'S MORE TO LOOK FORWARD TO FROM THESE POSITIONS . . . SALARIES TO \$20,000

CHIEF ENGRS, Sev'I PROJECT MANAGERS, Missiles, Nuclonics, Airbourne Fire Control, Computers Analogue & Digital, Radar & Antennas, Microwave Techniques, Pulse Radar, Servo Mechanisms, Transistor Applications, Frequency Division Multiplex, Propagation & Antennas, Engineering Writing, Data Transformation, Arming & Fuzing, Flight Simulation, Systems Analysis & Synthesis.

SENIOR & JUNIOR OPENINGS IN ALL PHASES OF ELECTRONICS

And no charge to you when you leave it to GUILFORD to locate the right position for you with one of America's leading companies. Interview, relocation expenses paid. Send 3 copies of resume to Box R-1M.

GUILFORD PERSONNEL SERVICE

502 American Building, Baltimore 2, Md.
MUIberry 5-4340

UNIVAC SCIENTIFIC

Remington Rand

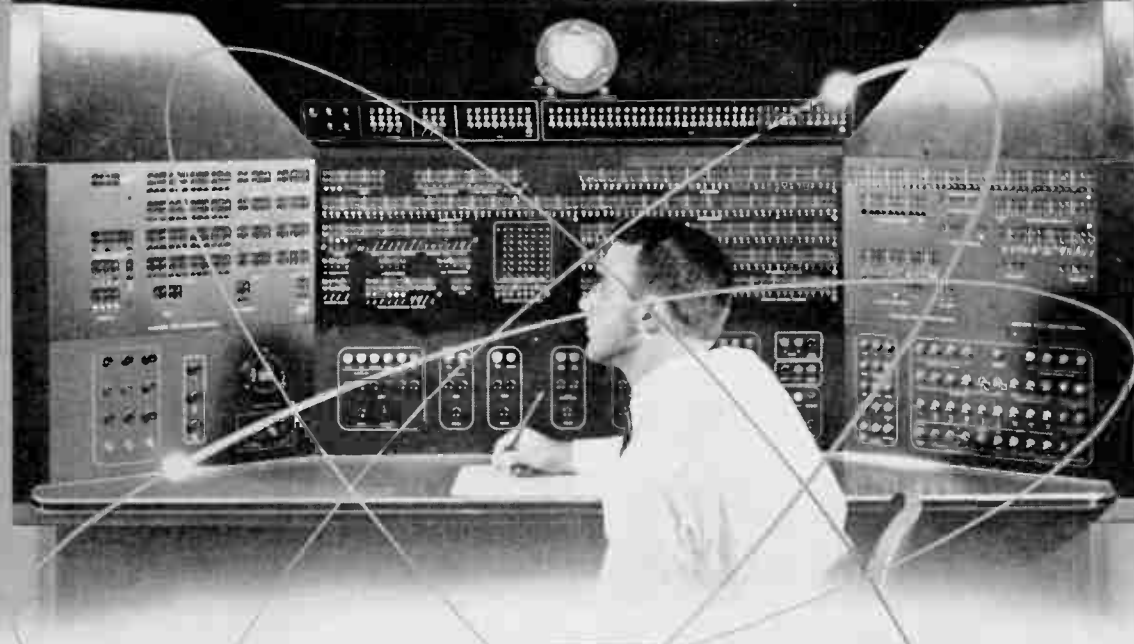

Challenge: Help develop the first electronic control center for a nationwide network of automated factories

Think of it . . . Completely automatic factories, hundreds of miles apart, all operated by a single Remington Rand Univac® computing system. Flow of materials, processing, quality control, packaging, even market analysis, controlled from the electronic "brain center" . . . control so complete that when a shift in the wind changes the draft of a chimney at a distant plant, the computer corrects the firing of a boiler.

Far fetched? Not at Univac. The Univac team of scientists, engineers and technicians has already designed the completely automatic factory. They have built a computer (Univac Scientific) capable of remote control of ten to a hundred factories. The next step—central control of chains of automated plants—will completely revolutionize American industry.

This is the kind of challenge that awaits you at Univac. As a Univac engineer or technician you'll find top salaries, excellent working conditions and opportunities unlimited—unlimited as the future of Univac itself.

IMMEDIATE OPENINGS FOR

ELECTRONIC DESIGN ENGINEERS—Must have degree and be experienced in pulse circuitry, digital computers, or data processing equipment.

ELECTRO-MECHANICAL DESIGN ENGINEERS—Should have bachelor's degree in Engineering. However, extensive mechanical design background may substitute for some college. Men selected will do basic preliminary design and layout of small mechanisms. Requires original ideas and application of logical analysis to design problems.

Send Complete Resumé to:

Remington Rand Univac

DIVISION OF SPERRY RAND CORPORATION

at any one of these four plant locations.

D. A. BOWDOIN
Dept. PD-1
2300 W. Allegheny Ave.
Philadelphia, Pa.

FRANK KING
Dept. ND-1
Wilson Avenue
South Norwalk, Conn.

CAL BOSIN
Dept. YD-1
315 Fourth Ave.
New York City

J. N. WOODBURY, Dept. SD-1, 1902 W. Minnehaha Ave., St. Paul W4, Minnesota

WHAT *inspired* ARCHIMEDES

The driving urge to find a way to do a thing which had never been accomplished . . . then, to improve. Today, Farnsworth's electronics programs would tax the talents and imagination of these famous four . . . and

DA VINCI

more. Tomorrow will obsolete today in the fantastic industrial revolution now being created through electronics . . . The Farnsworth tradition of superior competence in electronics research, development and pro-

FARADAY

duction is now and will continue to be one of the most salable articles on the American scene. For the engineer desiring association with one of the country's pioneers in missile guidance and control, systems

ROENTGEN

test equipment, radar, countermeasures, infra-red systems, antennas, microwaves, transistor and pulse circuitry, industrial electronics products . . . Write

Farnsworth



Address Technical Employment Director
FARNSWORTH ELECTRONICS COMPANY, FORT WAYNE, INDIANA
A Division of International Telephone and Telegraph Corporation

Your resume will receive
prompt, confidential attention.



News-New Products

These manufacturers have invited PROCEEDINGS readers to write for literature and further technical information. Please mention your IRE affiliation.

(Continued from page 166A)

20-KV 3-AMP Power Supply

Developed for powering 20-kw CW klystrons the Model PC 45 Power Supply produced by **Levinthal Electronic Products, Inc.**, provides zero-to-20-kv dc at currents up to 3 amperes with less than 1 per cent ripple and is operated from the remote-control console shown. The power supply utilizes



a motor-driven Powerstat and operates with a power input of 230

(Continued on page 170A)

ENGINEERS PHYSICISTS

Plot your future at

Admiral

Continued and steady growth of established research and development projects presents a number of unusual opportunities for men at all levels of experience.

- UHF-VHF Communications Systems
- Television—Military and Civilian
- I.F.F. and Other Forms of Radar
- Nuclear Radiation Damage Control

Current openings offer excellent income and employee benefits including retirement plan, paid group insurance and college tuition refund plan plus ideal working conditions.

Send a letter outlining your education and experience to Mr. W. A. Wecker, Personnel Division.

Admiral Corporation

3800 W. Cortland St. • Chicago 47, Ill.

another example of exciting work at los alamos...

PAPERS ACCEPTED BY THE...



INTERNATIONAL CONFERENCE ON THE PEACEFUL USES OF ATOMIC ENERGY

"The Intermetallic Compounds of Plutonium,"
Coffinberry, A. S. and Ellinger, F. H.

"Time-of-Flight Techniques Applied to
Fast Neutron Measurements,"
Cranberg, L.

"Gamma Rays from Neutron Inelastic Scattering,"
Day, R. B.

"Some Techniques for Measurement of
Fast Neutron Flux,"
Diven, B. C.

"Los Alamos Power Reactor Experiments,"
Froman, D. K., Hammond, R. P. and King, L. D. P.

"The Preparation of Kilocurie La 140 Sources,"
Hammond, R. P. and Schulte, J. W.

"Chemical Processing in Intense Radiation Fields,"
Hammond, R. P.

"The Role of Liquid Scintillators in
Nuclear Medicine,"
Hayes, F. N., Anderson, E. C. and Langham, W. H.

"Delayed Neutrons,"
Keepin, Jr., G. R. and Wimett, T. F.

"Liquid Scintillation Counting of
Natural Radiocarbon,"
Hayes, F. N., Anderson, E. C. and Arnold, J. R.

"Design and Description of Water
Boiler Reactors,"
King, L. D. P.

"Determination of Fission Quantities of
Importance to Reactors,"
Leachman, R. B.

"A Review of Americium and Curium Chemistry,"
Penneman, R. A. and Asprey, L. B.

"Techniques for Measurement of Neutron Cross
Sections and Energy Spectra for Sources Which
are Continuous in Energy and Time,"
Rosen, L.

"Techniques for Measuring Elastic, Non-Elastic
and Transport Neutron Cross Sections,"
Taschek, R. F.

"Angular Distributions and Non-Elastic
Neutron Scattering,"
Walt, M.

Los Alamos Scientific Laboratory is a non-civil service operation of the University of California for the U. S. Atomic Energy Commission.

The diversification of the Los Alamos papers accepted at the Geneva Conference dramatically illustrates a few of the challenging research problems being explored at the Laboratory, which welcomes applications for employment from qualified scientists and engineers.

For more information, write:
Director of Scientific Personnel
Division 1510

los alamos
scientific laboratory

OF THE UNIVERSITY OF CALIFORNIA

LOS ALAMOS, NEW MEXICO

This coupon mailed TODAY



... may bring you
a brighter **TOMORROW!**

There just isn't any question about it—the trained engineer of today has more opportunity than ever before.

However, and this is vitally important, the possibility for individual progress is far greater in certain organizations than in others. That's why every engineer concerned with his future should look into the job opportunities offered in the guided missile field.

Here at Bendix Products Division—Missiles, you can get in on the ground floor of a new, but proven, dynamic business with long-term potentials in the



development, engineering and manufacturing of the nation's most important weapons system. It is truly the business of the future with many commercial as well as military applications.

Then, too, at Bendix Products Division—Missiles, you have all the advancement possibilities of a compact, hard-hitting organization backed by the resources of the entire nation-wide Bendix Aviation Corporation.

So that you may analyze for yourself the various job opportunities and the possibilities of rapid advancement, we have prepared a thirty-six-page book which gives detailed background of the functions of the various engineering groups.

Any ambitious engineer looks forward to a brighter tomorrow. May we suggest that the first step toward this goal is the mailing of the coupon for your copy of "Your Future in Guided Missiles".

**Prime Contractor for
TALOS MISSILE**



News-New Products

These manufacturers have invited PROCEEDINGS readers to write for literature and further technical information. Please mention your IRE affiliation.

(Continued from page 168A)

volts, 3 phase, 60 cps. Meters for measuring beam voltage, beam current, collector current and body current are provided. The unit is completely protected by door, air, overload, time-delay, and external interlocks. A large blower cools the equipment and creates a positive pressure which keeps dust from entering the cabinet.

CECO Buys Community Antenna System

Community Engineering Corp., State College, Pa., manufacturers of electronic equipment for community antenna television systems, has just completed the purchase of the State College and Bellefonte (Pa.) community antenna systems, according to an announcement by James R. Palmer, President.

CECO will utilize the two newly

(Continued on page 172A)

ELECTRONIC ENGINEER

Immediate opening for recent college graduate, preferably with some experience in design and application of electronic equipment. Objective is the application of automation and remote control to present pipe line and distribution facilities, and the design, cost estimates, and installation of new facilities.

Progressive company, located in Southwest, providing liberal stock plan, retirement plan, group hospital and life insurance plan and other attractive benefits. Send resumé of education, experience, and salary requirements to Box 1004, Institute of Radio Engineers, 1 East 79th Street, New York 21, N.Y.



SYMBOL / OF AN ENGINEER'S FUTURE . . .

RCA offers the opportunity for you to apply your engineering talents to its Missile Test Project at Patrick Air Force Base, Florida—"Launching Site of the Satellite."

Here at the world's largest missile testing laboratory, extending from Florida far across the South Atlantic, you can enjoy professional status with the recognized leader in electronics. Unprecedented growth opportunities are offered in various phases of data acquisition, transmission and processing, including Radar—Communications—Optics—Computers—Timing—Telemetry.

At RCA's Missile Test Project you will enjoy professional advancement combined with famous Florida living. You and your family will appreciate the ideal climate on Florida's Central East Coast which allows year 'round outdoor activities.

Let MTP become a symbol of *your* future!

For complete information about this new and challenging field, write to:

Mr. Wm. T. A. Baxter,
Personnel Manager, Dept. N-8M
RCA Service Company, Inc.
Missile Test Project
P. O. Box 1226
Melbourne, Florida

MISSILE TEST PROJECT • MELBOURNE, FLORIDA

Tmk. ©

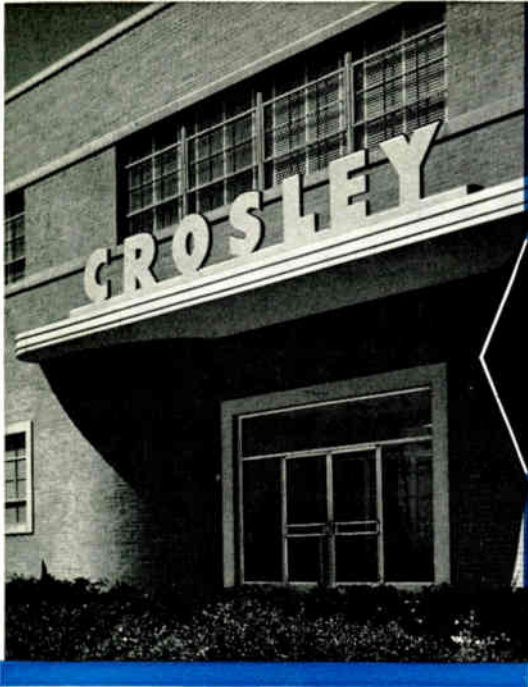

THROUGH THESE
DOORS...
Your Future

We have present openings for experienced Electronic Engineers in the design and development of ground radar systems, airborne transmitters and receivers and in the electrical systems of guided missile fuzes.

We also have a need for Mechanical, Aeronautical and Structural Engineers of the same experience levels in the design of servomechanisms, the design of large, light-weight structures of the airframe variety and the design and layout of electronic and electromechanical chassis and packages.

In the computer field, we have a need for Physicists and Mathematicians for the programming and solution of engineering problems utilizing analog computers and IBM equipment. Experience in the development of new applications and techniques for digital and analog computers combinations is also desirable. Attractive openings also available for Packaging Engineers, Technical Writers and Illustrators.

CROSLEY'S continued and extraordinary success in the sphere of government electronics, has placed the name of CROSLEY as one of the forerunners in this ever-expanding field. Our present and anticipated demands call for additional engineering personnel at all levels. CROSLEY offers you a partnership in its continued expansion program—"A Partnership in Opportunity."

CROSLEY has numerous company benefits including a group insurance and retirement plan, subsidized educational program, periodic merit reviews and up to three weeks paid vacation after five years. We would also pay relocation expenses including moving expenses, reporting to work pay, family transportation and a generous subsistence allowance.

Please send your
resume to
Director of
Engineering

Dept. T-15



2630 Glendale-Milford Road
Ewendale, Cincinnati 15, Ohio



News-New Products

These manufacturers have invited PROCEEDINGS readers to write for literature and further technical information. Please mention your IRE affiliation.

(Continued from page 170A)

acquired systems for the field testing of new electronic equipment currently being developed by the Corporation.

The Bellefonte system will be renovated to provide five channel service instead of the present three channel. Rebuilding will be accomplished by the use of CECO plug-in type distributed amplifiers designed by CECO specifically for rebuilding individual channel strip amplifier systems while retaining maximum use of existing equipment.

Tantalum Capacitor

The Size "M" Tan-O-Mite Tantalum capacitor produced by Ohmite Mfg. Co., 3649 Howard St., Skokie, Ill., is the latest addition to the Series TW. Tantalum capacitor is 0.095 inch in diameter by 11/64 inch long, and has a capacitance range of 0.02 to $\mu\mu\text{f}$.

The capacitors are designed for transistorized electronic equipment where small space and high reliability are of great importance.



Coupling, filter, and by-pass requirements at low voltage in hearing aids, miniature portable radios, and military equipment are met by these units. TAE capacitors have a usable temperature range from -55°C to $+85^{\circ}\text{C}$.

Capacitor construction consists of a tantalum wire anode, having a specially processed oxide film, contained in a tiny cylindrical silver case, which is the cathode (negative). The case is electrically "live" and has the negative wire lead fastened to the end. The case is filled with an electrolyte and sealed by a "Teflon" bushing. Request Bulletin 148 supplement.

(Continued on page 174A)

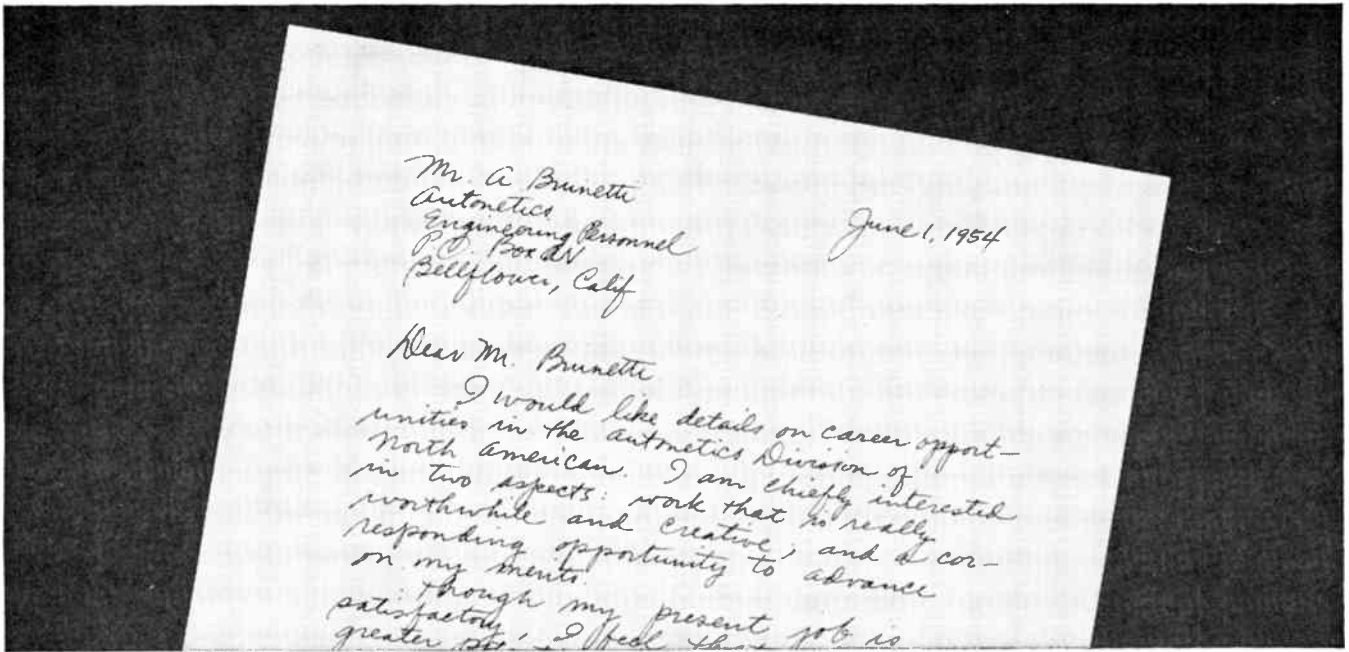

This letter moved a man ahead 5 years

Two years ago a man took 10 minutes to write this letter. Today he enjoys the responsibility and professional standing in the AUTONETICS Division of North American that might have taken 7 to 10 years to achieve in other fields.

THE FIELD AT AUTONETICS—A FIELD OF OPPORTUNITY

Now under way at AUTONETICS are nearly 100 projects, comprising some of the most advanced and progressive work being done today in the fields of Electronics, Electro-Mechanics, Control Engineering and Data Processing.

You will work on automatic control systems of many kinds, for manned and unmanned vehicles. Every state of the art is represented, from preliminary conception right through flight testing. Facilities are the finest obtainable. Your colleagues will be men of ability and imagination, of the highest professional standing.

The long-range potential in this field is truly limitless. The techniques being developed at AUTONETICS today will have the widest application in the industrial methods of tomorrow.

You owe it to yourself to consider how far you can advance by entering this exceptionally promising field right now. Here are the opportunities:

COMPUTER SPECIALISTS • COMPUTER APPLICATION ENGINEERS • ELECTRO-MECHANICAL DESIGNERS • ENVIRONMENTAL TEST ENGINEERS • ELECTRONIC COMPONENT EVALUATORS • INSTRUMENTATION ENGINEERS • FIRE CONTROL SYSTEMS ENGINEERS • FLIGHT CONTROL SYSTEMS ENGINEERS • ELECTRONIC RESEARCH SPECIALISTS • AUTOMATIC CONTROLS ENGINEERS • ELECTRONIC ENGINEERING WRITERS • INERTIAL INSTRUMENT DEVELOPMENT ENGINEERS • PRELIMINARY ANALYSIS AND DESIGN ENGINEERS • RELIABILITY SPECIALIST

Write your letter today. Decide now to get the facts, so you can make the most of your potential. Just put your address and brief qualifications on paper—handwritten will be fine. Reply will be prompt, factual, confidential.

Write: Mr. A. Brunetti, Autonetics Engineering Personnel,
Dept. 991-12 IRE, P. O. Box AN, Bellflower, California

Autonetics

A DIVISION OF NORTH AMERICAN AVIATION, INC.



A U T O M A T I C C O N T R O L S M A N H A S N E V E R B U I L T B E F O R E

SENIOR Engineering specialists *for* staff and project positions

CONTINUED expansion of the Aeronautical Division of Minneapolis-Honeywell has created a number of new staff openings for engineering specialists in the Division's Research and Development Planning activities. Men with advanced training and experience in the following areas are needed in Minneapolis for both staff and project positions:

AERODYNAMICS AND FLIGHT CONTROL SYSTEMS
INERTIAL NAVIGATION SYSTEMS
BOMBING AND FIRE CONTROL
DIGITAL COMPUTERS
INSTRUMENTATION AND DISPLAY SYSTEMS
MILITARY OPERATIONS ANALYSIS

RESEARCH

Research activities in these and related fields include basic system analysis, generation of new system concepts and configurations, application and feasibility studies and experimental confirmation. Extensive supporting facilities include an analog and digital computing center, plus first-rate laboratories, shops and test organizations. Either a direct project responsibility for specific studies in one's own field, or the broader range of duties of a staff specialist can be provided, depending on the interests, abilities, and experience of the individual.

PLANNING

Aero Division Development Planning provides long-range technical guidance for the Division R & D activities and product lines. Increased emphasis on this function has resulted in permanent openings for a number of staff engineers who have specialized in one or more of the above listed areas. The work involves feasibility studies, evaluation of developments, and analysis of trends in military operations and customer technical requirements. It will give real opportunity for original contributions in system analysis and in advanced design concepts.

Candidates should have broad experience and interest, well-developed critical faculties and ability to work closely with all levels of the line management organization. Each will be expected to initiate and carry through sound technical studies in his special field with a minimum of guidance or supervision, and to participate with other members of the Planning Office in joint investigations.

ACT NOW! For these and . . . other challenging jobs, send résumé to: Bruce D. Wood, Technical Director, Dept. T-3ES, Aeronautical Division, Minneapolis-Honeywell Regulator Company, 1433 Stinson Boulevard, N.E., Minneapolis 13, Minnesota.

MINNEAPOLIS
Honeywell

Aeronautical Division



News-New Products

These manufacturers have invited PROCEEDINGS readers to write for literature and further technical information. Please mention your IRE affiliation.

(Continued from page 172A)

Hunter Appointed by Eitel-McCullough

Captain Gould Hunter, U.S.N., retired, has been named assistant to the vice president, manufacturing, Eitel-McCullough, Inc., San Bruno, California, manufacturer of power vacuum tubes.



Hunter retired from the Navy on September 1, 1956, after 20 years service. A graduate of Annapolis, Class of '36, he also completed two years of post graduate work at Annapolis in electronics from 1942 to 1944. In his last assignment with the Navy, Hunter was Commanding officer of the Navy Electronics Laboratory at San Diego, Calif.

(Continued on page 178A)

STRAIGHT TALK

About an
ENGINEERING CAREER

at

OTIS ELECTRONIC DIVISION

The full resources of the century-old Otis Elevator Company are available for expansion of its new Electronic Division.

Under prime contract, this division is conducting basic development work in the most advanced areas of bombing navigation systems, radar systems and missile launching test equipment. Current openings are for engineers with knowledge of servomechanisms, analog computers, digital techniques, sweep circuits, or pulse techniques.

Otis' Electronic Division expects to explore commercial applications in the future . . . assuring job stability as well as a full measure of liberal benefits for which Otis is well known.

Send resumes to William B. DeFrancis for confidential interview.



ELECTRONIC DIVISION

OTIS ELEVATOR Co.

35 Ryerson St.,
Brooklyn 5, N.Y.



*... or however you express it—
that's your business... But — if
you're an Electronic Engineer
looking for a good position*

THAT'S OUR BUSINESS!

DOPPLER AND INERTIAL
RADAR SYSTEMS
AIRCRAFT INSTRUMENTATION
AIRBORNE RADAR AND
COMMUNICATIONS
DATA PROCESSING
EQUIPMENT
DIGITAL COMPUTERS
TRANSFORMER DESIGN

We offer opportunities for advancement within a rapidly expanding medium-size company. You'll benefit from the close personal association of a small laboratory with the versatility of a larger organization.

YOU MAY OBTAIN:

▶ *top starting salaries* ▶ *progressive wage reviews*
▶ *better starting positions* ▶ *continuous profes-
sional development* ▶ *unique educational advan-
tages* ▶ *full tuition for day or evening study*
at Boston's leading Universities

Send your resume or request for
additional information to:
DR. M. A. MEYER . . Chief Engineer



Remember —
your future
is NOW — at

LABORATORY FOR ELECTRONICS, INC.



BOSTON 14, MASSACHUSETTS

IRE remembers the man

New electronic markets grow
where this young man explores!



JACK E. BRIDGES, recipient of the IRE Browder J. Thompson Memorial Prize Award, 1956... for a manuscript by an author under 30 years of age which is the best combination of technical contribution and presentation of the subject.

IRE pays tribute to young *Jack E. Bridges* for his paper "Detection of Television Signals in Thermal Noise," which appeared in a recent issue of *Proceedings of the IRE*. His clear, concise theoretical investigation of what goes on in a TV set develops new approaches to picking up weaker signals and getting clearer pictures with less noise. His explorations can expand the TV market by reducing interference from adjacent channels and by improving fringe area reception. Mr. Bridges is still less than 30 years of age but he has proven his is the curiosity of a true radio-electronic engineer. This is the curiosity that builds markets... these are the men IRE always remembers.

The Institute of Radio Engineers is a professional Society of 50,000 radio-electronic engineers devoted to the advancement of their field of specialization. Their official publication, *Proceedings of the IRE*, is concerned solely with these men and their accomplishments. And *Proceedings of the IRE* is the only engineering journal in the radio-electronic industry exclusively edited by and for radio-electronic engineers.

Earth satellites, FM, TV, radar, computers, color TV, transistors, scatter propagation, solid state electronics... all that is history making in radio-electronics is first presented, then followed step-by-step in its development, on the pages of *Proceedings of the IRE* in authoritative articles by the men behind these advances.

IRE remembers the man! Is it any wonder that the men remember IRE? Best way to get *products remembered*, if they are sold in the radio-electronics field, is through advertising in the pages of *Proceedings of the IRE* for...if you want to sell the radio industry, you've got to tell the radio engineer!



THE INSTITUTE OF RADIO ENGINEERS
Proceedings of the IRE

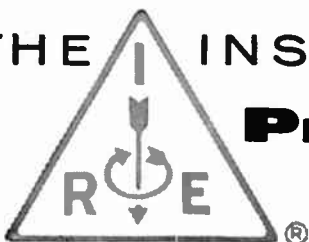

Adv. Dept., 1475 Broadway, New York 36, New York
Chicago • Cleveland • San Francisco • Los Angeles



IMPORTANT DEVELOPMENTS AT JPL

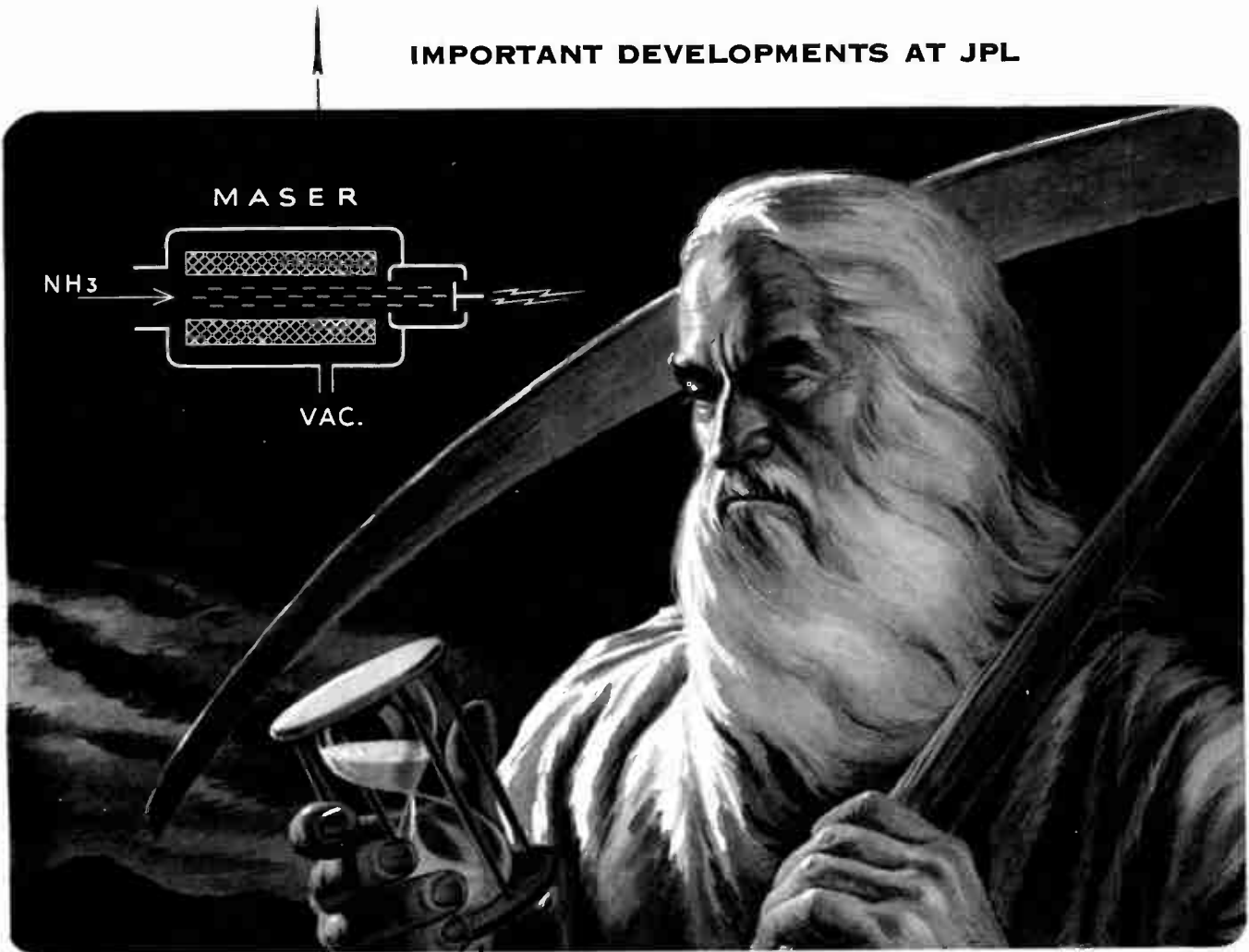

Pioneers in Electronic Research

The Jet Propulsion Laboratory is a stable research and development center located north of Pasadena in the foothills of the San Gabriel mountains. Covering an 80 acre area and employing 1600 people, it is close to attractive residential areas.

The Laboratory is staffed by the California Institute of Technology and develops its many projects in basic research under contract with the U.S. Government.

Opportunities open to qualified engineers of U.S. citizenship. Inquiries now invited.

Electronic research at the Jet Propulsion Laboratory covers many areas of interest to engineers working on problems of missile guidance and control. One of these is frequency and time standards—a prime requisite in Missile System Engineering.

The familiar crystal oscillator and similar timing sources have been exploited to the limits of their applicability. Looking to the future, our Electronics Research group is keeping abreast of developments in atomic and molecular resonance devices.

One such device under advanced development at the Laboratory is known as MASER (Micro Wave Amplification by Stimulated Emission of Radiation) invented by Prof. C. H. Townes of Columbia University. In MASER a beam of ammonia molecules is

separated into energetic and non-energetic parts by an electrostatic field. The energetic molecules then enter a microwave cavity and sustain an oscillation by giving up their energy to the microwave field. The frequency of oscillation is determined principally by those properties of the molecules which are independent of environment.

MASER is one of the most stable sources of oscillations and is therefore a prime source reference for frequency and timing information. This device will have many applications in future missile design and is one of many challenging research projects in electronics in which the Laboratory is engaged.

If you are interested in an exceptional research opportunity and are qualified to do truly creative work in this field, write us today.

JOB OPPORTUNITIES
IN THESE FIELDS NOW

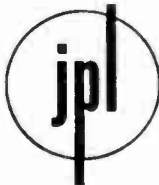

INSTRUMENTATION • APPLIED PHYSICS • DATA HANDLING • COMPUTERS
TELEMETERING • RADIO AND INERTIAL GUIDANCE • GUIDANCE ANALYSIS
SYSTEMS ANALYSIS • MICROWAVES • ELECTRO-MECHANICAL • PACKAGING
MECHANICAL ENGINEERING

JET PROPULSION LABORATORY

A DIVISION OF CALIFORNIA INSTITUTE OF TECHNOLOGY
PASADENA • CALIFORNIA



SYLVANIA'S CALIFORNIA RESEARCH LABORATORY

(San Francisco Bay Area—Near Palo Alto)

Needs experienced creative engineers for a long range research and development program in microwave electronic systems and components. Also needs experts in design and custom packaging of specialized electronic communications equipment.

We have specific openings for ENGINEERING SPECIALISTS, SENIOR ENGINEERS and ENGINEERS in:

SYSTEMS ANALYSIS For weapons systems planning, operational analysis and data handling problems.

MICROWAVE ANTENNAS For investigation of new concepts in polarization and pattern control, direction finding and multi-function radiators.

MICROWAVE CIRCUITS For advancements in synthesis of filters, broadband mixers, power dividers, etc., involving modern techniques of stripline, ridge guide and periodic structures.

TRANSMITTER DEVELOPMENT For research and development involving microwaves and pulse techniques.

FIELD ENGINEERING For advanced engineering field tests of prototype equipment.

MECHANICAL DEVELOPMENT Mechanical design of equipments and components for electronic systems

Sylvania offers the finest facilities and equipment available. We also provide financial support for advanced education, as well as a liberal insurance, pension and medical program.

Our Laboratory is located 5 miles from Palo Alto in the San Francisco Bay area, close to excellent schools and universities, unexcelled living conditions, ideal climate and ample housing.

RELOCATION EXPENSES PAID

Please send complete resume to
JOHN C. RICHARDS
Electronic Defense Laboratory
Box 205
Mountain View, California

ELECTRONIC DEFENSE LABORATORY

SYLVANIA
SYLVANIA ELECTRIC PRODUCTS INC.



News-New Products

These manufacturers have invited PROCEEDINGS readers to write for literature and further technical information. Please mention your IRE affiliation.

(Continued from page 174A)

Power Supply

The new Model 2500 voltage regulated power supply features a 0-2500 volt, 0-50 ma continuous duty dc output. Excellent regulation, low ripple, fast recovery time, good stability, and low output impedance distinguish this unit.



In the range 0-2500 volts, the output voltage variation is less than 0.1 volts for load variations from 0 to maximum current and

(Continued on page 180A)

Electronic Engineers
Mechanical Engineers
Advancement... Security
...Responsibility

Professional personnel needed at all levels to fill responsible openings at this steadily expanding Division of Bendix Aviation Corporation. It's your chance to get specific assignments at the peak of the art in ELECTRONICS and MICRO-WAVE DEVELOPMENT and DESIGN. Good salaries, all employee benefits, ideal suburban living conditions. Whether you be a Department Chief or a Junior Engineer with less than one year's experience, we have the opening and the shoes for you to fill.

Address: Chief Engineer Dept. P

Bendix
AVIATION CORPORATION
York
DIVISION

York, Penna. York 47-2611

STAFF COMPUTER ENGINEERS

Today all engineering recruiting advertisements talk of opportunity, yet most are, in spite of the most sincere intentions of the company seeking applicants, necessarily restricted to the offer of a chance to pursue substantially the same duties on another payroll. Moving to a new position may offer certain superficial advantages but the basic opportunity for long range growth may be restricted by the same factors which have limited advancement on the applicant's former job. We believe that we can offer an opportunity for analog computer operations engineers to utilize fully their previous experience in an area which offers broader responsibilities with commensurate increase in salary.

The adaptation of established analog computational techniques to the design of a permanent custom-built system for the simulation of a particular aircraft is the fundamental responsibility of our Engineering Division.

Staff Analog Computer Engineers (particularly those with aeronautical experience) are singularly qualified to accept major responsibilities in this area. The computer expert who fills this position will direct his efforts along the lines of product development and design on multi-million dollar projects; such an effort offers opportunities for advancement to upper management levels which are, we believe, denied most engineers working in a computer staff group. It should be recognized that by participating in this effort, an engineer is actively engaged in the direct support of our principal source of revenue rather than acting in an indirect supporting capacity with attendant lessening of overall responsibility. Lack of electronic design experience or the absence of a profound understanding of specialized electronic theory at a professional level should not be an appreciable handicap to the man who fills this position, as his efforts will be well-supported by an established team of electronic experts in our Research and Development organization.

It is essential that the applicant be capable of programming large-scale d-c analog systems for 3-dimensional real-time computation of flight dynamics. The applicant should also have full awareness of the shortcomings of analog computer elements and the effects of these faults on overall computer stability and accuracy. The successful applicant will probably find that his new responsibilities entail, in comparison to his previous job, greater emphasis upon accurate generation of functions of two or

more variables, maintenance of accuracy under unfavorable scaling conditions, and mathematical manipulation of standard equations to achieve improvements in accuracy or simplification of circuitry not feasible using a direct approach. Since the final result of his efforts will be embodied permanently in specialized computers manufactured in quantity, emphasis must be placed on optimization of equipment usage to an extent not commonly considered necessary in the temporary computer set-ups which characterize the operations of a computer laboratory staff group.

The responsibility for development of complex computer systems for production represents an additional challenge which increases the professional stature of the position and affords increased opportunity for growth.

Link Aviation, Inc. is located in Binghamton, New York, in an area of growing electronic and precision manufacturing activity. Several nationally known industries engaged in the manufacture of electronic equipment have moved to this area because of ideal living conditions, high standards of municipal and state government, excellent schools and absence of racial and delinquency problems. The Binghamton area traditionally has been favored by enlightened employee-management relationship techniques, a policy which has resulted in the absence of labor strife for over a decade.

The area is unusually well-situated for pleasant leisure activities. The near proximity of many lakes is attractive to boating enthusiasts and fishermen. The New York State Park System offers many well-developed recreational areas of unusual beauty. Skiing and hunting areas are within easy driving distance.

Link Aviation offers many attractive fringe benefits including a supplemental vacation plan for certain employees after a fixed length of service, an attractive profit sharing retirement plan and liberal insurance coverage. In addition, we are prepared to offer to key employees an unusually attractive plan for reimbursement of moving expenses which takes in account certain expenses not generally recognized by industry today. As a subsidiary of the General Precision Equipment Corporation, we can offer the many advantages of working with a medium-sized company (2400 employees) together with the prestige, financial stability and technological interchange advantages of a large corporation.

For further information please write or telephone long distance collect to:

John Hunt
Manager, Engineering Division
Link Aviation, Inc.
Binghamton, New York
Telephone 3-6311



Pioneer and World's Leading Producer of Flight Simulators

AVIATION, INC.

A SUBSIDIARY OF GENERAL PRECISION EQUIPMENT CORPORATION

BINGHAMTON, NEW YORK



ENGINEERS & PHYSICISTS

Electronics

APL-An Organization Of And For Technical Men And Scientists

The Applied Physics Laboratory (APL) of the Johns Hopkins University is an organization of and for technical men and scientists. Several factors allow for more effective utilization of "mind power" at APL. They lead to tangible and intangible satisfactions for staff members that could not be gained elsewhere.

Among them are:

1. Individual staff members are given a measure of responsibility and initiative much greater than in many comparable establishments. Decision-making, on all levels, is placed in the hands of scientists and technical men.
2. Staff members do not restrict their efforts to limited technical problems. Instead they are asked to assess and solve problems of a systems nature, including analyses of complete tactical problems.
3. APL handles technical direction of the work of many associate and subcontractors, including 21 universities and leading industrial organizations. As a result, APL staff members enjoy a rewarding exchange of ideas and techniques with other leaders in R & D.
4. The combined facilities of APL, its associate and subcontractors, and Government test stations provide opportunities for members of its technical staff to develop and exploit their varied capabilities in a unique environment where teamwork and individual initiative are fused.
5. This *esprit* and freedom to look into new concepts has resulted in a number of "quantum jumps" in defense capability, including the proximity fuze, the first supersonic ramjet engine, and the Navy's Bumblebee family of missiles which includes TERRIER, TALOS and TARTAR. APL is presently attempting break-throughs on several important fronts.

APL'S expansion program recently witnessed the completion of new laboratories covering 350,000 sq. ft. in Howard County, Maryland, equidistant from Washington, D.C. and Baltimore. Men of originality are invited to inquire about staff opportunities. Salaries compare favorably with those of other R & D organizations.

OPENINGS EXIST IN:

ANALYSIS: Dynamic analysis of closed-loop control systems; analysis and synthesis of guidance systems; counter-countermeasures systems; electrical noise and interference.

DESIGN: Control and guidance circuitry; telemetering and data-processing equipment; microwave components, antennas, and radomes; transistor and magamp applications; external missile systems.

TEST: Prototype engineering and field test evaluation.

Write: Professional Staff Appointments

The Johns Hopkins University Applied Physics Laboratory

8603 Georgia Avenue, Silver Spring, Md.



News-New Products

These manufacturers have invited PROCEEDINGS readers to write for literature and further technical information. Please mention your IRE affiliation.

(Continued from page 178A)

less than 0.2 volts for line fluctuation from 105-125 volts. The ripple is less than 3 millivolts RMS. Recovery time is less than 50 microseconds. Stability for a period of 8 hours is within 0.2 volts. Output impedance is less than 0.1 ohms from 20 cps to 100 kc and less than 0.5 ohms from dc to 20 cps. Physical size-height 12 $\frac{1}{4}$ width 19, depth 17 inches, weight 65 pounds. This supply is available with or without meters.

UTC Opens Pacific Div.

I. A. Mitchell, President of United Transformer Co., 150 Varick St., New York, N. Y., returned recently from the West Coast where he inspected the Pacific Division of U.T.C.

U.T.C. manufactures a complete line of transformers including everything from hermetic audio

(Continued on page 184A)

LIAISON ENGINEER for MICROWAVE SYSTEMS

Opportunity with Light Military Electronic Equipment Department of General Electric.

Capable of directing and coordinating the design and development of microwave projects on military airborne electronic systems.

Salary to \$11,000
commensurate with experience

Reply in confidence to:

Mr. John Sternberg, Dept. 804
Light Military Electronic
Equipment Dept.

GENERAL ELECTRIC

French Road
Utica, N.Y.

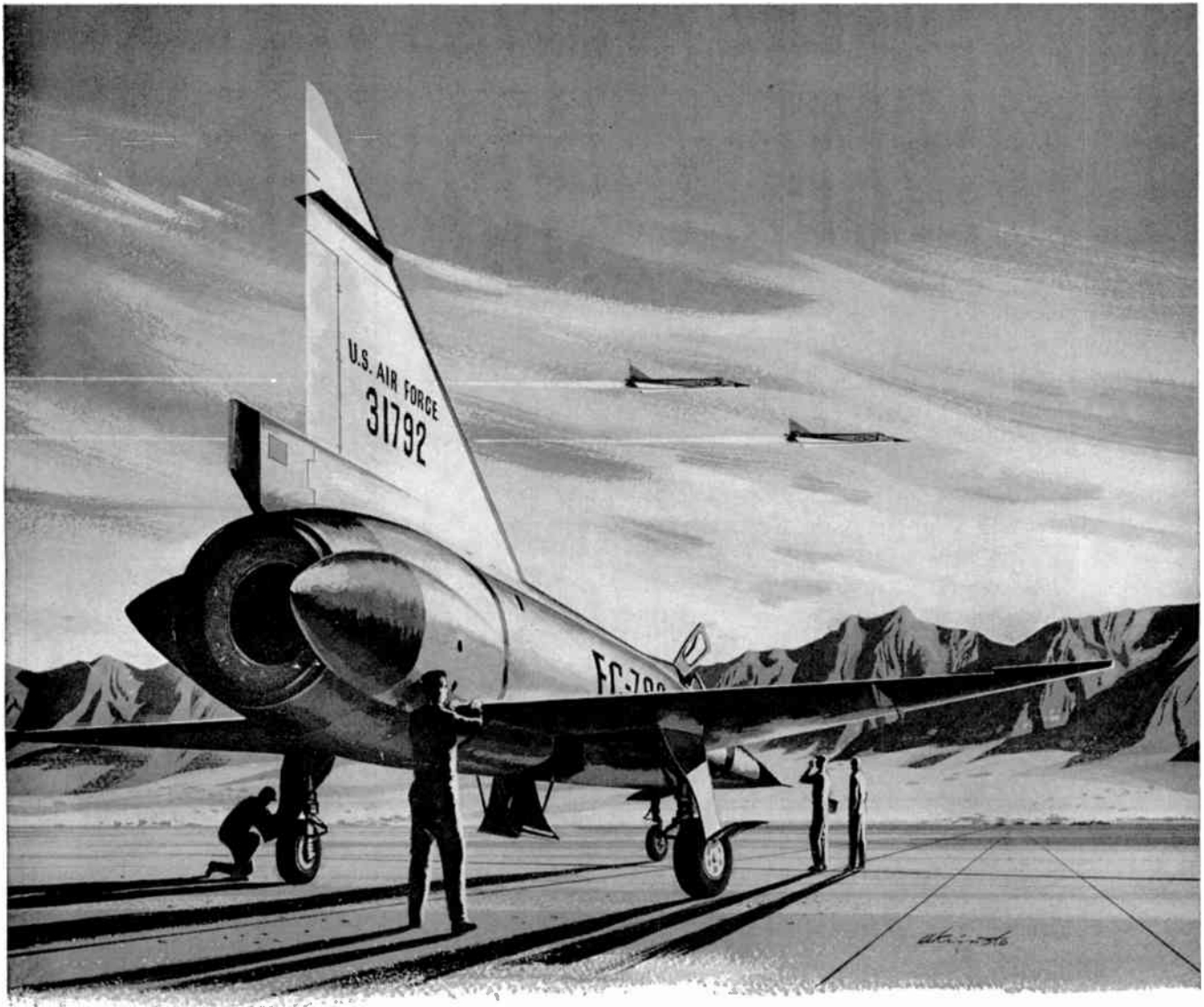

IDEAL ENGINEERING "CLIMATE"

The many advanced aircraft and missile programs at Convair San Diego today include: *The F-102A Supersonic Interceptor, The Atlas Intercontinental Ballistic Missile, The Metropolitan 440 Airliner, the new Convair 880 Jet-Liner, and a far-reaching study of Nuclear Aircraft.*

Within these vital, highly-diversified Convair projects in beautiful San Diego, California, engineers find the perfect "climate" for a challenging and rewarding engineering career. You will find Convair salaries, computer and test facilities, engineering policies, educational opportunities

and personal working advantages the most desirable in the industry.

What's more, you and your family will almost certainly enjoy a new, exciting, happier way of life here . . . where the weather year 'round is unsurpassed.

For a significant engineering career in the engineering "climate" *you* seek, we invite you to forward a full resume today. Write H. T. Brooks, Engineering Personnel, Dept. 824.

Generous travel and moving allowances to engineers.

CONVAIR
 CV GD
 A DIVISION OF GENERAL DYNAMICS CORPORATION

3302 PACIFIC HIGHWAY

SAN DIEGO, CALIFORNIA

ENGINEERS



Fulfill professional and personal objectives . . . with an outstanding firm in its field.

Challenging openings for experienced engineers with degrees or equivalent experience in:

- ELECTRICAL
- ELECTRONIC
- MECHANICAL

Research, Development, Design & Field Engineering on:

- | | | |
|---|---|--|
| <ul style="list-style-type: none"> ● Countermeasures ● Fire Control Radar Systems ● Underwater Sound Systems ● Magnetic Amplifiers ● Communications Equipment ● Coil & Transformer Design | <ul style="list-style-type: none"> ● Navigation Systems ● Beacons ● Flight Simulators ● Radar & Sonar Trainers ● Analog Computers ● Packaged Power Supplies | <ul style="list-style-type: none"> ● Instrumentation ● Microwave Test Equipment ● Guidance Systems ● Antennas ● Telemetry |
|---|---|--|

- DEVELOPMENT ENGINEERS
Junior & Senior
- DESIGN ENGINEERS
(Local & Field Assignments)
- TECHNICAL WRITER
- DRAFTSMEN

WHAT STAVID OFFERS YOU



LOCATION: On U.S. Highway 22, thirty miles (45 minutes) from New York City, near the beautiful Watchung Mountains, and within one hour's drive to the seashore. Enjoy all the advantages of the city, the mountains, and the seashore, as well as excellent schools, homes, churches and shopping facilities all conveniently located.

ENVIRONMENT: One of the finest plants of its kind . . . spacious, modern, air-conditioned. Conducive to bringing out the best of your abilities!

ABOUT THE COMPANY: Organized in 1945. Engaged in research, design and development for the Armed Services. The company has steadily progressed and grown since its inception, and now employs over 600. Positions are permanent, with opportunities for your development matching our own constant expansion.

ITS BENEFITS:

- Pension Plan
- Paid Vacations
- Group Life Insurance
- Education & Tuition Assistance
- Paid Holidays
- Other Group Insurances
- Paid Sick Leave
- Recreational programs: golf, softball, bowling, picnics, dances.

Interviews in Your Community by Appointment

Send complete resume, write or call:
Personnel Director



STAVID ENGINEERING, INC.

45 Minutes from New York City

U.S. Highway 22, Watchung, P.O. Plainfield, N.J. Plainfield 7-1600

ELECTRONIC ENGINEERS!

HERE'S THE OPPORTUNITY OF YOUR LIFETIME!



For Just Three Cents!



That's right! The stamp on your letter asking for more information about MEMCO opens the door of opportunity . . .

- to use your creative engineering talents.
- to work on all phases of your projects.
- to be appreciated as an engineer, not as a replaceable cog in a big machine.
- to get top pay and many benefits.
- to build a sound, worthwhile future.

So, if you are tied up in red tape . . . if the scope of your work is limited . . . if you can't use your creative engineering talents . . . then MEMCO offers you a welcome escape from stagnation and monotony.

For full details please write to:
Mr. J. E. Richardson,
Personnel Director

MARYLAND ELECTRONIC

MANUFACTURING CORPORATION
5009 Colvert Road
College Park, Maryland
(A suburb of Washington, D. C.)

ENGINEERS

Let's Talk Turkey



**At Hoover Electronics you
have the opportunity to exploit
and develop your talents.**

We are engaged in long range growth . . . insured by a substantial back-log of contracts and a staff of electronics engineers with national prestige. This combination of work and skill provides an atmosphere conducive to your maximum development. This development will carry with it optimum advancement with commensurate monetary reward.



Our present facilities comprise 28,000 square feet of floor space. To meet our expansion program a modern plant is under construction at Timonium, Maryland, one of Baltimore's most pleasant suburbs.

Hoover offers you a unique opportunity to work in a wholesome environment and give your creative talents the opportunity to progress in the following fields:

**TELEMETRY
ELECTRONIC RANGING
EQUIPMENT
RADIO NAVIGATIONAL
AIDS
COMPUTING EQUIPMENT
MISSILE GUIDANCE
SYSTEMS ANALYSIS
INSTRUMENTATION
INDUSTRIAL
ELECTRONICS
SPECIALIZED TEST
EQUIPMENT**

•
**SEND SUMMARY
TO
PERSONNEL DIRECTOR**



HOOVER ELECTRONICS CO.

3640 WOODLAND AVE. • BALTIMORE 15, MD.

Subsidiary The Hoover Company

ENGINEERS • PHYSICISTS

Big things
are happening

at the

MOTOROLA MILITARY ELECTRONIC LABORATORY IN CHICAGO

Important assignments from the armed forces have created *new* and outstanding opportunities at Motorola. This is your challenge to advance your career with a swiftly expanding company, working in a modern, well instrumented laboratory. You'll enjoy liberal employee benefits, including an attractive profit sharing plan, and association with men of the highest technical competence. Salaries are commensurate with ability.

If you possess the following techniques:

- Computers • Indicators and displays • Miniaturization • Transistorization • Pulse Techniques and Special Waveform Generation • Linear and Nonlinear Servo-Mechanisms

For application to systems in the following areas:

- Guidance • Data Handling • Data Transmission • Precision Distance Measuring • Weapon Control • Navigation • Ground Radar

CHICAGO, ILL.
MILITARY LABORATORY

write to:

Mr. L. B. Wrenn Dept. B
4501 Augusta Blvd., Chicago 51, Ill.

PHOENIX, ARIZONA
RESEARCH LABORATORY

write to:

Mr. R. Coulter, Dept. B
3102 N. 56th St., Phoenix, Ariz.

PHOENIX, ARIZONA
SEMI-CONDUCTOR DIVISION

write to:

Mr. V. Sorenson, Dept. B
5005 E. McDowell Road, Phoenix, Ariz.

RIVERSIDE, CALIF.
RESEARCH LABORATORY

write to:

Mr. C. Koziol, Dept. B
Box 2072, Riverside, Calif.

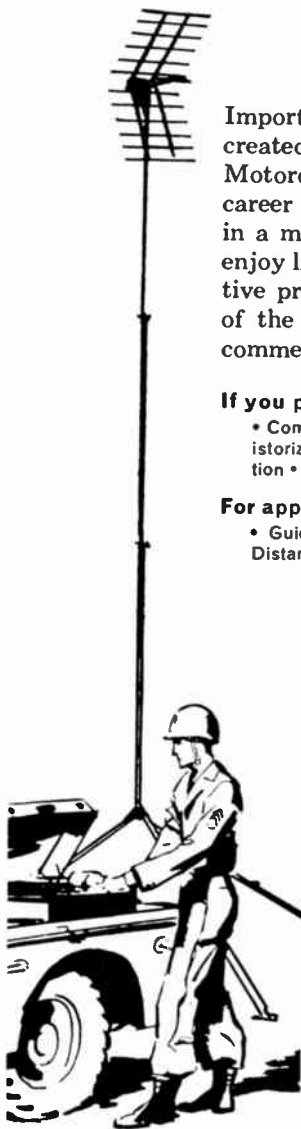

MOTOROLA



News-New Products

These manufacturers have invited PROCEEDINGS readers to write for literature and further technical information. Please mention your IRE affiliation.

(Continued from page 180A)

components to voltage adjusters and equalizers. According to Mitchell, "The U.T.C. Pacific division is now completely staffed and equipped to handle any and all special requirements from end equipment manufacturers on the West Coast. Engineering and production facilities are comparable to those of our plant in New York."

Size E Ignitron

A new Size E ignitron for resistance welding control applications has been developed by National Electronics, Inc., Geneva, Ill. The tube, designated as the NL-1054, is a mercury pool, metal constructed ignitron capable of controlling high peak currents. It is water cooled with an internal cooling coil for efficient cooling.

(Continued on page 186A)

THE HAPPIEST



CALIFORNIA* ENGINEERS ARE AT HELIPOT

besides being with a growth electronic company in a new \$2,000,000 plant . . . they overlook the blue Pacific. Top salaries and benefits . . . sell your car and buy a boat. E.E.'s, M.E.'s, Mfg., and Sales Engineers, write for Fact File 1.

* We also have a nice plant in Mountainside, N. J. overlooking the blue Atlantic. Our engineers there are very happy, too.

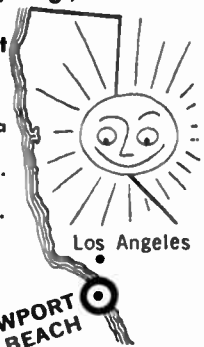

NEWPORT
BEACH

Beckman® Helipot Corp.

Newport Beach 12, Calif. / a division of Beckman Instruments, Inc.

Electronics Engineers

There's a significant trend in Chance Vought development achievements of the past 10 years. More and more of them can be catalogued as triumphs in electronics. The systems reliability of Chance Vought's Regulus I and II recoverable and tactical missiles, for one example. The pioneering work in electro-mechanical stabilization systems for another. And, most recently, the leadership established in improving weight, cost and performance factors in antenna design. Chance Vought's increasing reliance on your kind of knowledge has brought a nine-fold increase in our Electronics Section since 1950. It has prompted the establishment of five exceptionally competent laboratories for electronics research and development. It has created at Chance Vought a *professional headquarters* for electronics engineers who want to speak up and step up in their field. Examine our openings in electronics research, analysis and design. Just mail a resumé of your background to:

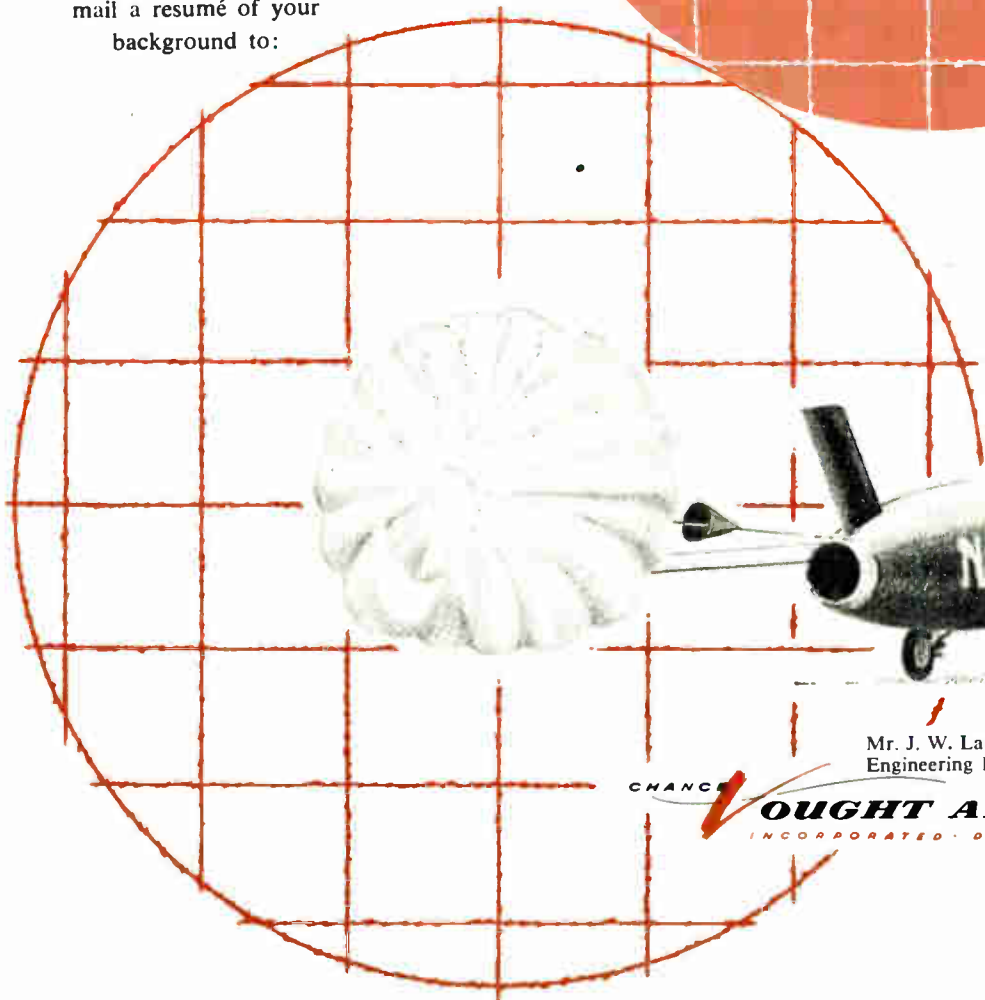
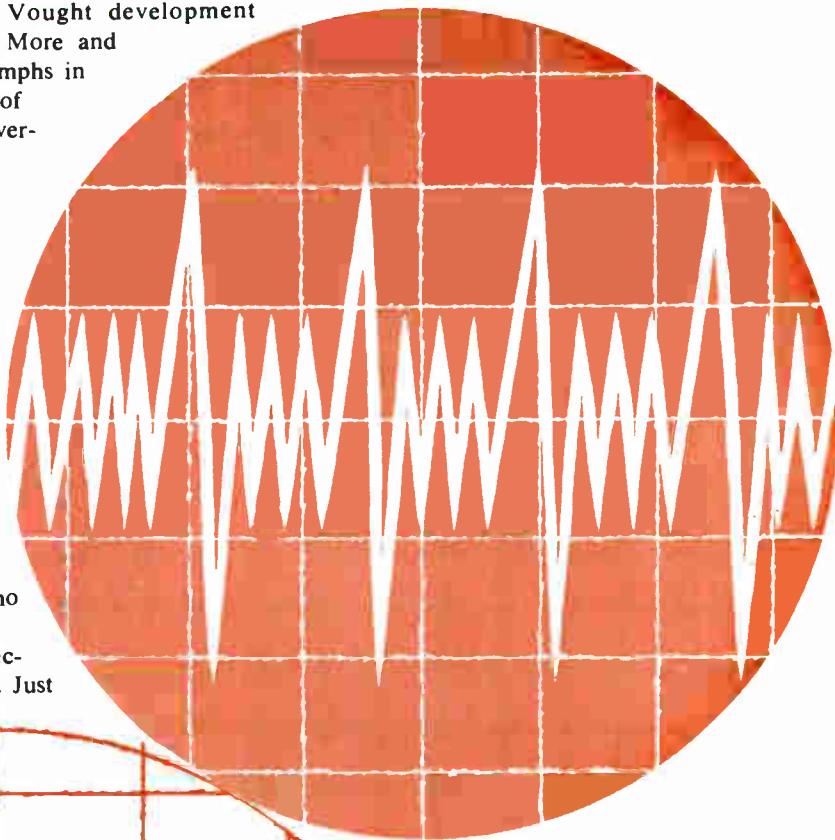

Mr. J. W. Larson, Asst. Chief Engineer
Engineering Personnel Dept. 12-2

CHANCE  **VOUGHT AIRCRAFT**
INCORPORATED - DALLAS, TEXAS

**BE HAPPY...
...GO BERKELEY!**

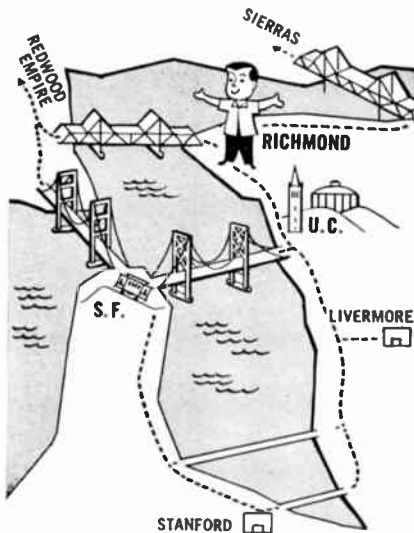

If you've looked around much for a new job, you know some companies solemnly offer you the moon on a silver platter. At Berkeley, we're fresh out of moons. But we can deliver something you won't find everywhere—a first-rate place to work and live. You can relax here and find satisfaction in your work. Nobody breathes down your neck—all the stuffed shirts were kicked out long ago. This is a fast-growing company, and you'll have plenty of responsibility and a chance to move ahead rapidly. Our engineers work in new, comfortable quarters, completely equipped for research and development. You'll be paid well, share in the profits, and receive many other benefits. Most of all, though, you'll be happy you made the change.

We shouldn't have to say much about the San Francisco Bay area. If you like living, you ought to try it here. Our plant in Richmond is just 22 minutes from the nearest cable car.

Basically, we're looking for effective electronic circuit designers. We need analog computer design engineers, computer applications engineers, field engineers with troubleshooting experience, industrial systems engineers, and electronic technicians. We also need men with experience in new techniques, such as transistors or magnetics, and in such specialties as microwave, uhf, nuclear radiation detection.

For details, write or phone:
HARRY MCELROY,
Personnel Director

Berkeley *division*
BECKMAN INSTRUMENTS INC
RICHMOND 3, CALIF. • LANDSCAPE 6-7730



These manufacturers have invited PROCEEDINGS readers to write for literature and further technical information. Please mention your IRE affiliation.

(Continued from page 184A)



NL-1054 ratings for two tubes connected in inverse parallel:
Anode volts—250 to 500 at 50 to 60 cps
Maximum demand—4800 kva with corresponding maximum averaging time—8.9 seconds at 500 volts and 17.8 seconds at 250 volts; cooling requirement at full load—6 G.P.M.

(Continued on page 190A)

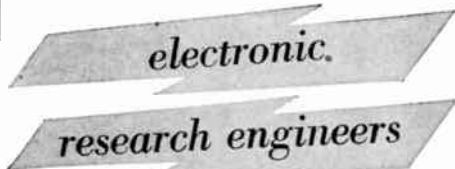

for **SYLVANIA'S**
APPLIED RESEARCH LABORATORY

If you are an electronic research engineer qualified to assume major project responsibility, there are excellent opportunities at Sylvania's new Applied Research Laboratory. We are presently forming groups to carry out theoretical and experimental research to establish system requirements for future aircraft ECM systems and airborne radars; devise and evaluate counter-countermeasures techniques; study low altitude clutter rejection problems; and investigate passive detection system requirements. If your interest is in one of these fields, you will find stimulating associates and unlimited opportunities to contribute and gain recognition at Sylvania.

For further information send resume to:
Dr. L. S. Sheingold, Manager
APPLIED RESEARCH LABORATORY



Waltham Laboratories
100-J1 First Avenue
Waltham, Massachusetts

**Promise of
professional
satisfaction
in New York
City... to
the engineer
who is
worth up to
\$15,000!**

**MICROWAVE
SYSTEMS ENGINEER...**

Experience required in planning and design of microwave radio relay systems. You should have basic knowledge of propagation, antenna and feed systems, receivers, transmitters and terminal gear. Practical experience in equipment design would be helpful.

Financial rewards accompany professional satisfaction for the right engineer who joins the growing New York City engineering operation of an electronics pioneer and leader. Stimulating projects beginning now.

To arrange confidential interview, send resume to Box 1006, Institute of Radio Engineers, 1 East 79th St., New York 21, N.Y.

New Horizons *for Research Engineers*

Engineers Apply Now for a Lifelong Career

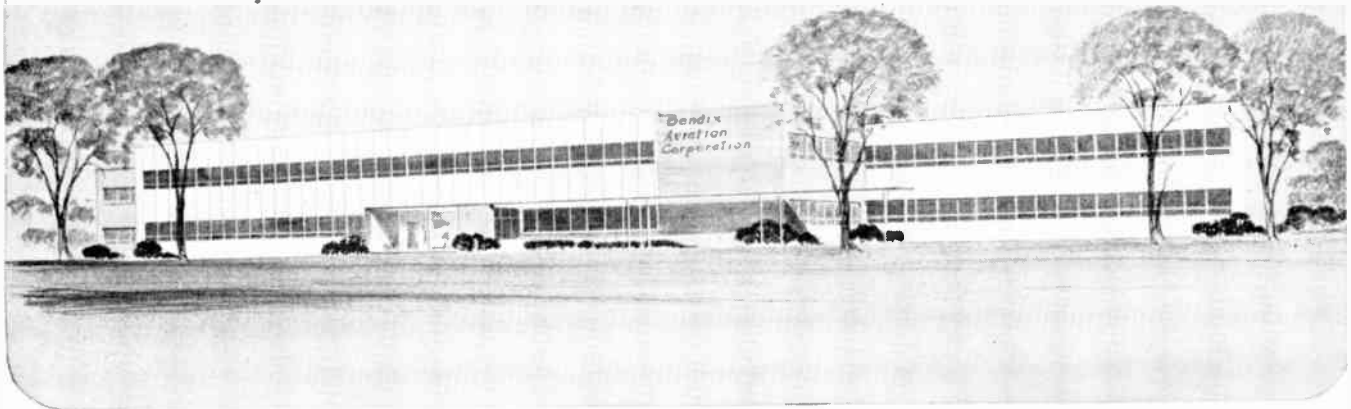

NEW BENDIX RESEARCH LABORATORY LOCATED IN SUBURBAN DETROIT OFFERS OUTSTANDING FUTURE

The imposing contemporary structure pictured above is destined to change the lives of many research engineers. *It may even change yours.* It is the new laboratory of the Bendix Aviation Corporation Research Laboratories Division, located in quiet, uncongested suburban Detroit. This modern installation is designed to provide the research man with ideal working conditions and atmosphere. Its facilities and equipment are the most modern, and it offers an unusually creative environment for advanced research and development

work in the following fields: 

For this modern laboratory, Bendix needs engineers and scientists with imagination and research ability for permanent career positions. Here is a tremendous chance to grow professionally . . . to do first-class research work . . . to take part in the exploration of new fields . . . and to become associated with one of America's great scientific organizations. If you're interested and would like to get in on the ground floor, act today!

WRITE
OR
WIRE

PERSONNEL DIRECTOR
RESEARCH LABORATORIES DIVISION
BENDIX AVIATION CORPORATION
4855 FOURTH AVENUE, DETROIT 1, MICHIGAN

ELECTRONICS
COMPUTERS
ANALOG
DIGITAL
SERVO MECHANISMS
RADAR RESEARCH
AND MICROWAVE
MECHANICAL SYSTEMS
AUTOMATION
MACHINE DESIGN
MACHINE TOOL CONTROLS
PHYSICS INSTRUMENTATION
MASS SPECTROSCOPY
SOLID STATE PHYSICS
MISSILE GUIDANCE AND
CONTROL SYSTEMS
MICROWAVE TUBE
DEVELOPMENT
NUCLEAR REACTION

RESEARCH LABORATORIES DIVISION OF



ENGINEERS: *Electronic & Mechanical* Physicists:

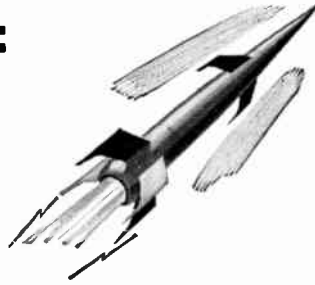

Work where PERFORMANCE pays off

Men of talent and drive can move ahead without delay or red tape at Melpar because skill, ability and performance are the *primary* factors governing advancement. Due to the fact that we've doubled in size every 18 months since our beginnings in 1945, middle and top level positions open up constantly.



Melpar believes that the engineer deserves an organization and facilities that can enhance his creative abilities. For this reason our laboratories were designed and built to specifications prepared by Melpar engineers. A wealth of equipment is available. Our project group system enables the engineer to participate in all phases of development problems and thus quickly acquire greater technical and administrative know-how, essential to eventual managerial responsibility. The system also enables us to more accurately evaluate the individual's contribution and more rapidly justify promotions.

Live Where You LIKE It

Living—for the whole family—is immensely rich in the two locales where Melpar's R & D activities are centered. Our 265,000 sq. ft. main laboratory near Washington, D. C., enables you to live in an area enjoying incomparable cultural and recreational advantages. The climate allows outdoor recreation 215 days of the year. Fine homes and apartments are available in all price ranges. Our Watertown and Boston, Mass. laboratories offer the unique advantages of cosmopolitan Boston with its theatres, concerts, art galleries, museums, universities and schools which are second to none. Nearby are seaside and mountain resorts offering a variety of winter and summer sports.

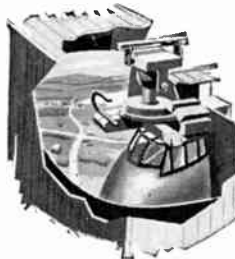

Openings Exist in These Fields:

Flight Simulators • Radar and Countermeasures • Network Theory • Systems Evaluation • Microwave Techniques • Analog & Digital Computers • Magnetic Tape Handling • UHF, VHF, or SHF Receivers • Packaging Electronic Equipment • Pulse Circuitry • Microwave Filters • Servomechanisms • Subminiaturization • Electro-Mechanical Design • Small Mechanisms • Quality Control & Test Engineering

Write for complete information. Qualified candidates will be invited to visit Melpar at Company expense.

Write: Technical Personnel Representative



MELPAR, Inc.

A Subsidiary of Westinghouse
Air Brake Company



3603 Arlington Blvd., Falls Church, Va.
10 miles from Washington D. C.

ENGINEERS

PARTS APPLICATION

(Reliability)

ME or EE degree with design experience and/or application experience. Job will be to recommend types of parts to be used and how these parts shall be used.

Qualified men will become a vital part of a Reliability Group.

GM

INERTIAL GUIDANCE SYSTEM PROGRAM

• ELECTRONICS DIV., Milwaukee 2, Wis.

Enjoy Challenging Opportunities in the most versatile Laboratories in the country. Work with the top men in the field and with the finest test, research and development facilities. We are in the process of a Major, Permanent, Expansion Program. New Plant facilities being added in suburban Milwaukee area.

To aid you in your professional advancement AC will provide financial assistance toward your Master's degree. A Graduate Program is available evenings at the University of Wisconsin, Milwaukee.

GM's Electronics Division aggressive position in the field of manufacture and GM's long-standing policy of decentralization creates individual opportunity and recognition for each Engineer hired.

Recent EE,ME Graduate Inquiries Also Invited

Milwaukee offers ideal family living in a progressive neighborly community in cool, southern Wisconsin where swimming, boating, big league baseball and every shopping and cultural advantage is yours for the taking.

To arrange personal, confidential interview in your locality send full facts about yourself today to

Mr. John F. Heffinger
Supervisor of Salaried Personnel

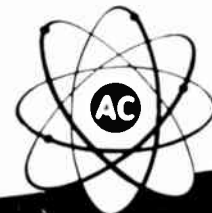

Electronics Div.
General Motors Corp.
FLINT 2, MICHIGAN
MILWAUKEE 2, WISCONSIN

nuclear *weapons* *development*

SANDIA CORPORATION OFFERS OPPORTUNITIES FOR . . . ENGINEERS, PHYSICISTS AND MATHEMATICIANS IN THESE FIELDS

RESEARCH:

Studies of the reliability of systems components, nuclear weapons effects, aerodynamic characteristics, and quality expectation.

DESIGN AND DEVELOPMENT:

Complex electromechanical systems, components, and handling equipment.

TEST ENGINEERING:

Design of test equipment and direction of exhaustive environmental and field tests to determine reliability of components and systems.

STANDARDS ENGINEERING:

Analysis of manufacturing and design procedures to determine and maintain proper standards.

MANUFACTURING RELATIONS ENGINEERING:

Establishment of contact with associated manufacturers to decide on production methods, tooling, and procedure.

QUALITY CONTROL ENGINEERING:

Determination and establishment of quality standards and enforcement of standards to assure quality of product.

Modern equipment in air conditioned laboratories, shops, and offices combines with liberal benefits, including free life insurance, sickness benefits, retirement and health protection plans, and extremely generous vacations and holidays to make Sandia an especially attractive place to work.

Albuquerque, with its exceptional climate and metropolitan blending of ancient and modern cultures, provides an informal, pressure-free environment for pleasant living. The city has an excellent school system. The University of New Mexico is also located here, providing opportunities for advanced study. Housing is readily available, and recreational facilities abound.

There are also openings for engineers and scientists in our expanding branch laboratory at Livermore, in the San Francisco area.

IF YOU'D LIKE MORE FACTS about Sandia Corporation, our background, our work, and the opportunities we offer, we'll be happy to send you our illustrated brochure which gives more details. Just write to Staff Employment Division 554A.



ENGINEERS & SCIENTISTS

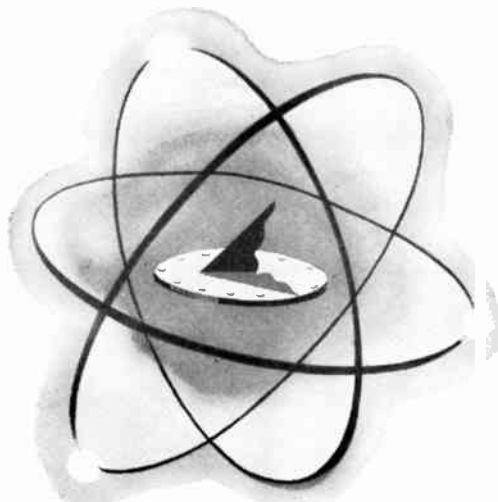

Announcing the Atomichron

A SIGNIFICANT "FIRST" FROM NATIONAL!

Now YOU can play an important part in its future development

National's Cesium-beam "atomic clock"...is the first commercial instrument to reduce the measurement of time and frequency to an atomic standard.

This opens up wide areas of usage.

The National Company welcomes men with the professional stature of its engineers and scientists who developed the ATOMICHRON... men with inexhaustible scientific curiosity, who are happiest working out the solutions to complex problems.

For over 40 years National has been a leader in electronics...making products and components for communications, industry and national defense. Here research-minded scientists and engineers find the latitude and diversification of a well-integrated smaller company...including the opportunity to see their projects through from start to finish.

If you are this type of engineer...and if you have experience in any of these fields:

.....
servo systems • divider circuits
high vacuum techniques • vibration and shock
rf circuits (110 kc to 10,000 mc)
.....

INVESTIGATE THIS OPPORTUNITY! Find out more about the ATOMICHRON and National's many other products.

Please forward your resume in confidence to:
Mr. John A. Bigelow



NATIONAL COMPANY, INC.

61 Sherman St., Malden, Mass.



News-New Products

These manufacturers have invited PROCEEDINGS readers to write for literature and further technical information. Please mention your IRE affiliation.

(Continued from page 186A)

Eimac Announces New San Carlos Facility

Construction of a new facility at San Carlos, Calif. for the manufacture of transmitting and ceramic receiving tubes will begin early next year it has been announced by W. W. Eitel, president of Eitel-McCullough, Inc.

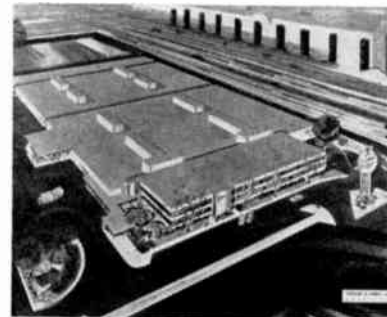

Addition of the 150,000 sq. ft. structure will complement the production and research activity at

(Continued on page 192A)

Electrical Engineers Physicists

Armour Research Foundation, one of the nations oldest and largest independent research organizations, has openings at all levels of experience for graduate scientists in TUCSON, ARIZONA OR CHICAGO. Some of the areas of particular interest are:

Communication Systems
Radar & Radio
Microwaves
Antennas & Propagation
Electronic Countermeasures
Electronic Components
Operations Research
Computer Development

At the Foundation you advance professionally through:

- Varied & Challenging scientific work.
- Association with highly competent research scientists.
- Enjoy tuition-free graduate study.
- Compensation to match your abilities & generous fringe benefits.

Send resume to:

J. A. Metzger
ARMOUR RESEARCH FOUNDATION
of Illinois Institute of Technology
10 W. 35th St.
Chicago 16, Illinois

Engineers AND DESIGNERS



now...enjoy a wonderful western way of life
...and a brilliant career...at the new

SPERRY UTAH ENGINEERING LABORATORY Salt Lake City

*Here is what you may expect when you join the new
Sperry Engineering Laboratory in Salt Lake City:*

STIMULATING CHALLENGE—Here, in Sperry's up-to-the-minute, air-conditioned plant, you'll work on the newest electronic projects, using the most modern facilities. Your opportunities for true creative engineering are as diverse as the diverse activities of the vast Sperry organization. Openings are at all levels and in almost every field of specialization, including:

*Telemetering
Electronics Circuit Design
Radars
Digital Computers
Heat Transfer
Servo Mechanisms*

*Automatic Controls
Structures
Vibrations
Air Borne Equipment Packaging
Inertial Guidance
Aerodynamics*

LIFETIME CAREERS—You will be joining a new division of the world-famous Sperry organization whose 50-year history is one of continuous achievement . . . and continuous expansion. You may look forward to a long-term future, secure in the knowledge that, as Sperry progresses, you will progress.

DELIGHTFUL LIVING—Your home will be in one of the most celebrated and cultured cities in the West. You will warm to Western hospitality. You'll live in the heart of a vast natural wonderland of scenic beauty. Here, every kind of recreation and sport may be enjoyed at its stimulating best—skiing, camping, fishing, hunting. Housing, schools, churches and stores in Salt Lake City are more than ample for every need and taste.

Submit Resume to:

SPERRY UTAH ENGINEERING LABORATORY

Sperry Gyroscope Co.

**Room 400A Deseret Building
Salt Lake City, Utah**

To the forward-looking engineer...

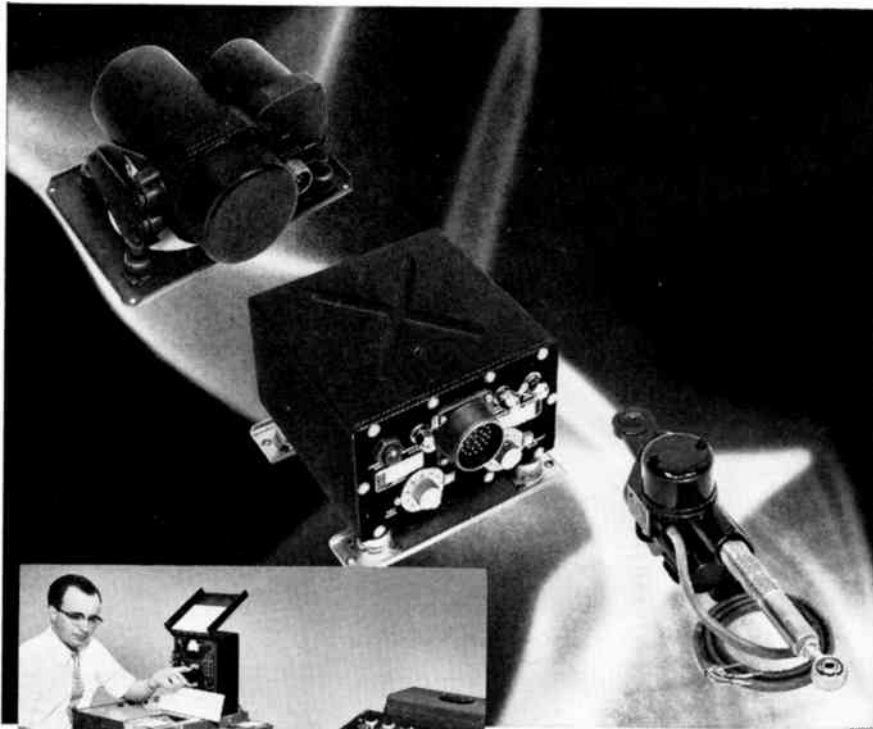

STICK-FORCE REVERSAL problems at sonic speeds are solved by this sensitive, accurate AiResearch air data system incorporating transducer, computer and actuator

▶ Garrett Corporation engineers are constantly called upon to provide solutions for seemingly insurmountable problems. The high degree of respect in which the Garrett engineer is held by his profession is a tribute to the accomplishments of our team.

If you qualify to join us, stimulating assignments in the work you like best are only part of what we offer. We pay a premium for ability. You'll work with the finest research and laboratory facilities at your disposal...live in the most desirable areas in America—California, Arizona, the East Coast.

All modern U.S. and many foreign aircraft are Garrett equipped. We have pioneered such fields as refrigeration systems, pneumatic valves and controls, temperature controls, cabin air compressors, turbine motors, gas turbine engines, cabin pressure controls, heat transfer equipment, electro-mechanical equipment, electronic computers and controls.

We are seeking engineers in all categories to help us advance our knowledge in these and other fields. Send resume of education and experience today to: Mr. G. D. Bradley

THE GARRETT CORPORATION

DIVISIONS:

9851 S. SEPULVEDA BLVD., LOS ANGELES 45, CALIFORNIA

AIRESEARCH MANUFACTURING, LOS ANGELES • AIRESEARCH MANUFACTURING, PHOENIX

AIRESEARCH INDUSTRIAL • REX • AERO ENGINEERING

AIRSUPPLY • AIR CRUISERS • AIRESEARCH AVIATION SERVICE



These manufacturers have invited PROCEEDINGS readers to write for literature and further technical information. Please mention your IRE affiliation.

(Continued from page 190A)

the main plant in San Bruno. It will be constructed on a portion of a 22 acre site purchased by Eitel-McCullough, a year ago.

Tube Catalog

International Electronics Corp., 81 Spring St., New York 12, N. Y., announces the publication of its new Mullard Preferred Tubes Replacement Guide. This is a comprehensive chart listing types and prices of hundreds of tubes for British and European equipment, particularly for high fidelity audio amplifiers, FM and AM tuners, tape recorders, and television sets. Most important is the cross reference data showing the interchangeability of Mullard tubes with American and European types. For a free copy of the Mullard Preferred Tubes Replacement Guide, write to International Electronics.

Hoekstra Joins ESC

ESC Corporation, 534 Bergen Blvd., Palisades Park, N. J. manufacturer of standard and custom-built lumped and distributed constant delay lines, announces the appointment of Evert M. Hoekstra as Project Engineer.



Hoekstra's responsibilities will include supervision of design, development, and new processing of delay lines, pulse forming networks, and related pulse equipment.

Prior to his joining ESC, Hoekstra was associated with Bach-Simpson Co., Ltd., Ontario, Canada; and Philips Laboratories, Eindhoven, Holland.

Chicago Telephone Expands Plant

92,000 sq. ft. has just been added to the Elkhart plant of **Chicago Telephone Supply Corp.**, Elkhart, Ind. This fifth major

(Continued on page 194A)



Can you help add to these achievements?

These accomplishments in pure and applied science are widely known. To this impressive list, scientists and engineers at the Laboratory's Livermore site are making equally important contributions in the fields of nuclear weapons design, nuclear rocket propulsion, controlled thermonuclear energy (Project Sherwood) and high current accelerators.

What you can do to help add to these accomplishments is limited only by yourself—your *ability* and your *interest*.

For the University of California Radiation Laboratory is managed and directed by outstanding scientists and engineers.

These men are your "team-mates"... offering pioneering knowledge of the nuclear field and the newest, most expansive laboratory facilities. Here—where new ideas and techniques are traditional—initiative is constantly encouraged and developed.

IF YOU are a **MECHANICAL** or **ELECTRONICS ENGINEER**, you may be involved in a project in any one of many interesting fields, as a basic member of the task force assigned each research problem. Your major contribution will be to design and test the necessary equipment, which calls for skill at improvising and the requisite imaginativeness to solve a broad scope of consistently unfamiliar and novel problems.

If you are a **CHEMIST** or **CHEMICAL ENGINEER**, you will work on investigations in radiochemistry, physical and inorganic chemistry and analytical chemistry. The chemical engineer is particularly concerned with the problems of nuclear rocket propulsion, weapons and reactors.

If you are a **PHYSICIST** or **MATHEMATICIAN** you may be involved in such fields of theoretical and experimental physics as weapons design, nuclear rockets, nuclear emulsions, scientific

photography (including work in the new field of shock hydrodynamics), reaction history, critical assembly, nuclear physics, high current linear accelerator research, and the controlled release of thermonuclear energy.

In addition, you will be encouraged to explore fundamental problems of your own choosing and to publish your

findings in the open literature.

And for your family—there's pleasant living to be had in Northern California's sunny, smog-free Livermore Valley, near excellent shopping centers, schools and the many cultural attractions of the San Francisco Bay Area.

You can help develop tomorrow—at UCRL today

Send for complete information on the facilities, work, personnel plans and benefits and the good living your family can enjoy.

© UCRL



DIRECTOR OF PROFESSIONAL PERSONNEL
UNIVERSITY OF CALIFORNIA RADIATION LABORATORY
LIVERMORE, CALIFORNIA

Please send me complete information describing UCRL facilities, projects and opportunities.

My specialty is _____

My degree(s) are _____

Name _____

Address _____

City _____ Zone _____ State _____

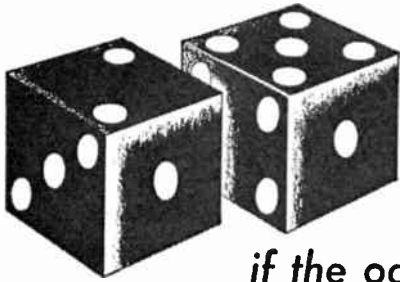

GAMBLE?

sure . . .

if the odds are in **YOUR** favor . . .

DECISION/INC—nationwide specialists in recruitment of engineering personnel—have an active and enviable record in developing job opportunities for men who want bigger salaries and a chance for greater personal achievement.

DECISION/INC is retained by more top-ranking firms thruout the nation than any other organization to *find the right man for each job.*

This confidential service costs you nothing.

It takes **TIME—MONEY—EFFORT** to improve your job situation. If you are an engineer or scientist, particularly in the **ELECTRONIC—AERONAUTICAL** or **GUIDED-MISSILE** field, **DECISION/INC** will do this *quickly, effectively at no cost to you.*

HOW? After a study of your outlined objectives, our placement specialist develops a plan "tailor-made" for you—which includes a resume of your experience . . . and then a review by selected companies leading to confidential interviews at your convenience and *our client's expense.*

NOW is the time for DECISION!

All you do *Now* is . . . send us your name, home address, job interest or title. We take it from there.

Write or phone:

OLIVER P. BARDES, President—DECISION/INC
1440-56 FIRST NATIONAL BANK BUILDING
CINCINNATI, OHIO Garfield 1-1700

Publishers of the authoritative **ENGINEERS' JOB DIRECTORY**

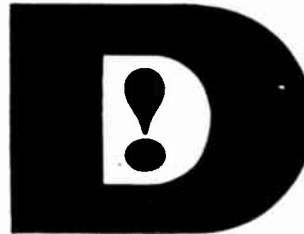

These manufacturers have invited **PROCEEDINGS** readers to write for literature and further technical information. Please mention your **IRE** affiliation.

(Continued from page 192A)

plant expansion in nine years has virtually quadrupled the sixty-year old firm's plant area from 87,000 sq. ft. in 1947 to its present 323,000 sq. ft. The entire Elkhart plant is devoted exclusively to the manufacture of variable resistors, in which **CTS** specializes. The company also has East Coast offices in Camden, New Jersey, and a newly formed subsidiary with a plant in South Pasadena, Calif., for the manufacture of coils, transformers custom compression moldings and variable resistors.

Plug-in Module Has Printed Circuits

A new modular construction using standard printed circuit materials and techniques and standard components has been announced by **Arthur Ansley Mfg. Co.**, New Hope, Pa. Called the **ANSLEY PLUS MODULE**, the unit is said to add a third dimension to printed circuitry. Patent applications are pending.



A standard size is offered, approximately $1\frac{3}{8}$ inches square and $2\frac{1}{2}$ inches high, either with an Octal plug-in base which makes the unit directly interchangeable with many hand wired modules, or with a new type of plug known as the **PLUS Base** that provides up

(Continued on page 199A)

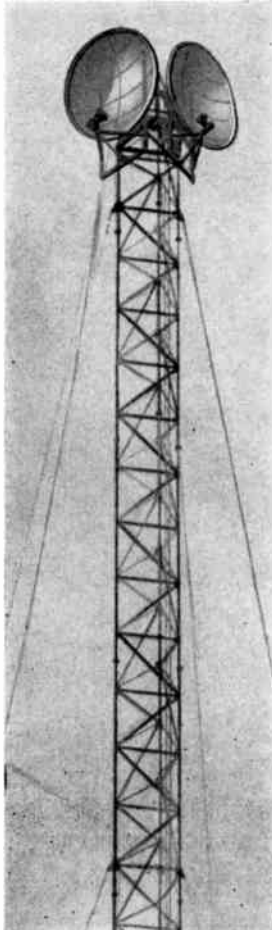

Unusual Opportunity for

TEST ENGINEERS

Carrier and Microwave Experience

Experience in maintenance of carrier and microwave installations desirable.

We offer an unparalleled opportunity for rapid advancement in one of the fastest growing companies in the communications industry. And you'll like living in Rochester—a city of fine homes, superb schools, vast facilities for leisure-time activities.

Immediate openings in Quality Control Dept. Other opportunities for electrical engineers in production engineering.

For immediate interview, send letter or resumé to
R. E. GOLEMB
Quality Control Manager, Telecommunication Division

STROMBERG-CARLSON COMPANY

A DIVISION OF GENERAL DYNAMICS CORPORATION
Rochester 3, N. Y.

Your Career Advances By DEGREES...

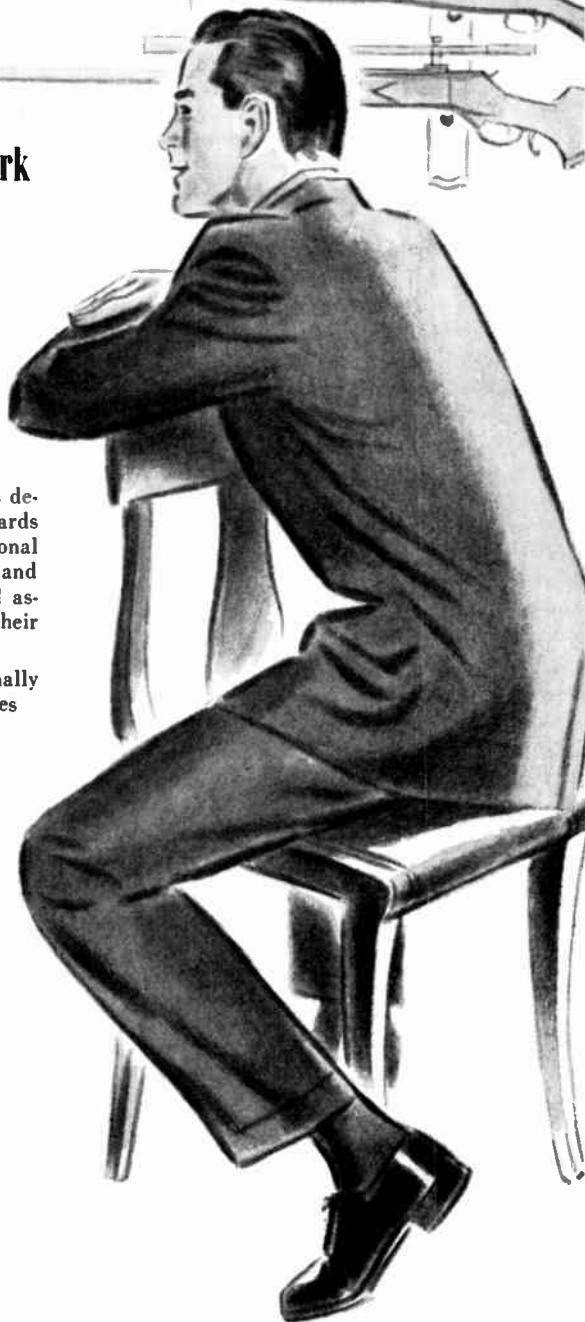
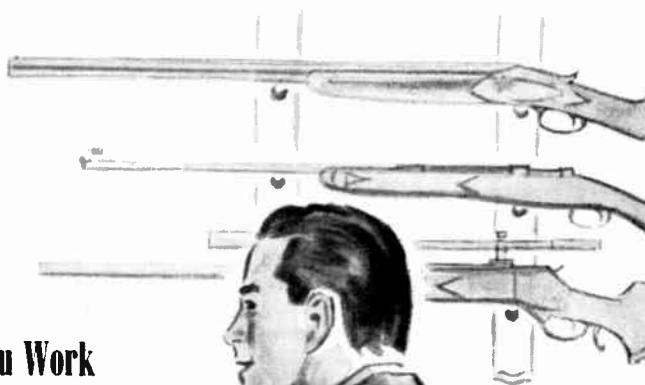

Continue Your Education—While You Work
with the Help of the
Graduate Study Program at
**WESTINGHOUSE
BALTIMORE**

The Westinghouse-Baltimore Graduate Study Program is designed to help young engineers continue their studies towards the advanced degrees that mean so much to their professional growth. In affiliation with The Johns Hopkins University and the University of Maryland, the program offers financial assistance to qualified employes who are working towards their graduate degrees.

If you are looking for an opportunity to grow professionally with an engineer's company—investigate the opportunities that await you at Westinghouse-Baltimore. Here, you can continue your education under the Graduate Study Program; grow through association with many of the leaders in the electronics field; and develop your own potentials to the limits of your abilities. You'll be backed up at every step by a management that respects and encourages engineers—because Westinghouse-Baltimore is an engineer's company—built, managed and dependent for its growth upon its engineers.

Baltimore Openings

CIRCUITRY	TRANSFORMERS
MICROWAVES	ANALOG COMPUTER DESIGN
SERVOMECHANISMS	VIBRATION
MAGNETIC AMPLIFIERS	RADAR DESIGN
DIGITAL COMPUTER DESIGN & APPLICATION	FIELD ENGINEERING
FIRE CONTROL SYSTEMS	INFRARED TECHNIQUES
OPTICS	ANTENNAS
COMMUNICATIONS	TECHNICAL WRITING
PACKAGING	TEST EQUIPMENT
	HYDRAULICS

To Apply:

For a confidential interview, send a resume of your education and experience to:

Dr. J. A. Medwin, Dept. 530
Westinghouse Electric Corporation
P. O. Box 746 • Baltimore 3, Maryland

WESTINGHOUSE—BALTIMORE

WHERE BIG THINGS ARE HAPPENING IN ENGINEERING CAREERS

TEST ENGINEERS

DO YOU LIKE YOUR ENVIRONMENT?

Investigate the Environment created at AC for its Advanced Development Programs on Missile Guidance and Aircraft Fire Control Systems.

OUR ENVIRONMENTAL LABORATORY

is one of the most Versatile Laboratories in the country and is in the process of a Major, Permanent Expansion.

Men hired will enjoy working with the finest of test equipment and facilities, together with top men of the field.

We are currently engaged in the following Types of Test Activities:

- VIBRATION TESTING
- COMPLEX WAVE ANALYSIS
- LOW TEMPERATURE—ALTITUDE
- HIGH TEMPERATURE
- RELIABILITY EVALUATION
- INSTRUMENTATION

Write Mr. J. Heffinger,
Supervisor of Salaried Personnel

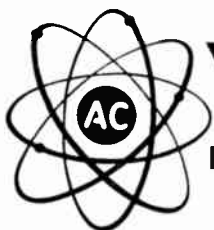

THE
ELECTRONICS
DIVISION

GENERAL MOTORS CORP.

Flint 2, Mich., Milwaukee 2, Ws.

COMMUNICATIONS SYSTEMS ENGINEERS

The expanding scope of advanced communications projects has created several unique positions in fields related to VHF, UHF, microwave transmission and reception, forward scatter and single sideband applications at Hoffman. Electronics engineers with appropriate backgrounds will find these new assignments professionally stimulating and financially rewarding. Please address Vice President of Engineering:

Hoffman LABORATORIES, INC.

A SUBSIDIARY OF HOFFMAN ELECTRONICS CORP.
3761 South Hill St., Los Angeles 7, Calif.
Telephone: RIchmond 9-4831.

ELECTRONIC ENGINEERS

Several attractive openings for men who can offer us light to heavy experience in:

- SERVOMECHANISMS
- ANALOG COMPUTERS
- FEED BACK TECHNIQUES
- SYSTEMS ENGINEERING

With an expanding research and development organization specializing in airborne systems and components offering you:

- CHALLENGING ENGINEERING PROBLEMS
- HIGH SALARIES • 3 MERIT REVIEWS ANNUALLY
- PERMANENT EMPLOYMENT • LIBERAL BENEFITS
- EXCELLENT WORKING CONDITIONS

All replies confidential. Interviews arranged at your convenience.
Phone ST 6-3315 FOR APPOINTMENT OR

SEND COMPLETE RESUME TO PERSONNEL MANAGER

AEROFLEX RESEARCH INCORPORATED

48-25 36 St., Long Island City 1, N.Y.

DU MONT

Technical Products Division

needs additional high calibre engineers

- Electronic Instrumentation
- Missile Work
- Test Equipment
- Timing and Pulse Circuits
- Video Circuits
- Electro-Mechanical Devices
- Recording Systems
- Communications Equipment
- Television Development

for both commercial and government output

Contact Mr. Martin E. Flynn

ALLEN B. DU MONT LABORATORIES, Inc.

35 Market Street East Paterson, N.J. or at 11800 W. Olympic Blvd. Los Angeles, California

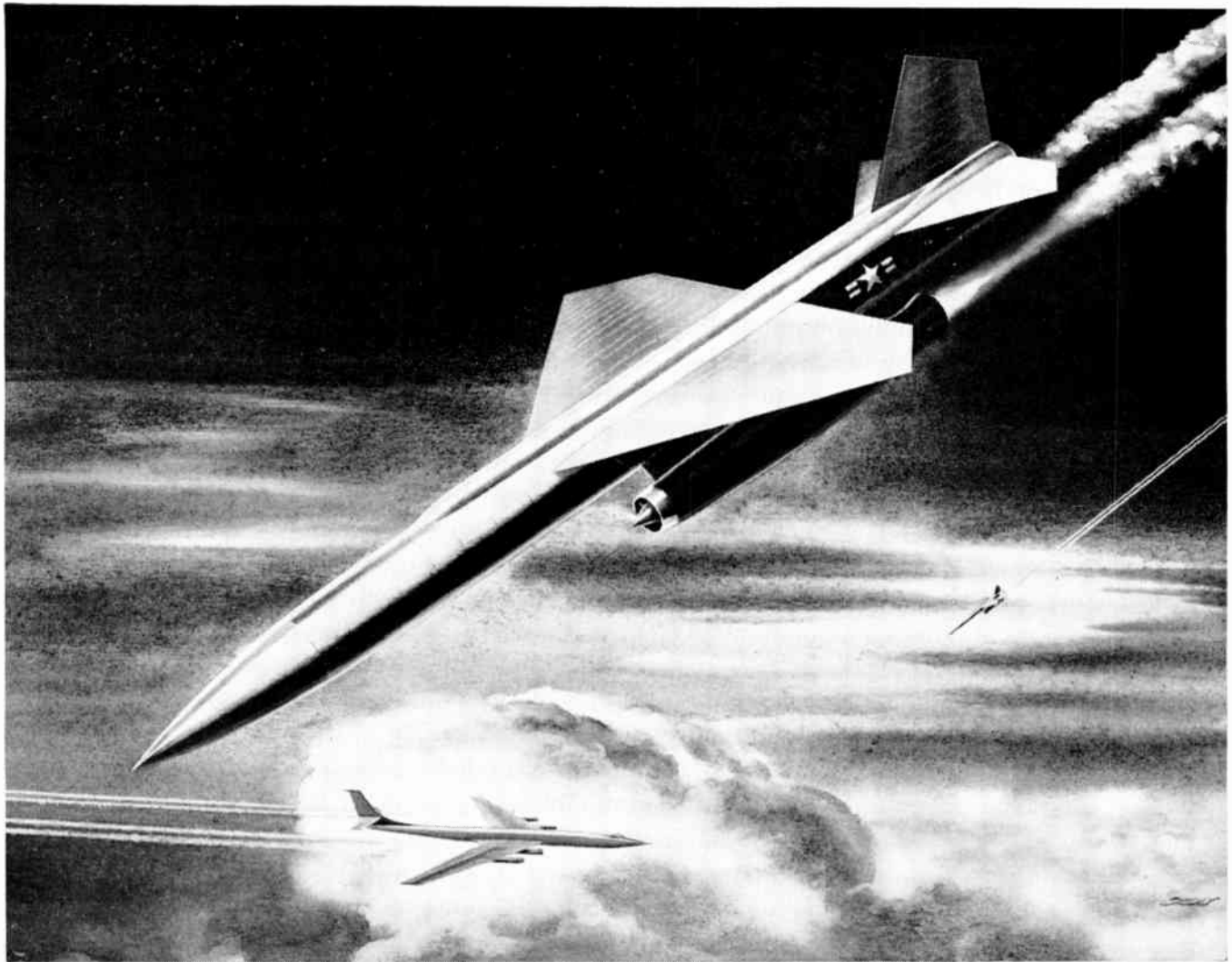

Boeing "E.E.'s" help develop new defense weapons system

Boeing's BOMARC IM-99 is a long-range guided missile designed to strike enemy bombers while still over areas away from vital targets. It's a supersonic spearhead of an entire defense weapons system that includes communications, bases, logistics.

Electrical engineers at Boeing have made major research contributions toward the development of this vital weapons system. Their guided missile work, most of it at the very frontiers of knowledge, includes guidance and target-seeker design, ground control and radar, flight control systems, command systems and control circuitry and systems. If this is the kind of pioneering that appeals to you, and if you enjoy working with engineers of outstanding professional stature, you'll like Boeing.

And you'll find plenty of room for advancement. Boeing's growth—a 400% jump in the number of Boeing engineers in the last 10 years—assures openings

ahead, and job stability. Boeing promotes from within, and every six months a merit review gives each engineer a *personal* opportunity for recognition, advancement, increased income.

Starting salaries at Boeing are high, and the company pays moving and travel expenses. If you are interested in continuing graduate studies, Boeing will arrange a special work schedule for you and pay all tuition and fees. Other Boeing advantages include a liberal retirement program and the backing of outstanding research and test facilities. Your family will enjoy life in any of the three young-spirited communities in which Boeing is located. Pick the climate and living advantages that suit you best. Each offers an abundance of recreational activities, plus good housing, schools, convenient shopping centers.

You'll be proud to be associated with a leader in one of the most exciting—and promising—industries in the country.

The first step is simple, and it'll pay you to take it now: fill out the coupon and get it in the mail, today!

- JOHN C. SANDERS, Staff Engineer — Personnel
- Boeing Airplane Co., Dept. G-58, Seattle 24, Wash.
- F. B. WALLACE, Staff Engineer—Personnel
- Boeing Airplane Co., Dept. G-58, Wichita, Kansas
- A. J. BERRYMAN, Manager — Administration
- Boeing Airplane Co., Dept. G-58, Melbourne, Fla.

• Mail this coupon to the address above from which you desire further information about advantages of a Boeing career.

• Name _____

• College(s) _____ Degree(s) _____ Year(s) _____

• Address _____

• City _____ Zone _____ State _____

• Telephone number _____

BOEING

Aviation leadership since 1916

SEATTLE, WASHINGTON WICHITA, KANSAS
MELBOURNE, FLORIDA

UNUSUAL OPPORTUNITIES AT ARMA

New long range projects assure not only challenging, high-level creative work, but security and job stability as well. Excellent starting salaries plus all the resort and cultural advantages of suburban Long Island living.

- (A) **DIGITAL COMPUTER ENGINEERS** for application of transistorized digital computers to Fire Control, Navigation and Missile Guidance Systems. Openings in Computer Applications, Logical Design, Dynamic Analysis, Circuit Development, Component Development, Packaging Design and Field Evaluation.
- (B) **TRANSISTOR CIRCUIT ENGINEERS** for applications in Fire Control, Navigation and Guidance Systems, utilizing analog and digital computing techniques.
- (C) **SYSTEMS EVALUATION.** Experience necessary in the following areas: Systems Analysis—Evaluation methods and techniques, data requirements, error analysis. Project Engineering—Planning functions, program scheduling, facility requirements, instrumentation—Electrical and mechanical design of ground and airborne instrumentation. Telemetry—Ground and airborne telemetry systems and telemetry checkout equipment.
- (D) **DATA REDUCTION & ANALYSIS ENGINEERS.** Experience required: General planning for Data Processing, including estimating and scheduling; specification of data transcription equipment and techniques; preparation of computational requirements, procedures, and knowledge of machine programming; mathematical studies, equation formulation, digital smoothing and filtering techniques; data reduction equipment, functional design and project engineering.
- (E) **MISSILE GUIDANCE SYSTEMS ENGINEERS** to work in the areas of System Synthesis (mathematical & functional); System Analysis and Evaluation (dynamic & error); System Instrumentation, System Integration (electrical & mechanical compatibility); System In-Plant Test. Degree in E.E., Physics or Mathematics necessary, with active participation in any of the following fields: Advanced mathematics; guidance and control systems; statistical error analysis; inertial navigation systems; stable platform; analog or digital computing systems; optical systems.
- (F) **ELECTRONIC SYSTEMS.** Advanced systems analysis and research in the fields of: Radar, Countermeasures, Guidance, Navigation, Communication, Propagation. B.S., M.S., or Ph.D., with heavy experience in military airborne and ground systems.

Fill out and mail the coupon to indicate your interest in any of these jobs. Or, simply check the second box if you would like to receive a free copy of "AN ANSWER RE: GUIDANCE," containing five technical papers discussing important questions relating to Inertial Navigation.

ARMA
 Division American Bosch Arma Corp.
 Roosevelt Field, Garden City, L.I., N.Y.
 Technical Employment Dept. 1-674

Gentlemen:

() Please send me additional information concerning the job coded _____

() Please send me a copy of "AN ANSWER RE: GUIDANCE." I understand I am under no obligation.

NAME

ADDRESS

CITYZDNE STATE

ELECTRONICS AND SYSTEMS PERSONNEL

Openings now exist at BATTELLE in the following areas

- Mathematical and Statistical Analysis
- Digital and Analog Computer Programming and Problems Analysis
- Communications and Telemetry Programming and Problems Analysis
 - Radio Optics Analysis and Development
 - Reliability Engineering
 - Nuclear Reactor Power System Control
- Theoretical Physics
 - Guidance and Control System Analysis and Development

Stable Platforms
 Space Reference Systems
 High Accuracy Servos

For Descriptive Material Regarding our Operations Write to:

**TECHNICAL PERSONNEL OFFICER
 BATTELLE INSTITUTE
 485 King Avenue, Columbus, Ohio**

*An Unusual
 Opportunity At
 Ramo-Wooldridge*

ELECTRONIC COUNTERMEASURES

A significant electronic countermeasures project is in progress at Ramo-Wooldridge. Circuit engineering responsibility for this project includes directing engineers in the translation of system functions into circuitry. New and unusual circuitry applications are an important aspect of the work. Applicable areas of experience are circuitry design for video, radar, or communication systems.

Scientists and engineers experienced in these fields are invited to explore this opening. Please address inquiries to: Mr. W. J. Coster.

The Ramo-Wooldridge Corporation

5730 ARBOR VITAE STREET • LOS ANGELES 45, CALIFORNIA



Electronic Engineers

IF YOUR ABILITIES & AMBITIONS ARE STYMIED,
YOUR TIME IS VALUABLE IN RESEARCH AT
CONTINENTAL OIL COMPANY
PONCA CITY, OKLAHOMA

SEND DETAILED RESUMÉ TO PERSONNEL DIVISION

ELECTRONIC ENGINEERS

Friez Division
Bendix Aviation Corp.
Towson, Md.

Newly organized group offering outstanding growth opportunities.

Electronic Engineers needed on Junior and Senior levels, with experience in radar or TV type pulse, sweep or video circuitry, for work on advanced industrial T.V., X-Ray and related commercial products.

Location in northside residential area of Baltimore.

For further information, please clip and mail to Dept. Chief Eng:

Mr. R. A. Lee
Bendix-Friez
Box 6860
Towson 4, Md.

Name:

Address:

.....

Phone:

All Communications Confidential.



(Continued from page 194A)

to 32 contacts. A seven or nine pin tube socket is incorporated in the top of the unit or it can be adapted to transistors or subminiature tubes. Other sizes and shapes can be made, supporting two or more tubes. The units are produced economically in small as well as in larger quantities. Consultation Available.

Rips New CE at Hamner

Ervine M. Rips has been named Chief Engineer of Hamner Electronics Co., Inc., Princeton, N. J. Rips was formerly Project Engineer of Beta Electric Corp., and prior to that was Assistant Chief Engineer of Central Transformer Co. Prior to that he was an assistant editor of "Electronics." He holds a B.S. in Electrical Engineering from M.I.T., 1942 and an M.S. in Electrical Engineering from Carnegie Tech, 1947. Hamner Electronics manufactures ad-

(Continued on page 200A)

WHAT "CAREER OPPORTUNITY"

Means to an Electronic Engineer at General Electric

"CAREER OPPORTUNITY"...two words you see used everywhere.

WE USE THEM a lot at Electronics Park. But with this difference. To every man who comes to work with us, "career opportunity" has a specific meaning.

And for a very good reason.

ELECTRONICS PARK is where many new concepts in electronics are born. The G-E organization here is primarily in the business of designing and developing new things—components, systems, equipments. Often a whole new product line results from applied research activities here—and after prelimi-

nary production and sales in this area, a new department is organized to handle it—a new plant built in another area—and a new management staff appointed to direct it.

AND MANY of the supervisory and specialist positions in such a new G-E department are drawn from the experienced development staff at Electronics Park.

JOIN US NOW... if you have a BS, MS or PhD degree in Electrical or Mechanical Engineering or Physics AND/OR electronic experience. Send the coupon below... or if you prefer, write us personally in complete confidence.

TO: GENERAL ELECTRIC
Electronics Pk.,
Syracuse, N. Y.
ATT: Dept. 12-6-P
Technical Personnel

I am interested in ...
... Advanced Development
... Design
... Field Service
... Technical Writing
... Sales

In the field of ...
... Military Radio & Radar
... Multiplex Microwave
... Mobile Communications
... Semiconductors
... Electronic Components
... Computers
... Tubes & Antennas
... Television Receivers
... Industrial Television

FROM:

NAME _____

ADDRESS _____

DEGREE _____

GENERAL  ELECTRIC

A HAPPY COMBINATION at

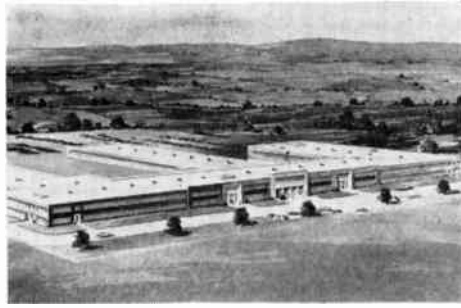

RAYTHEON'S WAYLAND LAB

—CHALLENGING WORK—

Our success in obtaining prime, long-range contracts for Aircraft Weapons Systems, major Defense Radars, Fire Control Systems and many others provides lasting and challenging opportunities for good Systems and Design Engineers who are ready, willing and able to work on some of the most advanced radar and weapons systems being designed today.

—PLEASANT LIVING—

Wayland and the surrounding territory constitute a select residential area where an acre-per-house is the rule. History records these towns—Lexington, Concord, Sudbury, etc.—as having famous beginnings; just the right amount of modern progress blended with this background renders them ideal for relaxed and pleasant New England living.



WAYLAND LAB

Send resume to:

Radar Professional Personnel
Box 242-D
Raytheon Manufacturing Company
Wayland, Massachusetts



News-New Products

These manufacturers have invited PROCEEDINGS readers to write for literature and further technical information. Please mention your IRE affiliation.

(Continued from page 199A)

vanced design nuclear and electronic instruments for research testing, medical and industrial applications. Principal products are Regulated High Voltage Supplies for Scintillation Spectroscopy, Combustion Non-Overload Amplifiers, Single Channel Pulse Height Analysers and the widely known Vari-Flex Chassis and Power Supplies.

Transistor Curve Tracer

Sonex, Inc., Upper Darby, Pa., has a new Transistor Curve Tracer which when used with an oscilloscope presents one curve at a time of the collector family (V_c vs I_c) with I_b held constant. This may be done on all NPN, PNP, surface barrier, grown or diffused junction transistors. The base current is indicated at all times on a four inch panel meter and can be varied

(Continued on page 202A)

RESEARCH AND DEVELOPMENT ENGINEERS

Career opportunities in Central Research Laboratory of stable, growing company. Electronic engineers with B.S. or M.S. for advanced circuit design on audio systems, magnetic recording, transistor control circuits for aircraft instrumentation and high frequency instruments. Positions offer opportunity for creative work in stimulating environment. Send resume to: Frank V. Paley, Professional and Technical Employment Manager,

THOMAS A. EDISON, Inc.

West Orange, N.J.

now entering production



LACROSSE MISSILE SYSTEM

RESEARCH AND DEVELOPMENT BY
CORNELL AERONAUTICAL LABORATORY

Cornell-created from the preliminary design stage to the point of final development, the Lacrosse guided missile system has been released by the Army for production at the Glenn L. Martin Co.

Now, the guided missile becomes a field weapon for the close support of infantry operations. With Lacrosse, our front-line soldier will have a deadly surface-to-surface guided missile system, with the mobility of a truck-mounted launcher and accuracy enhanced by its own guidance station. Its price tag to its present stage has been one of the lowest in missile-systems history.

Justly proud of a job well done, C.A.L. now moves on to new aeronautical frontiers—to more research in weapon systems, missile and aircraft design, electronics, gasdynamics, high temperature problems, hypersonics, and other challenging areas of modern flight.

We invite you to investigate the opportunities in research available at C.A.L. for the professional man. Write today—your inquiry will receive prompt and confidential attention.



CORNELL AERONAUTICAL LABORATORY, INC.
OF CORNELL UNIVERSITY

WRITE FOR FREE REPORT



The story behind Cornell Aeronautical Laboratory and its contributions to aeronautical progress is vividly told in a 68-page report, "A Decade of Research." Whether you are interested in C.A.L. as a place to work or as a place to watch, you will find "A Decade of Research" both useful and pertinent. Mail in the coupon now for your free copy.

W. P. DIEFENBACH
CORNELL AERONAUTICAL LABORATORY, INC.
Buffalo 21, New York

Please send me a copy of "A Decade of Research."

Name _____

Street _____

City _____

Zone _____

State _____

Please include employment information.

ENGINEERS

**NOW—CHOOSE YOUR ASSIGNMENT
AND LOCATION THROUGH OUR
NATION-WIDE PLACEMENT SERVICE
SALARIES \$7,500 TO \$18,000**

We can offer you a large selection of diversified positions with America's foremost electronic organizations. Some positions for non-citizens.

The following are just a few of a large number of desirable opportunities.

SR. ENGR.—DIGITAL COMPUTERS—
Exp. required in systems, logical design, packaging, system integration or pulse circuitry. To \$15,000

FLIGHT TEST EVALUATION—Sr. Opp.
in Ground & Flight Test on data links, precision transducers, telemetering equipment, power supplies, circuit monitors and impedance matching units. To \$15,000

RF ANTENNA—Proj. Engr. \$15,000

INFRA RED—Proj. Engr. \$15,000

PRODUCTION MGR.— Electrolytic Capacitors. \$10,000

ADVANCED SYSTEM DEVELOPMENT
—Supervisory position in digital computer, fire control or missile guidance development. To \$17,000

PHYSICIST Phd.—Nuclear experience pertaining to radiation from propulsion units—unusual opportunity. To \$18,000

PROJECT LEADER—Antenna Pedestals. \$13,000

PRODUCT ENGRS.—Electrolytic Capacitors. \$10,000

TUNER DESIGN ENGRS.—\$10,000

Just indicate where you would like to relocate and what you would like to do. We handle everything for you without cost or obligation.

LOCATION DESIRED

- New England
- Northern East Coast
- Southern East Coast
- Midwest
- Southwest
- West Coast

POSITION DESIRED

- Systems
- Radar
- Transistors
- Tubes
- TV Receivers
- Microwave
- Anal. Computers
- Dig. Computers
- Antenna
- Servo-Mechanisms
- Navigation
- Counter Measures
- Telemetering
- Nucleonics
- Ind'l. Instruments
- Components
- Circuit Design

WHAT SATISFIED ENGINEERS SAY:

Dear Mr. Brisk:

This is to advise you I have accepted employment with _____ Company as a project leader at \$15,000.

Your service has been a real help to me, for I am sure I could not have found this unusual opening by myself.

Thank you.

H.M.P.

Dear Mr. Brisk:

I have today advised _____ Company that I would be pleased to accept their offer. I start August 1st as a senior engineer at \$13,000.

The opportunity is one of the most outstanding I have seen.

J.S.E.

A National Electronic Placement Service Established in 1937.
You are assured of prompt and completely confidential service by forwarding three resumes to **HARRY L. BRISK, (Member IRE)**

APB Accredited Personnel Service

Employment Counselors Since 1937
Department A

12 South 12th Street, Philadelphia 7, Penna. WALnut 2-4460



News-New Products

These manufacturers have invited PROCEEDINGS readers to write for literature and further technical information. Please mention your IRE affiliation.

(Continued from page 200A)

from zero to 500 microamperes. The collector current can sweep out to 100 milliamperes while the limits of collector voltage being swept are controlled. Calibrated coordinate axes are displayed at all times.



Another use for the curve tracer is the presentation of the forward and reverse characteristics of crys-

(Continued on page 206A)

GOODYEAR ATOMIC CORPORATION ENGINEERS and PHYSICISTS M.S. - Ph.D.

Several engineers and physicists with extensive background in the fundamentals of analytical and laboratory research and development are needed for activities involving:

Computers, automatic controls, electromechanical designs.

Electronic circuit design and analysis.

Development and application of transistor circuitry.

Servomechanisms and control system analyses.

Instrument design—electronic and pneumatic.

Mass spectrometer development.

SEND COMPREHENSIVE RESUME INDICATING QUALIFICATIONS, MINIMUM SALARY REQUIREMENT AND AVAILABILITY FOR INTERVIEW. ALL REPLIES HELD IN STRICT CONFIDENCE.

EMPLOYMENT DEPARTMENT JJ
GOODYEAR ATOMIC CORPORATION
BOX 628, PORTSMOUTH, OHIO

engineers

SPERRY offers you a rewarding future
in a beautiful Long Island setting

... Where you'll
grow professionally
as Sperry
continues to
grow

... Where you'll
live, relaxed, in
the lovely Long
Island countryside

... Where you'll
enjoy a world of
recreational
and cultural
outlets

You should consider your career at Sperry
in two different, but equally advantageous lights.

Professionally, you will be joining an organization whose technical prestige and prowess are world-famous. You will be associating with outstanding Engineers and Scientists. You will be expected to help carry on the tradition of Sperry achievement . . . to contribute to the long line of Sperry "firsts" which have marked the past fifty years. In this connection, because Sperry activities are so diversified, your work will be on diverse and fascinating projects. Your rewards, of course, will be substantial. You will gain recognition, promotion and remuneration in direct proportion to your talent. Of prime importance is the fact that you will be with a company which is continuously expanding. And, certainly, as Sperry progresses, you will progress.

Personally, you will be discovering a new and very pleasant way of life. If ever a place can justifiably claim to "have everything," that place is Long Island. Like country? You'll thrill to the fields and flowers, the woodlands and lakes and quaint villages that abound on Long Island. Beaches? Take your choice of countless bay and ocean bathing parks, all clean and inviting. Homes? You may rent or buy on any scale you wish, from a modest suburban apartment to a sizeable country home. Wherever you live, you'll find schools, shops, churches, libraries nearby. And yet this whole wonderful environment lies not too far from New York's skyscrapers . . . close enough for you to enjoy dinner, the theater or a concert any evening the mood strikes you. Near at hand, too, are five universities at which you may study under Sperry's full tuition refund plan.

Make a date today to investigate the well-rounded life awaiting you at Sperry

APPLY IN PERSON

daily (including Sat.) Also Wed. eves.

OR SUBMIT RESUME

to Mr. J. W. Dwyer
Employment Manager

OR PHONE FOR APPOINTMENT

Fieldstone 7-3600, Ext. 2605 or 8238

SPERRY

GYROSCOPE COMPANY

DIVISION OF SPERRY RAND CORP.

GREAT NECK, LONG ISLAND, N. Y.

ENGINEERS

and other

SCIENTISTS

immediate permanent positions in

RESEARCH and DEVELOPMENT

**ELECTRICAL ENGINEERS
MECHANICAL ENGINEERS
ELECTRONIC ENGINEERS
COMPUTER ENGINEERS**

**SOLID-STATE PHYSICISTS
MATHEMATICIANS
PHYSICAL CHEMISTS**

ENGINEERING AND RESEARCH AT NCR:

- 1.** Immediate, permanent positions in Mechanical Engineering, Electrical Engineering, Defense and Experimental Engineering, Physics Research, and Chemical Research.
- 2.** Project work in Electronic Computers and related Data Processing Equipment, Accounting Machines, Cash Registers, Defense Contract Items, and all phases of Chemistry and Physics.
- 3.** Opportunities in research, design, development, production-engineering and packaging of mechanical,

electronic, and electro-mechanical devices.

- 4.** Some experience in research, development, design, and application of high-speed, light-weight mechanisms of the intermittent-motion type; or, experience in digital devices and components is desirable, but not essential.
- 5.** Ample training and orientation is available to all employees. Opportunities for further study with tuition refund plan.

AT NCR YOU, WITH YOUR FAMILY, WILL ENJOY:

- 1. UNLIMITED OPPORTUNITY** in the broad, ever-expanding field of Business Machine Engineering and Research.
- 2. AN EXCELLENT SALARY**, plus exceptional benefits of lifetime value for you and your family.
- 3. A RECREATIONAL PROGRAM** for year-round enjoyment of the entire family, including a new NCR Country Club with 36 holes of golf, and a 166-acre

employees' park for outings with swimming, boating, and supervised play for the children.

- 4. LIVING IN DAYTON . . .** considered a clean, attractive, progressive city with outstanding school facilities.
- 5. YOUR WORK AT NCR** with its friendly, family atmosphere, with its employee morale at a very high level, and with people who, like yourself, have decided to build their professional future with NCR.

Act at once—Send resume of your education and experience to:
EMPLOYMENT DEPARTMENT, PROFESSIONAL PERSONNEL, SECTION 5

THE NATIONAL CASH REGISTER CO.

Dayton 9, Ohio

LENKURT
Electric Company
INVITES
ENGINEERS
to work and live
on the beautiful
SAN FRANCISCO
peninsula

LEADING MANUFACTURER OF CARRIER TELEPHONE AND MICROWAVE EQUIPMENT HAS OPENINGS FOR:

*Communications Engineers
 Development Engineers
 Applications Engineers
 Mechanical Engineers
 Industrial Engineers
 Engineering Writers
 Engineering Reference Analyst*

HERE ARE EXAMPLES OF INTERESTING POSITIONS NOW AVAILABLE AT LENKURT:

PROJECT COMMUNICATIONS ENGINEER

Interesting work in advanced system planning for future products for large carrier and radio manufacturer. Direct contact with top executives of company and complete responsibility for large projects.

ENGINEERING WRITERS

Opportunity to write engineering level technical literature—operation, installation, theory and test instructions on complete telephone carrier and microwave systems. BSEE required. No writing experience necessary.

ENGINEERING REFERENCE ANALYST

Electronics Engineer to review incoming technical literature and perform literary research on assigned subjects. Objective to inform management and engineering groups of latest trends and techniques in communications and electronics. Reading knowledge of German required. Post graduate study available at nearby Universities.

BROADEN THE HORIZONS OF YOUR FUTURE! Wire . . . collect or send resume to:

MR. FOSTER
Engineering Employment Manager

LENKURT
Electric Co.,
 San Carlos, California

TOP careers for TOP
ENGINEERS
 at **"FTL"**

One of the world's great centers of electronic research and development

Top opportunities for achievement and recognition are available at Federal Telecommunication Laboratories, a division of the world-wide International Telephone and Telegraph Corporation.

Here, a man works with the finest facilities . . . with recognized leaders in his field. As a part of FTL's long-range development program he has a dependable road into the future . . . a future of stability, achievement, and commensurate rewards.

Why not write today for your copy of the booklet that tells the fascinating story of FTL . . . the broad and generous employee benefits . . . the many opportunities for permanence and satisfying progress.

Interesting Assignments in:

Radio Communication Systems • Electron Tubes
 Microwave Components • Electronic Countermeasures
 Air Navigation Systems • Missile Guidance
 Transistors and other Semiconductor Devices • Computers
 Antennas • Telephone and Wire Transmission Systems



FTL's famed Microwave Tower
 —28 minutes from N. Y. C.



MAIL THIS COUPON TODAY

Federal Telecommunication Laboratories
 500 Washington Avenue, Nutley, N. J.
 Please send a copy of your booklet describing opportunities at FTL.

Name _____
 Address _____
 City _____ Zone _____ State _____



Federal Telecommunication Laboratories
 A Division of INTERNATIONAL TELEPHONE AND TELEGRAPH CORPORATION

*Servo
Engineers*

**ELECTRICAL
MECHANICAL**
Inertial
Guidance
System
Program

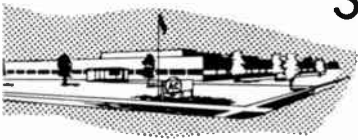

**Recent EE, ME
Graduate
Inquiries
Also Invited**

Enjoy Challenging Opportunities in the further development and systems testing of Inertial Guidance Systems and their Servo Loops in the most versatile laboratories in the country.

Work with the top men in the field and with the finest test, research and development facilities. New plant being added in suburban Milwaukee as a part of Major, Permanent, Expansion Program.

AC will provide financial assistance towards your Master's Degree. A Graduate Program is available evenings at the University of Wisconsin, Milwaukee.

GM's long-standing policy of decentralization creates individual opportunity and recognition for each Engineer hired.

Milwaukee offers ideal family living combining small town hospitality with every metropolitan shopping and cultural advantage.

For personal, confidential interview in your locality send complete resume to

Mr. John F. Heflinger
Supervisor of Salaried Personnel

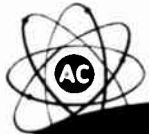

THE ELECTRONICS DIVISION
GENERAL MOTORS CORPORATION
FLINT 2, MICH. • MILWAUKEE 2, WIS.



These manufacturers have invited PROCEEDINGS readers to write for literature and further technical information. Please mention your IRE affiliation.

(Continued from page 202A)

tal diodes with the calibrated axes. The voltage versus current characteristic of thermistors and varistors can also be displayed simultaneously with calibrated axes.

ISB Spectrum Analyzer

A new Spectrum Analyzer, Model 1094, is announced by **Marconi Instruments, 44 New St., New York 5, N. Y.**

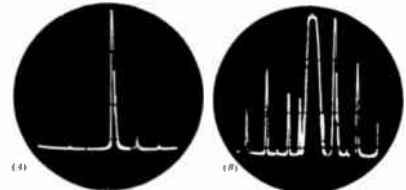

These two oscillograms show hum components in a hand extending 300 c/s on either side of the carrier in an i.s.b. transmitter. (A) Carrier and 100-c/s hum component at -29 db as displayed with Spectrum Analyzer in low-sensitivity condition. (B) Expanded view, as given with sensitivity increased by 30 db, revealing further components at -300, -200, -100, -50, +50, +200 and +300 c/s.

The instrument provides a means of measuring all intermodulation products in ISB transmitters and drive units. Other important applications include the measurement of hum level and carrier compression, and the display of the frequency spectra resulting from on/off or F.S. keying. It is particularly useful in making dynamic distortion test during transmitter setting up.

Model 1094 covers a frequency range of 3-30 mc and has a dynamic range of 60 db accurate to ± 1 db.

The instrument has a triple-superhet circuit with crystal controlled local oscillator to ensure high stability, and a frequency swept third oscillator. A calibrated control varies the width of frequency spectrum displayed from 30 kc down to about 200 cps permitting observation of either the whole transmitted bandwidth or closely spaced components. For example, 60 cps hum components as much as 50 db down can be accurately measured.

A long persistence CRT and sweep duration variable up to 30 seconds enable full advantage to be taken of the extremely high selectivity which is 6 cps to 3 db points.

(Continued on page 209A)

**MICROWAVE DESIGN ENGINEER
to \$12,000**

Capable of design and development of microwave components. Background in antennas, couplers, mixers, oscillators, phase shifters, TR devices or similar complex electronic components desired

You'll work with a major company that has made many contributions to the field of advance military electronics.

Location: resort area in Upper New York State, center of year-round outdoor recreation.

Reply in strictest confidence to Box 1015, Institute of Radio Engineers, 1 East 79 Street, New York 21, N.Y.

GENERAL ELECTRIC

French Road, Utica, N.Y.

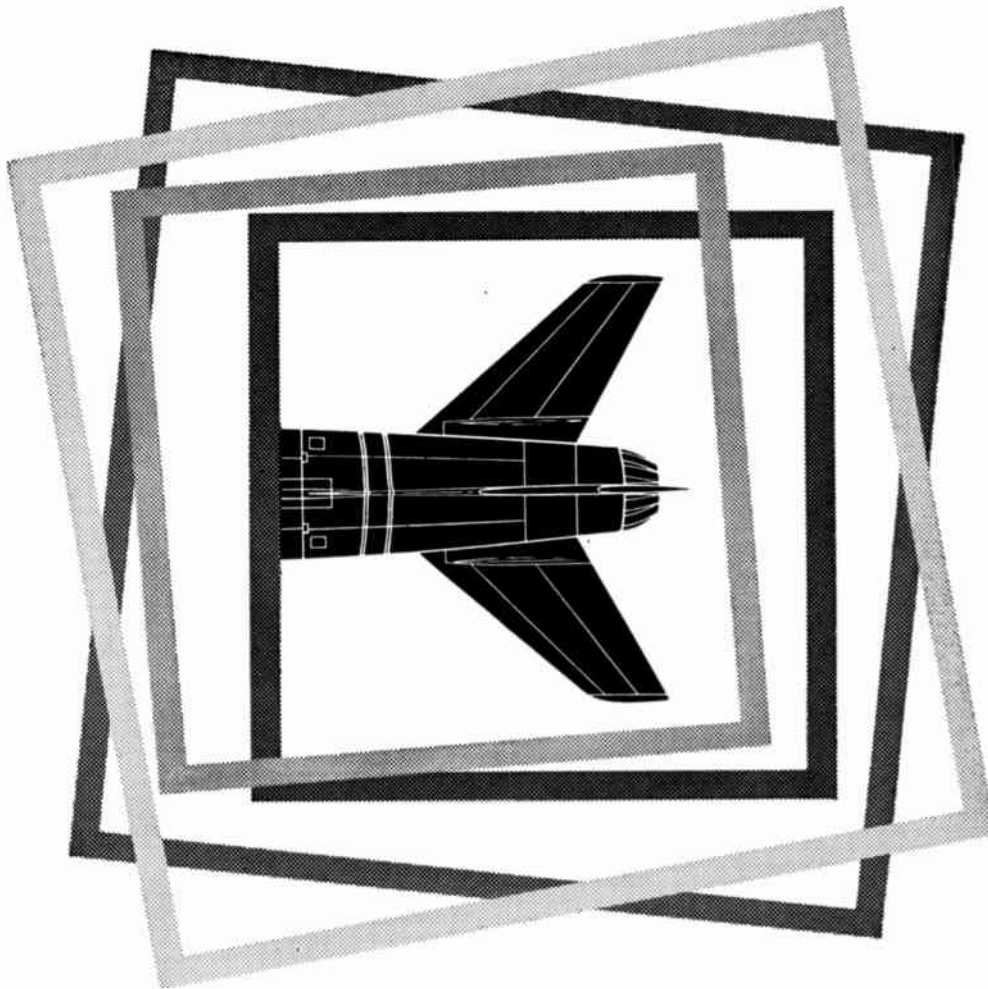

NEW DEVELOPMENTS in flutter, vibration,
electronics, many other specialized fields:
EXCEPTIONAL OPPORTUNITIES NOW

You can accelerate your own career considerably by working with us on some of the most advanced problems in the aviation industry—the problems of high performance aircraft, supersonic and hypersonic designs of the present and the future.

This high speed research includes design and test in Vibration, Aeroelastic and Flutter analyses, analog and digital computer techniques in Electronics, and many more.

The opportunities at North American, Los Angeles Division, are many and varied. You work surrounded by activities of a highly interesting nature, using facilities of the most advanced type. You'll enjoy wide scope for your talents, and you'll particularly like the climate of individualism and team spirit that exists. Your associates will be people who respect your opinions and professional status. Check the openings listed below.

OPENINGS ARE IMMEDIATE. PROFESSIONALLY QUALIFIED WOMEN ARE WELCOME

Recent Aeronautical Engineering Graduates • Recent Mathematics Graduates (Women) • M. E. Graduates with Vibration Experience • Recent Electrical Graduates, for Lab. work • Experienced Flutter Engineers (Aeronautical, Mechanical Engineers, Physicists, Mathematicians) • Experienced Vibrations Engineers • Experienced Instrumentation Engineers, electrical background • Experienced Analog or Digital Computer Engineers, either Electrical, Mechanical or Aeronautical Engineers, or Physicists. Heavy analog experience desirable.

ALSO NEEDED: Aerodynamicists, Systems Engineers, Instrumentation Engineers, Aero-Thermodynamicists, Aeroelastic Engineers, Cycle Analysis Engineers

Contact Les Stevenson, Engineering Personnel Office, Dept. 56-12 IRE
North American Aviation, Inc., Los Angeles 45, California

North American Aviation, Inc. is doing research and development on the X-15, a manned aircraft for investigation of speeds and temperatures at very high altitudes.

Los Angeles Division

NORTH AMERICAN AVIATION, INC.

NORTH AMERICAN HAS BUILT MORE AIRPLANES THAN ANY OTHER COMPANY IN THE WORLD



Scientists and Engineers



Operation Vanguard opens new era in space research

During the 1957-58 International Geophysical Year, the first man-made satellite to be launched by the U. S. will be directed into its orbit by an ultra sensitive guidance system for which Honeywell will supply precision gyro and reference platform equipment.

To help in this challenging and important work and other advanced projects, Honeywell needs outstanding, creative scientists and engineers, offers them unusual opportunities for recognition and advancement.

You can expect a first-rate salary at Honeywell. A liberal benefit program includes generous company-paid insurance, retirement plan and tuition allowances for advanced study.

You will work in small research and development teams which means your abilities will be quickly recognized. Salary increases and promotions are based entirely on merit.

You'll find Minneapolis a fine place to live, too. It's a city of lakes and parks, a city where you can find gracious living for your whole family just twenty minutes from where you work. Of course, Honeywell pays relocation and traveling expenses.

Senior positions are currently open in the following fields for Research, Design, Development and Production Engineers, Scientists and Aerodynamic Analysts with degrees in E.E., M.E., A.E., I.E., C.E., Metallurgy or Chemistry:

SATELLITE AND ICBM INERTIAL PLATFORMS
AND GUIDANCE SYSTEMS
DIGITAL COMPUTERS
AUTOMATIC FLIGHT CONTROL SYSTEMS
JET ENGINE POWER CONTROLS
ENGINE INLET DIFFUSER CONTROLS
AIR DATA COMPUTERS
BOMBING COMPUTERS
FUEL AND OIL GAGES
FLOATED AND NON-FLOATED GYROS
TRANSISTOR AMPLIFIERS

MINNEAPOLIS
Honeywell



Aeronautical Division

SEND RÉSUMÉ TODAY—If your interests and experience are related to the fields listed in the panel above, mail a résumé of your education and experience to Bruce D. Wood, Technical Director, Dept. T-3A, 1433 Stinson Boulevard, N.E., Minneapolis 13, Minnesota.

These manufacturers have invited PROCEEDINGS readers to write for literature and further technical information. Please mention your IRE affiliation.

(Continued from page 206A)

Cementable Teflon Tapes

Cementable Teflon Tape, either single or double-faced, in practically any desired thickness from 0.0005 to 0.060 inch and in widths from $\frac{1}{2}$ to 12 inches has been announced by the **Enflo Corp.**, Route 38 at Airport Circle, Pennsauken, N. J.

Either or both surfaces of the tape are treated by a special Enflo process, which makes the Teflon readily "bondable" to glass, steel, aluminum, plastics, or practically any other material including Teflon itself.

General purpose Epoxy resin adhesives including pressure-sensitive tapes serve as eminently satisfactory binding agents. Ultimate shear strength is on the order of 280 to 330 lbs. per square inch. Peel strength is approximately 40-45 lbs. per square inch.

Enflo Cementable Teflon Tapes are normally furnished in continuous rolls, although cut-to-size sheets also can be furnished to order. Standard thicknesses available are: 0.0005, 0.010, 0.015, 0.020, 0.025, 0.030, 0.035, 0.040, 0.045, 0.050 and 0.060 inch.

Samples and catalog available on request.

Ferrite Sample Kits

Three different Engineering Sample Kits are now available from **Aladdin Radio Industries, Inc.**, Nashville 2, Tenn., each containing a different line of ferrite cored inductors.

Kit #81 contains 19 different Green-Line inductors with nominal values ranging from 1 millihenry to 1 henry, in RETMA increments, ± 20 per cent. These are high-Q units wound on ferrite cores with a ferrite shield surrounding the coil and protected by a vitreous enamel finish. This line of inductors is used where highest quality and reliability, as well as small size, are required. They are used as low current chokes, in filters, in audio oscillators, and in impedance coupling circuits. They are suited for use in compact transistorized circuits.

Kit #82 contains 19 Green-Line

(Continued on page 210A)

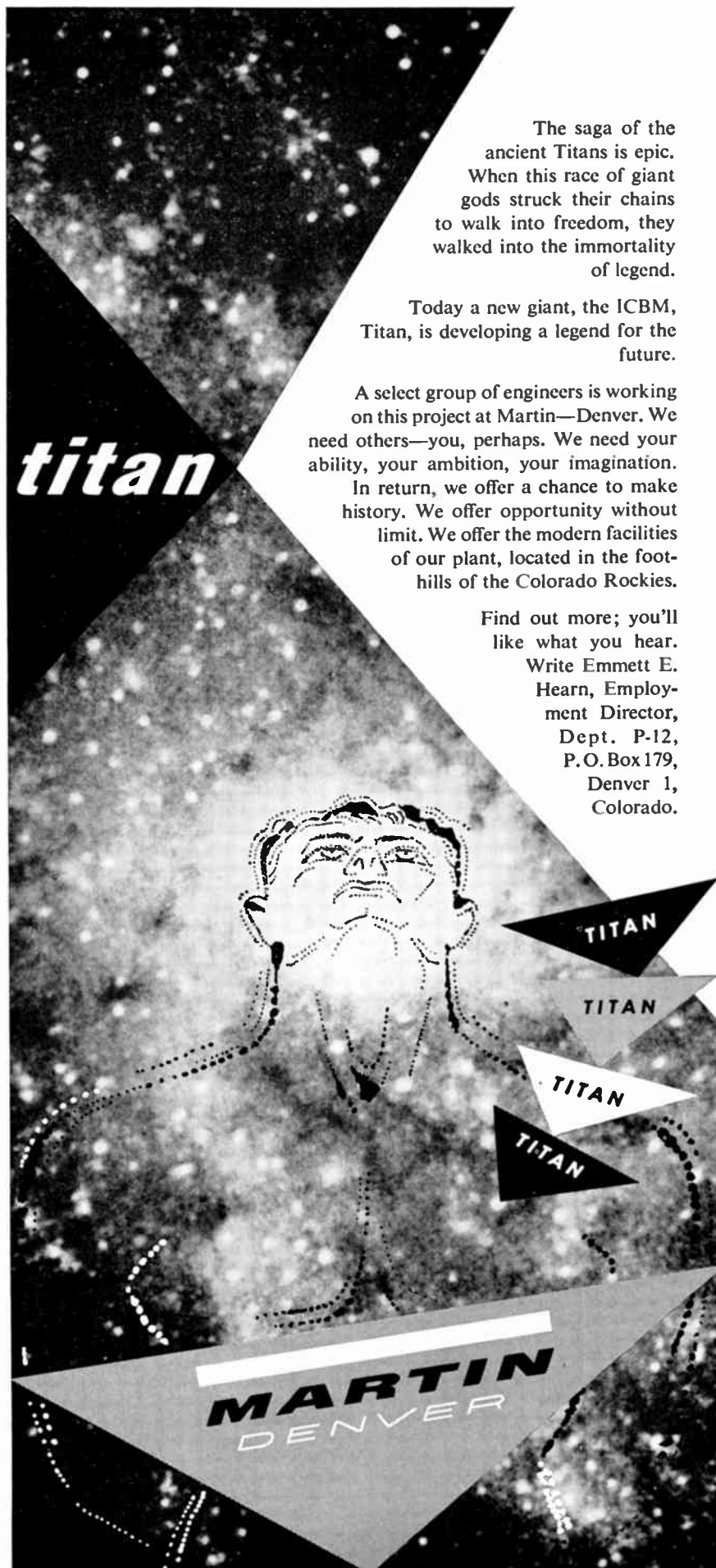

titan

TITAN

TITAN

TITAN

TITAN

MARTIN
DENVER

The saga of the ancient Titans is epic. When this race of giant gods struck their chains to walk into freedom, they walked into the immortality of legend.

Today a new giant, the ICBM, Titan, is developing a legend for the future.

A select group of engineers is working on this project at Martin—Denver. We need others—you, perhaps. We need your ability, your ambition, your imagination. In return, we offer a chance to make history. We offer opportunity without limit. We offer the modern facilities of our plant, located in the foothills of the Colorado Rockies.

Find out more; you'll like what you hear. Write Emmett E. Hearn, Employment Director, Dept. P-12, P.O. Box 179, Denver 1, Colorado.

IBM

needs

SEMI-CONDUCTOR ENGINEERS

Would you like to play a major role in the design, development and manufacture of transistors?

IBM now has challenging openings in the product development of semi-conductor devices for commercial data processing and airborne computers. There are unlimited opportunities for professional achievement and advancement in our new Semi-Conductor Engineering Laboratory and Manufacturing facility at Poughkeepsie, New York, and at our Airborne Computer Laboratories at Owego, New York.

If you are an electrical, mechanical or chemical engineer, physicist, metallurgist, or chemist with a B.S. or advanced degree and at least 2 years' experience in the design, development or manufacture of semi-conductor devices and materials, consider IBM's advantages:

Your advancement is based solely on merit.

IBM's growth is creating many unusually responsible career positions.

IBM serves large and small businesses, science, education, government and the military, assuring stability and continued growth.

Liberal company benefits and excellent salaries.

Family educational and country club facilities.

Moving and travel expenses paid.

Write, giving details of education and experience, to:
R. A. Whitehorne, IBM, Dept. 2712, 590 Madison Avenue,
New York 22, New York.



DATA PROCESSING • ELECTRIC TYPEWRITERS • TIME EQUIPMENT • MILITARY PRODUCTS



News-New Products

These manufacturers have invited PROCEEDINGS readers to write for literature and further technical information. Please mention your IRE affiliation.

(Continued from page 209A)

special units. These inductors are designed to have very high self-resonant frequencies. Like the regular Green-Line units, they range from 1 millihenry to 1 henry.

Kit #83 contains an assortment of Brown-Line and Tiny-L* inductors. 39 different ferrite-cored inductors, in RETMA increments from 0.22 microhenry through 100 millihenries, make up this assortment. The Tiny-L* Line (0.22 μ h to 6.8 μ h) is particularly well suited for high current (2 amperes) filament choke applications and in compensated video amplifier circuits. The Brown-Line (10 μ h to 100 mh) has been found very useful in general filtering applications as well as in compensated video amplifier circuits.

Any of these kits will be shipped, postage paid, out of stock. The prices are: No. 81—\$24.95, No. 82—\$24.95, No. 83—\$14.95. Request Bulletin No. 33A.

(Continued on page 212A)

Right here . . . right now Preview the position that holds your future

Many of today's most successful engineering careers began when men investigated Abbott opportunities.

Salaries to \$25,000

VICE PRESIDENT of ENGINEERING—Aircraft accessories
ENGINEERS—Industrial automatic controls advanced development
ENGINEERS—Theoretical analysis of communications equipment
ENGINEERS—Electron optics
ENGINEERS—Transistor circuitry
ENGINEER—Components applicator
DEVELOPMENT ENGINEERS—Countermeasures
DEVELOPMENT ENGINEERS—Gyros and servos
MANAGER—D & D of airborne fire control equipment
LEADER—Computer mechanization
SECTION HEAD—Instrumentation test equipment
MANAGER—D & D of Digital Communication Equipment
ENGINEERING SPECIALIST—Radar and antenna

For 32 years we have provided a confidential service for employees, making referrals to many of the leading companies throughout the U.S. Our clients will assume all expenses. Send detailed resume to Mr. George M. Sandel, Director.



EMPLOYMENT SPECIALISTS
333 Washington Street, Boston 8, Massachusetts

ENGINEERS

New Sylvania plant
in Williamsport, Pa.

means new
opportunities for you
in **MICROWAVE ENGINEERING**

Latest evidence of Sylvania's spectacular growth in electronics is our new facility — which offers you the chance to get in at the start on one of the most dramatic and promising fields open to engineers today.

WORK ON BACKWARD WAVE MAGNETRONS & OTHER MAGNETRON TYPES

Here is an area where Sylvania research is continually reaching out in new directions, and opening up new roads to promising careers. Research for the past three years on Sylvania's new Backward Wave Magnetron has created openings for Engineers in research development and production.

USE ALL YOUR ENGINEERING TALENTS

... in solving the challenging problems encountered in microwave work. Here's your chance to pioneer in a rising young industry, to work with a company where advancement is fast and success comes soon to able men.

OPENINGS AT ALL LEVELS OF EXPERIENCE

for engineers who welcome the stimulus of the fresh and unusual. The length of time you've worked doesn't interest us nearly as much as what you've done during that time — we have opportunities for men seeking career potentials.

Fill out the coupon below for immediate action:

Mr. Roland W. Coates Sylvania Electric Products Inc. Electronics Division 100 Sylvan Road, Woburn, Mass.	Name _____
	Age _____ Degree _____ Degree Date _____
	Address _____
	Interest in: RESEARCH <input type="checkbox"/> DEVELOPMENT <input type="checkbox"/> PRODUCTION <input type="checkbox"/>
	Years related experience _____ Years total experience _____
	Types of products _____ salary expected _____
	Resume enclosed YES <input type="checkbox"/> NO <input type="checkbox"/>





ENGINEERS

Challenging assignments for engineers with broad experience in

- TUNER DESIGN
- TV CIRCUITRY
- A.G.C. AND SYNC CIRCUITRY DESIGN & DEVELOPMENT

Many excellent company-paid benefits, attractive salaries and challenging assignments for those who can qualify.

Write, wire or call • Mr. Martin E. Flynn

ALLEN B. DUMONT LABORATORIES, INC.

35 Market Street, East Paterson, N. J. • MULberry 4-7400

MAKE A WISH



Man's age-old dream of a voyage to the moon may very likely become a vivid reality in our own lifetime. Recent breakthroughs in missile engineering and nuclear science have suddenly made the exploration of outer space a practical possibility. As the only corporation of its kind in the world to specialize in the research and development of interplanetary travel, Systems Laboratories offers unprecedented opportunities to professional men of vision, imagination and daring. If you are a scientist or engineer with first-class qualifications and a highly developed sense of adventure, write tonight to SLC's president, Dr. John L. Barnes. Your inquiry will receive his prompt attention and your confidence will be scrupulously respected.



SYSTEMS LABORATORIES CORPORATION
15016 Ventura Blvd., Sherman Oaks, Calif. in Los Angeles' San Fernando Valley



These manufacturers have invited PROCEEDINGS readers to write for literature and further technical information. Please mention your IRE affiliation.

(Continued from page 210A)

Analog Information Delay Generator

Donner Scientific Co., Concord, Calif., announces its new analog computer accessory, the Model 3770 information delay generator. This device accepts input information in the form of voltage varying with time and within the limits—100 to +100 volts. The Model 3770 delivers the same information at its output terminals, but delayed in time 0.02–0.2 seconds on the lower range, or 0.202 seconds on the upper range. The delay interval, indicated within 1 per cent on a large meter, is smoothly and linearly adjustable by a single knob. The input waveform is faithfully reproduced for all frequency components from dc to the inverse of delay interval.

Two or more Model 3770 generators may be cascaded for distortionless reproduction of even higher frequencies, or to achieve proportionately greater time delays. A second version of the standard generator provides a continuously adjustable delay up to 20 seconds, and the principle can be extended to even longer delays. The new unit is all-electronic and has no moving parts (except the control knob). It utilizes a new circuit (patent pending) invented by D. E. Bently, Donner engineer. The instrument finds applications in analog computer studies of control systems and servomechanisms, aircraft and missile work, heat transfer problems, and wherever process "time lag" exists. Time-scaling permits simulation of all physical delays, however short or long. Further information on request from Donner.

Aircraft Switch Catalog

Microswitch, Freeport, Ill., a division of Minneapolis-Honeywell Regulator Co., has just published a new catalog on aircraft switches, Catalog 77, Entitled "Enclosed Switches for Airborne Equipment," this 24 page catalog covers twelve different families of precision, snapaction aircraft switches. In all, over seventy different en-

(Continued on page 211A)

Transac miniature computer...



Miniature printed circuit cards, heart of the Transac Computer, contain all the elements for arithmetic and control functions.

TRANSAC—trademark of Philco Corporation for Transistor Automatic Computer

PERFORMS COMPLEX FLIGHT CONTROL INSTRUCTIONS ... EVERY 30TH OF A SECOND!

Now a high speed airborne computer that slips like a desk drawer into the nose of a supersonic Navy jet fighter and processes digital data derived from analog information *in split seconds*. TRANSAC—a completely transistorized control system—eliminates vacuum tubes, diodes and other bulky com-

ponents of ordinary digital computers. Philco is proud to have met the exacting standards of the Navy Bureau of Aeronautics. Industry too is watching the TRANSAC® computer with its high speed data processing capabilities make phenomenal contributions to business planning and operations.

At Philco, opportunities are unlimited in electronic and mechanical research and engineering.

PHILCO® ... Creative Engineering for a better way of life

GOVERNMENT AND INDUSTRIAL DIVISION • PHILADELPHIA 44, PENNSYLVANIA

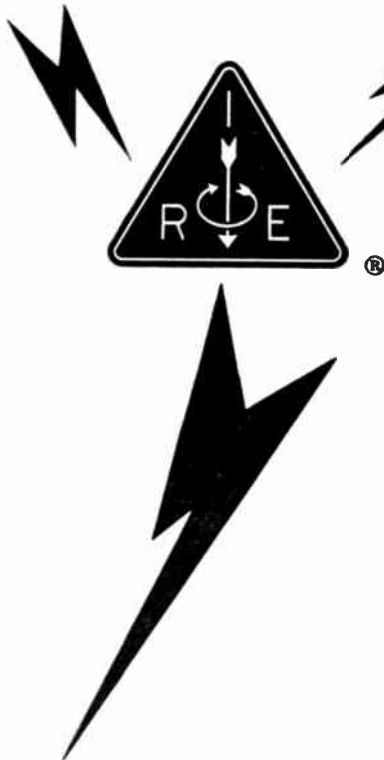

Invite you to the

3rd National Symposium on Reliability and Quality Control in Electronics

January 14 thru 16, 1957

Hotel Statler • **Washington, D. C.**
12 Sessions • **5 Panel Discussions**
• **4 Plant Tours** •

for information contact

M. A. TALL
General Chairman
Radio Corp. of America
Moorestown, New Jersey

or

R. G. MURRELL
Registration Chairman
Melpar, Inc.
Falls Church, Virginia

Jointly sponsored by • **I.R.E.** • **RETMA and ASQC**



News-New Products

These manufacturers have invited PROCEEDINGS readers to write for literature and further technical information. Please mention your IRE affiliation.

(Continued from page 212A)

closed switches are described.

Complete with photographs, dimensioned drawings, electrical rating, and technical information, Catalog 77 includes environment-proof switches, hermetically sealed switches, completely sealed cylindrical switches, high temperature switches, enclosed multi-circuit switches and switches which are "Jan," "AN" and/or "MS" approved. Many of the switches covered are available in a variety of actuator designs and contact arrangements.

Pulse Oscillator

The Model 342B pulse oscillator developed by Electro-Pulse, Inc., 11861 Teale St., Culver City, Calif., is a wide range trigger generator producing pulses at repetition rates from 100 cps to 3.3 mc. The instrument is particularly useful as a clock pulse generator, for flip-flop resolving time studies, and for general use in high speed pulse circuitry development.



Two separate blocking oscillator output pulse, each available positive or negative, are provided in a half-period relationship enabling, by mixing, such waveforms as alternate positive and negative pulses.

Output pulses are approximately 0.1 microseconds wide from an impedance level of less than 250 ohms, and with amplitude variable to 25 volts open circuit.

Weighing approximately 29 pounds, the instrument is provided in a wrinkle finish, fan cooled cabinet 5 1/4 x 19 x 13 inches, with a folding tilt-up bracket.

An integral power supply, operating on 115 or 230 volts, 50-400 cps ac (175 watts), is furnished.

(Continued on page 216A)



Computer manufacturers know General Transistor always delivers reliability. That's why they depend on GT quality and GT service, and that's why General Transistor is one of the largest suppliers of transistors for computers.

FOR COMPUTER RELIABILITY IT'S GENERAL TRANSISTOR

The Univac® File-Computer, a new intermediate sized data processing system designed and manufactured by Remington Rand Univac Division of Sperry Rand Corporation.

Write for Specification Bulletins covering your applications.

GENERAL TRANSISTOR CORP.
Richmond Hill 18, N. Y.
Virginia 9-8900



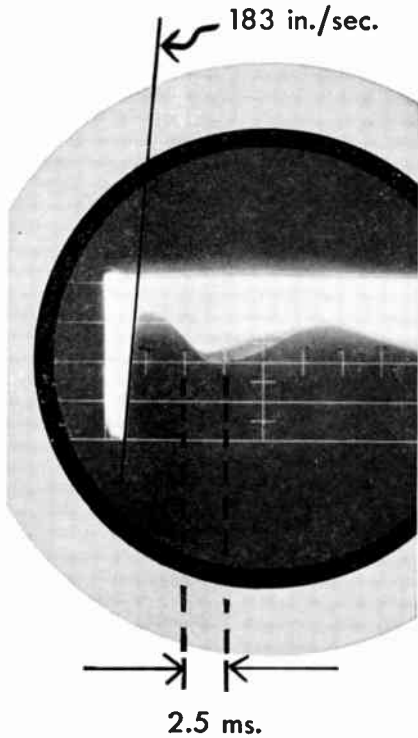

How to move a plunger at 900 g's

Problem: Design an assembly to release a gate on the sorting mechanism of a business machine.

The assembly must actuate a plunger, getting it out of the way in 2.5 milliseconds.

It must be reliable over a long life. Keep it small. Keep cost low.

Our solution: A marriage of pulse circuit techniques and electromagnetic plunger techniques in an electromechanical transducer.

The final unit develops an acceleration of 950 g's and a peak velocity of 183 inches per second. A force of 74 pounds moves the 1.25 ounce plunger .051 inches. The plunger moves 90% of this distance in only 0.5 millisecond—only 1/5th of the time allowed.

If you want an electronic assembly, designed and produced in large or small quantities, contact...

CALEDONIA
ELECTRONICS AND TRANSFORMER CORPORATION

Dept. PI-12, Caledonia, N. Y.

In Canada: Hackbusch Electronics, Ltd.

23 Primrose Ave., Toronto 4



News-New Products

These manufacturers have invited PROCEEDINGS readers to write for literature and further technical information. Please mention your IRE affiliation.

(Continued from page 214A)

Modular Cabinets

A method by which industry, selecting from 75 mass-produced "building block" metal cabinet enclosures and working with 125 different sub-parts, can work up infinite varieties of cabinets to house

instrumentation, automation, electronic, and electro-mechanical equipment, has been announced by Elgin Metalformers Corp., Elgin, Ill.

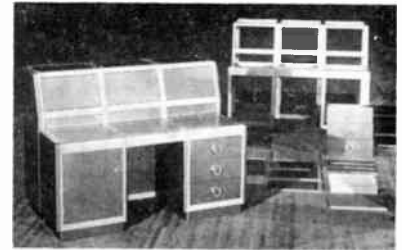

Airplane-type construction is

(Continued on page 220A)



... that Burnell can satisfy your needs for single side-band filters. Our active designs now cover a frequency range of 15 KC up to 15 MC... extending from low-cost filters for amateur receivers or inexpensive commercial equipment to crystal and complex toroidal networks. All Burnell filters are designed to meet the applicable portions of military specifications.

Typical examples of response characteristics for Burnell side-band filters

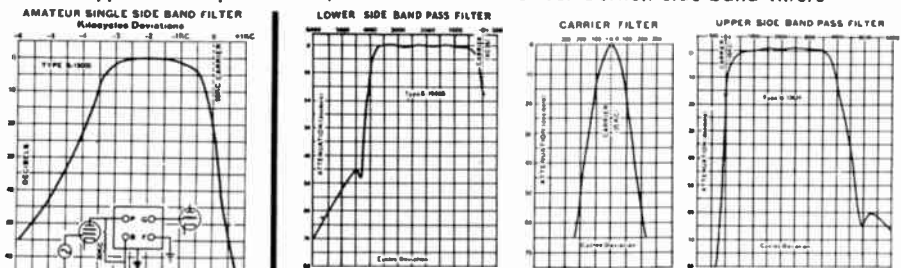

5-15,000
AMATEUR
SINGLE SIDE-BAND
FILTER

THE SINGLE SIDE-BAND PACKAGE CONSISTS OF:

- | | |
|--|--|
| 1) The 25kc Carrier Filter.....\$-13626 | 4) 3500 Cycle Demodulation Filter.....\$-13627 |
| 2) Lower Side Band Filter (3500 Cycles).....\$-13625 | 7) 6000 Cycle Demodulation Filter.....\$-14206 |
| 3) Upper Side Band Filter (3500 Cycles).....\$-13624 | 8) Bridging or "Roaming" Filter (25 kc) \$-14470 |
| 4) Lower Side Band Filter (6000 Cycles).....\$-14207 | 9) Discriminator Filter.....\$-14479 |
| 5) Upper Side Band Filter (6000 Cycles).....\$-14208 | |

Prices and additional literature on request.

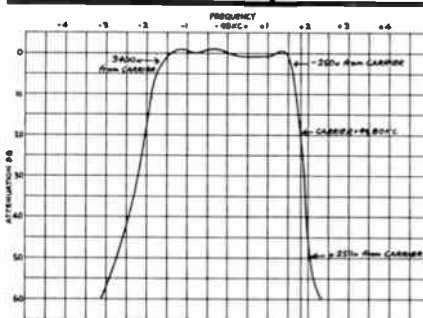

100 KC SIDE-BAND FILTER

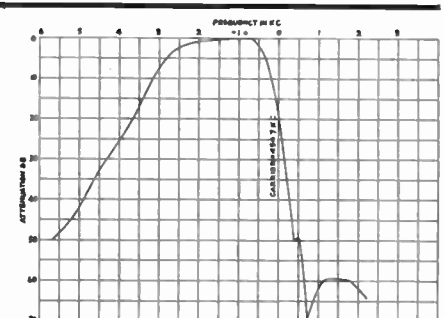

CRYSTAL-TOROID SINGLE SIDE-BAND FILTER TYPE TX-455-5B

write for your free catalog today to:



Burnell & Co., Inc.

DEPT. PI-12 45 WARBURTON AVENUE, YONKERS 2, N.Y. YONKERS 5-6800

Watch for forthcoming announcements concerning special developments in this field!

first in
toroids
filters and
related
networks

**SOLA CONSTANT
VOLTAGE TRANSFORMER**

+

**HIGH CAPACITANCE
FILTER SECTION**

+

**GERMANIUM
RECTIFIER**



DC SOLAVOLT, shown partly disassembled here, has major components identified. It is designed for relay-rack mounting on a standard, 19" frame or for bench use. Removable handles, for convenience when portability for bench use is desired, are available as accessory equipment.

Unique combination of components in adjustable "DC Solavolt" regulated power supply reduces conventional size, weight, and cost

Compact size, low weight, high efficiency, and moderate price distinguish the new "DC Solavolt" from conventionally-designed, regulated, adjustable dc power supplies. These outstanding advantages have been secured by using a unique assembly of components (shown above) that occupy only 7" of height and 12¼" of depth on a standard, 19" relay rack frame.

Along with design simplicity, the "DC Solavolt" provides laboratory standards of performance:

OUTPUT VOLTAGE REGULATED WITHIN $\pm 1\%$ at full load with supply voltage variations up to $\pm 15\%$. (Regulation within $\pm 1.5\%$ at 50% load and lowest voltage setting.)

RIPPLE VOLTAGE HELD WITHIN 0.10% (rms) at full load and nominal input voltage.

An important feature of this adjustable dc power supply is its ability to handle transient or "pulse" loads of up to twice the full load rating of the supply. The "DC Solavolt" has no tubes to replace, requires no "compensating" or "zero" adjustments, and needs no maintenance.

Six stock models provide outputs adjustable in voltage ranges between 5 and 400 volts and load currents up to 7 amperes. Your local electronic distributor now has the "DC Solavolt" in stock. He will be happy to give you further, technical information.

SOLA *Constant Voltage*
DC POWER SUPPLIES



Write for Bulletin DC-245
SOLA ELECTRIC CO.
4633 W. 16th Street
Chicago 50, Illinois

CONSTANT VOLTAGE TRANSFORMERS • FLUORESCENT LIGHTING BALLASTS • MERCURY VAPOR LIGHTING TRANSFORMERS
SOLA ELECTRIC CO., 4633 West 16th Street, Chicago 50, Illinois, Bishop 2-1414 • NEW YORK 35: 103 E. 125th St., TRafalgar 6-6464
PHILADELPHIA: Commercial Trust Bldg., Rittenhouse 6-4988 • BOSTON: 272 Centre Street, Newton 58, Mass., Blgelow 4-3354 • CLEVELAND 15:
1836 Euclid Ave., PRospect 1-6400 • KANSAS CITY 2, MO.: 406 W. 34th St., Jefferson 4382 • LOS ANGELES 23: 3138 E. Olympic Blvd., ANgelus
9-9431 • SOLA ELECTRIC (CANADA) LTD., TORONTO 17, ONTARIO: 102 Laird Drive, Mayfair 4554 • Representatives in Other Principal Cities

Partners in Performance



Electronic WIRES and CABLES

Since the earliest days of Radio . . . preferred by electronic engineers who put quality first. Rubber and Plastic wires for many modern uses, including a full line of

- MICROPHONE CABLES • SHIELDED WIRES**
- ALL-PURPOSE HOOKUP WIRES • TELEVISION DOWN LEADS**
- INTERCOMMUNICATION CABLES**

CUSTOM CORD SETS

Engineered the CORNISH way, to fit YOUR special requirements

MADE BY ENGINEERS FOR ENGINEERS

CORNISH WIRE COMPANY, INC.

50 Church Street

New York 7, N. Y.

MARCONI SPECTRUM ANALYZER

3 to 30 Mc

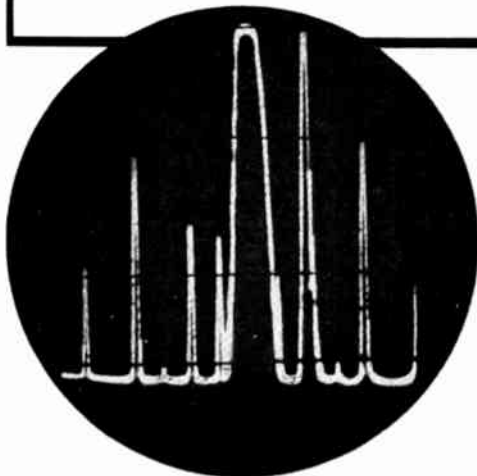

*Designed by GPO
Precision-built
by Marconi*

In transmitter hall or laboratory, Model 1094 will measure side-bands only 40 cycles off carrier frequency and 60 db down in amplitude.

Illustration shows spectrum width set to 600 cycles, range -30 to -60 db.

Hand calibrated and extremely stable, Model 1094 is a delight to use.

BRIEF SPECIFICATION

- Frequency: 3 to 30 Mc in 9 ranges
- Amplitude Range: 0 to -30 and -30 to -60 db
- Accuracy: ± 1 db
- Selectivity at 3 db points: 6, 30 and 150 cycles
- Spectrum width: variable, 100 cycles to 30 kc
- Sweep duration: 0.1, 0.3, 1, 3, 10 and 30 secs

4 Page illustrated brochure on request



MARCONI Instruments
44 New Street, New York, N.Y.

SUCCESSOR TO VTVM
measure amplify
uv...uaa



Universal DC Meter

This new microvolt-ammeter-amplifier will measure as little as 10 μv or 10 μma with accuracy. It may also be used as a DC amplifier with up to 80 db gain and only 10 μv drift. A zero-center mirrored scale provides instant polarity indication. Utilization of Kay Lab's chopper stabilized circuit provides versatility, accuracy, and stability that is unobtainable with conventional VTVM's. The Model 203 is the ideal general purpose laboratory meter, production test set, or null meter.

SPECIFICATIONS

- 100 μv to 1000 v fs
- 100 μma to 100 ma fs
- 25 ranges
- 100 megohms input
- 80 db gain as amplifier
- 10 μv equivalent input drift
- 1 volt output
- Price \$550.

*Representatives in all major cities
Write for literature or demonstration*



5725 KEARNY VILLA ROAD
SAN DIEGO 11, CALIFORNIA

IRE remembers the man

*He sent written words and pictures
by radio and created new markets!*



JOHN V. L. HOGAN, recipient of the IRE Medal of Honor, 1956 . . . for his contributions to the electronic field as a founder and builder of The Institute of Radio Engineers, for the long sequence of his inventions, and for his continuing activity in the development of devices and systems useful in the communications art.

IRE honors *John V. L. Hogan* for his leadership in electronics. His pioneering in the field of **FACSIMILE**, the electronic miracle of transmitting and receiving written words and pictures through the air, has helped build a new world market for many products and services. Mr. Hogan also established, and for many years operated, the nationally famous New York City radio station, **WQXR**. Radio engineers, such as Mr. Hogan, in reaching new frontiers of achievement, originate the demand . . . then, demand the supply. It is these men who are the creative forces in a dynamic, growing industry that IRE always remembers.

The Institute of Radio Engineers is a professional Society of 50,000 radio-electronic engineers devoted to the advancement of their field of specialization. Their official publication, *Proceedings of the IRE*, is concerned solely with these men and their accomplishments. And *Proceedings of the IRE* is the only engineering journal in the radio-electronic industry exclusively edited by and for radio-electronic engineers.

Earth satellites, FM, TV, radar, computers, color TV, transistors, scatter propagation, solid state electronics . . . all that is history making in radio-electronics is first presented, then followed step-by-step in its development, on the pages of *Proceedings of the IRE* in authoritative articles by the men behind these advances.

IRE remembers the man! Is it any wonder that the men remember IRE? Best way to get *products remembered*, if they are sold in the radio-electronics field, is through advertising in the pages of *Proceedings of the IRE* for . . . *if you want to sell the radio industry, you've got to tell the radio engineer!*



THE INSTITUTE OF RADIO ENGINEERS.
Proceedings of the IRE

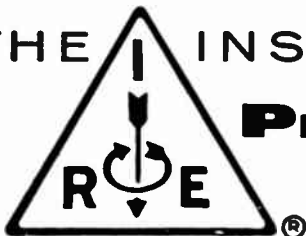

Adv. Dept., 1475 Broadway, New York 36, New York
Chicago • Cleveland • San Francisco • Los Angeles



PRECISION ATTENUATION to 3000 mc!

SINGLE "in-the-line" ATTENUATOR PADS and 50 ohm COAXIAL TERMINATIONS



PROTECTED UNDER STODDART PATENTS

This new group of pads and terminations features the popular Types C and N connectors, and permits any conceivable combination of the two styles.



PROTECTED UNDER STODDART PATENTS

six-position TURRET ATTENUATOR

- Frequency Range: dc to 3000 mc.
- Characteristic Impedance: 50 ohms.
- Available Attenuation: Any value from 1 db to 60 db.
- Accuracy: ± 0.5 db.
- Power Rating: One watt sine wave power dissipation.

STODDART
Aircraft Radio Co., Inc.
6644-C SANTA MONICA BLVD.
HOLLYWOOD 38, CALIF. • HO 4-9294



News-New Products

These manufacturers have invited PROCEEDINGS readers to write for literature and further technical information. Please mention your IRE affiliation.

(Continued from page 216A)

used in the skeleton frames: Panel mounting holes are punched automatically in long sections so that the entire interior of the frames are ready to take endless varieties of "skins." Forty different types of panels, four different size drawers ranging from 7 to 14 inches high, and 16 inches deep make up the component parts which can be fashioned to the frames.

Klystron Modulator

Designed for high-power tube-development applications, the Model PC 43 Modulator has been made available by Levinthal Electronic Products, Inc., 2979 Fair Oaks Ave., Redwood City, Calif. Equipment (illustrated, l. to r.) consists of 40-kw X-Band magnetron driver; a complete control console for remotely operating the klystron and all associated equipment; a line-type modulator oper-

(Continued on page 222A)

NEW... from ANTLAB

to achieve stable
modulation frequency



FORK CONTROLLED MODULATOR #7227

- Square Wave Modulation
- Power Sine Wave Modulation
- Sine Sample

One of the many Antenna pattern Range Components offered by ANTLAB . . .

ANTLAB, Inc.

4950 N. High St., Columbus 14, Ohio



CASCADE
RESEARCH
CORPORATION
FOREMOST IN

ferrite
MICROWAVE
APPLICATIONS

Introducing
another
broad-band

Uniline
load isolator

Model KU-143

FREQUENCY RANGE: 12.4 to 18.0 kmc. . . .

ISOLATION: 20 db at band center.
13 db at band edges.

INSERTION LOSS: 0.5 db.

VSWR: Less than 1.10

POWER: 100 watts, average. 100 KW, peak.

WAVEGUIDE: RG91/U. (.702" x .391")

FLANGES: UG419/U.

All specifications are nominal and subject to change.



CASCADE RESEARCH CORPORATION

53 Victory Lane, Los Gatos, Calif.

why companies find it
GOOD BUSINESS
 to specify panel instruments
 by *Simpson...*

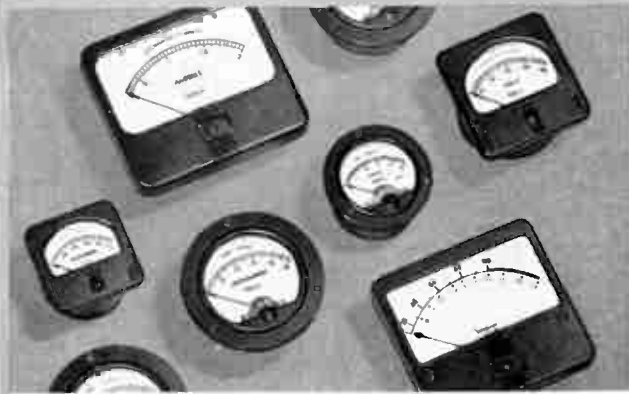

... **QUICK SERVICE** from **HUGE STOCKS!**

Over 50,000 stock units, in 800 sizes and types are available through 1,500 electronic distributors. Wherever you are located, Simpson instruments are obtainable promptly.

CORE MAGNET METER MOVEMENT

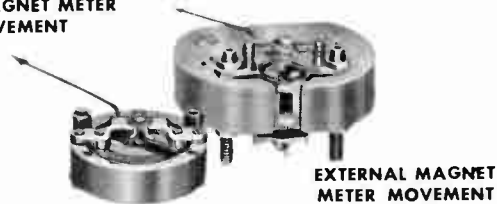

... **EXACT NEEDS CUSTOM BUILT!**

Many meters quickly built from *standing tools*, or designed to your exact specifications. Firm delivery schedules. Movements include the superb, *self shielded* Core Magnet Meter Movement.

● Simpson instruments have established a reputation for laboratory accuracy . . . yet they have the ruggedness to stand up under years of service and severe shocks. Write for new catalog.

SIMPSON ELECTRIC COMPANY

5200 W. Kinzie St., Chicago 44, Illinois
 Phone: EStebrook 9-1121
 In Canada: Bach-Simpson Ltd., London, Ont.



Instruments that stay accurate

Now... a low cost, reliable
SUPERSENSITIVE RELAY



NEW!

Simpson

METER RELAYS

of improved design and reliability

**Less than 50 Millimicrowatts
 Control Up to One Watt!**

Here is a line of improved Meter Relays that offers lower costs, plus circuit simplification for many alarm, control, and limit setting applications. The new design features platinum alloy contacts and increased contact force which minimizes sticking and provides extreme reliability. Simpson Meter Relays are a nonlocking type, currently available in 2" DC and 3" AC and DC models. Write for new Technical Bulletin No. 17, today.

SIMPSON ELECTRIC CO.

5200 W. Kinzie St.
 Chicago 44, Illinois
 Phone: EStebrook 9-1121
 In Canada:
 Bach-Simpson Ltd. London, Ont.



INSTRUMENTS THAT STAY ACCURATE

AMERICAN TELEVISION &
RADIO CO. ST. PAUL, MINN.

For those who
want the finest!

ATR TV

*Full Door Console
Receiving Sets*

UNSURPASSED
IN BEAUTY

UNEQUALLED
IN PERFORMANCE

UNMATCHED IN
QUALITY
CONSTRUCTION

exclusive
profitable
dealer
franchises
now available



*designed
with the
Serviceman
in mind
... easy to
get at*



WRITE TODAY FOR COLORFUL
BROCHURE SHOWING THE
NEW LINE OF ATR TV SETS

ALSO MANUFACTURERS OF DC-AC INVERTERS,
"A" BATTERY ELIMINATORS, AUTO RADIO VIBRATORS

ATR AMERICAN TELEVISION & RADIO CO.
Quality Products Since 1931
SAINT PAUL 1, MINNESOTA-U. S. A.



News-New Products

These manufacturers have invited PROCEEDINGS readers to write for literature and further technical information. Please mention your IRE affiliation.

(Continued from page 220A)

ating with a pulse length of 0.5 microsecond at repetition rates from 10 to 4000 cps; and a pulse transformer tank including a 140-kv 60-ampere pulse transformer and a capacitance voltage divider, as peak-current and average-current monitoring circuits.



The control console includes four 100-volt 10-ampere focusing-magnet supplies; a built-in Tektronix oscilloscope, which provides selector-switch monitoring of all significant system waveforms; four Hewlett-Packard meters for monitoring rf power from input and output directional couplers; a built-in cavity wave-meter; metering and controls for reservoir voltage to five 1754 hydrogen thyratrons; power-supply voltage and current meters along with meters for klystron body and collector current, klystron filament voltage; a complete 10 to 4000-cps trigger generator including two variable delay outputs, as well as all necessary controls, breakers, interlocks, and so forth etc., needed to control and protect the system.

Switch and Relay Catalog

A complete catalog of switches and relays manufactured by Jaidinger Mfg. Co., Inc., Hubbard St., Chicago 22, Ill. which shows approximately forty different switches and relays, ranging in size from standard size units to the miniature, and describes the operation and characteristics of each.

The catalog also shows many of the new developments in switches and relays and gives complete specifications, size, capacities and other information, and catalog inquiries should be addressed to the Service Department at that address.

(Continued on page 224A)

GET YOUR NEW

1957 Radio Electronic MASTER

(21st EDITION)

- What product best fills your needs?
 - What does it look like?
- How does it compare? • Who makes it?
 - What does it cost?

Up-to-the-minute answers to all these questions are in The MASTER. Containing four to five times the product coverage of any other buying guide — there is no catalog like it. It is 350 factory-prepared catalogs in one bound volume.

1546 PAGES...

the world's largest electronic parts catalog!



\$295
ONLY
from parts distributors

Over 93% of those who buy, specify or design electronic components rely upon and buy from up-to-date MASTER information. Its 125,000 products for research and production applications are systematically arranged by product sections for instant reference.

1546 PAGES OF THE MOST CURRENT DATA ON:

SPECIAL PURPOSE TUBES
TRANSISTORS—PRINTED CIRCUITS
MODULES—TEST EQUIPMENT
CAPACITORS—CONTROLS
TRANSFORMERS—RELAYS
WIRE & CABLE—TOOLS
NI-FI—PA SYSTEMS, ETC.

- Over 125,000 items
- Complete descriptions
- Specifications—Prices
- 11,250 illustrations
- Fully Indexed
- 8 1/2 x 11", 6 lbs.

No matter what electronic component you look for

**YOU FIND IT FASTER
IN THE MASTER**

Get the 1957 edition from local parts distributors — or write for list.

THE Radio-Electronic MASTER
110 Lafayette St., New York 13, N. Y.

Professional Group on Electron Devices

Developments in the field of electron devices have probably had a greater influence on radio-electronic progress than the developments of any other field. For it is the electron device which is the active, working element around which the rest of the equipment is built. It is this component which generates, modulates, converts, detects, and amplifies signals, and which enables the apparatus to perform its prescribed functions.

It is not surprising, therefore, that a great deal of effort has been directed toward improvements in electron tubes and semiconductors, and that the resulting advances have received close and widespread attention. The rewards have been impressive. Work on cathode-ray tubes, for example, was a prime factor in the successful evolution of television. The advent of klystrons, magnetrons and traveling-wave tubes made possible the development of equipment capable of operating in the microwave portion of the spectrum. The transistor offers new possibilities which are only now being realized.

IRE members who wished to keep abreast of the many developments in this important and rapidly moving field were greatly aided by the formation of the IRE Professional Group on Electron Devices in 1951. The Group immediately began to organize technical sessions in its field at many of the national meetings held during the year. This was followed by the formation of Group Chapters throughout the country which collaborate with IRE Sections to sponsor meetings locally.

Perhaps of greatest importance, the Group began publishing its own technical publication, called Transactions, which is distributed free to all members who pay the assessment fee of \$2.00. The Transactions is now issued quarterly to some 2700 members, and has become an invaluable source of information on the latest technical developments in the field of electron devices.

W. R. G. Baker

Chairman, Professional Groups Committee



At least one of your interests is now served by one of IRE's 24 Professional Groups

Each group publishes its own specialized papers in its *Transactions*, some annually, and some bi-monthly. The larger groups have organized local Chapters, and they also sponsor technical sessions at IRE Conventions.

Aeronautical and Navigational Electronics (G 11)	Fee \$2
Antennas and Propagation (G 3)	Fee \$4
Audio (G 1)	Fee \$2
Automatic Control (G 23)	Fee \$2
Broadcast & Television Receivers (G 8)	Fee \$2
Broadcast Transmission Systems (G 2)	Fee \$2
Circuit Theory (G 4)	Fee \$3
Communication Systems (G 19)	Fee \$2
Component Parts (G 21)	Fee \$2
Electron Devices (G 15)	Fee \$2
Electronic Computers (G 16)	Fee \$2
Engineering Management (G 14)	Fee \$1
Industrial Electronics (G 13)	Fee \$2
Information Theory (G 12)	Fee \$2
Instrumentation (G 9)	Fee \$1
Medical Electronics (G 18)	Fee \$2
Microwave Theory and Techniques (G 17)	Fee \$2
Military Electronics (G 24)	Fee \$1
Nuclear Science (G 5)	Fee \$2
Production Techniques (G 22)	Fee \$2
Reliability and Quality Control (G 7)	Fee \$2
Telemetry and Remote Control (G 10)	Fee \$1
Ultrasonics Engineering (G 20)	Fee \$2
Vehicular Communications (G 6)	Fee \$2

IRE Professional Groups are only open to those who are already members of the IRE. Copies of Professional Group Transactions are available to non-members at three times the cost-price to group members.



The Institute of Radio Engineers
1 East 79th Street, New York 21, N.Y.

USE THIS COUPON

Miss Emily Sirjane
IRE—1 East 79th St., New York 21, N.Y.

PG-12-56

Please enroll me for these IRE Professional Groups

.....\$

.....\$

Name

Address

Place

Please enclose remittance with this order.



Welwyn

High Stability Resistors

- DEPOSITED CARBON
- MINIATURE POTENTIOMETERS
- GLASS SEALED HIGH VALUE WELMEGS
- VITREOUS ENAMEL COATED WIRE WOUND
- ENCAPSULATED DEPOSITED CARBON RESISTORS

Welwyn precision products are manufactured in Canada and England. They are designed and constructed for the most exacting electronic requirements. These standards are uniformly maintained through rigid quality controls.

Please address communications to Dept. NM-4

Welwyn International, Inc.

3355 Edgecliff Terrace, Cleveland 11, Ohio



News-New Products

These manufacturers have invited PROCEEDINGS readers to write for literature and further technical information. Please mention your IRE affiliation.

(Continued from page 222A)

Stitzer Named Chief Engineer of Beta Electric

Jesse Stitzer has been advanced to the position of Chief Engineer of the Beta Electric Division, Sorensen & Co., Inc., 333 E. 103rd St., New York, N. Y.



He has been associated with Beta since 1950, first in their Test Laboratory and later in the Design Division. For the past three years he has served as a Project Engineer, doing applied research and development work on ultra-compact, high voltage dc power supplies, in which field he has several patents pending.

Miniature Sensitive Relay

A new sensitive relay in minimum size has been developed by the Electronics Div., Elgin National Watch Co., Elgin, Ill.

Designed to perform with low drain, the relay operates on as little as 10 mw of power.

In its primary application, the SN relay will be used in aircraft navigational control systems, but has equal application in power-premium communications equipment.

The relay measures 1 3/4 inches in height, is 0.968 inches square, and weighs 3 ounces.

It operates over a temperature

(Continued on page 226A)

The RADIO ENGINEERING SHOW

moves to the COLISEUM! MARCH 18-21 • NEW YORK CITY

SO BIG it takes all 4 floors of New York City's Coliseum to hold this year's great annual IRE Radio Engineering Show. For 4 phenomenal days the largest show ever assembled will open its doors to more than 41,000* engineers just 4 minutes from Times Square.

IS IT TOO BIG—not for a 12 billion dollar and still growing industry! More than 200 papers presented by 22 professional groups at the Convention's 55 technical sessions will summarize all that's new in radio-electronics research and development... the 834 exhibitors will also represent over 80% of the productive capacity of the industry. Not by a long shot is this show too big for what will soon be our nation's largest industry. Plan now to be at this vitally important radio-electronics show!

*41,017 engineers and businessmen from coast to coast and in every field of radio-electronics attended the 1956 Radio Show... the forecast for 1957 is even higher!

Registration:
IRE Members \$1.00
Non-Members \$3.00

OVER 800 NEW IDEAS
IN RADIO-ELECTRONICS
ENGINEERING
PRESENTED BY MORE THAN
800 EXHIBITORS!

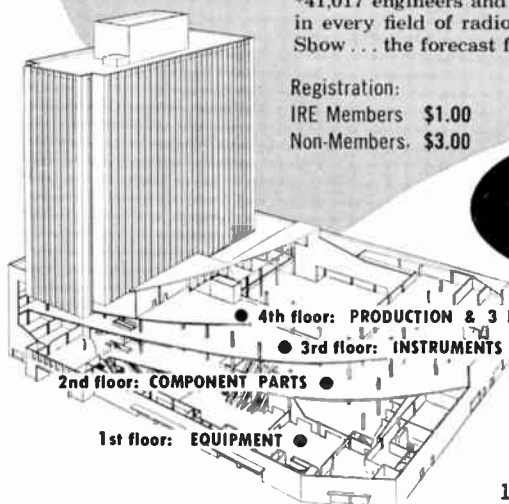

The
Institute of
Radio
Engineers

1 East 79th Street, New York 21, N. Y.



A combination . . . for going places

Laminated plastics . . . a combination of properties for doing things

Synthane laminated plastics work for industry in so many different ways because of their unusual combination of mechanical, electrical and chemical properties. Engineers in practically every major industry have put Synthane's many combination properties to work . . . providing unusual strength and toughness, high insulation resistance, low moisture absorption, good dimensional stability, and excellent resistance to corrosive acids, alkalis, salts and solvents in a variety of products.



Synthane Power Shovel Parts. Electrical insulating ability and mechanical strength are the properties most needed in this application. The Synthane grade selected is also wear resistant, easily fabricated to precise dimensions, and can be laminated directly over metal cores for extra strength.



A Synthane grade for you! Synthane offers over 30 individual grades in sheets, rods, tubes, moldings and completely fabricated parts. Send for free illustrated catalog today.



DIELECTRIC STRENGTH



IMPACT STRENGTH



HEAT RESISTANCE



LIGHT WEIGHT

SYNTHANE

S

SYNTHANE CORPORATION, 8 RIVER ROAD, OAKS, PA.



**you
can't
afford
to
"do
it
yourself"**

Where custom systems are involved, it just doesn't pay to do the work yourself. Not when EECO can do it for you—expertly, efficiently—without disrupting the normal productive activities of your engineering staff. Major EECO installations in operation in all parts of the country are proof of Electronic Engineering Company's ability to design and produce anything from single-rack recording systems to the most complex multi-console master installations. And EECO design techniques, perfected through years of systems work, are now ready to be put to work for you in an EECO engineered system to meet your exact requirements.



One wing of the EECO Central Dual Timing System at Patrick Air Force Base, Florida. This system is a master time signal generating installation for the base and ties in with all instrumentation operations for guided missile testing.

PLUG-IN CIRCUITS

...your key to lower design and production costs. These EECO plug-ins have proven themselves in scores of major installations...the one above contains more than 2,500 units. Originally designed for EECO systems, these packaged circuits are now available to you. Complete data on standard and custom circuits in catalog H-1.



ELECTRONIC ENGINEERS AND PHYSICISTS — EECO offers unusual career opportunities for advancement and professional growth in the creative field of systems and related electronic projects. Send resume to the attention of R. F. Lander.



Electronic Engineering Company
of California

and its subsidiary **Engineered Electronics Company**
180 South Alvarado Street • Los Angeles 57, California



News-New Products

These manufacturers have invited PROCEEDINGS readers to write for literature and further technical information. Please mention your IRE affiliation.

(Continued from page 224A)

range of from -65°C to $+105^{\circ}\text{C}$ with high vibration resistance in both SPDT and DPDT models.

At the 10 mw power rating the relay has coil resistances of 8,000 and 10,000 ohms and at 40 mw ratings of 500, 2,500, 8,000 and 10,000 ohms with others available upon request.

New P-N-P Transistor

Herman Fialkov, president of **General Transistor Corp.**, 130-11 90 Ave., Richmond Hill, L.I., N. Y., manufacturers of transistors and other semi-conductor products, announced the production of a new germanium P-N-P alloyed junction 3-lead transistor.

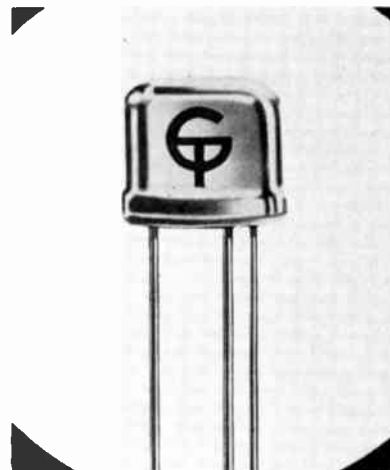

Known as type GT-109, it is designed primarily for use in low frequency push-pull stages such as audio amplifiers, portable radio receiver output stages and low frequency rf amplifiers. Used in class B circuitry, the GT-109 offers high efficiency and low battery drain.

The entire unit is hermetically sealed in a metal case with glass headers. The tinned flexible leads may be soldered into the circuit or used with standard plug-in sockets. They may also be mounted in any position.

**Use your
IRE DIRECTORY
It's valuable**

COMMUNICATIONS EQUIPMENT CO.

THERMISTORS

D-164699 Bead Type DCR. 1525-2550 Ohms @ 75 Deg. F. Coefficient: % Per. Deg. Fahr. Max. Current 25 MA AC/DC \$1.00
 D-167332 Bead Type DCR is 2525-2550 Ohms. Rated 25 MA at 825-1175 VDC \$1.00
 D-167613 Disk Type DCR: 355 Ohms @ 75 Deg. F. 1% 2.5%, 1 Watt \$1.00

MICROWAVE COMPONENTS

10 CM.—RG48/U Waveguide

POWER SPLITTER for use with type 726 or any 10 cm. Shpherd Klystron. Energy is fed from Klystron antenna through dual pick-up system to 2 type "N" connectors \$12.50
 LHTR. LIGHTHOUSE ASSEMBLY. Parts of RT39 APG 5 & APG 15. Receiver and Trans. Cavities w/ assoc. Tr. Cavity and Type N C.M.G. To Recv. Uses 2K40, 2C43, 1B27. Tunable APX 2400-2700 MCs. Silver Plated \$15.00
 BEACON LIGHTHOUSE cavity p/p UFN-2 Beacon 10 cm. Mfg. Bernard Rice, each \$27.50
 MAGNETRON TO WAVEGUIDE Coupler with 721-A Duplexer cavity, gold plated \$31.50
 721A TR BDX complete with tube and tuning plungers \$12.50
 GENUALLY KLYSTRON CAVITIES for 701A or 721A, 2700-2900 MC \$4.00
 HDLMDLL-TD-TYPE "N" Male Adapters. W. E. 51167284 \$2.75
 BEACON ANTENNA AS31/APN-7 in Lucite Ball. Type "N" feed \$22.50
 ANTENNA, AT49A/APR: Broadband Conical, 300-3300 MC Type "N" \$12.50
 "E" PLANE BENDS, 90 deg. less flanges \$7.50
 K-Band, X-Band Expt. Available. Send for List

X BAND—1" x 1/2" WAVEGUIDE



90 degree elbows. "E" or "H" Plane 2 1/2" radius \$8.50
 AT-66/UP 3 cm Horn with type N feed for receiver measurements, etc. New \$7.45
 RTDARY JDINT (AFS-6) Sperry PT 6658275, 180 deg. rotation, choke-to-choke. Has "Built-in" Di-Coupler, 20 DB, with "N" Takeoff \$22.50
 PARABOLIC DISH, 18" diam, Spun Aluminum, 8" Focus. For AN/APN-6 \$4.95
 3 CM. DIPPLE and Feed Assembly. (May be used with above dish) 3 inches long \$5.00
 FLEXIBLE SECTION 9 in. long. Cover-to-cover \$5.50
 RTDARY JDINT (AFS-6) Sperry PT 6658275, 180 deg. rotation, choke to choke. Has "Built-in" Di-Coupler, 20 DB, with "N" Takeoff \$22.50
 3 CM. DIPPLE Feed, 15" L for AFS-15 \$14.50
 MITRED ELBDW. Cast aluminum, 1 1/4" x 3/4" W x 1/2" H. Flanges "E" Plane \$3.50
 3 CM. ANTENNA ASSEMBLY: Uses 17" paraboloid dish, operating from 24 vdc motor. Beam pattern: 5 deg. in both Azimuth and elevation. Sector Scan: over 160 deg. at 35 scans per minute. Elevation Scan: over 2 deg. Tilt. Over 24 deg. \$35.00
 Cross-Guide Directional Coupler. UG-40 output flange. Main Guide is 8" long, with 90 deg. "E" Plane bend at one end, and is fitted with Std. UG 39/113 40 flanges. Coupling figure: 20 db Nominal \$22.50
 Rotating-Joints supplied either with or without deck mountings. With UG40 flanges \$17.50
 Bulkhead Feed-thru Assembly \$15.00
 Pressure Gauge Section with 15 lb. gauge \$10.00
 Directional Coupler. UG-40/U Take off 20db \$17.50
 MAGNET ANTI-STABILIZER CAVITY For 2J11 Magnetron \$24.50
 ADAPTER, waveguide to type "N". UG 81-U, p/o TS 12, TS-13, Etc. \$7.50
 ADAPTER. UG-163/U round cover to special BTL. Flange for TS-45, etc. \$2.50 ea.

COAXIAL R.F. FILTERS

F-29/SPR-2. Hi-Pass, with 1000 mc. Cut-off. Type "N" Input and Output, 50 Ohms Z \$9.50
 F-41/SPR-1. Hi-Pass, with 300 mc cut-off. Type "N" input and output, 50 Ohms Z \$10.50

MICROWAVE ANTENNAS

3 CM ANTENNA ASSEMBLY: Uses 17" paraboloid dish, operating from 24 vdc motor. Beam pattern: 5 deg. in both Azimuth and elevation. Sector Scan: over 160 deg. at 35 scans per minute. Elevation Scan: over 2 deg. Tilt. Over 24 deg. \$35.00
 3 cm. Horn, 1" x 1/2", with twist and 180 deg. bend. With dielectric window \$22.50
 AT49/APR—Broadband Conical, 300-3300 MC, Type N Feed \$8.95
 Discone Antenna. AN 125 APR, 1000-3200 mc. Stub supported with type "N" connector \$14.50
 AS14/AP, 10 CM pick up dipole array, complete w/ length of coax and "N" connectors \$4.50
 AS46/APG-3 Yagi Antenna, 5 element array \$22.50
 30" Parabolic Reflector Spun Aluminum dish 10 1/2" Focus \$4.85
 AN/APA-12—Sector Scan adaptor for AFS-2 radar—Complete Kit \$37.50
 LP-24 Alford loop, for use with at-the-path transmitters (MRN-1), etc. 100-108 mc. \$32.50
 18" PARABOLIC DISHES, spun aluminum. Focus approx. 8 inches \$4.95
 10 CM. ANTENNA ASSY. (Airborne). 30" dish with coax. dipole feed. Focal length is 10 1/2" Horiz. polariz. 350 deg. azimuth. Tilt: plus and minus 20 deg. 28 vdc drive motor, selsyn takeoff \$65.00

CBS TEST GEAR*

Bonton 110-A QX Checkers
 Bonton Assorted 111-A Coils
 202-B Bonton FM Signal Generators
 Browning MD-33 FM Deviation Monitor
 Brush BL-1502 Deviation Test Bridge
 General Radio 106-L Standard Ind.
 General Radio 107-K Variable Ind.
 107-D General Radio Variable Ind.
 General Radio 219-M Decade Cond.
 General Radio 546-B Audio Freq. Microvoltage
 General Radio 583-A Output Power Meter
 General Radio 722-D Precision Condenser
 General Radio 731-B Modulator Monitor
 General Radio 732-B Dist. & Noise Meter
 General Radio 732-PI Range Ext. Filter
 General Radio 740 Cap. Test Bridge
 General Radio 1021-P2 UHF Generator & Power Supply
 General Radio V-5 Varlac
 General Radio 715-A Direct Current Amp.
 General Radio 1000-P6 Crystal Diode Modulator
 General Radio 487-A Megohmmeter
 General Radio 1551 Sound Survey System
 1262-A General Radio Power Supply
 General Radio 1021-P2 UHF Unit
 Gerlach FM-3 Frequency Meter
 Hewlett-Packard 320-A Distortion Analyzer
 Hewlett-Packard 300-A AC VTVM
 Hewlett-Packard 325-B Noise Dist. Meter
 Hewlett-Packard 430-B Wattmeter
 Kay Electronics Dual Mega Marker Sr.
 Kay Electronics Mega Pix
 Kay Electronics Mega Marker Sr.
 Kay Electronics Mega Sweep
 Kay Electronics Mega Marker Sr.
 PRD 904 UHF/VHF Generator & Diode
 Sensitive Research ESH Electrostatic VTVM
 Sensitive Research IDCHI Kilovolt Meter
 Sensitive Research Model F Fluxmeter
 Sensitive Research Model GM Mutual Cond. Dynamometer
 Sensitive Research Model S DC Voltmeter
 Shallcross Power Factor % Standard
 Siemens & Halske Galvanometer
 Signal Corps 1-22A Signal Generator
 Simpson 276 Dcc. Calibrator
 Spence Kennedy 212CTV TV Amplifiers
 Sylvania 400 Oscilloscope
 Tarc 1051-AR Distribution Amplifier
 Telechrome 1603AR/1603AR2/513 ARM/Rack—Phase Delay Line Generator
 Telechrome 1600-AR Cal. Phase Shifter
 Tel-Instrument 2113 Signal Generator
 1211 Tel-Instrument UHF Wobulator
 Tel-Instrument 1500 RF Generator
 Tel-Instrument 1212 RF Wobulator
 Tel-Instrument 1902-A AM/FM Generator
 Tel-Instrument 1210 RF Wobulators
 Tel-Instrument 1500 Wobulators
 Tel-Instrument 180 Sine Frequency Generator
 Telechrome Type 1051 ARM 5 Chan. Hi-Level Video Distr. Amp.
 Telechrome Reg. Power Supplies
 Tarc Type 5-Channel Hi-Level Video Distr. Amp.
 Tarc Reg. Power Supplies
 Tarc VS-100 Video Line Selector
 Tarc DA-7100 Video Line Amplifier
 Telematic UH14-83 UHF Booster
 Telechrome 600-AR Patch Panel
 General Electric 8KT9F3 Timer
 Harvey 205TS Oscilloscope
 Industrial Transformer 1230 AC High Voltage Tester
 Instrument Electronics AC VTVM
 J.B.T. 30FX Line Freq. Meter (48-52: 58-62) in case Jones 711-N Micromatch
 Landa Electronics 25 Reg. Var. Vtgs. Power Supply
 Lambda Electronics Reg. Var. Power Supply
 Measurement 62 VTVM
 Measurement 80-5 db. Pad.
 Measurement M-286 Balun
 Measurement 62 VTVM
 Measurement 58Z12 Hi-imp. Probe
 Monarch 41 Output Meters
 Monarch 14 Signal Generator (Broadcast Band)
 Monarch 60-cycle Multi-Vibrator
 A.T.R. 110BT Inverter
 Bet Electric 102 Kilo Voltmeter
 Barker Williamson Sine Wave Clipper
 Bonton 509-A 20 db Attenuator
 Bonton 509-B 20 db Attenuator
 Blitz Electric T-12 Battery Charger
 Clough-Bregle 182-A Audio Sweep Generator
 Communications Meas. Lab 1100 Freq. Voltage Power Supply
 Cornell-Dubilier CDC-5 Decade Cap. Box
 Daven DP961 Power Output Meter
 Dumont 274-A Oscilloscope
 Dumont 264-B Voltage Cal.
 Dumont 164-E Scope
 Eico 221 VTVM
 Eico 241 VTVM (incomplete)
 Ferris 10-B Microvoltage
 Ferris 20-B Microvoltage
 Leeds & Northrup 21553 Ratio Boxes
 General Radio 804 CS Signal Generator, 8-330 Mc.
 TS 13 X-Band Signal Generator and Power Meter/Wavemeter/Monitor
 TS 47/APR VHF Oscillator, 50-500 mc. 110 vac. 50-400 cy.
 TS 100 Oscilloscope/range calibrator
 Sperry Klystron Power Supply and Modulator
 TS 35/AP, X-Band signal generator, 115V, 50-800 cy.
 RCA UHF Oscillator, 380-560 mc.
 General Radio 224 Precision Wavemeter

*A fortunate "buy" from local CBS mfr. enables us to pass on tremendous savings to you! All units are in used but excellent condition. Many more items too numerous to list, are in stock. Write for further information.

DYNAMOTORS

TYPE	INPUT		OUTPUT		Price
	VDLTS	AMPS	VDLTS	AMPS	
BDAR83	14		375	.150	\$6.50
PDSX-15	14	2.8	220	.08	8.95
DM33A	28	7	540	.250	3.95
B-19	12	9.4	275	.110	6.95
DA-3A*	28	10	300	.260	3.95
			150	.010	
			14.5	5.	
PE 73 CM	28	19	1000	.350	17.50
BD 60†	14	2.8	220	.08	8.95
DAG-33A	28	3.	450	.06	2.50
BDAR 93	28	3.25	375	.150	6.95
* Less Filter.					
† Used. Excellent.					
* Replacement on PE 94.					
PE 94 - Brand New					5.95

UNDERWATER MICROPHONE

Model JR-1 Hydrophone is a piezo-electric device using an array of 20 barium titanate cylinders enclosed in a rubber cylinder 4 1/2 inches L and 2 1/2 inches in diam. Sensitivity:—105 db/microbar relative to 1 v/microbar. Frequency response: 200-15,000 cps. Impedance 100-150 ohms. The response at all angles to axis is uniform over an azimuth of 360 deg. The Hydrophone may be operated at depths up to 1000 ft. and temperatures of -1 deg. C. to 35 deg. C. \$52.50

POWER TRANSFORMERS

COMBINATION—115V/60~INPUT		
CT-133	150-C-150V/65MA, 6.3V/2.5A, 6.3V/0.6A	1.79
CT-127	900V/25MA PK, 5V/2A, 2V/7.5A	2.79
CT-006	350-0.350V/120MA, 5VCT/3A, 2.5-VCT/12.5A, 2.5VCT/3.5A	4.39
CT-965	78V/0.6A, 6.3V/2A	1.95
CT-004	350-0.350V/90MA, 5VCT/3A, 2.5-VCT/12.5A	4.60
CT-002	350-0.350V/50MA, 5VCT/2A, 2.5VCT/7.5A	3.65
CT-479	7000V/.018V, 2.5V/5A/17.800 V, Test	22.50
CT-013	450-0.450V @ 200MA, 10V/1.5A, 2.5, 3.5A, 5V/3A	4.35
CT-403	350V/10.325A, 5V/3A, 6.3V/6A	2.75
CT-931	585VCT .086A 5V/3A, 6.3V/6A	4.25

PLATE—115V/60~INPUT

PT-07	400VCT/4.0 AMPS For RA43	17.50
PT-034	125V/1.06A (For Preamp)	1.15
PT-521	750V/.06A, Half Wave	59.50
PT-913	2500V/12 MA H'SLD	4.95
PT-38-2	37.5/40V AT 750 MA	2.15

FILAMENT—115V/60~INPUT

FT-157	4V/16A, 2.5V/2.75A	2.95
FT-101	6V/25A	7.49
FT-924	5.25V/21A, 2.75V/6.5A	14.95
FT-824	2x2.5V/2.5A, 16V/1A, 1.2V/7A, 6.4V/10A, 6.4V/2A	8.95
FT-463	6.3VCT/1A, 5VCT/3A, 5VCT/3A	5.49
FT-55-2	7.2V/21.5A, 6.5V/6.85A, 5V/6A, 5V/3A	8.95
FT-38A	6.3V/2.5A, 2x2.5V/1.5A	2.79
FT-650	250V/10.325A TEST LD-CAP	7.50
FT-025	2.5VCT/10A, 10KV TEST	6.95

PULSE TRANSFORMERS

352-7150, Primary 50 ohms, Secondary 1000 ohms, 12,000v, 12.0 Amp. Pulse: 1 or 2 usec. at .001 duty ratio. Fitted with magnetron well and bifilar winding for filament supply \$32.50
MAGNETRON PULSE TRANS. 964:
 Prim. Imp. 30 ohms, 1600 v, pulse ratio: 1 or 2 usec. at .001 duty ratio. Turns ratio sec:pri. is 7.5:1. Duty ratio is 0.001 at 1.2 usec. Bifilar winding 1.2A \$8.50
RAYTHEON WX 4208E: Primary 4KV, 1.0 USEC. SEC. 16K-16 AMP DUTY RATIO: 001 400 CYCLE PUL. TRANS. "BUILT-IN" \$22.50
GE 2K-2449A: Primary: 9.33 KV, 50 ohms Imp. Secondary: 28 KV, 450 ohms. Pulse length: 1.05/5 usec @ 635/120 PPS. PK Power Out: 1.740 KW. Bifilar: 1.5 amps. \$62.50
GE 2K-2748-A: 0.5 usec @ 2000 Pps. Pk. Pwr. out is 32 KW Impedance 40-100 ohm output. Pri. volts 2.3 KV Pk. Sec. volts 11.5 KV Pk. Bifilar rated at 1.3 Amp. Fitted with magnetron well \$24.50
K-2745: Primary: 3 1/2 R KV, 50 ohms Z. Secondary: 14/12.6 KV 1025 ohms Z. Pulse length: 0.25/1.0 usec @ 600/800 PPS. Pk. Power 200/150 KW. Bifilar: 1.3 Amp. Has "built-in" magnetron well \$32.50

PULSE NETWORKS

M-616	10KV, 2.2 usec., 375 PPS, 50 ohms Imp.	\$27.50
M-615	10KV, 0.85 usec., 750 PPS, 50 ohms Imp.	\$27.50
M-605:	25 KV, "E" CRT, 1.5 usec., 400 PPS, 50 Ohms Impedance, 5 sections	\$62.50
7-5E3-1-200-67P,	7.5 KV "E" Circuit, 1 microsec, 200 PPS, 67 ohms impedance, 3 sections	\$7.50
7-5E4-16-60-67P,	7.5 KV "E" Circuit, 16 sections 16 microsec, 60 PPS, 67 ohms impedance	\$15.00
7-5E3-3-200-67P,	7.5 KV, "E" Circuit, 3 microsec, 200 PPS, ohms Imp, 3 sections	\$12.50

MAIL ORDERS PROMPTLY FILLED. ALL PRICES F.O.B. NEW YORK CITY, N.O. OR CHECK. ONLY SHIPPING SENT C.O.D. RATED CONCERNS SEND P.O. PARCELS IN EXCESS OF 20 POUNDS WILL BE SHIPPED VIA CHEAPEST TRUCK OR RAILCAR.

343 Canal St., New York 13, N.Y. Dept. I-12 Chas. Rosen Phone: Canal 6-4882

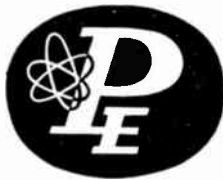

has the
most
complete
stock of

**RF COAXIAL
CONNECTORS
COAXIAL
CABLES
A N CONNECTORS
PLUG & JACK**

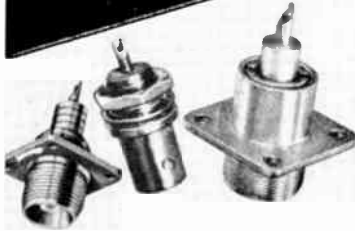

Largest inventory in the industry,
Orders Shipped the Same Day. All Jan.
Spec. Approved Components. Deal
with **PROGRESS** to Save Time and
Money.

Just off press—In our new catalog,
you will find a quick and easy reference to
determine what connectors and cables
should be specified for each application.
From this catalog you can also easily
determine what mating connectors should
be used to adapt between different series
of connectors.

Mail, Wire, Call
WOrth 2-8041

PROGRESS ELECTRONICS CO.

296 Broadway, New York 7, N.Y.

GENTLEMEN:

Please send at once your Catalog P-7, il-
lustrating and describing Coaxial Con-
nectors, Cables, Plugs and Jacks.

NAME

FIRM

ADDRESS

CITY STATE

PROFESSIONAL CONSULTING SERVICES

Advertising rates "Proceedings of the IRE"

Professional Consulting Service Cards.
1 insertion \$ 15.00
12 insertions \$120.00
50% discount to IRE members on 3 or more
consecutive insertions.
In IRE DIRECTORY \$15.00 flat rate.
1 inch only, no cuts or display type.

Advertising restricted to professional engineer-
ing and consulting services by individuals only.
No product may be offered for sale, and firm
names may not be mentioned in cards.

GEORGE W. BAKER

Electron tube consulting and design. Research
and development and preparation of prototype
electron tubes.

29 Holly Place, Stamford, Conn.
DAvis 3-5116

GLYN BOSTICK

Microwave Engineering & Design of
Coaxial and Waveguide components
and Test Equipment

8 Kay Ave., Bethpage, L.I., N.Y.
LEvittown 3-6167

Edward J. Content, P.E.

INTERNATIONAL RADIO CONSULTANT
Pan American Radio Bldg., Tangier Int'l Zone
16 Rue Delacroix Morocco
Specializing in the design & construction of
foreign electronic projects, and advising
governments at International Telecom-
munications Union.

BERTRAM M. HADFIELD, P.E.

Consulting Communications Engineer.
Electronic, Electro-mechanical Systems, and
Transmission Networks.

1295 Old Worcester Road,
Framingham Center, Mass.
TRinity 2-3452

C. M. JANSKY, JR. STUART L. BAILEY

Systems Engineering—Operational Research—
Communications Engineering—Broadcast &
Television Engineering—Applied Research
& Development

1735 De Sales Street, Washington 6, D.C.

LEONARD R. KAHN

Consultant in Communications and Electronics
Single-Sideband and Frequency-Shift Systems
Diversity Reception - Modulation Theory
Television Systems

Elizabeth Bldg., 22 Pine St., Freeport, L.I., N.Y.
Freeport 9-8800

RUSSIAN TRANSLATIONS

PHYSICS — ELECTRONICS
Herbert Lashinsky and associates
Specializing in ELECTRON PHYSICS — MICRO-
WAVES — ELECTROMAGNETIC THEORY —
SOLID STATE — GENERAL ELECTRONICS —
CIRCUIT THEORY — INSTRUMENTATION.
Room 531 10 East 39th St. New York 16, N.Y.
LE—2-0023

LEN MAYBERRY

ELECTRONICS CONSULTING ENGINEER
Laboratories and Staff

• Test Equipment Design • Proposal Writing
• Product Design • Engineering Assistance
603 W. Manchester Boulevard OREGON 8-4847
Inglewood, California

TRANSISTOR ENGINEERING

S. Moskowitz D. D. Grieg N. J. Gottfried
Product Transistorization. Complete service in
consulting, research, development, and produc-
tion on transistor circuitry, products and in-
strumentation.

67 East Centre Street, Nutley, N.J.
NUTley 2-5410

V. J. Nexon S. K. Wolf E. L. White
M. Westheimer F. W. Littell

Communications Consulting Engineers

Microwave Components Design & Development,
Propagation Studies, System Analysis, Micro-
wave profile survey & system design, Construc-
tion Supervision, Operational Training, Market
Research, Product Planning.
Times Tower Bldg., Times Square
New York 36, New York BRyant 9-8517

EVERT M. OSTLUND

Consulting Radio Engineer

Radio—Microwave—
Communication—Control—
Systems and Equipment—
Planning, Research—Development

ANDOVER, NEW JERSEY
Tel.: Lake Mohawk 8635

Benjamin Parzen

Radio—Electronics
Consulting—Research—Development
Environmental Tests Performed
for the Industry

34-01 38th Ave., Long Island City 1, N.Y.
EXeter 2-5200

WILLIAM R. SPITAL & Staff

Specialize in Design and Development of
Transformers, Chokes, etc.

for the
Electronic, Industrial and Allied Fields.
90 Magnolia Street
Westbury, L.I., N.Y. EDgewood 3-2933

TRANSLATIONS OF RUSSIAN PHYSICS AND ELECTRONICS LITERATURE

MIREK J. STEVENSON and associates
90 Laurel Hill Terrace, New York 33
WAdsworth 7-6337

Translation and abstracting services by physi-
cists and engineers in Solid State and Nuclear
Physics, Molecular Spectroscopy, Maser De-
sign, Microwave Components and Tubes.

DAVID E. SUNSTEIN

G. J. Laurent, Dr. R. W. Roop, B. D. Steinberg
Consulting Services for Research, Engineering
and Production of Industrial, Consumer, and
Government Products.

125 City Line Avenue
Bala-Cynwyd (Phla.), Pa.
MOhawk 4-0459 MOhawk 4-8090

HAROLD A. WHEELER

Laboratories and Engineering Staff
Radio and Electronics
Consulting — Research — Development
R-F Circuits — Lines — Antennas
Microwave Components—Test Equipment
Great Neck, N.Y. HUnter 2-7876

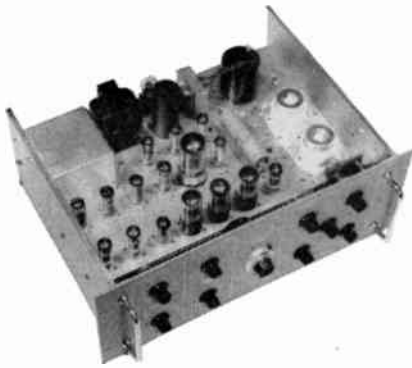

NOW . . . A HIGH IMPEDANCE CURRENT PULSE GENERATOR

FEATURES

- True Current-Source Generator
- Full Control Over Pulse Shape
- Heavily Regulated Power Supplies Throughout
- High Current, High Duty-Factor Output
- Amplitude Duty-Factor Insensitive
- Positive or Negative Pulses Output at ground level
- Compact Clean Design
- Metered average output current

The Model 1050 Generator was designed with the requirements of the magnetic circuit-device engineer in mind. Seven front panel controls permit predetermination of pulse shape and amplitude to a high degree of accuracy while the high impedance output made possible by use of air cooled, 4X150A tetrodes in the final amplifier, assures pulse shape and amplitude fidelity. A newly developed feedback clamp circuit makes amplitude independent of duty-factor, and results also in a precisely flat-topped output wave.

SPECIFICATIONS

PULSE AMPLITUDE:

0 to 2 Amperes, variable through 3600°

FREQUENCY RANGE:

50 PPS to 500,000 PPS through 4 ranges

PULSE WIDTH:

0.5 to 50 microseconds, through 2 ranges

DUTY-FACTOR:

300 Milliampere—maximum average a-c

RISE TIME-LINEAR:

0.1 to 2 microseconds, through 3 ranges

RISE TIME-EXPONENTIAL:

0.1 to 2 microseconds.

FALL TIME-EXPONENTIAL:

0.14 to 2 microseconds, (rise and fall time measurements made at 1 ampere)

FINAL CURRENT AMPLIFIER

Parallel 4X150A's operating from 525 Volts D.C.

POWER INPUT:

115 v.a.c., 1 k.w. maximum

Model 1050

Also available
on RESE EQUIPMENT
Lease Plan



rese engineering, inc.

731 Arch Street,
Philadelphia 6, Pa.
WALnut 2-5841

Manufacturers of a complete line of
Memory Core Test instruments

INDEX AND DISPLAY ADVERTISERS

Meetings with Exhibits	6A
Industrial Engineering Notes	8A
IRE People	18A
News—New Products	48A
Professional Group Meetings	101A
Section Meetings	106A
Membership	120A
Positions Open	140A
Positions Wanted by Armed Forces Veterans	144A

DISPLAY ADVERTISERS

AMP Incorporated	33A
Abbott's Employment Specialists	210A
Accredited Personnel Service	202A
Admiral Corporation	168A
Advance Electronics Lab., Inc.	229A
Aeroflex Research, Inc.	196A
Aerovox Corporation	26A, 27A
Airborne Instruments Laboratory, Inc.	2A
Aircraft Radio Corp.	101A
Airtron, Inc.	52A
Aladdin Radio Industries, Inc.	88A
Allen-Bradley Company	100A
Allied Radio Corporation	116A
American Electronic Labs., Inc.	34A
American Lava Corporation	5A
American Machine & Foundry Co.	158A
American Television & Radio Co.	222A
*Amperex Electronic Corp.	17A
Amperite Company, Inc.	124A
Amphenol Electronics Corp.	44A
Antlab, Inc.	220A
Argonne National Laboratory	143A
Arma Div., American Bosch Arma Corp.	198A
Armed Forces Communications and Electron- ics Assoc.	90A
Armour Research Foundation, Illinois Insti- tute of Technology	190A
*Arnold Engineering Company	109A
Artos Engineering Company	104A
Assembly Products, Inc.	68A
Autonetics Div., North American Aviation, Inc.	173A
Baker, George W.	228A
Ballantine Laboratories, Inc.	38A
Battelle Institute	198A
Bell Aircraft Corp.	154A
Bell Telephone Laboratories	4A
Bendix Aviation Corp., Friez Instrument Div.	199A
Bendix Aviation Corp., Guided Missile Sec- tion	170A
Bendix Aviation Corp., Pacific Division	142A
Bendix Aviation Corp., Radio Communication Div.	149A
Bendix Aviation Corp., Research Laboratories Div.	187A
Bendix Aviation Corp., York Div.	178A
*Berkeley Div., Beckman Instruments, Inc.	64A, 186A
Bird Electronic Corporation	46A
Bliley Electric Company	71A
Boeing Airplane Company	197A
Borg Corporation, George W.	98A
Bostick, Glyn	228A
*Burnell & Company, Inc.	216A
Burroughs Corporation	165A
Bussmann Mfg. Co.	79A

CBS-Hytron Div., Columbia Broadcasting Sys- tem	53A
Caledonia Electronics & Transformer Corp.	216A

* For more information, see advertisement in the multiple-page section of the 1956-1957 IRE Directory.

PRECISION PHASE METERS



TYPE 405

Features:
8 cps to 100 kc.
Accuracy $\pm 1/4^\circ$ relative,
 $\pm 1^\circ$ absolute
No amplitude adjustment.
Specifications:
Phase Range: 0-18, 0-36,
0-90, and 0-180 de-
grees.
Input Voltage: 0.3 to 70
volts.
Price: \$485.00, F.O.B. Pas-
saic, N.J.



TYPE 205

Features:
100 kc to 15 mc.
Accuracy $\pm 0.1^\circ$ or 1% of
the dial reading.
Specifications:
Resolution Time: 8×10^{-7} second;
smallest phase angle which can
be measured, 8×10^{-7} second x
360 x frequency in cps.
Sensitivity: Approximately 0.01
volt full scale maximum with-
out probe, or 0.1 volt with
probe.
Time Delay: .4 us for Type 205,
and 2.95 us for Type 205A.
Price: \$445.00 for Type 205; \$585.00
for 205A, F.O.B. Passaic, N.J.

WRITE FOR
DATA!

ADVANCE ELECTRONICS LAB., INC.

451 HIGHLAND AVE. • PASSAIC, N.J.

SPEED PRECISION PUNCHING



with
"TAPER-WEDGE"
design

WALSCO PIONEER CHASSIS PUNCH



Save time and labor with the "TAPER-WEDGE" design... a permanent, precision cutting edge that bites into metal and plastic. WALSCO Pioneer Chassis Punches make hole punching *faster, easier, more accurate*. Complete size range available at Parts Jobbers everywhere.

WALSCO HAM-R-PRESS

PORTABLE
OR BENCH
MOUNTED



No drilling... chassis punching is done quickly, economically with a hammer. Change dies in less than 20 seconds. WALSCO Ham-R-Press cuts *exact*, clean mounting holes in all chassis, metal panels, plastic sheets, etc. Many sizes of WALSCO "TAPER-WEDGE" punches and dies available. See your Parts Jobber

WALSCO ELECTRONICS CORP.

A SUBSIDIARY OF *Tellatograph* CORPORATION

3602 Crenshaw Blvd.,
Los Angeles 16, Calif.

DISPLAY ADVERTISERS

California Institute of Technology, Jet Propulsion Lab.	177A
Cannon Electric Company	24A-25A
Capitol Radio Engineering Institute	36A
*Cascade Research Corporation	220A
Chance Vought Aircraft, Inc.	185A
Chicago Standard Transformer Corp.	30A
*Chicago Telephone Supply Corp.	91A
Christie Electric Corporation	82A
*Clarostat Mfg. Co., Inc.	51A
Cohn Corporation, Sigmund	134A
Collins Radio Company	114A-115A, 164A
Communication Products Co.	35A
Communications Equipment Co.	227A
Computer-Measurements Corp.	54A
Content, Edward J.	228A
Continental Oil Company	199A
Convair Div., General Dynamics Corp.	152A, 181A
Cornell Aeronautical Lab., Inc.	201A
Cornell-Dubilier Electric Corp.	Cover 3
Cornish Wire Company, Inc.	218A
Craig Systems, Inc.	112A
Crosby Laboratories, Inc.	32A
Crosley Division, Avco Mfg. Corp.	172A
Crucible Steel Co. of America	85A
Cubic Corporation	166A
Curtiss-Wright Corporation	22A, 136A

D & R, Ltd.	28A
*Dale Products, Inc.	130A
Decision, Inc.	194A
Delco Radio Div., General Motors Corp.	111A
DeMornay-Bonardi	94A
Driver-Harris Company	47A
DuMont Laboratories, Inc., Allen B.	127A, 196A, 212A

E S C Corporation	134A
Eastern Industries, Inc.	41A
Edison, Inc., Thomas A.	200A
*Eitel-McCullough, Inc.	70A, 128A
Electra Mfg. Co.	126A
*Electro-Pulse, Inc.	120A
Electronic Associates, Inc.	66A
Electronic Engineering Co. of Calif.	226A
Electronic Research Associates, Inc.	6A
*Empire Devices Products Corp.	132A
Engineering Associates	108A
*Erie Resistor Corp.	56A

*F-R Machine Works, Inc.	55A
Farnsworth Electronics Co.	168A
Federal Telecommunication Labs.	205A
Firestone Guided Missile Div.	19A
Food Machinery & Chemical Corp.	158A
Freed Transformer Co., Inc.	18A

Garrett Corp., AiResearch Mfg. Div.	192A
*General Ceramics Corp.	31A
General Electric Co., Apparatus Dept.	89A, 107A
General Electric Co., Employment	144A, 180A, 199A
General Electric Co., Semiconductor Products Div.	20A
General Mills, Inc., Mechanical Div.	160A
General Motors Corp., A C Electronics Div.	155A, 188A, 196A, 206A
General Precision Lab., Inc.	142A
General Radio Co.	Cover 4
General Transistor Corp.	215A
Gertsch Products, Inc.	50A
Giannini & Co., Inc., G. M.	72A
Goodrich Sponge Products Div., B. F.	117A
Goodyear Aircraft Corporation	144A
Goodyear Atomic Corporation	202A
Grant Pulley & Hardware Co.	121A
Guilford Personnel Service	166A

Hadfield, Bertram M.	228A
Heath Company	60A
Helipot Corporation	105A, 184A
*Hewlett-Packard Company	37A

* For more information, see advertisement in the multiple-page section of the 1956-1957 IRE Directory.

UAC COMPLETELY ELECTRONIC DYNAMOTORS

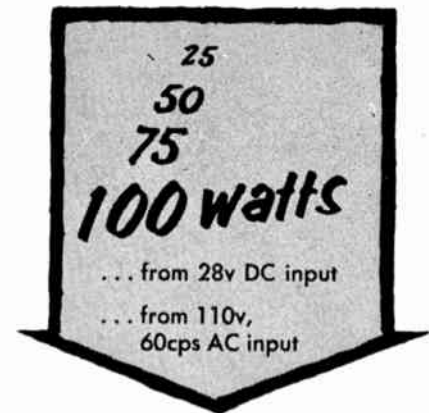

UAC 50W
DC POWER
SUPPLY : 2 lbs

1-500 WATT SEMI-CONDUCTOR
WEIGHT AND SPACE SAVING
POWER SUPPLIES

Efficiency up to 98%
FOR

RADIOSONDE
AIRCRAFT RADIO RECEIVERS,
TRANSMITTERS, COMPUTERS,
SERVOS, RADAR, TELEMETERING,

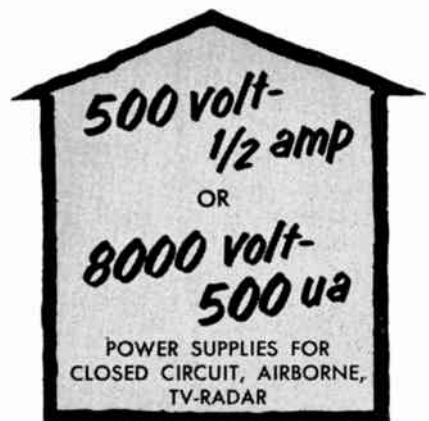

Write, wire, phone specifications today on your current production. Also ask for information about UAC transistorized radiation detection instruments

UAC® electronics
a division of Universal Atomics Corp.
50 Bond Street, Westbury L. I., N. Y.
Dept. IR12 EDgewood 3-3304

DISPLAY ADVERTISERS

Hoffman Laboratories, Inc.	8A-9A, 196A
Hoover Electronics Co.	183A
*Hudson Tool & Die Co., Inc.	21A
*Hughes Aircraft Company	15A, 81A
Hughes Research & Dev. Labs.	14A
Hycon Eastern, Inc.	58A-59A
Hycor Div., International Resistance Co.	40A
I-T-E Circuit Breaker Co.	129A
Institute of Radio Engineers, Inc.	92A-93A, 133A, 176A, 219A, 223A, 224A
International Business Machines Corp.	159A, 210A
International Electronic Research Corp.	45A
International Rectifier Corp.	13A
Jansky, C. M., Jr., & S. L. Bailey	228A
Johns Hopkins University, Applied Physics Lab.	180A
Johns Hopkins University, Operations Research Office	146A
*Jones Div., Howard B., Cinch Mfg. Corp.	86A
Kahn, Leonard R.	228A
Kahn Research Laboratories	104A
Kay Electric Company	7A
Kay Lab	218A
Kearfott Co., Inc.	82A
Kearfott Co., Inc., Western Div.	42A
Kennedy & Co., D. S.	83A
Kollman Instrument Corp.	142A
Laboratory for Electronics, Inc.	175A
*Lambda Electronics Corp.	69A
Lapp Insulator Co., Inc.	76A
Lashinsky, Herbert	228A
Lenkurt Electric Co., Inc.	205A
Link Aviation, Inc.	179A
Lippincott Company, J. B.	46A
Lockheed Aircraft Corp.	161A
Los Alamos Scientific Lab.	169A
Lowell Manufacturing Co.	137A
*Magnetic Amplifiers, Inc.	60A
Mallory & Co., Inc., P. R.	75A
Marconi Instruments	218A
Marion Electrical Instrument Co.	43A
Martin Co., Glenn L.	146A, 209A
Maryland Electronic Mfg. Corp.	182A
Massachusetts Institute of Technology, Lincoln Labs.	152A
Mayberry, Len	228A
Measurements Corp.	232A
Melpar, Inc.	188A
Microdot, Inc.	74A
Microwave Associates, Inc.	63A
Midland Mfg. Co., Inc.	52A
Millen Mfg. Co., Inc., James	119A
Minneapolis Honeywell Regulator Co.	145A, 174A, 208A
Missile Test Project, RCA Service Co.	171A
Moskowitz, S., D. D. Grieg & N. J. Gottfried	228A
Motorola, Inc.	184A
National Cash Register Co.	140A-141A, 204A
National Company, Inc.	190A
Nexon, Y. J., S. K. Wolf, E. L. White, M. Westheimer, & F. W. Littell	228A
Ney Company, J. M.	36A
Non-Linear Systems, Inc.	125A
North American Aviation, Inc.	147A, 173A, 207A
North Electric Company	74A
Northeastern Engineering	84A
Oak Manufacturing Co.	39A
Oster Mfg. Co., John	131A, 160A
Ostlund, Evert M.	228A
Otis Elevator Company	174A
Pacific Automation Products, Inc.	95A
Pacific Semiconductors, Inc.	97A
Packard-Bell Co.	138A
Panoramic Radio Products, Inc.	80A
Paramount Paper Tube Company	106A

* For more information, see advertisement in the multiple-page section of the 1956-1957 IRE Directory.

ENGINEERED

for those who expect much

PRICED

for those who must buy many

the
PRECISION
model

68

VTVM

METAL CASED

RUGGED



- **Peak-to-Peak Voltage Ranges**
up to 3200 volts peak-to-peak
- **Extra-Large 5 1/4" Wide-Angle Meter**
easy-reading, long scales
- **High-Impedance Voltage Ranges (AC and DC)**
up to 1200 volts
- **Measures Resistance up to 1000 Megohms**
in 5 overlapping ranges
- **Zero-Center Reference Ranges**
simplify FM discriminator balancing

Model 68: In rugged, blue-gray ripple-finished steel cabinet. Size 5 7/8" x 7 3/4" x 3 1/2". Complete with tubes, internal ohmmeter battery and detailed instruction manual. Net Price.....\$54.50

Accessories Available for Models 68 & 78
RF-12 High Freq. Probe...Net Price: \$10.95
TV-4 High Volt. Probe...Net Price: 14.75
Send for free 1956 catalog with detailed descriptions and specifications of the entire Precision line of test instruments for industry and electronic service-maintenance.



Model 78
Battery-Operated
VTVM

A must where power line is not available or where power line connection is undesirable. Provides every modern VTVM function. Metal cased. Rugged.

Net Price...\$62.50
(including Batteries)



PRECISION Apparatus Company, Inc.

70-31 84th Street, Glendale 27, L. I., N. Y.

Export: 458 Broadway, New York 13, N.Y., U.S.A. • Cables: MORHANEX
Canada: Atlas Radio Corp. Ltd. • 50 Wingold Ave., Toronto 10, Ontario

direct measurements on TRANSISTORS!

...using MEASUREMENTS'
STANDARD TEST SET
for Transistors

Model 505



- Provides rapid "go - no go" transistor testing — important for quality control, production, engineering groups.
- Useful for comparison of incoming or untested transistors with a reference transistor which meets device specifications.
- Extremely flexible — utility and type of measurement can be established by use of auxiliary equipment — makes all measurements.
- "h" or "r" parameters are measured by connecting external test equipment to applicable jacks and terminals on front panel.

Measurements' Model 505 Standard Test Set for Transistors is a self-contained, battery-powered instrument designed for rapid d-c measurement of important junction transistor parameters. Permits multiple testing of PNP and NPN small-signal, medium-power, and switching (computer) transistors.

SPECIFICATIONS

DIRECT MEASUREMENTS: Makes fundamental d-c measurements on small-signal, medium-power, and switching transistors operating in the common-emitter configuration. Measures collector-to-emitter leakage current from 0 to 10 ma; measures collector current from 0 to 10 ma. Measures direct current gain (d-c Beta) or "incremental current gain" from 0 to 200, or as calibrated. Indicates G_m from 0 to 0.39 mhos.

AUXILIARY MEASUREMENTS: External test equipment can be used for dynamic measurement of "h" or "r" parameters and switching transistor characteristics up to the megacycle region for selected values of operating biases.

POWER SUPPLY: Collector supply voltages of 6 and 12 volts from internal batteries, or from suitable external power supply.



DISPLAY ADVERTISERS

Parzen, Benjamin	228A
Philco Corporation	150A, 213A
Polarad Electronics Corp.	10A-11A, 122A-123A
*Poly-Scientific Corp.	88A
Polytechnic Research & Dev. Co.	135A
Precision Apparatus Co., Inc.	231A
Precision Paper Tube Company	78A
Progress Electronics Co.	228A
Pyramid Electric Company	87A
Radiation, Inc.	118A
*Radio Corp. of America	65A, 96A, 156A-157A
Radio Engineering Laboratories, Inc.	99A
Radio Engineering Products	50A
Radio Materials Corp.	73A
*Radio Receptor Co., Inc.	113A
Ramo-Wooldridge Corp.	198A
Raytheon Mfg. Co., Employment 151A, 162A, 200A	
Raytheon Mfg. Co., Microwave & Power Tube Operations	49A
Raytheon Mfg. Co., Semiconductor Div.	23A
Remington Rand Univac	167A
Rese Engineering, Inc.	229A
Resistance Products Co.	139A
Rosen Engineering Products, Inc., Raymond ..	116A
Rutherford Electronics Co.	106A
Sanders Associates, Inc.	43A
Sandia Corporation	189A
Sangamo Electric Co., Inc.	61A
Schweber Electronics	108A
*Shasta Division, Beckman Instruments, Inc.	86A
Sierra Electronic Corp.	16A
Simpson Electric Company	221A
Sola Electric Company	217A
Spectrol Div., Carrier Corp.	110A
Spencer-Kennedy Labs., Inc.	130A
Sperry Electronic Tube Div., Sperry Rand Corp.	163A
Sperry Gyroscope Co., Div., Sperry Rand Corp.	203A
Sperry Utah Engineering Lab., Div., Sperry Rand Corp.	191A
Spittal, William R.	228A
Sprague Electric Company	1A, 3A
Stavid Engineering, Inc.	182A
Stevenson, Mirek J.	228A
Stoddart Aircraft Radio Co., Inc.	220A
Stromberg-Carlson Co.	194A
Stupakoff Div., Carborundum Co.	67A
Sunstein, David E.	228A
Swift Industries, Inc.	40A
Switchcraft, Inc.	136A
*Sylvania Electric Products Inc.	57A, 102A-103A, 148A, 178A, 186A, 211A
Synthane Corporation	225A
Systems Laboratories Corp.	212A
Technical Operations, Inc.	164A
Tektronix, Inc.	62A
Tele-Dynamics, Inc.	116A
Texas Instruments Incorporated	29A
Times Facsimile Corp.	36A
Tramble, Jerome E.	148A
Transco Products Co.	108A
Transradio, Ltd.	32A
Triad Transformer Corp.	68A
United Catalog Publishers, Inc.	222A
United Transformer Co.	Cover 2
Universal Atomic Corp.	230A
University of Calif., Radiation Lab.	193A
*Varian Associates	77A
Walsco Electronics Corp.	230A
Weckesser Company	112A
Welwyn International, Inc.	224A
Western Gold & Platinum Co.	138A
Westinghouse Electric Corp.	153A, 195A
Wheeler, Harold A.	228A
Wheeler Laboratories, Inc.	28A
Wind Turbine Company	12A

* For more information, see advertisement in the multiple-page section of the 1956-1957 IRE Directory.



Leadership is hard to achieve and even harder to maintain. A stroke of genius or a lucky break may put you in a top position, but it takes stability of organization and persistent *product dependability* to keep you there. More C-D capacitors are sold because C-D capacitors are made better—not just in one big order, but in every order every year. Our leadership is added insurance for yours, because it is based on the high quality of every CORNELL-DUBILIER capacitor since 1910.

Write for catalog to Cornell-Dubilier Electric Corporation, South Plainfield, New Jersey.

Two of Thousands of C-D's Mica Types:

CERAMIC-CASED HIGH-POWER MICAS: Built to handle efficiently and economically the high kva requirements of transmitters, induction heaters, Loren circuits and a variety of other high-current equipment for military, communications and industrial applications.

"SUPER MICADONS": An entirely new concept in quality midget mica capacitor construction. Greatly increased capacitance over that of conventional units of the same case size.



CONSISTENT HIGH-DEPENDABILITY
CORNELL-DUBILIER CAPACITORS

*®



SOUTH PLAINFIELD, N. J.; NEW BEDFORD, WORCESTER & CAMBRIDGE, MASS.; PROVIDENCE & HOPE VALLEY, R. I.; INDIANAPOLIS, IND.; SANFORD, FUGUAY SPRINGS & VARINA, N. C.; VENICE, CALIF.; & SUBS: THE RADIART CORP., CLEVELAND, OHIO, CORNELL-DUBILIER ELECTRIC INTERNATIONAL, N. Y.

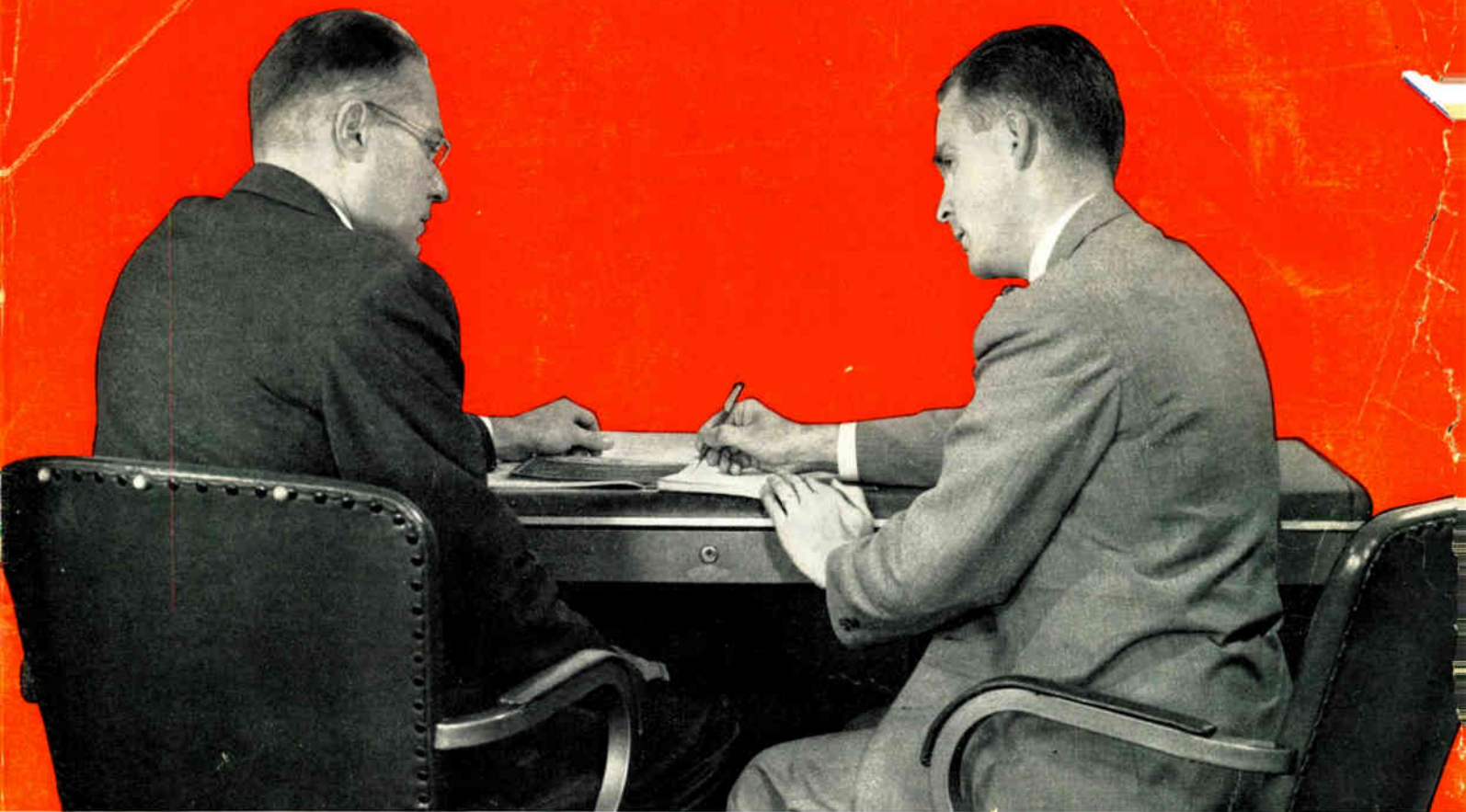

Not just another salesman... but a skilled engineer at your service

One of these two men is a G-R sales engineer — the other, a customer. You wouldn't know one from the other to hear them talk for there is no high-pressure sales campaign in progress. The General Radio man offers his engineering experience and extensive factory training to the solution of the customer's problem. Our man is on a straight salary; he will lose no commission if the sale of some particular piece of equipment is not made. In fact, he will recommend the equipment only if he finds it is completely suited to the customer's need.

The General Radio sales engineer has a substantial stake in his Company — he is an important member of the professional and management group who administer its operations. He realizes that the type of quality sales service he has to offer produces the lasting customer satisfaction upon which ultimately the future of his Company depends. *This is his basic incentive.*

"We sell direct" is a long established General Radio policy. Our many years of excellent sales engineer-customer relations prove the merit of this method.

General Radio Company, Cambridge, Massachusetts

*You can call the man we have described to aid in your particular problem!
You can reach him at any of the addresses listed at right.*

BOSTON — *TRowbridge 6-4400*
275 Massachusetts Ave.
Cambridge 39, Mass.

NEW YORK — *WHilney 3-3140*
Broad Avenue at Linden
Ridgefield, N. J.

PHILADELPHIA — *HAncock 4-7419*
1150 York Road
Abington, Pa.

WASHINGTON — *JUniper 5-1088*
8055 13th St.
Silver Spring, Md.

CHICAGO — *WAbash 2-3820*
920 S. Michigan Ave.

LOS ANGELES — *HOLlywood 9-6201*
1000 N. Seward St.

