

Proceedings



of the I·R·E

A Journal of Communications and Electronic Engineering
(Including the WAVES AND ELECTRONS Section)

November, 1949

Volume 37

Number 11



Allen B. Dumont Labs., Inc.

TELEVISION—STUDIO CONTROL ROOM EQUIPMENT

The necessary combination of video and audio techniques in television broadcasting has stimulated interesting apparatus developments.

PROCEEDINGS OF THE I.R.E.

Pulse-Multiplex System for Distance-Measuring Equipment
Interferometer for Microwave Measurements
Power Meter for Communication Frequencies
Microanalysis of Gas in Cathode Coating Assemblies
Electron-Beam—Magnetic-Field Theory
Modes in Interdigital Magnetrons
Solution of FM Steady-State Problems
Wide-Angle Conical Antenna Input Impedance
Two-Path Propagation Distortion Analysis
Pulse-Frequency Modulation
Fourier Transforms for Variable-Frequency Circuit Analysis

Waves and Electrons Section

Off the Editor's Chest
Special Relativity and the Electron
Electronic Differential Analyzer
Constant-Gain Frequency Changers and Amplifiers
Variable Phase-Shift FM Oscillator
Reactance-Tube Oscillator
Frequency Contours for Microwave Oscillator with Resonant Load
Band-Pass Filter Impedance Transformations
Planar Diode Transit-Time Solution
Abstracts and References

TABLE OF CONTENTS FOLLOWS PAGE 32A

The Institute of Radio Engineers

for

HIGH

frequencies efficiency



AX4-125-A
TETRODE



AX4-250-A
TETRODE



AX-9900
TRIODE



AX-9901
TRIODE



AX-9902
TRIODE

New **AMPEREX** TRANSMITTING TUBES "ALL-GLASS" types with **MAGNISORB*** ANODES for AM, FM, TELEVISION, INDUSTRIAL, and ELECTRO-MEDICAL APPLICATIONS

FEATURES

- **MAGNISORB*** is a graphite base material specially processed by AMPEREX for greatly increased gettering action and heat dissipation characteristics.
- **POWDER GLASS TECHNIQUES** resulting in **STURDY CONSTRUCTION** and **COMPACT SIZE** through the elimination of external bases, make these tubes desirable where space limitations and ruggedness are factors.
- **COOLER TUBE OPERATION** is effected through efficient internal shielding and elimination of the external base.
- **INCREASED ANODE SURFACE AREA** is obtained by virtue of the fact that the heavy walls are deeply milled with circumferential rings.
- **EXCELLENT INTER-ELECTRODE SHIELDING** reduces filament-plate capacity to a minimum in the triodes, for application in grounded grid amplifiers.

TETRODES

Type AX4-125-A and Type AX4-250-A are completely interchangeable, electrically and mechanically, with standard RMA equivalents.

TRIODES (Electrical Data)

	AX-9900	AX-9901	AX-9902
Filament — Thoriated Tungsten			
Voltage	6.3	5	10
Current (Amps.)	5.4	15	9.7
Amplification Factor	25	25	27
Maximum Ratings — Class "C" Telegraphy			
Plate Voltage	2500	3000	4000
Plate Current (Ma)	200	400	550
Plate Dissipation (Watts)	135	250	450
Frequencies (MC)	150 200	30 120	100
Typical Power Output (Watts)	390 200	820 520	1450
Inter-electrode Capacitances (mmf)			
Grid-Plate	5.5	8.0	8.0
Grid-Filament	5.8	8.0	11.0
Plate-Filament	0.1	0.3	0.3



re-tube with AMPEREX

Data sheets available on request

AMPEREX ELECTRONIC CORP.

25 WASHINGTON STREET, BROOKLYN 1, N. Y.

In Canada and Newfoundland: Rogers Majestic Limited
11-19 Brentcliffe Road, Leaside, Toronto, Ontario, Canada

Hermetically Sealed
FULLY APPROVED FOR JAN USES
... NEW COMMERCIAL TYPES



SPRAGUE
KOOLOHM®

POWER AND PRECISION RESISTORS

The only complete line of hermetically sealed wire wound resistors on the market today, Sprague Ferrule Terminal Koolohms offer types, sizes, and resistance values for every power or precision resistor need. Operating voltages range from milli-volts to kilovolts; resistance values from 0.5 ohms to 1,000 megohms. Fully protected by Sprague glass-to-metal seals, these ferrule terminal Koolohms will withstand the most severe salt water immersion and temperature shock tests. These standard Sprague resistor types meet all applicable JAN Specifications. Similar types with even higher power ratings are available for commercial applications where severe thermal shock is not a factor. *For complete description and rating data, write for Catalog No. 100E.*

SPRAGUE ELECTRIC COMPANY • North Adams, Mass.

WOUND WITH
 CERAMIC INSULATED
 WIRE

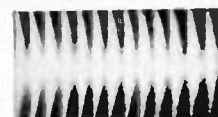

KOOLOHM layer winding turns cannot "swim" or short. Insulation has a dielectric strength of 350 volts per mil. at 400°C.



KOOLOHM interleaved winding—Resistors are available having negligible inductance, even at VHF.



Section of KOOLOHM wire with ceramic insulation removed to show contrast between bare and insulated wire. This flexible, heat-proof insulation is actually applied to the wire at a temperature of 1000°C.

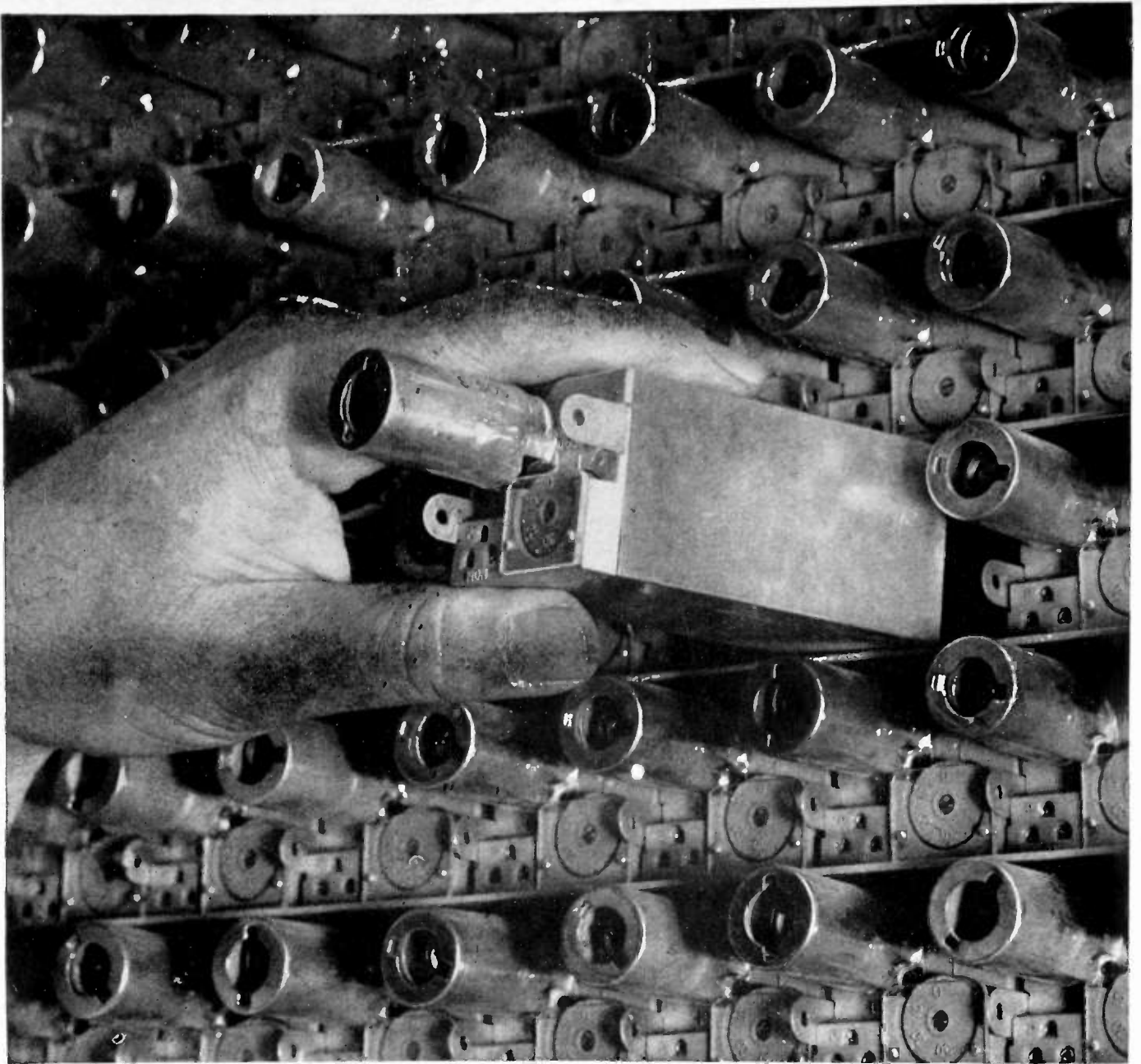

ANOTHER SCORE IN THE

battle of the inches

It takes many costly buildings to house your telephone system. Every inch saved helps keep down the cost of telephone service. So at Bell Telephone Laboratories engineers work constantly to squeeze the *size* out of telephone equipment.

In the picture a new voice frequency amplifier is being slipped into position. Featuring a Western Electric miniature vacuum tube,

tiny permalloy transformers, and special assembly techniques, it is scarcely larger than a single vacuum tube used to be. Yet it is able to boost a voice by 35 decibels. Mounted in a bay only two feet wide and 11½ feet high, 600 of the new amplifiers do work which once required a *room* full of equipment.

This kind of size reduction throughout the System means that

more parts can be housed in a given space. Telephone buildings and other installations keep on giving more service for their size — and keep down costs.

The new amplifiers, which will soon be used by the thousands throughout the Bell System to keep telephone voices up to strength, are but one example of this important phase of Laboratories' work.

BELL TELEPHONE LABORATORIES EXPLORING AND INVENTING, DEVISING
AND PERFECTING, FOR CONTINUED IMPROVEMENTS AND ECONOMIES IN TELEPHONE SERVICE



NEW **hp** 460A WIDE BAND AMPLIFIER

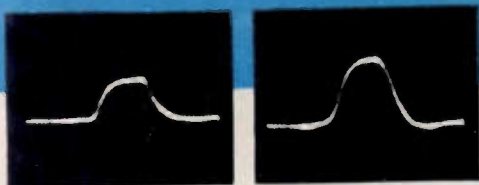

Figure 1

Actual photo of oscillograph trace showing .01 μ sec pulse (left) applied direct to CRT plates; (right) through -hp- 460A.

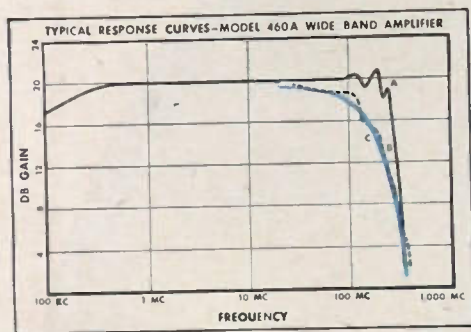

Figure 2

Typical response curves. Line A, with -hp- 410A VTVM. Line B, into 200 ohm load. Line C, Gaussian curve.

SPECIFICATIONS

Frequency Response: High frequency—closely matches Gaussian curve when operating into a 200 ohm resistive load. 3 db point is 140 mc.

Low frequency—when operating from a 200 ohm source and .01 blocking condenser, response off 3 db at 3 kc into an open circuit or succeeding amplifier. When operating into a 200 ohm load, off 3 db at 100 kc.

With -hp- 410A VTVM: ± 1 db, 200 kc to 200 mc.

Gain: Approx. 20 db into 200 ohm load, with tubes of G_m 5,000 micromhos. (When operating into 200 ohm load.) Gain control has range of 6 db. 5 or more amplifiers may be cascaded.

Output: Approx. 8 v. peak open circuit. Output impedance, 330 ohms.

Input Impedance: 200 ohms.

Delay Characteristics: Approx. .012 μ sec.

Rise Time: Approximately .0026 μ sec (10% to 90% amplitude). No appreciable overshoot.

Mounting: Relay rack, 5 $\frac{1}{2}$ " x 19" x 6" deep.

Power Supply: 115 v. 50/60 cps. self-contained.

Price: \$185 F. O. B. Palo Alto.

Data subject to change without notice.

SETTING A NEW STANDARD FOR FAITHFUL PULSE AMPLIFICATION!

True amplification of very short pulses. Rise time .0026 microseconds; 20 db gain; can be cascaded. For oscilloscope, TV, UHF, nuclear or general laboratory work. Increases voltmeter sensitivity 10 times over 200 mc band.

The new -hp- 460A Wide Band Amplifier is the first instrument of its kind to offer you *faithful amplification* of very short pulses without objectionable ringing or overshoot. The rise time of the amplifier itself is only .0026 microseconds; and its response matches the Gaussian curve (transmission ideal) more closely than any other instrument yet offered.

The exactness with which the new -hp- 460A amplifies very short pulses can be seen in Fig. 1. Left: shows a .01 μ sec pulse applied direct to plates of a 5XP11A cathode ray tube. Right: same pulse after passing through the -hp- 460A. Note the very short rise time and the absence of ringing or overshoot. Fig. 2, illustrates how closely the -hp- 460A conforms to the Gaussian ideal. As many as 5 amplifiers can be cascaded when high gain is necessary.

GENERAL AMPLIFIER

Fig. 2 also illustrates the wide fre-

quency response of this instrument. It offers flat response up to 200 mc when used with the -hp- 410A Vacuum Tube Voltmeter. Sensitivity is increased 10 times. The -hp- 460A may also be used as a general purpose laboratory amplifier.

ACCESSORIES

Since the -hp- 460A Amplifier operates best at impedances of 200 ohms, -hp- has designed a 200 ohm coaxial system of connectors and cables. These accessories include leads with fittings, panel jacks and plugs, adapters to connect into a 50 ohm Type N system; and a special adapter for use with the -hp- 410A Voltmeter.

Get complete information now! See your nearest -hp- representative or write to factory.

HEWLETT-PACKARD CO.

1936-D Pogo Mill Road, Palo Alto, California
Export: FRAZAR & HANSEN, LTD.
301 Clay Street, San Francisco, Calif., U. S. A.
Offices: New York, N. Y.; Los Angeles, Calif.

hp laboratory instruments
FOR SPEED AND ACCURACY

STAY AHEAD IN CHOOSE

CHARACTERISTICS TYPE 16GP4

Max bulb diameter	16 inches
Min useful screen diameter	14 $\frac{1}{2}$ inches
Heater voltage	6.3 v
Heater current	0.6 amp
Focusing method	magnetic
Deflecting method	magnetic
Deflecting angle (approx)	70 degrees
Screen fluorescent color	white
Over-all length	17 $\frac{1}{8}$ inches (max)
Bulb contact	metal-cone lip
Base	small-shell duodecal 5-pin

Max ratings, design-center values

Anode voltage	14,000 v
Grid No. 2, voltage	410 v
Grid No. 1, voltage	-125 v

Typical operating conditions

Anode voltage	12,000 v
Grid No. 2, voltage	300 v
Grid No. 1, voltage for cut-off	-55 v



TYPE 16GP4

16-inch metal picture tube, with wide-angle (70-degree) sweep, and high-contrast-glass face. Designed for modern receivers where size of the cabinet is restricted, yet the picture must be large, clear, and sharp. . . . Tube is less than 18 inches long; its weight is approximately half that of an all-glass type. . . . Generous picture area is 163 sq. inches when the entire tube face is scanned; 132.5 sq. inches when standard raster of 3-by-4 aspect is employed. . . . Special high-contrast-glass face helps produce a clear image with superior definition.

TELEVISION! GENERAL ELECTRIC TUBES!

LEAD, or be left behind! Designers and builders of TV receivers face that challenge. By specifying General Electric tubes, you (1) help assure the over-all advanced design of your product, and (2) make a popular move to meet the demand of buyers for what's newest and best in television home equipment.

Progress shows, for example, in every characteristic of G.E.'s new 16-inch wide-angle picture tube. Because of its comparatively short length, you can design a receiver about Type 16GP4 that will fit conveniently into the average small living-room. At the same time, the picture area is large, giving excellent visibility for a good-sized group of guests. The face of the tube is a special new dark-tone glass providing high contrast . . . images show more clearly,



G-E receiving tubes of advanced design spell progress and economy. The new 6BN6, a miniature gated-beam tube, functions as a limiter, discriminator, and audio-amplifier in TV and FM receivers, thereby replacing 3 tubes and associated components.

with sharper definition.

Other G-E picture tubes—Types 8AP4, 10BP4, 10FP4, 12KP4 and 12LP4—share in the advancements being recorded by General Electric's continuous research in television. And a full line of G-E receiving-type tubes is available, including such outstanding new designs for television use as the 6AB4, 6BN6, 12AT7, 12AU7, and 12AY7.

Choose General Electric tubes to make sure the product you design, build, and sell is in the forefront competitively! Experienced G-E tube engineers will be glad to work with you in selecting the right types for your circuit. Wire or write today to *General Electric Company, Electronics Department, Schenectady 5, New York.*

SHORTER—MAKES POSSIBLE A MORE COMPACT TV RECEIVER

Why Type 16GP4 picture tube is nearly 5 inches shorter than the standard 16AP4 16-inch type, is shown here. A sweep angle of 70 degrees for the 16GP4 against 53 degrees for the 16AP4 (portrayed in dotted lines) results in a flatter conical shell. This reduces the over-all length of the tube to 17 $\frac{1}{8}$ inches, compared with 22 $\frac{3}{8}$ inches for the 16AP4. Receivers using the new tube can be shorter and less bulky, consequently are more acceptable in the home.

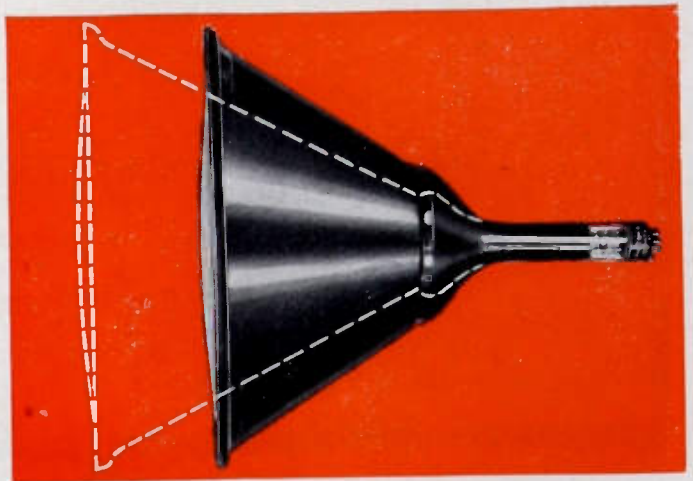

You can put your confidence in—

GENERAL  **ELECTRIC**

Magnetic Materials

The Arnold Engineering Company
offers to the trade a complete line of
Magnetic Materials



PERMANENT MAGNET MATERIALS

- Cast Magnets, Alnico I, II, III, IV, V, VI, XII, X-900
 - Sintered Magnets, Alnico II, IV, V, VI, X-900, Remalloy*
 - Vicalloy* • Remalloy* (Comol)
 - Cunico • Cunife • Cast Cobalt Magnet Steel

HIGH PERMEABILITY MATERIALS

- Deltamax Toroidal Cores • Supermalloy* Toroidal Cores
 - Powdered Molybdenum Permalloy* Toroidal Cores • Permendur*

*Manufactured under licensing arrangements with WESTERN ELECTRIC COMPANY

Write for information relating to any of these Magnetic Materials



THE ARNOLD ENGINEERING COMPANY

SUBSIDIARY OF ALLEGHENY LUDLUM STEEL CORPORATION

147 EAST ONTARIO STREET, CHICAGO 11, ILLINOIS

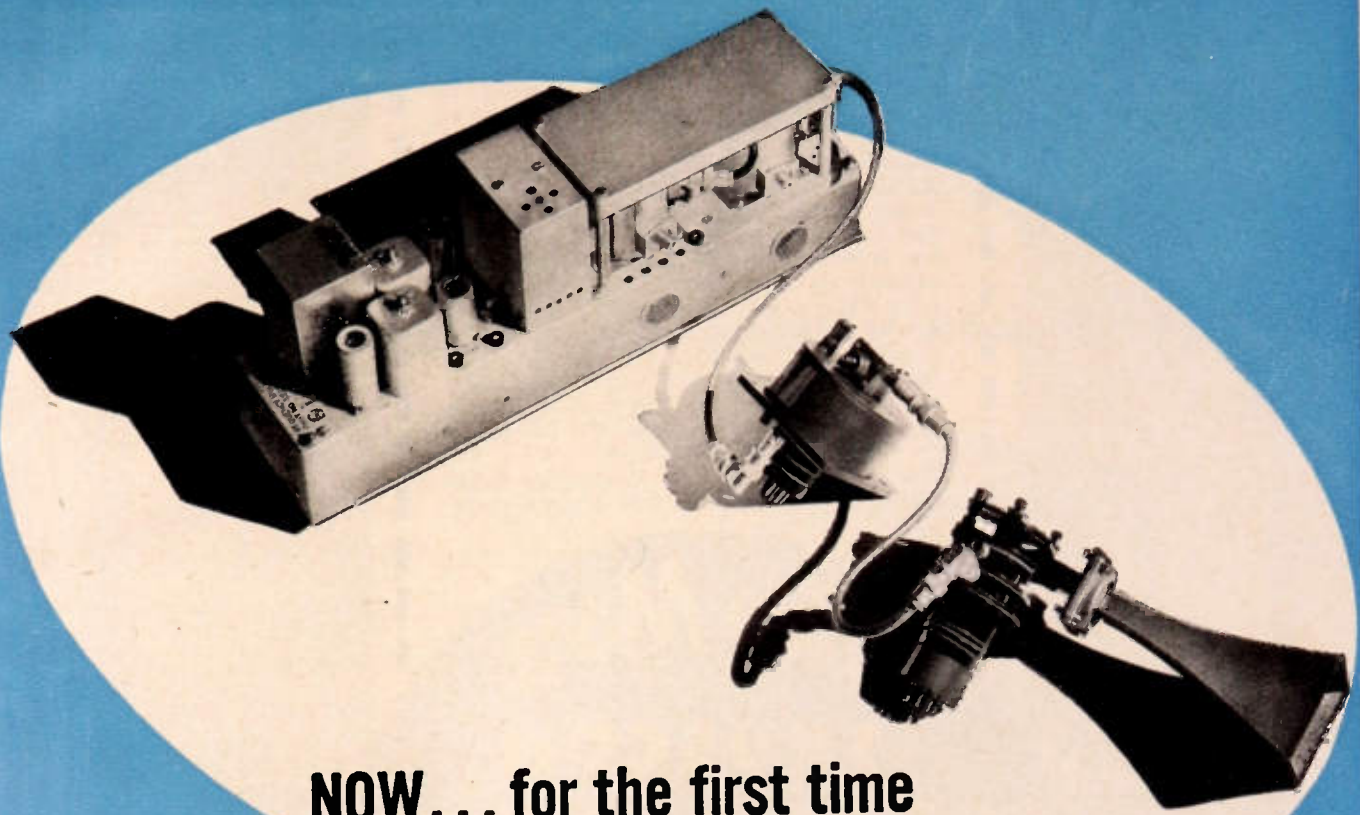

NOW... for the first time

SUBSTANTIAL POWER

At Microwave Frequencies with Direct Crystal Control

Now, with two new Sperry Klystron tubes, stabilized frequency control is possible at 10,000 mc. with 1 watt continuous wave power output. These multiplier tubes, the SMC-11 and the SMX-32, permit direct crystal control at microwave frequencies with this power level.

Starting with a 5 mc. crystal, the frequency is multiplied to 830 mc. by use of an *Exciter*. The SMC-11 Klystron multiplies the 830 mc. to a frequency of 5,000 mc. The SMX-32 then multiplies this frequency to 10,000 mc. with the same accuracy which exists in the control crystal ($\pm 0.0005\%$).

This practical achievement of 1 watt power output with continuous accuracy of frequency control at 10,000 mc. exists only through the use of these two Sperry Klystrons.

Write our Industrial Department for further information.



GYROSCOPE COMPANY

DIVISION OF THE SPERRY CORPORATION
GREAT NECK, NEW YORK

NEW YORK • CLEVELAND • NEW ORLEANS
LOS ANGELES • SAN FRANCISCO • SEATTLE



Serving two different needs
for KFOR and KFOR-FM,
Lincoln, Nebraska

Network AM programs are broadcast through KFOR's 250-foot Truscon Self-Supporting Radio Tower. For FM broadcasting by KFOR-FM the Cornbelt Broadcasting Company chose a similar but stronger 250-foot Truscon Tower which supports above its top a Federal 8-Bay Square Loop FM antenna. The overall height above ground is 330 feet.

Uninterrupted service in the rolling plains country, which these twin steel beauties serve, requires good structural stability. And, Truscon engineers designed and built this pair to fit the needs of that specific location.

Truscon engineers have a world-wide background of field experience to help you in evalu-

Two More
TRUSCON
TOWERS OF STRENGTH
250 FT. 330 FT.
HIGH
OVERALL

ating all local operating conditions, and in fitting the correct tower to them. It may be tall or small . . . guyed or self-supporting . . . tapered or uniform in cross-section . . . for AM, FM or TV. Your call or letter to any nearby Truscon District Office—or to our home office in Youngstown—will bring immediate, interested attention, with no obligation.

TRUSCON STEEL COMPANY

YOUNGSTOWN 1, OHIO

Subsidiary of Republic Steel Corporation

TRUSCON 
SELF-SUPPORTING
AND UNIFORM
CROSS SECTION GUYED **TOWERS**

Truscon Copper Mesh Ground Screen

Over 200 Manufacturers Use



COMPONENTS

and Praise Hi-Q Quality and Service

● Call the role of the electronic industry and practically every name you call will be a user of **HI-Q** Components. Ask them their opinion of **HI-Q**. They will point to a succession of repeat orders as proof of their complete satisfaction with **HI-Q** quality, dependability and service.

You are invited to take advantage of **HI-Q's** vast experience in the development and production of ceramic capacitors, trimmers, wire-wound resistors and choke coils. Our engineering staff is at your service whenever and as often as you see fit to call on it. Please feel free to wire, write or phone at any time you have a problem which we might help solve.

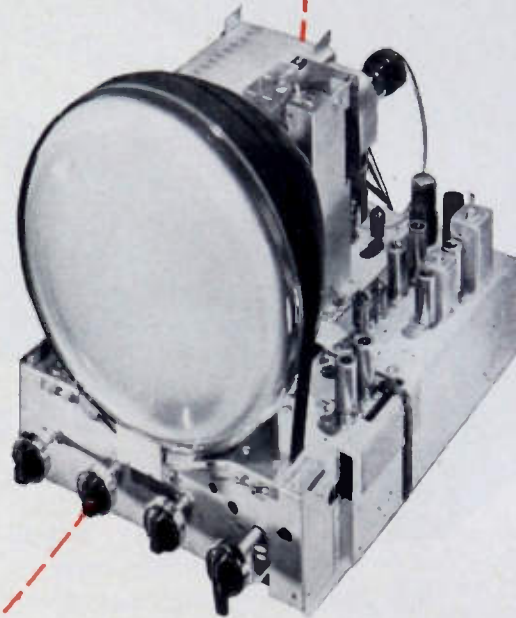

Admiral Model 20A1 Television Chassis uses numerous **HI-Q** Components to contribute to its dependable performance and long life.

Hi-Q COMPONENTS

BETTER 4 WAYS

PRECISION Tested step by step from raw material to finished product. Accuracy guaranteed to your specified tolerance.

UNIFORMITY Constancy of quality is maintained over entire production through continuous manufacturing controls.

DEPENDABILITY Interpret this factor in terms of your customers' satisfaction . . . Year after year of trouble-free performance. Our Hi-Q makes your product better.

MINIATURIZATION The smallest **BIG VALUE** components in the business make possible space saving factors which reduce your production costs . . . increase your profits.

JOBBERS—ADDRESS: ROOM 1332
101 Park Ave., New York, N. Y.

Hi-Q

Electrical Reactance Corp.

FRANKLINVILLE, N. Y.

Plants: Franklinville, N. Y.— Jessup, Pa.— Myrtle Beach, S. C.
Sales Offices: New York, Philadelphia, Detroit, Chicago, Los Angeles



Designers



A LINE-VOLTAGE STABILIZER

SO SMALL . . .

. . . it mounts on a radio chassis

These 15-, 25-, and 50-va G-E voltage-stabilizer units are only a little over 2 inches high and about 9 inches long. They'll mount easily on a medium-sized radio or electronic instrument chassis and will give you an even, non-fluctuating 115 volts for your equipment whether your line voltage is 95 or 130. A special transformer circuit provides a stabilized output voltage

within 1% of 115 volts for fixed, unity-power-factor loads.

Continuous operation under conditions of short or open circuits will not damage the stabilizer in any way. Since there are no moving parts, there is little maintenance to worry about. For complete information on voltage-stabilizer units of all sizes from 15-va to 5000-va, write for Bulletin GEA-3634.

AN EASY WAY TO PRODUCE SQUARE WAVES

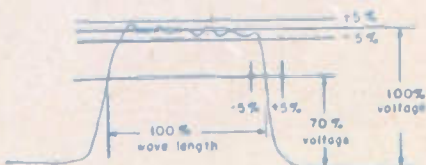

Specially designed G-E Type-E networks will produce impulses which have definite, known energy contents and durations, and thus are ideal for converting a-c or d-c charging voltages into approximately rectangular square waves. These networks consist of capacitor and coil sections adjusted to close tolerances and hermetically sealed in single metal containers.

G.E. helped meet wartime radar demands with thousands of these units and now offers them for commercial use. They are available in a wide range of designs,

impedances, ratings, and sizes for pulse lengths of 0.1 to 40 microseconds. See Bulletin GEA-4996.

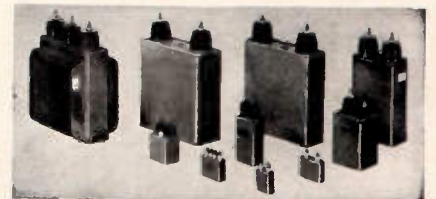

GENERAL ELECTRIC



667-3

Digest

TIMELY HIGHLIGHTS ON G-E COMPONENTS

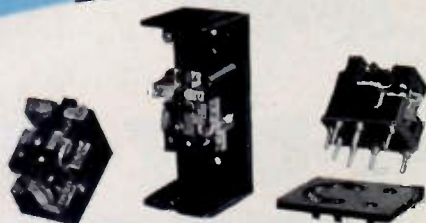

HEAVY-DUTY RELAYS THAT MOUNT 3 WAYS

This versatile, general-purpose, heavy-duty, a-c relay unit is available in three mounting arrangements: front connected, back connected, or plug-in connected. All three mounting types are available in open or enclosed models and are furnished in spst, dpst, or dpdt circuits. Heavy, long-lasting silver contacts carry 10 amps continuous. Normally-open forms make or break 45 amps; normally-closed forms make or break 20 amps. Relay coils come in 12-, 24-, 115-, or 230-volt, 60-cycle a-c sizes. D-c units are available in similar models. For full details see GEC-257.

ACCURATE BUT RUGGED

The new, modern-looking, easy-to-read 2½ inch G-E instrument line is improved inside as well as outside. A single, self-contained mechanism supported on an extremely strong Alnico magnet assures permanent alignment even under the most adverse operating conditions. This high-gauss Alnico magnet permits the use of a large air gap with a consequent smoother, non-sticking action. The greater torque-to-weight ratio means better damping and allows the use of heavier vibration-resisting pivots. Accuracy is 5% of full scale on rectifier types, 2% on all others. For complete details, send for Bulletin GEC-368.



SNAP-SWITCH INSTALLATION TIME CUT TO SECONDS

You'll have a firm electrical connection without the use of solder a few seconds after you begin to install this small but rugged Switchette. Only 1½ inches long and weighing only 9 grams, this 230-vac, 10-amp unit has solderless knife-contact terminals made of pure, tinned copper.

G-E Switchettes are available in a variety of forms and circuits, all of which have double-break contact structures. They're particularly well suited for electronic applications because of their low RF noise output (short contact-bounce).



For your convenience there are screw-terminal and soldering-lug types as well as this special quick-connect unit. Send for Bulletin GEA-4888.

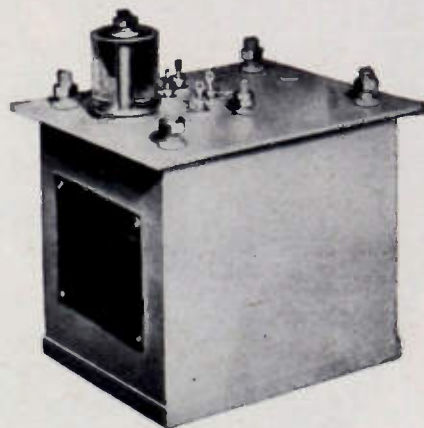

A SMALL PACKAGE OF WELL-REGULATED HIGH VOLTAGE

You get both high voltage and good regulation with small lightweight G-E precision rectifiers. This may interest you if you need compact, well-regulated, high d-c voltage sources for cathode-ray tubes, television camera tubes, radar indicator scopes, electron microscopes, Geiger-Mueller counters, or similar jobs.

These supplies are hermetically sealed and oil-filled. Typical units have outputs of 7 kv at 0.1 ma.—have only 3.5% deviation for every 0.1 ma load and output ripple of less than 1%. Size—only 6" x 6" x 7". Weight—8 lbs. For further data, write: General Electric Company, Section 667-3, Schenectady 5, N. Y., giving complete information on the proposed application with specifications required.

General Electric Company, Section G667-3
Apparatus Department, Schenectady, N. Y.

Please send me the following bulletins:

- | | |
|---|--|
| <input type="checkbox"/> GEA-3634 Voltage stabilizers | <input type="checkbox"/> GEC-257 Heavy-duty relays |
| <input type="checkbox"/> GEA-4888 Switchettes | <input type="checkbox"/> GEC-368 Instruments |
| <input type="checkbox"/> GEA-4996 Capacitor networks | |

NAME _____

COMPANY _____

ADDRESS _____

CITY _____ STATE _____

37% GREATER EFFECTIVENESS

in Television image

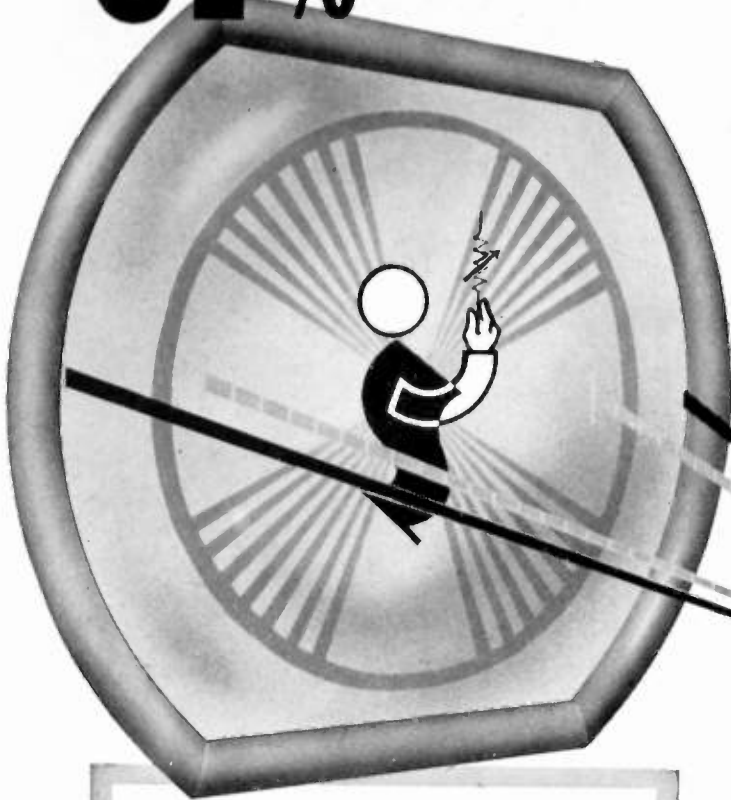

W-I-D-T-H CONTROL

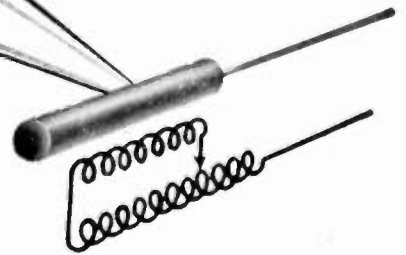

... and many times the permeability in half the size

FOR TV FLYBACK TRANSFORMER CORES

Permeability on the order of 10 to 1 by comparison with conventional iron cores for flyback transformer applications, is readily possible with the new Stackpole Ceramag types. In addition, Ceramag cores are much smaller, have higher resistance, operate cooler due to absence of eddy current losses.

Molded of a unique powdered material having exceptionally high permeability, Stackpole Ceramag iron cores bring a new, higher standard of efficiency to television horizontal image deflection circuits. In screen areas where there is a sudden voltage drop, Ceramag cores give ratios of from 1 to 8 or more compared with 1-5 for previous high permeability types. Complete details or samples to match your requirements sent on request.

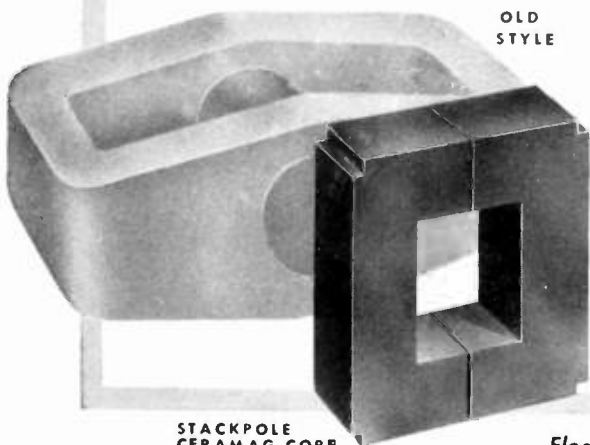

OLD
STYLE

STACKPOLE
CERAMAG CORE

Electronic Components Division

STACKPOLE

Ceramag

HIGH PERMEABILITY

Cores

STACKPOLE CARBON COMPANY • ST. MARYS, PENNA.

PERFORMANCE

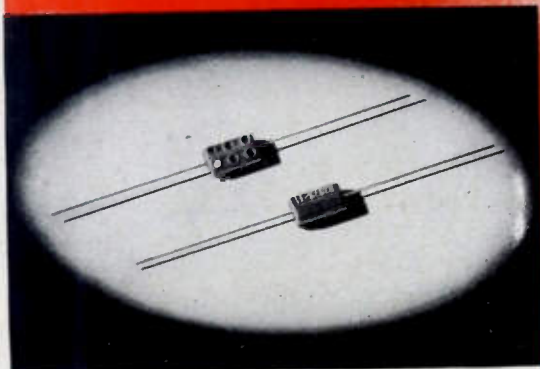
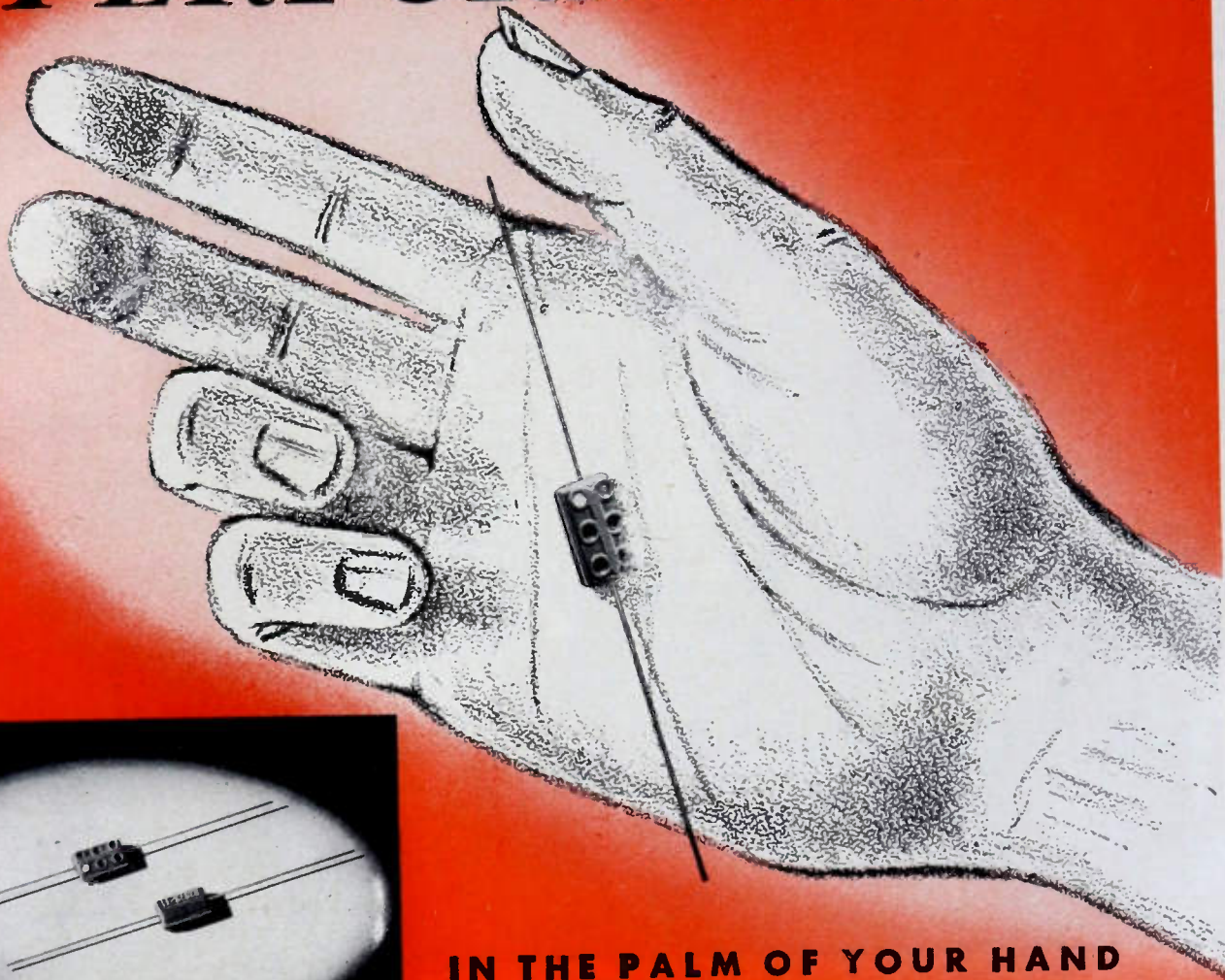

CM 15

Actual Size $9/32'' \times 1/2'' \times 3/16''$.
For Television, Radio and other
Electronic Applications.
2 - 420 mmf. cap. at 500v DCw.
2 - 525 mmf. cap. at 300v DCw.
Temp. Co-efficient ± 50 parts per
million per degree C for most
capacity values.
6-dot color coded.

IN THE PALM OF YOUR HAND

El-Menco Capacitors, mighty midgets of electronics, are so tiny you can hold a dozen of them in the hollow of your hand. Yet, their capacity, strength, long life and dependable performance under the most critical conditions are recognized throughout the industry.

The next time you need capacitors, call for El-Menco. Order the capacitors that are small in size but mighty in performance.

THE ELECTRO MOTIVE MFG. CO., Inc.
WILLIMANTIC CONNECTICUT



Write on your
firm letterhead for
Catalog and Samples

MOLDED MICA **El-Menco** **MICA TRIMMER**
CAPACITORS

FOREIGN RADIO AND ELECTRONIC MANUFACTURERS COMMUNICATE DIRECT WITH OUR EXPORT DEPT. AT WILLIMANTIC, CONN. FOR INFORMATION.
ARCO ELECTRONICS, INC. 135 Liberty St., New York, N. Y.—Sole Agent for Jobbers and Distributors in U.S. and Canada

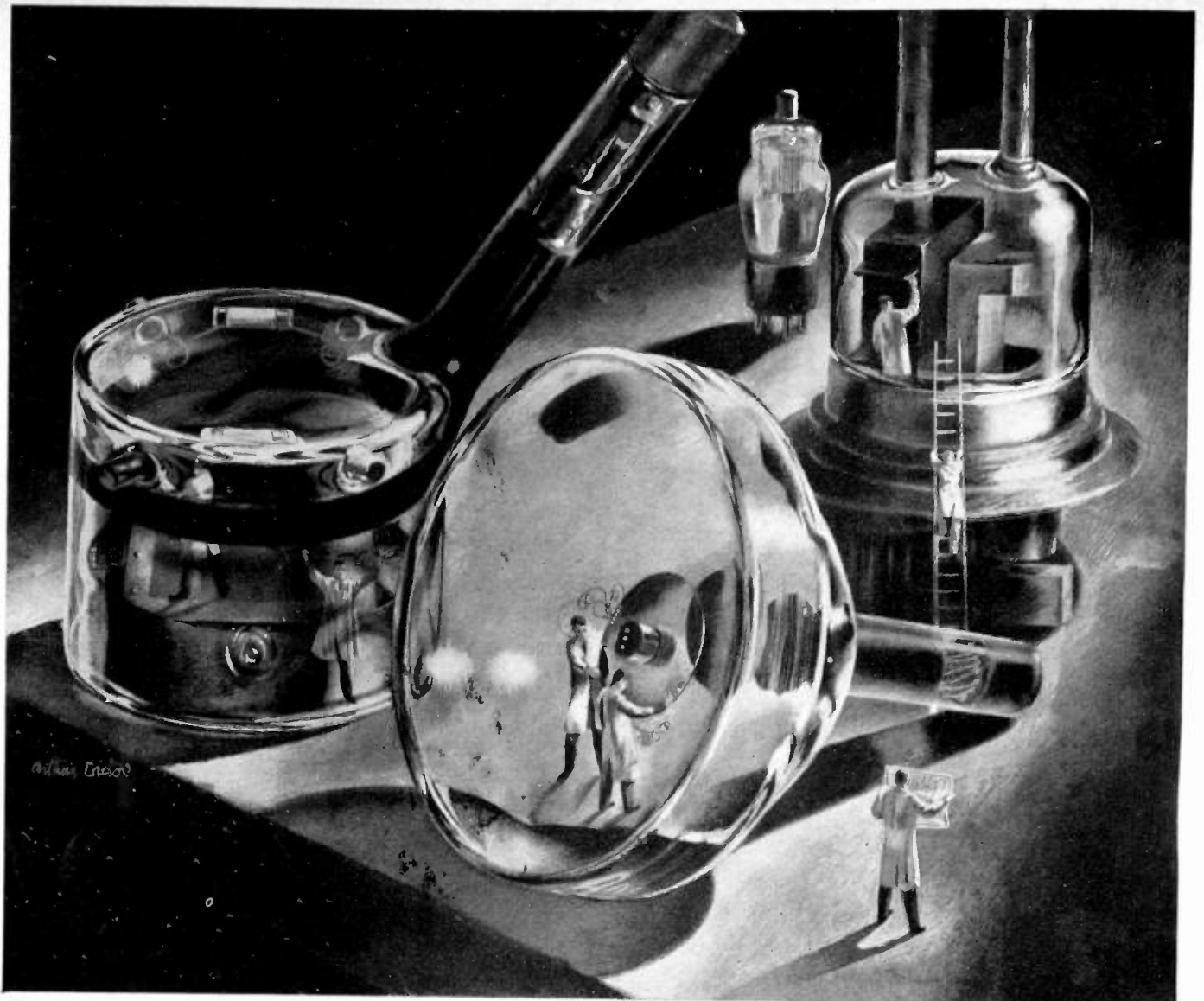

Scientists at RCA Laboratories solve exacting problems within the "nothingness" of vacuum tubes.

Inside story of Better Television

Now television is flashing *visual* entertainment, news, and educational material to millions of people. The "inside story" of its rapid growth is the history of some remarkable tubes. Inside these tubes, electrons are put to work—to perform, for your benefit, the miracle of long-distance vision.

The screen of your direct-view television receiver is actually the face of a tube—the kinescope developed by Dr. V. K. Zworykin and his colleagues of RCA Laboratories—on which electrons in motion "paint" pic-

tures. A tube, too, is the "eye" of RCA's supersensitive Image Orthicon television camera, which can "see" clearly by the light of a match.

And since you asked for big-picture television, they developed projection receivers—also a way to "weld" glass and metal, thus speeding the production of 16-inch direct-viewing tubes . . . at lower cost.

To these basic "firsts," RCA scientists have added advance after advance, which are daily bringing television into the lives of more and more people.

How you profit

Advanced research in television tubes is just one way in which RCA Laboratories work in your interest. Their leadership in science and engineering adds *value beyond price* to any product or service of RCA and RCA Victor.

Examples of the newest advances in radio, television, and electronics—in action—may be seen at RCA Exhibition Hall, 36 West 49th Street, New York. Admission is free. Radio Corporation of America, Radio City, New York 20.



RADIO CORPORATION of AMERICA

World Leader in Radio — First in Television

**Type 557
Ceramic
Trimmer**



1.5-7 MMF
3-12 MMF
5-25 MMF
5-30 MMF
8-50 MMF

**Type 554
Ceramic
Trimmer**



**Type 531 and 532
Tubular Trimmers**
0.5-5 MMF
1-8 MMF



Type TS2A Ceramic Trimmer
1.5-7 MMF 3-13 MMF 4-30 MMF
3-12 MMF 5-20 MMF 7-45 MMF

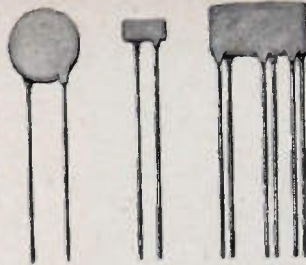

Erie Disc Ceramicon
Up to .01MFD



**Temperature Compensating
Molded Insulated Ceramicon***
0.5 MMF—550 MMF

**Temperature Compensating
Dipped Insulated Ceramicon**
0.5 MMF—1,770 MMF

**Temperature Compensating
Non-Insulated Ceramicon**
0.5 MMF—1,770 MMF

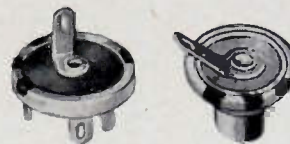

Button Mica Condensers
15 MMF—6,000 MMF



Erie "GP" Molded Insulated Ceramicon
5 MMF—5,000 MMF

Erie "GP" Dipped Insulated Ceramicon
5 MMF—10,000 MMF

Erie "GP" Non-Insulated Ceramicon
5 MMF—10,000 MMF

ERIE RESISTOR COMPONENTS

for better electronic products

THE dependability and accuracy to close tolerances required for Television and Broadcast applications are combined in Erie Ceramicon with compact design, tubular in form, for easy installation on the assembly line.

Erie manufactures a complete line of Ceramic and Button Mica Condensers for transmitter and receiver applications: Carbon Suppressors, Custom Injection Molded Plastic Knobs, Dials, Bezels, Name Plates and Coil Forms. Complete technical information on request.



Cinch-Erie Plexicon* Tube Sockets with 1,000 MMF built in by-pass condensers



Type 357

Type 362

Feed-Thru Ceramicon
5 MMF—1,000 MMF
5 MMF—1,500 MMF

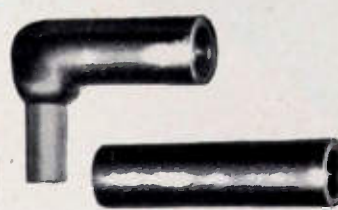

Types L-4, L-7, S-5 Suppressors for Spark Plugs and Distributors



Type 720A

Types 323 and 324 Insulated

Type 2322

Type 2336

Erie Stand-Off Ceramicon
5 MMF—5,000 MMF

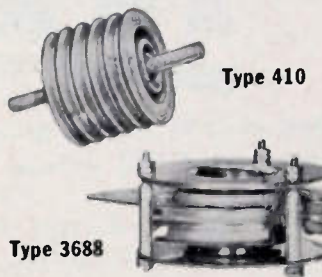

Type 410

Type 3688

High Voltage Double Cup and plate Condensers
Up to 15,000 VOLTS WORKING

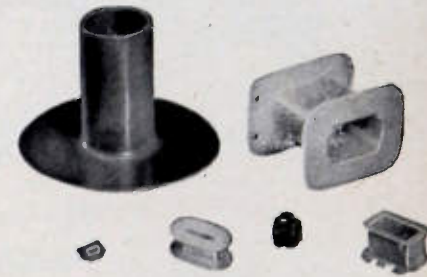

Custom Injection Molded Plastic Knobs, Dials, Bezels, Name Plates, Coilforms, etc.

*Ceramicon, HiK, GP, Button and Plexicon are registered trade names of Erie Resistor Corporation.



Follow the Leaders to

Eimac
REG. U. S. PAT. OFF.
TUBES

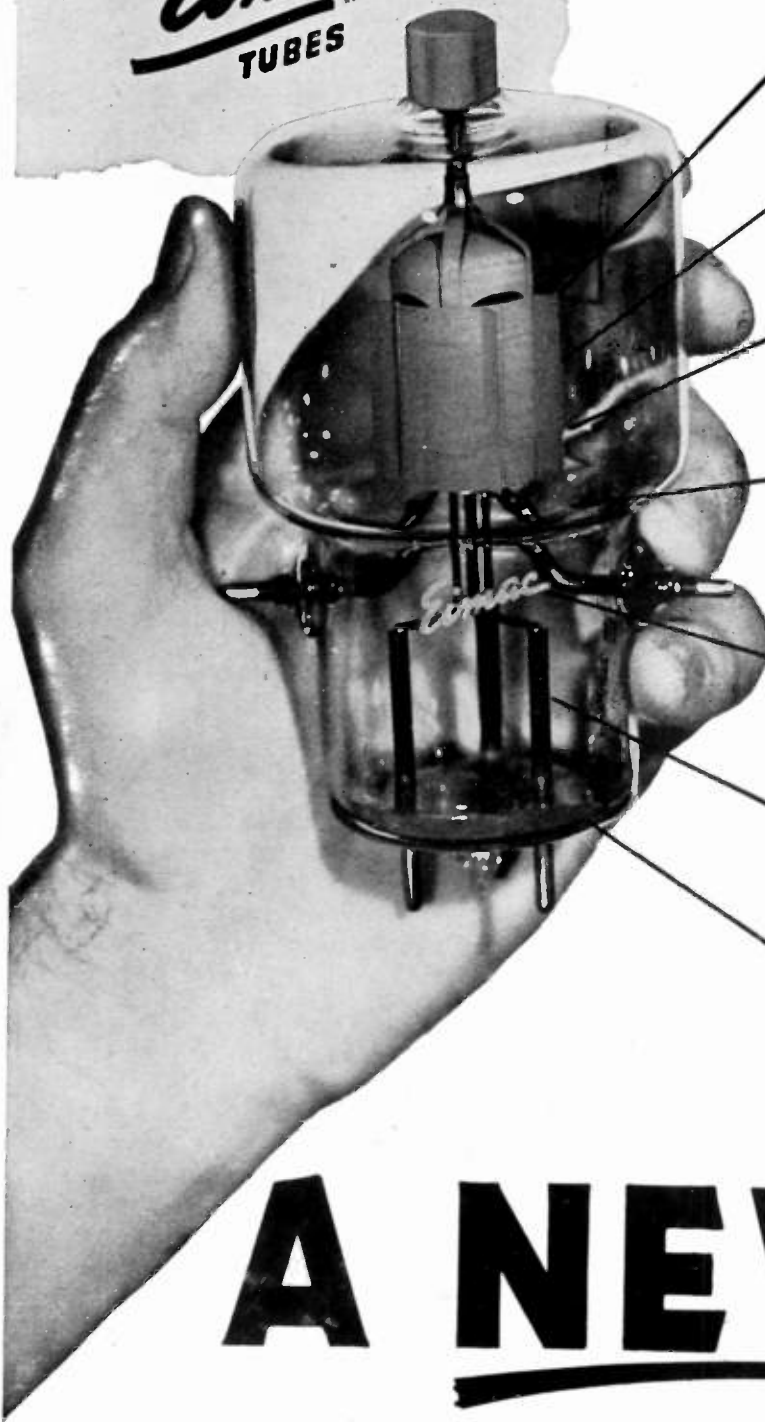

★ Pyrovac plate . . . for long life and to withstand momentary overloads.

★ Eimac non-emitting grid . . . for stability of operation.

★ Component materials are chemically stable . . . insuring long filament life.

★ Mechanical design of internal structures produces a high degree of rigidity and resistance to physical abuse.

★ Trade-marked "Eimac" . . . your assurance of superior performance and continuing service.

★ Tungsten leads . . . for low R-F resistance.

★ Eimac moulded glass base and precision aligned base pins.

A NEW 592

Developed and built by Eimac, the new 3-200A3/592 is directly interchangeable with existing tubes marked 592 without equipment modification.

The structural features indicated above impart to this new triode a long life span and rugged construction customarily associated with Eimac tubes.

Further information may be had by writing the Application Engineering Department of:

EITEL-McCULLOUGH, INC. SAN BRUNO, CALIFORNIA

Export Agents: Frazer & Hansen, 301 Cloy St., San Francisco, California

OHMITE

AVAILABLE for Immediate Delivery

From a Stock of Several Million

RHEOSTATS • RESISTORS • TAP SWITCHES • CHOKES

WHEN your purchasing orders for resistance units are stamped "Rush" . . . wire Ohmite. Chances are the exact unit you need can be shipped immediately from Ohmite stock—believed to be the largest supply of power rheostats, wire-wound resistors, rotary tap switches, and chokes in the world. Actually several million units—in 1859 types, sizes, and values—are ready for delivery. All, of course, of typically high Ohmite quality—*Industry's First Choice.*

Ohmite rheostats are characterized by their all-ceramic construction . . . their smoothly gliding metal-graphite brush . . . their uniform windings locked in place by vitreous enamel . . . and their ability to provide close control and trouble-free service under the toughest operating conditions.

Ohmite resistors are built on a strong ceramic core . . . wound with even windings that prevent "hot spots" . . . protected by special vitreous enamel. Terminal lugs are tin-dipped for easy soldering.

Ohmite tap switches are unsurpassed in combining high current capacity, large number of taps, and compactness.

Ohmite r-f chokes are "frequency rated" for easy selection and top performance.

Why not let Ohmite serve you when you need resistance units *fast?*



Write on company letterhead for your copy of the Ohmite Catalog and Engineering Manual No. 40

OHMITE MANUFACTURING CO., 4861 Flournoy St., Chicago 44

Be Right with-OHMITE

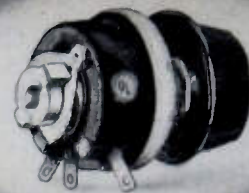

RHEOSTATS—Six stock sizes. Others to order. 25 to 1000 watts.



FIXED RESISTORS—Five sizes, 25 to 200 watts, 1 to 250,000 ohms.

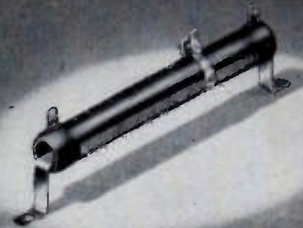

DIVIDOHM RESISTORS—Adjustable resistances. 10 to 200 watts.



THIN TYPE RESISTORS—Made to order only—five wattage sizes.



BROWN DEVILS—Vitreous-enamelled resistors. 5, 10, and 20 watts.

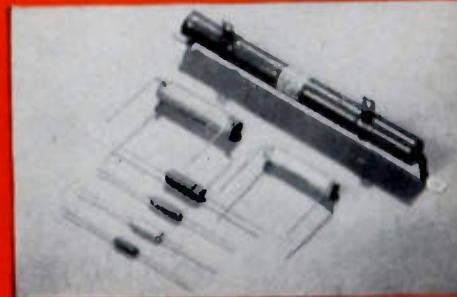

R-F CHOKES—Seven sizes, for frequencies from 1 to 520 megacycles.

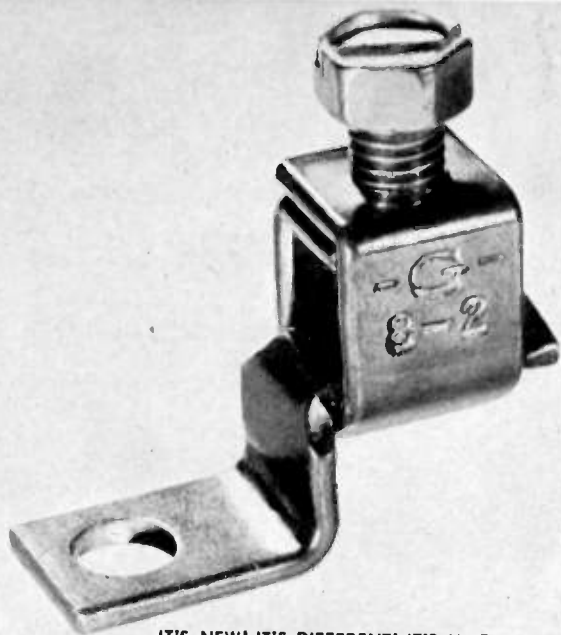

**What a Cold,
Calculating
Beating
this Lug takes!**

IT'S NEW! IT'S DIFFERENT! IT'S MADE OF REVERE COPPER
—The "Double G" Solderless Lug made by THE GREGORY
MANUFACTURING CO., INC., New Haven, Conn., for the
electrical field, comes in 6 sizes to accommodate from 14 ga
wire to 1,000,000 CM cables. Pressure screws are steel.



HOLD 'EM TIGHT—These sharp, deep-cut serrations on inside of both tubular sections and projection tang help to make firm, non-slip joints possible. They also increase the rigidity and conductivity of the connection. Note that these serrations were made cold, and without any distortion of the Revere Copper used. Lugs shown are twice actual size and are unretouched.

...and not a Scar to show for it!

Improved solderless lug of hard drawn Revere Copper, cold worked over and over without distortion, cracking, pitting or scarring.

Pierced, formed at short 45 degree and 90 degree angles and deeply serrated, this "Double G" solderless lug really gets a working over . . . and cold, too, no annealing. Yet, with all this, the surface remains absolutely smooth, the lug is not in any way weakened and there is no twisting, pitting, cracking or scarring of any kind. And, in addition, its dimensions are held.

When the Gregory Manufacturing Co., Inc., was developing this solderless lug, with its unusual features, it had a problem on its hands.

Their design called for copper strip that could stand a lot of cold working and when finally fabricated into a product of uniform quality, would not have a lot of twist, cracks, pitted or scarred surface. In their efforts to secure such a product their engineers had frequent consultations with Revere's Technical Advisory Service. The result was the product shown and described above, with production time and money saved and rejects held to the vanishing

point. The material used was Revere hard drawn copper strip with a temper of 36 to 46 Rockwell B Scale. This company feels that they could not have developed such a successful product if the quality of the copper was not of the best and did not possess the inherent working characteristics needed.

Perhaps Revere Copper or some other Revere Metal can be of help in developing or improving your product—cutting your production costs. Why not tell Revere's Technical Advisory Service about your metal problems? Call the Revere Sales Office nearest you today.

REVERE
COPPER AND BRASS INCORPORATED

Founded by Paul Revere in 1801
230 Park Avenue, New York 17, New York

Mills: Baltimore, Md.; Chicago, Ill.; Detroit, Mich.; Los Angeles and
Riverside, Calif.; New Bedford, Mass.; Rome, N. Y.—Sales Offices in
Principal Cities, Distributors Everywhere.

PROCEEDINGS OF THE I.R.E. November, 1949

HOW MANY
db?

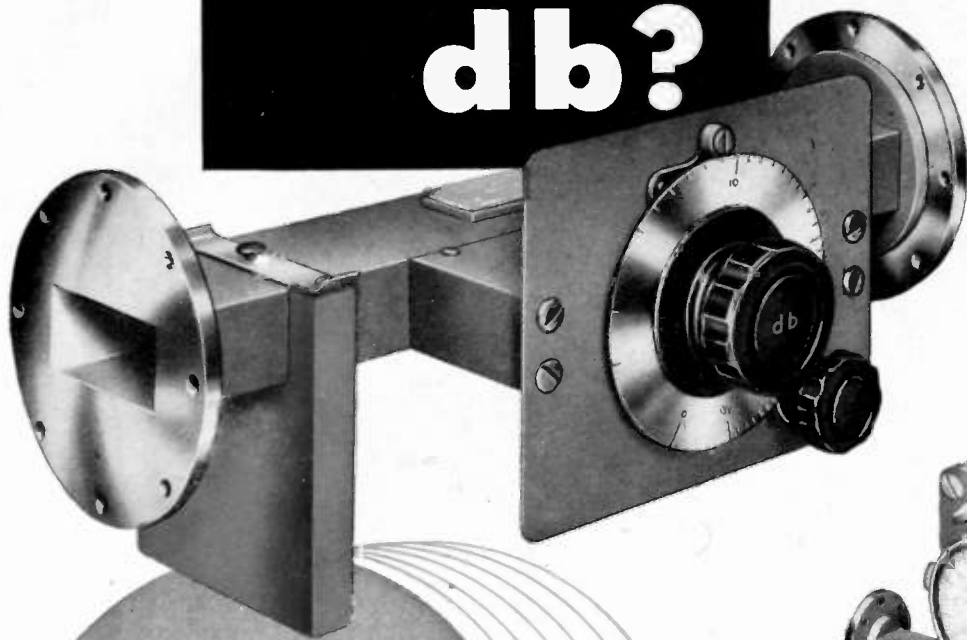

... AT 3,500
MEGACYCLES?

... AT 35,000
MEGACYCLES?

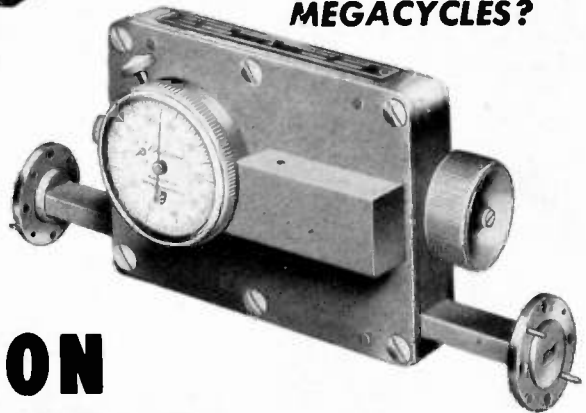

PRD

PRECISION VARIABLE ATTENUATORS

Features:

- METALLIZED-GLASS
ATTENUATING ELEMENTS
- PRECISE AND PERMANENT
CALIBRATION
- BROADBAND
CHARACTERISTICS
- NEGLIGIBLE INSERTION LOSS
- BACKLASH-FREE
VERNIER DRIVE
- LOW REFLECTION
- WELL SHIELDED CASING

The use of metallic-film-on-glass techniques to provide attenuation at microwave frequencies is no longer new. This type of PRD attenuator is now well recognized for its constancy of attenuation with time as well as for its insensitivity to variations of humidity and temperature.

PRD has now augmented this line of attenuators with units employing metallized mica elements to provide broader-band characteristics for the millimeter region of the microwave spectrum. As a consequence, it is now possible to offer complete coverage of the range from 2,600 to 40,000 megacycles per second in designs varying from a simple level set attenuator to a precisely calibrated secondary standard. Write Dept. R5 today for our complete new catalog of microwave test equipment.

202 TILLARY STREET
BROOKLYN 1, N. Y.

Polytechnic **RESEARCH
& DEVELOPMENT COMPANY, Inc.**

FP FOR TV



Television Demands Extra Margins of Safety

Everyone knows that higher temperatures hasten the destructive forces of corrosion. It's equally obvious that a capacitor which will take this extra punishment will stay on the job even longer at lower temperatures.

When you specify Mallory FP Capacitors for television receivers, or any equipment where heat is a problem, you can be sure

they will stand the gaff . . . they've always been designed to operate successfully at 85° C. And at normal temperatures, you get an extra margin of safety that pays off in longer, trouble-free performance.

Best of all, *you pay no premium* for this added dependability. Write for your copy of the new FP Capacitor Engineering Data Folder.

FP is the type designation of the Mallory developed electrolytic capacitor having the characteristic design pictured and famous throughout the industry for dependable performance.

P. R. MALLORY & CO., Inc.
MALLORY

P. R. MALLORY & CO., Inc., INDIANAPOLIS 6, INDIANA

SERVING INDUSTRY WITH

Capacitors	Rectifiers
Contacts	Switches
Controls	Vibrators
	Power Supplies
	Resistance Welding Materials

FREED

Instruments & Components "PRODUCTS of EXTENSIVE RESEARCH"



NO. 1110 INCREMENTAL INDUCTANCE BRIDGE
Inductance range from 1 MHY to 1000 H. Frequency range from 40 to 1000 cycles. D.C. range from .5MA to 1 Amp.



STEPDOWN TRANSFORMERS
High efficiency Auto Transformer can be used as either Step Up or Step Down transformer equipped with standard receptacle and line cord.



HIGH FIDELITY OUTPUT TRANSFORMER
High quality output transformer combines unusually wide frequency range together with very low phase shift and harmonic distortion. Frequency range 1/2 DB 20-30,000 cycles.



DISCRIMINATORS
For telemetering and remote control application using audio and super-sonic frequency sub-carriers.



NO. 1010 COMPARISON BRIDGE
For precision laboratory adjustment and incoming inspection of resistors, capacitors and inductors. Entirely self contained, A.C. operated and includes a three frequency oscillator, an A.C. bridge and a null detector.



NO. 1020 DIRECT READING MEGOHMMETER
Measures insulation resistances up to 2,000,000 megohms. 500 volts D.C. potential included in the instrument. Entirely self contained and A.C. operated.



NO. 1140 NULL DETECTOR
High gain Null Detector for bridge measurements. Contains selective circuit for 40-400-1000 cycles. Frequency range 30-20,000 cycles.



FILTERS
Narrow band pass filters for remote control and telemetering applications. High pass, low pass, band pass and band elimination filters for communication and carrier systems.



NO. 1030 "Q" INDICATOR
Frequency range from 20 cycles to 50 kilocycles. "Q" range from .5 to 500. "Q" of inductors can be measured with up to 50 volts across the coil.



HI-Q MINIATURE TOROIDAL INDUCTORS
Size 3/4" D. x 3/8" — weight 3/4 ounce. Type TI-5 Frequency range 1000 cycles - 15,000 cycles. Type TI-7 Frequency range 10,000 cycles - 100,000 cycles. Wound on molybdenum permalloy dust cores. Available in hermetically sealed cans, potted and cased or open units.



TOROIDAL INDUCTORS
Hi Q toroidal coils wound on powdered molybdenum permalloy. Can be supplied for frequencies from 200 cycles to 200 KC Available in hermetically sealed construction potted and cased or open type units.

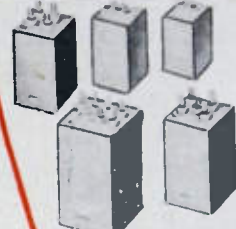

HERMETICALLY SEALED COMPONENTS
Class A Grade I components to meet JAN-T-27 specifications. Made to customer's requirements where temperature and humidity are factors.



NO. 1150 UNIVERSAL BRIDGE
For measurement of inductors, capacitors, and determination of resistive and reactive components of impedances. Frequency range 20 cycles - 20,000 cycles 1% accuracy.



NO. 1210 NULL DETECTOR & VACUUM TUBE VOLTMETER
Vacuum Tube Voltmeter: Sensitivity .1, 1, 10, 100 volts. Input impedance 50 megohms shunted by 20 mfd. Frequency range 20 cycles - 20,000 cycles. NULL DETECTOR: Gain 94 DB. Selective circuits for 40, 400, 1000 cycles. Frequency range 20-30,000 cycles.



NO. 1060 VACUUM TUBE VOLTMETER
For use at audio, super-sonic and radio frequencies. Frequency range from 10 cycles to 1.6 megacycles. Input impedance 50 megohms. Input capacity 15 MMF. Voltage range from .001 to 100 volts. Frequency range from 10 cycles to 2 megacycles.



NO. 1180 A.C. POWER SUPPLY
A valuable laboratory instrument with continuous variable output from .1 volt to 100 volts @ 60 cycles.

FREED TRANSFORMER CO., Inc.

DEPT. E O 1718-36 WEIRFIELD ST., (RIDGEWOOD) BROOKLYN 27, NEW YORK

A New Standard of Performance for Cathode-ray Oscillographs



DUMONT

TYPE 304-H

▶ NEVER BEFORE HAVE THESE FEATURES BEEN COMBINED IN ONE INSTRUMENT AND OFFERED AT SUCH LOW COST!

cathode-ray tube is possible, with the high resolution of a 5-inch screen. Full positioning is available over this entire expanded range on both axes.

HIGH-GAIN AMPLIFIERS X- AND Y-AXES

Sensitivity: X-Axis, 50 millivolts rms per inch (AC and DC). Y-Axis, 10 millivolts rms per inch (AC and DC).

Frequency Response: DC amp. X and Y Axes, 0-100,000 cps within 10%; 0-300,000 cps within 50%. AC amp. X and Y Axes, 20-100,000; cps within 10%; 20-300,000 cps within 50%.

No pattern "bop" even with sudden changes in signal level. Excellent stability and minimum microphonics and drift. Provision for applying signals directly to deflection plates.

STABILIZED SYNCHRONIZATION

Sync limiting provided on recurrent sweep, so that sweep length and synchronization are maintained as signal level varies.

EXPANSION OF DETAILS

Due to available deflection of over 4 times full-screen diameter on both X and Y Axes, performance equivalent to that of a 20-inch

RECURRENT AND DRIVEN SWEEPS

Variable from 2 to 30,000 cps. Sweep speeds faster than 0.75 inch/ μ sec. with fully expanded time base. Provision incorporated for sweeps of 10 seconds and slower through the connection of external capacitors at front-panel terminals. Sync amplifier with sync-polarity selection is provided.

INTENSITY MODULATION

Z-Axis input terminal on front panel is capacitively coupled to grid of cathode-ray tube. 15 volts peak will blank trace fully at normal intensity.

INCREASED ACCELERATING POTENTIAL

Du Mont Type 5CP-A Cathode-Ray Tube in the Type 304-H is operated at overall accelerating potential of 3000 volts, facilitating use of long-persistence screens to take full advantage of low-frequency recurrent sweeps, fast-driven sweeps, and DC amplifiers. Type 304, a lower-price version, is also available, operating at an overall accelerating potential of 1780 volts.

ADDITIONAL FEATURES

An engraved, permanently-mounted calibrated scale greatly facilitates quantitative measurements. Mu-Metal magnetic shield affords maximum protection of cathode-ray tube from effects of external magnetic fields. Du Mont Type 2501 Bezel permits attachment of such accessories as Du Mont Types 271-A or 314-A Oscillograph-Record Cameras.

MECHANICAL DETAILS

Height, 13½"; Width, 8¾"; Depth, 19"; Weight, 50 lbs. Housed in metal cabinet with gray wrinkle finish. Panel reverse etched—white on gray.

TRIED AND PROVED

This oscillograph has undergone a most rigid field test both in our own laboratories and again in selected laboratories and institutions throughout the country. In a great variety of applications, every feature has been given a thorough workout. The Type 304-H is not a new instrument of unknown quality, but definitely an oscillograph of TRIED AND PROVED EXCELLENCE.

PRICES

Type 304-H, \$307.50. Type 304, \$285.00.

▶ Full details of performance and applications are contained in a 12-page bulletin obtainable by writing to . . .

© ALLEN B. DU MONT LABORATORIES, INC.

ALLEN B. DU MONT LABORATORIES, INC.
CLIFTON, NEW JERSEY

What's Your
PANEL INSTRUMENT
Problem?



Simpson
ENGINEERS WILL HELP YOU
Solve It!

No matter what your panel instrument problem is, Simpson Electric Company engineers will be glad to help you solve it. Every day they are confronted with individual design problems.

Behind every Simpson instrument is a world-wide reputation for quality. Simpson movements have greater ruggedness and accuracy, because of the full bridge-type construction and soft iron pole pieces.

When Simpson helps you with your problem, you benefit from this world-wide reputation and the years of experience of Simpson engineers.

Let Simpson engineers help you with your next instrument problem and for your standard instrument requirements take advantage of our large stock, available for immediate delivery.



SIMPSON ELECTRIC COMPANY

5200-18 WEST KINZIE STREET, CHICAGO 44, ILLINOIS
IN CANADA: BACH-SIMPSON, LTD., LONDON, ONTARIO

Smaller

METALLIZED-PAPER CAPACITORS

Here's a 150 volt 5 mfd. Aerolite* metal-cased unit contrasted with the usual paper-and-foil capacitor of equivalent rating. Its Aerolite* hermetically-sealed metallized-paper section means smaller size, lighter weight, performance reliability, plus the unique self-healing characteristic. Aerovox application engineering assures satisfactory usage.

Smaller

BANTAM* ELECTROLYTICS

Type SRE Bantams* are the smallest electrolytics yet! Especially suitable for cathode by-pass applications, screen filter circuits and similar functions. Improved processing and materials combined with more efficient space utilization, means smaller size and no reduction in life.



Smaller

METALLIZED-PAPER TUBULARS

Aerolite* Type P'82 (front) and Type '84 usual tubulars are further examples of Aerovox's long line of size reductions. These miniature paper tubulars provide the maximum in performance, life, operating ranges and stability.



SMALL... SMALLER... Smallest

AEROVOX

Capacitors

WE MUST KNOW...

- 1 Life
- 2 Operating Voltage
- 3 Maximum Surge Voltage
- 4 Maximum Ambient Temperature ?
- 5 Duty Cycle
- 6 Humidity
- 7 Altitude
- 8 Shock
- 9 Terminals
- 10 Mounting

● How small is *small*? The radio-electronic miniaturization trend poses the question. And here's the Aerovox answer:

Small in capacitors means the *minimum* size required to meet actual performance requirements. There must be no secrets as to the operating conditions. To give you a true miniature capacitor, we must know the facts called for by the accompanying questions.

How small is *small*? Let Aerovox engineers, with their latest techniques and production processes, give you the practical answer.

● Submit your miniaturization or other capacitance requirements for engineering collaboration and quotations.

*Trade-marks



FOR RADIO-ELECTRONIC AND INDUSTRIAL APPLICATIONS

AEROVOX CORPORATION, NEW BEDFORD, MASS., U.S.A.
 SALES OFFICES IN ALL PRINCIPAL CITIES • Export: 13 E. 40th ST., NEW YORK 16, N. Y.
 Cable: 'ARLAB' • In Canada: AEROVOX CANADA LTD., HAMILTON, ONT.

**Industrial Research
Laboratories uses**

CLARE RELAYS

**in Electronic Crown
Detector Unit for
Bottling Machines**

**Send for CLARE
Engineering Data Book**

This book, sent on request, pictures and describes the complete CLARE line of relays and allied control apparatus to meet the widest variety of industrial uses.

This electronic device warns of any interruption of the crown supply in bottling operations. It is sold by Liquid Carbonic Corporation of Chicago and manufactured by Industrial Research Laboratories of Baltimore, Md.

A bottle feeler switch is inserted in the control grid circuit to close the circuit when a bottle passes between the poles. If a crownless bottle passes, an electronic tube momentarily operates the CLARE Type "C" Relay and an alarm sounds for a few seconds. Passage of the second crownless bottle causes the CLARE relay to stop the machine on the second operation.

CLARE relays were selected by Industrial Research Laboratories for this important operation because of their long reputation for accurate, long-life performance as components of devices designed for trouble-free operation, day in and day out. In larger plants, more than a million bottles per week pass through the machine.

If you have a difficult relay problem, a requirement where ordinary relays just won't do, why not take it up with our engineers? CLARE sales engineers are located in principal cities. They are experienced in the most difficult types of relay problems. We invite you to take advantage of their services. Call them direct . . . or write to C. P. Clare, 4719 West Sunnyside Avenue, Chicago 30, Illinois. In Canada: Canadian Line Materials Ltd., Toronto 13. Cable address: CLARELAY.



Typical bottling installation showing Red Diamond Electronic Crown Detector in operation.

Cover of control box removed to show installation of CLARE Type "C" Relay.

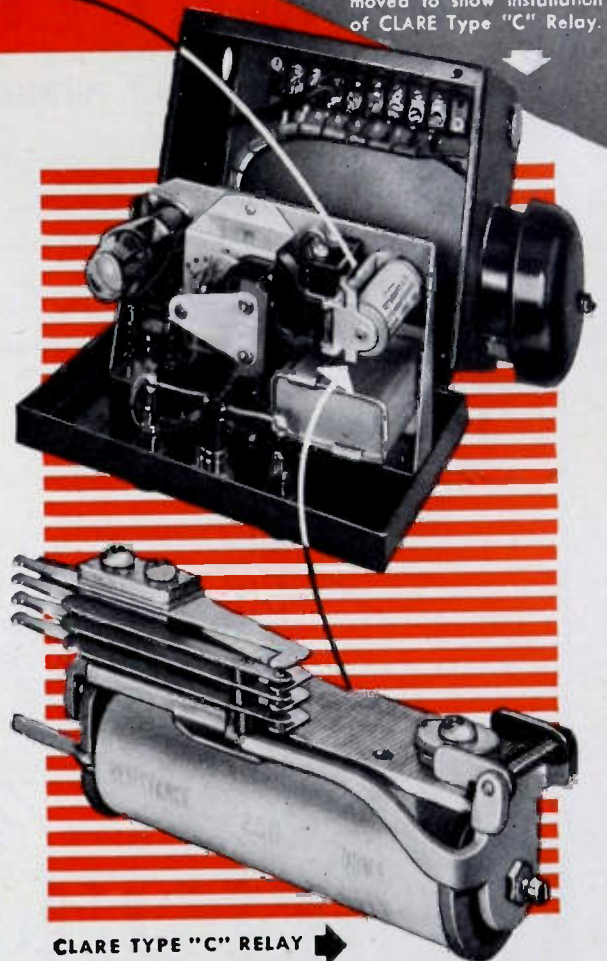

CLARE TYPE "C" RELAY

CLARE RELAYS

First in the Industrial Field

ENGINEERED AND PRODUCED TO MEET

Your Special Problems



COSMALITE* ENSURES SATISFACTION

SPIRALLY LAMINATED PAPER BASE PHENOLIC TUBING

#46 COSMALITE is designed for application where punching and stapling qualities are important. It is especially adaptable for threading or other requirements.

#SLF COSMALITE is designed for thin wall applications such as permeability tuners. It has unusual strength and excellent electrical properties.

#96 COSMALITE is the standard for all radio and television applications. It possesses excellent electrical and mechanical qualities and meets coil form requirements with high electrical strength and minimum surface leakage.

#102 REGULAR COSMALITE, designed for low moisture absorption, low power factor, low surface leakage and high dielectric strength. Especially suitable for use with frequencies as high as the ultra high frequency band.

#102 MODIFIED COSMALITE retains the excellent electrical properties of #102 along with the mechanical and versatile advantages of #96 COSMALITE. Designed especially for high voltage applications where staples or rivets are fastened on coil forms.

COSMALITE, backed by over 25 years of experience, equals or exceeds the performance of any phenolic tubing available.

Consult us on your needs.

* Reg. U.S. Pat. Off.

The **CLEVELAND CONTAINER Co.**

6201 BARBERTON AVE. CLEVELAND 2, OHIO

PLANTS AND SALES OFFICES at Plymouth, Wisc., Chicago, Detroit, Ogdensburg, N. Y., Jamesburg, N. J.
ABRASIVE DIVISION at Cleveland, Ohio
CANADIAN PLANT: The Cleveland Container, Canada, Ltd., Prescott, Ontario

REPRESENTATIVES

CANADA METROPOLITAN NEW YORK NEW ENGLAND	} WM. T. BARRON, EIGHTH LINE, RR #1, OAKVILLE, ONTARIO R. T. MURRAY, 614 CENTRAL AVE., EAST ORANGE, N. J. E. P. PACK AND ASSOCIATES, 968 FARMINGTON AVE. WEST HARTFORD, CONN.
---	--



Beat *the* Heat

specify

"NOFLAME-COR"
the TELEVISION hookup wire

by

APPROVED
BY
UNDERWRITERS
LABORATORIES
AT

90° CENTIGRADE _____ **600** VOLTS



Preferred more and more by particular manufacturers of television, F-M, quality radio and all exacting electronic equipment. Available in all sizes, solid and stranded; over 200 color combinations.

PRODUCTION ENGINEERS: Specify "NOFLAME-COR" for maximum output and minimum rejects. This is not an extruded plastic and therefore losses from "blobbing" under heat of soldering iron are avoided.

- ✓ Flame Resistant
 - ✓ High Dielectric
 - ✓ High Insulation Resistance
 - ✓ Facilitates Positive Soldering
 - ✓ Heat Resistant
 - ✓ Easy Stripping
- ✓ Also unaffected by the heat of impregnation—
therefore, ideal for coil and transformer leads

RUBBER	_____	75°
PLASTIC	_____	80°
"NOFLAME-COR"	_____	90°

"made by engineers for engineers"

CORNISH WIRE COMPANY, Inc.

605 North Michigan Avenue,
Chicago 11

15 Park Row, New York 7, N. Y.

1237 Public Ledger Bldg.,
Philadelphia 6

MANUFACTURERS OF QUALITY WIRES AND CABLES FOR THE ELECTRICAL AND ELECTRONIC INDUSTRIES

extreme precision, instant response in remote indication and control

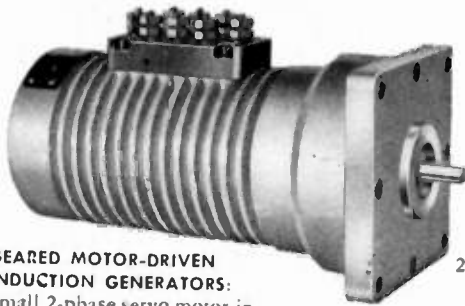

GEARED MOTOR-DRIVEN INDUCTION GENERATORS: Small 2-phase servo motor in combination with a compact gear-reducer and a low residual induction generator. Motor has high torque/inertia ratio and develops maximum torque at stall. Gear-reducer permits a maximum torque output of 25 oz. in. and is available in ratios from 5:1 to 75,000:1.



INDUCTION MOTORS: miniature 2-phase motors of the squirrel cage type. Designed specifically to provide fast response to applied control signals and maximum torque at zero r.p.m. Unit shown weighs 6.1 oz. and has stalled torque of 2.5 oz. in.

CIRCUTROL UNITS: rotary electro-magnetic devices for use as control components in electronic circuits and related equipment. Single and polyphase rotor and stator windings are available in several frame sizes. Deviation from sine accuracy of resolver shown is $\pm 0.3\%$ of maximum output.

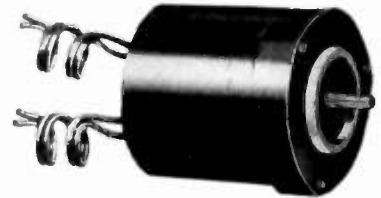

SYNCHRONOUS MOTORS: for instrumentation and other applications where variable loads must be kept in exact synchronism with a constant or variable frequency source. Synchronous power output up to 1/100 H.P.

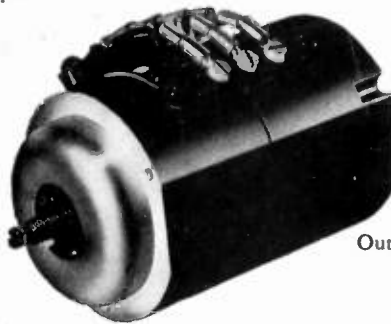

SYNCHRONOUS DIFFERENTIAL UNITS: electro-mechanical error detectors with mechanical output for use in position or speed control servo systems. These torque-producing half-speed synchros are composed of two variable frequency synchronous motors and a smoothly operating system of differential gearing.

Output: Speed = $\frac{N_1 - N_2}{2}$; Torque up to 1.0 oz. in.

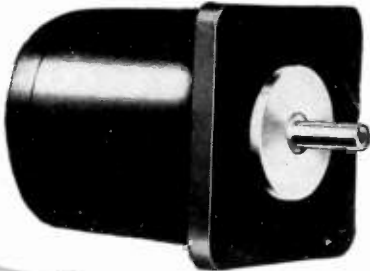

TELETORQUE UNITS: precision synchros for transmitting angular movements to remote points. Accurate within $\pm 1^\circ$. May be actuated by mechanisms that produce only 4 gm. cm. (.056 oz. in.) of torque.



ADDITIONAL SPECIAL PURPOSE AC UNITS BY KOLLSMAN

With the recent addition of new units to Kollsman's already widely diversified line, the electronics engineer will find the solution to an even greater variety of instrumentation and control problems. These lightweight, compact units offer the high degree of accuracy and positive action essential in dealing with exact quantities. They are the product of Kollsman's long experience in precision instrumentation and aircraft control — and of considerable work done in this field by Kollsman for special naval and military application. Most units are available at various voltages and frequencies. For complete information, address: Kollsman Instrument Division, Square D Company, 80-66 45th Avenue, Elmhurst, N. Y.

KOLLSMAN INSTRUMENT DIVISION

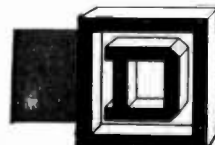

SQUARE D COMPANY

ELMHURST, NEW YORK

GLENDALE, CALIFORNIA

FILTER SPECIALISTS

PRODUCERS OF PERMALLOY DUST TOROID COILS AND FILTERS FOR OVER A DECADE

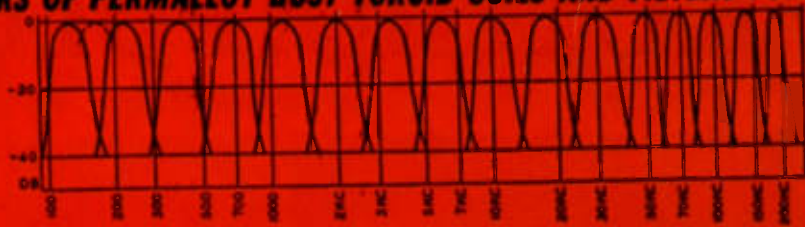

FOR FILTERS

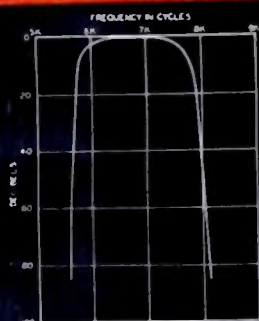

**BROAD BAND
SHARP CUTOFF
FILTER**

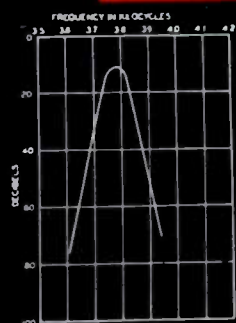

**NARROW BAND
SHARP CUTOFF
FILTER**

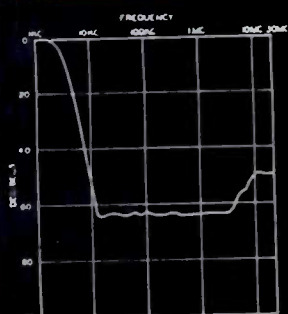

**ATTENUATES
10KC TO 30
MEGACYCLES**

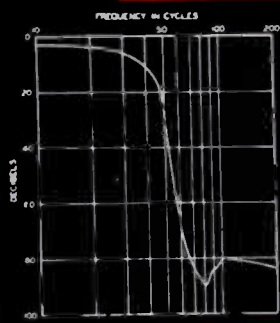

**LOW FREQUENCY
— LOW PASS
FILTER**

SUB-OUNCER TOROID FILTERS

Filters employing SUB-OUNCER toroids and special condensers represent the optimum in miniaturized filter performance. The band pass filter shown weighs 6 ounces.



**HQA, C, D
TOROID COILS**

1 1/8" Dia. x 1 7/8" High.



**HQB
TOROID COIL**

2 5/8" L. x 1 3/8" W. x 2 1/2" H.



UNCASED TOROIDS



**VIC
VARIABLE
INDUCTOR**

1 3/8" L. x 1 1/4" W. x 1 1/2" H.



FOR HIGH Q COILS

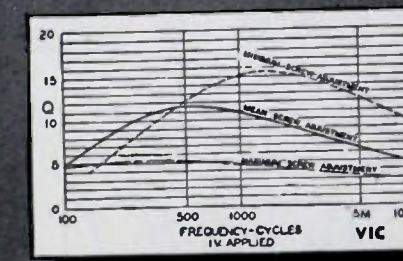
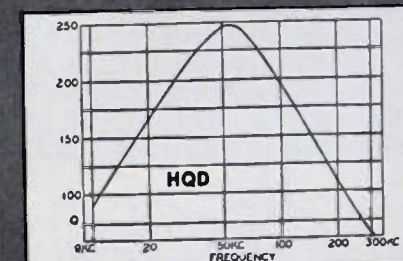
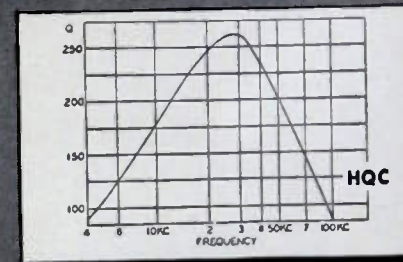
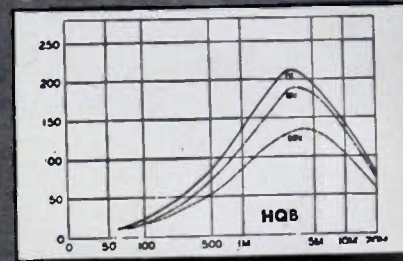
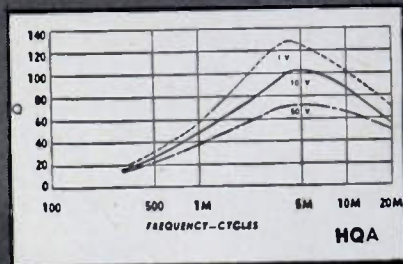

United Transformer Co.

150 VARICK STREET

NEW YORK 13, N. Y.

Precision products

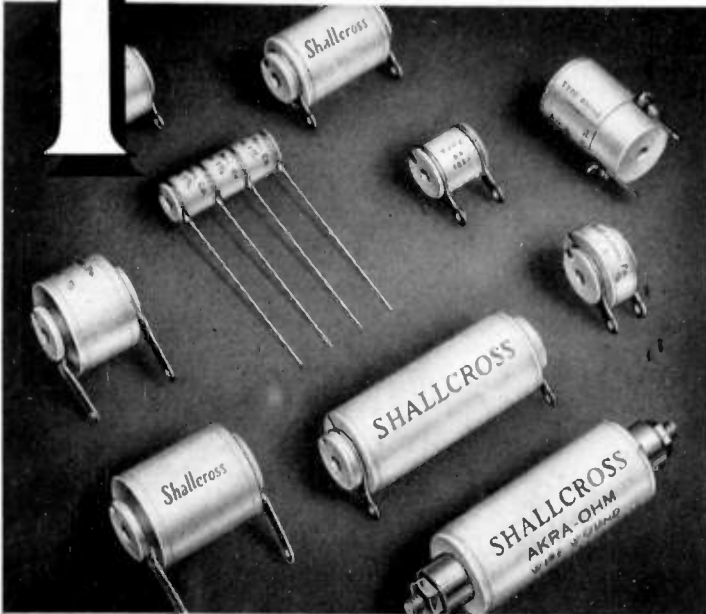

◀ CLOSE TOLERANCE RESISTORS

(JAN and standard types)

Wire-wound precision resistors have characteristics suitable for many exacting modern circuits. Shallcross Akra-Ohm resistors meet these requirements and are available in several types, shapes, and mounting styles. They are noted for high stability, low temperature coefficients, low noise levels, uniformity, long life, and extreme accuracy in matched pairs and sets. Ask for Bulletin R3.

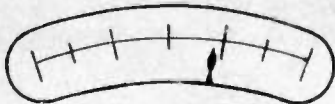

PRECISE ELECTRICAL ▶ MEASURING INSTRUMENTS

Resistance Standards	Decibel Meters
Decade Potentiometers	Tone Generators
Decade Resistance Boxes	Telephone Test Equipment
Bridges, Wheatstone	Low-Resistance Test Sets
Bridges, Kelvin-	Insulation Test Sets
Wheatstone	Bridge Components
Bridges, Limit	Write for Catalog No. 10.

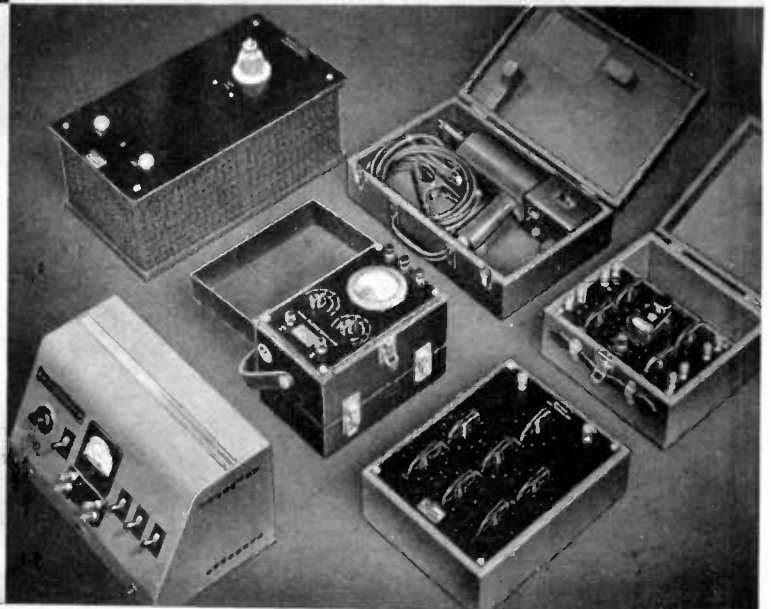

INDUSTRIAL RESEARCH AND DEVELOPMENT SERVICE

Today's complex circuits frequently require the design development, and production of highly specialized components, sub-assemblies, or instruments which fall outside the realm of standard engineering or production facilities. The Shallcross Research Department has been specifically formed to handle such assignments. Composed of electronic, electrical, instrument, mechanical, and chemical engineers of broad experience and backed with adequate modern facilities, this unique service group combines a highly technical as well as an intensely practical engineering-production viewpoint. We invite you to submit your requirements for review and recommendation.

SHALLCROSS MANUFACTURING

by SHALLCROSS

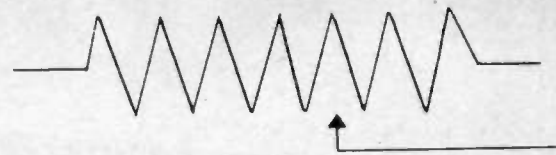
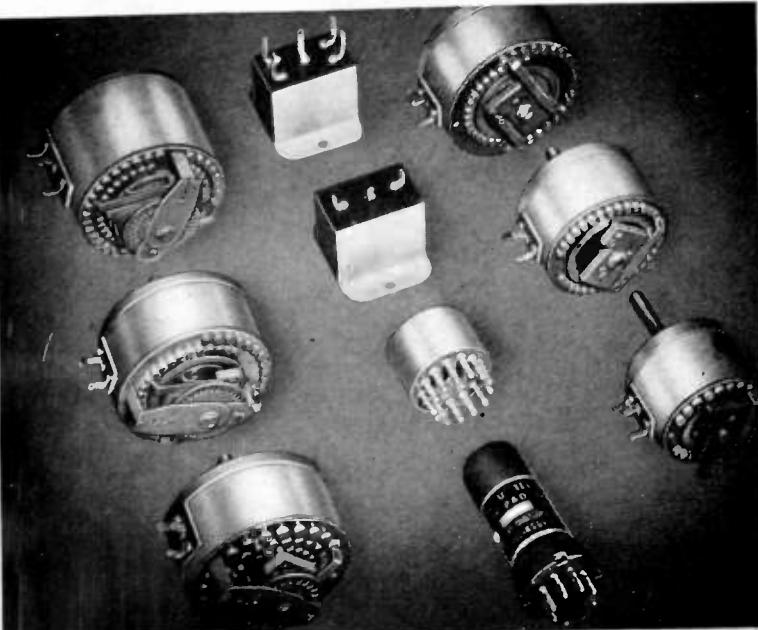

◀ HIGH QUALITY ATTENUATORS

Improved materials and production techniques for Shallcross Attenuators have resulted in a line that sets new higher standards of attenuation performance for practically every audio and communications use. Shallcross Audio Engineering Bulletin No. 4 will be sent on request.

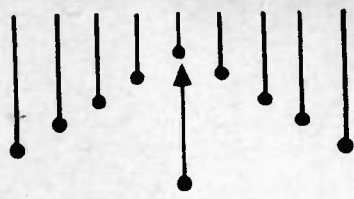

CUSTOM-BUILT SELECTOR SWITCHES ▶

Shallcross builds single or multiple deck selector switches having up to 180 positions. Test units have given satisfactory performance at 250 volts 10 amperes and at 2500 volts 1 ampere A.C. Contact resistance ranges from a low of 0.0005 ohms to a maximum of 0.005 ohms depending upon the size and material of the contact surfaces. You are invited to outline your requirements on Shallcross Specification Sheet No. 6.

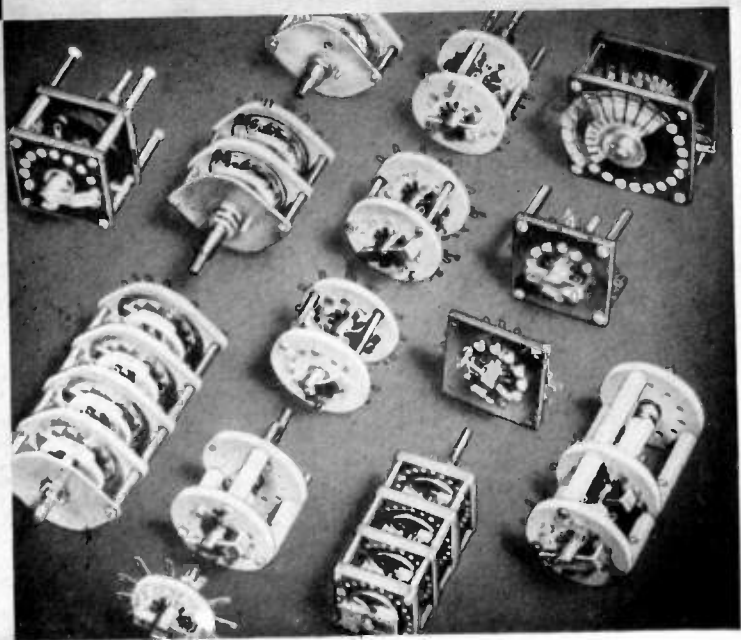

HIGH-VOLTAGE

Test and Measuring Equipment

Shallcross high-voltage instruments and corona-protected resistors provide maximum accuracy, safety, and dependability in a broad range of applications, from nuclear physics to electrostatic generators, precipitrons, power supplies, transmitters, and many others. Write for Bulletin F.

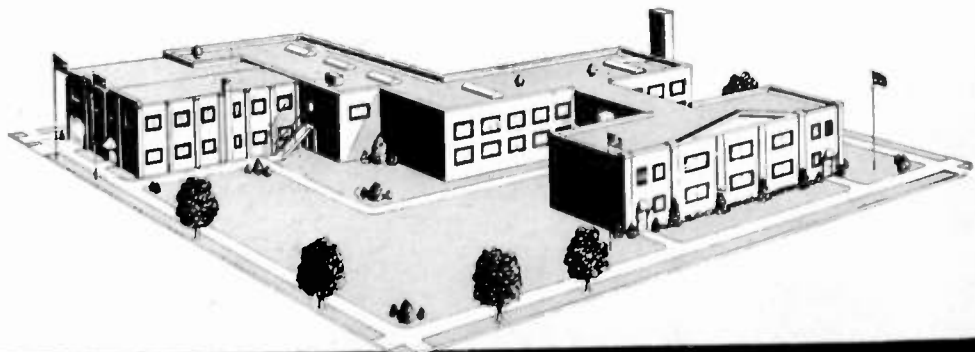

COMPANY Dept. PR-119 **Collingdale, Pennsylvania**

RCA PREFERRED-TYPE RECEIVING TUBES
Miniature Types are shown in italics

RECTIFIERS and DIODE DETECTORS	CONVERTERS	AMPLIFIERS, OSCILLATORS & MIXERS						OUTPUT AMPLIFIERS		KINESCOPIES
		Triodes			Pentodes					
		Single	Twin	With Diodes	Sharp Cutoff	Remote Cutoff	With Diode	354	3V4	
1B3-GT/8016 5U4-G 5Y3-GT 6AL5 6W4-GT 6X4 12AL5 35W4 117Z3	1R5 6BA7 6BE6 12BA7 12BE6	6C4	6J6 6SC7 6SN7-GT 12AU7 12AX7	6AQ6 6AV6 6BF6 12AV6	104 6AG5 6AU6 6SJ7 12AU6	114 6BA6 6BJ6 12BA6	1U5	354 3V4	5TP4 7JP4 10BP4 12LP4 16AP4 35C5 50C5	

Projection Type



The new RCA List of Preferred Receiving Tube Types fulfills the major engineering requirements for future receiver designs.

Most likely to succeed...

RCA preferred tube types for AM, FM, and TV receiver designs

WHETHER IT'S GLASS, metal or miniature—RCA preferred receiving tube types will serve your major requirements for a long time to come... and RCA preferred types are the tubes you can bank on for your future designs.

These RCA receiving tube types are especially recommended because their widespread application permits production to be concentrated on fewer types. Longer manufacturing runs reduce costs—lead

to improved quality and greater uniformity. These benefits are shared by you and your customers.

RCA Application Engineers are ready to suggest the best preferred tube types for your receiver design requirements. Just contact our nearest regional office—or write RCA, Commercial Engineering, Section 47KR, Harrison, New Jersey.

The Fountainhead of Modern Tube Development is RCA



RADIO CORPORATION of AMERICA
ELECTRON TUBES
HARRISON, N. J.

BOARD OF DIRECTORS, 1949

Stuart L. Bailey
President

A. S. McDonald
Vice-President

D. B. Sinclair
Treasurer

Haraden Pratt
Secretary

Alfred N. Goldsmith
Editor

W. R. G. Baker
Senior Past President

B. E. Shackelford
Junior Past President

1949-1950

Ben Akerman

J. V. L. Hogan

F. H. R. Pounsett

J. E. Shepherd

J. A. Stratton

H. E. Kranz

1949-1951

W. L. Everitt

D. G. Fink

1949

J. B. Coleman

M. G. Crosby

E. W. Engstrom

R. A. Heising

T. A. Hunter

J. W. McRae

H. J. Reich

F. E. Terman

H. A. Zahl

Harold R. Zeamans
General Counsel

George W. Bailey
Executive Secretary

Laurence G. Cumming
Technical Secretary

Changes of address (with advance notice of fifteen days) and communications regarding subscriptions and payments should be mailed to the Secretary of the Institute, at 450 Ahnaip St., Menasha, Wisconsin, or 1 East 79 Street, New York 21, N. Y.

All rights of republication, including translation into foreign languages, are reserved by the Institute. Abstracts of papers, with mention of their source, may be printed. Requests for republication privileges should be addressed to The Institute of Radio Engineers.

PROCEEDINGS OF THE I.R.E.

(Including the WAVES AND ELECTRONS Section)

Published Monthly by

The Institute of Radio Engineers, Inc.

VOLUME 37

November, 1949

NUMBER 11

PROCEEDINGS OF THE I.R.E.

Raymond A. Heising, Board of Directors—1949	1234
Feedback	Henry W. Parker 1235
3473. Pulse-Multiplex System for Distance-Measuring Equipment (DME)	Charles J. Hirsch 1236
3474. A Michelson-Type Interferometer for Microwave Measurements	Bela A. Lengyel 1242
3475. Power Meter for Communication Frequencies	R. L. Linton, Jr. 1245
3476. Microanalysis of Gas in Cathode Coating Assemblies	Harold Jacobs and Bernard Wolk 1247
3477. On the Theory of Axially Symmetric Electron Beams in an Axial Magnetic Field	A. L. Samuel 1252
3478. Modes in Interdigital Magnetrons	J. F. Hull and L. W. Greenwald 1258
3479. The Solution of Steady-State Problems in FM	Bernard Gold 1264
3480. Input Impedance of Wide-Angle Conical Antennas Fed by a Coaxial Line	Charles H. Papas and Ronold King 1269
3481. An Analysis of Distortion Resulting from Two-Path Propagation	Irvin H. Gerks 1272
3482. Theoretical Study of Pulse-Frequency Modulation	A. E. Ross 1277
3483. Application of Fourier Transforms to Variable-Frequency Circuit Analysis	A. G. Clavier 1287
Contributors to PROCEEDINGS OF THE I.R.E.	1291
Correspondence:	
3484. "A Generalized Formula for Recurrent Filters"	M. C. Pease 1293
3011. "The Blocking Oscillator as a Variable-Frequency Source"	Lawrence Fleming 1293
3126. "Distributed Amplification"	Th. Sárkány 1294
3252. "Notes on a Coaxial Line Bead"	Donald W. Peterson 1294
3485. "R-Q Factor"	W. W. Harman 1295
3486. "The Unit of Perveance"	G. D. O'Neill 1295
3356. "Elements of Electromagnetic Waves"	L. G. McCracken 1296
3487. "The Influence of Conductor Size on the Properties of Helical Beam Antennas"	John D. Kraus 1296

INSTITUTE NEWS AND RADIO NOTES SECTION

Industrial Engineering Notes	1298
I.R.E. People	1300
Sections	1303
Books:	
3488. "The Mathematics of Circuit Analysis" by Ernst A. Guillemin	Reviewed by F. W. Grover 1304
3489. "Fundamental Electronics and Vacuum Tubes" by A. L. Albert	Reviewed by S. N. Van Voothis 1304
3490. "Cybernetics, or Control and Communication in the Animal and the Machine" by N. Wiener	Reviewed by C. E. Shannon 1305
3491. "Foundations of Nuclear Physics," edited by Robert T. Beyer	Reviewed by Ralph E. Lapp 1305

WAVES AND ELECTRONS SECTION

I.R.E. Section Chairmen	1306
3492. Off the Editor's Chest	1307
3493. Special Relativity and the Electron	Willis W. Harman 1308
3494. An Electronic Differential Analyzer	A. B. Macnee 1315
3495. Frequency Changers and Amplifiers with Constant Gain	D. G. Tucker 1324
3496. A Variable Phase-Shift Frequency-Modulated Oscillator	O. E. De Lange 1328
3497. The Reactance-Tube Oscillator	H. Chang and V. C. Rideout 1330
3498. Frequency Contours for Microwave Oscillator with Resonant Load	M. S. Wheeler 1332
3499. Impedance Transformations in Four-Element Band-Pass Filters	R. O. Row Lands 1337
3500. Extension of the Planar Diode Transit-Time Solution	Nicholas A. Begovich 1340
3445. Addendum to "Cathode Neutralization of Video Amplifiers" by J. M. Miller, Jr.	1345
Contributors to Waves and Electrons Section	1345
3501. Abstracts and References	1347
Section Meetings	38A Membership 40A
Student Branch Meetings	40A Positions Open 50A
News—New Products	43A Positions Wanted 51A
Advertising Index	70A

EDITORIAL DEPARTMENT

Alfred N. Goldsmith
Editor

Clinton B. DeSoto†
Technical Editor,
1946-1949

E. K. Gannett
Technical Editor

Mary L. Potter
Assistant Editor

ADVERTISING DEPARTMENT

William C. Copp
Advertising Manager

Lillian Petranek
Assistant Advertising Manager

BOARD OF EDITORS

Alfred N. Goldsmith
Chairman

PAPERS REVIEW COMMITTEE

George F. Metcalf
Chairman

PAPERS PROCUREMENT COMMITTEE

John D. Reid
General Chairman

Responsibility for the contents of papers published in the PROCEEDINGS OF THE I.R.E. rests upon the authors. Statements made in papers are not binding on the Institute or its members.

† Deceased





Raymond A. Heising

BOARD OF DIRECTORS—1949

Raymond A. Heising was born in Albert Lea, Minnesota, on August 10, 1888. He was graduated from the University of North Dakota in 1912 with the E.E. degree, and he earned the M.S. degree from the University of Wisconsin in 1914. He was awarded the D.S. degree from the University of North Dakota in 1947 in recognition of his contributions to science and engineering.

Dr. Heising has been associated with the Western Electric Company and Bell Telephone Laboratories since 1914. Though serving as patent engineer since 1945, he was a radio research engineer for over thirty years. From 1914 through 1917 he played a major role in the original development of radiotelephony in the Bell System and contributed many firsts in this field. During this period he developed the radio transmitters in the Bell System tests at Montauk, Long Island, and Arlington, Virginia, and for the radio telephone sets which were used by the Signal Corps and the Navy in World War I.

After the war he participated in engineering pioneer transoceanic and ship-to-shore radio telephone circuits. He conducted or supervised much research work on

ultra short waves, electronics, and piezoelectric devices that underlie modern radio.

The creator of many important inventions, covered by more than 100 United States patents, he is best known for the constant-current or Heising modulation system. Dr. Heising has published numerous papers in the PROCEEDINGS OF THE I.R.E. and in other technical journals.

He joined The Institute of Radio Engineers in 1920 and became a Fellow in 1923. Dr. Heising served as President of the Institute in 1939; as Treasurer from 1943 through 1945; and has been a member of the Board of Directors for a total of 17 years. He was awarded the Morris-Liebmann Memorial Prize in 1921. Serving on many Institute groups, he has been Chairman of the Admissions, Sections, Constitution and Laws, Planning, Investment, and Nominations Committees. From 1943 through 1946 he served as Chairman of the Office Quarters Committee, which was responsible for the selection, acquisition, and renovation of the Institute headquarters building.

Feedback

HENRY W. PARKER

With the passage of time, most arts and sciences are broadened in scope and tend increasingly to overlap marginally with related fields. Further, in many instances they assume a social or political significance, hitherto lacking. Nuclear physics (and its child, the atomic bomb) clearly show these trends.

As is described in the following guest editorial by a Senior Member of The Institute of Radio Engineers, who is a staff engineer of Sylvania Electric Products Inc., the work of the IRE membership is in fields also showing these same tendencies. Communications and electronic engineering is proving to be a powerful tool for the understanding of some phases of the nature of man himself, both as an individual and in his group relationships. The ultimate value of such basic contributions to the future guidance of mankind may indeed be staggering.—*The Editor.*

Feedback is an old principle. The modern industrial age was born many years ago when feedback was applied in the design of the steam engine valve mechanism and governor. The more recent automatic ship's helmsman, developed by the mechanical engineering profession, predates the acceptance of the feedback principle by radio engineers.

The milestone, in the mathematical development of feedback theory and its applications to the electrical communication art, is the classical contribution described by H. Nyquist in the *Bell System Technical Journal*, Volume 11, 1932, and by H. S. Black in the January, 1934, issue of *Electrical Engineering*.

In the subsequent decade, it appeared that feedback was only a technical detail of particular interest to the engineering specialists in electrical communications; but the fuller significance of feedback was realized during the last war when the combination of already available electronic apparatus and daring "imagineering" stimulated the rapid exponential growth of servomechanisms, calculators, and control devices. When complex circuitry is equipped with reverberating memory circuits, information storage circuits, calculating circuits, motor circuits, and circuits which teleologically feed back a signal over a goal, these manifold electronic assemblies begin to exhibit frustration, inhibitions, and learning ability.

That "robots with inverse feedback have purposes that define their behavior" is the observation in Rosenbleuth, Wiener, and Bigelow in *Philosophy of Science*, Volume 10, 1943. Recognizing that philosophy is shaken to its roots by the power of the feedback concept, Professor F. S. Northrop in *Science*, Volume 107, 1948, advanced the idea that the feedback principle could be extended to the field of human relations.

Further, recognition of the feedback principle by the biophysicist has raised the curtain of mystery on how, in the animal, the reflex neural nets allow superb performance with mediocre parts. One choice morsel of the biologists' observations is the responsive pulse timing of the heart beat by means of a reflex feedback circuit which has a time delay in one of the branches that can be actuated by a thought!

The adopted feedback specialty of the electronic engineer is now being kidnapped by all of the professions. It is not a particular at all, but a universal principle in disguise.

Feedback is a universal principle which governs a purposeful assembly of parts, whatever they may be. Evolution has selected the survival of the organizations which have the best feedback. Biologically this means that the organization chosen for survival is one which has learned to think with the whole body. The magnitude of the wisdom of our forefathers who designed the Constitution of the United States and the Bill of Rights can be appreciated in its feedback aspect, which was purposely introduced to abolish tyranny forever from this Western world. The feedback aspects in our governing structure include the declaration of rights, the power of recall and impeachment and the referendum, the petition, the power of a free press, and the power of public opinion.

By the aid of these feedback principles we have, in the United States, a living organization which translates the desires of the electorate to the best advantage for all. It is, therefore, eminently well fitted for survival in competition with simple primitive and tyrannical systems.

Without the aid of feedback, a stable amplifier may be designed by wastefully and brutally enforcing low resistance; but the result is low gain. On the other hand, similarly fallacious is the misleading assumption that if all parts were perfect, the assembly would be perfect and feedback would be unessential. The feedback principle is the champion challenging the unnatural master patterns that would engulf the world.

Pulse-Multiplex System for Distance-Measuring Equipment (DME)*

CHARLES J. HIRSCH†, SENIOR MEMBER, IRE

Summary—Distance-measuring equipment (DME), developed for the USAF and CAA, providing automatic distance indications for aircraft navigation is described. Distance is measured with respect to a ground transponder beacon by the length of time elapsing between the transmission of a pulse "interrogation" signal from the aircraft and the reception of a similar pulse "reply" from the beacon. Traffic to and from several beacons is channeled by a combination of frequency and pulse-pair coding wherein each signal consists of a pulse pair of distinctive spacing. Circuits are described that recognize only pulse pairs whose leading edges are separated by the proper time interval (of the order of 10 to 25 microseconds). Data is presented of the extent to which such pulse pairs can be used to permit several transponder beacons, within overlapping service areas, to operate on common interrogation and common reply frequencies when serving a multiplicity of interrogator-respondors of the automatic searching and tracking type.

While the equipment described operates with only 52 channels, the experience obtained with this equipment has been used to standardize internationally the same channeling method on 100 channels.

I. INTRODUCTION

THE DISTANCE-MEASURING EQUIPMENT has been adopted for international standardization for air navigation. It is a unit of the rho-theta system of navigation wherein an airplane locates itself with respect to the origin of a polar co-ordinate system by means of (1) an airborne DME interrogator-respondor which gives him his distance (rho) from a DME ground transponder beacon, and (2) an omnirange receiver which gives him his azimuth (theta) with respect to a vhf omnidirectional range station. The DME ground beacon and the omnirange station are both located at the origin.

Each DME ground beacon requires one frequency for interrogation and another for reply. Pulse multiplex, as applied to DME, is a method of channeling using pulse-pair coding which permits the use of each frequency by several beacons, instead of limiting the use of each frequency to only one beacon. The saving in the number of frequencies can then be used (1) to allow wider tolerance in the frequency stability of the equipment because the total spectrum available is divided into fewer frequencies, or (2) to effect saving in spectrum.

The 52-channel equipment herein described was designed and built for the USAF and the CAA. Many units have been tested in hundreds of flights. The DME adopted internationally will make use of 100 channels.

* Decimal classification: R526. Original manuscript received by the Institute, January 24, 1949; revised manuscript received, July 19, 1949. Presented, IRE Long Island Section, Garden City, N. Y., May 12, 1948.

† Research Division, Hazeltine Electronics Corp., Little Neck, L. I., N.Y.

II. PRINCIPLE OF OPERATIONS

The function of the airborne distance-measuring equipment (DME) is to measure its distance from a ground transponder beacon. The principle of operation of the pulse multiplex DME system is shown in block diagram form in Fig. 1. An airborne interrogator-respondor (known as I-R) transmits a train of interrogation signals through a nondirectional antenna. Each signal of predetermined frequency consists of a pair of

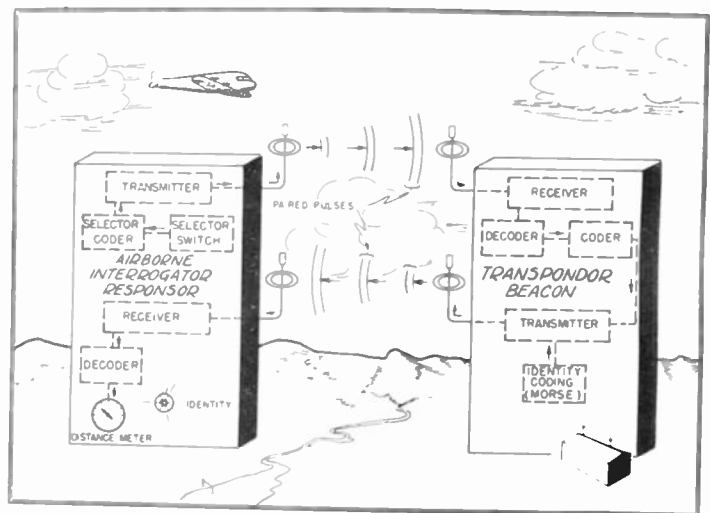

Fig. 1—Block diagram showing operation of pulse-multiplex DME.

consecutive rf pulses, which are separated from each other by a predetermined time spacing. This interrogation signal is picked up by the receiver of the ground transponder. The time separation between the two pulses comprising the signal is examined by a decoder.



Fig. 2—Airborne pulse-multiplex DME showing control box, interrogator-respondor, antenna, and distance indicator.

If the time spacing is acceptable, the beacon replies with a pair of consecutive rf pulses of predetermined frequency, which also have a characteristic time separation. The reply is received by the airborne receiver. The time separation between the two pulses of the reply signal is examined in turn by the decoder of the airborne receiver. If that spacing is acceptable, the time elapsed between transmission of the second interrogating pulse and receipt of the second reply pulse is measured, translated into a distance voltage, and displayed on an indicating meter.

An actual airborne equipment is shown in Fig. 2 which shows the I-R, the nondirectional antenna, the

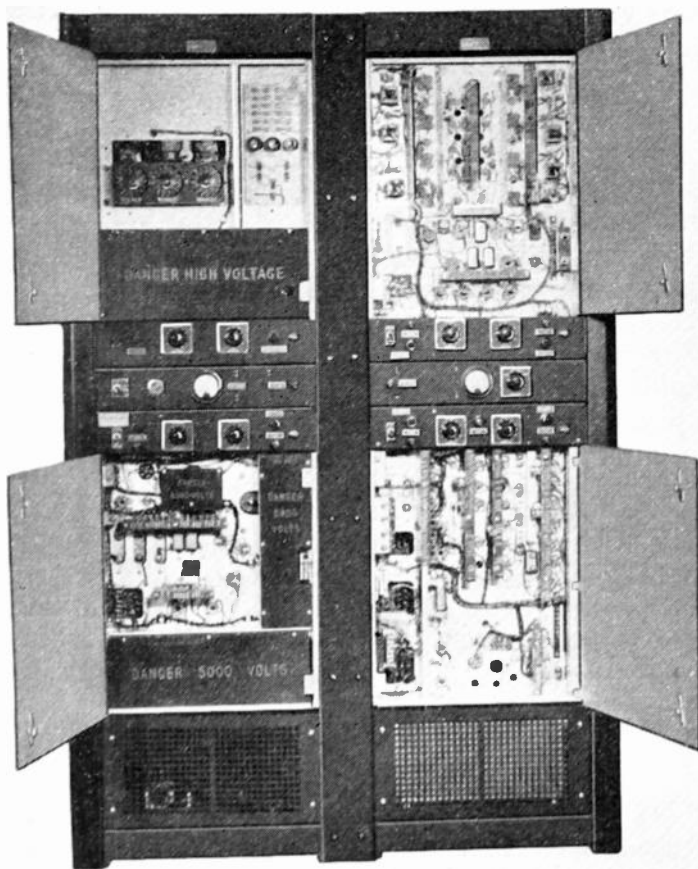

Fig. 3—Ground transponder beacon showing construction.

distance indicator, and the control box. The ground transponder is shown in Fig. 3.

III. NATURE OF THE CHANNELING SIGNAL (FOR 52 CHANNELS)

Pulse multiplex combines frequency and pulse-spacing channeling.

A. Frequency Channeling

Thirteen interrogation frequencies are used in combination (i.e. cross-banded) with 13 different reply frequencies to form $13 \times 13 = 169$ combinations of which only 52 are used to allow guard bands between adjacent

channels. No two beacons share the same combination of interrogation and reply frequency. For example, interrogation frequency f_1 is used by four beacons whose reply frequencies are f_{14} , f_{18} , f_{18} , and f_{20} , while the four beacons having reply frequency f_{14} are challenged by interrogation frequency f_1 , f_3 , f_6 , and f_7 . In this case, while each frequency is used by four beacons, any one combination of frequencies is used by only one beacon.

B. Pulse-Space Channeling (also called *moding*)

To prevent an aircraft from interrogating the other three beacons which share the interrogation frequency of the desired beacon, the interrogating signal consists of two consecutive pulses of distinctive time separation (10, 15, 20, or 25 microseconds). Each beacon has its own distinctive spacing. Thus no two beacons share the same combination of interrogation frequency and pulse spacing. Likewise to prevent the three beacons, which share a common reply frequency with the desired beacon, from interfering with the desired reply, the replies also consist of pulse pairs so that no two beacons have the same combination of reply frequency and pulse spacing.

C. Triple Uniqueness of Each Channel

To summarize, no two beacons share the same combination of (1) interrogation and reply frequencies, (2) interrogation frequency and interrogation pulse spacing, (3) reply frequency and reply pulse spacing. Therefore, acceptable codes, accidentally created by echoes, cannot cause an aircraft to "latch" on the wrong beacon because these codes would be on the wrong frequency.

D. International Standards

The recently adopted international standards are based on the performance of this equipment and expand the channeling scheme by using 10 interrogation frequencies, 10 reply frequencies, and 10 pulse spacings.

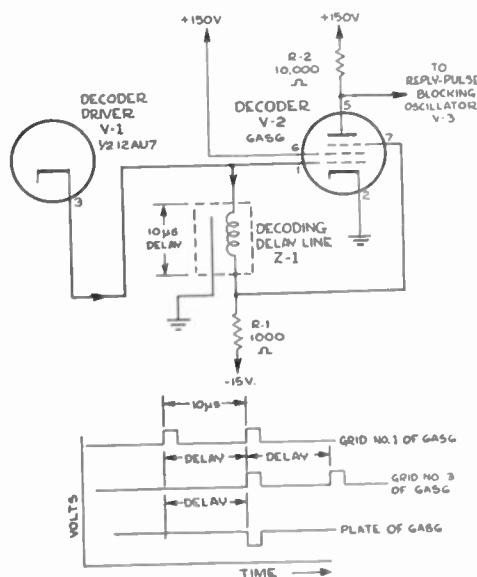

Fig. 4—Operation of decoder.

IV. OPERATION OF DECODER

Pulse spacings are recognized by a "decoder," an example of which is shown in Fig. 4. In this particular case, the desired pulse spacing is 10 microseconds. The pulse pair to be examined is impressed directly on the inner grid of tube V-2 and, through a delay line which delays each pulse by 10 microseconds, on the outer grid of the same tube. The plate current is cut off by biases on both grids. Current will not flow unless both biases are relieved. This occurs when the second pulse, which is undelayed, coincides in time with the first pulse which is delayed by 10 microseconds. This coincidence occurs only when the pulse spacing and the delay are the same. Fig. 5 shows the tolerance of an actual decoder set to recognize spacings of approximately 10 microseconds.

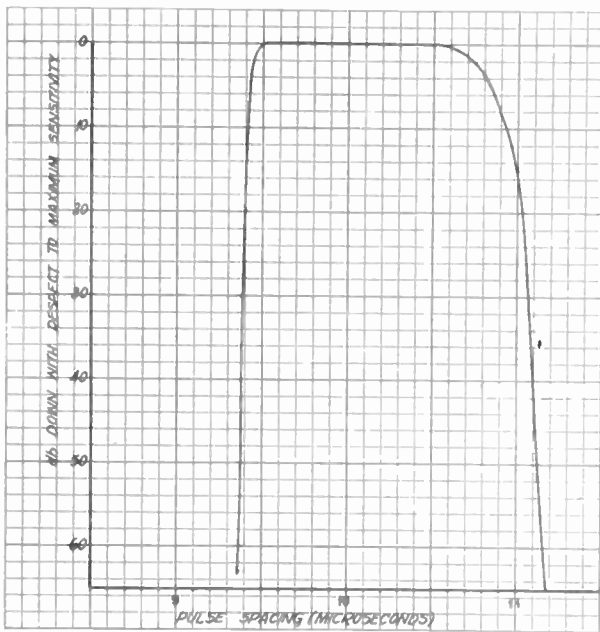

Fig. 5—Decoder performance curve tolerance in pulse spacing of a typical decoder set to accept 10-microsecond spacing.

In this equipment, a magnetostriction delay line was used with delays of 10, 15, 20, or 25 microseconds selected by means of a switch. The same delay line was used to create the interrogation spacing.

V. OVER-ALL SYSTEM TIMING

The timing of the DME system is shown in Fig. 6, where the abscissa shows elapsed time. The interrogation consists of a pair of pulses separated by time interval d_1 (line 1 of Fig. 6). It is received, detected, and decoded by the beacon after transmission time l (lines 2, 3, and 4). Since the signal is recognized after receipt of the second pulse, all timing is referred to it. The beacon replies, after a delay equal to δ with a pair of consecutive pulses spaced by a time interval d_2 (line 5). This reply is received, detected, and decoded by the aircraft receiver (lines 6, 7, and 8). Meanwhile a time-measuring saw-

tooth voltage was started at a time of emission of the second interrogation pulse (line 9), but this voltage was not effective until after the delay time δ because it was negative until that time. The timing sweep generates a narrow and a wide gate (approximately 10 and 20 microseconds respectively, which correspond to one and two miles), as shown on line 9, which straddle the received signal. The time of generation of the gates is determined from memory of their previous location (in time) from preceding interrogations and replies. There is an average of 30 interrogations per second.

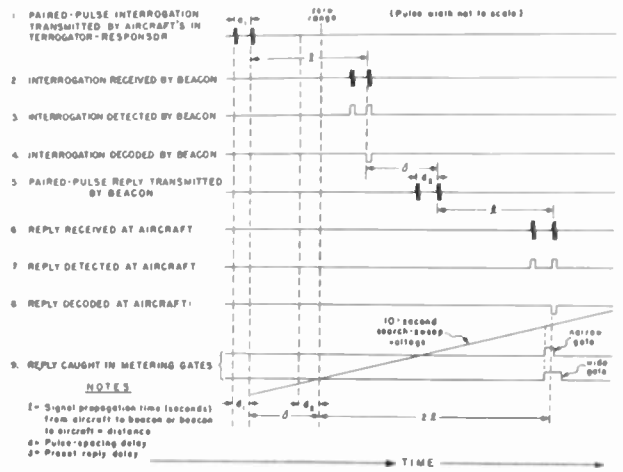

Fig. 6—DME over-all system timing.

Zero distance is computed after the fixed time delay δ . This delay allows the transponder beacon to be located away from the point of desired indicated zero distance, such as a runway touchdown point, by subtracting the time corresponding to that distance from the built-in delay (thereby keeping the total effective delay constant).

VI. TRACKING AND SEARCHING CIRCUITS

The operation of the tracking and searching circuits depends upon the fact that each desired reply is always received a fixed time interval after the Interrogation and can be made to coincide with a gate generated at that time. Interference, being random, only occasionally occurs at that time. The gate will, therefore, contain a preponderance of desired signals. The circuits are shown in simplified form in the block diagram in Fig. 7.

A. Tracking

Let us first assume that the equipment has found and is tracking a signal which has been received and decoded so that the tracking switch is closed. A dc voltage, proportional to the distance, and read on a voltmeter, appears across the cathode resistor of the range follower. This voltage is an amplified version of the voltage appearing across the storage capacitor in the input of the dc amplifier. The voltage on this capacitor depends on which of the two rectifiers is conducting. If the upper

rectifier conducts more often than the lower one, then the range voltage becomes more positive which corresponds to increasing range. Each rectifier is fed from the decoded reply signal through a gated amplifier. The two gates originate at the same time but one gate is longer than the other, as shown in line 9 of Fig. 6, and at the lower right-hand corner of Fig. 7. The amplifier which is gated by the narrow gate has a much higher gain than the amplifier which is gated by the wide gate. If, then, the signal is received in the narrow gate (as well as the wide gate), the charge on the capacitor becomes less positive and the range voltage is decreased. Conversely, if the signal is received in the wide gate only, the charge on the capacitor becomes more positive and the range voltage increases.

The two gates are generated when the timing sawtooth voltage (line 9 of Fig. 6 and the right-hand part of Fig. 7), which is triggered by the second interrogation pulse, is equal to the range voltage whose value is proportional to the distance. This equality is determined by applying the sawtooth timing sweep to the plate of the "gate-trigger" diode whose cathode is connected to the range voltage. The "gate-trigger" diode conducts when the sweep slightly exceeds the range voltage. This generates a trigger voltage which triggers the narrow- and wide-gate generators. The output of these generators in turn gate the two video amplifiers which feed the two rectifiers. The range voltage stabilizes itself to that value which results in the incoming reply pulse straddling the narrow and the wide gates. Due to the excess of gain of the narrow-gate amplifier,

the leading edge of the reply pulse lies inside the narrow gate but very close to its lagging edge.

B. Searching

When the signal is lost for more than the memory time (5 seconds in this case), the search relay K_1 connects the range follower to the search sweep generator (through the dc amplifier). This causes the output of the range follower to sweep through voltages corresponding to distances of zero to 115 miles in approximately 10 seconds. Since there are 30 interrogations per second, 300 interrogations are required to explore 115 miles. The gates are, therefore, generated at a progressively great distance ($115/300=0.4$ miles) after each interrogation. Each wide gate explores a 2-mile increment (see Over-all System Timing). Therefore, the replies to $2/0.4=5$ interrogations may be received at any one distance. If enough replies are passed by the video amplifier which is gated by the wide gate, the relay K_1 connects the range follower to the storage capacitor, thereby resuming tracking.

The memory circuits are so designed that memory is not restored until tracking is maintained for a minimum time. This prevents momentary interruptions of search, caused by interference, from unduly increasing the search time which would be the case if the full memory were applied each time that the search is interrupted.

VII. INCREASE IN TRAFFIC DUE TO "BUNCHING"

A spacing acceptable to the decoder can be created by chance from two single pulses, which may each be

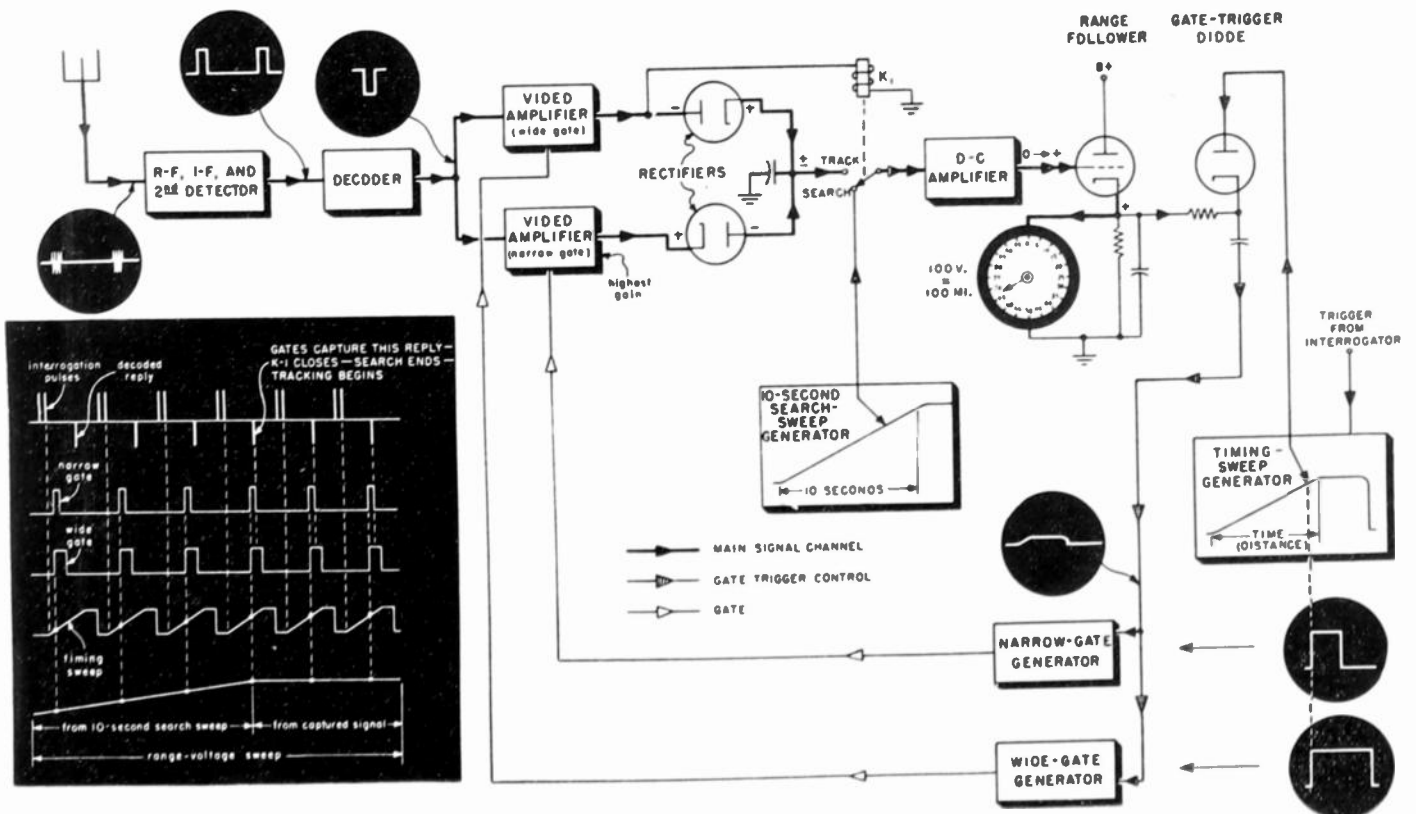

Fig. 7—Block diagram of tracking gate system.

long to a separate pulse pair having spacings which are not accepted by the decoder. This occurs when the two pairs are received by chance in such a time sequence that one pulse of one pair is followed by a pulse of the other pair after the time required by the decoder. This is shown in Fig. 8. In this figure, a decoder is set to recognize pairs having a spacing of 15 microseconds. It receives and ignores pair *A* and *B* which are separated by 10 microseconds, and pair *C* and *D* which are separated by 20 microseconds. However, pulses *B* and *C* are separated by 15 microseconds and form an acceptable pair which is accepted by the decoder.

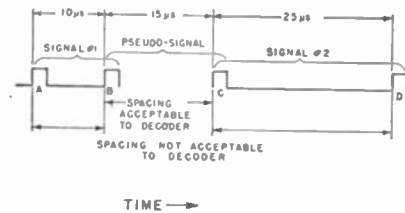

Fig. 8—Creation of false signals by bunching.

A. Bunching of Interrogation Pulse Pairs

This chance combination of unacceptable pulses into acceptable pairs results in the beacon being called upon to reply to more interrogations than are actually emitted. Fig. 9 shows the ratio n'/n of effective (n') to actual (n) interrogations as a function of (1) c , the number of beacons per interrogation frequency, and (2) n , the number of interrogations per beacon per second.

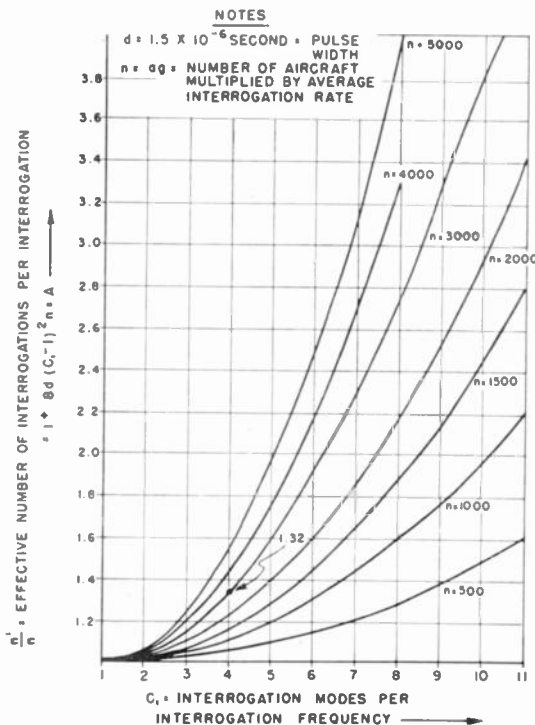

Fig. 9—Increase in effective interrogations per interrogation (n'/n) due to "bunching" as a function of (1) the number of beacons (modes) per interrogation frequency, and (2) the number of valid interrogations per beacon, n .

Example: If there were four beacons (i.e., $c = 4$) which share the interrogation frequency and each beacon is

interrogated by 100 aircraft each of which challenges its beacon 30 times per second (i.e., $n = 100 \times 30 = 3,000$) and each aircraft is within range of all beacons, then each beacon behaves as if it were challenged by 1.32 times as many aircraft.

B. Beacon Reply Efficiency

The beacon requires a certain recovery time t_r (also called dead time) to recover after it replies to an interrogation. An interrogation which is received while the beacon is recovering from a previous interrogation is ignored so that the number of replies is usually less than the number of interrogations. The ratio N/n of replies to interrogations is called "reply efficiency" and is equal to

$$N/n = 1/(1 + n't_r)$$

where n' is given in Fig. 9. N/n is also the probability that any one interrogation will elicit a reply from the beacon. Fig. 10 shows the reply efficiency (curves marked *A* and concave downward) as a function of c , the number of beacons per interrogation frequency; and n , the number of aircraft interrogations per beacon per second. Thus in the example given above, the transponder beacon reply efficiency is 72 per cent.

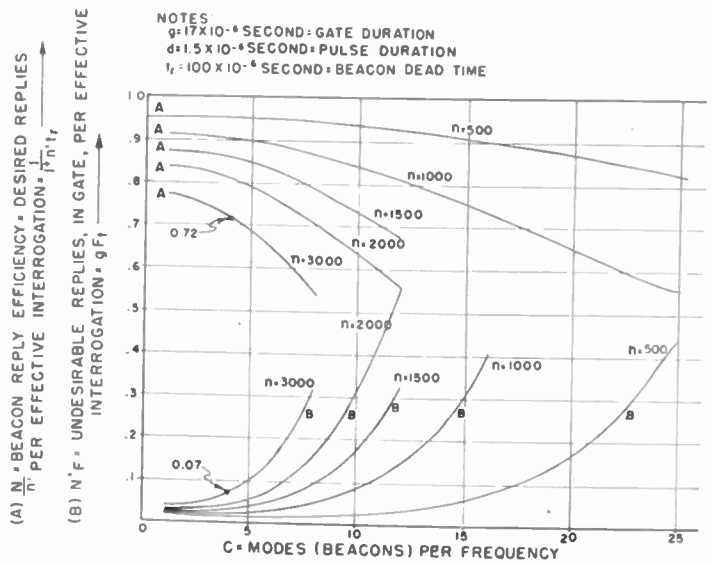

Fig. 10—Beacon reply efficiency and interference as a function of the number of beacons on each frequency.

The curves of Figs. 9 and 10 make the assumption that all beacons are within interrogation and reply range of all aircraft. Since the 52 beacons will be distributed over a 500-mile square, this assumption is seen to be ultraconservative.

C. Bunching of Reply Pulse Pairs

The paired pulses of a transponder's reply may also combine with those of another transponder into forming, by chance, a pulse pair whose spacing is accepted by the airborne decoder of an aircraft which is interrogating a third transponder. This results in increased interference. If there are F pairs per second of proper

spacing which occur as the result of (1) replies of the desired transponder to interrogations of other aircraft trafficking with the same transponder, and, in addition (2) the chance forming of the desired pulse spacing as described above; then a gate which is open for g seconds will capture, on the average, $N = gF$ unwanted decoded replies per interrogation. This value of N , the average number of unwanted fruit pulses captured by a gate having a duration of 17 microseconds for each interrogation, is shown as Fig. 10 (curves marked B and concave upward) as a function of c , the number of transponders sharing each frequency, and of n , the number of interrogations on each transponder. These curves show that for the example given above, 100 interrogations will result in an average of 7 unwanted replies being captured by the gate.

To summarize, (1) if each beacon shares its interrogation frequency with three beacons and its reply frequency with three other beacons, (2) each beacon is interrogated by 100 aircraft (i.e., 400 aircraft per frequency), and (3) all aircraft are in range of all beacons; then each 100 interrogations by each aircraft will result in an average of (a) 72 desired replies, (b) 7 undesired replies, and (c) 21 blanks.

D. Effect of Bunching on Airborne Equipment Performance

In order to evaluate these results and to determine the amount of interference through which the airborne equipment is capable of operating, the ultra severe test indicated in Fig. 11 was performed.

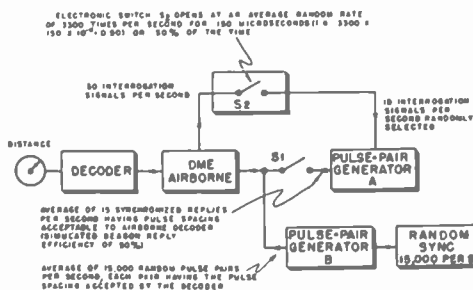

Fig. 11—Test of DME immunity to interference. Test results: On opening S_1 25 times, search was initiated, 6 times in no more than 5 seconds, 11 times in no more than 6 seconds, 8 times in no more than 7 seconds; on closing S_1 25 times, full 115-mile search was successfully completed, 1 time in no more than 14 seconds, 5 times in no more than 15 seconds, 6 times in no more than 16 seconds, 3 times in no more than 17 seconds, 4 times in no more than 18 seconds, 6 times in no more than 19 seconds.

The airborne interrogator emits interrogating synchronizing signals, at the rate of 30 per second, to trigger the pulse-pair generator into replying with a signal consisting of a pair of pulses having the spacing (10 microseconds) accepted by the airborne decoder. The synchronizing signal is transmitted through switch S_2 which is closed for 150 microseconds at an average random rate of 3,300 times per second. In other words, the switch is closed 50 per cent of the time ($150 \times 10^{-6} \times 3,300 = 0.5$) so that the pulse pair generator A replies at an average rate of 15 reply pulse pairs per second, simulating a beacon reply efficiency of 50 per cent. (Note

that the previous example gave a beacon efficiency of 72 per cent.)

The output of "pulse-pair generator A " is mixed with that of the pulse-pair generator B which is triggered at a random rate of 15,000 replies per second, each reply consisting of a pair of pulses having the spacing (10 microseconds) accepted by the airborne decoder. This results in each gate (which had a duration for this test of 20×10^{-6} seconds) capturing $20 \times 10^{-6} \times 15,000 = 0.3$ interfering replies. Stated in other words, an average of one interfering reply will be captured every $1/0.3 = 3.3$ challenges. (Note that the previous example results in each gate capturing only 0.07 interfering replies.)

Performance was determined by opening switch S_1 until the search was initiated. The actual memory time (set for 5 seconds) in the absence of interference until search is initiated was noted. (An excessively large amount of interference from pulse generator B might create enough of the "pseudo desired signal" to delay or even prevent the initiation of search.) As soon as the search was initiated, switch S_1 was closed and the time required to complete a successful search of 115 miles was noted. This was adjusted to 15 seconds in the absence of interference. Excessive bunching of interference may and does cause the search to end prematurely but the search is immediately resumed since the bunching of interfering pulses does not last long enough for the memory circuits to become active. However, these false interruptions of search result in increasing the total search time. Search was initiated 25 times by opening switch S_1 with the following results:

The longest delay in initiating search was 2 seconds (i.e., the memory was increased to 7 seconds). The longest time required to search 115 miles was increased by 4 seconds (i.e., the total search time was 19 seconds). Two searches had to be repeated.

In other words when the signal was lost, momentarily, neither the initiation of search nor the search time were unduly delayed by interference conditions which resulted in 30 per cent of the challenges eliciting false replies and only 50 per cent of the challenges resulting in the desired reply.

VIII. EQUIPMENT CHARACTERISTICS

A. Ground Transponder Beacon

1. Pulse duration—1.5 microseconds
2. Pulse spacing—10, 15, 20, or 25 microseconds
3. Reply delay—75 microseconds
4. Peak power—5.0 kw
5. Transmitter (reply) frequency—one of 13 frequencies in 1,087.5- to 1,215-Mc band
6. Receiver (interrogation) frequency—one of 13 frequencies in 960- to 1,087.5-Mc band
7. Reply sensitivity—86 db < 1 volt open circuit
8. Selectivity

3-db bandwidth	4.4 Mc
30-db bandwidth	8.5 Mc

9. Image ratio—52 db
10. Intermediate frequency—60 Mc

B. Airborne Unit

1. Challenge repetition frequency—30 per second
2. Transmitter (interrogation) frequency—same as beacon receiver frequency
3. Peak power—3 kw
4. Receiver (reply) frequency—same as beacon transmitter frequency
5. Search sensitivity—90 db < 1 volt open circuit

6. Selectivity

3-db bandwidth	5.0 Mc
30-db bandwidth	10.0 Mc
7. Image ratio—57 db
8. Intermediate frequency—60 Mc

C. Antenna

1. Airborne—nondirectional—one-half wavelength, vertically polarized
2. Ground—nondirectional—four wavelengths, vertically polarized.

A Michelson-Type Interferometer for Microwave Measurements*

BELA A. LENGYEL†

Summary—The optical Michelson interferometer is modified by replacing one of its branches by a directional coupler and a waveguide. The instrument serves many purposes, among which are: precision wavelength determination, the measurement of dielectric constants of materials available in sheet form, the determination of reflection from laminated sheets at normal incidence, the study of metal-loaded dielectrics and of parallel-plate metal lens media. An instrument operating at 3.2 cm is described.

I. INTRODUCTION

IN THE CLASSICAL Michelson interferometer, the beam of light is split by a half-reflecting mirror. One part of the beam travels a fixed path, the other a variable one, the two beams are reunited and produce the well-known interference patterns. In the optical instrument, the two paths are very similar, in fact, the only essential difference is in their length.

A scaled-up model of the optical interferometer for use in the centimeter region has been built by other investigators mainly for demonstration purposes.¹ When an interferometer is constructed with the purpose of obtaining quantitative measurements in the microwave region, it is not necessary to make the branches of the interferometer similar. The branch that supplies the reference signal can be replaced by a waveguide. This modification provides the instrument with greater flexibility than the completely optical arrangement. The basic feature of the instrument is that it compares phase and amplitude of an approximately plane wave with that of a reference signal.

The principal applications of the modified Michelson interferometer include precision wavelength measurements, the measurement of dielectric constant, and attenuation in dielectric materials available in the form

of uniform sheets, and the study of phase delay and reflections in the parallel-plate or metal-loaded media.

II. DESCRIPTION OF EQUIPMENT

The schematic diagram of the modified instrument is shown in Fig. 1 and a photograph in Fig. 2. As in Michelson's instrument, the incident beam is split by a half-reflecting mirror O , but only one of the resulting beams is used. This beam reaches the receiving horn H_2 after two reflections and is then united with a signal from the transmitter led through a waveguide and a variable attenuator. The signals are fed into opposite branches

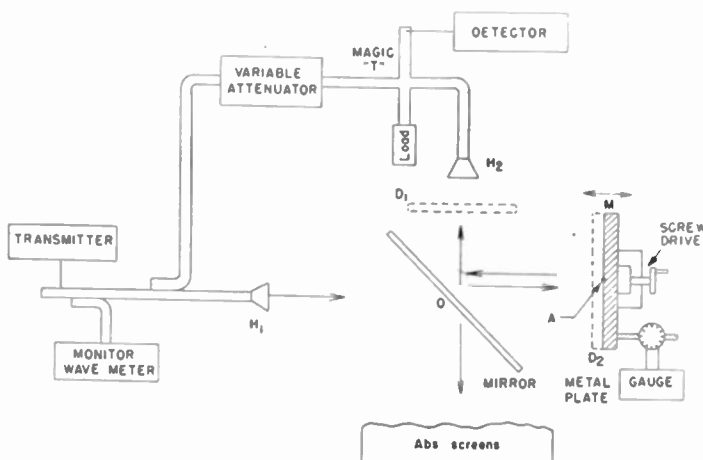

Fig. 1—Schematic diagram of the modified Michelson interferometer.

of a magic tee, one of the remaining arms being connected to the detector, the other to a matched load.

The silvered brass plate M serving as the movable mirror is mounted on a lathe bed and is constrained to move in the direction of its normal. Its displacement is measured with a micrometer or a dial indicator gauge mounted on the lathe bed.

* Decimal classification: R310XR200. Original manuscript received by the Institute, December 17, 1948; revised manuscript received, April 25, 1949. Presented, 1949 IRE National Convention, New York, N. Y., March 7, 1949.

† Naval Research Laboratory, Washington, D. C.

¹ C. L. Andrews, "Microwave optics," *Amer. Jour. Phys.*, vol. 14, pp. 379-382; November-December, 1946.

III. APPLICATIONS

The simplest application of the interferometer is to the measurement of wavelength. This is convenient for wavelengths in the 3-cm band and shorter, the maximum usefulness of the instrument being in the high-

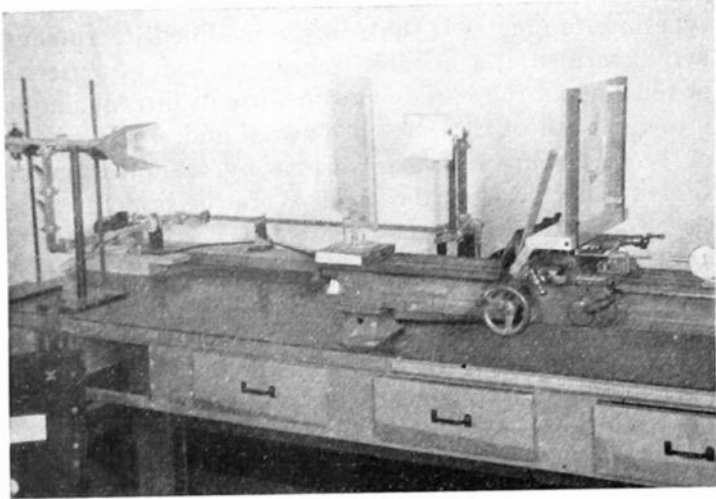

Fig. 2—Photograph of the modified Michelson interferometer.

frequency end of the microwave spectrum where other methods of wavelength measurement become increasingly difficult. As the reflector M is moved, maxima and minima alternate in the detector, the distance of adjacent minima corresponding to a reflector displacement of $\lambda/2$. An accuracy in the determination of λ of 0.0003 cm can be achieved in the 3-cm band.

The interferometer is well suited to the rapid determination of the dielectric constant (specific inductive capacitance) of materials available in the form of large, reasonably uniform sheets. The simplest method of measurement is applicable to sheets which are only moderately reflecting and absorbing.

The amplitudes in the two branches of the interferometer are first equalized by the adjustment of the attenuator for the highest SWR, then the position of the plate M for a minimum signal in the receiver is obtained. Next the dielectric sheet is introduced at D_1 and the displacement of M (toward O) required to restore a minimum is noted. This displacement is a measure of the phase delay caused by the introduction of the dielectric sheet in the path of the rays. It can be used for the computation of the dielectric constant k or the index of refraction $n = \sqrt{k} = \sqrt{\epsilon/\epsilon_0}$. A shift of the minimum position by $\Delta/2$ corresponds to a shortening of the optical path by Δ . When multiple reflections within the sample are neglected, the change in optical path length caused by the introduction at normal incidence of a sheet of thickness d and index of refraction n is $(n-1)d$, therefore

$$n = 1 + \frac{\Delta}{d} \quad (1)$$

When $n > 1.5$, the multiple reflections between the two faces of the sheet are no longer inconsequential and the value of n calculated from (1) will be in error unless the sheet happens to have a thickness which is an integral multiple of the quarter wavelength in the sheet. The index of refraction n can still be calculated from Δ , d , and λ , but the exact equation connecting these quantities is a transcendental one. In this case, the approximating method of Redheffer,² proposed in connection with a similar measurement, enables one to calculate n with a reasonable degree of facility.

A disturbing feature of an experiment of this type is the fact that, in the case of a highly reflecting sheet, a considerable fraction of the energy incident on the sheet is multiply reflected between D_1 and M to produce a complicated pattern of standing waves. The results of the measurement will then be dependent on the position of the sheet with respect to the horns. Tilting the sheet at an angle will lessen this difficulty.

When the material to be measured is highly reflecting, it is practical to employ the interferometer as the free-space analogue of the von Hippel shorted-line instrument. The dielectric sheet is then not placed at D_1 but is firmly held in contact with the metal mirror as shown at D_2 . Again the shift of the position for minimum is observed. In this manner, it is possible to calculate the distance of the first minimum of the electric field from the face of the dielectric sheet. Von Hippel's method requires this distance x_0 and m , the amplitude SWR, for the calculation of the complex propagation constant in the sheet. On the interferometer, m is determined by moving the sample sheet and the metal mirror and keeping the detector fixed.³

It is necessary to point out, however, that while a high SWR is easily obtained in an empty waveguide or coaxial line, such is not the case for the interferometer. This fact limits the application of von Hippel's general method, since the accurate measurement of the loss tangents requires a high SWR in the empty instrument.

While in the case of low-loss materials, the measurement of loss tangent by the von Hippel method is thus precluded, by a modified procedure, the interferometer lends itself to a rather direct determination of the same quantity. Two measurements have to be made with the dielectric sheet in different positions but the mathematical complications of the original von Hippel method are avoided. One of the measurements to be made is a direct determination of the power reflection coefficient of the dielectric sheet at normal incidence. This measurement, which is of great practical usefulness in itself, is performed as follows: A sheet of the size of the metal mirror M is cut and is mounted in place of M . Appro-

² C. G. Montgomery, "Technique of Microwave Measurements," vol. 11, Rad. Lab. Series, McGraw-Hill Book Co., Inc., New York, N. Y., 1947; p. 597.

³ In the case of the interferometer, it would be more proper to call m the maximum-minimum ratio.

appropriate measures are taken to prevent reflections from behind this sheet. Having previously adjusted the attenuator for equal amplitude in the two branches at the receiver, the SWR m is observed with the dielectric sheet replacing M . The ratio of reflected power to the incident power is then

$$|R|^2 = \left(\frac{1 - m}{1 + m} \right)^2.$$

Having measured the magnitude of the reflection coefficient of a sheet, the attenuation of the waves passing through the sheet can be determined by measuring the power transmitted through it. The transmitted amplitude $|T|$ is measured with the sheet at D_1 . It is calculated from maximum-minimum determinations in the same manner as $|R|$ is. The fractional power dissipated in the sheet is then

$$\frac{1 - |R|^2 - |T|^2}{1 - |R|^2}.$$

The basic feature of the interferometer is that it permits the measurement of the magnitude and the phase of a wave transmitted through a given sheet when the sheet is placed in the position D_1 and the measurement of the magnitude and phase of a wave reflected from the same sheet when the sheet is put in the position normally occupied by the metal reflector M .

The interferometer is particularly suitable for the study of laminated radome materials, of parallel-plate media of nominal dielectric constant less than one, and of loaded or artificial dielectric materials intended for microwave lenses. These media cannot readily be placed in a waveguide; all measurements are naturally performed in free space.

IV. DESIGN DATA

An instrument of the type described was constructed early in 1948 at the Naval Research Laboratory, primarily for the study of artificial dielectric materials. Applications to other materials available in sheet form followed.

The instrument operates around 3.2 cm. Transmitting and receiving horns are flared to 15 by 12 cm and are located about 50 cm from the center of the half-silvered mirror. The metal mirror is about 30 by 30 cm. In its operating range, it is located entirely within the first Fresnel zone of both horns. The half-silvered mirror is

larger than the metal mirror, in fact its dimensions are such that diffraction effects due to its finite size are negligible. Provision is made for the quick alignment of the instrument by optical means.

V. EVALUATION

The principal advantage gained over the fully optical type interferometer is that, in the modified instrument here described, it is possible to insert a sheet of material in the path of the variable beam without introducing it into the path of the reference signal and without seriously disturbing the observations by the presence of signals reflected from the sheet. Were the sample introduced somewhere between the half-reflecting mirror O and the metal mirror M , reflection from the front surface of the sample would interfere with the measurement of the radiation transmitted through same. The possibility of accurate adjustment of the reference signal level is another advantage. A disadvantage is the frequency sensitivity of all circuit elements; this is absent in the Michelson interferometer operating with mirrors only.

The limitations of the microwave interferometer are somewhat different from those operating at optical frequencies. The measurement of mechanical displacements to the required accuracy can be accomplished easily in the case of centimeter waves. Diffraction and scattering become the factors that limit the performance of the instrument. Another limiting factor is the presence of unwanted reflections. There are limitations inherent in the transmitting and receiving antennas, which are not reflectionless and which do not produce a narrow beam such as is commonly available in optics.

The principal drawback of the instrument is that it does not permit the production of a SWR as high as would be desirable for some applications. With a square-wave-modulated signal and a bolometer as a detector, the level of the minimum signal is about 33 db below that of the maximum. With the continuous-wave source and a spectrum analyzer as a detector, the minimum can be made lower and a maximum-minimum spread of more than 45 db can be obtained.

Studies are underway to determine the exact limitations of a system operating on CW and to compare the performance of the modified Michelson interferometer with the scaled-up model of the original optical one at 1.25 cm.



Power Meter for Communication Frequencies*

R. L. LINTON, JR.†, MEMBER, IRE

Summary—An instrument for measuring the power delivered to an antenna at communication frequencies is described.

INTRODUCTION

COMMUNICATION facilities aboard naval vessels must provide continuous coverage of extremely wide portions of the radio frequency spectrum. Space is at a very high premium and traffic handling capacity is very demanding in its requirements. Shortwave transmitters are required to deliver power to load impedances spreading through the widest imaginable gamut of magnitudes and phase angles.

It was desired that some convenient means be made available to determine, with nominal accuracy, the power of actually being fed to an antenna. The following rough specifications were set up as desirable of achievement in the development of the projected instrument:

1. Frequency range: 2 to 20 Mc.
2. Power range: 1 to 500 watts.
3. Portable, rugged; easy to use.
4. Low reaction on the test circuit.
5. Suitable for use in connection with loads of from a few ohms to 2,500 ohms, of any phase angle.
6. Accuracy: within ± 25 per cent.

THEORETICAL DISCUSSION

Analysis of the Problem

An rf load Z_L with a phase angle $-\phi$ radians, is fed with a current I/ϕ . The voltage E appears at its terminals. The power passing into the load we think of as

$$P = EI \cos \phi. \tag{1}$$

Let two complex voltages be delivered by a sampling device:

$$\bar{E}_e = k_e E / \epsilon \tag{2}$$

$$\bar{E}_i = k_i I / \phi + \iota. \tag{3}$$

Let E_e and E_i be combined into the parameter

$$p = E_e E_i \cos(\phi + \iota - \epsilon) = k_e k_i EI \cos(\phi + \iota - \epsilon). \tag{4}$$

Define the difference between the phase shifts of (2) and (3) as

$$\delta = \iota - \epsilon. \tag{5}$$

Then p of (4) relates to P of (1) thus:

$$p/P = k_e k_i \cos(\phi + \delta) / \cos \phi. \tag{6}$$

$\cos(\phi + \delta) / \cos \phi$ is the apparent power factor normalized against the power factor of the load. The behavior of this function explains the inherent difficulty involved in any attempt, so far discovered, to monitor rf power. It is extremely difficult to make δ , the phase error angle, sufficiently small to prevent large errors in indication when the power factor is small.

The Directional Coupler Loop

As a means of obtaining the samples of (2) and (3), consider the loop proposed by Early.¹ Let the loop be rotatable about a line through its midpoint, lying in its plane. When the loop is brought close to the transmission line, the voltage appearing between one terminal and ground will be $\bar{E}_e \pm \bar{E}_i$, the sign of the second member depending upon whether the terminal is nearer the generator or nearer the load.

The loop is assumed to have the following parameters: R_3 and R_3' are terminations with stray capacitances to ground of C_3 and C_3' farads, respectively. C_1 and C_2 are the total capacitances of the loop, respectively, to the high side of the transmission line and to ground. For purposes of analysis these are lumped at the center. L_2 and R_i are, respectively, the total series inductance and the internal resistance of the loop. M is the mutual inductance between the loop and the high side of the transmission line. The following relationships may be derived:

(a) From (2):

$$k_e \simeq (\omega R_3 R_3' C_1) / (R_3 + R_3') = \omega R_p C_1, \tag{7}$$

where R_p represents the parallel combination of R_3 and R_3' .

(b) From (3):

$$k_i \simeq (\omega M R_3) / (R_3 + R_3'). \tag{8}$$

(c) From (2):

$$\begin{aligned} \epsilon &\simeq \pi/2 - \arctan \omega R_p (C_1 + C_2 + C_3 + C_3') \\ &= \pi/2 - \arctan \omega R_p C, \end{aligned} \tag{9}$$

where the sum of all the C_e' is represented by C .

(d) From (3):

$$\begin{aligned} \iota &\simeq \pi/2 - \arctan \omega [L_2 - R_3'(R_3' C_3' - R_3 C_3)] / (R_3 + R_3') \\ &= \pi/2 - \arctan \omega [L_2 - R_3'(l_3' - l_3)] / (R_3 + R_3') \end{aligned} \tag{10}$$

* Decimal classification: R245. Original manuscript received by the Institute, March 28, 1949; revised manuscript received, August 15, 1949.

† Formerly, Antenna Laboratory, Division of Electrical Engineering, University of California, Berkeley, Calif.; now, Dalmo Victor Company, San Carlos, Calif. The work described in this paper was made possible through the support extended by the U. S. Navy Bureau of Ships, under Contract NObsr-39401.

¹ H. C. Early, "A wide-band directional coupler for wave guide," *Proc. I.R.E.*, vol. 34, pp. 883-887; November, 1946.

where the products of R and C are represented by t .

(e) From (5), (9), and (10):

$$\delta \simeq \arctan \omega [R_3 R_3' C - L_2 + R_3'(t_3' - t_3)] / (R_3 + R_3'). \quad (11)$$

However, if the time constants of the terminations of the loop, t_3 and t_3' , can be balanced to within 5 per cent, the last expression in the numerator of (11), $R_3'(t_3' - t_3)$, may be neglected:

$$\delta \simeq \arctan \omega (R_3 R_3' C - L_2) / (R_3 + R_3'). \quad (11')$$

When δ is brought to zero, in an effort to approach ideal indication, and R_3 solved for, we obtain

$$R_3 = \sqrt{L_2 / C}. \quad (12)$$

Indication

As a means of monitoring $\bar{E}_e \pm \bar{E}_i$, consider a 1N38 germanium crystal rectifier in series with a resistor and microammeter.

Some function of the microammeter current i will correspond to the desired voltage magnitude:

$$f(i) = |\bar{E}_e \pm \bar{E}_i|. \quad (13)$$

By open circuiting and short circuiting the load terminals of the power meter and measuring the rf line voltage and current, the following functions are obtained:

$$f_e = f/k_e = |\bar{E}_e \pm \bar{E}_i| / k_e \quad (14)$$

$$f_i = f/k_i = |\bar{E}_e \pm \bar{E}_i| / k_i \quad (15)$$

Define still another function as shown,

$$F_p = (f_e f_i) / 4. \quad (16)$$

From (14) and (15), (2) and (3):

$$F_p = |\bar{E}_e \pm \bar{E}_i|^2 / (4k_e k_i) \\ = [k_e^2 E^2 \pm 2k_e k_i EI \cos(\phi + \delta) + k_i^2 I^2] / (4k_e k_i). \quad (16')$$

Define the ratio:

$$R_k = k_i / k_e; \quad (17)$$

then (16') becomes:

$$F_p = E^2 / 4R_k \pm 1/2 EI \cos(\phi + \delta) + I^2 R_k / 4. \quad (18)$$

Then, where the superscripts indicate the sign to be taken in (18),

$$F_p^+ - F_p^- = EI \cos(\phi + \delta). \quad (19)$$

The change of sign in (18) may be accomplished by rotating the loop.

Shunting Effect

Under very low power factor conditions the output impedance of the transmitter and the input impedance

of the line will form a parallel tuned circuit. C_1 will then shunt a very high impedance, seriously affecting the transmission conditions.

Frequency Correction

Substituting (13), (7) and (8), where R_3 is taken equal to R_3' , into (16'):

$$F_p = f^2(i) / (\omega^2 R_3 M C_1). \quad (16'')$$

If the calibration, F_p , is run at some radian frequency ω_0 , then at some other frequency, ω :

$$F_p(\omega) = (\omega_0 / \omega)^2 F_p(\omega_0). \quad (20)$$

Hence, for a model calibrated in the middle of the frequency range:

$$P \simeq (6/f_{mc})^2 (F_p^+ - F_p^-). \quad (21)$$

Wave-Form Errors

On the basis of very rough assumptions,² the possible effect of the peak reading characteristic of the crystal circuit on the indication of the meter can be shown to be:

$$p' \simeq 2 \sum_{n=2}^N n e_n. \quad (22)$$

where p' represents the per cent error and e_n the per cent harmonic content, of order n , of the rf wave. The precise effect of the wave form will depend on the relative phase of the various components as well as the nature of the behavior of the load with frequency.

RESULTS

The results achieved with the power meter are as follows:

1. Frequency: 2 to 20 Mc.
2. Power: Below one to 200 watts.
3. Extremely portable, rugged, and simple to operate.
4. Shunting Effect: Equivalent to about 7 microfarads to ground.
5. Impedance and Power Factor: 5 to 1,000 ohms and down to 0.1 power factor.
6. Accuracy: Roughly 50 per cent over the above range of conditions.

ACKNOWLEDGMENT

The assistance and encouragement of J. H. Priedigkeit, who collaborated on the design of the model unit, is gratefully acknowledged.

² Load assumed resistive and the peak voltage output equal to the sum of all the amplitudes of the harmonic components.



Microanalysis of Gas in Cathode Coating Assemblies*

HAROLD JACOBS† AND BERNARD WOLK‡

Summary—A study of gases evolved from oxide-coated cathode assemblies was made during degassing and activation conditions. It was found, first, that the volume and nature of gases evolved from uncoated nickel cathode sleeves were practically independent of the three different cleaning methods used; and, second, that hydrogen-fired cathodes liberated slightly larger quantities of hydrogen when heated in vacuum. The release of hydrogen from nickel cathodes was not instantaneous, but was observed to continue even after two and one-half hours of continued heating at 900° C. Br.

When a similar analysis was made of gases liberated from nickel sleeves coated with alkaline earth carbonates, the evolution of hydrogen was reduced considerably, but with a corresponding increase of CO.

The chemistry of the gas condition in the tubes during cathode degassing is shown to be related to the speed of exhaust.

I. INTRODUCTION

THE PROBLEM of finding the relative values of those factors that affect electron tube life, whether detrimental or beneficial, is one with which tube engineers have been concerned for many years. Two related variables that generally have been considered as having a direct effect on tube life¹ are: initial activation conditions, and the evolution of gases.

Therefore, a program was set up in which tube performance was studied in relation to the gases that evolved when the various parts were heated. Along with this work, an attempt was made to find any correlation that might exist between these gases, thermionic emission, and life.

The purpose of this program was outlined as follows:

1. To determine the nature of the gases evolved, in order to provide suitable getter materials for particular gases.

2. To determine the time at which these gases appear, so that activating and bombarding schedules might be varied to produce optimum conditions.

3. To observe whether some gases when introduced during activation period enhance thermionic emission, and, if any were found, to investigate a means for simulating such conditions on rotary exhaust so that the desired effects could be produced.

The investigation which is reported here began with a study of gases coming from the following parts: (a) the unprocessed nickel cathode sleeve itself, (b) the cathode sleeve processed in various ways, and (c) the coating plus the cathode sleeve and heater.

II. UNCOATED NICKEL CATHODES

The initial phase of the work concerned only the cathode and heater parts, in which the cathode sleeve was

* Decimal classification: R 331. Original manuscript received by the Institute, January 18, 1949; revised manuscript received, April 18, 1949. Presented, 1949 IRE National Convention, March 9, 1949, New York, N. Y.

† Sylvania Electric Products Inc., Kew Gardens, L. I., N. Y.

‡ Effect of operating time on electrical characteristics.

uncoated. Four different lots of uncoated sleeves were studied. One lot was unprocessed. The other lots were prepared in three different ways as follows: (1) degreased, (2) hydrogen fired, and (3) electropolished.

The cathode sleeve employed in all of the foregoing work is of the lock-seam variety, having a major diameter of 0.084-inch, minor diameter of 0.034 inch, and length of 28.5 mm. The wall thickness is 0.0025 inch. A spectrographic analysis of the nickel material showed the presence of Fe, Co and Mg in quantities anywhere from 0.1–1 per cent; Al, B, Ca, Mn in still smaller concentrations (0.01–0.1 per cent); and Pb and Si present as a faint trace (0.001–0.01 per cent).

After various treatments on exhaust, the gases evolved from the parts were collected and quantitatively analyzed.²

Tubes were mounted and sealed in pilot-line production, using the lock-in stem.

Discussion

The gases evolved from 6.3-volt tungsten heaters coated with Al₂O₃ are recorded in Table I. It is interest-

TABLE I
ANALYSIS OF GASES IN FILAMENTS
(Heated to from 1000°C. Br.–1100°C. Br.)
(Al₂O₃ coated tungsten wire)

Average	¼-Hour Heating 3 tubes	Additional 2-Hour Heating 2 tubes
Total amount of gas in liter microns	3.08 ± 0.31	1.44
% CO ₂	21.4 ± 1.9	0
% H ₂	45	95.0
% O ₂	0	0
% CO	0	0
% N ₂	31.6	5.0

ing to note in observing Tables II and III that the materials from which the most gas evolved during the first half-hour of heating were the hydrogen-fired nickel sleeves.

The percentage of hydrogen yield seems quite high, even for the unprocessed and degreased specimens. It is interesting to note, too, that the only nickel sleeves which did not show carbon dioxide and oxygen, i.e., an oxidizing influence, were the degreased sleeves.

The unprocessed sleeves showed some CO₂ and O₂, as did the hydrogen-fired parts, though to a lesser extent. It is possible that this result is due to grease contamination, since degreasing seems to have eliminated the CO₂ and O₂ yield of the material.

² Saul Dushman, "Vacuum Practice," chap. 9, John Wiley and Sons, Inc., New York, N. Y., 1949.

TABLE II
UNCOATED NICKEL CATHODES $\frac{1}{2}$ -HOUR HEATING AT 900°C.
(Plus 3 minutes at 1000°C.)

Average	Unprocessed 5 tubes	Degreased 5 tubes	Hydrogen- fired 6 tubes	Electro- Polished 5 tubes
Total amount of gas in liter microns	9.59 ± 0.87	8.22 ± 0.67	11.2 ± 0.51	10.1 ± 0.33
% H ₂ O	trace	trace	trace	trace
% CO ₂	5.4 ± 1.3	0	6.0 ± 2.1	7 ± 2.5
% H ₂	41.2 ± 2.2	47.7 ± 2.4	52.0 ± 1.8	39.9 ± 5.6
% O ₂	7.2 ± 0.44	0	2.8 ± 0.04	1.5*
% CO	35.1 ± 0.7	42.5 ± 2.1	28.2 ± 1.6	42.2 ± 2.4
% N ₂	11.1 ± 0.5	9.8 ± 0.85	8.9 ± 1.1	11.1 ± 1.9

* Found in only two out of 5 samples.

TABLE III
UNCOATED NICKEL CATHODES
(Additional 2-hour heating at 900°C.)

Average	Unprocessed 2 tubes	Degreased 3 tubes	Hydrogen- fired 2 tubes	Electro- Polished 2 tubes
Total gas in liter microns	7.76 ± 0.05	5.60 ± 0.31	8.61 ± 0.0	5.91 ± 0.21
% CO ₂	5.2 ± 0.0	0	4.91 ± 0.0	0
% H ₂	91.0 ± 0.8	97.65 ± 0.05	92.5 ± 1.1	98.0 ± 0.15
% O ₂	0	0	0	0
% CO	0	0	0	0
% N ₂	3.7 ± 0.7	2.35 ± 0.05	2.6 ± 1.1	2.0 ± 0.15

In the second group of materials (shown in Table III) in which gases were collected for two hours at 900°C. after the previous half-hour period, the larger quantity of gas can be attributed to hydrogen. The fact that it takes a much longer time to drive the hydrogen out of the nickel than it does for any of the other gases is new information, as far as the authors have observed.

The reasons for this slow evolution of hydrogen is not known, but it is possible that hydrogen can form a compound with some of the impurities, such as iron, in the nickel cathode sleeve, and that much more thermal energy would be required for exhausting the compound than for diffusing hydrogen out of the nickel.

III. OXIDE-COATED NICKEL CATHODES

Following the study of gases in cathode nickel, another series of tests was initiated to determine the nature and quantity of the gases evolved during breakdown and subsequent prolonged heating of oxide-coated cathodes. The intention here was to approach more closely the problems involving tube life, initial emission, and the appearance of gases in tubes.

Method

The cathodes used in this phase of the work were of the same lot previously analyzed and reported. These cathodes were unprocessed prior to coating, and the coating used was a standard mixture of triple carbonate suspended in nitrocellulose lacquer.

Tubes were prepared, using a cathode coated to a diameter of 0.044 ± 0.001 inch, and containing 8.5 to 9.5 mg of material. Results are shown in Table IV.

Results

The heating schedules used in this phase of the work follow a definite set of purposes. The elevated temperature (1000°C. Br.) was required in order to break down the alkaline earth carbonates as in (1)

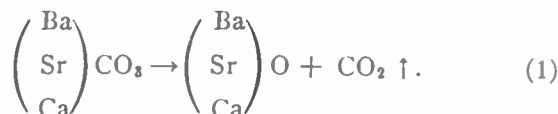

The 900°C. Br. treatment which was then given to the cathode represents an attempt to approximate the aging and operating conditions.

From Table IV, column A, it can be seen that of all the gases liberated during the breakdown process, CO₂ is the largest single component. This was expected, but the total quantity of gas was so great that the McLeod gauge was too small to determine this quantity exactly. However, the approximate figure of slightly greater than 400 liter microns was obtained. The individual components of the gas mixture were obtained by an analysis of a portion of the total sample.

Columns B and C record the composition of the gases evolved during a heating period of one-half hour after cathode breakdown had taken place. For data in column B, the system was previously closed to the pumps during the three-minute breakdown schedule, whereas the data in column C were obtained for the same half-hour period but with the initial breakdown gases immediately pumped off. Thus, a convenient method was available for noting the effects of retarded evacuation on the nature and quantity of CO₂ and H₂O, and an equally abnormal total lack of H₂ and O₂ gases. From previous work on uncoated nickel sleeves (Table II) it was found that the bulk of the gas evolved in the same half-hour period was H₂ and CO, along with a small quantity of O₂ and CO₂. It is, therefore, evident that in the presence of a large excess of CO₂ a series of reactions takes place, as in (2):



In column C, with less residual CO₂ during the half-hour aging at 900°C. Br., there is found a normal trace of H₂O, a smaller quantity of CO₂, and a large quantity of H₂.

Data in columns D and E show that initial slow removal of gases has only a slight effect on the gases evolved during the subsequent two hours of continued heating.

Only in the earlier stages of activation and aging does the speed of removal of gases change the nature of the gases surrounding the cathode.

With an early and rapid removal of gases, column C can be expected to show more H₂ and more CO on a per-

centage basis, and with a slow exhaust (column B), the atmosphere can be expected to tend more to H₂O and CO₂.

In addition, another point is of interest. Comparing Table III with columns D and E, it is found that in the two-hour period, i.e., longer life period, more total gas (7.76 ± 0.05 liter microns) escapes from the uncoated cathode than from the coated cathode (5.45 and 5.78, respectively). This difference may be due to the suppression of gas evolution by the formation of oxide interfaces at the cathode.

For instance, in the case of N₂, which is relatively inert, a smaller quantity was released in the two-hour period from the coated than from the uncoated cathodes. This theory seems to be consistent with the fact that oxidation increases the hot tensile strength of nickel, and it may be expected, then, that as hot tensile strength is increased, diffusion is decreased.

Discussion

When the study of gases evolved from oxide-coated cathode assemblies was completed up to the point of degassing and activation conditions, it was found, first, that the gases evolved from uncoated nickel cathode sleeves were qualitatively practically independent of the

three different cleaning methods of factory processing commonly, used, and, second, that hydrogen-fired cathodes liberated slightly larger quantities of hydrogen when heated in vacuum. In addition, the release of hydrogen from nickel cathodes was not instantaneous, but was observed to continue even after 2½ hours of continued heating at 900°C. Br.

When a similar analysis was made of gases liberated from nickel sleeves coated with alkaline earth carbonates, the evolution of hydrogen was reduced considerably, but with a corresponding increase of CO, indicating the reaction (see (2)):

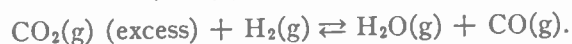

The gas condition in the tubes during cathode degassing was shown to be related to the speed of exhaust. The lower speed of exhaust produces a condition leading to the right side of (2), and a high exhaust speed produces conditions tending to retard the reaction to the right.

IV. EFFECTS OF GASES ON THERMIONIC EMISSION

As the third step in this investigation, a procedure was set up to determine the effects of some of these gases on thermionic emission.

TABLE IV*

	Gases evolved from coated cathodes heated to 1000°C. Br. for 3 minutes	Gas evolved in first ½ hour of heat treatment at 900°C. Br.	Gas evolved in first ½ hour of heat treatment at 900°C. Br.	Gases evolved during a 2-hour period of heat treatment at 900°C. Br.	Gases evolved during a 2-hour period following a treatment similar to that described in Col. D
	A	B ³	C ⁴	D ³	E ⁴
Total gas yield in liter microns	>400 LM	34.2 ± 3.1	5.43 LM ± 0.31	5.45 LM ± 0.2	5.78 LM ± 0.0
H ₂ O	trace	12.2% ± 0.9	trace	trace	trace
CO ₂	95.4% ± 0.3%	71.4% ± 2.6	12.0% ± 5.6	4.8% ± 0.8	0
H ₂	trace	0	37.3% ± 3.2	91.1% ± 1.5	94.6% ± 0.6
O ₂	↑	0	0	0	0
CO	2.7% ± 0.8%	15.5% ± 1.8	44.0% ± 5.0	0	0
N ₂	1.6% ± 0.1%	1.2% ± 0.15	6.7% ± 0.8	5.2% ± 1.5	5.4% ± 0.6

* All values shown represent averages.

³ System closed from the pumps during initial breakdown.

⁴ System open to pumps during initial breakdown.

TABLE V
EMISSION FROM GAS-CONTAMINATED OXIDE-COATED CATHODES

Sample Number	1	2	3	4	5	6	7	8
	Emission Current (Temperature Limited)							
Contaminating Gas	2.1 ma	2.0 ma	1.9 ma	2.5 ma	2.2 ma	1.7 ma	2.5 ma	2.5 ma
Control	8 μa	4 μa	< 1 μa	< 1 μa	—	—	—	—
Oxygen	2.2 ma	2.1 ma	3.0 ma	1.6 ma	—	—	—	—
Hydrogen	14 μa	30 μa	12 μa	—	—	—	—	—
CO ₂	1 μa	2.5 μa	2.5 μa	—	—	—	—	—
H ₂ O	2.0 ma	15.0 ma*	15.0 ma*	22.0 ma*	5.0 ma*	5.4 ma*	2.0 ma	2.0 ma
CO								

* Some tubes did not appear to saturate, indicating a gassy condition. Further activation in some cases resulted in tubes which saturated between 2 and 5 mils. This was characteristic only of CO contamination.

In order to test thermionic emission, standard diodes were made up using partially opened cylindrical nickel anodes, and were tested on the gas analysis system. For details of the exhaust schedule used, see Appendix I. The method of preparation of the gases is described in Appendix II.

Results

The saturation plate currents recorded in Table V show the effects of the contamination of oxide-coated cathodes by the different gases. (The testing procedure is given in Appendix III.) Molecular hydrogen does not appear to exert any enhancing influence on the emission level, and the oxidizing gases, such as O₂, CO₂ and H₂O, markedly destroy the cathode activity. Furthermore, CO not only results in no enhancement, but also appears to be the cause of a gassy condition. Only after additional activation and degassing do these latter tubes respond with a saturation level of two to three mils.

Discussion

In general, it was found that the oxidizing gases have a detrimental effect on the emission. Both oxygen and water vapor appear to have a somewhat more harmful effect than CO₂. An interesting feature, also, is the failure of a reducing gas, such as hydrogen, to enhance cathode emission when it is introduced during the period of cathode activation. As indicated in previous work, the cathode sleeve itself supplies about 4 to 5 liter microns of hydrogen during the first half hour of activation. In the present work, however, 20 to 50 liter microns of hydrogen was used. In effect, this means that even with an increase by a factor of 5 of the hydrogen employed during activation, no difference in the emission level could be detected.

It is well known in actual practice that the use of hydrogen or carbon monoxide flushing results in a considerable oxide cleaning up of anode and grid surfaces, thereby providing higher emission. But such a method is an indirect one, and as far as the direct or primary effects on emission are concerned, no initial enhancement due to heating the cathode in low pressures of either H₂ or CO₂ was observed.

In connection with the use of CO, a further observation should be made. There was in some instances a gassy condition that developed in tubes previously treated with CO. It is difficult to account for this condition in a definite manner, but it was noted that after heating the cathode in carbon monoxide, a considerably longer length of time was required for degassing than when the cathode was processed by heating in other gases. This would indicate that some secondary chemical process had taken place. One of the possibilities which could be pointed out is the formation of barium carbide in the following manner:



on further heating

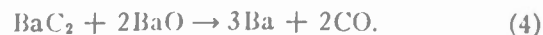

There is relatively little information on barium carbide in the literature, but there is some information on calcium carbide which can be applied.⁶ It is pointed out that calcium carbide melts above platinum at approximately 2300°C., indicating an exceedingly stable compound. If reactions occur, such as in (3) and (4), and if barium carbide is as stable as calcium carbide, then a considerable length of time for the reactions to go to completion could be expected. This theory is to some extent verified by the type of gases that were found to be coming off during the measurements of emission. By raising the liquid air to the condensation trap, it could be demonstrated that this gas was uncondensable, thereby precluding the existence of water vapor or carbon dioxide. Since the gas persisted even upon heating the palladium tube, it was demonstrated that the gas was not hydrogen. After so much processing, the gas could not have been nitrogen, since previous work on gas analysis indicated only a negligible amount of N₂. Only two gases remained—oxygen and carbon monoxide. Since the poisoning was not permanent and a good level of emission resulted after the gas was removed, it can be concluded that the gas was not oxygen. Thus, the remaining possibility is that the gas was actually CO. If it were simply adsorption, one would expect the gas to be very quickly released, but since the gas persisted despite high temperatures, certain chemical reactions must have taken place. One of the possibilities is therefore indicated in (3) and (4).

V. CONCLUSION

The speed of exhaust appears to be a very important factor from the point of view of activation of the cathode coating. This is due to the fact that the gases which are liberated from the cathode during breakdown, if given sufficient time, react with each other to form new compounds. Specifically, it was found that there exists an equilibrium equation as follows:



and that the formation of the products on the right will be favored by slow exhaust speeds, while rapid pumping suppresses the reaction to a great extent.

The gases most detrimental to emission are the oxidizing gases, CO₂ being the least harmful. Reducing gases, such as H₂, introduced during the activation period in pressures from 5 to 20 microns appear to have no enhancing effect on emission. When oxidizing gases were introduced into the system during the activation of one tube, other tubes which were sealed on the manifold exhibited the effect of poisoning when processed

⁶ W. Segerblom, "Properties of Inorganic Substances," Chemical Catalog Company, Inc., New York, N. Y., p. 38; 1927.

later, although the gases had been removed previously. Although no quantitative data are presented here, this poisoning by gases, perhaps occluded on the glass, was observed for long periods of time. (It can, therefore, be expected that an equivalent condition could occur when sudden leaks develop during Sealex operations.)

Although hydrogen is useful in removing oxide from the various tube elements around the cathode, it can be quite troublesome when applied to hydrogen firing of cathodes. Such cathodes have been found to evolve quantities of hydrogen, even after two hours of heating at 50 per cent above rated filament voltage. Since cathodes without a tube-processing history of hydrogen firing also seem to yield hydrogen after prolonged heating, a hydrogen gettering material would have considerable usefulness.⁶

APPENDIX I—EXHAUST SCHEDULE

1. The tubes were baked out at 350° to 400°C. for 30 minutes.
2. The plate was degassed with rf at 900°C. for 5 minutes.
3. E_f of 14 volts was applied for 3 minutes. (The tube contained a 6.3-volt indirectly heated cathode.)
4. The filament voltage was turned off and the tube exhausted for 3 minutes.
5. E_f of 9.5 volts was applied and the plate was simultaneously rf heated to 900°C. Br. for 3 minutes.
6. Liquid air was applied to the mercury pump trap.
7. E_f of 9.5 volts was maintained for an additional 5 minutes.
8. The system was closed off from the pumps and 20 microns of contaminating gas was admitted. The filament was heated while the gas was being introduced.
9. Heating of the cathode was continued at 9.5 volts E_f for an additional 5 minutes in the presence of the gas.
10. The system was opened to the pumps, thus exhausting the vacuum system, and the cathode was kept heated for a period of 20 minutes.
11. The plate was again heated by rf during the last 5 minutes of the 20-minute schedule in step 10.
12. The filament voltage was turned off.

⁶ The nickel material used in making cathode sleeves is melted under an atmosphere of hydrogen by the manufacturer.

APPENDIX II—PREPARATION OF THE GASES

1. *Oxygen*: This gas was introduced by the heating of silver oxide.
2. *Hydrogen*: Hydrogen was introduced by applying a gas flame to an electrically heated palladium tube until the McLeod gauge indicated the proper pressure.
3. *Water Vapor*: By heating the platinum wire located in the Toepler pump section of the apparatus, the combustion of oxygen and excess hydrogen could be initiated to form water. This water vapor was condensed in the cold trap prior to its use by means of dry ice and methanol. When it was released for contamination of an oxide cathode, its pressure was observed on a Pirani gauge which was previously calibrated for water vapor.
4. CO_2 : Carbon dioxide was stored for future use by means of the liquid air trap condensation of the cathode breakdown product.
5. CO : The preparation of carbon monoxide was somewhat more complex in that an additional cathode assembly was required. A tube containing a flag getter and a coated cathode was sealed to the gas analysis system so that it was external to the regular manifold section. After thorough degassing, its getter was flashed and immediately thereafter the cathode was broken down. The combination of the CO_2 thus released with the free barium yields CO according to the following reaction:



The CO was then collected in the Toepler pump prior to its release for contamination of the cathode as described in Appendix II, Step 8. The excess CO_2 in (5) was condensed by the liquid air trap.

The total time for cathode activation was thus in the order of 30 minutes. The control tubes were given the same treatment and activating time, except that in Step 8 no contaminating gas was introduced.

APPENDIX III—TESTING PROCEDURE

1. After exhaust processing mentioned above, two minutes were allowed to elapse before bringing E_f up to 4 volts, and an additional 2 minutes for temperature equilibrium to be established.
2. Plate voltage was slowly increased to 150 volts (maximum) and behavior of the filament current recorded.



On the Theory of Axially Symmetric Electron Beams in an Axial Magnetic Field*

A. L. SAMUEL†, FELLOW, IRE

Summary—One of the more perplexing problems in the design of klystrons and traveling-wave tubes has been the formation of well collimated electron beams. An axially symmetric form of an electron beam is proposed in which the space-charge repulsive forces are just balanced by magnetic focusing forces so that the beam may be made as long as desirable without any change in its cross section. The equations governing the existence of such beams are derived.

INTRODUCTION

HIGH-CURRENT electron beams are of considerable importance in connection with many electronic devices such, for example, as klystrons, traveling-wave tubes, and electron-wave tubes. These devices all employ axially symmetric beams of electrons, and, in general, require that the beams be projected for considerable distances without significant changes occurring in the cross-sectional area of the beam, or in the cross-sectional distribution of current and potential.

The properties of electron beams, both with and without axial magnetic fields have been studied by a great many workers.¹⁻¹³ Three general classes of solu-

tions have been obtained. The first class is restricted to situations in which space-charge forces can be neglected with the result that the laws of electron optics apply. Solutions of the second class attempt to make a first-order correction for space-charge forces. A final class of solutions is to be noted in which certain nonphysical constraints are introduced, the more usual being the assumption either that there is an accompanying flow of positive ions or that there is an infinitely strong magnetic field.

Contrasting with these approximate solutions, it is possible to obtain a rigorous solution for the necessary and sufficient conditions which must be met if the radial distribution of current and potential in a beam are to remain unaltered along the beam.¹⁴ These conditions are capable of physical realization and their consequences prove to be extremely useful and interesting.

For an electron beam to be stable, the forces acting on the electrons in the beam must be in equilibrium through the beam. If we wish to have a "uniform beam," the second time derivatives of the electron co-ordinates must vanish. One starts then by writing the Lorentz force equation in cylindrical co-ordinates and by equating the three components \bar{r} , $\bar{\theta}$, and \bar{z} to zero. This places restraints on the permissible values of the electric and magnetic fields. Additional conditions can then be imposed, not on the charge distributions but rather 1. on the magnetic field to conform with the requirement that the field be producible by field coils that are entirely external to the region occupied by the beam, and 2. on the magnetic-field conditions at the cathode from which the electrons are obtained. A final condition is imposed by Poisson's equation which must be satisfied subject to the prescribed boundary conditions fixed by external electrodes. Under these conditions, one can obtain a solution in which only physically realizable restraints are imposed and in which the current density and voltage conditions within the beam come out of the solution rather than being a part of the assumed conditions. This constitutes the complete solution of the steady-state conditions in the uniform portion of the beam.

We shall consider two special cases, the first in which we have a tubular beam inside of a conducting cylinder, and the second in which we have a tubular beam surrounding a metallic conductor. The solution for a solid

¹⁴ L. Brillouin, "A theorem of Larmor and its importance for electrons in magnetic fields," *Proc. N.E.C.*, vol. 1, pp. 489-499. Also published in *Phys. Rev.*, vol. 67, pp. 260-266; April, 1945. The magnetic field resulting from the motion of charges within the beam and all relativity corrections are ignored in the present treatment. These approximations introduce negligible error if the beam voltage is less than something of the order of 10,000 volts.

* Decimal classification: R138. Original manuscript received by the Institute, February 4, 1949; revised manuscript received, May 13, 1949. Presented, 1949 IRE National Convention, New York, N. Y., March 10, 1949. This work was done in the Electron Tube Research Laboratory of the University of Illinois and was supported in part by the United States Navy, Office of Naval Research under Contract N6-ori-71 Task XIX. Reproduction in whole or in part is permitted for any purpose of the United States Government.

† University of Illinois, Urbana, Ill.

¹ D. B. Langmuir, "Theoretical limitations of cathode-ray tubes," *Proc. I.R.E.*, vol. 25, pp. 954-976; August, 1937.

² J. R. Pierce, "Limiting current densities in electron beams," *Jour. Appl. Phys.*, vol. 10, pp. 715-724; October, 1939.

³ E. E. Watson, "The dispersion of the electron beam," *Phil. Mag.*, ser. 7, vol. 3, pp. 849-853; April, 1927.

⁴ B. V. Borries and J. Dosse, "Zerstreung von elektronenstrahlen durch eigene raumladung," *Arch. Elek. (Übertragung)*, vol. 32, pp. 221-232; 1938.

⁵ B. J. Thompson and L. B. Headrick, "Space-charge limitations on the focus of electron beams," *Proc. I.R.E.*, vol. 28, pp. 318-324; July, 1940.

⁶ H. Moss, "A space-charge problem," *Wireless Eng.*, vol. 22, pp. 316-321; July, 1945.

⁷ A. V. Haeff, "Space-charge effects in electron beams," *Proc. I.R.E.*, vol. 27, pp. 586-602; September, 1939.

⁸ L. P. Smith and P. L. Hartman, "Formation and maintenance of electron beams," *Jour. Appl. Phys.*, vol. 11, pp. 220-229; March, 1940.

⁹ D. P. R. Petrie, "The effect of space charge on potential and electron paths of electron beams," *Elec. Commun.*, vol. 20, no. 2, pp. 100-111; 1941.

¹⁰ J. R. Pierce, "Limiting stable current in the presence of ions," *Jour. Appl. Phys.*, vol. 15, pp. 721-726; October, 1944.

¹¹ K. R. Spangenberg, "Use of the action function to obtain the general differential equations of space-charge flow in more than one dimension," *Jour. Frank. Inst.*, vol. 232, pp. 365-371; October, 1941.

¹² L. M. Field, K. R. Spangenberg, and R. Helm, "Control of electron-beam dispersion at high vacuum by ions," *Elec. Commun.*, vol. 24, no. 1, pp. 108-121; 1947.

¹³ N. Wax, "Some properties of tubular electron beams," *Jour. Appl. Phys.*, vol. 20, pp. 242-248; March, 1949.

beam may be obtained from the first case by letting the inner radius of the beam go to zero and the case in which there are metallic conductors both inside and outside the tubular beam may be handled by superimposing the two special cases. In a similar fashion, the parallel-plane case is obtained by letting the radius of the beam go to infinity.

A practical solution to be complete must also include a specification of the conditions within the beam in the region where the three components of acceleration are not zero. This requires a more general treatment of the force equation, again subject to assumed boundary conditions along the edge of the beam. The equation governing electron trajectories within the beam may be derived in differential form and the solution of this equation obtained by numerical means. In a complementary paper by Wang,¹⁵ solutions are given for the shape of electron beams in which the electrons oscillate about equilibrium conditions. Wang's analysis is limited to solid beams in a uniform magnetic field and considers the motion of edge electrons only, while the present solution is for the equilibrium conditions within the beam and for the more general case of a tubular beam.

MATHEMATICAL FORMULATION OF PROBLEM

The Lorentz force equation for axially symmetric fields can be written in cylindrical co-ordinates as

$$\ddot{r} - r\dot{\theta}^2 = -\frac{e}{m} \left[E_r + \dot{\theta} \frac{\partial}{\partial r} (rA_\theta) \right] \quad (1)$$

$$r\ddot{\theta} + 2\dot{r}\dot{\theta} = \frac{e}{m} \left[\dot{z} \frac{\partial A_\theta}{\partial z} + \frac{\dot{r}}{r} \frac{\partial}{\partial r} (rA_\theta) \right] \quad (2)$$

$$\ddot{z} = -\frac{e}{m} \left[E_z + r\dot{\theta} \frac{\partial A_\theta}{\partial z} \right] \quad (3)$$

where r , θ , and z are the usual cylindrical co-ordinates, E_r and E_z are the radial and axial components of electric field and A_θ is the only component of the magnetic vector potential which need be specified to define an axially symmetric magnetic field.¹⁶ *Mks* units will be used.

By multiplying (2) by r and integrating, the usual equation for the conservation of angular momentum is obtained.

This takes the form

$$r^2\dot{\theta} - \frac{e}{m} rA_\theta = c_1 \quad (4)$$

where c_1 is a constant for any one electron trajectory.

Replacing (2) by its equivalent in the form of (4) and considering θ as an ignorable co-ordinate, we can obtain equations for the electron trajectories in the r, z plane.

UNIFORM FIELD CONDITIONS

Limiting ourselves for the present to the uniform region of the beam in which we may assume that \dot{r} , $\dot{\theta}$, \dot{z} are zero and in which there is a uniform magnetic field so that A_θ is independent of z and proportional to r , we can write from (1)

$$E_r = \frac{m}{e} r\dot{\theta}^2 - 2r\dot{\theta}A_\theta \quad (5)$$

where A_0 is the value of A_θ at a unit radius; i.e.,

$$A_\theta = rA_0. \quad (6)$$

Since the value of $\dot{\theta}$ is specified by conservation-of-angular-momentum considerations, (5) may be taken as being the defining equation for the radial electric field E_r , and through Poisson's equation as specifying permissible charge distributions within the beam. Particular solutions will result depending upon the choice of constant c_1 in (4).

Eliminating $\dot{\theta}$ from (5) by means of (4) and (6) we can write

$$E_r = \frac{m}{e} r \left(\frac{c_1}{r^2} + \frac{e}{m} A_0 \right)^2 - 2r \left(\frac{c_1}{r^2} + \frac{e}{m} A_0 \right) A_0. \quad (7)$$

Since there can be no axial or angular components of electric field, Poisson's equation can be written as

$$\frac{1}{r} \frac{d}{dr} (rE_r) = -\frac{\rho}{\epsilon} \quad (8)$$

and the potential at any point in the beam is similarly given by

$$\phi = -\int E_r dr + c_2 \quad (9)$$

where the constant c_2 is fixed by the boundary conditions. Given the charge distribution ρ the axial current density distribution is given by

$$J = \rho \dot{z}. \quad (10)$$

The value of \dot{z} can be calculated in terms of ϕ and $\dot{\theta}$ from conservation of energy considerations expressed as

$$\dot{z}^2 = 2 \frac{e}{m} \phi - (r\dot{\theta})^2 \quad (11)$$

where it is assumed that the potential ϕ is measured with respect to a single cathode from which all of the electrons originate.

The problem then reduces to that of choosing a physically realizable and reasonable value for c_1 , in (4) and then carrying out the indicated steps.

¹⁵ Dr. C. C. Wang is a research engineer with Sperry Gyroscope Co., Great Neck, L. I., N. Y.

¹⁶ As noted earlier, we ignore the components of A resulting from the current of the beam itself. We are at liberty to define the divergence of A in any way we choose, since the curl only enters into the force equation. In what follows we will assign A_θ a value of zero at the beam axis. A_z and A_r components, if they exist, will have to be constant and independent of the co-ordinates in order for the field to be axially symmetric.

TUBULAR BEAM WITH AN EXTERNAL CONDUCTOR

Consider the case of a tubular beam of outer radius r_b and inner radius r_a as shown in Fig. 1. For the moment,

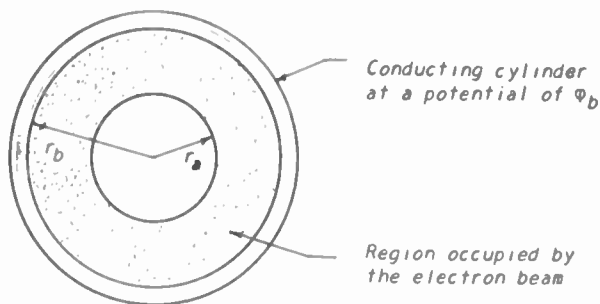

Fig. 1—Cross section of a tubular electron beam with an external conductor.

we will assume that the beam just fills a cylindrical conductor so that the potential at the radius r_b may be taken to be ϕ_b as fixed by the conductor. The potential within the beam will sag as a result of the space-charge effect with the maximum field existing at the outside at radius r_b and decreasing to zero at the inner radius r_a . We would like to choose the constant c_1 and the value of A_0 in (7) in such a way as to make the right-hand side of the equation zero at $r=r_a$ and a maximum at $r=r_b$ (so as to accommodate the maximum amount of space charge), and to have the resulting equation hold for all electrons. The requirement that $E_r=0$ at $r=r_a$ fixes the value of c_1 as

$$c_1 = -\frac{e}{m} A_0 r_a^2. \quad (12)$$

Substituting this value in (7) we find that

$$E_r = -\frac{e}{m} A_0^2 r \left[1 - \left(\frac{r_a}{r} \right)^4 \right]. \quad (13)$$

Before proceeding with the solution, it will be instructive to consider what this choice of c_1 implies.

Equation (4) now may be written as

$$\theta - \frac{e}{m} \frac{A_0}{r} = -\frac{e}{m} A_0 \left(\frac{r_a}{r} \right)^2 \quad (14)$$

which for the uniform-field region becomes

$$\theta = \frac{e}{m} A_0 \left[1 - \left(\frac{r_a}{r} \right)^2 \right]. \quad (15)$$

At r_a the angular velocity is zero, as previously noted, while at r_b the value is

$$\theta_b = \frac{e}{m} A_0 \left[1 - \left(\frac{r_a}{r_b} \right)^2 \right]. \quad (16)$$

Since the electrons will have originated at a cathode with zero angular velocity, the entire cathode area must be in a region where the value of rA_0 is constant and

equal to $A_0 r_a^2$. This means in effect that all of the magnetic flux which lies within the radius r_a in the uniform-field region must thread through a hole in the cathode and all of the rest of the flux which lies outside the radius r_a in the uniform-field region must surround the cathode, for otherwise, (14) will not apply to all electrons. This situation is illustrated in Fig. 2. Of course it would be possible to carry out a solution for the case where some of the flux threads through the cathode surface, but we will find that the present solution is of greater interest.

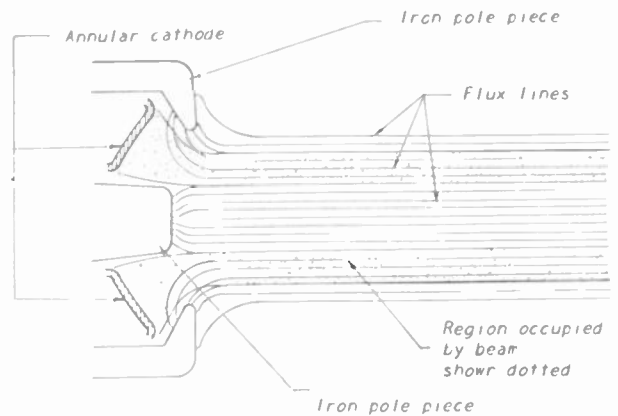

Fig. 2—The manner in which the magnetic flux must thread through the cathode to satisfy the assumptions made in the solution.

Another consequence of our choice of c_1 is that the beam does not rotate as a unit; instead, the electrons revolve in a laminar manner, the innermost electrons proceeding directly in the z direction with successive layers rotating at higher and higher angular velocities.

The solid beam obtained by letting $r_a \rightarrow 0$ is the exception. In this case the beam rotates as a unit with an angular velocity given by

$$\theta_0 = \frac{e}{m} A_0 \quad (17)$$

and all of the flux must surround the cathode.

Proceeding with the solution by introducing the value of E_r from (13) into Poisson's equation, we find that

$$\rho = 2\epsilon \frac{e}{m} A_0^2 \left[1 + \left(\frac{r_a}{r} \right)^4 \right]. \quad (18)$$

In general a nonuniform charge distribution is required, the exception being the solid-beam case.

Introducing the value of E_r from (13) into (9) and letting the potential ϕ equal ϕ_b at the radius r_b , we find that

$$\phi = \phi_b - \frac{1}{2} \frac{e}{m} A_0^2 \left[r_b^2 - r^2 + \frac{r_a^4}{r_b^2} - \frac{r_a^4}{r^2} \right] \quad (19)$$

which at the inner radius reduces to

$$\phi_a = \phi_b - \frac{1}{2} \frac{e}{m} A_0^2 r_b^2 \left[1 - \left(\frac{r_a}{r_b} \right)^2 \right]^2 \quad (20)$$

The original assumption that the beam just filled the containing cylindrical conductor can now be relaxed and the potential of the external conductor ϕ_e , can be expressed in terms of ϕ_b, ϕ_a , and the radii. The situation is illustrated in Fig. 3. Integrating ρ over the cross section, the total charge per unit length is given by

$$q = 2\pi\epsilon \frac{e}{m} A_0^2 r_b^2 \left[1 - \left(\frac{r_a}{r_b} \right)^4 \right] \quad (21)$$

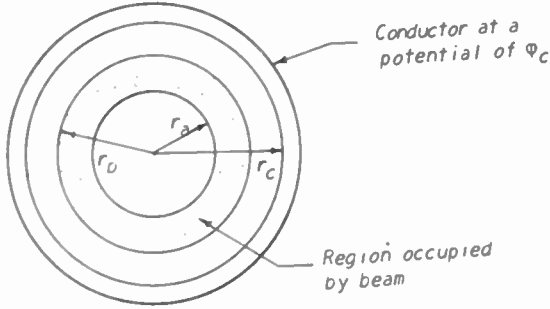

Fig. 3—A tubular beam with its outside radius less than the radius of the surrounding cylinder.

which may be written

$$q = 4\pi\epsilon(\phi_b - \phi_a) \frac{(r_b^2 + r_a^2)}{(r_b^2 - r_a^2)}. \quad (22)$$

Applying Gauss's law, the electric field in the region external to the beam is

$$E_r = - \frac{4(\phi_b - \phi_a)}{r} \frac{(r_b^2 + r_a^2)}{(r_b^2 - r_a^2)} \quad (23)$$

and the potential is

$$\phi = \phi_b + 4(\phi_b - \phi_a) \frac{(r_b^2 + r_a^2)}{(r_b^2 - r_a^2)} \ln \frac{r}{r_b}. \quad (24)$$

For the external electrode at a radius r_c this becomes

$$\phi_c = \phi_b + 4(\phi_b - \phi_a) \frac{(r_b^2 + r_a^2)}{(r_b^2 - r_a^2)} \ln \frac{r_c}{r_b}. \quad (25)$$

The electric field and the potential for the entire cross section of a typical beam are shown in Fig. 4. Three

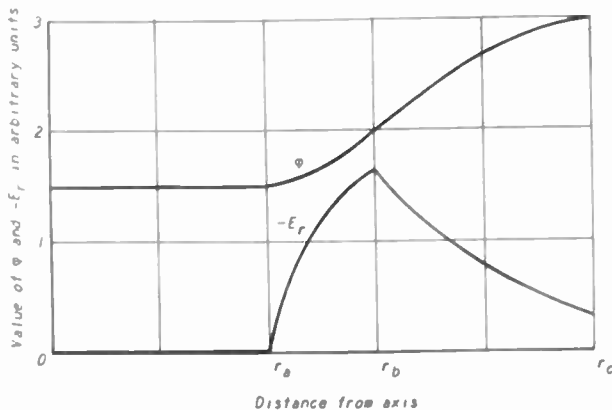

Fig. 4— Radial variation of potential and electric field for the case illustrated in Fig. 3.

regions are to be distinguished; 1. the region between the beam and the external cylinder, 2. the region occupied by the beam, and 3. the region inside the beam. Elementary considerations require that the electric field and the potential be continuous across the boundaries between these three regions. The slope of the electric-field curve is discontinuous because of the discontinuity in the charge density.

As usual, the solid-beam case may be obtained by letting $r_a \rightarrow 0$ giving for the potential in this case

$$\phi_a = \phi_b - \frac{1}{2} \frac{e}{m} A_0^2 [r_b^2 - r^2] \quad (26)$$

and for the center potential

$$\phi_0 = \phi_b - \frac{1}{2} \frac{e}{m} A_0^2 r_b^2. \quad (27)$$

Solving (15) for $(r\dot{\theta})^2$ we have

$$(r\dot{\theta})^2 = \left(\frac{e}{m} \right)^2 A_0^2 r^2 \left[1 - \left(\frac{r_a}{r} \right)^2 \right]^2. \quad (28)$$

Substituting (19) and (28) in (11)

$$\dot{z}^2 = 2 \frac{e}{m} \phi_b - \left(\frac{e}{m} \right)^2 A_0^2 r_b^2 \left[1 - \left(\frac{r_a}{r_b} \right)^2 \right]^2 \quad (29)$$

or finally by making use of (20)

$$\dot{z} = \left(2 \frac{e}{m} \phi_a \right)^{1/2}. \quad (30)$$

The axial velocity \dot{z} is found to be independent of r and to be the same for all electrons!¹⁷ This fact is of great practical importance in many applications and is a consequence of our particular choice for the constant in the angular-momentum equation.

The axial component of current density may be written in units of ϕ_b and A_0 by making use of (18) and (29) as

$$J = 2\epsilon \frac{e}{m} A_0^2 \left[1 + \left(\frac{r_a}{r} \right)^4 \right] \left\{ 2 \frac{e}{m} \phi_b - \left(\frac{e}{m} A_0 r_b \right)^2 \left[1 - \left(\frac{r_a}{r_b} \right)^2 \right]^2 \right\}^{1/2} \quad (31)$$

or it may be simplified by introducing the value of ϕ_a from (20) giving

$$J = 2\sqrt{2} \epsilon \left(\frac{e}{m} \right)^{3/2} A_0^2 \phi_a^{1/2} \left[1 + \left(\frac{r_a}{r} \right)^4 \right]. \quad (32)$$

Finally the total current can be obtained by integrating (31) over the beam area, giving

$$I = 2\pi\epsilon \frac{e}{m} A_0^2 r_b^2 \left[1 - \left(\frac{r_a}{r_b} \right)^4 \right] \left\{ 2 \frac{e}{m} \phi_b \right.$$

¹⁷ It can be shown that $c_1 = \text{constant}$ is the only solution that leads to $z^2 = \text{constant}$, if all electrons are to rotate about the beam axis.

$$-\left(\frac{e}{m} A_0 r_b\right)^2 \left[1 - \left(\frac{r_a}{r_b}\right)^2\right]^2 \}^{1/2} \quad (33)$$

which again can be simplified to

$$I = 4\sqrt{2} \pi \epsilon \left(\frac{e}{m}\right)^{1/2} \phi_a^{1/2} (\phi_b - \phi_a) \frac{r_b^2 + r_a^2}{r_b^2 - r_a^2} \quad (34)$$

The corresponding equations for the solid-beam case are obtained by replacing ϕ_a by ϕ_0 and by letting $r_a = 0$.

When written in perveance form, (33) becomes

$$\frac{I}{\phi_b^{3/2} \left[\frac{r_b^2 - r_a^2}{r_b^2 + r_a^2} \right]} = 2\pi \epsilon \left(\frac{e}{m}\right)^{1/2} Q^2 [2 - Q^2]^{1/2} \quad (35)$$

where

$$Q = \left(\frac{e}{m}\right)^{1/2} \frac{A_0 r_b \left[1 - \left(\frac{r_a}{r_b}\right)^2\right]}{\phi_b^{1/2}} \quad (36)$$

Maximizing (35) with respect to Q , one finds that

$$\left[\frac{I}{\phi_b^{3/2} \left(\frac{r_b^2 - r_a^2}{r_b^2 + r_a^2}\right)} \right]_{\max} = 25.4 \times 10^{-6} \quad (37)$$

and the optimum value of Q is

$$Q_{\text{opt}} = \left(\frac{4}{3}\right)^{1/2} \quad (38)$$

The corresponding value of ϕ_a is given by

$$\frac{\phi_a}{\phi_b} = \frac{1}{3} \quad (39)$$

A plot of (35) in practical units of amperes, volts, centimeters, and gauss is given in Fig. 5.

BEAM STABILITY

The problem of beam stability requires some further discussion. We have developed the concept of a tubular electron beam, immersed in a uniform axial magnetic field in which the electrons individually revolve around the common beam axis with just the required angular velocity to balance the space-charge forces. We have shown that such a solution is mathematically possible and that it leads to a situation in which the axial velocity is independent of the radius and hence is the same for all electrons. We must now inquire into the stability of such a charge distribution when subjected to minor perturbations.

Two types of possible instability bear investigation, the first in which most of the beam is well behaved and a small number of electrons are displaced from their equilibrium position, and a second in which the entire beam is distorted from its equilibrium condition. We will consider these separately.

Consider a single electron within the beam which fails to conform to the equilibrium conditions by having too low a value of \dot{z}^2 and by having corresponding value of

\dot{r}^2 as required by considerations of conservation of energy and of angular momentum. A brief analysis shows that such an electron will oscillate radially through the beam, moving at a constant radial speed

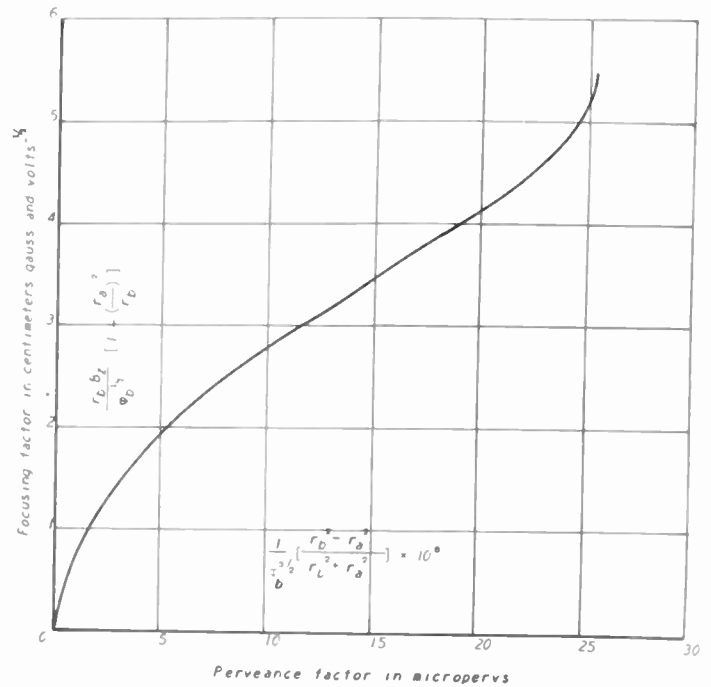

Fig. 5—Normalized curve giving the required magnetic field as a function of the beam perveance, voltage, and radii for a tubular electron beam with an external conductor as shown in Fig. 3. The symbol B_z refers to the axial component of magnetic flux

$\pm \dot{r}_0$ while in the region occupied by the beam and being subject to restoring forces while in other regions. The radius at the inner limit of excursion is

$$r_1 = \sqrt{r_a^2 + \left[\frac{\dot{r}_0}{2 \frac{e}{m} A_0} \right]^2} - \frac{\dot{r}_0}{2 \frac{e}{m} A_0} \quad (40)$$

and the value of \ddot{r} in the inner region is

$$\ddot{r} = \frac{e}{m} A_0 \frac{r_a^4 - r^4}{r^3} \quad (41)$$

The equations governing the motion of the electron in the region external to the beam are somewhat more complicated because of the electric field in this region. Under some circumstances, the limiting radius may be greater than the radius of the external cylinder in which case the electron will be collected and thus removed from the beam. The fact that no restoring force acts on the electron when it is in the region occupied by the beam is rather interesting but should not be considered as evidence of instability since this observation is true only in the limiting case when the charges displaced have negligible effect on the total space charge.

A second situation to be considered is that in which all of the electrons have an \dot{r} component when the beam

radii are those given by our defining equations and the value of \dot{z} is correspondingly altered. The solid-beam case has been considered in detail by Wang. His analysis shows that the beam radius will vary along the beam in a cyclic manner about an equilibrium radius corresponding to the conditions which we have treated. For the tubular-beam case, two interesting variations can occur, the one in which the inner and outer radii swell and shrink together, and the other in which they vary in opposite directions. Detailed study will show that both types are stable. This aspect of the problem will not be pursued further as it is adequately treated in Wang's paper.

TUBULAR BEAM WITH AN INTERNAL CONDUCTOR

The equations for the tubular beam with an inner conductor are obtained in a similar fashion. In this case, the value of c_1 for (4) becomes

$$c_1 = -\frac{e}{m} A_0 r_b^2 \tag{42}$$

and the electrons rotate in the opposite direction. Now all of the flux which lies within the radius r_b in the uniform field region must thread through the hole in the cathode. The same independence of \dot{z} with r is obtained and similar equations (with suitable interchanging of the roles played by r_a and r_b) are obtained.

TUBULAR BEAM WITH BOTH AN INTERNAL AND AN EXTERNAL CONDUCTOR

For some application, a tubular beam may be required for use with both an external and an internal conductor. The solution for this case can be obtained by fitting a solution for the external-conductor case to the solution for the internal-conductor case along a common radius for which the angular velocity is zero for both solutions. Electrons inside this radius will revolve in the opposite direction to those outside of it, but all must have the

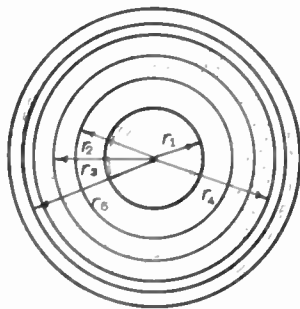

Fig. 6—A tubular beam with both inside and outside conductors.

same value for \dot{z} . Rewriting the equations in terms of the symbols shown on Fig. 6, we have

$$\phi_3 = \phi_4 - \frac{1}{2} \frac{e}{m} A_0^2 \frac{(r_4^2 - r_3^2)^2}{r_4^2} \tag{43}$$

and also

$$\phi_3 = \phi_2 - \frac{1}{2} \frac{e}{m} A_0^2 \frac{(r_3^2 - r_2^2)^2}{r_2^2} \tag{44}$$

so that

$$(\phi_4 - \phi_2) = \frac{1}{2} \frac{e}{m} A_0^2 \frac{(r_4^2 - r_2^2)(r_4^2 r_2^2 - r_3^4)}{r_4^2 r_2^2} \tag{45}$$

where the magnetic vector potential at the cathode must be given by

$$(A_\theta)_c = r_3 A_0. \tag{46}$$

For the most applications it would be convenient to have $\phi_4 = \phi_2$. Under these conditions, the relationship that must hold between the radii is

$$r_3 = \sqrt{r_2 r_4}. \tag{47}$$

However, in the most general case, any desired value of ϕ_4 and ϕ_2 may be used as long as (45) and (46) are satisfied. The values of ϕ_4 and ϕ_2 in terms of ϕ_6 and ϕ_1 are set by

$$\frac{\phi_6}{\phi_4} = 1 + 4 \frac{\phi_4 - \phi_3}{\phi_4} \left(\frac{r_4^2 + r_3^2}{r_4^2 - r_3^2} \right) \ln \frac{r_6}{r_4} \tag{48}$$

and

$$\frac{\phi_1}{\phi_2} = 1 + 4 \frac{\phi_2 - \phi_3}{\phi_2} \left(\frac{r_3^2 + r_2^2}{r_3^2 - r_2^2} \right) \ln \frac{r_2}{r_1}. \tag{49}$$

THE CASE IN WHICH θ NEVER GOES TO ZERO

In the interests of completeness, it should be pointed out that the case where θ is always of the same sign and does not go to zero can be obtained directly from the internal and external conductor case. If any portion of the beam for the case shown in Fig. 6 is removed and the potentials on the electrodes altered to provide the same potential at the newly created edge of the beam as existed there previously, then the remaining portion of the beam will be stable as before, and will require the same value of magnetic flux. It should be noted that distributions for the single-confining-electrode case are stable only if the value of θ is zero along the free edge of the beam (where $E_r = 0$).

MULTIVELOCITY BEAMS

We will now consider the conditions within a uniform beam having multiple-valued electron velocities. Such beams are employed in tubes of the so-called electron-wave type.

Consider the situation in which all of the electrons originate from two different cathodes which are at different potentials, but which are both in magnetic-field-free regions. To make the problem definite, we will restrict the discussion to a tubular beam with only an external conductor.

Two cases are to be distinguished, one in which the value of A_0 is the same for both cathodes and a more general case in which this is not so. In the first case, we

note that (12) to (22) inclusive still apply if ρ is now taken to be total charge density. We can assign the charge density ρ to the two beam components in any desired way even to the extent of assuming different radial distributions. However, the more reasonable case would be one in which the two components have the same radial distribution which we can symbolize by writing

$$\rho_\alpha = \alpha\rho \quad (50)$$

$$\rho_\beta = (1 - \alpha)\rho \quad (51)$$

where the subscripts α and β refer to the two components. Care must be taken to remember that the electron velocities may or may not be related to the values of ϕ depending upon the assumed cathode potentials. This difficulty arises in connection with (23). If we define potentials with respect to the cathode emitting the α designated electrons we may write

$$\dot{z}_\alpha = \left(2 \frac{e}{m} \phi_\alpha\right)^{1/2} \quad (52)$$

and if we call the potential of the second cathode ϕ_β ,

we also have

$$\dot{z}_\beta = \left[2 \frac{e}{m} (\phi_\alpha - \phi_\beta)\right]^{1/2} \quad (53)$$

The current density of the α beam is similarly

$$J_\alpha = 2\sqrt{2} \alpha \epsilon \left(\frac{e}{m}\right)^{3/2} A_0^2 \phi_\alpha^{1/2} \left[1 + \left(\frac{r_\alpha}{r}\right)^4\right] \quad (54)$$

while the current density of the β beam is

$$J_\beta = 2\sqrt{2}(1-\alpha) \left(\frac{e}{m}\right)^{3/2} A_0^2 (\phi_\alpha - \phi_\beta)^{1/2} \left[1 - \left(\frac{r_\alpha}{r}\right)^4\right] \quad (55)$$

If the two cathodes are not at the same value of A_0 useful solutions can still be obtained in which the inner radii of two beam components are not identical. If the inner radii are required to be the same, the beam conditions become somewhat more complicated. As this does not appear to be a useful arrangement, the solution will not be pursued.

One can conclude that multiple-valued velocity beams can be analyzed by our present methods and that such beams exhibit the same general properties.

Modes in Interdigital Magnetrons*

JOSEPH F. HULL† AND LEWIS W. GREENWALD‡

Summary—The increasing interest in pill-box-cavity interdigital magnetrons has led to the desirability of a set of design equations by which the resonant wavelengths and external Q's for the various modes of these magnetrons may be calculated. This paper presents these equations and their derivations, and shows how the results check the experimental observations.

SYMBOL DEFINITIONS

All symbols used in this paper and not listed here are standard in the mks system of units.

$$k_1 = 2\pi/\lambda$$

r_0 = radius of outer cylindrical wall of cavity

r_t = mean radius of tooth structure

α = number of teeth

Δr = radial tooth thickness

$\Delta\phi$ = angle between adjacent teeth

d = axial length of the cavity from one end surface to the other

C = total equivalent capacitance between adjacent teeth in the tooth structure per tooth

n = mode number, or the number of sinus-

oidal variations of the fields around the cavity

S = loop area

H_{ϕ_0} = magnetic-field intensity at the outer cylindrical wall (rms) (location of the loop)

V_l = induced loop voltage (rms)

L = loop inductance

I_l = loop current (rms)

Z_0 = characteristic impedance of output line

a = numerical coefficient which is equal to 2, when $n = 0$ and 1 when $n > 0$.

ϕ_l = angle between output loop and current maximum

M = fraction by which the radial component of magnetic flux is constricted as it threads through the tooth structure. M is equal to the ratio of the total area of the tooth structure between end surfaces at the mean tooth-structure radius to the total area of the apertures between teeth

ξ = factor by which the true capacitance between teeth is greater than the capacitance as calculated when fringing is neglected

G see description after equation (16)

$A, B,$ and D = field amplitude-determining constants which cancel out in resonant wavelength and external Q calculations.

* Decimal classification: R339.2. Original manuscript received by the Institute, May 10, 1948; revised manuscript received, April 13, 1949.

† Evans Signal Corps Engineering Laboratory, Belmar, N. J.
‡ Formerly, Evans Signal Corps Engineering Laboratory, Belmar, N. J., now deceased.

INTRODUCTION

INTERDIGITAL MAGNETRONS are not new. One of the earliest papers on interdigital magnetrons was by Gutton and Berline¹ and appeared in 1938. Benedict and others have developed a glass-enclosed, external-cavity, interdigital magnetron² which gives a peak pulse power output of 80 watts at 40 per cent efficiency. Crawford and Hare have developed an all-metal interdigital magnetron³ which gives a continuous-wave power output of 50 watts at about the same frequency and efficiency. Crawford and Hare present a resonant wavelength equation which is entirely empirical and is, therefore, restricted to interdigital magnetron structures which are not radically different from those which were discussed in their paper. It is the purpose of this paper to present a more general treatment of this problem by the use of Maxwell's field equations. Furthermore, this treatment enables one to calculate the fields within the cavity and thus to calculate the degree of coupling required for a desired value of external Q .

RESONANT WAVELENGTH CALCULATION

Fig. 1 is an interdigital magnetron cavity of the conventional type. For this discussion, it will be assumed

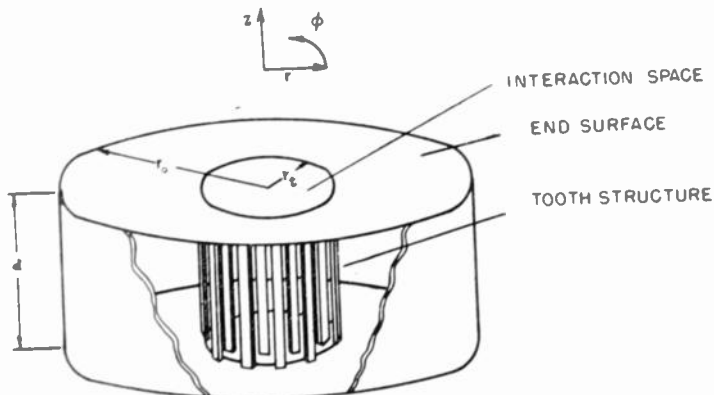

Fig. 1—Interdigital magnetron cavity.

that d and r_t are shorter than a half free-space resonant wavelength. It will also be assumed that the number of teeth α is much greater than the order of the mode n . It will also be assumed that the cathode is absent.

Briefly, the approach to the problem of the electromagnetic waves in this cavity is to solve Maxwell's equations in the toroidal region within the cavity, neglecting high-order modes which are beyond cutoff. The proper boundary conditions are applied at the end surfaces and outer cylindrical walls. At the tooth structure, the fields inside and outside the cavity are matched and the currents, induced by the magnetic field, which flow

into the tooth structure are equated to the product of the potential between adjacent teeth and the equivalent capacitive susceptance between teeth.

Solutions of Maxwell's equations in cylindrical co-ordinates assuming a propagation constant γ in the positive Z direction are well known.⁴ For transverse magnetic waves, the axial component of magnetic field is zero, and the following equations describe the fields in cylindrical cavities

$$E_z = RF(\phi)e^{(j\omega t - \gamma z)} \quad (1)$$

$$F(\phi) = D \cos(n\phi) \quad (2)$$

$$R = AJ_n(K_c r) + BN_n(K_c r) \quad (3)$$

$$E_r = -\frac{1}{K_c^2} \left(\gamma \frac{\partial E_z}{\partial r} \right) \quad (4)$$

$$E_\phi = -\frac{1}{K_c^2} \left(\frac{\gamma}{r} \frac{\partial E_z}{\partial \phi} \right) \quad (5)$$

$$H_r = \frac{1}{K_c^2} \left(\frac{j\omega\epsilon_1}{r} \frac{\partial E_z}{\partial \phi} \right) \quad (6)$$

$$H_\phi = -\frac{1}{K_c^2} \left(j\omega\epsilon_1 \frac{\partial E_z}{\partial r} \right) \quad (7)$$

where

$$K_c^2 = \gamma^2 + K_1^2 \quad \text{and} \quad K_1^2 = \omega^2 \mu_1 \epsilon_1.$$

If γ assumes any value other than 0 or $\pm \infty$ it may be seen from (4) through (7) that for a given sign of γ

$$E_r \propto H_\phi \quad (\text{for a given value of } n) \quad (8)$$

$$E_\phi \propto H_r \quad (\text{for a given value of } n). \quad (9)$$

At the end surfaces of Fig. 1, E_r and E_ϕ must be zero because these are conducting surfaces. In order that individual waves satisfy the conditions that $E_r = E_\phi = 0$ at the end surfaces when $\gamma \neq 0$, all the fields within the cavity must vanish. However, if for each value of n , waves of equal amplitude travel in opposite directions their E_r and E_ϕ components may cancel at these end surfaces, but, this would require that d be a half guide-wavelength. Since we are assuming that d is less than a half free-space wavelength, waves having values of γ other than 0 must exist within the cavity in a cutoff condition. It will be assumed that these waves existing beyond cutoff contribute to the equivalent capacitance of the tooth structure and redirect the main field components to conform to the shape of the tooth structure. By an argument similar to that used above, the transverse electric waves will be similarly considered.

When $\gamma = 0$, however, the boundary conditions of E_r and E_ϕ are automatically satisfied. Equations (8) and (9) are not valid when $\gamma = 0$ so H_r and H_ϕ are not neces-

¹ H. Gutton and S. Berline, "Research on the magnetrons: SFR ultra-short-wave magnetrons," *Bull. Soc. Franc. Elec.*, vol. 12, pp. 30-46; 1938.

² G. D. O'Neill, "Separate cavity tunable magnetrons," *Electronic Ind.*, vol. 5, pp. 48-50, 122-123; June, 1946.

³ F. H. Crawford and M. D. Hare, "Tunable squirrel-cage magnetron—the Donutron," *Proc. I.R.E.*, vol. 35, pp. 361-369; April, 1947.

⁴ S. Ramo and J. R. Whinnery, "Fields and Waves in Modern Radio," John Wiley and Sons, Inc., New York, N. Y., 1944; pp. 326, 327.

sarily 0. The assumption will be made that the fields within the cavity, for any given mode number n can be expressed by (1) through (7) with $\gamma = 0$ and $K_r = 2\pi/\lambda$. To satisfy the boundary conditions at the outer cylindrical wall, E_s will be set equal to 0 when $r = r_0$. This gives

$$E_s = AD \cos(n\phi) \left[J_n(K_1 r) - \frac{J_n(K_1 r_0)}{N_n(K_1 r_0)} N_n(K_1 r) \right] \quad (10)$$

$$H_\phi = -jAD \cos(n\phi) \sqrt{\frac{\epsilon_1}{\mu_1}} \left[J_{n-1}(K_1 r) - \frac{n}{K_1 r} J_n(K_1 r) - \frac{J_n(K_1 r_0)}{N_n(K_1 r_0)} \left(N_{n-1}(K_1 r) - \frac{n}{K_1 r} N_n(K_1 r) \right) \right] \quad (11)$$

$$H_r = -\frac{jn}{\omega\mu_1 r} AD \sin(n\phi) \left[J_n(K_1 r) - \frac{J_n(K_1 r_0)}{N_n(K_1 r_0)} N_n(K_1 r) \right]. \quad (12)$$

Before the boundary conditions at the tooth structure are applied, it will be instructive to observe the fields in a simple drum-shaped cavity with no tooth structure. It may be seen from (10) that the condition of resonance is that

$$J_n(K_1 r_0) = 0, \quad \text{or} \quad \lambda_{n,l} = \frac{2\pi r_0}{P_{n,l}}$$

where $P_{n,l}$ is the l th root of the n th order Bessel function. The magnetic-field distributions in the transverse magnetic modes in short cylindrical cavities are well known, since the magnetic-field distributions are the same as in circular waveguides operating in the transverse magnetic modes at cutoff. The TM_{01} , TM_{11} , TM_{21} , and TM_{02} are of most importance in this case. Now consider the addition of a tooth structure to this simple cavity. The fields will become distorted and the resonant wavelength will change. For example, the magnetic field lines in the TM_{11} mode will become like those of Fig. 2.

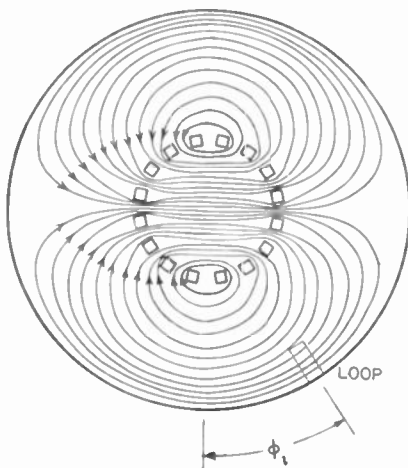

Fig. 2—Magnetic field lines in an interdigital magnetron cavity in $M=1$ mode.

Removal of the portion of the end surfaces that cover the interaction space completes the transformation from the simple cavity to the interdigital magnetron cavity.

Continuity of current at the tooth structure requires that the total current entering the tooth structure be equal to the product of the potential between adjacent teeth and the equivalent capacitive susceptance between those teeth. The charging current will be considered consist of two components: namely, a radial component—caused by the angular component of magnetic field—which flows from the end plate into the tooth structure, and another component caused by the radial component of magnetic field which threads through the tooth structure. Use will now be made of the relationship that for radio frequencies, the magnetic-field intensity at the surface of a plane perfect conductor is equal in magnitude, and is perpendicular to, the linear current density flowing on the conductor.⁵ Referring to Fig. 3, the radial component of current flowing from inside the cavity into the tooth structure per tooth due to H_ϕ is

$$I_{r/\text{tooth}} = \frac{2\pi r_t}{\alpha} H_\phi.$$

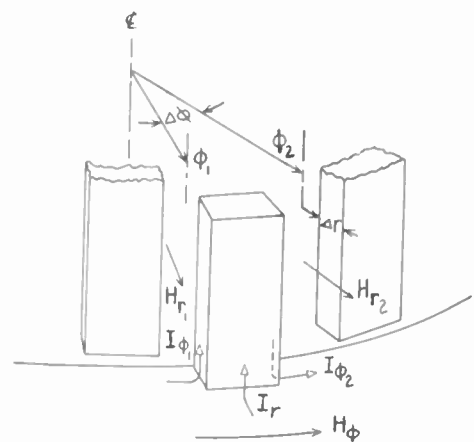

Fig. 3—Magnetic field and current components near the base of a tooth in an interdigital magnetron cavity.

The second component of charging current may be readily visualized in Fig. 3. Because the radial component of magnetic flux at the tooth structure must thread through the apertures between the teeth, currents must flow on adjacent edges of the teeth. This current at any angle ϕ_1 , is

$$I_{\phi_1} = \Delta r H_{r_1} M.$$

The current at the other side of a tooth at an angle $\phi_2 = \phi_1 + \Delta\phi$ is

$$I_{\phi_2} = \Delta r H_{r_2} M.$$

An expression will first be derived assuming that (a) the magnetic field in the interaction space is essentially radial at the inner surfaces of the tooth structure with no substantial net-current contribution. This corresponds to the assumption that the end surfaces do not

⁵ See p. 283 of footnote reference 4.

extend over the interaction space and that no currents flow on the outside surface of the cavity. Then a second expression will be shown on the assumption that (b) the end surfaces extend over the interaction space forming a definite boundary, and the effect of the fields within the interaction space will be taken into account. Since, in the practical tube, the end surfaces only partially cover the interaction space, the true result will lie between these two results. The practical result will be shown.

Under assumption (a) it may be seen from Fig. 3 that the total current entering the tooth structure per tooth is

$$I_{T/\text{tooth}} = I_r + I_{\phi_1} - I_{\phi_2} = \frac{2\pi r_t}{\alpha} H_\phi + M\Delta r(H_{r_1} - H_{r_2})$$

$$= \frac{2\pi r_t}{\alpha} H_\phi - M\Delta r \frac{\partial H_r}{\partial \phi} \Delta \phi.$$

But

$$\Delta \phi = \frac{2\pi r_t}{\alpha}$$

Therefore

$$I_{T/\text{tooth}} = \frac{2\pi r_t}{\alpha} \left[H_\phi - M\Delta r \frac{\partial H_r}{\partial \phi} \right]. \quad (13)$$

If V is the potential between teeth and $j\omega C$ is the admittance between teeth, the charging current per tooth is also given by

$$I_{T/\text{tooth}} = j\omega CV. \quad (14)$$

The voltage between adjacent teeth will be assumed to be equal to the line integral of the electric field from one end plate to the other at that point. Therefore

$$V = E_r d. \quad (15)$$

Combining (13), (14), and (15) and substituting the appropriate values of E_r , H_ϕ , and $\partial H_r/\partial \phi$ from (10), (11), and (12) one obtains the following expression for resonant wavelength

$$(n\lambda)^2 = \frac{2\pi\alpha Cd}{\epsilon_1 \left(\frac{M\Delta r}{r_t} + \frac{G}{n} \right)} \left[1 + \frac{\lambda r_t \epsilon_1}{\alpha Cd} \frac{J_{n-1}(K_1 r_t) - \frac{J_n(K_1 r_0)}{N_n(K_1 r_0)} N_{n-1}(K_1 r_t)}{J_n(K_1 r_t) - \frac{J_n(K_1 r_0)}{N_n(K_1 r_0)} N_n(K_1 r_t)} \right]. \quad (16)$$

G is equal to 1 when it is assumed that the interaction space is completely open at the ends and no currents flow on the outer surfaces of the cavity. When it is assumed that the ends of the interaction space are closed by an extension of the end surfaces, G becomes

$$\frac{K_1 r_t}{n} \frac{J_{n-1}(K_1 r_t)}{J_n(K_1 r_t)}$$

which to a good approximation equals 2 when $K_1 r_t$ is less than 1. When the ends of the interaction space are

partially closed such as by hollow pole pieces, etc., G lies between 1 and 2. A practical value of G has been found to be 1.5.

For the cavity mode, ($n=0$), (16) reduces to

$$\frac{\lambda}{2\pi r_t} \left(\frac{2\pi r_t^2 \epsilon_1}{\alpha Cd} \right) = \frac{J_0(K_1 r_t) - \frac{J_0(K_1 r_0)}{N_0(K_1 r_0)} N_0(K_1 r_t)}{J_1(K_1 r_t) - \frac{J_0(K_1 r_0)}{N_0(K_1 r_0)} N_1(K_1 r_t)}. \quad (17)$$

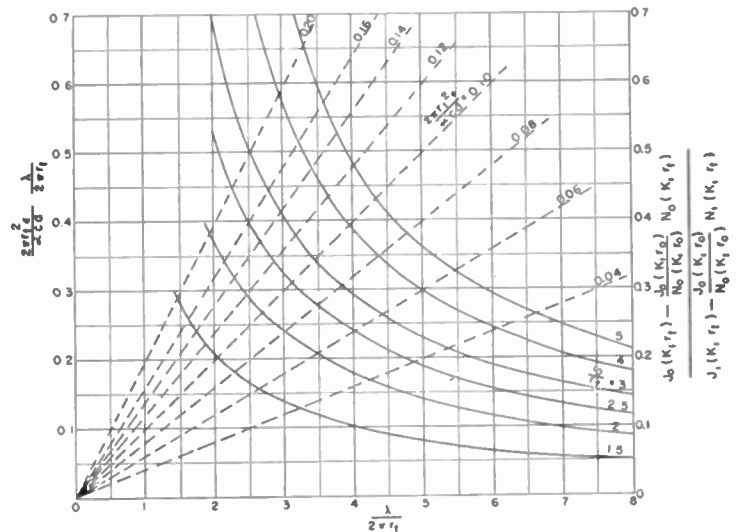

Fig. 4—Graphical solution of equation (17).

Although (17) is transcendental, it may be readily solved over a very wide range of parameters by means of Fig. 4. Equation (16) is also transcendental, but because of the form in which it is presented, it may be solved very accurately without any cut and try procedures. Since the term containing the Bessel functions in (16) is small compared to 1 for a very wide range of parameters, it may be considered only as a correction term. Therefore, λ can be calculated, neglecting the correction term and will be within 5 per cent of the correct value. This approximate value of λ is then substituted into the correction term and λ is then recalculated taking this term

into account. This yields a solution accurate to 0.1 per cent. It is interesting to note that when the correction term in (16) is neglected and straightforward approximations are made in expressing the parameters in terms of the tooth-structure dimensions, the following expression is obtained

$$n\lambda = \frac{\alpha d + 2\pi r_t}{\sqrt{1 + \frac{1.5 r_t}{M n \Delta r}}} \xi. \quad (16a)$$

This equation assumes that the gap between teeth is equal to the distance from the end of a tooth to the opposite end plate. ξ is the factor by which the true capacitance between teeth is greater than the capacitance as calculated when fringing is neglected. Since the quantity in the denominator of (16a) is found to be about 2 for most interdigital magnetrons, it is not surprising that the empirical formula

$$\lambda = \frac{\alpha d + 2\pi r_t}{2}$$

observed by Crawford and Hare³ for the first-order mode should check so many experimental tubes. It must be remembered, however, that the term in the denominator of (16a) is not independent of the tooth-structure parameters. Therefore, considering it constant is completely in error as borne out by fact that the Crawford and Hare formula gives a wrong prediction of direction of tuning of the donutron in the first-order mode.³

EXTERNAL Q CALCULATION

The external Q of a cavity is defined as follows:

$$\text{External } Q \equiv Q_x = \omega \frac{\text{Energy stored in cavity}}{\text{Power output}} \quad (18)$$

For the sake of simplicity it will be assumed that the power is coupled out by means of a loop.

The total loop voltage is equal to the difference between the voltage induced by the changing flux through it, and the product of loop current and the loop impedance. Taking H as the reference vector, the rms loop

$$V_T = adA^2D^2 \left\{ \pi\epsilon_1 \int_{r_t}^{r_0} r \left[J_n(K_1 r) - \frac{J_n(K_1 r_0)}{N_n(K_1 r_0)} N_n(K_1 r) \right]^2 dr + \frac{d\alpha C}{2} \left[J_n(K_1 r_t) - \frac{J_n(K_1 r_0)}{N_n(K_1 r_0)} N_n(K_1 r_t) \right]^2 \right\} \quad (20)$$

voltage is given by

$$V_t = S\mu_1 \left| \frac{\partial H_{\phi_0}}{\partial t} \right| - j\omega I_t L.$$

But

$$I_t = \frac{V_t}{Z_0} \quad \text{and} \quad \left| \frac{\partial H_{\phi_0}}{\partial t} \right| = \omega |H_{\phi_0}|.$$

Therefore

$$|V_t|^2 = \frac{S^2 \mu_1^2 \omega^2 |H_{\phi_0}|^2}{1 + \frac{\omega^2 L^2}{Z_0^2}}.$$

The power delivered to the output line is

$$P_o = \frac{|V_t|^2}{Z_0} = \frac{S^2 \mu_1^2 \omega^2 |H_{\phi_0}|^2}{Z_0 + \frac{\omega^2 L^2}{Z_0}} \quad (19)$$

The energy stored in the cavity must now be calculated. Since the electric field is 90° out of phase with the magnetic field as seen from (10) and (11), it follows that if the stored energy in the electric field is calculated at the instant of time when it is maximum, that energy will be the total stored energy of the cavity.

If E_z is the rms electric field, the peak electric-field energy stored per radian in the cavity at an angle ϕ is

$$U_{E/\text{radian}} = \epsilon_1 d \int_{r_t}^{r_0} r E_z^2 dr.$$

The peak electric-field energy stored in the tooth structure per radian is

$$U_{t/\text{radian}} = C(E_z)_t^2 d^2 \frac{\alpha}{2\pi}.$$

Integrating the sum of these two functions around the cavity the following expression for the total stored energy in the cavity is obtained

$a = 2$ when $n = 0$ and $a = 1$ when $n > 0$.

The term containing the integral may be simplified to the following expression without introducing appreciable error in the final result

$$\pi\epsilon_1 \left\{ r_t \left[J_n(K_1 r_t) - \frac{J_n(K_1 r_0)}{N_n(K_1 r_0)} N_n(K_1 r_t) \right]^2 \frac{(r_0 - r_t)}{2} \right\}.$$

Substituting this expression into (20) and combining equations (18), (19), and (20) the following expression is obtained for external Q :

$$Q_x = \frac{\omega ad \left[Z_0 + \frac{\omega^2 L^2}{Z_0} \right] \left[\pi\epsilon_1 r_t (r_0 - r_t) + d\alpha C \right] \left[J_n(K_1 r_t) - \frac{J_n(K_1 r_0)}{N_n(K_1 r_0)} N_n(K_1 r_t) \right]^2}{2S^2 K_1^2 \cos^2(n\phi_t) \left[J_{n-1}(K_1 r_0) - \frac{J_n(K_1 r_0)}{N_n(K_1 r_0)} N_{n-1}(K_1 r_0) \right]^2} \quad (21)$$

TABLE I

EXPERIMENTAL RESULTS. FOR CAVITIES 1, 2, AND 3: $\Delta r = 0.08$ CM, $r_i = 0.56$ CM, $\alpha C = 2.34 \mu\mu\text{f}$, $d = 0.76$ CM, $M = 1.9$, $L = 0.282 \times 10^{-8}$ HY. FOR CAVITIES 4, 5, AND 6: $\Delta r = 0.1$ CM, $r_i = 0.576$ CM, $\alpha C = 3.72 \mu\mu\text{f}$, $d = 0.47$ CM, $M = 2.30$, $L = 0.174 \times 10^{-8}$ HY. $Z_0 = 52$ OHMS FOR ALL CAVITIES. G WAS ASSUMED TO BE 1.5. THE ENDS OF THE INTERACTION SPACE WERE OPEN FOR ALL READINGS

Cavity Parameters			$n=0$ Cavity mode				$n=1$			
Cavity No.	r_0	S	λ_{calc}	λ_{meas}	$Q_x \text{ calc}$	$Q_x \text{ meas}$	λ_{calc}	λ_{meas}	$Q_x \text{ calc}$	$Q_x \text{ meas}$
1	1.91 cm	0.295 cm ²	12.9	12.96	101	104.5	8.3	8.34	164	157
2	2.54	0.290	14.7	14.80	211	238	8.67	8.77	360	345
3	3.18	0.295	16.0	16.02	370	400	8.93	9.10	580	485
4	1.91	0.182	12.8	12.55	121	116	7.96	8.30	138	115
5	2.54	0.179	14.6	14.40	302	320	8.31	8.74	402	300
6	3.18	0.182	15.9	15.91	485	503	8.56	9.03	620	440

ϕ_i is the angle between the current maximum and the loop (Fig. 2). Ordinarily ϕ_i will be either 0 or $\pi/2$ corresponding to the black and red mode respectively in the paper by Crawford and Hare. With mode favoring or suppressing devices, however, the angle ϕ_i is arbitrarily fixed.

EXPERIMENTAL RESULTS

Considerable data has been taken which substantiates (16), (17), and (21), some of which appears in a previous paper.⁶ More than 40 resonant wavelength and external Q measurements have been made on 12 different interdigital magnetron cavities in the cavity and first-order mode with the ends of the interaction space open and closed. The parameters r_i , r_0 , αC , d , S , and M for these cavities varied by a factor of 2 to 1 or more.

The results on 6 typical cavities appear in Table I. The discrepancies between measured and calculated values are seen to be relatively small except for the Q values when $n=1$ and the cavity length d is small. Care was taken in measuring the Q values to eliminate errors. For example, the output line was uniform and there was no glass in the output line. The errors in the Q values when $n=1$ are attributed to effectively larger loop area due to the opening in the coaxial output line where the loop joins the inner conductor. It can be shown that this should affect the $n=1$ mode more than the cavity mode ($n=0$), and should be much more pronounced when the cavity length is small, since the dimensions of the coaxial line remained the same.

In order to eliminate errors in calculations of tooth capacitance, this quantity was measured on a bridge to an accuracy of within 2 per cent. Because of special con-

struction loop inductances could be determined to an accuracy of within 4 per cent by flux-plotting techniques.

CONCLUSIONS

From (16), (17) and (21) the resonant wavelengths and external Q 's of interdigital magnetrons of pill-box cavity type may be calculated for various order modes.

Although a certain amount of indeterminateness exists in the resonant wavelength calculations when n is greater than 0 because of the open ends of the interaction space, the practical value of the constant G which is determined by this boundary has been determined for typical cavities. The theoretical value of G when the interaction space ends are closed has been verified experimentally.

It may be noted from Table I that the external Q for $n=0$ and $n=1$ are of the same order of magnitude. If the loop reactance is small compared to the output line impedance, the external Q 's of the $n=0$ and $n=1$ mode differ by a very small percentage.

It is to be pointed out that the assumptions in the derivation of these equations did not take into account currents flowing outside of the cavity due to cathode coupling.⁶ If the impedance presented to the tooth structure by the cathode is infinite, no correction for this effect is necessary. If this impedance is finite, it may be taken into account by means of the equivalent cathode circuit theory presented in the previous paper.⁶

Correction of the resonant wavelength equation for distortion of the fields within the interaction space by the cathode has been neglected because the effect is small. Typical resonant frequency changes due to insertion of the cathode are 3 per cent, being a frequency decrease for the cavity mode, and a frequency increase when $n > 0$.

⁶ J. F. Hull and A. W. Randals, "High-power interdigital magnetrons," Proc. I.R.E., vol. 36, pp. 1357-1363; November, 1948.



The Solution of Steady-State Problems in FM*

BERNARD GOLD†, MEMBER, IRE

Summary—If a physical network is approximated by a polynomial, the output wave may be expressed in terms of the derivatives of the input wave. This fact may be used to advantage in the solution of steady-state problems in FM, when the sideband method is impractical and the quasi-steady-state method invalid.

If the range of approximation of the network function coincides with the nonnegligible part of the spectrum of the input wave, and if an orthogonal polynomial is chosen as the approximating function, then a practical method of solving steady-state FM problems can be established. In this paper, such a method is established, the various problems related to its validity are investigated, and examples of the method are demonstrated.

I. INTRODUCTION

THE TWO WELL-KNOWN methods of dealing with steady-state FM problems are:

1. The sideband method whereby the FM wave is expressed as a Bessel function summation.
2. The quasi-steady-state (or instantaneous frequency) method, which assumes that the impedance of the network changes instantaneously with the frequency.

The sideband method is rigorous, and if the modulation index is not large, practical. For large modulation index, however, the number of sidebands become so large that the labor involved in computing a result is prohibitive.

The quasi-steady-state method allows for much simpler computation, but leaves unanswered questions concerning its validity.

Carson,¹ has expressed the total response as an infinite series, the first term of which is the quasi-steady-state response. He has also obtained an approximate result involving the quasi-steady-state result plus one correction term. Gladwin,² van der Pol,³ Jaffe,⁴ and others have made use of, or slightly extended this result. Franz⁵, by treating the network function as a Fourier series, has obtained a general result and has also estab-

lished a validity condition for which the quasi-steady-state method holds.

In his paper, Franz gives the reason for choosing, as an approximation to the network function, a Fourier series.

"The power and real exponential series were avoided because such series increase without bounds outside the chosen interval as the argument becomes large . . . the products of the side frequencies and the value of the series outside the interval of approximation might not be negligible in comparison with the products of the side frequencies and the series approximation within the interval."

It will be shown later that if the network function is approximated by a polynomial over a given range, then for all practical values of the parameters, the product of the polynomial and the sidebands outside the range of approximation is still negligible. Assuming that this is true, then the method to be described makes possible a general formulation of the problems, that is, the solution obtained applies to any type of modulating signal.

The sideband method affords a practical solution only when the number of sidebands is small. The quasi-steady-state methods affords a solution when the audio frequency is low, or the deviation is low. Furthermore, no simple criterion exists for the determination of the validity of this procedure.

Thus, a gap exists. It is proposed to help fill this gap by a method involving a polynomial representation of a physical network.

II. POLYNOMIAL METHOD OF SOLUTION

The admittance of a given network may always be expressed as the sum of its real and imaginary components. If, in addition, as is true in many cases,⁶ the real part is an even function of frequency and the imaginary part an odd function, then the former may be expressed as an even polynomial and the latter as an odd polynomial. Thus

$$Y(Z) = \sum_{n=0}^N a_{2n} Z^{2n} + i \sum_{n=0}^N a_{2n+1} Z^{2n+1}. \quad (1)$$

Now, the current output may always be written as an inverse Fourier transform.⁷ Thus

$$i(t) = \frac{1}{2\pi} \int_{-\infty}^{\infty} V(Z) Y(Z) e^{iZt} dZ$$

where

$$V(Z) = \int_{-\infty}^{\infty} v(t) e^{-iZt} dt. \quad (2)$$

* The solution will be carried through for these cases. However, the problem is not more complicated if no such assumption is made.
⁷ N. F. Gardner and J. L. Barnes, "Transients in Linear Systems," John Wiley and Sons, Inc., New York, N. Y., vol. I, p. 99.

* Decimal classification: R148.2×510. Original manuscript received by the Institute, December 6, 1948; revised manuscript received, March 31, 1949. The work described in this paper was accomplished at the Microwave Research Institute of the Polytechnic Institute of Brooklyn, under the auspices of the Office of Naval Research.

† Avion Instrument Corp., New York, N. Y.

¹ J. R. Carson and T. C. Fry, "Variable frequency electric circuit theory with application to the theory of frequency modulation," *Bell. Sys. Tech. Jour.*, vol. 26, pp. 513-541; October, 1937.

² A. S. Gladwin, "The distortion of frequency-modulated waves by transmission networks," *Proc. I.R.E.*, vol. 35, pp. 1436-1445; December, 1947.

³ B. van der Pol, "The fundamental principles of frequency modulation," *Jour. IEE (London)*, p. III, vol. 93, pp. 153-159; May, 1946.

⁴ D. L. Jaffe, "A theoretical and experimental investigation of tuned circuit distortion in frequency-modulation systems," *Proc. I.R.E.*, vol. 33, pp. 318-334; May, 1945.

⁵ W. J. Frantz, "The transmission of a frequency-modulated wave through a network," *Proc. I.R.E.*, vol. 34, pp. 114-125; March, 1946.

If, in addition, the spectrum of the input wave lies within a finite band, say $\pm \omega_c$, then in accordance with (1) and (2)

$$i(t) = \frac{1}{2\pi} \sum_{n=0}^N a_{2n} \int_{-\omega_c}^{\omega_c} V(Z) e^{izt} Z^{2n} dZ + i \sum_{n=0}^N a_{2n} \int_{-\omega_c}^{\omega_c} V(Z) e^{izt} Z^{2n+1} dZ. \quad (3)$$

Also, since

$$v(t) = \frac{1}{2\pi} \int_{-\omega_c}^{\omega_c} V(Z) e^{izt} dZ \quad (4)$$

then

$$\frac{dv(t)}{dt} = \frac{i}{2\pi} \int_{-\omega_c}^{\omega_c} V(Z) e^{izt} Z dZ \quad (5)$$

$$\frac{d^n v(t)}{dt^n} = \frac{(i)^n}{2\pi} \int_{-\omega_c}^{\omega_c} V(Z) e^{izt} Z^n dZ. \quad (6)$$

It is thus seen that the output, as given by (3), can be expressed in terms of the derivatives of the input wave. In fact, the output may immediately be written as follows

$$i(t) = a_0 v^{(0)} + a_1 v^{(1)} - a_2 v^{(2)} - a_3 v^{(3)} + a_4 v^{(4)} + a_5 v^{(5)} - \dots \quad (7)$$

where

$$v^{(n)} = \frac{d^n v}{dt^n}.$$

Equation (7) is the final formulation of the general problem. What must now be done is to:

1. Set up a convenient system of obtaining the best polynomial approximation to a given network.
2. Investigate the possible restrictions to its validity and determine the boundaries of practicality of this method with relation to the sideband and quasi-steady-state method.
3. Apply the procedure to a given network. A singly tuned circuit will be used to demonstrate the method. It should be pointed out, however, that once the constants of the polynomial are obtained, then the result has the same form for any network. This is apparent from (7) where it is seen that $i(t)$ is a function only of the polynomial constants and the input signal.

III. TECHNIQUE OF POLYNOMIAL APPROXIMATION

A real network function is completely defined by specification of its real and imaginary components. Furthermore, an approximation of these may be obtained to within any degree of accuracy desired. This approximation has been formulated by (1) and consists of a polynomial representation.

The following must be defined.

1. On what basis may the degree of the polynomial be determined?

2. How may the constants of the polynomial be determined in the simplest manner and to give the most accurate approximation?

To answer these questions, it is necessary to investigate the spectrum, or sideband distribution. First, it is convenient to introduce a few definitions.

- B = modulation index
 - p = audio frequency
 - D = deviation
 - α = bandwidth of network (3 db point)
 - n = number of significant sidebands.
- The following identities hold:
- $w = D/\alpha$
 - $D = pB$
 - $l = np/\alpha$.

The parameter l , which is the ratio of the width of the sideband spectrum to the defined bandwidth of the network, is the sole factor in determining the degree of the polynomial required (except for the shape of the particular network function), for it defines precisely the range over which the representation is to be valid. From the above definitions,

$$l = \frac{nw}{B} \quad \text{or} \quad \frac{l}{w} = \frac{n}{B}. \quad (8)$$

Since n is dependent entirely on B , it is possible to tabulate l/w as a function of B only. This is done in Table I, for a few values of B .

TABLE I

B	l/w
0.2	15
1.0	4
2.0	3
3.0	2.33
5.0	2
10.0	1.7
15.0	1.6
25.0	1.4

Table I is based on known tables of Bessel functions. For instance, for $B = 1$, 4 significant side frequencies appear; thus $n = 4$ and $l/w = n/B = 4$.

Thus, it is necessary to specify only w and B in order to carry through the problem.

Now the question of the determination of the polynomial constants should be investigated.

1. The most practical means of calculating the polynomial constants is on the basis of the least square approximation. This method insures that the magnitude of the area between the actual and approximating curves is a minimum. Stated mathematically, if $f(x)$ represents the actual function and $S(x)$ the approximation, then

$$\int_{-l}^l [f(x) - S(x)]^2 dx \quad \text{is a minimum.} \quad (9)$$

2. If an orthogonal set of functions is chosen as the approximate representation, then this automatically in-

tures that the least square approximation holds true. By an orthogonal set is meant the following. Let

$$S(x) = \sum_{r=1}^n a_r \Phi_r(x). \tag{10}$$

Then, if

$$\int_{-c}^c \Phi_r(x) \Phi_s(x) dx = \begin{cases} 0 & \text{for } r \neq s \\ 1 & \text{for } r = s \end{cases} \tag{11}$$

$S(x)$ is the development of the orthogonal set Φ_r .

3. There are many sets of functions which satisfy orthogonality conditions. Probably the most well known is the ordinary Fourier series. For our purposes, the Legendre polynomial is the most adequate. It is denoted by $P_r(x)$ and has the following property:

$$S(x) = \sum_{r=1}^n C_r P_r\left(\frac{x}{l}\right) \text{ with } C_r = \frac{r + \frac{1}{2}}{l} \int_{-l}^l f(x) P_r\left(\frac{x}{l}\right) dx. \tag{12}$$

The Legendre polynomials may be found in standard texts.

4. The great advantage of using an orthogonal polynomial can be summarized in two statements.

(a) There is no need to solve ponderous simultaneous equations.

(b) The values of the constants c_r are not interdependent. Thus, in order to make the representation more accurate, there is no necessity to retrace the previous steps. Each succeeding term makes the entire polynomial more accurate.

IV. GENERAL FORMULA FOR SINUSOIDAL MODULATION

The current response $i(t)$ will now be formulated for the case of pure sinusoidal modulation. The input voltage $v(t)$ is given by

$$v(t) = e^{iB \sin pt}. \tag{13}$$

It may now be noted that the polynomial expansion of $Y(Z)$ (as given by (1)) could have been made with respect to the ratio of frequency to bandwidth instead of with respect to frequency. That is, in (1), let $a_n = b_n/\alpha^n$.

Then, (1) becomes

$$Y(Z) = \sum_{n=0}^N \frac{b_{2n} Z^{2n}}{\alpha^{2n}} + i \sum_{n=0}^N \frac{b_{2n+1} Z^{2n+1}}{\alpha^{2n+1}}. \tag{14}$$

If this last formulation is used instead of (1), then the following replaces (7).

$$i(t) = b_0 v^{(0)} + \frac{b_1 v^{(1)}}{\alpha} - \frac{b_2 v^{(2)}}{\alpha^2} - \frac{b_3 v^{(3)}}{\alpha^3} + \dots \tag{15}$$

This last formulation is more convenient to use.

In the Appendix are tabulated the first 9 derivatives of $v(t)$. Using this and (15), the final result may be

written as follows:

$$i(t) = R + iX e^{iB \sin pt} \tag{16}$$

$$R = A_0 + A_2 \cos 2pt - B_2 \sin 2pt + A_4 \cos 4pt - B_4 \sin 4pt + A_6 \cos 6pt - B_6 \sin 6pt$$

$$X = A_1 \cos pt + B_1 \sin pt + A_3 \cos 3pt + B_3 \sin 3pt + A_5 \cos 5pt + B_5 \sin 5pt + A_7 \cos 7pt$$

$$A_0 = b_0 + \frac{b_2 w^2}{2} + b_4 w^4 \left(\frac{3}{8} + \frac{1}{2B^2} \right) + b_6 w^6 \left(\frac{5}{16} + \frac{15}{8B^2} + \frac{1}{2B^4} \right) + b_8 w^8 \left(\frac{35}{128} + \frac{35}{8B^2} + \frac{63}{8B^4} + \frac{1}{2B^6} \right)$$

$$A_2 = \frac{b_2 w^2}{2} + b_4 w^4 \left(\frac{1}{2} + \frac{1}{2B^2} \right) + b_6 w^6 \left(\frac{15}{32} + \frac{10}{B^2} + \frac{31}{2B^4} \right) + b_8 w^8 \left(\frac{7}{16} + \frac{315}{16B^2} + \frac{231}{2B^4} + \frac{127}{2B^6} \right)$$

$$A_4 = \frac{b_4 w^4}{8} + b_6 w^6 \left(\frac{3}{16} + \frac{65}{8B^2} \right) + b_8 w^8 \left(\frac{7}{32} + \frac{189}{8B^2} + \frac{1701}{8B^4} \right)$$

$$A_6 = \frac{b_6 w^6}{32} + b_8 w^8 \left(\frac{1}{16} + \frac{133}{16B^2} \right) \quad A_8 = \frac{b_8 w^8}{128}$$

$$B_2 = \frac{3b_3 w^3}{2B} + b_5 w^5 \left(\frac{5}{2B} + \frac{15}{2B^3} \right) + b_7 w^7 \left(\frac{105}{32B} + \frac{35}{B^3} + \frac{63}{2B^5} \right) + b_9 w^9 \left(\frac{63}{16B} + \frac{1575}{16B^3} + \frac{735}{2B^5} + \frac{255}{2B^7} \right)$$

$$B_4 = \frac{5b_5 w^5}{4B} + b_7 w^7 \left(\frac{21}{8B} + \frac{175}{4B^3} \right) + b_9 w^9 \left(\frac{63}{16B} + \frac{693}{4B^3} + \frac{3885}{4B^5} \right)$$

$$B_6 = \frac{21b_7 w^7}{32B} + b_9 w^9 \left(\frac{27}{16B} + \frac{1323}{16B^3} \right) \quad B_8 = \frac{9}{32B} b_9 w^9$$

$$A_1 = b_1 w + b_3 w^3 \left(\frac{3}{4} + \frac{1}{B^2} \right) + b_5 w^5 \left(\frac{5}{8} + \frac{15}{4B^2} + \frac{1}{B^4} \right)$$

$$+ b_7 w^7 \left(\frac{35}{64} + \frac{35}{4B^2} + \frac{63}{4B^4} + \frac{1}{B^6} \right)$$

$$+ b_9 w^9 \left(\frac{63}{128} + \frac{525}{32B^2} + \frac{735}{8B^4} + \frac{255}{4B^6} + \frac{1}{B^8} \right)$$

$$A_3 = \frac{b_3 w^3}{4} + b_5 w^5 \left(\frac{5}{16} + \frac{25}{4B^2} \right) + b_7 w^7 \left(\frac{21}{64} + \frac{35}{2B^2} + \frac{301}{4B^4} \right)$$

$$+ b_9 w^9 \left(\frac{21}{64} + \frac{1071}{32B^2} + \frac{7035}{16B^4} + \frac{3025}{4B^6} \right)$$

$$A_5 = \frac{b_5 w^5}{16} + b_7 w^7 \left(\frac{7}{64} + \frac{35}{4B^2} \right) + b_9 w^9 \left(\frac{9}{64} + \frac{861}{32B^2} + \frac{6951}{16B^4} \right)$$

$$A_7 = \frac{b_7 w^7}{64} + b_9 w^9 \left(\frac{9}{256} + \frac{231}{32B^2} \right) \quad A_9 = \frac{b_9 w^9}{256}$$

$$B_1 = \frac{b_2 w^2}{B} + b_4 w^4 \left(\frac{3}{2B} + \frac{1}{B^3} \right) + b_6 w^6 \left(\frac{15}{8B} + \frac{15}{2B^3} + \frac{1}{B^5} \right)$$

$$+ b_8 w^8 \left(\frac{35}{16B} + \frac{105}{2B^3} + \frac{1}{B^5} \right)$$

$$B_3 = \frac{3}{2} \frac{b_4 w^4}{B} + b_6 w^6 \left(\frac{45}{16B} + \frac{45}{2B^3} \right) + b_8 w^8 \left(\frac{63}{16B} + \frac{735}{8B^3} + \frac{483}{2B^5} \right)$$

$$B_5 = \frac{15b_6 w^6}{16B} + b_8 w^8 \left(\frac{35}{16B} + \frac{525}{8B^3} \right) \quad B_7 = b_8 w^8 \left(\frac{7}{16B} \right).$$

It should be noted that the number of harmonics contained in R and X is equal to the degree of the polynomial, whereas, in the sideband method, the number of harmonics is equal to the number of side bands.

V. INVESTIGATION OF ACCURACY AND VALIDITY

Two questions must be asked in this respect.

1. Does the known error in the polynomial approximation serve as a good indication of the error in the output?

2. Under what conditions is the contribution outside the range of approximation negligible, and non-negligible?

The first question is answered on the basis of linearity considerations. It follows immediately from an examination of the inverse Fourier transform that there is a linear relationship between the error in the polynomial and the error in the output.

In order to answer the second question, it is necessary to investigate the behavior of the products of sidebands and the polynomial outside the region of approximation. It is desired, therefore, to obtain an expression for Bessel functions which is valid for values of the order slightly greater than the argument and remains valid as the order is increased and the argument remains constant. Such an expansion is given in Watson⁸ for a Bessel function of order n .

$$J_n(n \operatorname{sech} a) \sim \frac{e^{n(\tanh a - a)}}{\sqrt{2\pi n \tanh a}} \left[1 + \frac{1}{8} - \frac{5}{24} \coth^2 a + \dots \right]. \quad (17)$$

Making the substitution $B = n \operatorname{sech} a$

$$J_{B \cosh a}(B) \sim \frac{e^{B(\sinh a - a \cosh a)}}{\sqrt{2\pi B \sinh a}} \left[1 + \frac{1}{8} - \frac{5}{24} \coth^2 a + \dots \right]. \quad (18)$$

Keeping B constant and varying a is equivalent to keeping the modulation index constant and varying the order of the Bessel function. It is to be noted, also, that the above expansion is not valid for very small values of a , since $\coth a$ becomes very large. However, we are interested in investigating the rapidity of convergence for values of $\cosh a$ of the order of 15 and greater. In that range, the expansion (18) can be represented quite accurately by the first term, becoming more accurate as a is increased.

⁸ G. N. Watson, "Bessel Functions," Cambridge University Press, 1944.

If two values of a are chosen, with $a_2 > a_1$, and the ratios of the corresponding Bessel functions taken, this is

$$\frac{J_{B \cosh a_2}(B)}{J_{B \cosh a_1}(B)} = e^{B(\sinh a_2 - a_2 \cosh a_2 - \sinh a_1 + a_1 \cosh a_1)} \times \sqrt{(\sinh a_1)/(\sinh a_2)}. \quad (19)$$

The expression within the brackets in the exponential is always negative over the range of validity of the expansion, and becomes more negative as the ratio of a_2 to a_1 increases. Thus, the ratio of the Bessel functions, denoted by r_1 , may be written

$$r_1 = e^{-tB} \sqrt{(\sinh a_1)/(\sinh a_2)}. \quad (20)$$

Now the ratio of an n th degree polynomial for two values of the frequency corresponding to a_1 and a_2 , is given by (if only the n th term of the polynomial is considered)

$$r_2 = \left(\frac{pB \cosh a_2}{pB \cosh a_1} \right)^n = \left(\frac{\cosh a_2}{\cosh a_1} \right)^n. \quad (21)$$

Thus

$$r = r_1 r_2 = e^{-tB} \left(\frac{\cosh a_2}{\cosh a_1} \right)^n \left(\frac{\sinh a_1}{\sinh a_2} \right)^{1/2}. \quad (22)$$

To obtain quantitative ideas as to the value of r , let us investigate t more closely. Therefore

$$t = -a_2 \cosh a_2 \left[\frac{\tanh a_2}{a_2} - 1 \right] + a_1 \cosh a_1 \left[\frac{\tanh a_1}{a_1} - 1 \right]. \quad (23)$$

As a_2 becomes larger, the value of $\tanh a_2/a_2$ becomes smaller compared with 1, and, if a_1 is kept constant

$$t = a_2 \cosh a_2 + a_1 \cosh a_1 \left[\frac{\tanh a_1}{a_1} - 1 \right]. \quad (24)$$

On the basis of (22), it follows that r goes to zero as a_2 increases, or, as the order of the Bessel function increases. This fact removes doubt as to the over-all validity and leaves open only the question of possible errors. For very small values of B_1 , the sideband method is preferable to the polynomial method. Thus, we may arbitrarily set up a boundary of practicality of the latter method. Let us choose $B = 7$ as this boundary. Furthermore, since it has been shown that the contribution far outside the range of approximation must be negligible, we need only investigate the comparative magnitudes of two sidebands relatively close to each other and close to the range of approximation. For instance, for $a_2 = 2.5$ and $a_1 = 1.5$, r becomes (for a 10th order polynomial) approximately equal to e^{-46} , which is surely negligible. Other numerical examples bear out the first one, namely, that for $B = 7$, the contribution outside the range of approximation may be ignored. Further, when it is

realized that just outside the region of approximation the polynomial representation is still not too inaccurate, it is safe to ignore the possible errors.

VI. REMARKS

Figs. 1 and 2 give the results of calculations applied to singly-tuned circuits and a comparison of the results obtained by various methods.

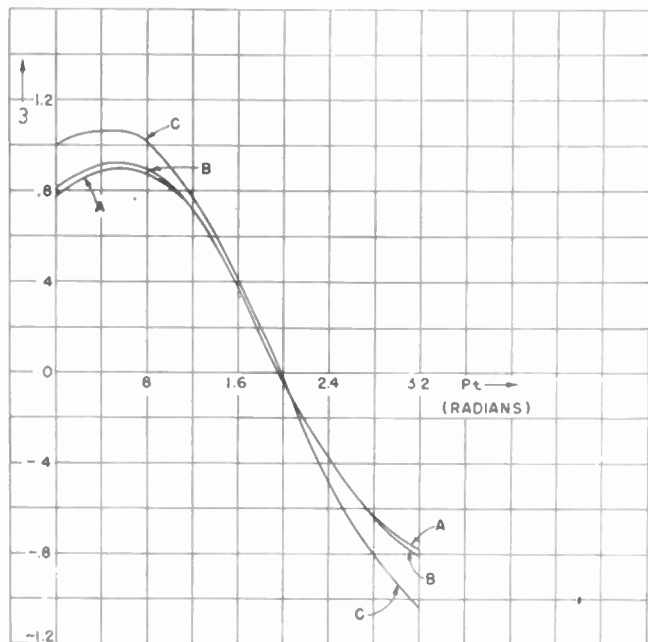

Fig. 1—Response of singly tuned circuit to sinusoidal FM ($w = \frac{1}{2}$, $B = 1$); plots of instantaneous frequency, A sideband method, B polynomial method, C quasi-steady-state method.

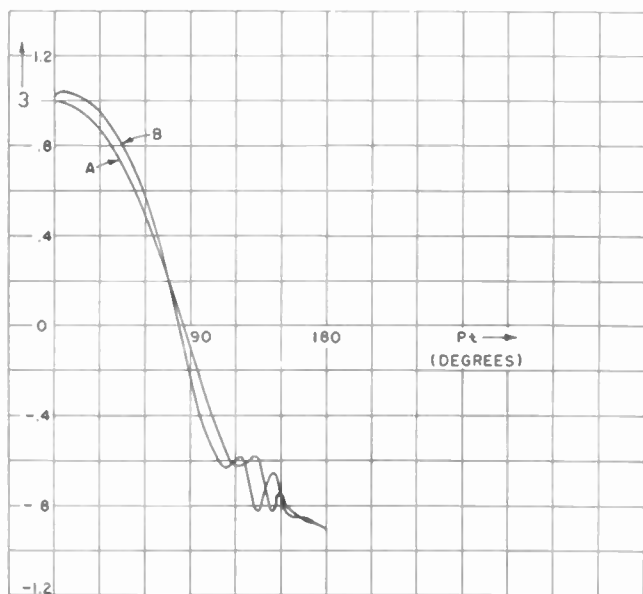

Fig. 2—Response of singly tuned circuit to sinusoidal FM ($w = 4$, $B = 20$); plots of instantaneous frequency, A sideband method, B polynomial method.

Most networks used in actual systems do not have the good fortune to be represented by a simple analytic

expression. Such networks are best treated from a graphical point of view. The method of polynomial representation lends itself to these networks just as easily as does the simple tuned circuit. Instead of the Legendre polynomial, we could make use of the Tschetscheff polynomial. The advantage of the latter lies in the fact that it is orthogonal with respect to a finite sum as well as with respect to an integral. Thus, the constants may be determined simply from a knowledge of the location of a finite number of points on the graph of the network function.

The procedure used in obtaining the constants of the Legendre polynomial is valid for any network whose function is analytically defined. The procedure used in obtaining the constants of the Tschetscheff polynomial is valid for any network whose function is graphically defined. In all cases, (16) gives the response of the network to sinusoidal FM.

APPENDIX

First 9 Derivatives of $e^{iB \sin pt}$

$$v^{(0)} = e^{iB \sin pt}$$

$$v^{(1)} = [iD \cos pt]v^{(0)}$$

$$v^{(2)} = -D^2 \left[\frac{1}{2} + \frac{1}{2} \cos 2pt + i \left\{ \frac{1}{B} \sin pt \right\} \right] v^{(0)}$$

$$v^{(3)} = D^3 \left[\frac{3}{2B} \sin 2pt - i \left\{ \left(\frac{3}{4} + \frac{1}{B^2} \right) \cos pt + \frac{1}{4} \cos 3pt \right\} \right] v^{(0)}$$

$$v^{(4)} = D^4 \left[\left(\frac{3}{8} + \frac{1}{2B^2} \right) + \left(\frac{1}{2} + \frac{7}{2B^2} \right) \cos 2pt + \frac{1}{8} \cos 4pt + i \left\{ \left(\frac{3}{2B} + \frac{1}{B^3} \right) \sin pt + \frac{3}{2B} \sin 3pt \right\} \right] v^{(0)}$$

$$v^{(5)} = D^5 \left[\left(\frac{5}{2B} + \frac{15}{2B^3} \right) \sin 2pt + \frac{5}{4B} \sin 4pt - i \left\{ \left(\frac{5}{8} + \frac{15}{4B^2} + \frac{1}{B^4} \right) \cos pt + \left(\frac{5}{16} + \frac{25}{4B^2} \right) \cos 3pt + \frac{1}{16} \cos 5pt \right\} \right] v^{(0)}$$

$$v^{(6)} = -D^6 \left[\left(\frac{5}{16} + \frac{15}{8B^2} + \frac{1}{2B^4} \right) + \left(\frac{15}{32} + \frac{10}{B^2} + \frac{31}{2B^4} \right) \cos 2pt + \left(\frac{3}{16} + \frac{65}{8B^2} \right) \cos 4pt + \frac{1}{32} \cos 6pt + i \left\{ \left(\frac{15}{8B} + \frac{15}{2B^3} + \frac{1}{B^5} \right) \sin pt + \left(\frac{45}{16B} + \frac{45}{2B^3} \right) \sin 3pt + \frac{15}{16B} \sin 5pt \right\} \right] v^{(0)}$$

$$v^{(7)} = D^7 \left[-i \left\{ \left(\frac{35}{64} + \frac{35}{4B^2} + \frac{63}{4B^4} + \frac{1}{B^6} \right) \cos pt + \left(\frac{35}{16B} + \frac{525}{8B^3} \right) \sin 5pt + \frac{7}{16B} \sin 7pt \right\} v^{(0)} + \left(\frac{21}{64} + \frac{35}{2B^2} + \frac{301}{4B^4} \right) \cos 3pt + \left(\frac{7}{64} + \frac{35}{4B^2} \right) \cos 5pt + \frac{1}{64} \cos 7pt \right] v^{(0)}$$

$$v^{(9)} = -D^9 \left[\left(\frac{63}{16B} + \frac{1575}{16B^3} + \frac{735}{2B^5} + \frac{255}{2B^7} \right) \sin 2pt + \left(\frac{63}{16B} + \frac{693}{4B^3} + \frac{3885}{4B^5} \right) \sin 4pt + \left(\frac{27}{16B} + \frac{1323}{16B^3} \right) \sin 6pt + \frac{9}{32B} \sin 8pt - i \left\{ \left(\frac{63}{128} + \frac{525}{32B^2} + \frac{735}{8B^4} + \frac{255}{4B^6} + \frac{1}{B^8} \right) \cos pt + \left(\frac{21}{64} + \frac{1071}{32B^2} + \frac{7035}{16B^4} + \frac{3025}{4B^6} \right) \cos 3pt + \left(\frac{9}{64} + \frac{861}{32B^2} + \frac{6951}{16B^4} \right) \cos 5pt + \left(\frac{9}{256} + \frac{231}{32B^2} \right) \cos 7pt + \frac{1}{256} \cos 9pt \right\} v^{(0)} \right]$$

$$v^{(8)} = D^8 \left[\left(\frac{35}{128} + \frac{35}{8B^2} + \frac{63}{8B^4} + \frac{1}{2B^6} \right) + \left(\frac{7}{16} + \frac{315}{16B^2} + \frac{231}{2B^4} + \frac{127}{2B^6} \right) \cos 2pt + \left(\frac{7}{32} + \frac{189}{8B^2} + \frac{1701}{8B^4} \right) \cos 4pt + \left(\frac{1}{16} + \frac{133}{16B^2} \right) \cos 6pt + \frac{1}{128} \cos 8pt + i \left\{ \left(\frac{35}{16B} + \frac{105}{4B^3} + \frac{63}{2B^5} + \frac{1}{B^7} \right) \sin pt + \left(\frac{63}{16B} + \frac{735}{8B^3} + \frac{483}{2B^5} \right) \sin 3pt \right\} \right]$$

Input Impedance of Wide-Angle Conical Antennas Fed by a Coaxial Line*

CHARLES H. PAPAS†, ASSOCIATE, IRE, AND RONOLD KING†, SENIOR MEMBER, IRE

Summary—The input impedances for conical antennas fed by a coaxial line have been computed for several flare angles. A graph of the auxiliary functions $\zeta_n(x)$ is included to facilitate impedance calculation for any large flare angle.

Specifically, the problem consists of determining the impedance which a wide-angle conical antenna of length a and flare angle θ_0 presents to a coaxial line with an infinite flange (Fig. 1). Its solution is formulated by con-

INTRODUCTION

IN THE FALL of 1946, L. Brillouin suggested the problem of determining the input impedance of a spherically capped conical antenna fed by a coaxial line. This paper deals with only those aspects of the solution which are of immediate engineering interest. A complete theoretical discussion of this problem¹ and a closely related one²⁻⁴ are found elsewhere.

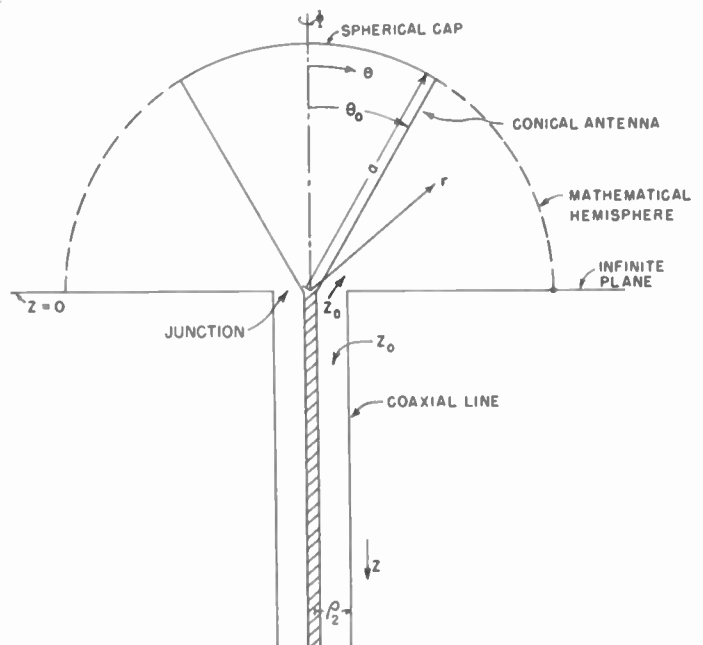

Fig. 1—Spherically capped conical antenna fed by coaxial feed line.

* Decimal classification: R326.612X R221. Original manuscript received by the Institute, March 15, 1949; revised manuscript received June 9, 1949. The research reported in this document was made possible through support extended Cruft Laboratory, Harvard University, jointly by the U. S. Navy Department (Office of Naval Research), the Signal Corps of the U. S. Army, and the U. S. Air Force, under ONR Contract N5ori-76, T. O. I.

† Cruft Laboratory, Harvard University, Cambridge, Mass.
 † C. H. Papas and R. King, "Input impedance of wide-angle conical antennas," Technical Report No. 52, Cruft Laboratory, Harvard University.

² P. D. P. Smith, "The conical dipole of wide angle," *Jour. Appl. Phys.*, vol. 19, pp. 11-23; January, 1948.

³ C. T. Tai, "Application of variational principle to the study of biconical antennas," Technical Report No. 75, Cruft Laboratory, Harvard University.

⁴ S. A. Schelkunoff, "Electromagnetic Waves," D. Van Nostrand Co., Inc., New York, N. Y., 1943; p. 472-473.

sidering two regions: the antenna region, $\rho_2 \leq r \leq a$, $\theta_0 \leq \theta \leq (\pi/2)$, and the radiation region $r \geq a$, $0 \leq \theta \leq (\pi/2)$. The nonvanishing components H_ϕ , E_θ , and E_r of the magnetic- and electric-field vectors are expanded in series of eigenfunctions appropriate to the two regions and the unknown constants of the expansions are determined by forcing the annihilation of E_θ over the spherical cap and the continuity of H_ϕ and E_θ across the mathematical surface $r=a$, $\theta_0 \leq \theta \leq (\pi/2)$. At the junction between the antenna and line, the higher nonpropagating modes are neglected from the start, but since it is assumed that the characteristic impedance of the antenna is equal to that of the line, the difference between the input impedance of the antenna and the equivalent impedance which the antenna presents to the end of the line is capacitive and assumed to be negligibly small. The formal solution finally appears in the form of an infinite set of simultaneous equations. The equations are quite unmanageable, but when it is noticed that, for large values of flare angle, the complementary modes in the antenna region can be neglected in comparison to the *TEM* modes (one outwardly propagating, the other reflected from the surface $r=a$, $\theta_0 \leq \theta \leq (\pi/2)$), the problem reduces to the evaluation of the reflection coefficient of the *TEM* wave.

IMPEDANCE FORMULA

Within the limits of the above-mentioned approximations, it is found that the input impedance of an antenna¹ of length a and flare angle θ_0 is given by

$$Z_{in} = Z_0 \frac{1 - \beta/\alpha}{1 + \beta/\alpha} \tag{1}$$

where

$$Z_0 = 60 \ln \cot \frac{\theta_0}{2} \tag{2}$$

$$\frac{\beta}{\alpha} = e^{-2ika} \frac{1 + i \sum_{n=1}^{\infty} \frac{2n+1}{n(n+1)} [P_n(\cos \theta_0)]^2 \zeta_n(ka)}{-1 + i \sum_{n=1}^{\infty} \frac{2n+1}{n(n+1)} [P_n(\cos \theta_0)]^2 \zeta_n(ka)} \tag{3}$$

and

$$\zeta_n(ka) = \frac{h_n^{(2)}(ka)}{h_{n-1}^{(2)}(ka) - \frac{n}{ka} h_n^{(2)}(ka)} \tag{4}$$

$h_n^{(2)}$ is the spherical Hankel function of the second kind, and $P_n(\cos \theta)$ is the Legendre polynomial of order n . The summation in (3) is over odd integral values. Z_0 is called the characteristic impedance of the antenna, β/α is the ratio of the amplitudes of the reflected and outwardly propagating *TEM* waves in the antenna region, and $\zeta_n(ka)$ is a complex auxiliary function of the real variable ka ($ka = 2\pi \div$ free-space wavelength). It should be emphasized that (1) accurately predicts the equivalent

impedance which the antenna presents to the end of the coaxial line only when the characteristic impedance of the feeding coaxial line; i.e., $60 \ln \rho_2/\rho_1$ where ρ_2 and ρ_1 are the radii of its outer and inner conductors, is made equal to the characteristic impedance of the antenna (2), and the flare angle is large. It is clear that there must be an upper bound to the admissible flare angles since, as the flare angle increases, the bend at the

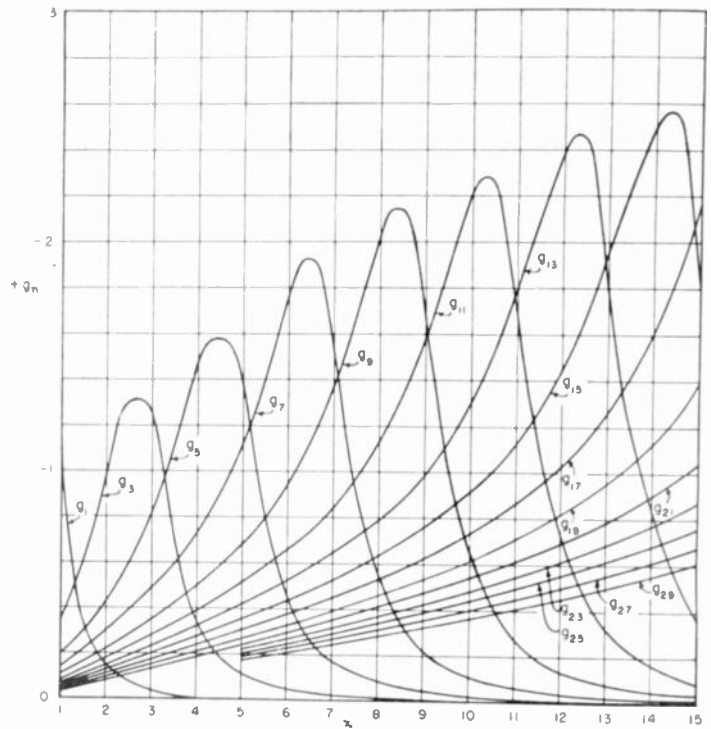

Fig. 2—Real part of the zeta function, $g_n(x)$ versus x .

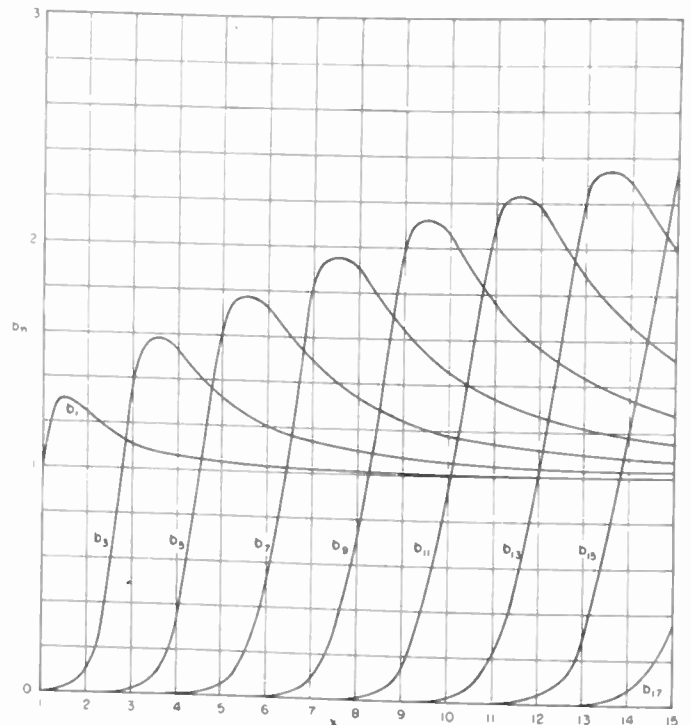

Fig. 3—Imaginary part of the zeta function $b_n(x)$ versus x .

junction becomes more severe thereby making the higher nonpropagating modes there far from negligible. From experimental results (Fig. 4), it is safe to choose 30° as the lower bound for θ_0 .

RESULTS

Using (4) the auxiliary functions $\zeta_n(x) = g_n(x) + ib_n(x)$ have been computed for various values of n and x (Figs. 2 and 3). With the aid of these computed functions, β/α and Z_0 can be evaluated for an antenna with length ka and flare angle θ_0 from (3) and (2) respectively. Substituting the values of β/α and Z_0 thus obtained into (1) yields the input impedance as a function of θ_0 and ka .

For $\theta_0 = 30^\circ, 40^\circ, 55^\circ, 70^\circ$, the input impedances were computed for values of ka ranging from 0 to 8 (Figs. 4, 5, 6, and 7). It is seen that the input resistance curves

curves start at large negative values and then perform damped oscillations about zero ohms. For $\theta_0 = 30^\circ$ the remarkably close agreement between the calculated and measured impedance⁵ is seen.

ACKNOWLEDGMENT

The authors wish to thank C. T. Tai for many valuable discussions, and also Mrs. R. Stokey, who performed all the computations.

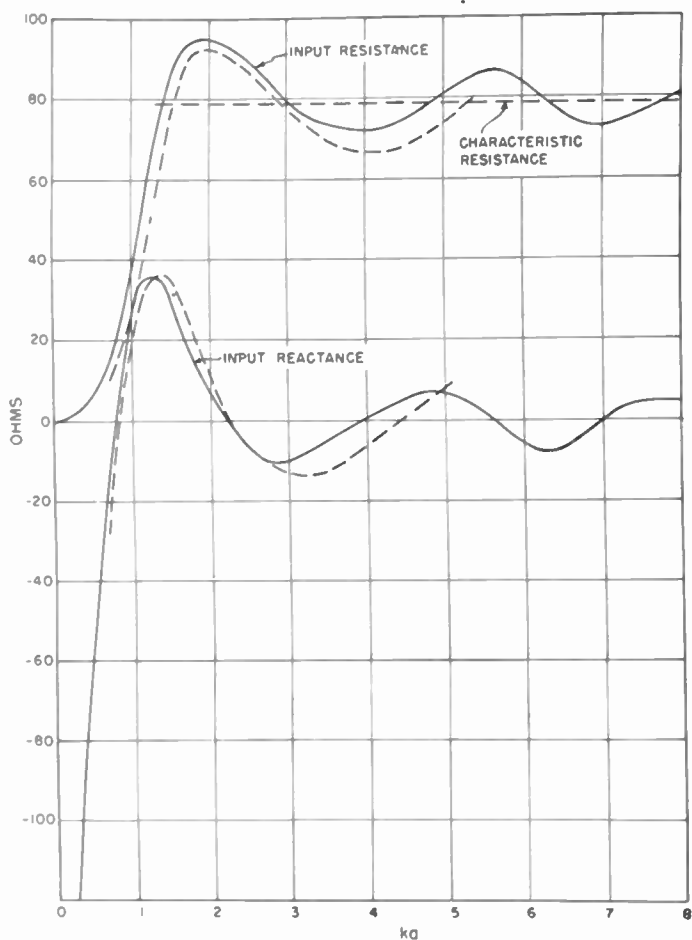

Fig. 4—Input resistance and reactance versus the parameter ka for $\theta_0 = 30^\circ$, solidline indicates calculated values; broken line, measured values.

rise from zero and perform damped oscillations about the characteristic resistances, and the input reactance

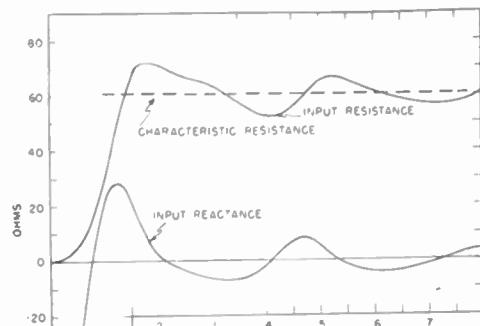

Fig. 5

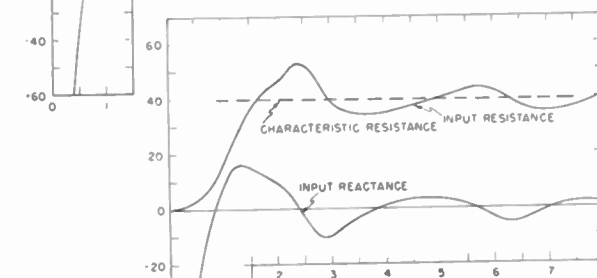

Fig. 6

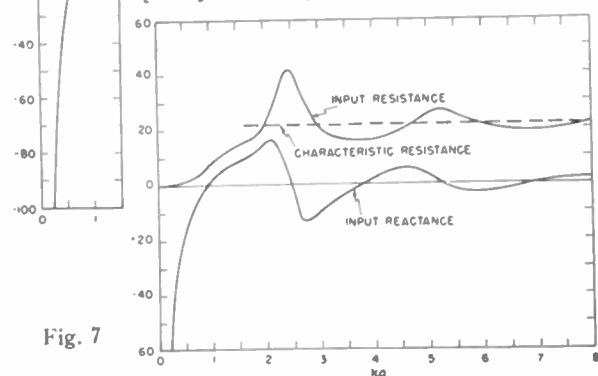

Fig. 7

Fig. 5—Input resistance and reactance versus the parameter ka for $\theta_0 = 40^\circ$.

Fig. 6—Input resistance and reactance versus the parameter for $\theta_0 = 55^\circ$.

Fig. 7—Input resistance and reactance versus the parameter for $\theta_0 = 70^\circ$.

⁵ Harvard Radio Research Laboratory Staff, "Very High, Frequency Techniques," McGraw-Hill Book Co., Inc., New York-N. Y., 1947; vol. 1, p. 103, Fig. 4-10(d).



An Analysis of Distortion Resulting from Two-Path Propagation*

IRVIN H. GERKST†, SENIOR MEMBER, IRE

Summary—It is shown that the nonlinear distortion caused by two-path propagation for the case of amplitude modulation is a result of overmodulation in the resultant signal. This distortion becomes severe only when the time delay on the secondary path is large and the amplitudes are nearly equal. In the case of an FM system, the instantaneous frequency of the resultant signal has sharp, spike-shaped variations which reach large amplitude when the signals are of nearly equal strength. It is shown that an averaging process occurs in the receiver tending to minimize distortion when the discriminator is so designed to respond linearly to a very wide frequency deviation. Such distortion may be quite small when the transmitter frequency deviation is made large. When the discriminator range is too narrow, the distortion is increased, especially for wide-band systems. A discriminator range of several thousand kilocycles may be necessary to achieve optimum suppression of distortion.

INTRODUCTION

IT HAS LONG been common knowledge that the arrival of a signal at a receiver over two or more paths of different and variable length may cause not only fading, but also severe distortion of the modulating wave shape.¹⁻³ No effort will be made here to review the conditions which give rise to multiple-path propagation. It is sufficient to indicate that, in the case of propagation by way of the ionosphere, one or more secondary paths may exist with a delay time as great as a millisecond. Recently it has been recognized that multiple-path propagation often occurs in the vhf and uhf bands, especially at large distances.⁴ In this case the relative delay time is much shorter, however, probably never exceeding a few microseconds. It will be shown that the distortion caused by secondary paths becomes severe only when the relative delay is great enough to cause a modulating-frequency phase lag of several degrees.

The distortion associated with multiple-path propagation was first recognized and studied in connection with systems employing amplitude modulation.^{1-3,5} A considerable degree of relief has been secured through the use of diversity reception, steerable antenna arrays, and single sideband systems. More recently it was observed

that a similar, and often more severe, form of distortion occurs in frequency-modulation systems.^{6,7} Various writers have presented studies to indicate the nature of this effect in FM reception.⁸⁻¹¹ In the analysis to follow, the previous work will be briefly summarized, and it will be shown that the distortion in FM systems can be considerably reduced by the proper choice of receiver characteristics. For the sake of simplicity, the treatment will be limited to the case of two propagation paths, a single modulating frequency, and a ratio of signal amplitudes near unity.

AMPLITUDE MODULATION

It will be assumed that two signals are similarly amplitude-modulated, and that one is delayed by a time Δt relative to the other. These signals are applied to an ideal AM receiver, which is assumed to be responsive only to the instantaneous amplitude or the envelope of the resultant of the two signals. Let signal 1 be represented by

$$e_1 = E_1(1 + m_a \sin pt) \sin \omega t, \quad (1)$$

and signal 2 by

$$e_2 = E_2[1 + m_a \sin p(t - \Delta t)] \sin \omega(t - \Delta t). \quad (2)$$

Then

$$\begin{aligned} e &= e_1 + e_2 \\ &= [E_1(1 + m_a \sin pt) \\ &\quad + E_2 \cos \beta \{1 + m_a \sin p(t - \Delta t)\}] \sin \omega t \\ &\quad - E_2 \sin \beta \{1 + m_a \sin p(t - \Delta t)\} \cos \omega t \end{aligned} \quad (3)$$

where $\beta = \omega \Delta t$. The two quadrature components of (3) may be combined to yield the envelope of the wave:

$$\begin{aligned} E^2 &= E_1^2[(1 + m_a \sin pt)^2 + b^2\{1 + m_a \sin(pt - 2\alpha)\} \\ &\quad + 2b \cos \beta(1 + m_a \sin pt)\{1 + m_a \sin(pt - 2\alpha)\}] \end{aligned} \quad (4)$$

* Decimal classification: R148.2. Original manuscript received by the Institute, July 2, 1948; revised manuscript received, May 13, 1949. Presented, 1949 IRE National Convention, New York, N. Y., March 9, 1949.

† Collins Radio Company, Cedar Rapids, Iowa.

¹ R. Bown, D. K. Martin, and R. K. Potter, "Some studies in radio broadcast transmission," *Proc. I.R.E.*, vol. 14, pp. 57-131; February, 1926.

² R. K. Potter, "Transmission characteristics of a short-wave telephone circuit," *Proc. I.R.E.*, vol. 18, pp. 581-648; April, 1930.

³ J. C. Schelleng, "Some problems in short-wave telephone transmission," *Proc. I.R.E.*, vol. 18, pp. 913-938; June, 1930.

⁴ Kenneth A. Norton, "Propagation in the FM Broadcast Band," *Advances in Electronics*, vol. 1, Academic Press Inc., New York, N. Y., pp. 381-421; 1948.

⁵ Charles B. Aiken, "Theory of the detection of two modulated waves by a linear rectifier," *Proc. I.R.E.*, vol. 21, pp. 601-628; April, 1933.

⁶ Murray G. Crosby, "Frequency modulation propagation characteristics," *Proc. I.R.E.*, vol. 24, pp. 898-913; June, 1936.

⁷ Murray G. Crosby, "Observations of frequency-modulation propagation on 26 megacycles," *Proc. I.R.E.*, vol. 29, pp. 398-403; July, 1941.

⁸ Murlan S. Corrington, "Frequency-modulation distortion caused by multipath transmission," *Proc. I.R.E.*, vol. 33, pp. 878-891; December, 1945.

⁹ S. T. Meyers, "Nonlinearity in frequency-modulation radio systems due to multipath propagation," *Proc. I.R.E.*, vol. 34, pp. 256-264; May, 1946.

¹⁰ Igor Plusc, "Investigation of frequency-modulation signal interference," *Proc. I.R.E.*, vol. 35, pp. 1054-1059; October, 1947.

¹¹ L. B. Arguimbau and J. Granlund, "The possibility of transatlantic communication by means of frequency modulation," *Proc. Nat. Elect. Conf.*, vol. 3, pp. 644-653; 1947.

where

$$b = \frac{E_2}{E_1} < 1$$

$$\alpha = \frac{p\Delta t}{2}$$

Since distortion is observed to be most severe when the carrier fade is deepest, we need investigate only one case, namely, $\beta = (2n-1)\pi$, $n = 1, 2, 3, \dots$, $\cos \beta = -1$. For this case, we have

$$E = E_1 \{ 1 + m_a \sin pt - b \{ 1 + m_a \sin (pt - 2\alpha) \} \}$$

$$= E_1(1-b) \left[1 + m_a \sqrt{1 + \frac{4b \sin^2 \alpha}{(1-b)^2}} \sin (pt + \delta) \right] \quad (5)$$

where

$$\tan \delta = \frac{b \sin 2\alpha}{1 - b \cos 2\alpha}$$

This envelope may be subjected to harmonic analysis to determine the magnitude of the various harmonics of the modulating frequency p . It will suffice here to indicate that (5) represents a reduced carrier of amplitude $E_1(1-b)$ modulated with an effective index

$$m_a' = m_a \sqrt{1 + \frac{4b \sin^2 \alpha}{(1-b)^2}} \quad (6)$$

It is apparent that m_a' may greatly exceed unity when $\sin \alpha$ is large. For the case where $\sin \alpha = 1$, we have

$$m_a' = m_a \left(\frac{1+b}{1-b} \right) \quad (7)$$

Thus, when $\alpha = 0.9$, $m_a' = 19m_a$. Furthermore, the effective modulation index varies widely with frequency, since α is proportional to p . We see that distortion in this case results essentially from a great increase in the effective modulation index at certain frequencies. However, so long as $\sin \alpha$ is kept very small or Δt is limited to values on the order of 1 microsecond, the distortion may generally be neglected for values of b less than about 0.95. Thus, little distortion may be expected on most tropospheric propagation paths when amplitude modulation is employed.

CASE OF TWO UNMODULATED SIGNALS APPLIED TO AN FM RECEIVER

The treatment of the behavior of an ideal FM receiver under conditions of multipath propagation is best introduced by assuming two unmodulated signals with an arbitrary frequency difference impressed upon the receiver and investigating the output of the receiver.^{10,11} It will be assumed that the receiver is totally unresponsive to any amplitude variation of the resultant signal and that the output is exactly proportional to the deviation of the instantaneous frequency from some fixed value.

Let the two signals be represented by

$$e_1 = E_1 \sin \omega_1 t \quad (8)$$

$$e_2 = E_2 \sin \omega_2 t \quad (9)$$

The resultant signal is

$$e = E_1(\sin \omega_1 t + b \sin \omega_2 t), \quad (10)$$

where $b = (E_2/E_1) < 1$. The instantaneous frequency of this signal is given by:

$$f_i = f_1 + \Delta f \left[\frac{b^2 + b \cos (\omega_1 - \omega_2)t}{1 + b^2 + 2b \cos (\omega_1 - \omega_2)t} \right], \quad (11)$$

where $\Delta f = f_2 - f_1$ is the beat frequency. Here E_1 is assumed to be larger than E_2 . If we had assumed $E_1 < E_2$, we would have obtained

$$f_i = f_2 - \Delta f \left[\frac{b^2 + b \cos (\omega_1 - \omega_2)t}{1 + b^2 + 2b \cos (\omega_1 - \omega_2)t} \right]. \quad (12)$$

By the usual methods of harmonic analysis, (11) and (12) may be reduced to

$$f_i = f_1 + \Delta f \sum_{n=1}^{\infty} (-1)^{n+1} b^n \cos n(\omega_1 - \omega_2)t \quad (13)$$

$$f_i = f_2 - \Delta f \sum_{n=1}^{\infty} (-1)^{n+1} b^n \cos n(\omega_1 - \omega_2)t. \quad (14)$$

Since the harmonic series contains no constant term, the average value of the frequency over a beat-frequency cycle is seen to be identically equal to the frequency of the stronger signal. Hence, if the beat frequency and its harmonics fall outside the limits of the frequency band accepted by the receiver, the receiver output is controlled only by the frequency of the stronger signal. The weaker signal is completely suppressed, however closely the ratio b approaches unity. If the beat frequency or any of its harmonics fall within the band accepted by the receiver, the weaker signal contributes a noise output, the root-mean-square value of which is proportional to

$$N_{rms} = \frac{\Delta f}{\sqrt{2}} \sqrt{\sum_{n=1}^{n_0} b^{2n}}, \quad (15)$$

where $n_0 \Delta f \leq$ cutoff frequency of receiver. Since the noise output is proportional to the beat frequency, such noise may be appreciably mitigated by the use of high-frequency de-emphasis in the receiver. It is found that, in a receiver having a cutoff frequency of 4,000 cps and a standard de-emphasis circuit, the maximum value of the noise output for $b = 0.9$ is about 33 db below the level corresponding to 75 kc frequency deviation. This occurs for a 4,000-cycle beat frequency.

Equations (11) and (12) show that the instantaneous frequency varies in an unsymmetrical manner about its average value. As b approaches 1, the denominator approaches zero at the point where $\cos (\omega_1 - \omega_2)t = -1$, and a very sharp, narrow spike occurs in the frequency curve. The excursion at this point is ordinarily so great that the frequency range of the discriminator is exceeded and peak clipping occurs. The result is that the positive and negative loops of the curve no longer cancel in the discriminator output, and the output may be

profoundly influenced by the weaker signal, even for beat frequencies far outside the receiver band. Hence, the receiver loses its fidelity of response to the stronger signal only, even though the beat-frequency noise may be unaffected. That is, peak clipping may occur only for the high beat-frequencies beyond the receiver acceptance band.

Substituting $\cos(\omega_1 - \omega_2)t = -1$ in (11) and (12), we get

$$f_{i \min} = f_1 - \frac{b\Delta f}{1 - b} \tag{16}$$

$$f_{i \max} = f_2 + \frac{b\Delta f}{1 - b} \tag{17}$$

The total possible frequency excursion is

$$f_{i \max} - f_{i \min} = \Delta f \left(1 + \frac{2b}{1 - b} \right) = \frac{1 + b}{1 - b} \Delta f. \tag{18}$$

For a presumed transmitter deviation of 75 kc, the maximum beat frequency is 150 kc and the maximum excursion in the discriminator is 19 times this value, or 2,850 kc, for $b = 0.9$. Since a discriminator is ordinarily designed for a range of only 150 kc, we see that a conventional receiver is unlikely to yield the fidelity of response to the stronger signal previously mentioned when b approaches unity.

CASE OF TWO SIGNALS SIMILARLY FREQUENCY MODULATED AND APPLIED TO AN FM RECEIVER

Various writers have presented an analysis for the case of two propagation paths and a single modulating frequency.⁸⁻¹⁰ For the sake of convenience, the method

is summarized here. Let signal 1 be represented by

$$e_1 = E_1 \sin \phi_1 \tag{19}$$

and signal 2 by

$$e_2 = E_2 \sin \phi_2 \tag{20}$$

where

$$\begin{aligned} \phi_1 &= \omega t + m_f \sin pt \\ \phi_2 &= \omega(t - \Delta t) + m_f \sin p(t - \Delta t). \end{aligned} \tag{22}$$

The resultant signal is

$$e = E_1(\sin \phi_1 + b \sin \phi_2) \tag{23}$$

where $b = (E_2/E_1) < 1$. In this case the instantaneous frequency of the signal e is given by

$$\begin{aligned} \omega_i &= \omega + D \cos pt + 2D \sin \alpha \sin (pt - \alpha) \\ &\cdot \left[\frac{b^2 + b \cos \{ \beta + 2m_f \sin \alpha \cos (pt - \alpha) \}}{1 + b^2 + 2b \cos \{ \beta + 2m_f \sin \alpha \cos (pt - \alpha) \}} \right] \\ &= \omega + D \cos pt + \omega_d \end{aligned} \tag{24}$$

where $D =$ transmitter angular frequency deviation $= pm_f$

$$\alpha = \frac{p\Delta t}{2}$$

$$\beta = \omega\Delta t$$

$\omega_d =$ distortion component of ω_i .

The distortion term may be written

$$\omega_d = pB \left[\frac{b^2 + b \cos \{ \beta + B \cos (pt - \alpha) \}}{1 + b^2 + 2b \cos \{ \beta + B \cos (pt - \alpha) \}} \right] \cdot \sin (pt - \alpha), \tag{25}$$

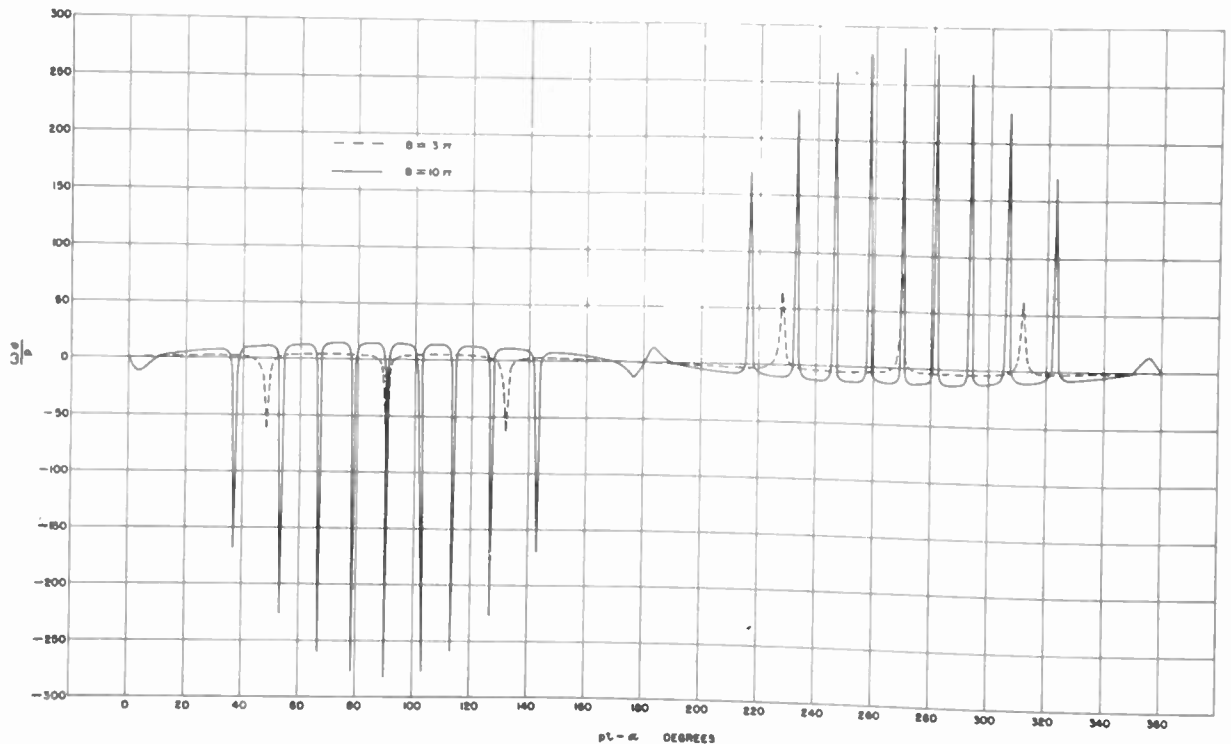

Fig. 1—Instantaneous frequency of the distortion term relative to modulating frequency plotted over one modulating-frequency cycle for $B = 3\pi$ and $B = 10\pi$, and for $b = 0.9$, $\beta = (2n - 1)\pi$. When the ordinates are multiplied by the modulating frequency, these curves show the wave shape of the distortion component in the output of an ideal FM receiver prior to filtering.

where $\beta = 2m_f \sin \alpha$. A plot of equation (25) is shown in Fig. 1 for the case where $\beta = (2n-1)\pi$, $b=0.9$, and $B=3\pi$ or 10π . It is seen that the beat frequency is both amplitude and frequency modulated by the frequency p . Large values of B , corresponding to large modulation index and large values of $\sin \alpha$, produce a high beat frequency over most of the modulation cycle, so that the averaging process formerly mentioned may be used to eliminate the effect of ω_d to a large extent if the discriminator responds faithfully to the spikes.

The distortion term ω_d may be resolved into a Fourier series in order to show the harmonic content and compute the effective value of the distortion.^{8,9} The result is

$$\omega_d = pB \left[\sum_{n=1}^{\infty} (-1)^{n+1} b^n \cos n\beta J_0(nB) \sin (pt - \alpha) + \sum_{n=1}^{\infty} \sum_{r=1}^{\infty} (-1)^{n+r+1} b^n \cos n\beta J_{2r}(nB) \{ \sin (2r+1)(pt - \alpha) - \sin (2r-1)(pt - \alpha) \} + \sum_{n=1}^{\infty} \sum_{r=0}^{\infty} (-1)^{n+r+1} b^n \sin n\beta J_{2r+1}(nB) \{ \sin (2r+2)(pt - \alpha) - \sin 2r(pt - \alpha) \} \right]. \quad (26)$$

For the sake of simplicity, only the case will be considered where the carrier fade is deepest, i.e., where β is an odd multiple of π radians. This produces a spike in the wave shape even for small values of B and yields the most severe distortion for small values of modulation index and of phase delay α . For this case

$$\begin{aligned} \sin n\beta &= 0 \\ \cos n\beta &= (-1)^n, \end{aligned}$$

and (26) reduces to

$$\omega_d = -pB \left[\sum_{n=1}^{\infty} b^n J_0(nB) \sin (pt - \alpha) + \sum_{n=1}^{\infty} \sum_{r=1}^{\infty} (-1)^r b^n J_{2r}(nB) \{ \sin (2r+1)(pt - \alpha) - \sin (2r-1)(pt - \alpha) \} \right]. \quad (27)$$

This may also be written

$$\omega_d = -pB \left[\sum_{n=1}^{\infty} b^n \{ J_0(nB) + J_2(nB) \} \sin (pt - \alpha) - \sum_{n=1}^{\infty} b^n \{ J_2(nB) + J_4(nB) \} \sin 3(pt - \alpha) + \sum_{n=1}^{\infty} b^n \{ J_4(nB) + J_6(nB) \} \sin 5(pt - \alpha) - \dots \right], \quad (28)$$

or

$$\omega_d = -pB \left[\sum_{n=1}^{\infty} b^n \frac{2J_1(nB)}{nB} \sin (pt - \alpha) - \sum_{n=1}^{\infty} b^n \frac{6J_3(nB)}{nB} \sin 3(pt - \alpha) + \sum_{n=1}^{\infty} b^n \frac{10J_5(nB)}{nB} \sin 5(pt - \alpha) - \dots \right]. \quad (29)$$

The infinite-series coefficients

$$A_1 = B \sum_{n=1}^{\infty} b^n \frac{2J_1(nB)}{nB} \quad (29a)$$

$$A_3 = B \sum_{n=1}^{\infty} b^n \frac{6J_3(nB)}{nB} \quad (29b)$$

etc., were computed from tables of Bessel functions¹² with arguments up to 100 and in some cases asymptotic formulas were used to determine the Bessel functions for arguments up to 200. The results are shown in Fig. 2. It is seen that the amplitude of the harmonic varies in a quite irregular manner with the parameter $B = 2m_f \sin \alpha$. In general, the amplitude of the harmonic increases with its order for a given value of B . The strength of the high-order harmonics is not surprising, when one considers the extreme sharpness of the spikes in the wave shape.

To illustrate the nature of the distortion produced in an FM receiver, we will first assume an ideal receiver with a perfect amplitude limiter and with a discriminator which has a sufficiently large linear range so that all variations of instantaneous frequency are converted to corresponding amplitude variations without change of wave shape. Moreover, it will be assumed that the detector and audio-frequency amplifier respond uniformly to all modulating signals with frequencies from 300 to 4,000 cps and effectively suppress output at frequencies outside this band. The combined effect of the harmonics which fall within the receiver pass band will be assumed to be given by the root-sum-square value. That is,

$$A = \sqrt{\sum_{v=1}^{v_0} A_v^2} \quad (30)$$

where v_0 is the highest harmonic which falls within the receiver pass band. Such a combination is shown in Fig. 3.

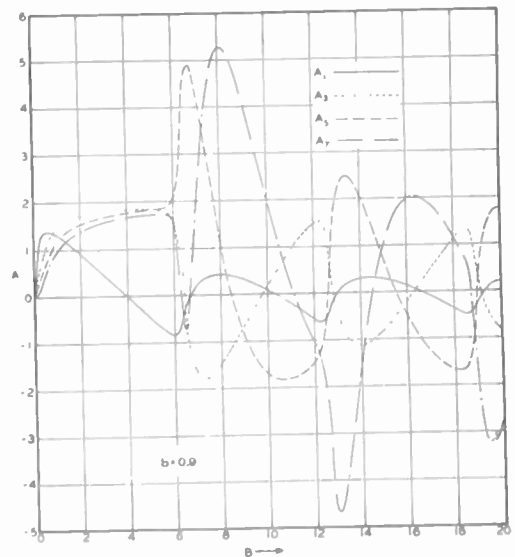

Fig. 2—The first four coefficients A_v appearing in (29) plotted as a function of B for $b=0.9$ and $\beta=(2n-1)\pi$. When the ordinates are multiplied by the modulating frequency, these curves show the amplitudes of the corresponding harmonics in the distortion term of the receiver output prior to filtering.

¹² Annals of the Computation Laboratory of Harvard University, vols. III-VI, Harvard University Press, Cambridge, Mass.; 1947.

Equation (24) shows that the desired receiver output is proportional to the transmitter frequency deviation D . Hence, the relative distortion is given by

$$\text{relative distortion} = \frac{\beta A}{D} = \frac{A}{m_f} \quad (31)$$

Fig. 4(a) shows how this relative distortion varies with the transmitter frequency deviation for various values of α , which is one-half the modulating-frequency phase delay angle, when the modulating frequency is held constant. It is seen that the distortion is roughly independent of α for large values of frequency deviation.

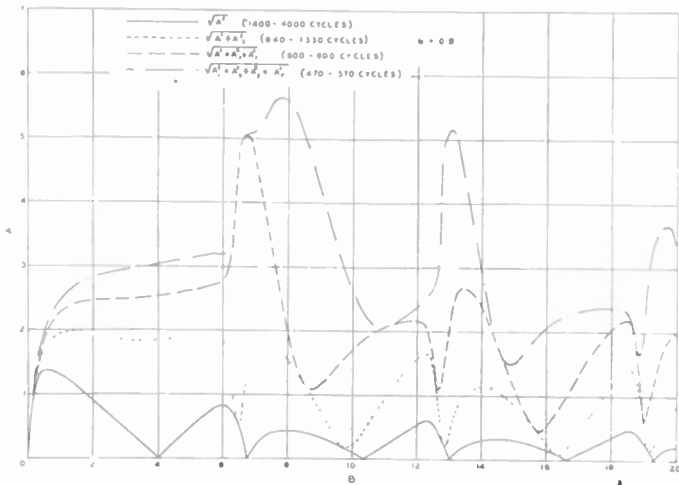

Fig. 3—Curves showing the combined harmonic amplitude effective in various frequency ranges as a function of B for $b=0.9$, $\beta=(2n-1)\pi$. When the ordinates are multiplied by the modulating frequency, these curves show the effective distortion output in a receiver with a pass-band of 300-4,000 cps.

small values of frequency deviation, a reduction in $\sin \alpha$ produces of a very pronounced reduction in distortion. However, even a value of $\sin \alpha$ as low as 0.02 ($\alpha \approx 1^\circ$) yields distortion in excess of 20 per cent for a frequency deviation less than about 4,000 cps. Fig. 4(b) shows how the relative distortion varies when the modulating frequency varies and $\sin \alpha$ is held constant at unity. This illustrates the tendency for the highest modulating frequency to yield the greatest distortion, even though only the first harmonic is passed by the receiver. This, coupled with the normal tendency for high-frequency sound components to be relatively weak and yield low transmitter deviation, emphasizes the need for transmitter pre-emphasis of the higher audio frequencies to minimize distortion. The trend of the curves in Fig. 4 leads to the conclusion that quite undesirable distortion may occur at carrier minimum when the frequency deviation is less than about 10 kc. With a suitably designed receiver, reduction of distortion can be achieved at the expense of increased channel bandwidth.

Fig. 4 shows a sharply increasing harmonic distortion with small decreasing value of frequency deviation. It may be shown that, for the case treated (β an odd multiple of π radians),

$$\lim_{\beta \rightarrow 0} (\text{relative distortion}) = 2 \sin \alpha \frac{b}{1-b} \quad (32)$$

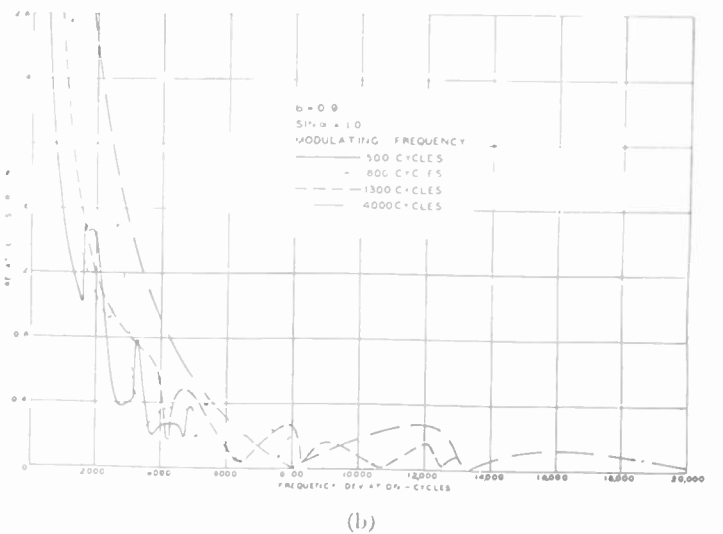
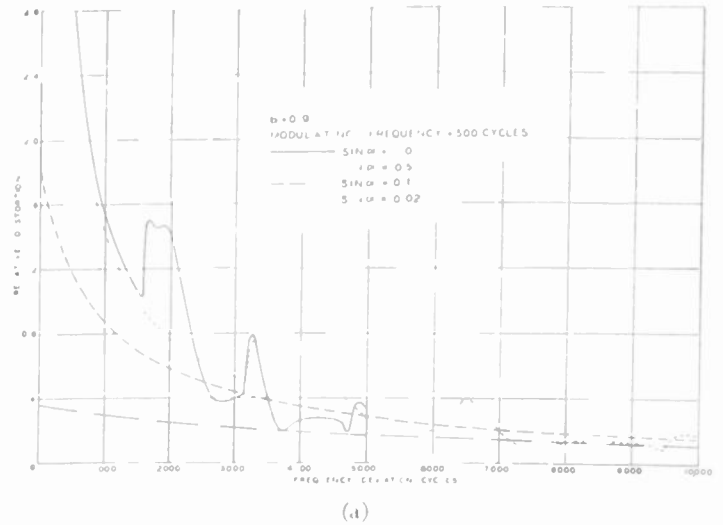

Fig. 4—Relative distortion appearing in the output of a receiver with a pass-band of 300-4,000 cps as a function of the maximum transmitter frequency deviation for the case where $B=0.9$, $\beta=(2n-1)\pi$.

As the modulation approaches zero, the higher harmonics disappear and the distortion term contains principally a fundamental-frequency component. Therefore, with very weak modulation the distortion term ω_d may merely increase the apparent modulation level without causing appreciable nonlinear distortion. A somewhat similar effect was found to exist in AM systems. However, in an FM system the nonlinear distortion builds up rapidly at first with increasing modulation and then decreases, whereas in an AM system nonlinear distortion may be absent until overmodulation occurs and will then build up rapidly for further increase in modulation level.

The general effect of insufficient range in the discriminator to accommodate the frequency range given by (18) is to increase the distortion. This has already been demonstrated on the basis of a weaker unmodulated signal interfering with a stronger signal. A study of Fig. 1 suggests that for large values of B , that is, high modulation index and long delay time, the wave is rich in high harmonics of large amplitude, which are naturally inaudible or can be eliminated with a filter. Clipping of the

spikes with a discriminator of inadequate range impairs the tendency of positive and negative loop areas of the curve to cancel and thus augments the magnitude of low harmonics. The effect is somewhat analogous to the detection of a high-frequency modulated wave with a rectifier. It appears, then, that much of the nonlinear distortion observed in FM systems with multipath propagation is attributable to nonlinearity in the discriminator, especially in the case of wide-band systems where very large spikes may occur in the wave shape.

It should be noted that no increase in bandwidth of the rf amplifier is required, since this portion of the re-

ceiver may be assumed to be linear and responsive to each signal individually. It is assumed also that limiter action is unimpaired, even when the carrier amplitude fades to a minimum.

It may be further noted that the foregoing analysis tends to indicate a method for reducing common-channel interference between two FM signals which are of nearly equal strength and which may be similarly or differently modulated. In case of dissimilar modulation, it is, of course, necessary to assure that the same signal always remains the stronger of several arriving simultaneously at the receiver.

Theoretical Study of Pulse-Frequency Modulation*

ARNOLD E. ROSS†, SENIOR MEMBER, IRE

Summary—In this paper, we study the pulse-frequency modulation method in pulse communication.

We do not restrict ourselves to the case when the number of samples per period of our signal, as well as per unit time, is very large. Hence, the accuracy in reconstruction of the signal will depend not only on the number of sampling points per period, but also upon their distribution.

We shall assume a fixed average pulse frequency (sampling rate), and will seek the maximal range of the signal frequency for which the corresponding periodic signal may be transmitted with acceptable accuracy.

Thus, we are interested in a kind of threshold problem. It is our aim to consider pulse-frequency modulation independently of the circuits used to realize it, insofar as this is consistent with lucidity of presentation.

In Sections 12, 15, 16, and 17, we study in detail the behavior of sampling in case the relative frequency ν (the ratio of the signal frequency to the pulse frequency) falls into the ranges (0.4855, 0.51625), (0.33599, 0.33863), (0.6450, 0.6626), and (0.402645, 0.403030), respectively. This information supplies the reason for the limitation of the useful range of the relative frequency spectrum.

Because of the extreme nonlinearity of pulse-frequency modulation, we cannot deduce the behavior of the general periodic signal from the behavior of its sinusoidal components, but we have to apply methods described in this paper directly to the particular wave form studied. This is illustrated by the example in the Appendix.

INTRODUCTION

1. Pulse Communication

THE FUNDAMENTAL idea in pulse communication is the transmission of samples of a continuous signal in such a way that, from these discrete samples, the original signal can be reconstructed with accuracy sufficient for the recognition of the message contained therein.

* Decimal classification: R148.6. Original manuscript received by the Institute, May 18, 1948; revised manuscript received, April 21, 1949. This paper is based on work done for the Office of Naval Research under Contract No. N60ri-187 with the Stromberg-Carlson Company. Presented, 1948 IRE National Convention, New York, N. Y., March 24, 1948.

† University of Notre Dame, Notre Dame, Ind.

The signal may be sampled by varying the height of the pulses in an equally spaced train of pulses, as shown in Fig. 1. This manner of sampling is spoken of as "pulse-amplitude modulation."

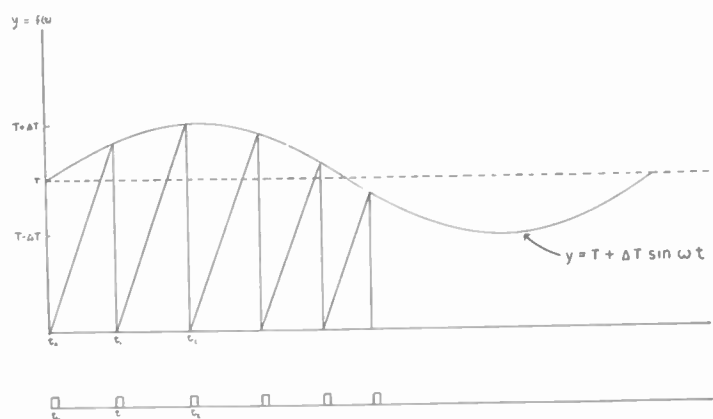

Fig. 1—The modulated sawtooth and the corresponding pulse train. The distance between successive pulse positions t_{i+1} and t_i is a linear function of the value of the signal at t_{i+1} .

The original message may be incorporated into the pulse train also by varying, in accordance with the signal, the width of the individual pulses, or by varying the distance of the pulses from their original positions in the equally spaced pulse train. These two schemes are called "pulse-width modulation" and "pulse-position modulation" (with fixed reference).

2. Pulse-Frequency Modulation

In the present paper we propose to discuss still another type of pulse modulation in which the information is transmitted through the variation of the distance between the pulses, and not in the variation of the distance of the pulses from a fixed reference (see Section 1). This type of modulation is called "pulse-frequency modulation" (pulse-position modulation without fixed reference). It may be achieved by employing a sawtooth wave in the manner shown in Fig. 1.

The positions of the pulses (the sampling points) coincide with those of the vertical edges of the modulated sawtooth wave whose peaks ride the curve of the modulating signal. Thus the information (in our case, a simple harmonic wave) is contained in the fluctuation of the distances between the pulses.¹

In developing the first formal version of the theory of pulse-frequency modulation we need not go into a discussion of the circuits employed, since the geometrical picture in Fig. 1 furnishes us with an accurate description of the performance of such circuits. We will therefore use the geometric representation in Fig. 1 as the starting point of our theory.

3. Nonlinearity of Pulse-Frequency Modulation

Because of the extreme nonlinearity of pulse-frequency modulation, the mathematical theory of this type of modulation cannot be constructed in the usual manner, with the harmonic analysis of the modulated pulse train as the starting point. The essential features and the type of regularity characteristic of this apparently random method of sampling begin to appear when we realize that these sampling points are iterations of a one-to-one continuous transformation (induced by the method of sampling) of the interval 0 to $2\pi/\omega$ (the period of our signal). [See Section 9.] A study of the properties of such transformations² yields information which, when applied to the particular case of the transformation of the type $\psi_f(t)$ in Section 9, yields information regarding the position of sampling points at once.

It is surprising that, after the equilibrium is reached, the positions of the sampling points do not depend upon the starting point, but only upon the ratio f_s/f_p of the frequency f_s of the signal to the unmodulated pulse repetition rate f_p , and upon the amplitude of the signal.

4. The Principal Aim of This Study

The principal aim in this paper is to study the intrinsic properties of pulse-frequency modulation. The whole process of coding (incorporating information into the pulse train) and decoding (extracting this information at the receiver end) in this type of modulation is achieved by fairly complex configurations of nonlinear circuits whose behavior cannot always be simply analyzed. Many of the behavior characteristics of pulse-frequency modulation are quite unexpected. It becomes desirable, therefore, even in the study of design, to be able to distinguish those features of the behavior which belong strictly to the type of modulation employed, from those which may be due to the defects of a special circuit pattern employed to achieve this type of modulation.

To illustrate this, we may mention the phenomenon of the occurrence of "subharmonics." Thus, when a sig-

nal of frequency equal to $2/3$ of the pulse frequency f_p was transmitted, the receiver also picked up a signal of frequency $1/3 f_p$. Far from being a defect in coding or decoding circuits, this proved to be a peculiarity of the pulse-frequency modulation, and similar subharmonics were predicted and observed for other frequencies.

THE FORMAL MATHEMATICAL THEORY

5. Preliminary Remarks

We will assume a fixed *unmodulated pulse rate* f_p . We will study the response of the circuit to a wide range of signal frequencies, and will seek the maximal range of the signal frequency for which the corresponding periodic signal may be transmitted with acceptable accuracy.

The troublesome part of the spectrum, namely, the principal intervals of stability (0.4855, 0.51625), (0.33599, 0.33863), (0.6450, 0.6626), and (0.402645, 0.403030), is studied in detail in Sections 12, 15, 16, and 17.

The study of response will consist of a comparison between a periodic signal as it enters the coder in the transmitter, and the decoded version at the output of the receiver.³ This comparison will be made upon the basis of the intrinsic properties of the given type of modulation. The degree of faithfulness in the reproduced signal, as deduced on this basis, will represent the best theoretical performance of this particular type of modulation.

At the receiver, the process of extracting the information (*decoding*) contained in the train of pulses, generated by the sawtooth modulated as above, consists of reconstruction of the sawtooth, replacement of the sawtooth by a step function approximating the signal curve, and finally in averaging this step function.

The discontinuities of this step-function approximation occur at the positions of the vertical edges of the sawtooth and the peak value of each tooth persists until the next discontinuity. Thus, the effect is that of approximating the signal curve by selecting the points of intersection with the sawtooth edges, i.e., the values of the signal at the sampling points, and constructing the step function upon the basis of this selection (see Fig. 2).

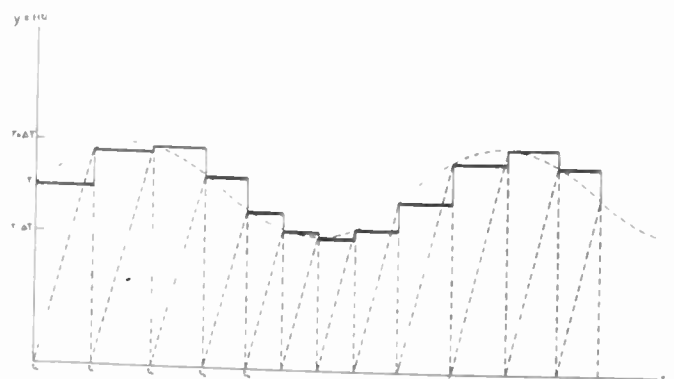

Fig. 2—The step function approximation to the signal.

¹ This type of pulse communication scheme was suggested in "Report on Pulse Modulation," December 27, 1944, an unpublished Stromberg-Carlson Report by Harold Goldberg, now at the Bureau of Standards, Washington, D. C.

² A. E. Ross, *Bull. Amer. Math. Soc.*, vol. 53, p. 287; 1947

³ See Section 19.

It will be shown that the accuracy in the reconstruction of the signal depends not only upon the number of sampling points per period of the signal, but also upon their distribution.

We will proceed with a detailed discussion of our problem.

6. The Sawtooth Wave

The ordinary sawtooth wave is the graph of a function

$$f(t) = m \left(t - \frac{qT}{m} \right); \quad \frac{qT}{m} < t \leq \frac{(q+1)T}{m};$$

$$q = 0, 1, \dots$$

Here, T is the height of each tooth and m is the slope of each edge. This function $f(t)$ is periodic with the period T/m , and is continuous except at

$$t = q \cdot \frac{T}{m},$$

where it jumps by the amount T . Such a function may be represented by a Fourier series. That is,

$$f(t) = a_0 + \sum_{k=1}^{\infty} (a_k \cos k\omega_p t + b_k \sin k\omega_p t), \quad \omega_p = \frac{2\pi m}{T}$$

7. Modulated Sawtooth Wave

If, in the definition of $f(t)$ in paragraph six, we do not use the straight line $y = T$, but the curve

$$y = T + \Delta T \sin \omega t,$$

oscillating with amplitude ΔT and frequency ω , as the locus upon which the peaks of the sawtooth wave lie, then we obtain a new function $f(t)$ which will usually not be periodic, and whose graph (see Fig. 2) may be called a *modulated sawtooth wave*. The sine curve

$$S = y - T = \Delta T \sin \omega t$$

may be called the modulating signal.

This new function $f(t)$, determined by the modulated sawtooth, may be characterized as follows:

$$f(t) = m(t - t_0); \quad t_0 < t \leq t_1;$$

$$t_1 = t_0 + \frac{T + \Delta T \sin \omega t_1}{m}$$

$$f(t) = m(t - t_1); \quad t_1 < t \leq t_2;$$

$$t_2 = t_1 + \frac{T + \Delta T \sin \omega t_2}{m}$$
(1)

Thus, the peaks are always considered as part of the graph.

We notice that if $f(t)$ is periodic of period P , i.e., if

$$f(t + P) = f(t)$$

for every t , then $t_k + P$, as well as t_k , is a point of discontinuity. Hence

$$\sin \omega(t_k + P) = \sin \omega t_k$$

and

$$\omega P = 2n\pi.$$

unless*

$$t_k - t_{k-1} = N \cdot \frac{\pi}{\omega}, \quad \text{while } t_k = g_k \cdot \frac{\pi}{\omega}, \quad (k = 1, 2, \dots)$$

n, N, g_k integers.

8. The Points of Discontinuity t_k of $f(t)$

The function whose graph is the modulated sawtooth wave is not necessarily periodic, i.e., it is not necessarily the resultant of a number of simple harmonic oscillations whose frequencies are integral multiples of a fundamental frequency.

One may then ask if this function $f(t)$ can be thought of as the resultant of sinusoidal oscillations of various frequencies not necessarily simply related to one another, i.e., if $f(t)$ is not periodic, is it "almost periodic"?

It seems that the most natural approach to the determination of the behavior of $f(t)$ is through the study of the distribution of the points of discontinuity, t_k of $f(t)$, when plotted on a circle of radius $1/\omega$ and circumference $2\pi/\omega$, the period of the modulating signal. If points t_k, t_s lie near one another on this circle, then $f(t_k)$ and $f(t_s)$ are nearly equal, and if t_k and t_s lead to the same point of this circle, then $f(t_k) = f(t_s)$.

9. Plotting of t_k on the ω^{-1} -Circle

Plotting t_k upon a circle of radius $1/\omega$ consists in measuring off along its circumference the distance t_k in a counterclockwise direction from an arbitrary reference point. Thus, two values t_k and t_s , differing by a multiple of $2\pi/\omega$, will be represented by the same point on the circumference of this circle (see Fig. 3).

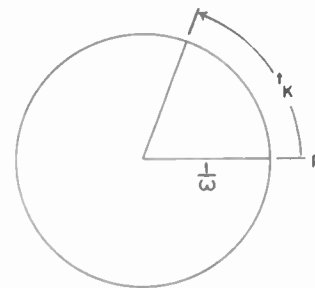
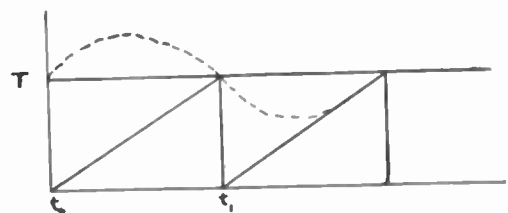

Fig. 3—The ω^{-1} -circle.

In view of the relations in (1), the two successive points of discontinuity, t_0 and t_1 , of the modulated signal

* I.e., for example:



are connected by the formula

$$t_0 = t_1 - \frac{T}{m} - \frac{\Delta T}{m} \sin \omega t_1. \tag{2}$$

The function

$$\Phi(i) = i - \frac{T}{m} - \frac{\Delta T}{m} \sin \omega i \tag{3}$$

is a single-valued steadily increasing function of i as long as its slope is positive. That is, as long as

$$\frac{\Delta T \omega}{m} < 1. \tag{4}$$

This has very simple physical significance regarding the relative positions of sampling points on the oscilloscope, when the full sweep corresponds to the period of our signal.

Inequality (4) may also be written in the following form:

$$\frac{\Delta T}{T} < \frac{1}{2\pi} \frac{f_p}{f_s}, \tag{5}$$

where $f_p = m/T$ is the unmodulated sawtooth (pulse) frequency. This restricts the value of the ratio of the signal voltage ΔT to the voltage height of the unmodulated sawtooth.

For $T=100$ v, the following table gives the approximate value of an upper bound B (measured in volts) of ΔT for $f_p/f_s = 1, 2, 3$.

$\frac{f_p}{f_s}$	1	2	3
B (Volts)	16	32	48

$$\Delta T \leq B.$$

However, the value of $\Delta T/T$ (the "depth of modulation") may be restricted in a more stringent manner by other physical characteristics of the system, as for example, by the pulsed power supply of a magnetron. Thus, the condition expressed by the inequality (5) or (4) is fulfilled in practice. To create an appropriate mathematical model which would make it possible for us to study in detail the behavior of sampling points, we note that as i varies from 0 to $2\pi/\omega$, $\Phi(i)$ varies from $-T/m$ to $-T/m + 2\pi/\omega$, and, hence, $\Phi(i)$ maps the ω^{-1} -circle into itself. Since $\Phi(i)$ is steadily increasing, its inverse $\psi_f(t)$ is also single-valued. Thus, $\psi_f(t)$ is a one-to-one continuous transformation of the ω^{-1} -circle into itself. Moreover, the set of all the discontinuities of the modulated sawtooth commencing at t_0 is exactly the set of the images,

$$t_1 = \psi_f(t_0), t_2 = \psi_f^2(t_0), \dots \tag{7}$$

of t_0 obtained by using the powers⁵ of the transformation $\psi_f(t)$. The problem of the distribution of the discontinuities of the sawtooth is therefore reduced to the study of the behavior of the chain (7) of images of the one-to-one continuous transformation $\psi_f(t)$ of a circle into itself. A detailed study of the fundamental properties of such transformations has been made elsewhere.² In what follows we will apply the general results to the special transformations $\psi_f(t)$ induced by the modulated sawtooth through (3).

10. The Significance of Fixed Sampling Points

Let ψ_f^k be the smallest power of ψ_f for which sampling points repeat. Then, there exists a finite chain of points t_0, t_1, \dots, t_{k-1} such that $t_{i+1} = \psi_f(t_i)$, and $t_0 = \psi_f(t_{k-1})$. These points are the fixed sampling points at which the sawtooth samples the sinusoidal signal of frequency f_s . Since the plot on the ω^{-1} -circle does not distinguish between points which are a distance $N \cdot 2\pi/\omega$ apart (N an integer), these sampling points

$$t_0 = \psi_f^k(t_0), t_1 = \psi_f(t_0), \dots, t_{k-1} = \psi_f^{k-1}(t_0) \tag{8}$$

need not all be in the same period, but may be spread over two or more, say n periods. In this case, the sawtooth is the graph of a periodic function with the period $n \cdot 2\pi/\omega$ and the fundamental frequency f_s/n . We shall designate such a closed chain of sampling points as an "equilibrium configuration." The case $n=2, k=3$ is illustrated in Fig. 4.

It is clear that the relationship between the audio signal and the step-function counterpart in the decoder and, hence, between this signal and its final reproduction in the receiver, depends upon the distribution of the sampling points. Therefore, it is important to study the above-mentioned equilibrium configurations belonging to various signal frequencies f_s . Since these configurations are determined by the position of the fixed points² of the transformation $\psi_f^k(t)$, one is led to the study of such fixed points.

INTERVALS OF STABILITY

11. Approximate Estimate: The Case $n=1, k=2$

In the following discussion, a fixed pulse repetition rate f_p and a fixed depth of modulation $\Delta T/T$ are assumed. The question which then arises is: What can be said about the value of the signal frequency f_s if it is known that it leads to an equilibrium configuration with a fixed n and a fixed k ? An estimate can first be made, as follows: Consider the case $n=1, k=2$. The finite chain (8) of images consists of two points t_0 and t_1 such that

$$t_0 = t_1 - \frac{T}{m} - \frac{\Delta T}{m} \sin \omega t_1 \tag{9}$$

⁵ Here, $t_2 = \psi_f^2(t_0) = \psi_f[\psi_f(t_0)] = \psi_f(t_1)$, where $t_1 = \psi_f(t_0)$. Similarly, $t_0 = \psi_f^3(t_0) = \psi_f[\psi_f^2(t_0)] = \psi_f(t_{0-1})$.

$$t_1 = t_0 + \frac{2\pi}{\omega} - \frac{T}{m} - \frac{\Delta T}{m} \sin \omega t_0. \quad (10)$$

That is,

$$t_1 = \psi_f(t_0), \quad t_0 = \psi_f^2(t_0).$$

Here, $\omega = 2\pi f_s$. Adding (9) and (10) transposing terms, and multiplying both members of the resulting equality by $m/\Delta T$, the result is

$$\frac{m}{\Delta T} \left(\frac{2\pi}{\omega} - \frac{2T}{m} \right) = \sin \omega t_0 + \sin \omega t_1. \quad (11)$$

Since the right-hand member does not exceed two in absolute value,

$$-2 \leq \frac{m}{\Delta T} \left(\frac{2\pi}{\omega} - \frac{2T}{m} \right) \leq 2,$$

and hence, first obtaining the inequality for $(f_s/f_p)^{-1}$, we have

$$\frac{1}{2} \cdot \frac{1}{1 + \frac{\Delta T}{T}} \leq \frac{f_s}{f_p} \leq \frac{1}{2} \cdot \frac{1}{1 - \frac{\Delta T}{T}}$$

because $\omega = 2\pi f_s$ and $m/T = f_p$. This inequality shows that every signal frequency f_s which leads to an equilibrium configuration with $n=1$ and $k=2$ must lie in an interval about $f_p/2$. The lower and the upper bounds for f_s/f_p depend upon the depth of modulation $\Delta T/T$.

12. Precise Determination of the Interval of Stability

Since the position of t_1 is known when that of t_0 is known, the whole configuration is determined by the position of its first fixed (or locking) point. Replacing t_1 in (11) by its value in (10), multiplying by $\Delta T/T$ and transposing some terms,

$$\left(\frac{f_s}{f_p} \right)^{-1} = 2 + \frac{\Delta T}{T} \left[\sin 2\pi f_s \cdot t_0 + \sin \left(2\pi f_s \cdot t_0 - 2\pi \frac{f_s}{f_p} - 2\pi \frac{f_s}{f_p} \cdot \frac{\Delta T}{T} \sin 2\pi f_s \cdot t_0 \right) \right]. \quad (12)$$

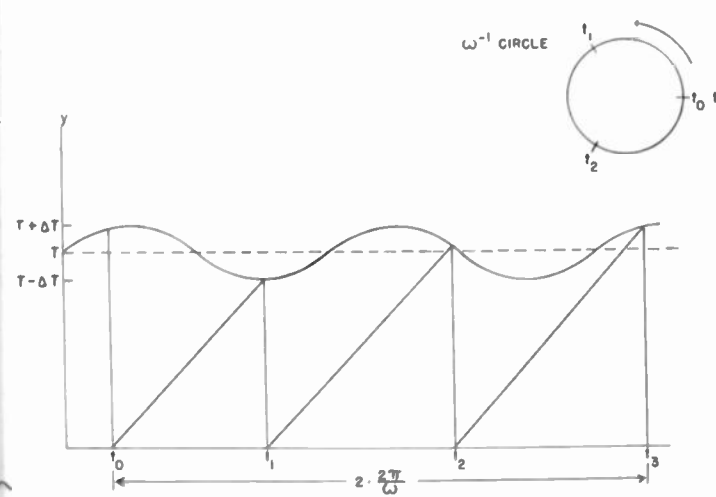

Fig. 4—The fixed sampling points for $n=2, k=3$.

For a fixed depth of modulation $\Delta T/T$ and a fixed pulse frequency f_p , this equation determines the ratio $U=f_s/f_p$ as a single-valued function $\phi(\omega t_0)$ of the position in the period of the locking point ωt_0 . The region of frequencies f_s for which f_s/f_p lies between the maximum and the minimum of $\phi(\omega t_0)$ for $0 \leq t_0 \leq 2\pi/\omega$, is the region of frequencies for which there exist equilibrium configurations with $n=1, k=2$. Fig. 5, in which the

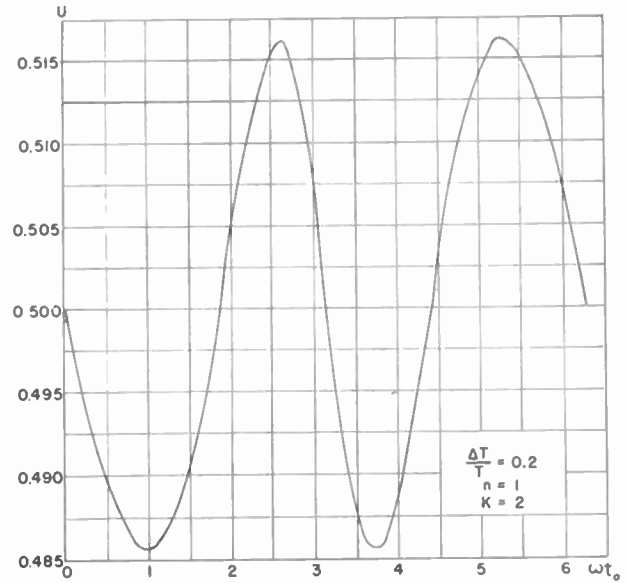

Fig. 5—Graph of $U = \phi(\omega t_0)$ for $n=1, k=2$.

graph of $\phi(\omega t_0)$ for $\Delta T/T = 0.2$ is drawn to a large scale, gives the values 0.4855 and 0.51625 for the minimum and the maximum of $\phi(\omega t_0)$, respectively. In constructing the graph of this function, the solution of (12) was carried out graphically.

All the fixed points of $\psi_f^2(t)$ are given by the values t_i of the points of intersection of a horizontal straight line drawn at $U=f_s/f_p$, and the curve $U=\phi(\omega t_0)$. There are four such intersections for each value of f_s . The first and the third of these determine one equilibrium configuration, the second and fourth determine another. Thus, in Fig. 5, $f_s/f_p = 0.5$ and the values t_i of the points of intersection of the line $f_s/f_p = 0.5$ are 0, $1.852/\omega$, $3.14/\omega$, $4.43/\omega (= -1.852/\omega)$. Of these, the chain 0, $3.14/\omega = \psi_{f_p/2}(0)$ gives one equilibrium configuration, and $1.852/\omega, 4.43/\omega = \psi_{f_p/2}(1.852/\omega)$ gives the other.

INTERVALS OF STABILITY—THE GENERAL CASE

13. An Estimate of the Location of the Intervals of Stability

Next to be investigated are the conditions imposed upon f_s by the requirement that the k th power of $\psi_f(t)$ should have fixed points. Here $\psi_f(t)$ is the transformation of the ω^{-1} -circle induced by the signal through (2).

In view of the interpretation of (2) in Fig. 3, two points, t and \hat{t} , on the time axis are represented by the same point $p_0 = p$ on the ω^{-1} -circle if, and only if, $t - \hat{t}$ is

an integral multiple of $2\pi/\omega$. Thus, if a chain

$$\begin{aligned} t_0 &= t_1 - \frac{T}{m} - \frac{\Delta T}{m} \sin \omega t_1 \\ t_1 &= t_2 - \frac{T}{m} - \frac{\Delta T}{m} \sin \omega t_2 \\ &\dots \\ t_{k-1} &= t_k - \frac{T}{m} - \frac{\Delta T}{m} \sin \omega t_k \end{aligned} \tag{13}$$

of images t_0, t_1, \dots, t_k is considered, then the point $p_0 = p_k$ is a fixed point of $\psi_j^k(t)$ if, and only if

$$t_k = t_0 + \frac{2n\pi}{\omega}, \tag{14}$$

where n is an integer. Substituting the value (14) into (13), adding all the equalities (13) and canceling similar terms,

$$0 = \frac{2n\pi}{\omega} - \frac{kT}{m} - \frac{\Delta T}{m} (\sin \omega t_0 + \dots + \sin \omega t_{k-1})$$

or

$$\frac{m}{\Delta T} \left(\frac{2n\pi}{\omega} - \frac{kT}{m} \right) = \sin \omega t_0 + \dots + \sin \omega t_{k-1}. \tag{15}$$

The right-hand member of (15) lies between $-k$ and k . Let

$$-\theta_1 k \text{ and } \theta_2 k$$

be its minimum and its maximum, respectively. Then

$$\theta_1 \leq 1 \text{ and } \theta_2 \leq 1.$$

Also, in view of (15),

$$-\theta_1 k \leq \frac{m}{\Delta T} \left(\frac{n}{f_s} - \frac{kT}{m} \right) \leq \theta_2 k. \tag{16}$$

Hence,

$$\phi_{\max} = \frac{n}{k} \cdot \frac{1}{1 - \theta_1 \frac{\Delta T}{T}} \geq \frac{f_s}{f_p} \geq \frac{n}{k} \cdot \frac{1}{1 + \theta_2 \frac{\Delta T}{T}} = \phi_{\min}. \tag{17}$$

Thus, for a given k and a given n in (14), the corresponding frequencies f_s lie in the interval

$$f_p \cdot \phi_{\max} \geq f_s \geq f_p \cdot \phi_{\min}. \tag{18}$$

14. Frequency f_s in an Interval of Stability, as a Real-Valued Continuous Function of ωt_0 for $0 \leq \omega t_0 \leq 2\pi$

To prove that for every ωt_0 there exists a unique corresponding frequency f_s in (18) such that t_0 is one of the points in a finite chain of k images, $(t_0, t_1, t_2, \dots, t_{k-1})$, (15) may be rewritten as follows:

$$\frac{m}{T} \cdot \frac{n}{f_s} = k + \frac{\Delta T}{T} (\sin \omega t_0 + \dots + \sin \omega t_{k-1}). \tag{19}$$

In view of (13),

$$\begin{aligned} \omega t_{k-1} &= \omega t_k - 2\pi \frac{f_s}{f_p} \left(1 + \frac{\Delta T}{T} \sin \omega t_k \right) \\ \omega t_{k-2} &= \omega t_{k-1} - 2\pi \frac{f_s}{f_p} \left(1 + \frac{\Delta T}{T} \sin \omega t_{k-1} \right) \\ &\dots \\ \omega t_1 &= \omega t_2 - 2\pi \frac{f_s}{f_p} \left(1 + \frac{\Delta T}{T} \sin \omega t_2 \right) \\ \omega t_0 &= \omega t_1 - 2\pi \frac{f_s}{f_p} \left(1 + \frac{\Delta T}{T} \sin \omega t_1 \right). \end{aligned} \tag{20}$$

If t_k is set equal to $t_0 + 2n\pi/\omega$, then the first $(k-1)$ equalities in (20) give ωt_j as a continuous and differentiable function of both f_s/f_p and ωt_0 for $j=1, \dots, k-1$. It is assumed that f_p is fixed. Thus, the right-hand member of (19) is a continuous and differentiable function of both f_s and ωt_0 . Write

$$\begin{aligned} k + \frac{\Delta T}{T} (\sin \omega t_0 + \dots + \sin \omega t_{k-1}) \\ = F \left(\frac{f_s}{f_p}, \omega t_0 \right). \end{aligned} \tag{21}$$

Then,

$$k \left(1 - \frac{\Delta T}{T} \right) \leq F \left(\frac{f_s}{f_p}, \omega t_0 \right) \leq k \left(1 + \frac{\Delta T}{T} \right). \tag{22}$$

On the other hand, the left-hand member (see equation 19) is

$$\frac{m}{T} \cdot \frac{n}{f_s} = n / \frac{f_s}{f_p}. \tag{23}$$

a steadily decreasing function of f_s/f_p alone, and its minimum and maximum in the interval (18) are, respectively,

$$k \left(1 - \theta_1 \frac{\Delta T}{T} \right) \text{ and } k \left(1 + \theta_2 \frac{\Delta T}{T} \right). \tag{24}$$

Comparing these values with the bounds in the inequalities of (22), it is seen that, for each fixed value of ωt_0 in the interval $(0, 2\pi)$, there exists a real value of f_s/f_p for which

$$n / \frac{f_s}{f_p} = F \left(\frac{f_s}{f_p}, \omega t_0 \right), \tag{25}$$

i.e., for which (19) holds true. The corresponding value f_s is the frequency for which ωt_0 is one of the points in an equilibrium configuration of k sampling points. As in Section 12: $f_s/f_p = \phi(\omega t_0)$. Since all the functions involved are continuous and differentiable in all the variables under consideration, $\phi(\omega t_0)$ is continuous in the neighborhood of any pair of values $f_s/f_p, \omega t_0$ satisfying (25).

EXAMPLES OF INTERVALS OF STABILITY FOR
ADDITIONAL VALUES OF n AND k

15. The Case $n=1, k=3, \Delta T/T=0.2$

Here the third power of $\psi_f(t)$ should have fixed points. Therefore, in view of (20)

$$\begin{aligned} \omega t_0 &= \omega t_1 - 2\pi \frac{f_s}{f_p} \left(1 + \frac{\Delta T}{T} \sin \omega t_1 \right) \\ \omega t_1 &= \omega t_2 - 2\pi \frac{f_s}{f_p} \left(1 + \frac{\Delta T}{T} \sin \omega t_2 \right) \\ \omega t_2 &= \omega t_0 + 2n\pi - 2\pi \frac{f_s}{f_p} \left(1 + \frac{\Delta T}{T} \sin \omega t_0 \right) \end{aligned} \quad (26)$$

and hence (see (19)), for $n=1$,

$$1/U = 3 + \frac{\Delta T}{T} (\sin \omega t_0 + \sin \omega t_1 + \sin \omega t_2), \quad (27)$$

where $U = f_s/f_p$. In view of (26), this equation determines U as a single-valued continuous function, $\phi(\omega t_0)$, of ωt_0 . This function is plotted in Fig. 6 for $\Delta T/T=0.2$. Here the minimum and maximum values of ϕ are 0.33599 and 0.33863, respectively.

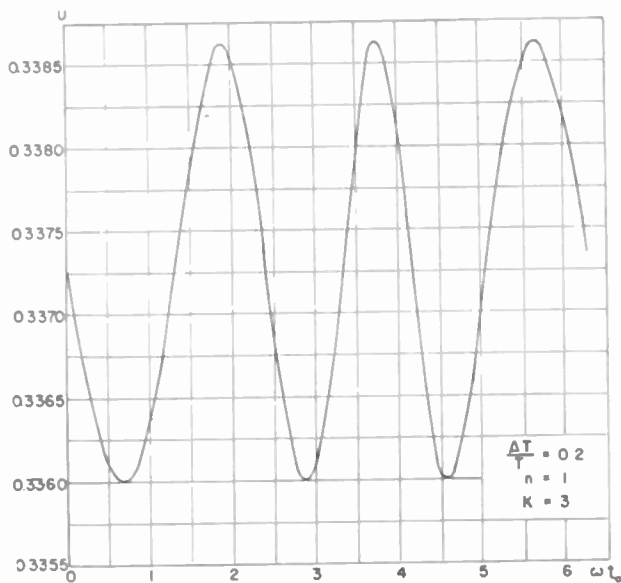

Fig. 6—Graph of $U = \phi(\omega t_0)$ for $n=1, k=3$.

16. The Case $n=2, k=3, \Delta T/T=0.2$

As in Section 15, here the third power of $\psi_f(t)$ should have fixed points. Hence (26) is again used and n is set equal to 2. From this is obtained

$$2/U = 3 + \frac{\Delta T}{T} (\sin \omega t_0 + \sin \omega t_1 + \sin \omega t_2), \quad (28)$$

where $U = f_s/f_p$. The function $U = \phi(\omega t_0)$ determined by this expression is plotted in Fig. 7. In determining the sampling points of the equilibrium positions corresponding to a fixed value of f_s/f_p it should be noted that in this case the points of intersection of the straight line

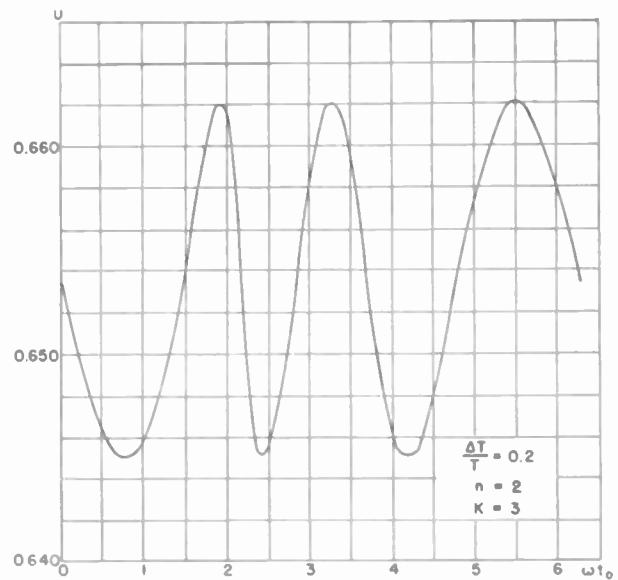

Fig. 7—Graph of $U = \phi(\omega t_0)$ for $n=2, k=3$.

$U = f_s/f_p$ with the curve do not give the sampling points in their proper sequence. For example, if $f_s/f_p = 0.6530$, the points as given by Fig. 7 are:

$$\frac{1.47}{\omega}, \quad \frac{2.83}{\omega}, \quad \text{and} \quad \frac{4.77}{\omega}$$

However, the actual sampling points are distributed over two periods, as follows:

$$t_0 = \frac{1.47}{\omega}, \quad t_1 = \frac{4.77}{\omega}, \quad t_2 = \frac{9.11}{\omega} = \frac{2.83 + 2\pi}{\omega}$$

Here the minimum and maximum values of ϕ are 0.6450 and 0.6626, respectively.

17. The Case $n=2, k=5, \Delta T/T=0.2$

Here the fifth power of $\psi_f(t)$ should have fixed points. Fig. 8 is the graph makes which it possible for us to de-

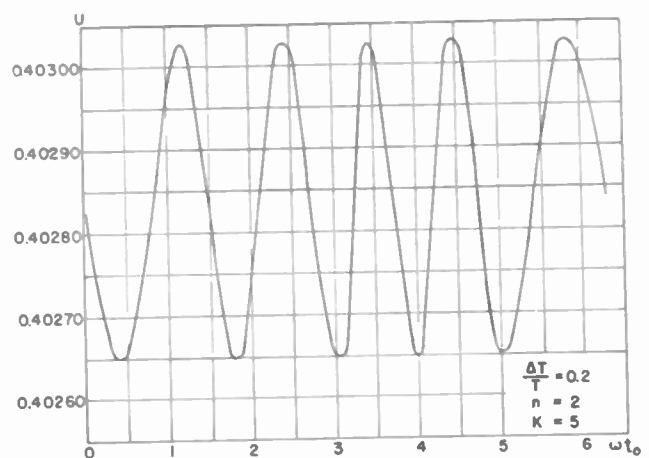

Fig. 8—Graph of $U = \phi(\omega t_0)$ for $n=2, k=5$.

termine the position of the fixed points in the spectrum region $0.402645 \leq f_s/f_p \leq 0.403030$.

We have made numerous oscilloscope photographs in which markers indicated the actual position of sampling

points in the period of our signal. These pictures are in remarkable agreement with theoretical prediction.

Such a photograph for the case $n = 1, k = 3$ is given in Fig. 9.

COMPARISON OF THE EXPERIMENTAL DATA WITH THE THEORETICAL PREDICTIONS

18. The Apparent Phase Shift

When the location of the points of equilibrium configurations was determined from the graph in Fig. 6, and when these results were compared with Fig. 9, the ob-

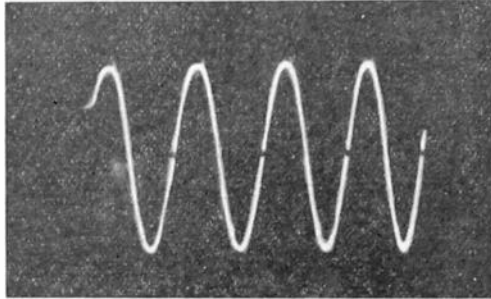

Fig. 9—Signal with markers to indicate the positions of sampling points for $n = 1, k = 3$.

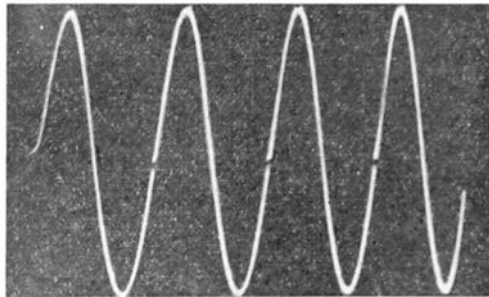

Fig. 11

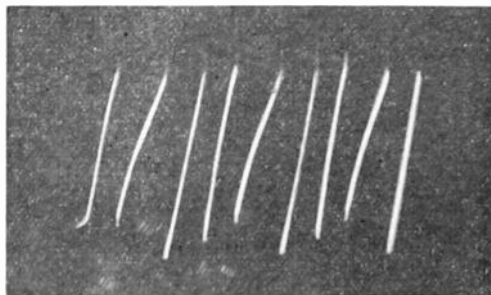

Fig. 12

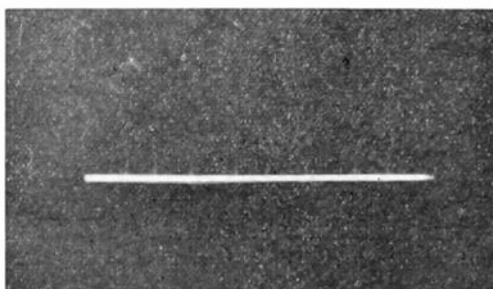

Fig. 13

served positions seemed to be shifted by the amount π/ω from the predicted locations. The reason for the apparent shift lies in the fact that the theoretical signal curve in Fig. 1 is in reality the negative of the actual signal translated vertically through the distance T . Fig. 10 shows the actual signal, the fictitious signal, and the sampling action of the sawtooth.

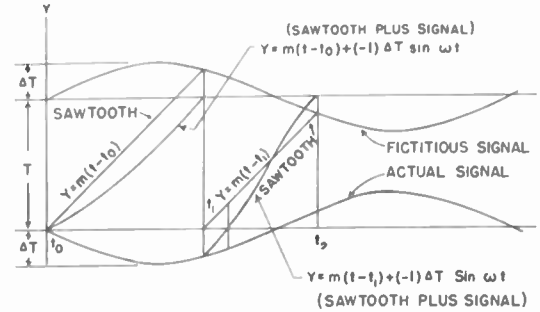

Fig. 10—The action of the sawtooth on the actual and fictitious signals.

19. An Experimental Study of Six Stages in the Coding and Decoding of a Sinusoidal Signal

Figs. 11 to 16 represent a study of what happens to the incoming information (here, a sinusoidal signal) at

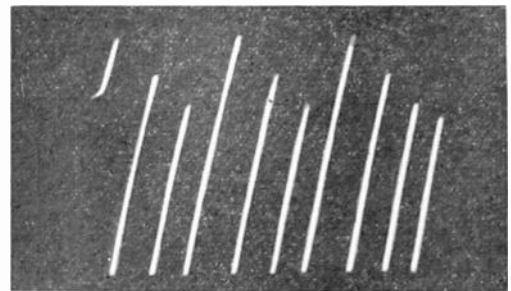

Fig. 14

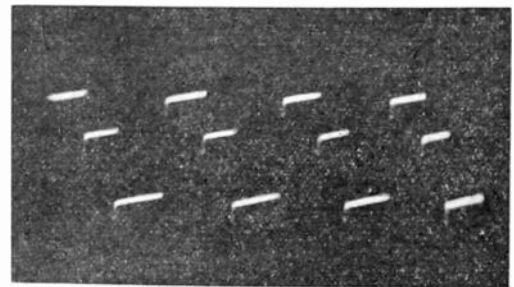

Fig. 15

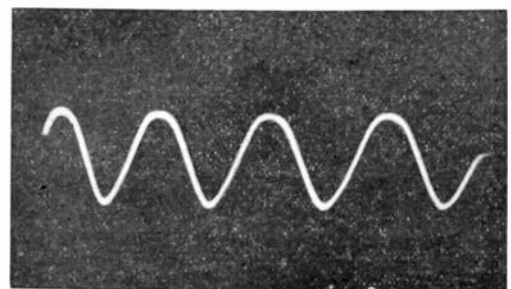

Fig. 16

Figs. 11-16—The photographs of the stable equilibrium conditions at various stages of coding and decoding.

various stages of transmission in pulse communication.

Fig. 11 shows the incoming signal with markers which indicate the position of sampling points. Fig. 12 corresponds to the theoretical representation of the sawtooth in Fig. 10; its lower part contains the information. Fig. 13 shows the modulated pulse train as it leaves the coder. The information is contained in the variation of the distance between successive pulses. The actual means of transmitting and receiving the coded energy are irrelevant here, so these topics are omitted. This allows the discussion to be resumed at the decoder input.

Fig. 14 shows reconstruction of that part of the sawtooth in Fig. 12 which contains the signal, while Fig. 15 contains a step function approximation (see Fig. 2) to the signal. Fig. 16 shows the fundamental of the step-function approximation. All other components have been effectively stopped by a low-pass filter. The curve in this picture indicates how the information in Fig. 11 appears at the receiving end.

$\sin \omega t$ become respectively 0.198 and -0.108 . To find the Fourier series expansion for the resulting signal, move the origin in Fig. 17 ($\pi+0.2$) units to the right. Then,

$$a_1 = \frac{1}{\pi} \int_{-\pi}^{-0.09} 0.198 \cos \omega t d(\omega t) - \frac{1}{\pi} \int_{-0.09}^{\pi} 0.108 \cos \omega t d(\omega t) = -0.0275$$

$$b_1 = \frac{1}{\pi} \int_{-\pi}^{-0.09} 0.198 \sin \omega t d(\omega t) - \frac{1}{\pi} \int_{-0.09}^{\pi} 0.108 \sin \omega t d(\omega t) = -0.1944.$$



Fig. 17—Locking points (0.2, 3.25) and (1.69, 4.25) $n=1, k=2, f_s/f_p=0.495$.



Fig. 18—Locking points (0.48, 3.42) and (1.45, 4.05) $n=1, k=2, f_s/f_p=0.49$.



Fig. 19—Locking points 0.08, 2.8, 4.82, 7.85, 10.09, 12.64 $n=1, k=5, f_s/f_p=0.402$.

FREQUENCY RESPONSE OF PULSE-FREQUENCY MODULATION SCHEME

20. General Considerations

It was established in Section 5 that for every fixed value f_s/f_p in a wide range of such values, fixed positions are obtained for the sampling points. If fixed points belonging to a stable equilibrium position are chosen, and the values of the signal at these points are used to construct a step function, the theoretical equivalent of the information received by the coder will be obtained. If this step function is represented in its Fourier series form, the effect of the low-pass filter in the output results in selection of the first few terms of the series.

In the case of a sinusoidal signal, the information to be considered relevant must be only that term of the Fourier series which corresponds to the frequency of the original signal. It should be noted, however, that this frequency is not necessarily the fundamental frequency of the step function (i.e., the Fourier series). In fact, for fixed values of n and k , this fundamental frequency is f_s/n . Thus, the proper signal frequency f_s occurs as the n th harmonic. This leads to a phenomenon which may be termed "frequency division." By the study of the frequency response of a pulse-frequency modulation scheme is meant the study of the variation in the amplitude of the term belonging to the frequency f_s in the output of the decoder as a function of f_s , or better, f_s/f_p . It is assumed, of course, that the amplitude of the coded signal of frequency f_s is of constant magnitude.

21. Frequency Analysis

The computational procedure employed may be understood from the text and Figs. 17 through 19.

(a) The case of $n=1, k=2, f_s/f_p=0.495$.

For the fixed or locking points (0.2, 3.25) the values of

The amplitude of the f_s component ($f_s=0.495 f_p$), as it appears in the decoder output is

$$\sqrt{a_1^2 + b_1^2} = 0.1968.$$

Similarly, for the locking points (1.69, 4.25)

$$a_1 = -0.3305, b_1 = -1.1068 \text{ and } \sqrt{a_1^2 + b_1^2} = 1.158.$$

This analysis and the figure (Fig. 17) contain both of the equilibrium configurations.

(b) The case of $n=1, k=2, f_s/f_p=0.49$.

n	k	locking points	a_1	b_1	$\sqrt{a_1^2 + b_1^2}$	f_s/f_p
1	2	0.48 3.42	-0.0464	-0.4643	0.4666	0.49
1	2	1.45 4.05	-0.2912	-1.052	1.091	0.49

Since the amplitude of the incoming signal is unity, the values given above of the amplitude of the same signal at the output of the coder give a clear idea of the degree of attenuation of the signal of this particular frequency.

(c) A case where fundamental frequency of the step function is equal to $1/2f_s$ is given in Fig. 19. Here the amplitude of the component corresponding to f_s is given by the second coefficients of the Fourier series. It is

$$\sqrt{a_2^2 + b_2^2} = 0.7520.$$

22. Conclusion

An analysis of pulse-frequency modulation has indicated that the accuracy in the reconstructed signal depends not only upon the number of sampling points per period of the signal, but also upon their distribution. In general, the distribution of sampling points does not seem to be periodic, but for a given pulse repetition rate (unmodulated) and depth of modulation there are certain frequencies for which the sampling becomes periodic, and for which the sampling points occur at definitely determined points of the signal wave. These points have been designated as fixed or locking points, and the conditions which produce them have been called equilibrium conditions. For a given set of conditions, the frequency range for which locking points may occur can be determined, and for a given frequency within this range the actual locking points can be found.

The theoretical analysis has been made on the basis of mathematical considerations from topology. This analysis indicates that the positions of the locking points do not depend upon the position of the first point at which the signal wave is sampled, but depend only upon the ratio of the frequency of the signal to the unmodulated pulse repetition rate and upon the ratio of the signal amplitude to the unmodulated amplitude of the sampling wave. This leads to the suggestion that, if the first sampling does not occur at a locking point, there must exist a transient interval during which the sampling process reaches an equilibrium condition. This question is to be studied in a subsequent paper. It has been shown also, in every case studied, that two sets of equilibrium conditions exist. That is, the signal may be sampled at either of two sets of locking points. The question as to whether both of these sets of locking points correspond to conditions of stable equilibrium or whether one set corresponds to an unstable condition is also considered in the subsequent paper.

The significance of this present study is that it lays a firm theoretical foundation upon which more extended theoretical and experimental studies of pulse-frequency modulation may be based.

ACKNOWLEDGMENTS

The author wishes to acknowledge his indebtedness to H. Boehmer for his help in obtaining the photographs, and to Miss M. Tinlot for the very extensive calculations involved in the construction of the theoretical graphs.

APPENDIX

The previous theory has been extended to include nonsinusoidal periodic signals and it is shown that here, too, there are stability intervals and chains of sampling points. The sampling points and all of the limits of the stability intervals may be found by the same methods used for the sinusoidal signals.

This more general theory has been developed without the simplifying assumption that the edges of the sawtooth are linear. The relationship between successive sampling points is given by the formula

$$t_i = t_{i+1} + RC \cdot \ln \left[1 - \frac{T}{E} + \frac{1}{E} \cdot \alpha(\omega t_{i+1}) \right],$$

where R , C , and E are circuit constants and where $\alpha(\omega t)$ is a general periodic signal of period $2\pi/\omega$.

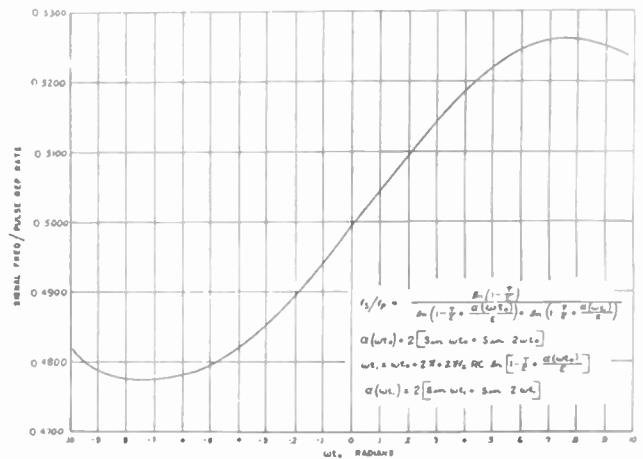

Fig. 20—A stability interval for a nonsinusoidal signal.

Fig. 20 describes the behavior of the nonsinusoidal signal

$$\alpha(\omega t) = 2[\sin \omega t + \sin 2\omega t]$$

in the interval of stability (0.4776, 0.5260) of the relative frequency spectrum.

TABLE OF SYMBOLS

ν , relative frequency.....	Summary
$\psi_f(t)$	Section 3
f_s , signal frequency.....	Section 3
f_p , pulse frequency.....	Section 3
$\Phi(i)$	Section 9
$\Delta T/T$, depth of modulation.....	Section 9
$f_s/f_p = \phi(\omega t_0) = U$	Section 12
ϕ_{max} = maximum of $\phi(\omega t_0)$	Section 13
ϕ_{min} = minimum of $\phi(\omega t_0)$	Section 13

Application of Fourier Transforms to Variable-Frequency Circuit Analysis*

A. G. CLAVIER†, FELLOW, IRE

Summary—Fourier transforms are very valuable for the analysis of the behavior of passive circuits when the driving force is frequency modulated. The output current or voltage is expressed in the form of a convolution integral, which can lead either to the expansion given by Carson and Fry or, preferably, to the van der Pol expansion in terms of the values of the transfer admittance or impedance for the instantaneous frequency, and its derivatives.

The proof given here lends itself to a discussion of the conditions for convergence. In certain cases, the convolution integral can be directly expressed in terms of known functions: this is the case, for instance, for broadband FM line discriminators, an analysis of which is given.

1. INTRODUCTION

CONSIDER a signal given as a function of time $f(t)$. With this signal can be associated a Fourier transform

$$T_{\omega} f(t) = \frac{1}{(2\pi)^{1/2}} \int_{-\infty}^{+\infty} f(t) \cdot \exp(-j\omega t) dt \quad (1)$$

This is a function of ω (angular frequency). There exists an extensive class of functions $f(t)$ (in particular, those for which $\int_{-\infty}^{+\infty} |f(t)| dt$ exists) for which the inverse transformation defined as

$$T_{\omega}^{-1} T_{\omega} f(t) = \frac{1}{(2\pi)^{1/2}} \int_{-\infty}^{+\infty} T_{\omega} f(t) \cdot \exp(j\omega t) d\omega \quad (2)$$

gives $f(t)$ as a result.

Extensive lists of Fourier transforms have been published;† all the main properties will be assumed to be known in the present paper.

A certain number of essentially singular functions can be associated with Fourier transforms. One of the most important is the unit impulse function, defined as follows.

Consider a rectangular pulse as shown in Fig. 1. Such a function has a regular Fourier transform which, according to the adopted definition, is found equal to

$$\frac{1}{(2\pi)^{1/2}} \frac{\sin \omega \frac{\tau}{2}}{\omega \frac{\tau}{2}}$$

Let τ tend towards 0. The limit is the unit impulse func-

tion, the Fourier transform of which is thus $1/(2\pi)^{1/2}$. By considering $1/(2\pi)^{1/2}$ in its turn as the limit of $\exp(-\alpha|\omega|)$ when the positive real number α tends toward

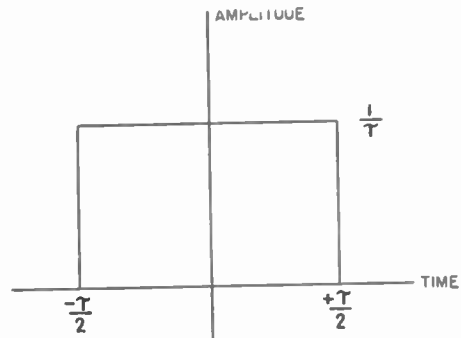

Fig. 1—Derivation of the unit impulse function.

0, it can be shown that $T_{\omega}^{-1}(1/(2\pi)^{1/2})$ corresponds to the unit impulse function, which we will designate as $S_0(t)$. It can be further shown that $S_0(t)$ and $1/(2\pi)^{1/2}$ considered in the previous light constitute a pair of Fourier transforms and can be treated in all mathematical problems as possessing the transformation properties associated with this mathematical concept. For instance, $S_0(t-t_0)$ and $1/(2\pi)^{1/2} \exp(-j\omega t_0)$ and conversely $S_0(\omega-\omega_0)$ and $1/(2\pi)^{1/2} \exp(j\omega_0 t)$ can be manipulated as valid pairs of Fourier transforms. This will be utilized in the following analysis.

2. GENERAL EXPRESSION OF THE RESPONSE OF A PASSIVE NETWORK²

The value of Fourier transforms resides in the following mechanisms. Starting from a known signal, let the associated Fourier transform be found. This Fourier transform is operated on by the circuit considered, the transfer characteristic of which is assumed to be known for all values of ω . The Fourier transform of the response is thus found, from which an inverse transformation T_{ω}^{-1} yields the response itself in the signal-time plane of co-ordinates. The general properties of the Fourier transforms will be found to lead quickly to the desired results in a number of cases, for which a more direct analysis is found to be lengthy and cumbersome.

Let a passive circuit be considered and its admittance $Y(j\omega)$ known for all values of ω . Let a signal $v(t)$ be applied, the response can be written symbolically

$$i(t) = T_{\omega}^{-1}[Y(j\omega)T_{\omega} v(t)] \quad (3)$$

* Decimal classification: R143. Original manuscript received by the Institute, November 17, 1948; revised manuscript received, July 11, 1949. Presented, Joint Meeting, URSI, American Section, and IRE, Washington Section, Washington, D. C., October 9, 1948.

† Federal Telecommunication Laboratories, Inc., Nutley, N. J.
¹ See, for instance, G. A. Campbell and R. M. Foster, "Fourier integrals for practical applications," *Bell Telephone System Monograph* B. 584.

² A. G. Clavier, "Application de la transformation de Laplace à l'étude des circuits électriques," *Rev. Gén. Elec.*, vol. 51, pp. 447-455; October, 1942.

To solve this equation, let a particular signal be applied to the network instead of $v(t)$ and, in fact, let it be the unit impulse function $S_0(t)$. The corresponding response will be

$$u(t) = T_{\omega}^{-1} \left[Y(j\omega) X \frac{1}{(2\pi)^{1/2}} \right]. \quad (4)$$

This is equivalent to

$$Y(j\omega) = T_{i^{\omega}}(2\pi)^{1/2} u(t). \quad (5)$$

The response $i(t)$ of the circuit to $v(t)$ can now be written

$$i(t) = T_{\omega}^{-1} [T_{i^{\omega}}(2\pi)^{1/2} u(t) \cdot T_{i^{\omega}} v(t)], \quad (6)$$

that is to say the Fourier transform of the response $i(t)$ is the product of two Fourier transforms: (1) the Fourier transform of the response of the network to the unit impulse function; (2) the Fourier transform of the signal $v(t)$ really applied.

The answer to this problem is given in tables of Fourier transforms. The response $i(t)$ is given by either one of the following equations

$$\left. \begin{aligned} i(t) &= \int_{-\infty}^{+\infty} u(t-x)v(x)dx \\ i(t) &= \int_{-\infty}^{+\infty} u(x)v(t-x)dx \end{aligned} \right\} \quad (7)$$

A result that is often expressed by saying that $i(t)$ is the convolution product of $u(t)$ and $v(t)$.

3. EXAMPLE: ELEMENTARY ANALYSIS OF LINE DISCRIMINATORS

The direct computation in closed form of the convolution product is possible in certain cases. Let, for instance, a line discriminator be considered (Fig. 2).

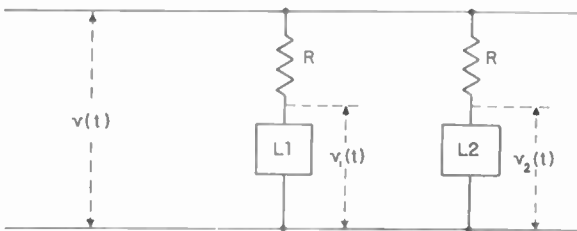

Fig. 2—Block schematic of the line discriminator.

L_1 and L_2 are supposed to be lossless high-frequency lines of characteristic impedance Z_0 . One is open-circuited, the other short-circuited. Let l be the electrical length of the lines and v the phase velocity at angular frequency ω . The input impedances of the line are the following

$$L_1(\text{short circuited}) \quad Z_{so} = Z_0 \frac{1 - \exp(-2j\omega l/v)}{1 + \exp(-2j\omega l/v)} \quad (8)$$

$$L_2(\text{open circuited}) \quad Z_{op} = Z_0 \frac{1 + \exp(-2j\omega l/v)}{1 - \exp(-2j\omega l/v)} \quad (9)$$

The transfer characteristics from v to v_1 , and to v_2 , respectively, are as follows, R being assumed equal to Z_0

$$A_1(j\omega) = \frac{v_1}{v} = \frac{1 - \exp(-2j\omega l/v)}{2} \quad (10)$$

$$A_2(j\omega) = \frac{v_2}{v} = \frac{1 + \exp(-2j\omega l/v)}{2} \quad (11)$$

The responses to unit impulse functions are respectively:

$$u_1(t) = T_{\omega}^{-1} \frac{A_1(j\omega)}{(2\pi)^{1/2}} = \frac{1}{2} \left[S_0(t) - S_0\left(t - \frac{2l}{v}\right) \right] \quad (12)$$

$$u_2(t) = T_{\omega}^{-1} \frac{A_2(j\omega)}{(2\pi)^{1/2}} = \frac{1}{2} \left[S_0(t) + S_0\left(t - \frac{2l}{v}\right) \right]. \quad (13)$$

Let a frequency-modulated wave be applied, that is to say $v(t) = \exp j(\omega_0 t + m \sin pt)$. Then

$$v_1(t) = \int_{-\infty}^{+\infty} u_1(t-x)v(x)dx \quad (14)$$

$$v_2(t) = \int_{-\infty}^{+\infty} u_2(t-x)v(x)dx. \quad (15)$$

The result is, immediately,

$$v_1(t) = \frac{1}{2} \left\{ \exp [j(\omega_0 t + m \sin pt)] - \exp \left\{ j \left[\omega_0 \left(t - \frac{2l}{v} \right) + m \sin p \left(t - \frac{2l}{v} \right) \right] \right\} \right\}. \quad (16)$$

$$v_2(t) = \frac{1}{2} \left\{ \exp [j(\omega_0 t + m \sin pt)] + \exp \left\{ j \left[\omega_0 \left(t - \frac{2l}{v} \right) + m \sin p \left(t - \frac{2l}{v} \right) \right] \right\} \right\}. \quad (17)$$

Now, let the electrical length l be equal to an eighth of the wavelength, that is $(2\omega_0 l/v) = \pi/2$. The following equations are obtained

$$v_1(t) = \frac{v(t)}{2} \left[1 + j(\exp jma) \right] \quad (18)$$

$$v_2(t) = \frac{v(t)}{2} \left[1 - j(\exp jma) \right], \quad (19)$$

where

$$\left. \begin{aligned} a &= \sin p \left(t - \frac{2l}{v} \right) - \sin pt \\ &= 2 \sin \frac{\pi}{4} \frac{p}{\omega_0} \cos p \left(t - \frac{l}{v} \right). \end{aligned} \right\} \quad (20)$$

The amplitudes of $v_1(t)$ and $v_2(t)$ are thus equal to the following

$$v_1 = \frac{2^{1/2}}{2} \left(\cos \frac{ma}{2} - \sin \frac{ma}{2} \right) \quad (21)$$

$$v_2 = \frac{2^{1/2}}{2} \left(\cos \frac{ma}{2} + \sin \frac{ma}{2} \right). \quad (22)$$

If v_1 and v_2 are applied to linear detectors and opposed, the following response is proportional to

$$V_2 - V_1 = 2^{1/2} \sin \left[m \sin \frac{\pi}{4} \frac{p}{\omega_0} \cos p \left(t - \frac{l}{v} \right) \right]. \quad (23)$$

If square-law detectors are utilized, the response is proportional to

$$V_2^2 - V_1^2 = \sin \left[2m \sin \frac{\pi}{4} \frac{p}{\omega_0} \cos p \left(t - \frac{l}{v} \right) \right]. \quad (24)$$

Provided that in the first case $m \sin \pi/4 p/\omega_0 \ll 1$ and in the second case $2m \sin (\pi/4) (p/\omega_0) \ll 1$; the output signals are to a close approximation proportional to:

$$\frac{\pi 2^{1/2}}{4} \frac{\Delta\omega_0}{\omega_0} \cos p \left(t - \frac{l}{v} \right) \text{ (linear detectors)} \quad (25)$$

$$\frac{\pi}{2} \frac{\Delta\omega_0}{\omega_0} \cos p \left(t - \frac{l}{v} \right) \text{ (square law detectors).} \quad (26)$$

It is thus shown, with a minimum of mathematics, that the dynamic response of line discriminators can be made very satisfactorily linear. The residual amount of distortion involved could be determined from the previous expressions.

4. GENERAL CASE: EXPANSION OF RESPONSE AS A FUNCTION OF INSTANTANEOUS FREQUENCY

Let us come back to the more general expression of the response

$$i(t) = \int_{-\infty}^{+\infty} u(x)v(t-x)dx, \quad (7)$$

where $u(t)$ is the response of the network to the unit impulse function applied at time $t=0$. This function is 0 for $t < 0$ so that

$$i(t) = \int_0^{+\infty} u(x)v(t-x)dx.$$

Let a frequency-modulated wave be applied, that is $v(t) = \exp [j(\omega_0 t + s(t))]$. The response $i(t)$ can be written

$$\begin{aligned} i(t) &= \int_0^{+\infty} u(x) \exp [j\omega_0(t-x)] \exp [js(t-x)] dx \\ &= \exp [j(\omega_0 t + s)] \int_0^{+\infty} u(x) \exp [-j(\omega_0 + s')x] \\ &\quad \cdot \exp [js(t-x) - s(t) + xs'(t)] dx. \end{aligned} \quad (27)$$

Assume that $s(t)$ is everywhere expansible in a Taylor series

$$s(t-x) = s(t) - xs'(t) + \frac{x^2}{2} s''(t) \dots, \quad (28)$$

which is certainly true for all signals formed with a finite number of sine waves, then the series

$$\begin{aligned} &\exp \{ j[s(t-x) - s(t) + xs'(t)] \} \\ &= 1 + j \frac{x^2}{2} s'' - j \frac{x^3}{6} s''' + \frac{x^4}{24} (js^{IV} - 6s''^2) \dots \end{aligned} \quad (29)$$

will be convergent for all values of x .

It can be shown that, since $u(t)$ is the response of a passive network to a unit impulse function, the series obtained by the term-by-term integration of

$$\begin{aligned} &\exp [j(\omega_0 t + s)] \int_0^{+\infty} u(x) \exp [-j(\omega_0 + s')x] \\ &\cdot \left[1 + j \frac{x^2}{2} s'' - j \frac{x^3}{6} s''' \right. \\ &\quad \left. + \frac{x^4}{24} (js^{IV} - 6s''^2) + \dots \right] dx \end{aligned} \quad (30)$$

will converge toward $i(t)$.

In this expression, $u(t)$ is the response of the network to the unit impulse function, so that

$$\left. \begin{aligned} Y(j\omega) &= (2\pi)^{1/2} T_{i\omega} u(t) \\ &= \int_0^{+\infty} u(t) \exp (-j\omega t) dt. \end{aligned} \right\} \quad (31)$$

On the other hand, $\omega_0 + s'(t)$ is the derivative with respect to time of the phase of the voltage $v(t)$ applied to the circuit and, therefore, its instantaneous frequency Ω .

The first term of the above integral is

$$\exp [j(\omega_0 t + s)] \int_0^{+\infty} u(x) \exp [-j\Omega x] dx, \quad (32)$$

that is to say $\exp [j(\omega_0 t + s)] Y(j\Omega)$.

This means that the first approximation of the response of the passive network to the impressed FM voltage is obtained by utilizing the stationary admittance for a value of frequency equal to the instantaneous frequency.

Let, for instance, a voltage be frequency modulated in such a way that the instantaneous frequency varies sinusoidally and this voltage be applied to a resonant circuit. Let the current be detected and its amplitude impressed on the vertical plates of an oscilloscope, the horizontal plates being submitted to the action of a voltage proportional to the instantaneous frequency. The curve on the screen will, to the approximation considered, be identical with the stationary resonance curve of the circuit.

The second term of the expansion is

$$\exp [j(\omega_0 t + s)] \int_0^{+\infty} j \frac{x^2}{2} s'' u(x) \exp [-j\Omega x] dx, \quad (33)$$

that is to say

$$i \frac{s''}{2} \exp [j(\omega_0 t + s)] \int_0^\infty x^2 u(x) \exp [-j\Omega x] dx.$$

The integral is the expression of

$$T_x^2 x^2 T_{\Omega^2} Y(j\Omega). \tag{34}$$

Utilizing one of the basic properties of the Fourier transforms, viz.

$$T_x^n x^n T_{\Omega^n} Y(j\Omega) = (-1)^n \frac{\partial^n Y(j\Omega)}{\partial (j\Omega)^n}, \tag{35}$$

the second term is equal to

$$j \frac{s''}{2} \exp [j(\omega_0 t + s)] \frac{\partial^2 Y(j\Omega)}{\partial (j\Omega)^2}, \tag{36}$$

similarly, the third term is

$$+ j \frac{s'''}{6} \exp [j(\omega_0 t + s)] \frac{\partial^3 Y(j\Omega)}{\partial (j\Omega)^3}, \tag{37}$$

and the fourth

$$\exp [j(\omega_0 t + s)] \frac{j s^{IV} - 6 s''}{24} \frac{\partial^4 Y(j\Omega)}{\partial (j\Omega)^4}, \tag{38}$$

and so on.

This expansion of the response of a passive network to a frequency-modulated wave in terms of the values of the admittance and its derivatives in which the stationary frequency is replaced by the instantaneous frequency was first arrived at by van der Pol,³ who, however, utilized a different demonstration.

Let us consider again the series resonant circuit for which it is desired to plot the response of a linear detector versus instantaneous frequency.

The high-frequency output response has just been found to be

$$\exp [j(\omega_0 t + s)] \left[Y(j\Omega) + \frac{1}{2} j s'' \frac{\partial^2 Y(j\Omega)}{\partial (j\Omega)^2} + \dots \right]. \tag{39}$$

Let us consider in which case the second term in the brackets can be neglected with respect to the first, so that the curve shown on the scope will be very close to the resonance curve of the circuit.

Let

$$s = \omega_0 t + \frac{\Delta\omega_0}{p} \sin pt. \tag{40}$$

then

$$s'' = - p \cdot \Delta\omega_0 \sin pt. \tag{41}$$

At maximum frequency deviation, $s'' = 0$ and the second term is zero. Let us investigate what happens at resonant frequency.

From

$$Y(j\Omega) = \frac{1}{R \left[1 + jQ \left(\frac{\Omega}{\omega_0} - \frac{\omega_0}{\Omega} \right) \right]}, \tag{42}$$

where Q is the usual "Q factor" of the circuit, it is found that

$$\frac{\partial^2 Y}{\partial (j\Omega)^2} = \frac{1}{R} \frac{2Q^2 \left[\frac{1}{\omega_0^2} + \frac{3}{\Omega^2} \right] - j \frac{2Q\omega_0}{\Omega^3}}{\left[1 + jQ \left(\frac{\Omega}{\omega_0} - \frac{\omega_0}{\Omega} \right) \right]^3}. \tag{43}$$

When the impressed frequency-modulated voltage passes through the resonant frequency, the first term of the expansion becomes $1/R$ and the second

$$- \frac{1}{R} \left[\frac{Qp \cdot \Delta\omega_0}{\omega_0^2} - j \frac{4Q^2 p \cdot \Delta\omega_0}{\omega_0^2} \right]. \tag{44}$$

The ratio of amplitudes is

$$4Q^2 \frac{p \cdot \Delta\omega_0}{\omega_0^2} \left(1 + \frac{1}{16Q^2} \right)^{1/2}.$$

For a circuit with a moderate or high Q factor, the two extreme points reached on the resonance curve and the resonant point itself will practically coincide with the stationary curve, provided

$$4Q^2 \frac{p \cdot \Delta\omega_0}{\omega_0^2} \ll 1.$$

As Q is equal to the ratio of ω_0 to 2π times the 3-db bandwidth B of the circuit, this can also be written, if $p = 2\pi f$ and $\Delta\omega_0 = 2\pi F$

$$4 \frac{fF}{B^2} \ll 1.$$

The van der Pol expansion can also be utilized for the computation of the distortion that will be due to a passive network when the output voltage is applied to a limiter-discriminator. According to cases, however, a more or less great number of terms will have to be considered and the phase of the output voltage determined and differentiated with respect to time.

An alternative solution to this problem was given by Carson and Fry⁴ in 1937. The expansion they used is not, however, in terms of the values of the transfer characteristics and its derivatives for the instantaneous frequency. The use of one or the other expansion will have to be determined by the amount of mathematical computation involved, once convergence of the expansions has been ascertained for the particular problem considered.

³ B. van der Pol, "Fundamental principles of frequency modulation," *Jour. IEE*, vol. 93, part III, pp. 153-158; May, 1946.

⁴ J. R. Carson and T. C. Fry, "Variable frequency electric circuit theory with application to the theory of frequency modulation," *Bell Sys. Tech. Jour.*, vol. 16, pp. 513-540; October, 1937.

Contributors to Proceedings of the I.R.E.

Irvin H. Gerks (A'32-M'41-SM'43) was born in New London, Wis., in 1905. He received the B.D. degree from the University of Wisconsin in 1927, and the M.S. degree from the Georgia School of Technology in 1932, both in electrical engineering. From 1927 to 1929 he was employed by the Bell Telephone Laboratories as a test engineer. Following this period, he became an instructor in communication and



IRVIN H. GERKS

electronic engineering at the Georgia School of Technology, where he remained until 1940.

During the war years, Mr. Gerks was an officer in the Army Signal Corps, being stationed first at Wright Field and later transferred to the Pacific Theater. At Wright Field he was in charge of the Communication and Navigation Division of the Aircraft Radio Laboratory. At present he is employed by the Collins Radio Company, where he is engaged in wave-propagation studies.

For a biography and photograph of A. G. CLAVIER, see page 409 of the April, 1949, issue of the PROCEEDINGS of the I.R.E.

The late Lewis W. Greenwald was born on October 25, 1918. He was graduated from the College of the City of New York in 1937 and was elected to Phi Beta Kappa. Mr. Greenwald obtained the masters degree in mathematics at the University of Cincinnati, where he was nominated as an associate member to Sigma Xi. He continued further studies leading toward a Ph.D. degree at New York University.



L. W. GREENWALD

At the start of World War II, Mr. Greenwald was employed by the Evans Signal Laboratory, Belmar, N. J., as a physicist, where he was engaged in research and scientific work in connection with vacuum tubes.

The Board of Education had also granted Mr. Greenwald a license to teach mathematics in the New York City High Schools. He was a member of the American Mathematical Society.

In September, 1947, Mr. Greenwald contracted leukemia and died on March 14, 1948.

Bernard Gold (M'49) was born in New York, N. Y., on April 1, 1923. He was graduated from the City College of New York in 1944 with the B.E. degree. From 1944 through 1946, he attended the Polytechnic Institute of Brooklyn, obtaining the M.E. degree. In August, 1946, he received the appointment of research fellow at the Micro-wave Research Institute of the Polytechnic Institute of Brook-



BERNARD GOLD

lyn. During the two years that followed, he completed his work for the Ph.D. degree in electrical engineering.

In 1944, Mr. Gold was employed by the Federal Telecommunications Laboratories, now of Nutley, N. J. He left this position in 1946 to obtain the fellowship mentioned above. Since October, 1948, he has been employed as senior project engineer with the Avion Instrument Corp., New York, N. Y.

Charles J. Hirsch (M'39-SM'43), was born in Pittsburgh, Pa., October 25, 1902. He received his early education in France, returning to this country in 1916. He was awarded the A.B. and E.E. degrees from Columbia University in 1923 and 1925, respectively. After graduation he was employed as development engineer by several radio laboratories, including John Hays Hammond Laboratory, Gloucester; Thomas A. Edison Industries, Orange, N. J.; and Fada Radio and Electric Co. From 1933 to 1937 he was chief engineer of radio companies in France and Italy, and returned to the United States in 1937 to become chief engineer for Majestic Radio and Television Corp.



C. J. HIRSCH

At the beginning of the war he joined Hazeltine Electronics Corp. to work on secondary radar and IFF systems. During the second half of the war he was in charge of the surface equipment section of a co-ordinated secondary radar system development. This development was carried out co-operatively by several radio manufacturers who pooled their engineers to form an integrated development staff under the direction of the Hazeltine Electronics Corp. He was awarded a Certificate of Commendation by the U. S. Navy for outstanding work in the radar and IFF fields.

After the war Mr. Hirsch became chief engineer in charge of radio aids to navigation, in which capacity the work on distance-measuring equipment (DME) was carried out. He is now chief engineer of the research department of Hazeltine Electronics Corp.

Joseph F. Hull was born in Montello, Wis., on August 25, 1921. He received the B.S. degree in electrical engineering from the University of Wisconsin in June, 1943. He joined the U. S. Army Enlisted Reserve Corps in 1942, but was placed on inactive status during the war in order that he might carry on research work at the General Electric Research Laboratory, under the sponsorship of the Office of Scientific Research and Development. From 1943 to October, 1945, he worked on the development of high-power continuous-wave magnetrons for radar countermeasures at the General Electric Company.



J. F. HULL

On October 3, 1945, Mr. Hull was called to active duty by the Army and was assigned directly to the Thermionics Branch of the Signal Corps Engineering Laboratories, Belmar, N. J., to carry on research in the field of microwaves. He was discharged from the Army on March 1, 1946, and has since been employed as a civilian research engineer by the Signal Corps.

He is a member of Tau Beta Pi and Eta Kappa Nu.

Harold Jacobs was born on November 21, 1917, at Port Chester, N. Y. He received the A.B. degree from The Johns Hopkins University in 1938, and continued work at New York University, where he received the M.A. and Ph.D. degrees.



HAROLD JACOBS

Dr. Jacobs was employed by the RCA Manufacturing Company at Lancaster, Pa., from 1942 to 1945, when he came to the Advanced Development Laboratory of Sylvania Electric Products Inc. He is currently working on problems concerning surface phenomena, including cathode surface emission in gas and vacuum tubes. He is a member of the American Physical Society.

Contributors to Proceedings of the I.R.E.

Bela A. Lengyel was born on October 5, 1910, in Budapest, Hungary. He attended the Polytechnic Institute and Pázmány University of Budapest obtaining a Ph.D. from the latter in 1935.



B. A. LENGYEL

In the fall of 1935, he came to the United States as a Research Fellow in Mathematics at Harvard University.

Dr. Lengyel taught mathematics at the Polytechnic Institute in Budapest from

1931 to 1934, and at Rensselaer Polytechnic Institute from 1939 to 1942. After one year in the physics department of the College of the City of New York in 1943, he became an assistant professor of physics at the University of Rochester.

At the end of the war, he joined the Naval Research Laboratory and is now specializing in antenna research and wave propagation in artificial dielectric materials.

Dr. Lengyel is a member of the American Mathematical Society, the Physical Society, and Sigma Xi.

Charles H. Papas (S'41-A'42) was born in Troy, N. Y., on March 29, 1918. He received the B.S. degree in electrical engineering from the Massachusetts Institute of Technology in 1941. He attended Harvard University on a Gordon McKay Scholarship from 1945 to 1948, receiving the M.S. degree in 1946 and the Ph.D. in 1948.



C. H. PAPAS

From 1941 to 1945 Dr. Papas was associated with the

Naval Ordnance Laboratory and the Bureau of Ships, Washington, D. C. Since 1948 Dr. Papas has been a research fellow at Harvard University, working on boundary value problems in electrodynamics.

Arthur L. Samuel (A'24-SM'44-F'45) was born on December 5, 1901, at Emporia, Kan. He received the A.B. degree from the College of Emporia in 1923; and the degrees of S.B. and S.M. in electrical engineering from MIT in 1926. He was awarded the honorary degree of S.D. from the College of Emporia in 1946.



ARTHUR L. SAMUEL

Dr. Samuel was employed by the General Electric Company intermittently

from 1923 to 1927, and was an instructor in the electrical engineering department at MIT from 1926 to 1928. Dr. Samuel joined the technical staff of the Bell Telephone Laboratories in 1928. From 1931 to 1946 his principal interest was in the development of vacuum tubes for use at ultra-high frequencies. In 1946 he joined the faculty of the University of Illinois where he is now professor of electrical engineering. He is a member of Sigma Xi, the American Physical Society, the American Institute of Electrical Engineers, and the American Association for the Advancement of Science.

Arnold E. Ross (SM'47) was born on August 24, 1906, in Chicago, Ill. He received the B.S. degree in 1928, M.S. in 1929, and Ph.D. in 1931, all from the University of Chicago. From 1931 to 1933 he held a post-doctoral National Research Council fellowship at the California Institute of Technology, University of Texas, and University of Chicago.

From 1935 to 1946 Dr. Ross was a member of the faculty of the mathematics department at St. Louis University. During



ARNOLD E. ROSS

the war he was engaged in research on communication problems as mathematical consultant for the Stromberg - Carlson Company. At present he is professor of mathematics and head of the department at the University of Notre Dame.

Dr. Ross is a member of the American Mathematical Society and of Sigma Xi.

Bernard Wolk was born in New York, N. Y., on February 10, 1923. He received the bachelor's degree from New York University



BERNARD WOLK

in 1943, and the master's degree from Columbia University in 1947. He was employed by the National Union Radio Corporation for three years, working on chemical problems connected with the production of receiving tubes and special tube types. In March, 1946, Mr. Wolk joined Sylvania Electric Products Inc., where he is concerned with problems of a physiochemical nature, in the chemical section of the research and development laboratories, at Kew Gardens, L. I., N. Y.

R. L. Linton, Jr. (S'41-A'44-M'46), was born on February 10, 1921, in Clemenceau, Ariz. He received the B.S. degree in electrical engineering from the University of California in May, 1942.



R. L. LINTON, JR.

From that date until March, 1943, he was employed at the Naval Research Laboratory. He transferred to the Bureau of Ships in 1943, and left in April, 1944, to join the University of California Radiation Laboratory. On the

formation of the Antenna Laboratory at that University in 1945, Mr. Linton became affiliated with the research group. Since that time he has engaged in instrument and antenna development.

In 1946 Mr. Linton became a member of the teaching staff of the electrical engineering division at the University of California, as a part-time lecturer. In July, 1949, he resigned to join the Dalmo Victor Company where he is now employed. He is a member of Tau Beta Pi and Sigma Xi.

For a photograph and biography of RONOLD KING, see page 1157 of the October, 1949, issue of the PROCEEDINGS OF THE I.R.E.

Correspondence

A Generalized Formula for Recurrent Filters*

Recent work on low- Q microwave filter structures has resulted in a useful generalization of the formula given by Fano and Lawson¹ for recurrent ladder networks. The generalized formula is particularly useful for the experimental determination of the effective quarter-wavelength spacing required for microwave structures of this design.

We consider n identical elements spaced at θ electrical degrees apart along a transmission line. θ will be, in general, a function of the frequency. For the curves in Fig. 1

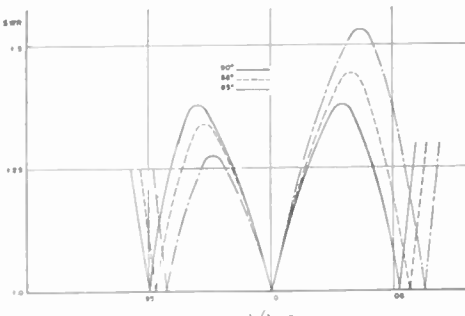

Fig. 1

it was taken as directly proportional to the frequency. Each element is considered to be in shunt to the line with a normalized admittance equal to $j2x$. For a band-pass filter where the elements are simply shunt-resonant and tuned to f_0 ,

$$x = Q_{2L}(f/f_0 - f_0/f)$$

where Q_{2L} is the doubly loaded Q , and f is the operating frequency.

We consider, as our unit structure, the element with a length of line $\theta/2$ on each side. The transmission matrix then is

$$\begin{vmatrix} \cos \theta - x \sin \theta & j(\sin \theta + x \cos \theta - x) \\ j(\sin \theta + x \cos \theta + x) & \cos \theta - x \sin \theta \end{vmatrix}$$

By the application of the Cayley-Hamilton theorem,² we can obtain the n^{th} power of this and show that the voltage transmission function t of n such identical units into a matched load is given by the formula

$$\left| \frac{1}{t} \right|^2 = 1 + x^2 U_n^2 \{ g(x) \},$$

where

$$g(x) = \cos \theta - x \sin \theta$$

and $U_n(y)$ is the Tschebyscheff polynomial of the second kind and order n .

The input VSWR, σ is then given by

$$\left| \frac{1}{t} \right|^2 = 1 + \frac{(\sigma - 1)^2}{\sigma}$$

To determine the effective quarter-wavelength spacing for low- Q elements, we construct the units separately, and measure Q_{2L} of each. They are then cascaded and the band-pass characteristic measured, with particular attention to the frequencies of minimum VSWR.

Typical theoretical curves are given in Fig. 1 for effective center-band spacings of 90° , 88° , and 85° , with elements of $Q_{2L} \approx 4$. As may be seen, the experimental sensitivity is at least as good as 1 per cent. With care, it is believed that still greater precision is obtainable—particularly with the use of a larger number of elements.

This permits us to determine with precision the effective spacing in a recurrent structure, even when the individual elements have very low values of Q_{2L} .

M. C. PEASE

Sylvania Electric Products Inc.
Boston 15, Mass.

The Blocking Oscillator as a Variable-Frequency Source*

Telemetry and other arts often require the translation of variations in a dc voltage into variations in the frequency of a sub-carrier. A suitable circuit is the positive-bias multivibrator.¹

The frequency versus bias curve can be linearized over a wide range, not only by means of cathode resistors but also by making the absolute value of the grid resistors high (Fig. 1). The frequency sensitivity is increased at the cost of linearity by imped-

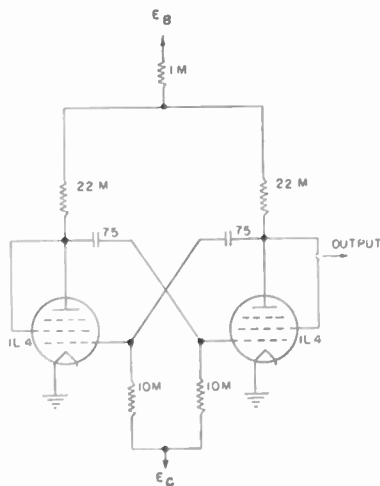

Fig. 1

ances common to the two cathodes or the two plates. The curvature penalty is much smaller in the latter case.

It has been found that, for these applications, a blocking oscillator (Fig. 2) can be

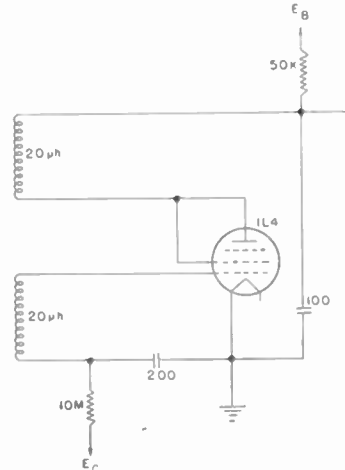

Fig. 2

arranged to be the full equivalent of the multivibrator, regarding the relationships between frequency and bias voltage. Essentially, the measured characteristics shown in Fig. 3 apply equally well to either circuit.

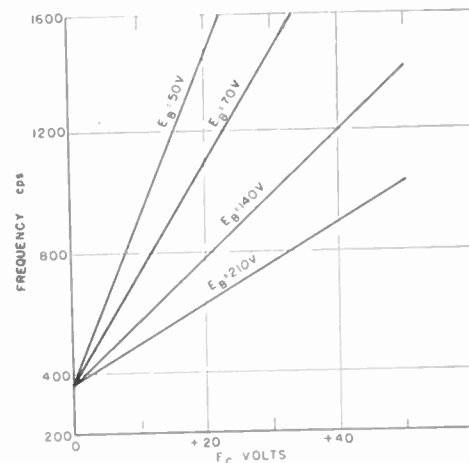

Fig. 3

For either circuit, the frequency varies linearly with bias within 5 per cent over the range shown. The wave form of the blocking oscillator differs, of course, from the trapezoidal output of the two-tube circuit. If the output be taken from a plate resistor, as shown in Fig. 2, it consists of pulses, and if it be taken from a tap on the grid resistance, it is a sawtooth.

The similarities in behavior of the two circuits suggests a certain fundamental equivalence which might bear further study, where time and circumstances permit.

LAWRENCE FLEMING
Natural Bureau of Standards
Washington, D. C.

* Received by the Institute, March 16, 1949.

¹ R. M. Fano and A. W. Lawson, "Microwave filters using quarter-wave couplings," *Proc. I.R.E.*, vol. 35, pp. 1318-1324; November, 1947.

² See, for example, L. A. Pipes, "Matrices in engineering," *Elec. Eng.*, vol. 56, pp. 1177-1191; September, 1937.

* Received by the Institute, May 10, 1949.

¹ Sidney Bertram, "The degenerative positive-bias multivibrator," *Proc. I.R.E.*, vol. 36, pp. 277-280; February, 1948.

Distributed Amplification*

May I draw to your attention an observation which occurred to me concerning the paper "Distributed Amplification," which appeared in the August, 1948, issue of the PROCEEDINGS OF THE I.R.E.¹ In Fig. 3

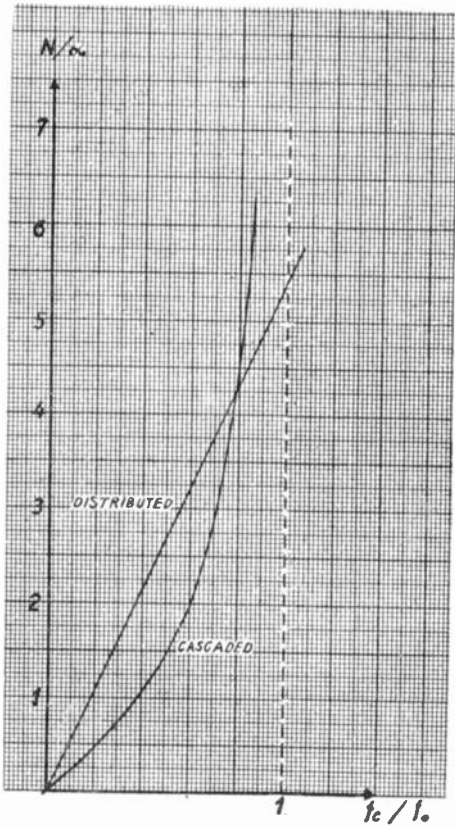

Fig. 1—The intersection of the two curves occurs at 0.78 f_c/f_o for all α , showing that below this bandwidth the cascaded, above this bandwidth the distributed amplification is to be preferred, whatever may be the gain.

of this paper, on page 958, the number of tubes required for gain e is plotted against the ratio of amplifier bandwidth to tube bandwidth index. This figure is based on equation (48), on page 966. Substituting in this equation $m = \log G$, equation (49), and also $G^{1/m} = e$, as the condition for using the least number of tubes, it follows that

$$\frac{N}{\alpha} = 2e \frac{f_c}{f_o} \tag{1}$$

where the notation $\alpha = \log G$ is used and $\alpha =$ amplification in nepers.

On the other hand, in a conventional cascaded amplifier containing N stages, it follows from the definition of Wheeler's bandwidth index that

$$\frac{N}{\alpha} = - \frac{1}{\log (f_c/f_o)} \tag{2}$$

Fig. 3 in the paper is essentially a plot of equations (1) and (2). It is not necessary, however, to pick out the rather arbitrary value of gain e , that is $\alpha = 1$, and examination of (1) and (2) shows that a somewhat clearer representation of the situation is found by using a universal scale N/α , that is, (num-

ber of tubes required)/(amplification in nepers). This is accomplished in Fig. 1, from which it appears that the superiority or inferiority of distributed to cascaded amplification, regarding the number of tubes required, is independent of gain, and depends only on the bandwidth required.

TIL SÁRKÁNY
Instrumentation Labs.
Orion Radio Co.,
Budapest, Hungary

Notes on a Coaxial Line Bead*

The bead-supported coaxial line offered by Mr. Cornes, in a recent issue of PROCEEDINGS¹ has wide usefulness. He has described a bead which produces a VSWR not over 1.025 from 0 to 4,000 Mc. This is accomplished by considering the bead as a low pass filter. The image impedance of the filter is made equal to the line characteristic impedance at some frequency in the pass band. Capacitances which exist at the faces of the bead are used as part of the filter. As pointed out by Mr. Cornes, however, one must still electrically parallel the insulators in rather limited numbers. An alternate approach to the design of undercut coaxial bead supports will be described.

The Washington test of a 504- to 510-Mc television system² made in the fall of 1948 was used to demonstrate the application of broad-band techniques wherever possible. Here a low-loss line approximately 400 feet long was required. Insulator reflections were to be kept to a minimum at all frequencies up to approximately 1,000 Mc. Three-inch copper tubing line of 52 ohms characteristic impedance was chosen. The line was assembled in twenty-foot lengths, with only as many "Teflon" insulators as required for mechanical centering of the inner conductor. Three insulators uniformly spaced were used every twenty feet to make a total of 60 insulators. Every third insulator served the dual functions of centering and anchoring to the outer conductor. The insulators were undercut to maintain 52 ohms characteristic impedance between the insulator faces.

Undercutting introduces an unwanted shunt capacity C_{sh} at the insulator faces. This capacity destroys the constant $Z_0 = \sqrt{L/C}$ required at every infinitesimal section of a uniform line, and would result in reflections at many frequencies if uncompensated.

- Z_0 = line characteristic impedance
- L = series inductance per unit length of line
- C = shunt capacitance per unit length of line.

Uniform properties are restored by placing at each insulator face a series inductance, L_s .³ The manner of inserting this inductance is shown in Fig. 1. The inserted series inductance is related to the unwanted shunt capacitance in a manner which makes the line uniform. The depth of groove required was experimentally determined. A twenty-

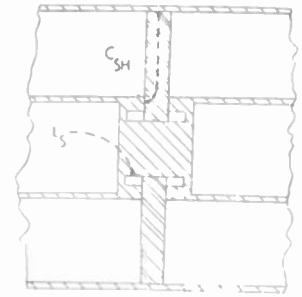

Fig. 1—Compensated undercut bead.

bead line with half-wavelength spacing was used to adjust the groove depth. Fig. 2 illustrates the effectiveness of the groove. The VSWR of 2.1 was reduced to 1.05 by introduction of the compensation.

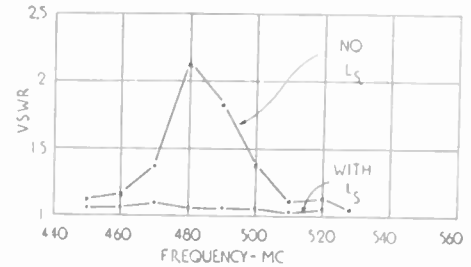

Fig. 2—Effect of compensation.

Measurements made up to 1,200 Mc with approximately 400 feet of line show that insulator reflections are almost negligible. The 60 insulators were electrically paralleled at many frequencies for which the spacings were integral half wavelengths. From these measurements it has been shown that the largest VSWR produced by one insulator was less than 1.004.

The photograph, Fig. 3 shows the parts used in the line assembly. The flanges are for joining line sections and housing a step in the outer conductor for anchoring the insulator.

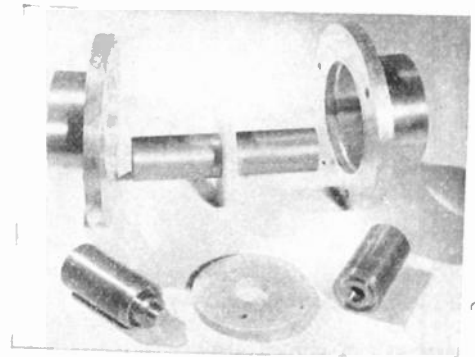

Fig. 3—Photograph of bead showing compensating grooves

The line was used in the Washington tests for high-quality picture transmission at 505.25 and 850 Mc with no perceptible deterioration of picture quality from bead reflections. It was also noted that the line loss was not appreciably greater than the copper loss alone. This results from the small amount of insulating material added to the line.

DONALD W. PETERSON
RCA Laboratories,
Princeton, N. J.

* Received by the Institute, May 23, 1949.
¹ E. L. Ginzton, W. R. Hewlett, J. H. Jasberg, and J. D. Noe, "Distributed amplification," Proc. I.R.E., vol. 36, p. 956; August, 1948.

² Received by the Institute, April 8, 1949.
³ R. W. Cornes, "A coaxial-line support for 0 to 4,000 Mc," Proc. I.R.E., vol. 37, pp. 94-98; January, 1949.
⁴ "Field test of ultra high-frequency television in the Washington area," p. 568, RCA Rev., Dec. 1948.
⁵ "Handbook of Design Data," Brooklyn Polytechnic Institute, Report No. R-158-47.

R-Q Factor*

High on the list of hard-to-get concepts for electrical engineering students is the relationship of the Q of an electrical resonator to its resonant or shunt resistance. Resonant cavities and circuits for many purposes—tuned circuits for amplifiers and oscillators, klystron resonators, wavemeters, to name a few—are made in the form of capacitively terminated sections of transmission line or waveguide, usually to facilitate tuning. The Q of such a circuit is easily measured and may be used as a sort of figure of merit for the resonator. For many purposes, however, a parameter of more direct interest is the impedance presented across the terminating capacity at resonance.

In a lumped-constant, parallel LC circuit, the relation $R=Q/\omega_0 C$ holds, ω_0 being the angular frequency at resonance. Here R is defined by $R=V^2/2P$ where P is the power loss with a peak voltage V across the capacitance. The fundamental definition of Q may be taken to be the ratio of energy stored to energy loss per radian. For a resonant circuit there are equivalent definitions involving half-power bandwidth or rate of susceptance change at resonance,

$$Q = \frac{\text{frequency}}{\text{bandwidth}} = \frac{1}{2} R \omega_0 \left(\frac{dB}{d\omega} \right)_{\omega=\omega_0}$$

If, now, the inductance is replaced by a shorted section of transmission line or waveguide with the same impedance appearing across its open terminals, the original $R-Q$ relationship no longer applies. There are several possible courses of action. Terman¹ defines an equivalent Q (which is incompatible with the energy definition of Q) to preserve the integrity of the formula. Slater² and Ramo and Whinnery³ prefer to retain the basic definitions of Q and R , but imply that some equivalent value of C (different from the C satisfying the resonance condition) will be chosen which will make everything come out all right.

If, however, we are willing to waive the inviolability of this relationship, it may be rewritten in such a way that we need introduce no ambiguity into the concept of Q and R , nor any divine guidance in the selection of an appropriate C .

It is possible to write $R=\xi Q/\omega_0 C$, where ξ is a number between 0 and 1 which might be called the $R-Q$ factor. It is a measure of how effectively the electric field in the resonator is concentrated in the capacitance.

It may be noted that this is exactly analogous to the conventional treatment of tapped resonant circuits. The input impedance at resonance of the tapped LC circuit of Fig. 1 is written

$$R = \left(\frac{C_1}{C_1 + C_2} \right) \frac{Q}{\omega_0 C_2}$$

There would seem to be no more need for defining equivalent Q 's or C 's for the resonant transmission line than in the tapped resonant circuit case.

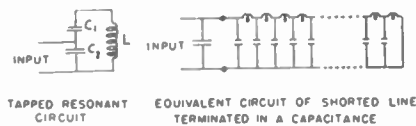

Fig. 1—Similarity between tapped resonant circuit and resonant transmission line.

The $R-Q$ factor is simply calculated from the rate of susceptance change expression for Q and the expression for total circuit admittance of a short transmission section terminated in a capacitance,

$$Y = j\omega C - \frac{1}{Z_0} \coth \gamma l$$

In addition to removing confusion from the $R-Q$ relationship, the concept of the $R-Q$ factor can be used as the basis for a method of obtaining a value of resonant resistance from a simply-made Q measurement, rather than from an experimentally-difficult direct measurement.

W. W. HARMAN
University of Florida
Gainesville, Fla.

The Unit of Perveance*

The names of units in which engineering quantities are measured appear to be of two kinds.

One kind of name is a single word not likely to have any other meaning. Very often it is that of a person prominently identified with an investigation of the quantity. The other kind of name is compounded from the names of two or more other units to which it is related as a product or quotient. Familiar examples of the first kind are the *ohm*, which is the quotient of *volts* by *amperes*, all three of these names having been assigned both as a convenience and as an expression of appreciation of the work of Ohm, Volta, and Ampère. An example of the second kind is the unit of electric field strength which is usually given in volts per centimeter.

In most cases the units expressed as a compound word or phrase cause no inconvenience. They are easily spoken and their abbreviations are readily understood.

An exceptional case is the unit of the perveance of an electron tube. The word perveance appears to have been coined by Kusunose¹ as the name of the "constant" G in the expression for the relation between current and voltage in a space-charge-limited diode: $I=GV^{3/2}$. No better term having since been offered, the word has become quite common in tube parlance.

No name for this unit has been assigned, and one can only speak of so many amperes or milliamperes per volt three-halves. The question of a suitable name has been discussed at times during meetings of technical committees at the Institute headquarters. No action has been taken, however, for the simple reason that name-coining is not a function of the committees.

If one were faced with the duty of choosing a name, he would be confronted with certain difficulties. The existence of the relation was probably recognized or suspected by the earliest workers who experimented with tubes. It was not until 1911 that Child² published the rigorous derivation of the special case in which, assuming zero initial velocity of electrons and infinite parallel-plane electrodes, the current was shown to vary with the three-halves power of the voltage. Rigorous expressions for electrodes having axial symmetry were given by Langmuir³ in 1913. Langmuir and Blodgett⁴ in 1924 gave the solution for spherical symmetry.

The effect of initial electron velocity upon the current-voltage relation was considered by Schottky⁵ in 1914, and by others during the next few years. Langmuir⁶ in 1923 published a much more rigorous paper than had previously appeared.

I have not been able to satisfy myself on the earliest proof of the general case for electrodes of any shape. That the current varies as the three-halves power of the voltage for any geometry, and that the current is constant voltage when all electrode dimensions are altered in like proportion, is shown in the paper by Langmuir and Compton.⁷

Thus no one person can be called the "discoverer" of perveance. However, it would seem from the foregoing that if the unit of perveance is to be named, and that if the choice is made on the basis of maximum contribution to our understanding of the subject, the name Langmuir should be favorably considered.

G. D. O'NEILL
Sylvania Electric Products Inc.
Bayside, L. I.
N. Y.

* Received by the Institute, June 2, 1949.

¹ F. E. Terman, "Radio Engineers Handbook," McGraw-Hill Book Co., New York, N. Y., Sec. 3, Par. 16; 1943.

² J. C. Slater, "Microwave electronics," *Rev. Mod. Phys.*, vol. 18, Ch. III, Sect. 6, p. 481; October, 1946.

³ S. Ramo and J. R. Whinnery, "Fields and waves in modern radio," John Wiley and Sons, Inc., New York, N. Y., Art. 10.04; 1944.

¹ Y. Kusunose, "Calculation of characteristics and the design of triodes," *Proc. I.R.E.*, vol. 17, pp. 1706-1750; October, 1929.

² C. D. Child, *Phys. Rev.*, vol. 32, p. 492; 1911.

³ I. Langmuir, *Phys. Rev.*, vol. 2, p. 450; 1913.

⁴ I. Langmuir and K. B. Blodgett, *Phys. Rev.*, vol. 24, p. 49; 1924.

⁵ W. Schottky, *Phys. Zeit.*, vol. 15, p. 526; 1914.

⁶ I. Langmuir, *Phys. Rev.*, vol. 21, p. 419; 1923.

⁷ I. Langmuir and K. T. Compton, *Rev. Mod. Phys.*, vol. 2, p. 191; April, 1931.

Elements of Electromagnetic Waves*

It is quite revealing to read a book review, compare it to the book, and note the conclusions of the reviewer. In the book review of "Elements of Electromagnetic Waves," by L. A. Ware, Pitman Publishing Corporation, 1949, the reviewer, L. J. Chu,¹ quotes incorrectly from the book and casts aspersions at the author's statements of fact. For example, the reviewer 'quotes' from the book

$$\oint \mathbf{E} \cdot d\mathbf{s} = E = -\frac{d\phi}{dt},$$

and that "The analysis of electric and magnetic fields are better carried out in terms of the gradients of the two scalar potentials

$$H = -\nabla m f \quad \text{and} \quad E = \nabla \phi."$$

On page 41 of the book, correct statements appear. These are:

$$\oint \mathbf{E} \cdot d\mathbf{s} = E = -\frac{d\phi}{dt}."$$

and "The analyses are, however, better carried out in terms of the gradients of the two scalar potentials, namely:

$$H = -\nabla m f \quad \text{and} \quad E = -\nabla \phi."$$

In the reviewer's criticism of equation (3.5), $B = \mu H = \phi/A$, it appears as though the reviewer has confused the vector potential A with the area A , for on page 42, the author points out that A is the area through which the flux is passing. In the book it is customary to represent vectors in bold, upright type and scalars in normal slanted type. The area A appears in the book as A , and it is, indeed, unfortunate that such a conspicuous typographical error should be open to harsh criticism.

The reviewer quotes material from page 65 and indicates that the material is not rigorous. While it is true that the manner in which it is concluded that $\nabla \times H = J$ is not rigorous, one would find that in an elementary course for juniors and seniors, too much rigor would lead to rigor mortis on the part of the student! The alert instructor may always institute the necessary rigor if his classes warrant it; thus the elementary framework laid down by the book can always be strengthened. Hence, it is felt that the author has provided a very useful, elementary text.

In passing, it should be noted that the reviewer's criticism concerning page 125 is correct, but since there are only three lengthy footnotes, one should not be too hasty in chastising the author for the use of footnotes. The reviewer is to be complimented for his keen eye, for the mistake in the footnote on page 125 is one of notation and is not, at first glance, obvious.

The book offers summaries for each chapter, numerous examples, and about 15 problems per chapter. The problems serve to illustrate the chapter material quite well, but they should be supplemented by problems requiring a greater degree of thought on the part of the student. Problems of the "thought" type are easily supplied by most instructors, so that this feature of the problems in the book is not a distinct weakness. Since the book is elementary in character, the author has been wise to retain simplicity by omitting cylindrical waveguides, dispersion, polarization, and other more advanced topics. The student who grasps the material in this book and who obtains an adequate mathematical background is in a better position to comprehend what appears in "Electromagnetic Theory," by J. A. Stratton, published by McGraw-Hill Book Co., Inc., 1941, than if he had only the mathematical background. Thus, the book does good service as an introductory text.

L. G. McCracken
Pennsylvania State College
State College, Pa.

The Influence of Conductor Size on the Properties of Helical Beam Antennas*

To determine the effect of conductor size, measurements have been made of three helices of identical construction, insofar as possible, except for conductor diameter. The helices are shown in Fig. 1. Each has 6



Fig. 1

turns and a pitch angle of 14° .¹ The diameter (center-to-center) is 21.9 cm and the spacing between turns (center-to-center) is 17.1 cm. The conductor diameters are 0.317, 1.27, and 4.13 cm, the ratio of the thickest to thinnest being about 13 to 1. The larger-size conductors are copper tubing and are substantially self-supporting. The smallest is copper wire and requires a light wooden

framework for mechanical support. The 4.13-cm diameter tubing is about the largest which could be bent to a radius of 10.95 cm. Characteristics of the three helices were measured over a wide frequency range, the axial or beam mode of radiation² occurring from about 300 to 500 Mc. At 400 Mc, the conductor diameters are 0.0042, 0.017, and 0.055 free-space wavelengths. A diameter of 0.017 wavelengths had been used in previous tests.¹ Field patterns and axial ratios were measured with each helix mounted on a sheet copper ground plane 66 cm in diameter. Impedances were measured with each helix mounted on a 1.5×1.5 meter square copper ground plane.

The two possible extremes in conductor size are an extremely thin conductor and a conductor of diameter equal to the spacing between turns. Although none of the conductors that were used approach closely to these extremes they do represent a considerable range in conductor size.

Although the measurements disclose minor differences, it is difficult, in most cases, to distinguish any marked trend as a function of conductor diameter in the frequency range of the beam mode. This fact further emphasizes the noncritical nature of helical beam antennas. More specifically and in more detail, the measurements indicate that, in the frequency range of the beam mode:

(1) The average half-power beam width of both field components (E_ϕ and E_θ) is nearly the same. However, there does appear to be a slight trend (of a few per cent) toward smaller beam widths with each increase in conductor size. There is also less difference between the beam widths for E_ϕ and E_θ with the largest conductor size.

(2) The ratio of the magnitude of the main lobe to the maximum minor lobe appears to be slightly (about 8 per cent) greater for the largest conductor size as compared to either of the smaller sizes.

(3) The axial ratio in the direction of the helix axis is nearly the same for the three conductor sizes (usually within ± 4 per cent).

(4) The terminal impedance is nearly a pure resistance. The average resistance over the frequency range of the beam mode differs by about ± 25 per cent from the smallest to the largest conductor sizes (this is the largest effect noted). However, the ratio of the maximum-to-minimum resistance is about the same in each case.

(5) The phase velocity of wave propagation along the helix is in the first approximation unaffected by the conductor size.

Although the above conclusions are probably quite general, they do not necessarily apply to helices of only 1 or 2 turns or to helices mounted on ground planes of insufficient size.

¹ J. D. Kraus, "The helical antenna," Proc. I.R.E., vol. 37, pp. 263-272; March, 1949.

THOMAS E. TICE
JOHN D. KRAUS
Dept. of Electrical Engineering
Ohio State University
Columbus, Ohio

* Received by the Institute, June 17, 1949.

¹ Book Review, Proc. I.R.E., p. 670; June, 1949.

* Received by the Institute, July 20, 1949.
¹ J. D. Kraus, "Helical beam antennas for wide-band applications," Proc. I.R.E., vol. 36, pp. 1236-1242; October, 1948.

Institute News and Radio Notes

TECHNICAL COMMITTEE NOTES

Under the Chairmanship of Axel G. Jensen, the Definitions Co-ordinating Subcommittee has completed **The Master Index** of approximately 4,500 IRE terms. The published list includes all terms proposed for definition, tentatively defined, or approved and printed by the Institute. . . . Several subcommittees of the Circuits Committee have been decided upon as follows: **4.1 Plus and Minus Signs Subcommittee**; **4.2 Linear Lumped-Constant Passive Circuits Subcommittee**; **4.3 Circuit Topology Subcommittee**; **4.4 Linear Varying-Parameter Circuits and Non-Linear Circuits Subcommittee**; **4.5 Time-Domain Network Analysis and Synthesis Subcommittee**; **4.6 Distributed-Parameter Circuits Subcommittee**; **4.7 Linear Active Circuits, Including Networks with Feedback and Servomechanism Circuits Subcommittee**; **4.8 Circuits Components Subcommittee**. . . . A new group has been established comprising Vice-Chairman R. A. Miller of the Audio Techniques Committee, W. J. Poch of the Video Techniques Committee, and H. E. Roys of the Sound Recording and Reproducing Committee. The purpose of the group is to eliminate overlapping in the work of these committees. . . . Scopes of the Technical Committees have been revised and approved by the Standards Committee and the Board of Directors of the Institute. . . . Chairman Harver Selvidge presided over the meeting of the Administrative Committee of the Nuclear Science Group on August 25, at Brookhaven National Laboratory. M. M. Hubbard was elected Vice-Chairman of the Professional Group on Nuclear Science, this post having been vacant heretofore. . . . Henceforth as a service to members, the *Standards* of the Institute will be published in the PROCEEDINGS OF THE I.R.E. The new procedure will go into effect with the December, 1949, issue. Each issue containing Standards will bear a notice on the front cover in red ink. Reprints of the Standards may be purchased from Headquarters, as long as available, for convenient filing.

IRE/AIEE CONFERENCE FEATURES RADIATION TOPICS

Around-table discussion on the "Evaluation of Radiation Hazards" by a four-man panel of scientific experts and an address by Lewis L. Strauss, a commissioner of the Atomic Energy Commission, highlighted the three-day Second Annual Joint IRE-AIEE Conference on electronic instrumentation in nucleonics and medicine, which was held on October 31, November 1 and 2, at the Hotel Commodore in New York, N. Y. Simultaneously with the conference, the first annual Nucleonics Manufacturers' Exhibit was held on November 1 and 2, also at the Hotel Commodore. Scalers, Geiger tubes, survey meters, scintillation counters, and industrial instrumentation utilizing radiation were featured.

The program for the Conference was as follows. J. G. Reid, Jr., National Bureau of Standards, presided on October 31, morning session—"Low-Frequency Spectrography: Some Applications in Physiological Research," by Robert Riesz, Bell Telephone Laboratories; "High-Fidelity Electrocardiography," S. R. Gilford, National Bureau of Standards; "Electrical Methods of Blood-Pressure Recording," Frank Noble, College of Electrical Engineering, Cornell University; Discussion by William C. Ballard, Cornell University. October 31, afternoon—"Stable DC Amplifier for Biological Recording," Harry Grundfest, Columbia University; "Design of Cathode-Ray Oscillographs for Biological Applications," W. A. Geohegan, Cornell University Medical College; "A 25-Channel Recorder for Mapping Cortical Potential Fields," John Lilly, Johnson Foundation, Philadelphia, Pa.

On November 1, G. W. Dunlap, General Electric Co., presided. Morning session—"Medical Applications of Ionizing Radiations," Edith Quimby, Radiological Research Laboratory, Columbia University; "Dosage Measurements of Ionizing Radiations," G. Failla, Radiological Research Laboratory, Columbia University; "Automatic Iso-dose Recorder," G. J. Hine, Sloan-Kettering Institute, New York, N. Y.

November 1, afternoon session—Subject, "Measurement of Low-Energy Beta-Ray Emitters." Papers presented were: "Ionization Chambers," Norman Baily, Radiological Research Laboratory, Columbia University; "Proportional Counters," C. J. Borkowski, Oak Ridge National Laboratory; "Internal Gas Counting of C^{14} and H^3 ," M. L. Eidinoff, Queens College and the Sloan-Kettering Institute for Cancer Research, New York, N. Y. Charles V. Robinson, of the Harvard Medical School, in Boston, Mass., presented the paper, "Small Geiger Counters for Biological Applications."

The November 1 evening program included a round-table discussion on the "Evaluation of Radiation Hazards" as well as Mr. Strauss' address. J. R. Dunning of Columbia University acted as moderator assisted by A. L. Baker, vice-president of the Kellogg Corp.; Ralph E. Lapp, nuclear physicist and author; Admiral W. S. Parsons of the National Military Establishment; and Shields Warren, Director of the Atomic Energy Commission's Division of Biology and Medicine.

Harner Selvidge, Bendix Aviation Corporation, Detroit, Mich., presided over the November 2nd session. The morning program comprised the following papers—"Scintillation Counter Spectrometer," P. R. Bell, Oak Ridge National Laboratory; "The Electron Statistics of Scintillation Counting," G. A. Morton, RCA Laboratories, Princeton, N. J.; "Phosphors for Scintillation Counters," R. H. Gillette, Linde Air Products Laboratories, Tonawanda, N. Y.; "Solids for Radiation Detection," R. M. Lichenstein, General Electric Laboratory, Schenectady, N. Y.

On the afternoon of November 2, these papers were read—"Some Design Features of Electrical Counting Systems," N. F. Moody, National Research Council of Canada, Atomic Energy Project; "Desirable Improvements in Nuclear Instruments," J. B. H. Kuper, Brookhaven National Laboratory; "Criteria in the Selection of Radio Isotopes for Industrial Use," Eric Clark, Tracerlab, Boston, Mass.

NATIONAL BUREAU OF STANDARDS PUBLISHES ATOMIC COMPILATION

Available from the U. S. Government Printing Office is a critically evaluated compilation of all known data on the energy levels of elements of atomic number 1 through 23 recently published by the National Bureau of Standards. Designed to meet the needs of workers in nuclear and atomic physics, astrophysics, chemistry, and industry, the publication is an up-to-date compendium of all energy levels for these elements, exclusive of those due to the hyperfine structure ascribed to atomic nuclei.

IRE/AIEE NEW YORK SECTIONS SPONSOR ANTENNA LECTURES

A series of six lectures on contemporary developments in antennas and their engineering design, sponsored jointly by the New York Sections of The Institute of Radio Engineers and the American Institute of Electrical Engineers, was begun on October 18, 1949, and will continue until November 29. The sessions will be held in room 502, Engineering Societies Building, 33 West 39 Street, New York, N. Y., at 7:00 P.M., where use will be made of scale and working models to illustrate many of the designs considered. A tuition fee of \$4.00 for members of AIEE, AIME, ASCE, ASME, and IRE, and \$8.00 to others, has been established for the series. The price for single lectures to members will be \$1.00 and \$2.00 for nonmembers.

J. F. Dreyer, of the Crosby Laboratories, spoke on "Fundamental Considerations and Appraisal of TV and FM Receiving Antennas" on the opening night, October 18. The subject for the October 25 lecture, delivered by A. G. Kandoian, of Federal Telecommunications Laboratories, was "Fundamental Considerations of Transmitting Antennas for TV and FM Broadcasting." On November 1, A. Alford, Consulting Engineer, will speak on "Special Problems in TV Transmitting and Receiving Antennas for UHF and VHF," followed by H. A. Wheeler, of Wheeler Laboratories, on November 15, whose subject will be "Omnidirectional Antennas for Vertical and Horizontal Polarization." J. B. Byrne, of Airborne Instruments Laboratory is the lecturer for November 22, on the topic, "Antennas for High Speed Aircraft." The final lecture will be given by W. E. Kock, of Bell Telephone Laboratories, speaking on "Lenses, Reflectors and Superdirectivity."

IRE PROFESSIONAL GROUP ON QUALITY CONTROL IS FORMED

The Institute of Radio Engineers announces the formation of the Professional Group on Quality Control. This group has as its major interest Quality Control of components and entire systems in the fields of radio, communication, television, electronics, and allied subjects.

The initial Administrative Committee meeting was held in the IRE Headquarters, 1 East 79 Street, New York, N. Y., on September 19, 1949. At the meeting the following officers were elected: Chairman, R. F. Rollman, Quality Control Section, Allen B. DuMont Laboratories, Passaic, N. J.; Vice-Chairman, B. Hecht, Manager, Quality Control Section, International Resistance Co., Philadelphia, Pa.; Secretary-Treasurer, Victor Wouk, Chief Engineer, Beta Electric Corp., New York, N. Y.

At the meeting, the constitution and by-laws of the group were formulated, and plans for the group activities during the forthcoming year were discussed. The newly formed committee sponsored a full session at the Radio Fall Meeting held in Syracuse, N. Y., on October 31, November 1 and 2. Three papers were presented at this panel.

ILLINOIS FELLOWSHIP AWARDS

Fellowship awards for the academic year 1949-1950 have been announced by the Graduate College of the University of Illinois and the Department of Electrical Engineering with the granting of the Westinghouse Educational Fellowship in electrical engineering to **J. E. Robertson** (S'48). Mr. Robertson was graduated in 1949 from Oklahoma A. & M. with the B.S. degree. He received the M.S. degree in 1948 from the University of Illinois. Mr. Robertson will specialize in the field of electronics.

Awards of third-year University graduate fellowships have been made to **C. L. Kang** (S'48), **J. S. Kerr** (S'48), **Y. T. Lo** (S'49), and **J. Y. Wong** (S'46).

Calendar of COMING EVENTS

- Armed Forces Communications Association 1950 Annual Meeting, April 26, Photographic Center, Astoria, L. I., N. Y.; April 27, New York City; April 28, Signal Corps Center, Fort Monmouth, N. J.
- AAAS 116th Annual Meeting, New York City, December 26-31
- Southwestern IRE Conference, Baker Hotel, Dallas, Texas, December 9-10
- Radio Fall Meeting, Syracuse, N. Y., October 31, November 1-2
- 1949 Nucleonics Symposium, New York City, October 31, November 1-2
- 1950 IRE National Convention, New York, N. Y., March 6-9
- URSI/IRE Joint Meeting, October 31, November 1-2, Washington, D. C.

Industrial Engineering Notes¹

TELEVISION NEWS

RMA has estimated that one million or more television receivers were produced during the first half of 1949. The estimate, based on reports from member companies, slightly exceeds the total television set production during the whole of 1948. RMA set manufacturers' output in the half year totalled 913,071 television sets as compared with 866,832 in 1948. . . . FCC has reported that there were a total of 74 television stations on the air at the end of July and there were 41 construction permits outstanding. . . . FCC has granted construction permits for microwave circuits estimated to cost \$17,800,000 to be used for telephone and television transmission. The actions, involving the A.T.&T. and Wisconsin Telephone Co., propose the following facilities: Between Pittsburgh and Chicago (paralleling present coaxial cable), 20 intermediate stations to cost \$12,000,000, between Chicago and Des Moines, 14 intermediate stations, \$4,000,000, between Albany and Syracuse, five stations, \$1,055,000. Between Richmond and Norfolk, four stations, \$635,000, between Milwaukee and Madison, four stations, \$110,000. . . . Special temporary authority was granted to two additional television stations to engage in experimental color transmissions. RCA's experimental TV station W3XEP at Camden, N. J. "will investigate 6-Mc color transmission on TV Channel 10 (192-198 Mc) during periods when WCAU-TV, Philadelphia is not operating, over a 60-day period commencing Aug. 1. WMAL-TV at Washington, D. C. was granted authority to pick up color programs broadcast by WMAR-TV of surgical and medical procedures originating at Johns Hopkins University, Baltimore, Md., and to transmit them to the National Guard Armory in the capital where they will be viewed on special receivers. WMAR-TV and CBS received similar authorizations recently." . . . Directors of the Motion Picture Association of America have asked the FCC for special channels for theater television and have been told to submit answers to six questions designed to clarify the needs of theaters for TV frequencies. . . . Two motion picture companies, Paramount and 20th Century Fox, have informed the FCC they are ready to proceed with commercial television theatre plans for the Los Angeles area as soon as they obtain permission. . . . RCA has reported it has developed a "new all-electronic, high-definition color television system, completely compatible with the present system of black and white television." It requires no changes in transmission standards of present black and white television and its performance is equivalent to the present black and white service. . . . In a technical report and analysis of eight color television system proposals, the RMA-IRE

¹ The data on which these NOTES are based were selected, by permission, from "Industry Reports," issues of July 29, August 5, 12, 19, 26, and September 2, 9, published by the Radio Manufacturers' Association, whose helpful attitude is gladly acknowledged.

Joint Technical Advisory Committee in a statement to the FCC recommended that it require "at least six months' public field tests of any color television system before it adopts standards". . . .

RADIO AND TELEVISION NEWS ABROAD

A special committee for the study and adoption of the necessary measures in order to install television equipment in Uruguay has recently been appointed by the Government.

British Postmaster General Wilfred Palling is expected to announce plans for the erection of three new television transmitting stations at a cost of seven million dollars. The additional stations would give Britain a total of five television stations, and would be located in Yorkshire, Scotland, and Wales.

The number of licensed radio receivers in Norway recently passed 700,000, an increase of 224,000 over the prewar record, the American Embassy at Oslo, Norway, has reported. Nearly every household in Norway now has a radio, the report added. The Department of Commerce has reported that British radio set licenses numbered 11,747, 992 and TV set licenses 141,953 as of June 30, 1949. Radio figures include England, Wales, Scotland, and Northern Ireland, but the television receivers are all in England.

L. B. Fanning, chairman of the Broadcasting Control Board of Australia, has announced the adoption of a 625-line system of television for that country. In a press statement to the U. S. Commerce Department he said: ". . . In Great Britain 405 lines are employed whilst in America 525 are used. It has been decided to adopt 625 for use in Australia and this in conjunction with the 7-Mc per second width channel, which is greater than that used in either of the coun-

Final Call!

Authors for National Convention!

R. M. Bowie, Chairman of the Technical Program Committee for the 1950 IRE National Convention, requests that prospective authors of papers to be considered for presentation submit the following information to him as soon as possible:

1. Name and address of author
2. Title of paper
3. Abstract of sufficient length to permit the Committee to assess the paper's suitability for inclusion in the Technical Program. Since the merit of the prospective paper must necessarily be judged by the abstract, it should be clear and informative.

Material should be mailed to R. M. Bowie, Sylvania Electric Products Inc., Box 6, Bayside, L. I., N. Y. The deadline date of November 21, 1949, is imminent. Immediate action will be required to meet it.

tries mentioned, will permit a very much clearer picture to be made available without increasing appreciably the cost of receivers. The Board has decided to incorporate in the standards amplitude modulation of the video carrier with negative polarity, frequency modulation of the video carrier with negative polarity, frequency modulation of the sound carrier, and horizontal polarization of the transmittal signal, which would also incorporate vestigial sideband operation. It was convenient because of the frequency of the power mains to adopt as standard the transmission of 25 complete pictures per second, each picture having an aspect ratio of 4 to 3."

An estimated one million radio sets are in operation in Switzerland and approximately 50 per cent of them were manufactured prior to 1939, according to a report received by the Department of Commerce. The report showed also that approximately 60 per cent of the Swiss sets were manufactured by a Netherlands concern.

Imports of radio receivers in Egypt during 1948 totaled 47,930 sets, of which 3,644 were American-made, 12,545 were imported from the Netherlands and 29,540 were imported from the United Kingdom.

FCC ACTIONS

The FCC has called an **informal conference on the proposed amendments to amateur rules**, to be held October 10. Present temporary authority for amateurs to use narrow-band frequency or phase modulation for radiotelephone communications in the bands 3,850 to 3,900 kc, 14,200 to 14,250 kc, 28.5 to 29 Mc, and 15 to 52.5 Mc, be extended for a period not to exceed one year ending July 31, 1950. . . . **Amendments of regulations governing restricted radiation services will be simplified** by a Commission plan to break down affected services into four categories: Part A of Docket 9288 will include incidental radiation devices, such as laboratory signal generators, beat frequency audio oscillators, and other oscillators; Part B includes carrier current communication systems, such as power companies, telephone companies and railroads; Part C, gadgets, such as garage door openers, control of model aircraft, and other remote controls; Part D, intercollegiate broadcasting and phono-oscillators. Copies of the ruling may be obtained from the FCC Secretary, Washington 25, D. C. . . . **Amendments will also be made by the FCC on its engineering standards for FM broadcast stations** to establish the ratio of desired to undesired signals for stations licensed with 400- and 60-kc separation. Ratios proposed are based upon the results of comprehensive selectivity tests of various FM broadcast receivers. The proposal results from interference caused by FM stations operating on alternate channels. . . . Action on a petition of the Seismograph Service Corp. will be extended until February 17, 1950 with temporary allocation of frequencies for the construction of a radio-location system to explore for oil in the Gulf of Mexico. A Government-Industry committee has been formed to obtain field-intensity measurements of line radiating devices and systems. The group has decided to limit studies to frequencies in the 10- to 535-kc

range and to make such measurements not only on the ground but in the air. Persons wishing to participate in the measurements should contact its Engineering Bureau. A target date of January 17, 1950, has been set for a further meeting to examine and collate available data. . . . An en banc hearing has been scheduled for December 12 to obtain complete information regarding **multiplex facsimile and FM broadcasting** to determine whether a suitable multiplex system has been developed which will not cause any degradation to the full-tone range of which FM is capable and thereby permit the Commission to amend its rules pertaining to multiplex facsimile on FM channels. Multiplexing concerns the simultaneous broadcasting of facsimile and FM aural programs on the same channel. . . . A public notice has been issued advising interested parties of the **progress and future plans for the new international table of frequency allocations** in the 415- to 550-kc band. The notice, which may be obtained from the FCC Secretary, also contains a list of station assignments in the 355- to 550-kc band. Broadcast at 540 kc within the U. S. will be determined subsequent to the forthcoming NARBA Conference. . . . Representatives of industry and other interested parties have been invited to attend a joint conference at the Commission's Washington offices November 1 in order to establish government-industry committees on the subject of "incidental radiation devices." . . . With the granting of a construction permit to William N. Greer for a standard (AM) station at Charlotte Amalie, Island of St. Thomas, the FCC authorized the **first broadcasting station in the Virgin Islands** to operate unlimited time on 1,340 kc with power of 250 watts. The Virgin islands is the only United States possession without a broadcast station, Puerto Rico has 28 broadcast authorizations (one FM), which is more than the number in any of 15 states. Alaska and Hawaii each have 9 authorized stations, all AM.

COLOR TELEVISION INC. REPORTS DEVELOPMENT OF NEW LINE SYSTEM

Color Television Inc. of San Francisco has reported to the FCC that it is the "developer of a system of high-fidelity color television which is fully compatible with existing black and white standards and which, if adopted, will avoid immediate obsolescence of existing black and white television receivers."

Arthur S. Matthews is president and George E. Sleeper, Jr., vice-president, of the company which filed a statement in which the system is termed "the line-sequential" method.

It is described in the statement as follows: "The proposed line-sequential method of color image representation uses successively traced image lines which appear in the receiver in different colors, following a selected sequence, as, for example, red, green, blue, red, green, blue and so on. It differs radically, therefore, from the so-called 'field-sequential' method in which each separate field is produced in one color only, the colors changing from field to field through the group of colors selected additively to pro-

duce a polychrome visual image. It also differs fundamentally from so-called 'simultaneous' methods, in which separate image rasters of the additive visual polychrome summation are separately but simultaneously traced or produced in the respective lights of the selected component colors."

AIRCRAFT SURVEY SHOWS LACK IN ELECTRONICS PRODUCTION

A shortage in the capacity of the electronics industry to produce certain components for military aircraft is indicated by a Munitions Board survey of the electronics aircraft requirements.

The survey, reported to the RMA, indicated that necessary steps, such as stockpiling some JAN components, will be taken to increase the capacity of the industry to meet the requirements of the military program.

ZENITH SEEKS AUTHORITY FOR PHONEVISION EXPERIMENT

Experiments employing Phonevision will be conducted by the Zenith Radio Corp. at its present experimental television station, W9XZV, with the permission of the FCC. Transmission of programs at the station will be tested "simulating actual conditions that would prevail were Phonevision in use today."

According to the petition, the company plans to use 300 test subscribers. Each would be furnished a receiver equipped for the new service. They will not be asked to pay for the programs or the broadcasting but will be asked to make a contribution substantially equivalent to the charge which would be made if Phonevision were in commercial use.

It is the opinion of the Zenith Corp. that unless a charge is made, a fundamental factor in determining the feasibility of Phonevision will be absent, for its basic theory assumes that television set owners would be willing to pay a reasonable sum directly to view programs of outstanding interest not otherwise available.

Tests will be conducted over a three-month period beginning in early December or in January.

NAB ANNOUNCED REORGANIZATION OF TELEVISION, AUDIO STATIONS

The Board of Directors of the National Association of Broadcasters has announced its approval of a plan for reorganization of NAB staff and services, including the separation of NAB activities and station membership into two principal divisions: Audio, which will include both AM and FM stations, and Video, to include television stations, and "other arts which may be developed in this field of electronic communications." Six general departments, legal, government relations, employee-employer relations, research, public relations and engineering, will serve both divisions.

SERVICE APPOINTMENTS

Major General Harold M. McClelland, U. S. Air Force, has been appointed Director of Communications-Electronics of the Department of Defense by Secretary of Defense Louis Johnson. His most recent assignment has been as Deputy Commander for Services of Military Air Transport Service which has its headquarters at Andrews Air Force Base, Camp Springs, Md.

The office has been established within the Department of Defense, under the direction and control of the Joint Chief of Staff, to insure maximum economy and efficiency of military communications.

The assignment of Captain Henry E. Bernstein, USN, as Director of the Armed Services Electro Standards Agency became

effective September 1. He is well known in the radio industry, and for a number of years worked in the Electronics Division of the Bureau of Ships in Washington. The directorship of ASESA will rotate among the three services.

SENATE COMMITTEE APPROVES RADIO LABORATORY

Approval of a four-million-dollar radio laboratory for the National Bureau of Standards has been granted by the Senate Interstate and Foreign Commerce Committee. The Committee also approved an additional \$360,000 for special equipment. The new laboratory, which will not be constructed on the present grounds of the Bureau, is

needed for studies of the characteristics of radio wave propagation and allied matters of interest to the military.

STRATOSPHERE DATA INSTRUMENT

A new instrument made practical by modern electronics engineering has provided detailed soundings of stratospheric temperatures and humidity at 99,000 feet, according to the Office of Naval Research. The new instrument was developed under the direction of Earl W. Barrett of the University of Chicago, under sponsorship of the Office of Naval Research. Formerly, the Navy said, instruments known as radiosondes were not dependable in the low vapor concentrations and cold temperatures of the stratosphere.



IRE People

Stanford Research Institute, Stanford, Calif., has announced the appointments of **Frank W. Clelland** (A'35-M'48) and **Donald R. Scheuch** (S'42-A'45-M'46) as research associates. Both men have just received their Ph.D. degrees in electrical engineering from Stanford University. Their theses were a joint work on a coupled-circuits analyzer, an electronic computer for solving systems of motion and useful in flutter problems when studying the behavior of aircraft at high speeds.

Dr. Clelland was a member of the Kerr group on microwave propagation in the Radiation Laboratory of MIT from 1943 to 1946. He went to Stanford in January, 1946, as a Hewlett-Packard Fellow, and during his final year and a half was a research associate on an Army contract at the University. He was chiefly concerned with low-frequency loran systems. At Stanford he has been assigned to projects on communications equipment.

Dr. Scheuch, who was a student at San Francisco Junior College, received the B.S. degree from the University of California at Berkeley. His war service was at the Harvard University Radio Research Laboratory, where, as a research associate, he was assigned the synthesizing of enemy radar systems. During latter part of the war he was a technical observer in radar counter measures for the United States Air Force in India.

While a graduate student at Stanford, Dr. Scheuch was a research assistant in electrical engineering. His special interests are circuits and communications, and his first assignment at Stanford is to assist in the development of a single-sideband suppressed carrier transmitter for the Army Signal Corps.

Walter J. Seeley (A'22-SM'46) and **Edward W. Davis** (A'40) were elected officers of the AIEE at the annual meeting held this summer at Swampscott, Mass. Professor Seeley was elected a vice-president of the Institute and Mr. Davis was named as a director.

Professor Seeley is head of the electrical engineering department at Duke University. He earned the electrical engineering degree June, 1947, at Polytechnic Institute in Brooklyn, N. Y.

A graduate of the University of California with a B.S. degree in electrical engineering, Mr. Davis is allocations engineer of Mutual Broadcasting System Inc. He is working on coverage studies for all stations on the broadcast band, allocation studies, and related investigations pertinent to the operation of the network.

Frank E. Sessler (M'47), senior development engineer of International Detrola, in Detroit, Mich., died recently.

Mr. Sessler, who was born June 4, 1903, at Paducah, Kentucky, studied at the high school there, and attended evening sessions of Washington University, St. Louis, Mo., during 1942, 1943, and 1944.

He specialized in circuit development work of radio receivers and included among his business connections working for Kingston Products Corp., Kokomo, Ind. and Continental Radio and Television Co., Chicago, Ill.

Vernon B. Bagnall (A'30-M'40-SM'43), formerly division plant superintendent in the long-lines department of the American Telephone and Telegraph Company, Washington, D. C., has been appointed division commercial manager in Chicago.

During the war he saw service as a colonel in the United States Signal Corps where he supervised the engineering of the communications arrangements for the Anglo-American and Big Three conferences at Quebec, Cairo, Teheran, Malta-Yalta, and Potsdam, and also supervised the installation and operation of facilities at the Potsdam and first Quebec conferences.

Mr. Bagnall was graduated from the University of Wisconsin in 1927 with the B.S. degree in electrical engineering and received the M.S. degree in 1933 from New York University.

He joined A.T. & T.'s longlines department in a technical capacity in 1927 and was later transferred to New York as radio engineer and circuit-layout engineer.

In 1942 Mr. Bagnall entered the Signal Corps with the rank of captain and served as officer in charge, radio branch, plant division. In 1943 he was appointed chief, communications engineering branch, Army communications Service, Office of the Chief Signal Officer. It was in this capacity that he served abroad at various international conferences.

Mr. Bagnall made two other trips to the European Theatre of War, the first to plan communications for the invasion of the continent. The second Journal was in connection with rehabilitation and establishment of communications in France. He was awarded the Bronze Star and the Legion of Merit.

IRE People

Four IRE members have been elevated to supervisory engineering posts by the General Electric Company. They are Edwin W. Kenefake (A'37-SM'46), H. B. Fancher (A'43-SM'48), Lawrence H. Junken (A'25), and Charles M. Heiden (S'40).

Mr. Kenefake has been appointed section engineer for carrier current equipment. He was born in Robinson, Ill., and was graduated from Notre Dame University, earning the B.S. degree in electrical engineering and the M.S. degree in physics. He joined the staff of the General Electric Company in 1936 and was enrolled in the test and the advanced engineering courses. Two years later he became an engineer on carrier current equipment and was named an assistant section engineer, a position which he held until his present appointment.

Mr. Kenefake is chairman of an AIEE committee for communications and secretary of the AIEE committee on carrier current. He is also a member of the Association of American Railroads committee on communication.

Mr. Fancher, formerly assistant section engineer in charge of television equipment, has become section engineer of broadcast studio equipment for the transmitter division. He is responsible for television and associated broadcast equipment and all phases of audio facilities.

A native of Hartford, Conn., Mr. Fancher was graduated from Brown University with the B.S. degree in science. He was enrolled in the GE test course in 1936 and was later assigned to the advanced engineering program, joining the transmitter division at Schenectady in 1940. During the war he was active in the development of microwave relay equipment and radar countermeasures. After the war he served as project engineer and then as assistant section engineer, until his current assignment.

Mr. Junken has been appointed design engineer for product engineering with responsibility for product design and manufacturing liaison on products of the transmitter division. A native of Pittsboro, Ind., he received B.S. degrees in electrical engineering from Tri-State College and from Purdue University.

He joined GE in 1916 and was assigned to the mechanical engineering section for the radio department at Schenectady. He has served as section leader in charge of the vacuum-tube application section, and as supervisor in charge of manufacturing planning and tool design for a line of broadcast superheterodyne receivers and a line of sound motion picture equipment. Mr. Junken was employed for four years by RCA, where he was assistant manager of quality control, manufacturing engineering, and section leader in charge of the capacitor section. He has been with GE continuously since 1934, and held other supervisory positions prior to his present appointment. He is associated with the RMA and is a member of Sigma Xi, Tau Beta Pi, and Eta Kappa Nu.

Mr. Heiden is now the section engineer of radio communications equipment for the transmitter division. Originally from Adams, Wis., he is a graduate of Valparaiso Technical Institute and holds the B.S. degree in electrical engineering from the University of Wisconsin.

Mr. Heiden was assigned to the test course when he joined General Electric in 1941. He was transferred to the transmitter engineering test section, and then to the government engineering transmitter section as an engineer. During the war he worked on the development of transmitters for the armed services. After peace was declared, he worked with the electronic heater engineering section and the marine engineering section. In January, 1946, he was transferred to the radio communications section and as section leader headed the operation until his new assignment. He is a member of the Railroad Vehicular communications committee; member of the executive committee; transmitter section of the RMA; and commercial member of the Association of Police Communication Officers.

❖

Andrew G. Tynan (M'43-SM'43), assistant chief engineer with the Delco Radio Division of General Motors Corporation at Kokomo, Ind., died recently.

Mr. Tynan, who was born December 28, 1907, in Pennsylvania, was educated at Allegheny High School, Pittsburgh, and was graduated in 1930 from the University of Pennsylvania with the B.S. degree in electrical engineering. He became affiliated with Delco Radio Division in 1934, working on radio and electronic development and production.

His business career commenced when he became a member of the transmission research group of Bell Telephone Laboratories, New York City, where he designed and built apparatus for telephoto and television transmission from 1930 until 1932. He then became affiliated with Pilot Radio and Tube Corporation, engaging in the production and development of radio receivers.

Stuart Luman Seaton (A'41-M'43-SM'43), who is director of the Geophysical Observatory at the University of Alaska, has been awarded the honorary degree of doctor of science. In conferring the degree May 16, 1949, the University of Alaska's citation acknowledged Mr. Seaton's contributions to knowledge of the upper atmosphere and especially his contributions to knowledge of the arctic.

Born November 16, 1906, at Kirkwood, Mo., he received his early education at McKinley School, Washington, D. C. He has studied at the University of Maryland, George Washington University and the University of Alaska.

Mr. Seaton commenced his professional career in 1929 with a magnetic survey of the Pacific Ocean from the yacht, "Carnegie." He continued with research of high-frequency communications and magnetic investigations at the Observatory, Huancayo, Peru.

Following this study, he was engaged in geophysical research, installation of seismographs communications equipment, spectrohelioscope design, and installation of ionospheric equipment at Western Australia College, Alaska.

From 1922 to 1929 Mr. Seaton worked on electrical design drafting for Potomac Electric Power Co., Washington, D. C., and the design and operation of radio communications equipment of eastern superpower network high-voltage tie lines.

❖

Neal McNaughten (A'44-M'45) is the new director of the National Association of Broadcasters' Engineering Department. He formerly was assistant director of the department, a post he has held since January 1, 1948. Before coming to NAB, he was with the FCC for seven years. From 1945 to 1948, he was chief of the Allocation Section in the FCC's Engineering Department, Standard Broadcast Division, in which position he administered the Commission's North American Regional Broadcasting Agreement activities.

Mr. McNaughten, who was born in Pueblo, Colo., entered the broadcast field in 1929 at radio station KGHF. In 1934 he became chief engineer at KRGV Weslaco, Texas, and remained at that station until his FCC appointment in 1941. After his appointment in 1945 as chief of the FCC Allocation Section, he was named by the President as Secretary to the U. S. Delegation to the Second NARBA Conference, with the ex-officio title of Secretary-General of the Conference.

His first FCC assignment was in 1941 to the West Indies, where he assisted in the development in the FCC's radio intelligence operations in that area. In 1942 and 1943 he was assistant supervisor of the FCC's Great Lakes monitoring area, in charge of the primary monitoring station at Allegan, Mich. In 1944 he became assistant chief of the Treaty Section, International Division.

Since his affiliation with NAB, Mr. McNaughten has assisted the former director in holding two annual NAB Broadcast Engineering Conferences. He has appeared before FCC in behalf of NAB, served as member and chairman of many subcommittees on preparatory work for the third NARBA Conference, and has recently completed the 675-page fourth edition of the NAB Engineering Handbook.

IRE People

Willis E. Phillips (A'37) is the new vice-president and general manager of The Rauland Corporation, manufacturers of television picture tubes, according to an announcement from E. N. Rauland, president. Formerly Mr. Phillips was assistant to the president.

Mr. Phillips, who was graduated from the University of Illinois in 1933 with the electrical engineering degree, started his business career as chief engineer of radio station WLL at Champaign, Urbana, the radio station of the University of Illinois. He has held executive engineering positions at Bendix and Zenith and managed the broadcast equipment division of Raytheon Manufacturing Company while this division was in Chicago. He came to Rauland Corp. from Motorola, where he was division chief engineer. As a registered engineer, Mr. Phillips is affiliated with the Radio Engineers Club of Chicago, as well as IRE.

❖

Geoffrey Parr (A'44-SM'47) has been appointed technical director of Chapman and Hall, publishers of scientific and technical books. Mr. Parr, who is a member of the Institution of Electrical Engineers and Secretary of the Television Society, formerly was editor of *Electronic Engineering* which he founded in 1941. He is also a member of the Board of Editors of the newly formed *Journal of Electroencephalography*, published in Canada.

❖

Thomas D. Fuller (S'46-A'49), formerly an industrial engineer, has been transferred to the sales merchandising department of the Radio Division, Sylvania Electric Products Inc. A native of Seattle, Wash., Mr. Fuller earned the B.S. degree in electrical engineering and the B.S. degree in industrial engineering from the University of Michigan. He also attended Carroll College at Helena, Mont.

Mr. Fuller is also a member of the National Association of Foremen, the American Legion, and Beta Theta Pi. During the war he served as an ensign and saw active duty in the 7th Pacific Fleet.

❖

John T. Wilner (A'37-M'46-SM'48) has been named engineering director of radio station WBAL in accordance with the expansion program of the Baltimore, Md., radio station facilities. Mr. Wilner, who was engineer-in-charge of CBS television transmitter development, is a graduate electrical engineer.

He joined CBS as a research engineer in 1937. From 1943 to 1944 he was loaned to

Harvard University as head of the transmitter development group at the American-British Laboratory at Malvern, England. As a group leader in counter-radar measures, he supervised the development of equipment which effectively blanketed Nazi radar-controlled gun positions on the French coast, and prevented heavy losses to the Allied invasion fleet.

Mr. Wilner has been active in pulse, multiplex, and FM transmission. Among his engineering contributions in the communications field are the design of the first 100-watt color UHF transmitter at 500 Mc; the first 1,000-watt UHF video transmitter for 490-550 Mc; the first 500-watt color and FM sound transmitter for 490-550 Mc; and the first 10,000-watt peak propagation transmitter for 700 Mc.

❖

Edwin Reginald Love (M'46), associate professor of electrical engineering at the University of Manitoba, died recently.

Born in England on January 18, 1912, he subsequently came to Canada and received his education at the Winnipeg schools and the University of Manitoba. He was graduated in 1934 with the B.S. degree in electrical engineering. For one semester after his graduation he was a demonstrator in electrical engineering at the University, and then he joined the Canadian Westinghouse Co., remaining on their engineering staff until 1940.

Professor Love received a commission in the Royal Canadian Corps of Signals in 1940 and rose to the rank of captain. Owing to a serious shortage of qualified instructors in electrical engineering, he was lent by the Army to the University of Manitoba for three successive semesters. Upon his demobilization in 1945, he was taken on the permanent staff as an assistant professor of electrical engineering. He was elevated to the position of associate professor in 1946.

❖

Dr. Oliver D. Sledge (S'39-A'41-SM'46) has been appointed to the staff of the National Bureau of Standards where he will do research in the Microwave Standards Section of the Bureau's Central Radio Propagation Laboratories. He will undertake research on microwave attenuation stand-

ards for frequencies above 300 Mc and on radio measurement methods.

Formerly a professor of electrical engineering at Georgia School of Technology, Dr. Sledge conducted radar research at that institution and did extensive work in the fields of electronic and radio engineering, including electronic digital computer circuits and radar equipment.

Dr. Sledge, who was born in Kyle, Texas, attended the University of Texas from 1927 to 1933, and received the degrees of bachelor of science in electrical engineering and master of arts in physics.

From 1936 to 1939 he attended Harvard University where he earned the degrees of S.M. and Sc.D. in 1937 and 1940, respectively. While at Harvard, he was awarded a scholarship in communication engineering for the years 1937 through 1939.

Dr. Sledge was a radio engineer associated with the Naval Research Laboratory, Washington, D. C., from August, 1939 to January, 1941, where he did research concerning frequency dividers, pulse amplifiers, sweep circuits, wide-band amplifiers of both low-pass and band-pass types.

He is a member of Tau Beta Pi and Eta Kappa Nu, and an associate member of Sigma Xi.

❖

Karl F. Kellerman (SM'46) has been placed in charge of the newly opened Washington, D. C., branch office of the Brush Development Company of Ohio, manufacturers of electronic and electromechanical products. He formerly was with Aircraft Radio Corporation of Boonton, N. J.

After his graduation from Cornell University with an electrical engineering degree in 1929, Mr. Kellerman joined the New York Telephone Company. During World War II, he headed the electronics co-ordination branch in the engineering division of the bureau of aeronautics, serving with the rank of commander.

He was responsible for the introduction and development of a complete line of "service standard" electronic test equipment, for the practice of pre-installation "systems test" of over-all electronic systems for aircraft and for progress in the reduction of interference to airborne electronic equipment. For these contributions he received an official Navy commendation for outstanding performance.

Immediately prior to his new affiliation, Mr. Kellerman was the first executive director of the United States government committee on guided missiles. He will continue as a special technical consultant to the Research and Development Board.

Mr. Kellerman is a member of Tau Beta Pi, Eta Kappa Nu, the Radio Club of America, the Cornell Society of Engineers, Aircraft Owners and Pilots Association, Rock Spring Golf Club, and Delta Upsilon fraternity.

Sections*

Chairman		Secretary	Chairman	Secretary
H. R. Hegbar 2145 12th St. Guyahoga Falls, Ohio	AKRON (4)	H. G. Shively 736 Garfield St. Akron, Ohio	G. L. Foster Spartan of Canada London, Ont., Canada	LONDON, ONTARIO (8) G. R. Hosker Richards-Wilcox London, Ont., Can.
H. I. Metz C.A.A. 84 Marietta St., N.W. Atlanta, Ga.	ATLANTA (6) Nov. 18-Dec. 16	M. S. Alexander 2289 Memorial Dr., S.E. Atlanta, Ga.	Bernard Walley Radio Corp. of Am. 420 So. San Pedro St. Los Angeles 13, Calif.	LOS ANGELES (7) J. J. Fiske Electronic Eng. Co. of Calif. 2008 W. Seventh St. Los Angeles 5, Calif.
E. W. Chapin 2805 Shirley Ave. Baltimore 14, Md.	BALTIMORE (3)	J. V. Lebacqz Owings Mills Maryland	D. C. Summerford Radio Station WKLO Henry Clay Hotel Louisville, Ky.	LOUISVILLE (5) R. B. McGregor 2100 Confederate Pl. Louisville, Ky.
T. B. Lawrence 1833 Grand Beaumont, Texas	BEAUMONT- PORT ARTHUR (6)	C. B. Trevey 2555 Pierce St. Beaumont, Texas	E. J. Limpel A. O. Smith Corp. 3533 N. 27 St. Milwaukee 1, Wis.	MILWAUKEE (5) W. H. Elliot 3564 N. Murray Ave. Milwaukee 11, Wis.
H. H. Scott Hermon Hosmer Scott, Inc. 385 Putnam Ave. Cambridge 39, Mass.	BOSTON (1)	F. D. Lewis General Radio Co. 275 Massachusetts Ave. Cambridge 39, Mass.	A. B. Oxley R.C.A. Victor Co. 1001 Lenoir St. Montreal, P.Q. Canada	MONTREAL, QUEBEC (8) Nov. 9-Dec. 14 H. A. Audet Canadian Broadcasting Corp. 1231 St. Catherine St. Montreal, Que, Can.
J. P. Arnaud Guemes 827 Vte. Lopez F.C.C.A., Argentina, S.A.	BUENOS AIRES	L. Brandt Uruguay 618 Buenois Aires, Argentina, S.A.	C. W. Carnahan 3169-41 Place Sandia Base Branch Albuquerque, N. M	NEW MEXICO (7) T. S. Church 3079 Q 34th St. Sandia Base Branch Albuquerque, N. M.
L. P. Haner 75 Koenig Rd. Tonawanda, N. Y.	BUFFALO-NIAGARA (4) Nov. 16-Dec. 21	K. R. Wendt Colonial Radio Corp. 1280 Main St. Buffalo 9, N. Y.	H. F. Dart 33 Burnett St. Glen Ridge, N. J.	NEW YORK (2) Earl Schoenfeld W. L. Mason Corp. 460 W. 34th St. New York 1, N. Y.
M. S. Smith 1701 10th St. Marion, Iowa	CEDAR RAPIDS (5)	V. R. Hudek Collins Radio Co. Cedar Rapids, Iowa	J. T. Orth 4101 Fort Ave. Lynchburg, Va.	NORTH CAROLINA- VIRGINIA (3) C. E. Hastings 117 Hampton Roads Ave. Hampton, Va.
E. H. Schulz Elec. Engr. Dept. Armour Research Found Chicago, Ill.	CHICAGO (5) Nov. 18-Dec. 16	L. H. Clardy Research Labs. Swift & Co., U. S. Yards Chicago 9, Ill.	M. W. Bullock Capital Broadcasting Co. 501 Federal Securities Bldg. Lincoln 8, Neb.	OMAHA-LINCOLN (5) B. L. Dunbar Radio Station WOW Omaha, Neb.
F. W. King 6249 Banning Rd. Cincinnati 24, Ohio	CINCINNATI (5) Nov. 15-Dec. 13	J. P. Quitter 509 Missouri Ave. Cincinnati 20, Ohio	A. W. Y. Des Brisay 240 Clemow Ave. Ottawa, Ont., Canada	OTTAWA, ONTARIO (8) Nov. 17-Dec. 15 A. G. Sheffield 11 Fern Ave. Ottawa, Ont., Canada
I. F. Dobosy 31748 Lake Rd. Avon Lake, Ohio	CLEVELAND (4) Nov. 24-Dec. 22	T. B. Friedman 2909 Washington Blvd. Cleveland Heights 18, Ohio	J. T. Brothers Philco Radio and Tele- vision Tiogo and 'C' Sts. Philadelphia 34, Pa.	PHILADELPHIA (3) Nov. 3-Dec. 1 L. M. Rodgers 400 Wellesley Rd. Philadelphia 19, Pa.
R. B. Jacques 226 W. Como Ave. Columbus, Ohio	COLUMBUS (4) Nov. 11-Dec. 9	S. N. Friedman 144 N. Edgevale Columbus, Ohio	M. Glenn Jarrett 416 Seventh Ave. Pittsburgh 19, Pa.	PITTSBURGH (4) Nov. 14-Dec. 12 W. P. Caywood, Jr. 23 Sandy Creed Rd. Pittsburgh 21, Pa.
Lawrence Grew S. N. E. Telephone Co New Haven, Conn.	CONNECTICUT VALLEY (1) Nov. 17-Dec. 15	J. E. Merrill 713 Montauk Ave. New London, Conn.	A. E. Richmond Box 441 Portland 7, Ore.	PORTLAND (7) Henry Sturtevant Rt. 6, Box 1160 Portland 1, Ore.
A. S. Levell 801 Telephone Bldg. Dallas 2, Texas	DALLAS-FORT WORTH (6)	E. A. Hegar 802 Telephone Bldg Dallas 2, Texas	E. W. Herold RCA Laboratories Princeton, N. J.	PRINCETON (3) W. H. Bliss 300 Western Way Princeton, N. J.
H. E. Ruble 3011 Athens Ave. Dayton 6, Ohio	DAYTON (5)	G. H. Arenstein 1224 Windsor Drive Dayton 7, Ohio	K. J. Gardner 111 East Ave. Rochester 4, N. Y.	ROCHESTER (4) Nov. 17-Dec. 15 Gerrard Mountjoy Stromberg Carlson Co. 100 Carlson Rd. Rochester, N. Y.
T. G. Morrissey Radio Station KFEL Albany Hotel Denver, Colo.	DENVER (5)	Hubert Sharp Box 960 Denver 1, Colo.	N. D. Webster 515 Blackwood N. Sacramento, Calif.	SACRAMENTO (7) J. R. Miller 3991 3rd Ave. Sacramento, Calif.
F. E. Bartlett Radio Station KSO Old Colony Bldg. Des Moines 9, Iowa	DES MOINES- AMES (5)	O. A. Tennant 3515 Sixth Ave. Des Moines Iowa	L. A. Mollman Union Electric Co. 12 and Locust Sts St. Louis 1, Mo.	ST. LOUIS (5) H. G. Wise 1705 N. 48 St. E. St. Louis, Ill.
C. F. Kocher 17186 Sioux Rd. Detroit 24, Mich.	DETROIT (4) Nov. 18-Dec. 16	P. L. Gundy 519 N. Wilson Royal Oak, Mich.	O. C. Haycock Dept. of Elec. Eng. University of Utah Salt Lake City, Utah	SALT LAKE (7) E. C. Madsen Dept. of Elec. Eng. University of Utah Salt Lake City, Utah
R. W. Slinkman Sylvania Elec. Prods Emporium, Pa.	EMPORIUM (4)	T. M. Woodward 203 E. Fifth St. Emporium, Pa.	C. L. Jeffers Radio Station WOAI 1041 Navarro St. San Antonio, Texas	SAN ANTONIO (6) L. K. Jonas 267 E. Mayfield Blvd. San Antonio, Texas
H. W. G. Salinger 2527 Hoagland Ave. Ft. Wayne 6, Ind.	FORT WAYNE (5)	J. F. Conway 4610 Plaza Dr. Ft. Wayne, Ind.	L. G. Trolese U. S. Navy Electronics Lab. San Diego 52, Calif.	SAN DIEGO (7) S. H. Sessions U. S. Navy Electronics Lab. San Diego 52, Calif.
C. R. Wischmeyer 808 N. Rice Ave. Bellare, Texas	HOUSTON (6)	Wayne Phelps 1710 Richmond Ave Houston 6, Texas	W. R. Hewlett 395 Page Mill Rd. Palo Alto, Calif.	SAN FRANCISCO (7) J. R. Whinnery Elec. Engr. Dept. University of Calif. Berkeley, Calif.
E. H. Pulliam 931 N. Parker Ave. Indianapolis 1, Ind.	INDIANAPOLIS (5)	J. H. Schult Indianapolis Elec. School 312 E. Washington St. Indianapolis 4, Ind.		
E. R. Toporeck Naval Ordnance Test Sta Inyokern, Calif.	INYOKERN (7)	R. W. Johnson 303 B. Langley China Lake, Calif.		
C. F. Heister Fed. Com. Comm. 838 U. S. Court House Kansas City 6, Mo.	KANSAS CITY (5)	Mrs. G. L. Curtis 6005 El Monte Mission, Kan.		

* Numerals in parentheses following Section designate Region number.

Sections

Chairman		Secretary		Chairman		Secretary	
J. M. Paterson 2009 Nipsic Bremerton, Wash.	SEATTLE (7) Nov. 10-Dec. 8	J. E. Hogg General Electric Co. 710 Second Ave. Seattle 1, Wash.		F. T. Hall Dept. of Elec. Engr. Pennsylvania St. College State College, Pa.	CENTRE COUNTY (4) (Emporium Subsection)	J. H. Slaton Dept. of Eng. Research Pennsylvania St. College State College, Pa.	
R. H. Williamson 161 Parkway Dr. Syracuse, N. Y.	SYRACUSE (4)	S. E. Clements Dept. of Elec. Engr. Syracuse University Syracuse, N. Y.		A. H. Sievert Canadian Westinghouse Co. Hamilton, Ont., Canada	HAMILTON (8) (Toronto Subsection)	J. H. Pickett Aerovox Canada Ltd. 1551 Barten St. E. Hamilton, Ont., Canada	
A. M. Okun 344 Boston Pl. Toledo 10, Ohio	TOLEDO (4)	R. G. Larson 2647 Scottwood Ave. Toledo 10, Ohio		R. B. Ayer RCA Victor Division New Holland Pike Lancaster, Pa.	LANCASTER (3) (Philadelphia Subsection)	J. L. Quinn RCA Victor Division New Holland Pike Lancaster, Pa.	
C. Graydon Lloyd Canadian General Electric Co., Ltd. 212 King St., W. Toronto, Ont., Canada	TORONTO, ONTARIO (8)	Walter Ward Canadian General Electric Co., Ltd. 212 King St., W. Toronto, Ont., Canada		O. M. Dunning Hazeltine Elec. Corp. 5825 Little Neck Pkwy Little Neck, L. I., N. Y.	LONG ISLAND (2) (New York Subsection)	David Dettinger Wheeler Labs. 259 09 Northern Blvd. Great Neck, L. I., N. Y.	
W. G. Pree 2500 W. 66 St. Minneapolis, Minn.	TWIN CITIES (5)	O. A. Schott 4224 Elmer Ave. Minneapolis 16, Minn.		H. Sherman Watson Labs.-ENRPS- Red Bank, N. J.	MONMOUTH (2) (New York Subsection)	W. L. Rehm Signal Corps Eng. Labs. Rm. 247, Squier Lab. Fort Monmouth, N. J.	
T. J. Carroll National Bureau of Stand. Washington, D. C.	WASHINGTON (3) Nov. 14-Dec. 12	P. DeF. McKeel 9203 Sligo Creek Parkway Silver Spring, Md.		N. Young, Jr. F.C.C. Nutley, N. J.	NORTHERN N. J. (2) (New York Subsection)	J. H. Redington Measurements Corp. Boonton, N. J.	
G. C. Larson Westinghouse Elec. Corp. Sanbury, Pa.	WILLIAMSPORT (4) Nov. 2-Dec. 7	R. C. Walker Box 414, Bucknell Univ. Lewisburg, Pa.		A. R. Kahn Electro-Voice, Inc. Buchanan, Mich.	SOUTH BEND (5) (Chicago Subsection) Nov. 17-Dec. 15	A. M. Wiggins Electro-Voice, Inc. Buchanan, Mich.	
SUBSECTIONS				R. M. Wainwright Elec. Eng. Department University of Illinois Urbana, Ill.	URBANA (5) (Chicago Subsection)	M. H. Crothers Elec. Eng. Department University of Illinois Urbana, Ill.	
Chairman		Secretary		R. D. Cahoon C.B.C. Winnipeg, Man., Canada	WINNIPEG (8) (Toronto Subsection)	J. R. B. Brown Suite 2 642 St. Marys Rd. Winnipeg, Man., Canada	
H. W. Harris 711 Kentucky St. Amarillo, Tex.	AMARILLO-LUBBOCK (6) (Dallas-Ft. Worth Subsection)	E. N. Luddy Station KFDA Amarillo, Tex.					

Books

The Mathematics of Circuit Analysis by Ernst A. Guillemin

Published (1949) by John Wiley and Sons, 440 Fourth Ave., New York 16, N. Y. 575 pages +14-page index +xiv pages. 6x9. \$7.50.

Three earlier books by members of the *Electrical Engineering* staff of the Massachusetts Institute of Technology have appeared as units of a series planned to present between them different portions of an integrated basic undergraduate course in electrical engineering theory. The present volume is a complementary contribution to this series. It is not a mathematical textbook on the principles of circuit analysis, but rather, as its title should be interpreted, a presentation, within the compass of a single volume, of material appropriate to provide for the student fundamental mathematical equipment for the understanding of the theory underlying advances in the subject of circuit analysis. Applications of the theory are reserved for later publications.

The subject matter of the present volume covers chapters on determinants, matrices, linear transformations as illustrated by transformation of co-ordinates, and quadratic forms. Especial attention is paid to the

theory of functions of a complex variable and conformal mapping. The final chapter is concerned with Fourier series and integrals, with special reference to the application of Fourier transforms to the study of impulses.

Each chapter furnishes a well-rounded treatment of its subject, and is so arranged and sectioned as to make reference to specific portions easy. It is especially emphasized that the book is written for engineers by an engineer, and no claim is made to mathematical rigor. However, this disclaimer by such an accomplished mathematician as the writer of this book seems to this reviewer unduly modest. The author is careful throughout to make manifest what are the underlying assumptions and limitations and to warn the reader where pitfalls await the unwary. The book is well suited to serve as a mathematical text for advanced students in general.

The style is clear and pleasing and, although designed especially for students in graduate schools, it should be useful also to the engineer as a reference book and for independent study.

FREDERICK W. GROVER
Professor (Emeritus) of Electrical Engineering
Union College, Schenectady, N. Y.

Fundamental Electronics and Vacuum Tubes by Arthur Lemuel Albert

Published (1947) by the Macmillan Co. 499 pages +10-page index +x pages. 326 figures. 6½x9½. \$6.00.

A revision and enlargement of the first edition that appeared in 1938, "Fundamental Electronics and Vacuum Tubes," is intended as before "for use in courses in electronics required of all electrical engineering students." The treatment is largely non-mathematical, formulas being quoted without deviation but with careful reference to one or more sources in which the derivation may be found. Familiarity with complex-number notation is assumed. Almost all of the references cited are dated 1945 or earlier. Nevertheless many of the important wartime developments such as multicavity magnetrons, velocity-modulation tubes, etc., are covered, though perhaps not with the same relative emphasis that will eventually seem proper. As an example, the two-cavity klystron is described at some length, while the single-cavity reflex oscillator is barely mentioned.

The number of errors and misprints occurring is reasonably small, with only a few being of any significance. Among these

Books

are Figure 6, which shows the way electrons do *not* act unless aided by time-varying fields or gas, and the discussion on page 277 where the role assigned to R_L is really played by a combination of R_L , R_g , and r_p , that for ordinary values depends very little on R_L . The book shows ample evidence of careful planning to find the best pedagogical approach to the material presented. As in the previous edition, references are cited for almost every statement made. In addition, the material at the end of each chapter has been expanded to provide both a list of review questions and a set of problems. The choice of topics and method of presentation may perhaps best be described as conservative. Voice communication and power rectification and control are emphasized, while such topics as transient response, gain-bandwidth relationships, noise figure, and the like receive little or no mention.

S. N. VAN VOORHIS
Department of Physics
University of Rochester
Rochester, N. Y.

Cybernetics, or Control and Communication in the Animal and the Machine, by Norbert Wiener

Published (1948) by John Wiley and Sons, Inc., 440 Fourth Ave., New York 16, N. Y. 194 pages. 6×9½. \$3.00.

The last decade has seen a considerable amount of research in a number of closely related fields centering on the general problems of communication and control. The development of large-scale computing machines, of fire-control equipment with its complex predicting and servo systems, and research in communication theory, and in the mathematics of the nervous system, are all parts of this general trend. Professor Wiener has coined the word "cybernetics" from the Greek word for "steersman" to cover this rapidly growing branch of science. Communication engineers have a charter right and responsibility in several of the roots of this broad field and will find Wiener's treatment interesting reading, filled with stimulating and occasionally controversial ideas.

After a lengthy introduction in which the author relates his own association with the problems of cybernetics, the author presents some of his central theses: the essential unity of the various disciplines involved, and the need for cross fertilization. Wiener sees the present historical period as one of a second industrial revolution, a revolution in which machines take over the more routine and clerical types of mental work. His outlook for an easy adaptation to this change is justifiably somewhat pessimistic.

His first three chapters are concerned with the relation of statistical theory to the

problems of cybernetics. Communication systems, and information processing devices generally, must operate on a statistical ensemble of possible inputs, and the statistical aspects are of paramount significance in the newer theories. One important result of this approach is Wiener's theory of linear least square filters and predictors, of which a summary is given. Wiener also considers some other questions in information theory and makes the interesting conjecture that the paradoxes of the "Maxwell demon" can be resolved by taking into account the information received by the "demon" in entropy calculations. If this could be given experimental verification, it would be of considerable significance in statistical mechanics.

The remainder of the book deals, for the most part, with problems of the nervous system and analogies between it and computing machines. The author stresses the importance of the feedback concept in understanding teleological behavior. Many interesting parallels can be drawn between certain nervous diseases, such as ataxia, and unstable oscillation of a servo system. Other pathological conditions are analogous to failure of the internal memory of a computer.

The book, unfortunately, contains numerous misprints, some of which, in the mathematical sections, make for difficult reading. There are also a few errors of the over-simplified statement, for instance, the attempt to construct an arbitrary ensemble from a Brownian motion. These criticisms, however, are minor. Professor Wiener, who has contributed much to communication theory, is to be congratulated for writing an excellent introduction to a new and challenging branch of science.

C. E. SHANNON
Bell Telephone Laboratories
Murray Hill, N. J.

Foundations of Nuclear Physics, edited by Robert T. Beyer

Published (1949) by Dover Publications Inc., 1780 Broadway, New York 19, N. Y. 139 pages + 117-page bibliography + vii pages. 57 figures. 6½×9½. \$2.95.

If one were to ask a group of nuclear physicists what they consider the thirteen most fundamental contributions to the literature of nuclear physics, undoubtedly all would agree upon such milestones as the work of Rutherford on alpha particle scattering and nuclear bombardment. Also they would be unanimous in including in the list Chadwick's paper on the discovery of the neutron, Fermi's theory of beta-decay, Anderson's investigations on the positron, and the classic experiments of Cockroft and Walton in England, as well as those of Curie and Joliot in France. Certainly no one would question such a choice. But beyond these

few, physicists probably would argue at length.

Dr. Robert T. Beyer, Assistant Professor at Brown University, has edited a book which he entitled, "Foundations of Nuclear Physics," in which he selects "the big 13 of nuclear physics" and reproduces facsimiles of each original article as it first appeared in print. In addition to all of the aforementioned papers, he lists the work of Gamow, Hahn and Strassmann, Lawrence and Livingston, Frisch and Stern, and Yukawa. He points out the fact that one can quarrel with the choice of the thirteen fundamental studies and concedes that others should have been added to the list. In writing in the field of nuclear physics, the problem generally is one of *containment* of the material to a size consonant with the economics of the publisher.

The effect of such a book as "Foundations of Nuclear Physics" is twofold. To the more mature physicist, it is an arresting experience. He will pause and reflect on the passage of time, recalling that it seemed only yesterday when some of the papers appeared in a current periodical. He will, perhaps, be a little shocked to be reminded of the crude and simple apparatus with which some of the fundamental discoveries were made; this the more so in view of the intricate complexity of the modern physics research laboratory. Words such as neutron, positron, and meson, now commonplace, may appear in new light when the original papers are read again. To the younger physicist the reading of the original papers will serve to give him new perspective in the field. It would appear that there is a definite place in the literature of nuclear physics for a more extensive source book with provision for the inclusion of the older, more-difficult to obtain research papers.

Dr. Beyer has appended an extensive bibliography to accompany the first part of the book. This section is divided into twelve categories in a fairly conventional manner. One minor criticism of the bibliography is indicated: the authors of each paper are listed by surnames only and no initials are given. This will probably occasion no confusion, but it will prove to be an inconvenience.

It is to be regretted that the bibliography, which is complete up to the spring of 1947, should appear with a delay of almost two years. There is a definite need for bibliographies such as Dr. Beyer has compiled. The shorter the delay in publishing, the more valuable they will be. Today the current physics periodicals bulge with the fast-breaking developments of nuclear physics. The physicist is hard pressed to keep up with the literature. Up-to-date bibliographies will be of considerable value.

RALPH E. LAPP
Buffalo, N. Y.

IRE SECTION CHAIRMEN

Henry I. Metz

ATLANTA SECTION

Henry I. Metz (A'38-SM'46) was born on August 17, 1904, in Pittsburgh, Pa. He received the B.S. E.E. degree from the University of Pittsburgh in 1927. After ten years with Westinghouse Electric Manufacturing Corporation, he joined the Bureau of Air Commerce, now Civil Aeronautics Administration, transferring to Indianapolis in 1939 for the installation and testing of the first CAA consolidated instrument-landing system. In 1947 he was appointed superintendent of communications for the CAA second region. In May, 1949, he became Deputy Chief, CAA Federal Airways Facilities Division, in Atlanta, Georgia.



Edward W. Chapin

BALTIMORE SECTION

Born in Freeburg, Ill., on July 23, 1908, Edward W. Chapin (M'45) became interested in radio early in life, operating a radio sales and service business while attending high school. He received the B.S. E.E. degree in 1930 from the University of Illinois, and was then employed by the Radio Division, U. S. Department of Commerce, as radio inspector at Fort McHenry, Baltimore, Md. In August, 1946, he became Chief of the Federal Communications Commission Laboratory Division at Laurel, Md. Mr. Chapin was a member of the Institute of Radio Conferees, which later disbanded and formed the IRE Baltimore Section.



Jean Paul Arnaud

BUENOS AIRES SECTION

Jean Paul Arnaud (A'35-M'40-SM'43) was born in London, England, in 1905. He received the industrial engineering degree in 1929, and studied at the Westinghouse Pittsburgh plant, and Columbia University during 1929-1932. He has taught radio engineering at the Army School of Engineering and at the National University of La Plata. In 1946 he joined Standard Electric Argentina, an IT&T associate, as chief engineer of their electronic division. In July, 1949, he was made head of the microwave development department of Direccion General de Fabricaciones Militares. Mr. Arnaud is the first professor of radio engineering in Argentina.



Edward R. Toporeck

INYOKERN SECTION

Edward R. Toporeck, (A'47-SM'49) was born in Winnipeg, Canada, on April 17, 1908. He received the B.S. E.E. degree at the University of Manitoba in 1929, and the S.M. E.E. degree in 1931 from Massachusetts Institute of Technology, where he instructed in electronics and electrical engineering until 1934. Mr. Toporeck was in charge of the MIT Research Group on microwave-guidance systems at the Bureau of Standards from 1944 to 1946, leaving to supervise the electronics development unit, Measurement Division, Naval Ordnance Test Station, Inyokern, Calif. He is now the acting head of the Measurement Division.



Bernard Walley

LOS ANGELES SECTION

Bernard Walley (A'38-SM'47) was born on January 27, 1913, in New Haven, Conn. After receiving the B.S. degree in electrical engineering from the California Institute of Technology in 1937, he joined the research and engineering section of the Radiotron Division, RCA Manufacturing Company, in Harrison, N. J., engaged mainly in gas tube design and applications. In 1941 Mr. Walley was made assistant section head of the data, rating and life test section and transferred to Los Angeles in 1945, as application engineer for the RCA Tube Department western region. Mr. Walley was Secretary-Treasurer of the Los Angeles Section in 1947 and Vice-Chairman in 1948.



D. C. Summerford

LOUISVILLE SECTION

D. C. Summerford (A'39-M'44) was born in Bexar, Ala., on April 23, 1906. He received the B.S. degree from the Alabama Polytechnic Institute, in 1930, followed by two years with the American Telephone and Telegraph Company. From 1932 to 1948 he was a staff member of radio station WHAS. In June, 1948, he was named technical director of radio station WKLO, Louisville, Ky., his present position. Mr. Summerford assisted in the formation of the IRE Louisville Section, and served two terms as Secretary-Treasurer.



E. Stewart Naschke

SACRAMENTO SECTION

E. Stewart Naschke (A'37-M'46) was born on September 25, 1914, at San Bernardino, Calif. He acquired his engineering training at San Bernardino Schools, Sacramento College, and the Capitol Radio Engineering Institute. From 1933 to 1938 he was on the technical staff of radio station KFXM, San Bernardino. Then he joined the California Highway Patrol, where he is still employed. His duties have included the planning and installation of various radio communication facilities throughout the state. Mr. Naschke was instrumental in the formation of the Sacramento Section, and has just completed his second term of office as Chairman. He has been succeeded by N. D. Webster.



John M. Paterson

SEATTLE SECTION

Born in Seattle, Wash., on April 3, 1914 John M. Paterson (S'35-A'38-M'45) was graduated from the University of Washington in 1935 with the B.S. E.E. degree. He was first employed at Colonial Radio Corporation, in Buffalo, N. Y. Later he became radio engineering representative for RCA Manufacturing Co., Far East Branch, returning to the United States in 1940 to join the Sparks-Withington Corporation, Jackson, Mich. Since 1942 Mr. Paterson has been with the Electronics Office, Puget Sound Naval Shipyard, Bremerton, Wash., and is now supervisor of the planning branch of the shore station division. He served in 1947 and 1948 as Secretary-Treasurer and Vice-Chairman of the Seattle Section.



Thomas J. Carroll

WASHINGTON SECTION

Thomas J. Carroll (M'44) was born in Pittsburgh, Pa., on April 26, 1912. He received the A.B. degree from the University of Pittsburgh in 1932, and the Ph.D. degree in physics in 1936 from Yale University. During 1941-1946 he was in the civilian employ of the Signal Corps and the Army Air Forces. Since 1946 he has been engaged in microwave propagation research at the Central Radio Propagation Laboratory of the National Bureau of Standards. Dr. Carroll served as Secretary of the Washington Section in 1947, and Vice-Chairman in 1948.



Off the Editor's Chest*

THE newest miracles of modern science, six million dollars worth of them, according to an official publicity release of The Institute of Radio Engineers, were on display at Grand Central Palace, New York City, during the 1949 National Convention of the Institute early in March. As the visitor to the Radio Show walked up the last of the long flight of steps at the entrance, he came face to face with a battery of television cameras. On several viewing screens, he could see television images of himself approaching and perhaps talking to a companion. The effect was startlingly impressive, if not exactly pleasing to those who were not "photogenic," as the term goes.

The slogan of the Show was "Radio-Electronics, Servant of Mankind," but it was not finished radio or television sets as displayed in an appliance store that formed the bulk of the Show's exhibits. Radio receivers were indeed rather conspicuous by their absence from the Show; only a few television receivers were in evidence. Interest chiefly centered in new parts and materials that may appear in equipment reaching the consumer a year or more from now, and, above all, in newly devised instruments used in the laboratories and factories where radio and television sets are designed, tested, and put into production. Loud-speakers, amplifiers, intermodulation test equipment, phonograph turntables, pickups and pickup cartridges, wire recorders, television and radar components, broadcast station and remote pickup equipment of all sorts, germanium diodes, oscilloscopes, filters and "wow-meters" are a few of the many items of equipment that were set up for inspection and demonstration to the visiting experts.

To the consumer whose knowledge of electronics goes no farther than plugging in a socket connection or turning the knob of a radio or television set, the Show would have appeared as a confused jumble of parts and instruments; only the radio or TV hobbyist among ultimate consumers would have been aware of the interest and significance of most of the things to be seen. To the engineer and scientist, it was an excellent opportunity to get new ideas for development and improvement of electronic devices which at some future time may bring about notable advances in present communication facilities, radio, television, and sound recording and transmitting devices.

The average consumer is unaware of the enormous amount of time, knowledge, experimentation, and expense that go into the development and improvement of products that he is accustomed to take for granted. Such work is costly and often unrewarding, for an entire line of inquiry and research may prove to be a blind alley and have to be discarded completely at the end of several years' time, after perhaps hundreds of thou-

sands or even millions of dollars have been spent in an attempt to reach a practicable, commercially useful solution. Many of the testing instruments at the IRE Show were custom-made and necessarily involved large outlays of money, up to several thousand dollars each, but through the use of some of them, engineers will find methods for working out the design of a finished ultimate-consumer product so that it can be made by an assembly-line technique and sold to users at prices that will seem reasonable and practical. A piece of equipment of which one specimen may cost ten thousand dollars today may at some future time, after much study and instrumentation, be practicable to design for mass-production and mass-marketing at two or three hundred dollars—yet a million dollars or several million dollars may be tied up in the equipment which made its final design and low-cost production possible.

One of the most interesting developments at the IRE Show, and one that promises to be of great interest to consumers, were the most modern magnetic tape recording systems. There were several makes of these operating at frequent intervals so that it was possible to make comparative listening tests of their respective performances. The successful operation of such devices depends upon a considerable number of interrelated factors: the tape itself, which must be produced at moderate cost and be easily handled without breaking or tangling; an efficient driving mechanism to feed it at very constant speed; a high-fidelity amplifier specially adapted to the characteristics of the magnetic record in the tape; and a high-fidelity speaker system able to reproduce a wide range of frequencies at a great range of volume without undue distortion or resonances.

Indications are that this type of recorder will soon make it possible for the smaller radio stations in remote areas to provide musical reproductions of top quality, practically as good as would be produced if the original symphony orchestra, chorus, or individual singers were present in the city where the broadcasting station is operated. This high-quality tape recording equipment is far too expensive, and involves too much in the way of knowledge and skilled handling at the present time for the average home, but it does lend itself for use by numerous individual FM and AM radio stations throughout the country whose listeners hunger for music of Philharmonic Orchestra quality, far better recorded than could be done by means of sound film, phonograph records, or other accepted means. With the super-quality tape recorders, the fidelity of the musical reproduction can greatly surpass the quality now available on "platters" or in music "piped in" to the local station over telephone lines (the method customarily used for feeding big-city and Hollywood broadcast programs to remote points).

The equipment shown at the IRE Show indicated quite clearly that television-set manufacture is considerably in advance of

the potentialities for test and evaluation of the completed products. (It has often happened that the engineers, from Edison's phonograph on, produce effective working designs before the scientists provide the means for their critical comparison and evaluation.) The television industry has done a remarkable job, but its instrumentation still has a long way to go, and until that is firmly established, it is impossible to say that television receivers have settled into clearly defined and dependable patterns of design and production.

The IRE Show furnished a remarkable demonstration of the contribution of the American system of free enterprise to the development of scientific progress. Many exhibits of great interest and value were shown by comparatively small companies making and selling a limited number of highly specialized and intricate devices and instruments. The man on the street will not even know of the existence of the companies nor of the apparatus which they are working on; he will never see their advertising, for it will not be found in the home magazines with national circulation figures in the millions. Any advertising they issue will consist of diagrams and technical descriptions useful only to engineers and scientists, yet the work which they do will appear, perhaps years from now, in the radio and television sets which the average man uses or in the broadcasting stations which provide him with radio and television entertainment.

Whether the different companies and laboratories achieve success will depend upon how effectively they have analyzed the needs and gauged the future trend of development in the industry they are striving to improve, and what acceptance is accorded that particular industry's products by the specialized technically-trained consumers who have use for their designs. The ingenuity and variety of their offerings was an indication that private initiative, which has been an important factor of our mass production of an almost endless variety of consumers' goods, still flourishes; that the small producer still can compete effectively; can perhaps by sheer brains and initiative develop a practical monopoly of design and quality in his field as against huge firms of great financial power.

The Show was so crowded with visitors (outsiders had to pay \$3 for admission) that there was no wish on the part of the Institute to have a larger audience, but it would be fine if something equivalent to it might be provided to permit visits from members of high school science and vocational classes, and so correct some of the harm which has been done by social studies teaching, much of which has given students the feeling that solutions of difficult technologic problems are chiefly arrived at by verbal techniques, by mere alertness or shrewdness, rather than the slow and painful processes of the laboratory and drafting room.

There has been an unfortunate tendency in the last decade (much deplored by scien-

* Decimal classification: R074. Original manuscript received by the Institute, July 19, 1949. Essentially as printed in *Consumers' Research Bulletin* for May, 1949; by special permission of the *Consumers' Research, Inc.*, Washington, N. J. The title, as it appeared in the *Consumers' Research Bulletin*, is retained.

tists and engineers) for the schools to substitute social studies, or methods of thinking about science for the more rigorous disciplines in chemistry, physics, mathematics, shop and drafting room skills, needed to provide the future engineer or scientist or businessman of exceptional responsibility with the solid foundation he must have to achieve success in today's complex technological world. While a number of the exhibits at the Show would have been beyond the understanding of students at the high school level, and often beyond the appreciation of college students without training in the physical sciences, even a brief tour of inspection of such a fine array of mechanical and electrical developments would have given them an appreciation of the complexity and scope of the knowledge involved in today's intricate mechanical inventions; an appreciation, too, that it is not politicians or thinkers or social theorists who must be

depended upon to solve the problems implied in the wide use of such complex entities.

Perhaps either the IRE or some of the largest companies in the communications field may in future provide for the inspiration of college and high school teachers and students to a higher level of scholarship by setting up exhibits of this general sort in at least the largest cities throughout the country and encouraging visits by considerable numbers of high school and college students in the sciences. At the present time there is too great a gap between the things which the scientist knows and does, and those which can be seen and understood by those who support his work. Such a situation is not healthy. Instead of a few hundred thousand people who understand the methods of work of scientists, there should be at least some millions, in order that our system may not only sup-

port science generously, but understand the need for and the value of what it is supporting, and understand also what sort of conduct and ideas, care, responsibility, and fine workmanship it may expect from trained scientists and engineers.

In no country in the world but the United States could such an exhibition have been presented, in such great detail, and with such amazing strength and variety of new invention and development. Only a competitive enterprise system, unhappily gone from most of the rest of the nations of the world, can give birth to and foster the astonishing developments exhibited by manufacturers under the auspices of The Institute of Radio Engineers. Not government agencies, but free men of science and technology working in a voluntary self-supporting association of their own, are the ones who produce and organize the marvels of the IRE's Annual Radio Show.



Special Relativity and the Electron*

WILLIS W. HARMAN†, STUDENT MEMBER, IRE

I. INTRODUCTION

AGENERATION ago the theory of relativity was the popular symbol of all abstract knowledge, the exclusive property of long-haired scholars. But scientific knowledge refuses to submit to autocracy. Decades ago the pure scientist lost sovereignty over the theories of the electronic nature of electricity and of the electromagnetic character of light. And now the special theory of relativity threatens to secede. Yesterday the remote domain of the philosopher-physicist, today it has passed into the province of the electrical engineer. It has become the everyday tool of the physicist, the astronomer, the electronics engineer, and, unfortunately for a society which has made no corresponding sociological development, of the general and the admiral.

The basic concepts of special relativity are by no means as abstract as, say, complex algebra or vector diagrams. Strangely enough, however, there does not seem to be available to the engineer a simple treatment particularly adapted to his needs. This very elementary paper attempts to introduce the subject of special relativity in a manner attractive to the engineer. It seeks to point out the important engineering consequences

of this extension of Newtonian and Maxwellian physics and to provide incentive for the study of more comprehensive treatments.^{1,2}

The engineer first encounters relativistic effects in connection with the motion of high-velocity electrons, so this will be the primary object of study for this discussion. The appearance of the world as seen by a moving electron will be considered. From this investigation it will be found possible to make certain predictions as to the reaction of the electron to its environment—that is, to the electric and magnetic fields about it. We shall determine a few simple facts about the motion of electrons as influenced by electric and magnetic fields, and apply these results to several engineering examples.

Experimental Basis for Relativistic Electronics

Generations of scientists have pried into the private life of the electron, and as a result a great many facts are known about its measurable properties and its habits. Of these, only two will be of interest in this restricted investigation. One is the measure of the effect of an electric field, or the electric charge, which for the electron is negative and has a magnitude e equal to 1.60×10^{-19}

coulombs. The other is inertia, or mass. The mass of an electron at rest, m_0 (we shall see presently why we make this qualification), is 9.11×10^{-31} kilograms.

We shall need, further, three experimentally determined laws:

1. The force on a particle in an electric field is given by the product of charge and field strength. Thus³

F (newtons)

$$= q \text{ (coulombs)} E \text{ (volts per meter)}. \quad (1)$$

2. The force acting on a body is equal to the time rate of change of the product of mass and velocity,

$$F = \frac{d}{dt} (mv). \quad (2)$$

This degenerates into the $F = ma$ of elementary physics if the mass is constant, but for a rocket, for instance, in which the mass changes as the fuel is consumed, the more general form must be used.

3. An equivalence between mass and energy is expressed by the relation

$$\Delta W = c^2 \Delta m. \quad (3)$$

That is, a given quantity of matter Δm (kilograms) may, under proper conditions, be converted into an amount of energy ΔW (joules) given by the mass multiplied by the square of the velocity of light in free space (3×10^8 meters per second). Historically this law was a consequence rather than a found-

* Decimal classification: R138 X537.1. Original manuscript received by the Institute, April 25, 1949; revised manuscript received, July 5, 1949. The work resulting in this paper was done under the generous provisions on an RCA fellowship in electronics, at Stanford University, Stanford, Calif.

† University of Florida, Gainesville, Fla.

¹ W. R. Smythe, "Static and Dynamic Electricity," Chap. XIV, McGraw-Hill Book Co., New York, N. Y.; 1939.

² P. G. Bergmann, "Introduction to the Theory of Relativity," Prentice-Hall, New York, N. Y.; 1947.

³ A newton is equal to 10^5 dynes.

dation of the theory. Since its enunciation, it has been more accurately and completely verified than perhaps any law of physics. Certainly none has been so spectacularly demonstrated.

With this background of information we are ready to project ourselves into the world of the electron.

II. THE IDENTITY OF ELECTRIC AND MAGNETIC FIELDS

Let us for the moment restrict our remarks to slowly moving electrons, that is, to those with velocities less than a few million meters per second (accelerated through potentials of not more than a few thousand volts). In this case we shall need only the first two of our experimental laws.

Consider, then, an electron moving with a velocity v between two charged plates as in Fig. 1. Suppose that each plate has a

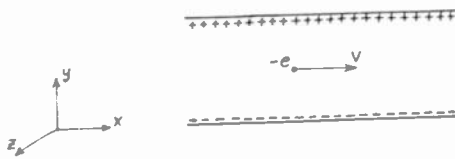

Fig. 1—Electron moving in an electric field.

surface charge density of Q coulombs per square meter, positive on the upper plate, and negative on the lower. The electric field between the plates will be Q/ϵ_0 volts per meter,⁴ in the negative y direction.

Now let us look at this situation from the point of view of the moving electron. From its vantage point it sees both plates apparently moving past it in the negative x direction (that is, with a velocity $-v$), and carrying their electric charge with them. But moving charge is an electric current, so as the electron sees things there is an electric current $I = Qv$ amperes for every meter width of the plates, flowing to the left on the upper plate and to the right on the lower (negative charge moving to the left). This is not all. Such a current sheet is shown to produce a magnetic field which is easily established to be in the positive z direction (out of the paper) and of a magnitude⁵ $B = \mu_0 I = \mu_0 Qv$ webers per square meter.⁶

Thus an observer on the plates sees an electric field $E_y = -Q/\epsilon_0$ while the electron is under the impression that besides this field there is also a magnetic field⁷ $B_z' = \mu_0 Qv$. Since $\epsilon_0 \mu_0 = 1/c^2$,

$$B_z' = \frac{Qv}{\epsilon_0 c^2} = -\frac{v}{c^2} E_y. \quad (4)$$

Of course, this is only of casual interest to the electron because, we recall, we are speaking of the fields which appear in the electron's world, in which the electron is sta-

⁴ $\epsilon_0 = (1/36\pi) \times 10^{-9}$ farads per meter, i.e., the capacity of a capacitor with plates one meter square spaced one meter apart.

⁵ $\mu_0 = 4\pi \times 10^{-7}$ henrys per meter, i.e., the inductance per meter of a single turn of flat sheet conductor enclosing a cross-sectional area of one square meter. Inductance is flux linkages per ampere; hence the above equation.

⁶ A weber per square meter equals 10^8 gauss.

⁷ Primed quantities will be used to represent those seen by an observer moving with a velocity v in the x direction.

tionary. A magnetic field exerts no influence on a stationary electron.

We see, therefore, that electric and magnetic fields are not unique quantities, but the magnitude of field observed may depend upon the state of motion of the observer.

Let us continue our investigation by considering the familiar case of a conductor moving through a magnetic field that is perpendicular to it and to the direction of motion. We know from elementary electrical theory that such a conductor, moving in the x direction with velocity v meters per second through a magnetic field of strength B webers per square meter (Fig. 2), will have

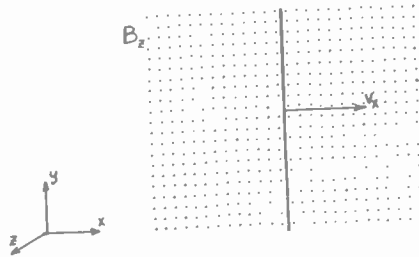

Fig. 2—Conductor moving in a magnetic field.

induced in it an electric field equal to the product of B and v . In other words, an observer riding on the conductor will see not only the magnetic field $B_z' = B_z$ but also an electric field

$$E_y' = -vB_z. \quad (5)$$

Now this electric field becomes known to a stationary observer by its effect on the electrons that are free to move in the conductor. It does not depend for its existence in any way upon the conductor; an insulator moving similarly experiences the same electric field but the phenomenon is not so apparent because the charges within the insulator are not free to move in response to the field. Likewise, an electron unattached to any such vehicle and moving through a magnetic field experiences an electric field equal in magnitude to Bv and in a direction perpendicular to the line of motion. This field produces a force on the electron equal to⁸ $eE' = eBv$, resulting in an acceleration $a = F/m = eBv/m$ always perpendicular to the direction of motion. But a path with constant acceleration perpendicular to the direction of motion is a circle (Fig. 3). In

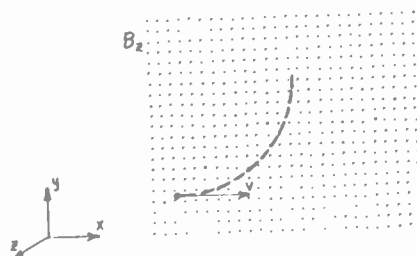

Fig. 3—Circular path of an electron moving in a magnetic field.

⁸ In all equations e is the magnitude of the electronic charge and is a positive quantity.

this case the electron will travel in a circular path with a radius $r = v^2/a = mv/eB$ meters. (This assumes that the acceleration is the same whether seen by the moving electron or a stationary observer, and for the slowly moving electron this is indeed the case.) The angular velocity $\omega = v/r = Be/m$ radians per second.

We have established two relationships between the fields seen by moving and stationary observers. This line of thought could be continued, but we have gone far enough to indicate how a general set of transformation equations might be found. We shall therefore write such a set of equations for the fields as seen by an observer moving in the x direction with the velocity v (primed), in terms of the fields as seen by a stationary observer (unprimed).

$$\begin{aligned} E_x' &= E_x & B_x' &= B_x \\ E_y' &= E_y - vB_z & B_y' &= B_y + \frac{v}{c^2} E_z \\ E_z' &= E_z + vB_y & B_z' &= B_z - \frac{v}{c^2} E_y. \end{aligned} \quad (6)$$

The term "stationary" is a purely arbitrary one, and these equations may be made to apply to the fields of the "stationary" observer in terms of the "moving" observer's fields simply by exchanging the primes and reversing the sign of v . Thus, $E_y = E_y' + vB_z'$, etc.

These transformations, and all others which will be given, can be obtained by a much more general procedure than the simple plausibility arguments presented here. For a first encounter, however, perhaps the simple visualizations are preferable.

Before we go on we shall take up one example illustrating how a problem may sometimes be simplified by transforming fields into another "frame of reference" (that is, into the world of a moving observer). Consider the motion of the electron in Fig. 4, which is initially stationary in a

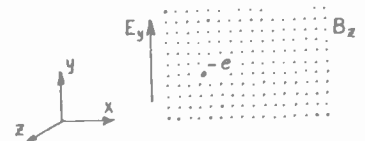

Fig. 4—Stationary electron in crossed electric and magnetic fields.

combined electric field E_y and a magnetic field B_z . We have previously used a transformation to introduce a field; this time we shall transform to eliminate a field.

Examining the second equation in (6), we see that a frame of reference may be chosen, moving in the x direction with a velocity v equal to E_y/B_z meters per second (if this is less than the velocity of light), such that the electric field disappears and only a magnetic field remains. Thus if we set $E_y = vB_z$ in the equations (6) we find that for the "moving" frame of reference

$$E_y' = 0; \quad B_z' = \left(1 - \frac{v^2}{c^2}\right) B_z,$$

which is nearly equal to B_z if v is small compared with c .

But in this frame the electron is moving with a velocity $-v$! We have already exam-

ined the case of a moving electron in a magnetic field and know that it will travel in a circle of radius mv/eB_s . Combining this motion with the motion of the frame of reference we see that the motion of the electron as seen by the "stationary" observer will be the motion of a point on a rolling circle with angular velocity $\omega = eB_s/m$ and linear velocity $v = E_y/B_s$. Thus the electron will follow the cycloidal path abc in Fig. 5.



Fig. 5—Cycloidal path of an electron in crossed electric and magnetic fields.

A simple extension of this argument allows the solution for electrons which are not initially stationary, but here also the resulting trajectory is made up of a combination of a circular motion plus a linear motion. If the electric field is very strong, so that the ratio of E_y to B_s is greater than c , the electric field can not be eliminated in any frame of reference but v can be chosen so as to eliminate the magnetic field in a moving frame of reference. In this case the electron motion will be a combination of a uniform linear motion of velocity v (plus any initial velocity) and an accelerated motion due to the electric field.

If the ratio of E_y to B_s is nearly equal to c the electron motion given by this method will be in error (as will that obtained by any nonrelativistic method). In order to see why this is so, it is necessary to consider our third experimental law.

III. THE NONCONSTANCY OF MASS

This law states the equivalence of mass and energy. The total energy of a particle is the sum of the energy inherent in its mass plus its kinetic energy. Consider an electron that has been accelerated by an electric field as in Fig. 6. The kinetic energy of an

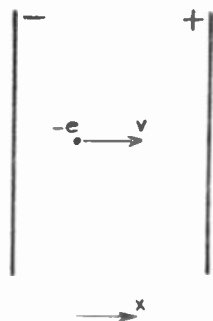

Fig. 6—Electron accelerated from rest by an electric field.

electron that has been accelerated through a potential of V volts is eV , so we write

$$\Delta W = eV = c^2\Delta m = c^2(m - m_0), \quad (7)$$

where m_0 is the rest mass, the mass when the velocity is zero.

Differentiating this energy equation with respect to distance along the line of motion,

we obtain an equation for force on the electron:

$$F = \frac{d(\Delta W)}{dx} = e \frac{dV}{dx} (= -eE) = c^2 \frac{dm}{dx} \quad (8)$$

But we have seen that

$$F = \frac{d}{dt}(mv) = m \frac{dv}{dt} + v \frac{dm}{dt} \quad (9)$$

Furthermore, we may write

$$\frac{dm}{dx} = \frac{dm}{dt} \frac{dt}{dx} = \frac{1}{v} \frac{dm}{dt} \quad (10)$$

Substituting these into (8), we have

$$m \frac{dv}{dt} + v \frac{dm}{dt} = \frac{c^2}{v} \frac{dm}{dt} \quad (11)$$

The differential dt may be eliminated and the equation rearranged to give

$$\frac{dm}{m} = \frac{v dv}{c^2 - v^2} \quad (11a)$$

This is a very simple differential equation which, when solved subject to the condition that m must equal m_0 when $v=0$, gives

$$m = \frac{m_0}{\left(1 - \frac{v^2}{c^2}\right)^{1/2}} \quad (12)$$

The mass, we see, depends upon the relative velocity and is different for different observers. The factor $1/\left(1 - v^2/c^2\right)^{1/2}$ will occur so often in the remainder of this work that we shall designate it by a single symbol κ . This factor is essentially unity for low velocities and approaches infinity for v approaching the velocity of light.

It is a matter of simple algebra to show from (7) that

$$\text{kinetic energy} = (\kappa - 1)m_0c^2, \quad (13)$$

and, if an electron is accelerated through a potential difference V_0 , its velocity

$$v = c \sqrt{1 - \frac{1}{\left(1 + \frac{V_0 e}{m_0 c^2}\right)^2}} \approx \sqrt{\frac{2eV_0}{m_0}} \left(1 - \frac{3}{4} \frac{V_0 e}{m_0 c^2}\right) \quad (14)$$

to a first-order approximation. By substituting appropriate values in these equations, it is easily demonstrated that the relativistic correction is completely negligible for accelerating potentials less than a few thousand volts.

But all of this has concerned the observations of a stationary observer. Let's get back to considering how things look to the electron. We have seen that the deluded electron takes its mass to be m_0 , whereas we, watching it go by, know it to have a mass of κm_0 . As we might suspect, the mass will not be the only physical entity which will appear different to the electron and a stationary observer.

IV. MEASUREMENTS IN THE ELECTRON'S WORLD AND IN OURS

If we are to maintain a properly unprejudiced attitude as befits a scientist, we must be willing to admit that the electron has as much right to its world as we have to ours. We must admit that the electron may be

"stationary" with the vacuum tube and laboratory rushing by. Furthermore, we have no reason for believing that the basic physical laws should not hold equally well in the electron's frame of reference as in our own. It is, then, not too much to presume that the charge of the electron is the same, whether it moves or stands still. (Actually, this follows from the assumption that the fundamental electrical laws are equally valid in either frame of reference.)

Let us return now to the electron of Fig. 6 which was being accelerated by the electric field between two charged plates. We take the direction of motion to be along the x axis of a co-ordinate system. This is a purely arbitrary choice, but once settled upon it will be implied in all the transformation equations following (Fig. 7).

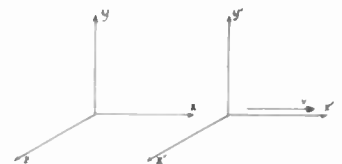

Fig. 7—Co-ordinate systems moving with relative velocity v in the x direction.

The amount of charge on the two plates appears the same to either electron or stationary observer and so, therefore, does the electric field. In the form of a transformation equation

$$E_x' = E_x. \quad (15)$$

So, also, does the force in the direction of motion appear the same in either frame of reference, or

$$F_x' = -eE_x' = -eE_x = F_x. \quad (16)$$

In the electron's world the usual physical laws hold, including $F_x' = m' dv'/dt' = m_0 a'$ since in this frame the electron is at rest. Similarly, the stationary observer writes

$$F_x = \frac{d}{dt}(mv) = \frac{d}{dt} \left[\frac{m_0 v}{\sqrt{1 - \frac{v^2}{c^2}}} \right],$$

which (when differentiated) gives

$$\left(1 - \frac{v^2}{c^2}\right)^{-3/2} m_0 \frac{dv}{dt} = \kappa^3 m_0 a.$$

But we have already decided that $F_x' = F_x$, so that we are led to the conclusion

$$a_x = \frac{1}{\kappa^3} a_x'. \quad (17)$$

Here is something apparently even more amazing than the change of mass with velocity—mass which is dependent upon the direction of the exerted force. If a force acts perpendicularly to the direction of motion, the electron is accelerated as though its mass were κm_0 . But if a force acts along the line of motion to accelerate (or decelerate) the electron, the apparent mass which is being accelerated is $\kappa^3 m_0$. Actually, of course, this comes about from the fact that in the first case the mass remains constant at κm_0 , whereas in the second case the force acts to change not only the velocity, but also κ and hence the mass.

V. FURTHER TRANSFORMATIONS

Continuing the search for new transformation laws, we consider two parallel beams of uniformly spaced electrons (Fig. 8(a))

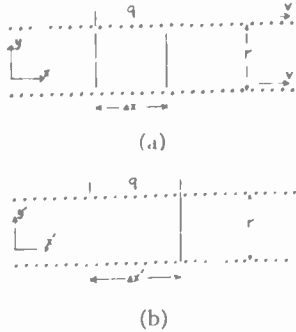

Fig. 8—Two parallel streams of electrons moving with the same velocity.

moving in the x direction with a velocity v . Let the distance between the beams be r . Now, taking a certain section of the beam Δx in length, suppose the total charge in the length Δx of each beam to be q .

Let us consider how things appear to an electron in one of the beams (Fig. 8(b)). In his frame of reference the electrons are all stationary, lying in two parallel rows a distance r apart. The same electrons considered above, a total charge of q in each beam, are contained in a section of the beam of length $\Delta x'$. (Here, as will be seen presently, we must allow the possibility that measurements of distance along the direction of motion in the moving and stationary systems may differ.)

We shall suppose that the spacing of the electrons is quite small compared with the distance r ; that is, that the two beams may be treated as line charges. Then the electric flux at one beam due to the presence of the other is the total charge q divided by the area of a cylindrical surface of radius r and length $\Delta x'$, or

$$D_{y'} = \epsilon_0 E_{y'} = \frac{q}{2\pi r \Delta x'} \quad (18)$$

The force on the beam due to the electric field E' is qE' , so that the repulsion force $F_{y'}$ between sections of the beams $\Delta x'$ meters long is

$$F_{y'} = qE_{y'} = \frac{q^2}{2\pi r \Delta x' \epsilon_0} \quad (19)$$

Coming back to the stationary observer, he must obviously observe an electric field E at one beam due to the presence of the other

$$E_y = \frac{q}{2\pi r \Delta x \epsilon_0} \quad (20)$$

Comparison of this with (18) shows that whatever the ratio of lengths along the direction of motion measured in the two systems, the electric fields as measured perpendicularly to the motion must be in the inverse ratio, or

$$\frac{E_y}{E_{y'}} = \frac{\Delta x'}{\Delta x} \quad (21)$$

The stationary observer must also observe, by analogy with (19), an electric

force of repulsion between the two sections of beam under consideration

$$F_{\text{electric}} = \frac{q^2}{2\pi r \Delta x \epsilon_0} \quad (22)$$

However, his instruments tell him that this is not the only force present; a magnetic force between the beams also exists. The moving line charges may be considered as currents equal in magnitude to $qv/\Delta x$, so that the magnetic field at one beam due to the current in the other is

$$B = \mu_0 I = \mu_0 \frac{qv}{2\pi r \Delta x} \quad (23)$$

and the magnetic attraction per length Δx is

$$\begin{aligned} F_{\text{magnetic}} &= B I \Delta x = \frac{\mu_0 q^2 v^2}{2\pi r \Delta x} \\ &= \frac{v^2}{c^2} \frac{q^2}{2\pi r \Delta x \epsilon_0} \quad \text{since} \\ \epsilon_0 \mu_0 &= \frac{1}{c^2} \end{aligned} \quad (24)$$

The total force, electric and magnetic, per length Δx is

$$F_y = \frac{q^2}{2\pi r \Delta x \epsilon_0} \left(1 - \frac{v^2}{c^2}\right) \quad (25)$$

Comparing (25) and (19), we find

$$\frac{F_y}{F_{y'}} = \frac{\Delta x'}{\Delta x} \left(1 - \frac{v^2}{c^2}\right) = \frac{1}{\kappa^2} \frac{\Delta x'}{\Delta x} \quad (26)$$

One more relationship is necessary to resolve (21) and (26) into transformations desired. This we obtain by considering the forces acting on two such beams as we have been studying, a distance r apart, the second moving with a relative velocity v with respect to the first (Fig. 9).



Fig. 9—Two parallel streams of electrons moving with relative velocity v .

In order to preserve the meanings of the symbols being used, measurements on beam 2 by an observer traveling with beam 2 will be primed, and the measurements on beam 2 by an observer traveling with beam 1 will be unprimed. But because there are no preferred frames of reference the measurements on beam 1 by observer 2 will likewise be unprimed.

Observer 2 sees in beam 1 a charge density $q/\Delta x$ and hence a force on a charge q in beam 2 of $F_{y'} = q^2/2\pi r \epsilon_0 \Delta x$. Similarly this observer sees in beam 2 a charge density $q/\Delta x'$ and a resulting force on a charge q in beam 1 of $F_y = q^2/2\pi r \epsilon_0 \Delta x'$. Combined, these give

$$\frac{F_y}{F_{y'}} = \frac{\Delta x}{\Delta x'} \quad (27)$$

Combining (21), (26), and (27) we have the desired transformations

$$\Delta x = 1/\kappa \Delta x' \quad (28)$$

$$F_y = \kappa F_{y'} \quad (29)$$

$$F_{y'} = 1/\kappa F_y \quad (30)$$

From these relations it is a simple matter to proceed to other transformations. For example, if two electrons, moving with uniform velocity v , are spaced along the line of motion a distance Δx , the elapsed time between the two passings of a given marker is $\Delta t = \Delta x/v$. In the electron's opinion the two are spaced $\Delta x'$ and the marker moves the distance between them in a time $\Delta t' = \Delta x'/v$. Thus, from (28) we infer

$$\Delta t = \frac{\Delta t'}{\kappa} \quad (31)$$

Similar considerations to those which led to equations (6) will now yield transformations valid for relative velocities comparable with the velocity of light. Rather than proceed further by this tedious process, we shall tabulate the transformations we have thus far tried to make plausible and list others which may be similarly arrived at (see Table I).

It must be borne in mind that, although we have made an effort to make these laws appear reasonable, we have proved nothing. The proof of the validity of these transformations is simply the vast amount of experimental evidence which confirms their predictions.

Coulomb's Law Examined

By way of demonstrating the method of using these transformations, it is illuminating to investigate the form of Coulomb's law for rapidly moving particles. This is of interest, for example, in considering space-charge effects in high-velocity beams. Consider first two electrons (Fig. 10) on a line

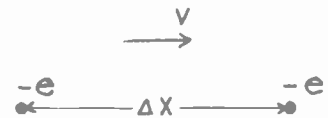

Fig. 10—Two electrons moving in a direction parallel to a line joining them.

parallel to the direction of motion, a distance Δx apart ($\Delta x'$ in their frame of reference). In the frame of reference in which the electrons are stationary we know that the electric field at one electron due to the presence of the other is $E_x' = e/4\pi(\Delta x')^2 \epsilon_0$, and the repulsive force is $F' = eE_x' = e^2/4\pi(\Delta x')^2 \epsilon_0$.

From the transformation equations of Table I, the expressions for electric field and force for a stationary observer are seen to be

$$\begin{aligned} E_x &= \frac{1}{\kappa^2} \frac{e}{4\pi(\Delta x)^2 \epsilon_0} \\ F_x &= \frac{1}{\kappa^2} \frac{e^2}{4\pi(\Delta x)^2 \epsilon_0} \end{aligned} \quad (32)$$

For the electrons of Fig. 11, on a line perpendicular to the direction of motion, a similar procedure yields, for the electric field at one due to the presence of the other, and for the repulsive force,

$$E_y = \frac{\kappa e}{4\pi(\Delta y)^2 \epsilon_0} \quad F_y = \frac{1}{\kappa} \frac{e^2}{4\pi(\Delta y)^2 \epsilon_0} \quad (33)$$

In this case F_y is not simply equal to eE_y since a magnetic force due to the motion of the electrons is also present.

TABLE I

	CONVERTING TO MOVING OBSERVER'S FRAME OF REFERENCE		CONVERTING TO STATIONARY OBSERVER'S FRAME OF REFERENCE	
	As seen by stationary observer	As seen by moving observer	As seen by moving observer	As seen by stationary observer
"Moving" observer's velocity*	v	0	0	v
"Stationary" observer's velocity	0	$-v$	$-v$	0
Distance between two points	$\Delta x; \Delta y$	$\Delta x' = \frac{1}{\kappa} \Delta x; \Delta y' = \Delta y$	$\Delta x'; \Delta y'$	$\Delta x = \frac{1}{\kappa} \Delta x'; \Delta y = \Delta y'$
Time interval	Δt	$\Delta t' = \frac{1}{\kappa} \Delta t$	$\Delta t'$	$\Delta t = \frac{1}{\kappa} \Delta t'$
Force	$F_x; F_y$	$F_x' = F_x; F_y' = \frac{1}{\kappa} F_y$	$F_x'; F_y'$	$F_x = F_x'; F_y = \frac{1}{\kappa} F_y'$
Mass	$m = m_0$	$m' = \kappa m_0$	$m' = m_0$	$m = \kappa m_0$
Acceleration from rest	$a_x; a_y$	$a_x' = \frac{1}{\kappa^3} a_x; a_y' = \frac{1}{\kappa^2} a_y$	$a_x'; a_y'$	$a_x = \frac{1}{\kappa^3} a_x'; a_y = \frac{1}{\kappa^2} a_y'$
Electric field	E_x	$E_x' = E_x$	E_x'	$E_x = E_x'$
	E_y	$E_y' = \kappa(E_y - vB_x)$	E_y'	$E_y = \kappa(E_y' + vB_x')$
	E_z	$E_z' = \kappa(E_z + vB_y)$	E_z'	$E_z = \kappa(E_z' - vB_y')$
Magnetic field	B_x	$B_x' = B_x$	B_x'	$B_x = B_x'$
	B_y	$B_y' = \kappa \left(B_y + \frac{v}{c^2} E_x \right)$	B_y'	$B_y = \kappa \left(B_y' - \frac{v}{c^2} E_x' \right)$
	B_z	$B_z' = \kappa \left(B_z - \frac{v}{c^2} E_y \right)$	B_z'	$B_z = \kappa \left(B_z' + \frac{v}{c^2} E_y' \right)$
Velocity	u_x	$u_x' = \frac{u_x - v}{1 - u_x v / c^2}$	u_x'	$u_x = \frac{u_x' - v}{1 + u_x' v / c^2}$
	$u_{y,z}$	$u_{y,z}' = \frac{u_{y,z}}{\kappa(1 - u_x v / c^2)}$	$u_{y,z}'$	$u_{y,z} = \frac{u_{y,z}'}{\kappa(1 + u_x' v / c^2)}$

* v assumed in x direction.



Fig. 11—Two electrons moving in a direction perpendicular to a line joining them.

We see that, although Coulomb's law is often regarded as a fundamental law of physics, it is actually a special case valid in general only for charges which are at rest with respect both to each other and to the observer. Furthermore, the electric field due to a moving electron is not the same in all directions but is greatest to the sides and least to front and rear, as in Fig. 12.

VI. RELATIVISTIC ELECTRODYNAMICS

We have been concerned thus far with developing a method for solving problems involving particles traveling with high veloc-

ities. This we have done by considering a frame of reference in which the ordinary low-velocity laws of mechanics and electromagnetic theory are valid, and then using certain transformation laws to convert the quantities in this frame of reference to that in which the observer makes his measurements.

An alternative plan could have been chosen, that of rewriting the laws of physics for the observer's frame of reference in such a way that they will be valid for particles traveling at any velocity. This is quite feasible, but the method lacks power to develop new relations. It may be more convenient for many purposes, however, and Table II lists several such relations.



Fig. 12—Representation of the electric field intensity about a rapidly moving charge ($\kappa = 2$).

A few examples will aid in illustrating the application of the laws of relativistic electrodynamics to engineering problems. First we shall write the expression for velocity in terms of accelerating voltage in a slightly different form. The velocity of an electron after being accelerated through a potential of V_0 volts is given by

$$v = c \sqrt{1 - \frac{1}{\left(1 + \frac{V_0}{V_n}\right)^2}} \cong \sqrt{\frac{2eV_0}{m}} \left(1 - \frac{3}{4} \frac{V_0}{V_n}\right) \tag{34}$$

to a first-order approximation, where V_n is a convenient normalizing voltage defined by

$$V_n = \frac{m_0 c^2}{e} = 5.11 \times 10^5 \text{ volts.} \tag{35}$$

This leads to a more convenient form for writing the mass expression, namely

$$m = \kappa m_0 = \frac{m_0}{\sqrt{1 - \frac{v^2}{c^2}}} = m_0 \left(1 + \frac{V_0}{V_n}\right) \tag{36}$$

Equations (34) and (36) may be used as the starting point for a relativistic investigation

TABLE II
LAWS OF RELATIVISTIC ELECTRODYNAMICS

Law	Relativistic statement	Reduces at low velocities to
Definition of momentum	$\hat{p} = \frac{m_0 v}{\sqrt{1-v^2/c^2}}$	$p = m_0 v$
Definition of kinetic energy	$W = m_0 c^2 \left(\frac{1}{\sqrt{1-v^2/c^2}} - 1 \right)$	$W = \frac{m_0 v^2}{2}$
Conservation of momentum	$\sum^* \frac{m_0 v_{x,y,z}}{\sqrt{1-v^2/c^2}} = \text{constant}$	$\sum m_0 v = \text{constant}$
Conservation of energy	$\sum \frac{m_0 c^2}{\sqrt{1-v^2/c^2}} + V = \text{constant}$	$\begin{cases} \sum \frac{m_0 v^2}{2} + V = \text{constant} \\ \sum m_0 = \text{constant} \end{cases}$
Newton's second law (Force \perp motion)	$F = \frac{m_0 a}{\sqrt{1-v^2/c^2}}$	$F = m_0 a$
Newton's second law (Force \parallel motion)	$F = \frac{m_0 a}{\left(1 - \frac{v^2}{c^2}\right)^{3/2}}$	$F = m_0 a$
Time to accelerate from velocity v to velocity u in same direction	$t = \frac{m_0}{F} \left(\frac{u}{\sqrt{1-u^2/c^2}} - \frac{v}{\sqrt{1-v^2/c^2}} \right)$	$t = \frac{m_0}{F} (u - v)$
Distance to accelerate from velocity v to velocity u in same direction	$s = \frac{m_0 c^2}{F} \left(\frac{1}{\sqrt{1-u^2/c^2}} - \frac{1}{\sqrt{1-v^2/c^2}} \right)$	$s = \frac{m_0}{F} \frac{(u^2 - v^2)}{2}$
Force on charge in electric field	$F = qE$	$F = qE$
Velocity of electron after being accelerated through potential V_0	$v = \sqrt{\frac{2eV_0}{m_0} \frac{1 + \frac{e}{m} \frac{V_0}{2c^2}}{\left(1 + \frac{e}{m} \frac{V_0}{c^2}\right)^2}}$	$v = \sqrt{\frac{2eV_0}{m_0}}$

* \sum denotes the sum of the quantities involved for all particles in a system.

of several simple electronic phenomena. They are plotted for a limited range of accelerating voltage in Fig. 13.

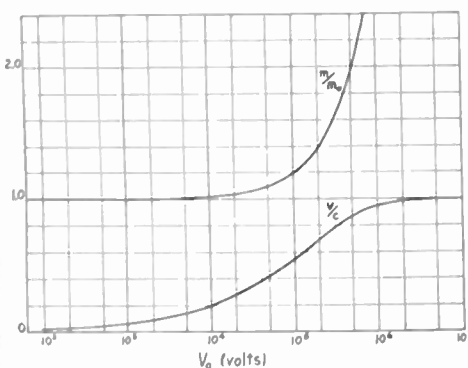

Fig. 13—Velocity and mass of an electron as functions of the accelerating voltage.

Cathode-Ray Tube

In certain types of tubes, such as cathode-ray tubes with electrostatic deflection, electrons are accelerated in a direction perpendicular to their motion. It is illuminating to examine the nature of the effect of the

high velocity correction on the action of such a device.

It is easily shown that, for the case of low accelerating velocity and small beam deflection, the deflection of the spot on the fluorescent screen caused by a voltage V_1 on the deflecting plates is given by

$$d = \frac{L}{2} \frac{b}{a} \frac{V_1}{V_0} \tag{37}$$

Here, b and a are the length and separation of the deflecting plates and L is the distance from the center of the deflecting plates to the screen.

If (37) is derived using (34) and (36), the resulting expression is

$$d = \frac{L}{2} \frac{b}{a} \frac{V_1}{V_0} \frac{1 + \frac{V_0}{V_n}}{1 + \frac{V_0}{2V_n}} \cong \frac{L}{2} \frac{b}{a} \frac{V_1}{V_0} \left(1 + \frac{1}{2} \frac{V_0}{V_n} \right) \tag{38}$$

to a first-order approximation. This reduces, as it must, to the ordinary deflection formula at low accelerating voltages.

Velocity-Modulation Tubes

In other tubes, such as velocity-modulation tubes, a small signal voltage acts to accelerate electrons in the direction of their motion. The fractional change in velocity caused by a change in accelerating potential from V_0 to $(V_0 + V_1)$ is

$$\frac{\Delta v}{v_0} = \sqrt{\frac{V_0 + V_1}{V_0}} - 1 \cong \frac{V_1}{2V_0} \text{ if } V_1 \ll V_0. \tag{39}$$

Making the same assumption as to the magnitude of V_1 (that is, neglecting higher order terms in V_1/V_0), but using the relativistic expressions (34) and (36), we find the fractional velocity change to be

$$\frac{\Delta v}{v_0} \cong \frac{V_1}{2V_0} \frac{2}{\left(1 + \frac{V_0}{V_n}\right) \left(2 + \frac{V_0}{V_n}\right)} \cong \frac{V_1}{2V_0} \left(1 - \frac{3}{2} \frac{V_0}{V_n}\right) \tag{40}$$

to a first-order approximation.

Thus the operation of a velocity-modulation tube with high accelerating voltages is seriously affected by the relativistic increase in electronic mass. The factor which measures the reduction of modulation from the nonrelativistic value amounts to 0.76 for a 100-kv accelerating voltage and 0.40 for 400 kv. These voltages are typical values for high-power klystrons now under consideration.

In high-power klystrons there is some compensation for the detrimental nature of relativistic effects on velocity modulation. These tubes depend for their action on the formation, by the velocity modulation, of periodic accumulations of electrons in the beam. From the discussion of Coulomb's Law we have seen that at high velocities we might expect a decrease in the tendency for the electrons to move apart under the influence of the electric forces present, (both because the forces decrease and because the mass of the electrons increases). Thus the debunching effects—the tendencies of the "bunches" of electrons to disperse—are reduced. This is true of both the longitudinal (that is, along the direction of motion) and the transverse debunching. Furthermore, the net energy required to produce the velocity modulation—the "beam loading"—is reduced from the nonrelativistic value by the same amount as the velocity modulation.⁹

Relativistic Form of Child's Law

The Langmuir-Child Law, expressing the dependence of space-charge-limited electronic current on the three-halves power of the accelerating voltage, is fundamental to electron-tube operation. The derivation for the plane diode may be found in any elementary electronics text. If (34) is substituted for the velocity in this derivation, it yields an integral which is not expressible in

⁹ M. Chodorow, "High Power Pulsed Klystron," Quarterly Report No. 1, Microwave Laboratory, Stanford University; September, 1947.

terms of elementary functions but gives, to a first-order approximation,

$$I \propto V_0^{3/2} \left(1 - \frac{3}{28} \frac{V_0}{V_n}\right). \quad (41)$$

Thus the current at high voltages is reduced somewhat from the Child-Langmuir value. Physically this is due to the fact that for any given voltage the electron velocity is less than that calculated from nonrelativistic considerations. The charge density is therefore greater, and the field in the region of the cathode correspondingly reduced.

Cyclotron, Synchrotron, and Betatron

Modern particle accelerators embody relativistic considerations, not as minor corrections to low-velocity theory, but as the *modus operandi* itself. We can not discuss these devices in detail but several excellent descriptive articles are available¹⁰⁻¹².

In one important generic class of accelerators the particles follow circular or outward-spiraling orbits during the time the accelerating force is applied. Two principles of acceleration prevail, as exemplified in the betatron and cyclotron types of accelerators. Magnetic fields perpendicular to the plane of motion determine the orbits in both types.

In the betatron the accelerating force is supplied by induction. The electrons travel in a circular orbit enclosing a time-varying magnetic field. In essence, the electron stream acts as the secondary of a transformer. The rate of change of momentum is proportional to the rate of change of magnetic field. The radius of the orbit is determined by the electron momentum and the magnetic field. Thus

$$r = \frac{mv}{Be} = \frac{m_0c}{Be} \sqrt{\left(1 + \frac{V_0}{V_n}\right)^2 - 1}, \quad (42)$$

where mv is the relativistic momentum, B is the magnetic flux density in the orbit, and V_0 is the kinetic energy of the electron in electron volts. In the region of the electron paths, the magnetic field is made to decrease with increasing radius. The electron momentum varies linearly with the total change in enclosed magnetic field in such a way that the electron finds a stable orbit radius where the magnetic field is half the average enclosed magnetic field.

With betatrons built for electron velocities at which the mass is increased to hundreds of times the rest mass, it is apparent that relativistic theory is no mere refinement.

The cyclotron utilizes electric field acceleration in the form of an rf field applied across a small portion of the orbit. Successive particle passages across the rf drop occur spaced in time by the period of rotation. Each passage is made to occur at a maximum

of rf voltage. A moderately high voltage is applied again and again to the moving particle which, if its motion is "resonant" with the frequency of the rf voltage, attains a high final energy.

The resonance condition is

$$\omega = \frac{Be}{m} = \frac{Be}{m_0 \left(1 + \frac{V_0}{V_n}\right)} \quad (43)$$

for electrons (and a similar form for other particles obtained by substituting appropriate values for charge, mass, and V_n). It will be seen that in order to maintain synchronism between the electron period and the applied rf voltage when the particle energy is high, either the frequency must be decreased as the particle energy increases (that is, a frequency-modulated voltage is applied and the device becomes a synchrotron^{13,14}) or the magnetic field must be increased. By examination of (42) and (43) it is seen to be possible to maintain a constant orbit radius by proper simultaneous variation of both B and ω .

Linear Electron Accelerator

Centripetal acceleration of charged particles results in radiation and accompanying loss of energy. Electrons in a high energy betatron travel hundreds of miles around a circular orbit in a fraction of a second and the radiation loss is considerable. For the production of extremely high-energy electrons, therefore, a linear type of accelerator appears to offer attractive possibilities.

One form of linear accelerator is illustrated diagrammatically in Fig. 14. A long, corrugated tube propagates electromagnetic waves with a velocity less than the velocity of light and a field pattern as sketched. (The arrows indicate the direction of force on an electron.) Bunches of electrons are formed in such a position, and the wave velocity is adjusted in such a way, that the electrons always ride the crests of the waves and feel an accelerating force.

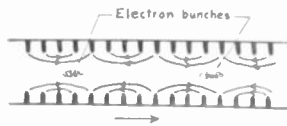

Fig. 14—Diagrammatic sketch of a linear electron accelerator. Field pattern and electron bunches move to the right.

On a second glance at Fig. 14, this device does not look very practicable. The geometry of the fields is such that if an electron departs ever so slightly from the axis, the radial

field components pull it over to the side of the tube. Furthermore, the forces between electrons tend to make the group of electrons disperse. It looks as though, before any useful acceleration could be attained, the electrons would all have slipped off to the side, as peas before a knife.

In fact, it is not until we consider the linear accelerator relativistically that there seems to be any hope for it at all. And it is not until electrons have been accelerated by some other means to velocities comparable with the velocity of light that the transverse spreading of the beam becomes small enough to allow the device to operate.

The reduction of interelectron forces at high velocities has been discussed previously. The increase of mass is even more important here. At the output end of a billion-volt accelerator the velocity of the electrons is 0.9999999 of the velocity of light, their mass has increased two thousandfold, and the effect of transverse forces is completely negligible.

Perhaps more illuminating yet is our earlier approach—that of looking at the entire problem from the standpoint of the moving electron. This is somewhat complicated in the linear accelerator by the fact that the electron is being continuously accelerated. Inspection of Table I tells us, however, that to the electron the corrugated tube will appear to be contracted in length and to rush by in a correspondingly shorter time. Thus in a billion-volt accelerator under construction¹⁵ the hundred-foot tube appears to the electrons but a few inches long. It flashes by in something like half a millimicrosecond, compared with the hundred or so millimicroseconds transit time of the electron as seen by an observer in the laboratory. And not only are the transverse forces reduced by hundreds of times, but their effect is so short in duration as to be completely ineffective in dispersing the electron bunches.

VII. CONCLUSION

Thus, we see that today's electronics engineer must reckon with special relativity. We have but sampled the potentialities here, of course. Important extensions of these arguments allow the treatment of impacts of particles with other particles or with quanta of light rays or X rays, where high velocities occur or energy-matter conversion takes place, and particle formations and disintegrations. But these matters lie in the realm of tomorrow for most engineers.

It is hoped that this utilitarian approach to special relativity may prove helpful. The philosophical implications of relativity are entrancing, but engineers are apt to suspect a philosophical approach as abstract and impractical until it has been demonstrated that the results will work out problems for them.

¹⁵ E. L. Ginzton, W. W. Hansen, and W. R. Kennedy, "A linear electron accelerator," *Rev. Sci. Instr.*, vol. 19, pp. 89-108, February, 1948.

¹⁰ "Development of electron accelerators," *Electronics*, p. 170, January, 1947.

¹¹ P. Morrison, "Physics in 1946," *Jour. Appl. Phys.*, vol. 18, pp. 133-153; February, 1947.

¹² L. I. Schiff, "Production of particle energies beyond 200 Mev," *Rev. Sci. Instr.*, vol. 17, pp. 6-15; January, 1946.

¹³ E. O. Lawrence, et al., "Initial performance of the 184-inch cyclotron at the University of California," *Phys. Rev.*, vol. 71, p. 449; April, 1947.

¹⁴ D. Bohm and L. Foldy, "The theory of the synchrotron," *Phys. Rev.*, vol. 70, p. 249; September, 1946.

An Electronic Differential Analyzer*

A. B. MACNEE†, ASSOCIATE, IRE

Summary—An electronic differential analyzer is described, capable of solving ordinary differential equations of orders through the sixth, both linear and nonlinear, and with coefficients that are either constant or variable. This analyzer has a high speed of operation and is extremely flexible with regard to equation parameters and initial conditions. The flexibility permits rapid investigation of wide ranges of equation solutions with regard to periodicity, instability, and discontinuities. It renders practicable the solution of end-point boundary-value problems; that is, problems in which the final rather than initial values are specified.

Two new computing elements, an electronic function generator and an electronic multiplier, are employed in this differential analyzer. A diode clamping circuit permits the use of ac coupled amplifiers.

A number of representative differential equations of the linear and nonlinear types have been solved. Comparison of observed and calculated solutions reveals an accuracy of from 1 to 5 per cent, while the precision (or repeatability) of the solutions ranges from 0.002 to 0.1 per cent. An analysis of the errors introduced into the differential-equation solutions by the frequency limitations of the computing elements, such as the integrators and adders, has been made, and the results of this analysis have been verified experimentally.

I. INTRODUCTION

THE PRESENT trend in mathematical calculators is toward large machines capable of solving more and more complicated problems with the greatest accuracies.¹⁻³ These large machines are extremely expensive to build and operate; the use of the MIT Differential Analyzer for an eight-hour day, for example, costs about \$400. This high cost, together with the limited number available, has prevented many investigators from realizing the advantages of these machines.

Early in the fall of 1945 it was felt that there was considerable need for a differential analyzer of somewhat different characteristics from any then in existence or under development.⁴ There appeared to be the need for a machine having the following characteristics: (a) moderate accuracy, of perhaps 1 to 10 per cent; (b) much lower cost than existing differential analyzers; (c) the ability to handle every type of ordinary differential

equation; (d) high speed of operation; (e) above all, extreme flexibility, in order to permit the rapid investigation of wide ranges of equation parameters and initial conditions.

A differential analyzer of this type bears the same relation to the larger differential analyzers which a slide rule bears to a desk calculating machine. Its uses are numerous: (a) It can be used, as a slide rule is used, to give rapid solutions of moderate accuracy to the differential equations encountered by the engineer, physicist, and mathematician. In this role it is valuable both in solving higher-order ordinary differential equations with constant coefficients, which are very tedious to handle analytically, and also nonlinear equations and equations with variable coefficients which often can not be solved at all analytically. (b) Such a differential analyzer can also be used as an adjunct to one of the larger differential analyzers. It is used then to carry out the time-consuming exploratory solutions necessary to determine the ranges of equation parameters and initial conditions of interest. This preliminary work can be done at a great saving in time and money, and then, if warranted, the larger and more accurate machine can be used to obtain the final desired solution. (c) Such a differential analyzer, by virtue of its moderate cost and great flexibility, is very useful as a teaching tool in the fields of mathematics, engineering, and physics.

In the author's opinion, the objectives of flexibility, moderate cost, and high-speed operation are most easily achieved with an all-electronic machine.

It is important to realize that the main advantage of the high speed of this analyzer is that it permits rapid exploration of a wide range of solutions. In a fundamental way this is perhaps the most significant advantage of the electronic differential analyzer over mechanical differential analyzers.

There are many important problems involving the solution of a differential equation in which the crux of the matter is to *find* the initial conditions for which the solutions (a) are stable, or periodic, or continuous, or (b) satisfy certain specified final conditions. Such problems frequently require exploration of 1,000 different solutions (e.g., 10 values for each of three parameters) and might well represent a prohibitive investment of time on a slow differential analyzer which requires several minutes for each solution; on the present electronic analyzer such an exploration can be carried out in an hour or two. An example of this sort (the solution of the equation $d^3y/dt^3 - y(t-t_0)/4 = 0$ over the range $0 \leq t \leq t_0$ for specified final conditions) is given in Section V-F.

For problems of this type, the usefulness of the electronic analyzer actually surpasses that of the more

* Decimal classification: R621.375.2. Original manuscript received by the Institute, March 22, 1949; revised manuscript received, August 3, 1949. Presented, 1949 National IRE Convention, March 8, 1949, New York, N. Y.

This work has been supported in part by the Signal Corps, the Air Materiel Command and Office of Naval Research.

† Research Laboratory of Electronics, Massachusetts Institute of Technology, Cambridge, Mass.

¹ V. Bush and S. H. Caldwell, "A new type of differential analyzer," *Jour. Frank. Inst.*, vol. 240, pp. 255-325; October, 1945.

² F. Rockett, "Selective sequence digital computer for science," *Electronics*, vol. 21, p. 138; April, 1948.

³ A. W. Burks, "Electronic computing circuits of the ENIAC," *PROC. I.R.E.*, vol. 35, pp. 756-767; August, 1947.

⁴ This need was first pointed out to the author by Henry Wallman, professor in the Department of Mathematics, Massachusetts Institute of Technology, who suggested such a machine. The author wishes to express to Prof. Wallman his deepest appreciation for his guidance of this work.

elaborate and accurate, but slower, mechanical differential analyzers.

II. THE ELECTRONIC DIFFERENTIAL ANALYZER SYSTEM

A. Necessary Basic Computing Elements

The electronic differential analyzer described here⁵ is of the continuous variable type, utilizing the basic feedback principle which was first applied to differential analyzers by Vannevar Bush.⁶ It employs voltages as the dependent variables and time as the independent variable; the basic functional operation of this analyzer is time integration.⁷

The components required by the electronic differential analyzer can be determined by considering typical differential equations. Linear differential equations with constant coefficients can be solved with two basic computing elements: time-integrators and adders. If these differential equations are inhomogeneous, a means of generating arbitrary functions of the independent variable, time, is required. The solution of nonlinear differential equations requires the generation of arbitrary functions of the dependent variables. A computing element which will generate arbitrary functions of either the dependent or independent variables will be designated as an arbitrary function generator. Finally if differential equations with variable coefficients are to be solved, an electronic differential analyzer requires a multiplying element in addition to the arbitrary function generator.

The electronic differential analyzer is built up from these four basic computing elements: time-integrators, adders, arbitrary function generators, and multipliers; with enough of these elements it is possible to solve any ordinary differential equation. The complexity of the equations which can be handled by a particular machine is limited then only by the number of elements available.

The solutions of the electronic differential analyzer are voltage functions of time. They are observed on a cathode-ray oscilloscope. The differential equation is completely solved sixty times per second;⁸ thus the solution appears as a stationary curve to the observer's eye.

⁵ This work is described in greater detail in a Massachusetts Institute of Technology doctorate thesis "An electronic differential analyzer," by A. B. Macnee, submitted to the Electrical Engineering Department, September, 1948.

⁶ V. Bush, "The differential analyzer. A new machine for solving differential equations," *Jour. Frank. Inst.*, vol. 212, pp. 447-488; 1931.

⁷ Limitations are imposed on time differentiators by amplifier bandwidths; therefore a general electronic differential analyzer cannot be designed using differentiators as basic units; in particular, differential equations whose characteristic roots have positive real parts cannot be solved with practical differentiators.

⁸ Component limitations at high and low frequencies introduce errors into solutions obtained on an electronic differential analyzer. The choice of repetition rate is a compromise: for a given accuracy a high repetition rate requires excellent high-frequency response in all analyzer components while a low repetition rate imposes stringent low-frequency response requirements. For this analyzer another consideration was the use of the computing elements as components of a high-speed product integrator.

If the sixty solutions per second are to appear as a stationary curve when superimposed on the face of the cathode-ray tube, the initial conditions for every solution must be identical. To accomplish this, approximately half of the solution period is used to solve the differential equation; the balance of the period is used to prepare the machine for the next solution period. This is accomplished as follows: (1) at the end of the solution all computing elements are turned off electronically, (2) the output voltage of every computing element is forced to some arbitrary reference voltage, usually zero volts, and (3) the final conditions from the previous solution are removed from all integrating condensers. Now at the beginning of the next solution period the computing elements are turned on, and the initial conditions are established by adding voltage steps of proper magnitude to the outputs of each integrating unit. These "initial value" voltage steps remain constant throughout the solution time; the operator adjusts them by means of potentiometers. As the operator varies the initial conditions, he sees instantaneously the effect of his adjustment because a new solution is traced every 1/60 of a second. Fig. 1 shows two complete solution cycles for the differential equation $dy/dt = ky$. Normally only a single cycle of the solution is displayed, and the off period is blanked from the screen by an intensity gate.

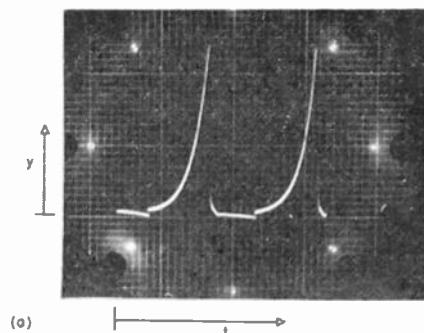

Fig. 1—Two complete periods of the solution of the equation $dy/dt = ky$.

III. COMPUTING ELEMENTS

A. Multiplier

It was necessary to develop a new multiplying circuit for the electronic differential analyzer because, although considerable work had been done on electronic multiplication, none of the existing multiplying circuits appeared to satisfy the requirements of four-quadrant operation together with the necessary high speed of response.⁹⁻¹² Four-quadrant operation denotes the ability to handle inputs of both algebraic signs.

⁹ H. E. Kallman, "Log bridge and ratio meter," Radiation Laboratory Internal Group Report, 41, July 16, 1945.

¹⁰ S. A. Wingate, "An electronic computing device," master's thesis in electrical engineering, MIT; 1946.

¹¹ J. M. Ham, "A general integrator for electronic analogue computation," master's thesis in electrical engineering, MIT; 1947.

¹² W. W. Seifert, "An electronic multiplier for use in an analyzer computation," master's thesis in electrical engineering, MIT; 1948.

Lack of speed in that channel of the multiplier which is connected into the differential-analyzer feedback loop can lead to serious errors, as discussed in Section IV-C. For the present electronic differential analyzer, the on-time is 8,300 microseconds. A rise time of about 5 microseconds has been found adequate for most problems considered. For many problems, extreme speed is required in only a single channel of the multiplier. Such a situation arises, for example, in equations with variable coefficients if the rate of change of the coefficient is much less than the rate of change of the solution.

B. The Crossed-Fields Electron-Beam Multiplier

The multiplying circuit employs an electrostatic-deflection cathode-ray tube; it will be called the crossed-fields electron-beam multiplier. Fig. 2 is a block diagram of this multiplier.

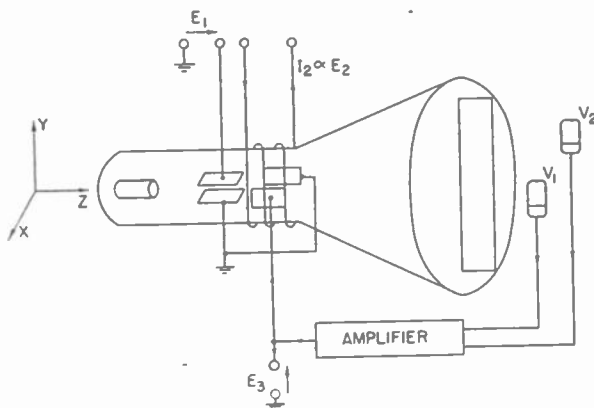

Fig. 2—The crossed-fields electron-beam multiplier.

The electron gun of the cathode-ray tube generates a sharply focussed beam of electrons moving in the z direction. After the electrons pass through the first pair of deflecting plates, they have a component of velocity \bar{v}_y in the y direction

$$\bar{v}_y \propto jE_1, \quad (1)$$

where E_1 is the voltage between the plates, and i, j, k are unit vectors in the x, y, z directions, respectively.

There is a coil wound around the second pair of deflecting plates of the cathode-ray tube, and the current I_2 in this coil generates an axial magnetic field, kB_z ; therefore there is a magnetic force acting on the electrons given by the relation

$$\bar{F}_{zm} = e(j\bar{v}_y \times k\bar{B}_z), \quad (2)$$

where \times denotes vector cross product, and e is the electron charge. This force, which is always in the x -direction, is evidently proportional to the product of E_1 and I_2 .

It can be measured by applying a voltage E_3 to the second pair of electrostatic deflecting plates. There will then be an electrostatic, as well as a magnetic field in the region, between these plates:

$$\bar{E}_x \propto iE_3. \quad (3)$$

This electrostatic field will produce a force on the electrons

$$\bar{F}_{xe} = e\bar{E}_x. \quad (4)$$

If the voltage E_3 is adjusted so as to make the electrostatic force \bar{F}_{xe} equal and opposite to the magnetic force \bar{F}_{zm} , then from (2) and (4)

$$\bar{E}_x = -(j\bar{v}_y \times k\bar{B}_z), \quad (5)$$

which, in turn, means that

$$E_3 = k(E_1 \cdot I_2); \quad (6)$$

that is, E_3 is proportional to the product of the voltage E_1 and the current I_2 .

The voltage E_3 is automatically adjusted, in the practical multiplier, by the feedback circuit shown in Fig. 2. Use is made of the fact that equal electrostatic and magnetic forces will result in zero x deflection. Photocells are placed on either side of a partition along the line of zero x deflection. The difference between the outputs of these two photocells is amplified and fed back to the second pair of electrostatic deflecting plates as the voltage E_3 . As long as the gain around this feedback loop is made sufficiently large, the feedback voltage E_3 will be proportional to the product $E_1 \cdot I_2$.

The crossed-fields multiplier¹³ has been in operation in a completely functioning differential analyzer since late in 1947.

C. Measured Characteristics of the Crossed-Fields Multiplier

An important feature of a multiplier is its usable dynamic range. This is controlled in a four-quadrant multiplier by the zero balances. These zero balances limit the degree to which the multiplier output is zero when one input is zero and the other maximum. The observed balance characteristic of one crossed-fields multiplier is

$$E_3 = k(E_1 \cdot I_2 + 0.009E_1^2 + 0.015I_2 + 0.0005), \quad (7)$$

where E_1 is the input controlling the y deflection, normalized to a maximum value of unity, and I_2 is the coil current, normalized to a maximum value of unity.

For the multiplier of this type used in the present electronic differential analyzer, the rise time of the output voltage E_3 for a step voltage applied at E_1 (see Fig. 2) is 5 microseconds. The rise time for inputs applied at I_2 (Fig. 2) is considerably slower, being about 50 microseconds. This could be improved, if required, by redesigning the amplifier supplying current to the magnetic field coil. The nonlinear distortion of the multiplier with a sinusoidal input is less than 2 per cent at maximum output.

D. Modification of the Crossed-Fields Multiplier for Division

The crossed-fields multiplier can be modified to per-

¹³ A more recent development of the same idea is described by E. M. Deely and D. M. MacKay, "Multiplication and division by electronic-analogue methods," *Nature*, vol. 163, p. 650; April, 1949.

form the operation of division, without the use of any additional computing components. If the amplified output from the pickup photocells is applied to the vertical rather than to the horizontal plates of the cathode-ray tube (Fig. 2), then the feedback voltage is E_1 , and E_2 becomes an input voltage. By controlling v_v , the feedback loop can still keep the two forces \bar{F}_{x_0} and \bar{F}_{x_m} equal in magnitude and opposite in sign, so (6) is still valid. Since the output voltage is now E_1 , this equation is re-written

$$E_1 = \frac{E_2}{kI_2}; \quad (8)$$

the voltage E_1 is thus proportional to the quotient of the two inputs I_2 and E_2 .

E. Arbitrary Function Generator

The function generator used in this electronic differential analyzer is shown in Fig. 3. This circuit was

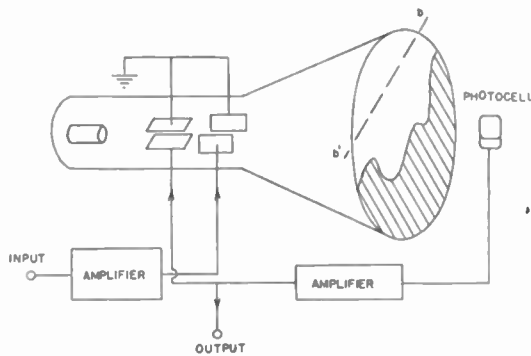

Fig. 3—A feedback arbitrary-function generator.

developed by the author in the summer of 1947. It has been described independently by other investigators in this country and England.¹⁴⁻¹⁶

As Fig. 3 shows, the arbitrary function is cut out of some opaque material in the form of a mask. This mask is placed across the face of the cathode-ray tube. The output of a photocell located in front of the masked cathode-ray-tube screen is fed through an amplifier to the vertical deflecting system of the tube. The phase of this amplifier is chosen to give a downward deflection of the cathode-ray-tube beam when there is light striking the photocell. With no light striking the photocell the electron beam strikes the cathode-ray tube face along the line $b-b'$. The feedback loop forces the electron beam downward until it is partially obscured by the edge of the function mask. With a sharply focused beam and sufficient gain in the feedback loop, the electron beam follows the edge of the function mask as

¹⁴ D. M. MacKay, "A high-speed electronic function generator," *Nature*, vol. 159, p. 406; March, 1947.

¹⁵ D. J. Mynall, "Electrical analogue computing," *Electronic Eng.*, vol. 19, pp. 178-181; June, 1947.

¹⁶ D. E. Sunstein, "Photoelectric waveform generator," *Electronics*, vol. 22, p. 100; February, 1949.

the beam moves in the horizontal direction. Because of the linear relationship between the vertical deflection of the electron beam and the voltage applied to the vertical deflecting plates, the voltage at the output of the feedback amplifier is the plotted function of the input voltage, which is applied to the horizontal deflecting system.

The function unit used with this electronic differential analyzer makes use of a 2½ inch square area in the face of the cathode-ray tube. The maximum nonlinear distortion is 2 per cent and the response to a one-inch step in the function generated exhibits a 5-microsecond maximum rise time.¹⁷

F. Addition and Integration

Electronic circuits performing the operations of addition and time-integration are well known. The adding and integrating circuits employed in this electronic differential analyzer are shown in Fig. 4. These basic circuits have been employed extensively for those specialized differential analyzers known as simulators.¹⁸⁻²¹

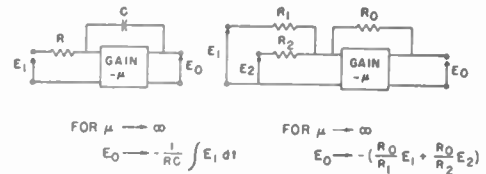

Fig. 4—Integrating and adding circuits employed in the electronic differential analyzer.

The circuits of Fig. 4 are usually built around high-gain dc coupled amplifiers which suffer from drift and warm-up problems. To avoid these problems, ac coupled amplifiers are employed in this differential analyzer.

G. The DC Clamping Circuit

Because the dc output of each computing element in the analyzer influences the initial conditions at the beginning of each solution period, means must be employed to fix the output of each computing element. This can be accomplished without losing the advantages of ac coupling by employing some form of dc clamping;

¹⁷ The cathode-ray tube utilized in both the crossed-fields multiplier and the arbitrary-function generator described here is the type 5LP11. The P-11 screen has proved to have a sufficiently short persistence for problems encountered to date on the electronic differential analyzer. If a faster response were required a cathode-ray tube with the P-5 screen might be employed. The photocells used in the multiplier and function generator are RCA 931-A's.

A number of modifications of the feedback loops employed for the crossed-field multiplier and the arbitrary function generator might be desirable in some applications. One such modification is replacement of the dc amplifier in Figs. 2 and 3 by a bandpass carrier amplifier, with modulation of the beam intensity of the cathode-ray tube at the carrier frequency. Another possibility is the replacement of the pickup photocells in Fig. 2 by a pair of collector plates mounted within the evacuated envelope of a special cathode-ray tube.

¹⁸ J. R. Ragazzini, R. H. Randall, and F. A. Russell, "Analysis in problems in dynamics by electronic circuits," *Proc. I.R.E.*, vol. 35, pp. 444-453; May, 1947.

¹⁹ G. A. Korn, "Elements of d-c analogue computers," *Electronics*, vol. 21, p. 122; April, 1948.

²⁰ S. Frost, "Compact analog computer," *Electronics*, vol. 21, pp. 116-122; July, 1948.

²¹ "Electronic Instruments," *Rad. Lab. Series*, No. 21, McGraw-Hill Publishing Co., New York, N. Y., 1948.

the dc clamping circuit used in the electronic differential analyzer is commonly employed to restore the dc component in television-camera amplifiers.^{22,23} This circuit is shown in Fig. 5. A circuit of this type is connected to each interstage coupling capacitor of the adding and integrating amplifiers. The gate pulses are applied during the off-time and removed at the beginning of each on-time.

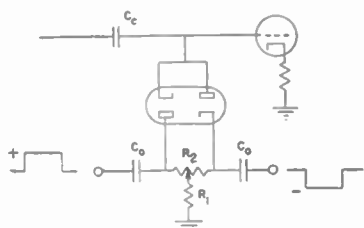

Fig. 5—A pulse-controlled clamping circuit.

The measured characteristics of the adding units are listed below in Table I.

TABLE I
Measured Adder Characteristics

low-frequency half-power point = 0.016 cps
high-frequency half-power point = 650 kc
rise-time (step-input) = 0.4 microsecond (10% to 90%)
overshoot = 2% or less
voltage gain = -150 times maximum
output noise = 0.4 to 5 mv
maximum output level = ± 25 volts
maximum output impedance = 10 ohms
nonlinear distortion < 0.2%

II. Integrator Initial Conditions

The integrator of Fig. 4, because dc clamped amplifiers are used, automatically discharges the integrating condenser during the differential analyzer off-time. The initial condition of the integrator is set by adding a voltage step of adjustable amplitude to the output of each unit. This initial-condition step is applied at the beginning of each solution period and remains constant for the duration of the solution. The three important characteristics of the integrators in this electronic differential analyzer are:

1. Low-frequency time constant of at least 0.75 second;
2. High-frequency transient decays to 2 per cent in 2 microseconds;
3. Output impedance of 100 ohms.

The electronic differential analyzer employing the dc clamped adders and integrators discussed above has a warm-up time of less than five minutes. The use of dc clamped amplifiers is advantageous for three reasons:

²² J. H. Roe, "New television field-pickup equipment employing the image orthicon," *Proc. I.R.E.*, vol. 35, pp. 1532-1547; December, 1947.

²³ K. R. Wendt, "Television dc component," *RCA Rev.*, vol. 9, pp. 85-112; March, 1948.

(a) it avoids the long warm-up period and (b) the long-time instability problem of conventional dc amplifiers; (c) it automatically turns off the analyzer and removes the final conditions from the integrator condensers at the end of every solution period; thus it permits the handling of differential equations whose solutions increase with the independent variable time.

IV. ERRORS DUE TO COMPONENT LIMITATIONS

Three principal types of error are encountered in the solution of differential equations by electronic means: random errors (lack of precision), and systematic errors due either to lack of calibration accuracy or to limitations in the time (or frequency) domain of the differential-analyzer elements.

A. Calibration Accuracy

Since the variables of this differential analyzer are voltages and time, calibrating units must be capable of measuring instantaneous voltages and times. The measurements are made on a cathode-ray tube in the present analyzer. Amplitudes are measured by direct calibration of the cathode-ray-tube oscilloscope; time is measured by linear oscilloscope sweeps and time pip-marker generators.²⁴ A calibration accuracy of 2 per cent is obtained in this manner, which is adequate for the present applications.

B. Precision

Precision (*repeatability*) is of great importance in this system of solving differential equations because of the high solution-repetition rate employed. The precision of the differential analyzer limits its operation when solving equations whose solutions increase rapidly with time. The observed variability in the initial values is about 0.4 millivolt. The maximum output level for this electronic differential analyzer is 25 volts; this shows that the initial conditions are precise to within 0.002 per cent of the maximum output level. With a more usual initial value of 1 volt the precision is 0.04 per cent.

Precision of the differential analyzer is important in the solution of nonlinear equations. Exploration of the regions between stable and unstable solutions requires extreme precision.

In order to obtain a good qualitative picture of the nature of the unknown solutions of a given differential equation with regard to instability, periodicity, discontinuities, etc., the important requirement on the differential analyzer is that of *precision*, rather than calibration accuracy. In this respect the present electronic differential analyzer is very satisfactory; for many engineering and physical applications what is most important is the resulting *qualitative* information alone.

²⁴ MIT Radar School Staff, "Principles of Radar," 2nd Edition, McGraw-Hill Book Co., New York, N. Y., 1946.

C. Errors Due to Frequency and Time Limitations of Components

The errors introduced into differential equation solutions on the electronic differential analyzer by the time or frequency limitations of its components are of the greatest importance. Because these limitations can cause the analyzer to solve an entirely wrong equation, they have been investigated in some detail for the case of

than the adding units employed.²⁵ For this reason it is reasonable to calculate the errors introduced into the solution of (9) by an adder of finite bandwidth, with all other components assumed ideal at high-frequencies.

If the adding unit has a bandwidth Δf , it can be shown that the characteristic roots of the equation actually solved will differ from the roots of (9) by the small quantity

$$e_n = \frac{s_n^2}{2\pi\Delta f} \left[1 + \frac{A_{m-1}}{A_m} \left(\frac{m-1}{m} \right) s_n^{-1} + \dots + \frac{A_1}{A_m} \left(\frac{1}{m} \right) s_n^{-m+1} \right] \tag{11}$$

linear differential equations with constant coefficients. One result of these investigations is summarized here.

The general ordinary differential equation with constant coefficients

$$\sum_{n=0}^m A_n \frac{d^n y}{dt^n} = F(t) \tag{9}$$

is solved on the electronic differential analyzer by the setup of Fig. 6. The solution of the reduced equation, obtained from (9) by making $F(t) = 0$, is

$$y = \sum_{n=1}^m C_n e^{s_n t} \tag{10}$$

where the C_n are constants depending upon the initial conditions of the particular solution desired and s_1, s_2, \dots, s_m are the characteristic roots of the differential equation.

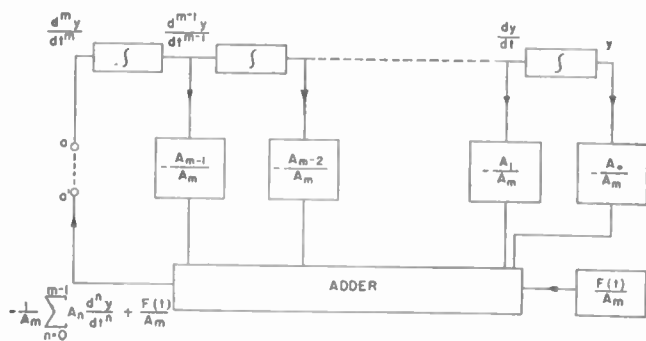

Fig. 6—A block diagram of setup for the solution of an ordinary linear differential equation of order m with constant coefficients.

If all the components in the setup of Fig. 6 are ideal, then the solution given by (10) is observed on the differential analyzer. Ideal components are not available. At high frequencies the response of the adding unit drops off because of the finite bandwidth of the amplifier employed. The response of the integrating units may also depart from the ideal at high frequencies; for this reason it is important to observe the pulse response of the integrators as well as the amplifiers and adders in an electronic differential analyzer. With proper care it has been found possible always to compensate the integrator high-frequency response sufficiently to make it better

for

$$n = 1, 2, \dots, m$$

and there will be a new root

$$s_{m+1} = -2\pi\Delta f. \tag{12}$$

Equations (11) and (12) enable one to determine the errors caused by the finite bandwidth of the adder in Fig. 6 if that bandwidth, the coefficients of the differential equation, and the roots of the characteristic equation of the differential equation are known.

An experimental check on errors due to the finite bandwidths can always be made by changing the scale factor of the equation being solved. This will change the values of the equation coefficients A_{m-1}/A_m and the characteristic roots s_n , but the value of Δf will remain constant; therefore the error e_n will change value. If no change in the character of the solution is observable when the scale-factor is changed, then the errors e_n are negligible.

If (11) and (12) are applied to

$$\frac{d^2 y}{dt^2} + \omega_0^2 y = 0, \tag{13}$$

the differential equation for an undamped sine wave, one finds that the sine wave observed on an electronic differential analyzer with a finite adder bandwidth increases in amplitude with time; that is, it is negatively damped. In order that this increase in amplitude be limited to one per cent over the solution time of approximately 1/100 second, it turns out to be necessary that the adder bandwidth be one thousand times the natural frequency of the sine wave being observed.

The influence of the adder bandwidth upon the solution of differential equations has been verified experimentally on the electronic differential analyzer. Analysis of low-frequency effects, such as the limitations imposed by the finite gain of integrator amplifiers, has also been made and verified.

²⁵ It will be noted that it should be possible to build an integrator with a perfect high-frequency response, since no gain-bandwidth limitations will be violated by such a requirement.

V. RESULTS

An electronic differential analyzer employing the system outlined in Section II has been built and used to solve a number of representative ordinary differential equations. Equations which have been considered in detail by analytic means were chosen so that a test of the differential analyzer operation could be obtained.

A. Solution of Simultaneous Second-Order Differential Equations

The solution of simultaneous linear differential equations with constant coefficients is of great practical importance to the engineer and physicist. Although it is possible to handle such equations directly by analytic means, a considerable amount of time and labor is required by this approach. The electronic differential analyzer affords a more economical means of obtaining such solutions when large numbers of solutions are required.

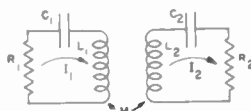

Fig. 7—Coupled-tuned circuits.

An example of a practical electric circuit requiring the solution of a pair of simultaneous differential equations is the coupled-tuned circuit of Fig. 7. For this circuit one can write the two differential equations

$$\frac{d^2 I_1}{dt^2} + \frac{R_1}{L_1} \frac{dI_1}{dt} + \frac{1}{L_1 C_1} I_1 - \frac{M}{L_1} \frac{d^2 I_2}{dt^2} = 0, \quad (14)$$

$$\frac{d^2 I_2}{dt^2} + \frac{R_2}{L_2} \frac{dI_2}{dt} + \frac{1}{L_2 C_2} I_2 - \frac{M}{L_2} \frac{d^2 I_1}{dt^2} = 0. \quad (15)$$

The setup for solving this pair of simultaneous differential equations on the electronic differential analyzer is given in the block diagram of Fig. 8. (In this and subse-

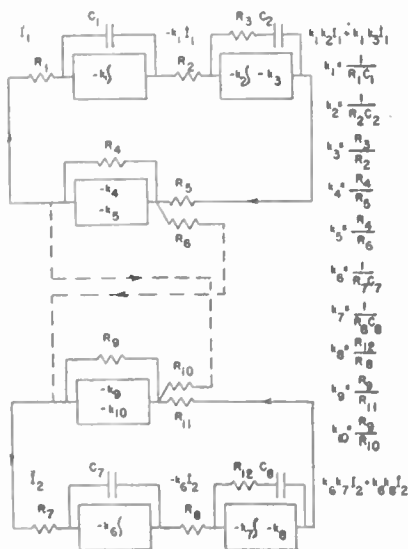

Fig. 8—A differential-analyzer setup for solving simultaneous second-order differential equations.

quent figures, the dot notation will be used for time derivatives. Thus, for example, the symbols \dot{I} and \ddot{I} will denote dI/dt and d^2I/dt^2 .)

It will be noticed that in the arrangement of Fig. 8 the integrators in the upper and lower right-hand corners have been modified slightly. With this modification, the output of the unit is the integral plus a fraction of the input as indicated.

A typical solution of (14) and (15) as observed on the electronic differential analyzer is shown in Fig. 9. This is a double-exposure photograph showing the primary and secondary currents as a function of time. The illuminated scale in the photograph is ruled on an illuminated graticule placed over the output cathode-ray-tube screen.

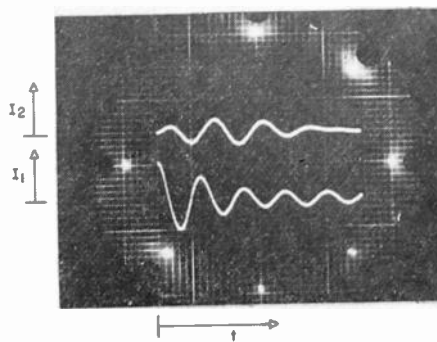

Fig. 9—Primary and secondary currents versus time, for coupled circuit with dissipation. $\dot{I}_{10} = \dot{I}_{20} = I_{20} = 0, I_{10} \neq 0$.

B. Solution of Time-Varying Force Equation

An interesting group of linear equations with variable coefficients, not easily treated by analytic methods, has the form

$$\frac{d^2 y}{dt^2} + F(t)y = 0. \quad (16)$$

$F(t)$ is called the "force function."

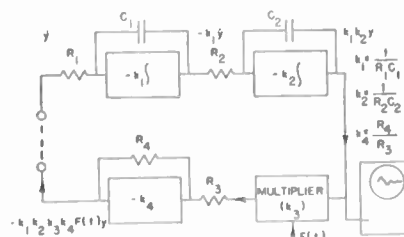

Fig. 10—A differential-analyzer setup for the solution of the equation $\ddot{y} + F(t)y = 0$.

The differential analyzer setup for the solution of such equations is given in Fig. 10. The multiplier shown in this figure is the crossed-fields multiplier discussed in Section III; the amplifier of gain $-k_4$ inserted in the setup is a convenience; its use permits an adjustment in scale factors to assure that the multiplying unit always operates over its most favorable range.

C. The Mathieu and Hill Equations

If one chooses

$$F(t) = \omega_0^2(1 + \epsilon \cos \omega_m t) \tag{17}$$

in (16), one obtains the well-known Mathieu equation. This equation is encountered in the solution of Laplace's equation in elliptical co-ordinates and in numerous other problems of physics and engineering.

The force function, (17), is generated by solving (13) as an auxiliary differential equation on another part of the differential analyzer.

The Mathieu functions are special solutions of the Mathieu equation which are periodic in behavior.²⁶ Fig. 11 shows the differential analyzer generation of the Mathieu function $ce_2(t)$.

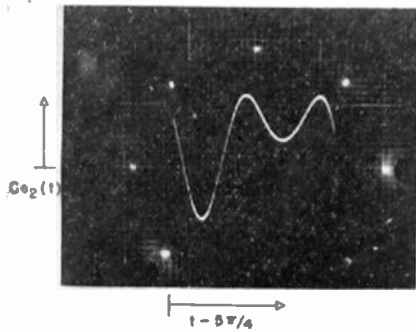

Fig. 11—Mathieu function, $ce_2(t)$, as observed on the differential analyzer.

If the force function of (16) is of the form

$$F(t) = \frac{\omega_0^2}{1 - \epsilon \cos \omega_m t} \tag{18}$$

one has an equation of the Hill type. This equation is of interest to engineers studying the problem of frequency modulation or the generation of acoustic warble tones.²⁷⁻²⁹

Solving the analytically more difficult Hill equation, instead of the Mathieu equation, requires only that the multiplier in the setup of Fig. 10 be replaced by a divider. The new setup is shown in Fig. 12. Division is per-

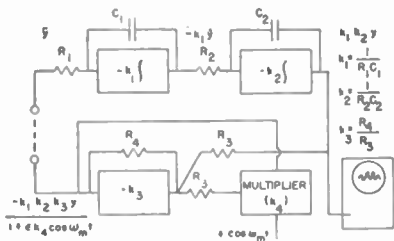

Fig. 12—A differential-analyzer setup for the solution of the Hill equation.

formed as shown in Fig. 12 by employing the crossed-fields multiplier as an element in the feedback loop of an adding amplifier.²¹ Comparing the two setups of Figs. 10 and 12 one sees that by moving one connection and adding one connection it is possible to shift the differential-analyzer setup from the Mathieu to the Hill equation, a simple operation, whereas the difficulty of the corresponding analytic change is enormous.³⁰ These analytic problems are so great as to have prevented any considerable use of equations of this level in normal engineering work. With the availability of the electronic differential analyzer, this situation no longer need exist.

A typical solution of the Hill equation is shown in Fig. 13. This is a triple-exposure photograph showing the

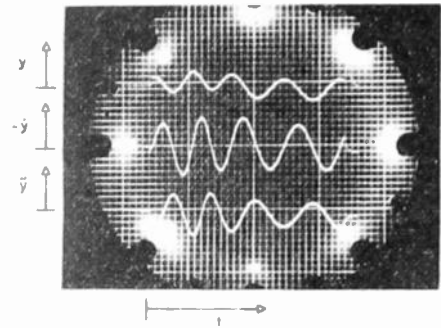

Fig. 13—Solution of the Hill equation,

$$\frac{d^2y}{dt^2} + \frac{\omega_0^2 y}{1 + \epsilon \cos \omega_m t} = 0$$

for $\epsilon=0.5$ showing y , $-y$, and \dot{y} versus t .

function and its first and second derivatives *versus* time for the case $\epsilon \approx 0.5$ and $\omega_0/\omega_m = 4$.

D. Nonlinear Differential Equation

The well-known van der Pol equation,³¹

$$\frac{d^2y}{dt^2} - (A - 3By^2) \frac{dy}{dt} + y = 0, \tag{19}$$

is an extensively studied nonlinear equation pertaining to many types of oscillations. This equation describes a system in which the damping is negative for small amplitudes of oscillation and positive for large amplitudes of oscillation.

Solution of the van der Pol Equation (19) on the electronic differential analyzer requires the use of a function generator to generate y^2 from y and a multiplier to form the product, $y^2 (dy/dt)$. From a practical point of view it is desirable to keep the number of multipliers and function generators required by the differential analyzer setup to a minimum, because these are the most complicated units of this electronic differential analyzer. It is worth while, therefore, to make a change of variable:

²⁶ N. W. McLachlan, "Theory and Application of Mathieu Functions," Clarendon Press, 1947.

²⁷ V. van der Pol, "Frequency modulation," Proc. I.R.E., vol. 18, pp. 1194-1206; July, 1930.

²⁸ W. L. Barrow, "Frequency-modulation and the effects of a periodic capacity variation in a nondissipative oscillatory circuit," Proc. I.R.E., vol. 21, pp. 1182-1203; August, 1933.

²⁹ E. Cambi, "Trigonometric components of a frequency-modulated wave," Proc. I.R.E., vol. 36, pp. 42-50; January, 1948.

³⁰ See footnote reference 28.

³¹ N. Minorsky, "Introduction to Nonlinear Mechanics," J. W. Edwards Co., Ann Arbor, Mich., 1947.

$$x = \int y dt. \quad (20)$$

Applying this to (19) and integrating term-by-term, with respect to time, one obtains the Rayleigh Equation

$$\frac{d^2x}{dt^2} - \left[A - B \left(\frac{dx}{dt} \right)^2 \right] \frac{dx}{dt} + x = 0. \quad (21)$$

The advantage of solving the Rayleigh equation lies in the fact that only a single function generator is required to generate the cube of the first derivative instead of a function generator plus a multiplier.

E. Typical Solutions

Rayleigh's equation has been solved on the electronic differential analyzer using the arbitrary function generator described in Section III. If the first derivative is displayed as a function of time, according to (20), the solution of the van der Pol equation is observed. A typical solution of the van der Pol equation, as observed on the electronic differential analyzer, is shown in Fig. 14(a). The case shown corresponds to what is normally referred to as the high- Q case in electrical engineering problems. It is the situation in which the energy increase per oscillation is small compared to the peak stored energy during the build up period; this means that a large number of oscillations occur during the build-up period. Mathematically the high- Q case indicates that both A and B in (21) are small compared to unity.

Another solution display, which is of great interest to the mathematician and engineer, is the "phase-space" plot, which is a plot of velocity *versus* displacement.²¹ Such a plot is easily obtained on the electronic differential analyzer. A phase-space plot for the van der Pol equation is shown in Fig. 14(b). The build-up to the steady-state "limit cycle" is clearly shown by this photograph. A low- Q solution, in which the oscillation very rapidly reaches its steady state, is plotted *versus* time in Fig. 14(c). The corresponding phase-space plot, with a now much distorted limit cycle, is shown in Fig. 14(d).

It should be emphasized that the time necessary to shift between these two widely different solutions of Figs. 14(a) and 14(c) on the electronic differential analyzer is merely the time necessary to adjust two or three knobs. One can, for example, explore in a very short period the solutions existing for the entire range between the two cases shown. If no record of the solutions is made, such an exploration takes the operator a matter of minutes; if photographic records are required, it is possible to obtain such recorded solutions at the rate of two or three per minute.

F. Solution of an End-Point Boundary-Condition Problem

As was indicated in the introduction, a most important result of the high-speed operation of the electronic differential analyzer is the ability to handle differential equations with unspecified initial conditions. An example of such a problem is that of finding the solution of

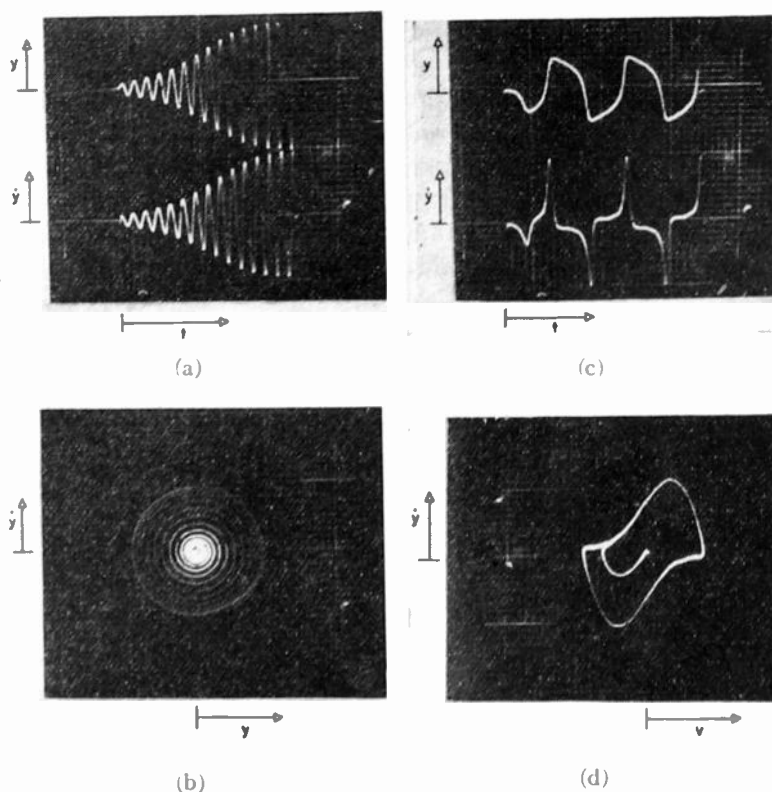

Fig. 14—(a) The solution of the van der Pol equation for the high- Q case as observed on the electronic differential analyzer. This is a double-exposure photograph showing y and \dot{y} as functions of time. (b) Phase-space plot for the van der Pol equation, high- Q case. (c) Solution of the van der Pol equation for the low- Q case. This is a double-exposure photograph showing y and \dot{y} as functions of time. (d) Phase-space plot for the van der Pol equation, low- Q case.

the variable coefficient equation

$$\frac{d^3 y}{dt^3} - \frac{y}{4}(t - t_0) = 0, \quad (22)$$

over the range $0 \leq t \leq t_0$, subject to the condition that at

$$t = t_0 = \frac{5\pi}{2}, \quad y = -1.84$$

$$\frac{dy}{dt} = 0,$$

and

$$\frac{d^2 y}{dt^2} = +0.64. \quad (23)$$

Fig. 15 gives solutions to (22) for $t_0 = 5\pi/2$. By observing the initial values of these curves, one finds that to satisfy the final conditions of (23) the initial conditions must be

$$y \Big|_{t=0} = -0.05,$$

$$\frac{dy}{dt} \Big|_{t=0} = 0,$$

$$\frac{d^2 y}{dt^2} \Big|_{t=0} = -0.03. \quad (24)$$

The solutions of Fig. 15 were obtained after about an hour of trial-and-error investigations, varying the unknown initial values. During this exploratory period, about 200 trial solutions were run; the same number of trial solutions on one of the mechanical differential analyzers would, conservatively estimated, require about three eight-hour working days.

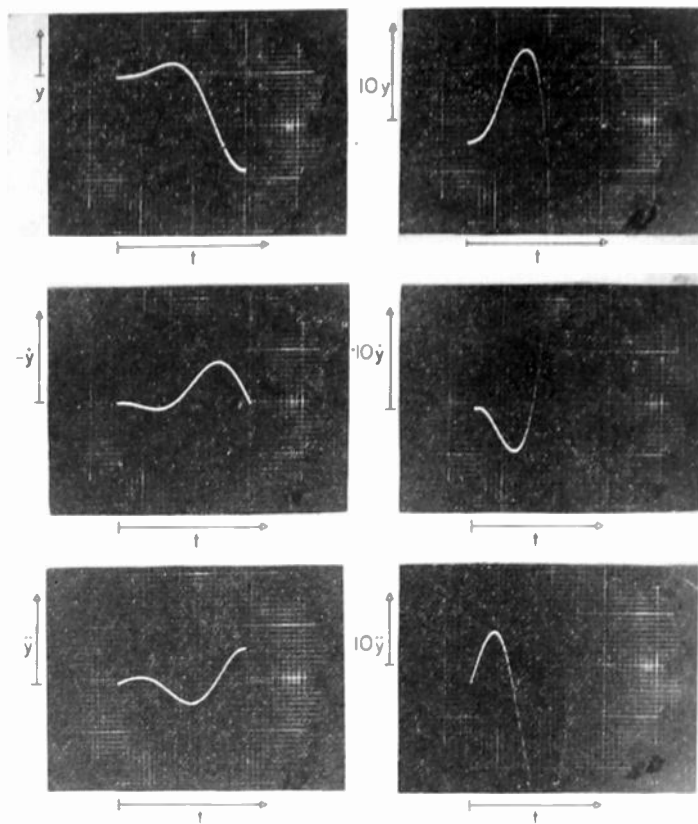

Fig. 15—Solution of the differential equation $\ddot{y} = y(t-t_0)/4$ for $0 \leq t \leq t_0$; plots of y , $-y$ and \dot{y} as functions of t .

ACKNOWLEDGMENT

In addition to thanks already expressed to Henry Wallman, the author wishes to acknowledge numerous conversations with Ronald E. Scott, R. Maartmann-Moe and other colleagues in the Research Laboratory of Electronics.

The author appreciates the interest of J. A. Stratton, A. G. Hill, and J. B. Wiesner, Directors of the Research Laboratory of Electronics of the Massachusetts Institute of Technology, where this work was carried out.

Frequency Changers and Amplifiers with Constant Gain*

D. G. TUCKER†

Summary—A method of applying negative feedback to a frequency changer by using a similar frequency changer in the feedback path is described. When the reduction of conversion gain due to the feedback is adjusted to 6 db, then complete stability is obtained against small and equal changes in the gain (or loss) of each frequency changer. Provided both do change equally, then for ± 2 -db change in each, the resulting change in over-all conversion gain is only ± 0.1 db. A typical circuit is described which uses pentode tubes

for the frequency changers. Nonlinear distortion is also reduced by the feedback.

The application of the principle to stable-gain linear amplifiers is briefly discussed, and while the constancy of gain compares very favorably with conventional feedback systems, it appears that the conditions for linearity may be more difficult to achieve.

I. INTRODUCTION

THE NEED FOR a frequency changer of constant conversion gain or loss arises in any frequency-selective measuring equipment, such as a wave

* Decimal classification: R361.216. Original manuscript received by the Institute, February 11, 1949; revised manuscript received, June 30, 1949.

† Post Office Research Station, London, England.

analyzer or transmission measuring set, where precision (especially long-term precision) is required. Most parts of the circuit of such instruments can be stabilized as much as necessary by the addition of negative feedback to amplifier sections, but the frequency changer has hitherto been more difficult to deal with. A feedback tube frequency changer has now been designed which achieves the stability in a very simple manner, and is likely to give the measuring equipment the stability required, together with improved linearity of response.

It is also shown that the same principle can be used to give a constant-gain amplifier, which may under specified circumstances have greatly improved linearity of response. This particular application of the principle is, however, really of much less practical value than in the frequency-changer, since similar results can be achieved with conventional feedback circuits.

II. PRINCIPLE OF A FEEDBACK FREQUENCY CHANGER

To obtain stability of conversion gain or loss it is necessary to feed a signal back into the input of the same frequency (or frequency spectrum) as that of the input signal, in antiphase, but of amplitude proportional to that of the wanted component of the output signal. This is then analogous to normal negative feedback and the same equations apply. Obviously there must be a frequency changer in the feedback path; the scheme is shown in Fig. 1. If we take μ as the conversion gain of

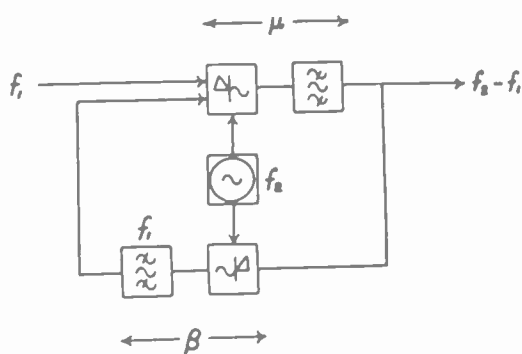

Fig. 1—General schematic.

the forward path and β that of the feedback path, then the conversion gain of the whole circuit is

$$G = \frac{\mu}{(1 + \mu\beta)} \tag{1}$$

In general, this circuit would perhaps be of little use in obtaining stability, since both μ and β are liable to variation. But if we can so arrange the circuit that μ and β both vary always in the same direction and with a constant ratio between them, then stability can be obtained for one particular amount of feedback. Thus

$$\frac{1}{G} = \frac{1}{\mu} + \beta,$$

and if $\beta = k\mu$, then $1/G = 1/\mu + k\mu$

$$\therefore \frac{d\left(\frac{1}{G}\right)}{d\mu} = k - \frac{1}{\mu^2}, \tag{2}$$

so that the conversion gain is independent of μ when

$$k = \frac{1}{\mu^2} \tag{3}$$

and in this condition the over-all gain is

$$G_c = \frac{\mu}{2}, \tag{4}$$

i.e. the feedback, expressed in the usual way as the reduction in gain, is 6 db.

If condition (3) is not met, then the error in gain for a small change in μ of $\Delta\mu$ is given by

$$\Delta\left(\frac{1}{G}\right) = \Delta\mu \cdot \frac{d\left(\frac{1}{G}\right)}{d\mu} = \Delta\mu \left(k - \frac{1}{\mu^2}\right). \tag{5}$$

If μ and β vary independently, then the error in gain is given by

$$\begin{aligned} \Delta\left(\frac{1}{G}\right) &= \Delta\mu \cdot \frac{\partial\left(\frac{1}{G}\right)}{\partial\mu} + \Delta\beta \cdot \frac{\partial\left(\frac{1}{G}\right)}{\partial\beta} \\ &= \Delta\beta - \frac{1}{\mu^2} \Delta\mu. \end{aligned} \tag{6}$$

The scheme could be used with rectifier modulators,¹ provided both were identical and aged in similar ways. Then temperature changes and time would not change the over-all conversion efficiency. To meet condition (3), since generally $\mu < 1$ in a rectifier modulator, we must have $k > 1$, which means an amplifier is required somewhere in the loop circuit. Unfortunately, experience shows that rectifiers have such variable characteristics that two identical modulators could hardly be made in practice.

Multielectrode tubes are more suitable as the modulators of this circuit, since there is more uniformity among them, and changes due to time and voltage variations tend to be more nearly the same for different tubes. There are also means of stabilizing tubes and of increasing the constancy of ratio between two tubes. The choice of a practical tube circuit is discussed in the next section.

III. DESIGN OF A TUBE FREQUENCY-CHANGER CIRCUIT

The schematic of a feedback frequency changer for a typical application is shown in Fig. 2. The anode load

¹ Where the word "modulator" is used, it refers to the basic modulating circuit only; a "frequency changer" is the complete circuit incorporating a modulator and some frequency-selective device, such as a filter.

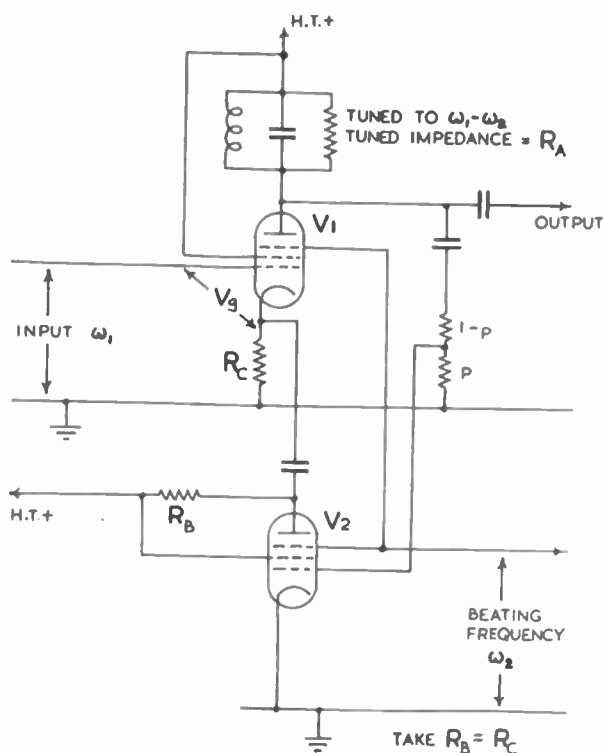

Fig. 2—Tube frequency-changer circuit.

of the main modulator tube ($V1$) is tuned, say, to the difference frequency, but the signal fed back to the grid-cathode circuit of $V1$ is not filtered after modulation by $V2$. It is convenient for analysis to make $R_B = R_C$, and R_A is taken as the effective anode load at resonance. The cathode resistance R_C is that used for the feedback connection; resistances needed only for bias have been omitted. Some local feedback which has no useful effect is also developed across R_C ; this can generally be ignored, except that the inclusion of the same amount of undecoupled resistance in the cathode of $V2$ is advantageous.

It is usually desirable to use a large voltage of the local beating frequency, since then the tubes are driven from their maximum mutual conductance (g_m) on one half-cycle to zero on the other, and the modulation gain is practically independent of variations in the local voltage. This is usually referred to as the "switching" condition, since the tubes are virtually switched on and off by the local frequency, which can then be referred to as the switching frequency.

Let the input signal be $E \cos \omega_1 t$ and the switching frequency be ω_2 so that the switching or modulating function (defined as the time function by which the input signal is multiplied to give the anode current, excluding the steady components at input and switching frequencies) is

$$\frac{2}{\pi} g_m (\cos \omega_2 t + \frac{1}{3} \cos 3\omega_2 t + \frac{1}{5} \cos 5\omega_2 t + \dots)$$

for each tube. If we take $E_0 \cos (\omega_1 - \omega_2)t$ as the output

signal, then the voltage fed back to the grid-cathode circuit of $V1$ is

$$\frac{p}{\pi} g_m R_C E_0 \cos (\omega_1 - \omega_2)t \left[\cos \omega_2 t + \frac{1}{3} \cos 3\omega_2 t + \frac{1}{5} \cos 5\omega_2 t + \dots \right].$$

This ignores components at the switching frequency and its harmonics, and also the steady component of frequency $(\omega_1 - \omega_2)$, none of which affects the operation of the circuit.

Therefore

$$\begin{aligned} V_v = & \left(E - \frac{p}{2\pi} g_m R_C E_0 \right) \cos \omega_1 t \\ & - \frac{p}{2\pi} g_m R_C E_0 \cos (2\omega_2 - \omega_1)t \\ & - \frac{p}{\pi} g_m R_C E_0 \cos (\omega_1 - \omega_2)t \\ & \left[\frac{1}{3} \cos 3\omega_2 t + \frac{1}{5} \cos 5\omega_2 t + \dots \right]. \end{aligned}$$

Now the output from $V1$, of angular frequency $(\omega_1 - \omega_2)$, is given by the component of frequency $(\omega_1 - \omega_2)$ in

$$V_v \cdot \frac{2}{\pi} g_m R_A (\cos \omega_2 t + \frac{1}{3} \cos 3\omega_2 t + \frac{1}{5} \cos 5\omega_2 t + \dots),$$

i.e.,

$$\begin{aligned} & E_0 \cos (\omega_1 - \omega_2)t \\ & = \left[\frac{1}{\pi} g_m R_A \left(E - \frac{p}{2\pi} g_m R_C E_0 \right) - \frac{1}{\pi} g_m R_A \cdot \frac{p}{2\pi} g_m R_C E_0 \right. \\ & \quad \left. - \frac{1}{3\pi} g_m R_A \cdot \frac{p}{3\pi} g_m R_C E_0 - \frac{1}{5\pi} g_m R_A \cdot \frac{p}{5\pi} g_m R_C E_0 - \text{etc.} \right] \\ & \quad \cos (\omega_1 - \omega_2)t, \end{aligned}$$

and therefore the over-all gain is

$$\begin{aligned} G = \frac{E_0}{E} = & \frac{\frac{1}{\pi} g_m R_A}{1 + g_m^2 R_A R_C \frac{p}{\pi^2} \left(1 + \frac{1}{9} + \frac{1}{25} + \dots \right)} \\ & \frac{\frac{1}{\pi} g_m R_A}{1 + \frac{p}{8} g_m^2 R_A R_C} \end{aligned} \quad (7)$$

since the sum of the infinite series $1 + 1/9 + 1/25 + \dots = \pi^2/8$. Complete stability is obtained when

$$\frac{p}{8} g_m^2 R_A R_C = 1. \quad (8)$$

It is interesting that there is no need to suppress the feedback component at frequency $(2\omega_2 - \omega_1)$, nor any of the products of the harmonics of the switching frequency.

Suitable numerical values for the pentode valve CV 329 working on a 130-volt power supply are

$$p = 1, \quad R_C = 200, \quad R_A = 5,000,$$

which give the following relationship between conversion gain and g_m . Shown in Table I.

TABLE I

$g_m(mA/V)$	1.74	2.18	2.61	2.74	2.87	3.48	4.35
G	2.27	2.45	2.51	2.51	2.51	2.45	2.28
db relative to max value of G	-0.84	-0.21	0	0	0	-0.21	-0.84

It is seen from this that for ± 0.1 -db error in conversion gain, a variation of ± 2 db in g_m can be tolerated if both V_1 and V_2 vary in the same way. It is interesting that exactly the same results apply if the circuit is used to demodulate an amplitude-modulated carrier signal with the local oscillator synchronized to the carrier as in a homodyne or synchrodyne radio receiver, and with the output tuned circuit replaced by a resistance and capacitance intended to pass the modulation frequencies but suppress the rf signals. As far as changes of plate and heater voltages are concerned, it has been found that with a typical pair of tubes a constancy of conversion

plifiers have gains proportional to one another, then stability against variations of gain can be achieved with a nominal feedback of 6 db (i.e. reduction of gain when feedback applied = 6 db). The conditions for linearity of response can be demonstrated analytically as follows: Consider for simplicity a two-tube circuit as used for the frequency changer. Suppose each tube has anode current related to grid voltage thus:

$$i_a = a_0 + a_1V_g + a_2V_g^2 + a_3V_g^3 + \dots, \quad (9)$$

and assume that the grid voltage of both tubes is the same.

Then

$$g_m = \frac{di_a}{dV_g} = a_1 + 2a_2V_g + 3a_3V_g^2 + \dots \quad (10)$$

Now take k_1 and k_2 , such that

$$G = \frac{k_1g_m}{1 + k_2g_m^2} \quad (11)$$

and when the adjustment for constancy is made, with $V_g=0$, then $k_2g_m^2=1$, i.e.,

$$a_1 = \frac{1}{\sqrt{k_2}} \quad (12)$$

Therefore

$$G = \frac{k_1 \left(\frac{1}{\sqrt{k_2}} + 2a_2V_g + 3a_3V_g^2 + \dots \right)}{1 + k_2 \left(\frac{1}{\sqrt{k_2}} + 2a_2V_g + 3a_3V_g^2 + 4a_4V_g^3 + \dots \right)^2}$$

$$= \frac{k_1}{2\sqrt{k_2}} \times \frac{1 + 2\sqrt{k_2}a_2V_g + 3\sqrt{k_2}a_3V_g^2 + 4\sqrt{k_2}a_4V_g^3 + \dots}{1 + 2\sqrt{k_2}a_2V_g + (2k_2a_2^2 + 3\sqrt{k_2}a_3)V_g^2 + (6k_2a_2a_3 + 4\sqrt{k_2}a_4)V_g^3 + \dots} \quad (13)$$

gain within 0.1 db can be obtained with the plate voltage supply varying from 130 to 80 volts and with the heater voltage varying from 6.3 to about 4 volts. This is more than sufficient to cover practical conditions. But to enable long-term stability to be obtained it may be necessary to adopt some form of compensation for differing rates of ageing of the two tubes in the modulator. One method is to run the two tubes in series from the plate supply, so that the ground side of one tube circuit becomes the plate connection for the other. The cathode currents are thus bound to be equal and the mutual conductances will tend to be.

IV. USE OF THE PRINCIPLE FOR A CONSTANT-GAIN AMPLIFIER

It is evident that the analysis of Section II applies equally to an amplifier without any frequency change. G is then just the normal amplification of the tube circuit. This means that if both forward and feedback am-

plifiers have gains proportional to one another if either

$$(a): \quad 3\sqrt{k_2}a_3 \gg 2k_2a_2^2; \quad 4\sqrt{k_2}a_4 \gg 6k_2a_2a_3; \quad \text{etc.} \quad (14)$$

or (b): All coefficients a_n are zero except one (where $n > 1$).

Since, in general, $a_2 \ll a_1; a_3 \ll a_1; \text{etc.}$ and since $a_1\sqrt{k_2} = 1$, then $a_2\sqrt{k_2} \ll 1; a_3\sqrt{k_2} \ll 1; \text{etc.}$, so that condition (14) holds if we can state that

$$a_2 \approx a_3 \approx a_4, \quad \text{etc.} \quad (15)$$

Another condition is evidently that the grid voltage of both tubes is the same; this can easily be arranged for small grid voltages, and the effect of the voltages becoming unequal as they increase, due to nonlinearity of the individual tubes, will be only second-order until overloading sets in.

It can be seen that, while good linearity is theoretically attainable, its realization in practice is accompanied by more restrictions in the circuit parameters than apply with conventional feedback circuits.

A Variable Phase-Shift Frequency-Modulated Oscillator*

O. E. DE LANGE†, ASSOCIATE, IRE

Summary—The theory of operation of a phase-shift type of oscillator is discussed briefly. This oscillator consists of a broad-band amplifier, the output of which is fed back to the input through an electronic phase-shifting circuit. The instantaneous frequency is controlled by the phase shift through this latter circuit. True FM is obtained in that frequency deviation is directly proportional to the instantaneous amplitude of the modulating signal and substantially independent of modulation frequency.

A practical oscillator using this circuit at 65 Mc is described.

INTRODUCTION

THE OSCILLATOR described here was developed to meet the requirements of a FM microwave repeater system which called for operation at a mid-band frequency of 65 Mc and linear frequency deviations of ± 2 Mc to ± 3 Mc at modulation frequencies up to 5 Mc with very little resultant AM. Although modulation is brought about by variations of a phase shift, the circuit is not the usual "phase-modulation" circuit which starts out with a voltage of fixed frequency and varies its phase. In this circuit, the frequency of oscillation of an oscillator is controlled by the amount of phase shift through an electronic phase shifter. The circuit also differs from the well-known reactance-tube modulator in that, for the reactance-tube circuit, the modulator is effectively in shunt with part or all of the oscillator tank circuit whereas, in the variable phase-shift circuit, the modulator is in series with the oscillator feedback path.

DESCRIPTION OF OSCILLATOR

Fig. 1 shows, in simplified block form, an oscillator of the phase-shift type. It is seen to consist of a broad-band amplifier, the output of which is fed back to the input through an electronic phase-shifting circuit. Switch S should be in position 2 for the oscillator connection. The switch and the voltage generator e_1 shown in Fig. 1 are not parts of the oscillator but are included here merely to illustrate the operation of the circuit.

The amplifier consists of a single vacuum tube with associated input and output impedances. These impedances, of course, have phase characteristics. The block Z of Fig. 1 represents an equivalent network having the same amplitude and phase characteristics as the *passive* circuits associated with the amplifier and phase shifter. Under ideal conditions, the amplitude characteristic of

Z would be flat and the phase characteristic would be linear over the desired frequency range.

The circuits are adjusted to make Z look like a pure resistance at midband frequency. Also, with no modulation voltage applied, the electronic phase shifter is adjusted to produce a phase shift of exactly 180° at midband frequency. Suppose the switch S of Fig. 1 to be in position 1 so as to apply the voltage e_1 to the amplifier input and let the frequency of e_1 be the midband frequency. Then the voltage e_2 appearing across the resistor R will be exactly in phase with e_1 . By adjusting the gain around the loop to a value of unity, the amplitude of the voltage e_2 will be made equal to that of e_1 . Since e_1 and e_2 are equal in both phase and amplitude, the circuit now satisfies all of the conditions for oscillation and if the switch S is thrown to its position 2 sustained oscillation at midband frequency will result.

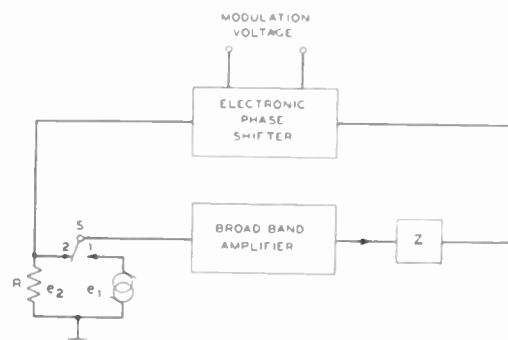

Fig. 1—Phase-shift oscillator, block form.

With the switch S back in position 1 consider what happens when the phase shift through the electronic phase shifter is changed from the 180° value as happens when modulation is applied. If the phase shift is made to differ from the 180° value by an amount α then the voltage e_2 will be out of phase with the voltage e_1 by the angle α and the circuit can not oscillate at this frequency. If the voltage e_1 is now changed in frequency from the midband value, it will be possible to find some frequency for which the phase shift through the impedance Z is equal to $-\alpha$ and thus compensate for the change of phase shift produced by the *active* elements of the phase shifter and for which the voltage e_2 will again be in phase with e_1 . If the switch S is thrown to position 2, the circuit will oscillate at the last-mentioned frequency. Thus, the frequency at which the circuit can oscillate is determined by the phase angle introduced by the electronic phase shifter and is hence capable of being modulated by this phase shifter. This can be shown mathematically as follows:

* Decimal classification: R355.914.31×R246.24. Original manuscript received by the Institute, January 13, 1949; revised manuscript received, July 19, 1949.

† Bell Telephone Laboratories, Inc., Deal, N. J.

Let Φ be the phase shift around the loop in Fig. 1, the switch being in position 1 and Φ being the shift from point 1 to point 2. Then Φ is a function of the modulating voltage v and of the frequency ω .

That is, $\Phi = \Phi(v, \omega)$

Differentiating,

$$d\Phi = \frac{\partial\Phi}{\partial v} dv + \frac{\partial\Phi}{\partial\omega} d\omega$$

where

$\frac{\partial\Phi}{\partial v}$ = the rate of change (at constant frequency) of phase through the phase-shifter circuit with voltage

$\frac{\partial\Phi}{\partial\omega}$ = the slope of the phase characteristic of the total circuit including the amplifier and the passive elements of the phase shifter

$\frac{\partial\Phi}{\partial\omega}$ = also the group delay around the loop.

For oscillation $\Phi = 360^\circ$ at all times and $d\Phi = 0$

$$\therefore \frac{d\omega}{dv} = - \frac{\partial\Phi}{\partial v} / \frac{\partial\Phi}{\partial\omega}$$

Modulation linearity and sensitivity are seen to depend essentially upon the phase characteristics of the electronic phase shifter and of the impedances represented by the Z of Fig. 1. If the phase-shift versus modulation-voltage characteristic of the phase shifter is linear and if the phase versus frequency characteristic of Z is linear or if the nonlinearities of these two characteristics cancel each other; i.e., if $(\partial\Phi/\partial v)/(\partial\Phi/\partial\omega)$ is independent of frequency, the resultant modulation will be linear. For maximum modulation sensitivity and linearity, the amplifier band should, in general, be made as broad as practicable.

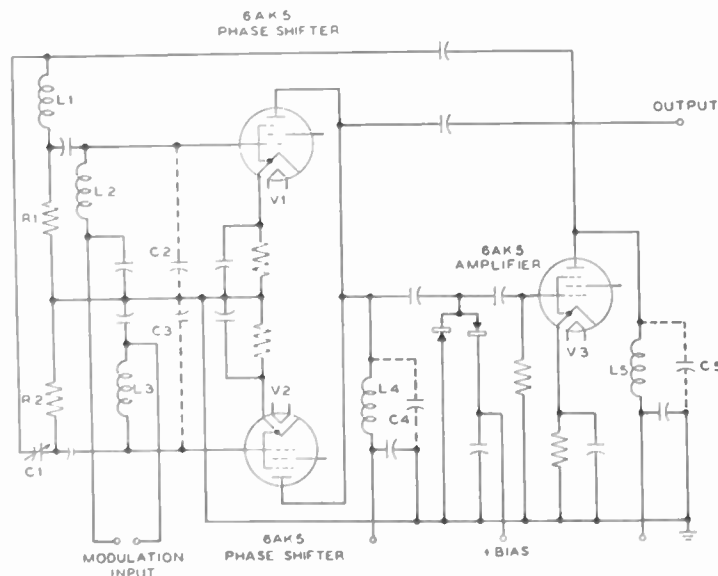

Fig. 2—Simplified schematic of oscillator.

The electronic phase shifter as used in this oscillator is shown at the left-hand side of the simplified schematic of Fig. 2. The inductances L_2 and L_3 serve merely to tune out the input capacitances of tubes V_1 and V_2 respectively. The phase-shift circuit consists of L_1 in series with R_1 and this series combination shunted by another consisting of C_1 in series with R_2 . If the elements are so chosen that $R_1 = R_2 = \sqrt{L_1/C_1}$, the impedance looking into the phase shifter is purely resistive and has the value R_1 at all frequencies. When $\omega = (1/\sqrt{L_1C_1})$, the grid voltages of tubes V_1 and V_2 are equal in magnitude and have their phases shifted by equal amounts but in opposite directions with respect to the input voltage.

The plates of the phase-shifter tubes are directly in parallel with the result that the current output of the phase shifter is the sum of the plate currents of tubes V_1 and V_2 .

In Fig. 3 is shown, in vector form, the action of the phase shifter when $\omega = 1/\sqrt{L_1C_1}$. The vectors OA_1 and OA_2 represent the plate currents of tubes V_1 and V_2 respectively when these tubes are adjusted to have equal values of transconductance. The resultant current I is in phase with the applied voltage.

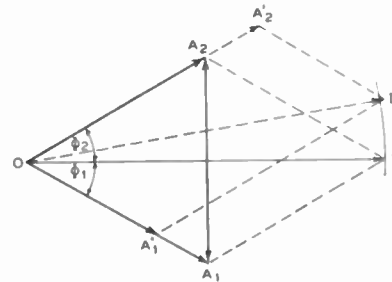

Fig. 3—Phase-shifter currents, vector diagram.

If now the transconductance of tube V_2 is increased from its former value and that of V_1 decreased by an equal amount, the current vectors become as shown by OA_2' and OA_1' and the resultant current I' leads the current I .

In order for the circuit to satisfy conditions for oscillation, it is necessary for the voltage e_2 of Fig. 1 to be equal in magnitude as well as in phase to the voltage e_1 ; i.e., there must be unity gain around the loop. Furthermore, for linear modulation, it is desirable to keep the total voltage on the grids of the modulator tubes below the overload value. To keep the amplitude of oscillation at a fairly low and constant level, a crystal limiter was added to the circuit. This limiter consists of a pair of 1N28 silicon crystals oppositely poled and shunted across one of the oscillator tuned circuits. Because of its extremely small time constant, this limiter performs satisfactorily for modulation frequencies well above 5 Mc.

PERFORMANCE

In order to determine the modulation capabilities of the oscillator, different amounts of 1,000-cps modulating voltage were applied and the amount of distortion re-

sulting at each level of modulation was determined. For a typical adjustment and a frequency shift of ± 2 Mc, second-harmonic amplitude was measured to be 32 db below that of the fundamental- and third-harmonic amplitude 37 db below fundamental. Somewhat better linearity of modulation has been obtained by more careful adjustment of the circuit.

When operated from regulated power sources, the 6AK5 oscillator proved to be quite free of frequency drifts. After a one-hour warm-up period, a drift of 25 kc

took place in the succeeding hour. Modulation at power-line frequency was measured and found to be ± 8 kc. AM effects have not as yet been evaluated but these effects are known to be small.

ACKNOWLEDGMENT

The writer wishes to acknowledge the helpful cooperation of W. M. Goodall and A. F. Dietrich of these Laboratories in the design and testing of this oscillator.

The Reactance-Tube Oscillator*

HAN CHANG† AND V. C. RIDEOUT†, MEMBER, IRE

Summary—The reactance-tube oscillator is a combination reactance-tube circuit and oscillator circuit which uses but a single tube. It has two forms—one derived from the capacitive reactance-tube circuit and one from the inductive reactance-tube circuit; with slight variations the first may be made to resemble the Hartley oscillator circuit, and the second the Colpitts oscillator circuit. Experiments with this oscillator have shown that linear frequency variation versus grid voltage change with constant output amplitude may be obtained over a range of more than five per cent in the region of 1 to 4 Mc.

I. ANALYSIS OF OPERATION

CONSIDER the schematic circuit of the reactance-tube shown in Fig. 1. The admittance across terminals *a-b* is:

$$Y_{ab} = \frac{1}{Z_1 + Z_2} + \frac{1}{r_p} + \frac{g_m Z_2}{Z_1 + Z_2} \tag{1}$$

The first term on the right side of equation (1) is the admittance of the phase-shifting network. The remain-

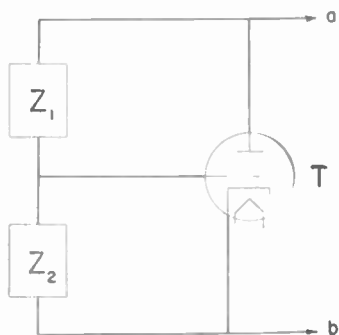

Fig. 1—Basic reactance-tube circuit.

ing terms represent the admittance added by the tube, which will be called Y_T . Let

$$\frac{Z_2}{Z_1 + Z_2} = Ae^{i\theta} = A \cos \theta + jA \sin \theta. \tag{2}$$

Then

$$Y_T = \frac{1}{r_p} + g_m A \cos \theta + jg_m A \sin \theta = \frac{1}{R_T} + \frac{j}{X_T} \tag{3}$$

Here R_T and X_T are the effective parallel resistive and reactive components of Y_T . It can be seen that R_T may be negative if r_p is large and $\cos \theta$ is negative. The necessary condition for $\cos \theta$ to be negative is that the reactive parts of Z_1 and Z_2 have opposite signs. If R_T can be made negative in this manner and if a parallel resonant circuit is connected across terminals *a-b*, oscillations may build up. Furthermore, since $1/r_p$ and g_m vary in the same way with grid bias voltage, R_T might be expected to remain constant over a considerable range.

Fig. 2(a) shows such an oscillator circuit derived from a capacitive reactance-tube circuit. In this case the frequency of and condition for oscillation are approximately given by

$$f = \frac{1}{2\pi\sqrt{L_p C_p(1+a)}} \left[1 + \frac{g_m C_0(L_p R_v + L_v R_p)}{C_p L_p(1+a)} \right]^{-1/2} \tag{4}$$

$$g_m \geq \frac{R_p C_p(L_p - L_v) + C_p L_p^2 / C_0 r_p + C_p^2 L_p R_p / C_0}{L_p L_v} \tag{5}$$

where

$$a = (C_0 / C_p)(1 + L_v / L_p). \tag{6}$$

Similar expressions for the oscillator circuit of Fig. 2(b), which is derived from the inductive reactance-tube circuit, are

$$f = \frac{\sqrt{1+b}}{2\pi\sqrt{L_p C_p}} \left[1 + \frac{g_m L_p R_v}{L_v(1+b)} \right]^{1/2} \tag{7}$$

$$g_m \geq \frac{(L_0 + L_p)(R_p C_v / L_p + C_0 / C_p r_p)}{L_p} + \frac{(C_p + C_v)(R_v + R_0)}{L_v} \tag{8}$$

* Decimal classification: R355.911.1. Original manuscript received by the Institute, April 4, 1949; revised manuscript received, August 1, 1949.

† University of Wisconsin, Madison, Wis.

where

$$b = (L_p/L_0)(1 + C_p/C_0). \tag{9}$$

In equations (4) and (7) the circuit constants are so chosen that the second term within the brackets is small. Both may then be expanded to show that a linear change in frequency with g_m is possible.

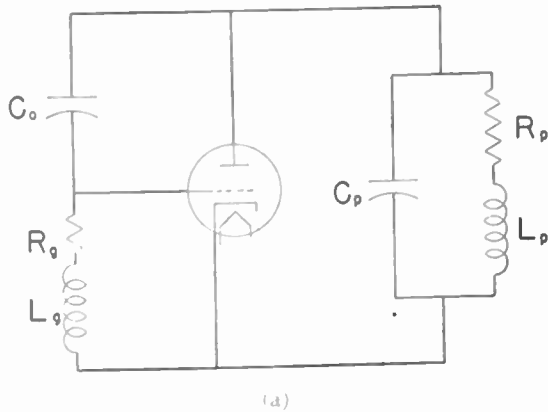

(a)

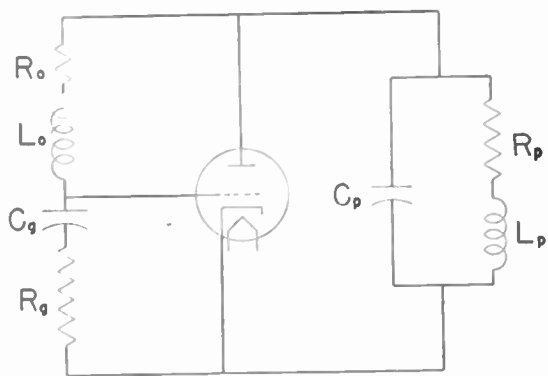

(b)

Fig. 2—(a) Capacitive reactance-tube oscillator circuit. (b) Inductive reactance-tube oscillator circuit.

From (6) it may be seen that the frequency of oscillation is lower than the natural frequency of the tank circuit, and that increase in g_m causes the frequency to become still lower, with resultant operation still further down on the resonance curve of the tank circuit. The reduced output voltage which might be expected in this case is counter-balanced by the increased plate current which results when grid bias is decreased to increase g_m . Thus it is possible to see in a qualitative way that reasonably constant output might be expected. By a similar argument, constant output may be expected in the inductive reactance-tube oscillator circuit. Here, however, operation is on the high-frequency side of tank-circuit resonance, and increasing g_m further increases frequency.

The circuits of Fig. 2 may be simplified by making C_p equal to zero in Fig. 2(a) or making L_p infinite in Fig. 2(b). It is interesting to note that the first reactance-tube oscillator circuit then resembles the Hartley oscillator and the second the Colpitts oscillator.

II. NOTES ON DESIGN

In both types of circuits the frequency is approximately $1/2\pi\sqrt{L_p C_p}$. The percentage frequency deviation can be determined by considering the term $g_m R_0 L_p / L_0$ in the inductive reactance-tube circuit and $g_m R_0 C_0 / C_p$ in the capacitive reactance-tube circuit. Note that the latter expression is obtained from (4) by assuming $L_p R_p \gg L_0 R_0$, a condition which is necessary in practice for good operation.

The ratios L_p/L_0 or C_0/C_p should be very small, say about 0.1. By fixing the g_m variation range, R_0 is determined. The impedance of Z_2 should be about one-fifth of the impedance of Z_1 . Under the above conditions a tank circuit of effective Q of about 20 was found satisfactory in the case of a 6L6 tube. The exact value of L_p or C_p is determined, with the help of the approximate frequency, by the condition for oscillation. This condition should hold at the smallest value of g_m in the range of operation.

III. EXPERIMENTAL RESULTS

Experiments have been conducted chiefly in the 1- to 4-Mc range. Fig. 3 shows typical sets of curves of frequency variation and radio-frequency current in the tank capacitor C_p as grid voltage is varied. Greater frequency variation is possible by increasing R_0 and then making other compensating adjustments, or by extending the grid voltage range to include positive voltages.

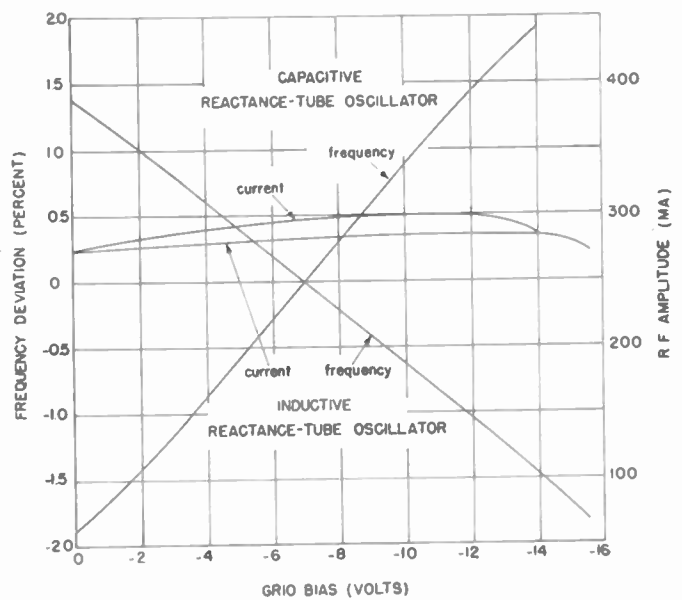

Fig. 3—Typical curves of frequency and amplitude for a capacitive reactance-tube oscillator (center frequency 1,322 kc), and an inductive reactance-tube oscillator (center frequency 1,553 kc).

A modified circuit resembling the Hartley oscillator was tested and was found to give a 7 per cent linear range of frequency variation with the constants used.

Tests made with a number of different types of tubes show that beam power tubes are most satisfactory, although power triodes have been used successfully.

Frequency Contours for Microwave Oscillator with Resonant Load*

M. S. WHEELER†, ASSOCIATE, IRE

Summary—A means of analysis is suggested for describing frequency and power relations in an oscillator when coupled through a transmission line to a frequency sensitive load. This attack is applied to a specific problem (a reactance tube coupled to a magnetron) and a solution is given with certain simplifying assumptions. A more general method is then shown in which these assumptions would not have to be made and this method is applied to the problem of finding the limiting conditions where frequency discontinuities first appear in the characteristics.

INTRODUCTION

THE PROBLEM of oscillation controlled by two resonant circuits has been considered by Sproull.¹ More generally, however, at microwave frequencies one finds a length of transmission line between an oscillator and its load such as in frequency modulation of a magnetron by a reactance tube or in the stabilization of a local oscillator by a reference cavity. In addition, at these frequencies one would like a solution in terms of measurable quantities such as resonant frequencies, Q 's, and line lengths.

SOLUTION

A general approach to this problem would relate the impedance-frequency contours (generally referred to as a Rieke diagram) of the oscillator to the frequency-impedance diagram of the resonant load, which is usually a circle in the reflection coefficient plane. Now the reflection coefficient plane

$$\vec{K} = \epsilon^{-2a} / -2\psi \quad (\text{defining } a \text{ and } \psi) \quad (1)$$

is the special case of the Smith chart (upon which the Rieke diagram is plotted) for zero line length. Thus at an arbitrary distance y along a line of characteristics $(\alpha + j\beta)$

$$\vec{W} = \epsilon^{-2(\alpha y + a)} / -2(\beta y + \psi) \quad (\text{defining } \vec{W}) \quad (2)$$

where \vec{W} will be recognized as the complex plane of the Smith chart. This reduces to

$$\vec{W} = \epsilon^{-2a} / -2\psi \quad (3)$$

for $y=0$, thus \vec{K} is merely rotated from the \vec{W} plane on a lossless line by $2\beta y$ radians.

* Decimal classification: R355.912×R141.1. Original manuscript received by the Institute, December 30, 1948; revised manuscript received, May 13, 1949.

† Westinghouse Electric Corp., Bloomfield, N. J.

¹ R. L. Sproull, "Reactance tube frequency modulation of microwave oscillators," Report No. 20, United States Navy Contract NXsa35042.

With this in mind, then, one could plot graphically, point for point, the frequency contours of the oscillator, given its impedance-frequency characteristic as well as the frequency-impedance characteristic of the load. This could be done, patience permitting, for very irregular curves in either chart, superimposing one upon the other and rotating the \vec{W} plane, consistent with the length of transmission line separating the oscillator from the load. The operating frequency would be given by the coincidence of equal frequency contours upon the curve of given load resistance. However, the process is anything but straightforward so that one is led to consider how these contours could be simplified for mathematical expression.

Generally speaking, both contours upon the Rieke diagram resemble circles almost coinciding with the contours of the Smith chart.² Likewise for the load, the diagram in the reflection coefficient plane is almost coincident with impedance lines. These conditions are especially true in devices with waveguide couplings. One need not start by making these assumptions, however,

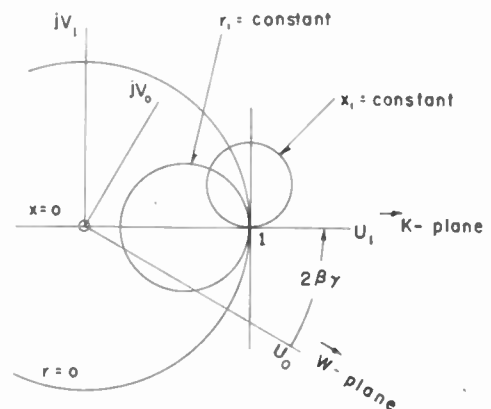

Fig. 1—Diagram of equation (2).

but may first find the coincidence of points in the \vec{K} plane with points in the \vec{W} plane when \vec{W} is displaced $2\beta y$ radians for a given line length as shown by Fig. 1.

Using subscript 0 for impedances in the \vec{W} plane and subscript 1 in the \vec{K} plane the equations for the circles in the \vec{K} plane are well known to be

$$\left(U_1 - \frac{r_1}{r_1 + 1} \right)^2 + V_1^2 = \frac{1}{(1 + r_1)^2} \quad (\text{constant } r) \quad (4)$$

² G. B. Collins, "Microwave Magnetrons," MIT Radiation Laboratory Series, Vol. 6, McGraw-Hill Book Co. Inc., New York, N. Y., p. 41; 1948.

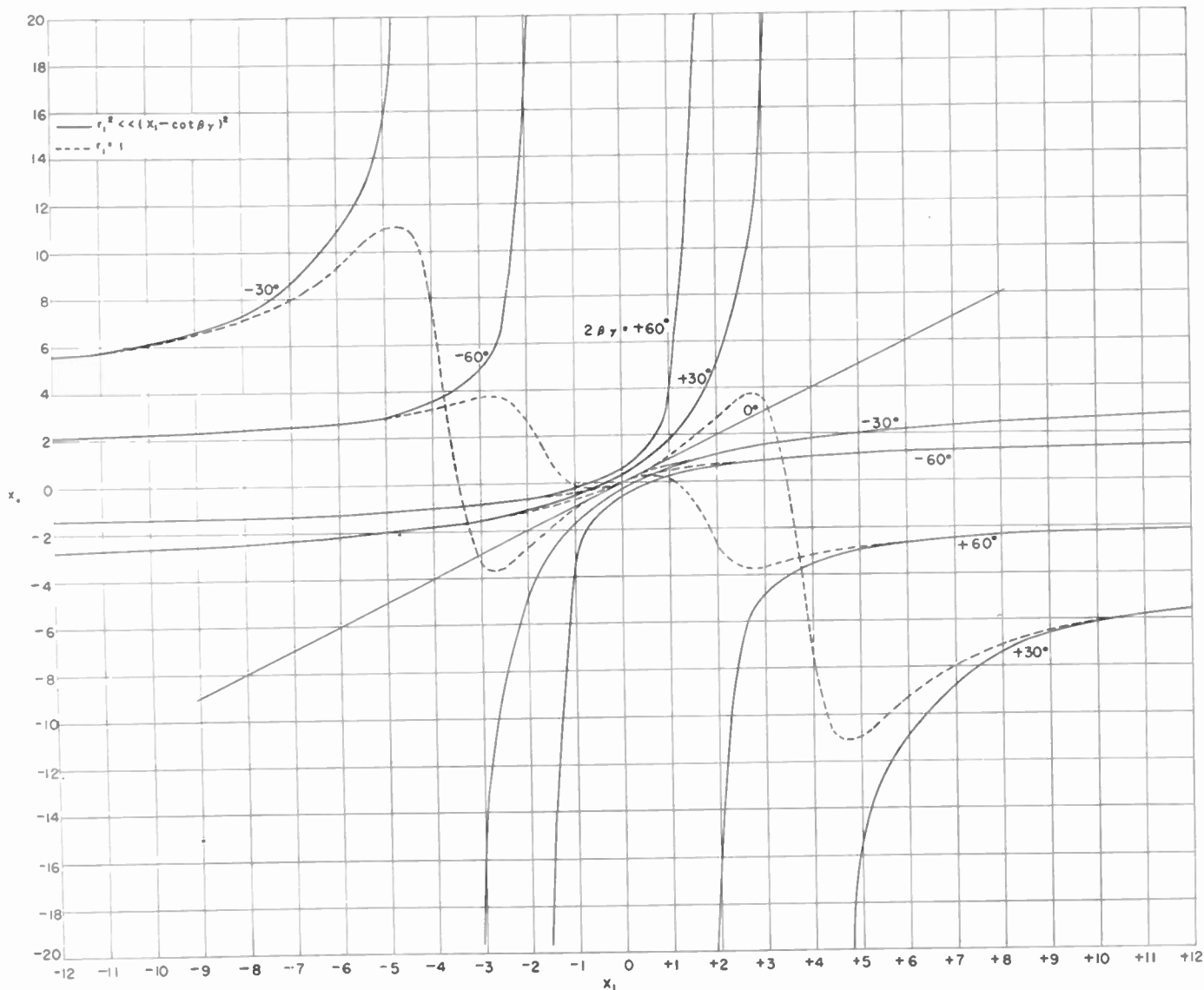

Fig. 2—Reactive contours of oscillator.

$$(U_1 - 1)^2 + \left(V_1 - \frac{1}{x_1}\right)^2 = \frac{1}{x_1^2} \text{ (constant } x) \quad (5)$$

U_1 and V_1 are the real and imaginary parts respectively of \vec{K} .

To write these in the \vec{W} co-ordinates, one may show that if a point in plane x - y is rotated about the origin from co-ordinates a, b by an angle γ the co-ordinates of the new point will be

$$x = a \cos \gamma - b \sin \gamma \quad (6)$$

$$y = b \cos \gamma + a \sin \gamma. \quad (7)$$

In the \vec{W} plane then

$$\left(U_0 - \frac{r_1}{r_1 + 1} \cos 2\beta y\right)^2 + \left(V_0 - \frac{r_1}{r_1 + 1} \sin 2\beta y\right)^2 = \frac{1}{(1 + r_1)^2} \quad (8)$$

$$\left(U_0 - \cos 2\beta y + \frac{\sin 2\beta y}{x_1}\right)^2 + \left(V_0 - \frac{\cos 2\beta y}{x_1} - \sin 2\beta y\right)^2 = \frac{1}{x_1^2} \quad (9)$$

while impedances already in the \vec{W} plane are similar to (4) and (5) except for subscripts.

Solving these simultaneously one obtains, after considerable algebra, the frequency characteristics

$$x_0 + \cot \beta y = \frac{-\csc^2 \beta y (x_1 - \cot \beta y)}{(x_1 - \cot \beta y)^2 + r_1^2} \quad (10)$$

and the power characteristic

$$r_0 = \frac{r_1 \csc^2 \beta y}{r_1^2 + (x_1 - \cot \beta y)^2}. \quad (11)$$

These characteristics are plotted in Figs. 2 and 3.

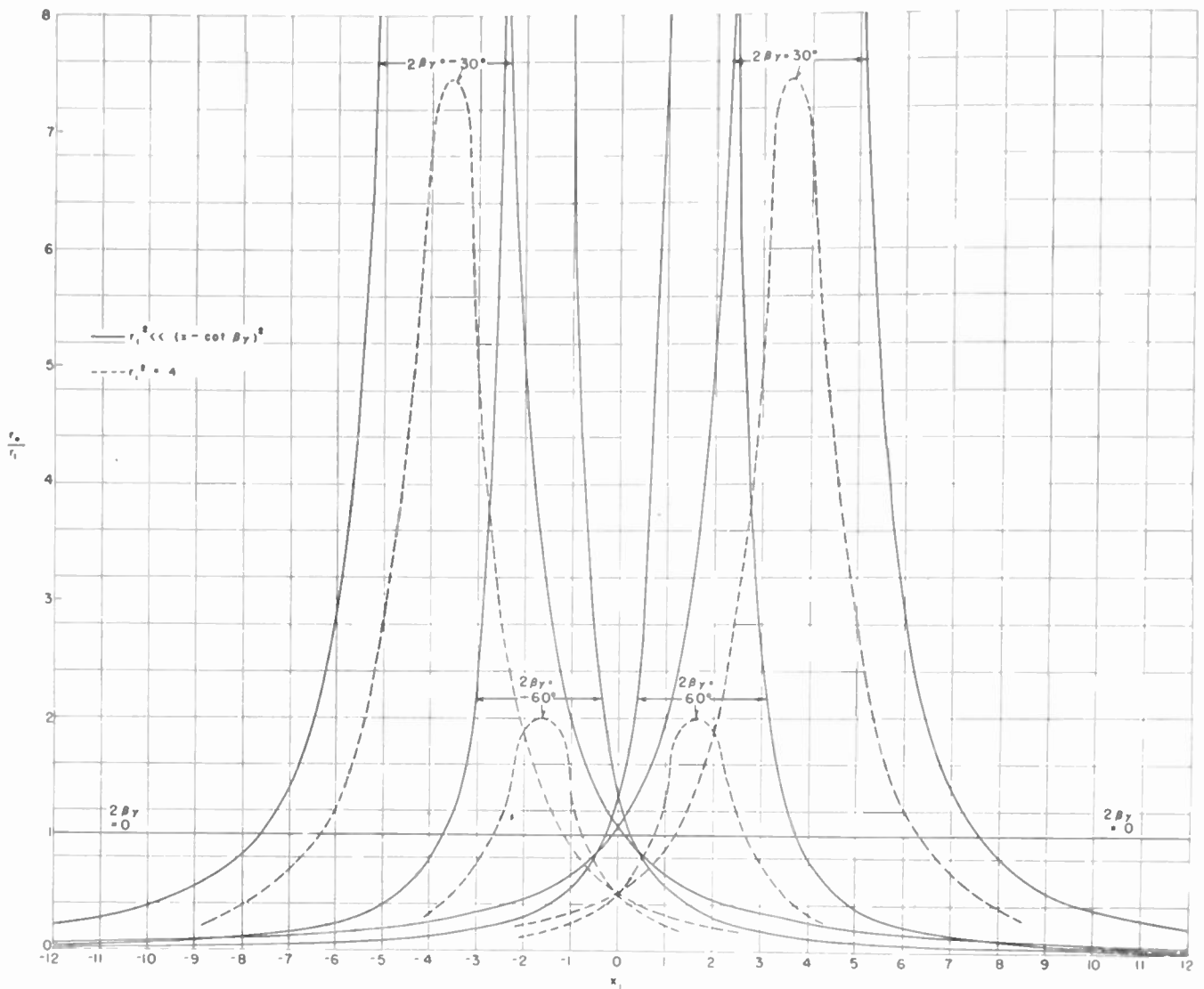

Fig. 3—Resistive contours of oscillator.

SPECIFIC EQUIVALENT CIRCUIT

Now to be more specific, one might consider the series equivalent circuit in Fig. 4 which is found to represent, for example, a magnetron and reactance tube with waveguide coupling. R_M and R_R are the characteristic impedances of quarter-wave transformers of the magnetron and reactance tube respectively.

Using conventional microwave definitions, the load circuit of Fig. 4 gives perfect reproduction of the \vec{K} plane for

$$x_1 = Q_{ER} \left(\frac{\omega}{\omega_1} - \frac{\omega_1}{\omega} \right) \tag{12}$$

with

$$\begin{aligned} r_1 &= \frac{Q_{ER}}{Q_{UR}}; & Q_{UR} &= \frac{\omega_1 L_1}{R_1} \\ \omega_1 &= \frac{1}{\sqrt{L_1 C_1}}; & Q_{ER} &= \frac{\omega_1 L_1 R_{UL}}{R_R^2} \end{aligned} \tag{13}$$

where the subscripts 1 and R refer to the reactance-tube load. It can be seen that x_1 depends upon frequencies

and a proportionality constant and r_1 is constant for a given transformer characteristic and load loss.

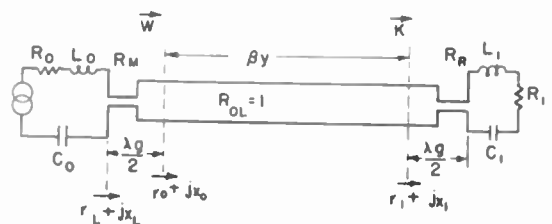

Fig. 4—Series equivalent circuit of oscillator with resonant load.

At the oscillator, on the other hand,

$$R_o Q_{UM} \left(\frac{\omega}{\omega_0} - \frac{\omega_0}{\omega} \right) + x_L = 0 \tag{14}$$

is the condition for oscillation provided the electronic reactance of the electron stream is zero.³ This is an as-

³ J. B. Fisk, H. D. Hagstrum, and P. L. Hartman, "The magnetron as a generator of centimeter waves," *Bell Sys. Tech. Jour.*, vol. 25, pp. 167-348, April, 1946; p. 238.

assumption not too difficult to make with many generators, but equating (14) to a constant and carrying it along through this problem could be done should the interest warrant it. Equation (14) then gives

$$x_0 = -Q_{EM} \left(\frac{\omega}{\omega_0} - \frac{\omega_0}{\omega} \right) \quad (15)$$

$$r_0 = \text{constant } x \text{ power output}^3 \quad (16)$$

with

$$\omega_0 = \frac{1}{\sqrt{L_0 C_0}}; Q_{EM} = \frac{\omega_0 L_0 R_{0L}}{R_M^2}, Q_{UM} = \frac{\omega_0 L_0}{R_0} \quad (17)$$

where the subscripts 0 and M refer to the magnetron. This gives perfect conformity to the contours of the W plane as ω depends upon x_0 , and r_0 is proportional to power output.

One might now, if he chose, combine (10), (12), and (15) to obtain the frequency contours giving the operating frequency of the system as a function of resonant frequencies, Q's, and a line length. The solution would be

$$\frac{\omega_1}{\omega_0} - 1 = \frac{4Q_{ER}Q_{EM} \left(\frac{\omega}{\omega_0} - 1 \right)^2 - 2 \left(\frac{\omega}{\omega_0} - 1 \right) \cot \beta y (Q_{ER} + Q_{EM}) - 1}{(4Q_{ER}Q_{EM} + 2 \cot \beta y Q_{EM}) \left(\frac{\omega}{\omega_0} - 1 \right) - 2 \cot \beta y Q_{ER} + 1} \quad (18)$$

after making the following approximations valid for high-Q devices.

$$r_1 \ll (x_1 - \cot \beta y)^2 \quad (19)$$

$$\frac{\omega}{\omega_0} - \frac{\omega_0}{\omega} = 2 \frac{\omega - \omega_0}{\omega_0} \quad (20)$$

Upon plotting this as in Fig. 5 for specific values of the Q's, the solution for ω/ω_0 is found to be double valued, the system selecting the solution giving the lowest total power dissipation as determined by (11). The phenomena of mode jumping is rather complex⁴⁻⁵ but the criteria of minimum dissipation checks well experimentally.

Equation (18) and others derivable from (10), (12), and (15) are, of course, useful for specific cases but are too cumbersome for analysis.

Consider, then, the contours of constant frequency from the equivalent circuit of Fig. 4 superimposed upon Fig. 2. Then, from (12) and (15) and making the small frequency deviation approximation,

$$x_0 = 2Q_{EM} \left(1 - \frac{\omega_1}{\omega_0} \right) - \frac{\omega_1}{\omega_0} \frac{Q_{EM}}{Q_{ER}} x_1$$

(contour of constant $\frac{\omega_1}{\omega_0}$) (21)

and

$$x_0 = 2Q_{EM} \left(1 - \frac{\omega}{\omega_0} \right).$$

(contour of constant $\frac{\omega}{\omega_0}$). (22)

These lines of constant frequency are shown in Fig. 6 with a typical reactive contour. The x_0 and r_0/r_1 curves are both symmetrical in x_1 about the centers $(-\cot \beta y, \cot \beta y)$. If there is to be a discontinuity in the frequency contour, it will occur along a line of constant ω_1/ω_0 between two equal values of r_1/r_0 where ω/ω_0 is double valued. This condition is satisfied in Fig. 6 by the ω_1/ω_0 contour through the center $(-\cot \beta y, \cot \beta y)$.

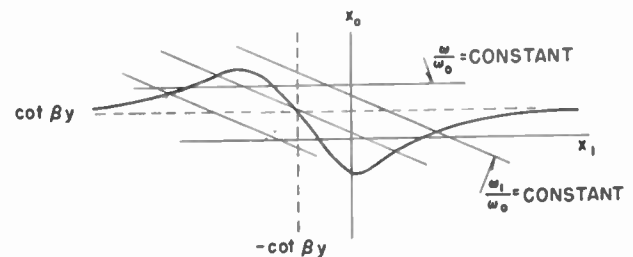

Fig. 6—Frequency contours of oscillator with resonant load.

EXAMPLE OF ANALYSIS FROM FREQUENCY CONTOURS

The reactive curves may be used in this manner for analysis by superimposing lines of slope

$$-\frac{\omega_1}{\omega_0} \frac{Q_{EM}}{Q_{ER}}$$

upon the x plane to visualize the frequency contours. Generally ω_1/ω_0 is sufficiently close to unity to be neglected and all lines have equal slope. For example, if one is interested in the limiting condition where discontinuities first appear in the frequency plane, it is when the slope of the reactive contours are equal to the slope of the lines of constant ω_1/ω_0 at the center points $(-\cot \beta y, \cot \beta y)$.

⁴ R. L. Sproull, "The diode frequency modulator," Report No. 16 United States Navy Contract NXsa35042.
⁵ B. Van der Pol, "On oscillation hysteresis in a triode generator with two degrees of freedom," *Phil. Mag.*, vol. 43, pp. 700-719; January to June, 1922.

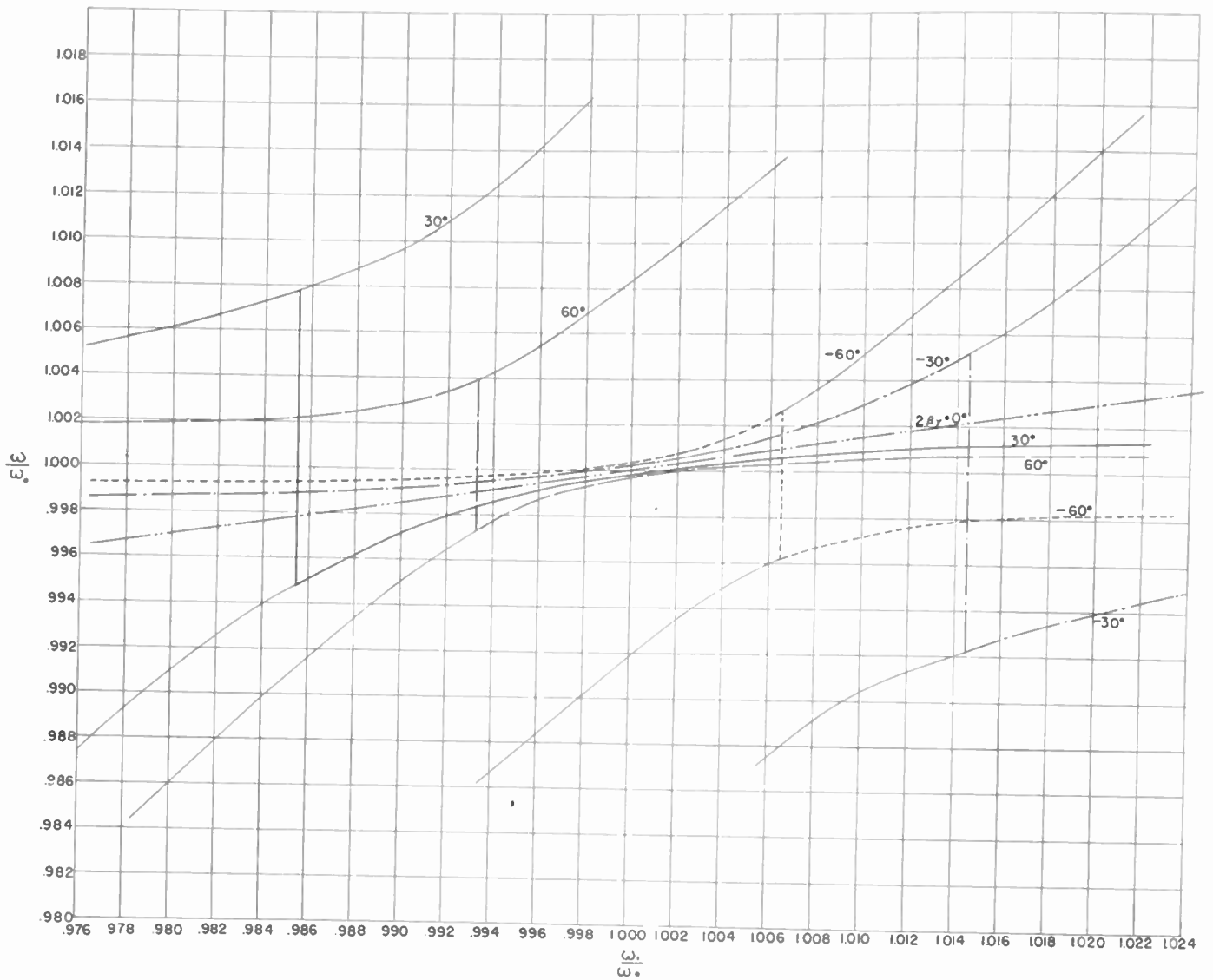

Fig. 5—Specific example of frequency contours for $Q_{EM}=700$, $Q_{VR}=1,500$. Magnetron frequency versus reactance-tube frequency normalized with respect to magnetron center frequency for various line lengths.

Now

$$\frac{dx_0}{dx_1} = \frac{\csc^2 \beta y [(x_1 - \cot \beta y)^2 - r_1^2]}{[(x_1 - \cot \beta y)^2 + r_1^2]^2} \quad (23)$$

which at center of interest reduces to

$$\frac{dx_0}{dx_1} = - \frac{\csc^2 \beta y}{r_1^2} \quad (24)$$

Equating this to the slope of the ω_1/ω_0 line

$$\csc^2 \beta y = \frac{Q_{EM} Q_{ER}}{Q_{VR}^2} \quad (25)$$

We have the limiting case when frequency discontinuities first appear. If the right side of (25) is less than $\csc^2 \beta y$ one has a discontinuous frequency characteristic at some value of the load resonant frequency.

ACKNOWLEDGMENT

I would like to express my appreciation to Miss S. Hamalian for assistance in computation and curve plotting.



Impedance Transformations in Four-Element Band-Pass Filters*

R. O. ROWLANDS†

Summary—In a recent paper by Belevitch¹ it was shown how a four-element band-pass filter with all its frequencies of peak attenuation located on the same side of the pass band, could be transformed into a structure having, with the exception of the terminating half sections, the configuration of a high- or low-pass filter, with a consequential saving in components. Although this was proved possible for particular cases, it was assumed to hold for the general case.

In the present paper it will be shown that, by using a different type of basic section for constructing the filter, a similar result may be obtained with slightly greater economy, and it will be proved that this can be achieved in the general case.

INTRODUCTION

THE THEORY will be developed for filters having their frequencies of peak attenuation located above the pass band. It can be extended to filters having their frequencies of peak attenuation located below the pass band by the principle of duality.

Consider, therefore, the networks of Fig. 1. They have been drawn as half sections so that the terms three and four element become apparent. Fig. 1(a) is a three-element filter from which the four-element filters are de-

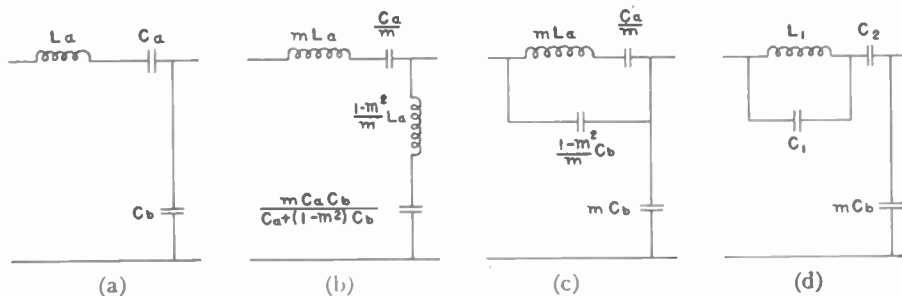

Fig. 1—Basic 3- and 4-element filters.

rived. It has an attenuation peak at infinite frequency, and its elements are given by

$$L_a = \frac{R}{2\pi(f_2 - f_1)}$$

$$C_a = \frac{f_2 - f_1}{2\pi f_1^2 R}$$

$$C_b = \frac{1}{2\pi(f_2 + f_1)R}$$

where R is the nominal impedance of the filter and f_1 and f_2 are the cutoff frequencies.

Fig. 1(b) is a series derived four-element filter in which

$$m = \sqrt{\frac{f_{2\infty}^2 - f_2^2}{f_{2\infty}^2 - f_1^2}},$$

$f_{2\infty}$ being the frequency of peak attenuation.

This is one of the configurations used by Belevitch in his analysis. Fig. 1(c) is a shunt derived filter having an attenuation characteristic similar to Fig. 1(b). Fig. 1(d) is identical to Fig. 1(c), except that the arrangement of the series arm is different. Its elements are given by

$$L_1 = \frac{mL_a C_a^2}{(C_a + (1 - m^2)C_b)^2}$$

$$C_1 = \frac{(1 - m^2)C_b(C_a + (1 - m^2)C_b)}{mC_a}$$

$$C_2 = (C_a + (1 - m^2)C_b)/m.$$

This type of structure is the one used in the filters discussed below. The full section is formed by connecting the half section to its mirror image on the left-hand side.

THEORY

Suppose that a composite filter is constructed by connecting in tandem a number of sections corresponding to Fig. 1(d), each having a frequency of peak attenuation which may or may not be different from the others. It does not affect the argument how the filter is terminated but as it is in general desirable for a band-pass filter to have a terminating image impedance of the second order, it will be assumed that the filter is terminated at each end in a three-element half section. The filter will then appear as shown in Fig. 2.

To simplify the calculations which come later, each resonant circuit has been designated Z_p and the remain-

* Decimal classification: R386.1. Original manuscript received by the Institute, November 17, 1948; revised manuscript received, April 27, 1949.

† British Broadcasting Corporation, Evesham, Worcestershire, England.

¹ V. Belevitch, "Extension of Norton's method of impedance transformations to band pass filters," *Elect. Commun.*, vol. 24, pp. 59-65; March, 1947.

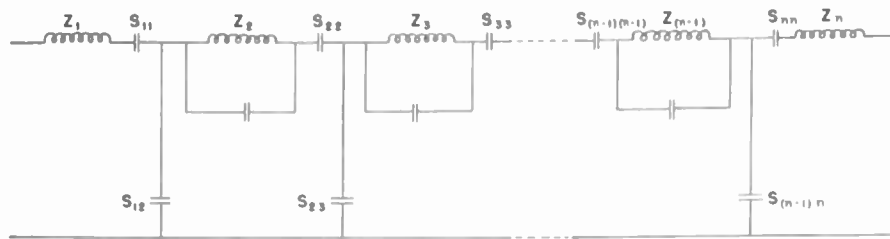

Fig. 2—Composite filter.

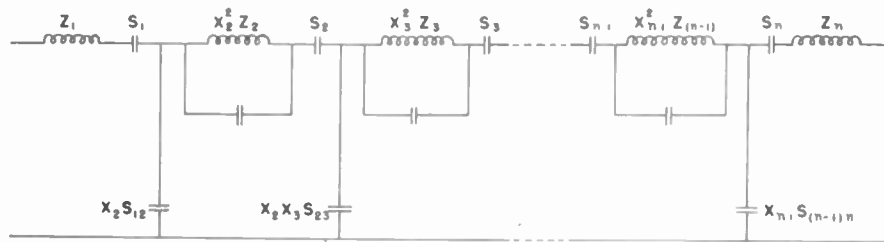

Fig. 3—Transformed composite filter.

ing capacitors S_{pq} , S being the reciprocal of the capacitance and pq being the meshes to which the capacitor is common. If meshes 1 and n are called the external meshes and the remainder the internal meshes, then the problem becomes that of retaining the ladder structure while altering the impedance of the internal meshes in such a manner that the capacitors $S_{22} \cdots S_{(n-1)(n-1)}$ disappear.

The first part of the problem is fulfilled by pre- and postmultiplying the matrices for the circuit components by a matrix in which all the elements except those in the main diagonal are zero and those at the extremities of the diagonal are unity.² If this operation is carried out on the capacitors we have

Since none of the Z 's appear as a mutual impedance between two meshes the effect of the operation is simply to multiply each Z_p by x_p^2 . The transformed network will then be as shown in Fig. 3, where

$$\begin{aligned} S_1 &= S_{11} + (1 - x_2)S_{12} \\ S_2 &= -x_2 S_{12} + x_2^2(S_{12} + S_{22} + S_{23}) - x_2 x_3 S_{23} \\ S_3 &= -x_2 x_3 S_{23} + x_3^2(S_{23} + S_{33} + S_{34}) - x_3 x_4 S_{34} \\ S_n &= (1 - x_{n-1})S_{(n-1)n} + S_{nn}. \end{aligned}$$

These equations are obtained by summing the terms in each row of the capacitor matrix. Since the shunt capacitors, being common to two meshes, will appear twice in each row, once with a positive sign and once

$$\begin{aligned} \begin{vmatrix} 1 & 0 & 0 & \cdots & 0 \\ 0 & x_2 & 0 & \cdots & 0 \\ 0 & 0 & x_3 & \cdots & 0 \\ \cdots & \cdots & \cdots & \cdots & \cdots \\ 0 & 0 & 0 & \cdots & 1 \end{vmatrix} \times \begin{vmatrix} S_{11} + S_{12} & -S_{12} & 0 & \cdots & 0 \\ -S_{12} & S_{12} + S_{22} + S_{23} & -S_{23} & \cdots & 0 \\ 0 & -S_{23} & S_{23} + S_{33} + S_{34} & \cdots & 0 \\ \cdots & \cdots & \cdots & \cdots & \cdots \\ 0 & 0 & 0 & \cdots & S_{(n-1)n} + S_{nn} \end{vmatrix} \times \begin{vmatrix} 1 & 0 & 0 & \cdots & 0 \\ 0 & x_2 & 0 & \cdots & 0 \\ 0 & 0 & x_3 & \cdots & 0 \\ \cdots & \cdots & \cdots & \cdots & \cdots \\ 0 & 0 & 0 & \cdots & 1 \end{vmatrix} \\ = \begin{vmatrix} S_{11} + S_{12} & -x_2 S_{12} & 0 & \cdots & 0 \\ -x_2 S_{12} & x_2^2(S_{12} + S_{22} + S_{23}) & -x_2 x_3 S_{23} & \cdots & 0 \\ 0 & -x_2 x_3 S_{23} & x_3^2(S_{23} + S_{33} + S_{34}) & \cdots & 0 \\ \cdots & \cdots & \cdots & \cdots & \cdots \\ 0 & 0 & 0 & \cdots & S_{(n-1)n} + S_{nn} \end{vmatrix} \end{aligned}$$

² E. A. Guillemin, "Communication Networks," vol. II, p. 234; John Wiley and Sons, New York, N. Y., 1931.

with a negative sign these will disappear in the sum, leaving only the series capacitors.

The conditions that the series capacitors in all the internal meshes vanish lead to $(n - 2)$ simultaneous equations in $(n - 2)$ unknowns. Namely,

$$- S_{12} + (S_{12} + S_{22} + S_{23})x_2 - S_{23}x_3 = 0 \tag{1.1}$$

$$- S_{23}x_2 + (S_{23} + S_{33} + S_{34})x_3 - S_{34}x_4 = 0 \tag{1.2}$$

$$\dots \dots \dots$$

$$- S_{(n-2)(n-1)}x_{n-2} + (S_{(n-2)(n-1)} + S_{(n-1)(n-1)} + S_{(n-1)n})x_{n-1} - S_{(n-1)n} = 0 \tag{1. (n - 2)}$$

These may be solved and the values of the x 's obtained. By inspection of Fig. 3 it will be seen that for the physical realizability of the filter every x must be positive and since in particular cases S_{11} and S_{nn} may be zero, both x_2 and x_{n-1} must be less than unity.

First, assume that x_2 is negative. From (1.1) we find that

$$x_3 = \frac{S_{22} + S_{23}}{S_{23}} x_2 + \frac{S_{12}}{S_{23}} (x_2 - 1), \tag{2.1}$$

i.e., x_3 is also negative and $\text{mod. } x_3 > \text{mod. } x_2$. From (1.2) we get

$$x_4 = \frac{S_{33} + S_{34}}{-S_{34}} x_3 + \frac{S_{23}}{S_{34}} (x_3 - x_2) \tag{2.2}$$

i.e., x_4 is also negative and $\text{mod. } x_4 > \text{mod. } x_3$, and so on, until we finally have from (1.($n - 3$)) that x_{n-1} is negative and $\text{mod. } x_{n-1} > \text{mod. } x_{n-2}$. These results are inconsistent with (1.($n - 2$)) as the left-hand side does not vanish and so these equations cannot yield negative values for x_2, x_3 , etc.

Next assume that x_2 is greater than or equal to 1. Equations (2.1), (2.2), \dots , (2.($n - 3$)) lead to the results that

$$x_{n-1} > x_{n-2} \dots x_3 > x_2 \geq 1.$$

These again are inconsistent with (2.($n - 2$)), and so x_2 must be less than unity.

Starting with (2.($n - 2$)), we can similarly prove that the only values of x_{n-1} consistent with (2.1) are positive values less than unity. The necessary conditions are therefore satisfied, and so the transformation is always possible.

EXTENSION OF THEORY

The theory will now be extended to include the series capacitors of the terminating half sections among those which are made to disappear. Consider the filters of Fig. 4.

Fig. 4(a) shows a filter in which all the series capacitors associated with the internal sections have been

eliminated. The terminating half sections are identical, and are shown as a general four-element type. One of the internal sections containing the impedance $x_k^2 Z_k$ is shown in full.

In Fig. 4(b) this section has been bisected, thus dividing the filter into two parts which have been designated A and B.

In Fig. 4(c) the positions of A and B have been interchanged, and in Fig. 4(d) the two similar impedances Z_1 have been combined as also have the capacitors S_1 . This shows that not only can the capacitors in the terminating half sections of a symmetrical filter be equally well

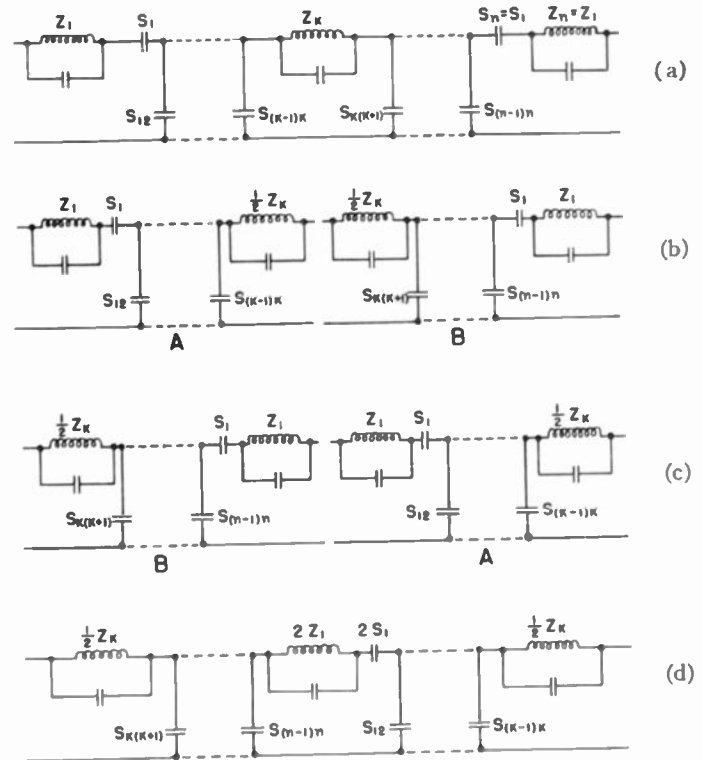

Fig. 4—Showing the rearrangement of the parts of a transformed filter.

made to disappear, but that an added advantage is to be gained, in that $n - 1$ capacitors may be eliminated in this case against $n - 2$ in the other. In obtaining the element values of such a filter it is, of course, only necessary to equate $n - 2$ of the first $n - 1$ S's to zero. S_n will then

automatically be zero.

It is interesting to note that the above transformations hold for any assembly of elements having a similar configuration to the above filters. The only condition is that all the elements represented by the S 's are similar in kind. The Z 's may consist of any combination of impedances.

The transformed circuits for a filter with attenuation peak frequencies below the pass band are shown in Fig. 5. The formulas for the elements are the same as for the filter with attenuation peaks above the pass band, provided that capacitance C is substituted for S , and admittance Y for impedance Z .

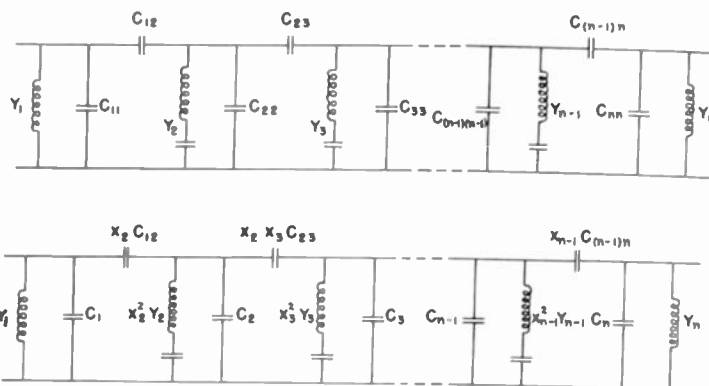

Fig. 5—Filters with attenuation peaks below the pass band.

Extension of the Planar Diode Transit-Time Solution*

NICHOLAS A. BEGOVICH†, ASSOCIATE, IRE

Summary—Llewellyn's small-signal theory for the parallel-plane diode is extended to include a closed-form second- and third-order solution for complete space-charge operation. Comparison with Benham's conservation of charge method of treating the electronic equations shows that additional terms not given by Benham are obtained in the present solution.

I. INTRODUCTION

LEWELLYN'S^{1,2} TREATMENT of the finite-transit-time behavior of the generalized diode is the extension of the Lagrangian method of solving the electronic equations first introduced by Muller.³ In his paper, Llewellyn gives the closed-form and series first-order solution for the generalized diode. The analysis to follow will extend the solution to a closed- and series-form second- and third-order solution for complete space-charge operation.

The important limitation of Llewellyn's theory and the extension here presented is the assumption of a single-valued electron velocity for all electrons crossing any plane parallel to the cathode surface; that is, electrons never pass each other in their transition from cathode to anode.⁴ This assumption leads to the dc potential and

current being related by Child's Law. It neglects important properties of the potential minimum that usually exist in front of a cathode which ejects electrons with a Maxwellian velocity distribution. Only when the distance from the cathode to the potential minimum is very small compared to the cathode-anode spacing in the diode will Llewellyn's, or any other solution based on single-value electron velocity, give a correct answer. A very useful recent paper by Kleynen gives tables for the calculation of the potential minimum distance.⁵

Units used throughout the analysis will be cgs practical units, the same as those used by Llewellyn.^{1,2}

II. ZERO TRANSIT ANGLE COMPLETE SPACE-CHARGE DIODE SOLUTION

In the calculation of the higher-order complete space-charge diode⁶ solution, it is convenient to consider two distinct modes of operation. These are:

Mode A

The independent variable in the analysis is the current through the diode which is composed of a dc and small single-frequency ac component.

Mode B

The independent variable in the analysis is the potential across the diode which is composed of a dc and small single-frequency ac component. Mode A operation of the diode requires the calculation of the applied voltages;

* Decimal classification: R134. Original manuscript received by the Institute, February 1, 1949; revised manuscript received, July 15, 1949.

† Hughes Aircraft Co., Culver City, Calif.

¹ Frederick B. Llewellyn, "Operation of ultra-high-frequency vacuum tubes," *Bell. Sys. Tech. Jour.*, vol. 14, pp. 632-665, October, 1935.

² Frederick B. Llewellyn, "Electron-Inertia Effects," Cambridge University Press, London, England 1941.

³ Johannes Muller, "Elektronenschwingungen im hochvakuum," *Hochfreq. und Elektroak.*, vol. 41, pp. 156-167, May, 1933.

⁴ An excellent paper on the implications of a single-valued velocity assumption has been given by L. Brillouin, "Influence of space charge on the bunching of electron beams," *Phys. Rev.*, vol. 70, pp. 187-196; August, 1946.

⁵ P. H. J. A. Kleynen, "Extension of Langmuir's (ξ , η) tables for a plane diode with a Maxwellian distribution of the electrons" *Philips Res. Rep.*, vol. 1, pp. 81-96; January, 1946.

⁶ Zero electric-field and electron-emission velocity at the cathode.

while mode B operation requires the calculation of the resultant diode currents. and

$$\frac{I_3}{I_0} = -\frac{1}{64} \left(\frac{v_1}{V_0} \right)^3 \{3 \cos \omega t + \cos 3\omega t\}. \quad (5c)$$

For a complete space-charge parallel-plane diode, the voltage across the diode V and the resultant current density I for zero electron transit angle⁷ (see equation (9)) are related by Child's Law

$$I = 2.33 \times 10^{-6} V^{3/2}/d^2 \text{ amps/cm}^2, \quad (1)$$

where d is the cathode-to-anode spacing in centimeters. For mode A operation of the diode, a Taylor series expansion of (1) when $I_0 + \Delta I$ ($\Delta I/I_0 < 1$) is written for I gives

$$V = V_0 \left\{ 1 + \frac{2}{3} \left(\frac{\Delta I}{I_0} \right) - \frac{1}{9} \left(\frac{\Delta I}{I_0} \right)^2 + \frac{4}{81} \left(\frac{\Delta I}{I_0} \right)^3 \dots \right\}. \quad (2)$$

Writing the voltage as a sum of the zero- and higher-order voltages namely

$$V = V_0 + V_1 + V_2 + V_3 \dots, \quad (3)$$

where V_0 is the zero-order voltage, V_1 the first-order voltage, and etc., and the incremental current $\Delta I = I_1 = i_1 \cos \omega t$, (2) becomes

$$\frac{V_1}{V_0} = \frac{2}{3} \left(\frac{i_1}{I_0} \right) \cos \omega t, \quad (4a)$$

$$\frac{V_2}{V_0} = -\frac{1}{18} \left(\frac{i_1}{I_0} \right)^2 \{1 + \cos 2\omega t\}, \quad (4b)$$

and

$$\frac{V_3}{V_0} = \frac{1}{81} \left(\frac{i_1}{I_0} \right)^3 \{3 \cos \omega t + \cos 3\omega t\}. \quad (4c)$$

Equations (4) show that to maintain a zero and a small single-frequency current through the diode, voltages of a fundamental- and higher-harmonic frequency must be applied across the diode, the number of harmonic voltages being determined by the relative value of i_1 to I_0 .

To calculate the diode current for mode B operation of the diode, $V_1 = v_1 \cos \omega t$ where $v_1/V_0 < 1$ is substituted for ΔV in (1) which is then expanded in a Taylor series⁸ giving the following first-, second-, and third-order currents

$$\frac{I_1}{I_0} = \frac{3}{2} \left(\frac{v_1}{V_0} \right) \cos \omega t, \quad (5a)$$

$$\frac{I_2}{I_0} = \frac{3}{16} \left(\frac{v_1}{V_0} \right)^2 \{1 + \cos 2\omega t\}, \quad (5b)$$

Writing $I_1 = i_1 \cos \omega t$, (5b) and (5c) can be written in terms of i_1 instead of v_1 by the use of (5a).

$$\frac{I_2}{I_0} = \frac{1}{12} \left(\frac{i_1}{I_0} \right)^2 \{1 + \cos 2\omega t\}. \quad (6a)$$

$$\frac{I_3}{I_0} = -\frac{1}{216} \left(\frac{i_1}{I_0} \right)^3 \{3 \cos \omega t + \cos 3\omega t\}. \quad (6b)$$

The equations written above for the two modes of operation of the complete space-charge diode are correct only when the electron transit angle is zero. The modifications produced by a finite electron transit angle will now be calculated using Llewellyn's equations.

III. FINITE TRANSIT ANGLE COMPLETE SPACE-CHARGE DIODE SOLUTION

To illustrate all the details required in calculating the higher-order finite transit-angle solution would require a prohibitive amount of space. Details of the required steps can be inferred by consulting the previously cited booklet.²

Mode A

For a finite electron transit angle and a first-order current $\Delta I = I_1 = i_1 \cos \omega t$, the first-, second-, and third-order voltages that must be applied across the diode are given by

$$\frac{V_1}{V_0} = \frac{2}{3} \left(\frac{i_1}{I_0} \right) \{X_{11} \cos \omega t + Y_{11} \sin \omega t\}, \quad (7a)$$

$$\frac{V_2}{V_0} = -\frac{1}{18} \left(\frac{i_1}{I_0} \right)^2 \{\Upsilon_{20} + X_{22} \cos 2\omega t + Y_{22} \sin 2\omega t\}, \quad (7b)$$

and

$$\frac{V_3}{V_0} = \frac{1}{81} \left(\frac{i_1}{I_0} \right)^3 \{3(X_{31} \cos \omega t + Y_{31} \sin \omega t) + (X_{33} \cos 3\omega t + Y_{33} \sin 3\omega t)\}. \quad (7c)$$

The zero-order current I_0 and voltage V_0 are related by (1). The transit-angle coefficients X and Y in (7) are as follows

$$X_{11} = \frac{12}{\theta^4} [2(1 - \cos \theta) - \theta \sin \theta], \quad (8a)$$

$$Y_{11} = -\frac{12}{\theta^4} \left[2 \sin \theta - \theta(1 + \cos \theta) - \frac{\theta^3}{6} \right], \quad (8b)$$

$$\Upsilon_{20} = -\frac{144}{\theta^6} \left[1 - \cos \theta - \theta \sin \theta + \frac{\theta^2}{2} - \frac{\theta^4}{8} \right], \quad (8c)$$

$$X_{22} = \frac{72}{\theta^6} \left[1 - 2 \cos \theta + \cos 2\theta - 2\theta(\sin \theta - \sin 2\theta) - \frac{\theta^2}{8} (9 \cos 2\theta - 1) - \frac{\theta^3}{4} \sin 2\theta \right], \quad (8d)$$

⁷ Stationary-field electron transit-time T measured in terms of the fundamental angular frequency ω , $\theta = \omega T$. See footnote reference 1 or 2.

⁸ This assumes that $V=f(I)$ is analytic. Experimental results presented by Balch, van der Pol, and T. J. Weijers in their paper, "Fine structure of triode characteristics," *Physica*, vol. 1, pp. 481-496, April, 1934; indicates this assumption is valid for zero transit angle.

$$Y_{22} = -\frac{144}{\theta^6} \left[\sin \theta - \frac{1}{2} \sin 2\theta - \theta(\cos \theta - \cos 2\theta) + \frac{9}{16} \theta^2 \sin 2\theta - \frac{\theta^3}{8} \cos 2\theta \right], \quad (8e)$$

$$X_{31} = -\frac{432}{\theta^9} \left[\sin \theta - \frac{1}{2} \sin 2\theta - \theta(\cos \theta - \cos 2\theta) - \frac{\theta^2}{2} (\sin \theta - 2 \sin 2\theta) - \frac{\theta^3}{2} \cos 2\theta + \frac{\theta^4}{8} (\sin \theta - \sin 2\theta) - \frac{\theta^5}{8} \cos \theta - \frac{\theta^6}{16} \sin \theta \right], \quad (8f)$$

$$Y_{31} = -\frac{216}{\theta^9} \left[3 - 4 \cos \theta + \cos 2\theta - 2\theta(2 \sin \theta - \sin 2\theta) + 2\theta^2(\cos \theta - \cos 2\theta) - \theta^3 \sin 2\theta + \frac{\theta^4}{2} \left(1 - \frac{1}{2} \cos \theta + \frac{1}{2} \cos 2\theta \right) - \frac{\theta^5}{4} \sin \theta + \frac{\theta^6}{8} \cos \theta \right], \quad (8g)$$

$$X_{33} = \frac{648}{\theta^9} \left[\sin \theta - \sin 2\theta + \frac{1}{3} \sin 3\theta - \theta(\cos \theta - 2 \cos 2\theta + \cos 3\theta) - \frac{\theta^2}{2} (\sin \theta - 4 \sin 2\theta + 3 \sin 3\theta) - \theta^3 \left(\cos 2\theta - \frac{4}{3} \cos 3\theta \right) - \frac{\theta^4}{4} (\sin 2\theta - 3 \sin 3\theta) - \frac{\theta^5}{4} \cos 3\theta - \frac{\theta^6}{24} \sin 3\theta \right], \quad (8h)$$

$$Y_{33} = \frac{648}{\theta^9} \left[\frac{1}{3} - \cos \theta + \cos 2\theta - \frac{1}{3} \cos 3\theta - \theta(\sin \theta - 2 \sin 2\theta + \sin 3\theta) + \frac{\theta^2}{2} (\cos \theta - 4 \cos 2\theta + 3 \cos 3\theta) - \theta^3 \left(\sin 2\theta - \frac{4}{3} \sin 3\theta \right) + \frac{\theta^4}{4} (\cos 2\theta - 3 \cos 3\theta) - \frac{\theta^5}{4} \sin 3\theta + \frac{\theta^6}{24} \cos 3\theta \right], \quad (8i)$$

The transit-angle θ that appears in the above coefficients can be determined from⁹

$$\theta = \omega T = \omega \left(\frac{6\epsilon d}{II_0} \right)^{1/3} = 6.69 \cdot 10^{-10} \omega \left(\frac{d}{I_0} \right)^{1/3} \quad (9) \quad \text{and}$$

The subscript notation used in the above transit-angle coefficients is the first number for the order and the sec-

⁹ $l = 10^7 |e|/m = 1.76 \times 10^{16}$ coulombs per gram, $\epsilon = 8.85 \times 10^{-14}$ farads per centimeter, and $\omega =$ angular frequency of I_1 . See (1) for d and I_0 .

ond for the particular harmonic. For example, X_{nm} is the m th harmonic transit-angle coefficient of the n th order solution.

For small transit angles, series expansions for the trigonometric terms in (8) give

$$X_{11} = 1 - \frac{1}{15} \theta^2 + \frac{1}{560} \theta^4 - \frac{1}{37,800} \theta^6 + \dots, \quad (10a)$$

$$Y_{11} = \frac{3}{10} \theta - \frac{1}{84} \theta^3 + \frac{1}{4,320} \theta^5 - \frac{1}{369,600} \theta^7 + \dots, \quad (10b)$$

$$Y_{20} = 1 - \frac{1}{40} \theta^2 + \frac{1}{2,800} \theta^4 - \frac{1}{302,400} \theta^6 + \frac{1}{46,569,600} \theta^8 - \dots, \quad (10c)$$

$$X_{22} = 1 - \frac{31}{40} \theta^2 + \frac{351}{2,800} \theta^4 - \frac{563}{60,480} \theta^6 + \frac{18,943}{46,569,600} \theta^8 - \dots, \quad (10d)$$

$$Y_{22} = \frac{6}{5} \theta - \frac{37}{105} \theta^3 + \frac{341}{9,240} \theta^5 - \frac{16}{17,325} \theta^7 + \dots, \quad (10e)$$

$$X_{31} = 1 - \frac{27}{80} \theta^2 + \frac{167}{5,600} \theta^4 - \frac{683}{504,000} \theta^6 + \dots, \quad (10f)$$

$$Y_{31} = \frac{3}{4} \theta - \frac{133}{320} \theta^3 + \frac{3,301}{184,800} \theta^5 - \frac{121,441}{230,630,400} \theta^7 + \dots, \quad (10g)$$

$$X_{33} = 1 - \frac{207}{80} \theta^2 + \frac{6,749}{5,600} \theta^4 - \frac{119,983}{504,000} \theta^6 + \dots, \quad (10h)$$

and

$$Y_{33} = \frac{9}{4} \theta - \frac{647}{320} \theta^3 + \frac{102}{175} \theta^5 - \frac{45,331}{537,600} \theta^7 + \dots, \quad (10i)$$

Note when θ goes to zero, all the Y coefficients go to zero while Y_{20} and the X coefficients go to unity. Thus, (7) for zero transit angle becomes identical with the expansion of Child's Law given by (4).

Using complex notation, we can write (7) as

$$\frac{V_1}{V_0} = \frac{2}{3} \left(\frac{i_1}{I_0} \right) \Upsilon_{11} e^{j\omega t}, \quad (11a)$$

$$\frac{V_2}{V_0} = -\frac{1}{18} \left(\frac{i_1}{I_0} \right)^2 \{ \Upsilon_{20} + \Upsilon_{22} e^{j2\omega t} \}, \quad (11b)$$

$$\frac{V_3}{V_0} = \frac{1}{81} \left(\frac{i_1}{I_0} \right)^3 \{ 3\Upsilon_{31} e^{j\omega t} + \Upsilon_{33} e^{j3\omega t} \}. \quad (11c)$$

The complex transit-angle coefficients Υ are related to X and Y as

$$\Upsilon(\beta) = X - jY, \quad \text{where } \beta = j\theta. \quad (12)$$

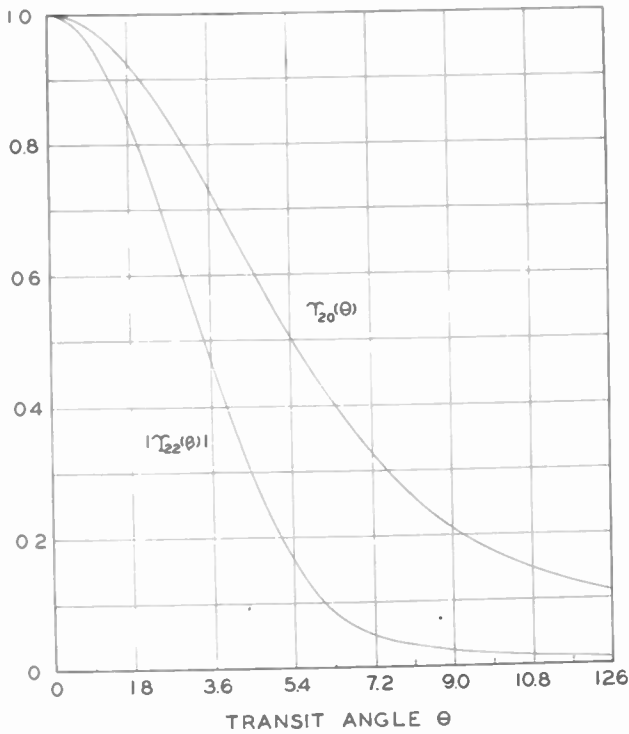

Fig. 1—Transit-angle variation of second-order transit-time coefficients for mode A operation.

$\Upsilon_{11}(\beta)$, Z/r_c in Llewellyn's notation, is plotted and tabulated.¹⁰ Υ_{20} and the absolute value of $\Upsilon_{22}(\beta)$ are plotted in Fig. 1 for $0 \leq \theta \leq 12.6$ radians.

Mode B

For mode B operation of the complete space-charge diode, the applied voltage is assumed to be

$$V = V_0 + v_1 \cos(\omega t - \phi), \tag{13}$$

where ϕ is an arbitrary phase angle and $v_1/V_0 < 1$. The first-order current that results from (13) is given by (7a) as

$$\frac{I_1}{I_0} = \frac{3}{2} \left(\frac{v_1}{V_0} \right) \left(\frac{1}{|\Upsilon_{11}|} \right) \cos \omega t, \tag{14}$$

where $|\Upsilon_{11}|$ is the absolute value of $\Upsilon_{11}(\beta)$ and ϕ in (13) is equal to ϕ_{11} where $\tan \phi_{11} = Y_{11}/X_{11}$. The second-order current that results from (13) is

$$\frac{I_2}{I_0} = \frac{1}{12} \left(\frac{i_1}{I_0} \right)^2 \left[\Upsilon_{20} + \frac{|\Upsilon_{22}|}{|\Upsilon_{11}(2\beta)|} \cos(2\omega t + \gamma_{22}) \right], \tag{15}$$

where $\gamma_{22} = \phi_{12} - \phi_{22}$. ϕ_{12} and ϕ_{22} are obtained from

$$\tan \phi_{12} = \frac{Y_{11}(2\theta)}{X_{11}(2\theta)} \quad \text{and} \quad \tan \phi_{22} = \frac{Y_{22}}{X_{22}}$$

In complex notation, (15) can be written as

$$\frac{I_2}{I_0} = \frac{1}{12} \left(\frac{i_1}{I_0} \right)^2 \left[\Upsilon_{20} + \frac{\Upsilon_{22}}{\Upsilon_{11}(2\beta)} e^{j2\omega t} \right]. \tag{16}$$

¹⁰ See page 51 of footnote reference 2.

Using (14), we can write (16) in terms of the applied voltage as

$$\frac{I_2}{I_0} = \frac{3}{16} \left(\frac{v_1}{V_0} \right)^2 [\Psi_{20} + \Psi_{22} e^{j2\omega t}], \tag{17a}$$

where the mode B second-order transit-time coefficients are given by

$$\Psi_{20} = \Upsilon_{20} \{ |\Upsilon_{11}(\beta)| \}^{-2}, \tag{17b}$$

and

$$\Psi_{22} = \Upsilon_{22} \{ \Upsilon_{11}(2\beta) \cdot |\Upsilon_{11}(\beta)|^2 \}^{-1}. \tag{17c}$$

The transit-angle coefficients that appear in the above are given by (8) and (10). The absolute value of the twice-frequency coefficient in (15) and (17) is plotted in Figs. 1 and 2. Using the series expansions given by (10) for the coefficients that appear in (16) and (17a), it is seen that when θ approaches zero, the above expressions become identical with that given by the expansion of Child's law, (6a) and (5b).

The fundamental-frequency component of the third-order current that results from (13) is

$$\frac{I_{31}}{I_0} = \frac{1}{72} \left(\frac{i_1}{I_0} \right)^3 \{ |\Upsilon_{11}(\beta)| \}^{-1} \left[\frac{|\Upsilon_{22}| |\Lambda_{31}|}{|\Upsilon_{11}(2\beta)|} + 2\Upsilon_{20} |\Phi_{31}| - \frac{1}{4} |\Upsilon_{31}| \right] \cos(\omega t + \gamma_{31}), \tag{18}$$

where $\gamma_{31} = \phi_{11} - \phi_{31}$, ϕ_{31} being determined by $\tan \phi_{31} = X_{31}/Y_{31}$.

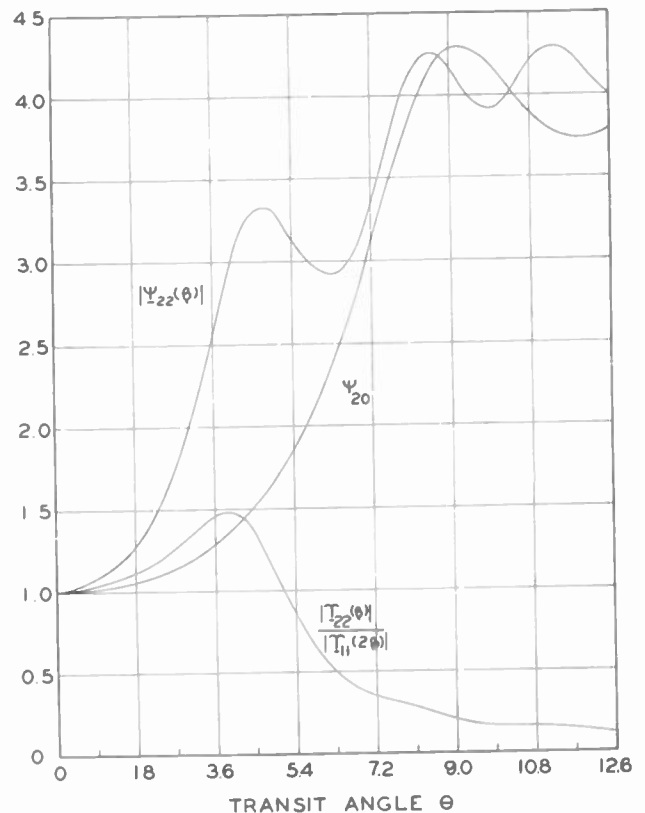

Fig. 2—Transit angle variation of second-order transit-time coefficients for mode B operation.

The triple-frequency component of the third-order current is

$$\frac{I_{33}}{I_0} = \frac{1}{72} \left(\frac{i_1}{I_0} \right)^3 \left\{ |\Upsilon_{11}(3\beta)| \right\}^{-1} \left[\frac{|\Upsilon_{22}| |\Lambda_{33}|}{|\Upsilon_{11}(2\beta)|} - \frac{4}{3} |\Upsilon_{33}| \right] \cos(3\omega t + \gamma_{33}), \quad (19)$$

where $\gamma_{33} = \phi_{13} - \phi_{33}$. The phase angles are obtained from

$$\tan \phi_{13} = \frac{Y_{11}(3\theta)}{X_{11}(3\theta)} \quad \text{and} \quad \tan \phi_{33} = \frac{Y_{33}}{X_{33}}.$$

The transit-angle coefficients $\Lambda = M - jN$ and $\Phi_{31} = P_{31} - jQ_{31}$ that appear in (18) and (19) are as follows

$$M_{31} = -\frac{9}{\theta^6} [1 - \cos 2\theta - 2\theta \sin 2\theta - 2\theta^3 \sin \theta + 2\theta^2], \quad (20a)$$

$$N_{31} = -\frac{9}{\theta^6} [2 \sin \theta - \sin 2\theta - 2\theta \cos \theta + 2\theta \cos 2\theta + 2\theta^3 \cos \theta], \quad (20b)$$

$$M_{33} = \frac{9}{\theta^6} \left[1 - \cos \theta - \cos 2\theta + \cos 3\theta - \theta \sin \theta - 2\theta \sin 2\theta + 3\theta \sin 3\theta - \frac{20}{9} \theta^2 \cos 3\theta - \frac{2}{3} \theta^3 \sin 3\theta + \frac{2}{9} \theta^2 \right], \quad (20c)$$

$$N_{33} = -\frac{9}{\theta^6} \left[\sin \theta + \sin 2\theta - \sin 3\theta - \theta \cos \theta - 2\theta \cos 2\theta + 3\theta \cos 3\theta + \frac{20}{9} \theta^2 \sin 3\theta - \frac{2}{3} \theta^3 \cos 3\theta \right], \quad (20d)$$

$$P_{31} = -\frac{12}{\theta^4} [6(1 - \cos \theta) - 4\theta \sin \theta + \theta^2 \cos \theta], \quad (20e)$$

and

$$Q_{31} = -\frac{12}{\theta^4} [2\theta - 6 \sin \theta + 4\theta \cos \theta + \theta^2 \sin \theta]. \quad (20f)$$

For small transit angles, the above can be written as

$$M_{31} = 1 - \frac{\theta^2}{4} + \frac{27}{1,400} \theta^4 - \frac{1}{302,400} \theta^6 + \dots, \quad (21a)$$

$$N_{31} = \frac{3}{5} \theta - \frac{8}{105} \theta^3 + \frac{1}{240} \theta^5 - \frac{1}{138,600} \theta^7 + \dots, \quad (21b)$$

$$M_{33} = 1 - \frac{7}{4} \theta^2 + \frac{451}{700} \theta^4 - \frac{32,959}{302,400} \theta^6 + \dots, \quad (21c)$$

$$N_{33} = \frac{9}{5} \theta - \frac{6}{5} \theta^3 + \frac{481}{1,680} \theta^5 - \frac{1,681}{46,200} \theta^7 + \dots, \quad (21d)$$

$$P_{31} = 1 - \frac{\theta^2}{5} + \frac{\theta^4}{112} - \frac{\theta^6}{5,400} + \dots, \quad (21e)$$

and

$$Q_{31} = \frac{3}{5} \theta - \frac{\theta^3}{21} + \frac{\theta^5}{720} - \frac{\theta^7}{46,200} + \dots \quad (21f)$$

Using (14), we can write (18) and (19) in terms of the applied voltage. The total third-order current is, then, using complex notation

$$\frac{I_3}{I_0} = -\frac{1}{64} \left(\frac{v_1}{V_0} \right)^3 \{ 3\Psi_{31} e^{j\omega t} + \Psi_{33} e^{j3\omega t} \}, \quad (22)$$

where

$$\Psi_{31} = \frac{1}{\Upsilon_{11}(\beta) \Upsilon_{11}(2\beta) |\Upsilon_{11}(\beta)|^3} [(4\Upsilon_{31} - 2\Upsilon_{20} \Phi_{31}) \Upsilon_{11}(2\beta) - \Upsilon_{22} \Lambda_{31}], \quad (23a)$$

and

$$\Psi_{33} = \frac{1}{\Upsilon_{11}(3\beta) \Upsilon_{11}(2\beta) |\Upsilon_{11}(\beta)|^3} [4\Upsilon_{33} \Upsilon_{11}(2\beta) - 3\Upsilon_{22} \Lambda_{33}]. \quad (23b)$$

By the use of the series expansions for the coefficients that appear in (23), it is seen that as θ goes to zero, the third-order transit coefficients Ψ_{31} and Ψ_{33} both approach unity and (22) reduces to (5c). In addition, note that for zero transit angle, (18) and (19) reduce to (6b).

IV. COMPARISON WITH BENHAM'S SOLUTION

Benham has calculated the second- and third-order solutions by the so-called "conservation of charge" method of solving the electronic equations.¹¹ His mode A solution which corresponds to (7) and (11) is given by [91a].¹² For the second-order solution, Benham has the same transit-angle coefficients for both the zero-frequency and the second-harmonic term; namely, $\Upsilon_{22}(\beta)$. For the third-order solution, the single- and third-harmonic terms have the same coefficient; namely, $\Upsilon_{33}(\beta)$.

For mode B operation, Benham's second-order solution is in agreement with (17). Note, however, in [95a], the $\Upsilon_6^2(\alpha)$ should have absolute bars and in [95b] v_0 should be squared. His third-harmonic component of the third-order solution is in agreement with (23b). However, his third-order fundamental-frequency component has two errors; namely Υ_{33} and Λ_{33} are written for Λ_{31} and Υ_{31} . In [95c] the absolute bars were omitted from $\Upsilon_6^3(\alpha)$ and in [97] $\Upsilon_6^4(\alpha)$ should be written $|\Upsilon_6(\alpha)|^3 \Upsilon_6(\alpha)$. To facilitate comparison of Benham's and the solution here presented, Table I relates the transit-time coefficient notations used in the two papers.

TABLE I

Benham's	This paper
Υ_6	Υ_{11}
Υ_9	Υ_{20}
Υ_{11}	Υ_{22}
—	Υ_{31}
Υ_{17}	Υ_{33}
Υ_6	Φ_{31}
—	Λ_{31}
Υ_{16}	Λ_{33}

¹¹ W. E. Benham, "A contribution to tube and amplifier theory," Proc. I.R.E., vol. 26, pp. 1093-1170; September, 1938.

¹² Benham's equation numbers will be given in brackets.

Addendum

The following tabulation is printed at the request of J. M. Miller, Jr., author of the paper, "Cathode Neutralization of Video Amplifiers," which appeared on pages 1070-1073 of the September, 1949, issue of the PROCEEDINGS OF THE I.R.E.

Since Mr. Miller has indicated his belief that this material, which lists the values of the various components in Fig. 2 of the above paper, is of considerable interest to readers of this journal, the editors are glad to publish the tabulation herewith.

R_{11}	470K Ω	C_6B	10 μ f	L_1	25 μ h solenoid
R_{12}	100 Ω	C_7	0.1 μ f	L_2	25 μ h solenoid
R_{13}	1,000 Ω	C_8	200 μ μ f	L_4	85 μ h
R_{14}	2,400 Ω	C_9	40 μ f		
R_{15}	470K Ω	C_{10}	0.1 μ f		
R_{16}	82 Ω	C_{12}	2 μ f		
R_{17}	3,000 Ω	C_{13}	0.1 μ f	V_1	6AG7
R_{18}	4,700 Ω	C_{14}	50 μ f	V_2	6AG7
R_{19}	470K Ω	C_{15A}	10 μ f	V_3	6AC7
R_{21}	12K Ω	C_{15B}	10 μ f	V_5	VR-150-30
R_{22}	6,600 Ω	C_{16}	0.1 μ f		
R_{24}	25K Ω				
R_{25}	50 Ω	R_{22}	100 Ω		
R_{26}	560 Ω	R_{24}	12 K Ω		
R_{27}	2,000 Ω	R_{26}	6.8K Ω		
R_{28}	4,700 Ω	R_{27}	25 K Ω		
R_{29}	100 Ω	R_{28}	120 Ω		
R_{30}	100 Ω	R_{29}	120 Ω		
R_{31}	6,600 Ω				
R_{32}	3,000 Ω				



Contributors to Waves and Electrons Section

Nicholas A. Begovich (S'41-A'48) was born November 29, 1921 in Oakland, Calif. He received the B.S., M.S., and Ph.D. degrees in electrical engineering at the California Institute of Technology in 1943, 1944, and 1948, respectively. From 1944 to 1948, he was employed by the California Institute of Technology as a research engineer on various war research projects, and as a teaching fellow and instructor in the electrical engineering department.



N. A. BEGOVICH

Since June, 1948, Dr. Begovich has been employed as research physicist in antenna research at the electronics department of Hughes Aircraft Co., Culver City, Calif.

Dr. Begovich is an associate of the AIEE. He is a member of the American Physical Society, American Association for the Advancement of Science, and Sigma Xi.

Han Chan was born on September 23, 1920, in Liaoning, China. A graduate of Southwest Associated University in 1943, he served first as an assistant and then as an instructor in Tsinghua University for five years. In 1948 he entered the graduate school of the University of Wisconsin, where he was awarded the M. S. degree in electrical engineering in June, 1949. Mr. Chan is at present engaged in further graduate work at the University of Wisconsin.



HAN CHAN

in further graduate work at the University of Wisconsin.

O. E. De Lange (A'41) was born at Koosharem, Utah, on August 12, 1906. He received the degree of B.S. in electrical engineering from the University of Utah in 1930 and the M.A. degree in physics from Columbia University in 1937.



O. E. DE LANGE

Since 1930 he has been a member of the technical staff of the Bell Telephone Laboratories. In the radio research department of these Laboratories, he has engaged in the study of FM systems, pulse systems, and broad-band amplifiers. The war years were spent on radar development.

Willis W. Harman (S'44) was born in 1918 in Seattle, Wash. He received the B.S. degree in electrical engineering from the

Contributors to Waves and Electrons Section

University of Washington in 1939, and the M.S. degree in physics and the Ph.D. degree in electrical engineering from Stanford University in 1948. He was employed by the General Electric Company from 1939-1941, when he became an electrical officer on the USS *Maryland*. During the last two years of World War II he was sent to the Navy Post-graduate School in Annapolis, Md.,



W. W. HARMAN

for a course in radio engineering.

During the period 1948-1949 Dr. Harman was an assistant professor of electrical engineering at Stanford University. He is at present with the University of Florida, in Gainesville, Fla.

Dr. Harman was a 1947-1948 recipient of an RCA fellowship in electronics. He is a member of Sigma Xi and Tau Beta Pi.

Vincent C. Rideout (M'44) was born in Alberta, Canada, on May 22, 1914. He received the B.Sc. degree in engineering physics from the University of Alberta in 1938, and the M.S. degree in electrical engineering from the California Institute of Technology in 1940. From 1939 to 1946 Mr. Rideout was a member of the technical staff of the Bell Telephone Laboratories, engaged in microwave radio and radar research. In 1946 he joined the staff of the University of Wisconsin as an assistant professor of electrical engineering, becoming an associate professor in 1948.



VINCENT C. RIDEOUT

Mr. Rideout is a member of Sigma Xi.

David Gordon Tucker was born in Chingford, Essex, England, on June 17, 1914. He obtained the degrees of B.Sc. in 1936, Ph.D. in 1943, and D.Sc. in 1948 in the Faculty of Engineering, University of London. He joined the engineering department of the British Post Office in 1932, and after a two-year general training course was appointed to the Research Station at Dollis Hill, London,



D. G. TUCKER

where he has worked on line communication development and research.

Since 1947 Dr. Tucker has been a group leader in charge of the development of transmission measuring equipment and research in modulator design and performance. He is an Associate Member of the Institution of Electrical Engineers, London.

Alan B. Macnee (S'42-A'45) was born on September 19, 1920, in New York, N. Y. He studied electrical engineering at the Massachusetts Institute of Technology, receiving the B.S. and M. S. degrees in 1943 and the D.Sc. degree in 1948. From 1943 to 1946 he was a staff member in the receiver group at the MIT Radiation Laboratory, specializing in the noise performance of intermediate-frequency amplifiers. From 1946 to August 1949 he was on the staff of the MIT Research Laboratory of Electronics engaged in research on high-speed electronic computation. He is now engaged in research on electronic computation at the Chalmers Institute of Technology, in Gothenburg, Sweden.



ALAN B. MACNEE

Dr. Macnee is a member of Sigma Xi and Eta Kappa Nu.

R. O. Rowlands was born in Llangefni, Wales, in 1914. He was graduated from the University College of N. Wales, in Bangor, with the B.Sc. degree in pure and applied mathematics. Following his graduation he joined the staff of the General Electric Company of Great Britain, at Coventry, where he eventually took charge of the laboratory group responsible for the design of filters, equalizers, and inductors.



R. O. ROWLANDS

Mr. Rowlands left General Electric to join the British Broadcasting Corporation in 1948, as a lecturer in the engineering training department, where he is now employed.

Myron S. Wheeler (A'43) was born at Pittsburgh, Pa., on January 15, 1920. He received the B.S. degree in electrical engineering in 1942 from the Pennsylvania State College, and the M.S. degree in electrical engineering from the Stevens Institute of Technology. Presently, he is doing graduate work at Brooklyn Polytechnic Institute and working with the Westinghouse Electric Corp. in a development section on radar.



M. S. WHEELER

Mr. Wheeler is a member of Eta Kappa Nu and Sigma Tau.



Abstracts and References

Prepared by the National Physical Laboratory, Teddington, England, Published by Arrangement with the Department of Scientific and Industrial Research, England, and *Wireless Engineer*, London, England

NOTE: The Institute of Radio Engineers does not have available copies of the publications mentioned in these pages, nor does it have reprints of the article abstracted. Correspondence regarding these articles and requests for their procurement should be addressed to the individual publications and not to the IRE.

Acoustics and Audio Frequencies	1347
Antennas and Transmission Lines	1348
Circuits and Circuit Elements	1349
General Physics	1351
Geophysical and Extraterrestrial Phenomena	1352
Location and Aids to Navigation	1352
Materials and Subsidiary Techniques	1353
Mathematics	1353
Measurements and Test Gear	1354
Other Applications of Radio and Electronics	1355
Propagation of Waves	1356
Reception	1357
Stations and Communication Systems	1357
Subsidiary Apparatus	1357
Television and Phototelegraphy	1357
Transmission	1358
Vacuum Tubes and Thermionics	1358
Miscellaneous	1360

The number in heavy type at the upper left of each Abstract is its Universal Decimal Classification number and is not to be confused with the Decimal Classification used by the United States National Bureau of Standards. The number in heavy type at the top right is the serial number of the Abstract. DC numbers marked with a dagger (†) must be regarded as provisional.

ACOUSTICS AND AUDIO FREQUENCIES

- 016:534 **2683**
References to Contemporary Papers on Acoustics—A. Taber Jones. (*Jour. Acous. Soc. Amer.*, vol. 21, pp. 146–152; March, 1949.) Continuation of 2114 of September.
- 534.2 **2684**
On the Theory of Steep-Fronted Plane Pressure-Waves—H. Priem. (*Akus. Zeit.*, vol. 6, pp. 222–224; July, 1941.)
- 534.21 **2685**
Sound Radiation from a Finite Cylinder—P. G. Bordoni and W. Gross. (*Jour. Math. Phys.*, vol. 27, pp. 251–252; January, 1949.) The radiated power and directional characteristics are calculated for a cylindrical source with one vibrating face. The approximate solution of the wave equation is determined by a minimum method. The results obtained are in good agreement with those derived for an equivalent spherical source.
- 534.21 **2686**
The Propagation of Sound in Composite Media—R. J. Urick and W. S. Ament. (*Jour. Acous. Soc. Amer.*, vol. 21, pp. 115–119; March, 1949.) Theory of a method for determining the propagation constant in media containing numerous small spherical particles.
- 534.213:629.13.038.1 **2687**
The Effect of its Aerodynamic Properties on the Sound Field and Radiation Power of a Propeller—W. Ernsthäuser. (*Akus. Zeit.*, vol. 6, pp. 245–261; July, 1941.)
- 534.213.4–14 **2688**
Propagation of Sound Waves along Liquid Cylinders—W. J. Jacobi. (*Jour. Acous. Soc. Amer.*, vol. 21, pp. 120–127; March, 1949.) A theoretical and experimental treatment of guided transmission within circular cylinders

The Institute of Radio Engineers has made arrangements to have these Abstracts and References reprinted on suitable paper, on one side of the sheet only. This makes it possible for subscribers to this special service to cut and mount the individual Abstracts for cataloging or otherwise to file and refer to them. Subscriptions to this special edition will be accepted only from members of the IRE and subscribers to the Proc. I.R.E. at \$15.00 per year. The Annual Index to these Abstracts and References, covering those published in the Proc. I.R.E. from February 1948, through January, 1949, may be obtained for 2s. 8d. postage included from the *Wireless Engineer*, Dorset House, Stanford St., London S. E., England.

of ideal liquid, with various nondissipative boundary conditions.

534.232 **2689**

Investigations on the Production of Pressure Pulses by Cavitation—H. G. Möller and A. Schoch. (*Akus. Zeit.*, vol. 6, pp. 165–173; May, 1941.) A magnetostriction oscillator with a fundamental frequency of about 9 kc was used. Cavitation occurred in water when the current through the oscillator coil exceeded 0.3 A. The pressure effects were observed both by a schlieren method and by means of quartz or tourmaline microphones for a wide range of sound pressures, the maximum oscillator current being 0.8 A. Sound-pressure oscillograms are reproduced. The results obtained with the microphones can only be regarded as qualitative.

534.26 **2690**

On Diffraction through a Circular Aperture—J. W. Miles. (*Jour. Acous. Soc. Amer.*, vol. 21, pp. 140–141; March, 1949.) Analysis based on the variational method of Schwinger.

534.26 **2691**

A Note on the Kirchhoff Approximation in Diffraction Theory—R. D. Spence. (*Jour. Acous. Soc. Amer.*, vol. 21, pp. 98–100; March, 1949.) The diffraction patterns calculated by use of the Kirchhoff approximation are compared with the exact theory for the special case of a circular aperture. The approximation may be used to determine the average value of the normal velocity provided that the mean radius of the aperture is greater than or not much less than λ . In this case the diffraction patterns calculated from the Kirchhoff approximation are reasonably accurate for angles less than that of the first minimum.

534.26:534.321.9 **2692**

Criteria for Normal and Abnormal Ultrasonic Light Diffraction Effects—G. W. Willard. (*Jour. Acous. Soc. Amer.*, vol. 21, pp. 101–108; March, 1949.)

534.321.9:534.6 **2693**

Investigations of Acoustic Phenomena in Solids by Means of F. M. Ultrasonic Vibrations—F. Kruse. (*Akus. Zeit.*, vol. 6, pp. 137–149; May, 1941.) The spectrum of a FM oscillation with a triangular modulation curve is considered. The application of such a "wobbed" oscillation to eliminate or reduce natural oscillations in samples under test is discussed and illustrated by the results of numerous experiments. The complete elimination of stationary waves is not practicable.

534.321.9.001.8 **2694**

The Production of High Intensity Ultra-

sonics at Megacycle Frequencies—G. G. Selman and M. H. F. Wilkins. (*Jour. Sci. Instr.*, vol. 26, pp. 229–231; July, 1949.) Details of apparatus designed for the irradiation of biological material. A high-power Hartley oscillator was used in conjunction with a piezoelectric generator immersed in oil. Increased power was not developed by the use of transmission plates. Various focusing devices were investigated. Beams of unfocused ultrasonic radiation were generated and measured calorimetrically up to a maximum intensity of 55 W/cm². The dielectric strength of the transformer oil used limited the power output.

534.373 **2695**

Sound Attenuation in Absorption Tubes—W. Willms. (*Akus. Zeit.*, vol. 6, pp. 150–165; May, 1941.) The walls of an absorption tube are coated with porous material. The attenuation in such tubes is treated by means of the expression for the wall resistance. The method of treatment is only valid for low frequencies. In the case where the absorbent lining is of very great thickness, the attenuation in the region of lowest frequencies is proportional to $f^{3/4}$, but at higher frequencies it is proportional to $f^{1/2}$. With linings of small thickness the attenuation is proportional to f^2 and decreases rapidly toward the lower frequencies.

The problem is also treated by means of wave theory, which is applied to propagation in a channel between two layers of absorbing material. At low frequencies the same results are obtained as by the first method, but the attenuation, after passing through a maximum at very high frequencies, thereafter decreases again in proportion to $f^{-1/2}$. Experimental results confirm the theory.

534.373:534.321.9 **2696**

On the Ultrasonic Opacity of Porous Media—G. A. Homès. (*Compt. Rend. Acad. Sci. (Paris)*, vol. 228, pp. 1695–1697; May 30, 1949.) Experiments at a frequency of 1 Mc indicate a definite correlation between the opacity of water containing air bubbles and the degree of aeration. Transmission through water containing many air bubbles was only 2 per cent of that for water free from bubbles. Similar results were obtained with disks of paraffin wax filled with metal balls of various diameters. With 1-mm balls the transmission was 2 per cent and with 5-mm balls 10 per cent of that for pure paraffin wax.

534.373:534.6 **2697**

On the Pulse Method of Measuring Ultrasonic Absorption in Liquids—J. M. M. Pinkerton. (*Proc. Phys. Soc. (London)*, vol. 62, pp. 286–299; May, 1949.) The choice of the op-

imum conditions for accuracy is discussed and illustrated by practical examples. Pulse equipment working on six frequencies between 7.5 and 67.5 Mc is described.

534.6:534.321.9 2698

Sound Analysis with an Ultrasonic Plate Spectroscope—E. Mohr. (*Akus. Zeit.*, vol. 6, pp. 209–222; July, 1941.) A spectroscope for sound analysis using a diffraction grating has been described by Meyer and Thienhaus (453 of 1935 and 630 of 1936). Instead of the grating the author here uses a plate analogous to the Fabry-Perot and Lummer-Gehrcke plates used in optics. The apparatus and its method of use are described. An ultrasonic oscillation of frequency 45 kc is modulated by the sound to be analyzed and the upper sideband is resolved by the plate spectroscope. For the low audio frequencies a resolution of about 60 cps is attained. Typical results are illustrated and phase errors are discussed.

534.62 2699

Principles of Design of [sound-] Deadened Rooms—M. Milosevic. (*Rev. Tech. Comp.* (France), Thomson-Houston, no. 12, pp. 17–34; May, 1949.) Detailed discussion, with special reference to the absorbent properties of the walls, floor and roof, thickness of absorbing material, insulation against external noise, and mechanical vibration. Examples of the acoustic characteristics obtained with various practical methods of construction are illustrated.

534.64 2700

Measurement of Acoustic Impedance—O. K. Mawardi. (*Jour. Acous. Soc. Amer.*, vol. 21, pp. 84–91; March, 1949.) The impedance of a sample of material forming one boundary of a shallow cylindrical cavity is measured by determining the sound pressure produced when a known volume current enters the cavity from a high-impedance source. The volume current is determined by observing the pressure when the cavity is rigidly terminated. The first radial mode of the cavity is suppressed by using a ring source; the frequency limit set by uniformity of pressure is thus extended by at least an octave. Secondary effects due to finite source and microphone impedance and to heat losses at the walls are evaluated. The method is simple, rapid, and precise.

534.64 2701

The Acoustic Reactance of Small Circular Orifices—R. H. Bolt, S. Labate, and U. Ingård. (*Jour. Acous. Soc. Amer.*, vol. 21, pp. 94–97; March, 1949.) A precise experimental measurement of the reactance of orifices 0.35–2 cm in diameter and with diameter/length ratios from 4 to 40, for the frequency range 200 to 1,000 cps. Comparison with calculated values shows agreement for the larger orifices only. The correction factor for small orifices of radius less than 1 cm is examined.

534.75 2702

Adaptation of the Ear to Sound Stimuli—E. Lüscher and J. Zwislocki. (*Jour. Acous. Soc. Amer.*, vol. 21, pp. 135–139; March, 1949.) Adaptation is defined as the elevation of the auditory threshold by a previous sound stimulus; for a stimulus 80 db above the auditory threshold the adaptation is 40 to 50 db. The entire process of adaptation and the return to normal sensitivity are each complete within a few tenths of a second. Methods and apparatus for measuring adaptation are described.

534.76:534.862 2703

The Fundamentals of Sound-Film Stereophonic Transmission for Halls—H. Warncke. (*Akus. Zeit.*, vol. 6, pp. 174–188; May, 1941.) A theoretical discussion. With a suitable arrangement of directional microphones for re-

ording, a 2-channel system feeding two loudspeakers can give good performance.

534.851:621.395.813 2704

Analysis, by the Two-Frequency Intermodulation Method, of Tracing-Distortion Encountered in Phonograph Reproduction—H. E. Roys. (*RCA Rev.*, vol. 10, pp. 254–269; June, 1949.)

534.851:621.395.813 2705

Tracing-Distortion in Phonograph Records—M. S. Corrington. (*RCA Rev.*, vol. 10, pp. 241–253; June, 1949.) The results of Lewis and Hunt (730 of 1942) for the amount of distortion produced when a spherical stylus traces a groove in a gramophone record are extended by considering more terms of the series.

534.86 2706

To What Extent does Distortion really matter in the Transmission of Speech and Music?—(*Proc. IEE* (London), vol. 96, pp. 235–236; May, 1949.) Continuation of the discussion noted in 2149 of 1948.

621.392.51 2707

A Theory of the Crystal Transducer for Plane Waves—W. G. Cady. (*Jour. Acous. Soc. Amer.*, vol. 21, pp. 65–73; March, 1949.) The vibration amplitude, radiated power, and electrical admittance are derived from the equations of propagation of acoustic waves through a solid medium. The transducer consists of a single element or a mosaic of crystals with a backing plate and a diaphragm. The general equations, which are valid for all conditions, are applied to the special case in which the backing is air. Particular attention is paid to the resonance conditions.

621.395.61/.62:537.228.1 2708

Rochelle-Salt Crystals in Telephony—I. Sengewitz. (*Fernmeldetechn. Z.*, vol. 2, pp. 219–222; July, 1949.) The replacement of magnet systems by crystal units in telephone operators' gear has resulted in a reduction in the total weight of the equipment from 430 g to 62 g. A simple type of crystal amplifier, with a moderately uniform frequency-response curve from 50 cps to 10 kc, is also described.

621.395.625.3 2709

The New Portable Tape Recorder—W. E. Stewart. (*Broadcast News*, no. 54, pp. 6–13; April, 1949.) Illustrated description and technical characteristics of the RCA Type RT-3A recorder. The amplifier is fitted in a separate carrying case. Tape speed can be either 7.5 or 15 inches per second and automatic torque and tension controls are provided. The "erase," "record," and "reproduce" heads are mounted in a single plug-in unit and tape threading is particularly simple. Response is essentially flat from 50 to 15,000 cps.

621.395.625.3:534.852.6 2710

Noise in Magnetic Recording Systems as Influenced by the Characteristics of Bias and Erase Signals—J. W. Gratian. (*Jour. Acous. Soc. Amer.*, vol. 21, pp. 74–81; March, 1949.)

681.85 2711

A Record Changer and Record of Complementary Design—B. R. Carson, A. D. Burt, and H. I. Reiskind. (*RCA Rev.*, vol. 10, pp. 173–190; June, 1949.) Equipment specially designed to minimize damage of records during handling or changing, to give a longer record life and improved quality of reproduction. The new type of record is much smaller than the usual 78-rpm type and is operated at 45 rpm. With 275 grooves per inch the playing time is $5\frac{1}{2}$ minutes.

621.392.51 2712

Electromechanical Transducers and Wave Filters [Book Review]—W. P. Mason. Publishers: D. Van Nostrand Co., New York, 2nd

ed., 1948, 419 pp., \$6.00. (*Rev. Sci. Instr.*, vol. 20, pp. 314–315; April, 1949.) "... a scholarly and thorough book on the theory of electrical networks and vibration of coupled acoustical, mechanical, and electrical systems employing electrical, mechanical, and acoustical analogies."

ANTENNAS AND TRANSMISSION LINES

621.392.26(083.74)† 2713

Standard for Waveguides—Fenn. (*See* 2861.)

621.396.67 2714

Aerials with Feedback—J. Grosskopf. (*Frequenz*, vol. 3, pp. 157–164; June, 1949.) In the case of rhombic transmitting antennas the energy arriving at the end remote from the feed point is usually absorbed in a resistance, but with a suitable transformer and double conductor the energy may be led back to the feed point. Theory of such an arrangement is given and practical methods are described, with a few experimental results on model equipment.

621.396.67 2715

On the Infinitely Long Cylindrical Antenna—C. H. Papas. (*Jour. Appl. Phys.*, vol. 20, pp. 437–440; May, 1949.) The method of steepest descents is used to obtain the asymptotic form of the current distribution for a perfectly conducting antenna excited by a localized emf. The H_f value of the radiation conductance is determined by integrating the radiated energy flux over a large sphere. See also 1589 of July (Hallén).

621.396.67:621.317.74.029.64 2716

A New Type of Slotted-Line Section—W. B. Wholey and W. N. Eldred. (*Proc. N.E.C.* (Chicago), vol. 4, p. 221; 1948.) Summary only. Conventional slotted lines require very accurate machining tolerances and care in construction if accurate measurements of voltage SWR are to be obtained. By use of the transformation $\omega = \tan Z$ the concentric line may be converted to two parallel semi-infinite planes with a slightly elliptical center conductor midway between. Simple modifications of this configuration will permit the construction of a slotted line section that is far less critical with respect to mechanical dimensions than its coaxial equivalent and will exhibit considerably less external energy radiation. Lines embodying this principle have been constructed and were found to have excellent electrical properties when only moderate mechanical accuracies were used in their construction. In a line covering the frequency range 500 to 4,000 Mc a SWR of only 1.006 was obtained for the basic slotted section and the necessary transition section to coaxial line.

This paper covers the theory of the "slab line" and the method of construction. Two types of line are described covering the frequency range 500 to 4,000 Mc and 3,000 to 10,000 Mc; performance and the experimental measuring procedure are briefly discussed.

621.396.67:621.396.931 2717

Mobile Radio Antennas for Railroads—W. C. Babcock. (*Bell Lab. Rec.*, vol. 27, pp. 172–175; May, 1949.) Discussion of rugged $\lambda/4$ antennas folded and bent so as to make full use of limited overhead clearance.

621.396.67:621.397.6 2718

Receiving Aerials for Television—H. C. Roosenstein. (*Radio Franç.*, no. 6, pp. 11–20; June, 1949.) Measurements on vertical receiving antennas were carried out at the end of a pier projecting into a lake, the transmitter being on a second pier 100 miles away. The results indicate that such antennas, when provided with parasitic stoppers, give good performance. Two types of antenna are described.

- 621.396.67:621.397.6 2719
Indoor Television Aerial—N. M. Best and P. J. Duffell. (*Wireless World*, vol. 55, pp. 255-258; July, 1949.) Discussion of the requirements of a compressed dipole for strong-signal areas, and the mechanical construction of a suitable dipole with loading coil and stub line.
- 621.396.677:621.397.16 2720
Reversible-Beam Antenna for Twelve-Channel Television Reception—O. M. Woodward, Jr. (*RCA Rev.*, vol. 10, pp. 224-240; June, 1949.) A combination of end-fire and broadside pairs of horizontal dipoles resonant at 65 Mc gives a unidirectional radiation pattern over the 54-88-Mc band. By loading the dipoles with V reactances, satisfactory patterns are also obtained over the 174-216-Mc band. By means of a "diplexer" bridge feed and balanced-line feeders, independent operation of the two arrays is ensured, ghost images are eliminated, and switched beam reversal is obtained. Field patterns and standing-wave characteristics of the system are given.
- 621.396.67 2721
Microwave Antenna Theory and Design [Book Review]—S. Silver. McGraw-Hill, London, 623 pp., 48s. (*Wireless Eng.*, vol. 26, pp. 199-200; June, 1949.) Vol. 12 of the M.I.T. Radiation Laboratory series. "... undoubtedly a very valuable addition to the literature of the subject. Although written by several authors it shows no sign of discontinuity. ... no trouble has been spared to make the book as authoritative and at the same time as readable as possible."
- 621.396.677:029.6 2722
Breitband-Richtstrahlantennen mit Anpassvierecken für Ultrakurzwellen. (Wide-Band Directive Aerials with Matching Quadripoles for Ultrashort Waves) [Book Review]—R. Peter. Publisher: Leemann, Zürich, 88 pp., 8 fr. (Swiss). (*Wireless Eng.*, vol. 26, p. 245; July, 1949.) The first section deals with non-directive cylindrical and conical antennas, their impedance, and equivalent circuits. Reflectors are considered next. The greater part of the book is concerned with filters and 4-pole matching devices, especially the use of ladder filters to obtain a wide passband.
- CIRCUITS AND CIRCUIT ELEMENTS**
- 621.3.012.2 2723
Standing Waves and Impedance Circle Diagrams—C. H. Westcott. (*Wireless Eng.*, vol. 26, pp. 230-234; July, 1949.) A graphical method of determining the form and phase of standing waves, and an explanation of impedance circle diagrams for transmission lines with and without attenuation.
- 621.3.015.3:778.3 2724
A New Method for the Photographic Study of Fast Transient Phenomena—J. S. Courtney-Pratt. (*Research* (London), vol. 2, pp. 287-294; June, 1949.) For transients lasting 10^{-7} - 10^{-8} seconds. An image-converter tube is used in equipment giving results similar to those obtained with drum cameras.
- 621.314.2 2725
Design Charts for Air-Cored Transformers—C. N. Jeffery. (*AWA Tech. Rev.*, vol. 8, pp. 167-183; April, 1949.) The charts are based on values of Nagaoka's constant. Their derivation is explained and examples of their application are given. They are suitable for various types of coaxial windings of common diameter and pitch. The choice of winding form is also considered.
- 621.314.2 2726
A Design for Double-Tuned Transformers—J. B. Rurld. (*AWA Tech. Rev.*, vol. 8, pp. 147-165; April, 1949.) Description of a method of designing transformers (including networks consisting of a pair of LC circuits with inductive or capacitive coupling) to provide uniform transmission of power over a range of frequencies. The resulting insertion-loss curve is approximately symmetrical when plotted on a linear frequency scale. The frequency variable used in the design equations allows a common representation of both inductively and capacitively coupled forms. The extent of the uniform transmission band and the transformation ratios possible with various types of coupling are discussed. Charts which simplify the process of design are included.
- 621.314.26:621.397.6:029.63 2727
Continuously Tuned Converter for U.H.F. Television—R. P. Wakeman. (*Electronics*, vol. 22, pp. 68-71; July, 1949.) The converter is designed to cover the band 475 to 890 Mc, to enable existing television receivers in the U. S. A. to cover the proposed uhf channels. It is a modification of the Karplus coaxial tuner (3260 of 1945).
- 621.314.3† 2728
Magnetic Amplifiers—A. G. Milnes. (*Proc. IEE* (London), vol. 96, pp. 89-98. Discussion, pp. 115-124; May, 1949.) An explanation of transductor action is given, and the effect of permeability on performance is described for the case of self-excitation. Arrangements of transductors to give duo-directional magnetic amplifiers are considered. Fundamental design principles are developed in which power output, amplification, and time lag are related to supply frequency, core area, and self-excitation or feedback.
 To obtain a high amplification/time-constant ratio, a high supply frequency should be used and several stages with positive feedback should be connected in cascade. Transductors are a valuable addition to circuit technique for the amplification of dc powers down to about 10^{-9} w. Reprinted *ibid.*, Part II, vol. 96, pp. 329-338. Discussion, pp. 355-364; June, 1949.
- 621.314.3† 2729
A Theoretical and Experimental Study of the Series-Connected Magnetic Amplifier—H. M. Gale and P. D. Atkinson. (*Proc. IEE* (London), vol. 96, pp. 99-114. Discussion, pp. 115-124; May, 1949.) The mathematical analysis of magnetic amplifiers is made difficult by the nonlinear characteristic of the iron. Neglecting leakage reactance and assuming an ideal B/H characteristic, a solution can be obtained which shows that the steady-state and transient operation of an amplifier with one of the two basic circuits here analyzed depend on only three dimensionless coefficients. This solution leads to simple semigraphical methods of determining the steady-state current and flux waveforms, and the response to sudden changes in input. Satisfactory agreement between theoretical and experimental results has been obtained. Improvements in core characteristics have led to a simplified method of designing amplifier windings, and amplifier delays have been reduced in a ratio of about 10:1 by the use of special circuits. Reprinted *ibid.*, Part II, vol. 96, pp. 339-354. Discussion, pp. 355-364; June, 1949.
- 621.314.3† 2730
Barkhausen Noise and Magnetic Amplifiers: Part I—Theory of Magnetic Amplifiers—J. A. Krumhansl and R. T. Beyer. (*Jour. Appl. Phys.*, vol. 20, pp. 432-436; May, 1949.) Open-circuit output voltages are calculated for nonlinear transformers driven by a sinusoidal primary current with or without a dc bias. The case of a loaded secondary is also considered; conditions for instability and for resonance are derived. See also 664 of 1948 (Sack et al.).
- 621.314.3† 2731
Feed-Back in Magnetic Amplifiers: Parts 1 & 2—A. S. Fitzgerald. (*Jour. Frank. Inst.*, vol. 247, pp. 223-243 and 457-471; March and May, 1949.)
- 621.314.63+621.315.59 2732
Semi-Conductors and Rectifiers—Mott. (See 2814.)
- 621.316.722.4 2733
The Problem of Voltage Division for Centimetre and Millimetre Waves—O. Macek. (*Frequenz*, vol. 3, pp. 117-121; April, 1949.) In waveguides of diameter d less than the critical diameter d_c for a particular wavelength, propagation cannot take place and the electric and magnetic fields decrease exponentially with distance along the waveguide. The decrease is the more rapid the smaller the ratio of d to d_c . Attenuation arrangements based on the above principle are described and formulas are given which are applicable to H and E waves. Practical applications in measurement technique are discussed.
- 621.316.729:621.396.615 2734
The Synchronization of Relaxation Oscillations at the Fundamental and Subharmonic Frequencies of the Applied Electromotive Force—V. V. Vitkevich. (*Radiotekhnika* (Moscow), vol. 4, pp. 76-77; May and June, 1949. In Russian.) The effects of various factors on the synchronization bandwidth are discussed.
- 621.316.8 2735
Fixed Resistors for use in Communication Equipment—P. R. Coursey. (*Proc. IEE* (London), vol. 96, pp. 169-180. Bibliography, pp. 180-182. Discussion, pp. 182-186; May, 1949.) An account of the historical development and a review of the construction and properties of eight different types. The manufacture and the main electrical and hf properties of the latest forms of pyrolytic-carbon high-stability resistors are discussed.
- 621.318.4 2736
On the Design of H.F. Coils with Powdered-Iron Cores—H. Nitsche. (*Funk und Ton*, vol. 3, pp. 320-327; June, 1949.) For determining the inductance, the most important quantity is what is termed the inductance factor $AL = \mu H/N^2$, where N is the number of turns and μ the core permeability. Curves are given showing how AL depends on the distribution of the winding in the slots of a 3-slot coil former and on the degree of filling-up of the slots, both for cylindrical and pot cores.
- 621.318.4:621.397.6 2737
Television I.F. Coil Design—J. H. Felker. (*Electronics*, vol. 22, p. 122; March, 1949.) A chart giving in one operation the number of close-wound turns of wire of given diameter required for a coil of given radius and inductance. Reprinted in *Bell Lab. Rec.*, vol. 27, p. 181; May, 1949.
- 621.318.42:621.394/.395].813 2738
The Frequency Dependence of the Voltage Distortion for Coils with Ordinary Commercial Laminated-Iron Cores—H. Kämmerrer. (*Fernmeldetech. Z.*, vol. 2, pp. 201-206; July, 1949.) Hysteresis and eddy-current theory indicates that the distortion in such coils should decrease with increasing frequency. Measurements on coils with cores of various commercially available materials, including mumetal, permennorm 3601 K1, traferperm 25 N1, and dynamo-sheet IV, confirm the theoretical conclusions. For some materials the measured change of distortion with frequency for very weak ac fields is in good agreement with the calculated variation. The discrepancies with other materials are attributed to magnetic inhomogeneity.
- 621.318.572 2739
Reactive Trigger Circuits—S. A. Drobov. (*Radiotekhnika* (Moscow), vol. 4, pp. 21-35; May and June, 1949. In Russian.) An analysis of such circuits which gives a clear picture of the processes taking place. An equivalent cir-

cult and its simplified triggering characteristics are discussed. The effects of various operating conditions on the triggering voltage, and applications to the lengthening and shortening of pulses, to frequency division, and to multi-vibrators are also considered.

621.318.572:539.16.08 2740

Electronic Counters for Pulses—P. Naslin and A. Peuteman. (*Onde Élec.*, vol. 29, pp. 241-254; June, 1949.) Essentially the same as 660 of April.

621.392 2741

Thévenin's Theorem—"Cathode Ray" (*Wireless World*, vol. 55, p. 275; July, 1949.) Helmholtz stated and used this theorem 30 years before Thévenin independently enunciated it very clearly and made it generally known. See also 1615 of July.

621.392.4 2742

Low-Frequency Discriminator—II. M., Crain. (*Electronics*, vol. 22, pp. 96-97; June, 1949.) A phase inverter which has equal anode and cathode loads is used to drive a R-C phase shifter. The output voltages behave like the voltages from conventional discriminators.

621.392.41:621.317.729 2743

An Electrolytic Tank for the Measurement of Steady-State Response, Transient Response, and Allied Properties of Networks—A. R. Boothroyd, E. C. Cherry, and R. Makar. (*Proc. IEE* (London), vol. 96, pp. 163-177; May, 1949.) A computer based on an analogy due to P. J. Daniell (Ministry of Supply Servo Library, Ref. B.39), relating the impedance function of a linear network of lumped elements to the potential distribution and current flow set up in a uniform sheet of conducting material by point electrodes. An over-all accuracy within 1 per cent has been obtained by the elimination of tank boundary errors and of electrode polarization troubles.

621.392.5 2744

Matrix Analysis of Linear Networks Including Active Quadripoles—A. Pinciroli and A. Tarabozetti. (*Alta Frequenza*, vol. 18, pp. 73-82; April, 1949. In Italian, with English, French, and German summaries.) Active and passive networks are considered as systems of 4-terminal components and this concept is applied to the study of networks which include tubes. General results are thus simply derived.

621.392.5 2745

The Synthesis of Passive, Resistanceless Four-Poles that may violate the Reciprocity Relation—B. D. H. Tellegen. (*Philips Res. Rep.*, vol. 3, pp. 321-337; October, 1948.) An investigation of the most general quadripoles of this type. They can be realized by means of inductors, capacitors, ideal transformers, and ideal gyrators. The "order" of a quadripole is the order of the differential equation of its free oscillations. There are two types of quadripole for each order, either of which can be transformed into the other by connecting an ideal gyrator to any of their terminal pairs. Necessary and sufficient conditions for realization are derived. See also 980 of May.

621.392.5 2746

The Double-T Resistance-Capacitance Network—L. Gerardin. (*Rev. Tech. Comp.* (France), no. 12, pp. 5-15; May, 1949. In French with English summary.) Analysis is based on the matrix theory of passive quadripoles. Transmission characteristics are fully discussed, numerous curves being given for particular cases, and general relations between the values of the circuit components are derived for the frequency at which the transmission is zero. The principal application of the double-T network, besides measurement or filter circuits, is in amplifier feedback circuits, where its use enables if amplifiers of high quality to be

produced cheaply, as well as oscillators with little distortion. Examples of such applications are discussed.

621.392.5:534.321.9 2747

Improved Ultrasonic Delay Lines—F. A. Metz, Jr. and W. M. A. Andersen. (*Electronics*, vol. 22, pp. 96-100; July, 1949.) Experiments were carried out to find a solid medium from which lines having delays of 3 μ s or more could be constructed for a carrier frequency of at least 10 Mc and a bandwidth greater than 2 Mc. Fused quartz and forged Mg alloys were found to give the least attenuation. The bandwidth of a solid delay line using cemented crystals was found to be too narrow for the storage of narrow pulses. Bonding between the crystal and the delay line was improved by pressure mounting, which gave an increased bandwidth. Tables of results, circuit diagrams, and oscillograms are given. See also 1578 of 1948 (Arenberg).

621.392.52 2748

General Forms of Ladder-Filter Half-Sections classed according to the Value of the Image-Impedance Transfer Index—J. E. Colin. (*Cables and Trans.* (Paris), vol. 3, pp. 229-247; July, 1949.) All inductances and capacitances are considered as positive, without loss and without mutual inductance. Definitions are given and fundamental ideas are reviewed. Discussion of the general laws for ladder filters is limited to those with direct application to sections with one or with two cut-off frequencies. Ladder filters of this type are classified and discussed and their characteristics are tabulated.

621.392.52 2749

Simplification of Bandpass Filter Calculations Using Curves applicable to any Bandwidth—J. C. Stewart and K. M. Garven. (*Commun. Rev.*, vol. 1, pp. 18-23; September, 1948.) Curves are plotted giving the attenuation as a function of the parameter y defined by

$$(f_2 \times f_1)y = f \times (f_1/f_2/f)$$

where the pass band is between frequencies f_1 and f_2 , and f is the operating frequency. Such curves can be applied to filters of any bandwidth and frequency. The calculation of the curves and procedure for using them are discussed; further details are given in Data Sheets Nos. 3-5 supplied with the journal.

621.392.52:621.317.729 2750

Empirical Determination of Wave-Filter Transfer Functions with Specified Properties—J. F. Klinkhamer. (*Philips Res. Rep.*, vol. 3, pp. 60-80 and 378-400, February and October, 1948.) The position of the transmission bands in the frequency spectrum, the permissible variation of the attenuation within these bands, and the position and minimum attenuation of the attenuation bands are supposed to be given. A method of determining the transfer function is described which is based on measurements in an electrolyte tank. The method is applicable to filters with several transmission and attenuation bands and is more general than that of Cauer (392 of 1942) though closely related to it. When the filter has one transmission band and one attenuation band, or several transmission bands and attenuation bands with equal attenuation properties, the results of the two methods are identical. The procedure adopted in the actual determination of a transfer function is fully described.

621.392.52:621.394.813 2751

Effects of Filtering on Telegraphy Distortion—H. Gardère. (*Cables and Trans.* (Paris), vol. 3, pp. 248-261; July, 1949.) If the total distortion of a communication link due to considerable variations of signal level and supply voltage is to be reduced to less than 5 per cent, that due solely to filtering must be small, probably not exceeding about 1 per

cent. The results of a study of the distortion of an elementary signal are applied to a theoretical low-pass filter and to a section of an actual low-pass filter. From this it appears that the required low distortion can only be attained with a bandwidth 1.5 times the telegraphy frequency.

621.392.52:621.395.44 2752

Band-Pass Filter, Band-Elimination Filter and Phase-Simulating Network for Carrier Program Systems—F. S. Farkas, F. J. Hallenbeck, and F. E. Stehlik. (*Bell Sys. Tech. Jour.*, vol. 28, pp. 196-220; April, 1949.) Design details and performance of three units for the carrier system noted in 2905 below.

621.395.665.1 2753

Contrast Expansion—L. J. Wheeler. (*Wireless World*, vol. 55, p. 277; July, 1949.) Correction to 2171 of September.

621.396.611.011.4:621.316.761.2 2754

Temperature Compensation of Oscillator Circuits—E. Roske. (*Funk und Ton*, vol. 3, pp. 328-340; June, 1949.) The temperature coefficients of capacitors made from the various ceramic products of the Hecho, Hermsdorf A. G. range from positive values of $90-180 \times 10^{-6}$ per 1° C. for calit to negative values of $680-860 \times 10^{-6}$ per 1° C. for capacitor. With proper selection and adjustment of trimmer capacitors it is thus possible to compensate for the positive temperature coefficients associated with normal inductors and capacitors and obtain a circuit whose temperature coefficient of frequency is nearly zero. Several numerical examples are given, including a series-parallel arrangement which reduces the capacitance temperature coefficient of a variable air-dielectric capacitor to a small negative value which is practically constant over the whole range.

621.396.611.1 2755

Q: How Many Kinds Are There?—"Cathode Ray" (*Wireless World*, vol. 55, pp. 267-271; July, 1949.) Consideration of the various interpretations of the symbol, as applied to coils and capacitors, and of their interconnection.

621.396.611.21:621.395.44 2756

A Crystal Oscillator for Carrier Supply—H. N. Hansen. (*Commun. News*, vol. 10, pp. 1-15; January, 1949.) All carrier frequencies of the system discussed in 2356 of 1948 (Bast, Goedhart, and Schouten) are derived from a single frequency of 60 kc, generated by a crystal-controlled master oscillator of the Colpitts type, in which the coil is replaced by the quartz crystal in series with a small capacitor serving for exact frequency adjustment. Frequency stability requirements and causes of drift are discussed, and the stability obtainable with a given crystal and a given tube are calculated. Results can be expressed in terms of straightforward equations, which are applied to a particular case. A practical circuit is given. The frequency stability of the well-known bridge-stabilized crystal oscillator is analyzed similarly.

621.396.615:621.396.611.32 2757

Phase-Shift Oscillators with Very Tight Coupling—M. Soldi. (*Alta Frequenza*, vol. 18, pp. 52-68; April, 1949. In Italian, with English, French, and German summaries.) The operating conditions are examined for single-tube oscillators with coupling much tighter than that necessary for self-oscillation. The R-C phase-shifting network may be either of the high-pass or low-pass type. The latter is particularly considered; the waveform in this case resembles that of a multivibrator.

621.396.615.17:621.317.755 2758

Shock-Impulsed Spiral Time Base—G. H. Rawcliffe. (*Wireless Eng.*, vol. 26, pp. 242-244;

July, 1949.) An impulse is applied to an L-C-R circuit and the resulting damped oscillation is split by a C-R circuit into two components in quadrature which are applied to the X and Y plates of a cr tube. An appendix discusses the geometry of the spiral and its relation to the Q of the oscillatory circuit. A similar circuit was described by Blok (4540 of 1938).

621.396.615.17:621.385.38 2759
A Thyatron Square-Wave Generator—L. Reiffel. (*Rev. Sci. Instr.*, vol. 20, pp. 218-219; March, 1949.) With argon-filled tubes the deionization time limits the frequency at which good square-waves can be produced to about 12 kc, but this may possibly be extended to 40 kc with hydrogen filling. Square waves of amplitude 1 kv can be obtained.

621.396.622.63 2760
Crystal Detectors—O. Döhler. (*Elektrotechnik*, (Berlin), vol. 3, pp. 167-175; June, 1949.) The physical properties of crystal detectors are reviewed, production methods in Germany and abroad are described, and applications in radio technique are discussed.

621.396.622.63 2761
Crystal Rectifiers—(*Radio Tech. Dig.* (France), vol. 3, pp. 7-19; February, 1949.) French version of 25 of February (Evans).

621.396.645 2762
Certain Additional Parameters of Valve [amplifier] Circuits—M. M. Ayzanov. (*Radio-tekhnika* (Moscow), vol. 4, pp. 73-75; May and June, 1949. In Russian.) A general method is proposed for studying multi-stage amplifiers including feedback circuits. The amplifier is replaced by an equivalent quadrupole system (Fig. 1) and various parameters of this system are derived.

621.396.645 2763
Earthen-Grid Power Amplifiers: Parts 1 & 2—P. A. T. Bevan. (*Wireless Eng.*, vol. 26, pp. 182-192 and 235-242; June and July, 1949.) The maximum power output and sideband response are compared for earthed-grid and earthed-cathode rf amplifiers used in television transmitters. The necessary driving-power and modulation requirements are considered and a practical circuit is given for a grid-modulated earthed-grid amplifier, driven by a cathode follower, with an output of 50 kw and a bandwidth of 6 Mc. Complete neutralization and adjustment procedure for such an amplifier is described and power-gain control for two methods of neutralization is discussed. Filament heating is considered and the electrical and mechanical arrangements are illustrated for 10-kw and 25-kw FM earthed-grid coaxial-line amplifiers for the range 88 to 108 Mc, and also for a 50-kw earthed-grid parallel-line push-pull amplifier.

621.396.645 2764
Amplification by Direct Electronic Interaction in Valves without Circuits—Guénard, Berterrotière, and Dohler. (See 2974.)

621.396.645.029.3 2765
Tunable A.F. Amplifier—O. G. Villard, Jr. (*Electronics*, vol. 22, pp. 77-79; July, 1949.) A variable-frequency circuit which can be used both as an af oscillator from 200 to 10,000 cps and as a selective amplifier for rejecting or emphasizing a particular frequency in this range.

621.396.645.029.42:621.362 2766
A Tuned Low-Frequency Amplifier for use with Thermocouples—D. A. H. Brown. (*Jour. Sci. Instr.*, vol. 26, pp. 194-197; June, 1949.) The radiation incident on the thermocouple is chopped at 5 cps by means of a sectored disk and the thermocouple output is applied to an amplifier tuned to this frequency. The

amplifier has a bandwidth of only 0.63 cps and a specially designed input stage, with a resulting low noise level. The design of an associated input transformer and a mechanical rectifier for the amplified signals is also described.

621.396.645.371 2767
When Negative Feedback isn't Negative—"Cathode Ray." (*Wireless World*, vol. 55, p. 277; July, 1949.) Corrections to 2197 of September.

621.396.645.371 2768
Negative-Feedback Amplifiers—C. F. Brockelsby. (*Wireless Eng.*, vol. 26, p. 247; July, 1949.) Author's reply to comment by McLeod (2196 of September) on 1910 of August.

621.396.662 2769
Calculation of Stagger-Tuned Circuits—F. Juster. (*Toute la Radio*, vol. 16, pp. 207-210; July and August, 1949.) Complete design formulas for 2, 3, or 4 circuits in cascade are tabulated and their use is illustrated by a numerical example.

621.396.69 2770
New Radio Components in the World Market—M. Alixant. (*Radio Tech. Dig.* (France), vol. 3, pp. 21-47; February, 1949.) A detailed review of American and European tubes, rectifiers, capacitors, transformers, coils, cr tubes, voltage-stabilizing tubes, microphones, and loudspeakers now available.

621.397.645.371 2771
Cathode-Compensated Video Amplification: Parts 1 & 2—A. B. Bereskin. (*Electronics*, vol. 22, pp. 98-103 and 104-107; June and July, 1949.) A feedback method, resulting in simpler design, reduced cost, improved linearity, and nearly constant amplitude and time delay over the useful frequency range of operation. Compensating procedure is described in detail. A general formula for the gain is obtained and special cases are discussed. The input admittance is derived theoretically and values obtained are compared with experimental results. The performance characteristics of this and other types of amplifier are compared. For earlier work see 847 of 1945.

621.3.015.3 2772
Pulses and Transients in Communication Circuits [Book Review]—C. Cherry. Chapman and Hall, London, 317 pp., 32s. (*Wireless Eng.*, vol. 26, p. 199; June, 1949.) The book is intended to "bridge the gap between simple alternating-current theory and operational methods." It is mainly concerned with the problem of estimating transient response, given the amplitude and phase characteristics. Approximate methods of general application are discussed, rather than precise calculations for given network configurations.

621.319.55 2773
Elektrische Kippschwingungen [Book Review]—H. Richter. Publisher; S. Hirzel, Leipzig, 1940, 154 pp., 11.50 RM. (*Akus. Zeit.*, vol. 6, p. 261; July, 1941.) Mathematical theory and practical circuits.

GENERAL PHYSICS

53 2774
Integral and Series Representations, in Rotation-Paraboloid Coordinates, for the Different Types of Wave of Mathematical Physics—H. Buchholz. (*Zeit. Phys.*, vol. 124, pp. 196-218; 1948.)

53.081+621.3.081 2775
On the Rationalization of Units and of the Formulae of Electricity and Magnetism. For and Against—L. Bouthillon. (*Bull. Soc. Franç. Élec.*, vol. 9, pp. 351-368; July, 1949.) Historical review, with comparison of the systems

proposed by Giorgi, Darrieus, and Sommerfeld. A note is added by É. Brylinski.

531.26 2776
Calculation of the Potential from the Asymptotic Phase: Part 2—C. E. Fröberg. (*Ark. Mat. Astr. Fys.*, vol. 36, 55 pp; May 4, 1949. In English.) In part 1 (3213 of 1948, whose U.D.C. should be as above) a rather complicated formula corresponding to Born's approximation was derived for determining the interaction between two particles from the phase shift under conditions of elastic scattering. A simplified formula is here given which can be generalized. A second approximation is also derived and methods of obtaining higher approximations are indicated. Necessary convergence conditions are deduced. The well potential, the Gauss potential, and the Yukawa potential are considered specially.

534.21:548 2777
Axial Length-Oscillations of a Straight Rod of Crystalline Material—R. Bechmann and V. Petrzilka. (*Zeit. Phys.*, vol. 122, pp. 589-599; 1944.) Theory of the elastic coupling between the longitudinal and transverse degrees of freedom explains the inclination observed between the direction of motion and the direction of wave propagation in the material. The direction of motion is determined by the polar surface of the fourth order and the nodal planes are tangential to this surface. Investigations with a number of X-cut rods, the angle between the rod axis, and the crystallographic z-axis ranging from 20° to 160°, confirm the theory.

534.21:548:549.514.51 2778
Elastic Natural Oscillations of a Rectangular Quartz Parallelepiped—R. Bechmann. (*Zeit. Phys.*, vol. 122, pp. 510-526; 1944.) Continuation of 860 of 1945. Experimental results for crystals of various dimension ratios are compared with the values to be expected theoretically. Agreement is in general satisfactory for longitudinal vibrations, though discrepancies occur both in this case and also in the special case of crystals of cubical shape. To get agreement for transverse oscillations it is necessary to introduce a correction factor. See also 2187 of 1943.

535.42:535.13 2779
Diffraction of Plane Light Waves by Black Screens—É. Durand. (*Rev. d'Optique*, vol. 28, pp. 325-351; June, 1949.) A formula obtained by the superposition of plane monochromatic waves, which is rigorously equivalent to Kirchhoff's formula, facilitates the passage from diffraction phenomena at a finite distance, of the Fresnel class, to phenomena at infinity, of the Fraunhofer type. The light vibrations are considered as scalar quantities, the modifications introduced by electromagnetic theory are only studied for systems of cylindrical symmetry. Semi-infinite screens, systems of parallel slits, and rectangular and circular holes are considered and also the bearing of the results on general electromagnetic theory and Huyghens' principle.

537.122:538.3 2780
On the Paraxial Electron-Optic Image—F. Borgnis. (*Helv. Phys. Acta*, vol. 22, pp. 261-264; June 30, 1949. In German.) Continuation of 1351 of June. The formation of real and of virtual images is considered.

537.525.8 2781
Some Aspects of the Glow Discharge between Coaxial Cylinders in the Presence of a Non-Homogeneous Axial Magnetic Field—J. M. Somerville, K. S. W. Champion, and E. K. Bigg. (*Aust. Jour. Sci. Res., Ser. A*, vol. 1, pp. 400-411; December, 1948.)

538.114 2782
Some Present Views on the Theory of

- Ferromagnetism**—L. Néel. (*Bull. Soc. Franç. Élec.*, vol. 9, pp. 308–315. Discussion, pp. 315–318; July, 1949.)
- 538.3:537.11 2783
The Law of Action between Moving Electric Charges, Theory and Applications—F. Guéry. (*Bull. Soc. Franç. Élec.*, vol. 9, pp. 262–272; June, 1949.) A consistent theory of such action is here developed from first principles. Although Maxwell's theory is universally accepted, and Lorentz' theory is merely Maxwell's theory applied to the electron, Lorentz' theory appears to violate Newton's third law of motion; this is because the part played by the electrons producing the electromagnetic field is neglected. Applications to problems of terrestrial electricity and magnetism are discussed.
- 538.311 2784
Production of a Uniform High-Frequency Field—E. Roeschen. (*Funk und Ton*, vol. 3, pp. 341–346; June, 1949.) The field due to the current in a circular coil is first calculated in terms of Legendre functions and the formulas are then applied to discussion of the field due to the currents in a symmetrical arrangement of two circular coils. The field between two such pairs of coils suitably dimensioned and spaced is essentially uniform for a considerable distance from the midpoint of the system.
- 538.566:537.562 2785
Plane Waves in an Ionized Gas with Static Electric and Magnetic Fields Present—V. A. Bailey. (*Aust. Jour. Sci. Res., Ser. A*, vol. 1, pp. 351–359; December, 1948.) General equations are derived which specify such waves to a first approximation when their amplitudes are small. The determinantal equation of dispersion is deduced and the nature of its roots is discussed. Under suitable conditions, some of the roots are associated with wave-groups which grow as they progress, and others with waves which grow with time. Previous results for electromagnetic propagation, plasma oscillations etc., are included as special cases. Applications to electrical oscillations, noise in discharge tubes, and cosmic noise are indicated.
- 539.23:537.311.31 2786
Reversible Effects of the Adsorption of Gases on the Electrical Conductivity of Very Thin Metallic Layers—N. Mostovetch. (*Compt. Rend. Acad. Sci. (Paris)*, vol. 228, pp. 1702–1704; May 30, 1949.) Experiments with layers of Mo, Pt, Rh, Ni, Au in low-pressure atmospheres of air, N, H, O, CO₂ show that the resistance of layers with negative temperature coefficients of resistance diminishes with adsorption of gas and increases reversibly when the adsorbed gas is set free again. The resistance of thicker layers with positive temperature coefficients of resistance, however, increases with gas adsorption and decreases on degassing. At low temperatures the effect is much more pronounced and the adsorption greater.
- 621.385.832 2787
Application of a Variation Method to the Theory of the Electric and Magnetic Deflection of Electron Beams—W. Glaser. (*Ann. Phys. (Lpz)*, vol. 4, pp. 389–408; May 6, 1949.) The principal results of a previous paper (1577 of 1939; corrections, 2168 of 1941) are summarized and it is shown that the results of Picht and Himpan for the electric deflection of electron beams (3091 of 1941) are included as a particular case of the author's more general theory when this is limited to purely electric deflection and stray lateral fields are absent.
- 538.1:538.56 2788
Elements of Electromagnetic Waves [Book Review]—L. A. Ware. Publishers: Pitman and Sons, London, 203 pp., 20s. (*Wireless Eng.*, vol. 26, p. 245; July, 1949.) Intended to meet the need for an elementary introduction to the basic ideas of electromagnetic theory; essentially mathematical in character and assumes a knowledge of calculus and fundamental ac theory.
- GEOPHYSICAL AND
EXTRATERRESTRIAL PHENOMENA**
- 523.53:621.396.9 2789
Radio Doppler Investigation of Meteoric Heights and Velocities—Manning, Villard, and Peterson. (See 2801.)
- 550.372:621.317.3 2790
Ground-Conductivity Measurements in Schleswig-Holstein—Grosskopf. (See 2832.)
- 551.510.535 2791
On Magnetic Triple Splitting in the Ionosphere—W. Dieminger and H. G. Möller. (*Naturwiss.*, vol. 36, pp. 56–57; May, 1949.) Triple splitting is frequently observed in high latitudes, but observations at Lindau über Northeim show that it sometimes occurs in medium latitudes. The third component f_3 has only been observed there when the f_o and f_z components show no definite limiting frequencies, but are split up into many lines, giving a feathery effect on the record. The f_3 component then appears as a single line. Sometimes the feathering is so wide that f_3 disappears within it. These effects occur during winter nights. Explanations are suggested.
- 551.510.535 2792
The Ionosphere over Mid-Germany in May 1949—Dieminger. (*Fernmeldetechn. Z.*, vol. 2, p. 223; July, 1949.) Continuation of 2519 of October. Abnormal values of critical frequencies are noted.
- 551.510.535 2793
The Influence of Vertical Ionic Drift on a "Chapman Region"—C. B. Kirkpatrick. (*Aust. Jour. Sci. Res., Ser. A*, vol. 1, pp. 423–442; December, 1948.) A theoretical discussion of an ionized region in which ion production and decay occur. Methods of computing the electron density are evolved for both moving and static layers. The effect of ion drift is investigated for conditions corresponding to those of the E layer and the solar atmospheric tide, and the departure from normal Chapman behavior is determined.
- 551.510.535:621.396.11 2794
The Longitude Effect of the F₂ Ionospheric Layer and Ionosphere Forecasting—F. Oboril and K. Rawer. (*Compt. Rend. Acad. Sci. (Paris)*, vol. 228, pp. 1962–1963; June 20, 1949.) The world zonal divisions decided on at the 1944 international radio-propagation conference, Washington, are found unsatisfactory, particularly for radio links with Africa. Comparisons between results obtained at various stations situated in different parts of the world but with approximately the same latitudes, indicate that the F₂ layer in Africa and in Europe corresponds closely to that in Asia. It is not correct to assign Africa and Europe to zone I; they belong properly to zone E. The Washington decisions were based on idealized geomagnetic coordinates, but between these and the actual geomagnetic data there is a very pronounced difference. The real geomagnetic equator, given by zero inclination, is well to the north of the geographic equator for both Africa and Asia. If a magnetic control of the ionospheric ionization actually exists, it should be related to the true geomagnetic distribution. It is suggested that a better zonal distribution would be as follows:—zone W, between 40°W and 100°W; zone E, between 0° and 160°E. Europe and the greater part of Africa would thus belong to zone E and zone I would include mainly the Atlantic and Pacific Oceans.
- 551.510.535:621.396.11 2795
The Investigation and Forecasting of Ionospheric Conditions—Appleton. (See 2894.)
- 551.510.535(98) 2796
Observations Made on the Ionosphere during Operations in Spitsbergen in 1942–43—A. B. Whatman. (*Proc. Phys. Soc. (London)*, vol. 62, pp. 307–320; May, 1949.) The observations were made between October 12, 1942 and June 8, 1943. High-frequency observations were taken with an early model of Admiralty equipment Type 249, described in 2240 of 1948 (Thomas and Chalmers). Each region of the ionosphere is considered in turn; the same main regions are found as elsewhere, but there are many abnormalities, including the "polar spur." Ionization often changes very rapidly. The effects of magnetic storms are described.
- 551.594.21:621.396.822 2797
Electromagnetic Noise of Thunderclouds—Y. Rocard and J. L. Steinberg. (*Compt. Rend. Acad. Sci. (Paris)*, vol. 228, pp. 1960–1962; June 20, 1949.) The principles used by Haefl in the electron-wave tube (1825 of July) may explain qualitatively certain effects observed by the authors and concerned with (a) the unexpected amplification of broadcasting signals, and (b) the uhf radio noise from thunderclouds. A solar-noise recorder operating on 1,200 Mc, when its parabolic antenna was directed toward a thundercloud, registered a power of 6×10^{-22} w per cycle per m² of antenna receiving surface, corresponding to numerous packets of noise radiation each lasting from a few seconds to half a minute. On another occasion a thundercloud gave noise packets more detached from one another and lasting longer, but not more than a minute, with a mean power of 4×10^{-22} w/cycle/m². In the same conditions the solar noise radiation on the same frequency was very steady, with a power of 25×10^{-22} w/cycle/m².
- 551.594.221 2798
Experimental Investigations of Resistance and Power within Artificial-Lightning Current Paths—H. Norinder and O. Karsten. (*Ark. Mat. Astr. Fys.*, vol. 36, part 4, 48 pp.; May 9, 1949. In English.) Apparatus and methods are fully described. Calculations based on the experimental results indicate that the internal resistance of a lightning path of length 1 km is of the order of 200 Ω. With the added resistances of branch paths within the cloud it would thus appear that only aperiodic or quasiperiodic lightning discharges can occur. This conclusion is fully borne out by Norinder's observations.
- 551.594.221:621.315.23 2799
Lightning Current Observations in Buried Cable—H. M. Trueblood and E. D. Sunde. (*Bell Sys. Tech. Jour.*, vol. 28, pp. 278–302; April, 1949.) An account of investigations in the territory round Atlanta, Georgia, during three seasons. The duration of lightning currents was found to be considerably longer than the average ordinarily assumed. The time to half-value of intense currents is of the order of 150 μs, with greater values for lower currents.
- LOCATION AND AIDS TO
NAVIGATION**
- 534.321.9:526.956.5 2800
Indicating and Recording Echo Sounder PEK-3G—S. von Melsted. (*Ericsson Rev.*, no. 1, pp. 10–16; 1949.) A magnetostriction 22-kc oscillator is used. The sounder has ranges of 0 to 100 m for coastal waters and 0 to 1000 m for the open sea. Design, construction, and operation are discussed. See also 2127 of 1948.
- 621.396.9:523.53 2801
Radio Doppler Investigation of Meteoric Heights and Velocities—L. A. Manning, O. G. Villard, Jr., and A. M. Peterson. (*Jour. Appl. Phys.*, vol. 20, pp. 475–479; May, 1949.) A cw

method, discussed theoretically by Manning (1392 of July), was tested during the 1948 Perseid meteor shower. Accuracy compares favorably with that of optical and other radio methods. Doppler methods have relatively great sensitivity.

621.306.932 2802
The Decca Navigator System—(*Engineering* (London), vol. 167, pp. 439-442, May 13, 1949.) For another account see 1678 of July.

621.306.932:061.3 2803
Operational Aspects of Marine Radar—(*Jour. Inst. Nav.*, vol. 2, pp. 93-158; April, 1949.) The following papers were read at a symposium held at the Institute of Navigation on February 18, 1949—Operational Factors and Operational Yields, by E. Parker and L. S. Le Page. The Fitting and Use of Navigational Radar, by H. R. Whitfield, A. Harrison, and T. J. Pope. Experience in Fitting Radar to Ships, by B. S. Millard. Constructing a Marine Radar to Operational Requirements, by B. R. Davies and L. W. Brown. Some Navigational Experience with Marine Radar, by O. S. Puckle. On Increasing the Radar Echoing Characteristics of Buoys and Small Boats, by A. L. P. Milwright. Charts and Chart Matching Devices, by P. G. Satow. The Operational Value of Shipborne Radar, by F. J. Wylie and M. W. Kaye. Methods of Using Shore Based Harbour-Super-Vision Radar, by W. R. Colbeck. Shore-Based Radar as an Aid to the Operation of Ferries, by L. D. Price. Radar in Ships of the United States Lines [summary only], by A. H. Andrews. Some American Views on the Operation of Marine Radar [summary only], by E. J. Isblater and W. R. Griswold. The Present Outlook, by R. F. Hansford. The full papers are included except where otherwise indicated; some of them are discussed on pp. 138-142.

621.306.933 2804
The Multiple-Track Range—M. Beard. (*Proc. IEE* (London), vol. 96, pp. 245-251; May, 1949.) A short-distance radio navigational aid similar in principle to Gee and Loran. Experimental equipment which was used near Sydney is described, accuracy and results of trials are discussed. See also 2527 of October (Downes).

621.306.933.23:621.315.2 2805
Landing Cable and its Possible Applications To-Day—S. Ostrovskow. (*Unde Elec.*, vol. 29, pp. 255-267, June, 1949.) Experiments in France in the period between the two world wars are reviewed. The main points of the theory of the field of such cables carrying of current are outlined and an automatic landing system is described.

621.306.9:621.385 2806
German Development of Modulator Valves for Radar Applications [Book Notice]—B.I.O.S. Final Report No. 1746. H.M. Stationery Office, London, 26 pp., 3s.

MATERIALS AND SUBSIDIARY TECHNIQUES

535.37 2807
The Electron Trap Mechanism of Luminescence in Sulphide and Silicate Phosphors—J. S. Johnson, F. E. Williams, and G. F. J. Garlick. (*Proc. Phys. Soc.* (London), vol. 62, pp. 317-319; May, 1949.) Comment on work noted in 2801, 3080, and 3421 of 1948.

538.213+538.541:669-41 2808
Permeability and Eddy Currents in Sheet-Metal Cores at Very High Frequencies—R. Feldtkeller. (*Frequenz*, vol. 3, pp. 111-116; April, 1949.) The behavior of the complex initial permeability at low and at high frequencies differs, in general, from that calculated for homogeneous sheet. The difference can be explained by assuming different values for the local initial permeability (a) within the material

and (b) near the surface. The change of the initial permeability from the surface to the middle is calculated from the values of the complex permeability.

538.22 2809
Nonmetallic Materials developed with Improved Magnetic Properties—(*Materials and Methods*, vol. 29, pp. 54-55; June, 1949.) The properties of ferrites, including various grades of "ferroxcube" made by the Philips Company, are described. Important features are high resistivity, high permeability, and low losses.

538.245 2810
A Recent Development in Soft Magnetic Materials—H. H. Scholefield. (*Jour. Sci. Instr.*, vol. 26, pp. 207-209, June, 1949.) The development, manufacture, structure, and properties of a new Ni-Fe material, "H.C.R.," having a rectangular hysteresis loop and suitable for magnetic-amplifier and heavy-current mechanical-rectifier circuits.

546.289:537.311.33 2811
The Electrical Conductivity of Germanium—E. H. Putley. (*Proc. Phys. Soc.* (London), vol. 62, pp. 284-292, May, 1949.) Experimental results are described and are explained by the theoretical calculations of Shifrin (2218 of 1946). The concentration of impurity centers and of thermally excited electrons and the position of the impurity levels are deduced.

549.514.51 2812
Production of Large Artificial Quartz Crystals—In 1964 of August please alter the name of the second author to M. Huot de Longchamp.

620.197.19 2813
A New Moisture-Sealing Compound—W. B. R. Agnew. (*Electronics*, vol. 22, pp. 165-168; July, 1949.) A mixture of 60 per cent Gilsonite and 40 per cent Hydrolene has satisfactory sealing properties, and is neither brittle at -55°C nor soft at +90°C. Gilsonite is a natural asphaltum mined in Utah; Hydrolene is the trade name of a Standard Oil Company brand of petroleum asphaltum.

621.315.59+621.314.63 2814
Semi-Conductors and Rectifiers—N. F. Mott. (*Engineering* (London), vol. 167, pp. 510-511; June 3, 1949.) Long summary of the 40th Kelvin lecture. General discussion of the mechanism of conduction in both excess and defect semiconductors and of the theory of rectification.

621.315.616 2815
Developments in Insulating Materials—C. G. Garton. (*Elec. Rev.* (London), vol. 145, pp. 93-96; July 15, 1949.) Terylene (poly-ethylene-terephthalate) a new filament-forming material, is not yet commercially available but promises to provide strong insulating fabrics little affected by either temperature or humidity. It is stable at 150°C and combines toughness with flexibility from sub-zero temperatures up to 60° or 70°C.

P.T.F.E. (poly-tetrafluor-ethylene) has the same low dielectric constant as polyethylene, does not soften or decompose at 250°C and is chemically inert. Although difficult to mold, it can be sintered and has been produced in thin films.

P.C.T.F.E. (poly-chlor-trifluor-ethylene) can be molded. It has mechanical and thermal properties intermediate between polyethylene and P.T.F.E., but a higher dielectric loss.

621.318.22:621.775.7 2816
Magnets from Pure Iron Powder—R. Steinitz. (*Metal Progress*, vol. 55, pp. 858-868; June, 1949.) The properties of iron powder consisting of particles of colloidal size (0.2μ or less) are quite different from those of solid iron. Magnets have been made in fairly large quantities

from such iron powder by the Société d'Électrochimie, d'Électrometallurgie, et des Aciéries Électriques d'Ugine, Grenoble, France, and much theoretical work has been done by Néel (3151 and 3152 of 1947). The powder is produced by the decomposition and reduction of iron formates. The method used for the production of magnets could be applied to other metals and to certain alloys. See also 1053 of 1948 (Stoner and Wohlfarth).

621.775.7 2817
Powder Metallurgy—Nguyen Thien-Chi. (*Ann. Radiolec.*, vol. 4, pp. 233-248; July, 1949.) General principles, with examples of their application for the production of refractory pseudo-alloys, cupro-nickel, permanent magnets, alloys for welding to glass, special types of cathode, etc.

549.514.51 2818
Etch and Percussion Figures, and Twinning of Quartz [Book Notice]—N. N. Padurov. F.I.A.T. Final Report No. 1098. H.M. Stationery Office, London, 41 pp., 7s. 6d.

620.179:621.38/.39 2819
Electronic Principles as applied in Germany to the Testing of Materials [Book Notice]—B.I.O.S. Final Report No. 724. H.M. Stationery Office, London, 194 pp.

621.315.59+621.314.6 2820
German Research on Rectifiers and Semi-Conductors [Book Notice]—B.I.O.S. Final Report No. 725. H.M. Stationery Office, London, 52 pp.

621.315.612:621.319.4 2821
Ceramic Dielectrics for Condensers [Book Notice]—F.I.A.T. Final Report No. 892. H.M. Stationery Office, London, 14 pp., 2s.

MATHEMATICS

518.5:681.142 2822
Calculating Machines—In future the U.D.C. number 681.142 will be used for calculating machines, in preference to the number 518.5 used hitherto.

681.142 2823
Programme Design for a High-Speed Automatic Calculating Machine—M. V. Wilkes. (*Jour. Sci. Instr.*, vol. 26, pp. 217-220; June, 1949.) Problems to be solved by means of a digital machine must first be reduced to a series of arithmetical operations. These must then be expressed in the code appropriate to the machine. This process is discussed with special reference to the EDSAC (3448 of 1948). Simple examples are given, specially designed to illustrate the use of conditional orders and the way in which ordered arithmetical operations may be performed.

681.142 2824
Electronic Analogue Computers—D. Fidelman. (*Radio and Television News, Radio-Electronic Eng. Supplement*, vol. 11, pp. 3-6, 30; December, 1948, and vol. 12, pp. 16-19, 30; January, 1949.) General design, and specific circuits and techniques used in the solution of equations.

681.142:681.17 2825
Electronic Computer Applications—Fidelman. (See 2886.)

51(083.5) 2826
Tafeln höherer Funktionen. (Tables of Higher Functions) [Book Review]—Jahnke-Emde. B. G. Teubner, Leipzig, 4th ed. 1948, 300 pp., 11.80 DM. (*Frequenz*, vol. 3, p. 121; April, 1949. Text in German and English.) The 1938 edition has been enlarged by the inclusion of some spherical and cylindrical functions. Many savants have assisted, by corrections and additions, in enhancing the well-known reliability and many-sidedness of the work.

- 517.43: [5+0] 2827
Operatorenrechnung nebst Anwendungen in Physik und Technik (Operational calculus with applications in Physics and Technics) [Book Review]—K. W. Wagner, J. A. Barth, Leipzig, 1940, 448 pp., 29.60 RM. (*Akus. Zeit.*, vol. 6, pp. 195-196; May, 1941.) After an introduction which includes an appreciation of the work of Heaviside, the general Laplace transformation and its operational laws are considered. The presentation is very clear. An excellent treatment of problems of low-current technics is given, including the theory of coupled systems, simple filter circuits, etc. Problems of mechanics and heat are also considered.
- 518.2(083.5) 2828
Tafeln elementarer Funktionen (Tables of Elementary Functions) [Book Review]—F. Emde. B. G. Teubner, Leipzig, 2nd ed. 1948, 181 pp., 11.60 DM. (*Frequenz*, vol. 3, p. 121; April, 1949. Text in German and English.) An almost unaltered reprint of the 1940 edition. The tables are principally intended for the use of the engineer and physicist.
- MEASUREMENTS AND TEST GEAR**
- 531.761 2829
A Simplified Chronotron-Type Timing Circuit—J. W. Keuffel. (*Rev. Sci. Instr.*, vol. 20, pp. 197-201; March, 1949.) The chronotron was noted in 762 of 1948 (Neddermeyer et al.). The arrangement here discussed has a parallel-wire polythene-tape line, Ge-crystal detectors, and a delay-line presentation circuit in which a single amplifier is used for all pulses. Accuracy is within 10^{-9} sec.
- 531.761 2830
Electronic Timing Test Set—M. E. Krom. (*Bell Lab. Rec.*, vol. 27, pp. 176-180; May, 1949.) Time intervals are indicated directly by a tube voltmeter across a capacitor charged from a constant-current source. Ranges are 0-20 μ s, 0-100 μ s, 0-500 μ s, and 0-5 sec.
- 531.764:621.316.7 2831
Automatic Synchronous Clock and Time Control—(*Engineer* (London), vol. 187, p. 566; May 20, 1949.) Improved equipment similar to that noted in 761 of 1948.
- 621.317.3:550.372 2832
Ground-Conductivity Measurements in Schleswig-Holstein—J. Grosskopf. (*Fernmel-detech. Z.*, vol. 2, pp. 211-218; July, 1949.) The results of numerous measurements show close correlation with the well-defined geological surface formations, so that conductivities can be found approximately from a geological map. A semigraphical method is given for determining, from known ground conductivity, the field-strength distribution of a transmitter at a particular place. In the medium-wave band and in flat country, reflections at slight surface irregularities are possible.
- 621.317.3:621.396.621:621.396.822 2833
Technique of Noise Measurement for U.H.F. Receivers—G. Naday. (*Ann. Radio-élec.*, vol. 4, pp. 257-260; July, 1949.) The various factors contributing to background noise in radar receivers are enumerated and simple methods of measuring them are described. A formula is given for calculating the receiver noise factor from the results of the measurements.
- 621.317.335.2†:621.319.45 2834
A Simple Arrangement for Measuring the Capacitance of Electrolytic Capacitors—W. Schmitz. (*Funk und Ton*, vol. 3, pp. 311-314; June, 1949.) A dc instrument is used to measure the voltage across the capacitor, which is charged through a half-wave rectifier from an ac source. Use of a shunt resistor of suitable value enables the meter scale to be calibrated directly in microfarads.
- 621.317.336+621.317.78]:029.62 2835
An Impedance and Power Meter for the 144-Mc/s Band—H. A. M. Clark. (*CRSGB Bull.*, vol. 25, pp. 6-11, 19; July, 1949.) The impedance to be measured is used to terminate an accurately constructed $\lambda/4$ section of air-dielectric 70- Ω coaxial line into which a 145-Mc signal is fed. Diode probes are used to measure the voltage on the line at the end and at two points respectively $\lambda/8$ and $\lambda/4$ from the end. The resistive and reactive components of the impedance and the power delivered to it may then be calculated or derived from charts. For indications of mismatch and power measurements the instrument may be permanently connected to a coaxial feeder. Details of construction are given.
- 621.317.34+621.317.373 2836
A Precise Direct Reading Phase and Transmission Measuring System for Video Frequencies—D. A. Alsborg and D. Leed. (*Bell Sys. Tech. Jour.*, vol. 28, pp. 221-238; April, 1949.) Equipment which compares, with respect to phase and amplitude, the outputs of two channels energized from the test oscillator, one channel serving as a standard and the other containing the network to be tested. A heterodyne method is used to transfer the phase and insertion-loss of the network from the variable test-frequency to a constant if of 31 kc at which the phase and insertion-loss standards operate. The test-frequency range is 50 to 3,600 kc. A slave oscillator automatically tracks at a constant frequency-difference of 31 kc from the master oscillator. The special features of the various units of the equipment, including oscillators, modulators, phase detector, phase shifter, and attenuator, are described.
- 621.317.34:621.396.82 2837
A Simple Method of Measuring Small Swings and Modulation Indices of Frequency-or Phase-Modulated Hum and Noise—W. W. Boelens and F. L. H. M. Stumpers. (*Commun. News*, vol. 10, pp. 15-19; Jan., 1949.) Hum and noise can be determined directly from a hf signal with the aid of a special converter stage and some filters. Measurements are made with a cro; the hum from the signal can easily be distinguished from that of other sources. The modulation index is found as the ratio of a measured quantity to a constant of the equipment; the frequency swing can be deduced.
- 621.317.361 2838
Accurate Frequency Measurement—W. F. Brown. (*Wireless Eng.*, vol. 26, pp. 218-229; July, 1949.) A proposed method for use from 100 Mc to 12,000 Mc, with an error not exceeding 5 parts in 10^6 at 5,000 Mc. The frequency difference between the unknown and a crystal-checked harmonic of a variable oscillator (300 to 600 Mc) is measured by means of an if amplifier (40 to 80 Mc) to which an if oscillator is ganged for the production of an audible beat.
- 621.317.372 2839
Q-Meter Controversy—E. D. Hart. (*Wireless World*, vol. 55, p. 276; July, 1949.) Further comment on 1121 of May (Spratt). See also 2267 of September.
- 621.317.382.089.6 2840
The Absolute Measurement of Low Power at 3000 Mc/s—R. Street. (*Proc. IEE* (London), vol. 96, pp. 237-242; May, 1949.) A general method is described in which a constant-flow calorimeter of measured insertion-loss is used for the calibration of cm- λ milliwattmeters. Results of measurements on milliwattmeters using bolometer lamps, thermojunctions, and thermistors are given. Reprinted *ibid.*, vol. 96, pp. 391-396; June, 1949.
- 621.317.411† 2841
On the Measurement of Magnetic Permeability at Ultra-High Frequency—J. Soutif-Guicherd and P. Grivet. (*Compt. Rend. Acad. Sci.* (Paris), vol. 228, pp. 1796-1797; June 8, 1949.) Bernier has shown that so long as the diameter of the central conductor of a coaxial resonator is more than 10 times the skin thickness, the displacement $\Delta\lambda$ of the natural wavelength of the resonator from its normal value λ_0 when the radius of the central conductor is large, is directly proportional to the square root of the permeability of the material of the central conductor. The Q factor is equal to $\lambda_0/\Delta\lambda$. Experiments using a central ferromagnetic wire of diameter 0.5 mm verified these results qualitatively for a resonator for which $\lambda_0=3$ cm. Permeability variations were obtained by application of a constant magnetic field of several hundred gauss to the central wire.
- 621.317.7:06.064 2842
Measurement Apparatus at the Paris Fair—J. Rousseau. (*TSF Pour Tous*, vol. 25, pp. 265-266; July and August, 1949.) Brief descriptions of selected exhibits.
- 621.317.715 2843
Coil Galvanometers with Some Novel Features—G. Ising. (*Ark. Mat. Astr. Fys.*, vol. 36, 15 pp; May 4, 1949. In English.) Details of two small sensitive galvanometers, one termed a sphere galvanometer and the other a toroid galvanometer on account of the shape of the iron pole-pieces within the moving coil. The weight of the coil system does not exceed 200 mg and may be much less. The period of the sphere galvanometer is usually between 0.1 sec and 4 sec; that of the toroid type, with its two coils at the ends of a light cross arm, may be as much as 20 sec. For geophysical measurements both types may be mounted in gimbals.
- 621.317.715:621.395.645 2844
A Galvanometer Amplifier—B. Frankenhäuser and D. K. C. MacDonald. (*Jour. Sci. Instr.*, vol. 26, pp. 145-147; May, 1949.) Series feedback into a light-beam galvanometer with differential photocell stabilization enables nerve potentials of 1 to 1 μ v to be recorded.
- 621.317.723.082.742:621.386.82 2845
A Direct-Reading Dynamic Electrometer—J. van Hengel and W. J. Oosterkamp. (*Philips Tech. Rev.*, vol. 10, pp. 338-346; May, 1949.) The unknown dc voltage is applied to a parallel-plate capacitor, one plate of which vibrates periodically, thereby producing an ac voltage. This is amplified in a conventional negative-feedback circuit and the rectified output voltage is registered by a moving-coil meter. Two instruments are described: a millivoltmeter (full scale 100 mv) and a dosimeter for X-rays. Each has an apparent input resistance $>10^9 \Omega$, and input capacitance 40 pf.
- 621.317.733 2846
A Wide-Range Capacitance-Conductance Bridge—R. H. Cole and P. M. Gross, Jr. (*Rev. Sci. Instr.*, vol. 20, pp. 252-260; April, 1949.) For measurement by direct balance in the frequency range 50 cps to 5 Mc. Two circuits developed from the work of Starr (1933 Abstracts, p. 110) and Young (1134 of 1947) are used.
- 621.317.733 2847
Design Factors in a Capacity Bridge of High Accuracy—C. A. Parry. (*Commun. Rev.*, vol. 1, pp. 27-41; September, 1948.) Detailed discussion of the design of a bridge using the hybrid-coil method of measuring impedances. Formulas are derived giving the limits of accuracy attainable. Indicator performance requirements are also considered.
- 621.317.733:629.135.052 2848
A Direct-Capacitance Aircraft Altimeter—W. L. Watton and M. E. Pemberton. (*Proc. IEE* (London), vol. 96, pp. 203-210. Discussion, pp. 210-213; May, 1949.) Two insulated metal electrodes are mounted on the aircraft

and an af measurement is made of the direct capacitance between them. This capacitance is affected by the earth and the resulting very small capacitance variations are measured in the presence of other larger capacitances by the double-ratio ac bridge discussed in 2850 below, which can be made sensitive to changes of 1 μ pf. Summary noted in 1126 of May. Reprinted *ibid.*, vol. 96, pp. 379-386. Discussion, pp. 386-389; June, 1949.

621.317.733.029.3 2849

The Maxwell Bridge at Low Frequencies—V. A. Brown and B. P. Ramsay. (*Rev. Sci. Instr.*, vol. 20, pp. 236-239; April, 1949.) The bridge can be used to measure inductance and ac resistance at periods from 0.01 sec to 200 sec. The effect of induced currents in inductor core material upon the bridge circuit is discussed.

621.317.733.3 2850

Double-Ratio A.C. Bridges with Inductively-Coupled Ratio Arms—H. A. M. Clark and P. B. Vanderlyn. (*Proc. IEE* (London), vol. 96, pp. 189-202. Discussion, pp. 210-213 May, 1949.) Part 1, which is the original work of the late A. D. Blumlein, is concerned with the theory of bridges having ratio arms consisting of tightly coupled inductors. With such arms, the direct impedance between two points can be measured independently of any indirect impedances between a third point and the two terminals of the impedance being measured. When two sets of such ratio arms are combined, the bridge can be used for very large ratios of the unknown and standard impedances.

Part 2 describes a general-purpose mutual-admittance bridge for a wide range of capacitance and resistance measurement. Components can be measured in situ, without isolating them from other components of a circuit, when this bridge is used. Summary noted in 1126 of May. Reprinted *ibid.*, vol. 96, pp. 365-378. Discussion, pp. 386-389; June, 1949.

621.317.74.029.64:621.396.67 2851

A New Type of Slotted-Line Section—Wholey and Eldred. (*See* 2716.)

621.317.755:621.317.373 2852

The Measuring of Phase Angles with an Oscillograph—L. Hintzbergen. (*Microtecnica* (Lausanne), vol. 3, pp. 61-67; March and April, 1949.) The elements whose phase difference is to be measured are connected respectively to the horizontal and vertical deflection plates of the cro, and the phase relation is deduced from the shape of the ellipse displayed.

621.317.755:621.317.791 2853

Vector Voltage Indicator—P. G. Sulzer. (*Electronics*, vol. 22, pp. 107-109; June, 1949.) For another account see 2569 of October.

621.317.761:621.317.755:621.396.615.17 2854

A Circular Time-Base Frequency Comparator—T. W. R. East and A. F. Standing. (*Jour. Sci. Instr.*, vol. 26, pp. 236-239; July, 1949.) Principles and practical design.

621.317.763.029.64:621.369.611.4 2855

A 10-cm Mechanically Swept Spectrometer—P. Andrews. (*Proc. IEE* (London), vol. 96, pp. 254-256; May, 1949.) A hybrid H_{011} coaxial-mode cavity is tuned by a motor over a frequency range of ± 8 Mc once every 2 sec at any predetermined point in the 3,000-Mc band. For monitoring a pulsed transmitter, the output pulses from the cavity are rectified, lengthened, amplified, and used to give a vertical deflection on a cr tube, the horizontal deflection being controlled by a potentiometer driven by the frequency-sweep motor. Accuracy is within about $\frac{1}{4}$ Mc. See also 1130 of May (Allan and Curling).

621.317.772:621.317.2 2856

Phase Meter for Laboratories and Test Departments—G. Grübel. (*Funk und Ton*, vol. 3, pp. 315-319; June, 1949.) Two voltages V_1 , V_2 , of the same frequency and nearly equal amplitudes, are applied through identical transformers across two bridges, each of which includes a variable capacitor. The voltages developed across the other diagonals of the bridges are applied between grid and cathode in a symmetrical arrangement of two triodes, whose output voltages feed the deflection plates of a cro. The variable capacitors are mechanically coupled so that the capacitance of one increases as that of the other decreases, and the phase difference between V_1 and V_2 is given directly on a calibrated scale when phase equality is indicated on the cro. Theory of the method is given, optimum values of the circuit components are indicated, and full details of the calibration of the capacitor scale are tabulated.

621.317.79:621.396.615.12 2857

Generator for A.F. Measurements—W. N. Eldred. (*FM-TV*, vol. 9, pp. 31-38; June, 1949.) Description of the Hewlett-Packard af signal generator Type 206A. The output voltage has a known amplitude and is transmitted at a known impedance level. Distortion is less than 1 per cent. The basic accuracy depends only on the attenuator system; the indicating meter is only required to be sensitive to small changes of signal level.

621.317.79:621.396.619 2858

Modulation Meter with S-Scale and Combined Peak and Mean-Value Indication—K. H. R. Weber. (*Frequenz*, vol. 3, pp. 179-181; June, 1949.) About half of the meter scale is used for the modulation range 0 to 10 per cent and the divisions are more evenly spaced than is the case with a logarithmic scale. From 80 per cent to 105 per cent the scale is linear. The indicating instrument is of the moving-coil type, with a mirror mounted on the coil spindle to give luminous indications on the translucent scale. Basic principles are discussed and a circuit diagram is given, with details of the arrangements for checking the scale at four points.

621.317.79:621.396.712 2859

A.M. and F.M. Broadcast Station Measurements—T. Downey. (*Electronics*, vol. 22, pp. 89-93; July, 1949.) Discussion of routine operating checks and proof-of-performance measurements required by law for regular operation, and of new af and noise measurements specified for AM transmitters.

621.317.794 2860

Measurement of Centimetre-Wave Power by means of Bolometers—J. Broc. (*Compt. Rend. Acad. Sci.* (Paris), vol. 228, pp. 1937-1938; June 20, 1949.) For accurate measurement the conditions must be known under which equivalence is obtained between the heating of a bolometer wire by centimeter waves and by dc. The temperature distribution along Pt wires of diameter from 1μ to 3μ was determined from the solution of a differential equation. The cooling along the wire depends appreciably on the gas pressure; pressures of 10^{-4} mm Hg or less are advantageous. A practical wattmeter for powers from 50μ w to 0.01μ w has been constructed and tested at $\lambda=3.2$ cm. The lowest power measurable with this instrument is about 10 times less than that which can be measured with a thermistor, and the bolometer is about 100 times less sensitive to variations of the ambient temperature.

621.392.26(083.74)† 2861

Standard for Waveguides—W. H. Fenn. (*Electronics*, vol. 22, pp. 110-111; June, 1949.) Commercial standards for rectangular waveguides announced by the Radio Manufacturers Association. Inside and outside dimensions

are tabulated, together with the frequency range for the dominant TE_{10} mode.

621.396.615.17:621.392.5 2862

The Pulse-Testing of Wide-Band Networks—D. C. Espley, E. C. Cherry, and M. M. Levy. (*Proc. IEE* (London), vol. 96, pp. 186-188; May, 1949.) Discussion on 1101 of 1948.

621.396.645.001.4:537.311.33:621.315.59 2863

Testing Transistors—K. Lehovec. (*Electronics*, vol. 22, pp. 88-89; June, 1949.) If all ac components are sufficiently small, the current through the emitter and that through the collector are linearly related to the voltages between each of these and the base. The four dynamic impedances which are the coefficients in these relations can be used to describe transistor operation; they are practically independent of frequency up to about 1 Mc. Test equipment is described which gives the direct currents and voltages of transistors at the operating point, corresponding ac values for zero and infinite collector load-resistance, and current and voltage amplification values. The impedance coefficients are then easily calculated.

621.396.9.001.4:621.314.25 2864

Incremental Phase Splitter—E. Kasner. (*Electronics*, vol. 22, pp. 94-95; July, 1949.) A range-simulator circuit which produces two signals of the same frequency but differing in phase from the original signal by fixed and equal amounts; it was developed for testing radar equipment.

621.317.3+621.317.7 2865

H.F. Instruments and Measuring Techniques [Book Notice]—B. I. O. S. Final Report No. 1228. H.M. Stationery Office, London, 29 pp.

621.317.33 2866

High Frequency Measuring Techniques using Transmission Lines [Book Review]—E. N. Phillips, W. G. Sterns, and N. J. Gamara. Publisher: J. F. Rider, New York, 1947, 64 pp., \$1.50. (*Proc. Phys. Soc.* (London), vol. 62, p. 336; May, 1949.) An account of various techniques for measuring impedances and the electrical characteristics of hf cables.

OTHER APPLICATIONS OF RADIO AND ELECTRONICS

531.768 2867

A Magnetostrictive Acceleration Meter—H. Wilde and E. Eisele. (*Z. Angew. Phys.*, vol. 1, pp. 359-366; May, 1949.) A device using a block of Ni stampings, cemented into a solid block with a thermoplastic cement and provided with a multturn coil. Calibration is effected by tests with the device mounted on a blunt-pointed carrier which is allowed to fall freely from various heights into sand. The measurement range can be varied within wide limits by changing the auxiliary mass attached to the stampings.

531.787.9:621.431 2868

Wide-Range Pressure Gauge for Explosion-Pressure Investigations [in internal-combustion engines]—W. Gohlke. (*Z. Angew. Phys.*, vol. 1, pp. 347-359; May, 1949.) Detailed description of a piezoelectric gauge using a highly-damped quartz disk, of natural frequency above 100 kc, mounted in the nose of the outer shell of a sparking plug. The associated wide-band amplifier and cro sweep circuit are also described and typical oscillograms obtained with the gauge at different points of an engine cylinder are reproduced.

534.321.9:620.179.16 2869

A Visual Method for Demonstrating the Path of Ultrasonic Waves through Thin Plates of Material—C. J. Burton and R. B. Barnes. (*Jour. Appl. Phys.*, vol. 20, pp. 462-467; May, 1949.)

- 539.16.08 2870
Rejuvenation of Geiger-Müller Tubes—L. Shepard. (*Rev. Sci. Instr.*, vol. 20, pp. 217-218; March, 1949.) The central wire is heated to a dull red glow by an electric current for about 10 min during evacuation, before filling with new gas.
- 539.16.08 2871
On the Construction of Geiger-Müller Counters of the Metal Type—M. Lesage, A. Rogozinski, and A. Voisin. (*Jour. Phys. Radium*, vol. 10, pp. 212-214; June, 1949.) Details of methods adopted at the cosmic-physics laboratory at Meudon observatory.
- 539.16.08 2872
Design and Performance of a Multicellular Geiger Counter for Gamma-Radiation—D. A. Lind. (*Rev. Sci. Instr.*, vol. 20, pp. 233-235; April, 1949.)
- 539.16.08 2873
Experiments on the Possibility of Increasing the Efficiency of Gamma [ray] Counters—H. Slätis. (*Ark. Mar. Astr. Fys.*, vol. 36, 12 pp; May 9, 1949. In English.) The efficiency of G-M counters for recording μ -quanta can be increased by inserting systems of concentric metal rings between the wire and the cylinder. By means of a potentiometer, a voltage is applied to each system equal to the voltage existing there in the absence of any rings. A counter based on the above principle, with three 24-ring systems, had an efficiency 2.5 times that of a conventional counter of the same size, and also a smaller resolving time.
- 539.16.08 2874
The Effect of External Quenching on the Life of Argon-Alcohol Counters—H. Elliott. (*Proc. Phys. Soc. (London)*, vol. 62, pp. 369-373; June 1, 1949.)
- 539.16.08:621.318.572 2875
Electronic Counters for Pulses—P. Naslin and A. Peuteman. (*Onde Élec.*, vol. 29, pp. 241-254; June, 1949.) Essentially the same as 660 of April.
- 621.365.55† 2876
H.F. Dielectric Heating—G. Gregoratti. (*Elettrotecnica*, vol. 34, pp. 80-85; March 10 and 25, 1947. Reprint.) A review of theory and fields of application, with brief indication of apparatus used. *Note.* The above U.D.C. number will in future be used for dielectric heating.
- 621.383.001.8 2877
Letter Reading Machine—V. K. Zworykin, L. E. Flory, and W. S. Pike. (*Electronics*, vol. 22, pp. 80-86; June, 1949.) For another account see 2593 of October and back references.
- 621.384.6 2878
The Development of Electron Accelerators—W. Graffunder. (*Helv. Phys. Acta*, vol. 22, pp. 233-260; June 30, 1949. In German.) Theory of resonator methods of acceleration.
- 621.385.833 2879
Use of Marginal Rays in the Study of the Asymmetry of Electrostatic Lenses—F. Berstein and E. Regenstreif. (*Compt. Rend. Acad. Sci. (Paris)*, vol. 228, pp. 1854-1856; June 13, 1949.)
- 621.385.833 2880
On the Aperture Errors of Electrostatic Electron Lenses—H. Mahl and A. Recknagel. (*Z. Phys.*, vol. 122, pp. 660-679; 1944.) Theoretical discussion and experimental results.
- 621.385.833 2881
Phase Contrast in Electron Microscope Images—E. G. Ramberg. (*Jour. Appl. Phys.*, vol. 20, pp. 441-444; May, 1949.)
- 621.385.833:061.3 2882
Summarized Proceedings of Conference
- Electron Microscopy: Cambridge—September 1948**—V. E. Cosslett. (*Jour. Sci. Instr.*, vol. 26, pp. 163-169; May, 1949.)
- 621.396.9:621.867 2883
Metal Detector for Conveyors—K. Urbach. (*Electronics*, vol. 22, pp. 80-83; July, 1949.) Metal articles passing near the tank coil of a stable oscillator cause a change in oscillator output due to eddy-current, hysteresis, and dielectric-loss changes. This change in output is detected, amplified, and used to actuate alarm or marker circuits.
- 621.398:621.396.621 2884
A Telecontrolled Tunable Receiver Installation: Part 2—J. E. Benson and W. A. Colebrook. (*AWA Tech. Rev.*, vol. 8, pp. 125-145; April, 1949.) The main difference between the installation here discussed and the earlier one noted in 466 of 1945 (Benson and Ross) is that the control functions are all performed over a single ac communication channel without a dc circuit. Coarse tuning, receiver change-over, and on/off switching of beat-frequency and calibration oscillators are performed by fixed-frequency tones. Fine tuning over ± 5 kc from any coarse-tuning position, rf gain, and telemetering of the coarse-tuning setting are performed by tones of variable frequency.
- 621.785.5 2885
Surface Hardening of Metals Using H.F. [induction] Currents—C. Egidi. (*Ingegneria*, vol. 21, pp. 627-630; September, 1947. Reprint.) A general introduction covering the physical and technical principles involved.
- 681.142:681.17 2886
Electronic Computer Applications—D. Fidelman. (*Radio and Telev. News, Radio-Electronic Eng. Supplement*, vol. 12, pp. 3-6, 27 and 6-9; March and April, 1949.) Various methods of using both digital and analogue computers for the solution of engineering problems, such as those connected with gun laying, and for automatic process-control in industry.
- 621.316.7+621.38.001.8 2887
Industrial Electronic Control [Book Notice]—B.I.O.S. Final Report No. 1198. H.M. Stationery Office, London, 39 pp.
- 621.365 2888
High Frequency Heating [Book Notice]—B.I.O.S. Final Report No. 866. H.M. Stationery Office, London, 32 pp.
- 621.38/39 2889
Advances in Electronics: Vol. 1 [Book Review]—L. Marton (Ed.). Academic Press, New York; H. K. Lewis and Co., London, 1948, 475 pp., \$9.00. (*Nature (London)*, vol. 163, pp. 893-894; June 11, 1949.) A new publication analogous to *Rep. Progr. Phys.*, dealing with the physics of electrons in the free state and engineering applications of a fundamental character. Future volumes will have European as well as American contributors. This volume includes articles by various authors on electron emission, beam deflection, television pickup tubes, accelerators, the ionosphere, cosmic noise, wave propagation in the FM broadcasting band and navigation aids.
- 621.38 2890
Electronics [Book Review]—F. G. Spreadbury. Publisher: Pitman, London, 698 pp., 55s. (*Proc. Phys. Soc. (London)*, vol. 62, p. 321; May, 1949.) Many aspects of the subject are covered. A knowledge of elementary physics and mathematics is assumed. "... there is much in the book that engineers will find of value. It is not likely to appeal to physicists."
- 621.384.611.1† 2891
European Electron Induction Accelerators [Book Notice]—B.I.O.S. Miscellaneous Report
- No. 77. H.M. Stationery Office, London, 68 pp., 6s 6d.
- PROPAGATION OF WAVES**
- 538.566 2892
Propagation of Electromagnetic Waves above the Ground. Solution of the Problem of the Surface Wave—T. Kahan and G. Eckart. (*Jour. Phys. Radium*, vol. 10, pp. 165-176; May, 1949.) A detailed discussion of (a) Sommerfeld's treatment of the radiation of a dipole over ground of finite conductivity, and (b) Wehl's treatment as simplified by Noether, shows that the two are essentially the same except that Sommerfeld overlooked a factor which completely annuls the so-called surface wave. Contrary to the view expressed by Epstein (4007 of 1947) the problem is determinate and unique. Epstein's argument shows, however, that the surface wave cannot be included in the solution. Experimental results confirm these theoretical conclusions. See also 951 of May.
- 538.566 2893
On the Normal Propagation of Electromagnetic Waves in Media with Any Type of Stratification—F. Abelès. (*Rev. d'Optique*, vol. 28, pp. 279-287; May, 1949.) The equations governing propagation in stratified media are derived and two invariants of the equations are pointed out. One of these leads very simply to general formulas for the case of piles of plates with parallel faces. Herpin (3865 of 1947) has shown that a system of thin layers is equivalent to two thin layers but not to a single thin layer. Matrix theory explains this, for the matrix of a single thin layer is reversible and keeps the same form when the input and output are interchanged and the direction of propagation is reversed. This is not true for a system of thin layers.
- Analogies are pointed out between the propagation equations for stratified media and (a) those for transmission lines, (b) the canonical equations of mechanics.
- 621.396.11:551.510.535 2894
The Investigation and Forecasting of Ionospheric Conditions—E. V. Appleton. (*Proc. IEE (London)*, vol. 96, pp. 213-214; May, 1949.) Discussion on 2048 of 1948.
- 621.396.11:551.510.535 2895
The Longitude Effect of the F₂ Ionospheric Layer and Ionosphere Forecasting—Oboril and Rawer. (See 2794.)
- 621.396.11:551.510.535 2896
Measurement of the Maximum Usable Frequency on Ionospheric Paths—E. Harnischmacher. (*Compt. Rend. Acad. Sci. (Paris)*, vol. 228, pp. 1936-1937; June 20, 1949.) An account of results obtained during February and March, 1948, at Freiburg, where the F₂ critical frequency was measured a few minutes before recording the hourly ionosphere-sounding signals from Lindau, 430 km away. After correction for the F₂-layer horizontal ionization gradient, the mean value of the ratio of the muf to the critical frequency at the midpoint of the path was found to be 1.127 for the day and 1.062 for the night.
- 621.396.812.029.62(94) 2897
Radio Superrefraction in the Coastal Regions of Australia—F. J. Kerr. (*Aust. Jour. Sci. Res., Ser. A*, vol. 1, pp. 443-463; December, 1948.) A survey based on systematic wartime observations on 200 Mc at Royal Australian Air Force coastal radar stations. The strengths of permanent echoes were observed at hourly intervals over periods up to 18 months. Results are analyzed in the light of meteorological conditions. See also 516 of 1947 (Booker) and T.R.E. Report T.1820, the latter being a special survey of Australian radio-climatology.

RECEPTION

621.396.1:621.396.5 2898
Double-Diversity Equipment for the Reception of Single-Sideband Radiotelephony—A. Sev. (*Ann. Radioléc.*, vol. 4, pp. 261–264; July, 1949.) The basic principles of diversity reception are outlined and the main features are described of the system developed by the Société française Radioélectrique. In this system, the reference level in the two channels is furnished by the mean level of the carrier wave, so that the change-over is independent of the modulation transmitted by the sidebands.

621.396.621 2899
Redifon Model R50—(*Wireless World*, vol. 55, pp. 251–254; July, 1949.) Test report and circuit details for a wide-range tropicalized communications receiver.

621.396.621 2900
Sensitivity of Receivers, with Complex Internal Resistance of the Generator (Aerial)—H. Behling. (*Frequenz*, vol. 3, pp. 93–101; April, 1949.) The signal-to-noise ratio is calculated for single-stage and 2-stage receiver input circuits connected to the antenna; results are presented graphically. An example illustrates the compromise usually necessary between selectivity and sensitivity. Formulas are given for determining the selectivity corresponding to any given value of sensitivity.

621.396.621:621.396.822:621.317.3 2901
Technique of Noise Measurement for U.H.F. Receivers—(See 2833.)

621.396.621:621.398 2902
A Telecontrolled Tunable Receiver Installation: Part 2—Benson and Colebrook. (See 2884.)

621.396.82:621.317.34 2903
A Simple Method of Measuring Small Swings and Modulation Indices of Frequency or Phase-Modulated Hum and Noise—Boelens and Stumpers. (See 2837.)

621.396.621 2904
Lehrbuch der Funkempfangstechnik. (Manual of Radio Reception Technique) [Book Review]—Pitsch. Publishers: Geest and Portig K.-G., Leipzig, 1948, 855 pp., 67 DM. (*Fernmeldelech. Z.*, vol. 2, pp. 225–226; July, 1949.) Excellent both for the student and as a reference book for the engineer. The use of advanced mathematics is avoided throughout. The principal section deals with receiving apparatus, from the antenna to the loudspeaker. Practical design is assisted by the provision of tables, curves, and charts, and many numerical examples are given.

STATIONS AND COMMUNICATION SYSTEMS

621.395.44 2905
A Carrier System for 8,000-c/s Program Transmission—R. A. Leconte, D. B. Penick, C. W. Schramm, and A. J. Wier. (*Bell Sys. Tech. Jour.*, vol. 28, pp. 165–180; April, 1949.)

621.395.44 2906
Delay Equalization of 8-kc/s Carrier Program Circuits—C. H. Dagnall and P. W. Rounds. (*Bell Sys. Tech. Jour.*, vol. 28, pp. 181–195; April, 1949.) Most of the equalization is effected at af, the remainder at carrier frequencies by means of quartz-crystal equalizers. The design of both the af and carrier-frequency equalizers is discussed, with diagrams and photographs of complete units.

621.396.1:621.396.931 2907
Radio Communications Services: Part 1—(*FM-TV*, vol. 9, pp. 17–19; June, 1949.) A quick-reference guide to the frequency assignments and technical requirements for the various classes of mobile radio service.

621.396.61/.62:621.318.572 2908

A New Principle for Transceivers—A. van Weel. (*Philips Res. Rep.*, vol. 3, pp. 361–370; October, 1948.) The self-oscillating triode mixing stages discussed in 1174 of May have distinct advantages for transceiver circuits, in particular for synchronized transmit-receive switching. An ultrasonic frequency can be used for switching, so that two-way communication is possible. A system is described for stabilizing the frequency of both the transmitting oscillator and the local oscillator for reception with the aid of a single cavity resonator.

621.396.619.16 2909

Narrow-Band Pulse Transmission—D. A. Griffin. (*QST*, vol. 33, pp. 11–16; July, 1949.) In adapting the pulse technique of radar to communications work, the wide bandwidth necessary for the sharp pulses of radar can be substantially reduced by using comparatively long pulses of sinusoidal shape. The same frequency channel can be used simultaneously for conventional transmissions and for pulse telegraphy, and a number of pulse transmitters can use the same channel if the time of emission of individual pulses are suitably spaced. The special requirements of transmitters and receivers are considered.

621.396.619.16 2910

Pulse-Splitting—A. S. Gladwin. (*Wireless Eng.*, vol. 26, pp. 210–211; June, 1949.) Indicates the conditions under which splitting occurs in PM systems, and their dependence on the amplitude and frequency of the modulating wave.

621.396.65:621.396.931 2911

The Applications of Radio Links to Railways—J. Walter. (*Bull. Soc. Franç. Élec.*, vol. 9, pp. 273–281; June, 1949.) Methods using induction, hf guided waves and uhf free waves are considered, with special reference to communication in marshalling yards.

621.396.931 2912

Diversity F.M. Transmission—(*Wireless World*, vol. 55, pp. 246–248; July, 1949.) Description of the GEC System comprising a mobile transmitter-receiver, a master transmitter, and two unattended satellite broadcasting stations synchronized on a frequency of 97.8 Mc. The radio links between the fixed stations operate on frequencies of 146.7, 154 and 155.4 Mc.

621.396.931:621.396.61/.62 2913

Equipment for Remote Pickups—F. T. Budelman. (*FM-TV*, vol. 9, pp. 13–16; June, 1949.) Transmitters and receivers designed for the revised F.C.C. vhf channel assignments, and the new 450 to 452-Mc band.

621.396.931:621.396.82 2914

Adjacent-Channel Operation of Mobile Equipment—D. E. Noble. (*Electronics*, vol. 22, pp. 90–95; June, 1949.) Receiver rf intermodulation is the main problem. By geographical separation of stations operating on adjacent channels, the extreme limits of intermodulation production in the receiver can be reduced to the point where the effects of special receiver design become significant.

621.396.97 2915

The War-Time Activities of the Engineering Division of the B.B.C.—H. Bishop. (*Proc. IEE* (London), vol. 96, p. 222; May, 1949.) Discussion on 2086 of 1948.

621.396.619.13/.14 2916

Advantages and Disadvantages of Frequency and Phase Modulation in the light of the Special Requirements Demanded by Aviation, as Well as Its Application to Wireless Navigation [Book Notice]—B.I.O.S. Miscellaneous Report No. 83. H.M. Stationery Office, London, 282 pp., 25s.

SUBSIDIARY APPARATUS

621.314.63 2917

On the Boundary-Layer Theory of the Dry Rectifier—E. Spenke. (*Z. Phys.*, vol. 126, pp. 67–83; 1949.) Within the framework of the simplified Schottky theory of the boundary layer (2192 of 1942), the concentration distributions of the defect electrons for different loading conditions are calculated. The results are shown graphically. The unipolarity of the boundary layer and the great difference between the resistances in the conducting and blocking directions depend less on the variation of the total thickness of the blocking layer than on the changes of shape of the concentration-distribution curves. The origin of these changes of shape lies in the totally different physical character of the conduction process in the two directions.

621.316.7 2918

Rototrol—J. Hélot. (*Bull. Soc. Franç. Élec.*, vol. 9, pp. 328–342; July, 1949.) The term "rototrol" is derived from the words "rotor" and "control." The main unit of the equipment resembles an ordinary dynamo, from which it differs only in the number of its inductor windings. A detailed description is given of the equipment, with examples of its use for the control of motor speed, voltage etc. See also 1193 of May (Galmiche).

621.396.68 2919

Portable High-Voltage Power Supply—V. Wouk. (*Electronics*, vol. 22, pp. 108–112; July, 1949.) Weighs less than 35 lb; uses rectified 60-cps power; output voltage continuously adjustable from 0 to 30 kv at currents up to 0.5 ma, with reversible polarity and about 5 per cent ripple at full load.

778.3:621.3.015.3 2920

A New Method for the Photographic Study of Fast Transient Phenomena—Courtney-Pratt. (See 2724.)

621-526 2921

Principles of Servomechanisms [Book Review]—G. S. Brown and D. P. Campbell. Publishers: J. Wiley and Sons, New York, 1948, 400 pp., \$5.00. (*Rev. Sci. Instr.*, vol. 20, pp. 315–316; April, 1949.) "... a correlated work suitable for use as a textbook in engineering schools."

621.314.6+621.315.59 2922

German Research on Rectifiers and Semiconductor [Book Notice]—B.I.O.S. Final Report No. 725. H.M. Stationery Office, London, 52 pp.

TELEVISION AND PHOTOTELEGRAPHY

621.397.242:621.397.6 2923

Experimental Transmitting and Receiving Equipment for High-Speed Facsimile Transmission: Part 4—Transmission of the Signals D. Kleis and M. van Tol. (*Philips Tech. Rev.*, vol. 10, pp. 289–298; April, 1949.) Part 3, 2657 of October (Sloof, van Tol, and Unk). Part 5, 2925 below.

621.397.331.2 2924

Development and Performance of Television Camera Tubes—R. B. Janes, R. E. Johnson, and R. S. Moore. (*RCA Rev.*, vol. 10, pp. 191–223; June, 1949.) A description of three types of image-orthicon tube suitable for various lighting conditions. Construction problems are discussed, and limitations and improvements are mentioned.

621.397.335 2925

Experimental Transmitting and Receiving Equipment for High-Speed Facsimile Transmission: Part 5—Synchronization of Transmitter and Receiver—D. Kleis and M. van Tol. (*Philips Tech. Rev.*, vol. 10, pp. 325–333; May, 1949.) Part 4, 2923 above.

- 621.397.335** 2926
Transitron Sync Separator—H. V. Versey. (*Wireless World*, vol. 55, pp. 249-250; July, 1949.) A single-tube circuit is described which produces a steep-fronted line-synchronizing pulse at the screen-grid and also a similar frame-synchronizing pulse at the anode. The separation is achieved by choosing a suitable time constant for the combination of a capacitor, connected between the screen and suppressor grids, and a resistor connected between the suppressor grid and cathode.
- 621.397.6** 2927
Experimental 729-Line Television Equipment—J. L. Delvaux. (*Rev. Tech. Comp.* (France), Thomson-Houston, no. 12, pp. 35-40; May, 1949.) Description and a few technical details of the demonstration equipment noted in 873 of April.
- 621.397.6:621.385.832** 2928
Picture Storage Tube—L. Pensak. (*Electronics*, vol. 22, pp. 84-88; July, 1949.) For another account see 2061 of August.
- 621.397.6:621.396.67** 2929
Receiving Aerials for Television—Roosenstein (See 2718.)
- 621.397.6:621.396.67** 2930
Indoor Television Aerial—Best and Duffell. (See 2719.)
- 621.397.6:621.396.677** 2931
Reversible-Beam Antenna for Twelve-Channel Television Reception—Woodward, Jr. (See 2720.)
- 621.397.62** 2932
Television Receiver, with Miniature Valves for 450 or 819 Lines—F. Juster. (*Radio Prof.* (Paris), vol. 18, pp. 16-19 and 12-13, 16; March and April, 1949.) Full circuit details of a receiver using the new American-type tubes (see 2079 of August) now made in France. Pentriode mounting is used for the valves in the hf video section. The circuits given are applicable to a 450-line system, but the modifications necessary to adapt the receiver to the new 819-line standard are also described.
- 621.397.62** 2933
Television Station Selection—W. T. Cocking. (*Wireless World*, vol. 55, pp. 242-246; July, 1949.) Discussion of the general specification of a suitable superheterodyne television receiver for future conditions when 5 stations may be broadcasting the same program simultaneously.
- 621.397.62:535.88** 2934
Projection-Television Receiver: Part 4—The Circuits for Deflecting the Electron Beam—J. Haantjes and F. Kerkhof. (*Philips Tech. Rev.*, vol. 10, pp. 307-317; April, 1949.) For previous parts see 1836 of July and back references.
- 621.397.7** 2935
WENR-TV—E. C. Horstman and J. M. Valentine. (*Broadcast News*, no. 54, pp. 14-31; April, 1949.) A detailed description of the American Broadcasting Company's Chicago station, including discussion of studio construction and equipment, mobile field equipment, transmitters, and antenna installation on top of the 550-ft Civic Opera Building.
- 621.397.7** 2936
WCAU-TV—J. G. Leitch. (*Broadcast News*, no. 54, pp. 52-73; April, 1949.) A fully illustrated description of the television station of WCAU Incorporated, Philadelphia, including discussion of the general arrangement of the various offices and studios, control and transmitting equipment, mobile unit, and 2-section pylon antenna mounted on top of a building nearly 500 ft. high.
- 621.397.823** 2937
Ignition Interference—W. Nethercot and S. F. Pearce. (*Wireless Eng.*, vol. 26, pp. 209-210; June, 1949.) Comment on 2355 of September (Callendar).
- 621.397.828** 2938
Minimizing Television Interference—P. S. Rand. (*Electronics*, vol. 22, pp. 70-76; June, 1949.) Types of interference are explained and techniques outlined for improving effective sensitivity and selectivity of receivers.
- TRANSMISSION**
- 621.396.61** 2939
An Experimental Frequency-Modulated Broadcast Transmitter—J. B. Rudd, W. W. Honnor, and W. S. McGuire. (*AWA Tech. Rev.*, vol. 8, pp. 97-123; April, 1949.) Reprint of 1220 of May.
- 621.396.61** 2940
A Criterion for the Stability of the Output Stages of High-Power Radio Transmitters—G. A. Zeytlenok. (*Radiotekhnika* (Moscow), vol. 4, pp. 3-20; May and June, 1949. In Russian.) The stability of the output stages is examined from the standpoint of their self-excitation at the operating frequency. The generation of parasitic oscillations is not considered. Various neutralizing circuits for a push-pull stage are discussed. With any of these circuits the stability of a stage, for a given type of tube and a given operating frequency and capacitance of the neutralized element, depends only on the ratio of the power output of the stage to the power necessary for its excitation. The normal neutralizing circuit is the least stable while the inverse circuit has the highest stability.
- 621.396.61:621.396.662** 2941
Automatic Tuning of Transmitters—W. L. Vervest. (*Commun. News*, vol. 10, pp. 20-29; January, 1949.) Description of universal click gear which can be used to set a tuning element in any of 11 predetermined positions. A twelfth position is provided for manual tuning. A torque-limiting clutch is included.
- 621.396.61:029.54** 2942
New B.B.C. Station at Norwich—(*RSGB Bull.*, vol. 25, p. 21; July, 1949.) Brief technical details of the 5-kw transmitter operating on 1013 kc which came into service on June 19, 1949.
- 621.396.615.16** 2943
Method of Multiple Operation of Transmitter Tubes Particularly adapted for Television Transmission in the Ultra-High-Frequency Band—G. H. Brown, W. C. Morrison, W. L. Behrend, and J. G. Reddeck. (*RCA Rev.*, vol. 10, pp. 161-172; June, 1949.) For ulf television broadcasting, operation of several transmitter tubes into a common load may be required. A bridge circuit is described which enables the total power of two generators to be fed into a single load without interaction, provided that a moderate control of the relative amplitude and phase of their outputs is maintained. Combinations of these "diplexers" may be built up to increase the number of feed tubes. Practical forms of the bridge circuit for various frequency-bands, with means for obtaining wide-band working and balanced-line connections, are given. An experimental 850-Mc television transmitter is described and illustrated.
- 621.396.619.23** 2944
Some Aspects of the Design of Balanced Rectifier Modulators for Precision Applications—D. G. Tucker.
The Effects of an Unwanted Signal mixed with the Carrier Supply of Ring and Cowan Modulators—D. G. Tucker. (*Proc. IEE* (London), vol. 96, pp. 215-220; May, 1949.) Discussion on 3542 and 3543 of 1948.
- VACUUM TUBES AND THERMIONICS**
- 621.383** 2945
Multilayer Photocells—H. Mayer. (*Z. Phys.*, vol. 124, pp. 345-347; 1948.) Discussion of the possibility of improving the efficiency of photocells by using many layers, of atomic thickness, on thin quartz plates mounted one behind the other, so as to absorb most of the incident light.
- 621.383** 2946
Photoelectric Properties of Alkali Layers of Atomic Thickness: Part 3—H. Mayer. (*Z. Phys.*, vol. 124, pp. 326-344; 1948.) Measurements of potassium layers vaporized on quartz show that between 2,500Å and 6,500Å the photoelectric effect is purely a surface effect. For layers one to two atoms thick the effect is practically equal to that of the massive metal.
- 621.385** 2947
Recent Developments in the Technique of Radio Valve Manufacture—(*Machinery* (London), vol. 74, pp. 848-852; June 23, 1949.) Long summary of 2085 of August (Davies, Gardiner, and Gomm).
- 621.385** 2948
New Types in the Series of Miniature Valves of the Société française Radioélectrique—(*Ann. Radioélec.*, vol. 4, p. 265; July, 1949.) Technical data are given of 5 tubes: V2.M70, full-wave rectifier; VM1, high-voltage half-wave rectifier; SM.150/30, voltage regulator; PM.04, variable-*h* hf pentode; TXM.100, tetrode gas-filled thyratron. Corresponding American tubes are respectively 6X4, 1654, 0A.2, 6BA.6, and 2D.21. The above tubes, together with the 7 previously described (2372 of September) fulfill all needs in applications requiring small, robust, and reliable tubes.
- 621.385** 2949
Transconductance as a Criterion of Electron Tube Performance—T. Slonczewski. (*Bell Sys. Tech. Jour.*, vol. 28, pp. 315-328; April, 1949.) Tube performance is usually assessed in terms of the anode-current/grid-voltage characteristic. For many purposes, a simplification results from consideration of the transconductance/grid-voltage characteristic. Formulas are quoted for the pentode amplifier, rectifier, modulator, and frequency doubler; the effects of third-order and fourth-order modulation are considered for single-frequency and 2-frequency inputs.
- 621.385-71** 2950
Water-Cooling Versus Air-Cooling for High-Power Valves—(*Proc. IEE* (London), vol. 96, pp. 220-221; May, 1949.) Air cooling appears to be best for low-power mobile equipment, while modern water-cooling systems are probably best for high-power fixed stations. The border line is near 5 kw.
- 621.385-713** 2951
Radiators for Transmitting Valves—A. J. Young. (*Marconi Rev.*, vol. 12, pp. 85-91; July and September, 1949.) Factors affecting the design of radiating fins are considered, for the case when the cooling air stream is parallel to the axis of the tube.
- 621.385.002.72** 2952
The Latest Methods of Cost Reduction applied in a Factory of the Société française Radioélectrique—L. Thibieroz. (*Ann. Radioélec.*, vol. 4, pp. 178-183; July, 1949.) New methods of tube assembly and pumping have resulted in a quality improvement of 15 to 20 per cent and a cost reduction of 35 to 40 per cent.
- 621.385.029.63/64** 2953
On the Efficiency of the Travelling-Valve Valve—O. Doehler and W. Kleen. (*Ann. Radioélec.*, vol. 4, pp. 216-221; July, 1949.) Expressions are derived for the electronic efficiency, the circuit efficiency, and the over-all

efficiency. The calculations are based partly on results previously given (250 of February).

621.385.029.63/1.64 2954

Comparison of the Measured Values for the Linear Gain of the Travelling-Wave Valve with the Values Indicated by Various Theories—L. Bruck. (*Ann. Radiotelec.*, vol. 4, pp. 222-232; July, 1949.) The gain was measured for several tubes as a function of the beam current and of the magnetic field used for focusing. The mean helix diameter was from 3.3 mm to 5.5 mm. In some cases the attenuation was distributed along the helix, with values between 30 db and 40 db, but one tube showed a localized attenuation of 50 db. The form of the gain curves is in general agreement with theory, but the theoretical values are much higher than the measured values. The calculated gain varies rapidly with the diameter of the electron beam, but the differences between observed and calculated values are too large to be attributed merely to uncertainty in the knowledge of the beam diameter. It would seem that the value of the coupling resistance in the theory of Doehler and Kleen, and the corresponding value in other theories, ought to be revised.

621.385.032.216 2955

The Effect of Gases and Vapours on the Emission of Oxide Cathodes—G. Herrmann and O. Krieg. (*Ann. Phys. (Lpz.)*, vol. 4, pp. 441-464; June 25, 1949.) An investigation of the effect of He, Ar, Kr, H₂, O, CO, CO₂, and some hydrocarbons. Ni cathodes were coated with a mixture of Ba and Sr oxides. Gas pressures ranged from 10⁻⁶ to 10⁻¹ torr and cathode temperatures from 300° to 1,500°K. The observed decreases of emission from cathodes with optimum activation can in all cases be explained by chemical or physical processes. So-called poisoning effects were not observed.

621.385.032.216 2956

Contribution to the Study of Oxide Cathodes—F. Violet and J. Riethmuller. (*Ann. Radiotelec.*, vol. 4, pp. 184-215; July, 1949.) Methods previously described (1095 of 1948) were applied to investigation of (a) the metal support, and (b) the emissive layer. The effect of impurities in the material of the support, the behavior of various grades of Ni and the effect of surface contamination were examined; experiments were also carried out with new supports whose composition could be controlled. Results are shown graphically. A secondary standard of emission was established for investigation of the properties of oxide coatings derived from the decomposition of mixtures of carbonates of the alkaline earths. The effects of composition, precipitation conditions, and grain size were studied and also the effect of contaminations introduced during the manufacture of the diodes used for the tests. Results are tabulated and discussed.

621.385.032.216 2957

Free Barium and the Oxide Cathode—R. O. Jenkins and R. H. C. Newton. (*Jour. Sci. Instr.*, vol. 26, pp. 172-174; May, 1949.) The greater part of the free barium produced by a modern oxide cathode is formed through chemical reduction by the impurities in the nickel core.

621.385.2 2958

The Flicker Effect in Saturated Diodes—L. de Queiroz Orsini. (*Compt. Rend. Acad. Sci. (Paris)*, vol. 228, pp. 1704-1706; May 30, 1949.) The theory of Macfarlane (4087 of 1947) leads to a formula of the type $i^2 = C i_m / f^n$ where i_f is the current fluctuation due to the flicker effect, i_m the saturation current, f the frequency at which measurements are made, and $m+n=1$. Experiments with a 6H6 diode at frequencies from 87 cps to 4,400 cps indicate values for m and n of 2.5 and 0.9 respectively, but the dispersion of the experimental results could account for an error of a few tenths in

these values. If the saturation current is of the order of 0.1 ma, the formula no longer holds. Macfarlane's theory indicates that the curve for the spectral distribution of frequencies should have a plateau below 400 cps even for oxide cathodes. This is not confirmed.

To investigate the dependence of the flicker effect on the type of cathode, the mean square of the total current fluctuation was measured for an oxide cathode and for the tungsten filament of a noise diode. On account of the difference in anode current only the general characteristics of the curves can be compared; a decided difference exists.

621.385.2 2959

High-Frequency Total-Emission Loading in Diodes—N. A. Begovich. (*Jour. Appl. Phys.*, vol. 20, pp. 457-461; May, 1949.) An expression is derived for the total-emission conductance produced by the electrons returned to the cathode of a diode operating with a retarding off-cathode field. The assumption of a linear potential distribution is justified for the retarding voltage and diode spacing used. Illustrative examples are discussed.

621.385.2:621.396.822 2960

Retarding-Field Current in a Cylindrical Diode—D. A. Bell. (*Proc. Phys. Soc. (London)*, vol. 62, pp. 334-335; May, 1949.) If a negative potential $-V$ is applied to a plane diode, the current flowing as a result of the initial emission is proportional to $\exp(-eV/k\theta)$ but for a cylindrical diode with thin cathode it is proportional to $\exp(-eV/2k\theta)$. This may explain the difference in noise level between plane and cylindrical diodes. See also 1894 of 1943 and 1829 of 1948 (Weinstein).

621.385.3 2961

The Electrostatic Field in Vacuum Tubes with Arbitrarily Spaced Elements—W. R. Bennett and L. C. Peterson. (*Bell Sys. Tech. Jour.*, vol. 28, pp. 303-314; April, 1949.) The derivations of the potential function for the anode/cathode space of a triode are reviewed and expressions are derived for other parameters, neglecting space-charge effects, for the case where the cathode/grid spacing d is less than the spacing a between adjacent grid wires. Curves are given showing amplification factor, cathode field-strength, current density, and transconductance as functions of distance along the cathode for $d/a=0.4$ to 1.0.

621.385.3:621.317.335.2† 2962

Triode Interelectrode Capacitances—R. H. Booth. (*Wireless Eng.*, vol. 26, p. 211; June, 1949.) Comment on 2101 of August (Zepler and Hekner).

621.385.3:621.396.822 2963

Note on the Reduction of Microphonics in Triodes—V. W. Cohen and A. Bloom. (*Jour. Appl. Phys.*, vol. 18, pp. 847-848; September, 1947.) Comment on 2981 of 1947 (Waynick).

621.385.3.029.64 2964

A Microwave Triode for Radio Relay—J. A. Morton. (*Bell Lab. Rec.*, vol. 27, pp. 166-170; May, 1949.) The close mechanical tolerances are achieved by using a planar electrode system with flat spacing rings. Cathode emission density is very high. The main characteristics of the triode at 1f, as an amplifier and as a modulator are tabulated. Construction and performance are discussed. See also 2390 of September.

621.385.3.032.29:621.317.335.2† 2965

Interelectrode Capacitance of Valves—(*Radio Tech. Dig. (Franc)*, vol. 3, pp. 48-54; February, 1949.) French version of 2102 of August (Humphreys and James).

621.385.38 2966

A New Line of Thyratrons—A. W. Coolidge, Jr. (*Trans. AIEE*, vol. 67, part 1, pp. 723-727; 1948. Discussion, pp. 727-728.) Full paper; long summary abstracted in 1834 of July.

621.385.4 2967

A New Subminiature Electrometer Tube—H. F. Starke. (*Proc. N.E.C. (Chicago)*, vol. 4, pp. 200-208; 1948.) A tetrode, Type CK571AX, with a 10-ma tungsten filament. Microphony noise is about 25 db below that for tubes with nickel-alloy filaments. The grid and filament are so close together that the ionization volume is low; grid current is of the order of 2×10^{-10} amperes.

621.385.5 2968

Design Considerations for a Dual Control Grid Pentode—R. W. Slinkman. (*Proc. N.E.C. (Chicago)*, vol. 4, pp. 209-219; 1948.) By use of space-charge effects and grid alignments, a No. 3 grid cutoff characteristic is achieved which is equal to or better than the No. 1 grid characteristic for sharpness, yet gives a reasonable ratio of anode to screen current at rated voltage.

621.385.5:537.533.8:621.396.645 2969

Secondary Emission in Output Valves—J. L. H. Jonker. (*Philips Tech. Rev.*, vol. 10, pp. 346-351; May, 1949.) Three methods for reduction of secondary emission are discussed. A combination of suppressor grid and coated anode, in output tubes, leads to improved characteristics. Output of a battery-driven pentode for 10 per cent distortion is increased from 200 mw to 260 mw by coating the anode with a porous layer of soot.

621.385.832 2970

Application of a Variation Method to the Theory of the Electric and Magnetic Deflection of Electron Beams—Glaser. (See 2787.)

621.396.615.141.2 2971

On the Dynatron Effect in Multi-Segment Magnetrons—V. I. Kalinin and G. M. Gershtein. (*Compt. Rend. Acad. Sci. (URSS)*, vol. 51, pp. 275-276; 1946. In English.) Secondary emission from the less positive segments is a possible reason for the disappearance of the static falling characteristic in multisegment magnetrons with oscillations in the circuit connected with the segments.

621.396.615.141.2 2972

Multiple Electronic Resonance in Single-Circuit Split-Anode Magnetrons—H. Ya. Levin. (*Radiotekhnika (Moscow)*, vol. 4, pp. 36-46; May and June, 1949. In Russian.) The design of a magnetron is considered in which only resonance oscillations are produced. The oscillatory system of such a magnetron should consist of a single tuned circuit with only one fundamental resonance frequency, and the anode segments to which the circuit is connected should be sufficiently narrow to ensure that any possible dynatron effect is negligible. An experimental investigation was carried out with two types of magnetron. One (Fig. 1) had a filament cathode; in the other (Fig. 8) the anode and cathode were made in the form of two coaxial cylinders and the filament (emitter) was mounted in a longitudinal slot in the inner cylinder. The theory of the two magnetrons is discussed and experimental results are given.

621.396.615.141.2:537.533.8 2973

On the Role of Secondary Emission in the Operation of Split-Anode Magnetrons—G. M. Gershtein. (*Radiotekhnika (Moscow)*, vol. 4, pp. 56-61; January and February, 1949. In Russian.) Experimental results show that the secondary current from less positive anode segments considerably affects the static characteristics of multisegment magnetrons, and this current may cause secondary-emission oscillations.

621.396.615.142 2974

On the [electron-] Velocity-Dependent Characteristics of High-Frequency Tubes—J. K. Knipp. (*Jour. Appl. Phys.*, vol. 20, pp. 425-431; May, 1949.) The electronic transad-

mittances, transmodulation functions, and other characteristics of a planar, multi-grid hf tube are expressed in terms of four fundamental admittance and modulation functions, which describe adequately the properties of the electron beam for low modulation levels.

621.396.619.23

2975

The Electron Coupler—A Developmental Tube for Amplitude Modulation and Power Control at Ultra-High Frequencies: Part I—Physical Theory—C. L. Cuccia. (*RCA Rev.*, vol. 10, pp. 270-303; June, 1949.) 1949 IRE National Convention paper noted in 1824 of July (Cuccia and Donal). A new uhf tube is described, by which control and modulation of power coupled from a generator into a load may be achieved without effect on the generator. A beam of electrons is passed through two resonant cavities in a longitudinal magnetic field. Power injected into the first cavity sets up a transverse electric field. The electrons describe spiral paths of increasing radius until the gap is reached. In the second cavity the radius of the spiral decreases, and power is given up to the output circuit. Modulation is effected by varying the beam current or the electron transit times. Theory of the electron behavior in the three regions is given, and the limitations on input power, the loading conditions for optimum power transfer, and the two methods of modulation are investigated.

621.396.622.6:621.396.822

2976

Background Noise of Crystal Diodes—H. F. Mataré. (*Onde Élec.*, vol. 29, pp. 231-240; June, 1949.) The mechanism of the asymmetric conductivity of semiconductors determines characteristics comparable with those of vacuum diodes with emissive cathodes. From this similarity a law governing the statistical deviations of semiconductors is derived. An equivalent circuit is considered and from its characteristics the mean square of the noise voltage is determined, neglecting the question of the noise temperature of the boundary layer. An analytical expression is introduced which results from comparison between the noise temperature of a diode with emissive cathode and that of the blocking layer of the semiconductor considered. A practical law can then be established for the statistical deviations of crystal diodes. The simplicity of this law permits extension to the dynamic case, starting from the static characteristics of a detector.

621.396.645

2977

Amplification by Direct Electronic Interaction in Valves without Circuits—P. Guenard, R. Berterottiere and O. Doehler. (*Ann. Radioélec.*, vol. 4, pp. 171-177; July, 1949.) By considering an electron beam as a medium possessing, for small perturbations, a natural frequency, the amplification in a tube with two electron beams of different velocities is simply explained. The theory is extended to the case of larger perturbations and the efficiency to be expected from double-beam tubes is estimated. For a difference of velocity corresponding to maximum gain, the efficiency is calculated to be about 14 per cent. See also 1540 of June (Nergaard), 1825 of July, (Haef), and 2486 and 2487 of October, (Pierce and Hebenstreit: Hollenberg).

621.396.645:537.311.33:621.315.59

2978

Transistron = Transistor + ?—E. Aisberg. (*Toute la Radio*, vol. 16, pp. 218-220; July and August, 1949.) The transistron is the French equivalent of the American transistor and was designed by engineers of the Service des Télécommunications. Secrecy regulations have hitherto prevented the publication of any information regarding the transistron and may have deprived France of priority of invention of this important development.

The transistron is in certain respects superior to its American relative. Its good performance is due principally to the composition of the Ge crystal used, the preparation of which has been supervised by MM. Welcker and Mataré. It consists of a ceramic tube with metal ends, through which the supports for the two fine-wire contacts pass, and a metal attachment at the middle in which the Ge crystal is fixed. The device has already reached the production stage. Photographs are reproduced of various apparatus in which transistrons are incorporated; these include (a) a miniature 2-transistron amplifier with components printed on a small plate of plexiglass; (b) a similar amplifier inserted in a telephone line; (c) a 6-transistron radio receiver; (d) a miniature transmitter for $\lambda=300$ m, of dimensions approximately $10 \times 4 \times 4$ cm; and (e) a 4-transistron telephony repeater with a gain of 45 db and passband 40 to 10,000 cps. One of these repeaters is to be put into service on the Paris/Limoges circuit. Further developments are in progress.

621.396.645:537.311.33:621.315.59

2979

Physical Principles Involved in Transistor Action—J. Bardeen and W. H. Brattain. (*Bell Sys. Tech. Jour.*, vol. 28, pp. 239-276. Bibliography, pp. 276-277; April, 1949.) Historical survey, with discussion of the observed dc and ac characteristics of triode transistors. Experimental characteristic curves are reproduced. The relationships between emitter and collector currents and potentials are described and the current multiplication-factor (μ) is defined. The dependence of μ on bias voltage, frequency, temperature, and electrode spacing is discussed and illustrated; positive feedback and instability are also considered. Ge point-contact rectifiers and the dependence of their performance on temperature and impurities are discussed, in terms of the Mott-Schottky theory. Numerical estimates of the factors which determine transistor action are in agreement with practical results. Reprinted in *Phys. Rev.*, vol. 75, pp. 1208-1225; April 15, 1949.

621.396.645.001.4:537.311.33:621.315.59

2980

Testing Transistors—Lehovec. (See 2863.)

621.396.822

2981

Are Transit-Angle Functions Fourier Transforms?—W. E. Benham. (*Wireless Eng.*, vol. 26, p. 210; June, 1949.) Expresses doubt that the hf performance (i.e. transit angle function) of a thermionic system is determined by the Fourier transform of a purely dc property of the system.

621.385

2982

R.C.A. Receiving-Tube Manual. Technical Series RC 15 [Book Notice]—Tube Department, Radio Corporation of America, Harrison, N. J., 256 pp., 35 cents. Data for the latest receiving tubes, including miniature types and kinescopes, and sections dealing with various tube applications, choice of tubes for particular services, AM and FM receiver circuits, and af amplifier circuits.

621.385

2983

R.C.A. Air-Cooled Transmitting Tubes. Technical Manual TT3 [Book Notice]—Tube Department, Radio Corporation of America, Harrison, N. J., 192 pp., 35 cents. In addition to full technical data for a wide variety of tubes, useful sections are included on transmitter design, rectifiers, and filters. Typical oscillator and amplifier circuits are also given.

621.385:621.396.9

2984

German Development of Modulator Valves for Radar Applications [Book Notice]—B.I.O.S. Final Report No. 1746. H.M. Stationery Office, London, 26 pp., 3s.

621.385.032.216

2985

Die Oxydkathode: [Vol. 1] [Book Review]—G. Herrmann and S. Wagener. J. A. Barth, Leipzig, 1948, 131 pp., 14.40 DM. (*Frequenz*, vol. 3, pp. 86-87; March, 1949.) The authors' aim has been to collect the principal results of the extensive literature on oxide cathodes into one book. Vol. 1 deals with physical principles, including thermionic emission of metals, and measurement method for emissivity, work function, and electrical conduction and diffusion in chemical compounds. Numerous curves and tables are included. Vol. 2 will discuss the technical production and the properties of oxide cathodes.

621.385.832

2986

The Krawinkel Image-Storing Cathode Ray tube [Book Notice]—F.I.A.T. Final Report No. 1027. H.M. Stationery Office, London, 19 pp., 4s.

MISCELLANEOUS

621.38/39

2987

Trends in Electronic Engineering—D. G. Fink. (*Trans. AIEE*, vol. 67, part 1, pp. 835-840; 1948.) A general survey, covering broadcasting, sound reproduction, pulse-code modulation, navigation aids, heating, machinery control, computers, etc.

621.396

2988

The Inventor of Radiotelegraphy—L. Cahen. (*Onde Élec.*, vol. 29, pp. 137-142; March, 1949.) An examination of this question with particular reference to recent articles in *Wireless Eng.* (2429 of 1948) and also to an article by M. Voisenat in *Annales Télégraphiques*, March and April, 1898.

621.396.6:623

2989

What should be the Design Considerations of Services' Radio Equipment?—(*Proc. IEE* (London), vol. 96, pp. 252-253; May, 1949.) The needs of the user must be met as far as possible. Ease of operation and of maintenance and fault-finding are important. Rapid mass-production must also be possible in war time. The influence of these factors on design is considered.

621.396.69:061.3

2990

Strolling at the Paris Fair—(*Toute la Radio*, vol. 16, pp. 221-224; July and August, 1949.) Impressions of the radio novelties recorded by "a group of strollers."

621.396.69:061.3

2991

Concerning the Paris Fair—M. Chauvrière. (*Radio Franç.*, no. 6, pp. 1-6; June, 1949.) A critical review, including discussion of the present situation of television in France.

621.396.69:061.3

2992

Radio at the 38th Paris Fair—(*Radio Prof.* (Paris), vol. 18, pp. 17-25; June, 1949.) Illustrated discussion of radio and television receivers, rectifiers, measurement apparatus, etc.

669.011.9

2993

Research in the Non-Ferrous Field as carried out at the Research Laboratories of the General Electric Company, Limited—I. Jenkins. (*Metall Treat.*, vol. 16, no. 57, pp. 49-57; Spring, 1949.) A survey of the activities of the metallurgy group, with particular reference to research on lamp and tube materials, powder metallurgy, process heating, etc.

621.396:061.3

2994

British Commonwealth Specialist Conference on Radio Research [Book Notice]—H.M. Stationery Office, London, 1949, 4d. (*Govt. Publ.* (London), p. 22; May, 1949.) Report of the proceedings at the conference held in London, August, 1948.

ADVENTURES IN ELECTRONIC DESIGN

Centralab's Great New Model 2 Radiohm*

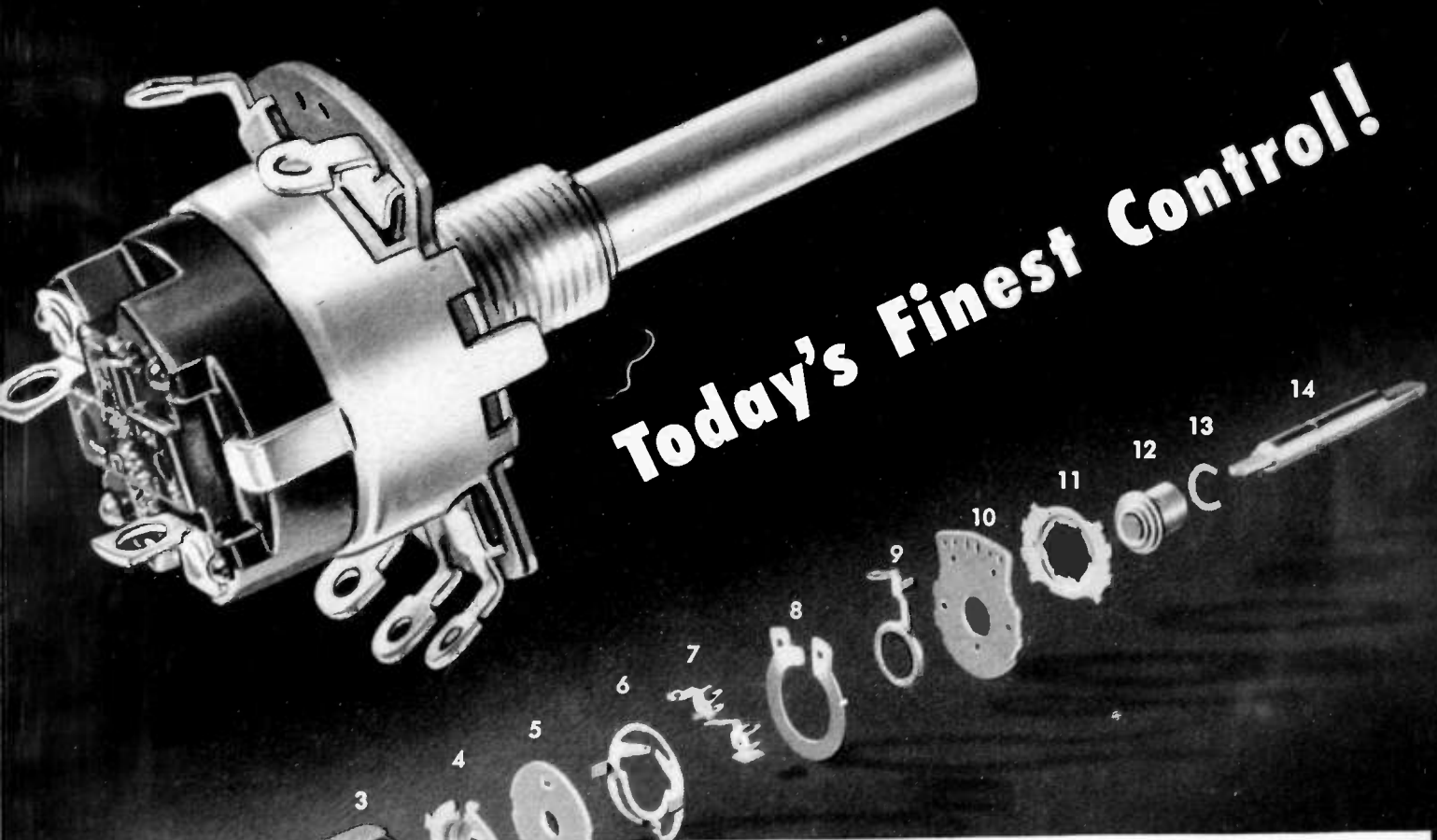

Today's Finest Control!

14 Good Reasons Why CRL'S Model 2 Radiohm is the Control for You!

1. *Switch* — with positive detent in both on and off positions. *Terminals* — with surfaces elevated to eliminate danger of shorting to cover legs . . . $\frac{1}{8}$ " hole diameter for simplified wiring . . . hot tin dipped for easy soldering . . . mechanical lock to prevent loosening in soldering operations.
2. Cadmium plated steel *cover* completely shields resistor.
3. *Insulator's* high dielectric strength permits breakdown test at 1000 volts R. M. S. Dust and dirt can't get in.
4. *Shoe*, of cup design, provides superior switch shielding . . . gives you excellent torque strength without distortion.
5. High grade laminated phenolic *base* maintains high insulation resistance under humidity conditions.
6. Contact Spring gives you double wiping contacts on both resistor and center terminal ring . . . is accurately formed to maintain uniform pressures and minimize noise.
7. Electro tin-plated *terminals* provide soldering ease. Tightly crimped terminals give you direct contact to resistor . . . assure constant contact under humidity and soldering conditions.
8. *Resistor* is made of special resistance material bonded to high quality phenolic for smooth operation, low noise level, outstanding humidity characteristics.
9. Cadmium-tipped *center terminal* provides easy soldering . . . good shelf life without oxidation. Adequately lubricated for good rotation life, center terminal is finished to give you smooth take-off . . . minimum noise.
10. Laminated phenolic *base* maintains high insulation resistance under humidity conditions.
11. Cadmium-plated steel *ground plate* assures positive grounded cover.
12. Cadmium-plated steel *bushing* is accurately finished and fit to shaft for smooth rotation.
13. *Retaining ring*.
14. *Shaft*. Unlimited variations available to meet your specifications.

*Switch Type, Tapped. Exploded View: Switch Type, Untapped.

Centralab — DEVELOPMENTS THAT CAN HELP YOU 

Division of GLOBE-UNION INC. • Milwaukee

Centralab reports to

NOVEMBER, 1949

Small Size
makes
Model 2 Radiohm
the Right Control
for many
different uses!

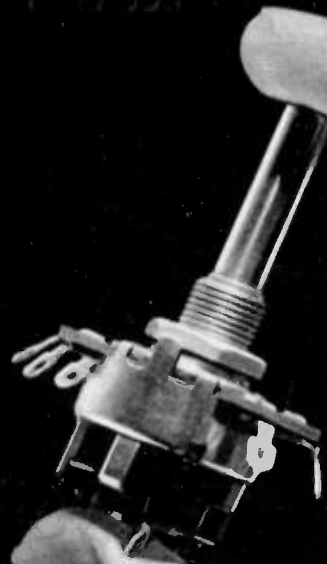

IMAGINE the large variety of uses for peak-quality controls that are only $15/16$ " in diameter, yet rated at $1/2$ watt. That's Centralab's great new line of Model 2 Radiohms. Designed for television and radio sets, sound and test equipment, the versatile Model 2 is just what you need for many other electronic uses where a combination of small size and finest performance is essential. CRL Model 2 Controls are precision built of the finest materials to give you lower noise level . . . longer life. Their clinched terminals insure rigid contact to the resistance element under humidity and soldering conditions. What's more, Model 2's complete line of 3 basic switches — 5, 8, and 1 amp. — provide 24 switch combinations for real flexibility in application and design. For all the facts, see your CRL representative or write direct.

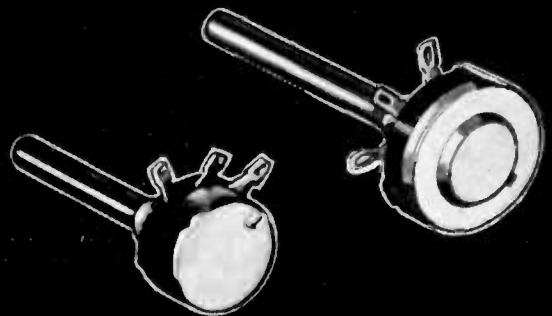
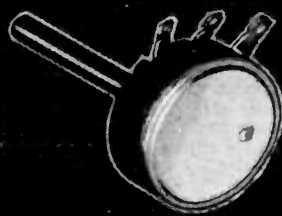

1 Model "1" Radiohm control, rated $1/10$ watt — plain and switch types. No larger than a dime. Designed for miniature uses.

2 Let Centralab's complete Radiohm line take care of your special needs. Wide range of variations: Model "R" — wire wound, 3 watts; or composition type, 1 watt. Model "E" — composition type, $1/4$ watt. Direct contact, 6 resistance tapers. Model "M" — composition type, $1/2$ watt.

Electronic Industry

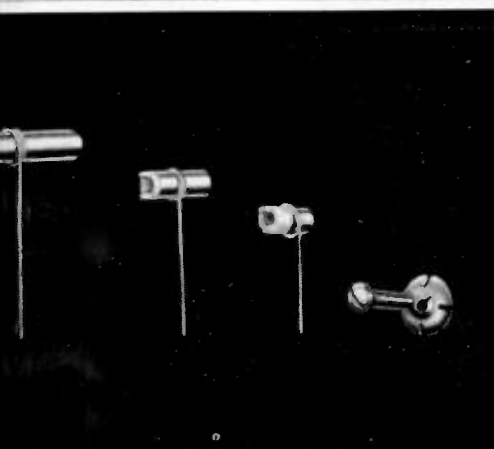

3 CRL's new Tubular *Trimmers* come in 3 basic types, 3 capacity ranges. Tinnerman locknut and adjusting screw available on special request.

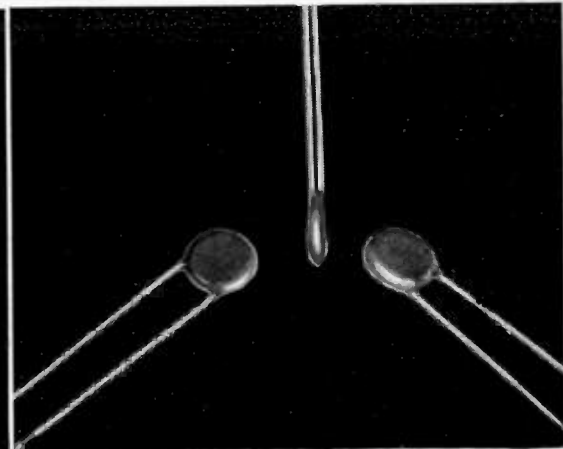

4 For by-pass or coupling applications, check Centralab's original line of ceramic disc *Hi-Kaps*. Disc *Hi-Kaps* are smaller than a dime!

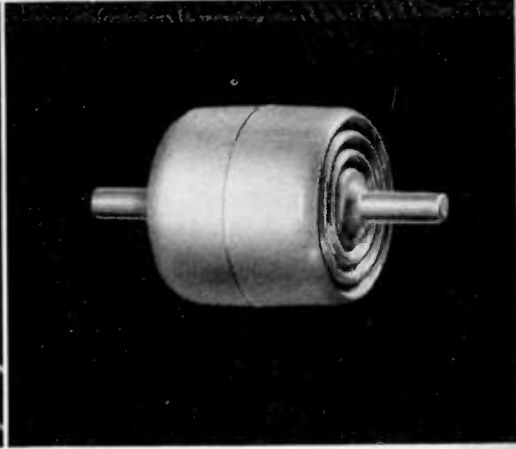

5 *Hi-Vo-Kaps* are filter and by-pass capacitors combining high voltage, small size and variety of terminal connections to fit most TV needs.

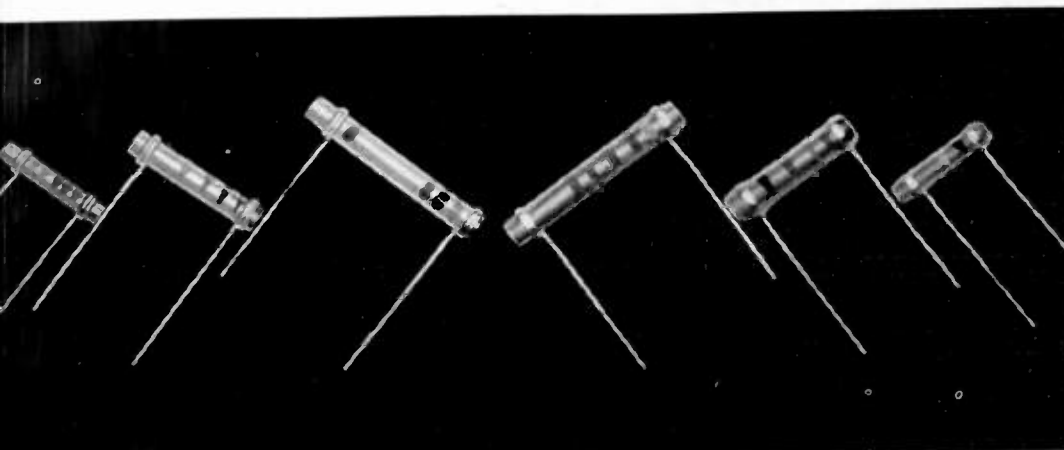

6 Centralab's TC (Temperature Compensating) Tubular *Hi-Kaps*, left, are the most stable capacitors available. With TC *Hi-Kaps*, there's practically no variation due to aging or changes in temperature or humidity. For applications where temperature compensation is unimportant, use Tubular BC *Hi-Kaps*, right.

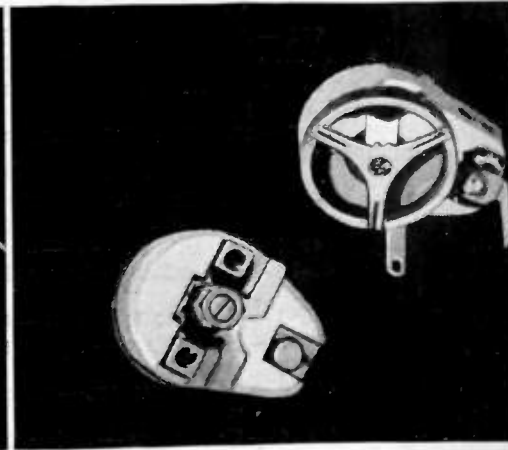

7 Ceramic *Trimmers* are made in five basic types. Full capacity change within 180° rotation. Spring pressure maintains constant rotor balance.

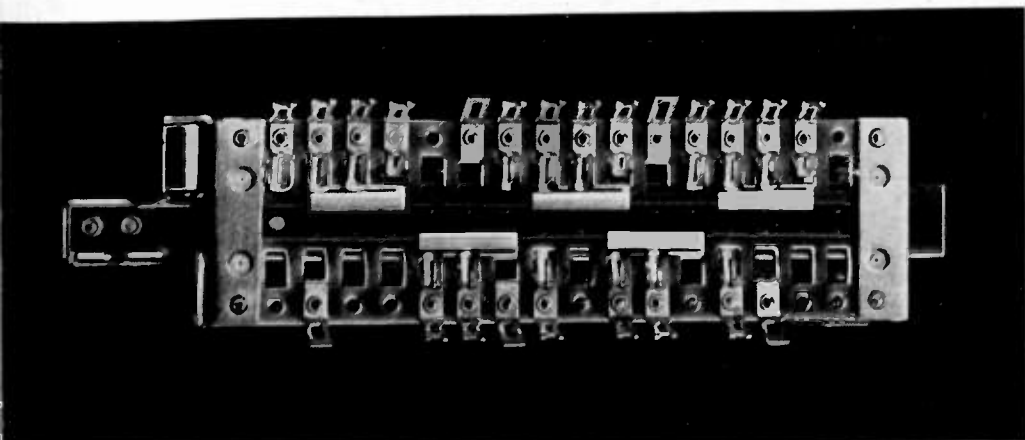

8 Centralab's development of a revolutionary, new *Slide Switch* gives you improved AM and FM performance! Flat, horizontal design saves valuable space, allows short leads, convenient location to coils, reduced lead inductances for increased efficiency in low and high frequencies. CRL *Slide Switches* are rugged and dependable.

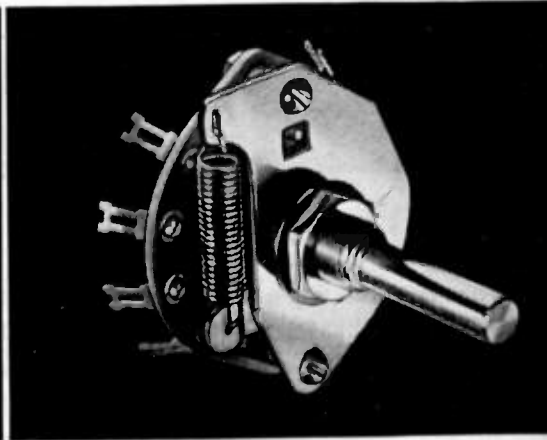

9 Great step forward in switching is CRL's New *Rotary Coil and Cam Index Switch*. Its coil spring gives you smoother action, longer life.

IMPORTANT BULLETINS FOR YOUR TECHNICAL LIBRARY!

They're factual!



THEY'RE FREE!

Choose From This List!

Centralab Printed Electronic Circuits

- 973 — AMPEC — three-tube P. E. C. amplifier.
- 42-6 — COUPLATE — P. E. C. interstage coupling plate.
- 999 — PENTODE COUPLATE — specialized P. E. C. coupling plate.
- 42-9 — FILPEC — Printed Electronic Circuit filter.

Centralab Capacitors

- 42-3 — BC TUBULAR HI-KAPS — capacitors for use where temperature compensation is unimportant.
- 42-4 — BC DISC HI-KAPS — miniature ceramic BC capacitors.
- 42-10 — HI-VO-KAPS — high voltage capacitors for TV application.
- 695 — CERAMIC TRIMMERS — CRL trimmer catalog.
- 981 — HI-VO-KAPS — capacitors for TV application. For jobbers.
- 42-18 — TC CAPACITORS — temperature compensating capacitors.
- 814 — CAPACITORS — high-voltage capacitors.
- 975 — FT HI-KAPS — feed-thru capacitors.

Centralab Switches

- 953 — SLIDE SWITCH — applies to AM and FM switching circuits.
- 970 — LEVER SWITCH — shows indexing combinations.
- 995 — ROTARY SWITCH — schematic application diagrams.
- 722 — SWITCH CATALOG — facts on CRL's complete line of switches.

Centralab Controls

- 42-7 — MODEL "1" RADIOHM — world's smallest commercially produced control.
- 697 — VARIABLE RESISTORS — full facts on CRL Variable Resistors.

Centralab Ceramics

- 967 — CERAMIC CAPACITOR DIELECTRIC MATERIALS.
- 720 — CERAMIC CATALOG — CRL steatite, ceramic products.

General

- 26 — GENERAL CATALOG — Combines Centralab's line of products for jobber, ham, experimenter, serviceman or industrial user.

Look to CENTRALAB in 1949! First in component research that means lower costs for the electronic industry. If you're planning new equipment, let Centralab's sales and engineering service work with you. For complete information on all CRL products, get in touch with your Centralab Representative. Or write direct.

CENTRALAB
Division of Globe-Union Inc.
900 East Keefe Avenue, Milwaukee, Wisconsin

113

Yes—I would like to have the CRL bulletins, checked below, for my technical library!

- | | | | | | | |
|-------------------------------|-------------------------------|--------------------------------|------------------------------|--------------------------------|-------------------------------|------------------------------|
| <input type="checkbox"/> 973 | <input type="checkbox"/> 42-9 | <input type="checkbox"/> 42-18 | <input type="checkbox"/> 953 | <input type="checkbox"/> 42-10 | <input type="checkbox"/> 722 | <input type="checkbox"/> 720 |
| <input type="checkbox"/> 42-6 | <input type="checkbox"/> 42-3 | <input type="checkbox"/> 695 | <input type="checkbox"/> 814 | <input type="checkbox"/> 970 | <input type="checkbox"/> 42-7 | <input type="checkbox"/> 26 |
| <input type="checkbox"/> 999 | <input type="checkbox"/> 42-4 | <input type="checkbox"/> 981 | <input type="checkbox"/> 975 | <input type="checkbox"/> 995 | <input type="checkbox"/> 697 | <input type="checkbox"/> 967 |

Name.....

Address.....

City..... State.....

TEAR OUT COUPON

for the Bulletins you want

Centralab
CRL

Division of GLOBE-UNION INC. • Milwaukee



51V-1 glideslope receiver, covers in place

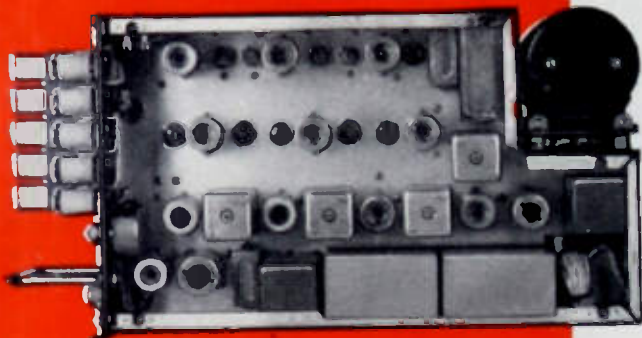

Collins 51V-1 chassis (right side)

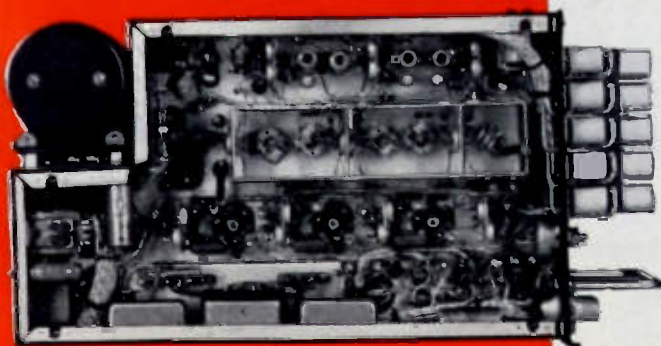

Collins 51V-1 chassis (left side)

Glideslope Receiver

51V-1

...inside and out

THIS is the new Collins 51V-1 glideslope receiver for aircraft. Note the orderly design, and the accessibility of all tubes, components, and wiring.

The 51V-1 provides reception of 90/150 cps tone modulated glideslope signals on any of the twenty channels in the uhf range of 329-335 mc. This receiver together with Collins 51R navigation equipment will fulfill ILS receiving requirements for military, commercial and private aircraft. The design of the 51V-1 is based on "Glideslope Receiver Characteristics" issued by Aeronautical Radio, Inc., and on U. S. Airforce specifications.

Output circuits of the 51V-1 receiver feed standard ID-48ARN deviation indicators including flag alarm. By means of the flag alarm the pilot has a positive indication of the reliability of the glideslope signals and instrumentation.

The 51V-1 control circuits are integrated with the standardized R/θ channeling system with channel selection provided by means of a Collins 314U remote control unit.

More complete information, in the form of an illustrated bulletin, is yours on request.

IN AVIATION RADIO, IT'S...



COLLINS RADIO COMPANY, Cedar Rapids, Iowa

11 West 42nd St.
NEW YORK 18

2700 West Olive Ave.
BURBANK

M & W Tower
DALLAS 1

Fountain City Bank Bldg.
KNOXVILLE

**AIRCRAFT
RADIO
CORPORATION**



Type H-12
SIGNAL GENERATOR
900-2100 MEGACYCLES



**-Simplified
-Compact
-Portable**

- 900-2100 megacycles, single band
- Directly calibrated, single dial frequency control
- Directly calibrated attenuator, 0 to -120 dbm
- CW or AM pulse modulation
- Internal pulse generator with controls for width, delay, and rate. Provision for external pulsing
- Controls planned and grouped for ease of operation
- Weight: 42 lbs. Easily portable—ideal for airborne installations
- Immediate delivery

*Built to
Navy Specifications
for research
and production
testing*

Write for specifications—investigate the advantages of this outstanding new instrument.

DEPENDABLE ELECTRONIC EQUIPMENT SINCE 1928

Aircraft Radio Corporation
BOONTON, New Jersey



BUENOS AIRES

"Section's Activity for 1948," by G. E. Van Spankeren, Chairman, and C. N. Cutler, Secretary-Treasurer; April 8, 1949.

"Ionospheric Propagation," by J. M. Onativia, Faculty of Ciencias Fisicas y Matematicas de Buenos Aires; April 22, 1949.

"Ultra-High Frequency Mobile Radiotelegraph Systems," by J. L. Coriat, Compania Standard Electric Argentina S.A.; June 13, 1949.

"New Procedure of Tube Manufacture," by J. M. Jadraque, Philips Argentina S.A.; July 1, 1949.

"Modern Systems on Single Side Band," by Adolfo Di Marco, Philips Argentina S.A.; July 15, 1949.

"Frequency Shift Keying System," by C. P. Perez, Standard Electric Argentina S.A.; August 5, 1949.

"Design of Broadcasting Studios," by L. L. Beranek, Vice-President, Acoustical Society of America; August 19, 1949.

CHICAGO

"Electrical Computers and Alternatives in Strategy," by C. E. Shannon, Bell Telephone Laboratories; and Election of Officers; May 13, 1949.

DALLAS-FORT WORTH

"Anechoic Chamber," by H. W. Rudmose, Faculty of Southern Methodist University; August 25, 1949.

DAYTON

"Design Trends in Home Television Receivers," by J. D. Reid, Crosley Division AVCO Manufacturing Company; September 8, 1949.

DENVER

"Experimental Television Camera Chain," by C. M. Eining, A. C. McClellan, W. S. Neal, Jr., and K. N. Raymond, Video Associates of Denver; September 9, 1949.

INVOKERN

"Recent High Power Microwave Developments at the University of California," by L. C. Marshall, Faculty of University of California; June 28, 1949.

KANSAS CITY

Student Paper Competition; April 26, 1949.

LOS ANGELES

"History and Objectives of United States Naval Ordnance Test Station," by B. E. Lawrence, U.S.N.O.T.S. "General Instrumentation at United States Naval Ordnance Test Station," by E. R. Toporek, U.S.N.O.T.S.; September 6, 1949.

NEW MEXICO

"Electronics in Measurement and Control," by R. H. Mueller; August 19, 1949.

PITTSBURGH

"Recent Trends in High-Fidelity Reproduction," by C. T. Hall, Hall Radio Laboratories; September 12, 1949.

PORTLAND

"Electronics in Paper Making," by J. F. Kovalsky, Westinghouse Electric Corporation; June 10, 1949.

"Contact Potentials of Tubes Operated at Low Potentials," by G. D. O'Neill, Sylvania Electric Products Company; September 6, 1949.

"Recent Actions of Federal Communications Commission in Television," by President S. L. Bailey, The Institute of Radio Engineers; August 29, 1949.

(Continued on page 40A)

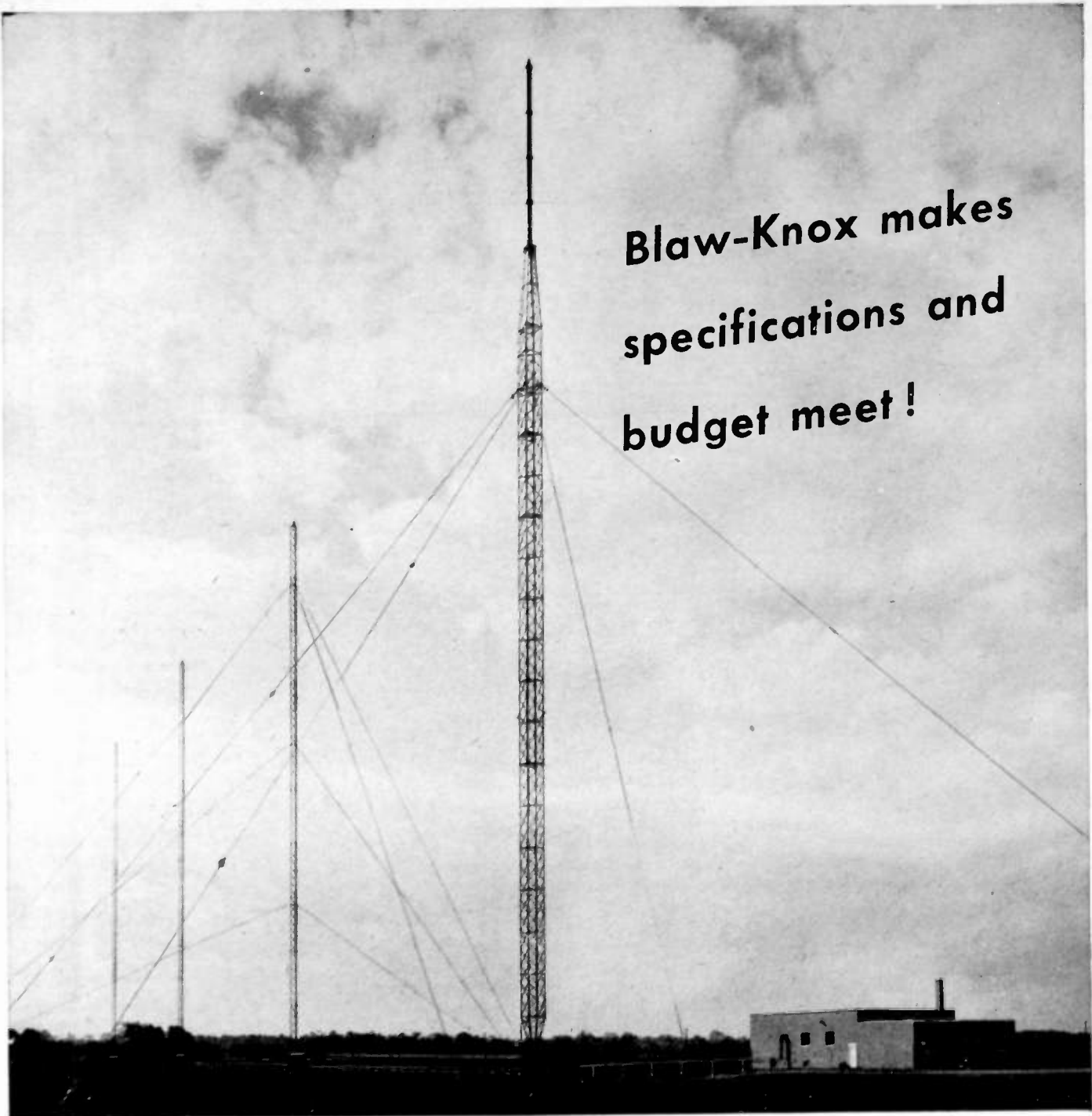

**Blaw-Knox makes
specifications and
budget meet!**

Station WICA, Ashtabula, Ohio

THE consulting radio engineer prescribed uniform cross section towers of maximum strength and efficiency for this directional array, but the budget demanded a minimum of expenditure. So there was only one place to take the prescription—BLAW-KNOX.

The three type LT towers illustrated, although low

in cost, have the strength and high factor of safety characteristic of Blaw-Knox design and engineering. The type SGN tower completing the array has the additional strength to support the heavy-duty FM pylon and any future TV requirements.

Your tower prescription will be promptly filled at BLAW-KNOX.

BLAW-KNOX DIVISION OF BLAW-KNOX COMPANY
2037 FARMERS BANK BUILDING, PITTSBURGH 22, PA.

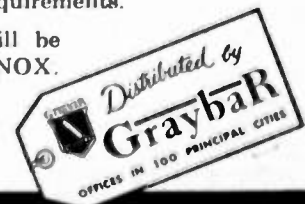

**BLAW-KNOX ANTENNA
TOWERS**



(Continued from page 38A)

WASHINGTON

"Television Broadcast Antennas Having Higher Gains and Directive Patterns," by L. J. Wolf, RCA Victor Division; and "Low Cost Television Stations," by Walter Lawrence, RCA Victor Division; September 12, 1949.



UNIVERSITY OF LOUISVILLE—IRE BRANCH Business Meeting; August 25, 1949.

POLYTECHNIC INSTITUTE OF BROOKLYN—IRE BRANCH

"Impedance Measurements at Microwave Frequencies," by Frank Klawsnik, Sperry Gyroscope Company; December 16, 1948.

Professional Discussion by David Vitrogen, Faculty of Polytechnic Institute of Brooklyn; H. R. Brownell, Consulting Engineer; and Robert Eiermann, Branch Chairman; April 7, 1949.

"The Design of Special Filters," by A. Boggs, Western Union Telegraph Company; April 28, 1949.

"Humanities and the Engineer," by R. H. Robins, Faculty of Polytechnic Institute of Brooklyn; May 12, 1949.



The following transfers and admissions were approved, and will be effective as of November 1, 1949:

Transfer to Senior Member

- Boyd, J. C., 9 N. Front, Clearfield, Pa.
- Cruickshank, J. E., 218 East Ave., Valley Stream, L. I., N. Y.
- Eberhard, E., 232 Ardmore Ave., Haddonfield, N. J.
- Goldsmith, B. M., 7 Lenox Terr., South Orange, N. J.
- Hager, F. M., Jr., 711 N. State St., Waseca, Minn.
- Hartley, H. F., Jr., 407 Drayton Rd., Oreland, Pa.
- Hegar, E. A., 802 Telephone Bldg., Dallas 2, Tex.
- Johnson, R. W., 303B Langley, U. S. Naval Ordnance Test Station, China Lake, Calif.
- Klinestiver, G. H., 356 E. Fifth St., Emporium, Pa.
- McGregor, J. C., 69-05A—186 Lane, Flushing, L. I., N. Y.
- McLean, T., Forest Dr., Ithaca, N. Y.
- Ordung, P. F., Dunham Laboratory, Yale University, New Haven, Conn.
- Phatak, R. K., 169 Vincent Rd., Bombay 14, India
- Seelen, H. R., RCA, Lancaster, Pa.
- Trainer, M. A., Bldg. 15-6, RCA Victor Division Front & Cooper Sts., Camden, N. J.
- Weller, D. A., Radio Station WISN, 123 W. Michigan St., Milwaukee, Wis.

Admission to Senior Member

- Coover, M. S., Electrical Engineering Department, Iowa State College, Ames, Iowa

(Continued on page 44A)

THESE THREE NEW DEVELOPMENTS ARE

Keeping *Astatic* Out in Front IN THE MANUFACTURE OF PICKUP CARTRIDGES

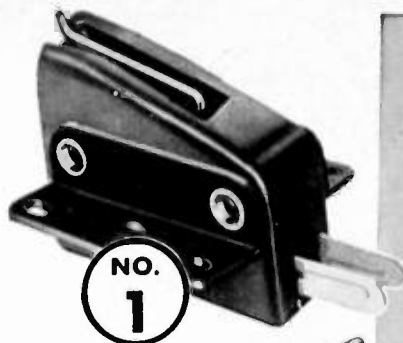

1 GC CERAMIC CARTRIDGE

First major engineering stride in phonograph pickup cartridges employing ceramic elements since Astatic pioneered in this type unit last year. The GC is the first cartridge of its kind with replaceable needle. Takes the special new Astatic "Type G" needle—with either one or three-mil tip radius, precious metal or sapphire—which slips from its rubber chuck with a quarter turn sideways. Resistance of the ceramic element to high temperatures and humidity is not the only additional advantage of this new development. Output has been increased over that of any ceramic cartridge available. Its light weight and low minimum needle pressure make it ideal for a great variety of modern applications.

2 CQ CRYSTAL CARTRIDGE

An entirely new Astatic design, featuring miniature size and five-gram weight. Model CQ-J fits standard 1/2" mounting and RCA 45 RPM record changers. Model CQ-IJ fits RMA No. 2 Specifications for top mounting .453" mounting centers. Needle pressure five grams. Output 0.7 volts at 1,000 c.p.s. Employs one-mil tip radius, Q-33 needle. Cast aluminum housing.

3 LQD Double-Needle Crystal Cartridge

The LQD Cartridge—for 45, 33-1/3 and 78 RPM Records—quickly became the first choice of many of the nation's largest users, on the basis of comparative listening tests, and is, today, the PROVED TOP PERFORMER for turnover type pickups. Outstanding for excellence of frequency response, particularly at low frequencies. A gentle pry with penknife removes ONE needle for replacement . . . without disturbing the other needle, without removing cartridge from tone arm. Gentle pressure snaps new needle into place. Available with or without needle guards. Stamped aluminum housing.



You can use a ball bat to make it fit...



But it's simpler to design the radio around the battery!

NO MATTER what size portable receiver you are designing, you'll find a compact, long-lasting "Eveready" battery to fit it. By designing your portables around "Eveready" batteries, you automatically insure that the user will get long-playing life and—very important—he can get replacements anywhere, anytime. "Eveready" brand batteries are always top-quality, always easy for the user to obtain.

SEND COUPON BELOW FOR LATEST BATTERY DATA

The registered trade-mark "Eveready" distinguishes products of National Carbon Company, Inc.

Please send me, free of charge, the 1949 Revision of "Battery Engineering Bulletin No. 1" which contains latest battery data for portable receivers and includes specifications for six completely new batteries of interest to designers.

Name _____

Street _____

City _____ State _____

NATIONAL CARBON COMPANY, INC.

30 East 42nd Street
New York 17, N. Y.

Unit of Union Carbide and Carbon Corporation



An Important Statement by



MYCALEX CORPORATION OF AMERICA

Issued in an effort to clear up and to avoid continued confusion

It has come to our attention that some electronic engineers and purchasing executives are under the erroneous impression that the MYCALEX CORPORATION OF AMERICA is connected or affiliated with others manufacturing glass-bonded mica insulation under other trade names, and that genuine "MYCALEX" and glass-bonded mica insulation made by such other companies are "all the same thing" . . . are "put out by the same people," . . . and "come from the same plant." NONE OF THIS IS TRUE.

THE FACTS ARE:

1. The MYCALEX CORPORATION OF AMERICA is not connected or affiliated with any other firm or corporation manufacturing glass-bonded mica insulation materials, except Mycalex Products Sales Corporation and Mycalex Tube Socket Corporation, which are exclusively licensed by the Mycalex Corporation of America to distribute and sell Mycalex components. These "Mycalex" companies are 100% American in ownership.
2. The word "MYCALEX" is not a generic term. It is a trade mark registered in the United States Patent Office, and owned by the MYCALEX CORPORATION OF AMERICA, and identifies the glass-bonded mica insulation products of formulae and design developed and manufactured in the plant of the MYCALEX CORPORATION OF AMERICA.
3. The General Electric Company, by virtue of a non-exclusive license it had under a MYCALEX patent through the MYCALEX COMPANY, LTD., of Great Britain, has been permitted to identify its glass-bonded mica insulating materials made under such license as "G-E Mycalex."
4. The MYCALEX CORPORATION OF AMERICA has behind it over 30 years of research leadership and owns U. S. patents and patent applications on improved glass-bonded mica insulation marketed under the trademarks "MYCALEX," "MYCALEX 410," "MYCALEX 410X," "MYCALEX 400," and "MYCALEX K."
5. All products of the MYCALEX CORPORATION OF AMERICA are given distinctive identifications incorporating the trade-marked name "Mycalex"; all such identifications are registered and may be legally used only by the MYCALEX CORPORATION OF AMERICA and those authorized by it.
6. "MYCALEX" in all the forms described above, is made by exclusive formulae and exclusive patented processes. It is impossible for anyone other than the MYCALEX CORPORATION OF AMERICA to supply any product, similar in appearance, as the very same thing.

MYCALEX 410, is the most versatile and nearly perfect insulation material yet developed for the electronics industry. Widely specified because of its low dielectric loss, high dielectric strength, high arc resistance, dimensional stability over wide humidity and temperature changes, resistance to high temperatures, mechanical precision, mechanical strength, and ability to be molded, with or without metal inserts, to extremely close tolerances and in irregular shapes. Priced to compete with less effective electrical insulation materials such as mica-filled phenolics, steatite, etc.

MYCALEX 410X (leadless formulation), can be injection molded, with or without metal inserts, to extremely close tolerances. Equal in versatility to MYCALEX 410, and used where somewhat lesser dielectric qualities are acceptable. Priced to compete with general purpose phenolics.

MYCALEX 400 fully approved by the Army and Navy as Grade L-4 insulation, is a low-loss Mycalex insulation—available in sheets and rods, and can be machined to size, shape and specifications.

MYCALEX K is a series of capacitor dielectrics that can be supplied in sheets, rods and molded parts, to special order.

MYCALEX STANDS ON ITS OWN REPUTATION



MYCALEX CORP. OF AMERICA

"Owners of 'MYCALEX' Patents"

Plant and General Offices, CLIFTON, N. J.

Executive Offices, 30 ROCKEFELLER PLAZA, NEW YORK 20, N. Y.

News—New Products

These manufacturers have invited PROCEEDINGS readers to write for literature and further technical information. Please mention your I.R.E. affiliation.

New Accessories for Electron Microscope

Three accessories permitting specialized application of the RCA electron microscope was announced by the Scientific Instruments Section, RCA Engineering Products Dept., Camden, N. J.

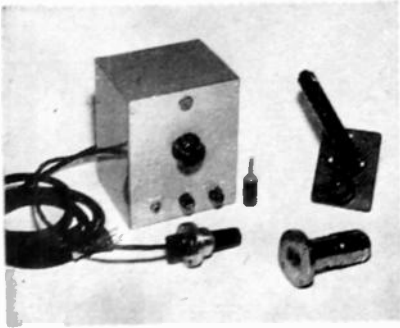

On the left, the EMN-1 charge neutralizer designed to neutralize charges produced on diffraction specimens by the primary electron beam of the microscope. Complete with power supply which operates from a 115-volt, 50 or 60 cps-ac line, and draws approximately 60 watts, the unit consists of a heated filament which sprays a low-velocity stream of electrons into the diffraction specimen chamber.

Above right, the type EMX-1 focusing magnifier consisting of a low-power microscope, which may replace either of the viewing chamber side windows a small prism coated on the upper face with fluorescent material, and a control handle to move the prism in and out of the electron beam path permits direct viewing of the image at 150,000 magnifications.

Providing controllable intense illumination with lower beam current, the self-bias gun kit, MI-12986, lower right, makes it possible to obtain maximum resolution in studies of a wide range of specimens. It is possible, when employing the diffraction adapter, to obtain diffraction patterns of specimens. The self-bias gun is interchangeable with the zero-bias gun which is standard equipment for the type EMU electron microscope.

Double-Pole Line Switch

A small-size (0.888 inch in diameter by 0.312 inch thick) double-pole line switch for volume, tone and other variable resistor controls has been announced by the Stackpole Carbon Co., Tannery St., St. Marys, Pa. The new unit is known as Switch Type A-10, and combines design simplicity with ample-sized contacts and positive contact wiping action. Standard types are rated 1 amp at 250 volts ac-dc, or 3 amperes at 125 volts ac-dc.

Other features include stationary contacts mounted on fibre surface phenolic material to reduce arc tracing, and a bakelite base held securely in the can.

(Continued on page 49A)

Announcing

MYCALEX 7 Pin Miniature Tube Sockets

For the first time a miniature tube socket of glass-bonded mica has been produced successfully by injection molding. It permits closer tolerances, low dielectric loss with high dielectric strength, high arc resistance and dimensional stability over wide humidity and temperature ranges. The technical skill and research of Mycalex Corp. of America has made it possible to produce insulating materials with extremely low loss factors at competitive prices.

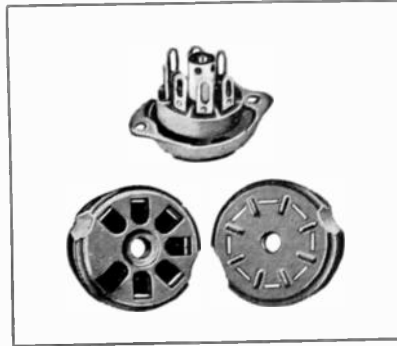

Above: Complete 7 pin miniature socket.
Below: Precision moldings in MYCALEX insulation—actual size, 2 side view.

MYCALEX 410 is designed to hold closer dimensional tolerances than ceramics and with a lower loss factor than mica filled phenolics with an advantage in economy.

MYCALEX 410X is designed to compare favorably with general purpose bakelite in economy but with a loss factor of only about one-fourth of that material.

The following ratings show the difference between Mycalex 410 and Mycalex 410X miniature tube sockets.

MYCALEX 410 (color grey)

600 V.ac
.015
1000 megohms
80° C.
375° C.

Rated Working Voltage
Insulation loss factor (at 1 M.C.)
Insulation resistance (Minimum)
Safe operating temperatures:
Brass contacts
Socket body

MYCALEX 410X (color lt. green)

600 V.ac
.083
1000 megohms
80° C.
375° C.

These sockets are now available, manufactured to precise specification and fully meet RMA standards. We would be glad to have our engineers consult with you on your particular design problems. Write for prices, complete data sheet and samples to:

Mycalex Tube Socket Corporation

"Under Exclusive License of Mycalex Corporation of America"

30 Rockefeller Plaza, New York 20, N.Y.

MYCALEX CORP. OF AMERICA



"Owners of 'MYCALEX' Patents"

Plant and General Offices: Clifton, N. J. Executive Offices: 30 Rockefeller Plaza, New York 20, N. Y.

*How much valuable time
do you lose in research?*

NOW . . . a complete bibliographical listing of electronic research from 1925 to the present!

The Electronics Research Publishing Co., makes a vital contribution to the continued development in electronics, optics, physics and allied fields with the new, greatly enlarged MASTER INDEXES which bring this vital information up to date.

THE ELECTRONIC ENGINEERING MASTER INDEX (Combined 1947-1948 edition now on press)

Over 13,000 listings of articles published in 234 international scientific magazines, journals and proceedings. 399 different subject headings. All the finest engineering text books published are listed in a special reference section.

SPECIAL FEATURE—Listings of declassified documents available from U.S., Canadian and British Governments.

EXTRA FEATURE—Listings of 5,500 patent references giving number, title and claims of electronic patents granted in the U.S. during the years of 1947-1948.

**CROSS REFERENCED CUMULATIVE SUBJECT INDEX OF
ALL PREVIOUSLY PUBLISHED ELECTRONIC MASTER
INDEX SUBJECTS APPEAR IN 1947-1948 ISSUE**

The 1949 MASTER INDEX will be ready in March 1950. It will contain the cumulative subject index of all previously published MASTER INDEX editions.

Another vital contribution to electronics

THE ELECTRONIC ENGINEERING PATENT INDEX

All electronic and related patents granted by the U.S. Patent Office since 1946 in three volumes. 1946 volume includes over 2,000 patents with circuit designs, components, manufacturing methods, etc. 1947-1948 combined issue covers 5,500 electronic patents. The 1949 issue covers approximately 3,000 electronic patents.

Books are heavy cloth bound 7 1/2 x 10 1/2 inches

The time saved in finding even one valuable reference often more than pays for the complete series of the Electronic Engineering Master Index. These books belong in the library of every electronic engineer, educational institution, research laboratory, patent attorney, government agency and industrial engineering department. Editions are limited, so please order your copies today



(Continued from page 40A)

Framme, R. J., 40 Triangle Ave., Dayton 9, Ohio
Heiden, C. M., 429 Plymouth Dr., Syracuse, N. Y.
Roads, J. A., 3960 Cherrywood St., Los Angeles 43, Calif

Transfer to Member

Annerman, C. R., Electrical Engineering Bldg., Pennsylvania State College State College Pa.
Blackwell, J. H., Physics Department, University of Western Ontario, London, Ont., Canada
Church, T. S., 3079-Q-34 Sandia Base Branch Albuquerque, N. Mex.
Climent, L. J., 984 Broadway, Brooklyn 21, N. Y.
Gainer, W. P., 5555 N. Bay Ridge Ave. Milwaukee 11, Wis
Hansen, E. L., 224-04—93 Rd., Queens Village 8 N. Y.
Lautinen, P. O., 119 Kinship Rd., Baltimore 22 Md.
LeVine, D. J., 2 Stuyvesant Oval, New York 9, N. Y.
Mahaffey, R. F., 1304 Michigan, Alamogordo N Mex
Moffet, J. A., 4831-1 S. 28 St., Arlington, Va
Singleton, C. M., Pan American-Grace Airways-Inc Communications Department Lima Peru
Swanson, E. H., 36 Harbour Way, Sea Cliff, L I N. Y.
Trevey, C. B., 2555 Pierce St., Beaumont, Tex
Volz, C., 160 W Hamilton Ave., State College Pa
Weeks, R. R., 3375 Third Ave S E Cedar Rapids, Iowa
Wonnell T. S., 2045 Allison St., Indianapolis, Ind

Admission to Member

Blasingame, J. J., 337 N Elm St., Osborn, Ohio
Cornwell, R. C., Federal Telephone and Radio Corporation, 100 Kingsland Rd Clifton N. J.
Davidson, A. R., 3422 Argyle Ave., Erie, Pa
Francis, C. A., 7401 Satsuma, Houston, Tex
Hammond, L. A., 44 Lippincott Ave., Long Branch N. J.
Holpuch, C. J., 2935 W Berteau Ave., Chicago 18 Ill.
Koppl, W., 9 St. John's Rd., Baltimore 10, Md
Kunz L. C., Jr., Bldg. 6, General Electric Company Electronics Park, Syracuse N Y
Luke, R. W., 171 John St., London, Ont., Canada
Nichols W. R., Box 1040, Alaska Broadcasting Company, Anchorage, Alaska
Quigley, F. T., 108 E. Sixth St., Emporium, Pa.
Randolph, G. W., Bendix Radio Division, Department 63, Towson, Md
Rao, C. B., Department of Radio Technology, S. J O. Institute Bangalore, India
Scalise, L. D., 300 Lincoln Ave., Warren, Pa
Sheriff, D. R., 57 W Mira Monte Sierra Madre Calif.
Tavernier, G. C., 7 Rue Du Vivier, Ixelles, Bruxelles, Belgium
Vore, W. E., 420A Nimitz Ave., China Lake, Calif
Warner, M., 5 Newman St., River Plaza, Red Bank, N. J.
Weinmann, R. H., 27 N Court, Roslyn Heights, L I. N Y

The following elections to Associate grade were approved and will be effective as of October 1, 1949:

Althouse, J. M., 1554 S. Smithville Rd., Dayton 10, Ohio
Baron, T., 3077 Lafayette Blvd., Lincoln Park 25 Mich.
Berliner, O., 1007 N Roxbury Dr., Beverly Hills, Calif
Bird, W. A., 208 E. 51 St., Brooklyn 3, N Y
Bishop, F. L., 54 Church St Merrimac Mass
(Continued on page 46A)

Mr. John F. Rider, President
Electronics Research Publishing Co., Inc.
480 Canal Street, New York 13, N.Y. IR-11

Please send me the volumes checked. I understand they can be returned in ten days if I am not satisfied and get a full refund. (charges shown are postpaid).

THE ELECTRONIC ENGINEERING MASTER INDEX
 1935-1945 (\$10.00) 1925-1945 (\$17.50)
 1946 (\$14.50) 1947-1948 (\$19.50) *1949 (\$17.50)

THE ELECTRONIC ENGINEERING PATENT INDEX
 1946 (\$14.50) †1947-1948 (\$19.50) *1949 (\$14.50)
 * available March 1950. † available Jan. 15, 1950.

Name

Company

Address

City Zone State

We pay postage if remittance accompanies order.
Mailing charges collect on C.O.D. orders.

Let **MARION** help you . . .

... seal components *hermetically*
... speed up sub-assemblies



**Marion portable,
bench-type induction
soldering unit**

- SMALL
- COMPACT
- ADAPTABLE
- EFFICIENT
- ECONOMICAL
- EASY-TO-USE

A PRODUCTION TOOL This unit was designed to simplify and improve both the quality and quantity of production of many different assemblies in the electronic and electrical fields. It has been used successfully for many years in the manufacture of Marion hermetically sealed instruments. Assembly applications include magnet assemblies, relay armatures, connectors, capacitors and transformer cans and germanium diode assemblies; also jewelry, watches, toys, automotive parts, household fixtures, etc.

HERMETICALLY SEALED COMPONENTS Because of the present intense interest in hermetically sealed components, Marion offers the benefit of its experience in true glass-to-metal hermetic sealing with the Marion Induction Soldering Unit and Marion metalized (platinum film) glass. Marion platinum film base glass has been developed to permit higher sealing temperatures, greater thermal shock range and resoldering if necessary.

PROFIT FROM EXPERIENCE Investigate now. Submit your requirements. We will be glad to supply samples and quotations. Ask for bulletin.



MANUFACTURERS OF
HERMETICALLY
SEALED METERS
SINCE 1944



MARION ELECTRICAL INSTRUMENT COMPANY

MANCHESTER, NEW HAMPSHIRE

Export Division, 45B Broadway, New York 13, U. S. A., Cables MORHANEX

IN CANADA: THE ASTRAL ELECTRIC COMPANY, SCARBORO BLUFFS, ONTARIO

Specify CP TEF-LINE SUPER TRANSMISSION LINE

A new transmission line based upon a new plastic—TEFLON

CP TEF-LINE transmission line, utilizing DuPont Teflon insulators, greatly reduces high frequency power losses. Furthermore, operation of transmission line at frequencies heretofore impossible owing to excessive power loss now becomes easily possible. For TV, FM and other services utilizing increasingly high frequencies, TEF-LINE by CP is a timely and valuable development worthy of investigation by every user of transmission line.

ONE-PIECE INNER CONDUCTOR

Seal-O-Flange Tef-Line is made of a single piece of copper tubing. Teflon disks are distributed to provide positive, permanent positioning.

COPPER INNER CONDUCTOR
OF A TEF-LINE
SEAL-O-FLANGE
TRANSMISSION LINE
SHOWING A ONE-
PIECE TEFLON
INSULATING DISK
FITTING INTO DEPRESSION
FORMED IN THE TUBE WALL.

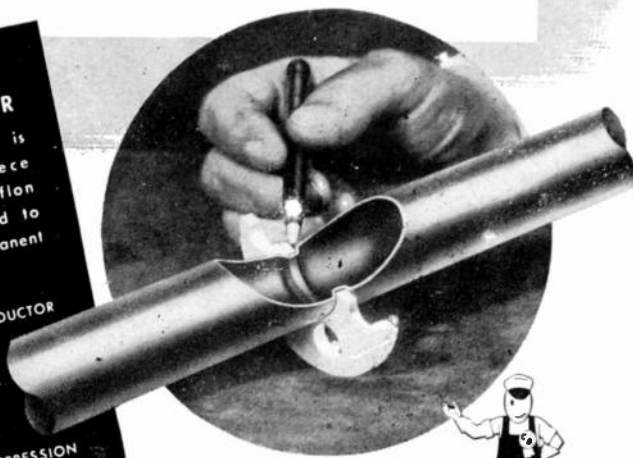

CP SUPER TEF-LINE IS AVAILABLE NOW!

Tef-Line can be delivered immediately in three standard sizes— $\frac{7}{8}$ " , $1\frac{1}{8}$ " and $3\frac{1}{8}$ ". With the exception of elbows and gas stops, the new Seal-O-Flange Super Transmission Line is interchangeable with all other CP fittings including end seals, tower hardware, flanges, "O" rings, inner conductor connectors and miscellaneous accessories.

Check your transmission line requirements with the new CP TEF-LINE BULLETIN which is available on request. If you need help in planning installations, our engineers will be happy to talk over specific problems at your convenience.

- TOWER HARDWARE
- AUTO-DRYAIRE DEHYDRATORS
- LO-LOSS SWITCHES
- COAXIAL DIPOLE ANTENNAS
- SEAL-O-FLANGE TRANSMISSION LINE

Communication Products Company, Inc.

KEYPORT  NEW JERSEY



(Continued from page 44A)

- Bolton, B. A., 2901 Elm St., Denver 7, Colo.
Boulet, L. A., 14495 Rochelle, Detroit 5, Mich.
Brickey S. F., 83 Walk Hill St., Jamaica Plain, Mass.
Brode, R. L., Box 32, Phoneton, Ohio
Brooks, W. O., 2105 Alma St., San Pedro, Calif.
Brunner, F., Sloane House 356 W. 34 St., New York, N. Y.
Bryan, J. F., Box 160, R.D. 1, Long Branch, N. J.
Bugg, R. W., Airway Communication Station, CAA Box 165, Calumet, Mich.
Casselberry, R. L., General Electric Company, 3037 Book Bldg., Detroit, Mich.
Carpenter, R. E., 506 Adams St., N. Abington, Mass.
Clark, R. M., Box 265A, Route 5, St. Joseph, Mo.
Cooper, P. V., 3965 S. Harvard Blvd., Los Angeles, Calif.
Cother, R. H., 15222 S. Atkinson Ave., Gardena, Calif.
Cox F., Box 741, Macon, Ga.
Cullen, A. E., Jr., 55 Campbell St., Woburn, Mass.
Dean, A. J., 1500 Bergen Blvd., Fort Lee, N. J.
Delano, H. C., 400 E. Donovan Rd., Kansas City, Kans.
Dowd, F. W., 1122 N. Ninth St., St. Joseph, Mo.
Dressel, H. O., 2459 Glebe Ave., New York 61, N. Y.
Eells, W. A., 1207 Gilham, Philadelphia 11, Pa.
Enyard, H. C., 83 Allerton Rd., Newton Centre 59, Mass.
Erdle, P. J., Sylvania Electric Products, Inc., Emporium, Pa.
Featherston, J. R., 205 N. Cuyler Ave., Oak Park, Ill.
Filko, P. P., R. D. 2, Box 399, Cuyahoga Falls, Ohio
Fratkin B., 309½ Flora Ave., Winnipeg, Man., Canada
Goldbaum, S., 1802 Ocean Pkwy., Brooklyn 23, N. Y.
Gregory B. J., 889 Jessie Ave., Winnipeg, Man., Canada
Guimaraes, B. Q., Rue Sampaio Viana No. 391, Sao Paulo, Brazil
Hanner, J. B., Research Laboratories, Swift and Company, Chicago 9, Ill.
Harp, M. C., 214 Beverly Ave., Millbrae, Calif.
Hellmann, R. G., 2108 Ryer Ave., New York 57, N. Y.
Horna, O. A., Praha XIX, Czechoslovakia
Horsman, J. O., 3331 Dumaine St., New Orleans 19, La.
Hoskins, J. W., 1439 Ohio St., Vallejo, Calif.
Huskey, H. D., 2237 Manning Ave., Los Angeles 25, Calif.
Jaehnic, R. H., 3215 N. 23 St., Milwaukee 6, Wis.
Jeffers, G. W., 28 Upper Ave., Dayton 7, Ohio
Kesgen, E. W., 286 Grove St., E. Rutherford, N. J.
Kelly, J. P., 92 Upland Ave., Newton Highlands 61, Mass.
Kolberg, E. G., 5700 W. Erie, Chicago 44, Ill.
Lannan, W. E., 44 Warren Ave., Woburn, Mass.
Maguire, L. R., 221½ E. Sixth St., Emporium, Pa.
Mayle, L. F., Capehart-Farnsworth Corporation, Fort Wayne, Ind.
McCarthy, H. J., 3537 W. 60 St., Chicago 29, Ill.
Ming, D. L., 2111 Pentland St., Temple City, Calif.
Mitchell, D. J., 14 Davison St., Hyde Park 36, Mass.
Moore, J. M., 1130—18 St., Manhattan Beach, Calif.
Mueller, P. J., 6085 S. 108 St., Hales Corners, Wis.
Noble, W. E., Box 1604, Ketchikan, Alaska
Novello, E. N., 1664—65 St., Brooklyn 19, N. Y.
Nunan, K. W., Sr., R.D. 4 Central St. George town, Mass.
Overholser, W. E., 33 N. Alder Ave., Dayton, Ohio
Papazian, M. G., 2108 Smith St., Fort Wayne 5, Ind.

(Continued on page 48A)

Comparisons

indicate this is the world's
finest recorder of its type

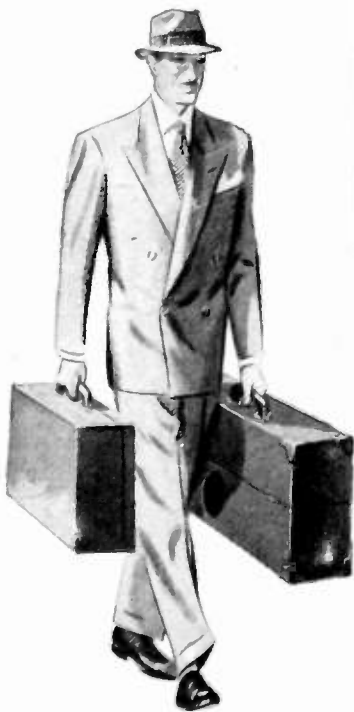
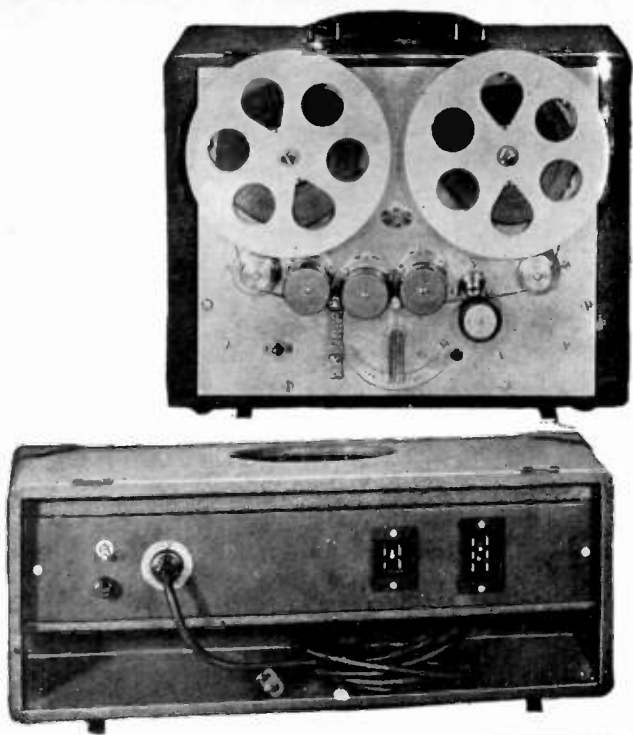

Complete in two easily portable cases—
one containing the recorder, the other
the amplifying equipment.

NEW PRESTO Portable Tape Recorder PT-900

MANY OUTSTANDING FEATURES:

- Three separate heads for superior performance (and for monitoring direct from tape). One head each to erase, record and play back.
- 3 microphone channels with master gain control in recording amplifier.
- Large V.U. meter with illuminated dial to indicate recording level, playback output level, bias current and erase current, and level for telephone line.
- 2-speed, single motor drive system. Toggle switch to change tape speeds from 7½" to 15" per second.

Don't choose your tape recorder until you see the *new* Presto Portable Tape Recorder. Write for complete details today.

Write today to be put on our mailing list for "The Presto Recorder," new house organ of practical ideas for anyone in the recording and broadcasting field.

Mailing Address: P. O. Box 500, Hackensack, N. J.
In Canada: WALTER P. DOWNS, Ltd., Dominion Square Building, Montreal

RECORDING CORPORATION
Paramus, New Jersey

Announcing

"Prodelin"

HIGH EFFICIENCY
TRANSMISSION LINE

JOB PACKAGED ENGINEERING

THROUGH THE MICROWAVE SPECTRUM

Complete with all necessary system components and designed for optimum performance ready to serve the most critical type service. Pre-installation system testing at our plant or in the field optional at additional cost.

"PRODELIN"* END SEALS

51.5-ohm end seals with our standard "Prodelin" coupling and 1/8" ips. pipe fitting, adapts Prodelin 7/8" line to RG-8/u cable.

Measured VSWR @ 2000mcs. less than 1.1 with end seals terminating 200 ft. of line.

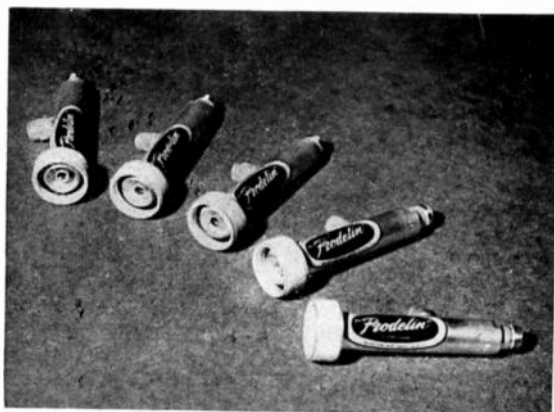

"Prodelin" Transmission Line Has High Efficiency

- Unique insulator design*
- Functional insulator spacings
- Maximumally flat line couplings
- Highest quality materials and workmanship
- Critical production control and testing
- Exceeds requirements of commercial specifications

"Prodelin" 51.5-ohm transmission lines, fittings, and tower accessories available in 7/8", 1-5/8", 3-1/8" and 6-1/8" sizes.

For additional information write for bulletin #1049.

Remember "Prodelin" for

- Rigid and semi-rigid coaxial line for high and low frequency application with low VSWR.
- Solid dielectric flexible coaxial cable and connector assemblies for feeding high and low frequency systems under normal temperatures or for extremely high or low temperature operating requirements.

* U.S. Patent 2,436,284 Feb. 17, 1948.

• Reg. Trade Mark.

PRODUCT DEVELOPMENT CO., INC.
ARLINGTON, NEW JERSEY



(Continued from page 46A)

- Patterson, K. P., 842 Fulton St., San Francisco 17, Calif.
 Pease, C. H., 20-42 Crescent St., Long Island City 5 N. Y.
 Perry, J. T., 2917 The Mall, Los Angeles 23, Calif.
 Poe, C. M., 2661 Jongull Dr., San Diego 6, Calif.
 Raupp, R. A., Box 151, Gurnee, Ill.
 Rimsky, E., 1952 N. Madison Ave., Pasadena 6, Calif.
 Roberts, J. V., 37 Burlington St., Ashton-Under-Lyne, Lancs., England
 Rogers, A. L., 827 Roswell Ave., Kansas City, Kans.
 Rogers, D.C., CAA, Section 67, Box 440, Anchorage, Alaska
 Ross, J. D., 8 Oaker Ave., Manchester 20, England
 Shaw, H. W., 1644 Baltimore Ave., Kansas City 8, Mo.
 Siefken, R. M., 104 Buckworth Dr., Kokomo, Ind.
 Siekanowicz, W. W., 105 Audubon Ave., New York, 32, N. Y.
 Smith, M. H., 3731 W. 59 Pl., Los Angeles 43, Calif.
 Sola, M. C., B. Mitre 366, Argentina
 Sulkoski, W. M., 334 Bridle Path, Worcester 4, Mass.
 Sundt, E. V., Littelfuse, Inc., 4757 N. Ravenwood Ave., Chicago 40, Ill.
 Talmadge, G. E., Electronics Officer, Naval Air Station, Atlanta, Ga.
 Toth, W., 4525 N. Clifton Ave., Chicago 40, Ill.
 Tutty, J. E., 286 Summer Ave., Newark 4, N. J.
 Wehrlin, R. F., 121 E. 24 St., New York 10, N. Y.
 White, S. B., 615 Monterey Ave., Dayton 9, Ohio
 Whitten, G. A., Box 115, Fort Wayne, Ind.
 Wild, A. F., General Electric Company, 140 Federal St., Boston, Mass.
 Wirth, S. R., 10835 Farragut Dr., Culver City, Calif.
 Wojcik, J. J., 7338 Rugby St., Philadelphia 19, Pa.
 Zerklin, M., 808A Bergen St., Brooklyn, N. Y.

The following transfers to the Associate grade were approved to be effective as of September 1, 1949:

- Aldrich, D. H., 1101 Ware Ct., Willow Village, Mich.
 Bell, N. W., 60 Oakridge Ave., Summit, N. J.
 Bernstein, M. I., 200 Queen St., Kingston, Ont., Canada
 Bertran, L. L., 77 Branch Ave., Red Bank, N. J.
 Betz, E. S., 418 Nelson Ave., Cliffside Park, N. J.
 Curren, W. T., 364 Lewis St., Ottawa, Ont., Canada
 Deitzler, R. P., 105 Church St., North Syracuse, N. Y.
 Green, E. D., 3112 Chesley Ave., Baltimore 14, Md.
 Greenquist, R. E., 3804 Bailey Ave., New York 63, N. Y.
 Horner, R. G., 1895 Grand Concourse, New York 53, N. Y.
 Johnson, R. D., 1507 Elmhurst Dr., N.E., Cedar Rapids, Iowa
 Judkins, J. R., 608 Waldron St., West Lafayette, Ind.
 Kitchens, J., 745 Pomona Ave., El Cerrito, Calif.
 Neuman, I., 120 East 11 St., New York 3, N. Y.
 New, R. F., 88 Crosby St., Hornell, N. Y.
 Norris, R. M., 1323 Fern Ave., Torrance, Calif.
 O'Hearon, J. B., Box 1594, R. D. 2, Auburn, Wash.
 Owens, H. A., Jr., Box 2091, University Station, Gainesville, Fla.
 Ripnitz, A., 121 Willow Ave., Takoma Park, Md.
 Rogers, J. A., 327 Fern St., Little Rock, Ark.
 Ryan, R. D., 83 Cottenham Ave., Kingsford, Sydney, N.S.W., Australia
 Schwartz, R. G., 2107 St. Paul St., Baltimore, Md.
 Spencer, D. L., 417 N. Simpson St., Philadelphia 31, Pa.
 Urkowitz, H., 5017 N. Fifth St., Philadelphia 20, Pa.
 Van De Riet, E. K., Box 158, Kenedy, Texas
 Weir, W. R., 310 Woodbury House, Hanover, N. H.

Cramer

TYPE TEC TIME DELAY RELAY



FUNCTION

Cramer TEC Time Delay Relays provide an adjustable or fixed time delay between the closing and opening of a load circuit. Automatic reset feature restores timer to normal start position when control circuit fails or is de-energized. Also available with reverse clutch that prevents reset in case of power failure.

CONSTRUCTION

Consist of a self-starting, slow speed synchronous motor with sturdy gear train . . . an electro-magnetically operated clutch . . . a switch and switch-tripping mechanism. Complete mechanism mounted on die-cast front plate with dust protected enclosure. Dials and cases conform to standard instrument panel specifications for either flush or surface mountings. Dials equipped with progress indicators, convenient thumbscrew setting.

TIME RANGES

Time Range	Dial Divisions	Minimum Setting	Type No.
15 sec.	.25 sec.	.75 sec.	TEC-15S
30 sec.	.5 sec.	1.5 sec.	TEC-30S
60 sec.	1 sec.	3 sec.	TEC-60S
2 min.	2 sec.	6 sec.	TEC- 2M
5 min.	5 sec.	15 sec.	TEC- 5M
15 min.	15 sec.	45 sec.	TEC-15M
30 min.	30 sec.	90 sec.	TEC-30M
60 min.	1 min.	3 min.	TEC-60M
3 hrs.	5 min.	15 min.	TEC- 3H
6 hrs.	10 min.	30 min.	TEC- 6H

Standard time ranges for Cramer Type TEC and TER Time Delay Relays are shown above. If your special requirement suggests variations from standard specifications, write us. For full technical description of all Cramer Time Delay Relays, send for bulletins 700C, 800E and 900D.

THE R. W. CRAMER COMPANY, INC.
Box #12, Centerbrook, Conn.

News—New Products

These manufacturers have invited PROCEEDINGS readers to write for literature and further technical information. Please mention your I.R.E. affiliation.

(Continued from page 43A)

New Preamplifier

A new preamplifier, Model 130H, to equalize low frequencies and provide necessary gain for magnetic pickups is announced by Pickering & Co., 308 Woods Ave., Oceanside, L. I., N. Y.



The preamplifier is self-powered, operates with any high-quality, high-input impedance amplifier, and installs by plugging in. It is said to be superior to most broadcast station equipment in its frequency response and accuracy or equalization; also, its intermodulation and harmonic distortion is said to be lower than engineering practice requires of professional equipment.

Substitution Tester

Oak Ridge Antenna, Div. of Video Television, Inc., 239 East 127 St., New York 35, N. Y. introduces the Model 101 Substitution Tester.

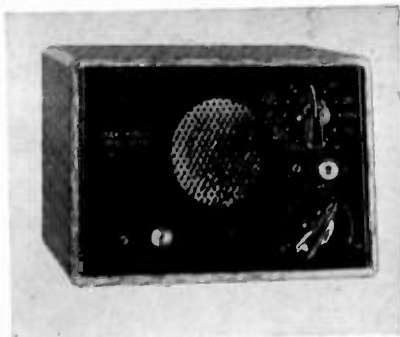

This compact (5½ inches X 3½ inches X 2½ inches) lightweight tester contains a range of substitute capacitors from 0.001 to 0.5 µfd, 600 volts, 30 µfd, 450 volts to 150 µfd, 150 volts, resistors from 100 ohm to 100,000 ohm 2 watt, a variable potentiometer 0-2 Mc, and a test speaker with connection to either voice, coil or transformer.

(Continued on page 55A)

Etched TUNGSTEN WIRE

FROM .0004" TO .00015"
DIAMETER AND EVEN SMALLER

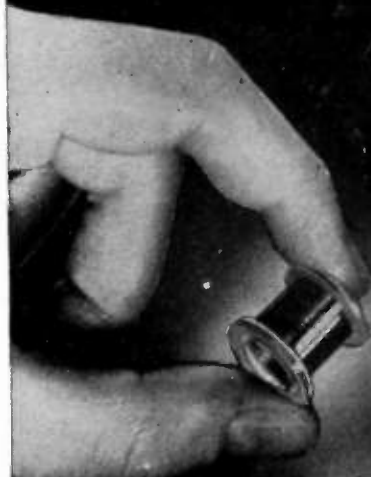

ACCURATE
UNIFORM
SMOOTH



also
available
in Molybdenum
and other metals

WRITE FOR FURTHER DETAILS AND LIST OF PRODUCTS

SIGMUND COHN CORP.

44 GOLD ST.

NEW YORK

SINCE



1901

INTERVAL - CYCLE - IMPULSE - PERCENTAGE TIMERS
RUNNING TIME METERS - GEARED SYNCHRONOUS MOTORS
4CR49

PROJECT ENGINEERS

Real opportunities exist for Graduate Engineers with design and development experience in any of the following: Servo-mechanisms, radar, microwave techniques, microwave antenna design, communications equipment, electron optics, pulse transformers, fractional h.p. motors.

SEND COMPLETE RESUME TO EMPLOYMENT OFFICE.

SPERRY GYROSCOPE CO.

DIVISION OF
THE SPERRY CORP.
GREAT NECK, LONG ISLAND

Positions Available for

ELECTRONIC ENGINEERS

with

Development & Design
Experience

in

MAGNETIC TAPE
RECORDING
MICROWAVE
COMMUNICATIONS

SONAR EQUIPMENTS

Opportunity For Advancement
Limited Only By Individual
Ability

Send complete résumé to:
Personnel Department

MELPAR, INC.
452 Swann Avenue
Alexandria, Virginia



The following positions of interest to I.R.E. members have been reported as open. Apply in writing, addressing reply to company mentioned or to Box No. . . .

The Institute reserves the right to refuse any announcement without giving a reason for the refusal.

PROCEEDINGS of the I.R.E.

1 East 79th St., New York 21, N.Y.

ENGINEER

Excellent opportunity for a man with experience in servo mechanisms and circuit theory work. Opportunity for graduate work available. Write Box 30, State College, Pennsylvania.

DEVELOPMENT PHYSICIST ENGINEER

Experienced in theory, design and construction of attenuators, D.C. to 3 KMC, and associated test equipment, well versed in physics, chemistry and application of conductive films, operation of power tools, advanced mathematics. Write giving complete education and experience to Weinschel Engineering Co., 123 William Street, New York 7, N.Y.

DIRECTOR OF TRAINING

Southern, G. I. approved, private vocational school desires capable man to take charge of teaching courses in radio and television. Salary \$300 to \$350 per month. Scholastic hours. Teaching experience preferred. Write Mr. J. D. Muse, P. O. Box 505, Atlanta, Georgia.

MECHANICAL ENGINEERS AND DESIGNERS

Fully qualified. Accustomed to working with small electromechanical devices. Write Mr. D. A. Murray, Mount Dennis, Toronto 15, Canada.

ELECTRONIC ENGINEER

Fully qualified. At least five years laboratory experience in circuit design and radio physics. Canadian national preferred. Write Mr. D. A. Murray, Mount Dennis, Toronto 15, Canada.

DEVELOPMENT ENGINEERS

All grades with degrees and experience in design and development of high quality instruments for research in physics, chemistry, etc. Applicant will be required to design and develop electrical, electronic and mechanical instruments for the nuclear field. Salary commensurate with ability to produce a final working model from the idea state. Box 577.

ELECTRONIC TECHNICIANS

For work in laboratory, assembling, wiring and testing of precision electronic design models. Applicants must have at least three years of similar experience and must be capable of producing the highest quality work. Box 577.

ENGINEER

Wanted, new electronic ideas, company with capital and manufacturing facilities is seeking new electronic products, inventions, or ideas to expand commercial business. Liberal arrangements with inventors. Box 578.

ENGINEERS

Electrical or Electronic engineers with experience in magnetic recording techniques and/or systems, preferably in the computer field. Box 579.

ENGINEER

A government-supported project with a college in NYC has an opening for an experienced vacuum tube development engineer. Duties are technical-administrative, with opportunity to initiate and conduct research part-time. State qualifications and salary requirements. Box 580

ELECTRICAL ENGINEERS

Highly interesting research and design positions are open at Army Security Agency, Washington 25, D. C., in the field of electronics for electrical engineers, grades P-3, \$3727.20 per annum through P-5, \$6235.20 per annum. Minimum requirements are a Master's degree or a Bachelor's degree from an accredited college or university, plus one year of professional engineering experience. All positions are permanent insofar as the Agency is concerned. Address reply to, Chief, Army Security Agency, CS/GAS-61, The Pentagon, Washington 25, D.C.

POSITIONS OPEN FOR PHYSICISTS SR. ELECTRONIC ENGINEERS

Familiar with ultra high frequency and micro wave technique

Experience with electronic digital and/or analog, computer research and development program

Salaries commensurate with experience and ability. Excellent opportunities for qualified personnel

CONTACT

C. G. Jones, Personnel
Department
GOODYEAR AIRCRAFT
CORPORATION
Akron 15, Ohio

POSITIONS OPEN

RADAR ENGINEER-PHYSICIST

Must have heavy experience in basic study and research on new radar systems and similar electronic equipment. Excellent opportunity for senior man. Juniors please do not apply. State particulars, reply confidential, to A. Hoffsommer, The W. L. Maxson Corp., 460 West 34 Street, New York 1, N.Y.

PATENT ENGINEER

A manufacturer of electrical and mechanical devices in the New York area, is in need of a man with legal, patent and engineering training and some experience, to act as liaison between engineers and sales executives and outside patent counsel. In reply give full particulars of experience and training. Address reply to Box 582.

ENGINEER OR PHYSICIST

Preferably with post-graduate degree, at least 5 years' experience advanced development or research on electrical circuits. Pulse experience preferred. Able to plan and direct an engineering group. Address reply to Personnel Manager, RCA Victor Company, Ltd., Montreal, Canada.

TELEVISION ANTENNA ENGINEER

Well established New York City manufacturer has immediate opening for engineer with thorough up-to-the-minute knowledge of commercial Television Receiving antenna theory, design and construction. Duties include sales engineering and execution of graphs and test patterns. Write Box 583.



Positions Wanted By Armed Forces Veterans

In order to give a reasonably equal opportunity to all applicants, and to avoid overcrowding of the corresponding column, the following rules have been adopted:

The Institute publishes free of charge notices of positions wanted by I.R.E. members who are now in the Service or have received an honorable discharge. Such notices should not have more than five lines. They may be inserted only after a lapse of one month or more following a previous insertion and the maximum number of insertions is three per year. The Institute necessarily reserves the right to decline any announcement without assignment of reason.

SALES ENGINEER

B.S. in G.E., Naval Academy. One year P.G. in applied communications. Five years Naval experience as radar, radio and communication officer. Tele-

(Continued on page 52A)

FOR Cathode-Ray Tube PRODUCTION



Kinescope manufacturing
RCA Tube
Department,
Lancaster,
Pennsylvania

THE CENCO-MEGAVAC PUMP

is an excellent mechanical unit for high speed evacuating in cathode-ray and television tube production. This pump is proved for fast initial evacuation and dependable and trouble-free service. Makes an ideal unit for backing glass or metal diffusion pumps. Speed at 1 micron, 375 ml; vacuum, 0.1 micron or better. Specify No. 92015A Cenco-Megavac Pump mounted with base and motor for 115 volt, 60 cycle AC operation. \$195.00

(Also available with motors for other voltages and frequencies.)

Write Dept. B.P. for engineering Bulletin 10
"High Vacuum Equipment."



CENTRAL SCIENTIFIC COMPANY

Scientific Apparatus • Instruments • Chemicals

1700 IRVING PARK ROAD, CHICAGO 13

NEW YORK BOSTON SAN FRANCISCO NEWARK LOS ANGELES TORONTO MONTREAL

Pioneer in Radio Engineering Instruction Since 1927

CAPITOL RADIO ENGINEERING INSTITUTE

An Accredited Technical Institute



ADVANCED HOME STUDY AND
RESIDENCE COURSES IN
PRACTICAL RADIO-ELECTRONICS
AND TELEVISION ENGINEERING

Request your free home study or residence school catalog by writing to
DEPT. 2611A

16th and PARK ROAD N.W.
WASHINGTON 10, D.C.

Approved for Veteran Training

NOW! A Dual-Channel Oscilloscope



**THAT BEATS MANY SINGLE SCOPES
IN WEIGHT . . . SIZE . . . COST**

Plus **THESE ADDITIONAL FEATURES**

- HIGH SENSITIVITY ON X OR Y AXIS
- DIFFERENTIAL OR SINGLE-ENDED INPUT
- INTERCHANGEABLE DEFLECTION CHANNELS
- TRIGGERED AND CONTINUOUS SWEEPS
2 cps to 50 kc
- CONTINUOUS CALIBRATION VOLTAGE
INDICATED ON PANEL VOLTMETER

The new H21 *Dual-Channel Oscilloscope* enables you to observe two independent signals simultaneously . . . without the frequency limitations of electronic switching or costly optical systems. Containing two complete electron guns in a single tube, it enables you to compare speed and vibration, input and output signals of amplifiers, or even a complete signal with an expanded portion of the signal. Vertical sensitivity is better than 0.1Vdc/in. Weight with cabinet 65 lbs.; for rack mounting 75 lbs. Dimensions: 14 $\frac{1}{4}$ " wide, 16 $\frac{3}{4}$ " high, 21" deep.

The new H21 *Dual-Channel Oscilloscope* is the result of years of experience E.T.C. has had as the pioneer manufacturer of multi-gun tubes and multi-channel oscilloscopes. If you have a problem which can be solved by utilizing 2, 4, 6, 8, or even 10 gun tubes, you'll find us ready, willing, and able to help. Write for full details.

E. T. C. — THE ORIGINAL MANUFACTURER OF MULTI-GUN TUBES

electronic tube corporation

PHILADELPHIA 18, PENNSYLVANIA



Positions Wanted

(Continued from page 51A)

phone, electrical design and production experience. Extensive background in electrical and electronic equipment. Widely traveled with positive aggressiveness and firmly settled on a sales career. Age 32. Married. Box 311 W.

TELEVISION ENGINEER

B.S.T.E., May 1949, American Television Institute of Technology. Age 29, married. 3 years communication maintenance U.S. Marine Corps. 2 years U.S. Border Patrol radio laboratories. 7 years bench and field electronics. 1st class FCC license. At present engaged in post graduate work on micro-waves. Desires position in electronic laboratory or TV Station engineer. Locate anywhere. Resumé upon request. Box 312 W.

ENGINEER

MS Communications Engineering Harvard University February 1948. BS physics, Harvard 1944. Married. 2 years communications officer U.S. Navy. 1 year experience electronic design. Desires position in New York area, electronic controls, computers or microwaves. Box 315 W.

ELECTRONIC ENGINEER

B.S.E.E. University of Connecticut. June 1949. Communications major. 3 years U.S.M.C. Radio Materiel School and experience as communication technician. Age 27. Married, no children. Desires position in electronic engineering. Prefer New England. Box 316 W.

ELECTRICAL ENGINEER

BEE January 1949, City College of New York. Several months experience in psycho-acoustics and medical electronics in leading medical institution. Will consider any offer in other fields. Box 317 W.

ELECTRONIC ENGINEER

Communications, B.E.E., recent graduate, ranked 9th, former Navy Electronic Technician. Design, development and research preferred. Anywhere in the U.S., salary secondary. Box 318 W.

ENGINEER

B.S. in E.E. June 1948, University of Michigan. Tau Beta Pi, Eta Kappa Nu. 2 years experience as Navy electronics technician, 1 year as product engineer for electronics firm. Desires position in production or development. New York City area preferred. Box 341 W.

TELEVISION ENGINEER

Graduate of American Television Institute of Technology, September 1949 with B.S.T.E. Age 23, single. 2 years technical experience. Desire design or development work anywhere in U. S. Box 342 W.

ENGINEER

B.S. in E.E. 1 year field engineering in relay and electronic circuits. 3 years technician. Age 27, single. Desires applications or development work in industrial electronics or relay engineering. West Coast. Box 343 W.

(Continued on page 53A)

Positions Wanted

(Continued from page 52A)

ELECTRO-MECHANICAL ENGINEER

B. Mech. E. February 1948, B.E.E. June 1949, New York University. 1½ years Navy and industrial electronic technician. 1½ years development stabilized aircraft radar. Age 23, single. Desire servo, instrument, or television work, N.Y.C. area. Box 344 W.

ENGINEER

B.S.E.E., July 1949. University of Missouri, School of Mines. Single, age 26. Attended Army Signal School for Radio and ultra-high frequency. Desires position with future anywhere within 100 miles of New York City. Box 345 W.

INSTRUMENT ENGINEER

5 years experience in design and development of strain gage, photo-electric, audio and high frequency. Industrial electronics experience in control and measurement. Desires position in textile or allied fields. Box 346 W.

ENGINEER

Graduate of American Television Institute of Technology. B.S. Television Engineering. Age 25. FCC license, commercial pilot's license, ex-Naval Aviator. Desires position research and development in Television or aviation electronics, or television AM or FM broadcast engineering. Will relocate. Box 347 W.

ELECTRONIC ENGINEER

B.S.E.E. Now obtaining credits of M.E.E. 2 years in U.S. Navy as electronic technician's mate, 1 year as Junior development engineer in radar circuits for guided missile. Desires position in Electronic development. Married. Will relocate. Box 348 W.

ENGINEER

B.S. in E.E. electronics major. 1½ years experience in design and operation of all types of test equipment. Some experience in Naval communication equipment. Prefer mid-west or West coast. Box 349 W.

COMMUNICATIONS ENGINEER

B.S.E.E., December 1948, Michigan State College; age 24, married. 1 year electrical test equipment maintenance in Navy, experienced in audio and mobile high frequency communication. Desire position in development in west or south-west United States. Box 319 W.

JUNIOR ENGINEER

Honor graduate, B.S.E.E., June 1949. Age 26. University of Illinois. 4 years varied electronics experience with emphasis on radar and audio. Prefers electronic and design development position in New York City area. Box 324 W.

ENGINEER

B.S.E.E., communications, June 1949, Louisiana State University. Age 28, single. 1st class phone license, clerical experience. Desires position in radio or television with future, anywhere in U.S. Robert S. Vincent, Box 874, De Quincy, Louisiana.

(Continued on page 54A)



BUD Has Them For You!

When it comes to sheet metal equipment . . . BUD has your housing problem solved.

We, at BUD RADIO, INC., make 337 different sheet metal products and 290 of them are available for immediate delivery, at this time. That means that 86% of the cabinets, chassis, utility boxes, carrying cases, etc., are waiting to be shipped to satisfy your needs.

Don't wait until too late . . . get into the position of being able to satisfy your NEEDS now! Check your requirements, now, and order your needs in the sheet metal line.

See the complete BUD miniature sheet metal housing line for the right answer to your problems on small cabinet ware.

Remember that when comparisons are made on the basis of QUALITY, UTILITY AVAILABILITY AND PRICE: BUD leads all the rest.

We are pleased to quote on your requirements for special sheet metal housings.

BUY THE BEST . . . BUY BUD

Write for Catalog



BUD DeLuxe Cabinet Racks



BUD Steel Chassis Bases



BUD Sloping panel Amplifier Foundations

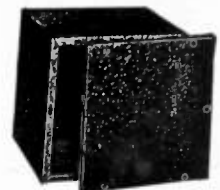

BUD Metal Utility Cabinets

RELAY RACKS CHASSIS CABINETS CONDENSERS COILS CHOKES TEST LEADS

THESE ARE SOME OF THE 1274 ITEMS AVAILABLE FROM BUD RADIO, INC.

BUD RADIO, INC.

2110 E. 55th ST. • CLEVELAND 3, OHIO

Look It Up In Your IRE Yearbook Use Its Engineering Products Listings!

"WANT TO KNOW WHY I'M SOLD ON sorensen?"



"Voltage regulators — even electronic regulators — are not all equally accurate! And I know ACCURACY is important! The Sorensen electronic voltage regulator gives me the kind of accuracy I want.

"But I don't want to buy accuracy and costly maintenance at the same time. The Sorensen Regulator is a strong rugged instrument designed to give accuracy at no sacrifice to low-cost-of-maintenance.

"Furthermore I like my instruments simple — well designed — because I know that a complex instrument loaded with added components can mean poor basic design — and inferior performance. The Sorensen Electronic Voltage Regulator is a beauty for simplicity."

"That's why I'm sold on **sorensen**"

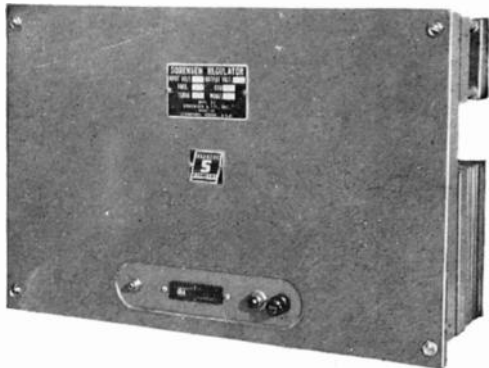

Get highly stabilized DC regulation with the NOBATRON and B-NOBATRON.

STANDARD AC SPECIFICATIONS

MODEL IN VA CAPACITY	1505 5005	2505 10005	2,0005 3,0005	5,0005 10,0005 15,0005
Harmonic Distortion	3% max.	2% max.	3% max.	3% max.
Regulation Accuracy	±0.1% against line or load			
Input Voltage	95-130 VAC; also available for 190-260 VAC Single Phase 50-60 cycles			
Output Voltage	Adjustable between 110-120; 220-240 in 230 VAC models.			
Load Range	0 to full load			
P. F. Range	Down to 0.7 P. F. All models temperature compensated.			
NOTE: REGULATORS CAN BE HERMETICALLY SEALED				

The ORIGINAL SORENSEN CIRCUIT is easily adopted to meet your special requirements. SORENSEN engineers are always available to solve any unusual problem not handled by the STANDARD SORENSEN LINE. JAN requirements can be met by all models.

Write for detailed "Sorensen Regulator Performance Chart"

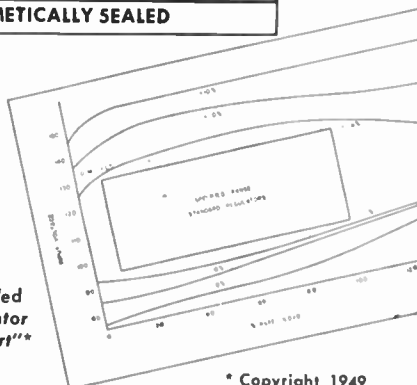

* Copyright 1949

Sorensen and company, inc.

375 Fairfield Ave., Stamford, Conn.

Positions Wanted

(Continued from page 53A)

ELECTRICAL ENGINEER

B.S. 1948, Tau Beta Pi, Eta Kappa Nu. Interested in electronics, television, and quality control. 2 years Navy experience in radio and radar as electronic technician. 1 year quality control experience in electronics industry. Prefer New York City or East Coast. Box 335 W.

ENGINEER

B.E.E. New York University, June 1949. Communication major minor in mathematics. Age 26, single. Have 3 years training and experience with airborne communication and navigational equipment, maintenance, inspection, repair. Desires position in electronics anywhere in U. S. Resumé on request. Box 336 W.

ENGINEER

B.E.E., June 1949, Georgia Institute of Technology, with honor. Age 23, single. Radio operator, U.S. Army. Member Phi Kappa Phi, Tau Beta Pi, Eta Kappa Nu. Interested in research, development and application in electronics and high frequency work. Box 337 W.

ENGINEER

B.S. in E.E. Age 25, Tau Beta Pi and Eta Kappa Nu. Desires position in electronic engineering. Location immaterial. 2 years experience as radar technician in the service. Plans to study for M.S. while working. Box 338 W.

QUALITY CONTROL ENGINEER

B.E. graduate with practical experience in administering scientific quality control, in design, receiving inspection and production inspection. Box 339 W.

ENGINEER

Harvard B. A. in physics, June 1949. 2 years in Navy, ETM 2/c; 2 summers at Naval Research Laboratory. Desires production or development work leading to application engineering. Age 22, single. Box 340 W.

TELEVISION TECHNICIAN

Electronics man with 8 years experience in operation and maintenance of Navy electronics equipment. Capitol Radio Engineering Institute graduate in radio and television engineering. 1st class radio telephone FCC license. Desires position with a television station as junior engineer or technician. Married, 2 children, age 26. Available May 1950. Box 350 W.

ENGINEER

B.S.E.E. 1943, Alabama Polytechnic Institute. A.A.R. Communication School, Yale University, Harvard, M.I.T. Radar School. 2 years as communications and radar officer. Served as instructor in electrical engineering briefly after discharge, also one year telemetering and 2 years industrial electronic experience. Age 27, married, no children. Desires position with a future in any section of U.S. Box 351 W.

JUNIOR ELECTRICAL ENGINEER

B.E.E. Age 26, 4½ years civilian and military skilled aircraft radio and radar maintenance technician. Desire laboratory, research, development or production in electronics, radio, television. Good practical background. East preferred. Box 354 W.

News—New Products

These manufacturers have invited PROCEEDINGS readers to write for literature and further technical information. Please mention your I.R.E. affiliation.

(Continued from page 49A)

All-Purpose Wire Stripper

A new all-purpose wire stripper has just been announced by the Walter L. Schott Co., 9306 Santa Monica Blvd. Beverly Hills, Calif

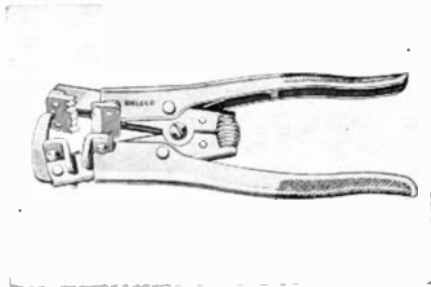

The Walsco wire stripper incorporates these features: strips all wires from 16 to 22 gauge; strips 300 ohm twin lead; and has built-in wire cutter and automatic locking device which prevents crushing of wires. It is further claimed that this tool will strip insulation cleanly and quickly, yet will not nick or cut wire strands. Blades are hardened and precision-ground, and are easily replaced when dulled.

(Continued on page 56A)

WESTINGHOUSE RESEARCH in TELEVISION PHYSICISTS-ENGINEERS

Specialists in OPTICS, ELECTRON-OPTICS, PHOSPHORS, PHOTO-SURFACES, SYSTEMS and CIRCUITS needed for an expanding program at the Westinghouse Research Laboratories, East Pittsburgh, Pa.

For Information write:
Manager, Technical Employ.
Westinghouse Elec. Corp.
306 4th Ave., Pittsburgh, Pa.

IT'S KINGS FOR CONNECTORS

Pictured here are some of the more widely used R. F. co-axial, U. H. F. and Pulse connectors. They are all Precision-made and Pressurized when required. Over 300 types available, most of them in stock.

Backed by the name **KINGS**—the leader in the manufacture of co-axial connectors. Write for illustrated catalogs. Department "T"

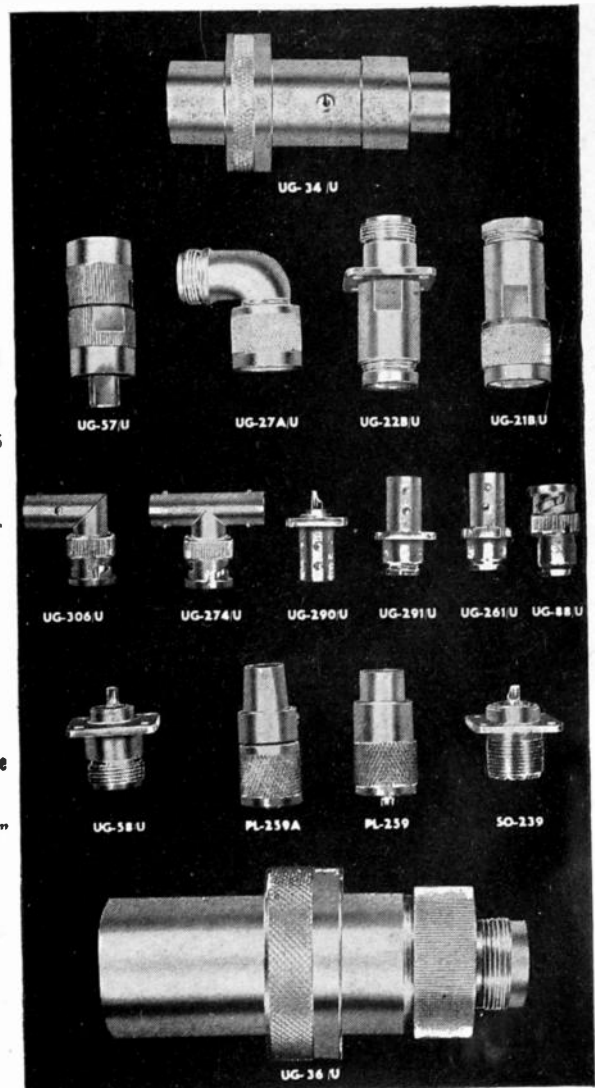

Manufacturers of Radar, Whip, and Aircraft antennas
Microphone Plugs and Jacks.
Radar Assemblies, Cable Assemblies, Microwave and
Special Electronic Equipment

Look It Up In Your IRE Yearbook Use Its Engineering Products Listings!

5⁰⁰ Television Scope

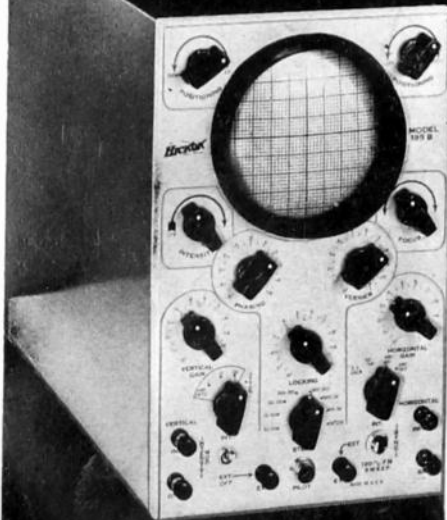

*Your
biggest value
in scopes!*

Wide band amplifiers to 1 m.c.

HIGHEST PRACTICAL SENSITIVITY
.03 volts per inch.

DEMODULATOR — RETURN ELIMINATOR
SYNCHRONIZED LINEAR FM SWEEP
PHASING CONTROL
SYNUSOIDAL SWEEP
DIRECT CONNECTION TO VERTICAL
PLATES AVAILABLE

Ideal for industrial and laboratory
applications, and for fast accurate re-
ceiver alignment. Model 195B. Write
for complete information today.

World Famous
for Accuracy
for 39 Years

HICKOK

THE
ELECTRICAL INSTRUMENT CO.

10587 Dupont Ave., Cleveland 8, Ohio

News—New Products

These manufacturers have invited PROCEEDINGS readers to write for literature and further technical information. Please mention your I.R.E. affiliation.

(Continued from page 55A)

Molded Insulating Spacers and Beads

Fabrication of its new packing material "Chemlon" into electrical insulating spacers and anchor beads has been announced by the Crane Packing Co., 1800 Cuyler Ave., Chicago 13, Ill. The trade name "Chemlon" represents the company's name for its line of products made by processing the plastic polytetrafluoroethylene.

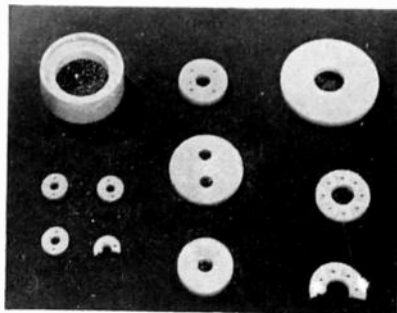

The company states that the electrical properties are low power factor and low dielectric constant; loss factor dielectric constant and dielectric strength do not vary with temperature changes below 400°F.; volume resistivity is not affected by moisture, and surface resistivity is quite high; the material is also resistant to arc exposure, as soon as the arc is extinguished, full insulation strength is restored.

Additional information about the molded insulation for high-frequency applications can be obtained from the manufacturer.

New Circuit Tester

A circuit tester that is small enough to fit into the pocket or tool box has just been introduced by the Gits Molding Corp., 4600 W. Huron St., Chicago 44, Ill.



Called the "Cord Visual Circuit Tester," the product is claimed by its manufacturer to be suited for checking a wide variety of circuit applications. Using two penlight battery cells, the new instrument is designed for use on all low resistance circuits of 50 ohms and under.

(Continued on page 57A)

NOT

"Just a Product"



TYPE
BH6

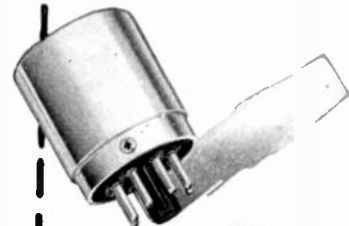

TYPE
TCO-1
OPER. TEMP. 75°C.
RATING 6.3V. - 5.5W

* |

But A COMPLETE
KNOWLEDGE OF
FREQUENCY CONTROL

Type BH6 . . . Miniature size crystal unit. Frequency range . . . 1 MC to 100 MC . . . Tolerances meet all commercial or military specifications . . . hermetically sealed . . . in demand where space limitations are a problem . . . precision performance based on Bliley's complete knowledge of frequency control applications.

Type TCO-1 . . . Temperature control oven . . . for performance $\pm .0001\%$ between -55°C and $+70^{\circ}\text{C}$. . . specify BH6 crystal units with TCO-1 temperature control ovens. (For dual units specify TCO-2). Precision performance based on Bliley's complete knowledge of temperature control ovens.

* | **"First . . . For 20 Years"**

Bliley CRYSTALS

BLILEY ELECTRIC COMPANY
UNION STATION BLDG., ERIE, PA.

News—New Products

These manufacturers have invited PROCEEDINGS readers to write for literature and further technical information. Please mention your I.R.E. affiliation. (Continued from page 56A)

Microwave Matching Transformers

Polytechnic Research and Development Co., Inc., 202 Tillary St., Brooklyn 1, N. Y. announce the development of a series of EH tuners providing coverage of the 12.4 to 40.0 kms band.



These matching transformers consist of hybrid-tee junctions in which movable choke-type shorts are placed in the shunt and series arms. By proper adjustment it is possible to reduce to a value less than 1.02 VSWR as high as 20.1 and of arbitrary phase.

Portable Television Field-Strength Meter

A lightweight, portable television field strength meter, Model A-460, has just been introduced by Approved Electronic Instrument Corp., 142 Liberty St., New York 6, N. Y.



Designed with self-contained power supply, 115 volts, 60 cps (65 watts), housed in a heavy gauge steel cabinet, the unit is said to reduce the work of installing a television receiver to one man. The field-strength meter is calibrated from 50 to 30,000 microvolts. An all channel selector on the panel is designed for fine tuning control.

(Continued on page 58A)

SPECIFY

AMPHENOL

"AN" CONNECTORS

On sizes 20 and up, Amphenol provides 70% thicker inserts . . . stronger to withstand roughest handling.

Contacts are selected high conductivity bronze alloys, silver plated and with pockets pre-tinned for soldering.

Both coupling rings and assembly screws are cross-drilled for safety wiring in accordance with Army-Navy specifications.

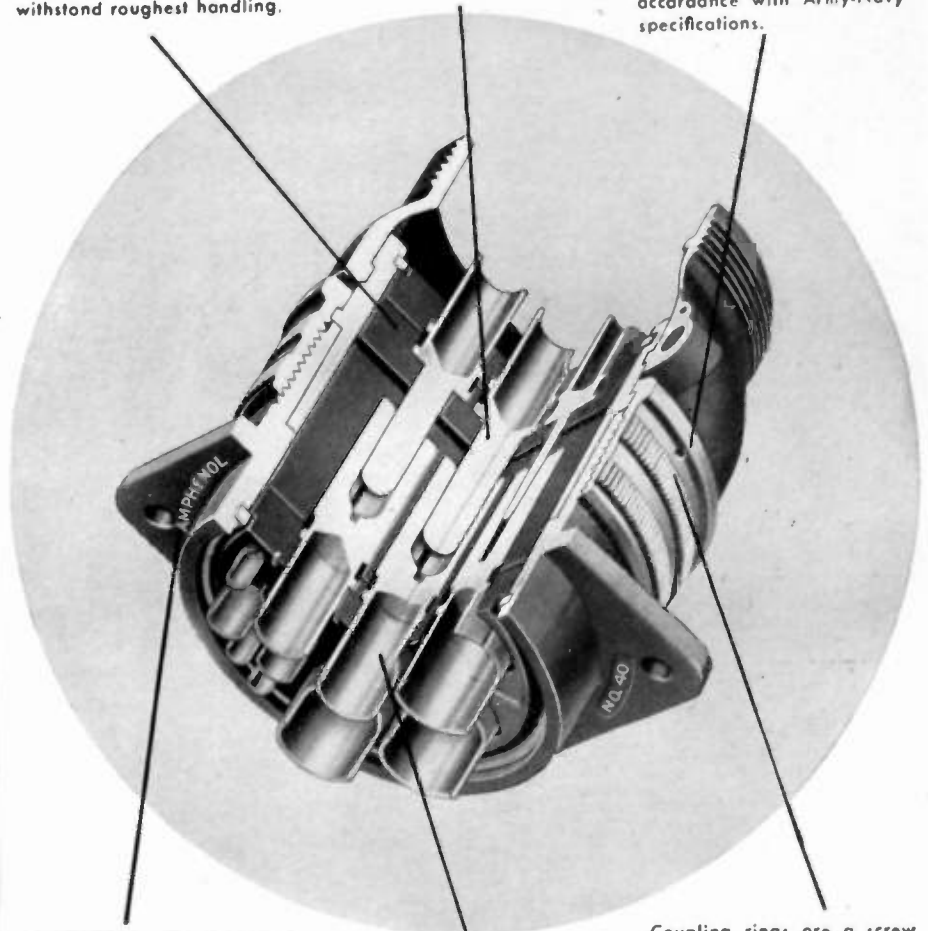

AMPHENOL — the assurance of absolutely dependable, weatherproof, vibration-proof service.

Non-rotating contacts with solder cups are uniformly aligned . . . saves 40% in assembling time, lowers cost.

Coupling rings are a screw machine port made from solid aluminum bar stock providing 80% greater tensile strength.

FOR POWER, SIGNAL and CONTROL CIRCUITS in AIRCRAFT and ELECTRONIC EQUIPMENT

Amphenol engineers and technicians are available without obligation to assist in specifying the right type of "AN" connector for application in instrument, power and control problems. Amphenol "AN" Connectors are available in five major shell designs, each accommodating over 200 styles of contact inserts.

COMPLETE LISTINGS OF "AN" CONNECTORS
Write for your copy of Amphenol's comprehensive and illustrated catalog on "AN" and "97" Connectors. Please send request on company letterhead.



AMERICAN PHENOLIC CORPORATION

1830 SO. 54TH AVENUE • CHICAGO 50, ILLINOIS

V.L.F.!

Very Low Frequencies covered by the...



STODDART NM-10A RADIO INTERFERENCE AND FIELD INTENSITY METER

- MEASURES radiated and conducted signals, including pulse or random interference.
- RANGE—14 kc to 250 kc.
- SENSITIVITY — Field strength using rod antennas one microvolt-per-meter to 2 volts-per-meter. Field strength using shielded loop antennas 10 microvolts-per-meter to 100 volts-per-meter. As a two-terminal voltmeter,
- either balanced or unbalanced, one microvolt to one volt.
- READS directly in microvolts and db.
- A.C. POWER SUPPLY REQUIREMENTS 105 to 125 volts or 210 to 250 volts A.C. Single phase source may be ANY FREQUENCY BETWEEN 50 CPS AND 1600 CPS. No shock hazard.
- GRAPHIC RECORDER included with versatile complement of accessories.

Write for complete technical data

STODDART AIRCRAFT RADIO CO.

Main office and plant: 6644 Santa Monica Blvd. Hollywood 38, Calif. Phone: Hillside 9294
 8-247 General Motors Bldg. Detroit 2, Michigan Phone: Trinity 1-9260
 1346 Connecticut Ave. duPont Circle Bldg. Washington 6, D. C. Phone: Hudson 7313

CO-AX AIR-SPACED ARTICULATED R.F. CABLES

4mm/ft

LOWEST EVER
CAPACITANCE &
ATTENUATION

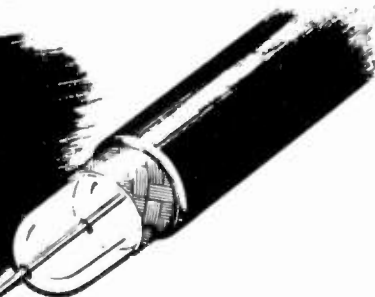

We are specially organized to handle direct enquiries from overseas and can give IMMEDIATE DELIVERIES to U.S.A.

Cable your rush order for delivery by air. Settlement in dollars by check on your own bank. Transaction as simple as any local purchase and delivery just as quick.

HIGH POWER FLEXIBLE

PHOTOCELL CABLE

VERY LOW CAPACITANCE CABLES

LOW ATTEN TYPES	IMPED. OHMS	ATTEN db/100 ft	LOADING K _{in} M _{in}	O.D.
A.1	74	1.7	0.41	0.36
A.2	74	1.3	0.24	0.44
A.34	73	0.6	1.5	0.85

FOR RADIO FREQUENCIES

LOW CAPAC. TYPES	CAPAC. mm ² /ft	IMPED. OHMS	ATTEN db/100 ft	O.D.
C.1	7.3	150	2.5	0.36
P.C.1	10.2	132	3.1	0.36
C.11	6.3	173	3.2	0.36
C.2	6.3	171	2.15	0.44
C.22	5.5	184	2.8	0.44
C.3	5.4	197	1.9	0.64
C.33	4.8	220	2.4	0.64
C.44	4.1	252	2.1	1.03

FOR VIDEO and SPECIAL APPLICATIONS

TRANSRADIO LTD

CONTRACTORS TO H.M. GOVERNMENT.

CABLES: TRANSRAD · LONDON

138A CROMWELL ROAD
LONDON, S.W.7 ENGLAND.

News—New Products

These manufacturers have invited PROCEEDINGS readers to write for literature and further technical information. Please mention your I.R.E. affiliation.

(Continued from page 57A)

High-Speed Mechanical Sampling Device

The development of a new high-speed mechanical sampling device with sampling rates up to and exceeding 5,000 cycles per minute, successfully achieved with good life, is announced by **The Applied Science Corp.** of Princeton, PO Box 44, Princeton, N. J.

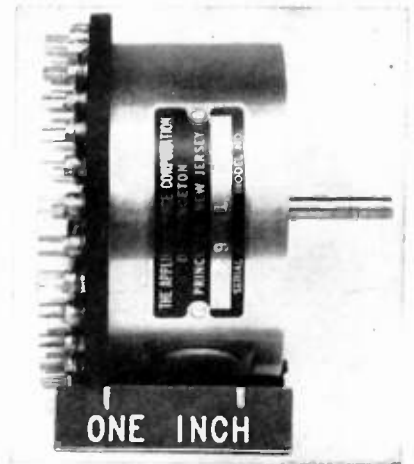

The switch is so designed that it may be driven by an external shaft thus permitting direct synchronization of electrical circuits with mechanical motion. The device may also be furnished in one unit with driving motor of any design or speed within the above limits. It is completely encased as a protection against foreign material, and it is said to be operable at wide temperature ranges and under high forces of acceleration. Sixty make-before-break contacts are sampled each cycle.

New TV Antenna

A new version of the Taco Lazy H antenna is announced by **Technical Appliance Corp.**, Sherburne, N. Y.

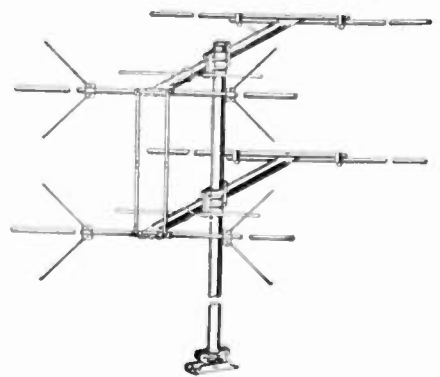

The Taco Type 912 incorporates all the latest developments in TV design. Spacing has been changed to render better performance throughout the 12 channels. High-frequency whiskers are added to the

(Continued on page 59A)

News—New Products

These manufacturers have invited PROCEEDINGS readers to write for literature and further technical information. Please mention your I.R.E. affiliation.

(Continued from page 58A)

dipoles to give a single lobe of greater gain in the high frequencies. An additional reflector is so spaced to serve these higher channels. The Type 912 is of all-aluminum construction except at points of insulation.

Paper Tubular Capacitor

A tubular capacitor, Type '87, said to approach the performance of a plastic-molded type without the additional cost, is announced by Aerovox Corp., New Bedford, Mass

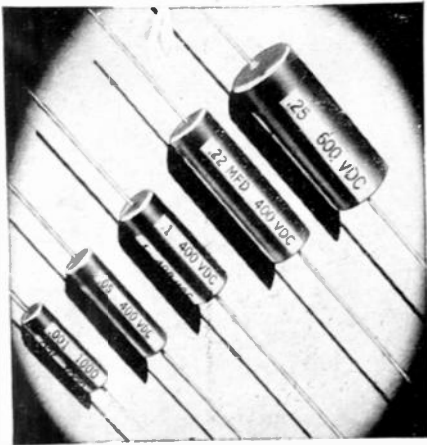

Molded in its own paper tube, the Type '87 has the appearance of the usual paper tube, with the exception of the Duranite sealed ends. An over-all wax dip further adds to the high humidity resistant characteristic. These new tubulars can be used without drips at 212° F. The absence of impregnating oils and waxes eliminates dripping or cracking of the wax coating which interaction might cause. It is further claimed that its dielectric strength at elevated temperatures is such that it can be operated at the rated voltage of 212°F. without danger.

Two New Tube Types

The initial production of two new tube types, the 1X2 and the 6BQ6GT, is announced by Raytheon Mfg. Co., Radio Receiving Tube Div., 55 Chapel St., Newton 58, Mass.

The 1X2 is a filament-type rectifier of miniature construction designed for use in television receivers as a high-voltage rectifier. It can be used in RF, flyback, and power line frequency types of rectifier circuits.

The 6BQ6GT is a beam pentode for use as a horizontal deflection amplifier in television receivers. Employing a T-9 bulb and a standard octal base, space savings can be effected. The plate connection is made through a top cap to allow for better isolation of the high plate voltage.

(Continued on page 60A)

NEW! THE CB AUTOMATIC AUDIO SWEEP GENERATOR

25 CYCLES TO 32,000 CYCLES IN ONE CONTINUOUS RANGE—WAVE FORM DISTORTION .005 (½ %) OR LESS — MANUAL OR AUTOMATIC OPERATION

Automatic Range adjustable from a minimum spread of 500 cycles to a maximum spread of 10,000 cycles. Sweep calibration is LINEAR and is adjustable from 2 to 10 sweeps per second.



CB MODEL 282A

The new CB Model 282A is built to highest precision instrument standards and has a wide application range. For complete construction details and performance data, write for Bulletin 27A.



The CLOUGH BRENGLE CO.

6012 Broadway

Chicago 40, Ill.

KENYON Fits Your Production To A "T"



KENYON "T's"—high quality, uniform transformers, are your best bet for development, production and experimental work. For over 20 years, the KENYON "K" has been a sign of skillful engineering, progressive design and sound construction.

Now—reduce inventory problems, improve deliveries, maintain your quality—specify KENYON "T's," the finest transformer line for all high quality equipment applications.

New Catalog Edition! Write Today!

KENYON new modified edition tells the complete story about specific ratings on all transformers. Our standard line saves you time and expense.

Send for your copy of our latest catalog edition now!

KENYON TRANSFORMER CO., Inc.

840 BARRY STREET · NEW YORK 59, N. Y.

**BETTER
RECEPTION**

**with
ACME ELECTRIC
TRANSFORMERS**

The definitely better reception of sets powered by Acme Electric transformers, is perceptible to the eye and audible to the ear. This better performance can well be a major sales feature in a competitive market. Our engineering department will assist you in all your transformer needs.

ACME ELECTRIC CORPORATION
4411 Water St. Cuba, N.Y.



News—New Products

These manufacturers have invited PROCEEDINGS readers to write for literature and further technical information. Please mention your I.R.E. affiliation.
(Continued from page 59A)

**Portable Beta and Gamma
Detector**

Designed and built exclusively for prospecting use by Kelley-Koett Mfg. Co., West Fourth St., Covington, Ky., the "Prospector," Model K-802, detects and measures beta and gamma rays emitted by uranium and other radioactive substances.



Two standard flashlight batteries power the unit through a vibrator power supply which furnishes the high voltage for the Geiger tube. The tube itself is a plug-in type, easily replaceable in the field. An off-on switch control is employed.

Small (6½ inches X 3½ inches X 2¼ inches) and light (2 lbs.), the "Prospector" can be carried in the hand by the plastic strap, hooked on the belt, or in the pocket.

For further details on this and other Kelley-Koett electronic instruments, write to the company for bulletin E-5

**High-Current Dual Rectifier
Elements**

According to claims, the largest known dual selenium rectifier elements have been developed by the International Rectifier

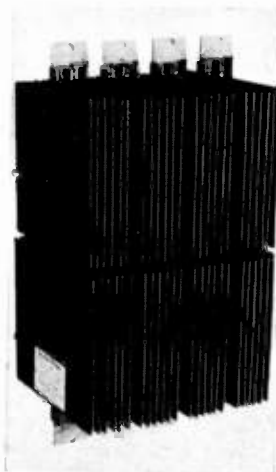

Corp., 6809 South Victoria Ave., Los Angeles 43, Calif.

(Continued on page 61A)



*Portable
Precision
for the
Field
Engineer!*

**STODDART NM-20A
RADIO INTERFERENCE AND FIELD INTENSITY METER**

- A portable unit that you can **DEPEND** upon! Designed especially to withstand the rigors of all-weather field operation and yet provide reliable performance.
- Measures **FIELD INTENSITIES** of radio signals and r.f. disturbances using either a rod antenna or a rotatable loop antenna.
- May be used as a two-terminal r.f. voltmeter (balanced or unbalanced), frequency selective over the **CONTINUOUS RANGE 150 kc to 25 mc.**
- **ONE MICROVOLT SENSITIVITY** as a two-terminal voltmeter; 2 microvolts-per-meter using rod antenna.
- Operates from self-contained dry batteries or external A.C. power unit providing well-regulated filament and plate supplies.

Write for complete technical data

STODDART AIRCRAFT RADIO CO.

Main office and plant:
6644 Santa Monica Blvd.
Hollywood 38, Calif.
Phone: Hillside 9294

8-247 General Motors Bldg.
Detroit 2, Michigan
Phone: Trinity 1-9260

1346 Connecticut Ave.
duPont Circle Bldg.
Washington 6, D. C.
Phone: Hudson 7313

COVERING THE ENTIRE RANGE OF COMPONENTS...

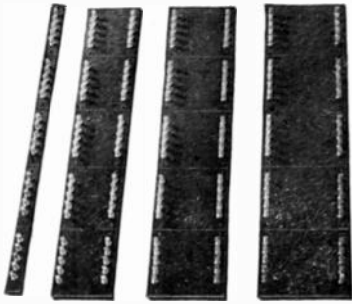

CTC ALL-SET Boards Speed Up Work On Assembly Lines And In Laboratories

CTC ALL-SET Boards are designed to save time and cut costs over a wide range of standard assembly operations.

Boards with Type 1724 Turret Lugs come in four widths: $\frac{1}{2}$ ", 2", $2\frac{1}{2}$ ", 3"; and in thicknesses of $\frac{3}{32}$ ", $\frac{1}{8}$ ", $\frac{3}{16}$ ". A Board with Type 1558 Turret Lugs, for miniature components, is $1\frac{1}{16}$ " wide, with thicknesses of $\frac{1}{16}$ " and $\frac{3}{32}$ " only (Type X1401E). This new miniature Board completes the CTC ALL-SET group.

Boards are all of laminated phenolic, in five-section units scribed for easy separation. Each section is drilled for 14 lugs, with 10 mounted, except X1401A ($\frac{1}{2}$ " wide), which is drilled for 7 lugs per section, with 5 mounted. All lugs are solidly and precisely swaged, and each whole board is ready for assembly.

Custom-Built Boards

are an important specialty at CTC. Avail yourself of our long experience in handling the widest range of materials and jobs — many of them requiring special tools — and in all types of work to commercial or government specifications.

CTC ALL-SET Terminal Boards, Custom-Built Boards and many other CTC Guaranteed Components are described and illustrated in our big new catalog #300. Send for your copy today.

Turret Lugs



Split Lugs



Terminal Boards



Double-End Lugs



Swagers



Custom or Standard The Guaranteed Components

CAMBRIDGE THERMIONIC CORP.
456 Concord Ave., Cambridge 38, Mass.

News—New Products

These manufacturers have invited PROCEEDINGS readers to write for literature and further technical information. Please mention your I.R.E. affiliation.

(Continued from page 60A)

Each dual element consists of two of the company's largest size ($6\frac{1}{4}$ inches by $7\frac{1}{4}$ inches) plates strapped in parallel and rated in a three-phase bridge circuit at 34 amperes for continuous duty self-cooling, 85 amperes for continuous duty fan-cooling, and 340 amperes for highly intermittent duty. These dual elements are assembled in a three phase bridge heavy-duty 10-kw rectifier stack rated at 1,500 amperes for such applications as magnetic inspection, etc. The stacks are designed on the basis of 16 kw per cubic foot and are provided with an interlocked assembly to prevent lug misalignment and plate rotation.

Operating efficiencies of 85 per cent can be obtained, and when aluminum plates are used, the weight per dual element minus the hardware is 9 ounces. Each 1,500 ampere stack is $7\frac{1}{4}$ inches wide by 12 inches long by $1\frac{1}{4}$ inches high.

Shielded Enclosure for RF Interference Evaluation

A screen room has been designed to help determine rf interference evaluation and suppression at levels as low as 1 microvolt in areas of undesired interference as high as 100,000 microvolts. Construction and engineering is by: **Ace Engineering & Machine Co., Inc.**, 3644 N. Lawrence St., Philadelphia 40, Pa.

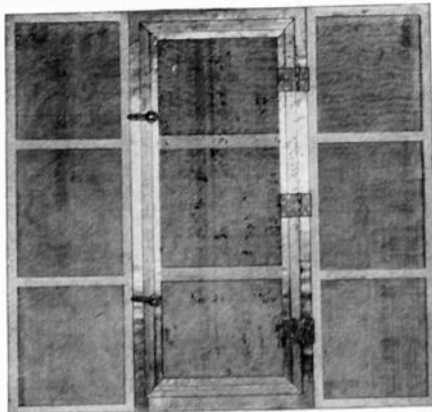

These rooms are constructed with cell-type panels eliminating the necessity of insulating the inner and outer shields from each other. Soldering between sections is not necessary. With panel construction, room size and location do not have to remain fixed.

Exclusive of the power line filters attenuation characteristics, the rooms provide not less than 100-db attenuation from 0.15 to 1,000 Mc.

Standard rooms are 7 feet high, 8 feet wide, and any length desired.

(Continued on page 62A)

JOHNSON Offers—

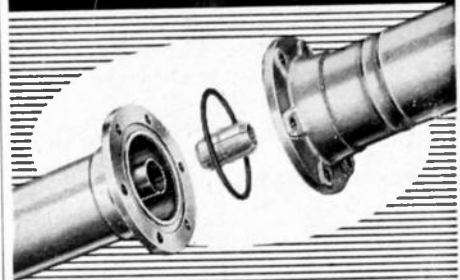

LONG-FLANGE CO-AX LINE...

GREATER MECHANICAL STRENGTH
No Brazing—No Cracking—No Distortion!
Solder Joint Stronger Than Tubing Itself!

This is the type of copper tubing joint which has proved most successful in other applications for many years!

There is less distortion, better all-around contact—a joint that is stronger than the tubing itself!

JOHNSON hard temper, 70 ohm, and 51.5 ohm, flange type line is supplied in 20 foot lengths. Special high conductivity copper is used in both outer and inner conductors and rigid tolerances are maintained to insure precision mechanical assembly, low loss and low standing wave ratio.

The 70 ohm line is intended primarily for AM and has grade L-4 or better steatite beads. The 51.5 ohm line was designed primarily for high frequencies, has grade L-5 or better steatite and meets RMA standards for FM line. Both are fitted with flange couplings at the factory, which greatly simplifies field installation.

In addition, JOHNSON manufactures a complete line of elbows, fittings, gas equipment and hardware for the above as well as semi-flexible, soft temper line in continuous lengths up to 1200 feet in $5/16$ ", $3/8$ " and $7/8$ ". No expansion joints nor elbows are needed for the latter because of its flexibility.

The $5/16$ " line is especially recommended for phase sampling and other low power applications.

Whatever your co-ax requirements may be, JOHNSON — the oldest manufacturer of concentric line in the field — can meet them to your utmost satisfaction.



JOHNSON

E. F. JOHNSON CO., WASECA, MINN.

PRECISION

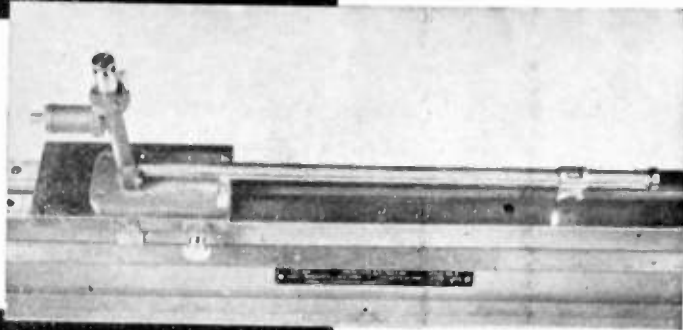

FTL-30A SLOTTED LINE

Designed for making impedance, standing wave ratio, and wavelength measurements in the range of 60 to 1000 megacycles per second. Careful design and precision manufacture enable highly accurate measurements to be made with the line. High sensitivity and selectivity due to efficient probe tuning. End connectors adapted to use of Type N or similar fittings for solid dielectric cables as well as for $\frac{7}{8}$, $1\frac{1}{8}$ and $3\frac{1}{8}$ inch air lines.

Write for complete
FTL-30A Brochure

Federal Telecommunication Laboratories, Inc.

500 WASHINGTON AVE.



NUTLEY 10, N. J.

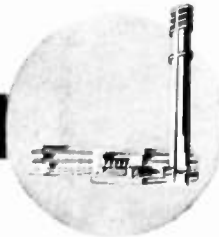

ONE OF A SERIES

PLATED PARTS

WHY BURLINGTON PANEL INSTRUMENTS PROVIDE UTMOST RELIABILITY . . .

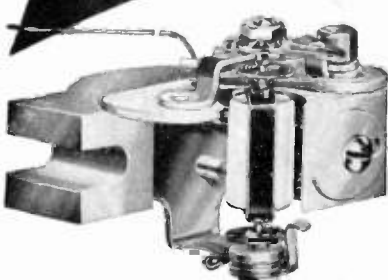

By maintaining its own plating facilities, Burlington assures proper control and protection of components against rust and corrosion. All ranges AC and DC available in rectangular or round case styles and are guaranteed for one year against defects in workmanship or materials. Refer inquiries to Dept. I-119.

Burlington INSTRUMENT COMPANY
BURLINGTON, IOWA

News—New Products

These manufacturers have invited PROCEEDINGS readers to write for literature and further technical information. Please mention your I.R.E. affiliation.
(Continued from page 61A)

Kit Form Signal Generator

Electronic Measurements Corp., 423 Broome St., New York 13, N. Y., has announced the marketing of their Model 500K RF Signal Generator in kit form.



The generator covers a range from 150 kc to over 30 Mc on fundamentals and over 100 Mc on harmonics. The manufacturer also announces that 400 cps internal modulation is also available, and provision is made for external modulation. One of the outstanding features of the generator is the fact that all coils not in use are automatically shorted out. It employs an electrostatically shielded transformer for 115-volt, 60-cycle operation.

Calibrated Pre-Amplifier

Designed by the Sound Apparatus Co., Stirling, N. J., to extend the sensitivity of their line of graphic recorders to 30 microvolts, the Model PR calibrated pre-amplifier is an all-purpose self-contained laboratory instrument, equally suitable for portable applications.



A flat response from 40 to 40,000 cps, a dynamic range in excess of 60 db, and a calibrated gain control in 5 db steps from 0 to 50 db, gives a calibrated amplification into a low output impedance. The Model PR amplifier is available with a selection of input impedances for use with a multiplicity of low-output devices.
(Continued on page 63A)

NOTE THIS NAME

**SUPER
RF AUDIO TV
COMPONENTS**

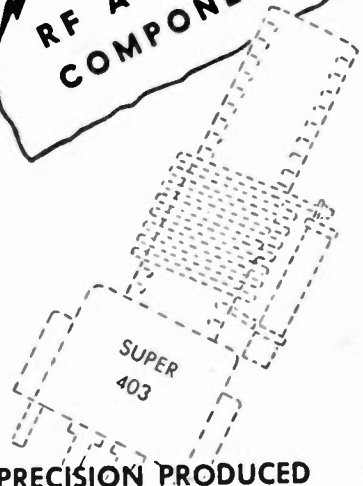

- PRECISION PRODUCED
- PERFORMANCE PROVED

SUPER ELECTRIC PRODUCTS CORP.

Pacing Electronic Progress With Ingenuity
1057 Summit Ave., Jersey City 7, N. J.

News—New Products

These manufacturers have invited PROCEEDINGS readers to write for literature and further technical information. Please mention your I.R.E. affiliation.

(Continued from page 62A)

Miniature Pentagrid Converter Tube

A new miniature pentagrid converter tube, designed especially for use in compact, light-weight portable radio receivers, where high operating efficiency at low plate voltages are desired, has been announced by the Radio Div. of Sylvania Electric Products Inc., 500 Fifth Ave., New York 18, N. Y.



The new tube, type 1L6, is supplied with a 1.4-volt dc filament cathode rated at 50 ma. Operated from a 90-volt B supply, its plate current is only 0.50 ma.

Sweep Calibrator

Designed to provide markers for accurate time calibration of synchroscopic sweeps, a new sweep calibrator, Model GL-22A, is announced by Browning Laboratories, Inc., 750 Main St., Winchester, Mass.

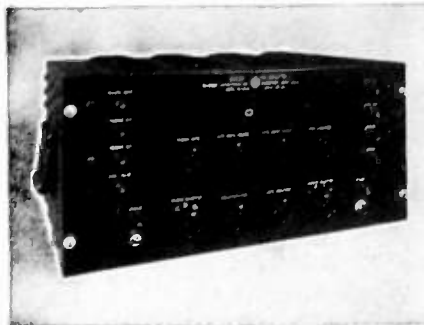

Markers at intervals of 0.1, 1.0, 10.0 and 100.0 microseconds are provided and are suitable for deflection-indicating or beam-blanking presentation. A self-contained trigger generator with positive or negative output can be used to drive the calibrator and associated equipment, or it may be triggered externally up to approximately 100 kc. Positive or negative gates

(Continued on page 64A)

MORE

CANNON PLUGS

FOR THE
RADIO
TECHNICIAN

TYPE DP

Rack & Panel type connectors with a variety of standard and coaxial contacts.

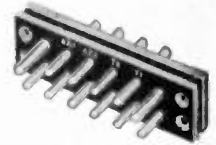

LABORATORY AND SWITCHBOARD

Connectors for experimental switchboards and testing equipment; 1 to 4 contacts; 75-amp.



TYPE AP

Seven different insert arrangements same as Type "P" 30 and 15-amp. rating, but with heavier shell, gasketed for weather resistance; coupling nut extraction means; cable clamp plug entries.



TYPE XK

Same inserts as Type "X"—1, 3 and 4 contacts; for No. 14 and 16 wire; coupling nut extraction means.



TYPE O

Latchlock sound-microphone series with oval shell; 3 contacts for No. 10 wire, 30 amperes.



AND 8 OTHER MAJOR TYPE SERIES—More than 400 radio parts distributors in the USA handle Cannon Plugs... twenty-six representatives located in principal cities are at your service. Or write direct to factory for new C-48 Condensed General Catalog, 32 pages of data and prices.

Cannon Electric also manufactures signal equipment for hospitals, industrial plants, schools, institutions and many other electrical specialties such as conduit fittings, D. C. Solenoids, fire alarm relays, cable terminals, indicator and pilot lights, etc., etc.

Address Cannon Electric Development Co., Division of Cannon Manufacturing Corporation, 3209 Humboldt St., Los Angeles 31, Calif. Canadian offices and plant: Toronto, Ontario. World export: Frazer & Hansen, San Francisco.

SINCE 1915

CANNON  ELECTRIC

410 7th Ave. N.Y.C.



THE NEW BERKELEY MODEL 700 DECIMAL COUNTING UNIT

This unique packaged component is easily built into your apparatus. It has true decimal reading, and simple binary circuit with reliable automatic interpolation. Miniature size. Moderate price. Immediate shipment.

Send for Bulletin DCU-116

Berkeley Scientific Company
SIXTH AND NEVIN AVE. - RICHMOND, CALIFORNIA

SAFE at 10,000V!

- ★ Factory-fitted to most Clarostat carbon and wire-wound controls.
- ★ Control-to-ground breakdown rating better than 10,000 v.
- ★ New design eliminates troublesome backlash. Permits more critical settings.



IMPROVED HIGH-VOLTAGE CONTROLS

Improved design high-voltage controls for TV sets, oscillographs and other high-voltage electronic assemblies. Safe operation up to 10,000 v.

Straight-through plastic shaft simplifies and improves operation. No back-lash to throw off critical adjustments. Cheaper. Better. Simpler.

Ask for Bulletin No. 120.
Let us quote on your needs.



CLAROSTAT



Controls and Resistors

CLAROSTAT MFG. CO., INC. • DOVER, NEW HAMPSHIRE • In Canada: CANADIAN MARCONI CO., LTD. Montreal, P. Q., and branches

News—New Products

These manufacturers have invited PROCEEDINGS readers to write for literature and further technical information. Please mention your I.R.E. affiliation. (Continued from page 63A)

of variable amplitude are available for obscuring retrace or timing purposes.

The design is flexible and permits operation in conjunction with any type of oscilloscope having synchroscope or triggered sweep facilities.

Rotary Actuators

To meet the increasing requirements of military aircraft for powerful, light-weight rotary actuators, Lear, Inc., Electro-mechanical Div., 110 Ionia Ave., N.W., Grand Rapids 2, Mich., announces the new Model Series 186, 188 and 189.

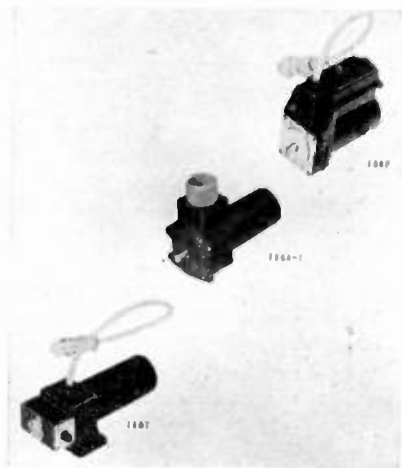

Basic features of these actuators are split-field, reversible, explosion-proof dc motor, electromagnetic brake, planetary gear assembly and circuit switch assembly within a small envelope, and with weight reductions up to 75 per cent over former models. Standard gear assemblies are designed to withstand a maximum load of 45 ounce-inches, special designs up to 200 ounce-inches.

For further details and catalog, contact Lear, Inc.

Du Mont Announces Plan to Repurchase VHF Transmitters

The television Transmitter Div., Allen B. Du Mont Laboratories, Inc., 42 Harding Ave., Clifton, N. J. have announced plans to repurchase Du Mont vhf transmitters from TV broadcasters and CP holders who, for the best interests of the public and television broadcasting industry, may be required to change operations from the vhf band to the uhf band.

The plan, outlined in individual letters to purchasers of complete Du Mont video and audio transmitters, provides for the repurchase of Du Mont vhf transmitters at an amount equal to the total depreciated value of the transmitter at the time it is repurchased by Du Mont. The repurchase value, which is applied as a credit against the purchase of a Du Mont uhf transmitter, is computed on a straight-line semi-annual basis which adheres as completely as possible to established procedures in determining depreciation.

(Continued on page 65A)

200 MC BAND WIDTH AMPLIFIERS

Model 202P Wide-Band Chain Amplifier with Regulated Power Supply.

Band Width: 100 KC to 200 MC. Gain: 20 db.

Impedance: 200 ohms. Rise Time: Less than .003 usec.

With the Model 202P: very fast pulses, transients and other high frequency voltages can now be amplified.

With the Model 202P: vacuum tube voltmeters and oscilloscopes are ten times more sensitive.

With the Model 202P: the output voltage of signal, sweep and pulse generators is ten times greater.

Other Wide-Band Chain Amplifiers available:

Model 200A — 10 db Gain. Model 204 — 40 db Gain.

Makers of chain amplifiers, temperature controls, variable electronic filters and power supplies.

Write for Bulletin 202P-1-R

SKL SPENCER-KENNEDY LABORATORIES, INC.
186 MASSACHUSETTS AVE., CAMBRIDGE 39, MASS.

News—New Products

These manufacturers have invited PROCEEDINGS readers to write for literature and further technical information. Please mention your I.R.E. affiliation.

(Continued from page 64A)

Recent Catalogs

••• An 8-page brochure describing the operation and uses of its new high-speed rectangular co-ordinate recorder, type 373, by Airborne Instruments Laboratory Inc., Mineola, N. Y.

••• The third edition of the Stancor Television Components Replacement Guide, Bulletin DD338B, 4 pages of reference data on replacements for use in 108 television receiver models by Standard Transformer Corp., 3580 Elston Ave., Chicago 18 Ill. Available from Stancor parts distributors or direct from company.

••• A 196-page catalog covering "everything in radio and electronics" with special emphasis on equipment for industrial maintenance, research, and production requirements by Allied Radio Corp., 833 W. Jackson Blvd., Chicago 7, Ill.

••• A 6-page bulletin describing the 2" high precision linear and nonlinear potentiometers together with general information on nonlinear potentiometers was issued by Technology Instrument Corp., 1058 Main St., Waltham 54, Mass.

••• Catalog D-20A giving contact ratings, coil specifications, sizes, and general information on industrial and general purpose relays carried in stock by Ward Leonard Electric Co., Electronic Distributor Div., 53 W. Jackson Blvd., Chicago 4, Ill.

••• A 12-page booklet dealing with new Du Mont types 304 and 304-H cathode-ray oscillographs, successors to the type 208-B, was released by Allan B. Du Mont Laboratories, Instrument Div., 1000 Main Ave., Clifton, N. J.

••• A new booklet, DB-19-025, of Westinghouse standard and high-voltage selenium rectifiers for power supplies and electronic circuits; efficiency curves for both the standard (type M) and high-voltage (type H) cells are included. For a copy, write Westinghouse Electric Corp., PO Box 868, Pittsburgh 30, Pa.

••• An illustrated booklet presenting the history and describing the plants, departments, and products of the Electrical Reactance Corp., Franklinville, N. Y.

••• A revised edition of a comprehensive technical manual containing basic application data for 637 radio receiving tube types and cathode-ray tubes used by circuit designers, radio and television set repairmen and industrial electronic engineers has been announced by the Radio Division, Sylvania Electric Products Inc., Emporium, Pa.

(Continued on page 68A)

NEW... Improved Wiring Eliminates Leakage

TYPE 12AT & TYPE 12ATK (KIT) TRANSMISSION MEASURING SET

Range: 111 db. in 0.2 steps.
Frequency resp.: 0.1 db. from 0 to 20 kc.
Accuracy: 0.1 db.
Impedance, load section: 4, 8, 16, 50, 150, 200, 500, & 600 ohms.
Impedance, trans. set.: 50, 150, 200, 500 & 600 ohms.
Reference level: 1mw. into 600 ohms.
Circuit: "T", unbalanced.
Attenuators: 10x10, 10x1 & 5x0.2 db.
Load carr. cap.: Transm. sect. 1 w. Load section 10 w.



A precision Gain Set with specially developed wiring that permits no troublesome leakage and provides improved frequency characteristics. Available completely assembled, or in kit form—which permits the sale of a high accuracy instrument at a low price.

WRITE FOR DESCRIPTIVE BULLETIN



Manufacturers of Precision Electrical Resistance Instruments
PALISADES PARK, NEW JERSEY

MEASUREMENTS CORPORATION MODEL 80 STANDARD SIGNAL GENERATOR



2 to 400 MEGACYCLES

MODULATION: Amplitude modulation is continuously variable from 0 to 30%, indicated by a meter on the panel. An internal 400 or 1000 cycle audio oscillator is provided. Modulation may also be applied from an external source. Pulse modulation may be applied to the oscillator from an external source through a special connector. Pulses of 1 microsecond can be obtained at higher carrier frequencies.

FREQUENCY ACCURACY ±.5%
OUTPUT VOLTAGE 0.1 to 100,000 microvolts
OUTPUT IMPEDANCE 50 ohms

MANUFACTURERS OF
Standard Signal Generators
Pulse Generators
FM Signal Generators
Square Wave Generators
Vacuum Tube Voltmeters
UHF Radio Noise & Field Strength Meters
Capacity Bridges
Megohm Meters
Phase Sequence Indicators
Television and FM Test Equipment

MEASUREMENTS CORPORATION
BOONTON NEW JERSEY



R. F. COMPONENTS—MICROWAVE—TEST EQUIPMENT

10 CENTIMETER

WAVEGUIDE TO 7/8" RIGID COAX "DOOR-KNOB" ADAPTER, CHOKE FLANGE, SILVER PLATED BROAD BAND \$49.50 ea.

WAVEGUIDE DIRECTIONAL COUPLER, 27 db. Navy type CABV-47AAN, with 4 in. slotted section \$42.50

SQ. FLANGE to rd choke adapter, 18 in. long OA 1 1/2 in. x 3 in. guide, type "N" output and sampling probe \$32.00

Crystal Mixer with tunable output TR pick up loop, Type "N" connectors. Type 62ABH \$14.50

Slotted line probe. Probe depth adjustable. Sperry connector, type CPR-14AAO \$9.50

Coaxial slotted section, 3/8" rigid coax with carriage and probe \$25.00

Waveguide Transition from 1 1/2" x 3" to 2" x 1" flanges \$45.00

Right Angle Bend 6" radius E or H plain \$27.50

Right Angle Bend 3" radius E or H plain—Circular flanges \$17.50

AN/APRSA 10 cm antenna equipment consisting of two 10 cm waveguide sections each polarized, 45 degrees \$75.00 per set

APN-7 TR Cavity for 721A, with tuning slugs \$55.00 ea.

PICKUP LOOP, Type "N" Output \$2.75

TR BOX Pick-up Loop \$1.25

POWER SPLITTER: 726 Klystron input dual "N" output \$5.00

MAGNETRON TO WAVEGUIDE coupler with 721-A duplexer cavity, gold plated \$27.50

10 CM WAVEGUIDE SWITCHING UNIT, switches 1 input to any of 3 outputs. Standard 1 1/2" x 3" guide with square flanges. Complete with 115 vac or dc arranged switching motor, Mfg. Raytheon. CRP 24AAS. New and complete \$150.00

10 CM END-FIRE ARRAY POLYRODS \$1.75 ea.

"S" BAND Mixer Assembly, with crystal mount, pick-up loop, tunable output \$3.00

721-A TR CAVITY WITH TUBE. Complete with tuning plungers \$12.50

10 CM. McNALLY CAVITY Type SG \$3.50

Type SF \$4.50

WAVEGUIDE SECTION, MC 445A rt. angle bend, 5/8" ft. OA, 8' slotted section \$21.00

10 CM OSC. PICKUP LOOP, with male Home-dell output \$2.00

10 CM DIPOLE WITH REFLECTOR in lucite ball, with type "N" or Sperry fitting \$4.50

10 CM FEEDBACK DIPOLE ANTENNA, in lucite ball, for use with parabola 7/8" Rigid Coax Input \$8.00

PHASE SHIFTER, 10 CM WAVEGUIDE, WE TYPE ES-683816, E PLANE TO H PLANE \$95.00

MATCHING SLUGS \$95.00

721A TR cavities. Heavy silver plated \$2.00 ea.

10 cm. horn and rotating joint assembly gold plated \$65.00 ea.

7/8" RIGID COAX—7/8" I.C.

7/8" rigid coaxial tuning stubs with vernier stub adjustment. Gold Plated \$17.50

7/8 RIGID COAX ROTARY JOINT. Pressurized Sperry #810613. Gold Plated \$27.50

Dipole assembly. Part of SCR 584 \$25.00 ea.

Rotary joint. Part of SCR 584 \$35.00 ea.

RIGHT ANGLE BEND, with flexible coax output pickup loop \$8.00

SHORT RIGHT ANGLE BEND, with pressurizing nipple \$3.00

RIGID COAX to flex coax connector \$3.50

STUB-SUPPORTED RIGID COAX, gold plated 5' lengths. Per length \$5.00

RT. ANGLES for above \$2.50

RT. ANGLE BEND 15" L. OA \$3.50

FLEXIBLE SECTION, 15" L. Male to female \$4.25

MAGNETRON COUPLINGS to 7/8" rigid coax, with TR pickup loop, gold plated \$7.50

FLEX COAX SECT. Approx. 30 ft. \$16.50

7/8" RIGID 1/4" IC

CG 54/U—4 foot flexible section 1/4" IC pressurized \$15.00

7/8 RIGID COAX. Bead Supported \$1.20

SHORT RIGHT ANGLE BEND \$2.50

Rotating joint, with deck mounting \$15.00

RIGID COAX slotted section CU-60/AP \$5.00

WAVEGUIDE

1/2 x 1/4" ID \$1.00 per foot

1 x 1/2 OD \$1.50 per foot

3/8 x 1/4 OD \$1.65 per foot

3/8 x 1/4 OD Aluminum \$1.75 per foot

1 1/2 x 3 OD \$3.00 per foot

2 1/2 x 3 OD \$3.50 per foot

1 x 1/2 OD Flexible \$4.00 per foot

7/8" rigid coax 1/4" IC \$1.20 per foot (Available in 10FT to 15ft. lengths or smaller.)

UG 65/U 10CM flanges \$6.75 each

UG 53/U Cover \$4.00 each

UG 54/U Choke \$4.50 each

3 CENTIMETER

(STD. 1" x 1/2" GUIDE UNLESS OTHERWISE SPECIFIED)

723 A/B Klystron mixer section with crystal mount, choke flange and iris flange output \$22.50

TR-ATR Section for above with 724 ATR Cavity \$8.50

90 degree twist, 6 inches long \$8.00

723 AB Mixer—Beacon Dual Oscillator Mount with crystal holder \$12.00

2 Way Wave Guide directional coupler, type N fitting 1 1/8" x 3/8" guide 26DB \$18.50

CG 98B/APG 13, 12" flexible section 1 1/4" x 3/8" OD \$10.00

TR-ATR Section, APS 15, for 1824, with 724 ATR Cavity with 1824 and 724 tubes. Complete \$21.00

Crystal mount in waveguide \$17.50

Stabilizer Cavity with bellows \$21.50

3 cm 180° bend with pressurizing nipple \$6.00 ea.

3 cm. 90 bend, 14 long 90° twist with pressurizing nipple \$6.00 ea.

3 cm. "S" curve 18 long \$5.50 ea.

3 cm. "S" curve 6 long \$3.50 ea.

3 cm. right angle bends. "E" plane 18" long cover to cover \$6.50 ea.

3 cm. Cutler feed dipole. 11" from parabola mount to feed back \$8.50 ea.

TWIST 45 deg., 6' long \$8.00

APS-31 mixer section for mounting two 2K25's Beacon reference cavity 1824 TR tube New and complete with attenuating slugs \$42.50 ea.

DUPLLEXER SECTION for 1824 \$10.00

CIRCULAR CHOKE FLANGES, solid brass .55 ea. \$55

FLEX, WAVEGUIDE TRANSITION 1 x 1/2 to 1 1/4 x 3/8. 14 in. \$8.00

"X" BAND PREAMPLIFIER, consisting of 2-723 A/B local oscillator-beacon feeding waveguide and TR/ATR Duplexer sect. incl. 30MC Pre Amp \$67.50

Random Lengths wavegd, 6" to 18" Lg. \$1.10/Ft.

WAVEGUIDE RUN, 1 1/4" x 1/2" guide, consisting of 4 ft. section with Rt. angle bend on one end 2" 45 deg. bend other end \$8.00

WAVEGUIDE RUN, 1 1/4" x 1/2" guide, consisting of 4 ft. long \$10.00

12" SECTION 45 deg twist 90 deg bend \$6.00

11" STRAIGHT WAVEGUIDE section choke to cover. Special heavy Construction, silver plated \$4.50

15 DEG BEND 10" choke to cover \$4.50

5 FT. SECTIONS choke to cover, Silver Plated \$10.00

18" FLEXIBLE SECTION \$17.50

"X" BAND WAVEGUIDE 1 1/4 x 3/8 OD 1/16 wall Aluminum Per Foot \$.75

WAVEGUIDE 1" x 1/2" I.D. Per Foot \$1.50

TR CAVITY For 724 A TR Tube \$3.50

3" FLEX SECT. sq. flange to Circ. Flange Adapt \$7.50

724 TR TUBE (41 TR 1) \$2.50

SWR MEAS. SECTION, & L with 2 type "N" output probes MTD full wave apart. Bell size guide. Silver plated \$10.00

ROTARY JOINT with slotted section and type "N" output pickup \$17.50

WAVEGUIDE SECTION, 12" long choke to cover 45 deg. twist & 2 1/2" radius, 90 deg. bend \$4.50

SLUG TUNER/ATTENUATOR, W. E. guide gold plated \$6.50

TWIST 90 deg. 5" choke to Cover w/press nipple \$6.50

WAVEGUIDE SECTIONS 2 1/2 ft: long silver plated with choke flange \$5.75

ROTARY JOINT choke to choke with deck mounting \$17.50

3 cm mitred elbow "E" plane unplated \$6.50 ea.

TS-108A/P DUMMY LOAD \$65.00

3 CM. HORN AT-48/UP model 710. Type "N" input Hvy. silver plated \$6.50

AT-68/UP 3 CM Horn with type N fitting \$5.00

1.25 CENTIMETER

"K" BAND DIRECTIONAL COUPLER CUI04/APS-34 20 DB \$49.50 ea

"K" BAND FEEDBACK TO PARABOLA HORN, with pressurized window \$30.00

MITRED ELBOW cover to cover \$4.00

TR/ATR SECTION choke to cover \$4.00

FLEXIBLE SECTION 1" choke to choke \$5.00

ADAPTER, rd. cover to sq. cover \$5.00

MITRED ELBOW and S sections choke to cover \$4.50

WAVE GUIDE 1/2 x 1/4 per ft. \$1.00

K BAND CIRCULAR FLANGES \$50g

3J31 "K" BAND MAGNETRON \$55.00

TEST EQUIPMENT

MODEL TS-268/U



Test set designed to provide a means of rapid checking of crystal diodes IN21, IN21A, IN21B, IN23, IN23A, IN23B Operates on 1 1/2 volt dry cell battery. 3x6x7. New \$35.00

10CM ECHO BOX CABV 14ABA-1 of OBU-3. 2890 MC to 3170 MCS direct reading micrometer head. Ring prediction scale plus 9% to minus 9%. Type "N" input. Resonance indicator meter. New and Comp. w/access. Box and 10 CM Directional Coupler \$350.00

3 CM RECEIVER, SO-3. Complete with W.G. Mixer Assy (723-A/B). Reg. Fil. Power Supply 6 stages IF (6AC7) \$99.50

10 cm. horn assembly consisting of two 5" dishes with dipoles feeding single type "N" output. Includes UG28/U type "N" "T" junction and type "N" pickup probe. Mfg. cable New \$5.56 ea.

10 cm. cavity type wavemeters 6" deep, 6 1/2" in diameter. Coax. output. Silver plated \$64.50 ea.

10 cm. echo box. Part of SFI Radar W/115 volt DC tuning motor Sub Sig 1118AO \$47.50

THERMISTOR BRIDGE: Power meter 1.203-A. 10 cm mfg W.E. Complete with meter, interpolation chart, portable carrying case \$72.50

W.E. 1138. Signal generator. 2700 to 2900 Mc. range. Lighthouse tube oscillator with attenuator & output meter. 115 VAC input reg Pwr. supply. With circuit diagram \$150.00

3 cm. wavemeter. Ordnance type micrometer head. New: Absorption type \$85.00
Transmission type \$92.50

SL. wavemeter. Type CW60ABM \$125.00

TS 235 UP Dummy Load \$87.50

TS 89/AP Voltage Divider. Ranges 100: 1/2 for 2000 to 20000v. 10:1 for 200 to 2000v. Input Z 2000 ohms. Output Z 4 meg ohms flat response 150 cy to 5 meg cy \$42.50

10 cm Wavemeter, WE type B 435490 Transmission type. Type N Fittings. Veeber Root Micrometer dial, Gold Plated W/Calib. Chart. P/o Freq. Meter X66404A. New \$99.50

Complete Radars Available

SO1 Used	\$1200.00
SO13 Used	\$1200.00
SE New	\$1200.00
SFI New	\$2800.00
SCR 533 Trailer unused	\$ 950.00
CX8R Beacon Used	\$1500.00
CPN3 Beacon Used	\$1500.00
APSA	
APSA5 Major Components	\$ 500.00
Airborne Radar Altimeter	\$ 175.00

SCR 584

SPARE PARTS AVAILABLE

APS 4 Complete sets and various components available. AIRBORNE RADAR

ALL MERCHANDISE GUARANTEED. MAIL ORDERS PROMPTLY FILLED ALL PRICES F.O.B. NEW YORK CITY SEND MONEY ORDER OR CHECK ONLY. SHIPPING CHARGES SENT C.O.D. RATED CONCERNS SEND P. O. MERCHANDISE SUBJECT TO PRIOR SALE

COMMUNICATIONS EQUIPMENT CO.

131 "I" Liberty St., New York, N.Y. Cable "Comsup" Ph. Digby 9-4124

MAGNETRONS - RADAR - PULSE EQUIPMENT

MAGNETRONS

Tube	Freq. Range	Pk. Pwr. Out	Price
2J31	2820-2860 mc.	265 KW.	\$25.00
2J21-A	9345-9405 mc.	50 KW.	\$25.00
2J22	3267-3333 mc.	265 KW.	\$25.00
2J26	2992-3019 mc.	275 KW.	\$25.00
2J27	2965-2992 mc.	275 KW.	\$25.00
2J32	2780-2820 mc.	285 KW.	\$45.00
2J37			
2J38 Pkg.	3249-3263 mc.	5 KW.	\$35.00
2J39 Pkg.	3267-3333 mc.	87 KW.	\$35.00
2J40	9305-9325 mc.	10 KW.	\$65.00
2J49	9000-9160 mc.	58 KW.	\$85.00
2J34			\$55.00
2J61	3000-3100 mc.	35 KW.	\$65.00
2J62	2914-3010 mc.	35 KW.	\$65.00
3J31	24,000 mc.	50 KW	\$55.00
5J30			\$39.50
71AY			\$25.00
718DY	2720-2890 mc.	250 K.W.	\$25.00
720BY	2800 mc.	1000 KW.	\$50.00
720CY	2860 mc.	1000 K.W.	\$50.00
725-A	9345 9405 mc.	50 KW.	\$25.00
730-A	9345 9405 mc.	50 KW.	\$25.00
728	A, B, C, D, E, F, G, Y		\$50.00
700	A, B, C, D		\$50.00
706	A, B, C, D, E, F, G, Y		\$50.00
Klystrons.	723A/8	\$12.50: 7078	\$20.00
	W/Cavity		
	417A	2K41	\$65.00

MAGNETRON MAGNETS

Gauss	Pole Diam.	Spacing	Price
4850	3/4 in.	5/8 in.	\$12.50
5200	2 1/32 in.	3/4 in.	\$17.50
1300	1 5/8 in.	1 5/16 in.	\$12.50
1860	1 5/8 in.	1 1/2 in.	\$14.50
Electromagnets for magnetrons			\$24.50 ea

GE Magnets type M7765115, GI Distance Between pole faces variable. 2 1/16" (1900 Gauss) to 1 1/2" (2200 Gauss) Pole Dia. 1 5/8" New Part of SCR 584 \$34.50

TUNABLE PKGD. "CW" MAGNETRONS

QK 61 2975-3200 mc.	QK 62 3150-3375 mc.	
QK 60 2800-3025 mc.	QK 59 2675-2900 mc.	
New, Guaranteed		Each \$65.00
QK 915 Raytheon		\$150.00

Fil Trans for above 115v 60 cy Pri Four 6.3v/4A Sec: 5000VT \$27.50
Magnetronkit. of four QK's 2675-3375 mc W/trans. Special \$250.00

BC 1277A Sig. Generator	\$300.00
APR4. Receiver 300-2000 mc.	\$475.00
CPD 10137 Dehydrating Unit	\$425.00

TELEPHONE EQUIPMENT

F.T. & R. 101-A APPLIQUE

Provides necessary balancing facilities for four wire repeater when used on two wire lines which may be voice-frequency telephone lines of open wire or non-loaded or loaded cable. Std. 19" channel from rack mtg. Price, new, complete with tech manual \$54.00

5B-19/GT CONSOLE

Provides facilities for patching and monitoring network of lines for telephone intercom, radio reception, telegraph reception, recording, etc. Complete central office supervising position \$350.00

BC 686 LINE AMPLIFIER

With magneto ringer, 3-tube 25L6 amplifier. For local point-to-point telephone operation, remote operation of Phone Xmtr. remove reception of receiver output, monitoring facility. Requires only 24 vdc for tube "8" plus supply for full operation.
New, less tubes, in wooden chest \$18.50
Per pair for 2-way pt-to-pt operation \$35.00

R. F. EQUIPMENT

LHTR. LIGHTHOUSE ASSEMBLY. Part of RT-39/APG-5 & APG-15. Receiver and Transmitter Lighthouse Cavities with assoc. Tr. Cavity and Type N CPLG. To Rcvr. Uses 2C40, 2C43, 1827. Tuneable APX 2400-2700 MCS. Silver plated \$49.50

Receiver transmitter, Rt-39A/APG-5 10 cm. gun laying RF package using 2C40 and 2C43. new \$150.00 ea.

APS-2 10CM RF HEAD COMPLETE WITH HARD TUBE (7158) Pulser, 714 Magnetron 417A Mixer all 7/8" rigid coax. incl. rcvr. front end \$210.00

Beacon lighthouse cavity 10 cm with miniature 28 volt DC FM motor. Mig Bernard Rice \$47.50 ea

T-128/APN-19 10 cm. radar Beacon transmitter package, used, less tubes \$59.50 ea

SO-3 "X" band 3 cm RF package, new complete, including receiver unit as illustrated on Page 337, Volume 23 RAD LAB Series \$375.00 ea

Pre-amplifier cavities type "M" 7410590GL to use 446A lighthouse tube. Completely tuneable Heavy silver plated construction \$37.50 ea

RT32/AP5 6A RF HEAD. Compl. with 725A Magnetron magnet pulse xmtr. TRA-ATR. 723 A/B local osc. and beacon mount, pre amplifier. Used but exc. cond. \$97.50

AN/AP5-15A "X" Band compl. RF head and modulator, incl. 725-A magnetron and magnet, two 723A/8 klystrons (local osc. & beacon), 1824, TR, rcvr-ampl. duplexer, HV supply, blower, pulse xmtr. Peak-Pwr Out: 45 KW apx. Input: 115, 400 cy. Modulator pulse duration .5 to 2 micro-sec. apx. 13 KV P1 Pulse. Compl. with all tubes incl. 715-8, 8298, RKR 73, two 72's. Compl. pkg., new \$210.00

"S" BAND AN/AP5-2. Complete RF head and modulator, including magnetron and magnet, 417-A mixer, TR, receiver, duplexer, blower, etc., and complete pulser. With tubes, used, fair condition \$75.00

10 CM. RF Package. Consists of: SO Xmtr.-receiver using 2J27 magnetron oscillator. 250 KW peak input. 707-8 receiver-mixer \$150.00

200 MC COAXIAL PLUMBING

Right Angle Bend	\$35.00
T Section	\$55.00
T Section with Adapter to 7/8" in rigid coax	\$65.00

5CM.
2" x 1" RT. ANGLE BEND CHOKE TO COVER SILVER PLATER \$38.50
WAVEGUIDE MIXER CV-12A/APR-6 \$55.00
RAPID W. G. FASTENING CLAMPS \$5.00

AN/APG2 Servo Amplifier less tubes, new \$35.00

SUPER SONICS

QCU Magneto striction head RCA type CR 278225. New	\$75.00
Stainless Steel streamlining housings for above	\$18.50
QBG Driver Amplifier. New	\$200.00
QCB Magneto striction head coil plate assembly, new	\$14.50
QCC-2/QCB Magneto striction head coil plate assembly	\$14.50

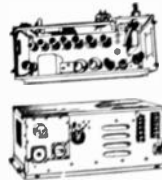

3 CM RECEIVER

SO-3. Complete With W.G. Mixer Assy (723 A/B Reg. Fil. Power Supply, 6 Stages IF 6AC7) \$99.50

CRYSTAL DIODES

No.	Each	2 for	10 for
IN21	\$1.00	\$1.79	\$ 8.30
IN22	1.50	2.79	14.00
IN23	1.50	2.79	14.00
IN26	3.00	5.90	27.50

PULSE EQUIPMENT

MIT. MOD. 3 HARD TUBE PULSER: Output Pulse Power: 114 KW (12 KV at 12 amp.). Duty Ratio: .001 max. Pulse duration: 5. 1.0 2.0 microsec. input voltage: 115 v. 400 to 2400 cps. Uses 1-715-8, 1-829-8, 3-72's, 1-73 New \$110.00

APQ-13 PULSE MODULATOR. Pulse Width .5 to 1.1 Micro. Sec. Rep. rate 624 to 1348 Pps. Pk. pwr. out 35 KW. Energy 0.018 Joules \$49.00

TP9-3 PULSE MODULATOR. Pk. power 50 amps. 24 KV (1200 KW pk); pulse rate 200 PPS. 1.5 microsec., pulse line impedance 50 ohms. Circuit-series charging version of DC Resonance type. Uses two 705-A's as rectifiers. 115 v. 400 cycle input. New with all tubes \$49.50

APS-10 MODULATOR DECK Complete less tubes \$75.00

APS-10 Low voltage power supply, less tubes \$18.50

PULSE TRANSFORMERS

G.E.K.-2745 \$39.50

G.E.K.-2744-A. 11.5 KV High Voltage, 3.2 KV Low Voltage @ 200 KW oper. (270 KW max.) 1 microsec. or 1/4 microsec. @ 600 PPS \$39.50

W.E. #D166173 Hi-Volt input transformer, W.E. Impedance ratio 50 ohms to 900 ohms. Freq. range: 10 kc to 2 mc, 2 sections parallel connected potted in oil \$36.00

W.E. KS 9800 Input transformer. Winding ratio between terminals 3-5 and 1-2 is 1:1:1, and between terminals 6-7 and 1-2 is 2:1. Frequency range: 380-520 c.p.s. Permalloy core \$6.00

G.E. #K2731 Repetition Rate: 635 PPS. Pri. Imp: 50 Ohms. Sec. Imp: 450 Ohms. Pulse Width: 1 Microsec. Pri. Input: 9.5 KV PK. Sec. Output: 28 KV PK. Peak Output: 800 KW. Rifler 2.75 Amp. \$64.50

W.E. #D169271 Hi Volt input pulse transformer \$27.50

G.E. K2450A. Will receive 13KV, 4 micro-second pulse on pri., secondary delivers 14KV. Peak power out 100KW G.E. \$4.50

G.E. #K2748A. Pulse Input, line to magnetron \$36.00

#280 Utah Pulse or Blocking Oscillator XFMR Freq. limits 790-810 cy-3 windings turns ratio 1:1:1 Dimensions 1 13/16 x 1 1/8" 19/32 \$1.50

Pulse 131-AWP L-421435 \$6.00

Pulse 134-8W-2F L-440895 \$2.25

358-2754 \$18.50

PULSE NETWORKS

15A-1-400-50: 15 KV. "A" CKT, 1 microsec., 400 PPS, 50 ohms imp. \$42.50

G.E. #6E3-5-2000-50P2T, 6KV. "E" circuit, 3 sections, .5 microsecond, 2000 PPS, 50 ohms impedance \$6.50

G.E. #3E (3-84-810; 8-2.24-405) 50P4T; 3KV. "E" CKT Dual Unit: Unit 1, 3 Sections. .84 Micro-sec

810 PPS, 50 ohms imp.; Unit 2, 8 Sections, 2.24 microsec. 405 PPS, 50 ohms imp. \$6.50

7.5E3-1-200-67P. 7.5 KV. "E" Circuit, 1 microsec., 200 PPS, 67 ohms impedance, 3 sections \$7.50

7.5E4-16-60-67P. 7.5 KV. "E" circuit, 4 sections, 16 microsec. 60 PPS, 67 ohms impedance \$15.00

7.5E3-3-200-6PT. 7.5 KV. "E" Circuit, 3 microsec., 200 PPS, 67 ohms imp., 3 sections \$12.50

DELAY LINES

D-168184: .5 microsec. up to 2000 PPS, 1800 ohm term. \$4.00

D-170499: .25/.50/.75, microsec. 8 KV. 50 ohms imp. \$16.50

D-165997: 1 1/4 microsec. \$7.50

163169 Delay Line. Small quantity available \$50.00

UG TYPE CONNECTORS

FULL LINE OF UG CONNECTORS IN STOCK. IMMEDIATE DELIVERY.

"AN" CONNECTORS



LARGE VARIETY AVAILABLE AT GREAT SAVINGS

Send your specs and let us quote

ALL MERCHANDISE GUARANTEED. MAIL ORDERS PROMPTLY FILLED. ALL PRICES F.O.B. NEW YORK CITY. SEND MONEY ORDER OR CHECK ONLY. SHIPPING CHARGES SENT C.O.D. RATED CONCERNS SEND P. O. MERCHANDISE SUBJECT TO PRIOR SALE

COMMUNICATIONS EQUIPMENT CO.

131 "I 11" Liberty St., New York, N.Y.

Cable "Comsupo" Ph. Digby 9-4124

News—New Products

These manufacturers have invited PROCEEDINGS readers to write for literature and further technical information. Please mention your I.R.E. affiliation.

(Continued from page 65A)

Wave Generator

A new instrument, completely self-contained and power line operated, known as a Complex Wave Generator, Model 57, has been made available by Alfred W. Barber Labs., 34-04 Francis Lewis Blvd., Flushing, L. I., N. Y.



The instrument will provide a fundamental and 2nd, 3rd, 4th, and 5th harmonics in any percentage and any relative phase. The frequency of the fundamental may be varied from 0 to 100 per cent of the fundamental. The phase of any harmonic may be varied through 360 degrees. The

fundamental and all harmonics are derived from the same two beating oscillators. Phase shifting is done at a single frequency by means of simple, substantially linear phase shifting circuits.

The manufacturer claims that the Complex Wave Generator has proved itself in the rapid solution of many problems which "hitherto were attacked in a very laborious manner."

Electronic Relay Switches for Automatic Controls and Gaging Devices

Coral Designs, P.O. Box 248, Forest Hills, N. Y., makes available a line of electronic switches that provide the means of using simple contact closure units as "off-on," two-position, three-position, or floating-type controllers to solve pressure, torque, position, movement, and other gaging problems.



Contact ratings may be obtained for controlling 5 amperes, 10 amperes, or 35 amperes at 115 Volts ac. Adjusting knobs provide operation of the probe resistance to values as high as 500,000 ohms. Operating voltage of all units is 115 volts (± 10 per cent) 60 cycles ac. Each unit employs but one tube with replacement life of 10,000 hours. Dust proof and explosion proof units are available for hazardous locations.

Wide-Range Power Oscillator

A new wide-range power oscillator has been developed by Airborne Instruments Laboratory, Inc, 160 Old Country Rd., Mineola, L. I., N. Y., for measurement and testing procedures in the 300- to 2,500-Mc range.

The Type 124A Power Oscillator consists of a grid separation coaxial oscillator employing a 2uc38 disk seal triode, an audio oscillator and modulator section, and a self-contained rectifier power supply. Cathode-grid and grid-plate lines are coupled to a single tuning control with provision for individual adjustment of the grid cathode line, if desired. Counter type indicators show the position of the tuning elements. An output coupling control with counter indicator is also provided

FLEXAGUIDE

A flexible waveguide with an electrically continuous FLEXIBLE CONVOLUTED bellows innercore protected by a specially LOW TEMPERATURE flexible molded jacket.

It is PRESSURE tight and electrically correct for all conditions of bending and flexing. Standing Wave Ratio is equivalent to standard rigid waveguide assembly throughout the flexing cycle and has excellent attenuation characteristics.

Send for latest information

Airtron

DESIGNS and PRODUCES

Electronic and Aircraft Components

105 East Elizabeth Avenue
Linden New Jersey

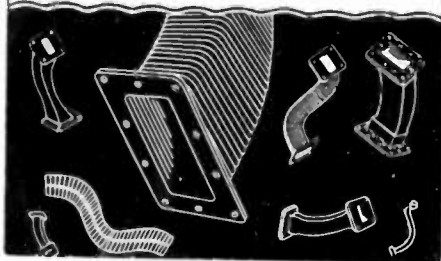

Available Now!

Easy, Fast

Ultrasonic Spectrum Analysis

WITH

MODEL SB-7

PANORAMIC ULTRASONIC ANALYZER

An invaluable new direct reading instrument for simplifying ultrasonic investigations, the SB-7 provides continuous high speed panoramic displays of the frequency, amplitude and characteristics of signals between 2KC and 300KC. The SB-7 allows simultaneous observation of many signals within a band up to 200KC wide. Special control features enable selection and highly detailed examination of narrower bands which may contain signals separated by less than 500c.p.s. The instrument is unique in that it provides rapid indications of random changes in energy distribution.

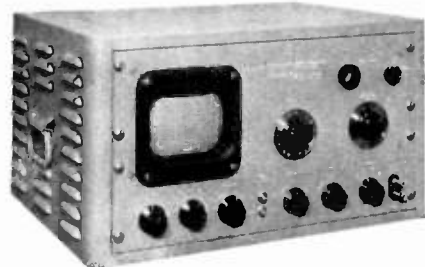

USES

- Ultrasonic Vibration Measurements
- Harmonic Analysis
- Cross Modulation Studies
- Noise Investigations
- Determining Transmission Characteristics of Lines and Filters
- Monitoring Communications Carrier Systems
- Checking Interference, Spurious Modulation, Parasitics, Effects of load changes, shock, humidity, component variations, etc. upon frequency stability
- Telemetry

SPECIFICATIONS

- Frequency Range: 2KC—300KC, stabilized linear scale
- Scanning Width: Continuously variable from 200KC to zero
- Four Input Voltage Ranges: 0.05V. to 50V. Full scale readings from 1 millivolt to 50 volts
- Amplitude Scale: Linear and two decade log
- Amplitude Accuracy: Within 1db. Residual harmonics suppressed by at least 50db.
- Resolution: Continuously variable. 2KC at maximum scanning width, 500c.p.s. for scanning widths below 8KC.

WRITE NOW For Complete Information,
Price and Delivery

Which
pin
saves
the
money?

Made by
Machining
and drilling



Made by
Stamping and
forming

Made by
Multi-Swage

Choose right and make Big Savings on SMALL METAL PARTS

COSTS HALVED! Instead of turning and drilling parts like these from solid rod, or stamping and forming them, the **BEAD CHAIN MULTI-SWAGE** Process automatically swages them from flat stock. By doubling the production rate and eliminating scrap, this advanced process can save you as much as fifty percent of the cost of other methods.

The **BEAD CHAIN MULTI-SWAGE** Process produces a wide variety of hollow or solid metal parts—beaded, grooved, shouldered—from flat stock, tubing, rod, or wire—of any metal. Sizes to 1/4" dia. and 1 1/2" length.

GET COST COMPARISON ON YOUR PARTS—If you use small metal parts in quantities of about 100,000, don't overlook the almost certain savings of this high-speed, precision process. Send sketch, blueprint or sample part and our engineers will furnish facts about Multi-Swage economy. Or, write for Catalog. The Bead Chain Manufacturing Co., 60 Mountain Grove St., Bridgeport, Conn.



Bearings, Shafts



Electrical and Electronic Ports



Friction Fasteners



Guides



Stops

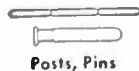

Posts, Pins

B **BEAD CHAIN**
MULTI-SWAGE
TRADE MARK **PROCESS**



VARIAN MICROWAVE ENGINEERING

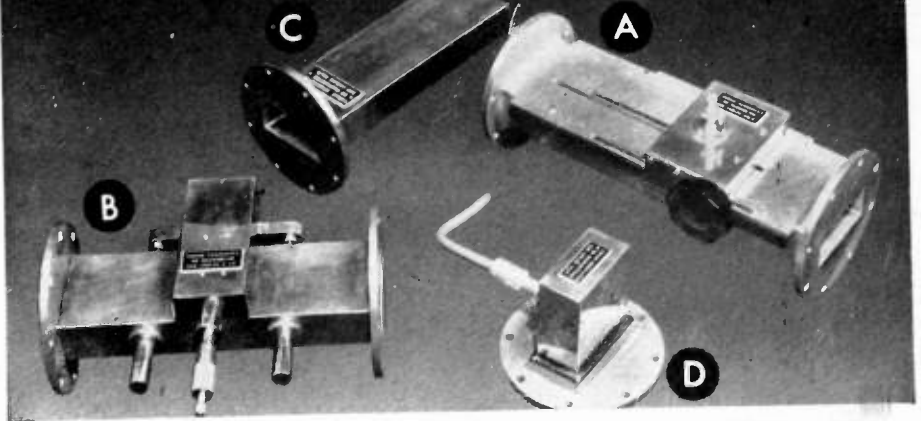

WAVEGUIDE TEST equipment for use between 2600 and 3950 mc; 1 1/2 by 3 by 0.080 in.; RG-48/U waveguide with UG-53/U flanges. These and special units for early delivery.

A Standing-wave detector. Precision ground for continuing accuracy better than 1 per cent.

B Variable attenuator. Attenuation 0.5 to 10 db; vswr less than 1.1, 2600 to 3400 mc; average power 1 watt, peak 1 kw.

C Termination. Average power 1 watt, peak 1 kw; vswr less than 1.05, 2600 to 3400 mc.

D Co-ax waveguide transition. Connectorless type for RG-5/U, RG-8/U, or RG-21/U flexible cable; vswr less than 1.25, 2700 to 3200 mc.

VARIAN
associates

99 *washington st.*
san carlos, calif.

ACCURATE PHASING WITH T.I.C. METHOD OF GANGING PRECISION POTENTIOMETERS

MECHANICAL SPECIFICATIONS

- Precision machined aluminum base and cover 2" diameter, 1" depth.
- Precision phosphor bronze bushing.
- Centerless ground stainless steel shaft.
- No set screws.
- Mechanical rotation—360°.
- Clamping method of ganging permits individual adjustment of angular position.
- Temperature range —85° to +165° F.
- Rotational Life—At least 1 million complete cycles of revolution.

ELECTRICAL SPECIFICATIONS

- Winding—both linear to 0.2% and nonlinear to 1% accuracies.
- Paliney contact to winding; two-brush rotor take-off assembly with precious metal contacts.
- High, uniform resolution provided by our method of winding non-linear resistances.
- Electrical rotation maximum 320°.
- All soldered connections (except sliding contacts.)

This general line of precision potentiometers was developed in collaboration with the Fire Control Section of the Glenn L. Martin Company

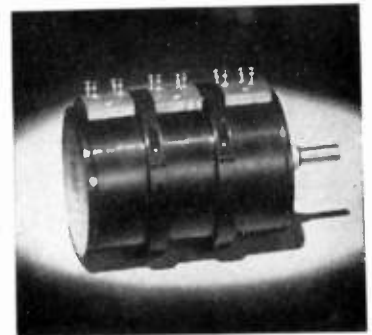

(3 gang RV-2)

Send for bulletins RV2-749 with full information on high precision linear and non-linear potentiometers.

Write today for bulletins on other T.I.C. products: Z-Angle Meter . . . R.F. Z-Angle Meter . . . R-F Power Oscillator . . . Translatory Variable Resistors . . . Slide Wire Resistance Boxes . . . Phase Angle Meter.

TIC **TECHNOLOGY INSTRUMENT CORP.**
1058 MAIN STREET, WALTHAM 54, MASS.

ENGINEERING REPRESENTATIVES

Chicago, Ill.—StAte 2-7444
Rochester, N.Y.—Charlotte 3193-J

Cambridge, Mass.—ELiot 4-1751
Dallas, Tex.—Logan 6-5097

Canaan, Conn.—Canaan 649
Hollywood, Calif.—HOLlywood 9-6305

TEKTRONIX SQUARE WAVE GENERATOR

Continuously Variable, 25 CPS-1 MC
Rise Time, .02 Microseconds

Direct Reading Frequency Meter
Versatile Output Circuit

Square wave testing techniques come into wider use as the need for good transient response in wide band amplifiers becomes increasingly important. In order to test the high frequency response it is necessary to have a signal which has a rise and fall at least equal to and preferably faster than the risetime of the amplifier being tested. In addition to a sharp rise and fall, the test signal should be free of over-shoot and other spurious responses. For examination of the low frequency response a square wave signal having flat horizontal portions is needed.

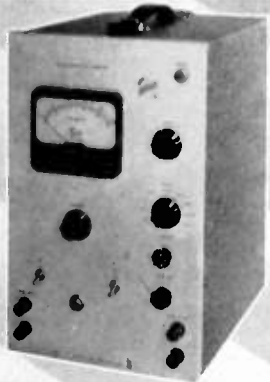

TEKTRONIX Type 105
Square Wave Generator
Price \$395.00 f.o.b.
Portland, Oregon

The TEKTRONIX Type 105 Square Wave Generator provides a suitable signal for both of the above tests. Its frequency range, extending continuously from 25 cycles to 1 mc., combined with its risetime of .02 microseconds, makes it possible to quickly and accurately test amplifiers, filters, etc., having pass bands from a few cycles to 20 mc.



Write Today for Detailed Specifications of
Type 105 and Other Tektronix Instruments

712 S. E. HAWTHORNE BLVD. PORTLAND 14, OREGON

INDEX AND DISPLAY ADVERTISERS

Section Meetings	33A
Student Branch Meetings	40A
Membership	40A
Positions Open	50A
Positions Wanted	51A
News—New Products	43A

DISPLAY ADVERTISERS

Acme Electric Corp.	60A
Aerovox Corp.	24A
Aircraft Radio Corp.	38A
Airtron, Inc.	68A
American Phenolic Corp.	57A
Amperex Electronic Corp.	Cover II
Arnold Engineering Co.	6A
Astatic Corp.	40A
Bead Chain Mfg. Co.	69A
Bell Telephone Laboratories	2A
Berkeley Scientific Co.	63A
Blaw-Knox	39A
Bliley Electric Co.	56A
W. J. Brown	71A
Bud Radio, Inc.	53A
Burlington Instrument Co.	62A
Cambridge Thermionic Corp.	61A
Cannon Electric Development Co.	63A
Capitol Radio Engineering Inst.	51A
Central Scientific Co.	51A
Centralab	33A, 34A, 35A, 36A
C. P. Clare & Co.	25A
Clarostat Mfg. Co.	64A
Cleveland Container Co.	26A
Clough-Bregle Co.	59A
Sigmund Cohn Corp.	49A
Collins Radio Co.	37A
Communication Products Co.	46A
Communications Equipment	66A, 67A
E. J. Content	71A
Cornell-Dubilier Electric Corp.	Cover III
Cornish Wire Co.	27A
R. W. Cramer Co.	49A
Crosby Labs.	71A

The new S.S. WHITE 80X HIGH VOLTAGE RESISTOR

(1/2 Actual Size)

4 watts • 100 to 100,000 megohms

Developed for use as potential dividers in high voltage electrostatic generators, S.S. White 80X Resistors have many characteristics—particularly negative temperature and voltage coefficients—which make them suitable for other high voltage applications.

They are constructed of a mixture of conducting material and

binder made by a process which assures adequate mechanical strength and durability. This material is non-hygroscopic and, therefore, moisture-resistant. The resistors are also coated with General Electric Dri-film which further protects them against humidity and also stabilizes the resistors.

WRITE FOR BULLETIN 4906

It gives complete information on S.S. White resistors. A free copy and price list will be sent on request.



S.S. WHITE INDUSTRIAL
THE S. S. WHITE DENTAL MFG. CO. DIVISION
DEPT. GR 10 EAST 40th ST., NEW YORK 16, N. Y.



FLEXIBLE SHAFTS • FLEXIBLE SHAFT TOOLS • AIRCRAFT ACCESSORIES
SMALL CUTTING AND GRINDING TOOLS • SPECIAL FORMULA RUBBERS
MOLDED RESISTORS • PLASTIC SPECIALTIES • CONTRACT PLASTICS MOLDING

One of America's AAAA Industrial Enterprises

Allen B. DuMont Laboratories, Inc.	22A
Eitel-McCullough, Inc.	16A
Electrical Reactance Corp.	9A
Electro-Motive Mfg. Co., Inc.	13A
Electro-Search	71A
Electronic Tube Corp.	52A
Electronics Res. Pub. Co.	44A
Elk Electronics Labs.	71A
Erie Resistor Corp.	15A
Federal Telecommunication Laboratories	62A
W. L. Foss	71A
Freed Transformer Co., Inc.	21A
General Electric Co.	4A, 5A, 10A, 11A
General Radio Co.	Cover IV
Paul Godley	71A
Goodyear Aircraft Corp.	50A
H. L. Gordon	71A
S. Gubin	71A
Hewlett-Packard Co.	3A
Hickok Electrical Inst. Co.	56A
Illiffe & Sons	72A
E. F. Johnson Co.	61A
Kenyon Transformer Co.	59A
Kings Electronics	55A
Kollsman Instrument	28A
P. R. Mallory & Co., Inc.	20A
Marion Electrical Inst. Co.	45A
Measurements Corp.	65A
Melpar, Inc.	50A
Mycalex Corp. of America	42A, 43A
National Carbon Co.	41A
Ohmite Mfg. Co.	17A
Panoramic Radio Products, Inc.	68A
Pickard & Burns	71A
Polytechnic Research & Development Co.	19A
Presto Recording Corp.	47A
Product Development Co., Inc.	48A
Radio Corp. of America	14A, 32A

Revere Copper & Brass, Inc.	18A
Paul Rosenberg	71A
Shallcross Mfg. Co.	30A, 31A
Simpson Electric Co.	23A
Sorensen & Co., Inc.	54A
Spencer Kennedy Laboratories	64A
Sperry Gyroscope	7A, 50A
Sprague Electric Co.	1A
Stackpole Carbon Co.	12A
Stoddart Aircraft Radio Co.	58A, 60A
Super Electric Products Corp.	63A
Tech Labs.	65A
Technical Materiel Corp.	71A
Technology Instrument Corp.	69A
Tektronix, Inc.	70A
Transradio, Ltd.	58A
Truscon Steel Co.	8A
United Transformer Co.	29A
Varian Associates	69A
Westinghouse Electric Corp.	55A
S. S. White Dental Mfg. Co.	70A

PROFESSIONAL CARDS

Samuel Gubin, Electronics
G. F. Knowles, Mech. Eng.
SPECTRUM ENGINEERS, Inc.
Electronic & Mechanical Designers
540 North 63rd Street
Philadelphia 31, Pa.
GRanite 2-2333; 2-3135

PICKARD AND BURNS, INC.

Consulting Electronic Engineers

Analysis and Evaluation
of Radio Systems
Research, Development & Design
of Special Electronic Equipment
240 Highland Ave., Needham 94, Mass.

PAUL ROSENBERG ASSOCIATES

Consulting Physicists

Main office: Woolworth Building,
New York 7, N.Y.
Cable Address Telephone
PHYSICIST WOrth 2-1939
Laboratory: 21 Park Place, New York 7, N.Y.

**TECHNICAL
MATERIEL CORPORATION**
COMMUNICATIONS CONSULTANTS
RADIOTELETYPE - FREQUENCY SHIFT
INK SLIP RECORDING - TELETYPE NETWORKS
453 West 47th Street, New York 19, N.Y.

W. J. BROWN
Consulting Engineer
**INDUSTRIAL ELECTRONICS
RADIO AND TELEVISION**
26 years active development experience
512 Marshall Bldg., Cleveland, O.
Telephone: TOWer 1-6498

EDWARD J. CONTENT
Acoustical Consultant
Functional Studio-Theater Design
FM — Television — AM
Audio Systems Engineering
Roxbury Road Stamford 3-7459
Stamford, Conn.

CROSBY LABORATORIES
Murray G. Crosby & Staff
FM, Communications, TV
Industrial Electronics
High-Frequency Heating
Offices, Laboratory & Model Shop at:
126 Old Country Rd. Mineola, N.Y.
Garden City 7-0284

ELK ELECTRONIC LABORATORIES
Jack Rosenbaum
Specializing in the design and
development of
Test Equipment for the communications,
radar and allied fields.
12 Elk Street Telephone:
New York 7, N.Y. WOrth 2-4963

Richard B. Schulz
Electro-Search
Radio-Interference Reduction;
Development of
Interference-Free Equipment,
Filters, Shielded Rooms
515 W. Wyoming Ave., Philadelphia 40, Pa.
GLadstone 5-5353

WILLIAM L. FOSS, INC.
927 15th St., N.W. RRepublic 3883
WASHINGTON, D.C.

PAUL GODLEY CO.
Consulting Radio Engineers
P.O. Box J, Upper Montclair, N.J.
Offs. & Lab.: Great Notch, N.J.
Phone: Montclair 3-3000
Established 1926

HERMAN LEWIS GORDON
Registered Patent Attorney
Patent Investigations and Opinions
Warner Building 100 Normandy Drive
Washington 4, D.C. Silver Spring, Md.
National 2497 Shepherd 2433



For Accurate and Up-to-date News of Every British Development in Radio, Television and Electronics

WIRELESS WORLD is Britain's leading technical magazine in the general field of radio, television and electronics. For over 37 years it has consistently provided a complete and accurate survey of the newest British technique in design and manufacture. Articles of a high standard include reviews of equipment, broadcast receivers and components, while theoretical articles deal with design data and circuits for every application.

Subscriptions can be placed with *British Publications Inc.*, 150 East 35th Street, New York, 16, N.Y., or sent direct by



WIRELESS ENGINEER is read by research engineers, designers and students, and is accepted internationally as a source of information for advanced workers. The Editorial policy is to publish only original work, and representatives of the National Physical Laboratory, the British Broadcasting Corporation and the Engineering Department of the British Post Office are included on the Editorial Advisory Board.

International Money Order to *Dorset House, Stamford Street, London, S.E.1, England.*
Cables: "Iliffepres. Sedist. London."

ASSOCIATED TECHNICAL BOOKS: "Radio Laboratory Handbook" (4th Edition) by M. G. Scroggie, B.Sc., M.I.E.E. 13 shillings (\$2.60)
"Radio Data Charts" (5th Edition) by R. T. Beatty, M.A., B.E., D.S.C., revised by J. McG. Sowerby, B.A., A.M.I.E.E. A series of abacs providing essential data required in receiver design. 8 shillings (\$1.75): available from the British address above.



HERE'S WHY THE C-D VIBRATOR IS THE BETTER VIBRATOR:

Designed by the finest vibrator engineering talent now working under the C-D banner. All the know-how and experience accumulated in the manufacture of vibrators for over 25 years concentrated in the new C-D vibrator line. Electronic micrometric equipment designed and produced at C-D has removed every bit of guess-work and factor of human error in C-D Vibrator manufacture. Samples to your specifications gladly furnished.

ONE OF THESE IS "HEADACHE-SEED"

**- the other's a
trouble-free
Cornell-Dubilier
Vibrator...
Yet both
look alike!**

You can't tell the difference from the outside except for one thing—*the name*. If it says Cornell-Dubilier that's all you need to know, to know you've got the best Vibrator your money can buy!

For it's what goes *inside* that determines its capacity for performance. And inside every Vibrator bearing the C-D name is that invisible but invaluable ingredient engineers call know-how. The fact that leading radio engineers specify C-D Vibrators is significant recognition of their superiority. Inquiries promptly and intelligently handled.

Cornell-Dubilier Electric Corporation,
Indianapolis, Ind., Dept. M119. Other
plants in South Plainfield, N. J., Brook-
line and Worcester, Mass.; Providence,
R. I., and subsidiary,
The Radiart Corp.,
Cleveland, Ohio.



A GREAT NAME IN CAPACITORS. A GREAT NAME IN VIBRATORS

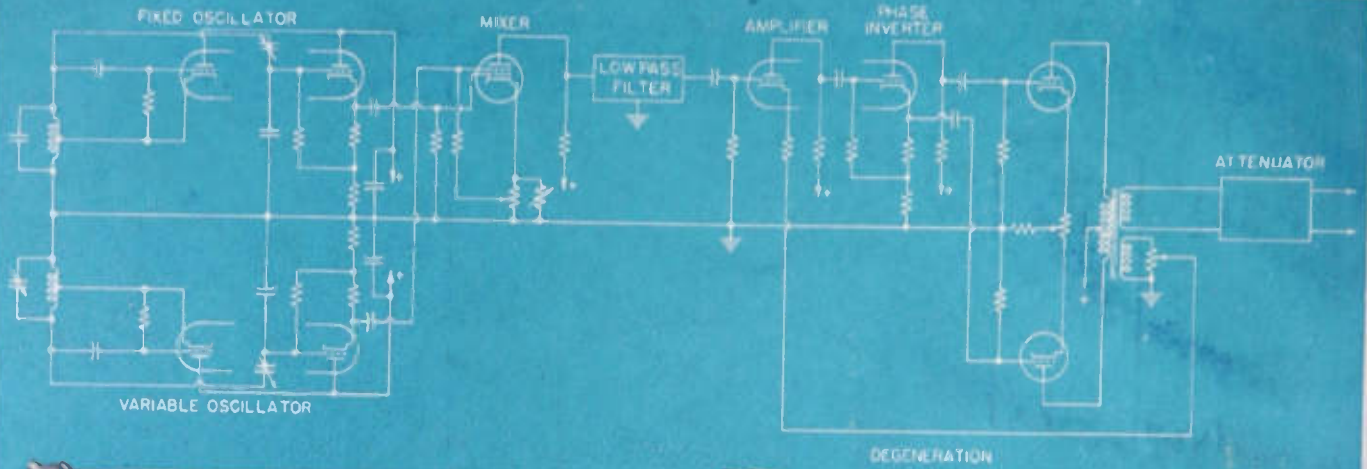

USE THIS OSCILLATOR FOR GREATER ACCURACY • LESS DISTORTION • IMPROVED ZERO ADJUSTMENT • MANY OPERATING CONVENIENCES

The popularity of the G-R TYPE 1304-A Beat Frequency Oscillator is due to these features:

- **FREQUENCY RANGE:** 20 to 20,000 cycles
- **FREQUENCY CALIBRATION:** can be standardized within 1 cycle at any time by setting instrument to line frequency or zero beat.
- **LOW DISTORTION:** harmonic content approximately 0.25% between 100 and 7500 cycles with 0.3 watt maximum output; on HIGH OUTPUT of 1 watt, distortion less than 1% between 100 and 7500 cycles. Below 100 and above 7500 cycles distortion is higher.
- **ZERO BEAT INDICATOR:** neon lamp for zero beat at line frequency or zero scale.
- **FREQUENCY STABILITY:** drift from cold start less than 7 cycles in first hour and completed in 2 hours.
- **OUTPUT IMPEDANCE:** 600 ohms, either grounded or balanced-to-ground, and essentially constant at all output voltages.
- **OUTPUT VOLTAGE:** approximately 25 volts open circuit. For matched resistive load voltage varies less than ± 0.25 db between 20 and 20,000 cycles.
- **OUTPUT CONTROL:** calibrated from +25 db to -20 db referred to 1 milliwatt into 600 ohms.

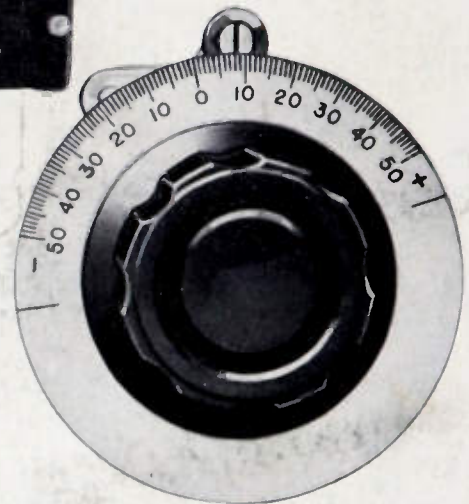

The frequency-increment dial, calibrated from +50 to -50 cycles is a great convenience. The main dial is engraved from 20 to 20,000 cycles with a true logarithmic scale; the calibration is accurate within $\pm(1\% + 0.5 \text{ cycle})$. The total scale length is 12 inches over an angle of rotation of 240°. This dial can be coupled to a recorder to record frequency characteristics.

TYPE 1304-A BEAT-FREQUENCY OSCILLATOR \$450.00

WRITE FOR COMPLETE DATA



GENERAL RADIO COMPANY

Cambridge 39, Massachusetts

90 West St., New York 6 920 S. Michigan Ave., Chicago 5 1000 N. Seward St., Los Angeles 38

