

# Proceedings



of the I·R·E

**A Journal of Communications and Electronic Engineering**  
(Including the WAVES AND ELECTRONS Section)

**May, 1947**

Volume 35

Number 5

PROCEEDINGS OF THE I.R.E.

Analysis of Problems in Dynamics  
by Electronic Circuits

Duct Propagation at 10 and 3 Cen-  
timeters

Microwave Oscillators Using Disk-  
Seal Tubes

Microwave Omnidirectional An-  
tennas

Q Circles—Part II

Voltage-Regulator-Tube Charac-  
teristics

Waves and Electrons  
Section

Impedance Measurement on Trans-  
mission Lines

Microwave Power Measurement  
Loop-Antenna Input-Circuit Design  
Radio Control of Model Flying  
Boats

Abstracts and References

TABLE OF CONTENTS FOLLOWS PAGE 32A

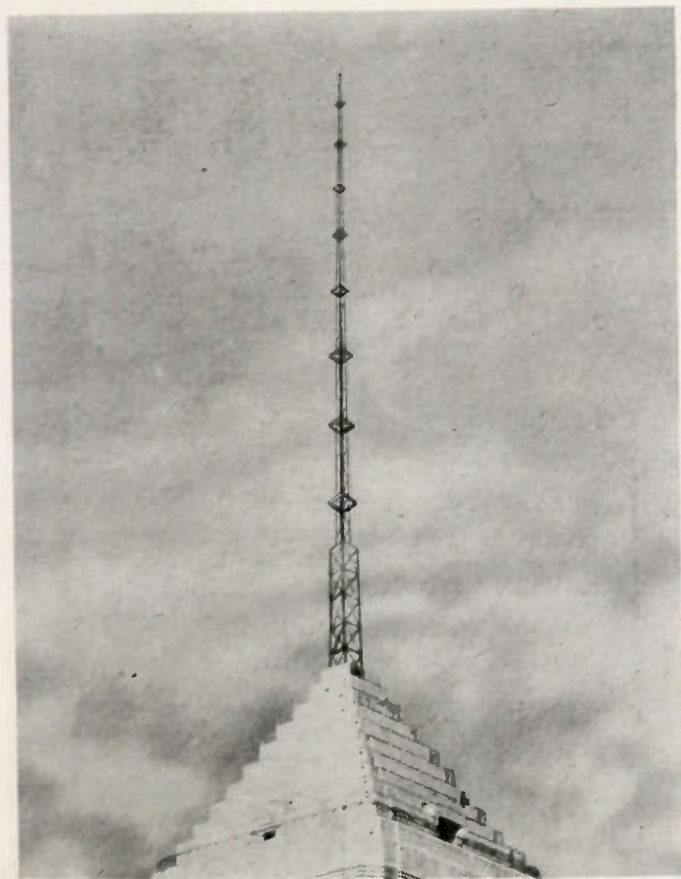

*Federal Telephone and Radio Corporation*

**MODERN FREQUENCY-MODULATION ANTENNA STRUCTURE**

Overlooking Minneapolis, Minnesota, an eight-element square-loop an-  
tenna will radiate broadcast signals in the hundred-megacycle band.

# The Institute of Radio Engineers



**THE OPERATION**

ULTRA SHORT WAVE DEEP HEATING within any part of the human body with full safety and perfect control at stabilized frequency. Associated functions: minor surgery with "electronic knife" and coagulation.

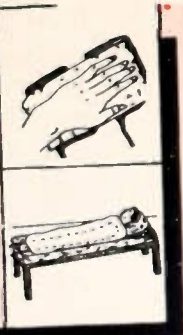

**THE EQUIPMENT**

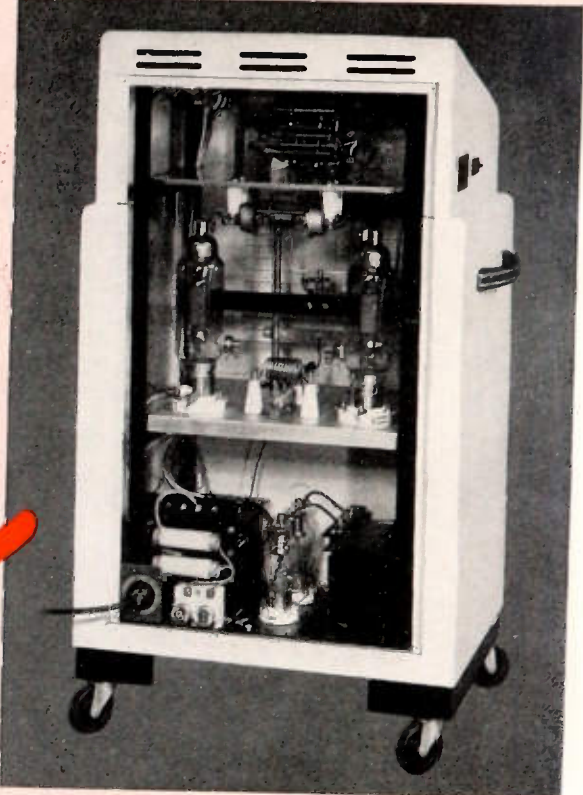

THE  
**AMPEREX**  
*tubes*  
THAT DO THE JOB!

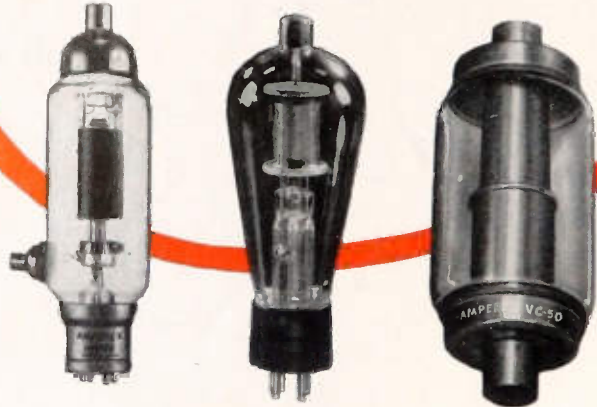

2 AMPEREX HF250 OSCILLATORS      2 AMPEREX 866A RECTIFIERS      1 AMPEREX VC50 CONDENSER

In electro-medical as in all electronic industrial, communication, rectification, special purpose and experimental equipment, Amperex tubes and circuits developed by Amperex spell performance, long life, and economy. As tube specialists, Amperex engineers are in a position to give detached counsel and information. *WRITE* Amperex Application Engineering Department.

Used at Bellevue and all other New York City hospitals, and scores of other leading institutions, including Mt. Sinai, New York; Cook County, Chicago; Johns Hopkins, Baltimore.

**MULTRATHERM "SENIOR"**

Built and guaranteed by  
**PEERLESS LABORATORIES**  
467 Tenth Avenue, New York 18, N.Y.

All known technics with ample reserve energy from single pair of treatment terminals... relatively same output irrespective of electrode air-gap space... frequency stabilized at 27.32 (plus or minus) 1/2% megacycles as assigned by FCC. Write for full details.

POWER TUBE SPECIALISTS SINCE 1925

**AMPEREX**  
ELECTRONIC CORPORATION

25 WASHINGTON STREET, BROOKLYN 1, N. Y. CABLES: "ARLAB"

In Canada and Newfoundland: ROGERS MAJESTIC LIMITED, 622 Fleet Street West, Toronto 28, Canada

COMMUNICATION  
RECTIFICATION  
INDUSTRIAL  
ELECTRO-MEDICAL  
SPECIAL PURPOSE





# 100%

## OF AMERICA'S MAJOR AIRLINES

# RELY ON BENDIX RADIO

Where scheduled, dependable airline operation is maintained—anywhere in the world—Bendix Radio equipment fills a vital need. For radio navigation and communication, Bendix is standard not only in America, but the world over. This wide acceptance is firmly based upon Bendix Radio's outstanding experience in building radio navigation and communication systems for all types of aircraft.

America's airlines specify Bendix Radio for the finest in radio equipment,  
— backed by the greatest name in aircraft radio.

### *It's New!... It's Bendix!*

## IMPROVED BENDIX TYPE **MN-76A** IRON CORE LOOP

For higher speed flying, Bendix Radio has the answer. This new, smaller iron core loop has a greatly improved electrical and aerodynamic design — outperforms older loops having ten times the drag. It's new — it's basically better—it's built by Bendix Radio.

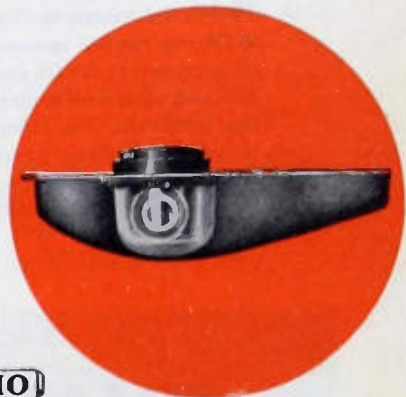

Write for a copy of this interesting book

**BENDIX RADIO DIVISION**  
OF BENDIX AVIATION CORPORATION  
**BALTIMORE 4, MARYLAND**

West Coast Branch: 1239 Airway, Glendale 1, California



PROCEEDINGS OF THE I.R.E., May, 1947, Vol. 35, No. 5. Published monthly in two sections by The Institute of Radio Engineers, Inc., at 1 East 79 Street, New York 21, N.Y. Price \$1.50 per copy. Subscriptions: United States and Canada, \$12.00 a year; foreign countries \$13.00 a year. Entered as second class matter, October 26, 1927, at the post office at Menasha, Wisconsin, under the act of March 3, 1879. Acceptance for mailing at a special rate of postage is provided for in the act of February 28, 1925, embodied in Paragraph 4, Section 412, P. L. and R., authorized October 26, 1927.

Table of contents will be found following page 32A



# Why

## this team is out



**1922.** One of the earliest audio systems, shown here at WWJ, Detroit, used a Western Electric 8-type amplifier, with keys, jacks and plugs provided for line selection and output switching.



**1926.** The first coordinated speech input system was this Western Electric 7A, with all controls in a wooden console mounted on a desk. First to use rectified a-c for plate supply.

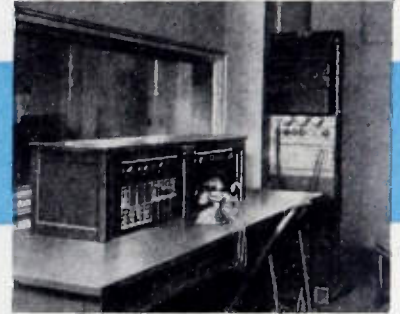

**1929.** Studio control equipment installed in the first New York studio of the Columbia Broadcasting System. This was one of the first custom-built audio systems.

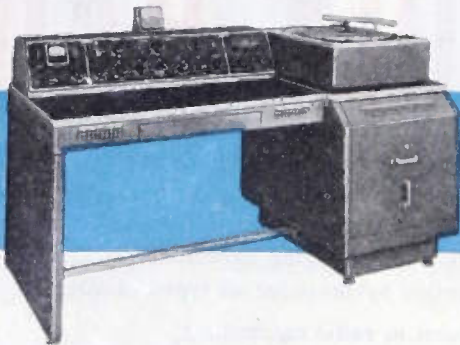

**1939.** This custom-built audio console for WOR was the first commercial type meeting all requirements for FM use. It provided circuits and equipment to meet specific operating conditions. The tailored metal desks mounted amplifiers, control and switching equipment and turntable units—all within easy reach of the operator.

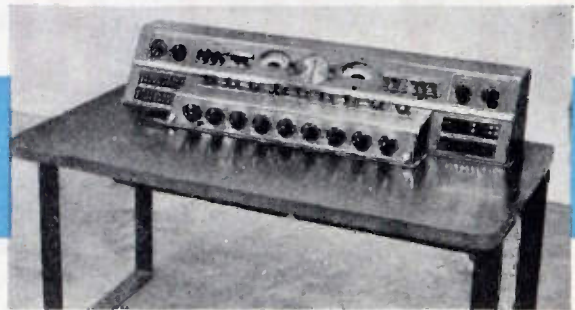

**1946.** The 25B console is an improved, enlarged version of the 25A, introduced in 1942. For either FM or AM use, the 25B provides two channels and controls two FM or AM programs simultaneously. This new equipment is compact, rugged and modern in appearance. Ease of control, instant accessibility, plug-in cable connections and a frequency response of  $\pm 1$  db, 50 to 15,000 cycles are some outstanding features.

## — QUALITY COUNTS —





# front in Broadcast Audio Systems

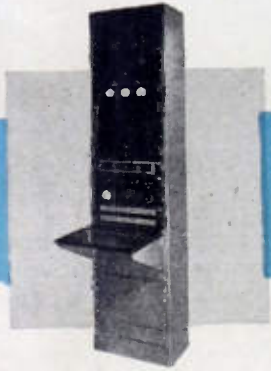

**1931.** This smartly styled 9A audio equipment was the first all a-c system. All controls in a single panel; frequency response stepped up to 10,000 cycles.



**1933.** The factory-assembled 700 series was the earliest to use recessed panel construction, interchangeable for rack or cabinet mounting. For multiple channel operation, several panels were combined.

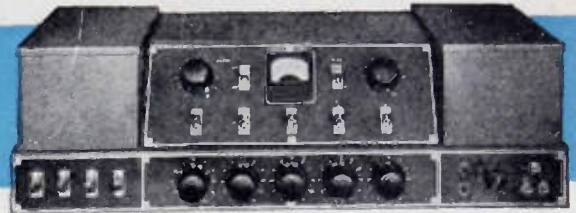

**1936.** The all a-c, console type, self-contained 23A studio control equipment introduced a brand new style for standardized studio units. First studio system to use stabilized feedback. The current 23C, with frequency response to 15,000 cycles, is widely used in AM and FM broadcasting.



**1947.** Typical of the custom-made broadcast audio systems being produced by the Bell Laboratories-Western Electric team is this up-to-the-minute custom console designed for KHJ, Hollywood. Custom-built equipment such as this is engineered to meet completely requirements of any station and provides the most flexible, versatile method of program control.

Ever since the Laboratories' scientists designed and Western Electric produced the first high power commercial broadcast transmitter and provided the audio facilities to go with it, this same team has pioneered in broadcast audio systems. Years of experience in the production of telephone amplifiers and switching equipment have given Bell Laboratories and Western Electric a head start in the broadcast audio facilities field—and constant research has kept them ahead.

When you need speech input equipment—for studio or portable use, standard console or tailor-made, AM or FM or both—look to Western Electric.



**BELL TELEPHONE LABORATORIES**

World's largest organization devoted exclusively to research and development in all phases of electrical communications.

## Western Electric

Manufacturing unit of the Bell System and the nation's largest producer of communications equipment.

# UHF tetrode



Eimac 4X150A Power Tetrode	
Electrical Characteristics	
Heater voltage	6.0 volts
Heater Current	2.7 amps.
Grid-screen amplification factor (approximate)	4.
Direct Interelectrode capacitance (typical)	
Grid-Plate	0.02 $\mu$ uf
Input	12.0 $\mu$ uf
Output	4.6 $\mu$ uf
Maximum Ratings	
DC Plate voltage	1000 volts
DC Plate current	200 ma.
Plate dissipation	150 watts
DC Screen voltage	300 volts

The 4X150A, a new Eimac tetrode, extremely versatile—diminutive in size, will fill the bill in all types of application and at all frequencies up to 500 mc. Performance characteristics include—high transconductance, low plate voltage operation, low grid drive, high plate dissipation, and traditional Eimac-tetrode stability. Physical features include:

- A Low inductance grid lead.
- B Close element spacing for UHF and high transconductance.
- C Screen grid, mounting, and ring connector design effectively isolates input and output circuits.
- D Heater isolated from cathode.
- E Indirectly heated cathode.
- F Low inductance cathode terminals, (four separate paralleled pins).
- G Controlled primary and secondary grid emission, by specially processed grids.
- H New molded glass header, precision pin alignment.
- I Forced air cooled (vertical finned).
- J Simple installation, adaptable to standard octal socket.

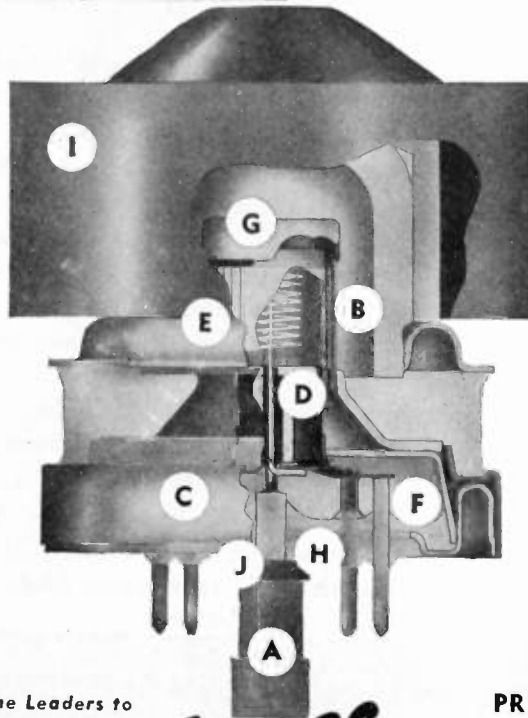

Follow the Leaders to

**Eimac**  
REG. U. S. PAT. OFF.  
**TUBES**

The Power for R-F

PRICE, \$31.00

You will find the 4X150A suited to your requirements, whether for wide-band low-efficiency service such as television video and audio or conventional application. For further information on this new, versatile, Eimac tetrode, type 4X150A, write to:

**EITEL-McCULLOUGH, INC.**  
1453 San Mateo Avenue  
San Bruno, California

EXPORT AGENTS: FRAZAR & HANSEN, 301 CLAY ST., SAN FRANCISCO 11, CALIFORNIA, U.S.A.



# HERMETIC SEALING

**a type for every requirement**

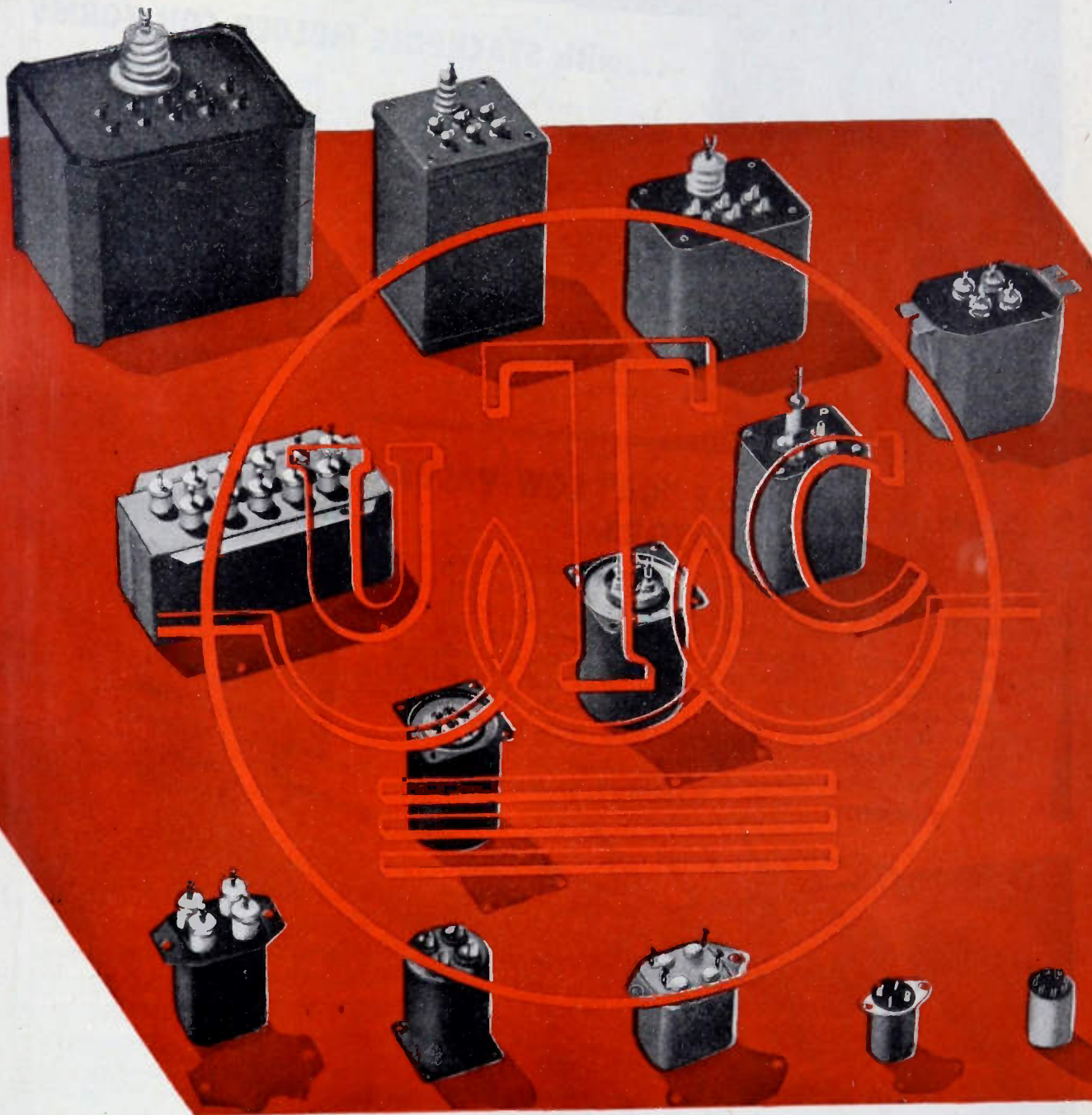

*May we cooperate with you on design savings for your application . . .*

*United Transformer Corp.*

150 VARICK STREET

NEW YORK 13, N. Y.

EXPORT DIVISION: 13 EAST 40th STREET, NEW YORK 16, N. Y.,

CABLES: "ARLAB"

# Improve YOUR Equipment ... Cut Assembly Costs



Look for the Stackpole Minute Man — your guarantee of highest quality in molded components.

## ...with STACKPOLE MOLDED COIL FORMS

You can save money, speed production and increase the efficiency of your equipment by using Stackpole Molded Bakelite Coil Forms as mechanical supports for coil windings. They take less space and require a third fewer soldered connections. Coils may either be wound directly on the forms or wound separately, then slipped over the forms.

Standard types include forms for universal winding, solenoid winding, tapped universal winding, antenna or coupled winding, iron cored universal winding, iron cored I-F transformer or coupled coils and many others. Molded iron center sections can be provided on forms where required. Write for details or samples to your specifications.

## ... with STACKPOLE "GA" LOW-VALUE CAPACITORS

When assembly time is considered, Stackpole GA Midget Capacitors may actually cost less than "gimmicks" formed by twisting insulated wires together — and are many times more efficient. Q is much improved, insulation resistance better,

breakdown voltage higher, mechanical construction far superior. GA Midgets are sturdily molded. Leads are anchored and tinned. Standard values include 0.68; 1.0; 1.5; 2.2; 3.3 and 4.7 mmfd. Tolerances are  $\pm 20\%$ . Write for details.

Electronic Components Division  
**STACKPOLE CARBON COMPANY, St. Marys, Pa.**

FIXED and VARIABLE RESISTORS • INEXPENSIVE SWITCHES • IRON CORES • POWER TUBE ANODES • SINTERED ALNICO II PERMANENT MAGNETS • RHEOSTAT PLATES and DISCS • ANODES and ELECTRODES, etc.

# STACKPOLE



# MAKING TUBES IS EASY..

## If YOU KNOW HOW!

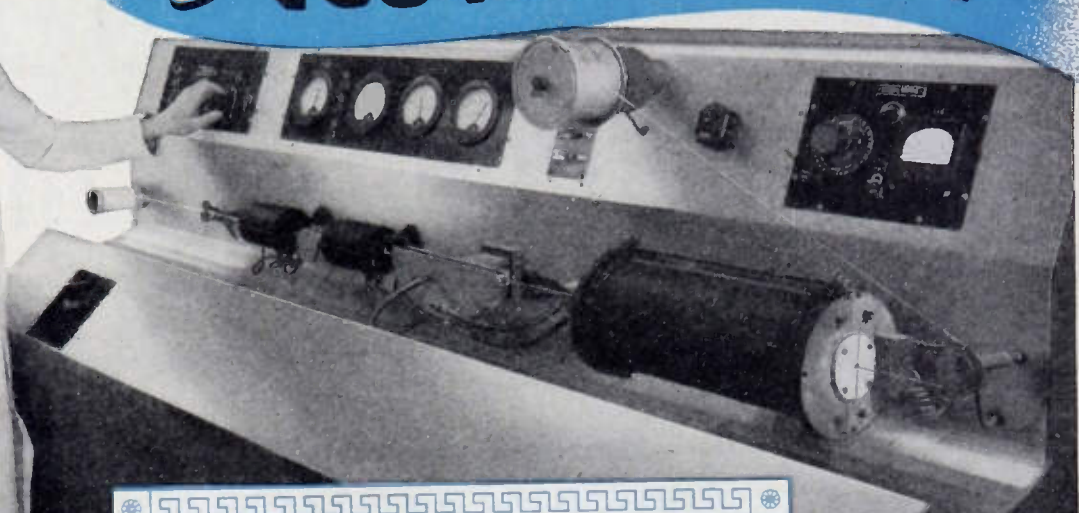

ΚΑΤΑΦΟΡΗΣΙΣ  
*...filament coating  
made Easier... Better*

HYTRON CATAPHORESIS COATING MACHINE—Filament wire proceeds from the large spool at top center through oxidizing oven, cataphoresis coating bath, and two small ovens. Finally, the coated wire is wound on the cylinder at the left.

**A** jawbreaker from the Greek, cataphoresis means simply "the movement of suspended particles through a fluid under the action of an applied electromotive force." At Hytron, filaments are not *sprayed* with electron-emissive coating, because that way precise control cannot be achieved. Rather, coating is electrically deposited by the cataphoretic movement of the carbonate molecules.

Drawn through a special coating solution, the filament wire itself serves as the anode; and a metallic plate, as the cathode. The solution consists of a triple precipitate of barium, calcium, and strontium carbonates plus a binder—all suspended in a special organic medium. A precisely adjusted electromotive

force uniformly deposits and bonds the electrically-charged salts onto the filament wire. Baking problems are simplified; coated wire is spooled directly on a cylinder, ready for use.

This new Hytron method of filament coating is so simple, so precise as to texture, weight, and adhesion. One wonders why it is not universal. The answer is simple. Cataphoresis coating is easy *only* if you possess the trade secret of the Hytron coating formula. Also, the applied voltage, timing, and resultant control of texture and emissive qualities in mass production represent months of persistent research. You profit by superior performance from all Hytron coated-filament tubes.

SPECIALISTS IN RADIO RECEIVING TUBES SINCE 1921

# HYTRON

RADIO AND ELECTRONICS CORP.

MAIN OFFICE: SALEM, MASSACHUSETTS



# SPRAGUE VITAMIN Q DIELECTRIC

(TRADEMARK REG. U. S. PAT. OFF.)

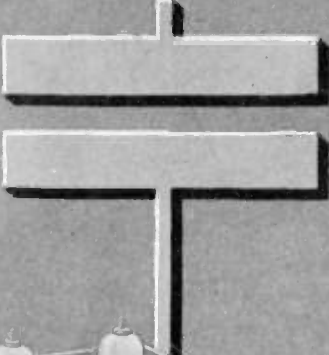

HAS PERMITTED  
SUBSTANTIAL RE-  
DUCTIONS IN BOTH  
THE SIZE AND WEIGHT  
OF MANY OIL-FILLED  
CAPACITOR TYPES



**TYPICAL!** Compact  
Capacitors for Photoflash  
and Energy Storage Uses

Sprague Capacitors with Vitamin Q dielectric have led in establishing new standards of compactness, light weight and dependability for electric flash tube (photoflash) photography. Also, they assure outstanding economies and greater efficiency for flash welding and time control circuits where duty cycles other than those used in photoflash work prevail. Write for Sprague Engineering Data Bulletin No. 3205.

**SPRAGUE ELECTRIC COMPANY, North Adams, Mass.**

PIONEERS OF ELECTRIC AND ELECTRONIC PROGRESS



# SENSATIONAL

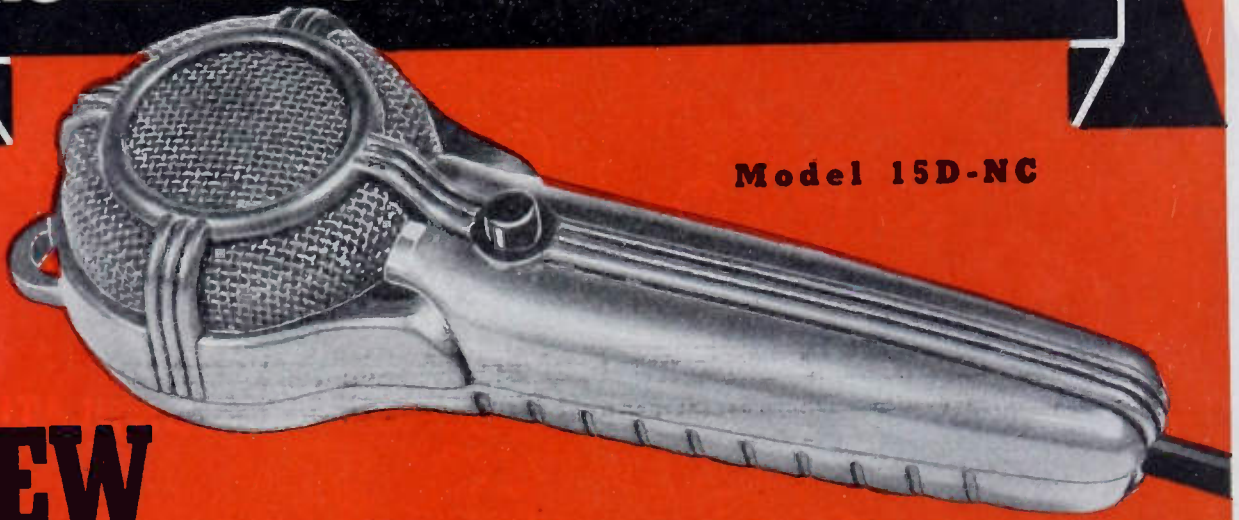

Model 15D-NC

## NEW

## Noise Canceling Microphone by **TURNER**

### Transmits only when spoken to at close range

A new Turner development . . . Now factories, machine shops, engine rooms, trains, aircraft, etc., can have sharp, clear communications. Turner engineers have solved the problem of effective speech transmission under adverse noise conditions. The Turner Model 15D-NC is so expertly designed and balanced it amplifies only sound originating close to its specially engineered diaphragm. Random sound (noise) arriving from a distance strikes both sides of the diaphragm simultaneously and is canceled out. This new microphone transmits only when spoken to at close range from the front.

**The LOUDER the noise—the BETTER the results**  
By speaking directly into the front side of the Turner Model 15D-NC clear cut results are achieved at ordinary levels of conversation. The din, clatter, and clang of machinery and other disturbances are canceled out. In fact, the higher the noise level, the more effective will be the results observed.

#### Designed for Convenience

The Model 15D-NC is a rugged dynamic built to stand severe operating conditions. It is housed in an attractive hand held case of light, tough alloy. When not in use, it may be hung on a hook. If desired, a "push-to-talk" thumb switch is built into the handle for on-off operation or relay work. Available in 50, 200, 500 ohms, or high impedance.

#### SPECIFICATIONS Turner Model 15D-NC

EFFECTIVE OUTPUT LEVEL: 56 db below 1 volt/dyne/sq. cm.  
FREQUENCY RESPONSE: 50 to 5000 c. p. s.  
OUTPUT IMPEDANCE: 50, 200, 500 ohms, or high impedance.  
DIRECTIONAL CHARACTERISTICS: Close talking only.  
DIAPHRAGM: High quality corrosive resistant aluminum.  
MAGNETIC CIRCUIT: High energy magnetic circuit with moving voice coil. Both sides of diaphragm exposed to balance out random sound.

CASE: Smooth, die cast alloy.  
FINISH: Gray gunmetal enamel.  
MOUNTING: Hand held. Hole provided at top of case for hanging on hook.  
CABLE: 7 foot attached, single conductor, shielded.  
DIMENSIONS: 7" long x 2 3/8" wide x 1 1/2" deep.  
WEIGHT: Approximately 24 ounces.  
OPTIONAL: "Push-to-talk" thumb switch for on-off or relay operation.

*Also available as Model 15D semi-directional dynamic without noise canceling feature. Level: 56 db below 1 volt/dyne/sq. cm. Response: 40 to 7500 c. p. s.*

*Visit the  
Turner Exhibit at the  
Parts Show Booth 49—  
Stevens Hotel,  
Chicago. May 13, 14, 15*

## THE TURNER COMPANY

909 17th Street N. E., Cedar Rapids, Iowa

**TURN TO TURNER FOR SOUND PERFORMANCE**

Microphones licensed under U. S. patents of the American Telephone and Telegraph Company, and Western Electric Company, Incorporated. Crystals licensed under patents of the Brush Development Company



# THIS PROVES IT!

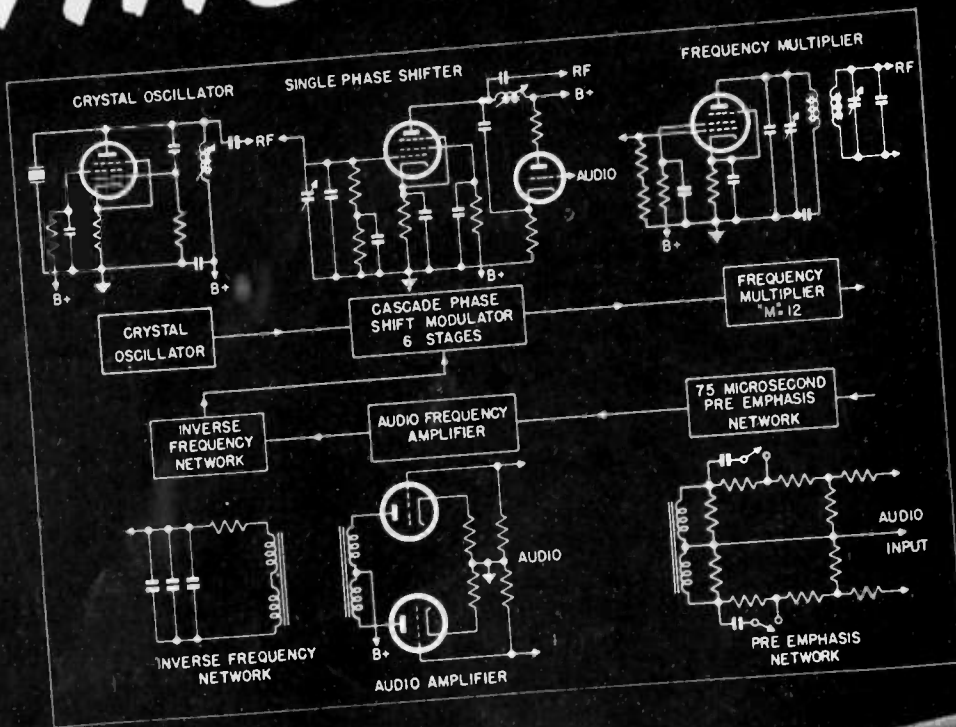

*Cascade*  
**PHASE  
 SHIFT  
 MODULATION**

# RAYTHEON FM

**IS BETTER...**

***12 Ways***



*Excellence in Electronics*

**BECAUSE IT:**

1. Features direct crystal control
2. Gives the most desirable electrical characteristics
3. Contains fewest circuits, fewest tubes
4. Has the simplest circuits
5. Is easiest to tune and maintain
6. Has *inherently* the lowest distortion level

**AND ELIMINATES ALL:**

7. High orders of multiplication
8. Complex circuits
9. Expensive special purpose tubes
10. Discriminator frequency control circuits
11. Pulse counting circuits for frequency control
12. Motor frequency stabilizing devices

See your consulting engineer and write for fully illustrated booklet giving complete technical data and information. Write today to:

**RAYTHEON MANUFACTURING COMPANY**

Broadcast Equipment Division, 7475 North Rogers Avenue, Chicago 26, Illinois





## **We put ourselves into our work...**

Skilled workmen always take great pride and satisfaction in performing effort that creates extra touches of quality.

We are fortunate in the high calibre of craftsmen who serve our organization. Here are men who like their work and who approach each new project with enthusiasm and confidence... who are forever working out new and ingenious methods of doing something a bit better.

Time and time again keen minds and skilled hands in our plant have licked that familiar old bugaboo, "It can't be done" by figuring out ways to do the unusual or the "impossible."

Have you a tough problem in sheet metal? We may have the solution waiting for you. Let us quote on your cabinets, housings, chassis, racks, boxes and enclosures—however unusual the design.

Write for our new catalog.



# **Karp**

## **METAL PRODUCTS CO., INC.**

*Custom Craftsmen in Sheet Metal...*

117-30th STREET, BROOKLYN 32, NEW YORK



# MANUAL OF *Electronic* RECEIVING TUBES

## *It's new!*



## *You need it!*

**\$5<sup>00</sup>**

Including revision service through 1948

## UP-TO-DATE, COMPLETE! A PRACTICAL APPLICATION HANDBOOK FOR ENGINEERS AND CIRCUIT DESIGNERS!

APPROXIMATELY 700 LARGE PAGES of performance curves, ratings, outline drawings, basing diagrams, and extensive text-matter, make up G.E.'s new and comprehensive manual of electronic receiving tubes. Here is the whole broad picture of modern receiving-tube design and practice. You also receive from time to time new pages that help keep this manual constantly up-to-date.

MINIATURES, THE NEW FM-AM TUNING INDICATOR TUBE, OTHER LATE-DESIGN TYPES are discussed fully as to performance and applications. Many typical circuits are given in the manual, and fundamental tube-application principles are reviewed so as to make the book a useful and complete working guide.

EQUIPMENT MANUFACTURERS AND ELECTRONIC DESIGNERS will find the new G-E receiving-tube manual a volume that aids them daily. Broadcast station engineers, users of aviation and other communications equipment, large radio repair centers—these also need the manual as a reference work. Tabbed dividers and indexed page corners make it easy to locate information.

HANDSOMELY AND STRONGLY BOUND in a stiff leatherette cover, the manual will stand up under constant use. A special loose-leaf format simplifies keeping the contents up-to-the-minute. Order direct from *Electronics Department, Building 267, General Electric Company, Schenectady 5, New York.*

### PLUS-VALUE INVESTMENT!

"Electronic Tubes, Receiving Types" comes to you for \$5. This price includes service on new and revised pages through 1948, by which time the contents of the manual will be greatly increased. A second binder, free of charge, will be sent you later to accommodate the extra pages—the manual thus becoming a 2-volume edition . . . Beginning with the calendar year 1949, further service to keep the manual up-to-date will be available at only \$1 a year.

ORDER TODAY "ELECTRONIC TUBES, RECEIVING TYPES" WITH SERVICE THROUGH 1948, ENCLOSED \$5 IN PAYMENT, OR GIVING AUTHORITY ON YOUR COMPANY LETTERHEAD TO INVOICE YOU.

# GENERAL ELECTRIC

176-P2-8880

FIRST AND GREATEST NAME IN ELECTRONICS



FOR LONG, EFFICIENT LIFE...

... A STURDY

**heart**



Rectifiers are the heart of the power circuits: ENGINEERED FOR ENGINEERS, Selenium Rectifiers are rapidly becoming standard for all industry.

Selenium Corporation of America meets exacting specifications of modern electronic developments in manufacturing a broad line of Selenium Power and Instrument Rectifiers, Self generating Photo-Electric Cells and allied scientific products.

Selenium Corporation of America's engineering and manufacturing experience can be called upon for the development and production of special rectifiers for any applications.



**INSTRUMENT RECTIFIERS**

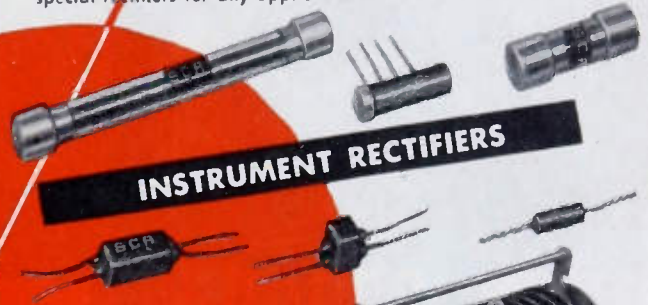

**POWER RECTIFIERS**

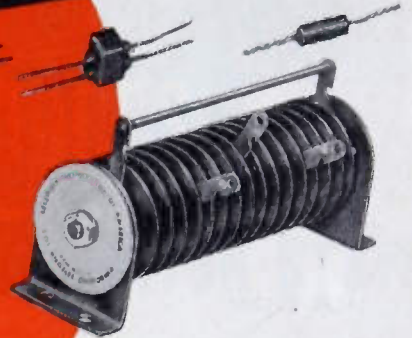
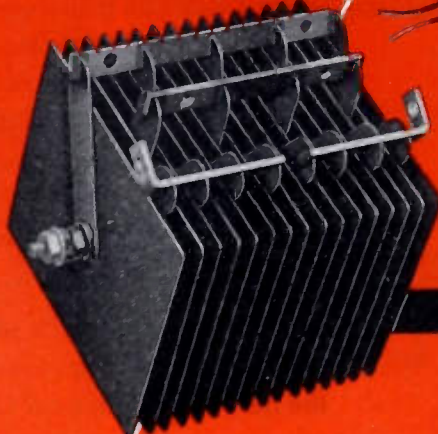

**PHOTO-ELECTRIC CELLS**

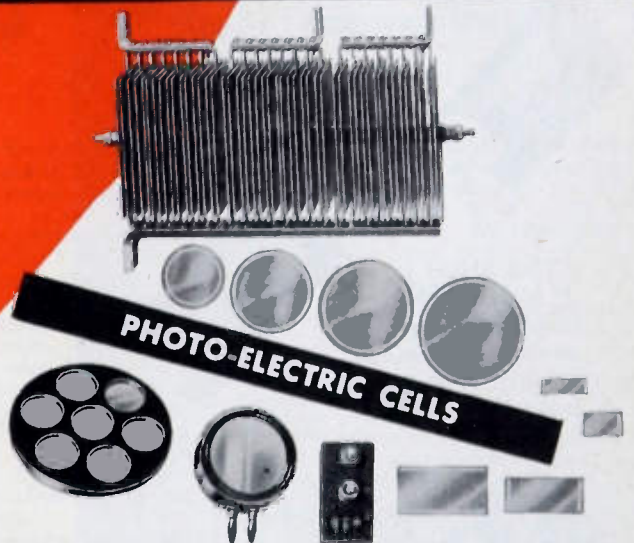

**SELENIUM CORPORATION OF AMERICA**

Affiliate of **VICKERS** Incorporated

2160 EAST IMPERIAL HIGHWAY, EL SEGUNDO, CALIF.



**CHECK THESE OUTSTANDING FEATURES:**

- ✓ Unlimited life—no moving parts.
- ✓ Permanent characteristics.
- ✓ Adaptability to all types of circuits and loads.
- ✓ Immunity to atmospheric changes.
- ✓ High efficiency per unit weight.
- ✓ From 1 volt to 50,000 volts rms.
- ✓ From 10 micro-amperes to 10,000 amperes.
- ✓ Economical—simple to install—no maintenance cost.
- ✓ Hermetically sealed units available.

# NEW

## SOCKETS AND SHIELDS...

### for miniature button base tubes

XOA Socket  
with XOS-3 Shield  
and Shield Base

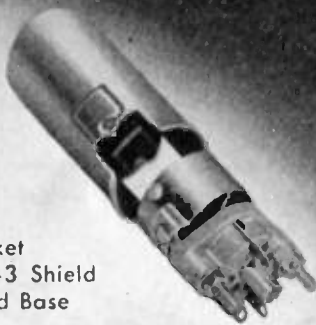

XOA Socket

XOR Socket



XOS-1 Shield  
for  $1\frac{3}{8}$ " high  
tube body  
(6AK5 type)



XOS-3 Shield for  
2" high tube body  
(OA2 type). Also  
available: XOS-2  
for  $1\frac{1}{2}$ " high tube  
body (6C4 type)



Shield Base for  
XOS-1, XOS-2  
or XOS-3



These new National sockets are of mica-filled natural molded Bakelite with silver-plated beryllium-copper contacts — designed for maximum dependability and adaptability. The contacts — either axially or radially mounted and removable for replacement — provide short leads and low inductance so vital to ultra-high frequency design. Sockets are built to JAN specifications — can be used with or without shields.

Made in three sizes to accommodate the various sizes of miniature tubes, the shields are of nickel-plated brass, with cadmium-plated phosphor bronze spring to provide correct tension to hold both tube and shield in place regardless of angle or vibration. Shield bases are of nickel-plated brass, with two  $4/40$ " spade bolts mounting both socket and shield base.

You'll find hundreds of other parts, both new and old, to improve your apparatus in the new 1947 National Catalog.



# NATIONAL

COMPANY, INCORPORATED

MALDEN, MASS.

MAKERS OF LIFETIME RADIO PRODUCTS



# Federal's Aircraft Antenna Wire

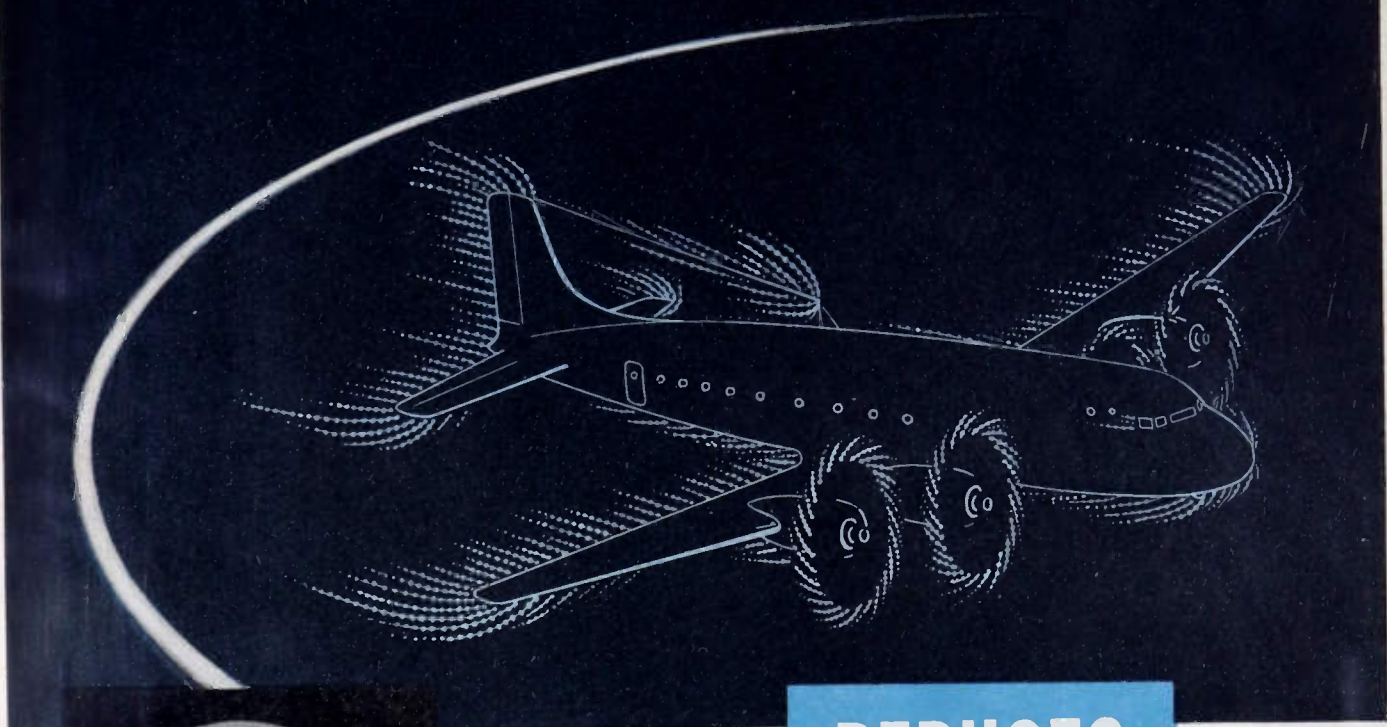

**REDUCES**

**PRECIPITATION STATIC**



POLYETHYLENE INSULATION

COPPERWELD CONDUCTOR

**WHAT IS PRECIPITATION STATIC?**

To the pilot, it's the ear-splitting noises he hears on his radio — frying sounds, intermittent crackling, moans and shrieks. It is caused by corona discharge (St. Elmo's Fire) of static potentials accumulated on a plane flying through rain, snow or dust, or near charged clouds — via protuberances on the aircraft surfaces including exposed antenna wires. This corona discharge is sometimes visible as a bluish halation radiating from the extremities of the plane, and it is the discharge from the antenna that is the first source of radio interference.

HERE'S A PRACTICAL, low-cost means of reducing precipitation static, a major flying hazard because it strikes when radio aids are needed most — in bad weather. Working in close cooperation with the U. S. Army Air Technical Service Command and U. S. Navy, Federal has developed and perfected a quality *insulated* antenna wire which, together with proper antenna hardware, reduces precipitation static. This wire, Intelin Type K-1064, AN designation, WS-5/U, has proved highly effective in actual service on U. S. Army and Navy planes. As a result of this service experience it has been adopted widely by the domestic airlines, and is now available for use on privately owned aircraft. The copperweld conductor gives high tensile strength, and the durable, weather resistant polyethylene insulation assures

long service life, even under the most severe conditions. Federal's Aircraft Antenna Wire can be obtained in the Type K-1064, designed to U. S. Army and Navy Specifications. For information, write today to Dept. D737.

**DATA**  
Federal's Intelin High-Strength Aircraft Antenna Wire Type K-1064

	OUTSIDE DIAMETER	
	Conductor	Insulation
Nominal	0.0508"	0.183"
Minimum	0.0498"	0.178"
Maximum	0.0518"	0.188"

**MATERIALS**  
Conductor — #16 AWG H.S. Copperweld (30% Conductivity)  
Insulation — Polyethylene (semi-transparent)

**TENSILE STRENGTH**  
127,000 psi minimum

*Federal Telephone and Radio Corporation*

# 1550 MILES A SECOND!!

That's the writing rate recordable with

## DU MONT'S Type 5RP CATHODE-RAY TUBE

operating at 25,000 volts accelerating potential!

▶ The speed at which this Du Mont tube clearly writes with adequate brilliance is indicative of the trend in modern oscillography toward high accelerating potentials without loss of deflection sensitivity. A total of 25,000 volts accelerating potential is applied by dividing that potential across multi-band intensifiers.

As exemplified by the Type 5RP, adequate brilliance is obtained from signals which cannot be seen on an ordinary cathode-ray tube, *without serious loss of deflection sensitivity and practically no distortion with Eb3/Eb2 ratios as high as 10!* For high-frequency signals, the Du Mont 5RP is especially useful because of its low-capacitance deflection system.

▶ Write for descriptive literature.

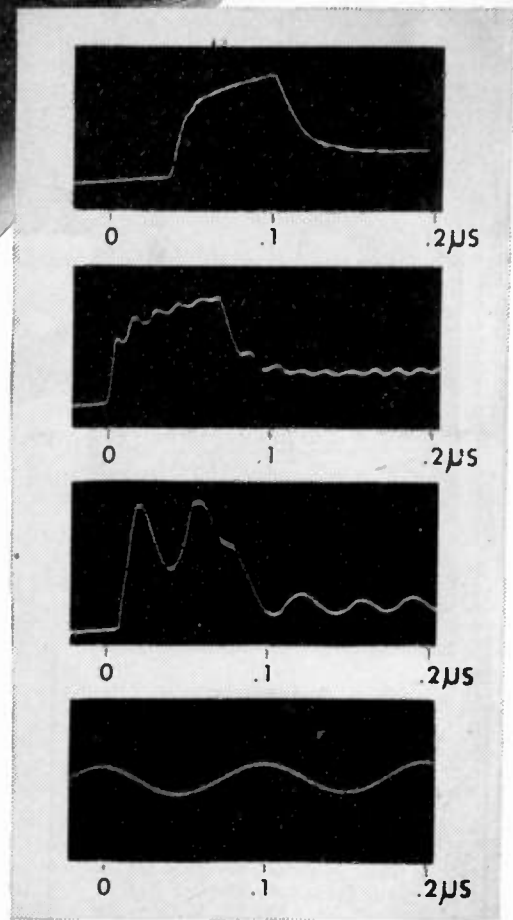

Typical high-speed single-transient recordings with 5RP at 18,000 volts accelerating potential. (Courtesy of Prof. M. Newman, Institute of Technology, University of Minnesota.)

© ALLEN D. DU MONT LABORATORIES, INC.

# DU MONT

## Precision Electronics & Television

ALLEN B. DUMONT LABORATORIES, INC., PASSAIC, NEW JERSEY • CABLE ADDRESS: ALBEEDU, PASSAIC, N. J., U. S. A.



# Have You Tried Ceramic Condensers for General Purpose Applications?

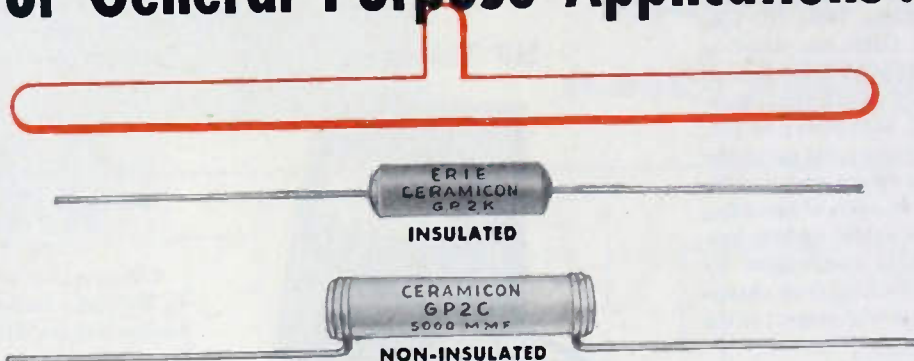

*Specify* **Erie "GP" Ceramicons** REG. U.S. PAT. OFF.  
*for best performance*

Many leading radio manufacturers have already switched to ERIE "GP" Ceramicons for general purpose applications. These ceramic condensers have all the well-known dependability of other ERIE Ceramicons with their sturdy compactness and ease of installation, *plus* an unprecedented economy for general purpose applications.

ERIE "GP" Ceramicons are designed for practically all applications in which the condenser is not directly frequency determining; for AVC Filtering, Resistance-Capacitance Audio Coupling, Tone Compensation, Volume Control R.F. By-Passing, Audio Plate R.F. By-Passing, Oscillator Grid Coupling, R. F. Coupling, Antenna Coupling.

The production of large quantities at one time of a given capacity value accounts for their economical price . . . *there is no sacrifice in quality.*

Condensers classified as GP1 have a temperature coefficient between +130 and -1600 P/M/°C and are available up through 150 MMF. Condensers classified as GP2, manufactured in capacities of 120 MMF and higher, may include all of the above dielectrics and, in addition, the ERIE Hi-K type.

ERIE "GP" Ceramicons are made in insulated styles in popular capacity values up to 5,000 MMF, and in non-insulated styles up to 10,000 MMF. Write for full details.

*Electronics Division*  
**ERIE RESISTOR CORP., ERIE, PA.**  
LONDON, ENGLAND • • TORONTO, CANADA





May, 1947

## Limiter Amplifier

Recently demonstrated in Auditoriums I and II, Grand Central Palace during the 1947 I.R.E. Radio Engineering Show, Altec-Lansing Corporation, 1680 N. Vine Street, Hollywood 28, Calif., has placed on the market its new Type A-322C Limiter Amplifier. It has rapid attack time, automatic volume control, high power output; and it limits with less thump. Its use in film and disc recording prevents overmodulation and the resulting dangers of exceeding modulation limits. In public address systems it will adequately compensate for variations in volume resulting from change in the speaker's position with respect to the microphone.

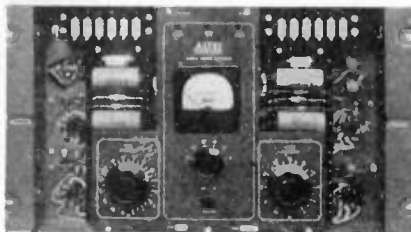

This unit operates as a true linear amplifier up to a specified level and then limits the volume output beyond this point. The signal circuit consists of three balanced push-pull stages. A pair of cathode followers bridges the plates of the output tubes and feeds a dual diode which rectifies the control voltage. The output of the cathode followers appears as a low-impedance charging source resulting in a very rapid attack time.

## Smallest Radio Tube

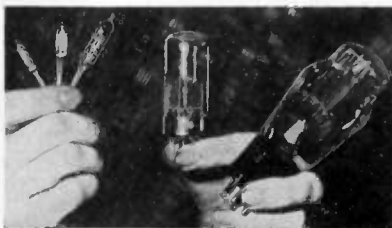

What is claimed to be the smallest radio tube in the world, extreme left, makes the wartime proximity-fuze tube, third from left, look big. Developed by Sylvania Electric Products, Inc., 500 Fifth Avenue, New York 18, N. Y., this tiny tube, Type T-1, is only  $\frac{1}{8}$ " long and slightly more than  $\frac{1}{16}$ " in diameter. It is shown in comparison with, right to left, the conventional tube of ten years ago, current lock-in tube, the proximity-fuze tube, and the Type T-2 tube about  $\frac{1}{4}$ " in diameter.

These manufacturers have invited PROCEEDINGS readers to write for literature and further technical information. Please mention your I.R.E. affiliation.

## HF Voltmeter



The Alfred W. Barber Laboratories, 34-14 Francis Lewis Blvd., Flushing, N. Y., announces a new high-frequency electronic voltmeter, Model 32, with a radio-frequency probe having an extremely low input capacity of 0.75 micro-microfarad at a Q of about 200. The range of measurement is 0.3 to 300 volts in five ranges at frequencies from 500 kilocycles to 500 megacycles.

## HF Triode Tube

A new triode electronic tube, Type GL-5549, furnishing 6 kilowatts of tube-power output under class C conditions for dielectric heating applications, has been announced by General Electric Company, Schenectady, N. Y. Operating with high plate voltage to match high-impedance load and functioning up to 50 megacycles at maximum plate input, this tube will be useful in high-frequency heating.

Forced-air-cooled with radiator construction, the three-electrode tube has filament voltage of 12.6 volts and a filament current of 56 amperes. Maximum anode ratings of the GL-5549: voltage 8500 volts; current, 1.25 amperes; input, 10 kilowatts; dissipation, 4 kilowatts.



## Vacuum Condenser

The first of a new line of vacuum condensers, Type RC100-20, rated at 100 mmf., and having high current and voltage characteristics, has been announced by Raytheon Manufacturing Co., Waltham 54, Mass.

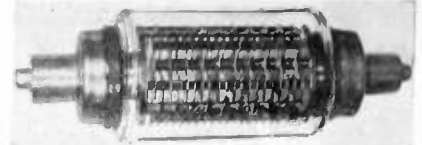

Construction features which contribute to low radio frequency resistance of these condensers are silver-plated copper terminals, large diameter copper-to-glass seals, and a multi-plate assembly which is brazed into a single unit. Due to this rigid construction, it was stated, there are no audio-frequency-mechanical resonances in the condenser to interfere with their operation in high-voltage plate-modulated tank circuits.

## AC Power Supply

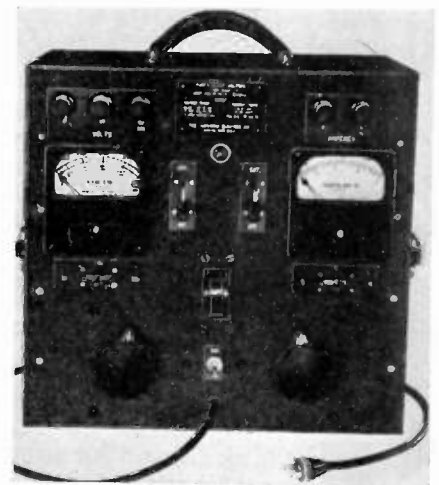

A portable source of metered, continuously-adjustable alternating current and voltage has been announced by The Superior Electric Company, 83 Laurel St., Bristol, Conn. It has available three ranges of output voltages up to 300 volts, and two ranges of output current up to 20 amperes. In this unit, known as Type S-245 Power Plant Voltbox, the voltage and current are varied independently, and are electrically isolated from each other. For metering purposes, a triple-range voltmeter and a double-range ammeter are supplied. Suitable switches provide a means for these meters to measure external circuits. A circuit-breaker offers complete instrument protection.

(Continued on page 66A)





# *Improved* **LAVOIE C-200** **Harmonic Frequency** **Generator with** **0.001% ACCURACY**

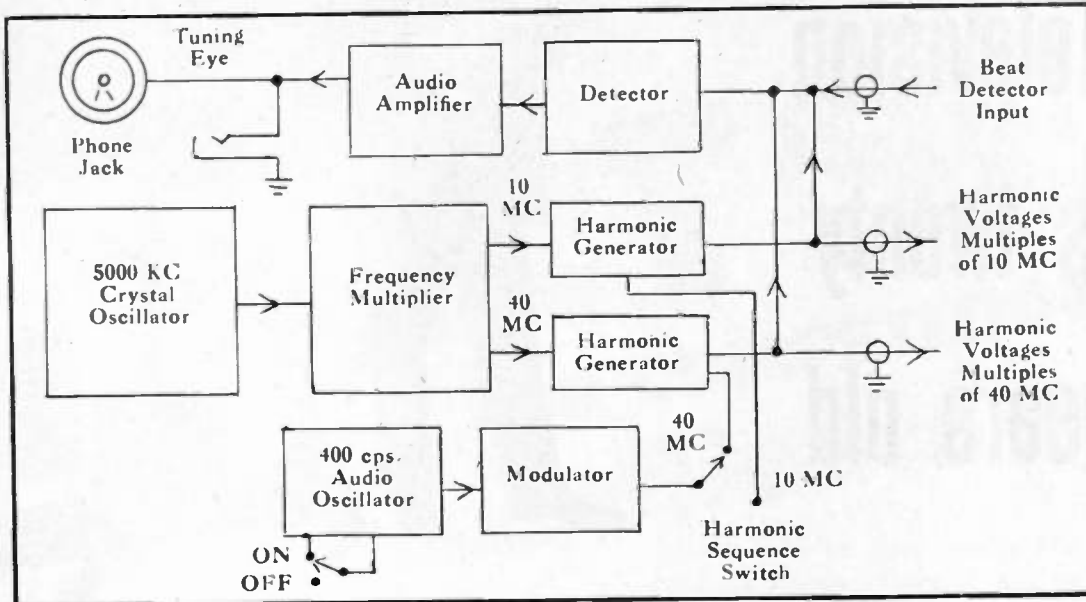

The Harmonic Frequency Generator has been improved for frequency standardization of receivers and frequency meters up to and beyond 2000 Megacycles. Also, by means of a beat detector built into the instrument, it is possible to standardize oscillators and signal generators with equal facility.

Further circuit refinements have produced a frequency accuracy of 0.001%, which extends from 100 Megacycles to 2000 Megacycles in either 10 Megacycle or 40 Megacycle steps.

The output voltage is supplied at a UG-58/U 50-ohm connector with output coupling controls to obtain peak performance for a given harmonic. A milliammeter is incorporated in the instrument to facilitate easy adjustment of the output controls. The output voltage may be either unmodulated or modulated with 400 cps internal oscillator. The generator provides output voltages every 10 Megacycles or every 40 Megacycles. This selection is made by a

switch on the front panel. The harmonic voltage is in the order of thousands of microvolts for each harmonic with a value of approximately 50,000 microvolts at 100 Megacycles and 1500 microvolts at 1000 Megacycles.

Provision is made for the standardization of signal generators and oscillators by the incorporation of a beat frequency detector in the generator. The output of this beat frequency detector may be monitored, either aurally or visually with a tuning eye indicator.

To facilitate harmonic identification, frequency identifiers can be supplied for any harmonic frequency (multiple of 10 Megacycles) between 100 and 1000 Megacycles. The identifier is adjusted at our factory.

This instrument is supplied with accessories needed for its operation, including tubes, 5 Megacycle crystal, output coupling cable and instruction book.



Write for Illustrated  
Descriptive Folder

## *Lavoie Laboratories*

RADIO ENGINEERS AND MANUFACTURERS  
MORGANVILLE, N. J.

**Specialists in the Development and Manufacture of UHF Equipment**

# Long-distance Television is twenty years old



*At the 1927 demonstration, Dr. Herbert E. Ives explained the television system developed in Bell Telephone Laboratories.*

APRIL 7 is a notable day in communication history, for on that day in 1927 was the first demonstration of television over long distances. Large-scale images were flashed from Washington, D.C., by wire and from Whippany, N.J., by radio to a public demonstration in New York City. "It was," said a newspaper, "as if a photograph had suddenly come to life and begun to smile, talk, nod its head and look this way and that."

That was the first of many public demonstrations, each to mark an advance in the television art. In 1929 came color television, and in 1930 a two-way system between the headquarters buildings of A. T. & T. and Bell Laboratories. When the first coaxial cable was installed

in 1937, television signals for 240-line pictures were transmitted between Philadelphia and New York and three years later 441-line signals were transmitted. By May, 1941, successful experiments had been made on an 800-mile circuit.

End of the war brought a heightened tempo of development. Early in 1946 began the regular experimental use of coaxial cable for television between New York and Washington, and a few months later a microwave system for television transmission was demonstrated in California.

Transmission facilities will keep pace as a great art advances to wide public usefulness.

**BELL TELEPHONE LABORATORIES**



EXPLORING AND INVENTING, DEVISING AND PERFECTING, FOR CONTINUED IMPROVEMENTS AND ECONOMIES IN TELEPHONE SERVICE





# GET SET

FOR COMPETITION

USE **alliance** MOTORS

Alliance Powr-Pakt Model MS motor is for 110 volts, 60 cycle operation. Model MS fills a growing need for small compact motors which increase the *motion* and *utility* features in thousands of new products.

For the designs of tomorrow, Alliance Motors mass produced at low unit cost, will be built with design variations to meet special small load operating conditions. They'll actuate controls, trip switches, move levers, cams and valves . . . perform thousands of tasks that require power at specific points!

Drive your products to market—use Alliance Motors to drive vital component parts. Big advantages for the Alliance Powr-Pakt line are compactness, light weight, versatile performance characteristics, and mass production at low cost.

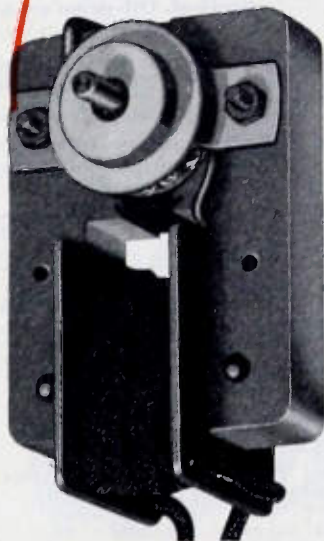

**Alliance Powr-Pakt Motors** are rated from less than 1/400th h.p. on up to 1/20th h.p. They'll supply just the *right amount of power at strategic points* to impart automatic action, instant control and greater usefulness for your products and processes.

MODEL MS

WHEN YOU DESIGN—KEEP

# alliance

MOTORS IN MIND

ALLIANCE MANUFACTURING COMPANY • ALLIANCE, OHIO  
Export Department; 401 Broadway, New York 13, New York, U.S.A.

# FOR TRANSMITTING • TIMING • FILTER CIRCUITS

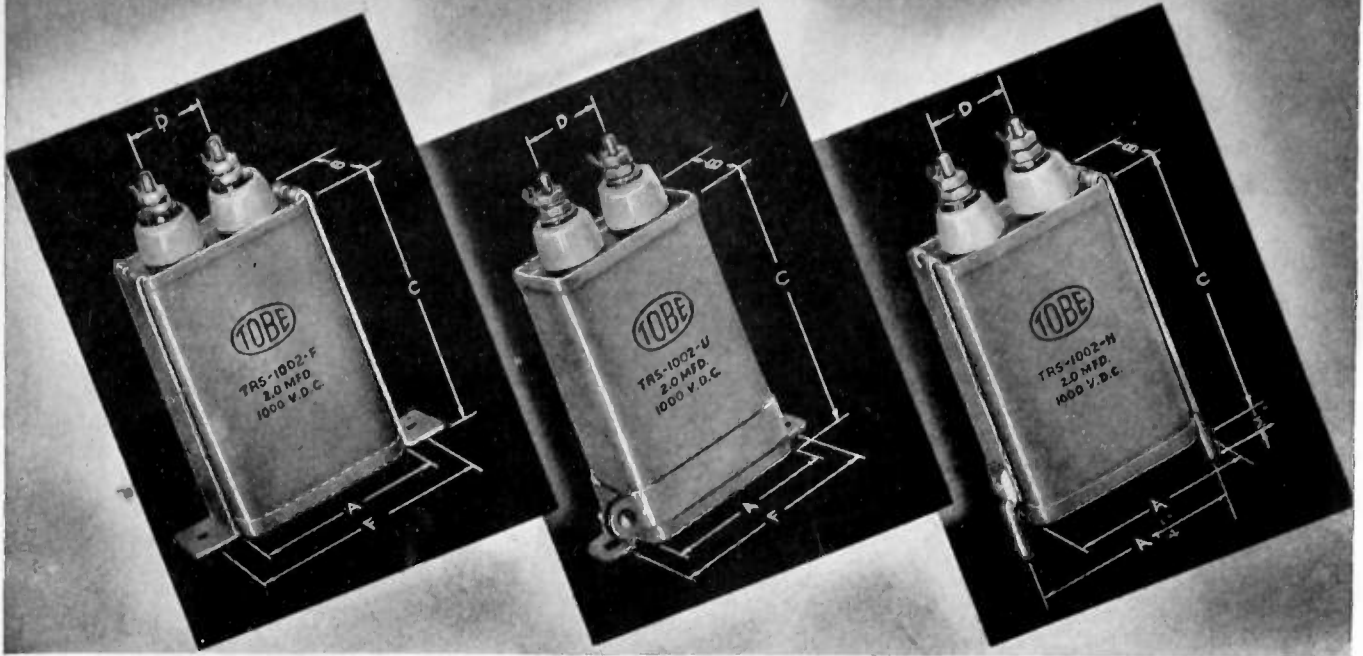

## TOBE TYPE TRS

THESE SPECIFICATIONS — the standards to which Tobe Type TRS capacitors are built — certify the ability to sustain high transient voltages and temperatures in transmitting, timing, and filter circuits.

A wide versatility of mounting provisions, capacitance ratings ranging from .03 to 50 Mfd., voltage ratings from 600 to 6000 volts d-c, permit you to match capacitor components exactly to your requirements.

## Specifications

**Winding:** non-inductive.

**Impregnation:** mineral oil.

**Case:** tinned, lead-coated steel, squeeze-seam type, hermetically sealed.

**Terminals:** brass studs with No. 10/32 threads; molded phenolic or glazed porcelain bushings; shake-proof solder lugs furnished. Metal-to-glass sealed terminals when specified. Oil-proof gaskets between all adjacent surfaces in assembly.

**Capacitance Tolerance:** 10%, 1 Mfd. and over; 20% below 1 Mfd.

**Operating Temp.:** —67F to 185F.

**Markings:** type, voltage, capacitance, and terminal identification ink-stamped on case.

CASE DIMENSIONS — Inches

Size	A Width	B Thickness	C Height
1	1 1/4	1 1/4	2 1/4
2	"	"	2 1/2
3	"	"	2 3/4
4	"	"	3
5	2 1/2	1 3/4	2
6	"	"	2 1/2
7	"	"	3 1/2
8	"	"	4
9	"	"	4 1/4
10	"	"	4 3/4
11	3 1/4	1 1/4	3 1/2
12	"	"	4
13	"	"	4 3/4
14	"	1 3/4	3 3/4
15	"	"	4 3/4
16	"	2 1/4	4
17	"	"	4 3/4
18	"	"	5
19	"	3 1/4	4 1/4
20	"	4 1/4	4*
21	"	"	4 1/4*
22	"	"	4 3/4*

\*Mfg. ctrs. 4 1/4 x 3 3/4 inches, except hook-type mfg. ctrs. are 4" x 3 3/4".

Mfd.	600 V. D-C		1000 V. D-C		1500 V. D-C		2000 V. D-C		2500 V. D-C		3000 V. D-C		4000 V. D-C		6000 V. D-C	
	TRS-Type No.	Case	TRS-Type No.	Case	TRS-Type No.	Case	TRS-Type No.	Case	TRS-Type No.	Case	TRS-Type No.	Case	TRS-Type No.	Case	TRS-Type No.	Case
.03					1510	1	2010	1	25003	1	30001	5				
.10					1525	1	2025	2			30002	6				
.20					1550	3	2050	3			3025	6			600025	12
.25					1501	4	2001	7	2501	14	3001	16	4001	18	6001	22
.50	650	1	1050	1	1502	9	2002	12	2502	15	3002	19				
1.0	601	1	1001	3												
2	602	3	1002	4												
3	603	4														
4	604	7	1004	10	1504	13	2004	16	2504	20	3004	22				
5	605	8	1005	12												
6	606	10			1506	15										
8	608	11	1008	13												
10	6010	12	10010	15												
12	612	13	10012	16												
15			10015	17												
20	6020	16														
40	6040	21														
50	6050	22														

Cases 1-4 D = 13/16" F = 2-1/4"

Cases 5-10 D = 1-1/8" F = 3"

Cases 11-22 D = 1-7/8" F = 4-3/8"



TOBE DEUTSCHMANN Corporation CANTON, MASSACHUSETTS



"Here's Your Proof in  
**BLACK and WHITE!**"



## TURQUOISE LINES REPRODUCE SHARPLY

Take a good look at any black-and-white print (or blueprint) made direct from a TURQUOISE pencil tracing, and *believe your own eyes.*

**EVERY DETAIL IS DISTINCT**, for the \*Electronic graphite is refined down to particle sizes of 1/25,000" to deposit knife-edge lines of extreme opacity!

**EVERY LINE IS UNIFORM**, because each degree of TURQUOISE is made from its own separate formula of graphite and clay. Wax is added for smoothness alone... never to change the grading.

Then try a TURQUOISE at your drafting board, and *believe your own hand.*

**THE POINT IS STRONGER**, because Eagle's patented super bonding process welds lead to wood for extra resistance to breakage.

**THE LEAD IS SMOOTHER**, for TURQUOISE leads are steeped in rare waxes until every particle of graphite glides on its own film of lubricant.

**For a Free Sample**, just write to Ernest Eagle, naming this magazine, your pencil dealer, and the degree you wish to try.

\*Reg. U. S. Pat. Off.

10¢ EACH  
 ... less in  
 quantities

**EAGLE** "Chemi-Sealed"  
 (SUPER BONDED)

# TURQUOISE

## DRAWING PENCILS AND LEADS

EAGLE PENCIL COMPANY, 703 E. 13th St., New York 9, N. Y.  
 EAGLE PENCIL COMPANY OF CANADA, LTD., TORONTO

# Centralab reports to

**MAY 1947**

Medium-duty  
power switches now  
available for  
special industrial  
and electronic  
uses!

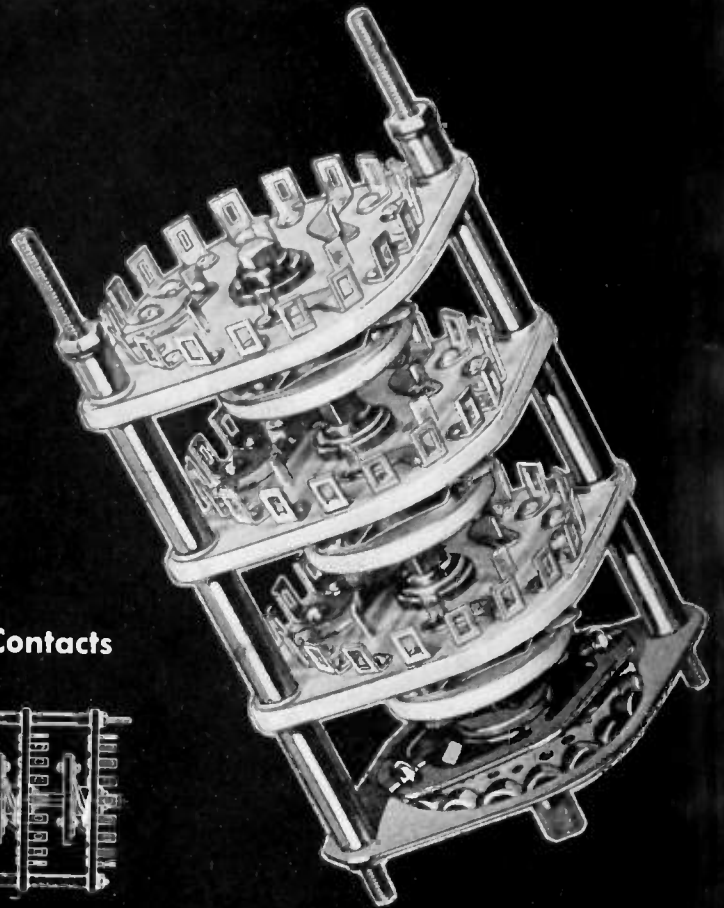

## Positive Action — Solid Silver Contacts

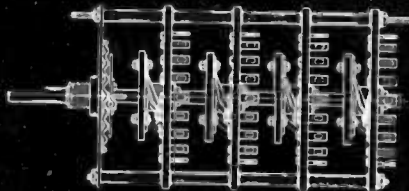

**1** Specially designed for transmitters, power supply converters, and a broad new range of industrial and electronic uses, Centralab's medium-duty power switches give you efficient performance up to 20 megacycles. Tests prove that these switches have a mini-

mum life operation of 25,000 cycles without failure. Rated at  $7\frac{1}{2}$  amperes, 60 cycles, 115 volts A.C. Minimum voltage breakdown between critical points is 3,000 volts RMS, 60 cycles. For complete information, send for Bulletin 722.

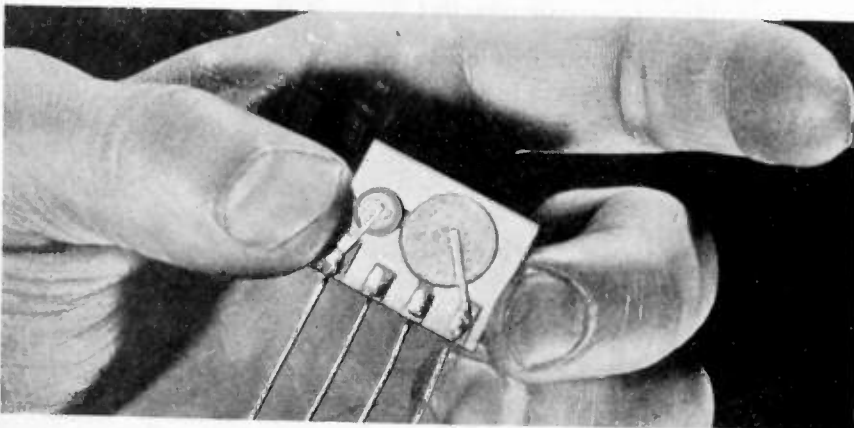

**2** First commercial application of the "printed circuit", and now available for the first time, Centralab's new *Couplate* is a complete interstage coupling circuit which combines into one unit the plate load resistor, the grid resistor, the plate by-pass capacitor and the coupling capacitor.

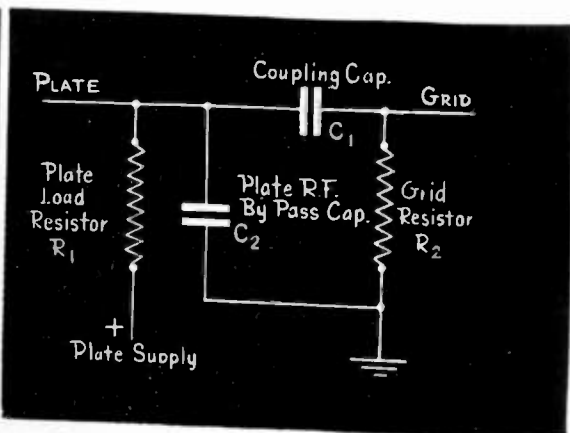

**3** Only four soldered connections are now required by the *Couplate* instead of the usual eight or nine (see above). That means fewer errors, lower costs!



# Electronic Industry

**FRONT**

**BACK**

**NOW SEE HOW  
THIS REPLACES THIS**

**C<sub>1</sub>**—Coupling Capacitor, .01 mfd. is standard.

**C<sub>2</sub>**—Plate R.F. By-Pass Capacitor, 250 mmf.  $\pm$  20% is standard.

**R<sub>1</sub>**—Plate Load Resistor, 250,000 Ohms  $\pm$  20% 1/5 watt is standard.

**R<sub>2</sub>**—Grid Resistor, 500,000 Ohms  $\pm$  20% 1/5 watt is standard.

*Other Values Available*

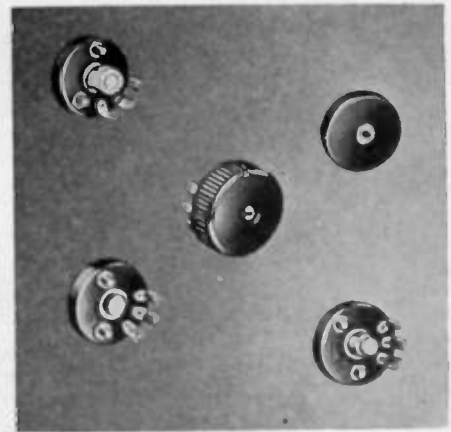

**4** Integral Ceramic Construction: Each *Couplate* is an integral assembly of "Hi-KAP" capacitors and resistors closely bonded to a steatite ceramic plate and mutually connected by means of metallic silver paths "printed" on the base plate. Think of what that means in terms of time and labor savings! Send for bulletin 943.

**5** Look at Centralab's newest control for miniature receivers and amplifiers. No bigger than a dime, high quality performance is assured.

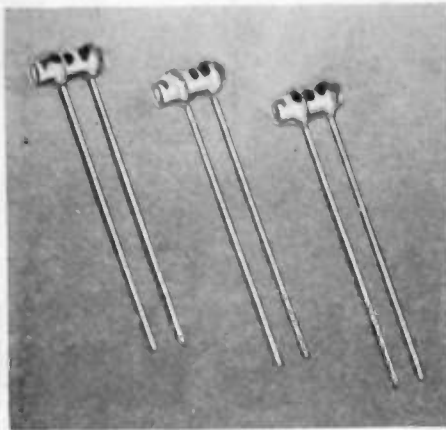

**Maximum Over-all Dimensions**

TUBE	D	L
BC 20	.200"	.400"
BC 25	.200"	.690"
BC 32	.225"	.860"
BC 35	.285"	1.165"



**6** Important: the recognized dependability and high quality of ceramic by-pass and coupling capacitors is now available at Centralab Distributors!

**7** Here for the first time, is a line of ceramic capacitors which combines economy, small size and extreme dependability.

**8** Made from Centralab's original ceramic-X, this new line is result of our continuing research in high dielectric constant ceramics. Order Bulletin 933.

**Look to Centralab in 1947! First in component research that means lower costs for electronic industry. If you're planning new equipment, let Centralab's sales and engineering service work with you. Get in touch with Centralab!**

# Centralab

DIVISION OF GLOBE-UNION INC., MILWAUKEE, WIS.

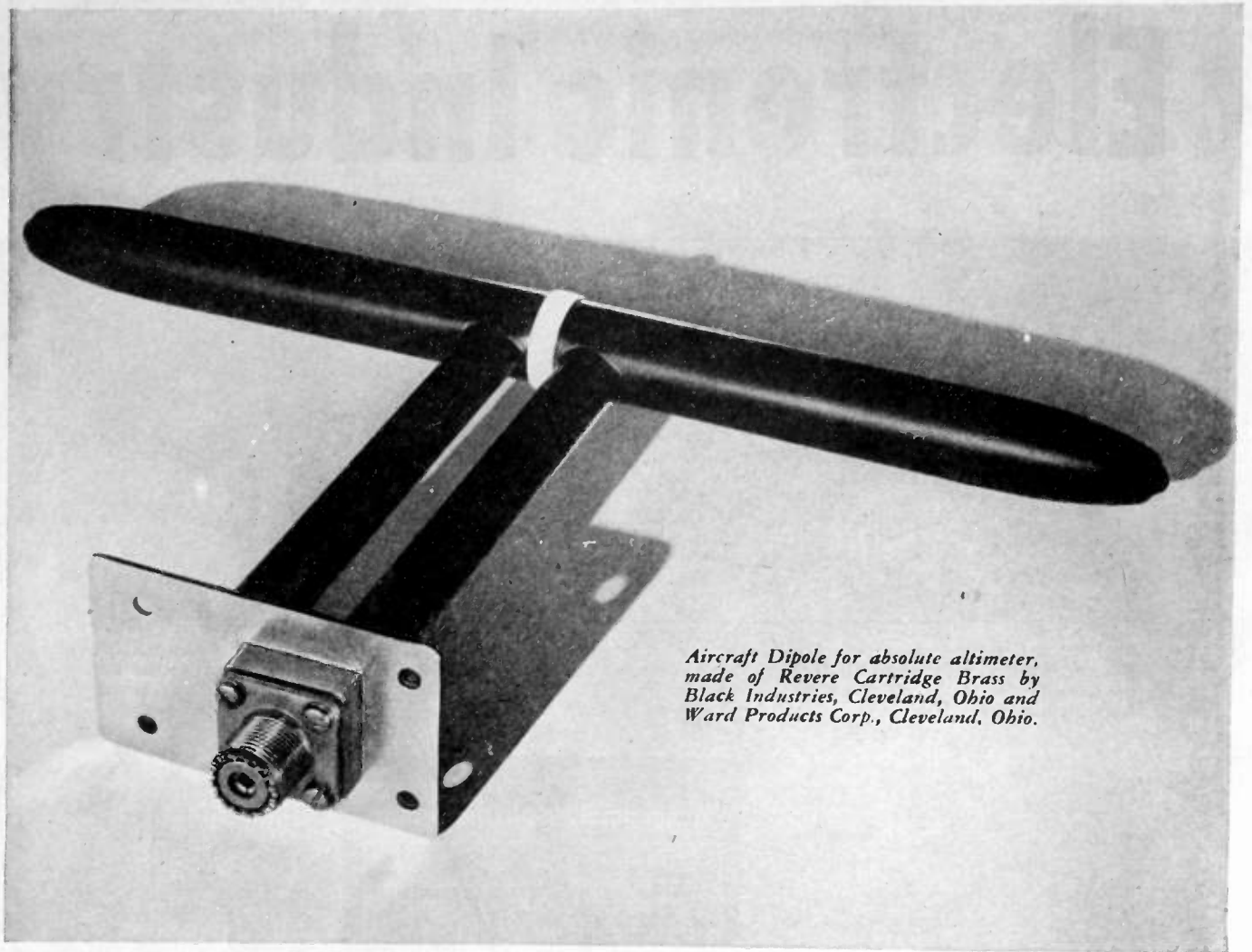

*Aircraft Dipole for absolute altimeter, made of Revere Cartridge Brass by Black Industries, Cleveland, Ohio and Ward Products Corp., Cleveland, Ohio.*

# Metal by REVERE in this dipole

**T**HIS dipole antenna is made chiefly of Revere 70-30 Cartridge Brass, an important feature of which is strength combined with easy workability. The dipole section is made of brass tube with the ends spun down. In order to reduce drag, the tube for the leads to the dipole was supplied by Revere specially drawn into an aerodynamic "teardrop" section. (Incidentally, Revere also makes electric-welded steel tube in the same cross section.) The base of the dipole is made of Revere brass sheet and rod. External surfaces have a black oxidized finish which is very durable and easy to obtain on brass. This is but one of many uses for Revere Brass in electronic equipment, others including cans for transformers and condensers, bolts and nuts, connectors, shafts and plates for variable condensers, name plates and similar applications requiring any or all of the following qualities: easy fabrication, corro-

sion resistance, and beauty. Revere offers mill products in the following forms: *Copper and Copper Alloys:* Sheet and Plate, Roll and Strip, Rod and Bar, Tube and Pipe, Extruded Shapes, Forgings; *Aluminum Alloys:* Tube, Extruded Shapes, Forgings; *Magnesium Alloys:* Sheet and Plate, Rod and Bar, Tube, Extruded Shapes, Forgings; *Steel:* Electric Welded Steel Tube in standard or special cross sections.

**REVERE**  
COPPER AND BRASS INCORPORATED

*Founded by Paul Revere in 1801  
230 Park Avenue, New York 17, New York  
Mills: Baltimore, Md.; Chicago, Ill.; Detroit, Mich.;  
New Bedford, Mass.; Rome, N. Y. — Sales Offices in  
Principal Cities, Distributors Everywhere.*





# Make it MALLORY... and Make SURE



Types and sizes vary,  
but standards  
of quality never!

**Y**OU don't need more than an elementary knowledge of vitreous enamel resistors to know that if they're conservatively rated to withstand severe overloads... if they're solidly constructed and strongly resistant to moisture, fumes and heat... if they're more reliable, more accurate and have a better appearance than the average... they're the kind of resistors *you* want. Mallory resistors *are* that kind, and that's why you'll find them in so many communications, industrial and laboratory applications, or whenever dependability is essential.

The Mallory line includes a large variety of standard fixed tab, adjustable and ferrule types... the famous series of "RN" resistors that meet JAN Specifications, Characteristic F. There are many different sizes and wattage ratings available, but the emphasis always is on premium quality. Write for our Engineering Data Folder giving full information, including charts and photographs, on all Mallory Vitreous Enamel Resistors.

**P. R. MALLORY & CO. Inc.**  
**MALLORY RESISTORS**  
**(FIXED AND VARIABLE)**

**P. R. MALLORY & CO., Inc., INDIANAPOLIS 6, INDIANA**



# GUARDIAN

presents...

a new **MIDGET**  
CONTACT ASSEMBLY  
*Interchangeable*

with the GUARDIAN Series 200  
STANDARD CONTACT ASSEMBLY  
AND COIL ASSEMBLY

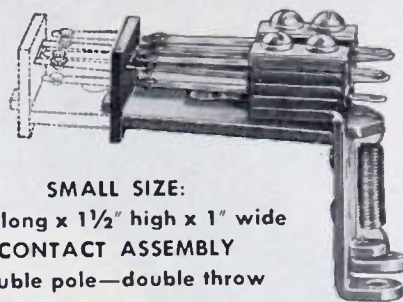

**SMALL SIZE:**  
1 5/8" long x 1 1/2" high x 1" wide  
**CONTACT ASSEMBLY**  
double pole—double throw  
Dotted line shows comparative size

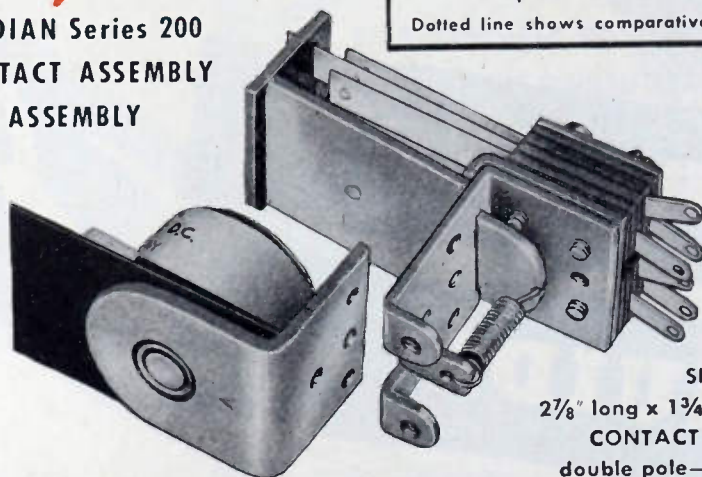

**SIZE**  
2 7/8" long x 1 3/4" high x 1" wide  
**CONTACT ASSEMBLY**  
double pole—double throw

## Popular RADIO RELAYS in the GUARDIAN line:

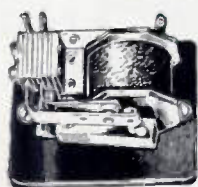

**K-100 Keying Relay** For low voltage control of high voltage transmission. Guardian Series K-100 Relay will follow key or bug at highest WPM rate attainable. High speed response, strong magnet and return spring give clean make and break, produce best CW note. Coils: 5 to 16 v., A.C.; coils for other voltages on specifications.

**B-100 Break-in Relay** For break-in operation on amateur transmitters. The Guardian B-100 Relay has laminated field piece and armature. Fine 1/4" silver DPDT contacts, capacity to 1500 watts, 60 c., non-inductive A.C., and in A.C. primary circuit of any inductive power supply delivering up to 1 KW, inclusively.

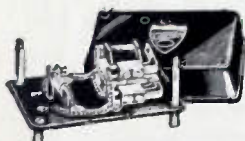
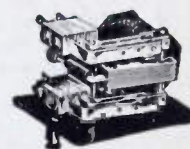

**T-100 Time Delay Relay** In radio transmitter circuits, Guardian's T-100 Time Delay Relay prevents damage of rectifiers and tube filaments by preventing plate current before filaments are sufficiently heated. Laminated field piece and armature. Mounted in dust-proof metal box.

**L-250 Overload Relay** Provides accurate, fixed overload protection against current surges and continuous overloads. Guardian's L-250 Relay replaces expensive, time-wasting fuses. Attracts armature on 250 mils. Max. drop across coil—10 v. Guardian's L-500 Relay attracts armature at 500 mils. Max. drop across coil—5 volts. Ideal for experimenters on new circuits.

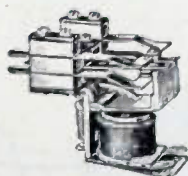
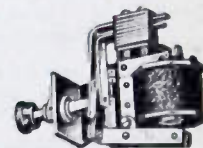

**A-100 Antenna Relay** A low loss AISiMag insulated relay. For single wire fed installations specify the A-100-C, SPDT unit. Two A-100-C in place of one A-100 in open wire line systems will avoid possible impedance mismatch. A very popular relay with radio amateurs.

**SEE THESE AND OTHER GUARDIAN RELAYS AT BOOTH 51, MAY 12-16, STEVENS HOTEL, CHICAGO, ILL.**

Ask your jobber for the new midget contact switch assembly which is interchangeable with the Guardian's Series 200 coil assembly. Your jobber carries a complete line of Guardian radio relays. If unable to attend Radio Parts Show, write for Bulletin R-6.

# GUARDIAN



# ELECTRIC

1628-F W. WALNUT STREET

CHICAGO 12, ILLINOIS

A COMPLETE LINE OF RELAYS SERVING AMERICAN INDUSTRY



# A BUYERS' GUIDE... for

**W**ar Surplus electronic tubes, devices and equipment declared surplus by the armed forces are available for purchase through "Approved Distributors". The War Assets Administration put this plan in operation to expedite the disposal of needed materials.

If you are a manufacturer, jobber or dealer, contact one of the approved distributors listed here. They will know what and how much of this property is available for immediate delivery. This is your opportunity to obtain needed equipment at a considerably reduced cost.





# fast action

**WAA APPROVED DISTRIBUTORS OF  
GOVERNMENT-OWNED SURPLUS  
ELECTRONIC EQUIPMENT**  
(wholesale only)

**American Condenser Co.**  
4410 No. Ravenswood Avenue  
Chicago 40, Illinois

**Automatic Radio Mfg. Co., Inc.**  
122 Brookline Avenue  
Boston 15, Massachusetts

**Belmont Radio Corporation**  
3633 So. Racine Avenue  
Chicago 9, Illinois

**Carr Industries Inc.**  
40-22 Lawrence Street  
Flushing, L. I., N. Y.

**Communication Measurements Laboratory**  
120 Greenwich Street  
New York 6, New York

**Cole Instrument Co.**  
1320 So. Grand Avenue  
Los Angeles 15, California

**Tobe Deutschmann Corporation**  
863 Washington Street  
Canton, Massachusetts

**Electronic Corporation of America**  
353 West 48th Street  
New York 19, N. Y.

**Electro-Voice, Inc.**  
Carroll & Cecil Streets  
Buchanan, Michigan

**Emerson Radio & Phonograph Corporation**  
76 Ninth Avenue  
New York 11, N. Y.

**Essex Wire Corporation**  
1601 Wall Street  
Ft. Wayne 6, Indiana

**General Electric Company**  
Building 267, 1 River Road  
Schenectady 5, New York

**General Electronics Inc.**  
1819 Broadway  
New York 23, N. Y.

**Hammarlund Mfg. Company, Inc.**  
460 West 34th Street  
New York 1, New York

**Hoffman Radio Corporation**  
3761 South Hill Street  
Los Angeles 7, California

**Hytron Radio & Electronics Corporation**  
76 Lafayette Street  
Salem, Massachusetts

**Johanns & Keegan Inc.**  
62 Pearl Street  
New York 4, N. Y.

**E. F. Johnson Company**  
206 Second Avenue, S. W.  
Waseca, Minnesota

**Majestic Radio & Television Corporation**  
125 West Ohio Street  
Chicago 10, Illinois

**National Union Radio Corporation**  
57 State Street  
Newark 2, New Jersey

**Navigation Instrument Co., Inc.**  
P. O. Box 7001, Heights Station  
Houston, Texas

**Newark Electric Co., Inc.**  
242 West 55th Street  
New York 19, New York

**Radio Parts Distributing Company**  
128 W. Olney Road  
Norfolk 10, Virginia

**Smith-Meeker Engineering Company**  
125 Barclay Street  
New York 7, N. Y.

**Southern Electronic Company**  
611 Baronne Street  
New Orleans, Louisiana

**Standard Arcturus Corporation**  
99 Sussex Avenue  
Newark 4, New Jersey

**Sylvania Electric Products, Inc.**  
Emporium, Pennsylvania

**Technical Apparatus Company**  
165 Washington Street  
Boston 8, Massachusetts

**Tung-Sol Lamp Works, Inc.**  
95 Eighth Avenue  
Newark 4, New Jersey

**W & H Aviation Corporation**  
Municipal Airport  
Rochester 3, New York

ELECTRONICS DIVISION

**WAR ASSETS ADMINISTRATION**



Offices located at: Atlanta • Birmingham • Boston • Charlotte • Chicago • Cincinnati • Cleveland  
Denver • Detroit • Grand Prairie, Tex. • Helena • Houston • Jacksonville • Kansas City, Mo.  
Los Angeles • Louisville • Minneapolis • Nashville • New Orleans • New York • Omaha • Philadelphia  
Portland, Ore. • Richmond • St. Louis • Salt Lake City • San Antonio • San Francisco • Seattle • Spokane • Tulsa

1062

# ANNOUNCING... RCA blue-sensitive Gas Phototubes



**Feature high sensitivity to blue radiation, no response to infrared, and high signal-to-noise ratio**

These five new phototubes represent another important tube development initiated by RCA with the introduction of the 1P37. They have the advantage of combining the S-4 response with gas amplification. Thus, the tubes offer exceptional sensitivity to blue radiation, no response to infrared, and a high signal-to-noise ratio.

The five types illustrated are especially valuable in sound reproduction from a dye-image sound track because of the total absence of masking of the modulation by infrared transmission. They are equally attractive for industrial applications involving measurement and color control where infrared radiation might mask the desired signal.

RCA 1P37, 5581, 5582, 5583, and 5584 Gas Phototubes have a maximum response at a wavelength of 4000 Angstroms and a maximum gas amplification factor of 5.5.

TABLE OF COMPARABLE TYPES		
NEW TYPES S-4 RESPONSE	INTERCHANGEABILITY	OLDER TYPES S-1 RESPONSE
5581 . . . . .		930
5582 . . . . .	The new RCA types are inter-	921
5583 . . . . .	changeable with these earlier	927
5584 . . . . .	types. In some cases, minor	920
1P37 . . . . .	circuit changes are necessary	868,918

Each of the five new types has comparable luminous sensitivity, anode characteristics, and structure to the older type having S-1 response. They may therefore be used interchangeably with the earlier types with minor circuit changes.

RCA Tube Application Engineers will be pleased to offer their services toward the use of these or other RCA tube types in your equipment. Meanwhile, send for the new Bulletin CRPS-102 covering the technical data on the complete line of RCA Cathode Ray, Phototube, and Special Types. Address all inquiries to Commercial Engineering, Section R-52E, Harrison, N. J.



**THE FOUNTAINHEAD OF MODERN TUBE DEVELOPMENT IS RCA**



**TUBE DEPARTMENT**

**RADIO CORPORATION of AMERICA**

**HARRISON, N. J.**



# PROCEEDINGS OF THE I.R.E.

(Including the WAVES AND ELECTRONS Section)

Published Monthly by

The Institute of Radio Engineers, Inc.

VOLUME 35

May, 1947

NUMBER 5

## BOARD DIRECTORS, 1947

Walter R. G. Baker  
*President*

Noel Ashbridge  
*Vice-President*

Raymond F. Guy  
*Treasurer*

Haraden Pratt  
*Secretary*

Alfred N. Goldsmith  
*Editor*

William L. Everitt  
*Senior Past President*

Frederick B. Llewellyn  
*Junior Past President*

1945-1947

Stuart L. Bailey  
Keith Henney  
B. E. Shackelford

1946-1948

Virgil M. Graham  
Frederick R. Lack  
Donald B. Sinclair

1947-1949

Murray G. Crosby  
Raymond A. Heising  
William C. White

1947

J. E. Brown  
Jack R. Poppele  
David Smith

Harold R. Zeamans  
*General Counsel*

George W. Bailey  
*Executive Secretary*

Laurence G. Cumming  
*Technical Secretary*

## BOARD OF EDITORS

Alfred N. Goldsmith  
*Chairman*

## PAPERS REVIEW COMMITTEE

Murray G. Crosby  
*Chairman*

## PAPERS PROCUREMENT COMMITTEE

Dorman D. Israel  
*General Chairman*

Edward T. Dickey  
*Vice General Chairman*

## PROCEEDINGS OF THE I.R.E.

Sections Representatives, 1947 National Convention . . . . .	442
The Position of the Engineer in Our Postwar Society . . . Dorman D. Israel	443
2783. Analysis of Problems in Dynamics by Electronic Circuits . . . . .	
John R. Ragazzini, Robert H. Randall, and Frederick A. Russell	444
2784. Wave Theoretical Interpretation of Propagation of 10-Centimeter and 3-Centimeter Waves in Low-Level Ocean Ducts . . . C. L. Pekeris	453
2785. Microwave Oscillators Using Disk-Seal Tubes . . . . .	
A. M. Gurewitsch and J. R. Whinnery	462
2786. Microwave Omnidirectional Antennas . . . . .	474
2787. Q Circles—A Means of Analysis of Resonant Microwave Systems . . . . .	
William Altar	478
2788. Characteristics of Certain Voltage-Regulator Tubes . . . . .	
George M. Kirkpatrick	485
2625. Discussion on "A Current Distribution for Broadside Arrays Which Optimizes the Relationship Between Beam Width and Side-Lobe Level," by C. L. Dolph . . . . .	489
Henry J. Riblet and C. L. Dolph	
Correspondence:	
2789. "Empirical Formula for Amplification Factor" . . . . . E. W. Herold	493
2790. "Note on the Sporadic-E Layer" . . . . . Oliver P. Ferrell	493
2791. "A Vacuum Heating Element" . . . . . Gerhard S. Lewin	494
2792. "Radar Reflections from the Lower Atmosphere" . . . . . H. T. Friis	494
2499. "Distortion and Acoustic Preferences" . . . . . James Moir	495
Contributors to the PROCEEDINGS OF THE I.R.E. . . . .	496

## INSTITUTE NEWS AND RADIO NOTES SECTION

Institute News and Radio Notes . . . . .	498
1947 I.R.E. National Convention . . . . .	499
I.R.E. People . . . . .	503
Sections . . . . .	505
Books:	
2793. "Introduction to Electron Optics," by V. E. Cosslett . . . . .	
Reviewed by V. K. Zworykin	506

## WAVES AND ELECTRONS SECTION

David J. Knowles, Secretary-Treasurer, Emporium Section—1946 . . . . .	507
The Need for Clear Terminology . . . . . Milton B. Sleeper	508
2794. Impedance Measurement on Transmission Lines . . . . . D. D. King	509
2795. Microwave Power Measurement . . . . .	
Theodore Moreno and Oscar C. Lundstrom	514
2796. Design Values for Loop-Antenna Input Circuits . . . . .	
Jay E. Browder and Victor J. Young	519
2797. Radio Control of Model Flying Boats . . . . . V. Welge	526
Contributors to Waves and Electrons Section . . . . .	530
2798. Abstracts and References . . . . .	532
Section Meetings . . . . . 35A	Positions Open . . . . . 50A
Membership . . . . . 40A	Positions Wanted . . . . . 54A
Advertising Index . . . . .	78A

## EDITORIAL DEPARTMENT

Alfred N. Goldsmith  
*Editor*

Helen M. Stote  
*Publications Manager*

Clinton B. DeSoto  
*Technical Editor*

Mary L. Potter  
*Assistant Editor*

William C. Copp  
*Advertising Manager*

Lillian Petranek  
*Assistant Advertising Manager*

Responsibility for the contents of papers published in the PROCEEDINGS OF THE I.R.E. rests upon the authors. Statements made in papers are not binding on the Institute or its members.

Changes of address (with advance notice of fifteen days) and communications regarding subscriptions and payments should be mailed to the Secretary of the Institute, at 450 Alhnaip St., Menasha, Wisconsin, or 1 East 79 Street, New York 21, N. Y. All rights of republication, including translation into foreign languages, are reserved by the Institute. Abstracts of papers, with mention of their source, may be printed. Requests for republication privileges should be addressed to The Institute of Radio Engineers.







Standing: Samuel Gubin, chairman, Philadelphia Section; J. T. Cimorelli, chairman, New York Section; A. N. Curtiss, secretary-treasurer, Philadelphia Section; M. E. Knox, chairman, Twin Cities Section; W. A. Dickinson, Emporium Section; Keith Henney, director I.R.E., New York Section; W. C. Freeman, Jr., chairman, Williamsport Section; Ellsworth D. Cook, member-at-large; R. A. Heising, director I.R.E., New York Section; E. M. Williams, vice-chairman, Pittsburgh Section; C. K. Gieringer, secretary, Cincinnati Section; J. D. Reid, chairman, Cincinnati Section; L. G. Smeby, chairman, Washington Section.

Seated: P. B. Laeser, chairman, Committee on Subsections; A. E. Newlon, chairman, Rochester Section; A. W. Graf, chairman, Chicago Section; H. E. Kranz, senior past chairman, Detroit Section; W. O. Swinyard, chairman, Sections Committee; A. B. Buchanan, Detroit Section; Richard White, chairman, Kansas City Section; B. E. Shackelford, director I.R.E., New York Section; J. P. Henderson, Ottawa Section; D. C. Kalbfell, past chairman, San Diego Section.



Standing: J. A. Green, chairman, Cedar Rapids Section, member, National Sections Committee; A. H. Wulfsberg, secretary, Cedar Rapids Section; G. A. Rosselot, Atlanta Section; L. R. Quarles, chairman, North Carolina-Virginia Section; L. L. Caudle, Jr., North Carolina-Virginia Section; J. D. Schantz, Fort Wayne Subsection; C. A. Norris, vice-chairman, Toronto Section; R. R. Batcher, New York Section; F. M. Deerhake, Syracuse Section; S. H. Van Wambeek, chairman, St. Louis Section; L. E. Packard, Boston Section; J. E. Shepherd, I.R.E. Convention Committee, New York Section.

Seated: T. A. Hunter, past chairman, Cedar Rapids Section; M. S. Smith, Cedar Rapids Section; J. R. Orth, secretary, North Carolina-Virginia Section; L. W. Butler, chairman, Milwaukee Section; H. C. Williams, chairman, Cleveland Section; P. O. Frincke, chairman, Detroit Section; J. E. Keto, chairman, Dayton Section; C. A. Priest, chairman, Syracuse Section; G. H. Browning, chairman, Boston Section; C. F. Kocher, secretary, Detroit Section.



Of recent years, an active debate has been carried on relative to the justification of work in the field of "pure science" as opposed to the desirability of endeavor in the domain of "applied technology." One group of thinkers has felt that the pursuit of truth for its own sake was not only more satisfying intellectually and more stimulating to the dignity of the investigator but also, in the long run, more likely to benefit science, engineering, and society through the discovery of basic facts susceptible of many later useful applications. Other thinkers have insisted that "pure science" was nothing more than a meaningless exploration in a social and economic vacuum, and that it constituted a sort of cloistered and self-indulgent scientific "doodling" by the research worker and was thus unworthy of encouragement. Society, these thinkers proclaim, is entitled to ask the expensively trained investigator, using costly facilities and the help of his fellow workers, to produce results markedly slanted toward practically immediate and major social benefit. As correlative disputes, there have been argued such questions as the following. Should research be institutionally subsidized by government? Should the engineer enter the political and industrial-management arenas to preside, at least in part, over the social destinies of his mental products? Can and should a research or development worker become an industrial leader or a political figure of prominence? And so the conflicts rage.

It is accordingly interesting to bring one viewpoint to our readers in the following forceful guest editorial by a leading engineer who is chairman of the Institute's Papers Procurement Committee and also vice-president of the Emerson Radio and Phonograph Corporation.—*The Editor.*

## The Position of the Engineer in Our Postwar Society

DORMAN D. ISRAEL

Despite extravagant promises made during the election campaign last fall, and even though the people had told many of the incumbent leaders that they had "had enough," every thinking person realizes that many social reforms of the recent decade will not be repudiated. It is no more possible to forget them than to eliminate the existence of the scientific advances made during the same period.

Engineers, along with other scientists, have given astounding technological developments to the world. Entrusting the unqualified exploitation of these innovations to others is to display a brand of naivete long since unbecoming to our profession.

The transitions in the development of the mechanical, economic, and social aspects of our age have become so closely related that it is hardly possible to locate the points of fusion. It follows that the engineer who usually led the chronology of major advances is likewise—if only by reason of his solid familiarity with the background and details—best set to carry on with the ensuing exploitive phases. That he has not been so appointed by society is only proof that the engineer has failed to realize and be equal to his total responsibility. It is well known that the human race cannot afford another failure in the management of the social and economic development of our technology.

The postwar job before the engineer transcends that of the pure scientist, and involves faithful attention to his regular duties as well as to each of the following:

1. Adequate time, effort, and skill must be devoted to the maintaining and further development of our national security. To expect a few self-sacrificing members of our profession to do all of this is to invite disaster. Each of us must make it our task to find a way to contribute from our skill in a definite manner.
2. The product for which he is responsible must not only be technically satisfactory but it must, furthermore, use materials and processes in a manner conducive to the encouragement of all workers associated with this product.
3. Methods, and particularly their mechanization, must be developed and put into effect to the optimum degree.
4. Plans always must be under way and continually in operation whereby new developments are being gradually introduced as though by normal evolution, thus avoiding sudden and abortive changes so damaging to worker morale and product quality.
5. The engineer's achievements, as such, are of no value. The social and economic phases of the production and use of the product—in other words, the service rendered—are what count. The evaluation by society of a product is only in terms of the service rendered.







The basic equation of the operational amplifier may be derived by reference to Fig. 2. Here, if it is assumed that the box marked *A* is a direct-current amplifier and

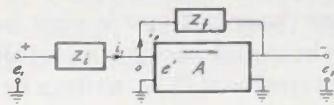

Fig. 2—Block diagram for basic feedback computation.

that the input at *o* is connected directly to the grid of the first tube, the currents at the junction *o* must add up to zero. Thus,

$$i_1 = i_2$$

or,

$$\frac{e_1 - e_1'}{Z_i(p)} = \frac{e_1' + e_2}{Z_f(p)} \tag{1}$$

where the voltages  $e_1$ ,  $e_2$ , and  $e_1'$  are functions of time and  $Z_i(p)$  and  $Z_f(p)$  are used in the manner of the Heaviside impedance operators. It is noted that, if  $A$  is the voltage gain of the amplifier,

$$e_2 = Ae_1'. \tag{2}$$

Using this relation and simplifying (1),

$$e_2 = \frac{Z_f(p)}{Z_i(p)} \left[ \frac{1}{1 + \frac{1}{A} \left( 1 + \frac{Z_f(p)}{Z_i(p)} \right)} \right] e_1. \tag{3}$$

If the amplifier gain  $A$  is made sufficiently large (5000 is a practicable value), the bracketed term will approach unity, so that, with but negligible error,

$$e_2 = \frac{Z_f(p)}{Z_i(p)} e_1. \tag{4}$$

Equation (4) is the basic equation for the high-gain direct-current feed-back amplifier, and is the justification for the term "operational" amplifier, as will be shown in the succeeding paragraphs.

It will be noted in Fig. 2 that the output voltage  $e_2$  is of opposite polarity from that of the input voltage  $e_1$ . Hence, if the impedances  $Z_f(p)$  and  $Z_i(p)$  are equal resistances, the amplifier will perform the simple operation of sign-changing. In fact, sign-changing will be included in all the operations which can be performed by the amplifier.

If the impedances of (4) are unequal resistances, a scale change will be accomplished, for

$$e_2 = \frac{R_f}{R_i} e_1. \tag{5}$$

It will be noted that the accuracy of the scale change depends only on the accuracy of the resistors, and does not depend on the amplifier components, so long as the

amplifier gain remains large for all frequencies of interest.

Often it is desired to vary the scale of a given input, or to make the output adjustable. Three methods of accomplishing this operation are shown in Fig. 3. The circuits are self-explanatory and all of them may be used interchangeably. It is to be noted that circuits (a) and (b) fully realize the low output impedances which result in degenerative feed-back amplifiers. On the other hand, the output impedance of circuit (c) may reach a value as high as one quarter the resistance of the output potentiometer. This output impedance may be important in producing computation errors if the circuit following has a low impedance. In case (a) the gain varies linearly with the resistance of resistor  $R_f$ ; in case (c) the output voltage will be linear with change in resistor  $R_c$ ; but in case (b) the gain will vary as the reciprocal of the resistance  $R_i$ . These facts are of particular importance when the parameter is to be varied by a servomechanism whose output angle is most readily made linearly variable with the applied voltage.

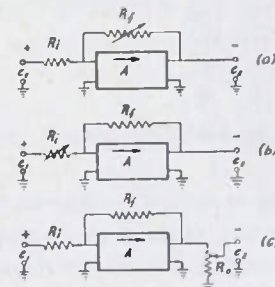

Fig. 3—Three methods for obtaining variable changes in scale or gain.

The more important operations which can be performed by virtue of (4) are those of the calculus, which make systems of these amplifiers capable of solving differential equations. Thus, if  $Z_f(p)$  is a capacitor whose impedance expressed operationally is  $1/Cp$ , and  $Z_i(p)$  is a resistance  $R$ , (4) becomes

$$e_2 = \left( \frac{1}{RC} \right) \frac{1}{p} e_1. \tag{6}$$

This amplifier is now an integrator which can accurately integrate input voltages with respect to time. It should be noted that the multiplying factor  $1/RC$  may be made unity by choosing  $R$  as 1 megohm and  $C$  as 1 microfarad, and that the sign of the output voltage  $e_2$  is negative as compared to the input voltage  $e_1$ . If the input voltage is constant, the output voltage will rise linearly with time up to the limit of the amplifier. If the input voltage is removed, the output voltage  $e_2$  will remain constant at the integrated value. To remove this output voltage it is necessary to provide a switch which short-circuits the capacitor  $C$ , thus returning the output voltage to zero.

If  $Z_f(p)$  is now made a resistance  $R$ , and  $Z_i(p)$  is made a capacitor whose impedance is expressed operationally

as  $1/Cp$ , (4) becomes

$$e_2 = (RC)pe_1. \tag{7}$$

The operational amplifier is now a differentiator whose output is the derivative of the input voltage. If a voltage of constantly increasing magnitude is applied to the input of this differentiator, the output will be a constant value. One of the disadvantages of the differentiator is its very good high-frequency response. For example, if the voltage fed to the differentiator is produced by a coarse potentiometer, the output voltage will contain high-magnitude pulses produced by each step of the contact arm.

Another basic operation which can be performed by the operational amplifier is the important one of summing the voltages obtained from any number of independent sources. A circuit to provide the summation of

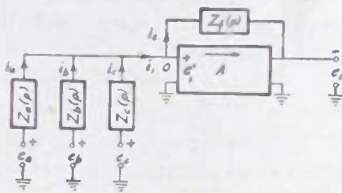

Fig. 4—Circuit for adding functions of three variables.

three input voltages is shown for illustration in Fig. 4. If it is assumed that the voltage  $e_1'$  is virtually zero, the current equation may be written in the same manner as was used to derive (4):

$$i_a + i_b + i_c = i_2. \tag{8}$$

So,

$$\frac{e_a}{Z_a(p)} + \frac{e_b}{Z_b(p)} + \frac{e_c}{Z_c(p)} = \frac{e_2}{Z_f(p)}. \tag{9}$$

Rearranging,

$$e_2 = \frac{Z_f(p)}{Z_a(p)} e_a + \frac{Z_f(p)}{Z_b(p)} e_b + \frac{Z_f(p)}{Z_c(p)} e_c. \tag{10}$$

If all the impedances are equal resistances, (10) reduces to a summation of the three input voltages:

$$e_2 = e_a + e_b + e_c. \tag{11}$$

This summation may be accomplished for any number of input voltages.

It is evident that the summation may be made algebraic (that is, may include subtractions) if the input voltages are of proper sign, and they may be made so by the use of sign-changing amplifiers where required. It is easy to see that scale-changing may be made to accompany the summation if the resistances  $R_a$ ,  $R_b$ , etc., are not selected to equal  $R_f$ , but ratios of  $R_f/R_a$ ,  $R_f/R_b$ , etc., are chosen to give the desired individual multiplying factors. Furthermore, it is possible to use the general equation (10) and perform calculus operations on the

input voltages at the same time they are summed and altered in magnitude. The only restriction is that the impedance  $Z_f(p)$  is common to all the operations involved.

The operations described above may be summarized and the process involved becomes generalized and capable of further extension if (4) is written in the form

$$e_2(t) = \frac{F_1(p)}{F_2(p)} e_1(t) \tag{12}$$

or

$$F_1(p)e_1(t) = F_2(p)e_2(t). \tag{13}$$

In this form, the equation may be used for the setting up of complicated systems, examples of which will be described in the ensuing pages. The functions  $F_1(p)$  and  $F_2(p)$ , as shown in Fig. 5, may be produced not only by

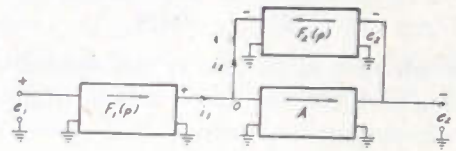

Fig. 5—Generalized circuit for operational computation.

passive circuits consisting of impedances, but also with additional operational amplifiers.

### III. SYNTHESIS OF COMPUTERS FOR LINEAR FIRST-DEGREE EQUATIONS

The techniques for setting up an electronic computer for an equation of a physical system can be divided into two classes, which will be referred to as the "in-line" and "current-junction" methods. One or a combination of these methods will apply to a particular problem. Usually there are many possible circuit arrangements, one of which will be more convenient to synthesize, more economical of equipment, or will permit easier adjustment of the desired parameters.

Before an equation is synthesized, it should be written in a form such that the independent variable is time, and the literal coefficients represent positive numerical values. A simple differential equation which fulfills the above conditions without rearrangement is that of the mechanical dynamics of a d'Arsonval meter or oscillograph element with constant rotational inertia  $J$ , viscous friction damping factor  $D$ , and stiffness factor  $K$ . The relationship between the angular displacement  $\theta(t)$  and the applied torque  $\tau(t)$  is given by the familiar second-order equation:<sup>3</sup>

$$J \frac{d^2\theta}{dt^2} + D \frac{d\theta}{dt} + K\theta = \tau(t) \tag{14}$$

or

$$(Jp^2 + Dp + K)\theta - \tau(t) = 0. \tag{15}$$

<sup>3</sup> R. E. Doherty and E. G. Keller, "Mathematics of Modern Engineering," vol. I, p. 17, John Wiley and Sons, New York, N. Y., 1936.



This equation, which can, of course, be solved by straightforward mathematical methods without recourse to a computer, will be used to illustrate the two techniques mentioned above.

(a) In-Line Technique

The in-line technique is adaptable to equations in which a number of functions of the independent variable are to be added to equal some function of the dependent variable. For example, if it is desired to examine the physical system of (15) in order to investigate the transient torque required to produce a given angular displacement for various values of inertia, damping, and stiffness, a computer would be synthesized to solve (15) for  $\tau(t)$  in terms of  $\theta(t)$ .

Synthesis by means of the in-line technique consists simply of feeding the independent variable as an input voltage into a series of operational amplifiers, each of which computes one of the desired functions. These functions are then algebraically added in a final summation amplifier to give the desired output or dependent variable.

In the system of Fig. 6(a), an applied voltage proportional to the angular displacement from rest,  $\theta(t)$ , is fed into the left-hand terminals from a relatively low-impedance source. Amplifier  $A_a$ , having unit input and

tively). Its output voltage is therefore proportional to  $p\theta$ . Amplifiers  $A_c$  and  $A_d$  receive  $p\theta$  and produce voltages proportional to  $-p\theta$  and  $-p^2\theta$ , respectively, the latter by means of another differentiation.

Assuming initially that the constant positive coefficients  $J$ ,  $D$ , and  $K$  are all to be adjusted to values between zero and one, potentiometers of relatively low impedance (e.g., 50,000 ohms) can then be arranged as shown to deliver fractions of the voltages symbolized by  $-p^2\theta$ ,  $-p\theta$ , and  $-\theta$ , respectively proportional to the coefficients  $J$ ,  $D$ , and  $K$ . These voltages are then summed in amplifier  $A_e$ , using high-resistance input-circuit resistors (e.g., 10 megohms) so that the equivalent resistance from the potentiometer tap to ground will cause a negligible addition to the input resistance of amplifier  $A_e$ .

Suppose, however, that  $1 < J < 10$ . Then the feed-back resistance of amplifier  $A_d$  could be made equal to ten times the input resistance, so that the voltage output would be proportional to  $-10p^2$ .

Economy of amplifiers can be obtained with the circuit of Fig. 6(b). In this circuit the summing amplifier  $A_e$  also differentiates  $-Jp\theta$ , thus producing  $Jp^2\theta$  without recourse to a separate differentiator and an additional sign-changing amplifier. In cases such as that described above, the potentiometer resistance to ground must be sufficiently low so that the real component of the capacitive input impedance will be negligible at the highest frequency for which accuracy of response is desired.

Many other circuit arrangements are possible, each having its advantages and disadvantages. It should be emphasized that all of these computer systems are unidirectional; a voltage proportional to  $\tau(t)$  in the present example can not be applied to the terminals at the right to obtain the angular displacement  $\theta$  as a voltage at the left-hand terminals. If it is desired to obtain  $\theta(t)$  as a function of  $\tau(t)$ , the technique of synthesis which follows must be employed.

(b) Current-Junction Technique

The second method by means of which computer circuits may be synthesized, which is referred to as the "current-junction" technique, is perhaps the most basic method of attacking the problem. It was demonstrated in (13) that any amplifier, including the summing amplifier, solves the general equation of the form

$$F_1(p)x - F_2(p)y = 0 \tag{16}$$

where  $F_1(p)$  is the operator for the independent variable  $x$  and  $F_2(p)$  is the operator for the feed-back terms of the dependent variable  $y$ .

In the general case there may be several independent variables  $x, x', x'',$  etc., each with its own operator; and several different operators for the dependent variable  $y$  all of which are fed to the current junction  $o$  of Fig. 5. Thus the general equation would be of the form

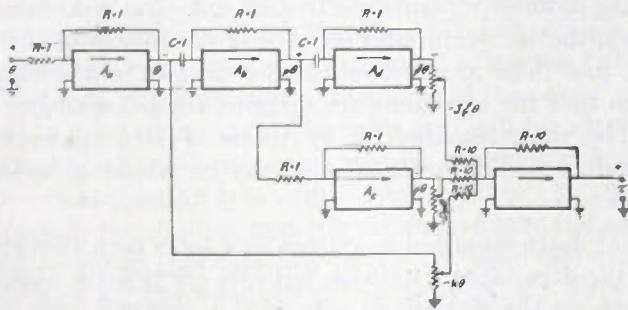

(a)

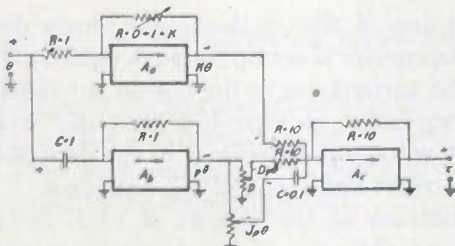

(b)

Fig. 6—(a) Example illustrating "in-line" technique of synthesis. (b) Simplified computer for above example.

feed-back resistors (say, one megohm each) operates as an isolating unit and sign-changing amplifier, giving an output voltage proportional to  $-\theta$ . This voltage is differentiated and again changed in sign by amplifier  $A_f$ , having a unit input capacitor and a unit feed-back resistor (say, one microfarad and one megohm, respec-



$$F_1(p)x + F_1'(p)x' + F_1''(p)x'' + \dots - F_2(p)y - F_2'(p)y' - F_2''(p)y'' - \dots = 0. \quad (17)$$

If the variables  $x, x', x'', \dots, y$  are voltages such as  $e_1(t)$  and  $e_2(t)$ , then the various expressions  $F(p)$  are admittances, and the synthesizing process consists of summing algebraically the currents flowing into the junction  $o$ , of an amplifier such as that shown in Fig. 5, and setting the result equal to zero. The various currents are mutually independent since the grid input terminal  $o$  is virtually at zero potential (since  $e_1'$  is negligibly small) and hence effectively grounded.

The technique is illustrated in Fig. 7(a) for (15), which is now to be solved for  $\theta(t)$  in terms of  $\tau(t)$ . Amplifier  $A_a$  is first assumed to produce an output voltage equal to  $\theta(t)$ . In order that  $\theta(t)$  may exist at this point, it is necessary to feed four currents (one for each term of the equation) to its grid input terminal, junction  $o$ , thus solving the equation

$$-\tau(t) + K\theta + Dp\theta + Jp^2\theta = 0. \quad (18)$$

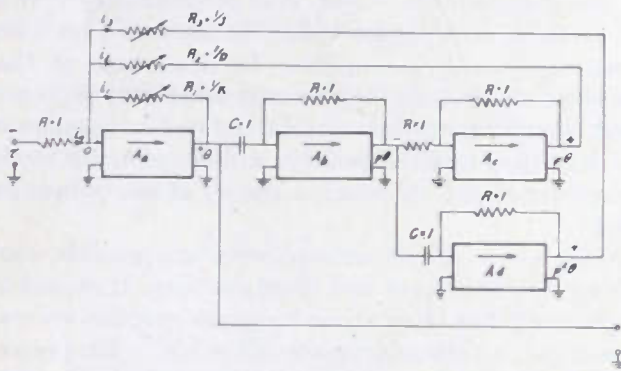

(a)

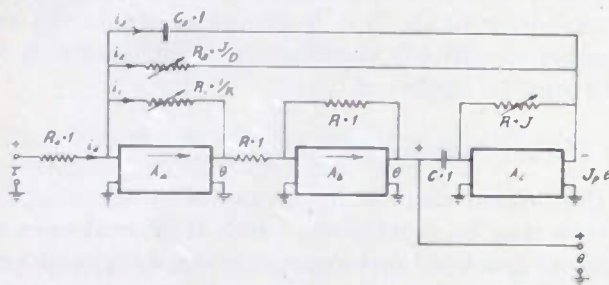

(b)

Fig. 7—(a) Example illustrating "current-junction" technique of synthesis. (b) Simplified computer for above example.

The current  $i_4$ , representing the term of the independent variable  $\tau(t)$ , will exist if we let the input resistor be a unit value and apply a voltage proportional to  $-\tau(t)$  at the left-hand terminals. The second term is  $K\theta$ , obtained by feeding back the voltage proportional to  $\theta$  through a conductance proportional to  $K$ , or a resistance,  $R_1 = 1/K$ . Thus a current  $i_1(t) = K\theta$  will also flow at junction  $o$ . Voltages proportional to  $p\theta$  and  $p^2\theta$ , neces-

sary to produce currents  $i_2(t)$  and  $i_3(t)$ , are produced by the in-line technique described previously. When the currents  $i_1, i_2, i_3, i_4$  are applied to junction  $o$ , the output of amplifier  $A_a$  must then be proportional to  $\theta(t)$ , as assumed at the start. The computer of the above example may be somewhat simplified, at the expense of having resistor  $R_2$  dependent on two of the coefficients,  $J$  and  $D$ , as shown in Fig. 7(b).

The choice of the computer system is sometimes determined by the variations of the coefficients of the equations. If the coefficients such as  $J, D$ , and  $K$  are merely adjustable but remain constant as inputs are applied, practically any system is workable. However, occasionally a coefficient is not constant but a function of either time or one of the variables of the system. In that case a circuit must be chosen so that the value of the coefficient is proportional to the angle of rotation of a potentiometer shaft, so that a simple servo-driven unit may be used.

#### IV. PROBLEMS INVOLVING SIMULTANEOUS EQUATIONS

Simultaneous integrodifferential equations arise when problems of coupled physical systems are encountered. Frequently it is inconvenient or impracticable to solve these equations mathematically for the desired unknown, and then set up a computer for the resulting equation. In addition, a solution may be desired for each of the unknown quantities. In such cases it is convenient to synthesize a computer for each of the equations of the set, and then to interconnect the circuits in a manner such that the equations are satisfied simultaneously.

The steps required for synthesis of a computer for simultaneous linear equations may be tabulated as follows:

(a) Each equation is written in a form such that one of the dependent variables, with its coefficients, stands alone on the right-hand side of the equation, this dependent variable being different for each equation of the set.

(b) By one of the methods previously described a separate computer is set up for each equation, assuming that all the variables save the one on the right are independent variables, so that the computer will produce an output voltage proportional to the dependent variable on the right-hand side of the equation.

(c) Functions of the output of each computer required to provide the proper input functions for the other computers are noted. Circuits are added to the output of each to provide these additional output functions.

(d) The heretofore-separate systems are cross-connected so that each input terminal receives its proper voltage from one of the outputs of the system. Only the input terminals for the true independent variable or variables will then be left free, and to these external driving functions will be applied, as in the cases discussed previously.



(e) Scales of computation are adjusted so that each amplifier will have a voltage output of reasonable magnitude.

As an example consider the airplane shown in Fig. 8, for which it is desired to make a study of the pitching characteristics when the elevators are manipulated. A pair of axes fixed in the airplane will be used as references, with the customary positive directions as shown.

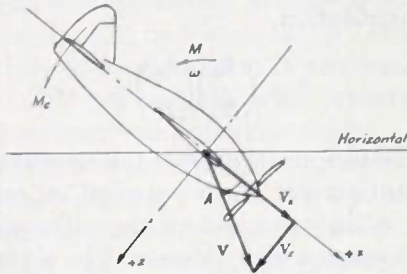

Fig. 8—Diagram illustrating notation for equations (19), (20), (21), and (22).

At the instant illustrated the airplane is pointing at a negative angle  $\theta$  from the horizontal, and is moving with a resultant linear velocity  $V$  in a direction at an attack angle  $A$  from the longitudinal axis. The velocity  $V$  is considered to have two rectilinear components,  $V_x$  and  $V_z$ .

It is desired to synthesize a computer which will solve for the disturbances or changes in angular velocity  $\omega$  and the disturbances or changes in the linear velocities  $v_z$  and  $v_x$ , caused by small moments  $M_s$  applied to the airplane by means of the elevators. The airplane is assumed to have a mass  $m$  and moment of inertia  $J$  about the  $y$  axis, perpendicular to the plane of the paper.

Let it be assumed that initially (at  $t=0$ ) the airplane is flying with velocities and angular positions indicated by upper-case symbols with the subscript  $o$ . Then equations for the changes or disturbances in linear and angular velocities (indicated by lower-case symbols) can be written for the symmetrical motions of the airplane. Three equations of motion are required, which are:<sup>9</sup>

(1) The sum of the  $x$ -directed forces equals zero;  $\sum f_x = 0$ .

(2) The sum of the  $z$ -directed forces equals zero;  $\sum f_z = 0$ .

(3) The sum of the angular moments about the center of gravity and the  $y$  axis equals zero;  $\sum M = 0$ .

With certain approximations,<sup>9</sup> these three equations can be written in the following form:

$$(p + k_{zz})v_z + V_o(\sin A_o)\omega + g(\cos \theta_o) \frac{\omega}{p} = k_{zx}v_x \quad (19)$$

$$-(p + k_{zz})v_x + V_o(\cos A_o)\omega - k_{zw}\omega + g(-\sin \theta_o) \frac{\omega}{p} = k_{zx}v_z \quad (20)$$

$$-(k_{Mz}p + k_{Mz})v_z + k_{Mz}v_x + \frac{M_o}{J} = (p + k_{M\omega})\omega \quad (21)$$

where  $V_o$ ,  $A_o$  and  $\theta_o$  are respectively the initial resultant velocity, attack angle, and angle from the horizontal (chosen negative);  $v_x$ ,  $v_z$ , and  $\omega$  are the increments in downward, forward, and angular velocities, respectively, for which solutions are desired; and the coefficients (all arranged so as to be numerically positive) are:

$$\begin{aligned} k_{zx} &= -\frac{1}{m} \frac{\partial f_x}{\partial v_x} & k_{zx} &= -\frac{1}{m} \frac{\partial f_z}{\partial v_x} \\ k_{xz} &= \frac{1}{m} \frac{\partial f_z}{\partial v_z} & k_{xz} &= -\frac{1}{m} \frac{\partial f_x}{\partial v_z} \\ k_{x\omega} &= -\frac{1}{m} \frac{\partial f_x}{\partial \omega} & k_{Mz} &= -\frac{1}{J} \frac{\partial M}{\partial v_z} \\ k_{Mz} &= -\frac{1}{J} \frac{\partial M}{\partial v_z} & k_{Mz} &= \frac{1}{J} \frac{\partial M}{\partial v_x} \\ k_{M\omega} &= -\frac{1}{J} \frac{\partial M}{\partial \omega} & g &= \text{gravitational constant.} \end{aligned} \quad (22)$$

(The symbol  $v_z$  represents the downward acceleration.)

The equations as written above are in the form required for synthesis of the computer, and this process can now be carried out as outlined. Three separate computers are planned, one for each of the three equations, arranged to solve for the variable on the right-hand side.

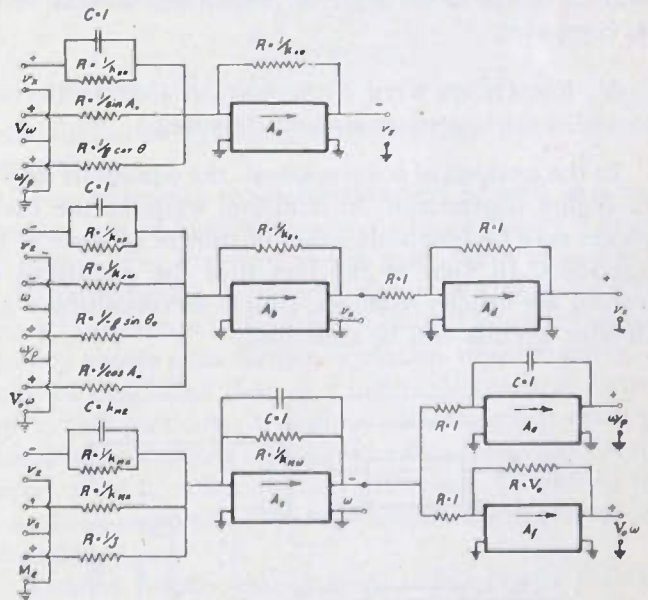

Fig. 9—Electronic computer for symmetric motions of airplane.

In Fig. 9, the output of amplifier  $A_a$  is chosen to be  $-v_x$ ; the feed-back network is chosen so as to multiply by the coefficient  $k_{zx}$ . Similarly, amplifiers  $A_b$  and  $A_c$  produce  $-v_z$  and  $-\omega$ , respectively; the feed-back networks provide for multiplication by  $k_{xz}$  and  $(p + k_{M\omega})$ , respectively. The required inputs are then assumed to be available, and input impedances are selected so that these inputs will be multiplied by the proper coefficients.

<sup>9</sup> W. F. Durand, "Aeronautic Theory," vol. 5, division N, by B. Melvill Jones, chap. 5, J. Springer, Berlin, 1934-1936.

It will be noted that, with the chosen feed-back impedances, it is possible to use capacitors to differentiate but not to integrate input terms. For this reason, it is necessary to assume as inputs the integrated quantities, such as  $\omega/p$ , where such are required. It is also convenient to assume that the multiplication by  $V_o$  is to be taken care of elsewhere, so that  $V_o\omega$  is available for an input. It is now evident that the inputs required include, in addition to the three outputs  $-v_x$ ,  $-v_y$ , and  $\omega$ , the quantities  $v_x$ ,  $\omega/p$ , and  $V_o\omega$ . Amplifiers  $A_d$ ,  $A_e$ , and  $A_f$  are added to the circuits in order to produce these terms.

The next step consists of interconnecting the three computers so that correspondingly labeled input and output terminals are connected; these wires are not shown on the diagram. When these connections are complete, the only input terminal left free is that of the independent variable  $M_e$ , the applied elevator moment. This moment may be assumed proportional to rudder angle, and may therefore be an input obtained from a potentiometer supplied with a direct voltage and attached to the elevator control operated by the "pilot" of the simulated airplane, or by an automatic pilot which it is desired to study.

There are, of course, further practical considerations, which have not been mentioned. Stabilization of each loop of the computer circuit must be accomplished, a problem to be discussed later. Scales must be adjusted so that the output voltages of the  $v_x$  and  $\omega$  computers will be of the same order of magnitude as that of the  $v_z$  computer.

V. EQUATIONS WITH NONCONSTANT COEFFICIENTS AND OF HIGHER DEGREE

In the analysis of some systems, the equations may be of higher degree and, in addition, some of the coefficients may be functions either of time or of some of the variables. In view of the fact that the quantities involved are usually voltages, simple servomultiplier and divider circuits will be described.

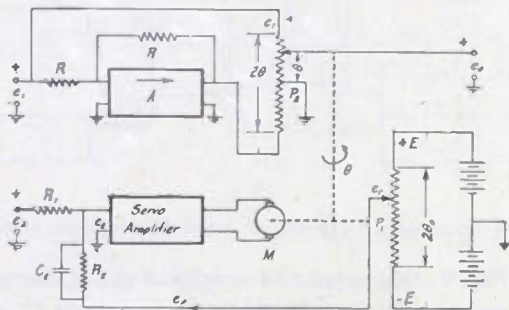

Fig. 10—Servomultiplier circuit.

As shown in Fig. 10, the servomechanism, being a degenerative device, causes the error voltage  $e_e$  to be brought to zero. The angle  $\theta$  at which the servomechanism just closes its error is given by the relation

$$\frac{e_r}{R_2} = \frac{e_2}{R_1} \tag{23}$$

and

$$e_r = \left(\frac{\theta}{2\theta_o}\right)2E = \left(\frac{\theta}{\theta_o}\right)E \tag{24}$$

where  $\theta$  is the shaft rotation and  $2\theta_o$  is the total angle subtended by the follow-up potentiometer  $P_1$ . Solving for the shaft rotation,

$$\theta = \left(\frac{R_2}{R_1}\right)\left(\frac{\theta_o}{E}\right)e_2. \tag{25}$$

To produce multiplication with the second voltage  $e_1$ , a second potentiometer  $P_2$ , is supplied on one side with the voltage  $e_1$  directly, and on the other side with the voltage  $e_1$  through a sign changer. The shaft of this potentiometer is connected to that of the servomechanism, so that its output is

$$e_o = \left(\frac{e_1}{\theta_o}\right)\theta, \tag{26}$$

substituting the value of  $\theta$  from (25),

$$e_o = \left(\frac{R_2}{R_1 E}\right)e_1 e_2. \tag{27}$$

By proper choice of  $R_2$ ,  $R_1$ , and  $E$ , a scale factor for the multiplication may be produced to specifications. The capacitor  $C_2$  is merely for stabilization of the servosystem and does not enter in the computation, except during transient conditions.

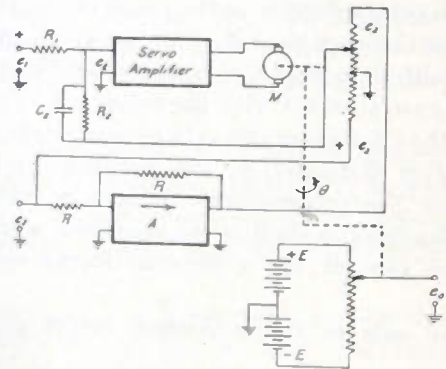

Fig. 11—Servodivider circuit.

In a similar manner, it is possible to divide one voltage by another using a servodriven potentiometer. A schematic circuit of this system is shown in Fig. 11. The servosystem closes the error voltage  $e_e$  to zero, so that

$$\frac{e_1}{R_1} = \frac{2\theta e_2}{2\theta_o R_2}. \tag{28}$$

Solving for the shaft rotation  $\theta$ ,

$$\theta = \left(\frac{R_2 \theta_o}{R_1}\right)\frac{e_1}{e_2}. \tag{29}$$



The output voltage  $e_o$  is obtained from a potentiometer on the same shaft supplied with  $\pm E$  volts to ground. Thus,

$$e_o = \left(\frac{2E}{2\theta_o}\right)\theta = \left(\frac{ER_2}{R_1}\right)\frac{e_1}{e_2} \quad (30)$$

It is observed that the output voltage  $e_o$  is the quotient of  $e_1$  and  $e_2$  multiplied by a scale factor. Thus it is possible to multiply or divide a term in any equation by another term with any suitable scale constant by use of these small servodriven potentiometers.

Frequently it is desired to insert a function of a given variable in the computer system. For instance, if a study of aerodynamic systems is made in which a coefficient is a function of wind velocity, it is possible to adapt one of the servodriven systems to perform this operation. One technique is to construct a servomechanism similar to the multiplier of Fig. 10, and to drive a cam through an angle  $\theta$  proportional to an independent variable  $e_2$ . The desired function may be cut on a cam which drives another linear potentiometer whose output voltage is the function of the independent variable. The same result may be obtained without a cam by winding a potentiometer whose voltage output is the desired function of shaft angle.

For instance, referring to the electronic computer for the symmetric motions of an airplane in Fig. 9, the quantity  $V_o$  is the initial airspeed which is constant. The term  $V_\omega$  produced by amplifier  $A_f$  is used in the computer for inputs which, for more accurate computations, should use the magnitude of the instantaneous velocity  $V$ , the vector value of which is given by the equation

$$\bar{V} = \bar{V}_o + \bar{v} \quad (31)$$

where  $\bar{v}$  is the change in velocity from the initial value  $\bar{v}_o$ . To make this correction in the computer, it would be necessary to vary the feed-back resistor  $R_{19}$  by means of a servodriven potentiometer whose shaft rotation is proportional to  $|V|$ .

Inputs to the computer can also be obtained by manual curve tracing. If a function of the independent variable is plotted and the plot rotated by means of the servomotor, the curve can be manually followed and the voltage output from a potentiometer used in the system. Such methods have been used in differential analyzers in the past and can be used in electronic computers as well.

Practical physical problems offer numerous examples of system variables which have fixed upper limits. For example, an angle specifying the position of a boat rudder may vary between zero and a fixed maximum. Similar limits apply to airplane controls. A mechanical system involving spring forces will often involve maximum spring extensions.

The purely mathematical solution of the dynamics of such systems where such limiting action occurs is often difficult. The electronic representation of such limits is

comparatively simple and can be introduced into the system wherever the limits occur. Fig. 12 shows one such circuit. Whenever the input voltage  $e_1$  exceeds the bias voltage  $E$ , one or the other diode will conduct, depending on the polarity of  $e_1$ . When this occurs the output voltage will be limited closely equal to the bias voltage, provided the resistance  $R$  is high compared to the diode resistance. A limiter of this type may be inserted in the computers previously described wherever needed.

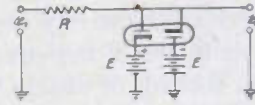

Fig. 12—Circuit for introducing nonlinearity in form of limits.

### VI. OPERATING CONSIDERATIONS

The frequency response of any operational amplifier may be obtained by replacing the operator  $p$  by the quantity  $j\omega$ . Thus the frequency response of an integrator is given by

$$\frac{E_2}{E_1} = \left(\frac{1}{RC}\right) \frac{1}{j\omega} \quad (32)$$

This expression indicates a gain characteristic which drops 6 decibels per octave. On the other hand, the frequency response of a differentiator is given by

$$\frac{E_2}{E_1} = (RC)j\omega \quad (33)$$

which indicates a gain characteristic that rises 6 decibels per octave.

These frequency characteristics may be used as a convenient test of amplifier accuracy in producing a given operation. For instance, if the gain curve of a differentiator indicates a linearly rising gain of 6 decibels per octave up to a given frequency, but beyond this frequency shows considerable deviation from linearity, it may be concluded that as a differentiator it is correct up to this particular frequency. If voltages containing frequency components of higher value are applied at the input, error in differentiation will result. Extending the frequency response of the base amplifier will correct the situation.

Without further explanation, it is evident that by proper choice of  $Z_f(p)$  and  $Z_i(p)$  many operational expressions may be set up accurately. The accuracy which will result depends on the maintenance of the high values of gain  $A$ , regardless of the rate of change or frequency component content of the input functions. A frequency range of from zero (direct current) to the highest frequency at which accurate computation is desired must be maintained in the amplifiers. In addition, the accuracy of the external circuit constants used must be assured.

For the impedance functions  $Z_f(p)$  and  $Z_i(p)$ , capacitors and resistors are generally used. It is evident that,



while theoretically usable, inductances are avoided, since at the relatively low frequencies involved it is difficult to obtain as pure or accurate an impedance function as can be obtained with a capacitor of low loss and low retentivity.

Whenever the computer involves the use of capacitors other than small ones inserted to achieve stability, considerable difficulty may be found due to retentivity of charge. It has been recommended by the Bell Telephone Laboratories that capacitors with polystyrene dielectric be used, as they are relatively free of this effect.

A perfect representation of the equation for a stable mechanical system should, of course, be stable electri-

response are, of course, attenuated as a result. In some cases it may be necessary to choose a new time scale<sup>10</sup> in which these attenuated high frequencies are well above the upper frequencies of response of the dynamical system being simulated.

While the amplifier units described earlier are reasonably drift free, residual drifts may often be annoying, particularly where small input voltages and long time intervals are involved. These effects can be readily minimized by changing the voltage scale and the time scale so that the useful voltages are large compared to the drift voltages and so that the experimental "run" is completed before errors have had time to accumulate.

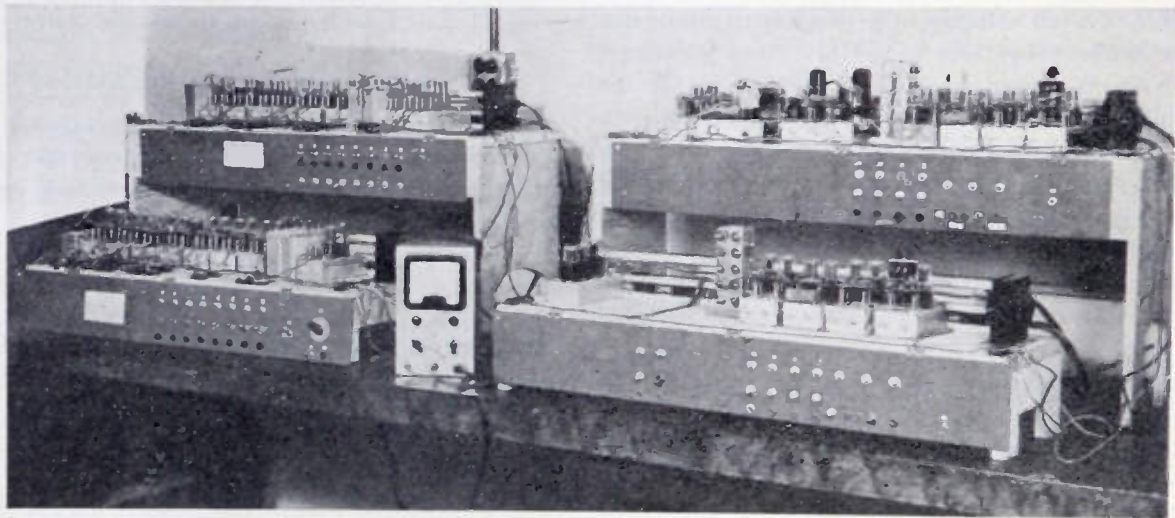

Fig. 13—Typical laboratory electronic-computer arrangement. One set of amplifiers in the lower bay on the left is the computer described in Fig. 9 for aircraft symmetrical motions.

cally. Unavoidable progressive phase shifts, both within individual amplifier units and appearing accumulatively when several units are connected in a loop, may lead to oscillation at some upper frequency. A careful redesign of the complete system will often minimize the number of separate amplifiers used in any single loop so that oscillation does not occur. The nature of the system itself which is being represented will often automatically stabilize the electronic equivalent, as, for instance, when a mechanical system having large mass will act as a low-pass filter, eliminating from the feed-back loop those higher frequencies for which phase shift may occur.

The individual amplifiers may exhibit instability when the over-all gain of the amplifier is too high. This condition may be overcome by inserting a small capacitor across the feed-back impedance of differentiators and scale changers, or by inserting a resistor in series with the capacitor of an integrator, thereby limiting the frequency response. The higher harmonics in the system

Drift and stability for these systems are functions of the direct-current power supply, which should be extremely well regulated and of low dynamic output impedance.

A typical laboratory electronic-computer arrangement is shown in Fig. 13.

## VII. ACKNOWLEDGMENT

The authors wish to express their appreciation to Section 7.2 of the National Defense Research Council, its chief, S. H. Caldwell, and the technical aides of that Section, G. A. Philbrick, J. B. Russell, and H. C. Wolfe, for their assistance, co-operation, and guidance in carrying out this work at Columbia University under contract number OEMsr-237. In addition, the authors wish to acknowledge the contributions of L. Julie and M. Hestenes to some phases of this development.

<sup>10</sup> J. L. Gardner and M. F. Barnes, "Transients in Linear System," vol. 1, p. 226; John Wiley and Sons, New York, N. Y., 1942.



# Wave Theoretical Interpretation of Propagation of 10-Centimeter and 3-Centimeter Waves in Low-Level Ocean Ducts\*

C. L. PEKERIS†

**Summary**—The data on the transmission of 10- and 3-centimeter waves in low-level ocean ducts obtained by the Naval Research Laboratory expedition to Antigua, British West Indies, were analyzed by wave theory. The analysis was made for a distribution of modified index of refraction with height (shown by curve *C'* in Fig. 1). Below the horizon, the 10-centimeter wave was found to propagate by the first normal mode with a theoretical decrement of 1 decibel per nautical mile, as against an observed value of about 0.8 decibel per nautical mile in the first 80 miles from transmitter.<sup>1</sup> Theory verified the observed constancy of decrement with height for this wavelength. Beyond 80 miles the observed rate of attenuation dropped to a low value of 0.2 decibel per nautical mile. This change of slope in the intensity curve is probably due to the emergence of scattered radiation after the direct diffracted beam had been depleted. With the exception of one point there is quantitative agreement between the observed and theoretical distribution of intensity with height (see Fig. 9) for the 10-centimeter wave.

The 3-centimeter wave was found to propagate below the horizon by the first and second modes, with theoretical decrements of zero and 0.5 decibel per nautical mile, respectively. The latter agrees with the observed values at high elevations, but near the surface, where theoretically attenuation should be negligible, the observed rate of attenuation exceeds the theoretical value by about 0.3 decibel per nautical mile. This is probably due to attenuation by scattering from horizontal inhomogeneities in the distribution of refractive index, and from the rough surface. Theory verifies the observed increase of decrement and decrease of intensity with height above about 10 feet for the 3-centimeter band.

## I. INTRODUCTION

IN THE SPRING of 1945, the Naval Research Laboratory organized an expedition to Antigua, British West Indies, for the purpose of studying propagation of microwaves over the ocean under conditions of low-level "ducts." A duct is a state of the atmosphere favorable to propagation of microwaves, which is brought about by a suitable variation with height of the refractive index of the air. When, for example, the index of refraction of the air decreases with elevation for some distance above the surface, the rays which start at the source at a slight upward inclination with the horizontal are bent downwards, and eventually suffer reflection at the surface, from where they are propagated further by additional reflections. The radiation which would under normal conditions escape to space is thus guided, to a greater or smaller degree, close to the surface, and is propagated out to great

ranges. Conditions which favor the establishment of a duct are a diminishing humidity, or an increasing temperature with elevation, or both. At Antigua the temperature was observed to decrease with elevation, but the rapid fall of the moisture content with height in the surface layer brought about a persistent surface duct extending to heights of 20 to 40 feet. As a result, it was observed that both 10- and 3-centimeter waves were propagated out to ranges of about 200 miles.

The island of Antigua is particularly suited for the study of propagation in oceanic surface ducts because of the persistent atmospheric structure that is characteristic of the northeasterly trade-wind belt. The air masses to the northeast of the island have had a long sojourn over the ocean, and are therefore horizontally homogeneous and representative of maritime conditions. Furthermore, the propagation measurements made were unusually extensive for this type of experiment in that continuous one-way transmission data were obtained at four or more elevations and for two positions of the transmitting antenna. The simultaneous measurements of propagation characteristics of the 10- and 3-centimeter bands offered, as will be shown later, an additional advantage in the rational interpretation of the data.

## II. METHOD OF ANALYSIS

In this section we shall give an outline of the method used in analyzing the transmission data by wave theory. The basic theory was developed in recent years by Booker, Burrows, Freehafer, Furry, Hartree, Pearcey, Pryce, and, independently in another field of application, by the writer. Our account will be limited principally to a statement of results, for the detailed proofs of which the reader is referred to the original memoirs.<sup>2</sup>

When the fractional change of the index of refraction  $\mu$  over a distance of a wavelength is small, the electromagnetic field is determined by a single Hertzian potential  $\Psi$  which satisfies the wave equation

$$\nabla^2 \Psi + k^2 \mu^2 \Psi = 0, \quad k = 2\pi/\lambda \quad (1)$$

where a time factor  $e^{i\omega t}$  has been assumed. For vertical polarization  $\Psi$  represents the vertical component of the electric Hertzian potential, while for horizontal polarization it represents the vertical component of the magnetic Hertzian potential. The observed field intensity is proportional to  $|\Psi|$  in each case. Equation (1) is to be

\* Decimal classification: R112.43. Original manuscript received by the Institute, July 18, 1946; revised manuscript received, October 2, 1946.

† Columbia University Mathematical Physics Group, on leave of absence from M.I.T. This paper is based on work done for the Naval Research Laboratory under contract N5ori-90 with the Navy's Office of Research and Inventions.

<sup>1</sup> The band actually used in the experiments was 9.1 centimeters rather than 10 centimeters. For a wavelength of 9.1 centimeters the theoretical decrement is 0.85 decibels per nautical mile.

<sup>2</sup> See W. H. Furry, "Theory of characteristic functions in problems of anomalous propagation," Radiation Laboratory Report 680, February, 1945, where references to other papers will be found.



solved subject to the following boundary conditions:

- (a)  $\Psi$  should reduce to the form  $e^{-ikR}/R$  for small distances  $R$  from the source,
- (b)  $\Psi$  should vanish at the ground, and
- (c)  $\Psi$  should represent an outgoing wave at great distances from the source.

The boundary condition (b) is not strictly true, but it is a good approximation for the low-order normal-mode solutions of (1).

The quantity  $\mu$  appearing in (1) represents the index of refraction of the air, which will be assumed to vary only with height above the ground, and the boundary condition (b) is to be satisfied at the spherical surface of the earth. The analysis can be simplified by the use of a device due originally to Schelleng, Burrows, and Ferrell<sup>3</sup> and later developed by M. H. L. Pryce,<sup>4</sup> whereby space is transformed so as to make the surface of the earth plane and the rays curved. The transformation can be accomplished by using in (1), instead of  $\mu$ , the so-called modified index of refraction  $N$  defined by

$$N = \frac{r\mu(r)}{b\mu(b)} \quad (2)$$

where  $r$  denotes the distance from the center of the earth and  $b$  is the radius at some reference level. Taking  $b = a$ , the radius of the earth, we have

$$\frac{r}{a} = 1 + \frac{h}{a}, \quad (3)$$

$$\frac{\mu(r)}{\mu(a)} = 1 + \dot{\mu}h + \mu'(h), \quad (4)$$

$$N \simeq 1 + h\left(\dot{\mu} + \frac{1}{a}\right) + \mu'(h). \quad (5)$$

Here  $h$  denotes height above ground,  $\dot{\mu}$  is the vertical gradient of the index of refraction in the *standard atmosphere*, and  $\mu'(h)$  denotes the *refraction anomaly* or the deviation of the refractive index from standard conditions. The term  $h\dot{\mu}$  in (5) has the effect of modifying the radius of the earth  $a$  to an effective value  $a_*$  determined by

$$\frac{1}{a_*} = \frac{1}{a} + \dot{\mu}. \quad (6)$$

The value of  $a_*/a$  is generally taken as 4/3. In practice it is convenient to use the quantity  $M$ , defined by

$$M - M_0 = 10^6(N - 1). \quad (7)$$

Substituting in (5) and using the dependence of  $\mu$  on atmospheric pressure  $p$  (millibars), temperature  $T$  (absolute scale), and the partial pressure of water vapor  $e$  (millibars), one finds that

$$M = \frac{79p}{T} + \frac{3.8 \times 10^5 e}{T^2} + 0.048h \quad (8)$$

<sup>3</sup> J. C. Schelleng, C. R. Burrows, and E. B. Ferrell, "Ultra-short-wave propagation," *Proc. I.R.E.*, vol. 21, pp. 427-463; March, 1933.

<sup>4</sup> Unpublished report. See also J. E. Freehafer, "The effect of atmospheric refraction on short radio waves," *Radiation Laboratory Report 447*, 1943; and C. L. Pekeris, "Accuracy of the earth-flattening approximation in the theory of microwave propagation," *Phys. Rev.*, vol. 70, pp. 518-522; October, 1946.

where  $h$  is expressed in feet. Here the term  $0.048h$  is  $10^6(h/a)$ ; under standard conditions the sum of the first two terms in (8) varies with height like  $-0.012h$ , giving

$$M_{std} = M_0 + 0.036h. \quad (9)$$

Barring certain pathological cases which we need not consider here,<sup>4</sup> it is possible to obtain a solution of (1) satisfying the boundary conditions in terms of *normal modes* as follows:

$$\Psi = -i\pi \sum_1^{\infty} H_0^{(2)}(k_m d) U_m(h_1) U_m(h_2) \quad (10)$$

where  $d$  denotes horizontal distance from source (i.e., distance along a great circle),  $h_1$  and  $h_2$  the heights of transmitter and receiver above ground, and the  $k_m$  are characteristic complex numbers whose imaginary parts are negative. The *height-gain functions*  $U_m(h)$  must satisfy the differential equation

$$\frac{d^2 U_m}{dh^2} + (k^2 N^2 - k_m^2) U_m = 0, \quad k = 2\pi/\lambda \quad (11)$$

and are to be normalized so that

$$\lim_{l(k) \rightarrow 0} \int_0^{\infty} U_m^2(h) dh = 1. \quad (12)$$

The method of deriving the normal-mode solution (10) of the wave equation (1) (by residues) is due originally to H. Lamb, who in a classical paper written in 1904<sup>5</sup> gave the first exact solution of the problem of radiation from a point source in an homogeneous elastic half-space. The problem treated by Lamb possesses only one normal mode (the Rayleigh wave); later H. Jeffreys<sup>6</sup> used the same method in a problem of a layered medium involving an infinite number of modes (love waves). A detailed development of the normal-mode expansion theorem in cases of media with continuous or discontinuous variations of the refractive index was given by the writer in May, 1943.<sup>7</sup> The problem was also treated by T. Pearcey,<sup>8</sup> W. H. Furry,<sup>9</sup> and G. L. Roe.

In order to meet the boundary condition (b) we must have

$$U_m(0) = 0. \quad (13)$$

Condition (c) is already met at large *horizontal* distances by the choice of the Hankel function of the second kind, because

$$H_0^{(2)}(k_m d) \rightarrow \sqrt{\frac{2}{\pi k_m d}} e^{-ik_m d + i\pi/4}. \quad (14)$$

<sup>5</sup> H. Lamb, "On the propagation of tremors over the surface of an elastic solid," *Phil. Trans. Roy. Soc. A*, vol. 203, pp. 1-42; January, 1904.

<sup>6</sup> H. Jeffreys, "The formation of love waves," *Beitrage zur Geophysik*, vol. 30, pp. 336-350; June, 1931.

<sup>7</sup> See reference 5, p. 2, of Radiation Laboratory Report 680, and C. L. Pekeris, "Theory of propagation of sound in a half-space of variable sound velocity under conditions of formation of a shadow zone," *Jour. Acous. Soc. Amer.*, vol. 18, pp. 295-315; October, 1946.

<sup>8</sup> See reference 6, p. 2, in Radiation Laboratory Report 680.  
<sup>9</sup> W. H. Furry, Radiation Laboratory Report 680, February, 1945.



In order to satisfy condition (c) at large heights we require that the base of  $U_m(h)$  should decrease with  $h$  for large  $h$ . The last condition and condition (13) can be satisfied only for a particular set of characteristic values  $k_m$ , and the resulting solutions of (11) represent the normal modes.

The normal modes can be roughly visualized as originating from constructive interference between plane waves incident at a grazing angle  $\alpha_m$ , and their reflections from the ground, the  $\alpha_m$  being determined from

$$k_m = k_n(h_1) \cos \alpha_m. \tag{15}$$

The existence of particular directions for which the reflected waves interfere *constructively* with the incident waves bears some analogy with diffraction spectra from gratings, where the spectra of various orders appear at particular angles.<sup>10</sup> These directions are such that the difference in optical path from two neighboring lines in the grating is one wavelength. The analogy with diffraction spectra is closer in the case of trapping, i.e., when the modified index has a minimum at some level, resulting in a channeling of the radiation through that level. For the purpose of bringing out this analogy we will assume a model of a surface duct consisting of a layer of constant modified index of refraction topped by a perfect conductor. The wave energy is then completely trapped between the conducting ground and the conducting ceiling. The field can then be represented as being due to the source and its images in the two conducting surfaces, the number of images being infinite in this case. *These images correspond to the lines in a diffraction grating.* Under actual conditions, the specular reflection from the idealized conducting ceiling is replaced by continuous reflection from levels in which the modified index decreases with height, and the infinite series of discrete images is replaced by a corresponding continuous distribution of images. The  $\alpha_m$  are under actual conditions complex numbers, so that their interpretation as grazing angles becomes strained, especially under standard or substandard refraction conditions where the  $\alpha_m$  are distinctly nonreal.

In solving (11) one finds that the two terms in the factor multiplying  $U_m$  nearly cancel each other. Hence it is convenient to write

$$k_m^2 = k^2(1 - \Lambda_m) \tag{16}$$

$$N^2(h) \equiv 1 + y(h); \quad y(h) = 2 \times 10^{-6}[M(h) - M_0], \tag{17}$$

whereby (11) is transformed into

$$\frac{d^2 U_m}{dh^2} + k^2[y(h) + \Lambda_m]U_m(z) = 0. \tag{18}$$

Equation (18) can be standardized by the introduction of nondimensional or *natural units of height and horizontal distance*. Let

$$g \equiv \text{standard slope of } N^2 \text{ curve} = 3/(2a), \tag{19}$$

where  $a$  is the radius of the earth. Then the natural units of height  $H$  and of horizontal distance  $L$  are defined by

$$H = (k^2 q)^{-1/2}, \quad L = 2(kq^2)^{-1/2}. \tag{20}$$

With

$$z = h/H, \quad x = d/L, \quad Y(z) = (k/q)^{2/3} y(h), \tag{21}$$

$$D_m = (k/q)^{2/3} \Lambda_m = B_m + iA_m, \tag{22}$$

(18) takes on the form

$$\frac{d^2 U_m(z)}{dz^2} + [Y(z) + D_m]U_m(z) = 0. \tag{23}$$

In terms of natural units and by the use of (14) one finds, on inserting the time factor  $e^{i\omega t}$ , that

$$\Psi = e^{i(\omega t - z + d/L)} \frac{2\sqrt{\pi}}{L} \frac{1}{\sqrt{x}} \sum_1^\infty e^{-\Lambda_m z + iB_m z} U_m(z_1) U_m(z_2). \tag{24}$$

Here  $U_m(z) = \sqrt{H} U_m(h)$ , so that, by (12),

$$\int_0^\infty U_m^2(z) dz = 1. \tag{25}$$

The normal-mode solution (24) is useful beyond the horizon and whenever only a few modes are excited.

Of particular interest to the interpretation of the Antigua experiment is the case of a linear-exponential  $M$  curve:

$$M = M_0 + 0.036h + g e^{-\gamma h}, \tag{26}$$

$$Y(z) = z + \alpha e^{-\gamma z}. \tag{27}$$

In Table I are given some numerical constants which are useful in computing natural units and in treating the exponential model. A value of 6371 kilometers for the mean radius of the earth was adopted. By the "decrement" is meant the rate of attenuation in the horizontal direction, *excluding the 1/d divergence factor, when only*

TABLE I  
CONVERSION FACTORS FOR NATURAL UNITS

Wave-length	$H$	$L$	$\alpha$	$\gamma$	Decrement
centi-meters	feet	nautical miles			decibels per nautical mile
$\lambda$	$7.243\lambda^{3/2}$	$3.304\lambda^{1/2}$	$3.848\lambda^{-1/2}$	$7.243\lambda^{3/2} g$	$2.629\lambda^{-1/2} A_m$
3	15.07	4.766	1.850g	15.07c	1.822A <sub>m</sub>
10	33.62	7.120	0.8290g	33.62c	1.220A <sub>m</sub>

*one mode is excited.* This term applies directly to the case when only the first mode persists at moderate ranges, but it is also useful in cases when the first few modes are completely trapped (attenuation zero) but the variations in the field are controlled primarily by the first leaky mode. The horizon is expressed by the equation

$$d = 1.063(\sqrt{h_1} + \sqrt{h_2}) \text{ nautical miles} \tag{28}$$

where  $h_1$  is the height of transmitter and  $h_2$  the height of a point on the horizon at a distance  $d$  from the transmitter, both expressed in feet.

In representing coverage diagrams we use the scale of *path attenuation*, which is defined as the ratio between

<sup>10</sup> J. C. Slater, "Microwave Transmission," p. 284, McGraw-Hill Book Co., New York, N. Y., 1942.



the power radiated by a doublet at one terminal of the path to the maximum power that can be recovered from a similar antenna at the other terminal, when the orientation of the antennas and the impedance of the load are adjusted for maximum power transfer. The formula for path attenuation is

$$P.A. = -20 \log_{10} \left( \frac{3\lambda |\Psi|}{8\pi} \right) \text{ decibels} \quad (29)$$

where  $\Psi$  is the Hertzian potential given by (24).

### III. THE *M* CURVE OBSERVED DURING THE ANTIGUA EXPERIMENT

Observations of the vertical distribution of temperature and humidity were made on board ship and on a halyard rig which ran from a pole at the top of a 90-foot wooden tower, located 60 feet from the shore, to the water's edge. On account of the state of the sea and the difficulties in aeration of the radiation shield when running with the wind, the ship data were of limited accuracy. However, when heading into the wind, representative psychrometric data were obtained at an elevation of 20 feet. These showed that the air at 20 feet was colder than the water. Our knowledge of the refraction conditions that prevailed during the Antigua experiment is therefore based mostly on the soundings made at the shoreline. The shore data showed that during the entire period of observations a simple surface duct existed over the water. The strength of the surface duct in the open sea must have been greater than was observed on the shore because of the modifying influence of the island. From observations made inland it appears that the duct is probably completely destroyed within one-quarter to one-half mile from shore. In judging the refraction conditions at sea one therefore has to increase suitably the *M* values in the surface layer as observed near the tower. An example of such an adjustment is shown by the *M* curve *C'* in Fig. 1.

The individual soundings showed considerable scatter both in the temperature and in the humidity readings. Representative *M* curves were computed from smoothed temperature and humidity data extending over a period of a given weather regime. Fig. 1 shows representative *M* curves under conditions of normal winds, low winds, and high winds. The observed values are plotted as dots, while the continuous curves show the degree to which the observed data can be approximated analytically by a linear-exponential expression.

The wave theoretical interpretation of the transmission data obtained in the Antigua experiment was made on the basis of the *M* curve *C'* in Fig. 1:

$$M - M_0 = 0.036h + 12.06e^{-0.0714h}, \quad (30)$$

*h* being expressed in feet. When expressed in natural units (see (21) and Table I), we obtain

$$Y(z) = z + 10e^{-2.4z} \quad (31)$$

for the 10-centimeter band, and

$$Y(z) = z + 22.31e^{-1.076z} \quad (32)$$

for the 3-centimeter band. The curve *C'* was adopted as representative for the open sea under normal wind conditions, after consultation with members of the Antigua

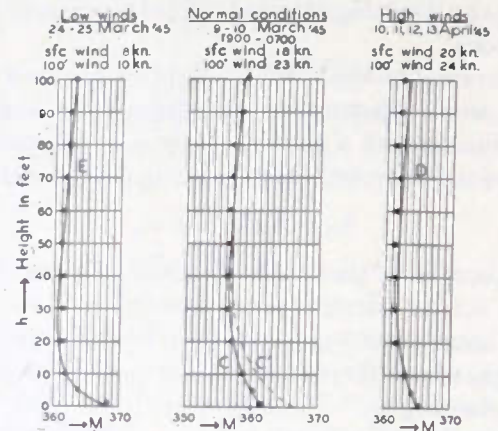

Fig. 1—Representative *M* curves at Antigua. • = Average observed points.

Curve	Equation of curve	Value of <i>M</i> at water surface
<i>C'</i>	$M = 354.7 + 0.036h + 12.06e^{-0.0714h}$	
<i>C</i>	$M = 354.7 + 0.036h + 7.6 e^{-0.0720h}$	389.3
<i>D</i>	$M = 359.8 + 0.036h + 5.85e^{-0.0881h}$	391.3
<i>E</i>	$M = 359.4 + 0.036h + 9.0 e^{-0.137h}$	394.4

expedition as to the magnitude of the correction to be applied to the observed shore data shown by curve *C* in Fig. 1. As explained above, this correction allows for the modifying influence of the island on the approaching air masses. That such a correction was necessary became apparent independently from a preliminary analysis of the transmission data for the 10-centimeter band. Using the phase-integral method, which though approximate is sufficient for the purpose in hand, it was found that for the 10-centimeter band the theoretical horizontal decrements are 2.1, 1.5, and 1.6 decibels per nautical mile for the *M* curves *E* (low), *C* (normal), and *D* (high), respectively. The observed decrements, when averaged over all transmitter heights and receiver heights, were 1.8, 0.9, and 0.6 decibels per nautical mile, respectively. While the effect of wind on transmission of the 10-centimeter band, especially the adverse effect of low winds, is qualitatively accounted for, the theoretical decrements for the *M* curves obtained on the shore line are considerably in excess over the values observed at sea. Curve *C'* was judged to represent the maximum correction for the land effect which is consistent with the rather reliable *M* values measured on board ship at elevations greater than 20 feet. Subsequently it was found that the theoretical decrement for curve *C'* is in agreement with the observed values.

### IV. THE NORMAL MODES

Having adopted the *M* curve given in (30), (31), and (32), our next step is to compute the characteristic values *D<sub>m</sub>* and the height-gain functions *U<sub>m</sub>* from (23),



subject to the normalizing condition (25) and to the boundary conditions stated on page 454. With these, the field is then computed from (24) and (29). At present there is no general method which is both convenient and exact for solving (23) in case  $Y(z)$  is a linear-exponential function of the form (27). However, several approximate methods have been developed, some of which are as yet unpublished, by which useful solutions can be obtained without an undue amount of labor in limited regions of the  $\alpha, \gamma$  plane. The accuracy of the approximate methods is judged either by criteria of convergence of successive approximations in an individual method, or by the degree of agreement between results obtained from two different methods, when more than one method is applicable. In this section we shall give an account of the computation of the field intensity for the  $M$  curve (30), both for the 3-centimeter and 10-centimeter bands. A detailed exposition of the methods used in the solution, some of which are applicable to more general types of continuous  $M$  curves, will be given in another paper.

1. The Normal Modes for the 10-Centimeter Band

For a wavelength of 10 centimeters we have

$$Y(z) = z + 10e^{-2.4z} \tag{31}$$

The computation of the characteristic value  $D_1$  for the first mode in this case proved to be most difficult because the parameters  $\alpha$  and  $\gamma$  happen to lie in a region where none of the available analytical methods are particularly effective. In Table II are listed several approximations to  $D_1$  obtained by different methods, together with supplementary information indicating the probable error of each determination.

The value adopted in the computations of the field intensity was  $D_1 = -1.25 + 0.84i$ . The reason for choosing this value is that, when using the form  $U_1 = A(z + bz^2)e^{-\alpha z}$

TABLE II

APPROXIMATE DETERMINATIONS OF THE CHARACTERISTIC VALUE OF THE FIRST MODE  $D_1$  FOR THE CASE  $Y(z) = z + 10e^{-2.4z}$

Method	Approximation	$D_1$
Phase integral	Leading term	$-1.41 + 0.72i$
	Including second term	$-1.30 + 0.62i$
Perturbation, <sup>11</sup> using linear combinations of standard functions.	Five standard modes	$-1.20 + 0.47i$
	Six standard modes	$-1.31 + 0.52i$
New phase integral <sup>12</sup> method.	Leading term; including first-order perturbation	$-1.09 + 0.56i$
		$-1.11 + 0.84i$
Variational method <sup>13</sup>	Using $U_1 = Aze^{-\alpha z}$	$-1.44 + 0.90i$
	Using $U_1 = A(z + bz^2)e^{-\alpha z}$	$-1.25 + 0.84i$

<sup>11</sup> C. L. Pekeris, "Perturbation theory of the normal modes for an exponential  $M$  curve in nonstandard propagation of microwaves," *Jour. Appl. Phys.*, vol. 17, pp. 678, 684; August, 1946.

<sup>12</sup> C. L. Pekeris, "Asymptotic solutions for the normal modes in the theory of microwave propagation," *Jour. Appl. Phys.*, vol. 17, pp. 1108-1124; December, 1946.

<sup>13</sup> C. L. Pekeris and S. Ament, "Characteristic values of the first normal mode in the problem of propagation of microwaves through an atmosphere with a linear-exponential modified index of refraction," to be published in *Phil. Mag.*

in the variational method, one obtains a value of  $D_1$  for the standard case which differs from the correct value by less than 1 per cent, and that this form of  $U_1$  would be expected to yield even better results as trapping is approached. However, from the values tabulated in Table II it would appear that an error of as much as 0.2 cannot be precluded. Such an error in the imaginary part of  $D_1$  would imply an uncertainty of about 0.25 decibel per nautical mile in the decrement. Since this is within the range of fluctuations of daily values of the observed decrement in a given weather regime, it did not seem worth while to seek a more refined value for  $D_1$ .

Having adopted a value for  $D_1$ , the height-gain function  $U_1$  was obtained by numerical integration of (23). For this purpose it was necessary to determine  $\dot{U}_1(0)$ , the derivative of  $U_1$  at the surface. The latter was obtained as follows. The constant  $A$  in

$$U_1 = A(z + bz^2)e^{-\alpha z} \tag{33}$$

was determined from the normalization condition

$$\int_0^\infty U_1^2(z) dz = 1, \tag{25}$$

and  $\dot{U}_1(0)$  was then computed from the relation

$$\dot{U}_1(0)^2 = - \int_0^\infty U_1^2(z)(1 - \alpha\gamma e^{-\gamma z}) dz, \tag{26}$$

which follows directly from the differential equation

$$\frac{d^2 U_1(z)}{dz^2} + [z + \alpha e^{-\gamma z} + D_1] U_1(z) = 0. \tag{34}$$

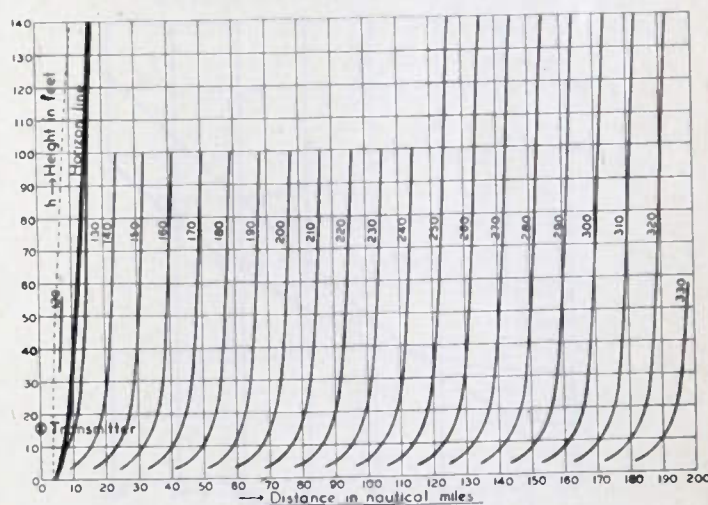

Fig. 2—Theoretical coverage diagram for a transmitter height of 16 feet.

Wavelength = 10 centimeters  
 $M - M_0 = 0.036h + 12.06 e^{-0.0714h}$   
 $Y(Z) = Z + 10 e^{-2.4Z}$

Numbers denote path attenuation in decibels.

Expression (33) was used in the integrand of (26). The value of  $\dot{U}_1(0)$  thus obtained was  $1.613e^{0.6961i}$ . Using the form  $U_1 = Aze^{-\alpha z}$  and the same method, one arrives at the value of  $1.658e^{0.6966i}$ .

The decrement of the first mode is 1.0 for the 10-centimeter band while that of the second mode is close to 4.



Hence the field of this band is determined primarily by the first mode alone, the second and higher modes disappearing after a short range beyond the horizon. The coverage diagram shown in Fig. 2 was computed for

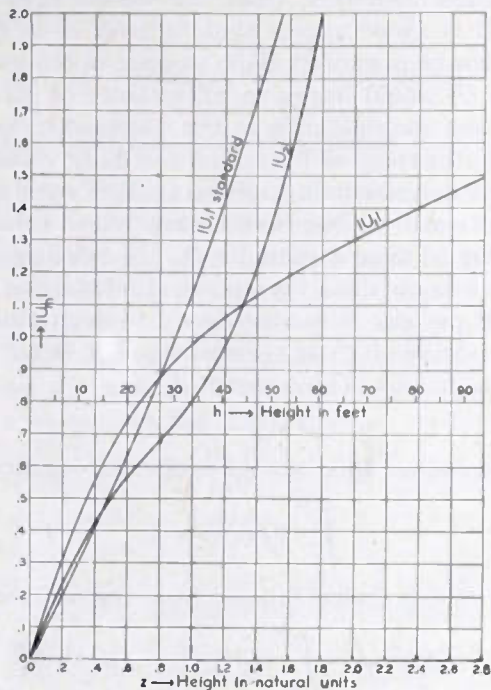

Fig. 3—Height-gain functions  $|U_1|$  and  $|U_2|$  for the first and second modes.

Wavelength = 10 centimeters  
 $M - M_0 = 0.036h + 12.06e^{-0.0714h}$   
 $Y(Z) = Z + 10e^{-2.4Z}$   
 Unit of  $Z = 33.62$  feet

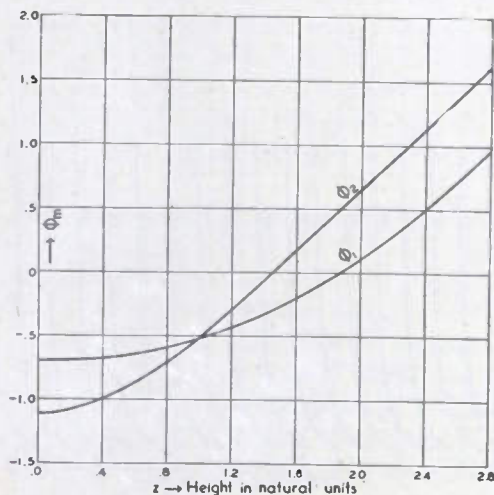

Fig. 4—Phases  $\phi_1$  and  $\phi_2$  of the first and second modes.

$U_m(Z) = |U_m(Z)|e^{-i\phi_m(Z)}$   
 Wavelength = 10 centimeters  
 $M - M_0 = 0.036h + 12.06e^{-0.0714h}$   
 $Y(Z) = Z + 10e^{-2.4Z}$

such ranges and elevations that the second mode did not contribute more than 25 per cent of the total intensity.<sup>14</sup> It will be seen that this region extends inwards up to the horizon, and to elevations of 100 feet. It follows that, in our application, neither the decrement nor

the height-gain function of the second mode needed to be known with high accuracy.

Using a linear combination of six standard modes in the perturbation method,<sup>11</sup>  $D_2$  was found to be  $-2.01 + 3.11i$ ; linear combinations of four and five standard modes yielded values  $-2.02 + 3.18i$  and  $-2.01 + 3.14i$ , respectively. Hence, in this case, the perturbation method leads to fairly accurate values for the characteristic value. The value of  $D_2$  obtained by the phase-integral method was  $-2.19 + 3.01i$ ; for the standard case  $D_2 = -2.04 + 3.54i$ . In the final computations of the field a value of  $-2.01 + 3.11i$  for  $D_2$  was adopted, and the height-gain function of the second mode was computed by the phase-integral method using Hankel functions of order  $1/3$  (R. E. Langer,<sup>15</sup> H. Jeffreys<sup>16</sup>). The height-gain function thus obtained is, of course, only approximate, but for the reasons explained above it is adequate for our particular application. Figs. 3 and 4 show the height-gain functions of the first two modes for the 10-centimeter band.

## 2. The Normal Modes for the 3-Centimeter Band

For a wavelength of 3 centimeters we have

$$Y(z) = z + 22.31e^{-1.076z} \quad (32)$$

In this case the first mode is completely trapped,  $D_1$  being equal to  $-8.01 + 5.5 \times 10^{-10}i$ , as determined by the phase-integral method (Gamow, Furry<sup>2</sup>). The height-gain function  $U_1$  was computed by a phase-integral method involving Bessel functions of order  $1/3$ .<sup>12</sup> It was accomplished by developing solutions of the Langer type near each turning point and then joining them at the duct height.

The second mode was found to be on the verge of trapping, yet with a decrement that was not too small to be negligible. For this mode the new phase integral method was found to be effective. Using the leading term in this method, a value of  $-3.66 + .18i$  for  $D_2$  was obtained; when a first-order perturbation was included the value changed to  $-3.63 + 0.26i$ . This value is probably accurate to within 0.02, judging from the success of the method in reproducing exact values of  $D_1$  which were determined in the same range of parameters  $\alpha$  and  $\gamma$  by the use of Hartree's differential analyzer.<sup>16</sup>

With an adopted value of  $-3.63 + 0.26i$  for  $D_2$ , the height-gain function  $U_2(z)$  was computed by integrating the differential equation (23), and using a value for  $U_2(0)$  as determined from the new phase-integral method.  $U_2(z)$  was also computed from the leading term in the phase-integral solution, and the results were found to agree closely up to 30 feet elevation, but between 30 and 90 feet the two solutions began to diverge, reaching a maximum discrepancy in amplitude of 25 per cent at 90 feet. In view of the fact that the perturbation term

<sup>15</sup> R. E. Langer, "On the connection formulas and the solutions of the wave equation," *Phys. Rev.*, vol. 51, pp. 669-676; April, 1937.  
<sup>16</sup> H. Jeffreys, "Asymptotic solutions of linear differential equations," *Phil. Mag.*, vol. 33, pp. 451-456; June, 1942.

<sup>14</sup> This 25 per cent line is given by the - - - - curve.



was not included in the second computation of  $U_2(z)$ , the result can be considered as satisfactory.

The third mode in the 3-centimeter band leaks heavily, with a decrement close to 4 decibels per nautical mile. Hence its decrement and height-gain function were computed only approximately, merely for the purpose of determining the region where its contribution to the

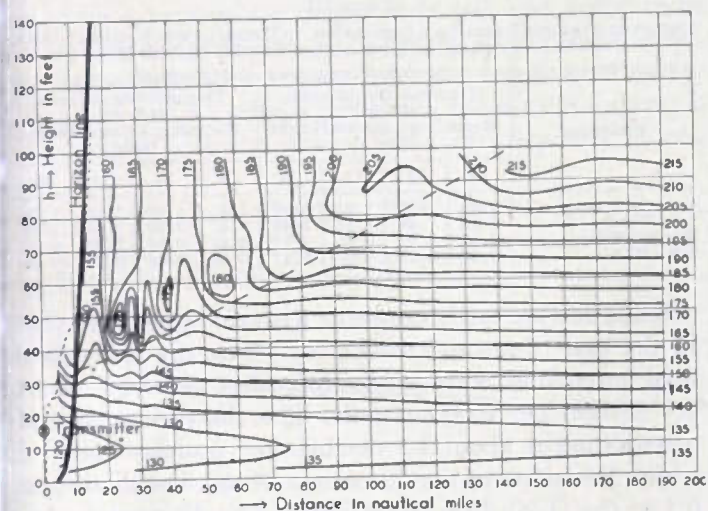

Fig. 5—Theoretical coverage diagram for a transmitter height of 16 feet.

Wavelength = 3 centimeters  
 $M - M_0 = 0.036h + 12.06 e^{-0.0714h}$   
 $Y(Z) = Z + 22.31 e^{-1.076Z}$

Numbers denote path attenuation in decibels.  
 --- Approximate line of demarcation between regions controlled by the first mode or by the second mode.

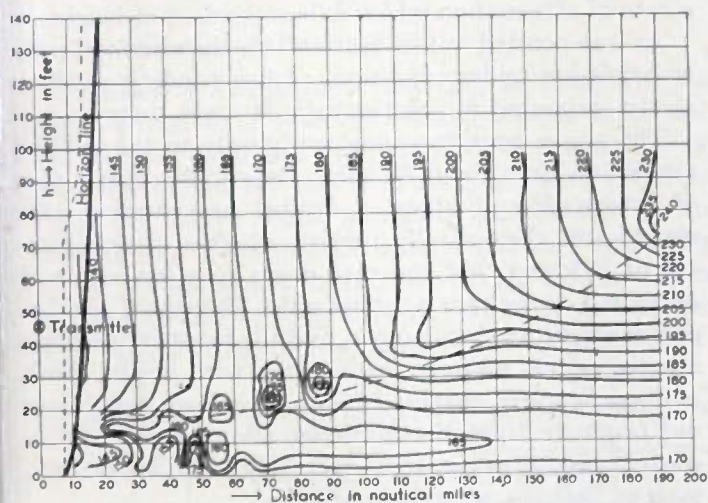

Fig. 6—Theoretical coverage diagram for a transmitter height of 46 feet.

Wavelength = 3 centimeters  
 $M - M_0 = 0.036h + 12.06 e^{-0.0714h}$   
 $Y(Z) = Z + 22.31 e^{-1.076Z}$

Numbers denote path attenuation in decibels.  
 --- Approximate line of demarcation between regions controlled by the first mode or by the second mode.

total field intensity is less than 25 per cent. This region is extensive and is shown in Figs. 5 and 6.<sup>14</sup> A value of  $D_3 = -3.13 + 2.16i$  was obtained from the phase-integral method, and  $U_3(z)$  was also computed by this method using the Hankel function of order 1/3. Figs. 7 and 8 show the height-gain functions of the first 3 modes for the 3-centimeter band.

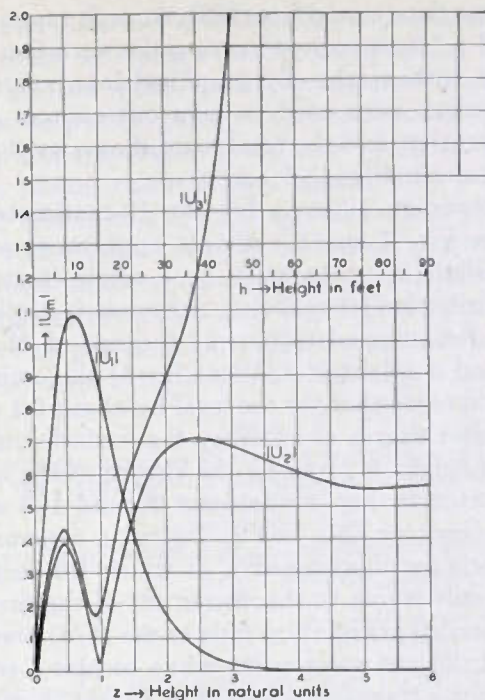

Fig. 7—Height-gain functions  $|U_m|$  for the first three normal modes.

Wavelength = 3 centimeters  
 $M - M_0 = 0.036h + 12.06 e^{-0.0714h}$   
 $Y(Z) = Z + 22.31 e^{-1.076Z}$   
 Unit of  $Z = 15.07$  feet

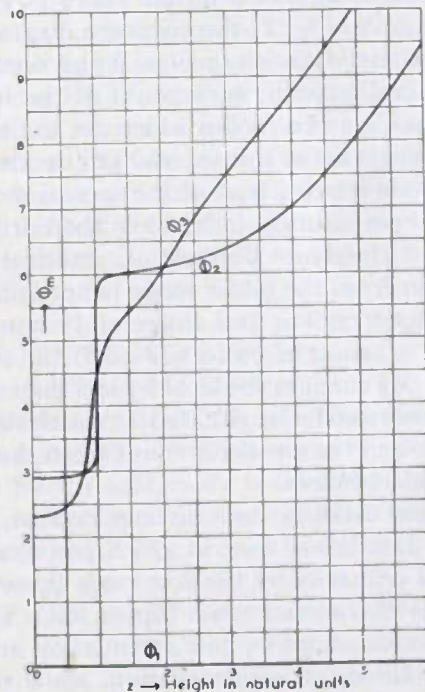

Fig. 8—Phases of the first three normal modes.

$U_m(Z) = |U_m(Z)| e^{-i\phi_m(Z)}$   
 Wavelength = 3 centimeters  
 $M - M_0 = 0.036h + 12.06 e^{-0.0714h}$   
 $Y(Z) = Z + 22.31 e^{-1.076Z}$

### V. DISCUSSION OF THE THEORETICAL COVERAGE DIAGRAMS

With the aid of the computed normal modes, the potential  $\Psi$  was computed from (24) at several ranges  $x$ , and the path attenuation below the horizon at these



ranges was determined from (29). At each range we thus obtained a "cross section" giving the variation of field intensity with height. By graphical interpolation, the cross sections were used to map out contour lines of equal intensity, and the results are shown by the coverage diagrams in Figs. 2, 5, and 6.

The coverage diagram for the 10-centimeter band shown in Fig. 2 has the simple appearance which is characteristic of propagation by a single (first) mode. The contribution from the second mode is negligible in most of the mapped region; at a range of 21.3 miles ( $x=3$ ) and a height of 134 feet ( $z=4$ ) the omission of the second mode changes the level by about 0.1 decibel. To the same degree of accuracy the variation of intensity with height is given by the square of the ordinate  $|U_1|$  plotted in Fig. 3. Between 20 and 100 nautical miles the contour lines in Fig. 2 give an attenuation of 1.1 decibels per nautical mile, of which 1.0 decibel per nautical mile is due to the decrement of the first mode and 0.1 decibel per nautical mile to the  $(1/d)$  divergence factor. It did not seem worth while to plot a coverage diagram for a transmitter height of 46 feet, as was done in the case of the 3-centimeter band, because it would have an appearance similar to Fig. 2. The only difference would be in the numerical value of path attenuation which would be less by  $20 \log_{10}(1.12/.635) = 5$  decibels at each level, as follows from the curve  $|U_1|$  in Fig. 3.

In contrast to Fig. 2, the coverage diagrams for the 3-centimeter band shown in Figs. 5 and 6 exhibit more of a structural pattern, on account of the interference between the first two modes which are excited in comparable strengths. For this wavelength the decrement of the first mode is zero, that of the second mode is only 0.47 decibel per nautical mile, while the third mode has a decrement close to 4 decibels per nautical mile. The contribution from the latter mode is negligible in most of the mapped region; at a range of 19 nautical miles ( $x=4$ ) and a height of 98 feet ( $z=6.5$ ) the omission of the third mode changes the level by less than 0.3 decibel when the transmitter is situated at an elevation of 16 feet, and by an even smaller amount when the transmitter is located at 46 feet.

Figs. 5 and 6 exhibit two distinct regions, separated roughly by the dashed line, in which propagation takes place either primarily by the first mode (lower right) or primarily by the second mode (upper left). The former region is characterized by low attenuation and a rapid decrease of intensity with elevation, while the second region is characterized by a rate of attenuation of about 0.6 decibel per nautical mile and a nearly uniform distribution of intensity with height. For the transmitter height of 16 feet (Fig. 5) the latter region is small, because at that level the amplitude of the first mode is high and the amplitude of the second mode is near a minimum (see Fig. 4). On the other hand, for a transmitter height of 46 feet the region in which propagation takes place via the second mode is more extensive, because the first mode is poorly excited at that level.

## VI. COMPARISON OF OBSERVED WITH THEORETICAL FIELD INTENSITIES

### 1. The 10-Centimeter Band

A. *Rates of Attenuation.* In Table III are listed the average observed rates of attenuation under various wind conditions.<sup>17</sup> It is seen that the observed rates of

TABLE III  
OBSERVED AVERAGE RATES OF ATTENUATION, IN DECIBELS PER NAUTICAL MILE, FOR THE 10-CENTIMETER BAND AT RANGES LESS THAN 80 MILES

Condition	(Transmitting Antenna, 16 feet) Recording Antenna Height (feet)				(Transmitting Antenna, 46 feet) Recording Antenna Height (feet)			
	14	24	54	94	14	24	54	94
General Average	0.84	1.00	1.03	1.07	1.31	1.10	1.26	1.24
Low Wind	1.38	1.49	1.55	1.44	2.42	2.30	1.96	1.84
Normal Wind	0.86	0.92	0.86	0.97	0.86	0.80	0.97	0.97
High Wind	0.46	0.57	0.57	0.57	0.69	0.46	0.80	0.80

attenuation are fairly constant with elevation, and that in the case of normal winds, for which the theoretical field intensities were computed, they average about 0.9 decibel per nautical mile. The theoretical rate of attenuation is about 1.1 decibels per nautical mile, of which 1.0 is due to the decrement of the first mode and 0.1 to the  $(1/d)$  divergence factor. The discrepancy between the theoretical and observed values is of the order of the uncertainty of either, so that for ranges less than about 80 miles the agreement in magnitude between observed and predicted rates of attenuation can be considered as satisfactory.

In agreement with observation, wave theory predicts a rate of attenuation which is independent of height.

As was pointed out in Section III, the observed poor transmission under conditions of low winds is qualitatively accounted for on the basis of wave theory.

The above considerations apply only to the field at ranges less than about 80 miles. Beyond 80 miles a rate of attenuation of about 1 decibel per nautical mile should still theoretically persist, whereas observationally it is found that the rate drops to a low value of about 0.2 decibel per nautical mile. The signal also becomes erratic at these ranges, and the intensity assumes a more or less uniform distribution with height. Both of these features suggest that the received signal does not originate from the diffracted direct beam, but is contributed by some secondary source of irradiation, such as, perhaps, scattered radiation.

B. *Variation of Field Intensity With Height.* One important result discovered in the Antigua experiment was that in the case of the 10-centimeter band the intensity increased with elevation from 14 to 94 feet. This is in contrast with the vertical distribution of intensity for the 3-centimeter band which was characterized by a drop of intensity with elevation above 14 feet. In Fig. 9, the curve shows the theoretical variation of intensity with height for the 10-centimeter band at a range of

<sup>17</sup> M. Katzin, R. W. Bauchman, and W. Binnian, "3- and 9-centimeter propagation in low ocean ducts," to be published in *PROC. I.R.E.*



21 miles and for a transmitter height of 46 feet. The dots represent average intensity levels observed at a range of 20 miles, when referred to the level of 94 feet as datum. The agreement between theory and observations is seen to be good from 24 up to 94 feet, but at 14 feet the observed mean level is below the theoretical by about 6 decibels. The variation of intensity with elevation for a transmitter height of 16 feet was found to be the same as for the 46-foot position of the transmitter, in agreement with theory, but the levels were everywhere about 5 decibels below the theoretical values, in conformity with the observed low intensity near 14 feet.

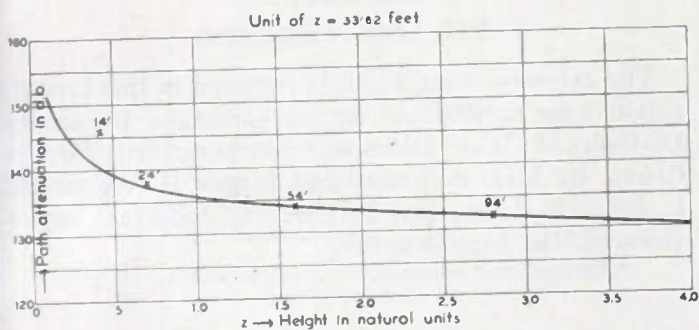

Fig. 9—Theoretical and observed vertical distribution of intensity of Antigua experiment at a range of 20 miles.  
 Wavelength = 10 centimeters  
 $M + M_0 = 0.036h + 12.06 e^{-0.0714h}$   
 $Y(Z) = Z + 10 e^{-2.4Z}$   
 Unit of  $Z = 33.62$  feet  
 — Theoretical  
 x Average observed levels relative to level at 94 feet

2. The 3-Centimeter Band

A. Rates of Attenuation. Referring to Table IV, the tabulated values of observed rates of attenuation of the 3-centimeter band are, with but three exceptions, lower than the values for the 10-centimeter band given in Table III. There is also a definite indication of an increasing rate of attenuation with elevation. Thus, in the case of normal winds, the increase of rate of attenuation between 14 and 94 feet, if at all real, is around 13 per cent for the 10-centimeter band, while for the 3-centi-

TABLE IV  
 OBSERVED AVERAGE RATES OF ATTENUATION, IN DECIBELS PER NAUTICAL MILE, FOR THE 3-CENTIMETER BAND

Condition	(Transmitting Antenna, 16 feet) Receiving Antenna Height (feet)					(Transmitting Antenna, 46 feet) Receiving Antenna Height (feet)				
	6	14	24	54	94	6	14	24	54	94
General Average	0.44	0.44	0.61	0.76	0.66	0.51	0.51	0.55	0.91	0.82
Low Wind	0.80	0.97	2.30	1.84	0.74	0.71	0.86	0.74	0.86	1.95
Normal Wind	0.42	0.34	0.51	0.69	0.69	0.46	0.51	0.51	0.74	0.74
High Wind	0.23	0.17	0.23	0.34	0.46	0.51	0.34	0.28	0.46	0.40

meter band it is of the order of 50 to 100 per cent. Both of these features are in qualitative agreement with theory.

When we come to make a quantitative comparison between the observed and computed rates of attenuation for the 3-centimeter band, we find that some schematization of the complex structure of the coverage

diagrams shown in Figs. 5 and 6 is necessary. For this purpose the computed "cross sections" at 19 miles ( $x=4$ ) and 95 miles ( $x=20$ ) were used to determine average theoretical rates of attenuation between these ranges, and the results are shown in Table V. In the regions where, theoretically, transmission takes place via the second mode, such as transmitter 16 feet, receiver 94 feet, and transmitter 46 feet, receiver 54 feet or 94 feet, the computed rate of attenuation of about 0.6 compares favorably with the observed rate of about 0.7 decibel per nautical mile, for normal winds. On the other hand, the very low rates of attenuation pre-

TABLE V  
 THEORETICAL AVERAGE RATES OF ATTENUATION IN DECIBELS PER NAUTICAL MILE BETWEEN THE RANGES OF 19 AND 95 NAUTICAL MILES FOR THE 3-CENTIMETER BAND

	Receiving Antenna Height (feet)				
	6	14	24	54	94
Transmitting Antenna 16 feet	0.09	0.09	0.09	0.24	0.58
Transmitting Antenna 46 feet	0.28	0.13	0.41	0.56	0.57

dicted by theory in regions where transmission takes place via the first mode (arising from the divergence factor only) are less than the observed values by about 0.3 decibel per nautical mile. This small excess of observed-rate attenuation could probably be attributed to scattering due both to horizontal inhomogeneities in the distribution of refractive index and to the roughness of the sea surface. The first mode is particularly susceptible to the influence of these secondary factors because, first, any small attenuation they bring about stands out against the theoretically vanishing decrement, and, second, because this mode channels the radiation in a layer centered around 9 feet above the surface (see Fig. 4), which is subject to disturbances by the sea waves running from 4 to 8 feet.

B. Variation of Field Intensity With Height. The influence of scattered radiation on transmission in regions governed by the first mode is reflected also in the observed distribution of intensity with height for the 3-centimeter band. Fig. 5, as well as Figs. 6 and 4, show that above an elevation of about 20 feet the intensity of the first mode should theoretically fall off with height at a rate of about 1 decibel per foot. Scattered radiation, if comparable in intensity to the direct diffracted beam, would tend to illuminate the dark regions at the expense of the bright ones, and thus bring about a less rapid variation of intensity with height. Furthermore, we must take into consideration the fact that on account of the rolling and pitching of the ship the heights of the transmitters varied, so that in comparing observed with theoretical vertical distributions of intensity one should average out the coverage diagrams over the corresponding height swung through by the transmitters. Although this averaging was not actually carried out, it is clear



that it would result in a more even distribution of intensity with height, and that it would probably eliminate the interference patterns shown on the coverage diagrams. In the case of the 10-centimeter band, where theoretically the intensity does not vary rapidly with height, the effect of the varying heights of transmitters is of course less.

For the reasons given above no quantitative comparison of observed with computed vertical distribution of intensity with height for the 3-centimeter band was attempted. At a range of 20 miles, Fig. 5 shows that for a transmitter height of 16 feet the intensity decreases with elevation between 6 and 24 feet at an average rate of about 0.45 decibel per foot; this compares favorably with the observed mean rate of decrease of about 0.35 decibel per foot at this range. However, as was mentioned before, the rapid theoretical fall of intensity between 24 and 50 feet, amounting to a rate of about 1 decibel per foot, is not verified observationally. The quantitative comparison with theoretical of observed vertical distribution at a range of 20 miles for a trans-

mitter height of 46 feet is further complicated by the changing interference pattern at that range shown in Fig. 6, and by the fact the observed distribution was deduced by interpolation from data taken at smaller and larger ranges than 20 miles.

*Theory, however, does verify the important qualitative difference in intensity distribution with height between the 10-centimeter and 3-centimeter bands, namely, that in the latter the intensity generally decreases with height above 6 feet. The observed optimum position of transmitter for the 3-centimeter band of between 6 and 15 feet is in agreement with theory.*

#### VII. ACKNOWLEDGMENT

The extensive computations required in this investigation were carried out at the Columbia University Division of War Research, Mathematical Physics Group, by Mrs. B. Brown and Misses D. Weinstock, L. Selig, F. Jones, and E. Herman, under the supervision of Miss Alice Osterberg.

## Microwave Oscillators Using Disk-Seal Tubes\*

A. M. GUREWITSCH†, SENIOR MEMBER, I.R.E., AND J. R. WHINNERY†, SENIOR MEMBER, I.R.E.

**Summary**—Some practical aspects of microwave oscillators using disk-seal tubes are discussed. Typical design and performance data are given.

A general small-signal oscillator theory is presented and applied to the re-entrant disk-seal-tube microwave oscillator.

It is shown how information on frequency of oscillation, tuning, and frequency stability can be obtained.

#### INTRODUCTION

THE USEFUL frequency range of space-charge-controlled tubes has been considerably extended during the war. A notable advance has been accomplished by the "disk-seal" tube. This tube is a triode of novel design.<sup>1</sup> It is formed by plane-parallel electrodes spaced sufficiently close to minimize harmful transit-time phenomena. The disk-seal construction enables the tube to be an integral part of the circuit.

Photographs of three different disk-seal tubes, now on the market, the 2C40, 2C43, and 2C39, are shown in Fig. 1. Their respective rated frequency ranges are at present as follows:

2C40—up to 3370 megacycles

2C43—up to 3370 megacycles

2C39—up to 500 megacycles.

It may be mentioned that these tubes are being con-

\* Decimal classification: R355.912. Original manuscript received by the Institute, April 4, 1946; revised manuscript received, August 28, 1946.

† General Electric Company, Schenectady, N. Y.

<sup>1</sup> E. D. McArthur, "Disk-seal tubes," *Electronics*, vol. 18, pp. 98-102; February, 1945.

stantly improved. For example, some of the developmental 2C39's have operated in oscillators as high as 3000 megacycles. These tubes may be used as oscillators or amplifiers in their respective frequency ranges.

The design of the disk-seal triode is particularly adapted to a so-called grid-separation or grid-return circuit. In such a circuit the output load is placed between the plate and the grid, as contrasted to the conventional arrangement where the output load is placed between

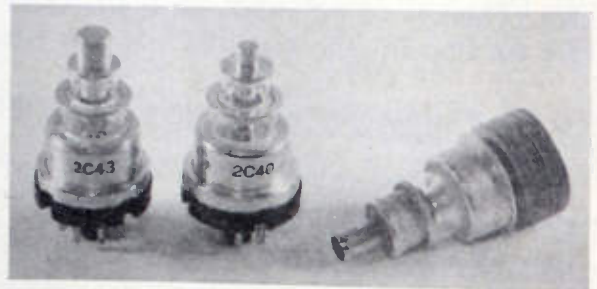

Fig. 1—Commercial disk-seal tubes.

the plate and cathode (see Figs. 2 and 3). It is readily seen that, if the cathode-grid resonator and the grid-plate resonator are not coupled by external means, the only way in which energy can be exchanged between the two resonators is through the electron beam and the electromagnetic coupling through the grid. In amplifiers the latter coupling should usually be small to avoid



undesirable regeneration. In oscillators or neutralized amplifiers, an additional coupling (feedback) of some kind between the output and input is necessary. This coupling is frequency sensitive and is one of the important problems in the design of tunable oscillators.

The circuit shown in Fig. 3 may be considered as the basic oscillator circuit using grid-separation ideas. Many somewhat different physical realizations of the circuit are possible, the best one for any given problem depend-

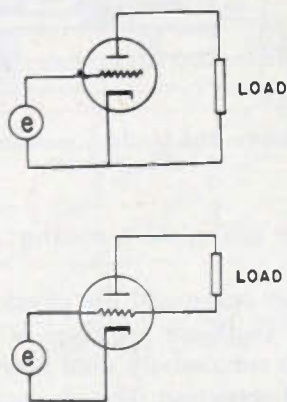

Fig. 2—Cathode-return and grid-return (grid-separation) circuits.

ing upon the application. A few of the considerations in choosing a design are:

- (1) Continuous-wave or pulsed operation
- (2) Tuning range
- (3) Number of controls permissible
- (4) Stability with variations in applied voltages
- (5) Stability with temperature
- (6) Stability with changes in load
- (7) Physical size
- (8) Importance of power output versus life, efficiency, or other factors.

Although, in continuous-wave operation, oscillations have been observed for wavelengths as low as 5 centimeters, reliable operation of the 2C40 tube is limited at present to the range above about 9 centimeters. In pulsed operation of 2C43 tubes, the lowest wavelengths so far observed were around 4 centimeters. Reliable operation can again be expected for wavelengths above 9 centimeters.

#### GENERAL CONSIDERATIONS IN OSCILLATOR DESIGN

We will first discuss some practical aspects of oscillator design and give a few typical examples; later, a general oscillator theory with some applications will be given.

A problem common to all circuits described here is that of establishing satisfactory contact between the tube elements and the circuit. Particular care must be taken in the case of the plate contact to assure both reliable electrical contact and thermal contact. The latter is necessary to prevent excessive seal temperatures which would lead to premature tube failures. Resilient

materials such as beryllium copper, phosphor bronze, or hard brass should be used. Pulling or shearing force upon the seals should be minimized.

A reasonable number of fingers with firm, positive contact pressure have been found superior to either a small number of fingers or a large number of flimsy fingers. The width of the slots between fingers must also be kept small to minimize unwanted leakage.

The problem of supplying the tube with the necessary direct-current potentials is usually solved by the well-known techniques of by-pass capacitors and resonant chokes. These may, in certain designs, be used also for tuning purposes; in other designs, sliding plungers, dielectric slugs, and similar tuning elements are employed. In the design of oscillators for pulsed operation, care should be taken not to distort the pulse form by the use of plate chokes or plate by-pass capacitors which introduce too large capacitive loading upon the pulser.

#### SOME EXAMPLES

##### A. "End-to-End" Oscillator

At first, we shall consider the most straightforward design, the so-called "end-to-end" oscillator. This oscillator type illustrates best the fundamental grid-separation circuit. The oscillator consists of two tunable cavities of the concentric-line type which are separated by the grid plane, as shown in Fig. 3. The tuning is accom-

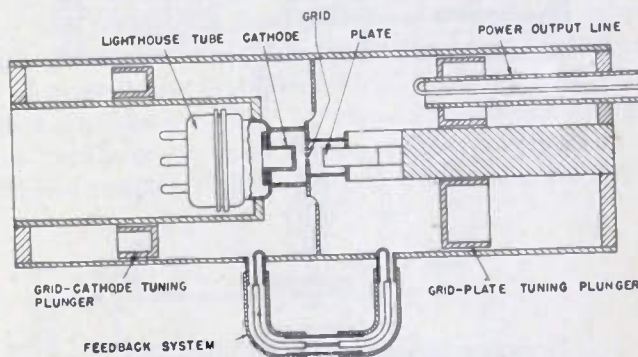

Fig. 3—A typical grid-separation circuit.

plished by a plunger in each resonator. The feedback is made by a feed-back system of concentric lines and loops. Various other feed-back designs are shown in Figs. 4, 5, and 6. The feedback is essentially a link through which the energy is exchanged between the two resonators, and, in conjunction with the resonators themselves, must satisfy certain phase and amplitude relations which will be considered in detail later. The feed-back circuits shown in Fig. 6 are very universal, in that phase and amplitude adjustments may be made more or less independently. Such circuits are recommended in cases where optimum performance is desired, rather than simplicity of operation, or for experimental study of oscillators. Figs. 4 and 5 show a few simpler arrangements which will perform satisfactorily if not too large a tuning

range is desired. For oscillators to be used over a wide tuning range, the feedback, which is generally frequency sensitive, may be coupled mechanically to the plunger as is shown, for example, in Fig. 7. The two resonators can be operated in a mode corresponding to an odd

The typical "end-to-end" oscillator of Fig. 3 shows the B-supply line filtered for ultra-high frequency by means of quarter-wavelength chokes designed for the range of operation. The power is usually taken out from such an oscillator by a concentric line terminated by a loop pro-

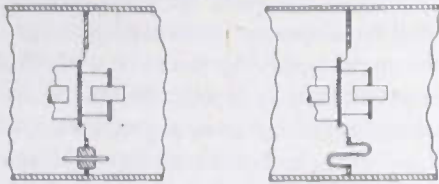

Fig. 4—Simple feed-back device.

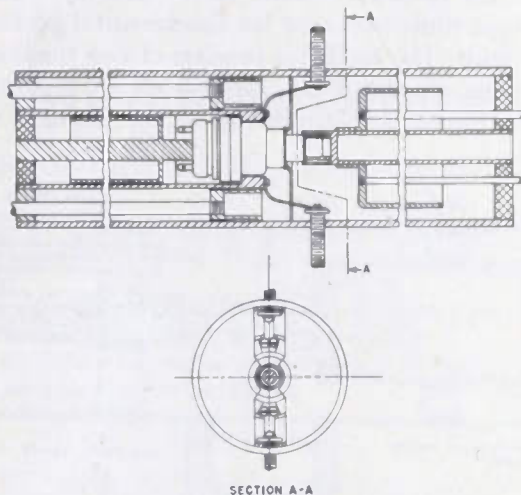
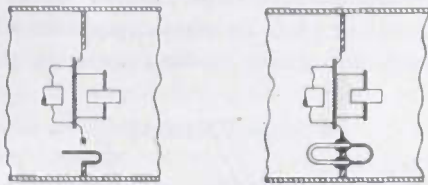

Fig. 5—Feedback with fine adjustment.

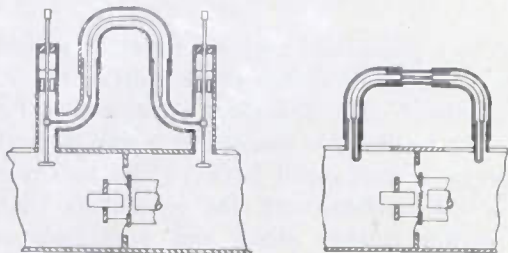

Fig. 6—Feedback with a wide-range adjustment.

number of quarter-wavelengths, corrected by the feedback, end effects, and electronics of the tube. All these factors will be considered in more detail later. However, the consideration of the frequency range of operation, physical size of the oscillator, and similar factors will determine the most appropriate mode of operation.

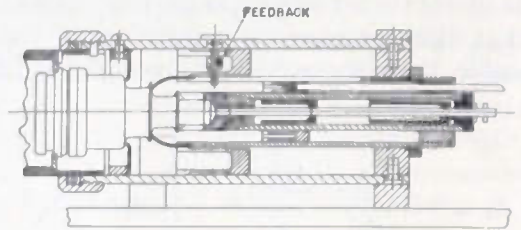

Fig. 7—Oscillator with feedback mechanically coupled to tuning plunger.

truding into the grid-plate resonator, as shown in the sketch.

A tuning-range curve and the physical dimensions of an "end-to-end" oscillator are given in Fig. 8. This type of oscillator was successfully used both for continuous-wave and pulsed operation. The advantage of this design is the accessibility of the two resonators. The disadvantage is its size (length) and the difficulty of ganging the two plungers.

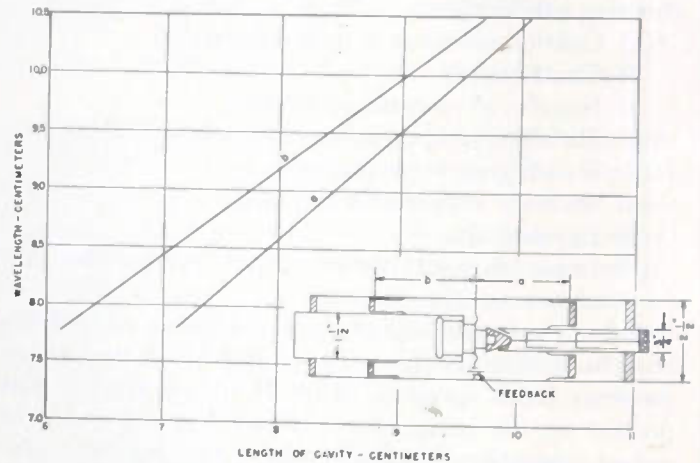

Fig. 8—Tuning curve and design dimensions for an "end-to-end" oscillator.

*B. The Folded-Back Oscillator*

Electrically, the folded-back oscillator is very similar to the "end-to-end" oscillator described previously. This oscillator can be considered as derived from the "end-to-end" oscillator by folding back the grid-cathode cavity over the plate-grid cavity or vice versa. The former possibility is illustrated in Fig. 8. The problem of feedback is similar to that in the "end-to-end" oscillator. Both types of circuits have at times in the past been used as oscillators without external feedback, the feedback in this case being provided by the interelectrode coupling in the tube, but results were usually not satisfactory and varied greatly from tube to tube. A feedback suitable



for fairly wide-range, single-control operation can be made as follows: a few fingers from the cathode plunger are removed and a screw attached to it protruding

is shown using a 2C39 tube. The advantages of the folded-back design are small physical size and ease of ganging the two plungers for tuning.

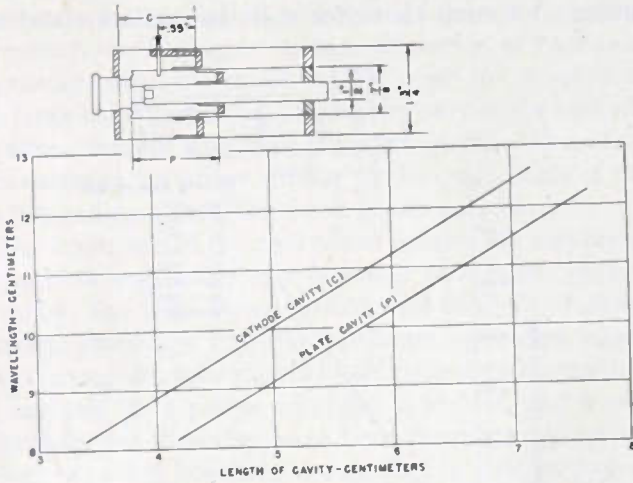

Fig. 9—Tuning curve and design dimensions for a "folded-back" oscillator with feedback coupled to tuning plunger.

through a slot in the grid cylinder into the plate-grid cavity. It was found that the proper location and adjustment of this screw assures satisfactory operation of the oscillator in the range of wavelengths from 9 to 12 centimeters (with a 2C40) without any readjustment of feedback. The tuning curve and design dimensions are given in Fig. 9. The tuning curve and design dimen-

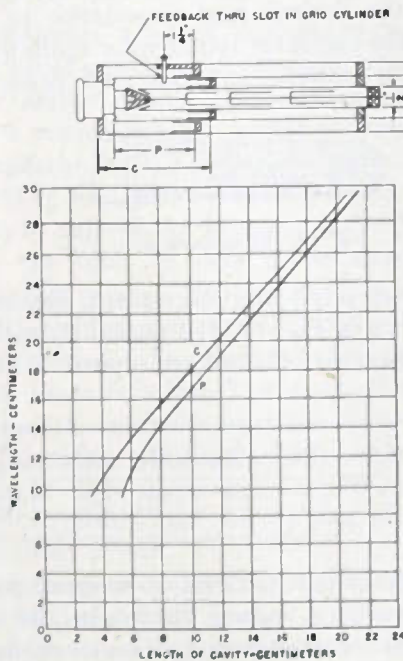

Fig. 10—A wide-range (9 to 30 centimeters) "folded-back" oscillator.

sions for an oscillator of similar type with a range of 9 to 30 centimeters is shown in Fig. 10. If only a small tuning range is required, a simpler feedback of fixed type can be used as in Fig. 11. In Fig. 12, an oscillator

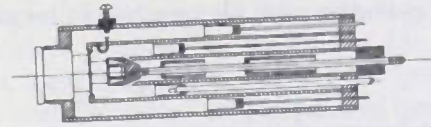

Fig. 11—"Folded-back" oscillator with fixed feedback.

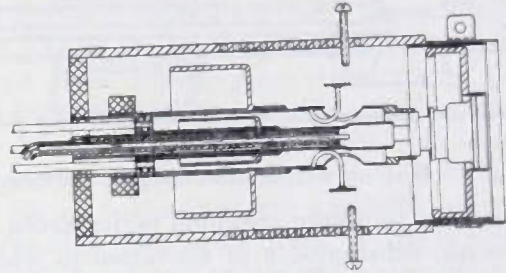

Fig. 12—An oscillator using a 2C39 tube.

### C. The Re-entrant Oscillator

This oscillator is considerably different from either of the oscillators described previously. It is simpler mechanically, easier to make oscillate, and it may be made tunable by a single control over a considerable range of frequency. The advantages of this circuit over the one previously described became evident in our early development of the circuit. Different modifications of this oscillator as applied to 2C40, 2C43, and 2C39 tubes are shown in Figs. 13, 14, and 15. As can be seen, this oscillator consists of an outer cylinder which makes a contact with the base of the tube, if a 2C40 or

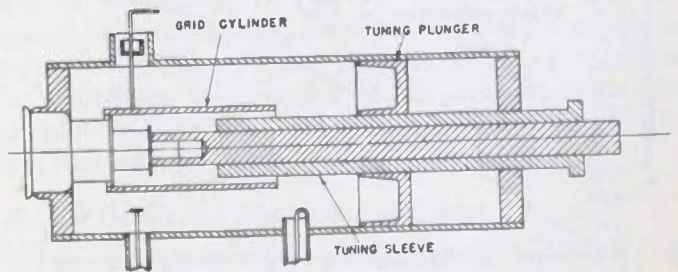

Fig. 13—Re-entrant oscillator with tuning device.

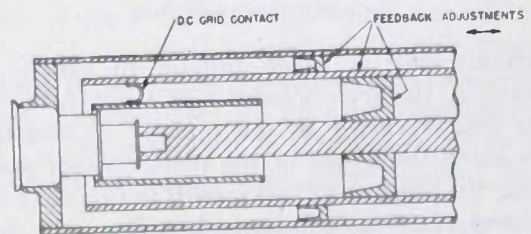

Fig. 14—A modified re-entrant oscillator.

a 2C43 is used, and with the plate if a 2C39 is used. An inner rod makes contact with the plate (or cathode in a 2C39 oscillator). Finger or capacitive plungers close up the resonant space. The grid connection consists of a

cylinder which clamps on the grid ring of the tube. A direct-current connection for grid bias is made at the proper point, or points, of the grid cylinder. The frequency of oscillation ordinarily depends upon the length of the grid cylinders; the plunger has to be placed at a

The tuner on the plate rod is first put as near the plate of the tube as possible and the plunger adjusted for optimum power. Then the plate tuner and the plunger are locked rigidly together and moved together for tuning. A tuning curve for such an oscillator and the

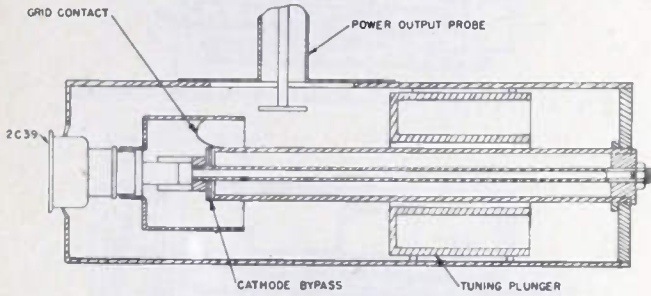

Fig. 15—A re-entrant oscillator using a 2C39 tube.

proper position to obtain optimum performance. There are, however, other modes of operation in which the plunger position is more important than the grid cylinder length in setting the frequency.

The following data represent physical dimensions of re-entrant oscillators built in this laboratory for different frequencies. Referring to Fig. 16:

<i>f</i> (mega-cycles)	<i>l<sub>p</sub></i> (inches)	<i>l<sub>g</sub></i> (inches)	<i>l<sub>d</sub></i> (inches)	<i>d<sub>p</sub></i> (inches)	<i>d<sub>g</sub></i> (inches)	<i>d<sub>a</sub></i> (inches)
3300	1.37	2.0	1.17	9/16	13/16	1.5
3000	1.75	2.4	1.55	9/16	13/16	1.5
1500	3.8	6.2	2.35	9/16	13/16	1.5
1000	5.6	9.4	1.76	9/16	13/16	1.5

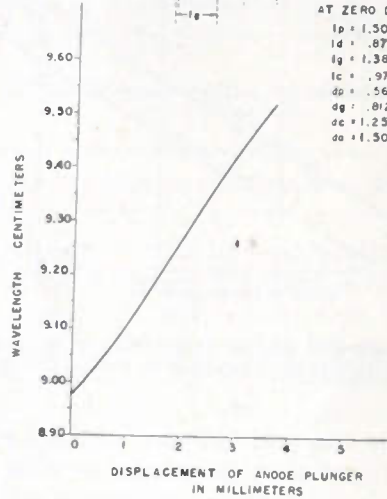
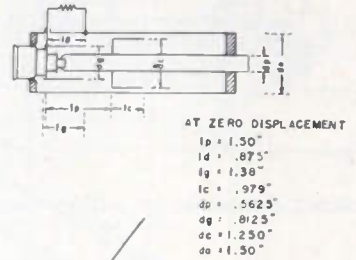

Fig. 17—Tuning curve and design dimensions for a re-entrant oscillator ( $\lambda = 9$  to 9.6 centimeters).

characteristic dimensions of the circuit are given in Fig. 17. The problem of power extraction is not much different from that in other circuits. It is of course one of matching the desired load impedance to the impedance that the oscillator requires for optimum operation. Points for power extraction will preferably be



Fig. 18—Plate extension.

chosen which are physically convenient. Several possibilities are shown in Fig. 13. For pulsed operation with the 2C43, the data given below are typical. Referring to Fig. 16:

<i>f</i> (mega-cycles)	<i>l<sub>p</sub></i> (inches)	<i>l<sub>e</sub></i> (inches)	<i>l<sub>d</sub></i> (inches)	<i>l<sub>b</sub></i> (inches)	<i>d<sub>a</sub></i> (inches)	<i>d<sub>b</sub></i> (inches)	<i>d<sub>e</sub></i> (inches)	<i>d<sub>g</sub></i> (inches)
3300	2.7	2.28	2.2	5.4	1 15/32	9/16	1 1/4	13/16
3000	3.5	2.5	3.0	6.2	1 15/32	9/16	1 1/4	13/16

A plate voltage of 2.5 to 3 kilovolts peak was used with these circuits. A power output in the order 1 kilowatt may be obtained with 3 kilovolts on the plate, 1000 pulses per second, and 1 microsecond pulse duration (2C43 tube).

THEORETICAL STUDIES OF SOME OSCILLATORS

Analysis of oscillator performance at the lower radio frequencies commonly falls into two parts. In one part, which might be called the small-signal analysis,

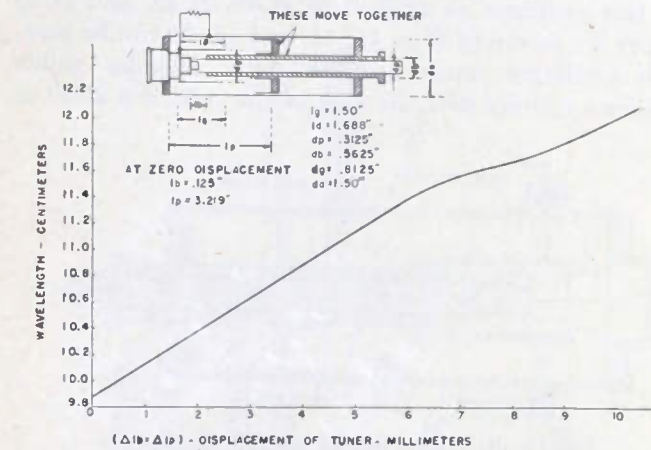

Fig. 16—Tuning curve and design dimensions for a re-entrant oscillator.

This circuit may be made tunable in various ways. For example, the grid cylinder may be made telescopic and its length varied as the plunger is moved. The motion along the anode of the plate-contact assembly including the plunger will also result in tuning (see Figs. 13, 16, and 17). For an increased tuning range, a plate extension as shown in Fig. 18 has been used in some practical applications. In Figs. 16 and 17, the tuning curves for re-entrant oscillators using the above method are given. Also are given the characteristic dimensions of the circuits. Fig. 13 shows an oscillator which has a moveable tuner on the plate rod and a separate plunger.



the tube is assumed to have a known and constant transconductance and plate resistance, and the relation between these constants and the circuit constants required for oscillations is studied by Kirchoff's Laws. The analysis is primarily useful for determining the frequency of oscillation and the necessary circuit adjustments for oscillation to begin. It does not give information on the power output, efficiency, or best tube operating point, which all depend upon the solution of the large-signal problem. The second part of the analysis is done, usually approximately, from the tube characteristics in a manner similar to the calculation of the corresponding quantities for a power amplifier.

Our approach to the analysis of microwave oscillators using disk-seal tubes has followed this same general division. The large-signal problem for analysis of power output, efficiency, and the optimum operating conditions for a given tube should be solvable once the method of analysis for a power amplifier is known, and so our efforts in this direction have been concentrated on the power-amplifier problem, as described in another paper.<sup>2</sup> The small-signal analysis has, however, been applied to a number of microwave oscillators using disk-seal tubes, with a number of useful results. As explained above, this analysis should be most successful in giving information concerning the required relations between the circuit and the tube to give oscillation at a given frequency. Since information on frequency is given by the analysis, tuning and frequency-stability problems can also be studied. The quantitative study of certain of these problems will be described in this paper.

### A. General Equivalent Circuit

Representative types of microwave oscillators using disk-seal tubes with coaxial resonant circuits have been described earlier in this paper. In any of these, there may be a resonant tank circuit for the cathode-grid region, another for the grid-plate region, and a means for providing feedback between the two. The feedback may consist only of the inherent cathode-plate capacitance of the tube, or may be obtained by coupling loops, probes, or holes between cavities, a transmission line with matching controls connected between cavities, or the transmission line built into the circuit in such a way that there is a less-clear separation between the cavities and the feedback, as in the re-entrant oscillator. Several of these techniques have been sketched, for example, in Figs. 3, 4, and 11. The output load, if properly matched, may be coupled in at nearly any point in either cavity.

It is convenient to make a division of functions in order to place the study of all of the types of microwave triode oscillators on a common basis. The cavities and feed-back arrangements, including the tube interelectrode capacitances if desired, may be considered as a linear four-terminal network connecting the grid-plate

<sup>2</sup> H. W. Jamieson and J. R. Whinnery, "Power amplifiers with disk-seal tubes," *PROC. I.R.E.*, pp. 483-489; July, 1946.

region of the tube to the cathode-grid region. The effects from the tube electronics are considered by including a certain input loading conductance  $g_1$  between cathode and grid terminals and a certain transadmittance<sup>3</sup>  $Y_m$  having both magnitude and phase angle, relating the alternating component of the grid-plate current to the alternating component of the cathode-grid voltage. More complete equivalent circuits for the tube electronics at high frequencies have been presented by Llewellyn and Peterson,<sup>4</sup> but the above quantities are usually sufficient for oscillator calculations. Some values of input loading and magnitude of transadmittance for typical disk-seal tubes have been measured by N.T. Lavoo.<sup>5</sup> The phase angle of transadmittance may be estimated from parallel-plane tube transit-time analysis,<sup>6</sup> since this quantity is believed to be least sensitive to differences between the actual and ideal triode that render calculated values of input conductance and magnitude of transadmittance unreliable. Finally, the output loading (plus losses in the cavity) is included as a conductance referred to the grid-plate terminals. The remaining interconnecting four-terminal network may then be considered as loss-free.

The resulting general equivalent circuit is shown in Fig. 19. The equations for the four-terminal network

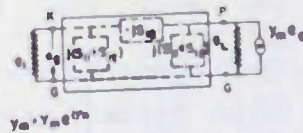

Fig. 19—General equivalent circuit for triode oscillator.

may be in any one of the many possible forms, making use of the impedance parameters, admittance parameters, the  $ABCD$  constants, the  $T$  or  $\pi$  equivalents, or any of the others. In Fig. 19, the network is interpreted in terms of the admittance parameters and  $\pi$ -equivalent. This particular representation is convenient in identifying one portion of the network with the cathode-grid cavity, one with the grid-plate cavity, and one with feedback between cavities.

### B. The Oscillation Equation and Curves

The requirement for oscillation in the system of Fig. 19 can be set down in any one of the equivalent ways used for studying oscillators. One of these states that the voltage fed through the network to the cathode-grid terminals must be equal in magnitude and phase to the initially assumed cathode-grid voltage, or it can simply be said that the requirements that  $e_0$  and  $Y_m e_0$  be consistent in this closed system supply certain relations between the parameters of that sys-

<sup>3</sup> B. J. Thompson, "Review of ultra-high-frequency tube problems," *RCA Rev.*, vol. 3, pp. 146-155; October, 1938.

<sup>4</sup> F. B. Llewellyn and L. C. Peterson, "Vacuum-tube networks," *PROC. I.R.E.*, vol. 32, pp. 144-166; March, 1944.

<sup>5</sup> To be published in *PROC. I.R.E.*

<sup>6</sup> F. B. Llewellyn, "Electron-Inertia Effects," The University Press, Cambridge, Mass., 1941.



tem. In general, two relations will result, one from real parts and one from imaginary parts of the equations.

$$\frac{s_{22}g_1}{Y_m^2} = \frac{\left(\frac{s_{12}}{Y_m}\right)\left[\left(\frac{s_{11}}{g_1}\right)\left(\frac{s_{12}}{Y_m}\right) - \left(\frac{s_{11}}{g_1}\right)\sin\phi_n - \cos\phi_n\right]}{1 + \left(\frac{s_{11}}{g_1}\right)^2} \quad (1)$$

$$\frac{g_L g_1}{Y_m^2} = \frac{\left(\frac{s_{12}}{Y_m}\right)\left[\sin\phi_n - \left(\frac{s_{11}}{g_1}\right)\cos\phi_n - \left(\frac{s_{12}}{Y_m}\right)\right]}{1 + \left(\frac{s_{11}}{g_1}\right)^2} \quad (2)$$

Equation (1) can be thought of as the tuning or frequency-determining equation. Actually, frequency is expressed only implicitly by the equation, the equation being written in such a way that  $s_{22}$ , the output susceptance, is given in terms of the other tube and circuit parameters.

Equation (2) relates the allowed load conductance to the tube and circuit parameters. The circuit will operate as an oscillator only over the region for which  $g_L$  is positive, since a negative value of  $g_L$  would mean that an additional external radio-frequency power source would have to be supplied to make the circuit self-consistent.

C. Application to the Re-entrant Oscillator

1. *Equivalent Circuit:* Typical re-entrant oscillators were discussed earlier and shown for example in Fig. 13. For purposes of discussing an equivalent circuit, let us divide this into several regions, as indicated in Fig. 20, which shows the significant radio-frequency aspects

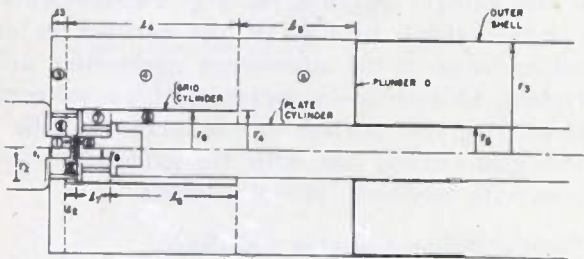

Fig. 20—Re-entrant oscillator.

of the oscillator simplified by the omission of direct-current connections, by-passes, and chokes. The regions are:

- (1) Input region of the tube between cathode face and grid
- (2) Region between cathode post of the tube and grid cylinder, up to end of grid cylinder
- (3) Region between cathode post and outer shell, from end of grid cylinder to end of cavity
- (4) Region between grid cylinder and outer shell
- (5) Region between plate cylinder and outer shell, from end of grid cylinder to plunger

- (6) Region between plate rod and grid cylinder, up to plate disk of tube
- (7) Region between anode post of tube and grid cylinder
- (8) Output region of tube between grid and face of anode.

The most elementary equivalent circuit for a basic re-entrant oscillator, neglecting all end effects, is shown in Fig. 21. Here a transmission line represents the cathode-grid cavity (4) of Fig. 20, a second transmission line represents the grid-plate cavity (6), and a

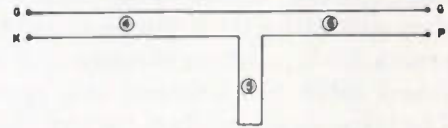

Fig. 21—Elementary equivalent circuit for a basic re-entrant oscillator.

third transmission line in series between the other two represents the region (5) between the end of the grid cylinder and the plunger.

A more complete equivalent circuit is shown in Fig. 22. The elements in the equivalent circuit correspond-

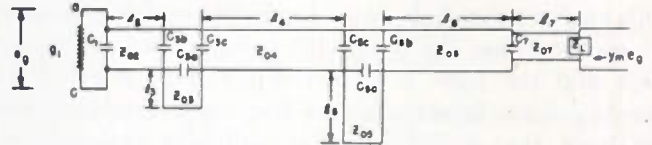

Fig. 22—A more complete equivalent circuit for a re-entrant oscillator.

ing to the divisions of Fig. 20 are given below, with methods for obtaining approximate element values.

1. The input of the tube presents electronic loading conductance  $g_1$  and hot capacitance  $C_1$  between cathode face and grid. For a 2C40,  $C_1$  is believed to be in the range of 1 to 1.5 micromicrofarad<sup>7</sup> and  $1/g_1$  in the range 200 to 400 ohms for small signals in the 10-centimeter region.

2. A small section of line of length  $l_2$  and characteristic impedance  $Z_{02} = 60 \ln(r_2/r_1)$ .

3. A small section of the line of length  $l_3$  and characteristic impedance  $Z_{03} = 60 \ln(r_3/r_1)$  in series between (2) and (4). Discontinuity capacitances<sup>8</sup>  $C_{3b}$ ,  $C_{3a}$ ,  $C_{3c}$  are shunted across lines 2, 3, and 4, respectively, at the junction. These capacitances are usually of the order of from a few tenths to one micromicrofarad. It should be noted that  $C_{3a}$  is negative.

4. Section of transmission line of length  $l_4$ , characteristic impedance  $Z_{04} = 60 \ln(r_3/r_4)$ .

5. Transmission line of length  $l_6$ , characteristic impedance  $Z_{06} = 60 \ln(r_3/r_6)$  in series with lines (4) and (6). Again discontinuity capacitances  $C_{6c}$ ,  $C_{6a}$ ,  $C_{6b}$  are

<sup>7</sup> Note that  $C_1$  does not correspond exactly to published values of input capacitance, since  $C_1$  is only the capacitance between grid and face of cathode plus a fringing or discontinuity capacitance.

<sup>8</sup> J. R. Whinnery and H. W. Jamieson, "Coaxial-line discontinuities," Proc. I.R.E., vol. 32, pp. 695-709; November, 1944.



shunted across lines 4, 5, and 6, respectively (see 3 above). These are usually of the order of a few tenths of a micromicrofarad, and  $C_{6a}$  is negative.

6. Transmission line of length  $l_6$ , characteristic impedance  $Z_{06} = 60 \ln(r_6/r_5)$ .

7. Transmission line of length  $l_7$ , characteristic impedance  $Z_{07} = 60 \ln(r_6/r_5)$ . A discontinuity capacitance  $C_7$  is shunted across the junction between lines (6) and (7).

8. Here load impedance  $Z_L$  (this is the quantity calculated) is shunted between grid and plate and the  $Y_{me}$  current generator is applied.

Once the equivalent circuit is set up, and a frequency selected, it can be reduced if desired to an equivalent network and the general results of (1) and (2) applied.<sup>9</sup> In the procedure usually followed, we select the complete set of dimensions in the oscillator and calculate the equivalent circuit. The approximate wavelength of oscillation is estimated either from experience or from an approximate equation to be given later. Several values of wavelength are then taken in this vicinity, and the value of load conductance and susceptance  $s_{22}$  are calculated, say by (1) and (2). The wavelength of oscillation is that for which the calculated value of  $s_{22}$  from (1) corresponds to the known value in the actual equivalent circuit of the cavity plus grid-plate capacitance. The oscillator will oscillate at this frequency only if the value of  $g_L$  calculated from (2) is at the same time positive. If desired, we may now go back and change some dimensions in the oscillator, set down the new equivalent circuit, and repeat the procedure, resulting in the new wavelength of oscillation and allowable load conductance. When enough points are obtained in this manner, the two quantities, frequency and allowable load, may be plotted as a function of the parameter which is being varied.

2. *Some Conclusions from the Re-entrant Analysis:* Study of the equivalent circuits and application to specific oscillators has led to certain general important conclusions. The most important probably is the division into functions; that is, it is found that in most oscillators studied, proportions are such that the regions 6, 7, and 8 of Fig. 20 essentially constitute the output tank circuit, so that tuning arrangements in this region are most effective. The remainder of the circuit has its main effect in changing feedback, thus explaining why varying the plunger  $D$  does affect strength of oscillations markedly, but is not as effective in tuning as might be expected. These and other conclusions are explained in more detail in the following:

a. *The tank circuit and approximate determination of oscillator frequency:* Because of the large reflection due to the series line (5) (see Fig. 20) there is a large standing wave in the line (6), and so this line, the region (7) around the plate post of the tube, and the grid-plate

<sup>9</sup> This is not necessary, of course, because all oscillation calculations can be performed directly on the equivalent circuit as originally set up in Fig. 22, if desired.

capacitance contain most of the circulating energy, and so constitute the major part of the tank circuit. Thus the high-impedance point appears in the line (6) near the end of the grid cylinder. A rough approximation to the wavelength of the oscillator may then be had by assuming that this is an infinite impedance point; that is, the line (6) may be considered as a half-wave resonant line foreshortened by the tube inductance and capacitance. Approximate resonant frequency may then be obtained by solving the transcendental equation:

$$\left( \omega L_7 - \frac{1}{\omega C_8} \right) = Z_{06} \cot \beta l_6 \quad (3)$$

where

$L_7 =$  inductance  $= 2 \times 10^{-9} l_7 \ln(r_6/r_5)$  henry

$C_8 =$  output capacitance (order of  $1.7 \times 10^{-12}$  Fd)

$Z_{06} = 60 \ln(r_6/r_5)$  ohms

$\beta =$  phase constant  $= \omega/3 \times 10^{10}$

$l_7$  and  $l_6$  being measured in centimeters.

Some comparisons are shown in Table I in which measured wavelengths are compared with values calculated from (3). The measurements were made on

TABLE I

$\lambda$ (measured)	$l_7$ (centimeter)	$r_1$ (centimeter)	$r_2$ (centimeter)	$r_3$ (centimeter)	$l_6$ (centimeter)	$\lambda$ calculated from Eq. (3)
9.2	2.08	0.714	1.032	0.275	1.03	11.35
10	3.05	0.714	1.032	0.275	1.03	12.6
20	8.25	0.714	1.032	0.275	1.03	19.95
29	12.80	0.714	1.032	0.275	1.03	28.35
9.1 pulsed	1.30	0.714	1.032	0.275	1.03	9.9
10 pulsed	2.10	0.714	1.032	0.275	1.03	11.35

several different oscillators with dimensions given earlier. The above comparisons stress the fact that this is to be considered only as an approximation. The values for the long wavelengths (20 and 29 centimeters), provide good checks, however.

b. *The feed-back circuit:* With the regions 6, 7, and 8 of Fig. 20 functioning mainly as the tank circuit, the remainder of the circuit acts primarily as the feed-back circuit. To be certain of optimum conditions for oscillation, both magnitude and phase of feedback should be under control, requiring two independent variable parameters in this feed-back circuit. The single plunger  $D$  is often the only variable control provided, and this may affect both phase and magnitude of feedback, but not independently.

Calculations made from the equivalent circuit with plunger position varied give curves of the form indicated in Fig. 23. Here wavelength and allowable load conductance calculated as described earlier are plotted as functions of plunger position. The range over which load conductance is positive is the range of plunger positions over which oscillations may exist, since the oscillator should stop oscillating on either side when allowable load conductance becomes negative. Of course, if there is already a fixed conductance  $g_{L0}$  (referred to the grid-plate region of the circuit) arising from circuit



losses or external loading, the range of oscillations will then be only over the region for which  $g_L$  exceeds  $g_{L0}$ , as is also indicated in Fig. 23.

The maximum value of  $g_L$  found on curves as in Fig. 23 may be used as a rough indication of the excellence of an oscillator, for it does at least indicate the amount that the oscillator could be loaded and yet oscillate. (A true comparison requires solution of the large-signal

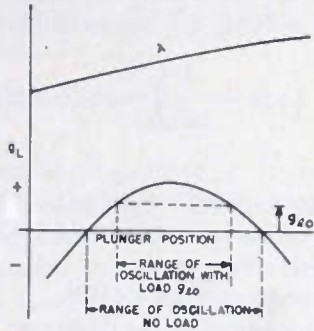

Fig. 23—Wavelength and allowable load conductance plotted as functions of plunger position.

problem.) Thus, if some parameter in the feed-back circuit, independent of plunger setting, is changed, different curves of  $g_L$  versus plunger position will be obtained, some having higher peaks than others and so probably representing better oscillators. This is indicated qualitatively in Fig. 24.

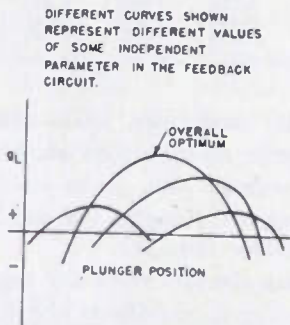

Fig. 24—Load conductance as a function of plunger position with some quantity in the feed-back circuit as a parameter.

It follows from the above considerations that adjustment in the feed-back circuit of any parameter independent of the plunger position may have these effects:

1. Slight change in wavelength of oscillation.
2. Change in plunger position for maximum output.
3. Marked effect on value of output at optimum plunger setting.

In practical oscillators, these effects have been especially noticeable when numbers and positions of grid cylinder supports were changed. In certain experimental oscillators, another independent plunger control on the cathode side of the cavity was also provided to give a second independent parameter in the feed-back circuit.

In Fig. 25 are shown some curves similar to those in Fig. 23, but actually calculated by the methods de-

scribed earlier for a given 30-centimeter re-entrant built in this laboratory. The range of plunger positions over which the actual oscillator operated was not measured accurately, but agreed within a few millimeters with the calculated range. The calculated change in wavelength over this range also agreed closely with the experimental. The setting of plunger maximum output agreed within 3 millimeters with that calculated. In

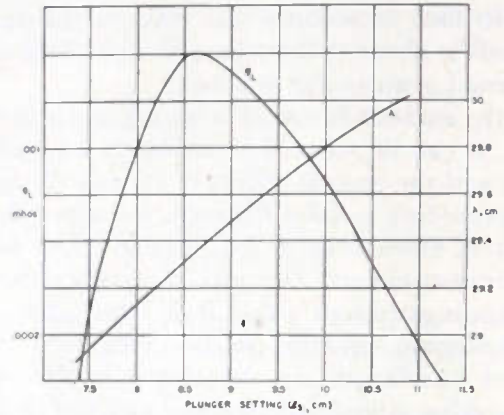

Fig. 25—Wavelength and allowable load conductance as functions of plunger position calculated for a 30-centimeter re-entrant oscillator.

Fig. 26 the length of the grid-cathode line  $l_4$  was selected as a parameter to vary in the calculations. (Although it could not be conveniently varied physically by itself, it served to prove the point in the calculations.) The different curves with different optimum plunger settings and values of maxima at these settings are observed as

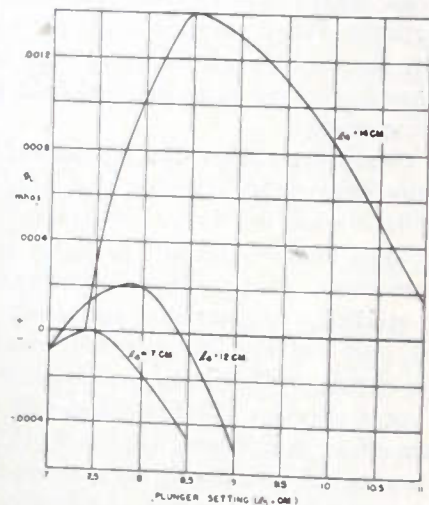

Fig. 26—Load conductance as a function of plunger setting with grid-cathode line  $l_4$  as a parameter.

described qualitatively above. It should be noted that there is no plunger setting for which the case with  $l_4 = 7$  centimeters would oscillate.

*c. Tuning:* It has been pointed out that tuning operations which act on the region of the plate-grid line are much more effective than in other parts of the circuit because of the relatively large standing wave in this region. As a matter of fact, the rough formula for



resonant wavelength given in (3) is dependent only upon that region.

As an example of relative effectiveness of quantities on the input and output, several curves are shown. In Fig. 27, calculated curves of wavelength as a function of cathode-grid capacity and of grid-plate capacitance are shown for the same 30-centimeter re-entrant used as an example above. The grid-plate capacitance is thus

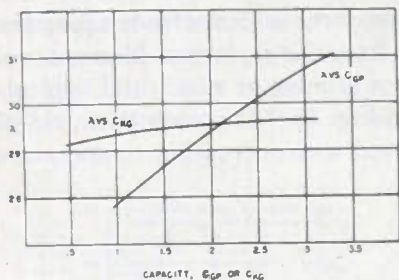

Fig. 27—Calculated curves of wavelength as a function of cathode-grid capacity and of grid-plate capacitance.

seen to be roughly five times as effective in tuning as the cathode-grid capacitance. Also in Figs. 28 and 29 are shown points taken with a great many tubes in a re-entrant oscillator used for acceptance tests by the Electronic Tube Division of this Company. Operating wavelength as a function of measured grid-plate capacitance is shown in Fig. 28, and as function of measured cathode-

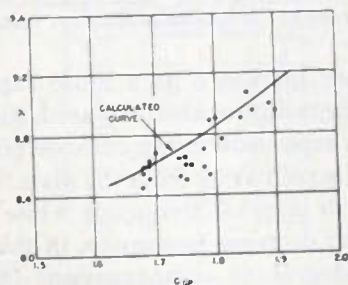

Fig. 28—Operating wavelength as a function of measured grid-plate capacitance.

grid capacitance in Fig. 29. In Fig. 28 is also shown a calculated curve using the equivalent circuit. Although the data is of a gunshot nature, agreement is satisfactory, and again the relative effectiveness of grid-plate capacitance over cathode-grid capacitance is demonstrated.

Although tube capacitances have been used as examples, other quantities give similar conclusions on relative effectiveness of tuning in the plate-grid region and in other parts of the circuit. For example, polystyrene disks movable in position have been found much more effective in tuning when placed in the plate line (6) of Fig. 20 than when placed in the grid line (4).

The following tuning means have been used in practice, all of which act on the region in the vicinity of the plate line:

1. Introduction of dielectric in plate-grid line movable in position.

2. Grid cylinder adjustable in length.
3. Sliding plate cylinder on plate cap of tube, thus adding a gap which may be considered as adding additional series inductance to this part of the circuit (Fig. 13).

Although the plunger  $D$  of Fig. 20 does give some tuning, it is not an ideal tuning means because:

1. Tuning range is relatively small (order of 3 to 6 millimeters in the 10-centimeter range).
2. Since the major function of the plunger is adjustment of feedback to an optimum, its use for tuning is not satisfactory.

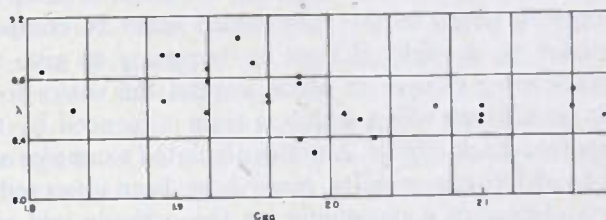

Fig. 29—Operating wavelength as a function of measured cathode-grid capacitance.

Oscillators have been made in which the range of tuning obtainable with the plunger alone is increased. These have larger-diameter grid cylinders, so that there is then not so much of a discontinuity between lines 5 and 6. More of the circulating tank-circuit energy is then in the region 5 and so may be affected by the plunger position.

*d. Frequency shift with voltage:* Analyses performed on re-entrant oscillators have revealed one major contribution to frequency shift with changes in voltage. This arises from the change in the phase angle of transadmittance with tube voltages. That is, the phase

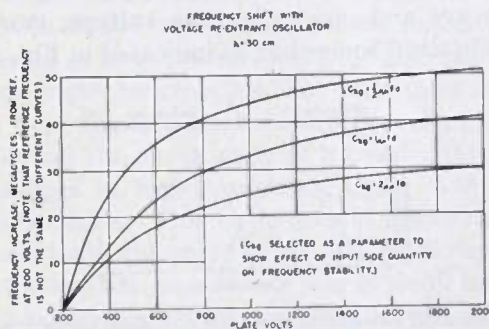

Fig. 30—Frequency shift with voltage re-entrant oscillator ( $\lambda = 30$  centimeters).

delay in the tube due to finite transit time of electrons is a definite part of the over-all phase shift about the circuit. As voltages change, so do the transit times, and therefore the phase delay through the tube (phase angle of transadmittance). Frequency must then shift slightly to maintain the phase through the feed-back path proper for oscillations. In Fig. 30 are plotted some curves of frequency shift with voltage calculated for a given 30-centimeter re-entrant including only this factor, and with several parameters varied. Measured



curves of frequency shift with voltage in this laboratory resulted in curves which were of the same general shape, had frequency changing in the same direction (increasing frequency with increasing voltage), and were of the same order of magnitude of frequency shift, although the measured amounts seemed to vary from time to time depending upon contacts, circuit adjustments, and other doubtful factors.

Note that, although operating frequency is determined mainly by quantities on the plate-grid side of the cavity, the amount of *frequency shift* with voltage may in certain cases be influenced more by quantities on the cathode-grid side. This is because the effect arises from changes in phase in the tube which must be compensated for by a slight change in frequency to give the corresponding change in phase around the entire feedback circuit—an effect which is thus influenced by the whole feedback circuit. Among calculated examples and measured frequency shifts, many have been observed in which change of a parameter on the cathode-grid side affected the amount of frequency shift with voltage more than the corresponding change on the grid-plate side.

*e. Readjustment of plunger from continuous-wave to pulse operation:* It has often been noted experimentally that if the plunger position was set for optimum operation under continuous-wave conditions, the oscillator would not operate at its optimum under pulse conditions (or might not even oscillate at all) unless the plunger were readjusted. This phenomenon is also revealed theoretically in the above analysis and is traceable to the change in phase angle of transadmittance with voltage, as was the frequency shift with voltage described above. Thus, if plots of allowable load conductance versus plunger position are made with two values of phase angle of transadmittance, one corresponding to a continuous-wave and one to a pulse voltage, two curves may be obtained somewhat as indicated in Fig. 31. The

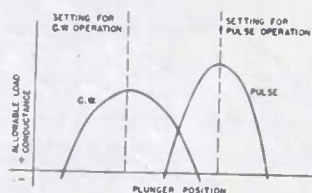

Fig. 31—Required plunger settings per optimum operation for continuous-wave and pulse operation.

required plunger shift from continuous-wave to pulse operation is shown by such curves. Although only a few cases were checked analytically, calculated, and observed, plunger shifts were in the same direction and agreed very well in magnitude. Phase angles of transadmittance were estimated from parallel-plane tube theory.

*f. Change in frequency with filament voltage:* In addition to frequency changes with plate voltage, it is known that there is a frequency shift occurring with changes in filament temperature. This shift is traceable to the

changes in interelectrode spacings with temperature, a factor which can effect frequency in at least four ways:

1. Through change in grid-plate capacitance.
2. Through change in cathode-grid capacitance.
3. Through change in phase angle of transadmittance affecting frequency through the mechanism described above.
4. Through change in cathode-plate capacitance, affecting feedback.

Curves of the three interelectrode capacitances (measured at low frequency) versus filament voltage were measured for a number of tubes, and typical curves are reproduced in Fig. 32.<sup>10</sup> It is seen that grid-plate capacitance decreased with increasing temperature, cathode-

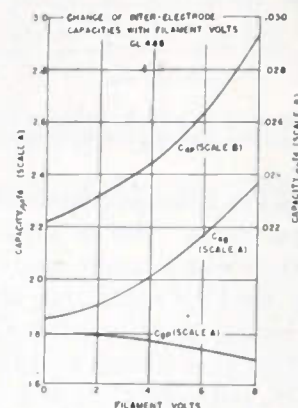

Fig. 32—The three interelectrode capacitances (measured at low frequency) as functions of filament voltage.

grid capacitance increased at a more rapid rate, and cathode-plate capacitance also increased, suggesting that there was both expansion in the cathode post and a motion of the grid screen away from the plate. The decrease in  $C_{cp}$  tended to increase frequency while the increase in  $C_{kp}$  tended to decrease frequency, in this case giving a remarkable degree of compensation. (Although the change in  $C_{kp}$  is considerably greater than the change in  $C_{cp}$ , its relative effectiveness on frequency is considerably less.)

Calculations indicated that the third factor (change in phase of transadmittance) was appreciable, although considerably less than either of the first two factors. This also acts to increase frequency with increasing temperature, since the spacing of the low-voltage (cathode-grid) region is decreased, thus giving the same direction of effect as an increase in voltage (see Fig. 30).

The importance of the fourth effect is not known, since  $C_{kp}$  has not been included in re-entrant analyses except for spot checks to justify its neglect, but it is believed to be small.

A rough calculation was carried through for frequency shift versus filament voltage, including only the first three factors and utilizing the data of Fig. 32. Frequency shift versus  $C_{cp}$  was estimated from curves on several re-entrant oscillators calculated and measured

<sup>10</sup> These are not representative of present production types.



in the 10-centimeter range; such as that of Fig. 28. It was assumed that the relative effectiveness of a given change in  $C_{k_0}$  and  $C_{op}$  was the same as found in Fig. 27, that is, about 1 to 5.5. It was also assumed that the changes in  $C_{k_0}$  and  $C_{op}$  represented proportional changes in interelectrode spacings, so that changes in transit angle could be calculated and the corresponding frequency changes estimated from Fig. 30. Finally, the total shift was taken as the sum of the above three components. This information is summarized in Table II. Here the compensation between the several factors is evident for changes due to  $C_{op}$  alone or  $C_{k_0}$  alone would give shifts of the order of 75 megacycles over the entire range, while the net shift is only 8.5 megacycles.

TABLE II

Filament volts	$\Delta C_{k_0}$ (in micro-microfarads)	$\Delta f$ due to $\Delta C_{k_0}$ (in megacycles)	$\Delta C_{op}$ (in micro-microfarads)	$\Delta f$ due to $\Delta C_{op}$ (in megacycles)	$\Delta f$ due to phase of $Y_m$ (in megacycles)	Total $\Delta f$ (in megacycles)
0	0	0	0	0	0	0
2	0.06	-8.1	-0.005	3.75	1.7	-6.4
4	0.21	-28.5	-0.02	15	3.5	-10
6	0.35	-47.6	-0.05	37.5	6.0	-4.1
8	0.56	-76.0	-0.10	75	9.5	8.5

The net shift from Table II is plotted versus filament volts in Fig. 33, together with a curve of measured frequency shift taken on an 11-centimeter re-entrant with

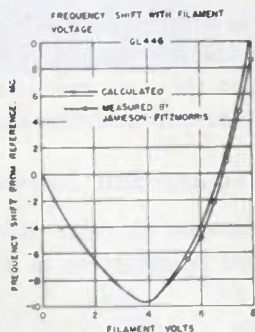

Fig. 33—Frequency shift as a function of filament voltage.

GL-446 tube. The closeness of agreement is surprising, considering that no maneuvering was done to make the agreement look good. Actually it is much better than is justified by the accuracy of the method. However, it does lend support to the factors chosen as important factors in this shift, and brings out these conclusions for the example studied:

1. Frequency shifts due to changes in  $C_{k_0}$  and  $C_{op}$  were both large, of the same order of magnitude, and opposite in direction, so that compensation occurred to a large extent.

2. Frequency shift from change in phase angle of transadmittance with changing spacings was smaller than either of the above changes alone, but was comparable to the net frequency shift because of the partial cancellation of the two large changes.

3. Since net frequency shift is the difference between fairly large shifts of opposite sign, changes in the circuit

or tubes may change the character of the net shift considerably. Thus frequency might increase with filament voltage over the entire range, decrease, or change direction somewhere in the range, as in the calculated curve of Fig. 33 where this change occurs at about 4 volts. With only slight changes in the conditions, the voltage corresponding to this change in direction could change considerably.

#### D. General Study of Frequency Stability and Tuning

Some detailed studies have been made of the dependence of oscillator frequency on small changes in the parameters of various parts of the oscillator circuit in order to investigate the effect of various quantities on frequency stability and tuning. The procedure followed was the obtaining of the total differential  $dS_{22}$  from the "frequency-determining" (1) in terms of differential changes in all other parameters. Each differential change is in turn divided into a part representing an independent variation in that parameter, and a second part representing the change because of frequency shift (if the particular element is frequency sensitive). From the resulting equation, the per-unit frequency shift can be solved for in terms of the per-unit changes of the various circuit and tube parameters. The procedure is straightforward, but the resulting equations are long enough so that space limitations do not permit their reproduction here. Conclusions derived from such studies can perhaps best be given by discussion of results from one particular study.

In the study of a certain pulsed 12-centimeter re-entrant oscillator by the above described procedure, it was found that the grid-plate capacitance was the most important factor in affecting frequency, an increase of 1 per cent in this capacitance causing roughly a 0.2 per cent decrease in frequency. The coefficient showing the importance of the part of  $S_{22}$  external to the tube was very nearly as large as that from the grid-plate capacitance, as might be expected. The next most important factors were the feed-back susceptance  $S_{12}$  external to the tube and the phase angle of transadmittance, 1 per cent changes in these causing roughly 0.03 per cent frequency shifts. The cathode-grid capacitance has about one tenth the effect of the grid-plate capacitance. The cathode-plate capacitance was of small importance in affecting frequency because its effects were masked by the larger feedback external to the tube in this re-entrant design. Magnitude of transadmittance and the tube input conductance were also found to have little effect on frequency, as might be guessed, and the input susceptance external to the tube was also ineffective because of the larger susceptance from cathode-grid capacitance which paralleled it.

If the above results were to be used in studying frequency stability under changes of voltage, load, temperature, etc., the changes of interest would first have to be converted to corresponding changes in elements of the equivalent circuit.



# Microwave Omnidirectional Antennas\*

HENRY J. RIBLET†, ASSOCIATE, I.R.E.

**Summary**—This paper describes briefly a number of radiating elements which have proved useful in the design of high- and low-gain omnidirectional antennas at wavelengths of 3 and 10 centimeters.

## INTRODUCTION

THE SUCCESS of microwave radars for military purposes has induced considerable interest in the development of omnidirectional microwave antennas. During the war these antennas, in conjunction with suitable transponders, were used for homing and identification purposes, and now they are seeing service with communication systems.

Active work on microwave omnidirectional antennas began at the Radiation Laboratory in 1942. A large number of individuals have contributed to the development of these antennas. This paper summarizes the work done at the Radiation Laboratory and is, therefore, a report on the activities of a group of men in the Laboratory rather than an account of the efforts of the author alone.

The use of centimeter wavelengths places a different emphasis on design than is encountered in low-frequency applications, so that, in deciding the place of these antennas in the general art, the following considerations should be kept in mind:

(a) High frequencies involve close tolerances when measured in inches, so that designs which are inherently reproducible are required.

(b) High-gain antennas can be made without excessive size, and this fact, coupled with relatively narrow radar bandwidths, shifts the design emphasis in many cases from bandwidth to pattern quality.

(c) Antennas with gains, relative to an isotropic antenna, ranging from  $3/2$  to 20 are of importance, so that a premium is placed on radiating elements or bays with easily variable impedances.

(d) Feed lines are large compared with radiating elements, so that older antenna forms usually have to be materially altered in order to be usable.

(e) Pressurizing and weatherizing means are electrically large, and hence become an integral part of the design.

The first efforts toward high-gain microwave omnidirectional antennas were in experiments with a biconical horn antenna.<sup>1</sup> However, it was soon realized that, for

the narrow-band problems encountered in radar practice, an array arrangement was much more economical of space and was more easily weatherized.

The considerations listed above have placed an emphasis on the development of a radiating element which, for a given polarization and frequency, has the following properties: (a) gives by itself a uniform azimuth pattern; (b) is small, mechanically reliable, and susceptible of quantity production; (c) when coupled to a line, has an impedance, either pure series or shunt, which is sufficiently flexible so that it can be used in a single-element antenna or in a high-gain antenna with many bays; and (d) has by itself an elevation pattern which does not differ too greatly from that of a dipole.

When an element is found which satisfies these conditions, for a given application, the design of arrays with a multiplicity of elements is straightforward. In all the applications which have been encountered, the peak of the radiation pattern should be on or near the horizontal plane. This condition is insured if pure series or shunt elements are spaced  $\lambda g/2$  apart on the feed line. In this case the pattern can easily be calculated and the impedance behavior is simple, since, if the elements are in shunt or series on the line and are spaced  $\lambda g/2$  apart, it will be found that they are essentially in parallel or series with each other and with the shorting stub.

## GROUND AND SHIP ANTENNAS

Fig. 1 shows a die-cast element which has been very useful for horizontal polarization in the 10-centimeter

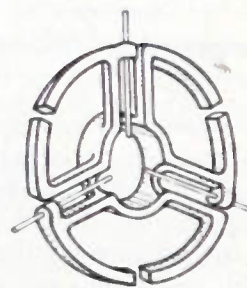

Fig. 1—Tridipole element.

band. It illustrates well the properties which a microwave omnidirectional element should possess. Its azimuthal pattern has a uniformity which is better than 2 to 1 in power<sup>2</sup> from 9 to 11 centimeters. It has been possible to eliminate the need for insulators or dielectric supports by the use of three-wire feeds. The flexibility of impedance is made possible by the fact that the exciting pins may be fastened directly to the inner conduc-

\* Decimal classification: R326.8. Original manuscript received by the Institute, April 5, 1946; revised manuscript received, September 4, 1946.

† Formerly, Radiation Laboratory, Massachusetts Institute of Technology, Cambridge, Massachusetts; now, Submarine Signal Company, Boston, Massachusetts.

This paper is based on work done for the Office of Scientific Research and Development under Contract No. OEMsr-262.

<sup>1</sup> W. L. Barrow, L. J. Chu, and J. J. Jansen, "Biconical electromagnetic horns," *Proc. I.R.E.*, pp. 769-779; December, 1939.

<sup>2</sup> All pattern data will be given in terms of power.



tor or capacitively coupled thereto. Fig. 2 shows a completed antenna using these elements. It has separate

elements, capacitive coupling has been convenient. In the latter case, over a 2 per cent band the standing-wave

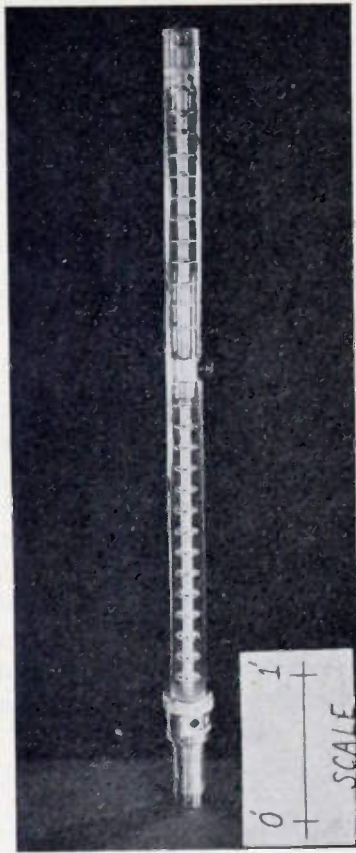

Fig. 2—Tridipole omnidirectional antenna.

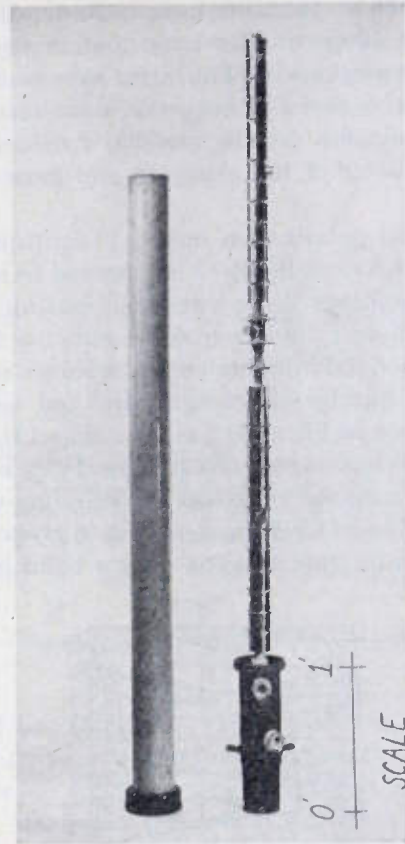

Fig. 4—Omnidirectional antenna using  $\lambda/2$  cylinders.

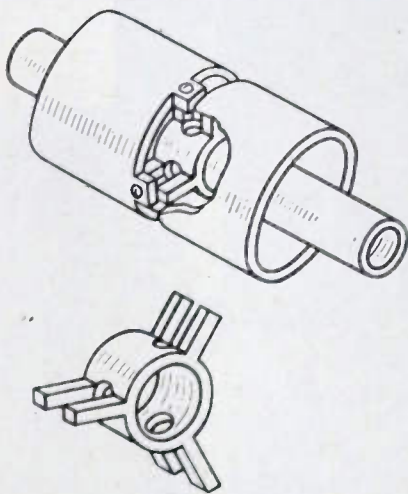

Fig. 3—Cylindrical element.

transmitting and receiving sections. Experience indicates that one, two, or three elements may be directly coupled to the line with reasonable bandwidths, i.e., standing-wave ratio  $< 1.4$  over a 10 per cent frequency band.<sup>3</sup> For an antenna with as many as fourteen ele-

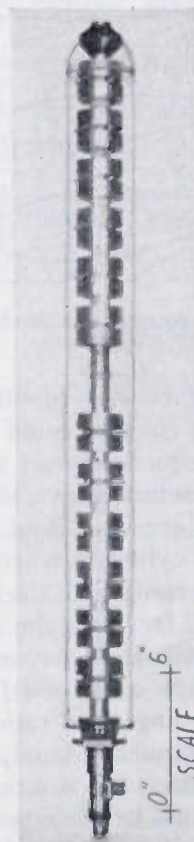

Fig. 5—Omnidirectional antenna using  $\lambda/4$  cylinders.

<sup>3</sup> All standing-wave ratios are measured in terms of voltage.

ratio  $< 1.4$ , while its elevation pattern, which has a half width of 8 degrees and side lobes less than 5 per cent, is unchanged. These elements have been die-cast in three sizes for the 10-centimeter band and in two sizes for 1000 and 700 megacycles. The latter have been provided with capacitive stubs at both the input terminals and ends of the dipoles, making possible a reduction in the relative diameter of the elements and greater pattern uniformity.

For vertical polarization in the 10-centimeter band, the basic idea shown in Fig. 3 has proved to be satisfactory. This employs three-wire lines exciting radiating cylinders. These cylinders may be either a half-wavelength long and fed from both ends, as shown in Fig. 4, or less than a quarter-wavelength and fed centrally in pairs, as shown in Fig. 5. It has been found that each of these schemes has its own advantages. For a six-element antenna having solid cylinders the standing-wave ratio  $< 1.2$  from 9.6 to 11 centimeters. Fig. 6 gives the elevation patterns for this antenna over a band of frequen-

and thus are independent of polarization and element geometry.

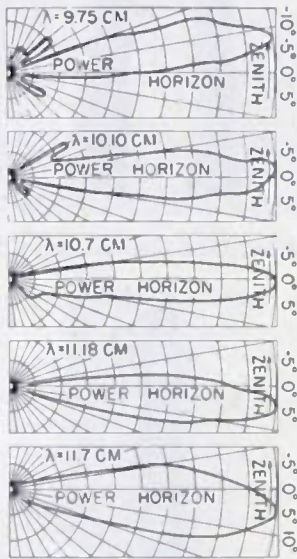

Fig. 6—Elevation patterns of a six-element antenna.

cies. The split elements were found to enjoy the advantage that a single element could be used in six-element arrays at all frequencies over a 20 per cent band centered at 10 centimeters, with a standing-wave ratio less than 1.4 over a 5 per cent band. This, of course, is not true for the solid cylinders, where the length of the cylinders varies of necessity with the frequency. A satisfactory arrangement for low-gain antenna design is shown in Fig. 7. Its elevation patterns, taken at 9, 10, and 11 centimeters, show a half width of approximately 50 degrees. The standing-wave ratio of this antenna, over a 20 per cent frequency band, is less than 1.25, while its azimuthal patterns have a three-fold symmetry with a ratio of maximum to minimum power of 1.6 to 1. Elevation patterns for the higher-gain antennas are determined by the ratio of over-all length to wavelength,



Fig. 7—Low-gain vertically polarized antenna.

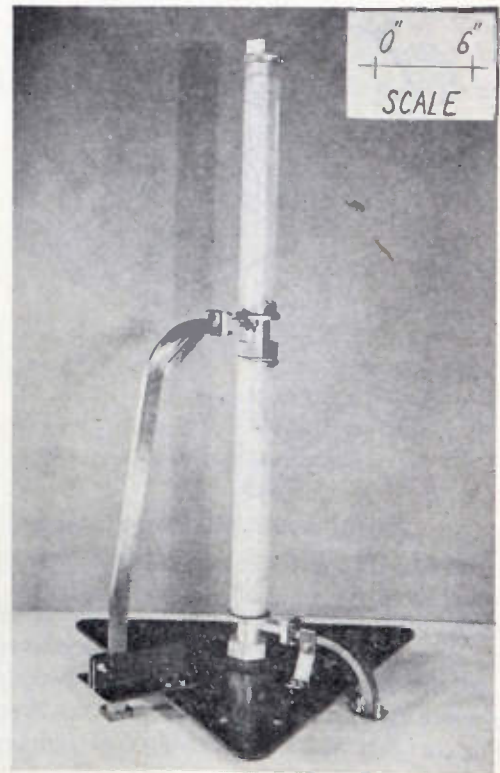

Fig. 8— $E_0$  wave-guide omnidirectional antenna.



Omnidirectional antennas at 3 centimeters have been horizontally polarized almost exclusively. At this frequency, tolerances are so close and feeding lines of practical size are relatively so large that attempts to build this type of antenna with dipoles have on several occasions in the past led to considerable difficulty.

Fig. 8 shows a completed 3-centimeter-band omnidirectional antenna. The upper of the two antennas acts as



Fig. 9—Slotted  $E_0$  wave guide.

a receiving antenna, while the lower acts as a transmitting antenna. Fig. 9 is a sketch of the radiating portion of the antenna. It consists of twelve bays or elements, each composed of seven vertical slots cut symmetrically in the circumference of 1- to 1/4-inch wave guide. These slots are approximately one-half wavelength long and are excited by pins on one edge projecting radially into the guide. The elements are reversed every half guide wavelength by alternately placing the pins on different sides of the slots. An additional set of

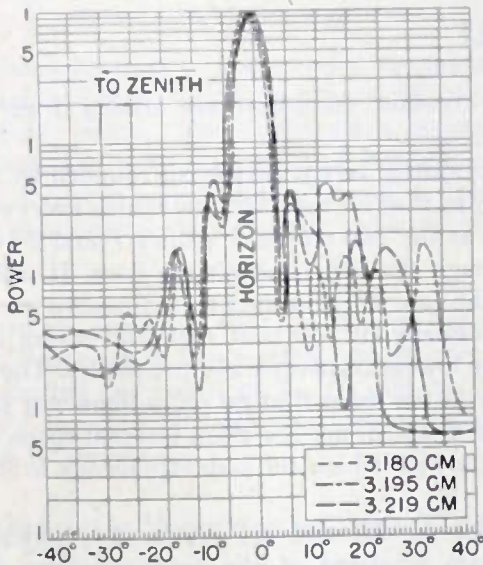

Fig. 10—Elevation patterns of twelve-bay 3-centimeter antenna.

matching pins is placed midway between the radiating elements for the purpose of increasing the bandwidth of the antenna. Not shown is a purely reactive terminating plug at the end of the antenna. The  $TM_{(0,1)}$  mode is excited by a special converter which in addition acts as a transition from rectangular to round wave guide. This mode is used, of course, because of its symmetric radial electric field.

Antennas using the principle just described have been built in 3-, 6-, and 12-bay sizes. The azimuth pattern of a typical 12-bay antenna is essentially a circle. Fig. 10

gives the elevation patterns of a 12-bay antenna over the operating frequency band. Fig. 11 shows the standing-wave ratio as a function of frequency for both a 12- and 3-bay antenna. To avoid the need for an external feeding line, a series of antennas using a double coaxial feeding line have been designed. These use either five or six slots on a 1-inch coaxial line with alternate elements staggered.

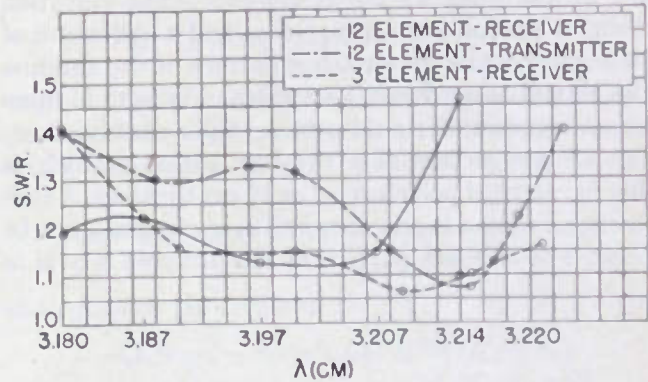

Fig. 11—Standing-wave ratio of slotted  $E_0$  wave-guide antennas.

It should be stated that the designer of a high-gain microwave omnidirectional antenna of the array type should have no difficulty in obtaining at least 90 per cent of the maximum theoretical gain available from a uniform line-current source of length  $L$ , where  $L$  equals the number of radiating elements times their spacing. This gain  $G$  is given by the expression

$$G = \frac{2L}{\lambda}$$

AIRBORNE ANTENNAS

The antennas described thus far have been used, principally, either in ground or ship installations. For fast aircraft the problem is different. Here, an enormous

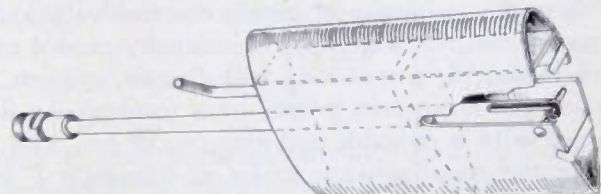

Fig. 12—Horizontally polarized half-slot antenna.

premium is placed on designs which lend themselves to streamlining. This requires an antenna which has one very narrow dimension. Both horizontally and vertically polarized streamlined antennas have been designed to meet this requirement.

Fig. 12 shows one version of a scheme which will give satisfactory performance for a horizontally polarized omnidirectional antenna at 10 centimeters. It is an experimental fact that a pair of slots centrally cut in the opposite sides of a thin wave guide, when excited 180 de-



grees out of phase, has a rather uniform azimuth pattern. These slots may be excited either by probes extending into the guides or by means of the slotted dipole shown in Fig. 12. Another antenna similar to that shown in Fig. 12 has been carefully tested. It has a full-length slot, approximately 0.7 wavelength long, centrally excited by means of the slotted dipole. The azimuthal patterns of these antennas are oval-shaped, with equal power in the fore and aft directions which exceeds the power at the sides by about 2.3 to 1. The elevation pattern for the full slot arrangement had a half width of 50 degrees, while the elevation pattern of the antenna of Fig. 12 had an 80-degree half width. For both of them the standing-wave ratio  $< 2$  over a 16 per cent band.

Fig. 13 is a picture of a two-bay antenna which is usable for vertical polarization at 10 centimeters. A thin protecting radome is not shown. These elements can be die cast. The azimuth pattern of this antenna is oval in

shape with a minimum in the plane of the dipoles which differs from the maximum by a factor of about 1 to 1.6.

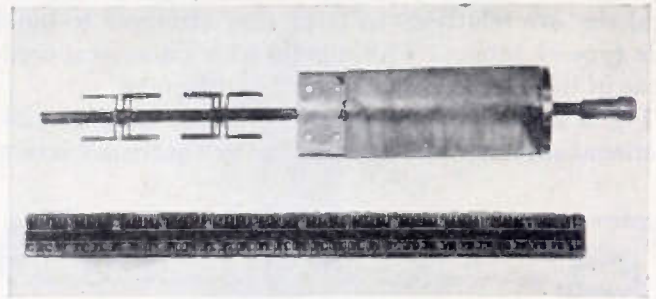

Fig. 13—Vertically polarized streamlined antenna.

Its elevation half-power width is 35 degrees and its standing-wave ratio  $< 1.3$  over a 7 per cent frequency band.

## $Q$ Circles—A Means of Analysis of Resonant Microwave Systems\*

WILLIAM ALTAR†

### Part II

#### 3. MICROWAVE SYSTEMS AND CIRCUIT ANALYSIS

Proof of the relations exploited in Part I rests on the validity of representing our system by the circuit of Fig. 1, which must now be justified on the basis of electromagnetic field theory. So far as the matching transformer is concerned, the  $Q$  circle is merely a particularly convenient form of what might be termed the reactance circle of the transducer  $M.T.$ , meaning the locus of reflection coefficients as seen at  $T$  while the load at  $T'$  goes through a sequence of purely reactive values. An alternative method, which has occasionally proved useful for measuring a matching transformer, consists in replacing the magnetron proper by a transmission line equipped with a movable end plug free of loss, and to measure the standing-wave ratios at terminals  $T$  for, say, four consecutive plug positions at eighth-wave spacings. The four chart points thus obtained can then be used in much the same manner as the four points  $A, B, C$  and  $O$  of Section II (Part I), for an evaluation of the transducer properties. This case offers a more clean-cut situation and will be discussed first, thus

\* Decimal classification: R119.3. Original manuscript received by the Institute, April 29, 1946; revised manuscript received, August 8, 1946. Part I of this paper was published in *Proc. I.R.E.*, vol. 35, pp. 355-361; April, 1947.

† This method was first developed in the early spring of 1943 and, under then existing security restrictions, received only limited discussion at that time.

† Westinghouse Electric Corporation, East Pittsburgh, Pennsylvania.

avoiding certain complications arising from cavity coupling.

Let the system be completely surrounded by a closed surface  $S$  so that all field vectors vanish everywhere on  $S$  except at the two reference planes  $T$  and  $T'$  where  $S$  cuts through the two transmission lines. It will suffice to treat the case where each of these lines is a wave guide (not necessarily of identical type) operating in their respective lowest transverse electric modes. The system is passive in the sense that no radio-frequency power is generated inside  $S$ , nor are there internal space charges or currents with which the radio-frequency fields could interact.

Then let  $E_1, H_1$  and  $E_2, H_2$  be two independent steady-state solutions of the field equations for the boundary conditions imposed by the nature of the system, and oscillating at the same frequency. Combining a well-known vector identity with the fact that the fields satisfy Maxwell's equations, one has:

$$\begin{aligned} \operatorname{div} (E_1 \times H_2) &= H_2 \cdot \operatorname{curl} E_1 - E_1 \cdot \operatorname{curl} H_2 \\ &= -jk(H_1 \cdot H_2 + E_1 \cdot E_2). \end{aligned} \quad (14)$$

Interchanging the subscripts and combining with (14), one has:

$$\operatorname{div} (E_1 \times H_2 - E_2 \times H_1) = 0 \quad (15)$$

which, by integration over the volume  $V$  inside  $S$ , reduces to a surface integral over  $S$ . The only contribu-



tions not zero come from the two wave-guide cross sections at  $T$  and  $T'$ , where the fields are well-defined mode functions and can be formally integrated. Changing the definition of the positive normal of  $S$  so that, by definition, the positive surface normals at both  $T$  and  $T'$  point in the assumed direction of transmission, one finds the integrated form of (15):

$$J_{12} = \int_T (E_1 \times H_2 - E_2 \times H_1) da$$

$$= \int_{T'} (E_1 \times H_2 - E_2 \times H_1)' da' \times J_{12}' \quad (16)$$

It is well known that wave-guide modes fall into the two classes of  $TE$  and  $TM$  modes. It will suffice here to carry the argument through for the case of a  $TE$  mode without, however, restricting its generality with regard to the cross-sectional shape of the wave guide. It is only necessary that the guide geometry be such as to exclude all other modes.

The guide field at  $T$  is then formally representable as follows:<sup>2</sup>

$$E_s = k(n \times \nabla)v(e^{ik_s z} + r e^{-ik_s z})$$

$$E_z = 0$$

$$H_s = k_z \nabla v(e^{ik_s z} - r e^{-ik_s z})$$

$$H_z = -j k_s^2 v(e^{ik_s z} + r e^{-ik_s z}) \quad (17)$$

where the subscripts  $s$  and  $z$  refer to the sectional ( $x, y$ ) and, respectively, to the normal ( $z$ ) components of the field vectors. The propagation constant  $k_z$  is found from  $k = 2\pi/\lambda_0$  by means of  $k_z = \sqrt{k^2 - k_s^2}$ . The function  $v(x, y)$  is independent of  $z$  and is a solution of the two-dimensional characteristic-value problem

$$(\Delta + k_s^2)v = 0, \quad (18)$$

subject to the condition that the normal derivative of  $v$  at the boundary of the section area be zero.

Substituting two solutions  $E_1, H_1$  and  $E_2, H_2$  of the type (17) into the left side of integral relation (16) gives the following:

$$J_{12} = k k_z \int_T \int_T (\Delta v)^2 da [(e^{ik_s z} + r_1 e^{-ik_s z})(e^{ik_s z} - r_2 e^{-ik_s z})$$

$$- (e^{ik_s z} + r_2 e^{-ik_s z})(e^{ik_s z} - r_1 e^{-ik_s z})] \quad (19)$$

which, with the help of the vector identity

$$(\nabla v)^2 = \text{div}(v \text{ grad } v) - v \Delta v = \text{div}(v \text{ grad } v) + k_s^2 v^2 \quad (20)$$

together with the boundary conditions for  $v$ , may be simplified to

$$J_{12} = 2k k_z k_s^2 V(r_1 - r_2) \quad (21)$$

where

$$V = \iint_T v^2 dx dy.$$

<sup>2</sup> E. U. Condon, "Microwave radio," *Rev. Modern Phys.* vol. 14, p. 355; October, 1942.

The case treated concerns cylindrical resonators and is closely analogous to that encountered in wave guides which interests us here.

A similar relation can be derived for the reference plane  $T'$  at the receiver, where a form analogous to (17) can be written down for the field, except that complex alternating-current vectors  $t_1$  and  $t_2$ , representing transmission coefficients of the transducer, must be applied to the two solutions. We write

$$E_s' = k(n \times \nabla)w t(e^{ik_s' z'} + r' e^{-ik_s' z'})$$

$$E_z' = 0$$

$$H_s' = k_s' \nabla w t(e^{ik_s' z'} - r' e^{-ik_s' z'})$$

$$H_z' = -j k_s'^2 w t(e^{ik_s' z'} + r' e^{-ik_s' z'}) \quad (22)$$

where  $k_s'$  and  $w'$  are eigenvalue and eigenfunction of the characteristic-value problem associated with cross section  $T'$ , in analogy to (18). One has, therefore,

$$J_{12}' = 2t_1 t_2 k k_z' k_s'^2 W(r_1' - r_2') w = \iint_{T'} w^2 da'$$

and equation (16) reduces to

$$k_z k_s^2 V(r_1 - r_2) = t_1 t_2 k_z' k_s'^2 W(r_1' - r_2') \quad (23)$$

If we want to eliminate all design parameters of the transmission line and such operating parameters as  $t_i$ , which are not usually measured along with the reflection coefficients, it will be easily seen that at least four pair of coexisting values ( $r_i, r_i'$ ) are needed so that an identical relation can be established between them. One then writes:

$$\frac{J_{13} J_{24}}{J_{14} J_{23}} = \frac{J_{13}' J_{24}'}{J_{14}' J_{23}'}$$

which, by (23), leads to

$$\frac{(r_1 - r_3)(r_2 - r_4)}{(r_1 - r_4)(r_2 - r_3)} = \frac{(r_1' - r_3')(r_2' - r_4')}{(r_1' - r_4')(r_2' - r_3')} \quad (24)$$

With the help of (24) one is in a position, from three known pairs ( $r_i, r_i'$ ) and with no reference to line constants, to compute all other pairs. This, it will be seen, leads to a linear relation of the form

$$r = \frac{Er' + F}{Gr' + H} \quad (25)$$

where the general circuit constants  $E, F, G, H$  are characteristics of the transducer and may be computed from the given complex values  $r_1, r_2, \dots, r_3'$ . Relation (25) is the exact mathematical equivalent of a well-known relation between load and looking-in impedance, which is used in the theory of four-terminal networks and which can in fact be derived from (25), seeing that  $Z$  and  $r$  are related to each other by a linear transformation. The existence of this linear so-called network transformation (25) in the complex plane is basic in the derivation of all circuit theorems; for example, in proving the existence of an equivalent pi or tee circuit.

Expressions of the type found in (24) play an important role in the theory of complex variables, being



the so-called anharmonic cross ratio of two pairs ( $r_1, r_2$ ) and ( $r_3, r_4$ ) of complex numbers. Using a notation common in that theory, we re-write (24):

$$R(r_1, r_2; r_3, r_4) = R(r_1', r_2'; r_3', r_4'). \quad (24a)$$

This expresses the fundamental theorem that the cross ratio of four numbers  $r_i$  remains invariant under any linear transformation of the type (25) simultaneously applied to the  $r_i$ 's.

We shall make extensive use of (24), frequently in a more general form which is not limited to one direction ( $TT'$ ) of transducer operation but which permits one to correlate freely results of both network transformations respectively associated with the two possible directions of transmission.

To this end we shall make a distinction between load and image points in the  $T$  chart, referring to points measured in the operating direction ( $T'-T$ ) as load points, and to measurements in the direction ( $T-T'$ ) as image points. In the  $T'$  chart, similarly, load and image points are respectively associated with the operating direction ( $T-T'$ ) and ( $T'-T$ ). Reference will also be made to inverted points, meaning the conjugate of the reciprocal of a load or image point. Thus an inversion is the same as a geometrical transformation by reciprocal radii.

Since a standing-wave pattern at  $T$  (or at  $T'$ ) can be represented either by  $r$ , or alternatively by  $1/r$  if the direction assumed to be positive is arbitrarily reversed, the following formulation of equation (24) is valid:

**THEOREM.** Let each of four complex numbers  $a, b, c$ , and  $d$  represent either a load point or an inverted image point in the  $T$  chart of a given passive transducer, and let  $a', b', c'$ , and  $d'$  be respectively the inverted image points, or the load points, depicting coexisting load conditions in the  $T'$ -chart. Then the two cross ratios are complex conjugates:

$$R(a, b; c, d) = \widehat{R}(a', b'; c', d'). \quad (24b)$$

By writing the network transformation in any of the forms (24) one opens the way for application of a number of useful geometrical rules dealing with anharmonic cross ratios of complex numbers and which are compiled here without proof for later reference:

A. Four points in the complex plane lie on a circle if, and only if, their cross ratio has a real value.

B. Two pairs of points ( $a, b$ ) and ( $c, d$ ) in the complex plane form a harmonic sequence if their cross ratio has the real value  $R(a, b; c, d) = -1$ . It follows that four harmonic points lie on a circle; also, that the two lines tangent to the circle at points forming one pair intersect at a point colinear (in a straight line) with the points forming the other pair.

C. If each of four complex numbers is subjected to the same linear transformation, the numerical value of the cross ratio remains the same. This is true, particu-

larly, for four complex quantities (four admittances, four impedances, or four reflection coefficients) simultaneously subjected to a network transformation.

D. Let  $P, A, B, C$ , and  $D$  be points on a circle. Four rays through  $P$  and intersecting the circle at the respective points  $A, B, C$ , and  $D$  will intersect an arbitrary straight line  $g$  in four points  $a, b, c, d$  so that the cross ratios are equal:

$$R(A, B; C, D) = R(a, b; c, d)$$

where the real quantities  $a, b, c, d$  are distances measured from an assumed zero on the straight line.

E. If the equation of a circle (general point  $r$ ) can be written in parameter form

$$r = \frac{P\alpha + Q}{R\alpha + S} \quad \begin{array}{l} P, Q, R, S \text{ complex constants, } \alpha \text{ a real} \\ \text{variable} \end{array}$$

we shall refer to  $\alpha$  as a linear parameter for points on the circle. If so, the cross ratio of any four points on the circle is equal to that of the respective parameter values

$$R(r_1, r_2; r_3, r_4) = R(\alpha_1, \alpha_2; \alpha_3, \alpha_4)$$

as a direct consequence of Rule C.

F. Three or more circles are called confocal if by a linear transformation they can be transformed into concentric circles. Confocal circles thus remain confocal under linear transformations. In analytic form, a family of confocal circles in the  $XY$  plane is represented by the equation:

$$\begin{aligned} (X - x)^2 + (Y - y_0)^2 &= (x^2 - d^2) \quad \text{or:} \\ X^2 - 2Xx + (Y - y_0)^2 + d^2 &= 0 \end{aligned} \quad (26)$$

where the parameter  $x$  is constant for each circle but varies from one circle to the next.

G. If a circle is orthogonal to two given circles, it is also orthogonal to all circles confocal with the given two circles. All circles which are orthogonal to a family of confocal circles pass through two points which are called the foci of the family.

H. Let  $a$  and  $b$  be the segments into which the chord of a circle is separated by one of its points,  $P$ . The product of these lengths,  $a \cdot b$ , a function only of the position of  $P$  and the circle but not of the particular chord chosen, is called the "power" of point  $P$  relative to the circle.

The locus of all points in the plane having a given constant ratio of "powers" relative to two given circles is itself a circle confocal with the given circles.

It remains for us to extend the procedure to the case where only one transmission line leads into the system, while the transducer at its other end is terminated in a resonant cavity of arbitrary shape. Instead of varying the load through a sequence of purely reactive values by means of a variable end plug, we can then accomplish the same purpose by the simple expedient of varying the frequency.



Retracing our steps through equations (14) to (16) but now assigning different values  $k_1$  and  $k_2$  to the two solutions, we obtain the following relation in place of (15):

$$j \operatorname{div} (E_1 \times H_2 - E_2 \times H_1) = (k_1 - k_2)(H_1 \cdot H_2 - E_1 \cdot E_2) \quad (27)$$

which, by integration over the volume  $V$  inside  $S$ , reduces to

$$\begin{aligned} j \iint_T da (E_1 \times H_2 - E_2 \times H_1) \\ = (k_1 - k_2) \iiint_V (H_1 \cdot H_2 - E_1 \cdot E_2) dv. \end{aligned} \quad (28)$$

Again we may carry out the surface integration by substituting the expressions (17), with the complication that the quantity  $\rho = k_s/k$  is no longer the same for solutions belonging to different frequencies. Unless these frequencies are close to cut-off, however, we may consider the ratios as constant, which entails the negligible error of omitting a term of the order  $(k_1 k_{2s} - k_2 k_{1s}) = 1/2(\alpha_1 - \alpha_2)k_s^2$ , and we arrive then at the same equation (21) as before.

To carry out the volume integration in (28), we must assume all frequencies to be so close to resonance that the actual fields in the system may be expanded in terms of orthogonal mode functions and that all but one expansion term may be discarded because the overwhelmingly strong effect of the near mode drowns out all the others. In this approximation one has

$$\begin{aligned} E &= \frac{jE_0}{k_0^2 - k^2} (k_0 A - kB) \\ H &= \frac{jH_0}{k_0^2 - k^2} (-kA + k_0 B) \end{aligned} \quad (29)$$

where the "excitation integrals"  $A$  and  $B$  are to be taken over the boundary inside which the unperturbed mode  $E_0, H_0$  is defined:

$$A = \iint_S \vec{E} \times H_0 \cdot da \quad \text{and} \quad B = \iint_S E_0 \times H \cdot da.$$

It will usually be possible and profitable to locate inside  $S$  a second closed surface  $S'$  which contains essentially all the stored energy associated with the operating mode but which excludes such amounts of stored energy as may be associated with modes other than the operating mode and which, therefore, do not vary appreciably throughout the frequency band studied. In view of (15) or (28), the surface integral of (28) should give the same result whether we integrate over  $S'$  or over  $S$ . For the volume integration, on the other hand, there may be considerable advantage in restricting the range of integration to within  $S'$ , where the approximation (29) is better justified.

Substituting the expressions (29) into (28) and using the notation

$$W_0 = \iiint_{V'} E_0^2 dv = - \iiint_{V'} H_0^2 dv$$

we find for the volume integral:

$$\begin{aligned} \iiint_{V'} (H_1 \cdot H_2 - E_1 \cdot E_2) dv \\ = \frac{W_0}{(k_0^2 - k_1^2)(k_0^2 - k_2^2)} [(k_0^2 + k_1 k_2)(A_1 A_2 + B_1 B_2) \\ - k_0(k_1 + k_2)(A_1 B_2 + A_2 B_1)]. \end{aligned}$$

For the unperturbed mode, the electric field  $E_0$  is orthogonal and the magnetic field  $H_0$  parallel to the boundary  $S'$  so that the integrals  $B$  of (29) are always zero. Thus the last expression, when introduced in (28), gives

$$2j\rho k_1 k_2 k_s^2 (r_1 - r_2) V = W_0 A_1 A_2 \frac{(k_0^2 + k_1 k_2)(k_1 - k_2)}{(k_0^2 - k_1^2)(k_0^2 - k_2^2)} \quad (30)$$

To simplify (30) we introduce the frequency parameter  $\alpha$ , in terms of which

$$\alpha_1 - \alpha_2 = \frac{(k_0^2 + k_1 k_2)(k_1 - k_2)}{k_0 k_1 k_2}$$

so that equation (28) assumes the final form

$$\begin{aligned} r_1 - r_2 &= j(\alpha_1 - \alpha_2) F_1 F_2 \\ F_i &= \frac{A_i}{(k_0^2 - k_i^2) k_s} \sqrt{\frac{k_0 W_0}{2\rho V}}. \end{aligned} \quad (31)$$

Next one eliminates the  $F_i$  factors much as in the case previously discussed, provided that four  $r$  values at terminals  $T$ , measured at known frequencies, are available. Forming again the anharmonic cross ratio of the  $r$ 's, one obtains, in view of (31),

$$R(r_1, r_2; r_3, r_4) = R(\alpha_1, \alpha_2; \alpha_3, \alpha_4) \cong R(f_1, f_2; f_3, f_4) \quad (32)$$

showing that  $r$  is a linear function of the frequency parameter; exactly as if the resonant region inside  $S'$  were a simple LC circuit accessible through a frequency-insensitive transducer:

$$r = \frac{K\alpha + L}{M\alpha + N} \quad (33)$$

From the values  $K, L, M$ , and  $N$  which are known functions of  $r_1, r_2, r_3, \alpha_1, \alpha_2, \alpha_3$ , one can in fact compute the lumped elements of a completely equivalent circuit, except for the unknown ratio of an ideal transformer at terminals  $T'$ . This leaves the characteristic impedance of the resonant element undetermined.

#### 4. INTERPRETATION OF Q-CIRCLE DATA— OUTLINE OF PROOFS

##### a. Q and $\alpha$ Contours

If the reflection coefficients are measured at four arbitrary frequencies at terminals  $T$  looking to the left

toward the transducer and resonant element, the anharmonic cross ratio of their complex values is real by virtue of (32), and the frequency locus is a circle in the Smith chart by virtue of Rule A. The  $Q$  circle is determined by the conjugates of any three  $r$  values (points  $A, B, C$  in Section 2).

If these three points belong to equidistant  $\alpha$  values, the fourth harmonic point, as defined by Rule B, is the off-resonance point  $O$ , because the cross ratio of these four points is:

$$R(O, B; A, C) = \frac{\alpha_2 - \alpha_3}{\alpha_2 - \alpha_1} = -1,$$

The geometrical relation which Rule B establishes between four points of a harmonic sequence makes it then possible to locate point  $O$  graphically from the given  $A, B$ , and  $C$  essentially as described earlier.

From (32) one also deduces that  $\alpha$  is a linear parameter for the  $Q$  circle within the meaning of Rule E, thus establishing the existence of a linear  $\alpha$  scale. If one makes line  $g$  of Rule D parallel to the line joining points  $P$  and  $O$ , projection of points on the circle from the projection center  $P$  on the line  $g$  will assign the correct parameter value  $\alpha = \infty$  to the infinite point on  $g$ ; it then suffices to correctly assign their  $\alpha$  values to two

Points  $O, S$ , and  $F$  are image points in the  $T$  chart corresponding to the respective frequencies  $\infty, f_0$ , and an arbitrary frequency  $f$ . The corresponding load points in the  $T'$  chart lie on the chart rim, being unit vectors  $r' = 1, r' = -1$  and  $r' = e^{j\theta'}$ . For the fourth point to be used in (27b) we choose the load point  $r = \text{zero}$ , i.e., a match at terminals  $T$ . Its corresponding image  $r_m'$  in the  $T'$  chart is found by substituting the four point pairs into (27a):

$$\begin{aligned} R(S, O; F, \infty) &= \widehat{R}(-1, 1; e^{j\theta'}, r_m') \\ &= R(-1, 1; e^{-j\theta'}, 1/r_m') \end{aligned} \quad (34)$$

or, explicitly,

$$\frac{S - F}{O - F} = \frac{1 - e^{-j\theta'}}{1 + e^{-j\theta'}} \frac{1 + r_m'}{1 - r_m'} \quad (35)$$

This equality between purely imaginary quantities can be rewritten after dropping a  $j$  factor:

$$\tan \psi/2 = \frac{1}{Q_m} \tan \psi'/2 \quad (36)$$

where  $\psi$  and  $\psi' = 180 - \theta'$  (Fig. 6) are the angles through which the point on the  $Q$  circle and the corresponding point on the rim of the  $T'$  chart, travel as the frequency

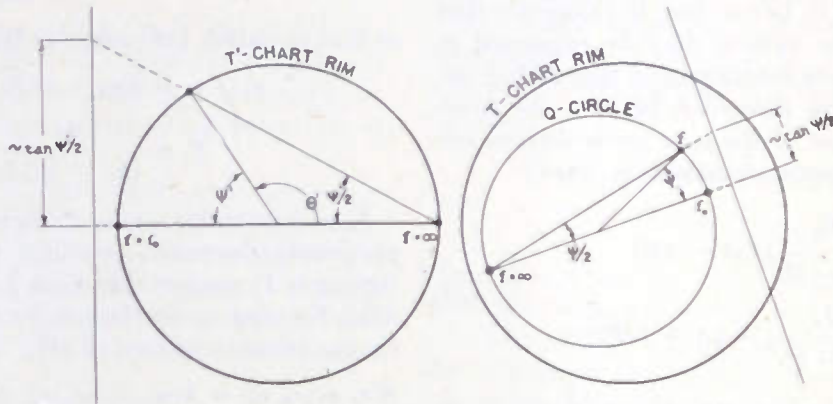

Fig. 6

more points on line  $g$  in order that all other points on  $g$  shall read correctly by linear interpolation. In particular, point  $P$  was chosen coincident with  $O$  in Section 2, thus making line  $g$  parallel to the tangent at  $O$ .

In order to determine  $Q_{\text{match}}$ , use is made of (24b) with a suitable choice of points; three load points and their images referring to transducer operation in the direction  $T-T'$  and the fourth to the opposite direction. It has been said earlier that the dividing line at  $T'$  is to be drawn in a manner so as to make the resonant frequency  $f_0$  of the resonant element the same as the resonant frequency  $f_m$  of the system when terminated in a matched load. Later it will be shown that point  $S$ , corresponding to  $f_m$  on the  $Q$  circle, lies diametrically opposite to the off-resonance point  $O$ . Points  $S$  and  $O$  are the respective short-circuit and open-circuit points of the transducer  $M.T$ .

shifts from  $f_0$  to  $f$ . Indeed, since the two vectors  $(O-F)$  and  $(S-F)$  are perpendicular, the left side of (36) is  $j \tan \psi/2$ . In the  $T'$  chart, where the load is purely reactive, the load point travels through the angular interval from  $\theta' = 180$  degrees (for  $f_0$ ) to  $\theta'$  (for  $f$ ). The second factor at the right of (35) is simply related to the loaded  $Q$  of the resonant system. Generally, the impedance which an arbitrary load presents at  $T'$  is

$$\frac{Z'}{Z_0'} = \frac{1 + r'}{1 - r'} = \frac{1}{Q} - j\alpha \quad (37)$$

where  $\alpha$  is the frequency parameter measuring the extent of frequency pulling by the external load. Indeed, the frequency for which the reactance  $Z_0'\alpha$  just neutralizes the image reactance presented becomes the resonant frequency for the loaded system.

For a matched load at  $T$ , because of our choice of refer-



ence zero for  $\alpha$ , (37) becomes simply  $1/Q_{\text{match}}$ , thus verifying equation (36). Now, in the  $T'$  chart, the frequency parameter  $\alpha$  and the angle  $\psi'$  are related:

$$\tan \psi'/2 = \frac{f}{f_0} - \frac{f_0}{f} = \alpha \tag{38}$$

so that the final formula is obtained:

$$Q_m = \frac{1}{\alpha} \tan \psi/2 \approx \frac{f_0}{2\Delta f} \tan \psi/2. \tag{39}$$

Proof of the formulas for mapping  $Q$  and  $\alpha$  contours proceeds along similar lines, using equation (24a) again with a slightly different choice of points. We identify the load conditions, associated with indexes 1 and 2, with open- and short-circuit at terminals  $T'$  while the indexes 3 and 4 will be identified with one match and one arbitrary load, both at terminals  $T$ . If we use a bar to denote the inverted image of a load, equation (24a) assumes the specialized form

$$R(1, -1; \bar{r}', \bar{r}_m') = R(\bar{O}, \bar{S}; r, \text{zero}) \tag{40}$$

or, explicitly,

$$\frac{1-r'}{1+r'} \frac{1+r_m'}{1-r_m'} = \frac{\bar{O}-r\bar{S}}{\bar{S}-r\bar{O}}$$

which, by (37), may be written

$$\frac{1}{Q} - j\alpha = \frac{1}{Q_m} \frac{\bar{O}\bar{S}-r}{\bar{S}\bar{O}-r} \tag{41}$$

We must forego details of the geometrical interpretation of the vector relation (41) by which one verifies the description given in Section 3, for mapping the  $Q$  and  $\alpha$  contours.

It remains to show that points  $S$  and  $O$  are diametrically opposite each other on the  $Q$  circle. The  $\alpha$  contours meet the inverted  $Q$  circle at points obtained by inverting the points on the  $Q$  circle which belong to the respective  $\alpha$  values. In particular, the  $\alpha$  contour passing through the center of the chart will, when subjected to an inversion, become that circle which passes through  $\bar{O}$  and through the infinite point, and will have to be perpendicular to the inverted  $Q$  circle. Hence, it must be the diameter of the  $Q$  circle at the off-resonance point q.e.d.

*b. Efficiency Contours*

Space would not permit us to derive here the functional relation between input and output power and the load for a given transducer by an independent method. It is more expedient to make use of known<sup>3</sup> formulas for the contour lines of circuit efficiency in the receiver chart of complex load admittance, and to translate them into

contour lines in our chart. In the plane of admittance  $Y=G-jB$ ,

$$\left[ G + \frac{1}{2k}(p-1/e) \right]^2 + \left[ B + \frac{q}{2k} \right]^2 = \left[ \frac{1}{2k}(p-1/e) \right]^2 + \left( \frac{q}{2k} \right)^2 - \frac{h}{k} \tag{42}$$

where the constants  $p, q, h, k$  are known functions of the general transducer constants and of no particular concern in the following.

Equation (42) must be transformed into an equivalent relation in the complex  $r$  plane, using the relation

$$Y = Y_0 \frac{1-r}{1+r} \tag{43}$$

Note first that (42) is of the form which, by Rule F (Section 3), is characteristic of a family of confocal circles.

$$(G-g)^2 + (B-b_\infty)^2 = g^2 - d^2$$

$$g = -g_\infty + \frac{R_\infty}{e} \quad d = \sqrt{g_\infty^2 - R_\infty^2} \tag{44}$$

where the center of the contour line  $e = \infty$  has the coordinates  $(-g_\infty, b_\infty)$  with  $g_\infty$  a positive number, and its radius is  $R_\infty$ . According to Rule F, the efficiency contours remain a family of confocal circles after the linear transformation (43) which transforms the admittance plane to the  $r$  plane. Moreover, they will be confocal in the  $r$  plane with the two known contour lines  $e = \text{zero}$ , which is the chart rim, and  $e = \infty$ , which is the inverted  $Q$  circles.

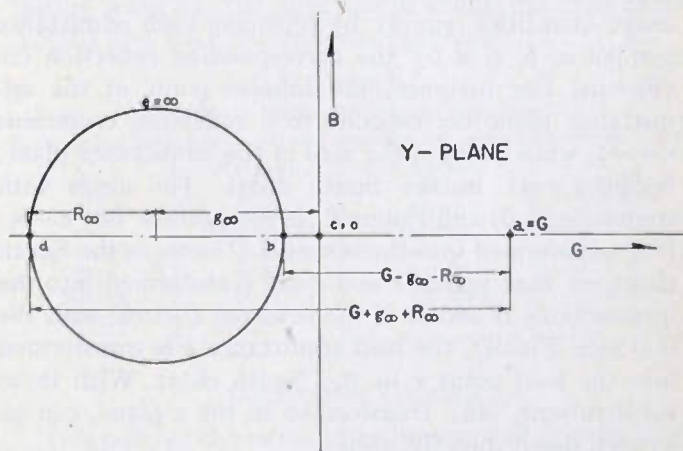

Fig. 7

Thus, we have reduced the mapping of the  $e$  contours to the purely geometrical problem of drawing circles confocal with two given circles: a straightforward geometrical construction which has been given in Section 2(c). It remains to locate the centers for given  $e$  values.

To this end, we solve the admittance equation (44) for  $e$ . Since circuit efficiency involves only active powers

<sup>3</sup> J. G. Tarboux, "Introduction to Electrical Power Systems," 1944. pp. 113-115, International Textbook Co., Scranton, Pa.

which do not vary along the loss-free output wave guide, it is permissible to temporarily shift the reference plane  $T$  of the guide until the centers of all  $e$  circles fall on the  $G$  axis, thus making  $b_\infty$  of (44) zero (Fig. 7). In the Smith chart, this is tantamount to a rotation of the diagram without affecting the relative configuration, and after completing the argument we shall restore the original reference terminals  $T$  simply by tilting the diagram back to its proper angular position.

With  $b_\infty = 0$ , one has from (44)

$$e = \frac{2R_\infty G}{(G + g_\infty + R_\infty)(G + g_\infty - R_\infty) + B^2} \quad (45)$$

Since the line  $B=0$  will be transformed into the real axis of the Smith chart, we ask for the points of intersection of the  $e$  contours with this line, first in the admittance plane and then in the Smith chart. With  $B=0$ , equation (45) assumes a simpler form which is entirely expressible in terms of anharmonic cross ratios, an important advantage for executing the transformation. One has in the admittance plane (Fig. 7)

$$\begin{aligned} (e)_{B=0} &= \frac{2RG}{G + g_\infty + R_\infty(G + g_\infty - R_\infty)} \\ &= \frac{(a - c)(b - d)}{(a - b)(a - d)} \\ &= R(a, b; c, d) \times R(a, c; \infty, b) \end{aligned} \quad (46)$$

where the quantities  $a, b, c, d$  are real, representing points along the  $G$  axis. Now because of the invariance of cross ratios under linear transformations (see Rule C), (46) can be transformed from admittance to Smith chart quantities, simply by replacing each admittance symbol  $a, b, c, d$  by the corresponding reflection coefficient. For instance, the infinite point of the admittance plane corresponds to a reflection coefficient  $r = -1$ , while point  $c$ , the zero of the admittance plane, becomes  $r = 1$  in the Smith chart. The circle with center  $(-g_\infty, 0)$  and radius  $R_\infty$  is the contour line  $e = \infty$ ; it is transformed into the inverted  $Q$  circle in the Smith chart, so that points  $b$  and  $d$  are transformed into the intersections  $B$  and  $D$  of the inverted  $Q$  circle with the real axis. Finally, the load admittance  $a$  is transformed into the load point  $r$  in the Smith chart. With these substitutions, (46), transformed to the  $r$  plane, can be written down directly, thus:

$$\begin{aligned} (e)_{B=0} &= R(r, B; -1, D) \times R(r, -1; 1, B) \\ &= \frac{(1+r)(D-B)}{(D-r)(B+1)} \frac{(1-r)(B+1)}{2(r-B)} \\ &= \frac{(D-B)}{2} \times \frac{(1-r^2)}{(D-r)(r-B)} \\ &= R_0 \frac{1-r^2}{(D-r)(r-B)} \end{aligned} \quad (47)$$

Using the terminology of Rule H, we express (47) in the form

$$e = R_0 \frac{\text{"power" of load point relative to the chart rim}}{\text{"power" of load point relative to inv. } Q \text{ circle}} \quad (48)$$

So far, we have proved (48) only for a purely resistive load, i.e., for the point of intersection of an  $e$  contour with the real axis, but we can remove this restriction, using the second statement of Rule H. Hence, (48) applies to any point in the load chart.

The "power" of the load point relative to the  $T$  chart rim bears a simple relation to the active power passing through the  $T$  reference plane. It is not difficult to show that the voltage, current, and complex power vectors at that reference plane when the outgoing wave has unity amplitude are respectively represented by  $(1+r)$ ,  $(1-r)$ , and  $(1+r') \times (1-r)$ . (Complex quantities!!) It follows that the active power output at  $T$  is given by

$$P = P_0(1 - |r|^2) \quad (49)$$

where  $P_0$  is the power output per unit amplitude supplied to a matched load. Comparison with (48) then leads to the following formula for the active input power  $P'$  at terminals  $T'$  under these conditions:

$$P' = P_0 \frac{\text{"power" of load point } r \text{ relative to inv. } Q \text{ circle}}{\text{radius of inverted } Q \text{ circle}}$$

Equation (47) assumes a particularly simple form for  $r=0$ , showing that the circuit efficiency of the system when terminated in a matched load is

$$e_{\text{match}} = \frac{R_0}{-BD} = \frac{D-B}{2BD} \quad (50)$$

Thus, one finds that  $e_{\text{match}}$  is numerically equal to the radius of the  $Q$  circle, verifying a previous statement to this effect.

To find the center of a given  $e$  contour, we rewrite equation (47) as a quadratic equation for  $r$ :

$$r^2(e - R_0) = 2rx_0e = \text{constant} \quad (51)$$

where  $x_0 = 1/2(D+B)$  is the abscissa of the center of the inverted  $Q$  circle. The center of each contour has an abscissa (measured along our temporary real axis)

$$x = 1/2(r_1 + r_2) = \frac{x_0 e}{e - R_0} \quad (52)$$

This shows that  $e$  is a linear parameter for the point sequence of centers along the  $x$  axis; hence the existence of a linear  $e$  scale follows in accordance with Rule E, and the procedure for setting up the  $e$  scale which was outlined in Section 2(c) need only be justified for three points, preferably for the centers of the contours  $e=0$  (chart rim),  $e=\infty$  (inverted  $Q$  circle), and for the  $e$  value which is numerically equal to  $R_0$  (contour a straight line; contours center at infinity).



# Characteristics of Certain Voltage-Regulator Tubes\*

GEORGE M. KIRKPATRICK†, MEMBER, I.R.E.

**Summary**—A quantitative presentation is made of the data from a large number of tests on three types of gaseous voltage-regulator tubes, VR75, VR105, and VR150, from several manufacturers. The effect of several factors, such as time and temperature, on the voltage stability has been investigated, and an equivalent circuit of the tube was experimentally determined. These results are especially applicable where the VR tubes are used as a source of reference voltage, such as in a degenerative electronic voltage stabilizer.

## INTRODUCTION

**G**ASEOUS voltage-regulator tubes are extensively used as a means of obtaining a reference voltage in the degenerative-type electronic voltage stabilizer. When this circuit is analyzed to determine the internal resistance and the regulating factor,<sup>1,2</sup> the voltage-regulator tubes are commonly considered to be the equivalent of a constant voltage in series with a linear resistance.

In the course of development work to obtain a regulated power supply of unusually high stability, a large number of tests were made on three types of voltage-regulator tubes, VR75, VR105, and VR150, from several manufacturers. A comparatively wide range of operating characteristics was found even in tubes of the same type, but enough quantitative data has been accumulated to enable a user to predict the order of stability to be expected.

If they are to be used as a means of obtaining a reference voltage, such tubes should have the following characteristics:

1. They should be free from spontaneous changes in voltage. This includes sudden "jumps," as well as random drifting of the voltage.
2. They should have a low temperature coefficient of voltage drift.
3. The tube voltage should be the same after each firing when the operation is at the same tube current.
4. The dynamic resistance should be as small as possible, though a negative dynamic resistance is not desirable.

The VR75 tubes tested were found to be better than the VR105 or VR150 tubes, as judged by the performance on the first three characteristics. However, the dynamic resistance of VR75 tubes has values intermediate to that of VR105 and VR150 tubes when the operation is at 20 milliamperes. The VR150 tube has the highest dynamic resistance, although there is considerable

variation among tubes of the same type, especially at low currents.

The data for the three types of VR tubes investigated are presented under headings which segregate the various effects as much as possible, although it must be realized that sometimes more than one factor is involved. This is intended to be a report of the results of a number of tests, and no attempt is made to explain the observed effects. For an explanation of the operation of voltage-regulator tubes, readers are referred to books and papers on the subject by several writers.<sup>3-5</sup>

## INITIAL DRIFT

The highest rates of drift of tube voltage are found to occur during the first few minutes of each operation. The percentage change in the tube voltage in an arbitrary period of five minutes, immediately after the tube is fired, is called the initial drift, for purposes of comparison. In the tests, for which the results are tabulated in Table I, the tubes were allowed to cool to room temperature before refiring.

The drift in the initial five minutes' operation of ten tubes of each of the three types was measured five times, and the average of the fifty readings for each type was then taken to obtain the average initial drift. The total change in the tube voltage in the five-minute period was used in computing the average, without regard to whether the voltage increased or decreased. While the tube voltage of the VR75 tubes consistently decreased during warmup, the direction of the initial drift of the VR105 and VR150 tubes was random.

TABLE I  
Drift in Initial 5 Minutes Operation

Tube Type	Average Initial Drift (per cent)	Maximum Initial Drift (per cent)	Tube Current (milliamperes)
VR75	0.03	-0.05	5.5
VR105	0.12	+0.80	20.0
VR150	0.18	-1.50	20.0

## OPERATING VOLTAGE

It is pointed out in the introduction that it is desirable that the tube voltage return to the same value after each firing when the operation is at the same tube current. A number of readings of the tube voltage following firing must be examined to determine the constancy of the operating voltage. As a measure of how well individual

\* Decimal classification: R338.2. Original manuscript received by the Institute, November 28, 1945; revised manuscript received, April 22, 1946.

† General Engineering and Consulting Laboratory, General Electric Company, Schenectady, N. Y.

<sup>1</sup> F. V. Hunt and R. W. Hickman, "On electronic voltage stabilizers," *Rev. Sci. Instr.*, vol. 10, p. 6; January, 1939.

<sup>2</sup> W. R. Hill, Jr., "Analysis of voltage-regulator operation," *Proc. I.R.E.*, vol. 33, pp. 38-45; January, 1945.

<sup>3</sup> J. D. Cobine, "Gaseous Conductors," chap. VIII, McGraw-Hill Book Co., New York, N. Y., 1941.

<sup>4</sup> L. R. Koller, "Physics of Electron Tubes," chap. X, McGraw-Hill Book Co., New York, N. Y., 1937.

<sup>5</sup> L. B. Loeb, "Fundamental Processes of Electrical Discharge in Gases," chap. XI, John Wiley and Sons, Inc., New York, N. Y., 1939.



tubes meet this requirement, ten tubes of each type were fired five times each, and the readings of the tube voltage were taken after five minutes of operation. These five readings of the tube voltage are tabulated in Table II for five tubes of each type.

TABLE II  
Tube Voltage after 5 Minutes of Operation

Tube Type	Tube No.	Tube Voltage				
		Test No. 1	Test No. 2	Test No. 3	Test No. 4	Test No. 5
VR75	22	72.57	72.57	72.57	72.58	72.59
VR74	13	71.94	71.94	71.93	71.93	71.94
VR74	S1	71.63	71.63	71.63	71.63	71.61
VR75	S2	72.12	72.11	72.09	72.11	72.09
VR75	S3	71.77	71.76	71.72	71.76	71.75
VR105	H	108.41	108.42	108.59	108.52	108.53
VR105	D	105.31	105.83	106.19	106.58	106.77
VR105	K	102.83	103.50	103.90	104.03	104.40
VR105	M2	107.72	107.71	107.72	107.73	107.89
VR105	EE	107.79	107.77	107.79	107.77	107.72
VR150	1	149.31	149.22	149.19	149.19	149.17
VR150	5	151.43	151.28	151.16	151.10	151.03
VR150	K2	151.97	152.35	151.80	151.67	151.83
VR150	DD	152.04	151.22	150.89	150.64	150.58
VR150	K7	152.95	152.80	152.74	152.74	152.84

The average voltage and extremes as tabulated in Table III are for all the fifty readings taken on each type. An estimate of how much the voltage across a tube might change in the first five minutes of operation can be made on the basis of the data in Table I. An examination of Table II shows that the tube voltage of the VR75 varies but little between successive operations, and is much more consistent than either the VR105 or VR150.

TABLE III  
Average, Maximum, and Minimum Tube Voltages (10 tubes)

Tube Type	Average Tube Voltage	Maximum Tube Voltage	Minimum Tube Voltage	Tube Current (milli-amperes)
VR75	71.90	72.59	71.13	5.5
VR105	106.68	108.53	102.83	20.0
VR150	151.25	152.95	149.40	20.0

### OPERATING DRIFT

In order to obtain data on the amount of drift in the VR-tube voltage with time, continuous recordings were made of the tube voltage for several hours. As in all voltage measurements, a fraction of the VR-tube voltage was compared with that of a saturated-type standard cell, and a self-balancing potentiometer circuit operated a recording microammeter to indicate the difference voltage. The VR tubes were operated in a vertical position on a testboard, and were subject to fluctuations in the ambient room temperature. The direct tube current was supplied by a regulated power supply.

The data available on the record rolls is difficult to present in a condensed form; however, some interpretations of this data can be made. The voltage of the three types tested drifted in a random manner, and it is probable that the variations in ambient room temperature accounted for most of the drifting. Changes in the ambient temperature of two or three degrees centigrade can produce voltage changes of the same order of magnitude as those recorded. The VR75 voltage, when the tube current is 5 milliamperes, drifts somewhat less than the VR105 or VR150 voltage. If the latter are operated at the same or higher tube currents, however, it is not easy to present data leading to this conclusion. The consistent low temperature coefficient of voltage change (see Table V) of the VR75 tube, as contrasted to the nearly seven-times-greater temperature coefficient of voltage change of the VR150, and the higher, unstable one for the VR105, leads to the conclusion that the VR75 tube would be more stable.

Some data from a few of the record rolls are presented in a condensed form in Table IV on operating-voltage drift, and are the greatest variation in an hour interval on each record. The greatest variation in a one-hour interval on a single record is termed the "maximum drift rate." This is the maximum drift in per cent per hour for that test, and would likely have another value if the test were repeated. The first hour of operation is excluded to avoid the high initial drift, and by taking the average over a one-hour period, exceedingly high rates of drift due to sudden fluctuations are excluded.

TABLE IV  
Operating Voltage Drift  
(Percentages are based on operating voltages)

Type	No.	Maximum Drift Rate*	Duration of Test	Total Change**	Tube Current
		per cent per hour	hours	per cent	milli-amperes
VR75	13	0.01	72	0.075	5.0
VR75	12	0.02	65	0.23	5.0
VR75	13	0.03	17	0.25	20.0
VR105	R	0.02	140	0.21	5.0***
VR105	R	0.03	53	0.06	20.0
VR105	M1	0.04	36	0.30	20.0***
VR150	10	0.04	25	0.22	20.0
VR150	K1	0.28	19	0.14	20.0

\* The first hour of operation was excluded in finding the maximum drift rate.

\*\* The total change is the difference between the voltage after one hour of operation and the voltage at the conclusion of that test.

\*\*\* Abrupt changes in the tube voltage, which are illustrated by Fig. 1, occurred during these tests.

### VOLTAGE JUMPS

Abrupt changes in the VR-tube voltage which are of a spontaneous nature have been termed voltage jumps. For the amplitudes of importance here, these have been found only in the voltage across the VR105 tube, and are illustrated by the recording of a VR105-tube voltage



reproduced in Fig. 1. Voltage jumps initiating spontaneously within the tube are found to occur in a large percentage of VR105 tubes and at all current levels tested. These voltage jumps may be as great as 0.2 per cent of the operating voltage, and occur in a random manner.

It has been found that, if the tube current is varied through a range of 2 milliamperes or more on each side of the chosen operating point at a frequency of 60 cycles per second, abrupt changes in the output voltage can be eliminated. Any sudden breaks in the current-voltage characteristic which are passed over in the current

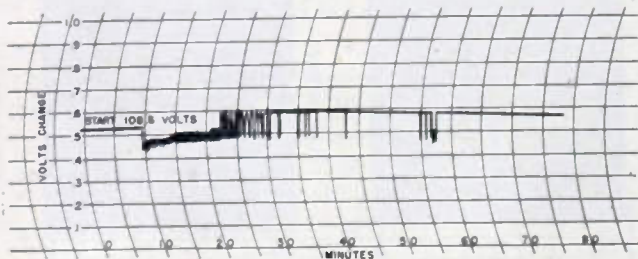

Fig. 1—Section of chart showing spontaneous changes in VR105-tube voltage.

sweeping give rise to voltages which are harmonics of 60 cycles and can be filtered out to give nearly pure direct voltage. The 60-cycle voltage will be about a tenth of a volt root-mean-square per VR105 tube, and can be reduced by a factor of 14 by using a single-section low-pass filter consisting of a 10-henry choke and a 10-microfarad capacitor.

If two VR tubes are to be used in series, then the alternating current can be introduced where the anode of one tube is connected to the cathode of the other, as shown in Fig. 2. This is found to reduce the alternating voltage across the tubes to about one third the value for one tube alone.

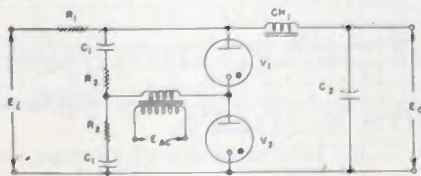

Fig. 2—Balanced circuit for use with two VR105 tubes.

TEMPERATURE COEFFICIENT OF VOLTAGE CHANGE

In order to obtain measurements on the voltage change with temperature, five tubes of each type, VR75, VR105, and VR150, were placed in an insulated box, and the temperature in the box was raised to 100 degrees centigrade. The voltage across one tube of each type was recorded continuously during the test, and measurements were made on the other tubes at the beginning at room temperature, at 100 degrees centigrade, and then again at room temperature. From these data an average temperature coefficient of voltage change was computed and tabulated in Table V for the VR75

and VR150. The change in the tube voltage of the VR105 with temperature was so erratic that no average coefficient was computed. A positive temperature coefficient of voltage change is one in which the tube voltage increases with increase of tube temperature.

TABLE V  
Temperature Coefficient of Voltage Change

Type	Average Temperature Coefficient (per cent per degree centigrade)	Tube Current (milliamperes)
VR75	-0.004	5.5
VR105	See text	20.0
VR150	+0.026	20.0

EQUIVALENT CIRCUIT OF VR TUBES

It has been determined experimentally that the equivalent circuit shown in Fig. 3 is valid over the frequency range investigated. The magnitude of the resistance is

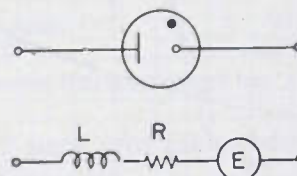
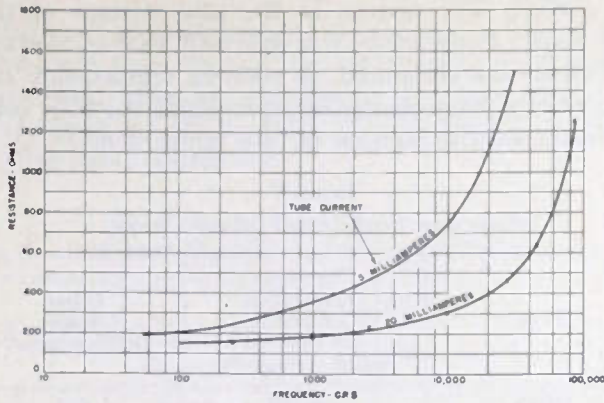

Fig. 3—Equivalent circuit for VR105 tube.

defined as the slope of the voltage-current curve at the operating current and is therefore a dynamic resistance, which is not constant when the tube current is varied (as can be seen by examination of Figs. 5 and 6). The ion inertia effects cause the dynamic resistance to change with frequency, as shown on Figs. 4(a), 4(b), and 4(c), and also introduces a quadrature component of tube current with the tube voltage leading the current. At a particular frequency the quadrature component of the tube current could be caused by an inductance, and the values of this inductance are plotted as a function of frequency on Figs. 4(d), 4(e), and 4(f). If the alternating-current amplitude is less than 10 per cent of the direct current, a voltage-regulator tube can be represented approximately for the purposes of equivalent circuit analysis by linear circuit elements in series with a constant voltage at a single frequency.

The values of the circuit elements were measured on a number of tubes of the three types investigated, and the values for one tube of each type are shown in Fig. 4(a) through 4(f). There is considerable variation of dynamic resistance and inductance values from tube to tube of the same type, particularly at low currents. The values of dynamic resistance as shown in Figs. 4(a), 4(b), and 4(c) are positive for most tube currents and frequencies; however, at a frequency of approximately 170 cycles per second and a current of 5 milliamperes the dynamic resistance of a VR105 is indicated as being zero on Fig. 4(b). Actually the dynamic resistance must have been





(a) Resistance of a VR75 tube.

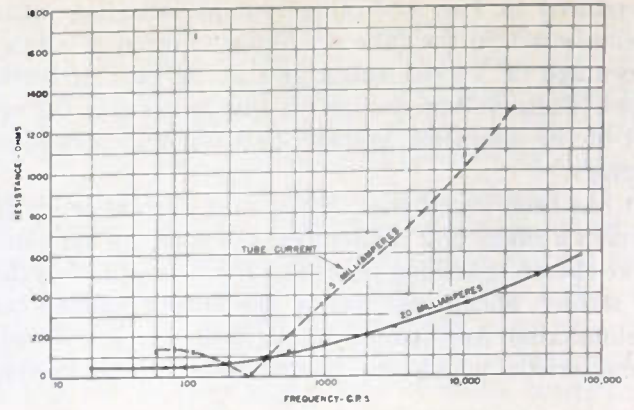

(b) Resistance of a VR105 tube.

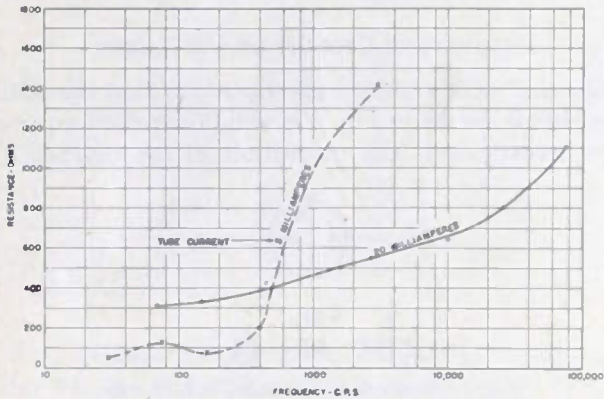

(c) Resistance of a VR150 tube.

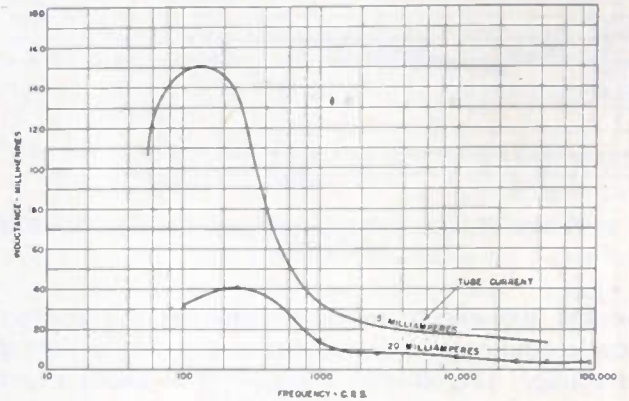

(d) Inductance of a VR75 tube.

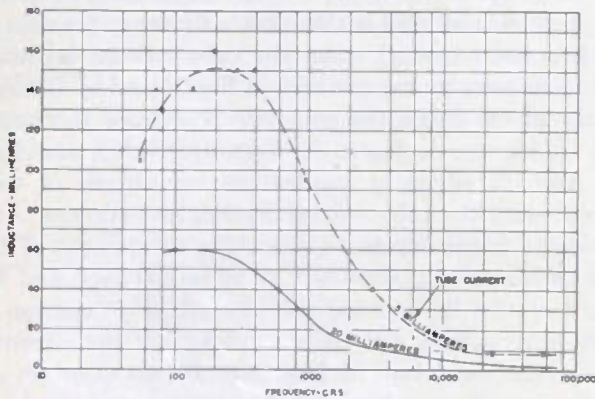

(e) Inductance of a VR105 tube.

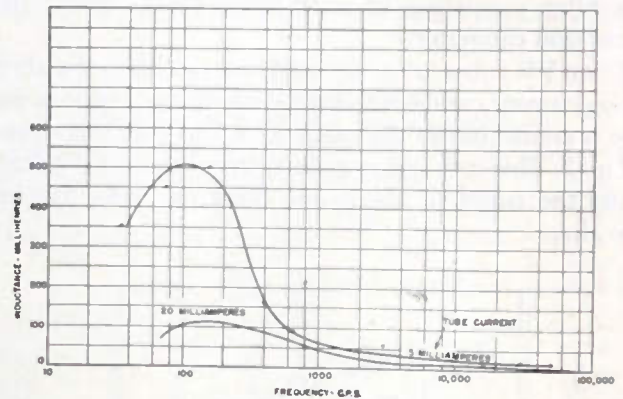

(f) Inductance of a VR150 tube.

Fig. 4—Measured values for circuit elements for the equivalent circuit.

negative at this point, as oscillations<sup>6</sup> of approximately sinusoidal wave form would take place in the circuit when the signal voltage source was shorted out. The magnitude of the negative dynamic resistance was not measured because of the tendency of the circuit to oscillate in an uncontrollable manner.

The dynamic current-voltage characteristics of several VR105 and VR150 tubes were obtained by causing

<sup>6</sup> F. A. Maxfield and R. R. Benedict, "Theory of Gaseous Conduction and Electronics," pp. 350-351; McGraw-Hill Book Co., New York, N. Y., 1941.

the current through the tubes to increase and decrease linearly and photographing a cathode-ray-oscillograph screen with the current on one axis and the voltage on the other axis. Figs. 5 and 6 show the regulation curves for a repetition rate of 4 per second, and a current range of 5 to 30 milliamperes. The voltage scale shows the change in voltage across the tube, and not the total tube voltage. The following facts about the curves are of interest:

1. The path followed for increasing current is not the same as for decreasing current, giving a "hysteresis loop" effect to the picture.



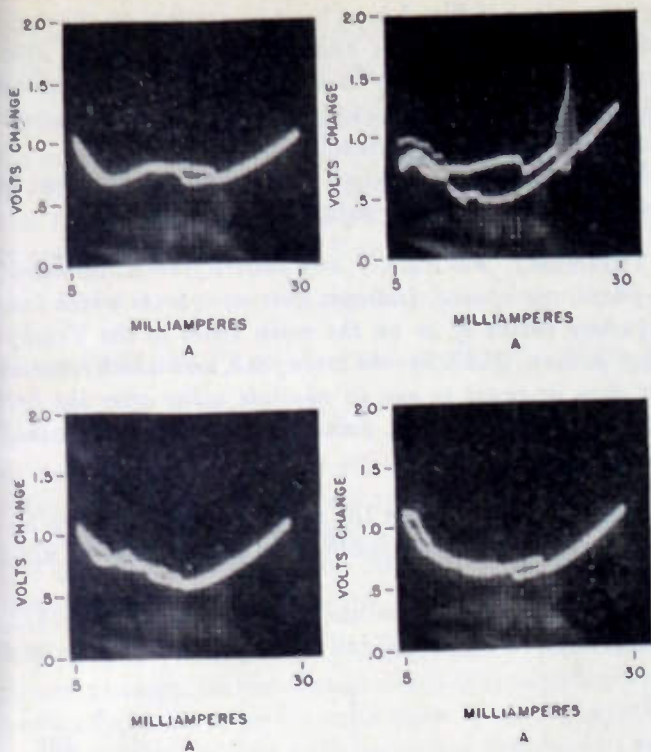

Fig. 5—Regulation characteristics of four VR105 tubes.

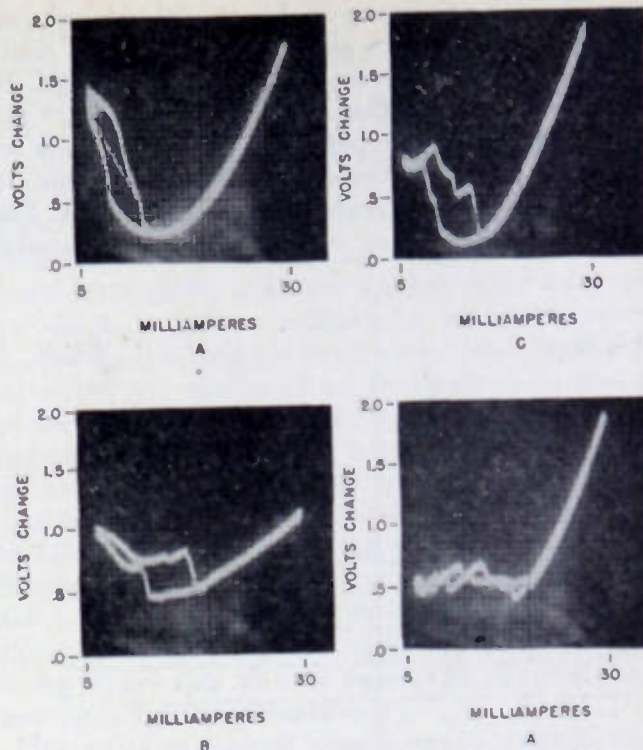

Fig. 6—Regulation characteristics of four VR150 tubes.

2. There are many abrupt changes of voltage over the operating current range. These are observed to occur simultaneously with sudden changes in cathode glow area.

3. Practically every curve has a negative slope over some current range, usually in the low-current region. One VR105-tube regulation curve shows an instability

and oscillation of some type taking place at a current of around 20 milliamperes.

4. The slope of the regulation curve is higher for VR150 tubes than for VR105 tubes. At 20 milliamperes the slope in the case of most VR150 tubes exceeds 100 ohms, whereas in the case of most VR105 tubes the slope is approximately 50 ohms.

#### Discussion on

## “A Current Distribution for Broadside Arrays Which Optimizes the Relationship Between Beam Width and Side-Lobe Level”\*

C. L. DOLPH

Henry J. Riblet:<sup>1</sup> C. L. Dolph, in a recent paper, has applied the properties of the Tchebyscheff polynomials to the problem of determining the current distribution in an equispaced broadside array which optimizes the relationship between beam width and side-lobe level. The following limitations may be removed by easy extensions of Dolph's method: (a) the spacing between radiators  $\geq \lambda/2$ ; (b) the beam width is characterized by the existence of a first null; (c) the current distribution is in phase; and (d) the current distribution is symmetrical about the center position of the array.

By the arguments of pages 336 and 337 of this paper, the voltage pattern of a symmetric, in-phase, equispaced linear array of  $n$  isotropic radiators is a polynomial in  $x$ ,  $x = \cos(d\pi/\lambda) \sin \theta$ . It is even and of  $n-1$  degree if  $n$  is odd, and odd of  $n-1$  degree, if  $n$  is even. The crux of the matter is that the pattern of the linear array is determined completely from a limited portion of the graph of an even or odd polynomial in  $x$ . Specifically, as  $\theta$  varies from  $-\pi/2$  through zero to  $+\pi/2$ ,  $x$  varies from  $\cos(d\pi/\lambda)$  to one and then back to  $\cos(d\pi/\lambda)$ . It was Dolph's idea to select the Tchebyscheff polynomial of correct degree and use its properties to obtain the desired pattern. To make the method clear, consider

\* PROC. I.R.E., vol. 34, pp. 335-348; June, 1946.

<sup>1</sup> Submarine Signal Company, Boston, Massachusetts.

the graph of  $T_8(Z)$  shown in Fig. 1. All the roots of  $T_8(Z)$  occur between  $\pm 1$  and the maximum and minimum values lying between  $\pm 1$  are alternately  $\pm 1$ . It can easily be argued that  $T_8(Z)$  increases as  $Z^8$  for  $|Z| > 1$ . The observable pattern is given by points on this curve which lie between  $a = \cos(\pi d/\lambda)$  and one. It has a number of lobes depending on  $d$  of equal size. For his purpose, Dolph has considered the polynomial

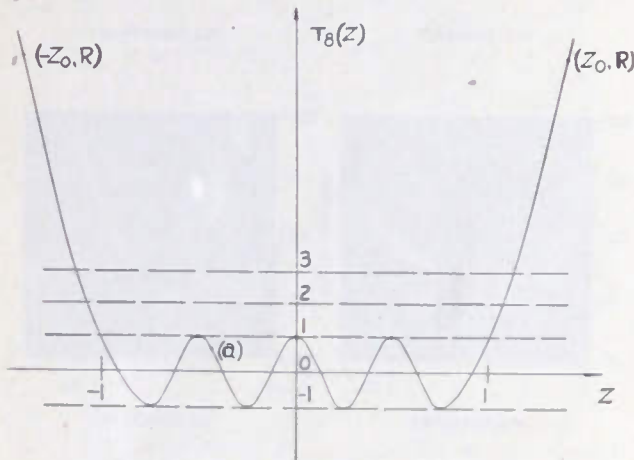

Fig. 1

graphed in Fig. 2 differing from the graph of Fig. 1 only by a change in the scale of the abscissa. It is clear that as  $x=Z$  ranges from  $\cos(\pi d/\lambda)$  to one, we first trace the side lobes and then reach the peak of  $R$  and retrace the pattern as  $x$  returns to  $\cos(\pi d/\lambda)$ . The side lobes are down by a factor of  $1/R$  and are all equal. The entire pattern is easily determined from Figs. 1 or 2. An antenna pattern obtained in this way may conveniently be called a Tchebyscheff pattern.

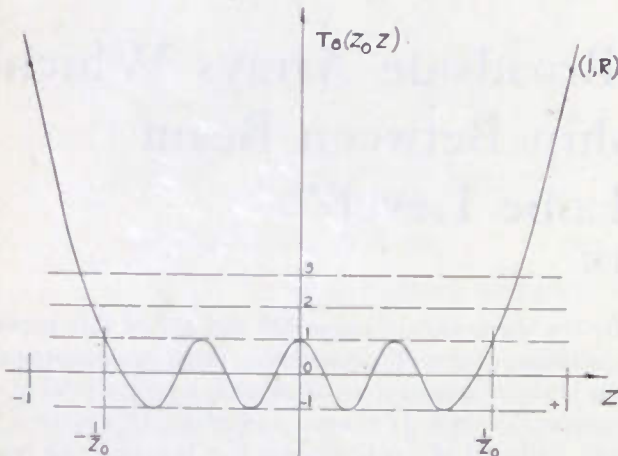

Fig. 2

The theorem that Dolph has used for his results is that any even polynomial of eighth degree which passes through  $(1, R)$  and the maximum null of  $T_8(Z_0Z)$  and for all smaller positive values of  $Z$  is less than or equal to 1 in absolute value, must coincide with  $T_8(Z_0Z)$ . It will be clear to the reader that such a curve would inter-

sect the curve of Fig. 2 in at least five points on the right side of the vertical axis and thus in ten points altogether. The fact that any two eighth-degree polynomials which have more than eight points in common must coincide, gives the desired result.

We are now in a position to extend the theorem of Dolph<sup>2</sup> in the following manner:

**THEOREM I.** For  $d \geq \lambda/2$ , any pattern from  $n$  symmetric, in-phase, equispaced, isotropic current sources which falls anywhere inside of or on the main beam of the Tchebyscheff pattern, which has the same peak, and which remains less than or equal to one in absolute value after the first side lobe of this pattern, coincides with the Tchebyscheff pattern.

*Proof* If  $d \geq \lambda/2$ , then the argument given above applies even though the hypothetical pattern has no nulls at all.

The reason for the condition on  $d$  is clear. If  $d < \lambda/2$ , then point  $a$  of Fig. 1 will fall on the right of the vertical

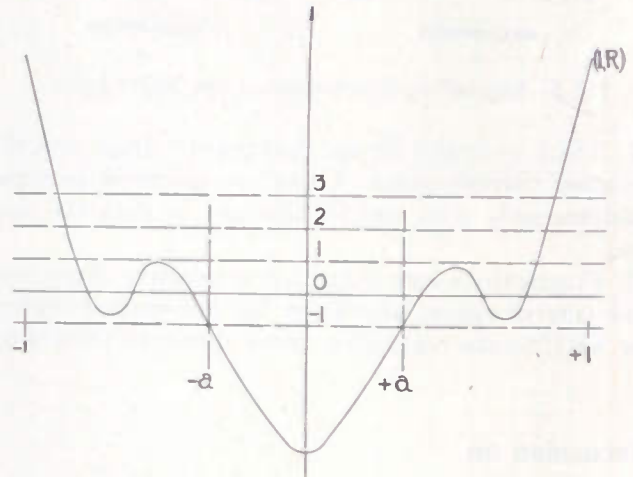

Fig. 3

axis and it is perfectly possible for an observable pattern to have side lobes which satisfy the conditions of Theorem I without getting any contradiction, since the corresponding polynomial is not restricted between  $\pm a$ . For example if  $d = \lambda/3$ , and  $a$  is equal to  $1/2$  polynomials of the appearance shown in Fig. 3 may be constructed having better side-lobe and beam-width characteristics than are obtainable from Dolph's procedure. A specific example is discussed later on.

**THEOREM II.** For  $d \geq \lambda/2$ , any pattern from  $n$  symmetric, equispaced, isotropic current sources which falls anywhere inside of or on the main beam of the Tchebyscheff pattern which has the same peak, and which remains less

<sup>2</sup> It is the theorem on antenna patterns implied by pp. 338-340 of the Dolph paper and is not to be confused with the theorem on polynomials referred to above.

<sup>3</sup> The proof given is probably not adequate when the hypothetical pattern merely touches the main beam of the Tchebyscheff pattern. A modification of the argument of the next theorem will cover this case.



than or equal to one in absolute value after the first side lobe of this pattern, coincides with the Tchebyscheff pattern.

*Proof:* The change in assumptions simply means that the polynomial  $P(x)$  in  $x$ , which defines the pattern of the linear array, will have complex coefficients in general. Let us assume that it is normalized so that its value at unity is the real number  $R$  and write it

$$P(x) = P_1(x) + jP_2(x)$$

where  $P_1(x)$  and  $P_2(x)$  have real coefficients. Now

$$|P(x)|^2 = P_1(x)^2 + P_2(x)^2$$

so that the general level of  $P(x)$  is greater than that of  $P_1(x)$  but  $P_1(x)$  is even or odd according as  $P(x)$  is even or odd and  $P_1(1) = R$ . Since it satisfies the assumptions of Theorem I it is  $T_{n-1}(Z_0x)$ , but  $P(x)$  falls inside or on this pattern and thus  $P_2(x) = 0$ .

**THEOREM III.** For  $d \geq \lambda/2$ , any pattern from  $n$  equispaced, isotropic current sources which falls anywhere symmetrically inside or on the main beam of the Tchebyscheff pattern, having the same peak, and which remains less than or equal to one in absolute value after the first side lobe of this pattern, coincides with the Tchebyscheff pattern.

*Proof:* It is clear that the most general pattern which a linear array can have is given by a limited range of values of  $P(x) + Q$  where  $Q$  has the form of (1) and (2) (page 336) except that cosine is replaced by sine. Since these functions are odd functions of  $\theta$  which contain  $y = \sin(\pi d/\lambda) \sin \theta$  as an odd factor, the remaining factor must be an even function of  $\theta$  and hence a polynomial in  $x$ . For example,

$$\sin 3 \frac{\pi d}{\lambda} \sin \theta = \sin \frac{\pi d}{\lambda} \sin \theta \{4x^2 - 1\}.$$

The most general linear array pattern then is obtained from a limited range of the expression

$$P = P(x) + yQ(x),$$

where the degree of  $Q(x)$  is one less than the degree of  $P(x)$  and where  $Q(x)$  is odd or even in  $x$  accordingly as  $P(x)$  is even or odd. Now it is clear from the evenness of  $x$  and oddness of  $y$  in  $\theta$  that if  $|P(x) + yQ(x)| \leq |P(x)|$  for  $\theta$ , that  $|P(x) + yQ(x)| \geq |P(x)|$  for  $-\theta$ . Thus  $|P(x) + yQ(x)| \leq 1$  for a range of plus and minus values of  $\theta$  only if  $|P(x)| \leq 1$  for the same values of  $\theta$ . A similar argument holds for any two points  $\theta_1$  and  $-\theta_1$  symmetrical about the peak of the Tchebyscheff pattern. Thus  $P(x)$  satisfies the hypothesis of Theorem II and so is  $T_{n-1}(Z_0x)$ ; but  $|P(x) + yQ(x)| \leq T_{n-1}(Z_0x)$  at  $\pm \theta_1$  and is less than or equal to 1 for plus and minus values of  $\theta$  after the first side lobe of the Tchebyscheff pattern only if  $y(\theta_k)Q(\theta_k) = 0$ , where  $\theta_k$  includes those values of  $\theta$  corresponding to values of  $x$  where  $|T_{n-1}(Z_0x)| = 1$  and  $\theta_1$ . Since  $y(\theta) \neq 0$  for any of these values it follows that

$Q(\theta)$  must have  $n$  roots. This, of course, is impossible unless  $Q(x) \equiv 0$ . It is to be observed that Theorems I, II, and III lose their meaning if  $d$  approaches  $\lambda$  too closely, since then  $a$  will fall to the left of  $-(1/Z_0)$ .

The condition that  $d$  must be greater than or equal to  $\lambda/2$  seems to have been overlooked by Dolph. If  $d < \lambda/2$  and the linear array has an odd number of radiators, it is possible to exhibit patterns with narrower beam widths and lower side lobes than those given by Dolph. In fact an optimum for which Theorems I, II, and III still hold can be shown for the following construction: We choose  $x = \cos(2\pi d/\lambda \sin \theta)$  so that the polynomial determining the pattern is general and of degree  $n$ , if there are  $2n+1$  isotropic radiators. Then, if we use  $T_n(x)$  and subject the abscissa to a translation and change of scale which places all of the small ripples of  $T_k(x)$  in the range from  $a$  to 1 so as to have the proper side-lobe level, we obtain an optimum pattern. Incidentally, this uses up all the Tchebyscheff polynomials so that there appears to be no equivalent procedure for linear arrays with an even number of elements spaced less than a half-wavelength apart.

By way of an example, consider seven radiators spaced  $\lambda/3$  apart. The most general pattern which they may have is obtainable from the expression

$$a_0 + a_1 \cos \frac{2\pi}{3} \sin \theta + a_2 \cos \frac{4\pi}{3} \sin \theta + a_3 \cos \frac{6\pi}{3} \sin \theta.$$

If we put

$$\frac{2\pi}{3} \sin \theta = \cos^{-1} x,$$

this may be written

$$a_0 + a_1x + a_2(2x^2 - 1) + a_3(4x^3 - 3x).$$

As  $\theta$  ranges from  $-\pi/2$  through zero to  $+\pi/2$ ,  $x$  varies from  $-1/2$  to 1 and back to  $-1/2$ . In order to locate all of the ripples of  $T_3(x)$  in this region and also obtain a side-lobe level  $1/9$  of the main lobe, we must subject the abscissa to a linear transformation  $ax + b$  so that

$$a(-1/2) + b = -1$$

$$a(1) + b = 3/2.$$

The number  $3/2$  is chosen because  $T_3(3/2) = 9$ . It is easily found that

$$a = 5/3 \quad \text{and} \quad b = -1/6.$$

So that

$$\begin{aligned} a_0 - a_2 + (a_1 - 3a_3)x + 2a_2x^2 + 4a_3x^3 &= T_3(5/3x - 1/6) \\ &= 18.5x^3 - 5.55x^2 - 4.45x + .481. \end{aligned} \quad (1)$$

From which we immediately conclude that

$$a_0 = -2.32; \quad a_1 = 9.45; \quad a_2 = -2.77; \quad a_3 = 4.63. \quad (2)$$

To return to the variable  $\cos(2\pi d/\lambda) \sin \theta$ , we replace  $x$  in (1) by  $2x^2 - 1$ .

We then have an even polynomial in  $x$  whose graph would be similar to that given in Fig. 3. By increasing the number of elements for any fixed over-all length, we can construct a linear array antenna of arbitrary beam width and side-lobe level. The current distribution given in (2) shows the rapid phase-reversal characteristic of "super-gain" antennas.

**C. L. Dolph:**<sup>4</sup> I am indebted to H. J. Riblet for his observation that the "optimum relationship between beam width and side-lobe level" which I derived in a recent paper is valid only if the spacing between the elements is greater than or equal to one-half wavelength and for his generalization of the method which removes this limitation. It should be remarked, however, that the absence of the optimum property for spacings less than one-half wavelength in no way affects the other characteristics of the Tchebyscheff distribution and which, therefore, still offers many advantages from the viewpoint of pattern control, even in this case.

I would like to take this opportunity to indicate how some of the calculations necessary for the determination of the Tchebyscheff distribution can be further simplified. In order to determine the Tchebyscheff distribution for a particular side-lobe level it is first necessary to solve the equation

$$T(z_0) = r \tag{24}$$

for  $z_0$ , where  $r/1$  represents the desired side-lobe level. Now it is known that<sup>5</sup>

$$T_M(z) = \frac{(z + \sqrt{z^2 - 1})^M + (z - \sqrt{z^2 - 1})^M}{2} \tag{a}$$

for all values of  $z$ . (To see that the expression on the right-hand side of the above equation agrees with  $\cos(M \arccos z)$  for  $|z| \leq 1$ , it is only necessary to set  $z = \cos \phi$  and use De Moivre's theorem.) Thus (24) can be replaced by

$$(z_0 + \sqrt{z_0^2 - 1})^M + (z_0 - \sqrt{z_0^2 - 1})^M = 2r. \tag{24.1}$$

Equation (24.1) can be solved explicitly for  $z_0$  by setting

$$(w)^{1/M} = z_0 + \sqrt{z_0^2 - 1} \tag{b}$$

and observing that

$$\left(\frac{1}{w}\right)^{1/M} = z_0 - \sqrt{z_0^2 - 1} \tag{c}$$

<sup>4</sup> University of Michigan, Ann Arbor, Michigan.  
<sup>5</sup> Courant-Hilbert, "Methoden der mathematischen physik," vol. 1, p. 439; Julius Springer, Berlin, 1931, and Interscience Publishers, Inc., New York, N. Y., 1943.

so that (24.1) becomes

$$w + \frac{1}{w} = 2r \tag{24.2}$$

or

$$w^2 - 2rw + 1 = 0 \tag{24.3}$$

which has the roots

$$w_1 = r + \sqrt{r^2 - 1}$$

and

$$w_2 = r - \sqrt{r^2 - 1}$$

with the property that

$$w_2 = \frac{1}{w_1}$$

From (b) it therefore follows that

$$\begin{aligned} z_0 &= \frac{1}{2} \left[ (w_1)^{1/M} + \left(\frac{1}{w_1}\right)^{1/M} \right] \\ &= \frac{1}{2} \left[ \left(\frac{1}{w_2}\right)^{1/M} + (w_2)^{1/M} \right] \end{aligned}$$

or, substituting the value of  $w_1$ , and rationalizing,

$$z_0 = \frac{1}{2} \{ (r + \sqrt{r^2 - 1})^{1/M} + (r - \sqrt{r^2 - 1})^{1/M} \}. \tag{24.4}$$

Thus one finds the remarkable result that to solve (24) or (24.1) for  $z_0$ , it is only necessary to interchange  $z_0$  and  $r$  and replace  $M$  by  $1/M$  in (24.1).

The determination of the currents  $I_k$  as functions of  $z_0$  can also be accomplished without the necessity of using the expansions of the pattern and  $T_M(z_0x)$  as polynomials in  $x$  which lead to (22) and (23). One merely observes that the problem of determining the  $I_k$ 's is equivalent to that of finding the coefficients in a finite Fourier series, which for the  $(2N+1)$  cases is explicitly

$$\sum_{k=0}^N T_k \cos 2ku = T_{2N}(z_0 \cos u).$$

This problem is, however, a standard one in interpolation theory, and it can be treated by standard techniques since by (a), with  $M=2N$ , the right-hand side can be simply computed at any desired point. Since a complete and immediately applicable discussion of this problem can be found in many books, including Whittaker and Robinson,<sup>6</sup> the explicit formulas for the  $I_k$ 's will not be repeated here. It is clear that, for arrays containing a great number of elements, this method possesses certain computational advantages.

<sup>6</sup> E. T. Whittaker and G. Robinson, "The Calculus of Observations," pp. 260-267; D. Van Nostrand Co., New York, N. Y., 1924.



# Correspondence

## Empirical Formula for Amplification Factor

The amplification factor  $\mu$  of vacuum tubes is ordinarily computed by the tube-design engineer using formulas developed from electrostatics. A formula derived from Maxwell was possibly the earliest to be proposed. Later, the improved formula of Vogdes and Elder<sup>1</sup> became commonly used, although its validity was questionable for ratios of grid-wire diameter to pitch greater than about 0.3. In 1944, Herne<sup>2</sup> supplied much more accurate calculations which apply up to ratios as high as 0.7. His results were obtained by involved calculation and are useful chiefly in tabular or curve form, for which Herne supplied numerical values.

A simple empirical formula of sufficient validity to be useful is often a great asset since it can be treated analytically, differentiated, integrated, etc. Van der Bijl, in 1914, found such a formula experimentally, but its results are not in good agreement with any of the more recent and theoretically accurate formulas. Herne stated his results in the following form:

$$\mu = (2\pi NS + c)b$$

where  $N$  is the turns per unit length of the grid,  $S$  is the grid-to-anode spacing factor,  $d$  is the grid-wire diameter, and  $b$  and  $c$  are very complicated functions of  $Nd$ . Ordinarily  $c$  (which has a maximum value of 0.7) can be neglected in comparison with  $2\pi NS$  and only the  $b$  function is of importance. Herne's table for the  $b$  values was used by the writer to obtain a simple empirical formula:

$$b = 0.2 + 6.8Nd + 680(Nd)^4$$

which gives agreement to better than 8 per cent with Herne's values between  $Nd=0.002$  and  $Nd=0.50$ . Since grids of larger or smaller  $Nd$  are extremely uncommon, the agreement is sufficient for practical use. For  $Nd$  less than 0.15, only the first two terms need be used. Thus it is seen that:

$$\mu \approx 2\pi NS[0.2 + 6.8Nd + 680(Nd)^4]$$

A plot of the error of the empirical formula, assuming Herne's table to be correct, is given on Fig. 1. The errors of the Maxwell and Vogdes and Elder formulas are also plotted. It is seen that the empirical formula is sufficiently close for most calculations needed in tube design, whereas even the Vogdes and Elder form is seriously in error above  $Nd=0.3$ . In using an empirical formula in analysis, the disagreement from correctness, which may be small in the function and its integral, may become much greater in the derivative. The derivative of the above formula was compared with that of Herne's calculated curve and found to agree within 15 per cent between  $Nd=0.01$  and  $Nd=0.45$ . This is again believed to be sufficiently accurate for most practical purposes.

It is customary to use such  $\mu$  formulas

with mesh grids by using the reasoning advanced by Kusunose.<sup>3</sup> As he pointed out,  $Nd$  is the fraction of the total area covered by the grid and  $N$  is the total lineal length of

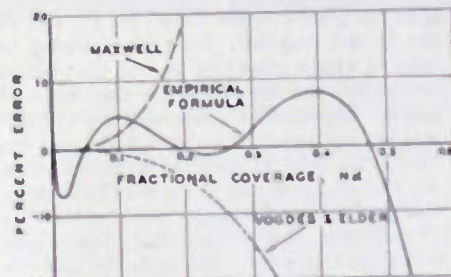

Fig. 1—Curve showing error of proposed empirical formula compared with the inexact theoretical formulas of Maxwell and Vogdes and Elder for amplification factor.

exposed grid conductor per unit area of the grid. When the grid-to-cathode distance is small compared with the grid pitch, any formulation of amplification factor must be corrected for variations along the cathode surface as suggested by Liebmann.<sup>4</sup>

E. W. HEROLD  
RCA Laboratories  
Princeton, N. J.

<sup>1</sup> Y. Kusunose, "Calculation of characteristics and the design of triodes," *Proc. I.R.E.*, vol. 17, pp. 1706-1740; October, 1929.

<sup>2</sup> G. Liebmann, "The calculation of amplifier valve characteristics," *Jour. I.R.E.*, vol. 43, Part III, pp. 138-152; May, 1946.

## Note on the Sporadic-E Layer

The analysis of the sporadic-E region at the Watheroo Magnetic Observatory by H. W. Wells<sup>1</sup> reintroduces the subject of the formation of the intense *Es* cloud. It has been established by Mimno and Pierce<sup>2</sup> that the vertical extent of the high-density *Es* cloud is less than 5 kilometers. Recently,<sup>3</sup> certain investigators of the Department of Scientific and Industrial Research in Great Britain have shown experimentally that the vertical thickness of the *Es* cloud is between 50 meters and 500 meters. The limited lateral extent of the *Es* cloud has been mentioned in the observations of Wilson,<sup>4</sup> Eyfrig,<sup>5</sup> and Conklin.<sup>6</sup> Much of the study of *Es* formation must be interpreted in terms of the relationship of radio wave propagation and maximum usable frequencies above 40 megacycles. These data may be obtained through the use of automatic ionospheric

<sup>1</sup> H. W. Wells, "Sporadic E-region ionization at Watheroo Magnetic Observatory 1938-1944," *Proc. I.R.E.*, vol. 34, pp. 950-955; December, 1946.

<sup>2</sup> H. R. Mimno and J. A. Pierce, "The apparent motion of clouds of abnormal E region ionization," *Phys. Rev.*, vol. 55, p. 1128; June 1, 1939.

<sup>3</sup> Discussion before the Royal Astronomical Society, London, England; May 31, 1946.

<sup>4</sup> M. S. Wilson, "Five-meter wave paths," *QST*, vol. 25, pp. 23-29; August, 1941.

<sup>5</sup> R. Eyfrig, "Echo measurements in long-distance transmission and their relation to zenithal reflections," *Hochfrequenz Tech. und Elektroakustik*, vol. 56, pp. 161-174; December, 1940.

<sup>6</sup> E. H. Conklin, "56 megacycle reception via sporadic-E-layer reflections," *Proc. I.R.E.*, vol. 27, pp. 36-41; January, 1939.

recorders<sup>1,2,3</sup> and vertical-incidence frequency measurements, or by numerous observations of point-to-point communication systems employing radio frequencies in excess of 40 megacycles.

With the exception of Wilson,<sup>4</sup> Fendler,<sup>7</sup> and Conklin,<sup>6</sup> there has been little work in the correlation of vertical-incidence frequency measurements and single-hop radio communication at the very-high frequencies. An initial examination by the writer of periods of time when *Es*-supported communication in the 56- to 60-megacycle radio amateur band indicates that the extent and density of the *Es* cloud may also be found by this method. An important result of this analysis is the spatial distribution of the points of incidence with the *Es* cloud for single-hop radio transmission, which appears to confirm the prevalence of large-scale air circulation at the height of the *E* region.

Air-mass circulation of high velocities at the *E*-region height has been particularly demonstrated in the rapid distortion of long-enduring meteor trains.<sup>8</sup> Rawer<sup>9</sup> has suggested that this mass transport of ions and free electrons within the *E* region to anti-cyclonic areas may create the *Es* cloudlike patches of very high density. The observations of Eyfrig<sup>5</sup> in Germany have, however, tentatively established the drift of *Es* clouds to be from 15 to 125 kilometers per hour. These were taken from vertical-incidence measurements at Kochel and Berlin which were made in 1939.

The limit of *Es*-supported very-high-frequency communication is approximately 1500 miles for a single-hop transmission. This has been correlated with amateur two-way contacts by Conklin.<sup>6</sup> By simple optics the midpoint in the great-circle path between any two radio amateur stations in two-way contact must represent the area of the *Es* cloud, assuming a constancy of height of about 110 kilometers. When over 95 two-way amateur contacts were examined in the 56- to 60-megacycle band on June 5, 1938, there was an apparent spatial and time distribution of the midpoints. Between 1730 and 1800 hours Eastern Standard time, approximately 80 per cent of the reported two-way contacts had points of incidence at the height of the *E* region centered directly over the Commonwealth of Pennsylvania. From 1815 to 1845 hours Eastern Standard time, approximately 75 per cent of the midpoints during this period were located within the area bounded by the northwest shore of Lake Erie and the southern border of the State of Ohio. From 1930 to 2000 hours Eastern Standard time, approximately 85 per cent of the points of incidence were calculated to be directly over the center of the State of Indiana. This corresponds to a drift of from 290 to 380 kilometers per hour. Al-

<sup>7</sup> E. Fendler, "The transmission of ultra-short waves through ionospheric action," *Hochfrequenz und Elektroakustik*, vol. 56, pp. 41-47; August, 1940.

<sup>8</sup> C. P. Olivier, "Long enduring meteor trains," *Proc. Amer. Phil. Soc.*, vol. 85, pp. 93-135; January, 1942.

<sup>9</sup> K. Rawer, "The formation of the abnormal E layer," *Naturwiss.*, vol. 28, p. 577; August, 1940.

<sup>1</sup> Vogdes and Elder, *Phys. Rev.*, vol. 24, p. 683; 1924; vol. 25, p. 255; 1925.

<sup>2</sup> H. Herne, *Wireless Eng.*, vol. 21, p. 59; February, 1944.



though these velocities are considerably higher than those obtained by Eyfrig, it is too early in this study to ascertain if they are abnormal.

Although Wells holds the C. T. R. Wilson<sup>10</sup> hypothesis of possible *Es* formation as the direct result of high electric fields to be untenable in view of his observations at Huancayo, Peru, it may become necessary to take into consideration certain factors of air circulation and subsidence at the *E*-region height before we may discard this suggestion. I should like to point out that the recent observations of Stoffregegen<sup>11</sup> in Upsala, Sweden, have again indicated a very close relationship between intense *Es* and thunderstorms. Whether the *Es* is the result of the runaway electron or is formed in the pocket above the heart of the thunderstorm remains to be determined.

OLIVER P. FERRELL  
CQ Magazine

342 Madison Ave., New York 17, N. Y.

<sup>10</sup> C. T. R. Wilson, "The electric field of a thundercloud and some of its effects," *Proc. Phys. Soc.*, vol. 37, pp. 32D-37D; February, 1925.

<sup>11</sup> W. Stoffregegen, "Ionospheric measurements in connection with thunderstorm research," *Arkiv. für Mat., Astr. and Fysik.*, Bd. 30, Hft. 4; Summer, 1944.

## A Vacuum Heating Element

The vacuum heating element to be described is a vacuum tube with an envelope temperature well over 1000 degrees centigrade.<sup>1</sup> Although a simple device, this unusual feature may render its description interesting to designers of electronic tubes in connection with problems which can be solved by increased envelope temperature.

This element is the continuation of a development initiated by Paul Schwarzkopf.<sup>2</sup> He designed a high-temperature heating element consisting of a molybdenum rod in a tightly fitting sillimanite tube with gas-tight terminals at both ends. Further improvements, such as higher resistance and location of both terminals at the same end, were desirable and resulted in the present construction, shown in Fig. 1.



Fig. 1

The gas-tight ceramic tube 22, which is closed at the lower end, contains the heater

<sup>1</sup> This heating element was developed at the Research Laboratories of the American Electro Metal Corporation in Yonkers, N. Y.

<sup>2</sup> P. Schwarzkopf, "Electrical resistance furnaces for high temperatures," *Metals and Alloys*, vol. 13, pp. 45-49; January, 1941.

coil 38. The lead wire 37 goes back to the terminal along the axis of the coil insulated by the ceramic tube 36. The heating portion of the element extends from the lower end of tube 22 to the plane 39. The section between plane 39 and the other end of the tube 22 is located within the furnace wall. Its length is determined by the thickness of the furnace wall. The end of the ceramic tube 22 is sealed vacuum tight to the metal tube 41 with the glass ring 40. Tubes 41, 42, and 43 are brazed together. Tube 45 is sealed to tube 43 with a glass ring 44, and the ends of the heater coil are welded to the tubes 43 and 45. The element is placed into a vacuum bell jar and evacuated through the gap between the tube 45 and the terminal screw 46. This gap is sealed in vacuum by melting down with high-frequency heating the ring 78 consisting of a brazing alloy. The supply wires are fastened to the screw 46 and the threaded part of tube 42.

The selection of materials depends upon the maximum temperature desired. The heating element was designed to operate at surface temperatures up to 1500 degrees centigrade. Under these conditions, mullite ( $3\text{Al}_2\text{O}_3 - \text{SiO}_2$ ) proved to be most suitable for the tube 22. Mullite is still fairly rigid at 1500 degrees centigrade, and is not reduced by the molybdenum heater wire. It also remains sufficiently vacuum tight. The diffusion of gas through high-refractory ceramic tubes has been investigated by William F. Roeser.<sup>3</sup> The basic mechanism does not seem to be very well understood. His measurements indicate that the leakage is very small up to 1000 degrees centigrade, and increases at a more rapid rate above this temperature. It varies considerably among different products and even among tubes of the same manufacture. An estimate based on his values indicates that the amount of air diffusing into the element is small enough to be taken up by an ample supply of the getter described below. It is not known whether the rate of diffusion changes during operation.

Mullite has approximately the same thermal expansion as tungsten. Hence kovar was used for the tube 41 and Corning 775 for the glass ring 40. The inner ceramic tube 36 consists of alumina. The temperature in the axis of the element may be considerably higher than the surface temperature. The difference depends upon the heat dissipation. The inner tube has to withstand the full supply voltage. One particular construction permitted a maximum alternating-current supply voltage of 75 volts at the maximum operating temperature of 1500 degrees centigrade.

It is common practice to connect a vacuum tube to an exhaust system and to degassify all elements by heating them for some time to a temperature well above operating temperature. This treatment cannot be applied to the heating element, as it will operate at the highest temperature the inner and outer ceramic will withstand. Elements which were not thoroughly degassed and did not contain a getter had a maximum life of several hours only. The molybdenum was transported from the coil

<sup>3</sup> W. F. Roeser, "The passage of gas through the walls of pyrometer protection tubes at high temperature," *Jour. Res. Nat. Bur. Stand.*, vol. 7, pp. 485-494; September, 1931.

to the inner wall and caused the short-circuiting of adjacent turns. This phenomenon, which is well known in poorly pumped incandescent lamps, is caused by traces of water vapor. It has been quantitatively treated for tungsten wire, which behaves similarly to molybdenum wire, by H. Alterthum and F. Koref.<sup>4</sup> The hot wire is oxidized; the oxide sublimates on the wall, and is there reduced.

It was possible to bind the oxygen released from the parts and diffusing through the wall during operation of the element by the employment of a getter. Various getters were tried, and zirconium proved to be the most suitable. Zirconium powder was mixed with a refractory oxide such a beryllium oxide or aluminum oxide and deposited between the turns of the coil. The zirconium is gradually converted into oxide (and possibly nitride) during operation. The oxide is not reduced by hydrogen or molybdenum at the operating temperatures.

A moderate vacuum was produced in the element in order to prevent the creation of a pressure in excess of one atmosphere within the element. This would occur since zirconium does not bind the nitrogen fast enough, especially at temperatures which are lower than the maximum operating temperature. But it may be possible to dispense with the evacuation.

At the maximum operating temperature of 1500 degrees centigrade, and with large heat dissipation, the mullite tube develops porous spots after approximately 500 to 800 hours. This is probably caused by the large temperature gradient in its wall, and could possibly be avoided by reducing the heat dissipation. Life tests were conducted at 1300 degrees centigrade with the heating elements operated continuously 16 hours a day. The elements were still in perfect operating condition after one and one-half years.

GERHARD S. LEWIN  
692 Valley Street

Maplewood, New Jersey

<sup>4</sup> H. Alterthum and F. Koref, "Heterogeneous equilibria between tungsten and oxygen and tungsten and water vapor at elevated temperatures," *Zeit. für Elek.*, vol. 31, pp. 508-511; September, 1925.

## Radar Reflections from the Lower Atmosphere

Radar reflections arising, apparently, from stratifications in the lower atmosphere at heights of from 100 to 1200 yards were observed recently in an exploratory experiment conducted at the Holmdel Laboratory.<sup>1</sup>

The existence of abrupt discontinuities in the dielectric constant of the atmosphere had been postulated in order to account for some of the multiple-path transmission phenomena observed during our microwave propagation experiments.<sup>2</sup> To see if more direct evidence of such reflecting layers could be obtained, the radar experiment was set up using apparatus which was immediately available, although perhaps not in first-

<sup>1</sup> Earlier evidence of radar echoes from the atmosphere has been reported by M. W. Baldwin, Jr., of these Laboratories: "Radar echoes from the nearby atmosphere," presented at the joint U.S.R.I.-I.R.E. Meeting, Washington, D. C., May 2-4, 1946.

<sup>2</sup> A. B. Crawford and W. M. Sharpless, "Further observations of the angle of arrival of microwaves," *Proc. I.R.E.*, vol. 34, pp. 845-848; November, 1946.



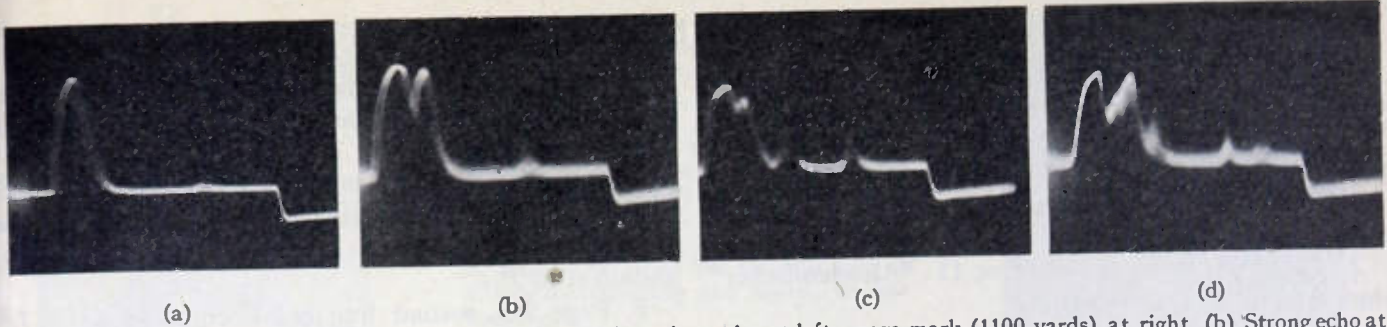

Fig. 1—(a) Taken under normal transmission conditions. Outgoing pulse at left, range mark (1100 yards) at right. (b) Strong echo at 150 yards. (c) Echoes at 100 yards, 325 yards, and 650 yards. (d) Multiple echoes.

class operating condition. This apparatus included a 3-centimeter radar transmitter, a double-detection receiver, a radar indicator, and two shielded-lens antennas with beams pointed upward. Separate antennas were used for transmitting and receiving to eliminate the radar transmit-receive switch with its relatively long recovery time.

During the day and on windy nights when a "standard atmosphere" and normal transmission conditions might be expected to exist, the radar oscilloscope usually appeared as shown in Fig. 1 (a), in which only the outgoing pulse is seen. On clear, calm nights, such as those favorable for anomalous propagation, echoes were observed as shown in Figs. 1 (b), (c), and (d). The echo activity varied greatly from instant to instant as well as from day to day. A particular echo usually did not persist for a long period of time; it might disappear after a few seconds or a minute only to reappear at approximately the same range a short time later.

It is rather surprising that atmospheric stratifications apparently can exist which are sufficiently abrupt as to cause reflections at normal incidence of waves as short as 3 centimeters. Also, these reflections may or may not be closely associated with the phenomenon of multiple-path transmission. However, the preliminary data we have obtained strongly suggest that here is a tool which might well be used along with the standard meteorological-balloon technique to investigate the role of the lower atmosphere in microwave propagation.

The experimental work described was carried out by W. E. Kock, A. B. Crawford, and V. C. Rideout of the Radio Research Department of Bell Telephone Laboratories.

H. T. FRIIS  
Bell Telephone Laboratories, Inc.  
Holmdel, New Jersey

### Distortion and Acoustic Preferences

I am inclined to believe that the contributions to the discussion on "Broadcast Listener Acoustic Preferences" have hardly done justice to Messrs. Eisenberg and Chinn.

Accepting the fact that amplitude distortion will result in listener preference for a restricted range, the whole problem divides very neatly into three sections:

- What amount of distortion is just recognizable?
- What frequency range is preferred if this limit is not exceeded?
- Would the preference be the same if electroacoustic equipment were not in-

terposed between the orchestra and the listener?

Data are available on all these points and, while not sufficient to "prove" the point, they do give considerable support to Messrs. Eisenberg and Chinn.

Regarding (a), Massa<sup>1</sup> published the results of an investigation in 1933, which indicated that 3 to 5 per cent was a lower limit of "just recognizable" distortion, even when comparison with the undistorted (?) was possible.

These results are now about 14 years old and were somewhat restricted in scope, but a much more detailed investigation was made by Braunmuhl and Weber<sup>2</sup> in 1937. This was particularly thorough in that second- or third-harmonic distortion (and appropriate intermodulation) could be introduced over the whole band or over restricted portions of the band.

Broadly the results serve to confirm Massa's figures of about 3 per cent as the "just recognizable" point. It will be remembered that Messrs. Eisenberg and Chinn quote figures below 1 per cent as their system distortion.

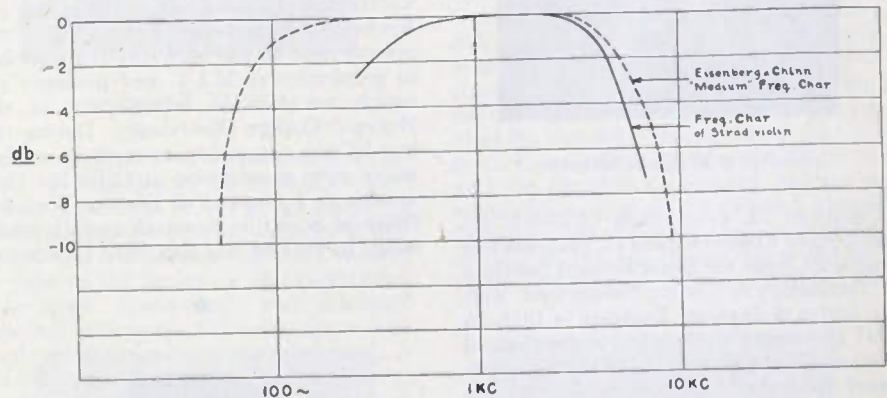

Fig. 1

Point (c) is really the whole crux of the question, as it would serve to settle the whole problem. Strong evidence is contained in a series of papers by Professor Saunders<sup>3</sup> on the factors that determine acceptable quality of tone in the violin. A wide range of suggestions was explored, but as the present discussion concerns frequency range, we will confine attention to this point. We may summarize the series of papers in stating

<sup>1</sup> F. Massa, "Permissible amplitude distortion of speech in an audio reproducing system," *Proc. I.R.E.*, vol. 21, pp. 682-690; May, 1933.  
<sup>2</sup> H. J. Braunmuhl and W. Weber, "Recognition of nonlinear distortion," *Akus. Zeits.*, pp. 135-147; 1937.  
<sup>3</sup> F. A. Saunders, "Mechanical action of instrument of the violin family," *Jour. Acous. Soc. Amer.*, vol. 17, pp. 169-187; January 1946.

that the chief difference between violins of the Stradivarius class and 30/— (\$6) models is that the energy output of the former is largely confined to the band below 6 kilocycles. For comparison the "frequency characteristic" of a typical Strad and the medium range used by Eisenberg and Chinn is plotted in Fig. 1.

The evidence is so strong that it is worth while examining the reasons for the belief that "wide band" should be preferred. These appear to be as follows:

- Analysis of the energy output of orchestral instruments indicates that there are components up to 20 or 30 kilocycles.
- Analysis of the performance of the human ear indicates that there is response up to 10 to 20 kilocycles, depending on age.
- An intuitive feeling that we ought not to restrict the range because the ear having wide range will appreciate wide-range noise.
- A lot of unco-ordinated evidence of the type, "I have a wide-range radio set and everybody says it's wonderful," etc. Our intuition may be right, but to the

best of the writer's knowledge every attempt to confirm point (4) (Messrs. Eisenberg and Chinn's experiment is the latest and most thorough attempt) has resulted in the rejection of wide range unless the audience was composed of engineers presumably aware of (1) and (2). There can be no doubt that there is something wrong either with our intuition or our experimental techniques, and that quibbling about minor points is not the right attitude. This thesis is elaborated in a contribution to appear shortly in *Electronic Engineering*.

JAMES MOIR  
The British Thomson-Houston Co., Ltd.  
Rugby, England



## CORRECTION

Dr. M. J. O. Strutt has called to the attention of the editor the following errors which appeared in his paper, "Noise Reduction in Mixer Stages," PROCEEDINGS OF THE I.R.E., vol. 34, pp. 942-950, December, 1946.

1. Page 943, footnote references 7 and 15: "Mautner" should read "Malter."

2. Page 943, footnote reference 11: "Alcademischer" should read "Akademischer."

3. Page 944, first column, first line below equation (9): the expression  $8kT_e T \Delta f$  should read  $8kT \Delta f$ .

4. Page 945, equations (10) and (11): one symbol  $T_e$  should be canceled. The same cancellation should be carried out on page 946, the eighth line below equation (21), and the fifteenth line below equation (21) (in both

expressions of the latter line), as well as on the nineteenth line from the bottom of the first column of page 948.

5. Page 946, first column, third line above the section III heading: the symbol  $F_2$  should read  $F_r$ . In the fifth line above the section III heading: the symbol  $P_{i,n}$  should read  $P$ .

6. Page 946, second line below equation (21):  $I_{f_{in}}^2$  should be  $I_{f_{in}}^2$ .

7. Page 949: in the last sentence of the caption of Fig. 6, the indications "a" and "b" should be reversed.

8. Page 950, second column, eighth line from top: the word "No" should start a new paragraph.

## Contributors to Proceedings of the I.R.E.



ANATOLE M. GUREWITSCH

Anatole M. Gurewitsch (A'38-SM'45) was born in Russia on June 12, 1911. He was graduated from the Swiss Federal Institute of Technology in Zürich, Switzerland, with the degree of Diploma Engineer in 1935. In 1937 he entered the employ of the General Electric Company, and in 1940 he was graduated from the three-year program of the advanced course in engineering of the General Electric Company. He is now a member of the General Electric Company Research Laboratory Staff, Schenectady, N. Y.

New York. He is a member of Sigma Xi, Tau Beta Pi, and Synton.



Chaim L. Pekeris was born in Alytus, Lithuania, in 1908. He received the B.S. degree in physics from the Massachusetts Institute of Technology in 1929, and the D.Sc. degree in meteorology in 1934. From 1934 to 1936 he carried on geophysical research at M.I.T. and Cambridge University, Cambridge, England, as a Fellow of the Rockefeller Foundation. From 1937 to the present time he has been research associate in geophysics at M.I.T. and honorary research associate in astrophysics at the Harvard College Observatory. During the war he was engaged in research on underwater wave propagation at Columbia University as a member of Division 6 of the Office of Scientific Research and Development. In 1945 he was appointed Director of



CHAIM L. PEKERIS

the Columbia University Mathematical Physics Group. The Columbia University Mathematical Physics Group has been engaged in extending the theory of microwave propagation under standard and nonstandard conditions of atmospheric refraction.

Dr. Pekeris' principal contributions have been in the field of wave propagation, including atmospheric waves, seismic waves, underwater acoustics, and microwaves. In 1946 he was awarded a Guggenheim Fellowship to write a book on Wave Propagation.

Dr. Pekeris is a Fellow of the American Physical Society. He is a member of the American Mathematical Society, the American Geophysical Union, and the Society of Exploration Geophysicists of the Seismological Society of America.



GEORGE M. KIRKPATRICK

George M. Kirkpatrick (S'41-M'45) was born on August 18, 1919, at Roseville, Illinois. He received the B.S. degree in electrical engineering in 1941 from the University of Illinois, and immediately entered the employ of the General Electric Company. He is at the present time associated with the advanced engineering training program of the General Electric Company in Schenectady,

For a photograph and biography of WILLIAM ALTAR, see page 379 of the April, 1947, issue of the PROCEEDINGS OF THE I.R.E.





JOHN R. RAGAZZINI

John R. Ragazzini was born in 1912 and received the degrees of B.S. and E.E. at the City College of New York in 1932 and 1933. He then received the degrees of A.M. and Ph.D. at Columbia University in 1939 and 1941. After a brief association with one of the City Departments he became an instructor in the School of Technology at the City College, and in 1941 joined the faculty of the School of Engineering of Columbia University. During the war he was in charge of two contracts with the Office of Scientific Research and Development, one of which involved electronic simulators and computers. He is a member of Phi Beta Kappa, Sigma Xi, and Tau Beta Pi, and is an associate member of the American Institute of Electrical Engineers.

Robert H. Randall was born in Grand Rapids, Michigan, in 1903. He undertook graduate work at Columbia College in New York, where he received the A.B. degree and his Ph.D. degree in 1930. In 1930 he was appointed instructor in physics at the City College of New York, where he has remained as teacher, now with the rank of assistant professor.

During the years 1930 to 1940, Dr. Randall performed research in several phases of



ROBERT H. RANDALL

experimental physics. One such study was the investigation of electron temperatures in mercury vapor, in conjunction with H. W. Webb, at Columbia University. Later a special grant made possible a series of studies of internal friction in metals, the work being performed at the City College by Dr. Randall and Dr. Clarence Zener. The results of these studies were published in the *Physical Review*. Shortly after the outbreak of the war he joined the technical staff at Columbia University and worked on war projects.

Dr. Randall is a member of Phi Beta Kappa, Sigma Xi, and the American Physical Society.



Henry J. Riblet (A'45) was born at Calgary, Canada, on July 21, 1913. He received the B.S. degree in 1935, the M.S. degree in 1937, and the Ph.D. degree in mathematics in 1939, from Yale University.

From 1939 to 1941 Dr. Riblet was instructor in mathematics at Adelphi College



HENRY J. RIBLET

and from 1941 to 1942 he was assistant professor of mathematics at Hofstra College. From 1942 to 1945 he was at the Radiation Laboratory, where he was in charge of that section of the antenna group which devoted its time to the design of omnidirectional, linear-array, broad-band, and circularly polarized microwave antennas. He is now employed in the radar engineering group at the Submarine Signal Company.

He is a member of Sigma Xi, the American Mathematical Society, and the American Physical Society.



Frederick A. Russell was born in New York City on April 18, 1915. He received the B.S. and E.E. degrees from Newark College of Engineering in 1935 and 1939, respectively, and the M.S. degree from Stevens Institute of Technology in 1941. He was employed for two years as a vacuum-tube development engineer with Arcturus Radio Tube Corporation, and then entered the teaching profession at Newark College of Engineering. During the war years he was employed as a senior research engineer by



FREDERICK A. RUSSELL

the Columbia University Division of War Research, working on a contract under the Office of Scientific Research and Development. At the conclusion of the war he returned to the Newark College of Engineering, where he is now assistant professor in electrical engineering and executive associate of the electrical engineering department.

Mr. Russell is a professional Engineer in the State of New Jersey, and a member of the American Institute of Electrical Engineers, the Society for American Engineering Education, and Tau Beta Pi.



J. R. Whinnery (A'41-SM'44) was born on July 26, 1916, at Read, Colorado. He received the B.S. degree in electrical engineering from the University of California in 1937, at which time he was employed by the General Electric Company at Schenectady, N.Y. In 1940 he was a graduate of the three-year program of the advanced course in engineering of the General Electric Company, and during the following two years supervised the high-frequency section of that program. From 1942 to January of 1946, he was with the electronics laboratory and the research laboratory of the General Electric Company. Mr. Whinnery is now with the division of electrical engineering of the University of California, in Berkeley, California.



J. R. WHINNERY



# Institute News and Radio Notes

## THE PAST AND FUTURE OF RADIO

Analyzing the history of radio and thoughtfully predicting its future possibilities in an optimistic vein, Brigadier-General David Sarnoff (F'17), president of the Radio Corporation of America, addressed a large audience last fall at a dinner given in New York to commemorate his forty years of service in the radio field.

In relation to the utilization of modern radio methods in the field of meteorology, General Sarnoff stated:

"Automatic radio weather stations in remote places in the polar regions, in deserts, in jungles, and on the seas can collect and broadcast weather data. Already radar spots a hurricane, peers into its vortex, plots its movement, and photographs it from minute to minute. Radio-controlled and electronically equipped rockets will permit exploration of the upper atmosphere. Within minutes, new electronic computing devices can analyze such information on a global basis."

He stressed that "the evolution of radio is unending" as indicated clearly by the evolution of television, radar, and the great assembly of other electronic devices and services. He felt that the future offered bright promise for further development.

"Our descendants," he suggested, "will look back upon the radio services of this era and compare them, as a candle to the electric light, the horse and buggy to the automobile, and the ocean liner to the stratosphere."

"Already, the electron tube responds to our sense of touch, sound, and sight. We shall learn how to make it respond also to our sense of taste and smell. The tireless workers of radio science will produce a radiomail system that will be inexpensive, secret, and faster than any mail-carrying plane can travel."

"Portable communication instruments will be developed that will enable an individual to communicate directly and promptly with anyone, anywhere in the world. As we learn more about the secrets of space, we shall increase immeasurably the number of usable frequencies until we are able to assign a separate frequency to an individual as a separate telephone number is assigned to each instrument."

The great social value of radio affords justification, were that needed, for the establishment of generally accepted freedoms. In this relation, General Sarnoff presented the following bases for public policy:

"In America, radio has grown rapidly as a great public servant—not only because of freedom to speak and freedom to listen but because of the freedom of science to advance. Science must be free. We can permit no restrictions to be placed upon the scientists' right to question, to experiment, and to think. Because America has held liberty above all else, distinguished men of science have come here to live, to work, and to seek new knowledge. The world has been the benefactor and science has moved forward."

In war, science dares the impossible; it must continue to dare the impossible in peace if a fuller life is to permeate society.

"Radio has never ceased to stir the imagination; it has continually inspired research. That is why radio is always new. It has met the challenges of two world wars and of the 20 years of peace that intervened."

"Radio has become one of the world's great social forces; it educates, informs, and entertains. Distance has been annihilated. All people have been brought within the sound of a single voice. A nine-word message has encircled the earth in nine seconds. The face of the moon has felt the ping of a radar pulse and echoed it back in two seconds to revive predictions of interplanetary communications."

He concluded on a note of optimism:

"As we look ahead through the vista of science with its tremendous possibilities for progress in peacetime, let us not feel that we are looking beyond the horizon of hope. The outlook is not discouraging, for there is no limit to man's ingenuity and no end to the opportunities for progress."

## Note from the Executive Secretary

Fellow-Members:

We here at Headquarters always like to hear from you. If something has gone wrong, it helps all of us here to know about it. If information of the sort that the Institute can properly furnish is needed, we would like to supply it. And if you happened to be pleased about something that the Institute, its officers, or its staff have done, all of us find the day more pleasant when you write us along that line.

The Institute has grown to over 20,000 members. Its mail is heavy. But every effort is made to acknowledge all letters promptly. We may not have the complete answer, but we always want you to know that your letter has reached us, and that we shall try to find the final answer as soon as we can.

If each one of you could be here at Headquarters for a day, we believe you would be pleased at the spirit you would find here. Everyone feels that the Institute belongs to *you*, and we are proud of having the responsibility of conducting the daily operations of so fine an organization.

GEORGE W. BAILEY

## SACRAMENTO SECTION

The petition for the formation of the Sacramento Section has been approved by the Board of Directors of the Institute at its March 4, 1947, meeting.

## DELEGATES TO INTERNATIONAL TELECOMMUNICATIONS CONFERENCE

Dr. W. R. G. Baker was designated, at the April 1, 1947, meeting of the Executive Committee, as the official delegate of The Institute of Radio Engineers to the International Telecommunications Conference at Atlantic City, New Jersey in May. Executive Secretary Bailey was designated as alternate.

❖

## I.R.E. REPRESENTATION ON A.S.A. SECTIONAL COMMITTEE ON OPTICS

The Institute of Radio Engineers has accepted the invitation of the American Standards Association to be represented on the Section Committee for the proposed Standards for Optics.

❖

## WIDENED SCOPE OF INSTITUTE ACTIVITIES

The scope of the Institute has been widened to include phonograph recording and reproduction, special electromagnetic-wave devices (e.g., X-ray equipment), and nuclear engineering involving electronic instruments and controls, with the result that the personnel of the Papers Procurement Committee and Papers Review Committee, as well as the Board of Editors, has been enlarged.

❖

## ELECTRON-TUBE CONFERENCE

An Electron-Tube Conference will be held at Syracuse University on Monday and Tuesday, June 9 and 10, 1947. This Conference, sponsored by the Electron-Tube Committee of The Institute of Radio Engineers, is held annually for active workers in the field of electron-tube research.

Notices have been mailed to those who attended the Conference held at Yale University last year.

Topics for this year's Conference have not definitely been selected; however, the traveling-wave tube undoubtedly will be included. A copy will be mailed to each of those who have registered.

Tube research workers who have not received notice in the mail and who feel that they could contribute to the success of the Conference are asked to communicate with the chairman of the invitations committee, Dr. L. S. Nergaard, RCA Laboratories Division, Princeton, New Jersey.

Advance registration will be required for attendance at this Conference.



## 1947 I.R.E. National Convention

FULLY exemplifying its basic theme, "Electronics at Peace," the 1947 National Convention and Radio Engineering Show of The Institute of Radio Engineers was an outstanding and memorable success, with a record registered attendance of 11,895 and 170 exhibitors. It was not only the largest radio engineering event in history, but probably enjoyed the most numerous attendance of any kind of engineers' gathering ever held. The 11,895 registration figure compared with a registered attendance of 7020 at the 1946 I.R.E. Winter Technical Meeting and an estimated 3000 the previous year.

Viewed in the light of I.R.E. President W. R. G. Baker's characterization of the meeting as "the annual audit of the technical phases of the radio and electronics industry," showing "to what extent the 20,000 scientists and engineers comprising the Institute of Radio Engineers have fulfilled their responsibility to the industry and the public," the Convention fully demonstrated the extension of wartime-developed research and production techniques into the nation's peacetime economy.

Under the competent planning and execution of Professor Ernst Weber and his technical program committee, approximately 120 technical papers (previously summarized in these pages)<sup>1</sup> were presented in twenty-five major sessions, each carefully planned and carried out meticulously on schedule.

All papers presented were selected as exceptionally significant contributions to the art. With so many major

<sup>1</sup> "Summaries of Technical Papers," PROC. I.R.E., vol. 35, pp. 173-182; February, 1947.

fields represented, it is difficult to select any as of outstanding interest. However, while all sessions had capacity attendance, four were noteworthy in that they had to be repeated for the benefit of crowds who were crowding the anterooms and unable to hear the first presentation. These were the sessions on "Microwave Components and Test Equipment" and "Television A" on Tuesday morning at Grand Central Palace, "Electronic Digital Computers" and "Television B" on Tuesday afternoon, and one paper on printed circuits on Wednesday morning at the Hotel Commodore. Also delivered to an overflow audience was the Monday afternoon session on "Particle Accelerators and Nuclear Studies."

The special Wednesday afternoon session on the engineering profession also was very well attended. Emphasizing the growing recognition of the engineering profession as a dominant factor in the social life of the nation, bringing with it added responsibility and the need for reorientation of engineering education, this symposium presented the respective viewpoints of the industrialists, represented by Dr. C. B. Jolliffe of the Radio Corporation of America, and the educators, as expressed by Dr. H. S. Rogers, Polytechnic Institute of Brooklyn.

The "get-together" party, held at the cocktail hour on March 3 in the Main Ballroom at the Hotel Commodore, was attended by over 1200 members of the Institute and their guests.

At the President's Luncheon on Tuesday, March 4, the incoming 1947 President of the Institute, Dr. W. R. G. Baker, was honored. Following brief talks by



Head Table at Press Luncheon, March 3, 1947.

Left to right: John M. Moorhead; Virgil M. Graham, Chairman, Publicity Committee; James E. Shepherd, Chairman, Convention Committee; W. R. G. Baker, President, I.R.E. 1947; George W. Bailey, Executive Secretary, I.R.E.; Frederick B. Llewellyn, President I.R.E., 1946; Ernst Weber, Chairman, Papers Committee, 1947 Winter Technical Meeting; and Clinton B. De Soto, Technical Editor, PROCEEDINGS OF THE I.R.E.



# 1947 National



Vice-Admiral Charles Andrew Lockwood, Jr., U. S. Navy, addressing the guests at the President's Luncheon, March 4, 1947.



Dr. Walter R. G. Baker, President of the I.R.E., presents the Morris Liebmann Memorial Prize for 1946 to Dr. Albert Rose and for 1947 to Dr. John R. Pierce.



Mr. Frederick R. Lack, Toastmaster at the Banquet.



Mr. William O. Swinyard, Chairman, Sections Committee.



# I.R.E. Convention



Mr. Charles R. Denny, Chairman, Federal Communications Commission, addressing the Annual Banquet, March 5, 1947.

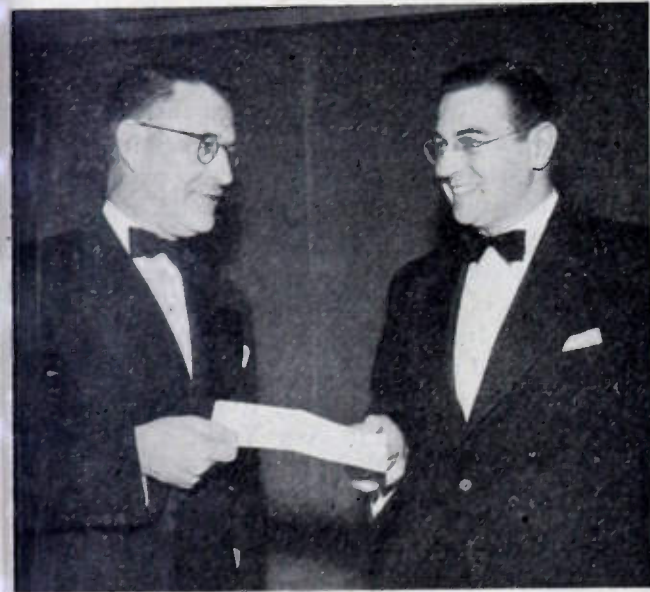

Dr. Baker presents the Browder J. Thompson Memorial Prize for 1946 to Dr. Charles L. Dolph.



Mr. Donald G. Fink makes speech of acceptance for recipients of Fellow Awards.



Dr. Frederick B. Llewellyn, President, 1946, and Dr. Walter R. G. Baker, president, 1947.





Dr. James E. Shepherd, Chairman 1947 I.R.E. National Convention.

Dr. Baker and by the junior past president, Dr. F. B. Llewellyn, the principal address was delivered by Vice-Admiral Charles A. Lockwood, formerly Commander of the submarine fleet in the Southwest Pacific and now Inspector-General of the U. S. Navy, who spoke on the subject, "Electronics and Submarine Warfare." Admiral Lockwood revealed, for the first time, many instances of the use and importance of electronic weapons in the undersea warfare conducted against the Japanese in the Pacific.

At the 35th Anniversary banquet on Wednesday evening, March 5, which was televised over WNBC, New York, and WTTG, Washington, D. C., the featured speaker was Charles R. Denny, chairman of the Federal Communications Commission. Mr. Denny, choosing as his topic "The Job Ahead," followed a tribute in light vein to the radio engineering profession with a discussion of current allocation problems, and concluded with a challenge to radio engineers to find means to prevent present limited radio facilities from "imposing a ceiling on the expanding communications and commerce of the world."

Dr. W. R. G. Baker also delivered a challenging, forward-looking address, stating, "It is the business of the scientist to find the fundamental means for the mastery of nature. It is the responsibility of the engineer to make these truths of use to mankind."

Dr. F. B. Llewellyn discussed analytically the topic "A Test for the Success of an I.R.E. Section."

Three special awards and twenty-five fellowships were presented at the annual banquet.

Two Morris Liebmann Memorial Prizes were pre-

sented, one for 1946 and one for 1947. The first award went to Albert Rose, for his contributions to the art of converting optical images to electrical signals, particularly the image orthicon; and the second to John R. Pierce, for his development of a traveling-wave amplifier tube having both high gain and very great bandwidth.

Twenty-five fellowships were awarded to:

George P. Adair, Benjamin de F. Bayly, George L. Beers, Lloyd V. Berkner, Edward L. Bowles, Robert S. Burnap, Robert F. Field, Donald G. Fink, William W. Hansen, David R. Hull, Fred V. Hunt, Karl G. Jansky, Ray D. Kell, Charles V. Litton, James W. McRae, Ilia E. Mouromtseff, Daniel Earl Noble, Pedro J. Noizeux, Robert M. Page, John A. Pierce, Frank H. R. Pounsett, Conan A. Priest, Winfield W. Salisbury, Robert Watson-Watt, and Edward N. Wendell.

Women's activities under the chairmanship of Mrs. F. B. Llewellyn were conspicuously successful. Of the 275 ladies registered at the Convention, over 200 attended the Institute Tea at the new I.R.E. Headquarters building. The Tea was very festive, with WOR providing an accordion player, wives of past presidents receiving, wives of Section Chairmen assisting, and two members of the Institute's Editorial Department staff conducting guided tours through the building. Many of the women whose homes are away from New York enjoyed the sightseeing trip of New York, a trip to the Cloisters, Empire State Building, and a "Behind the Scenes" expedition at R. H. Macy's (which included a fashion show). The broadcast studios were most generous in giving out tickets for their most special broadcasts. Tickets for the theater party were sold out well in



Mrs. Frederick B. Llewellyn, Chairman Women's Committee, 1947 I.R.E. National Convention.



advance, with luncheon gatherings at various hotels first. Three busses carried the group to the United Nations, where a welcome and talk were given to the ladies followed by attendance at one of the sessions. Luncheon at the Aviation Terrace Room at La Guardia Airport ended the women's activities of the four-day Convention.

The unexpected size of the registration—nearly double that of early estimates—imposed special problems on all concerned with the Convention, particularly on the registration and hospitality committees. Efficient preliminary planning by General Chairman James E. Shepherd and his committeemen had established procedures which carried the unanticipated load, however, and registration and other facilities functioned efficiently and smoothly. A novel aspect of the handling of this problem was the use for the first time in such an application of special International Business Machines tabulating equipment to record names and salient data concerning all registrants. So promptly did this system function that up-to-the-minute alphabetical lists of all those in attendance and their local addresses were constantly posted at both the Hotel Commodore and Grand Central Palace for the benefit of other members.

The greatest Radio Engineering Show in history filled the two principal floors at Grand Central Palace with the displays of 170 exhibitors, including practically every major industrial and manufacturing firm in the communication and electronics fields, the principal technical publications, and several government agencies. Presented at an investment by exhibitors of several hundred thousand dollars, according to Exhibits Manager W. C. Copp, radio and electronic equipment ranging from microscopic thermistors and other ultra-miniature

components to 10-kilowatt broadcast transmitters and full-scale frequency-modulation broadcast antennas and towers was on display. The largest exhibits in terms of space were those of the United States Army and Navy. Occupying a total of 2400 feet of floor space, these exhibits featured a variety of radar and radio systems and equipment, much only recently released from security classifications, including particularly an array of guided missiles of both automatic-radar and radio-controlled types.

To survey the Show as a whole would be to attempt to describe the entire field of current electronic engineering and production.

Essentially the exhibits divided into four basic groups: (1) new components; (2) new materials, such as metals, alloys, ceramics, and similar materials; (3) new techniques, notably in measuring equipment; (4) typical examples of operating equipment in the form of complete assemblies—transmitters, receivers, etc. Especially noticeable was the extraordinary variety of electron tubes of all sizes, types and applications, and the amount and variety of microwave (wave-guide, and the like) components. An especially strong impression was created by the multiplicity and scope of the measuring and testing devices on display, ranging from audio-frequency recording and reproduction to nucleonics instrumentation.

A number of interesting exhibits were presented in special demonstration rooms, including component units of the EDVAC electronic digital computer, declassified only the week before the show; the transformation through electronic means of the color in minerals and gems; and tiny "printed-circuit" miniature transmitters and receivers employing subminiature components.

## I.R.E. People

### FRED MULLER, SR.

Fred Muller, Sr., (M'30-SM'43) United States Naval Reserve, electronics officer of the Atlantic Reserve Fleet, was awarded the Marconi Memorial Medal of Achievement for "forty years of progressive achievement in the radio art" by the Veteran Wireless Operators Association at their 1947 annual meeting. Born in Paterson, N. J., Captain Muller joined the United States Navy in 1908, and after being graduated from the Navy Electrical and Wireless School, served in the Atlantic Fleet as general electrician in the installation and operation of the Navy's first advanced fire control and intercommunication systems. His enlistment terminated in 1912 when he was the senior wireless operator on board the flagship *USS Minnesota*, but during World War I, he rejoined the navy as assistant for communication personnel and materiel in the Third Naval Dis-

trict. While a civilian, he was associated with the Tropical Radio Telegraph Company as an inspector and then division superintendent, and with the Collins Radio Company as assistant to the vice-president and general manager.

In 1940 Captain Muller again was called to active duty with the Navy where he had the supervision of radio, radar, and sonar countermeasures and special devices, ship-board intercommunication, fire-control, sound-motion-picture, and entertainment systems. He was commended for meritorious service by the Chief of the Bureau of Ships for his work in the planning and production of electronics equipment for the amphibious force headquarters communication ships. In 1944 Captain Muller was selected by the Navy as electronics officer of the Tenth Naval District, and in 1945 was assigned to the position of electronics officer for the U. S. Atlantic Reserve Fleet.

### ROBERT E. MCCOY

Robert E. McCoy (A'41-M'46) has left the Radio Direction Finding Branch of the Signal Corps Engineering Laboratories to become an independent consulting engineer with headquarters in Gresham, Oregon.

Mr. McCoy received the B.S. degree in electrical engineering from the Oregon Institute of Technology in 1937. He was employed by Northwestern Electric Company from 1937 until 1942, when he entered the United States Army. After a brief tour of duty as a second lieutenant in the Signal Corps, he entered the Signal Corps General Development Laboratory, predecessor of SCEL, as a radio engineer. He remained with the RDF Branch nearly five years, first at Eatontown Signal Laboratory and then at Evans Signal Laboratory.

Mr. McCoy is a member of the American Institute of Electrical Engineers.



# I.R.E. People



Official Coast Guard Photo

## EDWARD M. WEBSTER

Edward M. Webster (A'30-M'38-SM'43-F'44) was nominated on March 7, 1947, by President Truman as one of the Federal Communications Commissioners. A retired commissioned officer of the United States Coast Guard, Commodore Webster was born in Washington, D. C., in 1889, graduated from the United States Coast Guard Academy in 1912, and saw service with the Navy during World War I. In 1923 he was made chief communications officer of the Coast Guard and established an efficient communications system for that branch of the Service. Retiring from active duty in 1934, he accepted a position with the Federal Communications Commission, later becoming assistant chief engineer. In this position, he administered in particular communication matters relating to marine, aviation, experimental, point-to-point, emergency and amateur services, and radio-operator problems.

Recalled to active duty in the Coast Guard in 1942, he was reassigned as chief communications officer with the rank of captain, and was promoted to rank of commodore in 1945. During this time he further increased the development of the Coast Guard communications system and was also active in other allied war communication activities. He was awarded the Legion of Merit by the President "for exceptionally meritorious conduct in the performance of outstanding services to the Government of the United States." Relieved from active duty in November, 1946, he was appointed director of Telecommunications of the National Federation of American Shipping, Inc.

Commodore Webster has been prominent for many years in co-ordinating communication activities within the government, acting on advisory and research committees, and has also attended international communications conferences as a government representative. He is a former director of The Institute of Radio Engineers, a member of the Propellor Club, the Veterans Wireless Operators Association, and the Army-Navy Club.

## I. J. YOUNGBLOOD

I. J. Youngblood (A'45) was recently appointed vice-president in charge of sales at Clarostat Manufacturing Company, Inc., Brooklyn, N. Y. Following his education at Drexel Institute of Technology, Mr. Youngblood served in the United States Navy from 1917 to 1923, where his work was concerned with radio compass and underwater detection. After a year with Atwater Kent, he went to Philco as production supervisor and was later given charge of components parts engineering and the development of sources for these. He spent a year with the Farnsworth engineering staff, and in 1940 joined Clarostat as sales engineer.



## WILLIAM C. SIMON

William C. Simon (M'32-SM'43) was awarded the Marconi Memorial Medal of Merit by the Veteran Wireless Operators Association, of which he is a Life Member, in recognition of his many years of service to the organization both as an officer and member of the Board of Directors. The presentation was made at the "United Nations Radio Dinner" of the Association on their twenty-second anniversary. Mr. Simon is General Manager of Tropical Radio Service Corporation.



## HAROLD O. BISHOP

Harold O. Bishop (M'45) has been elected to the board of directors of Stavid Engineering Corporation of Plainfield, N. J. During the war he served as a Lieutenant Commander on the Radar Staff of the Postgraduate School at Annapolis and at present is directing the research and development of guided missiles countermeasures for the Navy Department. Mr. Bishop owns the Electrical Service Company, Radio Station WABX in Harrisburg, Pennsylvania and Station KOAX in Albuquerque, New Mexico.

## WILLIAM G. ELLIS

Appointment of William G. Ellis (A'19-M'25-SM'43) as sales manager of industrial electronics sales was announced recently by T. A. Smith (J'25-A'26-SM'45) general sales manager of the Radio Corporation of America's Engineering Products Department. A native of Philadelphia, Mr. Ellis was graduated from the Drexel Institute of Technology as a mechanical engineer. Pioneering in radio as an amateur operator some forty years ago, he began his professional career in 1917 when he engaged in research in radio direction finding for the United States Navy.

In 1922 Mr. Ellis went into consulting industrial engineering and in 1927 entered the field of engineering sales of industrial equipment where he remained for 15 years. During the war, he served with a joint agency responsible for electronic production for both the Armed Services. Mr. Ellis is a member of the Franklin Institute, the American Society of Mechanical Engineers, and the American Institute of Electrical Engineers.



## WALTER A. WEISS

Walter A. Weiss (S'40-A'41-M'44) recently was appointed supervisor of quality control for the radio tube division of Sylvania Electric Products, Inc. Mr. Weiss, a graduate of Pennsylvania State College with a B.S. degree in electrical engineering, joined Sylvania in 1941 as a student engineer, later serving as a test-equipment engineer. In September, 1942, he was appointed supervisor of quality control for the Emporium plant.

Mr. Weiss is an associate member of the American Institute of Electrical Engineers and a member of the Society of Quality Control Engineers.



WALTER A. WEISS



## Sections

Chairman		Secretary	Chairman		Secretary
P. H. Herdon c/o Dept. in charge of Federal Communication 411 Federal Annex Atlanta, Ga.	ATLANTA May 16	M. S. Alexander 2289 Memorial Dr., S.E. Atlanta, Ga.	L. W. Butler 3019 N. 90 St. Milwaukee 13, Wis.	MILWAUKEE	E. T. Sherwood 9157 N. Tennyson Dr. Milwaukee, Wis.
H. L. Spencer Associated Consultants 18 E. Lexington Baltimore 2, Md. Glenn Browning Browning Laboratories 750 Main St. Winchester, Mass.	BALTIMORE	G. P. Houston, 3rd 3000 Manhattan Ave. Baltimore 15, Md.	J. C. R. Punchard Northern Electric Co. 1261 Shearer St. Montreal 22, Que., Can- ada	MONTREAL, QUEBEC June 21	E. S. Watters Canadian Broadcasting Corp. 1440 St. Catherine St., W. Montreal 25, Que., Can- ada
I. C. Grant San Martin 379 Buenos Aires, Argentina H. W. Staderman 264 Loring Ave. Buffalo, N. Y.	BOSTON May 22	A. G. Bousquet General Radio Co. 275 Massachusetts Ave. Cambridge 39, Mass. Raymond Hastings San Martin 379 Buenos Aires, Argentina	J. T. Cimorelli RCA Victor Division 415 S. Fifth St. Harrison, N. J.	NEW YORK June 4	J. R. Ragazzini Columbia University New York 27, N. Y.
J. A. Green Collins Radio Co. Cedar Rapids, Iowa	BUENOS AIRES	J. F. Myers Colonial Radio Corp. 1280 Main St. Buffalo 9, N. Y.	L. R. Quarles University of Virginia Charlottesville, Va.	NORTH CAROLINA- VIRGINIA	J. T. Orth 4101 Fort Ave. Lynchburg, Va.
A. W. Graf 160 N. La Salle St. Chicago 1, Ill.	BUFFALO-NIAGARA May 21	Arthur Wulfsburg Collins Radio Co. Cedar Rapids, Iowa D. G. Haines Hytron Radio and Elec- tronic Corp. 4000 W. North Ave. Chicago 39, Ill.	D. W. R. McKinley 211 Cobourg St. Ottawa, Canada	OTTAWA, ONTARIO May 15	W. A. Caton 132 Faraday St. Ottawa, Canada
J. D. Reid Box 67 Cincinnati 31, Ohio H. C. Williams 2636 Milton Rd. University Heights Cleveland 21, Ohio	CEDAR RAPIDS	C. K. Gieringer 303 W. Third St. Cincinnati 2, Ohio	Samuel Gubin 4417 Pine St. Philadelphia 4, Pa.	PHILADELPHIA June 5	A. N. Curtiss RCA Victor Division Bldg. 8-9 Camden, N. J.
E. M. Boone Ohio State University Columbus, Ohio Dale Pollack 352 Pequot Ave. New London, Conn.	CHICAGO May 16	A. J. Kres 16911 Valleyview Ave. Cleveland 11, Ohio	W. E. Shoupp 911 S. Braddock Ave. Wilkinsburg, Pa.	PITTSBURGH June 9	C. W. Gilbert 52 Hathaway Ct. Pittsburgh 21, Pa.
Robert Broding 2921 Kingston Dallas, Texas J. E. Keto Aircraft Radio Labora- tory Wright Field Dayton, Ohio	CINCINNATI May 20	C. J. Emmons 158 E. Como Ave. Columbus 2, Ohio	Francis McCann 4415 N.E. 81 St. Portland 13, Ore.	PORTLAND	A. E. Richmond Box 441 Portland 7, Ore.
P. O. Frincke 219 S. Kenwood St. Royal Oak, Mich.	CLEVELAND May 22	R. F. Blackburn 62 Salem Rd. Manchester, Conn.	A. E. Newlon Stromberg-Carlson Co. Rochester 3, N. Y.	ROCHESTER May 15	K. J. Gardner 111 East Ave. Rochester 4, N. Y.
N. J. Reitz Sylvania Electric Prod- ucts, Inc. Emporium, Pa.	COLUMBUS June 13	A. S. LeVelle 308 S. Akard St. Dallas 2, Texas	S. H. Van Wambeek Washington University St. Louis 5, Mo.	SACRAMENTO	N. J. Zehr 1538 Bradford Ave. St. Louis 14, Mo.
E. M. Dupree 1702 Main Houston, Texas	CONNECTICUT VALLEY May 15	Joseph General 411 E. Bruce Ave. Dayton 5, Ohio	Rawson Bennett U. S. Navy Electronics Laboratory San Diego 52, Calif.	ST. LOUIS	Clyde Tirrell U. S. Navy Electronics Laboratory San Diego 52, Calif.
H. I. Metz Civil Aeronautics Ad- ministration 84 Marietta St., NW Atlanta, Ga.	DALLAS-FT. WORTH	Charles Kocher 17186 Sioux Rd. Detroit 24, Mich.	C. A. Priest 314 Hurlburt Rd. Syracuse, N. Y.	SAN DIEGO June 3	F. R. Brace 955 Jones San Francisco 9, Calif.
R. N. White 4800 Jefferson St. Kansas City, Mo.	DAYTON May 15	A. W. Peterson Sylvania Electric Prod- ucts, Inc. Emporium, Pa.	H. S. Dawson Canadian Association of Broadcasters 80 Richmond St., W. Toronto, Ont., Canada	SAN FRANCISCO	J. M. Patterson 7200—28 N. W. Seattle 7, Wash.
J. R. Bach Bach-Simpson Ltd. London, Ont., Canada C. W. Mason 141 N. Vermont Ave. Los Angeles 4, Calif.	DETROIT May 16	L. G. Cowles Box 425 Bellaire, Texas	M. E. Knox 43—44 Ave., S. Minneapolis, Minn.	SAN DIEGO June 3	R. E. Moe General Electric Co. Syracuse, N. Y.
	EMPORIUM	M. G. Beier 3930 Guilford Ave. Indianapolis 5, Ind.	L. C. Smeby 820—13 St. N. W. Washington 5, D. C.	SAN FRANCISCO	C. J. Bridgland Canadian National Tele- graph 347 Bay St. Toronto, Ont., Canada
	HOUSTON	G. L. Foster Sparton of Canada, Ltd. London, Ont., Canada	L. N. Persio Radio Station WRAK Williamsport 1, Pa.	SAN FRANCISCO	Paul Thompson 4602 S. Nicollet Minneapolis, Minn.
	INDIANAPOLIS	Mrs. G. L. Curtis 6003 El Monte Mission, Kansas		TORONTO, ONTARIO	
	KANSAS CITY	G. L. Foster Sparton of Canada, Ltd. London, Ont., Canada		TWIN CITIES	
	LONDON, ONTARIO	Bernard Walley RCA Victor Division 420 S. San Pedro St. Los Angeles 13, Calif.		URBANA	
	LOS ANGELES May 20			WASHINGTON June 9	T. J. Carroll National Bureau of Standards Washington, D. C.
				WILLIAMSPORT June 4	R. G. Petts Sylvania Electric Prod- ucts, Inc. 1004 Cherry St. Williamsport, Pa.



# Sections

## SUBSECTIONS

Chairman		Secretary		Chairman		Secretary	
R. B. Jones City Signal Service 319 E. Main St. Fort Wayne 2, Ind.	FORT WAYNE (Chicago Subsection)	S. J. Harris Farnsworth Television and Radio Co. 3702 E. Pontiac Fort Wayne 1, Ind.		C. W. Mueller RCA Laboratories Princeton, N. J.	PRINCETON (Philadelphia Subsection)	A. V. Bedford RCA Laboratories Princeton, N. J.	
T. S. Farley 74 Hyde Park Ave. Hamilton, Ont., Canad	HAMILTON (Toronto Subsection)	E. Ruse 195 Ferguson Ave., S. Hamilton, Ont., Canada		A. R. Kahn Electro-Voice, Inc. Buchanan, Mich.	SOUTH BEND (Chicago Subsection) May 15	A. M. Wiggins Electro-Voice, Inc. Buchanan, Mich.	
K. G. Jansky Bell Telephone Laboratories Box 107 Red Bank, N. J.	MONMOUTH (New York Subsection)	L. E. Hunt Bell Telephone Labora- tories Box 107 Deal, N. J.		W. A. Cole 323 Broadway Ave. Winnipeg, Manit., Can- ada	WINNIPEG (Toronto Subsection)	C. E. Trembley Canadian Marconi Co. Main Street Winnipeg, Manit., Can- ada	

# Books

## Introduction to Electron Optics, by V. E. Cosslett

Published (1946) by Oxford University Press, 114 Fifth Ave., New York 11, N. Y. 269 pages + 3-page index + x pages. 155 figures + 8 plates.  $6\frac{1}{2} \times 9\frac{1}{2}$  inches. Price, \$6.50.

This new book is intended as a text for advanced undergraduates in physics. As the subtitle—"The Production, Propagation, and Focusing of Electron Beams"—implies, it covers, in addition to the motion of charged particles in electric and magnetic fields, the various known methods of producing electron currents. Furthermore, the principal applications of electron optics—cathode-ray tubes, electron multipliers, image tubes, television pickup tubes, electron-diffraction apparatus, electron microscopes, apparatus for separating and accelerating charged particles, and beam amplifiers—make up about a third of the subject matter. A brief chapter on velocity-modulated beams, an appendix setting forth the use of the iconals in the derivation of the aberration expressions, and some useful tables complete the book. The mathematical requirements are the usual ones, i.e., a knowledge of calculus and elementary partial differential equations.

The most fully covered and most adequate sections of the book are, properly, those dealing with the determination of field distributions, ray tracing, and the focusing properties of various types of electron lenses. While practically all methods of ray tracing are considered, the reviewer feels that a fuller treatment of the numerical integration of the ray equation and the introduction of Scherzer's form as well as a first-order form could well have replaced the

detailed treatment of the trigonometric method which is not suited to the aspheric shape of the equipotentials in electron optics. The employment of Scherzer's ray equation (eventually introduced on page 111) would also have prevented the introduction of an inaccurate expression for the weak-lens focal length. A ray equation for magnetic fields regarded by the author as more accurate than the paraxial-ray equation includes some higher-order terms, omits others of equal or lower order. It is unfortunate that the reader is not made aware of the universality of the rules regarding crossed principal planes and the non-existence of negative lenses.

The chapter on aberrations describes the character of the several geometric aberrations and presents Scherzer's convenient explicit formulas; axial chromatic aberration and Gabor's proposal for an aberration-free space-charge lens are also discussed. The discussion of the aberrations contains a number of errors which may prove disturbing; such as that the spherical aberration is corrected if the sine condition is fulfilled; that limitations introduced to reduce spherical and chromatic aberration generally largely eliminate distortion; that the dependence on voltage of the chromatic aberration of a cathode lens is the same as for other lenses; and that the spherical aberration of magnetic lenses may be reduced by increasing the accelerating potential. The author also has not escaped the unfortunately common confusion between particle and wave velocity in the statement of Fermat's theorem.

The discussion on the production of electron beams gives an interesting survey over thermionic emission, electron guns, field emission, the point-emission microscope, photoemission, image tubes, secondary emission, and electron multipliers. The treat-

ment is necessarily sketchy and not free of defects; examples of the latter are to be found in the discussion of the requirements for the ejection of secondary electrons by electrons and ions, an overestimate of the Schottky effect by 3 orders of magnitude, the statement of an exponential temperature dependence of the photoeffect, and the assumption that Pierce neglected space charge in determining electrode shapes for his high-current guns.

The several chapters on applications contain good descriptive sections giving an idea of the broad scope of electron optics. The weakest point here is the discussion of the principles of electron diffraction. The derivation of the diffraction limit of a microscope and the discussion of image formation in the electron microscope are also faulty. The author does not appear to distinguish clearly between the chromatic aberration of the electrostatic univoltage lens, which is large, and its very small sensitivity to voltage changes. The descriptive portion dealing with the several types of microscopes again is good, if brief and uninclusive.

Considering the book as a whole, it is well arranged, not unnecessarily repetitive, and quite readable. In a few cases terms are not defined and there are occasional inconsistencies, corresponding to some of the errors already mentioned. The plates are excellent, the drawings somewhat uneven—the reviewer noted seven of the latter which were misleading. Most of the errors in the equations are such that they will not lead a diligent student far astray. Interpreted by a capable teacher the book should quite satisfactorily fulfill its function as a class text on electron optics.

V. K. ZWORYKIN  
RCA Laboratories Division  
Princeton, N. J.





## David J. Knowles

Secretary-Treasurer, Emporium Section—1946

David J. Knowles was born on November 30, 1918, in San Francisco, California.

While studying pre-engineering and physics at San Antonio Junior College, from which he graduated in 1939, he acted as laboratory assistant in the physics and chemistry laboratories. During 1940 he was checking estimates and expediting for the Brandt Iron Works in San Antonio, Texas.

After receiving his B.S. degree in electrical engineering from the Rice Institute in 1942, Mr. Knowles went to Sylvania Electric Products, Inc., Emporium, Pennsylvania, as a vacuum-tube engineer engaged in the design, development, and production of a miniature thyratron for computers used by the armed forces, a subminiature glow tube for instrument use, and a special gas-filled voltage regulator. At present he is working on the design and development of rectifiers and power-output tubes, both standard receiving types and specialties such as the commercial versions of the T-3 proximity-fuze tubes.

Mr. Knowles joined The Institute of Radio Engineers in 1941 as a Student, became an Associate in 1943, and a Member in 1945. He is an Associate of the American Institute of Electrical Engineers and a member of Tau Beta Pi.

Unless terminology is clear and unequivocal in its import, discussions involving terms easily become confused and at cross purposes. The importance of definiteness and general agreement in nomenclature has been too often underrated, but is here suitably explained, and with appropriate recommendations, by a radio engineer of long and constructive experience who, for the last seven years, has edited the periodical *FM and Television*.—*The Editor*.

## The Need for Clear Terminology

MILTON B. SLEEPER

When the first Standardization Committee of The Institute of Radio Engineers was formed, its task of working out definitions for radio terms was relatively simple. I say relatively simple because there were so few terms used in the art.

I was a member of that first Committee, and blush to recall that I had at least an opinion to express on nearly every term we undertook to define. Since then the number of terms and the problems of defining them have multiplied manifold.

Today I am not even sure that it is still in order to speak of "radio terms," because it seems as if the word *radio* itself has given way to *electronics*, even among the members of The Institute of Radio Engineers.

Now I want to make a plea for re-establishing the use of *radio*, and setting up distinguishing definitions for radio and electronics. The reason is not nostalgic, but practical.

The need goes back to World War II practice of lumping everything related to the use of vacuum tubes under the heading of "electronics." The practice of combining electric-wave communications equipment with everything from tube-operated sound-ranging apparatus to calculating machines under the heading of "electronics" was further complicated by the inclusion of such mystery devices as radar and loran.

Resulting confusion, worse confounded by indiscriminate use of *electronics* in advertising and unscientific fiction, has now reached the point where, if a man says he is an "electronics engineer," it is necessary to question him to find out if he has been working on electrically warmed sleeping blankets, kidney-bean sorters, or printing-registry devices, if he really means that he's a radio engineer, or if he has been engaged in the development of tubes used for all those applications!

Certainly these conditions call for the revival of the noun and adjective *radio*. The Second Edition of Webster's International Dictionary defines the noun as "the transmission and reception of signals by means of electric waves without a connecting wire." The adjective is defined as

"of or pertaining to, employing, or operated by radiant energy, specifically that of electric waves; hence, pertaining to, or employed in radiotelegraphy or radiotelephony or other applications of radio waves."

These established definitions are so informative that the word to which they relate should not fall into disuse.

In fact, the definition of *electronics*, in the New Words section of Webster's Dictionary, shows clearly that it is not a generic term for all tube-operated devices, radio and otherwise, since the word denotes "that branch of physics which treats with the emission, behavior, and effects of electrons, especially in vacuum tubes, photoelectric cells, and the like."

It should be noted that, unlike *radio*, which is both a noun and an adjective, *electronics* is only a noun. The adjective form is *electronic*, defined merely as "of or pertaining to an electron or electrons."

Webster's Dictionary further disallows *electronic tube*, since it lists *electron tube*.

Thus, a radio engineer is properly one concerned with the applications of radio waves; and an electronics engineer is one who has to do with vacuum tubes, photoelectric cells, and the like. This indicates that an engineer who is concerned with the use of tubes for various nonradio electrical and mechanical devices and systems should be called a "tube-applications engineer."

Similarly, it appears that, since the application of the noun *electronics* is limited to use in connection with vacuum tubes, photoelectric cells, and the like, devices and systems operated or controlled by tubes should not be referred to as "electronic equipment," but as "tube-actuated equipment."

Finally, by established definition, radio equipment is that used for the transmission of signals by electric waves, without the use of a wire.

May I commend to Institute members the careful consideration of these definitions, to the end that we may plan to end the confusion now developing not only in our own ranks, but in the minds of the lay public which has such an intimate interest in so much of our work.



# Impedance Measurement on Transmission Lines\*

D. D. KING†, MEMBER, I.R.E.

**Summary**—A derivation of the formulas available for the measurement of terminal impedances on transmission lines is given in terms of hyperbolic functions. The accuracy and usefulness of a number of different methods are considered. Results are obtained in a form suitable for convenient application to practical measuring problems involving standing-wave and resonance-curve methods.

## INTRODUCTION

A STANDARD method of determining the impedance presented between the terminals of a given device consists in attaching these terminals to a properly designed transmission line; measurements are then carried out on the line. In the frequency range from 100 to several thousand megacycles this method is readily adaptable to a large variety of unknown load impedances ranging from antennas to vacuum tubes. It is the purpose of this paper to furnish a survey of various transmission-line methods, some more common than others, and to discuss their practical significance in impedance measurements.

Since the results are to be useful in experimental work, the subject is approached first from the point of view of the physically measurable quantities. From transmission-line theory formulas are then derived which conveniently relate the measured values to the desired unknown terminal resistance and reactance. The mathematical form of the relations involved has been chosen to make evident the basic similarities in different measuring procedures. Particular attention is devoted to the inherent accuracy of the various methods discussed and to their practical utility.

## PHYSICALLY MEASURABLE QUANTITIES

The impedance-measuring apparatus being considered consists essentially of a section of transmission line, parallel or coaxial, with right-hand terminals which permit attaching various load impedances, and the left end of which is coupled to a generator. The determination of current or voltage amplitudes on the line suffices for the measurement of terminal impedance; accordingly, a detector sensitive to amplitude but not to instantaneous phase is required. The measuring line on which this detector operates must permit at least one of the following quantities to be varied: (1) the position of the detector along the line; (2) the total length of line; or (3) the operating frequency of the generator.

The measurable quantities available correspond to the properties of the line. In the event the detector is moved along the line, a curve of voltage or current amplitude is obtained as a function of position along the

line. If the detector is kept at a fixed distance from the load, and the length of line between generator and load is varied, then a resonance curve is obtained giving the amplitude at the detector as a function of total line length. Finally, another type of resonance curve is available in case the frequency is altered with fixed line and detector adjustment. Here amplitude is plotted against frequency.

In order to utilize quantitatively the information contained in these plots of amplitude against a scale reading or against frequency, certain reference points are required. The first of these is taken as the position of the curve. This is defined as the value of the independent variable at the maximum or minimum detector amplitude. The independent variables which have been mentioned are the separation between detector and load, the total length of line, and the frequency. In addition to its position, a second property of each of these curves is its shape. This may be defined either by the width at an arbitrary level or by the ratio of maximum to minimum value. Thus, the width of resonance curves is commonly taken at a power level equal to half the peak power amplitude. In general, some other fraction of the maximum or a multiple of the minimum might prove useful in defining the level.

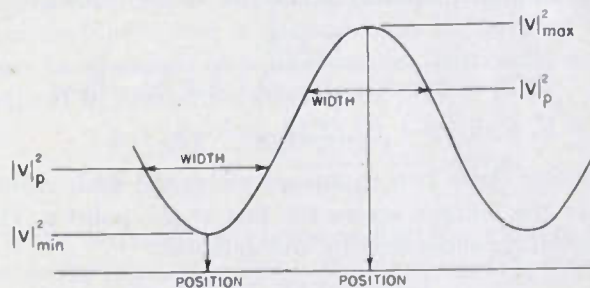

Fig. 1—Significant quantities in curves of detector output; the abscissa is either detector position or total line length.

The definitions of position and shape which have been made imply symmetrical curves; it will be shown later that only symmetrical curves need be considered. The quantities involved in the discussion above are illustrated in Fig. 1. The task of relating them to the terminal impedance of the line requires a general formula which may be derived from transmission-line theory.

## BASIC RELATIONS

A modified hyperbolic solution of the transmission-line equations forms the basis of the derivations to follow. This treatment of the solution has been discussed in the literature<sup>1,2</sup> but is not commonly used at present. However, it may be derived at once from standard forms

<sup>1</sup> R. King, "Transmission line theory and its application," *Jour. Appl. Phys.*, vol. 14, pp. 577-600; November, 1943.

<sup>2</sup> R. King, "General amplitude relations for transmission lines," *Proc. I.R.E.*, vol. 29, pp. 640-648; December, 1941.

\* Decimal classification: R244.4. Original manuscript received by the Institute, March 29, 1946; revised manuscript received, September 16, 1946. This work was partially supported by funds from the Office of Naval Research.

† Cruft Laboratory and Research Laboratory of Physics, Harvard University, Cambridge, Massachusetts.



to be found in texts on the subject. A diagram of the line is shown in Fig. 2. The load  $Z_r$  is located at a distance  $l$  from the sending end, the co-ordinate of which is 0. The voltage is measured at a distance  $z$  from the generator end which corresponds to a separation  $w$  from

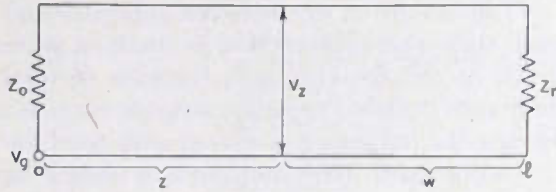

Fig. 2—Circuit of a measuring line; the unknown load is  $Z_r$  and the detector measures  $V_z$ .

the load; therefore  $w = l - z$ . A tabulation of the necessary quantities is written below.

$\gamma = \alpha + j\beta$ , the complex propagation constant, where  
 $\alpha$  = attenuation constant in nepers per meter,  
 $\beta$  = phase constant in radians per meter

$V_r$  = voltage across the load  $Z_r$

$V_z$  = voltage across the line at a distance  $z$  from the generator

$V_0$  = open-circuit voltage of the generator

$Z_0$  = equivalent series impedance of the generator

$Z_r$  = load impedance

$Z_c$  = characteristic impedance of the line.

Current amplitudes are omitted, since all of the final formulas obtained for measuring purposes apply equally to current detection. With the above notation the following standard equations may be written down:<sup>3</sup>

$$V_r = \frac{V_0 Z_c Z_r}{Z_c(Z_r + Z_0) \cosh \gamma l + (Z_c^2 + Z_r Z_0) \sinh \gamma l} \quad (1)$$

$$V_z = V_r \cosh \gamma w + (V_r/Z_r) Z_c \sinh \gamma w. \quad (2)$$

Combining these two equations yields the desired relation for the voltage across the line at the point  $z$ . This is the voltage measured by the detector.

$$V_z = V_0 Z_c \frac{\cosh \gamma w + (Z_c/Z_r) \sinh \gamma w}{(1 + Z_0/Z_r) \cosh \gamma l + (Z_c/Z_r + Z_0/Z_c) \sinh \gamma l}. \quad (3)$$

A great simplification in form is accomplished by substituting in terms of hyperbolic terminal functions involving the complex angle  $\theta_z$ . The defining equations are written as follows:

$$Z_0/Z_c = \coth \theta_0. \quad (4a)$$

$$Z_r/Z_c = \coth \theta_r. \quad (4b)$$

Omitting the subscript  $z$ , (3) takes on a much more compact form with the aid of these definitions:

$$V = V_0 \frac{\sinh \theta_0 \cosh (\gamma w + \theta_r)}{\sinh (\gamma l + \theta_0 + \theta_r)}. \quad (5)$$

Most detectors give an indication proportional to the

power level, and hence the square of the magnitude of (5) is of practical interest. The real and imaginary parts of the hyperbolic angle  $\theta$  are defined as follows:

$$\theta = \rho + j\Phi. \quad (5a)$$

The desired formula involving these quantities is

$$|V|^2 = |V_0|^2 \frac{(\sinh^2 \rho_0 + \sin^2 \Phi_0)(\sinh^2 (\alpha l + \rho_0 + \rho_r) + (\alpha w + \rho_r) + \cos^2 (\beta w + \Phi_r))}{\sin^2 (\beta l + \Phi_0 + \Phi_r)}. \quad (6)$$

At this point the reader may doubt the value of so much uncommon symbolism in the treatment of the practical problem of transmission-line measurements. The advantages of the method are twofold. In the first place, the resultant equations are of unusually simple form and permit making a clear comparison of the various measuring methods available. The remainder of the paper is devoted to this purpose. A second feature of the terminal functions is that they correspond to the physical variables of the problem. In effect, the use of terminal functions replaces the load impedance by a length  $s$  of a fictitious line, such that  $\rho = \alpha s$  and  $\Phi = \beta s$ . Thus, the termination damping  $\rho$  is a direct measure in nepers of the power absorbed in the termination. The value  $\rho = 0$  corresponds to a perfectly reactive load, while  $\rho = \infty$  applies to a matched or nonreflecting termination. Likewise, the termination phase shift  $\Phi$  measures the electrical length of the termination directly in radians. It has half the value of the reflection coefficient, as used on a Smith plot, for example. This representation in  $\rho$  and  $\Phi$  may be preferable to  $R$  and  $X$  in gauging the efficiency of a termination.<sup>4</sup> The relation between the terminal functions and the load resistance and reactance is given by the following:

$$R = \frac{R_c \sinh 2\rho}{\cosh 2\rho - \cos 2\Phi} \quad (7a)$$

$$X = \frac{-R_c \sin 2\Phi}{\cosh 2\rho - \cos 2\Phi}. \quad (7b)$$

Here it is assumed that the measuring line has low losses, i.e.,  $Z_c \approx R_c + j0$ ,  $\beta = 2\pi/\lambda$ . Computation from these relations is relatively simple, and complete curves are available which are to be published at a future date. Evidently the resistance and reactance of a given termination are completely specified by the terminal functions  $\rho$  and  $\Phi$ . It will be shown in the following sections that all the measurable quantities mentioned may be expressed conveniently in terms of  $\rho$  and  $\Phi$ .

Before proceeding, it is advisable to purchase some simplification of (6) at the price of additional notation. It will first be assumed that the generator voltage  $V_0$  and the contribution from the termination at the

<sup>3</sup> W. L. Everitt, "Communication Engineering," McGraw-Hill Book Co., New York, N. Y., 1937, pp. 157-160, equations (41) and (48).

<sup>4</sup> D. D. King and Ronald King, "Terminal functions for antennas," *Jour. Appl. Phys.*, vol. 15, pp. 186-192; February, 1944.



sending end,  $(\sin^2 \rho_0 + \sinh^2 \Phi_0)$ , both remain constant at all times. Also, define

$$f(\beta, w) = \sinh^2(\alpha w + \rho_r) + \cos^2(\beta w + \Phi_r) \quad (8a)$$

$$g(\beta, l) = \sinh^2(\alpha l + \rho_0 + \rho_r) + \sin^2(\beta l + \Phi_0 + \Phi_r). \quad (8b)$$

$$\left. \begin{aligned} A' &= \alpha w + \rho_r \\ A'' &= \alpha l + \rho_0 + \rho_r \\ F' &= \beta w + \Phi_r \\ F'' &= \beta l + \Phi_0 + \Phi_r \end{aligned} \right\} \quad (9)$$

Then

$$|V|^2 = K \frac{f(\beta, w)}{g(\beta, l)} \quad (10)$$

where  $K$  is a constant depending on the sending end. This equation forms the basis for all the methods of terminal-impedance measurement to be considered. Data from the measurable curves mentioned previously are used to obtain values of  $\rho$  and  $\Phi$  for an unknown terminating impedance. Determination of the phase shift  $\Phi$  is considered first.

PHASE-SHIFT MEASUREMENTS

The phase shift  $\Phi$  of a given termination is obtained from the position of either the voltage-distribution curve or the resonance curve. Since only one measurement is required, the frequency may be held constant. In accordance with the definition of position mentioned previously, that value of  $w$  or  $l$  must be found which yields maximum or minimum amplitudes. Maximum and minimum values of (10) are found by equating to zero the derivative with respect to  $w$  or  $l$ . The choice of variable depends on whether a movable detector is used or the line length is varied to produce a resonance curve. In either case, the following result is obtained:

$$\cos 2F = \pm \sqrt{1 - (\alpha/\beta)^2 \sinh^2 2A}. \quad (11)$$

This result applies to both the distribution-curve method ( $A'$  and  $F'$  in (9)) and the resonance-curve method ( $A''$  and  $F''$  in (9)). Whenever a result applies equally to either method the primes will be omitted.

A very simple final form is obtained by restricting the values of  $A$ . The physical meaning of this approximation is considered later.

$$(\alpha/\beta)^2 \sinh^2 2A \ll 1. \quad (12)$$

Subject to this condition, the extreme values of  $|V|^2$  in (10) occur at  $F = m\pi/2$ , where  $m$  is an integer. Now let  $F_1$  denote the extremized condition for the system with some standard termination  $\rho_{r1}$ ,  $\Phi_{r1}$  substituted for the load at the receiving end. Likewise, let  $F_2$  denote the extremized condition with the unknown termination  $\rho_{r2}$ ,  $\Phi_{r2}$  as the load. It follows that

$$\left. \begin{aligned} F_1 &= \beta \left\{ \begin{matrix} l_1 \\ w_1 \end{matrix} \right\} + \left\{ \begin{matrix} \Phi_0 \\ 0 \end{matrix} \right\} + \Phi_{r1} = m\pi/2 \\ F_2 &= \beta \left\{ \begin{matrix} l_2 \\ w_2 \end{matrix} \right\} + \left\{ \begin{matrix} \Phi_0 \\ 0 \end{matrix} \right\} + \Phi_{r2} = n\pi/2. \end{aligned} \right\} \quad (13)$$

In these equations the upper term in the brackets applies to the resonance method, the lower term to the distribution-curve method with movable detector. The same result is obtained for either method by subtraction.

$$\beta \left( \left\{ \begin{matrix} l_1 \\ w_1 \end{matrix} \right\} - \left\{ \begin{matrix} l_2 \\ w_2 \end{matrix} \right\} \right) + (\Phi_{r1} - \Phi_{r2}) = (m - n)\pi/2. \quad (14)$$

If the same maximum or minimum is used for both standard and unknown terminations, then the two integers  $m$  and  $n$  are equal. In case extra half-wavelengths are inadvertently included in the reading for either termination, the contribution to the left side of (14) will be plus or minus some integral multiple of  $\pi$  radians. Therefore the value of  $(m - n)$  on the right side is either zero or some even integer. Inspection of (7a) and (7b) shows that the impedance is unchanged by the addition or subtraction of some multiple of  $\pi$  to the termination phase shift  $\Phi$ . Therefore no ambiguity in the impedance value is possible for any consistent procedure to determine minima or maxima along the line. Having once determined  $l_1$  or  $w_1$ , as the case may be, the unknown phase shift  $\Phi_{r2}$  is given in terms of the known  $\Phi_{r1}$ , the length  $l_2$  or  $w_2$ , and the propagation constant  $\beta$ .

This result presumes the inequality (12) to be satisfied. The restrictions implied in this condition are later shown to be extremely mild.

DETERMINATION OF DAMPING

The shape of the distribution or resonance curves is a measure of the damping in the circuit. The simplest and most useful formula is derived from the ratio of maximum to minimum of a given curve. The result may be deduced by inspection from (10).

$$\frac{|V|^2 \max}{|V|^2 \min} = \frac{\sinh^2 A + 1}{\sinh^2 A} = \coth^2 A. \quad (15a)$$

If the variable is  $w$ , corresponding to a moving detector on the measuring line, a standard result is obtained.

$$\coth^2 A' = S^2. \quad (15b)$$

Here  $S$  is the voltage-standing-wave ratio. Equation (15b) affords a convenient relation between the damping in nepers and the usual standing-wave ratio. An analogous equation applies to the ratio of maximum to minimum of the resonance curve, as obtained by changing the length  $l$  of the line. The equation for this ratio,  $S_{res}$ , is included below.

$$\coth^2 A'' = S_{res}^2. \quad (15c)$$

These results assume that the frequency is held constant. Varying the frequency, i.e., varying  $\beta$ , yields results which involve the actual magnitude of  $w$  and  $l$ . In addition, it must be assumed that the damping is not a function of frequency. The method of frequency variation is better suited to the type of procedure considered below.

The analysis in terms of the width of a curve is most easily set up by following the experimental procedure.

Consider the case of a resonance curve obtained by changing the length  $l$  of the measuring line. The detector is kept fixed, as is the frequency. Accordingly, (10) takes the form:

$$|V|^2 = \frac{\text{constant}}{g(l)}. \quad (16)$$

As the length  $l$  is varied, a maximum value of  $|V|^2$ , namely  $|V|_m^2$ , will occur for which the denominator of (16) has the corresponding value  $g_m(l)$ . If the curve is symmetrical about the maximum, a smaller value of  $|V|^2$ , say  $|V|_p^2$ , is obtained at  $l + \delta l$  and  $l - \delta l$ . At these two points  $g(l)$  has the value  $g_p(l)$ . The width of the curve shown in Fig. 1 is  $2\delta l$ , as measured between points of amplitude  $|V|_p^2$ . Now let

$$|V|_p^2 = |V|_m^2/p^2. \quad (17)$$

Here  $p$  is the ratio of the two voltages. Then, by (16),

$$p^2 g_m(l) - g_p(l) = 0. \quad (18)$$

Using (8) and (9), this may be written

$$p^2(\sinh^2 A'' + \sin^2 F'') - (\sinh^2(A'' \pm \alpha\delta l) + \sin^2(F'' \pm \beta\delta l)) = 0. \quad (19)$$

Since  $A''$  and  $F''$  are taken to maximize (16), it follows that  $\sin^2 F''$  vanishes. The inequality (12) assures this and is assumed to apply. In order to secure a suitable final result, an additional restriction must be placed on the damping terms before expanding (19).

$$2\alpha\delta l \ll A'' \quad (20a)$$

$$2(\alpha\delta l)^2 \ll 1. \quad (20b)$$

Under these conditions (19) takes a simple form.

$$(p^2 - 1) \sinh^2 A'' = \sin^2 \beta\delta l. \quad (21)$$

The width of resonance curves is commonly measured between half-power points. According to (17), this means that  $p^2 = 2$ . For small values of damping the functions in (21) may be replaced by their arguments. Under these conditions the total damping  $A''$  is given by the following:

$$A'' = \beta\delta l. \quad (22)$$

The shape of the voltage-distribution curve obtained with a movable detector may be studied in identical fashion. In this instance (16) becomes

$$|V|^2 = (\text{constant}) f(w). \quad (23)$$

Since  $f(w)$  is in the numerator while  $g(l)$  was in the denominator, the same arguments are now applied to the *minimum* of the voltage-distribution curve as were previously applied to the maximum of the resonance curve.

The amplitude  $|V|_p^2$  is now larger than the minimum value  $|V|_m^2$ ; hence  $p^2$  must be replaced by  $1/p^2$  in (17). Likewise,  $1/f(w)$  is substituted for  $g(l)$  by virtue of (23). This gives the same form to (18). Accordingly (19) through (22) now apply to the minimum of the distribution curve with  $A''$  and  $l$  replaced by  $A'$  and  $w$  respectively.

In order to complete the discussion of the resonance and distribution curves obtained at constant frequency, the minimum of the resonance curve and the maximum of the voltage-distribution curve must be examined. The analysis proceeds in the same fashion as above. Consider first the resonance curve at constant frequency. Equation (19) is a convenient starting point; it must be written with  $p^2$  replaced by  $1/p^2$  to denote the fact that a minimum instead of a maximum is treated.

$$\sinh^2 A'' + \sin^2 F'' - \frac{1}{p^2}(\sinh^2(A'' \pm \alpha\delta l) + \sin^2(F'' \pm \beta\delta l)) = 0. \quad (24)$$

Here  $\sin^2 F''$  has the value of unity, since (16) is minimized. Subject to the same conditions as before, this yields:

$$(p^2 - 1) \sinh^2 A'' = 1 - p^2 \cos^2 \beta\delta l. \quad (25)$$

This applies to the region about the minimum of the resonance curve. Upon replacing  $A''$  by  $A'$  and  $l$  by  $w$ , the same equation applies to the region about the peak of the voltage-distribution curve. The analogy in the application of (21) and (25) to both resonance and distribution curves is complete.

The independent variables in the preceding discussion were  $l$  and  $w$ , corresponding to adjustment in line length or detector position. It remains to examine the situation when these quantities are fixed and the frequency is varied. The analysis proceeds from (10) written in the following form:

$$|V|^2 = K \frac{\sinh^2 A' + \cos^2(\beta w + \Phi_r)}{\sinh^2 A'' + \sin^2(\beta l + \Phi_0 + \Phi_r)}. \quad (26)$$

The line is now adjusted for maximum detector deflection, in accordance with the inequality (12). The method requires that  $A'' \approx A' \approx \text{constant}$  over the frequency range used.

$$|V|_m^2 = K \frac{\sinh^2 A + 1}{\sinh^2 A}. \quad (27a)$$

Since  $\beta = 2\pi f/v$  ( $v$  = phase velocity), a variation in frequency  $\pm \delta f$  or in equivalent electrical length  $\pm \delta\beta$ , above or below the value for maximum, produces some other amplitude  $|V|_p^2$ .

$$|V|_p^2 = K \frac{\sinh^2 A + \cos^2(\beta w + \Phi_r \pm w\delta\beta)}{\sinh^2 A + \sin^2(\beta l + \Phi_0 + \Phi_r \pm l\delta\beta)}. \quad (27b)$$

Equation (17) relates the two amplitudes, as before, and in combination with (27a) and (27b) yields the desired expression.

$$\sinh^2 A(p^2 - 1 - p^2 \sin^2 \delta\beta w - \sin^2 \delta\beta l) = \sin^2 \delta\beta l. \quad (28)$$

At this point it is expedient to assume small damping, thus replacing the functions by their arguments. Also, the width of the resonance curve is assumed to be measured at the half-power point,  $p^2 = 2$ . The resultant formula is similar to (22).

$$A = \delta\beta l / \sqrt{1 - 2 \sin^2 \delta\beta w - \sin^2 \delta\beta l}. \quad (29a)$$



Since small arguments were assumed, the radical may be set equal to unity. However, an important and fundamental point is involved in (29a). Evidently the equation as it stands makes the damping depend on the length of line  $l$ , even if the line were lossless and only the termination dissipative. The difficulty is that  $l$  is in the argument of a periodic function in the fundamental equation (26). The proper result is given by choosing  $l$  equal to the period,  $\lambda/2$ . Here  $\lambda$  is the wavelength at the center frequency  $f$  and the equivalent lengths of  $\Phi_0$  and  $\Phi_r$  are lumped with  $\beta l$  to make the argument  $\pi$  in (26) and (27b). Physically, this is equivalent to requiring the system to operate in the fundamental mode. This is a standard assumption in lumped-constant circuits; in the case of a transmission line more than one-half wavelength is regularly involved, and hence a special interpretation is required. A more familiar form for (29a) is now obtained in terms of the frequency, which is proportional to  $\beta$ .

$$A = \pi \delta f / f = (\pi/2) \frac{f'' - f'}{f} \quad (29b)$$

where  $f''$  and  $f'$  are the frequencies at the half-power points.

The equation is in agreement with the standard definition of the  $Q$  of a transmission line, provided only one half-wavelength is considered with lossless terminations. The  $Q$  of a line circuit with dissipative terminations evidently differs from the standard value  $\beta/2\alpha$ ; it is best defined in terms of the resonance curve only.

#### LIMITATIONS OF THE FORMULAS FOR PHASE SHIFT AND DAMPING

In order to indicate more clearly the range of loads that can be handled by the formulas which have been derived, the conditions assumed are restated in modified form. Thus, the general relation (12) is more easily interpreted if it is stated in terms of the standing-wave ratio in power,  $S^2$ , and the quality factor  $Q = \beta/2\alpha$  for the measuring line. With the aid of (15a) the inequality (12) becomes

$$\frac{S^2}{Q^2(S^2 - 1)^2} \ll 1. \quad (30a)$$

A sufficient condition is obtained after inverting and dividing by  $S^2$ .

$$(S^2 + 1/S^2 - 2) \gg 1/Q^2. \quad (30b)$$

Evidently a good line with a  $Q$  of the order of a thousand or higher permits accurate phase measurements with very low standing-wave ratios.

Additional restrictions are implied in the methods involving the width of resonance and distribution curves. If measurements are made at the half-power points, (20a) and (22) may be combined to give the condition

$$Q \gg 1. \quad (31a)$$

Likewise, if  $2\delta l = \lambda/2$ , which is certainly as wide as any curve can be, (20b) yields

$$Q^2 \gg \pi^2/2. \quad (31b)$$

Therefore, in practice the  $Q$  of the line does not limit the values of damping that can be handled by measuring the curve width. On the other hand, the largest value of  $A$  that can be handled by (21) is

$$A = \sinh^{-1} \sqrt{\frac{1}{p^2 - 1}}. \quad (31c)$$

In some instances a value of  $p^2$  less than the usual 2 may be desirable. The extended range is purchased at the price of decreased accuracy, however, since the measured width of the curve is now multiplied by a larger number, i.e.,  $1/\sqrt{p^2 - 1}$ .

An interesting consequence of these conditions from the experimental point of view is that resonance and distribution curves should be symmetrical. In effect,  $A \pm \alpha \delta x \approx A$  if they are fulfilled ( $x = l$  or  $w$ ). A common difficulty with the resonance procedure is generator loading. As the line is tuned through resonance the generator output changes to produce an asymmetrical resonance curve. This corresponds to a variable  $K$  in (10) and invalidates all the results obtained. Lack of symmetry of the resonance or distribution curves is therefore a useful indicator of improper circuit adjustment.

Either the peak of the resonance curve at constant frequency or the minimum of the distribution curve may be treated by (21) and (22). Experimentally, the two methods differ materially. In the resonance method the detector is kept fixed at the point along the line giving maximum deflection. The line length is then changed to produce a resonance curve. If this procedure is carried out with the unknown load and then repeated with a known standard termination, the difference between the two values of  $A''$  yields the true termination damping for the unknown. All detector loading and reflected damping from the generator is eliminated. On the other hand, when the detector is moved to obtain the shape of the distribution curve, its loading is no longer a constant and cannot easily be eliminated. However, the change in loading is small in the interval between half-power points.

The peak of the resonance curve is at a fairly high voltage amplitude. Therefore, the detector in the resonance method is favorably located. However, the generator must be loosely coupled, as mentioned before. In contrast, measurements on the width of the distribution curve are near the minimum voltage amplitude. This demands a more sensitive detector, but by way of compensation there are no longer any restrictions on the coupling between line and generator. In general, it appears that the width of the resonance-curve peak or the distribution-curve minimum is a convenient index of termination damping, provided it is not too large.

The standing-wave-ratio method with (15b) seems best suited to large damping, i.e., low standing-wave ratio. In case the standing waves are high, the operating range of the detector becomes very great and probe



loading effects appear.<sup>6</sup> The calibration for the detector must then also be extended unduly. However, the standing-wave ratio  $S$  is often used as a variable in charts and its usefulness here is not limited by experimental considerations. If desired, results in damping  $A$ , in nepers, can be converted easily to  $S$ . Equation (15a) is rewritten here to illustrate this.

$$S^2 = \frac{\sinh^2 A + 1}{\sinh^2 A} \quad (32)$$

Results from the other methods using (21) are expressed directly in  $\sinh^2 A$ . Accordingly, (32) affords a convenient step for expressing all results in  $S$  if desired, even though all the data are not best obtained by the standing-wave-ratio method.

Finally, the method of frequency variation remains to be mentioned; its application is restricted, since low damping and operation in the fundamental mode are required.

#### CALIBRATION

All damping measurements, and particularly the standing-wave-ratio method, require a calibrated detector. With crystal detectors, it is often advisable to repeat the calibration at intervals. The standard method of obtaining the desired calibration curve makes use of the upper portion of the distribution curve along a line with high standing waves. The curve is assumed to be a sinusoid; this permits plotting detector output against the true (sinusoidal) voltage along the line.

In order to test the validity of this procedure the shape of the curve near the maximum must be examined.

<sup>6</sup> W. Altar, F. B. Marshall, and L. P. Hunter, "Probe error in standing wave detectors," *Proc. I.R.E.*, vol. 34, pp. 33-44; January, 1946.

Equation (25) may be applied to the distribution curve, as explained previously, by substituting  $A'$  for  $A''$  and  $w$  for  $l$ . The damping  $A'$  may be replaced by the standing-wave ratio with the aid of (32). A convenient form of the resulting relation is

$$\beta\delta w = \sin^{-1} \left[ \frac{1 - 1/p^2}{1 - 1/S^2} \right]^{1/2} \quad (33)$$

The half-width  $\beta\delta w$  of the distribution curve is given by this equation at a power level  $(1/p^2) \cdot |V|_{\max}^2$ . A sinusoidal distribution is strictly true only when  $S^2 \rightarrow \infty$ . The deviation from the limiting case is obtained by substituting the actual value of the standing-wave ratio  $S^2$  in (33). An approximate result is available by inspection: the curve is very nearly a sinusoid provided  $S^2 \gg p^2$ . In case a calibration is to be carried out at a fairly low standing-wave ratio, (33) is useful in determining the range and accuracy obtainable.

#### CONCLUSION

The preceding treatment of equations for terminal impedance is intended to bring out the basic similarity in all of the formulas which depend on amplitude measurement. The various relations are couched in terms of directly measurable quantities, and hence have a simple physical meaning in terms of the parameters  $\alpha$  and  $\beta$  of the line. Examples of the application of the methods described may be found elsewhere.<sup>6,7</sup>

The writer is indebted to Ronold King for suggesting the subject and to J. V. Granger for assistance in preparing the manuscript.

<sup>6</sup> D. D. King, "Microwave antenna impedance measurement with application to antennas," *Jour. Appl. Phys.*, vol. 16, pp. 435-444; August, 1945.

<sup>7</sup> D. D. King "The measured impedance of cylindrical dipoles," *Jour. Appl. Phys.*, vol. 17, pp. 844-852; October, 1946.

## Microwave Power Measurement\*

THEODORE MORENO†, ASSOCIATE, I.R.E., AND OSCAR C. LUNDSTROM‡, ASSOCIATE, I.R.E.

**Summary**—Possible methods of microwave power measurement are reviewed. The design requirements for bolometric wattmeters are outlined, and examples are given of bolometer elements that have been developed to meet these requirements. A recently developed bolometer element that may be used over an exceedingly

wide band of frequencies is included. The results of experiments to investigate sources of error and to determine the accuracy of these wattmeters are summarized. These experiments indicate that, although serious errors are possible, proper usage will hold errors to within a few per cent.

### I. INTRODUCTION

AT ORDINARY radio frequencies, voltmeters and current meters may be used to determine power levels when impedances are known or measura-

ble. At higher frequencies, these meters are increasingly difficult to construct. When wave guides are used, voltage and current are ambiguous quantities that cannot be uniquely defined. It is therefore necessary at some point to turn to different methods of measurement.

### II. SUMMARY OF TECHNIQUES

(A) *Low-frequency techniques applicable at higher frequencies.*

Rectifiers, which are useful at lower frequencies, still find application at microwave frequencies in the form of

\* Decimal classification: R245.2. Original manuscript received by the Institute, April 19, 1946; revised manuscript received, August 5, 1946. Presented, 1946 Winter Technical Meeting, New York, N. Y., January 25, 1946.

† Formerly, Engineering Laboratories, Sperry Gyroscope Company, Inc., Garden City, L. I., N. Y., now, Research Laboratory of Electronics, Massachusetts Institute of Technology, Cambridge, Mass.;

‡ Engineering Laboratories, Sperry Gyroscope Company, Inc., Garden City, N. Y.



crystal rectifiers. However, these suffer from instability and temperature sensitivity, and require calibration against some absolute standard. Thermocouples are still of value at the highest frequencies, but also require calibration.

(B) *Techniques not extensively used at low frequencies.*

The techniques most suited for microwave power measurement generally involve the conversion of microwave power into heat. A further subdivision may be made into calorimetric and bolometric methods.

In the calorimetric method, the power to be measured is absorbed in a liquid or dissipated in a resistor which is cooled by a liquid. The power is then measured by determining the temperature rise and rate of flow of the liquid when equilibrium conditions have been established. Accuracy can be high, and calorimeters are frequently used as standards. However, the required equipment is bulky, time is required for equilibrium to be established, and the minimum power which can be measured accurately is a few watts. The calorimetric method is therefore suitable primarily for special laboratory measurements.

The bolometric method is generally more rapid, requires less bulky apparatus, and will handle lower powers. The required equipment is illustrated in Fig. 1. The heart of the wattmeter is a sensitive resistance element or bolometer whose resistance changes with temperature, and with power dissipated. This bolometer is usually a small bead of resistive material, such as the "thermistor," or a short length of fine wire. This element is placed in one arm of a direct-current bridge and heated by the direct current until the bridge is brought to balance. Dissipation of microwave power in the element will then unbalance the bridge.

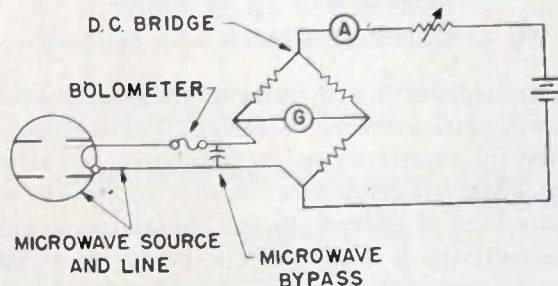

Fig. 1—Schematic circuit diagram of a bolometer wattmeter.

The degree of bridge unbalance may be used to measure the microwave power, with calibration accomplished by noting the unbalance caused by the addition of a known amount of low-frequency power to the sensitive element. Or the bridge may be rebalanced after addition of the microwave power, and the power measured is then said to equal the amount of direct-current power that it was necessary to subtract from the sensitive element in the rebalancing operation.

This type of measuring instrument is most useful at

microwave frequencies. But before discussing the design techniques that are applied to the components, it is well to look at the requirements which the instrument must meet.

### III. REQUIREMENTS TO BE MET BY A BOLOMETRIC WATTMETER

Certain fundamental requirements must be met by a bolometric wattmeter which is to be used for absolute power measurement. First among these is that all of the power to be measured be dissipated in the active element. Possible sources of loss which must be avoided include radiation, lossy dielectrics, poor conductors, and poor contacts between conducting surfaces. It is also necessary that the bolometer absorb substantially all of the power in the incident wave, and it must therefore be well-matched to the input transmission line.

An additional fundamental requirement is that direct-current and microwave power produce equivalent changes in resistance. This is necessary in order that the direct-current power which is subtracted from the bolometer in rebalancing the bridge be equal to the microwave power dissipated in the element.

Other bolometer characteristics are not so necessary for accuracy, but add to the ease and convenience of operation and minimize the possibility of error from improper use.

The sensitivity of the element is important, especially where small powers are to be measured. This sensitivity depends not only upon the ohms-per-watt sensitivity of the resistance, but also upon the current and resistance at which the element is operated. A high current and low resistance are desirable from this standpoint.

When larger powers are to be measured, the power-handling capacity of the element becomes more important than the sensitivity. High powers can always be cut down to the range of any element with the use of attenuators, but the design of suitable broad-band, high-power attenuators has proved in many ways to be more of a problem than the design of the wattmeter itself. So there is a definite need for bolometers which can handle large powers, and a corresponding loss of sensitivity can be tolerated.

The ability of the bolometer to withstand overloads without burning out must be considered. For some applications a large safety factor is essential, but there are many applications in which a 100 per cent safety factor is adequate.

The sensitivity of the bolometer element to changes in ambient temperature must also be considered. Ambient temperature sensitivity can be compensated for in the bridge design, but the bridge design is simpler if compensation is not necessary. To minimize the ambient temperature sensitivity, it is desirable to operate the element at a temperature far above ambient. This would indicate an incandescent element in a vacuum or in an inert gas.



A fast thermal time constant will increase the ease and rapidity with which measurements can be made. But if a bolometer with a very small time constant is used with certain bridges, errors in measurement may result when the microwave energy is amplitude-modulated. Some results of an investigation into this source of error are presented in Section V. In addition, a short thermal time constant increases the possibility of burn-out when pulsed power is being measured.

The construction and operating resistance of a bolometer depend to a great extent upon the holder with which it is used. A holder may be designed to adapt an existing element to a new type of transmission line or a new band of frequencies, but best results are usually obtained when an element and its holder are designed simultaneously, in order that they complement each other to the greatest possible extent.

It is advantageous, though, to have a bolometer element which may be adapted to a variety of holders, as this simplifies production and replacement problems. Distinct further advantages are gained if the elements are nearly enough identical to be interchanged or replaced without greatly altering the direct-current characteristics and without requiring retuning of the holder to maintain the desired impedance properties. It is also desirable that the desired impedance properties be maintained over the widest possible frequency band with the minimum number of adjustments.

#### IV. EXAMPLES OF MICROWAVE BOLOMETER ELEMENTS

Among the first bolometer elements to be used at microwave frequencies were the 5- and 10-milliamperer Littelfuses. The sensitive element is the platinum fuse wire, about 0.00006 inch in diameter. The resistance sensitivity is about 4 ohms per milliwatt, but the overload safety factor is not large. The impedance variation between elements is great enough so that at 9000 megacycles the holder must be retuned for each element. Better results are obtainable from a similar element which has been designed for the specific purpose of power measurement. An element of this type, often called a barretter, is shown in Fig. 2. These units have very uniform impedance properties, and may be interchanged in a 9000-megacycle holder without appreciably changing its microwave impedance. Fixed-tuned holders for this unit have been designed in wave guide for bands greater than  $\pm 10$  per cent with a standing-wave ratio under 1.26.

These bolometers, which employ very fine platinum wires suspended in air, are distinguished by their very short thermal time constant, in the order of 350 microseconds. They may therefore be used as detectors for audio-modulated signals and will measure rapid variations in power level. At the same time, as discussed in Section V, errors are possible when amplitude-modulated signals are being measured. Also, when measuring pulsed power as is used in radar sets, a typical unit will have

its power-handling capacity reduced from 30 milliwatts to an average power several times less. The elements are most satisfactorily used for measuring continuous power below 10 milliwatts.

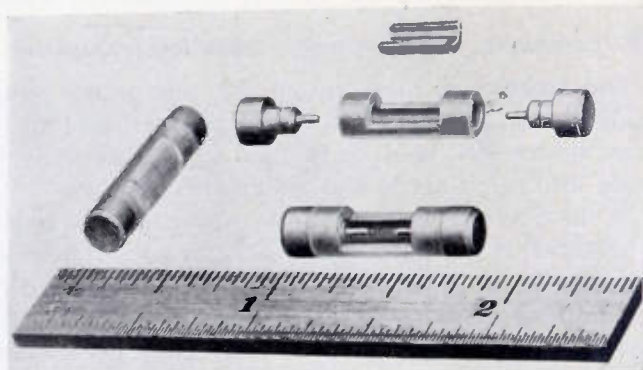

Fig. 2—Barretter element employing fine platinum wire for use in bolometric power measurement.

The "thermistor" has been extensively used as a bolometer element during the past few years. As used for power measurement, the thermistor takes the form of a small bead of resistive, temperature-sensitive oxides, suspended between two fine lead-in wires, and sometimes encased in a glass envelope as shown in Fig. 3. The resistor formed by the bead has a high negative temperature coefficient of resistance, which under typical operating conditions may be 15 ohms per milliwatt. The thermistor is therefore more sensitive than the platinum wire units, and is generally used for powers under 10 milliwatts.

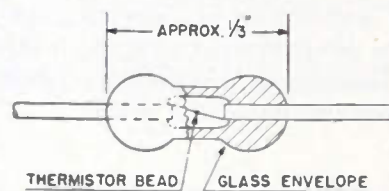

Fig. 3—Bead thermistor used in power measurement.

Thermistors will withstand much greater overloads than will platinum-wire barretters. Furthermore, their thermal time constant and heat capacity are relatively large. They are therefore ideally applicable to the measurement of pulsed power. The ambient temperature sensitivity is high, and the bridge must provide adequate compensation. The impedance variation is large enough to require retuning a 9000-megacycle holder when elements are changed, although a fixed-tuned holder may be used at 3000 megacycles.

For powers from 10 milliwatts to 15 watts, load lamps have been widely used as bolometer elements. A typical load lamp is shown in Fig. 4. It consists of a length of fine tungsten wire suspended in an evacuated or hydrogen-filled bulb. The lamp is intended for insertion in the center conductor of a coaxial line. This bolometer will give accurate results if properly used but is subject to possible gross error resulting from nonuniform current distribution along the filament when located near a



current node (see Section V). Furthermore, because of the resonant length of line beyond the filament, it is very difficult to match the lamp to a transmission line over any but a very narrow band of frequencies.

tended. The high-frequency limit  $f_0$  which may be reached in this manner is given (within the approximation  $2\pi l/\lambda \cong \tan 2\pi l/\lambda$ ) by

$$f_0 = \frac{\sigma \left(1 - \frac{1}{\sigma^2}\right)^{1/2} R c}{120\pi \ln b/a}$$

where  $\sigma$  is the maximum acceptable standing-wave ratio,  $R$  is the resistance per centimeter length of the filament at operating temperature,  $c$  is the velocity of light ( $c = 3 \times 10^{10}$  centimeters), and  $b/a$  is the diametric ratio of the line in which the filament forms the center conductor.

In one practical form of the bolometer, a carbon filament 2 mils in diameter has been chosen for its high resistivity, and bolometers have been matched to a 46-ohm coaxial line with a standing-wave ratio under 1.1 for all frequencies below 1100 megacycles, or with a standing-wave ratio under 1.4 for frequencies below 2900 megacycles. These values were predicted theoretically, and experimentally checked. They do not represent the maximum frequencies at which the lamps may be used. The range may be further extended with the use of more complex matching or equalizing networks, or holders may be designed which are not good at low frequencies but give satisfactory results over frequency bands higher than the above limits.

V. ERRORS ENCOUNTERED IN BOLOMETER WATTMETERS, AND ACCURACY OF POWER MEASUREMENT

A question that can always be asked about microwave wattmeters is whether they are actually measuring power, or just something proportional to power. At present, there is no generally accepted standard of power measurement against which comparisons may be made, although calorimeters are sometimes used for this purpose. But calorimeters are subject to errors if improperly designed or employed, and considerable care is required to reduce these errors to less than 2 or 3 per cent.

It is usually necessary to compare the results of 2 or three instruments and, from the results, make a judicious estimate of the errors involved in each measurement. This technique may also be used to measure the relative error as a function of some variable when only one of the instruments is subject to error from the variable conditions.

A number of experiments of this type have been performed. In some unpublished work, E. Feenberg and R. Kahal have shown theoretically that serious errors can result from nonuniform current distribution when the power-resistance relation of the bolometer is not linear and when the power being measured is a considerable part of the total power dissipated in the bolometer. For short filaments, the error will be large if the filament is at or near a current node. The magnitude of the error increases sharply with increasing power level for a given bolometer.

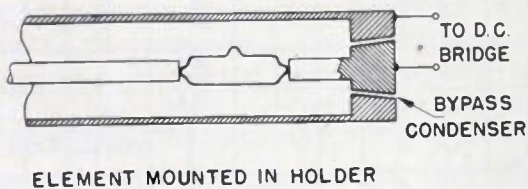
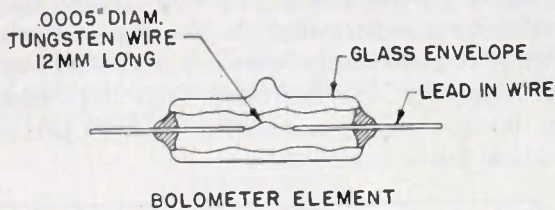

Fig. 4—High-power load lamp used for power measurement.

An improved type of load lamp and its associated holder are shown in Fig. 5. The sensitive element is again a short resistive wire, but is located at the end of the coaxial line. Mounting the wire adjacent to the short guarantees an essentially uniform current distribution along the filament, minimizing the possibility of error from this source. There is no resonant length of line beyond the filament, and matching problems are tremendously simplified.

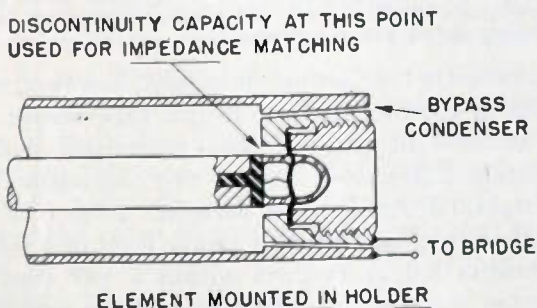
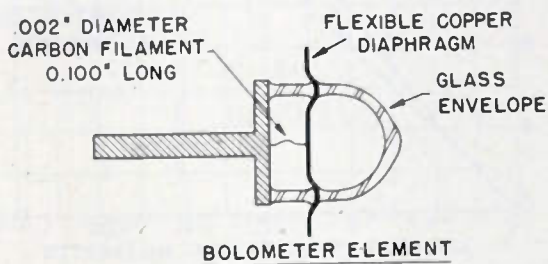

Fig. 5—Improved load lamp with broad-band impedance-matching properties.

If the filament is operated at a resistance near the characteristic impedance of the input line, the lamp in its holder will present a matched load to the line at all frequencies below that at which the inductance of the filament becomes appreciable. If this inductance is resonated with the discontinuity capacity at the filament input, the frequency range will be further ex-



The qualitative conclusions have been verified experimentally, although close quantitative checks have not been obtained. The results of a typical experiment are shown in Fig. 6. A holder and vacuum bolometer of the type shown in Fig. 4 were used at a frequency of 3000 megacycles. This bolometer has a power-resistance relation of the form  $R = A + BP^{1/3}$ , where  $R$  is resistance,  $P$  is power, and  $A$  and  $B$  are constants. The current distribution was varied by moving the position of the short behind the filament. The input power was continuously monitored by a calibrated probe and slotted section, and was adjusted to hold the power indicated

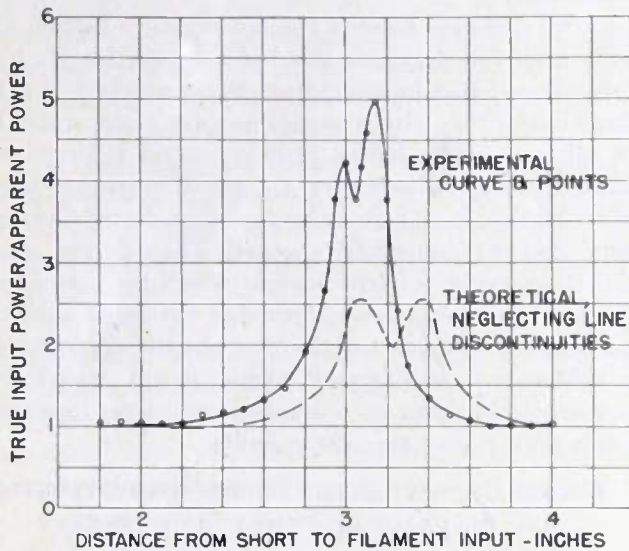

Fig. 6—Ratio of true input power to apparent input power with nonuniform current distribution along the sensitive filament.

by the bolometer wattmeter constant at 80 per cent of the total power required for balance. The ratio of true input power (as measured by the calibrated probe) to apparent power (as measured by the bolometer and bridge) is plotted in Fig. 6 as a function of the distance from the short to the filament input. Large errors were observed, larger than predicted by theory. This is believed the result of other sinks of power in the associated line and holder, whose effects were accentuated by the very high standing-wave ratio (up to 65) on the input line when the filament was located near a current node. This error is only one of maladjustment, but with the lamp and holder of Fig. 5 the error is not possible.

Errors may also arise with short-time-constant bolometers in certain bridge circuits if the input signal is amplitude-modulated at a frequency sufficiently low for the bolometer resistance to vary over the course of a cycle. This error was investigated by comparing the measurements of a thermistor to a platinum-wire barretter operating in an equal-arm, balanced bridge with matched source and galvanometer.

The power being measured was 100 per cent amplitude-modulated with a square wave, first at a frequency of 2 kilocycles, where the barretter resistance did not vary greatly over a modulation cycle, and second at a frequency of 20 cycles, where the barretter resistance

followed closely the modulation envelope. The thermistor resistance did not vary appreciably with the modulation.

The power indicated by the thermistor in these experiments is plotted in Fig. 7 as a function of the power indicated by the barretter. At the higher modulation frequency the two results were in agreement, but at the lower frequency the barretter error increased with power level, reaching a maximum of 40 per cent. A theoretical curve is also shown.

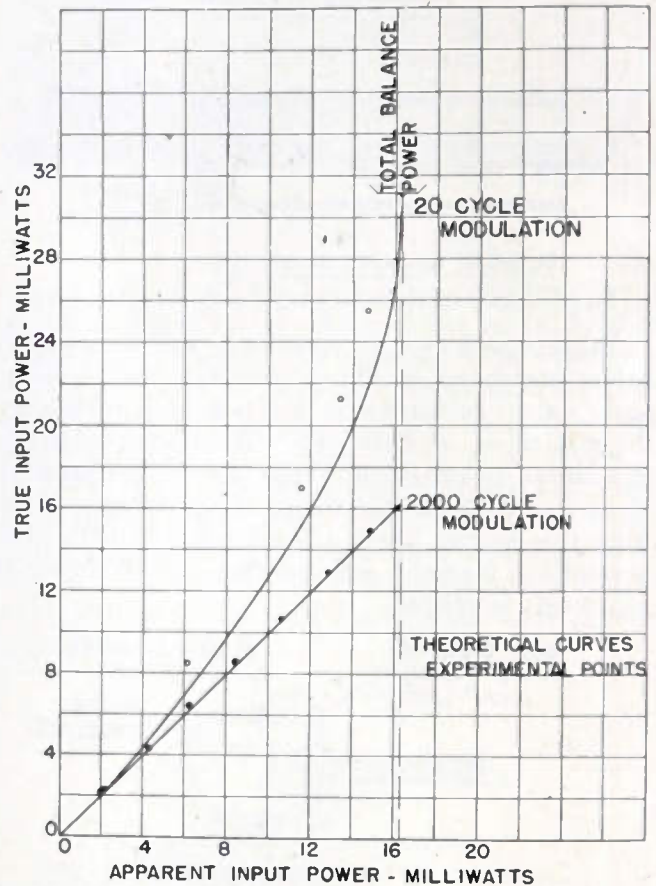

Fig. 7—Ratio of true input power to apparent input power for amplitude-modulated wave and equal-arm, matched bridge employing platinum-wire barretter.

Bolometers that are properly used, however, will give results in good agreement. In one experiment, carried out at 9400 megacycles, two thermistor mounts of Radiation Laboratory design, two thermistor mounts of English design, and a barretter mount of Sperry design were compared at a power level of 1 milliwatt. All results fell at random within 2 per cent of an arbitrary mean value, which was within experimental error.

Similar experiments at 3000 and 9400 megacycles which compared hot-wire bolometers and barretters with calorimeters have yielded agreement within 5 per cent, again within experimental error. It therefore seems reasonable to state that, at frequencies below 10,000 megacycles, a properly designed and properly employed bolometric wattmeter will measure true power within a few per cent.



# Design Values for Loop-Antenna Input Circuits\*

JAY E. BROWDER†, MEMBER, I.R.E., AND VICTOR J. YOUNG†

**Summary**—Design formulas and charts for the choice of inductances,  $Q$ 's, and coupling coefficients of loop-antenna coupling transformers are given on the basis of signal-to-noise characteristics. A method of determining these values when a cable or other primary capacitance is present is also given.

## INTRODUCTION

THIS ANALYSIS is based upon the fact that the power match of an antenna to a receiver is not necessarily the proper way to obtain best performance. In the transmitting case it is always desired that a maximum amount of power be transferred into the antenna, but with a receiver additional gain can always be supplied to make up for signal power. The signal-to-noise ratio that is obtained from the antenna cannot be improved in the receiver. The proper criterion for arranging receiver input circuits is that of obtaining a maximum signal-to-noise ratio. In the case of a loop receiving antenna, the power-matching criterion is never the proper one for determining the constants of the input circuit.

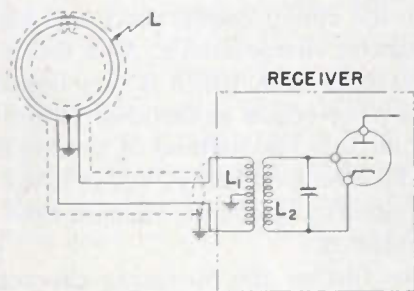

Fig. 1—A typical loop antenna in schematic form.

In Fig. 1 is shown a schematic drawing of a typical loop receiving-antenna input circuit. The shielded loop with its air gap is connected to a coupling transformer in the receiver either directly or through a transmission line. This coupling transformer, in turn, supplies the first vacuum tube and is tuned by a capacitor which must track with other tuning capacitors. It is the purpose of this paper to present the criteria that should be used in selecting the values of the various components for such an input circuit.

In specifying signal-to-noise ratios in terms of the circuit parameters, it will be necessary to assume that the resistive impedance of an antenna generates noise, just as does any other resistance, and that the normal strength of the noise generated in this way is obtained

by considering an equivalent resistor at a normal ambient temperature. It is well known that the noise power available from such a resistor is given by

$$N = kT\Delta f$$

where  $k$  is Boltzmann's constant,  $T$  is temperature in degrees Kelvin, and  $\Delta f$  is the bandwidth. In practice this may not always be true because the radiation resistance is concerned in this respect with external noise conditions. Such external noise fields may be thought of as changing the temperature of space. Thus external noise at a level other than the one used changes the quantitative results of the computation but does not affect their qualitative correctness.

## RELATIVE PERFORMANCE OF LOOP RECEIVING ANTENNAS

In order to compare the performance of various loop receiving antennas, it is necessary to assign a quantitative figure of merit to each antenna. As is common in most communication problems, the figure that has proven most versatile is a signal-to-noise ratio; it is the ratio of the signal strength to the thermal noise as measured at the open-circuited antenna terminals, under the assumption of a standard field strength and a standard bandwidth of the measuring equipment. It is also assumed in practice that the signal field strength in the neighborhood of the receiving antenna is larger than any noise fields which also exist in this region of space. This last assumption is, of course, not necessary as far as theoretical merit is concerned, but in practice if the noise field is larger than the signal field, nothing can be done to appreciably improve reception.

It is necessary to maintain both the standardization of bandwidth and a standard signal field strength in making absolute measurements of antenna performance. However, it is usually more convenient to deal entirely with ratios of performance between two or more antennas, whence it is necessary to specify the standard conditions to be maintained during any given set of tests. This means that the present discussion is not limited to any particular bandwidth or field strength.

The maximum open-circuit signal terminal voltage of any antenna is given by  $Eh_{eff}$ , and the thermal noise voltage of any resistor is given at room temperature by  $1.26 \times 10^{-10} \sqrt{R} \sqrt{\Delta f}$ . The condition for unity signal-to-noise ratio under the assumption of small noise field may then be written

$$E = \frac{1.26 \times 10^{-10} \sqrt{R} \sqrt{\Delta f}}{h_{eff}} \quad (1)$$

\* Decimal classification: R320.51XR325.3. Original manuscript received by the Institute, April 29, 1946; revised manuscript received, July 15, 1946.

† Sperry Gyroscope Company, Inc., Garden City, New York.

where

$E$  is the received signal field strength measured in volts per meter,

$R$  is the loop resistance, including radiation resistance

$\Delta f$  is the radio-frequency bandwidth

$h_{eff}$  is the effective height of the loop antenna, measured in meters.

But the effective height of a loop antenna may be given by

$$h_{eff} = \frac{2\pi A n}{\lambda} \tag{2}$$

where

$A$  is the area of the loop in square meters

$n$  is the number of turns

$\lambda$  is the wavelength in meters.

Making this substitution yields

$$E = \frac{1.26 \times 10^{-10} \sqrt{R} \sqrt{\Delta f} \lambda}{2\pi A n} \tag{3}$$

In this expression  $E$  is the minimum signal field strength which can be received with at least unity signal-to-thermal-noise ratio.

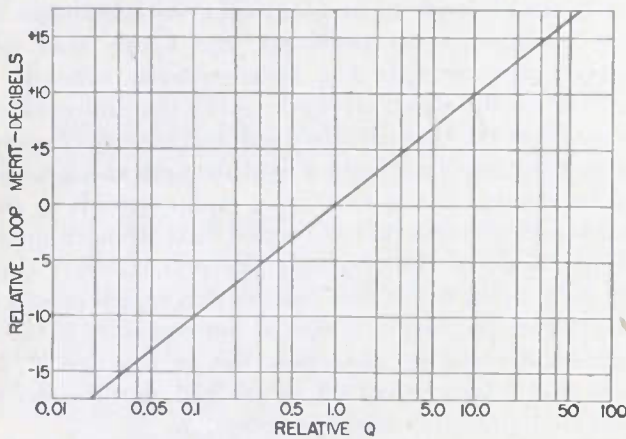

Fig. 2—Effect of loop  $Q$  on antenna merit for a loop having a constant area and form factor.

To compare one loop with another, it is only necessary to compare the corresponding minimum values of  $E$ . Doing this in ratio form, and using subscripts  $a$  and  $b$  to distinguish between the constants of the two installations,

$$\frac{E_b}{E_a} = \frac{A_a n_a \sqrt{R_b}}{A_b n_b \sqrt{R_a}} \tag{4}$$

This expression leads to the form

$$\text{Superiority of loop } b \text{ over loop } a = 20 \log \frac{A_b n_b \sqrt{R_a}}{A_a n_a \sqrt{R_b}} \text{ decibels.} \tag{5}$$

This formula gives a decibel comparison of the signal-to-noise merits of any two loops. When the expression

yields a positive number, loop  $b$  is that many decibels better than loop  $a$ . When the number computed is negative, it is loop  $a$  which is the best.

One interesting fact is immediately apparent from this expression. When loops of a given area and form factor (winding length divided by diameter) contain several turns (at least more than one), their inductance is proportional to the square of the number of turns. Thus, if under this condition the square roots of  $L_a$  and  $L_b$  are substituted for  $n_a$  and  $n_b$ , the formula can be modified to include only a constant and square roots of ratios of  $L_a$  to  $R_a$  and  $L_b$  to  $R_b$ . These ratios may, of course, be written as  $Q$ 's, and it can then be concluded that the merit of two loop antennas is identical as long as their  $Q$ 's, form factors, and areas are the same; or more specifically, that adding or subtracting turns to such a multiple-turn antenna will not change its merit.

In Fig. 2 is shown the relative merit of a direct-connected loop antenna which has multiple turns and constant area and form factor. As is shown, the merit of the loop is then dependent only on  $Q$ .

### INPUT-CIRCUIT NOISE FIGURE

It will be assumed in what follows that the receivers operate at low radio frequencies. Under this condition the input conductance of the first vacuum tube is small compared to the circuit conductance and hence can be taken as a circuit characteristic. As a result, the noise of the first vacuum tube, which is very important, may be treated as a correction to the noise factor of the rest of the input circuit. The method of making such a correction will be discussed below, but first the operation of the input circuit without the vacuum tube connected must be considered.

To describe further the operating characteristics of a loop-antenna input circuit, it is necessary to develop what is called the inherent thermal noise of a receiving antenna. Consider a loop or any other type of receiving antenna which is exposed to a radio-frequency field of strength  $E$  in volts per meter. Such an arrangement will give rise to an open-circuit terminal voltage.

$$e = E h_{eff} \text{ volts} \tag{6}$$

where  $h_{eff}$  is the effective height of the antenna. This voltage  $e$  will be due to the received signal. In addition, there will also be a noise voltage present at the terminals. The series-resistance term in the antenna impedance as measured at the open-circuited terminals is the factor which determines this noise voltage. This is true irrespective of what fraction of this resistance is attributable to radiation and what fraction depends upon the ohmic resistance of the conductors. If this resistive component of the antenna impedance is  $R$ , then at room temperature the open-circuit terminal noise voltage is given by

$$e_n = 1.26 \times 10^{-10} \sqrt{R} \sqrt{\Delta f} \text{ volts.} \tag{7}$$



In case the radiation resistance of the antenna presents greater than the normal noise voltage, the excess noise can be considered to be caused by an external noise field, and will not be considered in this analysis.

Clearly, if one could use perfect input circuits, a signal of strength equal to that of the noise could just be received. This occurs when  $e = e_n$ , or when

$$E = \frac{1.26 \times 10^{-10} \sqrt{R} \sqrt{\Delta f}}{h_{eff}} \quad (1)$$

With practical input circuits,  $E$  has to be larger than this in order that the signal-to-noise level of the system be equal to unity. Expressed in decibels, the amount that  $E$  must be raised to yield the desired level with a practical input circuit is called the noise figure of the input circuit. Strictly, noise figure is always a negative quantity because it represents a reduction in system performance, as compared to a noiseless standard. In this paper it always appears as a negative number of decibels.

Although only loop receiving antennas are discussed herein, the concept of input-circuit noise figure can equally well be applied to any antenna connection. This quantity puts the calculation and measurement of the operation of an antenna coupling circuit on an absolute basis. Noise figure is most conveniently expressed in decibels. If it is zero decibels, then reception can occur at the minimum field strength as determined by  $h_{eff}$  and  $R$  of the antenna itself, and no further improvement in the coupling circuit can possibly be made. If, however, the noise figure of a given arrangement is minus 10 decibels, then considerable improvement can be made by redesign or improvement of the input circuit.

### TRANSFORMER-COUPLED LOOP INPUT CIRCUITS

The actual circuit of a transformer-coupled loop input circuit is shown in Fig. 3(a).  $L$  and  $R$  represent the inductance and resistance of the loop. The other  $L$ 's and  $R$ 's specify the constants of the transformer as shown. For the purpose of analysis at the radio frequency, the circuit shown in Fig. 3(a) is replaced by the equivalent form shown in Fig. 3(b). Fig. 3(c) is also, in a sense, the same as that of Fig. 3(a) or 3(b). This follows from an application of Thevenin's theorem to the circuit of Fig. 3(b). Measurement of open-circuit inductance and resistance as seen at terminals  $AB$  will yield the values  $L_2'$  and  $R_2'$  and the complete circuit may be represented as shown in Fig. 3(c).

The circuits of Fig. 3 are used to determine the signal-to-noise ratio of the loop plus the input circuit. When a decibel comparison of this signal-to-noise ratio is made to the signal-to-noise ratio of the loop alone, the noise figure of the input circuit results.

When the loop is exposed to a radio-frequency field and properly oriented, a maximum signal voltage of strength  $e$  is induced in the antenna. In Fig. 3, this

voltage  $e$  may be thought of as being inserted in series with the loop at point  $P$ . As long as terminals  $AB$  are open,  $e$  will distribute itself only around the one available closed circuit and (assuming the  $R$ 's are small com-

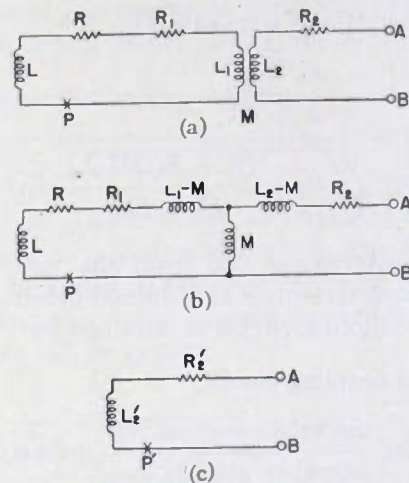

Fig. 3—Actual and equivalent loop-antenna transformer-coupling circuits.

pared to the  $X$ 's) the fraction of  $e$  which will appear across the inductance  $M$  of Fig. 3(b) will be given by

$$e_s = \frac{Me}{L + L_1} \quad (8)$$

Furthermore, as long as no load is placed on terminals  $AB$ , this is the voltage which will be observed at those terminals. Replacing  $M$  with  $k\sqrt{L_1L_2}$ , where  $k$  is the coupling coefficient of the transformer, the voltage at  $AB$  may also be written as

$$e_s = \frac{k\sqrt{L_1L_2}}{L + L_1} e \quad (9)$$

The impedance at terminals  $AB$ , called  $Z_{AB}$ , may be computed from Fig. 3(b). It is

$$Z_{AB} = R_2 + j[\omega(L_2 - M)] + \frac{(j\omega M)[R + R_1 + j\omega(L + L_1 - M)]}{R + R_1 + j\omega(L + L_1)} \quad (10)$$

This expression may be simplified because the  $R$ 's are normally small compared to the  $(\omega L)$ 's. It is specifically assumed that  $(R+R_1)^2$  is very small in comparison to  $[\omega(L+L_1)]^2$ . This is equivalent to saying that the  $Q^2$ 's must be large. In fact, for  $Q$ 's as small as 10, the value of  $Q^2$  is 100, and so the error of the approximation is equal to only 1 per cent. With this approximation and with the substitution of  $k\sqrt{L_1L_2}$  for  $M$ ,  $Z_{AB}$  may be rewritten as

$$Z_{AB} = \left[ R_2 + \frac{(R+R_1)k^2L_1L_2}{(L+L_1)^2} \right] + j\omega \left[ L_2 - \frac{k^2L_1L_2}{L+L_1} \right] \quad (11)$$

We may calculate the thermal noise level at terminals *AB* from the resistive component of this impedance in the usual way. Denoting the noise voltage as  $e_n$ , then the signal-to-noise ratio at terminals *AB* is  $e_s/e_n$ . Written out completely, the expression is

Signal-to-noise ratio at terminals *AB*

$$= \frac{\frac{k\sqrt{L_1L_2}}{L+L_1} e}{1.26 \times 10^{-10} \sqrt{R_2 + \frac{(R+R_1)k^2L_1L_2}{(L+L_1)^2}} \sqrt{\Delta f}} \quad (12)$$

From this expression and from the signal-to-noise ratio of the loop terminals as obtained before, the noise figure of the coupling circuit is obtained by

Noise figure of coupling circuit

$$= 20 \log \frac{\text{Signal-to-noise at } AB}{\text{Signal-to-noise in loop}} \text{ decibels.} \quad (13)$$

Making the appropriate substitution yields

Noise figure of transformer coupling

$$= 20 \log \frac{k}{\sqrt{k^2 + k^2 \frac{R_1}{R} + \frac{R_2(L+L_1)^2}{RL_1L_2}}} \quad (14)$$

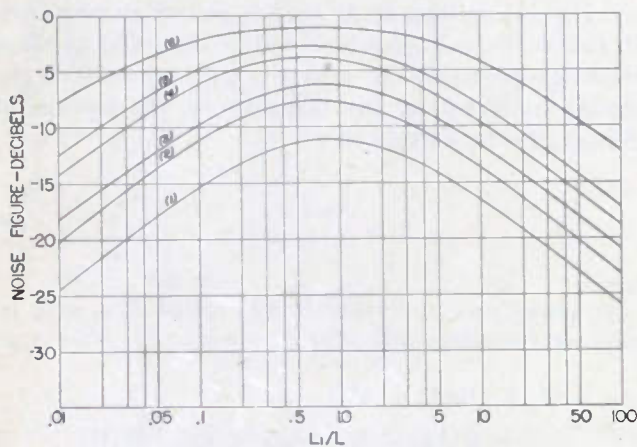

Fig. 4—Noise-figure variation with  $L_1/L$ .

- |                |           |         |
|----------------|-----------|---------|
| (1) $Q_2=Q_1$  | $Q_1=Q$   | $k=0.6$ |
| (2) $Q_2=Q_1$  | $Q_1=Q$   | $k=1.0$ |
| (3) $Q_2=2Q_1$ | $Q_1=2Q$  | $k=0.6$ |
| (4) $Q_2=2Q_1$ | $Q_1=2Q$  | $k=1.0$ |
| (5) $Q_2=2Q_1$ | $Q_1=3Q$  | $k=1.0$ |
| (6) $Q_2=2Q_1$ | $Q_1=10Q$ | $k=1.0$ |

Since it is more convenient to work with  $Q$ 's than with  $R$ 's, the appropriate  $\omega L/Q$  is next substituted for each  $R$ . The expression then becomes

Noise figure of transformer coupling

$$= 20 \log k - 10 \log \left[ k^2 + \frac{2Q}{Q_2} + \frac{k^2Q}{Q_1} \frac{L_1}{L} + \frac{Q}{Q_2} \left( \frac{L_1}{L} + \frac{L}{L_1} \right) \right] \quad (15)$$

This last equation gives the variation and values of the transformer-coupling noise figure with any values or changes of the parameters of the input circuit. In Fig. 4,

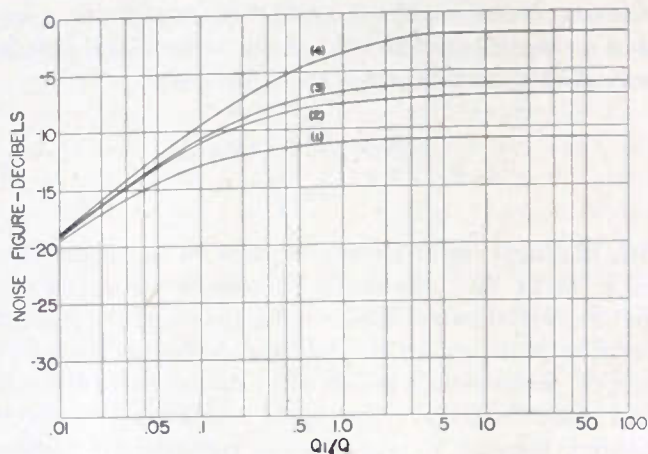

Fig. 5—Noise-figure variation with  $Q_1$ .

- |                  |           |         |
|------------------|-----------|---------|
| (1) $L_1/L=0.75$ | $Q_2=Q$   | $k=0.6$ |
| (2) $L_1/L=0.75$ | $Q_2=Q$   | $k=1.0$ |
| (3) $L_1/L=0.75$ | $Q_2=2Q$  | $k=1.0$ |
| (4) $L_1/L=0.75$ | $Q_2=10Q$ | $k=1.0$ |

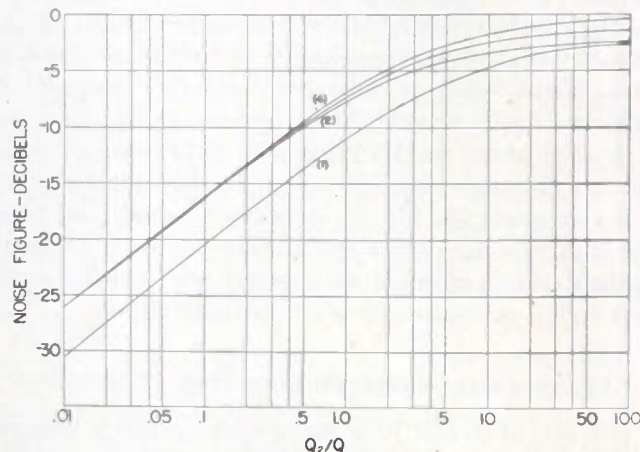

Fig. 6—Noise-figure variation with  $Q_2$ .

- |                  |           |         |
|------------------|-----------|---------|
| (1) $L_1/L=0.75$ | $Q_1=Q$   | $k=0.6$ |
| (2) $L_1/L=0.75$ | $Q_1=Q$   | $k=1.0$ |
| (3) $L_1/L=0.75$ | $Q_1=2Q$  | $k=1.0$ |
| (4) $L_1/L=0.75$ | $Q_1=10Q$ | $k=1.0$ |

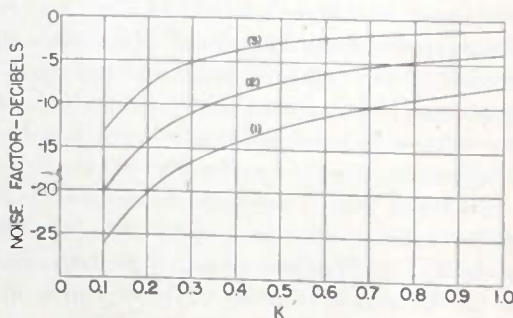

Fig. 7—Noise-figure variation with  $k$ .

- |                  |            |           |
|------------------|------------|-----------|
| (1) $L_1/L=0.75$ | $Q_2=Q_1$  | $Q_1=Q$   |
| (2) $L_1/L=0.75$ | $Q_2=2Q_1$ | $Q_1=2Q$  |
| (3) $L_1/L=0.75$ | $Q_2=2Q_1$ | $Q_1=10Q$ |



this equation is plotted so as to show the variation of noise figure with  $L_1/L$  for various values of the  $Q$  ratios. Since all of these curves show optimum operation for  $L_1/L$  equal to about 0.75, this value of  $L_1/L$  is chosen, and in Figs. 5, 6, and 7 it is used in showing variation with the various  $Q$  ratios.

EQUIVALENT NOISE OF INPUT TUBE

In the actual loop-coupling arrangement, two elements are connected across the terminals  $AB$  of Fig. 3. One is a capacitor which is tuned to resonate the loop, and the second is the grid of the first vacuum tube. The capacitor does not affect the noise figure which has been computed, and the tube adds a noise correction which may be evaluated.

To show that the capacitor does not affect the noise figure of the loop, refer to Fig. 3(c) and imagine that a source  $e$  is connected at point  $P'$  and a resonating capacitor connected across terminals  $AB$ . The resonant current may be computed so that the drop across the reactance, which is the terminal voltage at  $AB$ , becomes

$$e_s = \frac{\omega L_2'}{R_2'} e. \tag{16}$$

To obtain the signal-to-noise ratio under this condition, this quantity must be divided by  $1.26 \times 10^{-10} \sqrt{R_{res}} \sqrt{\Delta f}$ , where  $R_{res}$  is the resistance component of the resonant impedance as measured at  $AB$ . It can easily be shown that  $R_{res} = (L_2' \omega)^2 / R_2'$ . Thus the signal-to-noise ratio can be written as

Signal-to-noise ratio

$$= 20 \log \frac{1}{\sqrt{R_2'}} \frac{e}{1.26 \times 10^{-10} \sqrt{\Delta f}} \text{ decibel.} \tag{17}$$

Likewise, with no capacitor connected at terminals  $AB$ ,

$$e_s = e$$

and dividing by the noise voltage,  $1.26 \times 10^{-10} \sqrt{R_2'} \sqrt{\Delta f}$ , gives the same value of the signal-to-noise ratio. These results also show that resonating a transformer coupling does not affect the noise figure of that coupling.

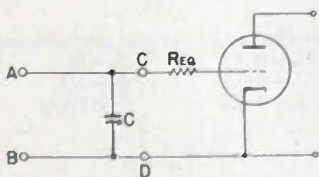

Fig. 8—Equivalent noise resistance of the input tube.

To evaluate the noise correction due to the presence of the tube, refer to Fig. 8. In this figure is shown the antenna connection to the first vacuum tube, and also the capacitor used for resonating the loop. The loop, or the loop and the coupling transformer, are considered

to be to the left of the terminals  $AB$ . The tube noise is represented by the equivalent resistant  $R_{eq}$  connected in series with grid. Aside from the noise it generates, this resistor has no circuit significance as long as the grid is assumed to draw little or no current.

The effect of  $R_{eq}$ , expressed in the same terms as were used for the input circuit proper, yields

Noise figure correction due to tube

$$= -10 \log \left( 1 + \frac{R_{eq}}{R_{res}} \right). \tag{18}$$

Values of this quantity may be obtained from Fig. 9. This measure of noise increase due to the first vacuum tube must be added to the noise figure of the input circuit to obtain the complete noise figure for the over-all performance of the system.

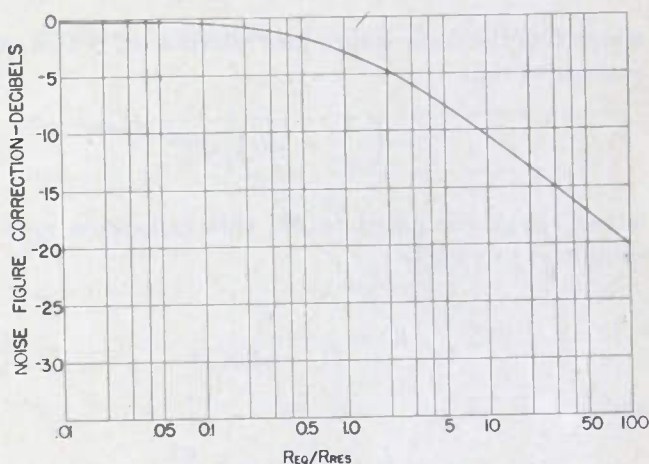

Fig. 9—Noise-figure correction variation with  $R_{eq}/R_{res}$ .

EFFECT OF LOOP CABLE

When the length of the cable connecting the loop to the transformer is at all significant, its effect on the performance of the system must be taken into account. If  $L'$  is defined as the inductance of the loop and connecting cable as seen at the primary terminals of the transformer, and  $R'$  is the resistance as measured at this same point, then in the formula which has been given for noise figure,  $L'$  can be substituted for  $L$ , and  $R'$  can be substituted for  $R$ .

Two cases are of interest: (1) when the connecting cable has appreciable electrical length; and (2) when the frequency and the length of the cable which is used is such that the cable length is very short in comparison to a quarter-wavelength.

For case (1), the most important parameter of the connecting cable is its characteristic impedance  $Z_0$ . In this case the cable is comparatively long and is being used as a transmission line. The values of  $L'$  and  $R'$  can be calculated from the equation

$$R' + j\omega L' = Z_0 \frac{Z_0 \sinh l + (R + j\omega L) \cosh l}{Z_0 \cosh l + (R + j\omega L) \sinh l} \tag{19}$$

where  $l$  is the electrical length of the transmission line measured as an angle.

Case (2), in which the cable is relatively short in comparison to a quarter wave, covers most of the cases generally encountered. Now the cable can be considered to represent lumped-constant elements in the circuit. Along with the capacitance of the cable, which is usually the most important factor, may well be included the distributed capacitance occurring at the loop and transformer ends of the cable.

The values of  $L'$  and  $R'$  for this lumped-constant case are obtained from the expression

$$R' + j\omega L' = \frac{(R + j\omega L) \left( -j \frac{1}{\omega C} \right)}{R + j\omega L - j \frac{1}{\omega C}} \quad (20)$$

where  $C$  is the capacitance just referred to. If  $C$  is small enough so that

$$\left( \frac{1}{\omega C} - \omega L \right)^2$$

is very large compared to  $R^2$ , this expression may be simplified to yield

$$R' = \frac{R}{(1 - \omega L \omega C)^2} \quad (21)$$

and

$$L' = \frac{\frac{L}{C} \left( \frac{1}{\omega C} - \omega L \right) \frac{R^2}{\omega C}}{\left( \frac{1}{\omega C} - \omega L \right)^2} \quad (22)$$

Frequently  $R$  and  $C$  are small enough so that

$$\frac{R^2}{\omega C \left( \frac{1}{\omega C} - \omega L \right)^2} \ll \frac{L}{C \left( \frac{1}{\omega C} - \omega L \right)}$$

and in this case the expression for  $L'$  may be further simplified to

$$L' = \frac{L}{1 - \omega L \omega C} \quad (23)$$

These formulas are of particular importance in calculating the apparent inductance as seen at the primary terminals of the coupling transformer. Graphical data concerning their solution are given in Fig. 10.

In those cases where the cable inductance is of importance in comparison to the loop inductance, it is usually adequate to add these two inductances and assume that the capacitances are in shunt with the total inductance. This is an approximation, and care must be

taken not to use this approximation where extreme accuracy is expected.

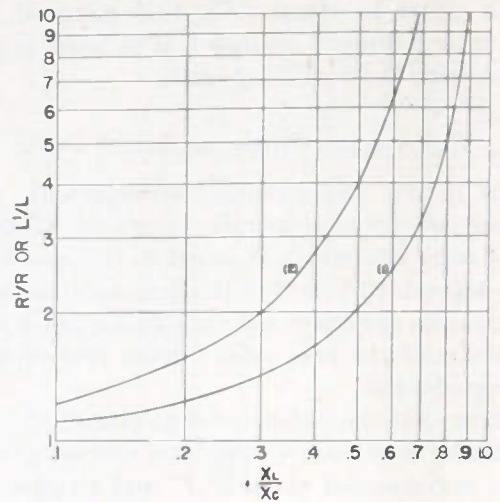

Fig. 10—Change of loop parameters with shunt capacitance.  
(1) Change of reactance with cable capacitance.  
(2) Change of resistance with cable capacitance.

### SYSTEM PERFORMANCE CHANGE WITH LOOP Q

If a loop antenna is coupled to a receiver, and if the  $Q$  of the loop is varied while all other circuit parameters are held constant, two factors will change. As is shown in Fig. 2, both the merit of the loop itself and the noise figure of the coupling circuit will be changed.

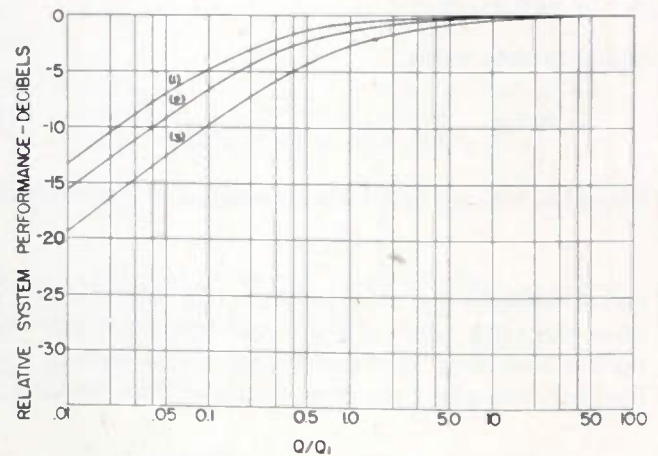

Fig. 11—Relative change of system performance with change of  $Q$ .  
(1)  $L_1/L = 0.75$        $Q_2 = Q_1$        $k = 1.0$   
(2)  $L_1/L = 0.75$        $Q_2 = 2Q_1$        $k = 1.0$   
(3)  $L_1/L = 0.75$        $Q_2 = 10Q_1$        $k = 1.0$

From the computations which have been made, these two decibel measurements of operation can be added so as to yield a measure of over-all system performance as a function of  $Q$ . This has been done, and under the restrictive conditions already mentioned, Fig. 11 shows the result in graphical form.

The curve of Fig. 11 increases steadily with increased  $Q$ . The practical limitation on  $Q$  depends upon



bandwidth. Just how this dependence occurs is discussed below.

APPARENT Q OF THE TRANSFORMER SECONDARY

The apparent Q, the ratio of the reactance to the resistance, of the loop and coupling arrangement as shown at terminals AB of Fig. 3 is the quantity that determines the antenna bandwidth. We shall call this quantity Q<sub>2</sub>'. Q<sub>2</sub>' also determines the manufacturing tolerances which can be allowed for the loop inductance, transformer inductances, and tuning-capacitor capacitance.

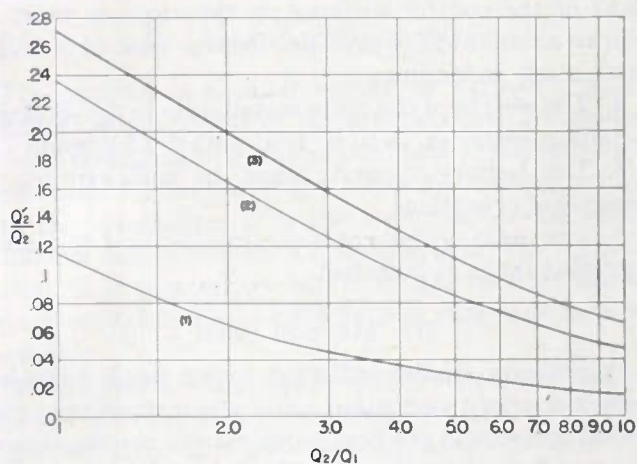

Fig. 12—Apparent Q of the secondary of the coupling transformer.  
 (1) L<sub>1</sub>/L=0.75      Q<sub>1</sub>=10Q      k=1.0  
 (2) L<sub>1</sub>/L=0.75      Q<sub>1</sub>=2Q      k=1.0  
 (3) L<sub>1</sub>/L=0.75      Q<sub>1</sub>=Q      k=1.0

To calculate Q<sub>2</sub>' we must evaluate ωL<sub>2</sub>' and R<sub>2</sub>'. From Fig. 3(b), Z<sub>AB</sub> has already been found, and since only inductances are involved, R<sub>2</sub>' and ωL<sub>2</sub>' can be immediately taken from the real and imaginary parts of that expression. Thus

$$Q_2' = \frac{\omega \left( L_2 - \frac{M^2}{L + L_1} \right)}{R_2 + \frac{(R + R_1)M^2}{(L + L_1)^2}} \quad (24)$$

Substituting Q's for R's, this may be rewritten as

$$\frac{Q_2'}{Q_2} = \frac{1 - k^2 \left( \frac{L_1}{L + L_1} \right)}{1 + k^2 \frac{Q_2}{Q} \frac{L}{(L + L_1)} \frac{L_1}{(L + L_1)} + k^2 \frac{Q_2}{Q_1} \left( \frac{L_1}{L + L_1} \right)^2} \quad (25)$$

Here Q<sub>2</sub>' is actually given as a ratio to Q<sub>2</sub>. This has been done only for convenience in the graphical representation of Fig. 12.

APPARENT INDUCTANCE OF THE TRANSFORMER SECONDARY

In order to design the loop-coupling transformer so that it will track with the other coils in the receiver, it is necessary to know the inductance of the secondary with the loop connected to the primary of the transformer. An expression for L<sub>2</sub>' was obtained as the imaginary part of (11). For convenience of graphical representation, this expression may be rewritten as

$$\frac{L_2'}{L_2} = 1 - k^2 \frac{L_1}{L + L_1} \quad (26)$$

Fig. 13 shows graphical values of this expression.

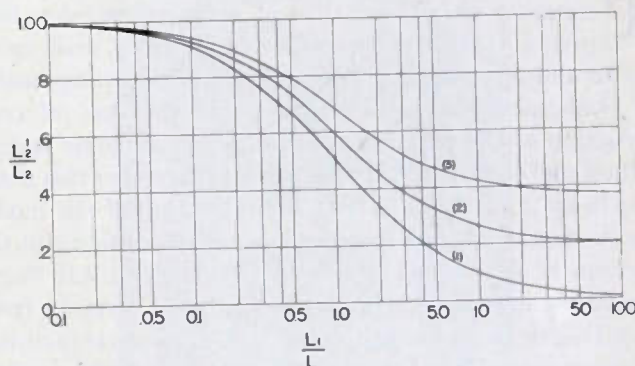

Fig. 13—Apparent inductance of the secondary of the coupling transformer.

- (1) k=1
- (2) k=0.9
- (3) k=0.8

CONCLUSION

The concept of the noise figure of an input circuit at comparatively low radio frequencies is a powerful aid in the analysis and improvement of input circuits. Formulas and charts which have been given cover the loop-coupling-transformer input circuit. Further design development of these transformers will proceed more rapidly if effort is expended on those parameters which theoretically will give the greatest benefits with the least change of the circuit elements. Unquestionably, there is much to be gained over those designs which have been so generally used in the past. The formulas and charts which have been given can be used directly for that purpose.

# Radio Control of Model Flying Boats\*

V. WELGE†, ASSOCIATE, I.R.E.

**Summary**—A new method of carrying on flying-boat hull design involves radio control of free-flight models. The scale factors of the models are such that severe weight and space limitations are imposed on the radio-control equipment, considering the complexity of control. Seven independent channels capable of simultaneous operation are needed. Five accomplish proportional positioning and two perform switching operations. A single radio-frequency carrier is used, amplitude-modulated by seven control tones.

The factors affecting the positioning accuracy are discussed. A compensating circuit is described which corrects for variations in receiver output with charges of battery voltage and distance from the control station. Over-all positioning accuracy is plus or minus 4 per cent.

Operating experience includes nearly 1000 test runs utilizing scale models of three different types of flying boats.

## I. INTRODUCTION

FLYING-BOAT hull research has followed a course roughly paralleling that of aerodynamic development. It has been expedient to employ scale models to allow research to be carried out in towing basins of convenient size and to minimize the cost of construction of the various hull configurations to be tested. Much useful information has been gathered in this manner in spite of the fact that the mounting of the model on the towing device imposes certain restrictions on the motion of the model. However, during the war emergency the existing towing basins (all at a distance from San Diego) became overloaded, and additional facilities became necessary. Radio control of free-flight models was proposed as an alternative to the construction of a towing basin at San Diego, and was selected for reasons of economy, availability of material, and freedom from restrictions on motion.

Considerable test data were available on  $\frac{1}{8}$ -scale towing-basin models, and it was desired to employ a radio-controlled model of the same scale to provide a direct comparison of results on the initial tests. Since, in a dynamically similar scale model, the weight scales down as the third power of the scale factor, this imposed severe weight restrictions on the radio equipment in the airplane. In the case of the first model, a two-engined flying boat, the weight allowance was 15 pounds. Inasmuch as no seven-channel proportional system existed in this weight bracket, it was necessary to develop one.

## II. SPECIFICATIONS

The following specifications were set up to serve as a guide in the development:

1. Seven independent controls are to be provided, capable of simultaneous operation. Five of these con-

trols are to be continuously variable throughout their range and are to accomplish a positioning which is proportional to the setting of the control levers at the ground station. These are to be used for rudder, ailerons, elevator, and two engine throttles. The other two controls switch off the ignition and lower the flaps, respectively.

2. The time lags between movement of the control wheel or rudder pedals at the ground station and movement of the control surfaces on the airplane must be held to a minimum to provide effective control of flight, particularly in landings.

3. The weight of the radio installation in the airplane, including batteries, is to be held within 15 pounds.

4. The battery capacity must be sufficient for 30 minutes of operation.

5. The radio equipment must provide for a maximum operating range of 2000 feet.

## III. METHOD USED

Preliminary studies indicated that a single radio-frequency carrier, modulated with seven amplitude-controlled tones, held the best promise from the standpoint of over-all simplification of equipment and weight reduction in the airplane installation.

The arrangement of the airplane equipment is shown in Fig. 1. Note that, in contrast to the nonproportional "bang-bang" type of control used in target airplanes,

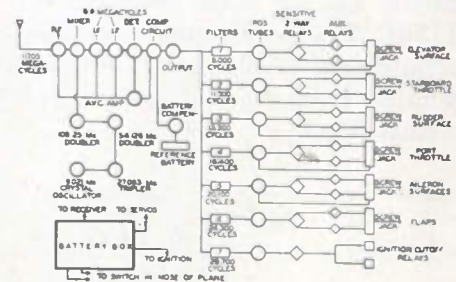

Fig. 1—Functional diagram of airplane installation.

which uses two tones for each control surface, this method uses only one. For example, bidirectional control is accomplished in the case of the elevator surface by having it position to the full-down attitude when the tone is at zero amplitude. Maximum amplitude of the tone positions the elevator to the full-up attitude. Any intermediate attitude can be achieved by the transmission of the corresponding amplitude of the elevator channel tone.

At the ground station a replica of the controls found in a cockpit are provided. Adjustment of the amplitude of a tone is accomplished very simply by mechanically coupling a control lever to a potentiometer wired across

\* Decimal classification: R570.1. Original manuscript received by the Institute, April 29, 1946; revised manuscript received, September 13, 1946.

† Consolidated Vultee Aircraft Corp., San Diego, California.







within the capabilities of the airplanes, which have gross weights ranging from 75 to 175 pounds.

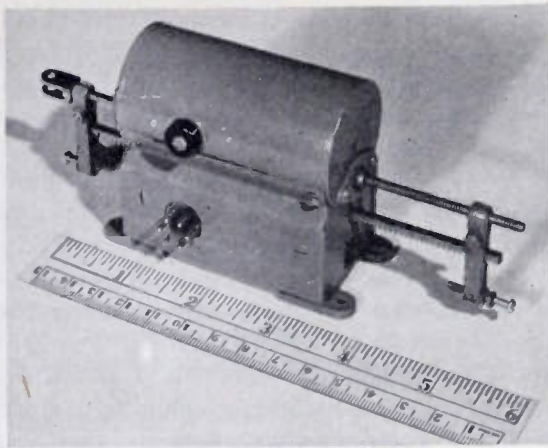

Fig. 5—Electric servomotor used to actuate control surfaces and throttles.

### V. GROUND-STATION EQUIPMENT

A cabinet, rudder pedals, and pilot's seat are mounted on a platform, as shown in Fig. 6. The control and pilot's seat are standard parts, tending to make the pilot feel as much at home as possible. An instrument panel is provided which includes an elapsed-time clock, ignition

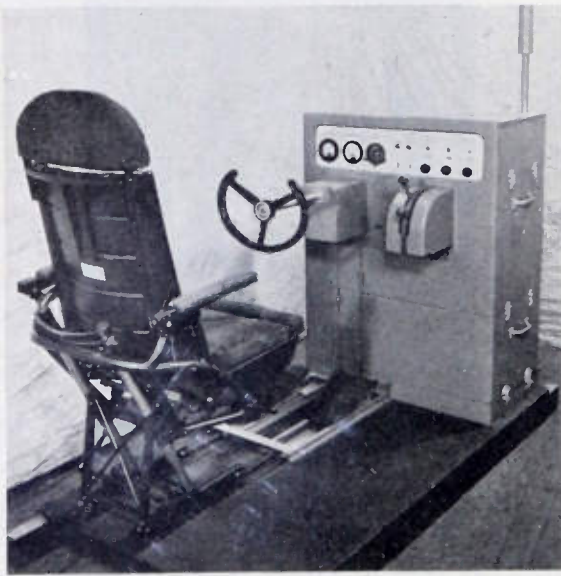

Fig. 6—Ground station.

switch, flap switch, and trimmers. The latter permit compensation for variations in the system which cause control surfaces to be "off center" when the levers are in mid-position.

The seven-channel oscillators are of the transitron type to obtain a high degree of stability and good wave shape. Low-impedance outputs to connect across the potentiometers coupled to the control levers are obtained by winding secondaries on the coils in the tuned circuits. The signals leaving the potentiometers are

combined through resistance networks to limit interaction of one channel upon another to prescribed limits.

Two stages of amplification are needed to raise the combined signal voltages to the level necessary to drive the modulator tubes, which are push-pull 845 tubes in class AB<sub>1</sub>. They are capable of .50 watts output at the plate voltage used.

The modulation transformer is an air-core type with an interlaced pie-wound construction. Its transmission varies less than plus or minus 0.4 decibels over the frequency range of 6000 to 30,000 cycles per second.

Seven frequencies between 116.0 and 118.5 megacycles were assigned to this project. It was considered necessary to be able to change from one to another in the event interference developed. Because of the crystal procurement problem, a resonant concentric transmission line was used. A vernier adjustment on the line allows selection of any of the operating frequencies. The stability is satisfactory for this class of service. Drift during a warm-up cycle approximates 0.02 per cent. Changes in ambient temperature at San Diego are not great, and line adjustments are seldom required to maintain the required plus or minus 0.05 per cent frequency tolerance.

Two buffer stages provide isolation for the oscillator and sufficient power amplification to excite properly the final amplifier. Resistance-loaded band-pass circuits are employed in these buffer amplifiers to reduce the number of tuning controls. The circuits pass the frequencies from 116.0 to 118.5 megacycles without adjustment.

The final amplifier is an 829 tube rated at 63 watts output. This is coupled into a vertical half-wave doublet antenna fed and supported by a concentric line.

### VI. FACTORS AFFECTING ACCURACY OF SYSTEM

The over-all error of plus or minus 4 per cent is a function of the sensitivity of the positioning circuits and

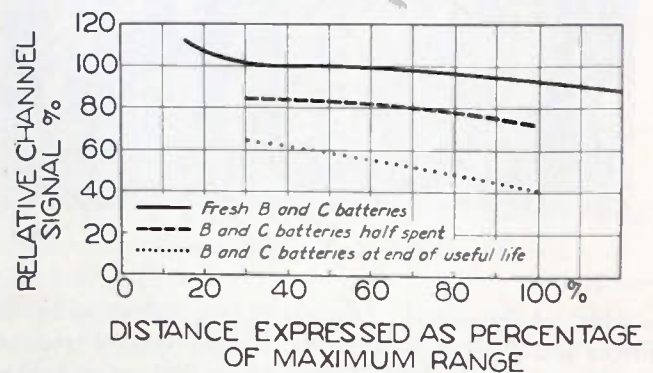

Fig. 7—Effect of distance from ground station upon receiver output for various battery conditions.

the ability of the radio link to transmit correctly the control signals. The major problem in the latter case is illustrated in Fig. 7. The output variation tolerated by the automatic volume control is on the order of 6 decibels. While this is perfectly satisfactory in the case of a



some radio, in this application it would result in a rudder shift from full left to trim position. To reduce this undesired variation, a compensating circuit, shown in Fig. 8, is used. A variable-mu tube is used in the first "audio" stage. A portion of the automatic-volume-control voltage furnishes the bias for this tube and compensates for the normal decrease in receiver output as the signal strength falls off. A comparator tube compares the B voltage to the fixed voltage across an un-

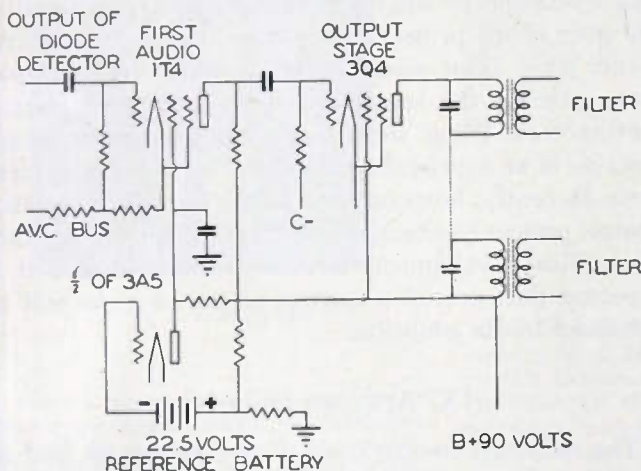

Fig. 8—Schematic diagram of compensating circuit.

loaded battery. This tube regulates the screen voltage on the first "audio" stage and compensates for the normal decrease in receiver output as the battery voltage falls off. The receiver performance is considerably improved, as may be seen by comparing Fig. 9 to Fig. 7.

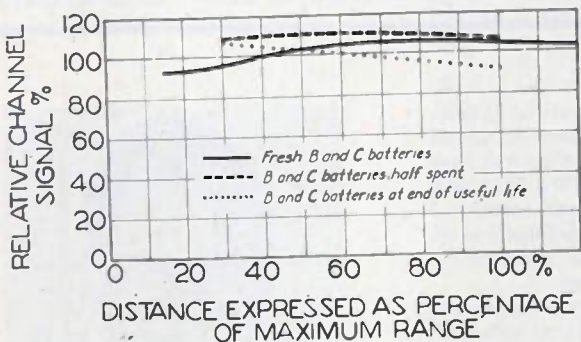

Fig. 9—Variations in receiver output remaining after installation of compensating circuit.

By using batteries which have a useful life that greatly exceeds the duration of a test run, and by arranging the geometry so that the distance from the ground station to the airplane remains essentially constant, the remaining variations do not exceed plus or minus 2.0 per cent.

Minor errors result from insufficient channel isolation in the receiver filter system and nonlinearity. The latter appears in the form of sum and difference beat notes, in the presence of harmonics, and in a change in channel amplitude when the other channels are varied. By conservative design and use of a moderate percentage of modulation, these errors are kept small as compared to the other errors in the system.

The filter selectivity is such that 6 per cent of a signal appears in the adjacent channel as interference. Inasmuch as this interfering voltage adds to the desired signal to give a resultant which is equal to the square root of the sum of the squares, the adjacent channel is vulnerable only when its signal is at a low amplitude. To limit this error, the positioning systems are arranged to be at the limits of their travels when the channel amplitudes are reduced to 10 per cent of full amplitude.

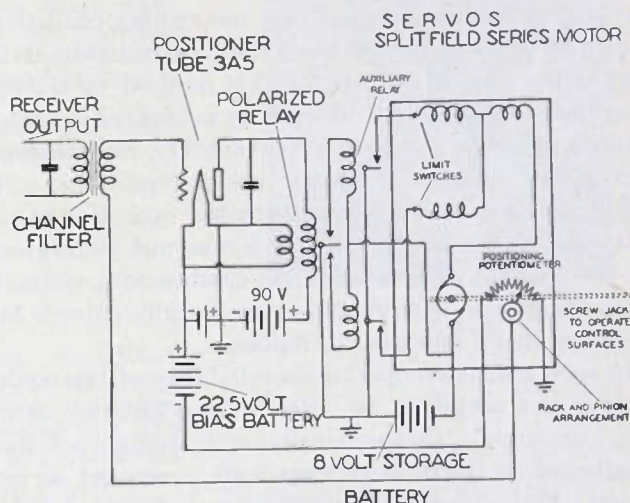

Fig. 10—Schematic diagram of positioning system.

The positioning-circuit performance is largely a function of the sensitivity of the polarized relay shown in Fig. 10. In addition to other modifications to the stock item, an auxiliary winding installed on the relay bucks

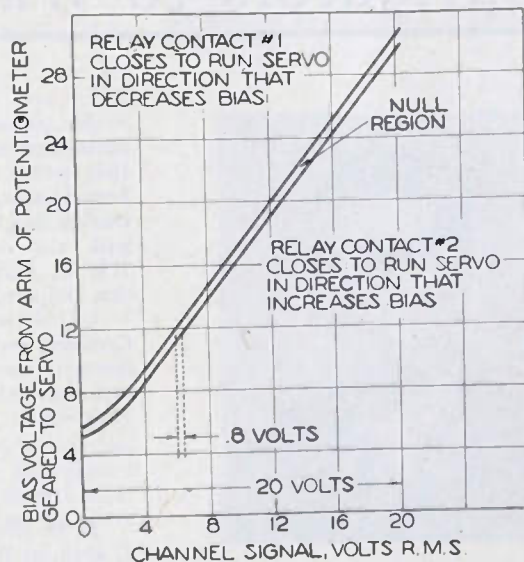

Fig. 11—Performance of positioning system.

the null current of the tube. This positioning tube operates on the lower bend of its plate-current/grid-voltage curve, and responds to a change in signal by a change in plate current. The relay closes, causing the servo to run in the appropriate direction until the bias matches the signal. As can be seen in Fig. 11, the sensitivity is one part in 25, or plus or minus 2 per cent.



### VII. OPERATION OF RADIO-CONTROL SYSTEM

The radio-control system has been in use for nineteen months at the time of writing. During this time nearly 1000 test runs of flying boats have been made, involving three different models fitted with one engine, two engines, and four engines, respectively. Some flights have been made, although emphasis in this particular program is placed upon performance while the flying boat is waterborne. Some crashes have occurred. These were due largely to operating a flying boat under conditions known to be too unstable to accumulate complete data. Herein lies one advantage of this method of testing. Operating a flying boat manned by personnel in such a manner would be dangerous. Fortunately, the construction of the model is such that major repairs can usually be made in a few days. With the exception of the first experimental receiver, which was not waterproof, the receivers have weathered the crashes with virtually no damage. The battery boxes are usually ruined, but these are cheap and easy to replace.

In such extensive operations reliability of the equipment is at a premium. In order to keep lost time down to a minimum, a comprehensive maintenance schedule is adhered to. Fifty trips constitute a normal service period for a receiver. It is of interest to note the number of operations performed during this period. Observation

of the pilot indicates that, on the average, each control lever is reset ten times a minute. During fifty trips of six minutes' average duration this represents 3000 adjustments per channel, or 15,000 operations in the five proportional channels.

### VIII. CONCLUSION

The equipment described above was constructed under the pressure of wartime urgency and was in satisfactory operation in August, 1944, thirteen months after the start of the project. Since that time some improvements have been made in the system; for example, waterproofing the receiver and enclosing the electric servomotors. Some work has been done on a simple receiver of an expendable nature for certain prospective tests. Recently, however, the main effort on this radio-control project has been on the development of an autopilot. This development is nearly complete, and it is expected that precision control of the airplane will be enhanced by its adoption.

### IX. ACKNOWLEDGMENT

The help and co-operation of the personnel, and of C. J. Breitwieser, chief of the Consolidated Vultee Radio and Electrical Laboratories, is gratefully acknowledged.

## Contributors to Waves and Electrons Section



JAY E. BROWDER

Jay E. Browder (A'38-M'44) was born at Wichita, Kansas, on November 24, 1911. He attended Kansas City, Kansas, Junior College from 1930 to 1932, and the University of Kansas from 1933 to 1934.

Mr. Browder was employed by Transcontinental and Western Airlines, Inc. from 1934 to 1939, stationed first at Camden, New Jersey, and later at Kansas City, Missouri. During this later period he was associated with the communication laboratory of T.W.A., working on airborne communication and navigation equipment.

In 1940 he joined the Sperry Gyroscope Company and has been associated with that company since that time working on airborne navigation, communication, and radar equipments.



D. D. King (M'46) was born on August 7, 1919, at Rochester, New York. He received the A.B. degree in engineering sciences from Harvard College in 1942, and the Ph.D. degree in physics from Harvard University in 1946. He was a teaching fellow in physics and communication engineering in 1943, serving as a staff member of the pre-radar Officer's Training School at Cruft Laboratory, Harvard University. During 1945 he was a research associate at Cruft



D. D. KING

Laboratory. At present he is engaged in work on antennas and ultra-high-frequency circuits as a research fellow at Harvard University.

Dr. King is a member of Sigma Xi and the American Physical Society.



# Contributors to Waves and Electrons Section



OSCAR C. LUNDSTROM

Oscar C. Lundstrom (S'42) was born at Morristown, South Dakota, on September 12, 1917. He was graduated from the University of California in 1941 with the B.S. degree in electrical engineering. From 1942 to 1944 he was a graduate student and acting instructor at Stanford University, from which he received the A.M. and E. E. degrees in electrical engineering. Since 1944 Mr. Lundstrom has been employed by the Sperry Gyroscope Company as an assistant project engineer. He is a member of Tau Beta Pi, Eta Kappa Nu, and Sigma Xi.



THEODORE MORENO

Theodore Moreno (S'41-A'44) was born at Palo Alto, California, on September 2, 1920. He received the B.A. degree from Stanford University in 1941, and the M.A. degree in 1942. From 1942 to 1946 he was employed in the research laboratories of the Sperry Gyroscope Company, first as assistant project engineer, and later as project engineer. Since 1946, he has been a research associate at the Massachusetts Institute of Technology.

Mr. Moreno is a member of Phi Beta Kappa, Tau Beta Pi, and Sigma Xi.



V. WELGE

V. Welge (S'33-A'43) was born in Johannesburg, South Africa, in 1912. He received the B.S. degree in electrical engineering from the University of California in 1933. This was supplemented in 1941 by graduate work in electromagnetic waves at the University of California. From 1933 to 1935 he was engaged in designing public-address equipment and broadcast-studio equipment for Rember Radio Co., San Francisco, California. In 1935 he joined the Associated Broadcasters Incorporated, in San Francisco, as transmitter engineer at KSFO. Mr. Welge's duties included the development of radio-relay equipment, and assistance in the design and installation of the directional antennas for KWID, a 100,000-watt short-wave broadcast station installed in 1942.

In 1943 Mr. Welge joined the Radio and Electric Laboratory of Consolidated Vultee Aircraft Corp., San Diego, California, where he has been engaged as a research engineer on the development of radio control and autopilot systems. He holds a pilot's license and he is a member of Phi Beta Kappa, Tau Beta Pi and Sigma Xi.



Victor J. Young was born at Albion, Michigan, on April 11, 1913. He received the A.B. degree from Albion College in 1935, and the Ph.D. in physics from the State University of Iowa in 1940.

Dr. Young was an instructor at New York University from 1940 to 1942, and has



VICTOR J. YOUNG

been employed as an engineer by the Sperry Gyroscope Company since 1942. At the State University of Iowa and at New York University, he did research in nuclear physics and worked with the electronic tools necessary in that field. At the Sperry Gyroscope Company Laboratory, he has taken an active part in the development of radar and microwave communication systems.

He is a member of Sigma Xi and of the American Physical Society. His book "Understanding Microwaves," was published in May, 1946.



# Abstracts and References

Prepared by the National Physical Laboratory, Teddington, England, Published by Arrangement with the Department of Scientific and Industrial Research, England, and *Wireless Engineer*, London, England

NOTE: The Institute of Radio Engineers does not have available copies of the publications mentioned in these pages, nor does it have reprints of the articles abstracted. Correspondence regarding these articles and requests for their procurement should be addressed to the individual publications and not to the I.R.E.

Acoustics and Audio Frequencies.....	532
Aerials and Transmission Lines.....	532
Circuits and Circuit Elements.....	533
General Physics.....	535
Geophysical and Extraterrestrial Phenomena.....	536
Location and Aids to Navigation.....	536
Materials and Subsidiary Techniques.....	537
Mathematics.....	538
Measurements and Test Gear.....	538
Other Applications of Radio and Electronics.....	538
Propagation of Waves.....	539
Reception.....	540
Stations and Communication Systems.....	541
Television and Phototelegraphy.....	542
Transmission.....	543
Vacuum Tubes and Thermionics.....	543
Miscellaneous.....	544

The number in heavy type at the upper left of each Abstract is its Universal Decimal Classification number and is not to be confused with the Decimal Classification used by the United States National Bureau of Standards. The number in heavy type at the top right is the serial number of the Abstract.

Correction: Abstract 38 of February, 1947, should read *Jour. British I.R.E.* instead of *Jour. I.E.E.*

## ACOUSTICS AND AUDIO FREQUENCIES

- 534+621.395.625.3 985  
**Second National Electronics Conference, Chicago, Autumn, 1946**—(*Elec. Eng.*, vol. 65, pp. 569-574; December, 1946.) Abstracts are given of the following papers read at the conference: "A Method for Changing the Frequency of a Complex Wave," by E. L. Kent; "The Reduction of Background Noise in the Reproduction of Music from Records," by H. H. Scott; and "Recent Developments in Magnetic Recording," by R. B. Vaile, Jr. For titles of other papers read, see other sections. For other abstracts see *Elec. Ind.*, vol. 5, pp. 46-47, 111; December, 1946.
- 534.321.9:620.179 986  
**Supersonic Flaw Detector**—J. H. J. (*Electronics*, vol. 19, pp. 198, 202; December, 1946.) 1-megacycle quartz-crystal generator to detect flaws in sheet aluminum alloy.
- 534.321.9.001.8 987  
**Supersonic Vibrations and Their Applications**—E. G. Richardson. (*Jour. Roy. Soc. Arts*, vol. 95, pp. 90-105; January 3, 1947.)
- 534.62 988  
**Realization of Dead Rooms [Chambres Sourdes] for Acoustic Tests**—A. Moles. (*Radio en France*, no. 4, pp. 14-20; 1946.)
- 534.756+621.39 989  
**Theory of Communication**—Gabor. (See 1057.) Part 1, analysis of information; Part 2, analysis of hearing; Part 3, frequency compression and expansion.
- 534.851:621.395.813 990  
**Periodic Variations of Pitch in Sound Reproduction by Phonographs**—U. R. Furst. (PROC. I.R.E. AND WAVES AND ELECTRONS,

The Annual Index to these Abstracts and References, covering those published from January, 1946, through December, 1946, may be obtained for 2s. 8d., postage included, from the *Wireless Engineer*, Dorset House, Stamford St., London S. E., England.

vol. 34, pp. 887-895; November, 1946.) The causes of 'wow' are discussed and an account given of the design and construction of an instrument for its measurement.

534.851:621.395.813 991  
**Dynamic Suppression of Phonograph Record Noise**—H. H. Scott. (*Electronics*, vol. 19, pp. 92-95; December, 1946.) A method of suppression of high- and low-frequency noise by automatic control of the bandwidth of an audio amplifier. Details of performance are given; a description of circuits and equipment will be published later.

534.862.4 992  
**Perfect v. Pleasing Reproduction**—Moir. (See 1185.)

621.395.623.73 993  
**Wide-Range Loudspeaker Developments**—H. F. Olson and J. Preston. (*Jour. Soc. Mot. Pic. Eng.*, vol. 47, pp. 327-352; October, 1946.) The duo-cone loudspeaker, consisting of two coaxial, congruent, separately driven cones appears to possess many advantages over other types. A detailed investigation was carried out to determine the best values of the constants of such a loudspeaker. Methods and results are described.

621.395.623.8 994  
**A Problem in Outdoor Sound**—A. B. Ellis and J. P. Gilmore. (*Electronics*, vol. 19, pp. 126-129; December, 1946.) High-quality amplifying equipment to cover a large open-air stage and audience.

621.395.625.6 995  
**Factors Governing the Frequency Response of a Variable-Area Film Recording Channel**—M. Rettinger and K. Singer. (*Jour. Soc. Mot. Pic. Eng.*, vol. 47, pp. 299-326; October, 1946.)

621.396.615.1 996  
**RC Low-Frequency Generators** (See 1038.)

621.396.615.11 997  
**Low-Frequency Generators**—Aschen. (See 1039.)

621.396.645.029.3 998  
**Amplifier with Very-High Musical Fidelity: Part 9**—Chrétien. (See 1047.)

621.396.645.029.4 999  
**Resistance Amplifiers: Part 1—Low Frequencies**—L. Chrétien. (*Toute la Radio*, vol. 13, pp. 4-7; December, 1946.) A general treatment, with special reference to the amplification of rectangular signals and the correction of phase distortion.

534.861+621.396.712.3 1000  
**Radio Sound Effects [Book Review]**—J. Creamer and W. B. Hoffman. Ziff-Davis Publishing Co., New York, N. Y., 1945, 61

pp., \$1.50. (PROC. I.R.E. AND WAVES AND ELECTRONS, vol. 34, pp. 865-866; November, 1946.) Gives a general background for broadcasting studio work. For another review see 1444 of 1946.

## AERIALS AND TRANSMISSION LINES

621.315.2:621.365.5 1001  
**Low Reactance Flexible Cable for Induction Heating**—M. Zucker. (*Trans. A.I.E.E. (Elec. Eng.)*, December, 1946), vol. 65, pp. 848-852; December, 1946.)

621.315.2.029.5:621.317.333.4 1002  
**New Methods for Locating Cable Faults, Particularly on High-Frequency Cables**—F. F. Roberts. (*Jour. I.E.E. (London)*, part III, vol. 93, pp. 385-395; November, 1946.) Discussion, pp. 395-404.) A theoretical survey is given of the possibilities of frequency modulation and pulse methods of locating cable faults. It is concluded that the pulse method is preferable, and in particular the direct-current pulse rather than the carrier pulse system. An instrument of the direct-current-pulse type is described which gives a location accuracy of faults on coaxial cables within 1 per cent at ranges up to 10 miles.

621.315.2.029.5:621.395 1003  
**High-Frequency Telephone Cables**—A. C. Holmes. (*Jour. I.E.E. (London)*, part I, vol. 93, p. 568; December, 1946.) Construction, attenuation, and current transmission are discussed and the advantages of coaxial cables over wave guides indicated. At the higher frequencies coaxial cables may be limited by the problems of equalization and temperature control, with an upper limit of about 10 megacycles and a maximum of 1000 to 1500 channels. Abstract of Chairman's address to the North Midlands Students' Section of the Institution of Electrical Engineers.

621.392+621.396.67 1004  
**Second National Electronics Conference, Chicago, Autumn, 1946**—(*Elec. Eng.*, vol. 65, pp. 569-574; December, 1946.) Abstracts are given of the following papers read at the conference: "The Theory and Design of Several Types of Wave Selectors," by N. I. Korman; "Aircraft Antenna Pattern Measuring System," by O. Schmitt; "Problems in Wide-Band Antenna Design," by A. G. Kandoian; and "Slot Radiators," by A. Alford. For titles of other papers read, see other sections. For other abstracts see *Elec. Ind.*, vol. 5, pp. 46-47, 111; December, 1946.)

621.392 1005  
**Wave Propagation in Curved Guides**—M. Jouguet. (*Compt. Rend. Acad. Sci. (Paris)*, vol. 222, pp. 537-538; March 4, 1946.) Expressions are derived for the field components on the assumption that the curvature does not exceed a certain value. Phase velocity and at-



attenuation are shown to be independent of the curvature to a first approximation.

- 521.392 1006  
**Reflection of an Electromagnetic Wave by a Disk Located in a Waveguide**—T. Kahan. (*Compt. Rend. Acad. Sci. (Paris)*, vol. 222, pp. 998–1000; April 24, 1946.) It is shown that (1) if a wave guide is terminated by an infinite section of the same cross section, no reflection occurs and therefore no standing waves; (2) if a guide is terminated by a semi-transparent disk, whose impedance is equal to the characteristic impedance of the guide, a system of stationary waves is produced; (3) if the guide is prolonged beyond the disk by an infinite similar guide, stationary waves appear; and (4) if the guide is terminated by a semi-transparent disk with a reflection coefficient of  $1/3$  and whose impedance is equal to the characteristic impedance of the guide, followed by a cavity whose length is an odd number of quarter waves, no reflection occurs. See also 1795 of 1946.
- 621.392:621.396.677 1007  
**A Wide-Band Directional Coupler for Wave Guide**—H. C. Early. (PROC. I.R.E. AND WAVES AND ELECTRONS, vol. 34, pp. 883–886; November, 1946.) This uses a small loop responding to both electric and magnetic fields. With a special section of ridge wave guide, a two-to-one frequency range can be covered with good directional characteristics.
- 621.392.22 1008  
**Propagation of an Electromagnetic Signal along a Heterogeneous Line**—F. Raymond. (*Compt. Rend. Acad. Sci. (Paris)*, vol. 222, pp. 1000–1002; April 24, 1946.) A method has previously been given (2317 of 1945) for solving the equations of propagation by developments in series, introducing the idea of two waves propagated in opposite directions along the bifilar line considered. Application to the case of a discontinuity in the line results in formulas for the reflection and transmission coefficients. Equations are derived, for signals which are any functions whatever of time  $t$  and distance  $x$  expressing the law of signal variation as a function of  $t$  and  $x$ . When the line has no loss, simple results are obtained which exhibit the reflection coefficient at the discontinuity.
- 621.396.67 1009  
**Antennas for Circularly Polarized Waves**—(*Electronics*, vol. 19, p. 214; December, 1946.) Construction and polar diagrams for a transmitting aerial are given; the receiving aerial is briefly described. Orientation of the receiving aerial is less critical for circular than for horizontal or vertical polarization.
- 621.396.67 1010  
**The Wide-Band Dipole**—F. Duerden. (*Elec. Eng.*, vol. 18, pp. 382–384; December, 1946.) The approximate bandwidth of a dipole is derived from a knowledge of the radiation resistance and the characteristic impedance, the latter being calculated from the dimensions. This gives a considerably greater value than can normally be expected since the impedance of the dipole changes with frequency; this causes serious mismatches in the feeding transmission line. Curves are therefore plotted of bandwidth against dipole dimensions for various values of permissible standing-wave ratios.
- 621.396.67.011.2 1011  
**Simplifications in the Consideration of Mutual Effects between Half-Wave Dipoles in Collinear and Parallel Orientations**—K. J. Affanasiev. (PROC. I.R.E. AND WAVES AND ELECTRONS, vol. 34, p. 863; November, 1946.) Fig. 7 of this paper, omitted from 23 of February.
- 621.396.674 1012  
**Radiation from Large Circular Loops**—E. B. Moullin. (*Jour. I.E.E. (London)*, part I, vol. 93, p. 609; December 1946.) Summary of 24 of February.
- 621.396.677 1013  
**Metal-Lens Antennas**—W. E. Kock. (PROC. I.R.E. AND WAVES AND ELECTRONS, vol. 34, pp. 828–836; November, 1946.) A discussion of their properties, methods of construction, and applications. The fundamental principles are given, and the equations of the plate profiles are derived for both plain and stepped lenses. Index of refraction, bandwidth, tolerances, and matching to the feed line must be considered in the design. Methods of construction for centimeter or meter wavelengths and of feeding by directive dipole or wave guide and horn are described. Parabolic reflectors and metal lenses are compared and possible applications of the latter are discussed. Field patterns are given for an experimental 40-wavelength-aperture lens, used with a conical feed horn having an aperture 2 wavelengths in diameter, and also illustrations of several types of lens.
- 621.396.677 1014  
**A Practical Calculator for Directional Antenna Systems**—H. A. Ray, Jr. (PROC. I.R.E. AND WAVES AND ELECTRONS, vol. 34, pp. 898–902; November, 1946.) This easily-constructed device can be used to calculate the ground and sky-wave patterns of two- and three-element arrays. The gain can be found by graphical integration.
- 621.396.677 1015  
**A Generalised Radiation Formula for Horizontal Rhombic Aerials: Part 3**—H. Caferata. (*Marconi Rev.*, vol. 9, pp. 102–108; July–September, 1946.) A formula is developed which is believed to be more inclusive than those previously published and expresses the radiation in any given direction in a spherical co-ordinate system at large distances from the source. The source considered is that of a multiple array of horizontal rhombic elements arranged  $n$  in cascade, with  $m$  cascades in parallel, and all contained in the same horizontal plane. The formula takes into account arbitrary phase relations between elements and between cascades and also includes the effect of attenuation along the conductors comprising the radiating system. Parts 1 and 2 of this article (1456 and 3188 of 1946) dealt with the development of the general formula for imperfectly conducting, and perfectly conducting earth. The list of symbols used in this development was presented in part 2 immediately adjacent to the general formulas in order to make reference as easy as possible. Part 3, now presented, deals with the derivation of formulas for particular cases representing the application of the general formula to radiation in the principal vertical and horizontal planes through the origin and principal axis of the system.

#### CIRCUITS AND CIRCUIT ELEMENTS

- 621-526 1016  
**Application of Circuit Theory to the Design of Servomechanisms**—A. C. Hall. (*Jour. Frank. Inst.*, vol. 242, pp. 279–307; October, 1946.) Laplace transform theory is applied to determine the response characteristics of servomechanisms, and a method is given for the determination of the sensitivity. Comparison is made with the feedback amplifier. Steady-state performance and dynamical characteristics of servomechanisms are discussed, and design methods given for lag-compensated networks and for circuits giving minimum steady-state errors.
- 621.315.2.011.3 1017  
**The Inductance of Wires and Tubes**—A. H. M. Arnold. (*Jour. I.E.E. (London)*, part II, vol. 93, pp. 532–540; December, 1946.) Maxwell's equations are used to develop formulas for the inductance of a single-phase system of wires or tubes arranged side by side or concentrically. Various functions required for numerical calculation are tabulated.
- 621.316.86:546.281.26 1018  
**Silicon Carbide Non-Ohmic Resistors**—Ashworth, Needham, and Sillars. (See 1115.)
- 621.316.86.023 1019  
**High Value Deposited Resistances at High Frequency**—A. Klemt. (*Arch. Tech. Messen.*, no. 112, pp. T117–118; October, 1940.) Cylindrical or helical deposits of carbon on a ceramic base provide resistances of low temperature coefficient and small phase angle. The skin effect is negligible since the thickness of the layer is usually less than 0.1 millimeters which is the penetration depth in carbon at 1000 megacycles. The influence of internal capacitances and their loss on the apparent high-frequency resistance is analyzed and the possibility of compensation is discussed.
- 621.319.4:533.5 1020  
**Vacuum Condensers**—H. A. H. Griffiths. (*Wireless World*, vol. 53, pp. 23–24; January, 1947.) Capacitors with large diameter glass to metal seals and of rigid cylindrical construction are described. They are much smaller in size than any other type of capacitor of equivalent rating and have low power factor and temperature coefficient of capacitance.
- 621.392.4 1021  
**Wideband Phase Shift Networks**—R. B. Dome. (*Electronics*, vol. 19, pp. 112–115; December, 1946.) Wide-band characteristics are achieved by the use of two networks, each variable with frequency but having a constant phase difference. Design calculations are indicated for a pair of resistance-capacitance networks which are preferable to inductance capacitance. Such networks are used for single side-band telephony, for increasing transmitter efficiency, for carrier-frequency adjustment, and for frequency shift keying.
- 621.392.5:621.396.96 1022  
**Precision Resistance Networks for [Fire-Control] Computer Circuits**—E. C. Hagemann. (*Bell Lab. Rec.*, vol. 24, pp. 445–449; December, 1946.) Design and development are considered in terms of the accuracy required for use under widely varying wartime conditions.
- 621.392.52 1023  
**Rational Calculation of Ladder-Type Filters**—P. Coulombe. (*Bull. Soc. Franç. Elec.*, vol. 6, pp. 103–110; March, 1946.) The problem of the attenuation due to any cell in a filter can be standardized by writing it in the form  $\Sigma \log [(\mu+x)/(\mu-x)]$ , where  $x$  is a function of the frequency and  $\mu$  a parameter characterizing the filter. Methods are developed, based on Tchebycheff's theory, for determining the values of  $\mu$  giving the most economical filter for assigned attenuation in one or two bands.
- 621.392.52 1024  
**Filters and Filter Problems**—F. Locher. (*Tech. Mitt. Schweiz. Telegr.-Teleph. Verw.*, vol. 24, pp. 194–203; October 1, 1946.) A review of present day practice in the audio-frequency and high-frequency ranges (to about 300 kilocycles). Damping and loss effects are discussed and examples given of crystal filters, some using quartz and others ammonium phosphate, and of electromagnetic narrow-band audio-frequency filters.
- 621.394/.397].645 1025  
**The Cathode Follower Driven by a Rectangular Voltage Wave**—M. S. McIlroy. (PROC. I.R.E. AND WAVES AND ELECTRONS, vol. 34,



pp. 848-851; November, 1946.) When a voltage wave is transmitted from a high-impedance source to a low-impedance load through resistance-capacitance coupling and a cathode follower, the position of the grid-return tap on the cathode resistor determines whether the output voltage is linearly related to the input or is affected by cut-off or over-driving. Four operating conditions are discussed, determined by the presence or absence of grid current and of plate current.

621.396.196 1026

Second National Electronics Conference, Chicago, Autumn, 1946—(*Elec. Eng.*, vol. 65, pp. 569-574; December, 1946.) Abstracts are given of the following papers read at the conference: "The Mechanical Transients Analyzer," by G. D. McCann; "An Oscillographic Method of Presenting Impedances on the Reflection Coefficient Plane," by A. L. Samuel; "A Permeability-Tuned 100-Mc Amplifier of Specialized Coil Design," by Z. Benin; "Very-High-Frequency Tuner Design," by G. Wallin and C. W. Dymond; "Frequency Modulation of High-Frequency Power Oscillators," by W. R. Rambo; "Design of Wide-Range Coaxial Cavity Oscillators using Reflex Klystron Tubes," by J. W. Kearney; and "Reflex Oscillators for Radar Systems," by J. O. McNalley and W. G. Shepherd. For titles of other papers read, see other sections. For other abstracts see *Elec. Ind.*, vol. 5, pp. 46-47, 111; December, 1946.

621.396.6.029.6 1027

The Interstage Auto-Transformer at Television Frequencies—P. Feldmann. (*Electronic Eng.*, vol. 19, pp. 21-22; January, 1947.) Formulas are derived for the evaluation of the stage gain of an auto-transformer coupled system and of the bandwidth of the response curve.

621.396.611:518.61 1028

Calculation of the Electromagnetic Field, Frequency and Circuit Parameters of High-Frequency Resonator Cavities—H. Motz. (*Jour. I.E.E. (London)*, part I, vol. 93, pp. 610-611; December, 1946.) Summary of 52 of February.

621.396.611.015.33 1029

The Transient Response of a Tuned Circuit—D. G. Tucker. (*Electronic Eng.*, vol. 18, pp. 379-381; December, 1946.) The circuit considered consists of a combination of inductance, capacitance, and resistance in parallel to which a constant current source is applied. The general differential equation

$$e/R + (1/L) \int e \, dt + C \, de/dt + B = i$$

is solved for (a) a direct-current applied signal, (b) an alternating-current applied signal. Oscillograms are given to illustrate the waveform of the solutions.

621.396.611.1 1030

The Relay Oscillator and Related Devices—R. L. Ives. (*Jour. Frank. Inst.*, vol. 242, pp. 243-277; October, 1946.) Relay oscillators can be made to cover the frequency range 100 cycles per second to 10 cycles per hour. A simple theoretical discussion is given of such oscillators and various related circuits. Many practical examples of their application to switching, sequence of operation devices, etc., are outlined.

621.396.611.1:621.385.38 1031

Multiple Thyatron Circuits—I. Sager. (*Electronics*, vol. 19, pp. 158, 178; December, 1946.) It is shown that the power capabilities of thyatrons can be improved by series, series-shunt, and shunt operation. A combination circuit is described which can produce powers up to 100 megawatts at 30 kilovolts.

621.396.611.1.015.33 1032

Effect of a Differentiating Circuit on a

Sloping-Wave Front—L. S. Schwartz. (*PROC. I.R.E. AND WAVES AND ELECTRONS*, vol. 34, p. 862; November, 1946.) Mathematical analysis showing the importance of specifying as steep a wave front as possible for a trigger pulse used to actuate a timing circuit after passing through differentiators.

621.396.611.4 1033

Methods of Driving a High Q Cavity with Many Self-Excited Oscillators—J. R. Woodyard, E. A. Martinelli, W. Toulis, and W. K. H. Panofsky. (*Phys. Rev.*, vol. 70, p. 447; September 1-15, 1946.) Discussion of the problem of driving a long cavity, to be used as a linear accelerator, in the lowest longitudinal mode by a large number of oscillators. Summary of American Physical Society paper.

621.396.611.4 1034

Apertures in Cavities—J. H. O. Harries. (*Electronics*, vol. 19, pp. 132-135; December, 1946.) The loading, internal-field distortion, energy transfer, and leakage loss vary with the size and position of slots or apertures in resonators. The variation of these factors with slot dimensions was measured for cylindrical and rectangular resonators at wavelength of 80 centimeters.

621.396.611.4:621.317.32 1035

Measurement of Electric Field Strength in a Cavity Resonant at 200 Mc/s—Panofsky. (*See 1131*.)

621.396.611.4.012.8 1036

Application of the Dynamical Theory of Currents to Cavity Resonators—A. Banos, Jr. (*Phys. Rev.*, vol. 70, p. 448. September 1-15, 1946.) The equivalent circuit of a cavity is derived from the Lagrangian equations with perturbations to include the effects of wall losses and of the external circuit. Summary of American Physical Society paper.

621.396.615 1037

Locking Phenomena in Oscillators—Z. Jelonek. (*PROC. I.R.E. AND WAVES AND ELECTRONS*, vol. 34, 863; November, 1946.) Letter describing results given in a Polish paper published in 1938. The method of analysis is compared with that of Adler (2522 of 1946).

621.396.615.1 1038

RC Low-Frequency Generators—(*Toute la Radio*, vol. 13, pp. 8-12; December, 1946.) Gives two circuits, one with continuously variable frequency and the other with a certain number or fixed frequencies.

621.396.615.11 1039

Low-Frequency Generators—R. Aschen. (*Radio en France*, no. 2, pp. 3-12; 1946.) Describes, with full circuit details, the Ferisol beat-frequency oscillator and discusses, with numerous diagrams, modern resistance-capacitance oscillators.

621.396.615.17:621.317.755 1040

Linear Sweep Circuits—R. P. Owen. (*Electronics*, vol. 19, pp. 136, 138; December, 1946.) Eight methods for the improvement of the linearity of saw-tooth generators are analyzed, with typical basic circuits for a 60-cycle sweep as examples.

621.396.621 1041

Selectivity by Counter-Retroaction—X. de Maistre. (*Radio en France*, no. 3, pp. 29-32; 1946.) A variable-selectivity circuit, controlled manually or responding automatically to signal intensity variation.

621.396.64:621.318 1042

Magnetic Amplifiers—L. Schoerer. (*Radio en France*, no. 4, pp. 24-30; 1946.) A static alternating-current system, based on magnetic saturation effects.

621.396.645 1043

Direct-Coupled R.F. Amplifier—E. Travis. (*Electronics*, vol. 19, pp. 154, 158; December, 1946.) For amplification of signal-generator output in bridge methods of aerial resistance measurement. A circuit diagram is given and advantages are indicated.

621.396.645 1044

Load Conditions in Class-A Triode Amplifiers—H. G. Foster. (*Electronic Eng.*, vol. 19, pp. 11-16; January, 1947.) Analysis of the ideal triode shows that there is no optimum value of the load resistance, but that the power increases with increase of load resistance and in the limit is equal to half the maximum safe anode dissipation of the tube, the anode efficiency approaching 50 per cent under Class-A conditions. Methods are given for selecting the load resistance and supply voltage for particular tubes. With equal supply voltages, the effective anode-to-anode load for two triodes in push-pull is about 50 per cent greater than the corresponding load resistance for a single triode and the power output is about 2½ times that of the single triode.

621.396.645 1045

Wide-Band Amplifiers—(*Wireless World*, vol. 53, pp. 25-26; January, 1947.) Design data for 3- and 4-stage amplifiers with stagger tuning.

621.396.645:621.396.822 1046

Background Noise in Amplifiers—Zelbststein. (*See 1200*.)

621.396.645.029.3 1047

Amplifier with Very High Musical Fidelity: Part 9—L. Chrétien. (*T.S.F. Pour Tous*, vol. 22, pp. 176-179; September, 1946.) One of a series of eleven articles in *T.S.F. Pour Tous*, vol. 22, 1946. This part describes the complete apparatus and gives a detailed diagram; it also recapitulates the previous articles. Parts 10 and 11 deal with assembly and testing.

621.396.645.35 1048

D. C. Amplifiers—B. E. Noltingk and R. A. Lampitt. (*Electronic Eng.*, vol. 18, p. 389; December, 1946.) Correspondence on 679 of March.

621.396.645.35 1049

Electrometer Input Circuits—H. A. Thomas. (*Electronics*, vol. 19, pp. 130-131; December, 1946.) It is shown theoretically that the use of negative feedback will reduce the time constant of the direct-current amplifier. A typical circuit is described and details of its performance given.

621.396.622:621.396.62 1050

The Design of Band-Spread Tuned Circuits for Broadcast Receivers—Hughes. (*See 1195*.)

621.396.662.2:621.396.615.17 1051

Non-Linear Coils for [Radar] Pulse Generators—H. A. Stone, Jr. (*Bell Lab. Rec.*, vol. 24, pp. 450-453; December, 1946.) The design and operation of these coils are fully explained. Magnetron voltage of about 25 kilovolts can be obtained from a 6-kilovolt rectifier. The peak power of the pulse can reach 1 megawatt.

621.396.69 1052

Components—M. Chauvierre. (*Radio en France*, no. 1, pp. 9-18; 1946.) Review of an exhibition of components including transformers, tuning units, fixed and variable capacitors, coils and coil formers, resistors, multiplugs and sockets, switches, etc.

621.396.694.001.8:621.385.5 1053

New Uses for Pentagrids—A. H. Taylor. (*Electronics*, vol. 19, pp. 142, 154; December, 1946.) A pentagrid can be used as a phase inverter and a high-stability single-coil oscillator, to supply alternate positive and negative syn-



chronization to a cathode-ray oscilloscope, or to act as a variable frequency oscillator for a transmitter.

621.3.01 1054  
**Circuit Analysis by Laboratory Methods [Book Review]**—C. E. Skroder and M. S. Helm. Prentice-Hall, New York, N. Y. 1946, 282 pp., \$5.35. (PROC. I.R.E. AND WAVES AND ELECTRONS, vol. 34, p. 865; November, 1946.) Gives theory and general laboratory material for the study of direct-current and alternating-current circuits and "is apparently intended for junior electrical engineering students."

621.3.011.3:518.2 1055  
**Inductance Calculations. [Book Review]**—F. W. Grover. D. Van Nostrand Co., Inc., New York, N. Y. 1946, 286 pp. \$5.75. (PROC. I.R.E. AND WAVES AND ELECTRONS, vol. 34, p. 865; November, 1946.) A collection of formulas and tables for the calculation of mutual and self-inductance at low frequencies. Magnetic forces between coils are also treated and data provided for determining inductance changes as the frequency is increased.

621.396.621 1056  
**Most-Often-Needed 1946 Radio Diagrams [Book Review]**—M. N. Beitman. Supreme Publications, Chicago, Ill., 1946, 192 pp., \$2.00. (PROC. I.R.E. AND WAVES AND ELECTRONS, vol. 34, p. 865; November, 1946.) An assembly of the available wiring diagrams and service information on radio-receiver models produced by approximately 40 manufacturers during the early part of 1946.

#### GENERAL PHYSICS

534.756+621.39 1057  
**Theory of Communication**—D. Gabor. (*Jour. I.E.E. (London)*, part III, vol. 93, pp. 429-457; November, 1946.) Part 1 describes a new method of analysis of signals in which there is symmetry between time and frequency, manifested in the Fourier transform relationships between the time function of the signal and its frequency spectrum. The accuracy with which the time  $t$  and frequency  $f$  can be simultaneously specified is limited by an uncertainty relation  $\Delta t \Delta f \geq \frac{1}{2}$ , which is closely linked to Heisenberg's principle of indeterminacy, and is derived by consideration of the 'effective duration' and 'effective frequency width' of the signal. This inequality defines a minimum area in the two dimensional 'information diagram' in which signals may be represented with time and frequency as co-ordinates. It is shown that the elementary signal which occupies this minimum area is the modulation product of a harmonic oscillation of any frequency with a pulse of the form of a probability function. Any signal can be expanded into elementary signals so that their representative areas cover the whole time-frequency area, and each elemental area, or logon, represents one quantum of information. The use of the information diagram is illustrated by two examples, a simple frequency-modulated signal, and time division multiplex telephony. The signal which can be transmitted in the shortest time through a channel, within a specified frequency band, is shown to have a sinusoidal frequency spectrum, and its effective duration and frequency width are found.

In part 2, an analysis of hearing sensations is made, the experimental results of various observers being considered in the light of the methods of part 1. It is deduced that in the frequency range 60 to 1000 cycles the human ear can discriminate nearly every second datum of information, but over the whole auditory range the efficiency is much lower since the discrimination falls off sharply at higher frequencies. Similar results obtained with signals of widely differing durations indicate that the threshold information sensitivity of the ear is

independent of the duration from 20 to 250 milliseconds, which means that the time constant of the ear appears to be adjustable over this range. To explain this it is necessary to postulate a new mechanism in the process of hearing, the nature of which is uncertain, but it is suggested that a new effect in nerve conduction may be responsible.

In part 3 the possibility is considered of transmitting audio signals in comparatively narrow wave bands by means of frequency compression in transmission and re-expansion on reception. A 'kinematical' method of doing this is described and analyzed theoretically, in which a record is scanned by a succession of moving slits in front of a 'window' of continuously graded transparency, behind which is a photocell. In order to simplify the analysis, the transparency variation is taken as following a probability law, though it is shown later that under optimum conditions a triangular or trapezoidal variation would produce less noise. For a sinusoidal 'input' the reproduced signal collected by the photocell is shown to have a line spectrum consisting of all combinations of the original frequency with the split repetition frequency. The action of the converter is shown graphically and the optimum operating conditions deduced. The full cycle of compression and re-expansion is considered and the result shown diagrammatically. It is found that the reproduction improves with increase in frequency, while the distortion occurring does so almost entirely in the expansion process.

An experimental test of the above mechanical system confirms the theoretical deductions. It is found that speech can be compressed into a frequency band as narrow as 500 cycles and still remain intelligible. Alternative kinematical methods of frequency condensation for transmission are described, of which the most convenient uses magnetic tape recorders.

In contrast, electrical methods of condensation are discussed, in which a nonsinusoidal carrier is used. The case in which a sinusoidal signal is modulated with repeated probability pulses is analyzed: compression only and not expansion is possible by this method. The original signal may however be restored in the receivers by a second modulation of the same type, and it is found that distortion similar to that in the kinematical case is again produced.

535.14 1058  
**Photophysics**—M. Boll. (*Télévis. franç.*, no. 17, Supplement *Électronique*, pp. 1-2, 5; September, 1946.) A brief résumé of modern theory.

537+538 1059  
**Second National Electronics Conference, Chicago, Autumn, 1946**—(*Elec. Eng.*, vol. 65, pp. 569-574; December, 1946.) Abstracts are given for the following papers read at the conference: "Bunching Conditions for Electron Beams with Space Charge," by L. Brillouin; and "Generalized Boundary Condition in Electromagnetic Problems," by S. A. Schelkunoff. For titles of other papers read, see other sections. For other abstracts see *Elec. Ind.*, vol. 5, pp. 46-47; 111; December, 1946.

537.523.4 1060  
**Physical Mechanism of the Spark**—S. Teszner. (*Bull. Soc. Franç. Élec.*, vol. 6, pp. 61-80; February, 1946.) Consideration of the initial stage phenomena of spark discharges shows that the theories of Townsend, Rogowski, and Loeb and Meek are not completely satisfactory, especially when the ignition is ultrarapid. For this case an explanation is given, based on an extremely rapid passage of electrons, combined with the development of the first avalanche. A theory is also presented for the effects observed in the established regime of high-frequency sparks.

537.525:538.551.25 1061  
**Excitation of Plasma Oscillations**—D. Bohm. (*Phys. Rev.*, vol. 70, p. 448; September 1-15, 1946.) Two cases are considered: (a) a beam of fast electrons injected from the cathode into the plasma, and (b) plasma containing high speed electrons moving at random. The energy of the resulting oscillations is deduced. Summary of American Physical Society paper.

537.291:621.396.615.14 1062  
**Induction Currents Produced by Moving Electrons**—Colino. (*See* 1269).

537.311.2 1063  
**What is Ohm's Law?**—G. W. Stubbings. (*Elect. Rev. (London)*, vol. 140, pp. 225-226; January 31, 1947.) A survey of a representative sample of scientific books reveals two views of the nature of Ohm's law: (a) that it is virtually the assignment of a name to the  $E/I$  ratio, and (b) that for certain materials the ratio  $E/I$  is constant and independent of  $I$ , provided all other conditions of the electric circuit remain constant.

537.533.7:538.245 1064  
**Forces on Ferromagnets Through Which Electrons are Moving**—D. L. Webster. (*Phys. Rev.*, vol. 70, pp. 446-447; September 1-15, 1946.) Summary of American Physical Society paper.

538.3 1065  
**Discovery and Title of the Elementary Law of Electromagnetism**—L. Bouthillon. (*Bull. Soc. Franç. Élec.*, vol. 5, pp. 352-363; November, 1945.) A comprehensive historical review shows that the formula  $dH = idl (\sin \omega)/r^2$  is due primarily to Biot, Laplace contributing to a much less extent. It is recommended that it should be known as the law of Biot and Laplace.

538.32:621.385.832 1066  
**An Analysis of Electromagnetic Forces**—W. A. Tripp. (*Elec. Eng.*, vol. 65, pp. 596-598; December, 1946.) Reply to criticism by A. Gronner (3253 of 1946) of an article by Tripp (587 of 1946). It is shown that the return to pre-Maxwell theory is necessary and that Gronner's relativity-cum-orthodoxy argument leads to an absurdity.

539.1 1067  
**The Nucleus of Atoms (Protons, Neutrons, Mesons)**—L. Leprince-Ringuet. (*Bull. Soc. Franç. Élec.*, vol. 6, pp. 43-55; February, 1946.)

539.22 1068  
**Relaxation Phenomena in Anisotropic Liquids in a Rotating Electrical Field**—V. N. Tsvetkoff. (*Bull. Acad. Sci. (U.R.S.S.)*, sér. phys., vol. 5, no. 1, pp. 57-67; 1941. In Russian, with English summary.) An investigation of the properties of anisotropic liquids composed of long chain molecules in a rotating electric field. It is found that the relaxation time in such liquids depends upon two factors, the time of polarization of a molecular group and the time of its revolution in the field. If the first of these factors is of the order of  $10^{-10}$  seconds (as is usual in polar liquids), then the second factor is a few tenths of a second for magnetic fields of several thousand gauss, or for electric fields of several centimeter-gram-second units.

621.31 1069  
**On the Theory of Electric Contacts between Metallic Bodies**—J. Frenkel. (*Zh. Eksp. Teor. Fiz.*, vol. 16, no. 4, pp. 316-325; 1946. In Russian.) An electric contact between two metals is treated as a gap which the electrons cross by the mechanism of thermionic emission. The effect of image forces is to reduce the potential difference between the two metals by an amount inversely proportional to the width of the gap. This explains why the electrical conductivity of fine metallic powders and



thin layers increases with temperature according to a law similar to that for semiconductors. For full English translation see *Jour. Phys.*, (U.S.S.R.) vol. 9, no. 6, pp. 489-495; 1945.)

621.396.615.142 1070  
Elementary Treatment of Longitudinal Debunching in a Velocity Modulation System—Feenberg. (See 1272.)

531.19 1071  
Statistical Thermodynamics [Book Review]—E. Schrödinger. Cambridge University Press, Macmillan, New York, N. Y., 1946, 86 pp., \$1.50. (*Amer. Jour. Sci.*, vol. 245, p. 59; January, 1947.) An inquiry confined to macroscopic systems. The points of view of Boltzmann, Gibbs, and Fowler are united "into one homogeneous aspect by combining the Gibbsian ensemble with the Darwin-Fowler mathematical tools."

539 1072  
Nucleonics [Book Review]—Progress Press, Washington, D. C. 38 pp., \$1.00 (*Nature* (London), vol. 158, p. 731; November 23, 1946.)

#### GEOPHYSICAL AND EXTRATERRESTRIAL PHENOMENA

523.16:621.396.822.029.62 1073  
Variation of Cosmic Radiation with Frequency—L. A. Moxon. (*Nature* (London), vol. 158, pp. 758-759; November 23, 1946.) Results are given of measurements at 40, 90, and 200 megacycles in Britain and in other latitudes, using directional aeriels. A diagram shows the increase of aerial noise temperature from the equatorial plane of the galaxy as a function of galactic longitude from 0 to 360 degrees. At 350 degrees longitude noise level is found to vary approximately as  $f^{-2}$ , while the minimum noise level varies approximately as  $f^{-2}$ , where  $f$  is the frequency.

523.72:621.396.822.029.62/.63 1074  
Origin of Radio-Waves from the Sun and the Stars—M. N. Saha. (*Nature* (London), vol. 158, pp. 717-718; November 16, 1946.) The emission of radio waves may be the result of nuclear transitions caused by the presence of a strong magnetic field. For the sodium atom two types of transition are possible; one gives rise to meter waves for fields of a few hundred gauss, while the other gives rise to centimeter waves for fields of the order of  $10^4$  gauss. Similar results hold for hydrogen and various hydrides occurring in solar and stellar atmospheres. The magnetic fields in sunspots are of the right order of magnitude to produce such transitions, if the assumption of a small additional cross field is made. This theory appears to explain the observed effects on meter wavelengths at times of sunspot activity, and suggests that there may also be emission of the centimeter range. The emission of centimeter waves from the Milky Way may indicate the development of spots in some of its stars, which would probably be too small for spectroscopic observation. See also 404 and 402 of March and back references.

539.16.08:537.591 1075  
Cloud Chamber for Airborne Cosmic-Ray Observations—W. E. Hazen. (*Phys. Rev.*, vol. 70, p. 445; September 1-15, 1946.) Summary of American Physical Society paper.

550.389 1076  
North Magnetic Pole Believed Moved 200 Miles—(*Sci. News Letter*, Wash. vol. 50, p. 280; November 2, 1946.) Recent observations indicate that the north pole is now at least 200 miles north and slightly east of its former position in Boothia peninsula.

551.510.535:523.746 1077  
The Current Sunspot Trend—H. T. Stetson. (*Sci. Mon.*, vol. 63, pp. 399-402; November, 1946.) Description of the correlation between

E-layer electron density and mean sunspot number. The next sunspot maximum should occur during the early part of 1948.

551.515.827:621.396.812 1078  
Reflection of Radio Waves from Tropospheric Layers—Smyth and Trolese. (See 1180.)

551.556.3 1079  
Wind Energy: Its Value and the Search for [Installation] Sites—P. Ailleret. (*Rev. Gén. Élec.*, vol. 55, pp. 103-108; March, 1946.)

551.578.1:621.396.812 1080  
Attenuation of 1.24-Centimeter Radiation through Rain—Anderson, Freres, Day, and Stokes. (See 1181.)

551.594.11 1081  
The Definition and Theory of the Potential Acquired by a Conductor in Atmospheric Electricity—R. Lecolazet. (*Compt. Rend. Acad. Sci.* (Paris), vol. 222, pp. 331-332; February 4, 1946.) A precise definition of the potential acquired by a conductor in the earth's electric field is used to develop an approximate theory of arrangements for measurement of the field.

551.594.13:621.317.723 1082  
Measurement of the Electric Conductivity of the Air by a Tetrode Electrometer—Lacaze. (See 1140.)

551.5(02) 1083  
Meteorology with Marine Applications [Book Review]—W. L. Donn. McGraw-Hill Book Co., New York, N. Y. 1946, 465 pp., \$4.50. (*Amer. Jour. Sci.*, vol. 244, pp. 813-815; November, 1946.)

551.5(023) 1084  
Handbook of Meteorology [Book Review]—E. A. Berry, Jr., E. Bolla, and N. R. Beers (Editors). McGraw-Hill Book Co., New York, N. Y. 1946, 1068 pp., \$7.50. (*Amer. Jour. Sci.*, vol. 244, pp. 813-815; November, 1946.)

#### LOCATION AND AIDS TO NAVIGATION

621.396.9.001.8 1085  
Guided Missiles in World War II—Selvidge. (See 1171.)

621.396.93 1086  
Frequency, Power, and Modulation for a Long-Range Radio Navigation System—P. R. Adams and R. I. Colin. (*Elec. Commun.*, vol. 23, pp. 144-158; June, 1946.) Ground stations must have a minimum range of 1500 miles. All aircraft within range must receive useful signals irrespective of climatic or propagation conditions. These assumptions restrict the frequency to below 300 kilocycles or between 2 and 30 megacycles. The transmission characteristics, signal-to-noise ratios, and aerial efficiency for the two bands are discussed and it is concluded that for maximum reliability and most economical working, the frequency should be about 70 kilocycles and the aerial power 10 to 100 kilowatts depending on static level and assuming a receiver bandwidth of 10 to 20 cycles. There is a comprehensive bibliography.

621.396.931/.933:22.029.62 1087  
Ultra-High-Frequency Radiosonde Direction Finding—L. C. L. Yuan. (*PROC. I.R.E. AND WAVES AND ELECTRONS*, vol. 34, pp. 852-857; November, 1946.) Description of a single direction-finder for measuring azimuth to within  $\frac{1}{2}$  degree and elevation to within  $\frac{1}{2}$  degree at 183 megacycles for a fixed transmitter; these errors are somewhat increased for a moving balloon transmitter. Measurements using Adcock and single dipole aeriels are described. Various types of reflector systems for shielding a dipole aerial from ground-reflected waves were tested; the corner reflector type of shield

with a simple half-wave dipole was found to be the most effective. See also 732 of April.

621.396.932 1088  
Electronics on World's Largest Liner—(See 1222.)

621.396.933 1089  
Second National Electronics Conference, Chicago, Autumn, 1946—(*Elec. Eng.*, vol. 65, pp. 569-574; December, 1946.) Abstracts are given of the following papers read at the conference: "Improvements in 75-Megacycle Aircraft Marker Systems," by B. Montgomery, "Automatic Radio Flight Control," by F. L. Moseley and C. B. Watts, "Naviglobe—Long Range Air Navigation System," by P. R. Adams and R. I. Colin; and "Teloran—Air Navigation and Traffic Control by means of Television and Radar," by D. H. Ewing and R. W. K. Smith. For titles of other papers read, see other sections. For other abstracts see *Elec. Ind.*, vol. 5, pp. 46-47, 111; December, 1946.)

621.396.933 1090  
New Radio Beacon Methods—E. Aisberg. (*Toute la Radio*, vol. 13, pp. 274-277; November, 1946.) A short historical survey, with discussion of the basic principles and operation of the loran system.

621.396.933 1091  
The Block System for Airway Control—(*Elec. Ind.*, vol. 5, pp. 54-56; December, 1946.) A method based upon railway block-signaling practice, using pulse technique for signaling codes and ensuring automatic safety on air routes.

621.396.933 1092  
[Long and Short Range] Aerial Navigation [Including Instrument and Automatic Landing] and Traffic Control with Navaglobe, Navar, Navaglide, and Navascreen—H. Busignies, P. R. Adams, and R. I. Colin. (*Elec. Commun.*, vol. 23, pp. 113-143; June, 1946.) Co-ordinated proposals for the step-by-step provision of these facilities over a period of years, using the minimum amount of aircraft equipment.

About 75 navaglobe transmitters on about 100 kilocycles provide equipped aircraft with fixes anywhere in the world. Each aircraft compares the amplitudes of three figure-of-eight diagrams to obtain a bearing, and two such bearings give a fix; an independent check is given by normal loop direction finding.

Navar is basically a 3000-megacycle ground surveillance radar at each airport and provides (a) normal plan position indicator, (b) plan position indicator on all aircraft carrying responders, or only on those at a selected height, (c) as (b), but on aircraft intending to land. Video signals from (b) are rebroadcast for display with a ground wind vector on the aircraft plan position indicator. Aircraft height can be measured, identification announced by means of coded responders, and prearranged orders automatically displayed to the pilot of any selected aircraft. The rotating beam of the ground radar and a timing signal provide the pilot with azimuth, while the aircraft pulse transmitter and a ground responder give him range from the airport or from the end of the runway when using navaglide.

Navaglide also uses the 3000-megacycle band to provide four signals for blind or automatic landing. Time sharing permits these and similar signals from nearby navaglides to use the same frequency so that only one receiver per aircraft is required. The above indications are automatically displayed to the pilot and where appropriate can be used for auto-pilot control.

Navascreen is a semiautomatic system for displaying on a large scale information about all nearby aircraft for the controllers use. An accelerated time device permits prediction of collisions and forecasts traffic density at the airport.



- 621.396.933 1093  
The Problems of Blind Landing—H. C. Pritchard. (*Jour. R. Aero. Soc.*, vol. 50, pp. 935-958; December, 1946. Discussion pp. 958-973.) A review of recently developed methods and a general discussion of the various problems involved. The methods include the American Civil Aeronautics Authority (see 2237 and 2655 of 1945), and SCS 51 systems, the GCA (ground-controlled approach) system and the BABS (beam approach beacon system). The GCA system comprises a mobile ground radar equipment which determines aircraft position and gives instructions to the pilot. It also includes a search system giving the plan position of all aircraft within about 15 miles and below, about 4000 feet. In the BABS system, aircraft transmissions are received by the ground station and reradiated on a slightly different frequency after a short time delay, with arrangements to give on a cathode-ray tube in the aircraft, short and long pulses whose relative amplitudes are determined by the angular position of the aircraft relative to the runway. A continuous range indication is also given and this, together with a barometric altimeter, is relied on for vertical guidance. The provision of adequate information for vertical guidance appears to be the most difficult landing problem and some form of radio altimeter the most promising solution.
- 621.396.933.1.029.62 1094  
An Ultra-High-Frequency Radio Range with Sector Identification and Simultaneous Voice—A. Alford, A. G. Kandoian, F. J. Lundberg, and C. B. Watts, Jr. (*Elec. Commun.*, vol. 23, pp. 179-189; June, 1946.) Reprint of 932 of 1946.
- 621.396.96 1095  
Minimum Detectable Radar Signal and Its Dependence upon Parameters of Radar Systems—A. V. Haeff. (*Proc. I.R.E. and Waves and Electrons*, vol. 34, pp. 857-861; November, 1946.) Discussion of the influence on the sensitivity of a pulse radar system of pulse repetition rate  $r$ , pulse length  $l$ , intermediate-frequency bandwidth  $B$ , and video bandwidth  $b$ . Experimental determination of the absolute value of the minimum pulse signal ( $V_{min}$ ) detectable visually through noise, is described with the apparatus used, and the results are expressed by the formula:  
$$V_{min} = \frac{1}{2} E_n B^{1/2} (1 + l/B) (1670/r)^{1/6}$$
where  $E_n$  is the noise voltage per unit of intermediate-frequency bandwidth.
- 621.396.96 1096  
Radar Demonstration by Hasler A. G. at Berne—W. Schiess. (*Tech. Mitt. Schweiz. Telegr.-Teleph. Verw.*, vol. 24, pp. 211-218; October 1, 1946.) Demonstration to representatives of the technical press of British 3-centimeter naval radar, and a simple explanation of radar and its operation, with some details of plan-position-indicator equipment.
- 621.396.96:621.392.5 1097  
Precision Resistance Networks for [Fire-Control] Computer Circuits—Hagemann. (*See* 1022.)
- 621.396.96(43) 1098  
Great Britain's Part in the Creation of Radar—R. W. Hallows. (*Toute la Radio*, vol. 13, pp. 201-203; September, 1946.) "Many mistaken ideas are current on the origins of radar. . . . In order to re-establish the truth, we have thought it useful to complete the study by M. Ponte (see 1099 below). . . . by another which brings to light the important contributions of British technicians."
- 621.396.96(44) 1099  
French Contributions to Radar Technique—M. Ponte. (*Toute la Radio*, vol. 13, pp. 204-207; September, 1946.) Reprint of 3290 of 1946. See also 1098 above.
- 621.396.96.001.8 1100  
Radar-Guided Bomb—(*Electronics*, vol. 19, pp. 186, 194; December, 1946.) Automatic radar control for glider-type Bat bomb.

## MATERIALS AND SUBSIDIARY TECHNIQUES

- 531.788.12 1101  
Improvements in the MacLeod Gauge—P. Tarbès. (*Le Vide*, (Paris), vol. 1, pp. 9-11; January, 1946.)
- 533.5+621.52 1102  
Vacuum Pumps—P. Pensa. (*Le Vide*, (Paris), vol. 1, pp. 4-8 and 48-53; January and March, 1946.) A short historical survey, with a description of Holweck's molecular pump, various rotary oil pumps, and the principles and construction of diffusion and condensation pumps.
- 533.5+621.52]:614.8 1103  
Safety Arrangement for Vacuum Plant—M. Schärer. (*Compt. Rend. Acad. Sci.* (Paris), vol. 222, pp. 997-998; April 24, 1946.) A simple device is described which depends on the action of a magnetic field on a gaseous discharge and which can be used to operate a stopcock.
- 535.37 1104  
Luminescence Processes in Zinc Sulphide Phosphors—G. F. J. Garlick and A. F. Gibson. (*Nature* (London), vol. 158, pp. 704-705; November 16, 1946.)
- 535.37:546.46.784 1105  
The Fluorescence of Pure Magnesium Tungstate—C. G. A. Hill. (*Trans. Faraday Soc.*, vol. 42, pp. 685-689; November, 1946.) Under optimum conditions of preparation, maximum fluorescence efficiency is given by the composition  $MgWO_4$ , the fluorescence being associated with a particular monoclinic crystal structure.
- 535.376 1106  
The Light Output of Zinc Sulphide on Irradiation with Alpha Rays—H. A. Klasens. (*Trans. Faraday Soc.*, vol. 42, pp. 666-668; November, 1946.) A critical review of the literature leads to the conclusion that the value of 80 per cent given by Riehl is much too high, most measurements giving values of the order of 10 to 15 per cent.
- 546.287 1107  
Silicones, New Electrical Insulating Materials—F. Appell. (*Rev. Gén. Elec.*, vol. 55, pp. 99-103; March, 1946.) A short account of the methods of preparation of silicone liquids, greases, rubbers, and resins; also of the physical properties of the various products and their applications in the electrical industry.
- 546.431.826:621.3.011.5 1108  
Oscillograph Study of Dielectric Properties of Barium Titanate—A. de Bretteville, Jr. (*Jour. Amer. Ceram. Soc.*, vol. 29, pp. 303-307; November, 1946.) See also 3625 of January.)
- 620.193.21:669.018.2.21 1109  
Weathering—Appreciation and a Study—G. D. Chapman. (*Light Metals*, vol. 9, pp. 593-608; November, 1946.) The significance of atmospheric corrosion of cast-iron alloys is reviewed and illustrated by some experimental work. The possible use of X-rays to determine the type and degree of attack is demonstrated.
- 620.197.6 1110  
Preventing Corrosion in Steel Chassis—(*Wireless World*, vol. 53, p. 22; January, 1947.) Extensive corrosion tests under tropical conditions have confirmed the superiority of electro-deposited tin-zinc alloys over either metal alone. Alloys with between 50 and 80 per cent tin show the highest corrosion resistance.
- 621.31 1111  
Contacts and Contact Materials—(*Elec. Times*, vol. 110, p. 841; December, 26 1946.) See also 781 of April. Notice of book published by Johnson Matthey and Co. and Mallory Metallurgical Products. Properties and tables of use for various alloys and pure materials are listed.
- 621.315.59:546.655.78 1112  
Cerium Tungstate as a Semi-Conductor—J. B. Nelson and J. H. McKee. (*Nature* (London), vol. 158, pp. 753-754; November 23, 1946.)
- 621.315.612.6.017.143.029.4+666.11 1113  
The Application of Low Frequency Spectra to Glass Technology—N. J. K. (*Glass Ind.*, vol. 27, pp. 609, 624; December, 1946.) Results obtained by P. Girard and P. Abadie published recently in *Bull. Inst. Verre* indicate the importance of power-loss measurements at wavelengths from 1 to  $10^6$  meters. With rubber, a direct correlation was found between the shape of the loss curve and the mechanical properties. The results for glass suggest the possibility of similar correlation.
- 621.315.612.6.017.143.029.64+666.11 1114  
Dielectric Properties of Glasses at Ultra-High Frequencies and Their Relation to Composition—L. Navias and R. L. Green. (*Glass Ind.*, vol. 27, pp. 615, 618; December, 1946.) Summary of paper already noted in 452 of March.
- 621.316.86:546.281.26 1115  
Silicon Carbide Non-Ohmic Resistors—F. Ashworth, W. Needham and R. W. Sillars. (*Jour. I.E.E.* (London), part I, vol. 93, pp. 595-958; December, 1946.) Discussion on 141 of February.
- 621.316.86.023 1116  
High Value Deposited Resistances at High Frequency—Klemt. (*See* 1019.)
- 621.318:539.16.08 1117  
Magnetic Field with Small Axial Variations—C. E. Nielsen. (*Phys. Rev.*, vol. 70, p. 450; September, 1-15, 1946.) Combinations of coils, iron bars, and rings to produce the types of field required for cloud chamber experiments. Summary of American Physical Society paper.
- 621.318.23:539.16.08 1118  
The Strengths of Some Model Magnets—S. B. Jones. (*Phys. Rev.*, vol. 70, p. 450; September 1-15, 1946.) Designs of permanent magnets made of Alnico V for use with airborne cloud chambers in cosmic ray studies. Summary of American Physical Society paper.
- 621.318.323.2.042.15.029.64 1119  
Iron Cores at Very-High Frequencies—J. Gouveritch. (*Radio en France*, no. 4, pp. 4-8; 1946.) Describes iron-dust materials and the best core shapes to realize  $Q$  values up to 280 at frequencies up to 50 megacycles.
- 669.26:621.385.032.2 1120  
Zirconium in Electron Tubes—Foote Mineral Co. (*Rev. Sci. Inst.*, vol. 17, p. 517; November, 1946.) Zirconium absorbs oxygen, nitrogen, and other gases at temperatures above 300 degrees centigrade, and may therefore be used as a continuous "getter" for certain types of tube. It can also act as a flux in welding tungsten, molybdenum, and tantalum and has a low coefficient of secondary emission. Abstract of article by G. A. Espersen in *Foote Prints*, vol. 18.
- 679.5 1121  
Unique Plastic makes Excellent Insulator—(*Sci. News Letter*, (Washington), vol. 50, p. 312; November 16, 1946.) "Teflon" is unharmed by temperatures up to 300 degrees centigrade and can be bent without cracking at +80 de-



grees centigrade. Its losses are low even at 3000 megacycles and it withstands every known solvent. Summary of an address to the Society of the Plastic Industry by E. B. Velton.

679.5:621.315.616 1122

Plastics as Insulation—(*Elec. Times.*, vol. 110, pp. 837-838; December 26, 1946.) Summary and discussion of a paper read before the Institution of Electrical Engineers Installations Section, on "The Growing Importance of Plastics in the Electrical Industry," by G. Haefely.

679.5 1123

Experimental Plastics and Synthetic Resins [Book Review]—G. F. D'Alcilio, J. Wiley and Sons, New York, N. Y. Chapman Hall, London, 1946, 185 pp., \$3. (*Nature* (London), vol. 158, p. 689; November 16, 1946.)

#### MATHEMATICS

517.54 1124

Second National Electronics Conference, Chicago, Autumn, 1946—(*Elec. Eng.*, vol. 65, pp. 569-574; December, 1946.) An abstract is given of a paper read at the conference entitled "Conformal Transformations in Orthogonal Reference Systems," by C. S. Roys. For titles of other papers read, see other sections. For other abstracts see *Elec. Ind.*, vol. 5, pp. 46-47, 111; December, 1946.

518.5:621.38 1125

A.C.E. The Automatic Computing Machine—Department of Scientific and Industrial Research. (See 1157.)

518.61 1126

Nomographs—(*Rev. Sci. Instr.*, vol. 17, p. 527; November, 1946.) A 'projected scale chart' used in conjunction with simple equations permits the construction of nomographs involving up to five variables. Developed by W. H. Burrows.

530.162:621.396.822 1127

On the First Passage Time Problem for a One-Dimensional Markoffian Gaussian Random Function—A. J. F. Siegert. (*Phys. Rev.*, vol. 70, p. 449; September 1-15, 1946.) The probability distribution of the first passage of a random variable through any given value is calculated. Summary of American Physical Society paper.

512.99:621.3 1128

Elementary Vectors for Electrical Engineers [Book Review]—G. W. Stubbings, Pitman and Sons, London, second edition, 6s.6d. (*Engineering* (London), vol. 162, p. 507; November 29, 1946.)

#### MEASUREMENTS AND TEST GEAR

621.3.011.3:389.6 1129

The Possibility of a Comparison of the Inductance Standards of the Various National Laboratories and the Part such a Comparison might play in Determinations of the Electromagnetic Unit of Resistance—M. Romanowski and R. Hérou. (*Bull. Soc. Franç. Elec.*, vol. 6, pp. 355-362; June-July, 1946.)

621.317.3.029.63/.64 1130

Radio Measurements in the Decimetre and Centimetre Wavebands—R. J. Clayton, J. E. Houlden, H. R. L. Lamont, and W. E. Willshaw. (*Jour. I.E.E.* (London), part III, vol. 93, pp. 457-459; November, 1946.) Discussion on 1914 of 1946.

621.317.32:621.396.611.4 1131

Measurement of Electric Field Strength in a Cavity Resonant at 200 Mc/s—W. K. H. Panofsky. (*Phys. Rev.*, vol. 70, p. 447; September 1-15, 1946.) Fields up to 25 kilovolts per centimeter are determined by measurement either of magnetic field by a loop method or of electrostatic force on the diaphragm of a con-

denser microphone. Summary of American Physical Society paper.

621.317.32.027.3 1132

High Voltage Measurement—(*Elec. Times.*, vol. 110, pp. 723-724; November 28, 1946; *Electrician*, vol. 137, pp. 1517-1518; November 29, 1946.) Summaries of two papers by F. M. Bruce noted in 472 of March.

621.317.333.4:621.315.2.029.5 1133

New Methods for Locating Cable Faults, Particularly on High-Frequency Cables—Roberts. (See 1002.)

621.317.335:621.396.694 1134

Measuring Inter-Electrode Capacitances—C. H. Young. (*Bell Lab. Rec.*, vol. 24, pp. 433-438; December, 1946.) A new type of bridge circuit with a double 3-terminal star network which can measure capacitance to within  $10^{-3}$  picofarad and conductance to within  $5+10^{-6}$  micromho.

621.317.34:621.396.44 1135

Receiver for Measurements on Carrier-Frequency Systems—H. G. Thilo. (*Arch. Tech. Messen.*, no. 112, p. T108; October, 1940.) Receiver covering the frequency range 120 to 280 kilocycles using a bridge-rectifier mixer circuit with a 2-stage intermediate-frequency amplifier at 350 kilocycles (bandwidth about  $\pm 10$  kilocycles). The circuit is arranged to measure the peak values of the modulated signal by suitable choice of time constants. Internal calibration is obtained by using the local oscillator as an intermediate-frequency generator after adjusting its amplitude to a standard value with the aid of the output voltmeter.

621.317.4.013.24:621.384.6 1136

A Method for Measuring Small Changes in Alternating Magnetic Fields—Powell. (See 1160.)

621.317.44+[621.38:531.765 1137

Electronic Meters—(*Elec. Times.*, vol. 110, p. 812; December, 1946.) Summary of two papers read before the Institution of Electrical Engineers' Measurements Section. The first entitled "A Millisecond Chronoscope," by R. S. J. Spilbury and A. Felton, describes an instrument on the capacitor charging principle, with a working range from 2 milliseconds to 1 second. The second, entitled "A Sensitive Recording Magnetometer," by A. Butterworth, describes a temperature compensated instrument using the change of alternating-current resistance of a mumetal wire when subjected to an axial magnetic field.

621.317.7 1138

Measurement Apparatus at the Paris Fair—G. Giniaux. (*TSF Pour Tous.* vol. 22, pp. 182-186) September, 1946.)

621.317.7 1139

Second National Electronics Conference, Chicago, Autumn, 1946—(*Elec. Eng.*, vol. 65, pp. 569-574; December, 1946.) Abstracts are given of the following papers read at the conference: "The Notch Wattmeter for Low-Level Power Measurement of Microwave Pulses," by D. F. Bowman; and "Microwave Frequency Stability," by A. E. Harrison. For titles of other papers read, see other sections. For other abstracts see *Elec. Ind.*, vol. 5, pp. 46-47, 111; December, 1946.

621.317.723:551.594.13 1140

Measurement of the Electric Conductivity of the Air by a Tetrode Electrometer—J. Lacaze. (*Compt. Rend. Acad. Sci.* (Paris), vol. 222, pp. 1242-1244; May 20, 1946.)

621.317.725 1141

Simple Valve Voltmeter—H. W. Baxter. (*Wireless World*, vol. 53, pp. 9-10; January, 1947.) The voltage to be measured is applied

to a diode, with a capacitor in the anode circuit, and the rectified output from the diode is balanced by a direct voltage from a potential divider, using the anode current of a second tube as a balance indicator. Peak voltages up to 90 volts can be measured using 9-volt batteries.

621.317.73 1142

Z-Meter—L. E. Packard. (*Elec. Ind.*, vol. 5, pp. 42-45; December, 1946.) This instrument measures the complex impedance of communication circuits, microphones, lines, transformers, and speakers at audio frequencies, giving both impedance and phase-angle independently of frequency. Stray capacitance and coupling are rendered negligible by means of a shielded and balanced input transformer. The range of impedance is from 0.5 to 100,000 ohms and of phase-angle from +90 to -90 degrees, over a frequency range of 30 to 20,000 cycles. The instrument will also measure  $R$  from 0.5 to 100,000 ohms,  $L$  from 5 microhenrys to 500 henrys,  $C$  from 0.0012 to 10,000 microfarads, the dissipation factor  $D$  of capacitors, and the  $Q$  of inductors.

621.317.76:389.6 1143

A Standard of Frequency and Its Applications—C. F. Booth and F. J. M. Laver. (*Jour. I.E.E.* (London), part III, vol. 93, pp. 427-428; November, 1946.) Discussion of 2973 of 1946.

621.317.76:389.6 1144

Frequency Standard—H. Gilloux. (*Radio en France*, no. 2, pp. 13-16; 1946.) Describes a secondary frequency standard, using a 500-kilocycle quartz crystal with multivibrator frequency-division stages, permitting direct-frequency measurement in 1-kilocycle steps to about 4 megacycles, in 20-kilocycle steps to 40 megacycles and in 100-kilocycle steps to 100 megacycles.

#### OTHER APPLICATIONS OF RADIO AND ELECTRONICS

539.16.08 1145

An Improvement on the Copper Evaporation Geiger-Müller Counter—P. J. G. de Vos, K. Gürgen and S. J. du Toit. (*Rev. Sci. Instr.*, vol. 17, p. 516; November, 1946.)

620.179:534.321.9 1146

Supersonic Flaw Detector—J.H.J. (See 986.)

621.3:629.1.001.4 1147

Vibration Exciter for Structural Tests—P. J. Holmes. (*Electronics*, vol. 19, pp. 96-100; December, 1946.) Description of electromagnetic shakers for vibration tests at mechanical resonance on aircraft structures. Circuits of carrier-type audio-frequency amplifier, phase shifter and phase indicator are given.

621.317.761:621.165 1148

An Electronic Frequency Meter and Speed Regulator—E. Levin. (*Trans. A.I.E.E.* (*Elec. Eng.*, December, 1946), vol. 65, pp. 779-786; December, 1946.) An attachment to a steam turbine which will indicate speeds to an accuracy of the order of 0.1 per cent and which holds the speed steady (within  $\pm 1/2$  per cent) at any speed between 10,000 and 100,000 revolutions per minute.

621.318.572 1149

High Speed Pulse Recording Circuit—B. E. Watt. (*Rev. Sci. Instr.*, vol. 17, pp. 338-342; September, 1946.) The circuits described are capable of driving a Cenco low-impedance counter at rates greater than 130 counts per second. Hard tubes are used, and the circuit cannot jam.

621.318.572 1150

Design and Operation of an Improved Counting Rate Meter—A. Kip, A. Bousquet, R. Evans, and W. Tuttle. (*Rev. Sci. Instr.*, vol. 17, pp. 323-333; September, 1946.) De-



sign and operation of the various components, viz., amplifiers, pulse equalizer, integrating circuit, degenerative vacuum-tube voltmeter, and the stabilized high- and low-voltage power supplies. Practical methods with curves are developed for determining the mean counting rate and its probable error directly from the output records.

621.318.572 1151  
Electronic Switch—F. Haas. (*Toute la Radio*, vol. 13, pp. 22–23; December, 1946.)

621.318.572 1152  
Current Integrator—B. E. Watt. (*Rev. Sci. Instr.*, vol. 17, pp. 334–338; September, 1946.) An integrator for the range 50 microamperes to below  $4 \times 10^{-3}$  microamperes, using the author's pulse recording circuit (1149 above). The charge per count is constant to within  $\pm 2$  per cent over the entire range, and is unaffected by power supply variations.

621.335.029.52 1153  
An Application of High Frequencies—L. Guerrier. (*Tele. Franç.*, Supplement *Électronique*, p. 5; September, 1946.) Russian experiments on traction powered by induction at 50 kilocycles.

621.36+621.38.001.8 1154  
Second National Electronics Conference, Chicago, Autumn, 1946—(*Elec. Eng.*, vol. 65, pp. 569–574; December, 1946.) Abstracts are given of the following papers read at the conference: "Detectors for Buried Metallic Bodies," by L. F. Curtis; "Electron Optics of Deflection Fields," by R. G. E. Hutter; "Microwaves and Their Possible Use in High-Frequency Heating," by T. P. Kinn and J. Marcum; "Ignitron Converters for Induction Heating," by R. J. Ballard and J. L. Boyer; "Dielectric Preheating in the Plastics Industry," by D. E. Watts, G. F. Leland and T. N. Willcox; "The Problem of Constant Frequency in Industrial High-Frequency Generators," by E. Mittelmann; "Large Electronic D.C. Motor Drives," by M. M. Morack; "Electronic Speed Control of A.C. Motors," by W. H. Elliott; "The Electronic Method of Contouring Control [following a master template by a tracer]," by J. Morgan; "Modulation of Infrared Systems for Signaling Purposes," by W. S. Huxford; "Photo Detectors for Ultraviolet, Visible, and Infrared Light," by R. J. Cashman; "Military Applications of Infrared Viewers," by G. E. Brown; "The Use of Radioactive Materials in Clinical Diagnosis and Medical Therapy," by J. T. Wilson; "The Mass Spectrometer as an Industrial Tool," by A. O. Nier; "The Cathode-Ray Spectrograph," by R. Feldt and C. Berkley; "Some Fundamental Problems of Nuclear Power Plant Engineering," by E. T. Neubauer; "An Accelerator Column for Two to Six Million Volts," by R. R. Machlett; "The Betatron Accelerator applied to Nuclear Physics," by E. E. Charlton and G. C. Baldwin; and "The Pressuregraph," and by A. Crossley. For titles of other papers read, see other sections. For other abstracts see *Elec. Indus.*, vol. 5, pp. 46–47, 111; December, 1946.

621.362 1155  
Vacuum Thermocouples for Radiation Measurement—F. Kerkhof. (*Arch. Tech. Messen*, no. 112, pp. T115–116; October, 1940.) The sensitivity (deflection for a given irradiation/mean zero fluctuation) of a vacuum thermocouple is far superior to that of a bolometer. The influence of the gas pressure, the material of the element and its blackening on the sensitivity is discussed. Some applications are given.

621.365:666.1 1156  
H. F. Glass Working—E. M. Guyer. (*Elec. Ind.*, vol. 5, pp. 65–67; December, 1946.)

High-frequency heating alone, or in combination with flame, simplifies many processes.

621.38:518.5 1157  
A.C.E. The Automatic Computing Machine—Department of Scientific and Industrial Research. (*Electronic Eng.*, vol. 18, pp. 372–373; December, 1946.) Gives some details of the automatic computing engine planned at the National Physical Laboratory.

621.38:531.765]+621.317.44 1158  
Electronic Meters—(See 1137.)

621.38.001.8 1159  
Punch Press Protector—J. Isaacs. (*Electronics*, vol. 19, pp. 101–103; December, 1946.) An electronic device for protecting a punch press from damage resulting from failure to eject disks from the die.

621.384.6:621.317.4.013.24 1160  
A Method for Measuring Small Changes in Alternating Magnetic Fields—W. M. Powell. (*Phys. Rev.*, vol. 70, p. 444; September 1–15, 1946.) Method using two search coils in compensating circuit with an amplifier and cathode-ray oscilloscope which enables variations of 0.1 oersted to be detected, e.g., in the betatron or synchrotron. Summary of American Physical Society paper.

621.384.6 1161  
Description of a Frequency Modulated Cyclotron and a Discussion of the Deflector Problem—E. J. Lofgren and B. Peters. (*Phys. Rev.*, vol. 70, p. 444; September, 1–15, 1946.) Summary of American Physical Society paper.

621.384.6 1162  
Frequency Modulation for Berkeley 37" Cyclotron—K. R. MacKenzie and F. H. Schmidt. (*Phys. Rev.*, vol. 70, p. 445; September 1–15, 1946.) Summary of American Physical Society paper.

621.384.6 1163  
Efficiency of Frequency Modulated Cyclotron—L. Foldy and D. Bohm. (*Phys. Rev.*, vol. 70, p. 445; September 1–15, 1946.) Summary of American Physical Society paper.

621.384.6 1164  
Frequency Modulated Cyclotron Characteristics—B. T. Wright and J. R. Richardson. (*Phys. Rev.*, vol. 70, p. 445; September 1–15, 1946.) Summary of American Physical Society paper.

621.384.6 1165  
Synchrotron Radiofrequency System—A. C. Helmholz, J. V. Franck, and J. M. Peterson. (*Phys. Rev.*, vol. 70, p. 448; September 1–15, 1946.) Summary of American Physical Society paper.

621.385.833 1166  
The Electrostatic Electron Microscope—P. Grivet and H. Bruck. (*Ann. Radioélect.*, vol. 1, pp. 293–310; April–July, 1946.) For another account see 3706 of January.

621.385.833 1167  
The C.S.F. Electrostatic Microscope—P. Grivet. (*Le Vide*, Paris, vol. 1, pp. 29–47; March, 1946.) A general discussion of electrostatic and electromagnetic electron microscopes and a detailed description of the C.S.F. instrument, with micrographs of crystals and microbes obtained with it. For another account see 3706 of January. (Bruck and Grivet.)

621.385.833:535.317.6 1168  
Reduction of Spherical Aberration in Strong Magnetic Lenses [in Electron Microscope]—L. Marton and K. Bol. (*Phys. Rev.*, vol. 70, p. 447; September 1–15, 1946.) Compound instead of single objective lenses are used. Summary of American Physical Society paper.

621.385.833:537.533.73 1169  
The Universal Electron Microscope as a High Resolution Diffraction Camera—R. G. Picard and J. H. Reischer. (*Rev. Sci. Instr.*, vol. 17, pp. 484–489; November, 1946.) Electron diffractions corresponding to spacings above 7 angstroms can be obtained by magnifying the camera image by means of an electron lens. A critical description is given of the modifications required to adapt an electron microscope for this purpose.

621.389:531.76 1170  
Aids to Stroboscopic Measurement—E. L. Thomas. (*Electronic Eng.*, vol. 18, pp. 369–371; December, 1946.) Devices to improve the accuracy and reliability of speed measurements.

621.396.9.001.8 1171  
Guided Missiles in World War II—H. Selvidge. (*Proc. Radio Club Amer.*, vol. 23, pp. 3–15; October, 1946.) An account of the principal features and methods of control of many types developed in the United States and in Germany.

621.398:629.13 1172  
Radio Control Systems for Guided Missiles—S. L. Ackerman and G. Rappaport. (*Electronics*, vol. 19, pp. 86–91; December, 1946.) A detailed description of methods and equipments. Circuit diagrams are given, and different control techniques discussed.

537.533.7(02) 1173  
Introduction to Electron Optics [Book Review]—V. E. Cosslett. Clarendon Press, Oxford; Oxford University Press, London, 1946, 272 pp., 25s. (*Nature* (London), vol. 158, pp. 685–686; November 16, 1946; *Jour. Sci. Instr.*, vol. 23, p. 302; December, 1946.)

621.385.833 1174  
Electron Optics and the Electron Microscope [Book Review]—V. K. Zworykin, G. A. Morton, E. G. Ramberg, J. Hillier, and A. W. Vance. John Wiley and Sons, New York, N. Y.; Chapman and Hall, London, 1945, 766 pp., \$10. (*Trans. Faraday Soc.*, vol. 42, pp. 702–704; November, 1946.) See also 1960 and 2358 of 1946. The present review is thorough, comprehensive, and critical. "... this book is valuable alike for its wealth of practical detail of the technique and for its mostly well-chosen presentation of the available theoretical considerations."

#### PROPAGATION OF WAVES

523.72:621.396.822.029.62/.63 1175  
Origin of Radio-Waves from the Sun and the Stars—Saha. (See 1074.)

551.510.535:621.396.24 1176  
Short-Wave Long Distance Links by Means of the Ionosphere—de Gouvenain. (See 1211.)

551.510.535:621.396.24 1177  
Application of the Theories of Indirect Propagation to the Calculation of Links using Decametre Waves—Aubert. (See 1210.)

621.396.11 1178  
Second National Electronics Conference, Chicago, Autumn, 1946—(*Elec. Eng.*, vol. 65, pp. 569–574; December, 1946.) An abstract is given of a paper read at the conference entitled: "Radio Propagation at Frequencies above 30 Megacycles," by K. Bullington. For titles of other papers read, see other sections. For other abstracts see *Elec. Ind.*, vol. 5, pp. 46–47, 111; December, 1946.

621.396.812 1179  
Five Metre Propagation Characteristics—D. W. Heightman and E. J. Williams. (*R.S.G.B. Bull.*, vol. 22, pp. 98–102; January, 1947.) Discusses chiefly tropospheric propagation of 5-metre waves, with special reference to



the effects of refraction, temperature inversions, humidity gradients, and general weather conditions.

**621.396.812:551.515.827** 1180  
**Reflection of Radio Waves from Tropospheric Layers**—J. B. Smyth and L. G. Trolese. (*Phys. Rev.*, vol. 70, p. 449; September 1-15, 1946.) Reflection coefficients are calculated for an elevated layer produced by a warm, dry air mass over a cool, humid air mass. Experimental data over a 90-mile-link on 52, 100, and 547 megacycles are compared with theory. Summary of American Physical Society paper.

**621.396.812:551.578.1** 1181  
**Attenuation of 1.24-Centimeter Radiation through Rain**—L. J. Anderson, C. H. Freres, J. P. Day, and A. P. D. Stokes. (*Phys. Rev.*, vol. 70, p. 449; September 1-15, 1946.) Experimental determination over a path of 6400 feet. A value of 0.37 decibel per mile per millimeter per hour was obtained, which is somewhat greater than the theoretical value deduced assuming incoherent scattering. Summary of American Physical Society paper.

**621.396.812.029.64** 1182  
**Measurement of the Angle of Arrival of Microwaves**—W. M. Sharpless. (*Proc. I.R.E. and Waves and Electrons*, vol. 34, pp. 837-845; November, 1946.) A description of the apparatus is given and a summary of the data collected during the summer of 1944 for two short optical paths using a wavelength of 3 1/4 centimeters. The beams of two receiving aeriols of width 0.36 degree are swept through small arcs, one vertically and the other horizontally, across the line of incoming waves. The signal level output is observed on a recorder giving an indication of the arrival direction.

The horizontal angle of arrival was found not to deviate by more than  $\pm 1$  degree, but vertical angles as much as 1/2 degree above the true angle of elevation were measured. Observations on reflected rays from land and sea were also made and evidence of trapping for both the direct and reflected rays was obtained.

**621.396.812.029.64** 1183  
**Further Observations of the Angle of Arrival of Microwaves**—A. B. Crawford and W. M. Sharpless. (*Proc. I.R.E. and Waves and Electrons*, vol. 34, pp. 845-848; November, 1946.) A metal lens aerial of 0.12 degree beam width and wavelength 1 1/2 centimeters was used. Results are compared with those for 3 1/4 centimeters described in an earlier paper (1182 above) and correlated with meteorological conditions. Six curves of modified atmospheric refractive index against height, representative of conditions over the path, were obtained daily from balloon and tower observations. A detailed analysis is given of multiple path transmission which occurred on two nights when there was definite evidence of inversions in the refractive index versus height curve near the line of transmission.

**621.397.81** 1184  
**A Modification to Ray Theory Allowing for Ground Contours**—H. P. Williams. (*Electronic Eng.*, vol. 19, pp. 17-20; January, 1947.) A simple empirical law is given which, by allowing for multiple, instead of single, reflection from the ground, gives greatly improved correlation with experimental field strength curves for television transmissions on wavelengths of 7 meters from Alexandra Palace to points of reception near the ground and within 20 miles. The law should be of value at meter wavelengths and whenever the points of transmission and reception are intervisible. Its application to shorter wavelengths may be open to question.

## RECEPTION

**534.862.4** 1185  
**Perfect v. Pleasing Reproduction**—J. Moir. (*Electronic Eng.*, vol. 19, pp. 23-27; January, 1947.) The results of comprehensive tests, in which a reproducer of the highest quality was used to determine the frequency range which would produce the most pleasing reproduction, indicate a decided public preference for a restricted frequency range. This optimum range is approximately 70 to 6500 cycles, but is somewhat dependent on program material. A similar preference appears to exist when electrical reproduction is not involved. It is suggested that the present practice of transmitting with the flat or slightly rising characteristic and providing each listener with a tone control is the correct procedure.

**621.396.44:621.317.34** 1186  
**Receiver for Measurements on Carrier-Frequency Systems**—Thilo. (*See* 1135.)

**621.396.619.13** 1187  
**Twelve-Channel F.M. Converter**—J. E. Young and W. A. Harris. (*Electronics*, vol. 19, pp. 110-111; December, 1946.) Telephone-dial selection of any of twelve stations in the new frequency-modulated band is achieved remotely with a prewar frequency-modulated receiver by use of a three-tube converter in which mixer input and oscillator are tuned by preset trimmers connected to a 12-position rotary selector switch.

**621.396.62+621.396.82** 1188  
**Second National Electronics Conference, Chicago, Autumn, 1946**—(*Elec. Eng.*, vol. 65, pp. 569-574; December, 1946.) Abstracts are given of the following papers read at the conference: "Interference between Very-High-Frequency Radio Communication Circuits," by W. R. Young, Jr.; "Front-End Design of Frequency Modulation Receivers," by C. R. Miner; and "A Single-Stage Frequency Modulation Detector," by W. E. Bradley. For titles of other papers read, see other sections. For other abstracts see *Elec. Ind.*, vol. 5, pp. 46-47, 111; December, 1946.

**621.396.62** 1189  
**Tendencies in the Design of the Communication Type of Receiver**—G. L. Grisdale and R. B. Armstrong. (*Jour. I.E.E.* (London), part I, vol. 93, p. 605; December, 1946.) Summary of 223 of February.

**621.396.62.029.62** 1190  
**The Professional Receiver**—R. Aschenbrenner. (*Radio en France*, no. 3, pp. 14-25; 1946.) Discusses in some detail the design of all the component stages of a communications receiver for the range 15 to 60 meters.

**621.396.621** 1191  
**Towards the Radio Receiver De Luxe**—L. Boë. (*Radio en France*, no. 1, pp. 26-33; 1946.) Reviews the conditions for quality reproduction and discusses a circuit fulfilling them.

**621.396.621** 1192  
**V5SR Communication Receiver**—(*Wireless World*, vol. 53, p. 36; January, 1947.) A commercial modification of the Royal Air Force type R1155. A complementary unit contains a 5- and 10-meter converter.

**621.396.621.029.64** 1193  
**First Steps in V.H.F. Exploration. A Practical Super-Regenerative Receiver**—"Cathode Ray." (*Wireless World*, vol. 53, pp. 15-17; January, 1947.) Details of a simple set of high sensitivity and low selectivity, permitting easy tuning.

**621.396.662:621.396.62** 1194  
**Tuning Devices for Broadcast Radio Receivers**—R. C. G. Williams. (*Jour. I.E.E.*

(London), part III, vol. 93, pp. 405-423; November, 1946. Discussion, pp. 423-427.) An historical discussion of tuning device evolution is followed by a description of listening tests on the degree of mistuning required for observable deterioration of quality. As a result of these a target tolerance of 1 kilocycle for long and medium waves and 2 kilocycles for short waves is suggested. Problems of design imposed by these criteria are discussed together with detailed descriptions of the chief systems of preset tuning and bandspreading hitherto used. In an appendix experimental measurements of the effect of mistuning on audio frequency response and harmonic distortion are described, and a theoretical analysis of the problem is given.

**621.396.662:621.396.62** 1195  
**The Design of Band-Spread Tuned Circuits for Broadcast Receivers**—D. H. Hughes. (*Jour. I.E.E.* (London), part III, vol. 93, pp. 459-460; November, 1946.) Discussion of 1803 of 1946.

**621.396.822** 1196  
**Noise Factor: Part 2. Methods of Measurement. Sources of Test Signals**—L. A. Moxon. (*Wireless World*, vol. 53, pp. 11-14; January, 1947.) Either a continuous-wave signal generator or a noise source can be used, and the latter is preferable. The most satisfactory noise source is a temperature-limited diode with a pure tungsten filament. For measurements in the 3000 to 10,000 megacycle range, the filament is mounted axially in a small-bore copper tube about 10 centimeters long. The correction factors for various possible errors can then be calculated. For part 1, see 864 of April.

**621.396.822:530.162** 1197  
**On the First Passage Time Problem for a One-Dimensional Markoffian Gaussian Random Function**—Siegert. (*See* 1127.)

**621.396.822:621.396.619.16** 1198  
**Pulse Distortion: the Probability Distribution of Distortion Magnitudes Due to Inter-Channel Interference in Multi-Channel Pulse-Transmission Systems**—D. G. Tucker. (*Jour. I.E.E.* (London), part I, vol. 93, pp. 611-612; December, 1946.) Summary of 230 of February.

**621.396.822:621.396.621** 1199  
**Note on the Theory of Noise in Receivers with Square Law Detector**—M. Kack and A. F. J. Siegert. (*Phys. Rev.*, vol. 70, p. 449; September 1-15, 1946.) The probability density of the noise emerging from a receiver consisting of intermediate-frequency amplifier, detector, and video amplifier, is calculated using the characteristic function method. Summary of American Physical Society paper.

**621.396.822:621.396.645** 1200  
**Background Noise in Amplifiers**—U. Zebstein. (*Toute la Radio*, vol. 13, pp. 2-3, 24; December, 1946.) Discusses thermal and shot effects.

**621.396.822.029.62:523.16** 1201  
**Variation of Cosmic Radiation with Frequency**—Moxon. (*See* 1073.)

**621.396.828+621.396.665** 1202  
**Noise and Output Limiters: Part 2**—E. Toth. (*Electronics*, vol. 19, pp. 120-125; December, 1946.) The operation of six types of radio- and audio-frequency limiters and a frequency modulated discriminator for amplitude modulation limit are described, and the characteristics of thermionic and crystal diodes when used as limiters are considered. Series-type noise-peak limiters are recommended for modulated continuous-wave reception and full wave audio-frequency shunt output types for continuous-wave reception. For part 1 see 867 of April.



## STATIONS AND COMMUNICATION SYSTEMS

- 621.315.668.2 1203  
The Reconstruction of Ten 305-Foot Tubular Steel Radio-Masts in Reinforced Concrete—J. P. Harding. (*Jour. Inst. Civil Eng.*, vol. 27, pp. 113-179; December, 1946.) An account of the encasing in reinforced concrete of the ten masts erected at Leafield in 1912 by the Marconi Company.
- 621.384.3:621.391.64 1204  
Lamp Enables Two-Way Talk Over Invisible Searchlight Beam—R.H.O. (*Jour. Frank. Inst.*, vol. 242, pp. 339-340; October, 1946.) A description of a 'talking lamp' using caesium vapour, which makes two way conversation possible by means of an invisible infrared beam. Secrecy is claimed, and speech is transmitted practically instantaneously with true telephone quality at conversational speed.
- 621.39+534.756 1205  
Theory of Communication—Gabor. (*See 1057.*) Part 1, analysis of information; part 2, analysis of hearing; and part 3, frequency compression and expansion.
- 621.394/.395["1939/1945"] 1206  
Telephony and Telegraphy—W. G. Radley. (*Jour. I.E.E.* (London), part I, vol. 93, pp. 569-576; December, 1946.) A review of improvements and developments in British Post Office equipment and methods in the last six years.
- 621.395.44:621.315.052.63 1207  
Field Tests on Power-Line Carrier-Current Equipment—R. H. Miller and E. S. Prud'homme. (*Trans. A.I.E.E. (Elec. Eng.)*, December, 1946), vol. 65, pp. 824-827; December, 1946.) Tests on the Pacific Gas and Electric Company's new telephone system included a comparison of the performances of frequency- and amplitude-modulation equipment. The results are expressed graphically.
- 621.395.5:621.317.34 1208  
Transmission Rating of Telephone Systems—W. A. Codd. (*Trans. A.I.E.E. (Elec. Eng.)*, October 1946), vol. 65, pp. 694-698; October, 1946.)
- 621.396 1209  
Colonial Telecommunication—(*Electrician*, vol. 137, pp. 1519-1520; November 29, 1946.) Summary and discussion of two papers read before the Institution of Electrical Engineers: "The Development and Design of Colonial Telecommunication Systems and Plants," by C. Lawton, and "The General Planning and Organization of Colonial Telecommunication Systems," by V. H. Winson. For another account see *Elec. Times*, vol. 110, pp. 729-750; November 28, 1946.
- 621.396.24:551.510.535 1210  
Application of the Theories of Indirect Propagation to the Calculation of Links Using Decametre Waves—R. Aubert. (*Bull. Soc. Franç. Elec.*, vol. 6, pp. 111-128; March, 1946.) A résumé is first given of the principal laws of propagation in an ionized medium. The general characteristics of the ionosphere and the seasonal variations of equivalent heights and critical frequencies are then surveyed; from a knowledge of these and of the variations of solar activity it is possible to predict similar data for several months in advance and to deduce maximum usable frequencies for given distances.  
The paper is mainly concerned with the calculation of the operating conditions for a short-wave link. This calculation involves the following factors: (a) The determination of the path of the wave—the angle of elevation of the ray must be as low as possible to give a minimum number of hops, but sufficient to avoid reflection at the E layer. Curves are given of minimum angle of elevation and corresponding distance per hop for a series of E-layer critical frequencies. (b) The determination of the maximum usable frequency for the given path—this is derived from seasonal world charts, published in Washington, which can be interpreted in terms of local time. (c) The choice of an optimum working frequency, usually about 20 per cent below the maximum usable frequency to ensure greater security of communication. (d) The calculation of loss by reflection at the F layer—this is a function of the ratio of optimum working frequency to maximum usable frequency; curves are given and approximations explained. (e) The calculation of loss by absorption in the E layer—during the day the absorption is proportional to  $\lambda^2$  and is a function of the altitude of the sun; curves proposed at the Bucharest meeting of the C.C.I.R. are reproduced. At night absorption is proportional to  $\lambda^{-0.2}$  for the first 3 or 4 hours and is negligible for the later hours.  
A detailed example of the use of the above data is given for the link Paris-New York, with explanations of the approximations necessary in practice.
- 621.396.24:551.510.535 1211  
Short-Wave Long Distance Links by Means of the Ionosphere—A. de Gouvenain. (*Toute la Radio*, vol. 13, pp. 264-269; November, 1946.) Discusses the effects of the E and F layers and explains the use of ionospheric charts for the choice of optimum operational frequencies and hours of traffic. See also 1210.
- 621.396.324.029.3 1212  
Multi-Channel Two-Tone Radio Telegraphy—L. C. Roberts. (*Bell Lab. Rec.*, vol. 24, pp. 461-465; December, 1946.) This voice frequency telegraph system can handle a large amount of traffic over a single radio frequency with comparatively low power per channel. It gives independent start-stop teletypewriter circuits which can be extended by land lines to teletypewriters situated at different places.  
For two-tone transmission, one channel is used for marking and an adjacent channel at a frequency 170 cycles higher is used for spacing. Selective fading is counteracted by simultaneous transmission of the same two-tone signals on two pairs of frequencies, corresponding members of which differ by about 1000 cycles. A channel shifter is used to enable 6 channels of the frequency-diversity system—24 tones—to be transmitted over a single radio channel.
- 621.396.41:621.396.619.16 1213  
Pulse-Time-Modulated Multiplex Radio Relay System—Terminal Equipment—D. D. Grieg and A. M. Levine. (*Elec. Commun.*, vol. 23, pp. 159-178; June, 1946.) The principles and advantages of the system are explained with numerous diagrams. A description is given of the physical and electrical characteristics of the terminal equipment of an operating 24-channel system which takes advantage of transmission technique developed during the war.
- 621.396.44 1214  
Carrier-Frequency Broadcasting—(*Electrician*, vol. 137, pp. 1503-1504; November 29, 1946.) An outline description of the new Rugby wired broadcasting system, including monitoring facilities, put into public service on November 22, 1946. Six programs are to be made available to subscribers over two polyvinyl-chloride covered wires by means of modulated carrier waves of frequencies up to 200 kilocycles spaced 20 kilocycles apart. It is estimated that the 6-watt output of the equipment is sufficient to provide for 3000 subscribers. For another account see *Elec. Times*, vol. 110, p. 725; November 28, 1946.
- 621.396.1:621.396.82 1215  
Interference Considerations Affecting Channel-Frequency Assignments—M. Reed and S. H. Moss. (*Jour. I.E.E.* (London), part I, vol. 93, pp. 603-604; December, 1946.) Summary of 241 of February.
- 621.396.619.11 1216  
Amplitude Modulated Waves—H. Moss. (*Electronic Eng.*, vol. 18, pp. 375-378; December, 1946.) The theory of amplitude modulation is considered in general and sinusoidal modulation in particular. The effects of modulation index above unity, of suppressing the carrier and of attenuating one sideband are discussed and examples of oscillographic measurements of modulation depth and distortion given. For previous parts in this series see 2966 of 1946 and back references.
- 621.396.619.13 1217  
Second National Electronics Conference, Chicago, Autumn, 1946—(*Elec. Eng.*, vol. 65, pp. 569-574; December, 1946.) Abstracts are given of the following papers read at the conference: "Frequency Modulation of High-Frequency Power Oscillators," by W. R. Rambo; "A Microwave Relay Communication System," by G. G. Gerlach; "Pulse Time Multiplex Broadcasting of the Ultrahigh Frequencies," by D. D. Grieg and A. G. Kandoian; and "Signal Systems for Improving Railroad Safety," by K. W. Jarvis. For titles of other papers read, see other sections. For other abstracts see *Elec. Ind.*, vol. 5, pp. 46-47, 111; December, 1946.
- 621.396.645:621.396.7 1218  
Remote Amplifier for Broadcast Service—P. Wulfsberg. (*Elec. Ind.*, vol. 5, pp. 70-71, 102; December, 1946.) An audio-frequency four-channel and master self-contained unit for operation with either alternating current or batteries. The gain is 92 decibels, and frequency response  $\pm 1$  decibel from 30 to 12,000 cycles; the unit gives 50 milliwatt output with 1 per cent or less distortion.
- 621.396.65.029.62/.64:621.396.619.16 1219  
A Multichannel Microwave Radio Relay System—H. S. Black, J. W. Beyer, T. J. Grieser, and F. A. Polkinghorn. (*Trans. A.I.E.E. (Elec. Eng.)*, December, 1946), vol. 65, pp. 798-806; December, 1946.) The AN/TRC-6 is an 8-channel relay system operating at about 5000 megacycles. Sharp beaming and the complete absence of interference greatly reduce the required transmitter power. "Short pulses of microwave power carry the intelligence of the eight messages utilizing pulse position modulation to modulate the pulses and time division to multiplex the channels."  
The eight high-grade telephone circuits can be used for various purposes. Two-way transmissions over distances of 1600 miles and one-way over 3200 miles have been achieved. See also 2315 of 1946 and back references.
- 621.396.712.3 1220  
Studio Control Unit—N. J. Peterson. (*Elec. Ind.*, vol. 5, pp. 68-69, 109; December, 1946.) All controls and amplifiers for one or two broadcasting studios, together with announcing booth, contained in a single desk cabinet.
- 621.396.93 1221  
Frequency, Power, and Modulation for a Long-Range Radio Navigation System—Adams and Colin. (*See 1086.*)
- 621.396.932 1222  
Electronics on World's Largest Liner—(*Electronics*, vol. 19, pp. 84-85; December, 1946.) Navigational aids aboard the liner Queen Elizabeth include radar, loran, depth-sounding, and radio installations.
- 621.396.712 1223  
Broadcasting Stations of the World [Book Review]—Wireless World, Hiffe and Sons, London, 1s. (*Elec. Rev.* (London), vol. 140,



p. 264; February 7, 1947.) Details of over a thousand stations, arranged for easy reference.

621-526+621.396.016.2.029.64 1224  
**Second National Electronics Conference, Chicago, Autumn, 1946**—(*Elec. Eng.*, vol. 65, pp. 569-574; December, 1946.) Abstracts are given of the following papers read at the conference: "High-Performance Demodulators for Servomechanisms," by K. E. Schreiner; and "Continuous-Wave Ultrahigh-Frequency Power at the 50-kW Level," by W. G. Dow and H. W. Welch. For titles of other papers read, see other sections. For other abstracts see *Elec. Ind.*, vol. 5, pp. 46-47, 111; December, 1946.

621.314.2.018.8 1225  
**Primary Oscillation Damper, using a Shunted Rectifier, for Transformers feeding X-Ray Tubes**—L. Maurice. (*Bull. Soc. Franç. Élec.*, vol. 6, pp. 98-102; March, 1946.)

621.314.6+621.319.4+621.383]:669.018 1226  
**Light Alloys in Metal Rectifiers, Photocells, and Condensers**—Continuing the series in *Light Metals* mentioned in 544 of March and 3768 of January.

(xii) vol. 8, pp. 348-359; July, 1945. "The properties of interleaving papers are critical and physically and chemically are related to the electrode metals."

(xiii) vol. 8, pp. 409-414; August, 1945. Summarizes practical requirements for interleaving papers.

(xiv) vol. 8, pp. 459-462; September, 1945. A detailed survey of the electrical, chemical, physical, and mechanical characteristics of impregnating media for fixed paper capacitors.

(xv) vol. 8, pp. 479-491; October, 1945. Continuing (xiv), with particular attention to chemical properties in relationship to the metal with which impregnating media come in contact.

(xvi) vol. 8, pp. 559-576; November, 1945. A discussion on the relationship between impregnated media and the service characteristics and life of fixed-paper capacitors.

621.316.53 1227  
**Some Technical Considerations concerning Contactors**—F. Bertholet. (*Bull. Sci. Ass. Inst. Électrotechn. Montefiore*, vol. 59, pp. 271-277, 319-341, 353-381; June-August, 1946.) In 13 chapters, dealing with the magnetic circuit, shape, and pressure of contacts, phenomena at make and break, arc extinction, effect of current intensity and of the connected circuits, contactors in oil, contact life, and auxiliary contacts.

621.316.935.078 1228  
**Saturable Reactors for Automatic Control**—W. D. Cockrell. (*Elec. Ind.*, vol. 5, pp. 48-53; December, 1946.) Theory and application of power control reactors using magnetic saturation effects.

621.385.4 1229  
**A Neon Stroboscopic Lamp**—(*Electronic Eng.*, vol. 18, p. 374; December, 1946.) Details of construction and operation of the Ferranti Neostrom Type NSP1, designed for short discharge flashes up to 250 per second.

621.391.64+621.384.3 1230  
**Some Developments in Infrared Communications Components**—J. M. Fluke and N. E. Porter. (*Proc. I.R.E. and Waves and Electrons*, vol. 34, pp. 876-883; November, 1946.) For communication at wavelengths 0.8 to 1.2 microns, the most suitable source is a caesium vapour lamp; power supply for it is considered. Plastic filters are more efficient than glass but cannot operate at such a high temperature. The three main types of receiver-phosphors, electron image tubes, and photocells are briefly discussed.

621.392.032.53:533.5 1231  
**Resonant Windows for Vacuum Seals in Rectangular Wave Guides**—M. D. Fiske. (*Rev. Sci. Instr.*, vol. 17, pp. 478-483; November, 1946.) They consist of a thin dielectric plate (glass) hermetically sealed to a Fernico metal frame. They are ground for tuning, deoxidized and soldered across the guide. They may be represented by a parallel resonant circuit shunted across a transmission line. Windows having a  $Q$  less than unity and giving 97 per cent power transmission have been constructed. Detailed design information is given for 3-centimeter windows.

621.394.652 1232  
**Telegraph Manipulating Key Design**—H. J. H. Wassell. (*Marconi Rev.*, vol. 9, pp. 109-115; July-September, 1946.) Conditions to be aimed at in key design are: (a) small mass of moving arm, (b) use of a 'dead' metal for the arm, (c) optimum arm length, (d) small gap, and (e) contacts at center of percussion. Some detailed observations of keying methods are given, and the design of a new manipulating key is described.

669.71+669.721]:621.3 1233  
**Aluminium and Magnesium in the Electrical Industries**—B. J. Brajnikoff. (*Light Metals*, vol. 9, pp. 393-397 and 609-618; August and November, 1946.) The first article describes the application of aluminium in high-voltage capacitors with compressed gas insulation; it is based on the researches of B. M. Hochberg and co-workers at the Leningrad Physico-Technical Institute. The second article considers modern developments of high-voltage generation for nuclear physics, X-rays, or industrial applications; high electrical efficiency is obtainable by using aluminium in the construction of alternators.

621.317.755 1234  
**Principes de l'Oscillographe Cathodique** [Book Review]—R. Aschen and R. Gondry. (*Éditions Radio, Paris*, 88 pp., 100 fr. (*Toute la Radio*, vol. 13, p. 273; November, 1946.)

#### TELEVISION AND PHOTOTELEGRAPHY

621.396.029.6 1235  
**The Interstage Auto-Transformer at Television Frequencies**—Feldmann. (*See* 1027.)

621.397.262 1236  
**Approximate Method of Calculating Reflections in Television Transmission**—D. A. Bell. (*Jour. I.E.E.* (London), part I, vol. 93, p. 605; December, 1946.) Summary of 553 of March.

621.397.3 1237  
**Choice of Definition in Television**—R. Barthélemy. (*Cah. Toute la Radio*, pp. 2-4; July, 1946.) Although a 900-line scan, with a frequency band of about 15 megacycles, causes a continuous appearance on the screen, both in the horizontal and vertical directions, in the case of some image structures the vertical definition is inferior to the horizontal. Without spoiling the definition, the use of interlacing produces a striation in the greater part of the picture equal to half the number of lines.

621.397.331.2 1238  
**New Cathode-Ray Tube for Television**—(*Radio en France*, no. 2, p. 46; 1946.) The tube has an over-all length of 35 centimeters and gives an image 12 by 16 centimeters. A directly heated filament takes under 1 ampere at 1.2 volts and the normal accelerating voltage is 2000 volts, which may be increased without danger to 3000 or 4000 volts.

621.397.5 1239  
**Second National Electronics Conference, Chicago, Autumn, 1946**—(*Elec. Eng.*, vol. 65, pp. 569-574; December, 1946.) Abstracts are given of the following papers read at the conference: "Color Television—Latest State of

the Art," by P. C. Goldmark; "Westinghouse Color Television Studio Equipment," by D. L. Balthis; "Television Transmitter for Black-and-White and Color Television," by N. Young; "Stratovision System of Communication," by C. E. Nobles and W. K. Ebel; "The Electrostatic Image Dissector," by H. Salinger; "The Use of Powdered Iron in Television Deflecting Circuits," by A. W. Friend; "Television Equipment for Guided Missiles," by C. J. Marshall and L. Katz; and "Results of Field Tests on Ultrahigh-Frequency (490 Mc/s) Color Television Transmission in the New York Metropolitan Area," by W. B. Lodge. For titles of other papers read, see other sections. For other abstracts see *Elec. Ind.*, vol. 5, pp. 46-47, 111; December, 1946.

621.397.5 1240  
**All-Electronic Color Television**—(*Electronics*, vol. 19, pp. 140, 142; December, 1946.) A method of simultaneous color transmission is described. With a cathode-ray tube as light source, the image is split into three color components and directed to separate channels by a mirror system. Three separately actuated cathode-ray tubes project the received images to form a composite picture. The color transmissions will form monochrome pictures on existing receivers, which may alternatively be adapted for full-color reception.

621.397.5(44) 1241  
**The Conditions for the Development of Television in France and the Problem of the Line Standard**—M. Chauvierre. (*Radio en France*, no. 2, pp. 33-35; 1946.) Discusses the difficulties of starting a television service in France. It is concluded that industrial development based on a 500-line standard is essential immediately.

621.397.5:515.6 1242  
**Perspective and Television**—P. Philippe. (*Télévis. Franç.*, no. 12, pp. 9-11; April, 1946.) A discussion of perspective effects arising from differences of the points of view of camera and viewer.

621.397.611 1243  
**From the Iconoscope to the Isoscope and towards Large Screen Television**—G. Barret. (*Toute la Radio*, vol. 13, pp. 97-98; March-April, 1946.) Principles and construction of the iconoscope and of the more recently developed Radio Corporation of America's orthiconoscope, and the Compagnie des Compteurs isoscope, both of which are better adapted for screen projection.

621.397.611:621.383 1244  
**The Isoscope**—R. Barthélemy. (*Télévis. Franç.*, nos. 13 and 14, pp. 12-14 and 3-5, 23; May and June, 1946.) A method of picture analysis by means of slow electrons use modulation of the cathode beam, near the point of impact, by photoelectric charges created by the light projected on the transparent mosaic. A beat-frequency method produces high-frequency modulation of the beam, so that in the tuned output circuit the high-frequency current has 100 per cent modulation. See also 445 of 1946.

621.397.62 1245  
**Television Receiver Construction. Part 1—Deflector Coils: General Principles**—(*Wireless World*, vol. 53, pp. 2-5; January, 1947.) Constructional details for those acquainted with sound-set construction and television circuit principles.

621.397.62 1246  
**R.C.A. Reveals First Electronic Color TV [Television]**—(*Elec. Ind.*, vol. 5, pp. 58-59, 103; December, 1946.) Three simultaneous color modulations are used to excite three small cathode-ray tubes and the light from these is



focused through appropriate filters on a translucent 15-inch by 20-inch screen.

621.397.62 1247  
**Problems on Theatre Television Projection Equipment. Parts 1 and 2**—A. H. Rosenthal. (*Jour. Telev. Soc.*, vol. 4, pp. 258-263 and 274-278; June and September, 1946.) Reprint of article abstracted in 461 of 1946.

621.397.62(44) 1248  
**The S.A.D.I.R. Receiver, Type R. 290**—(*Radio en France*, no. 2, pp. 43-45; 1946.) A short description of the 1943 television receiver with complete circuit diagram, and details of components used.

621.397.81 1249  
**A Modification to Ray Theory Allowing for Ground Contours**—Williams. (See 1184.)

#### TRANSMISSION

621.394.652 1250  
**Telegraph Manipulating Key Design**—Wassell. (See 1232.)

621.395.4 1251  
**Wideband Phase Shift Networks**—Dome. (See 1021.)

621.396.61.029.58 1252  
**Medium Power Short-Wave Telephone-Telegraph Transmitter Type T.F.S.31**—C. R. Staines. (*Marconi Rev.*, vol. 9, pp. 89-101; July-September, 1946.) Designed for use in communication circuits where rapid frequency changing is of first importance, e.g., aerodrome ground stations, ship-to-shore services, and point-to-point circuits. The frequency range covered is 3 to 22.2 megacycles with output power 4.0 to 5.0 kilowatts on telegraphy, and carrier power 3.0 to 3.5 kilowatts on telephony.

621.396.619.1 1253  
**Cascade Phase Shift Modulator**—M. Marks. (*Electronics*, vol. 19, pp. 104-109; December, 1946.) The general requirements of phase-shift modulators are discussed, and it is shown that addition of the phase shifts of a number of stages in cascade allows a lower order of frequency multiplication. The design of a six-stage modulator with low-noise and distortion characteristics is described, and the procedure given for tuning the modulator and aligning the transmitter. Distortion less than 1 per cent is claimed.

621.396.619.14 1254  
**Phase Modulation**—V. O. Stokes. (*Marconi Rev.*, vol. 9, pp. 116-122; July-September, 1946.) Phase modulation may conveniently be applied to telegraph transmitters as an anti-fading system. A modulation method using a reactance tube in one of the driven stages is described. Curves showing the amplitude of the carrier and sidebands for various modulation indexes are given and a method of measuring the modulation index (for sinusoidal modulation) is described in detail with a circuit diagram of the monitor unit. The application of the system to a typical transmitter is explained. Unintentional phase modulation may be produced by alternating-current heating of tubes, etc.; a special monitor unit has been developed for measuring this unwanted modulation. This unit can also be used for the separate measurement of 'amplitude noise.'

#### VACUUM TUBES AND THERMIONICS

621.317.7.085 1255  
**"Magic Eye" Indicators [with Positive Feedback]**—G. O. Thacker and R. Y. Walker. (*Wireless World*, vol. 53, pp. 30-31; January, 1947.) Criticizes the construction of wartime EM2 indicators and suggests that a short grid base and flat deflector vanes are necessary for high sensitivity.

621.383:621.391.64 1256  
**German Photo-Cells for the Infrared**—B.I.O.S. (*Jour. Telev. Soc.*, vol. 4, pp. 280-281; September, 1946.) An extract from a B.I.O.S. report by T. F. Johns, published by H. M. Stationery Office. The characteristics of lead sulphide and lead telluride photocells and German methods of producing them are briefly described.

621.385+621.396.694 1257  
**Magnetic Control of Anode Current**—C. R. Knight. (*Elec. Ind.*, vol. 5, pp. 72-73, 108; December, 1946.) Details of a new diode, type 2B23, in which the anode current is controlled by an external magnetic field. An illustration is given of its use as a voltage-control amplifier and a current-limit amplifier in an electronic motor control circuit. A more stable control circuit can be made using two such diodes differentially.

621.385 1258  
**Second National Electronics Conference, Chicago, Autumn, 1946**—(*Elec. Eng.*, vol. 65, pp. 569-574; December, 1946.) Abstracts are given of the following papers read at the conference: "Trends in Cathode-Ray Oscilloscope Design," by W. L. Gaines; "Production Test Facilities for High-Power Tubes," by W. L. Lyndon and B. Sheren; "The Cyclophon—A Multipurpose Beam Switching Tube," by J. J. Glauber, D. D. Grieg and S. Moskowitz; "An All Metal Tunable Squirrel Cage Magnetron," by F. H. Crawford, and "Bunching Conditions for Electron Beams with Space Charge," by L. Brillouin. For titles of other papers read, see other sections. For other abstracts see *Elec. Ind.*, vol. 5, pp. 46-47, 111; December, 1946.

621.385:389.6 1259  
**Service Valve Equivalents**—Incorporated Radio Society of Great Britain. List of commercial equivalents to service types. Booklet issued as supplement to *R.S.G.B. Bull.*, vol. 22, January, 1947.

621.385:533.5 1260  
**Evacuation of Mean and Low-Power Transmitting Tubes**—P. Plion. (*Le Vide* (Paris), vol. 1, pp. 71-78; May, 1946.) Discusses methods of degassing electrodes and envelopes and describes mass production evacuation methods used in France.

621.385.016.2 1261  
**Bettering Output from Power Tubes**—L. Dolinko. (*Elec. Ind.*, vol. 5, pp. 60-62, 104; December, 1946.) Improved performance by use of getter traps and graphite anodes.

621.385.029.63/.64 1262  
**The Beam Traveling-Wave Tube**—J. R. Pierce. (*Bell Lab. Rec.*, vol. 24, pp. 439-442; December, 1946.) For other accounts see 585 and 586 of March.

621.385.029.63/.64 1263  
**Broad-Band Tube**—(*Elec. Ind.*, vol. 5, pp. 57, 103; December, 1946.) A beam traveling-wave tube giving very high gain and a bandwidth about 80 times that hitherto practicable with other microwave tubes. See also 585 and 586 of March.

621.385.032.2:669.296 1264  
**Zirconium in Electron Tubes**—Foote Mineral Co. (See 1120.)

621.385.1.032.216 1265  
**Electronic Emission of Tungsten-Caesium and Tungsten-Thorium Cathodes**—C. Biguet. (*Le Vide* (Paris), vol. 1, pp. 13-20 and 54-60; January and March, 1946.) The emissive properties of a thin layer of caesium, at most mono-atomic, obtained by progressive condensation on a tungsten filament, are deduced from De Boer's theory of adsorption. By analogy it is shown that for thorium on tungsten there is an optimum thickness corresponding to at least a

mono-atomic layer of thorium. Intensities corresponding to different carburization treatments are tabulated. Micrographs reveal the nature of the surface of thoriated tungsten, the formation processes and emission characteristics of which are discussed in detail.

621.385.2 1266  
**Emission-Limited Diode**—W. E. Benham. (*Proc. I.R.E. and Waves and Electrons*, vol. 34, p. 863; November, 1946.) Comment on 3885 of 1945. In the case where the ratio of the radii of the cylinders exceeds about 10, the transit time is best obtained from Scheibe's formula.

621.385.38:621.3.018.41 1267  
**Frequency Performance of Thyratrons**—H. H. Wittenberg. (*Trans. A.I.E.E. (Elec. Eng., December, 1946)*, vol. 65, pp. 843-848; December, 1946.)

621.385.832 1268  
**The Ion Trap in C.R. Tubes**—J. Sharpe. (*Electronic Eng.*, vol. 18, pp. 385-386; December, 1946.) An electron beam is always accompanied by negative ions of various types which have undesirable effects on the cathode-ray-tube screen. Three methods for separating the ions from the beam are described, which depend on the difference in the behavior of the ions from that of the electrons.

621.396.615.14:537.291 1269  
**Induction Currents Produced by Moving Electrons**—A. Colino. (*Marconi Rev.*, vol. 9, p. 123; July-September, 1946.) A "simple and intuitive" treatment of Ramo's formula (131 of 1940) for induction currents due to movement of electrons in tube interelectrode spaces.

621.396.615.141.2.032.21 1270  
**Magnetron Cathodes**—M. A. Pomerantz. (*Proc. I.R.E. and Waves and Electrons*, vol. 34, pp. 903-910; November, 1946.) Thermionic emission densities and their effect on magnetron performance are considered; the technique of emission measurement, and the interpretation of results in terms of the Richardson, Langmuir-Childs, and Schottky equations is discussed. Sparking, pulse temperature rise, and back bombardment are briefly considered. The essential requirements of magnetron cathodes which are thus made clear appear to be better met by a new 'sintor' (sintered thorium oxide) cathode than by existing types.

621.396.615.142.2 1271  
**The Klystron**—A. V. J. Martin. (*Toute la Radio*, vol. 13, pp. 270-271; November, 1946.)

621.396.615.142 1272  
**Elementary Treatment of Longitudinal Debunching in a Velocity Modulation System**—E. Feenberg. (*Jour. Appl. Phys.*, vol. 17, pp. 852-855; October, 1946.) Plane parallel electrode systems of unlimited extent, coaxial circular systems of infinite axial length, and concentric spherical systems give rectilinear motion of the electrons, with or without velocity modulation. In these cases a complete evaluation is given of the effect of space charge on the bunching process in the range of drift space where overtaking (crossing of orbits) does not occur.

621.396.645 1273  
**Load Conditions in Class A Triode Amplifiers**—Foster. (See 1044.)

621.396.645:621.396.822 1274  
**Background Noise in Amplifiers**—Zelbetein. (See 1200.)

621.385.3+621.396.694 1275  
**The Gas-Filled Triode [Book Review]**—G. Windred. Hulton Press, London, 1946, 72 pp., 2s. 6d. (*Nature* (London), vol. 158, p. 689; November 16, 1946.) "Practical applications in industrial control and trigger circuits" and "a complete list of models available at the present



time, with operating conditions and possible circuits."

## MISCELLANEOUS

- 061.5:621.38/.39 1276  
**Electrical Communication: 1940-1945: Part 2**—(*Elec. Commun.*, vol. 23, pp. 214-240; June, 1946.) Developments by Federal Telecommunication Laboratories and Federal Telephone and Radio Corporation in various fields including direction finding and aerial navigation communication equipment for radio, telephony, and telegraphy, tubes, rectifiers, quartz crystals, and transformers. For part 1 see 3135 of 1946; in this, the Universal Decimal Classification number should read as above.
- 061.6 1277  
**Work on the E.R.A. [British Electrical and Allied Industries Research Association]**—(*Electrician*, vol. 138, pp. 441-442; February 7, 1947. Editorial comment, p. 427.) A summary of the report for the twelve months ended September 30, 1946. Remarkable progress has been made in the fundamental theory of dielectric breakdown, and of the general shape of resonance lines. Inadequate financial support for the activities of the Association is feared as a result of the new Electricity Bill.
- 081 Rutherford 1278  
**The Rutherford Papers in the Library of the Cavendish Laboratory**—E. B. Bond and W. L. Bragg (*Nature* (London), vol. 158, p. 714; November 16, 1946.) These have been classified and cover Rutherford's scientific career from his first research papers to his last contribution in *Nature*. "A rich mine of information, not only about Rutherford himself, but also about many famous men of his time."
- 389.6(73) 1279  
**The American Standards Association—Our Colleague in Standardization**—W. H. Crew. (PROC. I.R.E. AND WAVES AND ELECTRONS, vol. 34, pp. 874-875; November, 1946.)
- 41.316.3 1280  
**French Terms of English Origin**—E. Aisberg. (*Wireless World*, vol. 53, p. 21; January, 1947.) Some examples of French technical jargon and errors, e.g., "Courants de Eddy."
- 5+6]:011 1281  
**Bulletin Analytique**—A monthly review of scientific and technical abstracts published by the Centre de Documentation du Centre National de la Recherche Scientifique, 18 rue Pierre-Curie, Paris (5<sup>e</sup>). Each month's issue is in two sections, the first dealing with mathematics, physics, chemistry, and their applications and the second with biology and medicine. Microfilm copies of all articles mentioned are available for loan. The annual subscription is 1800 francs per section.
- 5 Fleming 1282  
**Ambrose Fleming—His Life and Early Researches**—J. T. Macgregor-Morris. (*Jour. Telev. Soc.*, vol. 4, pp. 266-273; September, 1946.) The first Fleming Memorial Lecture.
- 5 Mandelstam 1283  
**In Memory of Academician L. I. Mandelstam, 1879-1944**—(*Bull. Acad. Sci.* (U.R.S.S.), sér phys., vol. 9, nos. 1/2, pp. 1-132; 1945. In Russian.) Double issue devoted to appreciations and surveys of the work of L. I. Mandelstam in various fields of physics and radio.
- 522.1(42) Greenwich 1284  
**Greenwich Observatory**—W. M. Witchell. (*Weather* (London), vol. 2, pp. 23-29; January, 1947.) A sketch of the functions of the Royal Observatory and of its history from its foundation in 1676 to the present time.
- 537+538]:371.3 1285  
**Teaching Electricity and Magnetism**—V. P. Hessler. (*Trans. A.I.E.E.* (*Elec. Eng.*, December, 1946), vol. 65, pp. 828-833; December, 1946.) The importance of a full understanding of fundamental concepts is stressed. The order in which they should be taught is suggested, with careful distinction between definitions, experimental laws, and laws theoretically derived.
- 551.556.3 1286  
**Wind Energy: Its Value and the Search for [Installation] Sites**—P. Ailleret. (*Rev. Gén. Elec.*, vol. 55, pp. 103-108; March, 1946.)
- 621.3 1287  
**The Glasgow Technical Exhibition**—(*Electronic Eng.*, vol. 19, pp. 28-30; January, 1947.) A short review of some of the instruments, tools, and miscellaneous items shown at the Kelvin Hall, November, 1946.
- 621.3(44) 1288  
**The Role of the Société Française des Électriciens in French Electrical Activity**—R. Langlois-Berthelot. (*Bull. Soc. Franç. Elec.*, vol. 6, pp. 157-172; April, 1946.)
- 621.3.016.25 1289  
**Sign of Reactive Power**—F. B. Silsbee. (*Elec. Eng.*, vol. 65, pp. 598-599; December, 1946.) The definition of a quantity 'quadergy,' the time integral of the reactive power measured in kilovars, helps to reconcile the seemingly incompatible requirements that a vector diagram similar to admittance diagrams should be obtained and that an inductive circuit should be considered to absorb power. Comment on 971 of April.
- 621.315.3:389.6 1290  
**Views on the Wiring Codes—"Supervisor"** (*Electrician*, vol. 138, pp. 439-440; February 7, 1947.) Comment on two Codes of Practice concerning electrical installations now issued in draft form. It is felt that the Codes are too stringent for present conditions, and do not make the best use of available resources. Mains-borne radio interference should be suppressed at the source rather than by any choice of wiring system.
- 621.38/.39 1291  
**National Electronics Conference Papers**—(*Elec. Eng.*, vol. 65, pp. 569-574; December, 1946.) *Elec. Ind.*, vol. 5, pp. 46-47, 111; December, 1946.) Abstracts of papers to be published in the Proceedings of the second National Electronics Conference. For titles of papers read at the Conference, see other sections.
- 621.396 1292  
**Radio Amateur Call Book**—(*Wireless World*, vol. 53, p. 26; January, 1947.) Lists call signs, names and addresses in Great Britain, United States, and some seventy other countries. Quarterly publication has been resumed.
- 621.396:384 1293  
**The Radio Industry from an Economic Viewpoint**—D. A. Bell. (*Wireless World*, vol. 53, pp. 27-29; January, 1947.) A survey based on prewar figures. Postwar exports show a large increase. The economic need of the broadcast receiver industry at the present time is for more efficient organization of production.
- 621.396"20" 1294  
**Half a Century of Radio Communications (1896-1946)**—S. P. Chakravarti. (*Curr. Sci.*, vol. 15, pp. 299-305; November, 1946.)
- 678.1.02 1295  
**National Rubber Research at Stanford University**—(*Science*, vol. 104, p. 622; December 27, 1946.) An eight-month investigation to be carried out at Salinas, California, seeking to cultivate plants with high rubber content and develop economical processes of extracting the rubber.
- 744.34:621.3 1296  
**Cylindrical Draughting Machines for Electronic Diagrams, etc.**—A. M. Haworth. (*Electronic Eng.*, vol. 18, p. 387; December, 1946.) The paper is mounted on a cylinder which can be rotated about its horizontal axis. A straight edge is provided parallel to this axis. For drawing lines at right angles the cylinder is rotated and the pencil kept fixed.
- 6(02) 1297  
**Progress in Science [Book Review]**—W. L. Sumner. Blackwell, Oxford, 176 pp., 8s.6d. (*Nature* (London), vol. 158, pp. 646-647; November 9, 1946.) Survey of technical developments during the last few years, including electron applications, the electron microscope, radar, television, atomic energy, and plastics. Future applications of present-day researches are discussed. The author "has never forgotten that he has been writing for those only slightly informed of matters scientific."
- 621.3:69 1298  
**Electricity in the Building Industry [Book Review]**—F. C. Orchard. Chapman and Hall, London, 232 pp., 15s. (*Electrician*, vol. 137, p. 1597; December 6, 1946.) Deals with questions of installation, workshop wiring, and lighting, power costs, maintenance, and research.
- 621.3.004.5/.6(023) 1299  
**Electrician's Maintenance Manual [Book Review]**—W. E. Steward. G. Newnes, London, 144 pp., 6s. (*Electronic Eng.*, vol. 18, p. 388; December, 1946.)
- 621.3.029.6(02) 1300  
**Hyper and Ultrahigh Frequency Engineering [Book Review]**—R. I. Sarbacher and W. A. Edson. John Wiley and Sons, New York, N. Y., 644 pp., \$6.00. (*Telegr. Teleph. Age*, vol. 64, p. 27; December, 1946.) "By avoiding complex mathematical technology, the authors have succeeded in giving in an easily understood manner a complete treatment on guided waves, Maxwell's equations, ultra-high-frequency generation, and all related equipment."
- 621.396 1301  
**Reference Data for Radio Engineers [Book Review]**—W. L. McPherson. Standard Telephones and Cables, London, second edition, 175 pp., 5s. (*Wireless World*, vol. 53, January 1947.)
- 621.396 1302  
**Reference Data for Radio Engineers [Book Review]**—Federal Telephone and Radio Corp., Publication Department, New York, N. Y., second edition, 336 pp., \$2.00. (*Telegr. Teleph. Age*, vol. 64, p. 31; November, 1946.) "Revised and enlarged to cover important radio technical data developed during the war."
- 621.396(031) 1303  
**The Radio Amateur's Handbook, 1946 Edition [Book Review]**—Headquarters Staff of the American Radio Relay League. American Radio Relay League, West Hartford, Conn., 1946, 468+208 pp., \$1.00 in the United States; \$1.50 elsewhere. (PROC. I.R.E. AND WAVES AND ELECTRONS, vol. 34, p. 865; November, 1946.) Comparison with the preceding edition shows an expansion of the treatment of wave guides and cavity resonators and of the ultra-high-frequency section, but about half the material on measurements is deleted.



...a metal for inserts that won't work loose from ceramic insulation as temperatures fluctuate.

**Mycalex Corp.**

...a metal to hold other parts in place under the searing heat of a high-voltage discharge.

**General Electric Co.**

...a metal that won't develop high surface resistance because of corrosion.

**Vendo Corp.**

...a metal whose electrical resistance varies measurably with temperature changes.

**The Simmons Co.**

...a metal for an armature that vibrates continuously 94,000,000 times a year.

**Union Switch and Signal Co.**

...a metal that can stand spark erosion without pitting or burning.

**Scintilla Magneto Co.**

...a metal that will remain non-magnetic during spot-welding.

**General Thermostat Corp.**

THESE ARE TYPICAL METAL SELECTION PROBLEMS THAT WERE SOLVED BY USE OF  
**MONEL  
NICKEL  
INCONEL**

	MONEL	"R" MONEL	"K" MONEL	"KR" MONEL	"S" MONEL	NICKEL	"Z" NICKEL	INCONEL
-CORROSION RESISTANCE	HIGH	HIGH	HIGH	HIGH	HIGH	HIGH	HIGH	HIGH
-STRENGTH	GOOD	GOOD	HIGH	HIGH	GOOD	GOOD	HIGH	GOOD
-TOUGHNESS	GOOD	GOOD	HIGH	GOOD	GOOD	HIGH	HIGH	HIGH
-HARDNESS	GOOD	GOOD	GOOD	GOOD	HIGH	FAIR	HIGH	GOOD
MACHINABILITY	GOOD	HIGH	GOOD	HIGH	GOOD	GOOD	GOOD	GOOD
-NON-GALLING	NO	NO	NO	NO	HIGH	NO	NO	NO
-SPRING PROPERTIES	GOOD	NO	HIGH	NO	NO	GOOD	HIGH	HIGH
ELEC. CONDUCTIVITY	POOR	POOR	POOR	POOR	POOR	GOOD	GOOD	POOR
HEAT RESISTANCE	GOOD	GOOD	GOOD	GOOD	HIGH	GOOD	GOOD	HIGH
HEAT TREATABLE	NO	NO	YES	YES	YES	NO	YES	NO
-NON MAGNETIC	NO	NO	YES	YES	YES	NO	NO	YES

Think of the INCO Nickel Alloys first when you need a metal with a hard-to-find combination of properties.

These high-Nickel alloys are Strong... Tough... Hard... Rustless. They resist High Temperatures... Corrosion... Wear... Fatigue. Their use is insurance for long, trouble-free service.

**MORE INFORMATION!** Tell us the alloy that interests you, and we'll mail more information. Or, send for "List B-100" which lists over 100 bulletins explaining the properties and applications of the INCO Nickel Alloys.

**THE INTERNATIONAL NICKEL COMPANY, INC.**  
67 Wall Street, New York 5, N. Y.

**NICKEL  ALLOYS**

MONEL • "K" MONEL • "R" MONEL • "KR" MONEL  
"S" MONEL • INCONEL • NICKEL • "L" NICKEL • "Z" NICKEL  
Reg. U. S. Pat. Off.

# Announcing!



## ... NEW 1304 CABINET TYPE REPRODUCER SETS

Here are two brand new Western Electric Reproducer Sets for broadcast stations, recording studios and other professional users—designed from the ground up to bring out the full quality of today's finest transcriptions and records.

The 1304A includes the popular 9A Reproducer; the 1304B has the new 9B. Both equipments are available, less cabinet, as the 304A and 304B Reproducer Panels respectively. An entirely new drive mechanism with a belt and one-step helical gear reduction at both  $33\frac{1}{3}$  and 78 rpm provides constant-speed operation and extra long life. Mechanical filters isolate

the turntable effectively from vibration in the motor, the driving mechanism, and the cabinet.

A new, more efficient, *electrical* method of changing turntable speed, based on reversing the direction of rotation of the motor, eliminates the usual clash gears or planetary ball devices.

The attractively styled cabinet is adjustable in height to match various operating requirements. For full details, see your local Graybar Broadcast Equipment Representative — or write to Graybar Electric Company, 420 Lexington Avenue, New York 17, N. Y.

*Designed by Bell Telephone Laboratories*

# Western Electric

— QUALITY COUNTS —





# SECTION MEETINGS

## ATLANTA

"Transmitting Tubes for FM and Television," by H. L. Thorson, General Electric Company; February 21, 1947.

Election of Officers, February 21, 1947.

## BOSTON

"Low-Power Wide-Tuning-Range Microwave Oscillators," by W. H. Huggins, Cambridge Field Station; February 20, 1947.

"Thermistors," by C. B. Green, Bell Laboratories; March 20, 1947.

## BUFFALO-NIAGARA

"Radio Controlled Aircraft," by H. Hawkins, Bell Aircraft Corporation; March 19, 1947.

## CEDAR RAPIDS

"Design Considerations of a Pulse-Time Modulation MultiChannel Telephone System," by A. M. Levine, Federal Telecommunications Laboratories; March 10, 1947.

"The Resnatron," by J. J. Livingood, Collins Radio Company; February 19, 1947.

## CLEVELAND

"Pulse-Time Modulation," by S. Moscovitz, Federal Telecommunication Laboratories; December 5, 1946.

"Pickups," by D. Andrews, Radio Corporation of America, J. H. Keachie, Radio Corporation of America, W. S. Rockwell, Graybar Electric Company, and F. R. Walker, General Electric Company; January 23, 1947.

"Thomas Alva Edison," by W. E. Wickenden, Case Institute of Technology; February 11, 1947.

"Western Coast of South America" (Color Film), by C. Rakestraw, General Electric Illuminating Company; February 11, 1947.

## COLUMBUS

"Printed Circuits and VT Fuses," by C. Brunetti, U. S. Bureau of Standards; February 14, 1947.

"Television and How It Is Accomplished," by R. B. Jacques, Ohio State University; March 14, 1947.

## DALLAS-Ft. WORTH

"Jet Propulsion" (Sound Color Film), by T. E. Acord, General Electric Company; January 21, 1947.

Election of Officers; January 21, 1947.

"FM Broadcast Antennas," by R. L. Hammett, Associate of A. Earl Cullum, Jr.; February 20, 1947.

## DAYTON

"Frequency Synthesis in the VHF Band," by W. R. Hedeman, Bendix Radio Division; March 13, 1947.

## DETROIT

"Western Electric FM Transmitters," by B. J. Bishop, Bell Telephone Laboratories; February 21, 1947.

"Pulse-Time Modulation," by P. W. Sokoloff, Federal Telecommunications Laboratories; March 21, 1947.

## EMPORIUM

"Collecting Scientific Information in Germany," by B. S. Ellefson, Sylvania Electric Products, Inc.; February 27, 1947.

"Operations Crossroads," (Movies and Discussion) by H. C. Hodge; University of Rochester; March 20, 1947.

## HOUSTON

"The Application of Atomic Power," by B. Prentice, General Electric Company; February 21, 1947.

(Continued on page 36A)

Let CLAROSTAT  
*Solve*  
your  
RESISTANCE PROBLEMS

Let CLAROSTAT  
*Solve*  
your  
RELAY PROBLEMS  
*too!*



Clarostat telephone type relay. Great flexibility because of large variety of contact arrangements. Long life—many millions of operations. High sensitivity. Coil values up to 11,300 ohms. Available in long and short types.

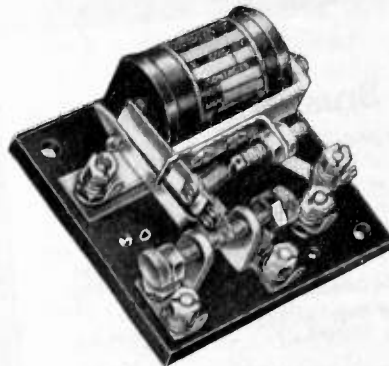

Clarostat sensitive relay. High-permeability nickel alloy. Normally adjusted to 14 milliwatts D.C. sensitivity, can be increased to 3 milliwatts. Coils up to 30,000 ohms. A.C. sensitivity of .35 VA at 60 cycles, or 0.5 VA at 25 cycles. Power factor of .4 and .25, respectively. Chatterless operation—suitable for high-speed keying.

★ Here's NEWS! Clarostat, long a favorite supplier of resistors, controls and resistance devices, also designs, develops and builds RELAYS!

Clarostat has an engineering staff of relay specialists second to none. These men have many years of experience in relay problems and solutions. They have built and supplied tens of thousands of relays of all types now found in the finest assemblies. Likewise mid-giet synchronous motors for clocks and time switches. Therefore...

Let Clarostat Solve Your Relay Problems, too! Submit your problems and requirements. Literature on request.

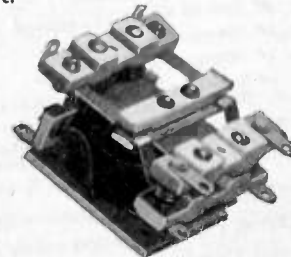

Clarostat ceramic relay featuring non-hygroscopic, low power-factor steatite insulation of 5000 v. to ground. Required input 2 watts D.C. or 4 VA A.C. Contacts good for 10 amperes. Coils up to 10,000 ohms.

CLAROSTAT

*Controls and Resistors*

CLAROSTAT MFG. CO., Inc. · 285-7 N. 6th St., Brooklyn, N. Y.



# Brush magnetic recording tape and wire are ready for America's homes and industry!

No matter what type of magnetic recorder you design, the low cost, excellent fidelity and uniformity of Brush Magnetic Tape and Wire assures you all-round quality in recording mediums. With these new developments by the pioneer and leader in the field of magnetic recording you can bring magnetic recording to the great mass market of all America!



The new Brush wire recording head



Cross section of Brush plated wire

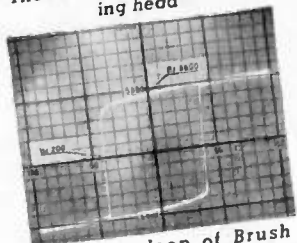

Hysteresis loop of Brush plated wire



The new Brush tape recording head

## Brush Paper Tape

- ✓ Easy to Handle
- ✓ Extremely low-cost
- ✓ Can be edited . . . spliced
- ✓ Greater dynamic range
- ✓ Minimum wear on heads
- ✓ Excellent high frequency reproduction at slow speed
- ✓ Permanent—excellent reproduction for several thousand play-backs

## Brush Plated Wire

- ✓ Constant plating thickness assures uniform signal
- ✓ Correct balance of magnetic properties assures good frequency response and high level
- ✓ Excellent surface finish assures low noise and minimum wear
- ✓ Corrosion resistant
- ✓ Easy to handle—ductile—can be knotted

Other Brush developments in magnetic recording components include Brush Plated Wire and vastly improved Tape and Wire Recording Heads and Cartridges.

These latest developments in magnetic recording equipment can now be obtained for radio combinations and other uses. Brush engineers are ready to assist you in your particular use of magnetic recording components.

Write today for further information

**The Brush Development Co.**  
3405 Perkins Avenue, Cleveland 14, Ohio



(Continued from page 35A)

"Frequency Modulation versus Amplitude Modulation," by G. K. Miller, Schlumberger Well Surveying Corporation; March 21, 1947.

### INDIANAPOLIS

"Design Considerations for Precision Master Oscillators," by T. A. Hunter, Collins Radio Company; February 21, 1947.

"Television Sweep Generator," by M. Wiegel, Tarzian Associates; February 28, 1947.

"Television Tuner Unit," by A. Valdetaro, Tarzian Associates; February 28, 1947.

"Acceleration of Particles to Very-High Energy," by L. M. Langer, Indiana University; February 28, 1947.

### LONDON, ONTARIO

"High-Frequency FM Links," by B. Brereton, Radio Corporation of America Victor Company; March 7, 1947.

### LOS ANGELES

"Electronics as a Control Communication and Power Supply," by L. Ryder, Paramount; March 4, 1947.

"Introduction to Sound Recording," by L. Ryder, Paramount; March 4, 1947.

"Theory and Mechanics of Sound Recording," by A. Frayne, Western Electric Company; March 4, 1947.

"Practical Techniques of Recording and Recording," by L. Grignon, 20th Century-Fox; March 4, 1947.

"Sound Reproduction, Mechanics, and Technique," by W. A. Mueller, Warner Brothers; March 4, 1947.

### MONTREAL

"Pitch, Loudness, and Quality of Musical Tone," by H. Fletcher, Bell Telephone Laboratories; March 13, 1947.

### NEW YORK

"Landing Aircraft with Ground Radar," by R. C. Ferrer and J. S. Engel, Federal Telephone and Radio Corporation; January 8, 1947.

"Electron Tubes in World War II," by J. E. Gorham, Evans Signal Laboratory; January 22, 1947.

"Frequency-Shift Telegraphy-Radio and Wire Application," by J. R. Davey and A. L. Matte, Bell Telephone Laboratories; February 5, 1947.

"Relative Amplitude of Side Frequencies in On-Off Frequency-Shift Keying," by G. S. Wickizer, Radio Corporation of America Laboratories; February 5, 1947.

### NORTH CAROLINA-VIRGINIA

"Vehicular Radiotelephone Equipment," by L. D. Chipman, Western Electric Company; March 21, 1947.

### OTTAWA

"Radio Aids To Air Navigation," by D. W. R. McKinley, National Research Council; March 13, 1947.

### PHILADELPHIA

"Theory of Multistage Wide-Band Amplifier Design," by W. E. Bradley, Philco Corporation; March 6, 1947.

### PITTSBURGH

"Reflex Oscillators for Radar Receivers," by W. G. Shepherd, Bell Telephone Laboratories; January 6, 1947.

"Sperry Loran," by W. Palmer, Sperry Gyroscope Company; February 10, 1947.

### PORTLAND

"Noise in FM Reception," by R. W. Deardorff, Pacific Telephone and Telegraph Company; February 26, 1947.

"The Traveling-Wave Tube," by L. M. Field, Stanford University; March 20, 1947.

(Continued on page 38A)





Keep the sparkle in your programs...

## with the New Collins 20T 1 kw AM transmitter

Let the brilliant overtones of high fidelity flow through circuits engineered for high fidelity. The 20T development, a new post-war success, reveals in each detail the quality of its design.

**Dual oscillators.** Two temperature-controlled oscillators, adjusted to your operating frequency, are self-contained in the 20T. A selector switch enables you to place the spare unit in operation when you remove the other for maintenance.

**Two cabinets.** Past practice has been to crowd a kilowatt transmitter into a single cabinet. The Collins 20T gives you two cabinets with lots of room, genuine accessibility, ample ventilation, and impressive appearance.

**Program protection and circuit protection.** In addition to magnetic circuit breakers and two-shot d-c overload relays, the 20T has high voltage capacitor fusing. Should a capacitor fail, the fuse opens the circuit and a spring bar shorts the capacitor terminals. The transmitter stays on the air and the faulty capacitor is indicated.

**Filament voltage regulator.** For longer tube life, and low noise and distortion levels, the 20T tube filaments have a constant voltage supply.

**Attractive styling.** The cabinets are attractively styled in three-tone gray. Their modern, distinctive appearance, simplicity of design, and pleasing color harmony will give many years of eye appeal and satisfaction.

Eye level metering—centralized controls—motor driven tuning elements—forced air cooling—high safety factors—30-10,000 cps audio response  $\pm 1.0$  db—3% audio distortion—minus 65 db noise level.

Only the Collins 20T gives you all these desirable and important features. Deliveries will begin early this year. We suggest you write for detailed specifications, study them, compare them, and then place your order for early delivery. Let us supply your entire equipment needs. You'll have an integrated system that will keep the sparkle in your programs and put a sparkle in your station.

FOR BROADCAST QUALITY, IT'S...

COLLINS RADIO COMPANY, Cedar Rapids, Iowa

11 W. 42nd St., New York 18, N. Y.



458 S. Spring St., Los Angeles 13, Calif.

It's Better Because It's Bendix!

*Now Available!*

Aviation Standard  
**Bendix DYNAMOTORS**

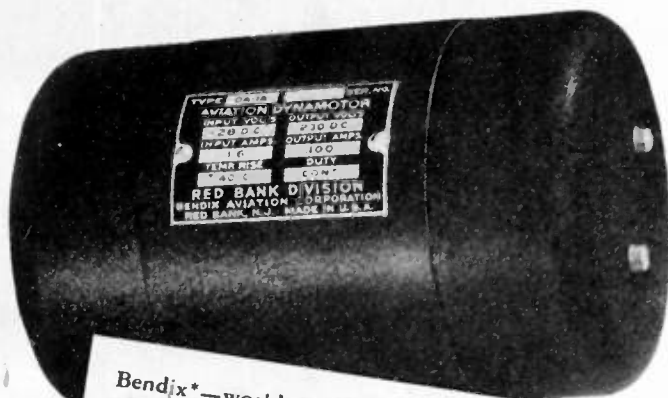

Bendix\*—world famous for top-flight aviation quality—now makes available to the radio industry these low-cost D.C. Transformers.

- Specially designed for long life, light weight, and low ripple.
- Standard diameters run 2¾, 3⅞, 4, 4½, 5 and 5¼ inches.
- From 12 to 1100 volts and from 15 to 500 watts output.
- Continuous duty—enclosed.
- Intermittent duty—ventilated.
- Single, dual, and triple output.
- Regulated and unregulated.

Write to the address below for detailed information on these and other Bendix Dynamotors to meet your power requirements.

\*REG. U.S. PAT. OFF.

STANDARD RATINGS					
Model	Frame Size	Input Volts	Output Volts	Output Watts	Approx. Weight
DA58A	2¾"	14	250	15	2 lb. 12 oz.
DA1A	3⅞"	14	230	23	5 lb.
DA77A	4"	5.5	600	104	9 lb. 12 oz.
DA1F	4½"	25	540	243	11 lb. 8 oz.
DA7A	5¼"	26.5	1050	420	26 lb. 10 oz.

RED BANK DIVISION of  
Red Bank, New Jersey



(Continued from page 36A)

ROCHESTER

"Teloran—Air Navigation and Traffic Control by Means of Television and Radar," by D. H. Ewing, Radio Corporation of America, Victor Division; February 27, 1947.

"Magnetrons as a Source of High Power Microwaves and their Applications to Radar," by G. B. Collins, University of Rochester; March 6, 1947.

ST. LOUIS

"Very-High-Frequency and Ultra-High-Frequency Antennas," by A. G. Kandoian, Federal Telecommunication Laboratories; February 27, 1947.

"RCA Direct-View Television Receivers," by A. Wright, Radio Corporation of America; March 11, 1947.

"The RCA Projection-Type Television Receiver," By E. L. Clark, Radio Corporation of America; March 11, 1947.

"Radar and Microwaves," by J. G. Perrine, American Telephone and Telegraph Company; March 20, 1947.

SAN DIEGO

"Crystals and Their Uses in Radio and Sonar," by W. G. Cady, Wesleyan University; March 4, 1947.

"Audio Distortion Measurements by the Two-Tone Intermodulation Method," by J. R. McGaughey, S. H. Sessions, R. S. Gales, and T. Shaffer, U. S. Navy Electronics Laboratory; March 21, 1947.

SAN FRANCISCO

"Atomic Energy for Power Generation," by C. P. Cabell, Ford Works; January 24, 1947.

"Analysis of Intermodulation Distortion Measurements," by W. J. Warren, Hewlett-Packard Company; January 29, 1947.

"Gain and Stability of Triode versus Tetrode Amplifiers at Very-High-Frequency," by W. C. Wager, Eitel-McCullough, Inc.; February 19, 1947.

SEATTLE

"Development of Germanium Crystals," by R. Smith, Boeing Physical Research Laboratory; February 14, 1947.

"Traveling-Wave Tubes," by L. M. Field, Stanford University; March 21, 1947.

SYRACUSE

"Microwave Transmission," by W. C. White, General Electric Research Laboratory; February 6, 1947.

Election of Officers; February 6, 1947.

TORONTO

"Cathode-Ray Direction Finders," by B. Graham, Sparton of Canada, and C. W. McLelsh, National Research Council; March 17, 1947.

WASHINGTON

"Electronic Aids to Scientific Computation," by S. N. Alexander, National Bureau of Standards; March 10, 1947.

WILLIAMSPORT

"Gathering Technical Information in Germany," by B. S. Ellefson, Sylvania Electric Products Inc., February 26, 1947.

"New Problems in Teaching Electronics," by E. B. Stavely, Pennsylvania State College; March 19, 1947.

SUB-SECTIONS

PRINCETON

"The Electrical Activity in Fibres of the Optic Nerve," by H. K. Hartlein, University of Pennsylvania; February 5, 1947.

WINNIPEG

"Design Considerations of a Pulse-Time Modulation Multichannel Telephone System," by A. M. Levine, Federal Telecommunications Laboratories, Ltd.; March 13, 1947.



# NEW SYLVANIA G-M TUBES

... FOR DETECTION AND MEASUREMENT OF RADIOACTIVITY!



For the first time, counter tubes of *stable, uniform characteristics* are now available for practical use in the field of radioactivity.

Formerly, tubes of this type were hand-made — delicate, variable products of the laboratory glass-blower. Through Sylvania research and development, vacuum tube production techniques have now been adapted to their manufacture, with the resulting advantages of stability during tube life, and uniformity from tube to tube.

Use of Sylvania laboratory and manufacturing techniques enables the external quench circuit tubes to be produced in quantity, to bring the customer the advantages of stability and much longer life.

## FEATURES

**LONG LIFE      UNIFORMITY**  
**DEPENDABILITY      STABILITY**  
**CONVENIENCE**

## APPLICATIONS OF SYLVANIA GEIGER-MUELLER TUBES

Sylvania Tube GB-302 is a beta-ray counter, utilizing a thin but rugged window of metal foil. It is extremely sensitive to the beta-radiation of the majority of available radioactive isotopes.

The GB-302 will be particularly valuable in tracer techniques, and is also well adapted to medical diagnostic and therapeutical uses.

Sylvania Tube GG-304 is the gamma-ray counting companion to the GB-302. It is useful in radiological safety surveys and other applications where gamma radiation must be efficiently measured. In addition, Sylvania Tube GG-304 can be used for cosmic ray studies, especially in coincidence work.

*Write for full details.*

# SYLVANIA ELECTRIC

Electronics Division . . . 500 Fifth Avenue, New York 18, N. Y.

MAKERS OF ELECTRONIC DEVICES, RADIO TUBES, CATHODE RAY TUBES, FLUORESCENT LAMPS, FIXTURES, WIRING DEVICES, ELECTRIC LIGHT BULBS

*Burned up—  
but still "alive"!*



**SHURE**

**T**HE "556" Broadcast Dynamic shown here unretouched was badly burned in a fire January 7 that gutted the Rita Theatre in Longview, Texas, where it was being used in a remote show for Radio Station KFRO. Surprising part of the story is that the Microphone worked perfectly when tested in our Service Department.



The excellent showing made by the Shure "556" Broadcast Dynamic Microphone is a "living" testimonial to the ruggedness and dependability of all Shure Microphones.

**SHURE BROTHERS, Inc.**

*Microphones and Acoustic Devices*

225 West Huron Street

Chicago 10, Illinois



The following transfers and admissions were approved on March 20, 1947, to be effective May 1, 1947:

**Transfer to Senior Member**

- Applegarth, A. R., Jr., P. O. Box 53, Gwynedd Valley, Pa.
- Breeze, J. E., Apt. 2, 865 Bronson Ave., Ottawa, Ont., Canada
- Campbell, R. L., 1055—9th, Boulder, Colo.
- Farrell, J. J., 424 Salt Springs Rd., Syracuse 3, N. Y.
- Gilman, G. W., Bell Telephone Laboratories, Inc., 463 West St., New York 14, N. Y. (Elected March 1, 1947)
- Hewlett, W. R., 2250 Byron St., Palo Alto, Calif.
- Hutchins, W. R., 10 Main St., Fairhaven, Mass.
- Larson, C. O., 7909 St. Louis Terr., La Jolla, Calif.
- Nyquist, H., Bell Telephone Laboratories, Inc., 463 West St., New York 14, N. Y.
- Parr, G., 68 Compton Rd., London, N. 21, England
- Roberts, F. F., Radio Branch (W41), P. O. Research Station, London, N.W. 2, England
- Sansbury, G. L., 2027 Bever Ave., S.E., Cedar Rapids, Iowa
- Saylor, W. R., General Radio Company, 275 Massachusetts Ave., Cambridge 39, Mass.
- Suter, H., 414 Weston Rd., Wellesley 81, Mass.
- Towilson, H. G., 220 Arlington Ave., Syracuse 7, N. Y.
- Waldschmitt, J. A., 711 Fifth Ave., Bethlehem, Pa.
- White, R. N., 4800 Jefferson St., Kansas City 2, Mo.

**Admission to Senior Member**

- Henderson, J. T., 194 Second Ave., Ottawa, Ont., Canada
- Homsy, J. H., 5122 Vanderbilt Ave., Dallas 6, Tex.
- Merchant, W. J., 8007 Eastern Dr., Silver Spring, Md.
- Murphy, J. V., 3420 N. Lorcom Lane, Arlington, Va.

**Transfer to Member**

- Bard, R. E., 1830 S. 54 Ave., Cicero 50, Ill.
- Bell, W. S., 5601—32 St., N.W., Washington 15, D. C.
- Braga, F. J., Bell Telephone Laboratories, Inc., 463 West St., New York 14, N. Y.
- Conrad, C. G., 4203 Arcadia Blvd., Dayton 10, Ohio
- Hagerty, G. E., Westinghouse Radio Stations, Inc., 1619 Walnut St., Philadelphia 3, Pa.
- Hixenbaugh, G. P., Radio Station WMT, Cedar Rapids, Iowa
- Jacobs, G. W., 50 E. Reid Place, Verona, N. J.
- Nikonenko, P. V., Naval Air Station, Electronics Test, Patuxent River, Md.
- Palin, E. L., 98 Donlea Dr., Leaside, Toronto 12, Ont., Canada
- Rataski, C. P., 393 E. Cliveden St., Philadelphia 19, Pa.
- Shepperd, I. J., 802 Domer Ave., Apt. #1, Takoma Park, Md.
- Waterman, C. H., 7 Rockville Park, Roxbury 19, Mass.
- Weaver, C., 3 Thompson Ave., Whitefield, Manchester, England
- Woods, D. C., WRVA Hotel Richmond, Richmond 12, Va.

**Admission to Member**

- Bark, A., 205 W. 15 St., Apt. 1-S, New York, N. Y.
- Brothers, A. L., Jr., 743 Patterson Rd., Apt. 2, Dayton 9, Ohio
- Burgess, L. M., 227 Follen Rd., Lexington, Mass.
- Burnsweig, J., Jr., 365 Orange Ave., Coronado, Calif.
- Byers, W. F., 25 Arlington St., Cambridge 40, Mass.
- Chubbuck, E. L., Jr., National Broadcasting Company, 30 Rockefeller Plaza, New York 20, N. Y.

(Continued on page 42A)





**PLANE AND PARALLEL SURFACES**

**ON ALSIMAG TECHNICAL CERAMICS**

To obtain truly plane and parallel surfaces on ALSiMag ceramics, we at American Lava Corporation have equipped our grinding department with the latest grinding equipment, of the type used for the production of quartz crystals or optical flats. It is possible to supply ceramic plates ground flat and parallel within .0001".

The designing engineer can now take full advantage

of the high mechanical strength and rigidity of our various ceramic materials. Ground to precision, the ceramic will maintain alignments regardless of strains or pressure. "Fatigue" or "cold flow" is unknown in the vocabulary of American Lava Corporation.

Here is just one instance where war production has taught us to produce something better at lower cost.

46TH YEAR OF CERAMIC LEADERSHIP

**AMERICAN LAVA CORPORATION**

CHATTANOOGA 5, TENNESSEE

**ALSiMAG**

SALES OFFICES: ST. LOUIS, MO., 1123 Washington Ave., Tel: Garfield 4955 • NEWARK, N. J., 671 Broad St., Tel: Mitchell 2 8150 • CAMBRIDGE, Mass., 38-II Rixville St., Tel: Rindland 4498  
CHICAGO, Ill., 5 Clinton St., Tel: Central 1771 • SAN FRANCISCO, 163 Second St., Tel: Douglas 2464 • LOS ANGELES, 324 N. San Pedro St., Tel: Mutual 9076 • PHILADELPHIA, 1649 N. Broad St.



(Continued from page 40A)

Cohen, H. A., 4004 Carlisle Ave., Baltimore, Md.  
Cummings, C. E., The Texas Company, Box 509,  
Beacon, N. Y.

Curtin, J. N., 372 St. Johns Pl., Brooklyn, N. Y.  
Daley, J. L., 1203 Dream's Landing, Annapolis,  
Md.

Erholm, W. H., Chief Engineer, Radio Services,  
Ministry P.T.T., Addis Ababa, Ethiopia  
Finocharo, J. J., 2319 Theodore Ave., Dayton 5,  
Ohio

Girard, P. A., Box 3746, San Juan, Puerto Rico  
Haynes, H. E., 604 Maple Ave., Audubon, N. J.  
Heald, D. W., 151 Valley Rd., Sherwood, Notting-  
ham, England

Healy, D. W., Jr., 71 Bay Dr., Bay Ridge, Annapo-  
lis, Md.

Hopkins, L. A., Jr., Box 5100, Albuquerque, N. M.  
Jonas, L. K., 403 E. Mayfield Blvd., San Antonio 4,  
Tex.

Kilroy, J. J., 458 Park Ave., East Orange, N. J.  
Kilne, M., 1188 East Eighth St., Brooklyn 30, N. Y.  
Kopp, C. J., 1830 West 105 St., Chicago 43, Ill.

Mack, M. C., Charles and Patapsco Rds., North  
Linthicum, Md.

MacLeod, W. R., 127 Solar St., Syracuse 4, N. Y.  
Margolin, J., 35 Marwood Rd. South, Port Wash-  
ington, N. Y.

Marsh, K. W., Barholm Ave., Springdale, Conn.  
Mathis, H. F., Project #29, Northwestern Univer-  
sity, Evanston, Ill.

McLaughlin, D. J., 1720 W St., S.E., Washington,  
D.C.

Miller, J. A., Department of Electrical Engineering,  
Ohio State University, Columbus 10, Ohio  
Morrissey, T. G., 4161 E. 16 Ave., Denver 7, Colo.

Newton, G. C., Jr., 50 Arcadia Ave., Waltham 54,  
Mass.

Pleasure, M., 3713—74 St., Jackson Heights, N. Y.  
Pratt, A., 119 Fairmount St., Lowell, Mass.

Pratt, H. A., 3750—39 St., N.W., Washington 16  
D. C.

Quart, R. D., 7430 Bayard Ave., Montreal, P. Q.,  
Canada

Ransom, F. A., 2929 Connecticut Ave., N.W.,  
Washington 8, D. C.

Rhoad, E. J., South River St., Marshfield, Mass.  
Schmuck, R. H., Rm. #202, Humble Bldg., Hous-  
ton, Tex.

Schwetman, H. D., 140 Upland Rd., Cambridge 40,  
Mass.

Thompson, R. R., Humble Oil and Refining Com-  
pany, Houston, Tex.

Wadsworth, C. A., 1007 Tulip St., Liverpool, N. Y.  
Waterfall, F. E., 1038 Cedar Ave., Elgin, Ill.

Wehner, R. S., Airborne Instrument Laboratory,  
160 Old Country Rd., Mineola, N. Y.

West, K. A., 10 Watson Pl., Eatontown, N. J.  
Winner, L., 245 West 107 St., New York 25, N. Y.

Wold, E. A., 4645 Ewing Ave., S., Minneapolis 10,  
Minn.

The following admissions to Associate were approved on April 1, 1947, to be effective May 1, 1947:

- Admission to Associate**
- Aas, E. A., Research Department, Farnsworth Telephone and Radio Corporation, Ft. Wayne 1, Ind.
  - Abell, G. R., Jr., 82 College Ave., Poughkeepsie, N. Y.
  - Abrahamsen, E. H., Box 71, Route 1, Osseo, Minn.
  - Achenbach, J. C., 309 Warwick Rd., Haddonfield, N. J.
  - Aitken, R. K., 50 Bar Beach Rd., Port Washington, N. Y.
  - Alexander, B., 193 Whitford Ave., Nutley, N. J.
  - Anderson, A. B. C., U. S. Naval Ordnance Test Station, RD and T Division, Inyokern, Calif.
  - Anderson, L. L., 1858 Overlook Terr., Louisville 5, Ky.

(Continued on page 44A)



OF COURSE you've heard . . . they're here . . . two excitingly NEW Phonograph Pickup Cartridges . . . somewhat different in appearance and characteristics yet happily alike in that they contribute, in greater measure than ever before, to the clarity and beauty of phonograph reproduction.

MODEL NYLON I-J

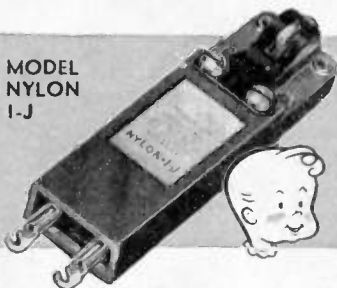

Astatic Patents Pending

MODEL "QT" (Quiet Talk)

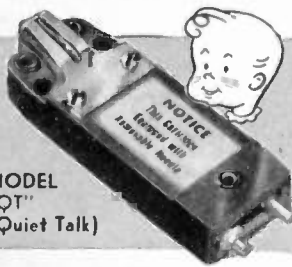

This is a special, high fidelity, wide-range cartridge for the reproduction of finest recordings. The Nylon I-J employs a genuine Nylon Chuck and MATCHED, sapphire or precious metal tipped, knee-action, REPLACEABLE Nylon Needle. Its use insures phonograph manufacturers and owners alike, that the quality of reproduction shall remain constant, regardless of needle replacements, because the needle is matched to the cartridge and is the only needle that can be used with it.

The "QT" Cartridge is highly recommended for its clear, clean, "quiet-talk" reproduction and its exceptional practicability for home use. The needle used in this cartridge is REPLACEABLE and is available with precious metal or jewel tip. The new and unusual design of this cartridge is such as to allow appreciably more vertical compliance than heretofore, resulting in a VAST reduction in surface noise and needle talk for finer reproduction.

NOTE: The needles used in these two cartridges are available for replacement purposes but can be used only in the cartridges to which they are MATCHED and for which they are intended.







# Steatite-Insulated Connectors

Designed for aircraft use

No insulation damage from flashover

2 to 19 contacts

24 combinations

Floating contacts in Plugs

Small-size pin-plug contacts in Receptacles (shown below)



Two Views of Typical Receptacle

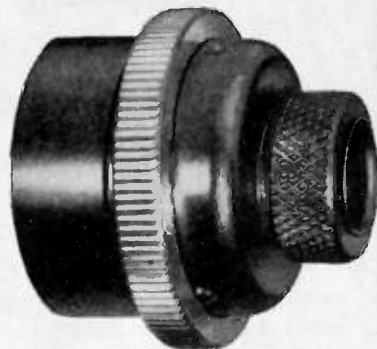

Two Views of Typical Plug

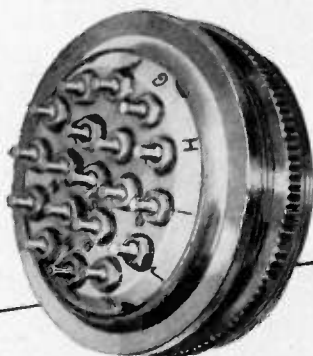

## INDIVIDUAL PIN-PLUGS ARE ALSO AVAILABLE

Unique construction originated by A.R.C.

Used by the millions in war-time aircraft.

Minimum spring fatigue.

Conservatively rated at 10 amperes in small size, or 20 amperes in medium size.



(ACTUAL SIZE)

The beryllium-copper contact springs are riveted and soldered at the tip. The other ends are free yet are confined in an annular recess at the base of the Pin-Plug. The four springs provide eight wiping contacts.

Write on your letterhead for our Catalog describing these and our other Component Parts.

# AIRCRAFT RADIO CORPORATION

DEPENDABLE ELECTRONIC EQUIPMENT SINCE 1928

Boonton, N. J.



# RADIO'S NEWEST MULTI-PURPOSE INSTRUMENT

## MEASUREMENTS

### Model 59

## MEGACYCLE METER

The Model 59 consists of a compact oscillator connected by a flexible cord to its power supply. The instrument is a variable frequency oscillator, an absorption wave-meter, an oscillating detector and a tuned absorption circuit detector. The engineer, technician, service man or amateur will find the Model 59 a most versatile instrument suitable for many applications.

#### SPECIFICATIONS:

##### FREQUENCY:

2.2 Mc. to 400 Mc.; seven plug-in coils.

##### MODULATION:

CW or 120 cycles; or external.

##### DIMENSIONS:

Power Unit, 5 1/4" wide; 6 1/2" high; 7 1/2" deep.  
Oscillator Unit, 3 3/4" diameter; 2" deep.

##### POWER SUPPLY:

110-120 volts, 50-60 cycles; 20 watts.

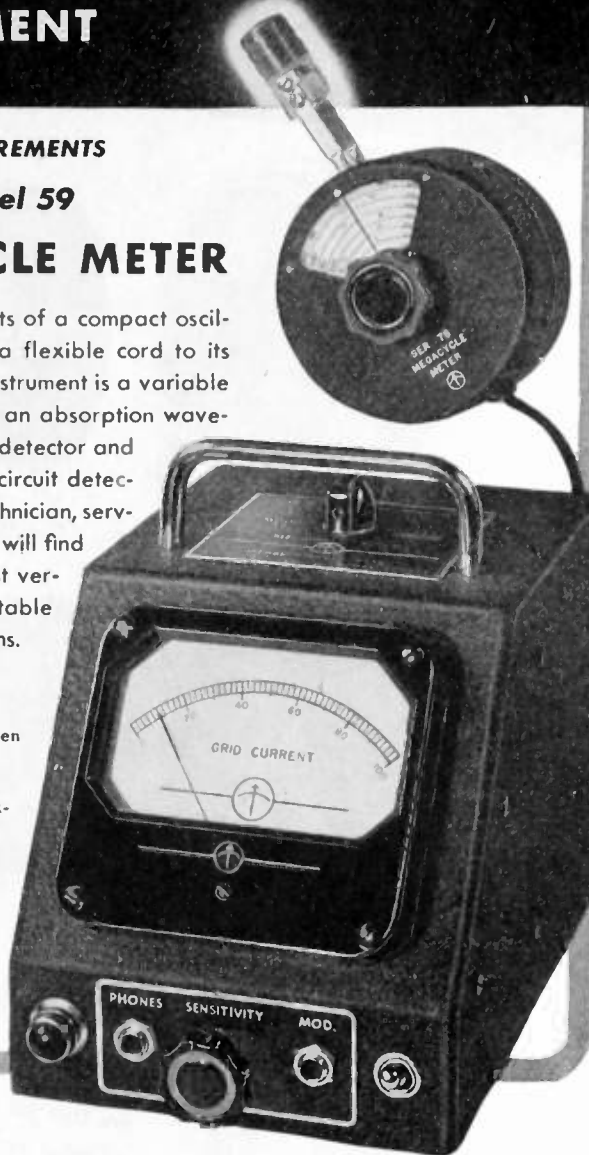

### MODEL 59 APPLICATIONS:

- For the determination of the resonant frequency of tuned circuits, antennas, transmission lines, by-pass condensers, chokes or any resonant circuit.
- For measuring capacitance, inductance, Q, mutual inductance.
- For preliminary tracking and alignment of receivers.
- As an auxiliary signal generator; modulated or unmodulated.
- For antenna tuning and transmitter neutralizing, power off.
- For locating parasitic circuits and spurious resonances.
- As a low sensitivity receiver for signal tracing.

Descriptive Circular on Request

**MANUFACTURERS OF**  
Standard Signal Generators  
Pulse Generators  
FM Signal Generators  
Square Wave Generators  
Vacuum Tube Voltmeters  
UHF Radio Noise & Field  
Strength Meters  
Capacity Bridges  
Megohm Meters  
Phase Sequence Indicators  
Television and FM Test  
Equipment

**MEASUREMENTS CORPORATION**  
BOONTON NEW JERSEY



(Continued from page 42A)

- Anderson, W. E., 3973 McLaughlin Ave., Culver City, Calif.  
 Apger, F. E., 1344 Eddy St., Chicago 13, Ill.  
 Armentano, J. A., 83-30 Kew Gardens Rd., Kew Gardens, L. I., N. Y.  
 Arnett, W., 215 E. 77 St., New York 21, N. Y.  
 Arnold, G. G., 216 Elmhurst Ave., Elmhurst, Ill.  
 Arnold, O. F. A., Fairhaven Rd., Mattapoisett, Mass.  
 Aucremann, R. C., 54 Franklin Ave., New Hyde Park, N. Y.  
 Backmark, N., Allingsavagen 54, Stockholm, Sweden  
 Baer, R. H., 1832 Grace St., Chicago 13, Ill.  
 Bahnson, F. N., 26 Fairfield Lane, New Hyde Park, N. Y.  
 Bailey, R. B., 35 Marion Ave., Nepera Park, Yonkers 2, N. Y.  
 Baker, F. J., 518 Monroe, Jackson, Mich.  
 Balasubrahmanyam, V., 33 Parthasarathy Naidu St., Triplicane, Madras, India  
 Balter, S. A., 1235 Grand Concourse, New York 52, N. Y.  
 Barker, J., 229 Holland St., Syracuse 4, N. Y.  
 Barnard, E. H., 2860 S. Abingdon, Arlington, Va.  
 Barnett, G. F., 904 Oak Lane Ave., Philadelphia, Pa.  
 Barrett, L. G., 80 Pennsylvania Ave., New Britain, Conn.  
 Barrett, L. C., Jr., 30 Asbury Ave., Atlantic Highlands, N. J.  
 Baron, A., 1618 Bay Court, Brooklyn 29, N. Y.  
 Barszcz, A. M., 2220 S. 15 Pl., Milwaukee 7, Wis.  
 Battle, R. P., 5036-213 St., Bayside, L. I., N. Y.  
 Baumann, J. A., 1937 Wynnewood Rd., Philadelphia 31, Pa.  
 Baumgartner, W. H., 1237 W. Seltzer St., Philadelphia, Pa.  
 Bauss, H. H., R.F.D. 5, 356 Fire Mile Rd., Midland, Mich.  
 Beane, S. M., 409-14 Ave., Belmar, N. J.  
 Bear, N., R.F.D. 1, Peninsula, Ohio  
 Bedford, P. L., 9511 Seminole St., Silver Spring, Md.  
 Beldler, S., 63-50 Wetherole St., Elmhurst, N. Y.  
 Bell, W. E., 20-F Parkway Rd., Greenbelt, Md.  
 Belmonte, J. C., 3 Washington Village, Asbury Park, N. J.  
 Belot, G. H., Box 366, AA & GM BR TAS, Fort Bliss, Tex.  
 Berner, G. P., 38-20-208 St., Bayside, L. I., N. Y.  
 Bernstein, J. J., 333 W. 26 St., New York 1, N. Y.  
 Binzel, M. S., 2402 Bellevue Ave., Maplewood 17, Mo.  
 Bitinas, J., 317 Ann St., Harrison, N. J.  
 Bitner, R. E., 270 Thompson Shore Rd., Manhasset, N. Y.  
 Blair, I. W., Main St., Richland, Pa.  
 Bloom, L. R., Department of Electrical Engineering, University of Illinois, Urbana, Ill.  
 Blumberg, M., 45 William St., Rochelle Park, N. J.  
 Bollum, C. W., Sr., Apt. 405, 3221 Connecticut Ave., N.W., Washington 8, D. C.  
 Bond, F. E., Coles Signal Laboratory, Red Bank, N. J.  
 Borden, E. W., 22 College Ave., Upper Montclair, N. J.  
 Bowen, W. V., 308 Robert St., Toronto 4, Ont., Canada  
 Bowie, W. S., 186 Madison Ave., Baldwin, N. Y.  
 Bracken, J. R., 631 Gerard Ave., Long Branch, N. J.  
 Bradshaw, G. V., Jr., 1552 Ellery Walk, Camden, N. J.  
 Brafman, H. E., 8 Marion Ave., N. Adams, Mass.  
 Brodhun, C. G., 272 Pasadena Ave., Hasbrouck Heights, N. J.  
 Brody, H. B., 137 Chelsea Ave., Long Branch, N. J.  
 Brogden, J. W., 2714 Minnesota Ave., S. E., Washington 19, D. C.

(Continued on page 46A)



*And now*—Kilovolt ratings matching the elevated peaks and transients of television and other cathode-ray tube circuits . . .

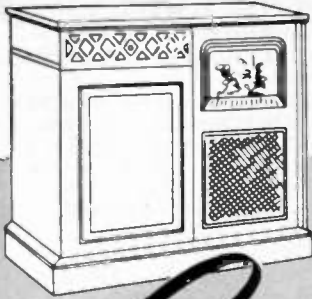

Typical high-voltage ratings—Series "84" tubular paper capacitor rated at 10,000 volts DCW, and Series "89" midget oil-filled tubular rated at 3500.

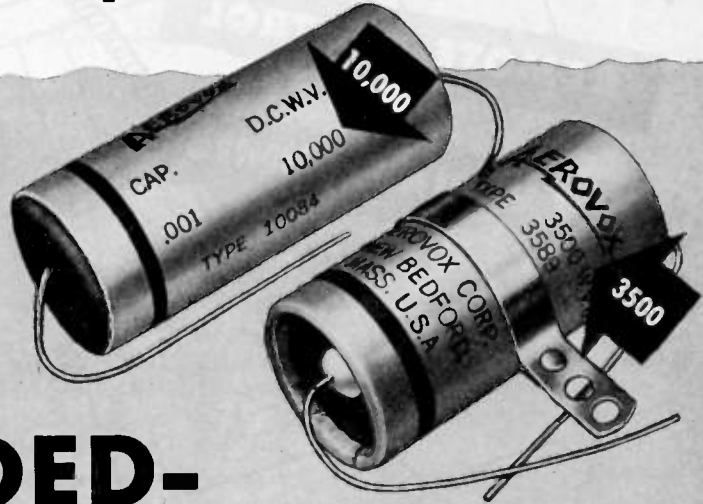

*Aerovox*

**EXPANDED-VOLTAGE RANGE**

*Capacitors*



Series "14" oil-filled capacitor, usually with single pillar terminal, now available in double-ended design for maximum insulation at higher potentials. This and the popular Series "12" double-pillar ribbed-cap oil capacitor, are available in voltage ratings up to 10,000 volts DCW.

• Before and since the advent of the first practical television receiver in 1939, Aerovox capacitors have marched along with the television pioneers.

Inherent Aerovox quality, PLUS Aerovox extra-generous safety factor, has successfully met the surges and transients, the heat and the humidity, and the other trying conditions of the twilight zone of television development. And that goes likewise for the severe service requirements of cathode-ray

oscillography.

With larger and more brilliant screen images calling for still higher working voltages, Aerovox is again ready with expanded voltage ratings. The Series "84" paper tubulars, the Series "89" midget oil capacitors, the Series "14" and other can-type oil capacitors are now available in higher voltage ratings to meet post-war television, oscillograph and other electronic needs.

• Submit your higher-voltage circuits and constants for our engineering collaboration, specifications, quotations. Literature on request.

**FOR RADIO-ELECTRONIC AND INDUSTRIAL APPLICATIONS**

AEROVOX CORPORATION, NEW BEDFORD, MASS., U.S.A.

SALES OFFICES IN ALL PRINCIPAL CITIES • EXPORT: 13 E. 40th ST., NEW YORK 16, N. Y.

Cable: 'ARLAB' • In Canada: AEROVOX CANADA LTD., HAMILTON, ONT.





(Continued from page 44A)

- Broomall, J. M., Hampton Rd. and Alfeld St., Philadelphia 18, Pa.
- Bromley, J. E., 513 Jefferson Ave., Avon, N. J.
- Brough, H. J., 5415 Charles St., Philadelphia 24, Pa.
- Brown, C. R., 19 Woodmere Ave., Ludl, N. J.
- Brown, H. A., 8 Fieldcourt, Bronxville, N. Y.
- Brown, J., 40 Monroe St., New York 2, N. Y.
- Brown, M. A., 404 Main St., Bradley Beach, N. J.
- Brunner, R. F., 415 Pennsylvania Ave., N. Wales, Pa.
- Buckley, F. A., 98 Hudson Ter., Yonkers, N. Y.
- Buegler, J. A., 94 Maple Ave., Red Bank, N. J.
- Buffa, A. J., Box 441, R.F.D. 2, Lakewood, N. J.
- Bunim, G. C., 111-32-76 Ave., Forest Hills, N. Y.
- Burdette, C. J., 998 N. Church, Spartanburg, S. C.
- Burkhard, H. F., R.F.D. 1, Box 301, Long Branch, N. J.
- Burnell, S., 592 Broad Ave., Leonia, N. J.
- Burns, E. P., 143-07 Sanford Ave., Flushing N. Y.
- Campbell, W. L., 6723 N.E. Alberta, Portland, Ore.
- Cannon, J. F., 227 Church St., New Haven 6, Conn.
- Carpenter, R. B., Jr., 58 Harding Rd., Lexington, Mass.
- Carter, H. T., 48 Maple Ave., Madison, N. J.
- Case, E. E., 224 Burcham, San Antonio 4, Tex.
- Castellini, N. R., 57 Belshaw Ave., Eatontown, N. J.
- Caulfield, J. T., Bell Telephone Laboratories, Inc., Whippany, N. J.
- Chambreau, W. J., 2700 Wisconsin Ave., N.W., Washington 7, D. C.
- Chang, S., Radio Department, Central News Agency, 72 Chung San Tung Rd., Nanking, China
- Chaudhuri, M., 20 Addiscombe Grove, East Croydon, Surrey, England
- Chaney, L. W., 619 East University, Ann Arbor, Mich.
- Chikar, R. E., 724 E. Cedar St., South Bend, Ind.
- Chichester, J. C., Sunset Rd., North Haven, Conn.
- Chismark, A. H., 92 Fourth St., Troy, N. Y.
- Cisne, L. E., 4 Hillside Ave., Summit, N. J.
- Clark, C. S., Engineering Division, General Electric Company, 840 S. Canal St., Chicago 80, Ill.
- Clere, M. C., 1407 W. Fourth St., Freeport, Tex.
- Code, G. E., 5857 Coolbrook Ave., Montreal, P.Q., Canada
- Cohen, I. S., Box 415, Wharton, N. J.
- Cohen, J., 1616 Fitzgerald Lane, Alexandria, Va.
- Cohen, S. B., 137 East 96 St., Brooklyn, N. Y.
- Collins, D. L., 3800 Perkins, Cleveland, Ohio
- Comstock, G. C., 160 Old Country Rd., Mineola, L. I., N. Y.
- Cooper, E. D., 50 Oak Ridge Ave., Summit, N. J.
- Cox, R. J., Chalk River Laboratory, N.R.C., Chalk River, Ontario, Canada
- Cramer, R. A., Apt. 4-H, 406 Prospect Ave., Hackensack, N. J.
- Crawford, C. H., 114 Russell Ave., Liverpool, N. Y.
- Crippen, C. E., 6331 Greene St., Philadelphia 44, Pa.
- Criss, G. B., 3301 Vista St., Philadelphia 36, Pa.
- Cullwick, E. G., Defence Research, Department of National Defence, Ottawa, Ont., Canada
- Cunningham, J. E., Box 1541, Jacksonville 1, Fla.
- Curl, G. W., University Exchange, Vermillion, S. D.
- Curtis, H. A., 215 Guava Ave., Chula Vista, Calif.
- Dammond, H. R., 1830 Paulding Ave., New York 60, N. Y.
- Daniels, F. B., 19 Crawford St., Eatontown, N. J.
- Davidoff, S., 105 Ave. P, Apt. 5C, Brooklyn 4, N. Y.
- Davis, G., 117-01 Park Lane S., Kew Gardens, Apt. 3H Bldg. A, L. I., N. Y.
- Davis, R. H., 366 High St., Closter, N. J.
- Davis, W. J., 13 Brenner St., Newark 3, N. J.
- Day, J. H., 712 Roanoke Ave., Riverhead, N. Y.
- Dayton, F. R., 6 Ambrose Court, Baldwin, N. Y.
- Dean, W. B., 15 Ricker Rd., Newton 58, Mass.
- DeArmond, J. K., 604 E St., Wright Field, Dayton, Ohio

(Continued on page 48A)

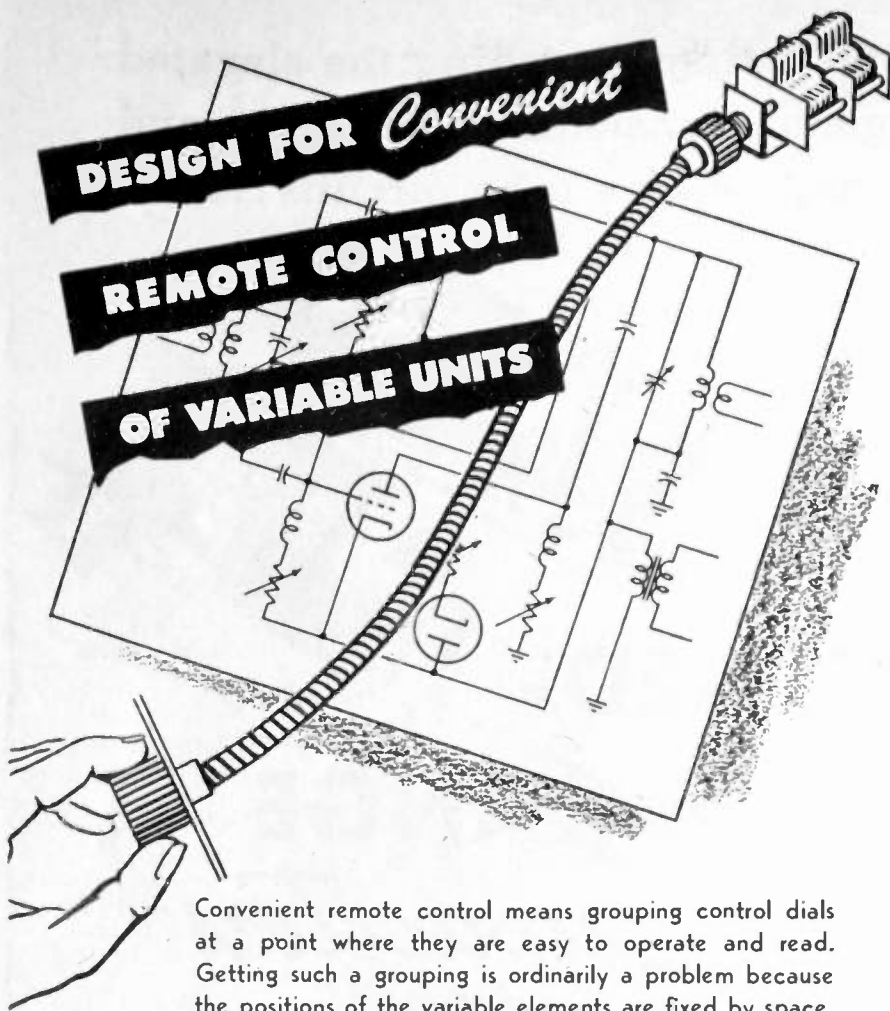

**DESIGN FOR** *Convenient*

**REMOTE CONTROL**

**OF VARIABLE UNITS**

Convenient remote control means grouping control dials at a point where they are easy to operate and read. Getting such a grouping is ordinarily a problem because the positions of the variable elements are fixed by space, circuit, or wiring requirements.

## S. S. WHITE

### REMOTE CONTROL FLEXIBLE SHAFTS

give you a simple, 100% satisfactory solution to this problem. Use them to couple the variable elements to their control dials. Then you can locate the dials anywhere you want them. What's more, these shafts—expressly engineered for remote control—work as easily and as smoothly as a direct connection. With proper application, they will give you any required degree of sensitivity in control.

WRITE FOR 260-PAGE HANDBOOK—FREE

It gives complete facts and technical data about flexible shafts and their application. A copy will be sent free if you write for it direct to us on your business letterhead and mention your position.



## S.S. WHITE

THE S. S. WHITE DENTAL MFG. CO.

## INDUSTRIAL DIVISION

DEPT. G 10 EAST 40th ST., NEW YORK 16, N. Y.



FLEXIBLE SHAFTS • FLEXIBLE SHAFT TOOLS • AIRCRAFT ACCESSORIES  
SMALL CUTTING AND GRINDING TOOLS • SPECIAL FORMULA RUBBERS  
MOLDED RESISTORS • PLASTIC SPECIALTIES • CONTRACT PLASTICS MOLDING

One of America's AAAA Industrial Enterprises



# Arnold presents:

another step towards a  
complete line of permanent  
magnet materials . . . . .

**CAST ALNICO I**

**CAST ALNICO II**

**CAST ALNICO III**

**CAST ALNICO IV**

**CAST ALNICO V**

**CAST ALNICO VI**

**CAST ALNICO XII**

**SINTERED ALNICO**

## SINTERED ALNICO

In general SINTERED ALNICO MAGNETS do not compete with, but rather supplement, magnets produced by the cast method to widen the scope of potential permanent magnet applications.

Alnico magnets weighing roughly one ounce or less should be produced by the sintered method.

Heavier magnets of more intricate shapes can be produced. For some applications Sintered magnets are more economical because:

1. Magnetic characteristics are practically the same as Cast Alnico.
2. Sintered Alnico is a fine-grain, homogeneous material which has more uniform flux density, is easier to grind, and provides better surface finish.
3. Sintered Alnico magnets can be produced to closer dimensional tolerances:

SINTERED ALNICO II	CAST ALNICO II
0.000 to 0.125 — ± .005	0.000 to 2.00 — ± 1/64
0.126 to 0.625 — ± .010	2.0 to 4.0 — ± 1/32
0.626 to 1.250 — ± .015	4.0 to 6.0 — ± 3/64
1.251 to 3.000 — ± .042	

Grinding can in many applications be eliminated.

4. More intricate shapes, including holes, inserts, etc., are more feasible.
5. Transverse modulus of rupture is several times greater.

All Alnico, and particularly Sintered magnets, have very high values of Coercive Force (which is the capability of resisting demagnetization or loss of magnetism due to stray fields and from heat and vibration).

The curves show roughly the effect of these demagnetization factors on Alnico compared to other alloy steels.

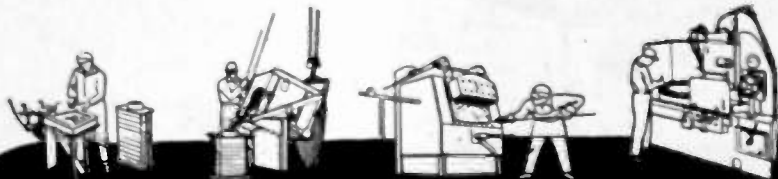
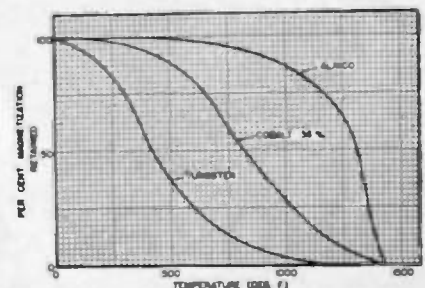
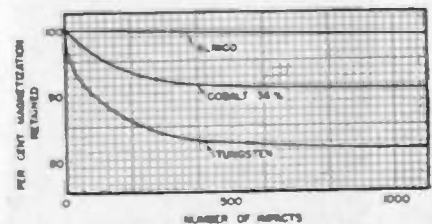
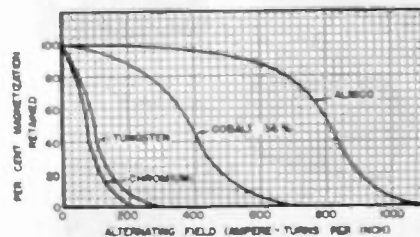

**THE ARNOLD ENGINEERING COMPANY**

SUBSIDIARY OF ALLEGHENY LUDLUM STEEL CORPORATION

147 EAST ONTARIO STREET, CHICAGO 11, ILLINOIS

Specialists in the manufacture of PERMANENT MAGNET MATERIALS



**Andrew Co.**  
begins its  
second  
decade of  
service  
to the  
industry



- Transmission lines for AM-FM-TV
- Directional antenna equipment
- Antenna tuning units
- Tower lighting equipment
- Consulting engineering service



WRITE FOR  
COMPLETE CATALOG

**ANDREW CO.**

363 EAST 75th STREET • CHICAGO 19

*Pioneer Specialists  
in the Manufacture  
of a Complete Line of  
Antenna Equipment*

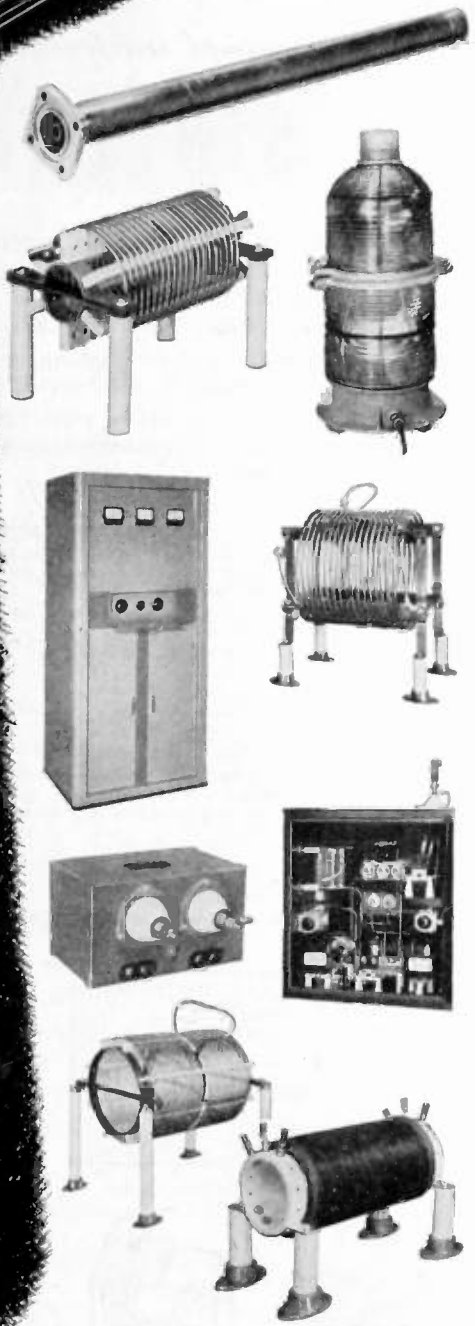
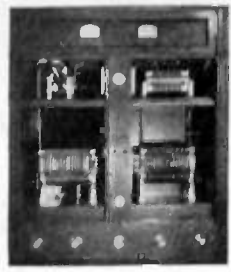

(Continued from page 46A)

- DeBoer, J. J., 307 Industria, Havana, Cuba  
Denike, E. H., Deep River, Ontario, Canada  
deOnia, A., 500 Riverside Dr., New York 27, N. Y.  
DesBrisay, A. W. Y., 240 Clemow Ave., Ottawa,  
Ont., Canada  
Detchemendy, J. A., 818 S. Kingshighway, St.  
Louis 10, Mo.  
Deters, A. A., 62 Arch St., Keene, N. H.  
Dewltz, G. H., 917 Mill Hill Ter., Southport, Conn.  
DeYoung, J. A., 260c Main St., Medford 55, Mass.  
Dilley, J. E., 720 Hoffman Ave., Trenton, N. J.  
Doering, K. M., Box 126, Shrewsbury, N. J.  
Dorfman, N. G., 314 W. 89 St., New York, N. Y.  
Dorne, A., 126 N. Ocean Ave., Freeport, N. Y.  
Dorney, T. A., 26 Abel Rd., Berea, Johannesburg,  
South Africa  
Doucet, M., Station CKAC, 980 St. Catherine St.,  
West, Montreal, P. Q., Canada  
Douglas, R. H., 325 Fifth Ave., New York, N. Y.  
Dove, J. B., 3511 Lansing St., Philadelphia, Pa.  
Dukat, F. M., 22 Madison Rd., Waltham 54, Mass.  
Duncan, N. L., 87 Goden St., Belmont, Mass.  
Duvall, G., AEO Bldg. FG-3, Naval Air Station,  
Quonset Point, R. I.  
Duzick, F. E., 209 E. 95 St., New York 28, N. Y.  
Dyer, F. C., 1108—16 St., Washington, D. C.  
Dyer, J. H., 242 N. Walnut St., East Orange, N. J.  
Eades, E. P., c/o Cable & Wireless Ltd., Harbour  
Grace, Newfoundland  
Eberhart, W. G., Radio Station WSBA, York, Pa.  
Ebright, J. L., 766 Pierce Dr., Apt. G, Columbus 8,  
Ohio  
Edgerton, J. F., 88 West Blvd., Bay Park Section,  
East Rockaway, N. Y.  
Egger, R. J., 64 Swan St., Aberdeen, Md.  
Ekblaw, W. E., Jr., 9117 Chafford Dr., Richmond  
Heights 17, Mo.  
Ellis, H. J., Jr., 85—21 Lefferts Ave., Richmond  
Hill, N. Y.  
Ellis, J. M., c/o Monarch Broadcast Company,  
Medicine Hat, Alta, Canada  
Emerich, W. E., 418 Dock St., Schuylkill Haven,  
Pa.  
Engberg, C. T., R.F.D. 1, Box 445A, Red Bank,  
N. J.  
Engstrom, O. D., 180 Varick St., New York, N. Y.  
Estler, L. K., 205 Rockaway St., Boonton, N. J.  
Fairfield, J. H., 142 Manning Ave., Toronto, Ont.,  
Canada  
Fairweather, R. W., 45 Colony St., West Hemp-  
stead, N. Y.  
Fast, S., 406 Broadway, Long Branch, N. J.  
Fehr, A. T., 701 N. Hazel St., St. Paul, Minn.  
Fenichel, I., 328 E. 180 St., New York, N. Y.  
Fine, S., 592 Snediker Ave., Brooklyn 7, N. Y.  
Flocken, L. H., 1119 Lunt Ave., Chicago 26, Ill.  
Flomenhaft, L., 245 Troy Ave., Brooklyn 13, N. Y.  
Follin, W. W., 605 Fulton Ave., Falls Church, Va.  
Ford, J. P., 5023 Catharine St., Philadelphia, Pa.  
Fowler, J. A., III, 36 E. 72 St., New York 21, N. Y.  
Frank, R. L., 142 West 62 St., New York 23, N. Y.  
Franke, H. C., Bell Telephone Laboratories, Inc.,  
463 West St., New York 14, N. Y.  
Franzel, I. H., 292 Rockaway Parkway, Brooklyn  
12, N. Y.  
Frase, E. C., Jr., Route 6, Box 1026, Memphis,  
Tenn.  
Fraser, R., 122 Cutter Mill Rd., Great Neck, N. Y.  
Fraser, R. M., 72 N. William St., Baldwin, L. I.  
N. Y.  
Gabriel, E. Z., 18 Crawford St., Eatontown, N. J.  
Gaither, T. B., 207 Jefferson, Valleso, Calif.  
Garkavenko, E., 7019 Pennsylvania Ave., Bywood,  
Upper Darby, Pa.  
Geller, D., 138 East 94 St., Brooklyn, N. Y.  
Gempp, T. A., 26 Lincoln Ave., Woodridge, N. J.  
George, T. S., Philco Corporation, Broad and  
Somerset, Philadelphia, Pa.  
Gilmartin, J. J., Jr., 24—79 Ave., New Hyde Park,  
L. I., N. Y.

(Continued on page 60A)



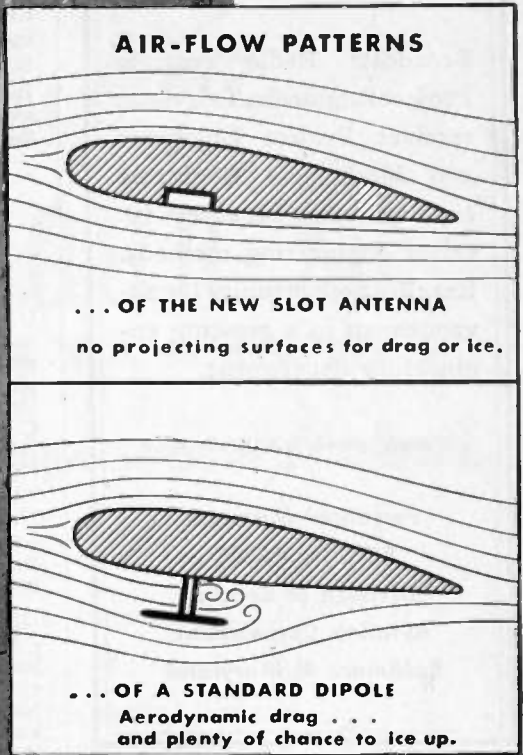
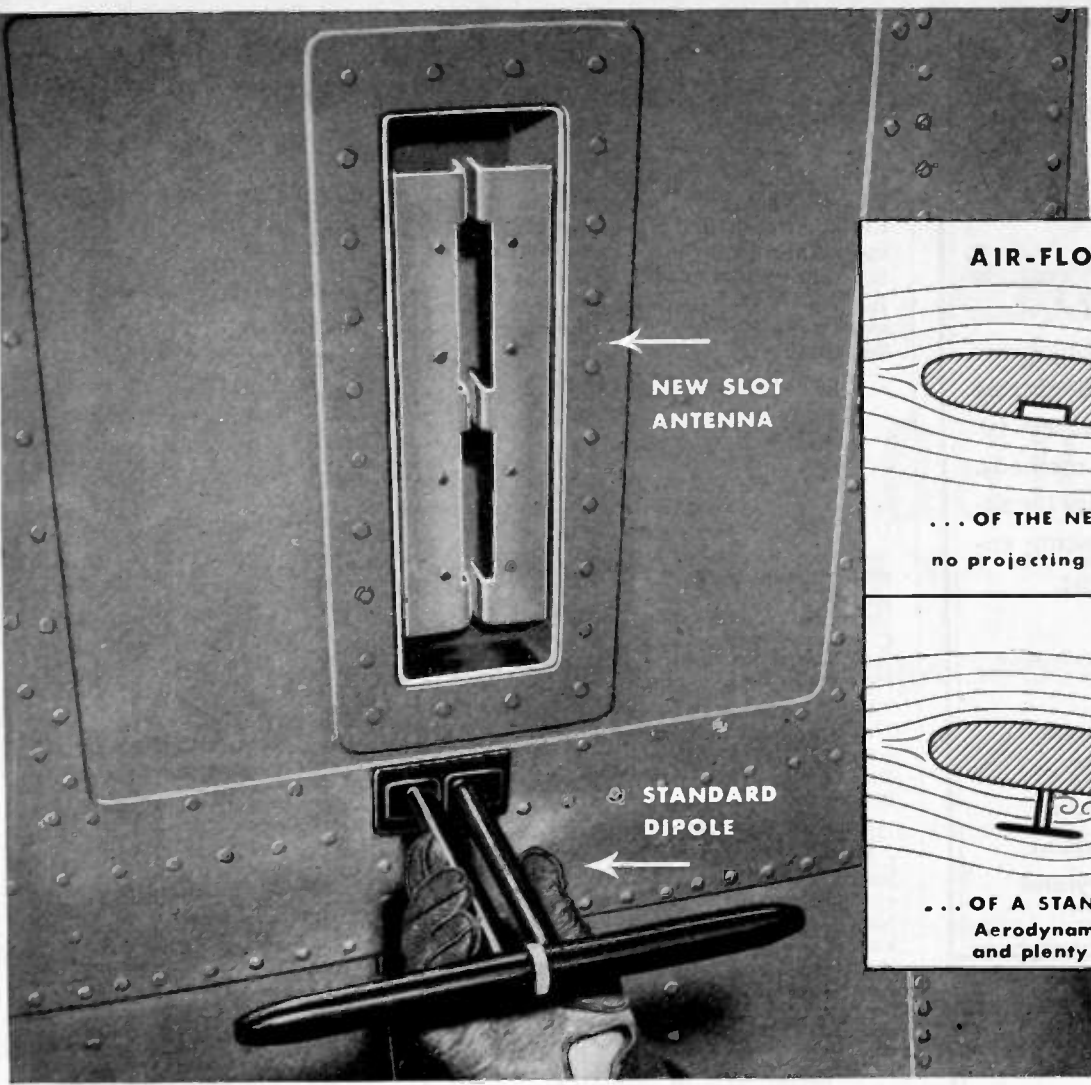

*No icing... no drag...*

**with the new RCA Slot Antenna for radar altimeters**

Designed so that it recesses flush into airplane wing or fuselage, this cavity-resonator antenna... with its plexiglass cover... meets aviation's need for a smooth-contour radiator that will not collect ice and will not create drag.

Producing a directional pattern equivalent to that of a quarter-wave dipole, RCA's Slot Antenna... actually smaller than a shoe box... includes

every desirable characteristic of a conventional dipole. It is foolproof in construction. It is ruggedly built. And it requires no adjustments after initial installation.

For complete information on this simple antenna... built to meet CAA type-certification requirements for scheduled airline operation... write RCA, Aviation Section, Dept. 67E, Camden, N. J.

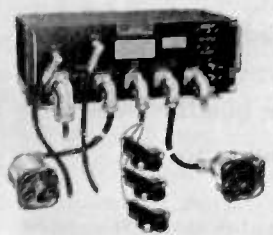

**MODEL AVQ-6, 0 to 4000 feet.** Accurately indicates absolute altitude (terrain clearance) on its direct-reading meter. Complete with transmitter, receiver, power supply, double-range altitude indicator, and two RCA Slot Antennas (when specified).



**MODEL AVQ-9, 0 to 40,000 feet.** Accurately indicates absolute altitude (terrain clearance) on its direct-reading meter. Complete with transmitter, receiver, power supply, and two RCA Slot Antennas (when specified).

RCA air-borne radar altimeters for every commercial altitude



**AVIATION SECTION**  
**RADIO CORPORATION of AMERICA**  
**ENGINEERING PRODUCTS DEPARTMENT, CAMDEN, N.J.**

In Canada: RCA VICTOR Company Limited, Montreal

# Engineers

Broadcast Radio receiver Project Engineers, Television receiver Project Engineers and Mechanical Engineers experienced in broadcast receiver engineering methods. Excellent opportunity for advancement in a growing engineering department.

Reply giving full details to

Personnel Manager  
BENDIX RADIO  
Division of Bendix  
Aviation Corporation  
Baltimore 4, Maryland

## WANTED PHYSICISTS ENGINEERS

Engineering laboratory of precision instrument manufacturer has interesting opportunities for graduate engineers with research, design and/or development experience on radio communications systems, electronic & mechanical aeronautical navigation instruments and ultra-high frequency & microwave technique.

WRITE TO BOX 1117

EQUITY ADVERTISING AGENCY

113 W. 42nd St., New York 18, N.Y.



The following positions of interest to I.R.E. members have been reported as open. Apply in writing, addressing reply to company mentioned or to Box No. ... The Institute reserves the right to refuse any announcement without giving a reason for the refusal.

### PROCEEDINGS of the I.R.E. 1 East 79th St., New York 21, N.Y.

#### ENGINEERS

The Naval Air Material Center has urgent need for engineers qualified under U. S. Civil Service Commission standards in the fields of radio and radar. Regular work consists of five eight hour days. Employees accrue vacation and sick leave. Permanent employees are also eligible for Civil Service Retirement. Salaries range from \$2,644.80 to \$8,179.00. Write to Naval Air Material Center, Industrial Relations Department, Building 75, U. S. Naval Base Station, Philadelphia 12, Pa., for particulars concerning the filing of applications, types of positions and appointments.

#### RECEIVER MECHANICAL DESIGN

Well known eastern manufacturer of broadcast and television receivers will employ one thoroughly experienced and highly competent man to head up their mechanical design staff. Only those who are easily qualified for above will be considered. This position will be filled without delay so your application must be received promptly. It will be held in confidence. Box 464.

#### INSTRUCTOR IN ELECTRICAL ENGINEERING

Electrical graduate with Master's degree and some teaching experience; to teach undergraduate courses in circuits and machinery. Opportunity to do graduate work. Salary \$3,000 for 9 months. Location, midwest. Box 465.

#### ASSISTANT PROFESSOR OF ELECTRICAL ENGINEERING

Electrical graduate with Master's degree and several years teaching experience; to teach AC and DC circuits, AC and DC machinery, and other power courses. Opportunity to do graduate work. Salary \$3,600 for 9 months. Location, mid-west. Box 466.

#### PHYSICISTS AND ELECTRICAL ENGINEERS

For vacuum tube research. Apply by letter stating qualifications to Director of Research, National Union Radio Corporation, 350 Scotland Road, Orange, New Jersey.

#### FACTORY ENGINEER

We have an opening in our factory engineering division for an outstanding man. This position requires experienced background of at least 5 years engineering work on factory problems relating to receiving tubes manufacture. An engineering degree would be helpful but the primary requirements of the position are the experience and the ability to successfully solve every day problems encountered in the manufacture of receiving tubes. Apply by letter to PERSONNEL DEPT. National Union Radio Corporation, Lansdale, Pa.

(Continued on page 52A)

- Electronic Engineers
- Physicists
- Senior Mechanical Engineer
- Junior Mechanical Engineer

—experienced in radar development, servomechanisms and computers.

—for airborne radar and guided missiles projects.

—excellent opportunities—salaries commensurate with experience and ability.

Write to:

FARNSWORTH TELEVISION & RADIO  
CORPORATION  
Fort Wayne 1, Indiana

Attention of:

J. D. Schantz  
Research Department

## ENGINEERS

Experienced senior electrical and mechanical project engineers needed for responsible positions in development and production of A.M., F.M., television receivers and components. Opportunity for advancement.

State qualifications in application to:

Employment Manager  
North American  
Philips Co., Inc.  
145 Fallside Street  
Dobbs Ferry, New York



# Mono-Sequence Tuning in the

## FOUR-20 TRANSMITTER



With MONO-SEQUENCE tuning you can tune four circuits to four different frequencies WITH ONE CONTROL. It's a patented Hammarlund invention which gives you highly efficient tuning and ease of control. The Four-20 is a complete CW rig for 80, 40, 20, or 10 meters. Plug in a crystal and a key and you're ON THE AIR.

## FOUR-11 MODULATOR



For years the name HAMMARLUND has stood for the finest in communications receivers. The same engineering skill and precision methods which produced the Super-Pro and the HQ-129-X, now bring you an entirely new transmitter. Combine the Four-11 Modulator with the Four-20 and you have a complete phone transmitter ready to go on any band. When you build that high power final, the Four-20 will make a perfect exciter and the Four-11 a fine speech amplifier.

BACKED BY **37** YEARS OF KNOW-HOW

# HAMMARLUND

THE HAMMARLUND MFG. CO., INC., 460 W. 34<sup>TH</sup> ST., NEW YORK 1, N.Y.  
MANUFACTURERS OF PRECISION COMMUNICATIONS EQUIPMENT

*write for*

Descriptive Booklet



# ELECTRONIC ENGINEER

## DEVELOPMENT LABORATORY

An experienced man to serve as project engineer in the development of RF test equipment.

Good opportunity for person with 10 years or more electronic experience.

Salary commensurate with ability. Replies held in confidence, please include résumé.

Dr. J. Downsborough  
BOONTON RADIO  
CORPORATION  
Boonton, N.J.



RCA has several attractive positions for electrical engineers, working in electronics, who are capable of accepting ideas released by the research laboratories and carrying them through the stages of development and design, into production.

Write to  
National Recruiting Office  
RCA Victor Division  
Camden New Jersey



(Continued from page 50A)

### INSTRUCTOR IN ELECTRICAL ENGINEERING

Instructors and professors to teach electrical engineering at prominent university in metropolitan area. Undergraduate and graduate courses in all fields and excellent research facilities. Professors must have advanced degrees. Salaries \$3,000 to \$7,500 depending on qualifications. Write to Box 459 with full details of education and experience.

### ELECTRICAL ENGINEERS WITH TEACHING BACKGROUND

A prominent Manhattan educational institution is now preparing a series of courses which are a post-high school level, and will have immediate need for instructors with the following background: Electrical engineering degree or better, teaching experience with several years of practical experience. Applicants should be able to teach various courses in electronics on an engineering level. Box 458.

### ENGINEERS

Communication—Mechanical—Sales

Chief Mechanical Engineer—Thorough knowledge of small metal parts design, preferably on radio components. To be in charge of all mechanical design. Splendid opportunity, permanent position for an aggressive and responsible engineer.

Communications Engineers—Well versed in mathematics and all phases of R.F. circuits for development projects. Experience in VHF microwave technique desirable. Applicants must possess initiative and be able to think analytically.

Sales Engineer—For factory sales office. Must be familiar with broadcast transmitter and industrial electronic circuits and components. B.S. degree and "Ham" license not mandatory but desirable. Little traveling. Interesting and varied work in a clean factory. For more information regarding the above write to: Mr. Lloyd W. Olander, Chief Engineer, E. F. Johnson Company, Waseca, Minnesota.

### PHYSICISTS

Arsenal has positions open for physicists in Civil Service. Salaries from \$2,644 to \$5,905 per annum. Apply to: Frankford Arsenal, Philadelphia 37, Pennsylvania.



### TELEVISION DESIGN ENGINEER

A graduate electrical engineer, whose experience has been mainly in the development and engineering field of television transmitters and associate equipment. Write giving full details. Box 461.

### RADIO ENGINEERS

Western educational institution has opening for an experienced engineer (graduate) thoroughly familiar with all phases of radio-electronics. Capacity to assume responsibility with minimum supervision. Top salary for high calibre man. Submit complete personal history. Replies held confidential. Box 462.

### SERVICE ENGINEERS

Men who would like to utilize their spare time repairing tower music systems, sound distribution systems and sound reinforcement systems within your state border. Traveling expenses and service charges paid by us. Write to: Schulmerich Electronics, Inc., Sellersville, Pennsylvania, Attention: H. B. Smith.

### ENGINEER—PHYSICISTS

Prominent communications development organization in metropolitan area has openings for men experienced in microwave systems development; UHF and VHF transmission, receiver and antenna circuits; and electro-mechanical design. Write details. Box 444.

### ENGINEER—EXECUTIVE

We need a top-flight executive to direct the engineering efforts of our young, expanding electronic manufacturing organization. Box 447.

### TELEVISION ENGINEER

Wanted by well-known manufacturer of television radio receivers. To be service manager for New York area. Write fully, giving experience and salary requirements. Box 540.

### DEVELOPMENT ENGINEERS

Guided Missiles

An experienced development and research engineer is needed to head new development group in Electronics Department. Design and development of radar and electronics controls, servomechanisms, and special devices for pilotless aircraft. Broad experience and Doctor's degree or equivalent required.

Positions also open for graduate engineers and physicists with electronic and mathematical-physics backgrounds.

Salaries \$5,000-\$8,000, commensurate with ability. Call or write F. Melograno, Pilotless Plane Division, Fairchild Engine and Airplane Corporation, Farmingdale, Long Island, New York.

### ENGINEERS AND TECHNICIANS

Engineers and Technicians familiar with the operation of the SCR-584 radar. Unusual opportunity. Salary commensurate with education and experience. California location. Box 457.



# A new principle

## SPECIFICATIONS

### VOLTMETER

Ranges: .015, .05, .15, .5, 1.5, 5, 15, 50, 150, 500, 1500 volts full scale.

Input Impedance: 1 megohm on all ranges with exception of 1500 Volt scale, where the impedance is 3 megohms. This gives a sensitivity of 68 megohms/volt on lowest range.

### MICROAMMETER

Ranges: .015, .05, .15, .5, 1.5, 5, 15, 50, 150, 500 microamps full scale.

Voltage Drop: Maximum .15 volts. On lower ranges it drops to .045 volts.

Ohmmeter: Resistance can be determined by measuring E & I from any external power supply. With 500 volts, 67,000 megohms give half scale reading; on maximum range.

Power Requirements: 115 volts, 60 cycles, 175 watts.

## FOR THE MEASUREMENT OF D. C. VOLTAGE . . .

### SHERRON D. C. Vacuum Tube Voltmeter-Ammeter

D.C. current is instantly converted to alternating voltages of a fixed frequency, amplified and metered. With the use of this principle, even the minutest flow of direct current can be read. Its extreme sensitivity heightens its value. Versatile, Model SE-519 has further application as a megohmmeter with external voltage source. . . . This instrument is essentially an average reading device. It will respond to low frequency A.C. as well as to D.C.—especially at frequencies of less than 500 cycles. . . . Thus, if the D.C. is superimposed on A.C., or vice versa, the meter will register the algebraic average.

**SHERRON ELECTRONICS CO.**  
Division of Sherron Metallic Corporation  
1201 FLUSHING AVENUE • BROOKLYN 6, NEW YORK

Sherron  
Electronics

W2XDK

Model SE-519

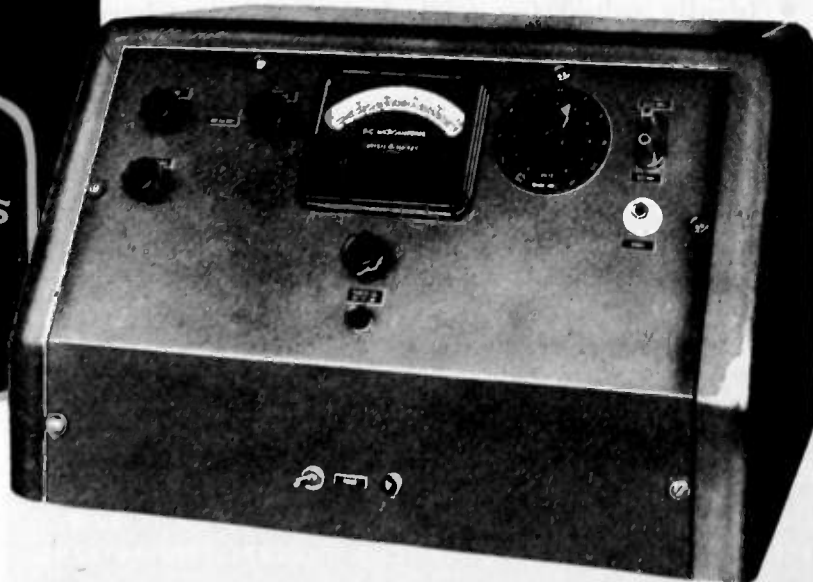



- The Sorensen NOBATRON provides a new source of DC voltages regulated at currents previously available only with batteries.
- Six standard NOBATRON models operate on a 95-125 volt AC source of 50 to 60 cycles and provide currents of 5, 10, and 15 amperes at output voltages of 6, 12, or 28.
- Ideally suited for critical applications where constant DC voltages and high currents are required, the NOBATRON maintains a regulation accuracy of  $\frac{1}{2}$  of 1%, RMS of 1% and has a recovery time of  $\frac{1}{5}$  of a second.

● Investigate the many advantages of Sorensen regulators applied to your unit. Write today for your copy of the new complete Sorensen catalog, S-P. It is filled with schematic drawings, performance curves, photos, and contains in detail, "Principles of Operations."

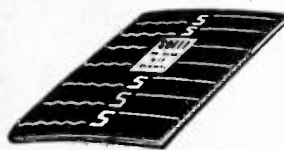

**SORENSEN & COMPANY, INC.**  
STAMFORD, CONNECTICUT

A LINE OF STANDARD REGULATORS FOR LOAD RANGES UP TO 30 KVA.  
SPECIAL UNITS DESIGNED TO FIT YOUR UNUSUAL APPLICATIONS.



## Positions Wanted By Armed Forces Veterans

In order to give a reasonably equal opportunity to all applicants, and to avoid overcrowding of the corresponding column, the following rules have been adopted:

The Institute publishes free of charge notices of positions wanted by I.R.E. members who are now in the Service or have received an honorable discharge within a period of one year. Such notices should not have more than five lines. They may be inserted only after a lapse of one month or more following a previous insertion, and the maximum number of insertions is three per year. The Institute necessarily reserves the right to decline any announcement without assignment of reason.

### JUNIOR ENGINEER

B.E.E., Cooper Union, Tau Beta Pi. Age 27. Three and one-half years ship power plant design, two years Army experience on aircraft instruments. Theoretical work completed for M.S. with thesis. Prefer New York City. Box 73W.

### ELECTRONICS PATENT ENGINEER

B.E.E. Graduate study. Age 28. Three years high voltage and dielectric research, four years patent experience, frequency modulation, television and radar. Formerly supervisory patent officer at M.I.T. Radiation Laboratory. Two years in Navy. Box 74W.

### RADIO ENGINEER

B.S.E.E. Purdue. Age 26. Four years civilian experience in design, development, test and installation electronic equipment. Currently developing VHF aircraft receiver. Box 75W.

### ENGINEER

B.A., M.A., E.E. Stanford University; first class radiotelephone license; Harvard—M.I.T. Officers' Electronics school. Age 27. Military research, supply and maintenance experience. Box 76W.

### JUNIOR ELECTRONICS ENGINEER

B.S. Physics, C.C.N.Y., 1947. Minor in electronics and communications. Age 23. Civil Service radio mechanic and instructor, one year. Signal Corps radar mechanic and instructor, three years. First class telephone operator's license. Prefers Metropolitan Area. Box 77W.

### SALES—ADMINISTRATIVE

Experience includes three years with large radio distributor, electronic research, advertising and sales. War years—Navy, ending as Force Radio Material Officer. Interested in good opportunity utilizing technical and administrative ability. Box 78W.

### ENGINEER

B.S.E.E., sea duty as electrical officer in Navy. Age 21. Single. Desires position in Providence or Boston area. Box 79W.

(Continued on page 56A)



# INVISIBLE BUT INVALUABLE

The invisible part of any Blaw-Knox Radio Tower is the *accumulated experience* gained by this company in the installation of thousands of towers in many quarters of the globe. This experience counsels the use of better material instead of cheaper material, higher safety factors instead of lower, the best construction instead of "good enough" and, in a word, the best.

The Blaw-Knox Tower you buy contains this priceless element without extra cost to you. Let us discuss your requirements without obligation.

**BLAW-KNOX DIVISION**  
OF BLAW-KNOX COMPANY  
2037 Farmers Bank Building, Pittsburgh 22, Pa.

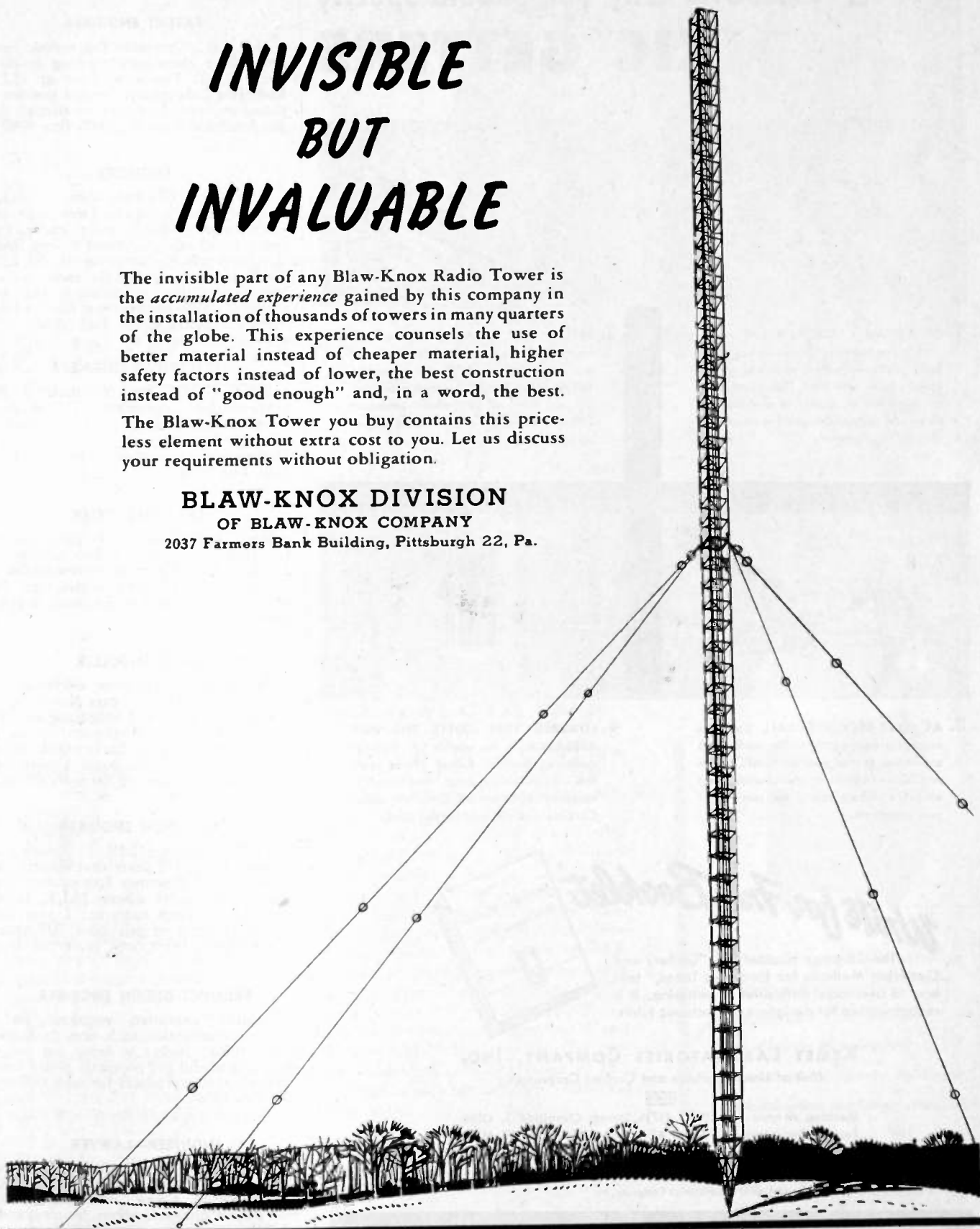

## BLAW-KNOX ANTENNA TOWERS

# 4 REASONS why you should specify "KIC" GETTERS

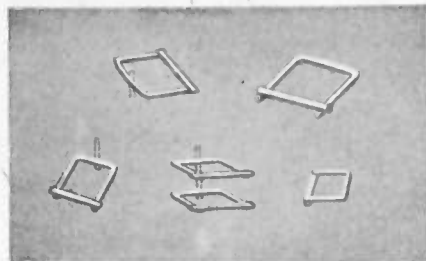

**1. 50 ASSEMBLY TYPES.** Kemet makes getter assemblies of barium, and of barium alloyed with magnesium, or with aluminum, or with both. These getter assemblies are produced in a variety of sizes and shapes designed to meet your specific requirements.

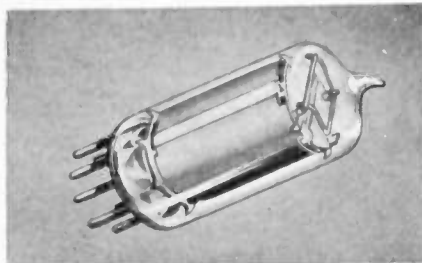

**2. BETTER GAS CLEANUP.** To adsorb residual gases most effectively, Kemet has designed the KIC getter assembly. This consists of a barium core protected by an iron sheath which promotes efficient dispersion of vaporized barium upon flashing.



**3. AT YOUR BECK AND CALL.** Kemet is always prepared to render on-the-job assistance to the user of KEMET products. Our engineers are available at all times to help you in the solution of your problems.



**4. LOWERED TUBE COSTS THROUGH RESEARCH.** In the search for superior gettering methods Kemet draws upon the experience and metallurgical research facilities of Units of Union Carbide and Carbon Corporation.

*Write for Free Booklet*

The 28-page booklet Z-1, "Getters and Gettering Methods for Electronic Tubes," tells how to overcome difficulties in gettering. It is recommended for designers of electronic tubes.

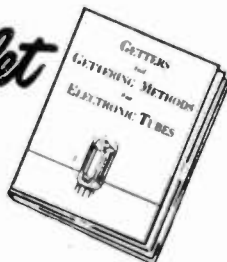

## KEMET LABORATORIES COMPANY, INC.

Unit of Union Carbide and Carbon Corporation



Modison Avenue and West 117th Street, Cleveland 1, Ohio  
Foreign Department—30 East 42nd Street, New York 17, N. Y.  
Cable Address: Kemetlab, New York

KEMET and KIC are trade-marks of Kemet Laboratories Company, Inc.

**KIC BARIUM GETTERS KEMET**

## Positions Wanted

(Continued from page 54A)

### PATENT ENGINEER

M.S.E.E., Worcester Polytechnic Institute. Navy electronics training at Bowdoin, M.I.T. Patent solicitor at M.I.T. Radiation Laboratory. Prefers position as patent engineer. Location immaterial. Age 26. Available June 30, 1947. Box 80W.

### ENGINEER

B.S. in E.E. Graduate work, Princeton, M.I.T. Three years, engineer with aircraft company, design group leader. Two years, naval officer, Armed Forces Radio Service station installation to 50 KW. Now commercial manager radio station. Desires position as technical engineer, executive, or sales engineer. Good writer. Minimum salary \$6,500. Box 68W.

### ELECTRICAL ENGINEER

B.E.E., 1942. Age 26; married. 3½ years civilian experience UHF development and production; 1 year servo-systems development with Army Air Forces. Desires position in environs of New York City. Box 69W.

### PART-TIME WORK

High British research qualifications; lecturing experience, radio, geophysics. Lately, Admiralty radar representative in U.S.A. Can undertake abstracting, literary, or other work in England, in spare time. Box 70W.

### SALES ENGINEER

Twelve years experience electronic engineering and sales; 5 years Navy, supervising installation and maintenance radio and radar; 2 years geophysical engineering. Successful sales background. Some college. Desires sales position with responsible company. Age 30; married. Box 72W.

### TELEVISION ENGINEER

B.E.E. (Commun)RPI, 1½ years test engineer G.E.; 1½ years development engineer Naval Research Laboratory; 2½ years naval radar officer M.I.T. radar laboratory project engineer; 1 year development engineer television. Minimum salary \$5,000. West coast preferred. Box 91W.

### PRODUCT DESIGN ENGINEER

Creative executive engineer seeks permanent affiliation with firm or financial facilities backer to bring out many obviously useful and popularly priced new radio-electronic products for wide civilian use. Box 92W.

### ENGINEER—LAWYER

L.L.B. and B.S. in engineering (electrical); 3½ years experience in U. S. Army Signal Corps, including radio, micro-wave communications, training, and administration; 2½ years experience in banking, including accounting and investments. Desires position offering opportunity to enter field of engineering administration. Box 93W.

(Continued on page 58A)



**PROFESSIONAL PERFORMANCE** — that keeps the original sound alive!

*Always  
on the nose*

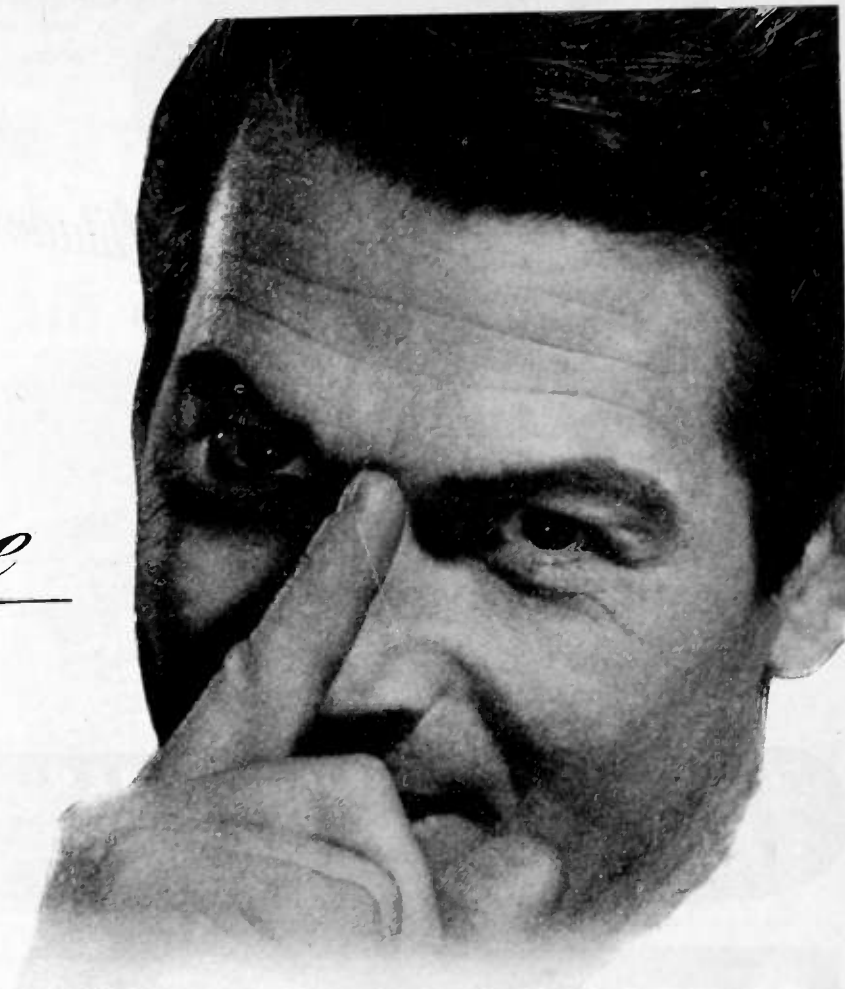

**—with split-second timing at 33.3 rpm**

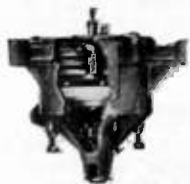

The way to a listener's pocketbook is through his ears. Give him the last full note of every record . . . a natural unhurried ending to every story on the program — and you'll keep him in a receptive mood for your spot commercials.

But cut his entertainment short; or mar its quality with speedups or slowdowns to compensate for faulty drive timing — and you'll never get his pocketbook open.

Professional recording and playback require precision timing. In maintaining broadcasting schedules, where seconds count, you're offered the positive Fairchild direct-from-the-center turntable drive, shown above. Rim or belt driven tables cannot duplicate Fairchild's split-second timing. The 33.3 rpm speed is obtained through a gear-and-worm reduction of its 1,800 rpm synchronous motor speed. The 78 rpm speed is obtained through a precision friction-ball-race stepup.

Fairchild's precision timing is available on Transcription Turntables, Studio Recorders and Portable Recorders designed in close collaboration with AM and FM broadcast and recording engineers to meet and exceed very exacting professional requirements for lateral recording on acetate or wax masters at 33.3 and 78 rpm. For complete information — including prompt delivery — address: 88-06 Van Wyck Boulevard, Jamaica 1, New York.



- Transcription Turntables**
- Studio Recorders**
- Magnetic Cutterheads**
- Portable Recorders**
- Lateral Dynamic Pickups**
- Utilized Amplifier Systems**



**CAMERA  
AND INSTRUMENT CORPORATION**



## Positions Wanted

(Continued from page 56A)

### RADIO OR SALES ENGINEER

Harvard, M.I.T., radio material Navy electronics training; 6 years radio material officer in charge at advanced base laboratory R.C.A.; Institutes, some college; 1st radio telephone, 2nd radio telegraph, class A amateur licenses, laboratory and maintenance experience. Box 94W.

### ELECTRONIC ENGINEER

B.S.E.E. by June 1947. Age 29; Experience: Troubleshooter on proximity fuses; Engineering assistant on pilot line; Assistant to chief propagation engineer of large short wave broadcasting station and assistant in laboratory doing research work on A.C. motor electronic speed controls. Member Eta Kappa Nu. Commercial and amateur radio licenses. Will consider foreign service. Box 95W.

### JUNIOR ELECTRICAL ENGINEER

B.E.E. 1946, Cooper Union. Age 22. Single. Majored in electronics—communications. Excellent college record. Desires position in New York or within commuting distance in communications or VHF field. Box 96W.

### ELECTRICAL ENGINEER

B.S.E.E. Worcester Tech. 1942. Age 27. Married. Three years production and design engineer at radio tube plant. Varied electronic experience for 2 years as Naval officer. Has held amateur radio license for 11 years. Desires responsible position with progressive concern in Metropolitan area. Detailed resumé on request. Box 97W.

### ELECTRONIC ENGINEER

B.E.E., 1943, College of the City of New York, graduate work. Age 25; married. Two years Army Signal Corps radar technician on pulse position modulated radar link communications equipment. One year microwave research experience. Desires electronics development work vicinity New York City. Box 98W.

### TELEVISION ENGINEER

B.S.E.E., Cooper Union. Age 24. Single. Desires position in radar or television development; New York City vicinity or northeast. 2½ years industrial experience in development and design of U. S. Navy airborne I.F.F. and airborne television receivers; also civilian television receivers. Maintenance and operation of ground radar sets in Army for 10 months. Box 99W.

### ELECTRONIC ENGINEER

B.E.E. Age 27; married. Graduate RCA Institutes; Signal Corps radar officer, trained M.I.T. Civilian electronics and Army radar development experience. Prefer electronics development. Box 100W.

### DRAFTSMAN

Attending evening engineering college, third year completed. Desires chance to get started. Resumé upon request. Box 101W.

### ELECTRICAL ENGINEER

B.S. from M.I.T. in 1942. M.A. Stanford University in 1946. Two years television experience with General Electric Co. Four years Navy radar officer. Age 29. Interested in research and design of radio and television equipment. Box 102W.



for experienced cooperation  
"call Cleveland"

**2** from a multitude of applications of  
**COSMALITE\***  
a spirally laminated paper base Phenolic Tube

No. 96 Cosmalite for coil forms in all standard broadcast receiving sets.

SLF Cosmalite for permeability tuners.

Advantages include lower costs and quicker deliveries

Ask also about our spirally wound kraft and fish paper Coil Forms and Condenser Tubes  
\* Trade Mark Registered

**The CLEVELAND CONTAINER Co.**  
6201 BARBERTON AVENUE CLEVELAND 2, OHIO

PRODUCTION PLANTS also at Plymouth, Wisc., Ogdensburg, N. Y., Chicago, Ill., Detroit, Mich., Jamesburg, N. J.  
PLASTICS DIVISIONS at Plymouth, Wisc., Ogdensburg, N. Y. • ABRASIVE DIVISION at Cleveland, Ohio  
New York Sales Office—1186 Broadway, Room 223  
IN CANADA—The Cleveland Container Canada Ltd., Prescott, Ontario



**PRECISION CRYSTALS**

*The* REEVES-HOFFMAN factory is equipped to manufacture a very large variety of quartz crystal units, both standard and custom. If you need quartz crystal units for use in the fields of communications, electronic control, ultrasonics, diathermy, instruments, or other special applications, REEVES-HOFFMAN can design and manufacture to fill your needs. Estimates and quotations promptly submitted.

REEVES-HOFFMAN Crystal Units Catalog RHC-1 lists standard crystal units complete with specifications. It also gives valuable information on how to order crystal units.

**REEVES-HOFFMAN CORPORATION**  
SALES OFFICE: 215 EAST 91 STREET, NEW YORK 28, N. Y.  
PLANT: 321 CHERRY STREET, CARLISLE, PA.



# Centralab Announces a Revolutionary New

# SLIDE SWITCH

## for Improved AM and FM Performance!

**New Design  
Saves Space, Reduces  
Lead Inductance**

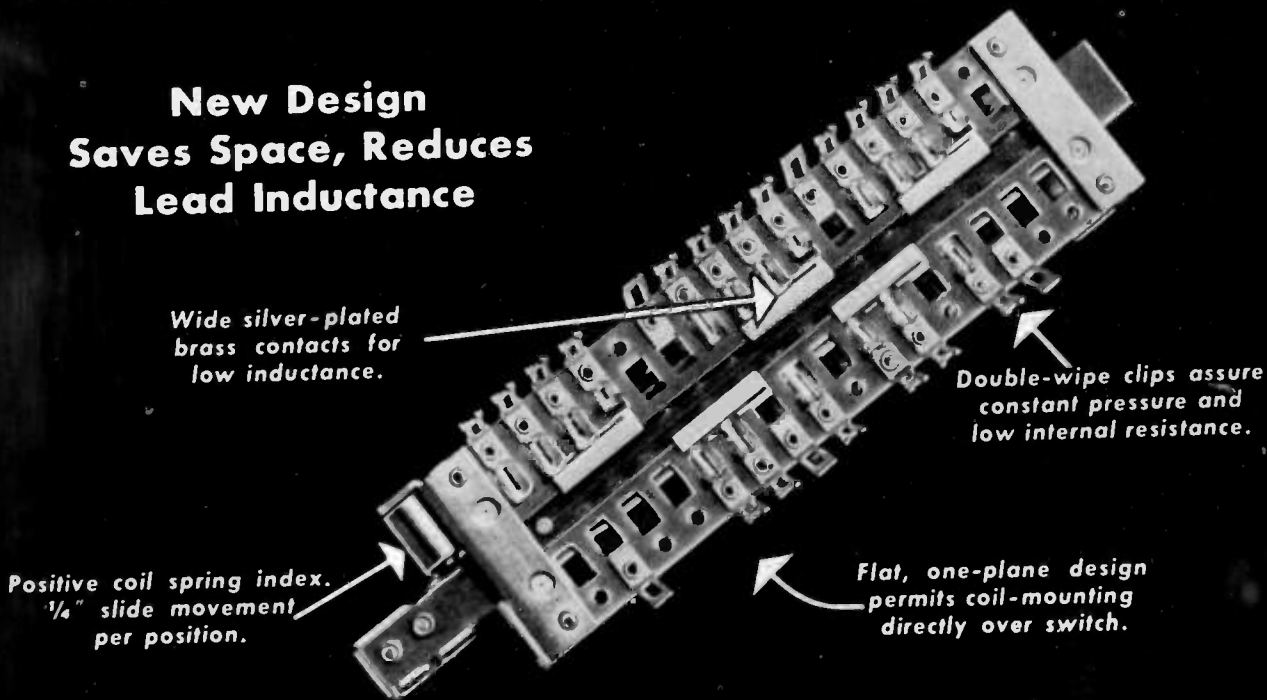

**Compact, Versatile, fits wide range  
of high frequency operations!**

TO MEET an ever-growing demand, Centralab now offers you an outstanding new slide switch, designed for peak AM and FM performance plus maximum reliability and long service life.

Flat, horizontal design saves valuable space, for the first time allows short leads, convenient location to coils, reduced lead inductances for new improved efficiency on low and high frequencies.

Note these fine points of construction and design: 4-point suspension with "twisted ear" mounting on base or panel from .038" min. to .052" max. . . . Optional size or length of unit — min. 5 clips per side, max. 20 clips per side . . . Standard brass silver-plated clips and contacts with original CRL double-wiping clip design . . . Index life — exceeds RMA standard 10,000 cycle minimum life test . . . 2 or 3 position, shorting type contacts . . . Movement of slide per position —  $\frac{1}{4}$  inch.

Write for complete information on this important new switch development. Send for bulletin 953.



Ceramic Trimmers  
Bulletin 630



Ceramics  
Bulletin 720



Variable Resistors  
Bulletin 697

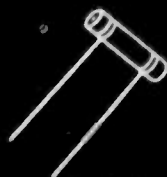

Ceramic Capacitors  
Bulletin 630



Selector Switches  
Bulletin 722

# Centralab

Division of GLOBE-UNION INC., Milwaukee

# MANY FEATURES IN ONE INSTRUMENT

The **METER**  
TYPE 160-A

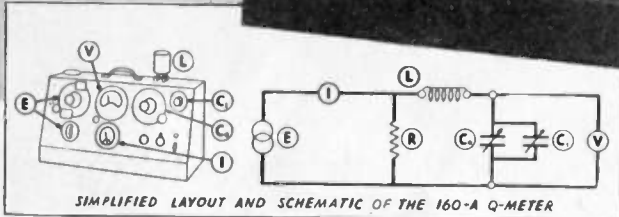
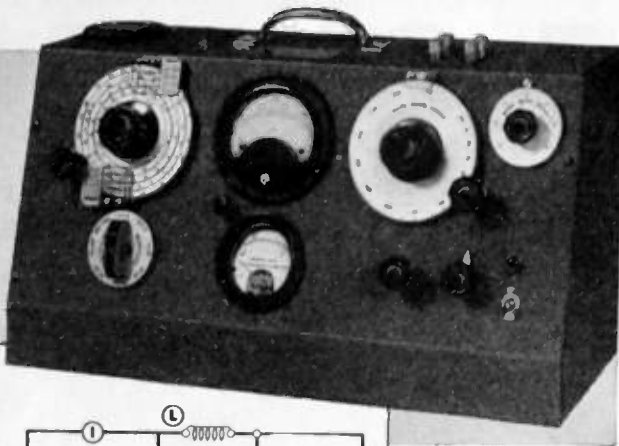

SIMPLIFIED LAYOUT AND SCHEMATIC OF THE 160-A Q-METER

**THE BASIC METHOD OF MEASUREMENT EMPLOYED IN THE 160-A Q-METER**  
An R.F. oscillator (E) supplies a heavy current (I) to a low resistance load (R), which is accurately known. The calibrated voltage across the load resistance (R) is coupled to a series circuit consisting of the inductance under test (L) and a calibrated variable air capacitor (C<sub>0</sub>) having a vernier section (C<sub>1</sub>). When this series circuit is tuned to resonance by means of capacitor (C<sub>0</sub>+C<sub>1</sub>), the "Q" of (L) is indicated directly by the V.T. Voltmeter (V). Variations of this method are used to measure inductance, capacitance and resistance.  
Oscillator Frequency Range: 50 kc. to 75 mc. in 8 ranges. Oscillator Frequency Accuracy: ±1%, 50 kc.—50 mc. Q-Measurement Range: Directly calibrated in Q, 20-250. Multiplier extends Q range to 625. Capacitance Range: Main section (C<sub>0</sub>) 30-450 mmf. Vernier section (C<sub>1</sub>) +3 mmf, zero, -3 mmf.

DESIGNERS AND  
MANUFACTURERS OF  
THE Q METER  
QX CHECKER  
FREQUENCY  
MODULATED  
SIGNAL GENERATOR  
BEAT FREQUENCY  
GENERATOR  
AND OTHER  
DIRECT READING  
TEST INSTRUMENTS

**BOONTON RADIO**

BOONTON · N · J · U · S · A ·

*Corporation*



*the Ideal Inductors for*  
*powers up*  
*to 500 Watts*  
**B&W "3400"**  
**SERIES**

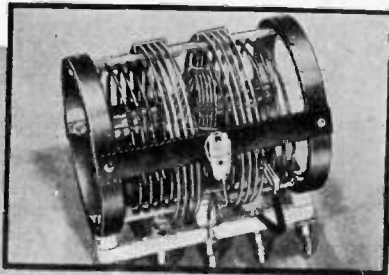

*More flexible electrically . . .*

*Exceptionally sturdy physically . . .*

For precise loading and impedance matching, the B&W series 3400 coil is tops. 80 and 40 meter coils have tapped external fixed links in series with internal rotary links only. 20, 15, and 10 meter coils have internal rotary links only. All coils will load and properly match power amplifiers of 500 watt rating to lines having an impedance of from 50 to 750 ohms. Once adjusted, the coil coupling remains constant. No further adjustment is necessary when bands are changed. Exceptional physical protection is obtained by B&W wartime "armored" construction.

Write for Catalog

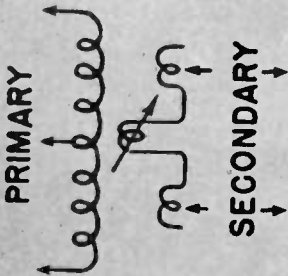

**BARKER & WILLIAMSON**

**B&W**

237 FAIRFIELD AVE., UPPER DARBY, PA.



(Continued from page 48A)

- Glassford, H. A., 1934 University Ave., New York 53, N. Y.  
Glazier, A. W., P. O. Research Station, Dollis Hill, London, N.W. 2, England  
Goetzl, M., 3015 Riverdale Ave., New York 63, N. Y.  
Goldberg, H. D., 3336 Hull Ave., New York 67, N. Y.  
Goldberg, M. I., 3336 Hull Ave., New York 67, N. Y.  
Goldfarb, B. J., 1731 Wayne Ave., Dayton 10, Ohio  
Goldstein, E., 3011 Ave. L, Brooklyn 10, N. Y.  
Goldstein, I. E., General Electric Company, Syracuse, N. Y.  
Govindarajulu, S., No. 6, Ramakrishnamutt Road Cross, Ulsoor, Bangalore Cantt., Bangalore, India  
Granler, S. G., Per Lindstroms vag 75, Hammarbyhojden, Sweden  
Gratama, S., Van Leydenstraat 6, Voorburg (Z.H.), Netherlands  
Greene, I., 1004 Montgomery St., Brooklyn 13, N. Y.  
Greene, W. E., Office of Naval Research, Navy Department, Washington 25, D. C.  
Greenwald, C., 737 Rockaway Ave., Brooklyn 12, N. Y.  
Greenwood, I. A., Jr., General Precision Laboratory, Pleasantville, N. Y.  
Grim, R. L., 215 W. 23 St., New York 11, N. Y.  
Grossfield, S., 18 West 25 St., New York 10, N. Y.  
Gulihur, D. L., 206 East Main Mexia, Tex.  
Hannon, S., Equipment Engineering Department, Raytheon Manufacturing Company, Waltham 54, Mass.  
Hanson, G., 176 Newport St., Arlington 74, Mass.  
Hanson, R. B., c/o Carl A. Stone Company, 3415 W. 8 St., Los Angeles 5, Calif.  
Harris, A. W., 3348 West Compton Blvd., Gardena, Calif.  
Harris, W. B., 300 N. Fourth St., Camden, N. J.  
Hartman, A. E., 6209 Ridge Rd., Parma 9, Ohio  
Harwood, E. E., Sr., Box 363, Washington 4, D. C.  
Hastings, M. S., 4041 Wilkens Ave., Baltimore, Md.  
Haugk, W. V., 58 Harrison St., Staten Island, N. Y.  
Hayward, G. H., 29-15—214 Place, Bayside, N. Y.  
Heacock, D. P., RCA Victor Division, Harrison, N. J.  
Hedene, T. H., 39 Curtis St., New Britain, Conn.  
Hegeman, A. S., Jr., 15 Hillside Ave., Glen Ridge, N. J.  
Hegeman, B. L., 11 Hillside Ave., Glen Ridge, N. J.  
Henrich, W. H., 56 Wilton Ave., Norwalk, Conn.  
Henry, E. A., 37 N. Dudley St., Camden, N. J.  
Hensell, R. L., 129 Glenwood Ave., East Orange, N. J.  
Herrmann, T. A., 2327 S.E. 72 Ave., Portland, Ore.  
Hill, D. R., 2015 Columbia Rd., N.W., Washington, D. C.  
Hillstrom, N. W., 149 S. Hayworth Ave., Los Angeles, Calif.  
Hines, J. P., 18 Hill Rd., Waltham, Mass.  
Hirshorn, R. W., 2520 Kings Highway, Brooklyn 29, N. Y.  
Hoffman, P. A., 307-C Holly Dr., Baltimore, Md.  
Hoffman, R. A., 20-43—120 St., College Point N. Y.  
Holmes, C. J., 4028 Cumberland St., El Paso, Tex.  
Holtum, A. G., Jr., 37 Washington Village, Asbury Park, N. J.  
Hom, W. R., 314 First St., Mineola, L. I., N. Y.  
Homburg, E. P., 1409 Staples St., N.E. Washington, D. C.  
Hood, C. R., 115 Madison St., Malden 48, Mass.  
Horn, W. F., 404 Travis, Wichita Falls, Tex.  
Horne, J. F., 874 North Ave., Westfield, N. J.  
Hougen, H. C., 6009 Blossom St., Houston 7, Tex.  
Hubscher, E. W., 1254 Shadycrest Dr., Pittsburgh 16, Pa.

(Continued on page 62A)



Output of one of the marker oscillators used in setting sweep speeds to known values. This case represents 0.2 microsecond/inch.

1.2 lines of television signal. Horizontal synchronizing and blanking pulses at each end. Video modulation in center.

Fractional part of a line. Horizontal synchronizing and blanking are shown.

### OTHER FEATURES...

Provisions for attaching recording camera. Fine, clear focus over entire length of trace.

**Y-axis:** Any degree of attenuation between 1:1 and 1000:1; great expansion of negative polarity signal; undistorted deflection of at least 2"; frequency response within 3 db. from 10 cps. to 10 mc.

**X-axis:** Time-base duration variable from 1 to 15,000 microseconds. Horizontal deflection of at least 4". SRP-A Cathode ray Tube. 12,000 volt accelerating potential.

Time-base can correspond with any horizontal line in either or both interlaced fields. Calibrating generator for calibration of sweep-writing speeds by signals of 10, 1, and 0.2 microsecond/cycle.

Wide range of sweep-writing speeds; continuous variation between 0.25 and 3000 microseconds/in.

Delay ranges of 100 or 1000 microseconds selectable for linear time base.

Indication as to exact occurrence of time-base with respect to overall television picture.

Interval of 0.25 microsecond may be measured to plus/minus 0.01 microsecond.

Fractional part of line near center of line. Video modulation produced by wedge, is shown.

Television waveforms selected even to the scanning line and fraction of that line, for critical study or recording, with the new

# DU MONT Type 280 *Cathode-ray* OSCILLOGRAPH

Vertical synchronizing and equalizer pulses as seen with 60-cycle-sweep repetition rate; used for checking interlace.

Fractional part of line near center of a test pattern where wedge elements are more closely spaced. Note loss in amplitude of modulation.

Trailing edge of horizontal synchronizing pulse.

DU MONT proudly announces the new Type 280 Cathode-Ray Oscilloscope especially designed for television studio and transmitter installations. Here at last is a means for accurately determining the duration and shape of the waveform contained in the composite television signal, as well as the character of the picture-signal video in conjunction with transmitter operation, according to FCC standards and practices.

Excellent for research on all tele-

vision equipment. Also for study of wide-band amplifiers. Well suited for industrial use wherever high-speed single transients are studied. Consists of four units mounted on standard relay-rack type panels and chasses, and installed on mobile rack. Removable side and rear panels. Grouped controls for easy operation.

By virtue of its great range of applications, Type 280 becomes a "must" for television studio and research laboratory.

◆ Further Details on Request!

© ALLEN B. DU MONT LABORATORIES, INC.

# DU MONT

## Precision Electronics & Television

ALLEN B. DUMONT LABORATORIES, INC., PASSAIC, NEW JERSEY • CABLE ADDRESS: ALBEEDU, PASSAIC, N. J., U. S. A.



A new antenna for two-way mobile radiophone service incorporating improved electrical matching of coaxial cable and single hole mounting requirement.



**H.H. BUGGIE & CO.**  
TOLEDO 1, OHIO

**MEMBERSHIP**

(Continued from page 60A)

- Hughes, B. F., 635 Trinidad, Beaumont, Tex.
- Hull, R. W., Bell Telephone Laboratories, Inc., Murray Hill, N. J.
- Humphrey, T. R., 40 Brainerd St., South Hadley Falls, Mass.
- Hunt, W. A., 17320 Rutherford, Detroit, Mich.
- Hunter, A. W., 156 Lombard St., Winnipeg, Man., Canada
- Hunter, D. J., National Bank Bldg., Lima, Ohio
- Huth, D. L., 611 S. Kingsley Dr., Los Angeles 5, Calif.
- Hutson, L., 960 Tinton Ave., New York 56, N. Y.
- Hutter, E. C., Box 182, Princeton, N. J.
- Ide, J. M., U. S. Navy Underwater Sound Laboratory, New London, Conn.
- Jacobson, E. R., 81 Ellsworth Ave., New Haven, Conn.
- Jaques, P. I., 115 Willis, Hawthorne, N. Y.
- Jasik, C., 940 Grand Concourse, New York 56, N. Y.
- Jewett, R. A., 83-30 Kew Gardens Rd., Kew Gardens, L. I., N. Y.
- John, L. E., Apt. A-5, 440 W. Queen Lane, Philadelphia, Pa.
- Johnson, E. A., 99 Sterling Rd., Fairmont, W. Va.
- Johnson, R. L., 308 North Sixth Ave., Maywood, Ill.
- Jones, G. V., 33 Orange Ave., Long Beach 2, Calif.
- Jones, L. F., 144 Columbus Ave., Valhalla, N. Y.
- Jones, M. A., 34 Nutley Ave., Nutley 10, N. J.
- Kaiser, H. R., c/o WWSW, Inc., Box 1555, Pittsburgh 30, Pa.
- Katz, S., 2046-71 St., Brooklyn 4, N. Y.
- Kavanaugh, E. V., 1 Sampson Pl., Long Branch, N. J.
- Kaye, H. W., 4 Cromwell Pl., White Plains, N. Y.
- Kearns, J. L., 331 S.E. 62 Ave., Portland 16, Ore.
- Keen, H. J., 7 Second Ave., Atlantic Highlands, N. J.
- Keener, C. E., 5510 Larchwood Ave., Philadelphia, Pa.
- Kees, D. F., 5 Rainbow Lane, Mill Valley, Calif.
- Keigher, B. J., 194 Bergen Pl., Red Bank, N. J.
- Keim, E. L., 11 Chantal Ave., Wheeling, W. Va.
- Kelly, R. L., 1553 Juneway Terr., Chicago 26, Ill.
- Kennedy, D. J., c/o P. J. Kennedy & Company, 380 High St., Holyoke, Mass.
- Kiblinger, W. H., W4JTG, Mineral, Va.
- Killian, T. J., 47 Maryland Ave., Annapolis, Md.
- King, E. J., 233 Linden Ave., Towson 4, Md.
- Kinney, R. V., Rm. 804, Radio Station WRRN, 2nd National Bank Bldg., Warren, Ohio
- Kinsey, G. B., 1231 Crescent St., Apt. 7, Montreal, P. Q., Canada
- Klemperer, H., 25 Ross Rd., Belmont, Mass.
- Kline, L. M., Jr., 5394-63 St., Ridgewood Plateau, Maspeth, N. Y.
- Knowles, D. D., 187 Sunset Ave., Verona, N. J.
- Koch, J. G., 460 W. Eighth St., Wyoming, Pa.
- Koch, J. F., Jr., 39 E. Knowles Ave., Glenolden, Pa.
- Koval, D., Atlantic Union College, S. Lancaster, Mass.
- Kramer, A., British Broadcasting Corporation, 630 Fifth Ave., New York 20, N. Y.
- Krieger, P., 1632 E. 18 St., Brooklyn, N. Y.
- Kudo, F. M., 601 W. 110 St., New York 26, N. Y.
- Kunze, A. A., 313 1/2 Jersey Ave., Spring Lake, N. J.
- Kurylo, E. F., 213 W. 21 St., New York 11, N. Y.
- Lahman, G. H., Route 1, Bucyrus, Ohio
- Lambert, F. C., 110 Court St., White Plains, N. Y.
- Landis, C. G., Safe Harbor, Box 6, Conestoga 2, Pa.
- Lane, R. N., 2210 San Gabriel, Austin, Tex.
- Langmuir, C. R., 49 Mulberry Rd., New Rochelle, N. Y.
- Larson, R. W., 1400 Longfellow St., N.W., Washington, D. C.
- Larson, W. C., 717 Cordilleras, San Carlos, Calif.
- Lasher, C. C., General Electric Company, Thompson Rd., Syracuse, N. Y.
- Laurent, G. J., Research Division, Philco Corporation, Broad and Somerset Sts., Philadelphia, Pa.

(Continued on page 64A)

**PRECIOUS METALS**  
PLATINUM METALS  
GOLD ALLOYS



SHEET  
FOIL  
RIBBON  
WIRE  
TUBING

WRITE for list of products





# INSTANTANEOUS VOLTAGE REGULATION

WITH 2½% MAXIMUM  
WAVEFORM DISTORTION

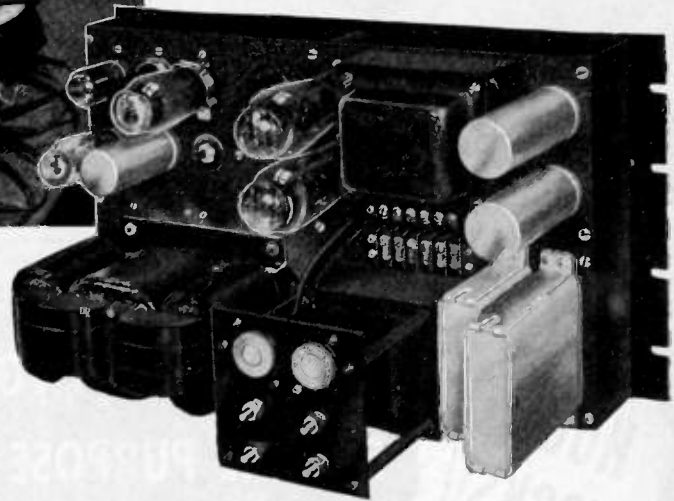
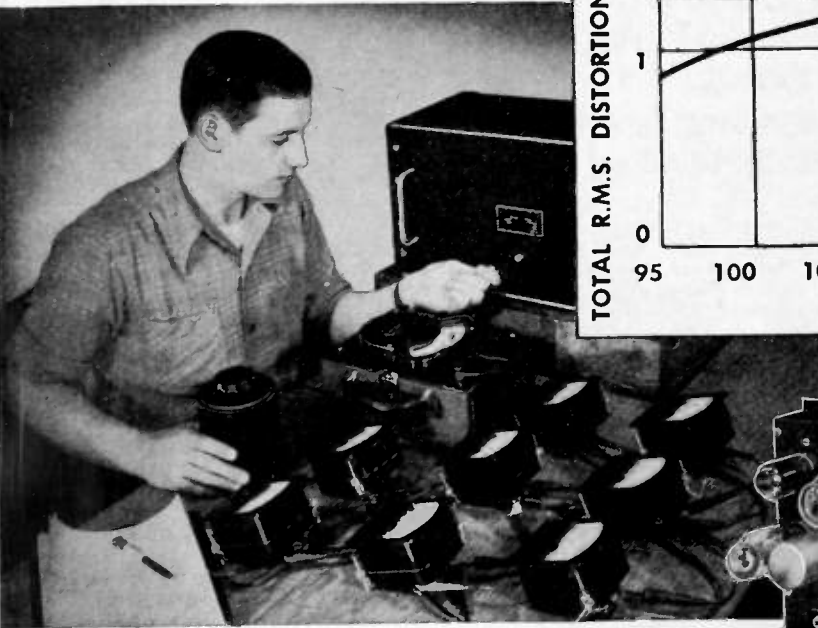
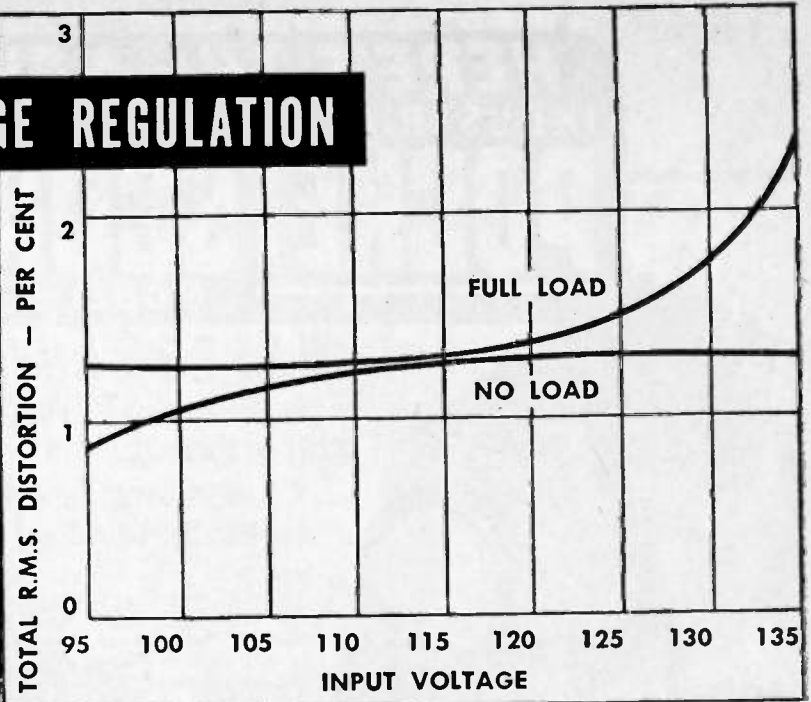

## STABILINE

*Instantaneous Electronic*  
**Voltage Regulator**

At no load ... full load (1KVA) ... or any intermediate load, the new STABILINE Type IE Voltage Regulator maintains a constant output voltage to within  $\pm .1$  volt of nominal with negligible waveform distortion. Examine the graph. Although the line voltage may fluctuate from 95 to 135 volts, the waveform distortion never exceeds 2½ per cent.

If your problem is maintaining a constant output voltage from a fluctuating line, you will want to investigate this new Superior STABILINE Voltage Regulator. Write for more graphic information illustrating performance at various frequencies, power factor loads, input voltages and other operating conditions.

Write Superior Electric 905 Laurel Street For Information and Literature

**THE SUPERIOR ELECTRIC CO.**  
BRISTOL, CONNECTICUT



POWERSTAT VARIABLE TRANSFORMERS • VOLTBOX A-C POWER SUPPLY • STABILINE VOLTAGE REGULATORS

# HERE'S THE NEW INDUSTRIAL and TELEVISION POCKETSCOPE MODEL S-II-A



**\$99**

F. O. B., PHILA.

by **WATERMAN!**

An OSCILLOSCOPE of UNUSUAL VERSATILITY,  
UTILITY and PERFORMANCE

**A 3 INCH OSCILLOSCOPE for  
MEASURING AC and DC!**

AMPLIFIERS for vertical and horizontal deflection as well as intensity... Linear time sweep from 4-cycles to 50-kc with blanking of return trace... Sensitivity up to 100 mv/in... Fidelity up to 350-kc through amplifiers... Attenuators for AC and for DC... Push-Pull amplifiers... Anti-astigmatic centering controls... Trace expansion for detail observations.

8 3/4 lbs. ... 11" x 7" x 5 1/2"

Chassis completely insulated from input circuits assures safety in industrial applications... Direct connections to deflecting plates and intensity grids from rear... Retractable light shield... Detachable graph screen... Handle... Functional layout of controls.



**WATERMAN PRODUCTS CO., INC.**  
PHILADELPHIA 25, PA.



(Continued from page 62A)

- Lawrence, F. G., Box 471, Clinton, Ont., Canada  
 Leddy, E., Jr., 16 Valley Pl., Tenafly, N. J.  
 Lee, F., 32A Sutter Ave., Brooklyn 12, N. Y.  
 Lerner, L., 35 E. 208 St., New York 67, N. Y.  
 Lesley, A. M., 114 S. 27 St., Camden, N. J.  
 Levens, L. M., 2000 Anthony Ave., New York 57, N. Y.  
 Levine, O. W., 470 Lincoln St., Pallsades Park, N. J.  
 LeVitin, M. L., Officer's Club, BOQ, Fort Monmouth, N. J.  
 Limansky, I., 1826-26 Rd., Long Island City, N. Y.  
 Limen, M. L., 612 W. 116 St., New York, N. Y.  
 Lippel, B., 600 Main St., Asbury Park, N. J.  
 Lloyd, J. S., WACE, 326 Chicopee St., Chicopee, Mass.  
 Lough, J. I., 860 East 17 St., Brooklyn 30, N. Y.  
 Loutlt, J. A., 119 Oxford St., Cambridge, Mass.  
 Lush, M. J., 320 Lake St., Belmont, Mass.  
 Lyons, R. C., 115-44-175 St., St. Albans, L. I., N. Y.  
 Macdonald, C. J., 457 Stuart St., Boston 16, Mass.  
 Mackey, R. W., 135 Lexington Ave., New York 16, N. Y.  
 Mackie, A. S., 120 Rockwell Ave., Toronto 9, Ont., Canada  
 Magin, J. J., Civil Aeronautics Administration, 385 Madison Ave., New York 17, N. Y.  
 Malheiros, L. G., 223 Beechwood Ave., Liverpool, N. Y.  
 Malone, J. P., Jr., 3431-91 St., Jackson Heights, N. Y.  
 Mandel, M., 2018 Dorchester Rd., Brooklyn, N. Y.  
 Mandler, E. S., 162 Greenwich St., New York, N. Y.  
 Marsh, W., 1264 Harbert, Memphis 4, Tex.  
 Martin, W. R., Rm. 1, Hanger 3, Lockheed Air Terminal, c/o Airborne Instruments Laboratory, Burbank, Calif.  
 Mason, H. L., 1 Park Pl., Noroton Heights, Conn.  
 Matzinger, K., Box 409, Red Bank, N. J.  
 Mazzei, A. L., 83-30 Kew Gardens Rd., Kew Gardens, L. I., N. Y.  
 McConnell, I. R., 1422 Tenth Ave., Neptune, N. J.  
 McGoldrick, J. P., Box 653, Scranton, Pa.  
 McKnight, D. R., Route 5, Box 521, Pensacola, Fla.  
 Medd, J. S., Box 342, Christian Ave., Stony Brook, N. Y.  
 Mehlman, S. J., 2150 East 21 St., Brooklyn 29, N. Y.  
 Meier, D. J., Watson Laboratories, Red Bank, N. J.  
 Meloy, T., 347 Madison Ave., New York, N. Y.  
 Meyers, K. D., 141 W. Pomfret St., Carlisle, Pa.  
 Mikos, E. J., 2428 N. Talman Ave., Chicago 47, Ill.  
 Miller, C. J., 1604 Frederick Rd., Catonsville 28, Md.  
 Mitchell, W. T., 4509 N. Keeler Ave., Chicago, Ill.  
 Mitra, S. N., Radio Group, Cavendish Laboratory, Cambridge, England  
 Montlor, J. A., 229 Summit Ave., Bogota, N. J.  
 Mooney, R. E., Box 298, Clinton, Ont., Canada  
 Morgan, J. G., 508 Garland, Beaumont, Tex.  
 Morris, M. M., 92 Barker Ave., Eatontown, N. J.  
 Morrison, W. B., 617 Egan Ave., Verdun, P. Q., Canada  
 Morton, R. C., 12 Humphreys Rd., West Barrington, R. I.  
 Moy, W. T., 634 W. 135 St., New York 31, N. Y.  
 Muller, R. H., 95 Douglas Rd., Belmont 78, Mass.  
 Murphy R., 8410 St. Clair Ave., Box 901, Ross-snoyne, Ohio  
 Murrell, T. A., OSW, 4E936, Pentagon Building, Washington 25, D. C.  
 Nagarjan, M. S., 31 Kamaleeswaran Koil St., Chidambaram, Madras, India  
 Nagel, G. W., 234 Cascade Rd., Pittsburgh 21, Pa.  
 Nearing, F. G., 414 Highland Ave., Passaic, N. J.  
 Neel, R. I., 560 Audubon Ave., New York 33, N. Y.  
 Nelson, A. A., 421 Marlboro St., Boston, Mass.

(Continued on page 66A)

## TRANSMITTING AND SPECIAL PURPOSE TUBES

**HUGE  
STOCKS!**

**WRITE FOR  
NEWARK'S LIST OF TUBES**

Make Newark your source, too, for all needed radio and electronic parts. Brisk, competent service assures quick delivery.

### NEWARK NOW AGENTS OF WAR ASSETS ADMINISTRATION

Newark has been appointed agents of the War Assets Administration for transmitting and special purpose electronic tubes.

### HUGE STOCKS! WIDE SELECTION!

This means that you can now get prompt Newark service on the previously hard-to-get tubes, priced at a fraction of their original cost. Make Newark your headquarters for tubes — whether it's for experimental work or production runs.

ACTING AS AGENTS FOR WAR ASSETS ADMINISTRATION UNDER CONTRACT WAS(p) 7-167

NEW YORK  
Offices & Warehouse  
242 W. 55th St., N.Y. 19

**NEWARK** TELEPHONE  
ELECTRIC COMPANY, INC. Circle 6-4060

New York City Stores: 115-17 W. 45th St. & 212 Fulton St.

• MAIL AND PHONE ORDERS  
FILLED PROMPTLY

• WRITE: 242-N WEST 55th  
STREET, NEW YORK CITY



says JOHN M. DERBY CO. Chicago (AUTHORIZED HALLCRAFTERS SERVICE CENTER)

# Your CCO is a Natural!

NO GUESS WORK ABOUT IT... SIGNAL SELECTION IS POSITIVE AND PRECISE"

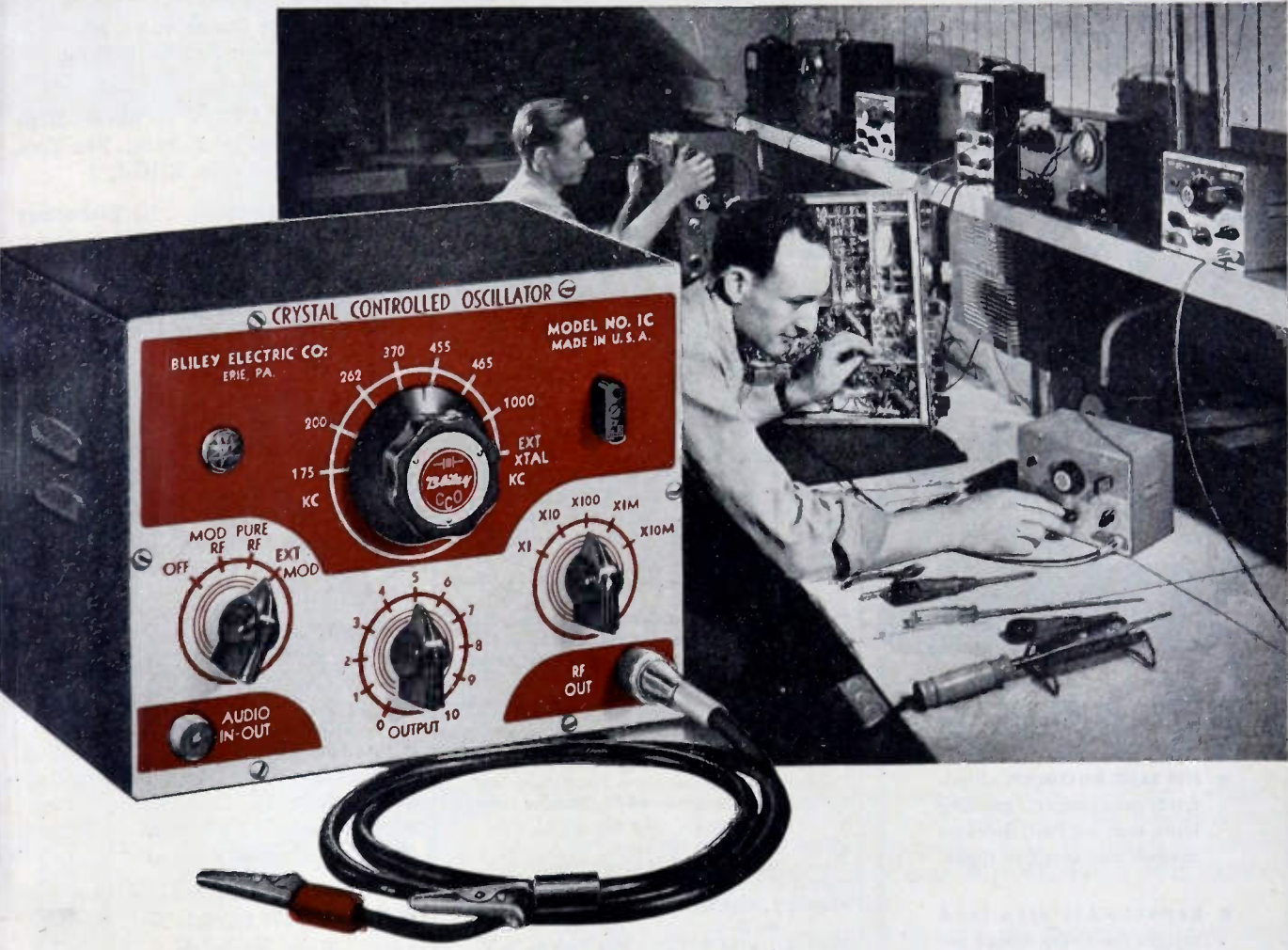

Yes, as John Derby says, the CCO eliminates any question or interpolation because each signal is directly controlled by an individual crystal oscillating at the required frequency. No need to identify confusing beat frequencies when you have *direct crystal control* in the CCO.

Precision is assured by seven Bliley crystals which are "on frequency" as soon as the oscillator is energized. No warm up time needed and no aging effects to compensate. All fre-

quencies are accurate, dependable and permanent with *direct crystal control* in the CCO.

This small compact instrument provides instant selection of crystals oscillating at 175 kc, 200 kc, 262 kc, 370 kc, 455 kc, 465 kc and 1000 kc. An external socket is provided to accommodate extra crystals that may be needed for special frequencies.

The CCO is a "techniquality" product of Bliley engineers and craftsmen who have pioneered in frequency control for over fifteen years. Ask your Bliley distributor, or write direct, for Bulletin 32 which gives complete details.



**\$69.50**

*Complete with 7 Bliley crystals, tubes and concentric output cable.*

BLILEY ELECTRIC COMPANY • UNION STATION BUILDING, ERIE, PENNSYLVANIA

PROCEEDINGS OF THE I.R.E. May, 1947

# MATCH UP

with

# TRIPLETT Meters

**5 BASIC  
MOVEMENTS  
IN SIZES FOR EVERY NEED**



## METER HIGHLIGHTS

- **FIVE BASIC MOVEMENTS**—Electrodynamometer, moving iron, moving coil, thermocouple and rectifier types.
- **RANGES**—All standard ranges for every major instrument need.
- **SIZES**—2", 3", 4", 5", 6" and 7".
- **STYLES AND FINISHES**—Round, rectangular, square and fan; wide flange, narrow flange, flush, projection or portable. Available in molded or metal case.
- **SPECIAL FEATURES TO ORDER**—Rear illumination, special dials and other features available on most models.

# Triplet

**ELECTRICAL INSTRUMENT CO.**  
BLUFFTON, OHIO



(Continued from page 64A)

Neuber, R. E., 1257 Fernwood Ave., Toledo 7, Ohio  
Neuschaeffer, G. C., 2010 Powell Ave., New York 6J, N. Y.  
Newhoffer, F. L., 45—03 Kissena Blvd., Flushing, L. I., N. Y.  
Newman, P., Watson Laboratories, Red Bank, N. J.  
Newton, K. V., Bay Shore Apts., Jamestown, R. 1.  
Norem, R. E., 114 E. Genesee St., Fayetteville, N. Y.  
Norwood, C. A., Box 12, Graham, N. C.  
Novak, A. J. W., 1825 E. 93 St., Cleveland 6, Ohio  
O'Connor, J. T., 168 S. Valley Rd., West Orange, N. J.  
O'Connor, R. A., 3210 Perry Ave., New York 77, N. Y.  
Oestermeyer, C. F., 246—286 East 131 St., Cleveland 1, Ohio  
Oettinger, A. G., 562 West 193 St., New York 33, N. Y.  
Olson, O. F., 46 Rockwood Ave., Dayton 5, Ohio  
O'Neill, L. H., Department of Electrical Engineering, Columbia University, New York, N. Y.  
Orwin, R. J., 1100—15 Rd., S., Arlington, Va.  
Osmundson, W. O., Box 939, Massapequa, N. Y.  
Ording, J. R., 253 Humble Bldg., Houston 2, Tex.  
Palmer, F. J., 49 Stow St., S. Acton, Mass.  
Parkinson, G. B., Deep River, Ont., Canada  
Parzen, B., 111-31—115 St., Richmond Hill, N. Y.  
Paskin, M., 2304 Sedgwick Ave., New York 53, N. Y.  
Patterson, T. A., Jr., 45 Warrington Pl., East Orange, N. J.  
Paulsen, R. C., 50 Morton Pl., East Orange, N. J.  
Payne, D. T., 161 Crestview Rd., Columbus, Ohio  
Pegg, B. A. G., 96 Bullsmoor Lane, Enfield, Middlesex, England  
Pellegrino, J., Jr., 426 West Vernon Ave., Los Angeles 37, Calif.  
Perez, M., 446 Columbia, Bridgeport 4, Conn.  
Perry, R. L., RFD 5, Portland, Me.  
Petersen, M. C., Route 1, Box 716, Colfax, Calif.  
Petitjean, A. E., 40-15—81 St., Jackson Heights, L. I., N. Y.  
Piazza, G., Aldabas 242, Lima, Peru  
Pineles, M. S., 10 E. 40 St., New York 17, N. Y.  
Pittard, F. L., 515 N. Lombard St., Portland 3, Ore.  
Plotkin, I., 1318 Saratoga Ave., N.E., Washington 18, D. C.  
Polk, M. L., 222 W. 72 St., New York 23, N. Y.  
Pope, W. T., Jr., Box 31, Sea Girt, N. J.  
Postle, A. H., 4717 Rising Sun Ave., Philadelphia 20, Pa.  
Potter, R. R., Rm. 1W96, Bureau of Aeronautics, Navy Department, Washington, D. C.  
Potts, T. J., Jr., c/o Hazeltine Corporation, 58—25 Little Neck Pkwy., Little Neck, L. I., N. Y.  
Prager, H. J., 39 N. Terr., Maplewood, N. J.  
Pratt, E. M., 147 Bridge Ave., Red Bank, N. J.  
Pratt, R. L., 152 DeSoto St., Pittsburgh 13, Pa.  
Prisament, N. T., 18 West 25 St., New York 10, N. Y.  
Procter, S. A., 587 N. State St., Elgin, Ill.  
Prosser, T. C., 12 Girard Pl., Maplewood, N. J.  
Putt, D. R., 85 Van Reypen St., Jersey City, N. J.  
Rabbin, I. G., 35 Fort Washington Ave., New York, N. Y.  
Rea, J. C., Jr., Union Switch & Signal Company, Swissvale, Pittsburgh 18, Pa.  
Rees, V. C., 1157 Prospect Ave., Toledo 6, Ohio  
Reese, H., Jr., 1819 Horner Ave., Merchantville, N. J.  
Reeves, J. F., 667 Rockaway St., Staten Island, N. Y.  
Reichert, H. A., 136 Central Ave., North Hills, Pa.  
Reinhard, F. C., 6621—77 Pl., Middle Village, N. Y.  
Reiniger, R. A., 901 Bond Ave., East St. Louis, Ill.  
Reyling, G. F., 11 Cedar Pl., Sea Cliff, N. Y.

(Continued on page 68A)

## News—New Products

(Continued from page 18A)

### Recent Catalogs

- On Carbon and Wire-wound Variable Resistors, by **P. R. Mallory & Company, Inc.**, 3029 E. Washington St., Indianapolis 6, Ind. Engineering Data Folder No. 247.
- On Electronic Servomechanism, by **W. C. Robinette Company**, 802 Fair Oaks Ave., So. Pasadena, Calif. Bulletin No. H-26.
- On Crystal Units, by **Reeves-Hoffman Corporation**, 215 E. 91 St., New York 28, N. Y. Bulletin No. RHC-1.
- On Z-Angle Meters, by **Technology Instrument Corporation**, 1058 Main Street, Waltham 54, Mass. Bulletin No. 310-A.
- On Tube Testers, by **Simpson Electric Company**, 5200 West Kinzie St., Chicago 44, Ill. Bulletin No. 1447.
- On Marketing Survey of Radios, Phonographs, and Records, by **Crowell-Collier Publishing Company**, 250 Park Avenue, New York 17, N. Y.
- On High Voltage Batteries, by **National Carbon Company**, 30 East 42 St., New York 17, N. Y. Engineering Bulletin No. 4.
- On Radios, Parts, and Test Equipment, by **Radio Wire Television Inc.**, 100 Sixth Avenue, New York, 13, N. Y. Catalog No. 144.
- On Constant Torque Power Unit (through limited rotation), by **Radio Condenser Company**, Davis Street & Copewood Avenue, Camden, N. J. Bulletin No. R/C Rotonoid.
- On Voltage Regulators, by **Sorensen & Company**, 375 Fairfield Ave., Stamford, Conn. Catalog No. S-2-47.
- Precision Resistors, by **Precision Resistor Company**, 336 Badger Avenue, Newark 8, N. J. Bulletin No. 347.
- On Radio Receiving Tube Data, by **Sylvania Electric Products, Inc.**, Emporium, Pa. Price 85¢.
- On Vacuum Pumps, Gauges, and Greases, by **Distillation Products, Inc.**, 755 Ridge Road West, Rochester 13, N. Y. Bulletins No. VE-46-1.
- On High Voltage Components for Broadcast and Commercial Transmitters, by **E. F. Johnson Company**, Waseca, Minn. Data Sheets No. 1947.
- On Folded Quadrupole Antenna, by **Andrew Company**, 363 E. 75 St., Chicago 19, Ill. Bulletin No. 46.
- On Silicones and Silicone Products, **Dow Corning Corporation**, Midland, Mich. Several Bulletins.

(Continued on page 68A)



# Fixed and Variable INDUCTORS for

BROADCAST AND COMMERCIAL  
TRANSMITTING • ELECTRONIC HEATING  
HIGH CURRENT • HIGH VOLTAGE  
R. F. APPLICATIONS

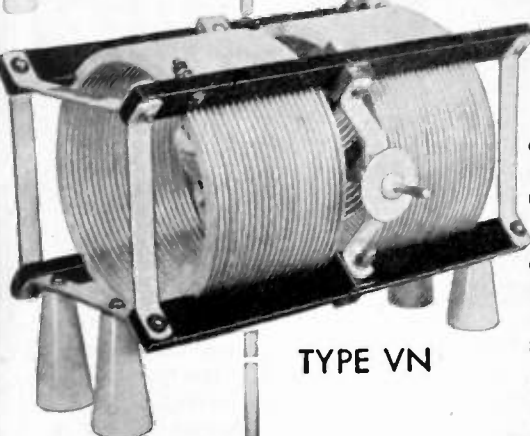
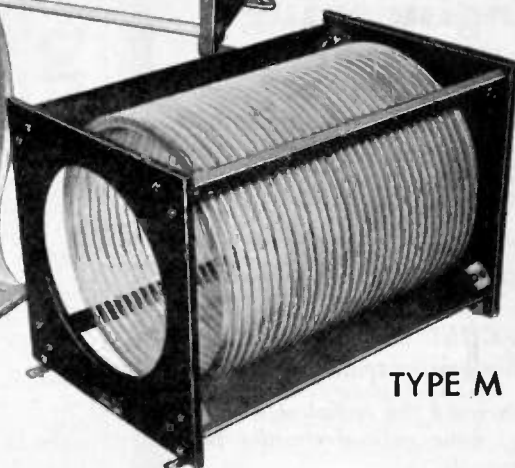
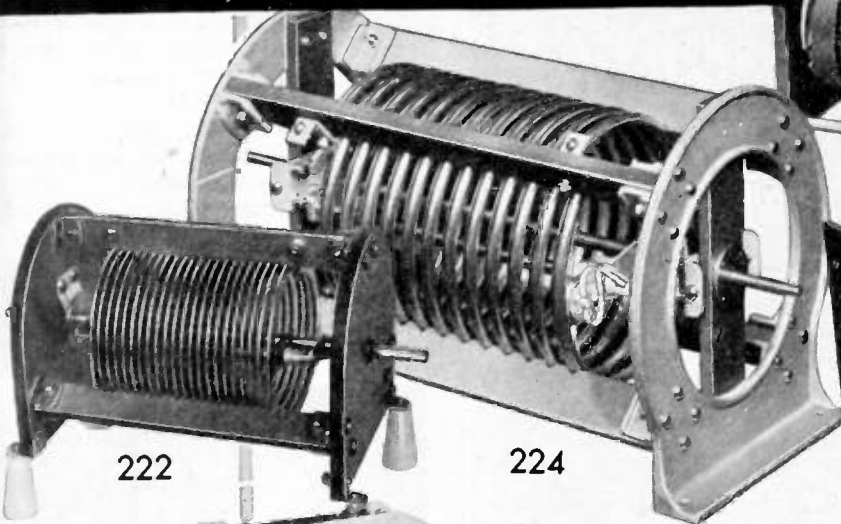
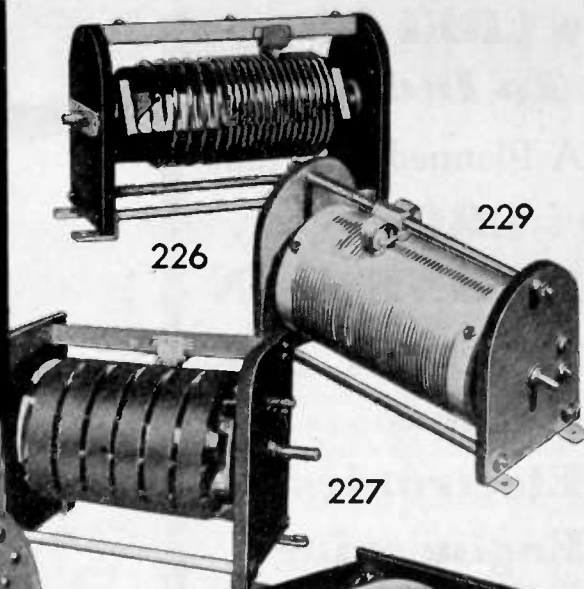

JOHNSON, a pioneer in high voltage, high current inductors for commercial equipment, offers you the benefits of many years of engineering achievement, highly advanced production techniques, and an unequalled choice of types and sizes.

The many variable types assure smooth tuning for low, medium, or high power applications. Types N and M can be supplied with variable coupling rotors, tuning flippers, or as variometers. Faraday shields may be incorporated in the Type M to minimize eddy currents and reduce electrostatic coupling.

The 227 series is engineered to meet the requirements of high current, high frequency, electronic heating and transmitter tank circuits. Dual models feature counter sliding contacts which provide automatic balancing for push-pull circuits.

The 226 series is recommended for high-frequencies and features optional variable pitch winding for wide band coverage. The 224 is wound with 3/8" or 1/2" copper tubing and offers the highest ratings of the types shown.

There is a JOHNSON inductor "your size" for they begin with small wire wound units for low power stages and extend through the big, high power, water cooled types. New data sheets covering the inductors shown have just been completed. We'll be glad to send them for your file or for your immediate requirements.

Write for data  
sheet series W

JOHNSON PRODUCTS INCLUDE

- Transmitting Capacitors • Inductors • Tube Sockets • R. F. Chokes
- Q Antennas • Insulators • Connectors • Plugs and Jacks • Hardware
- Pilot and Dial Lights • Broadcast Components • Directional Antenna Equipment



**JOHNSON** . . . a famous name in Radio

E. F. JOHNSON CO. WASECA, MINNESOTA

## News—New Products

These manufacturers have invited PROCEEDINGS readers to write for literature and further technical information. Please mention your I.R.E. affiliation.

(Continued from page 66A)

### New Enterprises

• • • Radio Engineering Company, 8 State Street, New York, N. Y., will specialize in high-quality receiver design.

### Interesting Abstracts

• • • On "Liveness in Broadcasting," a discussion of microphone placement, printed in the January 1947 issue of the *OSCILLATOR*, published by Western Electric Company, 195 Broadway, New York, N. Y.

• • • On "The Art of Machining for Vacuum Tubes" printed in the 1947 Winter issue of *CATHODE PRESS*, published by Machlett Laboratories, Inc., Springdale, Conn.

### HV Coupling Capacitors

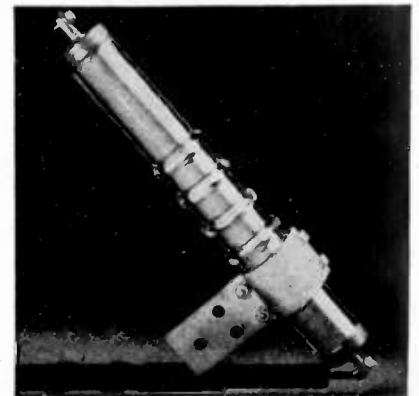

Designed to withstand 10 test impulses of 95 kilovolts, new high-voltage coupling condensers manufactured by the Sprague Electric Company, 189 Beaver St., North Adams, Mass., are expected to be the practical solution to the long-standing problem of coupling telephone equipment to existing 7200-volt alternating current distribution lines. These units have a capacity of 0.002 microfarad and are rated for 8700-volt 60-cycle operation.

### Solderless Coaxial Fittings

Solderless fittings for rigid coaxial transmission lines, available in both bronze and aluminum in all standard sizes, which are gas-tight and have excellent electrical characteristics are being manufactured by Raybould Coupling Company, Meadville, Pa. The manufacturer states that the new couplings will sustain sufficient end-pull to support the line, and their solderless feature simplifies field installations.

(Continued on page 74A)



(Continued from page 66A)

- Rheams, C. J. B., 246 E. Johnson St., Philadelphia, Pa.  
 Rich, P. A., 94 Watchung Ave., Upper Montclair, N. J.  
 Richman, W., 3438—90 St., Jackson Heights, L. I., N. Y.  
 Rife, W. E., 2661 Clime Rd., Columbus 4, Ohio  
 Riley, B. J., Jr., 225 S. Solomon St., New Orleans, La. (Elected April 1, 1947)  
 Roach, J. H., 435 Webster Ave., New Rochelle, N. Y.  
 Robinson, M. U., 203 N. Center St., Hartford, Mich.  
 Roemer, A. K., 2 Lawrence St., East Rockaway, N. Y.  
 Rose, H. E., 192 Shepard Ave., West Englewood, N. J.  
 Rosenzweig, H., 237 Bath Ave., Long Branch, N. J.  
 Roup, R. R., Globe-Union, Inc., Milwaukee 1, Wis.  
 Roush, R. G., 1653 Shadyside Rd., Baltimore, Md.  
 Rubel, S. J., 1872 Monroe Ave., New York 57, N. Y.  
 Rubin, S., 1825 W. Fifth St., Brooklyn 23, N. Y.  
 Russo, J. S., 2027 S. Ninth St., Philadelphia 48, Pa.  
 Sanchez, J. W., 27 Simon, Beverly, Mass.  
 Savigny, J. J., 568a Jarvis St., Toronto 5, Ont., Canada  
 Schafer, H. G., 2911—28 St., N. W., Washington 8, D. C.  
 Schaeperkoetter, L. C., 4148 Grove St., St. Louis 7, Mo.  
 Schatz, H. J., RFD 1, Box 100, State Highway 35, Red Bank, N. J.  
 Schneider, P., 175 Field Place, New York 53, N. Y.  
 Schiffman, J., 2501 N St., S. E., Washington, D. C.  
 Schnakenburg, C. J., 520 Hazel St., Glendale 1, Calif.  
 Schommer, G. R., 119 Lovington Dr., Apt. B, Fairfield, Ohio  
 Schuchman, N., 1375 E. Eighth St., Brooklyn 30, N. Y.  
 Schulz, E. A., 721 Sherwood Dr., Indianapolis 44, Ind.  
 Schwartz, P., 1883 E. 12 St., Brooklyn 29, N. Y.  
 Scroggs, J. R., Central Fire Station, Beaumont, Tex.  
 See, H. P., 8 Pinewood Rd., Plandome, L. I., N. Y.  
 Seidel, H., 2035 E. 13 St., Brooklyn 29, N. Y.  
 Setzer, L. E., 323 Manhattan Ave., Hawthorne, N. Y.  
 Shapiro, A., 857 E. 13 St., Brooklyn 30, N. Y.  
 Sharki, P., 169½ First Ave., Box 88, Manasquan, N. J.  
 Sharp, D. D., 2040—37 St., N. W., Washington 7, D. C.  
 Sharpless, T. K., 629 Walnut Lane, Haverford, Pa.  
 Sheets, M. J., 304 Summers Dr., Alexandria, Va.  
 Shelton, E. J., Jr., 1469 Beacon St., Apt. 7, Brookline 46, Mass.  
 Sidor, E. N., c/o Weldon & Carr, 1605 Connecticut Ave., N. W., Washington, D. C.  
 Sielke, E. L., Box 6000, Torresdale P. O., Philadelphia 14, Pa.  
 Silva, A. A., 71 N. Fifth Ave., Long Branch, N. J.  
 Simon, J. N., 122 S. Smithville Rd., Dayton 3, Ohio  
 Simonds, R. E., 104—30—187 St., Hollis, N. Y.  
 Singer, E. M., 1610 Lincoln Pl., Brooklyn 33, N. Y.  
 Slawek, J. E., 4202 Manayunk Ave., Philadelphia 28, Pa.  
 Smith, B. H., 26 Allen St., Arlington, Mass.  
 Smith, F. C., 209—79 St., Woodcliff, N. J.  
 Smith, H. E., 913A N. LaBrea, Inglewood, Calif.  
 Snyder, E. P., 22 E. 38 St., New York 16, N. Y.  
 Sokolski, E. A., 300 Riverside Dr., New York 25, N. Y.  
 Southwell, J. D., Central Fire Station, Beaumont, Tex.

(Continued on page 70A)

# ★ CREI Offers To Industry A Planned Program of GROUP TRAINING IN Practical Radio- Electronics Engineering

Here is a proved program of high calibre home-study technical training that will increase the efficiency of your staff engaged in any phase of Radio-Electronics.

The CREI "Employers' Plan" for group training will:

1. Increase the technical abilities of your radio-electronics personnel.
2. Enable them to perform their duties more efficiently and in less time.
3. Increase the value of their services to your organization.

No company time is required for this training . . . it is accomplished by spare-time home study to meet each individual organization's requirements.

The CREI "Employers' Plan" is useful for the up-grading of technical personnel in manufacturing, AM, FM, and television broadcasting, communications, industrial electronics, including the following:

Engineers	Testers
Engineering Aides	Technicians
Laboratory Assistants	Field Servicemen
Inspectors	Installers
	Maintenance Men

Your request will promptly bring an outline of the plan, as now in use with other organizations, and complete details will follow when your particular needs are known. No obligation or cost, of course. Write to—

## CAPITOL RADIO ENGINEERING INSTITUTE

E. H. Rietzke, President

An Accredited Technical Institute  
Dept. PR-5, 16th & Park Rd., N. W.

WASHINGTON 10, D. C.





# Be Right with.. OHMITE

## Vitreous Enameled Rheostats

Available in 10 sizes, ranging from 25 to 1000 watts, in a wide range of resistances. Ceramic parts insulate the shaft and mounting. The resistance winding is permanently locked in vitreous enamel. The metal-graphite brush provides unmatched smoothness of action. Engineered and constructed for long, trouble-free life.



## Non-Inductive Resistors

Used as dummy antennas for radio transmitters, load resistors in high frequency circuits, and terminating resistors for radio antennas. Available in vitreous-enamel type wound on a tubular ceramic core and in hermetically sealed-in-glass type mounted on a 4-prong steatite tube base. Sizes from 50 to 250 watts.

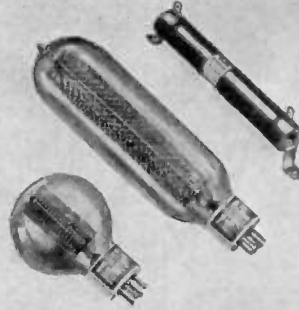

## All Ceramic Tap Switches

A popular switch for use with tapped transformers in power supply units. Compact, dependable, and convenient to operate. Available in ratings of 10, 15, 25, 50, and 100 amperes, A.C. Contacts are of the silver-to-silver, non-shorting type. Switch shaft is insulated by a strong ceramic hub. The heavy, one-piece ceramic body is unaffected by arcing.



## Parasitic Suppressor

Designed for the suppression of unwanted ultra-high frequency parasitic oscillations due to incidental resonance between tube plate and grid circuits of push-pull and parallel operated transmitting amplifiers. Consists of a 50-ohm vitreous enameled non-inductive resistor which supports a choke of 0.3 microhenries and .003 ohms d-c resistance.

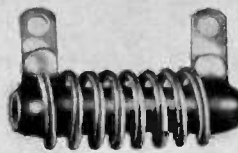

## Radio Frequency Plate Chokes

For use in the plate circuits of diathermy oscillators and amateur, aviation, police, and commercial short wave transmitters. Consists of a single layer winding on a steatite core, rigidly held in place, insulated and protected by a moisture-proof coating. Rated at 1 ampere.

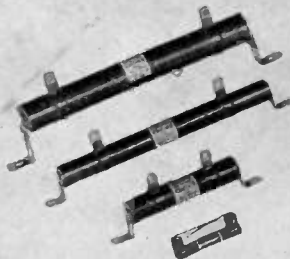

## Wire Wound Resistors

Ohmite offers a complete line of dependable resistors wound on a ceramic tube and protected by vitreous enamel. Ratings from 10 to 200 watts. Available in the fixed type for general use, and in the "Dividohm" type with adjustable lugs for use as a multi-tap resistor or voltage divider.

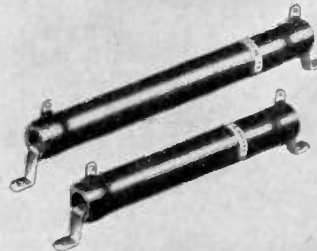

OHMITE MANUFACTURING CO., 4862 Flournoy St., Chicago 44, U. S. A.

# OHMITE

Write Today for Ohmite Catalog No. 18

Provides 16 pages of useful data on the selection and application of rheostats, resistors, tap switches, chokes, attenuators, and other equipment.



RHEOSTATS

RESISTORS

TAP SWITCHES

CHOKES

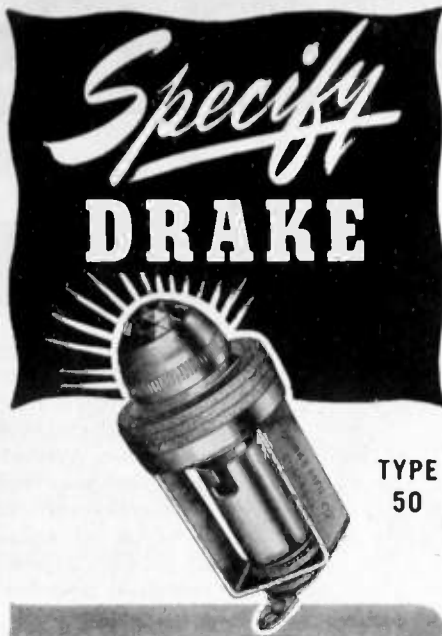

1. Precision Engineered
2. Rugged, Durable, Long-lived
3. Efficient, Dependable Operation
4. Economical

Every conceivable type of Socket and Jewel Light Assembly is available at DRAKE... all measuring up to the same high quality standards. We make over 950 different kinds of Mounting Brackets, to bring lamp filaments into desired positions. Should a new application call for a special design of Assembly or Bracket, our skilled engineers will work with you to design a unit to meet your specific needs. DRAKE quality, dependability and patented features are widely known and appreciated among those who know Socket and Jewel Assemblies best. Very large high speed production facilities assure reasonably prompt deliveries in any quantity. Write or wire for samples and full information.

**ASK FOR OUR NEW CATALOG • NO OBLIGATION!**



**Socket and Jewel  
LIGHT ASSEMBLIES**

**DRAKE  
MANUFACTURING CO.**  
1713 W. HUBBARD ST., CHICAGO 22

## Membership

(Continued from page 68A)

- Spector, M., 26 E. Sixth St., Clifton, N. J.  
 Spencer, R. H., Box 26, University of Connecticut, Storrs, Conn.  
 Sperr, A. E., 14 Saint Luke's Pl., New York 14, N. Y.  
 Spragg, L. A., 14996 Alexander, Detroit 23, Mich.  
 Spillner, H., Jr., 60 Merritt Ave., Dumont, N. J.  
 Stahell, G. D., 411 West Park Ave., Angola, Ind.  
 Stahman, J. R., 3108—30 Ave., S., Minneapolis 6, Minn.  
 Stanley, B. Z., 104-52—116 St., Richmond Hill, N. Y.  
 Stanney, W. J., 4 Avenue H, Alsen Village, Dorchester, Mass.  
 Stanton, L. J., 151 Eighth Ave., New York 11, N. Y.  
 Staples, E. B., 72 Sexton Ave., Westwood, Mass.  
 Staton, M. G., 135 Maple Terr., Merchantville, N. J.  
 Stecca, A. J., 4306 S. Capitol St., Washington 20, D. C.  
 Steck, G. W., 908 Berkeley Ave., Trenton, N. J.  
 Steele, E. R., 30 Trowbridge Ave., Newtonville 60, Mass.  
 Stein, R. S., 941 E. 19 St., Brooklyn 30, N. Y.  
 Stempler, S., 1856 E. 29 St., Brooklyn 29, N. Y.  
 Stokes, B. C., 29 Vanderbilt Ave., Floral Park, L. I., N. Y.  
 Stripp, W. G., 5 Clovelly Rd., Hornsey, London N. 8, England  
 Strom, C. A., Jr., 1910 Oak Dr., West Belmar, N. J.  
 Stubbe, R. R., 548 Weeks St., Palo Alto, Calif.  
 Sullivan, H., 45 Mansfield Ave., Darlen, Conn.  
 Sunue, H. E., 8621 Georgia Ave., Silver Spring, Md.  
 Sutter, A. W., 55 W. 42 St., New York 18, N. Y.  
 Svala, C. G., Marlestadv 28, Hammarbyhojden, Sweden  
 Svedlow, J. D., 1546 Selwyn Ave., New York, N. Y.  
 Svensson, R., Petrejusvagen 51, Hammarbyhojden, Sweden  
 Swafford, T. W., Jr., 236 E. Courtland St., Philadelphia 20, Pa.  
 Sweeney, F. C., 335 W. Passaic Ave., Bloomfield, N. J.  
 Taffel, B. R., 24 Waverly Pl., Red Bank, N. J.  
 Tescari, A., Beroldo 2, Milano, Italy  
 Thomas, D. E., Bell Telephone Laboratories, Inc., 180 Varick St., New York, N. Y.  
 Thomson, V. E., 140 Manor Ave., Hempstead, L. I., N. Y.  
 Town, R. A., 15768 Dexter Blvd., Detroit 21, Mich.  
 Trantham, H., Jr., Franklin Institute, Philadelphia, Pa.  
 Trauben, W., 3230 McMichael St., Philadelphia 29, Pa.  
 Triesner, J. E., 693 Penn Ave., Teaneck, N. J.  
 Trotter, W. E., Sylvania Electric Products, Inc., 83—30 Kew Gardens Rd., Kew Gardens, L. I., N. Y.  
 Tucker, W. J., Jr., 18 Pearl St., Mystic, Conn.  
 Tykulsky, A., 1132 Elberon Ave., Elberon, N. J.  
 Tyler, E. M., 28 Locust Ave., Millburn, N. J.  
 Uersepup, P. C., 326 Rutland Ave., Teaneck, N. J.  
 Vandenburg, A. A., 77 Christabel St., Lynbrook, L. I., N. Y.  
 Vorwerk, F. A., 909 Heck St., Asbury Park, N. J.  
 Wade, E. 5069—45 St., Woodside, L. I., N. Y.  
 Walcott, H. R., Jr., RFD 1, Allendale, N. J.  
 Walter, C. W. P., 427 Lincoln Ave., Rutherford, N. J.  
 Ward, B. R., 2720 Grand Concourse, New York 58, N. Y.  
 Warner, R. E., 514 N. E. Seventh St., Abilene, Kan.  
 Washileski, E., 131 Hudson Ave., Red Bank, N. J.  
 Watson, R. E., 5020 Erringer Pl., Philadelphia 44, Pa.  
 Weinstein, A., 3937 S St., S. E., Washington, D. C.  
 Welch, H. W., Jr., Department of Engineering Research, University of Michigan, Ann Arbor, Mich.  
 Weller, E. J., 103 Marlborough Rd., W. Hempstead, N. Y.  
 Wells, M., Box 6087, Cleveland, Ohio

(Continued on page 74A)

## BROWNING INSTRUMENTS

For Precise Communications

### S-4 FREQUENCY METER

Designed especially for mobile transmitters. Reading accuracy to one part in one thousand. Tests frequencies from 1.5 to 100 mc. Telescoping antenna forms convenient handle.

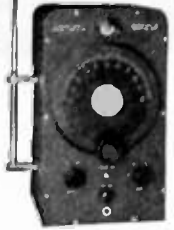

### RJ-12 FM-AM TUNER

Hi-sensitivity tuner for FM-AM reception. Separate RF and IF systems on both bands. Armstrong FM circuit. One antenna serves both FM and AM. Tuning eye shows correct tuning.

### OTHER BROWNING INSTRUMENTS

MJ-9 Frequency Meter and ECO for Homs. RH-10 Frequency Calibrator for full, accurate use of WWV signals. Model OL-15 Oscilloscope for laboratory work, production testing or research.

WRITE FOR DESCRIPTIVE LITERATURE



**BROWNING** LABORATORIES, INC.  
WINCHESTER, MASS.



**finch**

**first in facsimile  
for broadcasting and point-  
to-point communication!**

**FINCH TELECOMMUNICATIONS**

INCORPORATED

SALES OFFICE:

10 EAST 40th STREET, NEW YORK

FACTORIES: PASSAIC, N. J.



# MEISSNER

## FOR TWENTY-FIVE YEARS THE STANDARD OF COIL QUALITY

For over a quarter century the name Meissner has stood for the finest in electronic equipment. Founded in 1922 by the late William O. Meissner (famous for his outstandingly successful inventions in communications and electronics) this company has been the source of many new developments in the radio field.

First to build a complete line of jobber coils; first to design and build plastic IFs and to introduce Ferrous IFs, Meissner has long led in the development of fine coil equipment for every application. A pioneer in FM (holding the second license issued in this country) Meissner was also the first to manufacture radio receiver kits. The Meissner Signal Shifter is still the Number 1 requirement for the complete ham shack and the Meissner Analyst has saved thousands of man-hours for servicemen everywhere.

Today Meissner's original policy of aggressive research and development remains unchanged. Strengthened by 25 years of electronic manufacturing experience it is your guarantee of product quality . . . an assurance of perfect performance under all conditions.

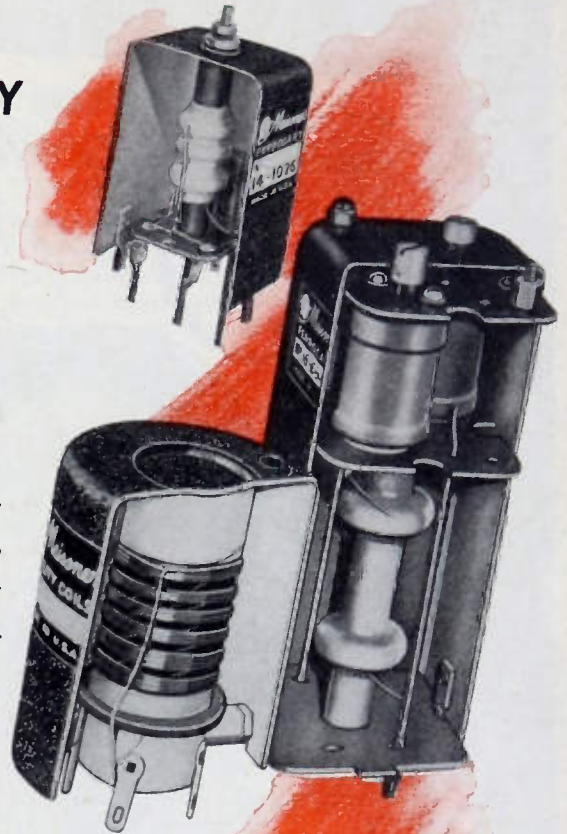

MEISSNER MOUNT CARMEL, ILLINOIS

ELECTRONIC DISTRIBUTOR AND  
INDUSTRIAL SALES DEPARTMENT

**MAGUIRE INDUSTRIES, INC.**

936 N. MICHIGAN AVENUE  
CHICAGO 11, ILLINOIS

*Meissner*

EXPORT SALES DIVISION, SCHEEL INTERNATIONAL INCORPORATED  
4237-39 N. LINCOLN AVENUE, CHICAGO 18, ILL. CABLE ADDRESS - HARSHEEL



Available in popular sizes and ranges for switch-board and panel requirements; including DC, AC (power frequencies and radio frequencies) rectifier types, and DB meters. Ask your local WESTON representative for full details, or write ... Weston Electrical Instrument Corporation, 589 Frelinghuysen Avenue, Newark 5, New Jersey.

**WESTON**

*Panel Instruments*



# WHAT'S NEW IN BRITISH RADIO, TELEVISION & ELECTRONICS ?

## These authoritative Journals answer this vital question

THE JOURNAL OF RADIO RESEARCH AND  
PROGRESS FOR ENGINEERS & PHYSICISTS

WIRELESS ENGINEER is read by research engineers, designers and students, and is accepted internationally as a source of information for advanced workers; its policy is to publish only original work. The Editorial Advisory Board includes representatives of the National Physical Laboratory, the British Broadcasting Corporation and the Engineering Department of the General Post Office, under the Technical Editorship of Prof. G. W. O. Lowe, D.Sc., M.I.E.E. Regular features include British patent specifications and abstracts and references compiled by the Radio Research Board.

### WIRELESS ENGINEER

PUBLISHED MONTHLY, 32 shillings (\$6.50) A YEAR.

THE JOURNAL FOR MANUFACTURERS AND  
TECHNICIANS OF ALL GRADES

WIRELESS WORLD is Britain's leading technical magazine in the general field of radio, television and electronics. Founded over 35 years ago, it has consistently provided a complete and accurate survey of the newest British technique in design and manufacture. Articles of a high standard cover every phase of the radio and allied industries, with reviews of equipment, broadcast receivers and components. Theoretical articles deal with design data and circuits for every application.

### Wireless World

PUBLISHED MONTHLY. 20 shillings (\$4) A YEAR

SUBSCRIPTIONS (by International Money Order) and correspondence should be addressed to:—  
Dorset House, Stamford Street, London, S.E.1, England. Cables: "Iliffepres, Sedist, London."

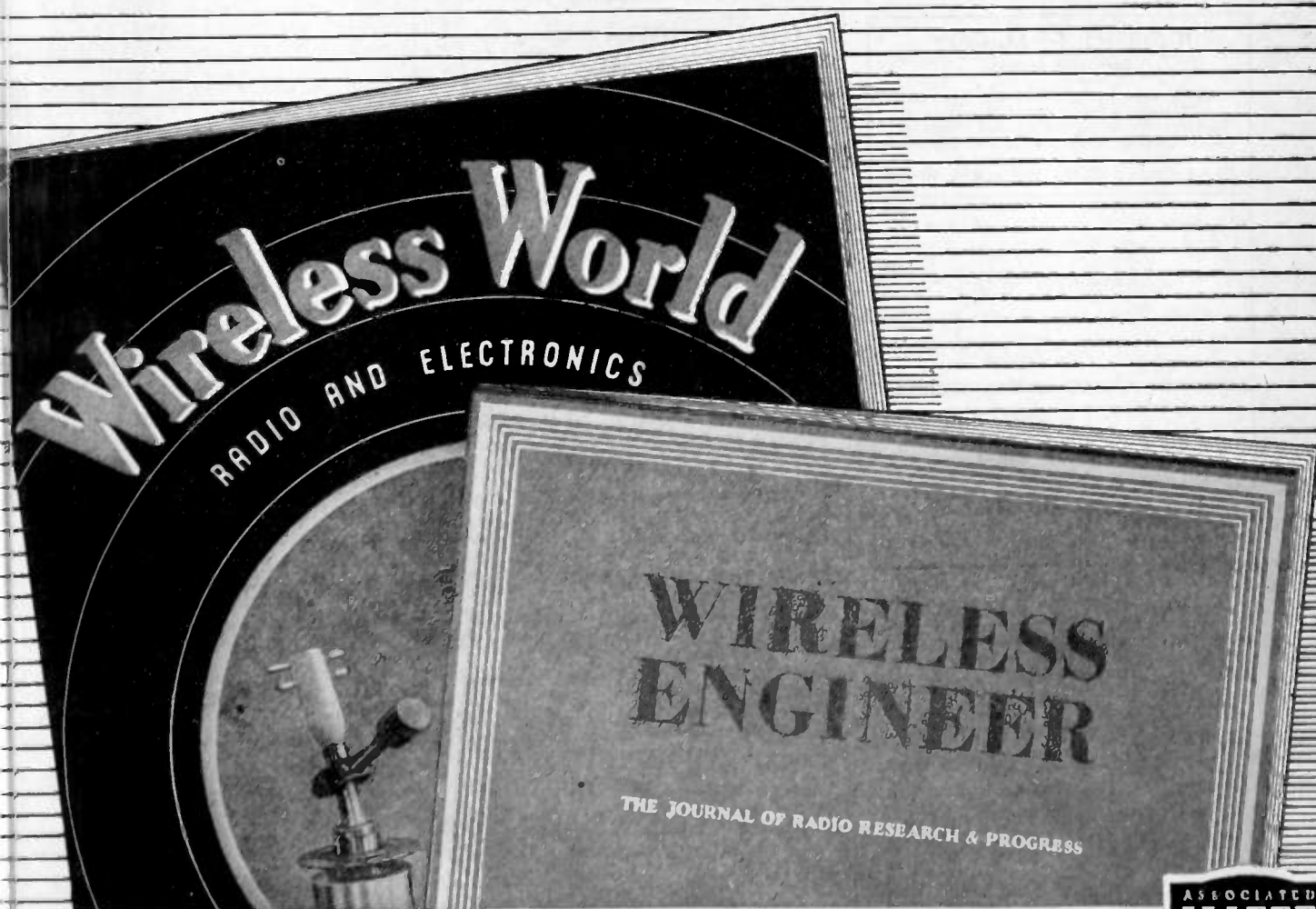

OTHER TECHNICAL BOOKS: "Television Receiving Equipment," by W. T. Cocking, M.I.E.E., editor of "Wireless World," an up-to-date and informative work, 13 shillings (\$2.60); "Basic Mathematics for Radio Students," by F. M. B.Sc., D.I.C., A.C.G.I., a particularly helpful new book, 11 shillings (\$2.20); available from the address above.

ASSOCIATED  
**ILIFFE**  
PUBLICATIONS

## PROFESSIONAL CARDS

### W. J. BROWN

*Electronic & Radio Engineering Consultant*  
Electronic Industrial Applications, Commercial and Broadcasting Transmitter and Receiver Design, Test Equipment, etc.  
23 years experience in electronic development  
P.O. Box 5108, Cleveland, Ohio  
Telephone, Yellowstone 7771

### EDWARD J. CONTENT

*Acoustical Consultant*  
*Functional Studio Design*

FM - Television - AM  
Audio Systems Engineering  
Roxbury Road Stamford 3-7459  
Stamford, Conn.

### HERBERT A. ERF

*Architectural Acoustics*  
Consultant

*STUDIO DESIGN*  
Standard Broadcast—FM—Television  
Cleveland 15, Ohio  
3868 Carnegie Avenue Express 1616

### DAVID C. KALBFELL, Ph.D.

*Engineer — Physicist*

Complete laboratory facilities  
Industrial instrumentation and control  
Broadcast engineering and measurements  
941 Rosecrans St. Bayview 7303  
San Diego 6, California

### ROBERT E. McCOY

Consulting Engineer

Antennas, Antenna-Coupling Systems,  
Direction Finders and Beacons.  
Electronic Circuits for Special Purposes:  
Measurement, Computation and Control.

301-302 Concord Bldg., Portland 4, Oregon

FAirmount 5105 Express 7766

FRANK MASSA  
Electro-Acoustic Consultant

3393 Dellwood Road 3868 Carnegie Avenue  
CLEVELAND, OHIO

Paul D. Zottu  
Consulting Engineer  
Industrial Electronics

High Frequency Dielectric and Induction  
Heating Applications, Equipment Selection,  
Equipment and Component Design, Development, Models.

272 Centre St., Newton, Mass. BIG-9240

## News—New Products

These manufacturers have invited PROCEEDINGS readers to write for literature and further technical information. Please mention your I.R.E. affiliation.

(Continued from page 68A)

### Plant Expansions

••• At Waseca, Minn., E. F. Johnson Company, to manufacture a line of Indicator Lights which was recently purchased from the Gothard Manufacturing Company.

••• At Canonsburg, Pa., by Radio Corporation of America, totaling 115,000 square feet, for the production of phonograph records.

(Continued on page 76A)

## Membership

(Continued from page 70A)

Werzyn, E. A., 7901—35 Ave., Jackson Heights, L. I., N. Y.  
Weyer, E. R., Research Corporation, 405 Lexington Ave., New York 17, N. Y.  
White, R. S., Systems Research Laboratory, Jamestown, R. I.  
Whitehurst, L. M., Box 313, College Park, Md.  
Whitlock, R. S., 515 Hadley Ave., Dayton 9, Ohio  
Whitmyre, R. P., 457 Wendell Terr., Syracuse 3 N. Y.  
Wilkinson, L. A., 24 Luther St., Hatboro, Pa.  
Wilkinson, R. J., 31—33—56 St., Woodside, L. I., N. Y.  
Williams, A. B., 327 E. 47 St., New York 17, N. Y.  
Williams, J. H., 44 Briscoe St., London, Ont., Canada  
Williams, S. B., 366 Clermont Ave., New York 5, N. Y.  
Williams, W. S., 1309 Randolph St., N. W., Washington 11, D. C.  
Wilson, A. L., Sylvania Electric Products, Inc., 83—30 Kew Gardens Rd., Kew Gardens, L. I., N. Y.  
Wilson, E. C., Communications Department, U.S. Naval Air Station, Quonset Point, R. I.  
Wilson, N. B., 5118—25 Rd., N., Arlington, Va.  
Wilson, W. E., 449 Wyoming Ave., Maplewood, N. J.  
Winfree, W. C., 12 and Main Sts., Jacksonville, Fla.  
Winter, N. L., 3831 Macomb St., N. W., Washington, D. C.  
Wood, K. P., 104 Bramshot Ave., London S.E. 7, England  
Wunsch, O. O., 830 Orleans, Beaumont, Tex.  
Zaret, M. E., 3941—48 St., Long Island City 4, N. Y.  
Zindel, G., Tioga & C St., Philadelphia, Pa.  
Zuckerberg, H., 570 Fort Washington Ave., New York 33, N. Y.

The following admissions to Associate were approved on March 2, 1947 to be effective April 1, 1947

Abel-Harry, C. B., 60 Highbury Park, Highbury London, N. 5, England  
Ball, N. T., 8 Leland Ct., Chevy Chase 15, Md.  
Barrack, I., 1011—50 St., Brooklyn 19, N. Y.  
Bawer, L. I., 79—30 Calamus Ave., Elmhurst, L. I., N. Y.  
Blow, A. H., Box 77, Mitchell, Ont., Canada  
Bresson, J., 168 Pembroke St., Brooklyn, N. Y.  
Chambers, W., Box 672, Odessa, Tex.  
Claydon, L. H., 510 Sprague St., Winnipeg, Manitoba, Canada  
Cohn, I. H., 86—07 Eliot Ave., Rego Park, N. Y.  
Cutler, C. R., 627 E. Carroll St., Macomb, Ill.  
Deal, W. R., CESTS, AGF Board No. 1, Fort Bragg, N. C.  
Demere, R. M., Jr., 1420 Southdown Rd., San Mateo, Calif.  
Dobbs, C. I., 5701 S. Hoyne Ave., Chicago, Ill.  
Egger, S. L., 328 S. Mesquite Ave., Box C-2, New Braunfels, Tex.  
Ehlers, D. E., 34—57—72 St., Jackson Heights, L. I., N. Y.  
Embre, R. R., 6512—31 Ave., S. W., Apt. 785, Seattle 6, Wash.  
Engle, B. E., Apt. 175, Santa Fe Heights, Clovis, N. M.  
Fechter, H. R., Boeing Rep., Army Base, Wendover, Utah  
Fioravanti, J. S., 234 Sixth Ave., Brooklyn 15, N. Y.  
Fisher, E. M., 572 Ridge Rd., Greenbelt, Md.  
Fong, S. G., 403 W. South St., Angola, Ind.  
Friedman, O., 2110 Honeywell Ave., New York 60, N. Y.  
Frohlich, A. J., 13 Crawford St., Eatontown, N. J.  
Gahm, W. L. RFD 1, Cove, Ohio  
Girkin, W. B., 2509 Liberty Pkwy., Dundalk, Baltimore 22, Md.

Glucksman, H. A., 431 Cambridge Y.M.C.A. Cambridge, Mass.  
Goff, R. H., Aberdeen Mission, WSPG, Las Cruces, N. M.  
Goldstein, A. D., c/o Steelman Radio Corp., 742 E. Tremont Ave., New York 57, N. Y.  
Graham, E. A., P. O. Box 428, Clinton, Ont., Canada  
Hale, W. B., 8713 Loch Bend Dr., Townson 4, Md.  
Harris, P. C., 1854 Kipling, Houston, Tex.  
Jackson, S. R., 1830 Bever Ave., S. E. Cedar Rapids, Iowa  
James, T. A. W., 89 Victoria Ave., W., Transcona, Man., Canada  
Kaplan, I., 715 Hopkinson Ave., Brooklyn 12, N. Y.  
Kleinman, J. M., 322 S. 43 St., Louisville, Ky.  
Knox, O. L., 818 E. 43 Pl., Los Angeles, Calif.  
Kuh, M. E., 240 S. Wetherly Dr., Beverly Hills, Calif.  
Kuykendall, J. H., 165 Beech St., Belleville, N. J.  
LeFevre, L. M., c/o USS Blackfin (SS322), F. P. O., San Francisco, Calif.  
Larrabee, C. W., 1563 Dean St., Schenectady, N. Y.  
Lewis, R. M., 208 S. Darling, Angola, Ind.  
Lira, A., Casilla Fl, Vina Del Mar, Chile  
Lockwood, L. W., National Broadcasting Co., 30 Rockefeller Plaza, Rm. 575, New York, N. Y.  
Lovenstein, A. J., 559 W. 158 St., Apt. 61, New York 32, N. Y.  
Mabry, J. H., 8 Charles Lane, San Antonio 2, Tex.  
Markel, A., 210 W. 78 St., New York 24, N. Y.  
McDade, J. G., 521 Sudbrook Ave., Pikesville 8, Md.  
McDonough, V. T., 66—38 Saunders St., Forest Hills, L. I., N. Y.  
McIlwain, McD. S., 4966 Woodland Ave., Cleveland 4, Ohio  
Nelson, H. C., Polytechnic Institute of Brooklyn, Microwave Research Division, 55 Johnson St., Brooklyn, N. Y.  
Pereda, E. F., 2E Southampton Ave., Hampton, Va.  
Petes, J., 9 Danbury St., S. W., Washington, D. C.  
Pond, J. F., 19 Larkin Ave., Toronto 3, Ont., Canada  
Posner, S., 645 Williams Ave., Brooklyn 7, N. Y.  
Post, D. B., 4536 Lake Park Ave., Chicago, Ill.  
Raman, A. A., c/o J. B. Rao, Goods Supdt., Wadi Bunder, Bombay, India  
Reed, C. W., 10113 Hunt Ave., South Gate, Calif.  
Rees, W. M., Jr., 7316 Pittville Ave., Philadelphia, Pa.  
Resnicow, L., 926 Clarkson Ave., Brooklyn, N. Y.  
Rodgers, G. H., 8133 Holy Cross Pl., Los Angeles, Calif.  
Rysuck, J., 141 Forrester Ave., Norfolk 8, Va.  
Schatz, F. W., 253 W. Castle St., Syracuse, N. Y.  
Sellars, E. A., 3364—18 St., N. W., Washington 10, D. C.  
Sherman, J. M., c/o Hobart Manufacturing Co., 448 Huffman Ave., Dayton 3, Ohio  
Shrock, J. B., 2543 Weisser Park Ave., Fort Wayne 5, Ind.  
Sivitz, A., 146 N. Roosevelt Ave., Bexley, Columbus, Ohio  
Smith, P. A., 44 Arden St., New York 34, N. Y.  
Smith, R. M., 458 E. Seventh St., Brooklyn, N. Y.  
Sproson, J., c/o 10, Kings Ave., Talbot Rd., Old Trafford, Manchester 16, England  
Steele, R. H., R & CS, Clinton, Ont., Canada  
Sutton, R. B., c/o Radio Station KPQ, Wenatchee, Wash.  
Swanson, C. D., 251 W. 22 St., New York 11, N. Y.  
Taffet, I., 1075 Grand Concourse, New York 52, N. Y.  
Tarrodachik, P., 912 S. Cherry St., San Antonio, Tex.  
Thomas, T. F., 4792 Dwight, San Diego 5, Calif.  
Wasley, R. L., 5100 Chowen Ave., S., Minneapolis, Minn.  
Webber, W. B., 3325 S. W. Primrose, Portland, Ore.  
Weiss, G., 260 Fort Washington Ave., New York 32, N. Y.  
Williamson, R. J., Jr., 317 Center St., Vermillion, S. D.  
Wissel, R. A., 2701 North Lehmann Court, Chicago, Ill.  
Young, A. H., Apt. 301, 2322—40 Place, N. W., Washington 7, D. C.



Going places  
(AGAIN)

hallicrafters

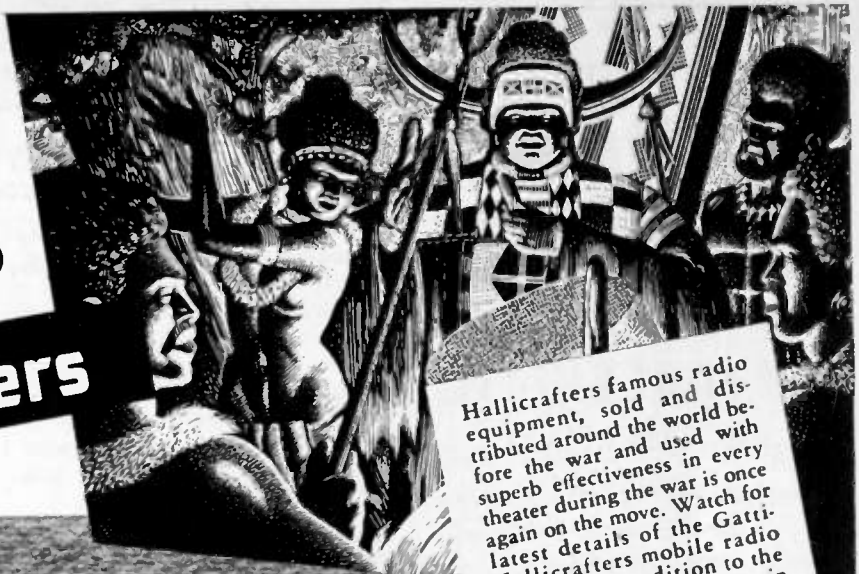

Hallicrafters famous radio equipment, sold and distributed around the world before the war and used with superb effectiveness in every theater during the war is once again on the move. Watch for latest details of the Gatti-Hallicrafters mobile radio equipped expedition to the Mountains of the Moon in deepest Africa—a new and exciting test for the ingenuity of hams and the performance of Hallicrafters equipment.

3 GREAT RECEIVERS designed and priced for hams who are going places, too



**Model SX-42** Described by hams who have operated it as "the first real postwar receiver." One of the finest CW receivers yet developed. Greatest continuous frequency coverage of any communications receiver—from 540 kc to 110 Mc, in six bands. FM-AM-CW. 15 tubes. Matching speakers available. **\$27500**



**Model S-40A** Function, beauty, unusual radio performance and reasonable price are all combined in this fine receiver. Overall frequency range from 540 kc to 43 Mc, in four bands. Nine tubes. Built-in dynamic speaker. Many circuit refinements never before available in medium price class. **\$8950**



**Model S-38** Overall frequency range from 540 kc to 32 Mc, in four bands. Self contained speaker. Compact and rugged, high performance at a low price. Makes an ideal standby receiver for hams. CW pitch control is adjustable from front panel. Automatic noise limiter. **\$4750**

BUILDERS OF *Skyfone* AVIATION RADIOTELEPHONE

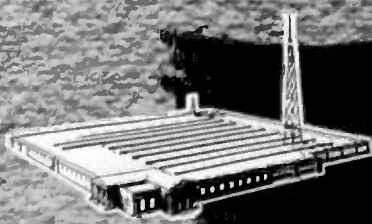

**hallicrafters RADIO**  
THE HALLICRAFTERS CO., MANUFACTURERS OF RADIO AND ELECTRONIC EQUIPMENT, CHICAGO 16, U. S. A.  
Sole Hallicrafters Representatives in Canada: Rogers Majestic Limited, Toronto-Montreal

# Specify MYCALEX

LOW LOSS INSULATION

Where high mechanical and electrical specifications must be met.

## MYCALEX 410

(MOLDED MYCALEX)

makes a positive seal with metals . . . resists arcing, moisture and high temperatures.

27 years of leadership in solving the most exacting high frequency insulating problems.

**MYCALEX CORPORATION OF AMERICA**

"Owners of 'MYCALEX' Patents"  
Plant and General Offices: Clifton, N.J.  
Executive Offices: 30 Rockefeller Plaza  
New York 20, N.Y.

for every  
photo tube  
application

there is a  
High Sensitivity

**RAULAND  
VISITRON**

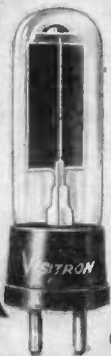

There is a Rauland VISITRON available for every phototube application . . . for industrial electronic control devices, sound-on-film, research and development. For high sensitivity, uniformity and dependability, Rauland VISITRONS are the preferred phototubes.

Specify VISITRON . . . and be sure!  
Send for valuable Rauland VISITRON Catalog—it's yours for the asking.

**THE RAULAND CORPORATION**  
CHICAGO 41, ILLINOIS

RADIO **Rauland** RADAR  
SOUND · COMMUNICATIONS · TELEVISION

## News—New Products

These manufacturers have invited PROCEEDINGS readers to write for literature and further technical information. Please mention your I.R.E. affiliation.

(Continued from page 74A)

### UHF Signal Generator

A particularly valuable laboratory standard for determining gain or alignment, obtaining antenna data or measuring standing-wave ratios; for reading single-stage or conversion gain, signal-to-noise ratios, circuit Q, or transmission-line characteristics, within its frequency range of 500 to 1350 megacycles, is being manufactured by the Hewlett-Packard Company, 395 Page Mill Road, Palo Alto, Calif.



This instrument, known as the 610A UHF Signal Generator, is described as unusually stable, and over its frequency range will supply accurately known voltages ranging from 0.1 microvolt to 0.1 volt. The radio frequency may be continuous, amplitude-modulated, pulsed, or square-wave-modulated. Pulse length can be readily controlled between 2 and 50 microseconds, and pulse rate is variable from 60 to 3000 times per second. A simplified direct-reading control is incorporated and operating charts are not necessary.

### Mercury Vapor Rectifiers

Further completing their line of electron tubes, Eitel-McCullough, Inc., 1018 San Mateo Ave., San Bruno, Calif., announces the availability of Types 866A and 872A mercury vapor rectifiers. These new low-priced rectifiers are directly interchangeable with Types 866A/866 and 872A/872 of other manufacture.

Type 866A/866 operates with 2.5 filament volts, peak inverse voltage as high as 10,000 volts, and a maximum average plate current of 0.25 amperes. The 872A/872 has a five-volt filament and carries a maximum peak inverse voltage rating of 10,000 volts and a maximum average current rating of 1.25 amperes.

### Hand Microphone

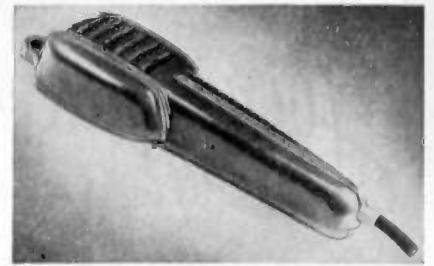

A newly developed hand microphone has been added to the line of microphones manufactured by The Turner Company, 909 17th Street, N.E., Cedar Rapids, Iowa. Designated as Model 20X, it features a "Metalseal" crystal which withstands humidity conditions not tolerated by the ordinary crystal. Factory tests reveal excellent response characteristics for a low-priced unit, which is light in weight and natural to hold.

### Lightweight Towers

Because of persistent demands from amateur radio operators for a lightweight tower for directional beam antennas, the Fabricated Lightmetals Company, 42 W. 15 Street, New York 11, N. Y., has introduced a new line of reasonably-priced aluminum towers which can be assembled by one man using only a common wrench. Other features of these 10', 20' or 30' self-supporting towers are that they require only small ground space, are excellent for roof-top mounting, and are easily insulated when desired. Maintenance is negligible, it is stated, requiring no painting in normal installations.

### Spot Frequency Generator



The Electronic Manufacturing Company, 714 Race St., Harrisburg, Pa., announces the production of its Spot Frequency Generator, Model #200. Engineered for use by the average service man, it contains 12 pre-set frequencies chosen to cover adequately 95% of the sets in use. Stability is assured by an electron-coupled circuit and low leakage is effected through use of double shielding. The manufacturer further points out that the unit attenuates to less than one microvolt.



# Compare!

## Here's the Helipot Principle that is Revolutionizing Potentiometer Control in Today's Electronic Circuits

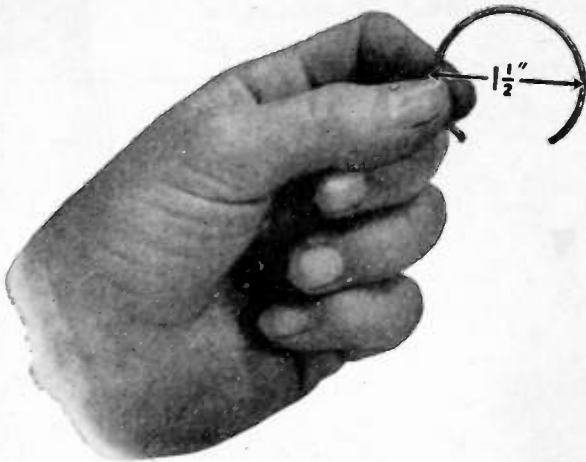

CONVENTIONAL POTENTIOMETERS have a coil diameter of approximately  $1\frac{1}{2}$ " and provide only 4" (about  $300^\circ$ ) of potentiometer slide wire control.



THE BECKMAN HELIPOT has the same coil diameter, yet gives up to 46" ( $3600^\circ$ )\* of potentiometer slide wire control—nearly TWELVE times as much!



Cutaway view of the Helipot

### Some of the multiple Helipot advantages

**E**XTENSIVELY used on precision electronic equipment during the war, the Helipot is now being widely adopted by manufacturers of quality electronic equipment to increase the accuracy, convenience and utility of their instruments. The Helipot permits much finer adjustment of circuits and greater accuracy in resistance control. It permits simplifying controls and eliminating extra knobs. Its low-torque characteristics (only one inch-ounce starting torque\*, running torque even less) make the Helipot ideal for power-driven operations, Servo mechanisms, etc.

And one of the most important Helipot advantages is its unusually accurate linearity. The Helipot tolerance for deviations from true linearity is normally held to within  $\pm 0.5\%$ , while precision units are available with tolerances held to  $0.1\%$ ,  $.05\%$ , and even less—an accuracy heretofore obtainable only in costly and delicate laboratory apparatus.

The Helipot is available in a wide range of types and resistances to meet the requirements of many applications, and its versatile design permits ready adaptation of a variety of special features, as may be called for in meeting new problems of resistance control. Let us study your potentiometer-rheostat problem and make recommendations on the application of Helipot advantages to your equipment. No obligation of course. Write today.

#### \* HELIPOTS ARE AVAILABLE IN 3 STANDARD SIZES:

**TYPE A**—5 watts, incorporating 10 helical turns and a slide wire length of 46 inches, case diameter  $1\frac{3}{4}$ ", is available with resistance values from 25 ohms to 30,000 ohms.

**TYPE B**—10 watts, with 15 helical turns and 140" slide wire, case diameter  $3\frac{1}{4}$ ", is available with resistance values from 100 ohms to 100,000 ohms.

**TYPE C**—2 watts, with 3 helical turns and  $13\frac{1}{2}$ " slide wire, case diameter  $1\frac{3}{4}$ ", available in resistances from 5 ohms to 10,000 ohms.

The Type B is also available in special sizes of 25 and 40 helical turns, with resistances ranging from 500 ohms to 300,000 ohms, and containing more than 100,000 change-of-resistance steps.

\*Data above is for the standard Type A unit.

Send for the New Helipot Booklet!



THE **Helipot** CORPORATION, 1011 MISSION STREET, SOUTH PASADENA 6, CALIFORNIA

# INDEX AND DISPLAY ADVERTISERS

Section Meetings .....	35A
Membership .....	40A
Positions Open .....	50A
Positions Wanted .....	54A
News-New Products .....	18A

## DISPLAY ADVERTISERS

Aerovox Corporation .....	45A
Aircraft Radio Corporation .....	43A
Alliance Mfg. Co. ....	21A
American Lava Corp. ....	41A
Amperex Electronic Corp. ....	Cover II
Andrew Co. ....	48A
Arnold Engineering Co. ....	47A
Astatic Corp. ....	42A
Barker & Williamson .....	60A
Bell Telephone Laboratories 2A, 3A, 20A, 34A	
Bendix Aviation Corp. (Radio Div.) ..	1A, 50A
Bendix Aviation Corp. (Red Bank Div.) ..	38A
Blaw-Knox Co. ....	55A
Bliley Electric Company .....	65A
Boonton Radio Corporation .....	52A, 60A
W. J. Brown .....	74A
Browning Laboratories, Inc. ....	70A
Brush Development Co. ....	36A
H. H. Buggie & Co. ....	62A
Cambridge Thermionic Corp. ....	78A
Capitol Radio Engineering Institute ..	68A
Centralab .....	59A, 24A, & 25A
Clarostat Mfg. Co. ....	35A
Cleveland Container Co. ....	58A
Sigmund Cohn & Co. ....	62A
Collins Radio Co. ....	37A
E. J. Content .....	74A
Cornell-Dubilier Electric Co. ....	Cover III
Tobe Deutschmann Corp. ....	22A
Drake Mfg. Co. ....	70A
Allen B. DuMont Labs., Inc. ....	16A, 61A
Eagle Pencil Co. ....	23A
Eitel-McCullough, Inc. ....	4A
Herbert A. Erf .....	74A
Erie Resistor Corp. ....	17A
Fairchild Camera & Instrument Corp. ...	57A
Farnsworth Television & Radio Corp. ...	50A
Federal Telephone & Radio Corp. ....	15A
Finch Telecommunications .....	70A

General Electric Company .....	12A
General Radio Co. ....	Cover IV
Guardian Electric Mfg. Co. ....	29A
Hallicrafters Company .....	75A
Hammarlund Mfg. Co. ....	51A
Helipot Corporation .....	77A
Hewlett-Packard Co. ....	27A
Hytron Radio & Electronics Corp. ....	7A
Iliffe & Sons .....	73A
Insulation Manufacturers Corp. ....	79A
International Nickel Co. ....	33A
International Tel. & Tel. Corp. ....	15A
E. F. Johnson Co. ....	67A
D. C. Kalbfell .....	74A
Karp Metal Products Co., Inc. ....	11A
Kemet Laboratories Company, Inc. ....	56A
Lavoie Laboratories .....	19A
Maguire Industries, Inc. ....	71A
P. R. Mallory & Co., Inc. ....	28A
Frank Massa .....	74A
Robert E. McCoy .....	74A
Measurements Corp. ....	44A
Mycalex Corp. of America .....	76A
National Co., Inc. ....	14A
Newark Electric Co. ....	64A
North American Philips Co., Inc. ....	50A
Ohmite Mfg. Co. ....	69A
Radio Corp. of America 32A, 49A, 52A, 80A	
Rauland Corporation .....	76A
Raytheon Mfg. Co. ....	10A
Reeves-Hoffman Corp. ....	58A
Revere Copper & Brass, Inc. ....	26A
Selenium Corp. of America .....	13A
Sherron Electronics Co. ....	53A
Shure Brothers, Inc. ....	40A
Sorenson & Company, Inc. ....	54A
Sprague Electric Company .....	8A
Stackpole Carbon Company .....	6A
Superior Electric Co. ....	63A
Sylvania Electric Products, Inc. ....	39A
Triplett Electrical Instrument Co. ....	66A
Turner Company .....	9A
United Transformer Corp. ....	5A
Union Carbide & Carbon Corporation ..	56A
War Assets Administration .....	30A & 31A
Waterman Products Co., Inc. ....	64A
Western Electric Company .. 2A, & 3A, 34A	
Weston Electrical Inst. Corp. ....	72A
S. S. White Dental Mfg. Co. ....	46A
Paul D. Zottu .....	74A

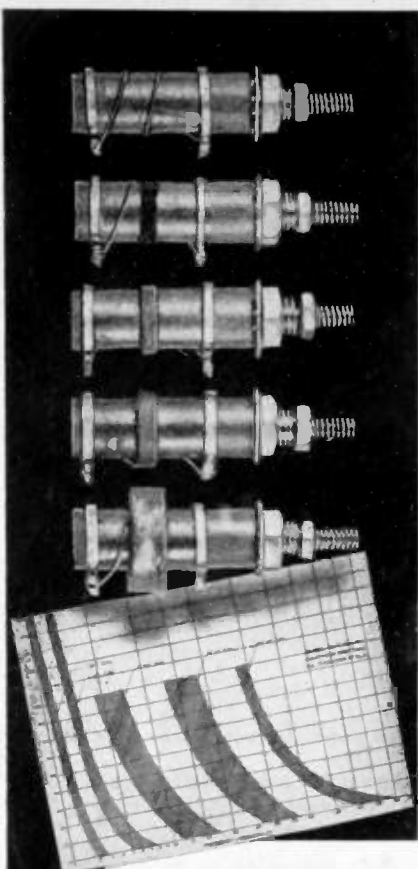

This graph shows frequency ranges covered by each unit. Write us for your full-size copy.

### Five Standard Slug-Tuned LS3 Coils Cover 1/2 to 184 mc

For strip amplifier work, the compact (1 1/8" high when mounted) LS3 Coil is ideal. Also for Filters, Oscillators, Wave-Traps or any purpose where an adjustable inductance is desired.

Five Standard Windings — 1, 5, 10, 30 and 60 megacycle coils cover inductance ranges between 750 and 0.065 microhenries.

CTC LS3 Coils are easy to assemble, one 1/4" hole is all you need. Each unit is durably varnished and supplied with required mounting hardware.

#### SPECIAL COILS

CTC will custom-engineer and produce coils of almost any size and style of winding... to the most particular manufacturer's specifications.

**Consult CTC for Three-Way Component Service**

Custom Engineering... Standardized Designs...  
Guaranteed Materials and Workmanship  
**CAMBRIDGE THERMIONIC CORPORATION**  
456 Concord Avenue, Cambridge 38, Mass.





The IMC Engineer ...on your staff



but not on your payroll....

OFFERS EXPERIENCED  
ELECTRICAL INSULATION  
ASSISTANCE...

If your problem is increased cost and assembly time, here's a ready answer. Call on your nearest IMC Engineer. He represents a complete line of insulating materials, and he's backed up with a wealth of experience that can help solve your problems. He can be a real help because he represents many manufacturers, and therefore can offer you the right product to best meet your needs. Ask him to...

- 1—Assist you in the selection of the best insulating material for your job.
- 2—Familiarize you with the proper method of application.
- 3—Suggest ways to eliminate waste.
- 4—Help increase your production.

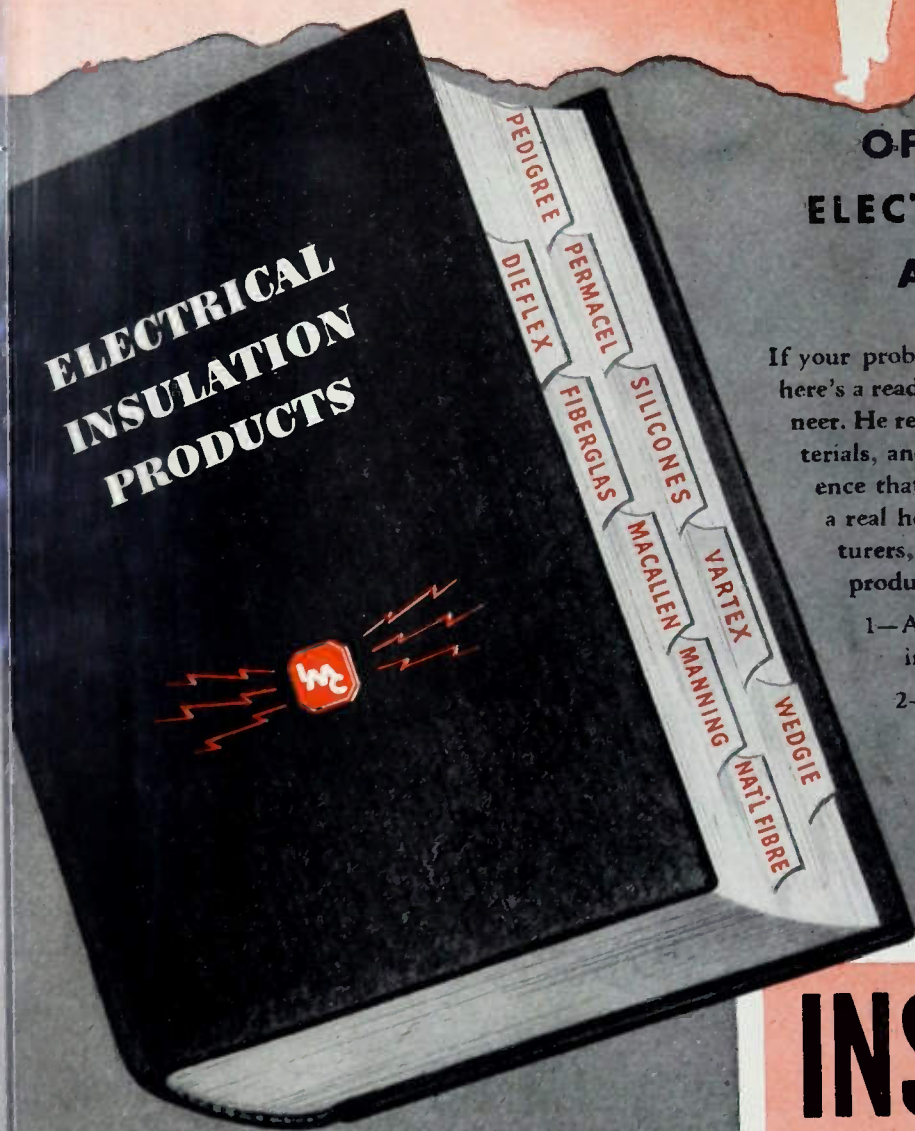

# INSULATION

MANUFACTURERS CORPORATION

\*CHICAGO 6  
565 West Wash-  
ington Blvd.

MILWAUKEE 2  
312 East Wisconsin  
Avenue



\*Local Stocks Available

\*CLEVELAND 14  
1231 Superior  
Ave., N. E.

DAYTON 2  
1315 Mutual Home  
Building.

IMC PRODUCTS: Macallen Mica Products—Vartex Varnished Cloth and Tapes—Varslot Combination Slot Insulation—Varnished Silk and Paper—Fiberglas Electrical Insulation—Manning Insulating Papers and Pressboards—Dow Corning Silicones—Dieflex Varnished Tubings and Saturated Sleeveings of Cotton and Fiberglas—National Hard Fibre and Fishpaper—Phenolite Bakelite—Permacel Adhesive Tapes—Asbestos Woven Tapes and Sleeveings—Cotton Tapes, Webbing, and Sleeveings—Pedigree Insulating Varnishes—Wedgie Brand Wood Wedges.



Television gives you a choice seat at the game.

## Television—a Season Pass to Baseball!

Every home game—day or night—played by the New York Giants, Yankees and Brooklyn Dodgers will be seen over television this season!

Owning a television receiver in the New York area will be like having a season pass for all three ball clubs. And in other cities, preparations for the future telecasting of baseball are being made.

When more than one home game is on the air, baseball fans can switch from one to the other—see the most exciting moments of each through television!

Those who own RCA Victor television receivers will enjoy *brighter, clearer, steadier* pictures through the exclusive RCA Victor Eye-Witness picture synchro-

nizer that “locks” the receiver in tune with the sending station.

To witness baseball or any other event in the ever-growing range of television programs—you’ll want the receiver that bears the most famous name in television today—RCA Victor.

When you buy an RCA Victor television receiver or radio, or Victrola radio-phonograph, or an RCA Victor record or a radio tube, you know you are getting one of the finest products of its kind science has achieved.

“Victrola” T.M. Reg. U.S. Pat. Off.

*Radio Corporation of America, RCA Building, Radio City, New York 20. Listen to the RCA Victor Show, Sundays, 2:00 P.M., Eastern Standard Time over the NBC Network.*



Several television cameras cover the baseball diamond to bring you a close-up of the action wherever it occurs. Here is a supersensitive RCA Image Orthicon television camera used by NBC’s New York station WNBT in televising home games of the New York Giants.



**RADIO CORPORATION of AMERICA**



# we've spent 37 years answering one question—*which capacitor?*

A mighty long time to answer one question, you say? Well, not when you've answered it 250,000 times . . . *with a different answer each time!* This is just another way of saying that C-D engineers have designed and built over a quarter-million different types of capacitors to meet manufacturers' specific requirements. And they've saved millions of dollars in manufacturers' assembly costs.

For many applications there is just one capacitor that will do the job right—for other applications several

types may be equally suitable. Whether *your* problem calls for special capacitor design . . . or a standard type unit . . . C-D's specialized experience in the field of capacitors will be able to meet your needs quickly and efficiently.

Consult with our engineers. Catalog of standard types will be mailed at your request. Cornell-Dubilier Electric Corporation, Dept. M5, South Plainfield, New Jersey. Other large plants in New Bedford, Worcester and Brookline, Mass., and Providence, R.I.



MICA • DYKANOL • PAPER • ELECTROLYTIC CAPACITORS

**CORNELL-DUBILIER**  
WORLD'S LARGEST MANUFACTURER OF  
**CAPACITORS**

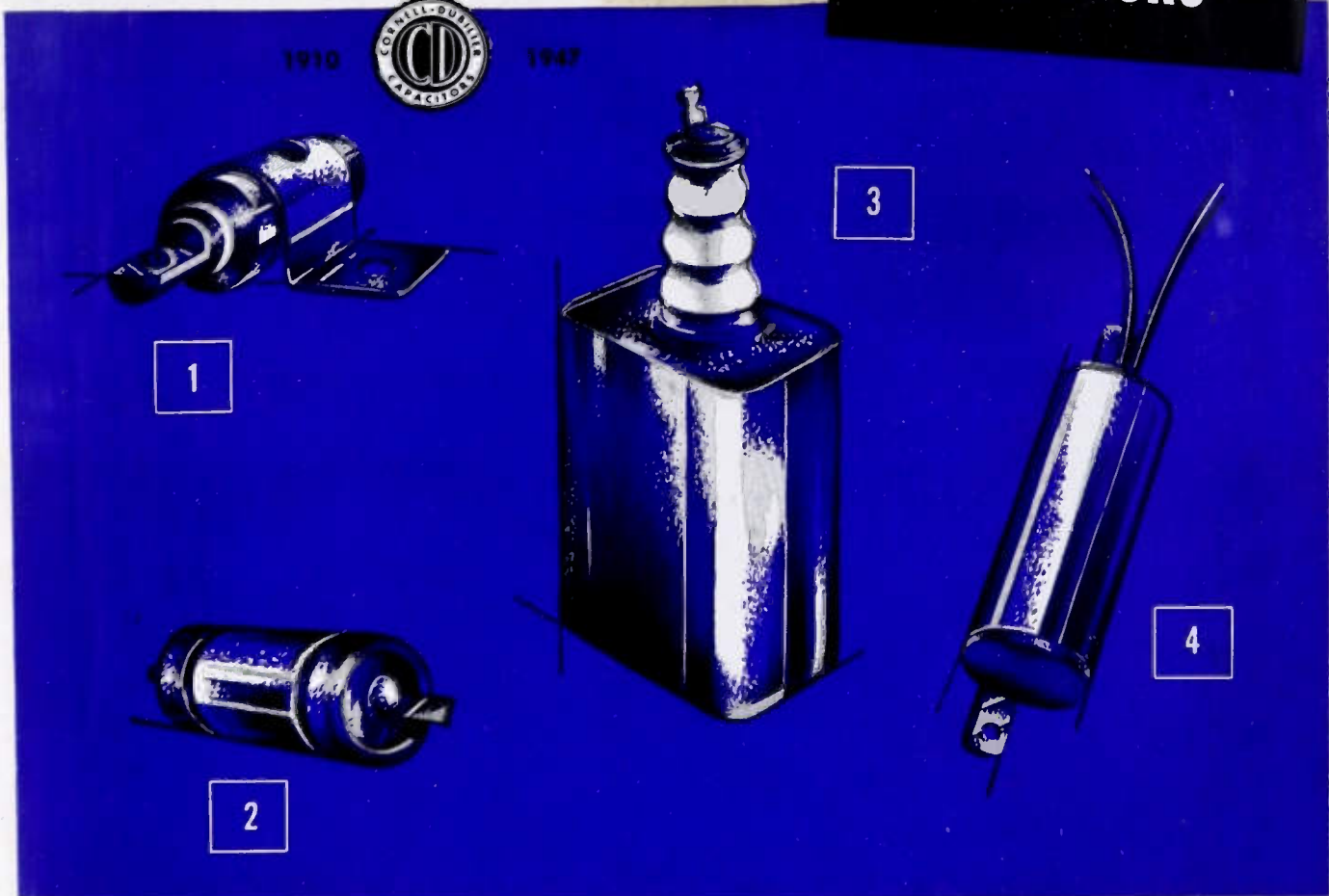

**CAPACITOR #1** One of the Type MC spark suppressors for use on heavy-duty vehicles. Capacitor unit is hermetically sealed, oil filled and impregnated.

**CAPACITOR #2** This is an oil impregnated paper capacitor for by-pass applications. Available in a wide variety of capacitances and voltage ratings to fit many applications where a sealed unit is desirable.

**CAPACITOR #3** This low capacity, high voltage capacitor unit was designed especially for FM and television applications. Hermetically sealed and provided with glass insulated terminal.

**CAPACITOR #4** A dual capacity unit, with one terminal connected to the case for operation on 220 V.A.C. Ideal for noise suppression, it is constructed for simple installation on flat or round surfaces.



# WAVEMETERS

0.5-150 Mc

55-400 Mc

IN STOCK!

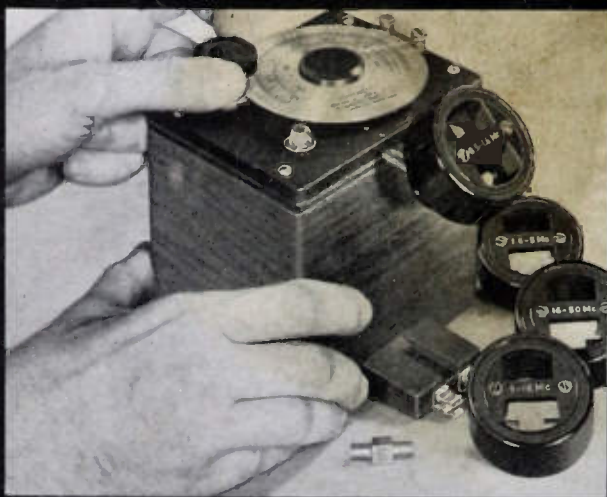

TYPE 566-A — 0.5 to 150 Mc

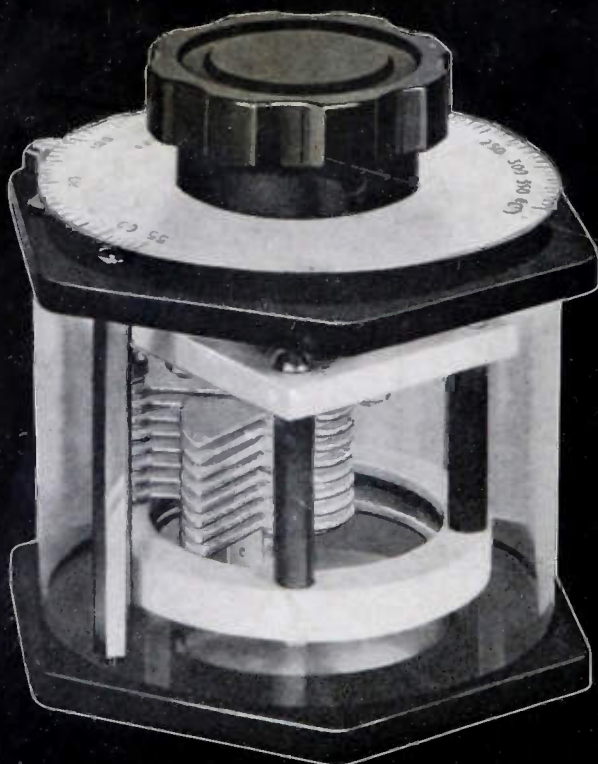

TYPE 758-A — 55 to 400 Mc

● To meet an insistent demand, we have concentrated some of our production facilities on these two popular wavemeters and have managed to accumulate a moderate stock of each.

Both are of the well-known absorption type with accuracies sufficient for a wide variety of routine frequency checks on the ranges of coils, oscillators, receivers, transmitters, etc.

The Type 566-A Wavemeter consists of a variable air condenser, five plug-in coils and an incandescent lamp for resonance indication. The Type 758-A Wavemeter covers its entire frequency range with a single-turn loop the inductance of which is varied simultaneously with the capacitance. An incandescent lamp is used for resonance indication. For low power uses (less than about 2 watts), resonance indication is obtained by the reaction of the wavemeters on the plate or grid currents of the oscillator.

These wavemeters are compact, rugged, inexpensive and direct reading in terms of our primary standard of frequency.

## TYPE 566-A WAVEMETER

**FREQUENCY RANGE:** 0.5 to 150 Mc

**COILS:** Five plug-in type, all supplied. When not in use coils can be plugged into a rack on side of the instrument case

**DIAL CALIBRATION:** Direct reading in frequency

**ACCURACY:**  $\pm 2\%$ , 0.5 to 16 Mc;  $\pm 3\%$ , 16 Mc to 150 Mc

**RESONANCE INDICATOR:** Incandescent lamp

**ACCESSORIES SUPPLIED:** Two spare indicator lamps

**DIMENSIONS:**  $4\frac{3}{4} \times 5\frac{7}{8} \times 5\frac{3}{4}$  inches, over-all

**WEIGHT:** 3 pounds

**PRICE:** Type 566-A WAVEMETER — \$60.00

## TYPE 758-A WAVEMETER

**FREQUENCY RANGE:** 55 to 400 Mc

**COILS:** A single turn loop; inductance and capacitance are varied simultaneously

**DIAL CALIBRATION:** Direct reading in frequency

**ACCURACY:**  $\pm 2\%$

**RESONANCE INDICATOR:** Incandescent lamp

**TEMPERATURE AND HUMIDITY:** Over ranges normally encountered, accuracy is independent of both

**DIMENSIONS:**  $5 \times 5 \times 4\frac{3}{4}$  inches, over-all

**WEIGHT:** 1 pound, 12 ounces

**PRICE:** Type 758-A WAVEMETER — \$35.00

**ORDER NOW — DELIVERY  
PROBABLY FROM STOCK**

# GENERAL RADIO COMPANY

Cambridge 39,  
Massachusetts

90 West St., New York 6

920 S. Michigan Ave., Chicago 5

950 N. Highland Ave., Los Angeles 38