

Proceedings



of the

I·R·E

OCTOBER 1943

VOLUME 31 NUMBER 10

Electronic Applications

Radio-Frequency Wood Gluing

Heat Conduction in Wood
Gluing

Antenna Current Distribution

Radio Reception at U.H.F.
Parts IV and V



*Official United States Navy Photograph
—Courtesy of Stromberg-Carlson*

TESTING NAVAL EQUIPMENT

Acoustic Treatment, Air Conditioning, Fluorescent Lighting, and Quick Electrical Connections Speed Equipment Flow

Institute of Radio Engineers

**UTC
LEADS
THE
FIELD**



UNITED TRANSFORMER CO.

150 VARICK STREET

NEW YORK 13, N. Y.

EXPORT DIVISION: 13 EAST 40th STREET, NEW YORK 16, N. Y., CABLES: "ARLAB"

- Lynde P. Wheeler, *President*
 F. Sherbrooke Barton,
Vice President
 Raymond A. Heising, *Treasurer*
 Haraden Pratt, *Secretary*
 Alfred N. Goldsmith, *Editor*
 Stuart L. Bailey
 Wilmer L. Barrow
 E. Finley Carter
 Adolph B. Chamberlain
 Ivan S. Coggeshall
 William L. Everitt
 Harold T. Friis
 Gilbert E. Gustafson
 O. B. Hanson
 Frederick B. Llewellyn
 Frederick E. Terman
 Browder J. Thompson
 Hubert M. Turner
 Arthur F. Van Dyck
 Harold A. Wheeler
 William C. White

•
 Harold R. Zeamans,
General Counsel
 •

BOARD OF EDITORS

- Alfred N. Goldsmith, *Editor*
 Ralph R. Batcher
 Philip S. Carter
 Lewis M. Clement
 Elmer W. Engstrom
 William L. Everitt
 Peter C. Goldmark
 Frederick W. Grover
 C. M. Jansky, Jr.
 John D. Kraus
 Frederick B. Llewellyn
 Samuel S. Mackeown
 Edward L. Nelson
 Harry F. Olson
 Greenleaf W. Pickard
 Haraden Pratt
 Conan A. Priest
 Lynne C. Smeby
 Browder J. Thompson
 Harold A. Wheeler
 Laurens E. Whittemore
 Gerald W. Willard
 William Wilson
 Charles J. Young

•
 Helen M. Stote,
Associate Editor
 William C. Copp,
Advertising Manager
 William B. Cowilich,
Assistant Secretary

Proceedings

of the I·R·E

Published Monthly by

The Institute of Radio Engineers, Inc.

VOLUME 31

October, 1943

NUMBER 10

Electronic Applications.....	R. E. Gillmor	527
Harold A. Wheeler.....		528
Radio-Frequency Heating Applied to Wood Gluing	R. A. Bierwirth and C. N. Hoyler	529
Heat-Conduction Problems in Presses Used for Gluing of Wood.....	George H. Brown	537
The Distribution of Current Along a Symmetrical Center-Driven Antenna... ..	Ronald King and Charles W. Harrison, Jr.	548
Some Aspects of Radio Reception at Ultra-High Fre- quency.....	E. W. Herold and L. Malter	
Part IV—General Superheterodyne Considerations at Ultra-High Frequencies.....	L. Malter	567
Part V—Frequency Mixing in Diodes.....	E. W. Herold	575
Correction to "Network Theory, Filters, and Equalizers," by Frederick Emmons Terman.....		582
Section Meetings.....		583
Institute News and Radio Notes.....		584
Board of Directors.....		584
Executive Committee.....		584
1943 Rochester Fall Meeting.....		585
Books:		
"First Principles of Radio Communications," by Alfred Morgan.....	Frederick W. Grover	585
"A Course in Radio Fundamentals," by George Grammer.....	Harold P. Westman	586
"Elements of Radio," by A. Marcus and Wm. Marcus.....	W. O. Swinyard	586
"Applied Electronics," by Members of the Staff of the Department of Electrical Engineering, Massachusetts Institute of Technology.....	E. B. Ferrell	586
"Tables of Functions with Formulae and Curves," by Eugene Jahnke and Fritz Emde.....	H. A. Wheeler	587
"Principles and Practice of Radio Servicing," by H. J. Hicks.....	Ralph R. Batcher	587
"Introduction to Circuit Analysis," by Abner R. Knight and Gilber H. Fett.....	Knox McIlwain	587
Institute Committees—1943.....		588
Institute Representatives in Colleges—1943.....		589
Contributors.....		590
Membership.....		34A
Positions Open.....		52A
Advertising Index.....		62A

Responsibility for the contents of papers published in the PROCEEDINGS rests upon the authors. Statements made in papers are not binding on the Institute or its members.



Entered as second-class matter October 26, 1927, at the post office at Menasha, Wisconsin, under the Act of February 28, 1925, embodied in Paragraph 4, Section 538 of the Postal Laws and Regulations. Publication office, 450 Ahnaip Street, Menasha, Wisconsin. Editorial and advertising offices, 330 West 42nd St., New York 18, N. Y. Subscription \$10.00 per year; foreign, \$11.00.

YOUR DOLLARS ARE NEEDED NOW . . . BUY MORE WAR BONDS AND STAMPS



Earned Prestige

One effective way of judging a product is by the quality of equipment in which it is incorporated. If it's a companion piece to the finest in the field, you can be sure that it, too, has earned its prestige.

In top-ranking motion picture sound recording studios, where standards are highest, DAVEN products are preferred. They are the original components in major fixed installations, and are also specified by studio engineers whenever special apparatus is developed.

DAVEN produces the most complete line of precision attenuators in the world, plus more than 80 models of laboratory test equipment for the broadcast, sound picture, television and electrical fields. May we send you a catalog?

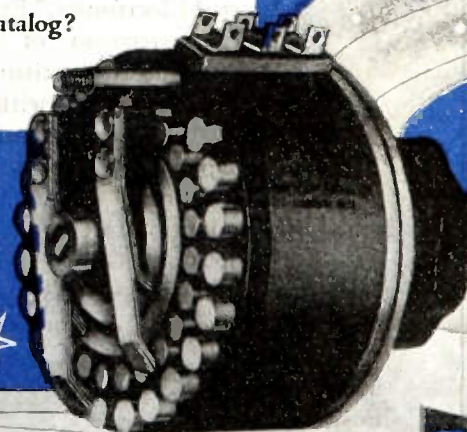

THE DAVEN COMPANY

191 CENTRAL AVENUE

NEWARK 4, NEW JERSEY

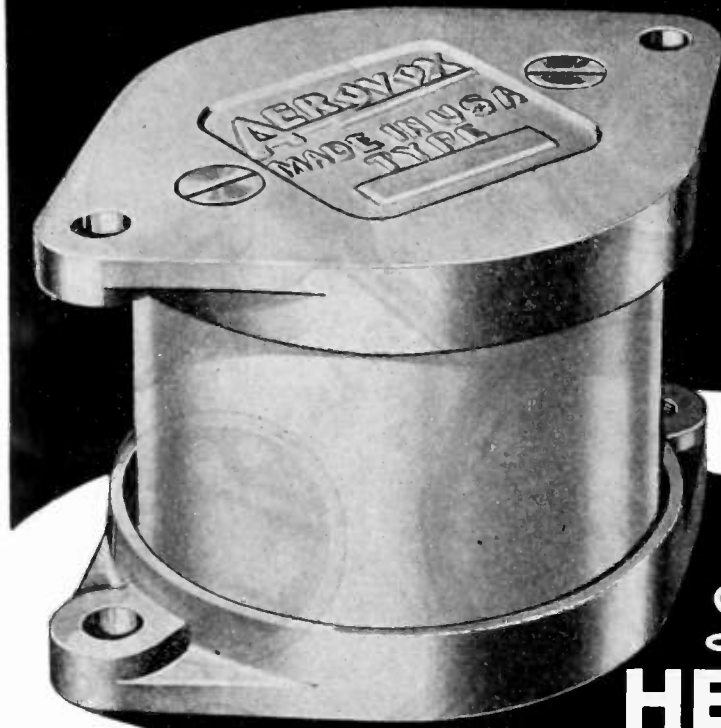

AEROVOX 1940 SERIES

- Type 1940: 8" dia. x 10" tall. .00001 mfd. 35000 v., to .01 mfd. 15000 v.
- Type 1950: 3 1/4" dia. x 2 1/2" tall. .00001 mfd. 6000 v., to .02 mfd. 3000 v.
- Type 1960: 4 1/4" dia. x 3" tall. .00001 mfd. 15000 v., to .25 mfd. 1000 v.
- Type 1970: 5 3/4" dia. x 4" tall. .00001 mfd. 20000 v., to .5 mfd. 1000 v.
- Type 1980: 5 3/4" dia. x 5 3/4" tall. .00001 mfd. 35000 v., to .05 mfd. 5000 v.

Stack-Mounting HEAVY-DUTY Mica Capacitors

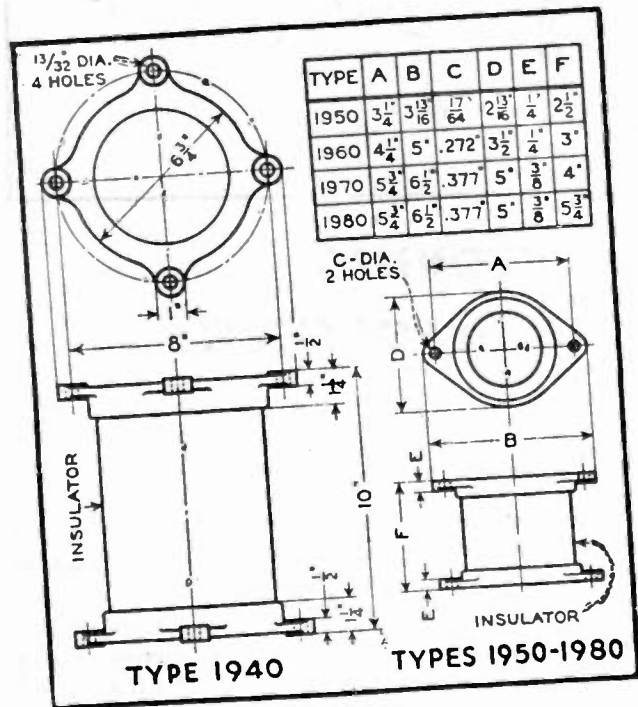

● Climaxing an outstanding selection of mica receiving and transmitting capacitors—from tiny "postage stamp" molded-in-bakelite types to the extra-heavy-duty micas—Aerovox offers its stack-mounting or 1940 series as standard items (subject to priorities, of course). Heretofore made in limited quantities, these capacitors are now in regular and large production. Note these quality features:

Special cylindrical low-loss glazed ceramic case. Long creepage path between terminals. Design eliminates corona losses inside and out, and provides uniform voltage gradient. Cast-aluminum terminals insure low contact resistance between units. Sections of finest grade India ruby mica dielectric, made to very close tolerance to equalize loading of series-connected sections.

Units conservatively rated to withstand surge voltages above rated values. Extremely low power factor to handle heavy kva. loads without overheating. Vacuum-impregnated sections imbedded in low-loss filler, reducing stray-field losses and safeguarding against moisture entrance. Mica stacks rigidly clamped in low-loss non-magnetic clamps, and heat-treated for maximum capacity-temperature stability.

● Ask for DATA . . .

Engineering data on these stack-mounting and other extra-heavy-duty transmitting capacitors, available on request.



Capacitors

INDIVIDUALLY TESTED

AEROVOX CORPORATION, NEW BEDFORD, MASS., U. S. A. • SALES OFFICES IN ALL PRINCIPAL CITIES
 Export: 100 VARICK ST., N. Y. C. • Cable: 'ARLAB' • In Canada: AEROVOX CANADA LTD., HAMILTON, ONT.

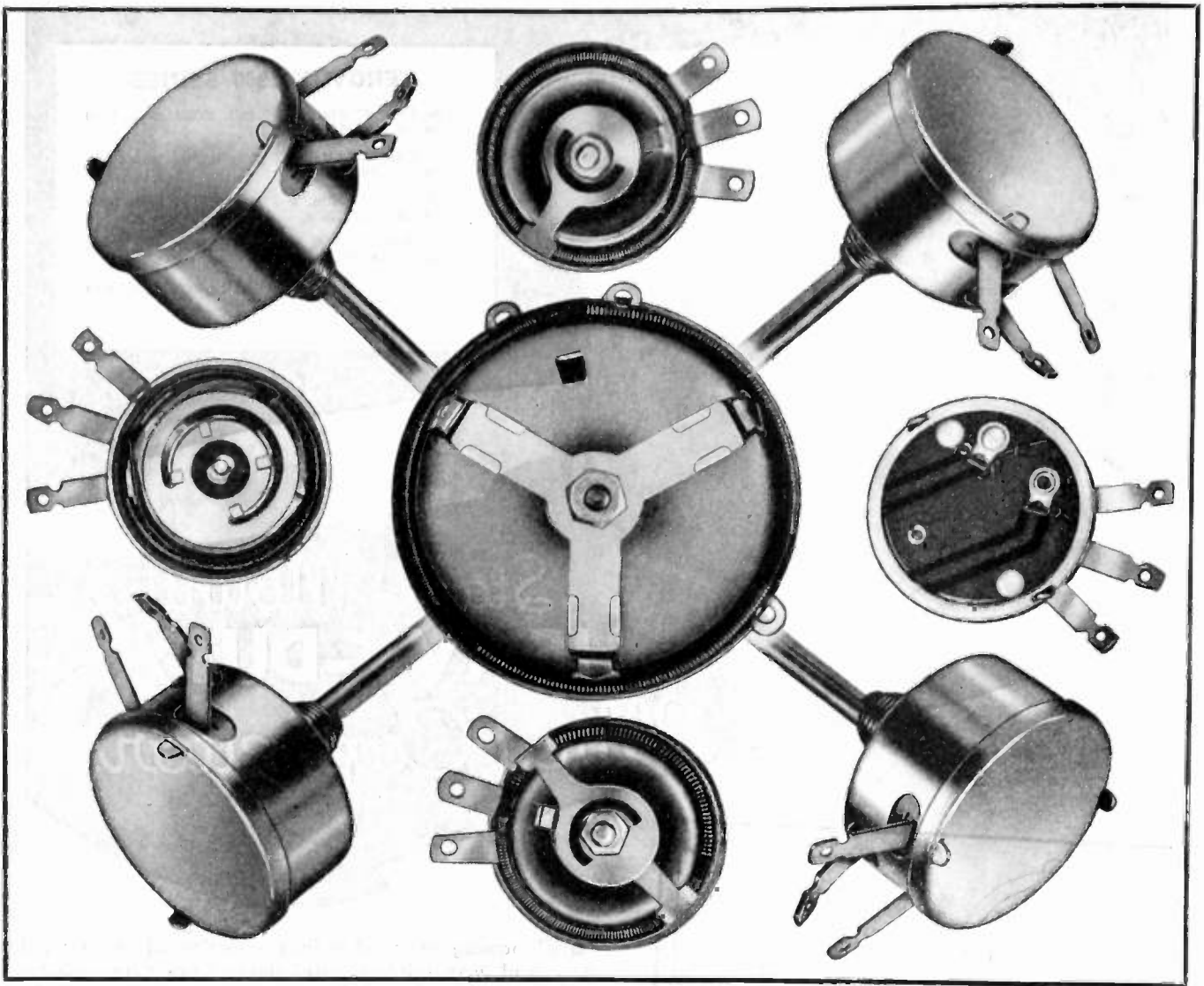

THESE VETERANS ARE SERVING ...WHERE RESISTANCE IS IMPORTANT!

IN MANY a war product—on land, at sea and in the air—Utah engineering and precision manufacturing safeguard the successful performance of many types of equipment. Indispensable to wartime service, Utah Wirewound Controls are passing the tough test of combat with flying colors.

Available in rheostats, potentiometers and attenuators, Utah Wirewound Controls are supplied in five sizes—3, 4, 9, 15 and 25 watts—with total resistances from 0.5 ohm to 25,000 ohms.

In all types of applications, under all kinds of operating conditions, Utah construction and design have proved their worth. In Utah Controls, high quality resistance wire is evenly wound on a substantial core, clamped

tightly to the control housing. The result is a rugged and dependable variable resistor.

Typical of the Utah line is Utah Potentiometer Type 4-P. This rugged control dissipates 4 watts over the entire resistance element. Resistance elements are clamped in place in a cadmium-plated, all-metal frame, resulting in maximum heat dissipation for its size.

Find out if Utah controls can solve your electrical control problems. It costs nothing to get the facts—and may save you a great deal of time and money. Write today for full engineering data on Utah Wirewound Controls.

UTAH RADIO PRODUCTS COMPANY, 842 Orleans St., Chicago, Ill. Canadian Office: 560 King St. W., Toronto. In Argentine: UCOA Radio Products Co., S.R.L. Buenos Aires.

PARTS FOR RADIO, ELECTRICAL AND ELECTRONIC DEVICES, INCLUDING SPEAKERS, TRANSFORMERS, VIBRATORS, VITREOUS ENAMELED RESISTORS, WIREWOUND CONTROLS, PLUGS, JACKS, SWITCHES, ELECTRIC MOTORS

CABLE ADDRESS: UTARADIO, CHICAGO





THIS picture might have been taken almost anywhere. All over the world small groups of soldiers are guarding our outposts against attack. Vigilant, lonely and unafraid, these men rely on their skill . . . and on radio. Radio for warnings. Radio for help when needed. Radio for coordination. Radio for entertainment. Radio for Victory.

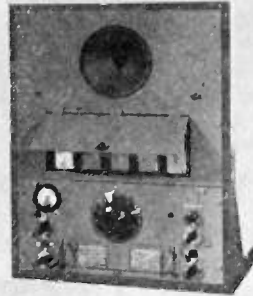

PHOTO BY
U. S. ARMY SIGNAL CORPS



NATIONAL COMPANY
MALDEN, MASS. U. S. A.



THE HORIZONS ARE BECOMING BROADER

Seeing into the impenetrable . . .

Hearing the inaudible . . .

New and amazing industrial processes and controls . . .

Yes, on every side the Horizons are becoming Broader as we enter the Age of Electronics.

Side by side with the achievements in the short- and ultra short-wave field has been the development of AlSiMag Steatite bodies for high frequency insulators of extremely low dielectric loss together with high mechanical strength and rigidity—assuring constancy under any operating condition.

Today for our fighting forces . . . tomorrow for our customers, American Lava Corporation is pledged to these principles: Production to the highest known standards . . . Research to find a Better Way.

AMERICAN LAVA CORPORATION
Chattanooga, Tennessee



AWARDED JULY 27, 1942



**STEATITE CERAMIC
INSULATORS**

CHARACTERISTICS TAILORED TO YOUR REQUIREMENTS

You can't see it... but it's there



THE MOST ACCURATELY machined rotating part ever built—although apparently in balance to the naked eye—may be out of balance.

You can't see the unbalance . . . even if it's there.

With the rapid development of high-speed machines, the need for *locating and correcting* unbalance in rotating parts has become vitally important—if you want smooth, vibration-free operation and long life.

In 1933, scientists in the Westinghouse Research Laboratories tackled this problem of quickly and accurately measuring the *static* and *dynamic unbalance* in rapidly whirling masses—both symmetric and asymmetric.

Through painstaking study and experiment, these Westinghouse research engineers discovered a totally new principle for balancing rotating parts of every shape and form . . . the "Dynetric Balancer."

Today, the Gisholt Dynetric Balancer . . . using Westinghouse *electronic equipment* . . . is solving the most difficult balancing problems in many war plants.

With this machine, vibrations as small as *twenty five millionths* of an inch in crankshafts, armatures, turbine rotors, propellers, and countless other whirling parts are located and measured in a matter of minutes, or even seconds!

Westinghouse Electric & Manufacturing Co., Pittsburgh, Pennsylvania.

THE PROBLEM OF UNBALANCE

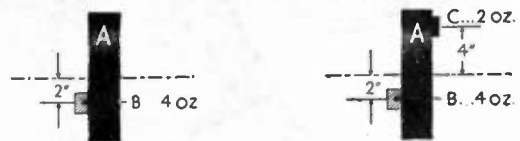

Static unbalance

(Left) Disc A is *statically unbalanced* by the 4 ounce weight, B, placed 2 inches from the axis.

(Right) This *static unbalance* can be corrected by placing a 2 ounce weight, C, 4 inches from the axis.

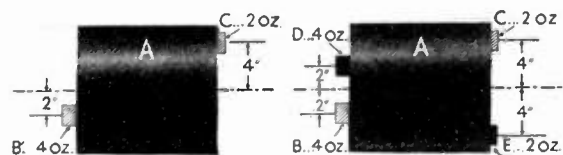

Dynamic unbalance

(Left) Cylinder A is *statically balanced*—by the weights B and C—but *dynamically unbalanced* by the twisting effect of these weights when the cylinder is rotated.

(Right) This *dynamic unbalance* can be corrected by placing weights D and E, as shown.

... AND ITS SOLUTION



On this Dynetric Balancer, *combined* static and dynamic unbalance in engine crankshafts is accurately and quickly measured by instrument readings. Corrections are then made by drilling holes in the crank arms.

Westinghouse

PLANTS IN 25 CITIES . . . OFFICES EVERYWHERE



NOW 3 TYPES OF TO FIT

I



Comparative Analysis of 3 Corning Coil Form Methods

	MULTIFORM COIL FORMS	BLOWN COIL FORMS	PRECISION GROUND COIL FORMS
O. D. Diameters	9/16" to 12"	1" to 3"	1/4" to 1 1/2"
Lengths	0.70" to 10 1/2"	2 1/2" to 9"	1/2" to 6"
Wall Thickness	3/32" to 7/8"	1/8" to 3/8"	3/64" to 3/16"
Maximum Threads per inch	32	12	24
Tolerance	± 2% but not less than ± 0.010" on all dimensions	± 0.015" on root diameter of thread	± 0.002" on root diameter of thread
Holes	Mold formed	Punched or ground	Punched or ground
Metallizing	Yes	Yes	Yes
Types of Glass	No. 790 Only	No. 707 or No. 774	No. 707 or No. 774

Comparative Properties of Corning Coil Form Glasses

	# 790	# 707	# 774
Maximum Operating Temperature (°C)	800	425	500
Linear Expansion (0-300°C) per °C x 10 ⁻⁷	8.5	31	32
Water Absorption—24 hrs. (%)	< .01	None	None
Volume Resistivity log R at 20° C	13.0	17.0	14.7
S.I.C.—20° C—1 MC	4.0	3.95	4.65
P.F.—20° C—1 MC	0.18	0.06	0.42
L.F.—20° C—1 MC	0.72	0.24	1.95

MULTIFORM COIL FORMS

This exclusive Corning Glass Works' method offers coil forms with all-round superior electrical characteristics . . . yet moderately priced in any quantity. Low coefficient of expansion. Most adaptable to complicated shapes or where multiple holes are required. Good thread contours. Can be metallized for applying mounting assemblies or terminal clips. Made from No. 790 glass only.

Pyrex Insulators

BRAND

"PYREX" is a registered trade-mark and indicates manufacture by Corning Glass Works

CORNING COIL FORMS EVERY NEED!

2



BLOWN COIL FORMS

In minimum quantities of 12,000 to 15,000 units for No. 774 glass, this Corning method provides coil forms at rock-bottom prices. Forms are unusually strong mechanically and are transparent for easy inspection of internal assemblies. Can be metallized for applying mounting assemblies or terminal clips. Can also be made from No. 707 glass in limited quantities by hand molding, for the duration.

3



PRECISION GROUND COIL FORMS

This method, while slightly more expensive, produces most accurate thread contours. Adaptable to any quantity. Has advantage of transparency. Mountings or terminal clips can be applied by metallizing. Made from either No. 707 or No. 774 glasses.

MAIL COUPON TODAY

Corning Glass Works
Insulation Division, Dept. P 10-6
Corning, N.Y.

Please send me the full story on Corning's 3 Coil form methods.

Name.....

Company.....

Street.....

City.....State.....



Will They Remember "Rola"?

SOME day . . . may it not be far distant . . . huge numbers of our military forces will be returning to Civilian life. When this happens and when these men again become "consumers", will they remember the names of any of the manufacturers who made their equipment, and will they think well of the manufacturer whose product "stood up", even under the toughest kind of usage?

We believe that they will, and, specifically, that the men who depended on Rola headsets and transformers and coils for their Communications in the Air, have acquired a confidence in the name

that will carry over to the new things Rola will be making after the war.

For that reason, if for no other, there can be no compromise with Quality in the Rola products of Tomorrow . . . no matter what they may be. THE ROLA COMPANY, Inc., 2530 Superior Avenue, Cleveland 14, Ohio.

If what you are making for the War involves Headsets, Transformers, Coils and similar equipment, we believe you should know about Rola's facilities for research, development and manufacture. A representative will gladly call.

★ ROLA ★

MAKERS OF THE FINEST IN SOUND REPRODUCING AND ELECTRONIC EQUIPMENT



“How would you like to be hit several times with a hammer?”

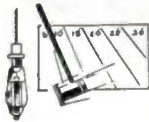

Pity the Hytron tubes struck several sharp blows by a heavy, swinging hammer during the Bump Test. Only by such rough treatment, can rugged Hytron tubes suitable for the shocks of mechanized warfare be selected.

Even this trial is not enough. These quality tubes must withstand many other mechanical shock tests during which the stability of electrical characteristics is carefully measured while the tubes are tortured by scientifically simulated jolts

and vibrations which might occur in actual combat.

Hytron engineers are quality conscious. Whether the test be mechanical or electrical, their purpose is the same—to supply our boys with tubes fit for service in bouncing jeeps, rattling tanks, shell-belching battleships, and darting, twisting, roaring fighter planes. Wherever Hytron tubes may be called upon to act as the dependable hearts of radio and electronic fighting equipment, they must be the best that can be made.



OLDEST EXCLUSIVE MANUFACTURER OF RADIO RECEIVING TUBES

HYTRON
CORPORATION ELECTRONIC AND RADIO TUBES
 SALEM AND NEWBURYPORT, MASS.



Destination Known

Somewhat at the mercy of the elements, a paratrooper can't always select the exact spot for his landing. But he will approach his objective.

With new applications for electronic devices appearing rapidly, we can't be very specific about our peacetime program now. One thing is certain, however... *we know where we are going.* If past performances and present accomplishments are any indication, we can anticipate our postwar objectives and plan for them accordingly. Specialists in the electronic field for almost a quarter century, ours is a progressive organization, with perfectly coordinated labor-management relations. Ever on the alert for new ideas, we cannot help but compile an enviable record of advanced designs and applications, many of which appear to be suited for postwar civilian requirements. Today, 100% in vital war work, production schedules occasionally permit us to accept additional contracts of a similar nature. May we be of service to you?

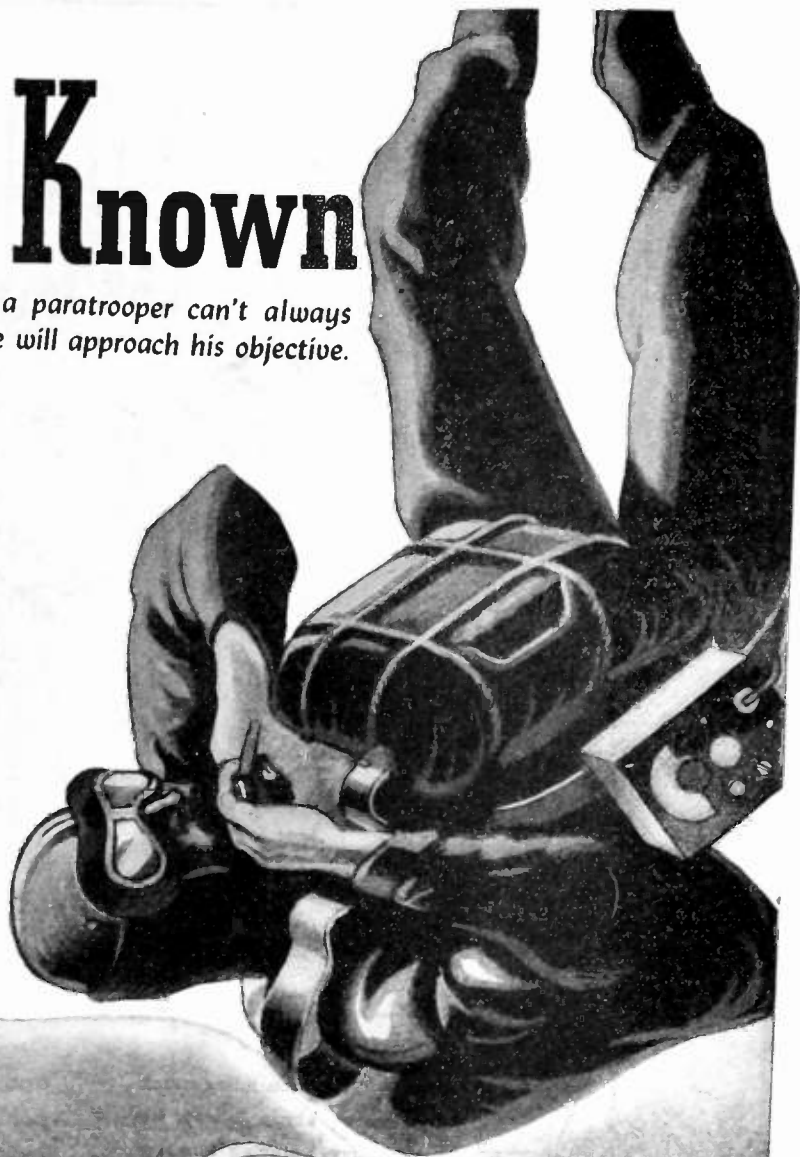

BACK
THE ATTACK

BUY MORE

WAR BONDS

Electronic Corp. of America

ELECTRONIC CORP. OF AMERICA

45 WEST 18th STREET • NEW YORK 11, N.Y. • WATKINS 9-1870

ATTENTION:
Design Engineers

3BP1

2AP1



SEPARATE LEADS AND WIDER PIN SPACING

make these RCA cathode-ray tubes useful for many war applications

Here are two RCA Cathode-Ray tubes that will fill many war applications. Both have electrostatic-deflection with a separate lead for each deflection plate and for the cathode; thus balanced deflection can be obtained. New base designs, too, with wide spacing between high- and low-voltage leads. Both are on the Army-Navy Preferred list.

RCA-2AP1: A 2-inch high-vacuum tube, similar to the RCA-902, but with separate leads to all electrodes, and higher anode voltage rating. Magnal 11-pin base.

RCA-3BP1: A 3-inch high-vacuum tube. Electrostatic focusing and deflection. Green fluorescence. Medium persistence. Neck diameter, 2 inches. Overall length, 10 inches. Diheptal base.

For other important uses here are three outstanding RCA Cathode-ray tubes

RCA-3EP1/1806P1: Similar to RCA-3BP1, except: a) Neck diameter is 1 3/8 inches; b) Magnal base; c) Cathode connected to heater inside of the tube.

RCA-5CP4: A 5-inch, high-vacuum tube with extra high voltage electrode, (anode No. 3). Electrostatic deflection and focusing. Separate leads to all electrodes. White fluorescence. Medium persistence. Neck diameter, 2 inches. Overall length 17 inches. Diheptal base. Anode No. 3 brought out to snap terminal on bulb.

RCA-7CP1/1811P1: A short, 7-inch, high-vacuum tube. Magnetic deflection. Electrostatic focusing. Green fluorescence. Medium persistence. Neck diameter, 1 3/8 inches. Overall length, about 13 1/2 inches. Octal base. Separate leads for all electrodes. Anode No. 2 brought out to snap terminal on bulb.

RCA Victor Division • RADIOD CORPORATION OF AMERICA • Camden, N. J.

The Magic Brain of All Electronic Equipment Is a Tube—and the Fountain-Head of Modern Tube Development Is RCA.



TUNE IN "WHAT'S NEW?"
RCA's great new show,
Saturday nights, 7 to 8,
E. W. T., Blue Network.

RCA ELECTRON TUBES

ASK FOR THESE SHEETS



RCA Commercial Engineering Section
Radio Corporation of America
510 South 5th St., Harrison, N. J.

Please send me the data sheets on the following tubes:

2AP1 3BP1 3EP1
 5CP4 7CP1

Name

Company

Street

City State

So that our guns will SHOOT STRAIGHT

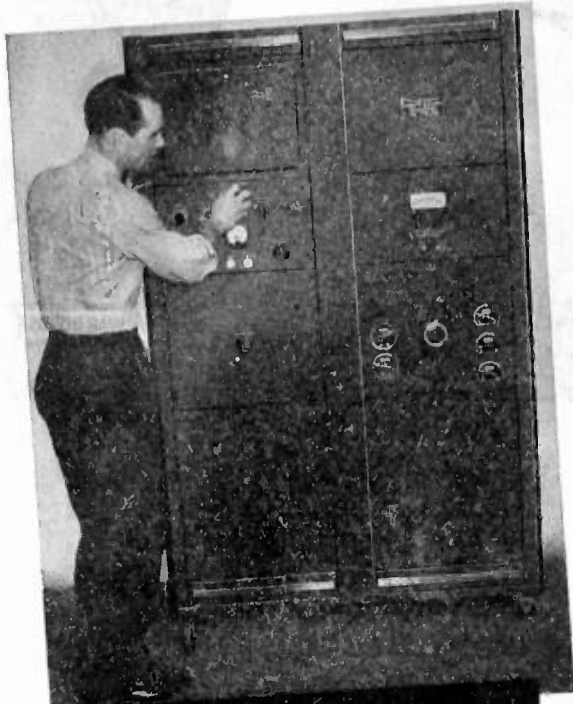

★ Knobs set. Camera ready. Firing circuit closed. BANG! Yet no sound, smoke, damage, to upset the serenity of the lab atmosphere. But . . .

Months later an American shell lands *smack* on the distant target. Precise powder charge has rounded out expert spotting, accurate calculations, fine gun-crew teamwork. To the growing consternation of our enemies, American marksmanship attains new heights of accuracy with its electronically-checked gunpowder. Specifically:

The DuMont Type 235 cathode-ray oscillograph is being used in conjunction with a closed-bomb method of powder testing. Signals for the oscillograph are generated by the closed-powder-bomb. Potentials furnished by burning powder provide the horizontal and vertical deflection signals. Luminous dots electronically imposed on the short-persistence screen provide an accurate calibration means. The resultant combination oscillogram is photographed for a permanent record.

Thus each lot of powder, whether experimental or in production, is checked for vital burning qualities. Uniformity is assured. Our gun crews can be confident that their powder charges are *right*.

All of which is but another example of how DuMont specialists work with technicians in many different fields, in the application of cathode-ray technique.

★ **Submit your cathode-ray problem.**
Write for latest literature.

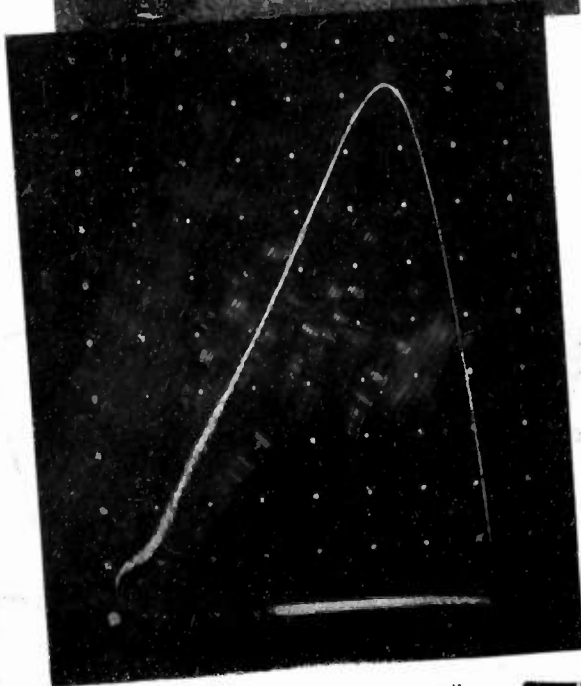

Above: DuMont Type 235 cathode-ray oscillograph. Below: Typical oscillogram for a given powder sample, showing matrix of dots providing an accurate reference or coordinate system for the burning powder graph, permanently photographed.

DUMONT

**ALLEN B. DU MONT
LABORATORIES, Inc.**

Passaic • New Jersey
Cable Address: Wespexlin, New York

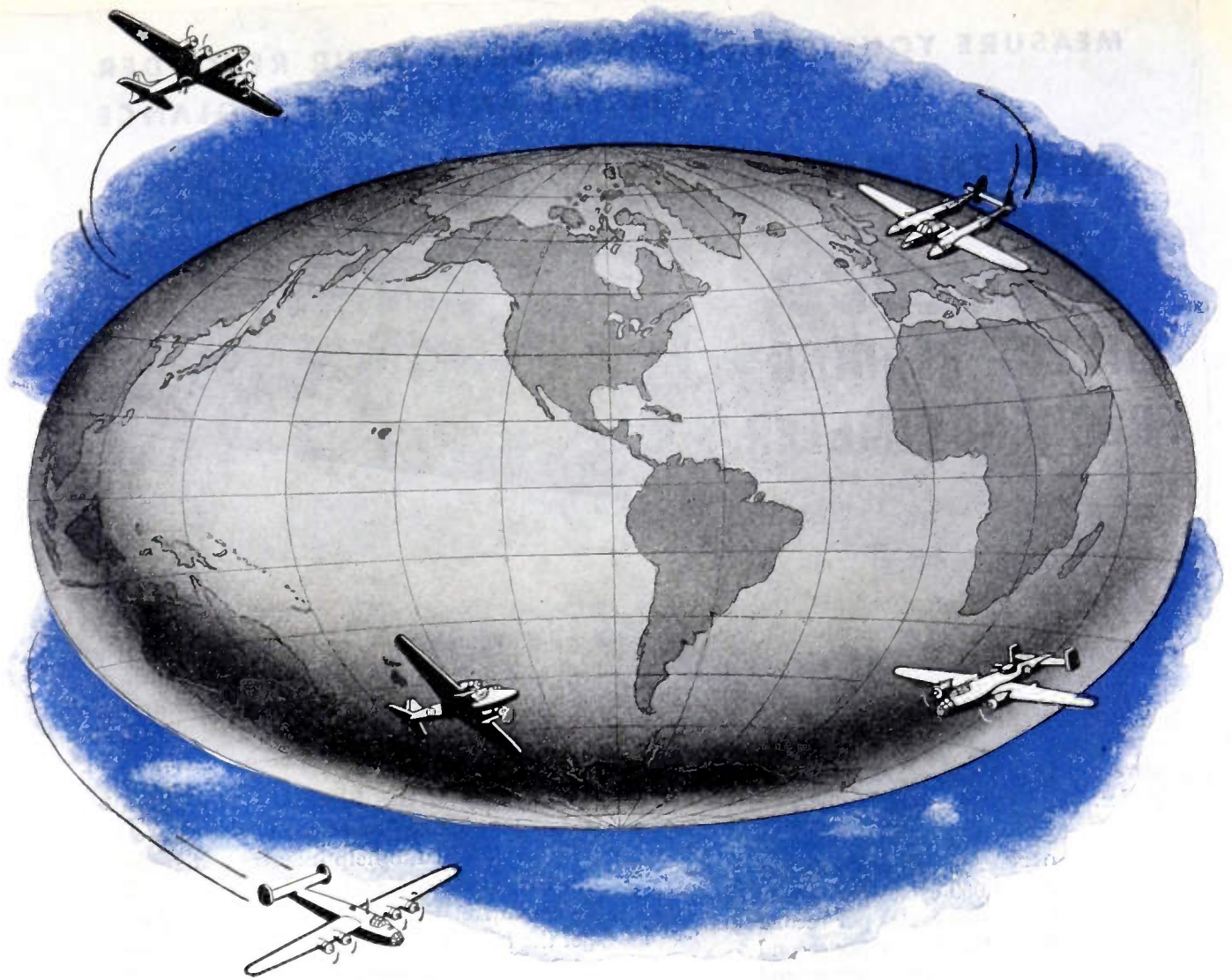

Serving the Air Routes of the World ...*TODAY* and *TOMORROW*

On established passenger and cargo airlines, as well as on military missions, dependable communications are vital. Wilcox Aircraft Radio, Communication Receivers, Transmitting and Airline Radio Equipment have served leading airlines for many years . . . and while, today, Wilcox facilities are geared to military needs, the requirements of the commercial airlines likewise are being handled. Look to Wilcox for leadership in dependable communications!

Proceedings of the I.R.E. October, 1943



**WILCOX
ELECTRIC COMPANY**
*Quality Manufacturing
of Radio Equipment*
14th & Chestnut Kansas City, Mo.

MEASURE YOUR FREQUENCY • DRIVE YOUR RECORDER
• SEE THE ANSWER AT A GLANCE

WITH THE NEW
Norelco
DIRECT READING
FREQUENCY METER



HERE is a brand new Norelco tool for industry—
an electronic direct reading frequency meter
remarkable for its compactness, simplicity and
wide range of applications.

Six scale ranges make possible the accurate
coverage of all frequencies from 0 to 50,000
cycles. The six scale ranges are:

- 0 — 100 cycles per second
- 0 — 500 cycles per second
- 0 — 1,000 cycles per second
- 0 — 5,000 cycles per second
- 0 — 10,000 cycles per second
- 0 — 50,000 cycles per second

Any standard 5 milliamperere recorder may be
connected to the frequency meter and be driven
without the aid of an auxiliary amplifier. It oper-
ates on 110 volts AC and requires only 100 watts
of power. It measures frequencies to an accuracy
within 2% regardless of the input voltage, which
may vary from ½ volt to 200 volts.

Adaptable for either relay rack or cabinet
mounting, the new Norelco Electronic Direct
Reading Frequency Meter is as useful in the lab-
oratory as it is in the industrial plant. This in-
strument can be used in testing quartz crystals,
or experimentally as the base of an FM modula-
tion indicator. Combined with a photo-electric

cell and amplifier, it can be made into a speed
indicator. It permits the reading of high speeds,
such as are encountered in *ultraspeed* centrifuges.
It is equipped with safety cutout to prevent meter
and recorder burnout from accidental overload.

The new Norelco Electronic Direct Reading
Frequency Meter is only one of several Norelco
devices designed to help industry achieve better
quality, flexibility and product control. Write
to North American Philips engineers today and
get the benefit of our wide experience in solving
problems for industry.

For our Armed Forces we make Quartz Oscil-
lator Plates; Amplifier, Transmitting, Rectifier
and Cathode Ray Tubes for land, sea and air-
borne communications equipment. *For our war
industries* we make Searchray (X-ray) apparatus
for industrial and research applications; X-ray
Diffraction Apparatus; Electronic Temperature
Indicators; Direct Reading Frequency Meters;
Tungsten and Molybdenum in powder, rod, wire
and sheet form; Tungsten Alloys; Fine wire of
practically all drawable metals and alloys; bare,
plated and enameled; Diamond Dies; High
Frequency Heating Equipment. *And for Victory
we say: Buy More War Bonds.*

Norelco ELECTRONIC PRODUCTS by
NORTH AMERICAN PHILIPS COMPANY, INC.

Industrial Electronics Division, 419 Fourth Ave., New York 16, N. Y.

Main factory and offices in Dobbs Ferry, N. Y.; other factories at Lewiston, Maine (Elmet Division); Mount Vernon, New York
(Philips Metalix Corporation). Represented in Canada by Electrical Trading Company, Ltd., Sun Life Building, Montreal, Canada

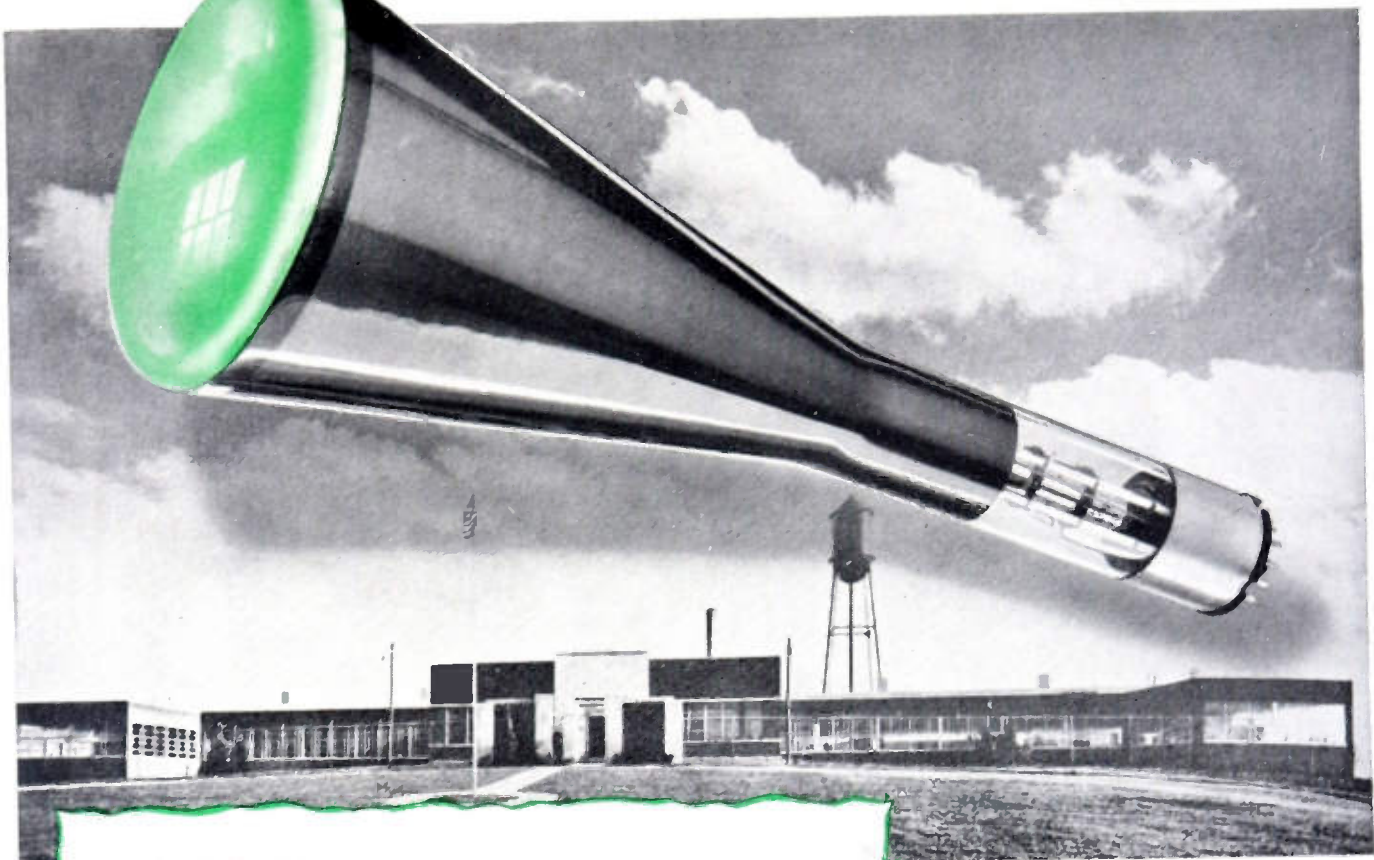

MEMO for Post-War Reference:

NATIONAL UNION IS ONE
OF THE LARGEST PRODUCERS
OF CATHODE-RAY TUBES

In our cathode-ray tube production record, now climbing upward week by week, we see the working out of plans made long ago. Here are the dreams of our engineers come true. Here is the model factory they planned and equipped especially for cathode-ray tube manufacture—one of the Industry's

largest. Here are the mass production machines they designed—built by this company's own equipment division. Here are the hundreds of skilled workers to whom they taught this special art of tube making that calls for the utmost precision and accuracy. Here are their laboratories with research continuing

at an even greater pace, as though their work had just begun. And here are the results of all this thought and effort—National Union Cathode-Ray Tubes *by the carload*. Today, enroute to those who need them most—our fighting forces! Tomorrow, destined to bring to millions of homes a marvelously improved kind of television with larger images, with greater sharpness, and reality, at mass-market prices—and to thousands of factories many new precision testing and measuring devices.

For engineers and production men, National Union is planning a comprehensive electronics industrial service—available as soon as war commitments permit.

NATIONAL UNION RADIO CORPORATION

NEWARK, N. J.

LANSDALE, PENNA.



NATIONAL UNION
RADIO AND ELECTRONIC TUBES



PAINTED FOR ELECTRONIC LABORATORIES, INC. BY BENTON CLARK

The 'Game Goose' gets home . . . again

● The old girl's done it again. She's laid her eggs where they'll count most—and in spite of hell and high flack, she'll soon be smoothing her ruffled feathers at home. —The capacity of America's fighting men and machines to absorb punishment, as well as dish it out—to come back again, and again, and again—is no accident.

Electronic Laboratories is proud of the *E·L* equipment that is helping the 'Game Goose,' and every American fighting plane, get home again.

On every front where the United Nations are in combat, *E·L* Vibrator Power Supplies are proving themselves as rugged and reliable as the company they keep. At high altitudes, in steaming jungles or blazing deserts, they perform their appointed task with the greater efficiency and freedom from wear, characteristic of *E·L* Vibrator Power Supplies.

Wherever electric current must be changed in voltage, frequency or type, *E·L* Vibrator Power Supplies and Converters offer many definite advantages, for peace, as well as for war.



★ For Operations of Radio Transmitter-Receiver—*E·L* Model S-1200 Vibrator Power Supply. Input Voltages: 12, 24, 32, and 110 Volts DC, and 110 Volts AC—50-60 Cycles; Output: 600 Volts DC at 150-250 MA.; 300 Volts DC at 75-150 MA.; 6-8 or 10 Volts DC at 1 A.; 110 Volts AC (50-60 cycles) at 75 Watts. Maximum Output Power: 280 Watts; Maximum Dimensions: 26¹/₁₆" x 14¹/₂" x 13³/₄"; Weight: 160 lbs.



Electronic

LABORATORIES, INC.

INDIANAPOLIS

E·L ELECTRICAL PRODUCTS—Vibrator Power Supplies for Communications . . . Lighting . . . Electric Motor Operation . . . Electric, Electronic and other Equipment . . . on Land, Sea or in the Air.





PARTS
by Centralab

CERAMIC TRIMMERS
HIGH FREQUENCY CIRCUIT SWITCHES
STEATITE INSULATORS
SOUND PROJECTION CONTROLS
CERAMIC CAPACITORS
WIRE WOUND CONTROLS

Centralab
CRL

Division of GLOBE-UNION INC., Milwaukee

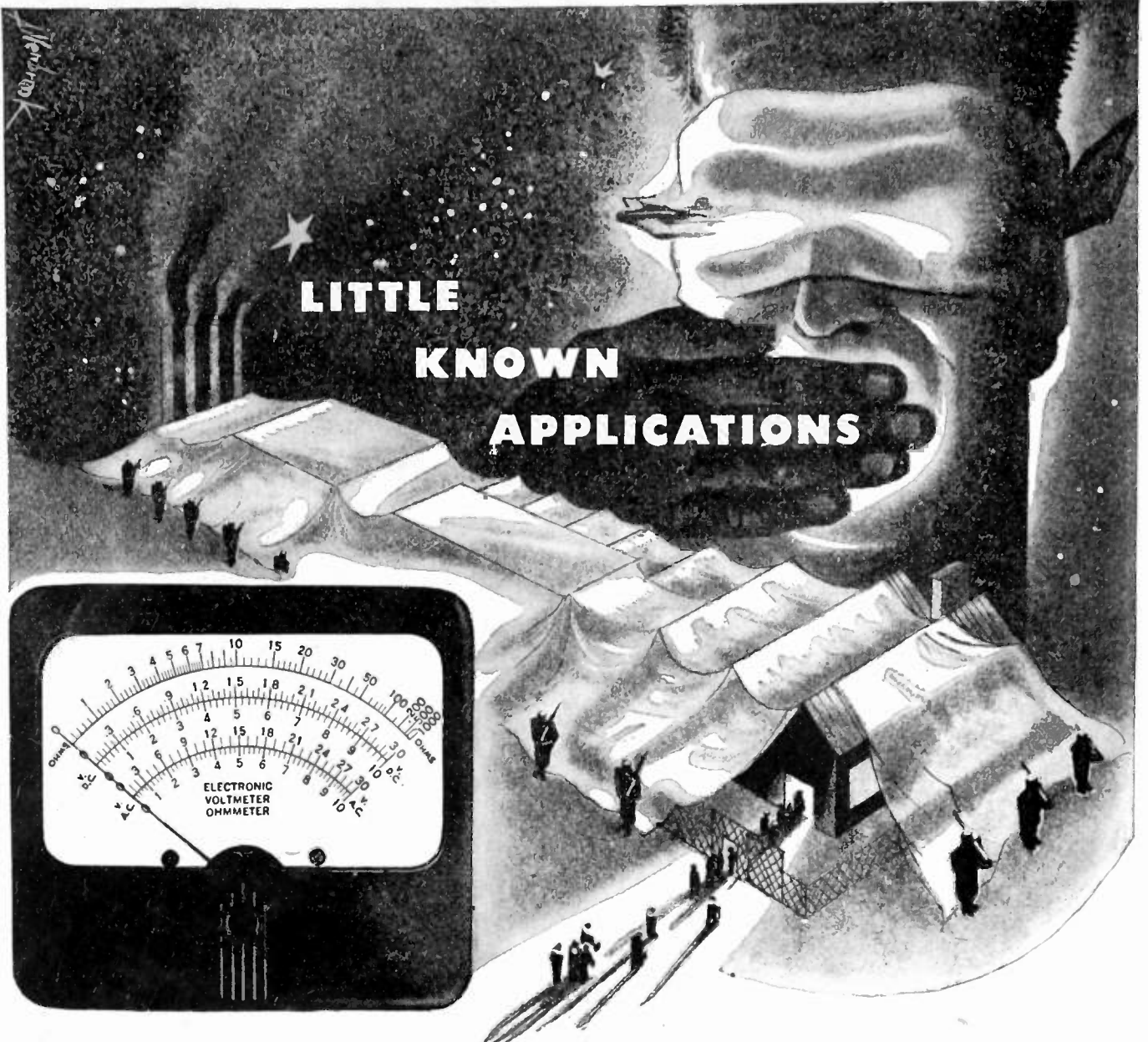

**LITTLE
KNOWN
APPLICATIONS**

Because of the secrecy encircling war production, little can be told of a meter's importance to almost every phase of the work. Suffice it to say that over a wide range of industrial electronic applications . . . heat treating, counting, refining, sound detection, color selection, and many others about which not a word has been spoken or written . . . electrical measuring instruments are universally used.

It is of interest to know . . . for present and future reference . . . that DeJur precision meters are built into the equipment employed by many war plants. Wherever used, these meters enjoy confidence from the standpoint of sensitivity, durability and dependability. Peace will usher in even more new uses for meters. To insure absolute satisfaction, specify DeJur.

Send your blood out to fight . . . donate a pint to the Red Cross today



*Awarded the Army-Navy
"E" for High Achievement*

DeJUR-AMSCO CORPORATION

SHELTON, CONNECTICUT

NEW YORK PLANT: 99 Hudson Street, New York City • **CANADIAN SALES OFFICE:** 560 King Street West, Toronto

electronic briefs: television

To produce a moving picture it becomes necessary to break down the action into a series of still pictures. Each still scene is flashed on the screen individually but done so rapidly that the human eye sees a smooth action. If the motion picture projector is slowed down the action becomes jerky. Each still picture is called a frame. The conventional movie projector flashes between 24 and 30 frames per second on the screen. Television is based upon the same principle but the problems involved are much more complex.

Television, using the same basis for creating picture action as the movies, breaks down the picture or scene to be broadcast into a series of still pictures called frames. But each frame must also be broken down into approximately 200,000 tiny segments, each segment being broadcast separately and reassembled at the receiving end so rapidly that 30 frames can be flashed on the screen every second. Thus some 6,000,000 separate signals must be transmitted per second. Furthermore each of these signals starts as light, broadcast into an electrical impulse, broadcast and then reconverted to light again. To make television talk, a conventional sound transmitter must be coordinated and synchronized with the picture broadcast.

As with all things in the field of electronics, vacuum tubes are what make television possible. Remember, Eimac tubes enjoy the enviable distinction of being first choice among leading electronic engineers throughout the world.

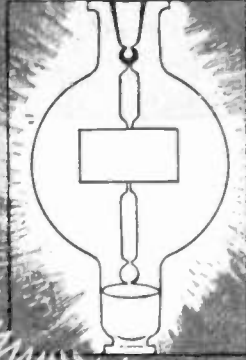

EITEL-McCULLOUGH, INC., SAN BRUNO, CALIFORNIA
 EXPORT AGENTS: FRAZAR & HANSEN, 301 CLAY ST., SAN FRANCISCO, CALIF., U. S. A.

Follow the leaders to

Eimac REG. U. S. PAT. OFF.
TUBES



Army-Navy "E" flag awarded for high achievement in the production of war material.

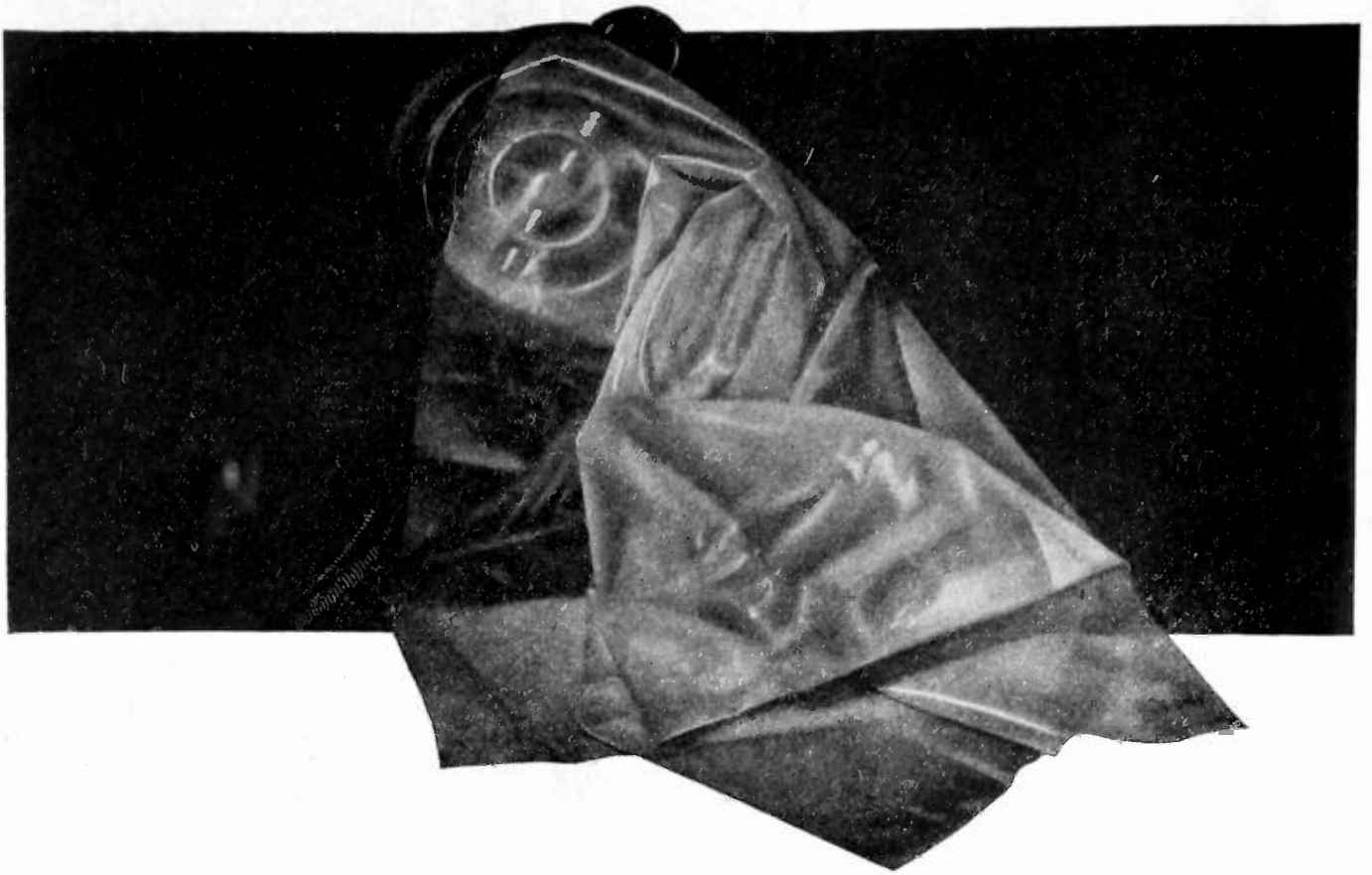

Can you use this new — .0004" — flexible material?

In developing and manufacturing entirely new Electro-Voice Microphones our engineers have had to experiment in nearly all branches of the scientific arts. About a year ago, one important microphone project was delayed because a thin and extremely flexible sheeting material was not available commercially.

Although we aren't chemists, we finally developed, what we believe to be, another Electro-Voice "first" . . . a method of sheeting a flexible material to as thin as four ten-thousandths of an inch. It is a material that can be stabilized, and one that will retain all of its characteristics from -40°F. to $+185^{\circ}\text{F.}$

We design and manufacture microphones . . . have been doing it for the past 16 years . . . and we intend to stick to our own field. However, if you're in war production and can use this new material, we'll be glad to save you the time and trouble of developing it yourself. Just tell us how much you need. . . we'll fill your order.



Blood donors are needed immediately . . . see your local Red Cross

Electro-Voice MICROPHONES

ELECTRO-VOICE MANUFACTURING CO., INC. • 1239 SOUTH BEND AVENUE • SOUTH BEND, INDIANA
Export Division: 13 East 40th Street, New York 16, N. Y. — U. S. A. Cables: ARLAB

Standard of Excellence

In War

In Peace

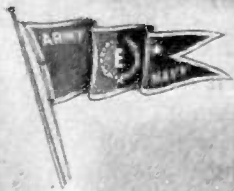
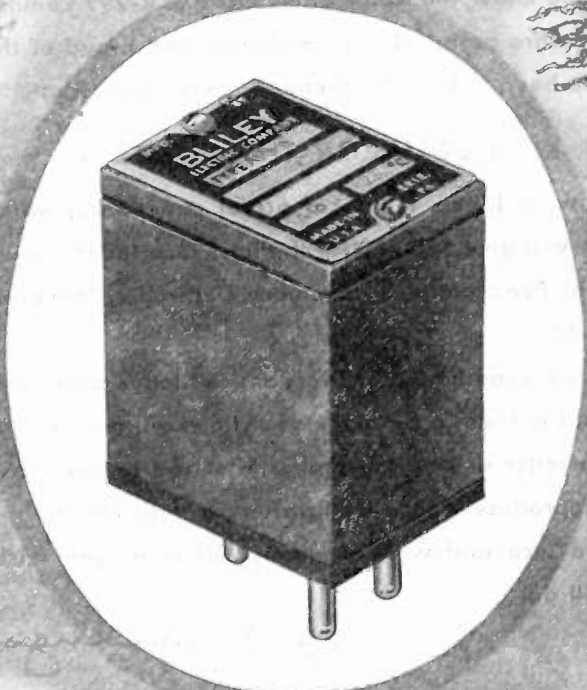

Accuracy and dependability are built into every Bliley Crystal Unit. Specify **BLILEY** for assured performance.



BLILEY ELECTRIC COMPANY · · · ERIE, PA.

Bliley Crystals

CASH PRIZE CONTEST!

FOR RADIO MEN IN THE SERVICE!

"Write A Letter"

As you know, the Hallicrafters make SCR-299 Communications trucks. We are proud of our handiwork and proud of the job you men have been doing with them on every battle front.

RULES FOR THE CONTEST

We want letters telling of actual experiences with SCR-299 units. We will give \$100.00 for the best such letter received during each of the five months of November, December, January, February and March!

We will send \$1.00 for every serious letter received so even if you should not win a big prize your time will not be in vain.

Your letter will be our property, of course, and we have the right to reproduce it in a Hallicrafters advertisement.

Good luck and write as many letters as you wish. V-Mail letters will do.



BUY MORE BONDS!



the hallicrafters co.
2611 INDIANA AVENUE, CHICAGO, U. S. A.
MAKERS OF THE FAMOUS SCR-299 COMMUNICATIONS TRUCK

The Army had a transmitter but no receiver



Have you ever heard the story of the Army's first experiment with short-wave radio?

It begins back in 1925 when Colonel Loughry, stationed at the Presidio in San Francisco, asked Ralph M. Heintz to submit a quotation on a short-wave transmitter. The cost was estimated at \$600, and in spite of the Colonel's eloquence, his senior officers were not persuaded that short-wave was promising enough to merit that amount of money.

But Colonel Loughry was not so easily defeated. There was a \$375 reserve in the Presidio mess fund. The Colonel decided that the military value of short-wave was worth risking the unauthorized transfer of this idle money. Then he and Ralph Heintz combed the Presidio junk pile, salvaging generators and other material from condemned trucks.

Came the day when the transmitter was ready to go on the air, and only then was it realized that the Army lacked a receiver capable of bringing in its new transmitter! So officers in Washington arranged to go to the home of a

local amateur to receive the Army's first short-wave message.

★ ★ ★ ★ ★

The Signal Corps and Heintz and Kaufman, Ltd. have both come a long way since this incident in 1925. The pioneer work of Heintz and Kaufman with high frequency transmission showed the need for specially designed tubes, and Gammatrons were developed to fill this need.

Through continuous research and improvement, Gammatrons have maintained their position of leadership in their field . . . their reputation for high efficiency at very high frequencies, for ease of neutralization, for long life, and for mechanical and electrical stability.

HEINTZ AND KAUFMAN, LTD.

SOUTH SAN FRANCISCO, CALIFORNIA, U. S. A.

Gammatron Tubes



HK-24—The long, capped tantalum plate confines the entire electron stream for useful output, and the grid is closely spaced to the filament for short electron time-flight. The result is high efficiency at very high frequencies. (Plate dissipation 25 watts, maximum power output 90 watts.)



STUPAKOFF

FOUNDED IN 1897

Ceramics for the World of Electronics

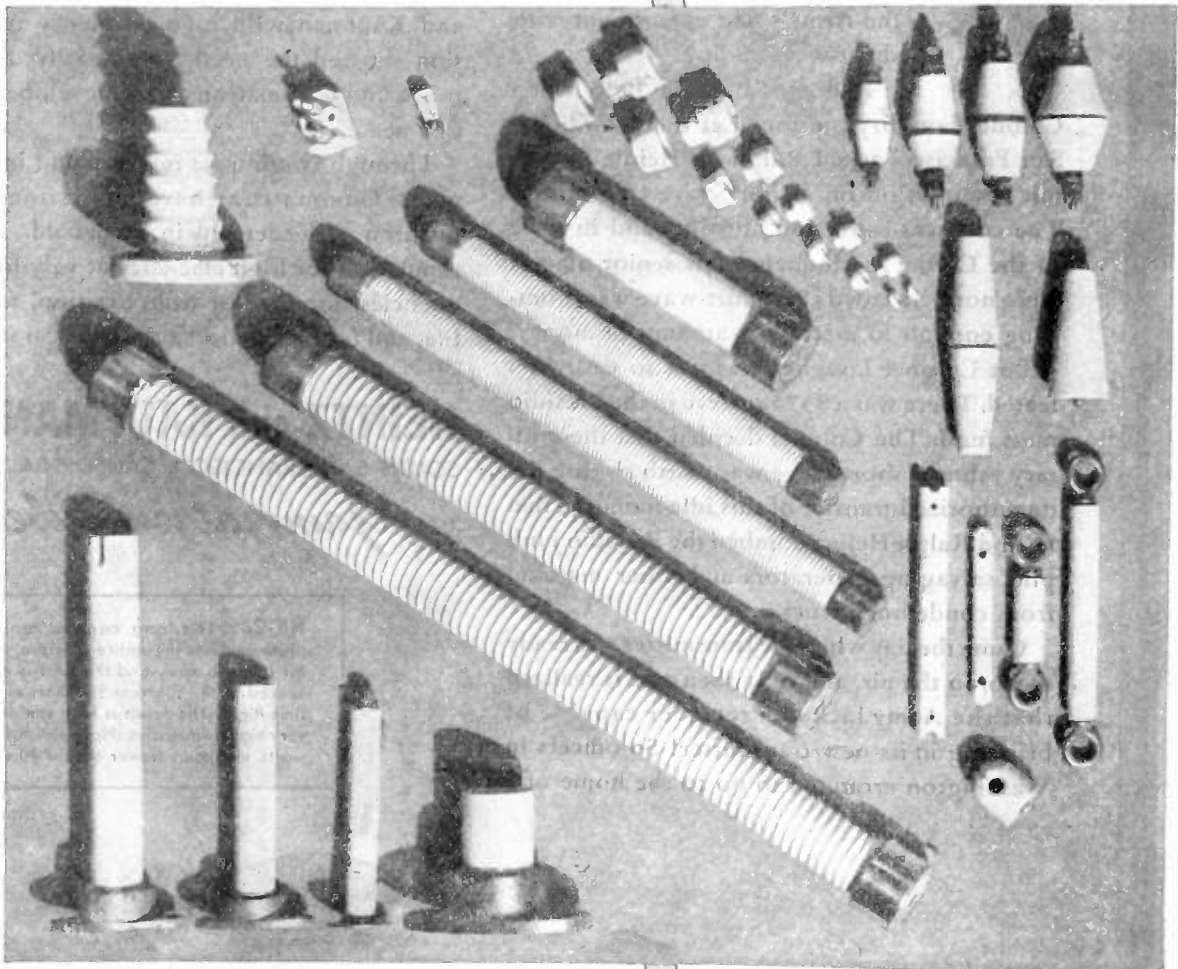

Low Loss Steatite Insulators and Assemblies

In addition to thousands of styles and shapes of low loss Steatite Insulators, we also manufacture many with METAL FITTINGS ATTACHED, ready for use. These include standoff, lead in, strain and other standard lines of Steatite Insulators.

Stupakoff Steatite Insulators are made to your specifications with or without metal attached. In addition to attaching preformed metal fittings, we plate ceramic insulators with ferrous and non-ferrous metals. Subsequent to applying this metal to ceramics, we machine or grind the metal surfaces to precision tolerances, as required.

BUY MORE WAR BONDS

STUPAKOFF

Steatite

INSULATORS

STUPAKOFF CERAMIC AND MANUFACTURING CO.
LATROBE, PA.

"for great
achievement"

LITTLE GIANTS OF DEPENDABILITY

JAMES KNIGHTS

Crystals



Crystals For Victory!

The men of the James Knights Company have pioneered in the manufacture of Crystals since 1932. Increased production during the present emergency period came naturally as already existing production facilities were called up. James Knights will be making Crystals too when this war is over—supplying them to those who demand the utmost in dependability and efficiency.

Any Type,
Cut or
Frequency

PRECISION CUTTERS OF QUARTZ
FOR COMMUNICATIONS AND OPTICAL USES

The JAMES KNIGHTS Company

SANDWICH, ILLINOIS

PHONE 65



A *TUBE*

made this possible!



You are looking at an after-war scene made possible by a *tube* . . . a 15 inch Cathode ray tube! For within this high powered "heart and brain" of television is marshalled the electronic energy which has already thrilled theatre audiences with televised projections on full size (15 foot x 20 foot) theatre screens. We can look forward to these coming events which would even now be in full swing but for the more serious obligations of Science to National War Emergency. Today, all of RAULAND engineering resources are at work for our war effort but RAULAND sights are set ahead to serve industry in the new days to come.

RADIO... SOUND...

Rauland

... COMMUNICATIONS

Electroneering is our business

THE RAULAND CORPORATION . . . CHICAGO, ILLINOIS

Buy War Bonds and Stamps! Rauland employees are still investing 10% of their salaries in War Bonds



Seeing ... **BY EAR**

A fighting man must fly blind sometimes, but deaf never. In long range bombers ... in scrappy pursuit planes ... whatever the visibility, vital communication channels must be kept clear. Unless the proper suppression filter system is installed, noisy radio interference acts like a pack of demons ... sabotages communications upon which the safety of men and their military missions depend.

Solar Elim-O-Stats are Communications' Life-savers. They are compact filters which protect against local static, absorbing it *right where it starts*—at generators, motors, contacts, and other sources. Solar Capacitors are reliable components used by practically all leading manufacturers of military radio equipment. From command car to jeep or tank ... from ship to ship or plane ... between planes—wherever radio is vital—Solar Capacitors and Elim-O-Stats help keep channels clear, so fighting men can hear.

If you have a problem concerning capacitors or radio noise suppression, call on Solar Manufacturing Corporation, 285 Madison Ave., New York 17, N. Y.



Solar **ELIM-O-STATS**

CAPACITORS AND RADIO NOISE-SUPPRESSION FILTERS

don't worry about details . . .

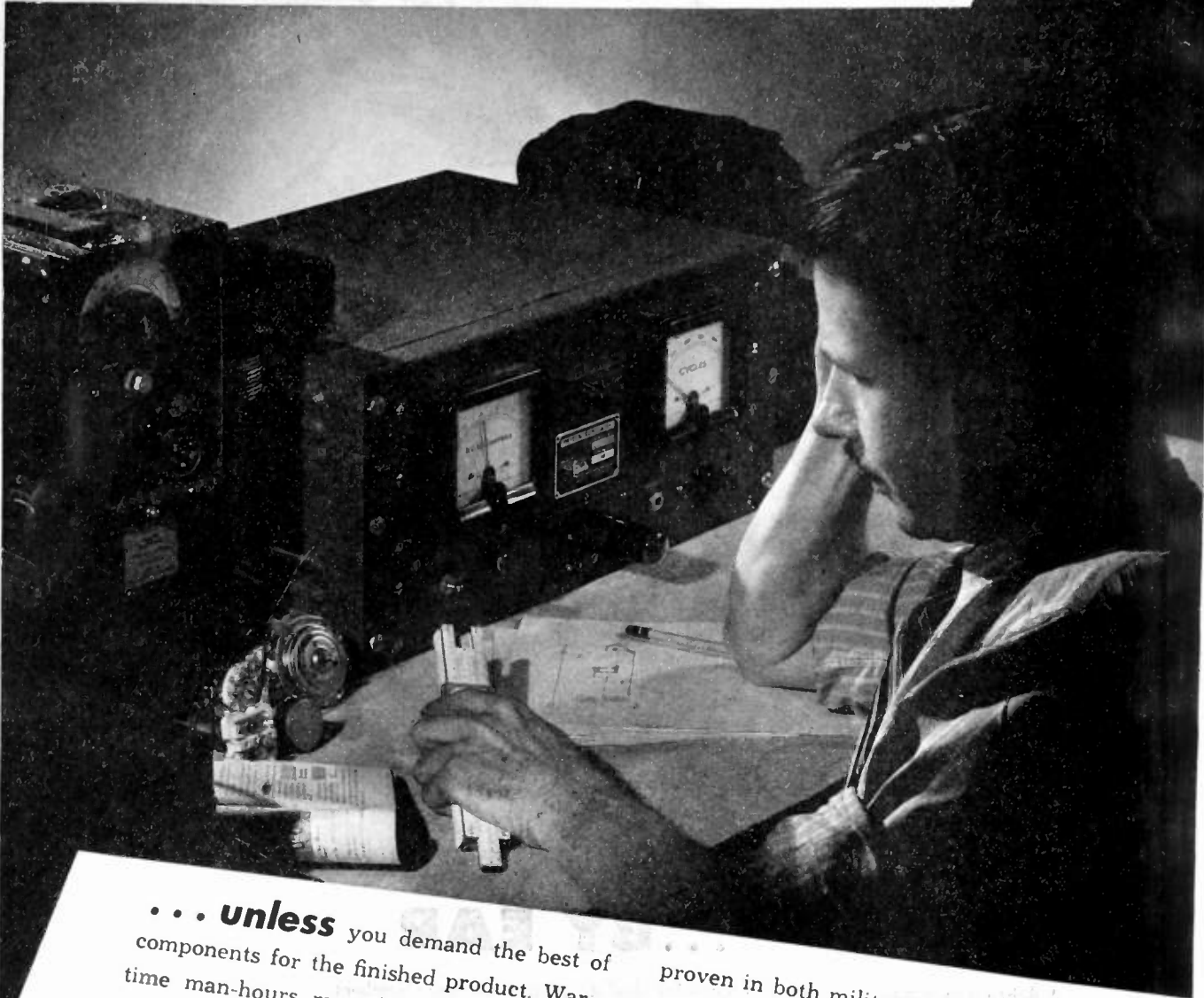

. . . unless you demand the best of components for the finished product. War-time man-hours must be spent with the greatest care to assure maximum results in terms of all-around performance and serviceability. Therefore, only the best of tubes should be incorporated into electronic designs. The quality and dependability of Raytheon Tubes is a time-tested fact,

proven in both military and civilian experience. Just how well Raytheon has succeeded in designing, developing and producing special tubes is apparent in Raytheon's unique production record. When these engineering skills and production facilities are again available for general domestic use, the Raytheon trademark will continue to play a leading part in the new era of electronics.

RAYTHEON

RAYTHEON MANUFACTURING COMPANY
Waltham and Newton, Massachusetts

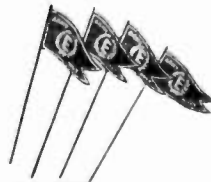

FOUR "E" AWARDS FOR EXCELLENCE
Each Division of Raytheon
has been Awarded the Army and Navy "E"

DEVOTED TO RESEARCH AND THE MANUFACTURE OF TUBES AND EQUIPMENT FOR THE NEW ERA OF ELECTRONICS

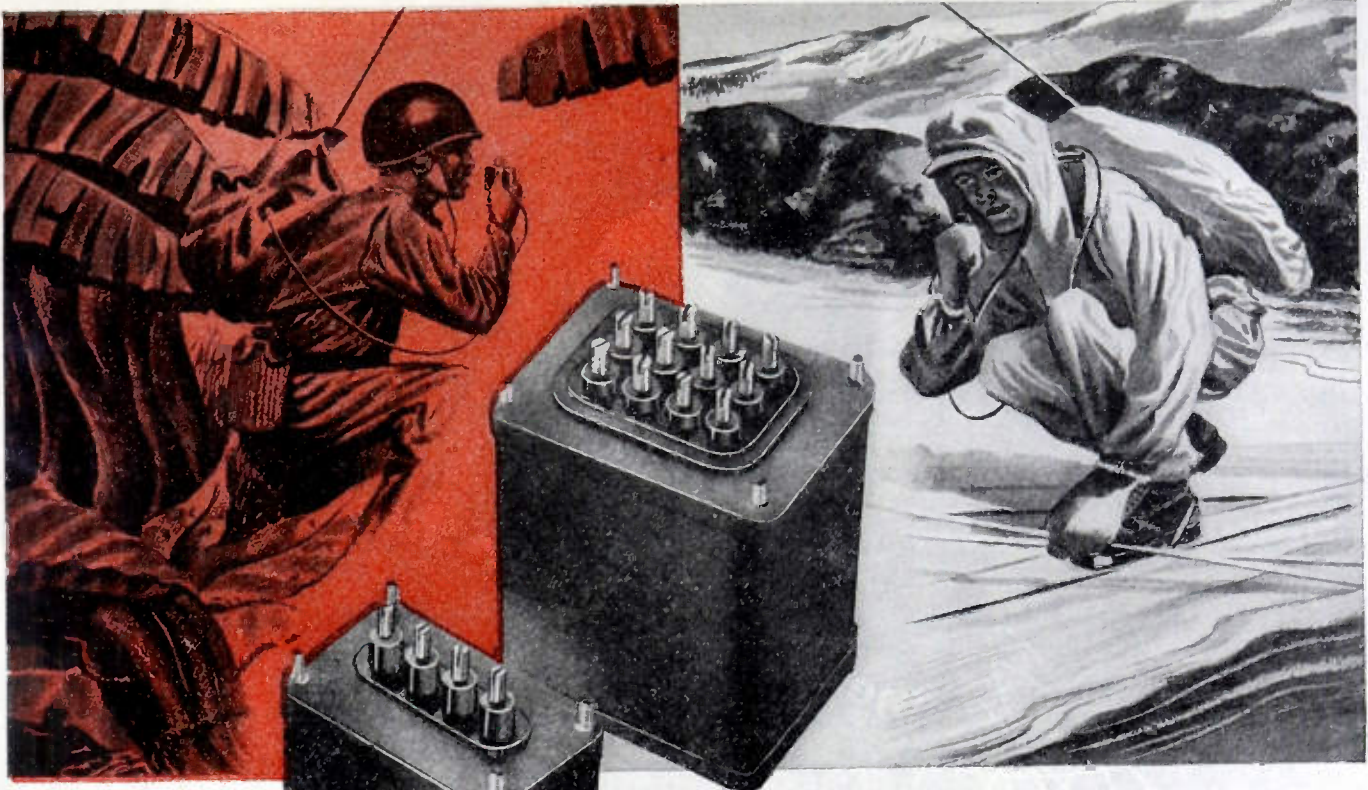

AMERTRAN HERMETICALLY SEALED TRANSFORMERS

... Impervious to all climatic conditions!



BECAUSE they must go with our Armed Forces everywhere, AmerTran Hermetically Sealed Transformers are built to remain water-tight, air-tight and fungus proof through Tropic Heat and Arctic Cold.

They are extremely flexible in size and terminal arrangement and are ideally suited for fine wire applications. As Transformers, as Reactors, as Wave Filters, they are used in communications, navigating, locating and controlling apparatus. Minimum weight and dimensions for their purposes make them ideal for airborne applications. Enclosing cases and terminal boards are die-made, insuring close tolerances and uniformity. AmerTran quality of design, materials and construction make these Transformers suitable for today's exacting requirements and tomorrow's better living.

AMERICAN TRANSFORMER COMPANY
178 EMMET STREET, NEWARK 5, NEW JERSEY



Pioneer Manufacturers of
Transformers, Reactors
and Rectifiers for
Electronics and
Power Transmission

AMERTRAN

MANUFACTURING SINCE 1901 AT NEWARK, N. J.



The biggest thing in the world to come

is the smallest object in the universe!

That's right. You guessed it: the *electron*. The war's demand for instant mastery of every method of communication has matured the science of electronics. When peace is won, the world will be in for a host of revolutionary surprises.

Stancor transformers are now doing a job for war . . . organizing electrons for battle. At the same time, Stancor engineers keep their eyes fixed on the new age of electronics that will appear when the curtain of military secrecy is lifted. Tested and trained by problems of war, they will be ready for the problems of peace.

STANCOR

STANDARD TRANSFORMER CORPORATION
1500 NORTH HALSTED STREET - CHICAGO



Locate your FM Transmitter
for maximum coverage

Locate your FM Studio
for convenience

Bridge the gap without
wires with a G-E S-T relay

PROGRAMS from W41MM, the Gordon Gray studio at Winston-Salem, N. C., are today being relayed, *without wires*, to its 3-kw transmitter high on Clingman's Peak 110 miles away. A G-E Station-to-Transmitter unit makes this wireless relaying possible. In similar use at FM stations in Chicago and Schenectady, and at international short-wave stations in Boston and New York, the S-T relay has proved its economy, reliability, and unequalled transmitting fidelity in months of flawless day-in, day-out service.

General Electric S-T equipment permits complete FM program fidelity from 30 to 15,000 cycles . . . the total range of the

human ear. This apparatus takes the place of technically inadequate or prohibitively expensive wire-line construction . . . for no connecting wires are needed! General Electric alone has pioneered and developed this wireless type of equipment . . . and G. E. is the only manufacturer who can supply it.

A complete General Electric S-T relay-equipment installation includes:

1. A 25-watt FM transmitter.
2. A rack-mounted station monitor.
3. A double-conversion, crystal-controlled superheterodyne FM receiver.
4. Special directional antennas that provide a 100-fold power gain between studio and transmitter.

It's not too soon now to start locating the site for your post-war FM transmitter. G. E. has the experienced engineering personnel to help you find the best location, the S-T relay transmitter and receiver to reach it, and the studio and antenna

equipment to operate it . . . plus broadcast and programming experience to help you select and train your future FM engineering and studio staffs. We welcome your inquiries. *Electronics Department, General Electric, Schenectady, New York.*

Tune in "THE WORLD TODAY" and hear the news direct from the men who see it happen, every evening except Sunday at 6:45 E.W.T. over CBS. On Sunday listen to "The Hour of Charm" at 10 P. M. E.W.T. over NBC.

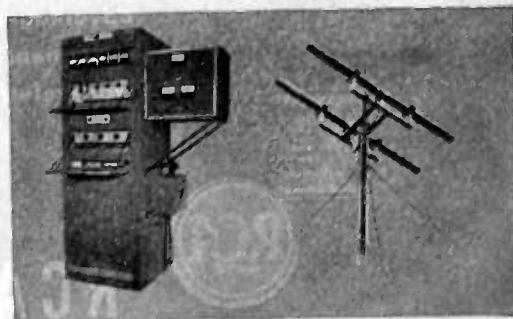

GENERAL  ELECTRIC

FM • TELEVISION • AM

STUDIO EQUIPMENT

• TRANSMITTERS

• ANTENNAS

• ELECTRONIC TUBES

• HOME RECEIVERS

Prepared For Action!



One day, nearly two years before Pearl Harbor, RCA called its peace-time army of tubes to order.

"Fall in—right dress—count off!"

"One-two-three-four-five" . . . and on up to many hundreds! Tall tubes, short tubes, squat tubes, skinny tubes.

But of that number, RCA had promoted from the ranks by inspection time that night exactly 36 receiving tubes for special duty. Each was picked, for some fundamental characteristic, as an *RCA Preferred Type Tube*.

Why did RCA do this? To develop larger manufacturing runs on fewer types, resulting in better tubes of greater uniformity at lower cost.

That this was a sound, forward-looking program is evidenced by the similar Army-Navy Preferred Type Tube program—to release for other uses materials formerly tied up in many styles of tubes, and to insure ready replacement of standard types on the fighting fronts. If you'd like a copy of the latest revised (March 1, 1943) "Army-Navy Preferred List of Tube Types", we will gladly send it to you.

Since this "Preferred Type" idea has such definite peace-time advantages, our application engineers invite inquiries now from equipment manufacturers as to tubes most likely to be on the post-war preferred types list.



RCA ELECTRON TUBES

RCA Victor Division • RADIO CORPORATION OF AMERICA • Camden, N. J.

The readers of the PROCEEDINGS OF THE I.R.E. are interested in the viewpoints of commercial leaders in the radio-and-electronic industry, in relation to technical and production trends under wartime and post-war conditions, as well as the part which the engineer should and can play in the corresponding activities. Accordingly the PROCEEDINGS here presents a "guest editorial," as received from its author, the president of the Sperry Gyroscope Company.

The Editor

Electronic Applications

R. E. Gillmor

For over twenty-five years the Sperry Gyroscope Company has specialized in three main fields of endeavor. First, marine-navigation instruments such as gyro compasses; second, aviation instruments such as blind-flying instruments and automatic gyro pilots; third, military equipment such as antiaircraft searchlights, sound locators, and bombsights.

There is nothing in the above list of products and instruments which would suggest any direct interest in electronics, and yet it is just because of that obscure connection that I am pleased to accept the opportunity to write this brief editorial for the PROCEEDINGS OF THE INSTITUTE OF RADIO ENGINEERS. My story is one which will show the naturalness and effectiveness of electronics in moving into these widely separated fields as a tool which has improved every one of the products.

It was twelve years ago that, in our search for a better method than trolley and contact for picking off the position of the compass gyroscope without pushing, dragging, or even touching it, we first experimented with electronics to do the job. The solution was a new type of amplifier which might be called a torque amplifier. The signal, made by the mere change of position of a small bar of iron carried on the gyro, caused almost zero torque and hence no disturbance to the gyro, but the output of the amplifier drove an azimuth motor with sufficient torque to operate repeater compass transmitters, metal mike, etc., with all the accuracy of the master gyro.

So electronics first stepped into the Sperry Company as a new tool which solved one of our tough gyro problems.

From there electronic power control moved onto our searchlights to train them and elevate them from remote selsyn motors. In aviation, although radio came aboard the airplane very early for communication purposes, electronics for control purposes had to wait the day when other more orthodox methods had reached their limitations. Sperry automatic pilots went through various stages of pneumatic bellows, mechanical clutches, hydraulic valves, and electric contactors. These well-known methods did the job of automatic piloting satisfactorily until recently when airplanes have become so large and, at the same time military needs called for such precision, that the only answer again has been to go to electronics for the huge and precise step of amplifying small gyro signal to large control force.

These examples show how, step by step, electronics has taken over certain functions in our products which have improved their performance but have not changed their names.

It is, however, even reaching farther than this. Some ten years ago, we decided after many experiments that the 60-inch high-intensity searchlight was as powerful as was practical to make. Larger lights gave almost no increase in range. To surpass the searchlight, we must have something better than light. Sound locators, we also realized were very limited in their range and could never be precision instruments; we needed something better than sound. After considerable search, we had found that the best solution probably lay in the field of radio. I need not go into further details. This again was a case of electronics coming in to aid or even supersede our antiaircraft weapons and accomplish the same functions better than by the old methods.

We never entered the electronic business as a distinct field. Electronics, on the other hand, entered our business, and our products have been vastly improved by its applications. We see no end in sight of utilizing more and more applications of this new tool, and our research laboratory is now as well equipped for electronics research as it has been for gyroscopics, hydraulics, and many other older fields.



Harold Alden Wheeler

Harold Alden Wheeler was born in St. Paul, Minnesota, in 1903. He developed an early interest in radio engineering and in 1925 he was graduated with the B.S. degree in physics from George Washington University. This was followed by postgraduate work at Johns Hopkins University where he specialized in the electrical field. His research work at this university won him election to Sigma Xi and Gamma Alpha.

In 1922 he constructed a neutralized tuned amplifier and in 1925 assembled an eight-tube superheterodyne receiver in which the novel features of diode linear detection and automatic volume control were included. While studying at Johns Hopkins University, Wheeler's research projects included a theoretical study of wave filters, an experimental test of the thermal noise formula, the detection of weak modulated light beams by a photoelectric cell and selective detector, and the design of a pulse amplifier for operation on the heart-action currents, problems closely related to those encountered in present-day radio and television work.

In 1922, Mr. Wheeler accidentally met Professor Alan Hazeltine with whom he found a common interest in neutralized amplification. He worked summers with Professor Hazeltine and continued with the Hazeltine Corporation from its inception in 1924. He was put in charge of the Bayside Laboratory in 1930 and was later made Vice President of what is now the Hazeltine Electronics Corporation, with laboratories located

at Little Neck, Long Island.

His scientific contributions have been numerous and varied. He developed special testing equipment, such as the piston alternator; he worked out a simple inductance formula for solenoid coils; his theoretical studies of distortion and wide-band amplifiers were the basis for the award to him in 1940 of the Morris Liebmann Memorial Prize; in his studies of frequency modulation, he substituted for the accepted attack of sine-wave modulation with its multiple sidebands, a generalized modulation, which yields simple relations of greater utility; he unified the formulas for the skin effect; and recently he has been developing charts and formulas for streamlining many phases of radio design. Much of his work has appeared in published papers in the PROCEEDINGS.

Mr. Wheeler has been active in Institute affairs from the time he attended Johns Hopkins. His work during the summers of 1921 and 1922 in the radio laboratory at the Bureau of Standards gave him his foundation for subsequent standardization work in the Institute. He served as chairman of the Technical Committee on Radio Receivers for the 1933 and 1938 reports, and he is now chairman of the Standards Committee. He was a member of the Papers Committee, and now is a member of the Board of Editors and a director of the Institute. He joined the Institute of Radio Engineers as an Associate in 1927, transferred to Member grade in 1928, and to Fellow in 1935.

Radio-Frequency Heating Applied to Wood Gluing*

R. A. BIERWIRTH†, NONMEMBER, I.R.E., AND CYRIL N. HOYLER†, ASSOCIATE, I.R.E.

Summary—Dielectric heating by radio-frequency power has been established^{1,2} as a practical means for rapidly gluing wood with thermosetting adhesives. To the radio engineer, such an application involves the correlation of power concentration, frequency, voltage gradient, dielectric constant, and power factor for the determination of reasonable operating parameters. An equation is developed showing the interdependence of these factors. Pertinent data on the dielectric properties of several kinds of wood are included covering a suitable range of frequency and for the temperatures and moisture contents commonly encountered.

The nonuniform heating likely to occur in large presses because of standing waves on the electrodes can be eliminated by "multiple tuning" in which each of several inductors tunes a section of the press electrodes to parallel resonance.³ A coupling network is evolved for feeding a tuned press so that variations in press capacitance during the gluing cycle become unimportant to the loading of the oscillator. Means for measuring the temperature at the glue line during the application of radio-frequency power are discussed.

I. INTRODUCTION

THE GENERATION of heat in dielectric materials by strong alternating electric fields has long been evident to radio engineers dealing with high power at the higher frequencies. However, when a poor dielectric material is purposely subjected to such a field, heat will be generated rapidly and uniformly throughout, in a manner that can be closely controlled. One industrial application of such radio-frequency heating is made in the wood-gluing industry where the recent increase in the use of laminated wood, as a material of construction, has accentuated the need for rapidity in curing the adhesives commonly used for bonding. Although gluing as an art and its application to the manufacture of plywood may be traced to ancient Egypt, it was not until the introduction of hot-plate presses about the time of World War I that the way was first pointed to a shorter gluing cycle and greater durability of the finished product. During the last decade the development of thermosetting adhesives of the synthetic-resin group has broadened the demand for a means of heating the glue line quickly and uniformly so that the inherent advantages of these modern adhesives could be most fully realized. Hot-plate presses can be used effectively where the glue lines are close to the surface, but when heat must be conducted through thick sections, the heating cycle becomes too long and excessive drying or scorching of the wood arises as a problem. Dielectric heating by radio frequency simplifies this problem since heat is generated uniformly through-

out the material and thus glue lines some distance from the surface may be as readily heated as those nearer the surface. In a paper by G. H. Brown,⁴ a theoretical examination has been made of the heat-conduction problems encountered in hot-press wood gluing where the heating energy is supplied either by hot plates or by radio-frequency power. Basic relationships between heating time, temperature rise and power concentration are also established in his paper. For the proper application of radio-frequency heating to presses designed for wood gluing some information must be assembled on the electrical properties of wood at several frequencies as well as the means by which the radio-frequency energy may be coupled to electrodes in the press. It is the object of this paper to discuss some of the practical aspects of radio-frequency heating as applied to wood gluing.

II. THERMOSETTING GLUES

The thermosetting glues most widely used in the woodworking industry today are either of the synthetic urea-resin type or of the synthetic phenolic-resin type.

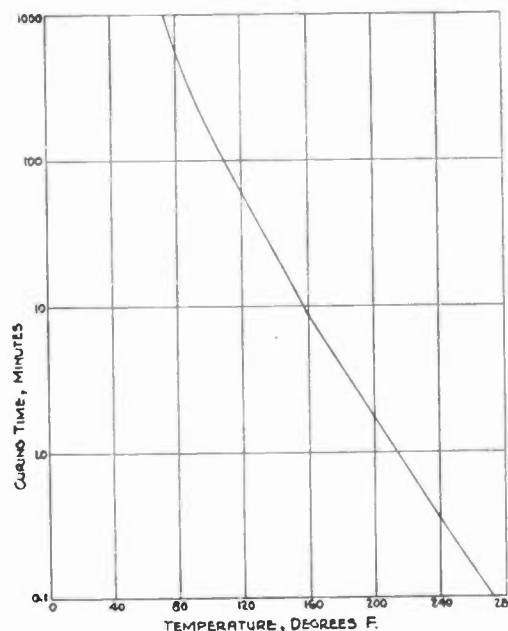

Fig. 1—Relationship of curing time and temperature for a catalyzed urea-resin glue.

Urea-resin glue can be obtained in the form of a liquid ready for use or in the form of a powder which must be dissolved in water before using. Fig. 1 shows a typical curing-time—temperature curve for a catalyzed glue of this type. It will be noted that for a temperature of 220 degrees Fahrenheit, the curing time is about one minute while at a room temperature of 75 degrees

⁴ George H. Brown, "Heat-conduction problems in presses used for the gluing of wood," *PROC. I.R.E.*, this issue, pp. 537-548.

* Decimal classification: R590. Original manuscript received by the Institute, March 9, 1943.

† RCA Laboratories, Princeton, New Jersey.

¹ "High-frequency heat used to make plywood," *Elec. World*, vol. 117, p. 2240; June 27, 1942.

² J. P. Taylor, "Heating wood with radio frequency power." Presented, annual fall meeting, American Society of Mechanical Engineers, Woodworking Section, Rochester, New York, October 12, 1942.

³ R. A. Bierwirth, United States Patent 2,308,043, 1943.

Fahrenheit the curing time is 13 hours. Although the curing time can be further reduced by the addition of more catalyst, the glue may then set too quickly at room temperature to be of practical use. Pressures of 150 pounds per square inch or greater should be maintained during the gluing cycle so that irregularities in the adjacent wood surfaces may be eliminated. If the bond is properly cured it is highly water resistant at ordinary temperatures but not at elevated temperatures. Urea-resin glue is lower in price than phenolic glue and can be extended by mixing with wheat or rye flour.

Phenolic-resin glue can be obtained in the form of a liquid, a film, or a powder. The powder must be dissolved in water or alcohol before use. For best results this type of glue generally requires a bonding temperature of 280 to 300 degrees Fahrenheit, maintained for several minutes with an applied pressure as great as the wood will stand without damage. The resulting bond is stronger than the wood and resistant to water even at its boiling point. Specific information on the curing time-temperature relation for any particular glue can be obtained from the glue manufacturer.

III. DIELECTRIC HEATING

Where a dielectric material is to be heated by radio-frequency power, it is usually placed between the plates of a condenser connected to a source of radio frequency and thus subjected to a strong alternating field. Such a condenser is shown in Fig. 2 with a small rectangular

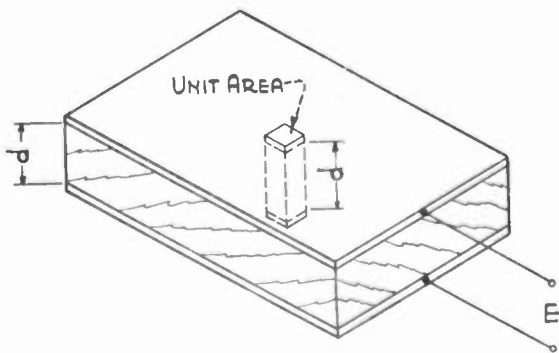

Fig. 2—Condenser with dielectric material between plates.

prism of unit cross-sectional area indicated at a location of uniform electric field. The capacitance of this elementary section of the condenser can be calculated from

$$C = 0.225\epsilon/d \text{ micromicrofarads} \quad (1)$$

if the dielectric constant ϵ of the material between the plates is known and the dimensions are given in inches.

When a radio-frequency voltage E is applied across the plates of this condenser the power absorbed by the rectangular prism is

$$P = (E^2/(\sqrt{R^2 + X^2})) (\cos \theta) \text{ watts} \quad (2)$$

where R and X in ohms are, respectively, the resistive and reactive components of the impedance for this elementary condenser and $\cos \theta$ is the power factor.

Rewriting (2) in the following manner

$$P = (E^2/X) \cdot (X/(\sqrt{R^2 + X^2})) (\cos \theta) \text{ watts} \quad (3)$$

shows the way to the further modification

$$P = (E^2/X)(\sqrt{1 - \cos^2 \theta}) (\cos \theta) \text{ watts} \quad (4)$$

since

$$X/(R^2 + X^2) = \sin \theta = \sqrt{1 - \cos^2 \theta}.$$

By using the computed value of C from (1), the value of X in this equation for a frequency of f megacycles may be found from $X = 1/2\pi fC$ and inserted into (4) which then can be written

$$P = (1.415 \times 10^{-6} f \epsilon E^2)/d \sqrt{1 - \cos^2 \theta} \cos \theta \text{ watts.} \quad (5)$$

For the power concentration P_c , in watts per cubic inch, (5) reduces to

$$P_c = 1.415 \times 10^{-6} f \epsilon (E_g)^2 \sqrt{1 - \cos^2 \theta} \cos \theta \text{ watts per cubic inch} \quad (6)$$

in which E_g is the voltage gradient across the condenser in volts per inch.

In a specific application of dielectric heating, the permissible voltage across the condenser is limited by such factors as configuration of electrodes, dielectric strength, presence of moisture with possible generation of steam, or irregularities in the wood such as knots. Since the power concentration will usually be fixed by oscillator output and volume of material being heated, a helpful revision of (6) is its solution in terms of the voltage gradient E_g . Thus:

$$E_g = 841 [P_c / (f \epsilon \sqrt{1 - \cos^2 \theta} \cos \theta)]^{1/2} \text{ volts per inch.} \quad (7)$$

It has been found, with reference to wood, that these last two equations may be somewhat simplified and the next section shows how such simplification may be effectively used.

IV. WOOD AS A DIELECTRIC

It is apparent from (6), for example, that at a given frequency the power absorbed by a dielectric is directly related to its dielectric constant and the power factor. For wood these values are not constant but change with frequency as shown in the curves of Figs. 3 and 4. To assemble the data represented by these curves, measurements were made on a number of samples of fir plywood, Sitka spruce, and walnut all of which were 4 inches long, 2 1/4 inches wide, and 1/4 inch thick. A type 170-A Q meter with a condenser of the form shown in Fig. 5 was used for these measurements. Attention must be drawn to the fact that the curves of Figs. 3 and 4 represent an average of a number of measured values as considerable variation is evident between samples. Such evidence is found in the behavior of several samples, each with 6 1/2 per cent moisture content, that were taken at random from a stock of spruce. Their measured power factor varied from 7 to 8 1/2 per cent and the dielectric constant varied between 2.6 and 3.2. Typical curves are shown in Fig. 6 for the relationship of moisture content with dielectric constant and power factor at 45 megacycles for spruce.

In view of the wide variations in the electrical

properties of these woods it may appear hopeless to find any equitable basis by which (6) or (7) may be adapted to simplified use. Nevertheless, for a first approximation, these curves show that for a moisture content of from 4 to 7 per cent the product of ϵ and $\cos \theta$ is found to be reasonably close to 0.177 by which (6) may be simplified to

$$P_c = 25 \times 10^{-8} (E_0)^2 f \text{ watts per cubic inch} \quad (8)$$

and then (7) becomes

$$E_0 = 2000 \sqrt{P_c / f} \text{ volts per inch.} \quad (9)$$

The restriction as to moisture content may be justified

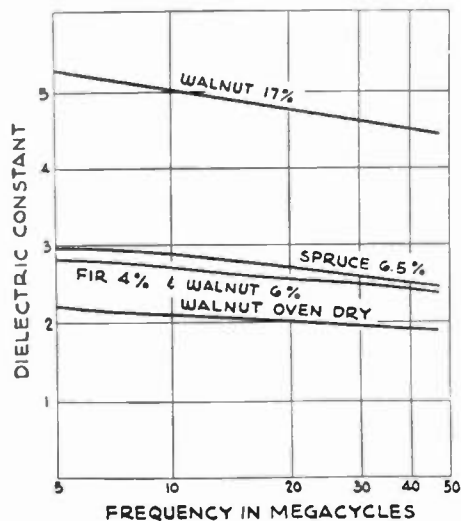

Fig. 3—Effect of frequency on dielectric constant of several species of wood at indicated moisture content.

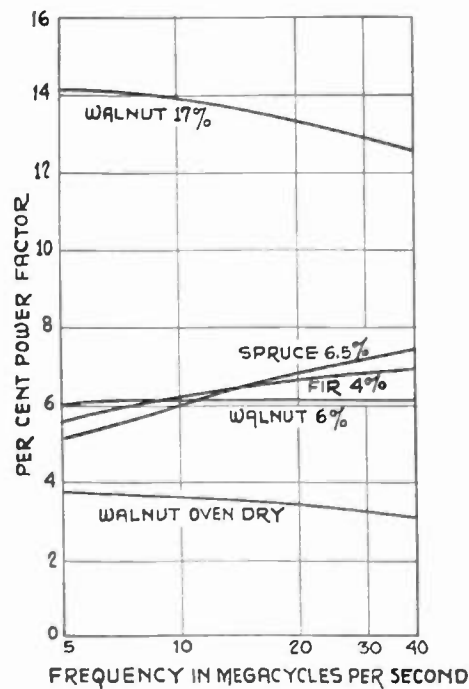

Fig. 4—Effect of frequency on power factor of several species of wood at indicated moisture content.

on the grounds that this range is representative of values which are frequently encountered in the wood-gluing industry. Allowing the approximations that have been made it can then be said that the voltage gradient

across a condenser with wood between its plates is directly proportional to the square root of power concentration and inversely proportional to the square root of frequency. Curves showing the relationships expressed by (8) and (9) are given in Figs. 7 and 8, respectively. Although these curves relate specifically to Sitka spruce they may be used for similar woods having moisture contents normally encountered. In actual gluing operations the power concentration has varied from 5 to 75 watts per cubic inch and the voltage gradient from 1000 to 4000 volts per inch at various frequencies ranging from 1.5 to 45 megacycles.

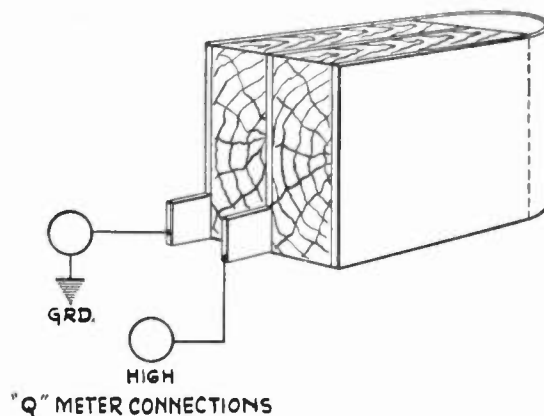

Fig. 5—Condenser for use with Q meter in determining dielectric properties of wood.

The factors determining a safe voltage gradient for dielectric heating have been discussed previously. In the gluing of wood, the voltage gradient that may be safely used rarely exceeds 4000 volts per inch and may be as low as 1000 to 2000 volts per inch where considerable moisture is present either in the wood or in the glue.

The curves of Figs. 7 and 8 show clearly the great advantage of using the higher frequencies for heating dielectrics in order that large power concentrations may

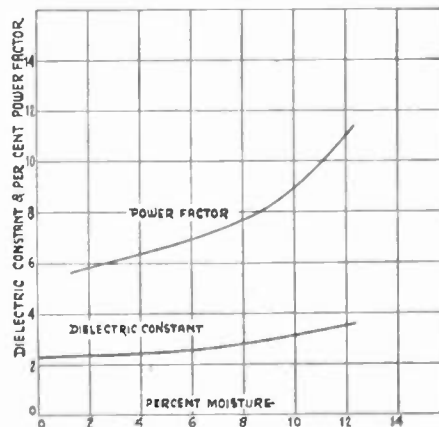

Fig. 6—Variation of power factor and dielectric constant with moisture content for spruce at 45 megacycles.

be used without excessive voltage gradients. Unfortunately, high power at high frequency becomes difficult to generate so that the actual choice of operating frequency may be a compromise. Practical experience has shown that frequencies in the 5- to 15-megacycle range

can be economically generated so that their use for wood-gluing applications can be readily justified.

Another factor that affects these electrical properties of the wood is temperature. In the course of a gluing

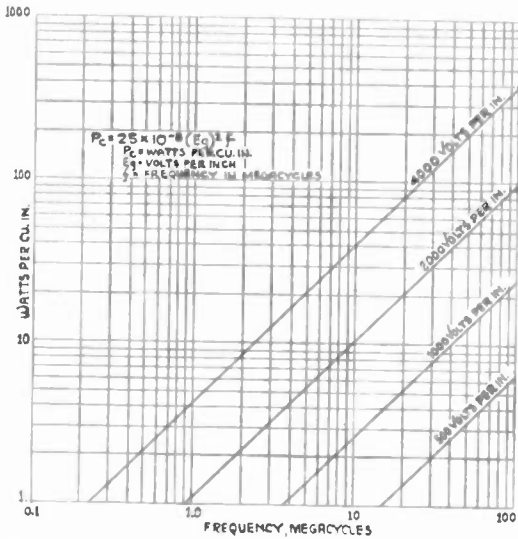

Fig. 7—Relationship of power concentration and frequency for different voltage gradients in spruce with 6 1/2 per cent moisture.

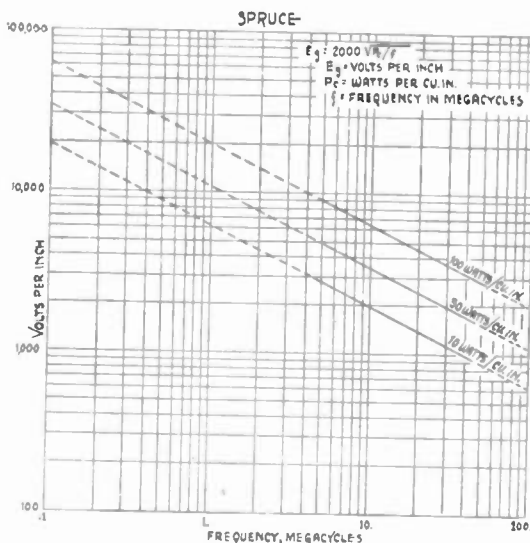

Fig. 8—Relationship of voltage gradient and frequency for different power concentrations in spruce with 6 1/2 per cent moisture.

cycle, the temperature at the glue line may reach 240 degrees Fahrenheit for catalyzed urea-resin glues and somewhat higher for the phenol glues. The curves of Fig. 9 represent typical changes in the dielectric constant and the power factor as temperature is increased. Here, it will be noted, the product of dielectric constant and power factor does not remain constant, so that a change in the voltage gradient and power concentration will become apparent. The capacitance will also change with dielectric constant, so that the consequent detuning may have an undesirable influence on the oscillator. Means for reducing the effect of this condition will be discussed later.

V. COUPLING PROBLEMS

A. Electrode Arrangements

Two typical electrode arrangements, by which radio-frequency power may be applied to wood-gluing presses, are shown in Fig. 10. In Fig. 10A the press plates are

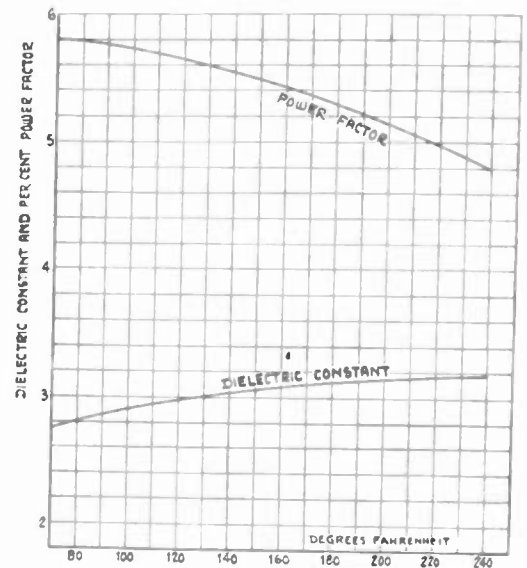

Fig. 9—Dielectric constant and power factor versus temperature for fir during a gluing cycle.

used as electrodes, the lower one being grounded and the upper one being used as the high-potential electrode, which must therefore be insulated from the rest of the press. Unless this insulation is of low-loss material it will absorb some of the applied energy and reduce the efficiency of the press. Another arrangement is shown in Fig. 10B where the high-potential electrode is sandwiched between two identical loads and thus the insulation losses of Fig. 10A are eliminated. This method permits the ready adaptation of existing presses to radio-frequency heating since the entire press remains at ground potential.

B. Coupling Networks to Reduce Effects of Load Variations

In practice, it is generally found necessary to connect the press electrodes to the oscillator through a short transmission line which preferably should be of the concentric type in order to eliminate grounding difficulties. To reduce to a minimum the volt-amperes which the line must transmit, it is desirable to tune the press to

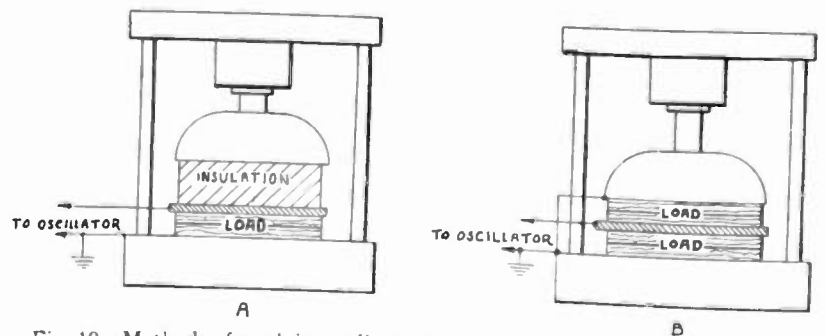

Fig. 10—Methods of applying radio-frequency power to wood-gluing presses.

parallel resonance by connecting an inductance of the proper value in shunt with the electrodes. However, Fig. 9 shows that the dielectric constant of wood varies with temperature so that the capacitance of the press will change during the gluing cycle thereby detuning the circuit and changing the oscillator loading. If the oscillator is self-excited, the frequency will shift to make partial compensation for the detuning, but unless the oscillator tank circuit is very closely coupled to the press the change in loading may be appreciable.

The use of a quarter-wave transmission line, coupled to the oscillator through a comparatively large reactance, has proved helpful in reducing the changes in loading brought about by the variations in press capacitance. Fig. 11 shows the reactance and resistance of the

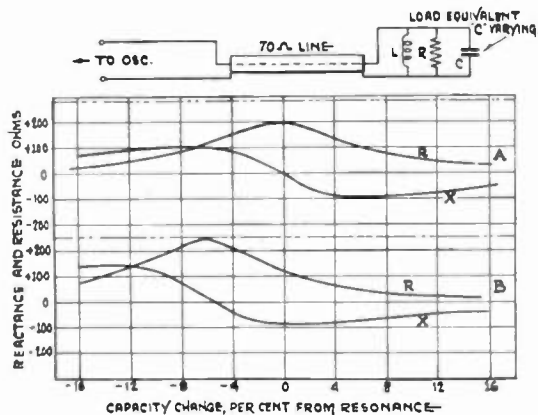

Fig. 11—Effect of capacitance change in the load on the resistance and reactance presented to the oscillator when coupled: A, directly, and B, through 18-degree 70-ohm line.

parallel-tuned press versus per cent capacitance change. Under typical operating conditions a 10 per cent change in capacitance is frequently encountered during the heating cycle which results in a 75 per cent change in the effective resistance of the press. Fig. 12 shows the resistance and reactance presented to the oscillator by a quarter-wave line when loaded at the other end by the parallel-tuned press. Now a 10 per cent change in capacitance results in only about a 10 per cent change in resistance. Consequently, if the line were supplied with a constant current, as can be approximated by feeding it through a reactance having a value 5 to 10 times that presented by the line, then the oscillator loading will be fairly constant.

If a line of a quarter wavelength cannot be conveniently employed, it can be partly or entirely replaced by a T or π network. Any transmission line may be represented by an equivalent T network⁵ as shown in Fig. 13 in which

$$Z_1 = 2Z_c \tanh P/2 \quad (10)$$

$$Z_2 = Z_c / \sinh P \quad (11)$$

where Z_c = characteristic impedance of the line

P = propagation factor of the line in the form $\alpha + j\beta$

⁵ E. A. Guillemin, "Communication Networks," John Wiley and Sons, Inc., New York, N. Y., 1936, vol. II, p. 178.

α = attenuation factor negligible for a short line

β = phase shift in degrees

Thus for a short line (10) becomes

$$\begin{aligned} Z_1 &= 2Z_c \tanh j\beta/2 \\ &= 2Z_c \sinh j\beta / (\cosh j + 1) \\ &= j2Z_c \sin \beta / (\cos \beta + 1) \end{aligned} \quad (12)$$

and (11) becomes

$$\begin{aligned} Z_2 &= Z_c / \sinh j\beta \\ &= -jZ_c / \sin \beta. \end{aligned} \quad (13)$$

In one laboratory application, the concentric line feeding the press was 18 degrees long for an operating fre-

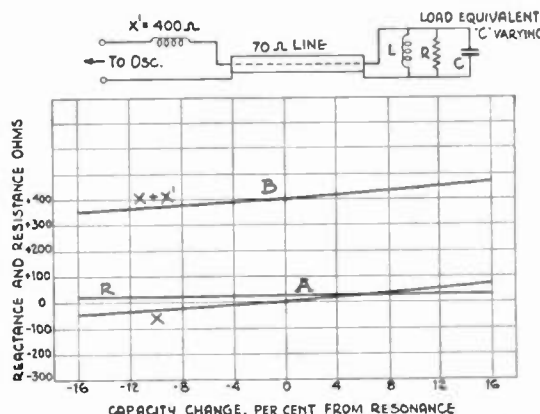

Fig. 12—Effect of capacitance change in the load on the resistance and reactance presented to the oscillator when coupled through a 90-degree line. A, resistance and reactance of load and B, reactance of load fed through same 90-degree line with 400-ohm series reactor (resistance remains the same as in A).

quency of 10 megacycles and had a characteristic impedance of 70 ohms. To "lengthen" this line to 90 degrees required the addition of a network which had a phase shift of $90 - 18 = 72$ degrees. From (12) and (13)

$$\begin{aligned} Z_1/2 &= 70 \sin 72 \text{ degrees} / (\cos 72 \text{ degrees} + 1) \\ &= 50.8 \text{ ohms (inductive)} \\ &= 0.8 \text{ microhenry at 10 megacycles} \end{aligned}$$

$$\begin{aligned} Z_2 &= -70 / \sin 72 \text{ degrees} = -73.5 \text{ ohms (capacitive)} \\ &= 218 \text{ micromicrofarads at 10 megacycles.} \end{aligned}$$

C. The Elimination of Standing Waves on Large Presses

The gluing of spars and similar long structures requires the use of presses having a length of twenty feet

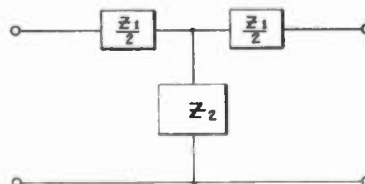

Fig. 13—Equivalent T-network for a transmission line.

or more. At mentioned above, to obtain a reasonably short gluing cycle and realize freedom from flashovers it is desirable to use a frequency in the order of 10 megacycles per second. However, when power at such a frequency is applied to long electrodes, the voltage distribution along the electrodes will be nonuniform because of standing waves unless proper precautions are taken.

The long electrodes may be considered as an unterminated transmission line and the standing waves thereon will have a length dependent on the frequency and the dielectric constant of the material between the electrodes.

In free space, the wavelength is given by the expression

$$\lambda_1 = v_1/f \text{ meters} \tag{14}$$

where v_1 is the wave velocity in free space (3×10^8 meters per second) and f is the frequency in cycles per second. The ratio of the wave velocity v in any other medium to that in free space is

$$v/v_1 = \sqrt{(\mu_1 \epsilon_1)/\mu \epsilon} \tag{15}$$

where $\frac{\mu_1}{\mu} = \frac{\text{the permeability of free space}}{\text{the permeability of the medium}} = 1$ for wood
 $\epsilon_1 = \text{the dielectric constant of free space} = 1$
 $\epsilon = \text{the dielectric constant of the medium.}$

The wavelength, when the press is loaded with wood, can be obtained by combining (14) and (15) as

$$\lambda = (3 \times 10^8)/(f\sqrt{\epsilon}) \text{ meters.} \tag{16}$$

For the wavelength in feet and the frequency in megacycles this expression becomes

$$\lambda = 984/(f\sqrt{\epsilon}) \text{ feet.} \tag{17}$$

If voltage at a frequency of 14 megacycles is applied to the plates at one end of a press 20 feet long as shown

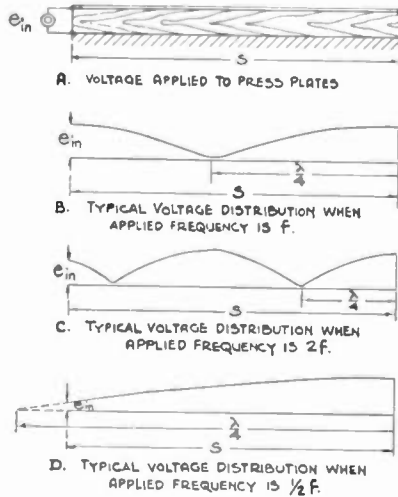

Fig. 14—Voltage distribution on long presses for several frequencies.

in Fig. 14A, then the standing wave of voltage will be as shown in Fig. 14B. The standing waves will have maxima at the open end and at a half wavelength and multiples thereof from the open end. The voltage will approach zero at points a quarter wavelength from the maxima. Figs. 14C and 14D show the standing waves for double and half the frequency, respectively, of Fig. 14B. In order to get reasonably uniform voltage on the plates when they are fed in this manner, it is apparent that the frequency applied to the press must be such that a quarter wavelength is considerably greater than the length of the press. For this condition the ratio of the minimum to the maximum voltage appearing on the press plates is given by

$$E_{min}/E_{max} = \cos(360s/\lambda) \tag{18}$$

where s is the length of the press in feet. Eliminating λ from (17) and (18) and solving for the frequency f yields

$$f = 2.74/(s\sqrt{\epsilon}) \cos^{-1}(E_{min}/E_{max}) \text{ megacycles} \tag{19}$$

where \cos^{-1} is expressed in degrees. Since it is desirable to keep the ratio of the minimum to the maximum voltage 0.9 or greater, long presses would require such a low frequency for a safe voltage gradient that the power concentration as obtained from Figs. 7 or 8 would be insufficient for a reasonably short gluing cycle.

A relationship between the length of a press and percentage variation in voltage or power due to standing waves is given by the graph of Fig. 15 for a number of

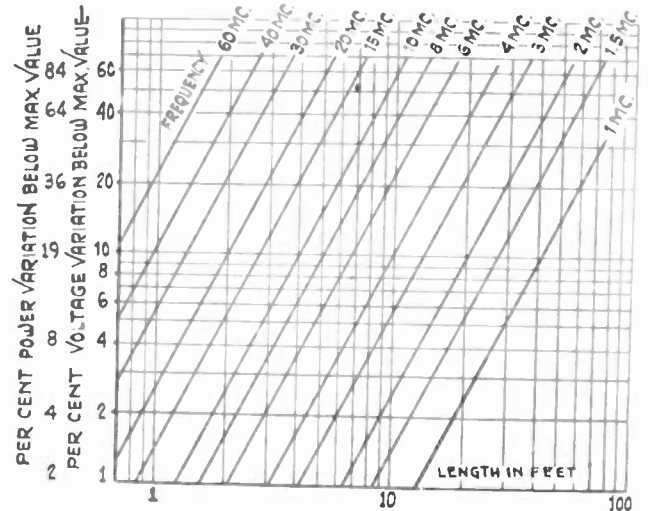

Fig. 15—Variations in power and voltage due to standing waves on long electrodes fed at one end.

different frequencies. If the voltage is applied to the plates at the center, each half of the press may be considered separately and the frequency for a given voltage variation is twice that permissible for the case where the voltage is applied at one end. This suggests a means whereby a more uniform voltage distribution may be realized. By feeding the press simultaneously at the centers of two or more equal divisions of the plates, a more uniform voltage distribution results, as shown in Fig. 16. As the number of divisions is increased, the frequency that may be used for a given voltage variation increases proportionately. The application of identical voltages at various points along the press plates by this method presents a somewhat difficult problem involving the use of a properly proportioned network of transmission lines. However, the improved voltage distribution resulting from this use of multiple feed lines can be more readily obtained by multiple tuning; that is, by replacing each feed line with an inductor of the proper value to tune its division to parallel resonance, as illustrated in Fig. 17. The transmission line from the oscillator may be connected to the plates at the end or any other convenient point. The spacing of these tuning elements d for any desired voltage ratio and frequency may be obtained from (19), noting that the value of s

in that expression is equal to one half of the spacing. Thus, in terms of d , (19) becomes

$$d = 5.48 / (f\sqrt{\epsilon}) \cos^{-1} (E_{min}/E_{max}) \text{ feet.} \quad (20)$$

The quantity ϵ in the above expression is the dielectric constant of the material between and around the plates.

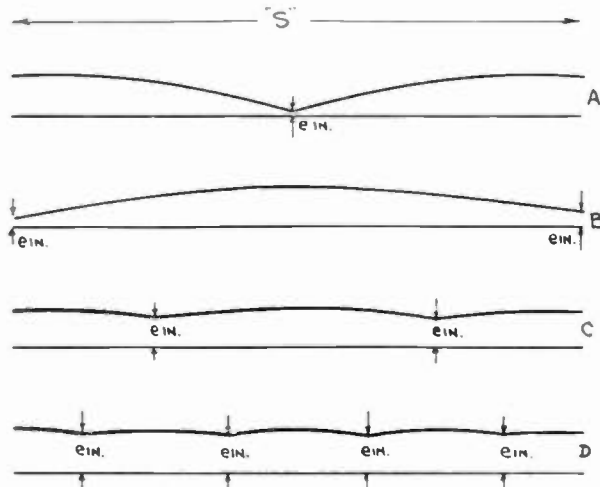

Fig. 16—Voltage distribution on press electrodes of length S for various points of feed.

If the dielectric constant of the wood between the plates is used, the value of spacing obtained will be somewhat conservative.

Since the tuning inductors placed in parallel across the electrodes must collectively tune the capacitance of the press to parallel resonance the inductance of each tuning inductor is given by

$$L = (n \times 10^6) / (4\pi^2 f^2 C) \text{ microhenries} \quad (21)$$

where n = the number of equally spaced tuning elements

f = the frequency in megacycles per second

C = the capacitance of the press plates in micro-microfarads.

At resonance the press will then present to the feed line a resistive load having a value of approximately

$$Z_r = 10^6 / (2\pi / C \cos \theta) \text{ ohms.} \quad (22)$$

Two illustrative examples of the use of multiple tuning in the elimination of standing waves on press plates

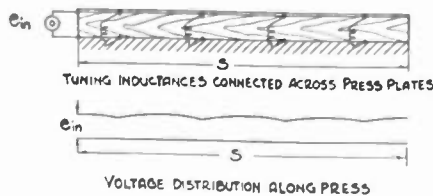

Fig. 17—Voltage distribution on press electrodes of length S fed at one end and "multiple-tuned" by inductors.

will be given. A conventional hot-plate gluing press with plates 13 feet long was adapted for the radio-frequency gluing of spruce spars. The spars were made up of three laminations each 13 feet long, 6 inches wide, and 5/16 inch thick. As shown in Fig. 18, a thick piece of fir planking was used to insulate the upper electrode from the upper pressure member of the press, and the bed of

the press was used as the lower grounded electrode. An oscillator with an operating frequency of 45 megacycles was available. Without multiple tuning the standing waves which resulted from the application of power to the press at this frequency are shown by curve A in Fig. 19. Measurement of this voltage distribution was

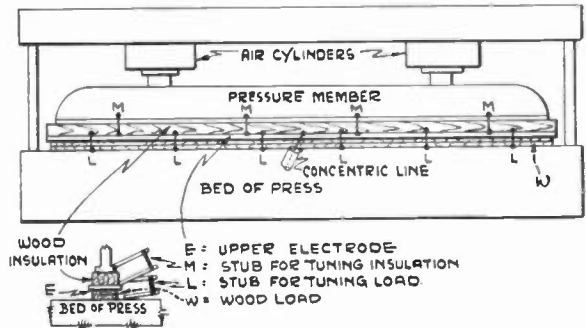

Fig. 18—Wood-gluing press adapted for radio-frequency heating at 45 megacycles.

made by taking vacuum-tube-voltmeter readings at 6-inch intervals along the press when low power was applied. The spacing of the tuning inductors used to correct this condition was calculated from (20) using the following constants:

- frequency, $f = 45$ megacycles
- dielectric constant for spruce, $\epsilon = 2.4$ (from Fig. 4)
- power factor for spruce, $\cos \theta = 0.076$ (from Fig. 3)
- length of plates, $s = 13$ feet
- capacitance of plates, $C = 700$ micromicrofarads (measured)
- voltage ratio, $E_{min}/E_{max} = 0.9$ (chosen value).
- The spacing $d = 5.48 / (45\sqrt{2.4}) \cos^{-1} 0.9 = 2.04$ feet.

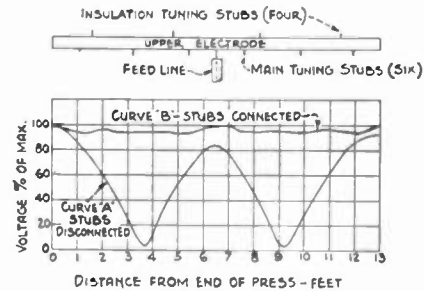

Fig. 19—Measured voltage distribution along press electrodes of Fig. 18 at 45 megacycles.

Actually six tuning elements were used with a spacing of 13/6 or 2.17 feet. The inductance value was obtained from (21) as

$$L = 6 / (4\pi^2 \times 45^2 \times 700) = 0.107 \text{ microhenries.}$$

Each inductor was made by bolting a 6-inch piece of 1/2-inch copper tubing to the upper and lower electrodes of the press and joining the ends by a movable strap to facilitate final tuning. With low power applied to the press, adjustment of the strap was made for maximum deflection in a thermogalvanometer loosely coupled to the inductor by a coil across its terminals. When the press is tuned to resonance its impedance is given by (22) as

$$Z_r = 10^6 / (6.28 \times 45 \times 700 \times 0.076) = 66 \text{ ohms (approximate).}$$

Curve B in Fig. 19 shows the voltage distribution with the tuning elements connected at the locations shown in the figure. It will be noted that tuning inductors were also connected from the upper electrode to the upper pressure member of the press to tune the insulation. With a power input of 28 kilowatts to the press, the temperature of the glue lines was raised to 260 degrees Fahrenheit in 2 minutes. The theoretical power requirements for no losses was calculated⁴ to be 18 kilowatts, indicating an efficiency of approximately 65 per cent. This low efficiency may be largely attributed to the losses in the insulating block.

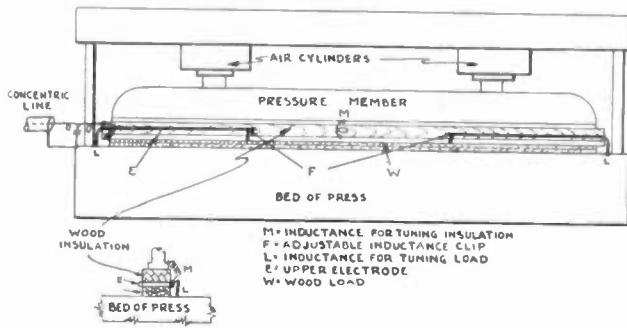

Fig. 20—Wood-gluing press adapted for radio-frequency heating at 10 megacycles.

This same press was later modified for the gluing of gusset joints in large plywood sheets. Because the large sheets had to be fed through the press, the tuning inductor arrangement of Fig. 19 was impracticable. The frequency was lowered to 10 megacycles so that only two tuning inductors would be required to give a sufficiently uniform voltage distribution. These inductors which had a value of about 0.6 microhenry were connected to the upper electrode at points three feet from the ends as shown in Fig. 20. As they were long enough to extend to the ends of the press where they were connected to the press bed, the passage of large sheets through the press was not obstructed. The voltage distribution on the press plates with and without the tuning inductors connected is shown in Fig. 21. This gluing

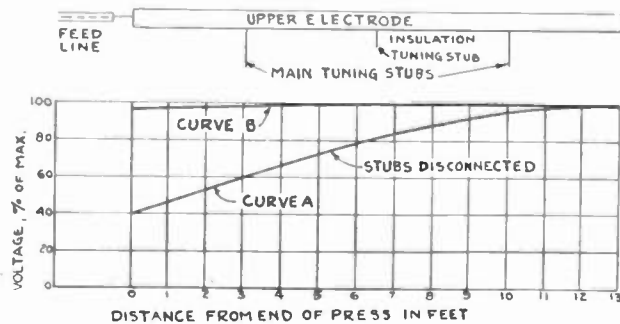

Fig. 21—Measured voltage distribution along press electrodes of Fig. 20 at 10 megacycles.

operation involved the heating of a glue line at the center of a volume of fir plywood 2½ inches wide, 0.5 inch thick, and 13 feet long to a temperature of 240 degrees Fahrenheit and was accomplished in 1.1 minutes with a power input to the press of 7½ kilowatts. The glue-line

temperature and power input to the oscillator during the gluing cycle are shown in Fig. 22.

VI. MEASUREMENT OF TEMPERATURE AT THE GLUE LINE

The glues that lend themselves most readily to a radiothermic application have a definite time-temperature relation which must be observed for reliable bonding. This makes temperature measurement at the glue line of importance during preliminary adjustments, so that a proper co-ordination between the applied power and gluing cycle may be established.

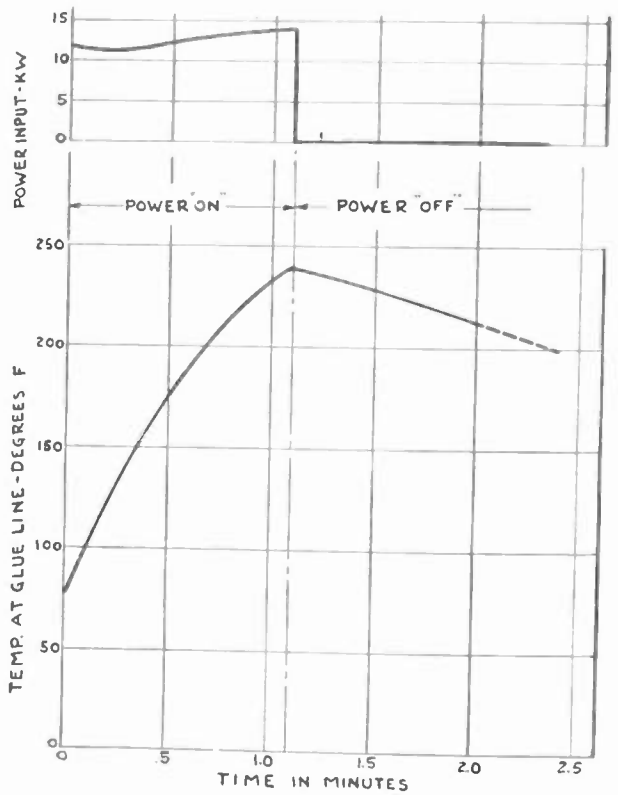

Fig. 22—Gluing cycle for ¼-inch plywood gusset joints.

The simplest means of doing this is to embed an iron-constantan couple in the glue line and permit the ends to extend slightly so that an instrument like the Leeds and Northrup temperature potentiometer may be quickly connected for a reading when the radio-frequency power is shut off. Such a plan is of small value if continuous temperature readings are desired, for with the instrument connected in this manner during the application of power, induced voltage may cause a spurious reading or may damage the potentiometer. One means of providing radio-frequency isolation of the thermocouple from the potentiometer is to wind a length of the paired wires into a choke coil of about 100 turns on a 7/8-inch diameter bakelite tube. This device permits continuous readings to be made on 10- to 15-megacycle gluing operations and was used to obtain the data of Fig. 22.

Another plan makes use of a well-known property of

concentric transmission lines by which a high impedance is developed across one end of a quarter-wave line when the other end is short-circuited. If the thermocouple leads are led through the inner conductor and by-passed to it at each end as shown in Fig. 23 the connections to the potentiometer will be at ground potential while the couple at the open end of the line may be operated at any potential. It is obvious that such a method can be used for any single frequency that is high enough to permit the use of a reasonable length of line.

VII. CONCLUSION

An examination has been made of the various factors involved in the rapid gluing of wood by means of radio-frequency power; namely, power concentration, frequency, voltage gradient, dielectric constant, and power factor.

Nonuniform heating in large presses due to standing waves on the electrodes may be eliminated by proper adjustment of inductive tuning stubs connected across

the load. The stubs may be used to tune the press to compensate for loads of varying characteristics.

An efficient means for coupling a large press to an oscillator has been developed and satisfactory glued joints may be made in a minute with catalyzed glue. A

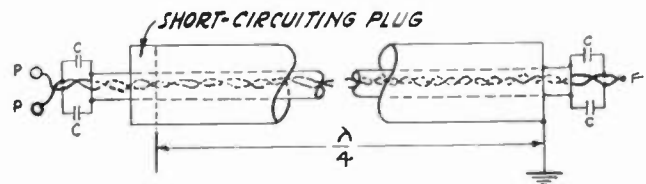

Fig. 23—Quarter-wave filter for thermocouple.

quarter-wave line or an electrically equivalent network is very helpful in reducing the effect of variations in the load on the oscillator during the gluing cycle.

It is hoped that this paper will help to emphasize the complementary advantages of radio-frequency heating and thermosetting glues for the rapid production of permanent wood bonds.

Heat-Conduction Problems in Presses Used for Gluing of Wood*

GEORGE H. BROWN†, FELLOW, I.R.E.

Summary—The application of heat-flow equations to the heat-flow problems in wood-gluing presses is considered. By means of a transmission-line analogy, the solution of heat-flow problems with internally generated heat is greatly simplified. The general equation is set up and applied specifically to the problem of radio-frequency heating of wood, while the wood is contained between two cool plates. Comparison of this type of heating with the usual hot-plate-press method reveals important advantages for the radio-frequency method.

The formulas developed have been illustrated by means of curves based upon the constants of wood. However, the general equations apply as well to the heating of any other insulating material, where the heating by radio frequency is done by essentially a dielectric-loss phenomena.

INTRODUCTION

HOT-PLATE presses are now used extensively in the wood-gluing industry in the manufacture of plywood, joining of sheets of plywood, the manufacture of spars from small straight-grained sections, and in the manufacture of propeller blanks. Recent work with cold-plate presses in which the wood sections are heated with radio-frequency power¹ has shown that this method has many advantages over the hot-plate methods.

It is the object of this paper to examine theoretically the heat-conduction problems encountered in both methods. In this way, the methods may be compared

* Decimal classification: R590×R536. Original manuscript received by the Institute, March 30, 1943.

† RCA Laboratories, Princeton, New Jersey.

¹ R. A. Bierwirth and C. N. Hoyer, "Radio-frequency heating applied to wood gluing," *Proc. I.R.E.*, this issue, pp. 529-537.

and also quantitative relations which are difficult to establish experimentally may be established.

THE DIFFERENTIAL EQUATION OF HEAT CONDUCTION²

In either method of gluing, the wood plates or strips are placed between two large pressure plates. Heat is then applied to the wood by conduction from the heated pressure plates or the heat is generated in the wood by means of radio-frequency power. In either case, the heat-flow problem is essentially that of a single dimension, normal to the faces of the pressure plates. That is, any plane through the wood parallel to the pressure plates is a plane of equal temperature.

Under this limiting condition, we shall now examine a small rectangular box of the material. (Fig. 1.) The box has a width a , height b , and a length dx . Heat may be generated in each cubic centimeter by electrical or chemical means. Let H be the rate at which heat is generated measured in gram calories per second per cubic centimeter. H is a function of both time and distance.

² Analytical studies of the flow of heat in solid bodies date back to 1812 when Fourier's memoir "Théorie du mouvement de la chaleur dans les corps solides" was presented to the French Academy. That the literature pertaining to heat flow is abundant is illustrated by calling attention to the references, seven hundred and eighty-nine in number, listed by William H. McAdams, pp. 419-448, "Heat Transmission," second edition, 1942, McGraw-Hill Book Company, New York, N. Y. It was the thought in preparing this section and the one following that it might be well to include the essential derivations so that the interested reader to whom the field is new could follow the reasoning without excursions to reference books which at times may not be readily available.

Then the heat generated within the small box in a short interval of time dt is

$$Q_0 = Hab \cdot dx \cdot dt. \tag{1}$$

The temperature at point 0 is u degrees centigrade. Then the increase in heat stored in the box during the time dt is

$$Q_1 = c\rho(du/dt)d \cdot ab \cdot dx \tag{2}$$

where c = density (grams per cubic centimeter)

ρ = specific heat (calories per gram per degree centigrade).

The temperature gradient at point 0 is $(du/dx)_0$. The gradient at point B is

$$(du/dx)_B = (du/dx)_0 + [d/dx(du/dx)]_{x_0} dx/2$$

and the gradient at point A is

$$(du/dx)_A = (du/dx)_0 - [d/dx(du/dx)]_{x_0} dx/2.$$

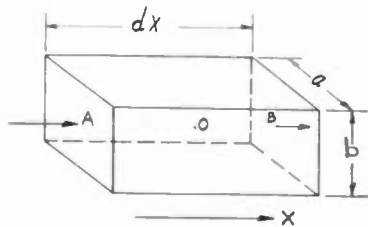

Fig. 1—Elementary box.

The heat flowing out through the face of the box at A in time dt is

$$Q_2 = k(du/dx)_A ab \cdot dt \tag{3}$$

where

$$k = \text{thermal conductivity} \left(\frac{\text{calories per square centimeter per second}}{\text{degrees centigrade per centimeter}} \right).$$

The heat flowing out through the face at B is

$$Q_3 = -k(du/dx)_B ab \cdot dt. \tag{4}$$

From the conservation of energy,

$$Q_0 = Q_1 + Q_2 + Q_3. \tag{5}$$

Thus

$$Hab \cdot dx \cdot dt = c\rho(du/dt) \cdot ab \cdot dx \cdot dt + kab \cdot dt [(du/dx)_0 - \{d/dx(du/dx)\}_{x_0} dx/2] - kab \cdot dt [(du/dx)_0 + \{d/dx(du/dx)\}_{x_0} dx/2] \tag{6}$$

or²

$$H = c\rho(du/dt) - k(d/dx)(du/dx). \tag{7}$$

THE CASE OF HOT-PLATE PRESSES

In the case of ordinary hot-plate presses, no heat is generated within the wood. Then (7) becomes

$$c\rho(du/dt) = k(d^2u/dx^2). \tag{8}$$

This equation is often written as

$$du/dt = \alpha^2(d^2u/dx^2) \tag{9}$$

where $\alpha^2 = k/c\rho$ is called the "thermal diffusivity." This

² Equation (7), which takes into account heat generated within the material, is given as equation (7.45), p. 232, Margenau and Murphy, "The Mathematics of Physics and Chemistry," D. Van Nostrand Company, Inc., New York, N. Y., 1943. However, further discussion of the solution of the equation by these authors is confined to the case where no time variation exists or to the case where no heat is generated within the material.

equation may be solved by the standard method of products. The temperature u is a function of both x and t . We assume that u may be expressed as a product of two functions X and T , where X is a function of x alone and T is a function of t alone.

$$u = X(x) \cdot T(t). \tag{10}$$

Substituting (10) in (9)

$$X \cdot (dT/dt) = \alpha^2 T (d^2X/dx^2) \tag{11}$$

or

$$\frac{dT/dt}{\alpha^2 T} = \frac{d^2X/dx^2}{X} \tag{12}$$

Since T is a function of t alone and X is a function of x alone, and since x and t are entirely independent vari-

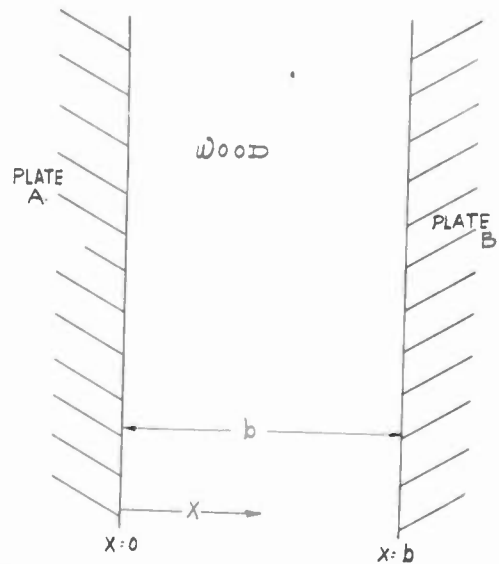

Fig. 2—Layer of wood between metal press plates.

ables, the relation of (12) may be satisfied only if each side of (12) is equal to a constant. Then

$$\frac{dT/dt}{\alpha^2 T} = \frac{d^2X/dx^2}{X} = -m^2 \tag{13}$$

where m is an unknown and arbitrary constant. Then $X = A \cos mx + B \sin mx$ and $T = C e^{-\alpha^2 m^2 t}$ satisfy (12), so that

$$u = e^{-\alpha^2 m^2 t} [M \cos mx + N \sin mx] \tag{14}$$

where m , M , and N must be determined by the boundary conditions.

At a time $t=0$, the piece of wood (or a stack of wood strips) of total thickness b is placed between the two metal plates A and B shown in Fig. 2. These plates are steam or electrically heated and have a great enough thermal capacity that the plate temperature stays essentially constant.

Let β = temperature of plate A .

γ = temperature of plate B .

At the time that the wood is placed between the plates, the temperature distribution through the wood is $f(x)$, a known function. Therefore, the solution (14) must satisfy the following boundary conditions.

When $x=0, u=\beta$ for all values of t
 $x=b, u=\gamma$ for all values of t
 $t=0, u=f(x)$.

Then (14) becomes⁴

$$u = \beta + (\gamma - \beta) \left[\frac{x}{b} + \frac{2}{\pi} \sum_{n=1}^{\infty} \left\{ \frac{(-1)^n}{n} \epsilon^{-(n^2 \pi^2 a^2 t)/b^2} \sin \left(\frac{n\pi x}{b} \right) \right\} \right] + \frac{2}{b} \sum_{n=1}^{\infty} \left\{ \epsilon^{-(n^2 \pi^2 a^2 t)/b^2} \sin \left(\frac{n\pi x}{b} \right) \int_{\lambda=0}^{\lambda=b} [f(\lambda) - \beta] \sin \left(\frac{n\pi \lambda}{b} \right) d\lambda \right\}. \tag{15}$$

(a) Two Equal-Temperature Hot Plates

The most common hot-plate press has two equal-temperature plates. Then $\gamma=\beta$. Since the behavior of temperature depends on differences of temperature rather than absolute temperature, we shall assume that the wood is a constant temperature throughout at time $t=0$, so that $f(x)=f(\lambda)=a$ constant = zero. Also we will set the plate temperature at unity, so $\gamma=\beta=1$. Then (15) reduces to

$$u = 1 + \frac{2}{b} \sum_{n=1}^{\infty} \left\{ \epsilon^{-(n^2 \pi^2 a^2 t)/b^2} \sin \left(\frac{n\pi x}{b} \right) \int_{\lambda=0}^{\lambda=b} (-1) \sin \left(\frac{n\pi \lambda}{b} \right) d\lambda \right\} = 1 - \frac{4}{\pi} \sum_{n=0}^{\infty} \frac{\epsilon^{-((2n+1)^2 \pi^2 a^2 t)/b^2}}{(2n+1)} \sin \left(\frac{[2n+1]\pi x}{b} \right) = 1 - \frac{4}{\pi} \left[\epsilon^{-(\pi^2 a^2 t)/b^2} \sin \left(\frac{\pi x}{b} \right) + \frac{\epsilon^{-(9\pi^2 a^2 t)/b^2} \sin (3\pi x/b)}{3} + \frac{\epsilon^{-(25\pi^2 a^2 t)/b^2} \sin (5\pi x/b)}{5} + \dots \right]. \tag{16}$$

Average values for the constants of wood are

- ρ = specific heat = 0.65 calorie per gram per degree centigrade
- c = density = 0.53 gram per cubic centimeter
- k = 0.00036 calorie per square centimeter per second for 1 degree centigrade per centimeter temperature gradient
- $\alpha^2 = k/c\rho = 0.00104$.

Then (16) becomes

$$u = 1 - \frac{4}{\pi} \left[\epsilon^{-(0.01025t)/b^2} \sin \left(\frac{\pi x}{b} \right) + \frac{\epsilon^{-(0.09231t)/b^2} \sin (3\pi x/b)}{3} + \frac{\epsilon^{-(0.2562t)/b^2} \sin (5\pi x/b)}{5} + \dots \right]. \tag{17}$$

In (17), t is expressed in seconds and b is in centimeters, while u is in degrees centigrade. Fig. 3 shows temperature of the wood at a number of points through the wood as a function of time. The abscissa scale is given on the basis of a number of wood thicknesses. This is possible since it is seen from (17) that the time required to reach a certain value of u is proportional to the square of the thickness b .

Fig. 4 shows temperature distribution through the wood for a number of time intervals.

While Fig. 3 is very general and contains all the neces-

sary information for a study of the problem, it seems desirable to use it more specifically. The ordinates of Fig. 3 represent wood temperature where the plate temperature is 1 degree centigrade and where the initial

wood temperature is 0 degree centigrade. These ordinates also may be regarded as a fraction of the temperature interval between the initial wood temperature and the plate temperature. Then, in any general case,

$$u_w = (u_p - u_0)u + u_0 \tag{18}$$

where u_p = plate temperature

u_0 = initial wood temperature

u = specific wood temperature from Figs. 3 and 4

u_w = wood temperature as a function of time.

It is apparent that as long as u is the fraction taken from Figs. 3 and 4, all other temperatures in (18) may be expressed in the centigrade or the Fahrenheit scale.

Fig. 5 shows the temperature at the center of the wood for a number of plate temperatures, where the initial wood temperature was 80 degrees Fahrenheit. The broken line marks 240 degrees Fahrenheit as the necessary wood temperature for catalyzed gluing.¹ The highest plate temperature used was 400 degrees Fahren-

heit since it has been experimentally determined that this is the scorch temperature of the ordinary woods used in the glue industry.

Fig. 6 was constructed from Fig. 5 and shows the plate temperature required to raise the wood from 80 to 240 degrees Fahrenheit in a time interval shown by the abscissa.

Fig. 7 shows Fig. 4 converted on the basis where the plate temperature was chosen to bring center of the wood to 240 degrees Fahrenheit in the time interval shown. The top curve is, of course, an absurd case since the plate temperature of 1145 degrees Fahrenheit would set the wood on fire immediately. It is included,

⁴ W. E. Byerly, "Fourier's Series and Spherical, Cylindrical, and Ellipsoidal Harmonics," Ginn and Co., New York, N. Y., 1893, page 108, example 1.

however, to illustrate the extreme temperature distribution encountered in hot-plate gluing.

The heat energy supplied to a box of the wood which is 1 square centimeter in cross section and b centimeters

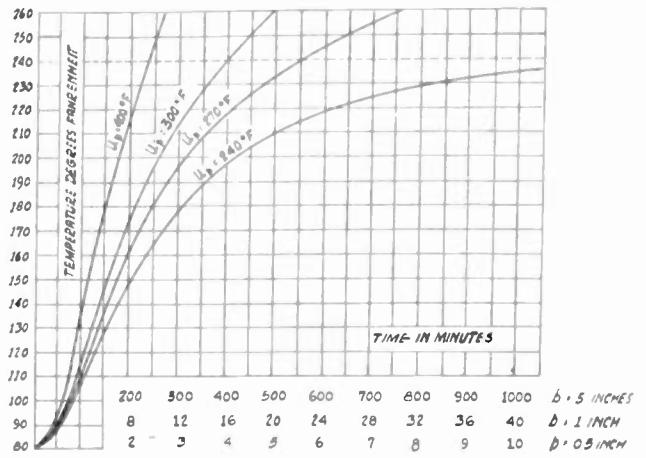
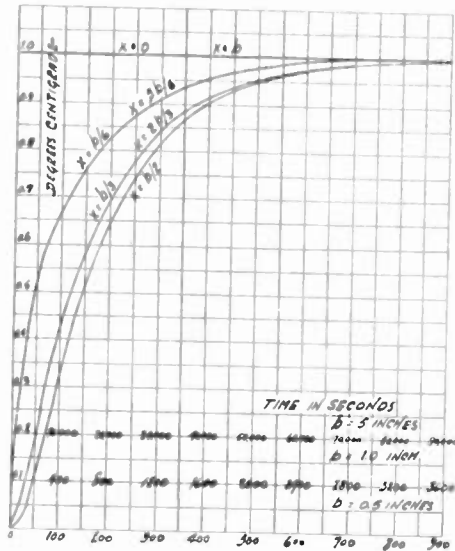

Fig. 3—Specific wood temperature as a function of time, at various points in the wood, when two equal-temperature hot plates are used.

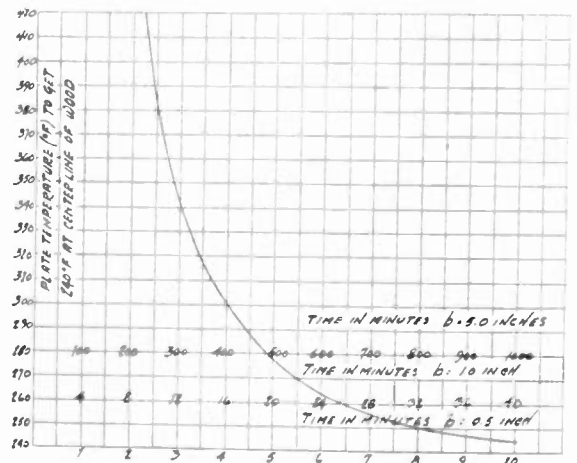
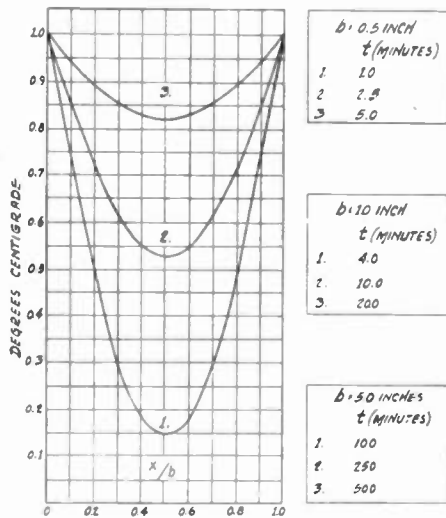

Fig. 6—Plate temperature required to raise the wood center line to 240 degrees Fahrenheit in the time interval shown by the abscissa. Initial wood temperature was 80 degrees Fahrenheit.

thick, in the time interval between time of application of the plates and any time t is

$$\text{calories} = c\rho \int_{x=0}^{x=b} u(x)dx \quad (19)$$

Substituting (16) in (19),

$$\text{calories} = c\rho b \left[1 - \frac{8}{\pi^2} \left\{ \frac{\epsilon^{-(\pi^2 a^2 t)/b^2}}{25} + \frac{\epsilon^{-(9\pi^2 a^2 t)/b^2}}{49} + \frac{\epsilon^{-(25\pi^2 a^2 t)/b^2}}{125} + \dots \right\} \right] \quad (20)$$

or watt-seconds per square centimeter of surface

$$= 4.187(u_p - u_0)c\rho b \left[1 - \frac{8}{\pi^2} \left\{ \frac{\epsilon^{-(\pi^2 a^2 t)/b^2}}{25} + \frac{\epsilon^{-(9\pi^2 a^2 t)/b^2}}{49} + \frac{\epsilon^{-(25\pi^2 a^2 t)/b^2}}{125} + \dots \right\} \right] \quad (21)$$

(u_p and u_0 in degrees centigrade).

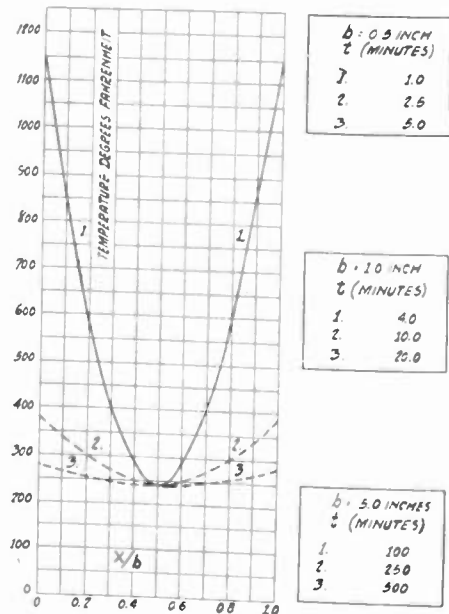

Fig. 7—This diagram, constructed from Fig. 4 and equation (18), shows temperature distribution through the wood for a number of plate temperatures chosen to bring the center line to 240 degrees Fahrenheit in the time interval chosen.

Using (21) and the times and plate temperatures of Fig. 6, Fig. 8 was prepared.

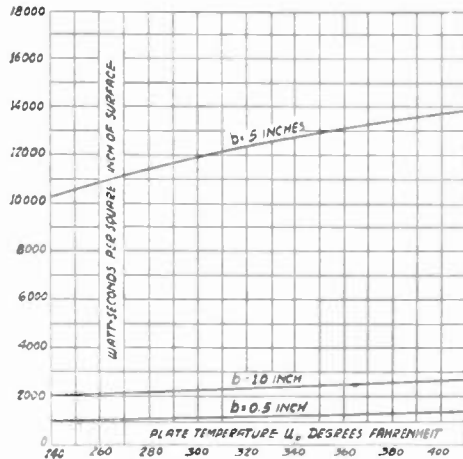

Fig. 8—Energy absorbed by wood versus plate temperature. The time is that required to raise the center line of the wood to 240 degrees Fahrenheit.

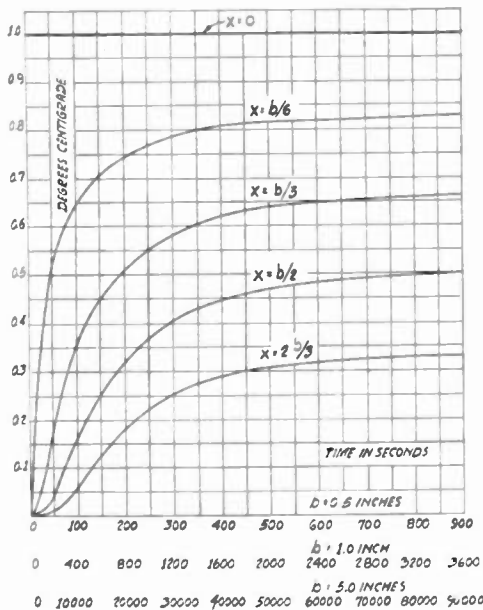

Fig. 9—Specific wood temperature as a function of time, when press uses one hot plate and one cold plate.

(b) One Hot Plate and One Cold Plate

A number of hot-plate presses use only one hot plate, with the other plate, which is generally the press bed, remaining at room temperature. At the time that the wood is placed in the press, it is also at room temperature. In Fig. 2, plate A is then at 1 degree centigrade, while plate B is at zero degrees centigrade. In (15), $\beta = 1$, $\gamma = 0$, and $f(\lambda) = 0$. Then (15) becomes

$$u = 1 - (x/b) - (2/\pi) \left[\epsilon^{-(\pi^2 a^2 t)/b^2} \sin(\pi x/b) + (\epsilon^{-(4\pi^2 a^2 t)/b^2})/2 \sin(2\pi x/b) + (\epsilon^{-(9\pi^2 a^2 t)/b^2})/3 \sin(3\pi x/b) + (\epsilon^{-(16\pi^2 a^2 t)/b^2})/4 \sin(4\pi x/b) + \dots \right]. \quad (22)$$

Fig. 9 shows the temperature as a function of time for a number of points in the wood, while Fig. 10 shows temperature distribution through the wood.

If the temperature of the wood at starting point is 80 degrees Fahrenheit, and plate B is at 80 degrees Fahrenheit, Figs. 11 and 12 apply for plate A at a temperature of 400 degrees Fahrenheit. These figures were constructed from Figs. 9 and 10 by applying (18).

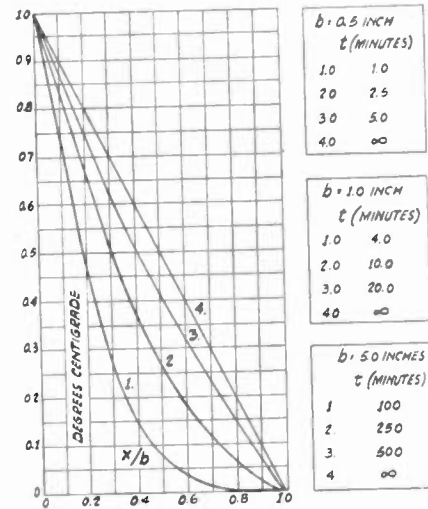

Fig. 10—Specific wood temperature distribution through the wood, with one hot and one cold plate.

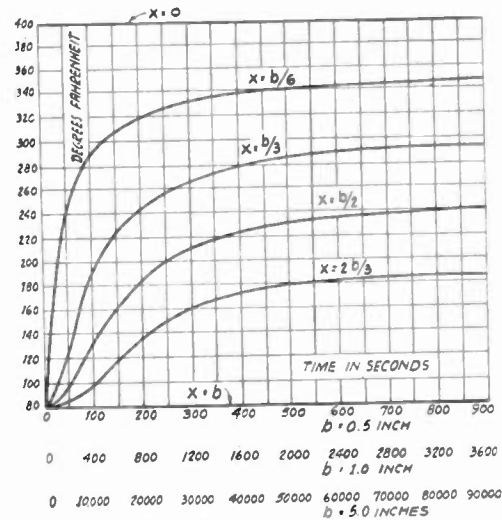

Fig. 11—Temperature of wood versus time. Hot plate at 400 degrees Fahrenheit. Cold plate at 80 degrees Fahrenheit. Initial wood temperature 80 degrees Fahrenheit.

In this case, the heat energy supplied by the hot plate cannot be reckoned from (19) because some heat is lost into the cold plate B. However, another method is just as simple:

$$\text{calories supplied} = \int_{t=0}^{t=1} [-k(du/dx)]_{x=0} dt. \quad (23)$$

Substituting (22) in (23), we find
 watt-seconds per square centimeter

$$= 4.187(u_p - u_0)b \left[(kl/b^2) + (2cp/\pi^2) \left\{ (1 - \epsilon^{-(\pi^2 a^2 t)/b^2}) + (1 - \epsilon^{-(2^2 \pi^2 a^2 t)/b^2})/2^2 + (1 - \epsilon^{-(2^2 \pi^2 a^2 t)/b^2})/3^2 + \dots \right\} \right]. \quad (24)$$

Since

$$2/\pi^2 \{ 1 + 1/2^2 + 1/3^2 + \dots \} = 2/\pi^2 \cdot \pi^2/6 = 1/3$$

equation (24) becomes

watt-seconds per square centimeter

$$= 4.187(u_p - u_0)b \left[kt/b^2 + c\rho/3 - 2c\rho/\pi^2 \left\{ \epsilon^{-(\pi^2 a^2 t)/b^2} + (\epsilon^{-(2^2 \pi^2 a^2 t)/b^2})/2 + (\epsilon^{-(3^2 \pi^2 a^2 t)/b^2})/3^2 + \dots \right\} \right]. \quad (25)$$

Fig. 13 was constructed from (25). The solid curve shows the total energy (joules or watt-seconds) supplied by the hot plate from starting time. The broken curve

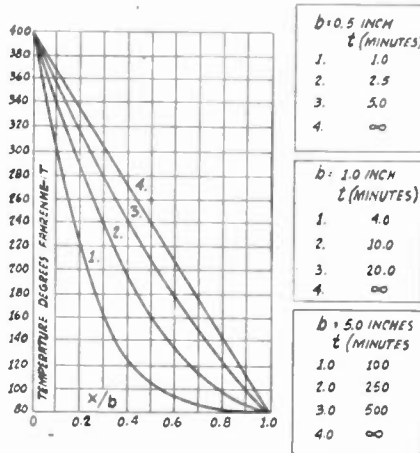

Fig. 12—Temperature of wood versus distance into the wood. Hot plate at 400 degrees Fahrenheit. Cold plate at 80 degrees Fahrenheit. Initial wood temperature 80 degrees Fahrenheit.

A is the temperature at the center of the wood. Curve B is the temperature in the wood if the same energy were released uniformly in the wood with no loss.

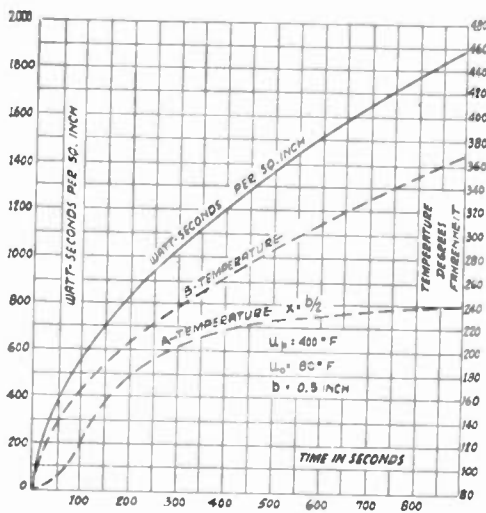

Fig. 13—Upper solid curve shows total energy supplied by the hot plate from starting time. Curve A shows temperature at the center of the wood, while curve B is the temperature of the wood if the same energy were released uniformly in the wood with no loss.

SOLUTION OF HEAT-FLOW EQUATIONS WHEN HEAT IS GENERATED WITHIN THE WOOD

It is well to restate that we are only considering heat flow in one dimension. Then, with energy generated within the wood, (7) holds. As stated previously, II may be a function of distance and time. The solution of (7) will be made by showing the direct analogy between

the heat-flow problem and a particular transmission-line problem.

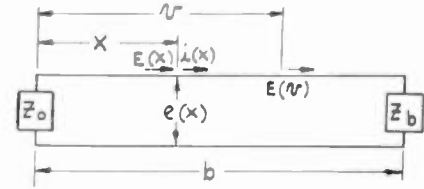

Fig. 14—Transmission line used in the heat-flow analogy.

In Fig. 14, we have a transmission line of length b . The uniformly distributed constants of the line are

- R = series resistance per unit length (ohms per centimeter)
- L = series inductance per unit length (henries per centimeter)
- G = shunt conductance per unit length (mhos per centimeter)
- C = shunt capacitance per unit length (farads per centimeter)

At one end, $x = 0$, the line is terminated in an impedance Z_0 while at $x = b$ the line is terminated in an impedance Z_b . In series with the line, we have an induced voltage set up by an external force. This voltage may be set up by an impinging electromagnetic field or by inserting a battery or generator in series with the line. This voltage intensity is $E(v)$ measured in volts per centimeter. We wish to find the current and voltage along the line at a point x units from the impedance Z_0 at any instant of time, under the condition that $E(v)$ is induced all along the line. $E(v)$ may be a function of both time and distance.

Let e = the voltage across the line x units from Z_0
 i = the current in the line x units from Z_0 .

Then $de/dx = -Ri - L(di/dt) + E(x)$ (26)

and $di/dx = -Ge - C(de/dt)$ (27)

or, making use of the differential operator p ,

$$de/dx = -(R + pL)i + E(x) \quad (28)$$

and $di/dx = -(G + pC)e$. (29)

From (29) $e = [(-1)/(G + pC)](di/dx)$ (30)

and $de/dx = [(-1)/(G + pC)](d^2i/dx^2)$. (31)

Substituting (31) in (28),

$$E(x) = (R + pL)i - (1/G + pC)(d^2i/dx^2) \quad (32)$$

The solution for the current i at a point x is

$$i(x) = \left\{ [Z_c^2 + Z_b Z_0] \int_{v=x}^{v=b} E(v) \cosh \gamma(b+x-v) dv \right. \\
+ [Z_c^2 - Z_b Z_0] \int_{v=0}^{v=x} E(v) \cosh \gamma(b-x-v) dv \\
+ [Z_c^2 + Z_b Z_0] \int_{v=0}^{v=x} E(v) \cosh \gamma(b-x+v) dv \\
\left. + [Z_c Z_b + Z_c Z_0] \int_{v=x}^{v=b} E(v) \sinh \gamma(b+x-v) dv \right.$$

$$\begin{aligned}
 &+ [Z_c Z_b - Z_c Z_0] \int_{v=0}^{v=b} E(v) \sinh \gamma(b-x-v) dv \\
 &+ [Z_c Z_b - Z_c Z_0] \int_{v=0}^{v=x} E(v) \sinh \gamma(b-x+v) dv \\
 &\div \{ 2Z_c \sinh(\gamma b) [Z_c^2 - Z_0 Z_b + (Z_0 + Z_b) Z_c \coth(\gamma b)] \} \quad (33)
 \end{aligned}$$

where $Z_c = \sqrt{(R + pL)/(G + pC)}$ (34)

and $\gamma^2 = (R + pL)(G + pC)$. (35)

We next propose that the resistance per unit length R and the shunt capacitance per unit length C be made zero. Then the transmission line has only the constants of series inductance L and shunt leakage G . Under this condition, (32) becomes

$$E(x) = pLi - (1/G)(d^2i/dx^2) = L(di/dt) - (1/G)(d^2i/dx^2) \quad (36)$$

and (30) is
$$e = - (1/G)(di/dx). \quad (37)$$

Comparing (36) with (7), we see that if $i(x)$ is analogous to the temperature u

$$L = c\rho \quad (38)$$

$$1/G = k \quad (39)$$

In the case of the wood-gluing press, where the heat is generated by means of radio frequency, we shall assume that the plates remain at zero temperature. Then $i_{x=0} = 0$ at all times, and $i_{x=b} = 0$ at all times. This is accomplished by open-circuiting the line at both ends, that is, $Z_b = Z_0 = \infty$. Also, we shall assume that the heat is generated uniformly throughout the wood, so that $II = E(x)$ is a constant. Under all these conditions, (33) becomes

$$\begin{aligned}
 i(x) = u(x) = \frac{E}{2Z_c \sinh(\gamma b)} &\left\{ \int_{v=x}^{v=b} \cosh \gamma(b+x-v) dv \right. \\
 &- \int_{v=0}^{v=b} \cosh \gamma(b-x-v) dv \\
 &\left. + \int_{v=0}^{v=x} \cosh \gamma(b-x+v) dv \right\} \quad (44)
 \end{aligned}$$

$$\text{or } u(x) = \frac{E}{\gamma Z_c} \left[\frac{\sinh(\gamma b) - \sinh(\gamma x) - \sinh \gamma(b-x)}{\sinh(\gamma b)} \right]. \quad (45)$$

Substituting (42) and (43) in (45),

$$u(x) = \frac{E}{pL} \left[\frac{\sinh(\sqrt{pLG} b) - \sinh(\sqrt{pLG} x) - \sinh(\sqrt{pLG} [b-x])}{\sinh(\sqrt{pLG} b)} \right]. \quad (46)$$

The operational solution of (46) is [see Appendix I, equation (75)]

$$u(x) = \frac{4EGb^2}{\pi^3} \sum_{s=1}^{\infty} \frac{\sin[(2s-1)(\pi x/b)]}{(2s-1)^3} [1 - e^{-((2s-1)^2 \pi^2 t)/b^2 LG}]. \quad (47)$$

Substituting (38) and (39) in (47)

$$\begin{aligned}
 u(x) &= \frac{4Ib^2}{\pi^3 k} \sum_{s=1}^{\infty} \frac{\sin[(2s-1)(\pi x/b)]}{(2s-1)^3} [1 - e^{-((2s-1)^2 \pi^2 \alpha^2 t)/b^2}] \\
 &= \frac{4Ib^2}{\pi^3 k} \left[(1 - e^{-(\pi^2 \alpha^2 t)/b^2}) \sin\left(\frac{\pi x}{b}\right) + \frac{(1 - e^{-(9\pi^2 \alpha^2 t)/b^2})}{3^3} \sin\left(\frac{3\pi x}{b}\right) \right. \\
 &\quad \left. + \frac{(1 - e^{-(25\pi^2 \alpha^2 t)/b^2})}{5^3} \sin\left(\frac{5\pi x}{b}\right) + \dots \right]. \quad (48)
 \end{aligned}$$

$$E(x) = II \text{ (gram calories per second per cubic centimeter)} \quad (40)$$

and from (37)

$$e = - (1/G)(di/dx) = - k(du/dx) \quad (41)$$

so that the voltage on the line is analogous to the heat flow across a surface (proportional to temperature gradient).⁵

Also $Z_c = \sqrt{pL/G} = \sqrt{p\rho k}$ (42)

and $\gamma^2 = pLG = p\rho/k = p/\alpha^2$. (43)

⁵ In his book, "Heaviside's Operational Calculus," E. J. Berg points out in chapter XXVII the analogy between the heat-flow equations and the equations of a transmission line. He chooses to set temperature equal to voltage, and thus uses a transmission line which is made up of series resistance and shunt capacitance. This method is very useful for solving the ordinary heat-flow problems where hot plates are applied to a boundary, for then the constant temperature of the boundary is represented by a constant voltage at this point. In the case of internally generated heat, it seems more reasonable to use current in relation to temperature, with a transmission line made up of series inductance and shunt leakage. In this way, one avoids the notion of constant current admitted to the line at a number of points in the line. It is evident that problems may be worked by either choice. After rather careful consideration, the writer decided on the temperature-current identity because of the nature of the problems to be considered.

This equation reveals a number of interesting facts concerning radio-frequency heating, a few of which we shall now examine. In the following calculations we will use $\alpha^2 = k/c\rho = 0.00104$, the same value as used in the hot-press calculations.

Figs. 15 and 16 were constructed from (48) to show the temperature distribution through the wood for a number of heating times. The temperature scale is purely relative.

We are generally interested in the temperature at the center of the wood. Under this condition, $x = b/2$ and (48) becomes

$$\begin{aligned}
 u\left(x = \frac{b}{2}\right) &= \frac{4Ib^2}{\pi^3 k} \left[\left(1 - e^{-(\pi^2 \alpha^2 t)/b^2} - \frac{(1 - e^{-(9\pi^2 \alpha^2 t)/b^2})}{3^3} \right. \right. \\
 &\quad \left. \left. + \frac{(1 - e^{-(25\pi^2 \alpha^2 t)/b^2})}{5^3} \dots \right) \right]. \quad (49)
 \end{aligned}$$

Fig. 17 shows the temperature rise at the center of the wood as a function of time for a wood thickness of 0.5 inch for a number of rates of energy generation.

(Watts = 4.187 X gram calories per second.⁶) Here it is assumed that the initial wood temperature is 80 degrees Fahrenheit and that the plates remain at 80 degrees Fahrenheit.

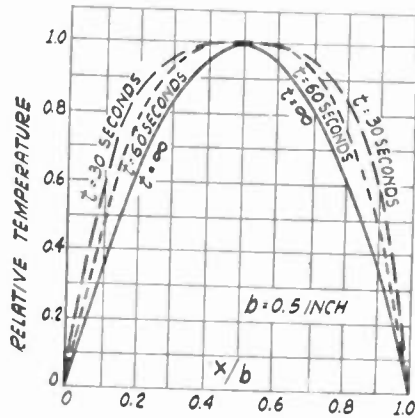

Fig. 15—Specific wood temperature distribution through the wood. Thickness of wood is one-half inch.

In Fig. 17, we see that for low power concentrations the wood temperature does not approach the necessary glue-setting temperature of 240 degrees Fahrenheit. It is interesting to examine (49) to establish the limits of temperature. As $t \rightarrow \infty$

$$u\left(x = \frac{b}{2}, t \rightarrow \infty\right) = \frac{4Ib^2}{\pi^3 k} \left[1 - \frac{1}{3^3} + \frac{1}{5^3} - \frac{1}{7^3} + \dots \right] = \frac{4Ib^2}{\pi^3 k} \left[\frac{\pi^3}{32} \right] = \frac{Ib^2}{8k} \quad (50)$$

This formula gives us Fig. 18, which shows the mini-

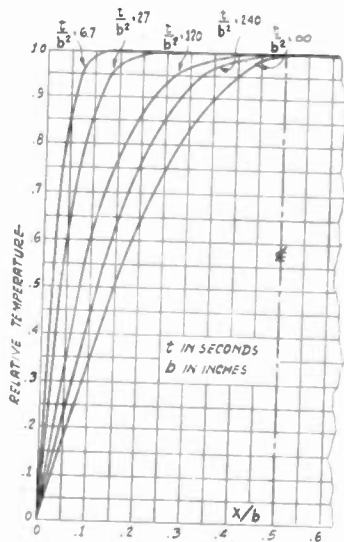

Fig. 16— Specific temperature distribution curves generalized with respect to time and wood thickness.

imum power concentration necessary to achieve a temperature increase of 160 degrees Fahrenheit at the center of the wood.

Now, if there were no loss of heat at the pressure plates, the temperature increment would be

⁶ 4.187 watts = 1 gram calorie per second.

$$u_{\text{NO LOSS}} = It/c\rho \quad (51)$$

So, from (49) and (51), the ratio of the temperature increments with plate losses and with no losses for equal power densities is $(k/c\rho = \alpha^2)$

$$\frac{\Delta u_{\text{LOSS}}}{\Delta u_{\text{NO LOSS}}} = \frac{4b^2}{\pi^3 \alpha^2 t} \left[\frac{1 - \epsilon^{-(\pi^2 \alpha^2 t)/b^2}}{3^3} - \frac{1 - \epsilon^{-(3^2 \pi^2 \alpha^2 t)/b^2}}{5^3} + \frac{1 - \epsilon^{-(5^2 \pi^2 \alpha^2 t)/b^2}}{7^3} + \dots \right] \quad (52)$$

and $\left(\frac{\Delta u_{\text{LOSS}}}{\Delta u_{\text{NO LOSS}}} \right)_{t \rightarrow \infty} = \frac{b^2}{8\alpha^2 t} \quad (53)$

Likewise, the power densities required to raise the wood through the same temperature increment in a given time is

$$I_{\text{LOSS}}/I_{\text{NO LOSS}} = 1/\text{equation (52)}. \quad (54)$$

Fig. 19 shows the ratio of temperatures for equal power densities, and the ratio power densities required

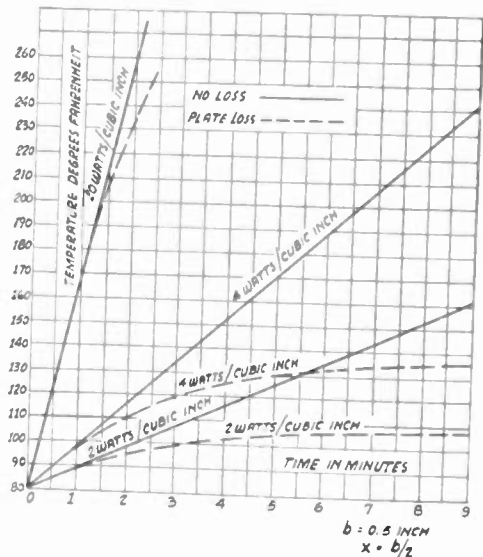

Fig. 17—Temperature rise at center of wood for a number of rates of energy generation.

to raise the wood through the same temperature increment in a given time. Note that the time scales vary as the square of the wood thickness.

Fig. 19 shows that economy in energy is attained by using short heating times. Fig. 20 shows the time allowable for heating various wood thicknesses where the power (and energy) does not exceed that used with no plate losses by more than 10 per cent.

Fig. 21 shows the time taken to achieve a given temperature increment as a function of the power density when no heat is lost in the press plates. Figs. 21 and 19 may be used for estimating purposes in planning a gluing installation.

By way of example, Bierwirth and Hoyler¹ found that 28 kilowatts applied to a press raised the temperature of a set of spruce boards to at least 260 degrees Fahrenheit in two minutes. The boards were each 13 feet long, 6 inches wide, and 5/16 inch thick. Three boards were stacked, making a total volume of $13 \times 12 \times 6 \times 15/16 = 878$ cubic inches, and $b = 15/16$ inch.

Assuming a starting temperature of 80 degrees Fahrenheit, we need an increment of 180 degrees Fahrenheit. From Fig. 21, for this increment and a time of two minutes, the power must be 20 watts per cubic inch with no losses. We next turn to Fig. 19. Two minutes with $b = 15/16$ inch corresponds to $2/(15/16)^2 = 2.275$

loss might be eliminated by using a low-loss insulator in place of the plank.

Another application was that of gluing plywood gusset joints, in which the total thickness was $b = 0.5$ inch

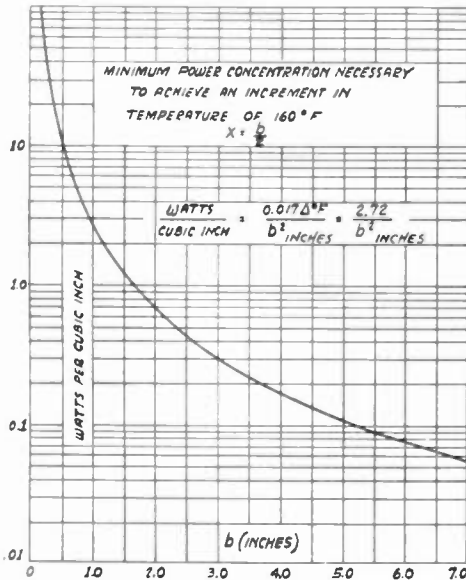

Fig. 18—Minimum power concentration necessary to achieve a temperature increment of 160 degrees Fahrenheit.

minutes on the $b = 1.0$ inch scale. Then the power ratio is 1.02, and the power density required is $1.02 \times 20 = 20.4$ watts per cubic inch or $20.4 \times 878 = 17,900$ watts is the total power requirement. Comparing this figure with the

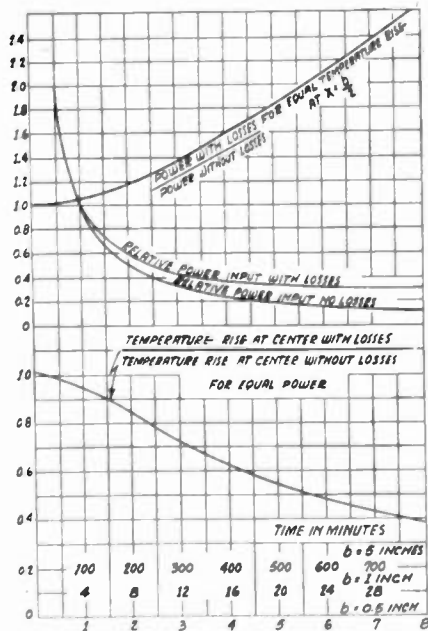

Fig. 19—Power ratio and temperature-increment ratio curves versus time.

28,000 watts fed into the press and coupling system, the efficiency is 64.0 per cent. This low efficiency is not astonishing, since an insulating wood plank two inches thick is in parallel with the sections being glued. This

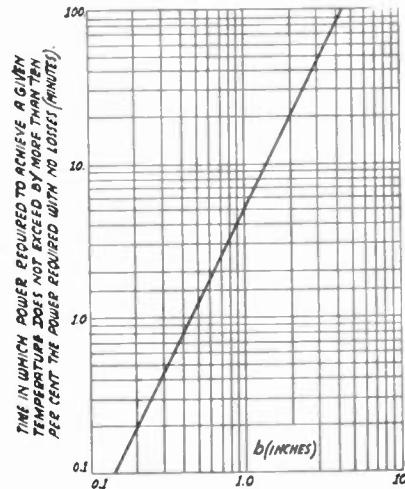

Fig. 20—Time allowable for heating when the power does not exceed by more than 10 per cent that required with no heat losses.

with a width of 2.5 inches and a length of 13 feet. The total volume was then 195 cubic inches. For a gluing time of 1.1 minutes and a temperature rise of 160 degrees Fahrenheit, Fig. 21 shows a power of 32 watts per cubic inch with no heat loss. Fig. 19 shows a correction factor of 1.07 so that the total power requirements are

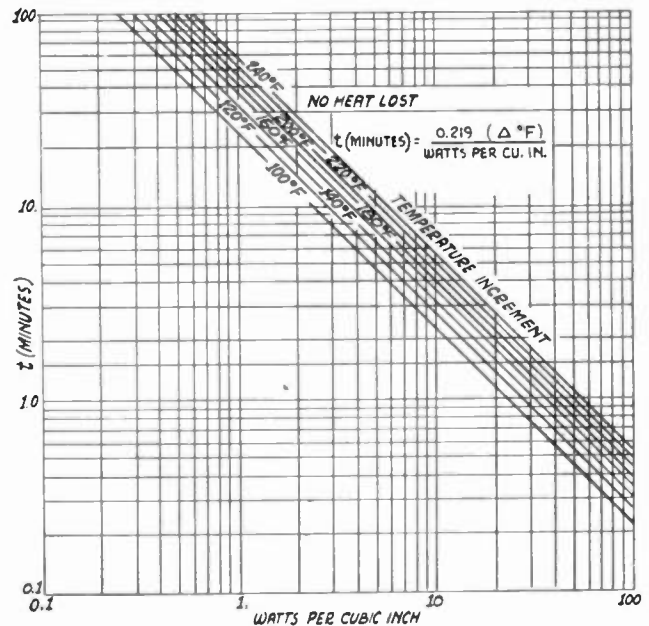

Fig. 21—Time required to achieve a given temperature increment versus power density. No heat is lost in the press plates.

$1.07 \times 32 \times 195 = 6670$ watts. Bierwirth and Hoyler report that the total input to the press was 7500 watts.

Another application of interest is that of a blank 6 feet long, 20 inches wide, and 6 inches thick, representing a total volume of 8650 cubic inches, with $b = 6$ inches. Suppose that we have a power into the press of 50,000 watts and a press efficiency of 75 per cent. Then the power

density is 4.33 watts per cubic inch. From Fig. 21, this corresponds to 8.2 minutes for a temperature rise of 160 degrees Fahrenheit with no heat loss. Turning to Fig. 19, and noting that $b=6$ inches and $t=8.2$ minutes corresponds to $8.2/6^2=0.228$ minutes on the $b=1.0$ inch scale, we find the loss factor to be unity, so we might expect the 50,000-watt oscillator to do the job in 8.2 minutes.

Table I summarizes the above results, and by re-

TABLE I

	Radio-Frequency Method			Hot-Plate Method		Hot-Plate Time R-F Time	Hot-Plate Energy R-F Energy
	Power into Wood (Watts)	Gluing Time (Min.)	Energy (Watt-min.)	Gluing Time (Min.)	Energy (Watt-min.)		
Gusset Joints 13' X 2.5' X 0.5" ($b=0.5'$)	6,670	1.1	7,350	2.375	8,520	2.155	1.16
Spar 13' X 6' X 15/16" ($b=15/16'$)	17,900	2.0	35,800	8.32	40,700	4.16	1.138
Blank 6' X 20' X 6" ($b=6'$)	37,500	8.2	307,500	342.	409,000	41.7	1.33

ferring to Fig. 6, compares the radio-frequency method with the best heating time obtained by a hot-plate press using the plates at a scorching temperature of 400 degrees Fahrenheit. It is interesting to note from Fig. 19 that if a certain power gives 1-minute gluing on a 1/2-inch board, reducing the power to one third of its original value extends the required gluing time to 7 minutes.

Another calculation of interest is that of the transient temperature state, where heat is generated within the wood from time $t=0$ to time $t=t_1$. At this point, the heat generation is stopped and the temperature goes into a decline. We may treat this case mathematically by means of the superposition principle. The expression for temperature at the center of the wood on the basis of heat generated throughout the wood is given by (49). This is also curve *A* in Fig. 22. This heat continues to be generated for all time. However, at time $t=t_1$ and be-

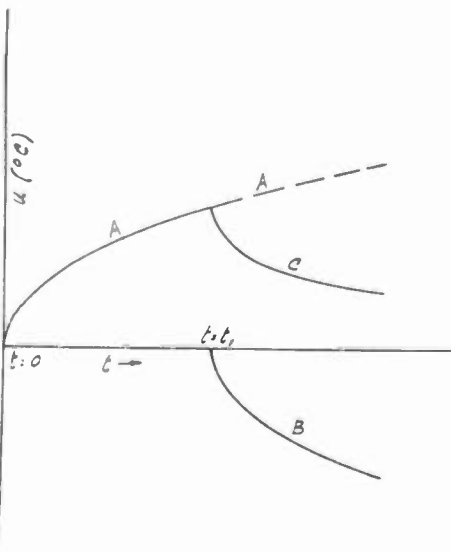

Fig. 22—Transient calculation by superposition method.

yond, a negative generation of heat is imagined which just cancels the positive generation. The temperature resulting from this negative generation is

$$u_B = - \frac{4I/b^2}{\pi^3 k} \left[\frac{(1 - e^{-(\pi^2 a^2 (t-t_1))/b^2})}{3^3} + \dots \right] \quad (55)$$

and is given by curve *B*, Fig. 22. Note that curve *B* is simply the negative of curve *A*, displaced to the right an amount equal to t_1 . Then for time greater than t_1 , the resultant temperature curve *C* is the algebraic sum of *A* and *B*. Once curve *A* has been calculated, it is a simple matter to construct curve *C* very quickly. In this

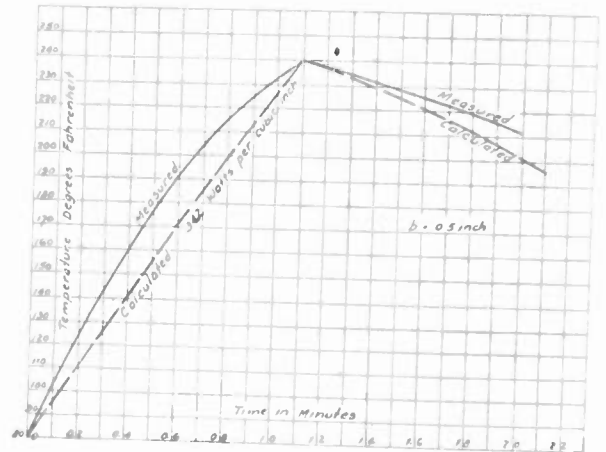

Fig. 23—Transient temperature curve with wood thickness equal to one-half inch.

manner, Fig. 23 was constructed, with $b=0.5$ inch, and a power density of 34.2 watts per cubic inch. The measured curve on this figure is taken from Fig. 22 of the paper by Bierwirth and Hoyler.¹

This method of transient calculation is of real importance in a treatment of the self-quenching of steels when case-hardening by radio frequency.

CONCLUSION

The problems of heat conduction in presses used for the gluing of wood have been examined theoretically.

In a hot-plate press, where only one plate is heated, the results are so poor that this method is of no importance compared to radio-frequency heating.

Where two hot plates are used, the speed of gluing is determined by the maximum usable plate temperature, that is, the scorch temperature of the wood. It is shown that radio-frequency heating is faster. As the wood section increases in thickness, the argument in favor of radio-frequency heating becomes stronger.

In radio-frequency heating, the central section of the wood is the hottest, while in hot-plate gluing, the central section is the coolest. Thus if a temperature of say 240 degrees Fahrenheit is needed for gluing in the center of the wood, the remainder of the wood will be at a temperature less than 240 degrees, while in two-hot-plate

gluing, the remainder of the wood will be at a temperature greater than 240 degrees. Obviously, with lower surface temperatures and shorter heating times, the surface of the wood will not be dried or subjected to surface strains in radio-frequency heating to the extent that occurs in hot-plate heating.

It is perhaps evident to the reader that the analysis presented in this paper is not limited to the heating of wood. The general equations of heat flow developed in this paper may be of interest in other heating problems, such as the heating or curing of plastics.⁷ In a curing problem, it may be desirable and even necessary to have a more uniform distribution of temperature than is indicated in Figs. 15 and 16. Heating of the press plates by steam or internal electrical heaters to prevent cooling at the surfaces of the plastic is desirable. By using press plates which are held at the final desired temperature and adjusting the total heating time by controlling the radio-frequency oscillator power, one may arrive at a final temperature distribution that is essentially a constant throughout the thickness of the material. Many plastic presses are equipped with water-cooled dies for cooling the material after curing. Since these dies must be heated for each pressure operation, it is possible to heat the dies at a uniform rate while the radio-frequency power is applied to the dielectric material. If the die-heating rate is controlled so that at each instant during the heating period the die is at the same temperature as the dielectric material, no heat will flow across the interface between the dielectric and the metal. Then because of the uniform nature of the generation of heat within the dielectric, the temperature throughout the dielectric will be indeed a constant.

The equations of heat flow, where the heat is generated within the object being heated, are shown to be exactly analogous to the equations of a transmission line with distributed voltage. The method of treatment is given in detail and will be used in a later paper as the basis for solving similar heat-conduction problems in metals.

APPENDIX I

The Operational Solution of Equation (46)

The operational equation (46) is

$$u(x) = \frac{E}{pL} \left[\frac{\sinh(\sqrt{pLG} b) - \sinh(\sqrt{pLG} x) - \sinh(\sqrt{pLG} [b-x])}{\sinh(\sqrt{pLG} b)} \right]$$

$$= \frac{E}{pL} \left[1 - \frac{\sinh(\sqrt{pLG} x)}{\sinh(\sqrt{pLG} b)} - \frac{\sinh(\sqrt{pLG} [b-x])}{\sinh(\sqrt{pLG} b)} \right] \tag{56}$$

We shall first solve the operational relation, $[-\sinh(\sqrt{pLG} x)]/[\sinh(\sqrt{pLG} b)]$ by means of the Heaviside Expansion Theorem.

Let

$$y = -\frac{\sinh(\sqrt{pLG} x)}{\sinh(\sqrt{pLG} b)} = -\frac{1}{\left[\frac{\sinh(\sqrt{pLG} b)}{\sinh(\sqrt{pLG} x)} \right]} = \frac{Y(p)}{Z(p)} \tag{57}$$

where $Y(p)$ is a function of the operator p , and $Z(p)$ is a function of the same operator.

From (57) $Y(p) = -1$ (58)

and $Z(p) = \frac{\sinh(\sqrt{pLG} b)}{\sinh(\sqrt{pLG} x)}$ (59)

The Expansion Theorem gives as a solution of (57)

$$y = \left[\frac{Y(p)}{Z(p)} \right]_{p=0} + \left[\frac{Y(p)\epsilon^{pt}}{p(dZ/dp)} \right]_{p=p_1}$$

$$+ \left[\frac{Y(p)\epsilon^{pt}}{p(dZ/dp)} \right]_{p=p_2} + \dots \tag{60}$$

where p_1, p_2, \dots , are roots of $Z(p)$, that is, the values of p at which $Z(p)$ vanishes.

Before proceeding with (60), we define an arbitrary number m as follows:

$$-m^2 = pLG \tag{61}$$

or $\sqrt{pLG} = jm$ (62)

Then (59) becomes $Z(p) = (\sin mb)/(\sin mx)$ (63)

Roots of (63) are $m = s\pi/b$ where $s = 1, 2, 3, \dots$,

and from (61) $p_1 = -(1/LG)(\pi/b)^2$

$$p_2 = -(1/LG)(2\pi/b)^2$$

and $p_s = -(1/LG)(s\pi/b)^2$ where $s = 1, 2, 3, \dots$

Now, $dZ/dp = (dZ/dm)(dm/dp)$ (64)

From (61) $-2m dm = LG dp$

or $dm/dp = -LG/2m$ (65)

From (63) $\frac{dZ}{dm} = \frac{b \sin mx \cos mb - x \sin mb \cos mx}{\sin^2 mx}$ (66)

Substituting (65) and (66) in (64),

$$\frac{dZ}{dp} = \left(-\frac{LG}{2m} \right) \left[\frac{b \sin mx \cos mb - x \sin mb \cos mx}{\sin^2 mx} \right] \tag{67}$$

From (61) and (67),

$$p \frac{dZ}{dp} = \frac{m}{2} \left[\frac{b \sin mx \cos mb - x \sin mb \cos mx}{\sin^2 mx} \right] \tag{68}$$

and $\left[p \frac{dZ}{dp} \right]_{p=p_s} = \frac{m_s b (-1)^s}{2 \sin(m_s x)} = \frac{s\pi (-1)^s}{2 \sin(s\pi x/b)}$ (69)

Also $[Y(p)/Z(p)]_{p=0} = -x/b$ (70)

so that (57) becomes

$$y = -\frac{x}{b} - \sum_{n=1}^{\infty} \frac{2(-1)^n}{s\pi} \sin\left(\frac{s\pi x}{b}\right) \epsilon^{-(s\pi/b)^2(t/LG)} \tag{71}$$

The third term in (56) is handled in exactly the same way and becomes

$$z = -\frac{(b-x)}{b} - \sum_{n=1}^{\infty} \frac{2(-1)^n}{s\pi} \sin\left[\frac{s\pi}{b}(b-x)\right] \epsilon^{-(s\pi/b)^2(t/LG)}$$

⁷ Cyril N. Hoyler, "An electronic sewing machine," *Electronics*, vol. 16, pp. 90-94; 160-168; August, 1943.

$$= -1 + \frac{x}{b} + \sum_{s=1}^{\infty} \frac{(2)(-1)^s}{s\pi} \cos(s\pi) \sin\left(\frac{s\pi x}{b}\right) e^{-((s\pi/b)^2 t)/(LG)}. \quad (72)$$

Substituting (71) and (72) in (56),

$$u(x) = \frac{4E}{\pi L} \frac{1}{p} \left[\sum_{s=1}^{\infty} \frac{\sin[(2s-1)(\pi x/b)]}{(2s-1)} e^{-((2s-1)^2 \pi^2 t)/(b^2 LG)} \right]. \quad (73)$$

But operationally

$$\frac{1}{p} = \int_{t=0}^{t-t} dt$$

$$\text{so } u(x) = \frac{4E}{\pi L} \left(-\frac{b^2 LG}{\pi^2} \right) \sum_{s=1}^{\infty} \frac{\sin[(2s-1)(\pi x/b)]}{(2s-1)^3} e^{-((2s-1)^2 \pi^2 t)/(b^2 LG)} \Big|_{t=0}^{t-t} \quad (74)$$

$$\text{or } u(x) = \frac{4EGb^2}{\pi^3} \sum_{s=1}^{\infty} \frac{\sin[(2s-1)(\pi x/b)]}{(2s-1)^3} [1 - e^{-((2s-1)^2 \pi^2 t)/(b^2 LG)}]. \quad (75)$$

which is (47), a solution of (46).

The Distribution of Current Along a Symmetrical Center-Driven Antenna*

RONOLD KING†, ASSOCIATE, I.R.E., AND CHARLES W. HARRISON, JR.†, ASSOCIATE, I.R.E.

Summary—The cylindrical, center-driven antenna is analyzed as a boundary-value problem of electromagnetic theory. An integral equation in the current (originally obtained in a different way by Hallén) is derived. Its solution is outlined briefly and the general formula is given. Complete curves for the distribution of current for a wide range of lengths and ratios of length to radius are given. These include curves showing the components of current in phase with the driving potential difference and in quadrature with this, and curves giving the magnitude of the current and its phase angle referred to the driving potential difference. The conventionally assumed sinusoidal distribution of current is shown to be a fair approximation for extremely thin antennas and for thicker antennas which do not greatly exceed $\lambda/2$ in length.

INTRODUCTION

THE distribution of current along a center-driven, symmetrical antenna of small circular cross section and half-length h is not the same as the distribution along the same conductors when these are folded together to form a closely spaced parallel-wire line of length h . Because the conductors are actually and identically the same in the two arrangements one might legitimately assume that the distributions of current would be similar. On the other hand the geometrical configuration of the two wires differs in such a fundamental way from the point of view of general electromagnetic theory that great differences in the distribution of current might also be expected. The fact is, that two parallel wires which carry equal and opposite currents sufficiently close together in terms of the wavelengths may be analyzed to a good approximation in terms of ordinary electric-circuit theory, whereas the same two wires placed end to end may not.

The criterion is this: If the resultant force acting at any instant on the charges in any small element of a conductor due to charges moving at appropriate earlier times in the rest of an extended circuit includes significant contributions *only* from neighboring parts of the circuit (that are not more than a very small fraction of a wavelength away) then ordinary electric-circuit theory is a good approximation. In this case radiation is neglected *because it is negligible*. If the spacing b of a parallel-wire line is sufficiently small ($b \ll \lambda$) then the forces on the charges in a given element ds of one of the two wires due to equal and opposite currents and charges in parallel elements which are more distant than ten times the spacing b practically cancel. All significant forces are due to charges moving in immediately adjacent parts of the two wires. In the case of the antenna no such cancellation of forces due to moving charges which are separated more than a small fraction of a wavelength occurs, and ordinary electric-circuit theory is not applicable. This is equivalent to stating that radiation is not negligible.

From the point of view of electromagnetic theory the parallel-wire line with an open end is a special case of the center-driven antenna, and it may be analyzed rigorously as such. On the other hand the antenna is in no fundamental sense a folded-open section of transmission line.

Two methods of attacking the problem of the distribution of current along the center-driven antenna suggest themselves. In the first of these one depends upon the similarity between the antenna and the open-end parallel-wire line, and assumes that by suitably correcting transmission-line theory a satisfactory approximation for the antenna may be devised. One might, for example, measure the input impedance of the

* Decimal classification: R121. Original manuscript received by the Institute, January 20, 1943.

† Cruft Laboratory and Research Laboratory of Physics, Harvard University, Cambridge, Massachusetts.

antenna for a given value of h , and then equate this to the general formula for the input impedance of a terminated section of transmission line of length h . By suitably adjusting two or more of the parameters involved, viz., the attenuation constant α , the phase constant β , the characteristic impedance Z_c , or the terminal impedance $Z = R + jX$, an "equivalent" line can be determined. If the value of h were varied over a wide range the "equivalence" which was established at one value would be only roughly maintained but the order of magnitude would be correctly given. One might then assume that the distribution of current along the "adjusted" parallel-wire line should be a rough approximation of that along the antenna. Correction factors to be applied to line theory in order to approximate the antenna may be devised in many ways, both experimental and theoretical.¹ All such methods are, however, essentially makeshifts which may lead to results which are adequate for many engineering purposes, but which do not actually solve the problem. By skillfully devising enough correction factors any theory can always be made to fit any problem. But such methods are justified only while a more rigorous approach has not been carried out.

The second method of attacking the problem of the distribution of current along a center-driven antenna does not attempt arbitrarily to correct a theory which does not actually apply. It proceeds rather, from the point of view that the antenna is a boundary-value problem in its own right which can certainly be formulated in general terms. If it cannot be solved in closed form, it can at least be evaluated approximately in terms of parameters which characterize the antenna itself, parameters such as the length and radius of the wire, rather than in terms of a characteristic impedance, an attenuation constant, or a terminal impedance which are essentially foreign to the antenna. The antenna was investigated from this general point of view by L. V. King² and by Hallén³ using different but comparable methods. Both are analytically complicated. Actually the problem can be set up formally much more directly than was done by either of these two investigators, and this will be done below. The formulation leads directly to the integral equation obtained by Hallén, rather than to that derived by King. The solution of this equation will be described only briefly because it differs in no essential way from that carried out by Hallén. Since Hallén's paper is not readily available it seems desirable to provide at least an outline of the analysis.

¹ See, for example, S. A. Schelkunoff and C. B. Feldman, "On radiation from antennas," *PROC. I.R.E.*, vol. 30, pp. 511-516; November, 1942.

² L. V. King, "On the radiation field of a perfectly conducting base-insulated cylindrical antenna over a perfectly conducting plane earth, and the calculation of radiation resistance and reactance" *Phil. Trans. Royal Soc. (London)*, vol. 236, pp. 381-422; November 2, 1937.

³ E. Hallén, "Theoretical investigations into the transmitting and receiving qualities of antennas," *Nova Acta, Royal Soc. Sciencas*, (Uppsala) vol. 11, pp. 1-44, November, 1938.

THE DIFFERENTIAL EQUATION

The analytical problem for the determination of the distribution of current in a cylindrical antenna of half-length h and radius a may be formulated in terms of the general boundary condition which requires continuity of the tangential component of the electric field across any boundary surface between two media. If the axis of the antenna is made to fall along the z axis of a system of cylindrical co-ordinates, r, θ, z , the following boundary conditions obtain:

$$(E_z^0)_{r=a} = (E_z^i)_{r=a} \text{ on the cylindrical surface} \quad (1a)$$

$$(E_r^0)_{z=\pm h} = (E_r^i)_{z=\pm h} \text{ on the end faces.} \quad (1b)$$

The superscript i refers to the interior of the conductor, the superscript 0 to space outside the conductor. The electric field in the conductor everywhere satisfies the relation

$$i = \sigma E. \quad (2)$$

Here σ is the conductivity and i is the volume density of current. In the idealized case of a perfect conductor the tangential components of E would vanish on the surface. If the end-faces are required to be small so that the following conditions are fulfilled:

$$a \ll h \quad (3a)$$

$$\beta a = (2\pi a/\lambda) \ll 1. \quad (3b)$$

then the average electric field $(E_r)_{z=\pm h}$ at the end faces must be less than the average field $(E_z)_{r=a}$ along the cylindrical surface. This follows because i_r near the end faces must vanish at $r=a$, and with (3b) it cannot reach a large amplitude between $r=0$ and $r=a$. Accordingly nothing of significance is neglected in so far as the antenna as a whole is concerned if no account is taken of the end faces and hence of $(E_r)_{z=\pm h}$. Thus one may assume the current to vanish at $z = \pm h$ without flowing radially inward on the end faces. (*Note added in proof:* The significance of the end faces and of the approximations involved in neglecting them has been considered by L. Brillouin in a paper which formulates the antenna problem in a mathematically more precise but very much more intricate way. For very thick cylindrical antennas this is important; for moderately thin ones as required by (3). The end faces can certainly have no greater effect than that due to an increase in h by a .)

In carrying out the analysis it will be taken for granted that the cross-sectional and axial distributions of current are mutually independent. This is always true to a very high degree of approximation in a good conductor provided (3) is fulfilled. It is commonly assumed in the derivation of the interval impedance per unit length z^i due to skin effect; it is also assumed in the derivation of the transmission-line equations. Accordingly, one may write

$$(E_z^i)_{r=a} = z^i I_z. \quad (4a)$$

Here I_z is the total current in the conductor at the cross section z , z^i is the internal impedance in ohms per meter. At high frequencies it is

$$z^i = \frac{1}{2\pi a} \sqrt{\frac{\omega \mu \Pi}{2\sigma}} \quad (4b) \quad A_z^0 = \frac{-j}{c} \left[C_1 \cos \beta z + C_2 \sin \beta z - z^i \int_0^z I(s) \sin \beta(z-s) ds \right]. \quad (13)$$

Here $\Pi = 4\pi \times 10^{-7}$ henry per meter; σ is the conductivity in mhos per meter; a the radius in meters, μ the relative permeability of the antenna.

The electric field at outside points is conveniently calculated from the vector potential defined by

$$\text{curl } A = B \quad (5a)$$

$$\text{div } A = -j(\omega/c^2)\phi \quad (5b)$$

using the relation defining the scalar potential ϕ . It is

$$-\text{grad } \phi = E + j\omega A. \quad (6)$$

This may be written in the form,

$$E = -\frac{j\omega}{c^2} \left(\text{grad div } A + \frac{\omega^2}{c^2} A \right) \quad (7)$$

if ϕ is eliminated from (6) using (5b).

Except at points very near the end faces one can write

$$A_r \ll A_z. \quad (8a)$$

One also has at all points,

$$A_\theta = 0. \quad (8b)$$

Accordingly the z component of the electric field has the following value except very near the end faces:

$$E_z = -j\frac{\omega}{\beta^2} \left(\frac{d^2 A_z}{dz^2} + \beta^2 A_z \right). \quad (9)$$

Here

$$\beta^2 \equiv \frac{\omega^2}{c^2}. \quad (10)$$

Upon substituting (9) and (4) in (1) the following differential equation in the vector potential is obtained:

$$\frac{d^2 A_z^0}{dz^2} + \beta^2 A_z^0 = j\frac{\beta^2}{\omega} z^i I_z. \quad (11)$$

The vector potential is thus seen to satisfy a one-dimensional wave equation which is homogeneous in the idealized case of an antenna which is a perfect conductor so that $z^i = 0$. It is readily verified using (5b) that the scalar potential satisfies an entirely similar equation. The total current does not satisfy such a simple equation as will be shown directly.

THE FORMAL SOLUTION OF THE EQUATION

The differential equation (11) is a nonhomogeneous equation which has a general solution involving the sum of a complementary function A_c^0 and a particular integral A_p^0 . The former may be written in the form

$$A_c^0 = \frac{-j}{c} [C_1 \cos \beta z + C_2 \sin \beta z] \quad (12a)$$

with C_1 and C_2 arbitrary constants of integration. A particular integral is

$$A_p^0 = \frac{jz^i}{c} \int_0^z I(s) \sin \beta(z-s) ds. \quad (12b)$$

It is readily verified by substituting (12b) in (11) that it satisfies the equation. Thus the general solution of (11) is

Let it be required that the antenna under consideration be symmetrical with respect to a pair of closely spaced driving points 0 and $0'$ at its center in such a way that the following symmetry conditions obtain:

$$I(z) = I(-z); \quad A^0(z) = A^0(-z). \quad (14)$$

The relation (13) is easily specialized to satisfy (14) by writing $|z|$ for z in $\sin \beta z$. Thus

$$A_z^0 = \frac{-j}{c} \left[C_1 \cos \beta z + C_2 \sin \beta |z| - z^i \int_0^z I(s) \sin \beta(z-s) ds \right]. \quad (15)$$

It is readily verified that (15) is unchanged if $-z$ is everywhere written for z . (In the integral the variable is changed by writing $s = -u$ after writing $-z$ for z .)

THE DRIVING-POTENTIAL DIFFERENCE

Let it be assumed that a driving-potential difference V_0^e is maintained between the two terminals 0 and $0'$ which are assumed to be separated an infinitesimal distance. In practice, terminals are always separated a finite distance but it is here postulated that it is in any case a negligible fraction of a wavelength. The actual case is readily reduced to the assumed one as shown in Fig. 1. The actual terminals are A and B and a transmission line is connected to them, as shown on the left. By filling the gap between A and B in the manner shown on the right, the equal and opposite currents in the indefinitely close parallel conductors from B' to $0'$ and from A' to 0 completely cancel in so far as could be determined at outside points. Thus the antenna may be assumed to extend without break across AB ; it includes a point generator maintaining the potential difference V_0^e across its terminals. In the same way the transmission line may be taken to extend from A' to B' without break with a point load concentrated midway between A' and B' .

The boundary condition on the scalar potential is

$$V_0^e = \lim_{z \rightarrow 0} \{ \phi^0(+z) - \phi^0(-z) \}. \quad (16)$$

From (5b) one has, since $A_r \ll A_z$, $A_\theta = 0$,

$$\frac{\partial A_z^0}{\partial z} = -j\frac{\omega}{c^2} \phi^0. \quad (17a)$$

Also,

$$\frac{\partial A_z^0(+z)}{\partial z} = -j\frac{\omega}{c^2} \phi^0(+z) \quad (17b)$$

$$\frac{\partial A_z^0(-z)}{-\partial z} = -j\frac{\omega}{c^2} \phi^0(-z) \quad (17c)$$

$$\text{so that } \phi^0(-z) = -\phi^0(z) = j\frac{c^2}{\omega} \frac{\partial A_z^0(-z)}{\partial z} \quad (18)$$

$$\text{and } V_0^e = 2 \lim_{z \rightarrow 0} \phi^0(+z) = \frac{2jc^2}{\omega} \lim_{z \rightarrow 0} \frac{\partial A_z^0(+z)}{\partial z}. \quad (19)$$

Upon differentiating (15) with respect to z and allowing z to approach zero one has

$$\lim_{z \rightarrow 0} \left(\frac{\partial A_z^0}{\partial z} \right) = \frac{-j\beta}{c} C_2 \quad (20)$$

so that with $\beta = \omega/c$, one obtains

$$C_2 = \frac{1}{2} V_0 \epsilon. \quad (21)$$

THE INTEGRAL EQUATION

It is shown in Appendix I that the vector potential at all points outside a cylindrical conductor (including its surface) except those within distances of an end face comparable with its radius is given to a good approximation by

$$A_z^0 = \frac{\Pi}{4\pi} \int_{-h}^{+h} I_z' \frac{e^{-i\beta R}}{R} dz'. \quad (22)$$

Here R is the distance from the point (r, θ, z) outside the conductor where A_z^0 is calculated to the center of the element dz' at z' on the axis. That is,

$$R = \sqrt{(z - z')^2 + r^2}. \quad (23)$$

The universal magnetic constant is

$$\Pi = 4\pi \times 10^{-7} \text{ henry per meter.} \quad (24)$$

If the integral (15) is specialized to the surface of the antenna, i.e., to $r = a$, and is then substituted in (13) one obtains

$$j \frac{c\Pi}{4\pi} \int_{-h}^{+h} I_z' \frac{e^{-i\beta R}}{R} dz' = C_1 \cos \beta z + \frac{1}{2} V_0 \epsilon \sin \beta |z| - z^i \int_0^z I(s) \sin \beta(z - s) ds. \quad (25)$$

In terms of the fundamental electric constant

$$\Delta = 8.85 \times 10^{-12} \text{ farad per meter} \quad (26)$$

and the magnetic constant defined in (24) one has

$$c = \frac{1}{\sqrt{\Pi\Delta}} = 3 \times 10^8 \text{ meters per second} \quad (27a)$$

and,
$$R_c = \sqrt{\frac{\Pi}{\Delta}} = c\Pi = 376.7 \text{ ohms.} \quad (27b)$$

Then
$$c\Pi/4\pi = R_c/4\pi = 30 \text{ ohms.} \quad (28)$$

This may be substituted in (25). The notation in terms of R_c (ohms) will be retained so that simple dimensional relations are at all times in view.

As a first step in the solution, the integral on the left in (25) may be expanded in the following way:

$$\int_{-h}^{+h} I_z' \frac{e^{-i\beta R}}{R} dz' = I_z \int_{-h}^{+h} \frac{dz'}{R} + \int_{-h}^{+h} \frac{I_z' e^{-i\beta R} - I_z}{R} dz'. \quad (29)$$

The first integral on the right can now be evaluated directly. It is

$$\int_{-h}^{+h} \frac{dz'}{R} = \ln \left[\frac{\sqrt{(h-z)^2 + a^2} + (h-z)}{\sqrt{(h+z)^2 + a^2} - (h+z)} \right]. \quad (30)$$

With the notation,

$$\Omega \equiv 2 \ln \left(\frac{2h}{a} \right) \quad (31)$$

$$\delta \equiv \ln \left\{ \frac{1}{4} \left[\sqrt{1 + \left(\frac{a}{h-z} \right)^2} + 1 \right] \cdot \left[\sqrt{1 + \left(\frac{a}{h+z} \right)^2} + 1 \right] \right\}. \quad (32)$$

Equation (30) may be written as follows:

$$\int_{-h}^{+h} \frac{dz'}{R} = \Omega + \ln(1 - z^2/h^2) + \delta. \quad (33)$$

It is to be noted that δ is negligible except very near the ends of the antenna and that (30), (which includes

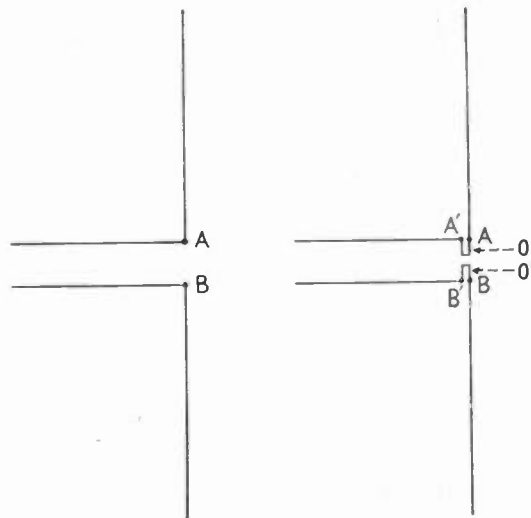

Fig. 1—Actual method of feeding and analytically equivalent method.

δ) is everywhere finite reducing to the following value at the ends:

$$\left[\int_{-h}^{+h} \frac{dz'}{R} \right]_{z=\pm h} = \frac{1}{2} \Omega + \ln 2. \quad (34)$$

Upon substituting (33) in (29) and then inserting (29) in (25) one readily obtains

$$I_z = \frac{-j4\pi}{\Omega R_c} \left\{ C_1 \cos \beta z + \frac{1}{2} V_0 \epsilon \sin \beta |z| - z^i \int_0^z I(s) \sin \beta(z - s) ds \right\} - \frac{1}{\Omega} \left\{ I_z \ln(1 - z^2/h^2) + I_z \delta + \int_{-h}^{+h} \left(\frac{I_z' e^{-i\beta R} - I_z}{R} \right) dz' \right\}. \quad (35)$$

Since the current vanishes at the ends and $\ln(1 - z^2/h^2) + \delta$ remains finite according to (33) and (34), one has, with $z = h$,

$$0 = \frac{-j4\pi}{\Omega R_c} \left\{ C_1 \cos \beta h + \frac{1}{2} V_0 \epsilon \sin \beta h \right\} - \frac{1}{\Omega} \left\{ \frac{j4\pi z^i}{R_c} \int_0^h I(s) \sin \beta(h - s) ds - \int_{-h}^{+h} I_z' \frac{e^{-i\beta R_h}}{R_h} dz' \right\}. \quad (36)$$

Here
$$R_h = \sqrt{(h - z')^2 + a^2}. \quad (37)$$

If (36) is subtracted from (35) one has

$$I_z = \frac{-j4\pi}{\Omega R_c} \left\{ C_1(\cos \beta z - \cos \beta h) + \frac{1}{2} V_0^e (\sin \beta |z| - \sin \beta h) \right\} - \frac{1}{\Omega} \left\{ I_z \ln(1 - z^2/h^2) + I_z \delta + \int_{-h}^{+h} \left(\frac{I_z' e^{-i\beta R} - I_z}{R} \right) dz' - \frac{j4\pi z^i}{R_c} \int_0^z I(s) \sin \beta(z-s) ds \right\} + \frac{1}{\Omega} \left\{ \int_{-h}^{+h} I_z' \frac{e^{-i\beta R h}}{R_h} dz' - \frac{j4\pi z^i}{R_c} \int_0^h I(s) \sin \beta(h-s) ds \right\}. \quad (38)$$

This expression is the same as that originally derived by Hallén in a somewhat different way. Since its evaluation from this point on follows in all essential respects the method used by Hallén it will not be reproduced in detail. A brief outline is given in Appendix II because Hallén's paper is not generally available at the present time.

THE FIRST-ORDER SOLUTION

By the method of successive approximations outlined in Appendix II, (38) may be expressed in the form of a series in the small quantity $1/\Omega$. By substituting this series in (36) the constant of integration C_1 may be evaluated. The zeroth and first-order terms in the solution are

$$I_z = \frac{j2\pi V_0^e}{\Omega R_c} \left\{ \frac{\sin \beta(h - |z|) + (1/\Omega) [M_1^I + jM_1^{II}]}{\cos \beta h + (1/\Omega) [A_1^I + jA_1^{II}]} \right\}. \quad (39)$$

Terms involving factors of order $1/\Omega^2$, $1/\Omega^3$, etc., are neglected in (39). The real functions M_1^I , M_1^{II} , A_1^I , and A_1^{II} , which are functions of h and z only and not at all of the radius a , are defined as follows in terms of the complex F and G functions given in Appendix II.

$$M_1^I + jM_1^{II} \equiv F_1(z) \sin \beta h - F_1(h) \sin \beta |z| + G_1(h) \cos \beta z - G_1(z) \cos \beta h \quad (40)$$

$$A_1^I + jA_1^{II} \equiv F_1(h). \quad (41)$$

These have been computed for several values of h as shown graphically in Figs. 2 to 6.

Let the numerator in the brace of (39) be denoted by

$$N^I + jN^{II} = N e^{i\psi_N} \quad (42a)$$

with

$$N^I = \sin \beta(h - |z|) + M_1^I/\Omega; \quad N^{II} = M_1^{II}/\Omega. \quad (42b)$$

Similarly let the denominator in (39) be

$$D^I + jD^{II} = D e^{i\psi_D} \quad (42c)$$

$$\text{with } D^I = \cos \beta h + A_1^I/\Omega; \quad D^{II} = A_1^{II}/\Omega. \quad (42d)$$

$$\text{Also let } f' = N \cos(\psi_D - \psi_N) \quad (42e)$$

$$f'' = N \sin(\psi_D - \psi_N). \quad (42f)$$

Both f' and f'' are functions of z , while D is not. With

this notation, (39) reduces to

$$I_z = \frac{2\pi V_0^e}{\Omega R_c D} (f'' + jf') = \frac{V_0^e}{60\Omega D} (f'' + jf'). \quad (43)$$

In amplitude-phase-angle form one has

$$I_z = \frac{V_0^e}{60\Omega D} \sqrt{(f'')^2 + (f')^2} e^{i\theta} \quad (44)$$

$$\text{with } \theta = \tan^{-1} \left(\frac{f'}{f''} \right). \quad (45)$$

If the applied voltage varies according to

$$v_0^e = V_0^e \sin \omega t \quad (46)$$

then the instantaneous current at a distance z from the center of the symmetrical center-driven antenna is

$$i_z = \frac{V_0^e}{60\Omega D} \sqrt{(f'')^2 + (f')^2} \sin(\omega t + \theta). \quad (47)$$

The distribution of current along a cylindrical antenna which satisfies the condition

$$\Omega^2 \gg 1 \quad (48)$$

has thus been obtained.

If (48) is interpreted to mean

$$\Omega \geq 10, \quad (49)$$

one can also write as an equivalent

$$\frac{h}{a} \geq 75. \quad (50)$$

Curves showing the functions f'' and f' for use with the formula (43) are reproduced in Figs. 7 to 12 for several lengths and three different thicknesses covering most of the practical range. Actually it is merely necessary to multiply the values of f'' or f' in the curves by $1/60\Omega D$ in order to obtain the corresponding components of current in amperes per input volt. Numerical values of this factor for the several cases plotted in the figures are given in Table I. Curves giving $\sqrt{(f'')^2 + (f')^2}$ and $\theta = \tan^{-1}(f'/f'')$ for use with (44) are shown in Figs. 13 to 18. Thus Figs. 7 to 18 together with (43) and (44) completely characterize the distribution of current along a typical center-fed antenna of circular cross section with radius a and of length h . Before discussing these general results it is well to consider first the input impedance and then two special cases.

THE INPUT IMPEDANCE

In considering the significance of the distribution curves for current it is instructive to examine simultaneously the input impedance of the antenna. This is defined simply as the potential difference V_0^e maintained at the input terminals divided by the input current. It may be obtained directly from (39) by writing $z=0$. Thus

$$Z_{00} = \frac{V_0^e}{I_0} = \frac{-j\Omega R_c}{2\pi} \left\{ \frac{\cos \beta h + (1/\Omega) (A_1^I + jA_1^{II})}{\sin \beta h + (1/\Omega) (B_1^I + jB_1^{II})} \right\} \quad (51)$$

with

$$B_1^I + jB_1^{II} = F_1(0) \sin \beta h + G_1(h) - G_1(0) \cos \beta h. \quad (52)$$

TABLE I

$\frac{h}{\lambda}$	H (radians)	$\frac{1}{60\Omega D}$ (multiply all numbers by 10^{-3})			$Y_{\infty} = G_{\infty} - jB_{\infty}$ (in mhos $\times 10^{-3}$)		
		$\Omega = 10$	$\Omega = 20$	$\Omega = 30$	$\Omega = 10$	$\Omega = 20$	$\Omega = 30$
0.2425	1.538	13.396	14.094	13.805	15.54 -j3.67	15.36 -j0.0	13.8 +j3.67
0.25	1.571	11.819	11.815	11.810	12.74 -j5.9	11.39 -j5.90	11.04 -j5.9
0.375	2.356	2.320	1.176	0.785	0.992 -j1.443	0.255 -j0.805	0.115 -j0.552
0.50	3.141	1.820	0.870	0.589	0.574 +j0.423	0.140 +j0.095	0.066 +j0.041
0.625	3.927	2.806	1.284	0.830	0.834 +j2.806	0.174 +j1.11	0.073 +j0.675
0.75	4.712	8.670			10.2 -j3.54		

This is exactly the expression from which curves for the input impedance have been computed.⁴

THE DISTRIBUTION OF CURRENT FOR AN INDEFINITELY THIN ANTENNA

The distribution of current along an indefinitely thin antenna is obtained from (39) by allowing the radius a to approach zero. This is equivalent to allowing the parameter Ω to approach infinity. Let the ap-

proach in both numerator and denominator in (39) and in (51) are large compared with the magnitudes of the factors involving $1/\Omega$.)

The distribution of current along an indefinitely thin antenna is seen to be very simple in form. Referred to the input current I_0 , defined by

$$I_0 = j \frac{2\pi V_0^e}{\Omega R_c} \tan \beta h, \tag{55}$$

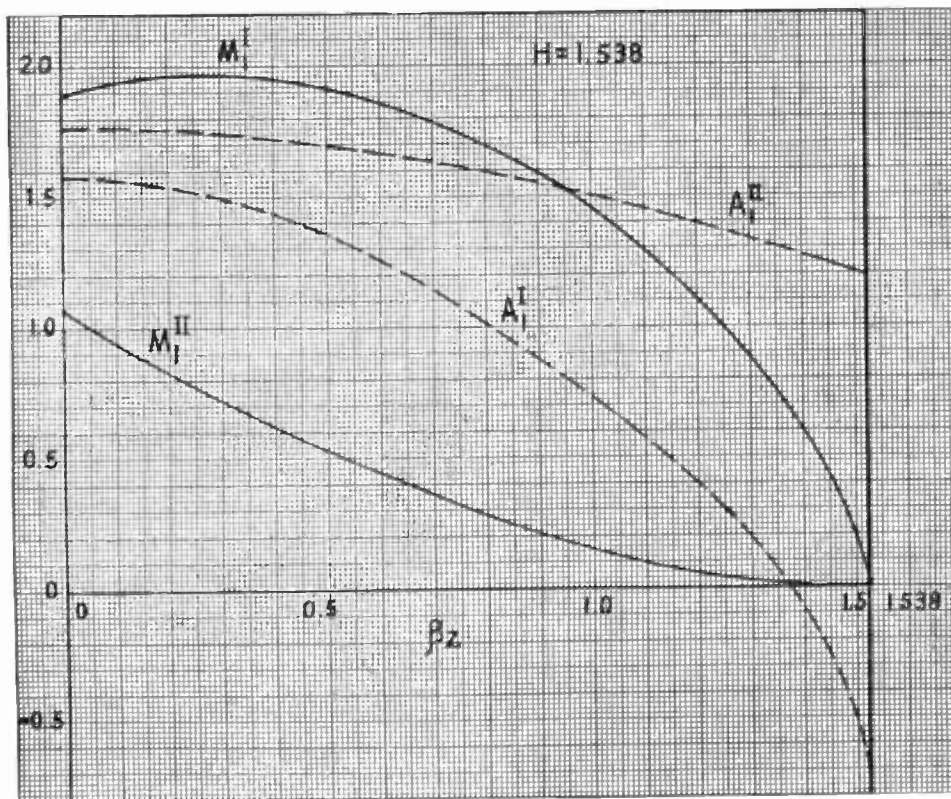

Fig. 2—The function A_1' , A_1'' , M_1' , and M_1'' for $H=1.538$.

plied potential difference V_0^e be increased with Ω so that the ratio V_0^e/Ω remains finite. One then has

$$I_z = \frac{j2\pi V_0^e}{\Omega R_c} \frac{\sin \beta(h - |z|)}{\cos \beta h} \tag{53}$$

The input impedance is formally expressed by

$$Z_{00} = jX_{00} = -j\Omega (R_c/2\pi) \cot \beta h. \tag{54}$$

(It is to be noted that (53) and (54) are actually good approximations for an antenna of very small but non-vanishing radius over those limited parts of the ranges of βh and $\beta(h - |z|)$ for which the trigonometric factors

$$I_z = I_0 \frac{\sin \beta(h - |z|)}{\sin \beta h} \tag{56}$$

Or in terms of the maximum value defined by

$$I_{max} = I_0 / \sin \beta h \tag{57}$$

$$I_z = I_{max} \sin \beta(h - |z|). \tag{58}$$

The current I_{max} is fictitious in all antennas for which h is shorter than $\lambda/4$.

The distribution (56), or its equivalent (58), is the one usually assumed for all straight antennas regardless of radius. It is here shown to be strictly correct for an antenna of indefinitely small radius. Distribution

⁴ Ronald King and F. G. Blake, "The self-impedance of a symmetrical antenna," PROC. I.R.E., vol. 30, pp. 335-349; July, 1942.

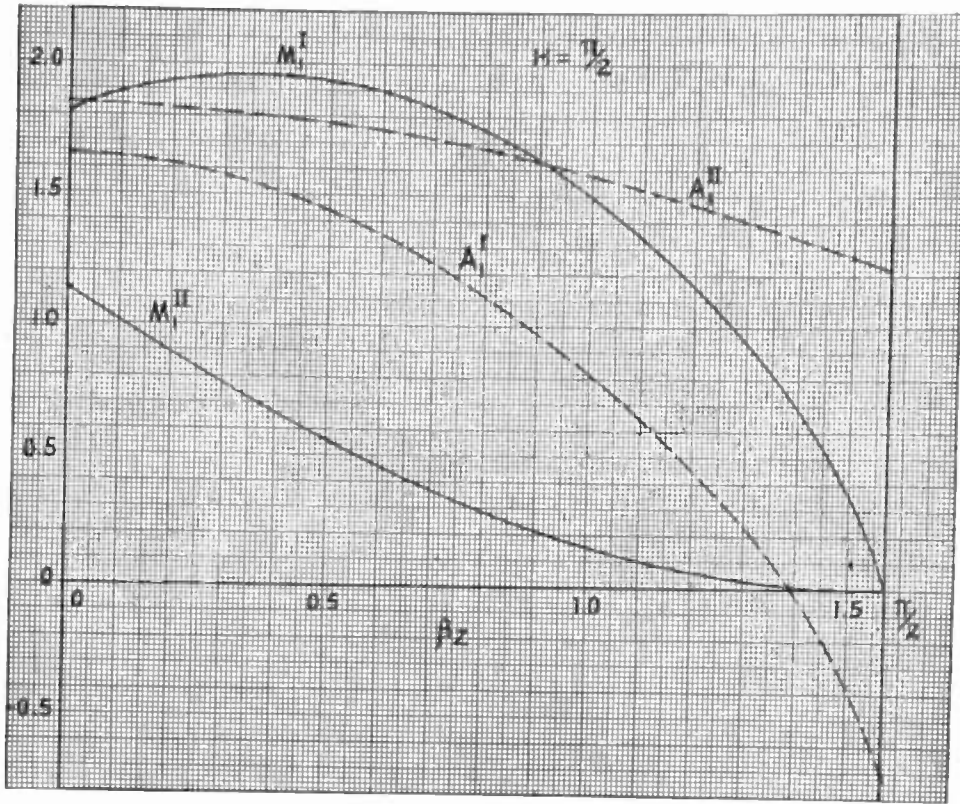

Fig. 3—The functions $A_1^I, A_1^{II}, M_1^I,$ and M_1^{II} for $H = \pi/2$.

curves computed from (58) are well known. A few are shown in Figs. 13 to 18 marked sine curve.

The input impedance of an infinitely thin antenna as given by (54) with Ω increasing without limit requires X_{00} to be negatively infinite for βh between 0 and $\pi/2$, π and $3\pi/2$, etc., and positively infinite for βh between $\pi/2$ and π , $3\pi/2$ and 2π , etc. The values at $\beta h = \pi/2$, π , $3\pi/2$, etc., are indeterminate. The formula (54) would be a good approximation for an extremely thin antenna except near the values of βh listed above. It is not a good approximation for thick antennas.

THE DISTRIBUTION OF CURRENT FOR AN ANTENNA APPROXIMATELY A HALF WAVELENGTH LONG

The simple sinusoidal form (53) for the distribution of current and the equally simple expression (54) for the input impedance are not useful at $\beta h = n\pi/2$ with n any integer even for indefinitely thin antennas. At $\beta h = n\pi/2$, one has from (39) and (51)

$$I_z = \frac{j2\pi V_0 e}{R_c} \left\{ \frac{\cos \beta z + (1/\Omega) [M_1^I + jM_1^{II}]}{A_1^I + jA_1^{II}} \right\} \quad (59)$$

$$Z_{00} = \frac{-jR_c}{2\pi} \left\{ \frac{A_1^I + jA_1^{II}}{1 + (1/\Omega) (B_1^I + jB_1^{II})} \right\} \quad (60)$$

These formulas are limited only by (48).

Since the functions $A, B,$ and M appearing in (59) and (60) depend upon the radius a only through terms involving the ohmic resistance (which are negligible in good conductors), it follows that (59) and (60) depend upon the radius only through the one term in which $1/\Omega$ appears as a factor. That means that the distribution of current (59) and the input impedance (60) of antennas for which $h = \lambda/4$ will vary only slightly with radius as compared with antennas of other lengths which depend on the general expressions (39) and (51) that have Ω as a factor in all terms. Thus, one might expect that a reasonably satisfactory approximation for a moderately thin antenna would be given by neglecting the terms in $1/\Omega$ in (59) and (60). If this is done one obtains formulas which are independent of the radius, and which are strictly accurate in the limit as the radius is made increasingly small

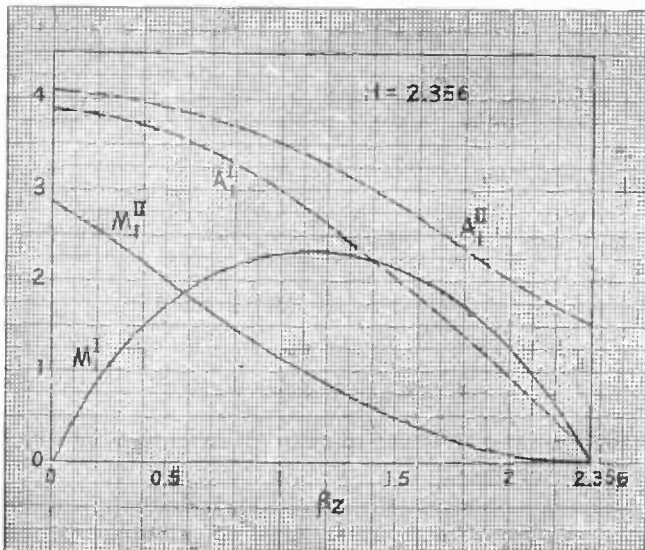

Fig. 4—The functions $A_1^I, A_1^{II}, M_1^I,$ and M_1^{II} for $H = 3\pi/4$.

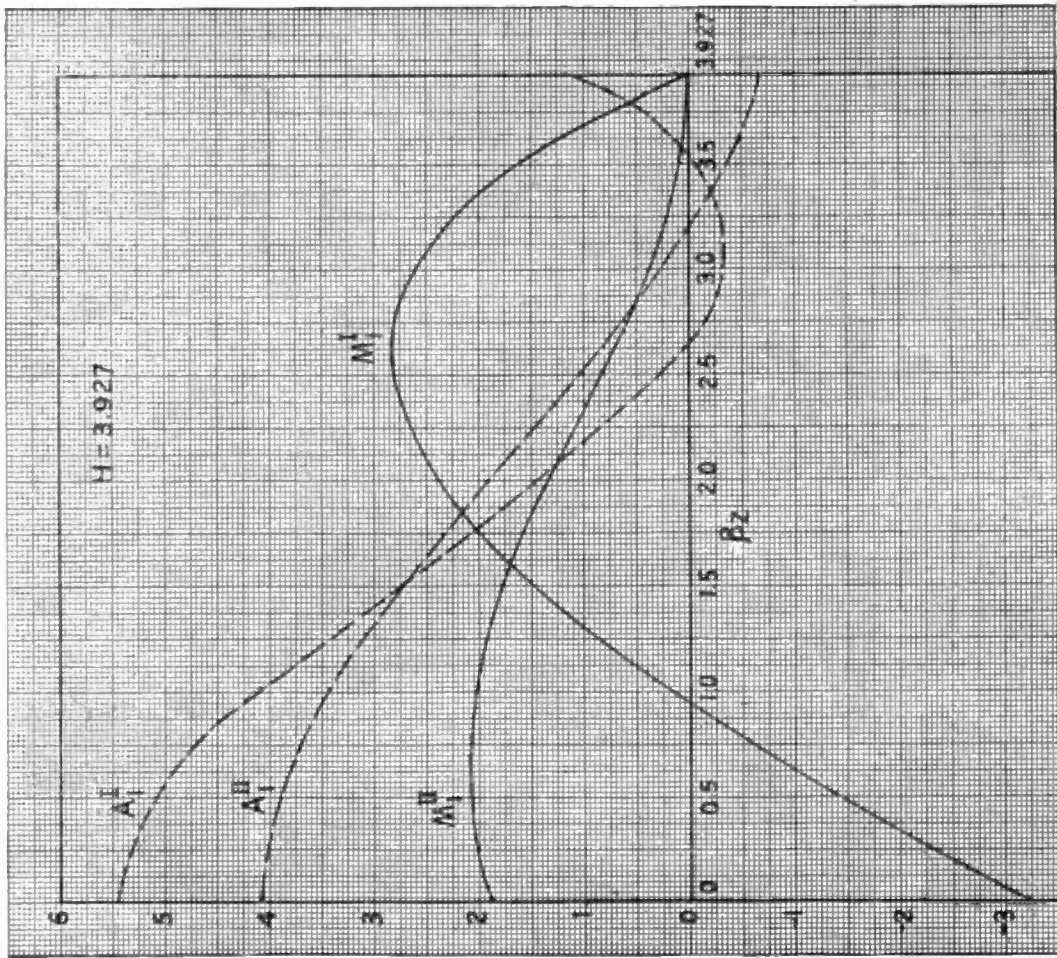

Fig. 6—The functions A_1^I , A_1^{II} , M_1^I , and M_1^{II} for $H = 5\pi/4$.

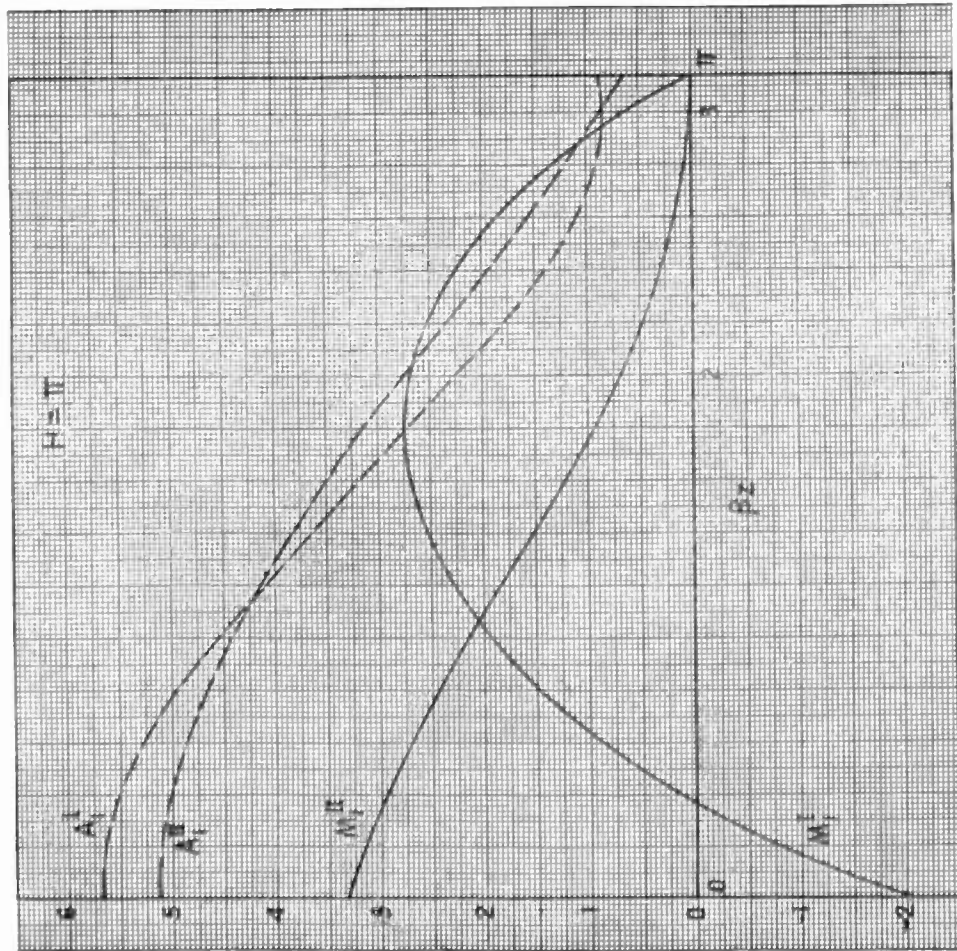

Fig. 5—The functions A_1^I , A_1^{II} , M_1^I , and M_1^{II} for $H = \pi$.

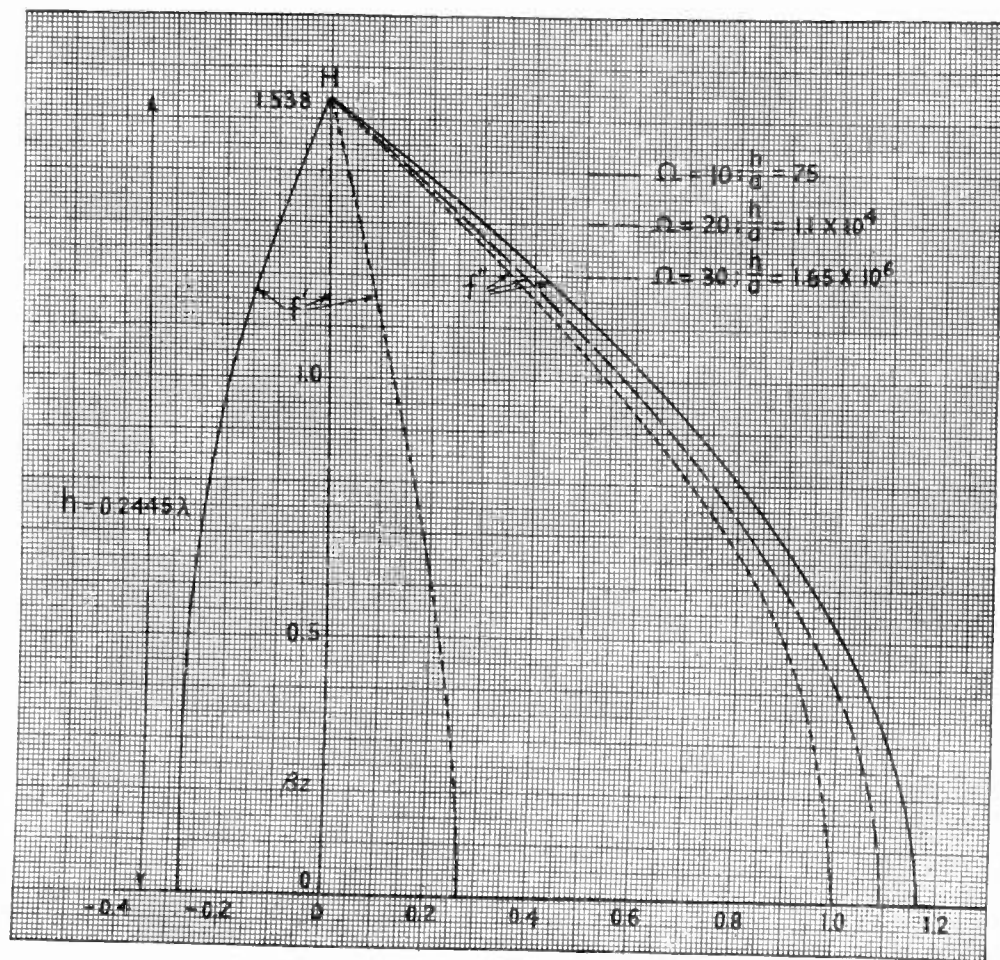

Fig. 7—The distribution functions f' and f'' for $H=1.538$.

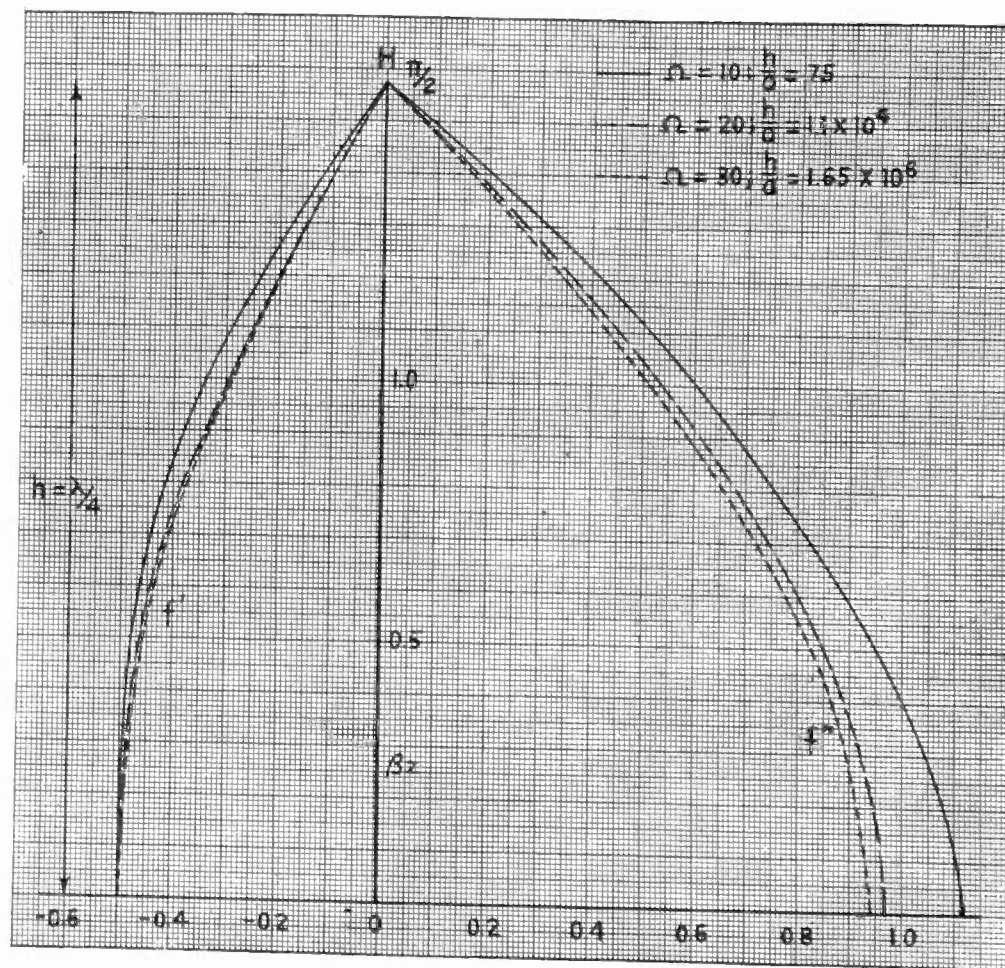

Fig. 8—The distribution functions f' and f'' for $H=\pi/2$.

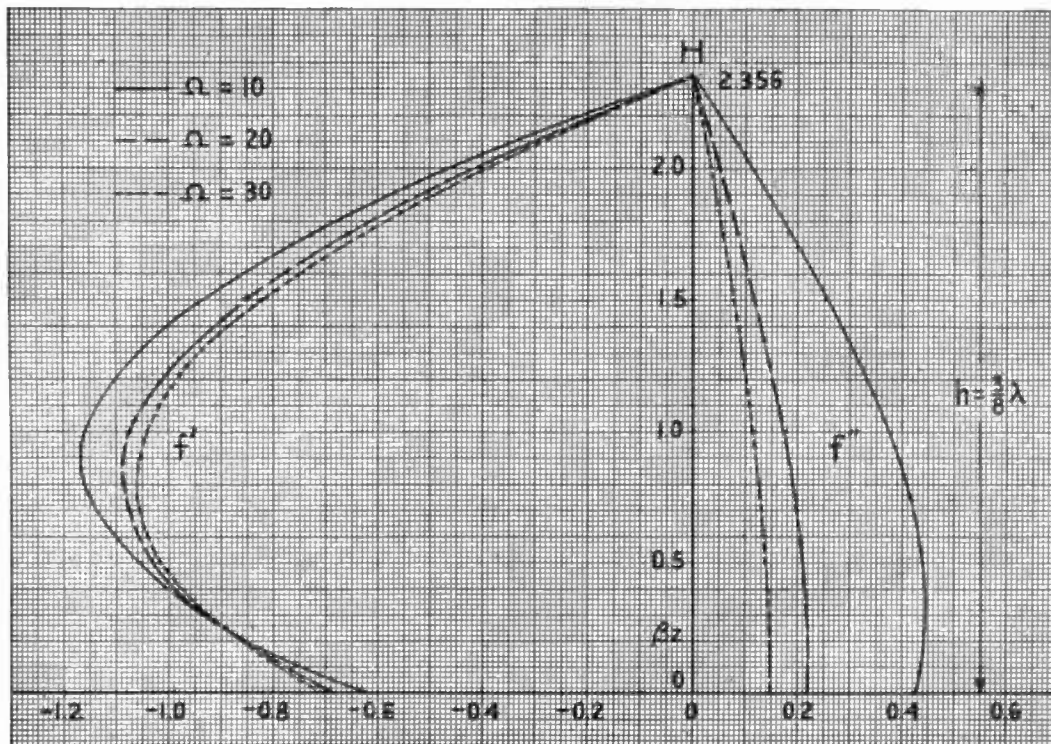

Fig. 9—The distribution functions f' and f'' for $H = 3\pi/4$.

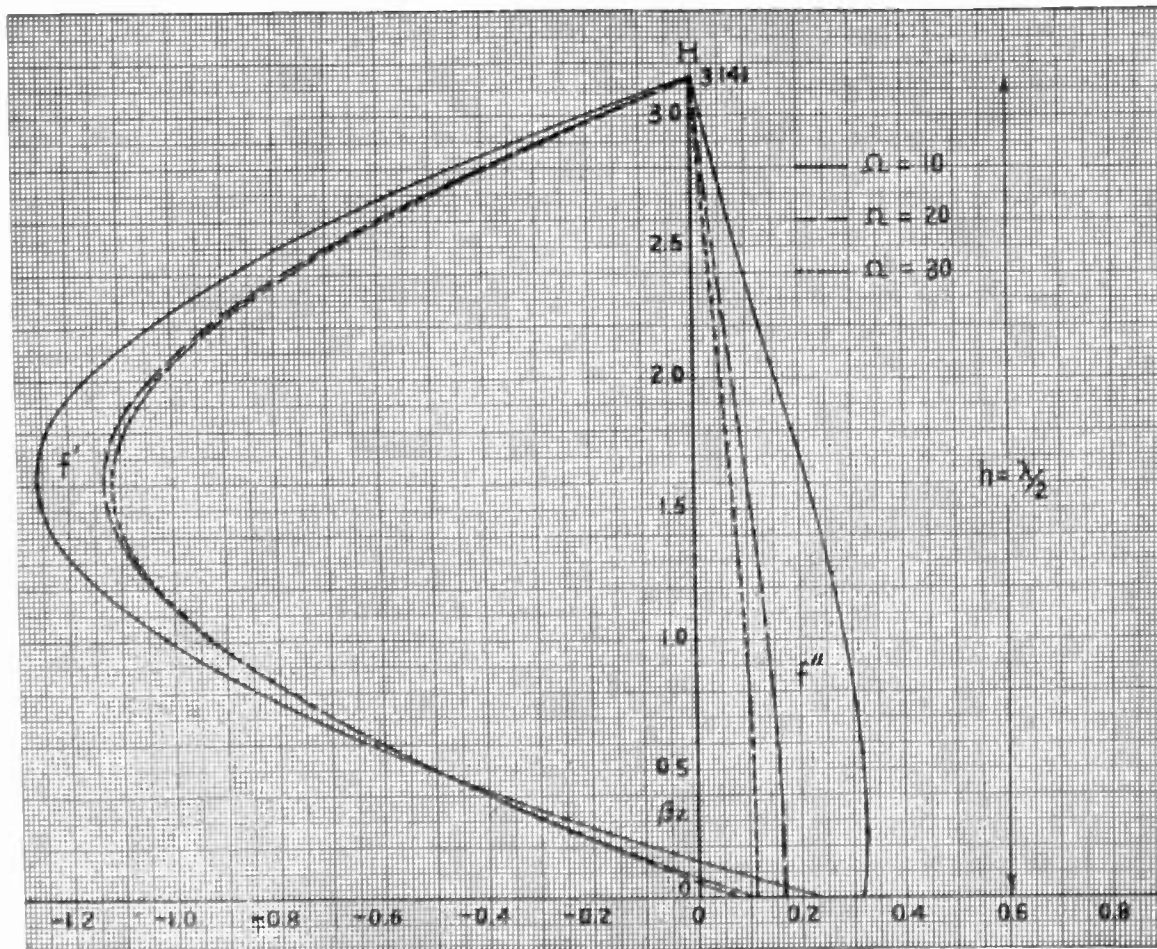

Fig. 10—The distribution functions f' and f'' for $H = \pi$.

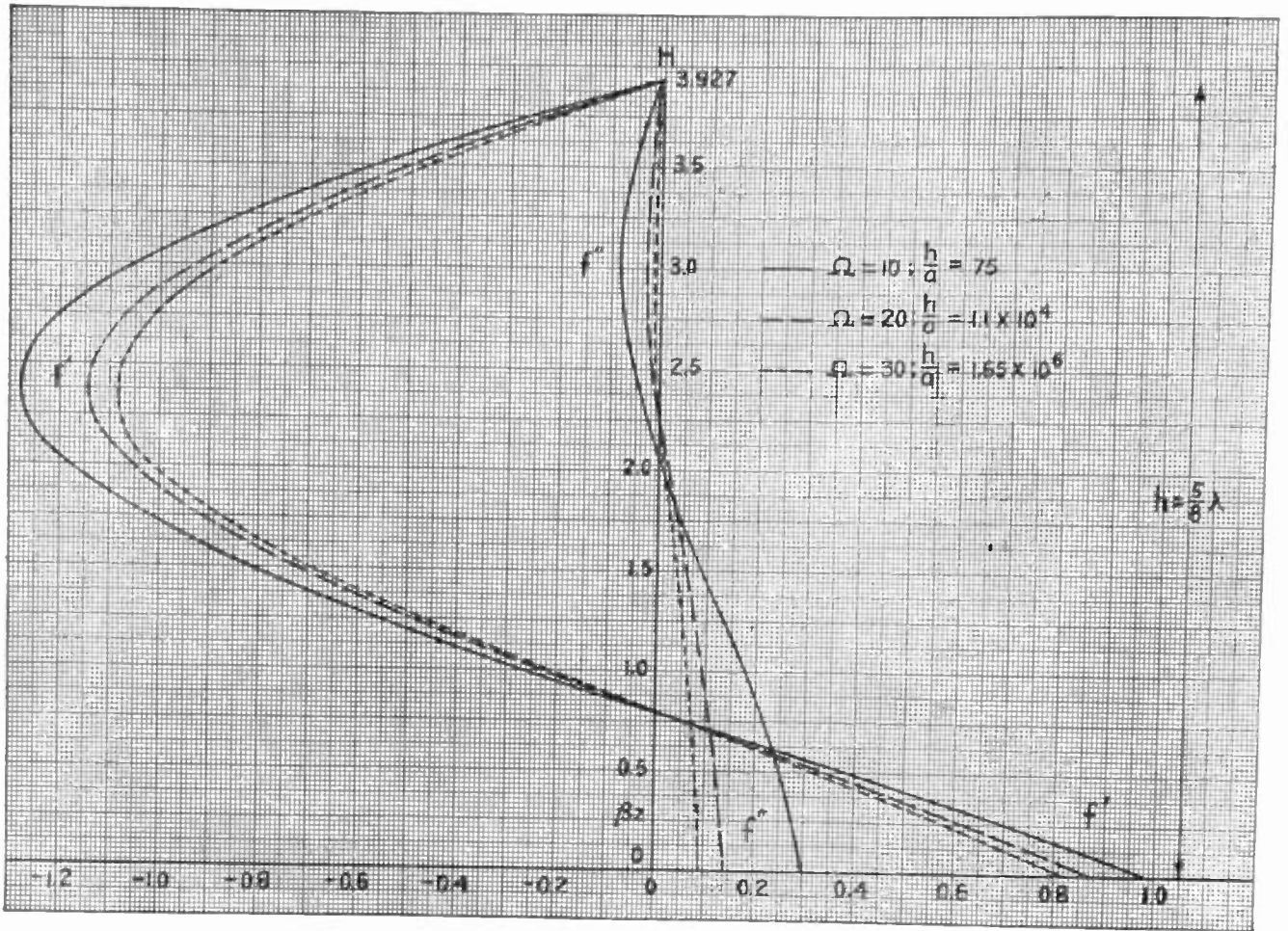

Fig. 11—The distribution functions f' and f'' for $H=5\pi/4$.

after βh has been fixed at $\pi/2$. It can be seen from the left half of Fig. 8 in footnote reference 4 that as the ratio a/λ becomes smaller and smaller the input-reactance curve approaches the vertical and its intersection with the $X_{00}=0$ axis moves to the right. Just before one passes to the actual limit, $a=0$, the reactance curve intersects the $X_{00}=0$ axis an infinitesimal distance to the left of $\beta h=\pi/2$, while its value at $\beta h=\pi/2$ is just a trifle below $X_{00}=42.5$. In the limit, the reactance curve is a vertical line from $-\infty$ to $+\infty$ at $\beta h=\pi/2$, so that values of $X_{00}=0$ or $X_{00}=42.5$ are equally correct but actually meaningless. The formulas which apply to $\beta h=\pi/2$ with the radius a approaching, but not quite reaching, zero are given below. They are not correct for the condition of resonance $X_{00}=0$, which occurs indefinitely near $\beta h=\pi/2$, as $a \rightarrow 0$ but considerably below this value even for small radii.

$$I_z = (V_0^\circ/Z_{00}) \cos \beta z \tag{61}$$

$$\text{with } Z_{00} = R_{00} + jX_{00} = (R_c/2\pi) (A_1^{II} - jA_1^I). \tag{62}$$

For $\beta h=\pi/2$ the numerical value is

$$Z_{00} = 73.13 + j42.5 = 84.5 \angle 30^\circ.2. \tag{63}$$

The formula (61) is as simple in form as (53) and permits writing

$$I_z = I_0 \cos \beta z \tag{64}$$

with I_0 now complex and given by

$$I_0 = V_0^\circ/Z_{00} \tag{65}$$

instead of the pure imaginary defined by (55). Thus (56) and (58) apply to an almost infinitely thin antenna with $\beta h=\pi/2$ and with $I_0 = I_{max}$ defined above.

The simple formula (61) is not strictly applicable to antennas of practical thickness any more than is (53). However, because $1/\Omega$ appears in the more correct formula (59) only in one small term, (61) is a better approximation for the case $\beta h=\pi/2$ than is (53) for other values of βh . Indeed, an examination of Figs. 8 and 14, (which give the distribution of current along antennas for which $\beta h=\pi/2$ and Ω has the values 10, 20, and 30) reveals that even for the thickest antenna ($\Omega=10$), I_z does not differ greatly from a simple cosine as given by (61), but with Z_{00} standing for the actual input impedance calculated from (60). These are

$$\Omega = 10, \quad Z_{00} = 64.8 + j29.7 = 71.2 \angle 24^\circ.6 \tag{66a}$$

$$\Omega = 20, \quad Z_{00} = 69.6 + j35.7 = 78.6 \angle 27^\circ.2 \tag{66b}$$

$$\Omega = 30, \quad Z_{00} = 70.3 + j37.6 = 79.8 \angle 28^\circ.2 \tag{66c}$$

Although the phase angle θ of the current as shown in Fig. 14 is not perfectly constant over the length of the antenna it varies only a few degrees from the value at the input terminals.

ANTENNAS IN GENERAL

If an antenna differs even slightly in half length from a quarter wavelength for which $\beta h = \pi/2$ it is not at all clear from (39) that an approximate formula of the type (61) or (53) may be used unless the antenna is infinitely thin. Because the term in $1/\Omega$ in the denominator of (39) is small, the term $\cos \beta h$ will be significant even though βh differs very little from $\pi/2$. The impedance formula (51) also changes very rapidly in the vicinity of $\beta h = \pi/2$. Nevertheless the actual computation of I_z for βh sufficiently below $\pi/2$ so that an antenna for which $\Omega = 20$ is self-resonant with $X_{00} = 0$ (Figs. 7 and 13) shows that $|I_z|$ differs but little from a sine curve measured from the upper ends with $h - |z|$ as variable, and that the phase angle θ stays very nearly constant at a value near that for I_0 even for thick antennas. On the other hand, antennas which are sufficiently long so that βh appreciably exceeds $\pi/2$, as in Figs. 15 to 18, $|I_z|$ cannot be represented very satisfactorily by a simple sine curve nor does the phase angle θ remain constant at anywhere near its value for I_0 . One must conclude, therefore, that the distribution of current along antennas only of such lengths that βh does not exceed appreciably the value $\pi/2$ may be represented with fair accuracy by

$$I_z = I_0 \frac{\sin \beta(h - |z|)}{\sin \beta h} \tag{67}$$

with $I_0 = V_0^\circ / Z_{00}$. (68)

Here Z_{00} is the input impedance computed from the accurate formula (51) or obtained from the curves given in footnote reference 4. If the half-length of the antenna is much greater than $\lambda/4$, in particular, if it approaches or exceeds $\lambda/2$, a representation in terms of (67) and (68) is not satisfactory.

Since a single distribution function with a constant phase angle is not in general adequate, one is faced with the necessity of complicating the representation. Clearly a much better approximation at the expense of only a small increase in complexity would result if each component I_z' and I_z'' in

$$I_z = I_z'' + jI_z' = \frac{V_0^\circ}{60\Omega} (f'' + jf') \tag{69}$$

were separately represented by a simple trigonometric function. This is actually possible to a very satisfactory degree of approximation. The representation is the following:

$$I_z = V_0^\circ \left[G_{00} \left(\frac{\cos \beta z - \cos H}{1 - \cos H} \right) - jB_{00} \left(\frac{\sin(H - \beta|z|)}{\sin H} \right) \right] \tag{70}$$

Here $H = \beta h$, G_{00} is the input conductance, and B_{00} the input susceptance of the antenna in question. The admittance, $1/Z_{00} = Y_{00} = G_{00} - jB_{00}$, for each of the several lengths considered above is given in Table I. In order to show that (70) is a good representation of the

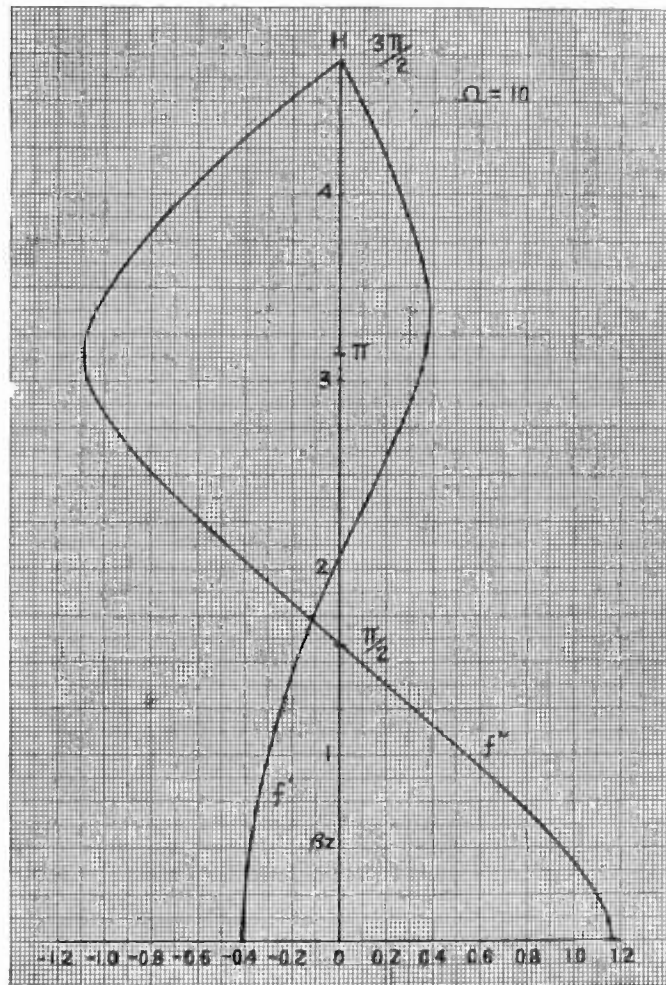

Fig. 12—The distribution functions f' and f'' for $H = 3\pi/2$.

actual distribution one notes in the first place that the input current I_0 is exactly right for all lengths. The distribution along the antenna given by (70) may be compared with the actual distributions using Figs. 19 and 20. These show the true distribution functions, f' and f'' , as obtained from Figs. 8 to 12 each plotted with the appropriate trigonometric function which is supposed to represent it approximately in (70). (In Figs. 19 and 20, f' and f'' have been adjusted in scale so that the values at $z = 0$ coincide. Actually the admittance factors G_{00} and $-B_{00}$ in (70) serve to change the scales of the trigonometric functions respectively to give the correct values at $z = 0$. For purposes of plotting and comparison it was more convenient to adjust f' and f'' to the trigonometric functions rather than vice versa.) It is seen that the representation of the analytically extremely complex functions f' and f'' in terms of the simple trigonometric functions is surprisingly good over practically the entire range of lengths shown. The poorest approximation is near $h = \lambda/2$, as shown in Fig. 19. Because no antenna of physically realizable radius is antiresonant at $h = \lambda/2$, B_{00} does not vanish and the imaginary term in (70) becomes infinite. This difficulty can be avoided by introducing a fictitious

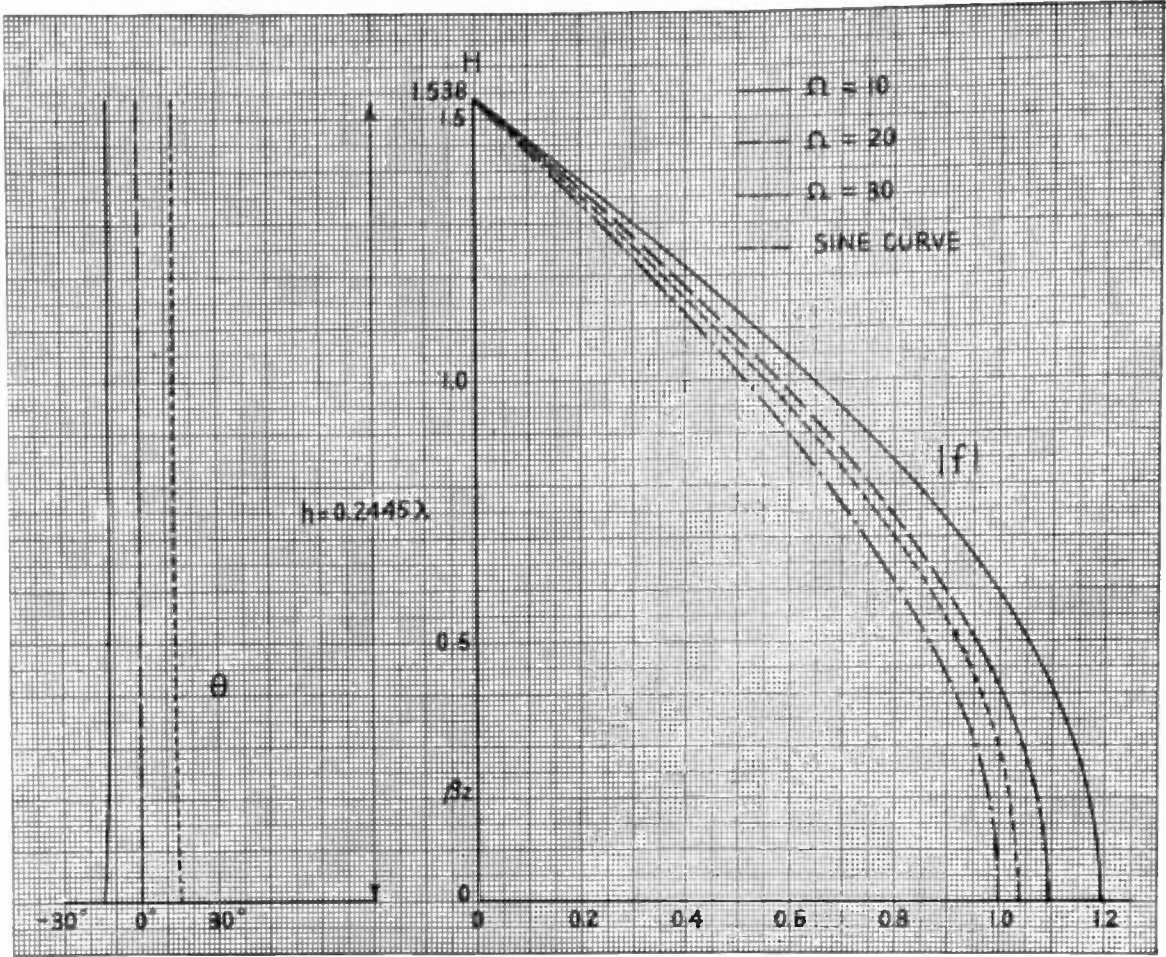

Fig. 13—The amplitude function $|f|$ and the phase function θ for $H = 1.538$.

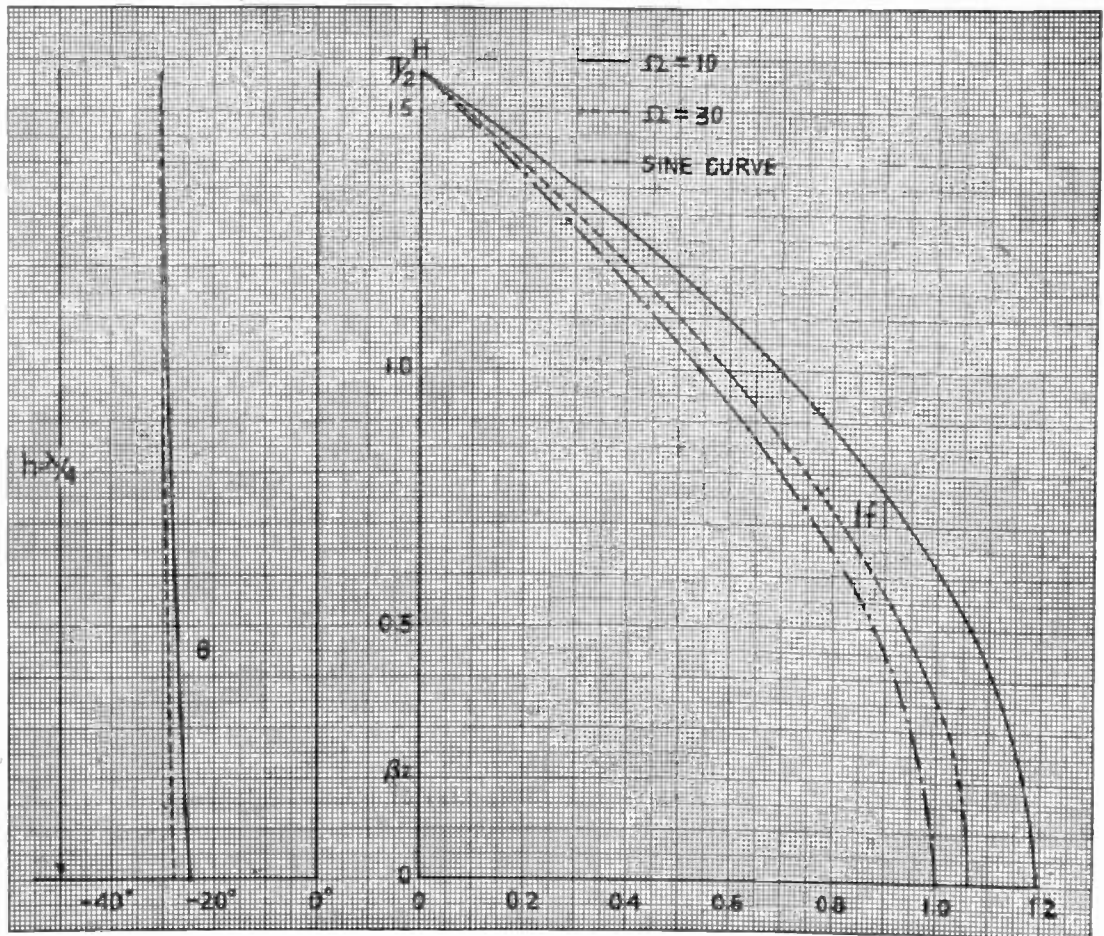

Fig. 14—The amplitude function $|f|$ and the phase function θ for $H = \pi/2$.

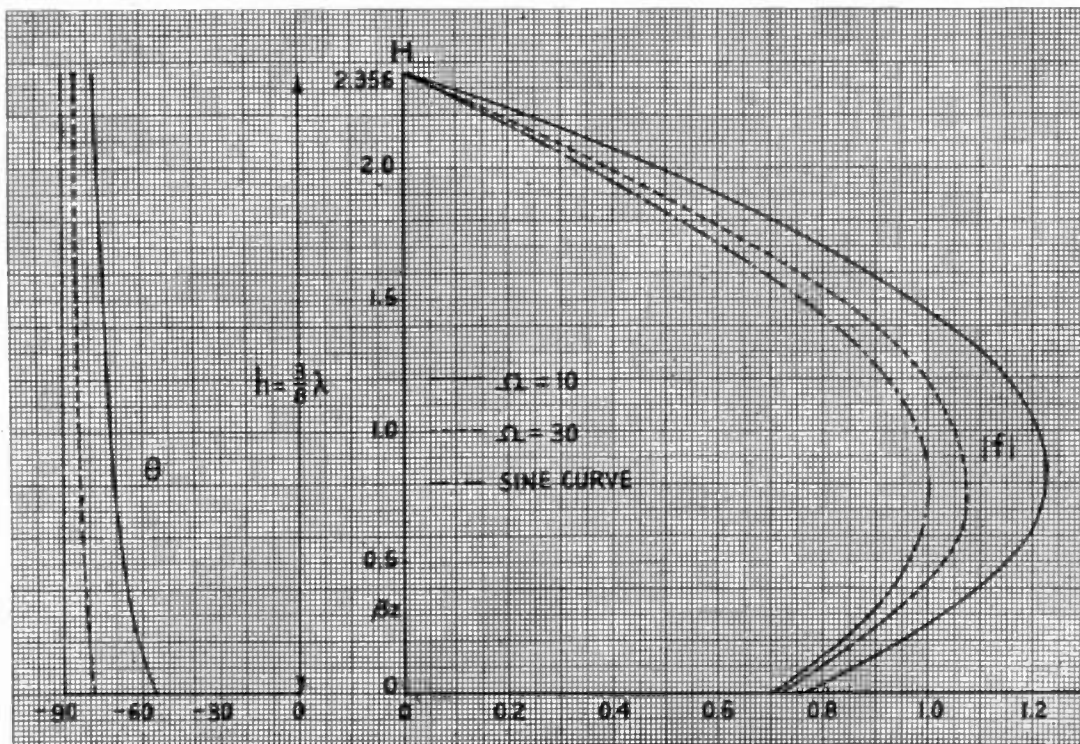

Fig. 15—The amplitude function $|f|$ and the phase function θ for $H = 3\pi/4$.

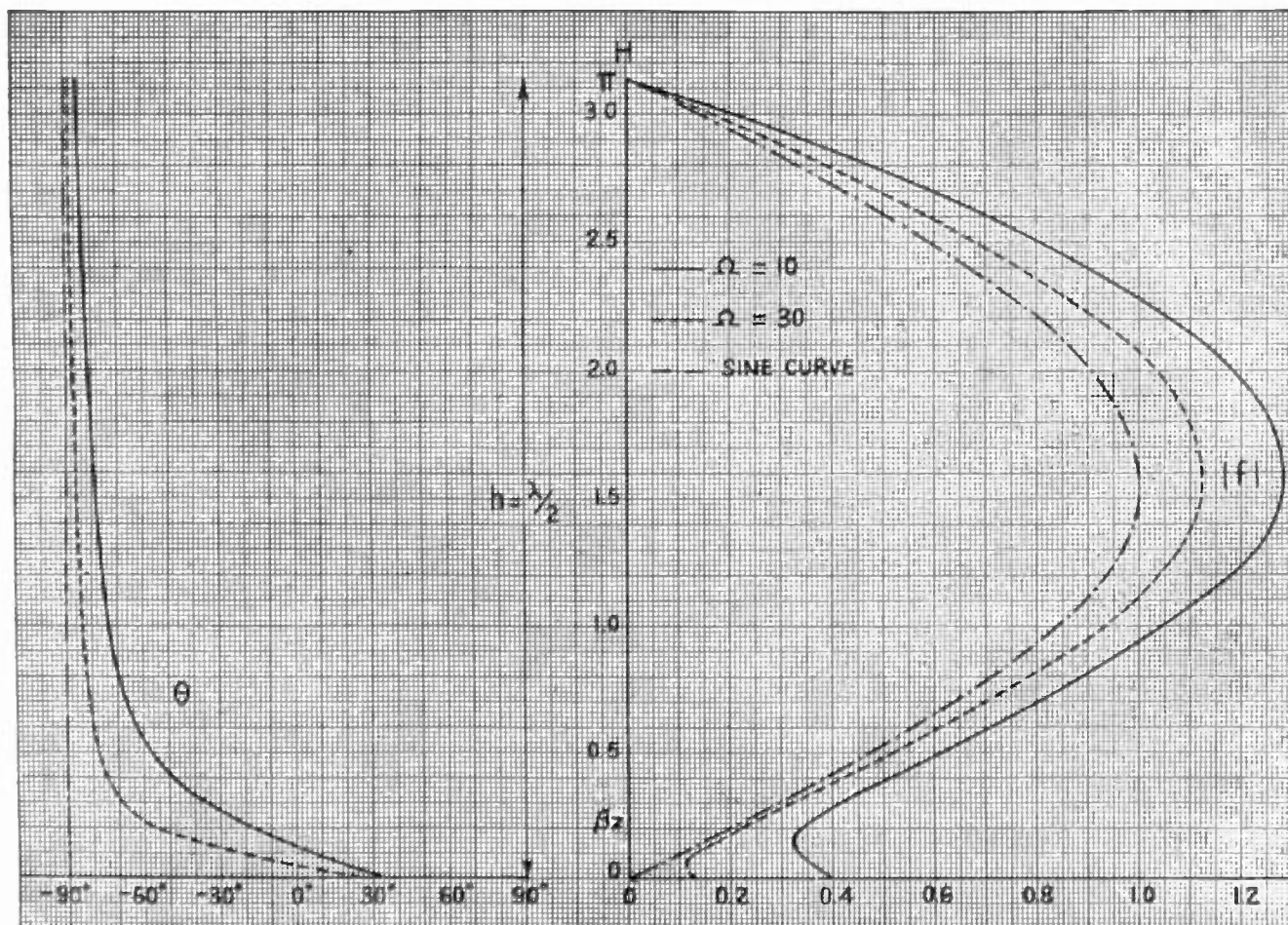

Fig. 16—The amplitude function $|f|$ and the phase function θ for $H = \pi$.

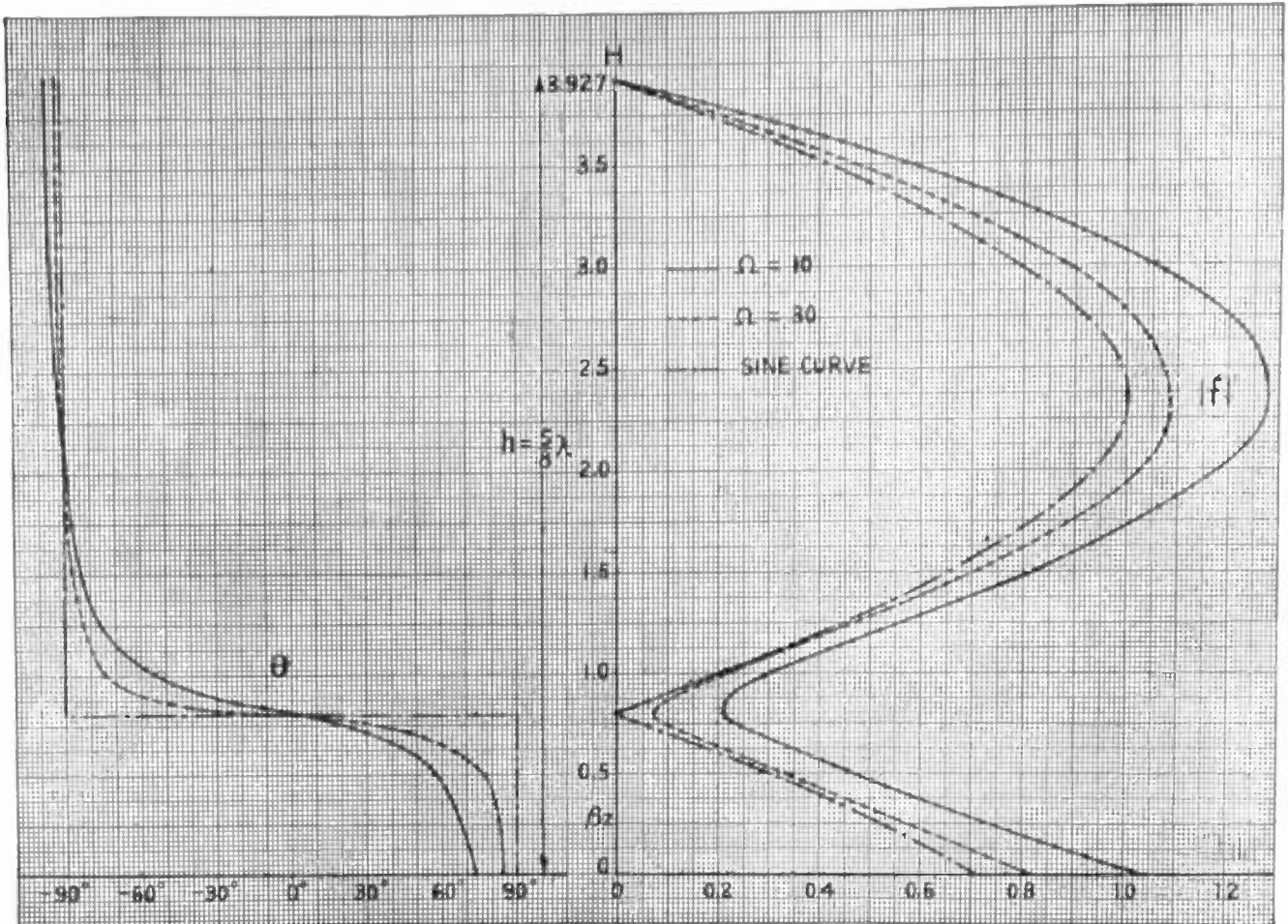

Fig. 17—The amplitude function $|f|$ and the phase function θ for $H=5\pi/4$.

and slightly greater length h' in the form $\beta h' = II'$ for II' in (70), and adjusting h' so that $\sin (II' - \beta|z|) / (\sin II')$ crosses the axis at or near the point where f' crosses it. ($II' - H$ should be approximately equal to $\pi/2 - II_r$, where II_r is the value of II producing anti-resonance for the particular choice of Ω . It may be obtained from Fig. 12 or equation (29b) in footnote reference 4.) At anti-resonance, both B_{00} and $\sin II'$ must vanish. The indeterminate form $(V_0 \epsilon B_{00}) / (\sin II')$ must then be replaced by the maximum value of I'_r . This always occurs near $z = h - (\lambda/4)$.

For purposes of calculating electromagnetic fields due to antennas of practically encountered thicknesses the distribution function (70) is a very much better approximation than the form (67) with (68) which is unsatisfactory over most of the range. (It is to be noted that at $H = n\pi/2$ with n odd (70) reduces exactly to (67).) The application of (70) in computing electromagnetic fields is reserved for a later paper.

RADIATION RESISTANCE REFERRED TO MAXIMUM CURRENT

A common method of estimating the total power radiated from an antenna is to integrate the Poynting vector over a spherical surface in the far zone of the

antenna. The calculation of the Poynting vector from the electric and magnetic fields is based on the assumption that the distribution of current has the simple sinusoidal form which is strictly accurate only for an indefinitely thin antenna. The total power so computed is then divided by the square of the maximum current (at $\lambda/4$ from the end of the antenna) to obtain the radiation resistance referred to maximum current. The curve marked $\Omega = \infty$ in Fig. 21 is that obtained and commonly reproduced for the sinusoidal distribution of current. Because the distribution of current in practical antennas is never exactly sinusoidal, even for $h = \lambda/4$ where the approximation is best, the radiation resistance so obtained is not accurate for them. Its correct value (neglecting power consumed in heating the antenna which is less than 3 per cent for copper antennas) can be determined as follows: Let the radiation resistance referred to maximum current be defined by

$$R_m^c = \frac{P_0}{|I_m|^2} \quad (71)$$

Here P_0 is the power supplied to the antenna at its input terminals and, neglecting power consumed in heating the conductor, also the power radiated.

$$|I_m|^2 = [\sqrt{I_r'^2 + I_r''^2}]_{\max} \quad (72)$$

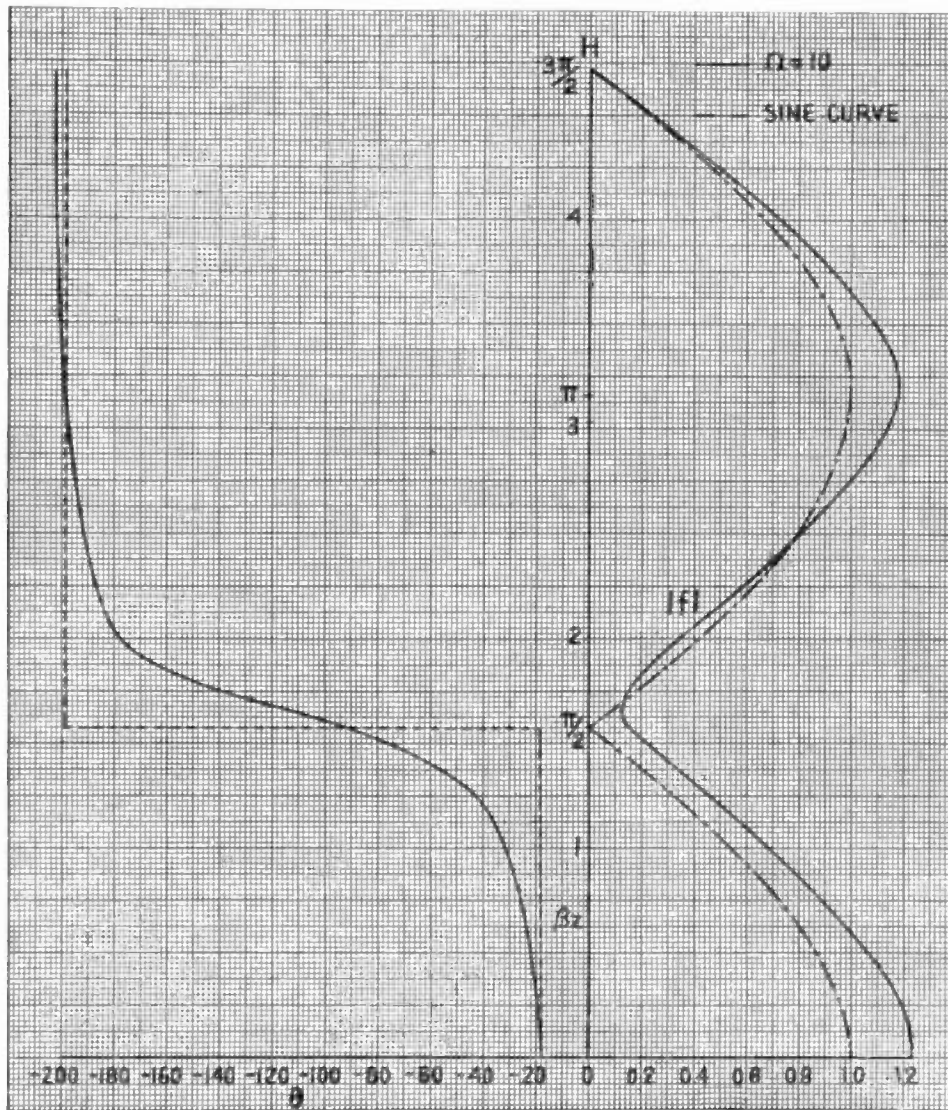

Fig. 18—The amplitude function $|f|$ and the phase function θ for $H = 3\pi/2$.

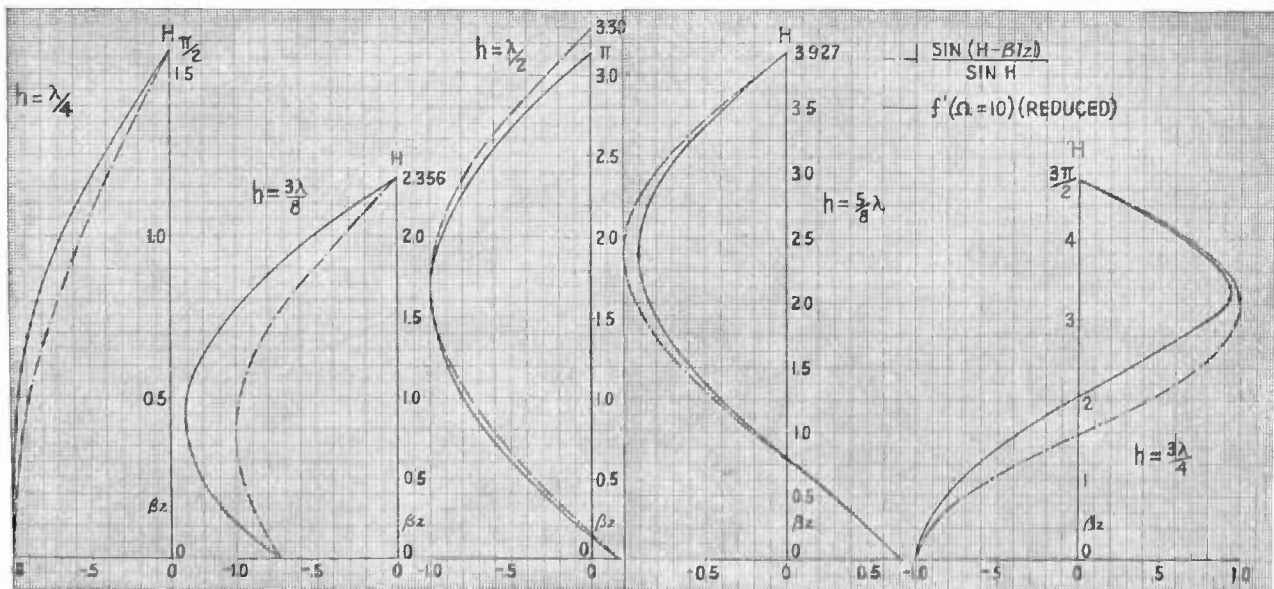

Fig. 19—The function $\sin(H - \beta|z|)/\sin H$ compared with the distribution function f' reduced to the same value at $z = 0$.

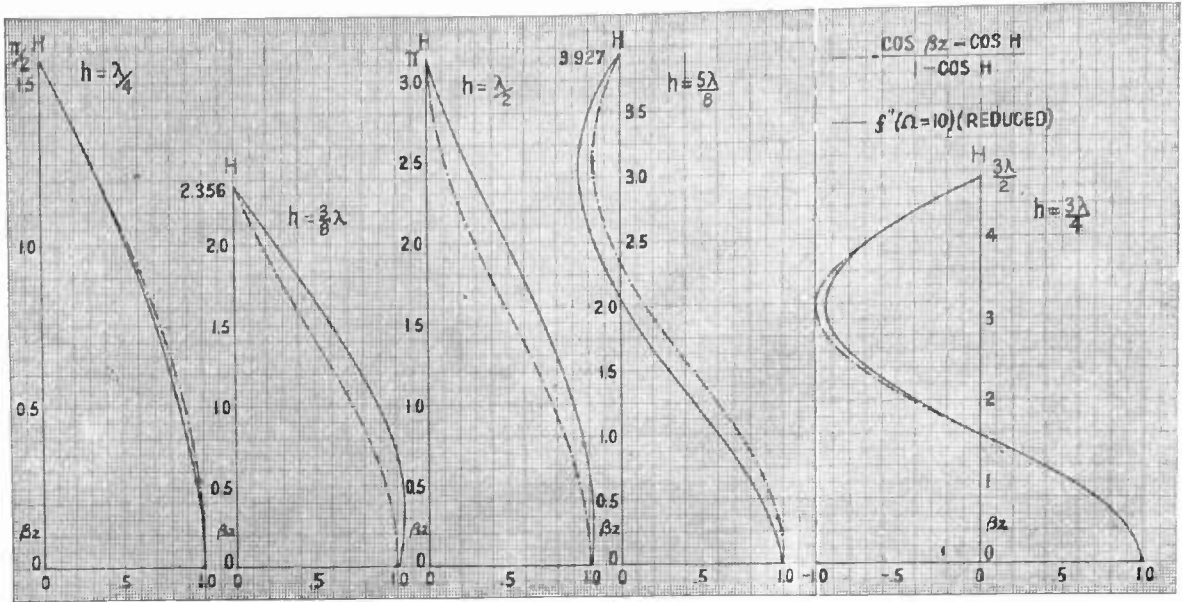

Fig. 20—The function $(\cos \beta z - \cos H)/(1 - \cos H)$ compared with the distribution function f'' reduced to the same value at $z=0$.

Since $P_0 = |I_0|^2 R_{00}$ (73)

one has $R_m^e = \left| \frac{I_0}{I_m} \right|^2 R_{00}$. (74)

Since $|I_0|$ and $|I_m|$ are readily determined from Figs. 13 to 18 and R_{00} may be computed directly from (11a), using Table I in footnote reference 4 for the particular value of Ω , R_m^e may be determined. The values so computed for the several lengths for which current data are available are shown plotted in small circles in Fig. 21 for a relatively thin antenna ($\Omega=30$) and a moderately thick antenna ($\Omega=10$). Although the number of avail-

able points is not sufficient to determine accurately the resulting curves near their maxima and minima, the general shape and position relative to the familiar curve for the simple sine distribution ($\Omega = \infty$) are correctly given. It is clear that the curve based on the sine distribution is not at all a good approximation for even moderately thick antennas except for lengths with H near $H = n\pi/2$ with n odd where the sinusoidal distribution is least in error. Even here it may be in error by as much as 50 per cent for very thick antennas. Actually R_m^e is completely unnecessary if the input impedance of an antenna is known.

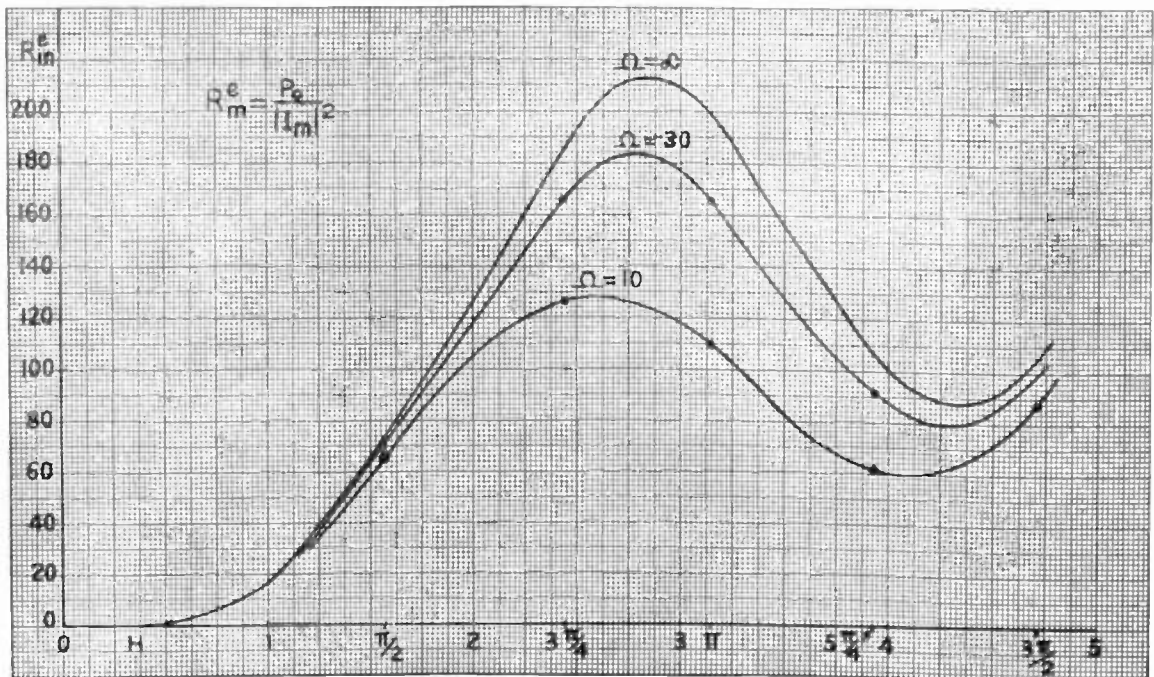

Fig. 21—The radiation resistance R_m^e referred to maximum current I_m . The curve marked $\Omega = \infty$ is accurately computed throughout. The curves marked $\Omega = 10$ and $\Omega = 30$ are estimated using only the insufficient number of accurately computed points shown by small circles.

APPENDIX I

The complex amplitude of the vector potential defined by (5) satisfies the Helmholtz equation

$$\nabla^2 A + \beta^2 A = i\Pi. \tag{75}$$

Here i is the volume density of current flowing, in this case, in the antenna. The Helmholtz integral which satisfies (75) is

$$A = \frac{\Pi}{4\pi} \int_{\tau} \frac{i'}{R_1} e^{-i\beta R_1} d\tau'. \tag{76}$$

Here τ is the volume of the cylindrical antenna, $d\tau'$ is an element of τ , i' is the current density at $d\tau'$, and R_1 is the distance between the point (r, θ, z) where A is computed and the element $d\tau'$ at (r', θ', z') . Since the radial component A_r can be due to i_r only, the inequality (8a) is readily verified. The z component is

$$A_z = \frac{\Pi}{4\pi} \int_{\tau} \frac{i_z'}{R_1} e^{-i\beta R_1} d\tau'. \tag{77}$$

It is to be proved that A_z evaluated from (22) on the cylindrical surface of the antenna differs by a negligible amount from A_z computed from the exact formula (75). I_z' in (22) is defined by

$$I_z' = \int_0^a \int_0^{2\pi} i_z' r dr d\theta = 2\pi \int_0^a i_z' r dr \tag{78}$$

since rotational symmetry may be assumed. Thus it must be shown that the following difference is vanishingly small.

$$D = \int_{-h}^{+h} \int_0^a \int_0^{2\pi} \frac{i_z'}{R_1} e^{-i\beta R_1} r d\theta' dr' dz' - \int_{-h}^{+h} \frac{I_z'}{R} e^{-i\beta R} dz'. \tag{79}$$

Here R is the distance from any point outside the antenna and not near the end faces where A is to be calculated, in particular a point on its cylindrical surface, to the element dz' on the axis of the antenna. R_1 is the distance from the same outside point to an element $rd\theta' dr' dz'$ in a cross section of the antenna at the center of which dz' is defined. This is illustrated in Fig. 22.

Because of rotational symmetry i_z' is independent of θ' and may be removed outside the sign of integration with respect to θ' . Thus with (78)

$$D = \int_{-h}^{+h} dz' \int_0^a i_z' r dr' \int_0^{2\pi} \left[\frac{e^{-i\beta R_1}}{R_1} - \frac{e^{-i\beta R}}{R} \right] d\theta'. \tag{80a}$$

It follows directly from (3) or from Fig. 22 that R_1 can differ from R at most by magnitudes of the order of the radius a of the cylinder. If R_1 and R are large compared with a , they will differ from each other by a negligible amount and the difference in the brackets in (6) will be vanishingly small. Accordingly, significant contributions to D for points on the surface of the antenna where $r=a$ can come only from that part of the integration with respect to z' for which $(z-z')$ is not large compared with a , i.e., from sections of the surface which are very close to the circumference at z' . It follows that the distribution of current at more distant

points and even the length of the antenna can make no difference in the integral except at points very near the ends. Thus one may integrate from $-\infty$ to $+\infty$ and assume i_z' independent of the integration with respect to z' . Furthermore, since significant contributions

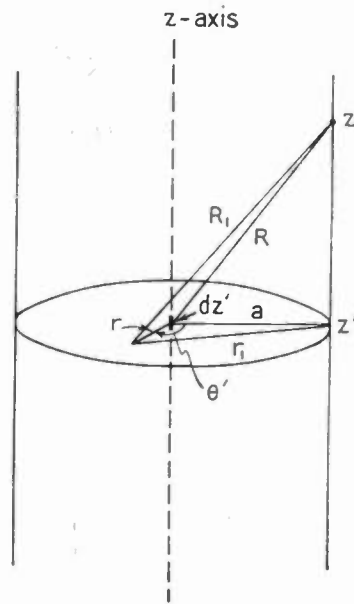

Fig. 22—A section through the antenna.

are obtained only for distances comparable in magnitude with a , and since with (3) $e^{-i\beta a} \approx 1$, the two exponentials may be set equal to unity in the range of significant contributions. This leaves

$$D = \int_0^a i_z' r dr' \int_0^{2\pi} d\theta' \int_{-\infty}^{+\infty} \left(\frac{1}{R_1} - \frac{1}{R} \right) dz'. \tag{80b}$$

The integral with respect to z' can be integrated directly into $\ln(a/r_1)^2$ with r_1 indicated in Fig. 22. If this is integrated with respect to θ' the integral vanishes. Thus D is entirely negligible except at points within distances of the ends of the antenna comparable with a . The contributions of these short sections were made negligible by imposing (3a).

(It is interesting to note that the rigorous derivation of the transmission-line equations for parallel wires from fundamental electromagnetic theory depends upon exactly the same demonstration in that (22) is assumed valid on the surface of each parallel wire.)

APPENDIX II

In order to derive the solution (39) from the integral equation (38) it is convenient to introduce the following shorthand notation:

$$F_0(z) \equiv \cos \beta z; \quad G_0(z) \equiv \sin \beta |z| \tag{81}$$

$$F_{0z} \equiv F_0(z) - F_0(h); \quad G_{0z} \equiv G_0(z) - G_0(h). \tag{82}$$

The first brace in (38) will be denoted by $(I_z)_0$. Using the above notation it is

$$(I_z)_0 = \frac{-j4\pi}{\Omega R_c} \{ C_1 F_{0z} - \frac{1}{2} V_0 G_{0z} \}. \tag{83}$$

It may be regarded as a zeroth order approximation for I_z . If it is substituted in the rest of the terms in (38), all

of which include the current as a factor, terms will be obtained which are multiplied by $1/\Omega^2$. They will be denoted by $(I_z')_0$. They are

$$(I_z')_0 = \frac{-j4\pi}{\Omega^2 R_c} \{C_1 F_{1z} - \frac{1}{2} V_0 \epsilon G_{1z}\} \quad (84)$$

with

$$F_{1z} \equiv F_1(z) - F_1(h); \quad G_{1z} \equiv G_1(z) - G_1(h) \quad (85)$$

and

$$F_1(z) = -F_{0z} \ln \left(1 - \frac{z^2}{h^2} \right) + F_{0z} \delta - \int_{-h}^{+h} \frac{F_{0z}' e^{-i\beta R}}{R} dz' - \left\{ -\frac{j4\pi z^i}{R_c} \int_0^z F_{0z} \sin \beta(z-s) ds \right\} \quad (86)$$

$$F_1(h) = - \left\{ \int_{-h}^{+h} \frac{F_{0z}' e^{-i\beta R_h}}{R_h} dz' - \frac{j4\pi z^i}{R_c} \int_0^h F_{0z} \sin \beta(h-s) ds \right\} \quad (87)$$

$G_1(z)$ is exactly like $F_1(z)$ with G written for F throughout. (88)

$G_1(h)$ is exactly like $F_1(h)$ with G written for F throughout. (89)

The first-order approximation for I_z is now given by $(I_z)_1 \equiv (I_z)_0 + (I_z')_0$

$$= \frac{-j4\pi}{\Omega R_c} \left\{ C_1 \left[F_{0z} + \frac{F_{1z}}{\Omega} \right] + \frac{1}{2} V_0 \epsilon \left[G_{0z} + \frac{G_{1z}}{\Omega} \right] \right\} \quad (90)$$

If this expression is substituted for I_z on the right in (38) a second-order approximation may be obtained. This may be substituted back in (38) to obtain a third-order solution. The process may be continued indefinitely to obtain a series solution of the form

$$I_z = \frac{-j4\pi}{\Omega R_c} \left\{ C_1 \left[F_{0z} - \frac{F_{1z}}{\Omega} + \frac{F_{2z}}{\Omega^2} + \dots \right] + \frac{1}{2} V_0 \epsilon \left[G_{0z} + \frac{G_{1z}}{\Omega} + \frac{G_{2z}}{\Omega^2} + \dots \right] \right\} \quad (91)$$

The constant of integration C_1 , can now be evaluated directly by substituting the solution (91) for I_z in (36). If this is done one has

$$0 = \frac{-j4\pi}{\Omega R_c} \left\{ C_1 \left[F_0(h) + \frac{F_1(h)}{\Omega} + \dots \right] + \frac{1}{2} V_0 \epsilon \left[G_0(h) + \frac{G_1(h)}{\Omega} + \dots \right] \right\} \quad (92)$$

This can be solved for C_1 as follows:

$$C_1 = -\frac{1}{2} V_0 \epsilon \frac{\{G_0(h) + (1/\Omega) G_1(h) + \dots\}}{\{F_0(h) + (1/\Omega) F_1(h) + \dots\}} \quad (93)$$

If this is inserted in (91) one has the solution for I_z . It is

$$I_z = \frac{j2\pi V_0 \epsilon}{\Omega R_c} \left\{ \frac{[F_{0z} + F_{1z}/\Omega + \dots][G_0(h) + G_1(h)/\Omega + \dots] - [G_{0z} + G_{1z}/\Omega + \dots][F_0(h) + F_1(h)/\Omega + \dots]}{F_0(h) + F_1(h)/\Omega + \dots} \right\} \quad (94)$$

After rearranging using (82) and (85) one has precisely (39).

In carrying out the evaluation of the function $F_1(z)$, $F_1(h)$, $G_1(z)$, and $G_1(h)$ as defined in (86) and (87), advantage can be taken of the fact that a^2 is negligible compared with $(h-z)^2$ and $(h+z)^2$ except for points very near the ends of the antenna. At the ends errors as large as 50 per cent are involved. However, since the current necessarily vanishes at the ends, the distribution of current is actually not significantly affected. At most the current within distances of the ends comparable with the radius a may be in error by an appreciable amount, but this error becomes negligible at distances of three or four times the radius from the end. Actually in computing the current, points need not be taken within distances of the ends comparable with the radius a and a curve connecting points at distances of $5a$ or more from the ends to zero values at the ends must give the correct distribution. Accordingly the term in δ may be neglected and one may write

$$R \doteq |z' - z| \quad (95)$$

in the integrals. It is especially important to note that the approximations here introduced are extremely good for the current at all points except near the ends where it is known to vanish. In particular, the input current, and hence the input impedance, is in no way affected if (3) is fulfilled.

If one makes use of (95) all integrals in (86) to (89) are readily evaluated without further approximations in terms of trigonometric functions or the integral functions defined below.

$$\int_a^b \frac{1 - \cos u}{u} du = \overline{\text{Ci}}(b) - \overline{\text{Ci}}(a) \quad (96)$$

$$\int_a^b \frac{\sin u}{u} du = \text{Si}(b) - \text{Si}(a) \quad (97)$$

The final forms are

$$F_1(z) = -(\cos \beta z - \cos \beta h) \ln(1 - z^2/h^2) + \frac{1}{2} \cos \beta z [\overline{\text{Ci}} 2\beta(h+z) + \overline{\text{Ci}} 2\beta(h-z)] + j \text{Si} 2\beta(h+z) + j \text{Si} 2\beta(h-z) - \frac{1}{2} \sin \beta z [\text{Si} 2\beta(h+z) - \text{Si} 2\beta(h-z)] - j \overline{\text{Ci}} 2\beta(h+z) + j \overline{\text{Ci}} 2\beta(h-z) - \cos \beta h [\overline{\text{Ci}} \beta(h+z) + \overline{\text{Ci}} \beta(h-z)] + j \text{Si} \beta(h+z) + j \text{Si} \beta(h-z) + j \frac{4\pi z^i h}{R_c} \left[\frac{z}{2h} \sin \beta z - \frac{\cos \beta h}{\beta h} (1 - \cos \beta z) \right] \quad (98)$$

$$G_1(z) = -(\sin \beta |z| - \sin \beta h) \ln(1 - z^2/h^2) - \frac{1}{2} \cos \beta z [\text{Si} 2\beta(h+z) + \text{Si} 2\beta(h-z)] - 2 \text{Si}(2\beta |z|) - j \overline{\text{Ci}} 2\beta(h+z) - j \overline{\text{Ci}} 2\beta(h-z) + 2j \overline{\text{Ci}}(2\beta z) - \frac{1}{2} \sin \beta z [\overline{\text{Ci}} 2\beta(h+z) - \overline{\text{Ci}} 2\beta(h-z)] + j \text{Si} 2\beta(h+z) - j \text{Si} 2\beta(h-z) - 2j \text{Si}(2\beta z)$$

$$\begin{aligned}
& -\frac{1}{2} \sin \beta |z| \left[4 \ln \frac{|z|}{h+|z|} - 2 \overline{\text{Ci}}(2\beta z) \right] \\
& - \sin \beta h [\overline{\text{Ci}} \beta(h+z) + \overline{\text{Ci}} \beta(h-z)] \\
& + j \text{Si} \beta(h+z) + j \text{Si} \beta(h-z) \\
& + j \frac{4\pi z^i h}{R_c} \left[\frac{\sin \beta |z|}{2\beta h} - \frac{|z| \cos \beta z}{2h} \right. \\
& \left. - \frac{\sin \beta h}{\beta h} (1 - \cos \beta z) \right] \quad (99)
\end{aligned}$$

$$\begin{aligned}
P_1(h) &= \frac{1}{2} \cos \beta h [\overline{\text{Ci}}(4\beta h) + j \text{Si}(4\beta h)] \\
& - \frac{1}{2} \sin \beta h [\text{Si}(4\beta h) - j \overline{\text{Ci}}(4\beta h)] \\
& - \cos \beta h [\overline{\text{Ci}}(2\beta h) + j \text{Si}(2\beta h)]
\end{aligned}$$

$$\begin{aligned}
& + j \frac{4\pi z^i h}{R_c} \left[\frac{\sin \beta h}{2} - \frac{\cos \beta h}{\beta h} (1 - \cos \beta h) \right] \quad (100) \\
G_1(h) &= -\frac{1}{2} \cos \beta h [\text{Si}(4\beta h) - 2 \text{Si}(2\beta h) \\
& - j \overline{\text{Ci}}(4\beta h) + 2j \overline{\text{Ci}}(2\beta h)] \\
& - \frac{1}{2} \sin \beta h [\overline{\text{Ci}}(4\beta h) + j \text{Si}(4\beta h) \\
& - 2j \text{Si}(2\beta h) - 2 \overline{\text{Ci}}(2\beta h) - 4 \ln 2] \\
& - \sin \beta h [\overline{\text{Ci}}(2\beta h) + j \text{Si}(2\beta h)] \\
& - j \frac{4\pi z^i h}{R_c} \left[\frac{\sin \beta h}{2\beta h} + \frac{1}{2} \cos \beta h - \frac{\sin \beta h \cos \beta h}{\beta h} \right] \quad (101)
\end{aligned}$$

The terms in z^i were neglected in computing the curves of Figs. 2 to 6. They are entirely negligible if the antenna is a good conductor.

It has been planned to present in the PROCEEDINGS of the I.R.E. instructional material of timely interest. This procedure was instituted some time ago, and here continues by the publication, in successive issues of the PROCEEDINGS, of a series of co-

ordinated parts, together entitled "Some Aspects of Radio Reception at Ultra-High Frequency" by Messrs. E. W. Herold and L. Malter. Parts IV and V of the five parts are here presented. Each Part is preceded by its own related summary. *The Editor*

Some Aspects of Radio Reception at Ultra-High Frequency*

E. W. HEROLD†, MEMBER, I.R.E., AND L. MALTER‡, ASSOCIATE, I.R.E.

PART IV. GENERAL SUPERHETERODYNE CONSIDERATIONS AT ULTRA-HIGH FREQUENCIES

L. MALTER‡

Summary—This paper presents a general survey of the problems encountered in the mixer or converter stage of superheterodyne receivers, particularly at ultra-high frequencies. The application of a strong local-oscillator voltage causes a periodic variation of the signal-electrode transconductance as a consequence of which intermediate-frequency-current components appear in the output circuit when a signal is also impressed upon the signal electrode. It is demonstrated that intermediate-frequency-current components are present in the output, which differ from the signal frequency by integral multiples of the local-oscillator frequency, if the Fourier analysis of the signal-electrode transconductance contains components which are integral multiples of the local-oscillator frequency. Methods of determining the conversion transconductance for so-called fundamental and harmonic conversion are given.

It is shown that the noise output and input loading of a mixer stage are given by averaging these quantities over a local-oscillator cycle. A discussion of mixer gain is included, with a demonstration that the gain of a mixer stage is given approximately by the product of the conversion transconductance and the impedance of the output circuit (for high-output-impedance tubes).

Considerations regarding image rejection and the undesirability of radiation of oscillator power lead to the conclusion that high intermediate frequencies are desirable.

An extended discussion of whether to use an amplifier or mixer stage in the first stage of a superheterodyne receiver is included. If

* Decimal classification: R361.2. Original manuscript received by the Institute, August 2, 1943.

† RCA Laboratories, Princeton, N. J.

‡ Formerly, RCA Laboratories, Princeton, N. J.; now, RCA Victor Division, Radio Corporation of America, Lancaster, Pa.

the received signal is strong, one should convert immediately, unless image rejection or the prevention of oscillator radiation necessitate the use of radio-frequency stages. If the received signal is weak, an amplifier stage should be used below a certain frequency and a mixer above, the transition frequency depending upon the characteristics of the tubes available and the bandwidth required. In general the transition frequency occurs at the point where available tubes will no longer give appreciable radio-frequency gain for the bandwidth required.

I. INTRODUCTION

IN PART II of this series we concerned ourselves primarily with the case wherein the signal voltages applied to the circuits and tubes of a receiver are so low in amplitude that the tubes can be considered as linear devices, wherein the output voltage or current is proportional to the signal-electrode voltage. This case will be recognized as being precisely that of the linear amplifier.

It is frequently convenient, however, to make use of the superheterodyne principle in receivers. In receivers of this type, the incoming signal is combined with a locally produced oscillation of different frequency to produce a third signal at a frequency referred to as the intermediate frequency, which is related to both the frequencies of the incoming signal and the locally produced oscillation. It is an essential characteristic of any

electrical device, wherein the simultaneous application of oscillating voltages results in the production of one or more oscillating quantities whose frequencies differ from those of any of the impressed quantities, that the device be *nonlinear*, i.e., that the relation between the output and input (i.e., impressed) variables be of such a nature that it cannot be reduced to a form wherein the variables appear as first-power terms, or that the nature of the device be such that, even though it be linear as regards the application of a single voltage, the simultaneous application of two voltages results in the appearance in the output of a quantity (e.g., a current change) which is dependent upon the product of the two impressed voltages. An example of such a device is a multigrid tube wherein two voltages may be impressed simultaneously on different grids. In this case the change in output current will be related to the changes in the two grid voltages by means of a relation of the form

$$i_p = b_0 + b_1e_1 + b_2e_2 + b_{12}e_1e_2 \quad (1)$$

where the b 's are constants, i_p is the change in plate current, and e_1 and e_2 are the changes in potential of the two grids. Since, in a superheterodyne receiver, the simultaneous application of two voltages of different frequencies results in the production of the intermediate-frequency signal whose frequency differs from those of the two original signals, the superheterodyne receiver must contain a device which has one of the two types of characteristics described above. This device is generally a tube which may (among others) be a diode, triode, or multigrid tube.

In Fig. 1 of Part V (which follows Part IV in this issue) there is shown an incoming signal and locally produced oscillation fed into a diode with the resultant production of intermediate-frequency output. The diode as a device for producing intermediate frequencies is sufficiently important and different from other tubes designed for the same purpose, so as to merit special treatment. It will form the subject matter of Part V of this series.

In the case of triodes or pentodes various modes of introducing the incoming signal and locally produced oscillation are possible. Thus, they may both be impressed between control-grid and cathode, as is illustrated in Fig. 1, or the incoming signal may be impressed between the control grid and ground, while the locally produced oscillation is impressed between cathode and ground. In general the incoming signal and the locally produced oscillations need not be impressed upon the same electrodes. Throughout the remainder of this paper the term signal electrode will refer to the control electrode upon which the incoming signal is impressed.

For many superheterodyne applications at frequencies below 30 megacycles or so, it has been found convenient to make use of multitube grids. In this case, in addition to the possibility of impressing both voltages on the same electrode, one can also have the local-oscillator voltage applied to an electrode which precedes the signal

electrode (inner-grid injection) or the converse (outer-grid injection). Since tubes of this type do not find much application at ultra-high frequencies, their consideration is here terminated, except to indicate that the interested reader may find a more extended treatment in the literature.¹

Before launching into a discussion of the mechanism of mixer action, it may be to the point to outline briefly the outstanding reasons for the use of superheterodyne receivers at ultra-high frequencies:

1. The tuned circuits in intermediate-frequency amplifiers are fixed in frequency, whereas in radio-frequency amplifiers they require tuning to the individual signal. If the receiver is to cover an extended frequency range, the tuning problem for the radio-frequency amplifier may be a serious one.
2. It is often possible to secure a higher gain per stage at intermediate frequencies than at radio frequencies.
3. Better control of frequency response can generally be achieved at intermediate frequencies, particularly if the receiver is to operate over an extended frequency range.
4. It may be possible to achieve a higher signal-to-noise ratio with a superheterodyne type receiver than with a radio-frequency amplifier type.

II. THE MECHANISM OF MIXER ACTION

The mechanism whereby the combination of the incoming signal and the locally produced oscillation serves to produce an intermediate frequency is referred to as "mixing action." The locally produced oscillation may either be generated in the same tube as that in which the mixing action occurs in which case this tube that serves a double function, is referred to as a converter, or the locally produced oscillation may be produced in a separate tube in which case the tube in which the mixing action occurs is referred to as a mixer.

The fact that a nonlinear device can be used for the production of an intermediate-frequency signal, is readily demonstrated by means of a simple illustration. In Fig. 1 there is shown a triode with input circuits upon

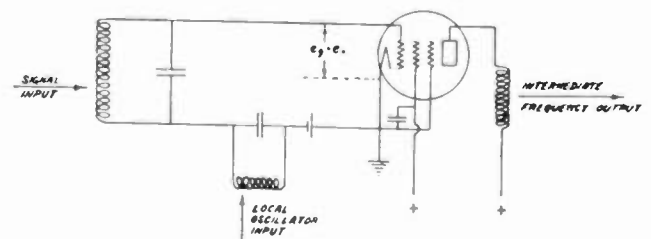

Fig. 1—Circuit of pentode mixer stage wherein incoming signal and local-oscillator voltage are both applied between control grid and cathode.

which are impressed an incoming signal and a locally produced oscillation. These will result respectively in the impression upon the grid of the triode of two

¹ E. W. Herold, "The operation of frequency converters and mixers for superheterodyne reception," *PROC. I.R.E.*, vol. 30, pp. 84-103; February, 1942.

oscillating voltages e_o and e_0 . The presence of these voltages will cause a change in plate current of an amount i_p . Since e_o , e_0 , and i_p are variations away from quiescent values, we can set (by the application of Taylor's theorem)

$$i_p = c_0 + c_1e + c_2e^2 + c_3e^3 + \dots \quad (2)$$

where $e = e_o + e_0$ and the c 's are constants which depend upon the tube and circuit characteristics. For the amplifier case, e is so small that the terms of higher power than the first may be neglected. Equation (2) then becomes

$$i_p = c_0 + c_1e. \quad (2a)$$

From (2a) it may be seen that i_p will contain as components, terms whose frequency is the same as those present in e . For the generation of current components of frequencies different from those of e_o and e_0 it is essential that e be sufficiently great so that some of the terms in (2) of the second or higher degree become of importance. Since e_s is, in general, comparatively small, e_0 must be comparatively large in order that the relation between i_p and e be nonlinear. Actually, while e_s is generally of the order of microvolts or millivolts, e_0 is usually measured in volts.

To see that a nonlinear relationship of the form of (1) results in the production of terms of frequencies different from those of e_o and e_0 , let us consider the simple case wherein the terms of powers higher than the second may be neglected. Then

$$i_p = c_0 + c_1(e_o + e_0) + c_2(e_o + e_0)^2. \quad (3)$$

$$\text{Let } e_s = E_s \sin \omega_s t \quad (4)$$

$$e_0 = E_0 \sin \omega_0 t. \quad (5)$$

$$\text{Then } i_p = c_0 + c_1E_s \sin \omega_s t + c_1E_0 \sin \omega_0 t + c_2E_s^2 \sin^2 \omega_s t + 2c_2E_sE_0 \sin \omega_s t \sin \omega_0 t + c_2E_0^2 \sin^2 \omega_0 t \quad (6)$$

$$= c_0 + c_1E_s \sin \omega_s t + c_1E_0 \sin \omega_0 t + (c_2E_s^2)/2 + (c_2/2)E_s^2 \sin 2\omega_s t + c_2E_sE_0 \cos(\omega_s - \omega_0)t - c_2E_sE_0 \cos(\omega_s + \omega_0)t + (c_2E_0^2)/2 + [(c_2E_0^2)/2] \sin 2\omega_0 t. \quad (7)$$

Thus, in addition to terms of angular frequency ω_s and ω_0 , there appear in the plate current terms of angular

frequency $2\omega_0$, $2\omega_s$, $|\omega_s - \omega_0|$, and $|\omega_s + \omega_0|$. If the output circuit in Fig. 2 is resonant to angular frequency $|\omega_s - \omega_0|$, voltage at this angular frequency will be developed across the circuit. This may then be applied to later intermediate-frequency amplifier stages. For the case just treated the intermediate frequency may be of angular frequency $|\omega_s - \omega_0|$ or $|\omega_s + \omega_0|$. For the general case as represented by (1), the intermediate-frequency term will be of the form $|n_1\omega_s \pm n_2\omega_0|$ where n_1 and n_2 are integers. The output circuit is made to resonate at the particular angular frequency which is chosen for intermediate-frequency amplification. The most common choice is the one wherein $n_1 = n_2 = 1$ and $\omega_i = |\omega_s - \omega_0|$, where ω_i is the angular frequency of the intermediate-frequency signal.

The preceding treatment, while of value in portraying the mechanism whereby the mixing action is brought about, is unsatisfactory for numerical computations, since, for normal tube characteristics, and for large oscillator voltages, it leads to exceedingly complex expressions and very laborious computations. A more elegant mode of attack upon the problem of computing mixer action has been described by Herold.¹ Before entering into this it is necessary to introduce the quantity known as conversion transconductance which is defined as the ratio of the intermediate-frequency output current to the signal-electrode input voltage.

As was pointed out above, one mode of operation is that in which the local-oscillator signal should be sufficiently large so as to result in nonlinear operation of the mixer or converter. While the nonlinearity was defined in terms of the relation of output-current-to-signal-electrode voltage, it is obvious that the nonlinearity must at the same time extend to the signal-electrode-to-plate transconductance. As a consequence, due to the presence of the "large" local-oscillator voltage, the instantaneous signal-electrode transconductance may be considered as varying periodically at local-oscillator frequency, and may thus be expressed in the form of a Fourier series

$$g_m = a_0 + a_1 \cos \omega_0 t + a_2 \cos 2\omega_0 t + \dots \quad (8)$$

where the a 's are constants which depend upon the tube characteristic, the quiescent or operating point, and upon the magnitude of the local-oscillator voltage. Since $\omega_0 = 2\pi f_0$, where f_0 is the local-oscillator frequency, the signal-electrode transconductance may be considered as being made up of an infinite number of components, the first being an average value a_0 , the second a term of oscillator frequency, the third a term of twice oscillator frequency, etc. Now, simultaneous with the application of the local-oscillator voltage, let a signal voltage $E_s \sin \omega_s t$ be applied to the signal electrode. Then the plate current will be given by

$$i_p = g_m E_s \sin \omega_s t. \quad (9)$$

For g_m in (9) we substitute its value from (8) and obtain

$$i_p = a_0 E_s \sin \omega_s t + E_s \sum_{n=1}^{\infty} a_n \sin \omega_s t \cos n \omega_0 t \quad (10)$$

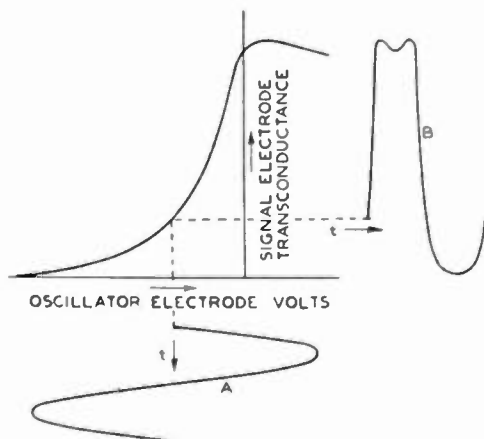

Fig. 2—Signal-electrode transconductance versus oscillator-electrode voltage for a typical mixer tube. The applied oscillator voltage is shown at A and the resultant time variation of the transconductance at B.

$$= a_0 E_s \sin \omega_s t + E_s/2 \sum_{n=1}^{\infty} a_n \sin (\omega_s + n\omega_0)t \quad (11)$$

$$+ E_s/2 \sum_{n=1}^{\infty} a_n \sin (\omega_s - n\omega_0)t.$$

The plate current thus contains components of angular frequency ω_s , $|\omega_s + n\omega_0|$, and $|\omega_s - n\omega_0|$. The first of these is one at signal frequency and does not concern us. The other terms are those which characterize the device as a mixer since they represent new frequency terms related to the signal and local-oscillator frequencies. It is customary to insert a tuned circuit in the output lead of the converter or mixer which is tuned to angular frequency $|\omega_s - \omega_0|$. The voltage developed across this circuit is then fed into the intermediate-frequency amplifier. While this mode of operation (referred to as fundamental operation, since the intermediate frequency is equal in absolute value to the difference between the signal frequency and the fundamental local-oscillator frequency) is generally the preferred one, in certain cases it is convenient to operate at one of the other possible intermediate frequencies for which $n \neq 1$; (referred to as harmonic operation). In these cases, the tuned output circuit is tuned to angular frequency $|\omega_s - n\omega_0|$. It should be noted that for harmonic operation it is not the oscillator voltage or tube current which must contain harmonic components, but the Fourier analysis of the signal-electrode transconductance, when the tube is operated as a mixer. Harmonic operation may be used when generation of a local-oscillator signal of sufficient power at fundamental frequency is difficult. However, in general, harmonic operation yields a lower signal-to-noise ratio than fundamental operation, and is thus avoided, if possible, where signal-to-noise ratio is of fundamental importance (as is the case in many ultra-high-frequency applications).

The conversion transconductance at the n th harmonic is given by

$$g_{c_n} = I(\omega_0 - n\omega_n)/E_s = a_n/2. \quad (12)$$

If one substitutes the value of the Fourier coefficient, there results

$$g_{c_n} = \frac{1}{2\pi} \int_0^{2\pi} g_m \cos n\omega_0 t d\omega_0 t. \quad (13)$$

When $n = 1$, the fundamental conversion transconductance is obtained.

The method of determining conversion transconductance can be made clear by means of an illustrative example. Let Fig. 2 represent the signal-electrode transconductance of a receiving tube as a function of oscillator-electrode voltage (it is assumed, as may be the case, that the oscillator voltage and signal voltage are not necessarily applied to the same electrode), and let A in the figure be the applied oscillator voltage (assumed to be sinusoidal). Then B is the resultant time variation of transconductance.

A Fourier analysis of B yields the desired conversion transconductance since for the n th harmonic mode of

operation it is simply half the n th Fourier coefficient, as was shown above. If, as is usually the case, the oscillator voltage is sinusoidal in shape, it is possible to make use of some convenient formulas of sufficient accuracy for most purposes. Referring to Fig. 3, a sinusoidal oscillator voltage is assumed and a seven-point analysis at 30-degree intervals is made. Then, the conversion transconductances for the fundamental and the first two modes of harmonic operation are

$$g_{c_1} = \frac{1}{12} [(g_7 - g_1) + (g_6 - g_3) + 1.73(g_6 - g_2)] \quad (14)$$

$$g_{c_2} = \frac{1}{12} [2g_4 + \frac{3}{4}(g_3 + g_5 - g_6 - g_2) - (g_7 + g_1)] \quad (15)$$

$$g_{c_3} = \frac{1}{12} [(g_7 - g_1) - 2(g_5 - g_3)]. \quad (16)$$

The values g_1, g_2 , etc., are obtained from the transconductance characteristic of Fig. 3 by means of the 30-de-

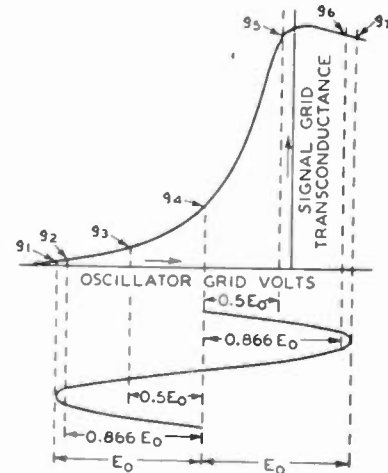

Fig. 3—Points used for 30-degree analysis of conversion transconductance.

gree analysis there indicated. An examination of (14) for g_{c_1} indicates that maximum possible fundamental conversion transconductance, (excluding negative transconductances) occurs when g_1, g_2 , and g_3 are zero and g_6, g_6 , and g_7 are large. This is achieved by operating so that the transconductance is cut off over slightly less than half the oscillator cycle and with oscillator-voltage amplitude of such magnitude that the tube operates to somewhat beyond the point of maximum transconductance.

In practical cases, wherein grid-controlled tubes are employed, the maximum possible fundamental conversion transconductance is given approximately¹ by 28 per cent of the maximum signal-grid-to-plate transconductance. The maximum attainable second-harmonic conversion transconductance is roughly half as great, and for third-harmonic conversion the maximum attainable transconductance is only about one third as great. Harmonic operation requires greater excitation, as a rule, than fundamental operation and the optimum operating point is differently located.

Thus an examination of the signal-electrode-to-plate transconductance curve quickly yields approximate values of the following quantities:

1. Optimum operating point for fundamental conversion.

2. Optimum local-oscillator excitation for fundamental conversion.

3. Conversion transconductances for fundamental, second harmonic, and third harmonic conversion.

III. NOISE OF CONVERTER OR MIXER STAGE

As was shown in Parts II and III of this series, fluctuation noise is measured by its mean-square value. In most vacuum tubes, the important part of the fluctuation noise comes from the plate or anode current. Under static conditions or with very small signals the mean-square noise current may be written as $\overline{i_{pn}^2}$. In the converter stage of a receiver, a large local oscillator voltage is usually applied to the converter or mixer so that $\overline{i_{pn}^2}$ fluctuates periodically at local-oscillator frequency. The mean-square noise current at the intermediate frequency, which is the one of concern here, is then the average value of the fluctuations, i.e., the time average over the oscillator cycle,

$$\overline{i_{i-f}^2} = \frac{1}{2\pi} \int_0^{2\pi} \overline{i_{pn}^2} d(\omega t).$$

Values for the plate noise $\overline{i_{pn}^2}$ of different types of tubes have been computed theoretically² and checked closely experimentally (except in the case of diodes) so that the mixer noise can readily be estimated by use of the above averaging process.³

It is convenient to express mixer noise in terms of an equivalent noise resistance (except perhaps for the diode mixer). This resistance is defined as that which, if connected across the input of a noise-free mixer with conversion transconductance equal to that of the tube under study, will produce the same noise current in the plate circuit as is present in the actual tube. Thus

$$\overline{e_n^2} = \overline{i_{i-f}^2} / g_c^2 \tag{17}$$

where g_c is the conversion transconductance and $\overline{e_n^2}$ is the mean-square noise voltage developed by the equivalent noise resistance.

$$R_{eq} = \overline{e_n^2} / (4kT\Delta f) \tag{18}$$

$$= \overline{i_{i-f}^2} / (4kTg_c^2\Delta f) \tag{19}$$

where $k = 1.37 \times 10^{-23}$ joule per degree Kelvin, T is the absolute temperature, and Δf is the noise bandwidth as defined in Part I of this series. As was shown in Part III, it is desirable from a signal-to-noise point of view to have as small a value for R_{eq} as can be obtained.

A convenient table of equivalent noise resistance values for triode and pentode mixers was given by Herold¹ and is reproduced in Table I. In the table, it is assumed that optimum oscillator excitation (i.e., optimized for maximum g_c) is used. The control-grid cutoff voltage is E_{c0} , the peak grid-to-cathode transconductance (usually taken at zero bias) is g_0 , and the peak cathode cur-

rent (also usually at zero bias) is I_0 . (Grid-to-cathode transconductance is defined as the rate of change of cathode current with respect to signal-electrode voltage. It is thus the sum of the transconductances measured between the signal-grid and the screen and plate.) For triodes, $\alpha = 0$, whereas for pentodes, α is the ratio of screen current to plate current. It will be shown in a later section that the average transconductance is of value in estimating the electronic input loading.

In the ultra-high-frequency field, multigrid mixers are not widely used because they are greatly inferior to triodes and pentodes from a signal-to-noise point of

TABLE I
MIXER NOISE OF TRIODES AND PENTODES
(Oscillator and Signal both Applied to Control Grid)

Operation	Approximate Oscillator Peak Volts	Average Transconductance $\overline{g_m}$	Average Cathode Current I_k	Conversion Transconductance g_c	Equivalent Noise Resistance R_{eq}
At Oscillator Fundamental	$0.7 E_{c0}$	$\frac{0.47}{1+\alpha} g_0$	$0.35 I_0$	$\frac{0.28}{1+\alpha} g_0$	$\frac{13}{g_0} + 90 \frac{I_0}{g_0^2} \alpha$
At Oscillator 2nd Harmonic	$1.5 E_{c0}$	$\frac{0.25}{1+\alpha} g_0$	$0.20 I_0$	$\frac{0.13}{1+\alpha} g_0$	$\frac{31}{g_0} + 220 \frac{I_0}{g_0^2} \alpha$
At Oscillator 3rd Harmonic	$4.3 E_{c0}$	$\frac{0.15}{1+\alpha} g_0$	$0.11 I_0$	$\frac{0.09}{1+\alpha} g_0$	$\frac{38}{g_0} + 260 \frac{I_0}{g_0^2} \alpha$

view³ and will not, as a consequence, be discussed here. The two-element mixer such as the diode, on the other hand, has been used to some extent⁴ but is sufficiently different in behavior to justify a separate treatment.⁵

IV. CONVERTER OR MIXER GAIN

The gain in a converter or mixer stage may be treated in exactly the same manner as for the case of the more familiar amplifier stages. The gain is defined as the ratio of the intermediate-frequency voltage on the control grid of the first intermediate-frequency amplifier tube to the signal voltage on the signal electrode of the converter or mixer tube. While the "gain" is a definite quantity which is a measure of the voltage ratio on the grids of successive tubes, it is not a true measure of the "step-up" between stages except at low frequencies where the tube loading is negligible. What is generally of greater interest than gain, is the voltage "step-up" between an antenna and the grid of the first intermediate-frequency tube. At ultra-high frequencies, this is determined not only by the mixer gain, but by the input loading on the signal grid of the mixer. It is thus seen that care must be taken in attempting to arrive at a relative evaluation of different tubes from the standpoint of "gain."

In the general case gain depends upon the conversion transconductance, internal plate resistance of the mixer, and upon the input and transfer impedances of the circuit joining the two tubes. The simple case of a single-tuned circuit joining a pentode mixer to the intermediate-frequency amplifier is illustrated in Fig. 4(a).

⁴ See "40-cm waves for aviation," *Electronics*, vol. 12, pp. 12-15; November, 1939.

⁵ See Part V of this series.

² B. J. Thompson, D. O. North, and W. A. Harris, "Fluctuations in space-charge-limited currents at moderately high frequency," *RCA Rev.*, vol. 4, pp. 269-285; January, 1940; vol. 4, pp. 441-472; April, 1940; vol. 5, pp. 106-124; July, 1940; vol. 5, pp. 244-260; October, 1940; vol. 5, pp. 371-388; January, 1941; vol. 5, pp. 505-524; April, 1941; vol. 6, pp. 114-124; July, 1941.

³ E. W. Herold, "Superheterodyne converter considerations in television receivers," *RCA Rev.*, vol. 4, pp. 324-337; January, 1940.

The gain may be determined with the aid of the equivalent circuit shown in Fig. 4(b), wherein R_p is the internal plate resistance of the mixer and R is the resonant impedance of the single-tuned network (assumed tuned to the intermediate frequency). $g_c e_s$ represents a constant-current generator, g_c is the conversion transconductance, and e_s is the signal-grid voltage. The voltage developed across R (i.e., the intermediate-frequency voltage across the input to the intermediate-frequency amplifier) is $g_c e_s (RR_p)/(R+R_p)$. This divided by the signal-grid voltage yields the conversion gain $g_c (RR_p)/(R+R_p)$. For pentodes, it is generally the case that $R_p \gg R$, and then conversion gain is equal to $g_c R$. This is similar to the corresponding expression for amplifier gain except that g_c replaces g_m . Under certain conditions the gain of a tube as an ultra-high-frequency amplifier bears a simple relation to its gain when employed as a mixer. In both

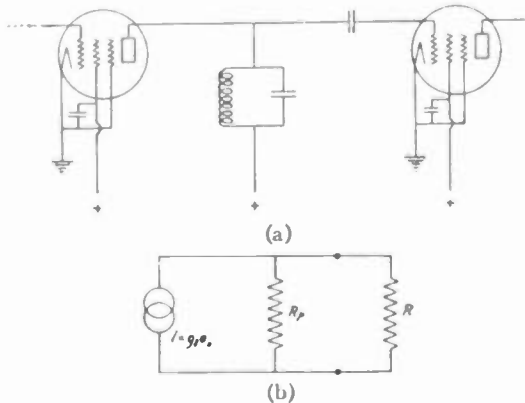

Fig. 4—(a) Circuit shows mixer stage coupled to intermediate-frequency stage by means of single-tuned circuit; (b) circuit which is equivalent of 4(a).

cases it will be assumed that the operating conditions are adjusted for maximum transconductance. It will also be assumed that the tube in each case is operating into a single-tuned circuit of maximum possible resonant impedance. It can be shown that in each case the resonant impedance is given by the expression $Z = 1/(2\pi C\Delta f')$ where C is the capacitance of the output circuit and $\Delta f'$ is its effective circuit bandwidth as defined in Part I of this series. Since it is desired that Z be as large as possible, C must be reduced to the unavoidable minimum due to stray tube electrode, lead, and circuit distributed capacitances. The limiting capacitance is largely due to the tube and leads so that the minimum value of C is about the same for either the radio-frequency or intermediate-frequency cases, i.e., for amplifier or mixer operation. Furthermore, at ultra-high frequencies, as well as at intermediate frequencies, the value of $\Delta f'$ is more often determined by the application at hand than by the unavoidable ohmic losses present in the circuit. Under these circumstances, the circuit must be "loaded down" with additional resistance so as to make its effective bandwidth sufficiently great to meet the needs of the application. Since this bandwidth requirement is the same regardless of the carrier frequency employed, $\Delta f'$ is seen to be the same for the

amplifier as for the mixer. As a consequence, the maximum output circuit impedance is the same regardless of whether the tube is used as an amplifier or as a mixer. The tube gain for this case has already been shown to be given by gR where g refers to g_m for the amplifier and to g_c for the mixer. Since R , the maximum output circuit impedance, is the same for both cases, the gains will be related in the same fashion as the transconductance. Since, as was indicated above, the maximum conversion transconductance is only about 28 per cent of the maximum amplifier transconductance, it follows that a given tube when used as an amplifier will produce about four times as much gain as when used as a mixer. While this conclusion was drawn for the case of a single-tuned coupling circuit it holds closely for more complicated network cases.

V. INPUT LOADING OF MIXER STAGE

In Part II of this series, the problem of input loading of vacuum tubes was discussed and expressions for loading due to lead inductances and finite transit angle in the cathode-control-grid region of conventional-type tubes, and the loading in velocity-modulation devices were developed. In mixer operation, the input loading will vary periodically at local-oscillator frequency, so that to determine the actual loading it is necessary to average the instantaneous values over the oscillator cycle. The averaging process is identical with that outlined in Section III where the noise of mixer stages was discussed, and need not be outlined in detail. Since, in many instances, the input conductance varies directly with the transconductance, the average transconductance can be used as a measure of the relative loading.

To see how the mixer loading is related to the instantaneous amplifier loading, let us examine an illustrative case treated by Herold.¹ Fig. 5 depicts the input

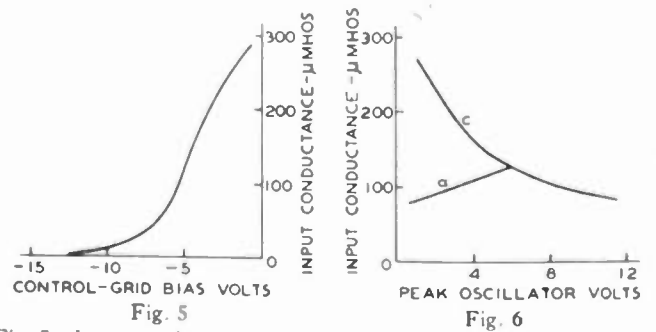

Fig. 5—Input conductance of a typical variable- μ , radio-frequency pentode at 60 megacycles. Fig. 6—Input conductance of a typical pentode when used as a mixer at 60 megacycles. *a* fixed-bias operation; *c* bias obtained by means of a high-resistance grid leak.

loading of a "typical pentode" at 60 megacycles as a function of control-grid bias. We consider two cases: 1. the tube is operated at a fixed bias, and 2. the bias is obtained by means of a high-resistance grid leak. The results obtained for mixer operation as a function of local-oscillator voltage (also applied to the screen grid) are shown as curves *a* and *c* of Fig. 6. It is interesting

to note that the loading actually decreases with increasing excitation for the case of grid-leak bias. This is due to the fact that the grid is biased further back towards cutoff with increasing oscillator voltage, so that the cathode current (and consequently, the loading) is cut off over a greater portion of the cycle. Thus, as the oscillator voltage is increased, the loading across the input circuit is reduced, and as consequence R_1 (the resonant impedance of over-all input circuit as defined in Part III) is reduced. For harmonic operation the oscillator swing should be further increased for best results, so that R_1 is greater than in the case of optimum fundamental conversion. At the same time, due to decreased g_e , R_{eq} is also increased. It has been shown by Herold⁶ that the ratio R_1/R_{eq} in the cases of second- and third-harmonic conversion with triodes is only slightly re-

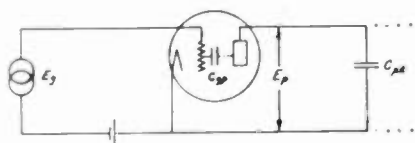

Fig. 7—Effective radio-frequency circuit of a triode mixer.

duced below the value for fundamental conversion. Since, as was shown in Part III, the signal-to-noise ratio depends largely on R_1/R_{eq} , it follows that for triode converters, the signal-to-noise ratio is not seriously affected by harmonic operation. The gain however, being determined by g_e , is reduced by harmonic operation. In addition, it may be difficult to obtain the larger oscillator excitation required.

From the fact that at ultra-high-frequencies the input loading varies as the square of the frequency, the results for any one frequency may be immediately extended to others.

VI. FEEDBACK IN TRIODE MIXERS AT ULTRA-HIGH FREQUENCIES

In general, mixer feedback is due primarily to the capacitance between the plate and signal grid. Since this is appreciable only for triodes, the discussion will be limited to that tube type. A triode mixer feeds into a network designed to have the desired bandwidth at the intermediate frequency. For maximum possible intermediate-frequency circuit impedance (as a condition for maximum gain) the output capacitance should be a minimum. As was previously shown, this is generally accomplished by limiting the output-circuit capacitance to that unavoidably present within the tube and that due to leads and stray and distributed capacitances. Since such inductances as are in the plate circuit are designed so as to result in the desired circuit characteristics at the intermediate frequency, any radio frequency present in the plate circuit will "see" capacitance only. To understand how this output capacitance affects the tube behavior at radio frequency consider the effective

triode circuit as shown in Fig. 7. Let the triode be fed by a signal source of negligible internal impedance of voltage amplitude E_g . This will cause a current I_p to flow in the plate circuit of magnitude $\overline{g_m}E_g$, where $\overline{g_m}$ is the average transconductance over the oscillator cycle. This in turn will result in voltage E_p across the effective output capacitance C_{pk} given by

$$E_p = (\overline{g_m}E_g)/(j\omega C_{pk}). \quad (20)$$

A capacitive current will flow in the input circuit, given by

$$I_{op} = j\omega C_{op}E_p = \overline{g_m}(C_{op}/C_{pk})E_g. \quad (21)$$

Therefore the input admittance due to feedback will be

$$A_o = I_{op}/E_g = \overline{g_m}(C_{op}/C_{pk}). \quad (22)$$

This is in the form of a conductance which will load down the input circuit, over and above the loading due to ohmic losses, and the loading due to the effects of lead inductance and finite transit angles as was discussed in Part II of this series. Since C_{op}/C_{pk} may be of the order of 0.3, it is seen that the input resistance due to feedback in a triode mixer may be of the order of several hundred ohms, and may thus have an appreciable effect upon the receiver performance.

VII. IMAGE FREQUENCIES AND INTERMEDIATE-FREQUENCY CONSIDERATIONS

Let us now consider a problem peculiar to mixers. It is best made clear by an example. If the signal frequency is 100 megacycles and the oscillator frequency is 101 megacycles, the frequencies in the output will include 100 megacycles, 101 megacycles, 201 megacycles (the sum frequency), and 1 megacycle (the difference frequency). Of these frequencies it can be assumed that the desired intermediate frequency is 1 megacycle. The undesired frequencies can be filtered out by the sharply tuned circuits in the intermediate-frequency amplifier. With the oscillator operating at 101 megacycles, it is obvious that an incoming signal of 102 megacycles will provide a difference frequency of 1 megacycle which is also capable of passing through the intermediate-frequency amplifier. Reception of this kind is known as image reception. This image should be avoided in good receiver design.

If a low value is chosen for the intermediate frequency it is difficult to attenuate the image without using tuned-radio-frequency stages ahead of the mixer. This may be undesirable because of practical tuning considerations or from the signal-to-noise standpoint. As a consequence it is generally desirable to use a high value for the intermediate frequency. For ultra-high-frequency applications this may range from 10 to 100 megacycles.

There is another factor which favors the use of high intermediate frequencies. Most ultra-high-frequency applications require the use of a wide-band amplifier following the second detector. Thus, e.g., the final amplification in a television amplifier occurs in the video amplifier which may amplify frequencies up to 4 megacycles. If the intermediate frequency is too low, it

⁶ E. W. Herold, "An analysis of the signal-to-noise ratio of ultra-high-frequency receivers," *RCA Rev.*, vol. 6, pp. 302-331; January, 1942.

becomes exceedingly difficult to keep some of it out of the video amplifier with resultant distortions and feedbacks of regenerative or degenerative nature.

VIII. RADIO-FREQUENCY AMPLIFICATION VERSUS CONVERSION IN FIRST STAGE OF A RECEIVER

On the basis of the preceding sections of this paper as well as of the earlier parts of this series we are now in a position to render judgment regarding a basic question which arises in the design of all superheterodyne-type receivers. Should one convert immediately in the first stage or should one first use one or more stages of radio-frequency amplification and then convert in a later stage? The answer to this question depends, in general upon the following considerations: 1. Magnitude of received signal; 2. Frequency of received signal; 3. Bandwidth required; 4. Image rejection; 5. Reradiation of local-oscillator power; and 6. Nature of tubes available, i.e., the "state of the art."

The first of these is tied up intimately with the importance of signal-to-noise ratio. If the received signal is large compared with the receiver noise, signal-to-noise ratio is of no importance. This simplifies the consideration of the strong signal case considerably. As was shown above, the gain of an amplifier stage is roughly four times that of a mixer stage. However, since a mixer stage must be used somewhere in a superheterodyne receiver, the lower gain of a mixer must be faced at some point, so that from gain considerations one can draw no positive conclusion concerning the location of the mixer stage. The important factors actually are those related to image rejection and reradiation. If the first stage were a mixer, the image rejection might be inadequate, in which case one or more stages of radio-frequency amplification would be required. By use of a high value of intermediate frequency, immediate conversion may be possible.

In some applications, the radiation from the antenna of local-oscillator power may be a serious factor as regards local interference or in revealing the presence of the receiver. This can be minimized by the use of a radio-frequency stage to isolate the local oscillator from the antenna. If the first stage is a mixer, reradiation can be reduced by the use of a high value of intermediate frequency, so that the antenna and input circuit are far out of tune with the local-oscillator frequency or by the use of balanced (neutralizing) circuits. In general, however, if image rejection and reradiation are not serious, immediate conversion is preferred in order to avoid the difficulties inherent in the tuning of radio-frequency amplifiers. This is particularly the case if the receiver is to be tunable. The bandwidth required and the nature of the tubes employed do not exercise an appreciable role for the case of strong-signal reception and will not be treated further at this point.

If the received signal is weak, the signal-to-noise ratio is of paramount importance. Let us first suppose that for a particular signal frequency and bandwidth appli-

cation, a tube is available from which a radio-frequency gain considerably greater than unity can be obtained. We postulate further that the bandwidth requirements are such that the circuits must be "loaded down" with external shunt resistance, in order to achieve the desired bandwidth, i.e., in the relation $Z = 1/2\pi C\Delta f'$, $\Delta f'$ is determined by the application at hand and not by tube and circuit losses. As has already been pointed out, under these conditions, the mixer gain available from a tube is only about one quarter as great as the available amplifier gain, but since this reduced gain must be faced eventually, no conclusions can as yet be drawn as to whether to make use of radio-frequency amplification or conversion in the first stage. However, the equivalent noise resistance R_{eq} is much lower for the amplifier case than for the mixer, and since this often means a higher signal-to-noise ratio, the use of one or more amplifier stages before conversion is definitely indicated. Now, let us suppose, as a first variation, that the operating frequency is increased. In this case, the circuit impedance which includes the tube loading, decreases with increasing frequency so that the circuit requires less and less additional external loading to achieve the desired bandwidth. Above a certain frequency (which we may call the crossover frequency) the circuit bandwidth, with no external loading, exceeds that required by the application at hand, this being increasingly the case as the frequency goes higher and higher. As a consequence, amplifier gain drops off above the "crossover" frequency. A point will finally be reached for which the amplifier-stage gain drops to unity or lower, in which case it would obviously be foolish to use such a stage, and conversion should be employed in the first stage. In fact, better signal-to-noise response can usually be obtained by immediate conversion for cases in which the amplifier gain is still somewhat above unity. Since the intermediate-frequency-circuit resonant impedance is independent of the signal frequency, the mixer gain remains unaltered as the signal frequency increases, so that the mixer-stage gain may eventually exceed that of the amplifier stage. This constitutes a further argument for immediate conversion above a certain frequency, which we may refer to as the "transition frequency."

The decreased radio-frequency gain with increased frequency is determined largely by tube losses and these in turn depend upon the nature of the tubes available. Thus we may conclude that the transition frequency above which immediate conversion is preferred depends in part, upon the "state of the art." In recent years advances in ultra-high-frequency receiving-tube design have extended the frequency range over which radio-frequency amplification yields better signal-to-noise ratio than is available with converter operation, so that the "transition frequency" is now considerably higher than it was several years ago.

As a second variation, let us suppose that the bandwidth requirements are increased. In that case, the

radio-frequency as well as the intermediate-frequency-circuit impedances must be lowered. As a consequence, since the tube loading plays a lesser role in this case, one can, in general, extend the range of amplifier operation to higher frequencies before the loss in gain becomes so serious as to justify immediate conversion.

IX. CONCLUSION

If the received signal is strong, one should convert immediately, unless image rejection or the prevention of oscillator radiation necessitate the use of radio-frequency stages. If the received signal is weak, an amplifier stage should be used below a certain frequency and a mixer above, the transition frequency depending upon the characteristics of the tubes available and the bandwidth required. In general the transition frequency occurs at the point where available tubes will no longer give appreciable radio frequency gain for the bandwidth required.

X. APPLICATION OF SECONDARY ELECTRON EMISSION TO SUPERHETERODYNE RECEIVERS

Secondary emission is ideally suited for application to converters and mixers. It was pointed out in Part II of this series that the gain of a secondary-emission multiplier falls off with increasing frequencies due to the transit-time spreads of secondary electrons. These spreads arise from the fact that different secondaries are emitted with different initial velocities and travel over different paths. This definitely limits the use of secondary-emission multipliers as ultra-high-frequency

amplifiers. However, at the intermediate-frequencies used in ultra-high-frequency receivers, the loss in gain described above is negligible so that secondary-emission amplification after conversion is possible and is generally advantageous.

In Part III it was shown that the noise contribution of circuits and tubes following the first stage may be of importance. Anything that can be done to reduce the noise contributed by what follows the first tube will thus improve the signal-to-noise ratio of the complete receiver. The coupling impedance joining the first tube to the second in a conventional-type amplifier is a source of noise and by permitting the plate current of the first tube to go through a secondary-emission multiplier the coupling circuit with its resultant noise contribution is shifted to a later stage where its noise contribution is negligible in comparison with the now greatly amplified noise from earlier sources. One must be sure, however, that the secondary-emission multiplier does not contribute noise in excess of that due to a coupling circuit or resistor. It has been shown⁷ that if the secondary-emission ratio n is high, the signal-to-noise ratio is inappreciably affected. If the primary current (plate current for our case) has only pure temperature-limited shot noise ($i^2 = 2eI\Delta f$) then the relative change in the signal-to-noise ratio due to a secondary-emission stage is given approximately by $\sqrt{n/(n+1)}$, which is obviously unimportant if n is large.

⁷ V. K. Zworykin, G. A. Morton, and L. Malter, "The secondary emission multiplier—A new electronic device," *Proc. I.R.E.*, vol. 24, pp. 351-376; March, 1936.

Some Aspects of Radio Reception at Ultra-High Frequencies*

E. W. HEROLD†, MEMBER, I.R.E. AND L. MALTER‡, ASSOCIATE, I.R.E.

PART V. FREQUENCY MIXING IN DIODES

E. W. HEROLD†

Summary—Although the diode is one of the simplest forms of vacuum tube, the behavior of the diode mixer in superheterodyne reception has not been well understood. One reason for this is that the conversion process is more complex than in other mixers in that it is bilateral, a radio-frequency input voltage giving an intermediate-frequency output current and the resulting intermediate-frequency output voltage in turn giving a radio-frequency current in the input. Analysis of the behavior leads, however, to a very simple equivalent circuit consisting of a symmetrical π circuit of three conductances whose magnitudes are determined by the average diode conductance and by the conversion conductance of the diode. The present paper derives this circuit and uses it to find the conversion loss of the converter stage both with and without input circuit loss. The results, although arrived at independently, are in agreement with the recent publication of James and Houldin.

If the conversion loss is to be held small, the diode must be operated so as to obtain the highest ratio of conversion conductance to average conductance. The upper limit of this ratio is unity and this is attained only when the mixer-stage impedance is infinite. Thus, circuit losses prevent the attainment of the condition of no conversion loss, in practice.

The signal-to-noise ratio of a receiver whose input stage is a diode converter is not determinable accurately because of uncertainties in the diode noise behavior. However, by using the conversion loss together with an effective noise temperature for the converter stage, an over-all noise factor can be given in terms of the noise factor of the intermediate-frequency amplifier, F_{i-f} which in the laboratory, is

$$F_{\text{over-all (in laboratory)}} = \frac{F_{i-f} + (1 - M)(T_L/T_R - 1)}{M}$$

where M is the ratio of intermediate-frequency output power to signal-input power of the converter stage, and T_L/T_R is the ratio of effective noise temperature to room temperature.

* Decimal classification: R361.2X R332. Original manuscript received by the Institute, June 28, 1943.

† RCA Laboratories, Princeton, New Jersey.

‡ Formerly, RCA Laboratories, Princeton, N. J.; now, RCA Victor Division, Radio Corporation of America, Lancaster, Pa.

The analysis of the average and conversion conductances of particular diodes may be made by use of Fourier analysis in the same manner as with other mixer and converter tubes. The behavior of many diodes is qualitatively shown by an idealized diode whose volt-ampere characteristic is given by two intersecting straight lines. Curves are given showing the conversion loss as a function of the ratio of direct-bias-to-peak oscillator voltage and including input-circuit loss. It is found that conversion at the second or third harmonic of the local oscillator is more critical than at fundamental, but under optimum conditions, the conversion loss is only a few decibels higher.

I. INTRODUCTION

THE general theory of superheterodyne frequency conversion is now well understood and it has given a reasonable complete understanding of the behavior as mixers of conventional triodes and multigrind tubes.¹ In the ultra-high-frequency region, however, the use of the two-element nonlinear device (e.g., the diode) as a frequency changer has been common. Although the diode is the simplest type of vacuum tube its behavior as a mixer has been very poorly understood. M. J. O. Strutt^{2,3} was early to publish on the subject but failed to make his analysis complete. During intervening years there has been unpublished work, notably that of W. A. Harris of the RCA Victor Division, but it was only a few months ago that a more adequate presentation has appeared in print.⁴ The following analysis was developed independently by the present writer some years ago by an extension of the method used for other types of converters or mixers.¹ However, it will be found that the end results are in agreement with those of James and Houldin.⁴

Most mixers and converters using separate signal-input and intermediate-frequency output electrodes are readily analyzed because there is no reverse conversion; i.e., the signal-electrode current is unaffected by the presence or absence of an intermediate-frequency voltage on the output electrode. The diode or two-terminal mixer, however, converts in both directions. The signal-frequency voltage is converted to an intermediate-frequency current and the resulting intermediate-frequency voltage is converted by the local oscillator to a signal-frequency current. Thus, the signal-frequency impedance of the mixer stage is affected by the intermediate-frequency load impedance and the output impedance is affected by the signal circuit. The problem of properly adjusting circuit bandwidths and of matching impedances becomes a complex one.

Finally, the problem of signal-to-noise relations in the two-terminal mixer is very involved. In the first place, the actual fluctuation noise of the two-terminal device must be known under actual operating conditions, i.e., with the local-oscillator voltage applied. Next, the

¹ E. W. Herold, "The operation of frequency converters and mixers," *Proc. I.R.E.*, vol. 30, pp. 84-103; February, 1942.

² M. J. O. Strutt, "On conversion detectors," *Proc. I.R.E.*, vol. 22, pp. 981-1008; August, 1934.

³ M. J. O. Strutt, "Diode frequency changers," *Wireless Eng.*, vol. 13, pp. 73-80; February, 1936.

⁴ E. C. James and J. E. Houldin, "Diode frequency changers," *Wireless Eng.*, vol. 20, pp. 15-27; January, 1943.

proper connection between signal-frequency and intermediate-frequency noise components must be clearly established since the bidirectional conversion process ties these two components closely together. This aspect of the diode mixer is not yet completely understood.

II. CONVERSION THEORY

1. Basic Analysis

The basic diode-converter stage consists of an input circuit tuned to the signal frequency, an output circuit tuned to the intermediate frequency, and a source of local-oscillator voltage. In operation, a signal-input voltage is impressed on the device and an output voltage of intermediate frequency is also present as a voltage drop across the intermediate-frequency circuit. Since, at the start, the phase relationship of these two voltages is unknown, it is best to proceed by assuming an arbitrary phase relationship, just as if the intermediate-frequency voltage were an impressed voltage rather than a voltage drop. After the currents flowing in the circuit have been found, the necessary conditions applicable to the actual case will be obvious and it will be possible to establish the correct phase relationship. The basic circuit is then shown in Fig. 1 where signal- and intermediate-frequency

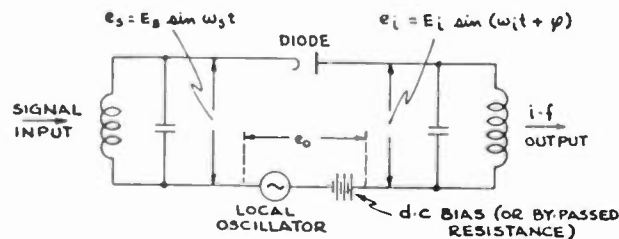

Fig. 1—Schematic circuit of diode converter stage.

voltages are indicated. The intermediate-frequency voltage is given an arbitrary phase angle ϕ .

An analysis will be made which is valid for small signal- and intermediate-frequency voltages, although no restriction is imposed on the magnitude of the local-oscillator voltage. This is in accord with established mixer practice in which comparatively large oscillator voltages are used, but in which the received signals are small. The characteristic of the two-terminal device may be written $i = f(e)$ so that, under mixer conditions,

$$i = f(e_o + e_i + e_s) \quad (1)$$

where e_o is the sum of the local-oscillator voltage and the direct-current bias, e_i is the intermediate-frequency voltage, and e_s is the signal voltage. Since the latter components e_i and e_s are small, a Taylor's expansion may be made about the point of operation determined by e_o ,

$$i = f(e_o) + (e_i + e_s)f'(e_o) + \dots \quad (2)$$

Higher-order terms than those shown will be neglected, thus implying that $(e_i + e_s)$ is sufficiently small. The first term of (2) contains only oscillator-frequency terms and is of no interest here. Since the conductance of the two-element device is $g = di/de = f'(e)$ it is evident that the

important part of (2) may be written

$$i = g(e_s + e_i) = g[E_s \sin \omega_s t + E_i \sin (\omega_i t + \phi)] \quad (3)$$

where g is the conductance of the two-element device when oscillator voltage and bias only are applied, i.e., when $e = e_0$. Equation (3) might well have been written directly.

It is clear that g , the conductance, varies in time periodically at the frequency of the local-oscillator voltage. The conductance, therefore, may be written as a Fourier series whose fundamental component is at local-oscillator frequency

$$g = g_0 + \sum_{n=1}^{\infty} g_n \cos n\omega_0 t \quad (4)$$

where the cosine series implies that the conductance is single-valued and that the oscillator voltage varies as $\cos \omega_0 t$. The coefficients g_0 and g_n are found by any of the usual methods of harmonic analysis based on the formulas⁵

$$g_0 = \frac{1}{2\pi} \int_0^{2\pi} g d(\omega_0 t)$$

$$g_n = \frac{1}{\pi} \int_0^{2\pi} g \cos n\omega_0 t d(\omega_0 t).$$

This is exactly the procedure followed in conventional converter theory. Substituting (4) in (3) we get

$$i = g_0 E_s \sin \omega_s t + g_0 E_i \sin (\omega_i t + \phi) + E_s \sum g_n \sin \omega_s t \cos n\omega_0 t + E_i \sum g_n \sin (\omega_i t + \phi) \cos n\omega_0 t$$

$$= g_0 E_s \sin \omega_s t + g_0 E_i \sin (\omega_i t + \phi) + E_s/2 \sum g_n \sin (\omega_s + n\omega_0)t + E_s/2 \sum g_n \sin (\omega_s - n\omega_0)t$$

$$+ E_i/2 \sum g_n \sin [(\omega_i + n\omega_0)t + \phi] + E_i/2 \sum g_n \sin [(\omega_i - n\omega_0)t + \phi]. \quad (5)$$

If any one of the low-frequency components is chosen as the intermediate frequency ω_i , then

$$\omega_i = \pm (\omega_s - n\omega_0) \quad (6)$$

where conversion is at the n th harmonic of the local oscillator. Rearranging (6) it is seen that

$$\pm \omega_i + n\omega_0 = \omega_s. \quad (7)$$

Using (6) and (7) in (5) and disregarding all the terms which contain frequencies other than ω_s or ω_i , the signal-frequency current i_s and the intermediate-frequency current i_{i-f} , are found to be⁶

$$i_s = g_0 E_s \sin \omega_s t + (g_n/2) E_i \sin (\omega_s t + \phi) \quad (8)$$

$$i_{i-f} = g_0 E_i \sin (\omega_i t + \phi) + (g_n/2) E_s \sin \omega_s t. \quad (9)$$

Finally, the original conception of $E_i \sin (\omega_i t + \phi)$ as an impressed voltage may be dropped and this term now considered as a voltage drop. The new concept may be simplified by assuming the intermediate-frequency load resistance to be tuned to the intermediate-frequency so that it presents a pure resistance R_{i-f} and, at the same time, by assuming the other circuit impedances to be negligible at the intermediate frequency. Then the volt-

age drop is $E_i \sin (\omega_i t + \phi) = -i_{i-f} R_{i-f}$. Substituting the value of i_{i-f} from (9) and rearranging, it is found that

$$(g_0 + 1/R_{i-f}) E_i \sin (\omega_i t + \phi) = -(g_n/2) E_s \sin \omega_s t. \quad (10)$$

Since this relation must hold for all values of t , it is clear that $\phi = \pi$, and that $E_i/E_s = g_{cn}/(g_0 + 1/R_{i-f})$ where g_{cn} has been written for $g_n/2$. It is seen, of course, that g_{cn} is simply the conversion conductance of the

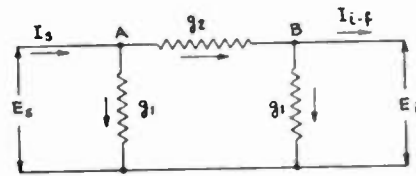

Fig. 2—Symmetrical π network whose equations resemble those for the diode mixer.

two-element mixer where conversion is at the n th harmonic of the local oscillator. It is analogous in every way to the conversion transconductance of other forms of mixer as given in a previous paper¹ and discussed in Part IV of this series.

Equations (8) and (9) can now be written (putting $\phi = \pi$)

$$i_s = g_0 E_s \sin \omega_s t - g_{cn} E_i \sin \omega_s t \quad (12)$$

$$- i_{i-f} = - g_{cn} E_s \sin \omega_s t + g_0 E_i \sin \omega_i t. \quad (13)$$

It is now possible to solve (10), (12), and (13) and find all the desired quantities. However, it is not necessary

to do this formally as will now be shown.

2. Equivalent Circuit for the Diode-Converter Stage

There is a similarity between (12) and (13) of the foregoing and the mesh equations for a symmetrical network of three conductances arranged in a π . Considering the symmetrical π network of Fig. 2, the Kirchhoff-law relation may be written for the sum of currents at points A and B respectively. It is seen that

$$I_s = E_s g_1 + (E_s - E_i) g_2$$

$$- I_{i-f} = E_i g_1 - (E_s - E_i) g_2$$

where currents entering the points are equated to those leaving the points. Rearranging it is found

$$I_s = E_s (g_1 + g_2) - g_2 E_i \quad (14)$$

$$- I_{i-f} = - E_s g_2 + (g_1 + g_2) E_i. \quad (15)$$

A comparison of (14) and (15) with (12) and (13) shows that the mixer circuit may be considered as equivalent to Fig. 2 as far as amplitudes of currents and voltages are concerned. As to frequencies, of course, the mixer circuit is always different from the passive network inasmuch as the frequency of the output voltage and current differs from the input frequency.⁷ Furthermore,

⁷ When the intermediate-frequency circuit has appreciable impedance at radio frequency or when the radio frequency circuit has impedance at intermediate frequency, these impedances should be included in the radio-frequency and intermediate-frequency branches of the circuit, respectively.

⁶ For derivation see any standard text, e.g., E. B. Wilson's, "Advanced Calculus," Ginn and Company, New York, N. Y., p. 458.

⁵ It may be noted that the magnitude of the local-oscillator voltage E_0 does not appear directly in the current relations. However, the Fourier coefficients g_0 and g_n depend on the local-oscillator voltage and thus the currents are dependent on E_0 to some extent.

if $g_0 = g_1 + g_2$ and $g_2 = g_{cn}$ so that $g_1 = g_0 - g_{cn}$ all the solutions to the mixer problem are found by simply solving the circuit of Fig. 3. Almost every relation of importance can be written down by inspection of this simple equivalent circuit.⁸

III. IMPEDANCES AND CONVERSION LOSS OF MIXER STAGE

1. Maximum Power Transfer: Image or Iterative Impedance

It can be shown⁹ that, barring negative resistance effects, the conversion conductance g_{cn} can never exceed the average conductance g_0 . Thus, in examining Fig. 3, the shunt arms may be considered as positive conductances and it is clear that the intermediate-frequency output voltage can never exceed the radio-frequency signal voltage, no matter how high the

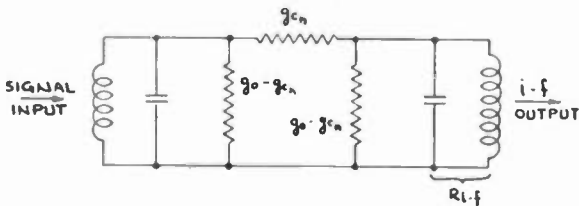

Fig. 3—The equivalent circuit for the diode mixer. This circuit gives the correct magnitude for input and output currents and voltages; however, the frequency of the input current and voltage is different from the output frequency.

intermediate-frequency circuit impedance is. The further discussion of the evaluation of g_0 and g_{cn} will be left for a later section. For the present, let the characteristics of the diode mixer stage be examined as they are indicated by the equivalent passive network of Fig. 3.

To begin with, it is clear that the mixer stage is basically a symmetrical π -type attenuator which, at the same time changes the frequency. If it is connected to the signal source and to the intermediate-frequency load through ideal transformers, maximum power transfer will occur when the transformers are adjusted to match the iterative or image impedance. This impedance is that which, when used as a termination, makes the input impedance of the mixer stage equal to this terminating value. In other words, by use of this impedance as a termination at each end, impedance matching is maintained throughout. The input conductance, when the intermediate-frequency conductance is g_x , can be written by inspection of Fig. 3.

$$g_{in} = g_0 - g_{cn} + \frac{g_{cn}(g_0 - g_{cn} + g_x)}{g_0 + g_x} = \frac{g_0^2 - g_{cn}^2 + g_0 g_x}{g_0 + g_x} \tag{16}$$

If this input conductance is equated to g_x then g_x becomes what might be called the iterative conductance and is given by

$$g_x^2 = g_0^2 - g_{cn}^2 \tag{17}$$

⁸ To the writer's knowledge this equivalent circuit was first used by W. A. Harris of the RCA Victor Division.
⁹ See Section IV, 1, of this paper.

This is one of the more important characteristics of the mixer stage.

2. Conversion Loss Under Matched Conditions: Circuit Losses Neglected

The minimum power loss in changing the signal frequency to the intermediate frequency occurs when the input and output are matched to g_x by ideal, loss-free circuits; the output-to-input power ratio is then given by the square of the voltage ratio (since the impedances are the same). Again examining Fig. 3 it is seen that if a voltage E_0 is impressed across the signal-input terminals, the voltage across the intermediate-frequency output E_i is by inspection

$$E_i = E_0 \frac{(g_0 - g_{cn} + (1/R_{i-f}))g_{cn}}{g_0 + 1/R_{i-f}} \cdot \frac{1}{g_0 - g_{cn} + 1/R_{i-f}} = E_0 \frac{g_{cn}}{g_0 + 1/R_{i-f}} \tag{18}$$

If the intermediate-frequency load is matched to the diode mixer, then $1/R_{i-f} = g_x$ and, using (17),

$$\frac{E_i}{E_0} = \frac{g_{cn}}{g_0 + \sqrt{g_0^2 - g_{cn}^2}} = \frac{g_{cn}/g_0}{1 + \sqrt{1 - (g_{cn}/g_0)^2}} \tag{19}$$

Since the input and output impedances are the same, this relation may be expressed as a conversion loss in decibels; a curve of conversion loss is plotted against g_{cn}/g_0 in Fig. 4.

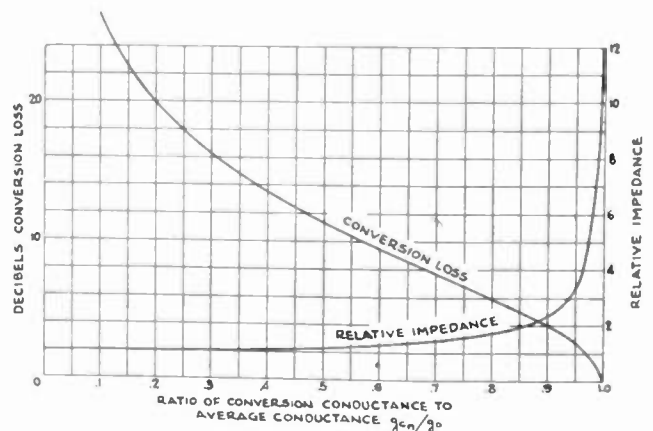

Fig. 4—The behavior of a diode mixer as a function of the two basic conductance components, assuming no loss in the input or output transformers and impedance matching throughout.

It is seen from Fig. 4 that, unless g_{cn}/g_0 is approximately unity the conversion loss is appreciable. However, an important factor to consider is the absolute magnitude of the matching conductance g_x . If this is very small (i.e., a very high impedance) it is not possible to match properly without the matching-circuit losses playing an important role. As g_{cn}/g_0 approaches unity, g_x approaches zero and the impedances needed to match approach infinity. The relative matching impedance g_0/g_x is plotted on a second curve on Fig. 4.

As will be seen later, the only way in which g_{cn}/g_0

can approach unity in a diode-mixer stage is for g_{cn} and g_0 separately to become very small. This in itself implies a very high matching impedance. If a particular diode is chosen, and by adjustment of operating conditions g_{cn}/g_0 is made to approach unity, the curve of matching impedance would rise much more steeply than that shown in Fig. 4.

It may be concluded first, that the diode mixer is not operable as a power-transfer device without appreciable

$$\frac{\text{output power}}{\text{input power}} = \frac{g_{cn}^2}{(2g_0^2 + 2g_0g_s - g_{cn}^2) + (g_0/g_{i-t})(g_0^2 - g_{cn}^2 + g_s g_0) + g_{i-t}(g_0 + g_s)} \quad (20)$$

conversion loss, and second, that circuit losses must be considered for any diode mixer whose conversion loss is small. Thus, it is logical to consider the next topic.

3. Conversion Loss Including Losses in Input Circuit

If the input circuit has a shunt loss which may be represented by a conductance g_s , the circuit becomes similar to the one shown in Fig. 5(a). For the purposes

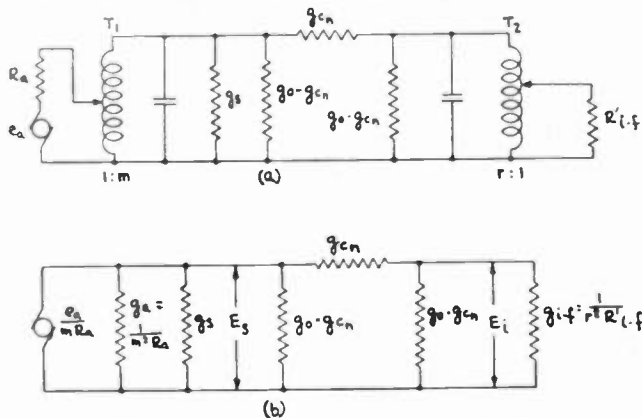

Fig. 5—(a) The schematic circuit of a diode mixer including input-circuit loss, shown as a conductance g_s . (b) An equivalent circuit wherein reflected current and conductances are substituted for the input and output transformers.

of this analysis, T_1 and T_2 may be assumed to be ideal transformers whose step-up adjustments permit optimum power transfer to be obtained from the signal source e_s to the intermediate-frequency load R'_{i-t} . The transformers T_1 and T_2 may be removed to give the equivalent circuit of Fig. 5(b) by inserting the impedances as seen from the diode-mixer input and output terminals. The conversion loss can now be computed from the ratio of power dissipated in the intermediate-frequency conductance, g_{i-t} , to that dissipated in the input, i.e., g_s combined with the diode input conductance. The power dissipated in g_{i-t} is output power $= E_i^2 g_{i-t}$ where E_i is the voltage across the output terminals (see Fig. 5). The input power is input power $= E_s^2 (g_s + g_{in})$ where E_s is the voltage across the input terminals and g_{in} is the diode input conductance. From (16)

$$g_{in} = \frac{g_0^2 - g_{cn}^2 + g_0 g_{i-t}}{g_0 + g_{i-t}}$$

and from (18)

$$\frac{E_i}{E_s} = \frac{g_{cn}}{g_0 + g_{i-t}}$$

Using these relations

$$\frac{\text{output power}}{\text{input power}} = \left(\frac{E_i}{E_s} \right)^2 \frac{g_{i-t}}{g_s + g_{in}} = \left(\frac{g_{cn}}{g_0 + g_{i-t}} \right)^2 \frac{g_{i-t}}{g_s + \frac{g_0^2 - g_{cn}^2 + g_0 g_{i-t}}{g_0 + g_{i-t}}}$$

Multiplying out, it will be found that this becomes

Considering g_{i-t} as a variable, the denominator contains the form $(ax^{-1} + bx)$ which was treated in Section II, 2, of Part III of this series. The maximum power transfer (minimum denominator) occurs when

$$g_{i-t}^2 = \frac{g_0(g_0^2 - g_{cn}^2 + g_s g_0)}{g_0 + g_s} \quad (21)$$

and is

$$M = \frac{\text{output power}}{\text{input power}} \Bigg|_{\max} = \frac{g_{cn}^2}{2g_0^2 + 2g_0g_s - g_{cn}^2 + 2\sqrt{g_0(g_0 + g_s)(g_0^2 - g_{cn}^2 + g_s g_0)}} = \frac{g_{cn}^2}{[\sqrt{g_s(g_0 + g_s)} + \sqrt{g_0^2 - g_{cn}^2 + g_s g_0}]^2} = \left[\frac{g_{cn}/g_0}{\sqrt{1 + g_s/g_0} + \sqrt{1 - (g_{cn}/g_0)^2 + g_s/g_0}} \right]^2 \quad (22)$$

Since g_{cn}/g_0 can approach unity only as g_{cn} and g_0 each approach zero, the effect of the shunt-input loss g_s is to impose a practical optimum value for g_{cn}/g_0 which is less than unity. Thus, the conclusion as to the impossibility of attaining conversion without appreciable loss seems to be further strengthened. In Figs. 9, 10, and 11 of a later section, curves will be shown for an idealized diode-mixer stage which show how g_{cn} and g_0 will vary with the operating parameters and which also illustrate the minimum conversion loss imposed by input-circuit loss.

4. The Over-All Signal-to-Noise Ratio

The over-all signal-to-noise ratio of a receiver with a diode-converter stage is a quantity of considerable importance but is not accurately predictable on theoretical grounds. There are several reasons for this statement. In the first place, the measured fluctuation noise in space-charge-limited diodes is usually considerably larger than would be expected by theory. The discrepancy was satisfactorily explained by North¹⁰ as due to elastically reflected electrons which disturbed the virtual cathode so as to upset the space-charge reduction of shot noise. Thus, an accurate measure of the noise is not available in general, and presumably changes in anode structure or material of a diode may alter the noise without in other ways affecting the diode performance. Second,

¹⁰ D. O. North, Part II of "Fluctuations in space-charge-limited currents at moderately high frequencies," *RCA Rev.*, vol. 5, pp. 117-124; July, 1940.

diode-noise fluctuations affect both the radio-frequency and the intermediate-frequency circuits and are not necessarily independent of each other. Finally, large-signal, transit-time effects cannot always be neglected at the ultra-high frequencies and may have a bearing on the noise behavior; such effects have not yet been fully investigated.

A rough qualitative notion of the effect of the diode-mixer stage on the signal-to-noise ratio of a receiver can be made, however. For one thing, the conversion loss cuts the signal available at the input of the intermediate-frequency amplifier so that the signal-to-noise ratio will be worse than that of the intermediate-frequency amplifier by a predictable amount on this score alone. If the diode-mixer stage adds some noise, and it usually will, this decreases the over-all signal-to-noise ratio still more.

It can be seen that the converter stage acts as an attenuator of the signal and as an additional noise source itself. Thus, a radio receiver may consist of an antenna of radiation resistance R_a , whose effective noise temperature is T_a , and which is connected to the intermediate-

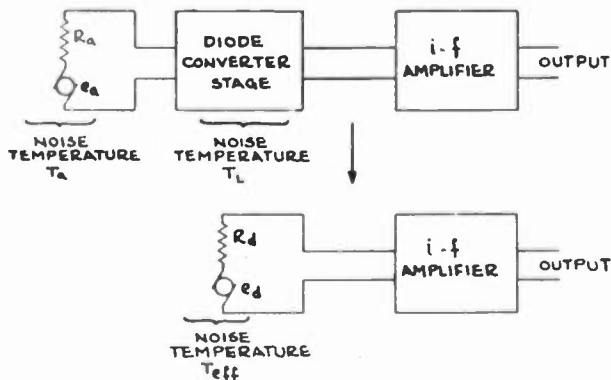

Fig. 6—A receiver consisting of an antenna, a diode mixer, and an intermediate-frequency amplifier may be analyzed for signal-to-noise ratio by replacing the antenna and diode mixer by an equivalent resistor at a noise temperature T_{eff} .

frequency receiver through the mixer as in Fig. 6. We may substitute for this combination of antenna and mixer, a resistance at the input to the intermediate-frequency amplifier by placing this resistor at an effective temperature T_{eff} for noise purposes and by assigning an available signal power (e_d^2/R_d of Fig. 6) which is at a lower frequency and is less than that of the actual antenna by the conversion loss of the mixer. This is almost exactly the problem which was treated in Section II, 7, of Part III of this series where the effect on signal-to-noise ratio of a passive transducer between antenna and receiver was worked out. Thus, if the diode-mixer stage is considered as a noise source at an effective noise temperature T_L , reference to Part III gives

$$T_{eff} = T_L(1 - M) + MT_a \quad (23)$$

where M is the conversion loss expressed as the ratio of output power to input power of the diode mixer (equation (22) above).

The intermediate-frequency system may be measured as if it were a receiver by itself, using a dummy antenna of value R_d (the output impedance of the diode mixer)

as shown in Fig. 6. If this dummy antenna is at room temperature, as in the laboratory, the intermediate-frequency system will have a noise factor¹¹ F_{i-f} . The over-all receiver including the diode-mixer stage will then have a noise factor

$$F_{over-all} = \frac{F_{i-f} - 1 + T_{eff}/T_a}{M} \quad (24)$$

In the laboratory, an over-all measurement would be made with a dummy antenna so that $T_a = T_R$ giving

$$T_{eff}/T_R = M + (1 - M)T_L/T_R$$

so that

$$F_{over-all} \text{ (in laboratory)} = \frac{F_{i-f} + (1 - M)(T_L/T_R - 1)}{M} \quad (25)$$

These relations are only of indirect value unless the effective noise temperature T_L of the converter stage is known. The measurement of F_{i-f} , $F_{over-all}$ and the conversion loss, M , will permit T_L/T_R to be calculated from (25).

The effective temperature will not be independent of operating conditions of the diode and may be substantially higher than would be expected on the basis of the highest temperature element in the converter stage. For a diode mixer with an oxide-coated cathode at 1000 degrees Kelvin, it would be improbable that T_L/T_R could be less than 2 and not out of reason to expect values of this ratio as high as 10 or more.

IV. THE EVALUATION OF AVERAGE AND CONVERSION CONDUCTANCES

1. The General Case

It has already been brought out that best mixer performance will be obtained when the conversion conductance g_{cn} approaches the average conductance g_0 , provided circuit losses can be neglected. The instantaneous conductance has been written as a Fourier series (equation (4)) so that the quantities g_0 and g_{cn} are given directly in terms of the Fourier coefficients,

$$g_0 = \frac{1}{2\pi} \int_0^{2\pi} g d(\omega t) \quad (26)$$

$$g_{cn} = \frac{g_n}{2} = \frac{1}{2\pi} \int_0^{2\pi} g \cos n\omega t d(\omega t) \quad (27)$$

If negative values of g are excluded, inspection indicates that, since the integrand of the second expression can never exceed that of the first (since $\cos n\omega t$ can never exceed unity), the integral in the second case can never exceed the integral in the first case, i.e., the conversion conductance g_{cn} can never exceed the average conductance g_0 . However, if the conductance g is an impulsive-type function of finite maximum value and if, during the entire time at which g is greater than zero, $\cos n\omega t$ is substantially unity, then the two integrals will each become small and will approach equality. It is therefore seen that, only in the relatively ineffectual case where both g_0 and g_{cn} are very small, can the two approach equality.

¹¹ See discussion of noise factor in Part III of this series.

It should also be noted that, in general, the Fourier series for g (equation (4)) will be convergent, so that conversion at oscillator harmonics is progressively less efficient as the order of harmonic is raised. Again, with the ineffectual impulsive function, all the conversion conductances (at different oscillator harmonics) approach each other in magnitude, but only as they all approach zero.

For a diode, or any other two-element nonlinear device for that matter, the mixer behavior can be estimated from its conductance-versus-voltage characteristic. From this characteristic, the conductance-versus-time curve may be obtained for any particular local-oscillator injection voltage, and a Fourier analysis made. It is more usual to make an analysis directly from points on the curve of conductance versus bias, and some simple 7-point formulas for g_{c1} , g_{c2} , and g_{c3} have been given.¹

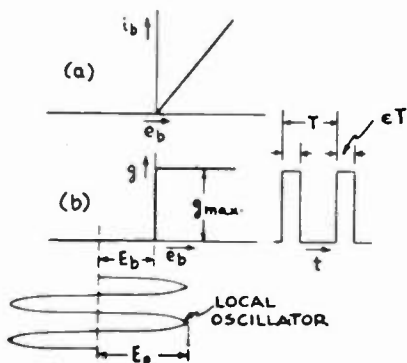

Fig. 7—(a) Plate-current-versus-plate-voltage characteristic of an idealized diode. (b) Conductance characteristic of idealized diode showing an applied oscillator with a bias E_b and the resulting rectangular pulses of conductance versus time.

It is also necessary to obtain g_0 , in the present instance. Using Fig. 2 (a) of reference 1 it may be shown that, to a sufficient accuracy for most purposes,

$$g_0 = 1/12 [g_1 + g_7 + 2(g_2 + g_3 + g_4 + g_5 + g_6)] \quad (28)$$

where the g_1 , g_2 , etc., are points on the curve of the figure.¹² The formula for g_{c1} as given in the reference is

$$g_{c1} = 1/12 [(g_7 - g_1) + (g_5 - g_3) + 1.73(g_6 - g_2)]. \quad (29)$$

It is clear by comparing these formulas for g_0 and g_{c1} that highest g_{c1} and lowest g_0 can be obtained by operating the device so that $g_1 = g_2 = g_3 = 0$, if this is possible. It is interesting to note that no use is ordinarily found for the diode current-versus-voltage characteristic, except when the average direct current is required.

2. An Idealized Diode

Much can be learned from an examination of the behavior of the idealized diode whose current characteristic is shown in Fig. 7 (a) and whose conductance characteristic is shown in Fig. 7 (b). If a local-oscillator voltage, of peak value E_0 , is applied, together with a direct-current bias of value E_b (from a battery or a by-passed resistor) then the conductance versus time will be the rectangular pulse function shown to the right

of Fig. 7 (b). Such a function has Fourier components such that

$$g_0 = g_{max}\epsilon \quad (30)$$

$$g_{cn} = g_{max}/\sin n\pi\epsilon/n\pi \quad (31)$$

where ϵ is the fraction of the time during which current flows, i.e.,

$$\pi\epsilon = \cos^{-1}(E_b/E_0). \quad (32)$$

Thus, when ϵ is small, it is seen that g_0 and g_{cn} are approximately equal and the conversion conductances at

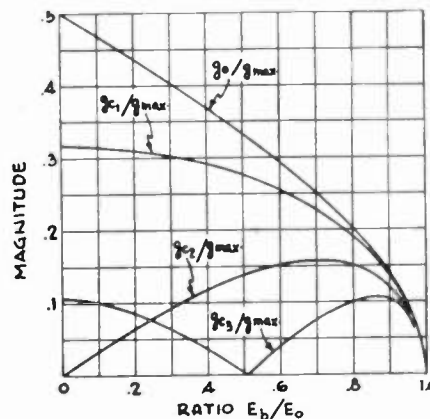

Fig. 8—Average conductance g_0 and conversion conductances g_{c1} , g_{c2} , and g_{c3} for the idealized diode of Fig. 7 as a function of the ratio of direct-current bias to peak oscillator voltage. The curves are plotted as ratios of the conductance to the maximum diode conductance g_{max} .

the different harmonics are all nearly equal but are all very small. Fig. 8 shows curves of the average diode conductance and of g_{c1} , g_{c2} , and g_{c3} as the ratio of bias voltage to peak-oscillator voltage is varied. It is seen that harmonic operation requires a greater bias than fundamental operation.

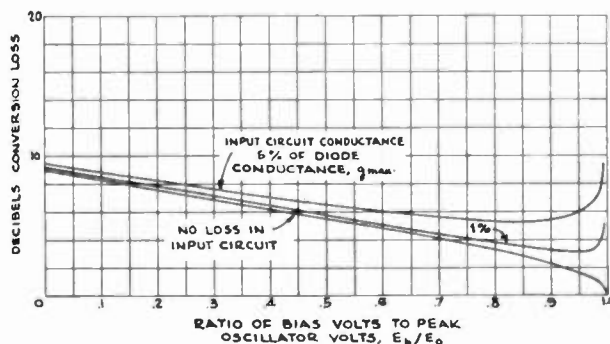

Fig. 9—The conversion-loss characteristic of an idealized diode whose maximum conductance is g_{max} . The curves are for conversion at oscillator fundamental and show the effect of loss conductance in the input circuit.

Of more direct interest are the curves of Fig. 9 which show the conversion loss, using oscillator fundamental, for the idealized diode, again as a function of the ratio of bias to peak oscillator voltage. These curves were computed from (22) and therefore represent optimum values. The curve for a perfect no-loss input circuit is an impracticable ideal which is shown only for comparison. The other curves give the results for an input circuit whose conductance g_i is 1 and 5 per cent, respectively, of the diode maximum conductance g_{max} .

¹² They are not to be confused with the g 's of the Fourier series used in the present paper in equation (4).

A similar set of curves for conversion at second and third harmonics are shown in Figs. 10 and 11. It is interesting to compare the optimum results for conversion at a harmonic with normal conversion at fundamental. Taking the minimum conversion losses from Figs. 9,

TABLE I
MINIMUM CONVERSION LOSS OF IDEALIZED DIODE

Operation at	Decibel Loss $g_b = 0.01 g_{max}$	Decibel Loss $g_b = 0.05 g_{max}$
Fundamental	3.2	5.3
Second Harmonic	4.0	6.6
Third Harmonic	4.6	7.6

10, and 11, Table I may be prepared. It is seen that harmonic operation is by no means out of the question

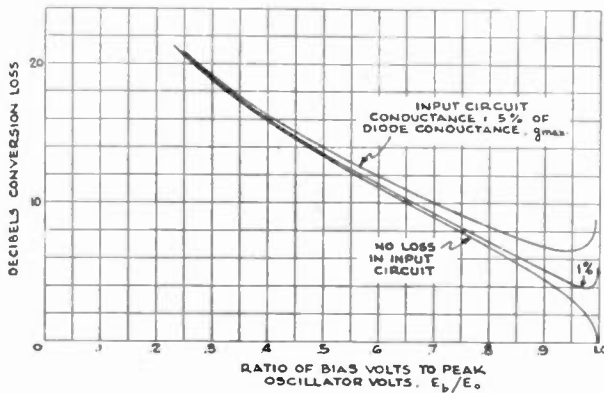

Fig. 10.—Conversion loss of an idealized diode with second-harmonic conversion. The curves show the effect of loss conductance in the input circuit.

if a decibel or two more conversion loss can be tolerated. However, Figs. 9, 10, and 11 show that the adjustment for lowest conversion loss is much more critical when harmonic conversion is used.

3. Discussion of Practical Diodes

Although the idealized diode which has been discussed in Section IV, 2, is not realizable in practice, the behavior shown is qualitatively applicable to practical diodes.

Particular characteristic-curve shapes may be more accurately analyzed by use of the general formulas in Section IV, 1, together with (22). The application of the integral formulas (26) and (27) to such a common characteristic as the 3/2-power law leads to results in terms of elliptic functions⁴ and it is often more rapid to use the 7-point approximate formulas (28) and (29). This is certainly true for more complex characteristics for which the analytic expression is difficult to handle.

When, as in practical diodes, the conductance rises gradually with an increase in applied voltage up to the value g_{max} , the results will, as a rule, be inferior to those shown in Figs. 9, 10, and 11. However, a large oscillator swing together with appropriately large bias does permit an approach to the results shown. In some instances, it may be necessary to take into account conduction in

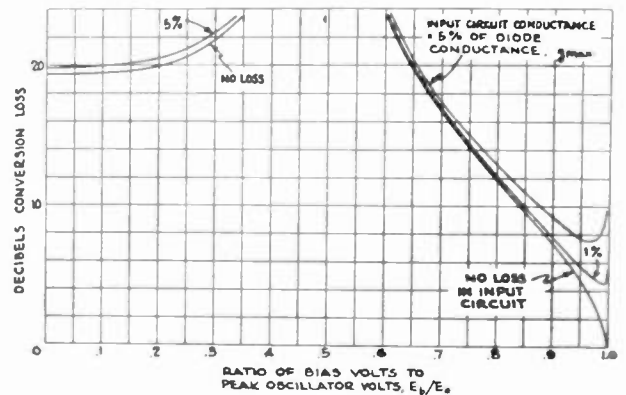

Fig. 11.—Conversion loss of an idealized diode with third-harmonic conversion. The effect of loss in the input circuit is shown.

both directions. It is clear that this phenomenon increases the average conductance and decreases the conversion conductance under any conditions whatever, so that it becomes impossible to equal the performance of the idealized diode. Analysis shows that there is then an optimum operating condition even if the input circuit is loss-free, and this optimum, of course, has a finite conversion loss.

Correction

It has been brought to the attention of the author, Frederick Emmons Terman, that an error appears in his book *Radio Engineers Handbook*, which has been recently published. This error is in equation (117) which appears on page 216 of the *Handbook*. This particular section of the *Handbook* was reprinted in the April, May, and June, 1943, issues of the PROCEEDINGS under the title of "Network Theory, Filters, and Equalizers." The error in question appears on page 234 of the May, 1943, issue of the PROCEEDINGS in equation (38). In place of reading

it should be

$$R_1 = R_1 \left(\frac{\alpha - 1}{\alpha + 1} \right)$$

$$R_2 = R_1 \left(\frac{2\alpha}{\alpha^2 + 1} \right)$$

$$R_1 = R_1 \left(\frac{\alpha - 1}{\alpha + 1} \right)$$

$$R_2 = \left(\frac{2\alpha}{\alpha^2 - 1} \right)$$

THE INSTITUTE OF RADIO ENGINEERS

INCORPORATED



SECTION MEETINGS

ATLANTA October 15	CHICAGO October 15	CLEVELAND October 28	DETROIT October 22
LOS ANGELES October 19	NEW YORK November 3	PHILADELPHIA November 4	PITTSBURGH November 8
			WASHINGTON November 8

SECTIONS

- ATLANTA**—Chairman, C. F. Daugherty; Secretary, Ivan Miles, 554—14 St., N. W., Atlanta, Ga.
- BALTIMORE**—Chairman, G. J. Gross; Secretary, A. D. Williams, Bendix Radio Corp., E. Joppa Rd., Towson, Md.
- BOSTON**—Chairman, R. F. Field; Secretary, Corwin Crosby, 16 Chauncy St., Cambridge, Mass.
- BUENOS AIRES**—Chairman, W. Klappenbach; Secretary, G. J. Andrews, Cia. Standard Electric Argentina, Cangallo 1286 Buenos Aires, Argentina.
- BUFFALO-NIAGARA**—Chairman, Leroy Fiedler; Secretary, H. G. Korts, 432 Potomac Ave., Buffalo, N. Y.
- CHICAGO**—Chairman, A. B. Bronwell; Secretary, W. O. Swinyard, Hazeltine Electronics Corp., 325 W. Huron St., Chicago, Ill.
- CINCINNATI**—Chairman, Howard Lepple; Secretary, J. L. Hollis, 6511 Betts Ave., North College Hill, Cincinnati, Ohio.
- CLEVELAND**—Chairman, F. C. Everett; Secretary, Hugh B. Okeson, 4362 W. 58 St., Cleveland, 9, Ohio.
- CONNECTICUT VALLEY**—Chairman, W. M. Smith; Secretary, R. E. Moe, Radio Dept., General Electric Co., Bridgeport, Conn.
- DALLAS-FORT WORTH**—Chairman, H. E. Applegate; Secretary, P. C. Barnes, WFAA-WBAP, Grapevine, Texas.
- DETROIT**—Chairman, F. M. Hartz; Secretary, E. J. Hughes, 14209 Prevost, Detroit, Mich.
- EMPORIUM**—Chairman, R. K. Gessford; Secretary, H. D. Johnson, Sylvania Electric Products, Inc., Emporium, Pa.
- INDIANAPOLIS**—Chairman, A. N. Curtiss; Secretary, E. E. Alden, WIRE, Indianapolis, Ind.
- KANSAS CITY**—Chairman, B. R. Gaines; Secretary, R. N. White, 4800 Jefferson St., Kansas City, Mo.
- LOS ANGELES**—Chairman, Lester Bowman; Secretary, R. C. Moody, 4319 Bellingham Ave., North Hollywood, Calif.
- MONTREAL**—Chairman, L. T. Bird; Secretary, J. C. R. Punchard, Northern Electric Co., 1261 Shearer St., Montreal, Que., Canada.
- NEW YORK**—Chairman, H. M. Lewis; Secretary, H. F. Dart, 33 Burnett St., Glen Ridge, N. J.
- PHILADELPHIA**—Chairman, W. P. West; Secretary, H. J. Schrader, Bldg. 8, Fl. 10, RCA Manufacturing Co., Camden, N. J.
- PITTSBURGH**—Chairman, B. R. Teare; Secretary, R. K. Crooks, Box, 2038, Pittsburgh, Pa.
- PORTLAND**—Chairman, K. G. Clark; Secretary, E. D. Scott, Rt. 14, Box 414, Portland, Ore.
- ROCHESTER**—Chairman, O. L. Angevine, Jr.; Secretary, G. R. Town, Stromberg-Carlson Tel. Mfg. Co., Rochester, N. Y.
- ST. LOUIS**—Chairman, N. J. Zehr; Secretary, H. D. Seielstad, 1017 S. Berry Rd., Oakland, St. Louis, Mo.
- SAN FRANCISCO**—Chairman, Karl Spangenberg; Secretary, David Packard, Hewlett-Packard Co., Palto Alto, Calif.
- SEATTLE**—Chairman, L. B. Cochran; Secretary, H. E. Renfro, 4311 Thackeray Pl., Seattle, Wash.
- TORONTO**—Chairman, T. S. Farley; Secretary, J. T. Pfeiffer, Erie Resistor of Canada, Ltd., Terminal Warehouse Bldg., Toronto, Ont., Canada.
- TWIN CITIES**—Chairman, E. S. Heiser; Secretary, B. R. Hilker, KSTP, St. Paul Hotel, St. Paul, Minn.
- WASHINGTON**—Chairman, C. M. Hunt; Secretary, H. A. Burroughs, Rm. 7207, Federal Communications Commission, Washington, D. C.

Institute News and Radio Notes

Board of Directors

A special meeting of the Board of Directors took place on July 21, 1943, and was attended by L. P. Wheeler, president; F. S. Barton, vice president; S. L. Bailey, W. L. Barrow, I. S. Coggeshall, W. L. Everitt, H. T. Friis, Alfred N. Goldsmith, editor; O. B. Hanson, R. A. Heising, treasurer; F. B. Llewellyn, Haraden Pratt, secretary; B. J. Thompson, H. M. Turner, H. A. Wheeler, W. C. White, and W. B. Cowilich, assistant secretary.

Secretary Pratt, in his capacity as chairman of the Radio Technical Planning Association, reported on the further progress made in the development of that agency and submitted the tentative draft of the "Organization and Procedure" which had been prepared jointly by the Institute and Radio Manufacturers Association committees. It was indicated that another meeting of the two committees would take place in August for the purpose of completing the plan.

Among the actions taken relative to the RTPA, which was discussed at length, were the appointments of Secretary Pratt to serve as representative of the Institute, and Mr. Thompson as alternate, when the named agency is established.

The Consultative Committee on Engineering (advisory to the War Manpower Commission) was discussed in connection with the report on that body, given by Secretary Pratt. It was noted that a number of other engineering societies had accepted the proposal to have all engineering-manpower matters, to be directed to the attention of the Government, clear through the Consultative Committee on Engineering. The proposal was favorably regarded but final endorsement was reserved for subsequent action to be taken when the complete plan is made available.

President Wheeler announced that the Executive Committee approved the preparation and submission of a supplementary appeal to the War Production Board for relief from the modified Paper Limitation Order L-244 of that agency, which places severe restrictions on the supply of paper made available for printing the PROCEEDINGS.

On recommendations of the Executive Committee, increased budgets were approved including those for the printing of the PROCEEDINGS and the Cumulative Index (1913-1942).

The 1942 Report of the Secretary was unanimously accepted and approved.

Mr. Coggeshall, chairman of the Public Relations Committee, reported that letters on and copies of the Institute's resolution on Senate Bill S-702 had been extensively distributed to the technical and lay press. Attention was also called to the replies concerning the resolution, received from Senator H. M. Kilgore and Representative Wright Patman.

Dr. Terman was appointed to serve as the representative of the Institute on the Division of Engineering and Research of the

National Research Council, Washington, for a term of three years beginning July 1, 1943.

A temporary committee on Institute's investments consisting of President Wheeler, Treasurer Heising, and Secretary Pratt was appointed to replace the present special committee.

The following appointments were also made: F. A. Polkinghorn, Admissions Committee; J. J. Callahan, Facsimile Committee; and H. N. Blackmon, R. K. Honaman, and E. L. Robinson, Papers Procurement Committee.

Unanimous approval was granted to these applications: for transfer to Member grade from R. G. Clark, E. N. Dingley, Jr., and A. J. Ebel; for admission to Member grade from L. J. Purgett; 19 for transfer to Associate grade; and 137 for Associate, 109 for Student, and 4 for Junior grades.

The area of the Chicago Section was enlarged to include the addition of the following counties, as recommended by the Executive Committee: Illinois—Champaign, Ford, Iroquois, Kankakee, Livingston, Marshall, McLean, Peoria, Putnam, Tazewell, Vermillion, Winnebago, and Woodford; Indiana—St. Joseph; Wisconsin—Dane, Jefferson, Kenosha, Milwaukee, Racine, Rock, Walworth, and Waukesha.

The printing of the Temporary Facsimile Test Standards, recently completed by the Facsimile Committee, and other temporary Standards reports during the period of the present war, was approved.

R. H. Dishington was conditionally appointed Institute Representative at the University of Southern California.

Executive Committee

The Executive Committee met on July 20, 1943, and those present were L. P. Wheeler, chairman; Alfred N. Goldsmith, editor; R. A. Heising, treasurer; F. B. Llewellyn, Haraden Pratt, secretary; H. A. Wheeler, and W. B. Cowilich, assistant secretary.

The applications for transfer to Member grade in the names of R. G. Clark, E. N. Dingley, Jr., and A. J. Ebel, and for admission to Member grade in the name of L. J. Purgett, were recommended to the Board of Directors for approval.

The 137 applications for admission to Associate, 109 to Student, and 4 to Junior grades, and the 19 applications for transfer to Associate grade, were also approved for confirming action by the Board of Directors.

Assistant Secretary Cowilich reported on office-personnel matters including the overtime work during the month of May, the setting up of the required bookkeeping records for the "Pay-As-You-Go" income tax, and the progress of the preparation of the Audit Bureau of Circulations statement for the first six-month period of 1943.

Chairman Wheeler stated that on July 1, 1943, he and Editor Goldsmith met with a representative of the War Production Board, at Washington, relative to seeking relief for

the PROCEEDINGS from that agency's modified Paper Limitation Order L-244. It was learned that WPB does not intend to make available to the Institute the paper tonnage that would be required to print the PROCEEDINGS at the present rate of increase in membership and in number of pages per issue.

Under the circumstances Editor Goldsmith announced that, effective with the August issue, the covers and inside pages of the PROCEEDINGS would of necessity be printed on still lighter-weight paper, certain typographical and related space-saving changes would be accomplished, and the number of surplus copies and pages per issue printed would be reduced.

In addition to making the reasonable paper economies, it was agreed to prepare and submit as soon as possible another supplementary appeal to WPB for relief from the named order.

Attention was called by Mr. H. A. Wheeler to the increased advertising rates for the PROCEEDINGS, which were authorized at the previous meeting as the result of a sharp gain in membership.

The recommendation was made to the Board of Directors that H. N. Blackmon, R. K. Honaman, and E. L. Robinson be appointed to the Papers Procurement Committee.

A revised budget for the PROCEEDINGS was recommended to the Board of Directors for approval as a result of the larger number of copies being printed, papers published, and advertisements carried, in addition to the possibility of having to make certain space-saving format changes due to the WPB Paper Limitation Order. A similar budget recommendation was made in the case of the Cumulative Index (1913-1942) in view of the necessity of printing more copies than were originally planned.

Dr. F. E. Terman was recommended to the Board of Directors for appointment as the Institute representative on the Division of Engineering and Research of the National Research Council, Washington.

The conditional appointment of Mr. R. H. Dishington as Institute Representative at the University of Southern California, to succeed Professor J. K. Nunan who is on leave of absence from that university, was also recommended for approval by the Board of Directors.

Dr. Llewellyn reported on the further progress that is being made in revising the list of Institute Representatives on Other Bodies.

Consideration was given to a request from the Subcommittee on Supplementary Finance of the American Standards Association.

Chairman Wheeler reported on an analysis relative to the request of the Chicago Section for enlargement of its official Section territory. On the basis of the report, it was recommended that the Board of Directors approve the addition of certain counties to the present Chicago Section area.

Matters pertaining to the New York and

Buenos Aires Sections were also discussed.

It was stated by Chairman Wheeler that a request had been received from the Associated Radio Technicians of British Columbia concerning the possibility of forming an Institute Section at Vancouver, British Columbia, Canada.

The 1942 Report of the Secretary was discussed and recommended to the Board of Directors for approval.

A discussion of the Rochester Fall Meeting Committee was also held.

Consideration was given to material recently received from National Inventors Council, Washington.

The appointment of F. A. Polkinghorn to the Admissions Committee was recommended to the Board of Directors for approval.

Dr. Llewellyn called attention to the Temporary Facsimile Test Standards report, recently completed by the Facsimile Committee and submitted by J. L. Callahan, chairman of that group. The recommendation was made that the Board of Directors approve the printing of this and other temporary standards during the war period.

Chairman Wheeler stated that the report on the Institute's long-range investment policy was progressing and would soon be available for discussion by the Executive Committee. The appointment of a standing committee on investments was recommended to the Board of Directors.

A request from the American Red Cross was considered.

1943 Rochester Fall Meeting

Sagamore Hotel, Rochester, New York
November 8 and 9, 1943

Program

Monday, November 8

8:30 A.M.

REGISTRATION

9:30 A.M.

TECHNICAL SESSION

"Review of the problem: Demountable Versus Sealed-Off Tubes," by I. E. Mouromtseff, Westinghouse Electric and Manufacturing Company.

"Recent Advances In Klystron Theory," by W. W. Hansen, Sperry Gyroscope Company.

12:30 P.M.

LUNCHEON

2:00 P.M.

TECHNICAL SESSION

"The Design of Intermediate-Frequency Transformers for Frequency-Modulation Receivers," by William H. Parker, Jr., Stromberg-Carlson Telephone Manufacturing Company.

"Vacuum Capacitors," by George H. Floyd, General Electric Company.

4:00 P.M.

COMMITTEE MEETINGS

6:30 P.M.

DINNER

8:15 P.M.

TECHNICAL SESSION

"The Signal Corps Looks to the Engineer," by Lieutenant Colonel Kenneth D. Johnson, United States Army Signal Corps.

Tuesday, November 9

8:30 A.M.

REGISTRATION

9:30 A.M.

TECHNICAL SESSION

"Message of RMA Director of Engineering," by Dr. W. R. G. Baker.

"Operating Characteristics of Ceramic Dielectrics with Constants Over 1000," by R. B. Gray, Erie Resistor Corporation.

"A Chamber of Commerce War Research Committee," by K. C. D. Hickman, Distillation Products, Inc.

12:30 P.M.

LUNCHEON

2:00 P.M.

TECHNICAL SESSION

"Report of RMA Data Bureau," by L. C. F. Horle

"New Low-Loss Ceramic Insulation," by Ralston Russell, Jr., and L. J. Berberich Westinghouse Electric and Manufacturing Company.

"Design of Intermediate-Frequency Systems," by J. E. Maynard, General Electric Company.

4:00 P.M.

COMMITTEE MEETINGS

6:30 P.M.

STAG BANQUET

Toastmaster, R. M. Wise
(Subject and Speaker to be announced later.)

An exhibit of the U. S. Army Signal Corps equipment will be a feature of both days.



ELMER C. GRIMLEY
1891-1943

Elmer C. Grimley of Montreal, president of RCA Victor, Ltd., was drowned on August 3, 1943, while sailing his boat on Lake Memphramagog.

Mr. Grimley was born in Cornwall, New York, on April 15, 1891. From 1908 to 1912 he was an apprentice in the engineering department and a junior draftsman with the Gregg Company, Ltd., at Hackensack, New Jersey. In 1916 he received the B.Sc. degree

from New York University. During 1916-1917 Mr. Grimley was a junior accountant with Marwick, Mitchell, Peat and Company in New York and a Lieutenant (J.G.) in the United States Navy from 1917 to 1919. From 1919 to 1935 he was with RCA Victor in the United States and in 1935 he went to Canada to be president of RCA Victor Company, Ltd.

Mr. Grimley was a past president and director of the Radio Manufacturers Association and a director of the Bankers Commercial Corporation. He joined the Institute of Radio Engineers in 1939 as an Associate.

Books

First Principles of Radio Communications, by Alfred Morgan

Published by D. Appleton-Century Co., 35 W. 32 St., New York, N. Y. 353 pages +12-page index+IX pages. 183 figures. 6x8½ inches. Price, \$3.00.

The author is a radio engineer who has written a number of popular books on scientific subjects. The purpose of the present work, as outlined in the publisher's notice, (there is no author's preface), is to provide a practical, nonmathematical, introductory course in radio communications for the novice.

The first 141 pages serve to lay a foundation of the broad principles of electrical science as an introduction to the later chapters on strictly radio matters. This preliminary material, which bases the treatment of electrical circuits on the conception of the electron, is presented clearly and in an interesting manner, with a minimum of formulas and only the simplest arithmetic. The diagrams throughout the book are clear and striking and are accompanied by well-chosen captions.

The later chapters on radio apparatus and accessories are also clear, informative, and up to date. The portions dealing with vacuum-tube circuits are less satisfactory, although the subject matter is well chosen and the treatment logical and accurate. The radio amateur and others who already are acquainted with elementary radio circuits may read this portion with profit, but it is not certain that the novice will find it as clear as the rest of the book. It may, however, be doubted whether the simplified method of presentation so successful in the other sections of the next, can be made to yield more than a superficial understanding of the complications of the circuits of a radio receiver, to the reader entirely unfamiliar with the subject, in the space available.

The author is, however, to be congratulated on the production of a concise, comprehensive, and accurate introduction to the chosen subject, which is well suited to serve as an inspiration to the beginner and as an incentive to further study on his part.

FREDERICK W. GROVER
Union College
Schenectady, N. Y.

A Course in Radio Fundamentals, by George Grammer

Published by the American Radio Relay League, West Hartford, Conn. 103 pages. 104 illustrations. 6½×9½ inches. Price, \$5.50.

"A Course in Radio Fundamentals" suggests that to the adage, "Don't judge a book by its cover" there be added "or its size." In the format of *QST*, of which the author of the book is Technical Editor, its narrow margins and small compact type make its 103 pages easily the equivalent of two or three times that many of the more-conventional variety.

Partaking more of the nature of a syllabus than of a text, it is the objective of this book to organize the approach of the new student of radio to the study of fundamentals as they are presented in "The Radio Amateur's Handbook."* In addition, it describes the apparatus and the procedure for a series of experiments to familiarize the neophyte with the operation of equipment. Examination questions are given at brief intervals to test the effectiveness with which the student is absorbing the knowledge to which he has been exposed. The answers may be found at the back of the book.

Characteristic of the technical view of the editorial group of the American Radio Relay League, the emphasis is placed firmly on matters of practical importance. Theory is used as a basic means to the building and use of equipment and not for mental acrobatics.

The reviewer confesses some bias, having been associated with *QST* for several years, and may thus be excused for hoping that some day *QST* and its companion publications will reserve the term "capacity" for the ability to do work and use "capacitance" to designate the property of a capacitor. "Condenser" can then be returned to the steam plant. This gives an orderly system of nomenclature:

<i>Device</i>	<i>Property</i>
Resistor	Resistance
Inductor	Inductance
Capacitor	Capacitance

While it may not be inevitable, it is not uncommon for the amateur to become a professional. Amateur training, therefore, is of importance to the engineering profession as it influences the thinking and terminology of many engineers. Habits learned early in life are hard to change as is indicated by a well-squelched preference developed by the reviewer when an amateur for "picofarad" rather than the cumbersome "micromicrofarad."

This pair of books is undoubtedly the biggest \$1.50 worth of technical radio literature offered the newcomer to the high-frequency radio field. It answers completely the question which many engineers face from time to time when advising those who are interested in getting started in radio. It is this aspect which justifies the engineer in buying the books to evaluate them and—not so incidentally—to spend a

* *Proc. I.R.E.*, vol. 31, p. 313; June, 1943.

few hours catching up on some of the branches of the field with which he may not be in daily contact.

HAROLD P. WESTMAN
Secretary, War Committee on Radio
American Standards Association
New York, N. Y.

Elements of Radio, by A. Marcus and Wm. Marcus

Published by Prentice-Hall, Inc., 70 Fifth Avenue, New York, N. Y. 684 pages +15-page index+xiii pages. 539 figures. 6½×9½ inches. Price \$4.00.

The authors' purpose in writing this book was to provide a basic and elementary course suitable for home study or as a classroom text on the fundamentals of radio for those having no previous experience in physics or mathematics. The method chosen to accomplish this can best be illustrated by a quotation from the preface: "The simple crystal receiver is chosen as embodying all the basic principles of any receiver."

To insure a complete understanding of this simple receiver, the device of the spiral is adopted in presenting the subject matter. Thus, at the first cycle an extremely elementary explanation of the radio is presented—tuning, detection, and reproduction. The next turn around covers the same ground at a slightly higher level. And so on, through the various cycles.

The authors consider the elimination of all formulas and mathematics a "must" and as a consequence, the first half of the book does not contain formulas. In this half of the book the student is taken from the most elementary concepts up through the operation of the superheterodyne receiver. It is interesting to note in the first edition of a new book that many of the diagrams and examples show circuits employing such tubes as the 01A, 27, 24A, and 47 and that the superheterodyne receiver discussed employs an intermediate frequency of 175 kilocycles.

The second half of the book takes up in a more technical manner the consideration of the nature of electricity and the radio wave. Here are introduced for the first time the technical definitions of such terms as inductance, capacitance, resonance, etc. Direct- and alternating-current circuits, electromagnetic waves, radio antennas and transmitters, vacuum-tube amplifiers and oscillators, and other subjects common to a book of this type are covered in this section.

The book incorporates a number of worth-while teaching devices. At the beginning of each chapter problems are set up, the answers to which are developed in the chapter. At the end of each chapter there is a concise summary, or glossary listing the important concepts and definitions covered in the chapter. This is followed by questions and problems.

The twenty-five pages preceding the appendix list demonstrations for each chapter in the book. There are from 1 to 13 suggested beginning with chapter 2. These require equipment which would be

readily available in any school with the ordinary equipment in physics with the addition of several old radio sets.

The appendix contains 9 pages of data including eventful dates in radio development, radio symbols and abbreviations, Radio Manufacturers Association color codes, international Morse code, soldering hints, and practical data.

Very little space is devoted to frequency modulation. The discussion of this subject is far too brief and inadequate, being confined to about three pages.

A half page is devoted to facsimile and a 14-page chapter to the cathode-ray tube and its application.

The subject of ultra-high frequency receivers and transmitters is not treated.

Since the book presupposes no earlier training in physics or mathematics on the part of the reader, and contains numerous errors and debatable statements, it will not be of interest to qualified engineers.

W. O. SWINYARD
Hazeltine Electronics Corporation
Chicago, Illinois

Applied Electronics, by Members of the Staff of the Department of Electrical Engineering, Massachusetts Institute of Technology

Published (1943) by John Wiley and Sons, Inc., 601 West 26 St., New York, N. Y. 772 pages, 738 pages+34-page index+xiii pages. 394 figures, 6½×9½ inches. Price, \$6.50.

This third volume in the "Principles of Electrical Engineering Series" by the staff at M.I.T. is a textbook, and its greatest use should be in the classroom. It is, in agreement with its subtitle, a "first course." The practicing engineer will find it a useful reference in the general field. It makes no pretense of being useful to the specialist in his own speciality.

The logical organization of the material will appeal both to the teacher and to the student. The first third of the book is spent inside the electronic tube, studying electron ballistics, emission, conduction through vacuum and gases, and tube characteristics. The last two thirds of the book deals with the circuits closely associated with the tube. It includes chapters on rectifiers, class A amplifiers, class AB, B, and C amplifiers, oscillators, and modulators and detectors.

Each chapter starts with a general description, usually followed by a brief mathematical discussion concerning basic relations or idealized cases. The remainder of the chapter then develops the broader problem. The emphasis marks with which the student usually decorates the important mathematical relations are already printed alongside the equation numbers.

The discussion of some subjects, such as feedback amplifiers, seems very brief, but more complete consideration of special problems can hardly be expected in a first course.

In the discussion of amplifiers, gain and

amplification are used without distinction. It is customary for communication engineers to use amplification for simple ratios and to use gain only when the units are decibels. This practice should be reflected in our textbooks.

In the discussion of units, p. 724, it is stated: "In any electromagnetic system of units, the only unavoidable dimensionless factor which appears because of the geometry is 4π ." It is unfortunate that the authors have not noted the existence of a well-known system of units which does avoid 4π and all other dimensionless factors which might enter because of the geometry or for any other reason. The authors are to be complimented on the use of the m.k.s system of units even in its incomplete form, but many will regret that they did not go all the way. A textbook concerned with the development of logical concepts and methods of analysis should distinguish between the effect of geometry in a system of units and its effect in a particular application which may involve those units.

At the end of each chapter is a rather generous list of very appropriate problems. These, together with the excellent general presentation, make this a very "teachable" book.

E. B. FERRELL
Bell Telephone Laboratories, Inc.
New York, N. Y.

Tables of Functions with Formulae and Curves, by Eugene Jahnke and Fritz Emde

Published by Dover Publications, 31 East 27 Street, New York, N. Y. Enlarged, revised edition, 1943. 303+76 pages. 212 figures. $6\frac{1}{2} \times 9\frac{1}{2}$ inches. Price, \$3.50.

The 1933 edition of this work received immediate recognition as a most valuable handbook of mathematical functions for the use of mathematicians, physicists, and engineers. The 1938 edition was enlarged and improved in some respects, but did not contain one valuable section of the previous edition, entitled "Tables of Elementary Functions." The 1943 edition is a reprint of the entire 1938 edition with the addition of this section, so it contains all the material of both previous editions. It has been published under license of the United States Alien Property Custodian to make this valuable handbook available to the growing army of scientists which has come to be recognized as one of the determining factors in the war. The photo-offset method of reprinting has been employed to minimize the delay in printing and the cost of reproduction, while assuring an exact copy.

The 1938 edition was reviewed in the PROCEEDINGS OF THE I.R.E. of July, 1942, page 353. For the benefit of more recent members, that review is quoted herewith.

"This volume is a monumental collection of short tables, formulas, and curves of a large variety of transcendental functions. Many of the functions are plotted in three dimensions to give a better picture of the functional relations. The contour method of plotting in two or three dimensions is used

in some cases. All subjects are well supported by references to more comprehensive specialized publications.

"The text is complete in both English and German, side by side.

"Some of the functions which are of greatest interest to radio engineers may be mentioned. The sine-integral, cosine-integral, and exponential-integral are useful in the analysis of transients in idealized filters. The error integral finds application in thermal agitation.

"Elliptic integrals are represented by one of the best short collections of formulas, curves, and tables; they find application in the inductance of coils, capacitance of rings, and special problems such as linear detection of modulated waves with unsymmetrical sidebands.

"The largest section, about one half of the book, is devoted to an excellent treatment of Bessel functions of integral and fractional orders with real, imaginary, and complex arguments. The essential relations are concisely formulated and illustrated graphically. Special attention is given to asymptotic formulas and to special properties such as the roots of the functions and their derivatives. There are 28 tables of the various cases. This section finds application to countless radio problems, from the high-frequency resistance of wires to the propagation in wave guides and attenuation in piston attenuators. Special applications are found in the transients in filters and the sidebands in frequency modulation."

H. A. WHEELER
Hazeltine Electronics Corporation
Little Neck, Long Island, N. Y.

Principles and Practice of Radio Servicing, by H. J. Hicks

Published by McGraw-Hill Book Company, 330 West 42 Street, New York, N. Y., and London, England. Second edition 1943. 380 pages+11-page index+XII pages. 311 figures and tables. $6\frac{1}{2} \times 9$ inches. Price, \$3.50.

This book seems to have been prepared as a connecting link between the technical radio theory of the classroom and the practical problems of a radio servicing shop. It may well serve (at some time) to reintroduce the subject of home-radio receiver repairing to the host of technicians who are trained in radio only as to its military aspects.

Starting with brief reviews of electrical and radio fundamentals and the basic principles of tubes and their uses in circuits, the author proceeds with descriptions of test equipment, amplifiers for various uses, power supplies, and detectors. Receiver circuit features and individual equipment components are described, followed by the circuit theory of receivers (including frequency modulation) and a general description of the generally accepted servicing methods. The book has a chapter on public-address systems and suggestions as to the business problems of the servicing game.

RALPH R. BATCHER
Hollis, L. I., N. Y.

Introduction to Circuit Analysis, by Abner R. Knight and Gilber H. Fett

Published (1943) by Harper and Brothers, 49 East 33 Street, New York, N. Y. 439 pages+7-page index+XX pages. 219 figures, $6\frac{1}{2} \times 9\frac{1}{2}$ inches. Price, \$4.00.

This is a very well written book. The explanations are clear and well thought out. There is an excellent use of graphical attack. The comparison of the systems of units is also fortunate. In fact for the purpose for which it is intended it seems like an excellent job.

This reviewer's only quarrel would be with the purpose of the book. It is "intended as a text for the initial and basic course in electrical engineering." As such it presumably follows right after physics and calculus are completed. From this start to cover circuit analysis in "a five-semester hour course" requires a superficiality of treatment that bodes ill for the student's depth of understanding of the subject. Direct-current problems are dismissed in one-half page. This completely neglects the opportunity to give such stimulating problems as the cube which is made up of 1-ohm resistors along each edge and whose resistance between diametrically opposed corners is required. Or some such as the double-track trolley system fed by a single feeder with different voltages at the two ends of the line. It is required to determine the minimum line voltages if the four cars on the line are never allowed to approach each other more closely than one mile on the same track. Such problems as the latter teach the young student to translate physical problems into mathematical language and so become familiar with the calculus as a working tool.

In fact the main criticism of the book is that the authors fall into the common engineering error of regarding calculus as a beautiful woman: lovely to behold but not to be used. For instance, the superposition theorem (p. 288) is not intuitively obvious, but a result of the facts that experimentally certain electrical circuits behave according to a linear second-order differential equation, and that the sums of solutions of such an equation are also solutions of the equation.

Of course what this reviewer decries about the book will appear a virtue to many. And for those to whom this will be true the book should be a very satisfactory one. The choice of material is good. It is a very gratifying to see the teaching of *mesh currents* in elementary courses increasing. Also the use of determinants in the solution of network problems.

The book has surprisingly few errors for a first edition. The most annoying is the misinterpretation of the rationalization of equation 13-12 appearing on page 374, since it distorts the physical facts. The book has evidently been carefully proofread; the format is good.

If I believed in the purpose of the book I should like to have written it.

KNOX McILWAIN
Hazeltine Electronics Corporation
Little Neck, Long Island, N. Y.

Institute Committees—1943

ADMISSIONS

G. T. Royden, *Chairman*

S. L. Bailey	G. E. Gustafson
H. H. Beverage	D. E. Harnett
F. J. Bingley	F. A. Polkinghorn
Lloyd Espenschied	B. J. Thompson
H. M. Turner	

AWARDS

H. A. Wheeler, *Chairman*

W. L. Everitt	J. C. Schelleng
D. D. Israel	B. E. Shackelford
F. E. Terman	

BOARD OF EDITORS

Alfred N. Goldsmith, *Chairman*

R. R. Batcher	H. F. Olson
P. S. Carter	G. W. Pickard
L. M. Clement	R. A. Powers
J. F. Dreyer, Jr.	Haraden Pratt
E. W. Engstrom	C. A. Priest
W. L. Everitt	H. J. Reich
P. C. Goldmark	L. C. Smeby
F. W. Grover	B. J. Thompson
C. M. Jansky, Jr.	H. A. Wheeler
J. D. Kraus	L. E. Whittemore
F. B. Llewellyn	G. W. Willard
S. S. Mackeown	William Wilson
E. L. Nelson	C. J. Young
P. D. Zottu	

CONSTITUTION AND LAWS

R. A. Heising, *Chairman*

W. L. Barrow	A. F. Van Dyck
B. J. Thompson	H. P. Westman
H. M. Turner	H. R. Zeamans

EXECUTIVE

L. P. Wheeler, *Chairman*

R. A. Heising, *Vice Chairman*
Haraden Pratt, *Secretary*

Alfred N. Goldsmith	A. F. Van Dyck
F. B. Llewellyn	H. A. Wheeler

ANNUAL REVIEW

L. E. Whittemore, *Chairman*

R. S. Burnap	R. F. Guy
C. R. Burrows	Keith Henney
W. G. Cady	I. J. Kaar
J. L. Callahan	G. G. Muller
C. C. Chambers	H. M. Turner
C. J. Franks	A. F. Van Dyck
H. A. Wheeler	

ELECTROACOUSTICS

G. G. Muller, *Chairman*

S. J. Begun	G. M. Nixon
F. V. Hunt	Benjamin Olney
V. N. James	H. F. Olson
Knox McIlwain	H. H. Scott
L. J. Sivan	

MEMBERSHIP

B. J. Thompson, *Chairman*

V. J. Andrew	L. G. Hector
C. R. Barhydt	C. M. Jansky, Jr.
C. M. Burrill	R. L. Kelly
J. M. Clayton	J. G. Kreer, Jr.
R. I. Cole	J. P. Minton
E. D. Cook	J. A. Morton
W. C. Copp	Albert Preisman
W. H. Doherty	J. L. Reinartz
A. V. Eastman	Bernard Salzberg
W. G. Eaton	R. B. Shanck
A. J. Ebel	J. E. Shepherd
W. N. Eldred	R. L. Snyder
W. L. Everitt	J. C. Stroebel
P. B. Findley	Sarkes Tarzian
D. G. Fink	Bertram Trevor
Samuel Gubin	K. S. Van Dyke
L. B. Headrick	H. M. Wagner

Ernst Weber

(Section Secretaries, ex-officio members)

NOMINATIONS

Haraden Pratt, *Chairman*

W. L. Barrow	J. V. L. Hogan
H. H. Beverage	L. C. F. Horle
Ralph Bown	F. E. Terman

PAPERS

F. B. Llewellyn, *Chairman*

H. A. Affel	Knox McIlwain
W. L. Barrow	H. R. Mimno
J. K. Clapp	G. G. Muller
I. S. Coggeshall	A. F. Murray
F. W. Cunningham	H. O. Peterson
R. B. Dome	A. F. Pomeroy
W. G. Dow	J. R. Poppele
E. B. Ferrell	Simon Ramo
D. G. Fink	F. X. Rettenmeyer
F. W. Grover	P. C. Sandretto
O. B. Hanson	S. A. Schelkunoff
J. V. L. Hogan	D. B. Sinclair
F. V. Hunt	Karl Spangenberg
Harley Iams	H. M. Turner
L. F. Jones	Dayton Ulrey
J. G. Kreer, Jr.	W. C. White
F. R. Lack	Irving Wolff
H. C. Leuteritz	J. W. Wright
D. K. Martin	H. A. Zeamans

PAPERS PROCUREMENT

D. D. Israel, *Chairman*

W. L. Everitt, *Vice Chairman*

J. R. Pierce, *Second Vice Chairman*

W. L. Barrow	H. K. Morgan
H. N. Blackmon	D. E. Noble
E. L. Bowles	A. A. Oswald
J. E. Brown	J. R. Poppele
R. S. Burnap	E. L. Robinson
E. L. Chaffee	P. C. Sandretto
J. D'Agostino	W. L. Schwesinger
E. T. Dickey	B. E. Shackelford
A. V. Eastman	H. C. Sheve
D. E. Foster	L. C. Smeby
V. M. Graham	Karl Spangenberg
O. B. Hanson	H. M. Turner
R. K. Honaman	A. F. Van Dyck
F. V. Hunt	H. A. Wheeler
H. S. Knowles	L. P. Wheeler
R. M. Wise	

PUBLIC RELATIONS

I. S. Coggeshall, *Chairman*

O. H. Caldwell	Keith Henney
E. K. Cohan	D. D. Israel
P. B. Findley	T. R. Kennedy, Jr.
George Grammer	J. R. Poppele
O. B. Hanson	A. F. Van Dyck

REGISTRATION OF ENGINEERS

H. B. Richmond, *Chairman*

J. K. Johnson E. L. Nelson

SECTIONS

R. A. Heising, *Chairman*

C. N. Anderson	J. H. Miller
E. D. Cook	F. A. Polkinghorn
V. M. Graham	G. T. Royden
J. K. Johnson	B. E. Shackelford
(Section Chairmen, ex-officio members)	

TELLERS

C. E. Scholz, *Chairman*

H. F. Dart	Beverly Dudley
W. J. Ponsolle	

Technical Committees

May 1, 1943, to May 1, 1944

ELECTRONICS

R. S. Burnap, *Chairman*

E. L. Chaffee	J. A. Morton
H. P. Corwith	I. E. Mourontseff
K. C. DeWalt	L. S. Nergaard
W. G. Dow	G. D. O'Neill
L. A. DuBridge	H. W. Parker
R. L. Freeman	H. J. Reich
T. T. Goldsmith, Jr.	A. C. Rockwood
L. B. Headrick	J. B. Russell
D. R. Hull	Bernard Salzberg
S. B. Ingram	C. M. Wheeler
Ben Kievit, Jr.	J. R. Wilson
J. M. Miller, Jr.	Irving Wolff
Jack Yolles	
H. A. Zahl	

FACSIMILE

J. L. Callahan, *Chairman*

Maurice Artzt	L. C. Horn
E. P. Bancroft	H. J. Lavery
J. C. Barnes	B. V. Magee
F. R. Brick, Jr.	Pierre Mertz
W. A. R. Brown	G. D. Robinson
J. J. Callahan	L. A. Smith
G. V. Dillenback, Jr.	F. T. Turner
J. V. L. Hogan	R. J. Wise
C. J. Young	

FREQUENCY MODULATION

C. C. Chambers, *Chairman*

J. E. Brown	V. D. Landon
W. F. Cotter	H. B. Marvin
M. G. Crosby	D. E. Noble
W. L. Everitt	B. E. Shackelford
R. F. Guy	D. B. Smith
C. M. Jansky, Jr.	L. P. Wheeler
W. D. White	

RADIO RECEIVERSC. J. Franks, *Chairman*

G. L. Beers
W. M. Breazeale
W. F. Cotter
Harry Diamond
W. L. Dunn
H. B. Fischer
H. C. Forbes
D. E. Foster

David Grimes
J. K. Johnson
Garrard Mountjoy
H. O. Peterson
E. K. Stodola
A. E. Thiessen
H. P. Westman
R. M. Wilmotte

RADIO WAVE PROPAGATIONC. R. Burrows, *Chairman*

S. L. Bailey
J. L. Barnes
J. H. Dellinger
W. A. Fitch
G. D. Gillett

H. R. Mimno
K. A. Norton
H. O. Peterson
H. P. Thomas
W. D. White

STANDARDSH. A. Wheeler, *Chairman*

R. S. Burnap
C. R. Burrows
W. G. Cady
J. L. Callahan
C. C. Chambers

C. J. Franks
R. F. Guy
I. J. Kaar
G. G. Muller
H. M. Turner

SYMBOLSH. M. Turner, *Chairman*

R. R. Batcher
M. R. Briggs
R. S. Burnap
C. R. Burrows
J. H. Dellinger

E. T. Dickey
H. S. Knowles
O. T. Laube
Allen Pomeroy
E. W. Schafer

TELEVISIONI. J. Kaar, *Chairman*

H. S. Baird
J. E. Brown
A. B. DuMont
D. E. Foster
L. M. Leeds
H. M. Lewis
A. V. Loughren
H. T. Lyman

P. C. Goldmark
T. T. Goldsmith, Jr.
A. G. Jensen
A. F. Murray
R. E. Shelby
D. B. Sinclair
D. B. Smith

TRANSMITTERS AND ANTENNASR. F. Guy, *Chairman*

Andrew Alford
Raymond Asserson
M. R. Briggs
W. W. Brown
Harry Diamond
W. S. Duttera
Sidney Frankel
F. A. Gunther

W. E. Jackson
R. W. P. King
J. F. Morrison
J. C. Schelleng
Robert Serrell
D. B. Sinclair
W. D. White
J. E. Young

Institute Representatives in Colleges—1943

Alabama Polytechnic Institute: Woodrow Darling
Alberta, University of: J. W. Porteous
Arkansas, University of: P. K. Hudson

British Columbia, University of: H. J. MacLeod
Brooklyn, Polytechnic Institute of: F. E. Canavacioli

California Institute of Technology: S. S. Mackeown
California, University of: L. J. Black
Carleton College: C. A. Culver
Carnegie Institute of Technology: R. T. Gabler
Case School of Applied Science: P. L. Hoover
Cincinnati, University of: W. C. Osterbrock
Colorado, University of: J. M. Cage
Columbia University: J. B. Russell
Connecticut, University of: P. H. Nelson
Cooper Union: J. B. Sherman
Cornell University: True McLean

Drexel Institute of Technology: R. T. Zern
Duke University: W. J. Seeley

Florida, University of: P. H. Craig

Georgia School of Technology: M. A. Honnell

Harvard University: E. L. Chaffee

Idaho, University of: Hubert Hattrup
Illinois Institute of Technology: P. G. Andres
Illinois, University of: H. J. Reich
Iowa, University of: R. C. Kent

Johns Hopkins University: Ferdinand Hamburger, Jr.

Kansas State College: Karl Martin
Kansas, University of: G. A. Richardson

Lawrence Institute of Technology: H. L. Byerlay
Lehigh University: C. B. Brenecke
Louisiana State University: Taintor Parkinson

Maine, University of: W. J. Creamer, Jr.
Manhattan College: J. F. Reintjes
Maryland, University of: G. L. Davies
Massachusetts Institute of Technology: W. H. Radford and E. Guillemin

McGill University: F. S. Howes
Michigan, University of: L. N. Holland
Minnesota, University of: O. A. Becklund
Montana State College: G. J. Fiedler

Nebraska, University of: F. W. Norris
Newark College of Engineering: Solomon Fishman
New York University: Philip Greenstein
North Dakota, University of: E. J. O'Brien
Northeastern University: G. E. Pihl
Northwestern University: A. B. Bronwell
Notre Dame, University of: H. E. Ellithorn

Ohio State University: E. C. Jordan
Oklahoma Agricultural and Mechanical College: H. T. Fristoe

Pennsylvania State College: G. H. Crossley
Pennsylvania, University of: C. C. Chambers
Pittsburgh, University of: R. C. Gorham
Princeton University: J. G. Barry
Purdue University: R. P. Siskind

Queen's University: H. H. Steward

Rensselaer Polytechnic Institute: H. D. Harris
Rice Institute: C. R. Wischmeyer
Rose Polytechnic Institute: G. R. Schull
Rutgers University: J. L. Potter

Southern Methodist University: R. E. Beam
Stanford University: Karl Spangenberg
Stevens Institute of Technology: F. C. Stockwell

Texas, University of: E. W. Hamlin
Toronto, University of: R. G. Anthes
Tufts College: A. H. Howell

Union College: F. W. Grover
United States Naval Academy: G. R. Giet
Utah, University of: O. C. Haycock

Virginia, University of: I. R. Quarles
Virginia Polytechnic Institute: R. E. Bailey

Washington, University of: A. V. Eastman
Washington University: Stanley Van Wambeck
Wayne University: G. W. Carter
Western Ontario, University of: G. A. Wootton
West Virginia University: R. C. Colwell
Wisconsin, University of: Glenn Kochler
Worcester Polytechnic Institute: H. H. Newell

Yale University: H. M. Turner

Contributors

R. A. Bierwirth was born at Anthon, Iowa, in 1901. He received the B.S. degree in electrical engineering from Iowa State College in 1925, and the M.S. degree in electrical engineering from Union College in 1928. Mr. Bierwirth was employed in the radio engineering department of the General Electric Company at Schenectady from 1925 to 1930; in the engineering department of RCA Manufacturing Company at Camden from 1930 to 1941; and is now engaged in re-



R. A. BIERWIRTH

search work on industrial applications of radio frequency at the RCA Laboratories at Princeton.

Charles W. Harrison, Jr. (A '36) was born in Virginia in 1913. The years 1932-1936 were spent in the U. S. Naval Academy Preparatory School and in the Academy. In 1939 Mr. Harrison received the S.B. degree in engineering and in 1940 the degree of electrical engineer from the University of Virginia. In 1942 he was graduated with the S.M. degree in communication engineering from the Cruft Laboratory, Harvard University, and during the summer was a student at the Massachusetts Institute of Technology. His experience includes amateur, naval, and broadcast station operation, as well as research work at the Navy Department in Washington. He is at the present time a member of the teaching staff of the Cruft Laboratory.



C. W. HARRISON, JR.

Cyril N. Hoyler (A '35) was born on August 8, 1905, at Edmonton, Alberta, Canada. He received the B.S. degree from Moravian College in 1928 and the M.S. degree in physics from Lehigh University in 1935. After teaching mathematics and German for one year in the public schools of Irvington, New Jersey, he was invited to join the faculty of Moravian College in 1929 to develop a department of physics at that institution. Mr. Hoyler held that position until 1941 when he joined the research laboratories of the RCA Manufacturing



CYRIL N. HOYLER

Company, Inc., and is now located in the RCA Laboratories at Princeton, New Jersey. He has held an amateur operator's license since 1930 and a broadcast operator's license since 1940.

Ronold King (A '30) was born on September 19, 1905, at Williamstown, Massachusetts. He received the B.A. degree in 1927 and the M.S. degree in 1929 from the University of Rochester and the Ph.D. degree from the University of Wisconsin in 1932. He was an American-German exchange



RONOLD KING

student at Munich from 1928 to 1929; a White Fellow in physics at Cornell University from 1929 to 1930; and a Fellow in electrical engineering at the University of Wisconsin from 1930 to 1932. He continued at Wisconsin as a research assistant from 1932 to 1934. From 1934 to 1936 he was an instructor in physics at Lafayette College, serving as an assistant professor in 1937. During 1937 and 1938 Dr. King was a Guggenheim Fellow at Berlin. In 1938 he became instructor in physics and communication engineering at Harvard University, advancing to assistant professor in 1939 and to associate professor in 1942.

For biographical sketches of George H. Brown, E. W. Herold, and L. Malter, see THE PROCEEDINGS for August, 1943.



MYCALEX
THE INSULATOR

"... is the most nearly perfect electrical insulator known today"

—an opinion subscribed to by leading engineers in radio, television and industry.

U. S. NAVY OFFICIAL PHOTO

THERE IS ONLY ONE MYCALEX

... but, to say that there is only one MYCALEX is not sufficient without the backing of fact. Whatever claims are made have been proved in actual "firing line" application throughout the far corners of the globe. Through intense heat and cold ... in days before the war, and in these critical times, MYCALEX has emerged predominant in its field and, as leading engineers in industry, radio and television have told us, "is the most nearly perfect electrical insulator known today."

These engineers specify MYCALEX because they prefer MYCALEX. Extremely versatile in its application, it may be cut, drilled, tapped, machined, milled,

ground, polished and moulded. It meets requirements for close tolerances. Moreover, MYCALEX is leadless. This, combined with low loss at all frequencies, gives it advantages over all other types of glass bound mica insulation.

MYCALEX is not the name of a class of materials, but the registered trade-name for low-loss insulation manufactured in the Western Hemisphere only by the *Mycalex Corporation of America*. Be sure to specify MYCALEX if you are looking for low power factor, low loss, negligible moisture absorption and high dielectric strength. *Sheets and rods immediately available for fabrication by us or in your own plant.*



Trade Mark Reg. U. S. Pat. Off.

MYCALEX CORPORATION OF AMERICA

Exclusive Licensee under all patents of MYCALEX (PARENT) CO. Ltd.

60 CLIFTON BOULEVARD

CLIFTON, NEW JERSEY



(Continued from page 34A)

- Chodorow, M., 165 W. 97 St., New York, N. Y.
- Clemens, G. J., 147 Woodbine Rd., Roslyn Heights, L. I., N. Y.
- Cockrell, J. L., 134 E. Clay St., Lancaster, Pa.
- Cohen, B. B., 1917 N.E. 10 Ave., Portland, 12, Ore.
- Cohen, O., 6550 S. Justine St., Chicago, 36, Ill.
- Curtis, W. C., Box 845, Tuskegee Institute, Ala.
- Day, E. C., 16 W. Mystic Ave., Mystic, Conn.
- Dean, W. W., 526-21 St., Schenectady, 4, N. Y.
- DeLucia, E. V., 34 Halloween Blvd., Stamford, Conn.
- Deutach, K. T., 1000 Brannan St., San Francisco, Calif.
- Dinzi, R. A., 648 Nottingham Pl., Westfield, N. J.
- Douglas, R. N., 224 Southcross Blvd., San Antonio, Texas
- Dowling, R. H., 1324 Paloma Ave., Burlingame, Calif.
- Dunn, H. C., Creek Rd., Marshallton, Del.
- Eherle, E. E., 6 Clover Ave., Floral Park, L. I., N. Y.
- Fallert, R. J., 655 Park Ave., New York, 21, N. Y.
- Ffoulkes, C. E., A.P.O. 7109, c/o Postmaster, New York, N. Y.
- Flowers, H. L., 47 Forrester St., S.W., Washington, 20, D. C.
- Frank, G. C., 12750 Dresden Ave., Detroit, 5, Mich.
- Frauman, M., 2936 Peabody Ave., Dallas, Texas
- French, H. M., A.R.R.L., 38 LaSalle Rd., West Hartford, Conn.
- Fritze, L. R., 2540 Folsom St., San Francisco, 10, Calif.
- Fruehan, H. L., 6 Sixth Ave., Brownsville, Pa.
- Gandolfo, A., Calle Independencia No. 1585, 7 piso, Depto. 4, Buenos Aires, Argentina
- Garzia, V. V., Jr., 7719-45 Ave., Elmhurst, L. I., N. Y.
- Geis, L., 115 Fourth Ave., S.W., Watertown, S. D.
- Gilbert, J. A., 1584 North Lake Ave., Pasadena, 6, Calif.
- Godfrey, E. H., 32 St. Mary's Ave., Finchley, England
- Gossland, J. K., Bell Laboratories School, 250 Hudson St., New York, N. Y.
- Gracely, F. R., Radio Section, National Bureau of Standards., Washington, D. C.
- Grene, R., 12 C Crescent Rd., Greenbelt, Md.
- Griffith, B. D., c/o Fleet Post Office, San Francisco, Calif.
- Gross, E. E., General Radio Co., 30 State St., Cambridge, Mass.
- Grow, R. E., ARES Rodgers Bldg., Franklin and Ludlow Sts., Dayton, Ohio

(Continued on page 38A)



Keep 'Em Running FOR THE DURATION!

It is difficult to secure new Generating Sets or new Rotary Converters... Pioneer is devoting all of its resources toward winning the war... but we can, and will, help you keep your present equipment running for the duration. Send your service problems, by letter, to Pioneer's Customer Service Department.

DYNAMOTORS · CONVERTERS · GENERATORS · DC MOTORS · POWER PLANTS
GEN-E-MOTORS

PINCOR Products

PIONEER GEN-E-MOTOR
CHICAGO, ILLINOIS · EXPORT ADDRESS: 25 WARREN STREET, NEW YORK CITY
CABLE ADDRESS: SIMONTRICE, NEW YORK CITY

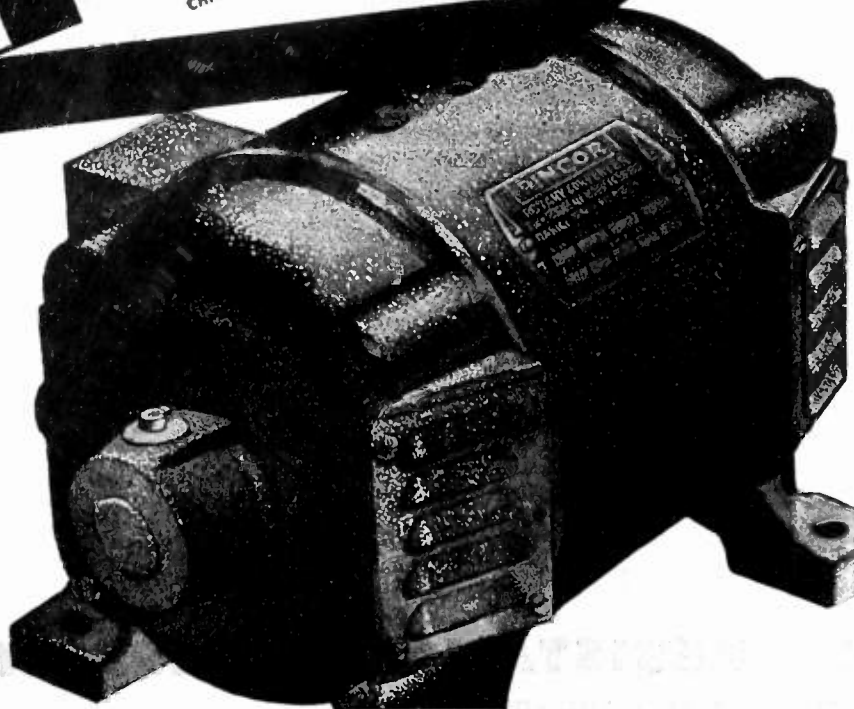

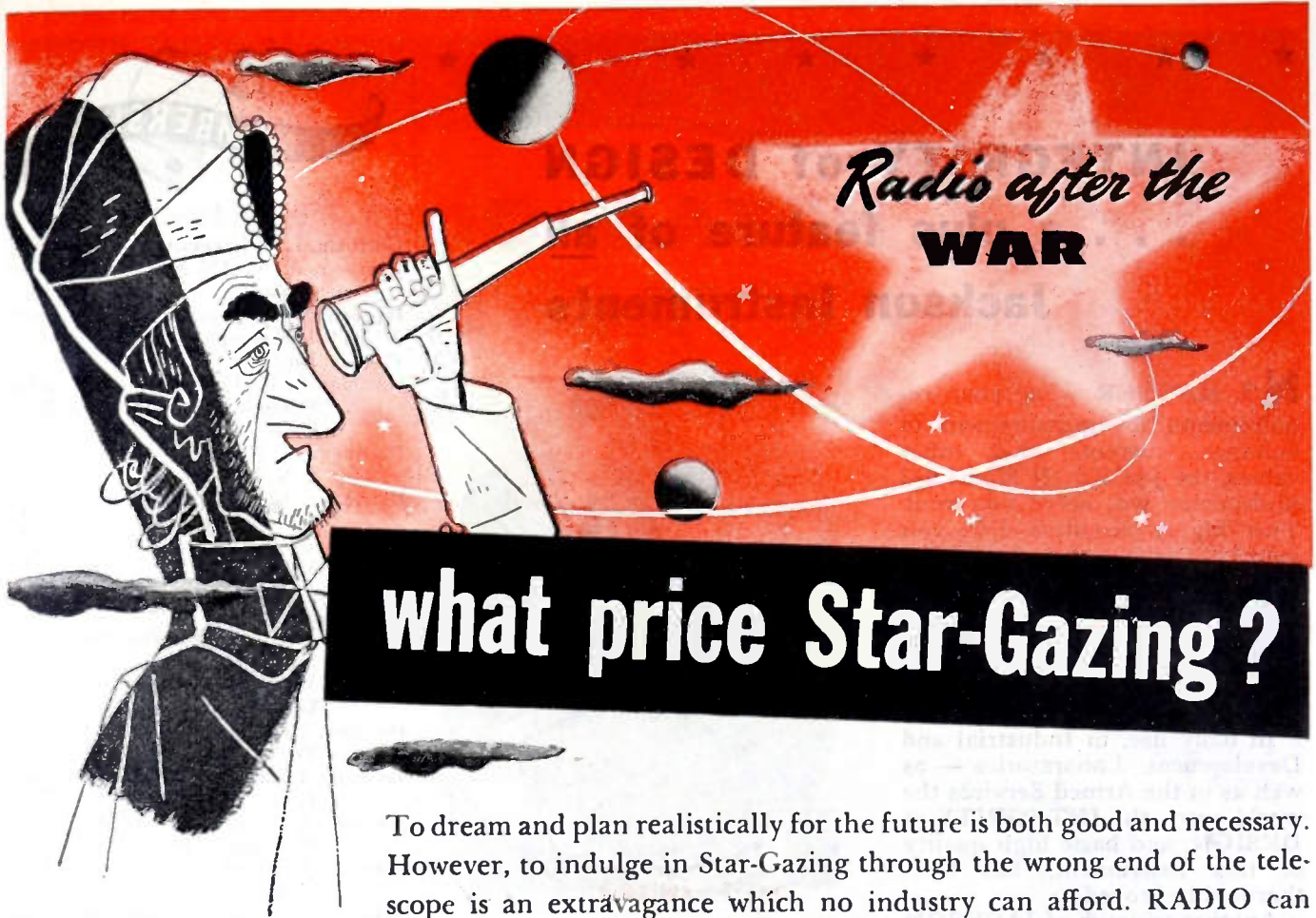

Radio after the
WAR

what price Star-Gazing?

To dream and plan realistically for the future is both good and necessary. However, to indulge in Star-Gazing through the wrong end of the telescope is an extravagance which no industry can afford. RADIO can point with pride to its achievements and its miraculous progress made under the impetus and emergency of war. But to promise that the miracles of Wartime Electronic development will be ready for delivery on V-Day... is to damage an otherwise glorious record.

THE FUTURE IS BRIGHT . . .

BUT LET'S KEEP OUR EYE ON THE BALL!

Our number one job right now is the production of Radio Communications Equipment for our armed services. These are weapons which will help win the war. The application of new Electronic knowledge to peacetime radio production will, of necessity, be a gradual and evolutionary process. We know too that Electronic research and development now entirely serving our war effort can and will elevate every phase of human living.

You May Expect Big Things from Motorola. We can't say when but we can say . . . no one will be ready sooner!



For the development and production of Radio Communications Equipment for our armed forces, the Motorola organization was awarded the Army-Navy "E" with added Star for continued excellence of performance. Motorola is proud of the part it has been privileged to play in the speeding of Victory.

Motorola RADIO
GALVIN FOR CAR & HOME
MANUFACTURING CORPORATION • CHICAGO

★ ★ ★ ★ ★ ★ ★

INTEGRITY of DESIGN

. . . a plus feature of all Jackson Instruments

NO MATTER what your requirements for measurement of voltages, currents, and other values, the JACKSON Model 642 Multimeter will serve you well. This highly sensitive DC volt meter has ranges up to 5,000 volts . . . also complete AC voltage ranges; also provision for ohm measurements up to 30 megohms. Other ranges are DC milliamperes, DC microamperes, DC amperes and decibels.

In daily use, in Industrial and Development Laboratories — as well as in the Armed Services the world over—the INTEGRITY of DESIGN, and basic high quality of this Instrument, has been thoroughly proved.

Another triumph of JACKSON engineering and INTEGRITY of DESIGN (also shown below) is the Audio Frequency Oscillator Model 652. This Instrument operates on the resistance-capacity tuned principle . . . has splendid stability . . . continuous frequency range from 20 to 20,000 cycles with excellent wave form. Model 652 is simple in operation, gives positive, trouble-free results; and is fulfilling a critical, full-time war job.

Production of JACKSON Instruments has been vastly in-



creased to meet urgent military needs. All JACKSON equipment continues available, subject to W.P.B. regulations. Write for catalog—and for an explanation of the full meaning of INTEGRITY of DESIGN.

/ / /

All Jackson employees—a full 100%—are buying War Bonds on a payroll deduction plan. Let's ALL go all-out for Victory.

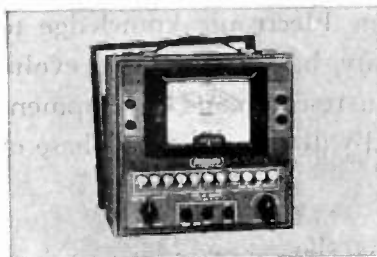

Model 642 Multimeter

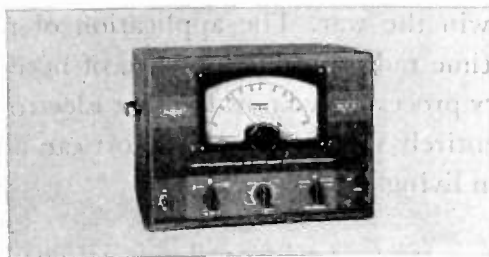

Model 652 Audio Oscillator

JACKSON

Fine Electrical Testing Instruments

JACKSON ELECTRICAL INSTRUMENT COMPANY, DAYTON, OHIO



(Continued from page 36A)

- Guttman, I., 15 Lakeview Rd., Deal, N. J.
 Harrison, A. A., 227 Newton Ave., Glen Ellyn, Ill.
 Hartley, M. S., Navy Office of Canada, 10 Haymarket St., London S.W.1, England
 Hastings, L. E., Federal Communications Commission, 404 Federal Bldg., Galveston, Texas
 Herrmann, F. J., 220 Cooper St., Camden 2, N. J.
 Herrmann, F. W., 4224 Drew Ave., S., Minneapolis, Minn.
 Hess, D. C., Jr., 8 Victory St., Aberdeen, Md.
 Hibbert, J. J., 44 Amsden St., Arlington, Mass.
 Hill, W. A., Jr., 1905 Bransford Ave., Nashville, Tenn.
 Hodges, M. F., 1723 Irving St., N. W., Washington, D. C.
 Huevner, G. L., Jr., 222 E. 57 St., New York, N. Y.
 Jacobsen, L. H., Box 565, Koloa, Kauai, T. H.
 Johnson, R. C., 2139 Penna. Ave., N.W., Washington, D. C.
 Karr, P. R., 3935 Newdale Rd., Chevy Chase, Md.
 Kelar, J., 52 South Walnut St., East Orange, N. J.
 Kelly, G. B., Airways, Kelly Field, Texas
 Kershner, S. W., 415 Third Ave., Asbury Park, N. J.
 King, I. A., Clemson College, Clemson, S. C.
 Klepper, A., 185 Erasmus St., Brooklyn, N. Y.
 Koleda, J. T., 114-15-128 St., Richmond Hill, L. I., N. Y.
 Kimball, R., 134 W. Colorado St., Pasadena, Calif.
 Langford, J. W., Jr., 23 Beech Ave., Aldan, Delaware County, Pa.
 Lauer, H., Plaza Hotel, Camden, N. J.
 Lear, P. R., 31 Hampton, Court Ave., East Molesey, Surrey, England
 Lewis, C., 4020 Mt. View Dr., Bremerton, Wash.
 Loeb, L. S., 240 A Avenue, National City, Calif.
 Long, A. W., 143 Hallock St., Riverhead, L. I., N. Y.
 Long, L. E., 148 W. Norman Ave., Dayton, Ohio
 Lovejoy, R. E., 712 Yuma St., S.E., Washington, 20, D. C.
 Marcinkowski, C. J., 1327 Fenwick I.a., Silver Spring, Md.
 Marshall, J. W., APO 869, c/o Postmaster, New York, N. Y.
 Marshall, T. A., 82 Daisy Ave., Floral Park, L. I., N. Y.
 Marzetta, L. A., Naval Research Laboratory, North Beach, Md.
 McElwain, J. L., Big Spring Heights, Newville, Pa.
 MacGillivray, J. A., 2950 Vieuxmont Ave., Montreal, Que., Canada
 McFarlane, D. J., 2 Bonad Rd., Winchester, Mass.

(Continued on page 42A)

Proceedings of the I.R.E. October, 1943

A GOOD MATCH FOR TODAY'S SPECIFICATIONS

... plus a few items for which
specifications have not been written



SPRAGUE CAPACITORS

ELECTROLYTIC CAPACITORS — All capacity and voltage ratings and combinations in containers to meet every requirement.

PAPER DIELECTRIC CAPACITORS — Wax or oil-impregnated sections in potted or oil-filled containers, A.C. and D.C.

MICA DIELECTRIC CAPACITORS — Low and intermediate voltage molded types.

RADIO NOISE-SUPPRESSION FILTERS

HIGH-VOLTAGE NETWORKS

KOOLOHM RESISTORS — Wire-wound power types, hermetically-sealed power types, precision meter multipliers, bobbin-type resistors, etc.

SPRAGUE SPECIALTIES COMPANY
NORTH ADAMS, MASS.

QUALITY COMPONENTS • EXPERTLY ENGINEERED • COMPETENTLY PRODUCED

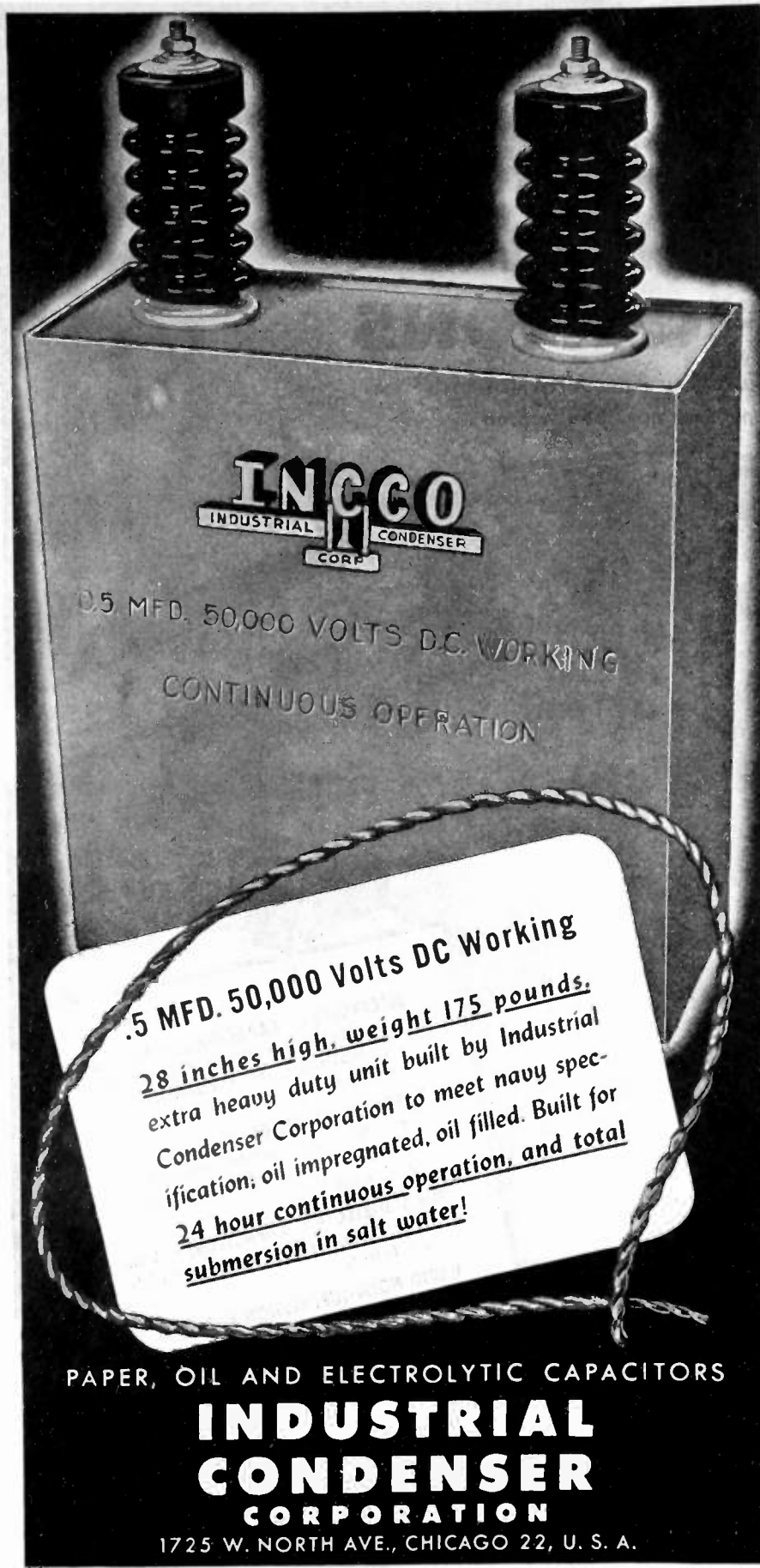

INCCO
INDUSTRIAL CONDENSER
CORP.

.5 MFD. 50,000 VOLTS D.C. WORKING
CONTINUOUS OPERATION

.5 MFD. 50,000 Volts DC Working
28 inches high, weight 175 pounds,
extra heavy duty unit built by Industrial
Condenser Corporation to meet navy spec-
ification; oil impregnated, oil filled. Built for
24 hour continuous operation, and total
submersion in salt water!

PAPER, OIL AND ELECTROLYTIC CAPACITORS

**INDUSTRIAL
CONDENSER
CORPORATION**

1725 W. NORTH AVE., CHICAGO 22, U. S. A.

DISTRICT OFFICES IN PRINCIPAL CITIES
QUICK DELIVERY FROM DISTRIBUTOR'S STOCKS

ACCURATE



UNFAILING accuracy is one of the many features of the new General Electric line of **ELECTRONIC MEASURING INSTRUMENTS**. Designed in the famous G-E electronics laboratories, this line offers a wide choice of compact apparatus for service, maintenance and research.

G-E unimeters, capacitometers, audio oscillators, wide band oscilloscopes, square wave generators, signal generators, power supply units—all give you dependable service in measuring electronic circuits and component parts.

These sturdy, shock-resistant units are now in production primarily for the Armed Forces. But they may be purchased on a priority if you are engaged in war work. After the war, of course, the full line will again be available to everybody. . . . *Electronics Department, General Electric, Schenectady, N. Y.*

• We invite your inquiry for G-E electronic measuring equipment made to meet your specific requirements

FREE CATALOG →

**ELECTRONICS DEPARTMENT
GENERAL ELECTRIC CO.
Schenectady, N. Y.**

Please send, without obligation to me, the General Electric Measuring Instrument Catalog, P-1 (loose-leaf), for my information and files.

Name _____
Company _____
Address _____

GENERAL ELECTRIC
177-82
Electronic Measuring Instruments

Proceedings of the I.R.E. October, 1943

Unexcelled for Lightness

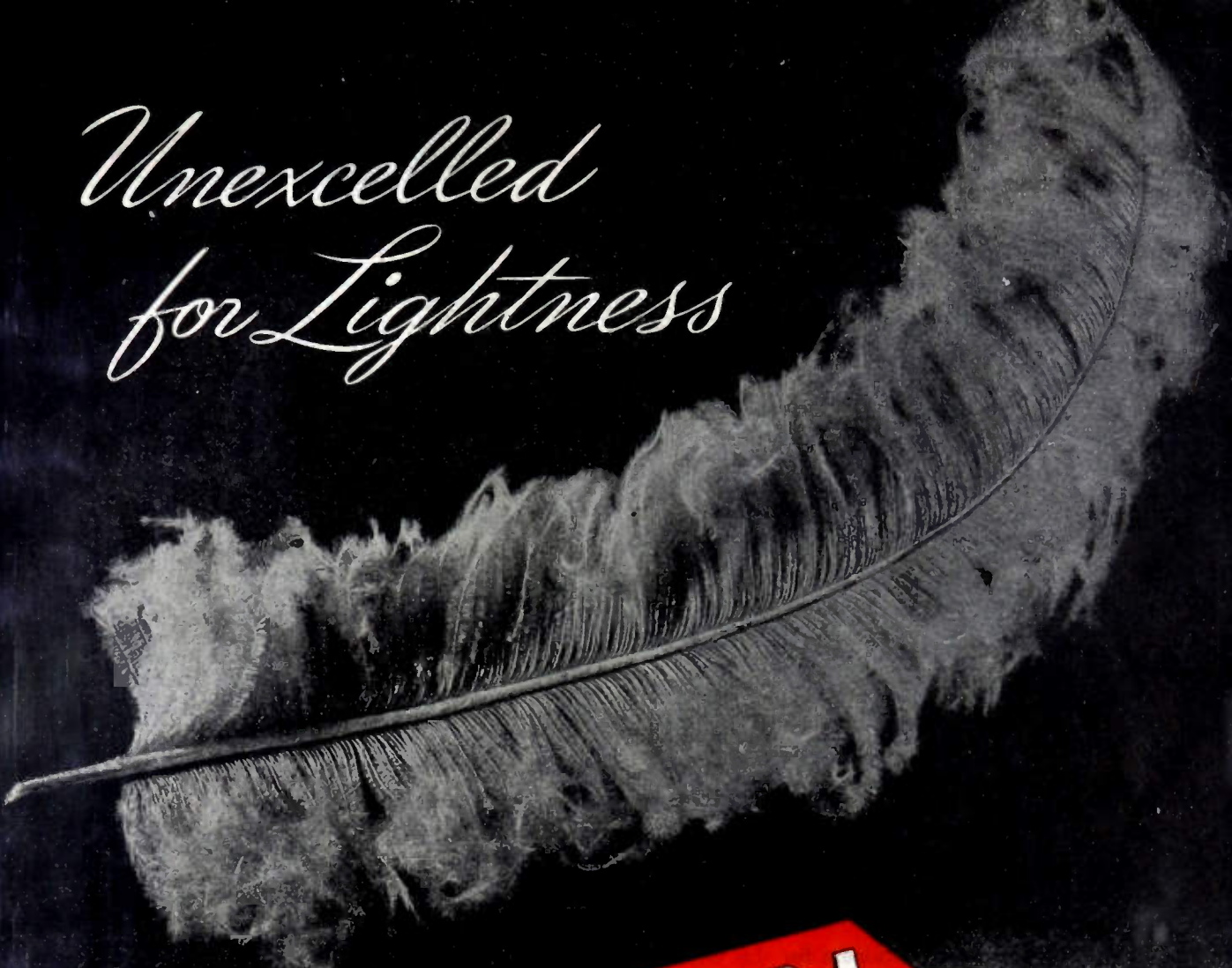

MYKROY

**FURTHER FACTS FOR ENGINEERS
ABOUT MYKROY'S SUPERIOR
INSULATING QUALITIES**

No. 4		No. 8
6.68.....	Dielectric Constant (Dry).....	6.75
6.73.....	Dielectric Constant (Wet).....	6.70
.00240.....	Power Factor (Dry).....	.00164
.00241.....	Power Factor (Wet).....	.00231
1.60.....	Loss Factor (Dry).....	1.11
1.62.....	Loss Factor (Wet).....	1.54
630 Volts per Mil.....	Dielectric Strength.....	660 Volts per Mil.

From Reports of Independent Testing Laboratories

ONE SQUARE INCH* of this fine glass bound mica insulating material weighs only .013 lbs. Yet MYKROY'S mechanical strength is comparable to that of cast iron.

This exceptional lightness factor in a ceramic insulator is a strategic advantage—especially in applications where a minimum of weight is vital to swift and easy mobility. Hence MYKROY is becoming a familiar part of such instruments as "Walkie-Talkie" and aircraft electronics devices.

If your equipment demands the most advanced and efficient insulation, let us demonstrate the specific advantages and uses of MYKROY.

* 1/8 inch thick.

MYKROY IS SUPPLIED IN SHEETS AND RODS . . . MACHINED OR MOLDED TO SPECIFICATIONS

MADE EXCLUSIVELY BY

**ELECTRONIC MECHANICS
INC.**

70 CLIFTON BOULEVARD • CLIFTON, NEW JERSEY
Chicago: 1917 NO. SPRINGFIELD AVENUE . . . TEL. Albany 4310



WHEN the squadron leader snaps instructions into his microphone, it's not time for doubt or confusion on the receiving end.

In manufacturing headsets for the use of our fighting forces, the main thing is to be certain each one is as perfect as it is possible to make it.

Experience since the early days of the telephone helped us, of course, but it wasn't enough to be sure that we were building mighty good equipment *on the average*. We developed special instruments which enable us to give each receiver a thorough test in a matter of seconds, right on the production line. Thus we kept output high, and quality a known factor.

Connecticut has been identified with "communications" for half a century. It has never been known as the largest, but always as among the very best, in design, engineering, and precision production. If your post-war plans involve the use of precision electrical devices, in connection with product development or production control, perhaps we can help you eliminate the "question marks".

CONNECTICUT TELEPHONE & ELECTRIC DIVISION



MERIDEN, CONNECTICUT



For the second time within a year, the honor of the Army-Navy Production Award has been conferred upon the men and women of this Division.

© 1943 Great American Industries, Inc., Meriden, Conn.



(Continued from page 38A)

- McNall, J. W., Research Department, Westinghouse Lamp Division, Bloomfield, N. J.
- Medill, J. W., 351 Garfield Ave., Valparaiso, Ind.
- Minnett, H. C., Radiophysics Laboratory, City Rd., Chippendale, Sydney, N.S.W., Australia
- Murtough, W. L., 70 Bingham Ave., Rumson, N. J.
- Moss, J. F., 118 North Clark Dr., Los Angeles, Calif.
- Navas, Y. F., 35-06-165 St., Flushing, L. I., N. Y.
- Nielsen, G. A., c/o Postmaster, San Francisco, Calif.
- Nightenhelser, K. W., 18 S. Cherrywood Ave., Dayton, Ohio
- Olmsted, J. M., 1101 Riverside Dr., Dayton, Ohio
- Olsen, W. E., R.F.D. 422, Riverhead, L. I., N. Y.
- Perkins, G. D., 212 Central Ave., Dayton, Ohio
- Pierson, C. D., Jr., 1717 Summerdale Ave., Chicago, Ill.
- Pike, D. E., Research Department, Farnsworth Television and Radio Corp., 3700 E. Pontiac St., Ft. Wayne, Ind.
- Ramanna, R., 1792 Pardmalaya, Sampige Rd., Malleswaram, P. O., Bangalore City, India
- Post, B. M., 1401 N. LaSalle St., Indianapolis, Ind.
- Pratt, G. W., 899 Pleasure Rd., Lancaster, Pa.
- Pueschner, H. O., 558 N. Oakland Ave., Indianapolis, Ind.
- Pummill, J. S., Aircraft Radio Engineering School, 355 S. Main St., Dayton, Ohio
- Reed, H., 3917 Madison St., Hyattsville, Md.
- Reynolds, F. L., 41 Westfield St., Rochester, 11, N. Y.
- Risenburg, L. C., 554 Tonawanda St., Buffalo, 7, N. Y.
- Rosenblum, B., 5 Wadsworth Rd., Greenford, Middlesex, England
- Rosentreter, E. W., Bldg. U., General Electric Co., West Lynn, Mass.
- Schach, A., Templeton Radio Co., Mystic, Conn.
- Schart, W. J., 425 Grand Ave., No. 3., Dayton, 5, Ohio
- Schuster, C. A., 193 Second St., Clifton, N. J.
- Shawhan, E. N., 2012 Ft. Davis St., S.E., Washington, 20, D. C.
- Shepard, B. R., 902 Delamont Ave., Schenectady, N. Y.
- Sicuranza, C. A., 4848 Broadway, New York, N. Y.
- Smith, E. H., 1620-14 Ave., Seattle, 22, Wash.
- Smith, T. O., 6814 Dartmouth Ave., College Park, Md.
- Smith, W. T., 138 Orchard St., Newark, N. J.

(Continued on page 44A)

ACTUAL-SIZE
ILLUSTRATIONS

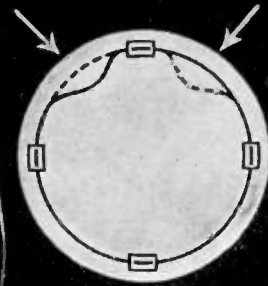

INDENTS
FACILITATE
TAPPING
OF ANY
TURN!

No. 1590

Single winding with indents. Weight complete, only 3¼ ounces. Coil 2" diam. x 4" long. 3¼" overall height.

No. 1591

Double winding (topped outer coil with inner winding for coupling to a low-impedance load). Weight complete, 2¾ ounces. Coil 2" diam. x 3" long. 3¼" overall height.

**MADE "SPECIAL"—MADE FAST—
and MADE RIGHT!**

These two Air-Wound units, designed for ship-to-shore radio telephone transmitters, are typical of B & W small coils now being produced to meet exacting specifications by modern production methods *at the rate of 1200 a day!*

Many outstanding advantages accrue to these coils as a result of the famous B & W Air-Wound construction: Exceptionally light weight; mechanical ruggedness (they are not

likely to be put out of commission by dropping or rough handling); adaptability to design or engineering changes in laboratory or field use; and the ease with which *ANY* of the closely-wound turns may be tapped, thanks to the special indent feature.

B & W Air Inductors of this general type are available for all normal frequency ranges. Literature on request.

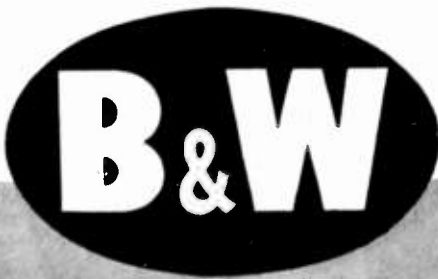

BIG COILS, TOO! →

Here you see the small No. 1591 Air Inductor shown in comparison to a B & W high-power unit for 10 KW. service. Details on any type gladly sent.

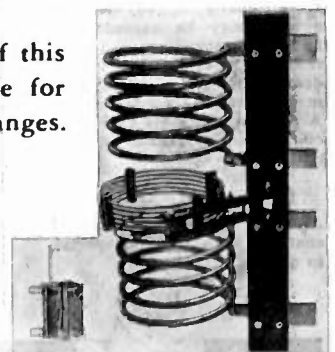

AIR INDUCTORS

Air-Wound and Ceramic and Phenolic Form Types

BARKER & WILLIAMSON, 235 Fairfield Ave., Upper Darby, Pa.

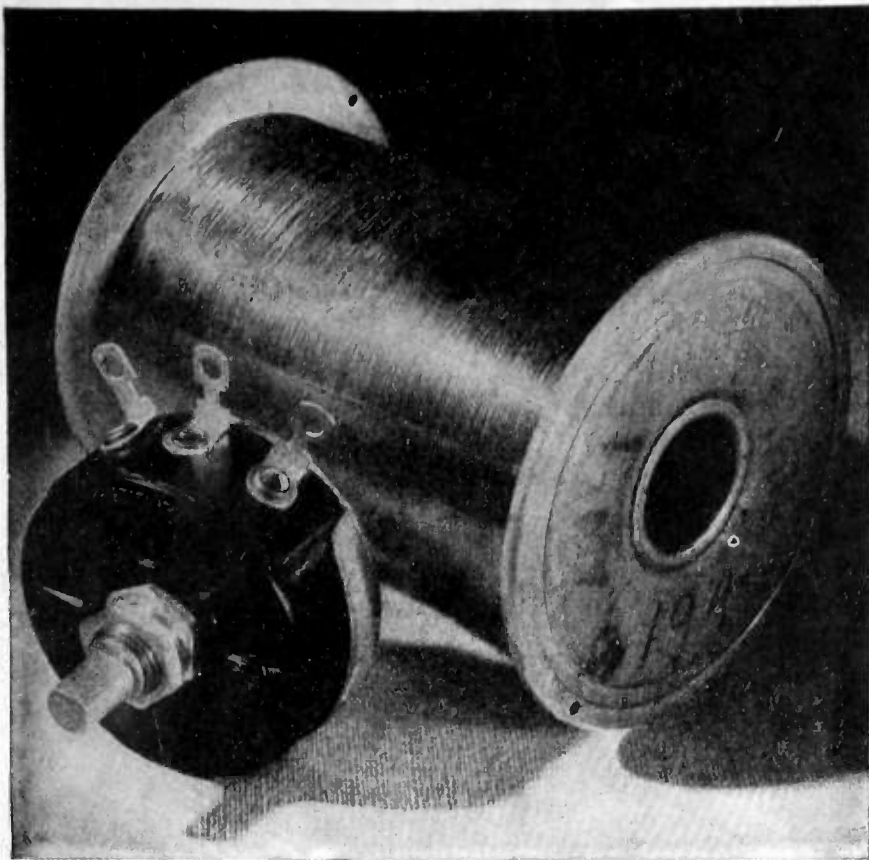

Wire-wound rheostats and potentiometers Type 58 shown above. 1 to 100,000 ohms. Choice of tapers. Linear, rated at 3 watts; tapered, 1.5 and 2 watts.

★

Multiple controls up to 20 units in tandem. Single shaft locks with rotor of each control. Interlocking resistance ratios provide any desired voltage or current at given degree of rotation, for each circuit.

★

Power rheostats in 25- and 50-watt ratings. 0.5 to 10,000 ohms. Exceptionally rugged. Normal current may be exceeded by 50% at any setting up to 1/3 rotation. Also available in tandem combinations. Special units made in strict accordance with Army and Navy Air Force specifications. Enclosed or armored units.

★

Also other types of wire-wound controls, standard and special, to meet all needs.

WIRE-WOUND

Controls

★ A 300% increase in winding capacity! This feature of Clarostat's recent production expansion climaxed by the opening of a second plant, is a vital contribution to the war effort. Please bear this wire-winding capacity in mind in connection with your high-priority requirements.

And remember also that for the past two decades Clarostat engineers have designed, built and steadily refined their *exclusive* winding machines. Marvels of mechanical ingenuity, these machines produce those precise windings of uniform or variable pitch; those round, square or flat windings; those tricky multiple-tapped windings; those high-ohmage windings requiring wire even as fine as .0009" (nine ten-thousandths—finer than human hair). All of which explains why most *really tough* control jobs usually come to Clarostat.

★ *Send Your Problem . . .*

If it deals with adjustable or fixed resistance send it to us for engineering collaboration, specifications, quotations. Literature on request.



Controls and Resistors

CLAROSTAT MFG. CO., Inc. · 285-7 N. 6th St., Brooklyn, N. Y.



(Continued from page 42A)

- Stahl, P. D., 1700 Bathgate Ave., New York, N. Y.
 Stephenson, I., 25 Springfield Pl., Bradford, Yorkshire, England
 Taidhoff, S. J., National Press Bldg., Washington, D. C.
 Taussig, O. C., 407 Sanders Ave., Schenectady, N. Y.
 Threadgill, A. R., 96 Goodrich Ave., Lexington, 33, Ky.
 Thurston, W. R., 111 Bay State Rd., Boston, 15, Mass.
 Unger, R. M., 295 Exchange St., Millis, Mass.
 Van Aller, H. T., c/o R.M.O. Office Roof Bldg. 3, Brooklyn Navy Yard, N. Y.
 Van Ryn, B., 29 Shrublands Close, Chelmsford, Essex, England
 Wardale, A. H., 25 Waratah St., Bexley, N.S.W., Australia
 Ware, W. H., c/o Hazeltine Electronics Corp., Little Neck, L. I., N. Y.
 Webster, C. J., 1116 South Washington St., Aberdeen, S. D.
 Weimer, P. K., 359 Nassau St., Princeton, N. J.
 Wilson, G. C., Morristown Y.M.C.A., Morristown, N. J.
 Wolfgram, W. R., 412 S. Knight Ave., Park Ridge, Ill.
 Yaffee, P., 317 Third St., S.E., Washington, 3, D. C.
 Youtz, P., 7250 Bennett Ave., Chicago, Ill.
 Young, C. R., 2252 Kenilworth Ave., Los Angeles, Calif.
 Zeldin, S. L., 1719 Townsend Ave., New York, N. Y.

The following indicated admissions and transfers of membership have been approved by the Admissions Committee. Objections to any of these should reach the Institute office by not later than October 31, 1943.

Transfer to Member

- Bronwell, Arthur B., Northwestern University, Evanston, Ill.
 Breazeale, Dr. William M., Radiation Laboratory, Cambridge, Mass.
 Chipp, Rodney D., 4805—14th St., N.W., Washington, D. C.
 Epstein, D. W., RCA Laboratories, Princeton, N. J.
 Gibson, William Thomas, Lopen House, Seavington, Somerset, England
 Hector, Dr. L. Grant, 57 State St., Newark, N. J.
 Hunt, Albert Brewer, Box 369, Montreal, Que., Canada
 Jenks, David W., Electronic Tube Engineering Division, General Electric Co., Schenectady, N. Y.
 King, Ronald W. P., Cruft Laboratory, Cambridge, Mass.
 Lidbury, Frank Austin, Box 346, Niagara Falls, N. Y.
 Nicoll, Frederick H., RCA Laboratories, Princeton, N. J.

(Continued on page 46A)



VITAL

. . . as a drop of rain

Spirit

Our enemies, who lack among their own peoples an idealism that motivates the individual from within rather than one forced upon him, are increasingly learning to count the cost of their gross ignorance and accordingly miscalculating that tremendous VITAL force - AMERICAN SPIRIT! Just as American Spirit is helping forge victories on the field of battle, so does American Spirit on the production front provide the priceless ingredient which, added to materials and skills, results in our unprecedented output.



WILBUR B. DRIVER CO.
NEWARK • NEW JERSEY



Designers and Manufacturers of
TRANSFORMERS
 for **ELECTRONIC DEVICES**

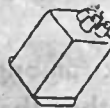

Chicago Transformer is an organization specializing exclusively in the design and manufacture of all types of small transformers and reactors.

Housed in our modern daylight plant are complete laboratory and plant facilities for the handling of every operation in the manufacture of fine transformers.



CHICAGO TRANSFORMER CORPORATION
 DIVISION OF ESSEX WIRE CORPORATION
 3501 WEST ADDISON STREET • CHICAGO, 18



(Continued from page 44A)

- Paddon, John Wreford, Canadian Department of Munitions and Supply, Washington, D. C.
- Pollack, Dale, Groton Long Point, Conn.
- Shanck, Roy B., 134 Manor Road, Douglaston, L. I., N. Y.
- Silver, McMurdo, 140 E. 28 St., New York, N. Y.

Admission to Member

- Barker, P. L., Grafton Hotel, Connecticut Ave., Washington, D. C.
- Levy, Sol J., 600 Fourth Ave., Bradley Beach, N. J.
- McCreary, Harold J., 320 Lewis Ave., Lombard, Ill.
- Moore, James R., Box 12, Dutch Neck, N. J.
- Ryder, Robert M., Bell Telephone Laboratories, Murray Hill, N. J.

The following admissions to membership were approved by the Board of Directors on September 8, 1943.

Admission to Associate

- Allard, E. V., Jackson Bldg., Ottawa, Ont., Canada
- Anderson, W. M., 4800 Oakland Ave., Minneapolis, 7, Minn.
- Androvich, C. N., 216 Ocean Pkwy., Brooklyn, N. Y.
- Armstrong, C. W., 45 Merion Rd., Merchantville, N. J.
- Armstrong, C. A., 1001 S. Columbus St., Arlington, Va.
- Bassette, C. S., Box 468, Tuskegee Institute, Ala.
- Birdsong, H. S., Barracks 55, USATTC, Memphis, Tenn.
- Boland, R. K., 223-14 Ave., S.E., Rochester, Minn.
- Brower, D. F., Co. B, 2510 Service Unit, AST, University of Maryland, College Park, Md.
- Charp, S., 6228 Pine St., Philadelphia, Pa.
- Clement, B. R., 36 Violet Ave., Mineola, L. I., N. Y.
- Clements, B. C., Ste 1-5 48 Bayfield St., Barrie, Ont., Canada
- Cohen, J. E., 67 Roosevelt Dr., Middletown, Conn.
- Collar, H. W., 1221 Wayne Ave., Dayton, Ohio
- Combs, E. C., 3419 Champion St., Oakland, Calif.
- Cottrell, B. P., Western Electric Co., Radio Division, 195 Broadway, New York, N. Y.
- Courtney, J. M., 1400 Chestnut, Kansas City, 1, Mo.
- Cox, A. E., Apt. 2, 300-34 St., S.E., Washington, D. C.
- Crevcling, R., 1726 Mound St., Springfield, Ohio
- Dettman, M. C., 9527 Glenwood Rd., Brooklyn, N. Y.

(Continued on page 48A)

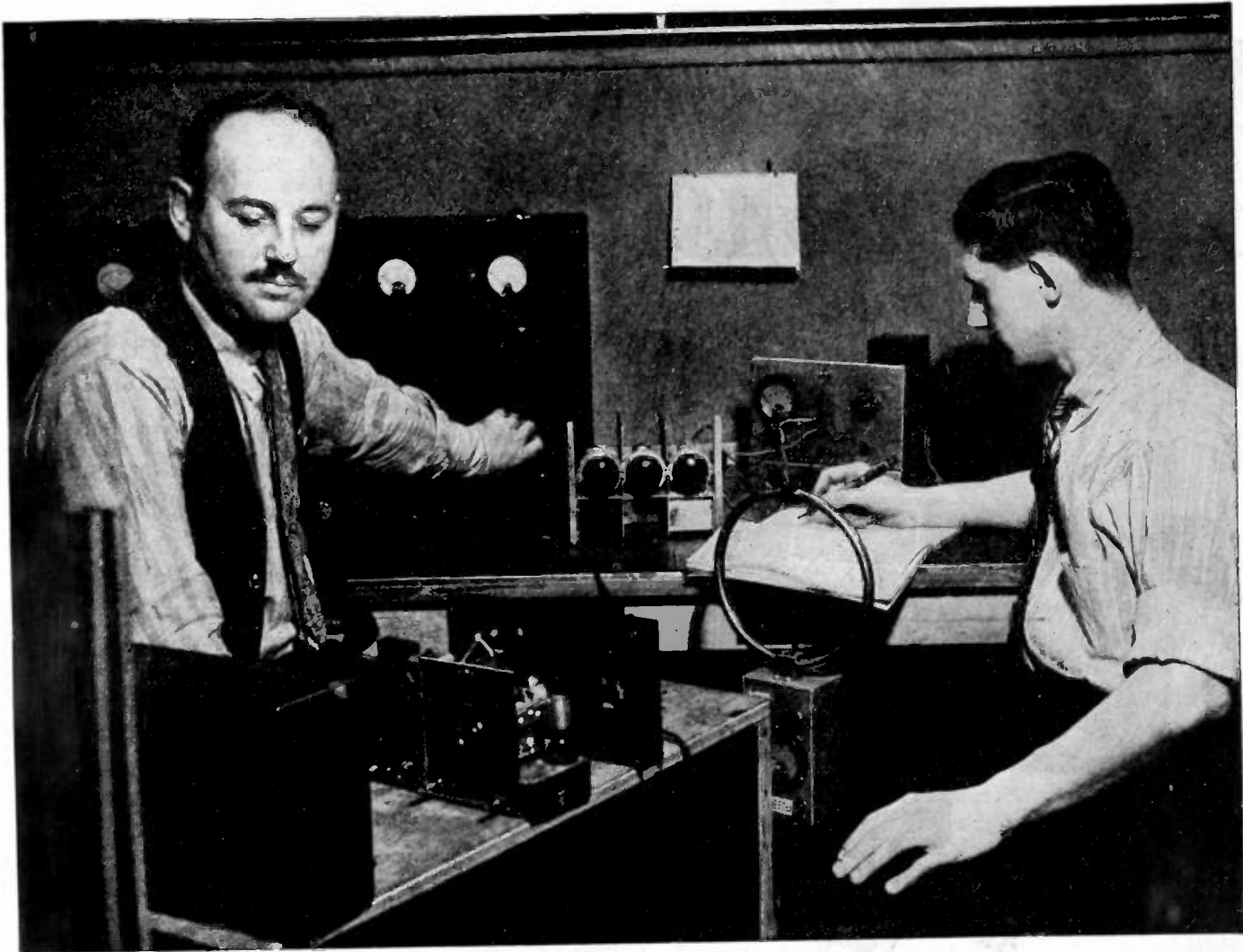

Performance Perfectionists

- Technical progress depends upon tireless experiment to perfect performance.

Sylvania circuit engineers are performance perfectionists. They conduct never-ending tests on new circuit and tube combinations using experimental equipment. They constantly improve radio and electronic tube quality. And they compile data that is the raw

material of invention.

This long-range Sylvania research policy, which maintained our standard of quality in peacetime, has proved invaluable in wartime. It has contributed to the improvement of military communications, to the volume production of cathode ray tubes, and to the development of timesaving electronic devices for war industry.

QUALITY THAT SERVES IN WAR



And it will prove no less valuable when victory widens the radio-electronics field. It will contribute to the development of FM radio and practical television. It will help to convert electronic military secrets of today into everyday miracles for better life and work tomorrow.



RADIO DIVISION

SYLVANIA

ELECTRIC PRODUCTS INC.

Emporium, Pa.

RADIO TUBES, CATHODE RAY TUBES, ELECTRONIC DEVICES, INCANDESCENT LAMPS, FLUORESCENT LAMPS, FIXTURES AND ACCESSORIES

ADC Makes the Filters You Need!

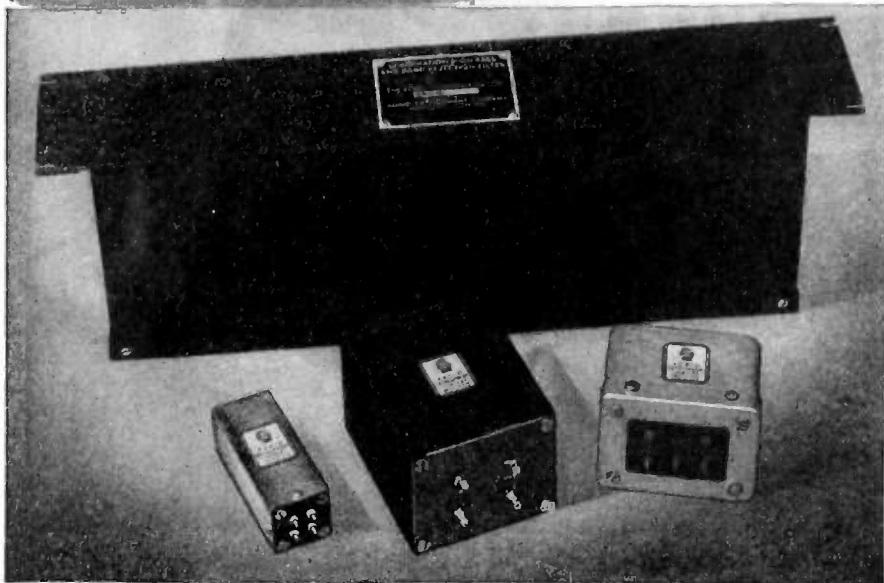

Any Frequency to 500 K C.

When your job calls for efficient filters you can depend on ADC to produce well-built, compact units to suit the most exacting requirements. From the moment your specifications are received, until production is actually complete, your particular problem becomes the immediate concern of our competent design engineering staff. Years of research and specialized experience is behind every ADC Filter.

ADC Filters are especially adapted to Aircraft, Marine, Portable and Stationary installations. They can be readily designed for high pass, low pass, band pass and band rejection, or for combinations of these to obtain several pass and attenuation bands. Too, you may be advantageously able to use an ADC Filter designed for impedance transformation — for example, from line to grid.

If you want the ultimate in advanced engineering, maximum efficiency and rugged mechanical design, you will do well to consult with us.

In addition to filters, Audio Development Company manufactures a complete line of specialized transformers, reactors, equalizers, key switches, jacks, plugs and other electronic equipment.



Audio Development Co.
2833 13th Ave. S., Minneapolis, Minn.

Membership

(Continued from page 46A)

- Divins, B., 735 Mace Ave., Bronx, 67, N. Y.
- Dorman, L. R., 226 Tama St., Boone, Iowa
- Dunlap, F. I., 41 C Tom McMillan Homes, Navy Yard, S. C.
- Dunn, S. C., 75 Craggs Ave., Paisley, Renfrewshire, Scotland
- Dutton, O. B., 2705 E. 46 St., Kansas City, Mo.
- Edwards, T. J., Rt. 1, Box 483-O, Ft. Worth, Texas
- Eldridge, H. C., Jr., 227 Oxford Rd., Franklin, Ohio
- Fogg, E. W., 78 Primandine St., Dorchester, 24, Mass.
- Fenyo, T., Casilla de Correo 2783, Buenos Aires, Argentina
- Free, G. O., 3231 Welsberg Dr., 21, St. Louis, Mo.
- Frizen, J. E., APO 825, c/o Postmaster, New Orleans, La.
- Gatton, H. F., 416 Park Ave., Elizabethtown, Ky.
- Gewirtz, H., 224 New York Ave., Brooklyn, N. Y.
- Golembieski, E. H., Ft. George Meade, Md.
- Green, M., 3318 Rodman St., Washington, D. C.
- Haines, B. P., Philco Corp., C and Tioga Sts., Ext. 894, Philadelphia, Pa.
- Hall, E. G., 6131 Locust, Kansas City, Mo.
- Hoffman, E. H., 519 Central Ave., Ardsley, Pa.
- Hagaman, B., Rt. 3, Rochester, Minn.
- Hogan, J. F., 78 Hyland Ave., Toronto, Ont., Canada
- Holmbeck, C. H., 829 Everhard, Jackson, Mich.
- Hoyle, W. E., 3831 Rainbow Blvd., Kansas City, Kan.
- Huggins, R. A., San Francisco, Calif.
- Hoyt, C. K., Caledonia St., North Sydney, N.S., Canada
- Isernia, A. R., Cochambamba 1266, Buenos Aires, Argentina
- Joarnski, T., 2633—16 St., N.W., Washington, D. C.
- Kemp, T. H., 20 Highwood Ter., Glen Rock, N. J.
- Kirkpatrick, C. H., 2617 E. 27, Kansas City, Mo.
- Kissler, R. G., 1 Madrona Pl., American Lake Gardens, Tacoma, Wash.
- Kreck, J. A., 915 N. Wayne, Arlington, Va.
- Lee, W. P., WIAK, Lakeland, Fla.
- Littler, R. C., 1400 St. Paris Pike, Springfield, Ohio
- Lounsberry, W. H., 2323 Tower Ave., Superior, Wis.
- McAfee, P. H., Jr., Naval Research Laboratory, Anacostia Station, D. C.
- McCoy, R. T., Radiation Laboratory, M.I.T., Cambridge, Mass.
- Maund, C. A., 2921 Milton, Dallas, 5, Texas
- Menkin, J. I., 524 W. Van Buren St., Chicago, Ill.
- Mebley, M. C., Jr., Box 31, Laurel, Md.
- Meyer, W. H., Canadian General Electric Co., 224 Wallace Ave., Toronto, Ont., Canada
- Montgomery, W. D., 225 E. Fourth St., Rm. 1008, Cincinnati 2, Ohio

(Continued on page 50A)

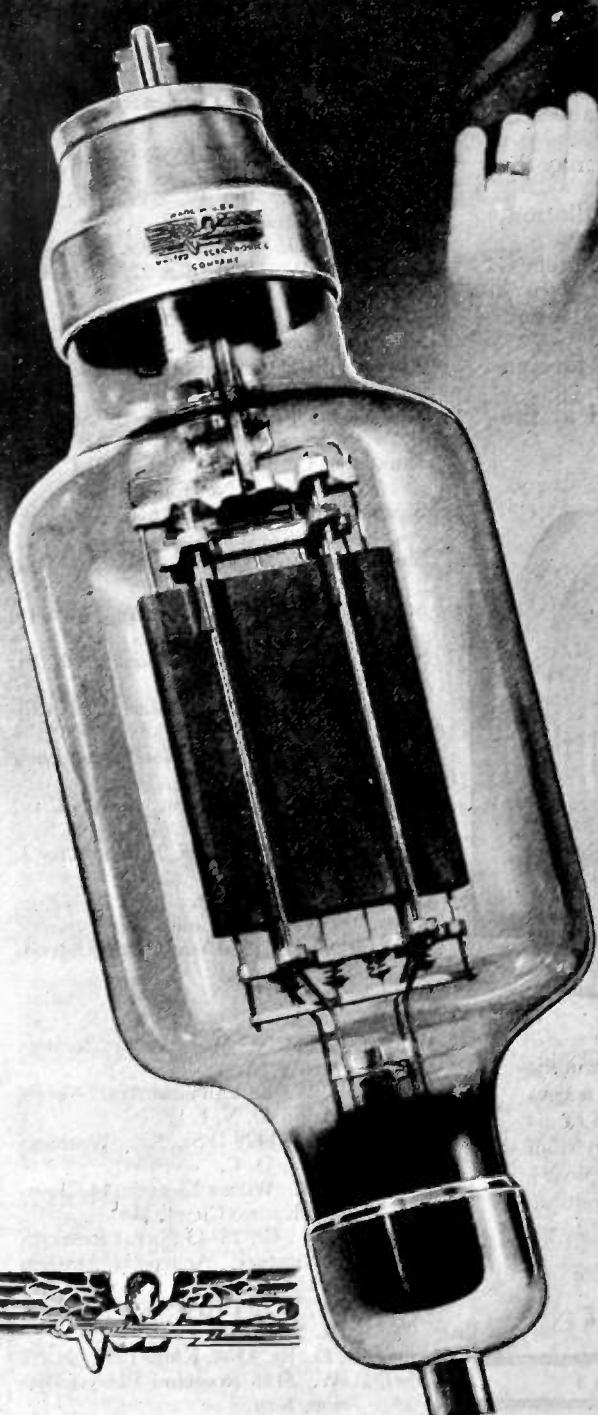

Our Country Honors
SKILLED HANDS
United for Victory

On August 12th, 1943, United Electronics Company received the coveted Army-Navy "E" Award for excellence in production of war materials.

In accepting the honor of flying the "E" burgee over our plant, we extend full and grateful recognition to the skill, the will and the spirit of loyalty which has motivated our personnel ever since Pearl Harbor. To the nation's official tribute we add a hearty "well done" for our family of workers which has achieved an outstanding production record in both quantity and quality of output.

Under the fresh inspiration of our "E" banner, we pledge ourselves to renewed and faithful effort. Our aim continues: more and better electronic tubes . . . for victory today and better living tomorrow.

UNITED

ELECTRONICS COMPANY
NEWARK NEW JERSEY





7/8" Soft Temper Copper
COAXIAL CABLE

1/2 YARD - OR 1/2 MILE

In One Piece !

The Andrew Company is now able to supply standard 70 ohm $7/8$ " soft temper coaxial cable in continuous lengths up to 4,000 feet! The cable is electrically identical to rigid cables of equal size, but has these extra advantages: the cable may be uncoiled and bent by hand, thus greatly simplifying installation; no connectors, junction boxes or expansion fittings are necessary, thus effecting a big saving in installation time and labor. To insure that all splices are pressure tight and that all foreign matter is excluded in shipment, the cable may be fitted at the factory and shipped to you under pressure.

The Andrew glass insulated terminal, an uniquely successful development, may be used with this flexible cable to provide a gas tight system.

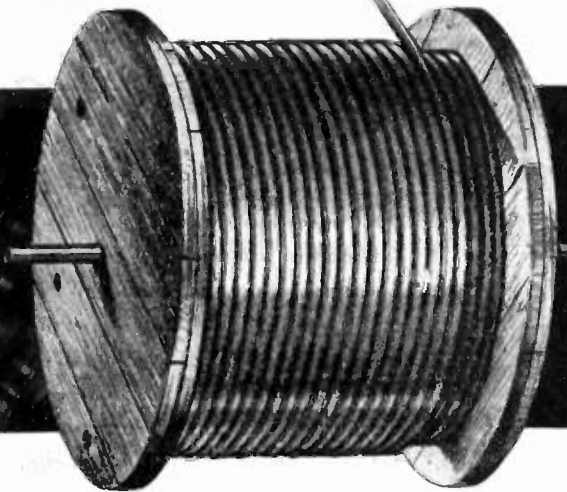

The Andrew Company is a pioneer in the manufacture of coaxial cables and accessories. The entire facilities of the Engineering Department are at the service of users of radio transmission equipment. Catalog of complete line free on request.

COAXIAL CABLES
 ANTENNA EQUIPMENT

363 EAST 75th STREET - CHICAGO 19, ILLINOIS

Membership

(Continued from page 48A)

- Moore, N., Legal Division, O.C.S., 4D329 Pentagon Bldg., Washington, D. C.
- Morton, P. L., Electrical Engineering Dept., University of California, Berkeley 4, Calif.
- Naber, J. S., 67 High St., East Haven, Conn.
- Naylor, B. W. P. C., Box 411, Clinton, Ont., Canada
- Norman, F. H., R.F.D., Rockfall, Conn.
- Numez, J., Strangford 5551, Buenos Aires, Argentina
- Oberly, J. J., 100 Brandywine Pl., S.W., Washington 20, D. C.
- Oldmixon, R., 4307-42 St., Sunnyside, L. I., N. Y.
- Olson, R. L., 5109 Indianola Ave., Minneapolis, Minn.
- Paul, W. E., 3835 Main St., Kansas City, Mo.
- Quan, T., 419 West Copper St., Albuquerque, N. M.
- Raybuck, C. B., 4602 Drexel Rd., College Park, Md.
- Robel, R. B., 400 W. Main St., New Prague, Minn.
- Roeder, W. O., 1912 S. 50 Ave., Cicero, Ill.
- Rogers, Y. W., Rt. 1, Box 27, Gainesville, Fla.
- Reukauf, D. C., R.F.D. 2, Box 10, Ft. Worth, Texas
- Rosier, H. L., 168 Cabot St., Newton 58, Mass.
- Samuelson, F. L., 311 North Superior, Angola, Ind.
- Saunders, C. T., C.A.P.O. 5 R.C.A.F., Overseas, Newfoundland
- Shackelford, J. W., Box 676, Auckland, New Zealand
- Showalter, E., Jr., 404 W. State St., Marshalltown, Iowa
- Smith, K. C., 128 1/2 Ferrier Ave., Toronto, Ont., Canada
- Smith, Z. R., 1404 E. Broward Blvd., Ft. Lauderdale, Fla.
- Soukup, J. C., 6240 S. Kedzie Ave., Chicago, Ill.
- Sperling, B. R., 295 Westwood Ave., Long Branch, N. J.
- Stone, J. B., 3835 Main St., Kansas City, Mo.
- Stone, J. W., 4939 Adams, Kansas City 3, Kan.
- Upton, L. R., 527 N. Grand Ave., c/o Fox Theatre, St. Louis, Mo.
- Virgeant, G. H., 1780 Van Dyke, Detroit, Mich.
- Walden, O. A., Rt. 5, Box 169, Dallas, Texas
- Wardale, A. H., 25 Waratah St., Bexley, N.S.W., Australia
- Warren, C. W., 88 Fairview Ave., North Plainfield, N. J.
- Watson, K. M., 1428 D St., S.E., Washington, 3, D. C.
- Welborn, D. L., Wilcox Electric, 14 Chestnut, Kansas City 1, Mo.
- Wilson, L. W., Cl. 13-43 Naval Research Laboratory, Anacostia Station, D. C.
- Young, A. F., 3916 Derry St., Harrisburg, Pa.
- Young, R. D., Rt. 25-A, Kings Park, N. Y.
- Zabel, L. W., 5116 Roseland Pkwy., Mission, Kan.

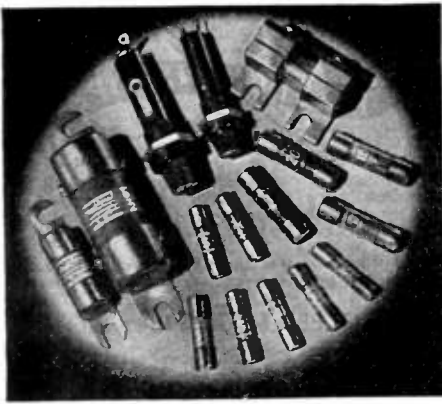

American Fighting Machines Require Littelfuses

Millions of Littelfuses are guarding countless electrical circuits of our fighting equipment in the air, on land, on sea, and undersea.

ON GUARD WHERE PROTECTION IS VITAL

Every circuit built into a plane, tank, boat, or submarine must withstand unprecedented shock, surges, and vibration.

Precision instruments, dials, indicators, radio, all delicate electrical mechanisms of aircraft are subjected to shocks of dives from 70° below zero, and temperatures to 150° above—in seconds. Fuses must not fail.

Littelfuses are engineered to meet all conditions: By mechanical depolarization, new protection against severest vibration; by spring-and-link elements protecting smaller fuses; by reinforcement counteracting expansion and contraction; by patented locked cap assembly sealing fuse element against moisture and preventing caps from loosening.

THE SHOW-DOWN SETS THE PACE

Besides supplying Army and Navy requirements, over 4000 manufacturers depend on Littelfuse products for sure and uninterrupted performance of their equipment for war use.



Mechanical Depolarization
New protection from severest vibration by twisting elements at 90°.



Spring-and-Link Element
(For 5 amp. rating or less)

Fusing section protected from vibration and crystallization by copper spring at middle of tube.



Non-Crystallizing Elements
Spring forming takes up contraction and expansion.



Locked Cap Assembly
(Patented)

Caps locked not cemented on tubes. Seals from moisture. Prevents cap loss.

Fuse Every Instrument and Electrical Circuit for Safety—With Littelfuses

Littlefuse Inc.

4782 Ravenswood Ave., Chicago 40, Illinois
252 Ong Street, El Monte, California

Proceedings of the I.R.E. October, 1943

SKILL

To Meet Your Specifications

PERFORMANCE is the real measure of success in winning the war, just as it will be in the post-war world. New and better ideas—production economies—speed—all depend upon inherent **skill and high precision** . . . For many years our flexible organization has taken pride in doing a good job for purchasers of small motors. And we can help in creating and designing, when such service is needed. Please make a note of Alliance and get in touch with us.

ALLIANCE DYNAMOTORS

Built with greatest precision and "know how" for **low ripple—high efficiency—low drain and a minimum of commutation transients**. High production here retains to the highest degree all the "criticals" which are so important in airborne power sources.



ALLIANCE D. C. MOTORS

Incorporate precision tolerances throughout. Light weight—high efficiency—compactness. An achievement in small size and in power-to-weight ratio. Careful attention has been given to distribution of losses as well as their reduction to a minimum.

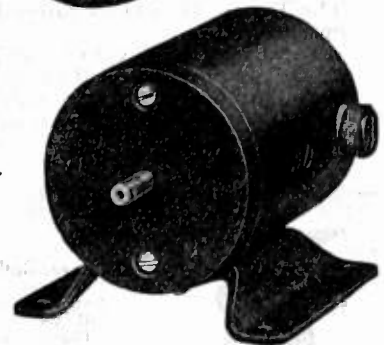

Remember Alliance!
—YOUR ALLY IN WAR AS IN PEACE

ALLIANCE

MANUFACTURING CO.

ALLIANCE . OHIO

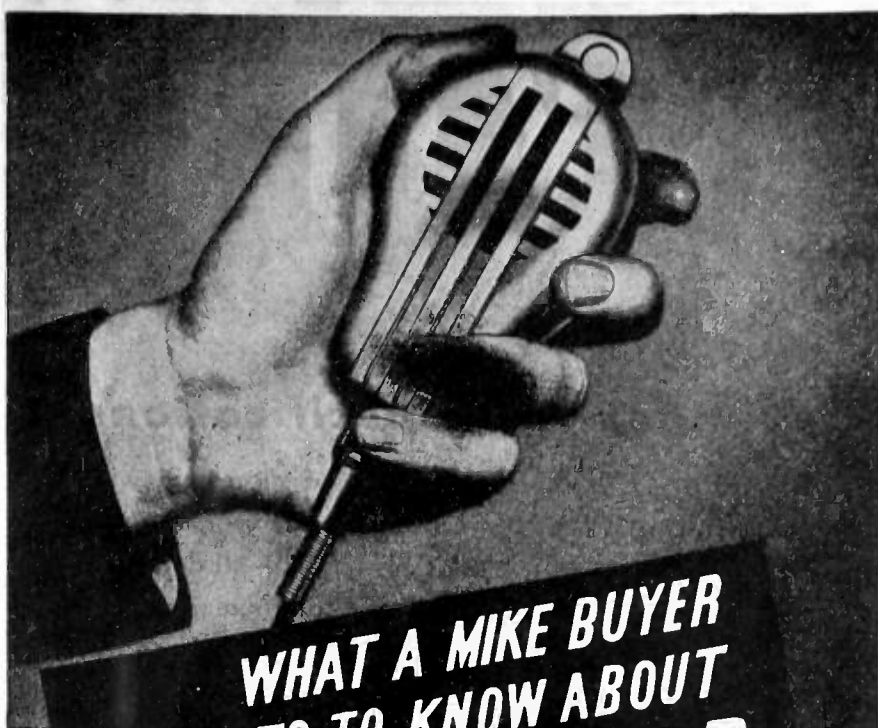

WHAT A MIKE BUYER WANTS TO KNOW ABOUT TURNER HAN-D

- It Does the Job of Several Mikes • You Can Hold It
- You Can Hang It • You Can Mount It on Standard Stands

A truly multi-purpose microphone, which can do the job of two or more units. It fits the hand snugly; is equipped with a suspension hook for hanging mike applications, stage work and call systems; it can be mounted on any standard floor or desk stand. Especially engineered for maximum voice response and smooth, natural response to music pick-ups. Gunmetal or chrome type finish.

The Turner Han-D is equipped with a contact slide switch, for easy on-off operation.

9X Crystal has level of -48 DB, range of 60-7,000 cycles.

9D Dynamic, especially recommended for use under bad climatic conditions, intense heat and rough handling. Level -50 DB Range 60-7,000 cycles. With 7 ft. removable cable set, available in 200-250 ohms, 500 ohms or hi-impedance.

TURNER THIRD HAND WITH L-40 MIKE



Leaves Both Hands Free for Other Jobs

For every spot where both hands are needed on the job, Turner 3-H-L40 is the lightweight unit to use. Defense plants use it for call systems. Police cars need it for better communications. The "Third Hand" holds the mike close to the mouth, giving tremendous volume without feedback.

Equipped with Turner L-40 microphone which has exceptionally high signal level. Gives more intelligible speech reproduction and minimizes feedback. Chest sounds are damped out. Gunmetal or chrome type finish. Level -48 DB.

The Turner Third Hand, 3-H, slips over the neck in a jiffy. Goose neck adjusts mike to any position. Can be used with long lines as traveling mike. Window demonstrators find 3-H indispensable. Can be ordered with mike switch at extra cost.

All Crystals Licensed Under Patents of the Brush Development Co.

Free New Turner Microphone Catalog, showing all available models. Write for yours today.

THE TURNER CO.
CEDAR RAPIDS, IOWA



POSITIONS OPEN

The following positions of interest to I.R.E. members have been reported as open. Apply in writing, addressing reply to company mentioned or to Box No.

The Institute reserves the right to refuse any announcement without giving a reason for the refusal.

PROCEEDINGS of the I.R.E.

330 West 42nd Street, New York 18, N.Y.

RADIO ENGINEERS

Transcontinental & Western Air, Inc. has openings at Kansas City for three Radio Engineers in the Communications Department. Applicants should have completed an electrical or radio engineering course, or should have had one to two years of practical experience. These openings are permanent.

For additional details and application forms, write to Personnel Department, Transcontinental & Western Air, Inc., Kansas City, Missouri.

PATENT ATTORNEYS

Patent attorneys, who are electronic physicists and electrical or radio engineering graduates who have maintained contact with the field of high-frequency electronics, radio manufacture, carrier-current telephony, and light-current circuit design and computing, can make a substantial contribution in research or development jobs with one of the National Defense Research Committee laboratories located in the East. The project is secret but is one of the most urgent of all research jobs now under way for the Government.

An electrical engineering background in light currents is essential, and amateur radio experience, inventive ability and ingenuity in the design and layout of radio equipment would be of considerable help.

(Continued on page 54A)

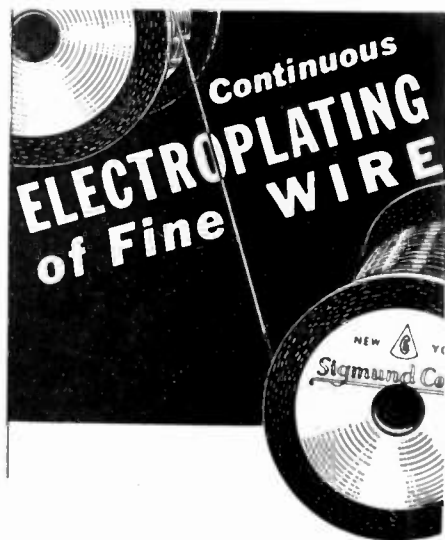

Continuous ELECTROPLATING of Fine WIRE

Complete equipment and staff of specialists for the continuous electroplating of fine wire. We can now plate a wide range of metals either on your own wire or on wire supplied by us . . .

Your inquiry is invited

SIGMUND COHN & CO.
44 GOLD ST. NEW YORK
SINCE 1901

**THE *Squint* THAT PRODUCED
A BETTER RADIO TUBE**

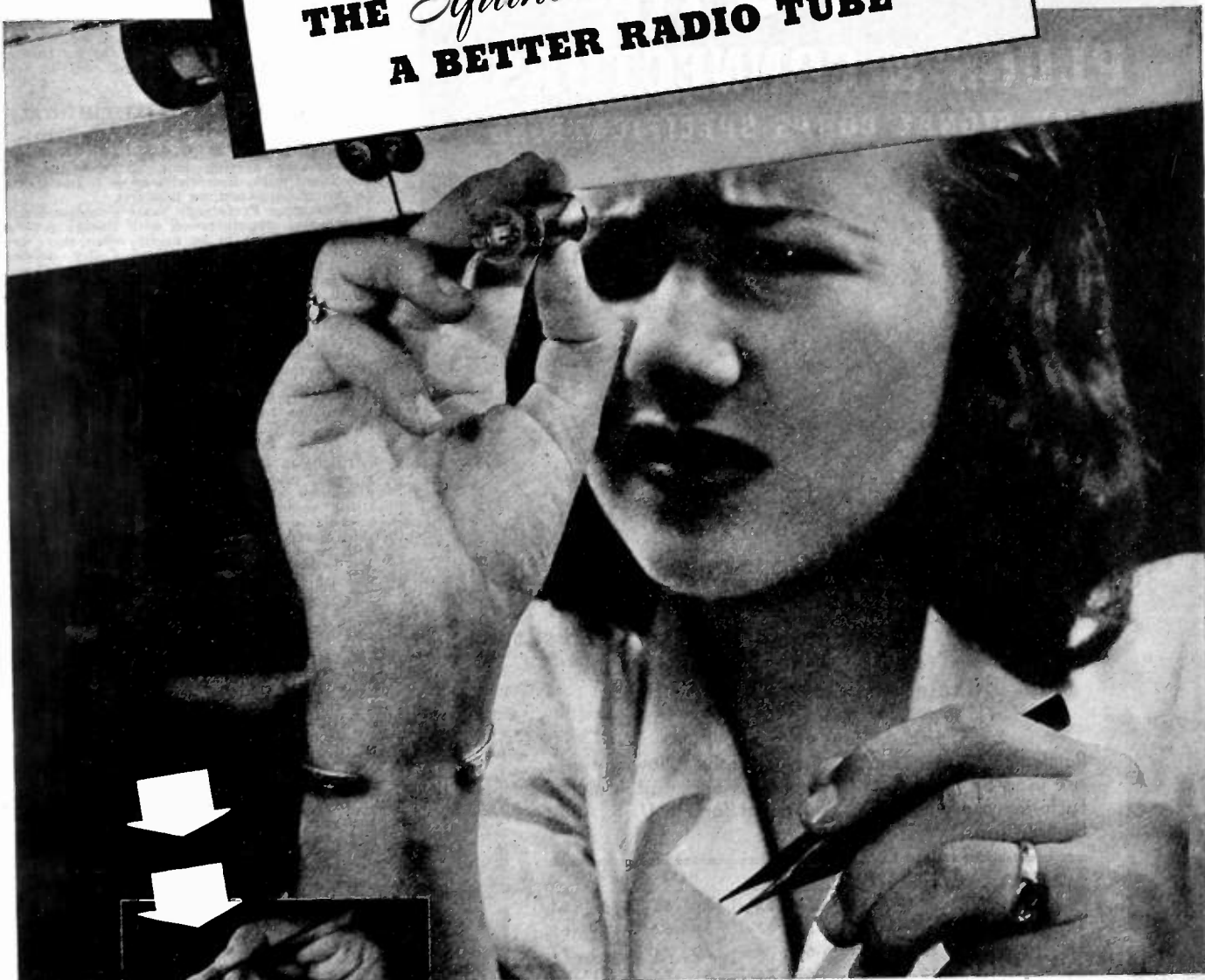

You'd squint too if you tried to worry a hair-like wire through an almost microscopic hole and direct it down through a ladder of cross wires and bring it through the corresponding hole at the bottom. But that was common practice in the entire tube industry in making this tube for "walkie-talkies." The nerve strain was terrific. Girls cracked up under it. Labor turnover on this bottle-neck operation actually jeopardized the production of this vital tube.

TUNG-SOL factory men solved the problem with the "lilly-jig" which directs the tiny filament into the top hole from where it is vibrated into place. Production immediately stepped up. Rejects went down. Critical materials were saved. Now every filament is positioned automatically. The result of this tired girl's squint is . . . better TUNG-SOL Radio Tubes.

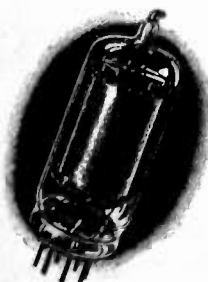

TUNG-SOL
vibration-tested
RADIO TUBES

TUNG-SOL LAMP WORKS INC., NEWARK, N. J., Sales Offices: ATLANTA, CHICAGO, DALLAS, DENVER, DETROIT, LOS ANGELES, NEW YORK
ALSO MANUFACTURERS OF MINIATURE INCANDESCENT LAMPS, ALL-GLASS SEALED BEAM HEADLIGHT LAMPS AND CURRENT INTERMITTERS

In a Hurry...

70 Types PLUGS & CONNECTORS ARMY SIGNAL CORPS SPECIFICATIONS

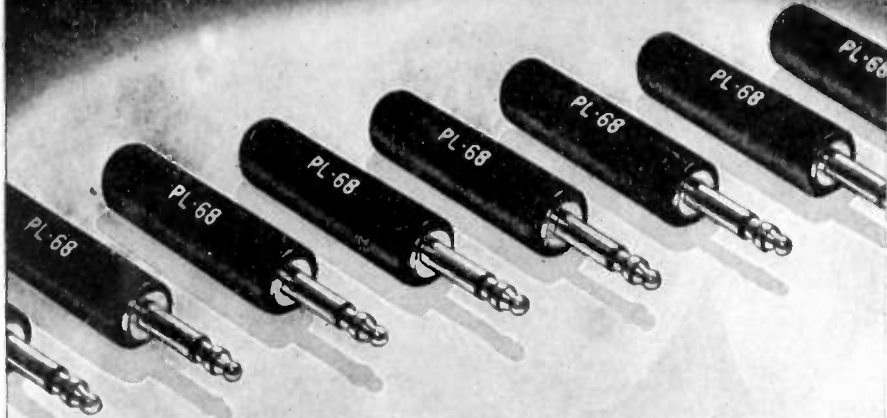

Remler Facilities and Production Techniques Frequently Permit Quotations at LOWER PRICES

Remler made plugs and connectors of the following types are used by more than fifty concerns engaged in manufacturing communications equipment for the U. S. Army Signal Corps:

Types:	PL			PLP		PLQ		PLS		
50-A	61	74	114	150	56	65	56	65	56	64
54	62	76	119	159	59	67	59	67	59	65
55	63	77	120	160	60	74	60	74	60	74
56	64	104	124	354	61	76	61	76	61	76
58	65	108	125		62	77	62	77	62	77
59	67	109	127		63	104	63	104	63	104
60	68	112	149		64		64			

Special Designs to Order

Remler Tool and Die, Plastic Molding and Automatic Screw Machine Divisions are equipped to manufacture plugs and connectors of special design in large quantities. Submit specifications.

Wire or telephone if we can be of assistance

REMLER COMPANY, LTD. • 2101 Bryant St. • San Francisco, 10

REMLER

Announcing & Communication Equipment

Manufacturers of Communication Equipment Since 1918



(Continued from page 52A)

Facilities for specialized refresher training and orientation in the particular field may be available. Anyone who possesses these qualifications and is interested in a vital wartime development job for the duration may get further details on request. All inquiries will be held confidential. Address Box 299.

AUDIO ENGINEER OR EXPERIMENTAL PHYSICIST

Work: Design of microphones, earphones, vacuum-tube hearing aids, general audio-development work. Essential war work and manufacturing on peacetime products.

Experience Preferred: Some electroacoustical design and manufacturing with enough general audio experience to be useful when there are no acoustical problems on hand. College degree. Over five years experience along these lines.

Would also consider a man with moderately broad audio-frequency design and experimental experience, good technical education, and good practical common sense. Over three years of good experience along these lines.

Location: Minneapolis, Minnesota.

Salary: Depends entirely on qualifications.

Interview: Will pay traveling expense of qualified applicants. Address letter of application to Box 300.

PATENT ATTORNEY

Patent attorney to join small Patent Department of mid-western concern engaged in development and production of electronic and allied equipment. Experience in electronics, acoustics or sound-recording field highly desirable. Salary open. Candidate must be citizen with proof of same. Write Personnel Director, The Brush Development Company, 3311 Perkins Avenue, Cleveland, Ohio.

ELECTRONIC ENGINEER

Electronic engineer with M.A., Ph.D., or the equivalent in physics, for research and design in geophysics. Experience in filter design and sound recording is desirable. Write to Independent Exploration Company, 901 Esperson Building, Houston, Texas.

(Continued on page 58A)



IN THOSE DAYS YOU DIDN'T CALL IT

"Electronics"

... but the first portable radio was just as amazing in its time as the electronic wonders that are helping win the war today... and will help you win business battles tomorrow! When you need help on electronic applications to your product or process, remember Operadio—builder of the first commercial portable radio and pioneer in electronic developments.

OPERADIO

Electronic Specialists

OPERADIO MANUFACTURING COMPANY, ST. CHARLES, ILL.

Proceedings of the I.R.E. October, 1943

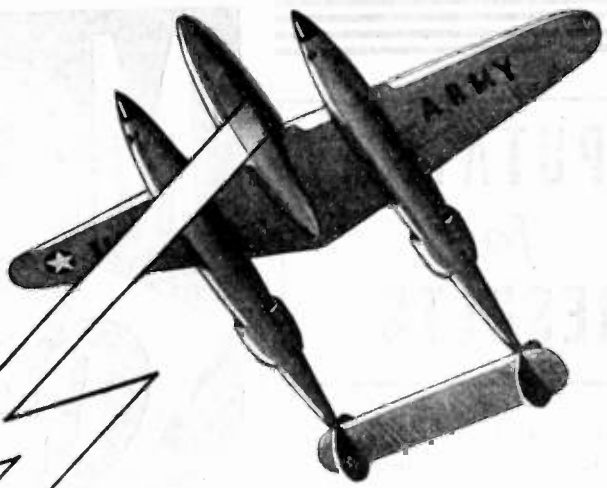

"ORANGE LEADER CALLING . . ." "ROGER!"

Pre-operational checking of transmitters helps make sure that messages will be received. Browning Frequency Meters (types S1 and S2) have for some years provided simple, comparatively inexpensive means for such checking. Type S2 is accurate to within .005%. They are easy to operate. They stand up under hard use. Full details are given in literature available upon request.

The balanced-capacitance Browning Signal System for plant protection without guard patrols is another product of Browning Laboratories research. A descriptive folder will be mailed when requested.



BROWNING
LABORATORIES, INCORPORATED
WINCHESTER, MASSACHUSETTS

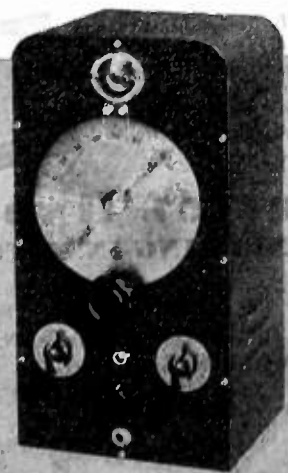

REPUTATION for RESULTS

The success of an educational institution is not marked by dollars and cents . . . but by the achievements and results enjoyed by its students.

In our entire 16 years the CREI home study courses have been written and planned exclusively for the professional radioman to enable him to improve his technical ability and to be in a position to assume added technical duties.

The remarkable achievements made by CREI men throughout the military, government, commercial and manufacturing radio fields are convincing testimony that our efforts, properly confined to this one important course in Practical Radio Engineering, have been of real value to the industry in training better engineers.

Alert engineers are quick to recognize the value of CREI technical training and the important part it plays in increasing the efficiency of their own personnel. CREI-trained men are the ones to whom added responsibilities and added technical duties can be relegated.

We will be glad to send our free descriptive booklet and complete details to you, or to any man whom you think would be interested.



CAPITOL RADIO ENGINEERING INSTITUTE

*Home Study Courses in Practical Radio
Engineering for Professional Self-Improvement*

Dept. PR 3224—16th Street, N.W.
WASHINGTON 10, D.C.

Contractors to the U. S. Signal Corps, U. S.
Navy and U. S. Coast Guard

Producers of Well-trained Technical Radiomen
for Industry

Masterpieces IN QUARTZ

Precision made, utilizing automatic, electronic testing and control, these tough little DX Xtals can take the hard knocks at -30° or 130° F. Ample production facilities now available for large lots or individual crystal orders.

BUY AN EXTRA BOND, TODAY!

DX CRYSTAL CO.

GENERAL OFFICES: 1843 W. CARROLL AVE., CHICAGO, ILL., U.S.A.

TRADE MARK

PERMANENT MAGNETS

THE Arnold Engineering Company is thoroughly experienced in the production of all ALNICO types of permanent magnets including ALNICO V. All magnets are completely manufactured in our own plant under close metallurgical, mechanical and magnetic control.

Engineering assistance by consultation or correspondence is freely offered.

THE ARNOLD ENGINEERING COMPANY

147 EAST ONTARIO STREET, CHICAGO 11, ILLINOIS

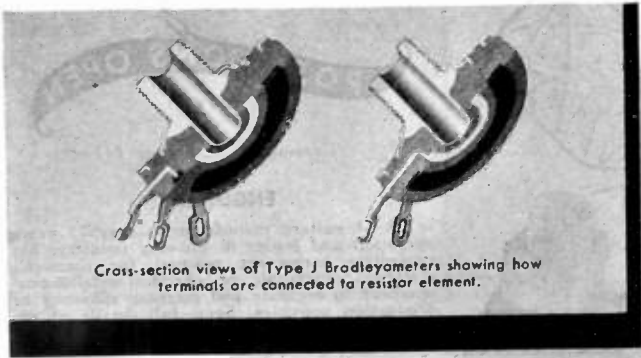

Cross-section views of Type J Bradleyometers showing how terminals are connected to resistor element.

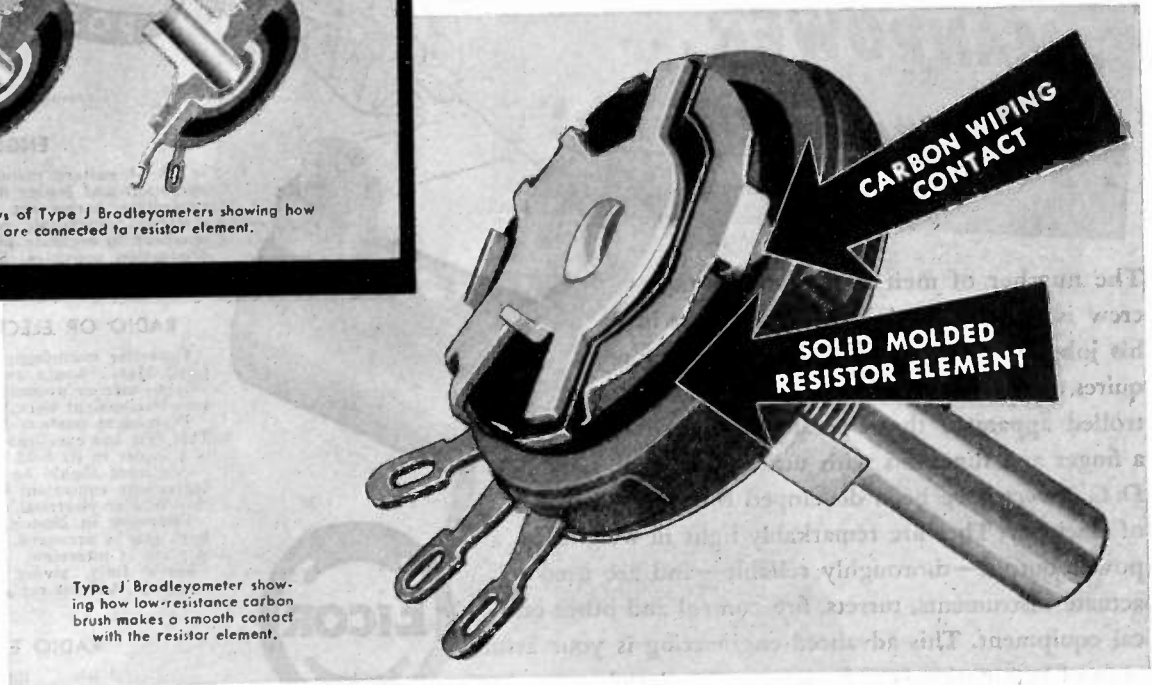

Type J Bradleyometer showing how low-resistance carbon brush makes a smooth contact with the resistor element.

Cold • Heat • Moisture cannot affect this **SOLID MOLDED** Resistor

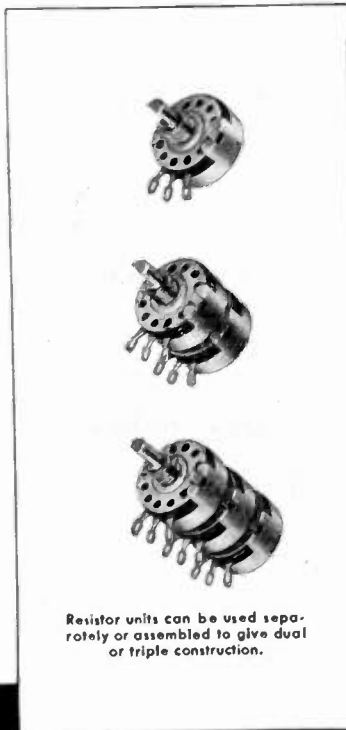

Resistor units can be used separately or assembled to give dual or triple construction.

The Type J Bradleyometer is the only variable resistor in which the resistor material, insulating material, terminals, face plate, and bushing are all molded into a single unit. The resistor material has substantial thickness and in this respect differs from the thin film types which consist of resistor material painted or sprayed on an insulation base. Once the A-B unit has been molded, the toughest war use cannot alter its performance. It remains quiet after hundreds of thousands of operations.

Actual experience in war service and laboratory tests has proved that Type J Bradleyometers function perfectly through a temperature range from -60° to $+70^{\circ}$ C. The resistor material is relatively inert, so changes due to moisture are negligible. The entire unit is corrosion-resistant and will easily pass the 200 hour salt spray test.

The simple construction of Bradleyometers means fewer parts and greater reliability. There are no rivets, no soldered or welded connections, and no conducting points. Can be supplied for rheostat or potentiometer applications, with or without a switch.

Write today for complete specifications.

Allen-Bradley Co., 114 W. Greenfield Ave., Milwaukee, Wis.



Type EB $\frac{1}{4}$ -watt insulated Bradleyunit molded fixed resistor. Actual length of element $\frac{1}{8}$ inch.



ALLEN-BRADLEY

FIXED & VARIABLE RADIO RESISTORS

QUALITY

MANPOWER... and Motor Power!

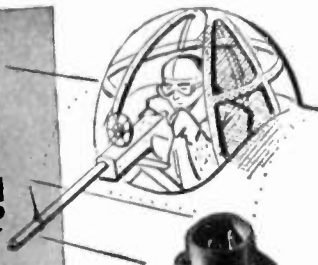

The number of men in a plane or tank crew is kept to a minimum. Each man has his job to do. This *minimum of manpower* requires a *maximum of motor power*... motor-controlled apparatus that operates at the touch of a finger and functions with utmost accuracy. *Eicor D. C. Motors* have been developed to a high degree of efficiency. They are remarkably light in weight for power output—thoroughly reliable—and are used to actuate instruments, turrets, fire control and other critical equipment. This advanced engineering is your assurance of better motors at lower cost *tomorrow!*

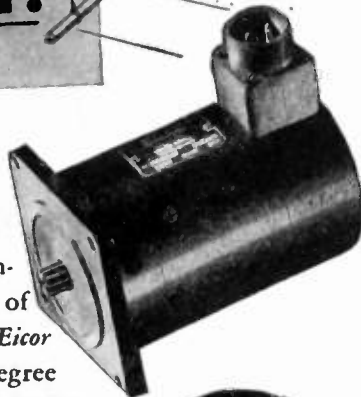

EICOR INC. 1501 W. Congress St., Chicago, U. S. A.
DYNAMOTORS • D. C. MOTORS • POWER PLANTS • CONVERTERS
Export: Ad Auriema, 89 Broad St., New York, U. S. A. Cable: Auriema, New York

**I-F
TRANSFORMER**

Precise . . . Simple

PERMEABILITY-TUNED

**CAMBRIDGE THERMIONIC
CORP.**
445 CONCORD AVE., CAMBRIDGE, MASS.

POSITIONS OPEN

(Continued from page 54)

ENGINEER

AAA-1 eastern manufacturer, over 75 years operation and leader in growing industry, has immediate permanent position for chemical, electrical, electronic or chemical-metallurgical engineer to organize and increase efficiency of production activities. Send full details of experience to Box 301.

RADIO OR ELECTRICAL ENGINEER

Capacitor manufacturer located in New Bedford, Mass., wants an electrical or radio engineer—man or woman—for equipment and circuit-development work.

Permanent postwar future for right person. This firm has excellent laboratory facilities and is a leader in its field.

Applicant should be college graduate with a degree—or equivalent experience—in radio engineering or electrical engineering.

Interview in Boston, New Bedford or New York can be arranged. Traveling expenses paid to place of interview.

Write fully, giving age, education, experience, etc. Address reply to Box 302.

RADIO ENGINEERS

Well-established international corporation, 100% in war work with definite postwar possibilities, needs several radio engineers who are familiar with the construction or use of automatic-receiving equipment. Also two transmitter engineers familiar with 40 k.w. equipment.

Applicants should have college degree or approximately ten years experience in radio. Openings in Chicago and New York. Salaries from \$100.00 a week dependent upon experience and ability.

In reply please give complete details of experience, age, education, present and former employers, present earnings and your telephone number. Enclose recent photo if available. Address reply to Box 303.

ELECTROACOUSTIC ENGINEERS

One experienced in laboratory development and research activities. New position open in the development of war-production items. Situation includes excellent opportunities for post-war employment. Salary open. Write Personnel Manager, Universal Microphone Co., Box 299, Inglewood, California.

RADIO ENGINEER

Wanted for general work covering design and installation with major communication company chiefly in New York area. Technical graduate preferred. Must have car. Position not limited to duration. Address Box 298.

RADIO ENGINEER

EDUCATION: Minimum of two years college in Electrical Engineering.

EXPERIENCE: Minimum of two years in radio test or engineering, or five years in electrical control work (power station or telephone central-office wiring, etc.).

Must be of a type qualified to interpret and clarify with inspectors and responsible executives electrical specifications, problems of manufacture, test and inspection. Address Box 290.

RADIO ENGINEER

Opening in engineering department of concern making communication apparatus. Prefer college graduate with ultra-high-frequency experience, but lack of experience in this field will not bar an adaptable man.

Duties involve developing, designing and carrying the product through the shop with a minimum of supervision. If inexperienced, the duties would be the same under supervision. The company is engaged in war activity exclusively at the present time and does not expect any curtailment of its activity after the war.

Salary \$2,500 to \$10,000 depending upon qualifications. Pleasant surroundings and working conditions. If now employed in war work, a release from the employer must be obtainable. Address: Chief Engineer, Templeton Radio Company, Mystic, Conn.

(Continued on page 60A)



She Still Has "The Voice With A Smile"

War traffic keeps her busier than ever but she manages to keep calm and pleasant.

She still has "The Voice With A Smile" even when the lights are thick on the Long Distance switchboard and the circuits are crowded. Even when she has to ask you to —

"Please limit your call to 5 minutes. Others are waiting."

That's to help everybody get better service and you couldn't ask for a better reason than that.

BELL TELEPHONE SYSTEM



The **BOOK**
EVERY
ENGINEER
SHOULD
HAVE!



The **NEW DIALCO CATALOG**
OF WARNING & SIGNAL
PILOT LIGHT ASSEMBLIES



24 pages of valuable data on the most extensive line of Warning & Signal Pilot Light Assemblies — completely covering all Electrical, Electronic, Radio, Marine and Industrial applications.

An indispensable guide for Engineers, Technicians, and Purchasing Agents.

Write for your copy, on company letterhead, today!

DIAL LIGHT CO. OF AMERICA, Inc.

90 WEST STREET • NEW YORK 16, N. Y.

POSITIONS OPEN

(Continued from page 58A)

INSTRUCTORS IN ADVANCED ARMY-NAVY PROGRAM

Prominent Eastern technical institute needs additional instructors in officer training program in modern electronics and radio applications. An excellent opportunity to acquire advanced knowledge and to render important service in war effort. Men having various degrees of qualifications are needed, from recent graduates in Electrical Engineering or Physics to those with long experience in radio engineering or teaching. Salary according to qualifications and experience. Applicants must be U. S. citizens of unimpeachable reputation. Any inquiries will be treated as highly confidential. Please send personnel data and photograph to Box 292.

RADIO AND ELECTRONIC ENGINEERS

First, we are seeking the services of one or two trained engineers who have had ample experience in electronic engineering. The men selected will not only be concerned with present war production, but should eventually develop key positions in postwar operation.

Second, we are also looking for a few young engineers who have had good schooling and background to be trained for specialized work with us.

This is an excellent opportunity for men who qualify to connect with a progressive, highly regarded manufacturer of transmitting tubes. Many special benefits will be enjoyed in your association with this company.

Write at once giving complete details of past experience. Interviews will be promptly arranged. Persons in war work or essential activity not considered without statement of availability. Chief Engineer, United Electronics Company, 42 Spring Street, Newark, New Jersey.

PHYSICIST OR ELECTRICAL ENGINEER

Leading manufacturer of industrial radio-frequency equipment desires the services of a physicist or electrical engineer to direct developmental and applications laboratory. This field is expanding rapidly and offers excellent opportunities for advancement. Position of a permanent nature. Present activities devoted entirely to the war effort. Address replies to Box 306.

SOUND AND PROJECTION ENGINEERS

Openings exist for sound and projection engineers. Several years experience in the installation and maintenance of 35 mm motion-picture equipment of all types required. Must be draft exempt or over draft age and free to travel anywhere in the United States. Basic starting salary \$3200. U. S. Army Motion Picture Service, Engineering and Maintenance Division, 3327-A Locust Street, St. Louis, Missouri.

ELECTRICAL ENGINEER

An opportunity is offered to do interesting, varied and broadening development and laboratory work on highest quality electromagnetic devices used in fighting equipment. Salary will be good and commensurate with experience. A good post-war position is indicated by our being a moderate-sized, live-wire, long-established company with a non-inflated engineering staff. A knowledge of communication circuits is desirable but not essential. An engineering or science degree and a good knowledge of fundamentals are required. Write to G-M Laboratories, 4326 N. Knox Avenue, Chicago, Illinois.

RADIO ENGINEERS

Permanent radio-engineering position in Southern California for men with creative and design aptitude, especially with UHF circuits. Starting salary and advancement depends upon the engineer's experience and ability.

Applications are solicited from persons that are not using their highest skills in war work.

Write complete qualifying educational training and experience to Chief Radio Engineer, Bendix Aviation, Ltd., in care of The Shaw Company, 816 W. 5th Street, Los Angeles 13, California.

The foregoing positions of interest to I.R.E. members have been reported as open. Apply in writing, addressing reply to company mentioned or to Box No.

CABINETS
PANELS

CHASSIS
RACKS



Serving the
 Electronics
 Field
 Exclusively

Write for
 Catalogue
 No. 41-A

Though manufactured by modern high-speed methods, Par-Metal products have a definite quality of craftsmanship — that "hand-made" quality which is born of years of specialization.

PAR-METAL PRODUCTS CORPORATION

32-62—49th STREET . . . LONG ISLAND CITY, N. Y.

Export Dept. 100 Varick St., N. Y. C.

LABORATORY STANDARDS

Standard Signal
Generators
•
Square Wave
Generators
•
Vacuum Tube
Voltmeters
•
U. H. F.
Noisemeters
•
Pulse
Generators
•
Moisture
Meters
•

**MEASUREMENTS
CORPORATION**

Boonton, New Jersey

THE BIG WORD in tube satisfaction



For dependable
SERVICE
it will pay to choose

CETRON



Phototubes

Used by the leading theatres and sound equipment manufacturers . . . wherever phototubes of the utmost efficiency and dependability are needed.



Rectifiers

Cetron Rectifiers are famous for their sturdy construction, and constant, high-efficiency, long-life service.



Electronic Tubes

Used and praised by the leading manufacturers in the industry. Naturally, Cetron creates and produces all kinds of special tubes for special purposes and if you have a problem along this line, we invite you to consult with our experienced engineers.



CONTINENTAL ELECTRIC COMPANY

CHICAGO OFFICE
902 MERCHANDISE MART

GENEVA, ILL.

NEW YORK OFFICE
265 W. 14th ST.



We KNOCK-OUT Delivery Delays

FOR BUYERS OF ELECTRONIC and RADIO SUPPLIES

SLOW service . . . that endless *waiting* for supplies to carry on rush electronic war work, has taken a knock-out blow from our nation-wide **EMERGENCY SERVICE!** Now, with necessary priorities, you can mail or phone the nearest distributor signing this message. Ask for one or one hundred, or more, different items with every assurance of getting them faster than you ever thought possible under present war conditions. Special departments, technical staffs, merchandise and methods have been streamlined to aid the war effort . . . to function with a degree of speed and efficiency heretofore unapproached, we believe, in the history of radio and electronic supplies distribution. Make us headquarters for *all* your electronic needs. Write or phone today for **REAL** cooperation.



Free

A big reference book and buyer's guide crammed with helpful information on thousands of Radio and Electronic parts and equipment. Free to Purchasing Agents and other officials responsible for buying and specifying in industries using this equipment. Ask for it **NOW** on company stationery, please.

WRITE OR PHONE YOUR NEAREST DISTRIBUTOR

TERMINAL RADIO CORPORATION

85 Cortlandt St.
Telephone: WOrth 2-4416

NEW YORK 7

WALKER-JIMIESON, INC.

311 South Western Ave.
Telephone: Canal 2525

CHICAGO 12

RADIO SPECIALTIES COMPANY

20th & Figueroa Streets
Telephone: Prospect 7271

LOS ANGELES 7

INDEX

Membership	34A
Positions Open	52A

DISPLAY ADVERTISERS

Aerovox Corporation	3A
Allen-Bradley Company	57A
Alliance Mfg. Company	51A
American Lava Corporation	6A
American Telephone & Telegraph Co.	59A
American Transformer Company	29A
Victor J. Andrew Company	50A
Arnold Engineering Company	56A
Audio Development Company	48A
Barker & Williamson	43A
Billley Electric Company	21A
Browning Laboratories, Inc.	55A
Cambridge Thermionic Corp.	58A
Capitol Radio Engineering Institute	56A
Centralab	17A
Chicago Transformer Corp.	46A
Clarostat Mfg. Company, Inc.	44A
Sigmund Cohn & Co.	52A
Connecticut Telephone & Electric Div.	42A
Continental Electric Company	61A
Cornell-Dubilier Electric Corp.	Cover III
Corning Glass Works	8A, 9A
Daven Company	2A
DeJur-Amsco Corporation	18A
To be Deutschmann Corp.	63A
Dial Light Co. of America, Inc.	60A
Wilbur B. Driver Co.	45A
Allen B. DuMont Laboratories, Inc.	14A
DX Crystal Company	56A
Eicor Inc.	58A
Eitel McCullough, Inc.	19A
Electronic Corp. of America	12A
Electronic Laboratories, Inc.	Facing 17A
Electronic Mechanics, Inc.	41A
Electro-Voice Mfg. Co., Inc.	20A
Galvin Manufacturing Corp.	37A
General Electric Company	31A, 40A
General Radio Company	Cover IV
Hallicrafters Company	22A
Heintz & Kaufman, Ltd.	23A
Hyltron Corporation	11A
Industrial Condenser Corp.	40A
International Resistance Co.	35A
Jackson Electrical Instrument Co.	38A
James Knights Company	25A
Littelfuse Inc.	51A
Measurements Corporation	61A
Mycalex Corp. of America	33A
National Company, Inc.	5A
National Union Radio Corp.	Facing 16A
North American Philips Company, Inc.	16A
Operadio Mfg. Company	54A
Par-Metal Products Corp.	60A
Pioneer Gen.-E-Motor Corp.	36A
Radio Corp. of America, Victor Div.	13A, 32A
RCA Aviation Radio	64A
Radio Specialties Co.	62A
Rauland Corporation	26A
Raytheon Manufacturing Company	28A
Remler Company, Ltd.	54A
Rola Company	10A
Solar Manufacturing Corp.	27A
Sprague Specialties Company	39A
Standard Transformer Corp.	30A
Stupakoff Ceramic & Mfg. Company	24A
Sylvania Electric Products Inc.	47A
Terminal Radio Corporation	62A
Thordarson Elec. Mfg. Company	34A
Tung-Sol Lamp Works, Inc.	53A
Turner Company	52A
United Electronics Company	49A
United Transformer Company	Cover II
Utah Radio Products Company	4A
Walker-Jimieson, Inc.	62A
Westinghouse Elec. & Mfg. Co.	7A
Wilcox Electric Company	15A

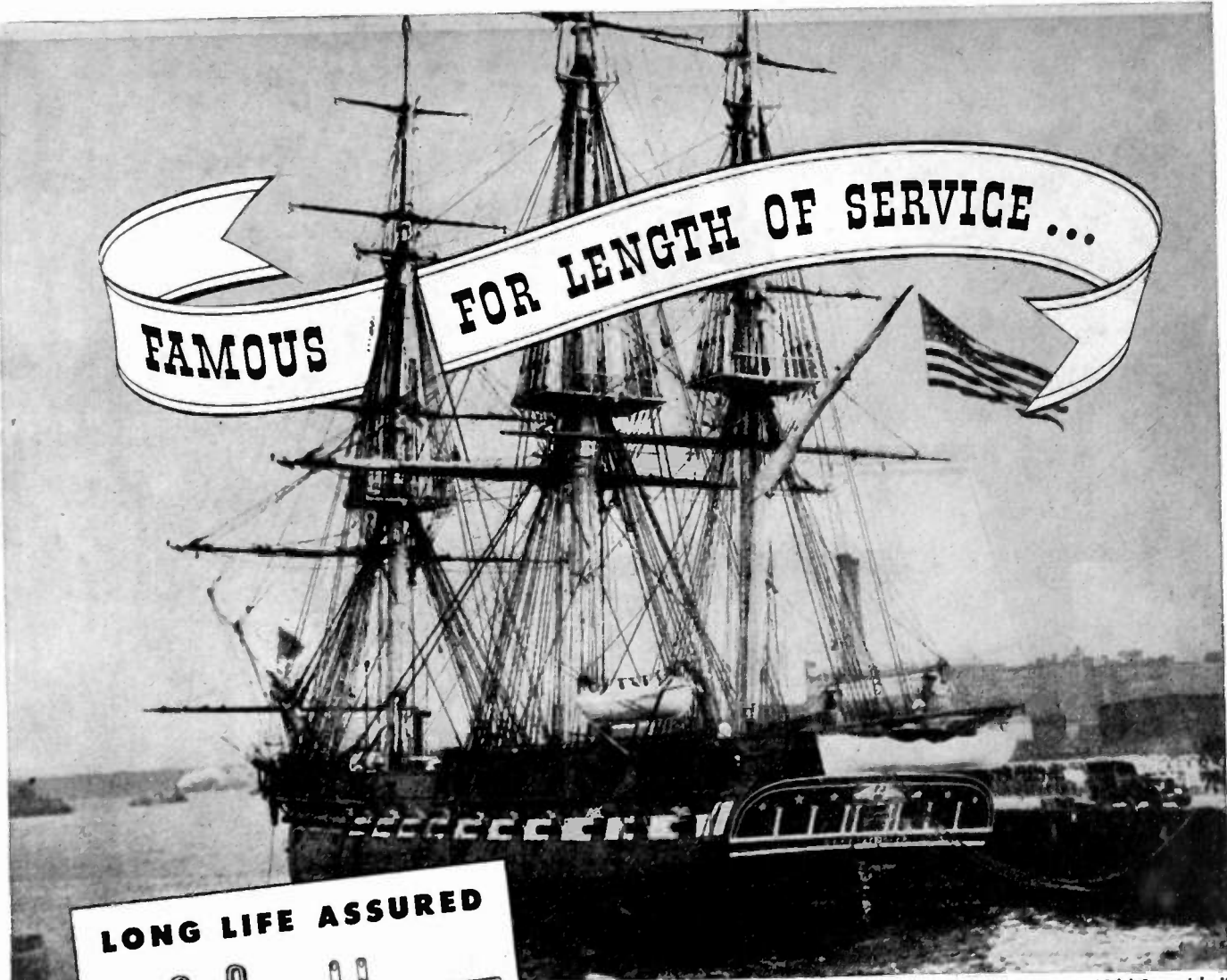

U. S. S. Constitution—"Old Ironsides"

LONG LIFE ASSURED

The new separate mounting is stronger and prevents oil leaks caused by breaks in can. This modern design takes the minimum of space.

YOU WANT capacitors that can stand up and take it. The well-nigh flawless record of Tobe Capacitors as to "returns" proves they have that outstanding requirement of durability.

This quality is built into each and every Tobe Capacitor by advanced engineering practices and production methods. And their rating is always an "understatement".

Shown here is the Tobe Oilmite Capacitor. Filled and impregnated with mineral oil it is used as a filter condenser in war equipment. The new hold-down bracket permits inverted or upright terminals, with wiring either underneath or on top of chassis.

TYPE RATINGS	OM .05 to 2.0 mfd. 600 V.D.C. .05 mfd. to 1.0 mfd. 1,000 V.D.C.
STANDARD CAPACITY TOLERANCE	= 10%
TEST VOLTAGE	Twice D.C. rating
GROUND TEST	2,500 Volts, D.C.
SHUNT RESISTANCE	.05 to 0.1 mfd. 20,000 megohms. .25 to 0.5 mfd. 12,000 megohms. 1.0 to 2.0 mfd. 12,000 megohms.
POWER FACTOR	At 1,000 cycles—.002 to .005
CONTAINER SIZE	Width 5/8", length 1-5/16", height 2 1/4"
MOUNTING HOLE CENTERS	1 1/2"



A SMALL PART IN VICTORY TODAY—A BIG PART IN INDUSTRY TOMORROW

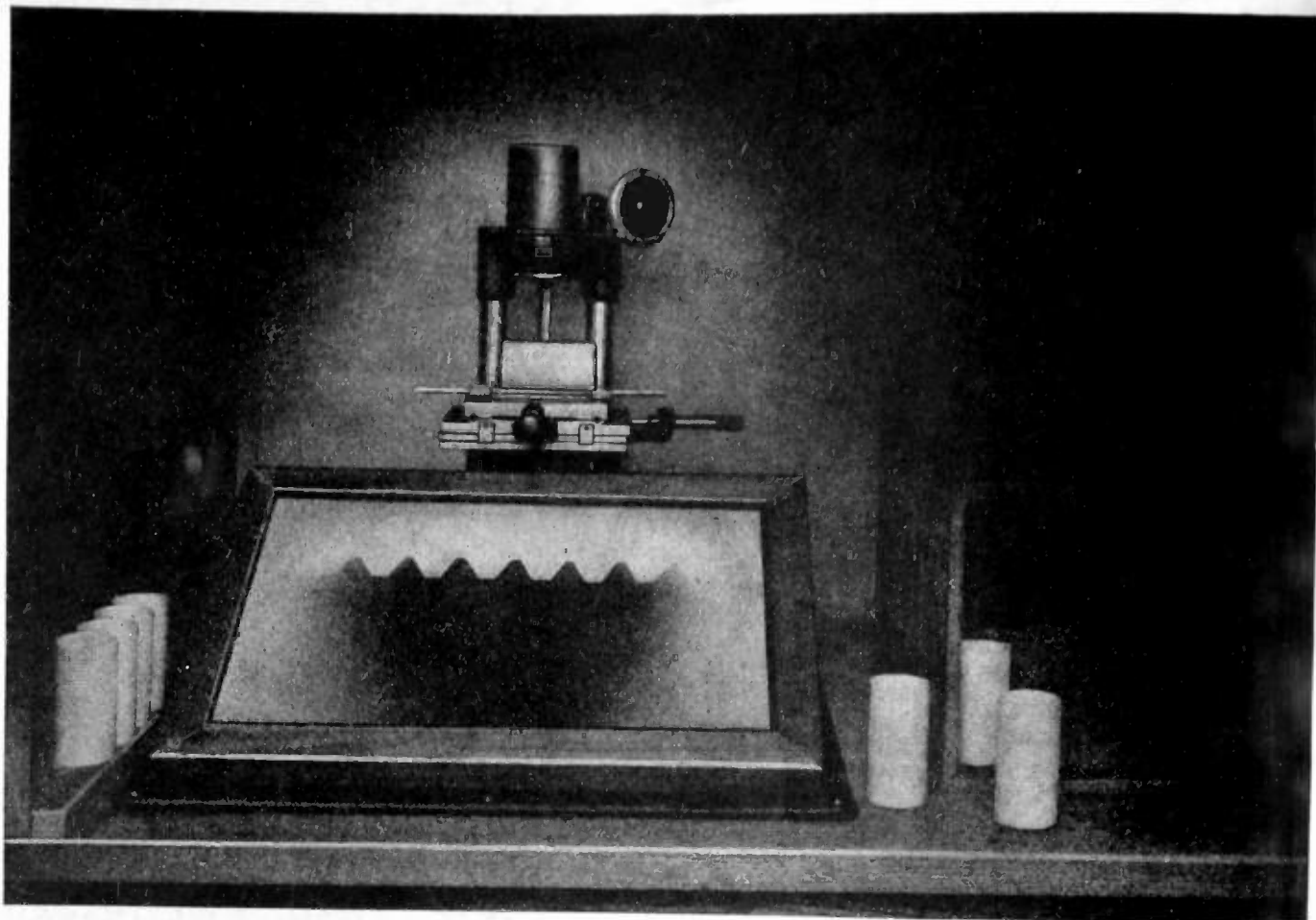

Shadowgraph

RCA aircraft radio transmitters are precision instruments—and are made as such.

For example, the grooves on the ceramic forms on which certain coils are wound must be exceedingly accurate—because even minute deviations will affect the length of the wire and alter the coil inductance. Yet, because of warping when the ceramic material is fired, such deviations can occur. Hence, every form must be carefully checked by means that reveal the slightest irregularity in the grooves. Only forms that pass this test can be accepted for quantity production.

RCA has solved this problem by developing a special application of the Shadowgraph to project an enlarged image of each coil on a ground glass screen on which is engraved a standard groove outline. Sharply defined

against this outline, any imperfection in the groove profile becomes conspicuous—and rejection follows.

That is one of many reasons why an aircraft operator when he sets up his RCA transmitter can be confident that its calibration chart or curve is accurate. Other precision parts of RCA aircraft radio equipment are likewise accurately checked by similar Shadowgraph procedure.

All of which is but another step in the long, rigid RCA routine which contributes so largely to RCA aircraft radio operating precision and dependability in military and transport planes. *Radio Apparatus Division, Radio Corporation of America, Camden, N. J.*

TUNE IN "WHAT'S NEW?"

*Radio Corporation of America's great new show,
Saturday nights, 7 to 8, E. W. T., Blue Network.*



RCA AVIATION RADIO



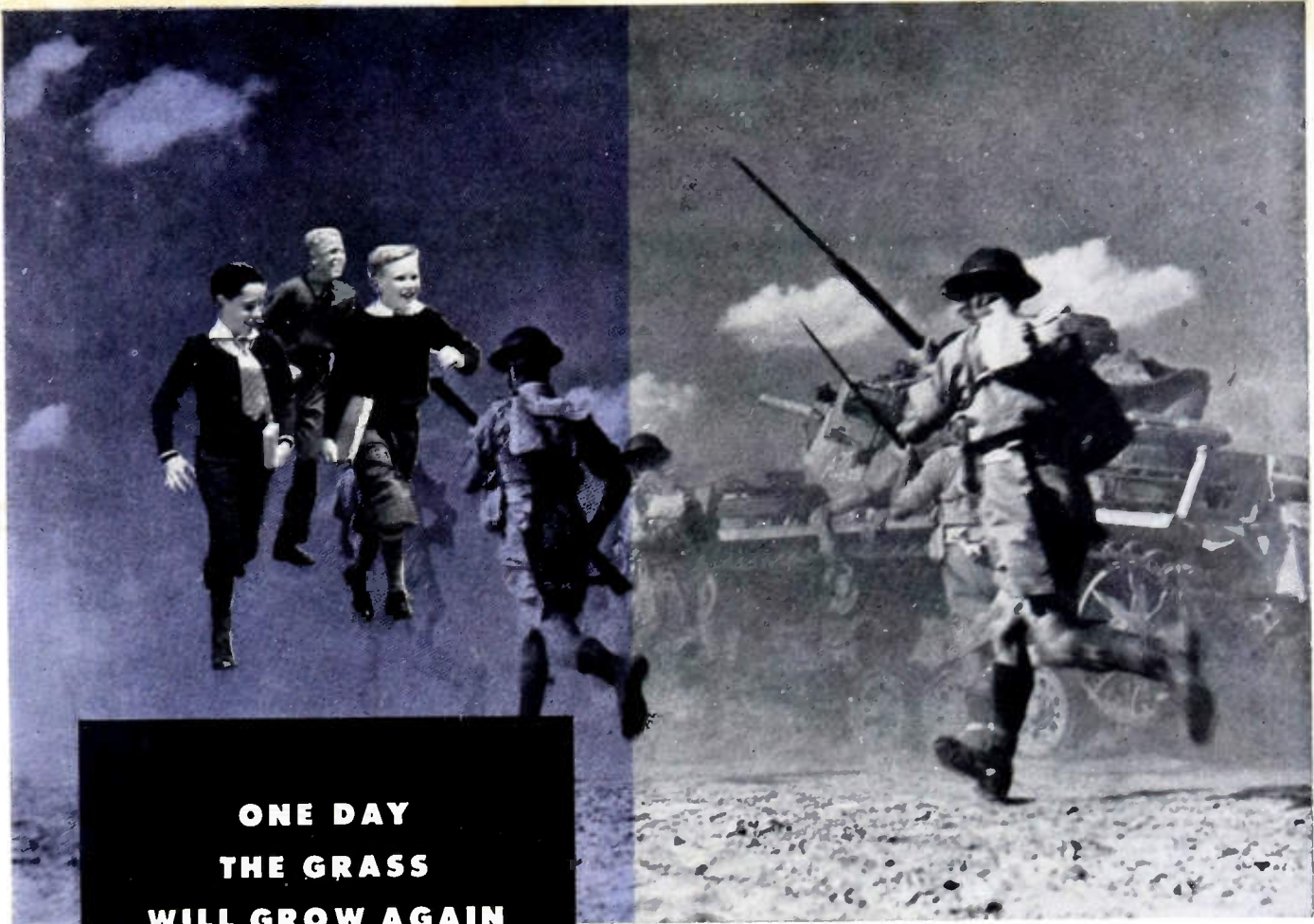

**ONE DAY
THE GRASS
WILL GROW AGAIN**

20th Century-Fox Film "Desert Victory"

One day the sound of running feet will be those of children at play, not the feet of men charging into battle over the battle-scarred earth. Then the grass will once more be green.

Because our job calls for constant action, we have never let the grass grow under our feet. For 33 years we have been building capacitors, and out of these years of specialization has come a product famous for extra long life and extra dependability.



**Low Capacity By-Pass Capacitors
Type DY**

Type DY Dykanol By-Pass Capacitors are non-inductively wound, and fill the need for dependable Capacitors of fractional capacities that will operate efficiently in r.f. and a.f. by-pass, audio frequency coupling and A.C. circuits under all humidity conditions and at temperatures up to 80°C. Hermetically sealed, they have been especially designed to fill the requirements of aircraft, submarine and marine applications for maximum capacity and voltage in minimum space. For further details write for Catalog No. 160T.

Today CD capacitors are known as the world's finest. That is why there are more CD's in use than any other make . . . for wartime as well as civilian applications.

Cornell-Dubilier
capacitors



MICA • DYKANOL • PAPER • WET AND DRY ELECTROLYTICS

**MORE IN USE TODAY
THAN ANY OTHER MAKE**

CORNELL-DUBILIER ELECTRIC CORPORATION, SOUTH PLAINFIELD, NEW JERSEY

METERS

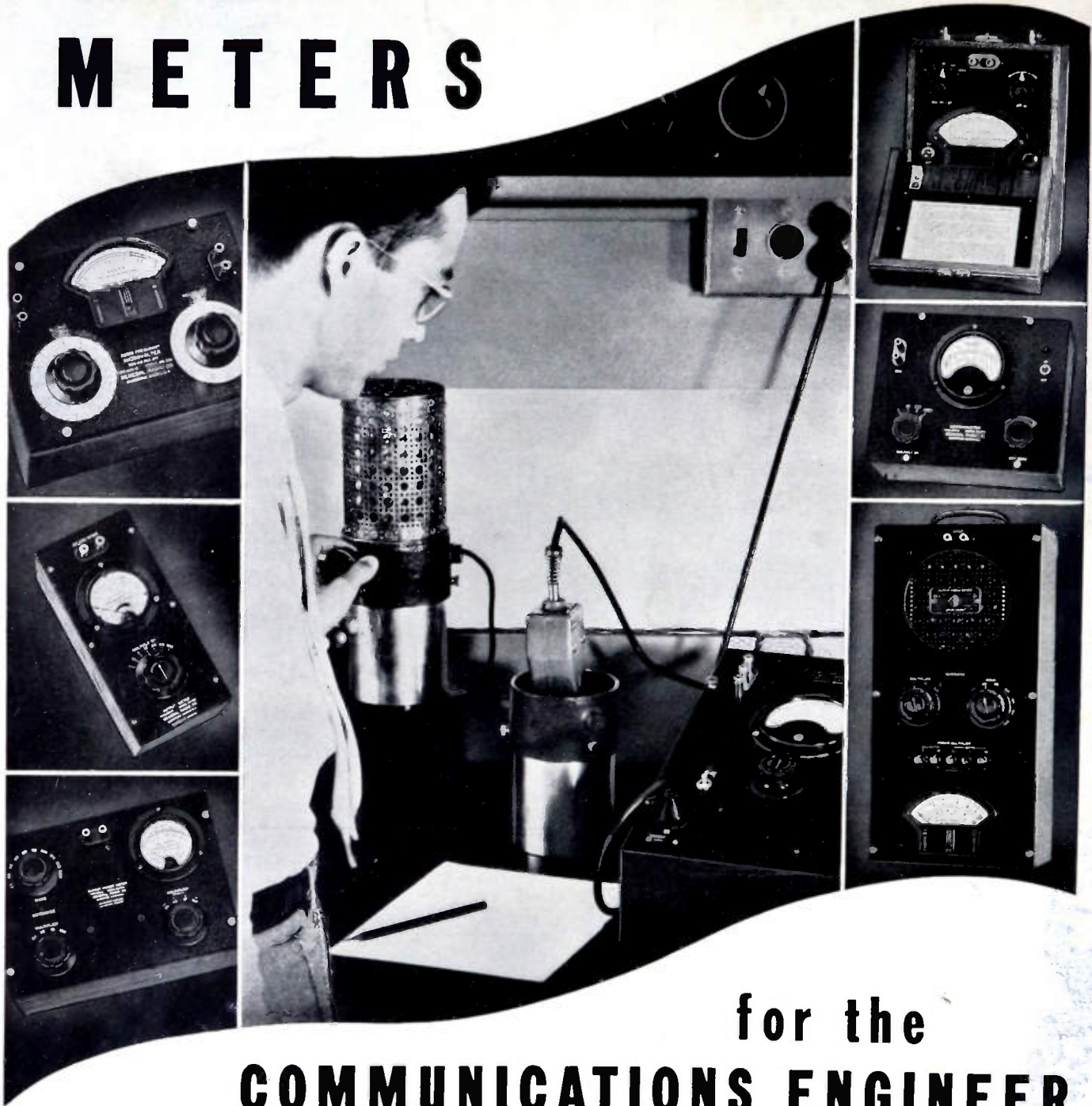

for the COMMUNICATIONS ENGINEER

Quantitative measurements of the performance of electrical circuits depend upon instruments for the measurement of voltage, current and power. Limited-range, single-frequency instruments are adequate at power frequencies, but measurements at communication frequencies require specialized types covering wide ranges of frequency and voltage.

Since 1915, the General Radio Company has been building these special-purpose meters for the communications industry. The present line includes both copper-oxide and vacuum-tube types covering a frequency range from d-c to ultra-high radio frequencies, and a voltage range from 50 millivolts to 300 volts.

In war time as well as in peace, the leading communication laboratories are equipped with General Radio instruments, backed by 28 years of experience in designing and building high-quality apparatus.



Because all our facilities are devoted to war projects, these meters are at present available only for war work.



GENERAL RADIO COMPANY · Cambridge 39, Massachusetts

NEW YORK 6

LOS ANGELES 38