

# Proceedings



*of the*

# I · R · E

MAY 1943

VOLUME 31

NUMBER 5

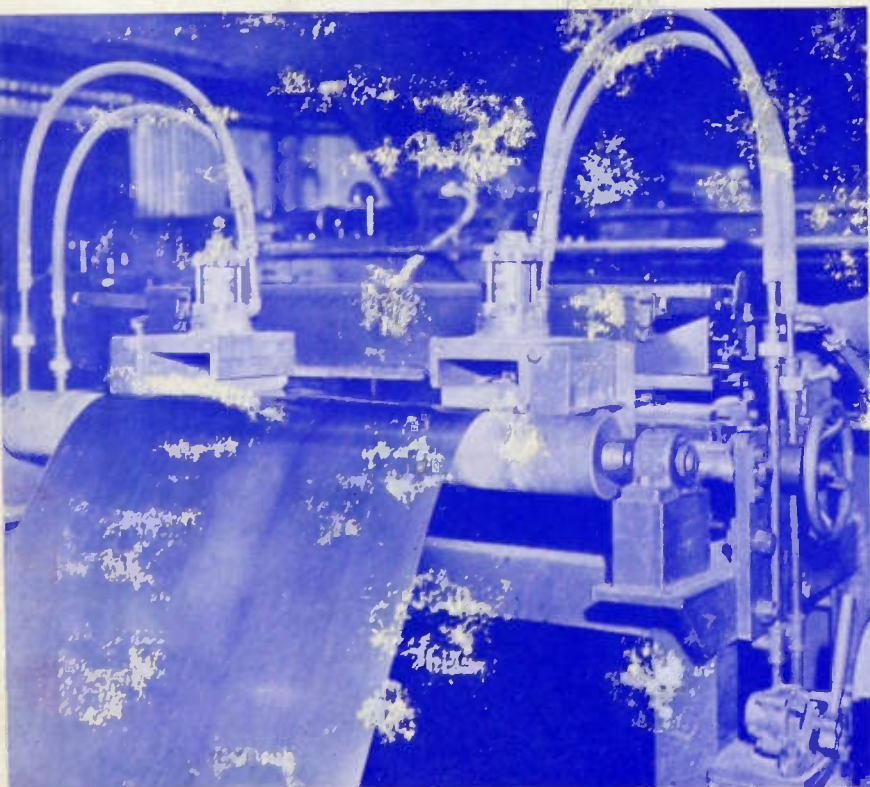

*General Electric Photo*

ELECTRONIC SCANNING  
Pinhole Detection in Tin Plate

Design for Blitz

Light Valve C-R Control

Television Light Valve

Antenna Current

Distribution

Network Theory—Part II

# Institute of Radio Engineers



A heavy responsibility rests on all men in war industries . . . especially upon executives and engineers.

Their knowledge of confidential operations should not be the subject of discussions beyond the confines of the plant . . . nor should their natural pride in accomplishments cause them to speak unthinkingly. Discretion is an essential part of war production.

**AMPEREX ELECTRONIC PRODUCTS**  
**79 WASHINGTON STREET      BROOKLYN, NEW YORK**

BOARD OF DIRECTORS

1943

- Lynde P. Wheeler, *President*
- F. Sherbrooke Barton,  
*Vice President*
- Raymond A. Heising, *Treasurer*
- Haraden Pratt, *Secretary*
- Alfred N. Goldsmith, *Editor*
- Stuart L. Bailey
- Wilmer L. Barrow
- E. Finley Carter
- Adolph B. Chamberlain
- Ivan S. Coggeshall
- William L. Everitt
- Harold T. Friis
- Gilbert E. Gustafson
- O. B. Hanson
- Frederick B. Llewellyn
- Frederick E. Terman
- Browder J. Thompson
- Hubert M. Turner
- Arthur F. Van Dyck
- Harold A. Wheeler
- William C. White

•

Harold R. Zeamans,  
*General Counsel*

•

BOARD OF EDITORS

- Alfred N. Goldsmith, *Editor*
- Ralph R. Batchner
- Philip S. Carter
- Lewis M. Clement
- Elmer W. Engstrom
- William L. Everitt
- Peter C. Goldmark
- Frederick W. Grover
- C. M. Jansky, Jr.
- John D. Kraus
- Frederick B. Llewellyn
- Samuel S. Mackeown
- Edward L. Nelson
- Harry F. Olson
- Greenleaf W. Pickard
- Haraden Pratt
- Conan A. Priest
- Lynne C. Smeby
- Browder J. Thompson
- Harold A. Wheeler
- Laurens E. Whittemore
- Gerald W. Willard
- William Wilson
- Charles J. Young

•

Helen M. Stote,  
*Associate Editor*

William C. Copp,  
*Advertising Manager*

William B. Cowilich,  
*Assistant Secretary*

# Proceedings

## of the I·R·E

*Published Monthly by*

The Institute of Radio Engineers, Inc.

VOLUME 31

*May, 1943*

NUMBER 5

Book Previews and Monographs .....	191
Design for Blitz .....	E. F. McDonald, Jr. 192
Nikola Tesla—1857—1943 .....	194
Cathode-Ray Control of Television Light Valves .....	J. S. Donal, Jr. 195
A Type of Light Valve for Television Reproduction .....	J. S. Donal, Jr., and D. B. Langmuir 208
Optimum Current Distributions on Vertical Antennas .....	Lincoln La Paz and Geoffrey A. Miller 214
Corrections to "Thermal-Frequency-Drift Compensation," by T. R. W. Bushby .....	232
Network Theory, Filters, and Equalizers—Part II .....	Frederick E. Terman 233
Institute News and Radio Notes .....	241
Future of Television .....	241
Board of Directors .....	241
Executive Committee .....	241
Correspondence: Proposed Constitutional Amendments .....	242
New York Section .....	243
Book Preview:	
"Electromagnetic Waves," by S. A. Schelkunoff .....	H. A. Wheeler 245
Books:	
"A Practical Course in Magnetism, Electricity, and Radio," by W. T. Perkins and A. Charlesby .....	Harry Rowe Mimno 245
Section Meetings .....	xxviii
Membership .....	xxx
New Equipment Notes .....	xl
Standards for Home Radio Replacement Parts .....	xliv
Army-Navy "E" Honor Roll .....	xlvi
Positions Open .....	l
Advertising Index .....	lxii

Responsibility for the contents of papers published in the PROCEEDINGS rests upon the authors. Statements made in papers are not binding on the Institute or its members.



Entered as second-class matter October 26, 1927, at the post office at Menasha, Wisconsin, under the Act of February 28, 1925, embodied in Paragraph 4, Section 538 of the Postal Laws and Regulations. Publication office, 450 Ahnaip Street, Menasha, Wisconsin. Editorial and advertising offices, 310 West 42nd St., New York, N. Y. Subscription \$10.00 per year; foreign, \$11.00.

# THE INSTITUTE OF RADIO ENGINEERS

INCORPORATED



## SECTION MEETINGS

<b>ATLANTA</b> May 21	<b>CHICAGO</b> May 21	<b>CLEVELAND</b> May 27	<b>DETROIT</b> May 21	
<b>LOS ANGELES</b> May 18	<b>NEW YORK</b> June 2	<b>PHILADELPHIA</b> June 10	<b>PITTSBURGH</b> June 14	<b>WASHINGTON</b> June 14

## SECTIONS

- ATLANTA**—Chairman, J. M. Comer; Secretary, Ivan Miles, 554—14 St., N. W., Atlanta, Ga.
- BALTIMORE**—Chairman, G. J. Gross; Secretary, A. D. Williams, Bendix Radio Corp., E. Joppa Rd., Towson, Md.
- BOSTON**—Chairman, R. F. Field; Secretary, R. O. Oberg, Northeastern Univ., Boston, Mass.
- BUENOS AIRES**—Chairman, J. P. Arnaud; Secretary, Alexander Nadosy, Florida St. 1065, Dept. C-16, Buenos Aires, Argentina.
- BUFFALO-NIAGARA**—Chairman, F. H. Scheer; Secretary, A. J. Dybowski, Dymac Radio, Inc., 1531 Main St., Buffalo, N. Y.
- CHICAGO**—Chairman, A. B. Bronwell; Secretary, W. O. Swinyard, Hazeltine Electronics Corp., 325 W. Huron St., Chicago, Ill.
- CINCINNATI**—Chairman, Howard Lepple; Secretary, J. L. Hollis, 6511 Betts Ave., Cincinnati, Ohio.
- CLEVELAND**—Chairman, F. C. Everett; Secretary, Hugh B. Okeson, 4362 W. 58 St., Cleveland, Ohio.
- CONNECTICUT VALLEY**—Chairman, W. M. Smith; Secretary, R. E. Moe, Radio Dept., General Electric Co., Bridgeport, Conn.
- DALLAS-FORT WORTH**—Chairman, H. E. Applegate; Secretary, P. C. Barnes, WFAA-WBAP, Grapevine, Texas.
- DETROIT**—Chairman, F. M. Hartz; Secretary, E. J. Hughes, 14209 Prevost, Detroit, Mich.
- EMPORIUM**—Chairman, R. K. Gessford; Secretary, H. D. Johnson, Sylvania Electric Products, Inc., Emporium, Pa.
- INDIANAPOLIS**—Chairman, S. E. Benson; Secretary, B. H. Rinehart, 1920 Park Ave., Indianapolis, Ind.
- KANSAS CITY**—Chairman, H. K. Morgan; Secretary G. L. Taylor, Midland Radio School Power and Light Building, Kansas City, Mo.
- LOS ANGELES**—Chairman, Lester Bowman; Secretary, R. C. Moody, Don Lee Broadcasting System, 5515 Melrose, Hollywood, Calif.
- MONTREAL**—Chairman, J. A. Ouimet; Secretary, J. R. Bain, Dept. 912, Northern Electric Co., 1231 Shearer St., Montreal, Que., Canada.
- NEW YORK**—Chairman, H. M. Lewis; Secretary, H. F. Dart, 33 Burnett St., Glen Ridge, N. J.
- PHILADELPHIA**—Chairman, J. B. Coleman; Secretary, H. J. Schrader, Bldg. 8, Fl. 10. RCA Manufacturing Co., Camden, N. J.
- PITTSBURGH**—Chairman, D. A. Myer; Secretary, A. P. Sunnergren, West Penn Power Co., Rm 1304, West Penn. Bldg., Pittsburgh, Pa.
- PORTLAND**—Chairman, K. G. Clark; Secretary, E. D. Scott, Rt. 14, Box 414, Portland, Ore.
- ROCHESTER**—Chairman, O. L. Angevine, Jr.; Secretary, G. R. Town, Stromberg-Carlson Tel. Mfg. Co., Rochester, N. Y.
- ST. LOUIS**—Chairman, P. S. McDaniel; Secretary, H. D. Seielstad, 1017 S. Berry Rd., St. Louis, Mo.
- SAN FRANCISCO**—Chairman, Karl Spangenberg; Secretary, David Packard, Hewlett-Packard Co., Palto Alto, Calif.
- SEATTLE**—Chairman, K. H. Ellerbeck; Secretary, H. E. Renfro, 4311 Thackeray Pl., Seattle, Wash.
- TORONTO**—Chairman, T. S. Farley; Secretary, J. T. Pfeiffer, Erie Resistor of Canada, Ltd., Terminal Warehouse Bldg., Toronto, Ont., Canada.
- TWIN CITIES**—Chairman, R. E. Allison; Secretary, A. G. Peck, Twin-Cities Studios, Columbia Broadcasting System, 625 Second Ave., Minneapolis, Minn.
- WASHINGTON**—Chairman, C. M. Hunt; Secretary, H. A. Burroughs, Rm. 7207, Federal Communications Commission, Washington, D. C.

# Continuous Service Rating Data

## TYPES 1550-1560-1570-1580-1590

Maximum Current in Amperes—Maximum Ambient Temperature 60° C

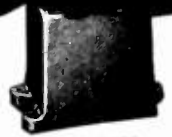

Type 1590

### TYPE 1590

Catalog Number	10,000 kc.	3000 kc.	1000 kc.	300 kc.	100 kc.	Cap. Mfds.	Test Volts Eff.	Catalog Number	10,000 kc.	3000 kc.	1000 kc.	300 kc.	100 kc.
1590-200		7.	4.5	1.5	.5	.01	8000	1590-217		16.	20.	15.	8.
1590-201		8.5	6.	3.	1.	.01	6000	1590-218		16.	20.	15.	8.
1590-202		6.	4.	2.	.7	.02	5000	1590-219		18.	20.	17.	10.
1590-203		10.	8.5	4.5	1.5	.03	4000	1590-220		18.	20.	18.	12.
1590-204		8.	7.	3.5	1.2	.04	4000	1590-221		18.	23.	20.	12.
1590-205		11.	11.	7.5	2.5	.05	4000	1590-222		18.	25.	22.	12.
1590-206		9.	8.	6.	2.	.05	2000	1590-223		18.	25.	22.	12.
1590-207		12.	14.	10.	5.	.1	2000	1590-224		18.	25.	22.	12.
1590-208		9.	10.	3.	3.	.1	1000	1590-225		18.	25.	22.	12.
1590-209		12.	14.	6.	4.	.2	600	1590-226		18.	25.	22.	12.
1590-210						.25	600	1590-227		18.	25.	22.	12.
						.3	600	1590-228		18.	25.	22.	12.
						.4	600	1590-229		18.	25.	22.	12.
						.5	600	1590-230		18.	25.	22.	12.
						.6	600	1590-231		18.	25.	22.	12.
						.8	600	1590-232		18.	25.	22.	12.
						1.0	600	1590-233		18.	25.	22.	12.

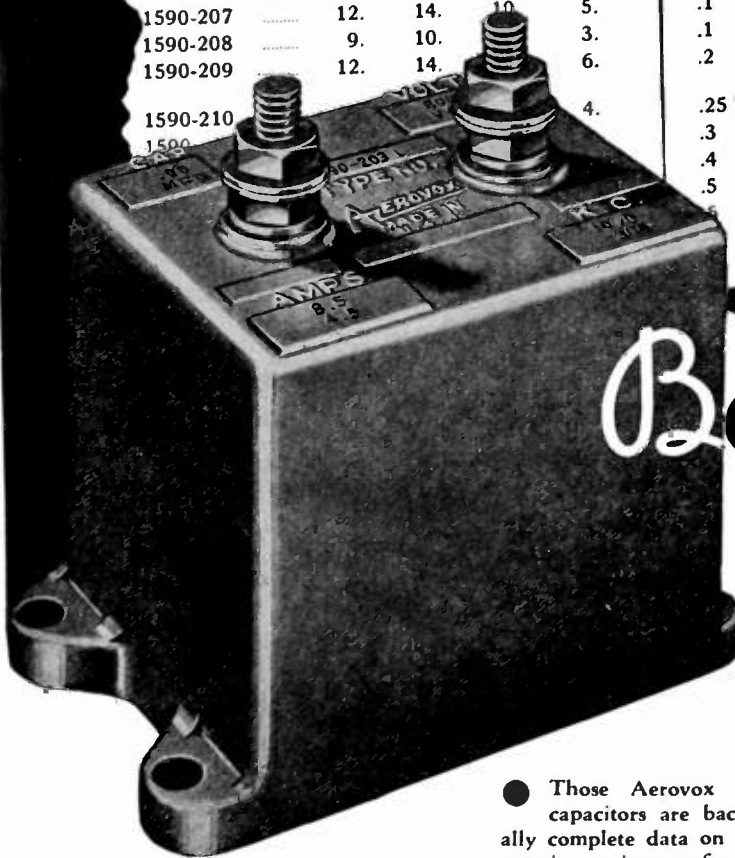

Aerovox mica transmitting capacitors are available in the widest range of types, capacities, working voltages. Type here shown is the bakelite-cased 1590 series for medium-duty high-frequency current-handling functions.

# Backed by

## the most complete CONTINUOUS SERVICE RATING DATA

● Those Aerovox mica transmitting capacitors are backed by exceptionally complete data on maximum current-carrying ratings at five different frequencies, in addition to capacity and test-voltage ratings. The unit best suited for given current at given voltage and frequency may thus be selected quickly and precisely. This data, the accumulation of years of research and experience based on extensive tests conducted with special test equipment, was determined in connection with standard circuits in which such units are extensively used.

Good capacitors, plus good application data, account for the tremendous popularity which Aerovox transmitting capacitors enjoy today.

Be sure to reserve your copy of the Aerovox Transmitting Capacitor Catalog, now in preparation, for your working library, if you are engaged in professional radio or electronic work.



# Capacitors

INDIVIDUALLY TESTED

AERVOX CORPORATION, NEW BEDFORD, MASS., U. S. A. • SALES OFFICES IN ALL PRINCIPAL CITIES  
Export: 100 VARICK ST., N. Y. C. • Cable: 'ARLAB' • In Canada: AERVOX CANADA LTD., HAMILTON, ONT.

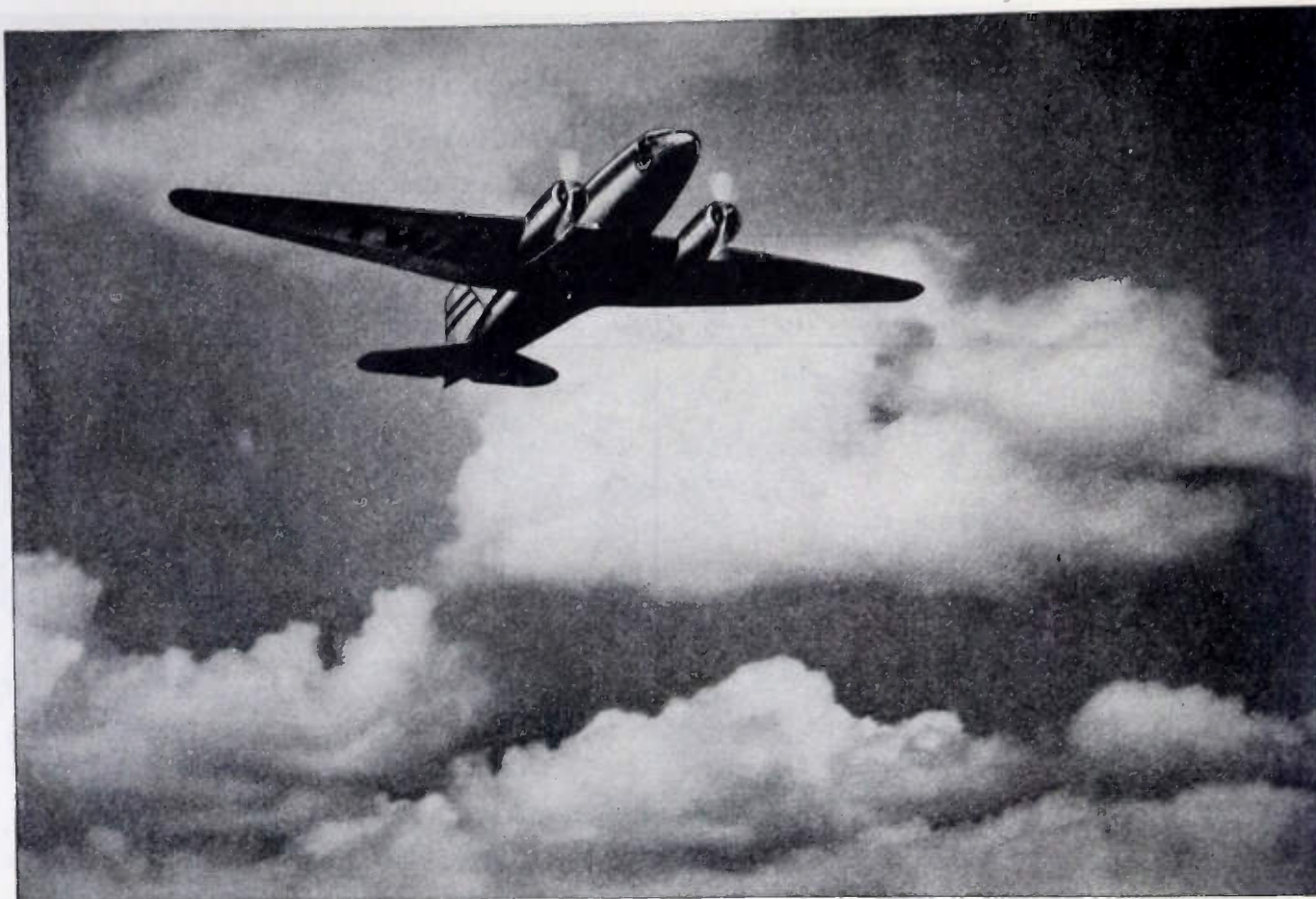

Photograph, courtesy Transcontinental and Western Air, Inc.

## **THERE MUST BE DEPENDABLE COMMUNICATIONS**

The reliability of Wilcox communications and other radio equipment has made them invaluable servants of leading commercial airlines.

Now, the entire output of Wilcox factories is going to wartime uses, and the experience gained during

peacetime is standing in good stead for military operations.

Thus, Wilcox is keeping pace with the miracles of flight... and, after Victory, new Wilcox developments will be available for the better-to-live-in, sane, sensible world ahead.

Communication Receivers  
Aircraft Radio



Airline Radio Equipment  
Transmitting Equipment

# **WILCOX ELECTRIC COMPANY**

*Quality Manufacturing of Radio Equipment*

14TH & CHESTNUT

KANSAS CITY, MISSOURI



## Neither were planned for war

We're not raising new generations to die on battlefields; we're not designing implements for future wars. We Americans are a peace and freedom-loving lot, with an economy that is geared to the home . . . washing machines, automobiles, radio . . .

But we first must finish an unpleasant job of blasting the daylights out of those who deliberately attacked our way of life. For that purpose, we've given our men. And our men are getting the very best tools for that piece of grim business.

We thank heaven that change, progress and mass production are an integral part of a system that enabled us to redesign our products for military applications. True, our new designs were speeded by war necessity—but we like to think of these latest Electro-Voice microphones as no different from the others in our evolutionary scale.

For, as eagerly as any soldier on a fighting front, we retain a vision of returning again to our natural mode of living. We plan to build better microphones for civilian communication . . . for music . . . for laughter . . .



# *Electro-Voice* MICROPHONES

ELECTRO-VOICE MANUFACTURING CO., INC.

1239 SOUTH BEND AVENUE, SOUTH BEND, INDIANA

*Proceedings of the I.R.E. May, 1943*

▼

# FILTERS— Designed for war



Unique characteristics of many UTC filters are the result of years of research on core materials and filter structures. We are proud of our part in the development of filters for wartime electronics. Here are a few typical elements, based on UTC design, which have led to UTC leadership in this field.

**May we design a "Victory" unit to your application?**

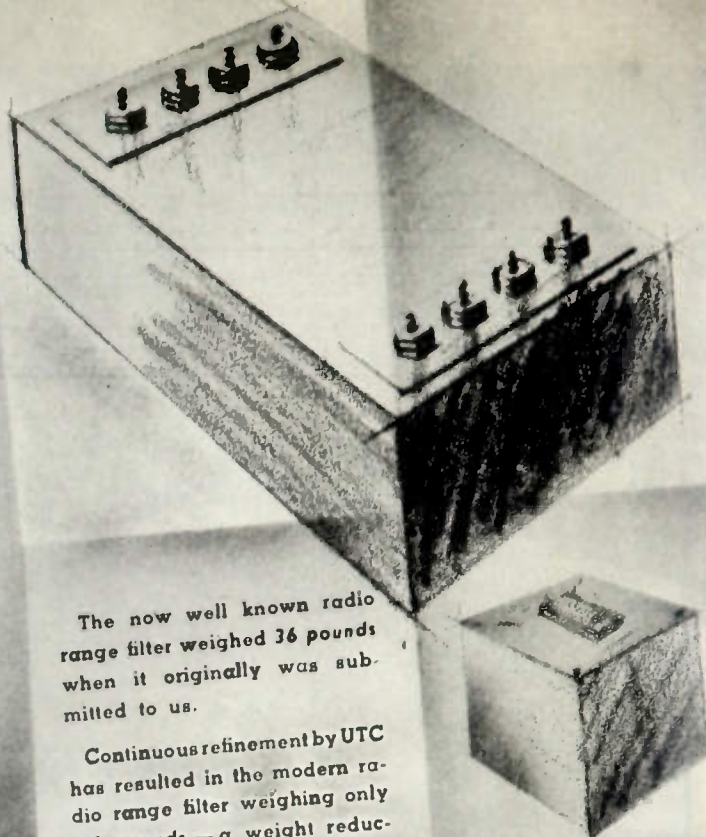

The now well known radio range filter weighed 36 pounds when it originally was submitted to us.

Continuous refinement by UTC has resulted in the modern radio range filter weighing only 1.6 pounds—a weight reduction of 95%.



This UTC development is a tunable inductance, adjusted in the same manner as an I.F. trimmer.



Designed for high frequencies, the Q of this coil is 300 at 20,000 cycles.

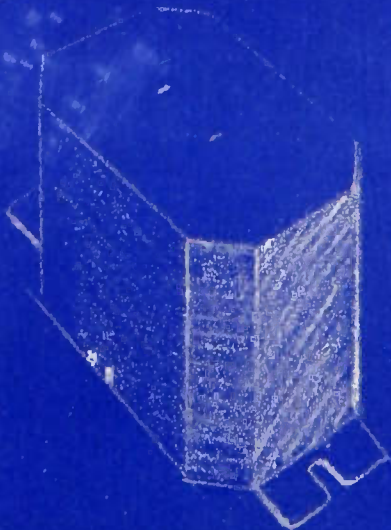

... For medium frequencies, the Q of this coil is 210 at 1,000 cycles.



... For low frequencies, the Q of this coil is 80 at 100 cycles.

# UNITED TRANSFORMER CO.

150 VARICK STREET



NEW YORK, N. Y.

EXPORT DIVISION: 100 VARICK STREET NEW YORK, N. Y. CABLES: "ARLAB"



# Communications from Westinghouse

Capacity is available to produce the following products for early delivery to communications equipment manufacturers. Watch this board for latest lists of manufacturing capacities.

## PRESTITE—CERAMICS

"Solder-Seal" hermetically tight bushings and terminal boards. Mechanical bushings, standoff insulators, coil forms. Grade "F" characteristics.

## BI-METAL THERMOSTATS

Both strip and disc type. Overheating or Temperature Control for cooling systems, crystal ovens, etc.

## HIPERSIL TYPE "C" CORES

Three grades of two-piece, laminated steel cores for power, audio, intermediate radio and higher frequencies. Space factors 95%, 92% and 89%. Windows down to  $\frac{1}{2}$ " x  $\frac{1}{4}$ ". These cores do not require dies or nickel.

## BLOWERS AND BLOWER MOTORS

400-800 cycle models, 6700 rpm, for cooling radio transmitters, magnesium housings.

## RECTOX—RECTIFIERS

Copper oxide rectifiers for power packs, instruments, etc.

## MICARTA—PLASTICS

Phenol-formaldehyde, thermosetting. 11-NEMA Grades including XXX, X, P, and LE. Plates, shapes, punchings, moldings.

## DYNAMOTORS

Types PE-59, 60, 86; DM-25, 32, 33, 34, 35, 36, 45, 53. Now in production.

## TUFFERNELL INSULATING MATERIALS

Varnished cambric and cotton tapes; synthetic, air drying and baking enamels; thinners; compounds and

## INERTEEN CAPACITORS

Noninflammable, hermetically-sealed, very compact. Ratings from 10,000 to 100,000 volts.

J-94556



For further information on products or deliveries, write to Westinghouse Electric and Manufacturing Company, Dept. 7N, East Pittsburgh, Pennsylvania.

# Westinghouse

PLANTS IN 25 CITIES... OFFICES EVERYWHERE

# PIONEERS...in war and peace

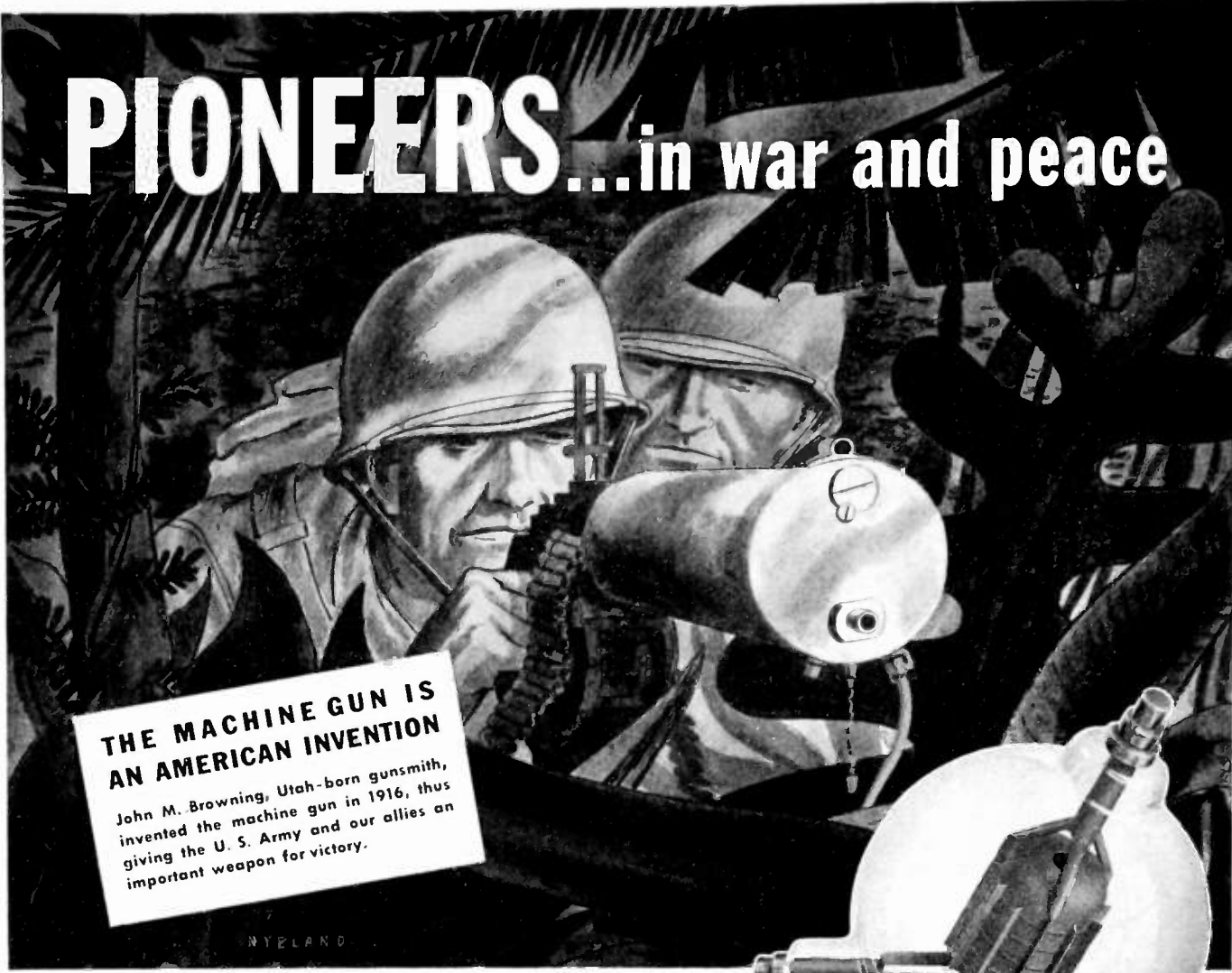

**THE MACHINE GUN IS AN AMERICAN INVENTION**

John M. Browning, Utah-born gunsmith, invented the machine gun in 1916, thus giving the U. S. Army and our allies an important weapon for victory.

NYELAND

## HEINTZ AND KAUFMAN ORIGINATED THE TANTALUM ELECTRON TUBE

GAMMATRON tubes exemplify the ability of Heintz and Kaufman engineers to meet difficult design problems with exceptional skill and ingenuity.

Faced with the need for tubes which can endure great physical and electrical punishment without faltering, our engineers were the first to appreciate the unique advantages of tantalum as a plate and grid material. In addition they pioneered new principles of construction which discarded all internal insulators. As a result, GAMMATRONS are inherently gas-free.

Heintz and Kaufman brought this same pioneering spirit to the UHF band. Some of the accomplishments of GAMMATRONS at high frequencies are well known, but many developments are today classed as restricted information. Until the full story can be told, keep GAMMATRONS in mind for postwar applications... for then as now they will help open new frontiers for electronics.

**HEINTZ AND KAUFMAN, LTD.**  
SOUTH SAN FRANCISCO • CALIFORNIA • U. S. A.

**Gammatron Tubes**

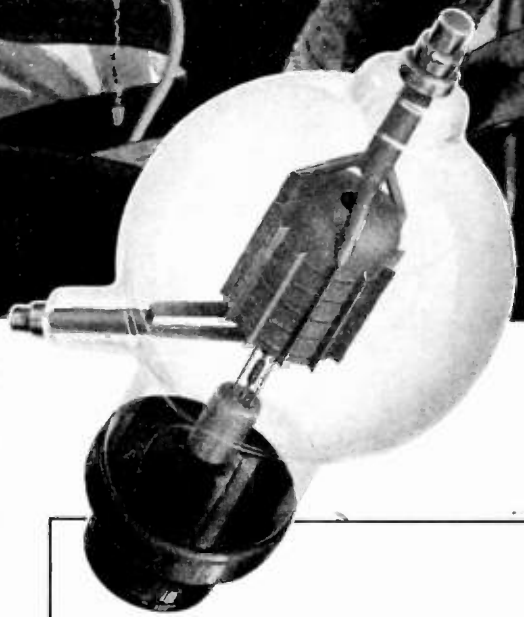

### HK-1054 TRIODE

#### OPERATING DATA

*As an RF Power Amplifier,  
Class C, Unmodulated.*

	Typical	Maximum
Power Output	3000 Watts	—
Driving Power	140 Watts	—
DC Plate Voltage	5000 Volts	6000
DC Plate Current	750 M.A.	1000
DC Grid Voltage	-950 Volts	-2000
DC Grid Current	105 M.A.	150
Peak RF Grid Volts	1475 Volts	—
Plate Input	3750 Volts	3750
Plate Dissipation	750 Watts	750

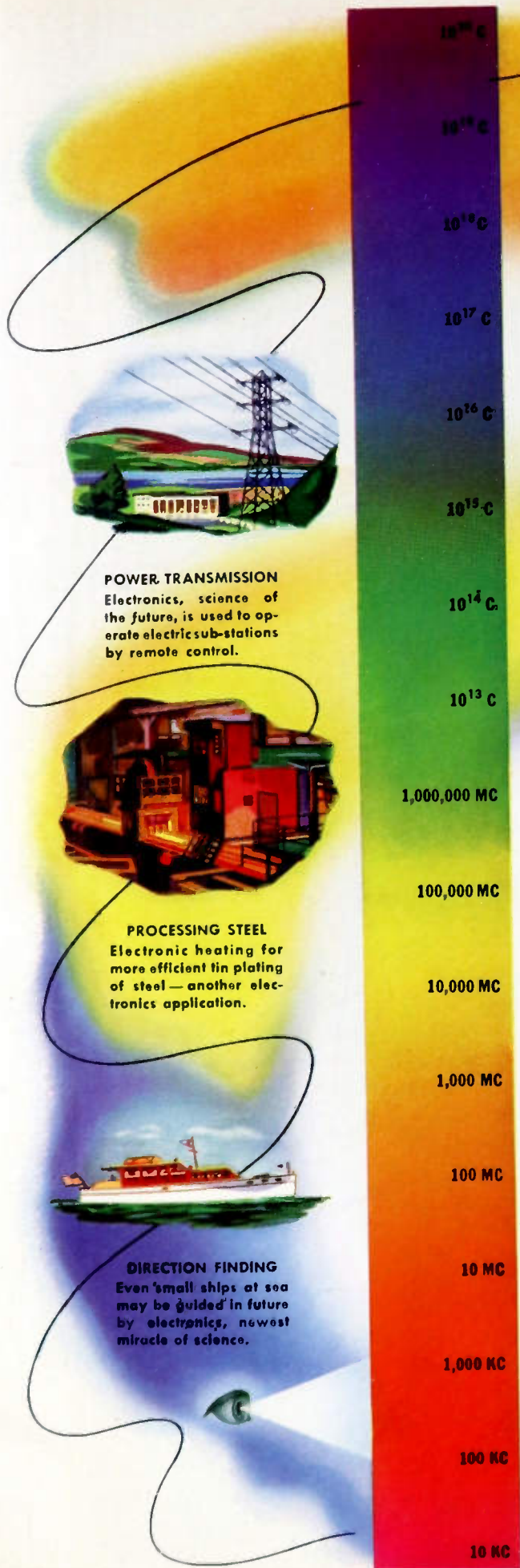

**POWER TRANSMISSION**  
 Electronics, science of the future, is used to operate electric sub-stations by remote control.



**PROCESSING STEEL**  
 Electronic heating for more efficient tin plating of steel—another electronics application.



**DIRECTION FINDING**  
 Even small ships at sea may be guided in future by electronics, newest miracle of science.

# THERE'S MAGIC IN ELECTRONICS... AND NEW CAREERS!

With electronics man can now see through stone and steel... detect smoke, dust and fog invisible to the eye. He can match colors and finishes... manipulate doors, furnaces, traffic—even make meat tender by means of the science of electronics.

The industrial uses for the magic of electronics appear almost endless. In the 100-1000 kilocycle range of the frequency spectrum, for example, the applications of electronics include operation of electric substations by remote control, more efficient tin plating of steel, maritime direction finding applied even to small pleasure craft.

And almost every day astounding new uses are being recorded—in transportation, food, medicine. With the dawn of peace, the range of useful electronic applications is expected to embrace almost every phase of modern living.

For the electronically-minded, there will be no limit to the opportunities when the war is won. Fascinating new careers, undreamed-of a few years ago, will be waiting—in the service of those who will produce the many electronic devices, as well as in the fields where this new science will be applied in the coming "Era of Electronics."

Isolantite has followed closely the development of science's newest miracle, aware of the possibilities for its commercial application at war's end. Aware, too, of the role *insulation* must play in adapting the electronic principle to new products and uses for peacetime living. The electronic world will not be delayed for want of high-grade insulating materials.

## ISOLANTITE

CERAMIC INSULATORS  
 ISOLANTITE INC., BELLEVILLE, N. J.

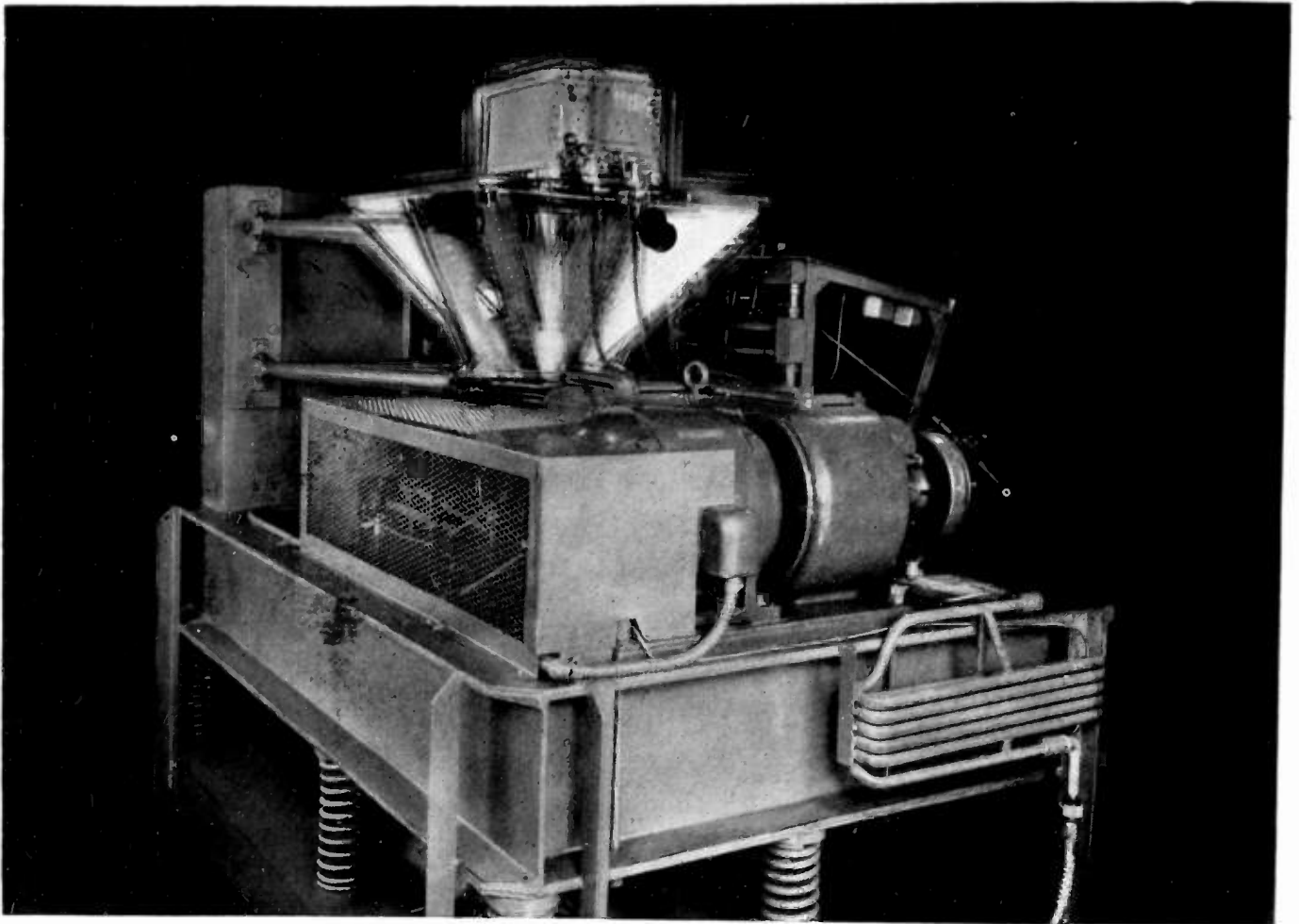

## TWO YEARS AT THE FRONT!...IN TEN MINUTES

Three thousand times a minute the aircraft radio equipment atop this machine lives through an acceleration that would cause the toughest young airplane pilot to "black out" in dive bombing. In a few minutes it lives through the jars and vibrations it would receive on ten round trips from Washington to Chungking. If there is a structural weakness in its design it shows up instantly; *before* it goes into service.

This is the largest and most powerful of the various types of vibration machines used by RCA in the development and production testing of aviation radios. It can duplicate the vibration of the smallest plane or the mightiest bomber. It can re-create the tremendous vibration strain caused by one motor being shot from a bomber, or by the diving of a plane with 250 pounds of radio at *ten times* the force of gravity! — In fact,

within three minutes the RCA vibrator can shake into pieces any radio set made — and it would probably shake down the building if its 6-ton concrete and steel base weren't mounted on those giant springs.

Thus, RCA research helps to make RCA's aviation radio equipment become more powerful, more effective, and more dependable, in performing its vital tasks.



## RCA AVIATION RADIO

RCA Victor Division • RADIO CORPORATION OF AMERICA • Camden, N. J.

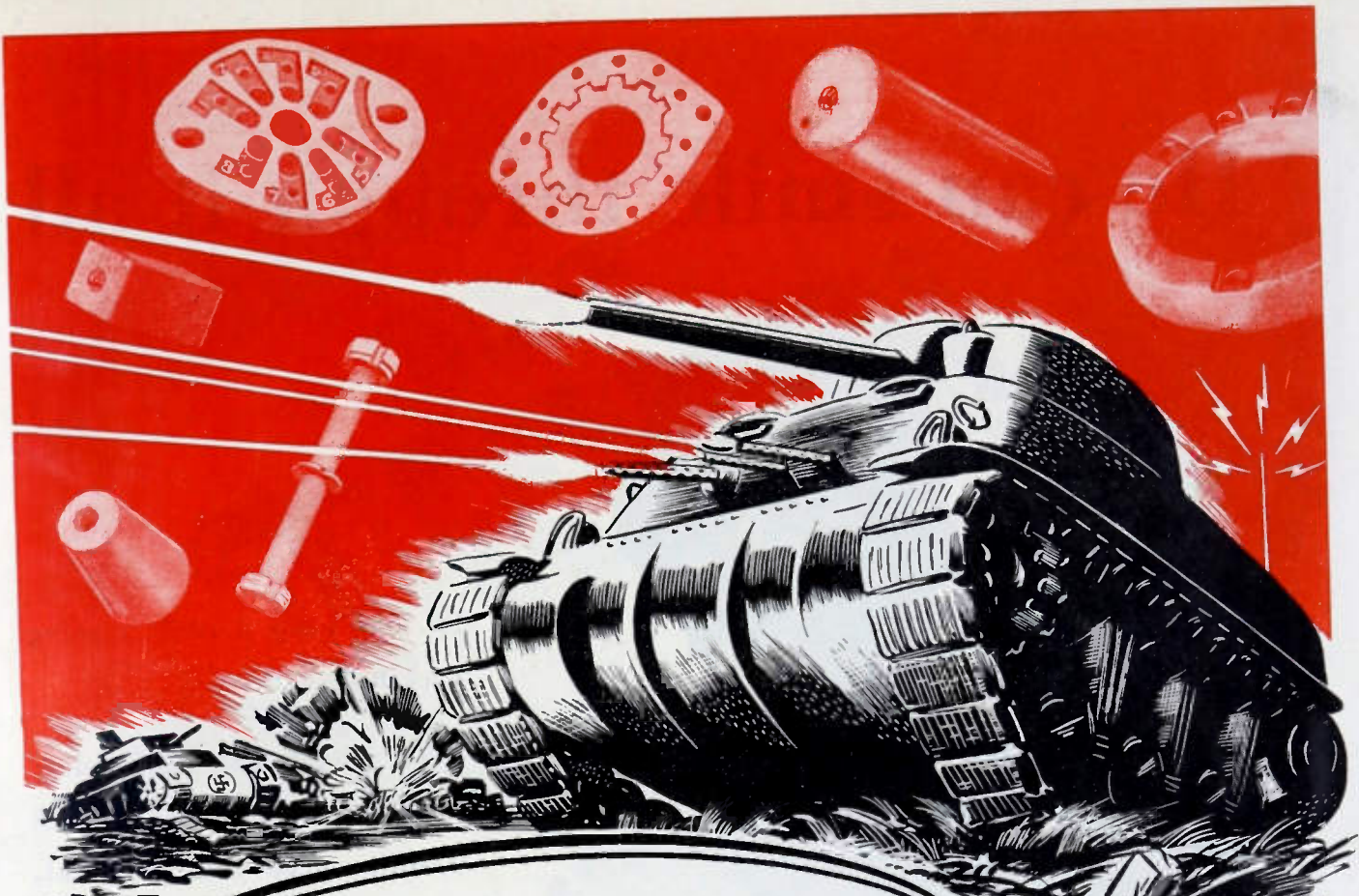

*Where the going is* **TOUGHEST**  
*You'll find* **ALSiMAG**

The decisive factor in many important battles is the shock action and mobile fire power of a tank charge. Success is dependent upon perfect timing, perfect coordination through instant and sure communication by voice radio between the various units.

Tank radios must be compact. Above all else they must be dependable--able to withstand terrific vibration, jolts and jars. They must operate under extremes of heat and cold. They must not fail.

That is why you find more and more tank radios of the Allied Nations equipped with ALSiMag steatite ceramic insulators . . . compact, tough, dependable.



AWARDED JULY 27, 1942

**ALSiMAG**  
TRADE MARK REGISTERED U. S. PATENT OFFICE

**AMERICAN LAVA CORPORATION**  
**CHATTANOOGA, TENNESSEE**

# He can smile through it all



So let's keep a smile a-going back here, too.

Even though war is crowding the wires, telephone people still want to give you pleasant, friendly service. Materials for new telephone facilities are not to be had. But there's no shortage of patience and understanding.

Takes a lot of pulling together to do this and we appreciate the help from your end of the line.

**BELL TELEPHONE SYSTEM**



## **WAR CALLS COME FIRST**

• Your continued help in making only vital calls to war-busy centers is more and more essential every day.

# THE TRUTH

## ABOUT STEATITE INSULATORS

Let's get this straight . . .

General Ceramics Steatite Insulators are available NOW . . .

There are adequate raw materials to meet the demand . . .

Our production facilities are greater than ever . . . our backlog of Steatite orders has been melted down . . . there's no basis for the belief that there is a current shortage of General Ceramics Steatite Insulators.

Sure, there *was* a shortage . . . a serious one, but we at General Ceramics met the problem with the "do-it" spirit which typifies American War Production . . . by the location of new sources of supply, rapid plant expansion, procurement of necessary equipment and the training of new employees—all in record time.

As a result, delivery time on General Ceramics' Steatite Insulators has been cut in half. Here is our record on that:

June 1942—delivery time—four months.

April 1943—delivery time—two months on standard parts from stock.

General Ceramics Steatite Insulators are available for you NOW

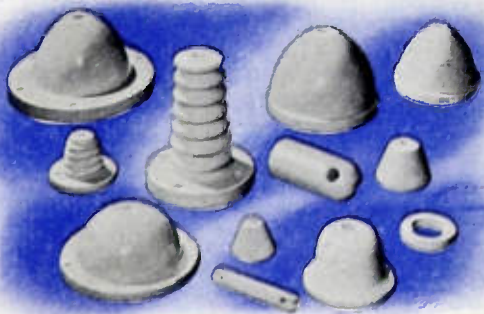

*If you have any insulator problem—whether specialized or standard—we'd like a shot at it. Your request will be given prompt, individual action.*

# General Ceramics

AND STEATITE CORP.  
KEASBEY NEW JERSEY



# STUPAKOFF

FOUNDED IN 1897

*Ceramics for the World of Electronics*

## Dependable, Low Loss Steatite Insulators

"**S**TEATITE" has become a magic word. It is not a copyrighted trade name, but is the geologic name for massive talc, a magnesium silicate, used in the production of "radio grade" ceramic insulators. However, Stupakoff Steatite Insulators, for low loss at high frequency, are superior in quality and dependability.

The dependability of Stupakoff Steatite Insulators is the result of a combination of important factors. They include the absolute control over raw materials, modern manufacturing facilities equipped with precision tools, correct engineering, and most important of all, the invaluable experience and knowledge gained through years of producing ceramic insulators.

Our ceramic manufacturing facilities are devoted entirely to the production of Stupakoff insulators for equipment used by the Signal Corps, Army and Navy. Never before has it been so important to have radio and electronic equipment perform with such a high degree of dependability. With this thought in mind, extra precaution is taken throughout our entire manufacturing process, so that Stupakoff Steatite Insulators will function under the most severe conditions.

STUPAKOFF CERAMIC AND MANUFACTURING CO.  
LATROBE, PA.

STUPAKOFF

*Steatite*

INSULATORS









Recently a new type cathode-ray tube was called for by our armed forces. Just an idea—something arising out of new conditions—not yet reduced to actual practice—and of course far from production.

Opinion generally was that this new tube might require months to develop, design, produce. Yet DuMont, with its exceptionally close coordination of experimental tube work and actual production, was actually ship-

ping that very tube in quantities within 10 days.

It is performance such as this that has made the name DuMONT the accepted abbreviation for "Cathode-Ray Tube Headquarters."

Write for latest listing of cathode-ray tube types. Also bulletins on latest cathode-ray equipment. Submit your problems.

▶
DUMONT

**ALLEN B. DU MONT  
LABORATORIES, Inc.**

Passaic • New Jersey

Cable Address: Wespexlin, New York



**IT WILL SAVE A LIFE**

**... but it will  
not work  
without tubes!**

ONE of the greatest developments in modern fire fighting is the pack communications unit, enabling firemen to keep in constant communications with their chief . . . not only does this unit provide the means of instant direction of men and equipment but it saves time and lives!

New tube applications are almost a daily occurrence as RAYTHEON'S vast wartime effort progresses . . .

RAYTHEON'S engineering skill and manufacturing facilities are responsible for RAYTHEON tubes being in the vanguard of tomorrow's march of progress.

**RAYTHEON**

**Raytheon Manufacturing Company**

WALTHAM AND NEWTON, MASSACHUSETTS

DEVOTED TO RESEARCH AND THE MANUFACTURE OF TUBES AND EQUIPMENT FOR THE NEW ERA OF ELECTRONICS

# Your local *RCA TUBE and EQUIPMENT DISTRIBUTOR*

✓ **TECHNICAL KNOWLEDGE**  
of things Electronic.

✓ **TRADE KNOWLEDGE** of what  
electronic materials are available, where they  
are available, and how they may be obtained  
as fast as circumstances permit.

✓ **NORMALLY LARGE STOCKS** of  
RCA Tubes and countless other Radio and  
Electronic items—for prompt deliveries upon  
receipt of the necessary priorities.

✓ **AN EFFICIENT ORGANIZATION**  
that is used to handling small orders—and  
equally well equipped to handle large ones, too.



## offers You *THESE SERVICES*

'Round the corner from your plant is a man whose chief stock in trade these days is his ability to help busy war industries get needed Radio and Electronic materials faster and use them to better advantage.

That man is your local RCA Tube and Equipment Distributor. Behind him is an organization which has been dealing with things Electronic since the "knee pants" days of Radio.

They know how to get the materials you need. They know how to use these properly

once they've been obtained. You'll find their technical advice and recommendations as big a help as their personalized expediting service which assures fast, accurate deliveries.

Whether it's one RCA Tube or a hundred—they're ready and geared to help you. They'll help you, too, in obtaining condensers, resistors, rheostats, controls, potentiometers, coils, transformers, wire, and numerous other Radio and Electronic components produced by many manufacturers.



### **RCA RADIO-ELECTRONIC TUBES**

RCA Victor Division, RADIO CORPORATION OF AMERICA, Camden, N. J.

## Book Previews and Monographs

The Editorial Division of the Institute is inaugurating a new service to authors and publishers in an attempt to expedite the publication of book reviews so they will be more useful to those engineers who may have long awaited the appearance of a book on a particular subject. Instead of waiting for the book to appear on the open market, the Division will try to secure an advance copy or page proof as a basis for the review. This will enable the reviewer to prepare his text so the office will have to fill in only the missing details about the volume at the time the review is sent to the printer. Usually these details will be available from the publisher so that the review can be set in type and perhaps even published in advance of public sale of the volume.

Reviews which are prepared on this basis will be captioned "Book Previews" to inform the reader of the special co-operation which has made the review possible and of the fact that the book may still not be available for immediate purchase. The preview will be published as soon as possible after the publisher is willing to accept orders for the book and can furnish the requisite information. If it is likely that the preview will be published in advance of public sale, the probable date at which the book will be available for delivery will be stated.

In addition to the above service for the book review column, it is suggested that some sections of books scheduled for future publication might be preprinted as monographs in the PROCEEDINGS.

By this means the value of the contribution to the radio-engineering profession would be increased to the extent of its earlier publication. The interest excited by the preprinted monographs will benefit the author and publisher also in creating more interest in advance of publication and a more receptive market for subsequent sale of the entire volume. This procedure is especially appropriate during the war period when so much useful material is being expedited to publication in book form and when the engineering war work benefits in proportion to the promptitude with which new material is made available.

Suggestions from readers of the PROCEEDINGS and authors and publishers will be welcomed in our effort to make this new "Book Preview" service fit the needs and desires of all persons involved and thereby to render still greater service to the members of the I.R.E. and other readers of the PROCEEDINGS. The first "Book Preview" to be published in the PROCEEDINGS will be found on page 245 of this issue.

Radio engineers can benefit greatly from the thoughtful and stimulating opinions of leading members in the radio industry. Accordingly the Institute is from time to time inviting such expressions of opinion from men who have contributed to the up-building of the radio industry. In pursuance of this plan, there is here presented a "guest editorial" from the President of the Zenith Radio Corporation of Chicago, Illinois. As appears suitable in such presentations, they are laid before our readers in the form in which they are received from their authors.

*The Editor*

## Design for Blitz

E. F. McDonald, Jr.

A few years ago I gave a party on my yacht *Mizpah* (since turned over to the Navy for sterner duty) for the astronomers who had gathered from all over the world for a meeting in Chicago.

After dinner in the evening, I was on the hurricane deck with a group of these distinguished astronomers, when a newspaper cameraman accompanying the group asked for a picture.

The astronomers gathered around me, as host, to pose for the shot. The newspaper man then asked me to assume the position of pointing out a new star to these "sky engineers."

The feeling I had when the newspaper man asked me to do this is about the same as I, a commercialist, now have in being asked to express some thoughts for the readers of the PROCEEDINGS of the I.R.E.

I told the newspaper photographer that if he could project Hollywood on the heavens, I'd be better qualified for selecting a star from that celestial display!

But, seriously speaking, we are in a fast-moving war. When Hitler turned loose his *blitzkrieg* on Poland and then on the Low Countries and France, it seemed to many that nothing could stop him. But he was stopped, stopped cold, in the Battle of Britain, stopped by the handful of RAF pilots who earned the priceless tribute, "Never have so many owed so much to so few." He was stopped because the RAF had gone him one better on the new weapon which had paced his early victories, *the only new weapon this war has produced*: Radionics.

We have heard much of new weapons, of secret weapons, in this total war of machines, and the public in general seems to believe that we have many *new* implements of destruction and defense. But have we? Are not the ships, submarines, guns, planes, tanks, and ammunition used in this war the same as those we used in the last great war, except for improvements in design and effectiveness? I repeat, our only *new* weapon is radionics!

The RAF's defense of Britain is a saga of gallant courage that will live throughout history. Day after day, combat pilots flew and fought long after the supposed limits of human endurance, destroying Nazi bombers by the hundreds until Hitler finally gave up. But it took more than even such superhuman courage and the superb British fighting aircraft to win that battle; it took Radar, which gave the British advance notice of every raid, which warned the RAF of impending raids while Hitler's bombers were still many miles away. The British have said that without this new radionic weapon the RAF would have lost the battle.

In communications we have come a long way from the original visual systems. Our own war between the states was run by courier and telegraph. The last war was run by telephone. This one,



at the front, is run by radio and radionic devices, which hurdle terrestrial obstacles, which tie an Army or a Navy with invisible strands to the will of its commanders.

The Axis has not been asleep in the field of radionics. Prodigal use of radio in tank and plane gave the Nazi blitz units the marvelous teamwork and concentrated striking power that scored their early victories. Radionic devices used by the *Bismarck* are credited with giving its batteries the phenomenal accuracy that blasted the *Hood* to oblivion in one salvo. There can be no doubt that Axis industries are leaning heavily on radionics, as are our own.

But in this field the Axis has more than met its match. The American radionic world, as represented by the thousands of radio engineers in service and in wartime laboratories, has "counter-blitzed" the Nazis, the Fascists, and the Japs with radionic miracle devices in a fashion never used before in any war.

That this is so is a tribute to our present-day radio engineers; young, energetic, curious, courageous, experimentative men of research for whom no task seems quite impossible. Cradled in the hard school of "ham" experimentation where no idea is rejected merely because it is not listed in the books, fortified by replacements from our progressive universities, these young explorers in the realm of radionics are never finished. They go on and on to new discoveries, pioneering in these new fields just as they pioneered a score of years ago in the development of short-wave, long-distance communication.

Our industry is famed for its ability to meet change. To keep out in front of the radio parade has taken all of the fast thinking and all of the ability for rapid change we can muster. Our engineers have mustered it. They have mastered their many problems with distinguished achievement.

A high-ranking officer connected with the Communications Branch of the Navy recently said to me:

"One of the marvels of the radio business is the way you fellows can turn on a dime and make rapid changes to keep up with ever-recurring military demands."

This officer pointed out to me that these repeated demands for change and improvement are necessary if we are to keep ahead of our enemy.

The answer to that one was easy. I replied:

"That's nothing new. Radio has always been a fast-moving business. It started from scratch within the memories of most of us, and has been snowballing ever since into a half-billion-dollar-a-year peacetime giant." True, we have a new set of unfriendly competitors in the Axis powers, but thanks to its engineers it is well trained to meet the wartime demands for its expansion.

A truth I have observed over the years is again at work. This truth will have a tremendous bearing on all of us once the peace is won. It is most simply stated by Alexander de Seversky, the great airplane pilot and designer, who said: "Because the instinct of self-preservation is greater than the profit motive or any other human urge, science, generally speaking, makes more progress in a year of war than in a decade of peace."

Our industry has concentrated its thinking on victory, and now we are directing every effort toward meeting and beating the challenge presented by the Axis nations.

And after victory, what? The time will come when the tremendous advances of science and invention, now aimed at the destruction of our enemies, will be turned again to the pleasant paths of peace.

In this peacetime to come, I now make the prediction that radio's future will be much more important to our world economy than has been its past. Aviation, chemistry, automotive industry, and radionics, I believe, will be the four great industries to lead us back to normalcy. Radionics will revolutionize and speed the great new form of transportation, aviation!

Radio has never been universally necessary in transportation before. In automobiles, on trains, it has been entertainment. In ships it has been a great aid, but not absolutely essential. But today, and for the future, in that great new universal transportation that is forming itself, preening its wings for what will be known as the era of aviation, radio is as essential as the airplane engine itself.

And so again, our radionic engineers have not finished. For them, in this coming era of air transportation, there are new heights to reach.



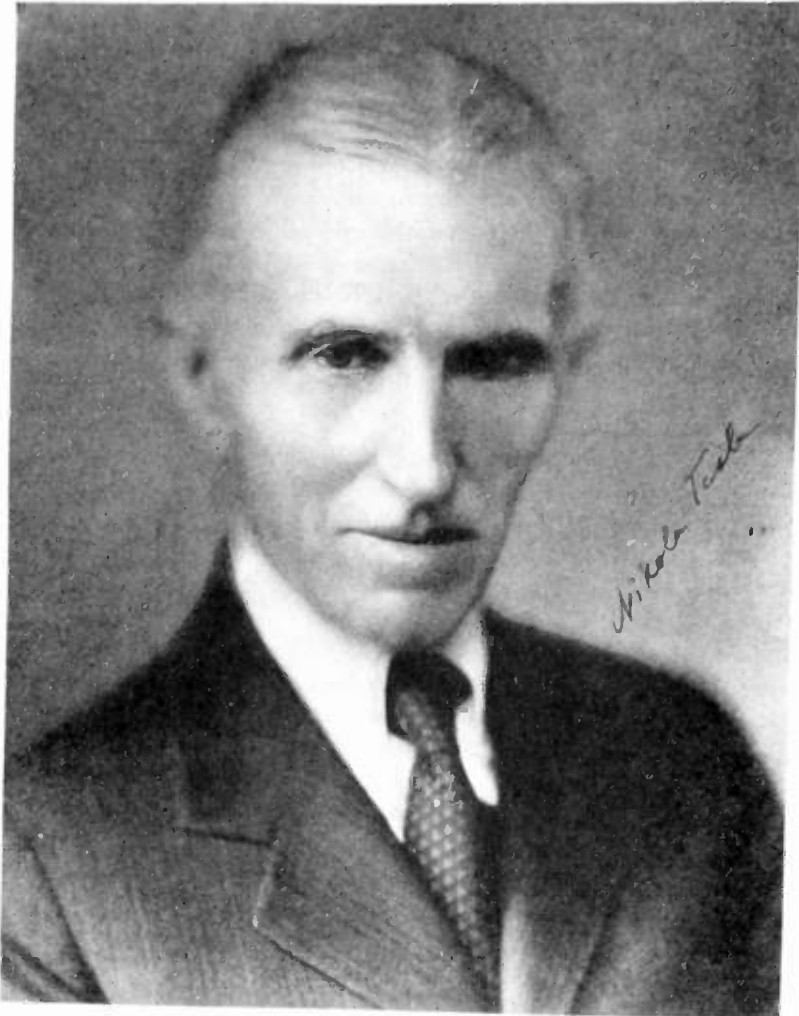

Atlas Photos

## Nikola Tesla

1857-1943

An engineering career of unique and unconventional nature was brought to an end by the death of Nikola Tesla in New York on January 7, 1943, at the age of 86. Some men pursue the even tenor of accustomed ways. Others of greater originality or enterprise live more intensely and often invade the world of imagination. These are the accepted types of research workers, inventors, and advanced development engineers. But Tesla was not found among either of these types of men. He was an example of a still rarer genus—those who consistently live in a land of brilliant concepts, idealized dreams, and aspirations so lofty as to be almost foredoomed.

The earlier stages of his career were indeed of a more recognizable and usual type. In 1888 he invented the induction motor. This basic step in utilization of alternating-current power would, in itself, have been a solid foundation of his engineering fame. Within a few years later he had devised the specialized high-frequency high-voltage transformer which bears his name. This ingenious application of electrical laws which were far from generally

understood in those days would as well have been a claim to highly favorable recognition.

At this stage of his career, Tesla cast off from the safe harbors of engineering thought and embarked bravely on an ocean of which each wave was a novel concept and each horizon a startling dream. In the generation starting in 1890, he tackled, among many other problems, that of the transmission of power without the use of the usual conductors. For such conductors, Tesla with characteristic audacity dared to plan to use nothing less than our terrestrial globe. He aimed to start at one point on this sphere electrical oscillations of superpotency and by means of them to create standing-wave patterns all over the surface of the earth, withdrawing energy as desired at the antinodes of potential. This theory of the transmission of radio-frequency energy is at variance with that now accepted—and Tesla was never able to bring his plans to fruition. But if he failed in practice in these attempts, none can deny that he aimed spaciouly and nobly.

Two of his books were published shortly before and after 1900. These dealt with "The Inventions, Researches, and Writings of Nikola Tesla" and "Experiments with Alternating Currents of High Potential and High Frequency." They were indeed remarkable revelations of the mental processes and intuitive scope of their writer. In them he accurately described complex phenomena which in some instances were not fully understood for many years. And in one of them he envisioned that day when radio communication would truly make all the world one neighborhood. He foresaw the time when a man might selectively summon his friend by a personal radio transmitter-receiver. And from the depths of a mine, the top of a mountain, or the vast reaches of an ocean, he would hear the voice of him whom he called. And, added Tesla if he did not hear an answer, he would know well that his friend was dead!

Thus Tesla was a catalyst in the realm of technology, a daring originator, and a dreamer on the grand scale. His passing seems in a sense the end of an epoch.



# Cathode-Ray Control of Television Light Valves\*

J. S. DONAL, JR.†, MEMBER I.R.E.

**Summary**—When a light valve is employed for the reproduction of television pictures, it is desirable to make use of a cathode-ray beam to control the light valve in order to preserve the all-electronic character of the television system. A number of procedures of cathode-ray control are described, the majority of which are applicable particularly to the control of the suspension light valve.

The general method employed is shown to be the production of an electric field through the light valve by bombarding one side of the valve with electrons of very high velocity, causing the valve areas to be charged in a negative direction toward the limiting potential of the bombarded surface. Removal of the electric field is then accomplished by charging these areas back toward their original potential by the use of electrons of substantially reduced velocity.

The most elementary procedure described is one in which a single beam of electrons of constant velocity is employed, discharge being accomplished by secondary electrons generated by the action of the beam of primary electrons.

The effects of polarization of the light valve, resulting from the comparatively low resistivity of the suspension, are described and explained. It is shown that a suspension of such low resistivity as to be uncontrollable by the other procedures may be made operative when the valve is used in combination with a spatially modulated electron spray and when, in addition, the potential of one wall of the valve is increased and decreased at a moderate frequency.

Of the procedures described, the most effective from the practical standpoint is shown to be one in which the light-valve field is developed by a scanning beam, and in which the field is later removed by rescanning with the same beam at a reduced electron velocity. A photograph is shown of a picture reproduced by the light valve when controlled by this method.

## I. INTRODUCTION

THE desirability of what may be termed the ideal television light valve is discussed in a separate paper.<sup>1</sup> This device may be thought of as a thin sheet of opaque material, the light transparency of which can be varied from point to point by means of the action of a cathode-ray beam. Light passing through the thin sheet could then be focused, as in the case of a lantern slide, upon the viewing screen. The cathode-ray beam would not have to generate the power to be converted into light, but would merely control the light from a constant source of high intensity. Furthermore, if the transparency of any valve area remained the same until the beam returned to alter it, each area of the valve would permit light from the source to contribute to the picture all of the time; hence, the maximum picture brightness would be limited only by the source, the lens system, and the maximum transparency of the light valve material.

The suspension light valve described<sup>1</sup> satisfies these criteria to a considerable degree. It can yield a large change of transparency and, hence, a high contrast

\* Decimal classification: R583×R388. Original manuscript received by the Institute, October 19, 1942. This paper reports work carried on, prior to 1940, as part of the television-development program of the RCA Manufacturing Company, Inc., Harrison, N. J.

† RCA Laboratories, Princeton, New Jersey.

<sup>1</sup> J. S. Donal, Jr., and D. B. Langmuir, "A type of light valve for television reproduction," *Proc. I.R.E.*, this issue, pp. 208-214.

between light and dark areas of the picture with a corresponding maximum transparency which is reasonably satisfactory. The time of response of the suspension appears to be adequate for television purposes if a sufficiently high potential difference is developed across the thin fluid layer.

The objective of the work reported here was to develop means of controlling a light valve of this nature by the use of an electron beam so that the device might serve for the reproduction of television pictures. Although the discussion will be limited to methods ap-

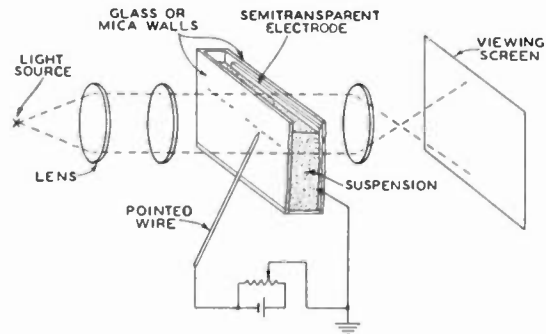

Fig. 1—Schematic representation of an elementary light valve.

A thin cell, with the walls which are perpendicular to the direction of the light made of thin mica or glass, contains the light-valve suspension. One wall has a semitransparent electrode on its inner surface, connected through a battery to a pointed wire. The wire may be used to hold areas of the other cell wall at potentials differing from that of the semitransparent electrode and thus orient the suspension. Light is passed through the cell and the suspension is focused upon a viewing screen.

licable in particular to the control of the suspension light valve, the procedures developed should find application in the control of any light valve in the form of a thin sheet, the transparency of which can be varied by the action of an electric field.

## II. ELEMENTARY LIGHT VALVE

In order to present the various problems which must be solved if a suspension light valve is to be controlled by means of a cathode-ray beam, it is assumed that an elementary picture is to be produced by the most simple form of valve of the suspension type. A thin cell containing the suspension, as shown in Fig. 1, may be chosen for descriptive purposes. One side of the cell is illuminated and the suspension is focused upon the viewing screen.

The walls of the cell must be transparent and may be constructed of mica or glass. One surface of the suspension layer is held at a fixed potential, ground potential if desired, by means of a semitransparent conducting coating on the inside of one wall of the cell, and the desired electric field through the suspension is produced by impressing other potentials on areas of the outside of the opposite wall of the cell. It is desirable to accomplish the charging of quite small areas

of the other wall of the valve to potentials differing from the potentials of neighboring areas in order to afford some degree of detail in the picture. Both the layer of suspension and the wall to be charged should be thin, of the order of the diameter of a desired picture element, if spreading of the lines of force from a small charged area is not to result in a large area of the valve being actuated with consequent overlapping of picture elements and loss of detail.

The cell of Fig. 1 with thin mica or glass walls enclosing a thin layer of suspension satisfies these criteria.

Perhaps the most elementary manner in which the potentials of areas of the insulating wall of the cell can be varied is to connect one terminal of a source of adjustable direct-current potential difference to the semitransparent electrode and the other terminal to a piece of thin wire the free end of which may be touched to the outside of the other wall of the cell. Alternatively, the charged wire may merely be brought close to the outside of this other wall. In either case, an electric field is produced between the tip of the wire and the semitransparent electrode. The portion of this field within the suspension acts upon the platelike particles to orient them and change the light transmission of the layer at that point.

Having produced a picture element, we next carry the charged wire along a straight line on the surface of the wall. If, as this is done, the potential of the wire with respect to the semitransparent electrode is varied, the suspension will respond along this line to a degree proportional to the square of this potential difference as already described.<sup>1</sup> The scanning of the line on the valve surface thus produces a line of the desired elementary picture if the square of the potential difference between the wire and the common electrode is made proportional to the brightness of the picture at each point along the line chosen for scanning.

It is now found that if the wire is not quite touching the surface of the wall the suspension will not respond if the wire is moved rapidly, whereas the suspension responds if the wire touches the surface as it moves. This arises from the fact that time is necessary for the orientation of the particles and only when areas behind the wire remain charged from having been touched by the wire is there sufficient time for the electric field to actuate the valve.

In the same manner in which a single line of the picture was produced, the wire may now scan other lines to orient the suspension from point to point and thereby reproduce the lights and shades of the complete picture. We may call the time of scanning of the whole picture the frame time, as is usual in television practice. Even in the elementary procedure under consideration, alternate lines of the picture might be scanned, and then the remainder, to simulate one of the types of interlacing which might be used if the valve in a more practical form were employed for the reproduction of a television picture.

Having scanned the picture once to produce a single frame of the picture, we next proceed to the production of the second frame. Assuming that the lights and shades of the second frame are to be different from those of the first, and in particular that some of the previously bright areas are to be darkened, the suspended particles must first be deoriented. This can be done by some form of mechanical stirring.

Deorientation of the suspension might be expected to be followed by its immediate reorientation to form the original picture since the original charge pattern will still be present to some degree on the insulating wall. Actually this will not be the case, for leakage through the suspension will have reduced the field across the fluid layer to zero. Furthermore, as will be explained in greater detail below, rescanning of the surface with the wire charged to the same potentials as during the first scanning would produce only a much fainter version of the original picture, while further scanning in an effort to reproduce the original picture would soon have no effect whatever on the suspension. Also, pictures of altered content would not be reproduced faithfully. It will be found that the only satisfactory manner in which consecutive pictures can be reproduced is to remove completely the pattern of charge corresponding to each picture so that all polarization effects may disappear and the cell may return to its original uncharged condition before the scanning of the next picture.

The removal of the pattern of surface charges must not be done in the period between the scanning of two frames which follow each other with only a short time interval intervening. If this were done the valve areas scanned in the latter part of the frame would have been charged only a short time and would not be as bright as areas scanned earlier in the frame. The charge removal must be accomplished in such a manner that all areas of the valve are charged for substantially the same length of time.

In the case of the valve under consideration, one method of discharge would be to cause a second wire, held at the potential of the semitransparent electrode, to scan the surface at the same rate of travel but at a time intermediate between successive scanings by the wire used to produce orientation. If interlacing is employed, the discharging wire should scan in between each field scanning by the charging wire, and should remove the charges from only the set of lines to be charged next. Another procedure might be to accomplish discharge by holding the wire at the potential of the semitransparent electrode during the scanning in alternate frames (assuming no interlacing, for simplicity of description). This would mean, of course, that during the frames used for discharging no new information could be conveyed to the picture. A third procedure in the case of the valve under consideration would be to brush the whole surface rapidly and repeatedly with a fine wire brush all during the scanning.

It is assumed that the circuit would be so arranged that each brushing carried the potential of the surface only part way toward the potential of the semitransparent electrode. This last method will find its analogue in one of the electron-beam procedures to be discussed later.

It will now be seen that with the cell described a television picture of low resolution and low frame frequency might be reproduced if the difference of potential between the wire and semitransparent electrode were modulated in accordance with the lights and shades of the picture. By use of a strong source of light, the surface of the valve could then be focused on the viewing screen to produce a very bright image. From the standpoint of an acceptable television reproduction system, however, the moving wire would be somewhat inconvenient. For this reason methods of improving the device by the employment of a cathode-ray beam will now be discussed. Means must be found to produce the desired electric fields during each scanning by changing the potentials of surface areas of the valve, these potential changes preferably being proportional to some easily controllable feature of the beam such as its current as governed by the potential of a control grid in the beam. The potentials of the surface must be returned to their original values, preparatory to the next scanning, by means of the action, directly or indirectly, of an electron beam. Finally, the effects of polarization must be overcome.

### III. TUBES FOR CATHODE-RAY CONTROL OF SUSPENSION LIGHT VALVES

Before discussing the methods developed to accomplish light-valve control, the type of cathode-ray tube employed will be described. In the interests of simplicity and flexibility, an elementary cell similar to that of Fig. 1 was attached directly to the end of a glass bulb, the tube face forming the scanned wall of the light-valve cell.

A photograph of one of the tubes employed is shown in Fig. 2, and a schematic diagram of the experimental arrangement is shown in Fig. 3.

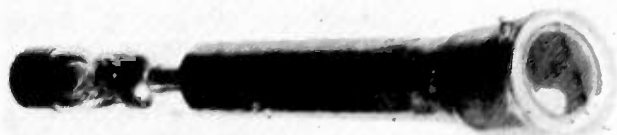

Fig. 2—Cathode-ray tube with a suspension light valve mounted on the outside of the mica tube face.

The face of the tube consists of a sheet of mica 0.010 to 0.020 inch thick, sealed directly to the glass bulb by a procedure described elsewhere.<sup>2</sup> A conventional elec-

<sup>2</sup> J. S. Donal, Jr., "Sealing mica to glass or metal to form a vacuum-tight joint," *Rev. Sci. Instr.*, vol. 13, 6, pp. 266-267; June, 1942.

tron gun is used to produce the electron beam focused upon the mica tube face. A metallic coating on the wall of the glass bulb serves as a second anode and electron collector.

A suspension of the type separately described<sup>1</sup> is mounted, under atmospheric pressure, in a chamber on the outside of the tube face. The suspension is stirred as desired to return the suspended particles to the deoriented state. The tube face forms one wall of

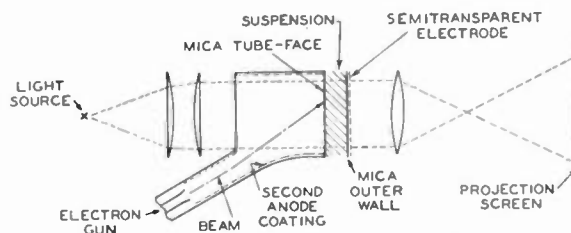

Fig. 3—Schematic arrangement for cathode-ray control of suspension light valve.

the suspension chamber, and the other wall consists of a second sheet of mica separated from the tube face by a spacing of 0.020 to 0.050 inch. The semitransparent electrode of Fig. 3 is a layer of metal sputtered on either surface of the mica outer wall of the suspension chamber. A small projector is used as a light source behind the suspension (Fig. 3). The changes in suspension transmission are usually observed directly by eye.

The electron beam, directed as shown in Fig. 3, charges the surface of the mica tube face to potentials differing from that of the semitransparent electrode on the other wall of the suspension chamber. The resulting electric fields, in the direction of the light, produce the desired changes in light transmission of the suspension.

Fig. 3 shows the advantage, from the standpoint of geometry, of the electric field being parallel to the light, for this avoids the necessity for tiny electrodes extending through the valve for the application of the field in a direction perpendicular to that of the light.

### IV. GENERAL PROBLEM OF LIGHT-VALVE CONTROL

Since the transparency of the thin sheet of suspension is a function of the electric field perpendicular to the sheet, the problem is then to scan the mica tube face with an electron beam, modulated by a picture signal, and so to develop on the scanned surface potentials corresponding to the light and shade of the television picture.

The principles of field development by a cathode-ray beam, which have already been discussed by von Ardenne,<sup>3</sup> derive from the fact that the potential of a bombarded insulator depends upon the secondary-emission ratio of the surface. This ratio may be greater or less than 1, depending upon the electron energy, as shown for a typical surface in Fig. 4. It is assumed

<sup>3</sup> M. von Ardenne, "Methoden und Anordnungen zur Speicherung beim Fernsehempfang," *Zeit. Telegraphen-, Fernsprech-, Funk- und Fernseh-Technik*, Bd. 27, Sonderheft, pp. 518-524; 1938.

that this curve is that of the mica tube face and that the semitransparent electrode and second anode of Fig. 3 are held at potential  $a$ , 5000 volts above the cathode of the electron gun. If the tube face is considered to have attained anode potential by leakage, a beam scanning the surface produces less secondary electrons than there are primary electrons arriving and the surface is charged in a negative direction, producing a field across the valve. In this example the highest

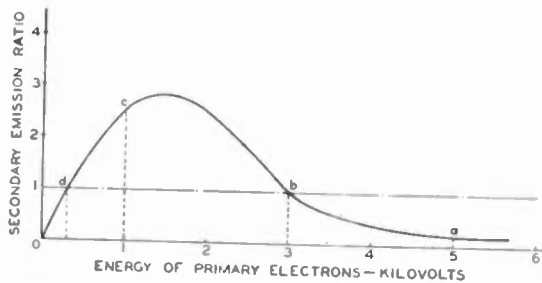

Fig. 4—Secondary-emission ratio of mica tube face.

field which may be developed corresponds to the charging of the surface to the limiting potential  $b$  where the secondary-emission ratio becomes unity and the surface potential reaches its equilibrium value. As the potential  $a$  from which charging occurs is raised, it will be seen that the intensity of the electric field which may be developed is almost unlimited.

Similarly the semitransparent electrode and the tube face might be held by leakage at potential  $c$  with the second anode being at some potential above  $b$ . In this case the electrons bombarding the mica surface would produce *more* secondary electrons than would be primary electrons arriving, and the surface would then be charged in the opposite direction toward  $b$ , producing a field in a direction the reverse of that considered above. Since the energy range from  $d$  to  $b$  is about 2000 to 3000 volts for most insulators, the difference in potential which may be developed across the valve is limited to this value if the surface is charged in the positive direction.

Obviously the mica surface might be charged in the same manner from potential  $d$  down to cathode potential, over the range of electron energies in which the secondary-emission ratio is again less than 1, but since this range is usually 200 volts or less the field so developed would be weak.

During the frame time, between one bombardment of a valve area and the next bombardment, it is desirable to have the electric field and, hence, the valve actuation persist as long as possible, in order to obtain high optical efficiency. With present methods of modulation of the beam, however, the field must be reduced to zero before the return of the beam if the light or shade desired during the next frame is to be reproduced. In the case of the suspension light valve it is not convenient to use leakage for the removal of fields produced by scanning since the resistance of the necessary valve wall (in this case the mica tube face) is

generally too high. Therefore it is advantageous to employ electrons for the discharge of the surface as well as for its charging. This discharge may be accomplished by a spray of electrons, by a beam from the charging gun at a later time, or by a beam from a second gun, the principle being the same in each case. Advantage is taken of the change in direction of charging of the surface with change in electron energy, which was described in the discussion of Fig. 4. The field is developed by means of a modulated beam, as already explained, and this field is removed by bombarding the surface, for the purpose of discharge, with electrons of substantially different velocity. It will be assumed for simplicity that these electrons, also, come from the cathode producing the modulated beam. During the period of discharge the cathode potential or the bombarded surface potential may be altered, either procedure resulting in a changed velocity of arrival of the electrons at the bombarded surface.

An example of this procedure is given in Fig. 5. As in Fig. 4 the second anode and the semitransparent electrode are held at potential  $a$  and the modulated charging beam carries the potential of the scanned surface to  $b$  in the high lights. The cathode potential is then raised to  $c$ , 2 kilovolts above its original value, and the valve is rescanned with an unmodulated beam. This beam now strikes the surface with an electron energy of arrival of only 1 kilovolt, as shown, and

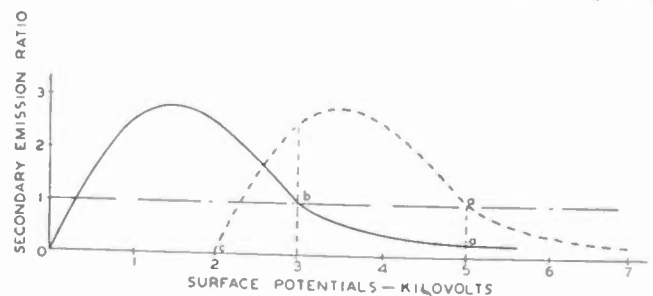

Fig. 5—Discharge by electron beam at reduced velocity.

charges the surface in a positive direction until the potential is reached at which the secondary-emission ratio is unity for these electrons. However, the cathode is raised to such a potential that this unity secondary emission is reached at potential  $a$  and, as a result, the surface potential returns to its initial value and the field is removed from the light valve.

It is not always necessary that the cathode potential be raised precisely to  $c$ . A somewhat higher potential would still result in discharge to second-anode potential at  $a$  since the surface potential cannot rise substantially above the potential of the collector for the secondary electrons. A cathode potential somewhat below  $c$  would discharge the surface to a potential below  $a$  and result in incomplete removal of the field in certain types of light valves, such as those employing zinc sulfide and, therefore, having high resistance. Incomplete field removal, analogous to a direct-current bias across the valve, would make no significant

difference, as will be made clear later, in suspension valves which polarize more rapidly.

For any type of light valve, the maximum field useful for valve control is that which can both be produced, and removed before the end of a frame time, preparatory to a change in picture content. In the representative procedure just described, removal of the field depends upon the secondary-emission ratio being greater than unity, so that the surface may be charged in a positive direction. Hence, the maximum useful repetitive field is limited by the energy range over which the secondary-emission ratio is greater than unity. If this range is insufficient, it may be increased, for example, by the evaporation of a material upon the surface which will raise the secondary-emission ratio of the scanned areas.

### V. POLARIZATION

Since the suspensions employed in this investigation polarized in a few hundredths of a second, any change in potential of a bombarded area resulted in a single flash of light, after which leakage reduced the field across the suspension to zero. A circuit analogy has been used<sup>1</sup> to describe the effects of suspension leakage. Particular attention is paid to the case now under consideration; i.e., that in which the area of the valve wall is charged and discharged by a beam, but is allowed to float between the times of charge and discharge. It was shown that the reversed potential across the suspension at discharge was not in this case equal to that developed at charging, and that the first discharge was not complete in that subsequent operation of the discharge mechanism resulted in additional, although decreasing, application of field to the suspension. Now that the general procedure of charge and discharge by the beam has been described, the effects of polarization upon the fields developed across the suspension will be covered in greater detail by means of an example.

It will be assumed in what is to follow that the resistivity of the suspension is such as to reduce the field across the suspension produced by scanning to substantially zero by leakage before the valve is discharged by a beam of different velocity. If this is the case the charge-and-discharge process of Fig. 5 would result in the potential distributions of Fig. 6 for one elemental area of the valve. All walls are assumed to be initially at 5000 volts above the cathode before scanning (line *a*). For simplicity, and since it will affect only the numerical values of the conclusions to be drawn, the dielectric constants and the thicknesses of the mica wall and the suspension layer are assumed to be equal, respectively, and the beam current is assumed to be sufficiently strong to carry the surface to its limiting potential. Charging of the scanned surface to 3000 volts (the surface limiting potential) then impresses a linear potential distribution across the wall and suspension (line *b*). Polarization, due to leakage

through the suspension, causes the field across the suspension to fall to zero (line *c*). As already described<sup>1</sup> the drop across the mica tube face may be considered to be unchanged when the drop across the valve fluid falls to zero. Hence, when the interface potential rises from 4000 to 5000 volts (line *c*) due to polarization, the potential of the recently scanned area rises from 3000 to 4000 volts as shown.

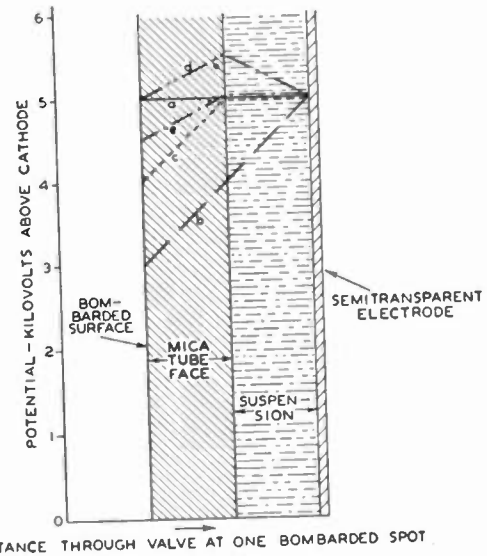

Fig. 6—Potential distributions through light valve during one cycle of operation.

- a* Before charging.
- b* Immediately after charging.
- c* After polarization following charging.
- d* Immediately after discharging.
- e* After polarization following discharging.

Later the discharge beam returns the potential of the mica surface from 4000 to 5000 volts, and a portion of this change of potential (one half, since the capacitance of the wall and suspension were assumed equal) is impressed on the interface, raising its potential to 5500 volts (line *d*). This reversed field reorients the suspension proportionately. Finally, the reversed field is reduced to zero by leakage and the recently scanned area falls in potential to 4500 volts (line *e*).

During the first cycle just described a potential difference of 1000 volts was impressed across the suspension at charging, and only a difference of 500 volts at discharging. This is not the final equilibrium state, however. Thus, the next charging changes the mica potential from 4500 volts (line *e*, Fig. 6) to 3000 volts, or by 1500 volts instead of 2000 volts as did the first charging. Half of this difference, or 750 volts, is impressed across the valve. Hence, during the second cycle, line *c* will strike the scanned mica surface at 3750 volts and line *d* will rise 625 volts above 5000 volts, or to 5625 volts at the interface. Thus, during the second cycle 750 volts are impressed on the suspension at charging and 625 volts at discharging.

Carrying out this process for the third cycle the charging beam is found to develop 687 volts across the suspension and the discharge beam 656 volts. It can

be shown that after a total of four or five cycles for our example both potential differences have approached 666 volts.

The procedure of charging and discharging will be considered at greater length in Section IX. At this point it is sufficient to conclude that several cycles are necessary in order to attain equilibrium in the process and that after equilibrium is attained the suspension is reoriented at the time of discharge to a degree substantially equal to the orientation at the time of charging.

#### VI. DISCHARGE BY SECONDARY ELECTRONS GENERATED BY CHARGING BEAM

In Section IV, a process was presented in which a beam of velocity differing from the charging-beam velocity is used to accomplish discharge of the light valve. In the course of experiments with a tube of the type shown in Fig. 2 it was found that secondary electrons generated by the electron beam may be employed to discharge the valve surface without the necessity for changes in cathode potential and rescanning to accomplish this end.

If the second anode and semitransparent electrode of the tube (Fig. 3) are held at 5 kilovolts, and a strong beam strikes the surface at one point, the surface bombarded is taken to the limiting potential and a flash of light through the valve results. If the beam is left on, no further change in potentials results, of course. Removing the beam and then allowing it to strike again a few seconds later produces no new valve actuation because the high-resistance mica permits no leakage in that time and the return of the beam can effect no further change in wall potential in the absence of a discharge mechanism.

However, if the beam is not removed but merely moved to a new valve area, its return to the original spot within even a very short time results in reactivation of the valve there. This shows that the presence of the beam on near-by areas results in discharge of the original spot. (Leakage from the collector was ruled out by a guard ring held at a potential below the limiting potential.)

The rate of discharge increases rapidly with the beam current. Thus, a line on the valve resulting from scanning in one direction only can be reactivated only once a second with a 3- or 4-microampere beam current, but 60 times a second at 50 to 100 microamperes. For the higher beam currents, when a single spot is bombarded for a few seconds and the valve has polarized, the sudden shifting of the beam to a new valve area results in a flash at the original area. This is caused by the discharge there being sufficiently rapid to develop the reversed field shown in Fig. 6 and, therefore, to reactuate the valve.

When a fixed spot on the valve is bombarded at *low* beam current and the potential of the semitransparent electrode is changed suddenly, the bombarded area of

the valve is actuated since it is held at the limiting potential by the beam. At high beam currents, however, the whole valve surface is actuated, showing that areas adjacent to the bombarded spot are held at collector potential. In contradistinction to this, when the semitransparent electrode is held at a fixed potential but the second-anode potential is changed suddenly to a few hundred volts above or below its usual value of 5 kilovolts, no portion of the valve is actuated at low beam currents but all areas *except the bombarded spot* are actuated at high beam currents. Changes in the collector potential can in neither case affect the potential of the bombarded spot, since it is held at the surface limiting potential and the bombarded spot is not actuated. However, the potential of adjacent areas must vary with collector potential when the beam current is high, since a change in collector potential actuates the valve in the areas not bombarded by the primary beam.

All of the above effects can be accounted for if a mechanism is found whereby secondary electrons reach a recently bombarded spot with such velocity as to charge this spot in a positive direction toward collector potential. This may happen in a number of ways. Thus, primary electrons reflected from the tube face may strike the tube walls and generate there secondary electrons of such velocity that they will arrive at the recently bombarded spot with velocities of several hundred volts. These would, from Fig. 4, tend to charge the mica in a positive direction and although their number would be small they might well serve to carry out the discharge in an appreciable fraction of a second. In addition, secondary electrons of such high velocity might proceed directly to a recently scanned area from an area being scanned and accomplish discharge in the same manner.

The above phenomena require the production at the mica or at the tube wall of secondary electrons of several hundred volts velocity in order that recently scanned areas may be carried above the first secondary-emission unity value of Fig. 4. In view of the considerations of Section V (Fig. 6), however, polarization may be seen to co-operate in this first stage of the discharge process, after which the discharge is completed by secondary electrons produced at the mica surface or at the tube wall. As was explained in Section V (Fig. 6), polarization, after charging, carries a recently scanned area in a positive direction. The beam when moved to a new area carries this in turn to the surface limiting potential. If the previous area is carried in a positive direction by more than about 100 volts by polarization, the large number of low-velocity secondary electrons being produced at new areas are *accelerated* to the previously scanned area and offer a powerful means of charging it still further in the positive direction by additional secondary emission. Also, the limiting potential of exposed glass areas of the tube walls has been found to be about the same as the

mica limiting potential and, thus, primary electrons reflected to the walls would generate a supply of secondary electrons which would likewise be accelerated to the recently scanned areas after these are carried somewhat above their limiting potential by polarization. Either of these mechanisms would explain the discharge effects described, particularly since they are much more noticeable as the beam current is increased.

It is interesting to note that secondary electrons arising with zero velocity at areas at the limiting potential may in turn charge areas to which they are accelerated to a potential above cathode equal to twice the surface limiting potential. Thus, in using this discharge mechanism there would be no object in employing a collector potential greater than twice the limiting potential of the mica tube face.

Considerable success has been had in the use of the secondary-electron discharge for the reproduction of black-and-white patterns with the light valve. However, it was found that sufficient secondary electrons for discharge necessitate an average beam current higher than that providing a half-tone range of charging of the low-capacitance valve. Thus, only that portion of the picture signal corresponding to almost black gives less than complete valve actuation.

Meshes in the path of the beam and held at suitable potentials increase the yield of secondary electrons for discharge purposes and permit the use of lower primary beam currents. Another procedure that could be employed is to bias the beam to very high currents at the picture borders, maintaining the beam current in the half-tone range in the useful portion of the raster.

#### VII. OVERCOMING OF EXCESSIVE VALVE POLARIZATION

In the following sections of this report it will be assumed that polarization of the suspension layer is substantially complete at the time when the surface is to be discharged in order to prepare it for another scanning. This was the case for the majority of the suspensions employed in this investigation. However, it might be desirable to use a suspension which polarizes in a considerably shorter time. If this is the case the flash of light through the valve at the time of charging by the beam will last so short a time as to give very low optical efficiency. If discharge is carried out by a beam there will be another flash at the time of discharge and, hence, an improvement in efficiency, but the efficiency will still be low. If the resistivity of the suspension is below about  $10^{-9}$  ohm-centimeter, polarization may be so rapid that orientation of the suspension may not take place to any appreciable degree. This section will be devoted to a method for controlling such a low-resistance suspension, since the procedures to be described in succeeding sections will in this case yield inadequate optical efficiency.

If the surface of the valve were scanned directly a

field could be maintained across even a low-resistance material, as long as a beam of sufficient current density remained on the area in question. With the high-resistance mica wall used in this investigation, however, keeping the beam on the area has no effect after the initial polarization. Nevertheless, since the orientation of the suspension is independent of field direction, a low-resistance suspension could be actuated and kept actuated, *as long as the beam remained on the mica wall*, if the potential of one valve wall were raised and lowered cyclically. This would develop a field across the suspension alternating in direction at a rate which could be made high enough such that polarization would not be completed in a half cycle. Since the procedure is effective only while the beam remains on the valve area, it does not lend itself to the use of a scanning beam, but is ideally suited to a device such as the image intensifier described by Iams.<sup>4</sup> In this reproduction tube a flood of electrons is caused to pass through a mesh electrode and strike the viewing screen. The degree to which the mesh will permit passage of the flood electrons is controlled by scanning the mesh with a picture-modulated electron beam to regulate, by means of secondary emission, the potentials of the mesh areas. In this case the flood electrons strike an area of the raster throughout a large fraction of the frame time and, thus, might be made to hold portions of the wall of a light valve at a fixed potential while the potential of the other wall is varied cyclically.

In this investigation of a preliminary nature, a modulated flood was not employed, but the strength of the beam bombarding a single spot was varied to simulate the point-by-point variation of the flood and to explore the problem of valve action.

The potential of the collector and the average potential of the semitransparent electrode of a tube such as shown in Fig. 2 were made 5000 volts. In addition, a 60-cycle alternating potential of 500 to 1000 volts (peak to peak) was superimposed on the average potential of the semitransparent electrode. A small spot on the valve was bombarded and so held at the surface limiting potential with respect to cathode. The resulting alternating field across the valve oriented the suspension at the bombarded spot. For zero beam current the whole valve was caused to swing capacitatively with the outside electrode and, therefore, no field was developed across the valve. As the beam current was increased, areas adjacent to the bombarded spot still were free to swing, but the spot itself was pinned to the limiting potential to an increasing degree as the beam current rose, giving a half-tone range.

The surface potentials of the bombarded spot and adjacent areas, resulting from the use of several different beam currents under the conditions just described, are indicated in Fig. 7. These were determined from the response of the light valve and verified by observations of the potential changes of a probe of platinum

<sup>4</sup> H. A. Iams, United States Patent 2,259,507.

deposited on the inside of the mica tube face and connected by a lead through the tube wall to a low-capacitance oscilloscope. When the beam was directed to the probe the latter took up the potential of a bombarded area. When the beam was directed to a mica area, the probe potentials represented those of areas adjacent to that being bombarded.

In Fig. 7, the beam currents are shown at the heads of the columns. Variation of electrode or surface potential is represented by a sine wave, as in the case of the

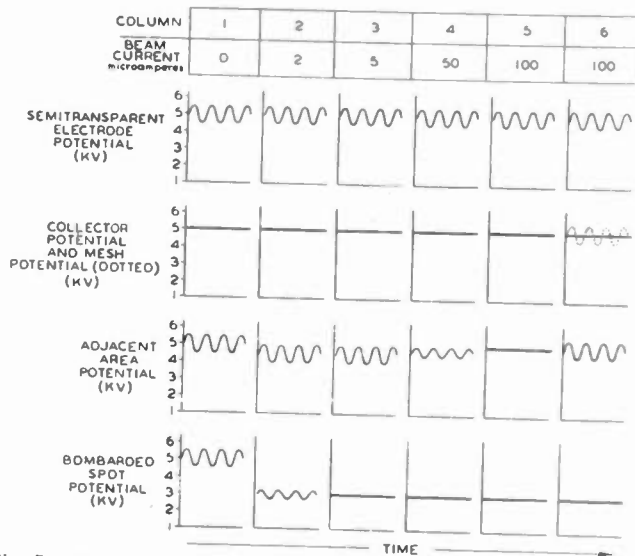

Fig. 7—Electrode and surface potentials (above cathode) for various beam currents.

The sine waves indicate a variation in time, between the limits indicated, when a sine-wave potential variation is impressed on the semitransparent electrode. The horizontal lines indicate a potential constant in time. In column 6 the variation is impressed on a mesh within the tube as well.

potential variations impressed on the outside (semitransparent) electrode for all beam currents. When the same variation is impressed on a portion of the inner surface, the valve is not actuated there. When the variation is reduced, some valve actuation results. When the variation is reduced to zero (horizontal line) the valve is fully actuated at that point. The collector was held fixed at 5000 volts for all beam currents (horizontal line).

Thus, for zero beam current all valve areas are swung capacitively with the outside, the mean potential of 5 kilovolts being determined by leakage from the collector. The valve remains deoriented.

For a beam current of 2 microamperes the potential variation of the adjacent areas is still equal to that impressed on the outside electrode and the adjacent areas are unactuated. Their maximum potential falls to collector potential, however, since if it rose above that value the areas would be the principal collector for the tube and would be charged down. The average potential of the bombarded area falls approximately to the sticking potential but the beam current is so low that the capacitive swing is not entirely suppressed; hence the valve is partially actuated and the response is in the half-tone range.

At 5 microamperes the adjacent areas are still unactuated but the beam current is sufficient to pin the bombarded area to the sticking potential and maximum actuation of the valve is obtained at the bombarded spot.

The bombarded area in these experiments was of 2 or 3 millimeters in diameter. For a smaller spot, a lower beam current would suffice to actuate the single bombarded spot. If the whole raster were bombarded with a spray beam, currents of the order of 50 to 100 microamperes would be needed. This current, however, would produce many more secondary electrons tending to bombard all raster areas and pin them to collector potential, causing indiscriminate lighting of the raster as explained in Section V.

This effect was simulated by further increase of beam current at the bombarded spot. Thus, at 50 microamperes and 100 microamperes, the bombarded spot was of course still fully actuated, but even at 50 microamperes the adjacent areas were partially actuated as well. Fall in their potential was impeded by secondary electrons from the bombarded spot striking them with such velocity (1000 to 2000 volts) as to charge them toward collector potential; therefore their potential swing was reduced as shown in column 4. At 100 microamperes the adjacent areas were kept charged to collector potential at all times, their potential swing was reduced to zero and all valve areas were fully actuated, completely destroying the ability of the focused spot to actuate chosen areas.

This spreading of the lighted valve areas at higher beam currents was overcome in a very simple manner. A mesh was placed in the tube, close to the bombarded mica wall, and connected to the outside semitransparent electrode (potential change shown dotted in column 6, Fig. 7). The beam still held the areas bombarded at the limiting potential, since even at the lowest potential impressed on the mesh (considered as a collector), the secondary-emission ratio was still less than unity and the sticking potential was thus independent of the collector potential. The situation was entirely different, however, for secondary electrons arising at the bombarded spot (or at the wall after reflection from the bombarded spot). These secondary electrons produced tertiary electrons on striking adjacent valve areas. The mesh collected these tertiary electrons. At the potentials impressed on the mesh (1500 to 2500 volts above the mica sticking potential), the tertiary-emission ratio was greater than unity and, hence, the adjacent areas were forced to follow mesh potential. This forced the adjacent areas to swing with the outside electrode and, hence, no field could be developed across the valve due to the action of the secondary electrons; thus the spreading of the light on the valve at high beam currents was completely eliminated.

Since the introduction of the mesh tended to cause defocusing and changes in deflection sensitivity, it was found helpful to introduce a second mesh, nearer the



gun, and held at fixed second-anode potential in order to act as an electrostatic screen for the anode region.

It should be pointed out that in the spray method of control discussed in this section, the question of discharge does not arise. This procedure is of value for the overcoming of rapid polarization. Valve response is had only so long as a portion of the spray is striking an area. Darkness at that area is produced by removing the spray striking it; any potential difference across that portion of the valve after the removal of the spray is reduced to zero very quickly by polarization.

### VIII. GRID EFFECTS

As described in the preceding section, no difficulty was experienced in actuating a small valve area bombarded with a beam kept on the area, as long as the outside electrode was varied in potential. For beam currents of 5 microamperes or less this could be accomplished without the mesh inside the tube (column 4, Fig. 7).

With such a tube, containing no mesh, the actuated spot faded out, however, as soon as the collector potential was reduced to values equal to or less than the surface limiting potential. (In a tube with the mesh varying in potential no actuation would be expected, of course, at collector potentials below the limiting potential, since even the bombarded areas would be forced to swing in potential with the outside electrode.)

The reason for this fading out of the focused spot at low collector potentials is made clear in Fig. 8, the data for which were obtained with a probe and oscilloscope as already described in Section VII. It was found (column 1) that, when the collector potential was made 2000 volts and the outside electrode potential was varied by 500 volts above and below this value, the adjacent areas varied in potential (by coupling to the outside electrode) with their maximum potential equal to collector potential (as in column 3, Fig. 7), giving no valve actuation in adjacent areas. *The potential of the bombarded area varied in the same way, however, and hence there was no valve actuation there either.*

It is believed that this effect is due to the grid effect of the adjacent areas, in that when these areas swing in a negative direction, secondary emission from the bombarded area is inhibited and, hence, the latter decreases in potential also. As soon as the adjacent areas start to return in potential toward the collector potential, secondary electrons can escape from the bombarded area and this is carried up to the collector as well. The resulting variation in potential of the bombarded area results in the loss of valve actuation.

In support of this theory, it was found that at larger beam currents the adjacent areas were kept charged to the collector potential by the action of secondary electrons from the bombarded spot (column 2, Fig. 8). Since this action removed the grid effect of the adjacent areas, the bombarded area was kept charged to the collector potential also. Therefore, the whole valve surface was actuated.

It would be expected that an area bombarded by a defocused spot would be less susceptible to the grid effect. This prediction was borne out by the results of column 3. In this case the larger bombarded area was actuated since the field from the adjacent areas, negative a portion of the time, could not act on the inner areas of the larger spot to inhibit loss of secondary electrons there. At the higher beam currents (column 4)

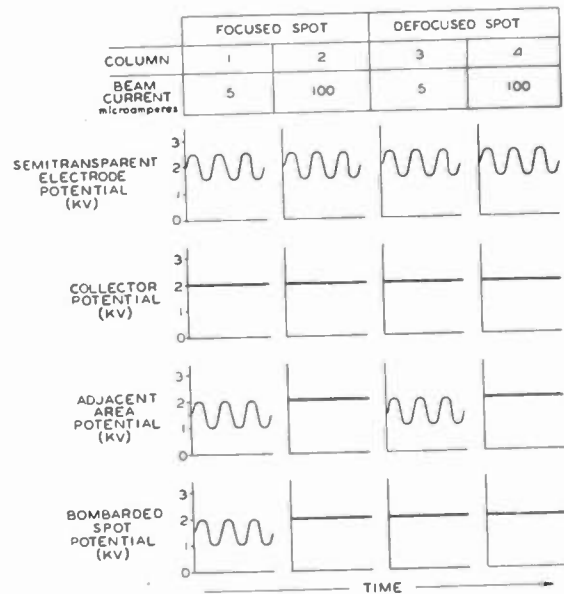

Fig. 8—Electrode and surface potentials with the collector potential below the surface limiting potential.

The sine-wave potential variation is impressed on the semitransparent electrode as in Fig. 7. Due to the coplanar grid effect, the bombarded spot can be actuated (without actuation of adjacent areas as well) only when the beam is defocused.

the adjacent areas were, of course, also kept charged to collector potential, and the whole valve surface was again actuated.

This grid effect is worth study because of its bearing upon the general problem of light-valve control. Analogous irregular charging effects would be expected even in the case of a scanning beam used to charge successive areas of a raster toward more positive potentials. Thus, in the course of the work to be described in the next section, in which a scanning beam is employed to return the raster from the surface limiting potential to a higher collector potential to accomplish discharge, it was found that discharge was imperfect unless the beam was defocused. In general, then, it will be found better to apply the field to the light valve by making the surface potential more negative with a focused modulated beam, and to discharge the surface back to the original positive potential by means of a defocused beam in order to overcome the grid effects.

It would be possible, of course, to use a focused beam to discharge the surface if the grid effect were overcome by an increase in collecting field. This might be done, as an example, by the use of a mesh held at collector potential to increase the collecting field at the bombarded surface.

### IX. PICTURE REPRODUCTION BY ALTERNATE CHARGE AND DISCHARGE WITH ONE BEAM

Both of the procedures of light-valve control treated in the two preceding sections are limited in application. The method employing secondary-electron discharge will not yield an adequate half-tone response at normal beam current unless special means are employed for producing a more dense rain of secondary electrons upon the scanned mica. Furthermore, the use of alternating potentials impressed upon the semitransparent electrode requires the use of a device such as the image intensifier described in Section VI which produces a spatially modulated rain of electrons upon the tube face throughout the greater portion of the frame time.



Fig. 9—Unretouched photograph of picture reproduced by the suspension light valve employing a single beam of alternately high and low velocity.

In Section IV it was pointed out that, after a field had been applied to the valve by reducing the surface potential approximately to the limiting potential with the scanning beam, the field might be removed by making the cathode more positive and rescanning with a beam from the same gun. The more positive cathode would result in a reduced electron velocity and, hence, in a secondary-emission ratio greater than unity, with the consequent removal of the light-valve field by the return of the surface to its original high potential.

The procedure described in this section differs merely in that the potential of the outside semitransparent electrode is made more negative, making the surface potential more negative by capacitance effect, before the discharge scanning. This likewise reduces the electron velocity during the discharge scanning in the same manner as would a more positive cathode potential. The tubes are identical with those already described, having a semitransparent electrode on the outer wall of a thin cell containing the suspension light valve, this cell in turn being mounted on the mica tube face. Scanning at the rate of 60 frames per second, with single interlacing, was employed.

Fig. 4 shows the secondary-emission ratio of the mica tube face. The outside electrode and collector are held at potential  $a$ , usually 5000 volts. Scanning of the

mica with the focused modulated beam carries its potential in the high lights to  $b$ , the limiting potential of the surface, thus imposing a field across the valve and actuating it. At the end of the first field of the interlaced scanning, the potentials of the collector and that of the outside electrode are changed from  $a$  to somewhere near  $b$  by a simple mechanical commutator. Those areas of the valve which have been reduced in potential to  $b$  by scanning are thus changed in potential to  $c$  by capacitive coupling to the outside electrode. This approximately equal change in potential of both walls of the valve of course develops no appreciable new field. During the next field of the interlaced scanning the mica wall is scanned with the beam defocused and at full beam current, to discharge the surface. Now, however, the secondary-emission ratio is above unity and the potential of the whole surface is raised to  $b$  (collector potential and limiting potential). Finally, the commutator returns the potentials of the collector, outside electrode, and valve wall (capacitatively) to  $a$  to complete the cycle.

Fig. 9 shows a picture reproduced by means of the procedure just described. The picture was photographed from the face of a tube incorporating a suspension light valve as previously described.<sup>1</sup> The picture signal was obtained from a "monoscope."

The use of the unmodulated beam during alternate scans removes difficulties of focus and registry at the changed anode voltage. The beam is defocused during the cycle in which the screen potential is made more positive by the beam, in order to remove the grid effects described in Section VIII. When the beam was refocused during its low-velocity phase, by an additional commutator segment, the response of the valve became very nonuniform over its surface.

The absence of modulation during alternate fields of the interlaced scanning, of course, reduces the resolution obtainable with a given television signal by a factor of 2. Since the modulated picture is reproduced by the reorientation of the suspension at discharge during alternate fields, the flicker frequency is 60 per second (assuming the use of 30 frames per second with single interlacing) although new information is imparted to any element only 30 times per second, i.e., during the modulated alternate-field scanings. If the capacitance change in screen potential were made at the end of a frame (30 times per second instead of 60) full resolution would be possible, since the beam would be modulated during alternate *pairs* of fields of the interlaced scanning. The flicker frequency would again approach 60 per second although the situation would be somewhat altered during discharge since the strong unmodulated defocused discharge beam would discharge most areas of the valve at its first passage (during the first of the two successive fields devoted to discharge) and the reorientation during the second passage would be weaker. New information would again be given any picture element only 30 times a second.

An interesting result was obtained when the latter procedure was tried with the same tube used above, which had no meshes. The picture was doubled, in that one field of the interlaced scanning was not registered with the other. This resulted from the fact that, during the first field scanning, areas already scanned had been left at a potential nearer the surface limiting potential while areas as yet unscanned were still at collector potential, whereas, during the second field scanning up to 50 per cent of all screen areas (a higher percentage if the spot size was too large to produce the resolution available in the signal) were near limiting potential at the start of the scanning. This situation resulted in a different electrostatic-field distribution and, hence, in a difference in the deflection sensitivity, in the two field scanings.

#### (a) Half Tones and Response to Changing Pictures

Before describing the performance of the light valve as regards half tones and response to a changing picture, some consideration must be given to the setting up of the charging and discharging equilibrium. A simple case, which is directly applicable to the procedure of this section, was treated at length in Section V. There the charge beam was assumed to be strong enough to charge the surface from collector potential (5000 volts) to the limiting potential (3000 volts), and an unmodulated strong discharge beam was assumed to return the scanned surface to collector potential. The procedure of this section is substantially the same, since only the difference in potential across the valve is important in equilibrium considerations. The semitransparent electrode and the collector and, therefore, both valve walls are carried to the limiting potential by a commutator; the surface, swung capacitatively below the limiting potential, is carried in a positive direction to the new collector potential by discharge; then the collector and the semitransparent electrode are returned by the commutator to their original potentials.

The equilibrium of Section V was of course a special case in that (a) the capacitive swing was equal to the higher collector potential minus the limiting potential; (b) the lower collector potential was equal to the surface limiting potential; (c) the beam current was more than sufficient to charge the surface to the limiting potential after equilibrium was established (hence, no consideration of change in charging efficiency with change in the region of the secondary-emission curve employed was necessary); and, finally, in that (d) the discharge beam was assumed to be focused and, hence, to discharge the surface on its first passage. Changing any of these factors would alter the manner in which the equilibrium is reached and such changes must be taken into account.

Consideration has been given to the equilibrium reached under various operating conditions. In general, such analyses are lengthy; accordingly, only the

conclusions reached will be presented here. These are:

1) It is not necessary that the capacitive swing be equal to the higher collector potential minus the limiting potential.

2) When the charge-beam current directed to any valve element is zero the potential of this element becomes the limiting potential plus the capacitive swing during the charging scans.

3) When, during several successive frames, the same signal is impressed on the beam charging any valve element, substantially the full desired valve potential difference is applied repetitively at each scanning by the charging beam beginning with the first, but 3 or 4 cycles are necessary before the discharge beam applies the desired equilibrium potential difference across the valve during the discharge scanings.

4) After equilibrium the potential difference developed by a focused discharge beam is always equal to that developed by the charging beam as was the case in Section V. (The defocused discharge beam will be considered later.)

5) After equilibrium, charging of the valve takes place from the surface limiting potential plus the capacitive swing, minus the potential difference developed repetitively across the suspension layer. (In Section V, analogously, charging took place from  $3000 + 2000 - 666$  or 4334 volts, after equilibrium.)

6) Equilibrium is approached more slowly as the potential drop across the suspension layer is increased relative to that across the mica tube face. (In Fig. 6 they were assumed to be of equal capacitance per unit area.)

As regards the reproduction of half tones, the following conclusions may be reached:

7) From (5) above, when the beam current is near that corresponding to its high-light value, charging starts in a region of the secondary-emission curve (Fig. 4) nearer the limiting potential than is the case for lower beam currents. Hence, the difference of secondary-emission ratio from unity is reduced and the charging applies less potential difference to the valve, per unit of beam current, than does the charging for the darker areas of the picture.

8) Since charging with higher beam currents carries the surface over a wider voltage range of Fig. 4, the limiting potential will be much more closely approached than it will for lower beam currents. Hence, there is an additional loss of charging efficiency at the higher currents.

9) Both (7) and (8) would be expected to reduce the valve response at the higher beam currents but this is partially compensated, as has been shown,<sup>1</sup> by the fact that the response of the valve is proportional to the square of the voltage across it. (In these tests a gamma control on the video amplifier was provided, but it has not been found necessary to use it up to the present.)

10) The half tones are preserved during the reorientation of the suspension at the time of discharge.

As regards the response to a changing or moving picture, the following may be concluded:

11) When the beam directed to a valve area is increased or decreased in strength, the impulse to the valve during charging changes to its new value at once, but the discharge beam requires several frames to reach equilibrium. The greatest adjustment of the impulse due to discharge takes place at the first discharge and the final value is approached asymptotically.

12) When the distribution of beam current to an extended valve area is suddenly changed, as when a picture area is moved to a new location, the various picture lights and shades in the area all approach equilibrium at the same rate, so that the proper picture gradations in the area are maintained. Thus, if the features of a face were to be produced suddenly on a previously dark picture area, the features would appear in their proper tonal relation at once, but would brighten slightly as a whole during the first few frames.

An effect will now be described which may improve the valve performance in that it may cause the above-mentioned equilibria to be approached more rapidly. In the equilibrium of Fig. 6 it was assumed that a focused discharge beam discharged the surface on a single passage and that polarization then caused the recently scanned surface to become more negative (line  $e$  of Fig. 6). It is precisely this drift in the negative direction which causes the delay in reaching equilibrium. In the procedure of this section, however, a defocused discharge beam is employed in order to minimize coplanar grid effects as already explained. This beam is usually defocused to about one quarter of the screen height. It will be seen that during this period of one quarter of a field scanning, portions of the defocused beam are crossing the valve element under consideration repeatedly, with only the time between scanning lines intervening. Since very little polarization takes place during these short intervals, the valve area may be considered to be pinned to the collector potential (or to the limiting potential, during the low-voltage cycle, which does not change these conclusions) for one quarter of a field time. During this time, however, a substantial portion of the polarization is over and, hence, after the discharge beam no longer pins the area to collector potential the surface will go much less negative due to polarization than would be the case if a focused discharge beam were used. Therefore, all equilibria are set up more rapidly. If the polarization is substantially over in a shorter time than a field-scanning time (that is, if the resistivity of the fluid is somewhat reduced) the polarization may be nearly over while the defocused discharge beam is still recrossing the valve element, and the delays in establishing changes of picture tone may become negligible.

It should be pointed out that while a valve area is pinned to collector potential or to the limiting potential by the defocused discharge beam, the capacitance of the mica is effectively in parallel with the suspension

capacitance and the polarization decay curve is less steep. This aspect of polarization has been discussed.<sup>1</sup> Nevertheless, the pinning of the surface during polarization results in a net increase in the rate at which equilibrium is approached.

It is also true that the diffuse leading edge of the defocused discharge beam will not completely discharge the valve element on its first passage, which will in general result in a slightly lower potential difference being applied to the valve during discharge than is developed at the charging scanning. The potential differences developed during discharge have their proper relative values, however, and the proper half-tone response of the valve, integrated over each complete frame, is maintained.

#### (b) *Limitations upon Field Developed Across the Suspension*

It was stated above that, after equilibrium is established, the scanned mica potential just before charging is the surface limiting potential plus the capacitive swing minus the difference of potential developed repetitively across the suspension. Therefore, the capacitive swing should be set at a value greater than the maximum potential difference it is desired to develop across the mica and suspension, plus the maximum desired potential difference across the suspension. Otherwise, charging even to the limiting potential will not develop the desired field.

As the beam current employed to bombard a picture area approaches zero, charging takes place from a mica potential which approaches the limiting potential plus the capacitive swing. The mica potential can never be above collector potential, for it would then become the collector of electrons and be charged negatively to near collector potential. Therefore, the collector potential (in the charging phase) should always be maintained at a potential above the limiting potential plus the capacitive swing.

There is, however, a limitation upon the capacitive swing and, hence, upon the field which may be developed. The highest beam current used charges the mica surface to the most negative value it attains during the charging scanning. If the capacitive swing in the negative direction carries this most negative area, after its potential has been altered by polarization, as already explained, below the first secondary-emission unity value of Fig. 4, the area will be carried to cathode potential by the discharge beam and this portion of the valve will become inoperative. If this limitation upon the capacitive swing does not permit sufficient light-valve field to be developed, a procedure, such as the evaporation of a material upon the mica surface, may be employed to raise the mica secondary emission. This will raise the mica limiting potential and, hence, the potentials at which charging begins and ends, and, therefore, a larger capacitive swing may be employed without danger of the surface being carried to cathode potential by the discharge beam.

### (c) Independence of Variations in Surface Limiting Potential

At first sight it seems that variations in the limiting potential over the surface might adversely affect the valve performance. Fortunately, this is not the case. Variations of limiting potential of 1 to 2 kilovolts from one area of the screen to another have been found to have no significant effect upon the picture when the electrode potentials are properly chosen.

The reason for this result lies in the fact that both charge and discharge take place from potentials bearing a fixed relation to the limiting potential. Hence, if the secondary-emission curves *have approximately the same shape*, over a reasonable range above and below the respective limiting potentials for the two areas of even widely different limiting potentials, the same beam current will have the same charging efficiency and, hence, produce the same valve response at the two areas.

It is necessary only that the collector potential and lowest limiting potential be high enough that the required light-valve field strength is permitted by the limitations described under (b) above.

### (d) Picture Distortions

When the charge beam is modulated during two successive fields of interlaced scanning (instead of the modulation during alternate fields as just discussed) a lack of registry of the two pictures is found, as described earlier in this section. A shift of picture position, similar to that caused by a difference in the electrostatic-field distributions during the two scans, would also be expected to occur to some degree when a change is made in the picture content. Thus, a large high light in the top of the picture would mean a screen area of lower potential and might result in the beam being bent toward the bottom of the picture as it scans the lower lines. The removal of this high light in a subsequent picture might then result in a raising of the lower portion of the raster. This effect has not been so pronounced as was expected even in the tubes without meshes near the screen, and it, therefore, has not seemed worth while to apply corrective measures.

### (e) Modulation of the Beam during Both Charge and Discharge Phases

If, in addition to the charging beam, the discharging beam (i.e., the beam during the scanning at reduced electron velocity) were modulated, a resolution corresponding to the full signal content would be possible with the full picture-repetition rate of 60 fields per second employed in this investigation. The electrode-potential change (yielding a capacitative swing of the scanned surface) may be applied between either fields or frames of the interlaced scanning.

The manner in which the charging and discharging equilibrium is reached would be somewhat more com-

plicated in that the surface is no longer discharged to the limiting potential by the strong unmodulated discharge beam. Instead, the discharge beam current also is adjusted to a value designed to give the desired valve response. To consider a simple example, let it be assumed that both charge and discharge beam currents have just been adjusted to a new value to give a change in the picture, at the area in question, which is to persist for several frames. If the charging beam initially varies the mica potential over a range of Fig. 4 which is farther from the limiting potential than the range of Fig. 4 over which the discharge beam varies the surface potential, the charging beam will produce the greater potential variation since the secondary-emission ratio differs more from unity. Hence, the charging beam will impart a greater negative impulse to the mica than the positive impulse imparted by the discharge beam, and the average mica potential will fall. Thus, after equilibrium, the charging process no longer starts from a potential equal to the limiting potential plus the capacitative swing, minus the difference in potential across the suspension, but from a potential such that the charging and discharging efficiencies are equal; the two modulated beams again develop the same difference in potential across the valve (the two beam currents having been assumed to be equal).

Whenever there is a change of beam current during either the charging or discharging scanning, the equilibrium just described will be re-established, while the equilibrium described earlier in this section is being established. In general, no longer time will be required for the double equilibrium and the only difference lies in the final potentials from which charging and discharging take place.

In the equilibrium described earlier the higher beam currents resulted in charging starting from lower screen potentials, relatively decreasing the valve response to the higher beam currents. The new equilibrium considered alone obviously requires that both charging and discharging start at potentials which are more removed from the limiting potentials for the higher beam currents. In the final equilibrium, which is a combination of the two, the effects are compensating and charging will start more closely from the same point on the curve of Fig. 4 for all beam currents. Referring to the conclusions concerning half tones in (a) of this section, we find this situation would leave only the effect mentioned there under conclusion (8) to be compensated by the square law of response of the suspension.

## X. CONCLUSIONS

The cathode-ray control of suspension light valves appears to be a procedure of practical utility for the reproduction of television pictures. The removal of fields produced by electron bombardment may be accomplished by means of secondary electrons produced by the electron bombardment. Considerable latitude is afforded in the choice of suspension characteristics

since the polarization of low-resistance suspensions may be overcome by the use of alternating potentials superimposed on the collector potential.

Of the several modes of operation reported here, alternate charge and discharge by one beam is the most useful, although in the method described the resolution is limited by the discarding of alternate fields of the interlaced scanning. The results obtained with this procedure are substantially independent of variations in secondary emission of the bombarded surface.

Although it is obvious that further work of a developmental nature must be done, the suspension light valve controlled by a cathode-ray beam is a promising approach to the problem of producing large, bright television pictures.

#### ACKNOWLEDGMENT

The author wishes to acknowledge his indebtedness to Dr. D. B. Langmuir for his valuable collaboration in much of the experimental work.

## A Type of Light Valve for Television Reproduction\*

J. S. DONAL, JR.†, MEMBER, I.R.E., AND D. B. LANGMUIR‡, MEMBER, I.R.E.

**Summary**—The desirability of a light valve for the reproduction of television pictures is discussed, and the use of a suspension of opaque platelike particles for this purpose is shown to offer the particular advantages that the electron beam would be only a control mechanism and the picture brightness would be limited only by the light source and lens system.

The theory of operation of such a suspension is described and it is demonstrated that inertial effects may be neglected and that the rate of orientation of the particles is independent of particle size and is a function of the viscosity and dielectric constant of the suspending medium and of the square of the applied voltage. The contrast ratio obtained may be made very high, although the optical efficiency will decline as the contrast ratio rises.

It is found that suspension resistivity must be considered in practical application of the light valve, for if the field is applied through an insulating wall the valve will respond only to changes in potential of the outside of this wall, since leakage will prevent a constant wall potential from maintaining a field across the suspension.

From the results of tests, the conclusions are drawn that the fundamental optical behavior of the suspensions considered is in accordance with the predictions of a theory based on simple assumptions, and that the suspensions fulfill the basic requirements of a television light valve.

### INTRODUCTION

THE development of television has seen progress in the reproduction of images, from the early scanning disks to the modern kinescopes, or cathode-ray tubes. Because of the limitations of kinescopes in the production of very large images, alternative reproduction devices have been studied.<sup>1</sup> This paper presents a description of a type of cathode-ray-controlled light valve which appears to offer promise in this field.

\* Decimal classification: R583XR388. Original manuscript received by the Institute, October 19, 1942. Presented, Fifteenth Annual Convention, Boston, Massachusetts, June 29, 1940. This paper reports work carried on, prior to 1940, as part of the television-development program of the RCA Manufacturing Company, Inc.

† RCA Laboratories, Princeton, New Jersey.

‡ Formerly, Research Laboratories, RCA Manufacturing Company, Inc., Harrison, New Jersey; now the Office of Scientific Research and Development, Washington, D. C.

<sup>1</sup> Dr. Rosenthal has described an alternative system, "the Skia-tron," which depends upon the development of opaque areas in microcrystalline layers of ionic crystals under the action of electron bombardment. See A. H. Rosenthal, "A system of large-screen television reception based on certain electron phenomena in crystals," *Proc. I.R.E.*, vol. 28, pp. 203-213; May, 1940.

Since a new type of television reproduction device is described, it may be helpful to compare its principles with those of other reproduction systems. Three examples will be considered: the combination of a scanning disk with a single light source modulated by a video signal; a nitrobenzene Kerr cell combined with a scanning disk; and a kinescope.

The system using the scanning disk has two major disadvantages. The light which produces the picture must be generated by power modulated at video frequencies. Also, light can be delivered to only one picture element at a time and the resulting picture must suffer in respect to brightness by a factor of many thousands relative to the limiting brightness which can be obtained with a lantern slide where, for example, light from every element reaches the observer's eye continuously.

The conventional Kerr cell has the theoretical advantage that the video signal is used as a control rather than as a generator of light. However, it suffers from the same unfavorable efficiency factor as does the scanning disk in that light reaches the observer's eye from only one picture element at a time.

In the kinescope, the light must be generated by modulated power, and it can be generated at only one picture element at a time, so that both of the disadvantages of the scanning disk are present. The success of the kinescope in television reproduction is due chiefly to certain special features of the device. Cathode-ray beams make it possible to concentrate power into small areas very effectively. The combination of such large power densities with phosphors which can efficiently transform the power into light produces a satisfactory result in spite of the theoretical disadvantages.

It is worth while to consider systems of television reproduction which are free from both of the stated handicaps. An ideal device, which may be called a television light valve, can be conceived as a lantern slide which at every point has an opacity that can be controlled instantaneously. Such a slide might be

scanned so that the transparency varies from point to point in accordance with the picture signal. If the transparency remained constant at the value set by the signal until the return of the beam during the next scan, light would reach the observer's eye continuously from all of the desired elements of the picture. The brightness of the picture would be limited only by the light source, the lens system, and the maximum transparency of the light valve; the electron beam would be only a control mechanism.

In exploring the groundwork for such a hypothetical system the variety of possibilities is large and it is difficult to limit them in any preconceived manner. However, confining the scanning systems to electron beams, and the controlling effects to voltages developed by the beams, certain almost inescapable features of a practical light valve can be defined in advance. First, the layer of optically controllable material must be thin, of the order of a few thousandths of the width or length. Second, the light-control effect must result from an electric field which is parallel to the direction of light transmission. While neither of these requirements is absolute or final, the complexities introduced by deviating from either of them militate against the practicability of a light valve which fails to meet them.

It is illustrative to consider the conventional type of nitrobenzene Kerr cell in the light of these conditions. Since such a cell must be at least several millimeters thick in the direction of light propagation in order to obtain useful transmission with the maximum electric field permitted by the dielectric strength of nitrobenzene, and since the lines of force must run perpendicular to this direction, neither basic requirement is fulfilled. The classical Kerr effect seems unsuited to the television light-valve problem.

In respect to frequency response the requirements for the optical medium in the present problem are much less stringent than those for a light valve used in conjunction with a scanning disk. Since any given picture element need respond only once during each frame period, the time of response of the light valve may be 1/100 second or even longer. The system may be considered to consist of a large number (one for each picture element) of parallel communication channels of very narrow bandwidth. Taken all together these transmit the same amount of intelligence as a single wide-band channel.

An optically sensitive medium which satisfies the basic requirements outlined and which has been found to possess many advantageous qualities consists of a suspension of small, flat, opaque particles in an insulating fluid. If the suspended platelike particles have a dielectric constant greater than that of the liquid, an electric field will cause them to align themselves parallel to the field. The shadow cast by the particles and, hence, also the light transmission of the suspension will therefore be subject to control by the field.

Theoretical and experimental investigations of such

suspensions are described in this paper. A separate paper<sup>2</sup> treats the methods by which cathode-ray beams can be made to control a light valve and describes a cathode-ray-controlled suspension light valve with which a high-definition television picture has been projected on a screen.

### THEORY

Consider a suspension in which there are  $n$  absorbing particles per cubic centimeter, each particle having a projected area  $a$  on a plane perpendicular to the  $x$  direction. Light traveling in the  $x$  direction will vary in intensity  $L$  according to the familiar exponential absorption law

$$\frac{dL}{dx} = -naL. \quad (1)$$

Integrating, we have

$$\frac{L}{L_0} = e^{-nax}. \quad (2)$$

Here  $L$  is the light intensity after traversing the distance  $x$  in the suspension, while  $L_0$  is the incident light intensity at  $x$  equals zero.

The quantity  $nax$  is equal to the sum of the projected areas of all particles in a suspension thickness  $x$ . Letting this total area equal  $A$ , we have

$$\frac{L}{L_0} = e^{-A}. \quad (3)$$

Now let  $A_1$  be the total projected area of the particles in the unoriented condition and let  $A_2$  be their projected area after having been aligned by the field, with  $L_1$  and  $L_2$  representing the corresponding light intensities after transmission through a suspension thickness  $x$ . Then, from (3),

$$\frac{L_2}{L_1} = e^{-(A_2 - A_1)}.$$

The ratio  $L_2/L_1$  is equal to the maximum contrast ratio obtainable while  $L_2/L_0$ , the ratio of emergent to incident light when all particles are lined up, may be called the high-light transmission or optical efficiency of the suspension. Designating these by  $C$  and  $E$ , respectively, and substituting, we obtain

$$C = e^{-A_2(1 - (A_1/A_2))} \quad (4)$$

$$= E^{(1 - (A_1/A_2))}. \quad (5)$$

This relationship between contrast, optical efficiency (or high-light transmission  $L_2/L_0$ ), and the shape factor  $A_1/A_2$  of the individual particles is presented graphically in Fig. 1. It is seen that the contrast ratio is by no means limited to a value equal to the shape factor, and that a contrast ratio of any desired magnitude can be obtained simply by increasing the total area of the suspended particles per unit area of the

<sup>2</sup> J. S. Donal, Jr., "Cathode-ray control of television light valves," *Proc. I.R.E.*, this issue, pp. 195-208.

valve. This can be done, for example, by increasing the thickness of the fluid layer, or by increasing the concentration of the particles. The optical efficiency will decline as the contrast ratio rises at a rate depending upon the shape factor of the particles.

The rate at which the particles are oriented by an applied field will depend upon their size, shape, and moment of inertia, and upon the fluid viscosity, dielec-

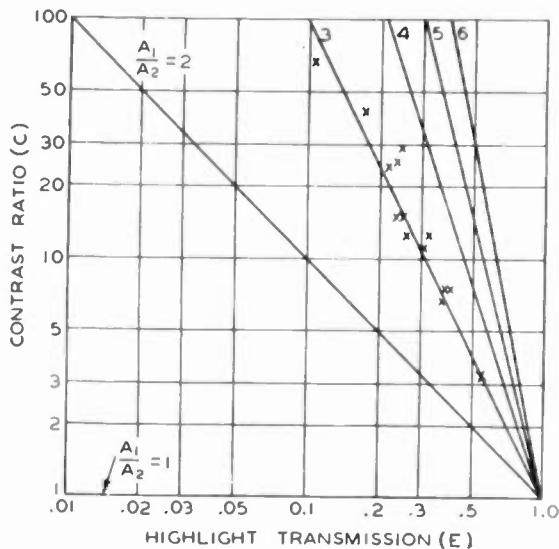

Fig. 1—Curves showing the contrast ratio obtainable from a suspension as a function of its light transmission in the completely oriented state for various values of the shape factor of the particles. The lines are theoretical. Experimental points for a suspension of graphite in castor oil are also shown.

tric constant, and density. An exact theory would be complicated. It can be shown, however, that inertial forces in the motion are very small compared to viscous ones, and need be considered only when the Reynolds number<sup>3</sup>  $R$  has a value of the order of magnitude of unity. The Reynolds number appropriate to this problem is

$$R = \frac{\rho \omega r^2}{\mu}$$

where (in the centimeter-gram-second system of units)

- $\rho$  = fluid density
- $r$  = equivalent particle radius
- $\omega$  = angular velocity of particle
- $\mu$  = coefficient of viscosity

For the range of values of the four variables which might be practicable in a television light valve  $R$  is much less than 1, so that viscous effects predominate overwhelmingly.

Since inertial effects may be neglected, the rate of orientation of the particles can be calculated quite simply if conducting plates, such as those of graphite, are considered. Such a particle is shown in an electric field in Fig. 2. The plane of the flat body is shown perpendicular to the page and its periphery may have any shape whatever.

<sup>3</sup> The significance of the Reynolds number in problems of this nature is stated at length by Sir Horace Lamb in his "Hydrodynamics," sixth edition, Cambridge University Press, Cambridge, England, 1932.

Consider the field  $E$  resolved into components  $E \cos \phi$  along  $OX$  and  $E \sin \phi$  along  $OY$ . The former may be considered to build up polarization charges on the plate so as to give it a double moment of strength  $M$ . The latter may be regarded as exerting a torque upon this dipole without affecting the value of  $M$ . If the size of the plate (proportional to  $r$ ) is varied, keeping the particle shape factor and the electric field  $E$  constant, the surface charge density at corresponding points will remain constant. The total polarization charges will therefore be proportional to the area of the plate and, of course, to  $\epsilon$ , the dielectric constant of the medium. Since the separation of positive and negative charges will be proportional to  $r$ , it is clear that

$$M = K_1 \epsilon r^3 E \cos \phi$$

where  $K_1$  is a constant depending upon the shape of the periphery of the plate.

The torque exerted on the plate by the field will be

$$\begin{aligned} L_E &= ME \sin \phi \\ &= K_1 E^2 \epsilon r^3 \sin \phi \cos \phi \\ &= K_2 E^2 \epsilon r^3 \sin 2\phi. \end{aligned}$$

This torque will be opposed by a torque due to viscous drag, for if the same plate as is shown in Fig. 2 is considered to be rotating in a viscous fluid, a torque will be exerted on it by the drag of the fluid. Since the

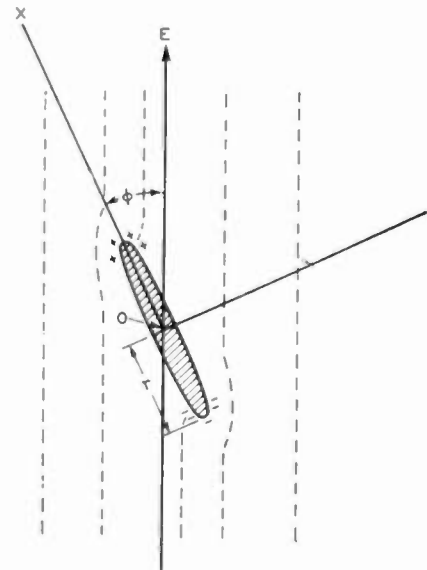

Fig. 2—A platelike particle is viewed edge on in an electric field. The field component parallel to the surface induces charges on the particle and the field component perpendicular to the surface acts upon these induced charges to produce a torque which tends to rotate the particle so as to place its long axis parallel to the electric field.

inertial forces may again be neglected, it can be shown from dimensional reasoning that

$$L_\phi = K_3 \mu \frac{d\phi}{dt} r^3$$

where  $\mu$  is the coefficient of viscosity.



The reason for the third-power variation with  $r$  can be summarized qualitatively as follows: As  $r$  increases with constant  $\mu$  and  $d\phi/dt$ , the area upon which shearing or pressure forces are exerted increases as  $r^2$ , while the lever arms by which the forces must be multiplied to give the torque increase as  $r$ . With constant  $d\phi/dt$  the rate of shear at corresponding points in the fluid remains constant as  $r$  increases since the increased velocity of parts of the system is counterbalanced by the increased scale of size of the system. Therefore, the net result is a torque increasing as  $r^3$ .

Equating these torques and rearranging, we obtain

$$\frac{d\phi}{dt} = K \frac{\epsilon}{\mu} E^2 \sin 2\phi.$$

This equation can be integrated, yielding

$$\tan \phi = \tan \phi_0 e^{-2ct} \tag{7}$$

where  $c = K(\epsilon/\mu) E^2$ ,  $t$  is the time, and  $\phi_0$  is the value of  $\phi$  when  $t = 0$ .

Since both the torques involved increase as the cube of the particle size, the rate of orientation is independent of the particle size. The time response of the suspension light valve depends therefore upon the square of the applied voltage and upon the viscosity and dielectric constant of the suspending medium.

The projected area of the suspended particles is equal to  $A_0 \sin \phi$ , where  $A_0$  is the total area presented by the

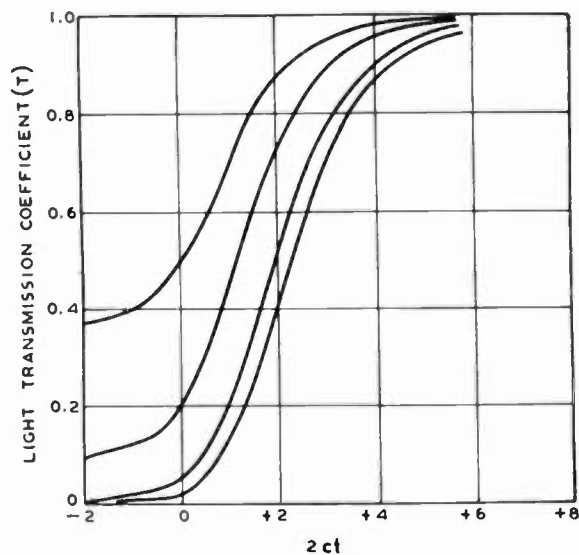

Fig. 3—Theoretical curves of light transmission as a function of time  $t$  for a suspension of particles of infinite shape factor, under a constant orienting field. The constant  $c = E^2(\epsilon/\mu)$ . At  $ct = 0$  all particles lie at 45 degrees to the field.

deoriented particles in 1 square centimeter of valve area. It is assumed that this projected area equals zero when alignment is complete. Therefore, the transmission coefficient  $T$  of the suspension as a function of time will be given by

$$T = e^{-A_0 \sin \phi} \tag{8}$$

where  $\tan \phi = \tan \phi_0 e^{-2ct}$  from (7).

The curves of Fig. 3 show the relations, derived from (8), between the transmission coefficient and the time for various initial values of light transmission in the deoriented condition.

For comparing theory with observed data, it is convenient to eliminate  $\phi$  from (7) and (8). When this is done the equations may be put into the form

$$\ln \ln \frac{1}{T} - \ln A_0 = \frac{1}{2} \ln(1 + e^{4ct}). \tag{9}$$

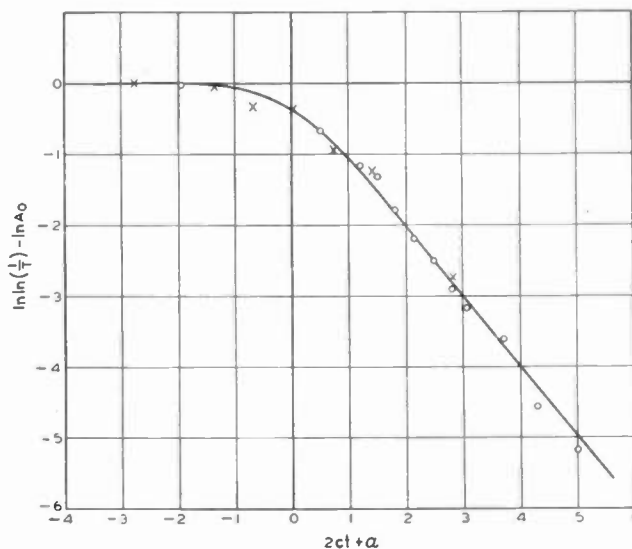

Fig. 4—Comparison between test and theory of light-transmission-versus-time curves. The two adjustable constants used in fitting the experimental points to the curve are discussed in the text.

The constant  $\phi_0$  is arbitrary and has been set equal to  $\pi/4$  in this case.

This equation is shown plotted in Fig. 4, together with observed points from two suspensions. The constant  $c$ , which is indeterminate because of its dependence upon the shape factor of the particles, has been adjusted to give the best fit. In addition the points have been shifted horizontally by means of the constant  $\alpha$  so as to make the curves coincide. The latter procedure is necessary since the time scale for the theoretical curve is essentially a relative one. An absolute origin for the time is indeterminate because we have no way of measuring the value of  $\phi$  when the electric field is first applied. The theory is at best approximate because of the adjustable constants and because of the assumption (not consistent with actual suspension characteristics) that the transmission coefficient approaches unity with complete orientation. The general behavior of the suspensions is seen, however, to be in conformity with that predicted by simple calculations.

### TESTS

Observations of suspension characteristics were made using cells with glass walls. The thickness of the fluid layer was varied from a few millimeters down to about 0.1 millimeter. Potentials were applied by means of semitransparent sputtered metal coatings in direct contact with the suspension. Light intensities were

measured with a phototube. When transient effects were studied this tube was connected to the input of a direct-current amplifier which controlled an oscilloscope having a long-persistence screen on which single traces could be studied.

In one series of tests the light transmission in the de-oriented and completely oriented states was measured for several different values of opacity controlled by the concentration of particles or the thickness of the cell. The results for a suspension of graphite in castor oil are shown as the crosses in Fig. 1. The theoretical relation-

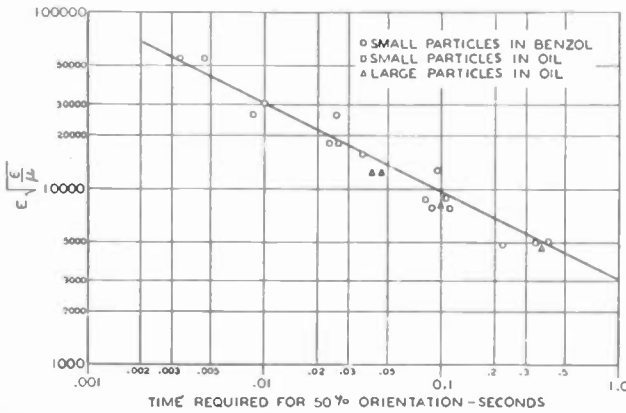

Fig. 5—Time required for light transmission to rise to half of its final value as a function of the parameter  $E\sqrt{\epsilon/\mu}$ . This curve checks the square-law response to field strength, the effect of dielectric constant and viscosity, and the independence of particle size upon rate of orientation.

ship between contrast and optical efficiency is seen to be verified. The effective shape factor of the particles is apparently between 3 and 4. A contrast ratio of 25 with an efficiency of 0.2 is seen to be obtainable.

Fig. 5 is a plot of the time required for the transmission of the suspension to reach half of its final value against the parameter  $E\sqrt{\epsilon/\mu}$ . The parameter was varied not only by applying different field strengths to the suspension, but by using fluids of different viscosity and dielectric constant. Suspended particles of differing sizes were also used. The time of orientation is seen to be proportional to the inverse square of  $E\sqrt{\epsilon/\mu}$  and to be independent of the particle size, as predicted by theory.

Fig. 4 showed a check of the detailed form of the transmission-versus-time curves. The theoretical curve as represented by (9) is shown by the solid line. Points measured experimentally with two different suspensions are also shown, and the agreement with theory is satisfactory.

POLARIZATION EFFECTS

In the experiments just described the potential difference was applied to the suspension from electrodes in contact with the fluid. The behavior observed was not a function of the conductivity of the suspension, the various values of fluid conductivity resulting merely in the passage of a greater or smaller conduction current. However, in important practical cases, as already described,<sup>1</sup> the potential differences may not be

applied directly to the fluid. One wall of the light valve might consist, for example, of mica or of thin glass which is charged on its outer face by an electron beam. In that case the conductivity of the suspension will have a marked effect upon the performance; therefore, it seems worth while to discuss the broader aspects of this phenomenon at this point.

Consider the behavior of a cell of which one electrode is in direct contact with the suspension and is grounded while the other electrode is the charged outer surface of a perfectly insulating wall. Two cases will be discussed. In the first, the potential difference between the two electrodes is held constant for a time long compared to the relaxation period of the suspension, while in the second case the charged electrode is allowed to float after bringing its potential to a certain value. In both cases the general behavior of the suspension will be the same; that is, when the charge is first applied a field will be established across the valve causing it to light up, but the potential drop across the leaky fluid will decline with time. If the particles are now de-oriented the valve will remain dark until the charge is removed from the electrodes, at which time another flash will occur due to the depolarization field set up when the charge on the inner wall of the valve leaks off.

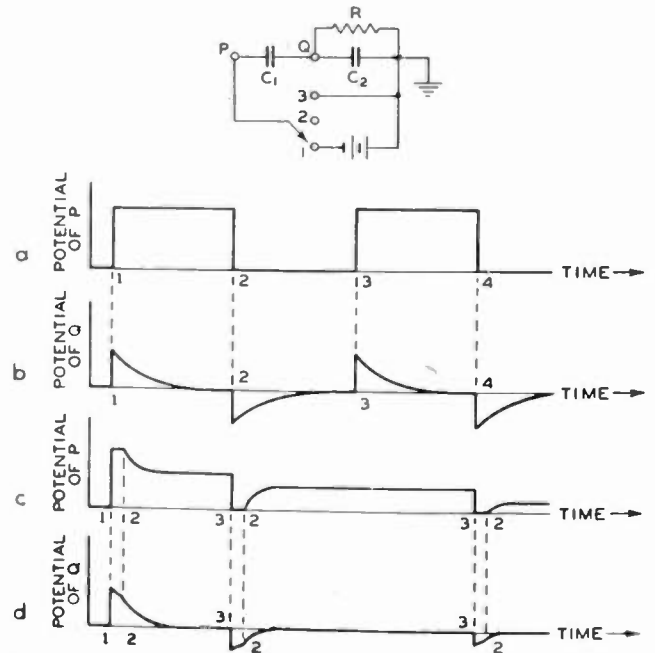

Fig. 6—Analogue to the behavior of a leaky suspension. (a) and (b) show the potential changes (assumed to be with respect to ground) when a constant potential difference is applied through an insulating wall and then removed; (c) and (d) show the potential changes when the suspension is actuated by charging the outside of an insulating wall which is then allowed to float until the charge is removed. The numerals on the abscissas indicate the positions of the switch in the diagram above.

The differences in detail, depending upon whether the outside of the insulating wall is held at a constant potential during the relaxation period, may be analyzed quantitatively in terms of the circuit of Fig. 6. The condenser  $C_1$  corresponds to the insulating wall, while the leaky condenser  $C_2$  represents the valve fluid.

Suppose a voltage is applied suddenly to the circuit (switch in position 1), held constant for a time long compared to the relaxation period, which in this case is  $R(C_1 + C_2)$ , and is then removed suddenly by changing the switch to position 3. The resulting changes of the potential of the point  $P$ , with respect to ground, are represented in Fig. 6(a). The potential differences across  $C_2$  may be represented by the variations of the potential of the point  $Q$  with respect to ground shown in Fig. 6(b).

After the initial potential difference across  $C_2$  has fallen to zero, the full applied voltage will be supported by the insulating wall. At the removal of the applied potential the voltage across  $C_2$  due to depolarization will be equal and opposite to that resulting from the initial voltage application. This reversed voltage falls to zero by leakage and the valve returns to its original potential distribution. The single removal of the applied potential by grounding point  $P$  completely discharges the valve provided  $P$  is kept grounded until the reversed potential across the suspension is reduced substantially to zero by leakage. Regrounding of point  $P$  at a later time would have no additional effect if there is no recharging in the meantime. Also, a subsequent application of a potential difference across  $C_1$  and  $C_2$  of a value equal to that applied initially (as shown in the second cycles of Fig. 6(a) and Fig. 6(b)), or of a different value, would produce proportionate potential differences across the valve suspension, uninfluenced by the potential differences of any preceding cycle.

The second of the cases mentioned above will now be considered. If instead of holding the voltage across the cell constant, we place the switch in position 2 after bringing the voltage to a steady value, the potential differences across the suspension will differ, as shown in Fig. 6(c) and Fig. 6(d), from those considered above. This case may be realized in practice if an area of the light valve is charged by an electron beam which then goes on to scan other valve areas. If an amount of charge sufficient to cause an initial potential difference  $V_0$  between  $P$  and ground is put on condenser  $C_1$  at  $P$ , the initial potential across  $C_2$  is of course  $V_0 C_1 / (C_1 + C_2)$  as before. However, this will decay exponentially at a rate more rapid (Fig. 6(d)) than in the case considered above since  $C_1$  and  $C_2$  are no longer effectively in parallel between point  $Q$  and ground and the time constant will now be reduced to  $RC_2$ . Instead of the entire initial potential difference being impressed across  $C_1$  as a result of leakage through the suspension, the potential difference across  $C_1$  will remain unchanged by the leakage through  $R$ , and, therefore, the potential of  $P$  above ground will fall from  $V_0$  to the asymptotic value  $V_0 C_2 / (C_1 + C_2)$  as indicated in Fig. 6(c). If now the valve is discharged by bringing the point  $P$  to ground potential suddenly and then allowing it to float again, a reversed potential difference will appear across  $C_2$ , (Fig. 6(d)), but of a magni-

tude smaller than that which occurred in the first direction, since the change in potential of  $P$  by grounding it is now only  $V_0 C_2 / (C_1 + C_2)$  instead of  $V_0$ , and the fraction  $C_1 / (C_1 + C_2)$  of this appears across  $C_2$ . This potential difference is then reduced to zero by suspension leakage.

It will be remembered that in the first case considered, the changes in potential produced by subsequent charging or discharging of the point  $P$  were independent of the first cycle just considered because the point  $P$  was kept grounded until the reversed potential difference across  $C_2$  had disappeared. Now, however, the situation is different, for the potential of  $P$  drifts away from ground (Fig. 6(c)) as the charge on  $C_2$  associated with the reversed potential difference leaks off. Thus, if the point  $P$  is again carried to ground potential (Fig. 6(c)) without an intermediate recharging, a second although still smaller reversed potential difference appears across  $C_2$  (Fig. 6(d)). On repeated discharge of  $P$  to ground, these reversed potential differences across  $C_2$  would approach zero asymptotically. Furthermore, if before this has occurred and before the potential of  $P$  is in equilibrium at ground potential, a new potential difference  $V_1$  (not shown in the figure) is applied between  $P$  and ground, the change in potential of  $P$  will be less than  $V_1$  and, hence, the new potential difference developed across  $C_2$  will be less than  $V_1 C_1 / (C_1 + C_2)$ .

From the practical standpoint, this phenomenon results in a delay in the response of the light valve coming into equilibrium with the impulses applied. This subject is discussed at greater length elsewhere.<sup>1</sup>

## DISCUSSION

From the foregoing it will be seen that the suspension of opaque platelike particles fulfills to a considerable degree the requirements of the ideal light valve in which the opacity of a thin sheet may be varied from point to point to reproduce the lights and shades of a picture.

The change in opacity of the suspension under the action of an applied potential difference, which limits the contrast obtainable, may be made as high as desired by increasing the concentration of the suspended particles. Although the optical efficiency declines with increasing contrast, the results show that with particles of easily obtainable shape factor and with sheets of suspension thin enough to afford the possibility of reasonable resolutions, high contrast can be obtained with an optical efficiency which is not unreasonably low.

Since any given point of the layer of suspension must respond only once in each frame time, the rate of response of the suspensions investigated appears to be fully adequate for television purposes. This is particularly true since the sheet of suspension must be thin, of the order of a line width in thickness, if adequate resolution is to be obtained. This requirement means that high fields will result from relatively moderate potential differences across the suspension layer.

Since the rate of orientation was found to be independent of the particle size, the principal limitation on particle size is that the individual particles shall not be evident in the reproduced picture. In general this condition will be satisfied if the particles are small compared to the size of a picture element.

Although polarization effects have been shown to

result in a delay in the attaining of an equilibrium between the response of the valve and the potential differences applied, the effects of these residual potential differences may be expected to be reduced in importance by the fact that the suspension responds to the square of the applied difference in potential.

## Optimum Current Distributions on Vertical Antennas\*

LINCOLN LA PAZ†, NONMEMBER, I.R.E., AND GEOFFREY A. MILLER‡, ASSOCIATE, I.R.E.

**Summary**—The theoretical optimum current distribution on a vertical antenna of given length is defined as that current distribution giving the maximum possible field strength on the horizon for a given power output. The problem of determining such distributions is set up as a problem in the calculus of variations, and solution functions are derived for antennas varying in length from one eighth of a wavelength up to a full wavelength.

It is shown that the apparent antenna performance obtained with the theoretical optimum distribution is as good as or better than that obtained with any practical distribution, and thus serves to bound the improvement in antenna performance which may be expected as a result of changes in current distribution. A curve of maximum possible field strength on the horizon for fixed power output versus antenna height is given.

Finally, these theoretical optimum current distributions are used to indicate the general class of distributions most likely to yield worth-while results in a search for practical optimum distributions. Several such practical distributions are considered in detail.

### I. INTRODUCTION

SOON AFTER vertical antennas made their appearance in practice in 1930, it was discovered that their radiating characteristics were considerably poorer than the characteristics predicted by the elementary theory in which a sinusoidal current distribution was assumed. However, it was shown almost immediately by Gehring and Brown<sup>1</sup> that the discrepancies between theoretical and actual performance were due very largely to the nonsinusoidal current distributions which actually existed on these early antennas as a result of their nonuniform cross sections. This discovery brought the entire question of current distributions on vertical antennas to the front, and numerous investigations were undertaken in the next five years in an attempt to discover distributions even more desirable than the sinusoidal.

However, these investigations were all made by "trial-and-error" methods. That is, each investigator

made a special study of particular current distributions which appeared promising to him.<sup>2</sup> Now it is clear at once that the results of such restricted investigations cannot be used to bound the general problem. Thus, to this day, engineers are still divided in their opinions as to the amount of improvement in antenna performance which may be expected to result from future discoveries of current distributions still more desirable than those now in use. It is clear that the general problem can be bounded only on the basis of the results of a general investigation taking *all possible current distributions* into consideration. Such an investigation is presented in this paper.

### II. THEORETICAL AND PRACTICAL OPTIMUM CURRENT DISTRIBUTIONS

In order to clarify the purposes of this paper the two following types of optimum current distributions are now defined:

1. *The theoretical optimum current distribution on a vertical antenna of given length may be defined as that distribution giving the maximum possible field strength on the horizon for a fixed power output.*

2. *The practical optimum current distribution on a vertical antenna of given length may be defined simply as that distribution most desirable for a fixed power output, in any particular case.*

In determining the theoretical optimum current distribution one is forced to consider the family of all continuous distributions giving a preassigned output, while in determining the practical optimum distribution one is forced to restrict attention to a subfamily of this general family. That is, many of the distributions considered in the former case are rejected at the outset in the latter case for various reasons; for example, because they may not be economically realizable. Thus, the theoretical optimum distribution will always give an apparent antenna performance equal to or better than that given by the practical optimum distribution. Therefore the apparent antenna performance obtained with the theoretical optimum distribution

\* Decimal classification: R120. Original manuscript received by the Institute, September 23, 1942. Presented, Summer Convention, Detroit, Michigan, June 23, 1941. The problem considered in this paper was first treated in a doctoral dissertation, bearing the same title, completed by Geoffrey A. Miller at The Ohio State University in 1940.

† Department of Mathematics, The Ohio State University, Columbus, Ohio.

‡ National Research Council, Ottawa, Ontario, Canada.

<sup>1</sup> H. E. Gehring and G. H. Brown, "General considerations of tower antennas for broadcast use," *Proc. I.R.E.*, vol. 23, pp. 311-356; April, 1935.

<sup>2</sup> See, for example, G. H. Brown, "A critical study of the characteristics of broadcast antennas as affected by antenna current distribution," *Proc. I.R.E.*, vol. 24, pp. 48-81; January, 1936.

serves as an upper bound on the improvement in antenna performance which may be expected in the future as a result of changes in current distribution.

The practical problem, which of course is the problem of interest to engineers, is clearly intractable because of many complicating factors such as those introduced through economic considerations. Nevertheless, the practical problem is readily bounded, as pointed out above, once a solution of the theoretical problem, which is free from all such complicating factors, has been obtained. The purpose of this paper is to solve the theoretical problem and use the results obtained to bound the practical problem.

### III. THE THEORETICAL OPTIMUM CURRENT DISTRIBUTION PROBLEM IN MATHEMATICAL FORM

As a general rule the current distribution on a vertical antenna is assumed to be a variable-amplitude constant-phase distribution. That is, the amplitude of the current is assumed to vary from point to point along the antenna, while the phase of the current is assumed to be the same at every point, a change in the sign of the amplitude taking care of phase reversals. Nevertheless, it is quite possible to construct antennas such that the phase varies from point to point as well as the amplitude. Therefore it would seem that perfectly general variable-amplitude *variable*-phase current distributions must be considered in this paper. However, it will be shown in the Appendix, that the theoretical optimum current distribution on a vertical antenna is necessarily a variable-amplitude *constant*-phase distribution, assuming only that the solution is unique. Thus the phase of the current along the antenna is considered constant in the following work.

Let the electrical length of the given antenna be  $L$  radians, and let the amplitude of the current at distance  $x$  radians from the antenna base be given by the function  $f(x)$ . Let  $H(f)$  be an integral giving the field strength at any point on the horizon due to radiation from the antenna, and let  $P(f)$  be an integral giving the total radiated power. Then, it is seen from the very definition of theoretical optimum current distribution, that the solution of the following problem is required.

**Problem:** To determine that current distribution  $f(x)$  on a vertical antenna of given length  $L$ , which *maximizes* the integral  $H(f)$  while satisfying the side condition  $P(f) = \text{constant}$ .

By a device familiar in the calculus of variations the problem just formulated may be restated in the following equivalent form:

**Equivalent Problem:** To determine that current distribution  $f(x)$  on a vertical antenna of given length  $L$  which *minimizes* the integral  $P(f)$  while satisfying the side condition  $H(f) = \text{constant}$ .

It happens that the problem is more tractable in the second form than in the first, as will become ap-

parent in the sequel, and consequently the latter form will be used exclusively in what follows.

The integrals  $H(f)$  and  $P(f)$  are readily set up by a well-known method presented in standard radio-engineering textbooks.<sup>3</sup> Using Gaussian units, these integrals are (see Fig. 1)

$$H(f) = H(f)_{\max} = \frac{2}{r_0 c} \int_0^L f(x) dx \quad (1)$$

and

$$P(f) = \frac{1}{c} \int_0^{\pi/2} \sin^3 \theta \left[ \int_0^L f(x) \cos(x \cos \theta) dx \right]^2 d\theta. \quad (2)$$

The squared integral occurring in  $P(f)$  as given above, appears to render the problem intractable, and so the following transformations are made.

In the first place the squared integral in  $P(f)$  is converted into a double integral by use of the following well-known relation:<sup>4</sup>

$$\left[ \int_0^L F(x) dx \right]^2 = \int_0^L \int_0^L F(x) \cdot F(y) dx dy.$$

Thus, the power integral takes the form

$$P(f) = \frac{1}{c} \int_0^{\pi/2} \sin^3 \theta \int_0^L \int_0^L f(x) \cdot f(y) \cos(x \cos \theta) \cdot \cos(y \cos \theta) dx dy d\theta.$$

Since the integrand function,

$$\phi(x, y, \theta) = f(x) \cdot f(y) \cos(x \cos \theta) \cos(y \cos \theta) \sin^3 \theta,$$

is continuous for  $0 \leq x \leq L$ ,  $0 \leq y \leq L$ , and  $0 \leq \theta \leq \pi/2$ , the order of integration may be changed to give

$$P(f) = \frac{1}{c} \int_0^L \int_0^L f(x) \cdot f(y) \int_0^{\pi/2} \sin^3 \theta \cos(x \cos \theta) \cdot \cos(y \cos \theta) d\theta dx dy.$$

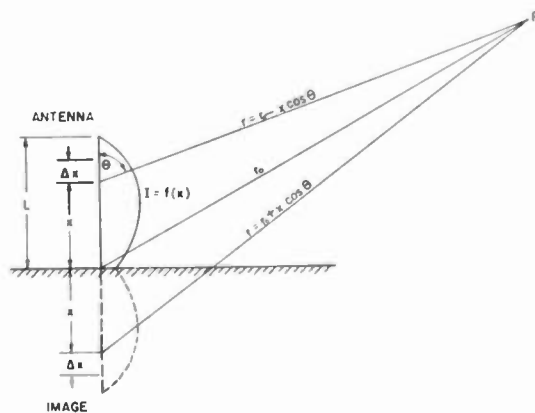

Fig. 1—The basic diagram for setting up the field equations for a vertical antenna.

In the second place a trigonometric transformation is made using the following identity:

<sup>3</sup> See, for example, W. L. Everitt, "Communication Engineering," Second Edition, McGraw-Hill Book Company, New York, N. Y., 1937, pp. 633-640.

<sup>4</sup> E. Goursat and E. R. Hedrick, "A Course in Mathematical Analysis," Ginn and Company, Boston, Mass., 1904, vol. 1, p. 257.

$$\cos A \cos B = \frac{1}{2} [\cos (A - B) + \cos (A + B)].$$

Application of this relation to the last expression obtained for  $P(f)$  gives

$$P(f) = \frac{1}{c} \int_0^L \int_0^L f(x)f(y) \int_0^{\pi/2} \frac{\sin^3 \theta}{2} [\cos \{ (x-y) \cos \theta \} + \cos \{ (x+y) \cos \theta \}] d\theta dx dy.$$

It is now possible to carry out explicitly the integration with respect to  $\theta$  by use of the formula

$$\int_0^{\pi/2} \sin^3 \theta \cos (q \cos \theta) d\theta = \frac{2}{q^3} (\sin q - q \cos q)$$

due to Poisson,<sup>5</sup> and easily verified by two successive integrations by parts. By use of Poisson's formula,  $P(f)$  takes the final form

$$P(f) = \frac{1}{c} \int_0^L \int_0^L f(x) \cdot f(y) \left[ \frac{\sin (x-y) - (x-y) \cos (x-y)}{(x-y)^3} + \frac{\sin (x+y) - (x+y) \cos (x+y)}{(x+y)^3} \right] dx dy.$$

Consequently, the problem of determining the theoretical optimum current distribution on a vertical antenna of given length  $L$ , is mathematically equivalent to the following isoperimetric problem of the calculus of variations.

*Problem: To find in the class of (current distribution) functions  $f(x)$ , defined, continuous, real, and single valued on the interval  $0 \leq x \leq L$ , and such that*

$$H(f) = \frac{2}{r_0 c} \int_0^L f(x) dx = \text{constant}, \quad (1')$$

*but otherwise arbitrary, that particular function which minimizes the integral*

$$P(f) = \frac{1}{c} \int_0^L \int_0^L f(x) \cdot f(y) \left[ \frac{\sin (x-y) - (x-y) \cos (x-y)}{(x-y)^3} + \frac{\sin (x+y) - (x+y) \cos (x+y)}{(x+y)^3} \right] dx dy. \quad (2')$$

*Admissible Functions:* The class of functions  $f(x)$ , defined, continuous, real, and single-valued on the interval  $0 \leq x \leq L$ , and such that  $H(f) = \text{constant}$ , but otherwise arbitrary, will hereafter be referred to as the class of *admissible functions*.

#### IV. RELEVANT REMARKS ON THE CALCULUS OF VARIATIONS

In a typical function problem of the calculus of variations one is given an integral  $I$  of the form

$$I = \int_{x_1}^{x_2} F(x, f, f') dx$$

and a class of so-called admissible functions  $\{f\}$  on each of which  $I$  is well defined (that is, for which  $I(f)$

is real, finite, and single-valued); and the question is to determine the admissible function  $f$  for which  $I$  takes on the smallest value. The class of admissible functions  $\{f\}$  may, on the one hand, be restricted to consist of all analytic functions which take on assigned values for  $x = x_1$  and  $x = x_2$ ; or, at the other extreme, as in the problem formulated in Section III, this class may be the very general class of merely continuous functions  $f(x)$ , satisfying an isoperimetric side condition  $H(f) = \text{constant}$ . In any case the set of values  $I(f)$  forms a linear point set possessing a greatest lower bound, finite or infinite. Only in case this greatest lower bound is finite and is actually attained, does the problem of minimizing  $I$  in the class of functions taken as admissible admit of a solution.

It is easy to verify that the power integral  $P(f)$  occurring in the isoperimetric problem under consideration has a finite nonnegative greatest lower bound  $B$ . In spite of this fact, one can no longer naively assume, as has been done up to this point, that there exists an admissible<sup>6</sup> current distribution function  $f(x)$  such that  $P(f) = B$ . Conceivably, the problem formulated above does not admit of an *exact* solution, although of course, the very existence of  $B$  guarantees the existence of a sequence of admissible functions such that for every positive  $\delta$  there exists an  $n_0(\delta)$  such that for  $n \geq n_0(\delta)$  it is true that  $P(f_n) - B < \delta$ .

From the electrical-engineering viewpoint it seems highly improbable that the well-set theoretical optimum-current-distribution problem does not admit of an exact solution; but whether it does or not, the existence of a sequence of admissible functions  $f_n(x)$  with the property just alluded to, shows that it is possible to solve the following:

*Approximate Optimum-Current-Distribution Problem: To find an admissible function  $f(x)$  such that  $P(f)$  approximates the greatest lower bound  $B$  to a preassigned degree of accuracy.*

One would naturally expect that an explicit solution to the theoretical optimum-current-distribution problem could be obtained by reference to the vast body of theory already developed and known as the *classical* calculus of variations. Unfortunately, the problem formulated in Section III differs in several important respects from any problem solved by the indirect methods of the classical theory, and therefore a *direct* attack is necessary.

The direct solution of a problem in the calculus of variations is essentially a solution by successive approximations. A law is set up by which one is able to proceed from one function to the next through a sequence of functions  $f_n(x)$ , approaching a solution function  $f(x)$  in the limit. Such a sequence of functions is

<sup>5</sup> D. Bierens de Haan, "Tables d'Intégrales Définies," M. Drabbe, Amsterdam, Holland, 1867, p. 133.

<sup>6</sup> For an example of a problem in which the integral  $I$  possesses a *finite* greatest lower bound but does *not* actually attain it in any admissible function, see Oskar Bolza, "Vorlesungen über Variationsrechnung," B. G. Teubner, Leipzig, Germany, 1909, p. 419.

called a *minimizing sequence*. The work required actually to solve a problem by this method is often prohibitive; but on the other hand, the limit function of the sequence is sometimes discovered directly, once the law determining the sequence is set up. The work required to solve the problem considered in this paper proves to lie in between these two extremes. As soon as the first step is taken in setting up a minimizing sequence, a condition is discovered both necessary and sufficient for a solution. This condition proves to be very useful in setting up minimizing sequences  $\{f_n(x)\}$  such that the integral  $P(f_n)$  converges very rapidly towards its greatest lower bound  $B$ , and in determining the order of approximation of  $P(f_n)$  to  $B$ .

V. A NECESSARY AND SUFFICIENT CONDITION FOR AN ABSOLUTE MINIMUM

Under the assumption that an *exact* solution of the theoretical optimum-current-distribution problem actually exists, a condition, which an admissible function  $f(x)$  must necessarily satisfy if  $f(x)$  is to minimize  $P(f)$ , will now be derived. Conversely it will be shown that in case an exact solution exists, satisfaction of this necessary condition by an admissible function  $f(x)$  is sufficient to insure that  $f(x)$  minimize  $P(f)$ . Analogous results concerning the *approximate* optimum current distribution problem are obtained in Section VI.

The first step in the direct attack on the theoretical optimum-current-distribution problem is to discover a law by which a minimizing sequence of admissible functions

$$f_1(x), f_2(x), f_3(x), \dots, f_n(x), \dots$$

can be set up such that

$$P(f_1) > P(f_2) > P(f_3) > \dots > P(f_n) > \dots$$

and such that  $P(f_n)$  approaches the greatest lower bound  $B$  of  $P(f)$  as  $n$  becomes infinite. In the present case, this law is set up on the basis of a clue discovered in the following manner:

Suppose  $f_m(x)$  a typical element of a sequence of admissible functions  $\{f_n(x)\}$ . Let  $J(y, f_m)$  be defined as the functional

$$J(y, f_m) = \frac{1}{c} \int_0^L f_m(x) \left[ \frac{\sin(x-y) - (x-y) \cos(x-y)}{(x-y)^3} + \frac{\sin(x+y) - (x+y) \cos(x+y)}{(x+y)^3} \right] dx \dots \quad (3)$$

Then the power integral (2) may be written

$$P(f_m) = \int_0^L f_m(y) J(y, f_m) dy.$$

Suppose that  $z = f_m(y)$  and  $z = J(y, f_m)$  have the graphs shown in Fig. 2, and that  $\bar{J}_m$  is the average value of  $J(y, f_m)$  on  $(0, L)$ ;  $J(y, f_m) \neq \bar{J}_m$  on  $(0, L)$ . Then the integral  $P(f_m)$  to be minimized is equal to the area

under the product curve  $z = f_m(y) \cdot J(y, f_m)$  between 0 and  $L$ , and the integral to be held constant according to the isoperimetric side condition (1') is proportional to the area under the curve  $z = f_m(y)$  between 0 and  $L$ .

Thus, the immediate problem is to discover another continuous function  $f_{m+1}(y)$  such that the area under the

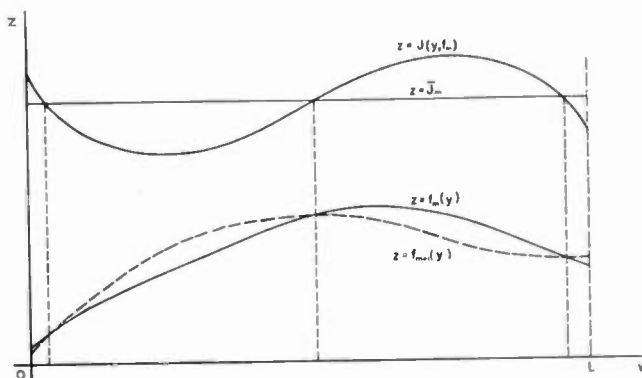

Fig. 2—A diagram showing the relation between two successive functions in the minimizing sequence of Section V.

product curve  $z = f_{m+1}(y) \cdot J(y, f_{m+1})$  between 0 and  $L$  is less than the area under  $z = f_m(y) \cdot J(y, f_m)$  between 0 and  $L$ , while at the same time the areas under  $z = f_m(y)$  and  $z = f_{m+1}(y)$  between 0 and  $L$  are equal. Suppose  $f_{m+1}(y)$  is defined as follows:

$$f_{m+1}(y) = f_m(y) - \alpha_m \{ J(y, f_m) - \bar{J}_m \} \quad (4)$$

where  $\alpha_m$  is a positive constant. It is easily shown that the areas under  $z = f_m(y)$  and  $z = f_{m+1}(y)$  are equal as required. Furthermore, if  $\alpha_m > 0$  is chosen sufficiently small, one would conjecture that  $J(y, f_{m+1})$  would lie very close to  $J(y, f_m)$  so that the two functionals would be relatively large or relatively small in almost exactly the same regions. One would also expect that the area under  $f_{m+1}(y) \cdot J(y, f_{m+1})$  would be less than the area under  $f_m(y) \cdot J(y, f_m)$  since  $f_{m+1}(y) < f_m(y)$  in regions where the two functionals are relatively large, and  $f_{m+1}(y) > f_m(y)$  in regions where the two functionals are relatively small (see Fig. 2).

A rigorous proof of the above conjectures will be given in lemma II below, using the following property of the functional  $J(y, f_m)$ .

Lemma I: For every positive  $\rho$

$$| J(y, f_m) - J(y, f_{m+1}) | < \rho \quad (0 \leq y \leq L)$$

provided

$$\int_0^L | f_m(x) - f_{m+1}(x) | dx < \rho.$$

Proof: Let the functional  $J(y, f)$  be written in the form

$$J(y, f) = \int_0^L f(x) \cdot K|x, y| dx$$

where

$$K[x, y] = \left[ \frac{\sin(x - y) - (x - y) \cos(x - y)}{(x - y)^3} + \frac{\sin(x + y) - (x + y) \cos(x + y)}{(x + y)^3} \right]$$

Then

$$|J(y, f_m) - J(y, f_{m+1})| = \left| \int_0^L \{f_m(x) - f_{m+1}(x)\} K[x, y] dx \right|$$

Therefore,

$$|J(y, f_m) - J(y, f_{m+1})| \leq \int_0^L \{|f_m(x) - f_{m+1}(x)\} | \cdot |K[x, y]| dx$$

But it is easy to show that the maximum value of  $K(x, y)$  for  $0 \leq x \leq L, 0 \leq y \leq L$  is equal to  $\frac{2}{3}$ . Hence the lemma follows.

The conjectures preceding lemma I may now be stated in the following concise form.

Lemma II: If  $f_m(x)$  is an admissible function, then unless

$$J(y, f_m) \equiv \text{constant}, \quad (0 \leq y \leq L)$$

there always exists another admissible function  $f_{m+1}(x)$  such that  $P(f_{m+1}) < P(f_m)$ .

Proof: Let the totality of the subintervals of  $(0, L)$  on which  $J(y, f_m) > \bar{J}_m$  be denoted by  $A$ , and let the totality of the subintervals on which  $J(y, f_m) \leq \bar{J}_m$  be denoted by  $B$  (see Fig. 2). Write

$$\int_A \{J(y, f_m) - \bar{J}_m\} dy = \Delta > 0. \quad (5)$$

Then from the very definition of  $\bar{J}_m$ , it is true that

$$\int_B \{J(y, f_m) - \bar{J}_m\} dy = -\Delta. \quad (5')$$

Again suppose that  $f_{m+1}(y)$  is defined as in (4). Then  $f_{m+1}(y)$  is surely continuous for  $0 \leq y \leq L$  since  $f_m(y)$  is admissible by hypothesis. Furthermore, since

$$\begin{aligned} \int_0^L f_{m+1}(y) dy &= \int_0^L f_m(y) dy + \alpha_m [\Delta - \Delta] \\ &= \int_0^L f_m(y) dy, \end{aligned}$$

it follows that  $f_{m+1}(y)$  satisfies the isoperimetric side condition (1'), since  $f_m(y)$  satisfies it. Thus  $f_{m+1}(y)$  as defined in (4) is an admissible function.

Introduce the quantities

$$P_{ij} = \int_0^L f_i(y) J(y, f_j) dy, \quad i, j = m, m + 1,$$

noting that  $P_{m,m}$  evidently represents the power output for the current distribution  $f_m(y)$ , and  $P_{m+1,m+1}$  the

power output for the distribution  $f_{m+1}(y)$ , while  $P_{m,m+1}$  and  $P_{m+1,m}$  are auxiliary double integrals which in view of symmetry (see (2')) have a common value.

Now consider the difference

$$\begin{aligned} P_{m,m} - P_{m+1,m} &= \int_0^L \{f_m(y) - f_{m+1}(y)\} J(y, f_m) dy \\ &= \int_A \alpha_m \{J(y, f_m) - \bar{J}_m\} J(y, f_m) dy \\ &\quad + \int_B \alpha_m \{J(y, f_m) - \bar{J}_m\} J(y, f_m) dy. \end{aligned}$$

But everywhere on  $A, J(y, f_m) > \bar{J}_m$ , and everywhere on  $B, J(y, f_m) \leq \bar{J}_m$ . Hence

$$\begin{aligned} P_{m,m} - P_{m+1,m} &> \int_A \alpha_m \{J(y, f_m) - \bar{J}_m\} \bar{J}_m dy \\ &\quad + \int_B \alpha_m \{J(y, f_m) - \bar{J}_m\} \bar{J}_m dy. \end{aligned}$$

In view of (5) and (5') the above relation reduces to

$$P_{m,m} - P_{m+1,m} > [\alpha_m \Delta \bar{J}_m - \alpha_m \Delta \bar{J}_m] = 0. \quad (6)$$

Next consider the difference

$$\begin{aligned} P_{m+1,m} - P_{m+1,m+1} &= P_{m,m+1} - P_{m+1,m+1} \\ &= \int_0^L \{f_m(y) - f_{m+1}(y)\} J(y, f_{m+1}) dy \\ &= \int_0^L \alpha_m \{J(y, f_m) - \bar{J}_m\} J(y, f_{m+1}) dy. \end{aligned}$$

Evidently

$$\begin{aligned} \frac{P_{m+1,m} - P_{m+1,m+1}}{\alpha_m} &= \int_0^L J(y, f_m) \cdot J(y, f_{m+1}) dy \\ &\quad - \bar{J}_m \int_0^L J(y, f_{m+1}) dy. \end{aligned}$$

Now by lemma I,  $J(y, f_{m+1})$  lies everywhere on  $(0, L)$  within a  $\rho$  neighborhood of  $J(y, f_m)$  where

$$\rho = \int_0^L |f_m(y) - f_{m+1}(y)| dy.$$

Since  $\rho$  approaches zero as  $\alpha_m$  approaches zero, it follows that as  $\alpha_m$  approaches zero,  $J(y, f_{m+1})$  approaches  $J(y, f_m)$ . Hence

$$\lim_{\alpha_m \rightarrow 0} \int_0^L J(y, f_m) \cdot J(y, f_{m+1}) dy = \int_0^L [J(y, f_m)]^2 dy$$

and

$$\lim_{\alpha_m \rightarrow 0} \bar{J}_m \int_0^L J(y, f_{m+1}) dy = \frac{1}{L} \left[ \int_0^L J(y, f_m) dy \right]^2$$

But in view of the integral inequality of Tchebycheff<sup>7</sup> which asserts that

<sup>7</sup> See p. 257 of foot note reference 4.



$$(b - a) \int_a^b [\phi(x)]^2 dx \geq \left[ \int_a^b \phi(x) dx \right]^2$$

for any continuous function  $\phi(x)$  defined on  $a \leq x \leq b$ , the sign of equality holding only if  $\phi(x)$  is a constant on  $(a, b)$ , it is true that

$$\int_0^L [J(y, f_m)]^2 dy > \frac{1}{L} \left[ \int_0^L J(y, f_m) dy \right]^2$$

since  $J(y, f_m)$  is not a constant on  $(0, L)$ . Hence

$$\lim_{\alpha_m \rightarrow 0} \frac{P_{m+1,m} - P_{m+1,m+1}}{\alpha_m} = \int_0^L [J(y, f_m)]^2 dy - \frac{1}{L} \left[ \int_0^L J(y, f_m) dy \right]^2 = \sigma > 0.$$

Hence for  $\alpha_m > 0$  but chosen sufficiently small it is true that

$$P_{m+1,m} - P_{m+1,m+1} > 0.$$

But by (6)

$$P_{mm} - P_{m+1,m} > 0.$$

Thus for  $\alpha_m > 0$  but sufficiently small

$$P_{m+1,m+1} < P_{mm}$$

and the lemma has been proved.

A necessary condition which an admissible function  $f$  must satisfy if it is to minimize  $P(f)$  now follows directly from lemma II.

*Necessary Condition*

If the admissible function  $f(y)$  is a solution function of the proposed problem, then necessarily  $f(y)$  satisfies the condition

$$J(y, f) \equiv \text{constant}, \quad (0 \leq y \leq L).$$

That this necessary condition is also sufficient is readily shown as follows:

Suppose there exists a pair of admissible functions,  $f_1(y)$  and  $f_2(y)$ , both satisfying the above necessary condition. Then

$$J(y, f_1) \equiv K_1 \quad (0 \leq y \leq L),$$

and

$$J(y, f_2) \equiv K_2 \quad (0 \leq y \leq L).$$

But

$$P_{11} = \int_0^L f_1(y) \cdot J(y, f_1) dy = CK_1 \quad (7)$$

and

$$P_{22} = \int_0^L f_2(y) \cdot J(y, f_2) dy = CK_2 \quad (7')$$

where  $C$  is the constant appearing in the isoperimetric side condition (1'). Furthermore

$$P_{21} = \int_0^L f_2(y) J(y, f_1) dy = CK_1 \quad (8)$$

and

$$P_{12} = \int_0^L f_1(y) J(y, f_2) dy = CK_2. \quad (8')$$

Now, from the symmetry of (2)

$$P_{12} = P_{21}.$$

Hence, by (8) and (8')

$$CK_1 = CK_2.$$

Thus,  $K_1$  is necessarily  $K_2$ , and therefore by (7) and (7')

$$P_{11} = P_{22}.$$

Thus all admissible functions satisfying the necessary condition reduce the integral  $P(f)$  to the same constant value. Therefore the integral  $P(f)$  realizes an absolute minimum on every admissible function  $f(x)$  satisfying the condition

$$J(y, f) \equiv \text{constant} \quad (0 \leq y \leq L).$$

The conclusions reached up to this point may now be summarized in the following theorem.

*Theorem: If the proposed problem actually has a solution in the class of admissible functions  $f(x)$ , then a necessary and sufficient condition that an admissible function  $f(x)$  furnish a minimum for  $P(f)$  is that  $f(x)$  be a solution of the integral equation*

$$\int_0^L f(x) K[x, y] dx = \text{constant} \quad (0 \leq y \leq L).$$

VI. A NECESSARY AND SUFFICIENT CONDITION FOR AN APPROXIMATE ABSOLUTE MINIMUM

It was pointed out in Section IV that the mere fact that the integral  $P(f)$  actually has a finite greatest

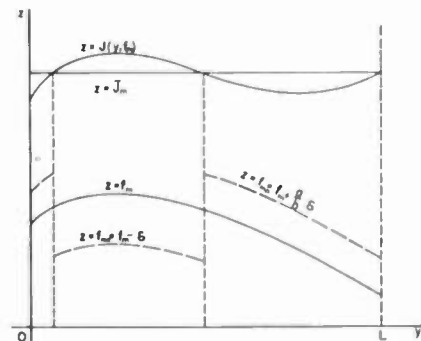

Fig. 3—A diagram showing the relation between the function  $f_m(y)$  and the auxiliary function  $f_{m+1}(y)$ .

lower bound does not necessarily imply that an exact solution exists for the problem under consideration. However, the existence of a finite greatest lower bound for  $P(f)$  does guarantee that functions  $f$  always exist such that  $P(f)$  approximates its greatest lower bound

to any assigned degree of accuracy. In this sense it may be stated that the problem under consideration certainly possesses an *approximate solution* whether it possesses an exact solution or not. On the basis of the necessary and sufficient condition for an exact solution, derived in Section V, a necessary and sufficient condition for  $f(x)$  to furnish an approximate solution will now be derived.

In what follows the order of the approximation of the integral  $P(f)$  to its greatest lower bound  $B$  will be defined as  $\epsilon$ , where

$$\epsilon = P(f) - B. \tag{9}$$

Similarly, the order of the approximation to which the condition

$$J(y, f) \cong \text{constant} \quad (0 \leq y \leq L) \tag{3'}$$

is satisfied will be defined as  $\Delta$ , where

$$\Delta = \int_A \{J(y, f) - \bar{J}\} dy = - \int_B \{J(y, f) - \bar{J}\} dy \tag{10}$$

and where  $\bar{J}$  is the average value of  $J(y, f)$  on the interval  $(0, L)$ . (Compare (10) with (5) and (5').) In view of these definitions and the necessary and sufficient condition stated above for an exact solution, one would naturally expect that the condition for an approximate solution would be as follows:

A necessary and sufficient condition that an admissible function  $f(x)$  furnish an approximate minimum for  $P$  of order  $\epsilon$  less than or equal to a preassigned positive quantity  $E$ , is that  $f$  satisfy the relation (3') to an approximation of sufficiently small order  $\Delta$ . It will now be shown that this is actually so.

Let  $f_m(y)$  be an admissible function giving  $P(f)$  the value

$$P(f_m) = B + \epsilon.$$

Then it will be demonstrated that the condition stated above is necessary by proving that unless  $f_m(y)$  satisfies the relation (3') to an approximation of sufficiently small order  $\Delta$ , the order  $\Delta$  approaching zero as  $\epsilon$  approaches zero, it is always possible to define a second admissible function  $f_n(y)$  such that  $P(f_n) < B$ , which is ridiculous. Unfortunately, this time  $f_n(y)$  cannot be taken in the simple form

$$f_n(y) = f_m(y) - \alpha_m \{J(y, f_m) - \bar{J}_m\}.$$

(Compare Section V, equation (4) and later sections where numerical solutions are actually derived.) Instead, for the purposes of this proof,  $f_n(y)$  must be taken in the following much less elegant form:

An auxiliary function  $f_{mn}(y)$  is first introduced, in terms of which the admissible function  $f_n(y)$  is defined. This auxiliary function is

$$f_{mn}(y) = f_m(y) - \delta$$

on  $A$ , and

$$f_{mn}(y) = f_m(y) + \frac{a}{b} \delta$$

on  $B$ , where  $a$  and  $b$  are the length sums of the sub-intervals in  $A$  and  $B$ , respectively, and where  $\delta$  is a positive number (see Fig. 3).

Now  $f_m(y)$  satisfies the isoperimetric side condition (1') so that

$$\int_0^L f_m(y) dy = C$$

and thus

$$\int_0^L f_{mn}(y) dy = \int_0^L f_m(y) dy - \int_A \delta dy + \int_B \frac{a}{b} \delta dy = C.$$

Therefore  $f_{mn}(y)$  also satisfies the isoperimetric side condition (1'). Now,  $f_{mn}(y)$  as defined above, contains

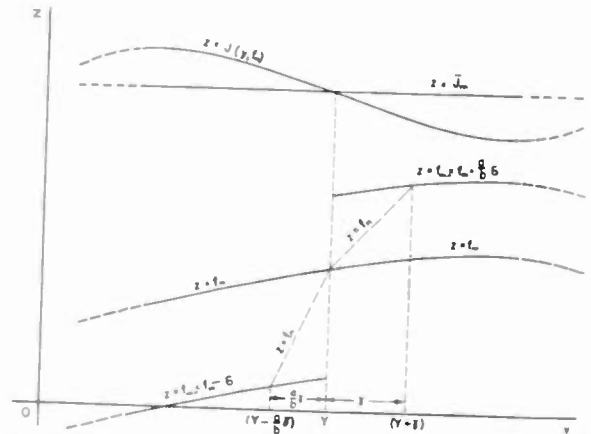

Fig. 4—A diagram showing the method of deriving a continuous function  $f_n(y)$  to follow the function  $f_m(y)$  in the minimizing sequence of Section VI, from the discontinuous auxiliary function  $f_{mn}(y)$ .

points of discontinuity and is therefore inadmissible. Nevertheless, the definition of  $f_{mn}(y)$  can be modified so as to give a second function  $f_n(y)$  which will not only satisfy the isoperimetric side condition, but will be continuous as well. In fact, let  $y_i$  be a typical point of discontinuity of the auxiliary function  $f_{mn}(y)$  (see Fig. 4), and let a new function  $f_n(y)$  be defined in terms of  $f_{mn}(y)$  as follows:

$$f_n(y) = f_{mn}(y)$$

except on the intervals  $(y_i - a\gamma/b, y_i + \gamma)$ , where  $\gamma$  is a positive number which may be chosen as small as desired. Furthermore, let

$$f_n(y) = f_m(y) - \frac{b(y_i - y)}{a\gamma} \delta, \quad \left( y_i - \frac{a}{b} \gamma \leq y \leq y_i \right)$$

and

$$f_n(y) = f_m(y) - \frac{a(y_i - y)}{b\gamma} \delta, \quad (y_i \leq y \leq y_i + \gamma).$$

Now it is clear that the function  $f_n(y)$  is continuous on  $(0, L)$ . It remains to be shown that  $f_n(y)$  also

satisfies the isoperimetric side condition (1'). Since  $f_{mn}(y)$  certainly satisfies the condition, this will be so, if

$$\int_0^L f_n(y) dy = \int_0^L f_{mn}(y) dy.$$

Or, since  $f_n(y) \equiv f_{mn}(y)$ , except on the intervals  $(y_i - a\gamma/b, y_i + \gamma)$ , this will be so, if

$$\int_{y_i - (a/b)\gamma}^{y_i + \gamma} f_n(y) dy = \int_{y_i - (a/b)\gamma}^{y_i + \gamma} f_{mn}(y) dy$$

for all values of  $i$ . The left-hand side of this relation has the value

$$\begin{aligned} \int_{y_i - (a/b)\gamma}^{y_i + \gamma} f_n(y) dy &= \int_{y_i - (a/b)\gamma}^{y_i} \left[ f_m(y) - \frac{b(y_i - y)}{a\gamma} \delta \right] dy \\ &+ \int_{y_i}^{y_i + \gamma} \left[ f_m(y) - \frac{a(y_i - y)}{b\gamma} \delta \right] dy \\ &= \int_{y_i - (a/b)\gamma}^{y_i + \gamma} f_m(y) dy. \end{aligned}$$

Hence, since

$$\begin{aligned} \int_{y_i - (a/b)\gamma}^{y_i + \gamma} f_{mn}(y) dy &= \int_{y_i - (a/b)\gamma}^{y_i} [f_m(y) - \delta] dy \\ &+ \int_{y_i}^{y_i + \gamma} \left[ f_m(y) + \frac{a}{b} \delta \right] dy \\ &= \int_{y_i - (a/b)\gamma}^{y_i + \gamma} f_m(y) dy, \end{aligned}$$

the left- and right-hand sides of the relation in question actually are equal, and therefore, the function  $f_n(y)$  is not only continuous but satisfies the isoperimetric side condition as well. Therefore  $f_n(y)$  is an admissible function.

Consider now the difference

$$\begin{aligned} P_{mm} - P_{nm} &= \int_0^L [f_m(y) - f_n(y)] J(y, f_m) dy \\ &= \delta \int_A J(y, f_m) dy \\ &\quad - \frac{a}{b} \delta \int_B J(y, f_m) dy + \beta_1 + \beta_2 \end{aligned}$$

where

$$\beta_1 = \sum_i \int_{y_i - (a/b)\gamma}^{y_i} \left[ \frac{b(y_i - y)}{a\gamma} \delta - \delta \right] J(y, f_m) dy,$$

and

$$\beta_2 = \sum_i \int_{y_i}^{y_i + \gamma} \left[ \frac{a(y_i - y)}{b\gamma} \delta + \frac{a}{b} \delta \right] J(y, f_m) dy.$$

It is noted that the function in the square brackets in  $\beta_1$  has a minimum value of  $-\delta$  and a maximum

value of zero. Similarly, the function in the square brackets in  $\beta_2$  has a minimum value of zero and a maximum value of  $(a/b)\delta$ . These maximum and minimum values are all independent of the choice of  $\gamma$ , and hence  $\beta_1$  and  $\beta_2$  approach zero as  $\gamma$  approaches zero, since  $J(y, f_m)$  is surely bounded.

Substituting from (5) and (5')

$$\begin{aligned} P_{mm} - P_{nm} &= \delta \left[ \int_A \bar{J}_m dy + \Delta \right] \\ &\quad - \frac{a}{b} \delta \left[ \int_B \bar{J}_m dy - \Delta \right] + \beta_1 + \beta_2 \\ &= \delta \Delta + \left[ \frac{a}{b} \delta \Delta + \beta_1 + \beta_2 \right]. \end{aligned}$$

Hence

$$P_{mm} - P_{nm} > \delta \Delta > 0 \quad (10)$$

if only  $\gamma$  is chosen sufficiently small to make

$$\left[ \frac{a}{b} \delta \Delta + \beta_1 + \beta_2 \right] > 0.$$

Next consider the difference

$$\begin{aligned} P_{nm} - P_{nn} &= P_{mn} - P_{nn} \\ &= \int_0^L [f_m(y) - f_n(y)] J(y, f_n) dy \\ &= \delta \int_A J(y, f_n) dy \\ &\quad - \delta \frac{a}{b} \int_B J(y, f_n) dy + \beta_3 + \beta_4 \quad (11) \end{aligned}$$

where  $\beta_3$  and  $\beta_4$  are equal to  $\beta_1$  and  $\beta_2$ , respectively, with  $J(y, f_m)$  simply replaced by  $J(y, f_n)$ . Evidently  $\beta_3$  and  $\beta_4$  also approach zero as  $\gamma$  approaches zero, for  $J(y, f_n)$  is also bounded.

Now it was shown in lemma I, Section VI, that  $J(y, f_n)$  lies everywhere on the interval  $(0, L)$  within a  $\rho$  neighborhood of  $J(y, f_m)$  where

$$\rho = \int_0^L | \{ f_m(y) - f_n(y) \} | dy.$$

Hence

$$\int_A J(y, f_n) dy > \int_A [J(y, f_m) - \rho] dy$$

and

$$\int_B J(y, f_n) dy < \int_B [J(y, f_m) + \rho] dy.$$

Substituting again from (5) and (5') these inequalities become

$$\int_A J(y, f_n) dy > | a\bar{J}_n + \Delta - a\rho |$$

$$\int_B J(y, f_n) dy < [b\bar{J}_n - \Delta + b\rho].$$

Substituting these last inequalities back in (11), it is seen that

$$P_{nm} - P_{nn} > \delta\Delta \left(1 + \frac{a}{b}\right) - 2a\delta\rho + \beta_3 + \beta_4.$$

But

$$\rho = \int_0^L |f_m(y) - f_n(y)| dy = 2a\delta + \beta_5 - \beta_6$$

where  $\beta_5$  and  $\beta_6$  are equal to  $\beta_1$  and  $\beta_2$ , respectively, with  $J(y, f_m)$  simply replaced by unity. Hence  $\beta_5$  and  $\beta_6$  also approach zero as  $\gamma$  approaches zero. Thus

$$P_{nm} - P_{nn} > \delta\Delta - 4a^2\delta^2 + \left\{ \frac{a}{b} \delta\Delta - 2a\delta(\beta_5 - \beta_6) + (\beta_3 + \beta_4) \right\}.$$

Let  $\gamma$  be chosen sufficiently small to make

$$\left\{ \frac{a}{b} \delta\Delta - 2a\delta(\beta_5 - \beta_6) + (\beta_3 + \beta_4) \right\} > 0.$$

Then

$$P_{nm} - P_{nn} > \delta\Delta - 4a^2\delta^2.$$

It is now seen that

$$P_{nm} - P_{nn} > 0,$$

if only

$$\delta \leq \frac{\Delta}{4a^2}.$$

Consequently, it is surely true that

$$P_{nm} - P_{np} > 0$$

if only

$$\delta \leq \frac{\Delta}{4L^2}$$

since  $L > a$ .

Now from (10)

$$P_{mm} - P_{nn} > \delta\Delta.$$

Hence, if only

$$\delta \leq \frac{\Delta}{4L^2}$$

$$P_{mm} - P_{nn} > \delta\Delta$$

and in particular, if  $\delta$  is taken equal to  $\Delta/4L^2$

$$P_{mm} - P_{nn} > \frac{\Delta^2}{4L^2}.$$

Thus, unless  $\Delta$  is sufficiently small and in fact actually approaches zero as  $\epsilon$  approaches zero, it is possible

to define a second admissible function  $f_n(y)$  such that

$$P_{mm} - P_{nn} > P_{mm} - B = \epsilon,$$

which is ridiculous.

Thus a necessary condition that the proposed problem realize an approximate solution of order  $\epsilon \leq E$  in the admissible function  $f(y)$  is that  $f(y)$  satisfy the relation

$$J(y, f) \cong \text{constant}, \quad (0 \leq y \leq L)$$

to an approximation of sufficiently small order  $\Delta$ , where  $\Delta$  actually approaches zero as the positive constant  $E$  is chosen smaller and smaller.

That this condition is sufficient as well as necessary can be shown as follows:

Suppose  $f_1(y)$  and  $f_2(y)$  are two admissible functions such that the relations

$$J(y, f_1) \cong \bar{J}_1$$

and

$$J(y, f_2) \cong \bar{J}_2$$

are satisfied to approximations of order  $\Delta_1$  and  $\Delta_2$ , respectively. Then

$$P_{11} = \int_0^L f_1(y) J(y, f_1) dy \cong C\bar{J}_1$$

to an approximation of order  $\leq |f_1|_{\max} \Delta_1$ , where  $C$  is the isoperimetric constant, and where  $|f_1|_{\max}$  is the maximum absolute value of  $f_1$ . Similarly

$$P_{22} \cong C\bar{J}_2$$

to an approximation of order  $\leq |f_2|_{\max} \Delta_2$ .

On the other hand the auxiliary integrals  $P_{12}$  and  $P_{21}$  can be approximated as follows:

$$P_{12} = \int_0^L f_1(y) J(y, f_2) dy \cong C\bar{J}_2$$

to an approximation of order  $\leq |f_1|_{\max} \Delta_2$ , and

$$P_{21} \cong C\bar{J}_1$$

to an approximation of order  $\leq |f_2|_{\max} \Delta_1$ . Now

$$P_{12} = P_{21}.$$

Hence

$$C\bar{J}_2 = C\bar{J}_1$$

to an approximation of order  $\leq [|f_1|_{\max} \Delta_2 + |f_2|_{\max} \Delta_1]$ . Whence finally

$$P_{11} = P_{22}$$

to an approximation of order

$$\leq [|f_1|_{\max} \Delta_1 + |f_1|_{\max} \Delta_2 + |f_2|_{\max} \Delta_1 + |f_2|_{\max} \Delta_2].$$

Evidently, by suitable choice of  $\Delta_1$  and  $\Delta_2$ , this approximation can be made as small as desired.

Thus, all functions  $f(y)$  satisfying the necessary condition stated above to an approximation of sufficiently small order reduce the integral  $P(f)$  to approximately the same value.

Therefore the integral  $P(f)$  realizes an approximate absolute minimum in every admissible function  $f(y)$  satisfying the condition

$$J(y, f) \cong \text{constant} \quad (0 \leq y \leq L)$$

to an approximation of sufficiently small order. Thus it has been proved:

*Theorem: A necessary and sufficient condition that an admissible function  $f(x)$  furnish an approximate absolute minimum for  $P(f)$ , is that  $f(x)$  satisfy the relation*

$$\int_0^L f(x) \left[ \frac{\sin(x-y) - (x-y)\cos(x-y)}{(x-y)^3} + \frac{\sin(x+y) - (x+y)\cos(x+y)}{(x+y)^3} \right] dx \cong \text{constant}$$

for  $0 \leq y \leq L$ , to an approximation of sufficiently small order  $\Delta$ .

## VII. THEORETICAL OPTIMUM CURRENT DISTRIBUTION ON VERTICAL ANTENNAS

It was pointed out in Section IV that the problem proposed in this paper cannot be solved by classical or indirect methods, and a direct attack is therefore necessary. The first step in setting up minimizing sequences, such as are essential in all direct attacks on variation problems was then taken, and a necessary and sufficient condition for a solution was immediately derived. Attempts to utilize this condition in reducing the labor involved in deriving actual solution functions lead at once to a study of the integral equation

$$\int_0^L f(x) \left[ \frac{\sin(x-y) - (x-y)\cos(x-y)}{(x-y)^3} + \frac{\sin(x+y) - (x+y)\cos(x+y)}{(x+y)^3} \right] dx = \text{constant} \quad (0 \leq y \leq L). \quad (12)$$

The question as to whether or not this equation actually possesses a solution arises immediately, for this is clearly equivalent to the question as to whether or not the proposed minimum problem possesses an exact solution. Next in order comes up the question as to the best methods of solving such equations, either exactly or approximately.

Equation (12) is recognized as a linear integral equation of the first kind and is, therefore, a member of a class of equations that has received considerable attention from mathematicians in the past hundred years.

It is known that an equation of this class may have either an infinity of solutions, a unique solution, or no solution at all; and various existence and uniqueness theorems for integral equations of the form

$$f(x) = \int_a^b K(x, y)\phi(y)dy$$

in which the kernel  $K(x, y)$  fulfills suitable conditions, have already been developed by numerous investigators.<sup>8-16</sup>

However, it has not been found possible to apply any of the existence criteria deduced by these writers to the particular equation (12). Consequently, it has not been possible actually to prove the existence of exact solutions for the proposed optimum-current-distribution problem. As a result it has been found necessary to limit attention to the derivation of approximate solutions. But this limitation is not a cause for concern, since, as has already been pointed out, approximate solutions are all that are required for engineering purposes. That such approximate solutions actually exist for the problem under consideration follows at once from the fact that the power integral  $P(f)$  is bounded below by zero.

Approximate solutions of the theoretical optimum-current-distribution problem may be obtained in two ways, both of which make use of the necessary and sufficient condition for an approximate solution derived in Section VII.

The first method of solution consists simply in deriving approximate numerical solutions to equation (12) by any one of a number of well-known procedures.<sup>17</sup> In each case the procedure is essentially to set up and solve  $n$  linear equations in  $n$  unknowns, where the  $n$

<sup>8</sup> Émile Picard, "Quelques remarques sur les équations intégrales de première espèce et sur certains problèmes de physique mathématique," *Comptes Rendus Hebdomadaires des Séances de l'Académie des Sciences*, vol. 148, pp. 1563-1568, 1707-1708; June, 1909.

<sup>9</sup> Émile Picard, "Sur un théorème général relatif aux équations intégrales de première espèce," *Rendiconti del Circolo Matematico di Palermo*, vol. 29, pp. 79-97; July, 1910.

<sup>10</sup> G. Lauricella, "Sull' equazione integrale di 1<sup>a</sup> specie," *Atti della Reale Accademia dei Lincei*, serie quinta, Rendiconti, vol. 18, part II, pp. 71-75; 1909.

<sup>11</sup> G. Lauricella, "Sulla risoluzione dell' equazione integrale di 1<sup>a</sup> specie," *Atti della Reale Accademia dei Lincei*, serie quinta, Rendiconti, vol. 20, part I, pp. 528-536; 1911.

<sup>12</sup> Attilio Vergerio, "Sull' equazione integrale di 1<sup>a</sup> specie," *Atti della Reale Accademia dei Lincei*, serie quinta, Rendiconti, vol. 23, part II, pp. 385-389; 1914.

<sup>13</sup> Attilio Vergerio, "Una condizione necessaria e sufficienti per l'esistenza di soluzioni nell' equazione integrale di 1<sup>a</sup> specie," *Atti della Reale Accademia dei Lincei*, serie quinta, Rendiconti, vol. 24, part I, pp. 1199-1205; 1915.

<sup>14</sup> Carlo Severini, "Sulle equazioni integrali di prima specie del tipo Fredholm," *Atti della Reale Accademia dei Lincei*, serie quinta, Rendiconti, vol. 23, part I, pp. 219-225, 315-321; 1910.

<sup>15</sup> Luigi Amoroso, "Sulla risolubilità della equazione integrale lineare di prima specie," *Atti della Reale Accademia dei Lincei*, serie quinta, Rendiconti, vol. 19, part I, pp. 68-75; 1910.

<sup>16</sup> Luigi Amoroso, "Intorno alla equazione integrale di prima specie," *Bollettino della Unione Matematica Italiana*, serie II, vol. 1, pp. 193-197; 1939.

<sup>17</sup> See, for example, Prescott D. Crout, "An application of polynomial approximations to the solution of integral equations arising in physical problems," *Jour. Math. and Phys.*, vol. 19, pp. 34-92; January, 1940.

unknowns are ordinates of the desired solution function, and where the coefficients are determined from the values of the kernel by one rule or another. For (12), the desired solution function is  $f(x)$ , and the kernel is the function

$$K[x, y] = \left[ \frac{\sin(x-y) - (x-y)\cos(x-y)}{(x-y)^3} + \frac{\sin(x+y) - (x+y)\cos(x+y)}{(x+y)^3} \right] \quad (13)$$

It can easily be shown that as the length of the interval of integration  $(0, L)$  decreases the kernel values all tend toward a common value  $\frac{2}{3}$ . Hence, as  $L$  approaches zero, the coefficients appearing in the  $n$  linear equations for the  $n$  unknown ordinates, which are constructed out of the kernel values by specified rules, tend toward a common value. Consequently, when the range of integration  $(0, L)$  is relatively small, accurate solutions for the  $n$  unknowns are very difficult. In fact, for (12), it was found that when  $L$  is less than  $\pi$  (i.e., the height less than  $\frac{1}{2}$  wavelength) it was impossible to determine approximate solutions with any accuracy because of the prohibitive amount of labor involved. Use of the special method devised by Moulton<sup>18</sup> did not remove this difficulty although it did make possible rough estimates of the nature of the approximate solution.

The physical significance of the mathematical difficulty just alluded to can be made clearer to engineers in the following manner. It is readily seen that on an antenna of height very small relative to a wavelength any particular admissible distribution is quite as good as any other, for in this case it is as though all radiation were coming from a point source. Thus, the optimum-current-distribution problem becomes indeterminate as the antenna height approaches zero.

The second method of obtaining approximate solutions of the proposed problem will now be described in detail, for it is the method that was actually used in obtaining the solution functions presented in this section. The procedure is simply to set up a minimizing sequence of admissible functions  $f_1(y), f_2(y), f_3(y), \dots, f_n(y)$  in the manner initiated in Section V, terminating the sequence in the first function  $f_n(y)$  for which the power integral  $P(f_n)$  is sufficiently close to its greatest lower bound  $B$  (that is, for which  $P(f_n) - B < E$ , where  $E$  is an assigned positive quantity).

It was pointed out in Section VI that if  $f_m(y)$  is an admissible function which does not satisfy the integral equation (12), then it is always possible to define a second admissible function

$$f_{m+1}(y) = f_m(y) + \alpha_m [\bar{J}_m - J(y, f_m)] \quad (14)$$

such that  $P(f_{m+1}) < P(f_m)$ , provided only that  $\alpha_m > 0$  and is chosen sufficiently small. Thus, starting with any admissible function  $f_1(y)$  a sequence of admissible functions

$$f_1(y), f_2(y), f_3(y), \dots, f_n(y), \quad (15)$$

can be derived by applying this rule, such that

$$P(f_1) > P(f_2) > P(f_3) > \dots > P(f_n). \quad (16)$$

If it so happens that the  $n$ th function in this sequence satisfies the integral equation

$$J(y, f_n) = \text{constant} \quad (0 \leq y \leq L)$$

then all functions beyond  $f_n$  coincide with  $f_n$  and the sequence may be thought of as a finite sequence. It has already been shown that such a function  $f_n$  would constitute an exact solution to the problem.

However, admissible functions satisfying the above integral equation are not likely to occur in practice, so that the sequence of functions (15) is usually non-terminating. Nevertheless, it does not follow that the sequence of values

$$P(f_1), P(f_2), P(f_3), \dots, P(f_n), \quad (17)$$

necessarily converges to the greatest lower bound  $B$  itself, even though  $\alpha_m$  is always small enough so that (16) is true. In fact it is easy to so select the  $\alpha$ 's that the sequence (17) converges to  $B + \tau$  where  $\tau$  is greater than zero. It is in making a suitable choice of the factor  $\alpha_m$  that the necessary and sufficient condition derived in Section VI for an approximate absolute minimum is used. This factor must be chosen so that the sequence (17) not only converges to  $B$  itself, but moreover converges to it as rapidly as possible.

Now it is clear from the necessary and sufficient condition just referred to that  $\alpha_m$  should be chosen to make  $J(y, f_{m+1})$  as flat as possible. The requisite procedure for achieving this end is illustrated in Fig. 5. An admissible function  $f_1(y)$  for the full-wave antenna ( $L = 2\pi$ ) is plotted together with the corresponding  $J$  function  $J(y, f_1)$ . Next, two possible derived functions,  $f_{21}(y)$  for  $\alpha_1 = 0.6$  and  $f_{22}(y)$  for  $\alpha_1 = 1$  are plotted together with their  $J$  functions. In view of lemma I, it is seen at once that the  $J$  function corresponding to  $\alpha_1 = 0.6$  is almost as flat as can be obtained in a single step and so

$$f_2(y) \equiv f_{21}(y) = f_1(y) + 0.6\{\bar{J}_1 - J(y, f_1)\}$$

is used as the second function in the sequence (15). The amount of labor involved in obtaining a suitable choice of the factor  $\alpha_m$  is not nearly as great as might at first be expected. This will become apparent in the sequel.

The procedure used in the derivation of the actual solution functions presented in this section was as follows:

1. An initial admissible function  $f_1(y)$  was selected; usually it was taken simply as unity.

<sup>18</sup> F. R. Moulton, "On the solution of linear equations having small determinants," *Amer. Math. Monthly*, vol. 20, pp. 242-249; October, 1913.

2. The corresponding  $J$  function

$$J(y, f_1) = \int_0^L f_1(x)K(x, y)dx$$

where  $K(x, y)$  is given in (13), was computed for nine values of  $y$  taken uniformly over the interval  $(0, L)$ , the integration being affected by Simpson's rule.

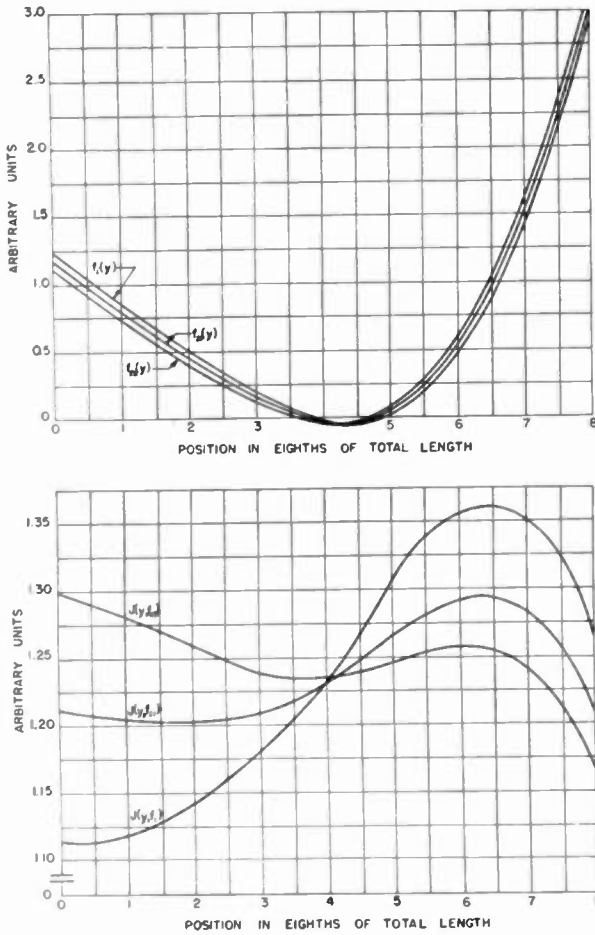

Fig. 5—A diagram showing the functions  $f_{21}(y)$  and  $f_{22}(y)$  above, derived from  $f_1(y)$  for two possible choices of  $\alpha$ , and showing the relative flatness of the corresponding  $J$  functions below.

3. The average value  $\bar{J}_1$  was next determined.
4. The nine corresponding ordinates of the function  $\{\bar{J}_1 - J(y, f_1)\}$  were next computed.
5. The second function in the sequence, viz.,

$$f_2(y) = f_1(y) + \alpha_1\{\bar{J}_1 - J(y, f_1)\},$$

can be computed for the nine points in question once  $\alpha_1$  has been suitably chosen (See 7 below).

6. Evidently

$$\begin{aligned} J(y, f_2) &= \int_0^L [f_1(x) + \alpha_1\{\bar{J}_1 - J(x, f_1)\}]K(x, y)dx \\ &= \int_0^L f_1(x)K(x, y)dx \\ &\quad + \alpha_1 \int_0^L \{\bar{J}_1 - J(x, f_1)\}K(x, y)dx. \end{aligned}$$

Now the first term on the right-hand side has already been determined for nine different values of  $y$ , and the coefficient of  $\alpha_1$  is next determined for each of these same nine values.

7. In any particular case, it was then a simple matter to select a value for  $\alpha_1$  such that the nine values of  $J(y, f_2)$  lie as nearly as possible on a horizontal straight line. For example, in the case of the quarter-wave antenna the choice of  $\alpha_1$  was made by simply equating the two end values of  $J(y, f_2)$ .

8. The same procedure was repeated in order to determine the third function in the sequence (15), viz.,  $f_3(y)$ , and so forth.

The functions of the minimizing sequence actually obtained in this manner for the full-wave antenna, are shown in Fig. 6, together with the corresponding  $J$  functions. The  $J$  functions flatten off progressively towards a horizontal straight line, as was to be expected, while the functions of the minimizing sequence are apparently approaching a *limit function*. This suggests that the specific theoretical optimum-current-distribution problem under consideration actually possesses an exact solution.

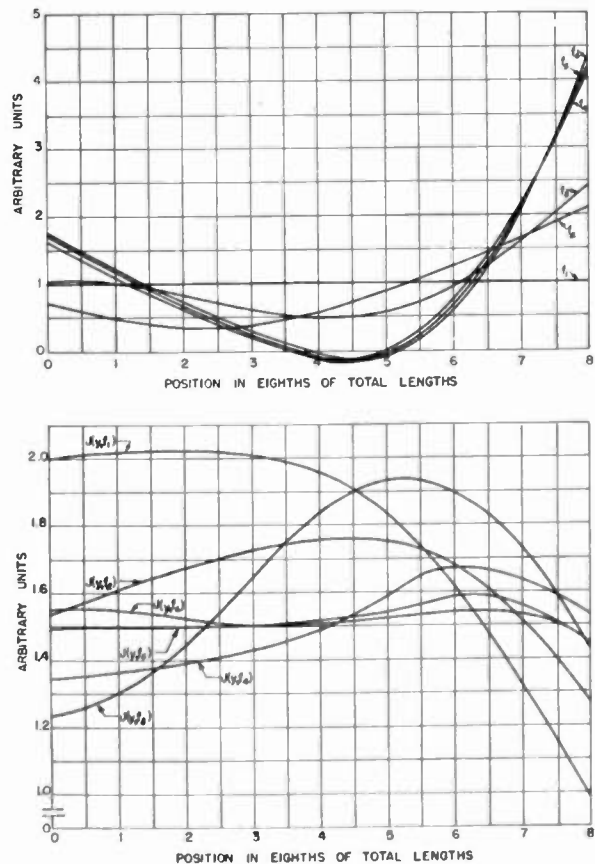

Fig. 6—A diagram showing a sequence of minimizing functions above, for a full-wave antenna, together with their corresponding  $J$  functions below.

The power integral  $P(f)$  has been computed for each of the six functions in the minimizing sequence, and plotted as shown in Fig. 7. It is seen that  $P(f)$  drops rapidly for the first four functions in the sequence, but

remains practically constant in value for the last three functions. Thus  $f_4$ ,  $f_6$ , and  $f_8$  may all be taken as reasonably satisfactory *approximate* solution functions.

The order of approximation

$$\Delta(f) = \int_A |J(y, f) - \bar{J}| dy$$

to which the integral equation

$$J(y, f) = \text{constant} \quad (0 \leq y \leq L)$$

is satisfied is also calculated for each function in the sequence and plotted in Fig. 7.

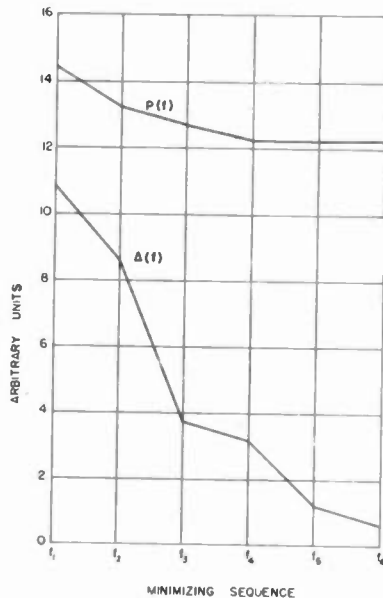

Fig. 7—A diagram showing how the power integral  $P(f)$  asymptotically approaches a minimum as the order of approximation  $\Delta(f)$  in the necessary and sufficient condition approaches zero.

Approximate solution functions were also found in a similar manner for  $\frac{1}{8}$ -,  $\frac{1}{4}$ -,  $\frac{3}{8}$ -,  $\frac{1}{2}$ - and  $\frac{3}{4}$ -wave antennas. These distributions are all shown in Fig. 8. They are not plotted either for the same power output for each antenna, or for the same field strength on the horizon for each antenna, because in either case it would be impossible to plot them all on the same sheet of paper. They are simply plotted in such a manner as to make it easy to obtain approximate optimum distributions at intermediate heights by interpolation.

It was pointed out in Section I that the theoretical optimum current distribution on an antenna of given height would be of considerable importance because it could be used to bound the improvement in the performance of the antenna which could be expected to result from changes in current distribution. This bound on antenna performance for various antenna heights is shown graphically in Fig. 9. Relative field strength on the horizon for the theoretical optimum current distribution on the antenna and for constant power output is plotted as a function of antenna height. The same curve for the usual sinusoidal current distribu-

tion on the antenna is plotted on the same diagram and may be used for purposes of comparison. Thus the greatest possible increase in field strength that can be hoped for with a  $\frac{1}{4}$ -wave antenna is about 35 per cent, while the greatest possible increase that can be hoped for on the  $\frac{5}{8}$ -wave antenna is only about 16 per cent.

#### VIII. PRACTICAL OPTIMUM CURRENT DISTRIBUTIONS ON VERTICAL ANTENNAS

The practical optimum current distribution on a vertical antenna of given length was defined in an earlier section as simply that distribution most desirable for a fixed power output, in any particular case. It is immediately clear that such a distribution cannot be determined, once and for all, by any exact mathematical process, because such distributions depend on a large number of factors, economic and otherwise, in a very complicated manner. Furthermore, the importance of most of these factors varies greatly from one antenna setup to another. For example, the fading due to the reflection of high-angle radiation from the ionosphere may greatly reduce the primary coverage of a high-power transmitter (say 50,000 watts), and yet have no effect on the coverage of a low-power transmitter (say 100 watts), because the direct signal from the low-power transmitter is too weak in the fading area to be of any value anyway. Then too, some of these factors actually vary with time. For example, the efficiency of antenna systems has been greatly increased in the past six years due to improved ground systems. Therefore, it is only desired in this section to indicate that certain improvements in antenna performance due to changes in current distribution can be expected while others definitely cannot, now that the theoretical optimum current distributions have been approximately determined.

The theoretical optimum current distributions for antennas ranging in height from a  $\frac{1}{8}$  wave to a full wave are shown in Fig. 8 of Section VII. But before attempts are made to find ways of approximately realizing these distributions in practice, the corresponding vertical-radiation patterns should be plotted and studied. These are shown in Figs. 10 to 13 inclusive for the  $\frac{1}{4}$ -wave,  $\frac{1}{2}$ -wave,  $\frac{3}{4}$ -wave, and full-wave antennas. It is seen that there is considerable high-angle radiation in each case, and this is usually undesirable. Therefore in seeking practical optimum distributions, the theoretical optimum distributions may be used as a guide, but special care must be taken to minimize the high-angle radiation.

The first antenna considered will be the  $\frac{1}{4}$ -wave, as this antenna has received a great deal of attention from earlier investigators, and as the results obtained in Section VII indicate that a 35 per cent increase in field strength on the horizon over that obtainable with the usual sinusoidal distribution is theoretically possible.

It should be recalled at this point that the integral



equation (12) was extremely difficult to solve by the usual numerical methods in the case of the  $\frac{1}{4}$ -wave antenna, because such short antennas are relatively

modified form gives a field strength on the horizon about 15 per cent less than that obtainable with the optimum distribution, but this is still somewhat

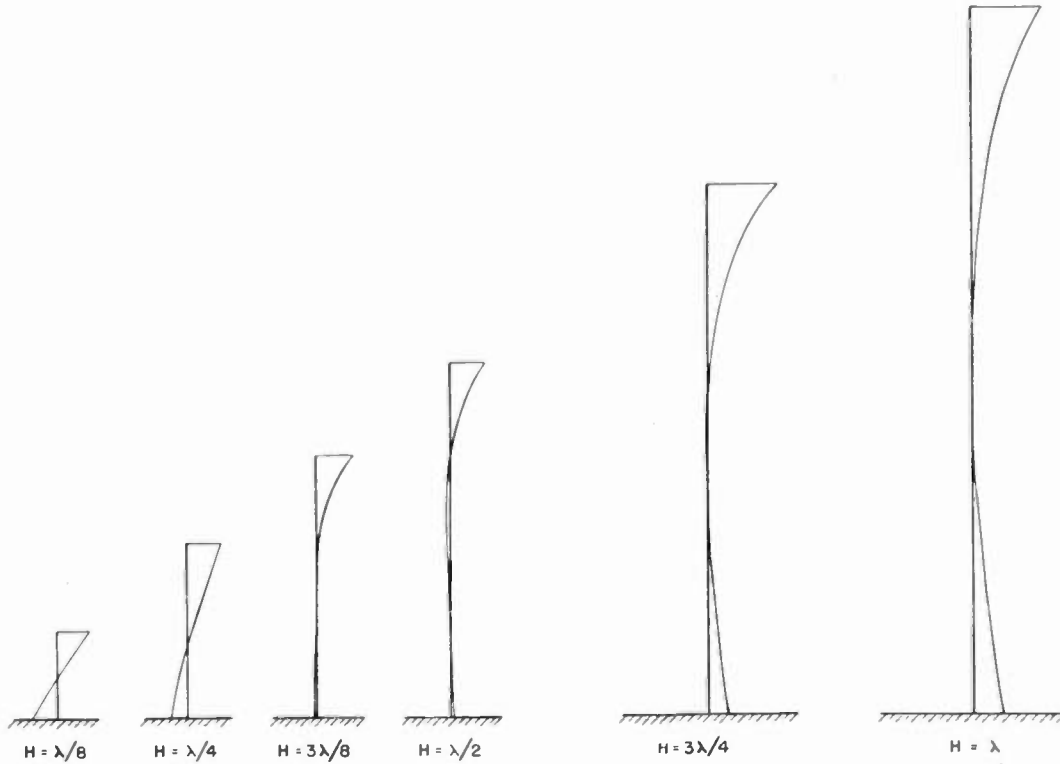

Fig. 8—Theoretical optimum current distributions on vertical antennas for heights varying from  $\frac{1}{8}$  wave-length to a full wave-length.

insensitive to changes in current distribution. This would lead one to expect the existence of distributions on the  $\frac{1}{4}$ -wave antenna varying considerably from that found in Section VII, and yet giving practically as good results. Two examples of such distributions are actually given in Fig. 14. The decrease in the field strength on the horizon from that obtainable with the optimum distribution and the same power output is, in both cases, quite negligible. Still another very approximate optimum distribution for the  $\frac{1}{4}$ -wave antenna was obtained by solving (12), using one of the usual numerical methods. This distribution was given to Jordan,<sup>19</sup> formerly at The Ohio State University, who set it up on an acoustic model of a  $\frac{1}{4}$ -wave antenna and checked its vertical pattern experimentally. The pattern was found to be almost as good as that obtained with a sinusoidal distribution on a  $\frac{1}{2}$ -wave antenna.

However, all these distributions give vertical-radiation patterns with large high-angle lobes similar to the lobe in the pattern for the optimum distribution on a  $\frac{1}{2}$ -wave antenna, and are therefore, unsatisfactory for most practical applications. Nevertheless, distribution (b) can be modified by taking  $d = 0.088\lambda$  instead of  $0.1\lambda$  to obtain a distribution giving a vertical pattern with little or no high-angle radiation. Such a pattern is shown in Fig. 15 together with the pattern for the optimum current distribution. Distribution (b) in this

greater than that obtained with the usual sinusoidal distribution on a  $\frac{1}{2}$ -wave antenna. Furthermore, distribution (b) in its modified form is quite readily realized in practice through a system of top-loading studied by Nickle, Dome, and Brown.<sup>20</sup> Thus distribution (b) in its modified form on a  $\frac{1}{4}$ -wave antenna has a very desirable radiation pattern, gives a field strength

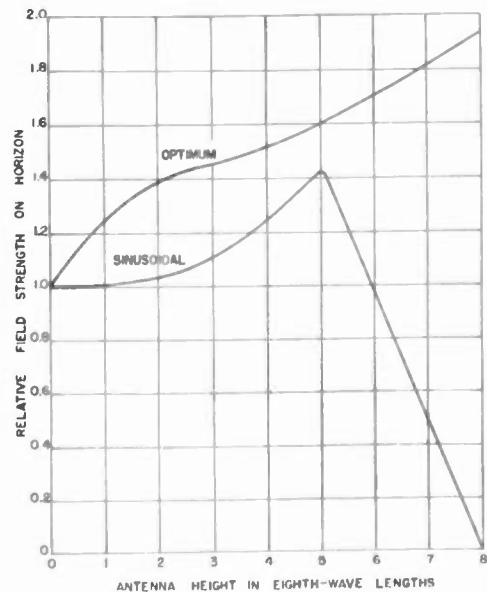

Fig. 9—Field strengths on the horizon for optimum current distributions and for sinusoidal current distributions plotted as functions of antenna height, all for constant power output.

<sup>19</sup> E. C. Jordan and W. L. Everitt, "Acoustic models of radio antennas," *Proc. I.R.E.*, vol. 29, pp. 186-194; April, 1941.

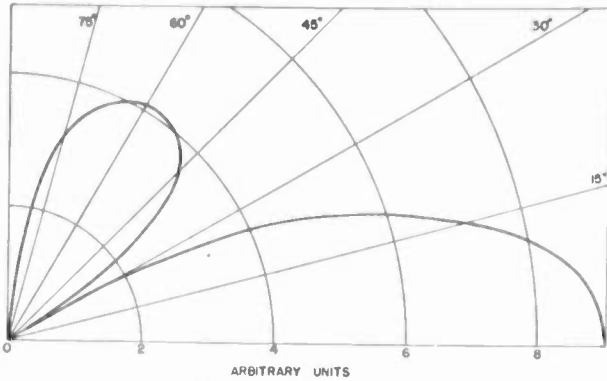

Fig. 10—Vertical radiation pattern for the theoretical optimum current distribution on a  $\frac{1}{2}$ -wave antenna.

on the horizon somewhat better than that obtainable for the same power output with the usual sinusoidal distribution on the very common  $\frac{1}{2}$ -wave antenna, and is physically realizable.

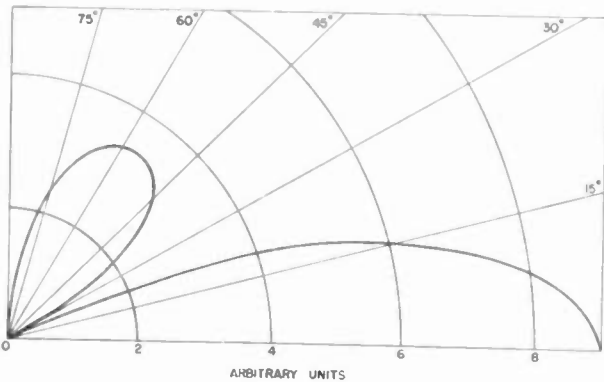

Fig. 11—Vertical radiation pattern for the theoretical optimum current distribution on a  $\frac{1}{4}$ -wave antenna.

Whether this distribution is economically realizable or not depends chiefly on two things: first, the cost of coupling into the antenna system, and second, the efficiency of the antenna system. Now, unfortunately,

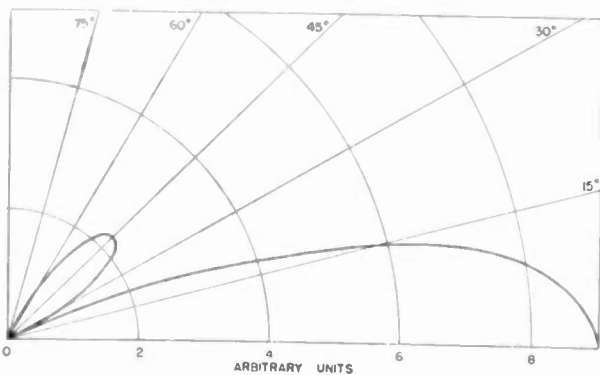

Fig. 12—Vertical radiation pattern for the theoretical optimum current distribution on a  $\frac{1}{4}$ -wave antenna.

the radiation resistance of a  $\frac{1}{4}$ -wave antenna with the modified form of distribution (b) upon it is extremely low, being only about 2 or 3 ohms referred to the base. Such a radiation resistance is not only too low to couple into at reasonable cost, but it is of the same order as the ohmic resistance of the antenna system.

Thus the efficiency of the system is unreasonably low as the power radiated and the power lost are of the same order of magnitude. The first of these difficulties might possibly be overcome by driving the antenna at the point of zero current where the radiation resistance

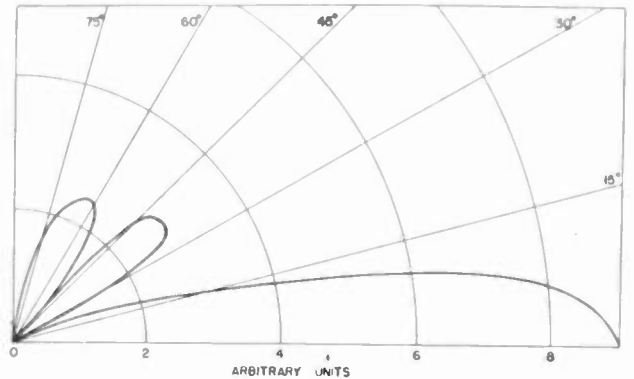

Fig. 13—Vertical radiation pattern for the theoretical optimum current distribution on a full-wave antenna.

is relatively high. But it is clear that the second difficulty would still remain, since the ratio of power radiated to power lost is entirely independent of the driving point.

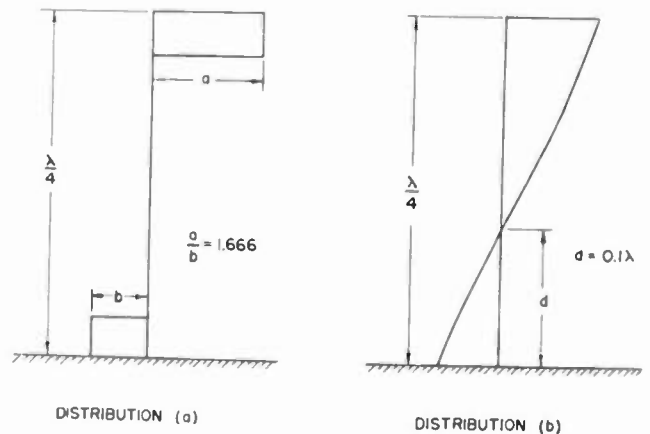

Fig. 14—Two quite arbitrary current distributions on a  $\frac{1}{4}$ -wave antenna giving vertical radiation patterns almost identical with that given by the optimum current distribution.

If the distance  $d$  (Fig. 14) of the point of zero current above the ground is allowed to vary from  $-0.25\lambda$  to  $0.25\lambda$ , a special family of  $\frac{1}{4}$ -wave current distributions is obtained. The radiation resistance referred to

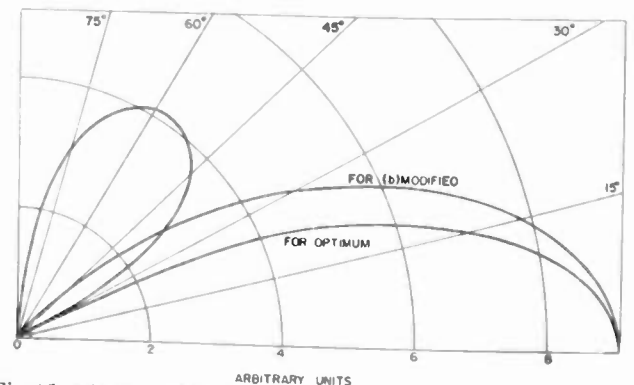

Fig. 15—Vertical radiation pattern for the optimum current distribution on a  $\frac{1}{4}$ -wave antenna together with that for a modified form of the distribution (b) shown in Fig. 14.

the antenna base and the relative field strength on the horizon for constant power output are shown for such a family in Fig. 16. It is seen that the radiation resistance rises rapidly as the distance  $d$  decreases from  $0.1\lambda$  while the field strength on the horizon drops off relatively slowly. Thus by operating with the zero at some point less than  $0.088\lambda$  it is possible to obtain a quite satisfactory radiation resistance and still produce a field strength on the horizon well above that obtained with the usual sinusoidal distribution for which  $d = -0.25\lambda$ . Nickle, Dome, and Brown<sup>20</sup> recommended in 1934 that such antennas be operated with  $d = 0$ , so as to reduce ground currents and thus ground losses to a minimum. However ground systems have been improved so greatly since 1934 that ground losses are now of the same small order as the losses in the antenna itself and may be neglected whenever the radi-

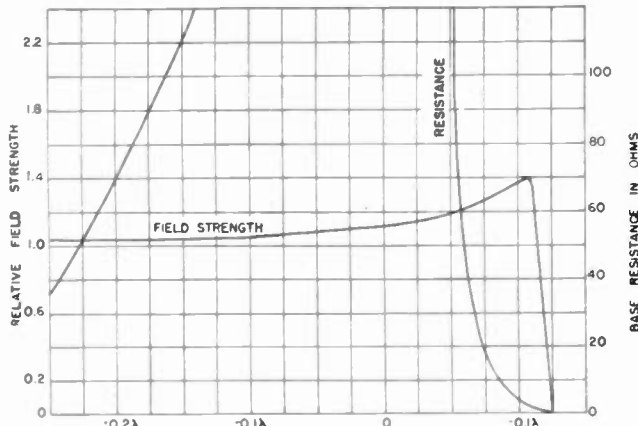

Fig. 16—Radiation resistance and relative field strength on the horizon for a sinusoidal current distribution on a top-loaded  $\frac{1}{4}$ -wave antenna, both plotted as functions of the position of the null in the current loop.

ation resistance is at all reasonable (say 20 ohms or greater). Thus, with modern ground systems, it would probably be best to operate such antennas with  $d$  somewhere between 0 and  $0.088\lambda$ .

Another distribution on the  $\frac{1}{4}$ -wave antennas giving an antenna performance very nearly equal to that obtained by the optimum distribution itself, was considered by Smith<sup>21</sup> but he found that this distribution also gave a very low radiation resistance. It will now be shown that extremely low radiation resistance is characteristic of all distributions on a  $\frac{1}{4}$ -wave antenna giving an antenna performance approaching the optimum performance.

It is observed that all possible distributions on a  $\frac{1}{4}$ -wave antenna can be approximated by a set of current elements such as the element shown in Fig. 17, where the amplitude and position of each element on the antenna is properly chosen. Now it is easily shown that the phase of the magnetic field in both time and space at any distant point, due to radiation both direct

and indirect from such an element, is quite independent of the height  $h$  of the element above the base. Thus the vertical-radiation pattern for a distribution made up of such elements is given by a simple alge-

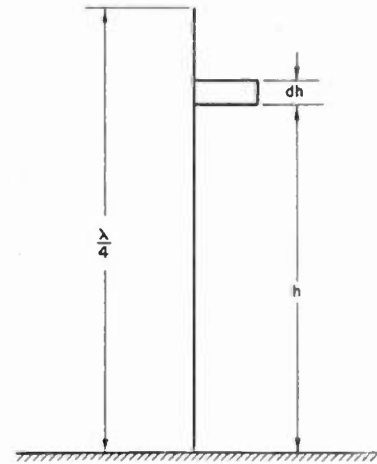

Fig. 17—A current element on a  $\frac{1}{4}$ -wave antenna.

braic summation of the radiation patterns corresponding to the component elements. The vertical-radiation patterns for the current element of Fig. 17 in various positions on a  $\frac{1}{4}$ -wave antenna are shown in Fig. 18. It is seen from this figure that the current element radiates the same amount of power in the horizontal direction, where the maximum radiation is desired, for all positions on the antenna, but radiates less power in all other directions the higher its position on the antenna. Therefore, if attention is restricted to elements of the same sign, it is seen that the distribution  $f(h)$  giving the maximum possible radiation in the horizontal plane while satisfying the isoperimetric side condition

$$\int_0^{\lambda/4} f(h)dh = \text{constant}$$

is simply that distribution concentrating all current elements at the top of the antenna.

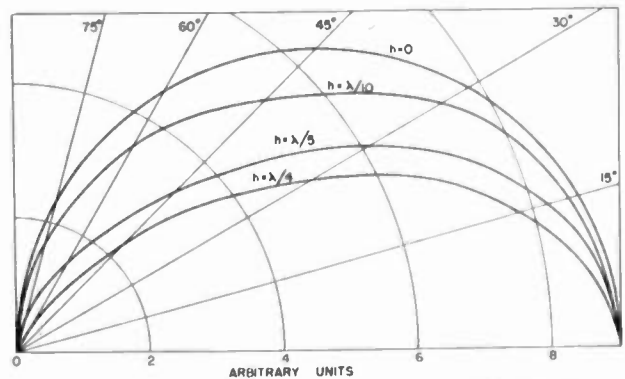

Fig. 18—Vertical radiation patterns for a current element at various heights on a  $\frac{1}{4}$ -wave antenna.

But the antenna performance obtained with such a distribution is still considerably poorer than that obtained with the optimum distribution on a  $\frac{1}{4}$ -wave antenna. Therefore, it is seen that the optimum performance on a  $\frac{1}{4}$ -wave antenna can be approached

<sup>20</sup> C. A. Nickle, R. B. Dome, and W. W. Brown, "Control of radiating properties of antennas," Proc. I.R.E., vol. 22, pp. 1362-1373; December, 1934.

<sup>21</sup> Carl E. Smith, "A critical study of two broadcast antennas," Proc. I.R.E., vol. 24, pp. 1329-1341; October, 1936.

only when current elements of opposite sign are admitted. But current elements of opposite sign on a  $\frac{1}{4}$ -wave antenna tend to cancel the radiation of the other elements at *all* angles. Thus, as optimum performance is approached, the amplitude of the standing wave of

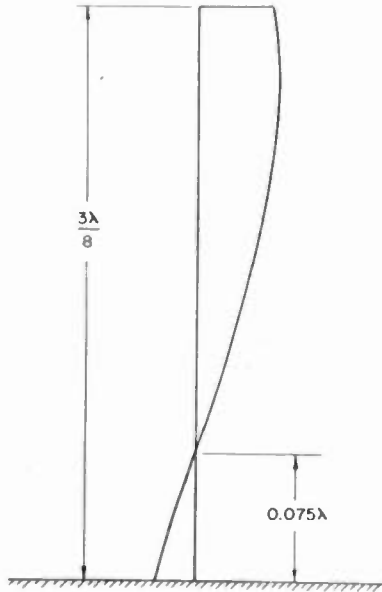

Fig. 19—A current distribution on a top-loaded  $\frac{3}{8}$ -wave antenna giving a performance comparable with that obtained with the usual  $\frac{1}{4}$ -wave antenna.

current on the antenna must go up very rapidly for a constant field strength on the horizon. Thus it is seen that a low-radiation resistance is characteristic of every current distribution on a  $\frac{1}{4}$ -wave antenna giving an antenna performance approaching the optimum performance.

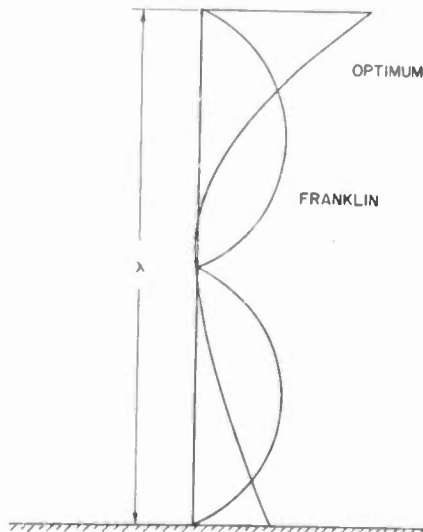

Fig. 20—Optimum current distribution together with the Franklin distribution on a full-wave antenna.

The next antenna to be considered here is the  $\frac{3}{8}$ -wave. Referring again to Fig. 9 it is seen that the optimum distribution gives a field strength about 30 per cent greater than the sinusoidal so that there is considerable room for improvement here. Furthermore, an

increase in field strength of only 12 per cent would give an antenna performance for the  $\frac{3}{8}$ -wave antenna equal to that for the very common  $\frac{1}{2}$ -wave antenna operated with the usual sinusoidal distribution. The distribution indicated in Fig. 19 actually gives such an increase in field strength with little or no high-angle radiation, and is physically realizable in the manner described by Nickle, Dome, and Brown.<sup>20</sup> Also, it is probably economically realizable, as it has a radiation resistance referred to the base of the order of 100 ohms.

Antennas greater than  $\frac{1}{2}$  wavelength in height are too costly to be considered for broadcast purposes. Nevertheless, it is of interest to point out here in closing, the similarity between the well-known Franklin distribution and the optimum distribution on a full-wave antenna. These are both shown in Fig. 20. The corresponding vertical-radiation patterns are shown in Fig. 21.

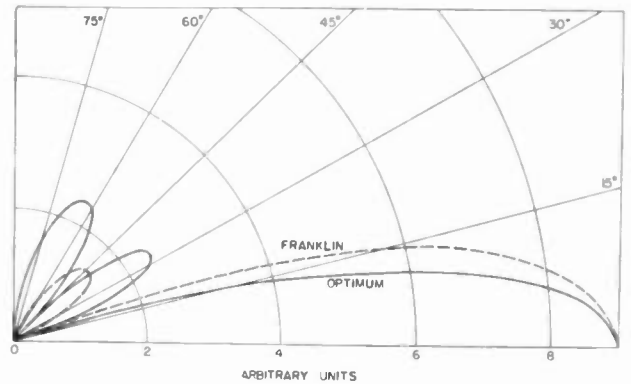

Fig. 21—Vertical radiation pattern for the optimum current distribution on a full-wave antenna together with that for the Franklin distribution.

## IX. CONCLUSIONS

1. The apparent antenna performance obtained with the theoretical optimum current distribution on a vertical antenna serves as an upper bound on the improvement in antenna performance which may be expected in the future as a result of changes in current distribution. Approximate theoretical optimum current distributions may be obtained by extracting approximate solutions from the integral equation

$$\int_0^L f(x) \left[ \frac{\sin(x-y) - (x-y)\cos(x-y)}{(x-y)^3} + \frac{\sin(x+y) - (x+y)\cos(x+y)}{(x+y)^3} \right] dx \cong \text{constant}.$$

Such solutions are shown in Fig. 8 for vertical antennas varying in height from  $\frac{1}{8}$  of a wavelength up to a full wavelength.

2. Extremely low radiation resistance is characteristic of all distributions on a  $\frac{1}{4}$ -wave antenna giving an antenna performance approaching the optimum performance.

3. With modern ground systems it would probably be best to operate top-loaded  $\frac{1}{4}$ -wave antennas with

the null in the current loop somewhere between the ground and a point  $0.088\lambda$  above the ground.

4. A top-loaded  $\frac{3}{8}$ -wave antenna operated with the null in the current loop  $0.075\lambda$  above the ground gives an antenna performance approximately equivalent to that obtained with the usual  $\frac{1}{2}$ -wave antenna, has little or no high-angle radiation, and is probably economically realizable as it has a radiation resistance referred to the base of the order of 100 ohms.

#### APPENDIX

##### Reduction of the Variable-Phase Problem to the Constant-Phase Problem

It was pointed out in Section III that the optimum current distribution on a vertical antenna might conceivably be a *variable-phase* distribution rather than the *constant-phase* distribution assumed in this paper. It can be pointed out immediately, that at least in special cases,<sup>21</sup> the variable-phase current distribution must reduce to a constant-phase distribution if it is to be an optimum distribution. Furthermore, under the customary fundamental assumption that the well-set theoretical variable-amplitude, variable-phase, optimum-current-distribution problem has a unique solution, it will now be shown that "the theoretical optimum current distribution on a vertical antenna is necessarily a variable-amplitude, constant-phase distribution." (Compare Section III, paragraph 1.)

Consider a vertical antenna on which both the amplitude and phase of the current are functions of the distance  $x$  from the base. Let the phase of the current at the base of the antenna be taken as a reference. Then the current at distance  $x$  from the base can be divided into two components, one in phase with the reference, and the other 90 degrees out of phase. Hence, at any point on the antenna

$$I = I_1 + jI_2$$

where  $I$  is of variable phase, and where  $I_1$  and  $I_2$  are of constant phase but separated 90 degrees in time.

Thus it is seen that a variable-phase vertical antenna is equivalent to two superimposed constant-phase antennas driven 90 degrees out of phase. In this manner the most general theoretical optimum-current-distribution problem is reduced to the determination of that pair of amplitude distributions  $I_1=f_1(x)$  and  $I_2=f_2(x)$ , on the two equivalent constant-phase antennas, which maximize the field strength on the horizon while holding constant the power output.

Consider the vertical antenna shown in Fig. 1. The field at a point in space due to radiation from the element  $\Delta x$  has two components, one due to direct radiation and the other due to reflected radiation. The components are equal in magnitude and have the same direction, but one is retarded  $(2\pi/\lambda)(r_0 - x \cos \theta)$  radians in time, and the other is retarded  $(2\pi/\lambda)(r_0 + x \cos \theta)$  radians. Thus the retardation of the resultant field at  $S$  is  $(2\pi/\lambda)r_0$ , and is independent of  $x$ . Conse-

quently the time phase of the field due to radiation from a constant-phase antenna is everywhere the same on the surface of the hemisphere of radius  $r_0$ , taken about the base of the antenna, and this is true regardless of the current-amplitude distribution.

Suppose  $H_1$  is the magnetic field at  $S$  due to a current-amplitude distribution  $f_1(x)$  on the first of the two equivalent antennas, and  $H_2$  the corresponding field due to a distribution  $f_2(x)$  on the second. Then, since  $f_1(x)$  and  $f_2(x)$  are superimposed but 90 degrees out of phase, it follows from the above considerations that the resultant field at  $S$  is simply

$$H = H_1 + jH_2.$$

Now the total power flowing outwards through an element of surface on the hemisphere at  $S$  is proportional to

$$H^2 = H_1^2 + H_2^2.$$

Hence the total power radiated is

$$P = P_1 + P_2$$

where  $P_1$  and  $P_2$  are the power radiated from the two equivalent antennas, each one considered separately.

Thus the problem is to determine those two current-amplitude distributions  $f_1(x)$  and  $f_2(x)$ , on the two antennas of the equivalent constant-phase system for which

$$H(f) = \sqrt{H(f_1)^2 + H(f_2)^2}$$

is a maximum while

$$P(f) = P(f_1) + P(f_2)$$

is a constant. It is understood that  $H(f)$  is evaluated for  $S$  on the horizon.

In view of the fundamental assumption made in the first paragraph of this Appendix there exists a unique pair of current-amplitude-distribution functions ( $f_1^*$ ,  $f_2^*$ ) which maximize  $H(f)$  while holding  $P(f)$  constant. But then  $f_1^*$  is obviously that distribution which maximizes

$$H(f) = \sqrt{H(f_1)^2 + H(f_2^*)^2} \quad (\theta = 90 \text{ degrees})$$

while holding constant

$$P(f) = P(f_1) + P(f_2^*).$$

Or, since  $H(f_2^*)$  and  $P(f_2^*)$  are both fixed,  $f_1^*$  is that distribution which maximizes

$$H(f) = H(f_1) \quad (\theta = 90 \text{ degrees})$$

while holding constant

$$P(f) = P(f_1).$$

Similarly  $f_2^*$  is that distribution which maximizes

$$H(f) = H(f_2) \quad (\theta = 90 \text{ degrees})$$

while holding constant

$$P(f) = P(f_2).$$

But these two isoperimetric problems are identical. Therefore,  $f_1^*$  and  $f_2^*$  are identically equal. But two identical amplitude distributions on the two super-

imposed constant-phase antennas driven 90 degrees out of phase are equivalent to a constant-phase distribution on the actual antenna.

Hence the theoretical optimum current distribution on a vertical antenna is necessarily a constant-phase current distribution.

---

### Corrections

T. R. W. Bushby has brought to the attention of the Editors certain errors in his paper, "Thermal-Frequency-Drift Compensation," which appeared in the December, 1942, issue of the PROCEEDINGS, on pages 546-554.

The I.R.E. affiliation of the author should be "Member" and not "Associate."

Page 546—Summary—Line 16—"capacitive coefficients" should be "capacitance coefficients."

Page 551—Equation (15), right-hand side, numerator, alpha ( $\alpha$ ) should be "a."

Equation (15c), right-hand side, first term, denominator alpha ( $\alpha$ ) should be "a."

Page 552—Equation (16a), right-hand side, first term, denominator " $k_n$ " should be " $kn$ ."

The Institute desires to present to the readers of the PROCEEDINGS effective material of timely value having major tutorial aspects. In pursuance of this policy there are included in the previous issue of the PROCEEDINGS, this issue, and in a subsequent issue, installments covering a portion of the text of a forthcoming volume entitled: "Radio Engineers Handbook." Through the courtesy of its author, Professor Frederick E. Terman (at present Direc-

tor of the Radio Research Laboratory operating under the supervision of the Office of Scientific Research and Development at Harvard University) and of the publishers, The McGraw-Hill Book Company, New York, N. Y., permission has been granted to the PROCEEDINGS to place this material before our readers. Appreciation of this co-operation is here expressed.

The Editor

# Network Theory, Filters, and Equalizers\*

FREDERICK E. TERMAN†, FELLOW I.R.E.

## PART II

### T Attenuators

**Summary**—Resistance attenuators of the T, L, ladder, and bridged-T types are considered, and design formulas are given. Decimal attenuators are described.

The relation existing between attenuation and phase shift in a four-terminal network is stated in several forms, including the phase-area theorem, and a formula which gives phase shift directly as a function of the rate of change of attenuation. The latter shows that the phase shift that exists at a particular frequency is determined primarily by the way in which the slope of the attenuation characteristic varies in the vicinity of this frequency. Consideration is also given to the case where the desired attenuation is constant over a portion of the frequency spectrum, while the phase shift is to be kept constant over the remainder of the spectrum. It is shown that a complete phase and attenuation characteristic is specified when such attenuation and phase fragments are given. This case corresponds to the transmission characteristics desired in the feedback loop of an ideal feedback amplifier.

The application of these principles to the design of practical feedback amplifier circuits is considered in detail. It is shown that nonoscillating feedback amplifiers can be designed by considering only the transmission characteristics of the feedback loop, since the transmission characteristics control the phase shift. Feedback amplifier circuits which give trouble from oscillation do so because there is some frequency, usually far outside of the useful range of frequencies, at which the transmission around the feedback loop falls off with excessive rapidity, corresponding to excessive phase shift. Methods for determining the optimum transmission characteristic of the feedback loop are given which enable any desired amount of feedback to be obtained with any number of amplifier stages, without any trouble from oscillations. The principles involved in such design are illustrated by two examples: one, a three-stage audio-frequency amplifier, the other, a broadcast transmitter having a measured frequency characteristic, to which it is desired to add feedback.

## IX. ATTENUATORS<sup>15-18</sup>

**A**TENUATORS are resistance networks used for the purpose of reducing voltage, current, or power in controllable and known amounts. The most commonly used types of attenuators are the T, L, ladder, and bridged-T types.

\* Decimal classification: R142×R390. Original manuscript received by the Institute, February 17, 1943. Prepublished by permission from "Radio Engineers Handbook" by Frederick E. Terman and the McGraw-Hill Book Company, New York, N. Y.

The T attenuator consists of three resistances arranged in a T, as shown in Fig. 23(a). Such an attenuator is usually designed with the two series impedances of the T identical, thereby making the two image impedances the same.

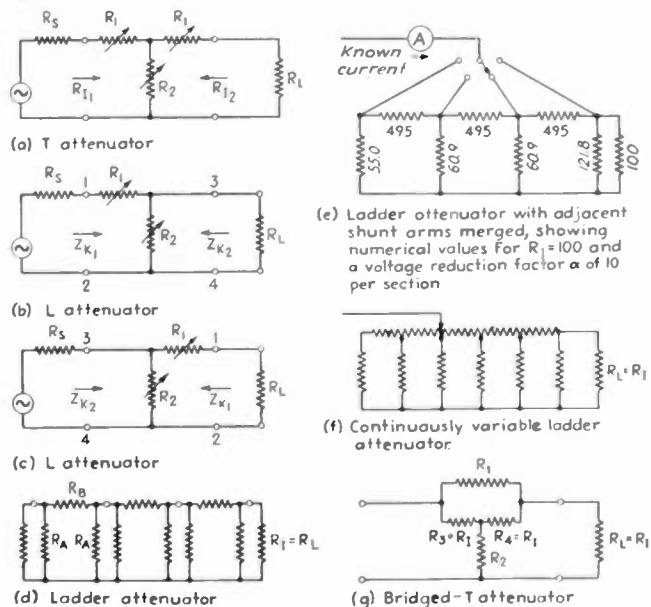

Fig. 23—Common attenuator networks.

For such a symmetrical T network composed of resistance elements, the relations expressed by (28) can be rewritten as

† Director, Radio Research Laboratory, Harvard University, Cambridge, Massachusetts.

<sup>15</sup> For further information on attenuators, and in particular for design information including tables giving the resistance values required in the arms for different values of attenuation, see references given in footnotes 16, 17, and 18.

<sup>16</sup> P. K. McElroy, "Designing resistive attenuating networks," *Proc. I.R.E.*, vol. 23, pp. 213-234; March, 1935.

<sup>17</sup> Guy C. Omer, Jr., "Lattice attenuating networks—Complete design tables," *Wireless Eng.*, vol. 17, p. 206; May, 1940.

<sup>18</sup> R. E. Blakey, "Network resistances for balanced attenuators," *Electronics*, vol. 8, p. 446; November, 1935.

$$\left. \begin{aligned} R_1 &= R_I \left( \frac{\alpha - 1}{\alpha + 1} \right) \\ R_2 &= R_I \left( \frac{2\alpha}{\alpha^2 + 1} \right) \end{aligned} \right\} \quad (38)$$

where  $R_1$  and  $R_2$  are the attenuator resistances, as shown in Fig. 23(a),  $R_I$  is the image impedance of the section, and  $\alpha$  is the number whose natural logarithm is the image transfer constant (i.e.,  $\alpha = e^\theta$ ). Thus when the generator and load impedances both equal the image impedance  $R_I$ , the insertion loss of the attenuator is  $\alpha$ , i.e., with image operation

$$\alpha = \frac{\text{load current without attenuator}}{\text{load current with attenuator}} \quad (39)$$

T attenuators are used where it is important that the presence of the attenuator in the circuit, and the amount of attenuation, have no effect upon the impedance relations existing in the circuit. This is achieved by making the image impedance of the T attenuator equal either the generator or load resistance.

#### L Attenuators

The L attenuator consists of two resistance arms arranged as shown in Fig. 23(b) or 23(c). The arms are so proportioned that one of the iterative impedances of the attenuator is constant irrespective of the attenuation introduced. The corresponding design formulas are

For  $Z_{k_1}$  constant (Fig. 23(b) or c):

$$\left. \begin{aligned} R_1 &= Z_{k_1} \left( \frac{\alpha' - 1}{\alpha'} \right) \\ R_2 &= \frac{Z_{k_1}}{\alpha' - 1} \end{aligned} \right\} \quad (40)$$

For  $Z_{k_2}$  constant (Fig. 23(b) or c):

$$\left. \begin{aligned} R_1 &= Z_{k_2} (\alpha' - 1) \\ R_2 &= Z_{k_2} \left( \frac{\alpha'}{\alpha' - 1} \right) \end{aligned} \right\} \quad (41)$$

Here  $\alpha' = e^P$ , where  $P$  is the iterative transfer constant. When the impedance connected between the pair of terminals opposite from the terminals having constant iterative impedance is equal to this design value of iterative impedance, then

$$\alpha' = \frac{\text{current in load without attenuator}}{\text{current in load with attenuator}} \quad (42)$$

L attenuators are less expensive than the T type, because only two instead of three variable resistances are required to control the attenuation. At the same time the L attenuator maintains impedance independent of attenuation at only one pair of terminals as the attenuation is varied, whereas the T attenuator main-

tains constant impedance at both terminals. L attenuators are commonly used where a number of loads are associated with a common generator and it is necessary to control the power delivered to each load without altering the impedance offered to the source of power.

#### Ladder Attenuators

Ladder attenuators consist of a series of symmetrical  $\pi$  sections designed so that the required ratio of voltage loss per section is obtained with image-impedance operation. A typical arrangement is shown in Fig. 23(d), where there is shown a chain of three  $\pi$  sections terminated at both ends with a resistance equal to the image impedance, and designed to produce the required attenuation when operated on an image-impedance basis. The appropriate design formulas for the individual sections are

$$\left. \begin{aligned} R_A &= R_I \left( \frac{\alpha + 1}{\alpha - 1} \right) \\ R_B &= R_I \left( \frac{\alpha^2 - 1}{2\alpha} \right) \end{aligned} \right\} \quad (43)$$

Here  $R_A$  and  $R_B$  have the meanings shown in Fig. 23(d),  $R_I$  is the image impedance, and  $\alpha$  is the factor by which each section reduces the current with image-impedance conditions (i.e., if  $\alpha = 10$ , then each section reduces the current in the load to one tenth of the load current that would be obtained with the section removed).

The impedance between any junction point in the ladder attenuator and the common ground side of the system is one half the image impedance.

Ladder attenuators such as are illustrated in Fig. 23(d) are used in signal generators and in other devices requiring that voltages and currents be reduced in known ratios. A typical arrangement for producing known voltages of small magnitude is illustrated in Fig. 23(e). Here a known current is supplied to the switch and directed so that it flows from one of the junction points to the common side of the system. This produces a known voltage across that particular branch of the shunt attenuator. The voltage appearing across the output terminals of the attenuator is then this voltage reduced in accordance with the number of attenuator sections between the input point and the load.

A continuously adjustable ladder attenuator is shown in Fig. 23(f), and is the same as the step attenuator of Fig. 23(e), except that the switch has been replaced by a slider that permits continuous variation of the input point. As actually constructed, the resistance shown horizontally along the top is an ordinary slide-wire potentiometer, to which suitable shunt resistances have been connected at regular intervals to form a series of  $\pi$  sections. Such an attenuator is inexpensive to construct, and maintains its input and output resistances constant within reasonably narrow limits for all attenuations except extreme values.



**Bridged-T Attenuators**

A bridged-T attenuator consists of four resistance arms arranged as shown in Fig. 23(g). When proportioned so that  $R_3 = R_4 = R_I$ , and  $R_1 R_2 = R_I^2$ , the image impedance will be a constant value  $R_I$ , irrespective of attenuation. With image-impedance operation

$$\frac{\text{load current with attenuator}}{\text{load current without attenuator}} = \frac{R_I}{R_1 + R_I} \quad (44)$$

The bridged-T attenuator is equivalent to a simple T attenuator but requires only two instead of three variable resistances.

**Decimal Attenuators<sup>19</sup>**

A decimal attenuator is a system of attenuators so arranged that a voltage or current can be reduced in decimal fractions. Such an attenuator is shown in Fig. 24, where any voltage from 0.001 to 1.0 times the input voltage can be obtained in steps of 0.001 volt. This decimal attenuator includes three similar L-type attenuators designed to operate between equal generator and load resistances and to have a constant output resistance equal to the generator resistance  $R_g$ . Each attenuator is adjustable in steps such that  $1/\alpha$  can be made 0, 0.1, 0.2, 0.3, etc., up to 1.0. The second of these L attenuators feeds into a single T attenuator having an input and output resistance equal to the output resistance of the L section and having  $\alpha = 10$ . The third of these attenuators delivers its output to two such T sections in tandem. These three systems hence give output voltages in steps of 0.1, 0.01, and 0.001, respectively. The outputs of all three attenuating systems are connected in parallel, so that when the output terminals are open-circuited, the load resistance for any one attenuator system consists of the output resistances of the other two systems in parallel. The output voltages of the three attenuators are thus superimposed upon each other, and add up directly without being affected by the fact that the load resistance for any one attenuator is supplied by the other two attenuators, which, at the same time, produce their own output voltages. The fact that there is a mismatch of resistance at the output need not be corrected for, since this changes all output voltages by the same percentage and so does not disturb the relative outputs. The output resistance to any load connected across the output terminals is the output resistances of the three attenuator systems in parallel. The addition of such a load merely increases the mismatch on the output side of the attenuator, and changes all output voltages by the same percentage without altering the relative values at the different attenuator settings.

<sup>19</sup> Decimal attenuators as described here were developed by the General Radio Company.

**X. RELATION BETWEEN ATTENUATION AND PHASE SHIFT IN FOUR-TERMINAL NETWORKS<sup>20</sup>**

For any four-terminal network connected between resistive terminal impedances, there is always a minimum possible phase change that can be associated with a given transmission characteristic. In such a *minimum-phase-shift network*, the phase characteristics can be calculated if the transmission characteristic is known, and vice versa.

Any actual four-terminal network will be a minimum-phase-shift network unless (1) the network contains a transmission line or an equivalent circuit with

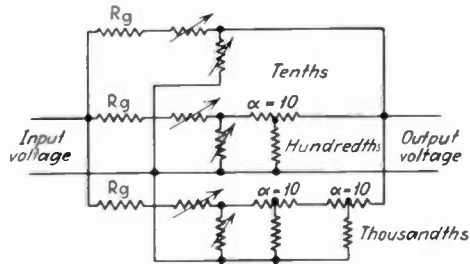

Fig. 24—Circuit diagram of decimal attenuator.

distributed constants, or (2) the circuit includes an all-pass section, either as an individual structure or in a combination that can be replaced by an all-pass filter section plus some other physical structure. It is to be noted particularly that all ladder networks are automatically of the minimum-phase-shift type, since it is impossible to form an all-pass filter section from alternate series and shunt impedances.

**Phase-Area Theorem**

One of the simplest relations existing between attenuation and phase shift is

$$\int_{-\infty}^{+\infty} B d\mu = \frac{\pi}{17.37} (A_{\infty} - A_0) \quad (45)$$

where  $B$  = phase shift, radians

$\mu = \log_e (f/f_0)$ , where  $f$  is the actual frequency and  $f_0$  is any convenient reference frequency

$A_{\infty}$  = attenuation, decibels, at infinite frequency

$A_0$  = attenuation, decibels, at zero frequency (not at frequency  $f_0$ )

The relation described by (45), expressed in words, is to the effect that the total area under the phase characteristics, when plotted on a logarithmic frequency scale, depends only upon the difference between the transmission (or attenuation) at zero and infinite frequency, and does not depend in any way upon the way in which the transmission varies between these limits; nor does it depend upon the physical configuration of the network, provided a minimum-phase-shift structure is employed. The equality of the phase areas under different conditions is illustrated in Fig. 25.

<sup>20</sup> H. W. Bode, "Relations between attenuation and phase in feedback amplifier design," *Bell Sys. Tech. Jour.*, vol. 19, p. 421; July, 1940; also, U. S. Patent No. 2,123,178.

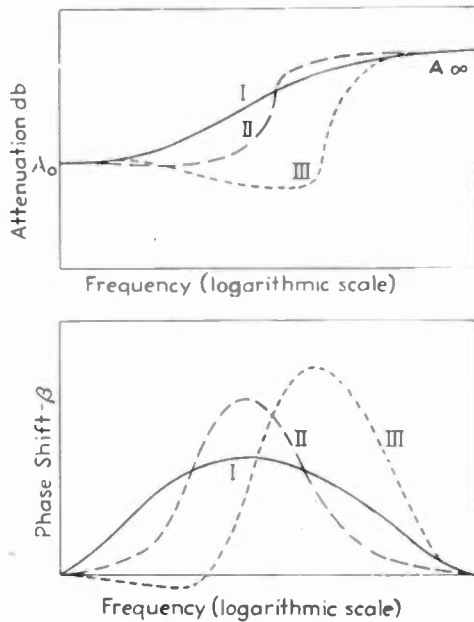

Fig. 25—Diagram to illustrate relation between area under phase-shift curve and the change in attenuation.

The relation expressed by (45) can be termed the *phase-area theorem*, and has several very important practical consequences. It means, for example, that if a network is employed to change the transmission from one fixed value to another fixed value and if, at the same time, the maximum phase shift that can be permitted at any frequency is limited to some relatively low value, then the region where the attenuation is changing must be spread out over a sufficiently wide frequency range so that the necessary area can be obtained under the phase curve without this curve having a maximum exceeding the allowable value. This fact is of considerable significance in connection with the design of feedback amplifier systems, since here the transmission around the feedback loop must have associated with it a phase shift that is always less than 180 degrees, even when the transmission is varying.

*Phase Shift as a Function of Attenuation Slope*

The minimum phase change associated with a given attenuation characteristic can be expressed as<sup>21</sup>

$$B_c = \frac{\pi}{12} \left( \frac{dA}{d\mu} \right)_c + \frac{1}{6\pi} \int_{-\infty}^{+\infty} \left[ \left( \frac{dA}{d\mu} \right) - \left( \frac{dA}{d\mu} \right)_c \right] \log_e \coth \frac{|\mu|}{2} d\mu \quad (46)$$

where  $B_c$  = phase shift, radians, at the frequency  $f_c$ .  
 $dA/d\mu$  = slope of attenuation curve, decibels per octave.  
 $\mu = \log_e (f/f_c)$ , where  $f$  is frequency and  $f_c$  the frequency at which  $B_c$  is desired.  
 $\coth x$  = hyperbolic cotangent of  $x (= 1/\tanh x)$ .  
 subscript  $c$  denotes evaluated at  $f = f_c$ .

<sup>21</sup> The  $\pi$  in the denominator in front of the integral represents the correction of an error in equation (10) of Bode's U. S. Patent No. 2,123,178, upon which the equation given here is based.

$\log \coth |\mu/2|$  denotes the real part of  $\log \coth \mu/2$  (which is complex when  $\mu$  is negative).

Equation (46) shows that the minimum phase change can be expressed as the sum of two components. The first of these is proportional to the slope of the attenuation characteristic when plotted on a logarithmic frequency scale, and amounts to 180 degrees when the attenuation is varying at the rate of 12 decibels per octave at the reference frequency. The second term is determined by an integral, the integrand of which is proportional to the weighting function  $\log_e \coth (|\mu|/2)$ , which is plotted in Fig. 26, and the difference between the slope of the attenuation characteristic at the desired frequency  $f_c$  and the slope elsewhere. Because of the symmetrical character of the weighting function, this second contribution to the phase shift is determined by the extent that the attenuation-slope characteristic fails to have negative symmetry (i.e., odd-function symmetry) about the reference frequency. Also, the shape of the weighting function is such that changes in the slope of the attenuation characteristic at frequencies close to the reference frequency have far more effect upon phase shift than do changes in the slope of the characteristic at more remote frequencies.

Examples of the relationship between attenuation characteristics and phase shift are given in Fig. 27 for several idealized cases.

*Specification of Complete Phase and Attenuation Characteristics from Attenuation and Phase Fragments*

Relations have been worked out from which the complete attenuation and phase characteristics of a minimum-phase-shift network can be determined by prescribing the attenuation characteristic over a portion of the frequency range and prescribing the phase-shift characteristic for the remainder of the frequency range.

Certain special cases of this character that are of particular importance are illustrated in Fig. 28. Here, the attenuation is specified as a constant value in the

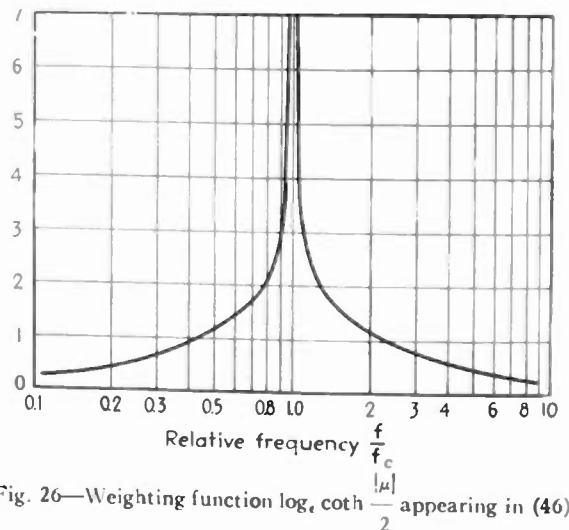

Fig. 26—Weighting function  $\log_e \coth \frac{|\mu|}{2}$  appearing in (46).

useful range of the circuit, while the phase shift is specified as having a constant value (normally slightly less than 180 degrees), outside the useful frequency range. The remainder of the characteristics are shown dotted. The essential formulas for the cases illustrated in Fig. 28 are

High-frequency cutoff (Fig. 28(a)):

$$B = k \sin^{-1} \frac{f}{f_2} \quad f < f_2 \quad (47a)$$

$$A = K + 8.69k \log. \left[ \sqrt{\left(\frac{f}{f_2}\right)^2 - 1} + \frac{f}{f_2} \right] \quad f > f_2. \quad (47b)$$

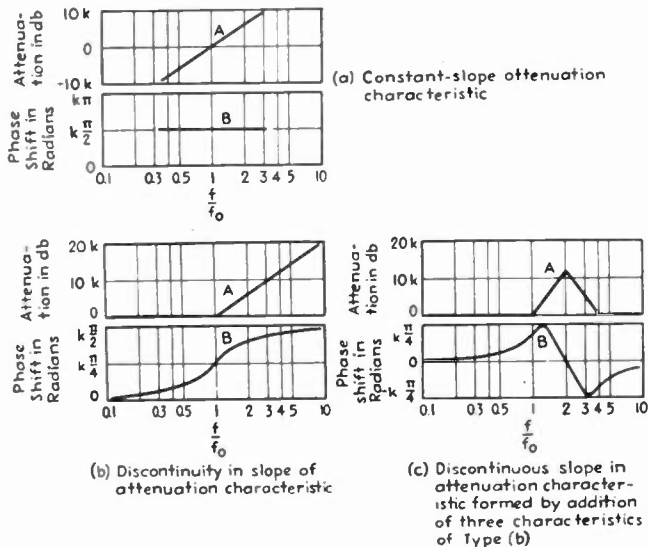

Fig. 27—Examples of the relationship between phase and attenuation characteristic in several idealized examples.

Low-frequency cutoff:

$$B = -k \sin^{-1} \frac{f_1}{f} \quad f > f_1 \quad (48a)$$

$$A = K + 8.69k \log. \left[ \sqrt{\left(\frac{f_1}{f}\right)^2 - 1} + \frac{f_1}{f} \right] \quad f < f_1. \quad (48b)$$

The notation either is as illustrated in Fig. 28 or is as previously used, with the addition that  $B$  is in radians,  $A$  in decibels, and  $K$  is the attenuation in the region where the attenuation is constant. These expressions can be considered as representing the fundamental formulas for the high- and low-frequency cutoff characteristics of the feedback loop of the ideal feedback amplifier.

*Application of Minimum-Phase-shift Principles to the Design of Feedback-Amplifier Circuits*

A schematic diagram of an amplifier provided with negative feedback is shown in Fig. 29. In this diagram, the portion  $CDE$  transmits a fraction of the output of the amplifier back to the input circuit, and superimposes this upon the applied signal. In the normal frequency range, the phase relations are so adjusted

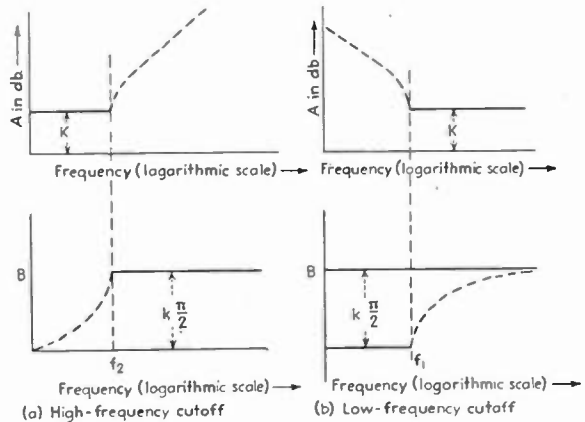

Fig. 28—Ideal low-frequency and high-frequency cutoff characteristics.

that this feedback action opposes the applied signal, thereby reducing the amplification and giving negative feedback. In order that such a system will not oscillate under any conditions, it is necessary that the transmission and phase characteristics of the "feedback loop"  $ABCDE$  be such that the transmission around this loop is less than unity when the phase shift reaches 180 degrees. The transmission around this loop is obtained by breaking the circuit at  $X$ , applying a signal voltage at point  $A$ , and comparing this signal voltage with the voltage that it produces at the point  $E$ .

In an ideal feedback-amplifier system, the transmission around the feedback loop would be constant throughout the useful band of frequencies, thereby giving constant negative feedback in the useful range. At the same time, the transmission around this loop should drop off as rapidly as possible outside the useful range of frequencies in order that the frequency range over which the transmission characteristics must be controlled accurately be no greater than absolutely necessary. Because of the phase-area theorem, this maximum rate of falling off in transmission outside the useful band will be obtained when the phase shift has a constant value that approaches as close to 180 degrees as is practical throughout the attenuating range. The ideal characteristic for a feedback loop is accordingly that shown in Fig. 28, with  $k$  given a value that is slightly less than 2 to provide a margin of safety.

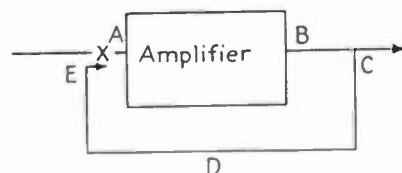

Fig. 29—Schematic feedback-amplifier diagram.

*Limitations Introduced by the Asymptotic Transmission Characteristics of the Feedback Loop at Extreme Frequencies*

The ideal feedback-loop characteristics cannot in many cases be realized at extremely high and extremely low frequencies, because at these extreme

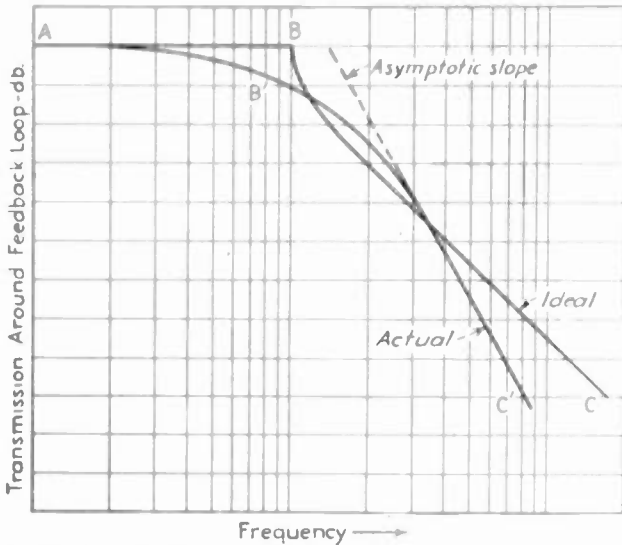

Fig. 30—Typical amplifier cutoff characteristic and ideal cutoff characteristic for feedback loop.

frequencies such factors as stray shunting capacitances, grid-leak-condenser combinations, etc., take over control of the characteristics and may cause the transmission to fall off more rapidly than permissible for an ideal feedback loop. This is illustrated in Fig. 30, where *ABC* is the ideal characteristic, but because of the asymptotic falling off in transmission of the amplifier at high frequencies, the actual characteristic is *AB'C'*. There is then an additional phase shift at high frequencies. The excess phase shift in the region where the feedback-loop transmission changes over from the ideal to the asymptotic characteristic (region *C* in Fig. 30), can be eliminated by the expedient shown in Fig. 31. Here a step of zero slope is introduced in the transmission characteristic just before the asymptotic characteristic is allowed to take control. The length of this step should be such that

$$\frac{f_a}{f_b} = \frac{f_{a'}}{f_{b'}} = \frac{\text{slope of ideal asymptotic characteristic in decibels per octave}}{\text{slope of actual asymptotic characteristic in decibels per octave}} \quad (49)$$

The type of phase-shift characteristic that results is shown in Fig. 31, and the total attenuation between  $f_{a'}$  and  $f_1$  (and  $f_2$  and  $f_b$ ) is very close to the largest that can possibly be obtained in this frequency interval without the maximum phase shift exceeding a fixed maximum value.

The slope of the actual asymptotic characteristic can be estimated by inspecting the circuits. Each resistance- or impedance-coupled amplifier stage will contribute 6 decibels per octave to the asymptotic slope at high frequencies, as will each output transformer fed from a tube and having a resistance load. An interstage coupling transformer will add 12 decibels per octave to the slope unless a resistance is shunted across the secondary. Similarly, at low frequencies, each grid-leak-condenser combination will cause 6 decibels per octave slope, as will each transformer (output, input, or interstage) excited from a resistance source

as a tube or line. Transformers with resonated primaries can contribute 12 decibels per octave at low frequencies.

The asymptotic characteristic is of importance only when it has a value approaching or exceeding 12 decibels per octave. Thus, with many two-stage amplifiers, the asymptotic characteristic is not a design limitation, and one can theoretically hope to realize the ideal feedback loop characteristics shown in Fig. 28 instead of being forced to the step transition of Fig. 31.

### Design Procedures and Considerations

The design of a feedback amplifier under conditions where the asymptotic characteristic must be considered can be best understood by considering several specific cases.

#### EXAMPLE 1

Assume that a three-stage amplifier has a useful frequency range of 100 to 10,000 cycles and that 30-decibel feedback is desired with an amplitude margin of safety of 9 decibels, a phase margin of safety of 30 degrees, and that the asymptotic slope is 18 decibels per octave for both high- and low-frequency cutoffs. The ideal transmission characteristic of the feedback loop can be calculated from (47) and (48) for high and low frequencies, respectively. These characteristics are plotted in Fig. 32(a), in which the transmission around the feedback loop in the useful frequency range is shown as being 30 decibels above zero level. The ideal characteristic is continued to 9 decibels below zero level to  $f_{b'}$  and  $f_a$  in order to provide the necessary amplitude margin, after which there is introduced a step having a length such that the frequencies at the two ends of the step are in the ratio 10:18 (or 18:10 as

the case may be), which is the slope ratio of the ideal and asymptotic characteristics (slope of the

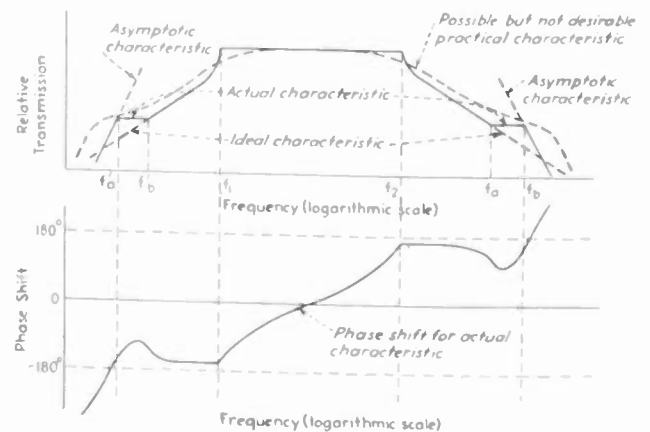

Fig. 31—Step transition to attenuation characteristic of high slope.

ideal characteristic with 30 degrees phase margin =  $12 \times \frac{150}{10}$ . Beyond the step, i.e., below  $f_a'$  and above  $f_b$ , the asymptotic characteristic is permitted to take control, as shown. The actual amplifier would then be built so that in the absence of feedback the amplification would fall to  $30 + 9 = 39$  decibels below the amplification in the useful range at the frequencies  $f_a'$  and  $f_b$ . The frequencies  $f_a'$  and  $f_b$  for this case, when calculated as above on the basis of the ideal step characteristic, are 7 and 150,000 cycles, respectively. In order to obtain the transmission actually required in order to avoid oscillation, i.e., the characteristics indicated by the heavy line in Fig. 32(a), additional circuit elements must be added either to the amplifier or to the feedback loop in order to cause added loss in the regions marked *B* and *C* in Fig. 32. It will be noted that the amplifier must be made much broader than the actual amplification characteristic needed.

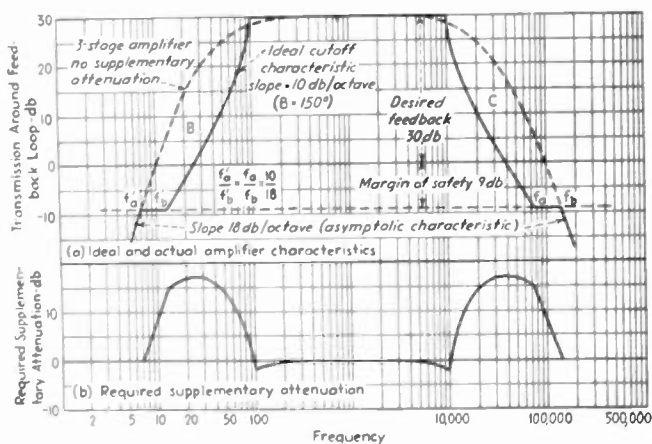

Fig. 32—Example of requirements imposed on amplifier designed to provide 30-decibel feedback with 9-decibel margin of safety.

EXAMPLE 2

Consider a broadcast transmitter in which it is desired to employ 20-decibel feedback, with 10 decibels of safety margin in amplitude and a 30-degree phase margin of safety ( $k = 1.67$ ), and is to maintain uniform response up to 10 kilocycles. Also, assume that the transmission characteristic around the feedback loop, as observed experimentally, when no special circuit elements are introduced to control feedback characteristics, is as shown by *AIIIJ* in Fig. 33(a), with 24 decibels per octave asymptotic slope. The optimum transmission characteristic, as calculated by (47), is the curve *ABCDG*, but because of the asymptotic slope near *G*, the practical curve required to give the required amplitude margin of 10 decibels is the step curve *ABCDE*. When this is compared with the actual curve *AIIIJ*, it is seen that in order to obtain the required characteristic, one must add circuit elements somewhere in the feedback loop that will add to the curve *AIIIJ* a characteristic such as illustrated by the curve

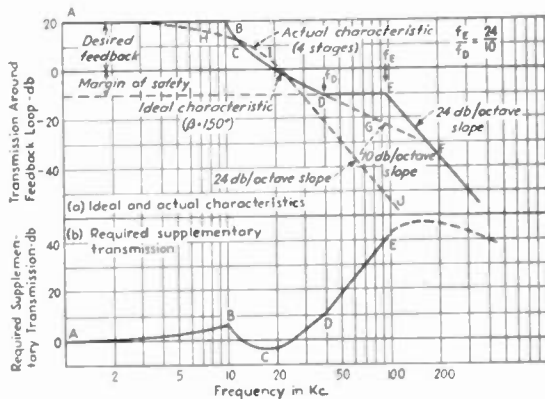

Fig. 33—Example a involving application of negative feedback to broadcast transmitter.

*ABCDE* of Fig. 33(b). This can be done by suitable design of circuit elements in the feedback loop, or it may be achieved by adding further stages of amplification either in the feedback path or in the audio-frequency part of the system. These additional stages need contribute little or nothing to the gain of the system in the useful range of frequencies, but must have a rising amplification in the frequency range *DE*. Beyond the point *E*, the amplification of the extra stages can fall off in any convenient manner. If additional stages of amplification are employed to give this required supplementary rising characteristic, these additional stages must be designed so that their asymptotic characteristic does not take control until a frequency is reached that is very much higher than the frequency corresponding to *E* in Fig. 33.

Control of the way in which the transmission around the feedback loop falls off outside the useful range of frequencies can be obtained in a variety of ways. Some of the simpler and more important expedients that can be employed, together with the corresponding transmission characteristics, are illustrated in Fig. 34. The number of such networks that can be devised is of course without limit, and under some circumstances the networks involved may become very complicated.

The frequency range over which the transmission characteristics of the feedback loop must be controlled is surprisingly high, and represents the price that is

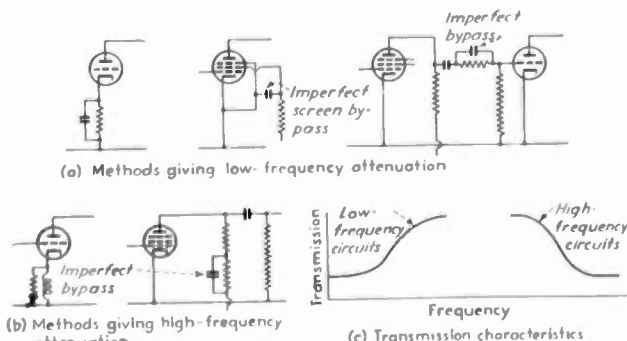

Fig. 34—Simple methods of modifying amplifier characteristics at high and low frequencies.

paid in order to obtain the benefits of negative feedback. *The cost is approximately 1 octave for each 10 decibels of useful feedback plus about 1 or 2 octaves extra as a margin of safety and to take care of failure to realize exactly the optimum characteristic.* Thus, if an amplifier with a useful frequency range of

60 to 15,000 cycles is to have 30 decibels of feedback, the characteristics of the feedback loop must be carefully controlled for at least 4 octaves beyond this range, or from about 4 to 240,000 cycles (compare with Fig. 32).

*(To be concluded)*

# Institute News and Radio Notes

## Future of Television

Greatly improved by the research now going on in connection with war productions, television promises to have a greater impact on American life in the post-war years than any of the countless other applications of electronics, according to David Grimes, vice president in charge of engineering for Philco Corporation, who spoke on March 5, 1943, to the New York Society of Security Analysts on the outlook for electronics.

"While our all-out war-production program has focused popular attention recently on some of the striking industrial uses of electronics, it appears likely that the development of television broadcasting stations and the availability of home receivers in the postwar period will have much greater effect on people's lives," Mr. Grimes said.

"Even before the war, television had been advanced to such a stage that it was possible to provide pictures of the same sharpness of detail as home movies. Through the development of successful radio links from New York to Philadelphia and Schenectady, the basis was laid for network television programs to bring outstanding entertainment and news events into people's homes over a wide area. All that will be necessary to extend the coverage to the entire nation is the erection of a large number of relay stations.

"Radio broadcasting, it will be remembered, did not reach maturity until network hookups were developed during the late '20s. It is significant, therefore, that unknown to most people, television has already reached this stage."

Scientific developments being rushed to completion because of the needs of the war emergency will insure the public of better television broadcasting and reception when the radio industry returns to peace-time production after helping to win the war, according to Mr. Grimes.

Referring to other important uses of electronics and the electron tube, including especially the long-distance telephone and talking movies, Mr. Grimes ventured the opinion that television in coming years would have an even more far-reaching effect than any of these on our customs and ways of life.

Mr. Grimes joined the Institute of Radio Engineers as an Associate in 1920 and transferred to Member grade in 1928.

## Board of Directors

The regular meeting of the Board of Directors, held on March 3, 1943, was attended by L. P. Wheeler, president; F. S. Barton, vice president; S. L. Bailey, W. L. Barrow, E. F. Carter, I. S. Coggeshall, W. L. Everitt, H. T. Friis, Alfred N. Goldsmith, editor; G. E. Gustafson, O. B. Hanson, R. A. Heising, treasurer; F. B. Llew-

ellyn, B. J. Thompson, H. M. Turner, A. F. Van Dyck, H. A. Wheeler, W. C. White, and W. B. Cowlich, assistant secretary.

There were 120 Associates, 81 Students, and 5 Juniors elected to the named grades of membership.

President Wheeler reported that the Institute had taken out a blanket bond applying to all its officers and employees, and had issued a revised contract including the previously approved change in rate of compensation being paid to W. C. Copp, advertising manager of the PROCEEDINGS.

The other actions of the Executive Committee at its meeting of February 3, 1943 were ratified.

The subject of postwar problems of the radio industry was discussed at length. Provision was made for the formation of a committee to make the preliminary study and recommendations relative to the nature, degree, and method of the Institute's participation in an attempted solution of the subject problems.

A reserve fund for a major postwar policy of expanded publication of then available technical material, as recommended by the Executive Committee, was authorized. Approval was also granted to a special method of publishing certain papers.

The following amended Sections 12 and 45 of the Institute's Bylaws were adopted:

Bylaw Section 12: "Admission or transfer to any grade except Fellow may be proposed by any member acting as sponsor, or by the Membership Committee, by supplying to the Admissions Committee sufficient information and testimonials from the required number of sponsors to satisfy the Admissions Committee as to qualifications. Such proposals shall be acted upon by the Admissions Committee, and, if approved, transmitted to the Board of Directors for their action. If approved by the Board of Directors, an invitation blank shall be sent to the proposed member inviting him to accept the grade of membership proposed, which membership grade shall become effective automatically and immediately upon his supplying the biographical and professional information required, paying the necessary dues and fees, and having satisfied the posting Bylaw. The name of an invitee shall be placed on the mailing list for the PROCEEDINGS immediately upon receipt of dues and fees. The proposal and invitation blanks shall be drawn up by the Membership Committee so as to avoid unconstitutional action due to the sponsor supplying incorrect information."

Bylaw Section 45: "The terms of appointments of the Admissions, Awards, Board of Editors, Constitution and Laws, Membership, Nominations, Papers, Public Relations, Sections, and Tellers Committees shall start with the first day of the month following appointment and continue until the date the succeeding

terms of appointments take effect. The Board may specifically advance or delay the terminating date of any committee and the starting date of a succeeding Committee."

B. J. Thompson, chairman of the Membership Committee, reported briefly on the planned activities of the committee.

The editorial, "Your Institute," from the Board of Directors, was approved for publication in the PROCEEDINGS.

The additional proposed Constitutional Amendments, to be submitted to legal counsel and in due course to the membership in accordance with the Constitution, are named below:

### ARTICLE V

Section 4. "Each year of a term of office established in Article V shall begin with the assembly of the Board of Directors at its annual meeting and terminate with the assembly of the Board of Directors at its following annual meeting."

### ARTICLE VI

Section 6. "Funds from this account may be deposited in other accounts authorized and limited in size by the Board of Directors. Funds from these accounts shall be withdrawable on the signatures of authorized bonded individuals for current disbursements. Before additional funds are transferred from the first-mentioned account to another account, the individuals responsible for such other accounts shall submit a statement of the disposition of the previously expended funds to the Treasurer."

### ARTICLE VII

Section 2. "The five appointed Directors, Secretary, Treasurer, and Editor shall be appointed by the Board of Directors at its annual meeting."

Sections 3 and 4. The intent of Section 3 was incorporated in the foregoing amended Section 2 and thus the wording of Section 3 in its present form was eliminated. With this omission, the present Section 4 was changed to Section 3 and, as a result, the existence of Section 4 was removed.

## Executive Committee

The Executive Committee meeting of March 2, 1943, was attended by L. P. Wheeler, chairman; Alfred N. Goldsmith, editor; R. A. Heising, treasurer; F. B. Llewellyn, A. F. Van Dyck, H. A. Wheeler, Haraden Pratt, secretary; and W. B. Cowlich, assistant secretary.

The report of the Assistant Secretary on the overtime work of office employees during January and February, was approved. The overtime work of the office executive staff was given consideration. Decisions were made relative to a number

of office matters, including the holidays to be observed by the Institute office.

The revised edition of the Code of Administrative Practice was accepted.

The Secretary drew attention to the blanket bond which had been taken out and which applies to all Institute officers and employees.

It was announced by the Assistant Secretary that the Audit Bureau of Circulation's statement for the PROCEEDINGS, covering the last six months of 1942, was completed in January, as required by that organization.

H. A. Wheeler reported on a special meeting, held earlier in the day, concerning certain possible effects of a paper shortage on the publication policy of the PROCEEDINGS.

Consideration was given to 120 applications for Associate, 81 for Student, and 5 for Junior grades, and they were approved for submission to the Board of Directors.

F. B. Llewellyn stated that letters were written to the chairmen of Technical Committees relating to the continuation in office of the present personnel until May 1, 1943, and the selection of the personnel for the next term of these committees.

The PROCEEDINGS editorial, "Your Institute," was accepted and recommended for confirming action by the Board of Directors.

Editor Goldsmith indicated that the preparation of the June issue of the PROCEEDINGS was well under way, and that sufficient papers were on hand for three additional issues.

At the suggestion of Editor Goldsmith, it was recommended to the Board of Directors that a reserve fund be established for the publication of wartime papers, expected to be available near the close of the war, in the form of added or special PROCEEDINGS volumes or supplements, the exact procedure to be determined later.

Approval was given to establishing a reserve fund for postwar advertising promotion, to consist of an unused portion of the current allowance for this purpose.

A suggestion for obtaining new Institute members was made by Editor Goldsmith.

The term, "radionics," was discussed and referred to the appropriate technical committee for consideration.

Several cover designs for the PROCEEDINGS, presented by Editor Goldsmith, were discussed.

Secretary Pratt reported on office matters, including the revised contract with W. C. Copp, advertising manager of the PROCEEDINGS, which had been drawn up and signed.

Approval was granted to reprinting a limited supply of copies of the Institute's "Standards on Electronics, 1938."

## Correspondence Concerning Proposed Constitutional Amendments

In the April, 1943, issue of the PROCEEDINGS, on pages 182 and 183, there are

recorded certain proposed constitutional amendments dealing with modification of the membership structure of the Institute. Mr. A. F. Van Dyck has prepared communications explaining the need for the proposed changes and Mr. H. P. Westman has sent in a communication questioning the advisability of the proposed changes. The letters follow, and their careful consideration by the membership is suggested.

From: A. F. VAN DYCK

The voting membership will shortly receive a copy of proposed amendments to the Institute Constitution and a ballot with which to vote upon them. The most important and larger part of the proposed amendments is concerned with the membership structure. It is to the interest of the membership to give this part considerable thought. Of the remaining amendments, some are to clarify uncertainties in terms of office and to surmount certain difficulties that have been encountered in managing the Institute, while one amendment concerns details in handling funds that properly belong to management.

Explanation of reasons for the proposed Constitutional change in the membership structure of the Institute is undoubtedly desirable, particularly for new members of the Institute, who may not be familiar with conditions of the early days of radio which led to the membership structure then adopted and which is still in force.

The present major grades are those of Fellow, Member, and Associate. The Fellow grade is honorary, with the highest requirements. The Member grade has very high requirements, which cannot be met by the majority of radio engineers, who, although in the profession as a lifetime career, have not been in it long enough to rate Member grade. The Associate grade is not restricted to the profession and is open to anyone interested in radio.

In the early days of radio, the structure as above outlined was satisfactory because few individuals were interested in radio except radio engineers, and the Associate grade was composed largely of men actually doing technical work of some kind in radio. With the expansion of radio which resulted from sound broadcasting, sound motion pictures, etc., many others than radio engineers became "interested" in radio.

Many Associate members who are radio engineers by training and profession, but who have not been eligible to Member grade with its stringent requirements, have expressed a desire for an arrangement which would segregate those trained engineers actively in the profession from those who were not actually engineers but merely interested in radio in some other way than engineering.

The Admissions Committee of the Institute has had increased difficulty in recent years as the number of border-line cases has increased. There are now thousands of radio engineers who should be Members of the Institute because they are trained engineers actually making a life career in radio engineering, but who are actually only Associates because the requirements for Member grade are so high.

These considerations make it appear logical that there should be two grades of Member (in addition to the purely honorary Fellow grade) to accommodate radio engineers of a few years' experience and those of longer experience. Some of the societies faced with the same diversity of membership that radio science has, like that in aeronautics, have as many as six or seven grades of membership in order to meet this problem with maximum precision, but this extreme should not be necessary in the radio engineering field.

The Board of Directors has had much spirited discussion over the matter of names for the new grades. There are objections to any names which have been proposed, and no one is satisfied completely by any proposal so far made. However, since the principle is obviously sound and unobjectionable, it is in the general interest not to quibble about names, which actually are not vitally important, and the Board has selected a certain set of names as given in the proposed Constitutional amendment, as being the best compromise of the many factors. It is hoped that the amendment will both alleviate some management difficulties and better satisfy the needs of many members.

From: H. P. WESTMAN

The proposal to add a new grade of membership appears to be based on a desire to bestow professional-grade recognition on young members after only three years of engineering work in radio or an allied field. The present Constitution requires four years of responsible radio engineering work and is considered as being too severe.

To test the severity of the present constitution, reference was made to the 1942 YEARBOOK which shows the following distribution of the membership.

		Per Cent
Fellows	174	2.7
Members	770	12.0
Associates	5437	84.6
Juniors	48	0.7
Total	6429	100.0

This would appear to bear out the assumption that the requirements for Member are such as to prevent a suitable proportion of the membership from being advanced to that grade.

To estimate to what degree technical qualifications enter into this situation, a check was made of the first 200 Associates whose titles and business connections are given. Rejecting all those who have not been in the Institute for at least 4 years (7 years in allied fields) and estimating, on the basis of a dozen years' experience with the Admissions Committee, the probable qualifications of the others, it appears that about 60 would have a good chance of being approved for Member under the present constitution. This indicates that about 30 per cent of our Associates, or more than 1500, are logical candidates for transfer right now. Perhaps there are some other factors which should be considered.

Transfer from Associate to Member requires an increase in dues from \$6 to \$10 a



year and a transfer fee of \$2. This looks like a double payment the first year and two thirds more each year thereafter for the rest of your life. The direct services received by a Member are not increased. While an engineer with strong professional feelings will readily make this additional contribution to his society on the assumption that his personal advancement is in no small part the result of what he has absorbed from the society's services to him, that view is not shared by all who are qualified by their work for advancement in grade.

This financial factor has not affected the radio engineer alone. The American Institute of Electrical Engineers assesses an Associate for Member dues after 6 years even though he is not qualified for transfer. The American Society of Civil Engineers requires its members to transfer from the lowest grade within a few years or have their memberships canceled. Thus the history of these much older societies, which now operate in relatively stabilized fields, shows not a need for a short cut to their higher grades but rather a stimulus in the form of penalties for failure to transfer within a reasonable time.

Further recourse to our first 200 Associates indicates the following:

	Per Cent	
Probably qualified for Member now	1631	30
Probably qualified for new Member	1468	27
Not actually engineers	598	11
Others	1740	32
	5437	100

Thus to "protect" about 57 per cent of the Associates from continuing in the company of some 11 per cent of questionable engineering attainments, it is proposed to move them into a new grade in spite of the fact that more than half of these can probably transfer into the present Member grade at any time they desire.

If the new grade is set up, it is almost certain that in the minds of most people no distinction will be made between Senior Member and Member. This will automatically place the Senior Member on a lower standing than is now enjoyed—a substantial disservice to 12 per cent of the membership.

The present grade structure has been established by 30 years of operation and is comparable to that of the American Institute of Electrical Engineers which is the only other large society of interest to electrical and radio engineers in this country. Any change, particularly in the Fellow and Member grades, will be confusing and damaging to both societies.

It is not intended to give the impression that there is nothing wrong with the membership structure of the Institute but only that an attempt is being made to solve an insignificant problem, each case of which may be cured in not over four years without action on the part of anyone, while a much more basic and extensive difficulty which has existed for many years, which has been faced by other societies, and



NEW YORK SECTION

B. E. SHACKELFORD  
*Meetings and Papers Committee*

H. M. LEWIS  
*Chairman*

J. E. SHEPHERD  
*Membership Committee*

## New York Section

On October 30, 1942, the Board of Directors approved a petition for the establishment of a New York Section. The first meeting was held on December 2, 1942, and a joint meeting was held with the New York Section of the American Institute of Electrical Engineers on February 10, 1943. Regular meetings, preceded by a dinner, are held on the first Wednesday of each month, with the exception of July and August, when no meetings are scheduled. Out-of-town members of the I.R.E. are cordially invited to attend any of the dinners and technical sessions.

An attempt is being made to reach the large membership of the Section to determine programs and to learn the requirements needed to be of real value. The officers of the Section welcome suggestions from the membership as to the best way to accomplish doing this.

The officers are as follows:

*Chairman*, H. M. Lewis, Hazeltine Electronics Corp.

*Vice Chairman*, M. G. Crosby, R.C.A. Communications, Inc.

*Secretary-Treasurer*, H. F. Dart, Westinghouse Electric and Manufacturing Co.

Other members of the Executive Committee are:

Keith Henney, *Electronics*

T. R. Kennedy, Jr. (Publicity), *New York Times*

Knox McIlwain (Inter-Societies Affairs), Hazeltine Electronics Corp.

J. E. Shepherd (Membership), Sperry Gyroscope Co.

B. E. Shackelford (Meetings and Papers Committee), Radio Corporation of America

which has hampered the Institute in its activities, is being completely ignored.

It might be considered reasonable to settle this little problem which is now under consideration and attack the larger one later. There is danger in such a proposal for once we set up a new grade and make the necessary changes in the others, it will be impossible to change back without substantial penalty to the Institute and its membership.

The Institute faces a major problem which the present proposal does not solve. If the new grade structure is adopted, it will make even more difficult the obtaining of a real solution to that problem. Many possible solutions are conceivable and should be discussed among the membership after this proposal has been rejected.

*From: A. F. VAN DYCK*

Mr. Westman's letter on the proposed amendments has come before me and I wish to make the following comments.

The matter of grade structure should be disassociated from the question of dues. The suggestion that dues be increased automatically with time in the Institute has been made before, and will in due course come up again for consideration by the Board. It is a good suggestion, but is a totally separate one. If it were to be adopted there would be still more need to have the proposed grade structure, because it would be unfair to increase dues to persons not in the profession, and merely interested in radio, as many of our Associates are. This condition (of merely "interested" members) does not exist in other engineering societies, where practically every member of every grade is actually in the profession. The proposed new grade structure is needed in the I.R.E. to separate engineers in the profession from persons interested in radio but not in the profession.

## Consultative Committee on Engineering of the Professional and Technical Division, War Manpower Commission

This committee is advisory to Dr. Edward C. Elliott, Chief of Professional and Technical Training, War Manpower Commission. Its chairman is Dr. R. E. Doherty, president, Carnegie Institute of Technology. Its membership includes representatives of major war industries and the engineering societies, the representative of the Institute of Radio Engineers being Mr. Arthur F. Van Dyck.

At a meeting on February 10, 1943, the Committee discussed various phases of the technical manpower problem, and adopted certain recommendations to the War Manpower Commission. These are as follows:

1. That the War Manpower Commission obtain through the Office of War Information assistance in the education of the public to the necessity of maintaining a continuing supply of professional personnel in certain critical fields.

2. That the W.M.C. survey of professional engineering manpower be carried forward as rapidly as practicable, placing emphasis upon (a) including only engineers at professional level, as generally represented by engineering graduates, and (b) including only absolutely essential needs.

3. That recommendations to the W.M.C., or such expressions as may be prepared for public use, be limited to brief categorical statements of requirements for professional men.

4. That a plan be set up to remove from the individual, the draft board, and the employer or college, the decision as to whether the individual is to go into the Armed Forces or remain where he is; and the most promising means of accomplishing this end would be to require that individuals be inducted into the Armed Forces only with the special permission of the W.M.C.

5. That there be created, as part of the regional or area organization of W.M.C. special committees, similar to the existing committee for physicists, to assist and advise the selective service boards, in individual cases, as to the necessity of retaining in civilian occupation for essential war purposes professional engineering and scientific personnel, such special committees to be constituted of professional personnel primarily of judicial mind and secondarily of engineering and scientific background appropriate to the major industrial activities of the particular region.

The representative of the Institute suggested that further time and effort not be expended in surveys to determine the exact quantitative degree of the shortage of engineers, since it is well known in the profession that the shortage is great enough to be damaging, and that instead efforts be directed toward education of draft boards, government officials, and the public as to the kind of war work performed by engineers, and to an explanation of the necessity and importance of that work. It is not necessary to prove to anyone that there is a shortage of engineers, but it is

necessary to prove that a shortage of engineers is serious. Everyone knows what a farm worker does, but the public in general, and draft boards in particular, are not clear on what the engineer does, and do not know its basic importance, or that competent engineers cannot be trained in six months. Some of the recommendations, particularly Nos. 1, 3, 5, are intended to meet this situation.

The Committee's recommendations are purely advisory, and it is not known whether the War Manpower Commission will adopt any of them.

## Radio Club of America Re-elects 1942 Slate of Officers

The Radio Club of America announces the re-election of the entire 1942 slate of officers for the 1943 term, as a result of the annual election just held. The slate is headed by Paul Ware, well-known radio pioneer and now general manager of Allen B. Du Mont Laboratories, Inc. Other officers are C. E. Dean, vice president; J. J. Stantley, treasurer; O. J. Morelock, corresponding secretary; and L. E. Packard, recording secretary. Austin C. Lescarboursa, widely known writer and advertising man in the radio field, has been reappointed chairman of the Publicity Committee for 1942.

Mr. Ware joined the Institute of Radio Engineers as an Associate in 1917; Mr. Dean became an Associate in 1926, transferring to Member grade in 1936; Mr. Morelock has been an Associate since 1935; and Mr. Packard, a Member since 1941.

## L. GRANT HECTOR

Dr. L. Grant Hector has joined the National Union Radio Corporation, radio-and-electronic-tube manufacturers, as director of engineering, as announced by S. W. Muldowny, president of the corporation. In his new position Dr. Hector will direct all electronic-tube research and engineering activities for the company's laboratories and manufacturing plants located in Newark, N. J., and Lansdale, Pa. Dr. Hector has had a varied background of electronic scientific-research experience. He is a graduate of Oberlin College and Columbia University, has served as physics instructor at Oberlin, professor of physics at the University of Buffalo and at the time he joined National Union was engaged in electronic-development work for the Office of Scientific Research and Development of the United States Government. He has been an Associate member of the Institute of Radio Engineers for many years. His memberships in scientific societies also include Fellow, American Physical Society; Fellow, American Association for Advancement of Science; Member, Acoustical Society of America; and Sigma Xi. Long-term assignments in which Dr. Hector has been engaged as an applied physicist and radio engineer included radio editorship of the *Buffalo Evening News*, consulting radio engineer of WBEN, and research director of the MacKenzie Muf-

fler Company and Buffalo Pressed Steel Company of Youngstown, Ohio.

Dr. Hector has gained recognition through his writings which include papers, articles, and books dealing with magnetic, dielectric, and acoustical measurements by electronic techniques. Text books by Dr. Hector include *Modern Radio Receiving* (1927), *Introductory Physics* (1933), and *Electronic Physics* now on the press. His papers and articles have been delivered before the American Physical Society and the International Scientific Radio Union, and have been printed in the *PROCEEDINGS of the I.R.E.*, *Physical Review*, and the *Review of Scientific Instruments*.

## K. C. DEWALT

K. C. DeWalt (A'29) has been named designing engineer in the tube division of the General Electric electronics department, at Schenectady, N. Y.

Mr. DeWalt, born in Vinton, Iowa, is a graduate of the University of Iowa where he received his B.S. in E.E. degree in 1927. Upon graduation, he immediately was employed by General Electric and went to work in the testing department. In May, 1928, he transferred to the research laboratory where he was engaged in power-tube circuit work. When the vacuum-tube engineering department was formed in January, 1930, Mr. DeWalt was transferred to that department, becoming section leader on high-vacuum tubes in 1933. When the department became a division of the electronics department in 1942, he continued in high-vacuum-tube engineering work until his new appointment.

## T. R. ROSEBRUGH

The death was announced on January 24, 1943, of Thomas Reeve Rosebrugh, M.A., D.Sc., F.R.S.C., professor emeritus of electrical engineering at the University of Toronto.

Professor Rosebrugh received the B.A. degree in mathematics from the University of Toronto in 1887 and the M.A. degree in 1893. He was graduated from the School of Practical Science in 1889 in engineering. When he retired from active teaching in 1936 the University conferred on him the degree of Doctor of Science, *honoris causa*. He was an excellent teacher, specializing in the application of mathematics to electrical engineering, in which field he made important contributions.

In 1893 he submitted for his Master's degree a thesis entitled "On the Use of Coplanar Quaternions in Alternating-Current Calculations." Unfortunately both copies of this paper have been lost, but it seems to have anticipated the present analytical methods by about four years. In 1894 he collaborated with his father, Dr. A. M. Rosebrugh, who was a pioneer in the telephone industry as well as an eye and ear specialist, in the invention of the "phantom circuit" used so extensively in communications.

In 1919, Professor Rosebrugh published "The Calculation of Transmission

Networks" in Bulletin No. 1, School of Engineering Research, University of Toronto. In this paper the first application of matrixes to electrical engineering appears to have been made. As far as is known he was the originator of the *A, B, C, D* notation for the auxiliary circuit constants.<sup>1</sup> In 1930, he presented "The Analytics of Transmission Calculations" at the Summer Convention of the American Institute of Electrical Engineers. This paper is a complete analysis of the basis of all circle diagrams and real-quantity calculations of transmission circuits.

Professor Rosebrugh was head of the department of electrical engineering from its inception until his retirement in 1936. He was not a prolific writer for publication, but he did much work which was never published. Sometimes this unpublished work found its way into his lectures without special mention, to the later astonishment of his pupils, when they discovered that some fact or method was unknown to the outside world.

He was a life member of the American Institute of Electrical Engineers (A'91) and was one of the organizers of the Toronto Section. He joined the Institute of Radio Engineers in 1915, resigning in 1934, and was a charter member of the Toronto Section of the I.R.E.

<sup>1</sup> *Trans. A.I.E.E.*, vol. 28, p. 687; 1909.

## Book Preview

### Electromagnetic Waves, by S. A. Schelkunoff

Published by D. Van Nostrand Co., Inc., 250 Fourth Avenue, New York, N. Y. 512 pages+preface+index. 320 figures. 6×9 inches. Price, \$7.50.

In this advanced treatment of the subject which is the basis of radio, Dr. Schelkunoff has gone far toward unifying the space concepts of waves and the network concepts of circuits. With this viewpoint, he has given a most thorough analysis of wave transmission with emphasis on wave guides, cavity resonators and antennas. In the process, he has introduced novel concepts and terminology which are stimulating to a better understanding of the subject.

As a textbook, this work requires a mathematical background as far as hyperbolic functions and the theory of functions of the complex variable. The book supplies its own introduction to vectors, cylindrical and spherical harmonics (Bessel and Legendre functions), and the Laplace transform (Fourier integral). While the introduction to alternating currents and elec-

tric circuits is complete, it is so brief that a prior course in alternating-current circuits is required and one in communication networks is advised. There is no reference to vacuum tubes because generators and indicators are assumed rather than described.

As a reference, this volume is useful because the results are expressed in simple form backed up by concise derivations. In many cases, the derivation is too intricate for reference purposes but the fact that it gives the underlying conditions makes it a valuable adjunct to the conclusions. Rationalized meter-kilogram-second (m.k.s.) units are used.

The first half of the book is mainly devoted to introductory material which presents the viewpoints of the author as well as his terminology. The mathematical introductions are followed by the theory of oscillations and one-dimensional waves, the fundamental electromagnetic equations, impedance networks, wave filters, transmission lines, and simple cases of radiation in space. Special attention is given to the peculiar properties of transmission lines and their practical utility.

The second half is devoted to waves, wave guides, and resonators, with special attention to antennas. The wave guides range from the simple coaxial line and parallel wires to metal pipes and dielectric wires. Sections of wave guides become resonators, with selectivity factors (*Q*) analogous to those of tuned circuits. Reflection from surfaces and diffraction at boundaries is described to the extent required for wave guides and antennas. A completely absorbing surface is described which is to plane waves what the ideal resistance termination is to waves in a transmission line.

Antennas are described which range from the common wires and arrays to the more recent conical antennas and horns. By the theory of nonuniform lines and wave guides, the impedance of practical antennas is derived over a wide range of frequency.

The volume concludes with a short discussion of the impedance concept and its significance at discontinuities in wave guides. This section is really an introduction to the wider application of wave guides and resonators which is now in the course of development.

"Electromagnetic Waves" is a masterful treatment of an elusive subject. It is recommended as a textbook for advanced students in communication courses or as a reference volume for radio engineers who have been initiated in the theory of waves and antennas.

H. A. WHEELER  
Hazeltine Electronics Corporation  
Little Neck, L. I., N. Y.

## Books

### A Practical Course in Magnetism, Electricity, and Radio, by W. T. Perkins and A. Charlesby

Published by the Chemical Publishing Company, Inc., Brooklyn, N. Y. 310 pp.+vii pp. +2-page index. 291 figures. 5½×8½ inches. Price \$4.00.

This appears to be an American edition of a British text, originally intended as a coaching manual for certain standard English civil-service examinations, with chief emphasis on elementary electricity and magnetism. The nomenclature and the illustrations are drawn exclusively from British sources, but since the material is elementary and basic, this feature will not be disadvantageous to non-British readers.

The book includes sections on Magnetism, Direct Current, Alternating Current, and Radio, the direct-current section receiving the greatest attention. Each of these sections includes a very compact summary of definitions and formulas followed by a number of complete experiments. In addition there are six experiments on motors.

Doubtless the book adheres strictly to the syllabus of the examinations mentioned above. This fact gives the book a certain "dateless" character, since nearly all of the text, including the brief radio section, could have been written in almost the same words at least 25 years ago. The old familiar experiments are compactly marshaled and marched in review with no concessions toward numerous "modern" innovations such as the Selsyn motor and the cathode-ray oscilloscope. For general purposes this emphasis on old and well-tried experiments, to the exclusion of all else, may be regarded either as an advantage or as a limitation.

Under present emergency conditions in America this book might be suggested as a handy "refresher" text, useful to many persons who were once familiar with all basic electrical-engineering concepts, and who now find it necessary to recall these half-forgotten ideas in preparation for further training. The text may be considered too concentrated for private study by persons who have had no previous training in the field. The numerous experiments on tangent galvanometers and on electrolysis are presumably superfluous for the majority of the highly specialized war courses now in progress.

HARRY ROWE MIMNO  
Cruft Laboratory  
Harvard University  
Cambridge, Massachusetts

# Contributors



T. R. W. BUSHBY

Thomas R. W. Bushby\* (A'33-M'40) was born on June 14, 1900, at Littlehampton, England. He entered the British Civil Service in 1916 and has been interested in radio since that date. He served as an operator in the Royal Engineers (Signal Service) during 1918-1919, and on demobilization was assigned to the Department of Scientific and Industrial Research, being posted to clerical duties with the Radio Research Board on its inception. In 1920 he went to Australia, and engaged in various activities until 1929, when he again became interested in radio as a profession, holding various positions in the industry. In 1936 he took up a post as design engineer with Amalgamated Wireless (Australasia), Ltd., and has served in the special products, aviation, special development, and mobile departments. Mr. Bushby is now with the standardization department at the Radio-Electric Works at Ashfield. He has held an amateur operator's license since 1927, and a broadcast operator's license since 1930. He is a foundation member of the Institution of Radio Engineers of Australia (1932), and was previously a member of the Wireless Institute of Australia. He was president of the New South Wales Division of the latter body in 1930-1931.

\* Paper published in the December, 1942, issue of the PROCEEDINGS.



J. S. DONAL, JR.

J. S. Donal, Jr. (M'40) was born on June 19, 1905, at Philadelphia, Pennsylvania. He received the A.B. degree from Swarthmore College in 1926 and the Ph.D. degree in physics from the University of Michigan in 1930. From 1930 to 1936, Dr. Donal was associated with the Johnson Foundation for Research in Medical Physics and with the department of pharmacology of the University of Pennsylvania. In 1936, he joined the research laboratories of the RCA Manufacturing Company, Inc., and is now located in the R.C.A. Laboratories at Princeton, New Jersey. He is a member of Sigma Xi and of the American Physical Society.



D. B. Langmuir (A'38-M'40) was born on December 14, 1908, at Los Angeles, California. He received the B.S. degree from Yale University in 1931 and the Ph.D. degree in physics from the Massachusetts Institute of Technology in 1935. Dr. Langmuir was associated with the research laboratories of the RCA Man-



D. B. LANGMUIR

ufacturing Company, Inc., Harrison, New Jersey, from 1936 until 1941. Since 1941, he has been with the Office of Scientific Research and Development, Washington, D. C. Dr. Langmuir is a member of Sigma Xi and of the American Physical Society.

Geoffrey A. Miller (S'33-A'42) was born in Edmonton, Alberta, Canada, February 22, 1910. He received the B.Sc. degree in electrical engineering in 1934, and the M.Sc. degree in radio engineering in 1936, both from the University of Alberta. In 1940 he received the Ph.D. degree in communication engineering from the Ohio State University. From 1940 to date he has been employed as a junior research engineer at the National Research Council, Ottawa, Ontario, Canada.



Lincoln La Paz was born at Wichita, Kansas, on February 12, 1897. He received the A.B. degree from Fairmont College, Wichita, in 1920; the A.M. degree from Harvard in 1922; and the Ph.D. de-



GEOFFREY A. MILLER

gree from the University of Chicago in 1928. He was an instructor in mathematics at Fairmont College from 1917 to 1920, university scholar during 1920-1921, and instructor in mathematics during 1921-1922 at Harvard, and an instructor in mathematics at Dartmouth College from 1922 to 1925. Mr. La Paz was a National Research Council Fellow at the University of Chicago during 1928-1929; instructor in mathematics, 1929-1930; assistant professor of mathematics, Ohio State University, 1930 to 1936, associate professor of mathematics, 1936-1942, professor of mathematics, 1942 to date, and investigator, Office of Scientific Research and Development, 1943. He is a Fellow, American Association for the Advancement of Science; president, Society of Research on Meteorites; member, American Mathematical Society, American Meteorological Society, Mathematical Association of America, Ohio Academy Science, Sigma Xi, and Pi Mu Epsilon.

Mr. La Paz, R. D. Carmichael, and J. H. Weaver are the authors of "The Calculus" published in 1937.



For a biographical sketch of F. E. Terman, see the PROCEEDINGS for April, 1943.



LINCOLN LA PAZ



# TIME OUT

## for credit where credit is due

With a brief departure from our customary advertising message, we salute the men and women of our laboratory and our factory. Work clothes are their uniforms.

Their diligent efforts have enabled us to produce the most complete line of precision attenuators in the world . . . in sufficient quantities. They know, and we of the management know, there's only one job that really is important . . . production!

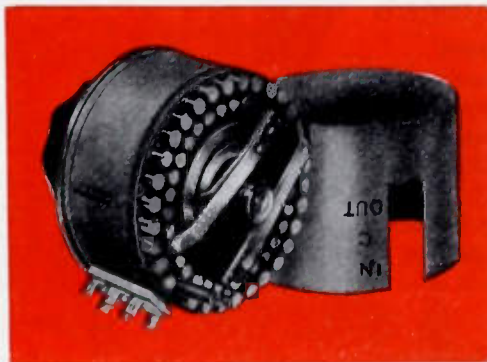

*Ordering standard components and equipment may facilitate deliveries*

## THE DAVEN COMPANY

158 SUMMIT STREET

NEWARK, NEW JERSEY



# HOW TO GET THE RIGHT CONTACTS FOR YOUR JOB!

The fact that Stackpole makes practically all types of copper-graphite, silver-graphite, and rare metal composition contacts is important. Even more so, however, is the proved ability of Stackpole engineers to help customers select exactly the *right* contact for their job—then to use it to best possible advantage.

This calls for a careful study of all operating conditions involved. Sometimes it calls for helping customers design breaker and relay assemblies for the specific contacts indicated—but, whatever the need, Stackpole is well equipped to meet it.

The first molded silver-graphite contact which revolutionized circuit breaker and circuit control equipment design over fifteen years ago was a Stackpole development—and Stackpole contact engineering has continued to lead the way ever since.

Our engineers will welcome the opportunity to cooperate in solving your contact problems. We are equipped to run actual acceptance tests on a wide variety of circuit breakers and control equipment for Aviation, Automotive, transport and domestic service.

## STACKPOLE MOLDED CONTACTS

SILVER-GRAPHITE  
SILVER-COPPER-GRAPHITE  
GOLD-GRAPHITE  
SILVER-NICKEL  
SILVER-MOLYBDENUM  
SILVER-TUNGSTEN  
SILVER-NICKEL-MOLYBDENUM  
SILVER-NICKEL-TUNGSTEN  
and dozens of special alloys

# STACKPOLE

CARBON COMPANY  
ST. MARYS, PA.

*Proceedings of the I.R.E. May, 1943*



## "Cruiser and transport ahead . . . **LET'S TAKE 'EM!**"

Messages like these "must go through," and to make certain they do, the communication systems in our Army and Navy aircraft are as sensitive, as rugged, and as trouble-defying as advanced design and precision manufacturing methods can make them.

Producing transformers, headsets and other communications equipment for the Army and Navy Air Forces is ROLA's present responsibility to the war program. To keep abreast . . . and ahead . . . of demands, new machines have been designed, new methods devised, new tests and inspections applied. Facilities have been

expanded, and production vastly increased.

All this is important to peacetime users of ROLA equipment, for it is only logical to believe that the research and the skill and the equipment inspired by wartime necessity will find important application in the Electronic World of Tomorrow.

*The "know how," gained through twenty years of leadership in the radio field, has enabled ROLA to meet . . . and exceed . . . every war demand made upon it, both as prime and as subcontractor. We have facilities available for additional contracts. If you are interested, we suggest you write us . . . or ask our representative to call. THE ROLA COMPANY, Inc., 2530 Superior Avenue, Cleveland, Ohio.*

# ★ ROLA ★

MAKERS OF THE FINEST IN SOUND REPRODUCING AND ELECTRONIC EQUIPMENT



★  
★  
**One basic symbol....**

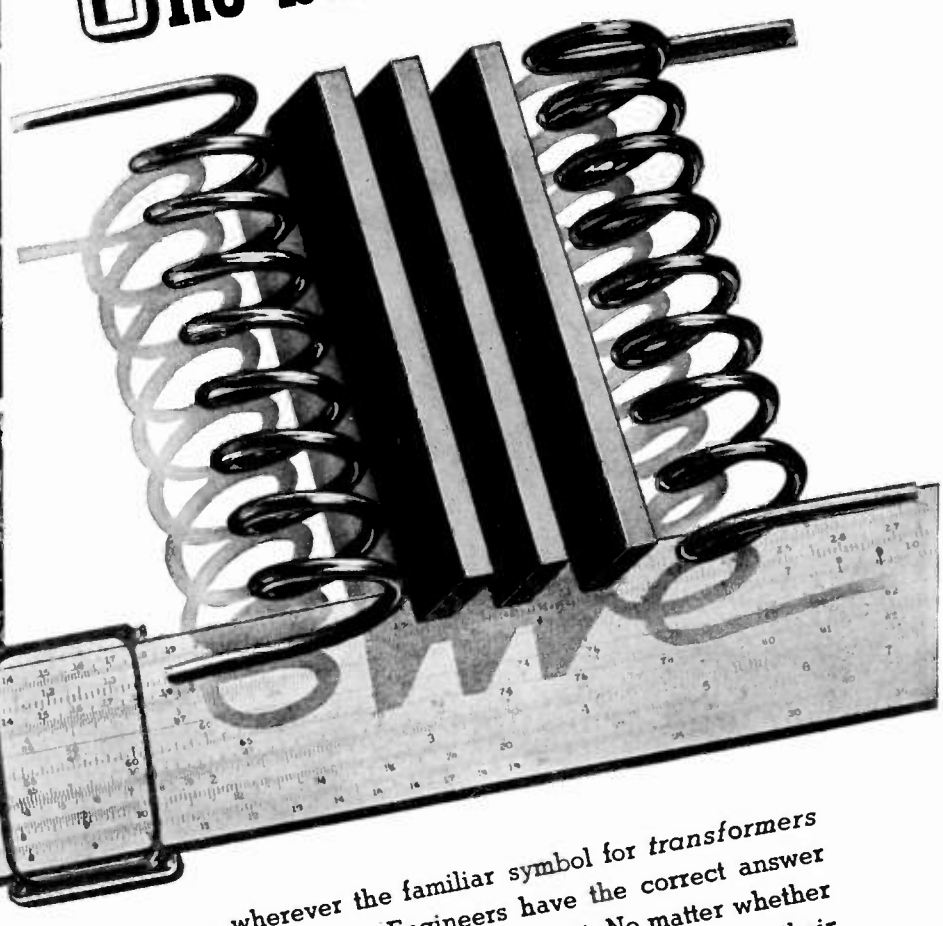

... wherever the familiar symbol for transformers appear—Stancor Engineers have the correct answer waiting for you—or they will find it. No matter whether the job is easy or tough — simple or complex — their broad experience and facilities may save you precious days of time and worry on rush work. And, when Tokyo and Berlin are finally blasted off the map these same brains — plus new knowledge gained in vital war developments — will be ready to help you swing back into profitable peacetime production.

**S T A N C O R**  
STANDARD TRANSFORMER CORPORATION • 1500 N. HALSTED STREET • CHICAGO







# F.M. Emergency Communications

by *Motorola*

**RADIO ENGINEERING FOR TODAY**  
*that means a lot for Tomorrow*

Pioneers in the development of Portable and Mobile F-M and A-M Radiotelephone Equipment, Motorola engineers are today applying their accumulated skills and scientific knowledge to solving problems which confront our country, its states, counties, cities and towns. Housed in a new

Engineering Building, with expanded facilities for research and engineering, the Motorola capacity for vital service is greater than ever. Electronic knowledge thus gained will one day soon be applied to the normal peacetime demands of a nation eager for better things in all phases of its living.



**THE ARMY-NAVY "E"**—Awarded for excellence in the production of Communications Equipment for America's Armed Forces

**Motorola Radio Communication Systems**  
**Designed and Engineered to Fit Special Needs**  
**GALVIN MFG. CORPORATION • CHICAGO**

# OHMITE

## Rheostats and Resistors

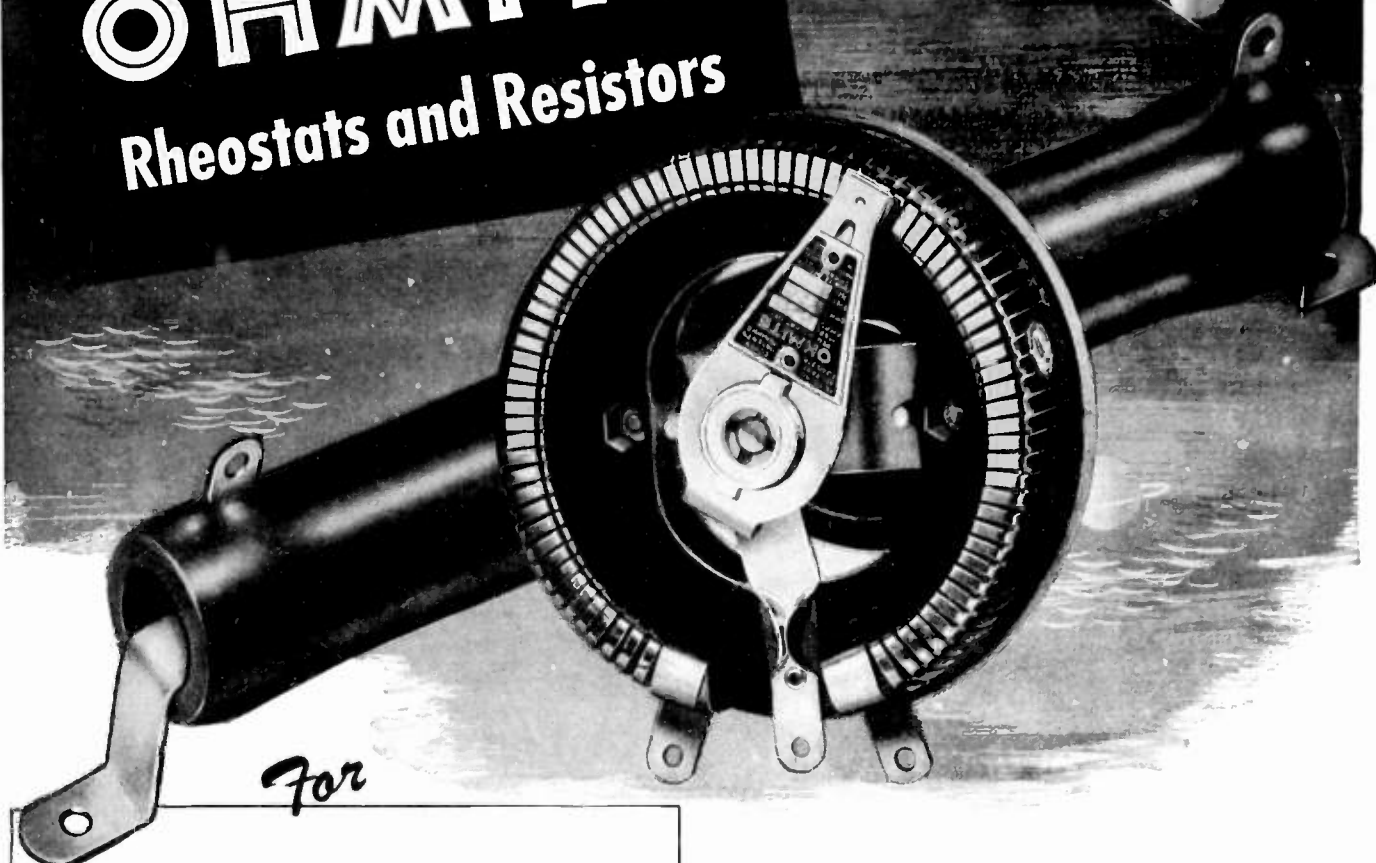

For

# CONTROL

*of Electronic Tubes and Devices  
... Today and Tomorrow*

The advancement of electronics has meant wider use of Ohmite Rheostats and Resistors . . . in science and industry, in laboratories, products and production. Engineers, scientists and manufacturers have come to know and rely on them for accurate, dependable control of electronic tubes and devices . . . from x-ray to radio and television, from instruments and machines to airplanes. These time-proved resistance units insure *permanent performance*.

Today, of course, Ohmite Rheostats and Resistors serve the Armed Forces and Industry in combat, production and research in an all-out effort to speed Victory. The electronic world of tomorrow will find Ohmite units ready to meet new requirements and Ohmite Engineers ready to help you on any problem.

Write on company letterhead for helpful 96-page Catalog and Engineering Manual No. 40—an invaluable guide in the selection and application of Rheostats, Resistors and Tap Switches.

**OHMITE MANUFACTURING CO., 4861 Flournoy St., Chicago, U. S. A.**

*Foremost Manufacturer of Power Rheostats, Resistors, Tap Switches.*



# SPRAGUE

TYPE PX-25, "VITAMIN Q"



## HIGH VOLTAGE PAPER CAPACITORS

to Stand 5,000 to 15,000 Volts at 110° C.

**S**prague has the answer to the problem of finding paper capacitors that will handle high voltages at high temperatures.

Typical of many other Sprague developments, these Type PX-25 units, with their exclusive "Vitamin Q" impregnant, have proved their dependability under the most rigorous war conditions. Voltages now available run from 5,000 to 15,000 volts and ambient temperatures are on the order of 110° C. Used at low and ordinary temperatures, these capacitors give a tremendously increased safety margin over the ordinary commercial types.



Sprague engineers welcome the opportunity to cooperate in solving your capacitor problems. An exceptionally broad background of engineering experience in designing and producing dozens of highly specialized capacitor types for ultra-exacting war uses is freely at your disposal.

**SPRAGUE SPECIALTIES COMPANY**  
North Adams, Mass.

### SUB-CONTRACTORS, ATTENTION!

Sprague Specialties Company will be glad to hear from reliable firms having screw machine and metal stamping facilities available for sub-contract work on high-priority orders; also from concerns equipped to make up jigs and fixtures, and having female help available.

F. W. McNAMARA, Purchasing Agent  
Telephone: NORTH ADAMS (MASS.) 804

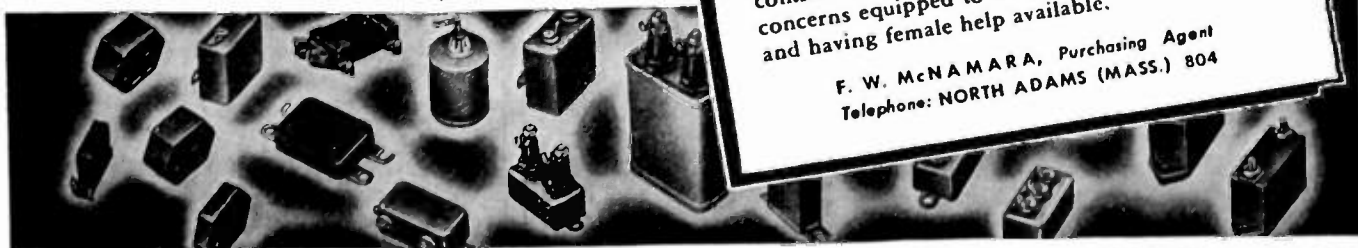

MANUFACTURERS OF A COMPLETE LINE OF RADIO and INDUSTRIAL CAPACITORS and KOOLOHM RESISTORS



**SENTINEL OF WAR TODAY...**

**GUIDE POST TO A NEW WORLD TOMORROW**

Today, the research and experience of the North American Philips Company in electronics are devoted to the single aim of aiding the United Nations war effort. Tomorrow, this knowledge will aid industry in creating a new world for free men.

Products for Victory include:  
Cathode Ray Tubes; Amplifier

Tubes; Rectifier Tubes; Transmitting Tubes; Electronic Test Equipment; Oscillator Plates; Tungsten and Molybdenum in powder, rod, wire and sheet form; Tungsten Alloys; Fine Wire of all drawable metals: bare, plated and enameled; Diamond Dies.

X-Ray Apparatus for industrial, research and medical applications. (Philips Metalix Corporation.)

**NORTH AMERICAN PHILIPS COMPANY, INC.**

*Electronic Research and Development*

Factories in Dobbs Ferry, N. Y.; Mount Vernon, N. Y. (Philips Metalix Corp.); Lewiston, Maine (Elmet Division)



## AIR-DESIGNED for Today and Tomorrow!

SINCE long before Pearl Harbor, the name BENDIX RADIO has stood for one thing: the finest precision-built aircraft radio equipment available. Proof of the superiority of this highly specialized equipment is its operation at extreme ranges of temperature, humidity, altitude... and its use in virtually all military aircraft of the United Nations.

In recent years, production of "BENDIX" Radio Equipment has been

many times multiplied. And important advances in BENDIX RADIO engineering have paralleled this progress in production.

Out of them have come many new electronic developments in communication, navigation and detection to help speed Victory. From the vast store of experience thus being constantly gathered will come equally great accomplishments to smooth the paths of Peace.

### BENDIX RADIO DIVISION

"BENDIX" Radio Equipment is a vital member of "The Invisible Crew" — precision equipment which 25 Bendix plants from coast to coast are speeding to our fighting crews on world battle fronts.



# TAYLOR TUBES

...Veterans in Freedom's Cause!

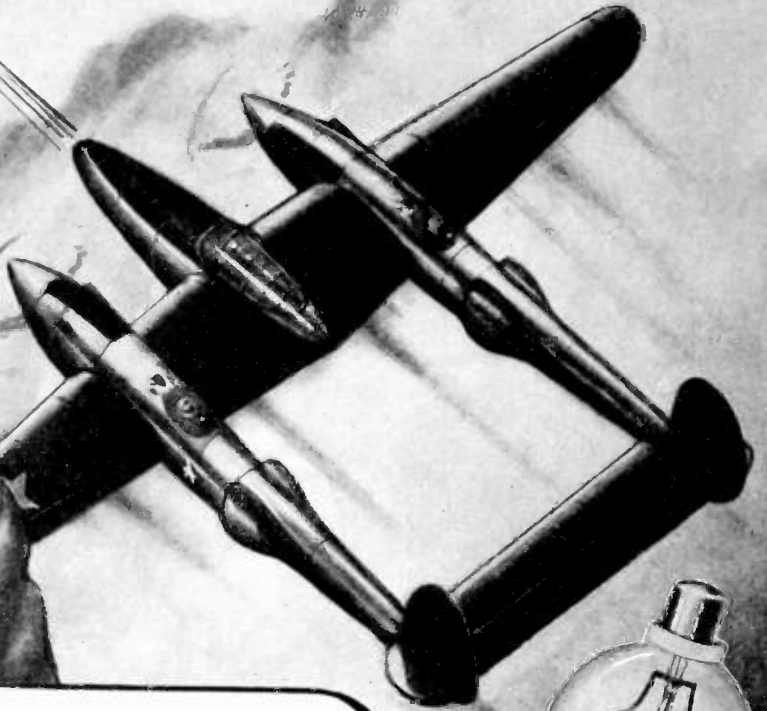

## ...WHEN YOU'RE IN THE THICK OF IT You Realize the Value of Superior Equipment

Long before America herself was at war, Taylor Transmitting Tubes proved they could stand up under the gruelling stress of actual combat on many Allied Battlefronts.

Today, thousands of Uncle Sam's fighting communications men know the assurance of Taylor dependability — know that Taylor Tubes deliver maximum power and extra hours of performance far beyond the needs of normal service.

With each passing day, the growing production of Taylor Tubes becomes an increasingly decisive contribution toward Victory. With this goal attained, Taylor will again supply many advanced types of "More Watts Per Dollar" tubes to peacetime America.

**Taylor** HEAVY **CUSTOM BUILT** DUTY **Tubes**

TAYLOR TUBES INC., 2312-18 WABANSIA AVE., CHICAGO, ILLINOIS

# CRYSTALS



## "SHORT ORDERS" IN A HURRY

If it's a "Rush" phone us, and your order for special crystals will go into work immediately under a competent crystal engineer personally charged with the responsibility for your project.

Our full facilities, including latest electrical and optical equipment, X-ray orientation, etc.—are at your service. John Meck Crystals are "Good Will Ambassadors of the Future" to acquaint you with our Family of Activities in the field of Sound and its Projection. That's why "Short Orders in a Hurry" are welcome.

*Phone* **CRYSTAL SERVICE DIVISION**  
**PLYMOUTH THREE THREE**



**JOHN MECK INDUSTRIES**  
**PLYMOUTH, INDIANA**



# No RF Circuits and plenty of output in this stable, accurate audio frequency oscillator

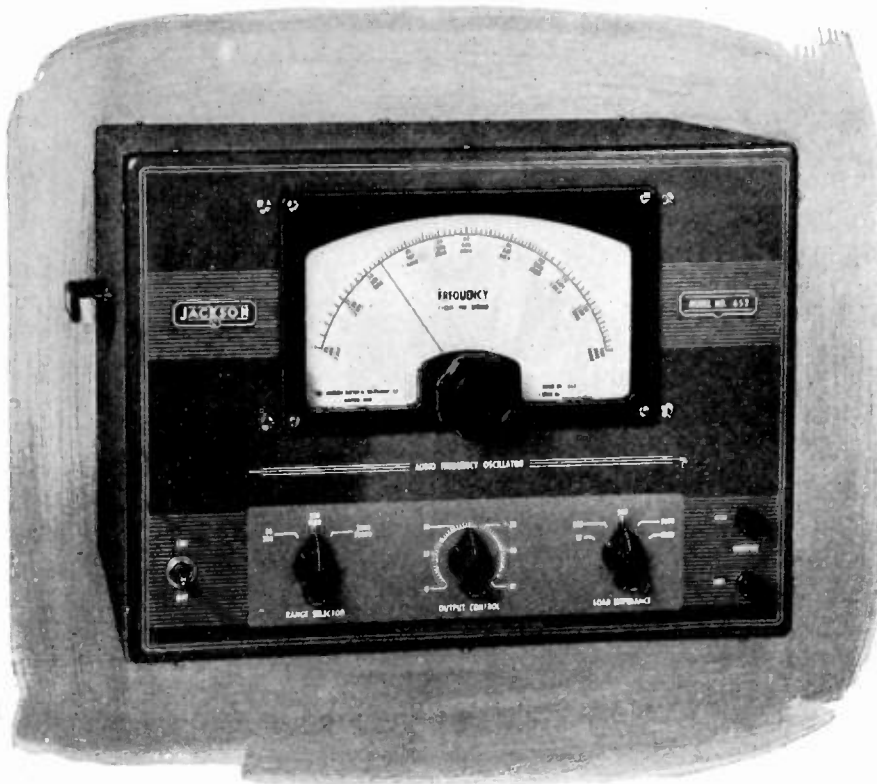

Here's an A.F. oscillator that gets down to fundamentals: sound in electrical and mechanical design—convenient to use—reliable in service. Entirely different from beat frequency oscillators, it develops output voltage directly at the desired fundamental frequency, free of any spurious signals or beats. There's no zero adjustment. Original calibration is permanently "locked."

*Range:* from 20 to 20,000 cycles. *Waveform:* excellent through entire frequency range, even with large changes in line

voltage. *Accuracy:* within 3% or 1 cycle. *Output impedance:* five convenient values—10,250,500,5000 ohms and high (controlled by selector switch). *Output control:* continuously variable from zero to maximum. *Output power:* approximately .5 watts, ample for all ordinary purposes.

This truly fine instrument may be the answer to many of your problems in audio frequency measurements. It, and many others from the Jackson line, are "in the service" now. They'll again be widely available when victory has been won.

# JACKSON

*Fine Electrical Testing Instruments*

JACKSON ELECTRICAL INSTRUMENT COMPANY, DAYTON, OHIO

xxviii

## Section Meetings

### ATLANTA

"Electronic Switching," by Professor B. J. Dasher, Georgia School of Technology, November 20, 1942.

Business Meeting of the Section, January 28, 1943.

### BALTIMORE

"Conserving Tin with Electronics," by C. J. Madsen, Westinghouse Electric and Manufacturing Company, March 18, 1943.

### BOSTON

"Signal Corps," by Captain E. B. Baker, Army-Navy Electronics Production Agency, February 26, 1943.

Sound Movies, "Signal Corps in Action," February 26, 1943.

### CHICAGO

"Application of Radio in the Handling of Emergencies on the Chicago Surface Lines System," by J. B. O'Connell, Chicago Surface Lines, February 19, 1943.

"Four-Terminal-Network Design," by Professor R. P. Siskind, Purdue University, February 19, 1943.

### CINCINNATI

"Planning for Peace While Producing for Victory," by D. C. Prince, General Electric Company, February 23, 1943.

### CLEVELAND

"The Cyclotron and Its Uses or Why an Atom Ought to Be Smashed," by J. A. Victoreen, The Victoreen Instrument Company, March 2, 1943.

### CONNECTICUT VALLEY

"Designing a Plastic Product," by F. J. Fleming, Foxboro Company, January 21, 1943.

"Obtaining Magnesium from Dolomite," by A. F. Stockwell, New England Lime Co., February 25, 1943.

### DALLAS-FORT WORTH

"Aircraft Communication Equipment," by C. H. Fox, Southwest Airmotive Company, March 10, 1943.

### DETROIT

"Radio Sonde," by Glenn Stallard, U. S. Weather Bureau, February 19, 1943.

"Controlled Rectifiers," by Dr. W. H. Bixby, Wayne University, March 19, 1943.

### LOS ANGELES

"Design of Direct-Current Amplifiers," by H. H. Cary, National Technical Laboratories, February 16, 1943.

"Microwave Electronics," by Dr. E. U. Condon, Westinghouse Research Laboratories, March 11, 1943.

### NEW YORK

"Functions, Organizations, and Activities of the Signal Corps," by Brigadier General F. E. Stoner, Signal Corps, U. S. Army, February 10, 1943.

(Continued on page xxx)

Proceedings of the I.R.E. May, 1943



# SELECT for SERVICE



## NEW HYTRON TUBES



Type	Description	Price
836	Half-wave, high-vacuum rectifier	\$11.50
837	12-watt, r.f. pentode	7.50
954	Sharp cut-off, acorn pentode	5.00
955	Acorn triode	3.00
956	Remote cut-off, acorn pentode	5.00
1616	Half-wave, high-vacuum rectifier	5.75
1625	25-watt, r.f. tetrode (12-v. heater)	3.50
1626	5-watt, triode oscillator	2.50
E1148	3.5-watt, a-b-f triode	2.25
VR105-30	Gaseous voltage regulator	1.25
VR150-30	Gaseous voltage regulator	1.25

### OTHER POPULAR HYTRON TUBES\*

Type	Description	Price
2C25	15-watt, medium- $\mu$ triode	\$3.00
2C45	7.5-watt, triode (modulator)	2.50
10Y	15-watt, general-purpose triode	1.50
801A/801	20-watt, general-purpose triode	2.50
HY61/807	25-watt, r.f. beam tetrode	3.50
841	15-watt, high- $\mu$ triode	2.25
844	Non-microphonic voltage-amp. triode	1.00
HY24	2-watt, power triode	1.50
HY31Z	30-watt, high- $\mu$ triode	3.50
HY65	15-watt, r.f. beam tetrode	3.00
HY69	40-watt, r.f. beam tetrode	3.95
HY75	15-watt, a-b-f triode	2.95
HY114B	(2C24) 1.8-watt, a-b-f triode	2.25
HY615	3.5-watt, a-b-f triode	2.25

\*This is not a complete list. Wattage ratings indicate instant-heating filament. Maximum plate dissipation. For complete characteristics consult Government specifications.

On this list of tubes which have recently joined the growing legions of Hytron types already marching on to Victory, you may find just the ones you want for your War equipments. Whether you choose the tiny "acorns" or the husky 1616 rectifier, you will discover the same high quality and design refinements which have made other Hytron tubes famous. If you place your orders well in advance, you will also be pleased by Hytron's on-schedule deliveries. Not too infrequently, deliveries are made from stock.

**HYTRON CORPORATION**  
SALEM AND NEWBURYPORT • MASS.  
Since 1921 Manufacturers of Radio Tubes





## "TELL 'EM WE COULDN'T DO WITHOUT THE PARTS THEY'RE GIVING UP"

*"Yeah, the folks back home are helping us plenty by giving up those radio and communication parts. See—over those hills! There's a bridge there. We just bombed hell out of it—cutting off an enemy tank column. With inadequate communications, we couldn't have done it!"*

COMMUNICATIONS are vital in this war of rapid movement—where success demands "co-ordination" of widely dispersed units.

When a swift PT boat gets its radio orders to torpedo an enemy transport . . . when a bomber drops its eggs over a submarine base . . . when an allied tank column, keeping in contact by radio, speeds over Sahara's sands . . . Utah Parts are playing their role in this war of communications.

Soldiers of production build dependability into those parts at the Utah factory. Utah engineers plan it in the laboratories . . . as they pore over blueprints far into the night.

Constantly, research is going on at Utah . . . new and better methods of production are being developed . . . to help keep the ears of the armed forces open. Tomorrow—when peace comes—this research and experience will be reflected in the many civilian products being planned at the Utah Laboratories. Utah Radio Products Company, 842 Orleans Street, Chicago, Ill. Canadian Office: 560 King Street West, Toronto. In Argentine: UCOA Radio Products Co., SRL, Buenos Aires. Cable Address: UTARADIO, Chicago.



**PARTS FOR RADIO, ELECTRICAL AND  
ELECTRONIC DEVICES, INCLUDING  
SPEAKERS, TRANSFORMERS, VIBRATORS,  
UTAH-CARTER PARTS, ELECTRIC MOTORS**

## Section Meetings

(Continued from page xxviii)

### PHILADELPHIA

"Television Video Relay System," by J. E. Keister, General Electric Company, March 4, 1943.

### ROCHESTER

"Ceramic Insulators—with Special Reference to Radio Applications," by G. W. Lapp, Lapp Insulator Company, Inc., February 11, 1943.

War Production Conference, M. H. Gregg and H. P. Ingels, War Production Board, February 25, 1943.

Panel Discussion on Production Inspection, by Lt. R. G. Wyld, U.S.N.R.; C. C. Phelps, Captain H. R. Couch, Captain W. R. Scholtzhauer, all of Rochester Ordnance District; and C. G. Newton, Pratt and Whitney, February 25, 1943.

### St. Louis

"Graphical Analysis of Current Distribution in Vertical Radiators," by V. J. Andrew, Consulting and Manufacturing Engineer, February 15, 1943.

### TORONTO

"Velocity-Modulated Tubes," by J. K. Hunton, Student, University of Toronto, January 28, 1943.

"Wide-Band Intermediate-Frequency Amplifiers," by R. W. Naylor, Student, University of Toronto, January 28, 1943.

"The Telephone in Wartime," by G. L. Long, Bell Telephone Company, February 5, 1943.

### WASHINGTON

"Absolute Measurement of Aircraft Speed and Course," by Lt. Col. D. K. Lippincott, Signal Corps, U. S. Army, February 8, 1943.

"War Production and Materials Control," J. A. Krug, War Production Board, March 9, 1943.

## Membership

The following indicated admissions and transfers of membership have been approved by the Admissions Committee. Objections to any of these should reach the Institute office by not later than May 31, 1943.

### Transfer to Member

Bennett, R., Radio Division, Bureau of Ships, Navy Dept., Washington, D. C.

Eilenberger, S. D., 6309-13-27 Ave., Kenosha, Wis.

Jutson, R. P., Bell Telephone Laboratories, 463 West St., New York, N. Y.

Long, F. V., Box 1925, Delray Beach, Fla.

Richey, J. L., Oaklynne, Princeton Junction, N. J.

Smith, A. H. R., College of Engineering, Rutgers University, New Brunswick, N. J.

(Continued on page xxvii)

Proceedings of the I.R.E. May, 1943



# Improved in War!

## ... for Better Peace-Time Reception

The rigors of modern warfare are the world's finest proving grounds for communications equipment . . . constant usage and unusual operating conditions in every climate are a severe test of the communications receiver. Hallicrafters equipment is proving its high quality performance capabilities with our armed forces.

Hallicrafters communications receiver Model SX-28 (illustrated) 15 tubes, 6 bands, delivers outstanding reception . . . your peace-time model will be worth waiting for.

# hallicrafters

CHICAGO, U. S. A.

The World's Largest Exclusive  
Manufacturer of Short Wave Radio  
Communications Equipment

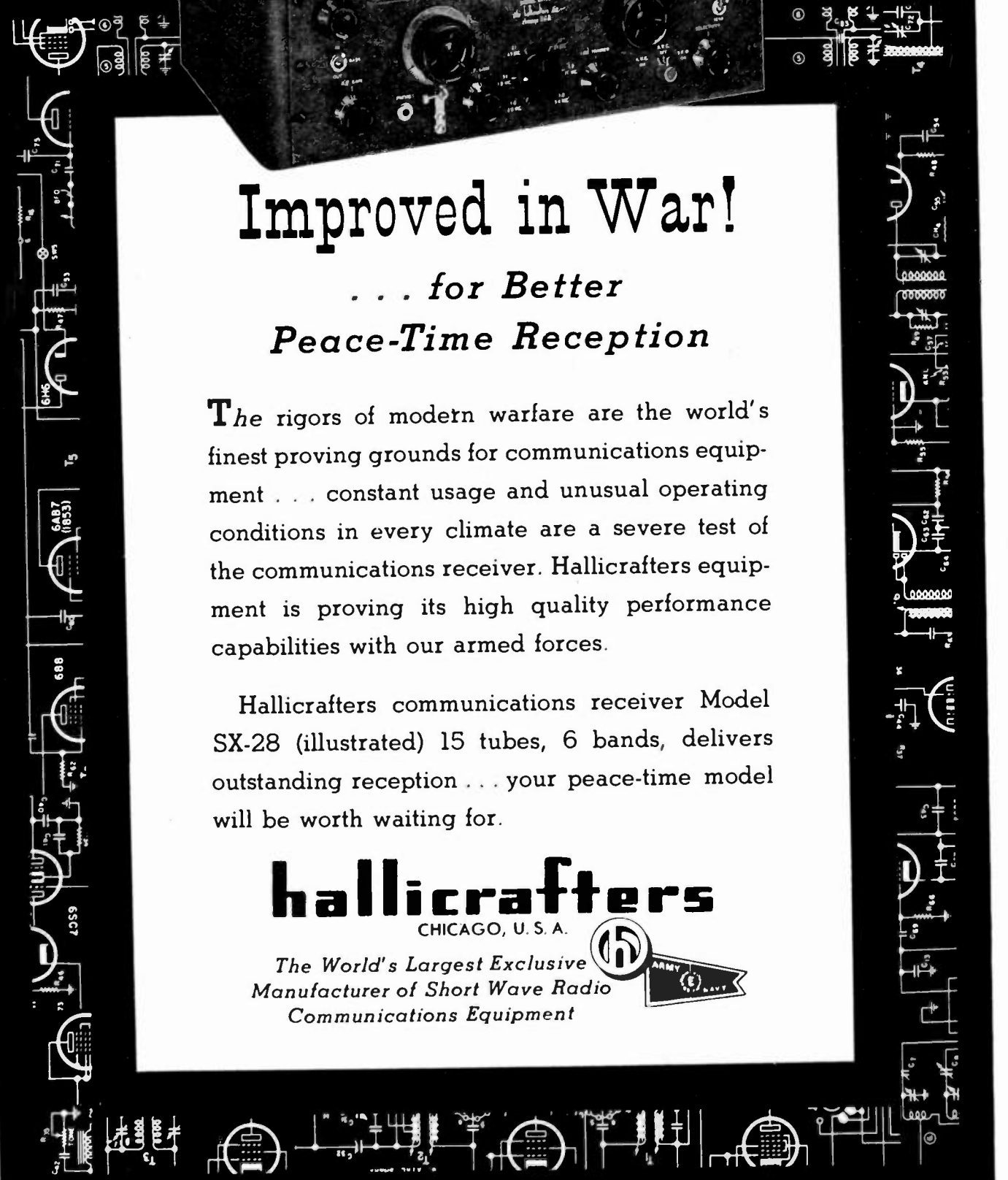

## "SHORTING" Switches

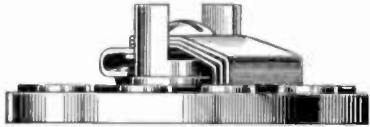

This is the shorting type. As the arm is rotated from one position to another the adjacent contact points are "shorted" (bridged).

or

## "NON-SHORTING" Switches

This is the non-shorting type. As the arm is rotated from one position to another, the arm lifts up, and only one contact is touched at a time.

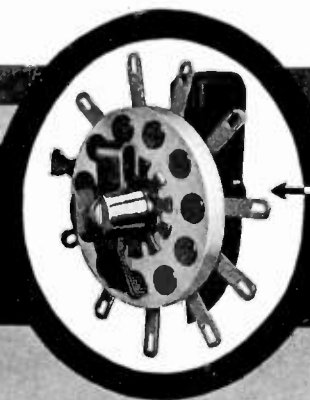
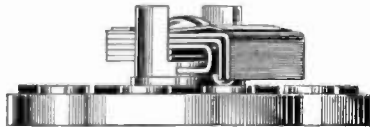

### OTHER SHALLCROSS

Switches are designed for use in your particular field.

Let Shallcross answer your problems.

Address Dept. C. 23

### THE No. 4605

is one of many Shallcross Switches extensively used in instruments and in many other applications.

## SHALLCROSS ROTARY SELECTOR SWITCHES USE SOLID SILVER CONTACTS, BECAUSE SOLID SILVER . . .

1. Has the highest conductivity of materials available.
2. Is superior to silver-plating which wears off, resulting in high resistance contacts.
3. Should it corrode the sulphide formed does not appreciably increase the contact resistance.

### Creators and Makers of

Accurate Resistors—Switches—Special Equipment and Special Measuring Apparatus for Production and Routine Testing of Electrical Equipment on Military Aircraft . . . Ships . . . Vehicles . . . Armament . . . and Weapons



# SHALLCROSS MFG. CO.

COLLINGDALE, PENNA.

## Membership

(Continued from page xxx)

Singelton, H. C., 2005 N.E., 28 Ave., Portland, Ore.

### Admission to Member

- Davis, S. L., Miller Rd. and Hoyt St., Darien, Conn.  
 Harvey, H. C., 406 E. Big Bend Blvd., Webster Groves, Mo.  
 Milne, G. O., c/o Blue Network Co., Inc., 30 Rockefeller Plaza, New York, N. Y.  
 Patrick, K. R., No. 1 Wireless School, Montreal, Que., Canada  
 Pumphrey, F. H., 4621—23 St., North Arlington, Va.  
 Tynan, A. G., 1525 Haynes Ave., Kokomo, Ind.

### Admission to Associate

- Aldridge, J. E., The Meridian Hill, Washington, D. C.  
 Alter, A. R., 1231 N. 13 St., Philadelphia, Pa.  
 Ames, I. M., 1878 Harrison Ave., Bronx, N. Y.  
 Anders, R. D., R. D. 2, Norristown, Pa.  
 Austin, B., 1406 E. Culver, Phoenix, Ariz.  
 Belcher, F. S., 1018 E. Whitton St., Phoenix, Ariz.  
 Bickel, J. J., Pan American Airways, Boeing Field, Seattle, Wash.  
 Bradburd, E. M., 72 W. 95 St., New York, N. Y.  
 Brandon, C. W., 909 E. Weldon St., Phoenix, Ariz.  
 Brown, W., 1155 Neilson Ave., Far Rockaway, L. I., N. Y.  
 Burda, A. J. Jr., Staff ComSeronSo'pac, F. P. O., San Francisco, Calif.  
 Burnett, R. D., Signal Corps at Large, 790 Blvd., N. E., Atlanta, Ga.  
 Butler, W. W., RCA Service Co., Inc., Camden, N. J.  
 Campbell, B. K., 768 Ninth Ave., Oakland, Calif.  
 Casabona, A. M., 474 Third Ave., New York, N. Y.  
 Cassidy, R. J., 1347 Villa Rd., Birmingham, Mich.  
 Cassidy, S. B., R. R. 1, Fredericton, N. B., Canada  
 Clark, D. E., Armour Research Foundation, 35 W. 33 St., Chicago, Ill.  
 Cockrell, H. E., 126 Hoover St., Ann Arbor, Mich.  
 Collyer, D. J., 250 Binley Rd., Stoke, Coventry, England  
 Conrad, K., Fleet Air Wing One, c/o Fleet P. O., San Francisco, Calif.  
 Costelow, J. A., 5208 Chadwick Rd., Johnson County, Kansas  
 Cummings, E. G., 303 Central Park Ave., Wilmette, Ill.  
 Davis, K. E., 52 Madison Ave., Oceanside, L. I., N. Y.  
 DeArcangelis, F. A., 506 Holmes St., Wilkesburg, Pa.  
 Dimeff, J., 3521 Nichols Ave., S. E., Washington, D. C.  
 Dixon, G. P., 3603 Brothers Pl., S. E., Washington, D. C.  
 Dorst, S. O., 82 Blackinton Crossroad, North Adams, Mass.

(Continued on page xxxiv)

Proceedings of the I.R.E. May, 1943

# RCA 849

R-F and A-F POWER  
AMPLIFIER, OSCILLATOR,  
MODULATOR

\$120



## LONGER LIFE

*instead of increased ratings*

### HOW TO MAKE TUBES LAST LONGER ON THE JOB . . .

RCA advertising, for months past, has been devoted to operating tips on making tubes last longer. This valuable material has now been collated into a booklet, copy of which will be sent upon request to Radio Corporation of America, Commercial Engineering Section, Harrison, N. J.



Ordinarily, when a Transmitting Tube has been improved, its ratings are raised—but not in these extraordinary times!

Today, it is long life that counts—not spectacular "peak" performance.

That is why, when the RCA-849 was materially improved over a year ago by use of the famous RCA zirconium-coated anode, you heard nothing about it—even after months of actual use had shown that the improvement was such as to warrant a substantial rating increase in normal times.

Instead of reflecting such an improvement in terms of higher tube ratings we utilized it to make conservative RCA tube ratings still more conservative. This program, we felt, was far more in keeping with the war effort because it assures longer life for tubes that are difficult to replace. This has been done, not only with the RCA-849, but with other RCA tubes as well.

The war has not stopped RCA engineering progress. It has only intensified it—a fact to which the thousands of hours of additional potential life now built in to many RCA Transmitting Tubes offer the most convincing proof.

**RATINGS\***  
FILAMENT VOLTAGE, 11 VOLTS  
FILAMENT CURRENT, 5 AMPERES



PLATE VOLTAGE, 2500 VOLTS, MAX.  
PLATE DISSIPATION, 400 WATTS, MAX.  
\*For class C telegraph service.

## RCA TRANSMITTING TUBES

PROVED IN COMMUNICATION'S MOST EXACTING APPLICATIONS  
RADIO CORPORATION OF AMERICA, RCA Victor Division, Camden, N. J.



## ОНИ ХОРОШИ ОНИ ЗАМЕЧАТЕЛЬНЫ

Don't speak Russian? Then let us translate the words of a Russian General to an American War Correspondent:

**"THEY'RE GOOD . . .  
THEY'RE EXCELLENT!"**

You see, the Correspondent had just remarked upon the number of "Connecticut" field telephones in use by the famed Cossack Cavalry. . . . Like many an American industry, our reputation for know-how rests today on the performance of our products in the service of the United Nations, all around the world. . . . When we can again freely solicit your patronage, there will be no testimonial to which we shall point with greater pride than the commendation of the fighting Russians.

### CONNECTICUT TELEPHONE & ELECTRIC DIVISION



MERIDEN, CONNECTICUT



## Membership

(Continued from page xxxii)

- Dowden, G. B., 453 Belmont Ave., Newark, N. J.  
 Duckwald, G. S., Jr., R. D. 5, 764 Lexington Ave., Mansfield, Ohio  
 Eannarino, J. M., 44 Veto St., Providence, R. I.  
 Edwards, R. O., 210 Angus Cres., Regina, Sask., Canada  
 Ehert, C. V., 200 Wagner Ave., Mamaroneck, N. Y.  
 Evans, N. O., R. D. 1, Box 382, Orange, Calif.  
 Evis, F. A., 25 Russell Hill Rd., Toronto, Ont., Canada  
 Faulkner, W. H., Jr., 1 West Lawn, University, Charlottesville, Va.  
 Finlay, E. A., 53 Burns Bay Rd., Lane Cove, N. S. W., Australia  
 Fitzgerald, J. A., 18A Elmbourne Rd., Tooting Bec Common, London, S. W. 17A, England  
 Fisk, R. H., 15420 Thomas St., Allen Park, Mich.  
 Fowler, R. W., 434 DeSoto St., Gainesville, Fla.  
 Freeman, L. S., Jr., 184 Pine Ridge Rd., Waban, Mass.  
 Fuchs, M., 3191 Rochambeau Ave., New York, N. Y.  
 Gaston, J. O., 3713 Alabama Ave., S. E., Washington, D. C.  
 Germany, O., 3839 Roulo St., Dearborn, Mich.  
 Gillespie, F. F., 941 E. 47 St., Chicago, Ill.  
 Graham, W. B., 601 W. 110 St., New York, N. Y.  
 Greenidge, G. F., Jr., 278 Macon St., Brooklyn, N. Y.  
 Grush, A., 881 Fox St., Bronx, N. Y.  
 Haddock, J. W., 1108 S. Columbus St., Arlington, Va.  
 Harmon, R. C., 1007 Tennessee St., Lawrence, Kan.  
 Hart, E. D., 18 Longlands Park Cres., Sidcup, Kent, England  
 Hawkins, M. F., 1107 Western Ave., Topeka, Kan.  
 Heikkela, R. A., 520 S. Meade St., Denver, Colo.  
 Hellermann, E., 5545 W. Cullon Ave., Chicago, Ill.  
 Hill, W. R., Jr., University of Washington, Seattle, Wash.  
 Holmes, E. A., III, Radiation Laboratory, M. I. T., Cambridge, Mass.  
 Hoffman, J. D., 723 N. 31 St., Billings, Mont.  
 Howard, L. R., 373 Cicotte St., Ecorse, Mich.  
 Hungerford, E. A., Jr., 4236 Second Road North, Arlington, Va.  
 Jacobi, T. E., 320 Washington, Ave., Haddonfield, N. J.  
 Jarema, E. D., 515 Fifth Ave., Belmar, N. J.  
 Jones, W. C. G., 1626 E. Turney Ave., R. 7, Box 138, Phoenix, Ariz.  
 Jordan, H. G., 463 West St., New York, N. Y.  
 Kadak, E., 5514 Selma Ave., Halethorpe, Md.  
 Kelton, K. O., 33 S. Fifth Ave., Tucson, Ariz.  
 Kimbrough, S. W., 906 E. Washington St., Charleston, W. Va.

(Continued on page xxxvi)

Proceedings of the I.R.E. May, 1943

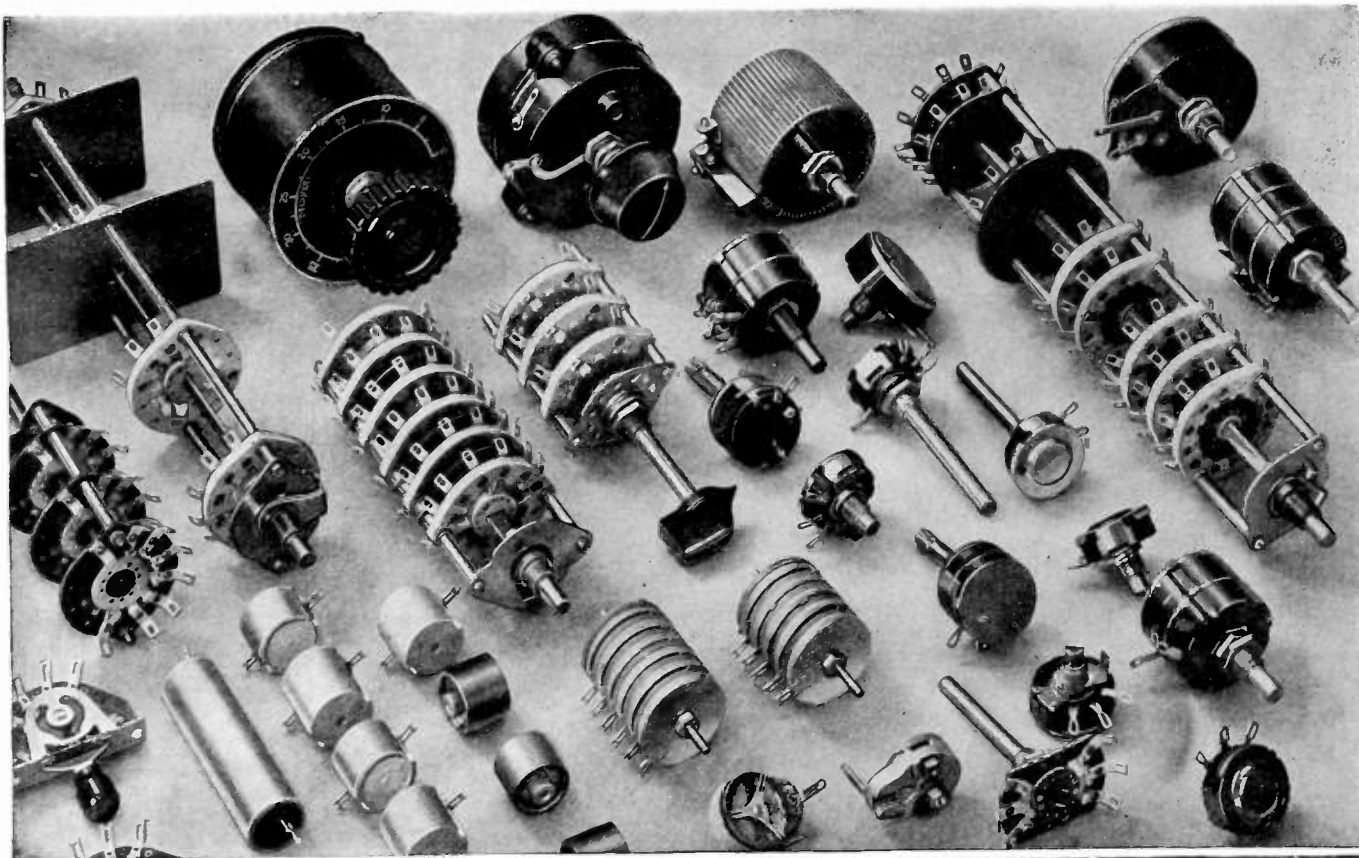

Serving the Electronic Industry since 1922...and now producing the following vital parts:

- CENTRALAB Steatite Insulators
- CENTRALAB Ceramic Trimmers
- CENTRALAB High Frequency Circuit Switches
- CENTRALAB Volume Controls
- CENTRALAB Ceramic Capacitors
- CENTRALAB Wire Wound Controls
- CENTRALAB Sound Projection Controls

# Centralab

Division of GLOBE-UNION INC., Milwaukee

*PARTS BY*  
*Centralab*

## Membership

(Continued from page xxiv)

- King, J., 535 S. St. Marys St., San Antonio, Texas
- Klopke, E. A., 3618 S. Seeley Ave., Chicago, Ill.
- Kuehl, W. J., 229 Third St., Neenah, Wis.
- Lamplugh, E. L., W.O.R.E.S. 16, Naval Research Laboratory, Anacostia Station, D. C.
- Landry, A. W., 12 Greenwood Rd., Yonkers, N. Y.
- Larson, R. E., 2222 Eye St., N. W., Washington, D. C.
- Lee, M. H., 4408—16 St., N. W., Washington, D. C.
- Levinson, S., 907 Argyle St., Chicago, Ill.
- Lewis, G., 4165 Georgia St., San Diego, Calif.
- Lockhart, R. W., 4010 N. Kenmore Ave., Chicago, Ill.
- Long, M. L., Jr., 46 Washington Elms, Apt. 463, Cambridge, Mass.
- Loranz, A. F., 30 Bay State Rd., Boston, Mass.
- Lorentz, G. B., 453 N. Third St., San Jose, Calif.
- Lund, J. E., 7604 Zimple St., New Orleans, La.
- Masters, V. V., 1506 W. Lynwood, Phoenix, Ariz.
- McKenna, W. E., 435 Walnut St., Lexington, Ky.
- McKenzie, D. S., 1244 S. Lake St., Los Angeles, Calif.
- Meisinger, H. P., 3005 Nelson Pl., S. E., Washington, D. C.
- Melman, I. J., 907 Argyle St., Chicago, Ill.
- Merill, J., CRM—U. S. Coast Guard, Ketchikan, Alaska
- Miller, J. E., 818 Tonawanda St., Buffalo, N. Y.
- Moore, E. K., 401 W. Jackson St., Phoenix, Ariz.
- Morgan, E., 20 Ghyllwood Dr., Bingley, Yorks, England
- Mosher, H. C., 3009 N. Second St., Phoenix, Ariz.
- Mueller, F. W., 1903 La Paloma, Alhambra, Calif.
- Nagy, J. J., 4203 N. Pershing Dr., Arlington, Va.
- Nelson, C. W., 100 Rugby Rd., Syracuse, N. Y.
- Newell, A. J., Shirley Court Apts., 105F Long La., and Bradford Rd., Upper Darby, Pa.
- Norris, R. O., 5407 Hudson St., Dallas, Texas
- Oswald, S., 66 Preston St., Belleville, N. J.
- Panter, F., 4845 Hutchinson St., Apt. 5, Montreal, Que., Canada
- Peterson, D. W., R. D. 2, Princeton, N. J.
- Phillips, N. A., 4923 Ferdinand St., Chicago, Ill.
- Pool, W. B., KOY, 838 N. Central Ave., Phoenix, Ariz.
- Price, D. B., 7901 Provident Rd., Philadelphia, Pa.
- Price, O. I., Frederick, Md.
- Randolph, L. W., 54 Pine St., Orono, Maine
- Rattner, S., 1140 College Ave., New York, N. Y.
- Rauh, M. A., 3130 Wisconsin Ave., N. W., Washington, D. C.
- Raymond, G. H., 407 Westview Ave., Mt. Airy, Philadelphia, Pa.

(Continued on page xxxviii)

Proceedings of the I.R.E. May, 1943

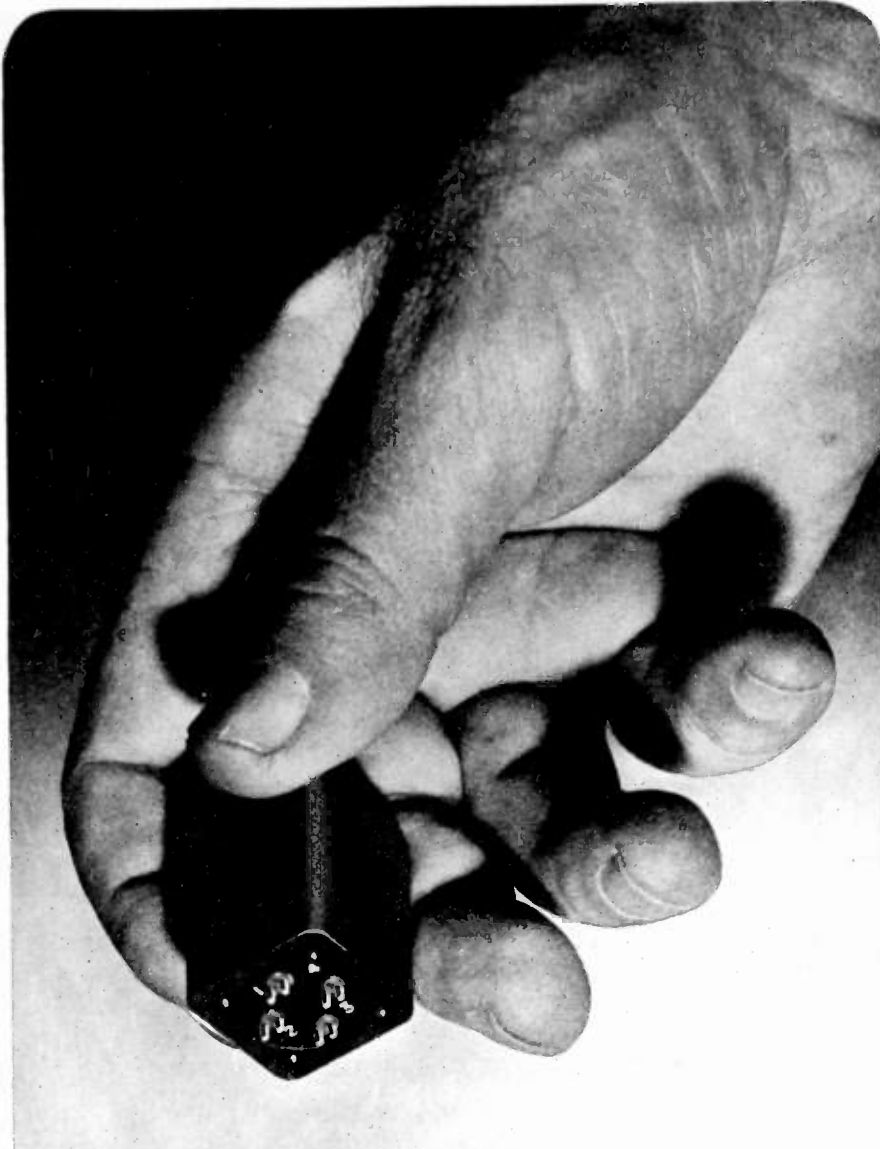

## LITTLE BUT SO IMPORTANT

*to New War Developments*

Ships, planes, tanks and the forces in the field depend on the constant performance of Electronic Instruments for coordination by communication, detection, controls and other war winning developments.

Transformers that are little and tough—designed and constructed to meet the most unusual requirements and conditions—are a vital part of these devices.

There is never an hour, day or night, around this war-torn world that Transformers are not helping to win this war by being an important part of the Electronic Units that are doing so much to aid the Armed Forces.



**CHICAGO TRANSFORMER**  
CORPORATION  
3501 WEST ADDISON STREET • CHICAGO



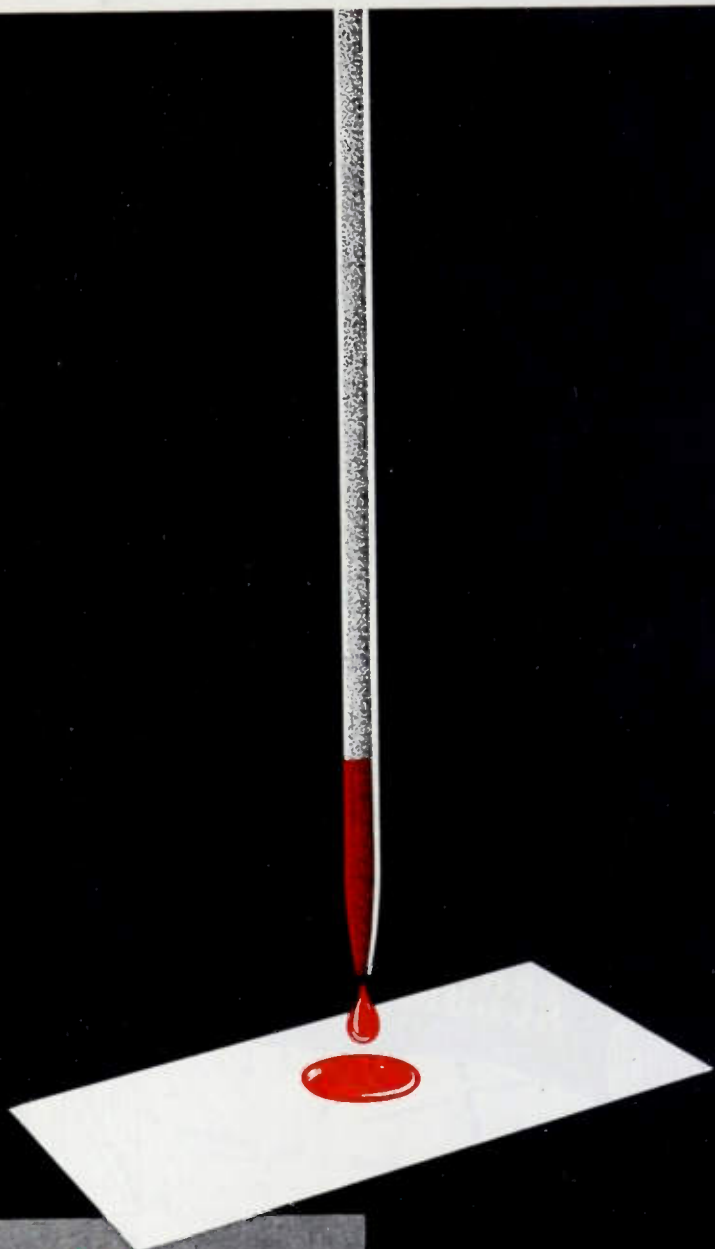

## *The Acid Test...*

WILL IT HELP THE WAR EFFORT  
... WILL IT SPEED VICTORY?

● The application of this inflexible test to every management or production action and problem is bearing us fruit in the form of an unprecedented output of special alloys used in their entirety for vital war applications ... special alloys that are helping the war effort and speeding VICTORY!

• RIBBON • STRIP •

R  
O  
D

**SPECIAL  
ALLOYS**

W  
I  
R  
E

**WILBUR B. DRIVER CO.**  
NEWARK • NEW JERSEY



## Membership

(Continued from page xxxvi)

- Read, C. T., 507 W. 62 St., Chicago, Ill.  
 Reedy, C. W., 2215 Minnesota Ave., S. E.,  
 Washington, D. C.  
 Remick, J. E., Chelton Apts., 17 and Chel-  
 ton, Philadelphia, Pa.  
 Restemeyer, W. E., College of Engineer-  
 ing, University of Cincinnati,  
 Cincinnati, Ohio  
 Richards, C. A., 4613 Harvard Rd., Col-  
 lege Park, Md.  
 Riggs, L. G., 158 Laurel Ct., Elgin, Ill.  
 Rosenberg, W., 46 Albert Rd., Manchester  
 16, England  
 Rothe, F. S., 310 Huston St., Scotia, N. Y.  
 Ruppel, A. E., 221-15 Hanlon Ave.,  
 Queens Village, L. I., N. Y.  
 Saffitz, I. M., Bliley Electric Co., Erie, Pa.  
 Schachte, W. L., Radio Material Section,  
 U. S. Navy Yard, Charleston,  
 S. C.  
 Schenck, J., 120 Prospect St., Princeton,  
 N. J.  
 Sheftelman, E. H., 311 Ninth Ave., Bel-  
 mar, N. J.  
 Shurkus, A. A., Bausch and Lomb Optical  
 Co., 635 St. Paul, Rochester,  
 N. Y.  
 Sievert, A. H., Canadian Westinghouse  
 Co., Ltd., Aberdeen Ave., Hamil-  
 ton, Ont.  
 Izer, V., 1125 Bryant Ave., Bronx, N. Y.  
 Simms, R., Melville Aero. Radio School,  
 45 W. 45 St., New York, N. Y.  
 Sleight, J. W., 1155 Greenwich, San Fran-  
 cisco, Calif.  
 Smalley, T., R.C.A.F., No. 1 Wireless  
 School, Montreal, Que., Canada  
 Smith, R., 232 E. Elliott Ave., Plymouth,  
 Ind.  
 Smith, V. M., 82 Webster St., N. E., Wash-  
 ington, D. C.  
 Speed, D. K., 439 Marlborough St., Bos-  
 ton, Mass.  
 Spinner, L. N., Race Rd. R. R. 14, Cheviot,  
 Ohio  
 Stenersen, H. P., 41 E. Riverview, Apt. 19,  
 Dayton, Ohio  
 Stevens, J. S., 434-60 St., Oakland, Calif.  
 Taylor, J. C., 6660 Cornelius St., Phila-  
 delphia, Pa.  
 Thornton, J. T., 429 S. Muskogee Ave.,  
 Tahlequah, Okla.  
 Tiley, J. W., 4226 Comly St., Philadelphia,  
 Pa.  
 Trippe, D. F., 1604 Angier Ave., Durham,  
 N. C.  
 Udell, C. D., 1128 N. Lockwood Ave.,  
 Chicago, Ill.  
 Updike, W. E., 1043 Cook Ave., Laurence  
 Harbor, N. J.  
 Valdetarro, A., RCA-Victor Division,  
 Bloomington, Ind.  
 Walker, C. A., Daniels Apts., Lee St.,  
 Starkville, Miss.  
 Walton, H. T., Box 1, Marion, Ind.  
 Wappler, A. C., 23-20-121 St., College  
 Point, L. I., N. Y.  
 Wei, C. C., Rm. 1335, 40 Wall St., New  
 York, N. Y.  
 Wellons, R. S., 247 Washington St., Win-  
 chester, Mass.  
 Wernicke, W. L., 135-34-78th Ave., Kew  
 Gardens Hills, L. I., N. Y.  
 Wesley, C. A., 432 W. 45 St., New York,  
 N. Y.

(Continued on page xl)

Proceedings of the I.R.E. May, 1943

The stature of  
**LEADERSHIP**  
 is measured by  
**ACCOMPLISHMENT**

Not fulsome promises... but perform-  
 ance!... THAT has been the keynote of  
 Thordarson's progress through the years.  
 Whenever, and wherever transformers are  
 discussed, the reputation for quality leader-  
 ship enjoyed by Thordarson is invariably  
 an important part of the conversation.

**THORDARSON**

ELECTRIC MFG. COMPANY  
 500 WEST HURON STREET, CHICAGO, ILL.

*Transformer Specialists Since 1895*

# SHADOW AND SUBSTANCE

In the highly specialized field of electronics, the question "Who made the tubes?" will always be a matter of vital importance. Power tubes bearing the name "United" are products of original pioneers in the miracle known today as electronics. Step by step these seasoned engineers helped evolve the principles and advance the science of fabricating transmitting tubes which hold a superb record of performance. The early pioneers at United are still actively pioneering! The wealth of experience which they have been privileged to accumulate under the demands of war will be available to you when "United" electronic tubes are available again on a peace-time scale for radio and industrial applications.

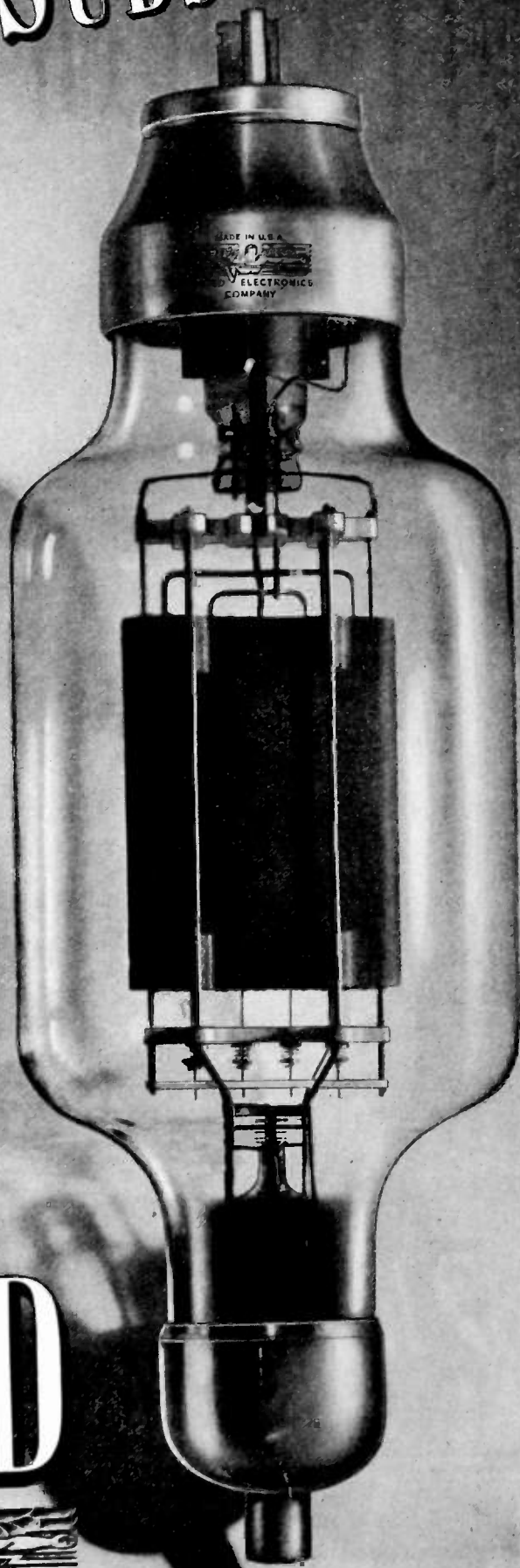

# UNITED

ELECTRONICS COMPANY  
NEWARK NEW JERSEY



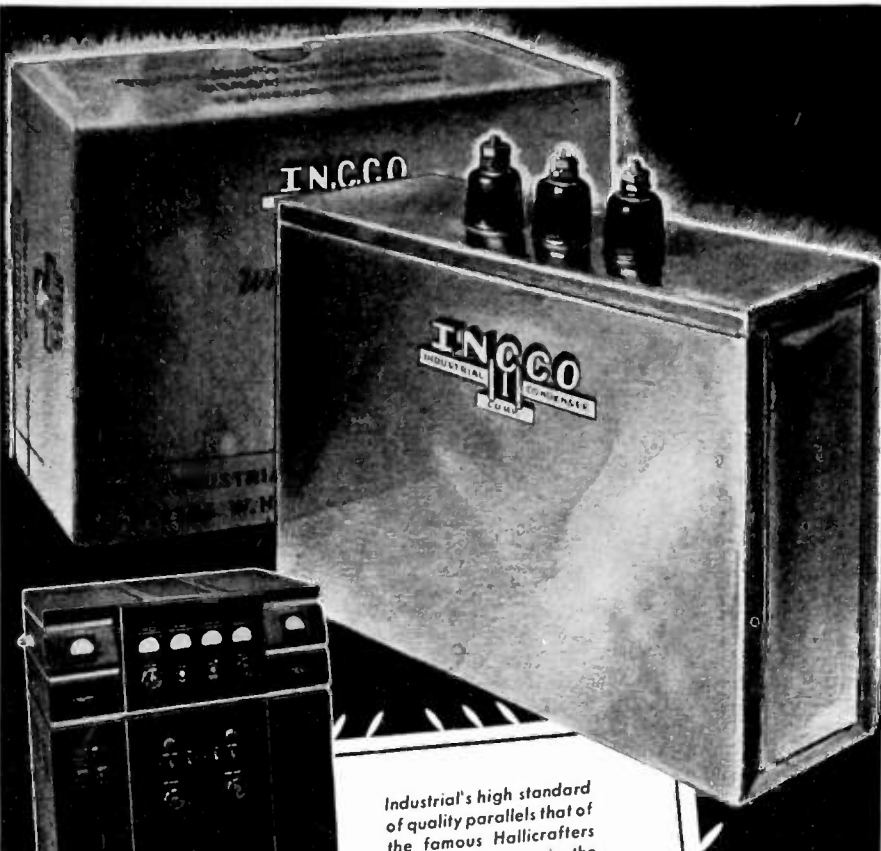

Industrial's high standard of quality parallels that of the famous Hallicrafters HT-4B transmitter in the field of communications.

**INDUSTRIAL  
CONDENSERS  
ARE ON EVERY  
BATTLEFRONT  
WITH THE  
WORLD-FAMOUS  
hallicrafters  
COMMUNICATIONS  
EQUIPMENT**

PAPER, OIL AND ELECTROLYTIC CAPACITORS

**INDUSTRIAL  
CONDENSER  
CORPORATION**

1725 W. NORTH AVE., CHICAGO, U. S. A.

DISTRICT OFFICES IN PRINCIPAL CITIES  
QUICK DELIVERY FROM DISTRIBUTOR'S STOCKS

## Membership

(Continued from page xxxviii)

- Westphal, W. B., 290 Massachusetts Ave., Cambridge, Mass.  
 Wirth, M. H., WJIM, Lansing, Mich.  
 Wright, O. L., 523 N. Jackson St., Belleville, Ill.  
 Wroblewski, T., The Lumens, Labor-In-Vain Rd., Ipswich, Mass.  
 Wyland, G. P., 1728 N. Mariposa Ave., Hollywood, Calif.  
 Zimmerman, S. W., 239 Main St., Dalton, Mass.

## New Equipment Notes

### Allied Control Company Introduces New Small Power Relays

The Allied Control Company announces that their Models BO and BJ Power Relays for flight, firing and communication control have been redesigned to require minimum mounting space and to permit variations in their mounting bases to make them widely interchangeable.

BO and BJ Relays have been available for two years and with their present variety of mounting bases meet the individual requirements for tanks, planes, and ships. The design and construction of Allied Models BO and BJ power relays include easily accessible terminal connections and a semi-balanced armature to withstand vibratory motion with minimum coil power.

The specifications of BO are: contact ratings, non-inductive, 15 amperes for 12



and 24 volts DC and 110 volts AC; single or double pole, double throw; weights, 4 ounces with screw or shake-proof nut mounting or 7 ounces with Bakelite mounting (model #BOB in Bakelite); withstands vibratory motion to 12G with 2½ watt operating power; operates at temperatures of +70° C. or -50° C.; resists corrosion beyond any present specifications; dimensions, (screw or shake-proof nut) 1½ × 1½ × 1½ inches—(Bakelite mounting, model BOB) 2½ × 1½ × 2½ inches.

The specifications for BJ are: contact ratings, non-inductive, 5 amperes for 12 and 24 volts DC and 110 volts AC; single or double pole, double throw; weights, 2½ ounces with screw stud mounting or 5½ ounces with Bakelite mounting (model #BJB in Bakelite); withstands vibratory motion to 12G with 2 watts operating power; operates at temperatures of +70° C. or -50° C. and resists corrosion beyond any present specifications; dimensions, (screw stud mounting) 2½ × 1½ × 1½ inches (Bakelite mounting, model BJB) 1½ × 2 × 1½ × 1½ inches.

(Continued on page xlii)

# Physicals

FOR  
CAPACITORS!



X-Ray Photo of  
Solar Molded  
Domino Capacitor

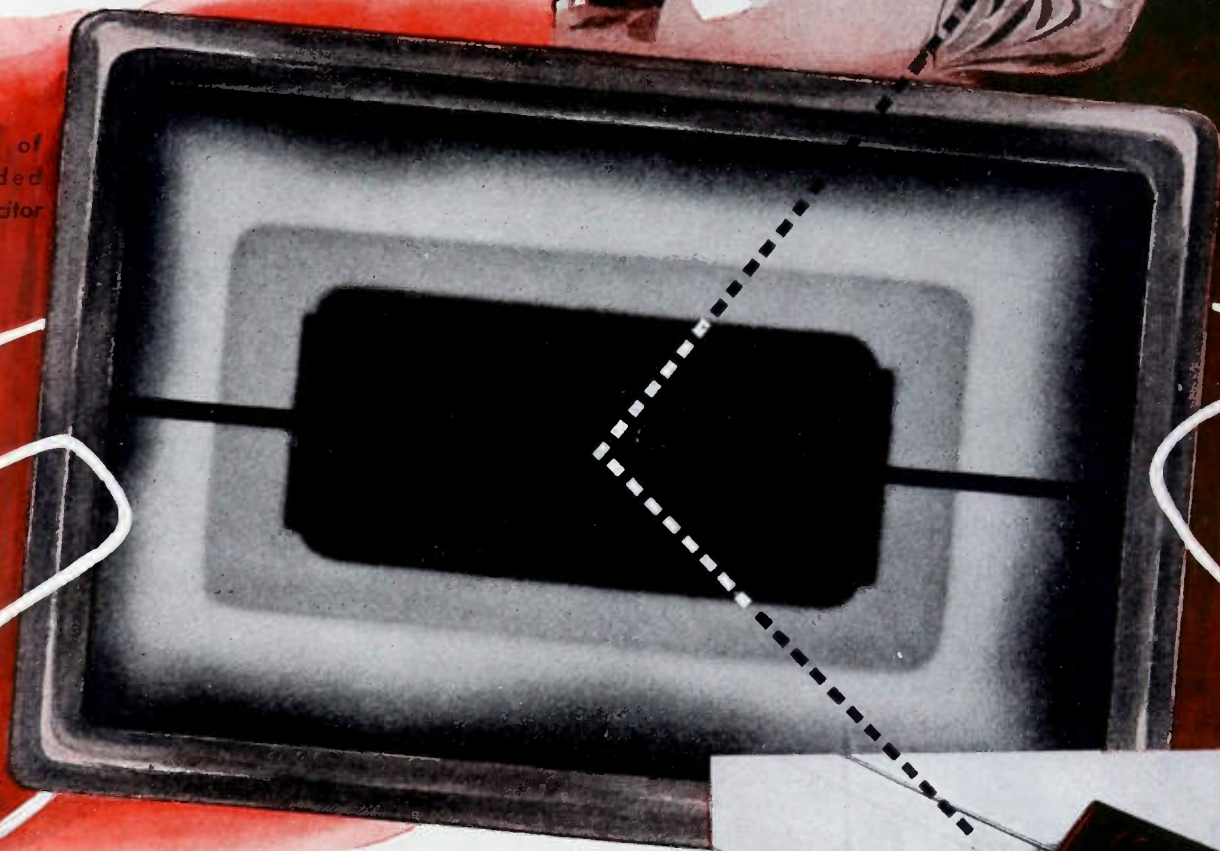

There's an inside story of capacitors, too.

The genius of Roentgen is helping select the A-1's, not only in the field of medicine but also for quality inspection of molded capacitors.

Today, fluoroscopic inspection is an established procedure at Solar, assuring accurate centering of windings in Domino Molded Paper Capacitors. This "ounce of prevention" guarantees capacitors which truly reflect "Quality Above All"!

Solar Manufacturing Corporation, Bayonne, New Jersey.



SOLAR DOMINO TYPE MPW

**Solar** **SOLAR** **II-CAPACITORS-II**



CAPACITORS: ELECTROLYTIC • MICA • PAPER • TRIMMER • TRANSMITTING

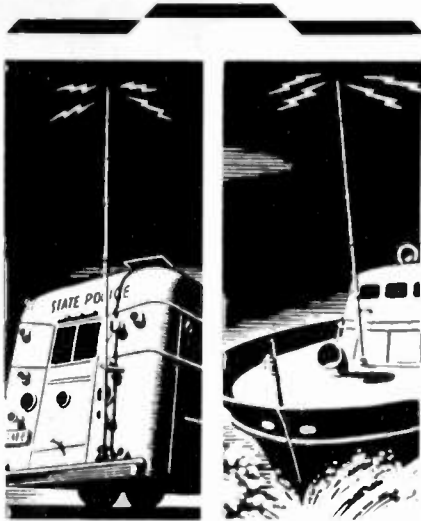

**PREMAX**

## TUBULAR METAL ANTENNAS

Premax Metal Antennas are meeting the rigid requirements of the fighting forces of the Allied Nations. Send for Bulletin of Standard designs, or submit your specifications for special type of Antennas and Mountings.

**Premax Products**

DIVISION OF  
CHISHOLM-RYDER CO., INC.

4301 Highland Ave.

Niagara Falls, N.Y.



## New Equipment Notes

(Continued from page xi)

### New Littelfuse Indicator Operates by Reflected Light

A new signal indicator for use in aircraft wherever a signal light is used promises improved indicating service in other fields as well, is announced by *Littelfuse Incorporated*, 4757 Ravenswood Avenue, Chicago, Illinois, and El Monte, California. It is the Littelfuse No. 1534 Signalette.

Indication by this unit is entirely by reflected light and radio activity. The Signalette operates by fluorescence under "black light" from the usual sources within aircraft. A radium-active fluorescent paint used on the indicator shows signals in total darkness. A saving in current is effected as it uses only 1.5 watts as against the approximate 4½ watts used by present lamps.

It does away with the blur occasioned by transmitted light, as from lamps in present use. Clear visibility of signals is dependably effected. The pilot's eyes do not have to adjust to the reflected light, which makes for better vision in night flying. Indication is free from glare in daylight as well as night-time use. One of the principal objections to light-transmitted indicators is that they dim out in bright sunlight. The Signalette makes the signals correspondingly brighter in the strongest light.

Another important improvement over glass signal lamps in use, is the Signalette's non-shatterable protection. Signalette carries a transparent plastic cap, which withstands the most severe tests of shock or explosion; and permits free penetration by ultra-violet rays.

The body of the Signalette indicator houses a solenoid, the armature of which is connected with the "butterfly" indication vanes by a simple lever hookup. The fluorescent "butterfly" opens instantly to show signals, reflecting the proper indicating light. "Butterflies" are furnished in red, amber and green. When not indicating Signalette is black. Original clarity and dependability were shown by Signalette after life-test operation in excess of 450,000.

### Scrap Salvage Manual

The proper handling of obsolete machinery or other factory material, as well as useful machinery which is not currently active can be learned from the 'Scrap Manual' which will be sent to those desiring to tackle salvage questions by the *Business Press Industrial Scrap Committee*, Room 3303, Empire State Building, New York, N. Y.

"The Committee suggests the following rule relative to equipment:

"If it has not been used in three months, and if someone cannot prove that it is going to be used in the next three—sell it—or scrap it!"

"It is pointed out that scrap and used equipment dealers pay well for usable machinery and materials. It is suggested further that attention should be directed to

'Obsolete machinery, tools, equipment, dies, jigs, fixtures, etc., which are incapable of current or immediate

(Continued on page xlviii)

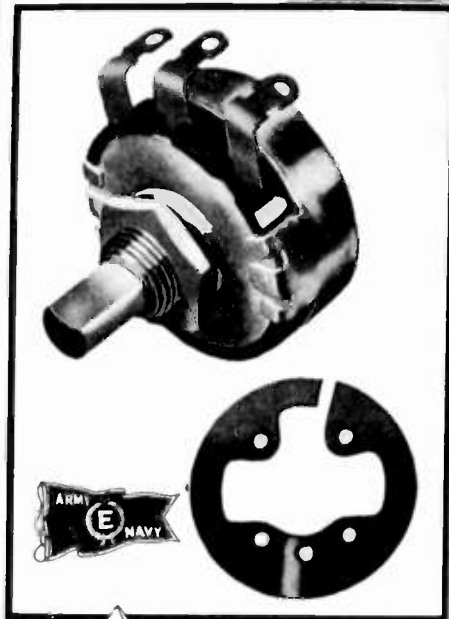

with the new

**STABILIZED**

*Element*

★ Quietly, modestly, quite unannounced Clarostat Series 37 controls have for many months past been coming through with the new *Stabilized Element*. We wanted this outstanding development to prove its worth out in the field, by users, in corroboration of our own critical tests.

Results have spoken for themselves. Users have promptly spotted something radically better in non-wire potentiometers and rheostats. Remarkably accurate resistance values first and last; extreme immunity to humidity; temperature and other climatic conditions; minimized wear and noise; smoother rotation—these features have been widely noticed in connection with the new *Clarostat Stabilized Element*—stabilized by heat-treatment, chemical-treatment, lubrication-treatment, for truly outstanding performance.

Consult us . . .



CLAROSTAT MFG. CO., Inc. - 285-7 N. 6th St., Brooklyn, N. Y.

Proceedings of the I.R.E.

May, 1943



**International small talk . . .**

... doesn't actually win the battle, but hobnobbing with a foreign buddy...  
 ... a form of wartime communication that builds international morale.  
 ... the picture two Americans and a French soldier tell it with gestures  
 ... of an English Tommy.

**Radio Electronics . . .** International communication is doing  
 more than any other single thing to win this war. Here the talk between soldiers  
 seems to be "small talk," for global strategy depends upon instantaneous com-  
 munication of big ideas. Thus the radio transmitting tube becomes the greatest  
 fighting tool ever placed at the disposal of armies.

... the same inherent characteristics . . . *high performance, stamina, dependability . . .*  
 ... that made Eimac Tubes first choice during peacetime have set them apart as the  
 ... pre-eminent leader during this global war. Just how important and how many  
 ... of them they are doing today is a story that will be told  
 ... when our victory is ours. In the meantime rest assured that  
 ... Eimac still remains a step ahead . . . is still first choice  
 ... among the leading engineers throughout the world.

Follow the leaders to

**Eimac**  
**TUBES**

GENERAL ELECTRIC, McCULLOUGH, INC., SAN BRUNO, CALIF.



Awarded for high  
 achievement in the  
 production of war  
 materials.



# Standards for Home Radio Replacement Parts

According to an announcement made recently by the *American Standards Association*, the first of a series of standards for "War Model" replacement parts designed to keep home radio sets running in spite of wartime shortages, have just been completed. This work, which is being done at the request of the Office of Price Administration after consultation with the War Production Board, indicates Washington's interest in keeping civilian radio sets operating at a good level of efficiency. Work includes a simplified line of parts sufficient to service an estimated 90 per cent of modern home receivers in use today.

As an additional piece of good news for the radio owner, production of parts to these standards will, it is expected, be scheduled by manufacturers to start in April; and the parts will be covered by price ceilings, which, with the performance requirements written into the standards will assure the radio owner of continuing quality at a fair price.

The first standards promulgated include a simplified list of the most critical replacement parts at present—capacitors (condensers), volume controls, power and audio transformers and reactors (chokes) and performance and constructional standards for both electrolytic and paper capacitors (condensers).

The list of replacement parts which is deemed adequate for servicing the great majority of home receivers shows a radical

reduction from the thousands of different types of each item available in the "Pre-Pearl Harbor" replacement parts field. The ASA list shows but nine paper condensers, nine electrolytic condensers, eleven values of volume controls, six power transformers, two chokes, two interstage audio transformers, one driver audio transformer, and three output audio transformers.

The performance and design standards for condensers provide for tubular cardboard-encased units using the very minimum of strategic materials. The required minimum performance characteristics have been chosen to be satisfactory from an electrical and service life standpoint, and so that there will be no need, it is hoped, for replacing replacement parts.

These standards provide for new "War Model" part numbers and a special symbol consisting of a V with the Morse Code "V"—three dots and a dash—enclosed in a circle to appear on all parts made in accordance with them. Likewise, it is expected that a manufacturer's identification symbol assigned by the WPB will appear on all parts so that responsibility for the quality of unbranded and private brand parts can be definitely ascribed to the original manufacturer.

The ASA War Committee on Replacement Parts for Civilian Radio has in these new standards reconciled the oft-times diverging viewpoints of the various branches

*(Continued on page 1x)*

## REMLER

### Plugs and Connectors

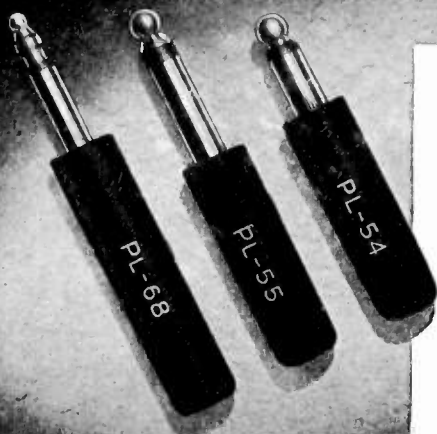

#### ARMY SIGNAL CORPS SPECIFICATIONS

- Also PL—PLP—PLQ and PLS Plugs
- M Type Connectors
- M Type Caps
- FT Type Fittings

Quantity Prices Quoted  
on receipt of Delivery  
Schedules

Manufacturers of Communication Equipment  
SINCE 1918

REMLER COMPANY, Ltd. • 2101 Bryant St. • San Francisco, Calif.

## Humor YOUR MICROPHONE

You'll Get  
More Out  
of It!



Like a bottle  
of Seltzer  
water, a mike  
deteriorates  
once it's been  
opened!

## How TURNER Microphones Can Live to an Active Old Age . . .

Turner Microphones are precision engineered to give you long and faithful service. However, all Microphones are delicate and sensitive instruments, and will serve longer and better when treated with respect.

**DO:** Use good judgment in handling your mike. Read the instructions and follow them. If it gives trouble, send it to the factory or its dealer for repair.

**DON'T:** Open the microphone case. To do so exposes the sensitive parts to mechanical and chemical damages which can and will ruin the microphone.



Write today for your  
free copy of the new  
Turner Microphone  
Catalog.

The  
**TURNER CO.**  
Cedar Rapids, Iowa, U.S.A.





**MYCALEX**  
THE INSULATOR

"... is the most nearly perfect electrical insulator known today"

— an opinion subscribed to by leading engineers in radio, television and industry.

## THERE IS ONLY ONE MYCALEX

MYCALEX is not the name of a class of materials. MYCALEX is the registered trade-name for low-loss insulation manufactured only by the Mycalex Corporation of America in the Western Hemisphere. MYCALEX is specified by engineers because MYCALEX is required.

More than a quarter century of extensive application here and abroad has made the name MYCALEX a familiar one in the electrical and communications industries, and we are proud of the important part this versatile insulation is playing today in the military and civil life of the United Nations. The snows of Russia, the sands of Africa, the sweating jungles of New Guinea, the mountains of China—MYCALEX is no stranger to these backgrounds. Unsolicited testimonials to the vital role being performed in the war program by MYCALEX have been given us generously by the Army and the Navy.

If your present insulation fails because of deformation at room temperature or because of failure to withstand elevated temperatures MYCALEX will solve your problem. If you must have hole diameters, hole spacings, or other dimensions with close tolerances, slots, grooves, or accurately tapped holes, combined with low loss at all frequencies, you should bear in mind that MYCALEX has been meeting these requirements for many years. If, on the other hand, dimensions and tolerances are not too critical but ability to withstand high voltages is paramount, MYCALEX is the ideal material for your purpose. The greater machinability of MYCALEX, which is leadless, gives it advantages over any other type of insulation. Our engineering service is available in all cases where the choice of the most reliable insulation is in doubt.

MYCALEX is not available, except in experimental quantities, for other than war applications.

**MYCALEX**  
THE INSULATOR

Trade Mark Reg. U. S. Pat. Off.

# MYCALEX CORPORATION OF AMERICA

Exclusive Licensee under all patents of MYCALEX (PARENT) CO. Ltd.

60 CLIFTON BOULEVARD

CLIFTON, NEW JERSEY

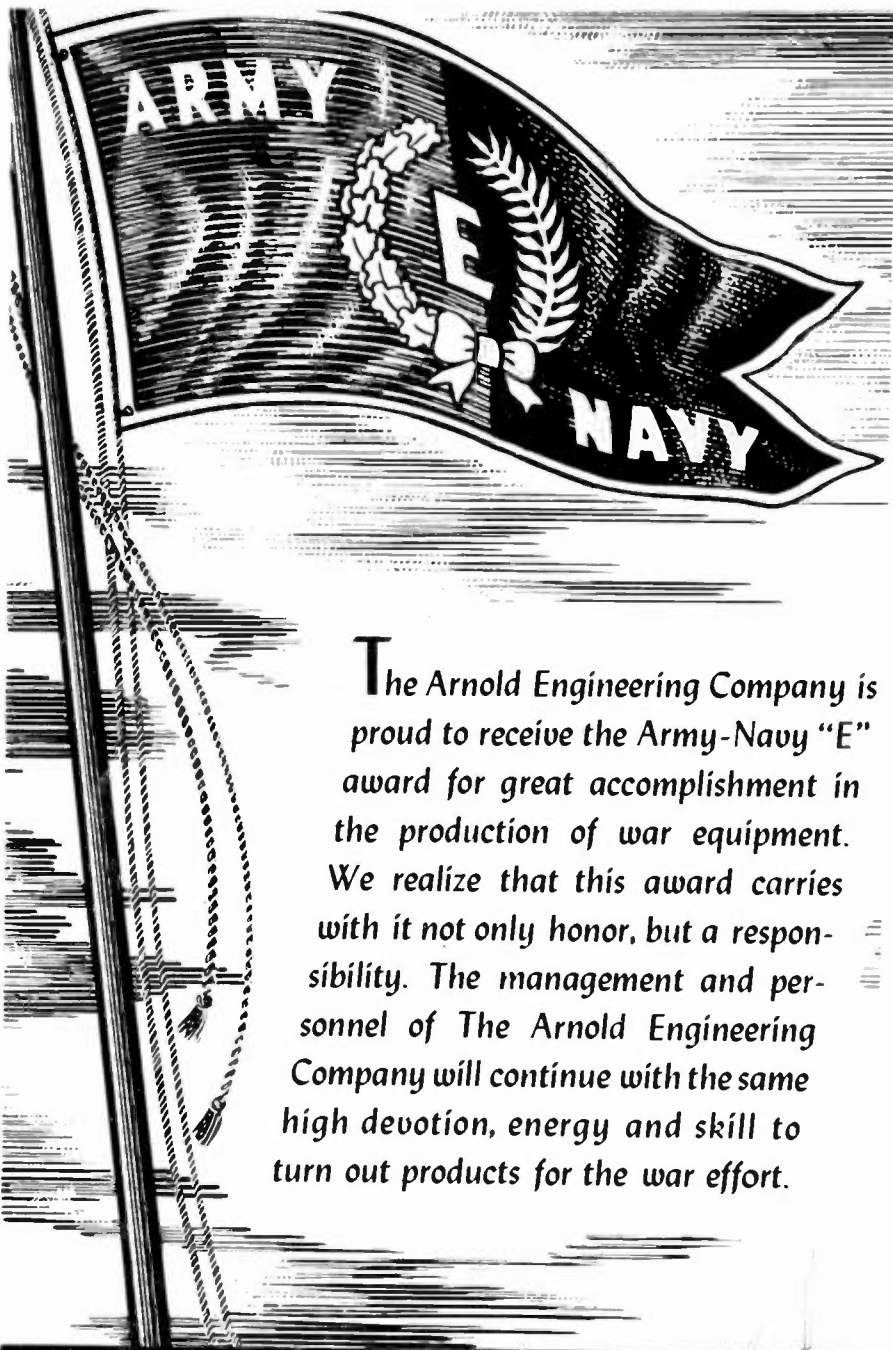

The Arnold Engineering Company is proud to receive the Army-Navy "E" award for great accomplishment in the production of war equipment. We realize that this award carries with it not only honor, but a responsibility. The management and personnel of The Arnold Engineering Company will continue with the same high devotion, energy and skill to turn out products for the war effort.

# THE ARNOLD ENGINEERING COMPANY

147 EAST ONTARIO ST. • CHICAGO, ILLINOIS

Specialists in the Manufacture of  
**ALNICO PERMANENT MAGNETS**  
**CAST ARMOR ★ SPECIAL ALLOYS**



## Army-Navy "E" Honor Roll

### Electronic Laboratories Wins "E"

*Electronic Laboratories, Inc., Indianapolis*, manufacturer of electrical products, has been awarded the Army-Navy "E" for excellence in war production. The ceremony was held in Indianapolis on February 2. The "E" pennant was presented by Lt. Colonel R. L. Finkenstaedt, Supervisor of the Indianapolis Area, U. S. Army Air Forces, to W. W. Garstang, Vice-President and General Manager of the Company. Norman R. Kevers, Electronic's President had charge of the arrangements. Lt. Commander Ralph Brengle, of the Bureau of Ships, Navy Department, Washington, D. C., presented the "E" pins to the representatives of Electronic's Employees, Miss Osra Brandenburg and W. Reed Smoot.

The Company engineered and manufactures the "Black Light" which is used to illuminate the instrument panels of our warplanes, as well as vibrator power supplies for the "Walkie Talkie" two-way radio and for communications equipment in tanks, peeps, jeeps, PT boats, planes.

The ceremony was held at the Murat Theatre in Indianapolis with all employees of Electronic Laboratories, Inc., present. The band and the Color Guard were provided by Fort Benjamin Harrison.

### Western Electric Wins White Star

For the second time, all three major Works of the *Western Electric Company* have received the Army-Navy Production Award for meritorious services, on the production front.

In notifying the workers of the honor, Under Secretary of War Robert P. Patterson said in part, "You have continued to maintain the high standard that you set for yourselves and which won you distinction more than six months ago. You may well be proud of your achievement.

"The White Star, which the renewal adds to your Army-Navy Production Award flag, is the symbol of appreciation from our Armed Forces for your continued and determined effort and patriotism."

Western Electric, which in peace time manufactures telephone equipment for the Bell System and today supplies large quantities of communications apparatus to the Armed Forces, was one of the first manufacturers to receive the Army-Navy "E" citation when that honor became available last year. All manufacturing employees of the Company then on the payroll received "E" pins in recognition of their individual production efficiency. With the present "star" award, the thousands of new workers, employed by Western Electric during the intervening six months, now receive the coveted "E" pins.

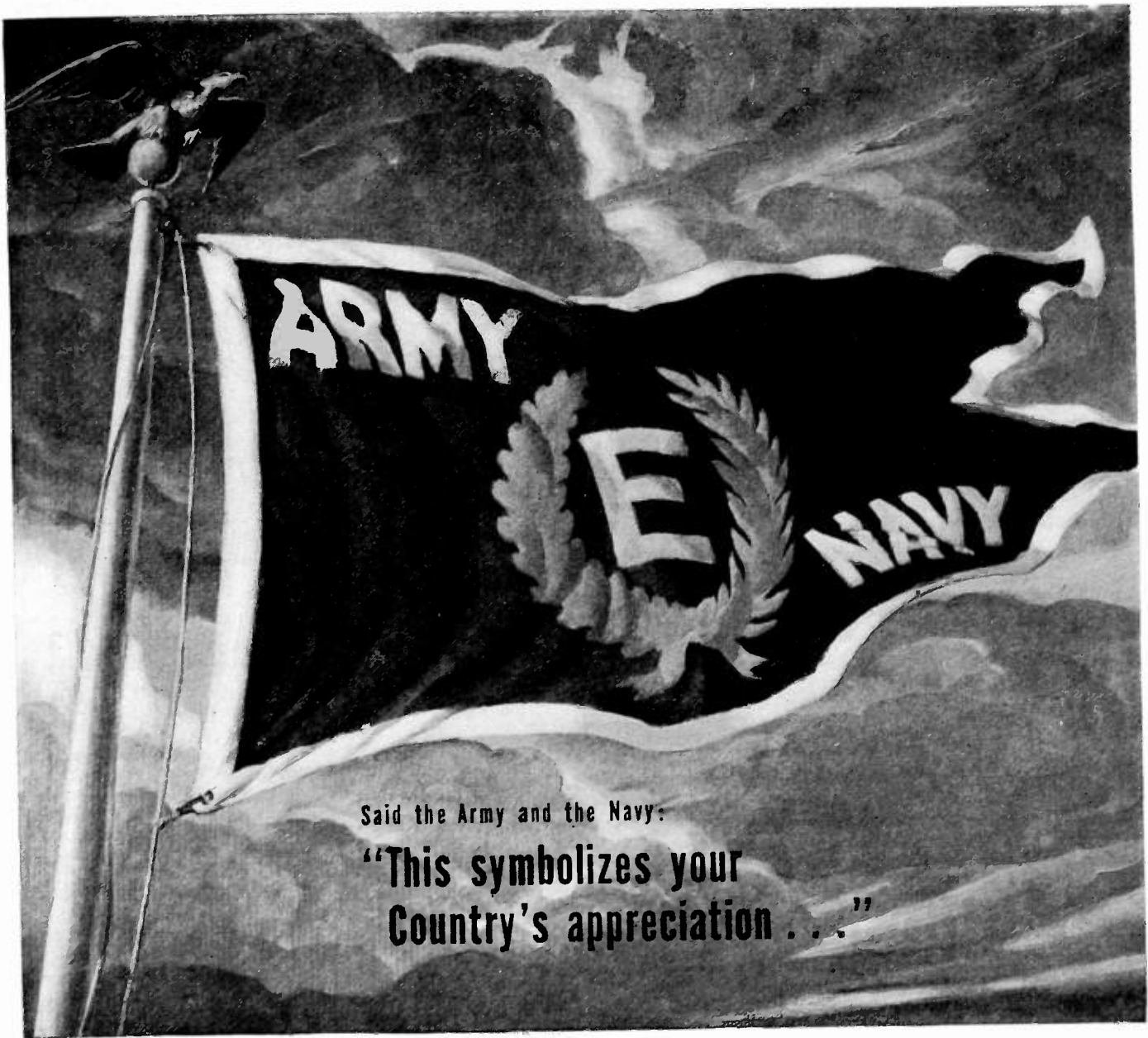

Said the Army and the Navy:

**"This symbolizes your  
Country's appreciation . . ."**

There it flies  
The coveted  
Army-Navy "E" . . .

We can't tell you  
Very much about  
The electronics research  
That won it . . .

Such matters are  
Wartime secrets . . .

But this we *can* say . . .  
In the words of  
The Army and Navy  
This pennant  
Represents  
"Great accomplishment

In the production  
Of war equipment."

Today  
Modern radio equipment  
Designed and developed  
By the Laboratories Division of  
Federal Telephone and Radio Corporation  
An I.T.&T. Associate  
Is helping Uncle Sam's fighting forces  
Work together  
On land, sea and in the air . . .

Tomorrow  
It will help build  
A better world  
For every man.

THE LABORATORIES DIVISION OF

*Federal Telephone and Radio Corporation*

67 Broad Street, New York, N. Y.

AN **I T & T** ASSOCIATE

(Continued from page xlii)

future use in the war production effort because they are broken, worn out, irreparable, dismantled or in need of unavailable parts necessary to re-employment'.

**Armored Insulation Plate Supply Transformer**

To overcome the effects of high voltage aging, the engineering laboratories of *The Acme Electric & Manufacturing Company of Cuba, New York*, have developed an armored-insulation High Voltage Plate Supply Transformer. Rated at 3300 volts, 1.8 amperes secondary, it is intended for transmitter service for DC rectifier systems. Sturdily constructed throughout, but with special emphasis being placed on the adaptation of its insulation, it is especially suitable for continuous service of radio transmission. Special engineering bulletin available by writing the manufacturer.

**Improved "Plug-in" Type Dry Electrolytic Condensers**

The Sprague "Plug-In" type of Dry Electrolytic Condenser which is pictured here is recommended for the elimination of low frequency ripple (2-100 cycles). This modern type of electric condenser can be sealed as well as any condenser. It can be easily mounted or removed. It is regarded as so reliable able to take abuse and deliver long life, that the manufacturer, *Sprague Specialties Company of North Adams, Mass.*, considers it entirely practical to solder or weld it into units.

Its basic qualities of small size and light weight are further enhanced by the fact that they perform uniformly up to the very last volt on the rating, and will take repeated surges even higher. Underloads likewise are no problem.

Special emphasis is placed on the ability of these "Plug-In" type dry electrolytic condensers to operate efficiently under adverse temperature and climatic conditions, whether at extremely high or at normal levels. The use of dry electrolytics is increasingly widespread.

**Clarostat Opens Second Plant**

As a further contribution to the war production effort and especially with an eye to that six-months' star for its Army-Navy "E," Clarostat Mfg. Co., Inc., Brooklyn, N. Y., announces the opening of its second plant in the same city. The new plant started production operations on March 15th, and is entirely financed by Clarostat.

Clarostat Plant 2 provides greater production floor space than that of the original plant, even though the latter occupies the five-story company-owned building which has been added to by an annex on the adjoining parcel of land. The new plant will be devoted exclusively to assemblies, while the original plant will be devoted to fabrication of parts, windings, engineering and general offices.

**WE TOO, FIGHT  
... FOR PEACE!**



**Lafayette** is doing its part to win the war...and the peace that must surely follow. We play the important part of speeding the war effort by supplying emergency requirements of radio, sound and electronic parts to all branches of the armed forces as well as to manufacturers and sub-contractors. Lafayette is in there fighting to save you time by supplying all of your needs in one order—quickly!

**Now** it is no longer necessary to comb the field to find the various parts you need. Due to Lafayette's extensive buying facilities and large, diversified stocks, one order (no matter how large or how small) will bring quick deliveries on all of your requirements.

Free catalog—Radio, Sound and Electronic Parts—Dept. 5113



"Quick Deliveries on Radio, Sound and Electronic Parts"

**2 BOOKS EVERY "WAR-TORN" ENGINEER NEEDS!**

**A-C CALCULATION CHARTS**

By R. LORENZEN

This new Rider Book greatly reduces the time required for alternating current engineering calculations—speeds up the design of apparatus and the progress of engineering students. Two to five times as fast as using a slide rule! Thousands of enthusiastic users.

A-C CALCULATION CHARTS are designed for use by civilian engineers and engineers of the armed forces who operate in the electrical—communication—power—radio—vacuum tube—telephone—and in general, the electronic field. Invaluable for instructors as well as students, and also administrative officers who check engineering calculations.



\$7.50  
160 pgs.  
(9 1/2 x 12 in.)

**CATHODE RAY TUBE AT WORK**

The Cathode Ray Tube at Work is the accepted authority on the subject. The cathode ray tube in the Oscillograph and its application to electronic and industrial work is fully discussed. Profusely illustrated. 338 pages . . . . . \$3.00

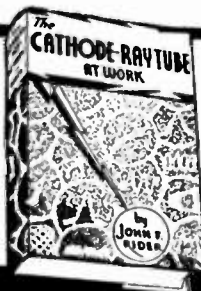

**JOHN F. RIDER PUBLISHER, Inc.**  
404 FOURTH AVENUE, NEW YORK CITY  
Export Division: Roche-International Elec. Corp., 100 Varick St., N. Y. C. - Cable: ARLAB

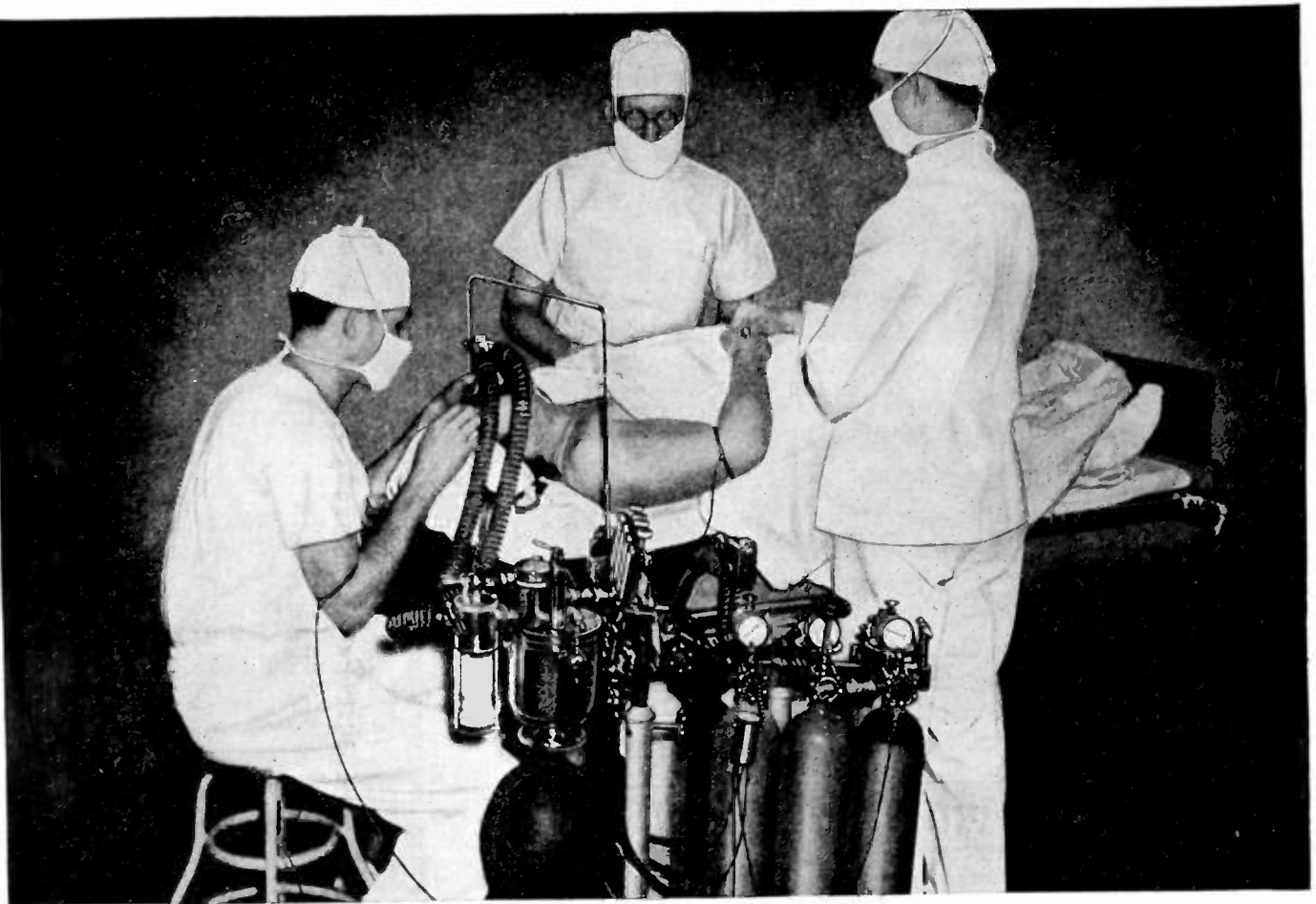

# CHAINED... FOR SAFETY

From the time of their earliest use in hospital operating rooms, the handling of most inhalation agents has been fraught with danger of fire or explosion from static sparks. However, this risk did not receive serious recognition until recent years when accepted engineering principles were applied to this aspect of anesthesia and surgery.

With the introduction of cyclopropane and other newer types of gases, further attention was focused on the elimination of this hazard. How could the electrical potentials of the anesthetists, the patient and the apparatus be equalized to eliminate the possibility of spark?

The answer was found in fastening the group together by means of silver chains and other conductive materials. Connected into the circuit, a device consisting of high resistances prevents the formation of a static charge of any important degree of intensity.

*IRC is proud to have been consulted and to have lent the aid of its research laboratories to this important scientific development.*

Though we may not be able right now to supply you with the Resistors you need for other than war uses, our engineers and executives are at your service for counsel, without obligation, to help you solve your Resistor problems. Please feel free to consult them in your search for the best obtainable resistance devices.



## INTERNATIONAL RESISTANCE COMPANY

401 N. BROAD STREET, PHILADELPHIA



# COAXIAL CABLES

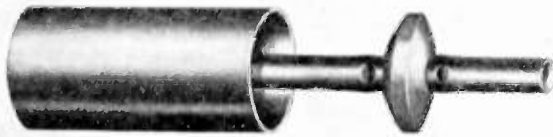

## ... for Radio Transmission Lines

The VICTOR J. ANDREW CO., pioneer manufacturer of coaxial cables, is now in a position to take additional orders, in any quantity, for all sizes of ceramic insulated coaxial cables and accessories. The Andrew Co. engineering staff, specialists in all applications of coaxial cables and accessories, will be pleased to make recommendations to meet your particular requirements.

### "Attention!"

If coaxial cables are your problem... write for new catalog showing complete line of coaxial cables and accessories.

**VICTOR J. ANDREW CO.**  
363 East 75th Street, CHICAGO, ILLINOIS  
ANTENNA EQUIPMENT

### EXTRAORDINARY OPPORTUNITY FOR

## Mechanical Engineers

who have specialized in DESIGN

**MECHANICAL ENGINEERS** who can demonstrate exceptional ability and who have specialized in design are always important men in the Bell & Howell organization. Thus, while we are now 100% engaged in war production, these openings offer immediate and future opportunity to those who can qualify. Inasmuch as the opportunities are exceptional, ability must be on the same plane.

Write us telling us your story—completely, and enclose your photograph. Do not call on us or phone until appointment has been arranged.

### Chief Engineer

## BELL & HOWELL COMPANY

7101 McCormick Blvd., Chicago, Ill.

MANUFACTURERS OF MOTION PICTURE CAMERAS AND PROJECTORS

### POSITIONS OPEN

The following positions of interest to I.R.E. members have been reported as open. Apply in writing, addressing reply to company mentioned or to Box No. ....



**PROCEEDINGS of the I.R.E.**  
330 West 42nd Street, New York, N.Y.

### INSTRUCTORS IN RADIO AND ELECTRICITY

50 civilian instructors needed immediately for Army Air Forces Radio Instructor School. Subjects of instruction: Direct current and alternating current electricity, vacuum tubes, standard radio receivers and transmitters; international Morse code, telegraph and radiotelephone procedure. Salaries follow Civil Service starting from \$2,000 per year. State experience, education, code speed, personal data. Positions open immediately. Saint Louis University, Army Air Forces Radio Instructor School, 221 N. Grand Boulevard, Saint Louis, Mo. A. H. Weber, Technical Director.

### RADIO ENGINEERS

Large New York City plant has excellent opportunities and immediate employment for those who can qualify as foremen, leaders, or designers in the production of aircraft radio equipment. Electrical engineer's degree or equivalent, with experience in manufacture of electronic equipment required. Lesser positions in many other classifications available for those lacking above qualifications. Send full details to Box 277.

### RADIO ENGINEER OR TECHNICIAN

Knowledge of circuits for supervisory position in transmitting tube circuit laboratory. Circuit knowledge and executive ability more important than college degree. Married man with children preferred. Salary open. Minimum \$250. Box 279.

### RADIO ENGINEER

Junior engineer, preferably with amateur radio experience, needed as assistant in administrative office of important company. Must know radiotelegraph. Write Box 286.

### RADIO, MECHANICAL AND ELECTRICAL ENGINEERS

Several men needed immediately for work on government radio equipment. Men with at least three years experience in design and development of quality equipment desired. College degree or equivalent experience necessary. Any person now employed at highest skill on war production work should not apply. Address Box 280.

### RADIO ENGINEERS AND TECHNICIANS

In critical war industry. Opportunity for several competent men in research and production engineering on Government contracts. Work is with a company well known in the radio industry, located in a Michigan city. Send full particulars of your experience and photo. Address Box 284.

### NAVAL ORDNANCE LABORATORY

The Naval Ordnance Laboratory, located in Washington, D.C., is a research development agency of the Bureau of Ordnance, concerned with the design of new types of naval mines, depth charges, aerial bombs and other ordnance equipment, including measures for the protection of ships against mines.

This laboratory needs physicists and electrical engineers with electronics experience, mechanical engineers familiar with the design of small mechanical movements or mechanisms, and personnel for technical report writing and editing. Write to Naval Ordnance Laboratory, Navy Yard, Washington, D.C.

(Continued on page lii)



BOEING STRATOLINER

*On the bench and in the blue ...*

# Constant voltage protection all the way

Ask the men who produce planes and the men who pilot them. They'll tell you what vital part *constant voltage* plays in modern aviation. In the sky, it's *constant voltage* on the directional beam which guides the ships through night and storm. In the shop, it's *constant voltage* on the production line which maintains the split-hair accuracy of precision airplane parts.

For the aircraft industry—and for your own—SOLA CONSTANT VOLTAGE TRANSFORMERS provide this all-important stabilized power. They stand between costly equipment and destructive voltage fluctuations now common on overloaded power

lines. Without supervision they instantly absorb power sags and surges as great as 30%.

For unerring operation of precision tools, and protection of almost irreplaceable instruments and electronic tubes, put SOLA CONSTANT VOLTAGE TRANSFORMERS on duty in your plant. They're built in standard units from 10 VA to 15 KVA capacity—self-protecting against short circuit and without moving parts. Special units can be built to specification.

---

**Note to Industrial Executives:** Find out how Sola "CV" transformers can solve voltage control problems in your operations. Send for bulletin KCV-74.

## Constant Voltage Transformers

# SOLA

Transformers for Constant Voltage • Cold Cathode Lighting • Mercury Lamps • Series Lighting • Fluorescent Lighting • X-ray Equipment • Luminous Tube Signs  
Oil Burner Ignition • Radio • Power • Controls • Signal Systems • Door Bells and Chimes • etc. SOLA ELECTRIC CO., 2525 Clybourn Ave., Chicago, Ill.

# Communications Engineers!

War Production positions  
NOW, with good post  
war futures

A long established manufacturer of high quality communications equipment is desirous of engaging competent engineers for war contracts now and later to work on post war problems. These positions are considered permanent.

Engineers not now employed to their fullest capacity in war work will find in these positions a chance to associate themselves with an industry working to capacity to supply the armed forces with communications equipment. If you are employed at your fullest capacity in war work, please do not apply. Typical openings:

**ELECTRICAL ENGINEER.** College graduate. Several years experience in the design of electric temperature control equipment, relays, telephone or radio components. Knowledge of vacuum tube applications very helpful. Prefer experience in development of apparatus rather than production. Wanted July 1st. In reply refer to T-103.

**ELECTRICAL ENGINEER.** College graduate to design and develop sound reproducers with amplifiers for assembly in sound systems for office and industrial applications. Wanted at once. Please refer to S-116.

**ELECTRICAL ENGINEER.** College graduate with experience in acoustics and development of audio frequency equipment. Knowledge of vacuum tube applications essential. Wanted at once. Refer to RS-122 in reply.

**ACOUSTICAL ENGINEER.** College graduate with degree in Physics or Electrical Engineering. Must be able to carry out mechanical design of loud speakers. Knowledge of manufacturing methods is essential. Wanted as soon as possible. Reply please to RS-124.

Up to 60 years, age is no barrier to employment provided you are in reasonably good health and have an acceptable record of performance and are not averse to working 48 hours per week under considerable pressure. In some instances an approved experience record in the particular field will be accepted in lieu of a college degree.

The plant is located in a conservative eastern city of 300,000 people, which is well known for its cultural and recreational advantages. Living conditions are good because the city is in no sense a "boomtown."

The openings listed are only a few of many developing. We invite your correspondence. Write fully, giving your qualifications in education, experience, salary expected and when available. Replies will be held in strict confidence.

**BOX NUMBER 291**

**Institute of Radio Engineers**  
330 West 42nd St.  
New York, N.Y.

(Continued from page 1)

## RADIO AND ELECTRONIC ENGINEER

For developmental work. Must combine practical ability with a little of the "dreamer." Excellent opportunity with alert organization. Write Radio Receptor Company, Inc., 251 W. 19th Street, New York, N.Y.

## ELECTRONIC ENGINEER, PHYSICIST AND DRAFTSMAN

Capable radio engineer for work on x-ray and allied applications, and physicist with specialized experience in electronics. Mechanical draftsman, with practical production experience, for work involving usual drafting for production of electronic devices, primarily in x-ray field. Write Philips Metalix Corporation, 419 Fourth Avenue, New York, N.Y.

## RADIO ENGINEERS AND TECHNICIANS

Technicians with specialized engineering knowledge. Perform efficient maintenance and adjustment of radiotelegraph operating office equipment. Technical knowledge of special radio and related equipment needed in the service. Must be capable of sending and receiving the International Morse Code at a minimum speed of 20 words per minute and must hold a Federal License as required by law.

Radio Instructor on operation and maintenance of radio transmitting equipment.

Maintenance Engineers to keep machinery, mechanical equipment, radio-communication operating machines, and radio instruments in good repair. Construct and install new apparatus. A combination of maintenance mechanic and machinist duties.

Maintenance Electricians to take charge of all plant maintenance pertaining to all the electrical facilities, wiring and machinery. Must be capable of doing mechanical construction of communication equipment and electrical wiring, and work from blueprints. Address Box 283.

## RADIO ENGINEERS AND MONITORING OFFICERS

Applications for positions with the Federal Government of radio engineer at \$2,600 to \$8,000 a year, radio monitoring officer at \$2,600 and \$3,200 a year, and radio mechanic technician at \$1,440 to \$2,600 a year, will be accepted at the Washington, D.C., office of the United States Civil Service Commission. Qualified persons urged to apply immediately. No written tests. Applicants will be rated on the basis of their statements in the application, subject to verification by Commission. For full information, and application forms, write to United States Civil Service Commission, Washington, D.C.

## COMMUNICATIONS ENGINEERS AND PHYSICISTS

Several openings in the Research Laboratory, Development and Engineering Divisions for communications engineers and physicists. Men holding Ph.D. and B.S. (E.E.) Degrees, and men with proven ability in physics or electrical engineering desired.

Other positions open for engineers and physicists with experience in development of microphones and telephone receivers to predetermined standards. Another position calls for experience in the design and measurement of microphones and telephone receivers. Another calls for acoustical engineering experience in communications. Opportunity is given for permanent post-war connections in the communications-equipment manufacturing industry.

Only American Citizens can be considered. Apply by letter stating full qualifications. Bert Holland, Personnel Manager, Kellogg Switchboard & Supply Co., 6650 South Cicero Avenue, Chicago, Illinois.

(Continued on page 1iv)

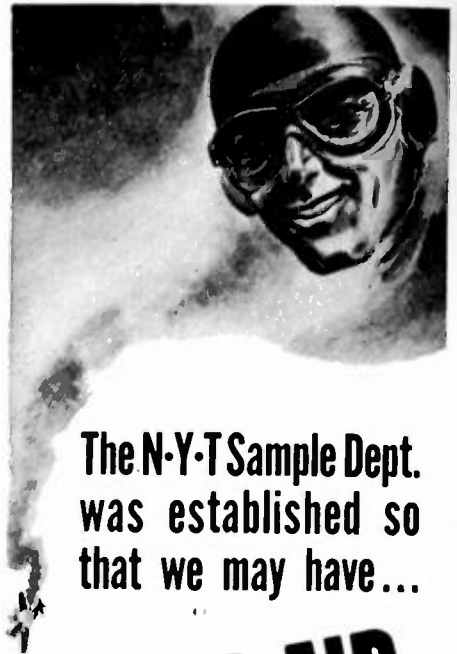

The N-Y-T Sample Dept.  
was established so  
that we may have...

# MAJOR AIR VICTORIES!

...without the world  
ending for Johnny Smith



An eighteen-to-one defeat for the enemy is good reading... however, let's give a thought to

Johnny Smith, pilot of the short-end of the score.

For the purpose of making good transformers better, to design and engineer them for more efficient and dependable functioning, the N-Y-T Sample Department was established. By intensive research and laboratory work, new developments are engineered, then made tangible components for ordnance machines and radio equipment. All of which means another day for the Johnny Smiths in our Army, Navy and Air Corps.

★ ★ ★  
The N-Y-T Sample Department is prepared to give immediate consideration to your special problems, and make deliveries within a matter of days. Inquiries invited.

## NEW YORK TRANSFORMER COMPANY



24-26 WAVERLY PLACE, NEW YORK, N. Y.

Proceedings of the I.R.E. May, 1943



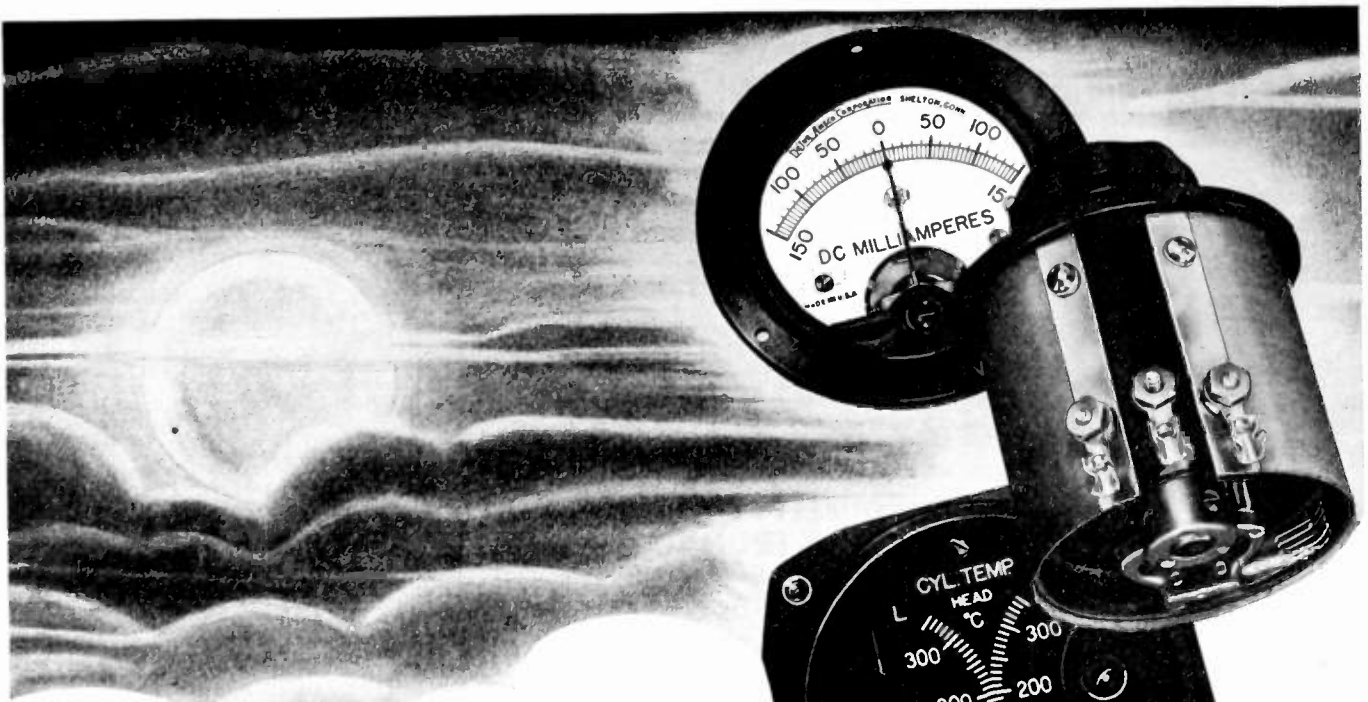

*One thing  
is certain*

... the American Military Machine must be equipped with superior materials of war. To this end, DeJur Aircraft and Electrical Instruments, Potentiometers and Rheostats are built to the most critical standards of quality and precision. Behind them are twenty-five years of experience and laboratory research. Before them stands the future of the democratic way of life. Neither you nor ourselves can afford to falter now.

Awarded for Excellence in Production and Quality of Material



**DeJUR-AMSCO CORPORATION**

**SHELTON, CONNECTICUT**

NEW YORK PLANT:  
99 Hudson Street, New York City

CANADIAN SALES OFFICE:  
560 King Street West, Toronto

*MORE THAN EVER... it's important to keep buying War Bonds and Stamps*

# IRON FERROCART CORES

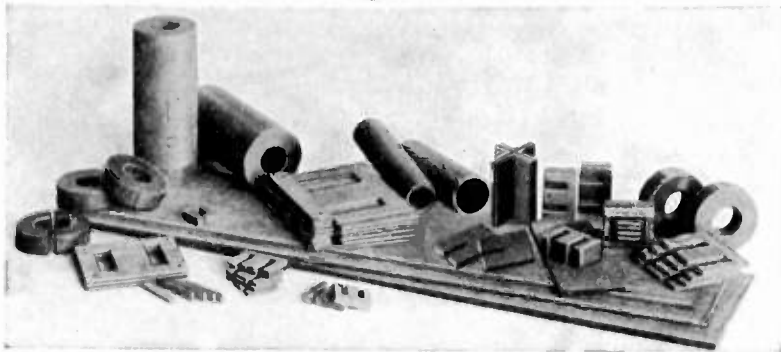

## MICROPERM QUALITY ULTRA-HIGH FREQUENCY IRON CORES

CAN BE ADVANTAGEOUSLY USED AT FREQUENCIES FROM 100 TO 200 MEGACYCLES AND ABOVE

Maintaining our leadership in the exclusive field of iron powder magnetic materials.

New developments include iron cores particularly useful at frequencies from 500 to 20,000 cycles.

Quality magnetic cores for all radio controlled apparatus—comply with the most rigid U. S. Government specifications for high "Q," high resistance, rust-proofing and physical strength.

Your R.F. or I.F. coil problems welcomed. Samples, quotations, specifications expeditiously handled.

100% on VICTORY ORDERS.  
FERROCART CORPORATION OF AMERICA

Plant and Laboratory  
HASTINGS-ON-HUDSON, N.Y.

Chicago: 149 W. Ohio St.    Los Angeles: 1341 S. Hope St.    San Francisco: 1355 Market St.  
Tel. Whitehall 7620    Tel. Richmond 9121    Tel. Underhill 2727  
Montreal: 995 St. James St. West    Indianapolis: 108 East 9 St.  
Tel. Platteau 7617    Tel. Riley 2518

I-F

TRANSFORMER

Precise . . . Simple

PERMEABILITY-TUNED

CAMBRIDGE THERMIONIC  
CORP.

445 CONCORD AVE., CAMBRIDGE, MASS.

(Continued from page lii)

### ELECTRO-MAGNETIC ENGINEER

Unusual opportunity for engineer with vision for new ideas in design work with nationally known, long established firm in Eastern Pennsylvania, now 100% on war work. Firm large enough to make remuneration attractive, small enough to insure recognition. Training in design of relays, timers and solenoids would be helpful. Write Box 285.

### RADIO INSPECTORS

Radio Inspectors sought by Federal Communications Commission. The positions pay \$2,000 and \$2,600 a year, and are located throughout the United States. Duties include inspection of radio equipment on ships and aircraft, or at land stations, the making of frequency runs and harmonic analyses, and the examination of radio operators.

No written test will be given to applicants. To qualify for Radio Inspectors, \$2,600 a year, applicants must have had education and experience as described in one of the following: (1) a full 4-year course in electrical or communications engineering at a recognized college or university, (2) a full 4-year college course with major study consisting of at least 24 semester hours in physics, (3) 4 years of technical experience in radio work, or (4) any time-equivalent combination of (1), (2), or (3). Amateur radio experience under a class A license may be substituted for 2 years or less of experience. For Assistant Radio Inspector, \$2,000 a year, only 3 years of this education and experience are required.

In addition, applicants must hold a valid second-class radiotelegraph operator's license, or must demonstrate during the first 6 months of service their ability to transmit and receive 16 code groups per minute in International Morse Code. They must also be able to drive an automobile.

Full information, and application forms, may be obtained at first- and second-class post offices, except in regional headquarters cities where they are available only at the civil service regional offices, or from the U. S. Civil Service Commission at Washington, D.C.

### RADIO INTERCEPT OFFICERS

Persons qualified to intercept radio messages are needed by the Federal Communications Commission. The positions pay \$2,000 and \$2,600 a year, plus overtime, which increases the salaries about 21% for 8 hours of overtime a week.

Radio intercept officers will participate with Army Air Forces in effecting radio silence and insuring compliance with silence orders, test the efficiency of methods of control, maintain a continuous watch on distress channels, and otherwise participate in monitoring assignments relating directly to the war effort.

For assistant radio intercept officer, \$2,600 a year, persons must have had either a full 4-year course in electrical engineering or physics at a college or university of recognized standing, 4 years of technical experience in the field of radio, or a time-equivalent combination of such education and experience. For the \$2,000 grade, less education and experience is required. Applicants for both grades must be able to transmit and receive in International Morse Code, and in some cases may substitute experience as a radiotelegraph operator, or as an amateur holding a Class A license, or radio and engineering study at a recognized college or radio institute for part of the prescribed education or experience.

No written test is required, and the only age limitation is that applicants must have reached their eighteenth birthday. Positions are to be filled throughout the United States.

Persons using their highest skills in war work are not encouraged to apply. Complete information and application forms may be obtained at post offices, from the United States Civil Service, Washington, D.C., as well as from civil service regional offices.

### PATENT ATTORNEY

Patent Attorney to join small Patent Department. Write Personnel Director, Brush Development Company, 3311 Perkins Avenue, Cleveland, Ohio.

(Continued on page lvi)

# WANTED

## TECHNICAL SPECIALISTS ~

MEN & WOMEN

The Colonial Radio Corporation needs immediately, for War Radio Work, the following technically trained personnel:

Radio Engineers  
Physicists—Radio  
Vacuum Tube Engineer  
Calibration Technician  
Mechanical Engineers  
Electro-Mechanical Engineers  
Mechanical Draftsmen  
Tool Designers  
Engineering Specification Writers  
Field Engineers—Radio  
Field Inspectors—Radio  
Model Makers  
Technical Assistants—Radio

These are NOT temporary positions. Satisfactory employees may expect PERMANENT employment. Qualified applicants, NOT now in WAR WORK, should write, giving full history of education, experience, and salary desired.



**COLONIAL**  
RADIO CORPORATION

254 RANO ST.

*Buffalo, N. Y.*



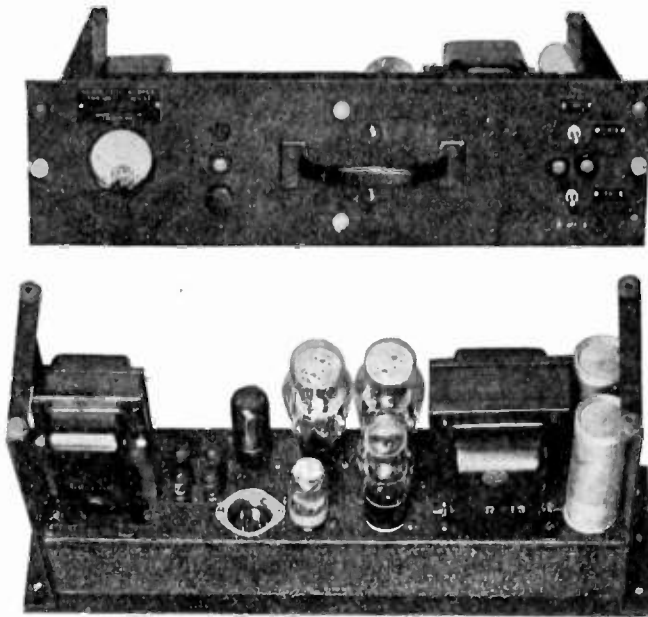

## STABILIZED POWER SUPPLY

A PRECISION INSTRUMENT FOR LABORATORY D. C. SOURCE

# HARVEY Radio Laboratories, Inc.

447 CONCORD AVENUE · CAMBRIDGE · MASSACHUSETTS

**MICROPHONES ★ PLUGS ★ SWITCHES**

GOVERNMENT SPECIFICATION ITEMS

AR-1M	PL-54	SW-141
CU-1	PL-55	SW-217
CU-2	PL-291	CD-318
1700-U	JK-26	CD-508
PL-68	JK-48	M-199

EARLIEST DELIVERIES

**UNIVERSAL MICROPHONE CO., LTD.**  
INGLEWOOD, CALIFORNIA, U. S. A.

(Continued from page liv)

### ENGINEERS

The salary is open and depends only upon the ability and experience of the engineer.

1. Electronic and radio engineers to design electronic navigation and communication equipment for aircraft.
2. Mechanical engineers familiar with and interested in the design of small precision equipment and familiar with shop practice and tools.
3. Engineers familiar with the design of components for electronic equipment.
4. Technical men able to write technical material for instruction books.

These positions can be permanent for the right men. Excellent opportunities for advancement.

Engineers with experience are preferred, but the right persons do not need experience if they have the ability to learn and the required aptitude. Applicants may be male or female. Persons already engaged in war work cannot be considered.

Write directly to Chief Engineer, Bendix Radio Division, Bendix Aviation Corp., Baltimore, Maryland giving complete details of education and experience.

### ELECTRONIC ENGINEERS

Engineers with backgrounds for acoustics, supersonics, broadcasting, frequency modulation, or ultra-high frequencies. Applicants should not be subject to immediate draft call and should not be engaged at their highest skilled war work. An engineering degree is desirable but not required.

Women with similar technical knowledge and experience will be considered.

Company is a large electrical manufacturer and is within twenty minutes commuting distance of New York City. Salaries are commensurate with education and experience. Address Box 287.

### RADIO ENGINEER

Experienced in the manufacture and testing of ultra-high-frequency apparatus; must be capable of taking complete charge of war projects. Splendid opportunity. War workers at highest skill need not apply.

Inquiries will be kept confidential. Please state age, experience, and salary expected. Write Box 288.

### RADIO INSTRUCTION-BOOK WRITERS

Thorough knowledge of radio principles and ability to describe in simple terms the operation of UHF circuits required. Work relates to instruction books for electrical apparatus. Excellent opportunity to do essential work in very essential war industry. Salary depends upon qualifications and experience.

Replies solicited from Engineers, Patent Attorneys, Teachers and others qualified.

Write complete qualifications and salary desired to Hazeltine Electronics Corporation, 1775 Broadway, New York, N.Y.

### RADIO ENGINEER

Mathematical knowledge to include trigonometry and elementary calculus. Must be familiar with all types of circuits for reception and transmission on frequencies up to 200 mc/s. Knowledge of transmission lines, aerial arrays, television and cathode-ray-tube technique desirable. Must also have knowledge of radio test equipment and must understand any circuit diagram.

Prefer man conversant with manufacture, repair and fault location on all types of transmitters and receivers. Address Box 289.

### RADIO ENGINEER

**EDUCATION:** Minimum of two years college in Electrical Engineering.

**EXPERIENCE:** Minimum of two years in radio test or engineering, or five years in electrical control work (power station or telephone central-office wiring, etc.).

Must be of a type qualified to interpret and clarify with inspectors and responsible executives electrical specifications, problems of manufacture, test and inspection. Address Box 290.

(Continued on page lviii)

# SALUTE TO THE WORKERS OF TOMORROW!

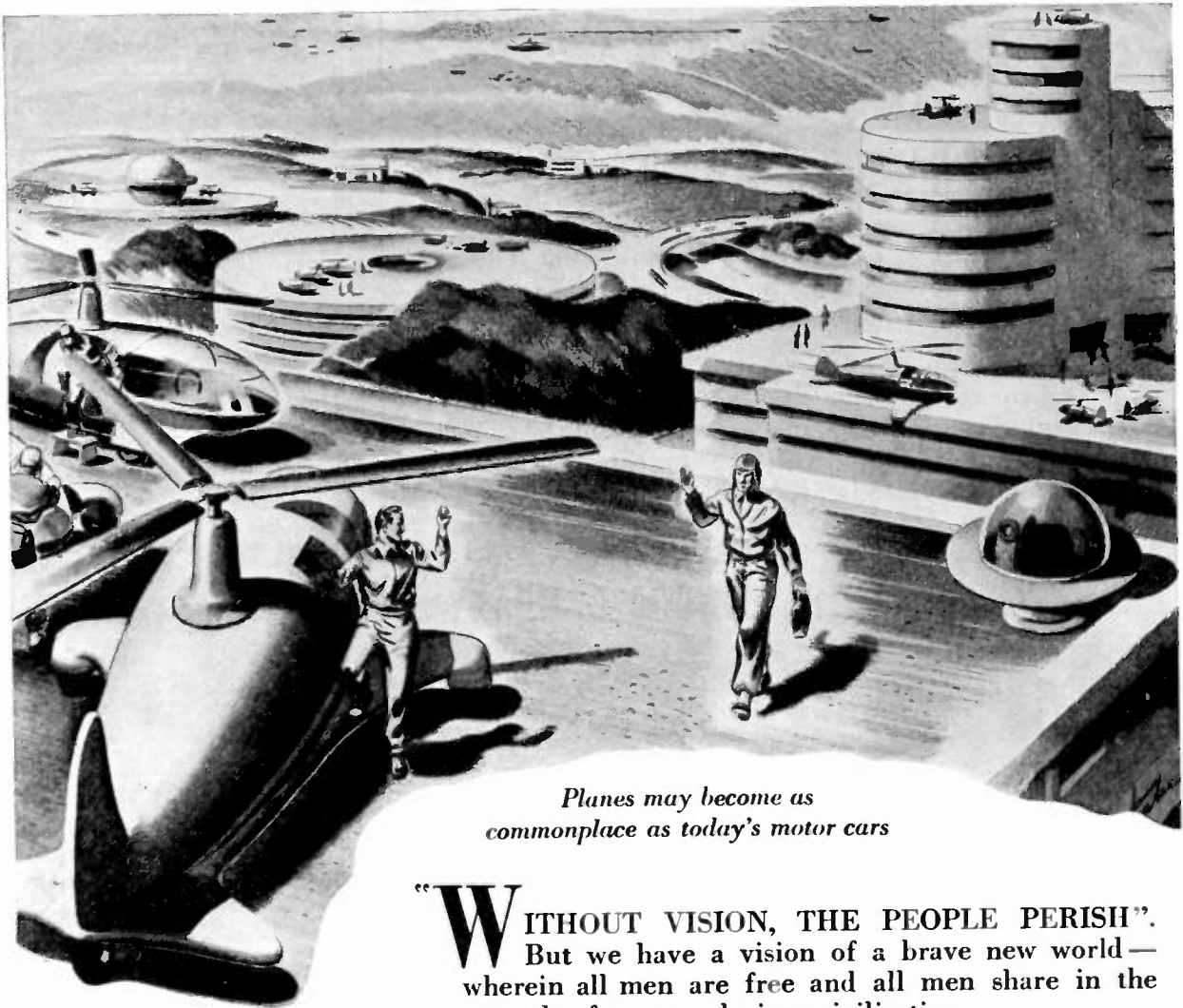

*Planes may become as commonplace as today's motor cars*

**“WITHOUT VISION, THE PEOPLE PERISH”.**  
But we have a vision of a brave new world—wherein all men are free and all men share in the rewards of a more glorious civilization.

What the face of this world will be like, none can know. Will factories be of revolutionary design—lighted by the health rays of artificial sunlight? Will the workers travel to and fro in their own planes—with ample leisure for education and relaxation?

This much we know. Out of modern, forward-looking industries such as Small Electric Motors (Canada) Limited, will come electrical equipment, for ships and planes, for factories and homes, of revolutionary design.

For here is a new company in Canada—with new ideas and ideals. Now engaged solely in original designing and precision making of essential war equipment, Small Electric Motors (Canada) Limited looks confidently to a brilliant post-war future.

## DESIGNERS AND MANUFACTURERS

of all types of precision electrical apparatus including

*D.C. & A.C. Motors for specialized purposes  
Aircraft Generators  
Aircraft Engine Starters  
Alternators  
Motor Generators  
Electric Pumps  
Motors with Governors  
Gyros, etc.*

## *Small Electric Motors (Canada) Limited*

and its subsidiary

*Semco Instruments Limited*

LEASIDE

TORONTO 12

CANADA

1-43

# The Erwood Sound Equipment Co.

will be known in future as

## THE ERWOOD COMPANY

Because of important engineering advances in the course of our participation in the war effort, our former name no longer describes our broadened program of probable future activities.

The change in name does not include any change in ownership, policy or personnel. Our experienced engineering organization will be maintained intact for the coming electronic era.

**THE ERWOOD COMPANY**  
223 W. Erie Street  
Chicago, Illinois

(Continued from page lvi)

### RADIO ENGINEER

Opening in engineering department of concern making communication apparatus. Prefer college graduate with ultra-high-frequency experience, but lack of experience in this field will not bar an adaptable man.

Duties involve developing, designing and carrying the product through the shop with a minimum of supervision. If inexperienced, the duties would be the same under supervision. The company is engaged in war activity exclusively and expects to continue this work after the war.

Salary \$2,500 to \$5,000 depending upon qualifications. Pleasant surroundings and working conditions. If now employed in war work, a release from the employer must be obtainable. Address: Chief Engineer, Templetone Radio Company, Mystic, Conn.

### TECHNICAL AND SCIENTIFIC AIDS

Federal government needs aids for research and testing in the following fields: chemistry, geology, geophysics, mathematics, metallurgy, meteorology, physics, and radio. The positions pay \$1,620 to \$2,600, plus overtime.

For the assistant grade, applications will be accepted from persons who have completed 1 year of paid experience or a war training course approved by the U. S. Office of Education. One year of college study, including 1 course in the option applied for, is also qualifying. Persons now enrolled in war training or college courses may apply, subject to completion of the course. For the higher grades successively greater amounts of education or experience are required.

The majority of positions are in Washington, D.C., but some will be filled in other parts of the United States. There are no age limits, and no written test is required. Persons using their highest skills in war work are not encouraged to apply.

Applications will be accepted at the U. S. Civil Service Commission, Washington, D.C., until the needs of the service have been met.

### ELECTRICAL ENGINEER

Thoroughly familiar with the manufacture and design of capacitors. We have an unusual opportunity open for an engineer experienced in the above line of work and who can also assume responsibility. Industrial Condenser Corporation, 1725 West North Ave., Chicago, Ill.

### INSTRUCTORS IN ADVANCED ARMY-NAVY PROGRAM

Prominent Eastern technical institute needs additional instructors in officer training program in modern electronics and radio applications. An excellent opportunity to acquire advanced knowledge and to render important service in war effort. Men having various degrees of qualifications are needed, from recent graduates in Electrical Engineering or Physics to those with long experience in radio engineering or teaching. Salary according to qualifications and experience. Applicants must be U. S. citizens of unimpeachable reputation. Any inquiries will be treated as highly confidential. Please send personnel data and photograph to Box 292.



### Attention Employers . . .

Announcements for "Positions Open" are accepted without charge from employers offering salaried employment of engineering grade to I.R.E. members. Please supply complete information and indicate which details should be treated as confidential. Address: "POSITIONS OPEN," Institute of Radio Engineers, 330 West 42nd Street, New York, N.Y.

The Institute reserves the right to refuse any announcement without giving a reason for the refusal.

# PRECISION-BUILT

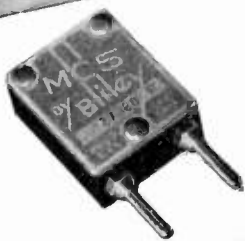

Accuracy and dependability are built into every Bliley Crystal Unit. Specify **BLILEY** for assured performance.

**BLILEY ELECTRIC COMPANY**  
BRIDLE, PENNSYLVANIA

# Bliley Crystals

# GLAD HE'S ON OUR SIDE!



Glider pilots have a job to do. They have to set them down at a certain place at a certain time, slug the enemy where it hurts him most, and hold till reinforcements arrive. Coordination with other arms must be perfect, and radio makes this coordination possible. It's a tough job for tough men, and we're glad this Marine Lieutenant is on our side. . . . Wonder where he is now?

**NATIONAL COMPANY, INC.**  
Malden, Mass.



PHOTO BY OFFICE OF  
WAR INFORMATION

# They can take it!

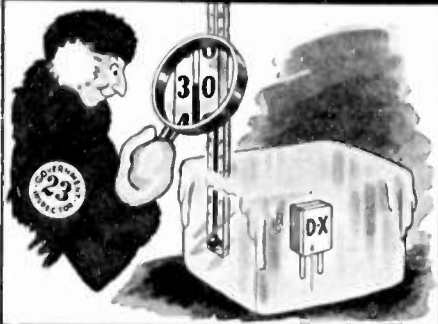

*--and dish it out!*

Buy War Bonds and Stamps

**DX CRYSTAL CO.**

GENERAL OFFICES: 1841 W. CARROLL AVE., CHICAGO, ILL., U.S.A.

**DX  
XTALS**

'the heart of a good transmitter'

TRADE MARK

## TRIPLLETT Combat line INSTRUMENTS

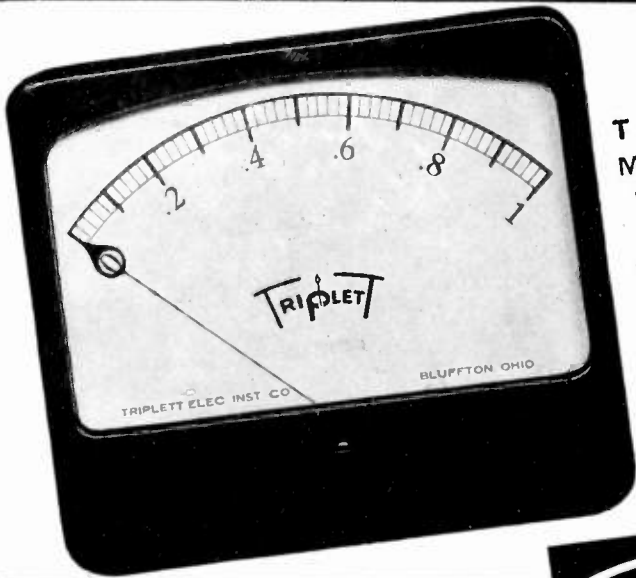

TRIPLLETT  
MODEL 626  
with long 5.60" scale

★  
This illustration is  
½ actual size. Note  
long scale and mini-  
mum panel space  
required.

### A WORD ABOUT DELIVERIES

Naturally deliveries are subject to necessary priority regulations. We urge prompt filing of orders for delivery as expeditiously as may be consistent with America's War effort.

TRIPLLETT ELECTRICAL INSTRUMENT CO. . . . . BLUFFTON, OHIO

**TRIPLLETT**

### Standards for Home Radio Replacement Parts

(Continued from page xlv)

of the radio industry including parts manufacturers, receiver manufacturers, service organizations, parts distributors and design laboratories, while defining a severely limited line of replacement parts.

A performance standard for power and audio transformers and reactors was expected to be available by mid-March with performance standards for volume controls and resistor-type line cords and plug-in ballast resistors, ready early in April. These will be incorporated in the government orders, when issued, it is understood.

The ASA committee is composed of independent experts in the radio industry, with Dr. O. H. Caldwell, Editor of Radio Today, Chairman, and John Borst, Chief Engineer, John F. Rider organization, Vice-chairman. In all its work the radio committee has been in close touch with E. A. Graham, Standards Division of the Office of Price Administration, and F. H. McIntosh, Radio and Radar Branch, War Production Board. Other members of the Committee are: M. M. Brandon of Underwriters' Laboratories, Inc.; Garrard Mountjoy, RCA License Laboratory; M. J. Schinke (Stewart-Warner Corporation) Chairman of Service Committee, Radio Manufacturers Association (P. R. Butler, General Electric Company, Alternate); George F. DuVal, Past President, Radio Servicemen of America (A. E. Rhine, Alternate); S. L. Chertok, ASA Secretary. Government liaison men on the committee include Frank H. McIntosh, Chief of the Domestic and Foreign Radio Section of the WPB (Samuel Weisbroth, Alternate); Karl S. Geiges, Simplification Branch, WPB; and Earl A. Graham, Chief, Consumer Durable Goods Section, Standards Division, OPA.

### OUR MEN NEED

★ BOOKS ★



SEND

ALL YOU CAN SPARE

GOOD BOOKS ARE ON THE MARCH from your bookshelves to our fighting men. Doubtless some of our soldiers and sailors are interested in modern radio engineering methods and will find your books on that subject helpful to them in their work. Get them out—leave them at the nearest collection center or public library for the 1943 VICTORY BOOK CAMPAIGN.





## A new approach to the problem of measuring audio frequency equipment

One of the most recent approaches to the problem of measuring the response of amplifiers and networks is to apply a square wave voltage and observe shape of the wave which is transmitted. The frequencies contained in a uniform square wave are given by the relation:

$$f(t) = \frac{4}{\pi} (\sin wt + 1/3 \sin 3 wt + 1/5 \sin 5 wt + \dots)$$

In practice a wave which appears to be perfectly square will contain thirty harmonics or more and when the amplitude or phase relation of the harmonics is disturbed the square wave will be distorted. Thus the application of a square wave to circuit shows up any irregularities in the amplitude or phase transmission of that circuit not only at the square wave frequency but also at frequencies far removed from the test point.

The square wave test is particularly important in feedback circuits where the circuit performance outside the normal transmission band is generally of interest. The application of a square wave test to a feedback amplifier will show in a single observation whether the amplifier is close to oscillation point.

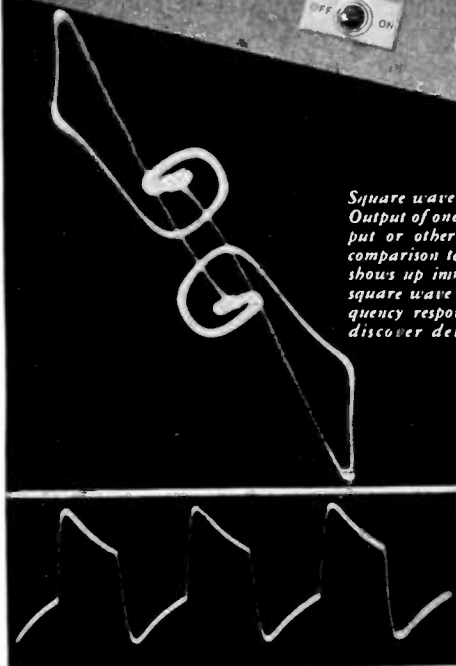

Square wave applied to two amplifiers. Output of one on horizontal plates, output of other vertical plates for rapid comparison test. One amplifier defective shows up immediately whereas without square wave a long point by point frequency response would be required to discover deviation from standard.

Square wave distortion from poor response at both low and high frequency. (Oscillogram taken on a typical public address amplifier.)

## SPEED UP PRODUCTION AND DEVELOPMENT WORK . . . .

 This Square Wave Generator will help you in Production and development work on A. F. amplifiers. As a general purpose instrument for laboratory work and as a time saver in production testing a square wave generator is an important instrument.

The *hp* model 210 Square Wave Generator provides an excellent square wave and is more useful than other instruments of this type because the frequency can be accurately set for quantitative measurements of decrement factor, time and other quantities to transient analysis. It will save valuable time in production testing because one or two observations will check the frequency response of apparatus where heretofore a large number of observations were necessary. This new instrument is an important tool for development work because it will show up phase shift and transient effects, both of which are rather difficult to study by other methods. In one observation a square wave applied to amplifier will check a wide frequency range, a range of 100 to 1 or

even more. This is extremely important because once the proper criterion has been established a production test can be set up with one or at the most two observations with a square wave.

No priority needed to avail yourself of our engineering help but *hp* instruments are going all-out for war and quick deliveries can be made only to people engaged in the war effort. However, we are making prompt deliveries to war plants and our capacity for fast production is ample. Write today for information.

Square wave test on feedback amplifier showing amplification peak at 9 times square wave frequency. (A normal frequency response measurement shows flat response from 20 cps to 20 ks.)

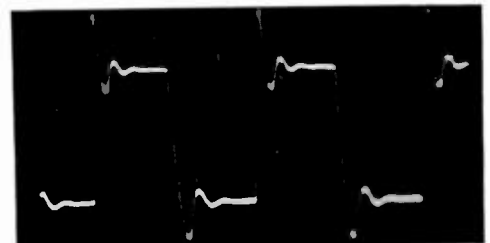

## HEWLETT-PACKARD CO.

BOX 135P, STATION A - PALO ALTO, CALIF.

*the*  
**Heart**

OF A POWER SUPPLY IS

*the*  
**Vibrator**

● Never before in the history of radio communication has research and development progressed at such a rapid pace. Particularly, is this true of Vibrator Power Supplies. Long the standard of the industry for heavy-duty commercial applications, Electronic Vibrator-type Power Supplies are today establishing new and amazing records for top performance, long life and absolute dependability . . . under the most exacting military requirements. Tomorrow they'll return to peacetime pursuits . . . at your service . . . *stronger and better* in every way because of their combat experience. Until then . . . **CARRY ON!**

**Electronic**  
**LABORATORIES, INC.**

Vibrator Power Supplies for  
Communications . . . Lighting  
. . . Electric Motor Operation  
. . . Electric, Electronic, and  
Other Equipment . . . on Land,  
Sea, or in the Air!

INDIANAPDLIS



## INDEX

Section Meetings	xxviii
Membership	xxx
New Equipment Notes	xl
Standards for Home Radio Replacement Parts	xliv
Army-Navy "E" Honor Roll	xlvi
Positions Open	l

### DISPLAY ADVERTISERS

Aerovox Corporation	iii
American Lava Corporation	ix
American Telephone & Telegraph Co.	x
Amperex Electronic Products, Inc.	Cover II
Victor J. Andrew Company	l
Arnold Engineering Company	xlvi
Bell & Howell Company	l
Bendix Aviation Corp.	xxv
Bliley Electric Company	lviii
Cambridge Thermionic Corp.	liv
Centralab	xxv
Chicago Transformer Corp.	xxxvi
Claroostat Manufacturing Co.	xlii
Colonial Radio Corp.	lv
Connecticut Telephone & Electric Div.	xxxiv
Cornell-Dubilier Electric Corp.	Cover III
Daven Company	xvii
DeJur-Amsco Corporation	liii
Tobe Deutschman Corp.	lxvii
Wilbur B. Driver Co.	xxxvii
Allen B. DuMont Laboratories, Inc.	xiv
DX Crystal Company	ix
Eitel-McCullough, Inc.	xliii
Electronic Laboratories, Inc.	lxii
Electro-Voice Mfg. Company, Inc.	v
Erwood Company	lviii
Federal Telephone & Radio Corp.	xlvii
Ferrocarril Corp. of America	liv
Galvin Mfg. Company	xxi
General Ceramics and Steatite Corp.	xi
General Radio Company	Cover IV
Hallicrafters Company	xxxii
Harvey Radio Laboratories, Inc.	lvi
Heintz & Kaufman, Ltd.	viii
Hewlett-Packard Company	lx
Hytron Corporation	xxxix
Industrial Condenser Corp.	xl
International Resistance Co.	xlix
International Telephone & Telegraph Corp.	xlvi
Isolantite	Facing xviii
Jackson Electrical Instrument Co.	xxviii
Lafayette Radio Corporation	xlviii
Littelfuse, Inc.	lxii
John Meck Industries	xxvii
Mycalex Corp. of America	xlv
National Company, Inc.	lix
National Union Radio Corp.	xiii
New York Transformer Co.	lii
North American Philips Co., Inc.	xxiv
Ohmite Manufacturing Co.	xxii
Premax Products	xlvi
Radio Corporation of America, Victor Div.	xvi, xxxiii
RCA Aviation Radio	Facing ix
Rauland Corporation	lxiv
Raytheon Manufacturing Company	xv
Remler Company, Ltd.	xliv
John F. Rider Publisher, Inc.	xlvi
Rola Company	xix
Shallcross Mfg. Company	xxxii
Small Electric Motors (Canada) Ltd.	lvii
Sola Electric Company	li
Solar Manufacturing Corp.	xli
Sprague Specialties Company	xxxiii
Stackpole Carbon Company	xviii
Standard Transformer Corp.	xx
Stupakoff Ceramic & Mdg. Co.	xii
Taylor Tubes, Inc.	xxvi
Thordarson Electric Mfg. Company	xxxviii
Triplett Electrical Instrument Co.	lx
Turner Company	xliv
United Electronics Company	xxxix
United Transformer Company	vi
Universal Microphone Co., Ltd.	lvi
Utah Radio Products Company	xxx
Westinghouse Electric & Mfg. Co.	vii
Wilcox Electric Company	lv

**NOW**  
**A SIGNAL INDICATOR**  
**THAT OPERATES BY**  
**REFLECTED LIGHT**

IN DAYLIGHT  
AT NIGHT TIME  
BY "BLACK" LIGHT  
AND  
NO LIGHT



LITTELFUSE  
No. 1534  
SIGNALETTE

SIGNALETTE IS INTER-  
CHANGEABLE WITH  
LAMP ASSEMBLY  
AC 4283593

**LITTELFUSE**

"BUTTERFLY"  
CLOSED  
NO  
SIGNAL



"BUTTERFLY"  
OPEN  
INDICATING

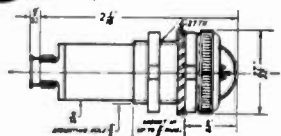

Indicates by reflected light, visible light, "black light," and by fluorescent-radio-active luminescence. Operates by solenoid. When activated, "butterfly" opens instantly showing signal. No blur, no dimming. Non-shatterable protection. Plastic cap withstands severest tests. No burn-outs as with lamps; no delicate parts to break from shock or shell explosion; no spare lamps required. Uses about 1/2 current of filament lamps.

Wire or write for Signalette Bulletin. Ask about samples for test.

**LITTELFUSE**  
**INCORPORATED**

4782 Ravenswood Avenue  
Chicago, Illinois

252 Ong Street  
El Monte (Los Angeles suburb)  
California

# Famous for **LONG LIFE!**

Assurance of long life is what you seek in a capacitor—and it's an asset that must be built into it by the maker.

Tobe Capacitors are *built* to last. From winding to shipping, each step is under rigid inspection to maintain the high standard set by twenty year's experience—and research is constant to raise the standard ever higher.

Below is shown a Tobe RLO Type Capacitor. It is impregnated and filled with mineral oil, made with watchful care and—like all Tobe Capacitors—rated conservatively. Let us know about your capacitor problems.

## **LONG LIFE ASSURED**



**CHARACTERISTICS — TOBE RLO TYPE CAPACITORS**  
MINERAL OIL IMPREGNATED—Mineral oil filled • RATINGS: .01 to 2.0 mfd., 600 V.D.C., .01 to 1.0 mfd., 1,000 V.D.C.  
POWER FACTOR: At 1,000 cycles—.002 to .005 • RESISTANCE: 8,000 megohms per microfarad • TEST VOLTAGE: Twice D.C. working voltage rating • TERMINALS TO CASE TEST: 2,500 Volts D.C. • STANDARD CAPACITY TOLERANCE: plus or minus 20% of nominal

A SMALL PART IN VICTORY TODAY



A BIG PART IN INDUSTRY TOMORROW

*Photo Courtesy of Southern Pacific Lines*

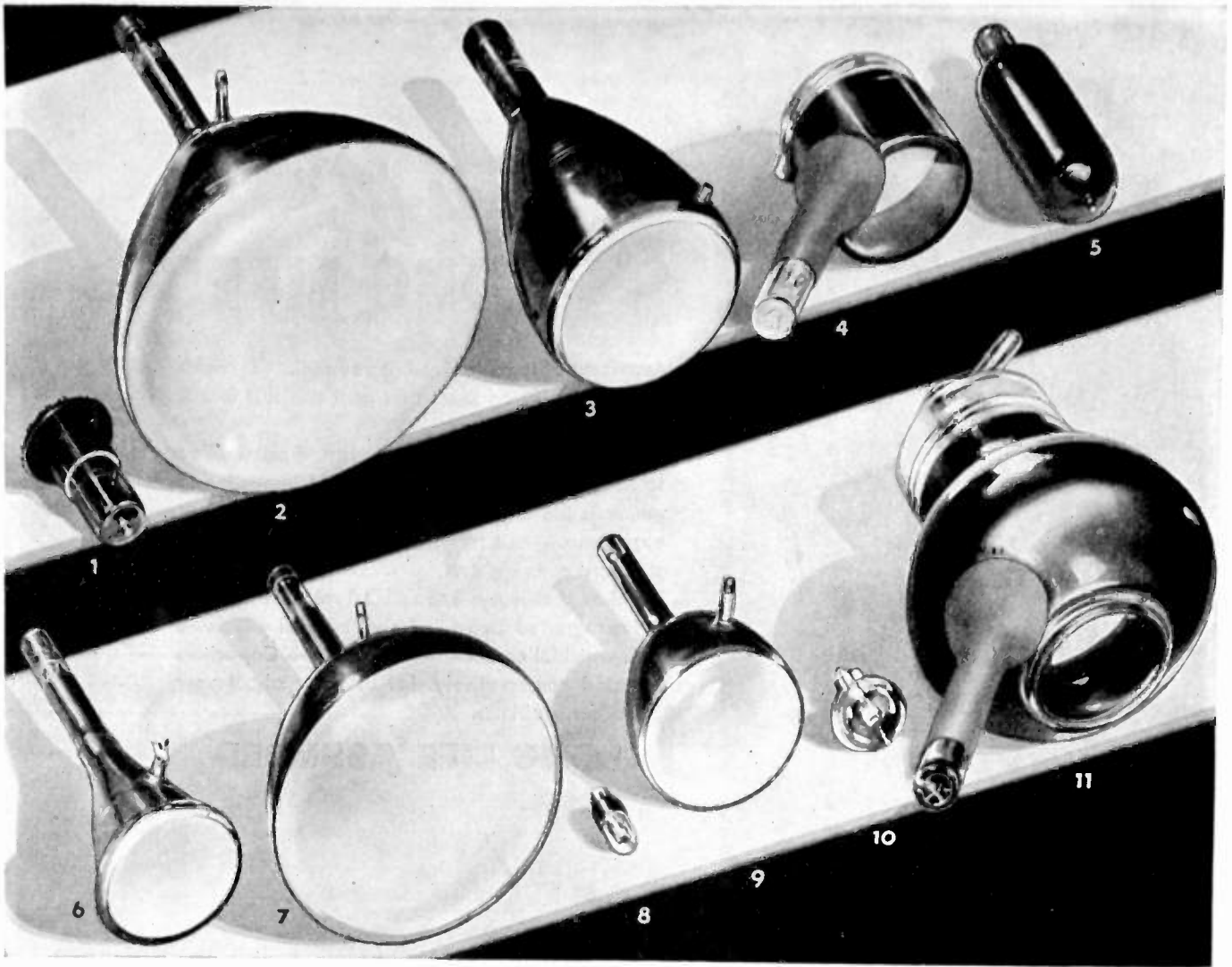

## "Name your weapon"

Made to order for specialized applications, these tubes best tell the story of versatility and range of RAULAND custom-engineering.

Properly identified, they are:

1. Multiplier Type Photo-cell Tube
2. 15-inch Cathode Ray Receiving Tube
3. 9-inch Electrostatic Cathode Ray Tube
4. 5½-inch Pipe Shape High Voltage Projection Cathode Ray Tube
5. Giant Photo-cell Tube
6. 5-inch Straight Projection Cathode Ray Tube
7. 12-inch Cathode Ray Receiving Tube

8. Sound Film Photo-cell Tube
9. 7-inch Straight Projection Cathode Ray Tube
10. Blue Sensitive Photo-cell Tube
11. 13½-inch Pipe Shape High Voltage Projection Cathode Ray Tube.

Each is designed to meet a specific need. From the tiny tube with power out of all ratio to its size, to the giant shapes conceived for services which cannot yet be told, RAULAND *Electroneered* cathode ray tubes foreshadow a new era of world economic advancement in the days to come.

RADIO...SOUND...

# Rauland

...COMMUNICATIONS

*Electroneering is our business*

THE RAULAND CORPORATION . . . CHICAGO, ILLINOIS

Buy War Bonds and Stamps! Rauland employees are still investing 10% of their salaries in War Bonds

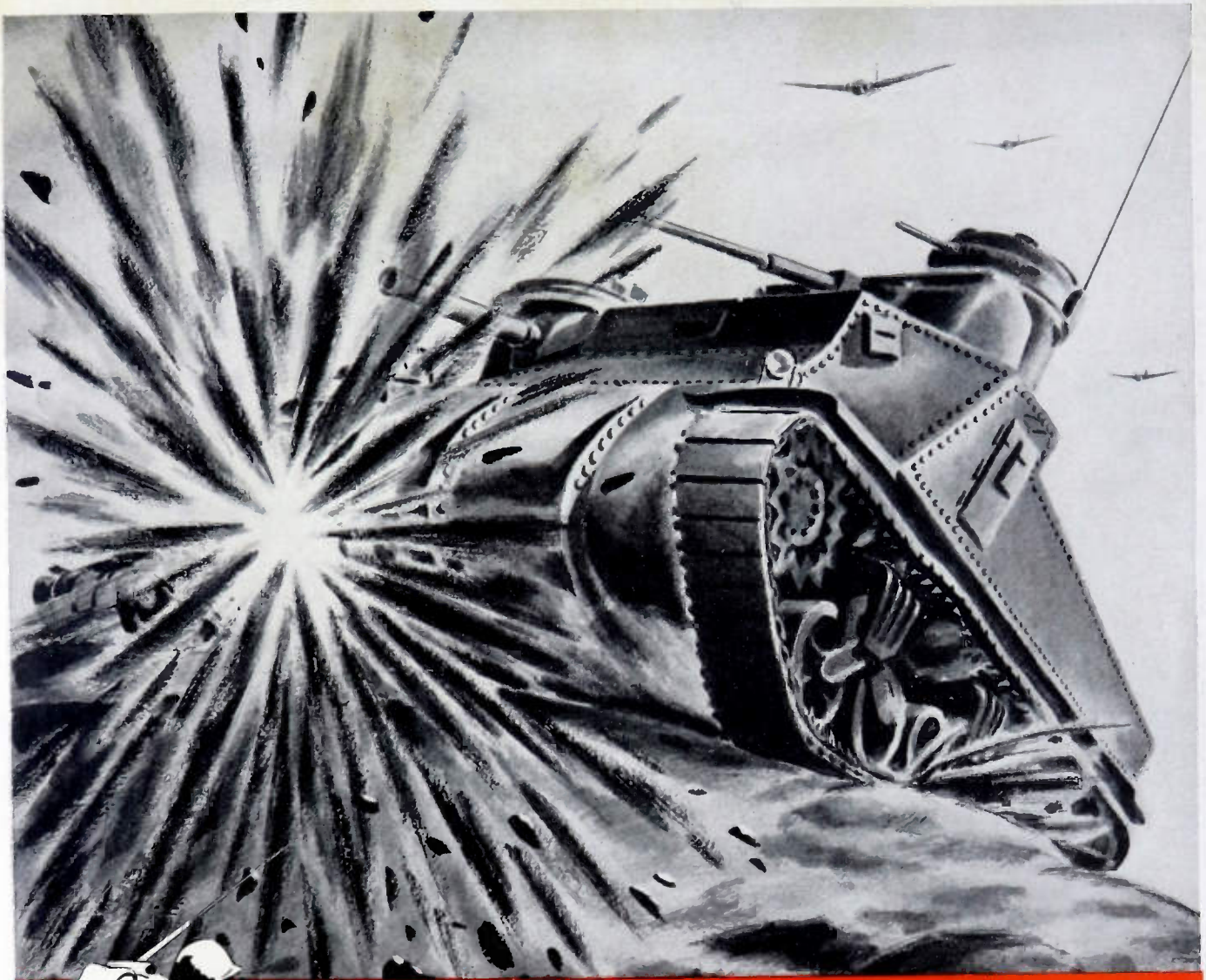

## "that darned walkie-talkie S-S-STUTTERED"

Stutterers don't give commands in the Signal Corps. In the stress of battle you can't have a man who stammers. Neither can you have equipment that will fail at the critical moment. Not when seconds mean the difference between success or failure in battle.

With men's lives at stake, you can't afford to use anything less than the best. When a design calls for Capacitors, specify C-Ds. Thirty-three years devoted to the exclusive manufacture of capacitors is your assurance of absolute reliability. Our Engineering department will be glad to cooperate with you. Cornell-Dubilier Electric Corporation, South Plainfield, New Jersey.



### DYKANOL FILTER CAPACITORS

#### Type TQ

The Type TQ Dykanol Filter Capacitors have been designed for low power transmitters, high power public address systems and portable power amplifiers. Several of the more important features are listed below:

*Impregnated and filled with Dykanol—a non-inflammable, high dielectric impregnant of stable characteristics.*

*Dried, impregnated and filled under continuous vacuum.*

*Hermetically sealed—these Capacitors are not affected by moisture, time or temperature up to approximately 200° F.*

*Conservatively rated—can be safely operated continuously at 10% above rated voltage.*

*For further details write for Catalog No. 160T.*

# Cornell-Dubilier

## capacitors



MORE IN USE TODAY  
THAN ANY OTHER MAKE.

MICA • DYKANOL • PAPER • WET AND DRY ELECTROLYTICS



## 5 KVA VARIAC

You may need this largest Variac for controlling voltage on motors, heaters, flood lights, transmitter tube filaments, rectifier systems, or process equipment. Wherever line voltage varies and operating voltage must be correct, you will find this manually operated, continuously adjustable autotransformer gives smooth control and good voltage regulation at high efficiency. Designed for circuits of moderately high power, the Type 50 Variac is rugged, dependable and convenient.

Prompt delivery can be made on priority rating of A A 3 or better.

### TYPE 50 VARIAC SPECIFICATIONS

**Input Voltage:** Type 50-A, 115 volts, and Type 50-B, 230 volts.

**Output Voltage:** Voltages up to 117% of line voltage can be obtained. Connection can also be made for maximum output voltage equal to line voltage.

**Load Rating:** 5 kva for the 115-volt model; 7 kva for the 230-volt model. Ratings are for 50° C. rise.

**Rated Current:** 40 amperes for the 115-volt model; 20 amperes for the 230-volt model.

**Maximum Current:** 45 amperes for the 115-volt model; 31 amperes for the 230-volt model.

**Regulation:** At output voltages ranging from 17% below to 17% above line voltage the full load regulation is less than 4%.

**Losses:** No load losses are about 1% of full-load power; full-load losses are about 2%; losses at half maximum output voltage are about 4%.

**Driving Torque:** From 1 to 2 pound feet.

**Net Weight:** 85 pounds.

**Dimensions:** Approximately 12 inches high x 16 inches diameter overall.

**Price:** \$100.00 F. O. B. Cambridge.

SEND FOR BULLETIN NO. 854



**GENERAL RADIO COMPANY · Cambridge, Massachusetts**

NEW YORK

LOS ANGELES