

Proceedings

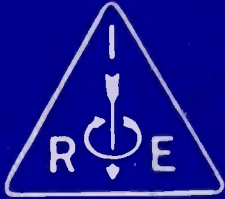

of the

I·R·E

JANUARY 1941

VOLUME 29

NUMBER 1

Shielding Radio-Frequency
Ammeters

Ultra-High-Frequency Tetrode
Diffraction Measurements at
Ultra-High Frequencies

Earth's Curvature and Ground-
Wave Propagation

Sinusoidal Variation of a
Parameter

After-Acceleration and
Deflection

Ionospheric Transmission

Institute of Radio Engineers

"Immune to Heavy Overloads... Gratifying Performance... Easily Driven..."

Writes FRITZ BAUER,
Chief Engineer, Radio
Station KGBX



FULL TIME
1230 KC

Owned and Operated by
SPRINGFIELD BROADCASTING CO.

BROADCASTING COMPANY
SPRINGFIELD, MISSOURI

December 18, 1940

OPTIONAL RED

OR BLUE NETWORK OF THE NATIONAL

Amperex Electronic Products, Inc.,
79 Washington Street,
Brooklyn, New York

Gentlemen:

Enclosed you will find the photographs of our new 5 Kilowatt Transmitter which you requested recently. The transmitter is now undergoing tests while we adjust the phasing equipment for our night time directional. The performance of your HF-3000's as final Class "C" R.F. amplifiers and ZB-3200's as high level modulators, is especially gratifying. The ease with which they can be driven to full output, the extreme simplification of cooling arrangements, the relative immunity to heavy overloads, and the moderate plate voltages required together with the inherent stability of the high level modulated Class "C" system results in a combination that is not easily surpassed for reliable broadcast service.

The entire 5 Kilowatt transmitter (excepting only the high voltage plate transformers and the modulator transformer and retard) is built into the 2 righthand cabinets. The third cabinet contains the distribution and phasing networks for the directional array.

Yours very truly,
RADIO STATION KGBX
Fritz Bauer
Chief Engineer

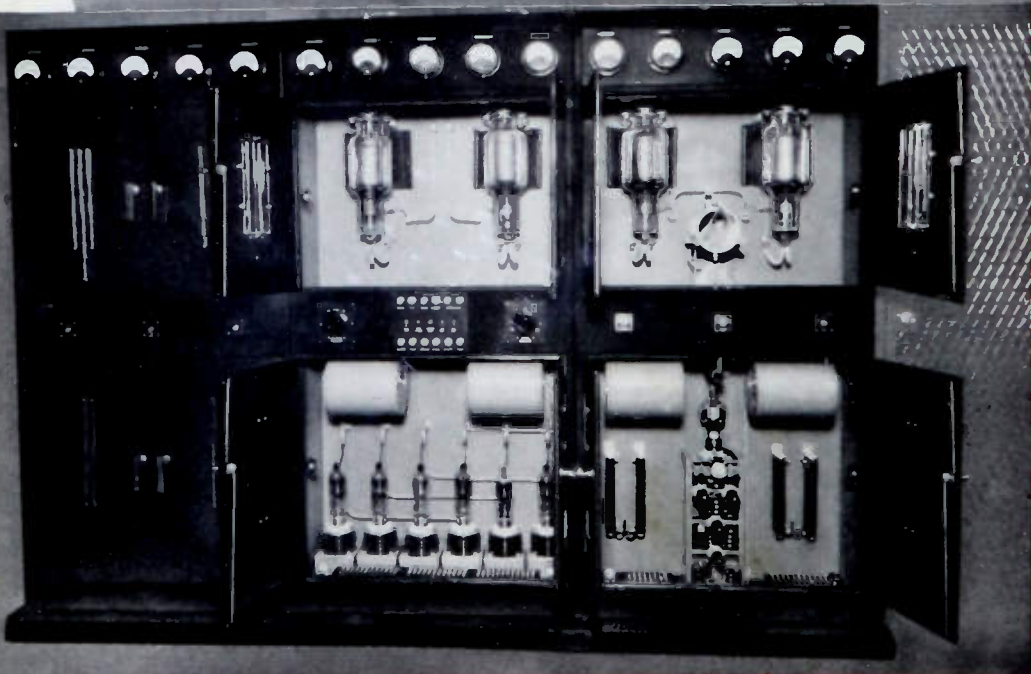

AMPEREX
HF-3000 ZB-3200

\$300

AMPEREX ELECTRONIC PRODUCTS, Inc.
79 WASHINGTON STREET BROOKLYN, NEW YORK

BOARD OF DIRECTORS

- Frederick E. Terman, *President*
- Adolfo T. Cosentino, *Vice President*
- Haraden Pratt, *Treasurer*
- Harold P. Westman, *Secretary*
- Austin Bailey
- Adolph B. Chamberlain
- Ivan S. Coggeshall
- Melville Eastham
- Harold T. Friis
- Alfred N. Goldsmith
- Virgil M. Graham
- O. B. Hanson
- Raymond A. Heising
- Lawrence C. F. Horle
- C. M. Jansky, Jr.
- Frederick B. Llewellyn
- Browder J. Thompson
- Hubert M. Turner
- Arthur F. Van Dyck
- Harold A. Wheeler
- Lynde P. Wheeler

BOARD OF EDITORS

- Alfred N. Goldsmith, *Chairman*
- Ralph R. Batcher
- Lloyd V. Berkner
- Philip S. Carter
- Lewis M. Clement
- Elmer W. Engstrom
- William L. Everitt
- Peter C. Goldmark
- Frederick W. Grover
- C. M. Jansky, Jr.
- John D. Kraus
- Frederick B. Llewellyn
- Samuel S. Mackeown
- Edward L. Nelson
- Harry F. Olson
- Greenleaf W. Pickard
- Haraden Pratt
- Conan A. Priest
- Leon J. Sivian
- Lynne C. Smeby
- Browder J. Thompson
- Harold A. Wheeler
- Lynde P. Wheeler
- Laurens E. Whittemore
- Gerald W. Willard
- William Wilson
- Charles J. Young

Helen M. Stote, *Assistant Editor*

John D. Crawford,
Advertising Manager

Proceedings of the I·R·E

Published Monthly by

The Institute of Radio Engineers, Inc.

VOLUME 29

January, 1941

NUMBER 1

The Shielding of Radio-Frequency Ammeters	J. D. Wallace	1
A New Ultra-High-Frequency Tetrode and Its Use in a One-Kilowatt Television Sound Transmitter	A. K. Wing, Jr., and J. E. Young	5
Diffraction Measurements at Ultra-High Frequencies	Harner Selvidge	10
The Effect of the Earth's Curvature on Ground-Wave Propagation	Charles R. Burrows and Marion C. Gray	16
Sinusoidal Variation of a Parameter in a Simple Series Circuit	Frank J. Maginniss	25
After-Acceleration and Deflection	J. R. Pierce	28
The Ionosphere and Radio Transmission, January, 1941, with Predictions for April, 1941		32
Institute News and Radio Notes		34
A Message to Institute Members		34
Coming Meetings		34
Board of Directors		35
Eta Kappa Nu Awards		35
I.R.E.-U.R.S.I. Meeting		36
Summer Convention Papers		36
Harold H. Beverage		36
Technical Committees		36
Sections		37
Membership		40
Contributors		41

Entered as second-class matter October 26, 1927, at the post office at Menasha, Wisconsin, under the Act of February 28, 1925, embodied in Paragraph 4, Section 538 of the Postal Laws and Regulations. Publication office, 450 Ahnaip Street, Menasha, Wisconsin. Editorial and advertising offices, 330 West 42nd St., New York, N. Y. Subscription, \$10.00 per year; foreign, \$11.00.

THE INSTITUTE OF RADIO ENGINEERS

INCORPORATED



New York Meeting—April 2, 1941



Joint Meeting with American Section, International Scientific
Radio Union, Washington, D.C., May 2, 1941

Summer Convention—Institute of Radio Engineers—Detroit, Michigan
June 23, 24, and 25, 1941

SECTION MEETINGS

ATLANTA March 21	DETROIT March 21	PITTSBURGH April 14
CLEVELAND March 27	LOS ANGELES March 18	WASHINGTON April 14
	PHILADELPHIA April 3	

SECTIONS

- ATLANTA**—Chairman, P. C. Bangs; Secretary, Adolph Andersen, Federal Communications Commission, 411 Federal Annex, Atlanta, Ga.
- BALTIMORE**—Chairman, Ferdinand Hamburger; Secretary, G. J. Gross, Pennsylvania Water and Power Co., 1611 Lexington Bldg., Baltimore, Md.
- BOSTON**—Chairman, W. L. Barrow; Secretary, P. K. McElroy, General Radio Co., 30 State St., Cambridge, Mass.
- BUENOS AIRES**—Chairman, A. T. Cosentino; Secretary, G. J. Andrews, Cia. Standard Electric Argentina, Cangallo 1286, Buenos Aires, Argentina.
- BUFFALO-NIAGARA**—Chairman, B. E. Atwood; Secretary, Leroy Fiedler, 53 Rosedale Ave., Hamburg, N. Y.
- CHICAGO**—Chairman, G. I. Martin; Secretary, R. A. Kay, RCA Institutes, Inc., 1154 Merchandise Mart, Chicago, Ill.
- CINCINNATI**—Chairman, J. M. McDonald; Secretary, W. L. Schwesinger, Crosley Corp., Cincinnati, Ohio.
- CLEVELAND**—Chairman, C. E. Smith; Secretary, W. G. Hutton, 7314 Dorothy Ave., Parma, Ohio.
- CONNECTICUT VALLEY**—Chairman, K. A. McLeod; Secretary, W. M. Smith, 250 Main St., Suffield, Conn.
- DALLAS-FORT WORTH**—Chairman, D. A. Peterson; Secretary, J. R. Sullivan, WRR, Dallas, Tex.
- DETROIT**—Chairman, M. Cottrell; Secretary, Paul Frincke, WJBK, 6559 Hamilton Ave., Detroit, Mich.
- EMPORIUM**—Chairman, R. K. Gessford; Secretary, C. W. Reash, Hygrade Sylvania Corp., Emporium, Pa.
- INDIANAPOLIS**—Chairman, Arthur Curtis; Secretary, B. V. K. French, P. R. Mallory & Co., E. Washington St., Indianapolis, Ind.
- LOS ANGELES**—Chairman, W. W. Lindsay, Jr.; Secretary, C. F. Wolcott, 1609 S. Western Ave., Los Angeles, Calif.
- MONTREAL**—Chairman, E. A. Laport; Secretary, W. A. Nichols, Canadian Broadcasting Corp., 1012 Keefer Bldg., Montreal, Que.
- NEW ORLEANS**—Chairman, G. H. Peirce; Secretary, D. W. Bowman, 8327 Sycamore St., New Orleans, La.
- PHILADELPHIA**—Chairman, C. M. Burrill; Secretary, R. L. Snyder, 103 Franklin Rd., Glassboro, N. J.
- PITTSBURGH**—Chairman, R. E. Stark; Secretary, M. G. Jarrett, Bell Telephone Company of Pennsylvania, Pittsburgh, Pa.
- PORTLAND**—Chairman, E. R. Meissner; Secretary, L. M. Belleville, 361 N. E. 75th Ave., Portland, Ore.
- ROCHESTER**—Chairman, H. C. Sheve; Secretary, O. L. Angevine, Jr., Stromberg-Carlson Telephone Manufacturing Co., Rochester, N. Y.
- SAN FRANCISCO**—Chairman, L. J. Black; Secretary, Karl Spangenberg, Electrical Engineering Dept., Stanford University, Calif.
- SEATTLE**—Chairman, K. H. Ellerbeck; Secretary, R. J. Gleason, Pacific Alaska Airways, Inc., 3314 White Bldg., Seattle, Wash.
- TORONTO**—Chairman, H. S. Dawson; Secretary, L. C. Simmonds, 301 King St., E., Toronto, Ont.
- WASHINGTON**—Chairman, M. H. Biser; Secretary, C. M. Hunt, WJSV, 817 Earle Bldg., Washington, D. C.

THE INSTITUTE serves those interested in radio and allied electrical communication fields through the presentation and publication of technical material.

THE PROCEEDINGS has been published without interruption since 1913 when its first issue appeared. The contents of each paper published in the **PROCEEDINGS** are the responsibility of the author and are not binding on the Institute or its members. Material appearing in it may be reprinted or abstracted in other publications on the express condition that specific reference shall be made to its original appearance in the **PROCEEDINGS**. Illustrations of any variety, however, may be reproduced without specific permission from the Institute.

STANDARDS reports are published from time to time and are sent to each member without charge. The four current reports are on Electroacoustics, Electronics, Radio Receivers, and Radio Transmitters and were published in 1938.

MEMBERSHIP has grown from a few dozen in 1912 to more than five thousand. Practically every country in the world in which radio engineers may be found is represented in our roster. Dues for the five grades of membership range from \$3.00 to \$10.00 per year. The **PROCEEDINGS** is sent to each member without further payment

SECTIONS in twenty-four cities in the United States, Canada, and Argentina hold regular meetings. The chairmen and secretaries of these sections are listed on the opposite page.

SUBSCRIPTIONS are accepted for the **PROCEEDINGS** at \$10.00 per year in the United States of America, its possessions, and Canada; when college and public libraries order direct from the Institute, the subscription price is \$5.00. For other countries there is additional charge of \$1.00.

The Institute of Radio Engineers, Inc.
Harold P. Westman, Secretary
330 West 42nd Street
New York, N.Y.

The Institute of Radio Engineers

Incorporated

330 West 42nd Street, New York, N.Y.

To the Board of Directors

Gentlemen:

I hereby make application for ASSOCIATE membership in the Institute of Radio Engineers on the basis of my training and professional experience given herewith, and refer to the sponsors named below who are personally familiar with my work.

I certify that the statements made in the record of my training and professional experience are correct, and agree if elected, that I shall be governed by the Constitution of the Institute as long as I continue a member. Furthermore I agree to promote the objects of the Institute so far as shall be in my power.

.....
(Sign with pen)

.....
(Address for mail)

.....
(City and State)

.....
(Date)

SPONSORS

(Signatures not required here)

Mr.

Address

City and State

Mr.

Address

City and State

Mr.

Address

City and State

REQUIREMENTS for Associate membership are that an applicant must be at least twenty-one years of age, of good character, and be interested in or connected with the study or application of radio science or the radio arts.

SPONSORS who are familiar with the work of the applicant must be named. Preferably these should be three Associates, Members, or Fellows of the Institute. In cases where the applicant is so located as not to be known to the required number of member sponsors, the names of responsible nonmembers may be given.

DUES for Associate membership are six dollars per year. The entrance fee for this grade is three dollars and should accompany the application.

(Typewriting preferred in filling in this form) No.

RECORD OF TRAINING AND PROFESSIONAL EXPERIENCE

Name
(Give full name, last name first)

Present Occupation
(Title and name of concern)

Business Address

Home Address

Place of Birth Date of Birth Age

Education

Degree
(College) (Date received)

TRAINING AND PROFESSIONAL EXPERIENCE
(Give dates and type of work, including details of present activities)

.....
.....
.....
.....
.....
.....
.....
.....
.....
.....
.....

Record may be continued on other sheets this size if space is insufficient.

Receipt Acknowledged Elected Notified

OTHER GRADES are available to qualified applicants. Those who are between the ages of eighteen and twenty-one may apply for Junior grade. Student membership is for full-time students in engineering or science courses in colleges granting degrees as a result of a four-year course. A special application blank is provided and requires the signature of a faculty member as the sole sponsor. Member grade is open to older engineers with several years of experience. Fellow grade is by invitation only. Information and application blanks for these grades may be obtained from the Institute.

BACK COPIES of the PROCEEDINGS may be purchased at \$1.00 per copy where available. Members of the Institute in good standing are entitled to a twenty-five per cent discount.

VOLUMES, bound in blue buckram, may be purchased for \$14.25; \$11.25 to members.

BINDERS are \$1.50 each. The volume number or the member's name will be stamped in gold for fifty cents additional.

INSTITUTE EMBLEMS of fourteen-carat gold with gold lettering on an enameled background are available. The lapel button is \$2.75; the lapel pin with safety catch is \$3.00; and the watch charm is \$5.00. All of these are mailed postpaid.

The Shielding of Radio-Frequency Ammeters*

J. D. WALLACE†, ASSOCIATE, I.R.E.

Summary—Radio-frequency current-measuring instruments, when operated at a point in a circuit at high radio-frequency potential with respect to ground or to other near-by low-potential objects, have introduced therein another type of error, that is, one additional to other basic or inherent errors. The error introduced by high-potential operation can be materially reduced by shielding the instrument. A design of shield for an instrument is described herein which has proved highly practicable for use in measuring radio-frequency currents at high-potential points in a circuit with less error than is present in an unshielded instrument.

A NUMBER of papers published during the past few years have discussed errors in radio-frequency ammeters at the higher radio frequencies and a few typical ones of this nature are listed in the Bibliography. This article will pertain to another type of error occurring in such instruments, which results during their operation under certain conditions.

Experience with various kinds of radio equipment employing a radio-frequency current-measuring instrument located at a point in a circuit, higher in radio-frequency potential than other objects in the proximity, leads one to conclude that an appreciable error occurs in the reading of the instrument which is not present when the same instrument is used in a circuit at or near ground potential. This conclusion is reached because various computations based on current measurements made under conditions where the instrument was placed at a high-potential point give results which are incompatible with known physical principles; from various observed data it is possible to determine that an instrument indicates more current, sometimes considerably more, than is actually flowing in the circuit.

A theoretical explanation will be offered first as to the cause of error under this condition of operation. Reference to Fig. 1, where a radio-frequency ammeter is placed in a circuit at a high-potential point to measure the current through an impedance, will prove to be of assistance in making an analysis of the cause of error. The portion of this illustration representing a radio-frequency ammeter is obviously not a complete drawing of an instrument, but it shows certain parts and connections employed in these devices. Certain of the internal parts of the instrument such as the moving coil, hairsprings, connecting leads from the thermocouple to the coil, the thermocouple itself, etc., have a small but appreciable capacitance to ground. Since the instrument is operated above ground potential, a charging current will flow into these parts through the thermocouple. This charging current will cause the thermocouple to receive heat additional to that im-

parted by the heater, thereby causing the instrument to indicate more current than is actually passing into the load. A capacitive path is also present between the heater itself and ground, so it too receives a charging current, which also adds to the heating effect of the load-circuit current through the heater, thereby causing an additional error in current indication. Thus an instrument located at a high-potential point in a circuit, as in Fig. 1, would not be expected to indicate the true current in the load circuit, because of the effect of the stray current. It would be expected that the error

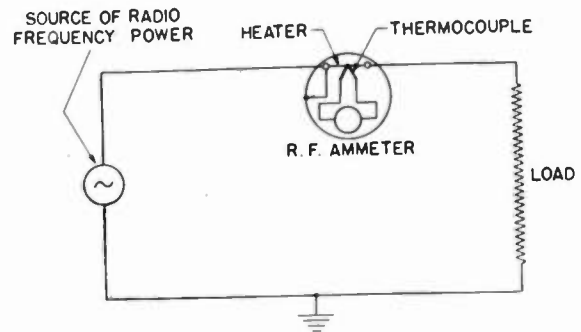

Fig. 1—Circuit employed in analysis of operation of a radio-frequency ammeter at a high-potential point.

resulting would increase approximately in proportion to the applied frequency, considering the nature of its cause. From the foregoing discussion, it is not difficult to realize that in the circuit shown in Fig. 1, the instrument will effectively indicate as though the load were shunted by a small condenser. This hypothetical condenser will be termed the "effective heater capacitance," and the stray current indicated by the instrument will be designated as "heater charging current."

No mention has yet been made as to the effect of charging current to such metallic parts of the instrument as the permanent magnet, bezel ring, scale plate, etc. However, stray current in these parts may be eliminated from the indicated value of current by properly connecting an instrument into a circuit. At least, this may be done in a well-designed ammeter of modern type. In order to explain the means of properly connecting an instrument into a circuit, reference is again made to the arrangement of parts within the instrument as shown in Fig. 1. The portion shown as a ring, enclosing the other parts, represents the permanent magnet, bezel ring, instrument-scale plate (usually of metallic construction in modern instruments), and certain other internal metallic parts, all of which are electrically bonded together. They are connected to eliminate the possibility of an internal radio-frequency flashover between parts, for this would likely occur were they not in electrical contact. Otherwise, various parts would assume different potentials

* Decimal classification: R242.12×R201.5. Original manuscript received by the Institute, July 25, 1940. Presented, joint I.R.E.-U.R.S.I. Meeting, Washington, D. C., April 28, 1939. The views stated herein are the personal ones of the author, and are not to be interpreted as the expression of an official opinion of the Naval Research Laboratory or of the Navy Department.

† Naval Research Laboratory, Bellevue, Anacostia, D. C.

in applications where the instrument is operated at a radio-frequency potential much higher than that of the surrounding objects, and this would be obviously conducive toward a flashover. The internally bonded type of construction is now employed in nearly all well-designed, self-contained types of radio-frequency current-measuring instruments. From the foregoing discussion as to internal arrangements, it is apparent that one of the instrument terminals is structurally the "low-potential" one. Suitable markings are usually ap-

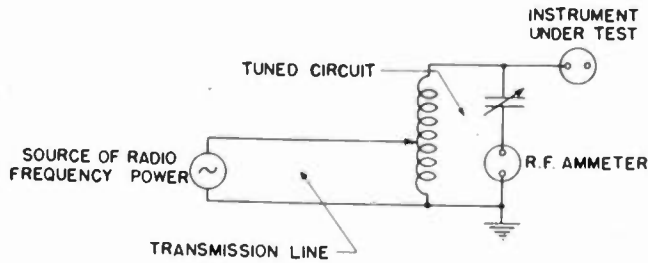

Fig. 2—Circuit used in determination of values of heater charging current.

plied to instruments by their manufacturers to allow one to differentiate between them. This type of structure allows an instrument to be connected into a circuit in a manner which will eliminate from its heater the stray current to the magnet, scale plate, bezel ring, etc. Thus when the low-potential instrument terminal is connected to the radio-frequency generator, and the other terminal to the load, stray current to the magnet, scale, and bezel ring is largely by-passed around the heater. This mode of connection always should be employed when a current measurement is to be taken at a high-potential point. Reversing connections to the instrument will often cause an appreciable error. It should be added, however, that "heater charging current" is not reduced by properly connecting an instrument into a circuit. Only the stray current to the bonded internal members is substantially eliminated by proper connections. Other measures, to be described later, are necessary to limit heater charging current.

The question may arise as to why it is necessary to place the current-measuring instrument at a high-potential point in a circuit, for instead, could it not be operated at or near ground potential, thereby eliminating the cause of such error. Where possible, placing an instrument at a low-potential point is obviously desirable. But in some instances it is permissible to place it only at a high-potential point. For example, in the determination of antenna current of a high-frequency transmitter, it is usually not valid to assume that the current measured in the ground lead is the same as that in the antenna, for many stray currents between the transmitter frame and ground most likely will be present. Determinations of radio-frequency transmission-line properties usually require current measurements at high-potential points. In making adjustments on directive-antenna arrays, frequently the

occasion demands that radio-frequency ammeters be placed at high-potential points. In the measurement of current at various portions of radio-frequency networks, it is often necessary to operate instruments at high-potential points. Therefore, it may be seen that the occasion frequently demands that instruments be used at high potential. Accordingly, the need for an investigation of the operation of instruments under these conditions can be appreciated.

Although the foregoing analysis of the action of instruments at high-potential points in a circuit has been based entirely upon theory, experiments have been made which show this concept to be valid, and indicate that appreciable errors in current measurements under such conditions do result at commonly used radio frequencies. By means of the circuit shown in Fig. 2, a direct measurement of the heater charging current in an instrument may be obtained. It may be seen that only one side of the circuit to the instrument under test has a metallic electrical connection to the source of radio-frequency potential, and the circuit is completed through the effective heater capacitance path of the instrument. By use of this circuit arrangement, no actual load circuit is associated with the instrument under test, hence no "load" current flows through the instrument. Accordingly, the only reading which can occur on the instrument will be due to its heater charging current. This circuit arrangement therefore provides a convenient means of measuring directly the heater charging current. Obviously, it is necessary to

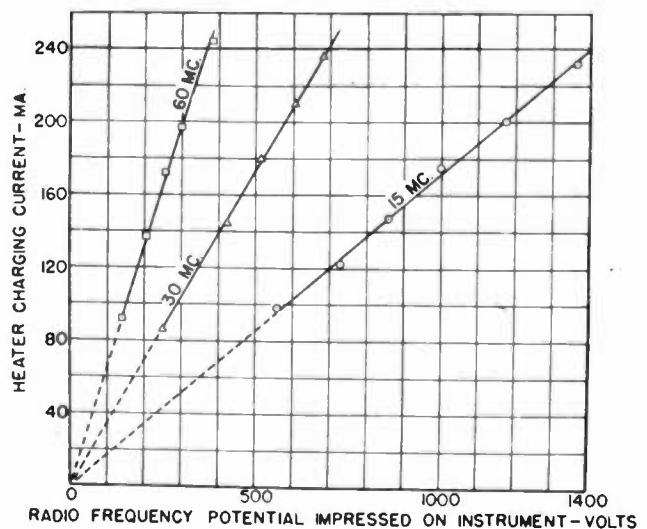

Fig. 3—Relationship between impressed radio-frequency potential and heater charging current in an unshielded instrument.

connect the source of voltage to the low-potential terminal of the instrument, for if the connection were made to the other terminal, not only would the heater charging current be indicated, but also that to the magnet, scale plate, bezel ring, and other associated metallic parts. The testing circuit illustrated in Fig. 2 is quite simple and requires little explanation. The source of radio-frequency power is connected through

a short transmission line to a tuned circuit which is resonated to the frequency of the power source. Accordingly, there will be produced at the ungrounded end of the tuned circuit, a radio-frequency voltage considerably above ground potential. The voltage applied to the instrument under test may be computed by well-known electrical laws from the condenser capacitance, the frequency, and the circulating current in the tuned circuit. The condenser used had very low losses, and this allows the equivalent series resistance of the condenser to be ignored in computing the voltage. With this testing equipment, it is possible to measure the heater charging current in an instrument, at various potentials above ground, and at any desired frequency. Some experimental data obtained in the measurement of heater charging current are shown in Fig. 3. These data were taken from a conventional, well-designed, $3\frac{1}{2}$ -inch (in diameter), panel-mounting, self-contained, thermocouple type of instrument, the full-scale range of which was 250 milliamperes. From an inspection of the data shown in Fig. 3, it is seen that the values of observed heater charging current are proportional not only to the voltage above ground at which the instrument is operated, but also to the applied frequency. From well-known electrical laws, it is apparent that the circuit equivalent formed by the flow of heater charging current is in the nature of a capacitance. Thus, if the instrument were used in a circuit like that of Fig. 1, the current indication would be as though the load were shunted by a small condenser. It may be readily shown also that a condenser of 1.8 micromicrofarads capacitance will pass currents substantially equal to the observed values of heater charging current, if similar voltages and the same frequencies are applied. Accordingly, this is the value of the effective heater capacitance of the instrument. At 30 megacycles, the reactance of a condenser of this size is the order of 3000 ohms. If the instrument is used on the high-potential side to measure the current into a high-impedance load, for example, a load of 1000 ohms, it is apparent that an appreciable error would result.

As would be expected not all instruments have the same value of effective heater capacitance, for this quantity depends somewhat on the design of the instrument. From the previous discussion it follows that it is desirable to use an instrument in high-potential applications which has the smallest possible effective heater capacitance. The value of the effective heater capacitance may also be considered a figure of merit in assigning ratings as to the relative suitability of various instruments for high-potential use.

From the previous discussion as to the cause of heater charging current in an instrument used at high potential, it follows that it should be possible to reduce materially the value of this undesired current by enclosing the instrument with an equipotential screen (or shield), operating both at the same radio-frequency

potential. Under this condition there would be an appreciable reduction in effective capacitance between the heater, the thermocouple (together with other related parts) and ground (or other low-potential near-by objects). This reduction in capacitance would restrict the flow of heater charging current to a value much below that which would be present in an unshielded instrument under similar operating conditions. The reason for the reduction in capacitance lies in the fact

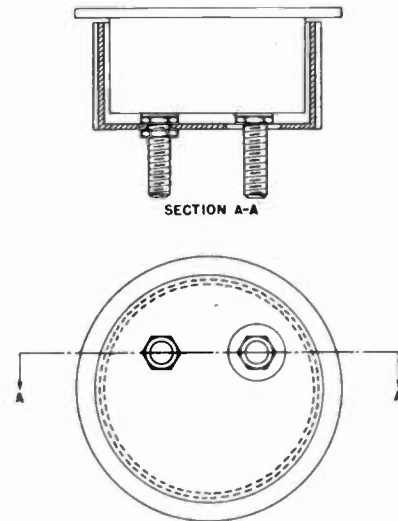

Fig. 4—Design of instrument shield.

that the lines of electrostatic flux leaving the instrument proper will then exist only between the attached screen and ground (or other low-potential objects in the proximity) and cannot extend through the screen (which is an electrical conductor) to the sensitive internal parts of the instrument. This is another aspect of the principles demonstrated by Faraday's "Ice-Pail Experiment." In practice it would not be expected that complete shielding would be attained, for some openings are necessary to give access for connection of the instrument into a circuit. Also, the parts of the instrument affected by heater charging current would still have a finite geometric capacitance which the enclosing shield would not eliminate. Now as previously mentioned, the instrument and screen must operate at the same radio-frequency potential; consequently, an electrical connection between them is necessary. As there will also be a flow of charging current to the screening device, the connection must be necessarily made at a point on the meter which eliminates stray current of this nature from the indication of the instrument. From the discussion furnished previously in this paper, it is apparent that the best point for connection to the instrument will be at its low-potential terminal.

The illustration in Fig. 4 shows the structure of an instrument shield which has proved effective for the purpose of limiting heater charging current. This device was designed for use with a small, panel-mounting type of meter, and is attached directly to its low-potential terminal. An enlarged aperture is provided for

making the other terminal accessible for connection into a circuit. The shield itself does not completely screen the inner mechanism of the instrument, but its shielding properties are augmented by certain internal meter parts in a manner that the sensitive actuating members are fairly well enclosed. The parts which function co-operatively with the shield are the scale plate, bezel ring, and magnet. This condition may be readily appreciated by the examination of the structure of any modern, small, panel-mounting type of instrument.

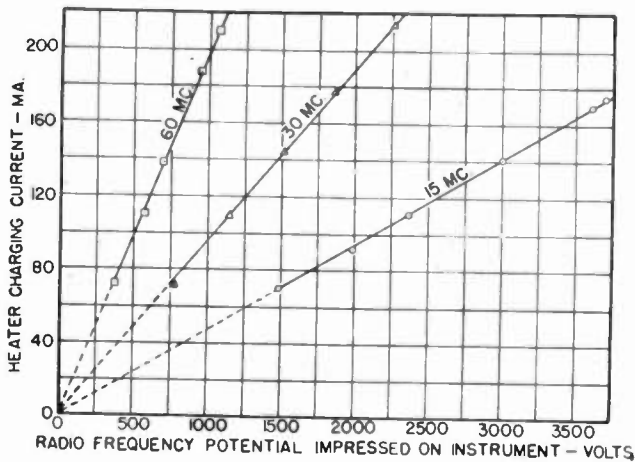

Fig. 5—Relationship between impressed radio-frequency potential and heater charging current in a shielded instrument.

In order to illustrate that the use of a shield of this type actually reduces the quantity of heater charging current in an instrument, the following test was conducted. Values of heater charging current with the shield attached were determined at various voltages and frequencies in the manner previously described in conjunction with the data shown in Fig. 3, using the same instrument in both series of tests. The observed data are shown in Fig. 5, and when comparing these graphs with those in Fig. 3, attention is directed to the fact that the abscissa scale in Fig. 5 covers a much greater range of voltage. A comparison of data obtained under the two conditions indicates that qualitatively the effects of operation at high radio-frequency potential points are the same; but it is also noted that the use of the shield materially reduces the value of the heater charging current under any particular set of operating conditions. It may be shown that the effective heater capacitance, with the shield attached, is approximately 0.51 micromicrofarad, which may be compared with 1.8 micromicrofarads, which was previously found to be the value without the shield. From the ratio of these values, it is apparent that the error in current indication due to operation at a high radio-frequency potential point in a circuit will be reduced by use of the shield to 28 per cent of what it would have been without employing this device. In Table I some test data on several radio-frequency current-measuring instruments are shown in order to

indicate how much reduction in effective heater capacitance is usually attained in practice by use of the shield. The 250-milliamper instrument, on which tests have been previously shown in Figs. 3 and 5, is designated as Instrument Number 3 in that table. Thus it is seen that a material reduction in effective heater capacitance is attained in all cases.

TABLE I
EFFECTIVE HEATER CAPACITANCE DATA

Instrument Number	Instrument Range	Effective Heater Capacitance	
		Without Shield	With Shield
	milliamperes	micromicrofarads	micromicrofarads
1	0-125	0.5	0.14
2	0-150	0.6	0.17
3	0-250	1.8	0.51
4	0-250	0.7	0.14
5	0-500	1.7	0.45
6	0-500	0.5	0.12
7	amperes 0-1	0.7	0.1

The question will arise as to whether the application of a shield to an instrument causes other types of errors to be introduced into the readings of current. Accordingly some test data have been taken as to the accuracy of the instruments when operated at ground potential, both with and without a shield. These tests were made with the instrument placed at a point in a circuit as near to ground potential as possible, for otherwise the error due to high-potential operation would confuse the issue, for it is realized that a shielded and an unshielded instrument would not have the same error when operated at high potential. The method employed in making these tests is described in the third paper of the Bibliography. The results of these tests are shown in Table II, and the numbers used therein to designate the instruments correspond with those of Table I. The negative sign before the values of percentage of error in Table II indicates that this

TABLE II
EFFECT OF SHIELD ON BASIC ERRORS OF INSTRUMENT

Instrument Number	Instrument Range	Error at 100 Megacycles	
		Without Shield	With Shield
	milliamperes	per cent	per cent
1	0-125	-14	-9
2	0-150	-19	-9
3	0-250	-22	-13
4	0-250	-8	-7
5	0-500	-8	-8
6	0-500	-6	-6
7	amperes 0-1	-9	-9

Note: These data taken with instruments as near to ground potential as possible.

quantity should be deducted from the reading of the instrument in order to obtain the true current. It may be seen that at low-potential operation, in some instances, less error is observed when using the shield. It may have been expected that if the shield in itself did not introduce errors, or otherwise alter conditions, that it would not have changed the observed values of error. The reason why the error is reduced in some cases, when the shield is attached, may be explained in this manner. Notwithstanding the fact that an effort

was made to operate the instruments at ground potential, due to the difficulty of obtaining suitable grounds at frequencies as great as one hundred megacycles, the instruments were actually operated somewhat above ground potential during the test, and the error due to heater charging current affected these measurements. For this reason, the use of a shield for instruments seems desirable in some cases, for current measurements at points in a circuit which are as near to ground potential as it is possible to attain.

Errors in radio-frequency current-measuring instruments due to high-potential operation are of greatest consequence in the more-sensitive types of meters; that is, those with a full-scale range of 1 ampere or less. In the higher ranges, the error is usually small in well-designed, modern instruments.

The use of shields on instruments in the cases where high-potential errors are of appreciable size has made it possible to make measurements with fairly small errors, which is evidenced by the fact that results obtained are much more reasonable, and too they are more consistent with known physical principles.

Although no detailed study of the matter was undertaken, sufficient data were obtained to indicate that instruments with external thermocouples usually have considerably higher errors during high-potential operation than similar self-contained instruments at frequencies greater than one megacycle. This is caused

by the fact that the relatively large capacitance to ground, due to the use of connecting leads between the two elements of such instruments, produces a considerable flow of heater charging current. In some designs of instruments, precautions are taken to isolate connecting leads from the thermocouple (from a radio-frequency standpoint) by means of chokes, by-pass condenser, etc., which in some instances produce marked improvement. But the fact remains that it is usually possible to obtain less error in measurements from a self-contained instrument than in the other type, especially where it is to be used over a wide band of frequencies.

ACKNOWLEDGMENT

The author wishes to express his appreciation for the assistance of Mr. A. H. Moore of the Naval Research Laboratory in making the various experimental observations herein reported.

Bibliography

- (1) L. T. Wilson, "A novel alternating-current voltmeter," *Jour. A.I.E.E.*, vol. 43, pp. 446-448; May, 1924.
- (2) J. H. Miller, "Thermocouple ammeters for ultra-high frequencies," *PROC. I.R.E.*, vol. 24, pp. 1567-1572; December, 1936.
- (3) J. D. Wallace and A. H. Moore, "Frequency errors in radio-frequency ammeters," *PROC. I.R.E.*, vol. 25, pp. 327-339; March, 1937.
- (4) H. M. Turner and P. C. Michel, "An electrodynamic ammeter for use at frequencies from one to one hundred megacycles," *PROC. I.R.E.*, vol. 25, pp. 1367-1374; November, 1937.
- (5) H. R. Meahl, "A bearing-type high-frequency electrodynamic ammeter," *PROC. I.R.E.*, vol. 26, pp. 734-744; June, 1938.

A New Ultra-High-Frequency Tetrode and Its Use in a 1-Kilowatt Television Sound Transmitter*

A. K. WING, JR.†, MEMBER, I.R.E., AND J. E. YOUNG‡, ASSOCIATE, I.R.E.

Summary—A new tetrode suitable for use in the final stage of a 1-kilowatt ultra-high-frequency sound transmitter is described. Two of these tubes operated under plate-modulated conditions in such a transmitter will deliver 1 kilowatt of carrier output at 108 megacycles. Among the novel features of the design are the use of a metal header to provide a low-impedance screen-grid connection, beam-forming grids, and a forced-air-cooled anode. The new RCA type S-1 transmitter which uses these tubes is described and its performance reported.

THE design of a 1-kilowatt television sound transmitter presented problems which could not be solved by existing tube types. These problems were, first, that two tubes in push-pull connection in the output stage must be capable of delivering sufficient power to supply circuit losses in addition to the desired 1000 watts output to the antenna. Second, this power must be delivered with good efficiency at frequencies up to approximately 110 megacycles. Third,

it was desired to eliminate as far as possible the need for neutralization. Finally, the tubes should preferably not require water-cooling. The design which was evolved as answering these requirements most satisfactorily is that of a beam tetrode wherein the principles of electron optics are utilized to minimize screen current and to provide characteristics approaching those of a pentode. Use is made of a novel design for the screen connection which possesses extremely low inductance and allows the screen to be maintained at radio-frequency ground potential.

Fig. 1 is a photograph of the completed tube which is designated as the RCA-827R. Use is made of an external anode structure equipped with a fin assembly for forced-air-cooling. This construction minimizes plate lead inductance. Forced-air-cooling allows high unit dissipations to be obtained as compared with conventional radiation-cooled designs. The stream of cooling air also allows the glass envelope to be made smaller than otherwise would be permissible, thus further

* Decimal classification: R331 X R355.5. Original manuscript received by the Institute, October 16, 1940. Presented, Fifteenth Annual Convention, Boston, Mass., June 28, 1940.

† RCA Manufacturing Company, Inc., Harrison, N. J.

‡ RCA Manufacturing Company, Camden, N. J.

aiding the reduction of lead length. The general arrangement of the tube terminals can be seen in this photograph.

The various features of mechanical construction by

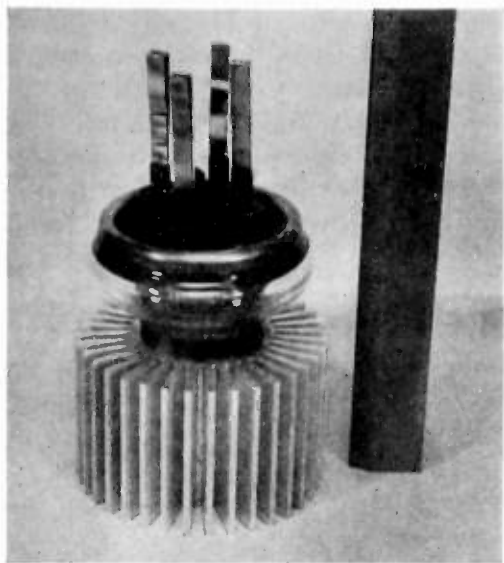

Fig. 1—The RCA-827R.

which these characteristics are obtained are best discussed with reference to Fig. 2, which is a cross section of the tube and shows the construction in more detail. The basis of the construction is the use of a metal header in place of the more conventional glass stem

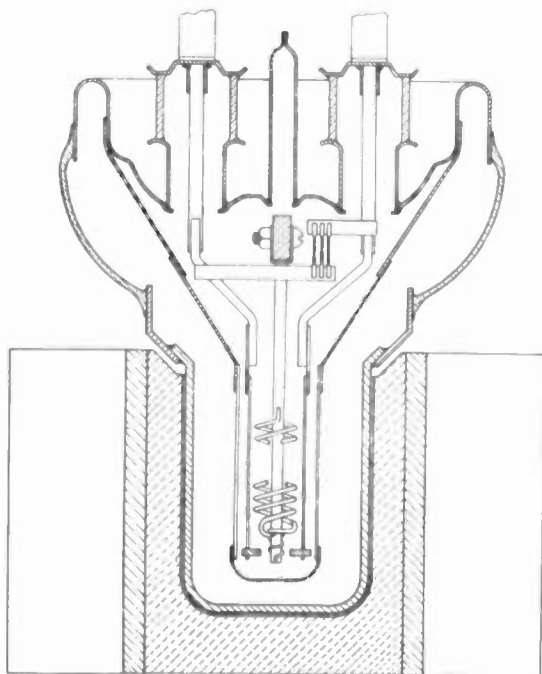

Fig. 2—Cross section of tube.

or dish. This header is drawn from Kovar shaped as shown to provide suitable flexibility at the outer edge for satisfactory sealing and to prevent deformation under the atmospheric pressure when the tube was exhausted. This header serves as a low-inductance ter-

minal for the screen which is mounted directly on it by means of a continuous conical support. External contact is made to the edge of the header, preferably continuously around its circumference; such contact resulting in minimum impedance and maximum effective shielding at the higher frequencies.

The connections to the control grid and filament are brought through the header by smaller Kovar-to-glass seals of the type shown in the cross section. It should be noted that all electrodes are supported from the header alone, no solid insulation being used between elements within the tube. Dielectric losses which would impair the performance of the tube are thereby eliminated. Rigidity of the electrodes is assured by the short, large-diameter leads supporting them. This lead structure aids in minimizing lead inductance and losses; connecting the two control-grid leads in parallel further reduces such effects. External connection to the

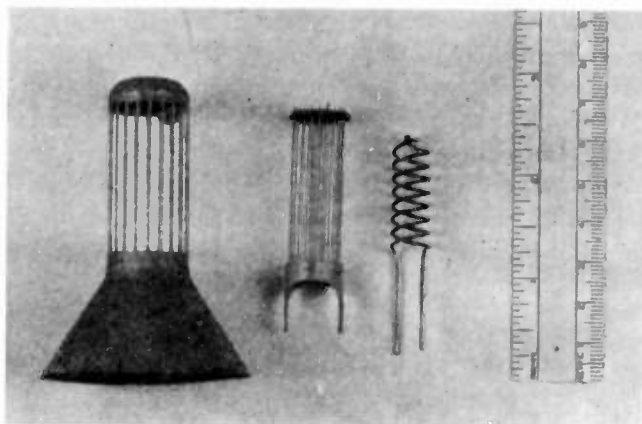

Fig. 3—Grids and filament.

control grid and filament is by flexible copper ribbons.

The construction of both the control and screen grids utilizes parallel, vertical wires, as shown in Fig. 3. The orientation of the two grids is such that the wires of the screen grid are located in the shadow of the wires of the control grid, thus forming electron beams between the wires which reduce considerably the current collected by the screen grid as compared with a structure having random alignment. A novel feature of the construction of the control grid is the use of a graphite spacer at the free end of the grid. This takes the form of a washer with a series of small holes around its edge to receive the grid wires. Three of the wires support the ring while the remainder are free to move longitudinally in the holes. In this way each wire can expand independently of the others so that any tendency to unequal expansion does not cause the wires to buckle and thereby cause internal short circuits or changes in characteristics. The heat of the filament is concentrated because of its compact arrangement, and since the spacing between the grid and the filament is small, special precautions were required to avoid undesirable emission from the control grid. The grid has been coated with zirconium to improve its

radiating properties and to reduce the tendency toward primary emission from the surface.

The filament of the tube is of thoriated tungsten and is double helical in form. The apex of the filament is free to expand along the center support, but a small flexible connection at that end maintains the center support at the same potential as the center of the filament and therefore eliminates microphonics which might be caused by a floating contact. The spacings between filament and grid and grid and screen are approximately 50 and 120 thousandths of an inch, respectively, resulting in short electron transit time. The spacing between screen grid and anode is approximately 360 thousandths of an inch, providing a potential minimum due to space charge in this space. At a frequency of 100 megacycles and under conditions of

soldered into this core. This method of construction offers savings in manufacturing cost and in weight of the finished tube. Fig. 4 shows the relation between the temperature in the copper core of the radiator and the flow of cooling air for various values of total dissi-

TABLE I
RATINGS AND CHARACTERISTICS
RCA-827R
TRANSMITTING BEAM POWER AMPLIFIER

Filament voltage	7.5	volts
Filament current	25	amperes
Grid-screen mu factor	16	
Direct interelectrode capacitances:		
Grid to plate (with external shielding)	0.18	maximum micromicrofarads
Input	21	micromicrofarads
Output	13	micromicrofarads

MAXIMUM RATINGS—CLASS C

	Plate-Modulated Telephony (carrier conditions)	Telegraphy (key-down conditions)	
Direct plate voltage	3000	3500	volts
Direct screen voltage	800	1000	volts
Direct grid voltage	-500	-500	volts
Direct plate current	400	500	milliamperes
Direct grid current	125	150	milliamperes
Plate input	1200	1500	watts
Screen input	100	150	watts
Plate dissipation	550	800	watts

peak positive grid swing at the carrier for class C plate-modulated telephony the transit angles in the three spaces are 14, 5, and 32 degrees, respectively.

Two other details of the construction are worthy of mention. The exhaust tubulation is made of metal tubing to allow the completed tip-off to be kept small and out of the way of the connections to the tube, while at the same time removing the hazard of breakage. The other detail is in the means of flashing the getter in the tube. A ribbon getter is connected between the two control-grid terminals just inside the header. During the exhaust process a radio-frequency voltage is connected to the two grid leads external to the tube. The difference in impedance of the two parallel paths through the getter ribbon and through the grid allows the current to heat the getter sufficiently to flash it with very little heating of the grid. Because of its location inside the screen-grid conical support, the getter flashes onto it rather than onto the glass bulb wall. Thus, there is no getter deposited upon the bulb where it can cause leakage or losses.

The construction of the radiator assembly involves several new features. A machined copper core is shrunk into a section of a hollow aluminum extrusion which forms the fins. The anode of the exhausted tube is

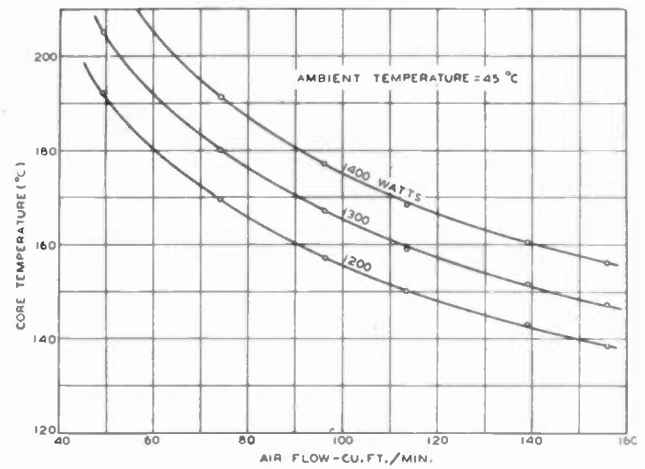

Fig. 4—Curve of radiator temperature versus air flow.

pation in the tube. The ambient temperature is 45 degrees centigrade. Maximum rated total dissipation is somewhat less than 1300 watts.

The essential characteristics of the tube are shown in Table I which gives the interelectrode capacitances and the maximum ratings for class C telephone and telegraph operation at frequencies up to 110 megacycles. Calculations indicate that at low frequencies

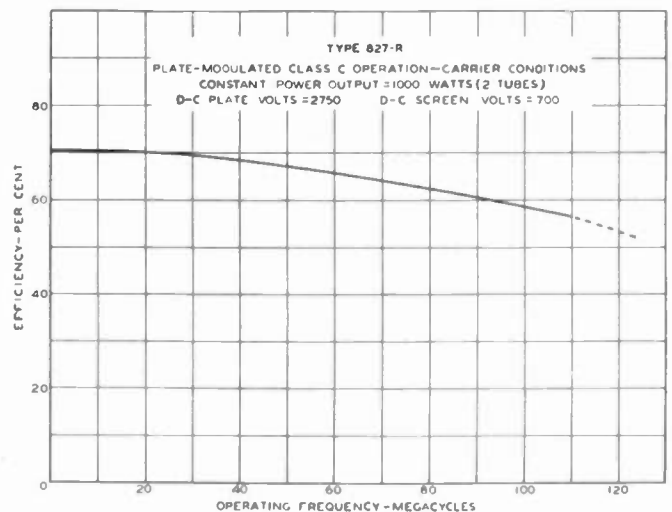

Fig. 5—Curve of plate-circuit efficiency versus operating frequency.

plate-circuit efficiencies of the order of 70 per cent should be obtained; measurements have shown that such efficiencies are realized. As the frequency is increased the efficiency would be expected to fall off because of transit-time effects and losses in leads and circuit. Fig. 5 shows an experimental curve of efficiency against frequency for the particular carrier operating conditions of the S-1 transmitter. The curve is for a constant power output of 1000 watts into a

load at the feeder terminals of the transmitter and with plate and screen voltages of 2700 and 700 volts, respectively. It will be seen that the efficiency at 20 megacycles is 70 per cent as predicted from calculation and that it decreases slowly to 56 per cent at 110 megacycles. Above this frequency data have not been taken and the dashed portion of the curve is, therefore,

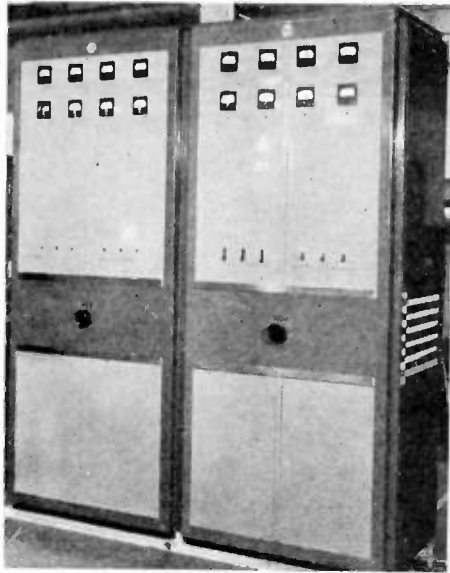

Fig. 6—Front view of type S-1 transmitter.

merely an extrapolation from the trend of the curve. It is, of course, possible to use higher values of input within the tube rating and thereby obtain outputs in excess of 1 kilowatt at these frequencies.

The television sound transmitter for which the 827R was designed is designated as the type S-1. The front view of this transmitter is shown in Fig. 6. A simple, pleasing appearance has been achieved by grouping all necessary meters and controls in logical and easily accessible positions. All tuning controls are terminated in flush, key-operated tuning positions. Elimination of knobs or handles on these controls prevents tampering with the adjustments by any unauthorized person, and at the same time enhances the appearance of the equipment. The adjustable elements in the circuit have been located for most efficient electrical operation and connection made to the grouped tuning controls on the front panel by bevel gear and shaft linkages. A tune-operate switch permits reduction of plate voltage for adjustment purposes, while a voltage regulator, hand-controlled, maintains all circuit voltages at the correct amplitude through considerable variation of the line voltage.

Fig. 7 shows a rear view of the transmitter. The mechanical mounting of the apparatus in each cabinet utilizes two vertical-L sections. All assembly and wiring are carried out before the sections are assembled into the cabinet, and as a result a considerable saving in cost is effected. The right-hand section of the transmitter is devoted to the radio-frequency portion of the

equipment. An RCA-807 crystal oscillator, employing one of two available harmonic crystals, drives an 814 doubler which excites two RCA-808's connected in push-pull as a tripler. This stage drives two RCA-8001's as a fundamental-frequency amplifier, tuned to the output frequency of the transmitter. The plate tank of this stage is inductively coupled to the grid circuit of the power amplifier. Inductive coupling is likewise used between the 827R plate tank, and the transmission-line coupling coil. The connections for air-cooling the anodes of the 827R tubes may be seen below the tubes, while the horizontal duct above the tubes supplies a small quantity of air to cool the headers as well as the bulbs of the tubes in previous stages.

The left-hand unit contains the power supply, modulator, and control equipment. One single-phase rectifier, using four 872 tubes in a center-tapped bridge connection, provides two direct voltages which together supply plate and screen voltages for all tubes. Plate and filament contactors are provided, as well as time delay and overload relays for complete tube protection. This protective system is backed up by the use of hand-operated overload breakers on the main power line and branch circuits.

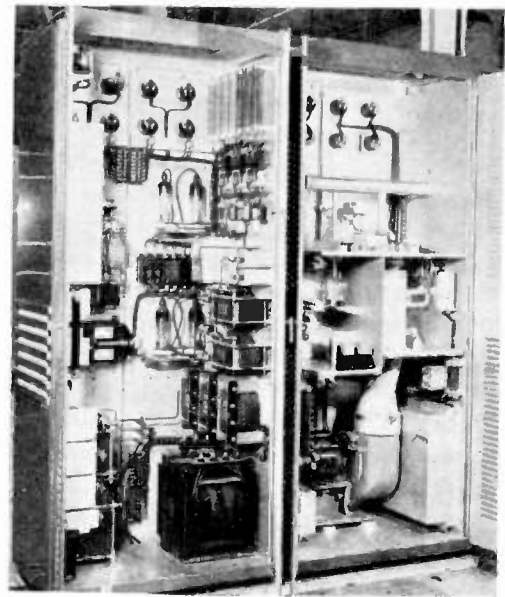

Fig. 7—Rear view of transmitter.

Two RCA-833 tubes used in the class B modulator have sufficient power capability to modulate the plates and screens of the output radio-frequency stage to well over 100 per cent. They are driven by an amplifier chain consisting of two RCA-1603's, two RCA-807's, and two RCA-845's which are connected in a cathode-follower circuit to secure the necessary low-impedance driver circuit for the grids of the RCA-833's. The cathode-follower circuit inherently provides 100 per cent feedback over the stages so connected. Another feedback path is provided from the plate circuit of the

modular tubes back through the first audio-frequency amplifier. A high order of performance is thus obtained without requiring critical tube or circuit adjustments.

The details of the mounting for the 827R tubes are shown in Fig. 8. The construction of the screen by-pass capacitors is clearly shown. Similar by-pass capacitors for the filament circuit are located on the upper side of the ground plate. They together form an assembly which slips down over the ring seal used as a screen connection; at the same time they form a part of the shield between the grid and plate circuits of the power amplifier. The spring clips which form the connection between the screen terminal and screen by-pass capacitors are clearly shown. The radiators of the 827R tubes rest on top of ceramic tubes through which the cooling air flows. They are held in position by split metal clamps. The plate tank and transmission-line coupling coil may be seen in the lower right-hand section of the

has also been possible to use concentrated inductors instead of transmission lines in the various tanks, thus effecting savings in space and cost without sacrifice of performance.

The plate efficiencies obtained in the output stage of the transmitter for carrier frequencies from 26 to 108 megacycles have already been mentioned in connection with the tube. Fig. 9 shows a summary of the perform-

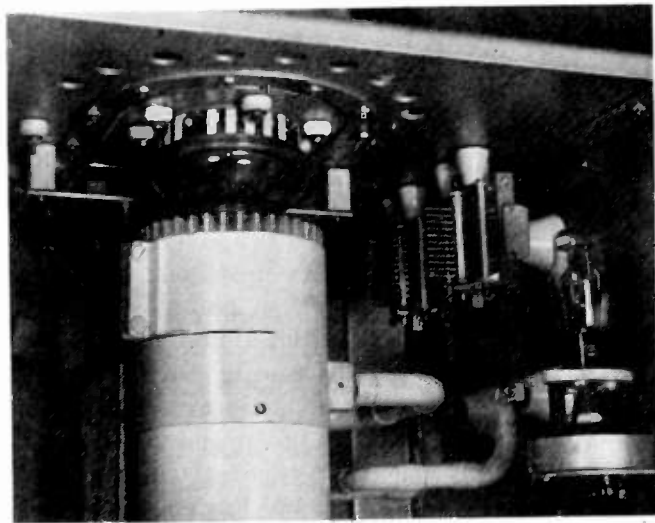

Fig. 8—The 827R tube mounting.

picture. The circuits are shown set up for operation at 108 megacycles. Through careful design, lead lengths and circuit capacitances have been held to a minimum so that it has been possible to use variable capacitors to tune all radio-frequency circuits. In the same way, it

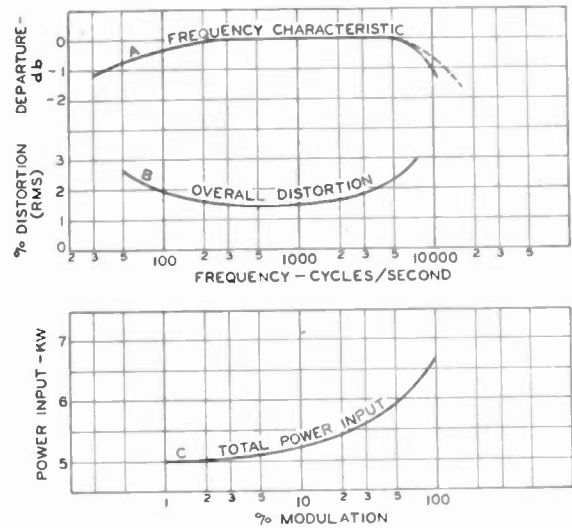

Fig. 9—Characteristics of type S1 transmitter. In the upper part of the figure is shown the normal frequency-response characteristic with the optional response (dashed) characteristic conforming to the Radio Manufacturers Association standard for high-frequency pre-emphasis.

ance of the transmitter in other respects. Curve A is the audio-frequency characteristic. If desired this characteristic may be altered to conform to the Radio Manufacturers Association standard which pre-emphasizes the high frequencies. Curve B shows the variation of root-mean-square distortion with modulating frequency at 95 per cent modulation. Curve C shows the total power input variation with sine-wave modulation varying in depth from 0 to 100 per cent.

By the addition of a type MI-19407 frequency-modulation exciter to this transmitter it becomes the type FM-1A 1-kilowatt frequency-modulation transmitter.

Diffraction Measurements at Ultra-High Frequencies*

HARNER SELVIDGE†, MEMBER, I.R.E.

Summary—Ultra-high-frequency field strengths are difficult to predict theoretically because of the inability to separate the effects of diffraction, reflection, and refraction on the measured field. A successful attempt was made to measure the diffraction effect alone. Measurements were made on the diffraction pattern set up by a knife-edge since this simple case lends itself to easy calculation. A natural knife-edge, consisting of a ridge on a peninsula on the Atlantic coast near Bar Harbor, Maine, was utilized, measurements being made on 55 and 110 megacycles. The diffraction was less for the higher frequency, as expected, and the field-strength patterns were fairly well predicted by the simple theory. It was found that horizontally polarized waves were diffracted more than vertically polarized waves over the horizontal knife-edge.

INTRODUCTION

WHILE innumerable measurements of signal strength and propagation characteristics of radio waves have given a fairly good idea of what can be expected in a wide variety of conditions, these data have generally given rise to empirical equations which while very useful, have not shed much light on some of the more fundamental principles of wave propagation. This is a perfectly natural out-

the case of ultra-high-frequency transmission beyond the optical horizon.

KNIFE-EDGE DIFFRACTION

One of the simplest cases of diffraction is that of waves passing across a knife-edge in a homogeneous medium. This is a well-known optical problem and can be readily computed. This case is diagrammatically represented in Fig. 1. It consists of a source and a screen with a knife-edge interposed between them. The amplitude of the light falling on the screen is plotted with the amplitude as the abscissa and the distance along the screen as the ordinate. The unit amplitude is that which exists along the screen when the knife-edge is removed. In consequence of the interference pattern set up by the introduction of the obstacle the amplitude varies as shown by the plotted curve. It will be noted that along the line of the source and knife-edge the amplitude has fallen to 50 per cent of the unobstructed value, while in the clear, a short distance above this line, the amplitude reaches a maximum greater than if the obstacle were not interposed. Further maxima and minima are found above the axis, decreasing in size, however, and the amplitude oscillates about, and approaches, the unobstructed value. The method used in computing the shape of the curve and the position of the maxima and minima for various wavelengths is given in Appendix I.

Unfortunately, a true knife-edge isolated in a homogeneous medium is seldom found in nature. It is true that the edges of buildings offer a good approximation, but in such cases the diffraction effect is usually masked by reflections from surrounding objects, making this solution unsatisfactory. Since measurements were planned for waves as long as 5 meters, it was neither mechanically nor economically feasible to construct a model knife-edge of large enough dimensions. In ordinary terrain such shaped hills are seldom found, but when they do exist they are usually surrounded by rough hilly ground with consequent distracting reflections making it impossible to measure accurately, or to compute, the diffraction field alone. However, since the ideal of a knife-edge in free space could not be realized it was desired to approach these conditions as nearly as possible on the surface of the earth, so that a theoretical computation of the expected results could be made. To facilitate the computations further and to eliminate reflections that could not be taken into account, it was decided to choose a source and knife-edge situated in isolated positions above some regular homogeneous medium whose constants were reasonably well known. Sea water seemed to be the logical medium for the solution of this problem. Financial

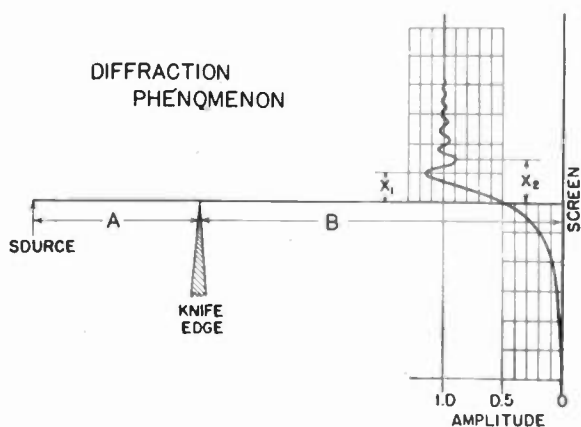

Fig. 1—Diffraction by a knife-edge.

growth of the fact that when the field strength is measured at any point in space the value will, in general, have been modified by (1) diffraction around intervening objects, (2) refraction in the transmission medium, and (3) reflection from near-by objects. In making a study of fundamental transmission phenomenon it would therefore seem logical to attempt to isolate these effects if possible, and measure each one separately. It would also be convenient to consider simple cases which can easily be computed from well-known optical principles. In actual practice refraction would be hard to set up under controlled conditions. In considering reflection and diffraction, the latter was chosen for measurement because of its application in

* Decimal classification: R113.6XR270. Original manuscript received by the Institute, December 3, 1940. Presented, joint meeting, I.R.E.-U.R.S.I., Washington, D.C., April 30, 1937.

† Kansas State College, Manhattan, Kansas. This work was performed while the author was at Cruft Laboratory, Harvard University, Cambridge, Mass.

considerations prevented the vertical exploration of the field by means of an airplane or balloon, so it was necessary that the signal source be elevated as much as possible so that the resulting diffraction pattern would be spread out on the surface of the water where it could be readily measured.

LOCALE OF MEASUREMENTS

A perusal of topographical maps showed that these necessary conditions were very well satisfied on the

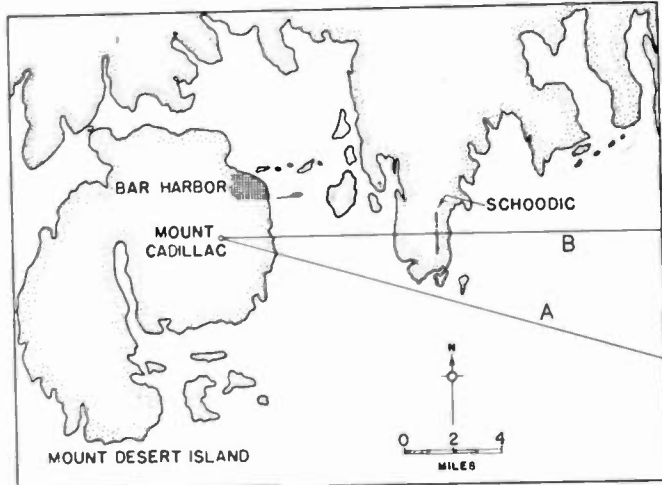

Fig. 2—Locale of measurements. Path *A* indicates unobstructed path traversed to compare with diffraction observations on path *B*.

Atlantic coast near Bar Harbor, Maine. There on Mount Desert Island, the highest peak is Mount Cadillac, rising 1532 feet above sea level, with its summit only two miles from shore. It is the highest point on the Atlantic coast. Five and one-half miles across Frenchman's Bay lies Schoodic Peninsula on which is a long ridge forming a blunt knife-edge which is 437 feet high for a length of a quarter of a mile. A map of this region is shown in Fig. 2, while Fig. 3 shows a close-up view of the knife-edge.

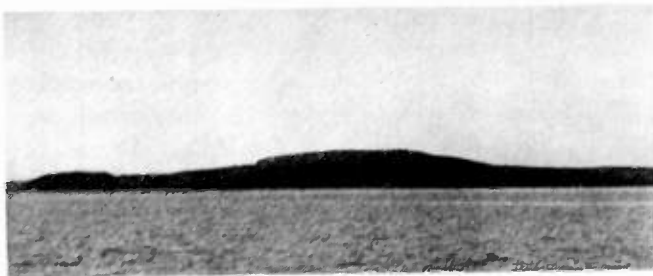

Fig. 3—Knife-edge looking west. Mount Cadillac is hidden behind it.

Fig. 4 shows a profile along the line *B* of Fig. 2. The three curved lines originating from the top of Schoodic are the loci of the first diffraction maxima for the three frequencies on which measurements were to be made, 55, 110, and 220 megacycles.¹ It will be seen that be-

¹ The onset of rough weather in the fall prevented the 220-megacycle measurements from being carried out as planned, the measurements on 55 and 110 megacycles having taken longer than anticipated.

cause of the curvature of the earth, the source on Mount Cadillac is not sufficiently elevated to cause the first maximum to fall on the surface of the sea for 55 megacycles. The computations indicated that the first maximum for 110 megacycles would fall on the surface at about 42 kilometers and for 220 megacycles at about

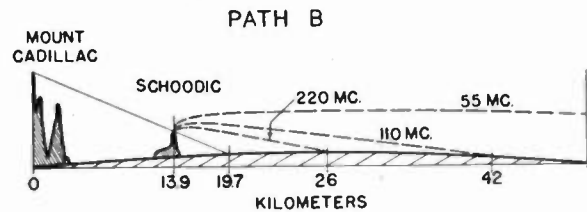

Fig. 4—Profile along path *B* (Fig. 2). Dashed curves originating at top of Schoodic are computed loci of first maximum in diffraction pattern. Vertical exaggeration 20-1.

26 kilometers. While these conditions were not perfect, it was believed that enough of the pattern lay on the surface to make the measurements worth while. An automobile road to the top of Mount Cadillac made it easy to transport the transmitting equipment to the summit.

METHOD OF MEASUREMENT

The transmitting equipment was located in a truck parked at the top of Mount Cadillac. It is shown in operating position in Fig. 5 with the vertical 55-megacycle doublet in place. Plug-in antennas were used, making it easy to shift from vertical to horizontal



Fig. 5—Transmitter truck in location on Mount Cadillac. 55-megacycle vertical antenna in place.

polarization in a very short time. Three transmitters capable of radiating 60 watts on the three frequencies were used. However, because of the sensitivity of the measuring equipment, only about 3 watts were radiated for the actual measurements.

The field-measuring equipment was installed on a small boat as shown in Fig. 6. The antenna was located at the top of the mast and arranged so it could be

rotated to receive signals of any polarization. The field strengths were measured by means of a calibrated receiver covering the frequencies used. Its output was calibrated before and after each run by setting up a standard known field by means of a small local generator.² A series of field measurements was usually taken going out on course *A* (Fig. 2) and returning on course



Fig. 6—Boat carrying measuring equipment. Receiver located in bow. Antenna shown in vertical position on rotatable wheel at top of mast.

B. Suitable correction was made for the asymmetry of the response pattern of the receiving antenna caused by its position on the boat.

RESULTS OF MEASUREMENTS

The results of the measurements as well as the computed theoretical curves are shown in Figs. 7 to 12 inclusive.³ Since the diffraction effect evidenced itself by a comparison between data taken on course *A* with that on course *B*, the absolute calibration of the field-strength-measuring equipment was unimportant, although it was believed to be within 20 per cent of the correct value. The precision of measurement was within 5 per cent for signal levels between 10 and 500 microvolts per meter, which was the important range. Each measured curve shown is an average of from three to six curves taken on different days. These separate curves were plotted to a very large scale, and an average taken at various distances. These average points are shown on the figures in this paper. The actual observed points were taken much closer together. The theoretical curves were computed⁴ for transmission

² The field generator was similar to that described by J. C. Schelling, C. R. Burrows, and E. B. Ferrell, in "Ultra-short-wave propagation," *PROC. I.R.E.*, vol. 21, pp. 427-463; March, 1933.

³ The usual practice is to plot propagation data, especially signal strengths, to a logarithmic scale but, in the opinion of the author, the analogy between the observed data and the usual knife-edge pattern (Fig. 1) is more apparent when the field strengths are plotted to a linear scale as is done in Figs. 7 to 12.

⁴ These computations were made by the use of equations similar to those given by Bertram Trevor and P. S. Carter, "Notes on the propagation of waves below ten meters in length," *PROC. I.R.E.*, vol. 21, pp. 387-426, March, 1933.

over sea water of a conductivity of 2.2×10^{10} electrostatic units. This was the measured value of the conductivity of Bar Harbor sea water.⁵

Measurements taken on very calm days were found to agree very well with those taken when the sea was quite rough. It was observed that surface waves whose size was comparable with that of the wavelength of the signal being measured caused little disturbance in the received field. It was only when the motion of the boat caused the mast carrying the receiving antenna to whip about badly that it was impossible to make satisfactory measurements.

UNOBSTRUCTED SIGNAL STRENGTHS

Figs. 7 and 8 show the case for unobstructed propagation over sea water for both vertical and horizontal polarization for 55 and 110 megacycles. The computed curves for free-space propagation as well as the two different polarizations over sea water are also shown. It will be seen that the curves of the vertically and horizontally polarized fields observed on 55 megacycles closely approach in shape and absolute magnitude the computed values. They are greater than the computed values for larger distances. This checks results obtained by others for sea-water propagation for lower transmitting antennas,⁴ and is probably due in part to diffraction around the curvature of the earth. It will be noted that the horizontally polarized signals

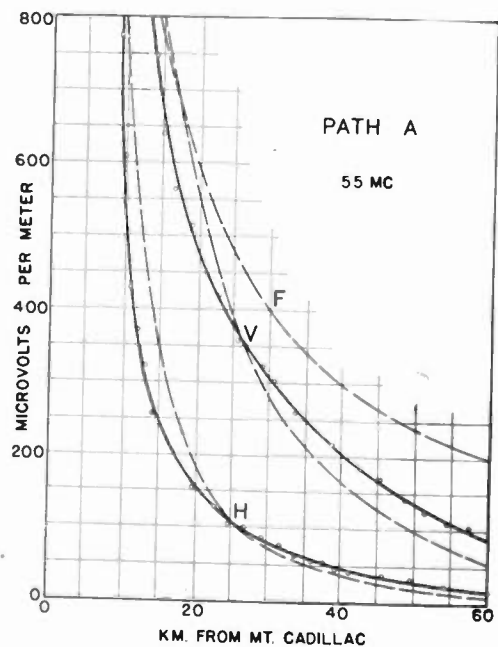

Fig. 7—Propagation over sea water measured on path *A*. Dashed curves are computed values. Free-space (*F*), horizontal (*H*), and vertical (*V*) polarization. Frequency, 55 megacycles.

are everywhere weaker than the vertical ones. This is true for propagation over a good conductor, such as sea water, as the reflected wave more nearly cancels the direct wave.

⁵ This conductivity measurement is briefly discussed in Appendix II.

For 110 megacycles, as shown in Fig. 8, the vertically polarized field strengths do not depart far from computed values, while the horizontally polarized values depart considerably from the theoretical curve. The reason for this is not known. This deviation was unimportant, however, as the computation of all the expected diffraction patterns was based on these observed curves for the unobstructed course. This method consisted substantially of using the measured data of Figs. 7 and 8 to determine an effective reflection coefficient for the surface of the water, this coefficient being used in the computation of the diffraction pattern.

DIFFRACTION CHARACTERISTICS

The diffraction characteristics are shown plotted in Figs. 9 and 10 for the two frequencies and polarizations. For comparison purposes the actual measured un-

This curve joins the unobstructed curve at about 53 kilometers, but at no time did it rise above the unobstructed value. However, it is of interest to note that at the edge of the geometrical shadow (19.7 kilometers) the signal strength is near 50 per cent of the

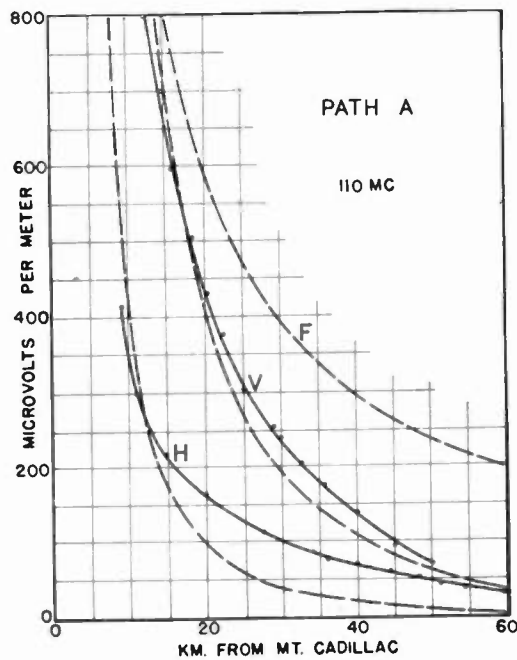

Fig. 8—Same as Fig. 7, but for 110 megacycles.

obstructed curves are reproduced from Figs. 7 and 8, as well as the computed diffraction-pattern data which are shown dotted. The positions and relative heights of Mount Cadillac and Schoodic are shown.

In Fig. 9, (55 megacycles), the computed diffraction characteristic indicates that at distant points a slightly stronger signal would be expected than for the unobstructed case for both polarizations. The curves of Fig. 4 indicate that the first diffraction maximum would not be reached on account of the curvature of the earth. The measured values for vertical polarization show a curve resembling the theoretical shape, but for distances beyond the geometrical shadow⁶ the signal strength was considerably below that predicted.

⁶ The term "optical shadow" is sometimes used to describe this region. However, Fig. 1 clearly shows that theoretically there is no exact boundary of the "shadow" cast by the obstacle. Therefore the region not within direct line of sight from the summit of Mount Cadillac is described as the "geometrical shadow" cast by Schoodic.

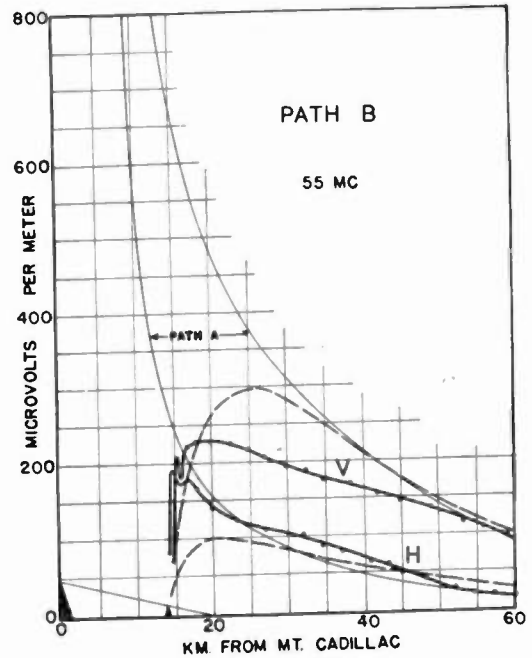

Fig. 9—Diffraction over knife-edge measured on path B. Dashed curves are computed values. Horizontal (H) and vertical (V) polarization. For comparison, corresponding observed curves for path A (unobstructed) are shown. Frequency, 55 megacycles.

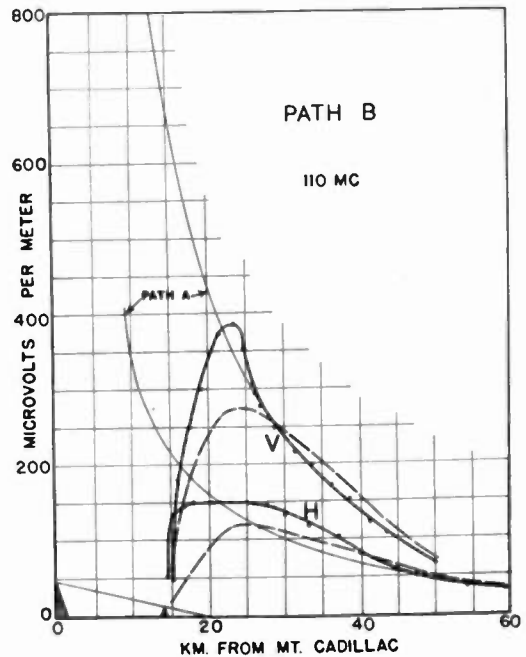

Fig. 10—Same as Fig. 9, but for 110 megacycles.

unobstructed value, as predicted by the simple theory. In none of the other measurements was this true.

For the horizontally polarized case the observed signal was larger than that computed most of the time. It was stronger than the unobstructed signal at all points between 23 and 52 kilometers, rising to a broad maximum at about 38 kilometers. Thus for the hori-

zontal case the first diffraction maximum was evidently passed.

While the horizontally polarized signal was smaller in magnitude than the vertical signal at nearly all points (on account of the previously mentioned cancellation of the direct by the reflected wave), the horizontally polarized signals showed the greater diffrac-

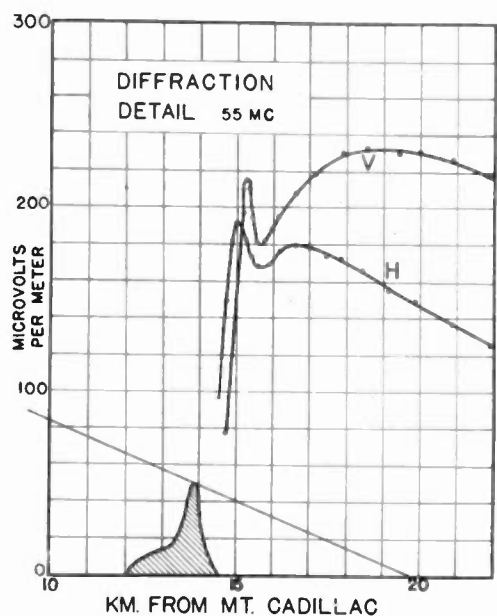

Fig. 11—Detail of diffraction pattern in "deep-shadow" region. Horizontal (*H*) and vertical (*V*) polarization for 55 megacycles.

tion. This was apparently predicted to a small extent by the theoretical curves, but not as much as was actually observed.

In Fig. 10 are shown the data for 110 megacycles. In this case the computations indicated that the first maximum should be reached at about 45 kilometers for the vertical polarization and at 50 kilometers for the horizontal polarization. These are the distances at which the obstructed signal is the largest percentage above the unobstructed signal amplitude. The measurements show that the vertical signal reached a maximum at 23 kilometers, rejoining the unobstructed curve at 27 kilometers.

There was no evidence of a minimum at any point following. The curve for horizontal polarization also reached its maximum before the predicted point, the observed maximum occurring at 32 kilometers instead of the computed value of 50 kilometers. Here again there was no evidence of any minimum following.

DEEP-SHADOW PHENOMENON

In Figs. 11 and 12 are plotted on a greatly enlarged scale the diffraction characteristics deep in the geometrical shadow. The theoretical curves of Figs. 9 and 10 indicate that the signal strength would be expected to fall off rather rapidly in this vicinity. However, since the measured diffraction curves showed the diffraction maxima to be shifted closer to the knife-edge,

the signal would be expected not to decrease much until well into the shadow. This is the case, the signal dropping suddenly to a very low level as the shore under the knife-edge is approached.

One point of interest is shown in Fig. 11. It is the presence of the sharp peaks close to shore. These two maxima showed consistently in the data and were observed time and again in exactly the same places, there being no doubt that they actually existed. However, there appears to be no satisfactory explanation for their presence. Several possibilities have been considered. One is that this might be a natural interference effect such as might be noticed approaching an elevated source. This would be the case if we considered the effective signal source as being at the top of the knife-edge. Maxima and minima would be expected on account of the addition to, or subtraction from, the direct wave, of the wave reflected from the surface of the water. Computations were made assuming the source at the top of Schoodic, and for the 55-megacycle case a rather broad maximum was found near where the sharp peak actually occurred. However, such a peak was also predicted for the 110-megacycle case, and for that frequency there was no trace of any such peak observed (Fig. 12). There seems to be no reason why it would be observed on one frequency and not on the other if it actually existed on both, so this path-difference explanation of the peaks seems dubious.

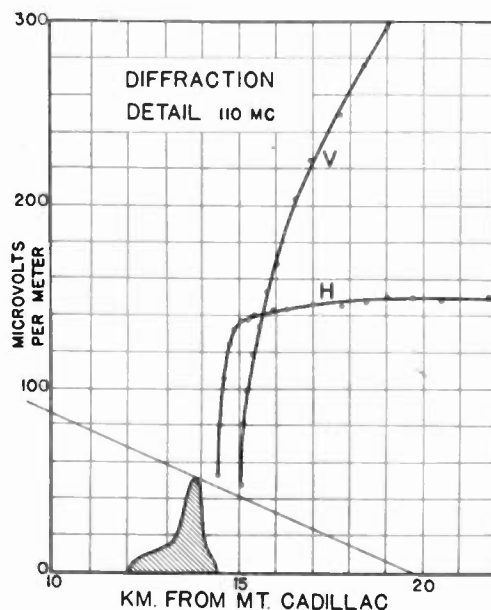

Fig. 12—Same as Fig. 11, but for 110 megacycles.

A change in signal strength might be expected at a point so close to shore that the (usually) canceling reflection from the water was absent, the indirect wave being now poorly reflected from the granite shore, but no changes were observed at this point. Indeed, the vertically polarized signals on both 55 and 110 megacycles had faded beyond the limit of sensitivity of the measuring apparatus shortly before the point was

reached where this would occur. It has also been suggested that there might have been some sort of focusing action caused by the concave side of the hill. This would seem doubtful on account of the relatively poor reflecting power of the granite, and the extreme angle through which the waves would have to be bent in order to strike the reverse side of the hill forming the knife-edge.

A point of more interest, however, is shown in both Figs. 11 and 12. It will be seen from Figs. 7 and 8 that for the case of propagation over sea water, horizontal polarization is inferior to vertical polarization. This is because the horizontally polarized waves reflected from a sea-water surface undergo a phase shift of practically 180 degrees for all angles of incidence. This means that the reflected wave will, in general, tend to cancel the direct wave. However, an examination of the data close to shore in Figs. 11 and 12 shows that horizontally polarized waves are diffracted much more around a horizontal knife-edge than are vertically polarized waves. It will be seen that close to shore, in the deep shadow, this greater diffraction of the horizontally polarized waves makes the observed horizontal signal strength stronger than that of the vertically polarized signal. In fact, at some spots in the deep shadow the horizontal signal is twice that of the vertical. Thus the greater diffraction of horizontally polarized waves over horizontal knife-edges more than overcomes its unfavorable reflection coefficient for sea water.

The author is unaware of any theoretical justification for the fact that horizontally polarized waves seem to be diffracted around horizontal obstacles better than vertically polarized waves, but these data would seem to indicate that such is the case. This would seem to indicate that when ultra-high-frequency coverage is desired in deep valleys, or behind any obstacle, such as a building which presents roughly a horizontal knife-edge, horizontally polarized transmission may be profitably employed.

CONCLUSION

The observed values of signal strength for propagation over a sea-water path were found to be in fair agreement with the computed values, and the results were similar to those obtained by other observers. The agreement was poorest for the case of 110-megacycle transmission at horizontal polarization. The reason for this is not known.

For the knife-edge formed by Schoodic the observed diffraction pattern was similar to that predicted by simple knife-edge theory, the actual values indicating that the diffraction was somewhat greater than predicted. The reason for this probably lies in the fact that the actual obstacle departed somewhat from a true knife-edge shape.

For both 55 and 110 megacycles the horizontally polarized signals were diffracted more around the obstacle, the horizontal signal being stronger than the

vertical signal in the deep shadow. In other regions vertical polarization gave stronger signals as predicted by theory.

The high-frequency signals were diffracted less than the low-frequency signals. This is in accord with theory.

On 55 megacycles unexpected peaks were observed in the diffraction pattern in the deep-shadow region. No satisfactory explanation of their appearance was obtained.

Surface waves on the sea of the order of a wavelength in size had no apparent effect on the fields within the precision of measurement.

The transmitted signals were observed to retain their initial polarization, the maximum signal in all cases being observed with the receiving antenna placed in space in the same sense as the transmitting antenna.

ACKNOWLEDGMENTS

The work described in this paper was performed while the author was a member of the staff of Cruft Laboratory, Harvard University. The assistance and encouragement of Professor H. R. Mimno of that institution is gratefully acknowledged. The author is also deeply indebted to Mr. J. A. Pierce of Cruft Laboratory who assisted in making the measurements as well as in the construction of some of the apparatus.

APPENDIX I

In order to determine the diffraction curve for the knife-edge as shown in Fig. 1, it is necessary to evaluate the well-known Fresnel integrals. Where extreme accuracy is not required, a convenient way to do this is a graphical method, using Cornu's spiral to determine the diffraction coefficients. This method is discussed in detail in most books on optics and for that reason will not be reproduced here. It was used in computing the curve shown in Fig. 1, as well as the theoretical diffraction curves shown in Figs. 4, 9, and 10.

A very good approximation to the knife-edge diffraction curve can be obtained if the maxima and minima are located. Then the curve can be sketched readily between these points by inspection. The positions of these points may be obtained from the following equations:

$$X_1 = \sqrt{\frac{B(A+B)(2n-1)\lambda}{A}}$$

$$X_2 = \sqrt{\frac{B(A+B)(2n\lambda)}{A}}$$

X_1 = distance from the center line to the first maximum

X_2 = distance from the center line to the first minimum

A = distance from the source to the knife-edge

B = distance from the knife-edge to the screen

n = any integer ($n=1$ for the first maximum or minimum)

λ = wavelength.

An additional point is known, for the amplitude at the screen on the extension of a line connecting the source and the knife-edge is always 50 per cent of the unobstructed amplitude.

APPENDIX II

In computing the theoretical curves for propagation over sea water, it is necessary to know the conductivity of the water. In nearly all papers on ultra-high-frequency propagation, figures are given for the conductivities of various earths, as well as salt and fresh water. However, little is said, usually, about how these values were determined, or how they might vary with frequency, temperature, or salinity in the case of sea water. This question of the possible variations at once arises when it is noted that in the literature values given for the conductivity of sea water range from 0.6 to 5.0 times 10^{10} electrostatic units.

The consensus of opinion among physicists seems to be that there is little change in the conductivity of water from audio frequencies up to several hundred megacycles. The relaxation time of the water dipole being approximately 10^{-10} second puts any effect due to dipoles well outside this range. Measurements of the conductivity of a good conductor, such as sea water, are very difficult at high frequencies. However, Feld-

man⁷ made measurements as high as 35 megacycles and found only a small increase in conductivity. At the outside, it would seem that the conductivity at ultra-high frequencies (up to several hundred megacycles) does not differ from that at audio frequencies by more than 15 per cent. Such a change would be of little consequence in most work, as it would hardly show in the plotted curves.

For the data in this paper, the conductivity of Bar Harbor sea water was measured at 1000 cycles on an impedance bridge. A sample of the water was placed in a cubical glass cell with platinum electrodes on two sides. The resistance of a centimeter cube of Bar Harbor sea water was found to be 41.7 ohms at 14 degrees centigrade, a conductivity of 2.2×10^{10} electrostatic units.

The Bar Harbor sea water was found to have a temperature coefficient of 0.16 ohm per cubic centimeter per degree centigrade. While this is quite large, compared to most metals, it was of little importance in these measurements. Probably most of the variations in published values of conductivities arise on account of variations in the salinity of the water at different locations.

⁷ C. B. Feldman, "The optical behavior of the ground for short radio waves," *Proc. I.R.E.*, vol. 21, pp. 764-801; June, 1933.

The Effect of the Earth's Curvature on Ground-Wave Propagation*

CHARLES R. BURROWS†, MEMBER I.R.E., AND MARION C. GRAY†, ASSOCIATE, I.R.E.

Summary—Curves are presented for the rapid calculation of the ground wave for radio propagation over a spherical earth of arbitrary ground constants, antenna heights, and polarization.

BASED on the pioneering work of G. N. Watson,¹ a rigorous theory of the propagation of electromagnetic waves round a spherical earth has been developed in the past twenty years. Watson developed his method in detail only in the limiting case of an earth of infinite conductivity, but his work has since been extended by various authors²⁻⁷ to cover

* Decimal classification: R113.7. Original manuscript received by the Institute, October 18, 1940. The work reported in this paper was undertaken for the Radio Wave Propagation Committee of the I.R.E.

†Bell Telephone Laboratories, Inc., New York, N. Y.

¹ G. N. Watson, "The diffraction of electric waves by the earth," *Proc. Roy. Soc. London, A*, vol. 95, pp. 83-89; October, 1918, and pp. 546-563; July, 1919.

² B. van der Pol and H. Bremmer, "The diffraction of electromagnetic waves from an electrical point source round a finitely conducting sphere, with applications to radiotelegraphy and the theory of the rainbow," *Phil. Mag.*, ser. 7, vol. 24, pp. 141-175; July, and pp. 825-864, November supplement, 1937; also vol. 25, pp. 817-834; June supplement, 1938, and vol. 27, pp. 261-275; March, 1939.

³ B. Wwedensky, "The diffractive propagation of radio waves," *Tech. Phys. (U.S.S.R.)*, vol. 2, pp. 624-639; no. 6, 1935; vol. 3, pp. 915-925; no. 11, 1936; and vol. 4, pp. 579-591; no. 8, 1937.

other values of the earth's conductivity. Theoretically, therefore, solutions are available for any values of the earth's constants (dielectric constant and conductivity) and for either vertically polarized or horizontally polarized waves. In practice, unfortunately, the computations required are lengthy and involved, and for the most part the recent theoretical papers have confined their calculations to a few specific values of the earth's constants. The present paper attempts to summarize the results so far obtained in a manner that will make them more easily available to the practical engineer, and to fill the gaps in these results by developing a series of curves from which the field for any values of the earth's constants may be read, with all

⁴ T. L. Eckersley and G. Millington, "Application of the phase integral method to the analysis of the diffraction and refraction of wireless waves round the earth," *Phil. Trans. Roy. Soc., London*, vol. 237, pp. 273-309; June, 1938.

⁵ T. L. Eckersley, "Ultra-short-wave refraction and diffraction," *Jour. I.E.E. (London)*, vol. 80, pp. 286-304; March, 1937.

⁶ G. Millington, "The diffraction of wireless waves round the earth," *Phil. Mag.*, ser. 7, vol. 27, pp. 517-542; May, 1939.

⁷ M. C. Gray, "The diffraction and refraction of a horizontally polarized electromagnetic wave over a spherical earth," *Phil. Mag.*, ser. 7, vol. 27, pp. 421-436; April, 1939.

the accuracy that could be expected in engineering practice.

The basis of this development is the introduction of a universal shadow-factor curve. The "shadow factor" is defined to be the ratio of the field received in propagation over a spherical earth to that which would be received over a plane earth with the same values of the earth's constants. The values for a plane earth theory are well established,^{8,9} and their use along with the shadow factor appears to offer the simplest method of determining the field when it is desired to include the effect of the earth's curvature.

It should be emphasized that all the theoretical work has been developed for highly idealized conditions. The earth is assumed to be a perfect sphere with homogeneous electrical properties. All irregularities on the surface are ignored, though it is obvious that the presence of obstructions such as hills and buildings between two radio stations must have serious effects on the received field. The theoretical values should thus be regarded as indications of the field that would be received with these idealized conditions, and very close agreement between theory and experiment need not be expected. For this reason the development of a fairly simple representation of the theoretical field has seemed desirable, the involved computations necessary for an accurate determination being time-consuming and not necessarily illuminating.

Another restriction on the present theory should also be mentioned; that it ignores completely the ionospheric waves (i.e., waves reflected from layers in the upper atmosphere) and the tropospheric waves (i.e., waves reflected at abrupt discontinuities in the lower atmosphere). These waves, of course, may be present in addition to the ground wave given by the curves of this paper.

While the effect of a sudden change of dielectric constant in the lower atmosphere (i.e., the tropospheric wave) has been ignored the effect of refraction is included in the general theory. This is the effect of the gradual decrease in the value of the dielectric constant of the earth's atmosphere as the height above the surface is increased. This refraction causes a bending of the radio waves towards the earth, and it has been shown^{4,10} that its effect is equivalent to increasing the value of the earth's radius. An average value of the factor by which the earth's radius has to be multiplied to account for refraction is 4/3, though other values may occur in practice. The curves of this paper may be used for any value of the modified radius and thus ac-

count for any continuous variation in atmospheric conditions.

PLANE-EARTH ATTENUATION FACTOR

For purposes of calculation it is convenient to express the field as

$$E = 2E_0 A_1 F_s G_1 G_2, \quad (1)$$

where E_0 is the free-space field ($2E_0$ is the field for vertical polarization over perfectly conducting plane earth), A_1 is the plane-earth attenuation factor, F_s is the shadow factor, and G_1, G_2 are the height factors. The important case of both antennas on the ground (zero antenna heights) will be treated first. Under these conditions $G_1 = G_2 = 1$ and A_1 is given by the previously published curves⁸ that are here reproduced as Fig. 1. These show the field for different values of the Q of the ground, in terms of a distance parameter ζ . In the M.K.S. system of units which is used throughout this paper, these parameters are defined as follows:

$$Q = \frac{\epsilon}{60\sigma\lambda}, \quad (2)$$

$$\zeta_e = \frac{2\pi d}{\lambda \epsilon_e} \text{ for vertical polarization,} \quad (3)$$

$$\zeta_m = \frac{2\pi d}{\lambda \epsilon_m} \text{ for horizontal polarization,} \quad (4)$$

$$\epsilon_e = \frac{\epsilon_0^2}{\epsilon_0 - 1}, \quad \epsilon_m = \epsilon_0 - 1, \quad (5)$$

$$\epsilon_0 = \epsilon - 60i\sigma\lambda. \quad (6)$$

Here ϵ is the specific inductive capacitance (or dielectric constant) of the earth referred to air; σ the conductivity in mhos per meter; d the distance and λ the wavelength, both measured in meters; and ϵ_0 is the so-called complex dielectric constant, really the square of the ratio of the propagation constant in earth to the propagation constant in air. Bearing these definitions in mind, the plane-earth field values are readily obtainable from Fig. 1. To obtain the field values for a spherical earth the plane-earth field is multiplied by the shadow factor F_s , which is discussed in the next section.

SHADOW FACTOR

Two shadow-factor curves were included in the first paper by van der Pol and Bremmer² for the limiting cases of "perfectly conducting" and "strongly absorbing" (or dielectric) earth. These descriptive terms are really mathematical abstractions and correspond only approximately to practical conditions. For a "perfectly conducting" earth the value of the earth's conductivity is assumed to be infinite, or rather, the value of the complex dielectric constant ϵ_0 , as defined above, is assumed to be very large. This is approximately true in the case of long waves over sea water and the shadow-factor curve for this case is that marked (1) on

⁸ C. R. Burrows, "Radio propagation over plane earth—field strength curves," *Bell Sys. Tech. Jour.*, vol. 16, pp. 45-77; January, 1937, and pp. 574-577; October, 1937.

⁹ K. A. Norton, "The propagation of radio waves over the surface of the earth and in the upper atmosphere," *Proc. I.R.E.*, vol. 24, pp. 1367-1387; October, 1936, and vol. 25, pp. 1203-1236, September, 1937.

¹⁰ J. C. Schelleng, C. R. Burrows, and E. B. Ferrell, "Ultra-short-wave propagation," *Proc. I.R.E.*, vol. 21, pp. 427-463; March, 1933, and *Bell Sys. Tech. Jour.*, vol. 12, pp. 125-161; April, 1933.

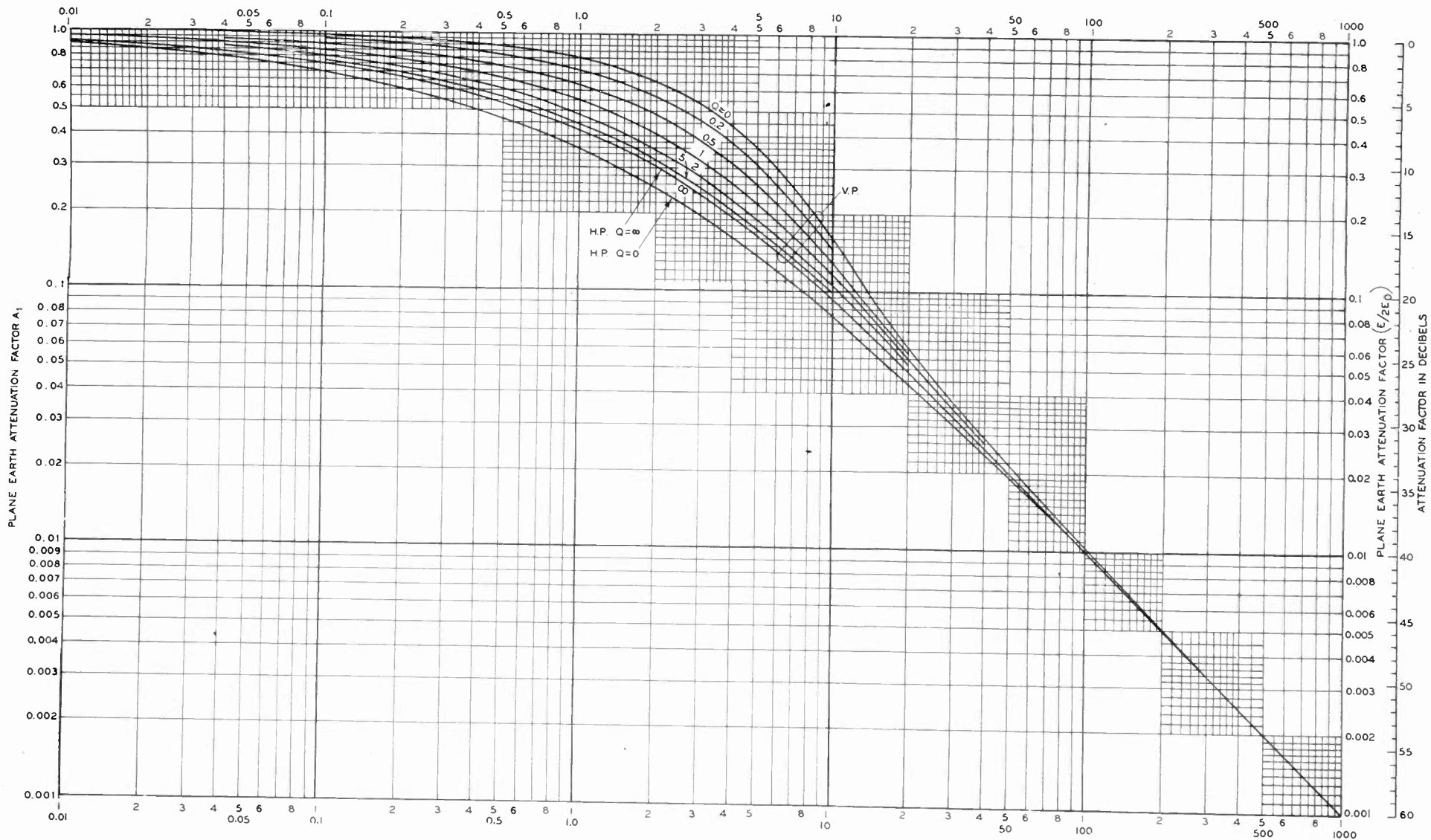

$$|s_e| = \frac{2\pi d/\lambda}{\sqrt{\epsilon^2 + (60\sigma\lambda)^2}} \sqrt{\frac{(\epsilon-1)^2 + (60\sigma\lambda)^2}{\epsilon^2 + (60\sigma\lambda)^2}} \quad \text{FOR VERTICAL POLARIZATION}$$

$$|s_m| = \frac{2\pi d/\lambda}{\sqrt{(\epsilon-1)^2 + (60\sigma\lambda)^2}} \quad \text{FOR HORIZONTAL POLARIZATION}$$

Fig. 1—Plane earth attenuation factor as a function of ξ .

Fig. 2. For a strongly absorbing earth, conversely, the value of ϵ_0 is assumed to be not much greater than unity, a condition which is approximately realized in short waves over dry land. The shadow factor for this case is the curve marked (2) on Fig. 2. It is interesting to note that the shadow factor derived for ultra-short-wave propagation over land by elementary means, curve 3, agrees remarkably well with the rigorous shadow factor for moderate distances.¹¹

Curves (1) and (2) were originally drawn for vertically polarized waves, but the corresponding theory for horizontally polarized waves has shown⁷ that curve (2) is the shadow factor for any earth constants and wavelength. Comparison of the two curves also shows that at distances which are not too small their slopes are very similar. It was this similarity that suggested the possibility of determining the shadow factor for any earth constants by a simple change of distance parameter rather than by a complex change of earth constants. Since the curve (2) represents the shadow factor for horizontally polarized waves it has been chosen as the universal shadow-factor curve, and is

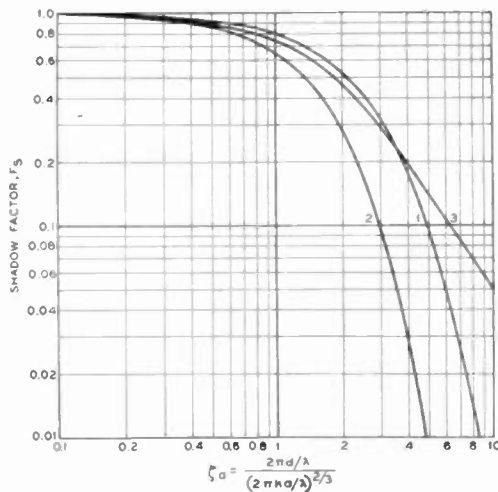

Fig. 2—The shadow factor as a function of

$$\zeta_a = \frac{2\pi d/\lambda}{(2\pi ka/\lambda)^{2/3}}$$

where ka is the effective radius of the earth. Curve 1 applies for vertical polarization over "perfectly conducting earth,"

$$\delta = \left(\frac{2\pi ka}{\lambda}\right)^{2/3} \frac{1}{\epsilon_e} \ll 1.$$

Curve 2 applies for vertical polarization over "perfectly absorbing earth," $\delta \gg 1$, and for horizontal polarization with any ground constants.

Curve 3 is the approximate shadow factor derived for ultra-short-wave propagation over land. (In the original figure, *PROC. I.R.E.*, vol. 23, p. 1519, Fig. 10, December, 1935, the abscissa was incorrectly labeled. See correction, *PROC. I.R.E.*, vol. 26, p. 242, footnote 7, February, 1938.)

replotted more accurately as curve 0 in Fig. 3. This curve represents the shadow factor as a function of a distance parameter η , which has still to be defined.

¹¹ C. R. Burrows, A. Decino, and L. E. Hunt, "Ultra-short-wave propagation over land," *PROC. I.R.E.*, vol. 23, pp. 1507-1535; December, 1935.

For horizontal polarization η is simply the spherical-earth distance parameter ζ_a , which has been used frequently in the theoretical developments,

$$\eta = \zeta_a = \frac{2\pi d/\lambda}{(2\pi ka/\lambda)^{2/3}} = 4.43 \times 10^{-5} \lambda^{-1/3} d, \quad (7)$$

where ka is the modified radius of the earth, taking refraction into account, and all lengths are measured

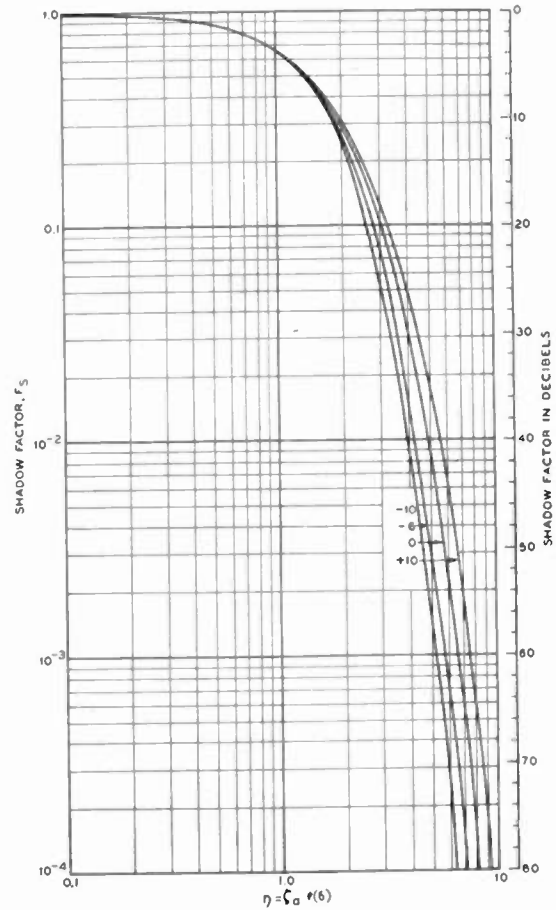

Fig. 3—The shadow factor as a function of $\eta = \zeta_a f(\delta)$.

The value of $f(\delta)$ and the appropriate curve is given in Fig. 4.

in the same unit. The numerical expression on the right is based upon an effective earth's radius of 4/3 times the actual and the unit is the meter.

For vertical polarization

$$\eta = \zeta_a f(\delta), \quad (8)$$

where $f(\delta)$ is the proportionality factor given by the solid lines of Fig. 4. These curves express $f(\delta)$ as a function of the ground constant δ ,

$$\delta = \left(\frac{2\pi ka}{\lambda}\right)^{2/3} \frac{1}{\epsilon_e}. \quad (9)$$

This proportionality factor is determined so that the shadow factor is exact for $\eta = 1.35$ which gives a shadow factor of one half. The shadow-factor curves for shorter distances then coincide within the accuracy with which they may be read. At the greater distances

there is a slight spreading of the shadow-factor curves for different ground constants. The extreme curves are indicated as -10 and +10 in Fig. 3. The curve appropriate to any value of the ground constants is given by the broken lines of Fig. 4. Linear interpolation between the curves of Fig. 3 will give the appropriate shadow-factor curve.

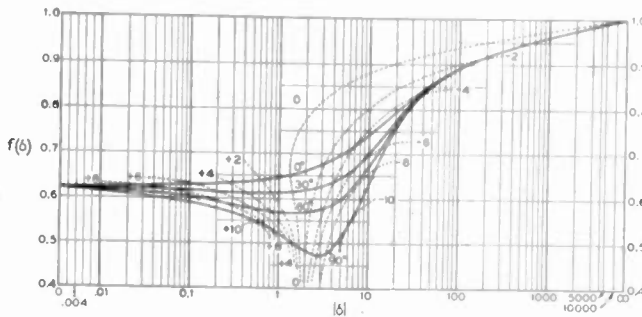

Fig. 4— $f(\delta)$ to give $\eta = \zeta_0 f(\delta)$ for Fig. 3. The abscissa gives the magnitude of

$$\delta = \frac{(2\pi ka/\lambda)^{2/3}}{\epsilon_r}$$

while the numbers on the curves give the argument of δ in degrees. The ordinate of the solid lines gives the value of $f(\delta)$ appropriate for the universal shadow factor curve of Fig. 3 for short distances. The numbers on the broken lines correspond to the number on the appropriate shadow-factor curve of Fig. 3 for all distances.

In order to facilitate the evaluation of δ for various ground constants its value is plotted in Figs. 5 and 6. The recognized values of the specific types of ground are given by the heavy lines of Figs. 5 and 6. Other values of ground constants are given by the thin lines. All of the transition curves from dielectric to conductive grounds are the same so that they may be readily sketched in. The intersection between these two asymptotes gives the wavelength for which the phase of δ is 45 degrees for any particular ground. Since the curves of Fig. 6 are all identical in shape this information also allows them to be sketched in for any particular ground.

LOW ANTENNAS

For moderate antenna heights the effect of raising either antenna off the ground is independent of the distance, curvature of the earth, and height of the other antenna. The antenna-height factors G_1 and G_2 are given by

$$G = 1 + i\chi \tag{10}$$

where

$$\chi = \chi_e = \frac{2\pi h}{\lambda \sqrt{\epsilon_e}} \tag{11}$$

for vertical polarization, and

$$\chi = \chi_m = \frac{2\pi h}{\lambda} \sqrt{\epsilon_m} \tag{12}$$

for horizontal polarization. Here h is the elevation of the antenna above the earth's surface. These height-

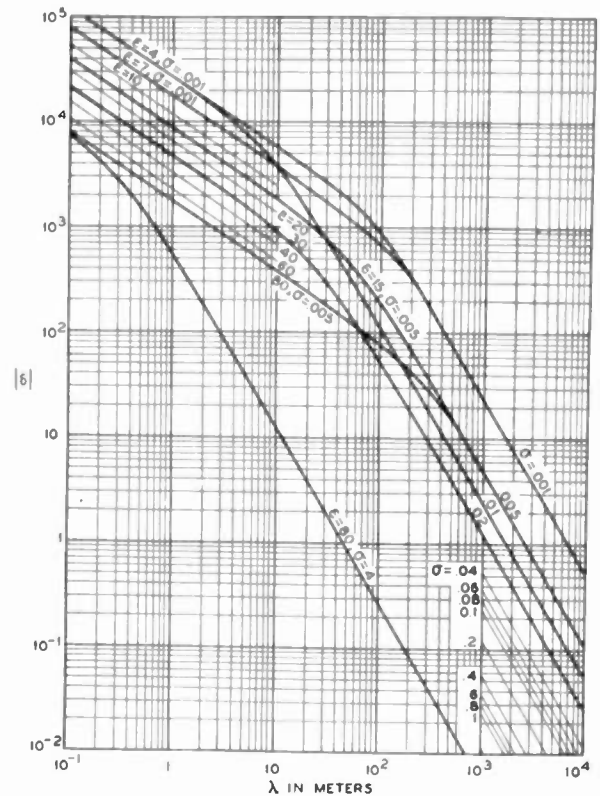

Fig. 5—Modulus of δ for different ground constants and an effective radius of the earth equal to 4/3 the actual radius.

- (1) sea water $\epsilon=80, \sigma=4$ mho per meter
- (2) fresh water $\epsilon=80, \sigma=5 \times 10^{-3}$ mho per meter
- (3) moist soil $\epsilon=30, \sigma=0.02$ mho per meter
- (4) fertile land $\epsilon=15, \sigma=5 \times 10^{-3}$ mho per meter
- (5) rocky ground $\epsilon=7, \sigma=10^{-3}$ mho per meter
- (6) dry soil $\epsilon=4, \sigma=10^{-2}$ mho per meter
- (7) very dry soil $\epsilon=4, \sigma=10^{-3}$ mho per meter

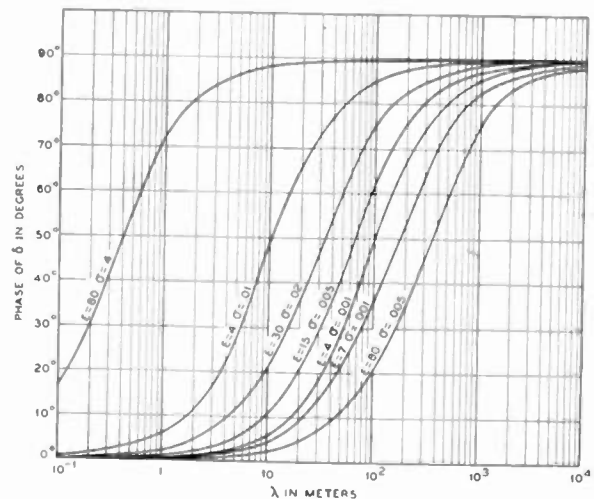

Fig. 6—Phase of δ for different ground constants.

gain factors are given in Fig. 7 which is adapted¹² from Fig. 13 of reference 8. The above relations are limited

¹² The equations of this paragraph appear as equation (28) of reference 8 for propagation over plane earth; as equation (10) of the last paper of reference 2 for vertical polarization over spherical earth; and as equation (47) of reference 7 for horizontal polarization over spherical earth. The derivation of (10) for plane earth is limited ζ_r or $\zeta_m \gg 1$. For vertical polarization on long waves over sea water this is beyond the practical range. In this case $\chi_e \ll 1$ for all practical heights and $G = 1$ so that (10) is still valid.

at short distances to heights for which $2\pi h_1 h_2 / \lambda d$ is somewhat less than unity, and at long distances to values of

$$\chi_a = \chi_e / \sqrt{\delta} = \frac{2\pi h}{\lambda} / \left(\frac{2\pi k a}{\lambda} \right)^{1/3} = 0.0167 \lambda^{-2/3} h \quad (13)$$

less than about 0.5. The numerical expression on the right is based upon an effective earth's radius of 4/3 times the actual and the unit is the meter.

MEDIUM ANTENNA HEIGHTS

For values of χ greater than about 20 the height-gain factor of Fig. 7 is substantially equal to χ_e or χ_m and since A_1 approaches $1/\zeta_e$ or $1/\zeta_m$, the field becomes

$$E = \frac{2E_0 \chi^2 F_s}{\zeta} = \frac{4\pi h_1 h_2}{\lambda d} E_0 F_s \quad (14)$$

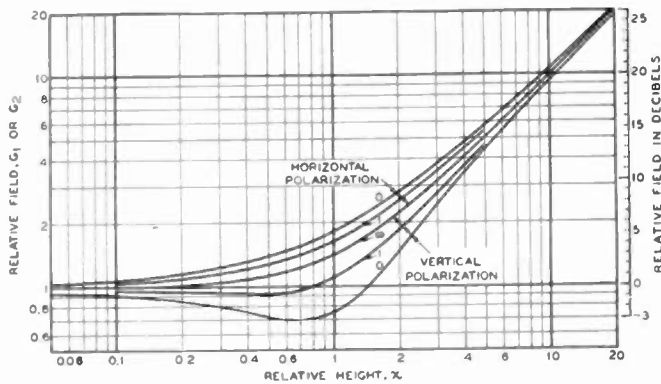

Fig. 7—Height-gain factor as a function of χ .

$$\chi = \chi_e = \frac{2\pi h/\lambda}{\sqrt{\epsilon^2 + (60\sigma\lambda)^2}} \sqrt{\frac{(\epsilon - 1)^2 + (60\sigma\lambda)^2}{\epsilon^2 + (60\sigma\lambda)^2}} \text{ for vertical polarization}$$

$$\chi = \chi_m = \frac{2\pi h}{\lambda} \sqrt{(\epsilon - 1)^2 + (60\sigma\lambda)^2} \text{ for horizontal polarization.}$$

The numbers on the curves give the ratio of the real to imaginary parts of ϵ_r or $1/\epsilon_m$ which may be taken as $Q = \epsilon/60\sigma\lambda$ for interpolation between the curves.

where h_1 and h_2 are the antenna elevations and F_s is the shadow factor given in Fig. 3. This is in agreement with the experimental fact that on ultra-short waves the field is substantially independent of the ground constants and polarization.

GREAT DISTANCES

At heights greater than $\chi_a = 0.5$, the field increases more rapidly with height than indicated by (14). This may be expressed

$$E = \frac{4\pi h_1 h_2}{\lambda d} E_0 F_s g_1 g_2 \quad (15)$$

where

$$g_{1,2} = G_{1,2} / \chi_{e,m} \quad (16)$$

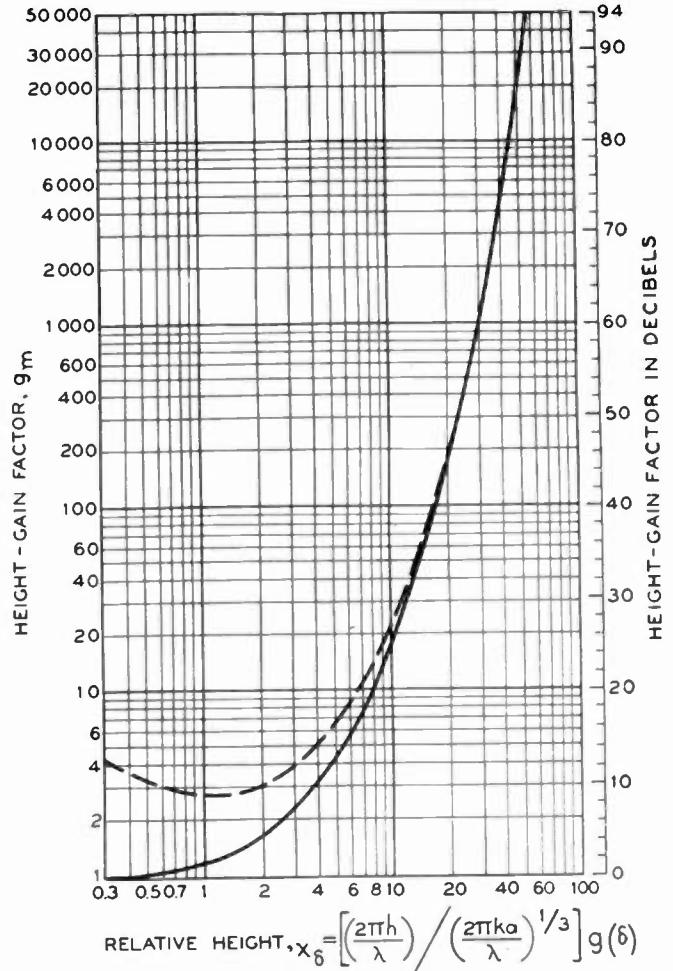

Fig. 8—Height-gain factor g_m for equation (15).

gives the increase of field with height above that of (14). For sufficiently great distances g_1 and g_2 are independent of distance. Fig. 8 gives the height-gain relation as a function of the height parameter χ_δ . For horizontal polarization χ_δ is equal to the height parameter χ_a , defined in (13), and g_1 and g_2 are equal to g_m , the ordinate of Fig. 8. For vertical polarization,

$$\chi_\delta = \chi_a g(\delta) \quad (17)$$

and

$$g_1 \text{ and } g_2 = g_\delta g_m \quad (18)$$

where g_δ and $g(\delta)$ are plotted in Fig. 9 as a function of δ . The solid curve of Fig. 8 gives the height-gain relation for horizontal polarization and for vertical polarization when $\delta \gg 1$. The broken line shows the deviation of the height-gain relation for the smaller heights on vertical polarization when $\delta < 1$. Under these conditions there is no region where the field is proportional to height, the variation with height going directly from that shown by the broken line to a constant value at low heights as indicated by the rise of this curve. For values of δ that are small but not negligible, the variable height curves of Fig. 7 should be used within their range of validity instead of the lower end of the curves of Fig. 8.

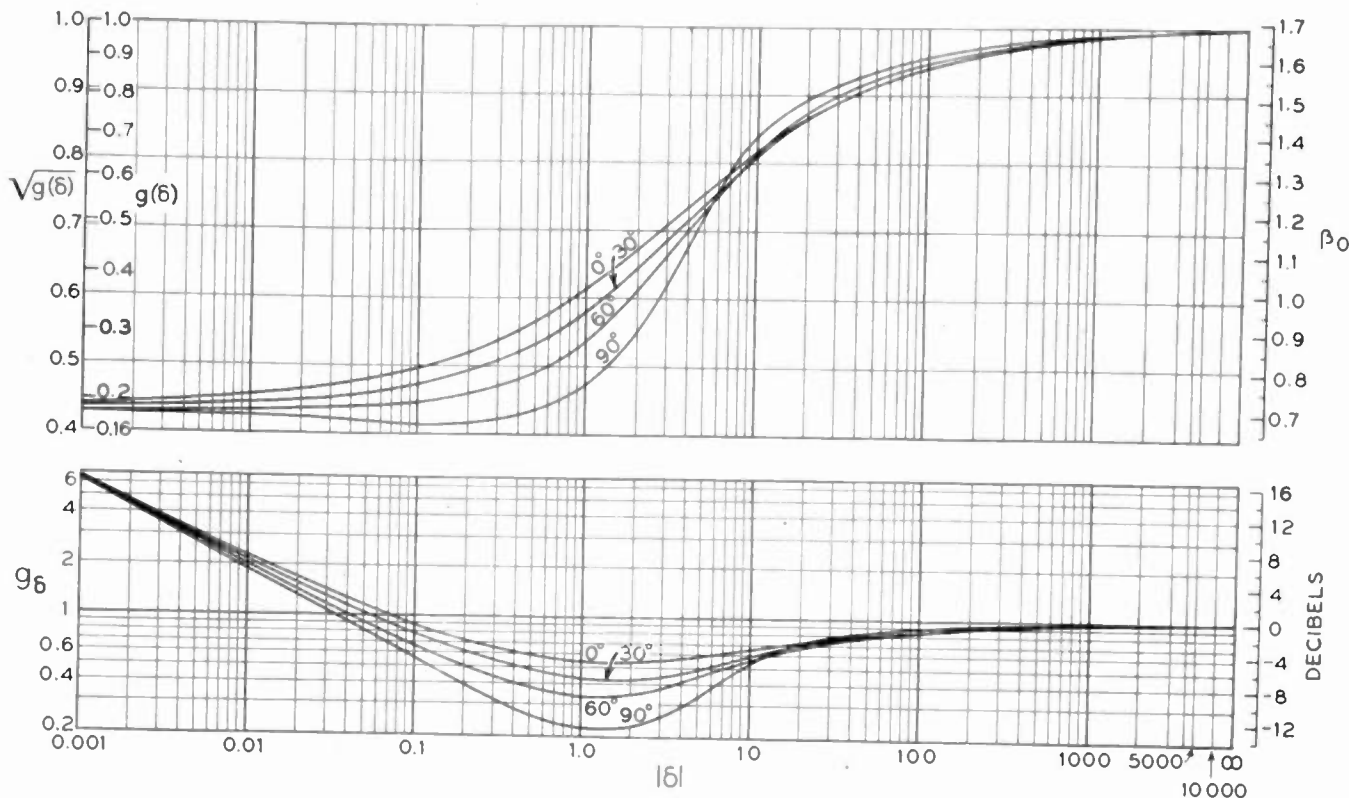

Fig. 9—The parameters $g(\delta)$ and g_δ for use with Fig. 8.

NEAR THE LINE OF SIGHT

If the two antennas are raised so that they remain at comparable heights the equations and curves of the

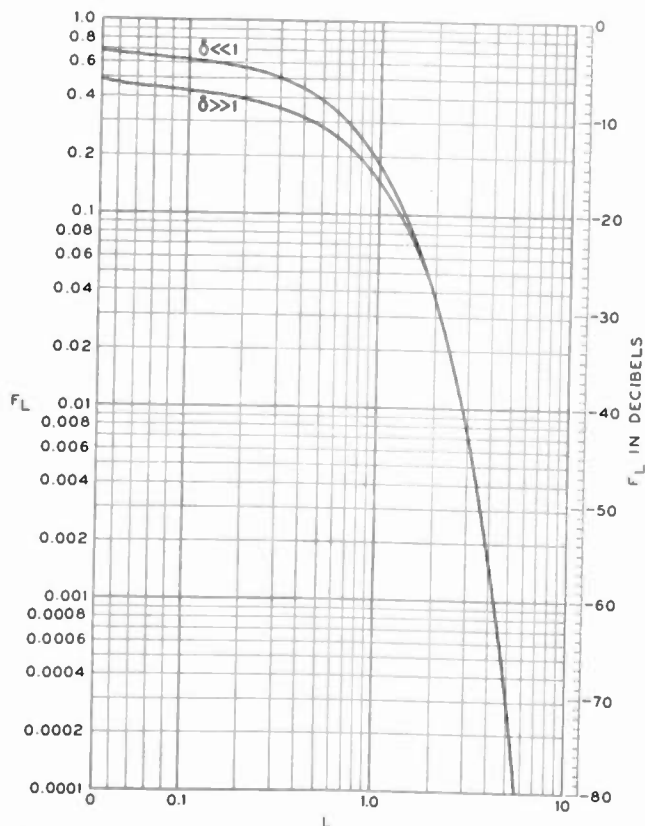

Fig. 10—The height-distance factor F_L of (19) as a function of $L = \sqrt{g(\delta)} (\sqrt{2\chi_0} - \sqrt{2\chi_a})$.

preceding sections are valid until the “optical” region considered in the next section is attained. But if one antenna is kept at a low height while the other is raised until it approaches the line of sight the regions of validity of the two sets of curves will no longer overlap. In this transitional region it is still possible to obtain a simple expression for the field if the following method is adopted.

As shown in the Appendix, when one antenna is low, $\chi_\delta < 0.5$, and the other elevated, $\chi_\delta > 20$, the field can be expressed as

$$E = 2E_0G_1L(\delta)\left(\frac{\chi_0}{\chi_a}\right)^{1/4}F_L \quad (19)$$

where G_1 is the height function for the low antenna as already defined, and the last two factors refer to the elevated antenna. The height and distance parameters are combined in a new parameter L :

$$L = \sqrt{g(\delta)} [\sqrt{2\chi_0} - \sqrt{2\chi_a}] \quad (20)$$

where $g(\delta)$ is the factor of Fig. 9 and χ_0 is the value of χ_a at the line of sight from the ground below the other antenna:

$$\chi_0 = \frac{1}{2}\zeta_a^2 \quad (21)$$

The function F_L is plotted as a function of L in Fig. 10. For horizontal polarization $L(\delta)$ has the simple value

$$L(\delta) = \frac{1}{\sqrt{\epsilon_m(2\pi ka/\lambda)^{1/3}}} \quad (22)$$

so that $G_1L(\delta) = \chi_a$ evaluated for the low antenna provided $\chi_m \gg 1$. For vertical polarization $L(\delta)$ is the function plotted in Fig. 11.

HIGH ANTENNAS

When the antenna heights are large compared with the deviations of the earth from a plane the field may be calculated by the laws of geometric optics. It is the resultant of a direct wave and one reflected from the ground

$$E = E_0 \left(\frac{e^{-2\pi i R_1/\lambda}}{R_1} + R \frac{e^{-2\pi i R_2/\lambda}}{R_2} \right), \quad (23)$$

where R_1 and R_2 are the lengths of the paths of the direct and reflected waves (see Fig. 12) and

$$R = -Ke^{i\psi}/s \quad (24)$$

is the reflection coefficient. K and ψ are the magnitude and phase of the plane-earth reflection coefficient, which are given in Figs. 5 to 12 of reference 8, and

$$s^2 = 1 + \frac{4h_1''d_2}{h_1'd} = 1 + \frac{4h_2''d_1}{h_2'd} \quad (25)$$

represents the effect of the earth's curvature in increasing the divergence of the wave at reflection. The quantities involved in (25) are defined by Fig. 12.

$$h_1'' = \frac{d_1^2}{2ka} \quad \text{and} \quad h_2'' = \frac{d_2^2}{2ka} \quad (26)$$

$$\tan \xi_2 = \frac{h_1'}{d_1} \quad \text{and} \quad \tan \xi_3 = \frac{h_2'}{d_2} \quad (27)$$

The best method of obtaining these parameters is to calculate ξ_2 as a function of d_1 for the given h_1 and ξ_3 as a function of $d_1 (=d-d_2)$ for the given h_2 . The value of d_1 is that for which $\xi_2 = \xi_3$.

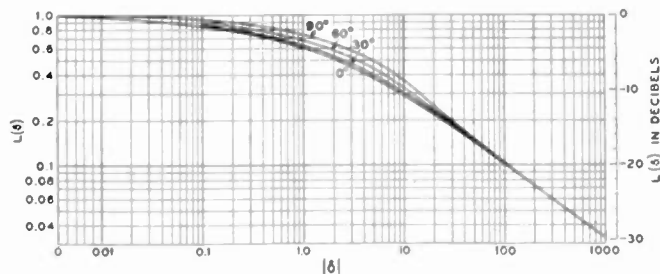

Fig. 11—The ground parameter $L(\delta)$ of (19) for vertical polarization.

If we write

$$\begin{aligned} \Delta &= 2\pi(R_2 - R_1)/\lambda \\ &= \frac{4\pi h_1' h_2'}{\lambda d} \left(1 - \frac{h_1'^2 + h_2'^2}{2d^2} + \dots \right) \end{aligned} \quad (28)$$

and

$$\gamma = \psi - \Delta \quad (29)$$

then (23) may be written

$$E = E_0 \sqrt{(1 - K/s)^2 + (4K/s) \sin^2(\gamma/2)}. \quad (30)$$

As h_1' and h_2' approach zero (23) and (30) give too great a field whereas the same equations with $s = 1$ give too small a field.

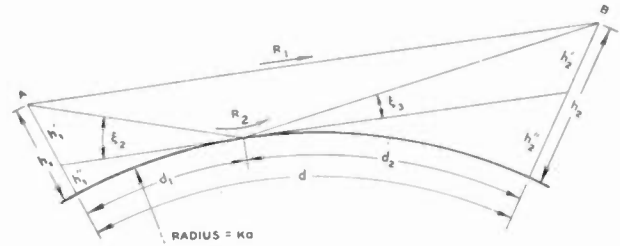

Fig. 12—Profile for elevated antennas at A and B

$$h_1 = h_1' + h_1'', \quad h_2 = h_2' + h_2''$$

$$h_1'' = \frac{d_1^2}{2ka}, \quad h_2'' = \frac{d_2^2}{2ka}$$

$$\frac{h_1'}{d_1} = \tan \xi_2 = \tan \xi_3 = \frac{h_2'}{d_2}$$

For $k = 4/3, 2ka = 17 \times 10^6$ meters.

CONCLUSION

With low antennas the field may be calculated by

$$E = 2E_0 A_1 F_s G_1 G_2 \quad (1)$$

where A_1 is the plane-earth attenuation factor for antennas on the ground, F_s is the shadow factor which is independent of the antenna height, and G_1 and G_2 are the height-gain factors which are independent of the earth's curvature and distance. These factors are given graphically in Figs. 1, 3, 4, and 7. At great distances the field may be calculated by

$$E = \frac{4\pi h_1 h_2}{\lambda d} E_0 F_s g_1 g_2 \quad (15)$$

where g_1 and g_2 are given in Fig. 8. For moderate heights $g_1 = g_2 = 1$ and the first factor of (15) equals $2A_1 G_1 G_2$ so that the ranges of validity of (1) and (15) overlap if the two antennas are of comparable heights. When one antenna is low and the other near the line of sight, the field is given by (19). For shorter distances the field is given by (23) or (30).

APPENDIX

The best available equation for radio propagation over spherical earth below the line of sight is that developed by van der Pol and Bremmer.² In the notation of this paper it may be written

$$E = 2E_0 (2\pi \zeta_a)^{1/2} \left| \sum_{n=0}^{\infty} f_n(h_1) f_n(h_2) \frac{\exp(-i\tau_n \zeta_a)}{\delta + 2\tau_n} \right| \quad (1a)$$

where the parameters τ_n are functions of the ground constants and the height functions $f_n(h)$ are independ-

ent of the distance between the antennas.¹³ The shadow factor curves of Fig. 3 were obtained by summing all the significant terms of (1a) for zero heights. It may be noted that at distances beyond the limits of Fig. 3 the value of the field can be found from the first term of the series using the value of $\beta_0(\tau_0 = \alpha_0 + i\beta_0)$ obtained from Fig. 9.

The height-gain curves of Fig. 8 refer only to the first term of (1a) since it is only when one term of the series is sufficient that the effects of height and distance can be evaluated separately. The curves of Figs. 10 and 11 have been developed to meet the conditions in which more than one term of the series has to be used, that is, when one antenna is low and the other is elevated near the line of sight.

In this case the height functions $f_s(h_1)$ referring to the low antenna have the same value for each term of the series (1a) while an asymptotic expansion for the height functions of the elevated antenna is

$$f_s(h) = \frac{3}{\sqrt{2\pi}} \frac{(2\chi_a)^{-1/4}}{\sqrt{-2\tau_s}} \frac{e^{-i\tau_s\sqrt{2\chi_a}}}{J_{1/3}(z_s) + J_{-1/3}(z_s)} \quad (2a)$$

where

$$z_s = \frac{1}{3}(-2\tau_s)^{3/2}e^{-i\pi} = \frac{1}{3}(2\tau_s)e^{i(\pi-3\theta_s/2)} \quad (3a)$$

and

$$\tau_s = r_s e^{-i\theta_s}.$$

Substituting (2a) in (1a) we obtain the expansion

$$\left| \frac{E}{2E_0} \right| = G_1 \left(\frac{2\chi_0}{2\chi_a} \right)^{1/4} \left| \sum_{s=0}^{\infty} \frac{e^{-i\tau_s(\sqrt{2\chi_0}-\sqrt{2\chi_a})}}{\frac{1}{3}\sqrt{-2\tau_s(\delta+2\tau_s)} [J_{1/3}(z_s) + J_{-1/3}(z_s)]} \right| \quad (4a)$$

¹³ After the work reported in this paper was undertaken, F.C.C. Mimeograph No. 39920, on "Hearing in the matter of aural broadcasting on frequencies above 25,000 kilocycles" appeared. In this K. A. Norton has given in graphical form the values of the parameters of the first term of equation (1a).

Here all the parameters have been defined except δ . For vertical polarization δ is given by (9) while for horizontal polarization

$$\delta = \delta_m = \left(\frac{2\pi k a}{\lambda} \right)^{2/3} \epsilon_m. \quad (5a)$$

For horizontal polarization or vertical polarization over dry ground at high frequencies the value of δ is large, while the Bessel function term is small, and an accurate approximation to (4a) is

$$\left| \frac{E}{2E_0} \right| = G_1 \left(\frac{2\chi_0}{2\chi_a} \right)^{1/4} \left| \frac{1}{\sqrt{\delta_m}} \sum_{s=0}^{\infty} \frac{e^{-i\tau_s(\sqrt{2\chi_0}-\sqrt{2\chi_a})}}{\frac{2}{3}\tau_s [J_{-2/3}(z_s) - J_{2/3}(z_s)]} \right| \quad (6a)$$

Equation (5a) may be put in the form of (19) by defining

$$F_L = \sum \frac{e^{-i\tau_s(\sqrt{2\chi_0}-\sqrt{2\chi_a})}}{\frac{2}{3}\tau_s [J_{-2/3}(z_s) - J_{2/3}(z_s)]}$$

and

$$L(\delta) = \frac{1}{\sqrt{\delta_m}}.$$

Equation (4a) may be put in the same form and the function F_L may be made independent of polarization and ground constants for L large by defining

$$F_L = \frac{1}{L(\delta)} \sum \frac{e^{-\tau_s(\sqrt{2\chi_0}-\sqrt{2\chi_a})}}{\frac{1}{3}\sqrt{-2\tau_s(\delta+2\tau_s)} [J_{1/3}(z_s) + J_{-1/3}(z_s)]}$$

and

$$L(\delta) = \frac{3\sqrt{3}/2\pi}{\sqrt{\tau_0(\delta+2\tau_0)} [J_{1/3}(z_0) + J_{-1/3}(z_0)]}$$

Sinusoidal Variation of a Parameter in a Simple Series Circuit*

FRANK J. MAGINNISS,† NONMEMBER, I.R.E.

Summary—A large amount of work has been done by others in analyzing the equivalent of a varying-parameter circuit on the assumption that L or C varies as $1/(1+k \cos \omega_s t)$. In this paper a brief comparison of these results is made with results obtained on the apparently more direct assumption that L or C varies as $(1+k \cos \omega_s t)$ with k sufficiently large for the two cases to yield appreciably different results. An indication of how previous analyses can be applied to the present case, and some data concerning that case are given.

RECENTLY the analysis of a problem¹, which in electric circuit terms is that of a simple non-dissipative series circuit in which either the inductance L (considered simply as the coefficient of di/dt) or capacitance C varies as $1/(1+k \cos \omega_s t)$ has been carried to a point where both the amplitude and the frequency modulation in the result are readily evident and other aspects are more or less easily discerned. A closely allied problem is one assuming L or C to vary as $(1+k \cos \omega_s t)$. Indeed from the point of view of electric circuits this appears the more direct approach to the varying-parameter series circuit. It therefore seems desirable at this time to compare the two cases and to indicate how the general theory of the first case can be applied to the second.

Consider (Case I), a nondissipative circuit containing inductance L and capacitance C , where

$$C = C_0(1 - k \cos \omega_s t)$$

(C_0 , k , and ω_s are constants) and assume further that $0 < k \ll 1$. Then, since $1/(1 - k \cos \omega_s t) = 1 + k \cos \omega_s t$ for $k \ll 1$,

$$\frac{d^2 q}{dt^2} + \frac{1}{LC_0} (1 + k \cos \omega_s t) q = 0$$

or

$$q'' + \epsilon(1 + \cos \tau)q = 0 \quad (1)$$

where $\epsilon = \omega_0^2/\omega_s^2$; $\omega_0^2 = 1/LC_0$; $\tau = \omega_s t$; and the primes denote differentiation with respect to τ . This is the equation Carson² solved for the case $k \ll 1$. Its mathematical form is that of Mathieu's equation and because of its appearance in numerous technical fields, considerable attention has been devoted to it without restriction on the magnitude of k . It thus happens that there have appeared more studies of circuits with capacitance equivalent to

$$C = \frac{C_0}{(1 + k \cos \omega_s t)} \quad (2)$$

* Decimal classification: R141. Original manuscript received by the Institute, June 11, 1940.

† Moore School of Electrical Engineering, University of Pennsylvania, Philadelphia, Penna.

¹ J. G. Brainerd "Note on modulation" PROC. I.R.E., vol. 28, 3, pp. 136-139; March, 1940.

² John R. Carson "Notes on the theory of modulation" PROC. I.R.E., vol. 10, pp. 57-64; February, 1922.

than with capacitance

$$C = C_0(1 + k \cos \omega_s t). \quad (2a)$$

Fig. 1 shows the solution of (1), and its derivative for $\sqrt{\epsilon} = 40$, and $k = 0.75$. Note that the restriction ($k \ll 1$) is not made here; as a result, the capacitance

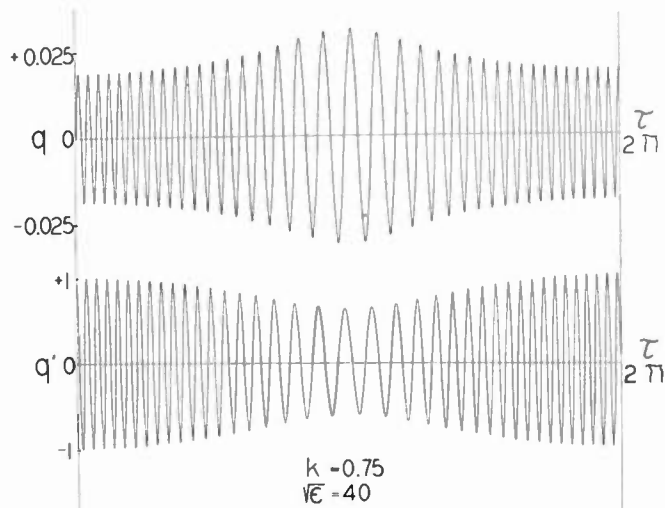

Fig. 1—Charge q and current q' for Case I [equation (1)]; $\sqrt{\epsilon} = 40$ and $k = 0.75$.

of the circuit is actually (2). The value of ϵ is sufficiently great to show the combined amplitude and frequency modulation in the result. Fig. 2 has been

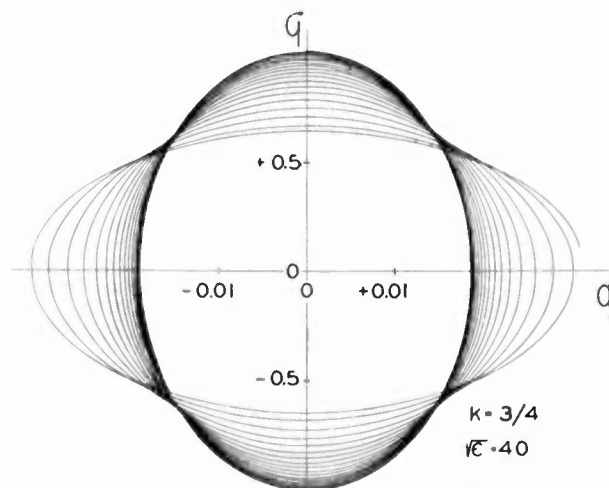

Fig. 2—Current q' versus charge q for Case I [equation (1)]; $\sqrt{\epsilon} = 40$ and $k = 0.75$.

inserted incidentally; it is the graph of q' versus q for $0 \leq \tau \leq \pi$ and is a picture of the type which might be obtained on a cathode-ray oscillograph. Theoretically it should be possible to pick out periodic solutions of (1) by adjusting L , C_0 , or k until this figure appeared as a closed curve.

Define g and h as those two particular solutions of

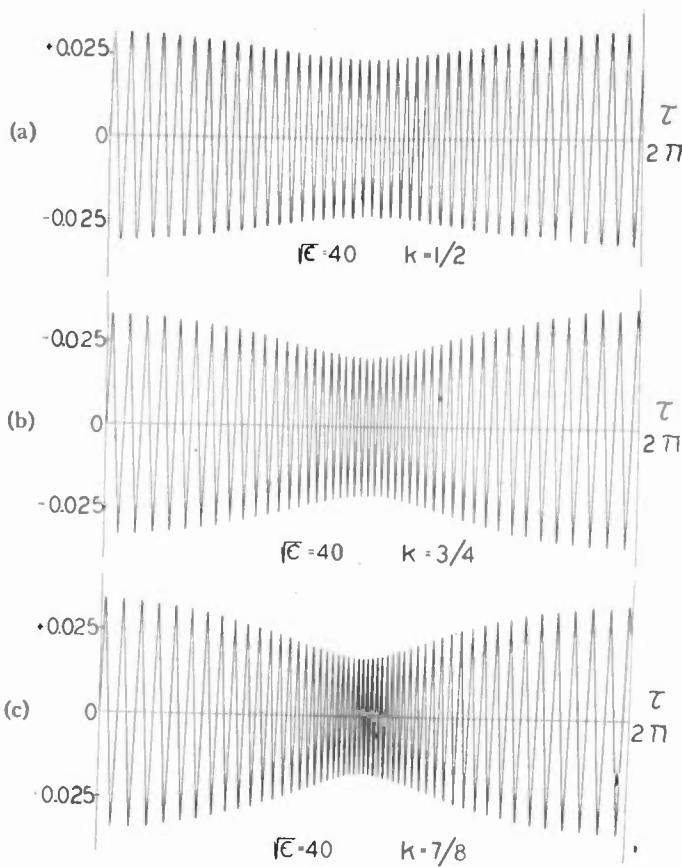

Fig. 3—Variation with k of charge q in Case II [equation (8)]; $\sqrt{\epsilon}=40$.

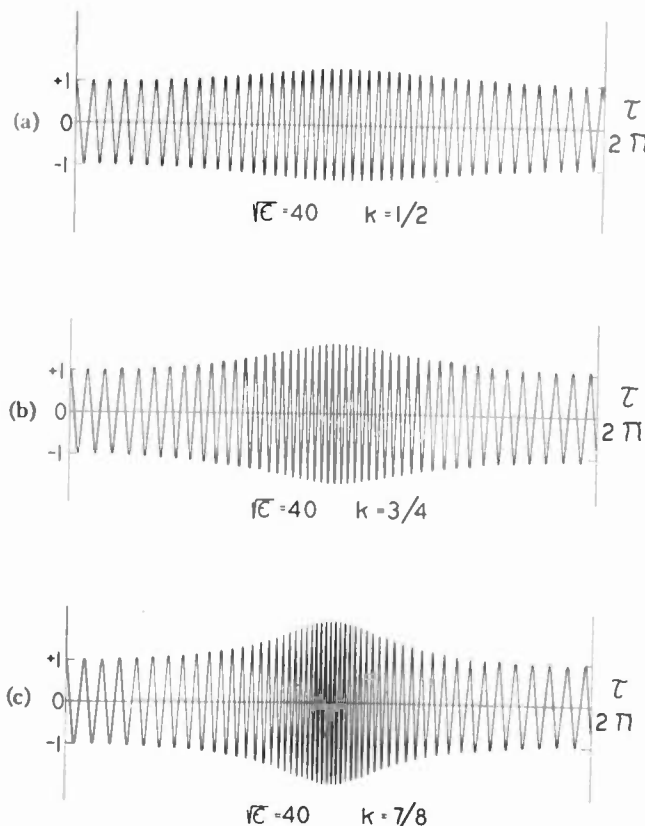

Fig. 4—Variation with k of current q' in Case II [equation (8)]; $\sqrt{\epsilon}=40$.

(1) which satisfy the initial conditions $g(0) = 1, g'(0) = 0$ and $h(0) = 0, h'(0) = 1$. Then Fig. 1 gives h and h' for $0 \leq \tau \leq 2\pi$. Any solution of (1) can be written (the C 's are constants)

$$q = C_1 g + C_2 h$$

and it has been shown³

$$g = [bh - h(t + 2\pi)]/h(2\pi) \quad (3)$$

$$g = u_1 \cos \mu t + u_2 \sin \mu t \quad (4)$$

$$h[\sqrt{1 - b^2/h(2\pi)}] \equiv H = u_1 \sin \mu t - u_2 \cos \mu t \quad (5)$$

$$b \equiv g(2\pi) = h'(2\pi) = \cos 2\pi\mu \quad (6)$$

where u_1 and u_2 are functions of τ , which are periodic with period 2π , and μ is defined by (6). Thus the h curve of Fig. (1) may be represented by

$$H = U \sin \left(\mu t - \tan^{-1} \frac{u_2}{u_1} \right) \quad (7)$$

where $U^2 = u_1^2 + u_2^2 = g^2 + H^2$ is periodic with period 2π . The following are first approximations¹:

$$U = U_0 - U_1 \cos \tau$$

$$\tan^{-1} \frac{u_2}{u_1} = -N\tau + \theta_1 \sin \tau$$

where U_0, U_1 , and θ_1 are constants, and N is a particular integer. Hence H may be approximated by

$$H = (U_0 - U_1 \cos \tau) \sin [(\mu + N)\tau - \theta_1 \sin \tau].$$

Assuming μ has its primary value as determined by (6) (approximately $\frac{1}{4}$), N for the solution given by Fig. 1 is 38. It is worthy of note that the number of "cycles" in a solution of (1) is always less than $\sqrt{\epsilon}$ and that when $\sqrt{\epsilon}$ is great enough so that U is practically the envelope of H , the envelope of (7) is periodic in 2π even though H may not be. Equations (4), (5), and (6) indicate that g and H themselves are periodic when

$$\mu = m \quad m = \dots - 2, -1, 0, 1, 2, \dots$$

$$\mu = \frac{p}{m} \quad p, m = \dots - 2, -1, 1, 2, \dots$$

the period being 2π in the former case and some multiple of 2π in the latter.

Turn now to the more exact equation (Case II) for either inductance or capacitance variation of the type indicated by (2a):

$$q'' + \frac{\epsilon}{1 + k \cos \tau} q = 0. \quad (8)$$

Since (1) and (8) are practically equivalent when k is very small, attention will be restricted in this paper to cases in which k is appreciably greater than zero, but less than unity to avoid negative inductance or capacitance.

³ J. G. Brainerd, and C. N. Weygandt, "Solutions of Mathieu's equations," to appear in the *Philosophical Magazine*.

Fig. 3 shows q and Fig. 4 q' for $\sqrt{\epsilon}=40$ and $k=0.5, 0.75,$ and 0.875 . Fig. 3(b) is more or less comparable to Fig. 1, q , since ϵ and k are the same for these two. The number of apparent cycles is greater than $\sqrt{\epsilon}$, a fact which has been found true in all of a large group of results obtained in connection with the present study. Fig. 3(a) ($k=0.5$) indicates the tendency for the percentage amplitude modulation to decrease with decrease in k . This is also true in the case of (1).

In⁴ Fig. 6 $b \equiv g_{2\tau} = h'_{2\tau}$ is plotted as ordinate against $\sqrt{\epsilon}$ as abscissa with $0 \leq \sqrt{\epsilon} \leq 2, k=0.75$ for Case II. Since μ is imaginary for $b > +1$ or < -1 (equation (6)), the shaded portion of Fig. 6 represents a range of $\sqrt{\epsilon}$ for this particular value of k for which the solutions of (8) are unstable. The fact that this curve appears to be approaching periodicity indicates that for sufficiently great ϵ and fixed k the number of apparent cycles in a solution of (8) should be directly proportional to $\sqrt{\epsilon}$.

When ϵ is sufficiently great, the number of apparent cycles in any range of τ can be closely approximated. At $\tau = \pi/2$, the "frequency" will be closely $f_1 = \sqrt{\epsilon}/2\pi$ and the "period" will be approximately $T_1 = 2\pi/\sqrt{\epsilon}$. If T_1 is small in comparison with 2π , the "period" of an adjacent "cycle" will be $T_2 = (2\pi/\sqrt{\epsilon})\sqrt{1+k \cos(\pi/2 + 2\pi/\sqrt{\epsilon})}$ and this process can be continued in both directions from $\tau = \pi/2$ until the period of each apparent cycle, and hence the number of "cycles" in 2π is obtained.

With the assumption that ϵ is not too small, the above process can be replaced by an integration. Thus the number of "cycles" in 2π will be the integral of the "instantaneous frequency"

$$f = \frac{\sqrt{\epsilon}}{2\pi\sqrt{1+k \cos \tau}}$$

from 0 to 2π . Let n be the number of cycles in 2π . Then

$$n = \frac{\sqrt{\epsilon}}{2\pi} \int_0^{2\pi} \frac{d\tau}{\sqrt{1+k \cos \tau}} = \frac{2\sqrt{\epsilon}}{\pi\sqrt{1+k}} K \tag{9}$$

where K is the complete elliptic integral of the first kind, modulus $\sqrt{2k/(1+k)}$. Tables of this quantity are readily available.⁵ As an illustration of the application of (9), the latter gives 42.18, 46.41, and 51.53 cycles, respectively, in 2π for the cases represented in Figs. 3(a), (b), and (c), whereas the number of apparent cycles as obtained from the curves is 42.13, 46.45, and 51.41. From (9) it follows that for a given k , $n/\sqrt{\epsilon}$ is a constant, as was anticipated from Fig. 6. For $k = \frac{3}{4}$, the validity of (9) has been checked over a large range of ϵ .

⁴ This curve anticipates more extensive curves of the same type for Case I which have been prepared in this laboratory and which will be published in connection with a further study of this case.
⁵ B. O. Peirce, "A Short Table of Integrals," Ginn and Company Boston, Mass., 1929.

Fig. 7, curve a shows the variation of $n/\sqrt{\epsilon}$ with k , curve b the corresponding variation for Mathieu's equation (1). In the case of the latter

$$\frac{n}{\sqrt{\epsilon}} = \frac{2\sqrt{1+k}}{\pi} E \tag{10}$$

where E is the complete elliptic integral of the second kind, modulus $\sqrt{2k/(1+k)}$. As a check, (10) gives

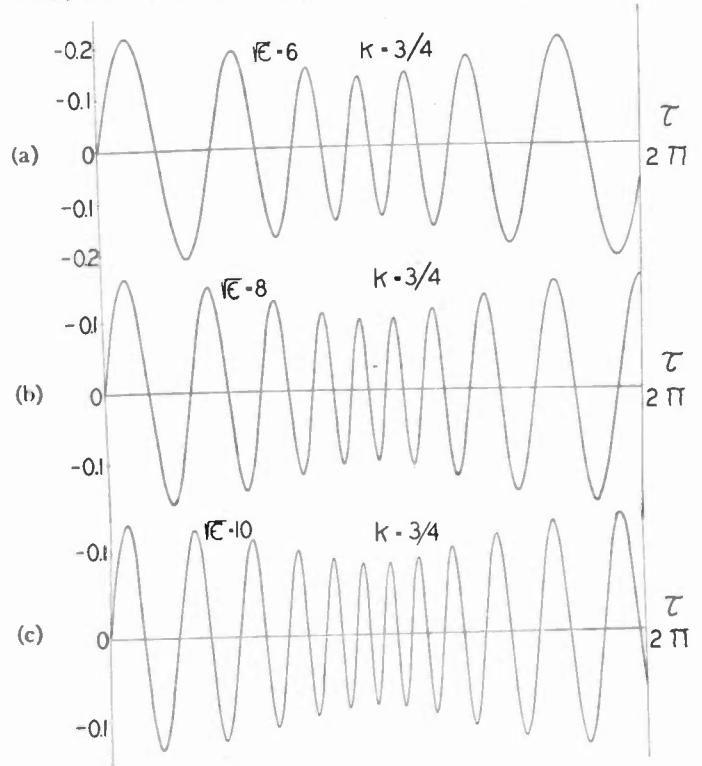

Fig. 5—Variation with $\sqrt{\epsilon}$ of charge q for Case II [equation (8)]; $k=0.75$.

38.34 "cycles" in 2π for $k = \frac{3}{4}$ and $\sqrt{\epsilon} = 40$, whereas Fig. 1 shows 38.25 "cycles" in 2π . Figs. 3 and 4 give an indication of the variation in q and q' (equation (8)) with k for constant ϵ . Fig. 5 illustrates the varia-

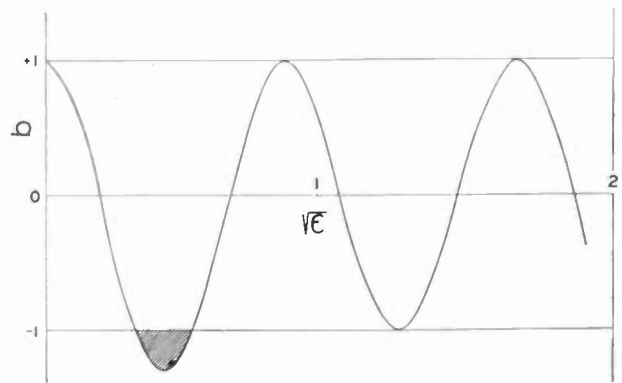

Fig. 6—Variation of b with $\sqrt{\epsilon}$ in Case II; $k=0.75$.

tion in q with ϵ for constant k . If g and h are defined for (8) in a manner similar to their definitions for (1), then (3) to (7), which are based only on the assumption that the coefficient of q in (1) is a periodic function of τ with period 2π , hold also for (8). The general solution can then be written

$$q = CU \cos(\mu\tau + \theta_U - \delta) \tag{11}$$

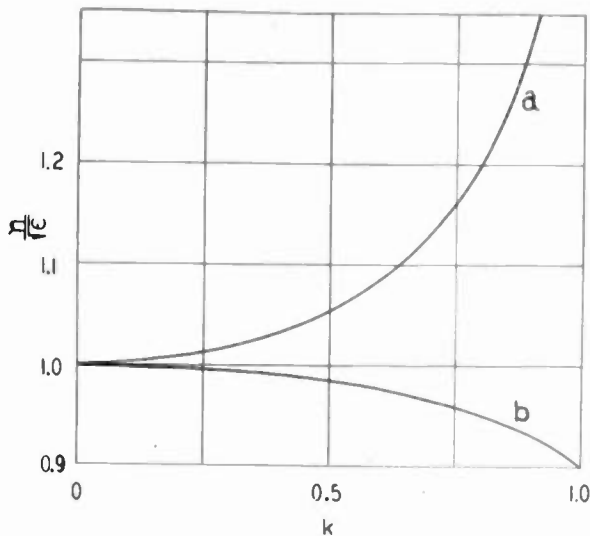

Fig. 7—Ratio of the number of “cycles” in 2π of τ to $\sqrt{\epsilon}$ as a function of k : (a) for Case II [equation (8)]; (b) for Case I [equation (1)].

where $U = u_1^2 + u_2^2$, $\theta_U = \tan^{-1} u_2/u_1$, C and δ are constants, and u_1 and u_2 are periodic functions of τ with period 2π . It is again of interest to observe that the “envelope” U is periodic although (11) is not necessarily so, and that the use of (9) gives a method of approximating the “characteristic exponent” when ϵ is not small, since the variable θ_U must range over some integer multiple of 2π because of the periodicity of the functions u_1 and u_2 . Whittaker and Watson⁶ state of Mathieu’s equation: “The crux of the problem is

⁶ E. T. Whittaker and G. N. Watson, “Modern Analysis,” Cambridge University Press, third edition, 1935.

to determine μ ; when this is done, the determination of $\phi(z)$ presents comparatively little difficulty.” The $\phi(z)$ mentioned by Whittaker and Watson is a combination of the u_1 and u_2 used above. To the extent that this statement applies to (8), which is more exact from the viewpoint of circuit theory, it is seen that the solution has been advanced mathematically. Physically the things which are of interest are the number of apparent cycles in a period 2π of τ which may be determined from (9) and the shape of the “envelope.”

APPENDIX

Failure to allow for resistance in the circuit represented by the Mathieu equation (1) constitutes no restriction on the generality of the results. For

$$\text{let } q = uv$$

$$\text{where } u = e^{a\tau}$$

and substituting in (1)

$$v'' + 2av' + [(\epsilon + a^2) + \epsilon k \cos \tau]v = 0$$

the solution of which is

$$v = qe^{-a\tau}$$

the q being the solution of the corresponding Mathieu equation.

A similar substitution in (8) gives a circuit which is an approximation of the original circuit containing resistance, this assumption being very good for practical values of ϵ , k , and the resistance.

After-Acceleration and Deflection*

J. R. PIERCE†, ASSOCIATE, I.R.E.

Summary—Deflection sensibility of a cathode-ray tube is defined as reciprocal of the change in deflecting voltage or current required to move the spot one spot diameter on the screen. By deflecting the electron beam in a region of low potential, deflection sensibility can be increased in the case of electrostatic deflection, but cannot be increased in the case of magnetic deflection. Any improvement achieved by after-acceleration is due only to the lowering of the potential in the region of deflection, and not to the peculiar electron-optical properties of the particular scheme employed.

I. AFTER-ACCELERATION

A NUMBER of workers have considered the possibility of reducing the deflecting voltage required in the operation of cathode-ray tubes at high voltages of impact on the fluorescent screen, by deflecting the electron beam in a region of low potential, and afterwards accelerating the electron stream to the high screen potential. The term “after-acceleration” will be used to refer to this mode of operation.

* Decimal classification: R388. Original manuscript received by the Institute, August 21, 1940; revised manuscript received, January 14, 1941. Presented, Sixteenth Annual Convention, New York, N. Y., January 10, 1941.

† Bell Telephone Laboratories, Inc., New York, N. Y.

Schwartz¹ has summarized and compared many schemes for after-acceleration in an interesting paper. Unfortunately, he overestimated the possibilities of one scheme by neglecting the lens action of a spherical double layer, or surface of potential discontinuity. One scheme not mentioned by Schwartz has been proposed by Rogowski and Thielen.²

II. DEFLECTION SENSIBILITY AND DEFLECTION SENSIBILITY

The efforts of after-acceleration are generally discussed in terms of deflection sensibility. The deflection sensibility of a cathode-ray tube is usually expressed as the reciprocal of the change in deflecting voltage or in deflecting current in a particular coil necessary to

¹ Erich Schwartz, “Zum Stande des Nachbeschleunigungsproblems bei Kathodenstrahlröhren,” *Fernseh A. G.*, vol. 1, pp. 19–23; December, 1938.

² W. Rogowski and H. Thielen, “Über Nachbeschleunigung bei Braunschen Röhren,” *Archiv für Elektrotech.*, vol. 33, pp. 411–417; June 14, 1939.

move the spot a unit distance on the screen. Deflection sensitivity is a term in wide usage which refers to an operating parameter of practical importance. It seems undesirable to use this term in more than one sense. There is another parameter of perhaps as great importance as deflection sensitivity; that is, the reciprocal of the deflecting voltage or current required to move the spot one spot diameter on the screen. It is proposed to call this quantity the "deflection sensibility" of the device.

In terms of deflection sensibility, after-acceleration may be discussed and its merits evaluated without reference to any particular mode of after-acceleration. This is the chief justification for the introduction of this new quantity. In other respects as well, deflection sensibility is a convenient quantity. It gives immediately the voltage or current required to scan a raster a given number of spot diameters wide. For a given gun and deflecting field, deflection sensitivity varies as the screen of the cathode-ray tube is moved farther away from the region of deflection, while deflection sensibility does not.

It will be shown in this paper that in the case of magnetic deflection, after-acceleration can result in no gain in deflection sensibility. It will be shown that in the case of electrostatic deflection, the improvement in deflection sensibility achieved through aberrationless after-acceleration is dependent only on the lowering of the potential in the region of deflection, so that all aberrationless systems of after-acceleration are equally good.

III. ANGULAR DEFLECTION REQUIRED AND AFTER-ACCELERATION

Fig. 1 shows a part of a cathode-ray tube in cross section. The beam, shown in dotted outline, passes through a region of deflection where, under the influence of electric or magnetic fields, the electron paths are changed in direction by an angle proportional to the deflecting voltage or current. The beam then passes through a "converging" region in which it narrows and finally forms a focused spot on the screen. The converging region may be a field-free region, as in an ordinary cathode-ray tube, or a region involving acceleration and focusing action, as in a tube in which after-acceleration is used. An assumption concerning this region will be made later, but it is one which will be true for any useful fields encountered. Thus the results which are to be derived will apply to any tube, whether or not that tube employs after-acceleration.

Let us consider conditions when no deflecting voltage or current is applied. Consider the beam at any point p in the region of deflection. Because of thermal velocities, electron paths will pass through this point in several directions. One possible path opo' , called a principal trajectory, will go to the center of the spot on the screen. Other possible paths through point p making slight angles with path opo' will go to points

just outside of the center of the spot. Some limiting possible paths, apa' and bpb' passing through p will go to the edges of the spot. Any paths making angles with opo' greater than do apa' and bpb' would represent paths of electrons falling outside of the spot. Hence, all possible electron paths at the point p are included in the angle α between the limiting paths apa' and bpb' . If the spot is circular, all these possible paths through p lie in a cone of peak angle α .

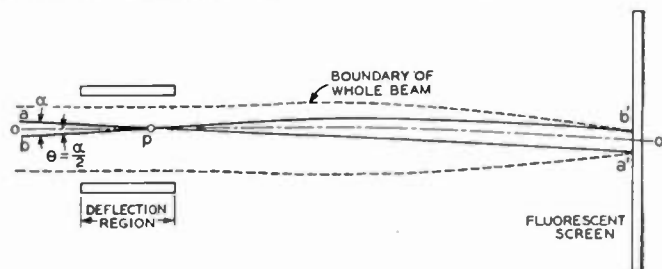

Fig. 1

In the above argument, an assumption is made concerning the converging region: that for electrons passing through a given point in the region of deflection, the position of arrival on the screen is monotonically related to the angle which their paths make with some principal path. Actually, in a practical tube, for small angles at least the linear deflection on the screen will be proportional to the angular deflection in the region of deflection, fulfilling the above condition. Further, the constant of proportionality must be the same for all paths if the spot is to stay together on deflection.

Since the factor relating the angle of paths to the position of arrival is constant across the beam, the angle α of the cone which includes all possible paths (that is, paths which would terminate inside the spot) will be constant across the beam. Thus, it is easy to see in terms of α how much the beam must be deflected to move the spot one spot diameter on the screen. If all the electron paths are deflected through an angle α , none of the new paths will lie within the cone between apa' and bpb' , which contains all the paths going to the undeflected spot position. The spot on the screen will have moved to a position just adjacent to the undeflected spot position, or will have moved one spot diameter.³

By means of a known relation, a minimum limiting value of α can be obtained in terms of certain parameters. It has been shown^{4,5} that in an electron beam, because of the thermal velocities of electrons leaving the cathode

$$j < j_l = j_0 \left(1 + \frac{11600}{T} V \right) \sin^2 \theta. \quad (1)$$

³ This argument does not hold in case there is gas focusing or focusing due to space charge following deflection, for in these cases the focusing fields move with the beam. Such effects should be small in good high-vacuum cathode-ray tubes.

⁴ David B. Langmuir, "Theoretical limitations of cathode-ray tubes," *Proc. I.R.E.*, vol. 25, pp. 977-991; August, 1937.

⁵ J. R. Pierce, "Limiting current densities in electron beams," *Jour. Appl. Phys.*, vol. 10, pp. 715-724; October, 1939.

Here j is the current density, j_l is the "limiting current density," j_o is the cathode-current density, T is the temperature of the cathode in degrees Kelvin, V is the potential at the point considered in volts, and θ is the half angle of a cone within which the paths of all incoming electrons lie. While (1) is usually applied at points of narrowest beam width, such as the spot on the screen of a cathode-ray tube, the relation can be obtained by integrating an expression for current density in velocity space which is valid for every point in the beam.⁵ Thus, (1) may be applied in the region of deflection. In the region of deflection, V will be large and θ will be small. Thus, the following approximate form of (1) will be justified:

$$j < j_l = j_o \frac{11600}{T} V \theta^2. \quad (2)$$

Considering the beam in the region of deflection, it is obvious that the current will be increased as more possible paths, that is, paths arriving within the spot on the screen, are actual paths of electrons. A limiting condition is that in which the electron flow fills a cone of peak angle α at each point in the beam cross section. From this consideration, and from (2), we see that

$$I < I_l = A j_{ld} = A j_o \frac{11600}{T} V_d \frac{\alpha^2}{4}. \quad (3)$$

A , the area of the beam, usually varies little through the region of deflection and will be taken as constant throughout this region. V_d is the potential in the region of deflection, also taken as constant. j_{ld} is the limiting current density associated with a cone of flow of peak angle α or half peak angle $\alpha/2$ at a potential V_d , as obtained from (2). I_l is the limiting beam current which would be obtained if the current density were j_{ld} over the whole beam cross section.

For given values of I , A , j_o , T , V_d , (3) enables us to write concerning the angle containing all possible electron paths

$$\alpha > \alpha_l = 2 \left(\frac{I}{A j_o} \right)^{1/2} \left(\frac{11600}{T} V_d \right)^{-1/2}. \quad (4)$$

α_l is the lower limiting cone angle α which can give a current as large as I . While (4) expresses only a limiting condition as far as α is concerned, consideration of conditions at the spot on the screen enables us to write an interesting equality concerning α .

In applying (1) or (2) at the screen, a meaning must be given to the angle θ which is consistent with the conditions which have been assumed in the region of deflection. The limiting current density in the region of deflection j_{ld} corresponds to flow occupying a cone of peak angle α at every point in the beam cross section. This is equivalent to saying flow in which current reaches every point of the spot on the screen from every point of the beam cross section in the region of deflection. Accordingly, the proper choice of θ_s , the value of θ at the screen, is the half angle of the cone

formed by electron paths reaching the point on the screen from the boundary of the beam in the region of deflection. The limiting current density at the screen then will be

$$j_{ls} = j_o \frac{11600}{T} V_s \theta_s^2. \quad (5)$$

Here V_s is the screen voltage.

If a is the area of the spot on the screen, the limiting screen current (or beam current) I_l may be expressed

$$I_l = a j_{ls} = a j_o \frac{11600}{T} V_s \theta_s^2. \quad (6)$$

I_l from (6) must be equal to I_l as obtained from (3). The quantities appearing in (6) are perhaps more easily measured or estimated than those appearing in (3).

We may define a quantity E which relates the beam current I to the limiting current I_l

$$E = \frac{I}{I_l}. \quad (7)$$

From (3), (4), and (7) we see that α can be expressed

$$\alpha = \frac{\alpha_l}{\sqrt{E}} = 2 \left(\frac{I}{E A j_o} \right)^{1/2} \left(\frac{11600}{T} V_d \right)^{-1/2}. \quad (8)$$

In (8), α is expressed in terms of quantities of easily appreciated significance. One of these, E , merits discussion at some length. E must be less than unity for several reasons. One is that the current density in a given angular range is necessarily less than the limiting density given by (1) or (2), and can approach the limiting density only as the ratio of cathode current to beam current is made to approach infinity.⁵ Further, the cones of possible paths, or paths terminating on the spot, may not be completely occupied by current flow. Even with perfect focusing, the aperturing system may cause the cones near the edge of the beam to be incompletely occupied. In case of aberration, the flow may actually lie in a number of small cones terminating at different points on the screen, or, electrons may not reach the spot on the screen from all points of the beam cross section in the region of deflection.

E is a measure of the goodness of the electron-optical system, and will be large for good tubes and small for poor ones. For a given finite ratio of cathode current to beam current, E will have a limiting value less than unity. Allowing complete freedom of design, theoretically E can be made to approach unity.

IV. MAGNETIC DEFLECTION AND AFTER-ACCELERATION

In magnetic deflection the angular deflection may be written

$$\alpha = \left(\frac{C}{V_d^{1/2}} \right) i. \quad (9)$$

Here i is the current in the deflecting coils, V_d is the

potential in the region of deflection, and C is a constant depending on the size, shape, and number of turns of the deflecting coils. Combining (8) and (9) we may write for the reciprocal of the current required to move the spot one spot diameter, that is, for the deflection sensibility,

$$1/i = \frac{C}{2} \left(\frac{11600 EAj_o}{IT} \right)^{1/2}. \quad (10)$$

It is seen that for magnetic deflection the deflection sensibility is independent of the potential in the region of deflection. For given values of C , I , A , j_o , and T , the only way that after-acceleration could change the deflection sensibility is through influencing E . As E is a factor dependent on the goodness of electron-optical design, it would seem hardly fair to regard increases in E in the presence of after-acceleration as due to the use of after-acceleration. Disregarding changes in E , we can say that in the case of magnetic deflection, deflection sensibility cannot be increased by after-acceleration.

V. ELECTROSTATIC DEFLECTION AND AFTER-ACCELERATION

In the case of electrostatic deflection, the angular deflection may be written

$$\alpha = \left(\frac{B}{V_d} \right) v. \quad (11)$$

For parallel deflecting plates

$$B = l/2d. \quad (12)$$

Here v is the deflecting voltage and V_d is the potential at the region of deflection. l is the length of the deflecting plates and d is their separation. Thus B is a constant depending on the geometry of the deflecting plates.

Combining (8) with (11) will give the reciprocal of the deflecting voltage v required to move the spot one spot diameter, or, the deflection sensibility,

$$1/v = \frac{2}{B} \left(\frac{11600 EAj_o}{IT} \right)^{1/2} V_d^{-1/2}. \quad (13)$$

For a given screen voltage, V_d can be lowered by after-acceleration. Thus, in the case of electrostatic deflection, after-acceleration is of some advantage in increasing the deflection sensibility. However, the gain is achieved solely through lowering the potential of the deflection region, and not through any special electron-optical property of the particular scheme of after-acceleration used.

VI. FUZZY SPOTS

The relations developed can be applied even in case the spot is not sharply defined. The magnitude of the quantity E will depend on the spot diameter assumed. The smaller the assumed spot diameter, the larger E and the better is the deflection sensibility. There is some uncertainty as to what diameter should be taken, but the range of reasonable choices is not overly wide. In comparing tubes with and without after-accelera-

tion it is sufficient that the same definition of spot diameter be used in all cases.

VII. DEFLECTION DEFOCUSING

In increasing the deflection sensibility by after-acceleration, the angular deflection required to move the spot one spot diameter is actually increased, as may be seen from (8). For a given set of deflecting plates, deflection defocusing increases when the angle of deflection increases. Thus, the deflection defocusing at a point a given number of spot diameters from the center of the screen will be worse with after-acceleration than without. This may be a serious objection to the use of after-acceleration, for deflection defocusing is a considerable aberration in most cathode-ray tubes employing electrostatic deflection, even when after-acceleration is not used.

VIII. CONCLUSION

Expressions for deflection sensibility have been derived which are valid for all cathode-ray tubes whether they involve after-acceleration or not.

It has been shown that in the case of magnetic deflection, assuming a constant electron-optical goodness, deflection sensibility is independent of the potential at the region of deflection. Thus, in this case after-acceleration can result in no gain, and merely increases aberrations.

In the case of electrostatic deflection, aberrationless after-acceleration may be used to increase deflection sensibility. The improvement is dependent only on the lowering of the potential in the region of deflection, and not on the particular mode of after-acceleration used. Through use of different modes of after-acceleration, either the spot size or the deflection sensitivity can be varied at will, but these quantities must be related so that the deflection sensibility is given by the same expression for all systems. From this point of view it would seem that the simplest system of after-acceleration is the best. The increase in deflection sensibility due to after-acceleration is accompanied by an increase in deflection defocusing for a deflection of a given number of spot diameters.

While the increase in deflection defocusing might make after-acceleration seem of dubious value when considered from the point of view of the small gain in deflection sensibility which is usually obtained, certain practical advantages can be achieved through its use. Thus, low-voltage tube designs can be adapted to use at higher voltages, and insulation and power-supply problems sometimes can be simplified.

ACKNOWLEDGMENT

The writer is indebted to Dr. C. J. Davisson for many valuable comments and criticisms and to Mr. C. J. Calbick, who arrived independently at some of the conclusions here presented, for valuable discussions during the preparation of this paper.

The Ionosphere and Radio Transmission, January, 1941, with Predictions for April, 1941*

NATIONAL BUREAU OF STANDARDS, WASHINGTON, D. C.

AVERAGE critical frequencies and virtual heights of the ionospheric layers as observed at Washington, D. C., during January are given in Fig. 1. Critical frequencies for each day of the month

are given in Fig. 2. Fig. 3 gives the January average values of maximum usable frequencies for radio transmission by way of the regular layers. The maximum usable frequencies were determined by the F layer at

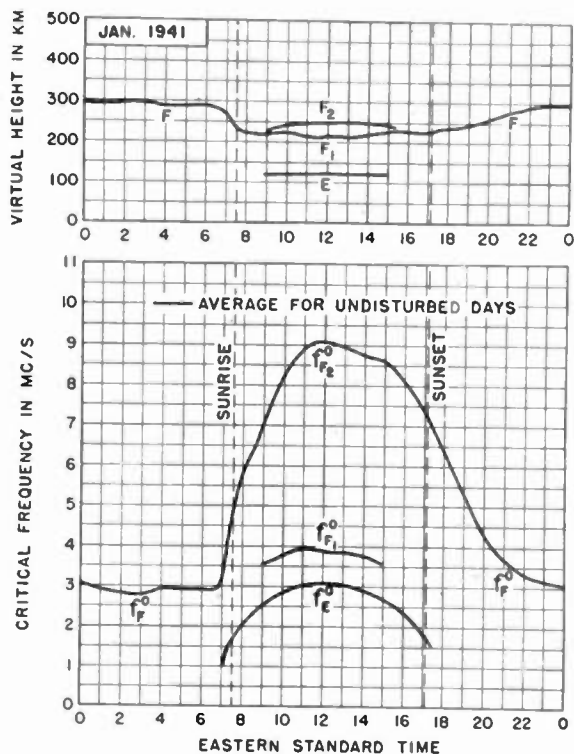

Fig. 1—Virtual heights and critical frequencies of the ionospheric layers, observed at Washington, D. C., January, 1941.

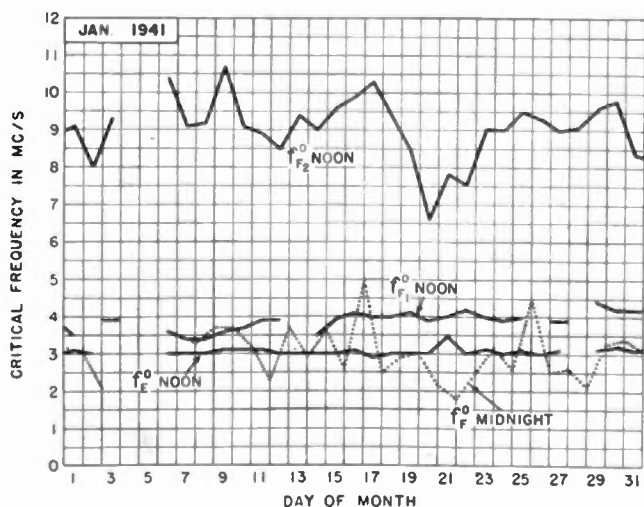

Fig. 2—Midnight f_F^0 and noon f_E^0 , $f_{F_1}^0$, and $f_{F_2}^0$, for each day of January.

* Decimal classification: R113.61. Original manuscript received by the Institute, February 10, 1941. These reports have appeared monthly in the PROCEEDINGS starting in vol. 25, September, 1937. See also vol. 25, pp. 823-840; July, 1937. Report prepared by N. Smith, T. R. Gilliland, A. S. Taylor, F. R. Gracely, and H. V. Cottony.

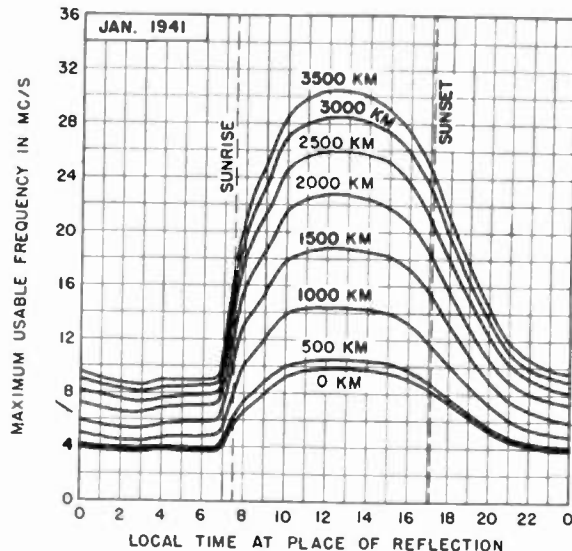

Fig. 3—Maximum usable frequencies for dependable radio transmission via the regular layers, average for January, 1941. These curves and those of Fig. 4 also give skip distances, since the maximum usable frequency for a given distance is the frequency for which that distance is the skip distance.

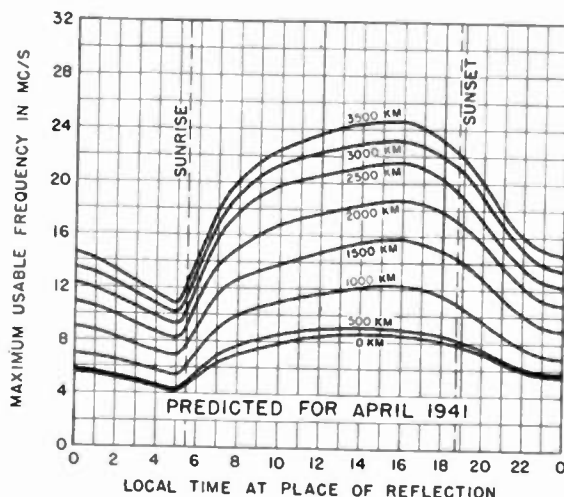

Fig. 4—Predicted maximum usable frequencies for dependable radio transmission via the regular layers, average for undisturbed days, for April, 1941. For information on use in practical radio transmission problems, see Letter Circulars 614 and 615 obtainable from the National Bureau of Standards, Washington, D. C., on request.

night and by the F_2 layer during the day. Fig. 4 gives the expected values of the maximum usable frequencies for radio transmission by way of the regular layers, average for undisturbed days, for April, 1941. All of the foregoing are based on the Washington ionospheric ob-

TABLE I
APPROXIMATE UPPER LIMIT OF FREQUENCY IN MEGACYCLES OF THE STRONGER SPORADIC-E REFLECTIONS AT VERTICAL INCIDENCE

Day	Hour, E.S.T.																							
	00	01	02	03	04	05	06	07	08	09	10	11	12	13	14	15	16	17	18	19	20	21	22	23
Jan.																								
2																				3.2	3.1	3.1	3.1	
3	4.2	3.5	6.5	4.2	4.2	3.2	3.5												9.0	9.0	10.0			
6		3.5	3.2	7.0	7.6	4.2										3.5								
7																					3.3			
8																			3.9					
9					3.4																			
10				2.8	3.5																			
11									4.5															
12																								
13													4.9	6.0	3.6	3.4								
14		3.5	4.6		3.1	3.1	3.2											4.6						
15					4.2	4.5	4.5																	
16						7.0	4.2	4.5																
17	3.5	3.5								5.2														
18										3.6	3.1	3.3	6.6	3.3	3.3			3.2	9.0	4.2	4.5	3.2		
21																								
22										3.3		3.4	3.3											
24										4.5														
26																								
27																								
28																								
29																								
30																								
31					4.5	3.1	5.0												4.6					

servations, checked by quantitative observations of long-distance reception.

No ionospheric storms or sudden ionospheric dis-

turbances were observed during January. Table I gives the approximate upper limit of frequency of strong sporadic-E reflections at vertical incidence.

Institute News and Radio Notes

A Message to Institute Members

Readers of the PROCEEDINGS will be pleased to learn that steps are being taken to bring the publication schedule of the PROCEEDINGS back to normal. This schedule has been somewhat disturbed in recent months by a relative scarcity of acceptable papers. To remedy the existing situation the following measures are being put into effect:

1. The type of acceptable papers has been broadened to include information now known only to relatively small groups of specialists, but which is of interest and value to a much wider group of Institute members. A committee, consisting of Dr. Shackelford, chairman; Dr. A. N. Goldsmith, and Mr. H. A. Wheeler is already actively working to obtain papers of this character.

2. A committee to stimulate the submission of an increased number of papers of the regular type has also been appointed and is now at work.

3. The process of reviewing, accepting, and publishing papers has been speeded up by added editorial personnel, a new expedited procedure, and an increase in safeguards against delay.

4. A publication schedule for the 1941 volume of the PROCEEDINGS has been submitted to the Board of Directors and approved by them. This provides that the October issue will be mailed be-

fore the end of that month, and that the December issue will be mailed in the first half of December.

Advantage is being taken of the present situation to attempt to present to the readers of the PROCEEDINGS a reasonably balanced schedule of papers on subjects of interest to them. An especial effort is being made to supplement the scientific type of material for which the PROCEEDINGS has been so noted in the past with an increased number of articles dealing with the engineering problems encountered by the average engineer in his day-to-day work. In particular, it is hoped to serve better certain groups of members, such as the broadcast transmitter engineers and the receiver design engineers.

Authors will be especially pleased to learn of the prompt service that they can expect on manuscripts submitted to the Institute. Under the new editorial procedure now being installed, a report on a submitted paper can be expected in approximately forty-five days provided no important differences of opinion are encountered in the reviewing process and provided the manuscript is submitted in *triplicate*. Publication of manuscripts that have been approved will then follow in forty to sixty days when only a normal amount of editing is required. This means that a large fraction of manuscripts accepted will be published within three to four months from the date of submission.

Under existing emergency conditions the full co-operation of the Institute membership will be necessary if the plans outlined above are to be fully effective, and if the publication standards and the service given to the membership through the PROCEEDINGS are to be at or above their normal level. Engineers or research workers who have on hand material that they feel is suitable for publication in the PROCEEDINGS under the new program are urged to consider making this available as soon as possible for consideration by the Institute. It will also be helpful in such cases if the secretary of the Institute could be informed immediately of such intentions, giving the title of the paper, its probable length, and the date of its anticipated receipt by the Institute.

The Institute is a co-operative and democratic organization. It is only through the united efforts of its membership that it can function with full effectiveness and be of maximum service. The efforts of the president, or of a few national officers, acting alone, are not sufficient. Every individual who can help the common cause has an obligation to do so as part of the responsibility of being a member of the Institute.

Frederick Emmons Terman
President

Alfred N. Goldsmith
Chairman, Board of Editors

COMING MEETINGS

Joint Meeting
I.R.E.—U.R.S.I.
Washington, D. C.
May 2, 1941

Summer Convention
Institute of Radio Engineers
Detroit, Michigan
June 23, 24, and 25, 1941

Board of Directors

A meeting of the Board of Directors was held on February 5 and attended by F. E. Terman, president; Haraden Pratt, treasurer; I. S. Coggeshall, Melville Eastham, H. T. Friis, Alfred N. Goldsmith, O. B. Hanson, R. A. Heising, L. C. F. Horle, C. M. Jansky, Jr., F. B. Llewellyn, B. J. Thompson, H. M. Turner, A. F. Van Dyck, L. P. Wheeler, and H. P. Westman, secretary.

A number of changes and additions were made in the personnel of the various committees which will serve the Institute during 1941.

The precise territory which will comprise the newly established Dallas-Fort Worth section of the Institute was designated.

A. B. Buchanan was named chairman of the committee in charge of the arrangements for the 1941 Summer Convention which will be held in Detroit on June 23, 24, and 25.

Section 23 of the Institute Bylaws concerning the operation of sections was amended to include a requirement that a minimum membership of 25 be maintained. The revised form of the Bylaw is given below:

Sec. 23—Failure of a Section to maintain the required activities, which shall include the holding of at least five meetings each year and also the maintenance of a minimum membership of 25 Associates, Members, and Fellows, shall place the Section on probation. All members of the Section shall be informed of the probation by the Secretary of the Institute who shall also call to their attention the requirements for maintaining the Section.

If the delinquency continues for a second year, a second notification to the Section membership shall be made by the Institute Secretary and the Board of Directors shall be informed of the probationary status of the Section.

If the delinquency continues for a third year, the Section shall, thereupon, be dissolved. The Secretary shall so report to the Board of Directors and so inform the Section membership.

With minimum provisions for section operation being prescribed on the basis of both the number of meetings to be held each year and the membership strength in the territory of the section, it is now reasonable to relax the minimum requirement for the establishment of new sections. The subjoined resolution was, therefore, adopted.

"RESOLVED, that the Board of Directors goes on record as favoring the formation of Institute sections whenever the number of Associates, Members, and Fellows residing within a reasonable section area is enough to indicate that the proposed section will be able to maintain a membership in excess of 25."

For the past several months, the PROCEEDINGS has been appearing irregularly and late. This has resulted entirely from



DONALD G. FINK



STUART C. HIGHT

Eta Kappa Nu Awards

Each year, Eta Kappa Nu, the electrical engineering honor society, recognizes an engineer less than thirty-five years of age and not more than ten years out of college as "an outstanding young engineer" and gives honorable mention to two others. For 1940, J. E. Hobson, a central-station engineer, received the main citation and two Institute members, Donald G. Fink and Stuart C. Hight, were given honorable mention.

Donald Glen Fink (A'35) was born at Englewood, New Jersey, on November 8, 1911. He was graduated from Massachusetts Institute of Technology in 1933 with a B.Sc. degree in electrical engineering. During 1933-1934 he served as a member of the staff of the electrical engineering and geology departments at Massachusetts Institute of Technology. In 1934 he joined the editorial staff of Electronics, where, in 1937, he was made managing editor.

Mr. Fink is the author of several books on radio and allied subjects and he has presented numerous technical papers and addresses. For the past six months he has

served on a panel of the National Television Systems Committee which is now engaged in setting up standards for commercial television transmission.

He is a member of the Radio Club of America, Tau Beta Pi, Sigma Xi, and Pi Delta Epsilon.

Stuart C. Hight, (A'31-M'39) was born on July 28, 1906, at Oakland, California. In 1930, he received the B.S. degree in electrical engineering from the University of California and in 1934 the M.A. degree in physics from Columbia University.

He has been a member of the technical staff of Bell Telephone Laboratories, Inc., since 1930, where he has been active in the development of piezoelectric plates and bars and circuits for the generation of constant-frequency oscillations. Mr. Hight holds several patents and has published extensively in scientific journals.

He is a member of the American Institute of Electrical Engineers, the American Physical Society, and the American Radio Relay League.

a lack of acceptable papers submitted for publication. To encourage the submission of manuscripts, two special committees have been established. One of these will invite papers of general educational or tutorial caliber which, although of relatively minor interest to those active in the particular field covered, should be of substantial value to those working in other fields. These papers when published will be designated as "invited papers." The other committee will invite papers of the variety normally carried in the PROCEEDINGS but will emphasize the desirability of papers of an engineering as contrasted to a scientific type.

A schedule was set up for the publication of the PROCEEDINGS during 1941.

A new Bylaw concerning the operation of the Nominating Committee was adopted and is given below:

Sec. XX—The Nominating Committee shall transmit its list of pro-

posed nominees to members of the Board of Directors at least a week before the date at which the Board is expected to act upon them.

A number of mechanical changes were made in the PROCEEDINGS to provide for the acceptance of color advertising on all covers and within the magazine itself. The inside front cover will be made available to advertisers.

Section 24 of the Institute Bylaws was revised to change the name of the "Publicity Committee" to "Public Relations Committee" and to provide for the Technical Committees on Frequency Modulation and Symbols. The technical committees are separated from the administrative committees and the Bylaw as amended is given below:

Sec. 24—The standing committees, each of which shall normally consist of five or more persons, shall include the following:

Admissions	Annual Review
Awards	Electroacoustics
Board of Editors	Electronics
Constitution and Laws	Facsimile
Membership	Frequency Modulation
New York Program	Radio Receivers
Nominations	Standards
Papers	Symbols
Public Relations Sections	Television
Tellers	Transmitters and Antennas
	Wave Propagation

I.R.E.-U.R.S.I. Meeting

The annual joint meeting of the Institute of Radio Engineers and the American Section of the International Scientific Radio Union will be held in Washington, D. C., on Friday, May 2. Meetings of other important scientific societies will be held in Washington during the same week. Titles and abstracts of the papers for the I.R.E.-U.R.S.I. meeting will be published in the PROCEEDINGS. The program will be available in booklet form for distribution before the meeting. Correspondence should be addressed to Dr. J. H. Dellinger, National Bureau of Standards, Washington, D. C.

Summer Convention Papers

Papers for presentation at our Summer Convention to be held in Detroit on June 23, 24, and 25 are now being solicited. Anyone desiring to present a paper at the convention should submit it to the Institute office by not later than April 20. The program will be completed shortly thereafter.

Technical Committees

Electronics Conference

A subcommittee under the Technical Committee on Electronics was placed in charge of arrangements for the Electronics Conference which was held at Stevens Institute of Technology in Hoboken, New Jersey, on October 11 and 12. Two meetings of this subcommittee and a meeting of each of three sub-subcommittees were required in preparing the program for the Conference.

On August 23 a meeting of the Electronics Conference subcommittee was attended by F. R. Lack, chairman; R. M. Bowie, Alan Hazeltine, F. B. Llewellyn, A. L. Samuel, R. W. Sears, F. C. Stockwell, B. J. Thompson, H. A. Wheeler, and H. P. Westman, secretary. Professors Hazeltine and Stockwell are of the faculty of Stevens Institute of Technology and offered their co-operation in the arrangements to be made for housing facilities.

At the September 20 meeting, those present were F. R. Lack, chairman; R. M.



HAROLD H. BEVERAGE

Harold Henry Beverage (A'15-M'26-F'28), President of the Institute in 1937, has been appointed Vice President in Charge of Research and Development of R.C.A. Communications, Inc.

Dr. Beverage was born in North Haven, Maine, on October 14, 1893. In 1915 he received the Bachelor of Science degree in electrical engineering from the University of Maine and entered the General Electric Company test course. During the next four years he was laboratory assistant to Dr. Alexander and participated in the development of the high-frequency alternator later used in the high-powered transatlantic transmitting stations.

From 1920 to 1929 his time was devoted to research on communication receivers for the Radio Corporation of America. Since 1929 he has been Chief Research Engineer of R.C.A. Communications, Inc. He was awarded the Morris Liebmann Memorial Prize in 1923 for his work on directional antennas.

In 1938 the degree of Doctor of Engineering was conferred on him by the University of Maine.

Bowie, F. B. Llewellyn, G. A. Morton, A. L. Samuel, R. W. Sears, B. J. Thompson, and J. D. Crawford, secretary to the committee.

The three sub-subcommittees met during September. On the 6th, the Sub-Subcommittee on Ultra-High-Frequency Measurements met and those present were B. J. Thompson, chairman; H. T. Friis, and J. D. Crawford, secretary to the committee. The Sub-Subcommittee on Dense Electron Beams met on September 13 and those in attendance were F. B. Llewellyn, chairman; A. V. Haeff, R. C. Hergenrother, and J. D. Crawford, secretary to the committee. On September 20, R. M. Bowie, chairman; C. H. Bachman, L. E. Flory, and H. P. Westman, secretary, attended a meeting of the Sub-Subcommittee on High-Vacuum Techniques.

Technical Committee on Frequency Modulation

A meeting of the Technical Committee on Frequency Modulation was held on

October 28 and attended by D. E. Noble, chairman; H. A. Wheeler, chairman of the Standards Committee; C. C. Chambers, E. D. Cook (representing H. B. Marvin), M. G. Crosby, R. D. Duncan (representing C. B. Jolliffe), A. L. Durkee (representing G. W. Gilman), James Parker (representing A. B. Chamberlain), and J. D. Crawford, secretary to the committee. A program of items to be considered by the committee was set up. A report of a Subcommittee on Definitions was received and acted on.

Subcommittee on Definitions

A Subcommittee on Definitions of the Technical Committee on Frequency Modulation held two meetings. C. C. Chambers, chairman, M. G. Crosby, G. W. Gilman, and J. D. Crawford, secretary to the committee; attended both these meetings which were held on September 11 and October 4. The terms which were referred to the committee for the preparation of definitions were the entire business of the meetings.

Technical Committee on Facsimile

To co-ordinate the activities of three subcommittees dealing with definitions, a meeting was held on October 25 and another on October 31 of the chairmen of the Technical Committee on Facsimile and the chairmen of the three subcommittees working on definitions. J. L. Callahan, chairman; W. A. R. Brown, R. E. Mathes (guest), Pierre Mertz, C. J. Young, and J. D. Crawford, secretary to the committee; attended both meetings.

Technical Committee on Radio Receivers

Subcommittee on Frequency-Modulated-Wave Receivers

Meetings of this subcommittee were held on September 16 and on October 30. Those present at the September meeting were R. M. Wilmotte, chairman; A. W. Barber, L. F. Curtis, M. L. Levy (representing W. F. Cotter), and J. D. Crawford, secretary to the committee. At the October 30 meeting, R. M. Wilmotte, chairman; D. E. Foster, chairman of the Technical Committee on Radio Receivers; A. W. Barber, R. I. Cole, L. F. Curtis, M. L. Levy (representing W. F. Cotter), J. A. Worcester (representing W. M. Angus), and J. D. Crawford, secretary to the committee; were present.

These meetings were devoted to the preparation of a number of tests on frequency-modulated receivers. In a number of cases, additional laboratory work had to be done before the effectiveness of certain proposals was evident.

Technical Committee on Symbols

A meeting of the Technical Committee on Symbols at which H. M. Turner, chairman; M. R. Briggs, R. S. Burnap, C. R. Burrows, J. L. Callahan, E. L. Chaffee,

E. R. Jervis (representing E. W. Schafer), O. T. Laube, F. B. Llewellyn, and J. D. Crawford, secretary to the committee; were present was held on October 18. Both letter and graphical symbols were considered at this meeting. A preliminary report on letter symbols was completed for letter ballot by the committee before being referred to the corresponding committee operating under the procedure of the American Standards Association.

Technical Committee on Television

Subcommittee on Methods of Testing Transmission Lines and Antennas

This subcommittee held two meetings, one on September 19 and the other on November 1. L. M. Leeds, chairman, J. Epstein (representing G. H. Brown), R. F. Lewis, N. E. Lindenblad, D. B. Sinclair, and J. D. Crawford, secretary to the committee; attended both meetings and C. R. Burrows also was at the November meeting. A substantial amount of material on subjects indicated by the title of the subcommittee was distributed prior to the meetings and considered at them.

Sections

Atlanta

A "Round-Table Discussion on Reproducing and Recording" was participated in by almost everyone at the meeting and was led by P. C. Bangs, M. K. Toalson, Ben Akerman, and J. M. Comer, Jr.

The various types of recordings that are being made at the present time were first discussed and their advantages and disadvantages considered. Standard types of equalization are not used in all recordings and work looking toward unifying practice in this field was considered desirable.

Various types of cutters, such as crystal and magnetic, were discussed in detail. In considering pickups, methods of avoiding and compensating for resonance in the mechanical structure were discussed.

Methods of driving turntables were considered and the characteristics of the various present methods were outlined.

The discussion included the subject of the patterns which are produced on a disk as a result of recording.

December 20, 1940, P. C. Bangs, chairman, presiding.

Baltimore

C. A. Ellert and K. A. Norton of the Federal Communications Commission staff presented a paper on "A Long-Range Field-Intensity-Recording Program for Studying Propagation Conditions."

A satisfactory allocation of radio frequencies depends on the grade of service to be rendered and this is closely related to the reception of undesired signals and noise. In the broadcast service, daytime transmission is chiefly by means of the ground wave and is readily calculable. At night, reception depends on the sky wave. The sky wave is an important factor and

it may arrive over any of various routes. This wave does not yield to calculation and measurements are being made to indicate the long-time trend of average values neglecting the wide fluctuation occurring in short-time intervals.

Recording stations have been established at Grand Island, Nebraska; Portland, Maine; and Baltimore, Maryland. Separate receivers are tuned to about eight broadcast transmitters located in various parts of the country and two additional receivers record the noise at each end of the broadcast band. A direct-current amplifier permits a recording millimeter to be operated from the voltage which appears across the receiver diode load resistor.

The receivers are calibrated by means of a standard-signal generator coupled to the input of the receiver through a capacitance equivalent to that of the antenna. A correction must be made for the effective antenna height if different antennas are used. Otherwise, several receivers may be operated from a single antenna if they are coupled to it through small condensers which reduce the effect of the interaction among the individual receivers.

The sensitivity of the receiver is affected greatly by the stability of the oscillator which is influenced by variations in line voltage and temperature. A voltage regulator is employed. Temperature changes are minimized by maintaining an ambient of about 110 degrees Fahrenheit inside a well-insulated shack in which the receivers are located and removing excess heat by a thermostatic-controlled blower.

Direct-current amplifiers are unnecessary with receivers having automatic volume control, the recording millimeter being inserted in place of the normal tuning indicator. This gives instantaneous values. Average values are obtained from the audio-frequency output by inserting between the recorder and the output stage a resistance-capacitance network having a time constant of from 80 to 90 seconds. Average and peak values are alternately recorded in 15-minute periods. Data obtained from some of these measurements were described and significant features pointed out.

January 17, 1941, V. D. Hauck, vice-chairman presiding.

Cincinnati

"The Microphone and Research" was the subject of a paper by F. S. Goucher of the Bell Telephone Laboratories.

There was presented first a brief history of the evolution of the carbon microphone. This development was traced from the early liquid transmitter developed by Bell through the early contact types of Berliner, Hughes, and Edison to the present-day handset. The speaking quality and efficiency of some of these early models were demonstrated and were compared with the early commercial types and those of present-day design. These demonstrations utilized a magnetic-tape recorder with playback to the audience through a loud-speaker system. Although carbon-contact microphones have been used for many years, research has but recently

made clear the precise behavior of the particles. The action depends on the elastic deformation of minute hills of roughnesses on the contact surfaces as affected by the minute motions between the contacting particles.

A demonstration was given to show the minuteness of the motion required to produce talking currents in a microphonic contact. A three-foot steel rail was supported at each end and against the center of it a carbon granule was brought into electrical contact. The rail could be deformed by placing weights on it and although its motion was of only molecular dimensions, the contact resistance was shown to change by as much as 10 per cent. Sufficient motion could be imparted to the rail under the action of speech to produce talking currents comparable in intensity to those first obtained by Bell.

This meeting was held jointly with the Cincinnati section and the University of Cincinnati student branch of the American Institute of Electrical Engineers. The presiding officer was the chairman of the student branch.

January 9, 1941, J. P. Quitter, presiding.

Dallas-Fort Worth

Although the Institute members in the Dallas-Fort Worth region have met regularly for over a year, their first meeting since the establishment of the section was held on January 11. D. A. Peterson of WFAA-WBAP, was elected chairman; T. I. Kimzey, of the Texas State Network, was named vice chairman; J. R. Sullivan, of WRR, was designated secretary; and P. M. Honnell of Southern Methodist University became treasurer.

Cecil Ross of the Graybar Electric Company presented three sound films describing the manufacture of telephone wire and vacuum tubes.

January 11, 1941, D. J. Tucker, presiding.

A paper on "Modern Conceptions of Acoustical Design" was presented by C. P. Boner of the physics department of the University of Texas. Starting with the interesting early work of Sabine, Dr. Boner traced the trend of acoustical design problems to the present-day technique. The part of the high-speed level recorder in this field was outlined. Some of the methods of acoustic control used in broadcast studios were then covered.

January 23, 1941, D. A. Peterson, chairman, presiding.

Detroit

"The Static and Dynamic Temperature Compensation of Radio-Frequency Oscillators" was the subject of a paper by M. Cottrell, research engineer of Philco Radio and Television Company (Detroit). The variation in oscillator frequency resulting from changes in temperature and humidity were considered. The component parts of the oscillator circuit were considered separately.

Various types of silvered mica condensers normally used in oscillator tank

circuits were described. Photomicrographs were shown to illustrate poor coatings on some condensers which result in erratic variations in their capacitance. A dynamic test to show this effect was demonstrated.

It was stated that by the proper choice of materials, the stability of oscillator coils can be greatly improved. Difficulties encountered with such materials as polystyrene, methyl-methacrylate, phenolic resins, and hard-rubber compounds were described. Brief tests were run to show the effect of temperature on the operation of coils not properly designed to compensate for these changes.

January 17, 1941, M. Cottrell, chairman, presiding.

Los Angeles

Three papers were presented at this meeting. The first two were on "X-Ray Equipment in the Aviation Industry."

T. A. Triplett, president of Triplett and Barton, Inc., discussed the basic procedure of making X-ray observations and described the equipment used for such purposes by the aviation industry in southern California. He related some of the major problems encountered in the development of X-ray tubes which would permit the inspection of thousands of pieces of equipment per day. Anode potentials starting at 175 kilovolts and ranging up to 900 kilovolts are being utilized. The anode voltage, current, and the exposure time must all be adjusted for a given particular piece to be photographed. Twenty-seven different types of film are required to obtain maximum detail in these various applications.

Other problems which were encountered included the construction of properly shielded booths suitable for high-speed inspection, the development and identification of films, and their interpretation.

When using the highest voltages, satisfactory definition can be obtained when photographing through 5 inches of steel. Although thicker pieces can be photographed, the number of defects observable makes interpretation difficult. At the present time about 75 per cent of the observations are on castings, 20 per cent are on sheet stock, and 5 per cent are miscellaneous items.

The discussion of this subject was continued by Donald Erdman, chief physicist of Triplett and Barton, Inc. He described the electronic-controlled circuits which permit rapid selection of the proper anode voltage, current, and time of exposure. When these factors have been set, a single push button initiates electronically the proper sequence of events, resulting in an exposure having an aggregate error of less than 6 per cent even though the primary line voltage may vary between 90 and 130 volts. To secure satisfactory stability in the high-voltage circuits, a saturated reactor controlled by a thyratron used in a circuit which depends primarily on power rather than voltage for its operation is employed.

The objective of further research is to develop an equipment which can be adjusted to a value assigned to each particular part and which will not require the wide

range of different films which are now considered necessary.

The third paper was presented by Fred Foulon of the engineering department of the Douglas Aircraft Company who discussed "A New Approach to Radio Interference Bonding and Shielding Requirements for All-Metal Aircraft."

It was stated that the early type of bonding and ignition harness used in aircraft to suppress radio interference is still maintained in the present all-metal equipment.

In analyzing the problem, it was pointed out that aircraft receivers have had very little attention paid to the filtering of supply leads. The better receivers have a noise susceptibility in the order of 20-1 whereas it is common for automobile radio receivers to show a susceptibility of only 10,000-1.

When proper consideration is given to the location of the radio receivers and the filtering of the leads entering the compartment, open wiring with its greater accessibility for servicing may be used where conduit is not needed for other reasons. A demonstration of the operation of such receivers concluded the paper.

January 21, 1941, W. W. Lindsay, Jr., chairman, presiding.

Montreal

"Atomic Physics and the Cyclotron" was the subject of a paper by J. S. Foster, Macdonald professor of physics, McGill University.

The more-important features of our knowledge of the atom and the means by which the information was obtained were first outlined. The cyclotron was then described and its use in producing artificially radioactive elements was discussed. The paper was concluded with a consideration of atom splitting with particular reference to uranium and the production of useful energy.

November 27, 1940, R. E. Hammond, vice chairman, presiding.

B. de F. Bayly, professor of electrical engineering at the University of Toronto presented a paper on "Measurements."

He developed first the principles basic to radio measurements and then showed their application to radio-frequency and ultra-high-frequency measurements. The use of the "45-degree point" theorem was discussed. Various features in the operation of cathode-ray oscillographs and bridges at radio frequencies were pointed out.

December 11, 1940, R. E. Hammond, vice chairman, presiding.

"Transoceanic Radio Communication" was the subject of the paper presented by C. W. Hansell, engineer in charge of engineering and research for R.C.A. Communications, Inc.

It was pointed out that the transatlantic cables first supplied communication across the ocean. The lack of effective research work to improve these circuits at that time permitted radio communication systems to become commercially feasible.

The transatlantic radio circuits started with long-wave equipment which later be-

came subordinate to the modern high-frequency system. These radio developments led to increased research on the part of the cable operators which resulted in a sharp increase in the traffic-handling capacities of the present world-wide cable system.

Two of the most difficult problems met in the development of the high-frequency circuits were the obtaining of satisfactory frequency stability and the avoiding of multipath transmission. Frequency stability was obtained by suitable equipment design. Phase and frequency modulation and space-wave keying were employed in an attempt to reduce traffic errors resulting from multipath transmission. Mention was made also of the 7-unit code and its use to replace the traffic procedure of repeats on letters or words.

January 15, 1941, E. A. Laport, chairman, presiding.

Pittsburgh

L. O. Grondahl, director of research and engineering, Union Switch and Signal Company, presented a paper on "Dry Rectifiers."

The history of dry rectifiers started in about 1906 with the introduction of the copper-sulphide type. From 1920 through 1926, the copper-oxide rectifier came into common use and was replaced to a large extent starting in 1930 with the selenium rectifiers.

The construction of each of these types of rectifiers was described and their characteristics were outlined. In operation, rectification appears to take place at a boundary and the process is similar in some respects to electrolytic rectification.

In an improved form of the copper-oxide rectifier, the layer of cupric oxide formed on the surface of the cuprous oxide is reduced to copper and nickel-plated to form the contact. This eliminates the necessity for a heavy clamping mechanism to secure satisfactory contact with the oxide layer thus considerably reducing the size and weight of the rectifier units.

Various applications of the copper-oxide units were described and range in power requirements from those associated with measuring instruments to units handling 150 kilowatts and 25,000 amperes. A number of copper-oxide units are used as modulators and nonlinear resistances.

January 13, 1941, R. E. Stark, chairman, presiding.

Portland

"Square Waves and Square-Wave Testing" was the subject of a paper by W. R. Hewlett of the Hewlett-Packard Company. A summary of this paper is given as a report of the Seattle section for November 25, 1940 which appears in the December PROCEEDINGS.

November 26, 1940, Marcus O'Day, chairman, presiding.

San Francisco

"American Defense beyond the Western Hemisphere" was a subject of a talk by David Barrows, major general, U. S. Army, retired. This meeting was held

jointly with a number of other engineering societies under the auspices of the San Francisco Engineering Council and was of general interest.

January 25, 1941.

Seattle

"Coastal Harbor Stations of the Bell System" was a subject of a paper by Austin Bailey of the American Telephone and Telegraph Company.

The development of equipment for radiotelephone communication with ships and regular telephone subscribers was started in 1916. By 1919 it was technically possible to establish this service but no demand existed for it. Service did not start until mid 1930.

A description was given of the existing system. A typical installation on shore consisting of a transmitter, one or more receivers, and the necessary control equipment was described. The control equipment is known as a codan (carrier-operated device, antinoise). It prevents the receivers from operating until a carrier having sufficient strength to override noise is present. It operates the signaling device and also controls the "transmit-receive" relays after the operator answers the call.

Based upon the number of vessels using the service, its growth has been tenfold in the past three years. The number of messages per vessel is increasing steadily and it is evident that this service is an important factor in the operation of coastal and harbor vessels.

January 9, 1941, K. H. Ellerbeck, presiding.

Toronto

E. A. Laporte of the RCA Victor Company (Montreal) presented a paper on "Recent Developments in Radio Aids for Instrument Flying on Civil Airways."

The subject was introduced with a statement that the present-day systems

are based on a standard "four-course" range and all discussion would deal with auxiliary equipment and improvements to this basic system. The introduction of many new possibilities in instrument flying techniques are deterred by the considerable investment in the equipment and pilot training for the present system which, for these reasons, is likely to continue in operation for some time to come. At the present time there are 264 radio range stations in the United States and 40 in Canada. A description of the basic system was given.

Originally, the "cone of silence" which occurs over a vertical radiator of a range station was used for position marking. It was found that if the plane flew as little as 200 or 300 feet off the position directly above the radiator the cone of silence would be missed. This brought about the use of an ultra-high-frequency transmitter to provide a positive indication by means of a sharp vertical beam. These marker beacons operate at 75 megacycles and a special receiver which is fixed-tuned and has moderate sensitivity is employed in the plane to indicate when the plane is above the marker. Another type of marker gives a fan-shaped radiation pattern. The pattern is very thin but wide across the course so that the plane will receive the signal even though it may be considerably to one side of the course on which it is supposed to be operating. It is particularly useful to mark boundaries such as of mountains and indicate to the pilot the necessity of increasing his altitude to some previously prescribed value until the second marker is passed indicating that the mountains have been left behind and the plane may descend.

The principle of position finding by the use of radio was described. Also, the approach sequence which must be followed when weather conditions necessitate an instrument landing was illustrated.

January 6, 1941, R. H. Klingelhoefter, vice chairman, presiding.

"Elliptical Speakers and Loud-Speaker Applications" was the subject of a paper by Austin Ellmore, chief Engineer of Utah Radio Products.

The subject was introduced with a résumé of loud-speaker-design practice which covered the various factors governing the efficiency of a speaker. Manufacturing considerations as well as general design were considered.

The characteristics of elliptical structures as compared with those of conventional circular form were given. It was pointed out that the requirements for tools and dies are one of the outstanding drawbacks to the use of elliptical speakers. In some cases this additional cost may be offset by improved space requirements particularly for automobile application.

It was pointed out that in some cases second-harmonic distortion near the point of resonance has been introduced intentionally to enhance the low-frequency reproduction.

January 20, 1941, R. H. Klingelhoefter, vice chairman, presiding.

Washington

E. V. Condon, associate director of the research laboratory of the Westinghouse Electric and Manufacturing Company, presented a paper on "Cavity Resonator—Directional Antenna."

A mathematical treatment of the problem of wave functions of cavity resonators was first presented. To illustrate the mode of oscillation in certain objects, the physical comparison was made with mechanical vibrations.

The subject of directional characteristics of antennas was then discussed. It was shown that the physical dimensions of antenna arrays must exceed the wavelength if the array is to have directional characteristics.

January 13, 1941, M. H. Biser, chairman, presiding.

Membership

The following indicated admissions to membership have been approved by the Admissions Committee. Objections to any of these should reach the Institute office by not later than March 31, 1941.

Admission to Associate (A), Junior (J), and Student (S)

- Abraham, G., (S) 19 W. 74th St., New York, N. Y.
- Alba, C. J., (A) 3224—16th St., N.W., Washington, D. C.
- Alcock, N. Z., (S) California Institute of Technology, Pasadena, Calif.
- Alexander, W. R., (A) 9 The Fairway, Upper Montclair, N. J.
- Anderson, D. B., (S) 1023 N. 29th St., Billings, Mont.
- Banner, P., (J) 1177 E. 55th St., Chicago, Ill.
- Barry, J. G., (A) School of Engineering, Princeton University, Princeton, N. J.
- Beagles, R., (S) Route 1, Newberg, Ore.
- Bensen, R. K., (J) 8 Grover Rd., Dover, N. J.
- Bigler, R. R., (S) R.D. 4, Massillon, Ohio
- Bohn, A. L., (A) 3015 Cresmont Ave., Baltimore, Md.
- Cameron, F. W., (A) 113 High St., Nelson, B. C., Canada
- Camras, M., (S) 1418 S. Karlov Ave., Chicago, Ill.
- Carpenter, L. B., (A) 1312 N. 24th Ave., Birmingham, Ala.
- Chatfield, J. K., (A) Route 4, 9414 Northcliff Dr., Dallas, Tex.
- Cleckley, J. T., (S) Box 332, Georgia School of Technology, Atlanta, Ga.
- Cochran, K. L., (S) 318 Welch Ave., Ames, Iowa
- Congdon, R. L., (S) 1400 Packard St., Ann Arbor, Mich.
- Cooper, R. A. G., (A) "Willow Dene," Ivy Lane, Wilstead, Beds., England
- Croner, A. J., (A) 1972 Eastern Pkwy., Schenectady, N. Y.
- De Arruda, P. R., (A) Rua Tibagy, 22 Apto. 201 (Laranjeiras), Rio de Janeiro, Brazil
- De Lano, R. B., Jr., (S) 499 Huntington Ave., Boston, Mass.
- Deme, J., (A) Box 77 Marion Ave., Marion, Conn.
- De Sampaio, O. F., (A) Rua Duvivier 50 (Copacabana), Rio de Janeiro, Brazil
- Dikmen, B., (S) 41 Vernon St., New Haven, Conn.
- Dorfman, E., (A) 1244 Grant Ave., New York, N. Y.
- Duckworth, G. W., (S) 312 Walsh Hall, Notre Dame, Ind.
- Eachus, I., Jr., (S) 207 N. Wayne Ave., Wayne, Pa.
- Eckert, J. P., Jr., (S) 1006 W. Cliveden Ave., Philadelphia, Pa.
- Edmonds, S. C., (A) 326 Beverly Hill Blvd., Billings, Mont.
- Eilenberg, C., (A) 140 Glenwood Ave., Jersey City, N. J.
- Evans, H. J., (S) 1218 S. University, Ann Arbor, Mich.
- Falwell, L. W., (J) 1604 Park Rd., N.W., Washington, D. C.
- Fiske, J. J., Jr., (S) International House, Berkeley, Calif.
- Flachbarth, C. T., (S) 669 Roxborough Ave., Philadelphia, Pa.
- Franck, J. V., (S) 14790 E. 14th St., San Leandro, Calif.
- Frekot, J. J., (A) 1614 Cadwallader St., Philadelphia, Pa.
- Fromm, W. E., (A) 3550 Park Ave., Kansas City, Mo.
- Gardner, F. H., (A) 25 Arnold Pl., Dayton, Ohio
- Genera, V. A., (A) 3224—16th St., N.W., Washington, D. C.
- Ghose, M. N., (A) 94/C, Garpar Rd., Calcutta, India
- Gorder, L. O., (A) 2149 Beechwood Ave., Wilmette, Ill.
- Gordon, I., (S) 643 Yale Station, New Haven, Conn.
- Goscinski, T., (A) 545 W. 50th St., New York, N. Y.
- Grew, L. B., (A) Southern New England Telephone Co., New Haven, Conn.
- Gruendel, G. F., (A) 32-15—34th St., Astoria, L. I., N. Y.
- Hammell, R., (A) 180 Spring St., Red Bank, N. J.
- Hammett, W. M. H., (A) Capitol Radio Engineering Institute, 3224—16th St., N.W., Washington, D. C.
- Harris, D. L., (A) 560 King St., W., Toronto, Ont., Canada
- Hatchwell, J., (S) 725 W. Roosevelt Blvd., Philadelphia, Pa.
- Heimark, H. M., (A) 4954 Race Ave., Chicago, Ill.
- Hooper, P. B., (J) 1463 Cuyler, Chicago, Ill.
- Horsley, G. E., (A) U.S.S. Whitney, San Diego, Calif.
- Hyal, F. A., (A) 14150 Young St., Detroit, Mich.
- Jaeger, J. E., (A) 1604 Park Rd., Washington, D. C.
- Jones, M. L., (A) 811 W. Lanvale St., Baltimore, Md.
- Kappelman, G. E., (J) 2234 E. 1st St., Brooklyn, N. Y.
- Kawatra, R. K., (A) c/o M/S Eiffel Radio Service, 91 Irwin Rd., New Delhi, India
- Kingman, R. W., (A) c/o H. C. Kingsbury, Park Ave., Keene, N. H.
- Klahn, L. H., (A) 3106 S.E. Belmont, Portland, Ore.
- Knapp, G. P., (A) 143 Montclair Ave., Montclair, N. J.
- Knowlton, C. S., (A) 540 W. Wilson Ave., Glendale, Calif.
- Kokubu, R., (A) 148 Setjo-Machi, Seta-gaya-Ku, Tokyo, Japan
- Kotowski, P., (A) Wittekindstr 83, Berlin-Tempelhof, Germany
- Kraus, F. A., (A) 7535 Beverly Rd., Philadelphia, Pa.
- Krishnamoorthy, V., (A) All India Radio, Delhi, Br. India
- Kromko, V. J., (A) 773—2nd St., Trenton, N. J.
- Kung, L. M., (A) 502 W. Gilmore St., Angola, Ind.
- Larick, S. H., (S) 2691 Reservoir Ave., New York, N. Y.
- Lazarus, M. I., (A) 675 West End Ave., New York, N. Y.
- Lee, J. A., (S) 1016 Yale Station, New Haven, Conn.
- Liss, I. M., (S) 10 Burnside Dr., Toronto, Ont., Canada
- Littlejohn, H. C., (A) 1737 Cambridge St., Cambridge, Mass.
- Lorenz, R. V., (S) Poling Hall, Corvallis, Ore.
- Luke, C. H., (A) 516 E. 3rd St., Mishawaka, Ind.
- MacAllister, A., Jr., (A) 263 Hornblower Ave., Belleville, N. J.
- Mayle, A. T., Jr., (A) 3733 Piqua Ave., Fort Wayne, Ind.
- Meyer, L. V., (A) Laboratorio Radio do D.C.T.-Morro de S. Bento, Rio de Janeiro, Brazil
- Michelfelder, L., (A) 3037 Ohio St., Coconut Grove, Fla.
- Miller, M., (S) 1089 Eastern Pkwy., Brooklyn, N. Y.
- Morrison, R. H., (S) 149 Andrew Pl., West Lafayette, Ind.
- Murphy, W. T., (A) "Wilton," 338 Beaconsfield Parade, St. Kilda, S.2, Victoria, Australia
- Nelson, F. H., (A) 777 E. Calvert St., College Park, Md.
- Nelson, R. H. E., (A) 7 R.S.S., R.A.F. Hill End, Henbury, Bristol, England
- Peterson, R. A., (S) 1721 Laramie, Manhattan, Kan.
- Platzer, H. L., (A) 112 Bay 29th St., Brooklyn, N. Y.
- Porter, J. D., (S) 57 Clearwater Rd., Chestnut Hill, Mass.
- Possner, L., (S) 2315 Dwight Way, Berkeley, Calif.
- Rast, R. E., (A) 1985 Powell Ave., New York, N. Y.
- Read, V. H., (A) 140 Church St., Watertown, Mass.
- Reintjes, J. F., (A) 34½ Van Corlear Pl., New York, N. Y.
- Rice, P., (A) 856 Montrose Ave., Chicago, Ill.
- Rochester, N., (S) 403 Memorial Dr., Cambridge, Mass.
- Roe, R. B., (A) 133 Kennedy Ave., Hempstead, L. I., N. Y.
- Rose, J. T., (A) 100 Ruth St., Pittsburgh, Pa.
- Ruda, A., (J) 1953—71st St., Brooklyn, N. Y.
- Rudenberg, H. G., (S) 32 Ross Rd., Belmont, Mass.
- Schlaflly, H. J., Jr., (S) 203 Walsh Hall, Notre Dame, Ind.

Schlegel, R. E., (A) 20 W. Ohio St., Chicago, Ill.
 Seibold, C. A., Jr., (A) 11 Linden Terr., Pikesville, Baltimore, Md.
 Sharp, J. W., (A) 542 N. Pine Ave., Chicago, Ill.
 Sheppard, C. B., (S) 439 Broadway, Camden, N. J.
 Siddappa, S. G. R., (A) c/o Settara Gubbiappa, Nelamangala, Bangalore, Mysore State, India
 Smith, D. I., (S) R.F.D. 2, Fleming, Ohio
 Smith, W. G., (A) 112 S. Wilton Pl., Los Angeles, Calif.
 Soderman, R. A., (S) Box 2488, Stanford University, Calif.
 Speller, J. B., (S) M.I.T. Graduate House, Cambridge, Mass.
 Stone, M. M., (S) 84 Harvard Ave., Allston, Mass.
 Sziklai, G. C., (A) 1220 Maxwell Lane, Bloomington, Ind.

Thatcher, T. W., Jr., (S) 254 N. Hyland, Ames, Iowa
 Thomforde, C., (S) 612 Pine St., Crookston, Minn.
 Thulin, C. W., (S) 24 Grammont Rd., Worcester, Mass.
 Tomiyasu, K., (S) 500 Riverside Dr., New York, N. Y.
 Trexler, J. H., (S) 3429 Haynie, Dallas, Tex.
 Tucker, D. G., (A) 31 Frederica Rd., Chingford, London E.4, England
 Upham, S. W., (S) 1840 Verona Rd., Kansas City, Mo.
 Velia, A. C., (A) Bell Telephone Laboratories, Inc., 180 Varick St., New York, N. Y.
 Wadthekar, S. V., (A) D.L.E.S. Corp., Ltd., Darbhanga, Bihar, India
 Waller, M. J., (S) Glen Cross, Ont., Canada

Walters, L. R., (A) 3680a Folsom Ave., St. Louis, Mo.
 Watts, G. J., (S) 811 S. Willson Ave., Bozeman, Mont.
 Weber, V. J., (A) c/o Bell Telephone Laboratories, Inc., 463 West St., New York, N. Y.
 West, S. F., (S) 2540 College Ave., Berkeley, Calif.
 Weston, A. H., (A) 9034 S. Commercial Ave., Chicago, Ill.
 White, G., (A) 1002 Santa Fe Bldg., Dallas, Tex.
 Wightman, P. E., (A) 108 McKinley Ave., Hyattsville, Md.
 Wilhelm, F. A., (A) 295 W. 11th St., New York, N. Y.
 Williams, S. B., (A) 254 Central Ave., West Caldwell, N. J.
 Woll, H. J., (S) 3254 S. Michigan Blvd., Chicago, Ill.

Contributors



CHARLES R. BURROWS

Charles R. Burrows (A'24-M'38) was born in Detroit, Michigan, on June 21, 1902. He received the B.S.E. degree in electrical engineering from the University of Michigan in 1924 and the A.M. degree in physics from Columbia University in 1927. Dr. Burrows was a research assistant at the University of Michigan during 1922-1923. Since 1924 he has been a member of the radio research department of the Western Electric Company and its successor, the Bell Telephone Laboratories. In this capacity he contributed to the development of the long-wave transatlantic radiotelephone transmitters for Rocky Point, New York, and Rugby, England. Early in the development of short-wave radio he entered that field and made analyses of this type of propagation, which formed the basis for short-wave transoceanic telephone service. From 1930 to 1938 he supervised a group of engineers investigating ultra-short-wave propagation. He received the E.E. degree from the University of Michigan in 1935 and the

Ph.D. degree from Columbia University in 1938. Recently he has been working on the development of short-wave and ultra-short-wave transmitters. Dr. Burrows is a member of Sigma Xi and the American Institute of Electrical Engineers.



Marion C. Gray (A'40) was born at Ayr, Scotland. She received the M.A. degree from Edinburgh University in 1922 and the Ph.D. degree in mathematics from Bryn Mawr College in 1926. After teaching physics at Edinburgh University and acting as mathematical research assistant at the Imperial College of Science, London, she joined the development and research department of the American Telephone and Telegraph Company in 1930. She transferred with that department to the Bell Telephone Laboratories in 1934 and has since been associated with



MARION C. GRAY



FRANK J. MAGINNISS

the mathematical group working on problems in electromagnetic theory.



Frank J. Maginniss attended New York University, evening course, and received the B.S. degree in physics in 1937. In 1938 he was an assistant in the physics department of the University of Pennsylvania and during 1939-1940 he was a research assistant at the Morre School of Electrical Engineering of the University of Pennsylvania where he operated the differential analyzer. He received the M.S. degree in physics from the University of Pennsylvania in 1940. At the present time Mr. Maginniss is employed at the Frankford Arsenal in Philadelphia working in experimental ballistics of small arms ammunition.



John R. Pierce (S'35-A'38) was born on March 27, 1910, at Des Moines, Iowa.



JOHN R. PIERCE

He received the B.S. degree in 1933; the M.S. degree in 1934; and the Ph.D. degree in 1936 from the California Institute of Technology. Since 1936, Dr. Pierce has been with the Bell Telephone Laboratories. He is a member of Tau Beta Pi, Sigma Xi, and the American Physical Society.



Harner Selvidge (A'31-M'40) was born at Columbia, Missouri, on October 16, 1910. He received B.S. and M.S. degrees in electrical engineering from the Massachusetts Institute of Technology in 1933, having taken the co-operative course in which he worked for the Western Electric Company in 1930, the New York Telephone Company in 1931, and the Bell Telephone Laboratories in 1932. In 1933 he also worked for the Yankee Network.



HARNER SELVIDGE

He received the M.S. degree in 1934 and the D.Sc. in 1937 in communications engineering at Cruft Laboratory, Harvard University, where he was instructor from 1935 to 1938. In the summer of 1939 he was associate engineer at Taylor Tubes, Inc., Chicago, and has been consulting engineer for the American Phenolic Corporation in Chicago since 1939. Since 1938 Dr. Selvidge has been assistant professor of electrical engineering at Kansas State College, Manhattan, Kansas, where he is engaged in television and ultra-high-frequency propagation research.



J. D. Wallace (A'29) was born on March 6, 1904, at Gloster, Mississippi. In



J. D. WALLACE

1925 he received a B.A. degree at the University of Mississippi and an M.A. degree from the same institution in 1927. He has been employed in the radio division of the Naval Research Laboratory since 1926.



A. Kyle Wing (J'28-A'30-M'40) received his B.S. degree in electrical engineering from Sheffield Scientific School, Yale University, in 1930, and his M.S. degree from Massachusetts Institute of Technology in 1931. During the summers of 1929 and 1930 he was employed in the vacuum-tube department of the General Electric Company. Following work on broadcast receiver development with the Kolster Radio Company, he spent three years on transmitter-tube development with the Federal Telegraph Company. Since 1934, Mr. Wing has been engaged in development work on transmitting



A. KYLE WING

tubes in the research and engineering department of the RCA Manufacturing Company at Harrison, New Jersey.



J. E. Young (A'37) was born in West Chester, Pennsylvania, on May 18, 1906. He received the B.S. degree in electrical engineering from Drexel Institute of Technology in 1928 and worked with the General Electric Company, radio department, Schenectady, New York, from 1928 to 1932, in high-power transmitter development and installation. Mr. Young has been in RCA Manufacturing Company since 1932 to date, doing transmitter-development, design, and installation work. He has been in charge of low-power transmitter product design from 1937 to date.



J. E. YOUNG

PERFORMANCE:

Unusual capabilities as yet unequalled in actual service. Used in hundreds of 1KW to 5KW stations up to 60 megacycles

DEPENDABILITY:

Many of the world's most important commercial stations report 10,000 to 15,000 hours of extremely superior service

ECONOMY:

Replaces tubes that cost more than twice as much . . . gives more watts of carrier and more watt-hours per dollar

When the Eimac 450T tube first made its appearance several years ago, some of radio's engineers scoffed at the idea of using so small a tube for such enormous powers as required in most commercial transmitters. It was a radical idea . . . unfeasible to their minds.

Today, however, it is a different story. This tube is now occupying the key sockets of some of the most important radio transmitters in the world. The ground stations in service for practically every major airline are built around the unusual capabilities of the Eimac 450T. Throughout the world hundreds of police radios and thousands of commercial transmitters requiring 1KW to 5KW output find the Eimac 450T vastly superior to most other tubes of like ratings. In Frequency Modulation too, Eimac tubes lead the way. This recognition is proof enough, not only of its feasibility but of the decided advantages to be gained by adapting Eimac tubes . . . the only tubes which are unconditionally guaranteed against failures caused by gas released internally.

Be sure you get the original, the tried and proven tube
LOOK FOR THE EIMAC SIGNATURE ON EACH BULB

Eimac 450T sets the pace in modern radio!

EIMAC REPRESENTATIVES

California, Nevada
HERB BECKER, 1530 W.
104th St., Los Angeles, Cal.

Wash., Ore., Idaho, Mont.
GENERAL SALES CO.,
Verner O. Jensen, 2605-07
Second Ave., Seattle, Wash.

Ohio, Mich., Ky., Ind., Minn.,
Mo., Kan., Neb., Iowa
RICHARD A. HYDE, 4253
Quitman St., Denver, Colo.

Peel Sales Engineer-
ING CO., E. R. Peel, 154
E. Erie St., Chicago, Ill.

N. Y., N. J., Penn., Md., Del.,
Dist. of Col., Maine, N. H.
R. I., Conn., Mass.

ADOLPH SCHWARTZ,
14726 Elm Ave., Flushing,
New York.

Texas, La., Okla., Ark.
J. EARL SMITH, 2821 Live
Oak St., Dallas, Texas.

Chicago, Illinois, Wisconsin
G. G. RYAN, 549 W.
Washington Blvd., Chicago,
Ill.

N. Caro., S. Caro., Georgia,
Tenn., Flor., Ala., Miss.
JAMES MILLAR, 316 Ninth
St. N. E., Atlanta, Georgia.

Eitel-McCullough, Inc. San Bruno, Calif.

HERE'S THE NEW **Jensen**

"Speech Master"

REPRODUCER

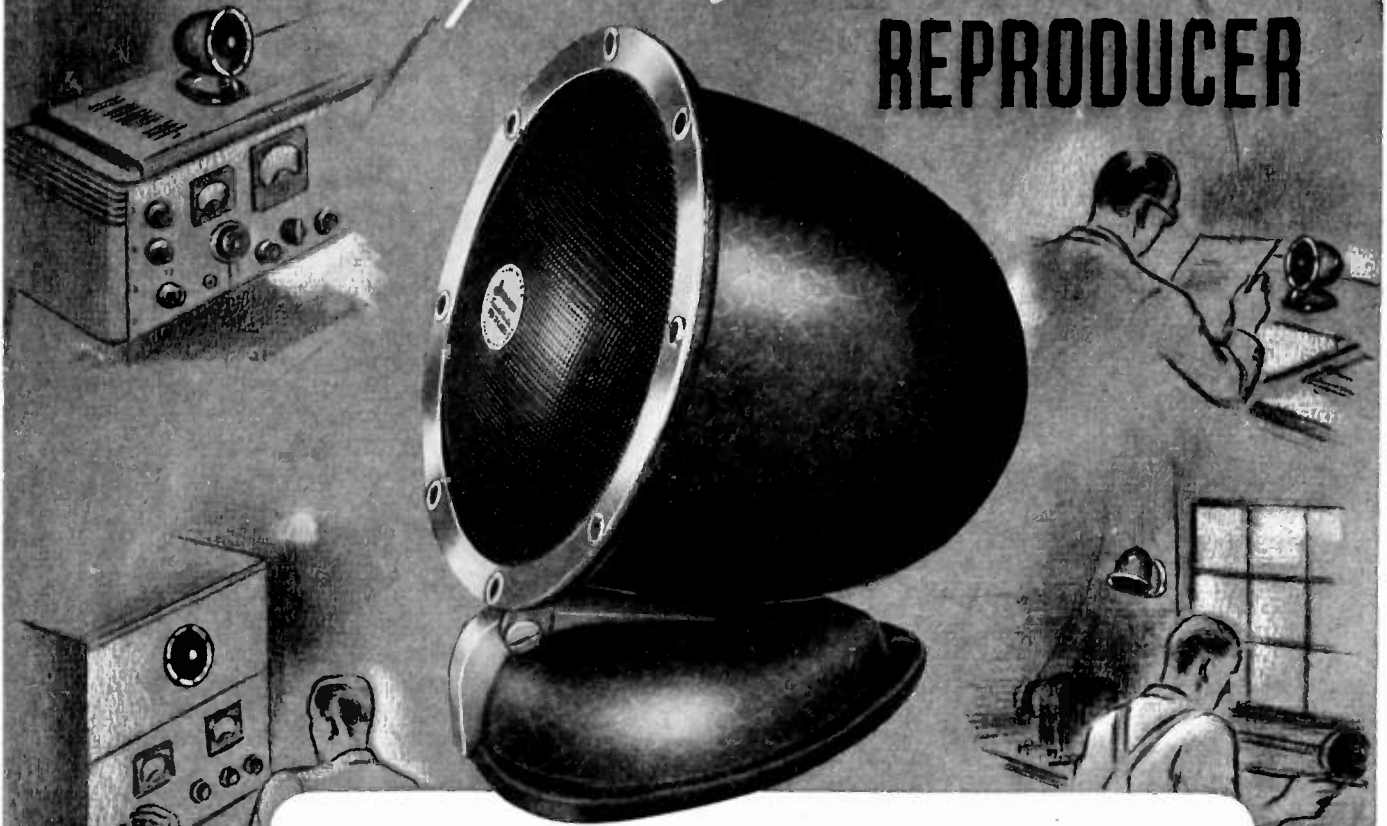

FOR DESK, WALL OR PANEL MOUNTING

ATTRACTIVE streamlined appearance, versatile utility, and exceptional acoustic performance are capably combined in the new JENSEN "Speech Master"—designed especially for highly effective speech reproduction at moderate levels. Efficient, fully-enclosed PM structure. Rugged moving system. Internal provision for transformer mounting.

Desk Type . . . complete with base . . . "tilt" adjustment . . . for desk or wall mounting . . . List Price \$9.95.
Panel Type . . . for rack or cabinet assemblies . . . List Price \$8.10.

Bulletin 106 gives complete details.

Especially Designed for
Radiophone Communication
Airline—Police
Aviation—Commercial

Intercommunication
One-Way & Talk-Back

Paging Systems
Low-Level Stations

Public Address
Low-Level Extensions

Jensen
6601 SOUTH LARAMIE AVENUE • CHICAGO
CABLE ADDRESS: JERAD, CHICAGO
R E P R O D U C E R S

KILOVOLT TESTER FOR TELEVISION AND HIGH VOLTAGE

Model
1280



\$31.50 DEALER NET

**RED • DOT LIFETIME
GUARANTEED INSTRUMENT**

Model 1280 is truly the tester for use in your experimental work, and also is invaluable for regular testing requirements. Ranges begin at 2500 and go to 10,000 volts. Also measures Direct Current. This High Voltage Tester gives you a new testing procedure. Metal contacts and instrument parts are removed a minimum of one inch from sides of the case. The prods attached to the test leads are inserted through holes in the top panel to the contacts in the sub-panel beneath. Tests AC-DC Volts in steps of 2500 and 10,000 (25,000 ohms per volt DC). DC Micro-amperes 0-50-500-5000. Sturdy metal case with red suede enamel finish. . . . Dealer Net Price . . . \$31.50.

MODEL 625

NEW Precision Portables. . . . Clear Readability. . . . Models 625 (DC Moving Coil Type) . . . 635 (AC Movable Iron Vane Type) and 665 (Electro-dynamometer Type) . . . Have mirror scales and knife-edge pointers . . . Scale length 4.88" — Accuracy within 1%. Black molded case . . . 6" x 5 1/2" x 2 1/2".



WRITE FOR CATALOG
Section 211, Harman Avenue

TRIPLETT ELECTRICAL INSTRUMENT CO.
Bluffton, Ohio

OFFICE OF THE
CHIEF OF POLICE

CITY OF NATIONAL CITY
POLICE DEPARTMENT
NATIONAL CITY, CALIFORNIA

IN REPLYING PLEASE GIVE OUR
REFERENCE NO. _____

October 26, 1940.

Bliley Electric Company,
Union Station Building,
Erie, Pennsylvania.

Gentlemen:

In the past, our greatest difficulty has been in keeping the oscillator section of our mobile police radio transmitters in operation. We have considerable patrolling on dirt roads and that, of course, is hard on any crystal.

Two years ago this month (October 4, 1938), we wrote you an inquiry regarding crystals for the mobile transmitters. Due to continual trouble with the crystals previously purchased, we were desperate indeed for a unit that would function dependably under mobile conditions.

The unit we purchased from you at that time and the subsequent ones ordered during the few months following have all been in constant service to date, and the results have been most gratifying. No transmitter servicing has been necessary as a result of the crystals failing to operate.

Yours very truly,
National City Police Dept.
James Butler, Sgt.
Communications Officer

*Bliley
Dependability
speaks for itself!*

BLILEY ELECTRIC COMPANY
UNION STATION BUILDING
ERIE, PA.

OHMITE *Ohm's Law Calculator*

Solves any Ohm's Law problem with one setting of the slide

Handiest Ohm's Law Calculator ever devised. Requires no slide rule knowledge. All values are direct reading. Scales on both sides cover the range of currents, resistances, voltages and wattages commonly used in Radio, Electronic, and Industrial fields. Convenient Stock

Unit selector—a setting of the slide tells the stock number of the resistor or rheostat you need. Size 4 1/8" x 9". Specially designed by Ohmite Engineers. Available for only 10¢ to cover handling cost. Send coupon or write on company letterhead today.

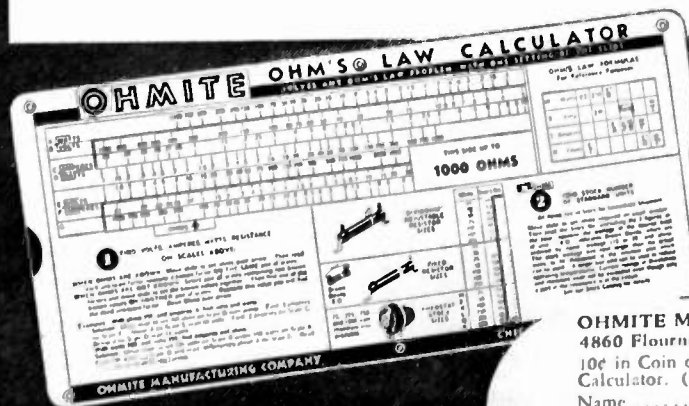

*It's
NEW*

*It's
Complete*

OHMITE MANUFACTURING CO.
4860 Flournoy St., Chicago, U.S.A.
10¢ in Coin enclosed. Send Ohm's Law
Calculator. (Please Print Clearly)

IRE
Jan

Name
Firm Name
Position
Address
City State

Be Right with OHMITE
RHEOSTATS • RESISTORS • TAP SWITCHES

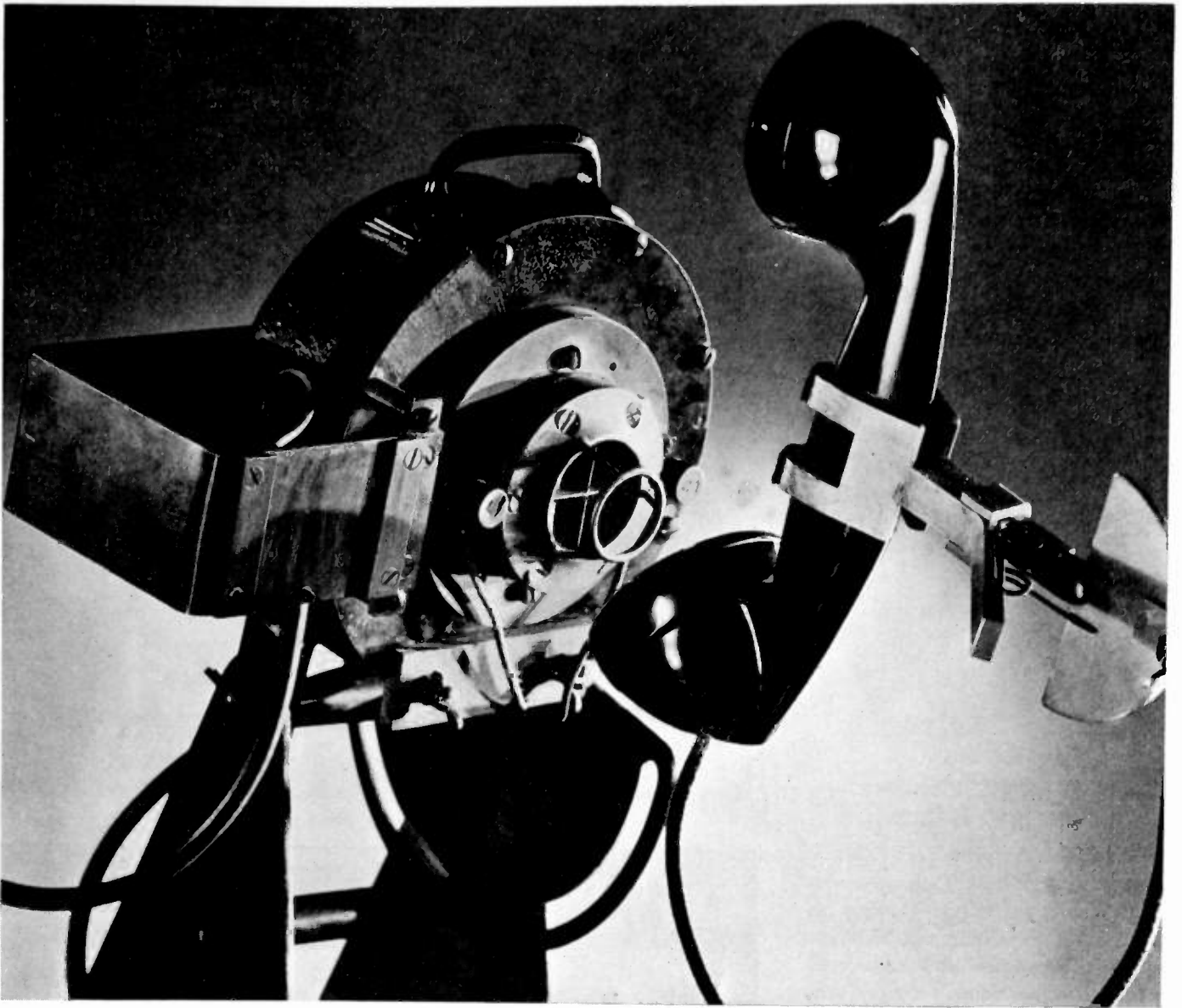

SAID THE ELECTRICAL MOUTH TO THE ELECTRICAL EAR . . .

*"Joe took father's shoe bench out.
She was waiting at my lawn."*

If you were passing through the Bell Telephone Laboratories today you might hear an electrical mouth speaking this odd talk, or whistling a series of musical notes, to a telephone transmitter.

This mouth can be made to repeat these sounds without variation. Every new telephone transmitter is tested by this mouth before it receives a laboratory or manufacturing O.K. for your use.

This is only one of the many tests to which telephone equipment is subjected in the Bell Telephone Laboratories. And there is a reason for the selection of those particular words.

It happens that the sentence, "Joe took father's shoe bench out," and its more lyrical companion, "She was waiting at my lawn," contain all the fundamental sounds of the English language that contribute to the intensity of sound in speech.

Busily at work in the interest of every one who uses the telephone is one of the largest laboratories in the world. The development of the telephone in this country is proof of the value of this research. In times like these, the work of the Bell Telephone Laboratories is especially important.

BELL TELEPHONE SYSTEM

The Bell System is doing its part in the country's program of National Defense



HURMAN

LEACH

RELAYS

Insulated with

ALSiMAG

ALLIED

GUARDIAN

The Best Relays have the Best Insulation. **ALSiMAG**

The absolute and permanent rigidity of ALSiMag insulators holds spring assemblies of relays in positive alignment. This enables contacts to "make" and "break" without hesitancy or chattering. High contact pressure is easily handled due to ALSiMag's outstanding mechanical strength. ALSiMag meets the requirements for R. F. insulation. It falls within the specifications of Army and Navy. When you specify ALSiMag, you specify the best in insulation.

ALSiMAG

Trade Mark Reg. U. S. Pat. Off.

FROM CERAMIC HEADQUARTERS

AMERICAN LAVA CORPORATION • CHATTANOOGA • TENNESSEE
CHICAGO • CLEVELAND • NEW YORK • ST. LOUIS • LOS ANGELES • SAN FRANCISCO • BOSTON • PHILADELPHIA • WASHINGTON, D. C.

Specify DAVEN ATTENUATORS

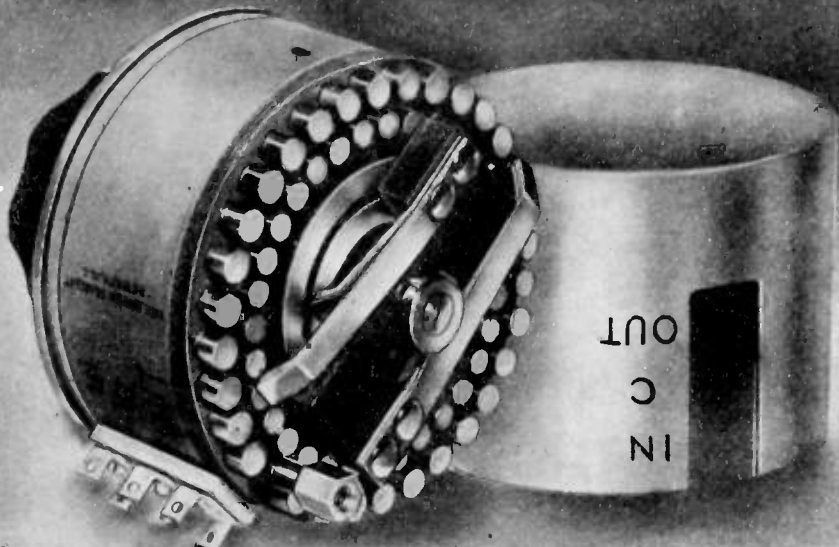

To INSURE PRECISE QUALITY
and RUGGED DEPENDABILITY
in your SPEECH INPUT EQUIPMENT

Substitutes, whose only merit can be a claim that they are "just-as-good", are **NEVER** the equal of the original. When ordering new speech input equipment, insist upon **DAVEN ATTENUATORS**, particularly when these precision components **COST YOU NO MORE**. **DAVEN** leadership in the field is clearly indicated not only by the caliber but also the number of organizations who are satisfied users.

Our catalog lists the most complete line of precision attenuators in the world. However, due to the specialized nature of high fidelity audio equipment, a large number of requirements are encountered where stock units may not be suitable. If you have such a problem, write to our engineering department.

THE DAVEN COMPANY
158 SUMMIT STREET • NEWARK, NEW JERSEY

POSITIONS OPEN

The following positions of interest to I.R.E. members have been reported as open on February 28. Make your application in writing and address to the company mentioned or to

Box No.

PROCEEDINGS of the I.R.E.
330 West 42nd Street, New York, N.Y.

Please be sure that the envelope carries your name and address

ELECTRICAL ENGINEERS

For transmitter or receiver designing on radio or special apparatus. Opening for U.S. Citizens only. Offering excellent opportunities to men with experience in the design of radio or special electrical apparatus. In reply state experience, education, age, present salary, etc. Box 228.

ENGINEERS

Mechanical Designers

Needed by radio manufacturer. Splendid opportunities for men with radio or equivalent experience such as required for designing the mechanical features of speakers, receivers, transmitters or special apparatus. Steady work, large manufacturer located in Eastern part of United States. Write for interview, giving full qualifications. Box 229.

PHYSICISTS

The Civil Service Commission has modified the requirements for the positions of physicist (various grades) and extended the application deadline to December 31, 1941. These positions pay from \$2,600 to \$5,600 per year. For further information, consult the Secretary of the Board of Civil Service Examiners at any first- or second-class post office.

RECEIVER DESIGN ENGINEERS

A large midwestern radio-receiver manufacturer has openings for experienced automotive and household radio-receiver-design engineers. Applicants should state education, experience, and give references. Our own employees know of these openings. Box 233.

HIGH-SPEED RADIO-EQUIPMENT OPERATORS

To meet the urgent need for high-speed radio-equipment operators for the National Defense Program, the United States Civil Service Commission has announced that it will accept applications to fill these positions until further notice. One year of experience as radio operator in commercial or Government radio communications work is required. Although training in radio operation at a service school may be substituted for this experience, all applicants must have had three months' experience in the operation of high-speed radio-communication equipment such as transcribing to typewriter siphon recorder tape and transmitting messages by hand or bug. For further information and application forms, consult the Secretary of the Board of U. S. Civil Service Examiners at any first- or second-class post office.



Attention Employers . . .

Announcements for "Positions Open" are accepted without charge from employers offering salaried employment of engineering grade to I.R.E. members. Please supply complete information and indicate which details should be treated as confidential. Address: "POSITIONS OPEN," Institute of Radio Engineers, 330 West 42nd Street, New York, N.Y.

The Institute reserves the right to refuse any announcement without giving a reason for the refusal.

Medium-duty transmitting capacitors in molded bakelite cases. Greater load-carrying capacity than for molded-in-bakelite units. Handle not only elevated voltages but afford higher current ratings as well.

Catalog data indicates maximum current-carrying ratings at five different frequencies, in addition to capacity and test voltage rating. Units best fitted for given current at given voltage readily selected.

India ruby mica and foil sections. Permanently and non-magnetically clamped. Stable characteristics, foils soldered together and in stack. Positive low-resistance contacts. Non-turnable brass terminal studs. Vacuum-impregnated stack assembly. Low-loss filler. One-piece molded bakelite case. In standard brown and in yellow (low-loss) XM bakelite.

Also shown is Type 1650 high-voltage molded-in-bakelite capacitor. Voltage ratings up to 10,000. Available with screw terminals or slip-through. Also with ceramic stand-off insulators.

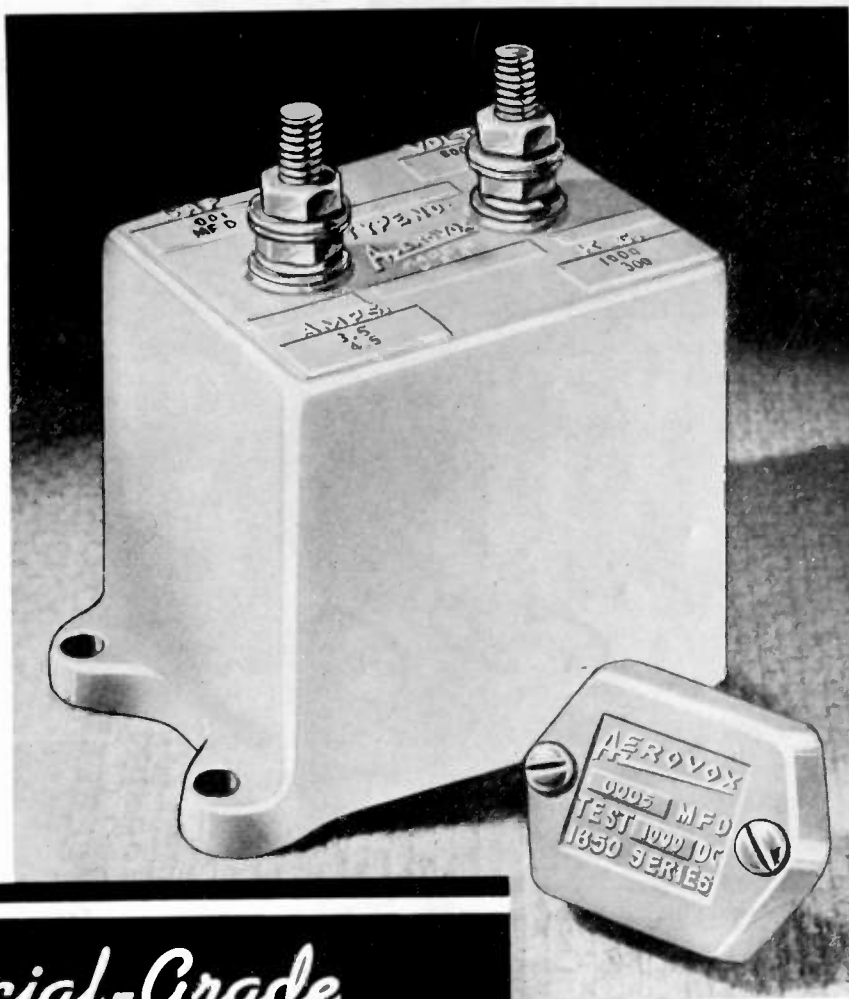

Commercial-Grade CAPACITORS

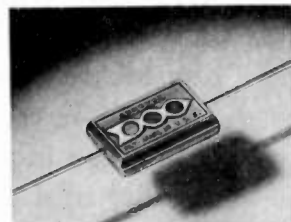

SILVERED-MICA . . .

Designed for the most critical applications calling for precise capacity values and extreme stability. Similar externally to standard "postage-stamp" molded bakelite units, but molded in red bakelite for silvered-mica identification.

Silver coating thoroughly bonded with mica. Permanent capacity value. Sections wax-impregnated and molded in bakelite casing. Units heat treated and wax-impregnated externally.

Average temperature coefficient of only .002% per deg. C. Excellent retrace characteristics. Practically no capacity drift with time. Exceptionally high Q—as high as 3000 to 5000 attained in higher capacities. Plus or minus 5% tolerance, standard. Also 20%, 10%, 5%, 3%, 2% and 1%.

● What were made-to-order types of mica capacitors now become standard Aerovox types, in regular production and with corresponding economies. Aerovox lists three solid pages of bakelite-cased transmitting capacitors alone, in its Transmitting Capacitor Catalog. You have the greatest choice of capacities and voltages yet offered by any manufacturer. Just check this statement for yourself.

And aside from this prime factor of choice, the specifications and performance records of these Aerovox units leave nothing to be desired.

Likewise with the molded-in-bakelite mica capacitors. Over two dozen standard types to choose from, in standard brown bakelite or in low-loss (yellow) XM bakelite.

Transmitting Capacitor Catalog . . .

● The new Aerovox Transmitting Capacitor Catalog is available to radio men engaged in designing, producing and maintaining commercial radio and electronic equipment. Write for your copy, on your business letterhead. Meanwhile, submit that capacitor problem.



AEROVOX CORPORATION

New Bedford, Mass.



Sales Offices in All Principal Cities

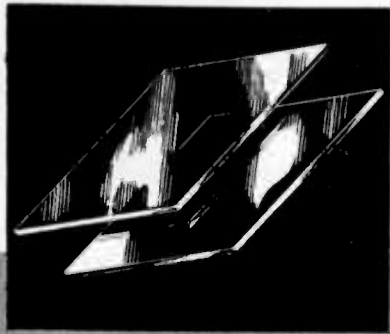

ONLY AN EXPERT can distinguish shatterproof glass from the ordinary. Capacitors, too, look alike. But what a difference in performance. That's why it pays to get the "inside story". It's the hidden qualities that determine capacitor stamina.

EXTRA STAMINA!

C-D Capacitors have it

HIDDEN IN THE CAPACITOR INGREDIENTS —
THE SECRET OF C-D'S EXTRA PERFORMANCE

IT'S that extra measure of stamina built into Cornell-Dubilier capacitors that wins the engineer. You'll discover it hidden in the ingredients—the big difference between C-Ds and capacitors that "look just like" C-Ds. For these ingredients—in their extra quality and experienced assembly—reveal the secret of Cornell-Dubilier's surviving soundness. You won't find such extra performance every day, because Cornell-Dubilier's 31 years of capacitor specialization is unique. You will find, though, that there are more Cornell-Dubilier capacitors in use today than any other make!



Only Cornell-Dubilier Electrolytics offer all these EXTRA FEATURES!

- Special high voltage paper separator
- C-D etched plate
- Special C-D electrolyte
- Special high formation process



For complete technical information, write for engineering bulletin 170.

**CORNELL-DUBILIER
ELECTRIC CORPORATION**

1006 HAMILTON BLVD. • SO. PLAINFIELD, N. J.

REMEMBER!

Only in Cornell-Dubilier union-made capacitors

*You get
the extras*

—AT NO EXTRA COST!

A NEW RECTIFIER WITH A LONGER LIFE!

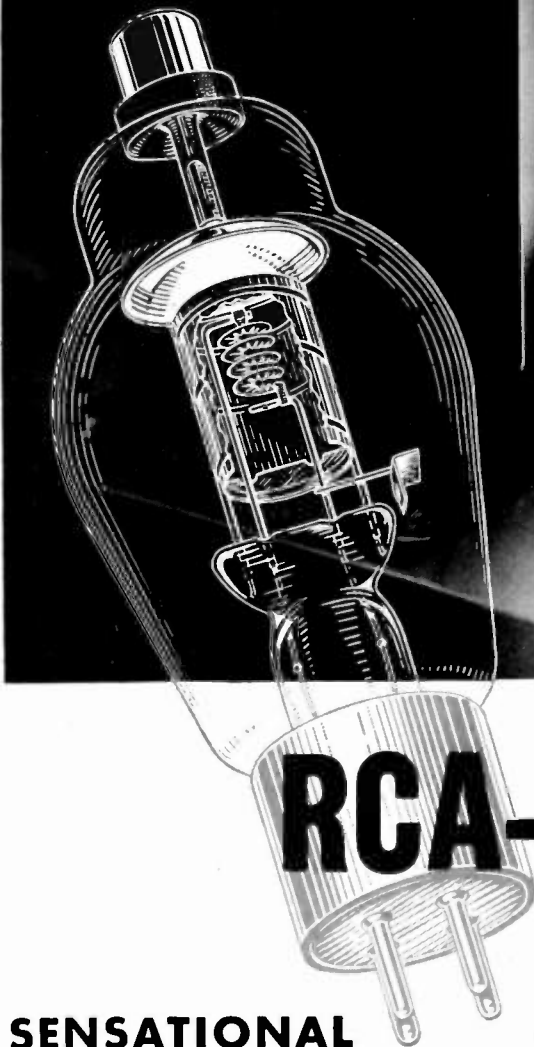

RCA-866-A/866

Half-Wave
Mercury-Vapor
Rectifier

SENSATIONAL PERFORMANCE

...at a New Low Price!

LONGER LIFE—Assured by radically improved new filament, dome bulb and insulated plate cap.

HIGH RATING—10,000 volts, peak inverse voltage. 1000 ma., peak plate current.

ENORMOUS EMISSION RESERVE
—Provides ability to withstand high peak loads.

RCA-866-A/866 Half-Wave Mercury-Vapor Rectifier Tube represents a big forward step in providing higher voltage at lower initial cost. Equally important is the amazingly long life achieved by virtue of the new edgewise-wound coated ribbon filament and other features of design and construction. Judged from any angle, it is far and away the finest rectifier tube value RCA has ever offered—both a money-saver and a truly de luxe performer.

This new tube supersedes the 866 and the 866-A and may be used in equipment designed for these types. It combines the high conductivity of the 866 at low plate voltages with the ability of the 866-A to withstand a high peak inverse voltage—and, in addition, gives *plus* performance all along the line.

RCA-866-A/866's new edgewise-wound filament has great mechanical strength and provides more cathode area for the same filament-power rating.

Important among other features of the tube is the special filament shield which makes practical the use of a very low starting voltage. A ceramic cap insulator and new dome-top bulb minimize danger from bulb cracks caused by corona discharge and resultant electrolysis.

Install 866-A/866's and forget rectifier tube problems for a long, long time to come!

RATINGS:	Filament Voltage (A-C).....	2.5 volts
	Filament Current.....	5.0 amperes
	Peak Inverse Voltage:	
	Up to 150 cycles per second.....	10,000 max. volts
	Up to 1,000 cycles per second.....	5,000 max. volts
	Peak Plate Current.....	1.0 max. ampere
	Average Plate Current.....	0.95 max. ampere
	Tube Voltage Drop (approx.).....	15 volts

\$ 50
• NET



Secret of 866-A/866 superiority is another top-notch RCA engineering achievement—the edgewise-wound ribbon filament utilizing a new alloy material which not only has tremendous electron-emitting capabilities but which holds the key to longer life.



Transmitting Tubes

PROVED IN COMMUNICATION'S MOST EXACTING SERVICES
RCA MANUFACTURING CO., INC., CAMDEN, N. J. • A Service of The Radio Corporation of America

In Canada: RCA VICTOR COMPANY LIMITED, MONTREAL

A Few Seconds A Year

THIS IS THE FACE of the most accurate commercial clock in the world . . . the 1,000-cycle clock controlled by the General Radio Type C-21-HLD Primary Standard of Frequency. This clock

is used to compare directly the accuracy of the primary standard with the generally available standard time intervals obtained from astronomical observations and transmitted at frequent intervals by U. S. Naval Radio Stations to all parts of the world.

From these time signals the user of the G-R Primary Standard of Frequency can conveniently and accurately check the operation of the frequency standard.

The G-R Standard, in its elements, consists of a 50-kc piezo-electric oscillator with very accurate temperature control; several frequency dividers controlled by the oscillator; the clock driven at 1,000 cycles; an oscillator control panel; an a-c power supply and a terminal board.

Although the standard is an extremely accurate timekeeper, its primary use is a generator of radio and audio frequencies, the exact frequency of which is known with considerable accuracy. With suitable auxiliary interpolation and measuring apparatus, the direct precision measurement of any frequency in the audio or radio-frequency spectrum is possible.

A large number of G-R Primary Standards of Frequency have been sold to educational, commercial and governmental organizations throughout the world. These standards are accurate enough to be used in such delicate scientific experiments as the determination of the force of gravity, the speed of light and the time of flight of bullets where measurements of the highest accuracy are necessary.

In the General Radio laboratories the bench of each engineer is provided with terminals from which the worker may obtain frequencies from a central Primary Standard of Frequency. Use is made of this standard in the design, manufacture and calibration of many G-R instruments.

The G-R Primary Standard of Frequency is not a scientific tool demanding the constant attention of an engineer . . . it is a workaday instrument which runs for years with only slight attention and it can be used for precise frequency measurements by unskilled technicians.

GENERAL RADIO COMPANY
Cambridge, Massachusetts

