

# Proceedings

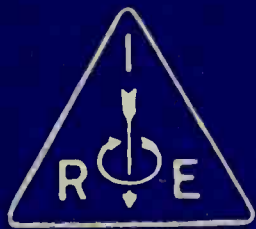

*of the*

# I·R·E

SEPTEMBER 1940

VOLUME 28

NUMBER 9

Rochester Fall Meeting

Some Problems of Disk Recording

Right- and Left-Handedness of Quartz

Generation of Synchronizing Pulses by  
Impulse Excitation

Motorcar Ignition Between 40 and  
450 Megacycles

A Useful Network Theorem

Potential Distribution in  
Electrostatic Fields

Ionospheric Characteristics

Institute of Radio Engineers



Rochester Fall Meeting  
Rochester, N. Y., November 11, 12, and 13, 1940

Sixteenth Annual Convention  
New York, N.Y., January 9, 10, and 11, 1941

New York Meeting—December 4, 1940

SECTION MEETINGS

ATLANTA  
November 15

BALTIMORE  
November 15

CLEVELAND  
November 28

DETROIT  
November 15

LOS ANGELES  
November 18

PHILADELPHIA  
November 7

PITTSBURGH  
November 11

WASHINGTON  
November 11

SECTIONS

- ATLANTA—Chairman, P. C. Bangs; Secretary, Adolph Andersen, Federal Communications Commission, 411 Federal Annex, Atlanta, Ga.
- BALTIMORE—Chairman, Ferdinand Hamburger; Secretary, G. J. Gross, Pennsylvania Water and Power Co., 1611 Lexington Bldg., Baltimore, Md.
- BOSTON—Chairman, W. L. Barrow; Secretary, P. K. McElroy, General Radio Co., 30 State St., Cambridge, Mass.
- BUENOS AIRES—Chairman, A. T. Cosentino; Secretary, W. J. Andrews, Cia. Standard Electric Argentina, Cangallo 1286, Buenos Aires, Argentina.
- BUFFALO-NIAGARA—Chairman, B. E. Atwood; Secretary, Leroy Fiedler, 98 West Ave., Lockport, N. Y.
- CHICAGO—Chairman, E. H. Kohler; Secretary, P. C. Sandretto, United Air Lines Transport Co., 5936 S. Cicero Ave., Chicago, Ill.
- CINCINNATI—Chairman, C. H. Topmiller; Secretary, W. L. Schwesinger, WSAI, Cincinnati, Ohio.
- CLEVELAND—Chairman, R. L. Kline; Secretary, J. D. Woodward, WGAR, Hotel Statler, Cleveland, Ohio.
- CONNECTICUT VALLEY—Chairman, K. A. McLeod; Secretary, W. M. Smith, 250 Main St., Suffield, Conn.
- DETROIT—Chairman, J. D. Kraus; Secretary, Paul Frincke, WJBK, 6559 Hamilton Ave., Detroit, Mich.
- EMPORIUM—Chairman, C. R. Smith; Secretary, H. L. Ratchford, Hygrade Sylvania Corp., Emporium, Pa.
- INDIANAPOLIS—Chairman, Arthur Curtis; Secretary, B. V. K. French, P. R. Mallory & Co., E. Washington St., Indianapolis, Ind.
- LOS ANGELES—Chairman, A. C. Packard; Secretary, J. N. A. Hawkins, 3239 Laclede Ave., Los Angeles, Calif.
- MONTREAL—Chairman, H. M. Smith; Secretary, W. A. Nichols, Canadian Broadcasting Corp., 1012 Keefer Bldg., Montreal, Que.
- NEW ORLEANS—Chairman, G. H. Peirce; Secretary, D. W. Bowman, 8327 Sycamore St., New Orleans, La.
- PHILADELPHIA—Chairman, C. M. Burrill; Secretary, R. L. Snyder, 103 Franklin Rd., Glassboro, N. J.
- PITTSBURGH—Chairman, R. E. Stark; Secretary, M. G. Jarrett, Bell Telephone Company of Pennsylvania, Pittsburgh, Penna.
- PORTLAND—Chairman, Marcus O'Day; Secretary, Earl Schoenfeld, 1627 S. E. Elliott Ave., Portland, Ore.
- ROCHESTER—Chairman, H. C. Sheve; Secretary, O. L. Angevine, Jr., Stromberg-Carlson Telephone Manufacturing Co., Rochester, N. Y.
- SAN FRANCISCO—Chairman, Carl Penther; Secretary, H. E. Held, 420 Market St., San Francisco, Calif.
- SEATTLE—Chairman, R. M. Walker; Secretary, L. B. Cochran, University of Washington, Seattle, Wash.
- TORONTO—Chairman, G. J. Irwin; Secretary, L. C. Simmonds, 301 King St., E., Toronto, Ont.
- WASHINGTON—Chairman, L. C. Young; Secretary, E. M. Webster, Federal Communications Commission, Rm. 5319, New Post Office Bldg., Washington, D. C.

BOARD OF DIRECTORS  
 Lawrence C. F. Horle, *President*  
 Frederick E. Terman,  
*Vice President*  
 Melville Eastham, *Treasurer*  
 Harold P. Westman, *Secretary*  
 Austin Bailey  
 W. R. G. Baker  
 Frederick W. Cunningham  
 Henry C. Forbes  
 Alfred N. Goldsmith  
 Virgil M. Graham  
 O. B. Hanson  
 Raymond A. Heising  
 C. M. Jansky, Jr.  
 Frederick R. Lack  
 Frederick B. Llewellyn  
 Haraden Pratt  
 Browder J. Thompson  
 Hubert M. Turner  
 Arthur F. Van Dyck  
 Harold A. Wheeler  
 Lynde P. Wheeler

BOARD OF EDITORS  
 Alfred N. Goldsmith, *Chairman*  
 Ralph R. Batcher  
 Philip S. Carter  
 Elmer W. Engstrom  
 Frederick W. Grover  
 J. Warren Horton  
 Greenleaf W. Pickard  
 Benjamin E. Shackelford  
 Karl S. Van Dyke  
 Harold P. Westman, *ex officio*  
 Harold A. Wheeler  
 Lynde P. Wheeler  
 Laurens E. Whittemore  
 William Wilson

PAPERS COMMITTEE  
 William Wilson, *Chairman*  
 Frederick B. Llewellyn,  
*Vice Chairman*  
 Herman A. Affel  
 Edmond Bruce  
 Howard A. Chinn  
 James K. Clapp  
 Tunis A. M. Craven  
 Robert B. Dome  
 Paul O. Farnham  
 Enoch B. Ferrell  
 Elmer L. Hall  
 Dorman D. Israel  
 Loren F. Jones  
 De Loss K. Martin  
 Harry B. Marvin  
 Harry R. Mimno  
 Albert F. Murray  
 Harold O. Peterson  
 Ralph K. Potter  
 Hubert M. Turner  
 Dayton Ulrey  
 Arthur F. Van Dyck  
 Paul T. Weeks  
 William C. White  
 Irving Wolf

Helen M. Stote, *Assistant Editor*  
 John D. Crawford,  
*Advertising Manager*

# Proceedings of the I·R·E

*Published Monthly by*  
 The Institute of Radio Engineers, Inc.

VOLUME 28 *September, 1940* NUMBER 9

Some Problems of Disk Recording.....	S. J. Begun	389
On the Right- and Left-Handedness of Quartz and Its Relation to Elastic and Other Properties.....	Karl S. Van Dyke	399
The Generation for Television of Horizontal Synchronizing Pulses from Vertical Pulses by Means of Impulse Excitation.....	Jesse B. Sherman	406
Field Strength of Motorcar Ignition Between 40 and 450 Megacycles.....	R. W. George	409
A Useful Network Theorem.....	Jacob Millman	413
Determination of the Axial Potential Distribution in Axially Symmetric Electrostatic Fields.....	Sidney Bertram	418
The Ionosphere and Radio Transmission, August, 1940, with Predictions for November, 1940.....		421
Institute News and Radio Notes.....		423
Rochester Fall Meeting.....		423
Board of Directors.....		423
Sections.....		423
Personal Mention.....		427
Membership.....		428
Correspondence: "Piezoelectric Crystals," W. P. Mason and G. W. Willard.....		428
Contributors.....		429

## THE INSTITUTE

The Institute of Radio Engineers serves those interested in radio and allied electrical-communication fields through the presentation and publication of technical material. In 1913 the first issue of the PROCEEDINGS appeared; it has been published uninterruptedly since then. Over 1800 technical papers have been included in its pages and portray a currently written history of developments in both theory and practice.

### STANDARDS

In addition to the publication of submitted papers, many thousands of man-hours have been devoted to the preparation of standards useful to engineers. These comprise the general fields of terminology, graphical and literal symbols, and methods of testing and rating apparatus. Members received a copy of each report. A list of the current issues of these reports follows:

Standards on Electroacoustics, 1938  
Standards on Electronics, 1938  
Standards on Radio Receivers, 1938  
Standards on Radio Transmitters and Antennas, 1938.

### MEETINGS

Meetings at which technical papers are presented are held in the twenty-three cities in the United States, Canada, and Argentina listed on the inside front cover of this issue. A number of special meetings are held annually and include one in Washington, D. C., in co-operation with the American Section of the International Scientific Radio Union (U.R.S.I.) in April, which is devoted to the general problems of wave propagation and measurement technique, the Rochester Fall Meeting in co-operation with the Radio Manufacturers Association in November, which is devoted chiefly to the problems of broadcast-receiver design, the Pacific Coast Convention, which is held each year during the summer months and is supervised by a joint committee of our four Pacific Coast sections, and the Annual Convention, which will be held in New York City during January.

### MEMBERSHIP

Membership has grown from a few dozen in 1912 to more than five thousand. Practically every country in the world in which radio engineers may be found is represented in our membership roster. Approximately a quarter of the membership is located outside of the United States. There are several grades of membership, depending on the qualifications of the applicant. Dues range between \$3.00 per year for Students and \$10.00 per year for Members. PROCEEDINGS are sent to each member without further payment.

### PROCEEDINGS

The contents of each paper published in the PROCEEDINGS are the responsibility of the author and are not binding on the Institute or its members. Material appearing in the PROCEEDINGS may be reprinted or abstracted in other publications on the express condition that specific reference shall be made to its original appearance in the PROCEEDINGS. Illustrations of any variety may not be reproduced, however, without specific permission from the Institute.

Papers submitted to the Institute for publication shall be regarded as no longer confidential. They will be examined by the Papers Committee and Board of Editors to determine their suitability for publication. Suggestions on the mechanical form in which manuscripts should be prepared may be obtained from the Secretary.

### SUBSCRIPTIONS

Annual subscription rates for the United States of America, its possessions, and Canada, \$10.00; to college and public libraries when ordering direct, \$5.00. Other countries, \$1.00 additional.

The Institute of Radio Engineers, Inc.

Harold P. Westman, Secretary

330 West 42nd Street

New York, N.Y.



Copyright 1940 by The Institute of Radio Engineers, Inc.



# Some Problems of Disk Recording\*

S. J. BEGUN†, NONMEMBER, I.R.E.

*Summary*—The general trend of recent statistics indicates that recordings have become more and more important in the radio and home-entertainment field. It is therefore timely to investigate the present status of the art.

It is shown that the lack of standardization in the recording characteristics of commercial shellac pressings makes it rather difficult to provide correct equalization for playback. A compromise equalization is suggested. It is also pointed out that new lightweight pickups with their permanent jewel styluses do not require the abrasive surfaces which are provided in present shellac pressings. Considerable improvement can be expected with respect to the signal-to-noise ratio of recordings if the general use of lightweight pickups makes it possible to use better disk materials.

Vertical versus lateral recording is briefly discussed, and it is pointed out that even for transcription work the likelihood is that lateral recording will regain its predominance.

The almost complete lack of standardization in the field of instantaneous recording is shown.

Some general problems in the field of disk recording are discussed and considerations entering into the design of a cutter are outlined.

Since the art of instantaneous recording has just begun to develop, new recording materials will have to be investigated in order to cut the price to the point where direct recording can enter the home-entertainment field.

The relative merits of different methods of regulating the depth of cut are discussed. The requirements for matching a cutter to an amplifier for different frequency characteristics of cut are also explained.

## I. INTRODUCTION

ABOUT 35 million phonograph records were pressed in 1938 and the broadcast chains were experimenting with instantaneous recorders. In 1939, over 60 million records were pressed, and instantaneous recording became a common technical requirement of the well-equipped broadcast station. In 1940, the industry enjoyed another sharp increase in record sales and instantaneous records became second in importance only to commercial pressings.

These already impressive figures will become even more important when one considers that during 1938 only 63,000 radio-phonograph combinations were sold; during 1939, this figure jumped up to 600,000 combinations and it is generally expected that during the present year 1,000,000 radio-phonograph combinations will be sold.

These figures, large as they are in themselves, indicate an even more impressive total in the near future. To cope with this situation requires of the radio technician an adequate knowledge of the state of the art today, particularly of instantaneous recording, which, strong evidence suggests, is the next acoustical device to capture the public's fancy.

Disk recording conveniently may be divided into three main fields. The first, and largest, includes shellac pressings, such as are sold to the public at large. Enormous quantities of these pressings are also

used in many of the smaller broadcast stations, where in some cases they actually constitute a majority of program time.

The second classification includes the electrical-transcription material, prepared at some central point and distributed only to broadcast stations for broadcasting at convenient hours. This classification includes the vertical, or so-called "hill-and-dale" recording, as well as the more conventional lateral recording.

The third classification, which this article chiefly treats, includes the instantaneous recording. Use of this field is being very rapidly embraced by educational institutions and by the theater and other arts. As a means of objective criticism of voice and music it stands unquestionably first. The instantaneous recorder has also become standard equipment in most broadcast stations where it serves in several capacities, but stars in its ability to store a program temporarily until a "free" time makes its use advantageous.

The greatest use of instantaneous recording, however, is just beginning. This is as an adjunct to the home radio. There is ample evidence to support the conclusion that this newest art may very soon become one of the most active forces in the home-entertainment field. Already many manufacturers are in production with radio-phonograph combinations incorporating an instantaneous recorder, and virtually all of the radio manufacturers are actively studying the field.

## II. SHELLAC PRESSINGS

It is generally assumed that no special experience is required to obtain good reproduction from commercial pressings. If the equipment is good, which means that a good turntable, pickup, amplifier, and speaker system be used, the operator has a right to expect an entirely satisfactory response. Unfortunately, however, this is not quite true, since pressings of different makes have different recording characteristics. These characteristics are deviations from constant velocity and constant amplitude. Before explaining further what these deviations are, it may be desirable to point out the differences between the terms "constant velocity" and "constant amplitude." "Constant amplitude" means that, given a constant voltage at the grids of the output tubes of the recording amplifier, the amplitude of the resulting cut will be a constant, and not dependent upon the frequency being recorded. "Constant velocity," on the other hand, means that, given a constant voltage at the grids of the output tubes of the recording amplifier, the ampli-

\* Decimal classification: 621.385.971. Original manuscript received by the Institute, March 6, 1940; revised manuscript received, July 8, 1940. Presented, New York Meeting, February 7, 1940.

† The Brush Development Company, Cleveland, Ohio.

tude of the resulting cut will be inversely proportional to the frequency. In other words, in constant velocity, the product of amplitude and frequency is a constant. Fig. 1 shows these points graphically.

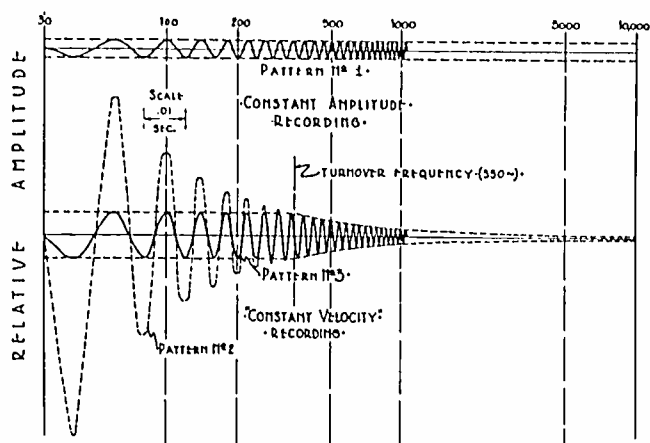

Fig. 1—The wave pattern obtained for constant-amplitude recording is shown in pattern No. 1 and that for constant-velocity recording in pattern No. 2. The solid-line pattern, No. 3, is for constant amplitude below 350 cycles and constant velocity at higher frequencies.

With regard to commercial recordings, it is general practice to cut constant amplitude up to some frequency known as the "transition frequency." Above this transition frequency, the general practice is to cut constant velocity. In addition to this first transition frequency, it has become current practice of at least one of our largest record manufacturers to "turn over" again at some higher frequency, and cut thereafter somewhere between the two characteristics of constant velocity and constant amplitude up to the cutoff frequency, which is generally in the neighborhood of 7000 cycles. These transition frequencies vary with the manufacturer, but, in general, the first transition frequency lies between 300 and 800 cycles and the second transition point, where it exists at all, varies from about 1000 cycles to about 3000 cycles. In addition to these discrepancies, cutoff frequencies also vary.

In the light of the foregoing, it is easy to see the impossibility of providing perfect equalization for all shellac pressings. Fig. 2 shows graphically the results

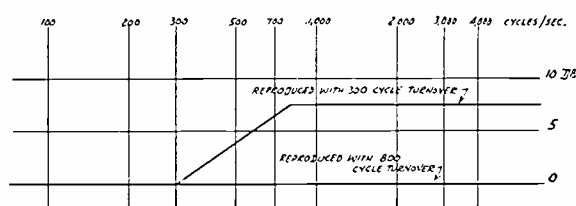

Fig. 2—Results of reproducing a frequency spectrum with a recorded transition frequency of 800 cycles and with pickups equalized for 300 and 800 cycles, respectively.

of playing a record with a recorded first turnover frequency of 800 cycles with a pickup equalized for a turnover of 300 cycles. The radio engineer faces the problem of providing a workable compromise or of using different equalization for different series of pressings. The conclusion which experience has drawn for us, in this case, is that a compromise is adequate for

most cases. The compromise frequency best suited for this purpose seems to be 500 cycles, which provides a minimum of error for most records now on the market. It sometimes appears best also to provide a gently falling equalization above 2000 cycles, being down about 8 decibels at 8000 cycles.

This suggested equalization, although a compromise, as pointed out above, is for most purposes entirely adequate. This comes from the fact that the ear is not greatly sensitive to small departures from a linear frequency response, providing these departures do not take the form of sharp peaks. Even small sharp peaks, however, are likely to introduce noticeable distortion, and should be severely guarded against. A smooth response curve, however, even if not quite flat, will be relatively free from distortion, and as explained before, is quite acceptable to the ear.

For some broadcast applications, however, these compromises may not be sufficient and individual engineering must answer the question of what must be used.

It may be of interest to point out the reasons why such queer recording characteristics are used by the manufacturers of shellac pressings. The answer for the most part may be traced back to the early magnetic system, whose electromechanical construction gave to it a constant-velocity response throughout its principal frequency range. The usual unequalized magnetic pickup has the property of giving a constant voltage from a constant-velocity recording, and thus, with the usual amplifier and speaker, a constant sound pressure. The so-called "acoustical" phonograph also will give a constant sound pressure from a constant-velocity recording. These facts led very naturally to the adoption of constant-velocity characteristics for commercial recordings. It was found, however, that a constant-velocity cut throughout the frequency range would lead to excessively large amplitudes in the very low frequencies. This fact is illustrated graphically in Fig. 1. The results of such large amplitudes, of course, would be to limit severely the number of lines per inch which could be cut on a disk.

But the characteristics of a constant-velocity system are such as to emphasize high-frequency noise, and therefore, constant-velocity recordings were troubled with too much background hiss in playback. To solve this problem, the practice has become more and more to record the higher frequencies with a rising characteristic with reference to a constant-velocity characteristic. This helps to mask the hiss, particularly if a playback equalizer is used, dropping the highs somewhat.

The background noise, or hiss, which is the source of this trouble, is largely generated by the abrasive nature of the material which is added to the disk compound to give it greater resistance to wear. This abrasive material quickly grinds the conventional steel stylus to the proper fit to the record groove. If this

were not done, the usual heavy pickup would quickly spoil the shellac pressing.

Measurements<sup>1</sup> have been made of the average grit size used in the better shellac pressings. These particles are individually very small, and tend to cause a random noise up to a frequency determined by the particle itself. If the particles were regularly spaced and were as close together as possible, that is, in contact, they would produce a vibration of the pickup stylus representing the wavelength of their size itself. Since the distance between any two particles, however, is extremely irregular, all frequencies from the lowest frequency up to the grit-size frequency can be expected. It is an effect much like the well-known "shot-effect" in a vacuum tube, which produces a random noise throughout the entire frequency range (up to the transition period of the electron itself).

The spectrum of this random noise is shown in Fig. 3. The ratios of voltages are shown for both constant-amplitude and constant-velocity equalizations. The constant-velocity system, of course, increases the noise 6 decibels per octave above the constant-amplitude response, as shown.

Inspection of Fig. 3 also shows an increase in the low-frequency noise. This noise is generated by mechanical vibration inherent to some extent in even the best turntable. The ear sensitivity is down at the low frequencies, however, so this low-frequency background noise is generally not objectionable in the usual system. It should be pointed out, however, that a poor or average turntable may well be the weak link in an otherwise good disk-record reproducer. Excessive low-frequency noise from a poor turntable, even though not particularly audible to the ear, does represent a driving voltage on the associated amplifier, and may actually cause cross-modulation effects with the high frequencies being reproduced by the system. The need for a good turntable, therefore, cannot be lightly dismissed.

Returning to the random noise caused by the grit, however, the point of the matter is that the signal-to-noise ratio of the constant-velocity system becomes progressively worse as the recorded frequency becomes higher. This noise, caused by the grit, is undoubtedly objectionable. Furthermore, the pickups which use steel needles have a high needle pressure, and this excessive pressure damages the records. Obviously, to improve the art, something had to be done about this.

This "something" is already out of the laboratories. It consists of using a pickup with a very low-inertia moving part, and one, therefore, which will have a stylus pressure of less than 1 ounce. When this is done, it becomes practicable to use a permanent sapphire stylus, since under such a light pressure, a stylus of this kind will not wear out, nor will it wear out the records. Such a pickup also has the obvious advantage

that it is unnecessary to change needles. Furthermore, such a light pickup is almost essential where it is required to play instantaneous recordings any great number of times.

Also, the light pressure makes it possible for record manufacturers to leave the abrasive out of their pressings and the high-frequency background noise in playback becomes considerably reduced. As a matter of fact, laboratory pressings have been made using material free from grit, and the improvement is very great. It is hoped that the day may soon come when commercial pressings will be available without the objectionable grit.

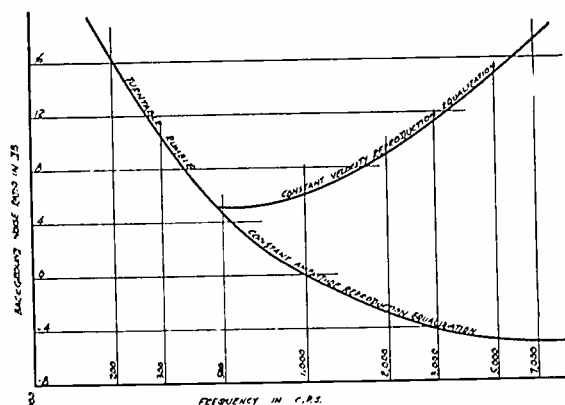

Fig. 3—Background noise spectrum of an average shellac pressing.<sup>2</sup>

### Pickup Design

Magnetic, as well as crystal, pickups have been designed with low needle pressure. It is the writer's opinion, however, that it is somewhat more difficult to build a magnetic pickup with light needle pressure than it is to engineer a crystal pickup of the same characteristic. During the reproduction of high frequencies, the vibratory system of a pickup is inertia controlled, and the forces required to move the stylus point depend upon the moment of inertia of the vibratory system. In a magnetic pickup, the stylus has to move either a small armature or a coil to generate a voltage. On the other hand, the crystal element in a crystal pickup generates a voltage depending upon the pressure exerted on the crystal element, requiring exceedingly little motion. By properly designing a crystal pickup, only the stylus point itself and its mounting represent the inertia of the vibratory system, while in a magnetic pickup other parts have to be moved in addition to these.

It has already been stated that several pickups have been designed having a low stylus pressure, and it may be of interest to explain briefly one such development.<sup>3</sup> It is a crystal pickup, and features a very small stylus assembly and a permanent sapphire stylus. Fig. 4 is a photomicrograph of the entire generating element of this pickup, compared with a standard steel-chromium needle. Obviously the moment of

<sup>1</sup> H. J. Von Braunmuhl and W. Weber, "Einführung in die Angewandte Akustik," Hirzel, Leipzig, p. 114, 1936.

<sup>2</sup> The curve shown is one taken at the Brush Development Company. On page 114 of reference,<sup>1</sup> a like curve is shown.

<sup>3</sup> The Brush PL-50 and PL-20 crystal pickups.

inertia of such a system will be far below that of a conventional pickup using a detachable needle.

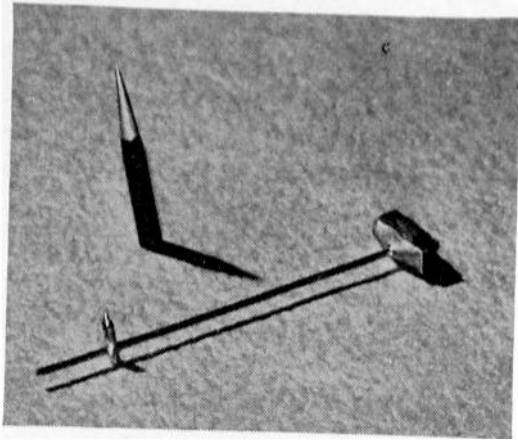

Fig. 4—Permanent-sapphire-stylus assembly. Standard steel stylus included for comparison.

Fig. 5 shows the finished pickup tracking a record. The stylus pressure of this pickup is approximately  $\frac{1}{2}$  ounce, and the moving element is so light that there is practically no possibility of wearing either the records or the sapphire stylus.

### III. ELECTRICAL TRANSCRIPTIONS

Electrical transcriptions, a recording service restricted to broadcast stations, are almost completely standardized at  $33\frac{1}{3}$  revolutions per minute.

Equalization here is not so great a problem since manufacturers of such recordings inform the broadcast stations more completely of the required characteristics.

Most commonly used of these types of recordings is the so-called "hill-and-dale" recording, which merely means that the cut, instead of being from side to side in the plane of the record, is an up-and-down cut in the disk material itself.



Fig. 5—Pickup tracking a record.

There are two main reasons why this method has become so popular. First, it is easily possible to obtain a 15-minute recording from a 16-inch disk. Second, it is generally supposed that such recordings have less distortion than lateral-cut records. It is possible to obtain the long playing time by cutting a greater number of lines to the inch than is ordinarily done with lateral records. This is possible because the stylus,

instead of swinging from side to side in the recording material, as is the case in lateral recording, moves up and down in the depth of the material. Since the recording stylus used for vertical recording has a smaller tip angle, this moving up and down of the stylus results in a smaller deformation in the surface plane of the material than would result were a lateral swing used. Also, overcutting in a lateral cut is disastrous, because a stylus tracking such an overcut will likely break entirely through from one groove to another. At any rate, the too closely adjacent grooves of such an overcut will be badly distorted. With the vertical cut, however, even when cuts are so severe as partially to tear down the wall between adjacent grooves, a pickup will track them without any great trouble or distortion.<sup>4</sup>

But the claims of longer playing time and less distortion from vertical recording are both open to attack.

A constant-amplitude lateral cut, recorded with an average peak of 10 decibels less than the average peak amplitude of a conventional constant-velocity cut, will allow as many lines per inch as a hill-and-dale cut. Furthermore, a constant-amplitude cut requires no equalization from either a crystal cutter or a crystal pickup, resulting in really flat frequency characteristics and no equalizer problems whatsoever.

It is easily possible to cut 150 to 200 lines per inch with a constant-amplitude lateral cut, and this, compared with the usual 96 of the conventional shellac pressing, results in up to more than twice the playing time from a disk of given size. If, in addition,  $33\frac{1}{3}$  revolutions per minute are used, as is common practice with the hill-and-dale cut, the time will be increased again, resulting in a safe 15 minutes for one side of a 16-inch disk.

#### *Lateral versus Vertical Cut*

The claim that the hill-and-dale cut has less distortion than a lateral cut also seems to be ill-founded. Hunt and Pierce of Cruft Laboratories at Harvard University, as well as other workers, have shown that vertical as well as lateral recordings have inherent distortions.

These distortions are produced as follows: During the recording process, the shape of the modulated groove cut into the record is determined only by the motion of the sharp stylus tip. In playback, however, a spherical stylus tip has to be used, changing the contact point between groove and stylus over the wave front. The result is that the reproducing stylus traces a wave form differing slightly from the recorded wave form. Fig. 6(a) shows a laterally recorded sine wave being tracked by a stylus of conventional dimensions. This curve has been found by assuming that the spherical stylus tip is for the complete wavelength in

<sup>4</sup> H. A. Frederick, "Vertical sound records," *Jour. Soc. Mot. Pic. Eng.*, vol. 18, pp. 141-163; February, 1932.



contact with both walls of the groove. It will be seen that the path traced by the stylus is very closely the same as the recorded wave form.

Fig. 6(b) shows a hill-and-dale recorded sine wave being tracked by a stylus of conventional dimensions. Here the trace, it is plain, is much more distorted than it was in the case of the lateral recording. Note

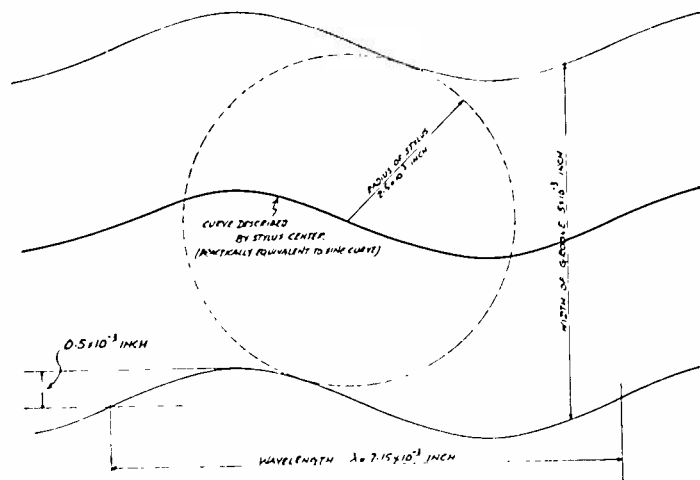

Fig. 6(a)—Drawing showing curve described by center of reproducing stylus when tracking a lateral cut. This trace is very closely a sine curve and in fact cannot be determined differently in the drawing. Frequency = 4000 cycles, distance to center of disk =  $3\frac{1}{2}$  inches, amplitude =  $0.5 \times 10^{-3}$  inch.

that the same frequency, wavelengths, and amplitude are used in both cases. An analysis of these two curves, according to Hunt and Pierce, shows that a lateral recording acts somewhat like a push-pull amplifier stage<sup>5</sup> in that all even harmonics are canceled out. The hill-and-dale recording, on the other hand, corresponds to the single output tube, and has both even- and odd-number harmonics. From these considerations, it is hard to see any advantages in vertical, or hill-and-dale, recording, and this writer is of the opinion that even in the electrical-transcription field, lateral recording will regain the predominant position which it had a few years ago.

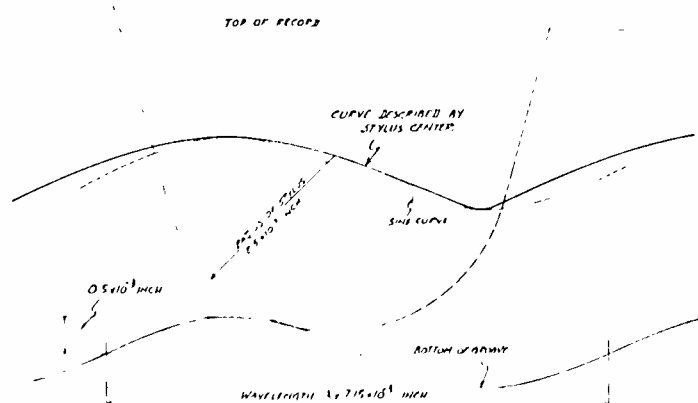

Fig. 6(b) Drawing showing curve described by center of reproducing stylus when tracking a vertical recording. This trace departs materially from a sine curve and represents a considerable harmonic distortion. Frequency = 4000 cycles, distance to center of disc =  $3\frac{1}{2}$  inches, amplitude =  $0.5 \times 10^{-3}$  inch.

It is obvious from Fig. 6(a) and (b) that distortions in reproducing will become particularly bad when the

<sup>5</sup> F. V. Hunt and G. W. Pierce, "Distortion in sound reproduction from phonograph records, *Jour. Soc. Mot. Pic. Eng.*, vol. 31, pp. 157-182; August, 1938.

radius of curvature of the stylus tip is of the order of the radius of curvature of the modulated sine wave in the groove. Fig. 7, therefore, shows graphically the relationship between frequency and radius of curvature in the modulation, while amplitude of cut, radius of groove, and turntable speed are parameters.

In this connection, it is interesting to analyze a constant-amplitude versus a constant-velocity cut. It has been found practicable to record with constant amplitude a 10-decibel lower average amplitude at 300 cycles than when a constant-velocity signal is engraved. This fact is shown graphically in Fig. 1. It will be seen that in the higher frequencies, a constant-

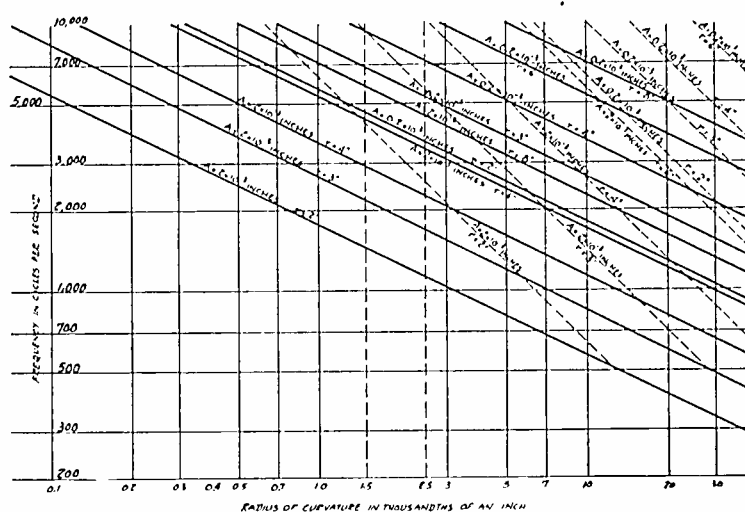

Fig. 7—Minimum radius of curvature in thousandths of an inch of engraved sine wave. The velocity is 78 revolutions per minute. The solid lines are for constant-amplitude recording and the dotted lines are for constant-velocity recording.

amplitude cut has a higher amplitude of cut than is the case for a constant-velocity cut. This means that the radius of curvature for the modulated grooves will be smaller for the constant-amplitude cut than for the constant-velocity cut. But even so, the level to be expected in the upper-frequency range is so small that even the higher recording level for the upper frequency range does not cut modulations in the record with an objectionably small radius of curvature. That this is so is borne out from the following considerations: The distribution of energy of speech and music is shown<sup>6</sup> in Fig. 8. The peak of the energy spectrum is in the neighborhood of 300 cycles, and the contributing part of a frequency of 5000 cycles is 24 decibels below the signal level of the peak level. This shows how unlikely it is that sufficient energy will be present in the high frequencies to cause excessively small radii of curvature of cut.

#### IV. INSTANTANEOUS RECORDINGS

Instantaneous recordings may be either constant amplitude, constant velocity, or any combination of the two which seems best. The turntable speed may be

<sup>6</sup> Harvey Fletcher, "Some physical characteristics of speech and music, *Bell Sys. Tech. Jour.*, vol. 10, pp. 349-373; July, 1931. Other works to establish energy spectra of speech and music have been published more recently, but all the data to date indicate a rapid fall-off in the higher frequencies.

either  $33\frac{1}{3}$  or 78 revolutions per minute. Such a great lack of standardization is, of course, not desirable, but it seems that little can be done toward standardization while such a great variety in number and quality of cutters and recording machines exists. It has already been pointed out that good crystal cutters and

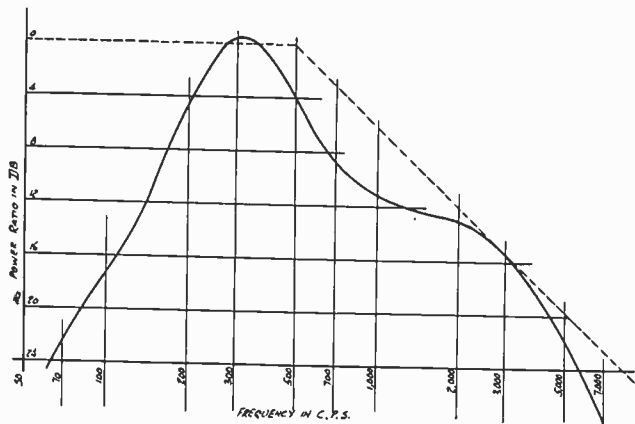

Fig. 8—Most probable peak-energy spectrum for 75-piece orchestra. The dotted line is an amplitude spectrum engraved by a constant-energy input, using a constant-velocity characteristic. The solid line is an amplitude spectrum of a 75-piece orchestra.

pickups, when used without any equalization whatsoever, will cut and reproduce a constant-amplitude cut. Since such a characteristic has many advantages, such as longer playing time and lower background noise, it seems that such a characteristic must become increasingly important and popular in the near future.

#### Record Wear

Instantaneous recording materials are, of course, comparatively soft, and are very easily damaged by badly shaped or rough-surfaced needles. Even when properly shaped and smooth-surfaced, however, a needle can quickly damage these soft cellulose-nitrate disks if its mechanical impedance and pressure are too high. Here, then, is a strong need for a lightweight pickup. As a matter of fact, work has been done to determine the critical stylus pressure which will cause damage to an average cellulose-nitrate disk, and the

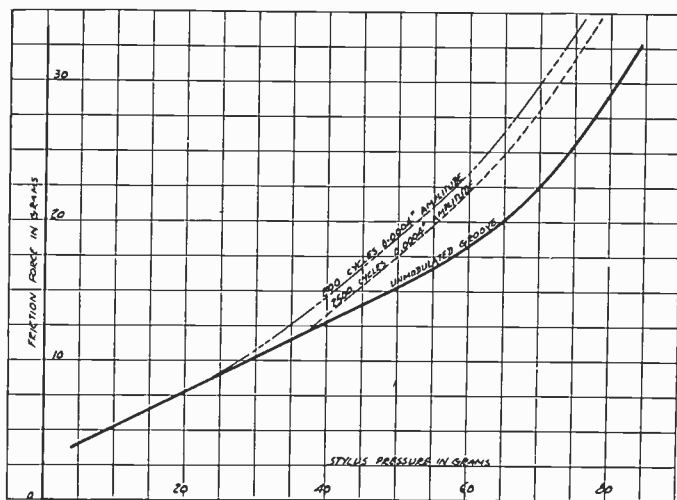

Fig. 9—Friction versus stylus pressure of a reproducing stylus on cellulose-nitrate recording material at 78 revolutions per minute. Radius to cut =  $4\frac{3}{4}$  inches.

results of these investigations are pictured<sup>7</sup> in Fig. 9. In this figure, stylus friction is plotted against stylus pressure. On an unmodulated groove, the friction force is, up to about 55 grams stylus pressure, proportional to the stylus pressure. On a groove modulated with 200 cycles, the departure of the curve from proportionality takes place just above 25 grams. The 2500-cycle groove shows this effect above about 35 grams. As soon as the relationship between stylus pressure and friction force becomes unproportional, the stylus begins permanently to deform the disk material, resulting in excessive wear. This fact has been qualitatively confirmed by microscopic examination of the grooves while the experiment was going on. The results of this work indicate that no higher stylus pressure than about 1 ounce should be used, if permanence of soft nitrate records is wished. It is obvious that only carefully polished styluses should be used. The use of a polished-jewel stylus is therefore strongly indicated.

The apparatus used in making these friction measurements is shown in Fig. 10, and its construction and use have been explained in detail<sup>7</sup> in the literature.

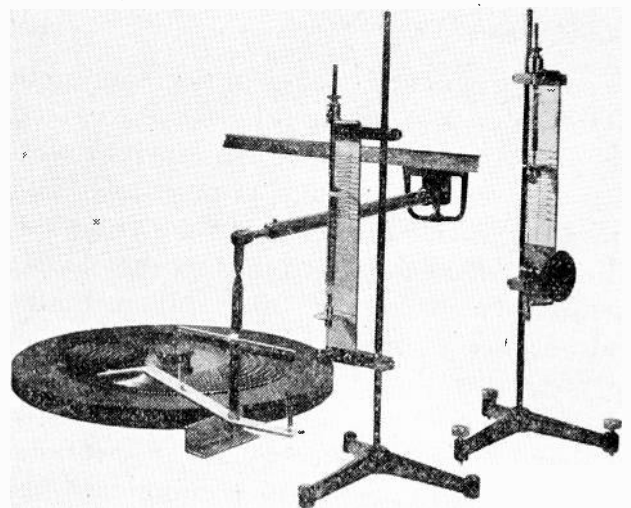

Fig. 10—Photograph of the device used to measure the reproducer-stylus friction as a function of stylus pressure.

#### V. RECORDING TECHNIQUE AND PROBLEMS

The cutting of a really high-quality record into wax or cellulose-nitrate requires not only a very fine machine, but also considerable knowledge on the part of the operator. The cutting of records involves so many variables that it is quite impossible to discuss them all in this article. Some of the more important considerations, as well as the results of some new investigations, will be discussed at some length.

##### Turntable Power

It has been determined from measurements made in The Brush Development Company laboratories, concerning cellulose-nitrate records, that the tangential force generated between the cutting stylus and the

<sup>7</sup> A. L. Williams, "Further improvements in light-weight record reproducers, and theoretical considerations entering into their design," *Jour. Soc. Mot. Pic. Eng.*, vol. 33, pp. 203-223; August, 1939.

disk is fairly independent of the turntable speed, within the speed range of interest. This force is, however, proportional to the cross section of the material being removed. If a steel stylus be used, the cut is approximately triangular shaped, since the stylus tip may be ground very sharp; for this case, the force is proportional to the square of the depth of cut. On the other hand, the usual sapphire stylus has a rounded tip, and thus cuts a groove with a rounded bottom. Fig. 11 is calculated for the sapphire stylus, and shows the cutting force as a function of the depth of cut. These measurements (Appendix) give a good clue to the power required to drive a turntable safely at a constant speed. Fig. 12 shows this quantitatively. Naturally, a large margin of safety must be used in a practical system, but Fig. 12 is indicative, at least, of the minimum power which is required. Figs 13 and 14 illustrate the device used for making the measurements shown in Fig. 12.

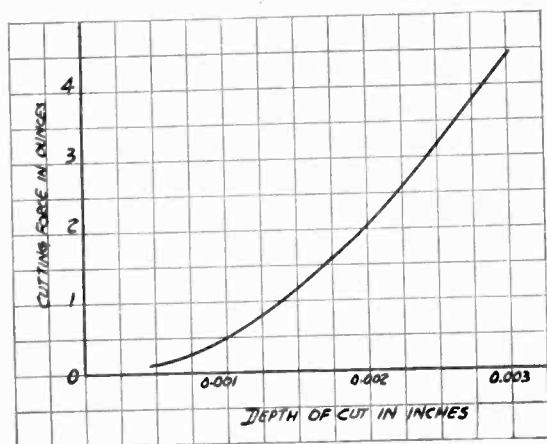

Fig. 11—Cutting force in ounces as a function of the depth of the cut using a sapphire stylus on a cellulose-nitrate record rotated at 78 revolutions per minute.

Of course, the material which is being cut not only loads the turntable, but also functions to load the cutter when a modulated cut is being made. But obviously a cutter whose response is going to be dependent upon the material it is cutting, is not a good cutter, since the resistance of all cutting materials changes somewhat from brand to brand and also from time to time. Temperature and humidity also affect most recording compounds. To make a cutter independent of these variables and also independent of depth of cut, it is obviously necessary to provide a considerable power reserve in the cutter. This would insure that the same cut, as far as amplitude and frequency range are concerned, could be expected in any recording material, at any time.

Cutter Design

The forces which the cutter can supply to the cutting stylus are a function of the electrical and mechanical impedances of the cutter. By properly selecting the different impedance components, a cutter can be designed so as to be independent of the afore-mentioned variables. Cutters have been developed which are

highly satisfactory from this point of view, and which have such a high power reserve that cutting is not influenced by depth of cut or type of materials.

It is relatively easy to control the stiffness of a crystal element, and it is therefore possible to construct a crystal cutter whose resonant frequency will

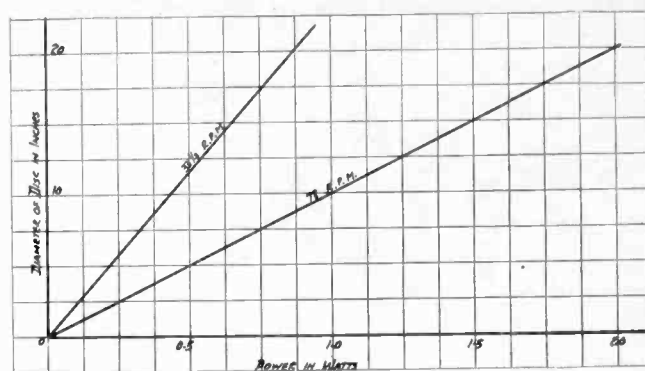

Fig. 12—Power required to drive the turntable against the cutter, neglecting the friction losses in the turntable bearings. The sapphire cut is 0.003 inch deep.

be in the upper audible frequency range. In such a case, the vibratory system of the cutter will have a high stiffness in the range below its resonant frequency, and thus will be greatly independent of the friction forces which the stylus must overcome while cutting.

One such cutter<sup>8</sup> is shown in principle in Fig. 15. A 4-ply crystal element is held by koroseal pads, giving not only a very stiff mounting support, but also a suitable damping for reducing the peak at the natural frequency of the cutter. The stylus chuck is connected to one end of the crystal element, and this stylus chuck differs greatly from the usual stylus mountings. This chuck has a V groove which is bent in the form of an arc, permitting the stylus to rest upon two points. The stylus is pressed against the V groove by means of a screw. The screw is mounted in the cutter housing,

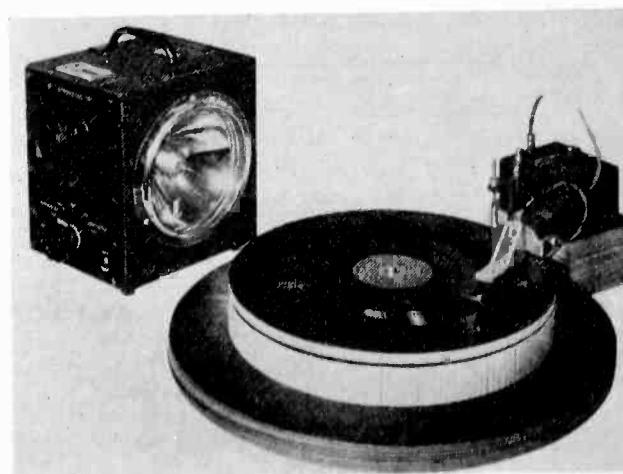

Fig. 13—Device for measuring the recorder-stylus friction.

and its axis is located on the neutral axis of the cutter; therefore, it does not participate in the motion of the stylus. This eliminates any additional inertia which would otherwise be necessary to move the screw. The

<sup>8</sup> The Brush RC-20 crystal cutter.

reason for using the chuck just described is to give the stylus a very long support. After experimenting with usual commercial styluses, it was found that such styluses have a tendency to break up when cutting higher frequencies, if not supported at sufficient points over their length. The response frequency and distortion of this cutter are shown in Fig. 16.

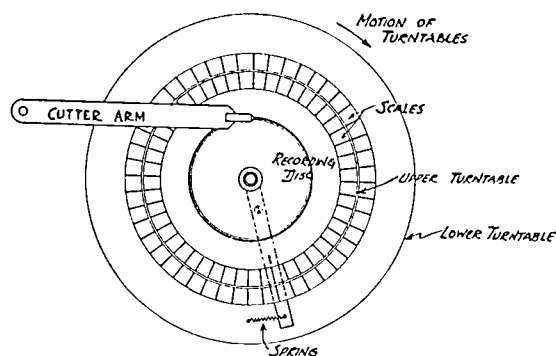

Fig. 14—Device to measure the stylus drag.

With regard to the measurement of harmonic distortions of the cutter, it is rather difficult to obtain an accurate picture of these distortions by recording different frequencies, and making the measurements during playback. When taking measurements in this way, the errors while reproducing must be taken into account. Furthermore, the flutter of the turntable makes accurate measurements difficult; therefore a direct method for taking such measurements has had to be devised. It has been found that the optical method gives the most accurate results, particularly for a cutter which is not affected by the frictional forces developed on the stylus tip while cutting. For the case of the cutter under discussion, it has been found by microscopic examination that the amplitude of stylus swing is the same in air as it is in cutting cellulose-nitrate disks.

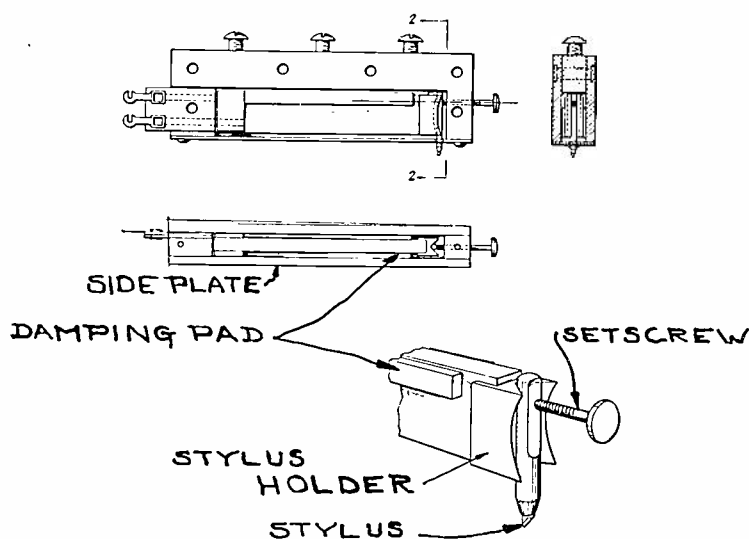

Fig. 15—Schematic diagram of the RC-20 cutter.

Fig. 17 shows in principle the arrangement used for these measurements. A lamp, condenser, lens, and the cutter, as well as a photoelectric cell, are mounted on an optical bench. The cutter stylus is placed in the

beam of light, and the moving cutting stylus changes the area of light band, corresponding to the motion of the stylus. The photoelectric cell will generate a voltage, therefore, corresponding to these changes. A harmonic analyzer is connected to the output of the photoelectric cell to make accurate readings possible. Fig. 18 shows an actual picture of the device which was used for these measurements.

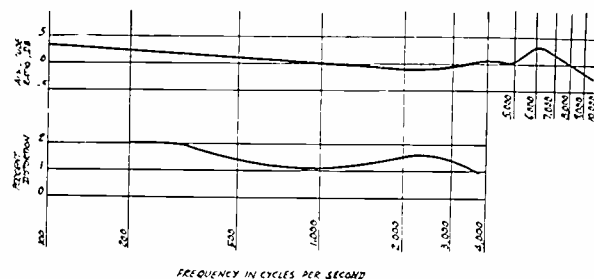

Fig. 16—Response curves of the RC-20 crystal cutter. The frequency curve was recorded with 60 volts across the cutter. The amplitude of the cut was 0.5 mil at 500 cycles. The curves were taken on a constant-amplitude basis but the distortion curves have been weighted for probable peak amplitudes. See Fig. 8. Temperature = 26 degrees centigrade.

It has been suggested before in this article that it is quite important that a cutter be rather independent of depth of cut, temperature of material used for recording, and of the material itself.

It is pertinent to ask at this point why it is so important to have a cutter which is independent of the hardness of the material being used. There are really two reasons: First, all instantaneous recording materials now available are affected by temperature, and humidity affects some of them. Time also has a deleterious effect upon many of them. Thus their hardness and resistance to cut varies not only from brand to brand, but also from time to time within a brand, depending upon conditions of humidity, temperature, and age.

The second reason is that industry is now experimenting with new materials for cutting and already some favorable materials are in sight. Some of these materials are considerably harder than the cellulose nitrate now being used.

Cellulose-nitrate has been almost the sole instan-

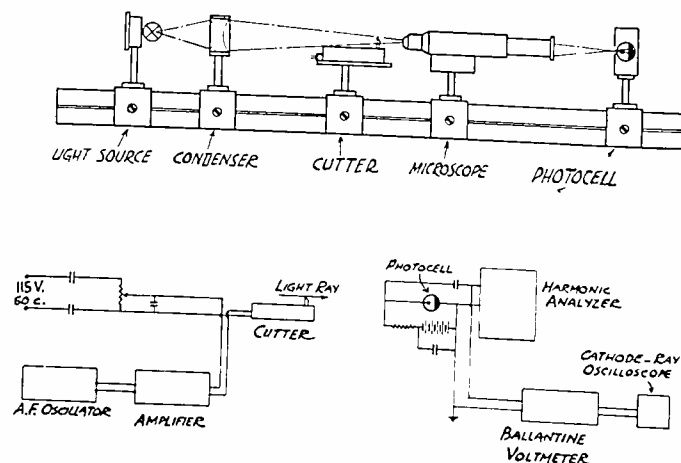

Fig. 17—Device for measuring cross modulation and distortion in cutters.

taneous recording material, but it is expensive, and its chips constitute a fire hazard. It has a tendency to age and introduces distortions in a cut. These defects make it a difficult substance to sell to the home-entertainment field. It seems, then, quite obvious that the near future will introduce other materials more completely to meet the requirements of the art.

*Depth of Cut*

There has been considerable discussion about the different methods for keeping the cutting depth uniform. This is quite an important problem. The cutting stylus has an approximately triangular shape, and therefore the width of the groove depends greatly upon the depth of cut. The deeper the groove is, the less will be the wall thickness between the grooves for the same number of lines cut per inch. Therefore, to obtain the maximum number of lines and still retain good coupling between reproducer stylus and groove, it is necessary to keep the depth of cut constant within close limits. Furthermore, the cellulose-nitrate records now in use have an aluminum base and only a thin coating of cellulose-nitrate. By cutting too deeply, it is possible to break through the coating and to run the stylus into the aluminum, thus destroying the stylus tip and spoiling the record. It is therefore

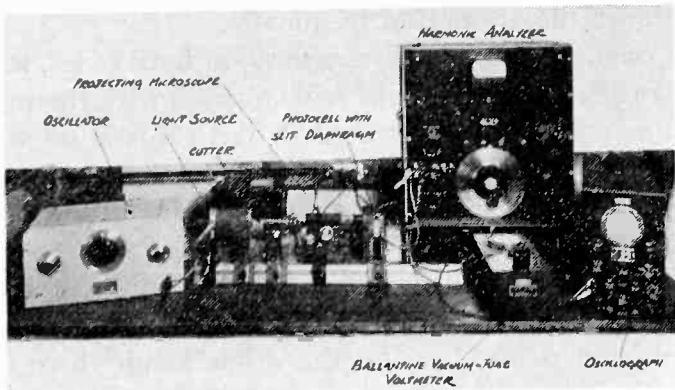

Fig. 18—Photograph of the optical bench.

necessary to provide a means for maintaining the depth of cut at an optimum. Two to three mils depth of cut are generally sufficient to meet these requirements.

Two methods are used for controlling the depth of cut. First, the cutting head is counterbalanced in such a way as to give sufficient average pressure on the cutting stylus for cutting a suitable groove. Second, an advance ball can be utilized, this ball to ride on the surface of the record just ahead of the stylus, and being adjusted in such a way with respect to the stylus point that the stylus will penetrate into the record for a predetermined depth. In the latter case, a part of the cutter weight rests upon the advance ball.

Both of these methods have their advantages and disadvantages. Most record surfaces are uneven to a certain degree. Measurements have been made to determine the average unevennesses of typical recording

disks.<sup>7</sup> Fig. 19 shows the vertical unevenness of such a disk as a function of the angular position. The stylus and cutter assembly must follow this unevenness. Lift-

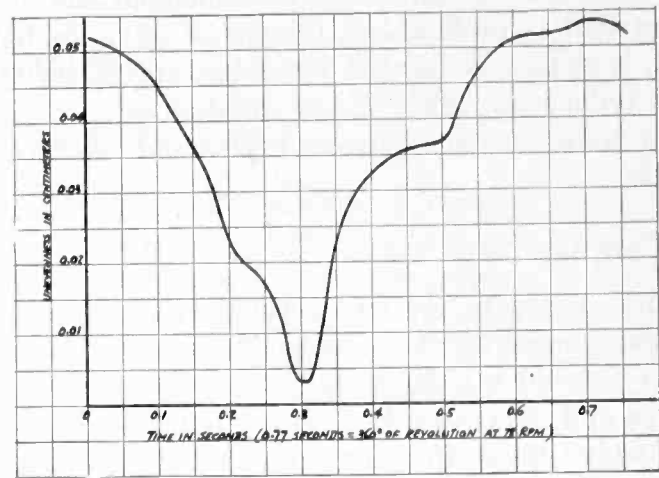

Fig. 19—The unevenness of a typical pressing.

ing the cutter by a hump in the record surface generates an additional pressure due to the mass of the cutter assembly, adding to the normal stylus pressure, and this results in a deeper cut. On the other hand, if the stylus approaches a hollow, the mass of the cutter assembly will develop a subtractive force, reducing the normal stylus pressure and resulting in a more shallow cut. These conditions can be aggravated to such an extent that the stylus alternately may actually not cut at all into the record or may cut completely through the cellulose-nitrate coating. An analysis of these considerations makes it necessary, if a counterbalancing system for regulating depth of cut is used, to reduce the moment of inertia of the cutter assembly to a minimum in a vertical plane. This calls for a light cutter and for a suitable arrangement of the pivoting point of the cutter.

In the horizontal plane, however, the cutter should be rigidly coupled to a considerable mass, in order that it may represent a fixed point from which the stylus may move. It may be added here that this pivoting point should be ideally located in the record plane, and, for practical applications, as close as possible to the record plane, so as to minimize the effect of the moment caused by the forces developed on the cutting stylus, as indicated by Fig. 20.

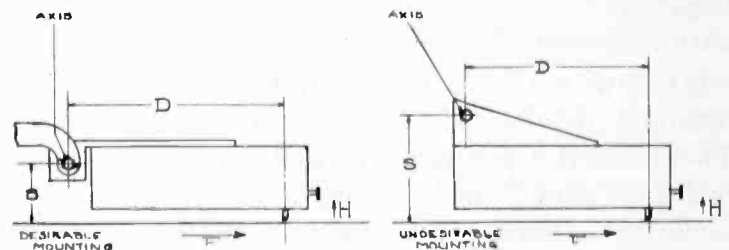

Fig. 20—Desirable and undesirable mountings.

$$\begin{aligned}
 M &= FS & HD &= FS \\
 HD &= M & H &= FS/D \\
 H &\rightarrow 0 \text{ when either } S \rightarrow 0 \text{ or } D \rightarrow \infty
 \end{aligned}$$

If the afore-mentioned condition can be met, the counterbalancing system, to achieve uniform depth of

cut, is not only the simplest, but also the best, method. On the other hand, if the design of the cutter requires considerable mass in the cutter assembly, the counterbalancing system cannot be recommended and an advance ball is preferable. If such an advance ball is used, it should be located very close to the stylus, so as to reduce the effect of any differences in the plane of the record surface between stylus and advance-ball location.

#### *Feed Mechanism*

With regard to the feed mechanism, any such device will be satisfactory which has no backlash and which provides a rigid coupling between the turntable motion and the cutter. Preferable are the feed mechanisms which move the cutter along a diameter across the record, thus providing regular groove spacing and no tracking error. For practical purposes, however, where a simple and inexpensive feed mechanism is required, such as is the case in the home-entertainment field, the cutter may be held on an arm like a pickup. This arm may be coupled in any one of several ways to the turntable to provide a feed. Such mechanisms perform perfectly satisfactorily in their field.

#### *Electrical Network*

The best turntable, cutter, and feed mechanism, however, will not produce a good record if the microphone and amplifier used are not adequate to the task. As in every other system, a chain is no stronger than its weakest link. Therefore, some consideration must be given to the amplifier, and particularly to the driving network and driving stage of the amplifier. In the home-entertainment field, it is quite likely that a cutter will be driven by a pentode output tube, and such a pentode output tube will develop considerable distortion if it is not loaded with a resistive load of the value recommended for the particular output tube and voltages used.

All cutters, either magnetic or crystal, have a variable impedance with different frequencies. The magnetic cutter represents, for the greater part of the audible range, an inductive load but at low frequencies it is largely resistive. This means that its impedance increases approximately proportionally with frequency. The crystal cutter, on the other hand, represents a capacitive load, meaning that its impedance decreases while the frequency increases. Therefore, if a pentode output stage is used, this output stage should, in addition, be loaded with a resistor so as to eliminate the effect of the changeable impedance of the cutter. If, for some reason, it is not desirable to use such a resistor, negative feedback is recommended in conjunction with a pentode or beam-power output stage.

A triode output stage is always more desirable,

since the harmonic distortion generated by it is largely independent of load conditions.

#### *Cutter Equalizers*

And now, a few words should be added regarding the problem of matching a cutter to the output circuit of an amplifier. A stiffness-controlled magnetic cutter requires a constant current for a constant displacement of the cutting stylus. The crystal cutter, on the other hand, requires a constant voltage for a constant displacement. Knowing, furthermore, the impedance characteristic of such cutters and knowing the desired cutting characteristic, it is not difficult to design a suitable network for driving such cutters.

For constant-velocity recording, the magnetic cutter referred to has to be supplied, up to the transition frequency, with constant current, and above this transition frequency, with a current changing inversely with the frequency. This can be attained by making the resistance of the driver circuit equal to the impedance which the cutter represents at this transition frequency.

The crystal cutter, on the other hand, requires a constant voltage up to the transition frequency, and thereafter a constant current. As before, this can be obtained by making the resistance of the driver circuit equal to the impedance which the cutter represents at the transition frequency.

Constant-amplitude recording, in both cases, means that this transition point will coincide with the upper-frequency limit to be recorded. With this in mind, the principle necessary for the design of the feeding network remains the same; only the magnitude of the various components changes.

This method of equalizing in recording constant velocity does not, of course, provide a very sharp transition point, but, on the other hand, there is no reason for requiring such a sharp point. The gradual turnover makes it very easy to equalize a pickup for reproducing such a record.

#### APPENDIX

##### *Device for Measuring Cutting Force*

The device used to measure this cutting force is shown in Figs. 13 and 14. Essentially, it consists of one turntable mounted on top of another turntable. Connecting the two turntables are very smooth, frictionless bearings, allowing the two turntables to turn easily with respect to one another. A spring connects the turntables; thus it follows that any force generated in the plane of the upper turntable surface, perpendicular to any radii in the disk, will cause the spring to stretch, resulting in a displacement between any two points on the rims of the turntable. Affixed to these rims are two identical scales, and these scales are read stroboscopically by means of a Strobotac, while the turntables are rotating and while a cut is being made.

# On the Right- and Left-Handedness of Quartz and Its Relation to Elastic and Other Properties\*

KARL S. VAN DYKE†, MEMBER, I.R.E.

*Summary*—The confusion concerning the elastic properties of quartz which exists in the literature of the piezoelectric resonator is pointed out. Emphasis is placed on the accepted definitions of right and left quartz and of right- and left-handed optical rotation, the disregard of which by authors, together with a rather free use of axial systems of their own choosing, sometimes obscurely defined, is responsible for the confusion.

An independent experimental investigation is made of the interrelations between piezoelectric polarization, optical rotatory power, elastic compressional compliance, and characteristic etch markings and thereby with the natural face forms of the quartz.

Particular care is taken to avoid any possible errors in sign in relating these properties, and a number of such errors in the literature are pointed out.

The etch pattern on a quartz sphere is described as well as its use as a reference standard in determining the orientation of quartz resonators by means of the etch patterns on their faces.

## INTRODUCTION

### *Importance of Elastic Properties in Resonator Behavior*

THE elastic properties of quartz vary with the direction of the strain. It is well known that Young's modulus has different values parallel and perpendicular to the optic axis. For oblique directions its value depends not only upon the inclination with respect to the optic axis, but also upon the azimuth of the direction, that is, the angle that the plane containing the optic axis and the given direction makes with the  $X$  and  $Y$  axes of the crystal. Voigt<sup>1</sup> gives the equations for its computation as well as the values of the fundamental elastic constants which are involved, and in an early paper<sup>2</sup> shows curves to indicate the type of variation which is to be expected in the different planes. Wright and Stuart<sup>3</sup> and Straubel<sup>4</sup> and later others<sup>5</sup> computed curves for this elastic constant from Voigt's equations.

The first hint of the importance of the elastic anisotropy of quartz for the performance of the resonator is found in the Meissner<sup>6</sup> paper of 1927. Here though the

\* Decimal classification: 537.65. Original manuscript received by the Institute, June 24, 1940. Presented in part before I.R.E.-U.R.S.I., Washington, D.C., April 26, 1940, under the title "The use of an etched sphere of quartz in identifying the orientation of quartz plates."

† Wesleyan University, Middletown, Conn.

<sup>1</sup> W. Voigt, "Lehrbuch der Kristallphysik," Teubner, Leipzig, Germany, 1910. Compare page 751, equation 456 and page 753.

<sup>2</sup> W. Voigt, "Bestimmung der Elasticitätsconstanten von Beryll und Bergkrystall," *Ann. der Phys.*, vol. 31, Heft 8a, pp. 701-724, plate IV, Fig. 15, 1887.

<sup>3</sup> R. B. Wright, and D. M. Stuart, "Some experimental studies of the vibrations of quartz plates," *Bur. Stand. Jour. Res.*, vol. 7, pp. 519-553; September, 1931.

<sup>4</sup> J. I. Straubel, "Schwingungsform und Temperaturkoeffizient von Quarzoszillatoren," *Hochfrequenz. und Elektroakustik*, vol. 38, pp. 14-17; July, 1931.

<sup>5</sup> W. P. Mason, "Electrical wave filters employing quartz crystals as elements," *Bell Sys. Tech. Jour.*, vol. 13, pp. 405-452; July, 1934.

<sup>6</sup> A. Meissner, "Piezo-electric crystals at radio frequencies," *Proc. I.R.E.*, vol. 15, pp. 281-296; April, 1927.

sides of the plates used were cut parallel to the crystallographic axes the vibration was shown to be unsymmetrical in the plate. Wright and Stuart and Straubel, soon demonstrated the close connection between the unsymmetry of the elastic properties and the direction of the vibration. In the Mason paper of 1934 the use of the elastic unsymmetry and the coupling between two modes of vibration was developed to provide resonators with selected frequency-temperature characteristics.

### *Purpose of Present Paper*

Unfortunately there are such differences in the conventions used by the different authors, even obscurity as to their precise conventions, that in a study of their curves, their disagreement is almost more obvious than the facts regarding the elastic moduli.

It is because of the diverse systems of axes used by Voigt, Wright and Stuart, Mason, and Straubel in their curves of the elastic properties of quartz, their differing rules of signs, and the confused state which has resulted, that it is here proposed to restate some of the facts. These will be stated in terms of well-established reference planes in the crystal, thus avoiding for the purposes of this paper the adoption of any one of the axial systems. We defer to a subsequent paper the recommendation of a system of axes, which we believe will avoid the confusion of those heretofore used, since such a recommendation has to do with the setting up of new conventions rather than the establishment of accepted usage, which is the purpose of the present paper. The nomenclature will conform to that widely accepted by the physicist and the crystallographer.

## ACCEPTED DEFINITIONS AND CONVENTIONS

### *Right and Left Quartz Defined*

Quartz occurs in two characteristic forms, right quartz and left quartz. When these two varieties occur mixed in the same crystal the quartz is said to be twinned. Twinned quartz is of little use in making piezoelectric resonators unless the twinned portions are removed, for its behavior is both inferior and unpredictable. Resonators cut from either right or left quartz are equally effective and no differences between the two kinds of quartz are known other than those which are inherent in mirror imagery, except that the left variety is found more frequently in nature.

The crystal of left quartz is the mirror image of that of right quartz both in the external orientation of the

planes of its faces and in the internal properties, whether elastic, electric, optical, or thermal. The orderly array of the atoms in one of these enantiomorphic forms is the exact mirror image of that in the other, and this is, of course, the fundamental cause of the relation of the left to the right crystal in both external and internal properties.

Crystallographers distinguish the left and the right quartz by reference to the order in which the natural crystallographic faces occur around the crystal. It is their standard practice in describing the location of the faces of such a crystal to place the crystal with the six prismatic faces vertical, so situated that one of the faces of the positive primary rhombohedron comes directly above the prismatic face that is most nearly toward the observer. This prismatic face is usually made to face slightly to the observer's left. The crystallog-

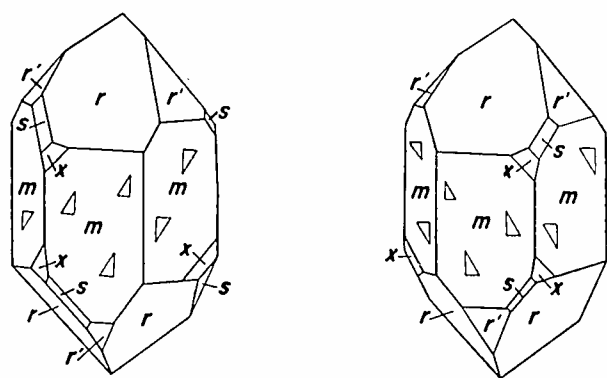

Left Quartz

Right Quartz

Fig. 1—The two forms of quartz. (The right triangles indicate characteristic etch figures.)

rapher designates the six prismatic faces as  $m$  faces and the positive primary rhombohedral faces as  $r$  faces. As is true of all faces on crystals of the class to which quartz belongs the  $r$  face can occur in six places around the complete crystal, three equally spaced around the upper half of the crystal and three around the lower. Stated differently, identical planes in the lattice occur in sets of three inclinations and a given face can be parallel to any one of these three. The crystallographers then define the quartz as left quartz if, with the crystal held in the position stated, the trapezohedral faces  $x$  and  $s$ , when present at all, occur at the left of the  $r$  face; right quartz if the  $s$  and  $x$  faces occur at the right of the  $r$  face (Fig. 1). These faces may not happen to be developed on the particular crystal under examination, and one must then have recourse to other tests in identifying the crystal as right or left.

#### Right and Left Optical Rotation Defined

One of the most useful of the correlated properties is the ability of the crystal to rotate the plane of polarization of light when the light travels parallel to the optic axis. In the very early days of discovery and application of optical rotation there was confusion as to which sense of rotation should be called right-handed and which left-handed. Today, however, there is a well-

established practice in this regard among physicists and among chemists and mineralogists. The accepted convention is that the rotation of the plane of polarized light shall be called right-handed when an observer looking back toward the source of light through the rotating medium turns the analyzer clockwise to follow the rotation, left-handed if from this point of view the rotation has been counterclockwise. In the alternative convention which is not in use today, the question of right- or left-handedness was determined by the clockwise or counterclockwise nature of the rotation, as judged when one took the point of view of the light in its travel from the source toward the analyzer.

By the accepted convention it happens that right quartz, as defined by the crystallographer from the array of its faces, is also dextrorotatory, while left quartz is to be associated with left-handed rotation of the plane of polarized light.<sup>7</sup> While there may be certain logic in the earlier definition of right- and left-handed optical rotation there is, so far as we are aware, no precedent for extending the reversal of point of view from the optical to the crystallographic. It is certainly to be hoped that in the interest of a literature as free from confusion as possible the well-established conventions of the older fields of physics and crystallography will be followed in the newer field of crystal resonators.

#### Elastic Properties of Right and Left Quartz

From the elastic data of the authors above referred to, it is evident that Young's modulus follows a law of variation with direction in the quartz which is symmetrical on the two sides of the optic axis, if the variation is limited to the  $XZ$  plane.<sup>8</sup> In this plane the maximum values of the modulus occur at angles of about 30 degrees from the  $Z$  axis. The symmetry in this plane is, of course, obvious from the symmetry of the quartz itself, as is also the unsymmetry of the variation of the modulus in the  $YZ$  plane. The conflicting conventions and the vagueness about axial systems leaves room, however, for doubt as to just which side of the axis in the  $YZ$  plane to expect the modulus to take its maximum value, and which side its minimum. A key fact to the interpretation or test of the correctness of the data of others is the following conclusion from the present experimental work. In this conclusion no convention of the sense of axes is involved and its statement is true for all axial systems and for right or left quartz: *The maximum value of Young's modulus in quartz occurs in a direction which is approximately perpendicular to an  $r'$  face of the crystal.*

<sup>7</sup> R. B. Sosman, "The Properties of Silica," Chemical Catalog Co., New York, N. Y., 1927, p. 649.

<sup>8</sup> There is agreement regarding the definitions of  $XY$ ,  $XZ$  and  $YZ$  planes in the quartz, even though not in the senses of the axes themselves. Hence reference will be made only to the planes. The  $XY$  plane is perpendicular to the optic, or  $Z$  axis, the  $YZ$  plane perpendicular to some one of the prismatic faces and includes the optic axis, and the  $XZ$  plane perpendicular to these two planes; the latter is, therefore, parallel to the bisector of the dihedral angle between two adjacent prismatic faces. The  $X$  and  $Y$  axes are frequently called in the resonator literature the electric and the mechanical axes of the crystal.



Both the maximum and the minimum values attained in quartz by Young's modulus or by its reciprocal, the compressional compliance,  $s_{33}'$ , occur in the  $YZ$  plane. More precisely, the maximum of the modulus, or the minimum of the compliance, are found at about 48 degrees, while the minimum of the modulus and maximum of the compliance are at about 72 degrees from the optic axis.

It is the purpose of this paper to link these facts with some of the other identifiable characteristics of direction in the quartz which are useful in determining orientation. Thus pertinent facts regarding the charges developed on compression, optical rotation, and the figures which are produced by etching are investigated, and in every case the sense of the phenomenon carefully checked with the facial configuration of the natural quartz.

It should be pointed out that there has been no attempt to secure precision of numerical values in the experimental work, but only certainty beyond all doubt regarding senses of polarization, angles, optical rotation, and etch figures, and to avoid any possible confusion of right and left quartz.

The experimental data for the elastic tests as functions of direction are not presented. They do, however establish the absolute correctness as to sense and the approximate correctness as to value of the equations and constants as given by Voigt. And, though the computed magnitudes are in agreement with the computations of others, we plot another curve of values,<sup>9</sup> computed from Voigt to add to those of Wright and Stuart, Straubel, and Mason (Fig. 2). In this figure computed values of compressional compliance ( $s_{33}'$ ) are plotted in polar diagrams as radius vectors against angles in the  $XZ$  and  $YZ$  planes. The curves are the envelope of the function  $s_{33}'$  (reciprocal of Young's modulus). No explicit rules of signs of angles are needed. Directions in the two planes shown are plotted as they appear when the polar diagram is held up in front of a suitably oriented quartz crystal, or model. For the curves in the  $XZ$  plane the crystals should be held in the standard position in which a crystallographer draws the crystal. For the curves in the  $YZ$  plane the reader should face a dihedral angle between prism faces rather than a prism face itself, and the angle should be one of those three which terminate above and below in  $s$  and  $x$  faces. Stated in terms of a piezoelectric test the reader should look at an edge which becomes negative on  $x_z$  compression. Stated in terms of etch patterns which develop on a quartz sphere he should be facing the center of the "bar" to be later described. The arrowheads shown in the figure indicate correctly the sense of axes only in the case of right quartz with Voigt's conventions. In the figure for left quartz the arrows are mirror images of these.

Comparison of Fig. 2 with the curves of Straubel<sup>4</sup> for Young's modulus shows the latter to be correct when

<sup>9</sup> Computed for the author by H. P. Blakeslee, in 1929.

the intended senses of the axes are known. Straubel's reference is to an early work of Voigt<sup>10</sup> but, as might be inferred from the difference in the sign of the  $s_{14}$  term in the equation which he quotes from Voigt, and in equation 456 on page 751 in Voigt's "Lehrbuch der Kristallphysik," Voigt's axial conventions were different in 1898 than in 1910. Straubel's axes are not those of Voigt's well-known Lehrbuch. He makes a diagram for the axes but this lacks essential data. Mason's<sup>5</sup> curves are found to be correct when interpreted in the light of the explanatory sentence in his recent paper.<sup>11,12</sup> Wright and Stuart's curves appear to be correct though there is some confusion in their statement of axes.

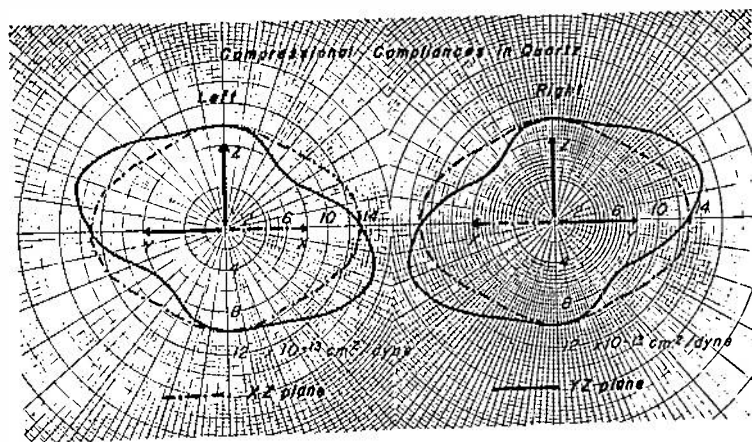

Fig. 2

### Confusion of Axes

The differences in choice of axes among the group of authors already referred to are responsible for some of their graphical data showing maximum values of Young's modulus at +48 degrees in the  $YZ$  plane, and other data at -48 degrees. Agreement on this sign of angles on the part of two authors is, however, not an indication that their axial systems are identical. Mason<sup>13</sup> and Wright and Stuart, for example, use different rules for signs in defining the sense of angles, while at the same time they seem to choose opposite positions from which to view the rotation which the angle specifies.

## EXPERIMENT

### Tests for Axes and Kind of Quartz

In making the present determination we have avoided the possibility that an error in the sense of orientation by the lapidary who cut the crystals might affect the conclusions. Several X-cut bars cut from different crystals and making angles ranging from about 70 degrees on one side of the optic axis to 70 degrees on the other side were used. All were about 50×5×5 millimeters, the long dimension making the angle in ques-

<sup>10</sup> W. Voigt, "Die Fundamentalphysikalischen Eigenschaften der Krystalle in Elementarer Darstellung," Teubner, Leipzig, Germany, 1898. Page 164, also pages 100 and 169.

<sup>11</sup> W. P. Mason, "Low temperature coefficient quartz crystals," *Bell. Sys. Tech. Jour.*, vol. 19, pp. 74-93; January, 1940. Compare line 2 on page 80.

<sup>12</sup> W. P. Mason and G. W. Willard, *Proc. I.R.E.*, this issue, p. 428.

<sup>13</sup> That is, after rewriting Mason's statements in terms of the standard conventions as to right and left quartz.

tion. Instead of using the data regarding angles given by the lapidary, the angles of the bars were experimentally determined after they were cut. This was done by means of three tests. The first two supply the complete information; the third, the etching test, constitutes a completely independent check on the correctness of the other two.

#### Optical Rotation Test

First, each bar was tested for the right- or left-handedness of the quartz. Since its surfaces were ground, and thus not transparent when dry, the bar was wetted with nitrobenzene. Then it was held between crossed polaroids in the path of a convergent beam of light from a Sodium Lab-arc, and viewed through an eyepiece. After the inclination of the quartz bar is adjusted a system of concentric interference circles is seen when the axis of the convergent beam coincides with the optic axis of the quartz. By turning the bar the direction of the optic axis was located. The right- or left-handedness of the quartz was then determined from the following well-known rule<sup>14</sup> regarding the behavior of these circles when the quartz has plane parallel sides. Rotation of the analyzer in a clockwise direction, as judged by an observer looking back toward the source of light, causes the interference circles to expand if the quartz is right quartz, contract if left.

#### Piezoelectric Test

Second, each bar was subjected to a piezoelectric test by which the sense of the charge on compression was determined. The bars were all *X* cut. They were submitted, for a double check, to both  $X_x$  and  $Y_y$  stresses, by squeezing first parallel to  $X$  and then along their lengths. These two tests, of course, gave opposite polarities. It will later be shown that for either right or left quartz it is the prismatic edge of the crystal carrying the *s* and *z* faces which becomes negatively charged on compression along the *X* axis. Thus, by the optical and piezoelectric tests both the angle of cut and its sense were determined in relation to the natural crystal faces, as well as the right- or left-handedness. This orientation of the bar with respect to the faces of the natural crystal is best visualized by holding the bar, with its optic axis and its charged faces suitably oriented, before a model or a drawing of the right or left quartz crystal, such as Fig. 1.

#### Etching Test

The third test was by means of the etch figures which are developed on the quartz by the action of concentrated hydrofluoric acid. The faces of the bars were examined under the microscope and the figures noted were compared with those on a quartz sphere which had been similarly etched.<sup>15</sup> A sphere, since it has

elements of surface at every possible orientation, is a particularly convenient standard of reference. By means of the etch figures, at least two of the surfaces on each bar were definitely identifiable as to both position and orientation on the sphere. Thus, from this test alone, its cut was determined to within a few degrees, as well as the right- or left-handedness of the quartz. The etched sphere which we had available was of left quartz, and, as some of the bars were of right quartz, allowance for this fact had to be made in the comparison.

A number of discrepancies in the literature are noted. In addition to the confusion of axes and of right- and left-handedness already mentioned, we find in two optics texts<sup>16,17</sup> the obsolete definition of the sense of optical rotation; in one optics<sup>18</sup> and one crystallography<sup>19</sup> text drawings of right and left quartz misnamed, and in two other cases<sup>20,21</sup> error in the relation of the etch figures to the right- or left-handedness of the quartz. Except for those in the texts of Edser and Taylor all of these are believed to have been mere typographical errors and not instances of adoption of a different definition of right- and left-handedness of the quartz. Edser and Taylor are among the oldest of the textbooks examined and thus are considered to be decidedly outweighed by the complete agreement of the many newer standard advanced texts with one another.

#### Elastic Test by Resonance Frequency

The long-dimension resonance frequency for compressional vibrations of each bar was determined and the effective values of Young's modulus along its length computed from the equation relating frequency  $n$ , Young's modulus  $E$ , length  $l$ , and density  $\rho$ ,  $n = 1/2l \times \sqrt{E/\rho}$ . As has been stated the resulting elastic constants are in good agreement with values computed from Voigt and plotted in Fig. 2.

plates. Since that time an excellent set of photomicrographs of the etch figures which develop at various positions on a spherical quartz surface has been published by W. L. Bond, "Etch figures of quartz," *Zeit. für. Krist.*, vol. 99, pp. 488-498; August, 1938.

<sup>16</sup> E. Edser, "Light," Macmillan Co., London, England, 1902, p. 504.

<sup>17</sup> L. W. Taylor, "College Manual of Optics," Ginn and Co., Boston, Mass., 1924, p. 163.

<sup>18</sup> F. A. Jenkins and H. E. White, "Fundamentals of Physical Optics," McGraw-Hill Book Co., New York, N. Y., 1937, p. 370.

<sup>19</sup> F. Rinne, translated by W. S. Stiles, "Crystals and the Fine Structure of Matter," E. P. Dutton and Co., New York, N. Y., 1922, p. 36. In this book were noted two cases of omission of essential data for the complete interpretation of drawings. On page 27 are shown apex views of left and right quartz crystals, but it is not stated which is right and which left. They can be identified by comparison with our Fig. 4. On page 130 sulphur and red-lead patterns on a quartz crystal are shown; not only is there no statement whether the charges which caused the figures were developed on warming or cooling the crystal, but the figure and its explanation are also ambiguous.

<sup>20</sup> O. Meyer and S. L. Penfield, "Results obtained by etching a sphere and crystals of quartz with hydrofluoric acid," *Trans. Conn. Acad.*, vol. 8, pp. 158-165; December, 1889.

<sup>21</sup> P. Groth, "Krystallographie," Wilhelm Engelmann, Leipzig, Germany, 1905, Taf. III, shows on his drawings of quartz crystals microscopic triangles on *m* faces drawn in the opposite sense from those found by the present author, left-handed right triangles on a right-handed crystal, and vice versa. The etching medium, however, was warm potassium carbonate instead of hydrofluoric acid.

<sup>14</sup> A. E. H. Tutton, "Crystallography and Practical Crystal Measurement," Macmillan Co., New York, N. Y., 1911, p. 813.

<sup>15</sup> The sphere had been etched a number of years ago in the hope that it might be useful in determining the orientation of quartz

## THE QUARTZ SPHERE

*The Etch Pattern on a Quartz Sphere*<sup>22</sup>

The pattern which develops on the quartz sphere in the etching process helps to make more concrete the relations between the two enantiomorphic forms and to emphasize the fact that it is the internal structure of the quartz which determines the orientation of the natural faces of the crystal.

Our sphere was first polished and then immersed in concentrated hydrofluoric acid at room temperature. The first areas to show the action of the acid were the regions around the poles of the optic axis. Here triangular areas consisting of tiny triangular pyramidal marks appeared in ten or fifteen minutes. After a number of hours of etching the large-scale pattern shown in the photographs (Fig. 3) was fully developed. Its outstanding characteristic is that it has the symmetry of the quartz crystal. There are the two triangular areas mentioned which mark the axis of trigonal symmetry. These have now developed extensions from their vertices which curl around the sphere like the tentacles of an octopus. In Scott Laboratory the figure is called a "tripus." The direction of curl is characteristic of the left quartz of which the sphere is made. The "tripus"

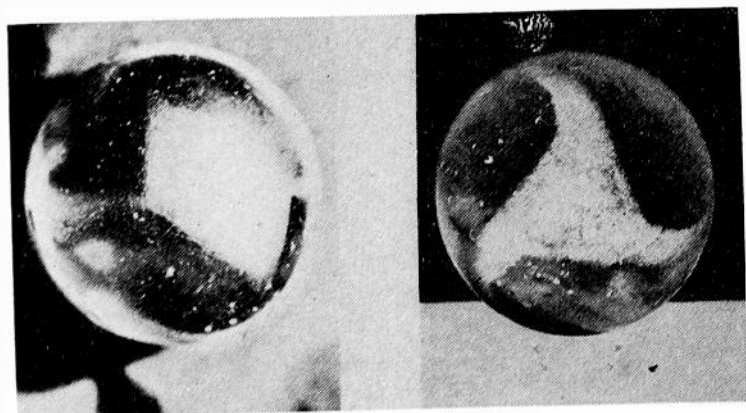

Fig. 3—Two views of the etch pattern on a 50-millimeter left quartz sphere. At the left, view toward an *m* face with an *r* face above it. At the right, view along optic axis.

represents the area of most rapid action of the acid. In Fig. 4 the "tripus," which appears, of course, only on a sphere, has been sketched for reference on the apex view of the faces of right and left quartz with due regard to orientation about the trigonal axis. This shows very strikingly how this region of most rapid etching extends along the intersections of *r* faces and then stays just above the *r'* and *s* faces as they border on an *r* face. The trigonal symmetry, in addition to being obvious in the "tripus" itself, is evident also in the pattern found near the equator of the sphere, the center of each "tripus" regarded as marking a pole. The equator is divided by the etching into six regions of 60 degrees each. Three alternate sections around the equator are oblique parallelograms with their shorter diagonals along and their shorter sides perpendicular

<sup>22</sup> The author is indebted to Karl S. Van Dyke, Jr., for assistance in the detailed study of the etch patterns on the sphere.

to the equator. The diagonals do not show, for the equator has no distinctive marking within the parallelogram, and the whole area of the parallelogram has almost the same sheen, due to the very slight action by the acid.

The parallelograms are joined by a clear marking of the line of the equator itself between parallelograms. This line has some breadth, is slightly wider in the middle than at its ends, but is nowhere wider than one

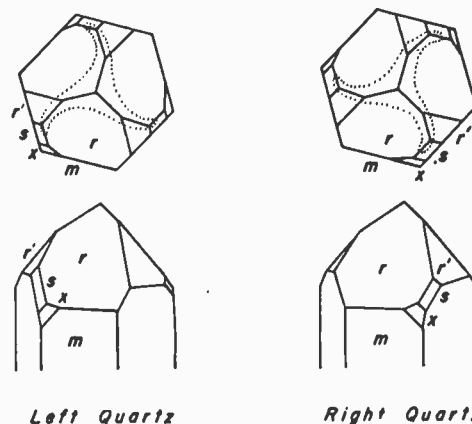

Fig. 4—Drawings of quartz crystals. "Tripus" sketched on apex view.

tenth of the sphere's radius. In this paper this line pattern is called a "bar." Upon microscopic examination it is seen to consist of fine etched straight lines all parallel to the optic axis, i.e., perpendicular to the equator, the length of these etched lines being the width of the "bar." The complete pattern, except for the "tripus," is rather difficult to see from any one position as it seems at first to consist merely of slight differences in the sheen of the surface. One must rotate the sphere from one position to another, depending upon the illumination, to bring out first one part of the pattern and then another. For this reason it is particularly difficult to photograph. But by rotation as suggested the pattern is seen to be geometrically much simpler than corresponding diagrams given by Nacken.<sup>23</sup> The parallelogram pattern is seen also in the photographs (Fig. 5) by Meyer and Penfield<sup>20</sup> whose paper is perhaps the best-known work on the etching of a quartz sphere. Though they left their sphere in the acid for a month the polish still remained on these parallelogram areas. Their sphere in this time was reduced in the direction of the optic axis to a small part of its original diameter by the action of the acid. We should point out that we suspect the Meyer and Penfield sphere to have been of left quartz though they state it to have been right. Our conclusion is based on the inclination of the parallelograms, for this too is characteristic of the right- or left-handedness of the quartz. We judge their parallelogram to be inclined to the left in their Fig. 6 (our Fig. 5(b)), and our left quartz sphere also develops a large-scale parallelogram pattern with its longer sides sloping upward to the left.

<sup>23</sup> R. Nacken, "Ätzversuche an Kugeln aus Quarz und  $\alpha$ -Quarz," *Neues Jahrb. Min.*, 1, pp. 71-82, plates 10 and 11, 1916. Reproduced in Sosman, footnote reference 7, pp. 508, 509, and 513.

On a right quartz sphere, by the laws of mirror imagery, the inclination would have been upward to the right. Meyer and Penfield based their conclusion as to the right-handedness of their sphere on electrical tests, the familiar Kundt's red-lead and sulphur patterns deposited on a crystal which is cooling, and give a reference to von Kolenko<sup>24</sup> for the interpretation of their test. We have verified the statements of von Kolenko in this regard finding them to be correct. But we find

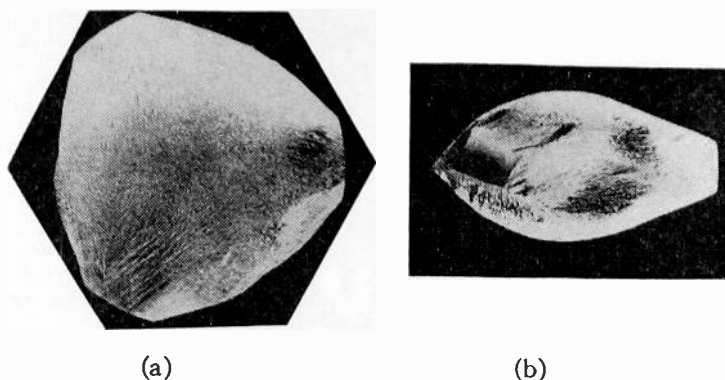

Fig. 5—Sphere of quartz after long continued etching. (Reproduced from Meyer and Penfield, footnote reference 20.)

that Meyer and Penfield have drawn a conclusion as to the kind of quartz from the fact that yellow sulphur deposits on the parallelogram area, while the fact is that the sulphur deposit must occur on this area on spheres of both right and left quartz as is obvious from considerations of mirror imagery. From this test they were not justified in drawing any conclusion as to right- or left-handedness. They apparently made no optical test.

From considerations of the symmetry of the etch pattern and of the quartz crystal itself, combined with the piezoelectric test, we identify regions of the etch pattern with the natural faces of the quartz. The digonal ( $X$  or electric) axis is obvious, running from the middle of a bar to the middle of the parallelogram diametrically opposed, but its sense must be determined electrically. Here we find, in accord with the red-lead and sulphur test mentioned, that on compression along  $X$  a negative charge is developed at the middle of the etched "bar," and this should be true for either left or right quartz. Von Kolenko showed that the negative charge on  $X_z$  compression occurred at those edges between prismatic faces which terminate in the trapezohedral  $x$  and  $s$  faces. Thus on the etched sphere  $s$  faces are located immediately above and below the middle of a "bar."

In the Kundt test it is the charges which develop due to the strains set up on heating or cooling the quartz which are responsible for the separation of the red lead and the sulphur. Care must be taken to discharge the surface of the quartz before the heating or the cooling takes place. One possible source of error, which may yield charges of the wrong sign, is to discharge the surface before the cooling has set in throughout the entire quartz. If the cooling method is to be

<sup>24</sup> B. von Kolenko, "Die Pyro-elektricität des Quarzes in Besuch aus sein Kristallographisches System," *Zeit. für Krist.*, vol. 9, pp. 1-28, 1884.

used the quartz first should be heated gradually enough to avoid fracturing it, and the heating then discontinued for a period long enough to reverse the temperature gradient<sup>25</sup> throughout the quartz before discharging preparatory to the development of the cooling charges. Further cooling then produces a consistent charge pattern. The charges which are set up on cooling, i.e., due to a temperature gradient such that the internal temperature is higher than that of the surface, have the same signs as those which are developed by  $X_z$  compression, and the red-lead deposits on the places which would become negative on this compression. Charges which develop on heating have the opposite sign because of the opposite sign of the gradient.

From the crystallographers' measurements<sup>26</sup> of the angles between faces and from the definition of left quartz in terms of the order of the faces it is now a simple matter to locate the poles of all of the faces of the natural crystal on the etched sphere. The faces thus located are marked on both the right and left spherical models shown in Fig. 6 in which the boundaries of the large-scale etch pattern have been drawn in white on black spheres for emphasis of the patterns.

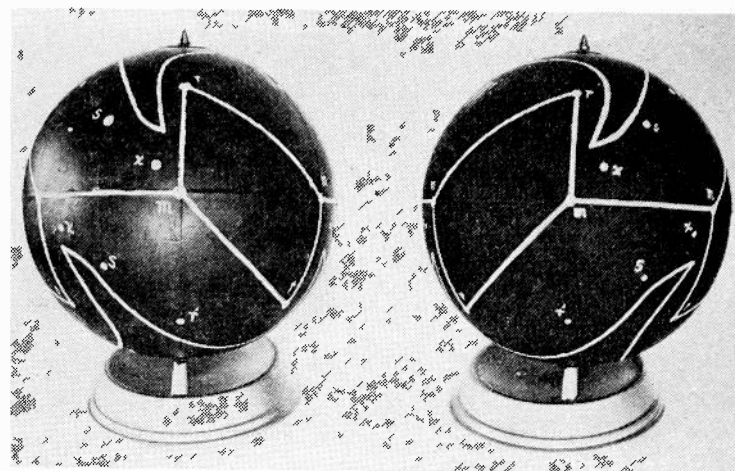

Fig. 6—Models of left and right quartz spheres showing outlines of etch patterns and the poles of the faces. (Left quartz is on the left.)

Note that the four corners of the parallelogram are marked by  $m$  and  $r$  faces. The long sides of the parallelogram mark the great circles on which all of the faces lie but only the  $m$  and  $r$  faces actually border on the parallelogram itself, the others lying rather on the extensions of the line of the long sides.

#### Etch Figures

One further consideration from the etch figures is of interest. The microscopic figures which make up the large-scale pattern also have orientations which are characteristic of the kind of quartz. Thus in the position where the sphere's surface is parallel to an  $m$  face

<sup>25</sup> Quartz, of course, does not exhibit true pyroelectricity, in which charges appear for a uniform change in temperature throughout the entire crystal. It shows rather, what Voigt termed, "false pyroelectricity." A temperature gradient is required for the development of charges.

<sup>26</sup> A. E. H. Tutton, "Crystallography and Practical Crystal Measurement," Macmillan Co., New York, N. Y., 1911, p. 368.

there are the microscopic right triangles which crystallographers describe for etched  $m$  faces. On left quartz the triangles are of a left-handed variety (Fig. 2), while in right quartz they have the opposite sense. The more acute vertexes of the right triangles which appear on  $m$  faces always point<sup>27</sup> toward the  $r$  faces.<sup>21</sup>

It is to be noted that Bond's<sup>16</sup> photomicrographs of an etched spherical surface show figures which enable us to identify his quartz as right quartz. His paper is thus written in the accepted convention. In addition to the right-handed triangles which are recognizable in his Figs. 1 and 3 there can be seen in Fig. 4 a microscopic parallelogram. A few such microscopic figures can be seen on our sphere also, located as Bond shows them to be at the end of the  $X$  axis which becomes positively charged on  $X_z$  compression. That is, on our sphere they are in the center of the large-scale parallelogram. Furthermore their inclination is opposite to that of the large-scale parallelogram in which they occur. The left inclination of Bond's small parallelogram figure also shows his quartz to be right quartz. He does not show the large-scale patterns at all.

#### Optical Rotation in a Quartz Sphere

The test by which we determined the left-handedness of the quartz sphere will be described. It also indicates the method of assuring ourselves that the sphere was free from optical twinning. Several spheres which were twinned have been etched in this laboratory, but always with resulting irregularities of pattern.

When a sphere is tested for right- and left-handedness the observer must be on his guard against drawing false conclusions. With the polished sphere between crossed polaroids in monochromatic light, systems of concentric light and dark circles can be seen for a number of orientations of the sphere. Such circles may come from two causes, rotation of the plane of polarized light and double refraction in the quartz. The latter phenomenon is not directly useful in the present test, and is responsible, independently from the rotatory property, for circles<sup>28</sup> which are most distinct when the optic axis makes an angle of 45 degrees with the plane of polarization.

The rotation of the plane of polarization occurs for light traveling along the optic axis. Concentric circles due to this property in quartz spheres look characteristically different from those of pure double refraction, being somewhat more coarse and, if the sphere is in air, showing a peculiar "bull's-eye" or central ring which appears to the eye to be in a different plane than the outer circles, and to be nearer to the eye than the surface of the sphere itself. Photographs of these systems of rings due to optical rotation in the sphere are shown in Figs. 7 and 8. In Fig. 7 the sphere

was in air, and in Fig. 8 it was immersed in nitrobenzene.<sup>29</sup>

When the sphere is in air the refraction conditions are such that it is difficult to arrange for the light to consist of parallel rays within the sphere. No light at all traverses the peripheral regions of the sphere, and when the beam is convergent or divergent the Maltese cross is superimposed on the rings. With suitable immersion there is no refraction at the surface of the

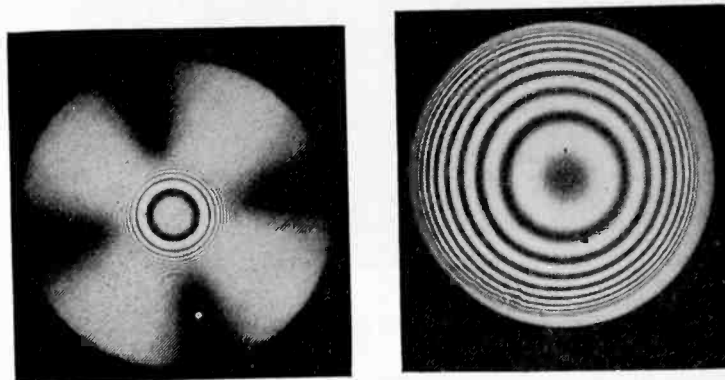

Fig. 7—Rings in 80-millimeter quartz sphere in air with convergent polarized sodium light.

Fig. 8—Rings in 80-millimeter quartz sphere in nitrobenzene with parallel polarized sodium light. Slight twinning is noticeable. The shaded area which is slightly eccentric to and surrounds the ring system is entirely outside of the sphere and is due to the container.

sphere and it is a simple matter to secure a parallel beam which will traverse the full cross section of the sphere parallel to the optic axis. Rotation is then proportional to the lengths of chords parallel to the optic axis.

For the 80-millimeter sphere in nitrobenzene, of which the photograph of Fig. 8 was taken, there are seen to be, as there should be, eight or nine dark rings. There is one ring for each 180 degrees of rotation of the plane of polarization and this rotation is well known to be 21.7 degrees per millimeter for the sodium  $D$  lines. The sense of the rotation in a quartz sphere is that which must be given to the analyzer to cause the ring system to contract, for this rotation continually makes the chord length greater while effecting the contraction of a circle.

When the sphere is not immersed and the light travels through some parts of the sphere obliquely to the optic axis there is opportunity for error in determining the rotatory sense of the quartz from the contraction of the circles. Comparison of the rule just given for a parallel beam in the sphere with that given earlier<sup>30</sup> for a convergent beam in a bar shows the two rules to be just opposite. Where the light is oblique forming a cone around the optic axis double refraction combines with optical rotation to produce a greater number of circular fringes. Depending on the angular field of the light in the quartz either contraction or

<sup>27</sup> Allowance must be made for the inversion of the image in the microscope. The sense shown in the present paper is that of the figures on the quartz.

<sup>28</sup> For a discussion of the formation of a system of circles of this general type in a concave doubly refracting plate see Tutton, footnote reference 14, p. 659.

<sup>29</sup> Monobrom benzene has an index of refraction which is nearer to that of quartz but is not usually so readily available.

<sup>30</sup> The earlier rule is conveniently restated: The sense of the optical rotation (convergent light in a flat plate) is the same as that which must be given to the analyzer to cause the ring system to expand.

expansion of these circles may be obtained for the same quartz sphere and the same rotation of the analyzer. In general, however, if when the sphere is not immersed the unaided eye be placed several sphere diameters away from the sphere and a diffusing screen near the sphere be used as the source, the rule given for the immersion case (where the light is parallel to the optic axis in all parts of the sphere) can be used.

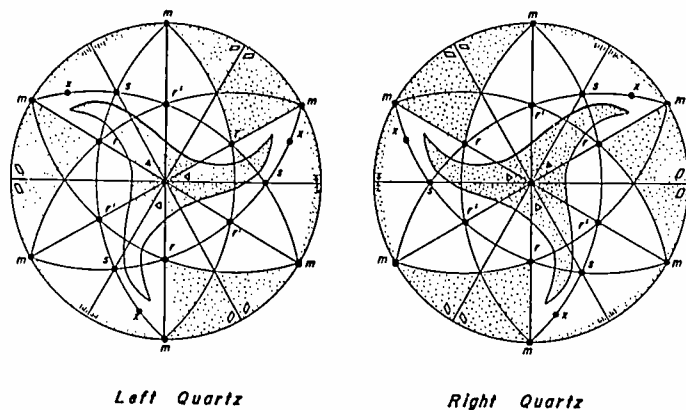

Fig. 9—Stereographic projections of left and right quartz with etch pattern and etch figures indicated.

The great advantage of immersion is that it permits the entire sphere to be examined for twinning, while the available section is limited when the sphere is in air, as may be seen from a comparison of Figs. 7 and 8. In Fig. 8 there are observable at the lower left-hand corner of the picture breaks or irregularities in the five outer circles. This is an indication of a very slight amount of twinning of the quartz in that region, the intrusion of the twinned growth having a rather common pyramidal structure. The photographs of the systems of circles shown here were taken on a larger sphere than the one used in the etching experiments. The etched sphere, which was about 50 millimeters in diameter, was judged to be entirely free from twinning since its system of concentric rings consisted of unbroken circles throughout its full cross section.

### The Stereographic Projection

Some of the facts of the crystallography of quartz are summarized on the stereographic projections of Fig. 9. This projection is a common device of the crystallographer to show the relationship of the crystal faces to the symmetry. Two projections are really involved. First, in a spherical projection the faces of a natural crystal are projected onto a sphere and are there represented by the poles of the faces. At such a pole the sphere is parallel to the face in question. The etched sphere itself may be conveniently regarded as a spherical projection of the quartz crystal, and it is the poles of the faces in such a projection which have been indicated by dots in Fig. 6 and whose positions have been related to the etch pattern. The poles on one hemisphere of the spherical projection are then projected stereographically onto the plane of the equator by means of chords drawn from the poles of the faces to the far pole (in the other hemisphere) of the axis of trigonal symmetry. These chords locate the poles of the faces in the stereographic projection at the points of their intersection with the plane of the equator. Owing to the symmetry of quartz the poles of all faces lie on three great circles in the spherical projection and on three arcs in the stereographic projection. In the projection of Fig. 9 the poles of the faces of only the upper hemisphere are shown.

The stereographic projection which is shown differs from those commonly found in crystallographic texts by the inclusion of data on the etch pattern of the sphere, also projected from the sphere stereographically. In the figure the upper halves of the parallelogram are shown; also the "bars" alternating with parallelograms around the equator, which is the full outer circle of the diagram, and the "tripus." Individual microscopic etch figures have also been indicated for some of the characteristic positions.

## The Generation for Television of Horizontal Synchronizing Pulses from Vertical Pulses by Means of Impulse Excitation\*

JESSE B. SHERMAN†, ASSOCIATE, I.R.E.

**Summary**—Impulse excitation is employed to produce horizontal synchronizing pulses for television directly from the vertical pulses. The simple equipment to do this and to produce odd-line interlaced synchronizing are described.

### INTRODUCTION

THE production of related synchronizing pulses is commonly accomplished by starting with a stable oscillator operating at the horizontal frequency, and deriving the vertical frequency by divi-

\* Decimal classification: R583. Original manuscript received by the Institute, June 24, 1940.

† Electrical Engineering Department, The Cooper Union, New York, N. Y.

sion in several multivibrator stages.<sup>1</sup> It is also necessary to synchronize the vertical frequency with that of the power supply, in order to render stationary the hum patterns produced on the kinescope screen by residual power-supply ripple in the system.<sup>2</sup> This is accomplished by comparing the low-frequency multivibrator output with the power-supply frequency in

<sup>1</sup> Donald G. Fink, "Principles of Television Engineering," McGraw-Hill Book Co., New York, N. Y., 1940, p. 402.

<sup>2</sup> R. D. Kell, A. V. Bedford, and M. A. Trainer, "Scanning sequence and repetition rate of television images," PROC. I.R.E., vol. 24, pp. 559-576; April, 1936.

some form of phase detector which actuates an automatic-frequency-control circuit. This in turn operates

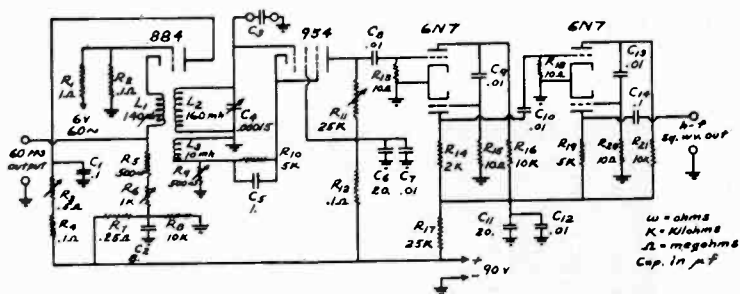

Fig. 1—Schematic wiring diagram.

on the original high-frequency oscillator, so that departures of the derived low frequency from the power-supply frequency produce compensating changes in the oscillator frequency.<sup>1</sup>

It was desired to obtain interlaced scanning in the laboratory without this extensive arrangement, and the present method was accordingly developed.

PRINCIPLE OF METHOD

In the present method, an impulse at frame frequency is applied to a circuit tuned to the required high frequency. With pure impulse excitation, the

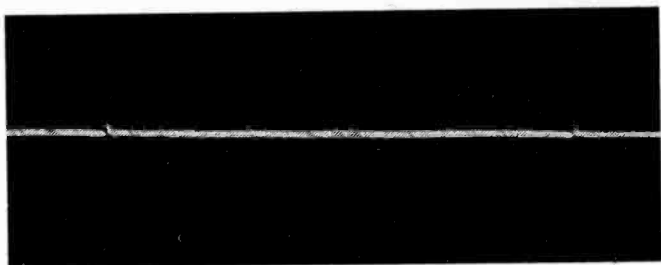

Fig. 2—884 cathode current pulse.

number of free oscillations which occur for a given ratio of initial amplitude to final amplitude ( $I_0/I_n$ ) is given by<sup>3</sup>

$$n = \frac{\log_e \frac{I_0}{I_n}}{\delta}$$

where the logarithmic decrement  $\delta = R/2fL$ . The  $Q$  ( $\omega L/R$ ) required for a given ratio  $I_0/I_n$  and a given number of oscillations is thus

$$Q = \frac{n\pi}{\log_e \frac{I_0}{I_n}}$$

If the ratio of initial amplitude to final amplitude is not too great, the familiar process of amplifying and clipping can be applied to obtain from the damped wave train a rectangular wave of constant amplitude. The actual  $Q$  of the coil used can be made of secondary importance by the use of regeneration to reduce the effective decrement.

<sup>3</sup> Bureau of Standards, Circular no. 74, "Radio Instruments and Measurements," second edition, 1924, p. 92.

CIRCUIT

The circuit employed is shown in Fig. 1. The impulse is produced by means of the type 884 gas triode. Condenser  $C_1$  is charged through resistances  $R_3$  and  $R_4$  and is discharged when the striking potential of the tube is

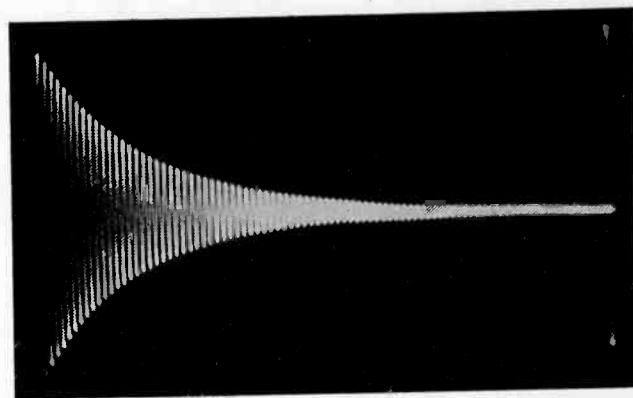

Fig. 3—Voltage across  $L_2$  without regeneration.

reached, producing the usual saw-tooth wave form in the plate circuit. During discharge, most of the condenser voltage appears across the external cathode

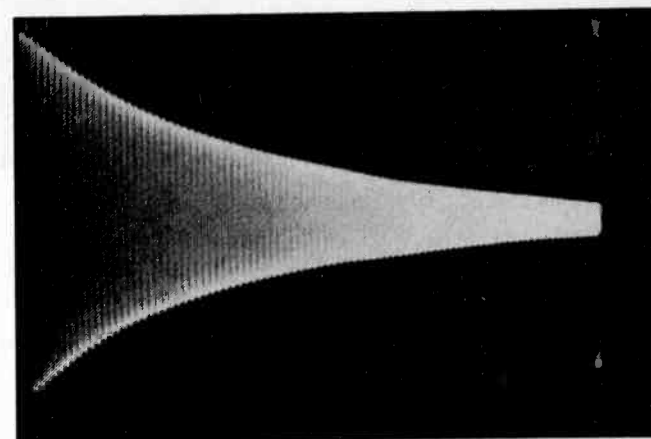

Fig. 4—Voltage across  $L_2$  with regeneration.

impedance, giving the current pulse shown in the oscillogram of Fig. 2. The pulse frequency is 60, and is synchronized with the 60-cycle-per-second power supply. This current is induced in  $L_2$  by inductive coupling with  $L_1$ .

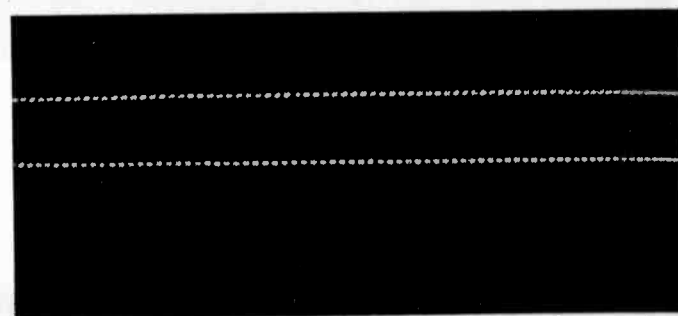

Fig. 5—Rectangular-wave output.

When  $C_3 = 0.005$  microfarad, the circuit tunes from about 5.5 kilocycles to about 5.6 kilocycles. The oscillogram of Fig. 3 shows the voltage produced across  $L_2$  at these frequencies by the pulse of Fig. 2, without regeneration. On introducing regeneration by cutting in  $R_0$ , the voltage shown in Fig. 4 is obtained, the

amplitude at the end of the train depending of course on the amount of feedback introduced. After leaving the regenerative tube (954), the damped train is suc-

quency but in the difficult fashion to be expected of a sine-wave oscillator. This last condition is probably of little interest. The first can be achieved by using a good coil so that little or no regeneration is necessary. The second is of value in the application described below.

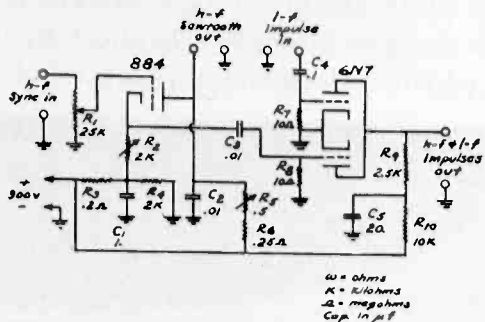

Fig. 6—Circuit for illustrating production of interlace.

cessively amplified and clipped in the two type 6N7 double triodes. The clipping is accomplished by driving each triode beyond cutoff. The clipped output is shown in Fig. 5 to a 60-cycle time base, the oscillograph sweep being somewhat nonlinear.

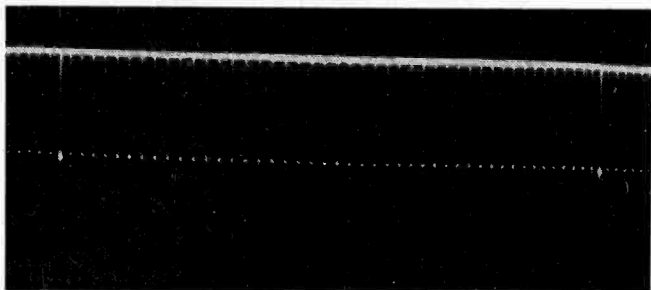

Fig. 7—Pulses for noninterlace—first condition.

When the amount of feedback is zero or slight, the frequency can be set by means of  $C_4$  to any value without regard to the pulse frequency and will remain as constant as the tuned circuit permits, the 954 input admittance of course being part of the circuit. As the feedback is increased, the circuit tends to lock posi-

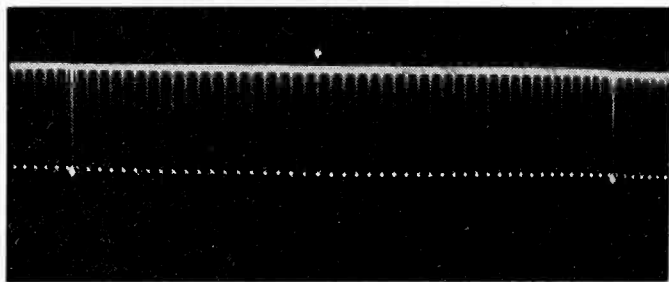

Fig. 8—Pulses for noninterlace—second condition.

tively at multiples of the pulse frequency. When the feedback is so great as to permit self-oscillation, the circuit also tends to lock at multiples of the pulse fre-

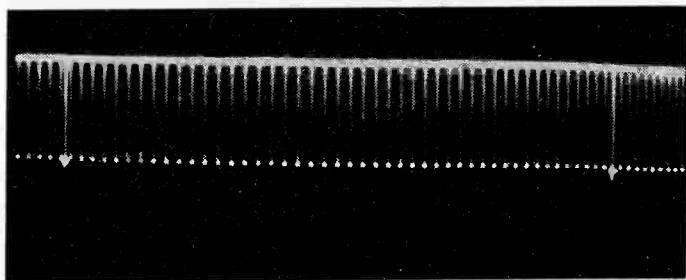

Fig. 9—Pulses of interlace.

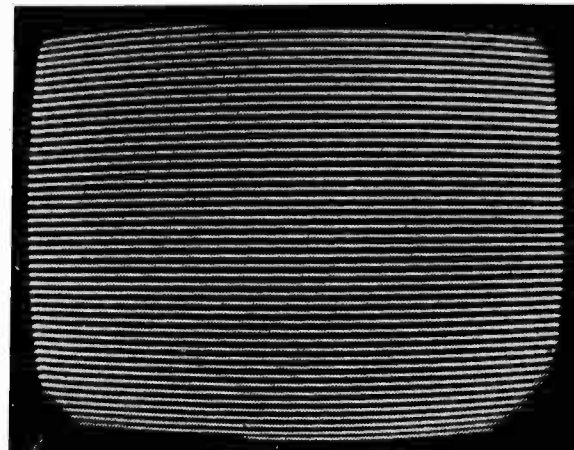

Fig. 10—Noninterlaced raster.

#### METHOD OF OBTAINING ODD-LINE INTERLACE

Let the tuned circuit be adjusted so that an even number of high-frequency cycles occur between driv-

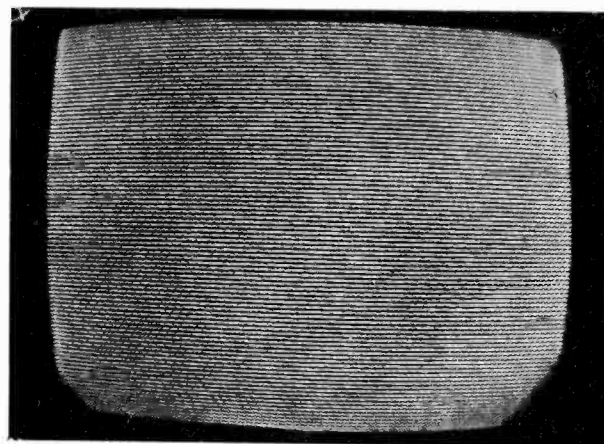

Fig. 11—Interlaced raster.

ing pulses, and let a relaxation oscillator operating at half the output frequency be synchronized from the output. Then successive driving pulses will bear an identical time relation to the half-frequency oscillations. If, however, the tuned circuit is adjusted so that an odd number of high-frequency cycles occur between driving pulses, then *alternate* pulse intervals will be

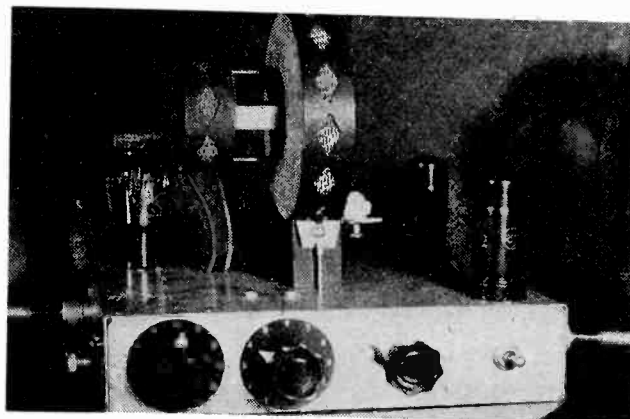

Fig. 12—Top view of chassis.



identical, and successive pulses will be displaced with respect to the half-frequency by one half the period of the latter.

The circuit of Fig. 6 can be used to illustrate the preceding. The 884 operates at half the frequency of the square wave of Fig. 5. Its cathode pulse is mixed in the 6N7 with the original 60-pulse-per-second signal, so that both appear in the common 6N7 plate circuit. The oscillograms of Figs. 7 and 8 show the relation between the 60-pulse-per-second signal and the half-frequency derived signal when  $C_4$  of Fig. 1 is adjusted to give an output frequency of  $60 \times 92 = 5520$ . Either Fig. 7 or 8 may be obtained depending on the instant of locking of the half-frequency oscillator, the frequency of which can be seen to be  $60 \times 46 = 2760$ . When  $C_4$  is adjusted to give an output frequency of  $60 \times 93 = 5580$ , the oscillogram of Fig. 9 is obtained, showing  $46\frac{1}{2}$  half-frequency cycles. This, with constant vertical-deflection amplitude, is the condition for odd-line interlace.

Fig. 10 shows a scanning raster corresponding to Figs. 7 or 8. Fig. 11 shows the interlaced scanning raster corresponding to Fig. 9. The vertical-deflection frequency is 60, synchronized with the 60-pulse-per-second signal of Fig. 1. The horizontal deflection is taken from the saw-tooth output of Fig. 6. The only change from

Fig. 10 to Fig. 11 was the 60-cycle difference in tuning  $C_4$ .

#### APPARATUS

The apparatus of Fig. 1 has been built into a chassis measuring  $7 \times 9 \times 2$  inches, and is shown in Figs. 12 and

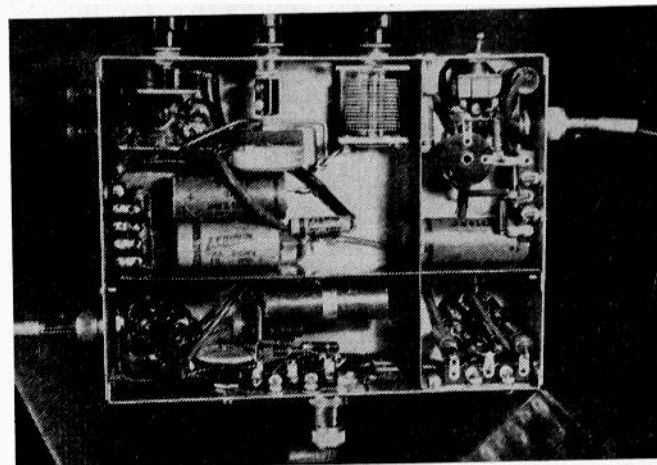

Fig. 13—Underside view of chassis.

Fig. 13. The inductances  $L_1$  and  $L_2$  are honeycomb coils, while  $L_3$  is a small radio-frequency choke coil mounted on the base of  $L_2$ . Terminals are provided for external connection of  $C_3$  to make various frequencies available. Frequencies of the order of 20 kilocycles have been produced without difficulty.

## Field Strength of Motorcar Ignition Between 40 and 450 Megacycles\*

R. W. GEORGE†, ASSOCIATE, I.R.E.

**Summary**—Measurements of motorcar-ignition peak field strength were made on frequencies of 40, 60, 100, 140, 180, 240, and 450 megacycles. Propagation was over Long Island ground and the receiving antennas were 35 feet high and 100 feet from the road. Under these conditions, the average field strength varied about 2 to 1 over the frequency range. Curves show the maximum field strength versus frequency for 90, 50, and 10 per cent of all the measurements. Vertical and horizontal polarization are compared showing slightly greater field strength, in general, for vertical polarization. New cars, old cars, and trucks are compared showing no large differences of ignition field strength.

Some of the factors involved in motorcar-ignition radiation are mentioned. Theoretical propagation curves are included and the measuring system is briefly discussed.

IT IS generally appreciated that motorcar ignition produces radio waves which are rather difficult to measure and evaluate. The annoyance factor of ignition interference cannot be established without reference to the type of communication service, the nature of the intelligence to be received, the over-all discrimination against, or tolerance for such interference, propagation factors, and the sources.

Ignition interference can, for a large number of services, be estimated when the probable peak value of

\* Decimal classification: R270. Original manuscript received by the Institute, May 27, 1940. Presented, joint I.R.E.-U.R.S.I. meeting, Washington, D. C., April 26, 1940.

† R.C.A. Communications, Riverhead, L.I., N. Y.

ignition field strength is known. It is not practical to consider in this paper all the factors involved, but a given application will indicate the factors, some of which may be evaluated from the experimentally derived peak ignition field-strength curves. These curves

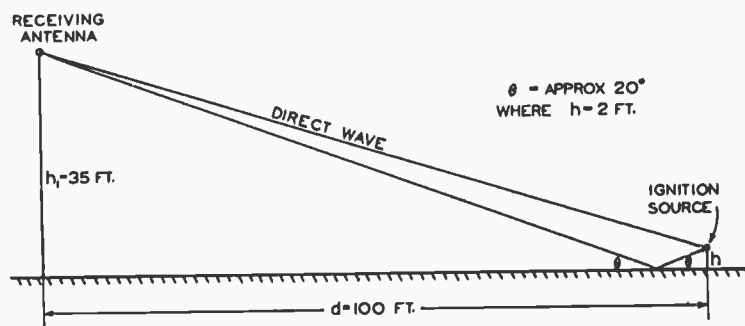

Fig. 1—Geometry of propagation paths.

were made from data taken with the receiving antenna 35 feet high and 100 feet from a standard two-lane highway near Riverhead, L. I., N. Y. The peak ignition field strength of each car was measured as it passed the point nearest the antenna.

The geometry of the propagation paths is shown in Fig. 1. This receiving antenna height and distance

were chosen as being what might be considered a fairly common receiving condition. If the height  $h$  above ground of the ignition source is assumed to be 2 feet, the angle of reflection  $\theta$  is about 20 degrees which is

entirely too many unknown transmission factors are involved to assume this to be true.

MEASURING EQUIPMENT AND METHODS

The receiver was of the superheterodyne type covering from 60 to 500 megacycles. The input to the first intermediate-frequency amplifier of 40 megacycles was brought to terminals to permit reception of 40-megacycle signals. The second intermediate-frequency amplifier at 4.1 megacycles was equipped with a rela-

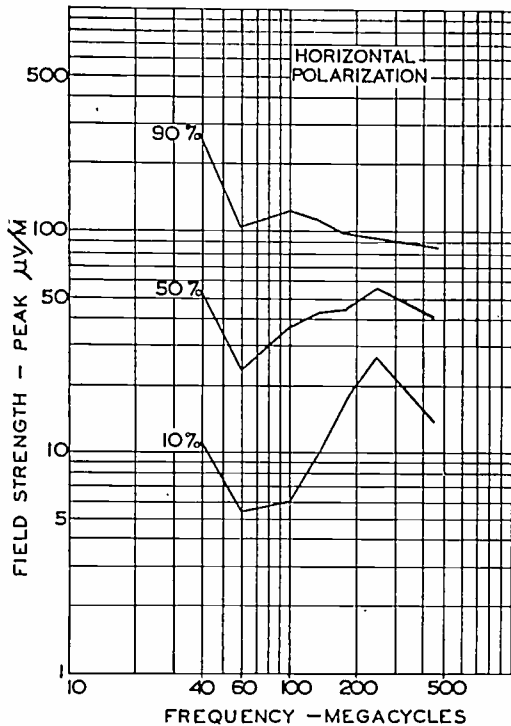

Fig. 2—Motorcar-ignition radiation, horizontal polarization. Peak field strength versus frequency for a 10-kilocycle band. 90, 50, and 10 per cent of all cars and trucks produce less than the field strength indicated by the curves. Receiving antenna 35 feet high and 100 feet from road.

near the Brewster angle for Long Island ground. For this condition it was thought that vertically polarized waves would be received with a minimum of indirect-wave interference and therefore indicate the relative power radiated at the different frequencies. Appar-

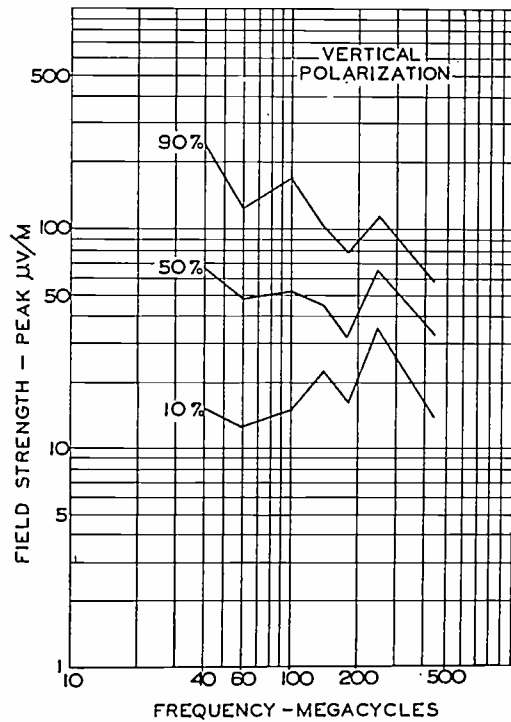

Fig. 3—Motorcar-ignition radiation, vertical polarization. Peak field strength versus frequency for a 10-kilocycle band. 90, 50, and 10 per cent of all cars and trucks produce less than the field strength indicated by the curves. Receiving antenna 35 feet high and 100 feet from road.

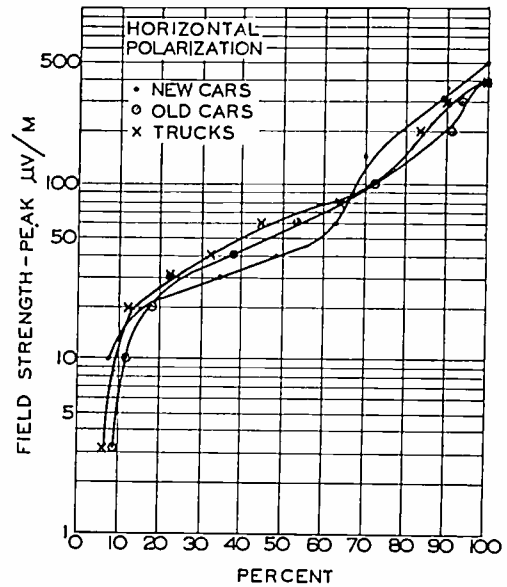

Fig. 4—Motorcar-ignition radiation at 40 megacycles for horizontal polarization. Curves show per cent of cars or trucks giving less than the indicated peak field strength for a 10-kilocycle band. Receiving antenna 35 feet high and 100 feet from the road.

tively strong local oscillator to beat with incoming signals. The audio-frequency output was passed through a 5-kilocycle low-pass filter in order to determine the band width corresponding with the peak measurements. The filter output was subsequently amplified and measured by means of a peak-voltage-indicating instrument. The peak-indicator circuits were such that only one or two short impulses, the minimum lengths of which were determined by the

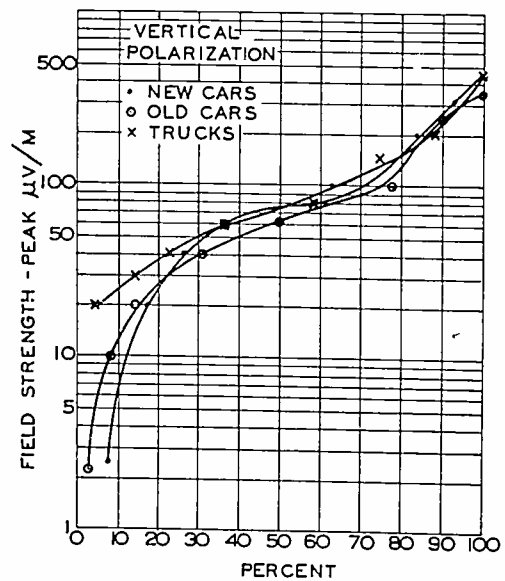

Fig. 5—Motorcar-ignition radiation at 40 megacycles for vertical polarization. Curves show per cent of cars or trucks giving less than the indicated peak field strength for a 10-kilocycle band. Receiving antenna 35 feet high and 100 feet from the road.

band width of the audio-frequency filter, were required to charge the condenser in a resistance-capacitance time circuit to over 90 per cent of the peak voltage of the impulse. The charging time was on the order of 15 microseconds. A decay-time constant of 1 second was used. This gave sufficient time to read the peak deflection on a properly damped milliammeter which was indirectly operated by the voltage across the time circuit.

Calibration of the peak indicator was obtained by

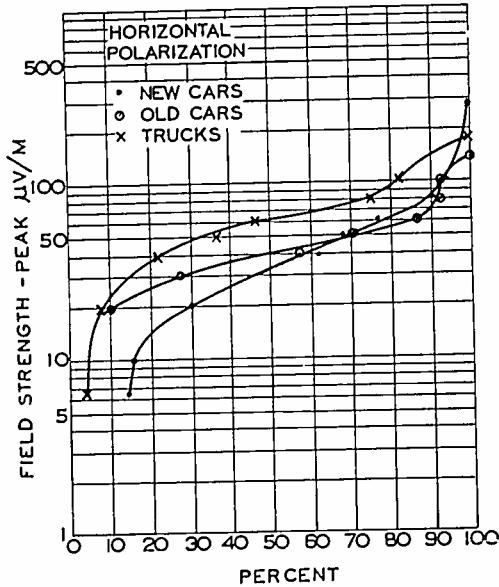

Fig. 6—Motorcar-ignition radiation at 180 megacycles for horizontal polarization. Curves show per cent of cars or trucks giving less than the indicated peak field strength for a 10-kilocycle band. Receiving antenna 35 feet high and 100 feet from the road.

reference to signal frequencies supplied by standard-signal generators connected to the transmission line in place of the antenna. Over-all equipment calibrations of this kind were made at each frequency. Half-wave dipoles were used to provide known antenna constants. At 450 megacycles, the dipole was backed by a parabolic reflector giving 11 decibels gain over a dipole in free space. This gain at 450 megacycles was desir-

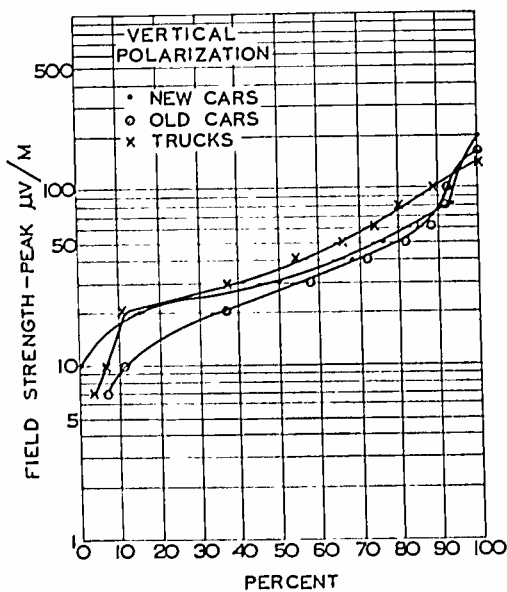

Fig. 7—Motorcar-ignition radiation at 180 megacycles for vertical polarization. Curves show per cent of cars or trucks giving less than the indicated peak field strength for a 10-kilocycle band. Receiving antenna 35 feet high and 100 feet from the road.

able in order to provide signals strong enough to override the receiver noise. It is estimated that the errors of measurement were within plus or minus 2 decibels.

The equipment was set up on a level plot of ground

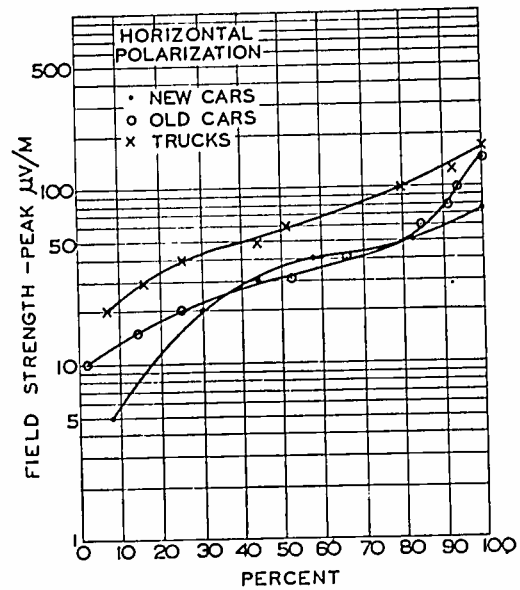

Fig. 8—Motorcar-ignition radiation at 450 megacycles for horizontal polarization. Curves show per cent of cars or trucks giving less than the indicated peak field strength for a 10-kilocycle band. Receiving antenna 35 feet high and 100 feet from the road.

having a frontage clear of obstructions for over 100 feet on both sides. A few power and telephone wires on the opposite side of the road were not considered to be objectionable. Between 22 and 50 cars of each classification were measured at each frequency and polarization.

DATA

The peak ignition field-strength data are summarized in a general way in Figs. 2 and 3. It will be noted that all data in this paper are for a band width of 10 kilocycles.

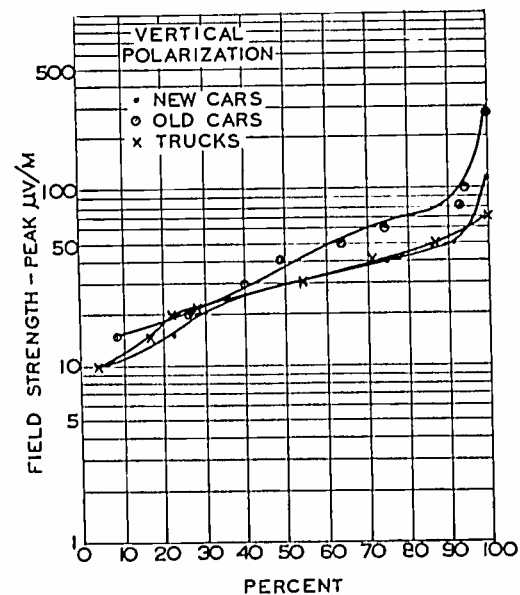

Fig. 9—Motorcar-ignition radiation at 450 megacycles for vertical polarization. Curves show per cent of cars or trucks giving less than the indicated peak field strength for a 10-kilocycle band. Receiving antenna 35 feet high and 100 feet from the road.

Figs. 4 and 5 are for horizontal and vertical polarization, respectively, showing the maximum field strength for 0 to 100 per cent of new cars (approximately 1936 to 1940 models), old cars, and trucks, at 40 megacycles. Figs. 6, 7, 8, and 9 are data of the same type for the frequencies of 180 megacycles and 450 megacycles.

Figs. 10 and 11 are theoretical propagation curves based on the use of a transmitting antenna 2 feet high and a receiving antenna 35 feet high. Calculations for both horizontal and vertical polarization are for re-

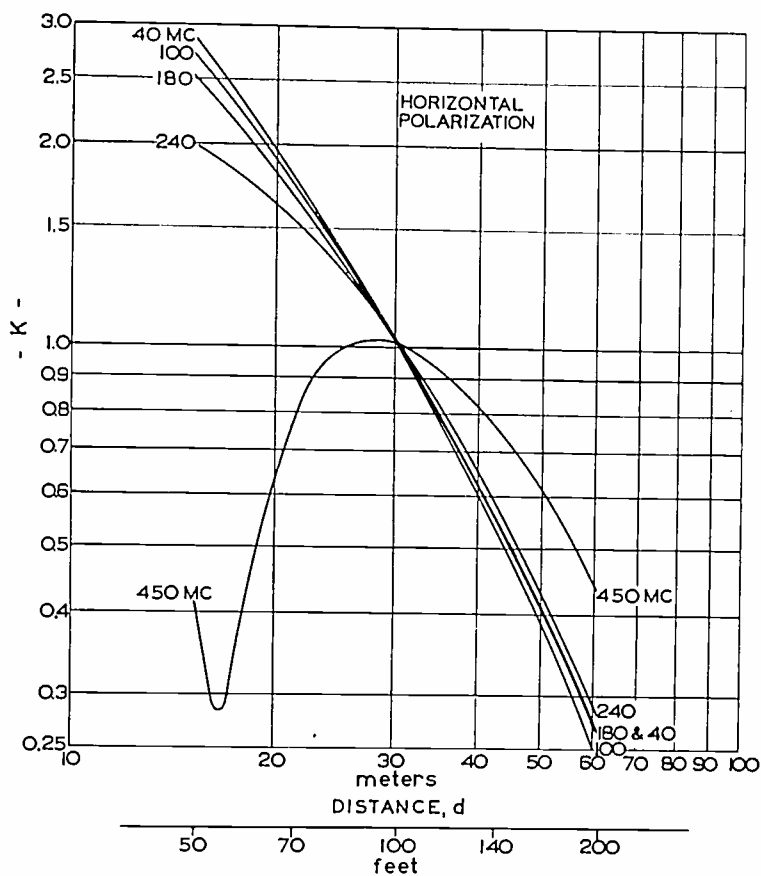

Fig. 10—Theoretical propagation curves for horizontal polarization. Field strength at distance  $d$  equals the field strength measured at a distance of 100 feet, times the indicated factor  $K$ . Transmitting and receiving antennas 2 feet and 35 feet high. Propagation over ground having a dielectric constant of 10 and negligible conductivity.

flection from earth having a dielectric constant of 10 and negligible conductivity in order to conform reasonably with the conditions under which the previous data were measured. From these curves the field strength at distances from 50 to 200 feet can be estimated by multiplying the actual field strength measured at a distance of 100 feet, by the indicated factor. The height of the transmitting source is assumed to be 2 feet which may be reasonable, however, this factor is probably variable and is difficult to determine.

CONCLUSIONS

Although these data are not comprehensive of the subject, they do show that appreciable motorcar-ignition interference can be expected at frequencies up to 450 megacycles. The height of the source above ground is indefinite. The radiation from the ignition system undoubtedly is modified by the body of the car which surrounds it. The polarization of the radiation can be of all kinds. Furthermore, these and other particulars are subject to variation even between cars of identical design. There are several factors which are favorable

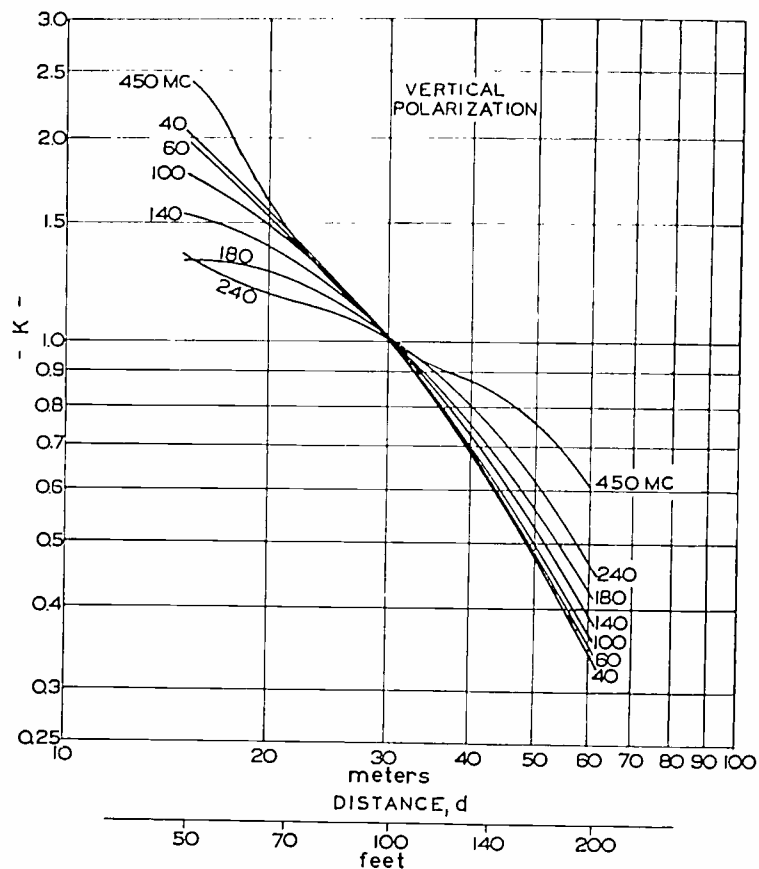

Fig. 11—Theoretical propagation curves for vertical polarization. Field strength at distance  $d$  equals the field strength measured at a distance of 100 feet, times the indicated factor  $K$ . Transmitting and receiving antennas 2 feet and 35 feet high. Propagation over ground having a dielectric constant of 10 and negligible conductivity.

to the production of ignition interference at the higher frequencies. More or less obvious, these are improved propagation conditions due to increased phase difference between direct and reflected waves at a given point except for short distances; and the metal sections of the car and the ignition leads are more comparable in size with short wavelengths, thus acting as less effective shields and more effective radiators. It will be apparent that the radio-frequency power in ignition systems could fall off considerably with increasing frequency and still produce substantial field strengths.

# A Useful Network Theorem\*

JACOB MILLMAN†, NONMEMBER, I.R.E.

**Summary**—A theorem is developed for finding the steady-state voltage between two points 0 and 0' of a network having the following characteristics. Any number of (linear bilateral) impedances meet at the junction 0'. The voltages from 0 to the opposite ends of these impedances are known. These voltages and impedances are all that need be specified about the network.

The theory is both simple to remember and simple to apply in problems where either a literal or a numerical solution is desired. In complicated networks it is a considerable timesaver over the more conventional method involving the simultaneous solution of a number of Kirchhoff's mesh equations. The theorem should find wide application, particularly in many linear-amplifier problems.

The method of using the theorem and the relative simplicity with which results can be obtained is illustrated by considering five physically different (although mathematically quite similar) types of networks; namely, a T network, an unbalanced three-phase Y-connected network, a triode amplifier (account being taken of its interelectrode capacitances), the conventional resistance-capacitance coupled amplifier, and a two-stage parallel-feedback amplifier.

## I. INTRODUCTION

THE theorem which forms the basis of this article has been found to save considerable time in obtaining solutions to certain types of problems. A further advantage of the theorem is that a solution to a problem is often obtained in such a concise form that the various circuit parameters, upon which the result depends, are clearly indicated; whereas, the same result obtained by more conventional circuit analysis often leads to a much more formidable expression. Special cases of the theorem applied to three-phase circuits are found in the literature, but the author is unaware of any discussion of the generalized theorem. In particular, specific applications to the field of electronics are very uncommon. Yet, as will be shown below, the solutions of many amplifier problems can be effected with a minimum of time and effort through the use of this theorem.

## II. THE THEOREM

Consider the network of Fig. 1. The impedances

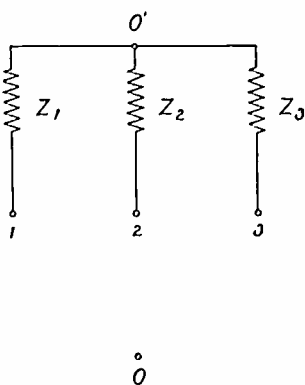

Fig. 1—The type of network to which the theorem applies.

$Z_1$ ,  $Z_2$ , and  $Z_3$  terminate in a common junction 0'. The opposite ends of these impedances are numbered 1, 2,

\* Decimal classification: R140. Original manuscript received by the Institute, July 17, 1940.

† The School of Technology, Electrical Engineering Department, The College of the City of New York, New York, N. Y.

and 3, whereas 0 is any other point in the network. It is not necessary to know the network interconnections between the points 0, 1, 2, and 3. The theorem which will now be proved is that the voltage drop  $V_{00'}$  from the point 0 to the point 0' is given by

$$V_{00'} = \frac{V_{01}Y_1 + V_{02}Y_2 + V_{03}Y_3}{Y_1 + Y_2 + Y_3} \quad (1)$$

where  $V_{0k}$  ( $k=1, 2$ , or  $3$ ) is the voltage drop from the point 0 to terminal  $k$  of the  $k$ th impedance and where  $Y_k = 1/Z_k$  is the admittance corresponding to the  $k$ th impedance. In the above equation all voltages and impedances are complex numbers.

Proof: The voltage drop across  $Z_1$  is  $V_{10'} = V_{00'} - V_{01}$  and hence the current through  $Z_1$  is

$$I_{10'} = V_{10'}/Z_1 = V_{10'}Y_1 = (V_{00'} - V_{01})Y_1.$$

Similarly the currents in the other two branches are

$$I_{20'} = (V_{00'} - V_{02})Y_2 \quad \text{and} \quad I_{30'} = (V_{00'} - V_{03})Y_3.$$

From Kirchhoff's point law, the sum of the three currents meeting at the point 0' must be zero. Hence  $(V_{00'} - V_{01})Y_1 + (V_{00'} - V_{02})Y_2 + (V_{00'} - V_{03})Y_3 = 0$  from which (1) is readily obtained.

The theorem is not restricted to three impedances as shown in Fig. 1. The proof given above can easily be generalized to include any number  $n$  of impedances terminating in a common junction 0'. The result is

$$V_{00'} = \frac{\sum_{k=1}^n V_{0k}Y_k}{\sum_{k=1}^n Y_k} \quad (2)$$

where, as usual,  $\sum_{k=1}^n$  means a summation of  $n$  terms.

Equation (1) is a special case of (2) with  $n=3$ .

Several observations concerning the generality of the theorem will be made before giving specific illustrations of its use. The derivation inherently assumes that the  $Z_k$ 's are linear bilateral impedances and that all electromotive forces in the network are of the same frequency. Furthermore, it is assumed that steady-state operation of the circuit has been reached.<sup>1</sup>

If several sources of different frequency are present, then the well-known principle of superposition can be applied. This means that the theorem is applied for one frequency at a time (with all sources of different frequency short-circuited out), and then the resultant

<sup>1</sup> The author has extended the theorem to include the transient behavior of a network of the type depicted in Fig. 1. As this involves the use of transform-circuit analysis, it is thought advisable not to introduce the generalization here, but to leave it for a subsequent paper.

voltage drop from 0 to 0' is obtained by adding the  $V_{00'}$ 's due to each individual frequency as given by (2).

The theorem applies to networks where the voltages are all direct, since such a system may be considered as a special case of alternating current, with the frequency of operation vanishingly small. The alternating voltages are replaced by direct voltages, and the impedances will all be pure resistances. (If there are any reactive elements in the network, then it must be remembered that under steady-state direct-current conditions an inductance behaves as a short circuit and a capacitance as an open circuit.)

It should be noted in particular that no restrictions other than those imposed above are placed upon the type of network between the points 0, 1, 2,  $\dots$ ,  $n$ . Any of these points may be connected together with a short-circuiting link or through active or passive elements in any fashion whatsoever. In order to apply the theorem it is only necessary that the voltages  $V_{0k}$  be known.

### III. ILLUSTRATIONS

Five specific applications of the above theory will now be given. The first is a simple T network fed either by one or two generators. The second is an unbalanced Y-connected three-phase network. The third is a triode amplifier, with due consideration taken of the inter-electrode capacitances. The fourth is the conventional resistance-capacitance-coupled amplifier. The fifth is a two-stage parallel-feedback amplifier.

(a) A type of network that frequently arises in either power or communication circuits is that of two generators feeding a common load, in the manner shown in Fig. 2. The impedances  $Z_1$ ,  $Z_2$ , and  $Z_3$  might be the

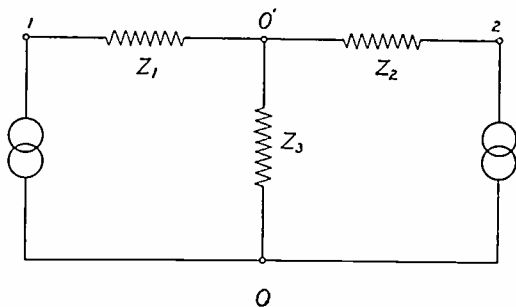

Fig. 2—Two generators interconnected with a T load.

equivalent T impedances of a complicated network interconnecting the two generators.

The voltage drop across  $Z_3$  is immediately given by (1) or (2) as

$$V_{00'} = \frac{V_{01}Y_1 + V_{02}Y_2}{Y_1 + Y_2 + Y_3} \quad (3)$$

where  $V_{01}$  and  $V_{02}$  are the voltage drops across the two generators.  $V_{03}$  does not appear in this equation since terminal 3 and terminal 0 are common.

If the currents in the various impedances are desired they are easily found from the following equations:

$$\left. \begin{aligned} I_{00'} &= V_{00'}Y_3 \\ I_{10'} &= (V_{00'} - V_{01})Y_1 \\ I_{20'} &= (V_{00'} - V_{02})Y_2 \end{aligned} \right\} \quad (4)$$

It is to be noted that the voltages and currents are obtained directly, whereas in the more-conventional analysis, using Kirchhoff's mesh equations for the voltages and point equations for the currents, a system of simultaneous algebraic equations for the unknowns  $I_{00'}$ ,  $I_{10'}$ , and  $I_{20'}$  must be solved.

(b) As a special case of the above circuit, consider the same network with only one generator present. Assume, for example, that  $V_{02}=0$ . A glance at Fig. 2 shows that under the above condition, this reduces the network to the familiar series-parallel combination of impedances fed from one voltage source. The solution of this problem is given in very concise form by (3) and (4) with  $V_{02}$  set equal to zero.

(c) Consider an unbalanced Y-connected load supplied by a three-phase Y-connected generator as shown in Fig. 3. The voltage drop between the neutral of the

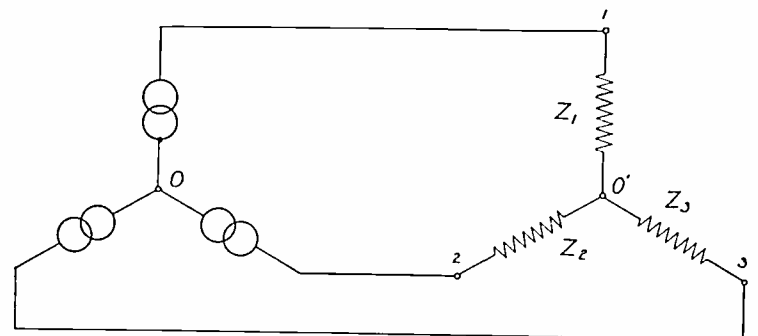

Fig. 3—An unbalanced three-phase Y-connected load fed by a Y-connected alternator.

generated voltages 0 and the floating neutral 0' of the load is given by (1) or (6) as

$$V_{00'} = \frac{V_{01}Y_1 + V_{02}Y_2 + V_{03}Y_3}{Y_1 + Y_2 + Y_3} \quad (5)$$

where  $V_{01}$ ,  $V_{02}$ , and  $V_{03}$  are the three-phase voltages of the generator.

The currents are then calculated from

$$\left. \begin{aligned} I_{10'} &= (V_{00'} - V_{01})Y_1 \\ I_{20'} &= (V_{00'} - V_{02})Y_2 \\ I_{30'} &= (V_{00'} - V_{03})Y_3 \end{aligned} \right\} \quad (6)$$

(d) The above currents can be found in a somewhat simpler fashion if the alternator is considered to be  $\Delta$ -connected as shown in Fig. 4. The voltage drop across any of the load impedances can be found directly with the aid of the theorem. If, for example, we consider point 0 to coincide with 1, then (1) becomes

$$V_{10'} = \frac{V_{12}Y_2 + V_{13}Y_3}{Y_1 + Y_2 + Y_3} \quad (7)$$

where  $V_{12}$  is the voltage between lines 1 and 2, and  $V_{13}$  is the voltage between lines 1 and 3.

The load current through  $Z_1$  is

$$I_{10'} = V_{10'} Y_1 \quad (8)$$

Similar expressions can be readily found for the other two line currents.

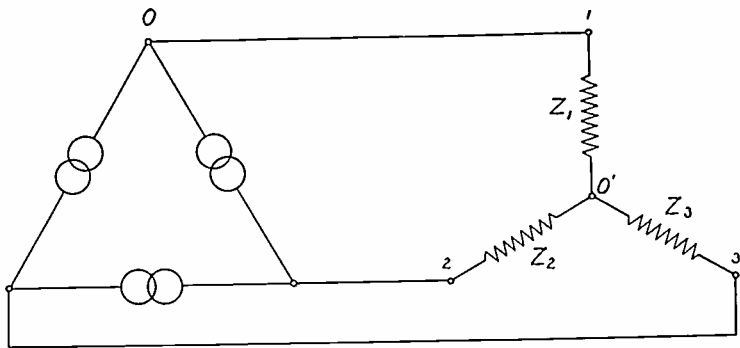

Fig. 4—An unbalanced three-phase Y-connected load fed by a Δ-connected alternator.

The special cases (c) and (d) of the general theorem discussed in this article can be found in the literature.<sup>2-5</sup> However, this method is not used as widely as it should be, considering that it is the simplest method of obtaining the solution to the unbalanced three-phase Y-connected load problem.

It should be noted that (5), (6), (7), and (8) are valid, even if the impressed voltages are unbalanced.

Furthermore, the same results are valid, even though the generators are *not* the component parts of a three-phase system. (As a matter of fact, a little thought will show that Figs. 3 and 4 represent mathematically identical networks, even though they refer to physically different systems.)

(e) Consider the simple triode amplifier of Fig. 5A. If the interelectrode capacitances are taken into account, then the equivalent circuit will be as shown in Fig. 5B. *G* represents the grid, *P* represents the plate, and *C* represents the cathode. The condenser  $C_1 \equiv C_{CG}$  represents the capacitance from cathode to grid, the condenser  $C_2 \equiv C_{CP}$  represents the capacitance from cathode to plate, and  $C_3 \equiv C_{GP}$  represents the capacitance from grid to plate. The tube plate resistance is  $R_P$  and the amplification factor is  $\mu$ . The polarity of the fictitious generator, which replaces the triode, is such as to indicate clearly that the equivalent generated voltage is 180 degrees out of phase with respect to the input voltage, so far as the load impedance  $Z_L$  is concerned.

If the mesh-current equations for the above network were set up in conventional form, their solution would represent a formidable problem. With the aid of the theorem developed here, however, the output voltage across the load impedance  $Z_L$  can be written down immediately. Thus, in (2) the point 0 corresponds to the cathode *C* terminal and the point 0' to the plate termi-

nal *P*. There are four branches ( $k=4$ ) that need be considered between points *C* and *P* of the network. The load impedance  $Z_L$  in series with no voltage forms one branch. The second branch consists of the condenser  $C_2$  in series with no voltage. The voltage drop  $\mu E$  in series with  $R_P$  is the third branch, and the voltage rise  $E$  in series with  $C_3$  forms the fourth branch. The condenser which parallels the input  $E$  does not enter into the theorem. This follows from the fact already emphasized that the circuit connections between the points 0, 1, 2, and 3 of Fig. 1 are immaterial and that it is only necessary to know the voltage drops from 0 to 1, 2, and 3. Equation (5) dictates that

$$V_{CP} = \frac{\mu E Y_P - E Y_3}{Y_P + Y_3 + Y_2 + Y_L} \quad (9)$$

where

$Y_L = 1/Z_L$  is the admittance corresponding to  $Z_L$   
 $Y_2 = j\omega C_2$  is the admittance corresponding to  $C_2$   
 $Y_P = 1/R_P$  is the admittance corresponding to  $R_P$   
 and  $Y_3 = j\omega C_3$  is the admittance corresponding to  $C_3$ .

The minus sign in the numerator of (9) arises from the fact that the voltage *drop* of the input voltage in the direction from *C* to *G* is  $V_{CG} = -E$ .

$V_{CP}$  is the voltage across the load impedance or the output-voltage drop. The quantity that one is usually interested in, namely, the voltage gain of the amplifier, is defined as

$$K \equiv \frac{\text{output-voltage drop}}{\text{input-voltage drop}} = \frac{V_{CP}}{V_{CG}} = \frac{V_{CP}}{-E} \quad (10)$$

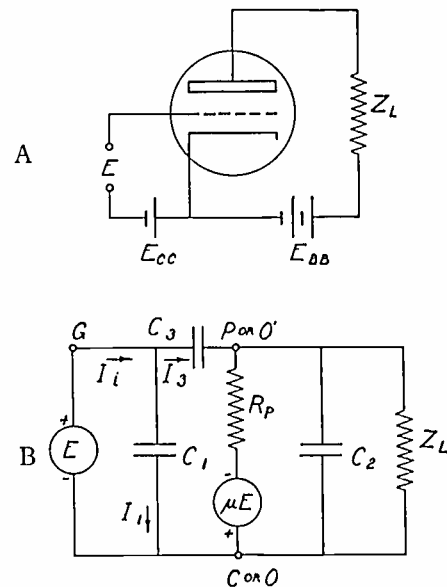

Fig. 5—A triode amplifier and its equivalent circuit, with due account taken of the interelectrode capacitances.

It is to be noted that as given above,  $K$  is a complex number.

Remembering that the transconductance of the tube is given by  $G_m = \mu/R_P = \mu Y_P$  then

$$K = \frac{Y_3 - G_m}{Y_P + Y_3 + Y_2 + Y_L} \quad (11)$$

(f) The input admittance  $Y_i$  of the amplifier can

<sup>2</sup> K. Y. Tang, "Alternating Current Circuits." The International Textbook Co., Scranton, Penna., 1940, p. 249.

<sup>3</sup> H. Sherman, "Letter to the Editor," *Elec. Eng.*, vol. 59, p. 166; April, 1940.

<sup>4</sup> V. G. Smith, "Letter to the Editor," *Elec. Eng.*, vol. 59, pp. 166-167; April, 1940.

<sup>5</sup> H. Wolf, "Supplementary notes for alternating current circuit theory," Electrical Engineering Dept., The College of the City of N. Y., New York, N. Y.

now be found easily. This is defined as the total input current  $I_i$  to the amplifier divided by the input voltage, or

$$Y_i = \frac{I_i}{E}$$

As seen from Fig. 5B.

$$I_i = I_1 + I_3.$$

But

$$I_1 = EY_1$$

where  $Y_1 = j\omega C_1$  is the admittance corresponding to  $C_1$ . Also

$$I_3 = (E + V_{CP})Y_3.$$

Hence,

$$Y_i = \frac{I_1 + I_3}{E} = \frac{EY_1 + (E + V_{CP})Y_3}{E}$$

or

$$Y_i = Y_1 + (1 - K)Y_3 \quad (12)$$

where use has been made of (10).

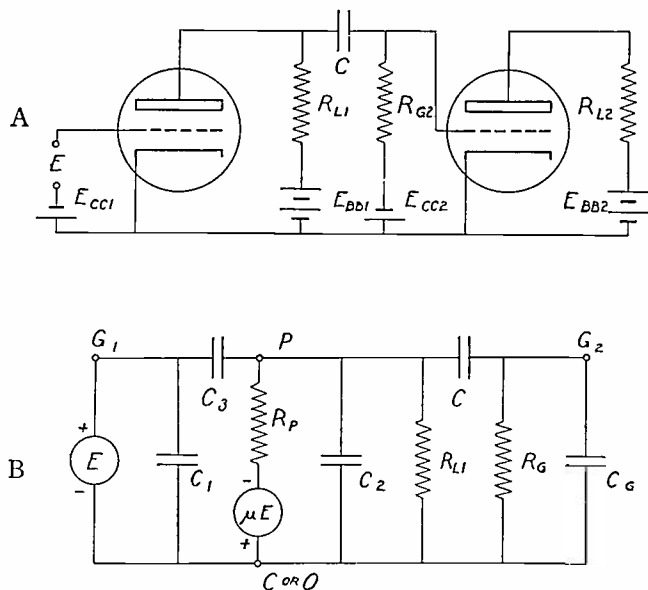

Fig. 6—The conventional resistance-capacitance-coupled amplifier and its equivalent circuit.

The simple expressions (11) and (12) clearly show the factors upon which the gain and input admittance of the tube depend. Furthermore, it is simple to apply them to any particular case to obtain a specific numerical result.

In the above analysis the leakage conductances  $G_k$  between tube terminals were considered small enough to be neglected. Even if this were not true the analysis would still be correct, provided that the interelectrode admittances are considered to be of the form  $Y_k = j\omega C_k + G_k$  instead of merely  $j\omega C_k$ .

(g) The conventional audio-frequency resistance-capacitance-coupled amplifier is shown in Fig. 6A. The equivalent circuit is given in Fig. 6B. The point  $G_1$  denotes the grid of the first tube,  $G_2$  the grid of the second tube,  $P$  the plate of the first tube, and  $C$  the common cathode terminal. The interelectrode capacitances  $C_1$ ,

$C_2$ , and  $C_3$  of the first tube are those discussed in Fig. 5B. The parameters  $R_P$ ,  $\mu$ , and  $R_L$  refer to the first tube. The input capacitance of the second tube is  $C_g$ ; whereas  $R_g$  is the combined parallel resistance of  $R_{g2}$  and the input resistance of the second stage. The method of obtaining the input admittance of this stage was given in the last section.

The rather complicated-looking network of Fig. 6B can be solved in a simple manner with the aid of the theorem developed above. In (2), point 0 will once again be replaced by the cathode point  $C$  and point  $0'$  by the grid point  $G_2$ . Between these two junctions only three branches need be considered. The first consists of  $C_g$  in series with no voltage, the second contains  $R_g$  in series with no voltage, and the third consists of the coupling condenser  $C$  in series with the cathode-plate voltage  $V_{CP}$  of the first tube. Thus

$$V_{CG_2} = \frac{V_{CP}Y_C}{Y_C + Y_{R_g} + Y_{C_g}} \quad (13)$$

where  $Y_C = j\omega C$ ,  
 $Y_{C_g} = j\omega C_g$ , and  
 $Y_{R_g} = 1/R_g$ .

In order to be able to calculate the output voltage  $V_{CG_2}$  it is necessary to know  $V_{CP}$  which appears in the above equation. This is found by applying (2) once more, this time between points  $C$  and  $P$ . There are now five branches meeting at  $P$ . These consist of  $C$  in series with  $V_{CG_2}$ ,  $R_P$  in series with  $\mu E$ ,  $C_3$  in series with  $-E$ ,  $R_L$  in series with no voltage, and  $C_2$  in series with no voltage. Thus

$$V_{CP} = \frac{V_{CG_2}Y_C + \mu EY_P - EY_3}{Y_C + Y_P + Y_3 + Y_2 + Y_L} \quad (14)$$

where  $Y_3 = j\omega C_3$ ,  
 $Y_2 = j\omega C_2$ ,  
 $Y_P = 1/R_P$ , and  
 $Y_L = 1/R_L$ .

Substituting (14) into (13), an expression for the output voltage can be found. However, before doing this it is expedient to simplify the above equation. It is simple to show that within the audio-frequency range  $Y_3$  is very small in comparison with  $\mu Y_P = G_m$ . Thus, even for 20,000 cycles, and a value of  $C_3 = 10$  micro-microfarads,  $Y_3$  is of the order of one micromho, whereas  $G_m$  is at least several hundred, if not thousand, micromhos. Hence, in the numerator of (14),  $EY_3$  can be neglected in comparison with  $\mu EY_P$ . The coupling condenser  $C$  is about 1000 times as large as the interelectrode capacitances  $C_2$  and  $C_3$ , and hence  $Y_2$  and  $Y_3$  can be neglected in the denominator of (14) without introducing appreciable error. Under these conditions (14) reduces to

$$V_{CP} = \frac{V_{CG_2}Y_C + G_m E}{Y_C + Y_P + Y_L} \quad (15)$$

Since neither  $C_1$ ,  $C_2$ , nor  $C_3$  appear in (13) and (15),



they may be omitted completely in Fig. 6, and the equivalent circuit reduces to that shown in Fig. 7.

This means that the gain of an audio-frequency resistance-capacitance-coupled amplifier does *not* depend upon the interelectrode capacitances of that stage, but is a function of the input admittance of the *next* stage.

The gain of the amplifier is now readily determined. Combining (13) and (15), there results

$$K = \frac{-G_m Y_C}{(Y_C)(Y_P + Y_L + Y_{R_\theta} + Y_{C_\theta}) + (Y_{R_\theta} + Y_{C_\theta})(Y_P + Y_L)} \quad (16)$$

The dependence of gain upon circuit parameters for the various frequency ranges (low, intermediate, and high) can readily be found from this equation.

(h) Consider the parallel-feedback two-stage resistance-capacitance-coupled amplifier depicted<sup>6</sup> in Fig. 8. This is identical with the conventional amplifier of Fig. 6A except that now the plates of the two tubes are tied together through the feedback resistor  $R_3$ . If the blocking condenser  $C$  is large enough, then its admittance may be assumed negligible, and the equivalent

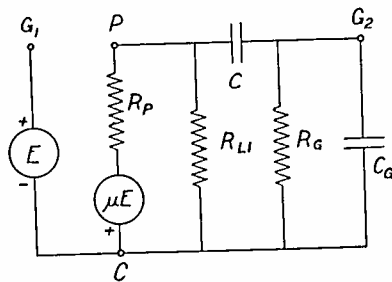

Fig. 7—A close approximation of the equivalent circuit of Fig. 6.

circuit is that shown in Fig. 9. Interelectrode capacitances have not been included in this figure. The notation should be clear from the previous illustrations. The output voltage  $V_{CP_1}$  of the first stage (which is, of course, the input voltage to the second stage  $V_{CG_2}$ ) is obtained by applying the theorem between the points  $C$  and  $G_2$ . Thus, from (2), there results

$$V_{CG_2} = \frac{-V_{CP_2} Y_3 + \mu_1 E Y_{P_1}}{Y_3 + Y_{P_1} + Y_{L_1} + Y_{\theta_2}} \quad (17)$$

$$\begin{aligned} \text{where } Y_3 &= 1/R_3, \\ Y_{P_1} &= 1/R_{P_1}, \\ Y_{L_1} &= 1/R_{L_1}, \text{ and} \\ Y_{\theta_2} &= 1/R_{\theta_2}. \end{aligned}$$

Since all the elements are pure resistances, the admittances used above are really simple conductances.

The output voltage  $V_{CP_1}$  of the amplifier is obtained by applying (2) between the points  $C$  and  $P_2$ . The result is

$$V_{CP_2} = \frac{V_{CG_2} Y_3 - \mu_2 V_{CG_2} Y_{P_2}}{Y_3 + Y_{P_2} + Y_{L_2}} \quad (18)$$

$$\begin{aligned} \text{where } Y_{P_2} &= 1/R_{P_2} \text{ and} \\ Y_{L_2} &= 1/R_{L_2}. \end{aligned}$$

<sup>6</sup> RCA Application Note No. 93.

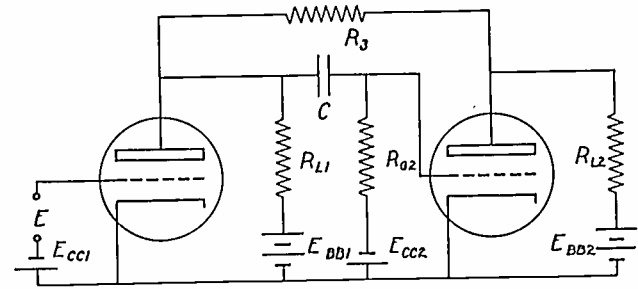

Fig. 8—A two-stage resistance-capacitance-coupled amplifier with a feedback resistor  $R_3$  connecting the plates of the two tubes together.

The gain  $K_2$  of the second stage is defined, as usual, as the ratio of the output to the input voltages. Hence

$$K_2 = \frac{V_{CP_2}}{V_{CG_2}} = \frac{Y_3 - G_{m_2}}{Y_3 + Y_{P_2} + Y_{L_2}} \quad (19)$$

where  $G_{m_2} = \mu_2 Y_{P_2}$  is the transconductance of the second tube.

It is interesting to note that if  $Y_3 = G_{m_2}$ , then the gain is reduced to zero.

Introducing the abbreviation  $Y_0 \equiv Y_3 + Y_{P_1} + Y_{L_1} + Y_{\theta_2}$  (17) becomes

$$Y_0 V_{CG_2} = -V_{CP_2} Y_3 + G_{m_1} E. \quad (20)$$

where  $G_{m_1} = \mu_1 Y_{P_1}$  is the transconductance of the first tube.

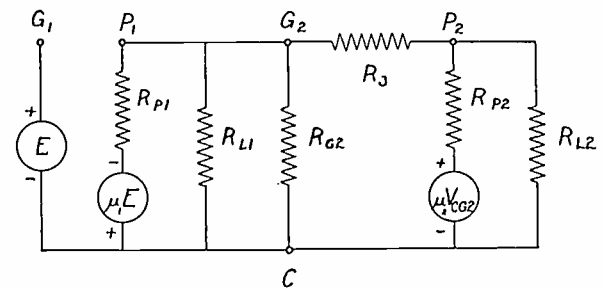

Fig. 9—The equivalent circuit of the amplifier of Fig. 8.

The gain  $K_1$  of the first stage can now be readily found by combining (19) and (20). The result is

$$K_1 = \frac{V_{CG_2}}{-E} = \frac{-G_{m_1}}{Y_0 + K_2 Y_3} \quad (21)$$

Finally, the over-all gain of the amplifier is

$$K = K_1 K_2 = \frac{-K_2 G_{m_1}}{Y_0 + K_2 Y_3}$$

The above illustrations show how to apply the theorem developed. Undoubtedly, other types of networks to which the theorem can be applied suggest themselves to the reader.

#### ACKNOWLEDGMENT

The author wishes to thank his colleague, Dr. Samuel Seely, for many interesting discussions of the material covered in this article. He is also indebted to Mr. John S. Hickey, Jr., for drawing the figures in their final form for publication.

# Determination of the Axial Potential Distribution in Axially Symmetric Electrostatic Fields\*

SIDNEY BERTRAM†, ASSOCIATE, I.R.E.

*Summary*—It has long been known that the potential distribution in axially symmetric electrostatic fields can be expressed in terms of a Fourier integral. This form of solution is not generally very useful because of the difficulties encountered in evaluating the integral. The present paper shows how this integral can be evaluated for a particular type of potential distribution, and shows how it may be applied to obtain the variation in potential along the axis when the potential variation along any cylinder is known. The result is then used to obtain an approximate solution for the particular case of two infinitely long cylinders of equal diameter separated by an amount comparable to their diameters.

**A** CALCULATION of the trajectories of electrons in such devices as cathode-ray tubes, image converters, kinescopes, etc., requires a knowledge of the potential distribution within the devices. Since a large number of electronic devices are symmetrical with respect to the central axis a simple method of calculating the electric field in such cases would be very valuable. In particular the potential along the axis is of interest since it has been shown that the entire field can be described in terms of this potential and its derivatives.<sup>1</sup> The present paper gives the derivation of a definite integral for this axial potential in terms of the potential along a cylinder concentric with the axis.

Since the problem is one of axial symmetry we start with Laplace's equation for the potential expressed in cylindrical co-ordinates

$$\nabla^2 V = \frac{\partial^2 V}{\partial r^2} + \frac{1}{r} \frac{\partial V}{\partial r} + \frac{\partial^2 V}{\partial z^2} = 0 \quad (1)$$

where  $V = V(r, z)$  is the potential at a radius  $r$  from the axis and at a distance  $z$  from a reference plane. Several general solutions of this equation have been given; the particular solution which we shall make use of is in the form of a Fourier integral

$$V(r, z) = \frac{1}{2\pi} \int_{-\infty}^{\infty} a(k) J_0(jkr) e^{ikz} dk \quad (2)$$

where the term  $a(k)$  is a function of the arbitrary parameter  $k$  and must be chosen so that  $V(r, z)$  satisfies the boundary conditions. The usefulness of this equation is limited by the difficulty of finding  $a(k)$  in the general case and in integrating the resulting expression.

If the potential at some radius  $R$  is known as a func-

tion of  $z$ , then  $a(k)$  can be found by means of the Fourier transform<sup>2</sup>

$$a(k) J_0(jkR) = \int_{-\infty}^{\infty} V(R, z) e^{-ikz} dz. \quad (3)$$

It is convenient at this point to introduce a particular type of potential-distribution function which we might term a differential cylinder potential  $U(R, \zeta) d\zeta$ . This we will define to be a potential equal to zero everywhere on the cylinder  $r = R$  except for a differential length  $d\zeta$  at  $z = \zeta$  where the potential is unity (Fig. 1). It is evident that any potential distribution along the cylinder  $r = R$  can be described in terms of  $U$  by allowing  $\zeta$  to take on all values and using a suitable multiplying factor which will be a function of  $\zeta$ .

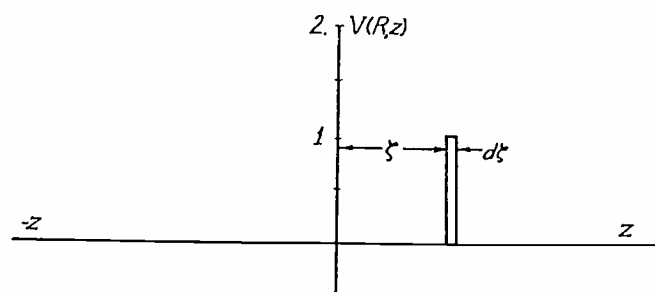

Fig. 1—Differential cylinder potential  $U(R, \zeta) d\zeta$ .

In terms of this differential cylinder potential (3) now becomes<sup>3</sup>

$$\begin{aligned} a(k) J_0(jkR) &= \int_{-\infty}^{\infty} U(R, \zeta) d\zeta e^{-ikz} dz = \int_{\zeta}^{\zeta+d\zeta} e^{-ikz} dz \\ &= \frac{j}{k} [e^{-ikz}]_{\zeta}^{\zeta+d\zeta} = \frac{j}{k} [e^{-ik(\zeta+d\zeta)} - e^{-ik\zeta}], \end{aligned}$$

and letting  $e^{-ikd\zeta} = 1 - jkd\zeta$  we obtain

$$a(k) = \frac{j e^{-ik\zeta}}{kJ_0(jkR)} [e^{-ikd\zeta} - 1] = \frac{e^{-ik\zeta}}{J_0(jkR)} d\zeta. \quad (4)$$

Equation (2) can now be expressed for the differential cylinder potential  $U(R, \zeta) d\zeta$ .

$$U(r, z) d\zeta = \frac{1}{2\pi} \int_{-\infty}^{\infty} \frac{e^{-ik\zeta}}{J_0(jkR)} d\zeta \cdot J_0(jkr) e^{ikz} dk, \quad (5)$$

and by taking all dimensions in terms of  $R$ , so that

\*Decimal classification: R139XR388. Original manuscript received by the Institute, June 6, 1940.

† Graduate Student, Ohio State University, Columbus, Ohio.

<sup>1</sup> Good general references for the fundamental equations are I. G. Maloff and D. W. Epstein, "Electron Optics in Television"; McGraw-Hill Book Co., New York, N. Y., 1938; V. K. Zworykin and G. A. Morton, "Television" John Wiley and Sons, New York, N. Y., 1940; and L. M. Myers, "Electron Optics, Theoretical and Practical" D. Van Nostrand Co., New York, N. Y., 1939.

<sup>2</sup> G. A. Campbell and R. M. Foster, "Fourier Integrals for Practical Applications," Bell Telephone System Technical Publications, Monograph B584; also, Collected Papers of George A. Campbell, American Telephone and Telegraph Company, New York, N. Y., 1938.

<sup>3</sup> As used in the following formula  $a(k)$  is differentially small.

$R=1$ , we have for the potential along the axis  $r=0$ , (giving  $J_0(0)=1$ )

$$\begin{aligned} U(0, z) &= \frac{1}{2\pi} \int_{-\infty}^{\infty} \frac{e^{jk(z-\zeta)}}{J_0(jk)} dk \\ &= \frac{1}{2\pi} \int_{-\infty}^{\infty} \frac{e^{jk\xi}}{J_0(jk)} dk, \quad \xi = z - \zeta. \end{aligned} \quad (6)$$

We next expand  $1/J_0(jk)$  in a Fourier series

$$1/J_0(jk) = \sum_{n=0}^{\infty} A_n \cos \frac{nk}{2}$$

valid in the interval  $-2\pi < k < 2\pi$  by numerical integration. At the limits  $-2\pi$  and  $+2\pi$ ,  $1/J_0(jk)$  has dropped to roughly  $1/90$  of its maximum value. Since the function  $e^{jk\xi}/J_0(jk)$  has an oscillatory character it was assumed that the function for values of  $k$  outside of these limits would not contribute appreciably to the integral. The first six terms in the expansion are

$$\begin{array}{lll} A_0 = 0.3288 & A_2 = 0.1643 & A_4 = 0.0129 \\ A_1 = 0.4366 & A_3 = 0.0499 & A_5 = 0.0022 \end{array}$$

In terms of the expansion (6) now becomes

$$\begin{aligned} U(0, z) &= \frac{1}{2\pi} \sum_{n=0}^{\infty} A_n \int_{-2\pi}^{2\pi} \cos \frac{nk}{2} e^{jk\xi} dk \\ &= \frac{1}{2\pi} \sum_{n=0}^{\infty} A_n \int_{-2\pi}^{2\pi} \cos \frac{nk}{2} (\cos k\xi + j \sin k\xi) dk. \end{aligned}$$

Since  $\sum_{n=0}^{\infty} A_n \cos nk/2$  is an even function the integration from  $-2\pi$  to  $+2\pi$  involving the sine term is zero. Expanding the product of the two cosine terms we next obtain

$$\begin{aligned} U(0, z) &= \frac{1}{4\pi} \sum_{n=0}^{\infty} A_n \int_{-2\pi}^{2\pi} \left\{ \cos k \left( \xi + \frac{n}{2} \right) \right. \\ &\quad \left. + \cos k \left( \xi - \frac{n}{2} \right) \right\} dk \\ U(0, z) &= \frac{1}{2\pi} \sum_{n=0}^{\infty} A_n \left\{ \frac{\sin 2\pi \left( \xi + \frac{n}{2} \right)}{\xi + \frac{n}{2}} + \frac{\sin 2\pi \left( \xi - \frac{n}{2} \right)}{\xi - \frac{n}{2}} \right\} \end{aligned}$$

and since

$$\sin 2\pi \left( \xi \pm \frac{n}{2} \right) = \sin (2\pi\xi \pm n\pi) = (-1)^n \sin 2\pi\xi$$

$$\begin{aligned} U(0, z) &= \frac{1}{2\pi} \sum_{n=0}^{\infty} A_n (-1)^n \sin 2\pi\xi \left\{ \frac{1}{\xi + \frac{n}{2}} + \frac{1}{\xi - \frac{n}{2}} \right\} \\ &= \frac{\xi}{\pi} \sin 2\pi\xi \sum_{n=0}^{\infty} \frac{A_n (-1)^n}{\xi^2 - \frac{n^2}{4}}. \end{aligned} \quad (7)$$

In the above expression the summation in  $n$  can be evaluated as a function of  $\xi = z - \zeta$ . The resulting func-

tion is plotted in Fig. 2. It will be observed that this is just the potential function on the axis due to a differential cylinder element at  $z = \zeta$ ,  $r = R = 1$ . It is found that a very good approximation to this curve<sup>4</sup> is given by  $U(0, z) = (\omega/2) \operatorname{sech}^2 \omega\xi$  where  $\omega = 4A_0 \approx 1.32$ .

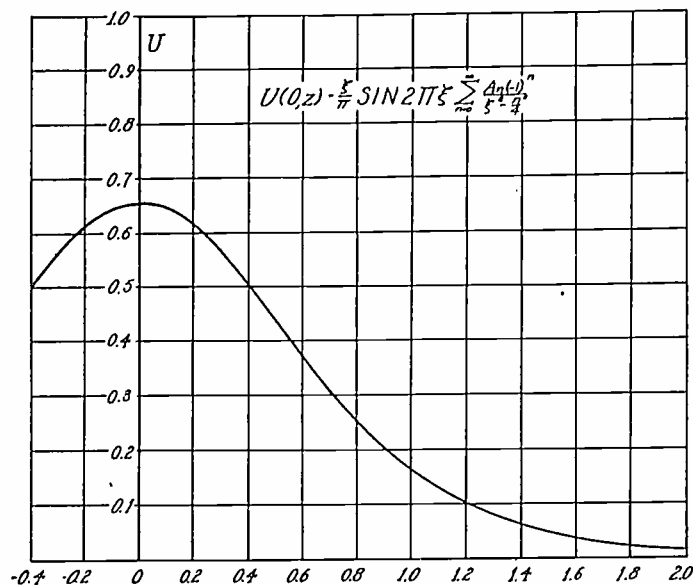

Fig. 2—Distribution of potential on axis due to differential cylinder potential.

The potential on the axis due to an arbitrary potential distribution at a radius  $r=1$  of  $V(1, z)$  can now be found by multiplying the differential cylinder function corresponding to a particular value of  $z = \zeta$  at  $r=1$  by the potential for this value  $V(1, \zeta)$  and summing up over-all values of  $\zeta$ . We obtain

$$V(0, z) = \frac{\omega}{2} \int_{-\infty}^{\infty} V(1, \zeta) \operatorname{sech}^2 \omega\xi d\zeta. \quad (8)$$

Since  $V(1, \zeta)$  will be zero for all values of  $\zeta$  outside of certain limits the above integral becomes a regular integral between finite limits.

As an example of the use of (8) consider the electrode system of Fig. 3. Two infinitely long cylinders of unit radius separated a distance  $S$  have potentials  $V_1$  and

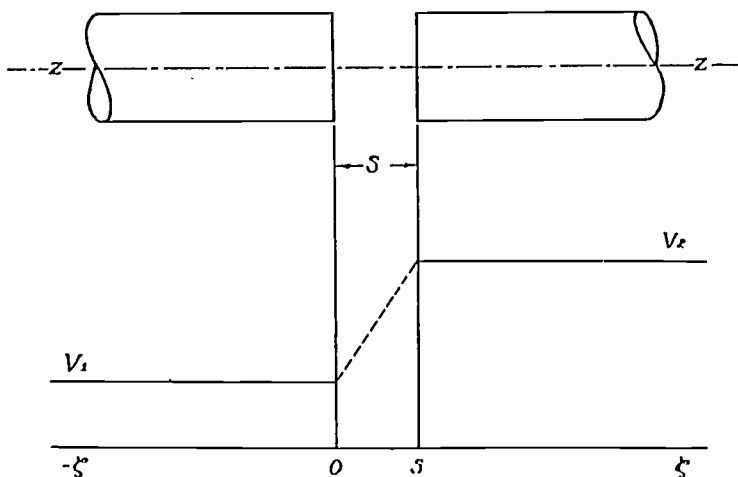

Fig. 3—Infinitely long conducting cylinders with finite separation  $S$ ; potential along cylinder surface.

<sup>4</sup> An alternative expression is  $U(0, z) = \omega/2 e^{-2\xi^2} + 0.2\xi e^{-\xi^2}$ .

$V_2$ . If we assume an approximation to the potential in the gap to be given by a straight line, we have

$$V(1, \zeta) = \begin{cases} V_1 & \zeta < 0 \\ V_1 + \left(\frac{V_2 - V_1}{S}\right)\zeta & 0 < \zeta < S \\ V_2 & \zeta > S \end{cases}$$

$$z - \zeta = \xi \quad d\zeta = -d\xi$$

$$V(0, z) = \frac{\omega}{2} V_1 \int_{-\infty}^0 \operatorname{sech}^2 \omega \xi d\xi + \frac{\omega}{2} \int_0^S \left\{ V_1 + \left(\frac{V_2 - V_1}{S}\right)\zeta \right\} \operatorname{sech}^2 \omega \xi d\xi + \frac{\omega}{2} V_2 \int_S^{\infty} \operatorname{sech}^2 \omega \xi d\xi$$

$$= -\frac{\omega}{2} V_1 \int_{\infty}^z \operatorname{sech}^2 \omega \xi d\xi - \frac{\omega}{2} \int_z^{z-S} \left\{ V_1 + \left(\frac{V_2 - V_1}{S}\right)(z - \xi) \right\} \operatorname{sech}^2 \omega \xi d\xi - \frac{\omega}{2} V_2 \int_{z-S}^{-\infty} \operatorname{sech}^2 \omega \xi d\xi$$

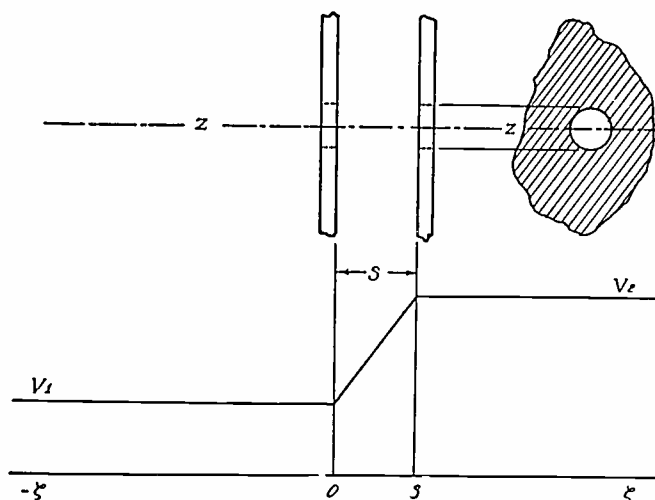

Fig. 4—Assumed potential distribution along equivalent cylinder through coaxial apertures in infinite diaphragms.

$$= -\frac{1}{2} \left\{ (\tanh \omega \xi) V_1 \right\}_{-\infty}^z + \left( \frac{V_2 - V_1}{S} \right) \left[ \left( \frac{z - \xi}{\omega} \right) \right]_z^{z-S} + \left( \frac{V_2 - V_1}{S} \right) \left[ \left( \frac{z - \xi}{\omega} \right) \right]_{z-S}^{\infty} \right\} + \frac{(V_2 - V_1)}{2\omega S} \left[ \omega \xi \tanh \omega \xi - \log \cosh \omega \xi \right]_z^{z-S}$$

which becomes

$$V(0, z) = \left(\frac{V_1 + V_2}{2}\right) + \left(\frac{V_2 - V_1}{2\omega S}\right) \log_e \frac{\cosh \omega z}{\cosh \omega(z-S)} \quad (9)$$

For  $S=0$ , this equation reduces to

$$V(0, z) = \left(\frac{V_1 + V_2}{2}\right) + \left(\frac{V_2 - V_1}{2}\right) \tanh \omega z$$

which is identical to that given by Gray<sup>5</sup> for this case.

A variation in the use of the formulas is suggested by the work of Gans.<sup>6</sup> He has calculated the potential distribution between two perforated diaphragms. If we assume the field intensity on the cylinder joining the two apertures to be constant and the voltage on the extensions of the cylinder outside the diaphragms to be constant then the situation is identical to that for which (9) was derived (Fig. 4). Gans has taken a separation between diaphragms equal to three times the aperture radius, one diaphragm being at zero potential and the other at unit potential. Thus in (9) we would have  $V_1=0$ ,  $V_2=1$ , and  $S=3$ . The tabulation below gives values of  $V(0, z)$  for several values of  $z$  as calculated by (9) and as calculated by Gans using the formulas derived for circular apertures. Fig. 5 is a graph of

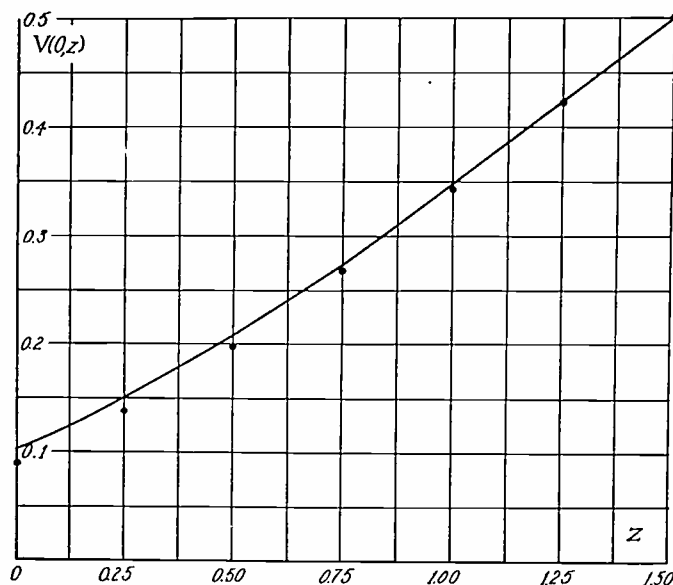

Fig. 5—Axial potential distribution between coaxial apertures, separation  $S=3R$ ,  $V_1=0$ ,  $V_2=+1$ ; curve drawn according to calculations of Gans. points from (9).

$V(0, z)$  for this case. The comparison is favorable considering the simple assumptions we have made.

$z$	$V(0, z)$ formula 9	$V(0, z)$ Gans
0	0.088	0.103
0.25	0.137	0.150
0.50	0.196	0.209
0.75	0.267	0.275
1.00	0.342	0.347
1.25	0.422	0.423
1.50	0.500	0.500

#### ACKNOWLEDGMENT

The author wishes to express his appreciation to Professor E. M. Boone of The Ohio State University for introducing him to the subject of electron optics and for his encouragement during the investigation discussed in this paper.

<sup>5</sup> Frank Gray, "Electrostatic electron optics," *Bell Sys. Tech. Jour.*, vol. 18, pp. 1-31; January 1939.

<sup>6</sup> R. Gans, "Strahlingang in elektronen optischen Systemen," *Zeit. für Tech. Phys.*, vol. 18, pp. 41-48, nr. 2, 1937.

# The Ionosphere and Radio Transmission, August, 1940, with Predictions for November, 1940\*

NATIONAL BUREAU OF STANDARDS, WASHINGTON, D. C.

AVERAGE critical frequencies and virtual heights of the ionospheric layers as observed at Washington, D. C., during August are given in Fig. 1. Critical frequencies for each day of the month are given

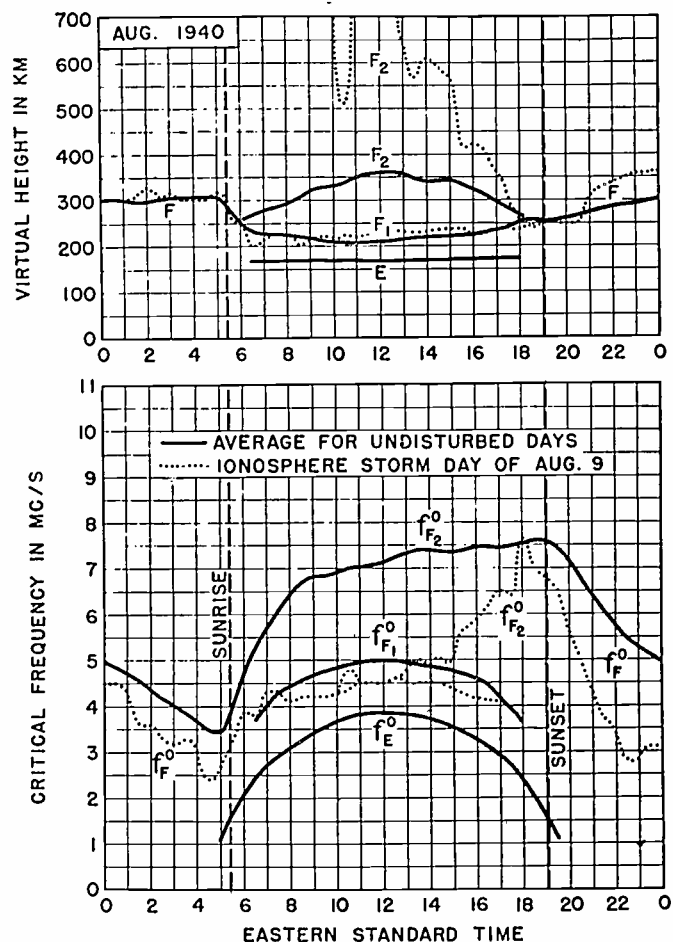

Fig. 1—Virtual heights and critical frequencies of the ionospheric layers, observed at Washington, D. C., August, 1940.

in Fig. 2. Fig. 3 gives the August average values of maximum usable frequencies, for undisturbed days, for radio transmission by way of the regular layers. The maximum usable frequencies were determined by the F layer at night and by the F<sub>2</sub>, F<sub>1</sub>, and E layers during the day. Fig. 4 gives the expected values of the maximum usable frequencies for radio transmission by way of the regular layers, average for undisturbed days, for November. All of the foregoing are based on the Washington ionospheric observations, checked by quantitative observations of long-distance reception.

\* Decimal classification: R113.61. Original manuscript received by the Institute, September 12, 1940. These reports have appeared monthly in the PROCEEDINGS starting in vol. 25, September, 1937. See also vol. 25, pp. 823-840; July, 1937. Publication approved by the Director of the National Bureau of Standards of the U. S. Department of Commerce. Report prepared by S. S. Kirby, N. Smith, F. R. Gracely, and A. S. Taylor of the National Bureau of Standards.

TABLE I  
IONOSPHERIC STORMS (APPROXIMATELY IN ORDER OF SEVERITY)

Day and hour E.S.T.	$h_F$ before sunrise (km)	Minimum $f_{F_2}^o$ before sunrise (kc)	Noon $f_{F_2}^o$ (kc)	Magnetic character <sup>1</sup>		Ionospheric character <sup>2</sup>
				00-12 G.M.T.	12-24 G.M.T.	
August						
{ 9 (from 0130)	308	2400	<4500	0.8	1.1	1.4
{ 10 (through 2100)	352	1900	4800	0.4	0.5	1.2
{ 3 (from 0200)	334	2900	5100	0.8	1.0	1.1
{ 4 (through 2000)	343	2500	5300	0.3	0.0	1.1
{ 6 (from 0330)	317	3100	5100	0.6	0.5	1.0
{ 7	347	2600	5500	0.4	0.4	1.0
{ 26 (from 1700)	—	—	—	0.4	0.9	1.0
{ 27	338	3000	5400	0.9	0.5	0.8
{ 28 (through 0200)	328	—	—	0.5	0.4	—
{ 12 (from 0600)	—	—	5300	0.4	0.1	0.8
{ 13	329	3000	5200	0.0	0.0	0.8
{ 14 (through 0100)	—	—	—	0.5	0.0	—
22 (0700 through 1900)	—	—	5500	0.2	0.4	0.4
For comparison: average for undisturbed days	304	3490	7140	0.2	0.3	0.0

<sup>1</sup> American magnetic character figure, based on observations of seven observatories.

<sup>2</sup> An estimate of the severity of the ionospheric storm at Washington on an arbitrary scale of 0 to 2, the character 2 representing the most severe disturbance.

TABLE II  
SUDDEN IONOSPHERIC DISTURBANCES

Day	G.M.T.		Locations of transmitters	Relative intensity at minimum <sup>1</sup>	Other phenomena
	Beginning	End			
August 5	1620	1640	Ohio, D. C.	0.1	
15	1430	1530	D. C.	0.0	
18	1538	1610	D. C.	0.05	

<sup>1</sup> Ratio of received radio field intensity during fade-out to average intensity before and after; for vertical-incidence ionospheric reflections at 3000 kilocycles.

TABLE III  
APPROXIMATE UPPER LIMIT OF FREQUENCY OF THE STRONGER SPORADIC-E REFLECTIONS AT VERTICAL INCIDENCE

Day	00	01	02	03	04	05	06	07	08	09	10	11	12	13	14	15	16	17	18	19	20	21	22	23
August																								
1								3										5	4					
2								7													4	3	4	10
3																					3	3		
4	10	7	7	4	7	4	5	8	5	4								7	8	3	4			
5																5								
6																								
7		4	3			5		4	3	3	5			5					8	7	4			
8																			8	9	9	10	8	4
9		4																	8	9	3	7	5	6
10		7	9	5	3	3	4	5											3	8		3		7
11		4	4	3	5	5	3	4		5									6	8	7	7	8	10
12													4	5	7	10			7	8	9	6	7	10
13		9	3	5	3	3	3	5	5										5	5	5	4	8	4
14		4	4																4	5	4	7	9	7
15						3	4												4	4	7	9	7	6
16		5	5																4	4			4	3
17		4	4	5	5	4													6	6	8	6	5	10
18		4	4																6	6	8	6	5	10
19		8	7	5	4	4	4	4	4	5	5			5	5						5			
20																								
21																						4	5	5
22																						5	7	4
23																						4	5	7
24		4	4	4	4	4	4	5	5	5	5	5	4	4	5	5					4			
25		4	4				6	4	5															
26												5												
27																						3	4	
28													5											
29																		4						
30								4	5													4		
31																								

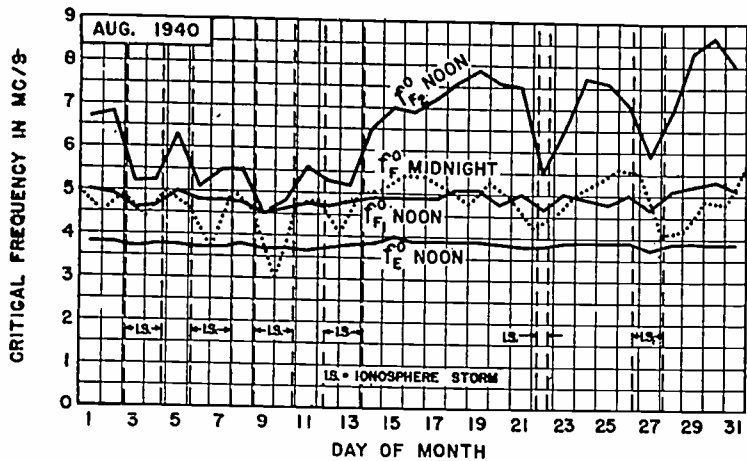

Fig. 2—Midnight  $f_{F_1^0}$  and noon  $f_{E^0}$ ,  $f_{F_1^0}$ , and  $f_{F_2^0}$  for each day of August. The times during which ionospheric storms occurred are indicated by the vertical dashed lines.

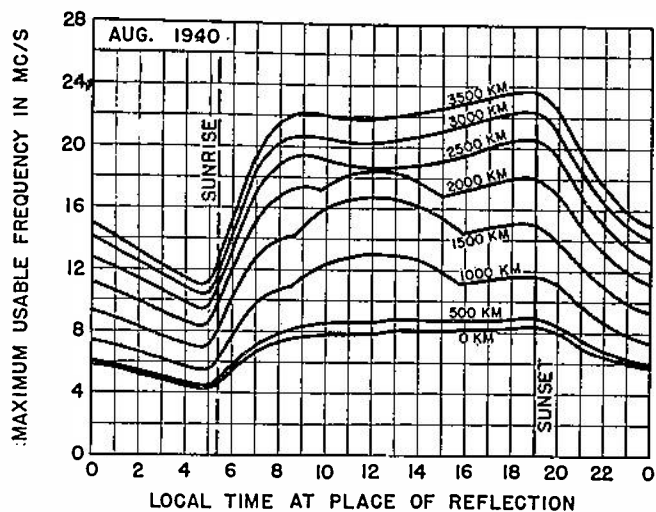

Fig. 3—Maximum usable frequencies for dependable radio transmission via the regular layers, average for undisturbed days for August, 1940. The values shown were considerably exceeded during frequent irregular layer periods because of reflections from patches of sporadic-E layer.

Ionospheric storms and sudden ionospheric disturbances are listed in Tables I and II, respectively. The details of one ionospheric storm are shown in Fig. 1, and the times during which all ionospheric storms oc-

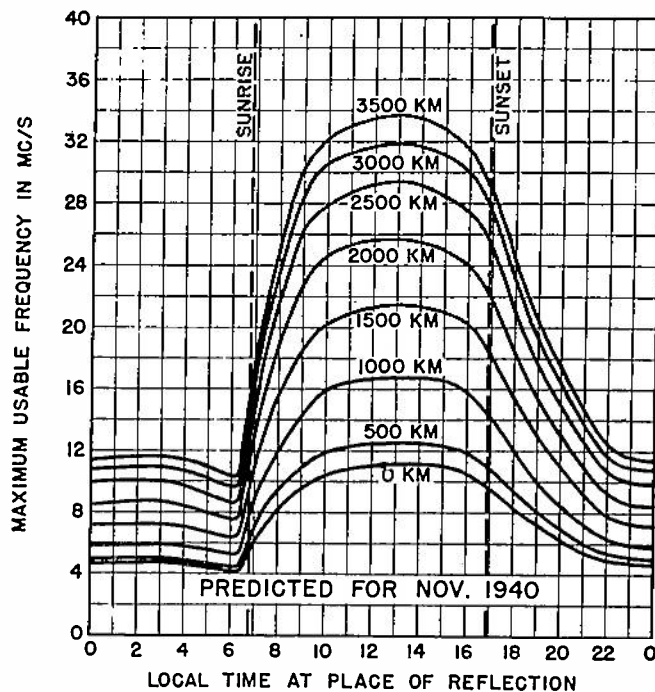

Fig. 4—Predicted maximum usable frequencies for dependable radio transmission via the regular layers, average for undisturbed days, for November, 1940. For information on use in practical radio transmission problems, see Letter Circular 575 obtainable from the National Bureau of Standards, Washington, D. C., on request.

urred are indicated by the vertical dashed lines in Fig. 2. Table III gives the approximate upper limit of frequency of strong sporadic-E reflections at vertical incidence.

# Institute News and Radio Notes

## Rochester Fall Meeting

The Rochester Fall Meeting will be held on November 11, 12, and 13, at the Sagamore Hotel in Rochester, New York. The technical papers which are to be presented at the meeting are listed below by titles and the sessions in which they will be given are indicated.

### Technical Program

#### Monday, November 11

9:30 A.M.

"Measurement of Electrode Temperatures of Tubes During Exhaust and Operation," by A. D. Power, RCA Manufacturing Company, RCA Radiotron Division.

"Notes on the Use of Inverse Feedback in Electric Phonographs," by H. P. Kalmus and D. D. Israel, Emerson Radio and Phonograph Corporation.

"Recent Improvements in Frequency-Modulated-Wave-Receiver Design," by J. A. Worcester, General Electric Company.

2:00 P.M.

"The Role of the Limiter in Noise Suppression in Frequency Modulation," by C. W. Carnahan, Zenith Radio Corporation.

"The Application of Inductive Tuning to Ultra-High Frequencies," by B. V. K. French, P. R. Mallory and Company.

"A Phase-Curve Tracer for Television," by B. D. Loughlin, Hazeltine Service Corporation.

#### Tuesday, November 12

9:30 A.M.

"Annual Message of the Radio Manufacturers Association Director of Engineering," by W. R. G. Baker.

"Dielectric Characteristics of a New Cellulose-Ester Sheet Plastic," by C. E. Hall, Eastman Kodak Company.

"Common-Channel Interference from Two Frequency-Modulated Signals," by H. A. Wheeler, Hazeltine Service Corporation.

"Radio Tubes Today," by R. M. Wise, Hygrade Sylvania Corporation.

2:00 P.M.

"The Coaxial Tuning Condenser," by F. W. Godsey, Jr., Sprague Specialties Company.

"Television in Color," by P. C. Goldmark, Columbia Broadcasting System.

"A Study of Impulsive Noise in Frequency-Modulated-Wave Receivers," by V. D. Landon, RCA Manufacturing Company, RCA Victor Division.

#### Wednesday, November 13

9:30 A.M.

"Special Oscilloscope Tests for Television Wave Forms," by A. V. Loughren and W. F. Bailey, Hazeltine Service Corporation.

"Extending the Range of Audio-Frequency Reproduction," by H. F. Olson, RCA Manufacturing Company, RCA Victor Division.

"The Kettledrum Baffle," by R. T. Bozak, Bozak Associates.

"Improvements in High-Fidelity Audio-Frequency Amplifiers," by Lincoln Walsh, Consulting Engineer.

2:00 P.M.

"The Evolution of a New Type of Metal Receiving Tube," by D. W. Jenks, General Electric Company.

"Discussion of Fluorescent Materials," by B. F. Ellefson, Hygrade Sylvania Corporation.

"Summary of the Significance of the Papers at this Meeting," by D. G. Fink, McGraw-Hill Publishing Company.

Reservations for hotel rooms should be made directly to the Sagamore Hotel. If space is not available at the Sagamore, the reservations will be transferred to a neighboring hotel.

## Board of Directors

A special meeting of the Board of Directors was held on August 21 and those present were L. C. F. Horle, president; W. R. G. Baker, F. W. Cunningham, H. C. Forbes, Alfred N. Goldsmith, Virgil M. Graham, R. A. Heising, F. R. Lack, F. B. Llewellyn, Haraden Pratt, B. J. Thompson, H. M. Turner, A. F. Van Dyck, H. A. Wheeler, L. P. Wheeler, and H. P. Westman, secretary.

Thirty-six applicants for Associate, four for Junior, and fifteen for Student grade were elected.

A special technical committee was established to report to the Standards Committee and develop standards, particularly of terminology, in the field of piezoelectric crystals.

A National Television Systems Committee was established by the Radio Manufacturers Association, with the cooperation of the Federal Communications Commission, to make a comprehensive analysis of television. Because of the broad scope of this committee and the undesirability of duplicating work, the Institute's Special Committee on Television was offered to the National Television Systems Committee as the personnel for its Panel 2 on "Subjective Aspects" of television. On its acceptance by the National Television Systems Committee, the Institute committee will be dissolved.

Dr. Goldsmith was appointed representative of the Institute and H. A. Wheeler as alternate on the National Television Systems Committee.

A petition naming F. E. Terman as a candidate for the Presidency of the Institute for 1941 was received in proper order and this name was added to the ballot.

A regular meeting of the Board of Directors was held on September 4 and those in attendance were L. C. F. Horle, president; W. R. G. Baker, Alfred N. Goldsmith, Virgil M. Graham, O. B. Hanson, C. M. Jansky, Jr., F. B. Llewellyn, B. J. Thompson, H. M. Turner, A. F. Van Dyck, H. A. Wheeler, L. P. Wheeler, and H. P. Westman, secretary.

It was reported that the National Television Systems Committee had accepted the personnel of the Institute's Special Committee on Television as the personnel of its Panel 2. This acceptance automatically dissolved the Institute committee.

The appreciation of the Board was expressed to W. S. Fitzpatrick and G. H. Clark for their gift of two duplicate volumes of the PROCEEDINGS of the Wireless Institute.

It was agreed that the Institute would accept for publication in the PROCEEDINGS papers of satisfactory caliber of the survey type based on material which may be known generally to specialists in the field covered but which would probably be of interest to engineers active in other fields.

A regular meeting of the Board of Directors was held on October 3. Those present were L. C. F. Horle, president; Melville Eastham, treasurer, Austin Bailey, F. W. Cunningham, H. C. Forbes, Alfred N. Goldsmith, Virgil M. Graham, O. B. Hanson, R. A. Heising, C. M. Jansky, Jr., F. R. Lack, F. B. Llewellyn, Haraden Pratt, B. J. Thompson, H. M. Turner, A. F. Van Dyck, L. P. Wheeler, and H. P. Westman, secretary.

Thirty-seven applications for Associate, one for Junior, and four for Student grade were approved.

A small editing committee was appointed to make final revisions in a manual of section operation which will be circulated to all sections.

## Sections

### Detroit

I. R. Weir, engineer for the General Electric Company (Schenectady) presented a paper on "Field Comparison Tests of Wide-Band Frequency versus Amplitude Modulation."

In comparing the two systems, as many elements as possible were used for both types of transmission. The transmitting and receiving antennas, the trans-

mitter output stages, and transmitter carrier power all remained unchanged. The same receiver was used with a change in the type of detector only.

With the receiver mounted in an airplane or in an automobile, tests indicated about sixty per cent greater service range for frequency modulation. An improvement of about twenty-five decibels in favor of frequency modulation was indicated on signal-to-noise ratio tests.

The tests discussed included single-channel operation of two stations both within and beyond the line of sight and adjacent-channel operation of two stations within the line of sight.

In tests in which the power of the amplitude-modulated transmitter was raised until apparent equality existed in the signals from it and from a frequency-modulated transmitter, it was found that the same signal-to-noise ratio was obtained with one watt in the case of frequency modulation and fifty watts with amplitude modulation.

If two transmitters of equal power are operated on the same frequency, the frequency-modulated-wave system will give a service area about thirty-three times as large for each transmitter than would be obtained with amplitude-modulated-wave transmissions. This feature may compensate for the greater band width required for frequency modulation.

With two stations operating on the same frequency and with a band width five times greater for frequency than for amplitude modulation, a frequency-modulated-wave system will give thirty-three times the coverage of the amplitude-modulated-wave system when the power ratio of the two stations is 1:1, twenty-seven times for a ratio of 10:1, and fifteen times when the ratio is 100:1.

March 15, 1940, J. D. Kraus, chairman, presiding.

E. C. Denstaedt, supervisor of radio of the Detroit Police Department, presented a paper on "Recent Developments in Police Communication Systems." In 1873 the wire telegraph offered the fastest means of communication. This was contrasted with the present-day two-way radio system of communication between moving cars and headquarters, the national police radiotelegraph network, and the teletypewriter system.

The present police radio central is located on Belle Isle. It consists of numerous antenna systems, five transmitters which operate on twelve different channels, ten receivers, and three teletype circuits. The plant cost about \$75,000.

At the close of the meeting a visit was made to the police radio central.

April 19, 1940, J. D. Kraus, chairman, presiding.

In a joint trip with the Detroit Physics Society, the Detroit Section of the Institute visited the departments of physics and electrical engineering of the University of Michigan.

Before touring the laboratories, short talks were given to describe the equipment to be inspected. A glossary of terms com-

monly used in nuclear physics was distributed.

The 100-ton cyclotron which is in charge of Professor J. M. Cork, was inspected. Energies in the neighborhood of ten million electron volts are obtained with it.

The high-voltage ion accelerator, the operation of which is under Professor H. R. Crane, was next. It produces potentials



EMPORIUM MEETING

*The five authors of the papers that were presented at the Fourth Summer Seminar of the Emporium Section appear in the above photograph. James Day of Columbia University is seated and those standing are, left to right, B. F. Ellefson, Austin Bailey, A. W. Keen, and M. A. Acheson. Dr. Bailey is on the technical staff of the American Telephone and Telegraph Company, and the other three authors are engineers with the Hygrade Sylvania Corporation.*

of one million electron volts and is used in research in nuclear physics.

The transmission of supersonic vibrations was demonstrated by J. R. Frederick.

Professor N. H. Williams displayed the centimeter-wave generating equipment and wave guides which are being used in connection with the transmission of radio waves through gases. Wavelengths of 0.6 centimeter, equivalent to fifty kilomegacycles, have been produced.

A demonstration of frequency modulation was conducted by L. N. Holland and Messrs. Wiesner and Giacchetto of the electrical engineering department.

May 17, 1940, J. D. Kraus, chairman, presiding.

## Emporium

D. E. Harnett of the Hazeltine Service Corporation presented a paper on "Frequency Modulation and Frequency-Modulated-Wave-Receiver Design."

The operation of a frequency-modulated-wave system was described briefly and the band-width requirements and the effect of interstation interference were stressed. By means of vectors, representing

signal strength, it was shown that disturbances produced by an interfering carrier or by noise pulses are reduced to negligible proportions when the desired signal has a peak amplitude at least twice that of the interfering signal.

In designing receivers, the following subjects were discussed: the amount of gain required for maximum usable sensitivity, the amount of distortion resulting from the use of a slightly narrowed intermediate-frequency band width, the use of a limiter to flatten out the over-all intermediate-frequency—gain characteristic and the performance of typical limiter circuits using various input voltages and time constants of the grid-bias circuits.

March 21, 1940, C. R. Smith, chairman, presiding.

R. F. Shea of the General Electric Company (Bridgeport), continued the subject of the previous meeting with a paper on "Frequency-Modulated-Wave-Receiver Design."

Several general design principles were discussed and included: the distribution of gain and selectivity in the various receiver circuits, methods of compensating for oscillator drift thus reducing the amount of intermediate-frequency band width which must be provided, the factory alignment of circuits, and the desirability of a tuning indicator to reduce the possibility of mistuning with its attendant impaired quality of reproduction. The paper was concluded with a demonstration showing the discrimination between and reception of two transmitters on the same frequency.

April 18, 1940, C. R. Smith, chairman, presiding.

"Selenium Rectifiers" was the subject of a paper by C. L. Clarke of the International Telephone Development Corporation. The properties of selenium rectifiers and their operating characteristics, which included behavior in various circuit arrangements and over an extended range of temperatures, were outlined. A number of rectifiers of various types were displayed.

May 9, 1940, C. R. Smith, chairman, presiding.

The Fourth Summer Seminar of the Emporium Section was held on August 2 and 3, and consisted of inspection trips through various manufacturing plants at Emporium and St. Marys on August 2, a technical session on each of the two days, and an outing on the afternoon of August 3.

In the technical sessions, four papers were presented. The first by B. S. Ellefson, of the Hygrade Sylvania Corporation, was on "Fluorescent Materials" and included a demonstration. Austin Bailey, of the American Telephone and Telegraph Company, then presented a paper on "Coastal-Harbor Stations of the Bell System." A demonstration was given with this paper also.

The second technical session included two papers. The first was "Notes on Frequency-Modulated-Wave Receivers" by James Day of Columbia University, and the second was on "New Tubes for Hearing Aids and Their Application," by M. A.



1940

Acheson, and A. W. Keen of the Hygrade Sylvania Corporation.

## Indianapolis

"The Indianapolis Instrument Landing System" was discussed by J. C. Hromada and H. I. Metz, engineers of the Civil Aeronautics Authority.

W. E. Jackson, chief of the radio development section of the Civil Aeronautics Authority, first spoke briefly about the activities of the Indianapolis laboratory. Recent extensions of ultra-high-frequency services into aerial navigation were then discussed by Mr. Hromada, chief engineer, of the Indianapolis laboratory.

Mr. Metz, then described the ultra-high-frequency blind-landing system installed at the Indianapolis airport.

March 29, 1940, I. M. Slater, chairman, presiding.

## Montreal

"Fundamentals of Antenna Design" was the subject of a paper by E. A. Laport, who is in charge of transmitter and special products design for RCA Victor (Montreal).

The graphical solution of problems of antennas, coupling networks, and field distribution from single antennas and arrays were discussed. A method of determining the voltage and current distribution in an antenna and from this the impedances was described. The determination of field disturbances about a single antenna or an array for both the grounded and free-space conditions was then covered. An outline of a method of calculating coupling networks for both arrays and single antennas concluded the paper.

March 13, 1940, A. B. Oxley, chairman, presiding.

## Philadelphia

"Frequency Modulation" was the subject of a paper by P. A. de Mars, technical director of the Yankee Network.

The frequency-modulated-wave system of broadcasting was described. It was pointed out that although coverage in the high-frequency region was limited and a broad frequency band is required, the quality of reproduction is much better and noise is practically eliminated.

The transmitter at Paxton, Massachusetts, was then described. It is of 50 kilowatts and operates at about 80 megacycles, using a band width of 200 kilocycles. With an antenna at an altitude of 1800 feet above sea level, a range of between 100 and 150 miles is obtained. This is over a fairly level terrain and assumes a receiving antenna 30 feet above ground. With a power of two kilowatts, a range of approximately fifty miles is obtained.

Programs are relayed from Boston, about forty-three miles distant, by frequency modulation at 133 megacycles. The over-all circuit shows a response-frequency characteristic which varies less than one decibel up to an audio frequency of 17,000 cycles.

April 4, 1940, R. S. Hayes, chairman, presiding.

"The Technical Status of Television" was discussed by E. W. Engstrom and A. V. Bedford, of the RCA Manufacturing Company (Camden). The basic principles on which a system of television must be built were first outlined. The standards which must be established to provide a successful commercial broadcast service were then considered.

Brief descriptions were given of scanning methods, the operation of the iconoscope, shading, video-frequency amplifiers, keystoneing, blanking, synchronizing methods, motion-picture-film pickup, vestigial-sideband operation, the isolation of synchronizing pulses, the kinescope, and a number of other features.

This was the annual meeting and C. M. Burrill, research engineer, RCA Manufacturing Company (Camden), was elected chairman; C. C. Chambers, assistant professor of electrical engineering, University of Pennsylvania, was named vice chairman; and R. L. Snyder, consultant, was re-elected secretary-treasurer.

May 2, 1940, C. M. Burrill, chairman, presiding.

## Pittsburgh

"Crystal Devices Applied to Miniature Amplifiers" were discussed by Dan Domizi, development engineer of The Brush Development Laboratories. The operating principles in the manufacture of Rochelle-salt crystals were first considered. In their use in hearing aids, bimorph units consisting of two crystal elements cemented together with their optic axes at right angles to produce bending or twisting are used. Crystals are applied to both microphones and headphones. Several hearing aids equipped with vacuum-tube amplifiers were exhibited.

March 19, 1940, R. E. Stark, vice chairman, presiding.

A student meeting was devoted to three papers by students of the Carnegie Institute of Technology. They were "Coaxial Cables" by P. R. Sprowl, "Bio-Electric Phenomena" by R. C. Fox, and "Frequency Modulation" by G. J. Stuart, Jr.

April 16, 1940, J. E. Baudino, chairman, presiding.

"Electronic Development Applied to Atom Splitting in the Cyclotron" was the subject of a paper by A. J. Allen, associate professor, and W. A. Andrews, assistant, of the Physics Department at the University of Pittsburgh.

Dr. Allen discussed the use of artificial radio activity to identify atoms in medical and biological studies. The Geiger counter was described and its sensitivity to alpha, beta, and gamma rays was demonstrated. A detailed description was given of the cyclotron and included the theory of its operation. The van de Graaf generator was also described.

Mr. Andrews treated the use of electronic circuits for the precise regulation of the field current of cyclotrons. He described the action of scaling circuits which are used to add the pulses from Geiger counters with rapidity and accuracy.

May 21, 1940, J. E. Baudino, chairman, presiding.

The annual meeting of the Pittsburgh section resulted in the following elections to office: chairman, R. E. Stark, consultant; vice chairman, P. N. Bossart, research engineer, Union Switch and Signal Company; and secretary-treasurer, M. G. Jarrett, engineer, Bell Telephone Company of Pennsylvania.

It was agreed that the meeting date would be changed to the second Monday of each month.

No technical paper was presented as the meeting was held in the form of a banquet.

June 11, 1940, J. E. Baudino, chairman, presiding.

## Portland

A Saturday afternoon and evening meeting was held at Oregon State College. Five technical papers were presented after an inspection trip of the laboratories, Aperson Hall, and the physics building.

"Sunspots and Radio Transmission" were discussed by E. A. Yunker, associate professor of physics. "Earth Currents and Wire Transmission" was the subject of a paper by A. L. Albert, professor of communication engineering. These were presented at the afternoon session which was presided over by G. S. Feikert.

During dinner the "Present Status of KOAC-KOY Controversy" was discussed by F. O. McMillan, head of the department of electrical engineering and supervising engineer of KOAC. Don Morgan, a senior student in electrical engineering, presided.

In the evening "Modern Broadcast Transmitter Design" was discussed by G. S. Feikert, assistant professor of electrical engineering, and chief engineer of KOAC. F. A. Everest, assistant professor of electrical engineering, then discussed the "Design of Directional Broadcast Antennas." This session was presided over by E. A. Yunker.

April 27, 1940.

"An Analysis and Demonstration of Frequency Modulation" was presented by R. W. Deardorff of the Pacific Telephone and Telegraph Company, and L. M. Belleville of the United States Forest Service Radio Laboratory.

It included an analysis of frequency, amplitude, and phase modulation. Noise effects were described by both vector and sideband concepts. Models showed the effects in envelope resulting from different phasing of the carrier and the sidebands. A demonstration using a low-power transmitter, receiver, and a source of noise indicated the susceptibility of the systems to noise.

May 22, 1940, Marcus O'Day, chairman, presiding.

"Frequency-Modulation Field Tests and Operating Experience" were described by M. V. Kiebert, Jr., of Jansky and Bailey.

June 13, 1940, Marcus O'Day, chairman, presiding.

## Rochester

G. R. Town, engineer in charge of the television development laboratory of the Stromberg-Carlson Telephone Manufacturing Company, presented a paper on the "Latest Improvements in Television."

This was the annual meeting and H. C. Sheve of the Stromberg-Carlson Telephone Manufacturing Company was elected chairman; E. C. Karker of the Rochester Mechanics Institute was named vice chairman; and O. L. Angevine, Jr. of the Stromberg-Carlson Telephone Manufacturing Company became secretary-treasurer.

May 16, 1940.

## San Francisco

"Electrical Power and Sound Problems in the Motion-Picture Industry" was the subject of a paper by O. L. Dupy, recording supervisor in the sound department of Metro-Goldwyn-Mayer Pictures. The author first pointed out that many branches of radio contribute to the making of a modern motion picture. Problems of distributing power for lighting stages and other sets, for the operation of such devices as treadmills, wind machines, cameras, amplifiers, and recording equipment requires extensive wiring and large amounts of power with an enormous ratio between the peak demand and the average load.

Camera drives and the history of the 1200-revolution-per-minute drive speed for sound recording were discussed. A method of eliminating mechanical gears by using electrical methods was covered.

A push-pull method of recording sound on film uses two sound tracks, 180 degrees out of phase, and reduces noise. An automatic starting system for shooting which was developed by the author has reduced the time for starting a "take" from over a minute to about four seconds.

The meeting was held jointly with the American Institute of Electrical Engineers.

March 29, 1940, Carl Penther, chairman, presiding.

"The Generation of Square-Wave Voltages at High Frequencies" was presented by W. H. Fenn of the University of California. The second paper was by C. A. Moreno of Stanford University, and was on "The Application of Network Theory to the Improvement of the Frequency Response of Audio-Frequency-Transformer Circuits."

Both of the authors were students and competed for a prize of a year's membership in the Institute. The prize was awarded to Mr. Fenn.

April 17, 1940, Carl Penther, chairman, presiding.

G. C. Connor, commercial engineer for Hygrade Sylvania Corporation, presented a paper on "Frequency-Modulated-Wave-Receiver Circuits."

It was pointed out that because of the wide-band characteristics, high- $Q$  circuits were not necessary. Radio-frequency stages ahead of the converter are not required. A minimum of two intermediate-frequency stages are needed with a worth-while gain to be obtained by using three such stages.

Frequency drift of the oscillator is a major problem and makes desirable the use of a voltage-regulator tube on the power supply to the oscillator.

A comparison of the interference between frequency and amplitude modulation systems was given.

May 2, 1940, L. J. Black, vice chairman, presiding.

R. S. Julian and T. R. Ferry of the University of California, presented a paper on "Wave Guides and Electromagnetic Horns."

It included the general theory and applications of the transmission of waves in hollow tubes and radiation from electromagnetic horns. The first author treated the mathematical phases and the second author discussed the practical applications.

May 22, 1940, L. J. Black, vice chairman, presiding.

W. W. Hansen, professor of physics of Stanford University, presented a paper on "The Klystron"

June 20, 1940, Carl Penther, chairman, presiding.

## Seattle

D. H. Loughridge, professor of physics at the University of Washington, presented a paper on "Radio Control of Model Airplanes." The equipment which he described was the result of the work of a group which included the author's son, who constructed the plane; C. B. Merry, who built the engine; and Don Burcham and Ray Wilson, who were responsible for the radio control equipment.

The model is a monoplane, of approximately ten-foot wing span, equipped with a 6-cylinder radial engine developing about two horsepower. The weight including the radio equipment is twenty pounds.

With models of this size, radio control is essential as their altitude and speed give substantial cruising distances with the possibility of loss or damage if control cannot be maintained from the ground.

The plane was demonstrated under captive flying conditions.

April 5, 1940, R. M. Walker, chairman, presiding.

E. E. Williams of the General Electric Company (Schenectady) presented a paper on "Frequency Modulation—Factors in Equipment Design and Application."

It was pointed out that the fundamental patents covering frequency modulation are approximately fifteen years old. The early attempts to introduce the system were unsuccessful and were restricted to the use of narrow-band transmission.

The present frequency-modulated-wave broadcast transmitters operate in the high-frequency region and use a carrier swing of about 75 kilocycles both sides of the mean frequency with channels 200 kilocycles wide. For emergency services and for voice transmission, 30-kilocycle modulation bands are sufficient and channels 40 kilocycles wide are adequate. Interference between stations operating on the

same frequency with varying powers was described. The weaker station suffers relatively small loss in service area as compared to amplitude-modulated-wave operation.

Receiver circuit designs were described and their interference-reducing properties discussed.

May 10, 1940, R. M. Walker, chairman, presiding.

## Toronto

"Converter Tube Applications" was the subject of a paper by W. R. Jones, commercial engineer for the Hygrade Sylvania Corporation.

The difficulties of getting stable and reliable operation of converter tubes, particularly at the high frequencies, were discussed. A number of precautions which must be taken and some which are desirable in the design and construction of circuits were pointed out. Modifications in the design of these tubes to accomplish certain desired results have occurred during the past year or two. The single-ended tubes, which are relatively new, are more effective than the older types using top cap connectors. The improvements in the characteristics of the 6K8 as compared with the older 6A8 were pointed out.

December 11, 1939, G. J. Irwin, chairman, presiding.

"Recent Developments in Indicating Instruments" was presented by H. L. Olesen, assistant sales manager of the Weston Electrical Instrument Corporation.

The improvements which have been made in the last ten years have resulted in increased sensitivity of the direct-current instruments. An important part of these improvements has resulted from better permanent magnets. Manufacturing problems in the construction of small indicating instruments were stressed and particular attention given to problems of handling the fine wire used for moving coils. In some cases a wire one mil in diameter is used. The enamel coating may be stronger than the wire itself and open circuits which are not visible to the eye occur.

February 9, 1940, G. J. Irwin, chairman, presiding.

M. E. Strieby of the Bell Telephone Laboratories discussed "Coaxial-Cable Systems."

The subject was considered primarily from the standpoint of radiotelephone transmission. The characteristics of coaxial cables were described and compared with other types of lines. The very compact amplifiers used as repeaters for such a system were described. They transmit wide frequency bands, utilize reverse feedback to give desired operating characteristics, and can be replaced quickly with duplicate equipment. Dual tube complements keep the amplifier in operation even though one tube may burn out. The amplifiers are operated from sixty-cycle power carried over wires contained within the outer sheath of the coaxial cable.

In the Chicago-Milwaukee cable link there are two coaxial lines in each direc-

tion. Repeaters are located about every forty miles. Methods of laying the cable and installing the amplifiers were described.

This meeting was held jointly with the local section of the American Institute of Electrical Engineers.

February 22, 1940, G. J. Irwin, chairman, presiding.

## Washington

A tour through the new fifty-kilowatt station of WJSV at Wheaton, Maryland, was the main event of the meeting. Clyde Hunt, chief engineer, J. L. Middlebrooks, in charge of transmitter construction for the Columbia Broadcasting System, and several other members of the Columbia Broadcasting System engineering staff, acted as guides and explained the various details of the installation.

April 8, 1940, L. C. Young, chairman, presiding.

E. H. B. Bartelink of the General Electric Company (Schenectady) presented a paper on "Stability of Wide-Band Amplifiers."

He treated amplifiers passing frequencies between 30 cycles and 4.5 megacycles and included the determination of the conditions of stability. It was pointed out that for television use, an amplifier must have not only a flat response-frequency characteristic but should have a minimum phase shift over the frequency range. A high-gain amplifier based on the principles outlined was described.

May 13, 1940, L. C. Young, chairman, presiding.

"Low-Coefficient Quartz Crystals and the New GT Cut, which Has a Very Constant Frequency over a Wide Temperature Range" was the subject of a paper by W. P. Mason of the Bell Telephone Laboratories.

The author reviewed first the existing low-temperature-coefficient quartz crystals which included coupled crystals, the long bar crystals, high-frequency AT and BT shear-vibrating crystals, and the low-frequency CT and DT shear-vibrating crystals. Characteristics of each of these were discussed.

These crystals are zero temperature coefficient at one temperature only. The new GT cut has not only a zero first derivative of frequency with respect to the temperature but also a zero second derivative. As a result a frequency change of not more than one cycle in a million over a range in temperature of 100 degrees centigrade results. Methods of obtaining these crystals and their properties were discussed.

GT crystals are being used extensively in frequency standards, in the transatlantic radio systems, and in unattended coastal-harbor radio receivers which are subject to large temperature variations.

June 10, 1940, L. C. Young, chairman, presiding.

## Personal Mention

The following members have informed us of changes in their company affiliations or titles to those given below:

- Bender, Louis B.;** Engineer, Research Products Department, Westinghouse Electric and Manufacturing Company, Baltimore, Md.
- Bond, Clyde H.;** Engineer, RCA Manufacturing Company, Camden, N. J.
- Boyd, Bruce;** Engineer, Radio Division, Westinghouse Electric and Manufacturing Company, Baltimore, Md.
- Browder, Jay E.;** Product Engineer, Sperry Gyroscope Company, Inc., Brooklyn, N. Y.
- Campbell, Walter H.;** Procurement Planning Section, Signal Corps, Washington, D. C.
- Carnahan, Chalon W.;** Zenith Radio Corporation, Chicago, Ill.
- Crom, George C., Jr.;** Major, Army Industrial College, Washington, D. C.
- Dow, Jennings B.;** Commander, U. S. Navy, Navy Radio and Sound Laboratory, San Diego, Calif.
- Everett, Leonard, Jr.;** The Intercontinent Corporation, Rangoon, Burma.
- Filgate, John T.;** Chief Engineer, Communications Division, Philco Corporation, Philadelphia, Pa.
- Fowler, Newton B.;** Staff Supervisor, American Telephone and Telegraph Company, St. Louis, Mo.
- Gall, James E.;** Radio Division, Naval Research Laboratory, Anacostia Station, Washington, D. C.
- Glauber, John J.;** Champion Radio Works, Danvers, Mass.
- Glover, George A. J.;** Member of engineering staff, Transmission Equipment Pty. Ltd., Melbourne, Victoria, Australia.
- Glover, Ralph P.;** Jensen Radio Manufacturing Company, Chicago, Ill.
- Goldstein, Maxwell K.;** Naval Research Laboratory, Anacostia Station, Washington, D. C.
- Guaragna, Luis F.;** International Division, RCA Manufacturing Company, Camden, N. J.
- Hall, Graham G.;** Development Engineer, E.T.C. Industries, Ltd., Sydney, N.S.W., Australia.
- Hellmann, Reinhard K.;** Electrical Engineer, Connecticut Telephone and Electric Corporation, Meriden, Conn.
- Hillyer, Curtis, Jr.;** Consulting Engineer, Fairchild Aviation Corporation, Jamaica, L. I., N. Y.
- Hoag, J. Barton;** U. S. Coast Guard Academy, New London, Conn.
- Hobbs, Marvin;** E. H. Scott Radio Laboratories, Chicago, Ill.
- Horne, Charles F.;** Lieutenant, U. S. Navy, U.S.S. *Long*, San Francisco, Calif.
- Hucke, Herbert M.;** Manager, Aviation Radio Sales Division, RCA Manufacturing Company, Camden, N. J.
- Ireland, Frederick;** General Radio Company, Hollywood, Calif.
- Kent, Earle L.;** Research Engineer, C. G. Conn, Ltd., Elkhart, Ind.
- King, Cary J., Jr.;** Captain, Headquarters, Sixth Corps Area, Chicago, Ill.
- Kreager, Paul H.;** Engineer, Bendix Radio Corporation, Baltimore, Md.
- Lingard, Aldro;** Lieutenant, U. S. Air Corps, Austin Hall, Langley Field, Va.
- Little, David S.;** Radio Engineer, American Airlines, Inc., New York, N. Y.
- Lorenzen, Howard O.;** Naval Research Laboratory, Anacostia Station, Washington, D. C.
- Lytle, Chester W.;** Senior Radio Engineer, Zenith Radio Corporation, Chicago, Ill.
- Maddox, Charles H.;** Commander, U. S. Navy, Naval War College, Newport, R. I.
- McConnell, Harold E.;** Consulting Geophysicist, Geophysical Surveys, Houston, Tex.
- McKee, Charles W.;** Radio Engineer, Aeronautical Radio, Inc., Washington, D. C.
- Miller, Horace G.;** Consulting Engineer, Belleville, N. J.
- Morris, George W.;** Major, Signal Corps, U.S. Army, New York, N. Y.
- Noble, Daniel E.;** Galvin Manufacturing Corporation, Chicago, Ill.
- Organ, William H.;** Lieutenant, U. S. Navy, U.S.S. *Nevada*, San Francisco, Calif.
- Palik, Frank;** U. S. Radio Inspector, Federal Communications Commission, Cleveland, Ohio.
- Peckham, Malcolm A.;** Electrical Engineer, National Electric Welding Machines Company, Bay City, Mich.
- Pepperberg, Louis E.;** Engineer, Wells-Gardner and Company, Chicago, Ill.
- Pratt, Dana;** RCA Manufacturing Company, Chicago, Ill.
- Robinson, Edwin B.;** Lieutenant, U. S. Navy, U. S. Naval Station, Tutuila, American Samoa.
- Schoenwolf, Fred L.;** Lieutenant, U. S. Naval Reserve, Navy Department, Communication Office, Cavite, P. I.
- Schrader, William A.;** Civil Aeronautics Authority, La Guardia Field, N. Y.
- Serrell, Robert;** Television Engineering Department, Columbia Broadcasting System, New York, N. Y.
- Siegmund, E. Lee;** Development Engineer, Airplane and Marine Direction Finder Corporation, Clearfield, Pa.
- Slater, Ira M.;** P. R. Mallory and Company, Inc., New York, N. Y.
- Tellman, Herbert A.;** Lieutenant Commander, U. S. Navy, U. S. Navy Yard, Cavite, P. I.
- Tharp, Llewellyn D.;** Major, First Armored Corps, Fort Knox, Ky.
- Upp, Charles B.;** U. S. Naval Research Laboratory, Anacostia, D. C.
- Whalley, Wilfrid B.;** Physics and Electrical Engineering Division, National Research Council, Ottawa, Ont., Canada.
- Woodward, John D.;** Bendix Radio Corporation, Baltimore, Md.

## Membership

The following indicated admissions to membership have been approved by the Admissions Committee. Objections to any of these should reach the Institute office by not later than November 30, 1940.

### Admission to Associate (A), Junior (J), and Student (S)

Alzona, A. L., (A) Avda. Ing. Huergo 1167, Buenos Aires, Argentina.  
 Amoo, L. R., (A) 621 Fourth St., N.W., Jamestown, N. D.  
 Apps, D. C., (A) 10351 Skeman Rd., Brighton, Mich.  
 Bartko, J. J., (A) Naval Research Laboratory, Washington, D. C.  
 Bejarano, E. P., (A) Jose Bonifacio 2593, Buenos Aires, Argentina.  
 Burlingame, E. D., (A) 171 Parkwood Ave., Kenmore, N. Y.  
 Collins, E. F., (A) 73 Birmingham St., Stratford, Ont., Canada.  
 Combs, G. B., Jr., (A) 240 Tenth Ave. N.E., St. Petersburg, Fla.  
 Cutler, C. C., (A) Bell Telephone Laboratories, Inc., Deal, N. J.  
 Des Meules, H. A., (A) Father Point, Rimouski, Que., Canada.  
 Dickson, D. L., (A) Naval Radio Station, Arlington, Va.

Fitch, W. L., (A) Venezuela 613, Buenos Aires, Argentina.  
 Fox, R. C., (S) 1 Ingram Ave., Pittsburgh, Pa.  
 Fuqua, C. E., (A) U.S.S. Astoria "NC" Division, c/o Fleet Post Office, Pearl Harbor, T. H.  
 Guntsche, G. E., (A) Bogota 3355, Buenos Aires, Argentina.  
 Hammer, T. E., (S) AXM, 140 N. Third St., Lewisburg, Pa.  
 Hammond, G. H., (A) 90 South St., Bedford, Mass.  
 Harpster, W. A., (A) U.S.S. *Cincinnati*, c/o Postmaster, San Diego, Calif.  
 Haun, A. H., (A) Brantford Pl., Buffalo, N. Y.  
 Huntoon, R. D., (A) Hygrade Sylvania Corporation, Emporium, Pa.  
 Jennings, L. J., (A) 75 Hume Ave., Medford, Mass.  
 Johnson, H. C. L., (A) 500 Fifth Ave., New York, N. Y.  
 Kurokawa, H., (A) Komukioku Teishinsho, Otemachi, Kojimachiku, Tokyo, Japan.  
 Mead, P. H., (A) "Boscobel," Mytchett, Aldershot, Hants., England.  
 Miller, E. W., (J) Columbia Broadcasting System, 485 Madison Ave., New York, N. Y.  
 Neves, J. A. G., (A) A.G.C.T.T., Ponta Delgada, S. Miguel, Azores.  
 Padilla, P., (A) Juan B. Alberdi 2452, Buenos Aires, Argentina.

Partis, G., (A) Naval Research Laboratory, Washington, D. C.  
 Perrine, C. D., Jr., (A) Hughes Aircraft Company, 7000 Romaine, Hollywood, Calif.  
 Raffaelli, J. C. (A) Pueyrredon 1462, Buenos Aires, Argentina.  
 Roes, G. E., Jr., (A) 600 E. Walnut St., Goldsboro, N. C.  
 Rogers, D. H., (A) 39 Winfield Ave., Jersey City, N. J.  
 Schimmelpfennig, W., (A) U. S. Naval Research Laboratory, Washington, D. C.  
 Seidner, J. H., (A) 119 W. Sixth St., Emporium, Pa.  
 Silhavy, W. M., (A) 1844 Hanscom Dr., South Pasadena, Calif.  
 Smuts, M. N., (A) "Eikenhof," Lovers Walk, Rondebosch, Cape Province, South Africa.  
 Stevens, L. G., (A) 6536 Kimbark Ave., Chicago, Ill.  
 Takizawa, Z., (S) 11 Aoyamakitamachi-5-chome, Akasaka-ku, Tokyo, Japan.  
 Vaughan, E. W., (A) 250 Pine St., Newport, N. H.  
 Weiss, W. A., (S) The Christabelle Club, Emporium, Pa.  
 White, A. D., (A) 72 Rowe St., Auburndale, Mass.  
 Yamashita, S., (A) Mitsubishi Denki Kaisha, Wadamisaki, Kobe, Japan.

## Correspondence

### Piezoelectric Crystals

In this issue of the PROCEEDINGS there appears an article by Professor Karl S. Van Dyke discussing the various conventions used with regard to quartz crystals and methods for establishing correct orientations in the crystal. He points out the need for standardizing on methods for designating crystals. This is a project in which we have tried to arouse interest without much success. When the first useful oriented cuts were discovered, the convention for right- and left-handed crystals adopted by the Bell System followed that given by the most prominent book on crystal oscillators and resonators<sup>1</sup> which stated that "a right-handed quartz crystal rotates the plane of polarizations to the right and a left-handed crystal rotates it to the left." At the same time a shop procedure was adopted which distinguished the two types of crystals by observing a section through a conical viewing system along the optic axis, and noting whether the series of concentric rings expanded or contracted when the analyzer was rotated in a clockwise direction. In conformance with the above definitions of right- and left-handedness a convention was adopted that a positive angle about the  $X$  axis was one in which a

clockwise rotation was made when an electrically positive  $X$  axis (determined by compression) is up and the crystal is one in which the rings contract on rotating the analyzer in a clockwise direction. If the rings expand a positive angle is a counterclockwise rotation about the  $X$  axis.

In 1938 a pamphlet by the National Physical Laboratories appeared which attempted to standardize a notation with respect to quartz. In this pamphlet the opposite notation with respect to handedness was adopted and a number of other suggestions were made. It appeared to us that there was a need for standardization of terms pertaining to quartz and the attached letter was sent to the Editor of the PROCEEDINGS. Unfortunately publication was withheld at that time on the ground that the matter was not of sufficient interest to readers of the PROCEEDINGS.

It still appears desirable to have these matters considered by a standardizing committee. Since the maker or the user is not interested in whether the crystal is called left or right-handed but only in whether the desired characteristics have been obtained, it would appear desirable to frame the definitions on orientation in terms of shop procedure—as the one given above is defined—rather than in terms of the handedness of the crystal. Since Professor Van Dyke has investigated the matter of terminology and conventions ap-

plicable to quartz rather completely, we suggest that he be appointed chairman of such a committee.

W. P. MASON  
 G. W. WILLARD  
 Bell Telephone Laboratories, Inc.  
 463 West St.  
 New York, N. Y.  
 August 9, 1940

In a recent pamphlet<sup>2</sup> by the National Physical Laboratory, an attempt has been made to standardize some of the terminology dealing with piezoelectric quartz crystals and their applications. This is a worthwhile project and one which should be supported. However, we find that some of the terminology proposed is contrary to American usage and believe that the matter deserves study by an appropriate committee with a view toward standardizing a terminology for American usage.

In considering the report the following differences in usage were noticed.

1. In the report the definition of right- and left-handed quartz follows the facet definition which depends upon the location of the small  $s$  natural faces of the crystal with respect to the small  $x$  faces. This is consistent with the original definition given by Biot. At the Bell Telephone Labora-

<sup>2</sup> "Notation for piezo-electric quartz," *Nat. Phys. Lab.*, pp. 1-10, 1938.

<sup>1</sup> P. Vigoureux, "Quartz Resonators and Oscillators," His Majesty's Stationery Office, London, England, 1931, p. 12.

tories the viewpoint of the physicist due originally to Herschel<sup>3,4</sup> is followed. According to this a right-handed crystal<sup>5</sup> is one in which the plane of polarization of a plane polarized light ray traveling along the optic axis in the crystal is rotated clockwise as viewed by an observer located at the light source. This physicist's definition and the facet definition referred to above do not agree. What is right-handed according to one system is left-handed according to the other. Apparently those using the facet definition do not all agree among themselves. It is desirable, therefore, that some agreement be reached as to what will be called right-handed and left-handed quartz crystals.

2. After agreement on the handedness of crystals it is desirable to specify means which will enable anyone to identify the handedness of crystals. The report of the National Physical Laboratory uses the respective location of the  $s$  and  $x$  natural faces to define their handedness. This is one method for identifying the handedness but in view of the fact that crystals seldom show all of the desired faces it is of advantage to mention other systems which may be used. In one very convenient system there is used a source of light, a polarizer, a pair of lenses which produces conical illumination of the crystal, and an analyzer. When light traverses the crystal along the optic axis interference rings contract or expand on rotating the analyzer in one direction, depending upon the handedness of the crystal. Another well-known system uses an ordinary light source and the handedness is determined by the order of the colors appearing as the analyzer is turned. These systems can be used without reference to presence of any faces.

<sup>3</sup> J. Herschel, *Trans. Camb. Phil. Soc.*, vol. 1, p. 431, 1821.

<sup>4</sup> A good discussion of the two definitions on handedness is given by F. Cheshire, *Nature*, vol. 110, p. 807; December 16, 1922.

<sup>5</sup> This definition has been used rather extensively in the crystal literature. For example see P. Vigoureux, footnote reference 1.

3. In Figs. 1 and 2 of the report a right-handed system of axes is used for both right- and left-handed quartz crystals. This has the disadvantage that some of the piezoelectric and elastic constants change sign for right- and left-handed crystals, while if the system of axes follows the handedness of the crystal the equations in

ommends that the cuts should be designated by the two (three?) angles. It appears to the writers, however, that just as places on the map of definite longitude and latitude are designated by certain city names, so specific crystal cuts having wide range of usefulness, such as the AT and BT crystals, are more easily and descriptively

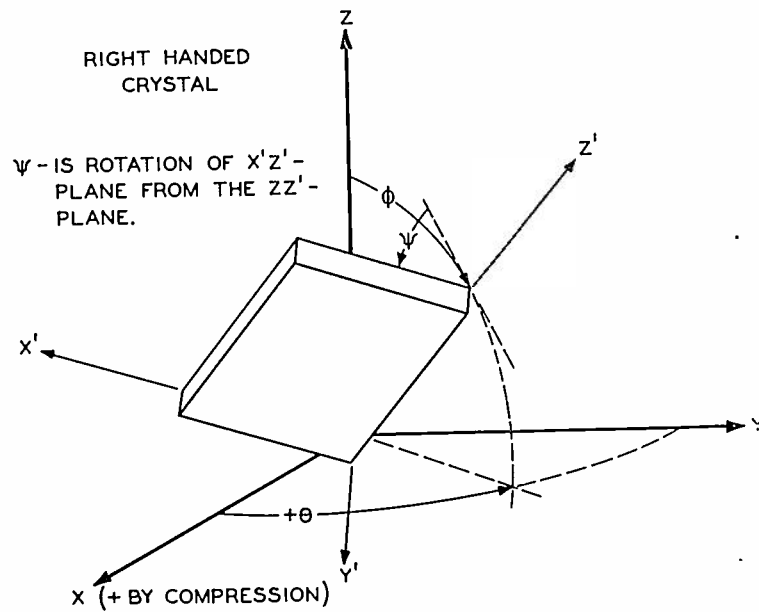

Fig. 1

toto constants, signs, and all are applicable in either case.

4. The report recommends  $\lambda$ ,  $\mu$ , and  $\nu$  for the direction cosines whereas most textbooks use the more conveniently written letters  $l$ ,  $m$ , and  $n$ .

5. The recommended symbols for stress and strain  $\Pi_x$  and  $\xi_x$  do not seem to be as appropriate as the more commonly used and more descriptive symbols  $X_x$  and  $x_x$  of Voigt.

6. The report states that all types of cuts can be specified by two sets of angles  $\eta$  and  $\zeta$ . Actually for all possible orientation it requires three angles. Fig. 1 shows the three angles used at the Bell Telephone Laboratories. The report furthermore rec-

ommends that the cuts should be designated by names than by three orientation angles.

Aside from these specific comments on the National Physical Laboratory's report, it appears desirable to standardize what is meant by such terms as quartz plate, quartz crystal, quartz element, holder, quartz assembly, and many other terms. It is suggested therefore that this letter be published in the PROCEEDINGS and that it also be brought to the attention of the Chairman of the Standardizing Committee.

W. P. MASON  
G. W. WILLARD  
May 23, 1939

## Contributors

S. J. Begun was born in the free city of Danzig on December 2, 1905. He received his Master's degree in electrical engineering in 1929 from the Institute of Technology in Berlin, and in 1933 he received the Doctor's degree. During 1928-1929 he was with the Automatische Telephon, Berlin, where he designed circuits for automatic long-distance telephone systems; from 1929 to 1930 with Ferdinand Schuchhardt, working with magnetic, disk, and film sound-recording equipment; from 1930 to 1932 with the Echophon Maschinen working with development and sales of recording and dictating machines; from 1932 to 1935 with C. Lorenz, where he had charge of the Electro-Acoustic Laboratory and supervised production of technical specialties; from 1935 to 1937 as chief of the

Development Laboratory of Guided Radio where he developed emergency communication systems for ships; from 1937 to 1938, associated with Acoustic Consultants, where he did consulting work in connection with room acoustics, public-address systems, and other acoustic problems. Since 1938 Dr. Begun has been with the Brush Development Company supervising the design and production of magnetic disk systems.



Sidney Bertram (A'36) was born at Winnipeg, Canada, on July 7, 1913. He attended the Los Angeles City College from 1930 to 1933, and from 1934 to 1936 he was an instructor at the Radio Institute of California, leaving to enter the Cali-

fornia Institute of Technology where he received the B.S. degree in engineering with honor in June, 1938. Later Mr. Bertram was employed as a research engineer by the International Geophysics Company. In September, 1939, he entered the Ohio State University where he is now working towards his Ph.D. degree in electrical engineering. He is a member of Tau Beta Pi.



Ralph W. George (A'31) was born on July 19, 1905, at Jamestown, North Dakota. He received the B.S. degree in electrical engineering at Kansas State College in 1928. Since that date he has been with the field laboratories of R.C.A. Communications.



S. J. BEGUN



SIDNEY BERTRAM



RALPH W. GEORGE

Jacob Millman received the B.S. degree in physics from the Massachusetts Institute of Technology in 1932. A traveling Fellowship took him to the University of Munich for the following year. Dr. Millman was an assistant in physics for one semester in 1935-1936 at M.I.T. where he received the Ph.D. degree in physics in 1935. Since that time he has been an instructor in electrical engineering at The School of Technology of The College of the City of New York. In collaboration with Dr. Samuel Seely he has completed a textbook on Electronics which will be published in the summer of 1941. Dr. Millman is a member of the American Physical Society and the American Institute of Electrical Engineers.



Jesse B. Sherman (J'28-A'32) was born on February 8, 1910, at New York City. He received the B.S. degree in electrical engineering from Cooper Union Night School of Engineering in 1933; the B.S. degree in electrical engineering from New York University, Evening Engineering Division, 1935; and the M.E.E. degree from Polytechnic Institute of Brooklyn, 1938. Mr. Sherman was service manager of the Colen-Gruhn Company, Inc., from 1930 to 1935, and in the research and engineering department of the RCA Manufacturing Company, Inc., RCA Radiotron Division from 1935 to 1939. Since 1939 he has been an instructor in electrical engineering at The Cooper Union in New York City.



Karl S. Van Dyke (A'15-M'26) was born at Brooklyn, New York, on December 8, 1892. He received the B.S. degree in 1916 and the M.S. degree in 1917 from Wesleyan University, and the Ph.D. degree in 1921 from the University of Chicago. From 1916 to 1917 Dr. Van Dyke was an assistant in physics at Wesleyan University; 1917 to 1919 in the general engineering department of the American Telephone and Telegraph Company; 1919 to 1921, assistant in physics at the University of Chicago; 1921 to 1925, an assistant professor of physics at Wesleyan University; 1925 to 1928, associate professor; and 1928 to date, professor. He is a Fellow of the American Association for the Advancement of Science, and a Member of the American Physical Society, the Acoustical Society of America, and Sigma Xi.



JACOB MILLMAN

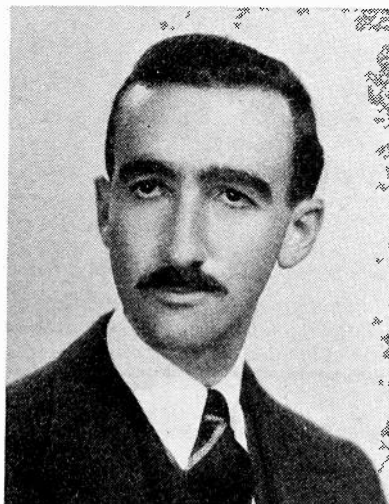

JESSE B. SHERMAN

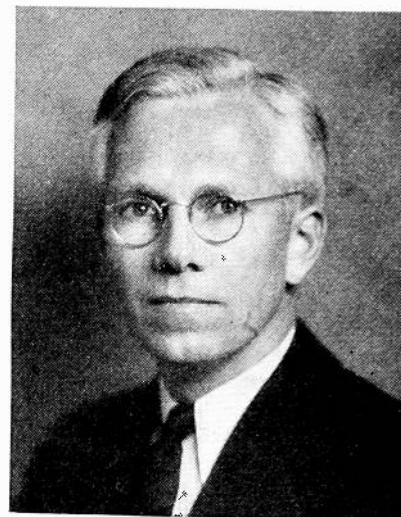

KARL S. VAN DYKE

# OUR PART IN NATIONAL DEFENSE

*THE BELL SYSTEM IS A NATION-WIDE  
TELEPHONE SYSTEM — READY TO SERVE  
THE UNITED STATES IN NORMAL TIMES  
OR EMERGENCY. IT HAS . . .*

1. The trained forces to operate telephone equipment and plant.
2. The trained staffs to direct these operations.
3. The latest motorized, mechanized telephone groups of great mobility which can concentrate anywhere quickly.
4. A dependable service of supply that reaches anywhere in the United States.
5. A source of supply—the Western Electric Company, devoted to telephone manufacture.
6. A great laboratory that brings the advance of science to bear on the improvement of telephony.



*Walter S. Gifford, President, American Telephone  
and Telegraph Company*

7. The financial strength to keep going and work ahead for the future.

Each is important. All are necessary for good telephone service from day to day and for the needs of national defense. It is the organization, the team-work, that counts. That means trained, experienced men and management, working together and planning ahead, so that the right material and the right "know how" will be at the right place at the right time.

*Walter S. Gifford*

THE BELL SYSTEM IS READY TO DO ITS PART IN THE NATION'S PROGRAM OF NATIONAL DEFENSE



# Frequency Modulation



## EXTENDED RANGE—HIGH FIDELITY

THERE is now available a complete family of special Jensen products for Frequency Modulation and Television receivers—as well as for monitoring and studio work. ¶ Illustrated below is the beautiful new Walnut "CA" type *Bass Reflex* cabinet—available in two sizes. One houses the new 12-inch PM extended range speaker. The other utilizes the new dual-unit 15-inch PM speaker complete with filter network. ¶ Below is also illustrated the "M" type *Bass Reflex* reproducer finished in brown lacquer—available with either the 8", 12" or 15" dual-unit extended range speaker. They are all extremely modestly priced. The three speakers are, of course, obtainable without the enclosures. The 15-inch dual-unit in Permanent Magnet design complete with filter network is only \$46.50 LIST. The 8" and 12" speakers show an extended high frequency response up to 10,000 cycles. The 15-inch dual-unit model is extended to 14,000 cps. ¶ Jensen Radio Mfg. Co., 6601 S. Laramie, Chicago.

Jensen  
*Bass Reflex*  
REPRODUCERS



*The*

**FIRST LINE OF**

**RESISTANCE**

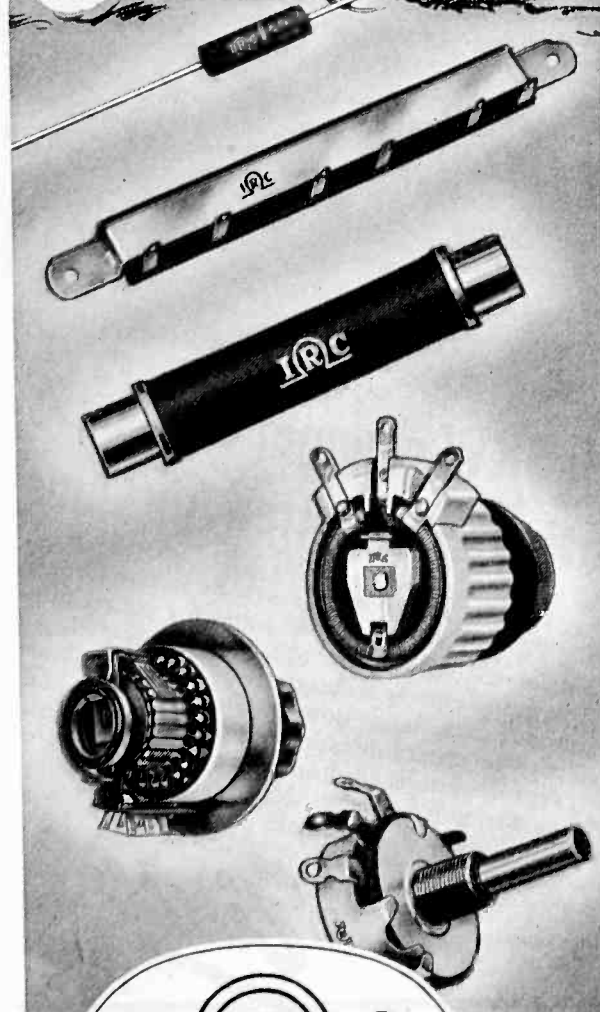
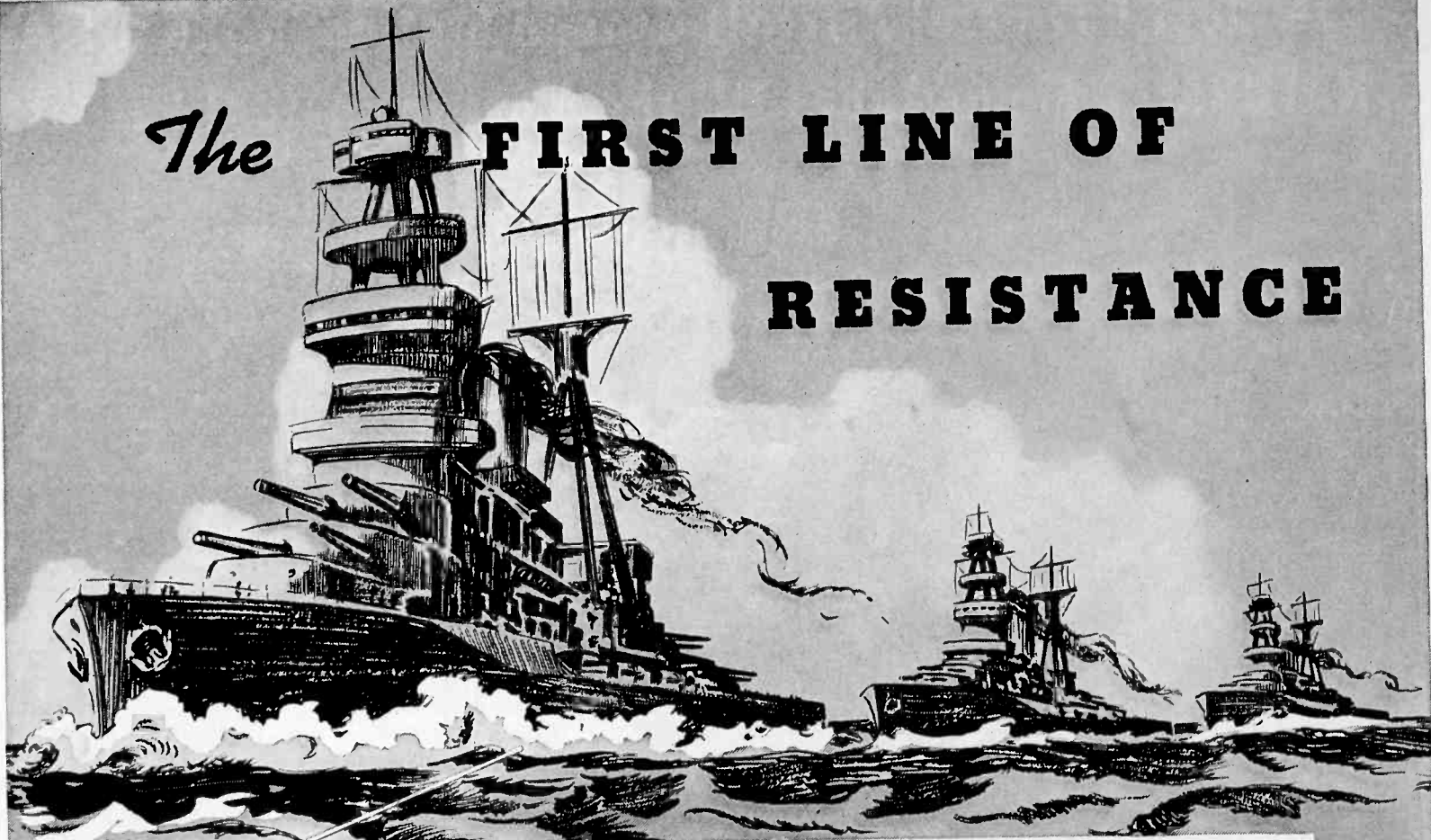

When the going gets tough outside, we come to appreciate the value of protection.

In the unpredictable times ahead, it is reassuring to be able to turn to an organization which has devoted its life to that job — which takes nothing for granted.

★ ★ ★

The Defense forces, as well as their contractors and hundreds of other industrial concerns, count us in their "first line". We know our job for we have made nothing but resistors for fifteen years.

If you want 50 million insulated resistors a year, or only one that will work at 100 megacycles; if you want standard volume controls by the thousand or only a few adapted to special specifications; if you want a "bleeder" resistor for 1,000,000 volts, climate-proofed wire wound resistors for dependable service under all conditions of use; or almost any other resistance shape, type or size called for in modern applications and in any quantity, look to IRC.



**MAKERS OF RESISTANCE UNITS OF MORE TYPES, IN MORE SHAPES, FOR MORE APPLICATIONS THAN ANY OTHER MANUFACTURER IN THE WORLD**

**INTERNATIONAL RESISTANCE COMPANY**

**431 North Broad Street, Philadelphia, Pa.**

# The Most Powerful Aircraft Ground Station in the U.S.A. NATURALLY Eimac Tubes Fill the Most Important Sockets

United Air Lines

TRANSPORT CORPORATION

IT PAYS TO FLY



Mr. P. C. Sandretto, Supt. of Communications for United Air Lines with Mr. Devereaux Martin of the Federal Telegraph Co. inspect one of the Eimac 450T tubes which is being installed

## 4 Eimac 450T tubes in each 5KW channel of 11 new multifrequency ground stations for United Air Lines

Another of the world's leading air transport corporations, The United Air Lines, with the considered judgment of its superintendent of communications, Mr. P. C. Sandretto, chooses Eimac tubes for its important ground stations. Proof again, the Eimac tubes offer more in dependability and performance. The fact becomes all the more potent when you consider that these new transmitters are the most powerful

aeronautical ground stations in the U.S.A. You'll insist on Eimac tubes for your equipment too, when you become fully acquainted with their many decided advantages. Learn more about these tubes now—write direct to the factory or communicate with the nearest Eimac representative. Find out how you can get better performance, greater dependability and longer tube life at less ultimate cost.

{ Above is the first of 11 new ground stations which are being built for the United Air Lines by the Federal Telegraph Company }

**Eimac**  
TUBES

**Eimac**  
**450T**

### EIMAC REPRESENTATIVES

California, Nevada  
HERB BECKER, 1530 W. 104th St., Los Angeles, Cal.  
Wash., Ore., Idaho, Mont.  
GENERAL SALES CO., Verner O. Jensen, 2605-07 Second Ave., Seattle, Wash.

Colo., Wyo., New Mexico, Arizona, Utah  
RICHARD A. HYDE, 4253 Quitman St., Denver, Colo.  
N. Caro., S. Caro., Georgia, Tenn., Flor., Ala., Miss.  
JAMES MILLAR, 316 Ninth St. N. E., Atlanta, Georgia.

N. Y., N. J., Penn., Md., Del., Dist. of Col., Maine, N. H., R. I., Conn., Mass.  
ADOLPH SCHWARTZ, 14726 Elm Ave., Flushing, New York.  
Texas, La., Okla., Ark.  
J. EARL SMITH, 2821 Live Oak St., Dallas, Texas.

Chicago, Illinois, Wisconsin  
G. G. RYAN, 549 W. Washington Blvd., Chicago, Ill.  
Ohio, Mich., Ky., Ind., Minn., Mo., Kan., Neb., Iowa  
PEEL SALES ENGINEERING CO., E. R. Peel, 154 E. Erie St., Chicago, Ill.

EITEL - McCULLOUGH, INC. • SAN BRUNO, CALIFORNIA



Special cylindrical low-loss glazed ceramic case providing long creepage path between terminals.

Designed to eliminate corona losses inside and outside alike, and also to provide uniform voltage gradient.

Cast-aluminum terminal ends provide low-contact resistance between units.

Sections of finest grade India ruby mica dielectric, made to very close tolerances in order to equalize loading of series-connected sections.

Cast-aluminum top and bottom terminals permit stacking and connecting in series, parallel and series-

parallel, providing all operating voltage ratings and capacity values.

Bolts may be slipped through holes of aluminum caps for secure electrical and mechanical connections. Units may be mounted horizontally or vertically to meet particular application problems.

Ceramic insulating containers are available as standoffs in supporting and insulating active units away from frame, and for isolating or separating active units in stack.

In five sizes; .00001 mfd. to .5 mfd., and from 1,000 to 35,000 test volts effective.

## STACK-MOUNTING HEAVY-DUTY *Mica Capacitors*



● Yes, the Aerovox line of Transmitting Capacitors includes these stack-mounting mica units for various transmitting applications such as grid, plate-blocking, coupling, tank, and by-pass functions.

Conservatively rated to withstand surge voltages above rated values. These capacitors have extremely low power factor so as to handle large kva loads without overheating. Vacuum-

impregnated sections are imbedded in low-loss filler which reduces stray-field losses and safeguards against moisture entrance. Mica stacks are rigidly clamped in low-loss non-magnetic clamps and heat-treated for maximum capacity-temperature stability.

Available in five standard sizes in capacities from .00001 to .5 mfd., and from 1000 to 35,000 test volts eff.

### *Transmitting Capacitor Catalog . . .*

● Full data covering these stack-mounting mica and other heavy-duty capacitors, sent on request to any designer, engineer or builder of radio or electronic equipment, writing on business letterhead. Submit capacitor problems for engineering aid, specifications, quotations.



**AEROVOX CORPORATION**  
*New Bedford, Mass.*

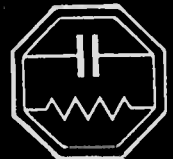

Sales Offices in All Principal Cities

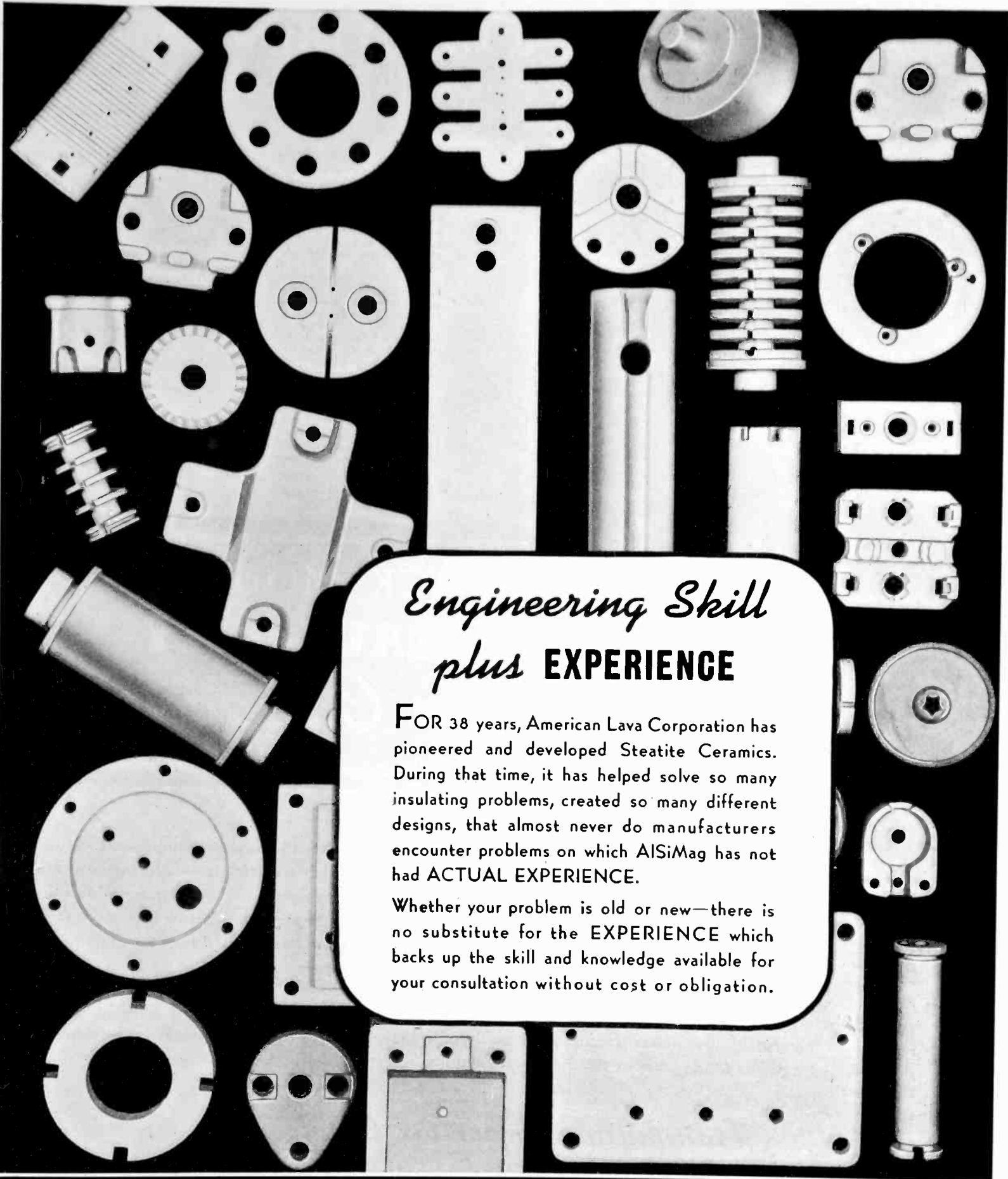

*Engineering Skill*  
*plus* **EXPERIENCE**

FOR 38 years, American Lava Corporation has pioneered and developed Steatite Ceramics. During that time, it has helped solve so many insulating problems, created so many different designs, that almost never do manufacturers encounter problems on which ALSiMag has not had ACTUAL EXPERIENCE.

Whether your problem is old or new—there is no substitute for the EXPERIENCE which backs up the skill and knowledge available for your consultation without cost or obligation.

**ALSiMAG**

Trade Mark Reg. U. S. Pat. Off.

**FROM CERAMIC HEADQUARTERS**

**AMERICAN LAVA CORPORATION • CHATTANOOGA • TENNESSEE**

CHICAGO • CLEVELAND • NEW YORK • ST. LOUIS • LOS ANGELES • SAN FRANCISCO • BOSTON • PHILADELPHIA • WASHINGTON, D. C.

# IRE membership offers many services to the radio engineer

**Proceedings**—An outstanding publication in the radio engineering field. Over a quarter of a century of service to the world in publishing important radio engineering discoveries and developments, the PROCEEDINGS presents exhaustive engineering data of use to the specialist and general engineer. A list of its authors is a "Who's Who" of the leaders in radio science, research, and engineering.

**Standards**—Since 1914 our standards reports have stabilized and clarified engineering language, mathematics, graphical presentations, and the testing and rating of equipment. They are always in the process of revision and thus remain up to date.

**Meetings**—In twenty-two cities in the United States and Canada, meetings of the Institute and its sections are held regularly. Scores of papers on practically every branch of the field are presented and discussed. Several convention meetings are sponsored by the Institute and add materially to its effectiveness in distributing data of value to engineers.

## The Institute of Radio Engineers

Incorporated

330 West 42nd Street, New York, N.Y.

To the Board of Directors  
Gentlemen:

I hereby make application for ASSOCIATE membership in the Institute of Radio Engineers on the basis of my training and professional experience given herewith, and refer to the sponsors named below who are personally familiar with my work.

I certify that the statements made in the record of my training and professional experience are correct, and agree if elected, that I shall be governed by the Constitution of the Institute as long as I continue a member. Furthermore I agree to promote the objects of the Institute so far as shall be in my power.

.....  
(Sign with pen)

.....  
(Address for mail)

.....  
(City and State)

.....  
(Date)

### SPONSORS

(Signatures not required here)

Mr. ....

Address .....

City and State .....

Mr. ....

Address .....

City and State .....

Mr. ....

Address .....

City and State .....

# Associate membership affiliates you with the Institute and brings you the PROCEEDINGS each month as well as notices of meetings held near you.

(Typewriting preferred in filling in this form) No.....

## RECORD OF TRAINING AND PROFESSIONAL EXPERIENCE

Name .....  
(Give full name, last name first)

Present Occupation .....  
(Title and name of concern)

Business Address .....

Home Address .....

Place of Birth ..... Date of Birth ..... Age .....

Education .....

Degree .....  
(College) (Date received)

### TRAINING AND PROFESSIONAL EXPERIENCE (Give dates and type of work, including details of present activities)

---

---

---

---

---

---

---

---

---

---

---

---

---

---

---

---

---

---

---

---

---

---

---

---

Record may be continued on other sheets this size if space is insufficient.

Receipt Acknowledged ..... Elected ..... Notified .....

Requirements—For Associate membership, an applicant must be at least twenty-one years of age, of good character, and be interested in or connected with the study or application of radio science or the radio arts.

Sponsors—Three sponsors who are familiar with the work of the applicant must be named. Preferably these should be Associates, Members, or Fellows of the Institute. In cases where the applicant is so located as not to be known to the required number of member sponsors, the names of responsible nonmember sponsors may be given.

Dues—Dues for Associate membership are six dollars per year. The entrance fee for this grade is three dollars and should accompany the application.

Other Grades—Those who are between the ages of eighteen and twenty-one may apply for Junior grade. Student membership is available to full-time students in engineering or science courses in colleges granting degrees as a result of four-year courses. Member grade is open to older engineers with several years of experience. Information on these grades may be obtained from the Institute.

---

# COMPLETE YOUR FILES OF

## PROCEEDINGS of The Institute of Radio Engineers

### WHILE BACK ISSUES ARE STILL AVAILABLE

Now is the time to fill out the gaps on your *Proceedings* shelf and replace lost or borrowed copies. Already, more than 25% of all back numbers are no longer available. Order from the following list (subject, of course, to prior sale) :

<b>1913-1915</b>	<b>Volumes 1-3</b>	<b>Quarterly</b>	<b>\$1.00 per copy</b>
1913 Vol. 1	Jan. (a reprint).	1915 Vol. 3	Dec.

<b>1916-1926</b>	<b>Volumes 4-14</b>	<b>Bi-monthly</b>	<b>\$1.00 per copy</b>
1916 Vol. 4	June, Aug.	1922 Vol. 10	All 6 issues
1917 Vol. 5	Apr., June, Aug., Oct., Dec.	1923 Vol. 11	All 6 issues
1918 Vol. 6	Feb., Apr., June, Aug., Dec.	1924 Vol. 12	Aug., Oct., Dec.
1919 Vol. 7	Apr., Dec.	1925 Vol. 13	Apr., June, Aug., Oct., Dec.
1920 Vol. 8	Apr., June, Aug., Oct., Dec.	1926 Vol. 14	All 6 issues
1921 Vol. 9	All 6 issues		

<b>1927-1940</b>	<b>Volumes 15-28</b>	<b>Monthly</b>	<b>\$1.00 per copy</b>
1927 Vol. 15	Apr. to July, inc., Oct., Dec.	1934 Vol. 22	All 12 issues
1928 Vol. 16	Feb. to Dec., inc.	1935 Vol. 23	All 12 issues
1929 Vol. 17	Apr. to June, inc., Aug., Dec.	1936 Vol. 24	Jan. to April, inc., June
1930 Vol. 18	Jan., Feb., Apr. to Dec., inc.	1937 Vol. 25	Feb. to Dec., inc.
1931 Vol. 19	All 12 issues	1938 Vol. 26	All 12 issues
1932 Vol. 20	Jan., March to Dec., inc.	1939 Vol. 27	All 12 issues
1933 Vol. 21	All 12 issues.	1940 Vol. 28	Jan. to date

#### I.R.E. MEMBERS . . . PUBLIC AND COLLEGE LIBRARIES

I.R.E. members in good standing are entitled to a discount of 25% from the above prices. Information about discounts to accredited public and college libraries will be supplied on request.

#### POSTAGE

Prices include postage in the United States and Canada. Postage to other countries: 10 cents per copy.

**Remittance should accompany your order**

**THE INSTITUTE OF RADIO ENGINEERS, Inc.**  
**330 WEST 42nd STREET, NEW YORK, N. Y.**

★

# HARDLY A HANDFUL

But Its OUTPUT  
Is 1800 Watts  
up to 150 MC!

★

And the air-cooled  
GL-8002-R  
puts out 1800 watts  
up to 120 MC.

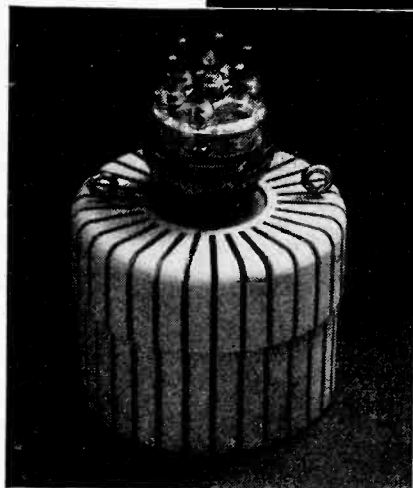

**B**UILT to speed the conquest of the ultra-highs, General Electric's latest are marvels of vacuum-tube design.

These tiny triodes lick many basic U-H-F design problems almost singlehanded! And they're top performers at lower frequencies as well.

Small in size, their leads are short. But, in addition—their three grid leads make possible separation of excitation and neutralizing circuits, lowering common inductance, and thereby *greatly reducing neutralizing difficulties*.

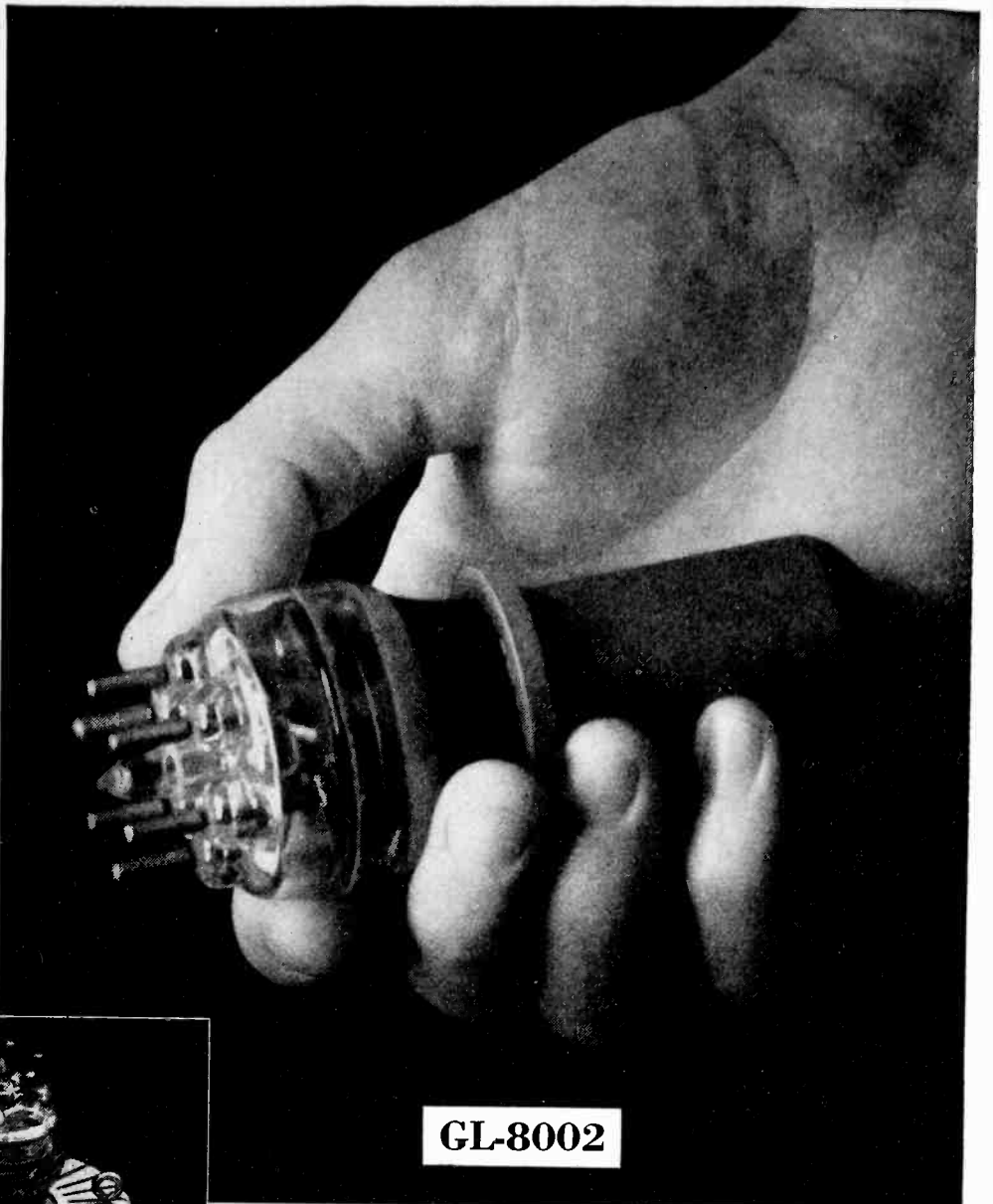

GL-8002

GL-8002-R's radiator is milled from solid copper. Air passages are of uniform width for more efficient cooling. Total height, including radiator, is 5 3/8 inches; total diameter, 3 11/16 inches.

**Characteristics—GL-8002 and GL-8002-R**

Fil Volts . . . . . 16	Mutual Conductance . . . . .
Fil Current . . . . . 39 amp	8850 mmhos
Direct Interelectrode Capacitances, Approx.:	Class C Telegraph Rating
Grid to plate . . . . . 9 mmf	Plate Volts . . . . . 3000
Grid to filament . . . . . 8 mmf	Plate Input, Watts . . . . . 3000
Plate to filament . . . . . 0.5 mmf	Plate Dissipation, Watts 1200
<b>GL-8002—\$180</b>	<b>GL-8002-R—\$250</b>

Use of center-tapped filaments permits paralleling of filament leads for low inductance r-f feed. Reduced ratings permit operation up to 200 mc air-cooled, 300 mc water-cooled.

Two GL-8002-R's are used in the final amplifiers of both the G-E 3-kw frequency-modulation transmitter and the G-E 1-kw television sound transmitter.

GL-8002 and GL-8002-R are "sister" tubes of the GL-880, GL-889, and GL-889-R—all developed and introduced by General Electric, Schenectady, N. Y.

**GENERAL**  **ELECTRIC**

161-11



# POSITIONS OPEN

The following positions of interest to I.R.E. members have been reported as open on October 15. Make your application in writing and address to the company mentioned or to

Box No. ....

**PROCEEDINGS of the I.R.E., 330 West 42nd Street, New York, N.Y.**

*Please be sure that the envelope carries your name and address*

## ENGINEER WITH WRITING ABILITY

Wanted—by large tube manufacturer—radio engineer with writing ability for commercial engineering activities. Tube and amateur radio experience desirable. State all qualifications, including writing and technical experience in detail, and salary desired. Replies will be held confidential. Box 219.

## TUBE AND CIRCUIT ENGINEERS WITH EDITORIAL EXPERIENCE

A well-known overseas manufacturer of tubes and radio equipment has openings in its New York office for 2 radio engineers with technical writing and editorial experience. One position requires an engineer with experience on circuits; the other an engineer familiar with tube manufacturing and customer application work. Applicants must be American citizens with engineering degrees and be capable of assuming responsibility. Present staff in the U.S.A. knows of these openings. Box 220.

## RADIO ENGINEER

A position is open for a good all-around versatile engineer with a B.S. degree in engineering. A young man is preferred; one who has taken advanced studies in

communications and who has had from 3 to 5 years of commercial experience of diversified design and development of special receivers, transmitters or precision equipment to meet government specifications. Applicants should be American born and have an agreeable personality, and be able to cooperate well. (This same manufacturer also wants to employ a draftsman, Box 222.) Box 221.

## RADIO DESIGN DRAFTSMAN

An equipment manufacturer wishes to obtain an experienced radio design draftsman who has either an electrical- or a mechanical-engineering degree and 3 to 5 years of commercial experience in drafting and design work on communication equipment. (This same manufacturer wants to employ a radio engineer, Box 221.) Box 222.

## TRANSMITTER ENGINEER

A transmitter engineer is required to assist in the design and construction of low-power, high-frequency transmitter. He should have had a considerable amount of experience, but a college degree is not essential. He must be an American citizen. Present staff knows of this opening. Box 223.

## RADIO AND MECHANICAL ENGINEERS

Engineers with two or more years radio design experience wanted. Apply stating education, experience and salary required. Colonial Radio Corporation, 254 Rano Street, Buffalo, N.Y.

## JUNIOR ENGINEER

An Eastern research and development organization has an opening for an engineering graduate with an aptitude in physics and mathematics. He should have sufficient drafting experience to enable him to prepare graphical presentations of engineering data. Box 224.

## BROADCAST RECEIVER ENGINEER

An experienced engineer is wanted to supervise the design and production of broadcast receivers and phonograph combinations in a small eastern organization. Box 225.

## CONDENSER-DESIGN ENGINEER

A manufacturer of components and special equipment has an opening for an engineer capable of assisting in the design of special variable air condensers. Box 226.

## POSITIONS OPEN, PREVIOUSLY ANNOUNCED

### INSPECTORS, NAVY RADIO MATERIALS

The Civil Service Commission is holding examinations for the positions of inspector and senior inspector of radio materials at salaries of \$2000 and \$2600 per year, respectively.

Further information regarding the examination is contained in the formal announcement, which with the proper application forms may be obtained from the Secretary of the Board of U. S. Civil Service Examiners at any first- or second-class post office, or from the U. S. Civil Service Commission, Washington, D.C.

### AUTO RADIO DESIGNERS

An established manufacturer needs men who have had experience with the electrical and mechanical design of automobile radio receivers. Experience is an essential prerequisite. Box 212.

### ELECTRO-MECHANICAL ENGINEER

Leading parts manufacturer has opening for electro-mechanical engineer with knowledge and experience in the design of attenuators for communication systems, and of other component parts. Position affords worthwhile opportunity. Give full details. All replies confidential. Our own organization knows of this advertisement. Box 213.

### DESIGN AND PRODUCTION ENGINEERS

Midwest plant wants several experienced men for design, development, and production engineering on transmitting and receiving apparatus. Experience on government equipment highly desirable. Box 214.

### RADIOSONDE TECHNICIANS

In connection with the National Defense Program the Civil Service Commission has announced an examination to secure radiosonde technicians for Government Service. The salary of the position is \$2000 a year.

Persons appointed will have responsibility for the installation, inspection, and maintenance of radiosonde ground equipment at new stations in Alaska, the continental United States, and the Caribbean area. Applicants will be rated on their experience as shown in their applications, and on corroborative evidence. While experience in the installation, maintenance and repair of radio equipment forms the greater part of the requirement, applicants must have had at least 6 months of experience in the installation, maintenance and repair of radiosonde ground receiving and recording equipment.

Further information regarding the examination is contained in the formal announcement, which with the proper application forms may be obtained from the Secretary of the Board of U. S. Civil Service Examiners at any first- or second-class post office, or from the U. S. Civil Service Commission, Washington, D.C.

### DESIGN ENGINEER

A long-established manufacturer of communication equipment has an opening in Chicago for a man with at least two years of direct design and development experience in the immediate past on automobile or aircraft receivers, including a comprehensive familiarity with design factors leading to production economy. This is an opportunity for a man who is

now employed directly as a designer, to enter a stable organization. This opening is known to associated employees. Box 215.

### INSPECTORS OF SIGNAL CORPS EQUIPMENT

Applications are being received and rated until further notice by the Civil Service Commission for the positions of Inspector, three grades, Signal Corps Equipment, salaries ranging from \$2000 to \$3200 a year. These examinations are announced for the Signal Corps, War Department, for duty in the field. Applicants must show 4 years of college study leading to a bachelor's degree in electrical or radio engineering. In addition, for the Senior Inspector and Inspector grades, they must have had experience in the inspection and/or testing of varied signal corps equipment, radio, telephone, telegraph, and power units, etc., to determine compliance with specification.

Application forms and information may be obtained from the Secretary, Board of U. S. Civil Service Examiners, at any first- or second-class post office, or from the Commission's Washington office.

### BROADCAST FIELD ENGINEER

An engineer with some experience in the broadcast field is wanted for field-strength measurements and other outside work by a firm of consulting engineers. He will be expected to work without detailed supervision. Box 217.

Attention  
Employers . . .



Announcements for "Positions Open" are accepted without charge from employers offering salaried employment of engineering grade to I.R.E. members. Please supply complete information and indicate which details should be treated as confidential. Address: "POSITIONS OPEN," Institute of Radio Engineers, 330 West 42nd Street, New York, N.Y.

The Institute reserves the right to refuse any announcement without giving a reason for the refusal

# BLILEY CRYSTALS



## HOLDERS OVENS

for . . .

**BROADCAST  
SERVICE**

for . . .

**GENERAL  
SERVICE**

for . . .

**HIGH AND  
ULTRA-HIGH  
FREQUENCIES**

for . . .

**FREQUENCY  
STANDARDS**

Catalog G-11 contains complete information.  
Ask for your copy.

**BLILEY ELECTRIC CO.**  
UNION STATION BUILDING ERIE, PA.

## DISPLAY ADVERTISERS

	<b>A</b>	
Aerovox Corporation . . . . .		v
American Lava Corporation . . . . .		vi
American Telephone & Telegraph Company . . . . .		i
	<b>B</b>	
Bliley Electric Company . . . . .		xii
	<b>C</b>	
Cornell-Dubilier Electric Corporation . . . . .		xiv
	<b>D</b>	
Daven Company . . . . .		xii
	<b>E</b>	
Eitel-McCullough, Inc. . . . .		iv
	<b>G</b>	
General Electric Company . . . . .		x
General Radio Company . . . . .		Cover IV
	<b>I</b>	
International Resistance Company . . . . .		iii
	<b>J</b>	
Jensen Radio Manufacturing Company . . . . .		ii
	<b>O</b>	
Ohmite Manufacturing Company . . . . .		xiii
	<b>R</b>	
RCA Manufacturing Company, Inc. . . . .		Cover III
	<b>T</b>	
Triplett Electrical Instrument Company . . . . .		xiii

## NEW TRANSMISSION MEASURING SET



The Type 6C Measuring Set provides an accurate and rapid method for measuring the transmission characteristics of networks at audio frequencies.

This new set has the following outstanding features which contribute to its usefulness in the radio broadcasting field.

- ★ **REFERENCE LEVEL:** New standard of 1 mw. in 600 ohms.
- ★ **METERS:** New Type 30 standards.
- ★ **ATTENUATION RANGE:** Zero to 110 db. in steps of 1 db.
- ★ **POWER RANGE:** Calibrated from -16 to +45 db.
- ★ **FREQUENCY RANGE:** 20 to 17,000 cycles.
- ★ **IMPEDANCES:** Dial selection of useful network input and load impedances.
- ★ **MISMATCH ADDITIONS:** No additions necessary for change of impedance.

**TYPE 6C TRANSMISSION MEASURING SET.. \$325.00**

Write for additional technical information.

**THE DAVEN COMPANY**  
158 SUMMIT STREET NEWARK, NEW JERSEY

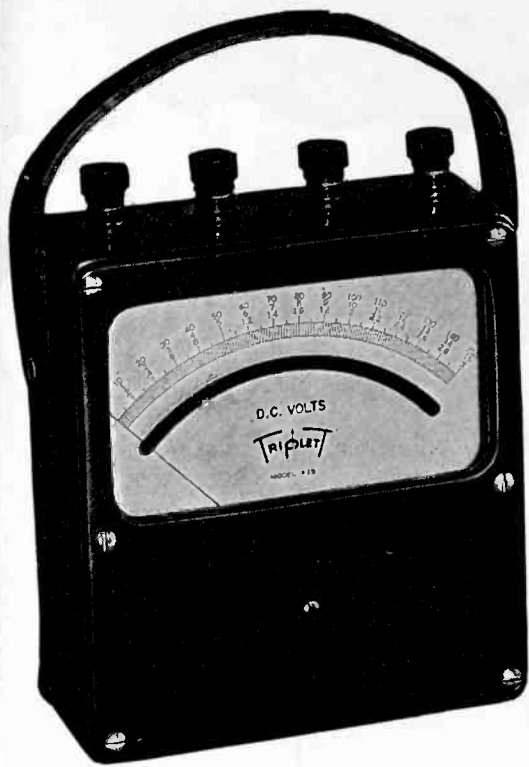

## NEW PRECISION PORTABLES



MODEL 625  
Clear Readability

Models 625 (DC—Moving Coil Type)—635 (AC—Movable Iron Vane Type) and 665 (Electrodynamometer Type)... new molded case portables, may be obtained with extreme sensitivity for laboratory use—as well as those for general commercial and industrial testing purposes. Have mirror scale and knife-edge pointer to assure quick, accurate readings. Scale length is 4.58"—Accuracy within 1%. Attractive black molded case, 6" x 5 1/2" x 2 1/2". Attached leather strap handle.

### MODEL 725

Model 725—Another popular line of portables includes Models 725 (DC)—735 (AC). This popular style has a precision instrument with long 6" mirror scale. Oak case is 11" x 9" x 4".

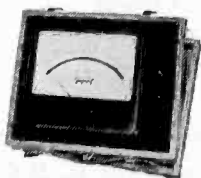

### MODEL 626

Model 626—Another of the new panel instrument case styles being added constantly to the Triplet line. This 6" rectangular molded case instrument offers unusually long readable scales—5.60" DC; 5.30" AC—One of Triplet's 25 case styles.

Write for Catalog—Section 219 Harmon Dr.

TRIPLET ELECTRICAL INSTRUMENT CO.  
Bluffton, Ohio

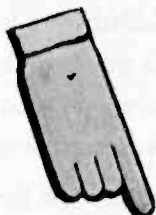

## A Wealth of Valuable Data on the Use of Resistors, Rheostats, Tap Switches, Chokes, Attenuators

*It's More Than A Catalog*—it's a complete handy reference on the use of resistors, rheostats, tap switches, chokes and attenuators in radio and electronic equipment—in the control of motor speed, of generator fields, of heat and light, of signal and supervisory circuits—in products and special applications—in instrument rooms, maintenance and production.

96 Pages full of helpful information—practical engineering data—manual of resistance measurements—handy reference tables and dimensional drawings—wide range of stock and special resistance units for Laboratory, Precision, R.F. and industrial applications.

*There's Nothing Like It!*—an invaluable guide packed full of tangible, useable data for engineers, production managers, and purchasing departments!

Clip this coupon to your company letterhead or write us on company stationery giving your name and position. Catalog 40 will be sent to you at once without charge.

★ Send Coupon Now!

OHMITE MANUFACTURING COMPANY  
4862 Flournoy Street, Chicago, U.S.A.  
Please Send Catalog 40. No obligation.

Company .....  
Individual .....  
Position .....  
Address .....  
City ..... State .....  
IRE September

Be Right with  
**OHMITE**

RHEOSTATS · RESISTORS · TAP SWITCHES

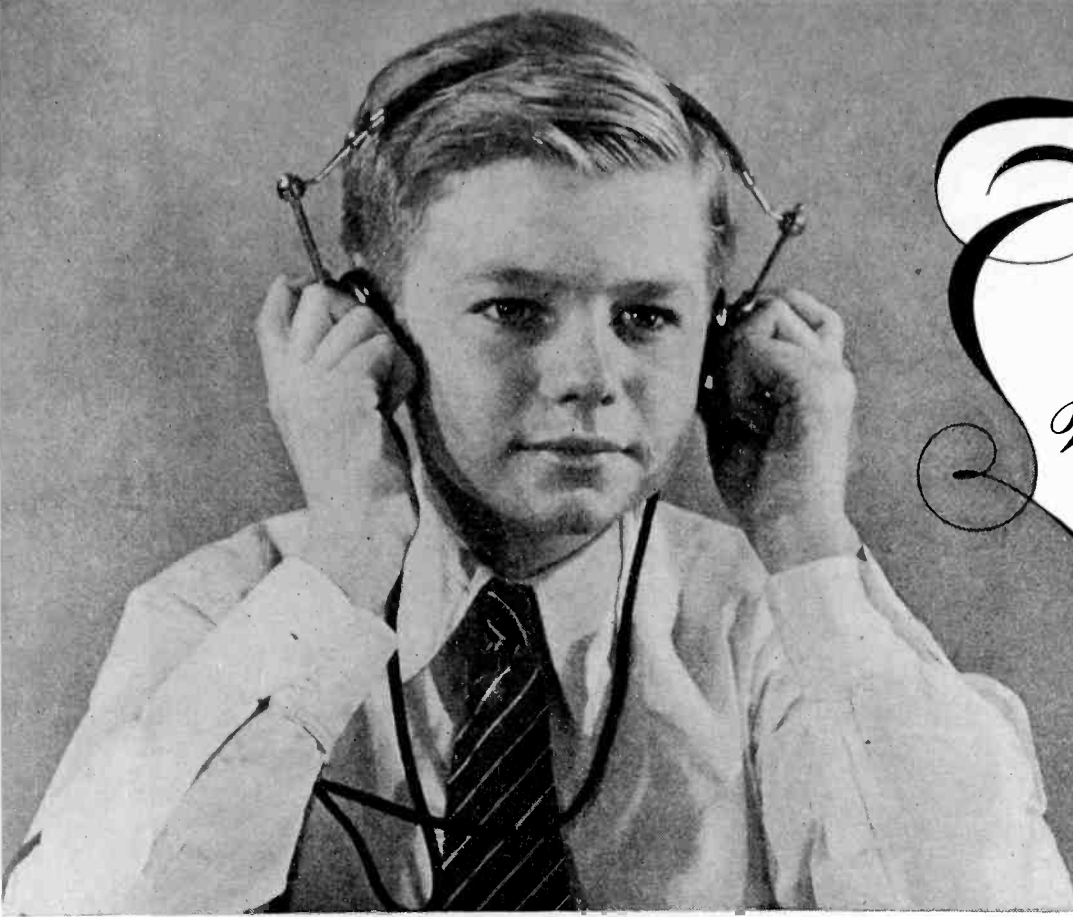

# RADIO,

*We knew you when...*

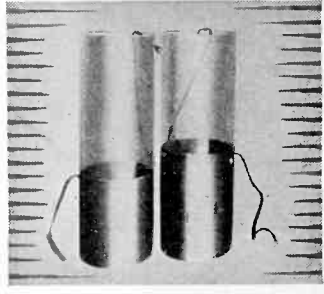

LEYDEN JAR

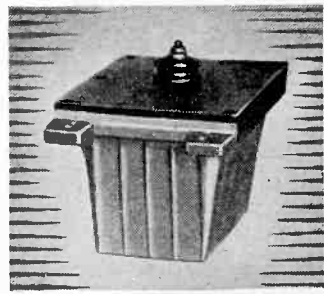

ORIGINAL  
DUBILIER  
TRANSMITTING  
CAPACITOR

**T**hose first crude efforts to communicate sound—we all do we remember. We had just developed the first transmitting capacitor, replacing the old cumbersome Leyden jar. And you, Radio, made it your own.

How quickly you grew, and how big. Each swiftly changing scene in your meteoric career brought new demands . . . demands undreamed a decade before. Yet, through it all, Cornell-Dubilier kept pace. In laboratories whose lights burned far into the night, our staff of researchers worked hand in hand with seasoned engineers exploring, developing, perfecting new capacitor types to meet your expanding broadcast requirements.

Yes, Radio, we kept the pace. Indeed, we have been ahead of you at times, anticipating your capacitor needs even before they had arisen. But it is not for this we pride ourselves. Rather, it is your unswerving loyalty to us over the trying years.

Early that confidence you displayed in the ability of Cornell-Dubilier to deliver became as a challenge to us. So have we cherished it. So did we, time and again because of it, redouble our efforts, check back, make certain that the C-D capacitor of the day possessed all of the dependability it was possible for the hand and brain of man to achieve.

So, Radio, we stand with you today, shoulder to shoulder, as a bright new dawn comes over the horizon—Television! And the courage of the pioneer that has served us for three dramatic decades, made of us the world's largest manufacturer of capacitors exclusively, will not fail us now. For Radio, we knew you when.



*Complete listing of Mica and Dykanol capacitors in all capacities—up to 100,000 volts rating.*

**CORNELL - DUBILIER ELECTRIC CORPORATION**  
1012 HAMILTON BOULEVARD • SOUTH PLAINFIELD, N. J.

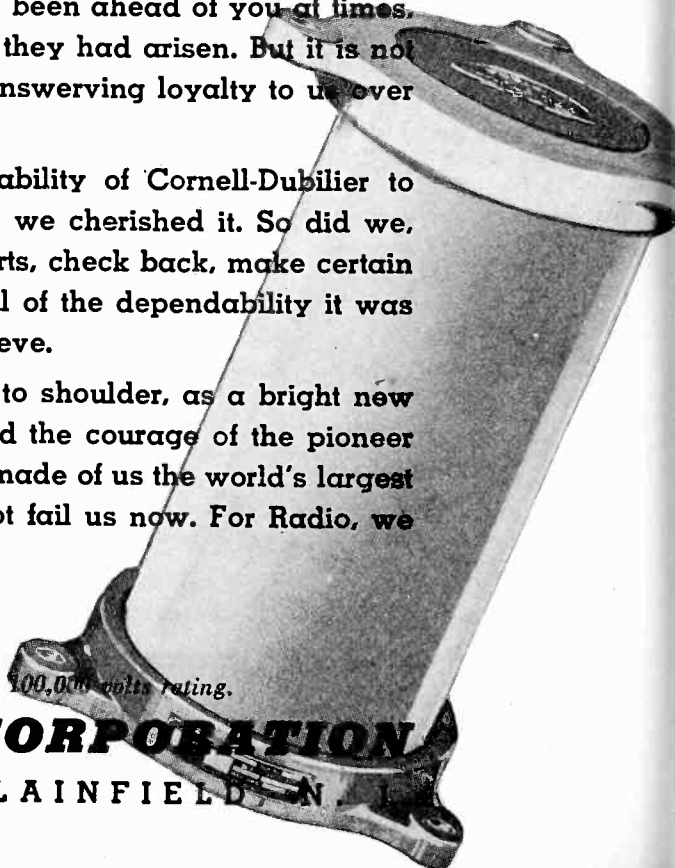

# 5,000,000 SETS *this year*

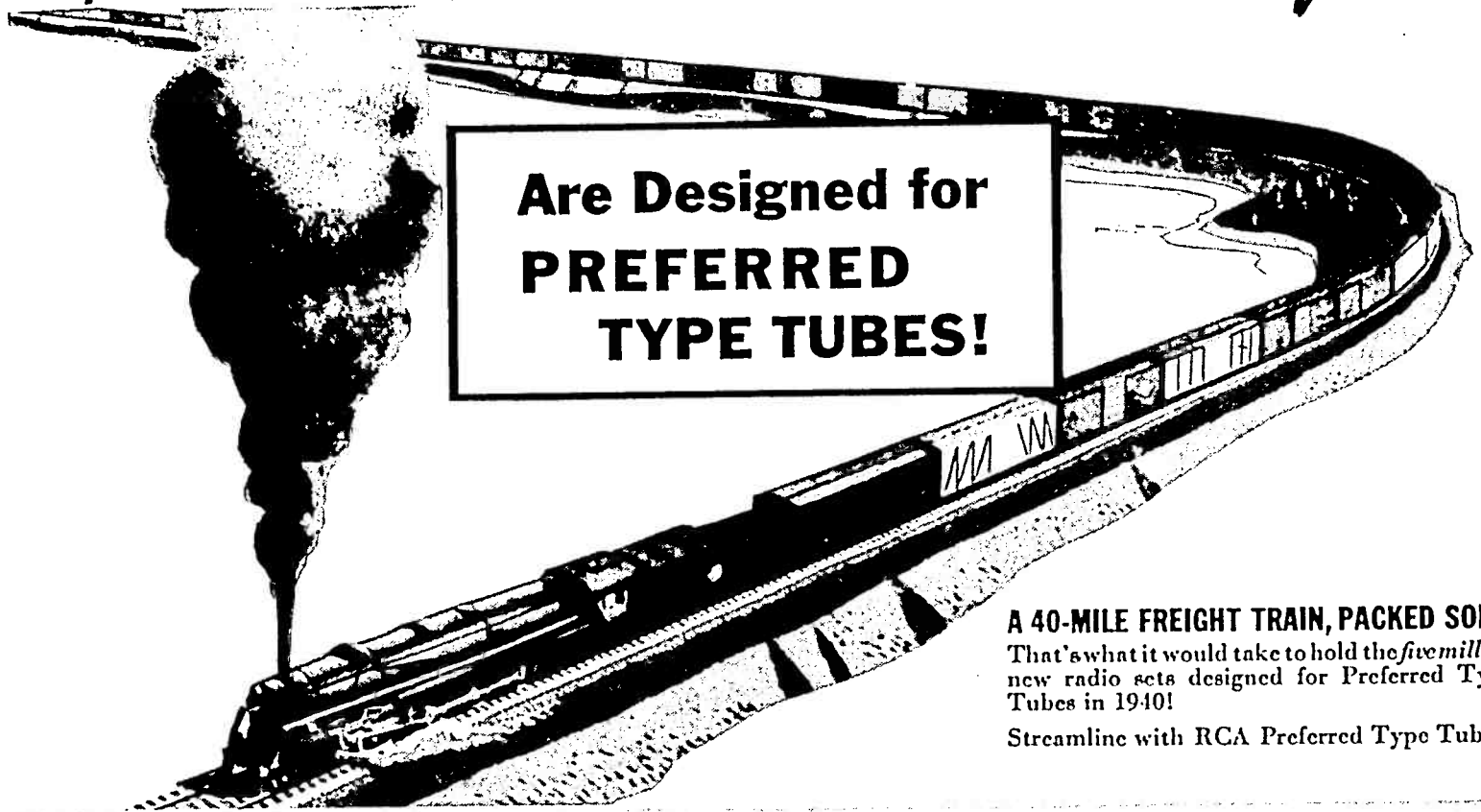

Are Designed for  
**PREFERRED  
TYPE TUBES!**

**A 40-MILE FREIGHT TRAIN, PACKED SOLID**  
That's what it would take to hold the *five million* new radio sets designed for Preferred Type Tubes in 1940!

Streamline with RCA Preferred Type Tubes!

## **WHO** Prefers "Preferred Type Tubes" . . . ?

17 Manufacturers of radio receivers in addition to RCA Victor have publicly endorsed the RCA Preferred Type Tubes Program. 17 Manufacturers in addition to RCA Victor *are engineering their current models* around Preferred Type Tubes! Almost 5 million sets coming off the production lines this year will use Preferred Type Tubes—approximately half the industry's entire output!

## **HOW** Has This Acceptance Taken Hold . . . ?

When the Program was first announced, only 32% of all RCA Tubes taken by manufacturers for new equipment were Preferred Types. By April, 1940, this percentage had spurted to better than 78%. Today, it is around the 90% mark!

## **WHY** Has Such Backing Been Given . . . ?

Manufacturers were quick to agree that inventories could be simplified; warehousing costs lowered; deliveries speeded; and better, more uniform tubes turned out at lower costs, with *fewer* tube types in use. With *preferred* types, manufacturers can now design and build practically any type of radio receiver for best performance at lowest overall cost!

## **WHEN** Will The Industry Benefit . . . ?

These manufacturers are benefiting *today*. They have found that the Preferred Type Tubes Program performs as promised! And as this year's 5,000,000 sets built around the program go into use, the *replacement* tube market will improve equally. Distributors, dealers and servicemen will all find that increased turnover of fewer, faster-moving types means more profitable business . . . better tubes *and* better service to consumers!



*Preferred  
Type Tubes*

RCA Manufacturing Co., Inc., Camden, N. J.  
A Service of Radio Corporation of America

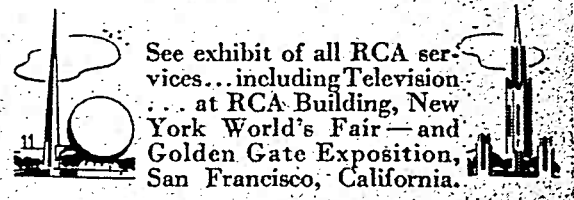

C.N.Y.W.F.

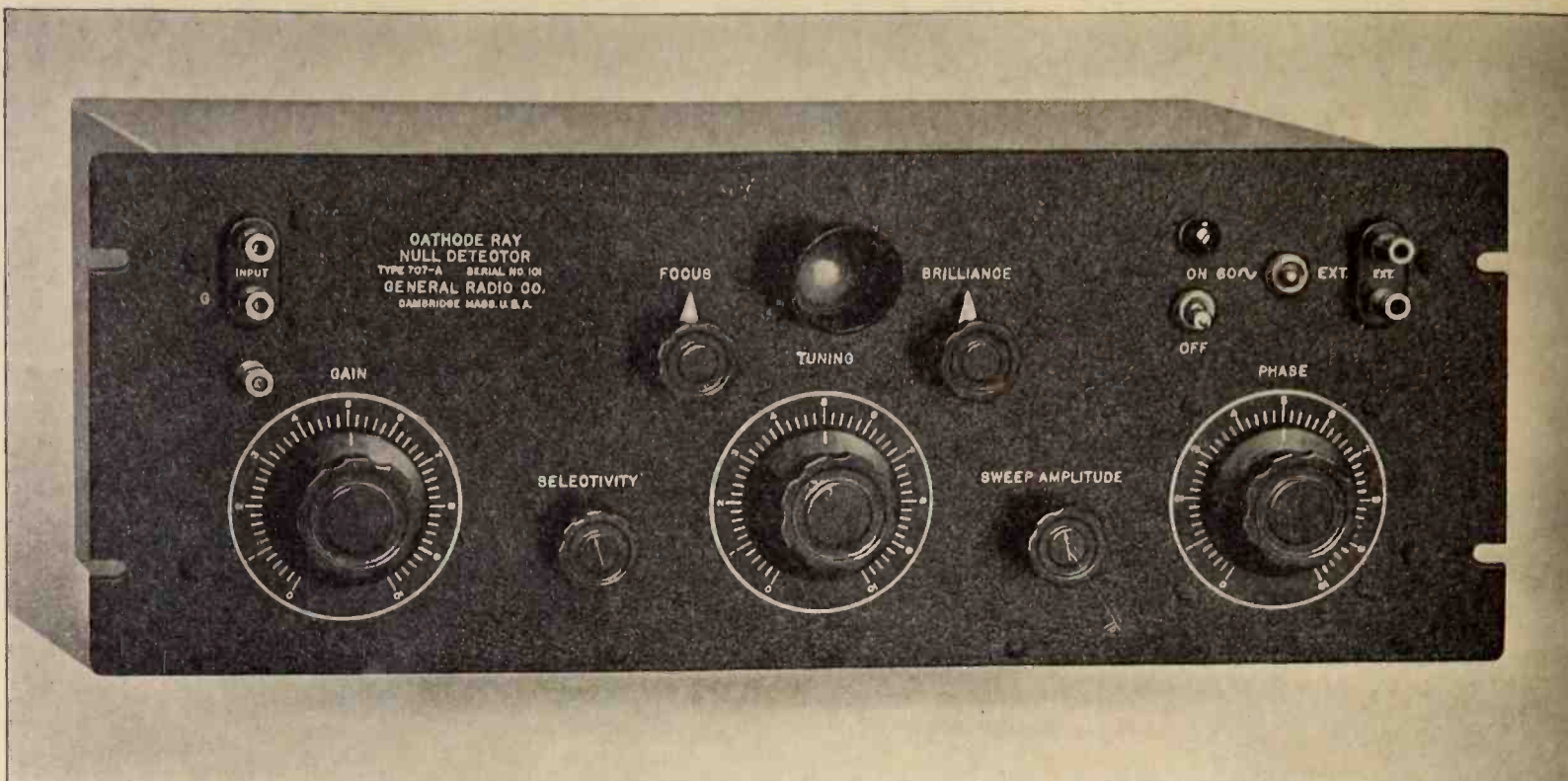

# IMPROVED NULL DETECTOR

for a-c Impedance Bridges

SENSITIVE • RUGGED • CONVENIENT TO OPERATE

**T**HE G-R TYPE 707-A NULL DETECTOR uses a one-inch cathode-ray tube in a non-inductive degenerative amplifier circuit, with tuning and phasing networks and sweep and sensitivity controls. As a null detector on any a-c impedance bridge its advantages over former types of detectors are numerous and include:

- |   |   |
|---|---|
| <p>1—Operation in noisy locations</p> <p>2—Not affected by strong fields</p> <p>3—May be used at all frequencies up to 20 kilocycles</p> <p>4—Separately indicates balance of the resistive and reactive components</p> <p>5—Makes possible precise balancing of either component with only moderately close balance of the other</p> <p>6—Precise measurement of the steady component can be made while the other varies erratically</p> | <p>7—Shows immediately any drift of either or both components</p> <p>8—Provides positive indication of the direction of off-balance for either component as selected</p> <p>9—Can be calibrated to show the degree of unbalance</p> <p>10—Can be used at all times at maximum sensitivity, even with the bridge far off balance</p> <p>11—Supplies instantaneous response</p> <p>12—Will withstand any overload caused by marked off-balance and is instantaneous in recovery</p> |
|---|---|

The input impedance of the detector is one megohm. Its sensitivity is 100 microvolts at 60 cycles and 200 to 300 microvolts at 1,000 cycles. Its selectivity is 40 db against the second harmonic. Plug-in units tune the amplifier to any operating frequency desired between 20 and 2,000 cycles with a continuous tuning range of  $\pm 5\%$  for each unit.

*Type 707-A Cathode-Ray Null Indicator* ..... \$195.00

*Write for Bulletin 647 for complete information*

**GENERAL RADIO COMPANY**

*Cambridge, Massachusetts*

BRANCHES: NEW YORK • LOS ANGELES

**MANUFACTURERS OF PRECISION ELECTRICAL LABORATORY APPARATUS**

