

Proceedings

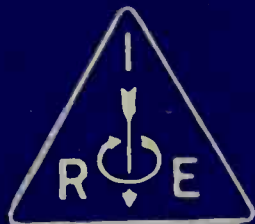

of the

I · R · E

JULY

1940

VOLUME 28

NUMBER 7

Field-Strength at 52.75 Mc

Acoustics in Studios

Troposphere and Radio Waves

Transversal Filters

Impedance Measurements at 30 Mc

Focus of Electron Beams

Electron Tubes at High-Frequencies

Ionspheric Characteristics

Institute of Radio Engineers



Rochester Fall Meeting

Rochester, N. Y., November 11, 12, and 13, 1940

16th Annual Convention

New York, N.Y., January 9, 10, and 11, 1941

New York Meeting—October 2, 1940

SECTION MEETINGS

DETROIT

September 20
October 18

PITTSBURGH

September 9
October 7

LOS ANGELES

September 17
October 15

WASHINGTON

September 9
October 7

ATLANTA

September 20
October 18

CLEVELAND

September 26
October 24

PHILADELPHIA

October 3

SECTIONS

ATLANTA—Chairman, P. C. Bangs; Secretary, Adolph Andersen, Federal Communications Commission, 411 Federal Annex, Atlanta, Ga.

BALTIMORE—Chairman, C. A. Allert; Secretary, Alexander Whitney, 105 Shady Nook Ct., Catonsville, Md.

BOSTON—Chairman, W. L. Barrow; Secretary, P. K. McElroy, General Radio Co., 30 State St., Cambridge, Mass.

BUENOS AIRES—Chairman, A. M. Stevens; Secretary, E. E. Kapus, Bolivar 1743, Buenos Aires, Argentina.

BUFFALO-NIAGARA—Chairman, B. E. Atwood; Secretary, Leroy Fiedler, 98 West Ave., Lockport, N. Y.

CHICAGO—Chairman, E. H. Kohler; Secretary, P. C. Sandretto, United Air Lines Transport Co., 5936 S. Cicero Ave., Chicago, Ill.

CINCINNATI—Chairman, C. H. Topmiller; Secretary, W. L. Schwesinger, WSAI, Cincinnati, Ohio.

CLEVELAND—Chairman, R. L. Kline; Secretary, J. D. Woodward, WGAR, Hotel Statler, Cleveland, Ohio.

CONNECTICUT VALLEY—Chairman, R. N. Ferry; Secretary, W. M. Smith, 250 Main St., Suffield, Conn.

DETROIT—Chairman, J. D. Kraus; Secretary, Paul Frincke, WJBK, 6559 Hamilton Ave., Detroit, Mich.

EMPORIUM—Chairman, C. R. Smith; Secretary, H. L. Ratchford, Hygrade Sylvania Corp., Emporium, Pa.

INDIANAPOLIS—Chairman, Arthur Curtis; Secretary, B. V. K. French, P. R. Mallory & Co., E. Washington St. Indianapolis, Ind.

LOS ANGELES—Chairman, A. C. Packard; Secretary, J. N. A. Hawkins, 3239 Laclede Ave., Los Angeles, Calif.

MONTREAL—Chairman, A. B. Oxley; Secretary, W. A. Nichols, Canadian Broadcasting Corp., 1012 Keefer Bldg., Montreal, Que.

NEW ORLEANS—Chairman, G. H. Peirce; Secretary, D. W. Bowman, 8327 Sycamore St., New Orleans, La.

PHILADELPHIA—Chairman, C. M. Burrill; Secretary, R. L. Snyder, 103 Franklin Rd., Glassboro, N. J.

PITTSBURGH—Chairman, R. E. Stark; Secretary, M. G. Jarrett, Bell Telephone Company of Pennsylvania, Pittsburgh, Penna.

PORTLAND—Chairman, Marcus O'Day; Secretary, Earl Schoenfeld, 1627 S. E. Elliott Ave., Portland, Ore.

ROCHESTER—Chairman, H. C. Sheve; Secretary, O. L. Angevine, Jr., Stromberg-Carlson Telephone Manufacturing Co., Rochester, N. Y.

SAN FRANCISCO—Chairman, Carl Penther; Secretary, H. E. Held, 420 Market St., San Francisco, Calif.

SEATTLE—Chairman, R. M. Walker; Secretary, L. B. Cochran, University of Washington, Seattle, Wash.

TORONTO—Chairman, G. J. Irwin; Secretary, N. Potter, Canadian National Carbon Co., Ltd., 805 Davenport Rd., Toronto, Ont.

WASHINGTON—Chairman, L. C. Young; Secretary, E. M. Webster, Federal Communications Commission, Rm. 5319, New Post Office Bldg., Washington, D. C.

BOARD OF DIRECTORS
 Lawrence C. F. Horle, *President*
 Frederick E. Terman,
Vice President
 Melville Eastham, *Treasurer*
 Harold P. Westman, *Secretary*
 Austin Bailey
 W. R. G. Baker
 Frederick W. Cunningham
 Henry C. Forbes
 Alfred N. Goldsmith
 Virgil M. Graham
 O. B. Hanson
 Raymond A. Heising
 C. M. Jansky, Jr.
 Frederick R. Lack
 Frederick B. Llewellyn
 Haraden Pratt
 Browder J. Thompson
 Hubert M. Turner
 Arthur F. Van Dyck
 Harold A. Wheeler
 Lynde P. Wheeler

BOARD OF EDITORS
 Alfred N. Goldsmith, *Chairman*
 Ralph R. Batcher
 Philip S. Carter
 Elmer W. Engstrom
 Frederick W. Grover
 J. Warren Horton
 Greenleaf W. Pickard
 Benjamin E. Shackelford
 Karl S. Van Dyke
 Harold P. Westman, *ex officio*
 Harold A. Wheeler
 Lynde P. Wheeler
 Laurens E. Whittemore
 William Wilson

PAPERS COMMITTEE
 William Wilson, *Chairman*
 Frederick B. Llewellyn,
Vice Chairman
 Herman A. Affel
 Edmond Bruce
 Howard A. Chinn
 James K. Clapp
 Tunis A. M. Craven
 Robert B. Dome
 Paul O. Farnham
 Enoch B. Ferrell
 Elmer L. Hall
 Dorman D. Israel
 Loren F. Jones
 De Loss K. Martin
 Harry B. Marvin
 Harry R. Mimno
 Albert F. Murray
 Harold O. Peterson
 Ralph K. Potter
 Hubert M. Turner
 Dayton Ulrey
 Arthur F. Van Dyck
 Paul T. Weeks
 William C. White
 Irving Wolf

Helen M. Stote, *Assistant Editor*
 John D. Crawford,
Advertising Manager

Proceedings

of the I·R·E

Published Monthly by

The Institute of Radio Engineers, Inc.

VOLUME 28

July, 1940

NUMBER 7

Field-Strength Survey, 52.75 Megacycles from Empire State Building	G. S. Wickizer	291
Acoustics in Studios	M. Rettinger	296
The Troposphere and Radio Waves	R. C. Colwell	299
Transversal Filters	Heinz E. Kallmann	302
The Twin-T—A New Type of Null Instrument for Measuring Impedance at Frequencies up to 30 Megacycles	D. B. Sinclair	310
Space-Charge Limitations on the Focus of Electron Beams	B. J. Thompson and L. B. Headrick	318
The Operation of Electron Tubes at High Frequencies	H. Rothe	325
Characteristics of the Ionosphere at Washington, D. C., May, 1940, with Predictions for August, 1940	T. R. Gilliland, S. S. Kirby, and N. Smith	332
Characteristics of the Ionosphere at Washington, D. C., June, 1940, with Predictions for September, 1940		334
Institute News and Radio Notes		336
Board of Directors		336
Committees		337
Membership		340
Books		340
"Static and Dynamic Electricity," by William R. Smythe	L. P. Wheeler	
"Funktechnische Formelsammlung," by Otto Schmid and Max Leithiger	L. P. Wheeler	
"Antennen, Ihre Theorie und Technik," by H. Brückmann	L. P. Wheeler	
"Fundamentals of Electricity and Electromagnetism," by Vernon A. Suydam	H. M. Turner	
Contributors		342

Entered as second-class matter October 26, 1927, at the post office at Menasha, Wisconsin, under the Act of February 28, 1925, embodied in Paragraph 4, Section 412 of the Postal Laws and Regulations. Publication office, 450 Ahnaip Street Menasha, Wisconsin. Subscription, \$10.00 per year; foreign, \$11.00.

THE INSTITUTE

The Institute of Radio Engineers serves those interested in radio and allied electrical-communication fields through the presentation and publication of technical material. In 1913 the first issue of the PROCEEDINGS appeared; it has been published uninterruptedly since then. Over 1800 technical papers have been included in its pages and portray a currently written history of developments in both theory and practice.

STANDARDS

In addition to the publication of submitted papers, many thousands of man-hours have been devoted to the preparation of standards useful to engineers. These comprise the general fields of terminology, graphical and literal symbols, and methods of testing and rating apparatus. Members received a copy of each report. A list of the current issues of these reports follows:

Standards on Electroacoustics, 1938
Standards on Electronics, 1938
Standards on Radio Receivers, 1938
Standards on Radio Transmitters and Antennas, 1938.

MEETINGS

Meetings at which technical papers are presented are held in the twenty-three cities in the United States, Canada, and Argentina listed on the inside front cover of this issue. A number of special meetings are held annually and include one in Washington, D. C., in co-operation with the American Section of the International Scientific Radio Union (U.R.S.I.) in April, which is devoted to the general problems of wave propagation and measurement technique, the Rochester Fall Meeting in co-operation with the Radio Manufacturers Association in November, which is devoted chiefly to the problems of broadcast-receiver design, the Pacific Coast Convention, which is held each year during the summer months and is supervised by a joint committee of our four Pacific Coast sections, and the Annual Convention, which will be held in New York City during January.

MEMBERSHIP

Membership has grown from a few dozen in 1912 to more than five thousand. Practically every country in the world in which radio engineers may be found is represented in our membership roster. Approximately a quarter of the membership is located outside of the United States. There are several grades of membership, depending on the qualifications of the applicant. Dues range between \$3.00 per year for Students and \$10.00 per year for Members. PROCEEDINGS are sent to each member without further payment.

PROCEEDINGS

The contents of each paper published in the PROCEEDINGS are the responsibility of the author and are not binding on the Institute or its members. Material appearing in the PROCEEDINGS may be reprinted or abstracted in other publications on the express condition that specific reference shall be made to its original appearance in the PROCEEDINGS. Illustrations of any variety may not be reproduced, however, without specific permission from the Institute.

Papers submitted to the Institute for publication shall be regarded as no longer confidential. They will be examined by the Papers Committee and Board of Editors to determine their suitability for publication. Suggestions on the mechanical form in which manuscripts should be prepared may be obtained from the Secretary.

SUBSCRIPTIONS

Annual subscription rates for the United States of America, its possessions, and Canada, \$10.00; to college and public libraries when ordering direct, \$5.00. Other countries, \$1.00 additional.

The Institute of Radio Engineers, Inc.

Harold P. Westman, Secretary

330 West 42nd Street

New York, N.Y.



Copyright 1940 by The Institute of Radio Engineers Inc.



Field-Strength Survey, 52.75 Megacycles from Empire State Building*

G. S. WICKIZER†, ASSOCIATE, I.R.E.

Summary—This paper outlines the results of a field-strength survey which was conducted on the audio-frequency channel of the National Broadcasting Company television transmitter, operating on a frequency of 52.75 megacycles. The test transmissions were horizontally polarized. Continuous mobile recordings were made over land in a number of directions along radials from the transmitter out to the limit of the receiver sensitivity, which was reached at a distance of 70 or 80 miles, at a field strength of about 10 microvolts per meter.

From the recorded data, coverage maps based on average field strength were drawn. The maps are supplemented by graphs showing the deviation to be expected because of irregular terrain and refraction effects at the greater distances. In general, local variations of 20 decibels in field strength were caused by irregular terrain, buildings, and other objects.

THE recent trend toward the use of ultra-high frequencies for various types of broadcast service has increased the importance of field-strength measurements on these frequencies. Field-strength surveys at the lower frequencies have been made by a combination of calculation and measurement, with satisfactory results. At the ultra-high frequencies, however, greater dependence must be placed on measurement, since variations caused by local objects are not readily calculated.

A number of papers have been published on the subject of ultra-high-frequency propagation between two terminals, or between a transmitter and a number of points located along a line away from the transmitter.¹⁻⁵ In studying the variation of field strength with distance, if measurements are made at fixed points, a great number of observations are necessary to average out the wide local variations. It appears then that a continuous record of field strength versus distance is desirable to insure sufficient data being taken. This fact has been recognized, and the method has been described in a paper by Burrows, Hunt, and Decino,⁶ and a number of examples of mobile recording have been published in a paper by Englund, Crawford, and Mumford.³ The present paper describes a comprehensive field-strength survey conducted in this

manner, on a frequency of 52.75 megacycles, with the transmitting antenna located on top of the Empire State Building, in New York City.

The receiving equipment, with power supplies and antenna, was installed in a 1937 Plymouth, two-door sedan. Suitable precautions were taken to prevent mechanical vibration of the equipment when the car was in motion.

The receiving antenna was a short doublet made of two pieces of $\frac{5}{8}$ -inch diameter, duralumin tubing, supported at a height of 10 feet above the ground. The



Fig. 1—Mobile field-strength survey car.

tubing was clamped in a bakelite head, which was attached to a wooden shaft about 4 feet long. This shaft was mounted on the roof of the car by a mechanical assembly which extended through the roof, behind the rear seat. The mechanical fitting on the car was constructed to permit rotation about a vertical axis, and also to allow the antenna to be folded down against the roof when not in use. A small steering wheel and indicator were provided inside the car to assist in setting the bearing of the antenna when receiving horizontal polarization. A picture of the survey car is shown in Fig. 1.

The receiver was a triple-detection superheterodyne, equipped with automatic gain control to compress the wide range of field strength to be measured. The direct-current output of the receiver diode detector

* Decimal classification: R 270. Original manuscript received by the Institute, March 15, 1940. Presented, joint I.R.E.-U.R.S.I. meeting, Washington, D. C., April 28, 1939.

† R.C.A. Communications, Inc., Riverhead, L. I., N. Y.

¹ Bertram Trevor and P. S. Carter, "Notes on propagation of waves below ten meters in length," *Proc. I.R.E.*, vol. 21, pp. 387-426; March, 1933.

² J. C. Schelleng, C. R. Burrows, and E. B. Ferrell, "Ultra-short-wave propagation," *Proc. I.R.E.*, vol. 21, pp. 427-463; March, 1933.

³ Carl R. Englund, A. B. Crawford, and W. W. Mumford, "Some results of a study of ultra-short-wave transmission phenomena," *Proc. I.R.E.*, vol. 21, pp. 464-492; March, 1933.

⁴ Charles R. Burrows, Alfred Decino, and Loyd Hunt, "Ultra-short-wave propagation over land," *Proc. I.R.E.*, vol. 23, pp. 1507-1535; December, 1935.

⁵ H. H. Beverage, "Some notes on ultra-high-frequency propagation," *RCA Rev.*, vol. 1, pp. 76-87; January, 1937.

⁶ C. R. Burrows, L. E. Hunt, and A. Decino, "Mobile urban ultra-short-wave transmission characteristics," *Elec. Eng.*, vol. 54, pp. 115-124; January, 1935.

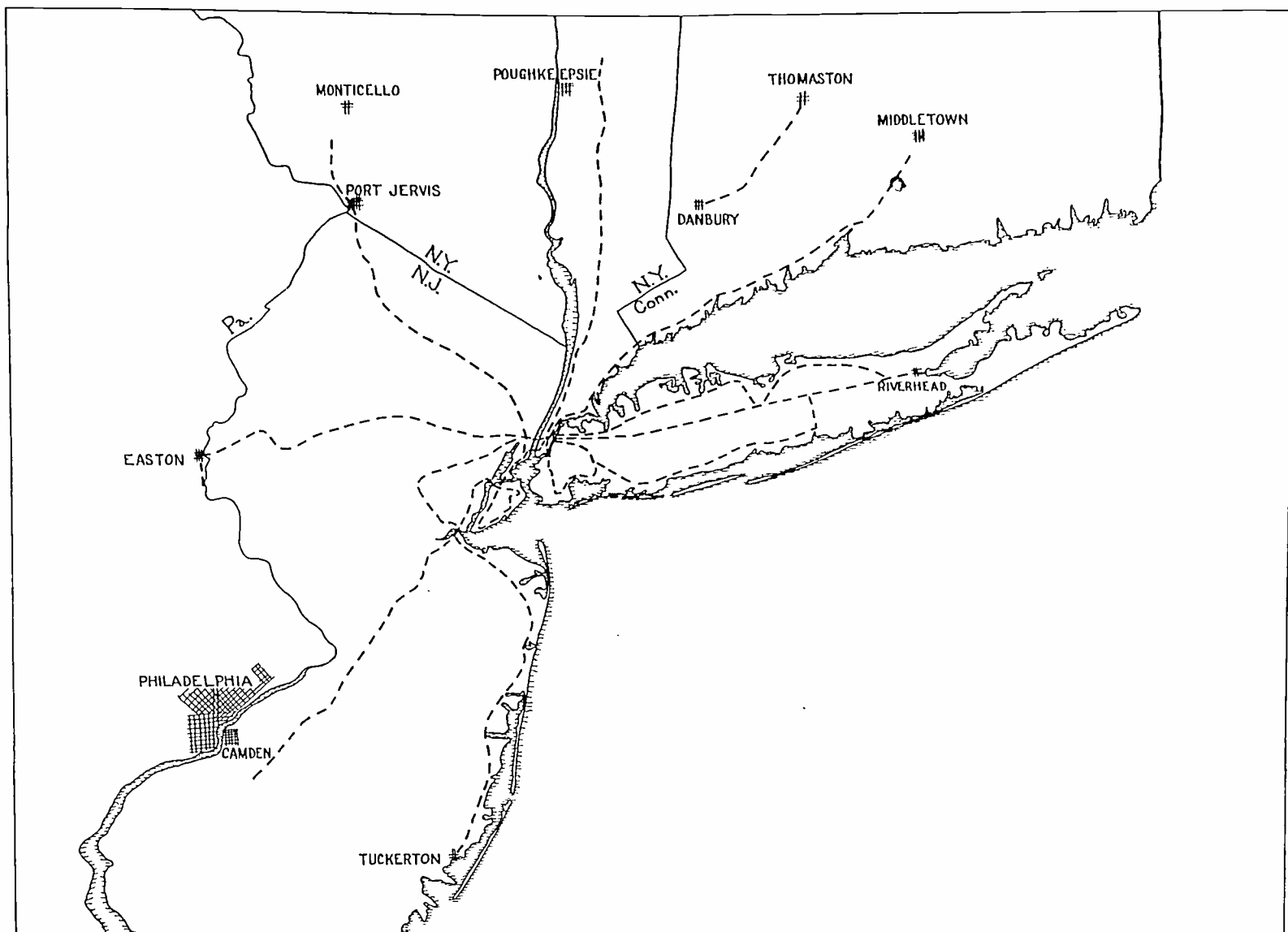

Fig. 2—Routes covered by mobile field-strength survey. 52.75 megacycles, 3.6 kilowatts. May and June, 1937.

was amplified and applied to a Bristol recording milliammeter. This type of recorder produces a continuous ink record on a paper chart which is drawn under the pen at a known rate.

To associate the record with geographical location, the chart was driven from the car drive shaft, through a suitable reduction gear mechanism. With this arrangement, the recorder chart speed was either 5 inches per mile or 20 inches per mile, and the charts were numbered consecutively every inch.

Power for the receiver was obtained from 6-volt storage batteries, which drove two 250-volt dynamotors. The batteries were connected to the car generator

to reduce the net current drain from 15 to about 7 amperes.

The transmitting antenna was a triangular array of stacked horizontal doublets, located on top of the Empire State Building tower, approximately 1300 feet above sea level. The field strength on 52.75 megacycles produced by this antenna at low vertical angles, in all horizontal directions, was the same as would be received at right angles to a half-wave horizontal doublet radiating 3.6 kilowatts.

Field-strength recordings were made in six general directions from the transmitter, covering over 800 miles of road. A map showing the routes taken by the survey car is found in Fig. 2. It was felt that this amount of field work was ample for a general survey, since variations due to local objects and irregular terrain are relatively large, and since refraction effects cause increasing variation at the greater distances.

A short sample of a field-strength record is shown in Fig. 3. Geographical locations were identified on the chart from the observer's log, which correlates chart numbers with significant locations along the route. The distances on the chart may be read to 0.1 inch, which is equivalent to 114 feet on the road, at a chart speed of 5 inches per mile.

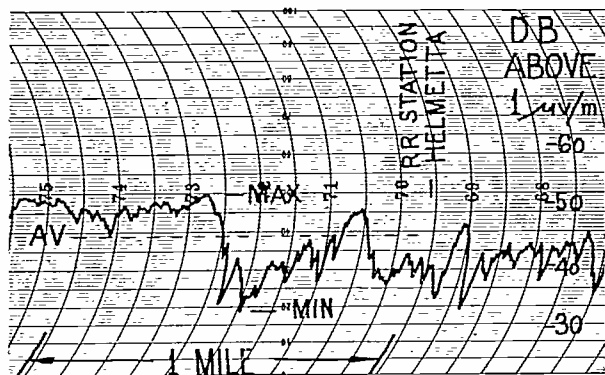

Fig. 3—Sample of mobile recording.

The recorded charts were analyzed in small sections which could be readily identified on a map. This was necessary to provide a measurement of the air-line distance from the transmitter to the middle of each section. The length of these sections varied from half a mile near the transmitter to 3 or 4 miles at the far end of the trips.

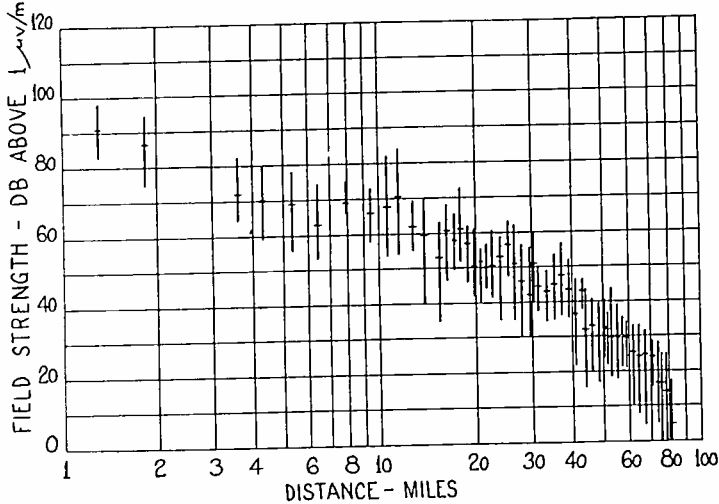

Fig. 4—Summary of field-strength record taken between New York City and Camden, N. J.

The field-strength record was summarized by noting the maximum, minimum, and average value of field strength on each section of the chart. This summary was then plotted with distance as the abscissa and field strength as the ordinate. Fig. 4 is the summary of a field-strength record taken between New York City and Camden, New Jersey, over rolling terrain. Fig. 5 is the summary for a record made between New York City and Middletown, Connecticut, a route which

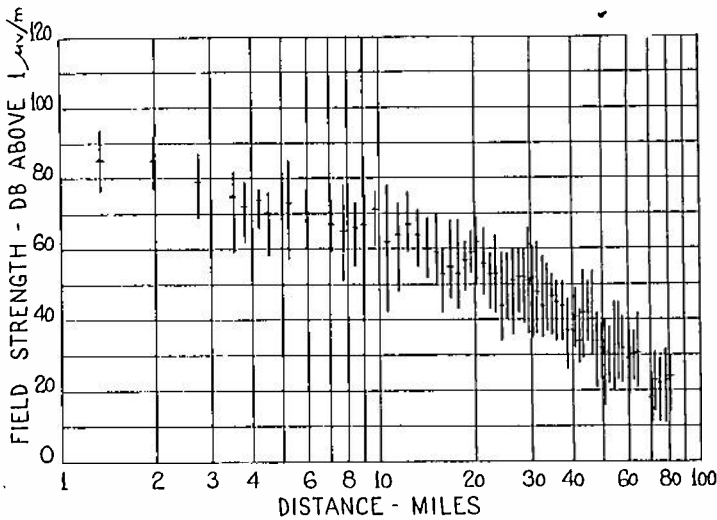

Fig. 5—Summary of field-strength record taken between New York City and Middletown, Conn.

follows the north shore of Long Island Sound for most of this distance. Fig. 6 represents a record taken over the relatively mountainous country from New York City to Port Jervis, New York. The maximum field strength appearing at 52 miles on the graph was measured at High Point State Park, at an altitude of approximately 1800 feet above sea level.

The range of field strength in each short section of chart is represented by a vertical line drawn at the

average distance from the transmitter. The average field strength in each section is then indicated by a short horizontal mark crossing the vertical line. It will be noted that this form of graph shows the upper and lower limits of field strength as well as the average value.

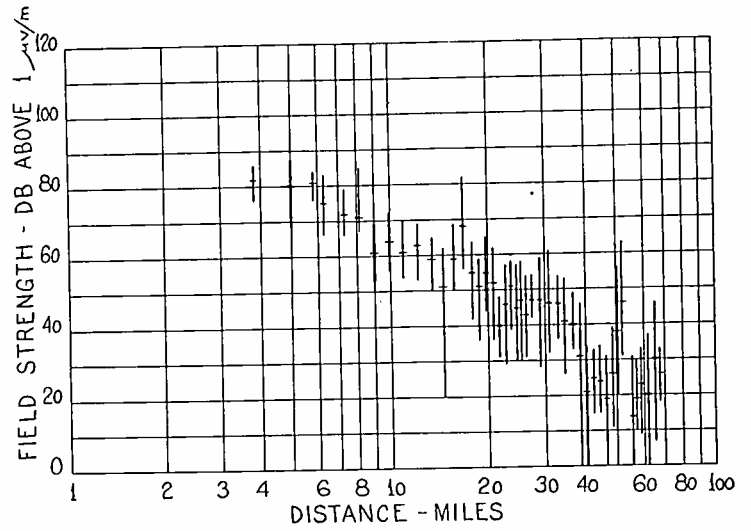

Fig. 6—Summary of field-strength record taken between New York City and Port Jervis, N. Y.

Fig. 7 was derived from Fig. 4 by plotting only the average values of field strength, corrected for a receiving antenna height of 30 feet. Since the survey was made with a receiving antenna height of 10 feet, it was thought advisable to correct the data to a height more representative of residential installations. A height of 30 feet was chosen, since individual installations would probably not vary more than two to one from this height. A factor of +10 decibels was used

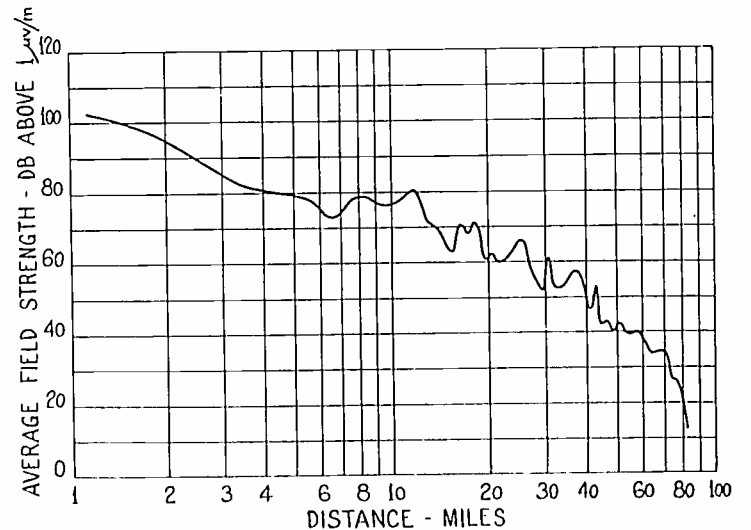

Fig. 7—Average field strength, New York City to Camden, N. J. Corrected to receiving-antenna height of 30 feet.

in converting the curves from 10 to 30 feet receiving-antenna height. Theoretically this correction is somewhat large at distances less than 5 miles, but this is offset by the shielding effect of buildings which would be greater at 10 feet than at 30 feet.

Average field-strength curves similar to Fig. 7 were drawn for each route covered in the survey. From these curves, the distance at which each curve crossed 10-decibel intervals was plotted on the map along the

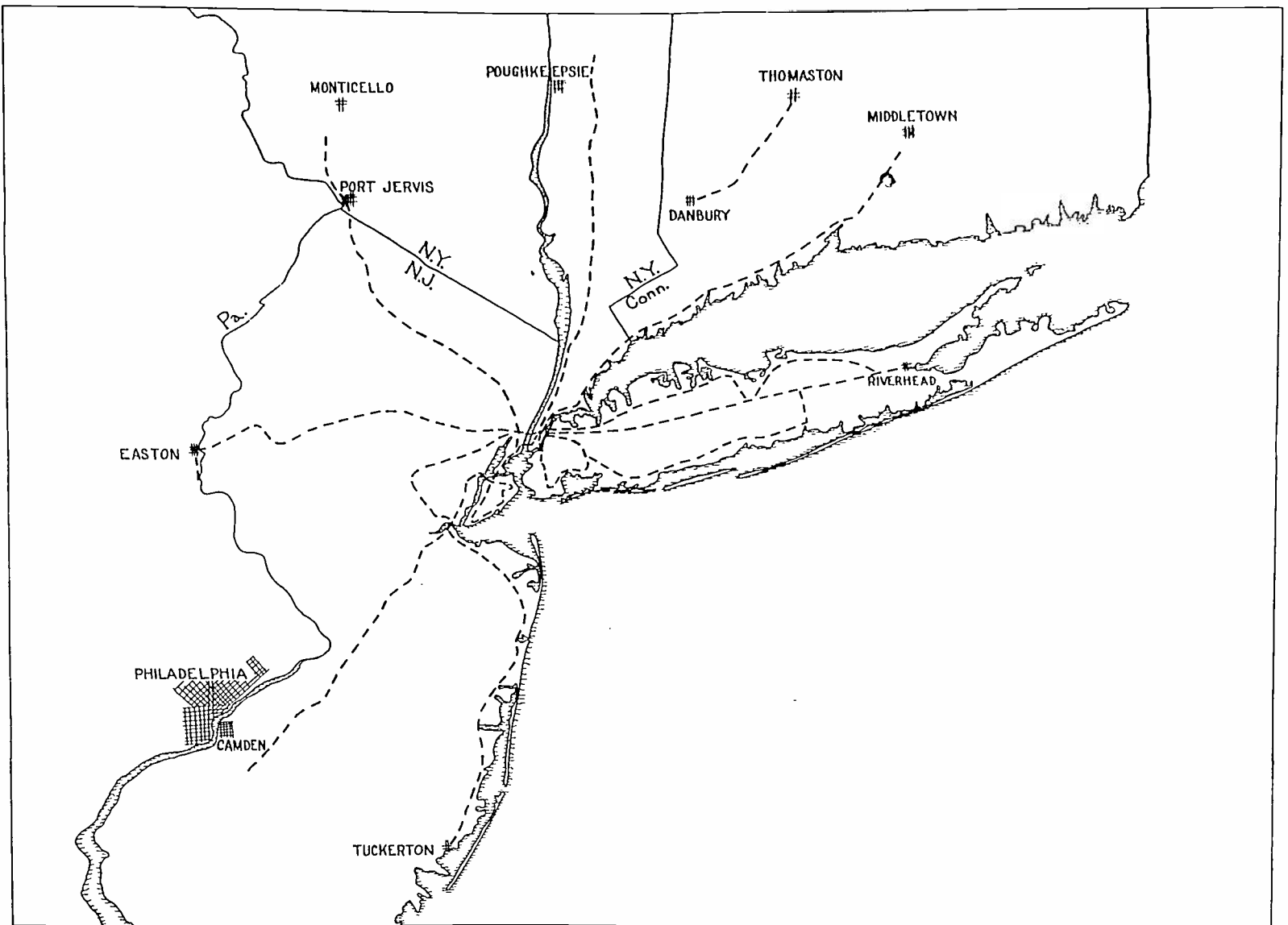

Fig. 2—Routes covered by mobile field-strength survey. 52.75 megacycles, 3.6 kilowatts. May and June, 1937.

was amplified and applied to a Bristol recording milliammeter. This type of recorder produces a continuous ink record on a paper chart which is drawn under the pen at a known rate.

To associate the record with geographical location, the chart was driven from the car drive shaft, through a suitable reduction gear mechanism. With this arrangement, the recorder chart speed was either 5 inches per mile or 20 inches per mile, and the charts were numbered consecutively every inch.

Power for the receiver was obtained from 6-volt storage batteries, which drove two 250-volt dynamotors. The batteries were connected to the car generator

to reduce the net current drain from 15 to about 7 amperes.

The transmitting antenna was a triangular array of stacked horizontal doublets, located on top of the Empire State Building tower, approximately 1300 feet above sea level. The field strength on 52.75 megacycles produced by this antenna at low vertical angles, in all horizontal directions, was the same as would be received at right angles to a half-wave horizontal doublet radiating 3.6 kilowatts.

Field-strength recordings were made in six general directions from the transmitter, covering over 800 miles of road. A map showing the routes taken by the survey car is found in Fig. 2. It was felt that this amount of field work was ample for a general survey, since variations due to local objects and irregular terrain are relatively large, and since refraction effects cause increasing variation at the greater distances.

A short sample of a field-strength record is shown in Fig. 3. Geographical locations were identified on the chart from the observer's log, which correlates chart numbers with significant locations along the route. The distances on the chart may be read to 0.1 inch, which is equivalent to 114 feet on the road, at a chart speed of 5 inches per mile.

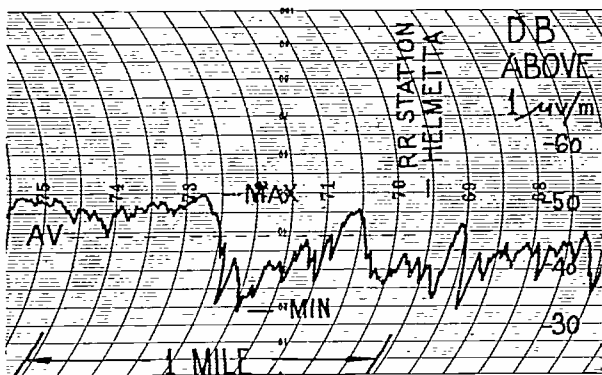

Fig. 3—Sample of mobile recording.

The recorded charts were analyzed in small sections which could be readily identified on a map. This was necessary to provide a measurement of the air-line distance from the transmitter to the middle of each section. The length of these sections varied from half a mile near the transmitter to 3 or 4 miles at the far end of the trips.

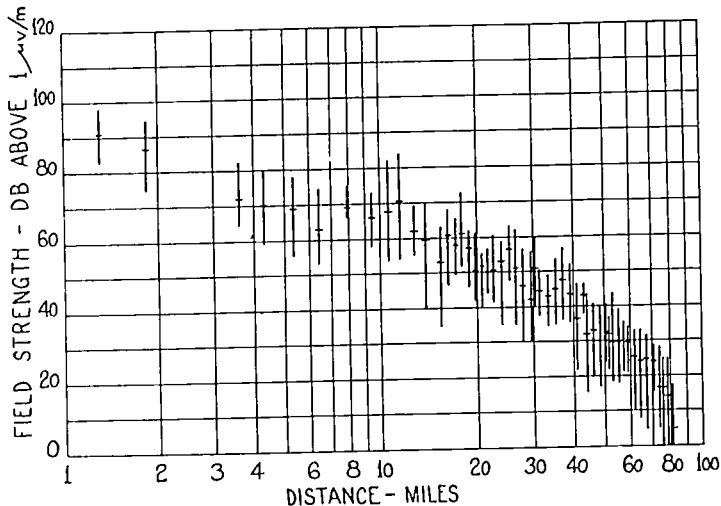

Fig. 4—Summary of field-strength record taken between New York City and Camden, N. J.

The field-strength record was summarized by noting the maximum, minimum, and average value of field strength on each section of the chart. This summary was then plotted with distance as the abscissa and field strength as the ordinate. Fig. 4 is the summary of a field-strength record taken between New York City and Camden, New Jersey, over rolling terrain. Fig. 5 is the summary for a record made between New York City and Middletown, Connecticut, a route which

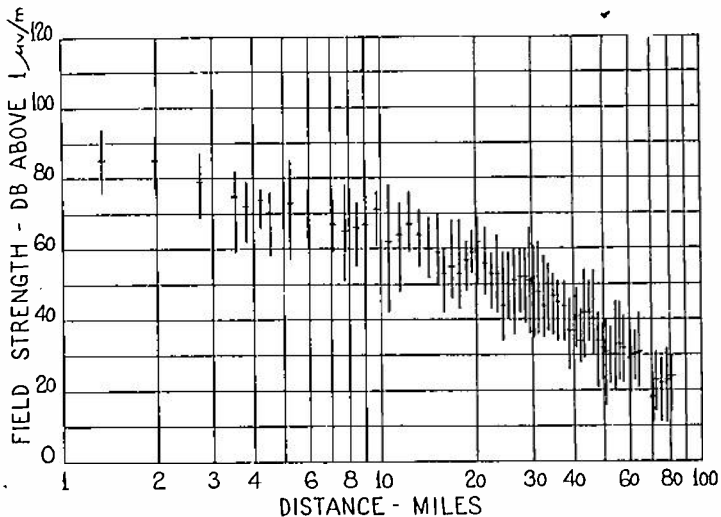

Fig. 5—Summary of field-strength record taken between New York City and Middletown, Conn.

follows the north shore of Long Island Sound for most of this distance. Fig. 6 represents a record taken over the relatively mountainous country from New York City to Port Jervis, New York. The maximum field strength appearing at 52 miles on the graph was measured at High Point State Park, at an altitude of approximately 1800 feet above sea level.

The range of field strength in each short section of chart is represented by a vertical line drawn at the

average distance from the transmitter. The average field strength in each section is then indicated by a short horizontal mark crossing the vertical line. It will be noted that this form of graph shows the upper and lower limits of field strength as well as the average value.

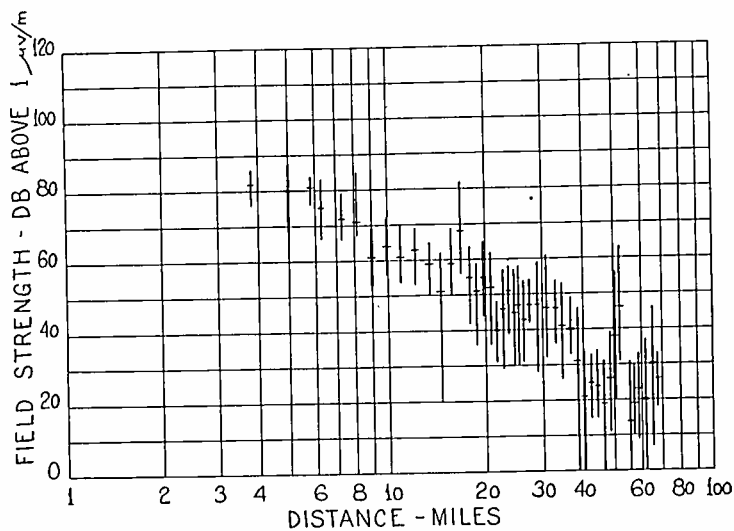

Fig. 6—Summary of field-strength record taken between New York City and Port Jervis, N. Y.

Fig. 7 was derived from Fig. 4 by plotting only the average values of field strength, corrected for a receiving antenna height of 30 feet. Since the survey was made with a receiving antenna height of 10 feet, it was thought advisable to correct the data to a height more representative of residential installations. A height of 30 feet was chosen, since individual installations would probably not vary more than two to one from this height. A factor of +10 decibels was used

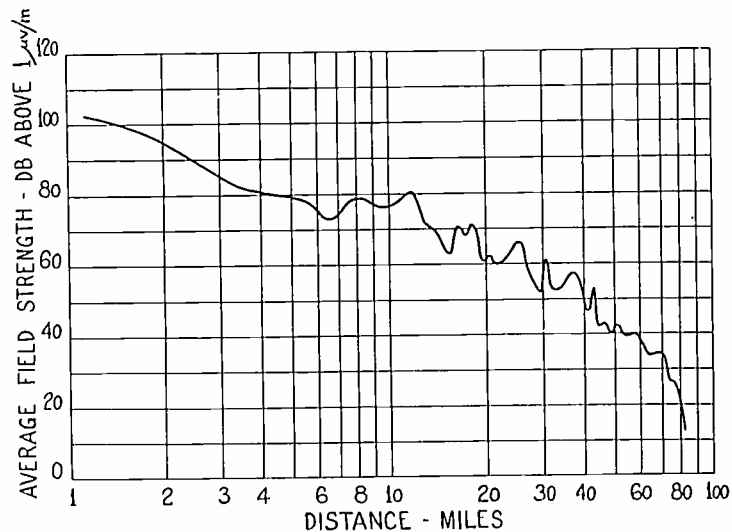

Fig. 7—Average field strength, New York City to Camden, N. J. Corrected to receiving-antenna height of 30 feet.

in converting the curves from 10 to 30 feet receiving-antenna height. Theoretically this correction is somewhat large at distances less than 5 miles, but this is offset by the shielding effect of buildings which would be greater at 10 feet than at 30 feet.

Average field-strength curves similar to Fig. 7 were drawn for each route covered in the survey. From these curves, the distance at which each curve crossed 10-decibel intervals was plotted on the map along the

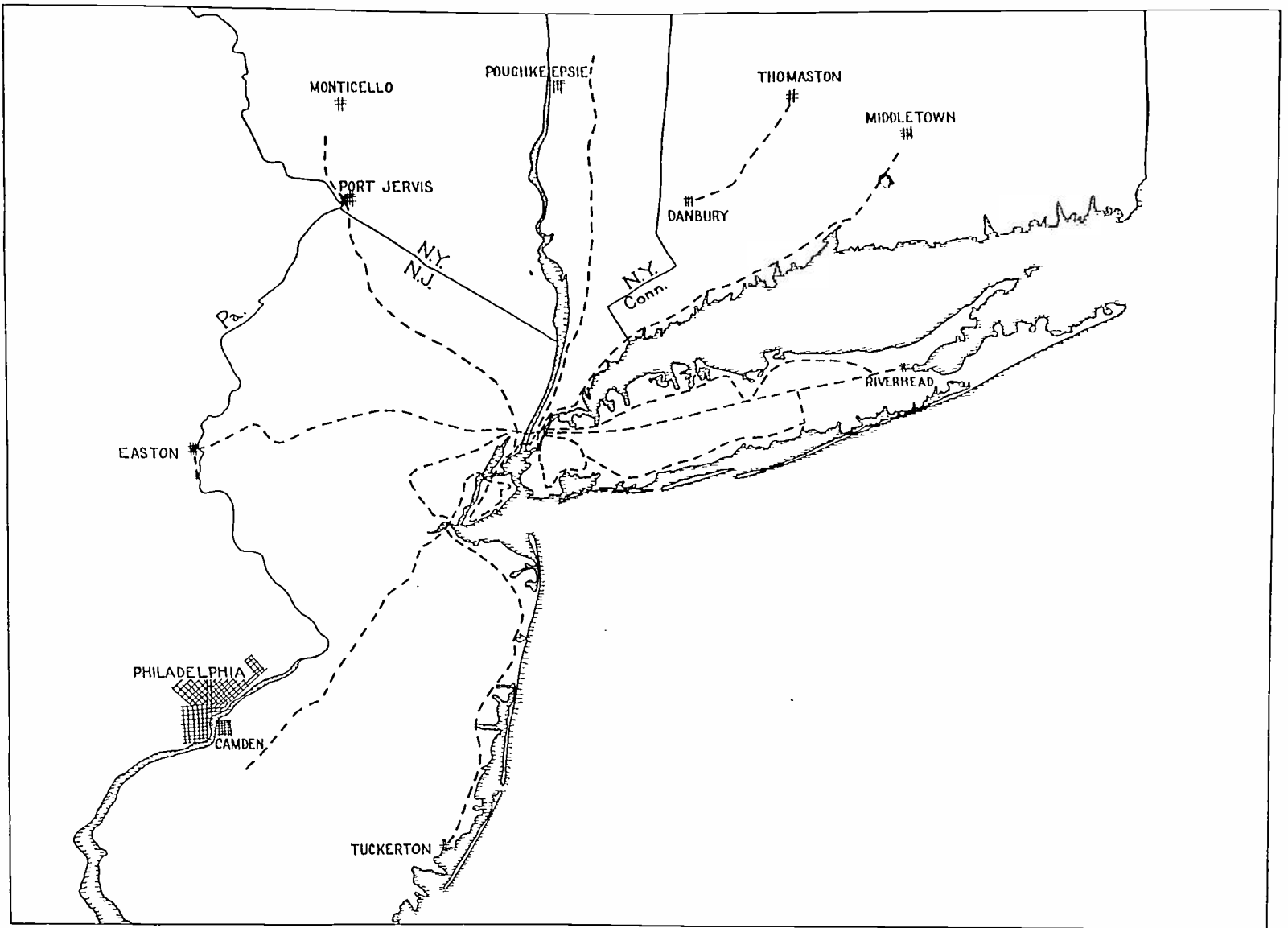

Fig. 2—Routes covered by mobile field-strength survey. 52.75 megacycles, 3.6 kilowatts. May and June, 1937.

was amplified and applied to a Bristol recording millimeter. This type of recorder produces a continuous ink record on a paper chart which is drawn under the pen at a known rate.

To associate the record with geographical location, the chart was driven from the car drive shaft, through a suitable reduction gear mechanism. With this arrangement, the recorder chart speed was either 5 inches per mile or 20 inches per mile, and the charts were numbered consecutively every inch.

Power for the receiver was obtained from 6-volt storage batteries, which drove two 250-volt dynamotors. The batteries were connected to the car generator

to reduce the net current drain from 15 to about 7 amperes.

The transmitting antenna was a triangular array of stacked horizontal doublets, located on top of the Empire State Building tower, approximately 1300 feet above sea level. The field strength on 52.75 megacycles produced by this antenna at low vertical angles, in all horizontal directions, was the same as would be received at right angles to a half-wave horizontal doublet radiating 3.6 kilowatts.

Field-strength recordings were made in six general directions from the transmitter, covering over 800 miles of road. A map showing the routes taken by the survey car is found in Fig. 2. It was felt that this amount of field work was ample for a general survey, since variations due to local objects and irregular terrain are relatively large, and since refraction effects cause increasing variation at the greater distances.

A short sample of a field-strength record is shown in Fig. 3. Geographical locations were identified on the chart from the observer's log, which correlates chart numbers with significant locations along the route. The distances on the chart may be read to 0.1 inch, which is equivalent to 114 feet on the road, at a chart speed of 5 inches per mile.

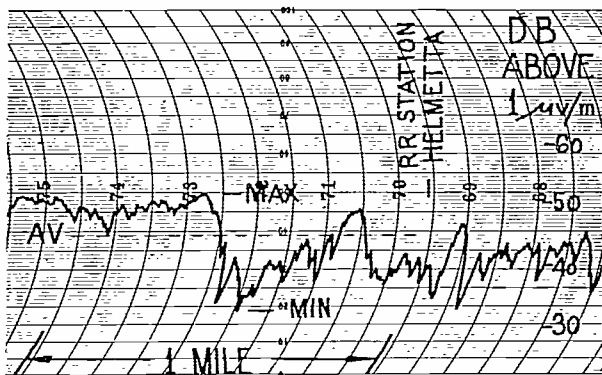

Fig. 3—Sample of mobile recording.

The recorded charts were analyzed in small sections which could be readily identified on a map. This was necessary to provide a measurement of the air-line distance from the transmitter to the middle of each section. The length of these sections varied from half a mile near the transmitter to 3 or 4 miles at the far end of the trips.

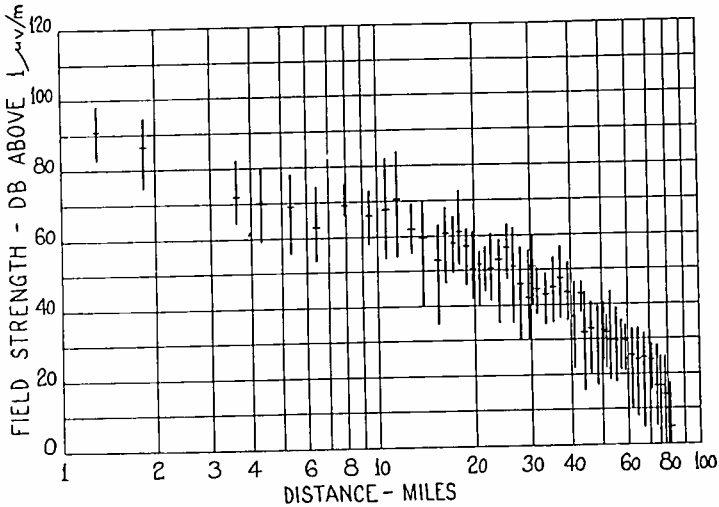

Fig. 4—Summary of field-strength record taken between New York City and Camden, N. J.

The field-strength record was summarized by noting the maximum, minimum, and average value of field strength on each section of the chart. This summary was then plotted with distance as the abscissa and field strength as the ordinate. Fig. 4 is the summary of a field-strength record taken between New York City and Camden, New Jersey, over rolling terrain. Fig. 5 is the summary for a record made between New York City and Middletown, Connecticut, a route which

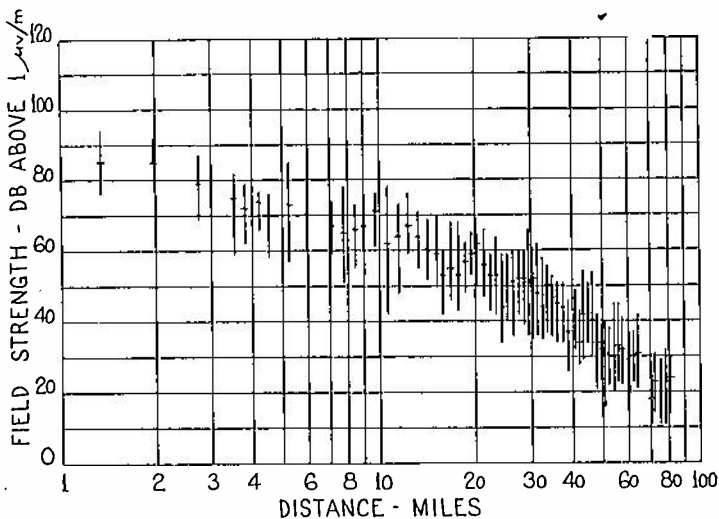

Fig. 5—Summary of field-strength record taken between New York City and Middletown, Conn.

follows the north shore of Long Island Sound for most of this distance. Fig. 6 represents a record taken over the relatively mountainous country from New York City to Port Jervis, New York. The maximum field strength appearing at 52 miles on the graph was measured at High Point State Park, at an altitude of approximately 1800 feet above sea level.

The range of field strength in each short section of chart is represented by a vertical line drawn at the

average distance from the transmitter. The average field strength in each section is then indicated by a short horizontal mark crossing the vertical line. It will be noted that this form of graph shows the upper and lower limits of field strength as well as the average value.

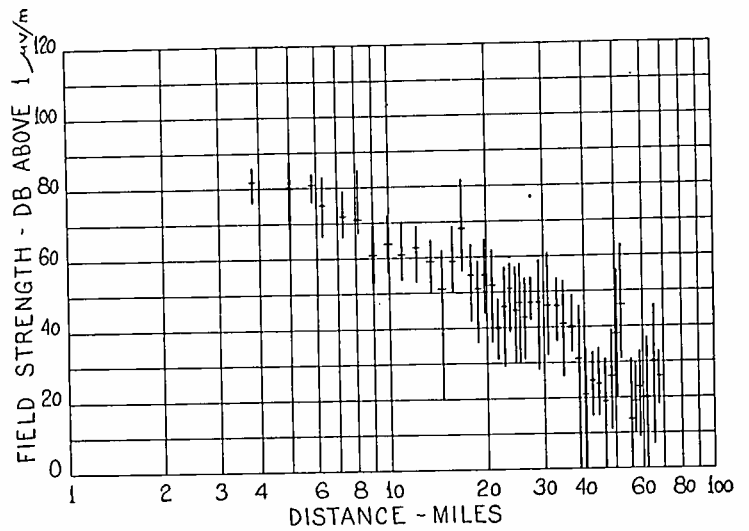

Fig. 6—Summary of field-strength record taken between New York City and Port Jervis, N. Y.

Fig. 7 was derived from Fig. 4 by plotting only the average values of field strength, corrected for a receiving antenna height of 30 feet. Since the survey was made with a receiving antenna height of 10 feet, it was thought advisable to correct the data to a height more representative of residential installations. A height of 30 feet was chosen, since individual installations would probably not vary more than two to one from this height. A factor of +10 decibels was used

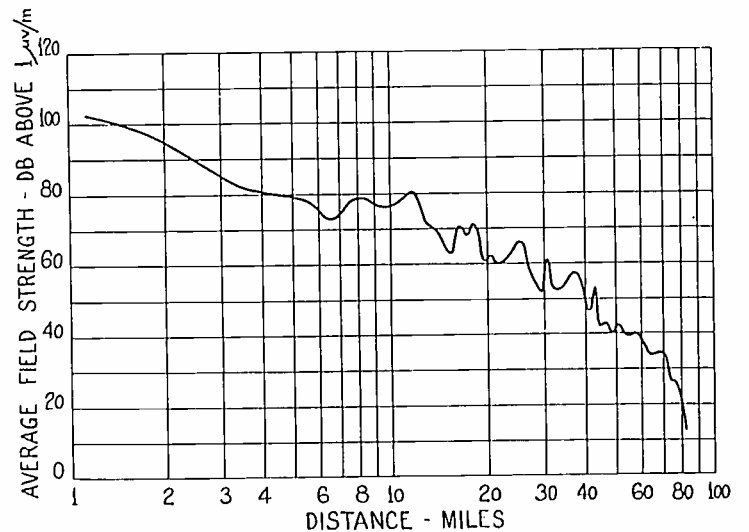

Fig. 7—Average field strength, New York City to Camden, N. J. Corrected to receiving-antenna height of 30 feet.

in converting the curves from 10 to 30 feet receiving-antenna height. Theoretically this correction is somewhat large at distances less than 5 miles, but this is offset by the shielding effect of buildings which would be greater at 10 feet than at 30 feet.

Average field-strength curves similar to Fig. 7 were drawn for each route covered in the survey. From these curves, the distance at which each curve crossed 10-decibel intervals was plotted on the map along the

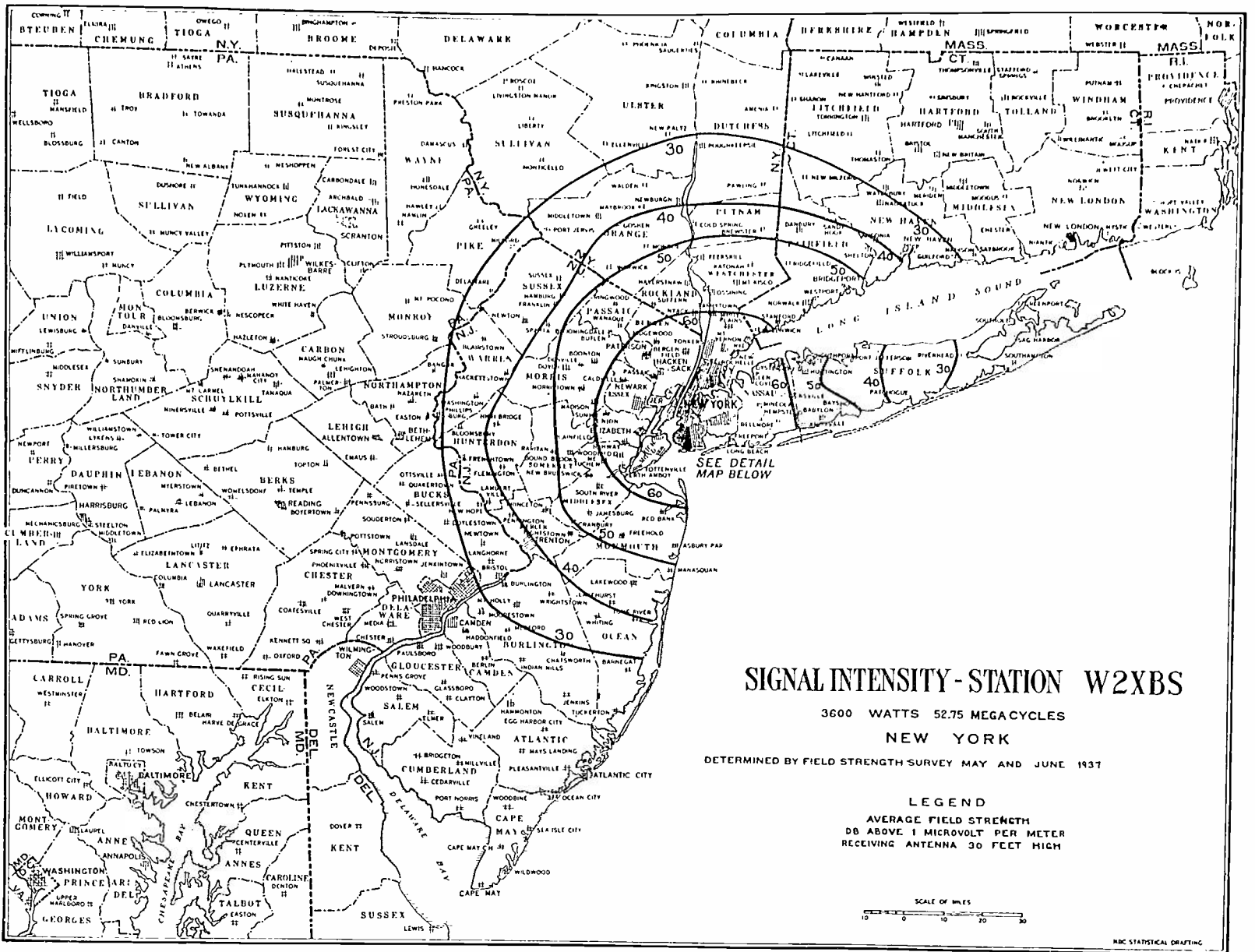

Fig. 8—Field strength beyond the Metropolitan area.

route taken by the survey car. The points of equal signal were connected by lines, producing the field-strength maps found in Figs. 8 and 9.

TABLE I
SUMMARY OF MEAN DEVIATIONS FROM AVERAGE FIELD STRENGTH.

Route	Topography	Maximums Decibels Above Average	Minimums Decibels Below Average
New York City to Huntington, L.I.	Rolling	9.1	11.8
Coram to Brooklyn	Level	5.9	9.6
South Huntington to Long Island City	Fairly level	7.7	9.6
New York City to Middletown, Conn.	Rolling	8.7	10.5
New York City to Millbrook, N.Y.	Rolling	8.6	11.8
Port Jervis to New York City	Mountainous	10.3	12.4
New York City to Easton, Pa.	Mountainous	10.3	13.6
New York City to Camden, N.J.	Rolling	8.7	11.7
Tuckerton to Middletown, N.J.	Level	7.9	10.3
Average for all routes		8.6	11.3

Several factors must be considered when interpreting the coverage maps. It must be remembered that the maps represent average field strength measured along highways and accordingly do not apply to specific locations far removed from average conditions in any particular area. However, more exact information may be obtained by considering the de-

viation from the average field strength, as found in the original data. A table of the mean deviation from the average field strength for the principal survey routes is shown in Table I. It is apparent that the deviation depends somewhat on the topography of the survey route, and that the average field strength is slightly nearer the maximum than the minimum value.

The screening effect of buildings, wires, and other objects causes the field strength to drop to low minimum values for short intervals. The shielding effect of horizontal wires was observed a number of times during the survey, the amount of shielding depending upon the number of wires, and their location. In one case, a 20-pair open-wire line, paralleling the road, caused a 12-decibel reduction in field strength. The shielding effect of low buildings may be noticed in Fig. 7, at distances up to ten miles. This is especially true between Jersey City and Bayonne, N. J., where the mobile receiving antenna was screened by buildings and trolley wires. The bend in the 80-decibel contour of Fig. 9 near Bayonne probably would not be found if the receiving antenna were higher than the surrounding buildings.

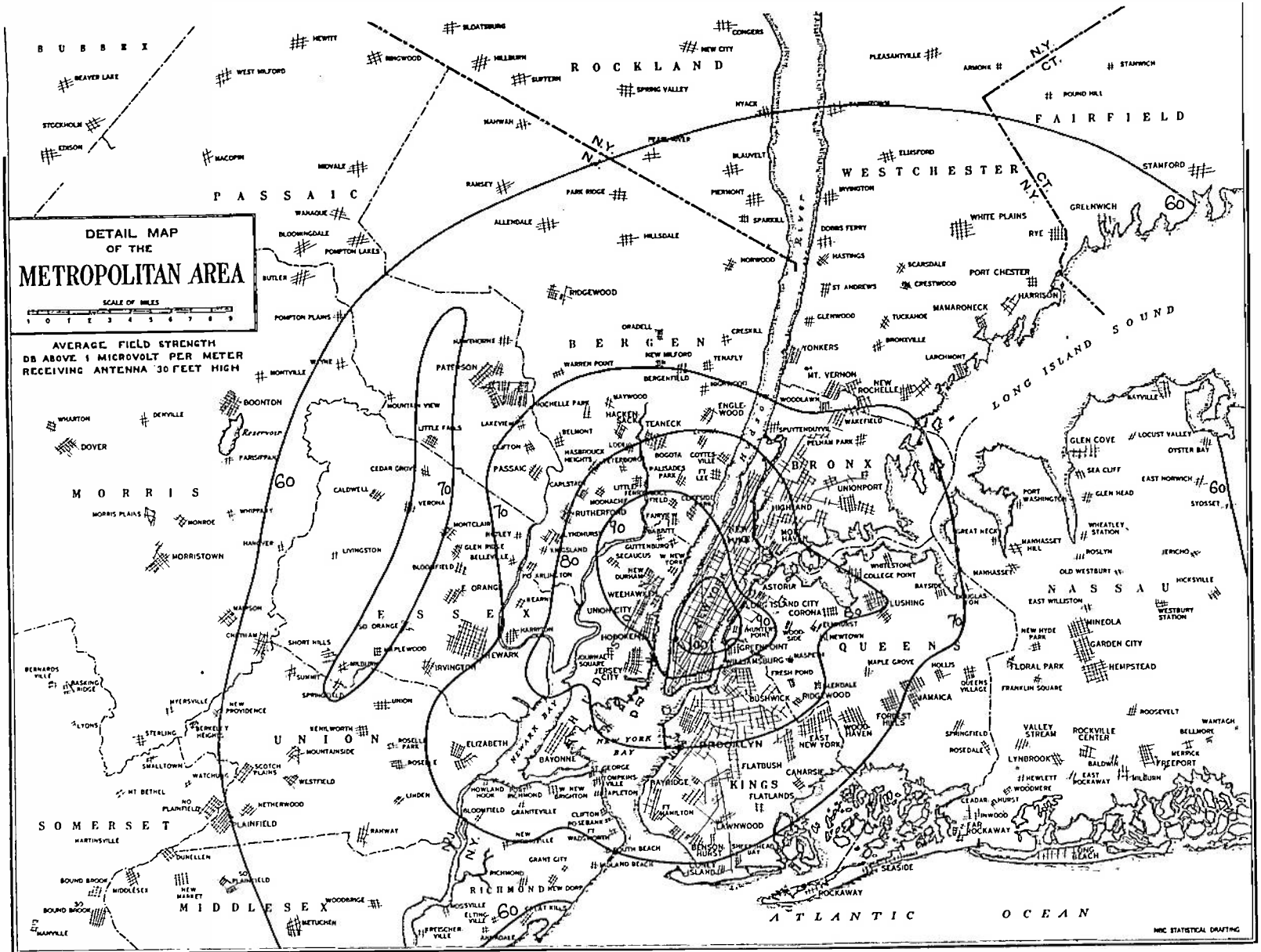

Fig. 9—Field strength near New York City.

In transferring the average field-strength curves to the coverage maps, some irregularities in the average curves were smoothed out. This smoothing process

adds slightly to the over-all deviation to be expected in practice. However, on the basis of Table I, it is probably safe to assume the mean deviation from the average field-strength contours will be roughly 10 decibels above and below the values shown on the maps.

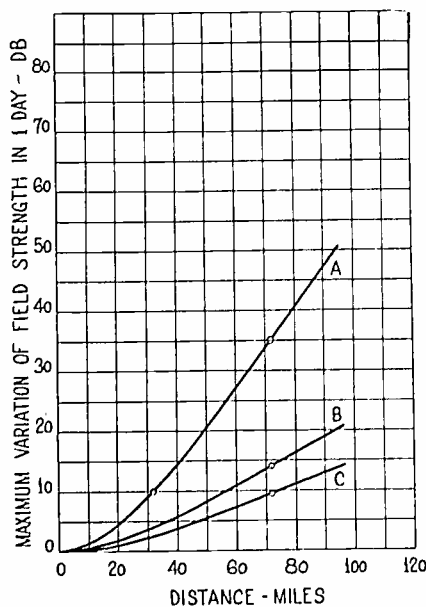

Fig. 10—Field-strength variation at various distances. Curve A—Maximum variation observed in one day. Curve B—Variation neglecting highest and lowest 5 per cent of time. Curve C—Variation neglecting highest and lowest 10 per cent of time.

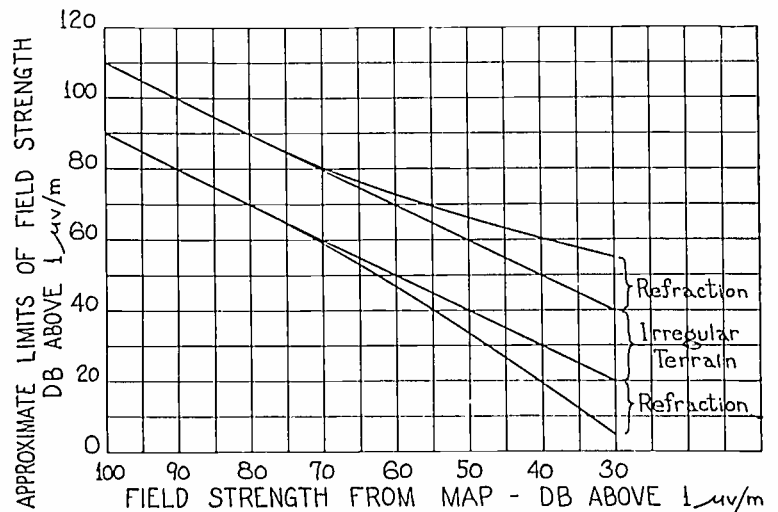

Fig. 11—Approximate limits of field strength, W2XBS, 52.75 megacycles, 3600 watts.

Near the horizon, and beyond, refraction in the lower atmosphere causes an appreciable variation in

field strength. Some idea of the magnitude of this variation may be obtained from the curves of Fig. 11, taken from a previous paper on this subject.⁷ Here the variation in field strength at various distances from the transmitter has been plotted in curve form. It may be seen that the maximum variation observed in a single day is relatively large at the more distant points. For example, the maximum variation at 32 miles, which lies near the 60-decibel (1-millivolt-per-meter) contour, was 10 decibels, or the difference between adjacent contours. If the extreme maximum and minimum values are neglected, the variation is naturally much smaller, as shown by the lower curves, *B* or *C* in Fig. 11. This last comparison, between the variation during the total time (curve *A*) and the variation during the time when the highest and lowest values of field strength were omitted (curve *B* or *C*), indicates that the extreme fluctuations occur during a small percentage of the time.

Variations due to refraction were no doubt present when the mobile surveys were made, and consequently the original data contain a variable. However, since refraction is considerably less during the daytime

⁷ K. G. MacLean and G. S. Wickizer, "Notes on the random fading of 50-megacycle signals over nonoptical paths," *Proc. I.R.E.*, vol. 27, pp. 501-505; August, 1939.

and since the extremes of variation occur during a small part of the time, the effect of refraction on the original data was neglected.

The information contained in Table I and Fig. 10 has been combined in Fig. 11, to assist in interpretation of the coverage maps. From these the discussion of the coverage maps may be summarized by saying that residents on any contour should receive, as their normal field, at least the field strength of the next lower contour, and some should receive as much as the next higher contour. Superimposed on this average field will be a variation (due to refraction) increasing from zero very near the transmitter up to about 15 decibels at the 30-decibel contour.

ACKNOWLEDGMENT

This project is a continuation of the ultra-high-frequency propagation studies conducted by R.C.A. Communications, Inc., under the supervision of H. H. Beverage and H. O. Peterson. The field work described in this paper was made possible by the co-operation of the Development Group of the National Broadcasting Company, who operated the transmitter throughout the measurements, and also contributed the blank maps on which the contours were drawn.

Acoustics in Studios*

M. RETTINGER†, NONMEMBER, I.R.E.

Summary—In the first part of the paper are pointed out the disadvantages of using truly parallelepiped rooms for the recording of sound—the tendency of such rooms to have harmonically related eigentones, to exhibit coincident regions of maximum and minimum sound pressure, and to be too "dead" because of the large amount of acoustic material required to suppress echoes. The second part of the paper is devoted to the description of a scoring stage recently completed in Hollywood.

IN THE matter of acoustics in broadcast and sound-recording studios, the architect and acoustic engineer are often confronted with the problem of the dimensions, or optimal dimensions, for the enclosure. Ratios of dimensions of 1:2:3, 2:3:5, and others, for height, width, and length of a rectangular room are frequently recommended, and charts have been prepared showing these desirable proportions as a function of the volume of the enclosure.

Such rules are helpful when the contemplated studio is in the form of a parallelepiped, and studios so built and having the correct reverberation characteristic have stood the acid test of providing an enclosure which "works." However, certain considerations appear to indicate that a rectangular room does not represent the preferred shape of a studio, and it may be desirable to review some of the features not favoring this form.

Regarding room resonance, or the number of eigentones in an enclosure, the following may be of interest.

* Decimal classification: R 534×550. Original manuscript received by the Institute, January 29, 1940.

† RCA Manufacturing Company, Hollywood, Calif.

The number of eigentones below a certain frequency F is the same for all rooms of equal volume (barring negligible second-order effects) regardless of their shape. This number¹ is given by

$$N = \frac{4VF^3}{3C^3} \pi$$

where

V = volume of room

C = velocity of sound.

Likewise, the number of eigentones in any given frequency interval extending from F to $F+dF$ is independent of the shape of the enclosure, and is represented by

$$dN = \frac{4\pi VF^2}{c^3} dF.$$

Nor does it appear that rooms of irregular shape possess discrete normal frequencies less sharp than those in rectangular rooms, or that any standing-wave pattern is less well defined. It does appear, however, that various series of modes in a rectangular room are related harmonically, and have coincident regions of maximum and minimum pressure, while in nonrectangular rooms the harmonic relations of such a series are disturbed and the modes do not necessarily have as marked regions of coincident reinforcement.

¹ Philip M. Morse, "Vibration and Sound," McGraw-Hill Book Company, New York, N. Y., 1936, p. 295.

If liberty is granted to the use of the somewhat antedated method of geometric acoustics another interesting condition may be shown to exist in rectangular rooms, which is not likely to occur in a room of different shape. Fig. 1 shows a cross-sectional plan of a rectangular room, and it is seen that the angle of

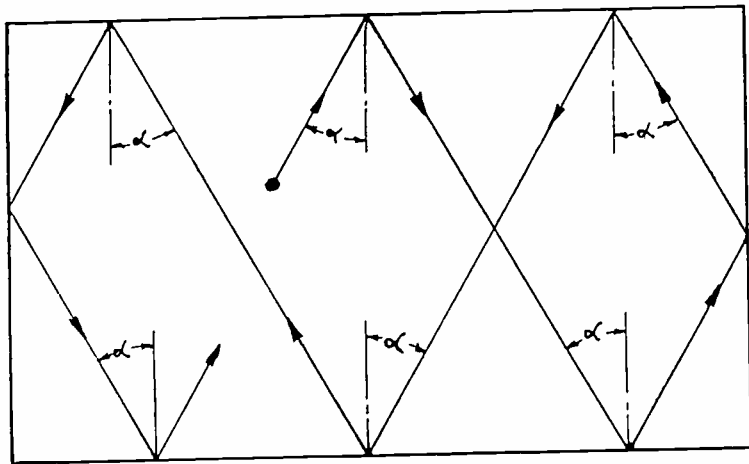

Fig. 1

incidence of all reflected sound "rays" remains the same, no matter how many times the wave has traveled back and forth in the room. In the case of a narrow high-frequency beam, it is possible therefore that the absorptivity of the wall material, as usually obtained under the random incidence conditions of a laboratory, cannot be realized, and that moreover the establishment of a diffuse sound condition is reduced.

Another undesirable feature existing in rooms with parallel walls is that, often, excessive acoustic treatment is required to overcome the effect of echoes, with consequent reduced reverberation and lack of "liveness" in the studio.

It may be of interest at this point to describe in a general way the construction of a scoring stage recently completed in Hollywood.

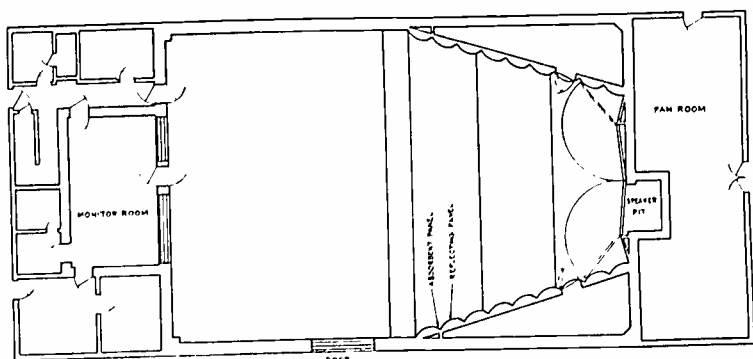

Fig. 2

Fig. 2 shows a plan of the stage and Fig. 3 shows an elevation view of it. The maximum dimensions for the height, width, and length of the room are respectively 30, 50, and 75 feet. Because of the complex nature of the "shell" it stands to reason that the eigentones in the enclosure as a whole are extremely unlikely to be of a harmonic order. Actual calculations of their order are, of course, extremely difficult, and no attempt was made at such computations.

The wall construction of the stage was of the "double-stud wall" type. The outer (street side) row of studs consisted of 2×8-inch timber, on the outer face of which was applied a sheet of 1-inch Fir-Tex fiberboard sheathing. On the outer face of this fiberboard were applied a layer of building paper and a layer of the conventional stucco wire netting. Stucco was applied to a thickness of 1 inch, and a layer of additional wire netting was applied between two layers of stucco to prevent the plaster from cracking. No material was applied to the inner (stage-face) face of these 2-×8-inch studs. A row of 2-×4-inch studs was erected at a distance of 2½ inches from the inner face of the outside row of studs, and a layer of ½-inch plasterboard was applied to the outer face of this inner row of studs (actually the plasterboard had been applied before the fiberboard was nailed to the outer row of studs). The space between the 2-×4-inch studs was then filled with rock wool battens carrying, according to the specifications, no "shot" in excess of 3/16 of an inch in diameter.

Viewing Fig. 3, perhaps what becomes at once most noticeable is the concert hall band-shell effect for the

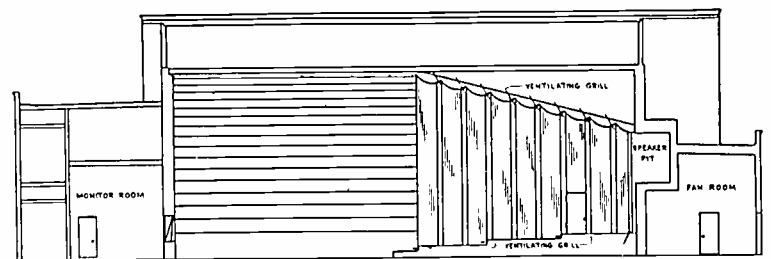

Fig. 3

"live" end of the stage. A similar effect exists in some other stages, but it is believed appears accentuated here. We see thus both the ceiling and the side walls converging towards the rear of the room; the large convex reflective corrugations and the smaller flat and reverse-angled absorbent splayed absorbers lining up in ordered fashion with corresponding corrugations on the ceiling; and the permanent musicians' platform, staggered and almost 4 feet high at the last riser to aid the artists in the impression of looking down upon an imaginary audience in the more voluminous "dead" part of the stage.

Often the question arises as to what the "optimal" dimensions of a scoring stage should be. However, since a rectangular room is not the preferred shape of a recording studio, at least not for the "live" position, the problem must be divided into two parts. First, given the probable number of musicians that the stage is to accommodate, a band-shell design must be worked out to provide satisfactory placement of instruments. This shell should not be too narrow, to prevent crowding in a lateral direction; and not too deep, to avoid undesirable time lags between string and percussion instruments. Once the proportions of the shell are established, the second part of the prob-

lem presents itself, that is, the proportions of the "dead" part of the stage. Here any abrupt change in the vertical cross-sectional dimension should be avoided. Making the "dead" part of the stage abruptly wider or narrower than the widest part of the shell means a change in the acoustic impedance at the interface, that is, at the boundary line between the "live" and the "dead" parts of the studio. Clearly then, the width of the "dead" part (if this portion is rectangular) is the width of the widest part of the shell. The length and the height may be chosen with an eye to the preferred microphone distances employed, while still providing the recommended volume per musician for the entire stage. It is seen, therefore, that the problem of the studio dimensions is unique, calling for proportions to satisfy a given probable number of instru-

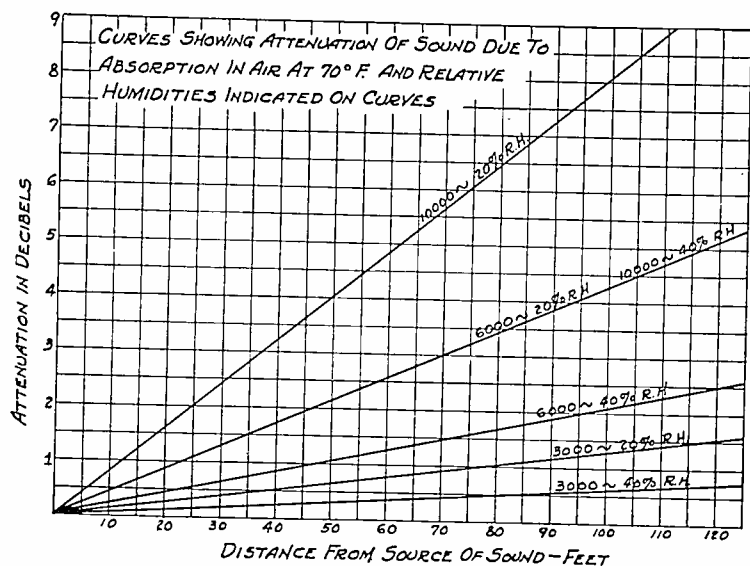

Fig. 4

ments and to permit "optimal" recording for a band of such size. In practice, however, it will be found that no difficulty is presented to record a smaller band in a studio designed for a greater number of musicians. The reverse of this, however, is not true, a large band in a small studio being notoriously a bane to all those entrusted with the recording of the music from it. This is so because much can be done with the inexpensive use of portable hard flats positioned around a small group of musicians, while no expedient exists to enlarge "aurally" a room actually small.

It is known that for the satisfactory recording of music there should be provided a region in space sufficiently "live" to sustain harmony and to enrich tonal articulation, yet not so reverberant as to impair the individual character and beauty of each note or chord in rapidly moving music. Each note should persist long enough to enable the artist to choose accurately the true pitch of the following note and to obtain without effort an exact and natural balance between bass and treble. It is only in this manner that the music of a group of instruments can be blended with the composite music of the ensemble to achieve a harmoniously balanced tone fusion which can be recorded with a minimum number of microphones.

For recorded music to sound pleasing, however, it is not sufficient that the composition be rendered in a "live" room, but that, in addition, reflecting surfaces be distributed in proximity of the instruments. This will tend to reinforce all the frequency components of music save perhaps the very low nondirectional registers calling for extremely large reflectors. In this manner not only will the musicians be better "supported," but a maximum of diffused, polyphased, high-frequency sound will strike the microphone in front of the shell before these higher registers become noticeably attenuated by the space in back of the transmitter. Indeed, a geometry of reflecting surfaces about the band can be worked out to give to the recorded music the vital reverberatory character which music would have were it played in a "liver" room intended for binaural hearing in which high-frequency air absorption is compensated by lesser absorption distributed uniformly in the room. It is well known that for frequencies above 5000 cycles this absorption of sound by the air can be as large and larger than the room surface absorption, even under normal temperature and relative humidity conditions (20 degrees centigrade and 40 per cent relative humidity).^{2,3} It is indeed not possible to construct under these conditions a room having a reverberation time at 10,000 cycles longer than 1.2 seconds, even if all the surfaces in the room had zero absorptivity. Absorption of high-frequency sound makes itself felt even after the sound has traveled through but a short distance, as may be seen from Fig. 4 showing the attenuation of high-frequency sound as a function of distance at 70 degrees Fahrenheit and at two different relative humidities.

Because of the large number of reflective splays utilized to achieve an efficient dispersion of sound, measures had to be taken to prevent excessive liveness in the shell. This was accomplished by installing absorptive material at reversed angles to the geometric arc chords of the convex splays, particularly because the reverberation time of the stage as a unit was made slightly longer than hitherto recommended. In this manner, the mean free path of the stage was also reduced, as this path is inversely proportional to total exposed surface area.⁴ It is well known that the shorter the mean free path of an enclosure the more reflections per second take place at any point in the room, thereby increasing the diffusion of the sound therein.

In the manner of construction the convex reflective splays of this stage were built up out of $\frac{1}{4}$ -inch layers of plywood sprung over 2-inch thick wood forms and nailed securely to them with long galvanized nails.

² V. O. Knudsen, "Absorption of sound in air, in oxygen, and in nitrogen; effects of humidity and temperature," *Jour. Acous. Soc.*, vol. 5, pp. 12-23; October, 1933.

³ V. O. Knudsen, "The effect of humidity upon the absorption of sound in a room, and a determination of the coefficients of absorption of sound in air," *Jour. Acous. Soc.*, vol. 3, pp. 120-128; July, 1931.

⁴ The mean free path of an enclosure of this shape is approximately given by $4V/S$, where V is the volume and S the exposed surface area of the stage.

The use of convex reflective splays made of plaster was considered, but wood was chosen for its acknowledged superior tonal response.

The acoustic treatment of the side walls of the "dead" part of the stage consists as follows. After rockwool had been packed between 2- \times 4-inch vertical studs, 1- \times 2-inch wood strips were applied to the studs horizontally and graduated in spacing from 27 inches near the wainscoting to 12 inches near the ceiling. Fiberboard $\frac{1}{2}$ of an inch thick and plywood $\frac{3}{8}$ of an inch thick were applied to the studs between the stripping to produce, in effect, a series of horizontal rockwool, fiberboard, and plywood panels. Care was taken not only to insure contact between the fiberboard (as well as the plywood) and the rockwool in back of these panels, but also to stagger the panels in such a manner across the stage that no two plywood panels could face each other. Since the wood strips were thicker than the applied panels between them, a sheet of flameproofed 40-44 muslin could be stretched over the entire side wall to obtain a monolithic surface broken only by narrow decorative mouldings which fastened the muslin to the furring strips. Such a construction will not only absorb the low frequencies more efficiently than any nonflexible porous material of practical thickness is able to absorb, but will also avoid the tone bias that undamped and equally dimensioned panels are able to create. A further advantage of having hard and soft panels adjacent to each other is that sound will tend to become diffused because of the translatory flow of energy from regions near the reflective surfaces to regions which are absorbent.

A similar treatment was selected for the ceiling. There, however, because of the reflective floor parallel to it, no plywood panels were used, and the unequally dimensioned fiberboard panels were kept considerably more narrow throughout to avoid echoes.

A treatment similar to that on the side walls was employed for the rear wall. In the past, the rear wall

of a studio was frequently made highly absorbent, much more so than the side walls or the ceiling. Here, the walls outside the shell have practically all the same absorptivity. The shell, liver when empty than the "dead" part of the stage, will appear considerably less live when occupied by the number of musicians for which the room is intended (approximately 45). It is seen, therefore, that this studio represents a considerable variation from the "live-end dead-end" stage which carries no acoustic material in the shell and has an extremely highly absorbent rear wall. Decay curves made in this stage also bore out the fact that sound in the enclosure is dying away in the logarithmic manner desired, a condition not so frequently encountered in stages in which the acoustic material is less uniformly distributed.

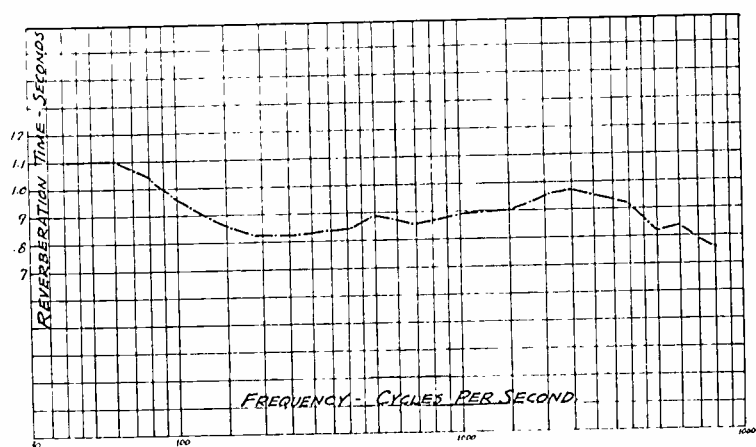

Fig. 5

Fig. 5 shows the reverberation characteristic of this scoring stage and it is seen that the curve as a whole is smooth and shows no marked rise for the reverberation times at the lower frequencies. This no doubt accounts for the total absence of any boominess in any of the recorded sound, vocal or instrumental, a condition which exists even for microphone distances in excess of those normally employed for the recording of music.

The Troposphere and Radio Waves*

R. C. COLWELL†, MEMBER, I.R.E.

Summary—The effect of tropospheric reflections upon both long and short waves is explained by assuming a fairly strong reflection from inversion layers located from 1 to 10 kilometers above the earth's surface. Weather conditions influence the propagation of wireless waves because the changing cyclones and anticyclones vary the height and the reflecting power of the inversion discontinuities. At times the reflected wave from the inversion layer is very strong.

WHEN Marconi succeeded in sending radio signals from England to Newfoundland in 1900, it was at once realized that such bending of the radio waves could not be due to diffraction alone. Kennelly and Heaviside made the hypothesis that this

* Decimal classification: R 113. Original manuscript received by the Institute, May 6, 1940.

† West Virginia University, Morgantown, West Virginia.

bending must be caused by an electrified layer some 100 kilometers above the surface of the earth. Extensive experiments made between 1925 and 1940 have shown that this hypothesis was in the main correct. However, it was assumed by everyone that the lower region of the atmosphere (the troposphere) had very little effect upon the propagation of radio waves. This assumption was upset by the investigations of Ross Hull,¹ who found that short waves were influenced by the passage of high- and low-pressure areas over the

¹ Ross A. Hull, "Air-mass conditions and the bending of ultra-high frequency waves," *QST*, vol. 19, pp. 13-18, 74, 76; June, 1935.

sending and receiving stations. He further showed that the variations were due largely to the presence of "inversions" in the atmosphere a few kilometers above the surface of the earth.

Although Hull's researches showed definite relations between intensity of reception and atmospheric inversions, other investigators had found similar effects as far back as 1902 but they were not able to explain them in terms of waves reflected from low-lying discontinuities in the atmosphere. Jackson² states that during certain electrical disturbances, the signals are received over a much shorter distance than usual. "A very marked case is given as an example. Two ships

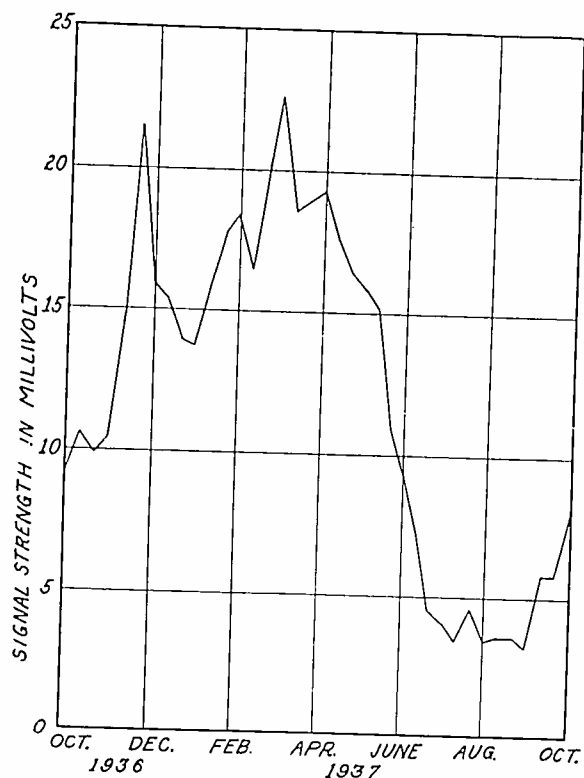

Fig. 1—The signal strength is measured at the receiver for a fixed antenna system.

whose instruments were in perfect order and whose sea-signalling distance was about 65 miles, opened their distance from each other on a fine, calm, bright day; when they were 22 miles apart the signals died away, though there was no intervening land or other apparent cause for this, but it was noticed that the barometer was falling; the ships closed and got into communication again. A few hours later a heavy winter gale came on, and its approach had evidently been foretold by the falling barometer, the loss of distance in signalling and the electrical disturbances in the atmosphere."

In 1925, it was noticed by the writer³ that the signals from KDKA at Pittsburgh varied in intensity at Morgantown, West Virginia, according to the passages of cyclones and anticyclones over the two stations. Morgantown is located 100 kilometers south of East

² H. B. Jackson, "On some phenomena affecting the transmission of electric waves over the surface of the sea and earth," *Proc. Roy. Soc. (London)*, vol. 70, pp. 254-272; May, 1902.

³ Robert C. Colwell, "Fading curves along a meridian," *Proc. I.R.E.*, vol. 16, pp. 1570-1573; November, 1928.

Pittsburgh, the former site of KDKA. Whenever a low-pressure area passed to the north of Morgantown, the day signal from KDKA was below the night signal. When a high-pressure area passed over KDKA, the night signal did not rise above the day signal. If the cyclones and anticyclones passed to the south of Morgantown, they did not seem to affect the signal intensity to any great extent.

In 1928, Pickard⁴ discovered that night reception and temperature at the receiver are directly related, maximum reception being associated with maximum temperature and vice versa. This is the reverse of the relation previously found by Austin for day reception where falling temperature improved reception. The day reception shows a decrease before and a rise after the passage of an area of low pressure, while reception is better before and worse after the passage of an area of high pressure. Cold waves are related to improved day and lowered night reception. That cold weather improves the day reception is shown by Fig. 1. The strength of the signal from KDKA was measured every day at noon (except Sundays) for a complete year. In order to eliminate any effect due to changing local weather conditions, each ten days intensity was averaged throughout the year. These averages when plotted indicate very clearly that the day reception is much stronger in the winter than in the summer.

The same tendency for the day reception to increase with a decrease in temperature is shown in Table I which gives the readings on KDKA from February 2 to March 25, 1940.

TABLE I

Date 1940	Temperature Degrees Fahrenheit	Signal Strength KDKA Microvolts per Meter	Date 1940	Temperature Degrees Fahrenheit	Signal Strength KDKA Microvolts per Meter
2/15	32	480	3/5	43	175
2/16	32	480	3/6	40	110
2/17	36	400	3/7	43	150
2/19	45	175	3/8	33	200
2/20	39	68	3/9	39	100
2/21	33	300	3/11	33	175
2/22	37	175	3/12	40	200
2/23	38	340	3/13	50	130
2/24	44	80	3/15	38	175
2/26	36	175	3/16	42	110
2/27	40	20	3/18	64	200
2/28	41	100	3/19	48	480
2/29	42	68	3/20	55	480
3/1	47	175	3/21	45	480
3/2	45	80	3/22	31	590
3/4	42	160	3/23	28	300
			3/25	32	300

This table also indicates that there is no simple relation between temperature and signal strength and that other factors must be taken into account. This will be done after Hull's results for short waves are examined. His observations showed that a 60-megacycle signal could be heard regularly over a distance of 100 miles (Boston to West Hartford), even though the stations were far below the line of sight. The highest peaks of signal level were, almost invariably, a prelude to precipitation and a reversal of weather conditions. The

⁴ Greenleaf W. Pickard, "Some correlations of radio reception with atmospheric temperature and pressure," *Proc. I.R.E.*, vol. 16, pp. 765-772; June, 1928.

worst signal fluctuations occurred on hot days when the atmosphere was most turbulent and at certain periods during the passage of storm fronts. The general relationship resolved itself into an intimate connection between periods of pronounced temperature inversion. That is to say a layer of warm air overrunning colder air invariably accompanied good transmission periods. An extensive subnormal lapse rate anywhere in the region between 300 and 2500 meters is accompanied by a high 60-megacycle signal level over the path between West Hartford and Blue Hill. From late October through the entire winter period, low-level signals invariably prevailed during the presence of fresh polar air.

All the phenomena hitherto described may be explained in a general way on the theory that long waves (broadcast band) and short ones (ultra-high-frequency) are all reflected to some extent at the inversion boundaries in the troposphere. These boundaries are usually from 1 to 10 kilometers above the earth's surface but they may be higher or lower. It is also assumed that the short waves have a much higher angle of radiation than the long waves, because the short waves are not diffracted very much around the earth's curvature and hence tend to rise toward the inversion layers at a much steeper angle than the long waves. When the inversion layers get close to the earth's surface, the short waves are reflected at such a steep angle that over any great distance they undergo double or maybe triple reflection. They are therefore very much weakened when the inversion boundary is low. At the same time when the inversion boundary is low the long waves meet it at almost glancing incidence and are therefore strongly reflected. In the cold front of an advancing cyclone, the cold air overtakes and pushes up the warm air from the ground. This gives a low inversion layer and accounts for the phenomena described above. For long waves a strong day reflection from a low inversion boundary means that not much radiation goes through to the E region. Hence on cold, clear days with a rising barometer the night reception is no stronger than the day reception. On the contrary in the warm front of a cyclone, warm, moist air rises above the cold air on the ground. Then the inversion boundary is high, and reception from short waves is good. Also the long waves meet this boundary at a steeper angle than usual and reflection is reduced; the day signal is weak. Since a great deal of radiation passes through to the E region, the night signal is strong. This warm front is usually followed by rain which according to amateur radio engineers "washes out the short-wave signals." What actually happens is that the forward movement of the cyclone from west to east across the continent brings the inversion boundary closer to the earth. This process finally results in double reflection and a very great diminution in signal intensity.

In order to make these general statements amenable

to mathematical calculation it is necessary to work out the amplitude of the reflected wave from Maxwell's equation. The resulting equation for perpendicular incidence⁵ is

$$R = \frac{n(\mu^{1/n} - 1) \sin k\epsilon_1^{1/2}t \left(\frac{\mu + n}{n + 1}\right)}{2k\epsilon_1^{1/2}t} \quad (1)$$

in which R is the ratio of the reflected to the incident wave, n may have any value but for sharp boundaries is equal to unity, $k = 2\pi$ frequency/ c , ϵ_1 and ϵ_2 are the dielectric constants of the two layers of air, and μ is the index of refraction $= (\epsilon_2/\epsilon_1)^{1/2}$. For sharp boundaries and normal incidence (1) reduces to

$$R = \frac{\mu - 1}{2} \quad (2)$$

by means of the approximation

$$\frac{\sin k\epsilon^{1/2}t \left(\frac{\mu + n}{n + 1}\right)}{k\epsilon_1^{1/2}t} \cdot \frac{\mu + 1}{2} \doteq 1.$$

Now $\mu - 1 = \Delta\mu = (1 + \Delta\epsilon)^{1/2} - 1 \doteq (\Delta\epsilon/2)$. Therefore (2) takes the form $R = \Delta\epsilon/4$.

If the incident angle is ϕ instead of zero (normal incidence) the reflected ray from Fresnel's theory becomes

$$R = \frac{\Delta\epsilon}{4 \cos^2 \phi} \quad (3)$$

This equation is fairly accurate when $\Delta\epsilon \ll 4 \cos^2 \phi$, i.e., at angles close to normal incidence. It shows also that at glancing incidence ($\phi = 90$ degrees), the reflected wave is quite strong even though the change in the dielectric constant $\Delta\epsilon$ is small. The highest possible value of $\Delta\epsilon$ is about 4×10^{-5} . This is the difference between a layer of cold, dry air lying below a warm layer saturated with water vapor. At normal incidence, (3), only 10^{-5} of the incident wave would be reflected. For $\phi = 60$ degrees and above, the reflected intensity increases rapidly so that at grazing incidence ($\phi = 90$ degrees) almost all the impinging wave is reflected. These are the considerations taken into account in the preceding paragraphs. They also show why it is advantageous to have a short-wave station on a high mountain. In that case some of the waves meet the inversion layer near the horizon at glancing incidence and so give propagation over a long distance. This refers to the so-called ground wave and not to the space wave which is reflected from the F region.

The presence of reflection from inversion discontinuities is further shown by the fact that this phenomenon is most prevalent in May and June, the period when there is the greatest contrast between cold

⁵ C. D. Thomas and R. C. Colwell, "Wave reflections from diffuse boundaries," *Phys. Rev.*, vol. 56, pp. 1214-1216; December 15, 1939.

and warm layers. Abercromby and Goldie⁶ remark that "first of all we note the great difference of temperature in the months of May and June and more especially in May between air masses of different origins. Anyone can recall that in these months in various years any kind of weather has been experienced from great heat on the one hand to the type in which snow appears on the higher mountains. These extremes correspond to the extremes of tropical air and the extremes of polar air, respectively, but even between the average specimens of air masses of different kinds there is in these months a mean difference of temperature of the order of 20 degrees Fahrenheit. As the summer advances, this difference in temperature becomes almost obliterated so that in July and August at least at lower heights, polar air by the time it reaches the British Isles is almost as warm as tropical air."

Observations seem to prove that at certain times the reflection of short waves from the inversion discontinuities is much stronger than indicated by the theoretical equations. During the eclipse of June 19, 1936, an intense magnetic storm was in progress. On that day reflections at normal incidence from an inversion discontinuity were very strong.⁷ Although no mention of any peculiarity in atmospheric conditions has been made in the United States, an observer⁸ in Italy noticed an enormous augmentation of atmospheric conductivity. He found that in the maximum

⁶ Ralph Abercromby and A. H. R. Goldie, "Weather: The nature of weather changes from day to day," The Sherwood Press, New York, N. Y., p. 82, 1935.

⁷ A. W. Friend and R. C. Colwell, "The heights of the reflecting regions in the troposphere," *Proc. I.R.E.*, vol. 27, pp. 626-634; October, 1939.

⁸ Mariano Pierucci, "A strange observation during the partial eclipse of the sun," *Il Nuovo Cimento*, vol. 16, pp. 225-228; May, 1939.

phase of the eclipse the discharge of an electroscope was reduced to 12 seconds gradually returning to 1020 seconds at the end. These observations lend weight to the assumption that certain magnetic storms on the sun send out a radiation which can penetrate the atmosphere even to the surface of the earth (or at least cause electrical effects at the earth's surface).

Occasionally short-wave stations (5 meters) located in Nebraska are heard at Morgantown with a signal strength equal to that of near-by broadcast stations such as WMMN at Fairmont, West Virginia, and KDKA, Pittsburgh. E. P. Tilton, of the American Radio Relay League, has furnished some important data regarding short-wave reception. His station is located atop Wilbraham Mountain about 8 miles east of Springfield, Massachusetts. He can communicate with several stations near New York City on 56 megacycles at any time of day and on any day of the year. The signals are usually weak but when pronounced bending is present, the signals are very loud. On June 2, 1939, he communicated with 20 stations which were more than 120 miles distant. On September 14, 1939, he was able to exchange signals with Aliquippa, Pennsylvania, a distance of 400 miles. It is conceivable that a reflecting layer may be at just the right height to give glancing incidence at 200 miles so that the signal is propagated from Springfield to Aliquippa with a single reflection. Because of the high ridge of the Alleghany Mountains it is more likely that the signal is propagated with at least two reflections. If such is the case, the reflected amplitude must be much more than the 10^{-5} given by theory. It seems, therefore, that at certain times something takes place in the troposphere which greatly increases the reflecting power of the inversion layer.

Transversal Filters*

HEINZ E. KALLMANN†, ASSOCIATE, I.R.E.

Summary—Transversal filters, the electrical analogue to the grating spectroscope, offer close approximation to any desired amplitude response without any phase distortion. They consist of a series of matched delay cable sections to which energy is fed at one end to be dissipated in the termination resistance at the other end. Signals are derived as the sums or differences of voltages tapped off at equidistant points along the cable. Electronic devices are described which are suitable for the summation of such voltages without interaction and without causing reflections in the cable, as well as "condensed cables" which provide, without appreciable dispersion, the necessary delays for a wide range of frequencies.

CONVENTIONAL filter networks, consisting of lumped inductances and capacitances, fill adequately all those needs of the communication technique where some phase distortion can be tolerated. In many cases however, especially in television, phase distortion must be avoided throughout the amplified

range. Phase-corrector circuits are capable of smooth and lasting compensation only in ranges of reasonably steady phase response and fail near the limits of the pass band where usually the phase changes become more violent as the amplitude cutoff becomes sharper.

The main advantage of the types of filters described here is that they either show no phase distortion at all or that their phase response varies slowly and steadily regardless of the amplitude response and is thus easily corrected. These filters differ fundamentally from the conventional types in that they are built exclusively of nondispersive delay sections, for example, pieces of cable, and further in that only a negligible fraction of the transmitted energy is used to control electronic devices whereas the main part of the energy is dissipated in a terminating resistance.

* Decimal classification: R 386. Original manuscript received by the Institute, March 18, 1940.

† New York, N. Y.

SINGLE-SECTION FILTERS

Fig. 1 shows the basic scheme in which a piece of loss-free cable of impedance Z is fed with a voltage E_0 from a matched generator G and is loaded with a matched resistance R . The cable is tapped at two points A and B of such separation that an electric wave takes the time T to travel from A to B . The generator G may feed sine waves of different frequencies to the cable and any voltage difference E between the points A and B may be observed with a voltmeter of infinite input impedance. Then zero frequency, corresponding to an infinite wavelength on the cable, will not cause any phase difference between points A and B and the voltage E between them will be zero. E will also be zero for all frequencies $f = 1/T, 2/T, 3/T \dots$, where A and B are separated by phase differences of

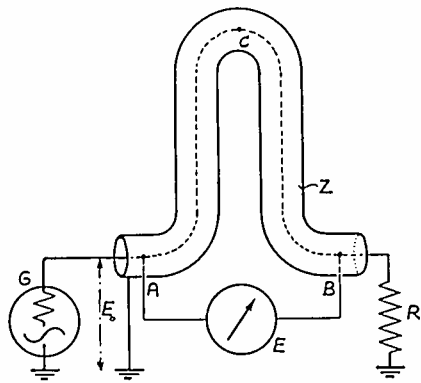

Fig. 1

360, 720, 1080, \dots degrees. In all other cases however the phase difference between A and B will result in a voltage difference $E = 2E_0 \sin \pi f T$. Thus for $f = 0.5/T$ there will be phase opposition and $E = 2E_0$. The amplitude of E as a function of the frequency f is shown in Fig. 2(a); it is of sinusoidal shape and, in the case of an ideal cable, continues to oscillate unattenuated to infinity. That the function is periodical in $2/T$ and that the voltage E assumes alternately the positive and the negative sign follows from the vector diagrams in Fig. 2(b) showing the relative position of the vectors A and B . If, for example, the phase at the center point C of the cable is taken as reference, indicated as the dotted vector C , then for values of $f = 0.5/T, 2.5/T, \dots$ the resultant vector E , that is, the sum of the vectors A and B is of the same phase as C ; for the values of $f = 1.5/T, 3.5/T \dots$ it is of opposite phase. The phase angle ϕ between E and C is plotted versus frequency f in Fig. 2(c). It lags $\pi/2$ for zero frequency, then rises linearly with f . The phase lag may be neglected for small values of $\Delta f/f$, for example, when f is large, but for very low values of f it must be corrected by means of any of the known phase-corrector circuits which will easily provide the required slow and steady phase change.

No such phase lag is encountered if, instead of the difference, the sum of the voltages at points A and B is utilized. Assume that the scheme in Fig. 1 is modi-

fied in that now the sum of the voltages from point A to ground and point B to ground is measured. Then evidently the amplitude response of Fig. 3(a) will result: $E = 2E_0 \cos \pi f T$. This is also oscillatory but dis-

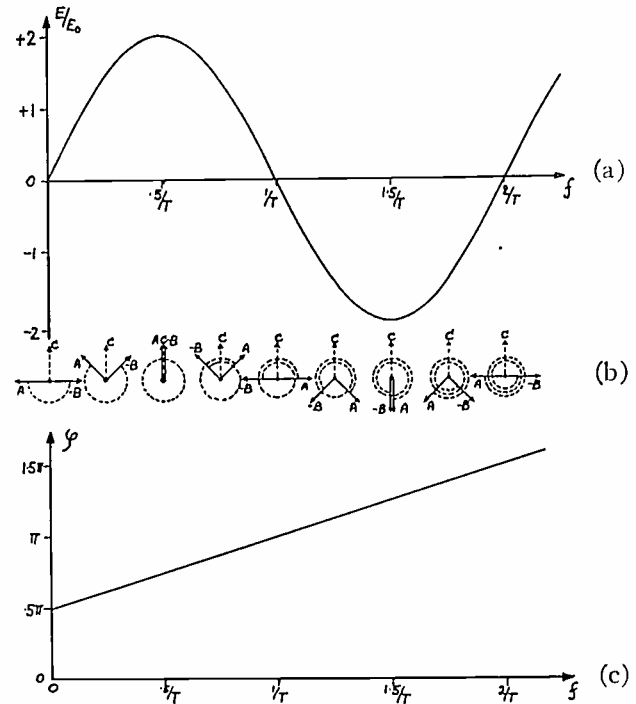

Fig. 2

placed by $0.5/T$. The voltages at points A and B will cancel each other for the values of $f = 0.5/T, 1.5/T, 2.5/T \dots$ and maximum sum voltages will occur at the frequencies $f = 0, 1/T, 2/T, 3/T \dots$, again with alternating signs if the voltage at C is taken as refer-

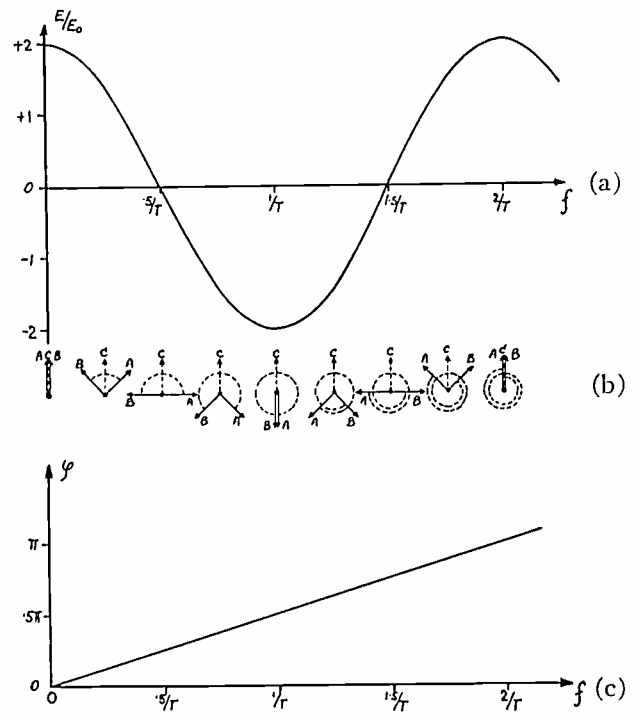

Fig. 3

ence, as shown in Fig. 3(b). The phase angle ϕ increases linearly with frequency, Fig. 3(c), but without any initial lag. Thus in the sum of the voltages at A and B all frequencies are delayed an equal time, this being the time of their arrival at the point C .

MULTISECTION FILTERS

The above systems may be called single sections of the sine and cosine type. Each offers a frequency response periodical in $2/T$; thus if the length T of the cable is varied, the frequency scale of the amplitude response is varied in inverse proportion. Moreover, combinations of cable sections of different lengths will result in amplitude-response curves shaped like sums

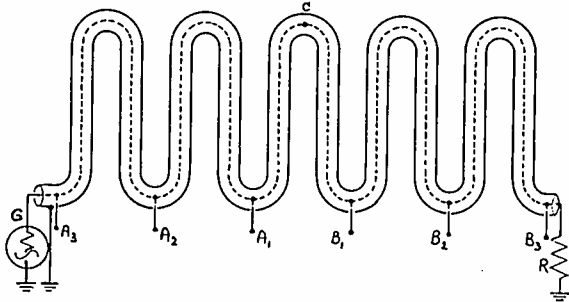

Fig. 4

of different sine waves. To obtain such responses, a single piece of cable, which, as in Fig. 4, is long enough to accommodate the longest delay required, may be tapped at various pairs of points: A_1B_1 , A_2B_2 , A_3B_3 , \dots . All the voltage differences in the case of the sine-type filter, all the sums in the case of the cosine-type filter, may simply be added together, for example, in an electronic device described later. This addition is permissible because all frequencies are delayed an equal time if all pairs of tapings A_1B_1 , A_2B_2 , \dots are symmetrically disposed around the center point C .

Any combination of such pairs of tapings which satisfies this condition may yield a useful shape of amplitude response, though these responses are no longer periodical in frequency. In order to maintain this periodicity, the distances A_2B_2 , A_3B_3 , \dots must all be exact multiples of the distance A_1B_1 , which means that all the tapings must be equidistant.

On the basis of Fourier's theorem any periodical function F can be represented as the sum of sine waves, the lowest of which is of the same period as

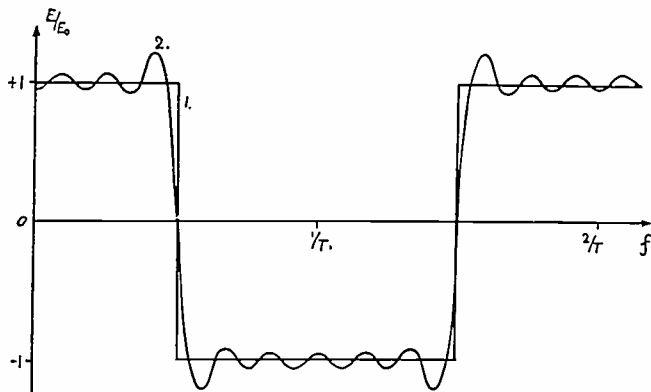

Fig. 5

the function F and the higher ones are harmonics of the lowest. For example, the ideal square wave, curve 1 in Fig. 5, is represented by

$$F = 4/\pi (\cos \omega t - \frac{1}{3} \cos 3\omega t + \frac{1}{5} \cos 5\omega t - \dots).$$

The more terms of the series used, the closer the ap-

proximation to the ideal square wave; but curves so obtained show ripple (Gibbs phenomenon) of the frequency at which the series is broken off, for example of the frequency of 12ω in curve 2 of Fig. 5; it was obtained in a cosine-type filter by adding the fractions $(A_1+B_1)+1/5(A_3+B_3)+1/9(A_5+B_5)$ and subtracting from this sum the fractions: $\frac{1}{3}(A_2+B_2)$; $1/7(A_4+B_4)$ and $1/11(A_6+B_6)$.

Since this filter has equal time delay for all frequencies, its transient response must be strictly anti-symmetrical. It is easily plotted, as in curve 1 of Fig. 6, by simply adding the 12 unit steps each corresponding to a tapping, with proper delay, amplitude, and sign. Smaller preceding and subsequent oscillations, missing in this figure, would correspond to the higher harmonics above the sixth term of the Fourier series. The many sharp corners indicate contributions of an infinite frequency range. They are rounded off if the frequency band is restricted; curve 2 in Fig. 6 results, if only the lowest pass band is left. It is plotted accord-

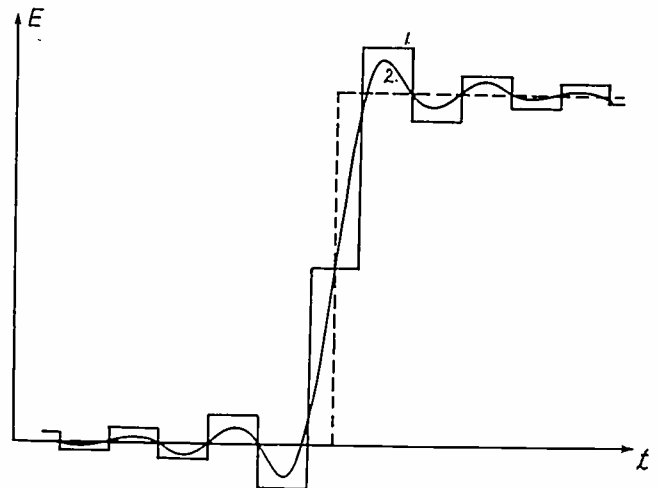

Fig. 6

ing to the equation $E = 0.5 + 1/\pi \text{Si}(\omega t)$, representing the transient response of an ideal low-pass filter cutting off at the ripple frequency.

That curve 2 in Fig. 5 has a gradual instead of an infinitely steep cutoff is an unavoidable consequence of the restricted band width; but the other difference from curve 1, that it has ripple, can be avoided if the harmonics of the Fourier series, instead of being suddenly broken off, are more gradually attenuated. To find a suitable law of attenuation reduces to the familiar problem of finding for a given frequency range the steepest possible nonoscillatory transient response. As shown elsewhere,¹ the very suitable transient response shape of Fig. 7, with less than 2 per cent overshoot, corresponds to the rapidly falling amplitude response plotted in Fig. 8, according to

$$A = e^{-(y^2+y^4)/2}, \quad \text{where } y = \omega/\omega_0.$$

Thus any filter with an amplitude response as in Fig. 8 will change a square wave to the shape shown in Fig.

¹ H. E. Kallmann, R. E. Spencer, and C. P. Singer, "Transient response in television," Proc. I.R.E., vol. 27, p. 613; September, 1939. (Summary only.)

7; the steepness of its transitions depends on the number of harmonics passed by the filter. If, as in this case, 7 harmonics were chosen, then each should be attenuated according to the value A at $1/13, 3/13, 5/13 \dots 13/13$ of the highest significant value y_{max} , e.g., $y_{max} = 1.3$, of the curve in Fig. 8. Table I shows these values A for each of the harmonics, then these

TABLE I

n	1	3	5	7	9	11	13	15
A	0.995	0.950	0.845	0.675	0.475	0.265	0.115	0.035
A/n	+0.995	-0.316	+0.169	-0.0965	+0.053	-0.024	+0.009	-0.0023
appr.	+1	-0.32	+0.17	-0.10	+0.053	-0.025	+0.01	-

values A multiplied with the Fourier coefficient $1/n$, which in this case is equal to $1/10y$, and finally the round figures from which the curve in Fig. 7 was calculated. The approximation to the theoretical shape is already very close; the top is flat within ± 0.005 , the nearly straight cutoff occupies about 16 per cent of the band width. Even saving two cable sections by

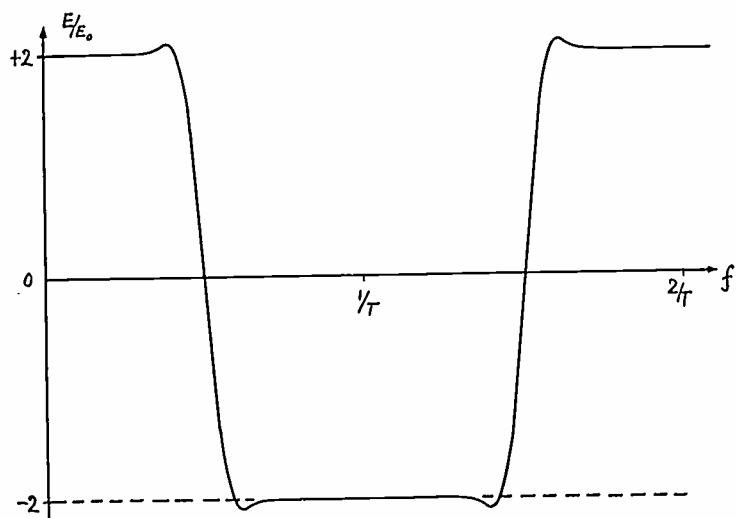

Fig. 7

fully suppressing the 13th harmonic will merely cause 1 per cent ripple without affecting the steepness of cutoff.

If, instead of pass bands with alternating positive and negative signs, alternating pass and stop bands are desired, it is merely necessary to add to, or to subtract from, the signal obtained from the filter, another from the same source which is unattenuated but equally delayed. This may be done by tapping the cable at the point C . At this point the signal has the right amplitude and delay in the case of the cosine-type filter, but requires a 90-degree phase change in the case of the sine-type filter. This subtraction does not change the shape of the response curve, it merely moves the zero line to another position, such as is shown by the broken line in Fig. 7, or to any other determined by the amplitude of the added signal.

Such a filter may well have its use in the transmission of semi-single-sideband television.

DIRECT SYNTHESIS OF TRANSIENTS

As distinct from the previous analysis, the approximation of a certain low-pass filter response by means

of a multisection transversal filter may equally well be described as a method of defining the frequency response of a system by forcing its transient response into a certain shape. Here, this is done in two steps;

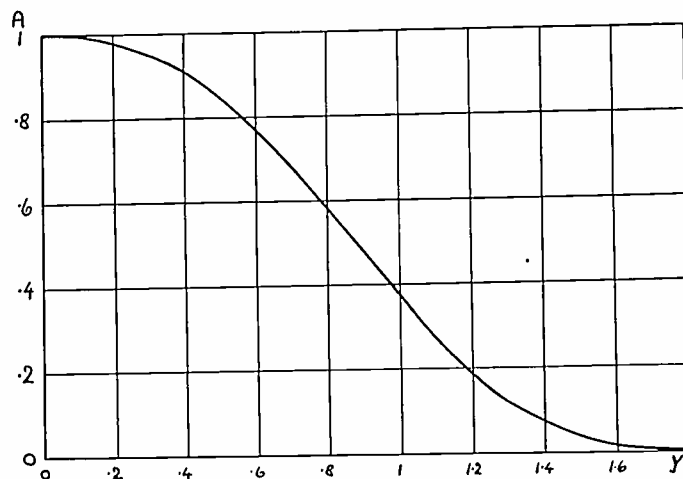

Fig. 8

at first the rectangular transient response of curve 1 in Fig. 6 is produced by combining suitably delayed and attenuated unit-step transients, and then this response is rounded by suppressing all unwanted pass bands by means of a conventional filter whose dispersive cutoff regions are far outside the desired frequency range $f \leq 0.5/T$, as in Fig. 9 in which the shaded area indicates the pass range of such a filter. Another way of manipulating the transient response had been proposed by A. D. Blumlein.² He derives unit-step transients without causing reflections from a series of tapings along a delay cable, Fig. 10, attenuates the height, and flattens the slope of each separately so that each approximates a short piece of the desired total transient, and finally adds all. Fig. 11 shows as an example how to approximate an ideal low-pass filter; the transient corresponding to it is composed of 19 straight pieces, each derived from one

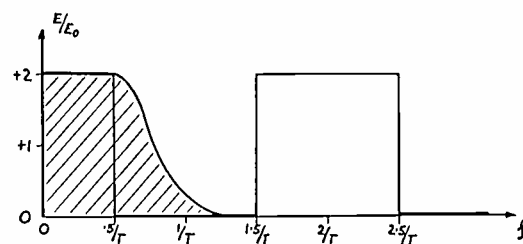

Fig. 9

of the 19 tapings on the cable in Fig. 10, and flattened to the proper slope. The frequency response thus prescribed will more nearly resemble the ideal, the closer Fig. 11 resembles curve 2 in Fig. 6. Unfortunately, very minute deviations from the smooth transition, such as residual corners, correspond to considerable departures from the ideal frequency response, especially unwanted pass ranges at high frequencies.

² A. D. Blumlein, British Patent No. 517516.

THE OPTICAL ANALOGUE

After entering a conventional filter system, the signal, while passing through its whole length, is subject to the dispersion of each section and is finally received at the other end. In comparison with this, the "longitudinal" type of filter, the types of filters here described may be called "transversal" filters. The signal proper passes through it undistorted,³ and is absorbed in the termination. Merely the phases of its component frequencies after various delays are compared by devices consuming negligible energy and in

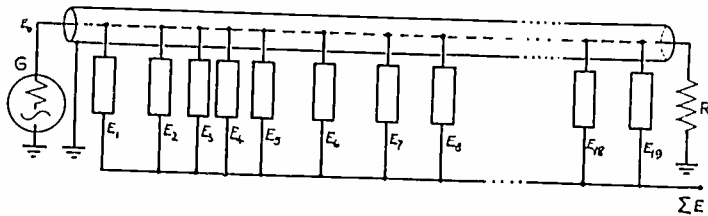

Fig. 10

the output of these devices the component frequencies are then accordingly emphasized or canceled. Thus transversal filters differ from a resonance system as a grating spectroscope differs from one utilizing a prism,

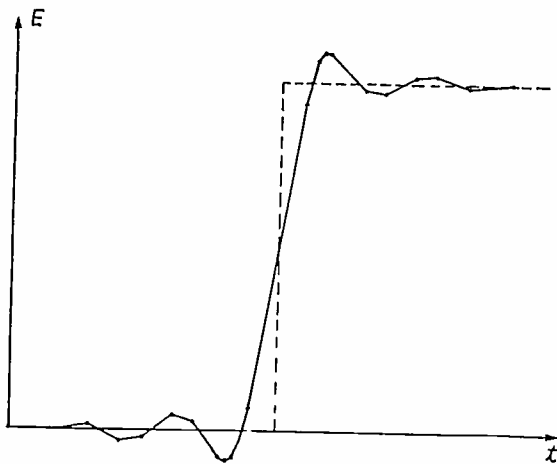

Fig. 11

in that they yield very small energy and produce an infinite number of orders, the resolving power increasing with higher orders and with the number of lines (tappings). To the sharp lines usual in an optical spectrum corresponds the frequency response, Fig. 12, obtained by summing up with equal amplitude the signals from a very large number of equidistant tappings.⁴

In a grating spectroscope, light waves are allowed to propagate along straight lines, forming an interference pattern in a two-dimensional continuum. Lacking space for the longer electric waves, it is necessary to bend their path so that points of different delays can be brought together and made to interfere with

each other. A cable which can be bent together or coiled up makes this possible. A fixed length of time, given by the length of a cable section, prescribes an oscillatory amplitude-frequency response just as a

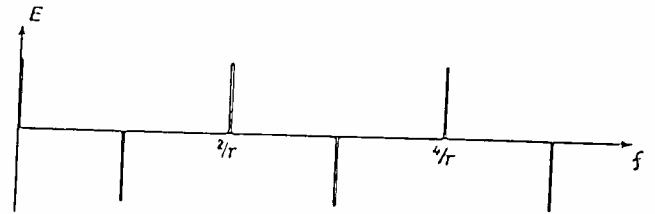

Fig. 12

fixed frequency commonly prescribes an oscillatory amplitude-time response.

CONDENSED CABLES

To use, as had been assumed, coiled up sections of actual cables would be very cumbersome, apart from causing too much attenuation. Any delaying means suffices which has negligible attenuation and phase distortion within the contemplated frequency range. Even ordinary low-pass filters may be used up to perhaps one half of the nominal cutoff frequency; but generally many sections will be required. An arrangement intermediate between a cable and a multisection low-pass filter would be most suitable. To devise such a "condensed cable" a transmission line is modified by increasing, but not actually lumping, its distributed inductance L and capacitance C , so that a short section will yield a large time delay $T = \sqrt{LC}$. In order to maintain simultaneously a high image impedance $Z = \sqrt{L/C}$, it is desirable to increase the inductance at least as much as the capacitance, their values being $L = TZ$ and $C = T/Z$.

Capacitance is increased by giving the medium between the conductors a high dielectric constant; inductance by winding one or both conductors in the form of long cylindrical coils and by introducing paramagnetic material. The resulting arrangement is shown in Fig. 13. The cylindrical core M is of binder-insulated iron

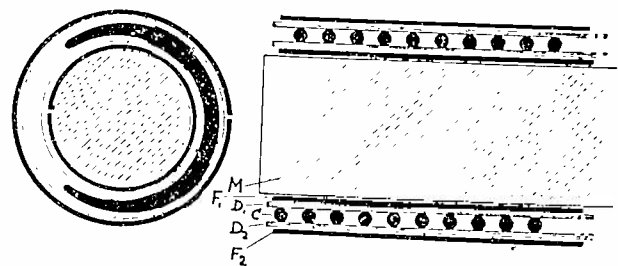

Fig. 13

dust, as used in radio-frequency coils. A layer of very thin copper foil F_1 is wound around it, almost, but not quite, completing one turn, so as to avoid eddy currents in a closed turn. This constitutes one of the conductors, preferably that connected to ground. Around this is wound an insulating layer D_1 of 0.001-inch mica or of 0.001-inch Trolitul foil, a low-loss polystyrene dielectric. Then follows the other conductor, a single-layer coil C of bare copper wire, wound

³ Norbert Wiener and Yuk-Wing Lee describe an intermediate system in U. S. Patents No. 2024900 and 2128257. Signal voltages are tapped off after each of a number of filter sections of equal cutoff frequency, then attenuated and summed up. Change of wave impedance in each section allows each section to be loaded with a voltage divider.

⁴ A proposal to increase in this way the selectivity of a radio receiver has been found in the U. S. Patent No. 1477899 by C. W. Rice.

with a pitch of about twice the wire thickness. It may, or may not, be surrounded by another insulating layer D_2 and then another copper foil F_2 (also not forming a closed turn) connected to the inner copper foil and thus simultaneously increasing the distributed capacitance and providing an electrostatic screen against external fields.

The inductance of the system is that of the coils C , calculated as that of a very long single-layer coil on a paramagnetic core. The capacitance of the system is that between the coil C and the copper foils F_1 and F_2 . Losses arise from ohmic resistance in the wire, in the iron core, and in the dielectric material. The latter are negligible for the materials mentioned. But dielectric losses become overwhelming in the otherwise attractive scheme to wind insulated wire directly on the inner copper foil, thus using the insulator as the dielectric; these losses exclude the use of silk-, cotton-, or enamel-insulated wire. Attempts were made to coat copper wire with polystyrene as a low-loss enamel.

Of the two inherent limitations of such an arrangement the one is that an undesirable periodicity in the capacitance is caused at each turn by the slot in the copper foil, making each turn a "section" of a low-pass filter and so establishing a finite cutoff frequency. This effect is minimized by making the two edges of the copper foil overlapping, separated by an insulator, and by subdividing the copper foil into several longitudinal strips; this increases the number of gaps per turn and with it the cutoff frequency. The other limitation is caused by the magnetic coupling between turns of different or even opposite phase. Turns which are of opposite phase at the highest used frequency should be at least twice their diameter apart and more than that if a paramagnetic core is used.

Pencil-sized "time sticks" wound as described on a $\frac{3}{8}$ -inch iron-dust core had about $\frac{1}{4}$ microsecond per inch for an impedance Z of 1000 ohms and were useful up to about 1 megacycle. In a more conservative design without iron-dust core the copper foil F_1 was wound on a $\frac{3}{4}$ -inch insulator of 8-inch length. The dielectric was 0.001-inch Trolitul, the winding C of copper strip 0.001 inch thick, 0.08 inch wide (bright though soft after annealing in an inert atmosphere), pitch 0.16 inch. Without a second dielectric and copper foil this unit had a time delay of 0.20 microsecond at $Z = 100$ ohms, both within 1 per cent of the calculated value, and its losses even at several megacycles were too small for accurate measurement.

For higher image impedance Z it has been suggested to give both conductors the shape of copper strips, pitch wound in opposite directions. This approximately quadruples the inductance and may reduce by as much the capacitance per unit length.

ELECTRONIC DEVICES FOR VOLTAGE SUMMATION

The requirement that there be no reflections on the tapping points as would be caused by a capacitive or

resistive load is probably best met⁵ by connecting each tapping to a control electrode, that is, a grid or deflection plate, of an electronic device. Each should be connected to a separate electrode to avoid coupling between them. To use a separate screen-grid amplifier tube for each, with the control grids connected to theappings and all anodes connected together, is practicable in simple cases, but in complicated filters this requires a large number of tubes. Barring tubes with subdivided control grids having each section brought out separately, the revival of tubes with external control electrodes⁶ seems attractive. The cross section of such a tube is shown in Fig. 14(a); the "grid" consists

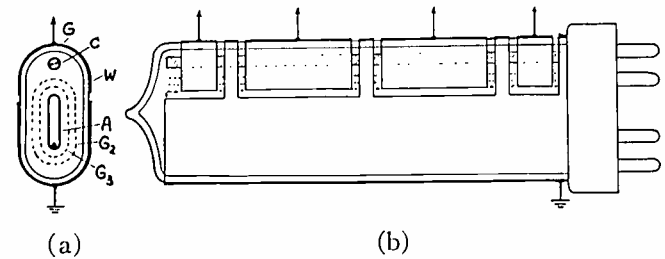

Fig. 14

of a metal coating G on the outside of the wall W which is made of slightly conducting glass to provide leakage. The "grid" controls, through the wall W , the flow of electrons from the cathode C to the anode A , which may perhaps be surrounded by a screen grid G_2 and a suppressor grid G_3 . The external control electrode lends itself well to subdivision according to requirement, for example, as shown in Fig. 14(b), into 4 parts separated by grounded screens. Their relative length is determined by the attenuation coefficient for each tapping.

A different arrangement is shown in Fig. 15, a cathode-ray tube⁷ in which at least a crude form of a spot is formed by a cathode C , a focusing electrode G , and a first anode A_1 . Numerous pairs of deflection plates $P_1Q_1, P_2Q_2, P_3Q_3, \dots$, are arranged in a common plane, separated by screens S_1, S_2, S_3 . The movement of the spot on the target will then represent the sum of all individual deflections, the contribution of each pair depending on its length, its distance from the target, and the velocity of the beam when passing it. A crude attenuation of the higher harmonics results from assigning to them short plates near the target, a fine setting for each pair P_nQ_n from controlling the stiffness of the beam with the potential of the next following screen electrode S_n . The target⁸ T shown in Fig. 15 serves to derive a voltage which is proportional to the angle of deflection. A strip of resistive material is connected at one end to the anode supply A_2 , its

⁵ For an alternative see N. Wiener and Yuk-Wing Lee, footnote reference 3.

⁶ R. A. Weagant 1915-1917, see G. Jobst et al. *Tel. Zeit.*, No. 55, pp. 38-47, 1930.

⁷ British Application No. 4940. 1939.

⁸ When provided with a fluorescent screen and a horizontal pair of deflection plates for saw-tooth scanning at the frequency of the lowest harmonic, both not shown, this tube may be used as a harmonic synthesizer.

other end is the output terminal. The beam striking it will cause a voltage drop on it in proportion to the distance of its focus from the end connected to the anode supply; this voltage drop appears at the output terminal. No sharp focus is required in this device,

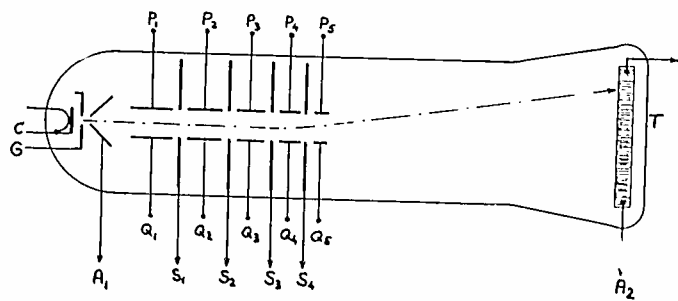

Fig. 15

permitting its use at low anode voltage, with good sensitivity.

Two modifications would improve this scheme. First, the resistive strip should be curved to fit a circle around the center of deflection, whenever the deflection angles are so large that $\sin \alpha \neq \alpha$. Further, as indicated in Fig. 16, the beam is not only subject to deflection but also to parallel displacement whenever

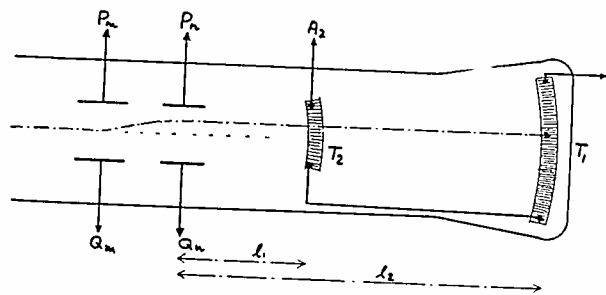

Fig. 16

subsequent deflection plates act upon it in opposite directions. In order to compensate for this effect, a part of the beam, e.g., one half, is directed onto a second resistive strip T_2 which is close to the deflection plates and which is connected in opposition to the main target T_1 . A parallel displacement of the beam will then cause equal and opposite changes in the output signals of both targets, which thus cancel. The deflection sensitivity is reduced in the ratio of the effective lever length, from l_2 to $l_2 - l_1$.

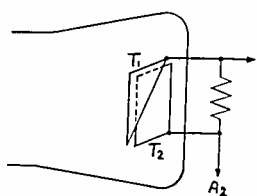

Fig. 17

Another form of target is shown in Fig. 17, consisting of two electrodes T_1 and T_2 , one partly covering the other. Deflection of a thick spot will change the fraction of the current through the upper electrode T_1 and the voltage drop on an external resistance.

THE MULTIPLE-ECHO CABLE

No such special tubes are required for simple filters, corresponding to a single or to only a few pairs of tappings. In such cases delayed signals can be obtained as the "echoes" from the unterminated end of a cable. Fig. 18(b) shows the basic scheme as developed from a single pair of tappings shown in Fig. 18(a). The signal is fed from a matched source G to a cable section of the impedance Z and of the length $T/2$. The other end may be either short-circuited or open, according to whether a sine-type or a cosine-type amplitude response is wanted.

In either case the resulting signal at the input terminal will be composed of that from the generator and that reflected from the far end. In the case of Fig. 18(b), where the end is open, the sum voltage is $E = A + B$, which is identical to that of Fig. 18(a),

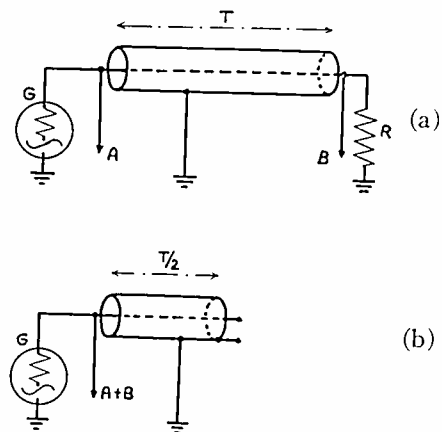

Fig. 18

varying cosinusoidally with frequency as shown on Fig. 3(a). Another way of describing the arrangement is that the input impedance of the open cable which is shunted across G is equal to zero whenever its length is $1/4f, 3/4f, 5/4f, \dots$, and equal to infinity whenever its length is equal to $0, 2/4f, 4/4f, 6/4f, \dots$.

The reflected wave, the "echo," is absorbed in the matched generator resistance; however, if this is large compared with Z , the signal is reflected back and forth with slowly decaying amplitude; the well-known quarter-wave tuner results.⁹ Its response differs from that of the "grating," Fig. 12, in that it has phase distortion, corresponding to an asymmetrical transient response in which all the "echoes" before the main signal are missing.

Multiple-echo cables differ from the simple-echo cable in that their wave impedance changes abruptly wherever an echo is wanted, the increase and decrease of the impedance corresponding to positive and negative echoes, respectively, of the amplitude

$$E'/E = (Z_n - Z_{n+1}) / (Z_n + Z_{n+1}).$$

However, this scheme is useful only in the cases of a few and weak echoes, when secondary echoes can be

⁹ F. E. Terman, "Resonant lines in radio circuits," *Elec. Eng.*, vol. 53, pp. 1046-1053; July, 1934.

neglected. Mismatch between the apparent impedance of the generator and the impedance of the first section of the cable may provide the first echo. Thus 4 echoes, corresponding to the first 2 terms of the Fourier series, can be obtained from 3 sections each of length $T/2$.

By way of example, a frequency response with reasonably straight amplitude cutoff and negligible

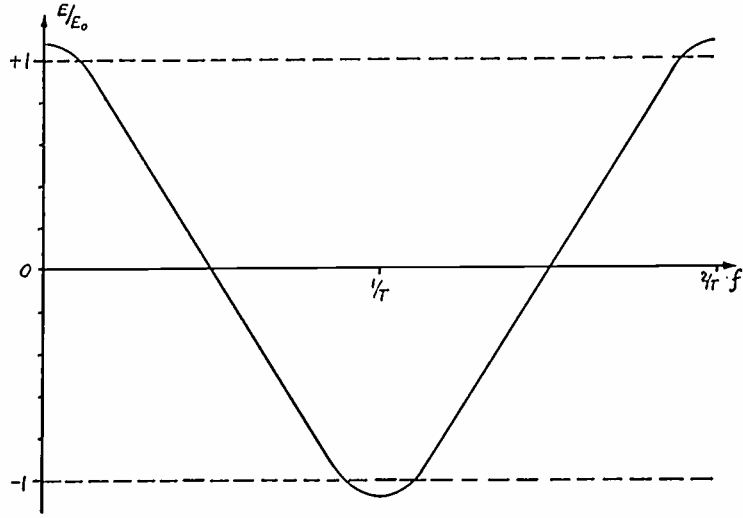

Fig. 19

phase distortion may be required for the demodulation of frequency-modulated television transmission. Fig. 19 shows that such a straight slope can be closely approximated with the sum of only the first and third harmonic

$$E/E_0 = \cos x + 1/12 \cos 3x,$$

which departs nowhere between the values -1 and $+1$ more than ± 0.013 from the ideal.

A bridge circuit suggests itself for suppressing the unwanted original signal E_0 in the output of the filter.

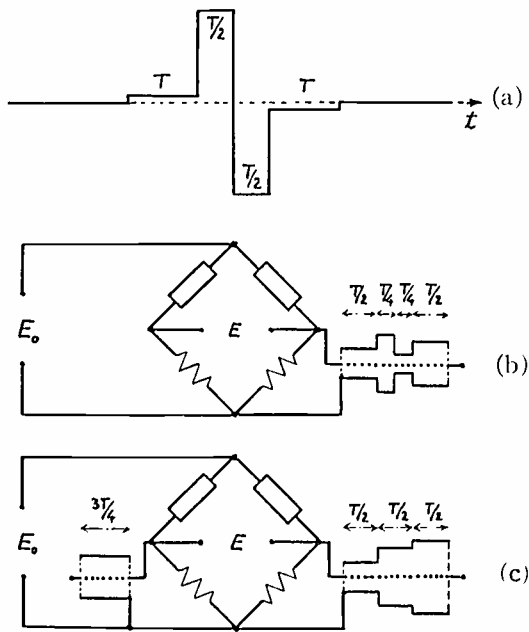

Fig. 20

Furthermore, in order to permit the use of the full length of the straight slope, the zero line of the response is to be shifted to one of the two positions indicated as broken lines in Fig. 19. This is done by either adding or subtracting the unattenuated but

equally delayed signal. The transient response corresponding to the latter case then assumes the shape of Fig. 20(a), the 5 unit steps having the amplitudes $+1/26, +12/26, -1, +12/26, +1/26$. Such a signal may be obtained from either of the two bridge circuits, Fig. 20(b) or 20(c). Both suppress the original signal; in the one, Fig. 20(b), the unattenuated negative cen-

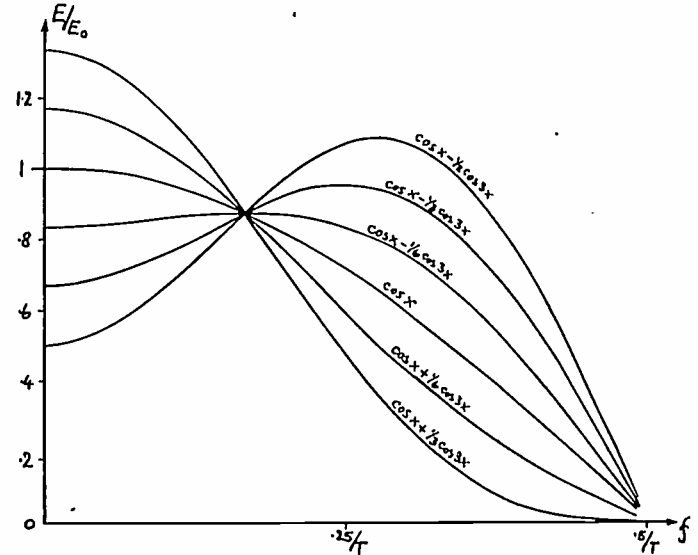

Fig. 21

ter echo is derived from an impedance decrease in the middle of the echo cable, in the other, Fig. 20(c), an additional delay cable of the length $3/4 T$ is introduced in the other bridge arm.

If cable sections of exactly the impedance required become impracticable, shunting the point of discontinuity with an external resistance may provide a solution. The echo amplitude may be controlled by varying these resistances. Variation of the sign and amplitude of the first and last echo between the limits

$$E/E_0 = \cos x + \frac{1}{3} \cos 3x \text{ and } E/E_0 = \cos x - \frac{1}{2} \cos 3x$$

would perhaps be suitable as high-frequency control without phase distortion; the family of amplitude responses is shown in Fig. 21.

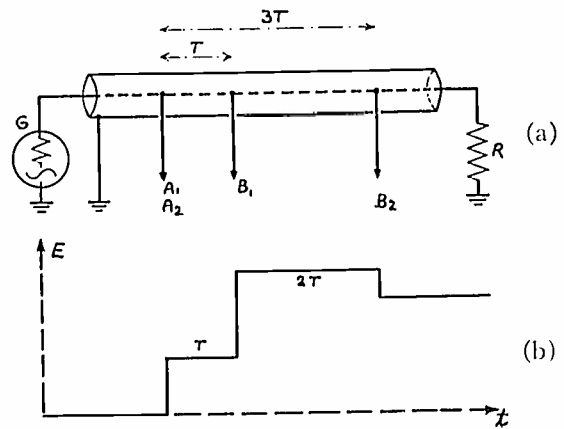

Fig. 22

With all these networks it is important that all the pairs of tappings or echoes be symmetrically disposed around the center point C of the cable, delaying all their sums by the same time. Failing this the components can no longer simply be added. The required

vectorial addition of components displaced in time leads to shapes of little use; e.g., the arrangement of

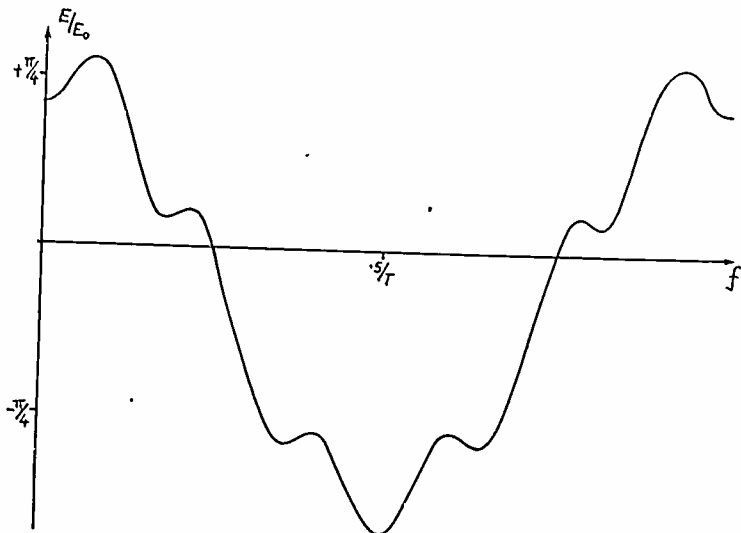

Fig. 23

Fig. 22(a) giving the sum $(\cos x - \frac{1}{3} \cos 3x)$ results in the amplitude response shown in Fig. 23. This is attended by phase distortion as is evident from the

asymmetry of the corresponding transient response Fig. 22(b).

Mechanical analogues may merely be mentioned; they yield, because of the low velocity of sound waves, large time delays in a small space. So will a metal rod, excited by a telephone at one end, act literally as an "echo" cable, variations of its thickness providing sources of echoes. A metal rod as an artificial reverberation system is an obvious application; avoiding sharp interferences by giving the rod a stepped or slanting termination will even out the oscillatory frequency response.

ACKNOWLEDGMENT

Large parts of this paper are based on work² done in the Research and Designs Laboratories of the Electric and Musical Industries, Ltd., Hayes, Middlesex, England. I am indebted to Mr. W. S. Percival for helpful comments. Among other contributions he recognized first the superiority of the cosine-type over the sine-type filter in being inherently free from phase distortion and he also put forward the multiple-echo cable.

The Twin-T A New Type of Null Instrument for Measuring Impedance at Frequencies up to 30 Megacycles*

D. B. SINCLAIR†, MEMBER, I.R.E.

Summary—A null instrument for measuring impedance at high frequencies is described. The circuit used is of the parallel-T, rather than of the conventional bridge type. The inherent adaptability of this circuit for use at high frequencies makes possible an upper frequency limit of 30 megacycles, which is considerably higher than that previously obtainable in commercial types of null instruments. The residual parameters causing error are noted and measures taken to minimize them discussed. Methods of measuring them and of correcting for their effects are given.

INTRODUCTION

AT THE annual meeting of the Institute of Radio Engineers in New York in June, 1938, W. N. Tuttle of the General Radio Company discussed the characteristics of general parallel-T circuits and derived the conditions for zero transfer admittance.¹ The present paper describes the commercial exploitation of one of the specific circuits that he used for illustration, in a null instrument for measuring impedance at high frequencies. The circuit is illustrated in Fig. 1.

BALANCE CONDITIONS

The balance conditions for this circuit are given by²

$$G_L - R\omega^2 C' C'' \left(1 + \frac{C_G}{C'''}\right) = 0 \quad (1)$$

$$C_B + C' C'' \left(\frac{1}{C'} + \frac{1}{C''} + \frac{1}{C'''}\right) - \frac{1}{\omega^2 L} = 0. \quad (2)$$

If the circuit is initially balanced to a null and then rebalanced by means of the condensers C_G and C_B , when an unknown admittance, $Y_x = G_x + jB_x$, is connected to the terminals marked UNKNOWN in Fig. 1, the unknown conductive and susceptive components can be found from

$$G_x = \frac{R\omega^2 C' C''}{C'''} (C_{G_2} - C_{G_1}) \quad (3)$$

$$B_x = \omega(C_{B_1} - C_{B_2}) \quad (4)$$

in which C_{G_1} and C_{B_1} represent the capacitance values for the initial balance and C_{G_2} and C_{B_2} the capacitance values for the final balance.

ADVANTAGES OF CIRCUIT

Used in this way, the circuit is seen to provide a parallel-substitution measurement of the unknown admittance, with the conductive component proportional to the incremental value of one variable air condenser and the susceptive component proportional

* Decimal classification: R 204×241.5. Original manuscript received by the Institute, April 8, 1940.

† General Radio Company, Cambridge, Mass.

¹ W. N. Tuttle, "Bridged-T and parallel-T null circuits for measurements at radio frequencies," Proc. I.R.E., vol. 28, pp. 23-29; January, 1940.

² See footnote reference 1. Equations are rearranged from Tuttle's equations (21) and (24), p. 28.

to the incremental value of another variable air condenser. Since each balance is independent of the other, the circuit is well fitted for use in a direct-reading instrument for measuring admittance.

Two particular advantages of the circuit for use at radio frequencies are as follows:

1. There is a common ground point for one side of the generator, one side of the detector, one side of the conductive balance condenser C_G , one side of the susceptive balance condenser C_B , and one side of the unknown admittance Y_x . Not only does the common ground eliminate the need for the shielded transformer required in bridge circuits but it renders innocuous many of the residual circuit capacitances, as can be seen from Fig. 1. Capacitances from points a and c to ground, for instance, fall across the generator and detector and cause no error. Capacitances from points b and d to ground fall across the susceptance balance condenser C_B and the conductance balance condenser C_G and affect the initial susceptive and conductive balances of the circuit. For measurements of an unknown admittance, however, they drop out in taking capacitance increments.

2. The conductive component of an unknown admittance is measured in terms of a fixed resistor and a variable condenser. It has been common experience that the design of a satisfactory variable resistor for use at radio frequencies is much more difficult than that of a fixed resistor,³⁻⁷ while the variable air condenser has proved, over many years, to be the freest of all the common circuit elements from unwanted residual parameters.

These two features, in themselves, either minimize or eliminate certain unwanted residual parameters. The general circuit arrangement, in addition, disposes of others. Capacitance between points a and b of Fig. 1, for instance, falls across condenser C' and capacitance between points b and c falls across condenser C'' . While these residual capacitances enter into the balance conditions, they may be considered as part of C' and C'' and, consequently, included in the initial calibration of the instrument. A similar argument applies to capacitance between points a and d , which falls across condenser C''' .

Capacitance between points c and d falls across the standard resistor R and affects its characteristics. Provided, however, that the capacitance does not become

too large, the effect is beneficial rather than deleterious since the capacitance tends to neutralize positive re-

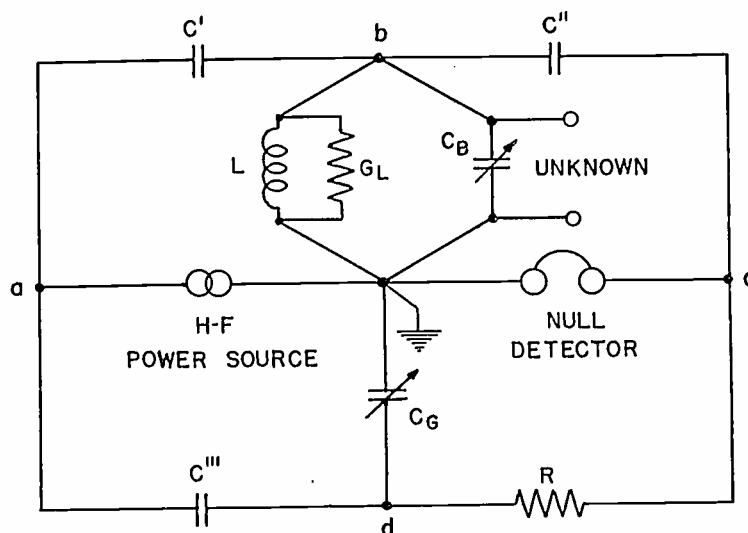

Fig. 1—Basic circuit diagram of twin-T impedance-measuring circuit.

actance caused by the residual inductance of the resistor over a considerable frequency range.^{8,9}

Direct capacitances between points a and c and points b and d cause error and must be eliminated by shielding.

GENERAL DESIGN CONSIDERATIONS

The frequency range of an instrument embodying the twin-T circuit was chosen to extend from 0.5 to 30 megacycles, so as to include both the standard broadcast and the so-called short-wave bands.

In order to cover such a wide frequency range continuously, two major problems must be solved; namely,

1. It must be possible to obtain an initial balance of the circuit at any frequency in the range.
2. It must be possible to obtain a satisfactory range of measurement of conductance and susceptance at any frequency in the range.

A glance at (2) shows that the twin-T acts very much like a parallel-resonant circuit, consisting of a coil L shunted by an effective capacitance $C_B + (C' + C'' + C'C''/C''')$. In order to obtain a balance for susceptance at different frequencies, it is therefore necessary to switch the coil L whenever the tuning range of condenser C_B is exceeded.

For any given coil, the magnitude of condenser C_B for balance is uniquely determined by the frequency. If all of this capacitance is actually in the standard condenser used for measuring unknown susceptance, an undesirable lack of freedom results, not only because the initial setting of C_B cannot be made an even number of micromicrofarads, but because the setting may approach too closely one end of the scale. Since measurement of an unknown capacitive susceptance requires a decrease in capacitance of C_B from the

³ The search for an accurate variable resistance standard to use in conventional bridge circuits at radio frequencies has led to many ingenious solutions for specific problems. No completely satisfactory general design, however, has yet appeared. See, for instance, footnotes 4, 5, 6, and 7.

⁴ R. F. Field, "Constant-inductance resistors," *Gen. Rad. Exp.*, vol. 8, p. 6; March, 1934.

⁵ C. Austin and A. L. Oliver, "A high-frequency resistance bridge," *Marconi Rev.*, no. 63, p. 22; November-December, 1936.

⁶ Kenneth A. Cole and Howard J. Curtis, "Wheatstone bridge and electrolytic resistor for impedance measurements over a wide frequency range," *Rev. Sci. Instr.*, vol. 8, p. 333; September, 1937.

⁷ C. L. Fortescue and G. Mole, "A resonance bridge for use at frequencies up to 10 megacycles per second," *Proc. Wireless Section I.E.E.* (London), vol. 13, p. 112; June, 1938.

⁸ D. B. Sinclair, "The type 663 resistor—A standard for use at high frequencies," *Gen. Rad. Exp.*, vol. 13, p. 6; January, 1939.

⁹ "Präzisions-Widerstände für Hochfrequenz," *Archiv für tech. Messen*, Z-115-1, T 81, June, 1939.

initial value and measurement of an unknown inductive susceptance requires an increase in capacitance of C_B from the initial value, it is highly desirable that the initial setting be adjustable. This is accomplished by putting in parallel with the standard condenser another adjustable condenser that may be used to obtain the initial balance with the standard condenser set at any part of the scale.

Equation (1) shows that the effective negative conductance used to nullify the coil conductance G_L varies as the square of the frequency. Since the conductance G_L does not, in general, vary in this way, the setting of condenser C_G for the initial balance will also vary with frequency. Since, for any given coil, the frequency uniquely determines the value of C_G for balance, it is again necessary to use an auxiliary trimmer

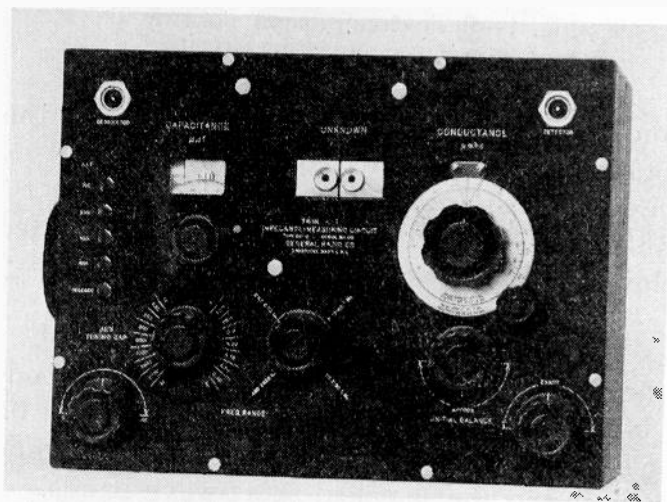

Fig. 2—Panel view of experimental model of twin-T impedance-measuring circuit. At the left of the panel are the susceptance condenser (CAPACITANCE $\mu\mu\text{f}$) and the auxiliary tuning condenser (AUX. TUNING CAP.). At the right are the conductance condenser (CONDUCTANCE μmho), and the parallel trimmer condensers (INITIAL BALANCE). The remaining controls (FREQ. RANGE) are the coil switch, at the left, and the conductance range switch, at the right.

condenser, in parallel with the condenser used for conductance measurement, so that the conductance dial can be initially set to zero.

In addition to the question of initial conductance balance, the question of range must be considered. If no circuit elements but the coil L are altered as the frequency is varied, (3) shows that the conductance range increases as the square of the frequency. In practice, this law of variation is not desirable since it would cause a variation in range of 3600:1 over the frequency band from 0.5 to 30 megacycles. A more reasonable variation can be secured by switching, at specified frequencies, either condenser C''' or condensers C' and C'' , in order to establish new scales. If, for instance four switch positions are used, with a new scale established at each of the frequencies 1, 3, 10, and 30 megacycles, the variation of scale reading between successive switching frequencies will be only 9:1. The range at each of these frequencies can be made the same, if desired. Consideration of the frequency char-

acteristics of common types of circuit elements, however, leads to the conclusion that an increase in range at each switching frequency as a linear function of the frequency may be more desirable. For instance, the conductances of coils that are tuned with the same variable condenser over different wave bands and that have the same Q 's will increase linearly with frequency. Similarly, the conductance of condensers and dielectric samples having constant power factor will increase linearly with frequency.

Fig. 2 is a panel view of the Type 821-A Twin-T Impedance-Measuring Circuit, which was designed with the various factors discussed in mind. The controls, shown in the photograph, include

1. A variable condenser used to measure susceptive components and having a dial directly calibrated from 100 to 1100 micromicrofarads.
2. An auxiliary condenser, consisting of a bank of fixed condensers controlled by push buttons and a small variable section, in parallel with the susceptance condenser, for making the initial susceptance balance.
3. A coil switch marked with the frequency range covered by each tuning coil.
4. A variable condenser used to measure conductive components and having two scales, one reading from 0 to 100 micromhos and one reading from 0 to 300 micromhos.
5. A 4-position switch, used to establish a scale on the conductance dial from 0 to 100 micromhos at 1 megacycle, from 0 to 300 micromhos at 3 megacycles, from 0 to 1000 micromhos at 10 megacycles, and from 0 to 3000 micromhos at 30 megacycles.
6. Two small variable condensers, in parallel with the conductance condenser, for making the initial conductance balance.

SPECIFIC DESIGN FEATURES

So far, attention has been centered largely on the general properties of the circuit and upon the effects to be expected of some of the major residual capacitances. From a more specific standpoint, it is essential to consider very carefully the effects of residual parameters in both the wiring and the circuit elements and minimize or eliminate the effects of these in the instrument design.

In the wiring, the most serious residual parameter is the inductance. At frequencies of the order of 10 megacycles and higher, for instance, a 1-inch length of No. 16 wire can easily produce a serious reactance error when it is connected in series with a large condenser or when it forms a common part of two circuits that are supposed to connect together only at a point.

On this account, it is vital that the leads between condensers C' , C'' , and C''' and resistor R be as short as possible and of as large a periphery as is feasible. In the twin-T, copper strip is used for these connections and, by careful attention to design, the lead lengths are all made less than about 1 inch. The loca-

tion of junction points b and d is also of great importance, because residual inductance in series with condensers C_B and C_G limits the size of these condensers, for a given error, and consequently limits the instrument range. The junction points are therefore located as nearly as possible at the condenser plates themselves. Figs. 3, 4, 5, and 6 are back-of-panel views

importance.¹⁰ It can be reduced from the value obtained with ordinary end-feeding of the rotor and stator stacks by symmetrical feeding at one or more points,¹¹ and this principle has been applied in the condenser used in the twin-T. A further gain, however,

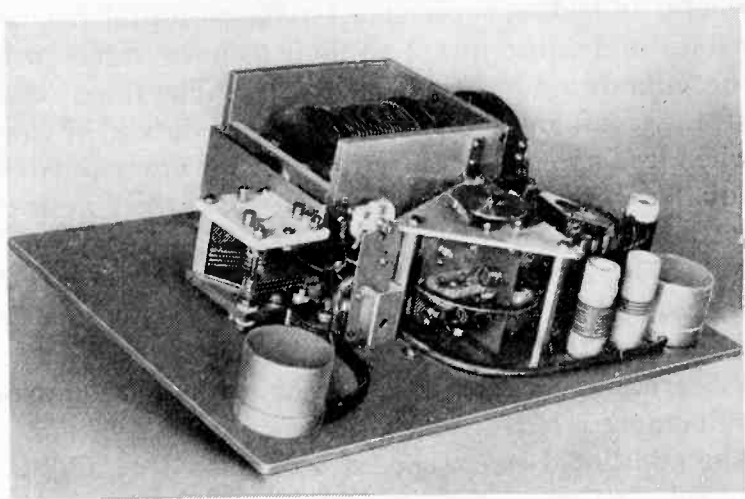

Fig. 3—Back-of-panel view of experimental model of twin-T impedance-measuring circuit.

of the instrument, showing the location of parts and the nature of the wiring.

The circuit elements, themselves, should obviously be as nearly perfect as possible. With respect to residual parameters, the most critical is the condenser C_B , across which the unknown admittance is connected.

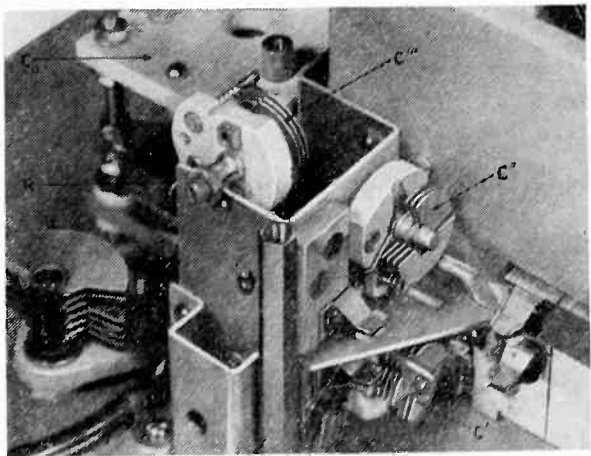

Fig. 4—Close-up view of assembly carrying condensers C' and C'' used at 30 megacycles. The lead from the aluminum block brought out through the side of the susceptance condenser to these condensers is less than half an inch long.

This condenser should be as large as possible, in order to cover the large ranges of susceptance that may be encountered in practice. From previous experience it has been found that an incremental range of 1000 micromicrofarads is generally satisfactory, the actual capacitance range becoming 100 to 1100 micromicrofarads for a linear direct-reading scale. With such relatively large capacitance values, residual inductance included between the condenser terminals is of great

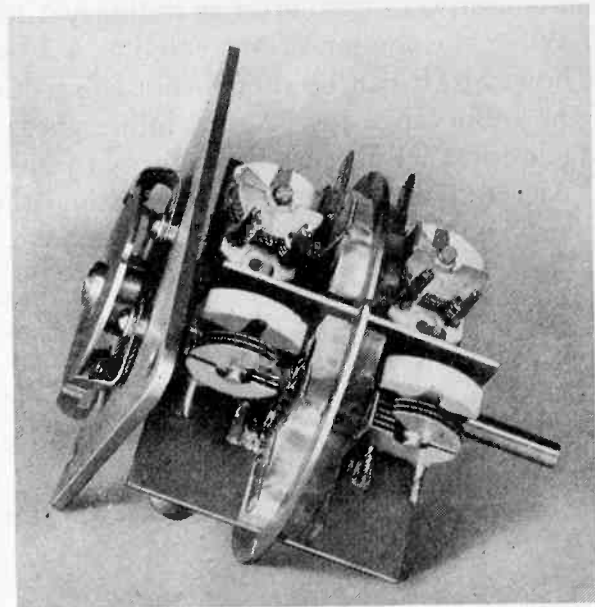

Fig. 5—Range switch used to change the scale of the conductance condenser. Different small condensers carried on this switch are connected in parallel with the C' and C'' condensers shown in Fig. 4 for operation at frequencies of 1, 3, and 10 megacycles.

has been realized by making the condenser essentially a 3-terminal device.

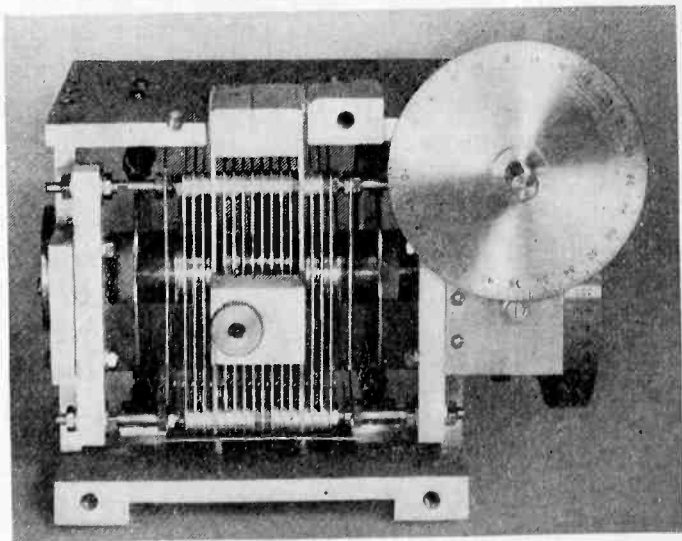

Fig. 6—View of susceptance condenser C_B showing the two aluminum blocks used to feed from the stator to the internal circuit and to the panel terminal, and brass disks grounding the rotor to the frame through low-inductance brushes.

¹⁰ It has been shown, for instance, that in a conventional type of precision condenser, designed for low-frequency service, the inductance may be of the order of 59×10^{-9} henrys. This inductance will cause an error of 10 per cent in capacitance measurement at a setting of 1100 micromicrofarads and a frequency of 6 megacycles. See R. F. Field and D. B. Sinclair, "A method for determining the residual inductance and resistance of a variable air condenser at radio frequencies," *Proc. I.R.E.*, vol. 24, pp. 255-274; February, 1936.

¹¹ For a discussion of current distribution in condenser stacks and the effect of different methods of feed on condenser inductance and resistance see D. B. Sinclair, "A high-frequency model of the precision condenser," *Gen. Rad. Exp.*, vol. 13, p. 10; October-November, 1938.

The 3-terminal construction follows naturally from the fact the the condenser must have one stator lead going to a terminal on the panel and another stator lead going to the junction point marked *b* in Fig. 1. Each of the leads has an inductance that would be measured as a part of the total condenser inductance if the condenser were treated as an ordinary 2-terminal device. When the condenser is treated as a 3-terminal device, however, it can be shown that the sectionalizing of the inductance into 2 lead inductances and a common inductance materially reduces the resultant errors. An equivalent circuit representing the condenser is shown¹² in Fig. 7.

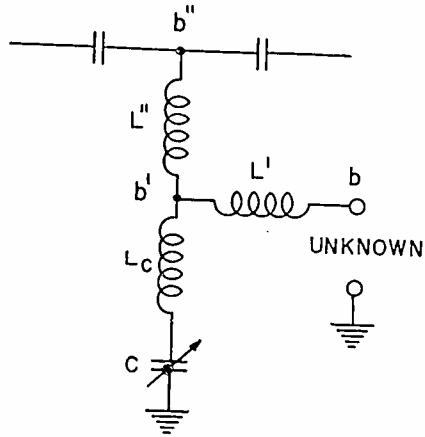

Fig. 7—Approximate equivalent circuit of susceptance condenser *C_B* showing residual inductances of leads to internal circuit and to panel terminal and common residual inductance in stack structure.

Under any condition encountered in practice with the twin-T, the conductance component of the admittance from point *b''* to ground is small compared with the susceptance. With regard to the effects of residual inductances, therefore, it is sufficiently accurate to treat the circuit as dissipationless.

The effect of the inductance *L'* of the lead to the panel terminal is simply to put a small positive reactance in series with the unknown admittance. To a first approximation, this causes the effective value *Y_{x'}*, of the unknown admittance measured by the circuit at point *b'*, to differ from the true value *Y_x*, appearing at point *b* by the amount shown in (5).

$$Y_{x'} = G_{x'} + jB_{x'} \cong \frac{G_x}{(1 - \omega L' B_x)^2} + j \frac{B_x}{1 - \omega L' B_x} \quad (5)$$

For capacitive unknown susceptances, the measured admittance components are therefore larger than the true values while, for inductive unknown susceptances, the measured admittance components are smaller than the true values.

The effect of the common inductance *L_c* is to make the effective capacitance of the standard condenser *C_e* larger than the static capacitance *C* by the amount shown in (6).

$$C_e = \frac{C}{1 - \omega^2 L_c C} \quad (6)$$

¹² For a justification of this equivalent circuit and the equivalent circuit of Fig. 5, in the 2-terminal case, see reference in footnote 10.

This effective increase in capacitance from point *b'* to ground above the static value, when an unknown susceptance is measured, makes the measured value, as read from the condenser dial, less than the true value, as shown in (7).

$$B_{x'} = \omega(C_{e1} - C_{e2}) \cong \frac{\omega(C_1 - C_2)}{1 - \omega^2 L_c(C_1 + C_2)} \quad (7)$$

where, as before, subscripts 1 refer to initial balance values and subscripts 2 to final balance values with the unknown admittance connected. The importance of the common inductance is immediately obvious when it is noted that the error in *B_{x'}* is approximately equal to the sum of the capacitance errors at each setting.

The 3-terminal construction, in practice, makes *L'* and *L_c* approximately equal, each being about half the inductance that would be measured at the terminals of a 2-terminal condenser. The error caused by common inductance is consequently reduced by the same factor. The additional error, caused by *L'*, is either additive or subtractive, depending upon the sign of the unknown susceptance to be measured but is never as large as the error caused by *L_c* because *B_x* is always less than $\omega(C_1 + C_2)$.

The inductance *L''* of the lead to the circuit junction point *b''* has no effect on the susceptance measurement since the susceptance from point *b'* to ground is made the same at both the initial and final balance points. It does affect the conductance measurement, however, because the circuit actually measures the change in conductance *G_{x''}* from point *b''* to ground

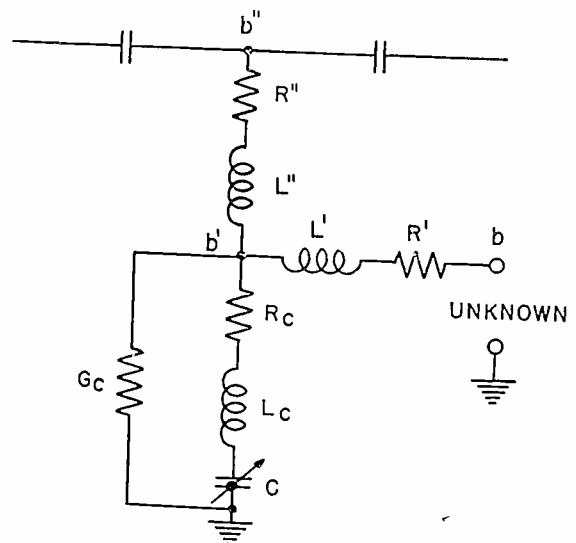

Fig. 8—Approximate equivalent circuit of susceptance condenser *C_B* including residual resistances caused by losses in metal structure and dielectric supports.

when the unknown admittance is connected. This conductance value is related to the true value *G_x* by (8).

$$G_{x''} \cong \frac{G_{x'}}{(1 - \omega^2 L'' C_{e1})^2} \cong \frac{G_x}{(1 - \omega^2 L'' C_{e1})^2 (1 - \omega L' B_x)^2} \quad (8)$$

Of these errors, the one caused by *L''* always makes the measured conductance appear too high, while the sense

of the error caused by L' depends upon the sign of the unknown susceptance.

The complete equivalent circuit for the variable condenser must include the ohmic resistances associated with each of the residual inductances and a conductive parameter to represent losses in the dielectric structure. Figure 8 is a satisfactory representation.¹²

The residual resistances R' and R'' of the condenser leads are so small that they have a negligible effect on the accuracy of the instrument. The conductance G_c , which represents the loss in the dielectric structure, is constant, independent of dial setting.¹² It therefore drops out when taking admittance differences by the parallel-substitution method. The common resistance R_c , however, causes an additional error in conductance measurement since it introduces, from point b' to ground, a conductance component G_o that varies with the dial setting according to (9).

$$G_o \cong R_c(\omega C_e)^2. \quad (9)$$

When measuring an unknown admittance that has a susceptive component not equal to zero, this conductance component will cause an error in conductance measurement δG , given by (10).

$$\delta G \cong R_c \omega^2 (C_{e2}^2 - C_{e1}^2) = -R_c \omega B_x' (C_{e1} + C_{e2}). \quad (10)$$

For capacitive unknown susceptances, this error tends to make the measured conductance less than the true value while, for inductive susceptances, it tends to make the measured conductance greater than the true value.

A photograph of the condenser used in the twin-T is shown in Fig. 6. Considerable attention was given, in the design of this condenser, to reduction of the small residual parameters causing the errors expressed in (5), (7), (8), and (10). The resultant outstanding constructional features are as follows:

1. Double end-feed of the rotor stack through two large brass disks, each grounded to the cast aluminum frame through two low-inductance brushes. Each brush provides 12 individual contacts to the disks, resulting in 48 points of current entry.

2. Double feed of the stator stack through projecting ears on two specially shaped stator plates. One pair of ears projects through a rectangular opening in the panel and supports the ungrounded UNKNOWN terminal. The other pair of ears projects through a rectangular opening in the side of the cast frame and serves as the junction point to the circuit marked b in Fig. 1. In order to minimize inductance, and to furnish a convenient mounting surface, a block of aluminum is inserted between each pair of ears.

3. Elimination of conventional binding posts as UNKNOWN terminals. It is interesting to note, from the standpoint of order of magnitude, that the inductance of a pair of binding posts, $\frac{3}{4}$ of an inch long by $\frac{3}{8}$ of an inch in diameter, spaced $\frac{3}{4}$ of an inch apart, is almost as large as the *total* residual inductance of the condenser measured from the panel.

Averaged values of the various residual parameters measured are tabulated below:

$$L' = 6.8 \times 10^{-9} \text{ henry}$$

$$L_c = 6.1 \times 10^{-9} \text{ henry}$$

$$L'' = 3.15 \times 10^{-9} \text{ henry}$$

$$R_c = 0.026 \text{ ohm.}$$

While extremely small, compared with those ordinarily found in precision variable condensers, the residual parameters listed are still the limiting factors that determine the upper frequency at which accurate measurements can be made. A short description of the methods of determining their values will indicate both the nature and order of magnitude of the errors that they produce.

1. Measurement of L_c

Equation (7) shows that, if an unknown susceptance B_x' is connected between point b' and ground, the change in dial reading of the standard condenser to restore balance does not give an accurate measurement of the unknown susceptance because of error caused by the common inductance L_c . The fact that this error is a function of the initial balance setting of the condenser leads to a simple method of determining the residual inductance that causes it.¹³

If a small fixed condenser is measured by connecting and disconnecting it from the UNKNOWN terminals on the panel, the susceptance B_x' appearing from point b' to ground will be constant, independent of the dial setting of the standard condenser, though different from the true value B_x because of the residual inductance L' . If this measurement is made with various values of initial capacitance C_1 and values of $C_1 - C_2$ plotted as a function of $C_1 + C_2$, a straight line will therefore result, having a slope equal to $-\omega L_c B_x' = \omega^2 L_c C_x'$ and an intercept with the ordinate axis equal to $B_x'/\omega = C_x'$. The inductance L_x therefore equals $-(1/\omega^2)$ (slope/intercept). A typical plot taken with the twin-T at a frequency of 30 megacycles is given in Fig. 9. The error caused by neglecting L_x is seen to become 10 per cent at an initial capacitance setting of about 300 micromicrofarads. Fig. 10 is a plot of the rise in capacitance δC caused by a value of L_c of 6.1×10^{-8} henry at a frequency of 30 megacycles. From this plot, C_o can be determined for any given capacitance setting C by simple addition.

2. Measurement of L''

Equation (8) shows that, if an unknown conductance G_x' is connected between point b' and ground, the conductance G_x'' measured by the circuit is not the same because of error caused by the lead inductance L'' . This error also depends upon the initial setting of the standard condenser.

¹³ See reference in footnote 10 for a description of this method applied to 2-terminal condensers.

If a small fixed resistor, having a negligible susceptive component,¹⁴ is measured by connecting and disconnecting it from the UNKNOWN terminals on the panel, the conductance G_x' appearing from point b' to

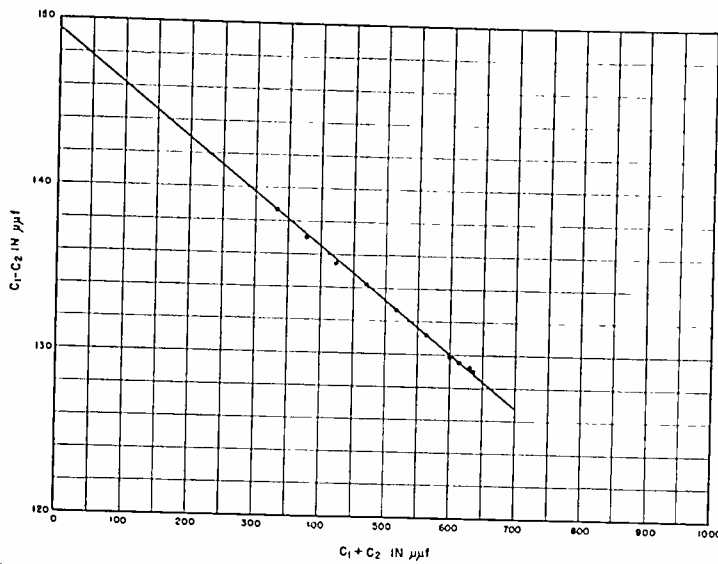

Fig. 9—Plot for determination of common internal inductance L_c of susceptance condenser C_B .
Slope = 0.0323
Intercept = 149.4 micromicrofarads
 $L_c = 6.08 \times 10^{-9}$ henry

ground will be constant, independent of dial setting of the standard condenser, though very slightly different from the true value G_x because of the residual inductance L' . If this measurement is made at different initial settings of the standard condenser, and

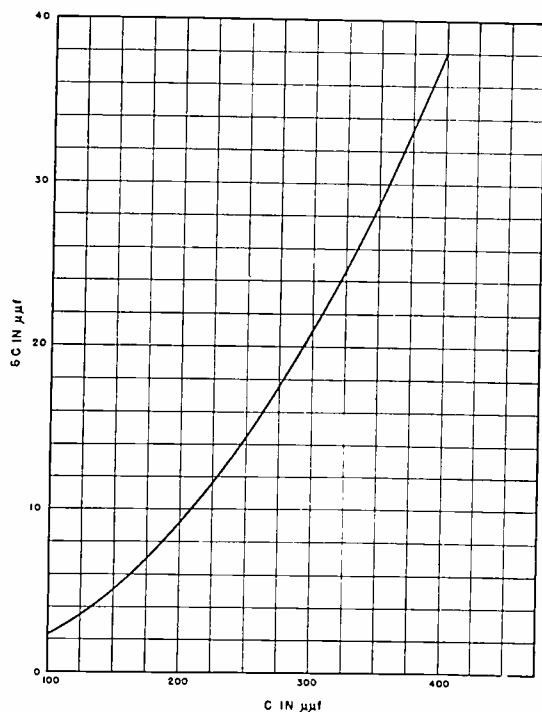

Fig. 10—Plot of capacitance rise δC caused by common inductance $L_c = 6.1 \times 10^{-9}$ henry, as a function of static capacitance setting of susceptance condenser C_B at a frequency of 30 megacycles.

values of $1/\sqrt{G_x''}$ plotted as a function of C_{c1} , a straight line again results, having a slope equal to $-(\omega^2 L''/\sqrt{G_x'})$ and an intercept with the ordinate axis equal to

¹⁴ International Resistance Company type F "metallized" resistors have been found satisfactory for this test.

$1/\sqrt{G_x'}$. The inductance L'' , therefore, equals $-(1/\omega^2)$ (slope/intercept). A typical plot taken with the twin-T at a frequency of 30 megacycles is given in Fig. 11. The error in conductance measurement caused by neglecting L'' is seen to become 5 per cent at a capacitance setting of about 225 micromicrofarads.

3. Measurement of R_c

Equation (10) shows that, if an unknown admittance, having both conductive and susceptive components, is connected between point b' and ground there is a further error in conductance measurement caused by the change in effective conductance of the standard condenser between the initial and final balance setting. This error, caused by the common re-

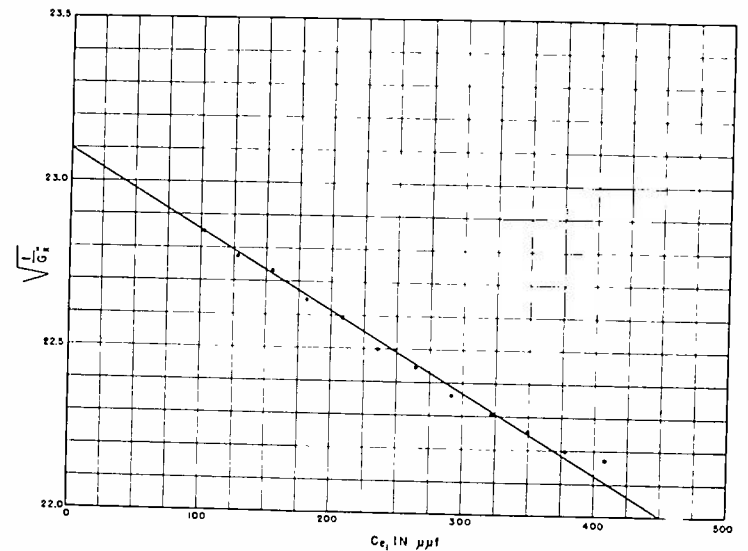

Fig. 11—Plot for determination of residual inductance L'' in lead from circuit to susceptance condenser C_B .
Slope = 2440×10^6
Intercept = 23.10
 $L'' = 2.97 \times 10^{-9}$ henry

sistance R_c , is a function both of the initial setting and the unknown susceptance.

The error is most pronounced when the unknown admittance has a small conductive component associated with a large susceptive component. It is therefore convenient to use the conductance measurements necessarily obtained while making the susceptance measurements required for the determination of L_c . From the values of G'' , between point b'' and ground, as read from the dial, the values of G' , between points b' and ground, can be obtained from the plot of Fig. 11. Each of these values is the sum of the constant conductive component G_x' and the change in condenser conductance G between the condenser settings, C_1 and C_2 . A plot of G' as a function of $C_{c1} + C_{c2}$ therefore yields a straight line having a slope equal to $-R_c \omega B_x' = -R_c \omega^2 C_x'$ and an intercept with the ordinate axis equal to G_x' . From Fig. 9, C_x' can be obtained from the intercept with the ordinate axis and $R_c = -(1/\omega^2)$ (slope/ C_x'). The conductance data corresponding to the susceptance data of Fig. 9 are shown plotted in Fig. 12. Neglect of the residual resistance R_c will result in apparent negative values of conductance for this particular un-

known condenser at initial settings of the standard condenser above about 325 micromicrofarads. At frequencies below 30 megacycles, R_c decreases approximately as the square root of the frequency until its effect becomes negligible.

4. Measurement of L'

Equation (5) shows that, if an unknown admittance is connected across the UNKNOWN terminals, both the conductive and susceptive components measured by the instrument from point b' to ground are in error because of the lead inductance L' . Since this type of error is independent of the setting of the standard condenser, it must be determined by a somewhat different method from those previously described.

A practical method of determining the value of L' is as follows:

1. Measure the susceptance B_x' of a condenser having a relatively good power factor.
2. With the condenser left connected across the UNKNOWN terminals, measure the change in conductance G_x' when a resistor, having a relatively small susceptive component, is connected across it.
3. Repeat these measurements with a number of condensers of different capacitance but with the same resistor.

By means of the corrections previously discussed, the values of the conductance and susceptance changes from point b' to ground can be found. To a first ap-

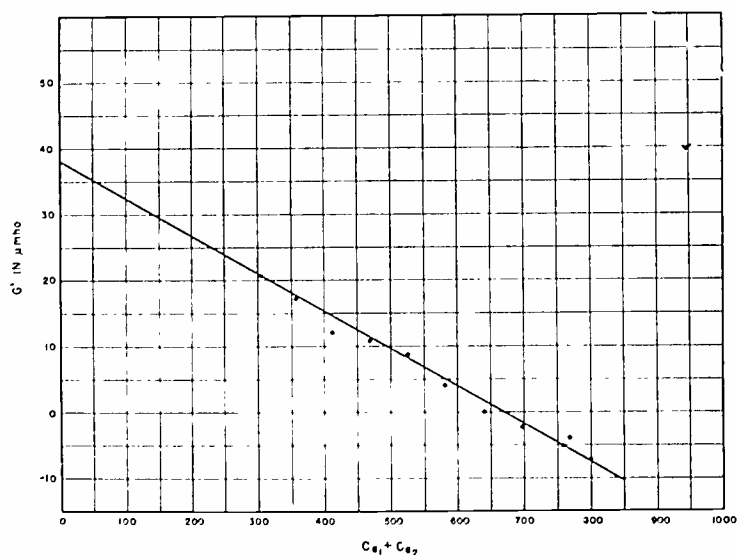

Fig. 12—Plot for the determination of the common internal resistance R_c of the susceptance condenser.

$$\begin{aligned} \text{Slope} &= 0.0575 \times 10^6 \\ \text{Intercept} &= 38.2 \text{ micromhos} \\ R_c &= 0.027 \text{ ohm} \end{aligned}$$

proximation, B_x' can be used in the conductive term of (5) instead of B_x . A plot of $1/\sqrt{G_x'}$ as a function of B_x' yields a straight line, having a slope equal to $-(\omega L'/\sqrt{G_x'})$ and an intercept with the ordinate axis equal to $1/\sqrt{G_x'}$. The inductance L' , therefore, $= (1/\omega)(\text{slope}/\text{intercept})$. The value of L' found from this plot can now be used to find B_x from B_x' and a second approximation made by plotting $1/\sqrt{G_x'}$ as a function of B_x . Fig. 13 shows a second-approximation

straight-line plot of data taken at a frequency of 30 megacycles.

The errors caused by the various residual parameters in the standard condenser are seen to be of paramount importance at frequencies of the order of 30 megacycles. Since they depend greatly upon different factors, such as the sign of the unknown susceptance,

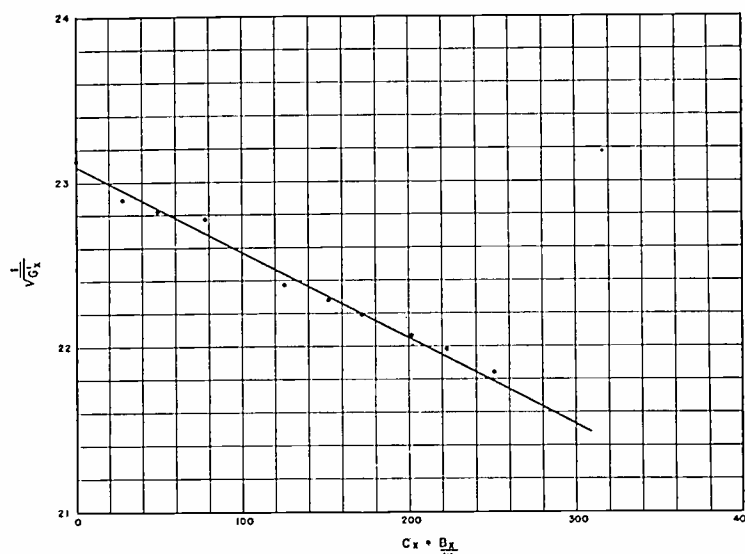

Fig. 13—Plot for determination of residual inductance L' of lead from susceptance condenser C_B to panel terminals.

$$\begin{aligned} \text{Slope} &= 5220 \times 10^6 \\ \text{Intercept} &= 23.09 \\ L' &= 6.36 \times 10^{-9} \text{ henry} \end{aligned}$$

the relative magnitudes of the unknown susceptive and conductive components, and the initial setting of the standard condenser, the over-all error cannot be simply arrived at for general conditions. With accurate values of the residual parameters known, however, systematic application of the corrections expressed in (5) to (10) will yield results that are limited in accuracy mainly by the calibration accuracy of the instrument. As the frequency is lowered, the errors quickly become negligible since they all vary about as the square of the frequency.

The effects of residual parameters in the other condensers and associated wiring have all been made negligible at frequencies up to 30 megacycles by using small low-loss capacitances. Approximate values are as follows:

$$\begin{aligned} C_G &\cong 10\text{--}30 \mu\mu\text{f} \\ C' = C'' &\cong 54 \mu\mu\text{f} \text{ for } 100\text{-}\mu\text{mho range at } 1 \text{ Mc} \\ &\cong 31 \mu\mu\text{f} \text{ for } 300\text{-}\mu\text{mho range at } 3 \text{ Mc} \\ &\cong 17 \mu\mu\text{f} \text{ for } 1000\text{-}\mu\text{mho range at } 10 \text{ Mc} \\ &\cong 10 \mu\mu\text{f} \text{ for } 3000\text{-}\mu\text{mho range at } 30 \text{ Mc} \\ C''' &\cong 3 \mu\mu\text{f} \end{aligned}$$

The standard resistor, denoted by R in Fig. 1, is of the straight-wire type. The stray capacitance occurring across its terminals is augmented by a small trimming capacitance, adjusted to give essentially zero effective reactance¹⁶ at frequencies up to 30 megacycles.

¹⁶ See references in footnotes 8 and 9 for an analysis of the effect of added capacitance across a resistor having a small inductive reactance.

CONCLUSION

Through the use of a new circuit, the twin-T, an instrument has been designed that covers a frequency range from 0.5 to 30 megacycles. The upper frequency limit, at which precise measurements can be made by

null methods, has thereby been extended greatly over the limit commonly found in commercial radio-frequency bridges. By means of a systematic analysis of errors, corrections have been determined that enable the full precision to be translated into accuracy.

Space-Charge Limitations on the Focus of Electron Beams*

B. J. THOMPSON†, FELLOW, I.R.E., AND L. B. HEADRICK†, MEMBER, I.R.E.

Summary—A calculation has been made of the effect of space charge in the region between the lens and the focal point on the focus of electron beams of rectangular and circular cross section under conditions of zero velocity of electron emission and with the lenses free from spherical aberration.

The results show that for an electron beam of circular cross section having a given current and voltage, and included in a cone of a given initial angle, there is a resultant minimum beam diameter at the focal point a given distance from the lens which cannot be reduced by changing the radial force, or focusing component, of the lens. The value of the minimum beam diameter is nowhere zero and it increases more rapidly than the distance between the lens and focal point. Thus, for the production of a television picture with a given angle of deflection the definition should improve as the screen approaches the lens.

For a beam of circular cross section the factors determining this minimum spot size at a given distance from the lens are the initial beam radius R_0 , the beam velocity V_a , and the current I . The spot size may be reduced only by increasing R_0 , increasing V_a , or decreasing I .

For a rectangular beam with one dimension infinite, the minimum beam thickness depends upon the perpendicular force or focusing component supplied by the lens. The beam thickness may be zero up to a given distance from the lens and beyond this distance the minimum beam thickness increases with distance from the lens. To increase the distance from the lens at which the beam thickness can be made zero, an increase in the initial beam thickness or in the beam velocity or a decrease in current would be required.

The spreading of the electron beam between the final lens and the luminescent screen, caused by space charge, is a small fraction of the spot size obtained in direct-viewing kinescopes as used for television reception. However, this is not necessarily true of the projection-type kinescope where much higher values of beam current density are generally employed. Because at such high values of beam-current density the position of the focal point will change considerably with beam current or with picture-signal modulation there may be a large change in spot size at the screen.

INTRODUCTION

IN cathode-ray tubes for television and oscillograph purposes, it is desired to obtain a small beam diameter at the screen with a relatively large current in the beam, because spot size determines the definition and the current the brilliance of the image or trace. From the point of deflection to the screen, the electron beam passes through a constant potential region where if the effect of the deflecting field is neglected no focusing force exists. All focusing is accomplished by radial components of velocity given the electrons toward the axis of the beam as they leave the electron gun or final lens. If we assume that all electrons have the same axial velocity and that these initial inward radial components of velocity are proportional to the radial distances of the electrons from

the axis, the only factor which prevents a point focus on the beam axis is the mutual repulsion between the electrons in the beam. In beam tubes for various applications it is usually desired to obtain a narrow-line focus at the collector, with an electron beam of rectangular cross section, the width of which is large compared to the thickness. In this type of tube all of the focusing is done in the narrow dimension of the beam. It is clear that electron repulsion will affect the focus of such a beam as well. This paper discusses the limitations to beam focus resulting from such electron repulsion for both of the above-mentioned types of electron beams.

The field of electron optics has grown rapidly during the last few years and numerous papers have appeared on this subject. However, little attention has been paid to the effect of electron space charge on the focus of the beam in the region between the final lens and the screen. E. E. Watson¹ in an early paper calculated the spreading of an essentially parallel cylindrical electron beam moving in a field-free space produced by the electron space charge, but the results are not in a form which is readily adaptable to focused electron beams. Recently B. von Borries and J. Dosse² have calculated the spreading of electron beams by space charge and have applied the results to several examples.

In the present paper the effect of space charge on the focus of electron beams of both circular and rectangular cross section is calculated.

The following are the symbols used in the development of equations:

- r = beam radius in centimeters
- r_m = minimum beam radius in centimeters
- R_0 = initial beam radius in centimeters
- V_r = initial radial component of electron velocity inward in centimeters per second
- v_r = radial component of electron velocity inward in centimeters per second
- $\ddagger I$ = electron beam current in electrostatic units

* Decimal classification: R 583. Original manuscript received by the Institute, February 23, 1940. Presented, Rochester Fall Meeting, November 9, 1937.

† Research and Engineering Department, RCA Manufacturing Company, Inc., Harrison, N. J.

¹ E. E. Watson, "Dispersion of electron beams," *Phil. Mag.*, 7th series, vol. 3, p. 849, 1927.

² B. von Borries and J. Dosse, "Spreading of electron beams by space charge," *Archiv. für Electrotech.*, vol. 32, pp. 221-232, 1938.

- $\ddagger V_d$ = electron velocity along beam axis in centimeters per second
 m = electron mass in grams
 e = electronic charge in electrostatic units
 $\epsilon = 2.718$ = base of natural logarithms
 $2y$ = beam thickness in centimeters
 $2y_m$ = minimum beam thickness in centimeters
 $2Y_0$ = initial beam thickness in centimeters
 V_y = initial y component of electron velocity toward the beam axis in centimeters per second
 v_y = y component of electron velocity toward the beam axis in centimeters per second
 $\ddagger I_1$ = electron beam current per unit width of beam in electrostatic units per centimeter
 v_d = electron velocity along beam axis in centimeters per second where there is an axial potential gradient
 E_t = plate voltage in volts
 d = distance in centimeters from lens to any point of the beam with radius r
 D = distance from lens to screen or collector in centimeters
 t = time in seconds required for the beam to reach any radius r
 t_m = time in seconds required for the beam to reach the minimum radius r_m

DERIVATION OF EQUATIONS FOR A BEAM OF CIRCULAR CROSS SECTION

The equations derived are based upon the following assumptions:

(1) The radial component of the velocity of the electrons as they leave the electrostatic focusing field, or lens, is assumed to be proportional to their distance from the beam axis.

(2) The beam is assumed to be a uniform cylinder of electrons moving in a field-free space, except for the field due to the electron charge density of the beam.

(3) The axial velocity of the electrons in the beam is assumed to be constant.

Assumption (1) is the condition for a point focus of the beam, when the effects of space charge of the beam, as well as lens aberration and velocity of electron emission, are neglected.

Assumption (2) introduces an approximation which is very close since for the electron beams considered the beam radius varies from nearly zero to about 0.2 centimeter while the length lies between 4 and 40 centimeters.

Assumption (3) is justified because the velocity distribution of the major portion of the electrons from a thermionic cathode is extremely small compared with the final velocity of the electron beam in cathode-ray tubes, and because the difference in po-

\ddagger Where the resulting equations are converted into final form for calculation and for the curves, the electron velocity along the beam axis V_d is given in volts and the currents I or I_1 are given in amperes or amperes per centimeter respectively.

tential between the center and the boundary of the beam resulting from space-charge effects is very small compared with the beam voltage.

It can easily be seen that these assumptions represent a case which can only be approximated experimentally. Because in practice the deviations from the assumptions tend to increase the size of the focused spot, it is expected that the results which follow set a lower limit to the beam size obtainable with electron lenses in a high vacuum.

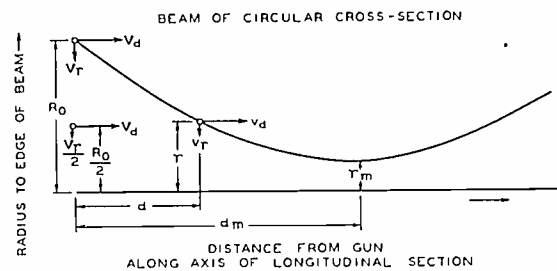

Fig. 1—Diagram of a half-longitudinal section of a beam of circular cross section beyond an electron lens.

Fig. 1 represents a longitudinal section of a beam of circular cross section with one surface only shown. If the electron density across the circular section of the beam is constant and the radial component of velocity is proportional to the radius initially, they will remain so throughout the length of the beam; therefore, only the outer surface need be considered.

The radial kinetic energy of an electron in the outer surface is given by

$$\frac{mv_r^2}{2} = \frac{mV_r^2}{2} - \int_{R_0}^r \frac{dE}{dr} cdr. \quad (1)$$

The last term is the work done on the electron as it moves against the voltage gradient dE/dr at the surface of the beam from the radius R_0 to any radius r .

The voltage gradient at the surface of the beam (assumed to be cylindrical) is equal to the electrostatic flux per unit area. Thus

$$\frac{dE}{dr} = \frac{4\pi \left(\frac{I}{V_d} \right)}{2\pi r} = \frac{2I}{rV_d}$$

where

$$\frac{I}{V_d} = \text{charge per unit length.}$$

Then

$$\frac{mv_r^2}{2} = \frac{mV_r^2}{2} - \int_{R_0}^r \frac{2Ie}{V_d} \frac{1}{r} dr \quad (3)$$

$$= \frac{mV_r^2}{2} - \frac{2Ie}{V_d} \log \frac{R_0}{r} \quad (4)$$

and

$$r = R_0 \epsilon^{-(V_d m / 4Ie)(V_r^2 - v_r^2)}. \quad (5)$$

At the point of minimum radius r_m , $v_r = 0$; hence,

$$r_m = R_0 \epsilon^{-(V_d m / 4Ie)V_r^2}. \quad (6)$$

We have in the above a value for the minimum radius of the beam, but no means of telling at what distance d_m this radius occurs. If we can determine the

time t required for the beam to reach any radius r , in the equation

$$d = V_d t \quad (7)$$

we shall have a complete solution for the shape of the beam.

Since the acceleration of the electron is equal to the

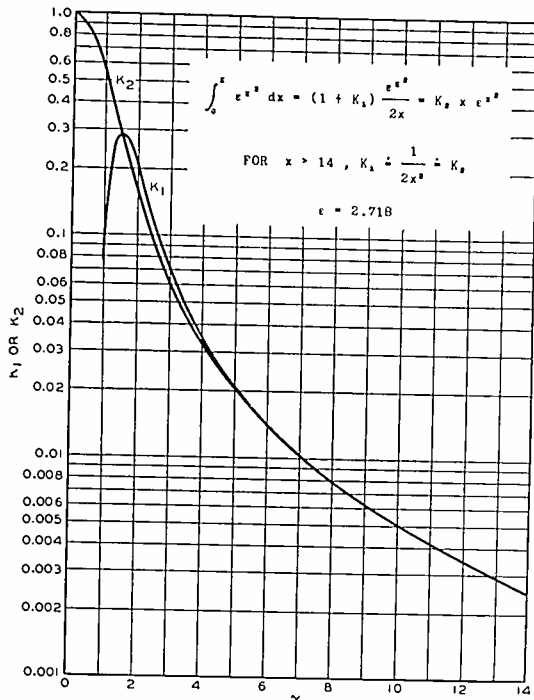

Fig. 2—Values of the functions K_1 and K_2 in the equation for the integral ϵ^{x^2} for $x=0$ to 14.

force acting on it in a radial direction divided by its mass, we may write

$$\frac{dv_r}{dt} = - \frac{2Ie}{V_d m} \frac{1}{r} \quad (8)$$

whence

$$dt = - \frac{V_d m}{2Ie} r dv_r. \quad (9)$$

If we substitute the value of r from (5), we have

$$t = - \int_{v_r}^{v_r} \frac{V_d m}{2Ie} R_0 \epsilon^{-(V_d m/4Ie)(V_r^2 - v_r^2)} dv_r. \quad (10)$$

The substitution of

$$x = \left(\frac{V_d m}{4Ie} \right)^{1/2} v_r$$

in (10) results in

$$t = \left(\frac{V_d m}{Ie} \right)^{1/2} R_0 \epsilon^{-(V_d m/4Ie)V_r^2} \int_{(V_d m/4Ie)^{1/2} v_r}^{(V_d m/4Ie)^{1/2} V_r} \epsilon^{x^2} dx \quad (11)$$

and

$$t_m = \left(\frac{V_d m}{Ie} \right)^{1/2} R_0 \epsilon^{-(V_d m/4Ie)V_r^2} \int_0^{(V_d m/4Ie)^{1/2} V_r} \epsilon^{x^2} dx. \quad (12)$$

The value of the integral must be obtained from tabulated values. However, the values given in available tables do not cover a sufficient range for a practical application of this equation to focusing of electron beams. Therefore, to extend the range of integral of

$$\epsilon^{x^2} dx,$$

W. R. Ferris of this laboratory has obtained the following solution:

$$\int_0^x \epsilon^{x^2} dx = (1 + K_1) \frac{\epsilon^x}{2x} = K_2 x \epsilon^{x^2}.$$

The curves of Fig. 2 give values of the functions K_1 and K_2 from which values of the integral

$$\int \epsilon^{x^2} dx$$

can be obtained from $x=0$ to $x=14$. The values of the functions K_1 and K_2 are given rather than values of the integral because of the enormous range of values covered by the integral which would require a large amount of space for accuracy.

Equations (5), (7), and (11) give us the complete solution for the shape of the longitudinal section of the beam.

The force acting on an electron is proportional to its radial distance from the axis of the beam. Hence, if the initial radial components of velocity are proportional to the radial distances, all electrons will reach zero radial velocity in the same time after having traveled inward a distance proportional to their radial distances. Thus the beam retains its initial uniform distribution and lies entirely within the boundary we have determined.

The results of the above derivation may be put into the following form for convenient use.

On substituting (11) and (12) into (7), we obtain, respectively,

$$d = V_d \left(\frac{V_d m}{2Ie} \right)^{1/2} R_0 \epsilon^{-(V_d m/4Ie)V_r^2} \int_{(V_d m/4Ie)^{1/2} v_r}^{(V_d m/4Ie)^{1/2} V_r} \epsilon^{x^2} dx \quad (13)$$

$$d_m = V_d \left(\frac{V_d m}{2Ie} \right)^{1/2} R_0 \epsilon^{-(V_d m/4Ie)V_r^2} \int_0^{(V_d m/4Ie)^{1/2} V_r} \epsilon^{x^2} dx. \quad (14)$$

Equations (6) and (14) show that the factors determining the minimum spot size at any given distance from the final lens are the initial radius R_0 , the beam velocity V_d , and the beam current I . For given values of the other two parameters, the spot size at a given distance may be reduced only by increasing R_0 , increasing V_d , or decreasing I . The equations show, a further item of interest, that the minimum spot size decreases more rapidly than d , so that for cathode-ray-tube television reception the picture definition should be improved as the screen approaches the gun for a constant deflection angle. The minimum value of beam diameter at a given distance from the screen is also a function of the radial component of velocity V_r supplied by the focusing field, but this minimum value cannot be reduced below a certain value, for given values of R_0 , V_d , and I , by changing V_r . The relations between these variables will be shown by the curves of Fig. 3.

For the purpose of calculation (5), (6), (13), and (14) may be put into a still simpler form by substitution as follows:

$$r = R_0 \frac{\epsilon^{-AB}}{\epsilon^{-A_1 B}} \quad (15)$$

$$r_m = R_0 \epsilon^{-AB} \quad (16)$$

$$d = \frac{(1.151 V_d^{3/4} \times 10^{-2})}{(I^{1/2})} R_0 \epsilon^{-AB} \int_{(A_1 B)^{1/2}}^{(AB)^{1/2}} \epsilon^{x^2} dx \quad (17)$$

$$d_m = \frac{(1.151 V_d^{3/4} \times 10^{-2})}{(I^{1/2})} R_0 \epsilon^{-AB} \int_0^{(AB)^{1/2}} \epsilon^{x^2} dx \quad (18)$$

where

$$B = \frac{m \times 10^{-2}}{2.016e} \quad (19)$$

$$A = \frac{V_r^2 V_d^{1/2}}{I} \quad (20)$$

$$A_1 = \frac{v_r^2 V_d^{1/2}}{I} \quad (21)$$

It must be understood that V_d the beam velocity in centimeters per second is related to voltage simply by

$$V_d = 5.97 \times 10^7 E_A^{1/2}$$

where E_A is the potential of the final anode with respect to the cathode. This transformation is made without change of symbols and, therefore, in these equations V_d is expressed in volts and I is given in amperes, while V_r and v_r remain in centimeters per second.

It can be seen by examination of (15), (16), (17), and (18) that if a series of values of A are selected arbitrarily in a given range and substituted in these equations, values of r and d will be obtained for given values of beam current and voltage which can be used to plot longitudinal sections of the electron beam.

RESULTS FOR A BEAM OF CIRCULAR CROSS SECTION

1. Initial Radial Component of Velocity Variable—Beam Current, Voltage, and Initial Radius Held Constant

The curves in Fig. 3 show the outer edge of the electron beam for different values of radial component of electron velocity V_r , supplied by the focusing field for a beam of initial radius of 0.1 centimeter and current of 1×10^{-3} ampere at 10,000 volts. With small values of V_r , the minimum value of the beam radius is rather large and at some distance from the lens. As V_r is increased, the minimum beam radius r_m decreases and follows the curve labeled locus of minimum points. It will be noted that adjusting V_r to cause the minimum beam radius to occur at a given distance from the lens does not give the absolutely smallest spot size at this distance, as indicated by the difference between the two curves marked locus of minimum points and minimum beam radius for focus at any distance from the electron gun or lens. This difference means that when the beam is focused for the smallest spot size

on a screen at a given distance from the lens, the beam has a smaller radius at some point between the lens

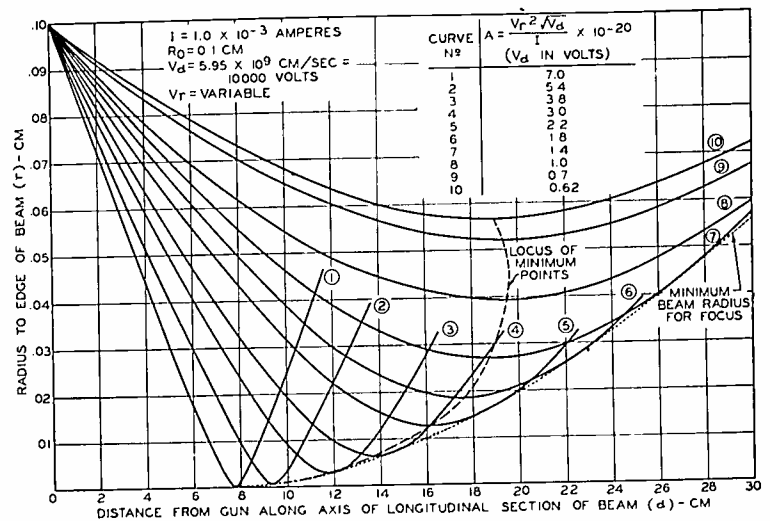

Fig. 3—Half-longitudinal sections of an electron beam of circular cross section with the initial radial component of electron velocity as a parameter. The other variables, i.e., beam current, initial radius, and voltage are held constant.

and screen. If R_0 is changed, corresponding values of r and d are changed in the same ratio.

2. Beam Current Variable—Beam Voltage, Initial Radius, and Initial Radial Component of Velocity Held Constant

The curves of Fig. 4 show the outer edge of the electron beam for different values of beam current I , for a beam of initial radius 0.1 centimeter, at 10,000 volts and $V_r = 1.036$ volts. The minimum beam radius is large for large values of beam current and decreases as the beam current is decreased according to the curve marked locus of minimum points. Here again it will be noted that the smallest spot size on a screen is not obtained by producing the minimum point of the beam at the screen.

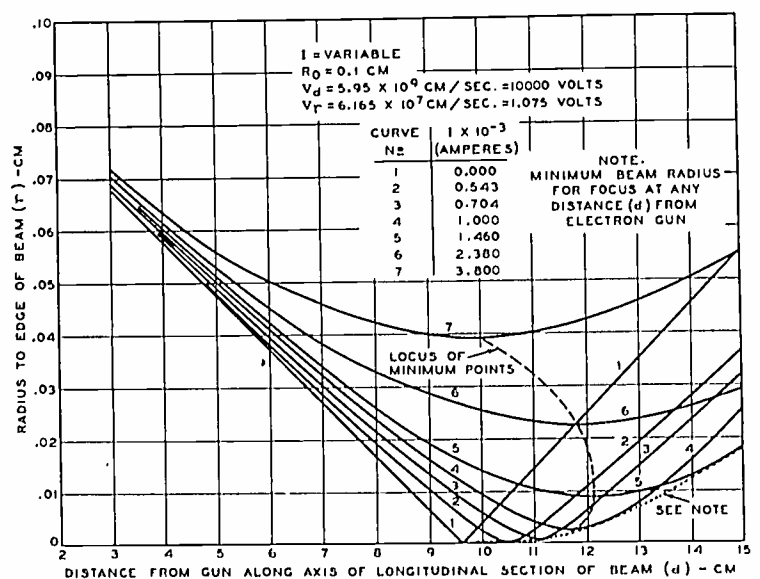

Fig. 4—Half-longitudinal sections of an electron beam of circular cross section with the beam current as a parameter. The other variables, i.e., initial beam radius, beam voltage, and initial radial component of electron velocity are held constant.

3. Beam Voltage Variable—Beam Current, Initial Radius, and Initial Radial Component of Velocity Held Constant

The curves of Fig. 5 show the outer edge of the electron beam for different values of beam voltage V_d for the beam current of 1×10^{-3} ampere, initial radius 0.1 centimeter, and $V_r = 1.036$ volts. Here it will be

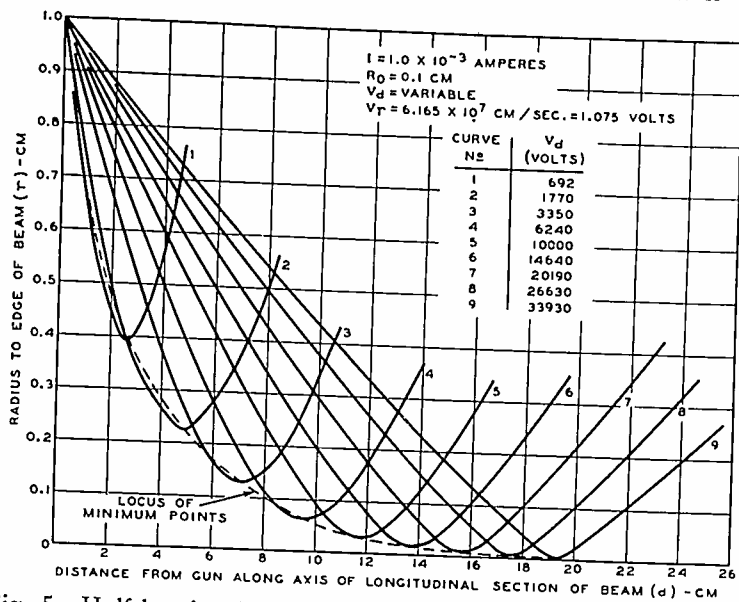

Fig. 5—Half-longitudinal sections of an electron beam of circular cross section with the beam voltage as a parameter. The other variables, i.e., initial radial component of electron velocity, beam current, and initial beam radius are held constant.

noted that the minimum beam radius decreases rather rapidly with increasing beam voltage as well as occurring at a greater distance from the lens.

4. Initial Beam Radius Variable—Beam Current, Voltage, and Initial Radial Component of Velocity Held Constant

Here the curves of Figs. 6 and 7 are plotted as a function of beam angle $2R_0/d_m$ which for constant values of d_m represent changes in R_0 , and the line width in per cent of the theoretical value for a 441-line picture. The 441-line picture is assumed to contain 400 scanning lines and a 33 per cent overlap of lines is considered to be allowable in the high lights of the picture for the direct-viewing kinescope. Due

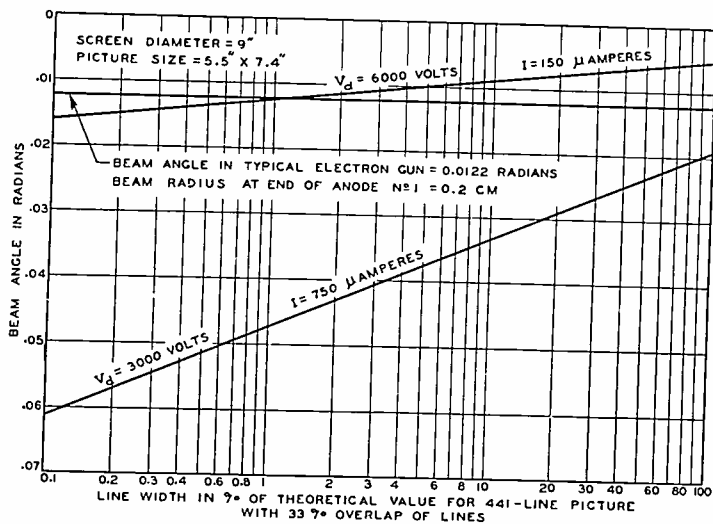

Fig. 6—Percentage of the theoretical line width which can be attributed to space charge in the region between lens and focal point as a function of the initial beam angle is shown for a 441-line picture on a 9-inch, direct-viewing kinescope. The variables, i.e., beam voltage, current, and initial radial component of electron velocity are held constant for each curve.

to a certain amount of loss of detail in a lens used for projection the allowable overlap of lines on the projection kinescope is arbitrarily reduced to 16 per cent, about half that for the direct-viewing kinescope. The

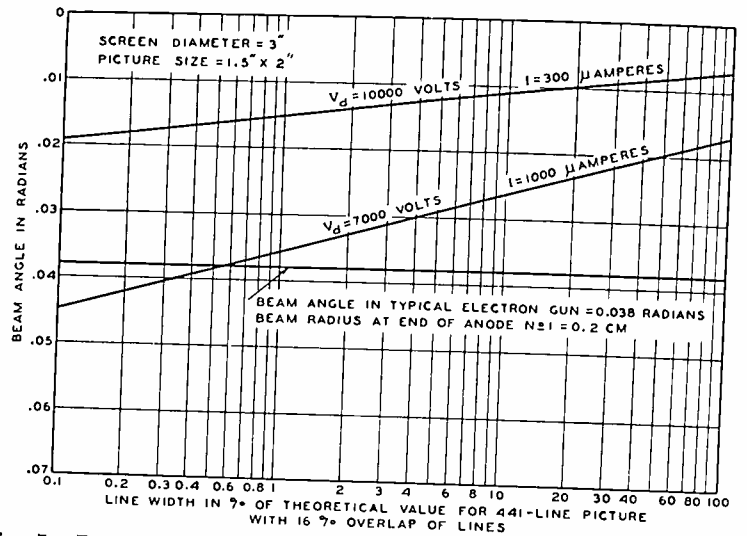

Fig. 7—Percentage of the theoretical line width which can be attributed to space charge in the region between lens and focal point as a function of the initial beam angle is shown for a 441-line picture on a 3-inch projection kinescope. The variables, i.e., beam voltage, current, and initial radial component of electron velocity are held constant for each curve.

purpose of plotting the data in this form is to facilitate comparison with results obtained in developmental kinescopes used for television reception. The curves in Fig. 6 are calculated for two different values of beam current and voltages for a 9-inch diameter tube, with a picture size of $5\frac{1}{2} \times 7\frac{3}{8}$ inches. The vertical line shows the beam angle for the above tube with an initial beam radius of 0.2 centimeter and a lens-to-screen distance of 35.5 centimeters. The intersection of this vertical line with curve (1) shows that a maximum of about 1.5 per cent of the actual line width required for a 441-line picture could be attributed to space-charge spreading for a beam current of 150 microamperes at 6000 volts, which is a normal operation condition for a 9-inch kinescope. However, if it is desired to operate the tube at 3000 volts the beam current would have to be increased to about 750 microamperes to obtain the same light output. Here we see from curve (2) that a spot size larger than that desired could be due to space-charge spreading of the beam. Therefore, to meet these requirements under ideal focusing conditions, the beam angle would have to be increased. The increase in beam angle introduces more aberration into the electron lens system and more distortion into the deflection. This example brings out forcibly one reason for using high second-anode voltages for cathode-ray tubes intended for television use.

The curves in Fig. 7 are of the same type as those in Fig. 6 except that they were calculated for a 3-inch diameter projection kinescope with a picture 1.5 by 2 inches for a beam current of 300 microamperes at 10,000 volts, curve (1), and a beam current of 1000 microamperes at 7000 volts, curve (2). The latter

condition can readily be obtained as shown by the intersection of the vertical line for a developmental kinescope. These data indicate that only a small percentage of the spot size required for a 441-line picture can be attributed to space charge.

DERIVATION OF EQUATIONS FOR A BEAM OF RECTANGULAR CROSS SECTION

Fig. 8 represents a longitudinal section of a beam of rectangular cross section with one surface only shown. It is assumed that the beam is very wide compared to its thickness, and that all focusing is done in the latter dimension. As a further limitation of the scope of the discussion, it is assumed that all focusing is due to transverse components of velocity given the electrons at some point to be considered the initial point, and that no transverse voltage gradients exist in the beam beyond this initial point, except those due to the electron space charge. There is a longitudinal voltage gradient due to the potential of the anode. However, for the moment we shall neglect this longitudinal voltage gradient and introduce its effect later.

Let us consider a beam of electrons of infinite width, thickness equal to $2y$, longitudinal velocity equal to v_a , and carrying a current I per centimeter width. If there is no longitudinal voltage gradient the transverse voltage gradient at the edge of the beam is given by

$$\frac{dE}{dy} = -4\pi\rho y \quad (22)$$

where

$$\rho = -\frac{I}{2v_a y} \quad (23)$$

whence

$$\frac{dE}{dy} = \frac{2\pi I}{v_a} \quad (24)$$

It is thus concluded that the gradient at the edge of the beam is independent of the thickness of the beam. Further, it is to be seen that the gradient at any distance y' less than y from the longitudinal axis is given by

$$\frac{dE}{dy} = \frac{2\pi I y'}{v_a y} \quad (25)$$

if the electron density is uniform over the thickness of the beam.

At the initial point it will be assumed that the electrons at the outer edge of the beam have a longitudinal velocity v_a , and a transverse velocity toward the axis V_y , and that the beam has a thickness equal to $2y_0$. The longitudinal velocity is constant across the thickness of the beam, while the transverse velocity is proportional to the distance y' from the axis.

Since the transverse voltage gradient is proportional to the distance y' from the axis of the beam, and we have assumed the transverse velocities to be likewise so proportional, it follows that the electrons inside the boundary will traverse paths similar to those of the

border electrons, and hence the uniform distribution will be maintained. Thus, we need consider only the boundary conditions.

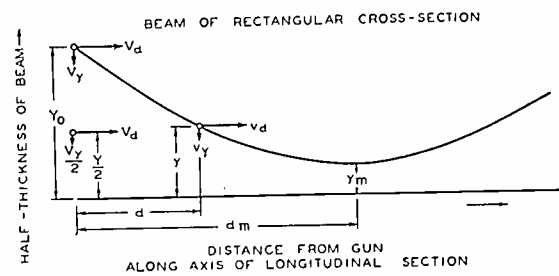

Fig. 8—Diagram of a half-longitudinal section of a beam of rectangular cross section beyond an electron lens.

At any time t after a boundary electron passes the initial point, its distance from the longitudinal axis of the beam is given by

$$y = y_0 - \int_0^t v_y dt \quad (26)$$

where v_y is the transverse velocity, as given by

$$v_y = V_y - \int_0^t \frac{dE}{dy} \frac{e}{m} dt, \quad (27)$$

where e and m are, respectively, the charge and the mass of the electron. From (24) we may rewrite (27) as follows

$$v_y = V_y - \int_0^t \frac{2\pi I e}{m v_a} dt. \quad (28)$$

Since the electron has an initial longitudinal velocity V_a and is under a longitudinal gradient E_b/D , we may write

$$v_a = V_a + \frac{E_b e}{D m} t. \quad (29)$$

If we substitute (29) and (28) we obtain

$$v_y = V_y - \int_0^t \frac{2\pi I e}{m} \left(V_a + \frac{E_b e}{D m} t \right)^{-1} dt \quad (30)$$

which on integration becomes

$$v_y = V_y - \frac{2\pi I D}{E_b} \log_e \left(1 + \frac{E_b e}{V_a D m} t \right). \quad (31)$$

We shall now substitute this value for v_y in (26) which results in

$$y = y_0 - \int_0^t \left[V_y - \frac{2\pi I D}{E_b} \log_e \left(1 + \frac{E_b e}{V_a D m} t \right) \right] dt \quad (32)$$

which on integration becomes

$$y = y_0 - V_y t + \frac{2\pi I D^2 V_a m}{E_b^2 e} \left(1 + \frac{E_b e}{V_a D m} t \right) \cdot \left[\log_e \left(1 + \frac{E_b e}{V_a D m} t \right) - 1 \right] + \frac{2\pi I D^2 V_a m}{E_b^2 e}. \quad (33)$$

The distance d along the longitudinal axis traveled by the electron in time t is given by

$$d = V_d t + \frac{E_b e}{2Dm} t^2. \quad (34)$$

Thus we have in (33) and (34) a solution for the boundary of the electron beam under the assumed conditions. It is to be understood however, due to the limitation of (24), which fails to indicate the reversal of gradient at the longitudinal axis, that (33) applies only up to the point where y reaches zero.

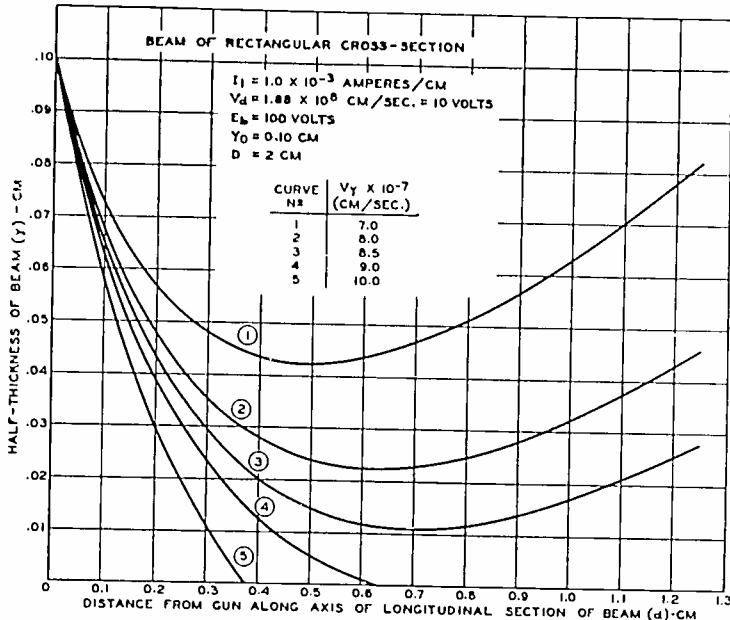

Fig. 9—Half-longitudinal section of an electron beam of rectangular cross section with the initial perpendicular component of electron velocity as a parameter. The variables, i.e., beam current per unit length, beam voltage, initial beam thickness, anode voltage, and distance from anode to cathode are held constant.

Since (33) is indeterminate when E_b equals zero, a solution for this special case is also presented.

The time t for the boundary electron to reach a distance y from the axis is given by

$$t = \int_{v_0}^v \frac{1}{v} dy \quad (35)$$

where

$$v_y = - \left[V_y^2 - \frac{4\pi I e}{V_d m} (Y_0 - y) \right]^{1/2} \quad (36)$$

whence

$$t = - \int_{v_0}^v \left[V_y^2 - \frac{4\pi I e}{V_d m} (Y_0 - y) \right]^{-1/2} dy \quad (37)$$

$$= \frac{V_d m}{2\pi I e} \left\{ \left[V_y^2 - \frac{4\pi I e}{V_d m} (Y_0 - y) \right]^{1/2} - V_y \right\} \quad (38)$$

and

$$d = \frac{V_d^2 m}{2\pi I e} \left\{ \left[V_y^2 - \frac{4\pi I e}{V_d m} (Y_0 - y) \right]^{1/2} - V_y \right\}. \quad (39)$$

Equation (39) is a complete solution for the boundary of the beam. It will be apparent that y may not equal zero where

$$V_y^2 < \frac{4\pi I e}{V_d m} Y_0.$$

The curves in Fig. 9 show the outer edge of the electron beam for different values of the perpendicular component of electron velocity V_y supplied by the initial focusing field of the lens for a beam of initial thickness 0.2 centimeter, 1×10^{-3} ampere per centimeter at $E_b = 100$ volts. With small values of V_y the

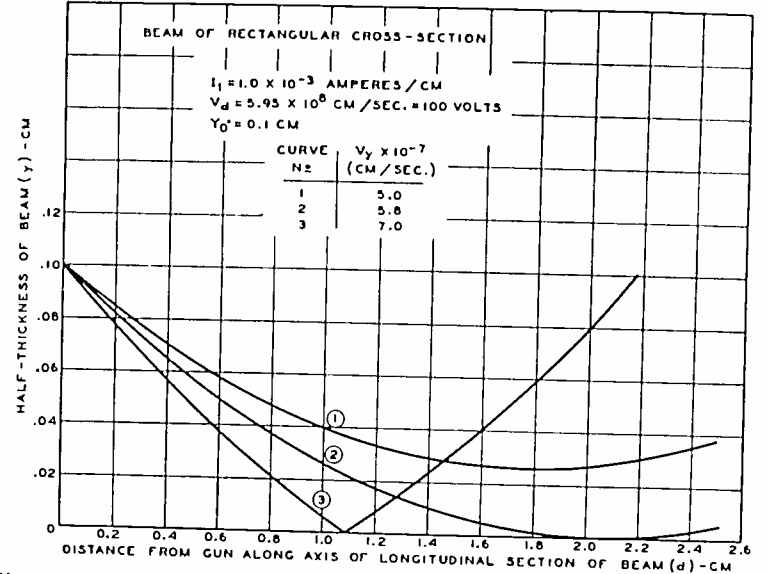

Fig. 10—Curves similar to those of Fig. 9, except that no longitudinal potential gradient exists.

beam has a rather large minimum width which can be reduced to zero by increasing V_y . A line focus of infinitesimal thickness may not be obtained under the conditions assumed at a greater distance than about 0.8 centimeter from the initial point. To increase this distance an increase in Y_0 , V_d , or E_b/D , or a decrease in I would be required.

The curves in Fig. 10 are similar to those in Fig. 8 except that there is no longitudinal gradient. Here, under the conditions assumed, a line focus of infinitesimal thickness may not be obtained at a greater distance than about 2 centimeters from the initial point or lens. To increase this distance would require an increase in Y_0 or V_d or a decrease in I .

As a concluding comment on these analyses for a beam of rectangular cross section, it might be worth while to defend the prediction of a line focus of infinitesimal thickness under ideal conditions. This, of course, involves infinite charge density in the beam. However, the force acting on the electrons is determined by the charge per unit area of surface, not by the charge per unit volume. Since the surface of the beam under consideration does not change, the force acting on the electrons is finite and constant.

The Operation of Electron Tubes at High Frequencies*

H. ROTHE†, MEMBER, I.R.E.

Summary—Electrons passing from cathode to plate induce charges on all electrodes. When the electron current has an alternating component, induced alternating currents flow to all electrodes including negatively biased grids. These currents may have resistive components because of finite transit time.

Calculations of the alternating currents to electrodes in diodes and amplifier tubes and of the resulting impedances are compared and interpreted. Measurements of diode impedances and of the input impedance of amplifier tubes confirm the analysis up to 300 megacycles. Tubes with normal space-charge control show positive input resistance and capacitance change when placed in operation. Tubes whose static characteristics are concave downwards have a negative input resistance and a negative capacitance change. Confirmation is presented by measurements on diodes and on hexodes with current-distribution control. The negative resistances found may produce high-frequency oscillations.

ELECTRON tubes may be considered as operating inertialess at frequencies up to about 1 megacycle; thus their characteristic properties measured at low frequencies remain unchanged. At higher frequencies the electron transit time is of importance, and entirely new phenomena occur. The principles of these have been explained in the works referred to in this paper. In the following the principles will be applied to special effects in space-charge diodes, standard triodes, and pentodes. It will be shown also how tubes with specially shaped characteristic curves can display negative resistance when operated with negative control grids.

I. SPACE-CHARGE-LIMITED DIODES

For planar tubes, the Langmuir-Schottky equation applies, giving for the static characteristic

$$I_a = \frac{1}{9\pi} \sqrt{\frac{2e}{m}} \frac{(\text{area})}{d^2} V_a^{3/2} = KV_a^{3/2}. \quad (1)$$

If now a sinusoidal alternating voltage $NV_a \cos \omega t$ of small amplitude ($N \ll 1$) is superposed on the direct voltage V_a , then an electron alternating convection current I_{conv} flows to the anode in addition to the direct current. In accordance with this alternating current, the density ρ_x of electrons fluctuates everywhere and likewise the charge induced on the electrodes fluctuates thus producing an induced current $I_{\text{ind}} = dQ_{\text{ind}}/dt$. The sum of these two alternating currents produced through the passing of the electrons is $I_{\text{loc}} = I_{\text{conv}} + I_{\text{ind}}$. The normal capacitive current I_{cap} is superposed on these two and may be calculated in the usual way from the capacitance C_1 measured in the absence of space charge. The capacitive current is necessarily always

* Decimal classification: R130. Original manuscript received by the Institute, December 12, 1938; revised manuscript received, March 20, 1940. Previously published in *Die Telefunkenröhre*, p. 33; September, 1937.

† Röhren-Laboratorium der Telefunken G.m.b.H., Berlin, Germany.

90 degrees in advance of the alternating voltage, while the phase of the other two current components is dependent upon the transit angle $\theta = \omega\tau$.

The analysis of these effects in diodes has been worked out by Benham¹ and by Müller,² and has been extended to include a control grid by Llewellyn^{3,4} and by North.⁵ Without repetition of the details, the results as given by North may be stated as follows:

With a total plate voltage

$$V_a = V_a(1 + N \cos \omega t) \quad (2)$$

and with a direct plate current I_a the total anode current amounts to

$$\frac{I_{\text{tot}}}{I_a} = NF \left[\frac{18}{\theta^4} (2 - 2 \cos \theta - \theta \sin \theta) \cos \omega t + j \frac{3}{\theta^4} (-\theta^3 - 6\theta - 6\theta \cos \theta + 12 \sin \theta) \sin \omega t \right] \quad (3)$$

where F is a function of θ which is practically unity when $\theta < \pi/2$.

Similarly the convection current at the anode is

$$\frac{I_{\text{conv}}}{I_a} = NF \left(\frac{6}{\theta^6} [-6(\theta^2 + 4) - (\theta^4 + 6\theta^2 - 24) \cos \theta + \theta(\theta^2 + 24) \sin \theta] \cos \omega t + j \frac{6}{\theta^3} [(\theta^2 + 12) - (\theta^2 + 12) \cos \theta - \theta(\theta^2 + 6) \sin \theta] \sin \omega t \right) \quad (4)$$

and the capacitive current is

$$\frac{I_{\text{cap}}}{I_a} = -j \frac{V_a N \omega C}{I_a} \sin \omega t = -j \frac{3}{4} N \theta \sin \omega t \quad (5)$$

where the appropriate relation

$$C_1 = \frac{3}{4} \tau \frac{I_a}{V_a}$$

has been employed.

¹ W. E. Benham, "Theory of the internal action of thermionic systems at moderately high frequencies," *Phil. Mag.*, vol. 5, p. 641, 1928, and vol. 11, p. 457, 1931.

² J. Müller, "Elektronenschwingungen in Hochvakuum," *Zeit. Hochfrequenz.*, vol. 41, p. 156, 1933.

³ F. B. Llewellyn, "Operation of ultra-high-frequency vacuum tubes," *Bell. Sys. Tech. Jour.*, vol. 14, pp. 632-665; October, 1935.

⁴ F. B. Llewellyn, "Note on vacuum tube electronics at ultra-high frequencies," *Proc. I.R.E.*, vol. 23, pp. 112-127; February, 1935.

⁵ D. O. North, "Analysis of the effects of space charge on grid impedance," *Proc. I.R.E.*, vol. 24, pp. 108-158; January, 1936.

In the upper part of Fig. 1 these three alternating currents are represented vectorially as functions of θ . Considering first the curve of I_{tot} we see that for $\theta=0$ the total current is a pure convection current amounting to $3/2(NI_a)$. While θ is increasing, the total current includes a capacitive component which increases while the real component may be decreasing. The real component passes through zero at $\theta=2\pi$, and alternates between positive and negative values thereafter as θ increases. At very large values of θ corresponding to very high frequencies the capacitive current represents a greater portion of the total current.

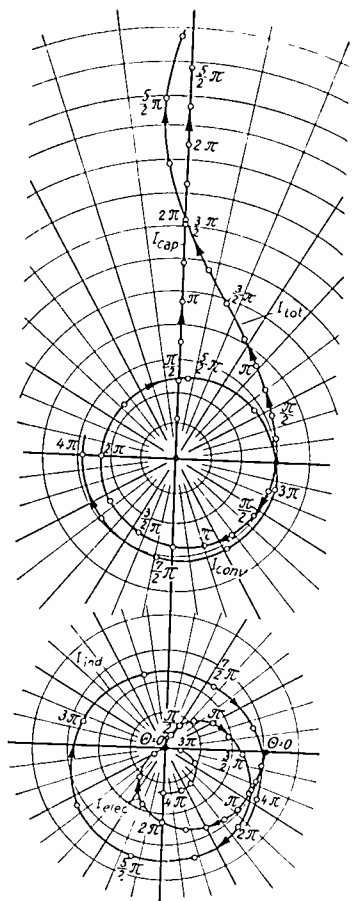

Fig. 1—Vector-diagram of the alternating-currents in a space-charge-limited diode.

The convection current merely undergoes a lagging phase with small amplitude fluctuations as the frequency increases. In tubes with negative control grids, only this component of the total current passes through the grid lattice and enters into the space between grid and plate. As a first approximation the slope of the plate current may be assumed to be proportional to the convection current of the diode, which in turn is practically the same as the slope of the static characteristic, even at the highest frequencies. Because of transit time however, the slope suffers a lagging phase.

In practice, the capacitive current can be determined by means of a constant capacitance C_1 connected in parallel with the tube. Hence attention may be restricted to the electron current $I_{elec} = I_{conv} + I_{ind}$. In the lower part of Fig. 1 this is shown as a function of θ . It has the general form of a spiral. The equation for I_{elec} may be derived from (3) and (5). For small

values of θ the circular functions of θ may be expanded in series form to give

$$I_{elec} = I_{tot} - I_{cap} \\ = NI_a \left(\frac{3}{2} \cos \omega t + j \frac{3}{10} \theta \sin \omega t \right). \quad (6)$$

When I_a is expressed in terms of the voltage V_a and it is remembered that NV_a is the alternating voltage across the tube, it is easy to see that (6) represents a circuit consisting of a resistance R_i in parallel with a reactance. Taking the latter to be a capacitance ΔC_i we can calculate the values in terms of the direct-current slope of the static characteristic $1/R_0$ and the "cold" capacitance C_1 . The result is

$$R_i = R_0 \quad \text{and} \quad \Delta C_i = -\frac{2}{3}C_1.$$

The lower part of Fig. 1 shows a curve representing the induced current,

$$I_{ind} = I_{elec} - I_{conv} = I_{tot} - I_{conv} - I_{cap}.$$

This is of no immediate interest in the simple diode because the components I_{conv} and I_{ind} of the electron current always flow to the plate together and need not be separated. With negative control grids this is not the case. Here the convection current passes through the grid while most of the induced current and the capacitive current flows to it. These latter currents therefore determine the input impedance of the control grid and the induced current accordingly becomes of special interest in amplifier tubes.

From (3), (4), and (5) and for small values of θ we have

$$\frac{I_{ind}}{I_a} = N \left(\frac{3}{2} \frac{\theta^2}{20} \cos \omega t - j \frac{\theta}{4} \sin \omega t \right). \quad (7)$$

Using the slope of the static characteristic of a triode, $g_m = 3/2(I_a/V_{eff})$ and the cathode-grid capacitance for an extremely fine-meshed grid $C_g = C_1 = \frac{3}{4}\tau I_a/V_{eff}$ we can handle (7) in a manner similar to (6) and write the circuit for the induced current in the form of a resistance R_g in parallel with a capacitance ΔC_g . Thus,

$$1/R_g = g_m \theta^2 / 20 \quad \text{and} \quad \Delta C_g = \frac{1}{3}C_g.$$

The total input impedance of the tube is therefore composed of the parallel combination of R_g , ΔC_g and C_g itself, the first two elements being produced by the electron stream.

For larger values of θ the formulas may be applied without expansion in series form to give the curve of R_g and ΔC_g shown in Fig. 2. Both elements alternate between positive and negative values, R_g attaining a minimum negative value of $-1/g_m$. This is more favorable for oscillation production than the simple diode where the negative resistance never attains a value less than four or five times the static slope resistance. Moreover, the grid electrode of the triode does not receive any convection current and therefore no direct-current energy. The oscillation energy is

taken from the kinetic energy of the electrons which hit the plate at a lower velocity than that corresponding to the plate direct-current potential.

A further conclusion may be drawn from Fig. 1. At the cathode the field strength is zero. The charge on the cathode must also be zero, which means that $I_{cap} + I_{ind}$ is zero. The entire current at the cathode must therefore be a pure convection current. At high frequencies this is many times greater than the convection current at the plate. This naturally applies only to the alternating convection current, the direct current over the entire discharge space being constant.

II. THE INPUT IMPEDANCE OF AMPLIFIER TUBES

In the foregoing it was assumed that the control grid was of an infinitely fine mesh so that its capacitance to the cathode was the same as that of a solid plane. It was also assumed that the slope of the triode static characteristic was the same as that of the diode. More accurately, we may write

$$C_{cu} = \sigma C_1$$

and

$$g_m = \sigma g_{diode}$$

where

$$1/\sigma = 1 + \frac{1}{\mu} \left(1 + \frac{4}{3} \frac{d_2}{d_1} \right).$$

In a similar way, the relation between the actual capacitance C_{up} between grid and plate and the capacitance C_1 between a solid plane at the grid and the plate may be written

$$C_{up} = \sigma C_2.$$

In these formulas, μ is the electrostatic amplification factor and d_1 and d_2 represent, respectively, the dis-

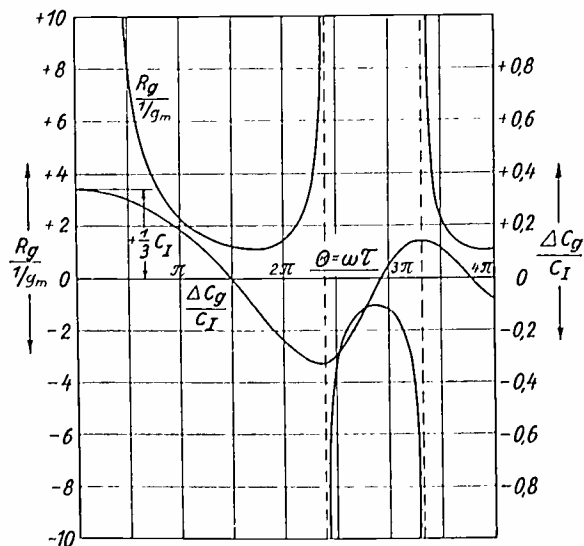

Fig. 2—Dynamic input resistance and capacitance of the control grid as a function of the transit angle, neglecting the grid-anode space.

tance between grid and cathode and between grid and plate. The induced current is reduced by the same factor σ which reduces the diode capacitance and slope conductance.

Thus the relations developed above apply to real control grids provided the capacitance C_{cu} is substi-

tuted for C_1 and the actual g_m of the triode is substituted for the g of the diode. The effect of the grid-plate space can then be determined in a similar manner to that of the cathode-grid space.

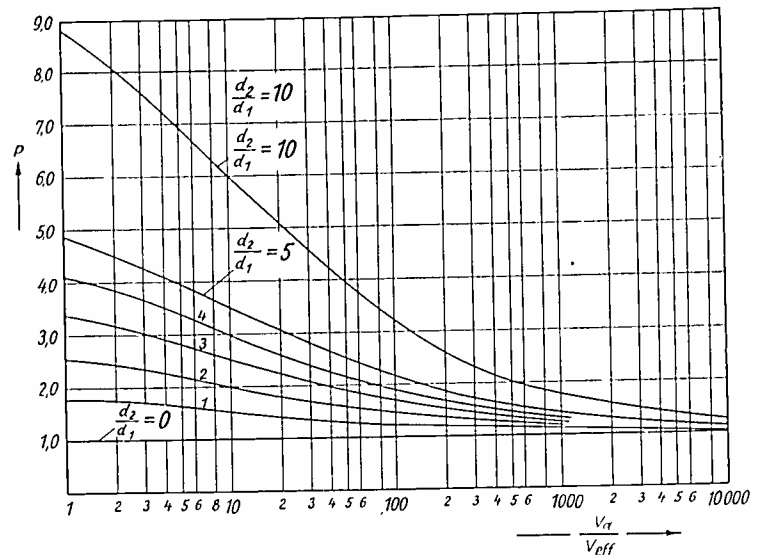

Fig. 3—The factor p which represents the influence of the grid-anode space on the input capacitance.

North accomplished a calculation of the total current passing through the grid-plate space neglecting, however, the space charge in that region. From this he determined the input impedance, while Llewellyn accomplished this calculation taking into consideration the space charge. In these calculations we shall use formulas which are correct for small values of τ_2 and τ_1 because they are sufficiently accurate for those ranges in which amplifier tubes are practically used. Thus, we get for the total input capacitance

$$C_u = \frac{4}{3} C_1 \left[1 + \frac{\tau_2}{\tau_1} \left(1 - \frac{1}{k+1} + \frac{1}{3(k+1)^2} \right) \right] + C_{up} \quad (8)$$

where

$$k = \sqrt{\frac{V_a}{V_{eff}}}$$

Subtracting the cold input capacitance $C_{cu} + C_{up}$ we have

$$\Delta C_u = \frac{1}{3} C_1 \left[1 + 4 \frac{\tau_2}{\tau_1} \left(1 - \frac{1}{k+1} + \frac{1}{3(k+1)^2} \right) \right]. \quad (9)$$

This shows that the effect of taking the grid-plate space into account is merely to modify the value of ΔC_u by the addition of τ_2/τ_1 term in (9). It can be shown that

$$\frac{\tau_2}{\tau_1} = \frac{2}{3} \frac{d_2}{d_1} \frac{1}{k+1} \quad (10)$$

and ΔC_u may then be written

$$\Delta C_u = \frac{1}{3} C_1 \left[1 + \frac{8}{3} \frac{d_2}{d_1} \left(\frac{1}{k+1} - \frac{1}{(k+1)^2} + \frac{1}{3(k+1)^3} \right) \right] = \frac{1}{3} C_1 p. \quad (11)$$

The value of p as a function of V_a/V_{eff} is shown in Fig. 3 with d_2/d_1 as a parameter. It is seen to be greater

than unity for all cases and the inclusion of the grid-plate space in the calculations materially increases ΔC_v .

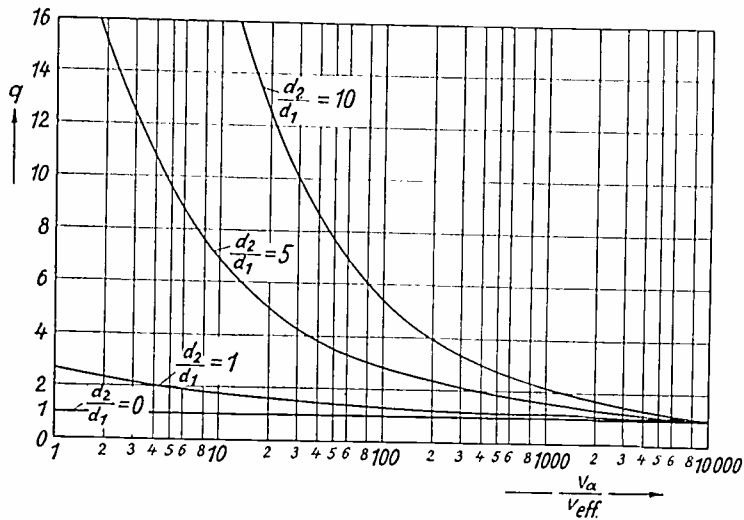

Fig. 4—The factor q which represents the influence of the grid-anode space on the input resistance.

The input resistance calculated by North may be written

$$\frac{1}{R_o} = \frac{g_m \theta^2}{20} q \tag{12}$$

where

$$q = 1 + \frac{2}{3} \frac{d_2}{d_1} \frac{1}{k+1} \left[\frac{44}{9} + \frac{1}{k+1} \left(\frac{10}{3} \frac{d_2}{d_1} - \frac{34}{9} \right) - \frac{140}{27} \frac{d_2}{d_1} \frac{1}{(k+1)^2} + \frac{40}{3} \frac{d_2}{d_1} \frac{1}{(k+1)^3} \right] \tag{13}$$

Here the effect of including the grid-plate space is given by the factor q . Its value is plotted in Fig. 4 which shows that the influence of the grid-plate space is very important.

All of the above formulas apply only when the plate potential has no alternating component. Thus they apply quite directly to screen tubes.

III. EXPERIMENTAL DETERMINATION OF INPUT IMPEDANCE

Experimental investigations were made in a circuit as shown in Fig. 5. An oscillatory circuit was connected

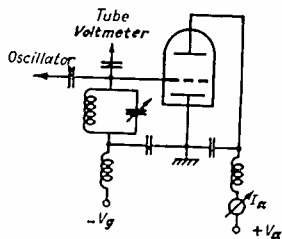

Fig. 5—Schematic diagram of the test circuit for investigating the grid input impedance.

to the grid of the tube under test, and the remaining electrodes were grounded for alternating currents. The input voltage of 0.1 volt was introduced through a small coupling condenser and measured by means of an acorn tube SD1 in a plate-rectifier circuit with compensation for direct current. Measurements down to 1 meter were made with accuracy.

The testing procedure was as follows: The anti-resonant resistance of the input circuit was measured without the tube by detuning the circuit until the voltmeter reading was halved. The grid of the unheated tube was then connected and resonance was re-established by varying the tuning condenser. The change in voltmeter reading measured the dielectric losses of the cold tube. Next the cathode was heated with the grid bias sufficiently negative to prevent current flow to the plate. This increases the tube capacitance somewhat because of the apparent increase in the cathode diameter. At the same time the voltmeter deflection increased because the resistance across the oxide cathode coating is reduced by heating.^{6,7} Finally, the values of R_o and ΔC_o were determined at various operating points by noting the required changes in the input circuit condenser to restore resonance together

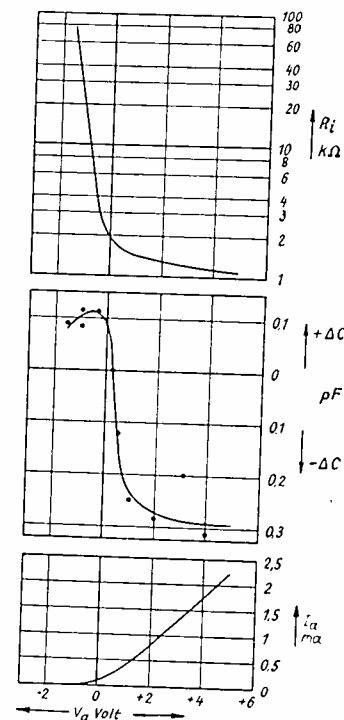

Fig. 6—Characteristic of the dynamic resistance R_i and dynamic capacitance ΔC of a diode ($\lambda = 1.7$ meters).

with the voltmeter readings. Resistances as high as thirty times that of the input circuit could be measured with accuracy.

Fig. 6 shows measurements made on a type SA1 diode at a wavelength of 1.7 meters. Except at the left-hand end, the values of ΔC were negative as predicted by theory. At the right-hand end they agreed fairly well with the theoretical value of $-(2/5)C_1$ which in this tube was $-(2/5)(0.8) = 3.2$ micromicrofarads.

According to (12) the input resistance of triodes should become zero at the cutoff where g_m is zero. Such a curve is shown at a in Fig. 7. However, ini-

⁶ M. J. O. Strutt and A. van der Ziel, "Messungen der charakteristischen Eigenschaften von Hochfrequenzempfangsrohren zwischen 1, 5 und 60 Megahertz," *Elek. Nach. Tech.*, vol. 12, p. 347, 1935.

⁷ M. J. O. Strutt and A. van der Ziel, "Einfache Schaltmassnahmen zur Verbesserung der Eigenschaften von Hochfrequenz-Empfangsrohren im Kurzwellengebiet," *Elek. Nach. Tech.*, vol. 13, p. 260, 1936.

tial velocities of the electrons cause the transconductance to decrease more rapidly than the transit time increases as cutoff is approached. The result is an increase in R_g according to b in Fig. 7. For tubes with

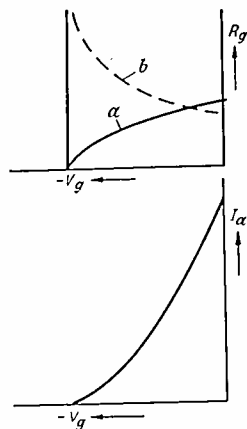

Fig. 7—Theoretical (a) and actual (b) curves of the grid input resistance.

extremely large separation between cathode and grid, seldom met in practice, Bakker and de Vries⁸ have shown that a is approximated.

Values of R_g and ΔC_g measured on the more normal acorn pentode type SF1A are shown in Fig. 8. Here the screen was tied directly to the plate and the frequency employed was 12.5 megacycles. The R_g curves are of type b in Fig. 7. Further comparison of measured

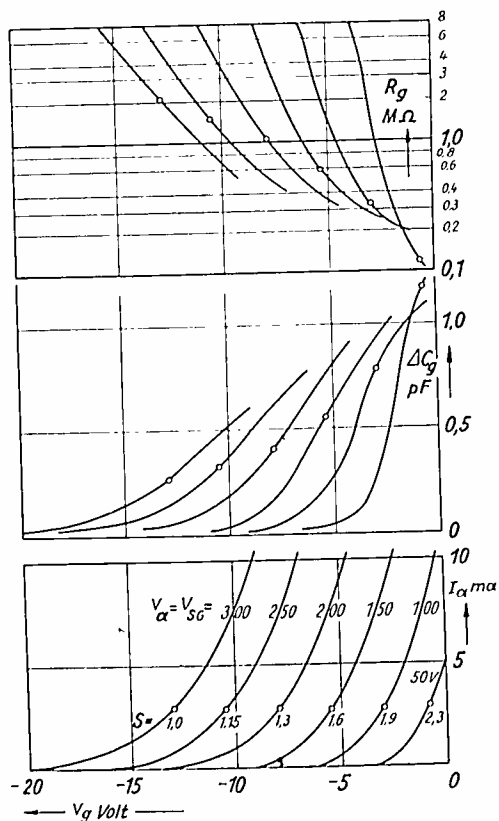

Fig. 8— R_g and ΔC_g of a pentode for a wavelength of 24 meters.

and calculated values of ΔC_g have been made by Kettel⁹ and by Ferris.¹⁰ Except as explained above for R_g , the

⁸ C. J. Bakker and G. de Vries, "On vacuum tube electronics," *Physica*, vol. 2, p. 683, 1935.

⁹ E. Kettel, "Messungen über den Einfluss der Raumladung auf die Eingangskapazität von Verstärkerröhren," *Telefunken-Röhre*, vol. 9, p. 15, 1937.

¹⁰ W. R. Ferris, "Input resistance of vacuum tubes as ultra-high-frequency amplifiers," *Proc. I.R.E.*, vol. 24, pp. 82-104; January, (1936).

measurements in other respects prove that the theory is a correct representation of conditions, although in tubes with very high transconductances, such as the AL4, the actual input resistance is less than the calculated value.

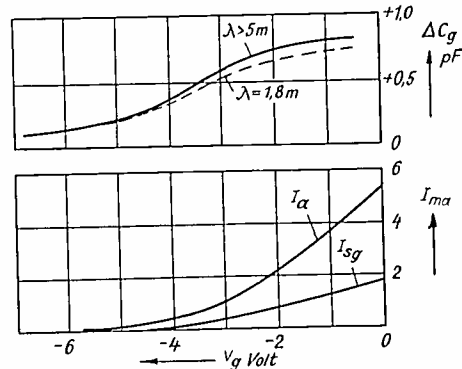

Fig. 9— R_g and ΔC_g of the acorn-type pentode SF1A for different wavelengths ($V_a = 150$ volts, $V_{sg} = 75$ volts).

Values of ΔC_g were found to be practically independent of frequency up to 150 megacycles beyond which a small decrease was noted. This is shown by Fig. 9 for a tube of type SF1A.

Further measurements on a number of different types of tubes substantiate the results of Ferris¹⁰ which show that the input resistance varies inversely as the square of the frequency.

IV. THE PRODUCTION OF NEGATIVE RESISTANCE BY THE INDUCED CURRENT

In the preceding discussion and measurements, complete space charge was postulated. For that condition, the charge induced on the grid by the electrons is directly proportional to the effective grid potential V_{off} . The following rule then applies:

When the characteristic follows the 3/2-power law, $I = K V_{eff}^{3/2}$, then for small values of transit angles both R_g and ΔC_g are positive.

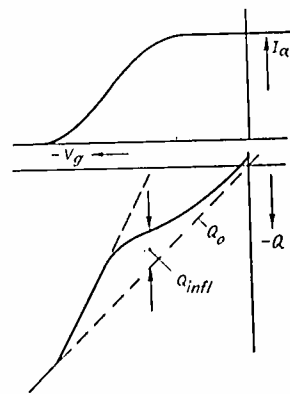

Fig. 10—The grid charge of a tube whose characteristic curve does not follow the space-charge law.

What would be the effect of characteristics other than the 3/2-power law? There is no need to discuss $n > 3/2$ because that condition is always produced by superposition of several 3/2-power curves shifted in relation to each other. They therefore show positive values of R_g and ΔC_g , but with changed proportions along the characteristic curve. Entirely different, however, are the characteristics with $n < 3/2$ because they

can be produced only through discharge effects quite different from ideal space charge.

For a tube with a total cathode emission of I_s , the characteristic follows the 3/2 law for low voltages only, and then turns toward the horizontal, as in Fig.

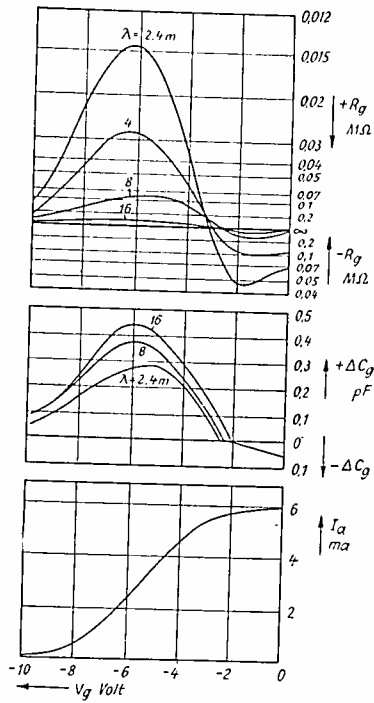

Fig. 11— R_g and ΔC_g of a tube with a thoriated-tungsten cathode.

10. In the lower portion of the curve the induced grid charge is proportional to the effective potential, but as the curve straightens out, the induced charge on the grid must become less than it would be with complete space charge. In the horizontal or saturation portion the induced charge approaches zero, leaving only the electrostatic surface charge on the grid. The induced alternating current, being proportional to the slope of the curve of induced charge versus V_{eff} , must therefore change from a capacitive phase with a

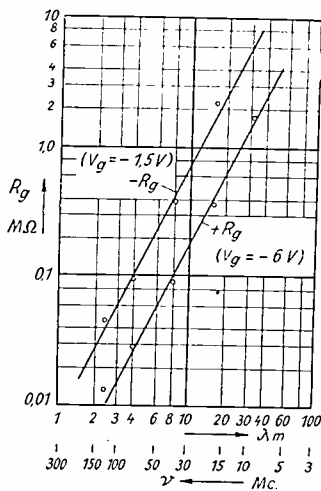

Fig. 12—Positive ($V_g = -6$ Volts) and negative ($V_g = -1.5$ Volts) input resistance of the same tube as in fig. 14 as a function of frequency.

positive ohmic component in the lower portion on the characteristic, and pass through zero, finally assuming an inductive phase with a negative ohmic component. The values of ΔC_g and R_g likewise change from posi-

tive to negative values, ΔC_g passing through zero while R_g passes through infinity.

Experimental confirmation of these theoretical conclusions is shown in Fig. 11 for a tube with thoriated-tungsten cathode. The negative values of ΔC_g and of R_g at the upper bend of the static characteristic are unmistakably shown even though they are not very large. In Fig. 12 R_g is plotted against frequency for values of V_{eff} of -6 volts and of $-1/5$ volt. Both curves are proportional to the inverse square of the frequency. We have here an example of a negative resistance which is not produced by inversion of any particular property but which is present at the lowest frequencies. If this negative resistance has escaped the notice of all but a few,¹ it is because oxide cathodes, which show no indications of saturation, have been

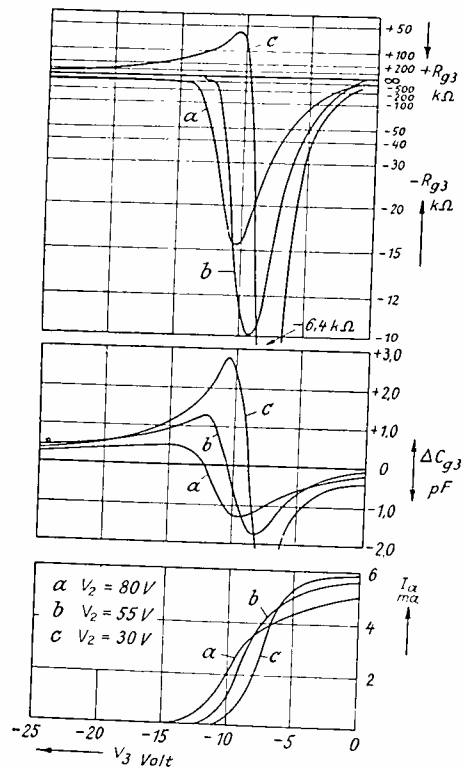

Fig. 13— R_g and ΔC_g of the control grid 3 of the hexode RENS 1234 for different voltages of the front screen grid ($\lambda = 28.5$ meters).

used in the development of high-frequency measuring methods.

In the theoretical aspect, induction from the grid-plate space, disregarded above, can cause only an amplification of the induced current in the grid-cathode space. The essential condition for the effect is that with rising effective potential, the charge density is decreasing at every point of the discharge space, and with it therefore the total induced charge is decreasing, not only relative to the case of complete space charge, but also on an absolute basis. This applies to the grid-plate space as well as to the grid-cathode space. The value of the characteristic exponent n is the external manifestation of the situation. The above rule can therefore be extended as follows.

If the static characteristic has an exponent less than 3/2 then ΔC_g and $1/R_g$ are smaller than when n equals 3/2. If the exponent drops below a certain critical

value slightly less than unity, then at low frequencies both ΔC_g and $1/R_g$ become negative.

This is further illustrated in Fig. 13 which shows data on a hexode RENS 1234 tube. As shown previously^{11,12} the characteristic of the third grid follows Below's law for weak currents. In each curve of Fig. 13 the fourth grid (screen) was connected to the anode and operated at 300 volts while the first grid was biased to give about the same current when the third grid was at ground potential. Measurements were made at 28.5 meters.

In curve *c* a virtual cathode formed in the lower part of the characteristic and a wider range of the portion where $n > 1$ is obtained than in the other curves. This produces positive values of R_g in the lower range for curve *c* while for curves *a* and *b* the values of R_g are negative throughout. The same tendency is exhibited by ΔC_g , which however is always slightly positive in the extreme low ranges for all three curves. This is because, even in the absence of plate current, electrons reversing in front of the control grid 3 induce a charge and hence a positive induced current. The large values of $1/R_g$ shown in Fig. 13 explain oscillations which frequently occur in short-wave frequency changers and which were previously explained as Barkhausen-Kurz oscillations.

Under suitable conditions the negative values of ΔC_g can become larger than the cold capacitance, giving an over-all negative input capacitance. Details of this effect are, however, beyond the scope of the present paper.

The measurements of ΔC_g confirm previous theory^{11,12} concerning the disappearance of a virtual cathode when the voltage is varied. With increasing plate current the virtual cathode moves toward the control grid, increasing the induced charge, and producing positive values of ΔC_g . At a certain plate current the virtual cathode must disappear. The characteristic curve makes a turn and with the consequent decrease in space charge the induced charge must likewise decrease. This means a rather sudden shift of

ΔC_g to negative values. These effects are in conformity with the measurements.

The curves of Fig. 13 clear up another puzzling phenomenon. If, during operation on curves *a* or *b*, the lead wires to grid 3 are cut, then according to the external circuit conditions, either the grid 3 drops to zero potential allowing a strong plate current to flow, or else it assumes highly negative values with resulting decrease in plate current. The first case will simply result in a grid voltage corresponding to the prevailing grid current. The second case, however, can be explained only by the fact that the free grid with its feed-wire capacitance forms an oscillatory circuit which is excited by the induced current. These cause the displacement of the grid bias to values so far negative that the oscillations can scarcely remain constant or steady. This oscillation cannot be determined externally because the other electrodes may all be grounded for high-frequency alternating currents.

Measurements at 125 meters on the RENS 1234 hexode under normal operating voltages showed large negative values of ΔC_g and of $1/R_g$ for the third grid. These are explained by the large separation between the second and third grids which produces a large induced charge as well as long transit times. Similar measurements on the AH1 hexode showed much smaller negative values, and here the separation between grids was likewise much smaller.

Further measurements of ΔC_g and of $1/R_g$ for the first grid of these tubes showed positive values corresponding to its space-charge operation. These were strongly affected by the potential of the third grid. Increasingly negative bias on the third grid causes an increase in the number of returning electrons which pass through the first grid and a resulting increase in ΔC_g and $1/R_g$.

Exactly the same effects which were observed on the third grid of the hexode will naturally be found likewise on the control grids of space-charge-grid tubes, of pentagrid converters and of octodes. As shown previously^{11,12} the virtual cathode usually exists up to about the center of the characteristic curves, thus giving positive values of ΔC_g and $1/R_g$ for the lower portion and negative values for the upper portion. As the phenomena are closely akin to those described above, detailed description is not needed.

¹¹ H. Rothe and W. Kleen, "Stromverteilung—4. Abhandlung: Stromverteilungssteuerung," *Telefunken-Röhre*, vol. 8, p. 158, 1936.

¹² H. Rothe and W. Kleen, "Stromverteilung—5. Abhandlung: Stromverteilung und Raumladung," *Telefunken-Röhre*, vol. 9, p. 90, 1937.

Characteristics of the Ionosphere at Washington D. C., May, 1940, with Predictions for August, 1940*

T. R. GILLILAND†, ASSOCIATE, I.R.E., S. S. KIRBY†, ASSOCIATE, I.R.E.,
AND N. SMITH†, NONMEMBER, I.R.E.

DATA on the ordinary-wave critical frequencies and virtual heights of the ionospheric layers during May are given in Fig. 1. Fig. 2 gives the monthly average values of the maximum usable frequencies for undisturbed days, for radio transmission

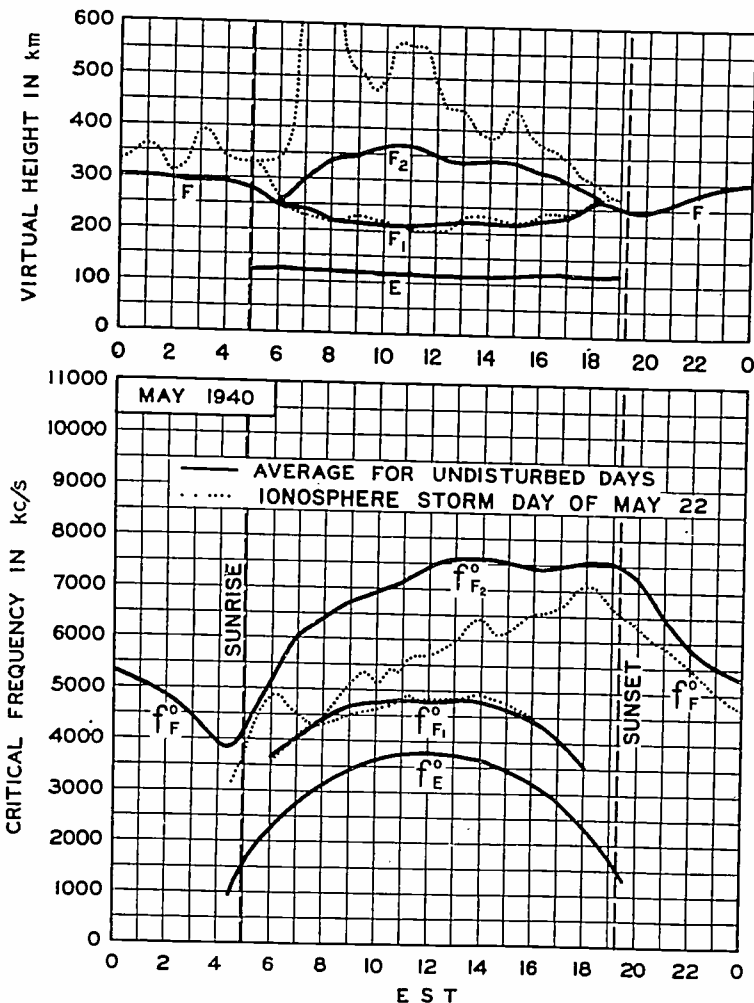

Fig. 1—Virtual heights and critical frequencies of the ionospheric layers, May, 1940.

by way of the regular layers. The maximum usable frequencies were determined by the F layer at night and by the E, F₁, and F₂ layers during the day. Fig. 3 gives the distribution of hourly values of F and F₂ critical frequencies about the undisturbed average for the month. Fig. 4 gives the expected values of the maximum usable frequencies for radio transmission by way of the regular layers, average for undisturbed days, for August, 1940.

* Decimal classification: R113.61. Original manuscript received by the Institute, June 10, 1940. These reports have appeared monthly in the PROCEEDINGS starting in vol. 25, September, 1937. See also vol. 25, pp. 823-840; July, 1937. Publications approved by the Director of the National Bureau of Standards of the U. S. Department of Commerce.

† National Bureau of Standards, Washington, D. C.

TABLE I
IONOSPHERIC STORMS (APPROXIMATELY IN ORDER OF SEVERITY)

Day and hour E.S.T.	h_f before sunrise (km)	Minimum $f_{F_2}^o$ before sunrise (kc)	Noon $f_{F_2}^o$ (kc)	Magnetic character ¹		Iono-spheric character ²
				00-12 G.M.T.	12-24 G.M.T.	
May 16 (after 2100)	—	—	—	0.0	0.1	0.2
17	326	4200	6500	0.3	0.1	0.5
18	320	diffuse	<4700	1.1	0.8	1.6
19 (until 0500)	333	2600	—	0.3	0.1	0.2
22	346	diffuse	5700	1.1	0.4	1.4
24	no vertical-incidence data; see text			1.4	1.1	—
25	no vertical-incidence data; see text			0.5	0.3	—
26	no vertical-incidence data; see text			0.9	0.9	—
27	no vertical-incidence data; see text			0.5	0.5	—
14 (after 0100)	325	2700	5300	0.5	0.4	0.9
15	312	4000	6200	0.4	0.5	0.5
12 (until 1500)	326	3500	6400	0.6	0.4	0.5
11 (until 0500)	332	3100	—	0.6	0.4	0.3
For comparison: average for undisturbed days	297	3910	7350	0.2	0.2	0.0

¹ American magnetic character figure, based on observations of seven observatories.

² An estimate of the severity of the ionospheric storm at Washington on an arbitrary scale of 0 to 2, the character 2 representing the most severe disturbance.

Ionospheric storms and sudden ionospheric disturbances are listed in Tables I and II, respectively. Table III gives the approximate upper limit of frequency of strong sporadic E reflections at vertical incidence, for the days during which these reflections were most prevalent at Washington.

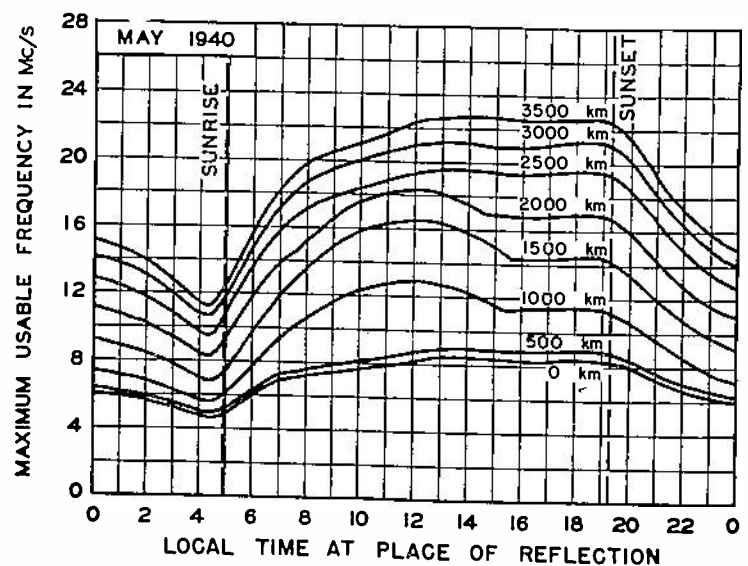

Fig. 2—Maximum usable frequencies for dependable radio transmission via the regular layers, average for undisturbed days for May, 1940. The values shown were considerably exceeded during irregular periods because of reflections from clouds of sporadic E layer. For information on use in practical radio transmission problems, see Letter Circular 575 obtainable from the National Bureau of Standards, Washington, D. C., on request.

TABLE II
SUDDEN IONOSPHERIC DISTURBANCES

Day	G.M.T.		Location of transmitters	Relative intensity at minimum ¹	Other Phenomena
	Beginning	End			
May 11	2005	2025	Ohio	0.05	Ter. mag. pulse, ² 1751 to 1805
14	1748	1808	Ohio, Cuba	0.0	
25	1830	1850	Ohio, Cuba, England	0.05	
25	2048	2110	Ohio, Cuba, England	0.05	

¹ Ratio of received field intensity during fade-out to average field intensity before and after, for station WLWO, 6060 kilocycles, 650 kilometers distant.
² As observed on Cheltenham magnetogram of United States Coast and Geodetic Survey.

No vertical-incidence ionosphere measurements were made from May 23 to 28, inclusive. For this reason no ratings were given to the ionospheric storms which occurred during this period. Information on sudden ionospheric disturbances and some information on ionospheric storms during this period were obtained from oblique-incidence field-intensity records.

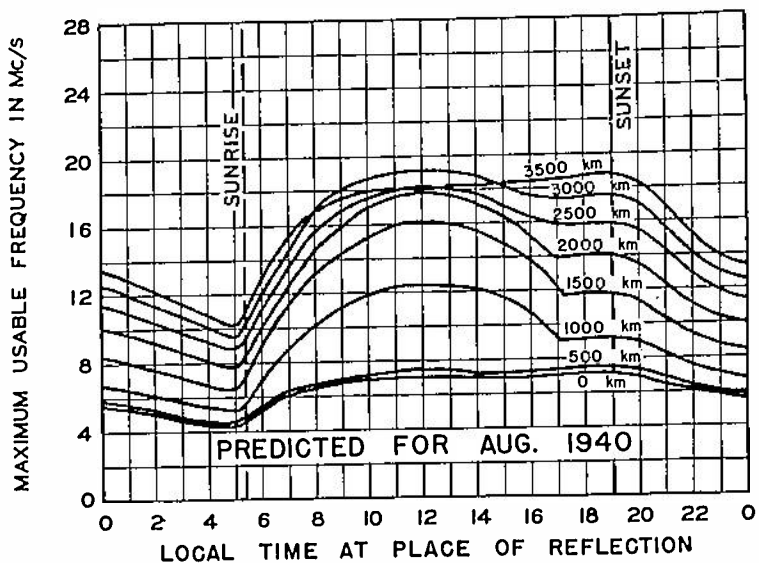

Fig. 4—Predicted maximum usable frequencies for dependable radio transmission via the regular layers, average for undisturbed days, for August, 1940. The values shown will be considerably exceeded during irregular periods because of reflections from clouds of sporadic E layer. For information on use in practical radio transmission problems, see Letter Circular 575 obtainable from the National Bureau of Standards, Washington, D. C., on request.

TABLE III
SPORADIC E
APPROXIMATE UPPER LIMIT OF FREQUENCY OF THE STRONGER SPORADIC E REFLECTIONS AT VERTICAL INCIDENCE

Midnight to noon												
Hour												
Date	00	01	02	03	04	05	06	07	08	09	10	11
May 2	8	8		4.5						4.5	8	8
5	6	4.5								9	8	8
19	8	9	8	8						4.5	8	8
Noon to midnight												
Hour												
Date	12	13	14	15	16	17	18	19	20	21	22	23
May 1												
4	4.5						6	8	8	6	6	8
18			4.5	4.5	4.5		6	8	8	8	8	8
21				4.5			4.5	8	8	4.5	8	8
29	6	8	6	4.5			9	9	4.5	4.5	4.5	

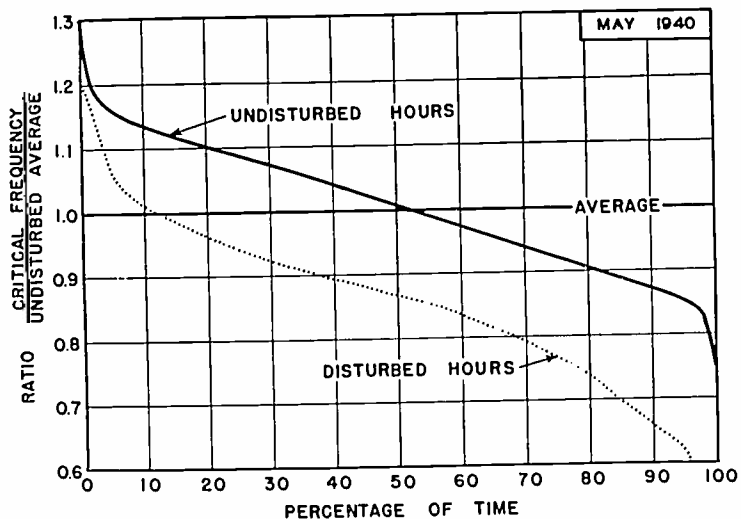

Fig. 3—Distribution of F- and F₂-layer ordinary-wave critical frequencies (and also approximately of maximum usable frequencies) about monthly average. Abscissas show percentages of time for which the ratio of the critical frequency to the undisturbed average exceeded the values given by the ordinates. The solid-line graph is for 376 undisturbed hours of observation; the dotted graph is for 138 disturbed hours of observation listed in Table I.

Characteristics of the Ionosphere at Washington, D. C., June, 1940, with Predictions for September, 1940*

DATA on the ordinary-wave critical frequencies and virtual heights of the ionospheric layers during June are given in Fig. 1. Fig. 2 gives the monthly average values of the maximum usable frequencies for undisturbed days, for radio transmission by way of the regular layers. The maximum usable

Ionospheric storms are listed in Table I. No sudden ionospheric disturbances were observed. Table II gives the approximate upper limit of frequency of strong sporadic-E reflections at vertical incidence, for the days during which these reflections were most prevalent at Washington.

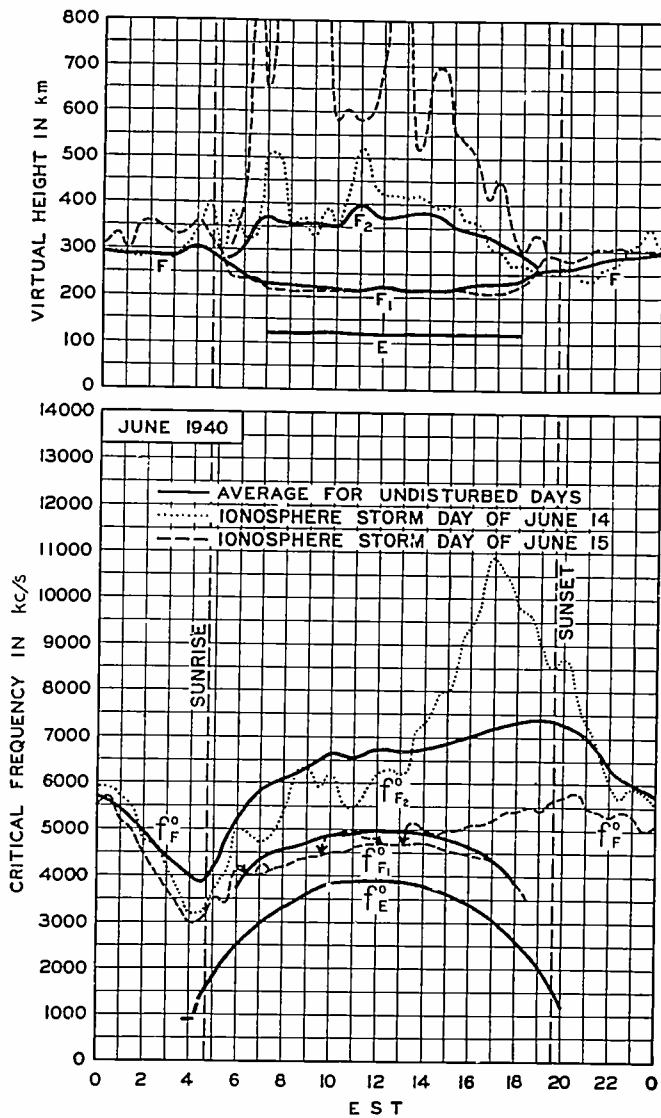

Fig. 1—Virtual heights and critical frequencies of the ionospheric layers, June, 1940.

frequencies were determined by the F layer at night and by the E, F₁, and F₂ layers during the day. Fig. 3 gives the distribution of hourly values of F and F₂ critical frequencies about the undisturbed average for the month. Fig. 4 gives the expected values of the maximum usable frequencies for radio transmission by way of the regular layers, average for undisturbed days, for September, 1940.

* Decimal classification: R113.61. Original manuscript received by the Institute, July 11, 1940. These reports have appeared monthly in the PROCEEDINGS starting in vol. 25, September, 1937. See also vol. 25, pp. 823-840; July, 1937. Publication approved by the Director of the National Bureau of Standards of the U. S. Department of Commerce. Report prepared by S. S. Kirby, N. Smith, and F. R. Gracely of the National Bureau of Standards.

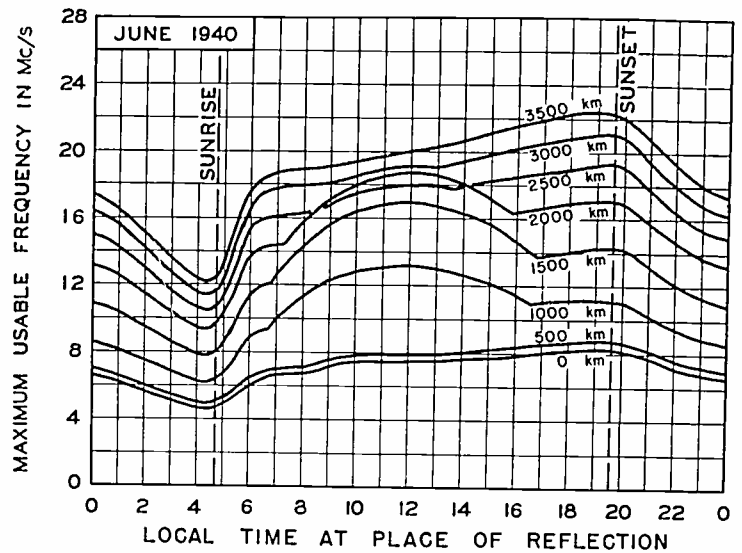

Fig. 2—Maximum usable frequencies for dependable radio transmission via the regular layers, average for undisturbed days for June, 1940. The values shown were considerably exceeded during frequent irregular periods because of reflections from patches of sporadic E layer. For information on use in practical radio transmission problems, see Letter Circular 575 obtainable from the National Bureau of Standards, Washington, D. C., on request.

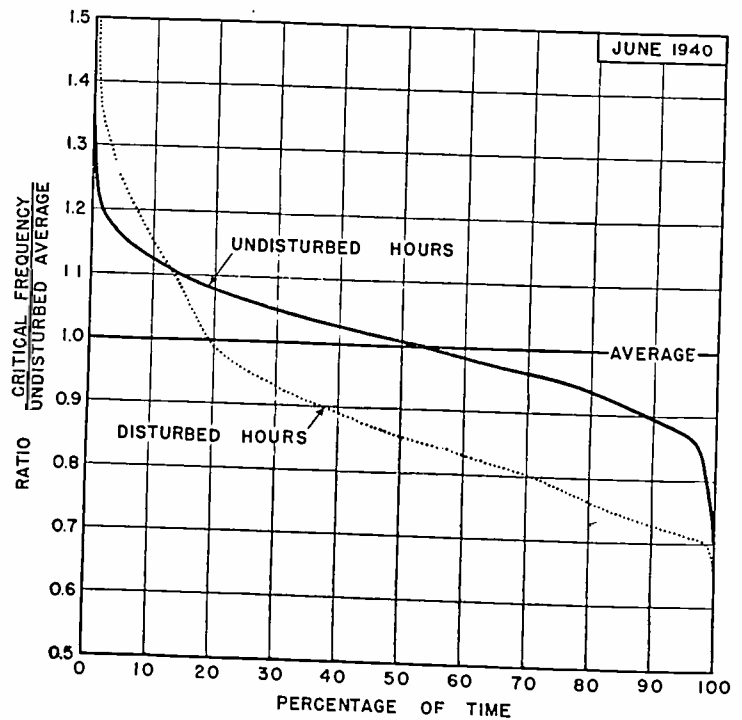

Fig. 3—Distribution of F- and F₂-layer ordinary-wave critical frequencies (and also approximately of maximum usable frequencies) about monthly average. Abscissas show percentages of time for which the ratio of the critical frequency to the undisturbed average exceeded the values given by the ordinates. The solid-line graph is for 417 undisturbed hours of observation; the dotted graph is for 151 disturbed hours of vertical-incidence observations listed in Table I.

TABLE I
IONOSPHERIC STORMS (APPROXIMATELY IN ORDER OF SEVERITY)

Day and hour E.S.T.	h_F before sunrise (km)	Minimum $f_{F_2^0}$ before sunrise (kc)	Noon $f_{F_2^0}$ (kc)	Magnetic character ¹		Iono-spheric character ²
				00-12 G.M.T.	12-24 G.M.T.	
June 24	No vertical-incidence data. See text.			0.6	0.5	—
25	No vertical-incidence data. See text.			1.3	1.8	—
26	No vertical-incidence 5600 data. See text.			0.8	0.6	—
27 (until 0400)	300	2800	—	0.2	0.1	0.3
14 (after 1300)	—	—	—	0.5	1.1	1.5
15	330	3000	4800	1.0	0.6	1.3
16 (until 0400)	320	2500	—	0.5	0.5	0.7
5 (after 1700)	—	—	—	0.1	0.6	0.6
6	318	3200	6100	1.1	0.6	1.0
7	312	3200	4900	0.9	0.6	0.7
8 (until 1000)	342	2900	—	0.6	0.6	0.5
18	352	3500	5700	0.9	0.4	0.5
19 (until 0700)	294	3200	—	0.5	0.3	0.2
For comparison: average for undisturbed days	294	3900	6740	0.1	0.1	0.0

¹ American magnetic character figure, based on observations of seven observatories.

² An estimate of the severity of the ionospheric storm at Washington on an arbitrary scale of 0 to 2, the character 2 representing the most severe disturbance.

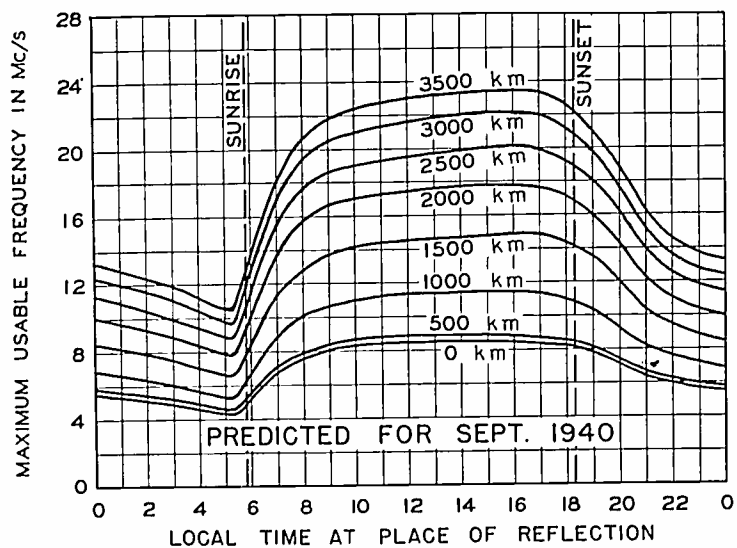

Fig. 4—Predicted maximum usable frequencies for dependable radio transmission via the regular layers, average for undisturbed days, for September, 1940. For information on use in practical radio transmission problems, see Letter Circular 575 obtainable from the National Bureau of Standards, Washington, D. C., on request.

No vertical-incidence ionosphere measurements were made from 0400, June 23, to 1100, June 26. For this reason no ratings were given to the ionospheric storms which occurred during this period. Information on sudden ionospheric disturbances and some information on ionospheric storms during this period were obtained from oblique-incidence field-intensity records.

TABLE II
SPORADIC E

APPROXIMATE UPPER LIMIT OF FREQUENCY OF THE STRONGER SPORADIC E REFLECTIONS AT VERTICAL INCIDENCE

Midnight to noon												
Hour												
Day	00	01	02	03	04	05	06	07	08	09	10	11
June 24	—	7	7	7	5	5	5	—	—	—	—	—
11	—	—	—	—	—	—	—	—	—	—	10	—
12	—	—	—	—	—	—	—	—	—	7	7	9
13	9	7	5	5	5	7	5	10	7	8	5	5
17	—	—	—	—	—	—	—	7	9	—	—	—
27	10	7	10	7	7	—	—	10	7	6	8	7
Noon to midnight												
Hour												
Day	12	13	14	15	16	17	18	19	20	21	22	23
June 2	—	—	—	—	—	7	7	7	7	7	7	7
4	—	—	—	—	—	5	5	7	7	7	5	5
12	9	—	8	—	—	5	—	4	9	10	10	9
13	9	7	7	—	—	8	10	4	4	8	5	—
14	9	8	—	—	—	—	—	—	—	—	—	—
16	—	5	6	—	—	7	8	7	6	7	5	5
19	—	—	—	—	—	—	10	9	7	7	7	5
20	—	—	—	—	—	5	5	10	5	—	—	—
21	8	—	5	—	—	4	6	6	—	—	—	—
26	—	5	—	—	9	—	5	—	—	8	8	9
27	—	—	—	—	—	—	5	—	—	9	8	—
28	9	7	5	—	—	—	—	—	—	—	7	7

It is of interest to note in Fig. 1 the abnormally high values of F_2 - and F-layer critical frequencies on June 14 during the early stages of the ionospheric storm beginning on this day. This phenomenon has also been shown in previous reports.

The average value of $f_{F_1}^0$ for the disturbed days listed in Table I, for which vertical-incidence data were available, was 150 kilocycles less than for the undisturbed days. This is a measure of the ionospheric storm effect in the F_1 layer. This depression, as also for the $f_{F_2}^0$, was less in the afternoon than in the forenoon.

Institute News and Radio Notes



L. C. F. HORLE
President, 1940

Lawrence C. F. Horle was born in Newark, N. J., on May 27, 1892. He received the M.E. degree from Stevens Institute of Technology in 1914 and was an instructor at that college for the next two years.

From 1917 to 1920 he served in the United States Navy Department in Washington as an expert radio aide. He then became chief engineer of the de Forest Radio Telephone and Telegraph Company until 1921. From 1921 to 1924 he was a consultant at the radio laboratory of the Bureau of Standards in Washington, D. C. He was chief engineer of the Federal Telephone and Telegraph Company and vice president of the Federal Telephone Manufacturing Company from 1924 to 1929. Since then he has practiced as a consultant.

Mr. Horle is a Fellow of the American Institute of Electrical Engineers and of the Radio Club of America. He joined the Institute as an Associate in 1914, transferring to Member in 1923 and to Fellow in 1925.

Board of Directors

The April 3 meeting of the Board of Directors was attended by L. C. F. Horle, president; Melville Eastham, treasurer; W. R. G. Baker, Alfred N. Goldsmith, Virgil M. Graham, O. B. Hanson, R. A. Heising, C. M. Jansky, Jr., F. B. Llewellyn, B. J. Thompson, H. M. Turner, A. F. Van Dyck, L. P. Wheeler, and H. P. Westman, secretary.

At the request of H. A. Wheeler, chairman of the Standards Committee, a Technical Committee on Frequency Modulation which is to develop standards on all aspects of the subject except receivers was established.

Adolfo T. Cosentino was transferred to Fellow grade. Paul Adorjan, J. G. Chaffee, L. G. Dobbie, P. C. Sandretto, and C. H. Starr were transferred to Member grade and E. S. Lee and P. F. Siling were

admitted to that grade. Fifty-one were elected to Associate, four to Junior, and twenty-one to Student membership.

W. R. G. Baker was nominated for the Presidency for 1941 and A. T. Cosentino for the Vice Presidency for that year. Six nominations were made for the three Directorships which will be voted on, the terms to be for the years 1941-1943. Those nominated were J. E. Brown, E. T. Dickey, H. T. Friis, O. B. Hanson, F. E. Terman, and L. P. Wheeler.

H. B. Richmond was named chairman of the Committee on the Licensing of Engineers. This committee was instructed to include in its scope all phases and conditions concerning the licensing of engineers in the United States.

The Sixteenth Annual Convention of the Institute will be held in New York City on January 9, 10, and 11, 1941.

A request from the Portland Section for permission to affiliate with the Oregon Technical Council was approved.

On May 1 a meeting of the Board of Directors was attended by L. C. F. Horle, president; Melville Eastham, treasurer; Austin Bailey, W. R. G. Baker, H. C. Forbes, Alfred N. Goldsmith, Virgil M. Graham, R. A. Heising, C. M. Jansky, Jr., F. R. Lack, F. B. Llewellyn, Haraden Pratt, B. J. Thompson, H. M. Turner, A. F. Van Dyck, L. P. Wheeler, and H. P. Westman, secretary.

Approval of forty-eight applications for Associate, two for Junior, and thirty-two for Student membership was granted.

On recommendation of the Awards Committee, it was agreed that starting in 1941, the Medal of Honor would be presented at the Annual Convention which is to be held in New York City each January, and that the Morris Liebmann Memorial Prize be given to the recipient at the summer convention which will be held in June each year in some city other than New York.

The Medal of Honor for 1940 was awarded to Lloyd Espenschied for his accomplishments as an engineer, as an inventor, as a pioneer in the development of radiotelephony, and for his effective contributions to the progress of international radio co-ordination.

The Medal of Honor for 1941 will be awarded to Alfred Norton Goldsmith, for his contributions to radio research, engineering, and commercial development, his leadership in standardization, and his unceasing devotion to the establishment and upbuilding of the Institute and its PROCEEDINGS.

The Morris Liebmann Memorial Prize for 1940 was awarded to Harold A. Wheeler for his contribution to the analysis of wide-band high-frequency circuits particularly suitable for television.

The Medal of Honor and the Morris Liebmann Memorial Prize for 1940 are to be presented at the Fifteenth Annual Convention to be held in Boston.



W. L. BARROW
Convention Committee Chairman

The large attendance at our Fifteenth Annual Convention which was held in Boston was evidence of the effective work of the Convention Committee under the chairmanship of Professor Barrow.

W. L. Barrow was born in Baton Rouge, Louisiana, on October 25, 1903. He received the B.S. degree in electrical engineering from Louisiana State University in 1926 and the M.S. degree from Massachusetts Institute of Technology in 1929. He was a Redfield Proctor Fellow in physics at the Technische Hochschule in Munich, Germany, receiving the Sc.D. degree in 1931.

From 1931 to 1936 he was an instructor in the Communications Division of Massachusetts Institute of Technology and was also a member of the Round Hill research group. He was appointed a professor of electrical communications in 1936.

Professor Barrow became an Associate member of the Institute in 1928 and transferred to Member in 1940. He has written a number of papers for the PROCEEDINGS and has been active in the management of the Boston Section.

The Medal of Honor for 1941 will be presented at the Sixteenth Annual Convention in New York in January, 1941.

On recommendation of the Awards Committee the following transfers to Fellow grade were approved to be made at the Convention in Boston: John A. Balch, Lewis W. Chubb, Elmer W. Engstrom, Archibald J. Gill, Gilbert E. Gustafson, Samuel S. Mackeown, Francis M. Ryan and William C. White.

H. M. Turner was designated the representative of the Institute on the Sectional Committee on Letter Symbols and Abbreviations for Science and Engineering of the American Standards Association to fill the vacancy resulting from the death of Dr. Kennelly.

A Special Committee on Television was established to make a study of the basic

scientific principles of television systems. Dr. Goldsmith was named chairman.

A meeting of the Board of Directors was held on June 27. Those present were L. C. F. Horle, president; F. E. Terman, vice president; Austin Bailey, Ralph Bown (guest), Virgil M. Graham, O. B. Hanson, R. A. Heising, C. M. Jansky, Jr., F. R. Lack, F. B. Llewellyn, Haraden Pratt, B. J. Thompson, H. M. Turner, A. F. Van Dyck, H. A. Wheeler, and H. P. Westman, secretary.

Approval was granted the following applications for transfer to member grade: J. G. Aceves, J. P. Arnaud, H. B. DeVore, A. V. Haeff, C. N. Kimball, G. R. Kilgore, D. B. Langmuir, R. R. Knox McIlwain, Albert Rose, and H. M. Wagner.

In the absence of any objections received prior to August 7, 1940 the following transfers to Member grade were approved as of that date: Andrew Alford, E. I. Anderson, R. B. Ayer, V. B. Bagnall, W. L. Barrow, F. J. Brott, Homer Courchene, J. S. Donal, Jr., J. F. Hirlinger, J. B. Johnson, Garard Mountjoy, Fred Schumann, S. W. Seeley, G. R. Shaw, B. N. Singh, H. E. J. Smith, Dayton Ulrey, A. K. Wing, Jr., and R. J. Wise.

Forty-eight Associates, three Juniors, and twenty-eight Students were elected to membership.

In view of the problems which will undoubtedly be encountered in any wide-scale communication developments for national defense purposes, the President was authorized to appoint a committee to consider methods of collecting and utilizing such information and to report thereon to the Board.

Fifteenth Annual Convention

Our Fifteenth Annual Convention which was held in Boston, Massachusetts, on June 27-29 was attended by 955 men and 116 women. The full program was published in the May PROCEEDINGS and forty-four technical papers were presented. The papers by H. A. Brown and R. E. Moe were not presented because unanticipated conditions prevented the authors from being present. The various trips were well attended.

Committees

Board of Editors and Papers Committee

A joint meeting of the Board of Editors and the Papers Committee was held on July 25 and those present were: Alfred N. Goldsmith, chairman of the Board of Editors; F. B. Llewellyn, vice chairman of the Papers Committee; H. A. Affel, R. R. Batcher, R. S. Burnap (representing Dayton Ulrey), P. S. Carter, H. A. Chinn, E. W. Engstrom, P. O. Farnham, E. B. Ferrell, L. F. Jones, D. K. Martin, H. B. Marvin, H. O. Peterson, B. E. Shackelford, H. M.

Turner, H. A. Wheeler, L. E. Whittemore, H. P. Westman, secretary; J. D. Crawford, advertising manager; and Helen M. Stote, assistant editor.

In view of the fact that the Institute is now up to date in its publication program and the time required for publishing is determined almost entirely by the time needed for editing and printing, all papers will be published as nearly as possible in the chronological order of their submission to the Institute. This policy has been in effect for about a year.

The PROCEEDINGS will not publish papers which have appeared elsewhere in English in a medium having wide circulation among PROCEEDINGS readers. There is no restriction placed on the publication of English translations of foreign papers and anyone who feels that a particular foreign-language paper is especially meritorious would assist greatly by making a suggestion concerning it to the Secretary. Upon examination, if the editorial groups feel that the suggestion is sound, the author will be invited to supply a suitable translation for subsequent publications in the PROCEEDINGS.

Co-ordinating Committee

A meeting of the Co-ordinating Committee of the Board of Editors was held on July 2 and was attended by Alfred N. Goldsmith, chairman; R. R. Batcher, Helen M. Stote, assistant editor; L. E. Whittemore, and H. P. Westman, secretary. A number of papers were given final consideration and several were approved for publication in the PROCEEDINGS.

Admissions Committee

Meetings of the Admissions Committee were held on April 3 and June 5. The early meeting was attended by A. F. Van Dyck, chairman; C. W. Horn, H. B. Marvin, H. M. Turner, and R. M. Wise. At this meeting eleven applications for transfer to Member grade were approved and one for admission to that grade was accepted.

The June meeting was attended by A. F. Van Dyck, chairman; F. J. Bingley, A. B. Chamberlain, F. W. Cunningham, C. W. Horn, H. B. Marvin, H. A. Richmond, F. E. Terman, R. M. Wise, and H. P. Westman, secretary. On fifteen applications for transfer to Member one was tabled, two were rejected, and twelve were approved. The seven applications for admission to Member which were considered were approved.

Awards Committee

Three meetings of the Awards Committee were held to recommend recipients for the Institute Medal of Honor for 1940 and 1941, for the Morris Liebmann Memorial Prize for 1940, and for those who are to be invited to transfer to Fellow grade. This is the first year of operation under the new constitution which makes all transfers to Fellow grade by invitation only. The specific decisions of the Committee in regard to these various awards

are given in the report of the meeting of the Board of Directors for May 1.

At the April 4 meeting of the Awards Committee H. M. Turner, chairman; W. R. G. Baker, Ralph Bown, Virgil M. Graham, H. B. Marvin, Haraden Pratt, and H. P. Westman, secretary; were present.

On May 1 a meeting of the Committee was held at which H. M. Turner, chairman; Ralph Bown, Virgil M. Graham, H. B. Marvin, Haraden Pratt, A. F. Van Dyck, and H. P. Westman, secretary; were in attendance.

H. M. Turner, chairman; Ralph Bown, H. B. Marvin, Haraden Pratt, F. E. Terman, and H. P. Westman secretary; attended the June 4 meeting of the Committee.

Membership

A meeting of the Membership Committee was held on April 3. Those present were E. D. Cook, chairman; I. S. Coggeshall, H. F. Dart, H. C. Gawler, L. G. Pacent, C. R. Rowe, Bernard Salzberg, C. E. Scholz, John D. Crawford, secretary to the committee; and H. P. Westman, secretary.

Some special cases concerning the admission of Students to membership and the continuance of others in that grade for a substantial period of years were examined.

In view of the part each section plays in the obtaining of new members, the presentation of information and suggestions on this subject at the Annual Meeting of the Sections Committee to be held during the convention was considered desirable.

The May meeting of the Membership Committee was held on the 1st and those present were E. D. Cook, chairman; I. S. Coggeshall, H. F. Dart, C. R. Rowe, Bernard Salzberg, R. L. Snyder (Philadelphia), L. M. Ewing (representing W. M. Smith, Connecticut Valley), John D. Crawford, secretary to the committee; and H. P. Westman, secretary.

The chairman reported that the Membership Committee had been invited to attend the Annual Meeting of the Sections Committee.

A bulletin-board poster in which can be inserted a meeting notice card and which may be used on a semi-permanent basis was approved.

On June 5 a meeting of the Membership Committee was held at which there were present E. D. Cook, chairman; I. S. Coggeshall, L. G. Pacent, Bernard Salzberg, C. E. Scholz, F. E. Terman, H. P. Westman, secretary; and J. D. Crawford, committee secretary.

The Committee reviewed a draft of a new membership leaflet.

Matters to be considered at the Annual Meeting of the Sections Committee to which the Membership Committee was invited were discussed.

Nominations Committee

The Nominations Committee met on April 3 and prepared a slate of candidates which was submitted to the Board of

Directors and approved by that body at its meeting on the same date. Those present at the meeting were Alfred N. Goldsmith, chairman; Ralph Bown, Virgil M. Graham, L. C. F. Horle (ex officio), C. M. Jansky, Jr., R. H. Manson, H. B. Richmond, W. C. White, and H. P. Westman, secretary.

Sections Committee

The Annual Meeting of the Sections Committee was on June 26, the evening before the opening of the Fifteenth Annual Convention at Boston, Massachusetts. Those present were J. H. Miller, chairman, Sections Committee; E. D. Cook, chairman, Membership Committee; L. C. F. Horle, president; F. E. Terman, vice president; R. A. Heising, past president; W. L. Barrow, J. E. Brown, C. M. Burrill, J. M. Clayton, L. A. Gebhard, E. L. Gove, Virgil M. Graham, Ferdinand Hamburger, Jr., F. V. Hunt, Ernest Kohler, J. D. Kraus, S. G. Lutz, P. K. McElroy, R. S. Ould, A. B. Oxley, P. C. Sandretto, G. E. Scholz, H. C. Sheve, C. R. Smith, H. M. Smith, W. M. Smith, R. E. Stark, and H. P. Westman, secretary. In addition to representatives of thirteen sections of the Institute, a representative of the members in the Dallas-Fort Worth area who have petitioned for the formation of a new section was present.

Data on the meetings held and the membership of each section of the Institute were considered. The financial activities of the sections were reported and discussed.

It was recommended that the Board of Directors consider the establishment of a New York Section.

An extensive discussion was held on the subject of the affiliation of sections with local groups such as city, state, or regional engineering societies. A number of points bearing on this subject were discussed and several suggestions were prepared for the Board of Directors.

The chairman of the Membership Committee, E. D. Cook, and the chairman of its subcommittee on student membership, F. E. Terman, discussed the problems of obtaining suitable new members and retaining existing members.

The desirability of having notices of section meetings posted on the bulletin boards of the various organizations in the section territory in which important groups of engineers are located was stressed. The bulletin-board poster designed for this purpose should be of substantial help in getting these notices to the attention of all interested individuals.

A draft of a "Manual of Section Operation" prepared from comments made at the previous annual meeting of the Committee and those received in the interim was discussed in general. A number of additional views were expressed and the manual will be revised before being distributed to the section officers and committee chairmen.

The desirability of increasing contact between engineering personnel and executives in industry was discussed.

Technical Committees

Electroacoustics

The Technical Committee on Electroacoustics met on May 3 and those present were H. S. Knowles, chairman, R. B. Moe (representing V. N. James), G. G. Muller, G. M. Nixon, H. F. Olson, and H. P. Westman, secretary.

The Annual Review for 1939 which was published in the March, 1940, PROCEEDINGS was discussed in general. Preliminary plans for the preparation of the 1940 review were considered.

A subcommittee was appointed to prepare definitions on some terms which have not previously been treated in our standards reports.

The committee agreed to proceed with the preparation of a report on microphones and to discontinue any work now in progress on loud speakers in view of the fact that the 1938 report treats loud speakers but not microphones.

Electronics

On June 10 a meeting of the Technical Committee on Electronics was held. Those present were P. T. Weeks, chairman; R. L. Freeman, F. B. Llewellyn, Ben Kievit, Jr., G. D. O'Neill, L. G. Pollard, (representing H. P. Corwith), J. R. Wilson, and John D. Crawford, committee secretary.

A review was made of the preparations for the Electronics Conference which will be held in October.

The present standard definitions do not all include the effects of transit time and other phenomena encountered in the ultra-high-frequency operation of electron devices. The committee spent most of its time in a revision of those definitions.

Electronics Conference

Two meetings of the subcommittee responsible for the preparations for the Electronics Conference for 1940 were held. The earlier on May 22 was attended by F. R. Lack, chairman; R. M. Bowie, F. B. Llewellyn, G. A. Morton, R. W. Sears, B. J. Thompson, H. A. Wheeler, and J. D. Crawford, secretary to the committee, and the second meeting on June 26 was attended by F. R. Lack, chairman; R. M. Bowie, F. B. Llewellyn, R. W. Sears, B. J. Thompson, and A. L. Samuel.

High-Frequency Tubes

This subcommittee of the Electronics Committee met on May 13 and those present at the meeting were F. B. Llewellyn, chairman, R. L. Freeman, L. S. Nergaard, A. L. Samuel, J. D. Schantz, and J. D. Crawford, secretary to the committee. Advance preparations were made for the gathering of information on which the annual review of this field for 1940 will be based.

A number of matters pertaining to items which appear in the 1938 standards on electronics were discussed.

Large High-Vacuum Tubes

Three meetings were held by the Subcommittee on Large High-Vacuum Tubes of the Technical Committee on Electronics.

The April 6 meeting was attended by E. L. Chaffee, chairman; K. C. DeWalt, H. E. Mendenhall, I. E. Mouroumself, Alexander Senauke, E. E. Spitzer, C. M. Wheeler, and J. D. Crawford, secretary to the committee.

The second meeting was on May 9 and those present were E. L. Chaffee, chairman; K. C. DeWalt, H. E. Mendenhall, E. E. Spitzer, C. M. Wheeler and J. D. Crawford, secretary to the committee.

At the third meeting which occurred on June 24, E. L. Chaffee, chairman; K. C. DeWalt, C. E. Fay (for H. E. Mendenhall), Alexander Senauke, and J. D. Crawford, secretary to the committee, were present.

These three meetings were devoted entirely to standardization work and included recommendations as to the typographical form of the standards, definitions of terms which are included in the existing standards and others which have not been adopted previously, and methods of testing large high-vacuum tubes.

Small High-Vacuum Tubes

This subcommittee of the Technical Committee on Electronics met on April 19 and those present were R. S. Burnap, chairman; E. C. Homer (representing H. P. Corwith), G. D. O'Neill, E. A. Veazie, and J. D. Crawford, committee secretary.

The testing methods outlined in the 1938 report were examined and preparations made for their detailed revision.

Frequency Modulation

This was the initial meeting of this recently established technical committee and work was immediately started on the development of definitions of terms used in frequency-modulation work. Those who attended the meeting were D. E. Noble, chairman; S. L. Bailey (representing C. M. Jansky, Jr.), J. E. Brown, M. G. Crosby, C. C. Chambers, G. W. Gilman, L. C. F. Horle (ex-officio), C. B. Jolliffe, H. B. Marvin, J. D. Parker (representing A. B. Chamberlain), D. B. Smith, H. A. Wheeler (guest), and J. D. Crawford, committee secretary.

Radio Receivers

Broadcast Receivers

The Subcommittee on Broadcast Receivers of the Technical Committee on Radio Receivers met on May 7 and June 7 with L. F. Curtis, chairman; E. T. Dickey, D. E. Foster (guest), C. J. Franks, and J. D. Crawford, committee secretary; present in addition, C. B. McKennie, who represented H. B. Fischer, attended the May meeting.

The meetings were devoted chiefly to the problems of noise and included methods of rating the random-noise characteristics and the susceptibility to noise entering from the power lines of broadcast receivers.

Frequency-Modulated-Wave Receivers

The Subcommittee on Frequency-Modulated-Wave Receivers operating un-

der the Technical Committee on Radio Receivers held meetings in April, May, and July.

The April meeting was held on the 22nd and was attended by R. M. Wilmotte, chairman; W. M. Angus, D. E. Foster (guest), and J. D. Crawford, secretary to the committee.

The second meeting on May 20 was attended by R. M. Wilmotte, chairman, E. H. Armstrong, A. W. Barber, R. I. Cole, M. L. Levy (representing W. F. Cotter), and J. D. Crawford, secretary to committee.

On July 15 the third meeting of the Committee was held and those present were R. M. Wilmotte, chairman; E. H. Armstrong, A. W. Barber, R. I. Cole, L. F. Curtis, J. A. Worcester (representing W. M. Angus), and J. D. Crawford, committee secretary.

It is the scope of this committee to prepare a standards report on preferred methods of testing frequency-modulated-wave receivers. It is anticipated that this report will follow the general style and extent of the 1938 report on the testing of broadcast receivers. These meetings were devoted to the drafting of material for inclusion in such a report.

Television Receivers

Three meetings of the Subcommittee on Television Receivers operating under the Technical Committee on Radio Receivers were held.

On April 23 those who met were D. D. Israel, chairman, D. E. Foster (guest), E. C. Anderson (representing David Grimes), D. E. Harnett, R. S. Holmes, and J. D. Crawford, secretary to the committee.

The May 22 meeting was attended by D. D. Israel, chairman; E. C. Anderson (representing David Grimes), D. E. Harnett, Gerard Mountjoy (guest), W. A. Tolson (representing R. S. Holmes), and J. D. Crawford, secretary to the committee.

Those who were present at the July 10 meeting were D. D. Israel, chairman; E. C. Anderson (representing David Grimes), D. E. Foster, (guest), D. E. Harnett, R. S. Holmes, and J. D. Crawford, committee secretary.

As in the case of the committee whose report appears directly above, this committee has the responsibility of preparing a group of standard tests for the measurement of the performance of television receivers and these three meetings were devoted to analyzing the problem and preparing drafts of parts of the report.

Symbols

The Technical Committee on Symbols met on March 29 and on April 30. Those present at the March meeting were H. M. Turner, chairman, R. R. Batcher, R. S. Burnap, C. R. Burrows, J. L. Callahan, George Lewis, J. O. McNally (representing F. B. Llewellyn), A. A. Gibson (representing E. W. Schafer), and J. D. Crawford, secretary to committee.

At the April meeting the attendance consisted of H. M. Turner, chairman,

R. R. Batcher, R. S. Burnap, C. R. Burrows, J. L. Callahan, O. T. Laube, F. B. Llewellyn, E. W. Schafer, and J. D. Crawford, secretary to committee.

This committee has the responsibility for letter and graphical symbols. There are a number of standards in both these fields which the committee reviewed. A number of serious conflicts have existed for years in the graphical symbols used by the electric-power field and the radio field. An attempt is being made to resolve this difficulty through the work of the American Standards Association. The committee devoted its time to both types of symbols, developing proposals for increasing the extent to which we now over these fields.

Television

The Technical Committee on Television met on April 1 and on July 17. The earlier meeting was attended by I. J. Kaar, chairman; H. S. Baird, D. E. Foster, G. W. Fyler, P. C. Goldmark, T. T. Goldsmith, Jr., A. G. Jensen, L. M. Leeds, H. M. Lewis, A. V. Loughren, R. E. Shelby, D. B. Sinclair, and J. D. Crawford, secretary to the committee.

The July meeting was held with the following in attendance: I. J. Kaar, chairman; R. R. Batcher, E. W. Engstrom, D. E. Foster, G. W. Fyler, P. C. Goldmark, A. G. Jensen, L. M. Leeds, George Lewis, H. M. Lewis, A. V. Loughren, R. E. Shelby, D. B. Sinclair, and J. D. Crawford, secretary to the committee.

Five subcommittees were set up on the general subjects of definitions, special test methods, symbols, transmitting equipment, and transmission lines and antennas.

The scope of activity of these several subcommittees was discussed. Between the two meetings of the Committee, the subcommittees held meetings and their preliminary reports were reviewed at the July meeting of the Television Committee.

Definitions

On June 4 and 11 meetings of the definitions subcommittee were held. T. T. Goldsmith, Jr., chairman, A. G. Jensen, and H. M. Lewis were in attendance and in addition J. D. Crawford, secretary to the committee, was at the June 11 meeting.

The committee prepared a draft of problems and definitions which it felt should be included in any standards report on the subject of television.

Special Test Methods

This Subcommittee on Special Television Test Methods held meetings on May 3 and July 3, both of which were attended by A. V. Loughren, chairman; N. W. Baldwin, A. V. Bedford, L. J. Hartley, D. B. Sinclair, and J. D. Crawford, committee secretary.

The various types of tests that would be of especial interest in television were discussed and as a start, the committee

will consider the measurement of fidelity, both by transient-test methods and test charts, and the measurement of flicker.

Transmission Lines and Antennas

On May 23, June 20, and July 18, meetings of the subcommittee on Methods of Testing Transmission Lines and Antennas operating under the Technical Committee on Television were held.

L. M. Leeds, chairman; C. R. Burrows, J. Epstein (representing G. H. Brown), N. E. Lindenblad, R. E. Smith, and J. D. Crawford, secretary to the committee, were present at the May meeting.

The June meeting was attended by L. M. Leeds, chairman; Andrew Alford, C. R. Burrows, R. B. Hoffman (guest), N. E. Lindenblad, M. W. Schedlorf (guest), and J. D. Crawford, secretary to the committee.

At the July meeting there were present L. M. Leeds, chairman; G. H. Brown, C. R. Burrows, R. F. Lewis, N. E. Lindenblad, and J. D. Crawford, secretary to the committee.

The work of the committee on methods for measuring the principal characteristics of transmission lines used for television was divided into two parts. One of these will treat lines used at ultra-high frequencies of about 50 megacycles and above while the lines which are used for transmitting video-frequency currents extending from about 0 to 5 megacycles will comprise the other portion of the report. A considerable amount of material for the computation and measurement of transmission-line characteristics was discussed by the committee.

It is probable that the television antennas tests will attempt to treat the antenna as a two-terminal box whose internal input impedance and radiation characteristics are of the greatest importance.

Wave Propagation

The Technical Committee on Wave Propagation met on April 25 and on June 26.

At the April meeting were J. H. Dellinger, chairman, N. I. Adams, S. L. Bailey, L. V. Berkner, C. R. Burrows, Harry Diamond (guest), W. A. Fitch, G. D. Gillette, S. S. Kirby (guest), K. A. Norton, H. O. Peterson, N. Smith (guest), and J. D. Crawford, secretary to the committee.

Those present at the June meeting were J. H. Dellinger, chairman; S. L. Bailey, L. V. Berkner, C. R. Burrows, W. A. Fitch, H. O. Peterson, and H. P. Thomas.

General preparations were made for gathering data for the annual review for 1940 which will be completed at the end of this year and early next year.

The major portion of the time at these two meetings was devoted to standardization matters. They included both definitions and methods of making measurements of interest to those working in the field of the propagation of radio waves.

Membership

The following indicated admissions and transfers of memberships have been approved by the Admissions Committee. Objections to any of these should reach the Institute office by not later than August 30, 1940.

Transfer to Member

- Alford, Andrew, Mackay Radio and Telegraph Company, 67 Broad St., New York, N. Y.
 Ayer, R. B., RCA Manufacturing Company, Inc., Harrison, N. J.
 Bagnall, V. B., American Telephone and Telegraph Company, 32-6th Ave., New York, N. Y.
 Barrow, W. L., Massachusetts Institute of Technology, Cambridge, Mass.
 Brott, F. J., 609 Washington Blvd., Seattle, Wash.
 Courchene, H. B., 4808 Stanley Ave., Downers Grove, Ill.
 Hirlinger, J. F., RCA Manufacturing Company, Inc., Harrison, N. J.
 Mountjoy, Garrard, 9 Robin Rd., Manhasset, L. I., N. Y.
 Schumann, Fred, 1902 W. Berteau Ave., Chicago, Ill.
 Smith, H. E. J., Casilla 669 La Paz, Bolivia, South America.
 Ulrey, Dayton, RCA Manufacturing Company, Inc., Harrison, N. J.
 Wing, A. K., Jr., 72 Chatham St., Chatham, N. J.

Admission to Member

- Anderson, E. I., 215-37-43rd Ave., Bay-side, L. I., N. Y.
 Donal, J. S., Jr., RCA Manufacturing Company, Inc., Harrison, N. J.
 Johnson, J. B., Bell Telephone Laboratories, Inc., 463 West St., New York, N. Y.
 Seeley, W. S., 60 Squirrel Hill Rd., Nor-gate, Roslyn, L. I., N. Y.
 Shaw, G. R., RCA Manufacturing Company, Inc., Harrison, N. J.
 Singh, B. N., Physics Department, Benares Hindu University, Benares, India.
 Wise, R. J., Western Union Telegraph Company, 60 Hudson St., New York, N. Y.

Admission to Associate (A), Junior (J), and Student (S).

- Alexander, R. G., (A) General Radio Company, 30 State St., Cambridge, Mass.
 Auerbacher, W. F., (A) 35-20-73rd St., Jackson Heights, L. I., N. Y.
 Baker, H. F., (S) R.D. 2, Uniontown, Pa.
 Biggs, H. C., (S) 2627 Ridge Rd., Berkeley, Calif.
 Blackie, C. B., (A) 21 Chestnut Heights, Newfoundland Airport, Newfoundland.
 Brown, R. L., (S) 246 W. Woodruff Ave., Columbus, Ohio.

- Buchanan, G. C., (A) 3645 Southwestern Blvd., Dallas, Tex.
 Burge, F. L., (S) 246 W. Woodruff Ave., Columbus, Ohio.
 Chisholm, Edward, (A) 1047 Seymour St., Vancouver, B. C., Canada.
 Delany, F. J., (S) 34 Fruit St., Worcester, Mass.
 Early, H. C., (S) 1357 N. Main St., Ann Arbor, Mich.
 Erwin, W. S., (S) Men's Dormitory, University of Cincinnati, Cincinnati, Ohio.
 Freeman, G. A., (A) KRSC, 819 Fairview Pl., Seattle, Wash.
 Freitag, W. O., (A) 6149 Alcott St., Los Angeles, Calif.
 Garland, O. K., (A) WJHL, Inc., Johnson City, Tenn.
 Gethmann, R. B., (S) 640 Oxford Rd., Ann Arbor, Mich.
 Geyer, J. H., (A) U.S.S. Semmes, c/o Postmaster, New York, N. Y.
 Gordon, W. G., (S) Curtis Cts., Topeka, Kan.
 Gove, K. G., (A) P.O. Box 993, Plainfield, N. J.
 Graham, Edward, (A) 1st Communications Squadron, March Field, Calif.
 Greenleaf, F. D., (S) South St., Foxboro, Mass.
 Hagopian, J. J., (S) 129 Church St., Whitinsville, Mass.
 Hanchett, J. D., Jr., (S) Glen St., Natick, Mass.
 Harashima, O., (A) 169 Tairacho, Meguro-ku, Tokyo, Japan.
 Hart, Jules, (A) 103 Avenue "B," New York, N. Y.
 Hartley, K. A., (S) 154 Stamford Rd., Lees, Nr. Oldham, Lancs., England.
 Hartman, C. J., (J) 804 Mt. Ephraim Ave., Camden, N. J.
 Heffelfinger, J. B., (S) 2139 Summit St., Columbus, Ohio.
 Hicks, W. L., Jr., (S) Clemson College, S. C.
 Hollfelder, E. J., (A) Headquarters Sqdn. 18th Wing, Hickam Field, T. H.
 Jackson, C. H., (S) R.R. 1, Lafayette, Ind.
 James, G. E., (S) 6742-37th Ave. S.W., Seattle, Wash.
 Krissiep, Max, Jr., (S) 938 Franklin St., Wyomissing, Pa.
 La Violette, Fred, (S) 615 Catherine St., Ann Arbor, Mich.
 Cathey, S. L., (A) 328 N. Denver, Dallas, Texas.
 Liebmann, Gerhard, (A) 188 Gilbert Rd., Cambridge, England.
 Light, Louis, (A) 721 W. 2nd St., Grand Island, Neb.
 Linell, A. E., (A) 119 Forest St., Worcester, Mass.
 Lingenfelder, C. E., (S) 1707 York Ave., Memphis, Tenn.
 Luke, T. C., (A) 38-A Donezette St., Wellesley, Mass.
 MacGregor, R. R., (S) 453 Dawson Ave., Bellevue, Pa.
 Mackey, C. D., (A) Box 84, Albrook Field, C. Z.
 Malik, Howard, (S) 2248 N. 70th St., Milwaukee, Wis.
 Marsh, D. R., (S) 210 Ash Ave., Ames, Iowa.
 Marshall, J. R., (S) 23 Middle St., Farmington, Me.
 Martin, D. W., (A) 117 W. Markland Ave., Kokomo, Ind.
 Martin, S. J., (S) 31-20-85th St., Jackson Heights, L. I., N. Y.
 Medrow, K. R., (S) 2226 Rusk St., Madison, Wis.
 Metzger, Sidney, (A) Signal Corps Laboratories, Fort Monmouth, Oceanport, N. J.
 Miehler, W. W., (A) 72 Kirkland St., Cambridge, Mass.
 Miller, Edward, (A) 5757 Pemberton St., Philadelphia, Pa.
 Miller, K. W., (S) Route 1, Box 180, Monroeville, Ohio
 Morton, G. E., (A) 318 Cambridge Ave., Elyria, Ohio
 Myers, M. D., (A) KGKO Transmitter, Arlington, Tex.
 Neukom, R. L., (A) 6425 N. Campbell Ave., Chicago, Ill.
 Nishio, Hidehiko, (A) 1817 Hiyoshihonomachi, Kohoku-ku, Yokohama, Japan.
 O'Donnell, Harold, (S) 1227 P St., Sacramento, Calif.
 Owens, L. E., (A) 1213 Walmsley St., Dallas, Tex.
 Pieracci, R. J., (S) 60 W. 9th Ave., Columbus, Ohio.
 Quinn, J. L., Jr., (A) 29 Elmora Ave., Elizabeth, N. J.
 Record, F. A., (A) 37 Parkway Crescent, Milton, Mass.
 Roberts, E. M., Jr., (S) 1433 Partridge, University City, Mo.
 Rone, J. R., (S) 23 Waldron St., West Lafayette, Ind.
 Sampathu, S., (J) c/o G. Ramaswami, Narsing Bhuvan, Brahmin Wada Rd., Matunga, Bombay, India.
 Sandiford, P. L., Jr., (S) 2859 Walnut St., Huntington Park, Calif.
 Sandor, Julius, (A) 1238 Tonawanda St., Buffalo, N. Y.
 Schall, L. H., (S) 64 Fairfield St., Dedham, Mass.
 Segal, Bernard, (S) 1218 Pine St., Philadelphia, Pa.
 Sellers, J. E., (A) 912 Commerce St., Dallas, Tex.
 Steinberger, I. W., (A) 2430½ Rimpau Blvd., Los Angeles, Calif.
 Swain, C. W., (S) Route 2, Prosser, Wash.
 Talcott, L. E., (S) 1640 Walnut St., Berkeley, Calif.
 Tash, Bertram, (A) 516-3rd Ave. N., Saskatoon, Sask., Canada.
 Valdes, E. B., (S) Calle i esq. 13, Vedado, Havana, Cuba.
 Wahlgren, W. W., (A) 2120 St. Jarlath Ave., Oakland, Calif.

Books

Static and Dynamic Electricity, by William R. Smythe.

Published by the McGraw-Hill Book Company, 330 West 42nd St., New York, N. Y. 560 + xviii pages. 6×9 inches. Price, \$6.00.

This book is a text prepared for advanced students in physics. It is also intended to be used as a reference manual for the most effective methods of attack on problems in electricity and magnetism for the research physicist and engineer. It is prepared for the advanced student who, though familiar with routine problems normally treated in textbooks, realizes his inability to work out original problems encountered in experimental work and who desires through self-study and practice to become proficient in this respect.

The subject is treated in 15 chapters. Nine of these cover electrostatics, electric current and interaction of currents, transient phenomena in networks, eddy currents, and magnetism. Three chapters are devoted to electromagnetic waves, the special relativity theory, and the static electrical properties of matter. The remaining three chapters are devoted to general theorems, particularly with reference to potential distributions in two and three dimensions. These three chapters, the third, fourth, and fifth, will be found to be most valuable for reference purposes. All of the usual methods of attack for problems of this nature, including the method of images, conjugate functions, and the differential-equation method, together with the special harmonic functions which arise in the solution of certain of the equations, are adequately discussed. The problem of the determination of boundary conditions is also satisfactorily handled. The appendix contains a complete system of conversion tables enabling results of calculations to be expressed in any units.

The centimeter-gram-second electrostatic and electromagnetic system of units is used consistently throughout the book for electrical and magnetic quantities, the Gaussian system being used in those chapters covering wave propagation. In all of the chapters an unusual number of problems are worked out in detail, each being chosen to illustrate the usefulness of concepts of theory or a particular mathematical device previously developed. At the end of each chapter is a long list of specially chosen practical problems together with answers, also an extensive list of references for further study of the topics treated. These references also contain notations explaining the character of the material contained in them.

In all, this book will be found to be of considerable value for the audience to which it is addressed.

L. P. WHEELER
Federal Communications Commission
Washington, D. C.

Funktechnische Formelsammlung, by Otto Schmid and Max Leithiger.

Published by Wiedmannsche Verlagsbuchhandlung Berlin. 202 + vii pages. $5\frac{1}{2} \times 8\frac{1}{4}$ inches. Price, RM 9.00 (bound).

This book is a collection of formulas and tables for the radio engineer. It is arranged in three parts, the first consisting of general and mathematical material, the second of the basic electrical (mostly alternating-current and vacuum-tube) formulas, and the third of practical design matters. It covers in a very compact form nearly all the formulas an applied, as distinguished from a research, engineer needs. A total of 633 formulas are included. No formulas are derived and all are given in a form suitable for numerical computation. An example of such computations is appended to many of the formulas.

While the book may very well fulfill a useful function in Germany, its acceptability in this country would seem to be problematical. In addition to the language difficulty, it would seem, judging by comparable American handbooks, that our engineers prefer somewhat more extended explanatory matter in the text and more complete tables of mathematical functions. In particular, the relative inadequacy of this German text in respect to graphical methods of computation will hinder its acceptance here. A somewhat ultranationalistic bias is suggested by the appended bibliography which consists of one English and forty-one German titles.

L. P. WHEELER
Federal Communications Commission
Washington, D. C.

Antennen, Ihre Theorie und Technik, by H. Brückmann.

Published by S. Hirzel, Leipzig, Germany. 334 pages+5-page index, 169 figures. $6\frac{1}{4} \times 9\frac{1}{4}$ inches. Price, RM 22.00.

This is the fifth volume of the series under the general editorship of Dr. H. Fassbender entitled "Physik und Technik der Gegenwart." It is divided into three parts—Theory, Practical Installations, and Antenna Measurements. The first part, comprising nearly three quarters of the text, presents a conventional development of the radiation patterns of the usual antenna systems including directional arrays, together with a full treatment of the questions of radiation resistance, coupling between the units of arrays, antenna

reactances, antenna losses, etc. The second part, comprising some 20 per cent of the text, is concerned with matters of design for particular antenna structures, mostly German installations, although some attention is given to the WOR and KDKA installations. The third part, comprising about 5 per cent of the text, covers the methods of measurement of effective height, field strength, directivity, radiation resistance, antenna capacitance, etc. This part, largely owing to its brevity, is the least satisfactory part of the book.

There is appended a bibliography (largely German) and a satisfactory index, together with charts to aid in certain graphical computations.

The American radio engineer will possibly be disappointed to find no treatment of some of the more recent antenna developments such as the rhombic, musa, etc. The author, however, states in the preface that these and other matters which one might expect to find in a book devoted to such a specialized field will be found in other volumes of the series. Within the limitations which the author has set, the book can be recommended to those possessing an adequate facility in reading German.

L. P. WHEELER
Federal Communications Commission
Washington, D. C.

Fundamentals of Electricity and Electromagnetism, by Vernon A. Suydam.

Published by D. Van Nostrand Company, Inc., 250 Fourth Ave., New York, N. Y. 681 pages+8-page index. 337 figures. 6×9 inches. Price, \$4.75.

Despite the large number of books available on elementary principles of electricity and magnetism, this new text by Dr. Suydam presents a somewhat different point of view and supplies additional details that contribute to a more complete understanding of the subject. The style is good and the ideas are clearly presented. Although written as a second course in Physics it will prove valuable as a reference for communication and research engineers. The sections dealing with electric circuits, transient phenomena, wave propagation and electronics are sufficiently complete to provide a working knowledge of the subject.

H. M. TURNER
Yale University
New Haven, Conn.

Contributors



ROBERT C. COLWELL

Robert C. Colwell (A'21, M'29) was born at Fredericton, N. B., Canada, on October 14, 1884. He received the A.B. degree from Harvard University, the M.A. degree from the University of New Brunswick, and the Ph.D. degree from Princeton University. From 1913 to 1923 Dr. Colwell was Professor of Physics at Geneva College; since 1924 he has been Assistant Director of the Radio Laboratory at West Virginia University. He is a member of the American Physical Society, the Franklin Institute, and the American Mathematical Society.



Lewis B. Headrick (A'36, M'38) was born on June 6, 1904, at Chattanooga, Tennessee. He received the B.S. degree from the University of Chattanooga in 1926; the M.S. degree from the University of Michigan in 1928, and the Ph.D. degree in 1930. Dr. Headrick entered the Department of Engineering Manufacture of the Western Electric Company in 1930. Since 1931 he has been engaged in television research and development in the Chemical Section of the Research and



LEWIS B. HEADRICK

Engineering Department of the RCA Manufacturing Company, RCA Radiotron Division. He is a member of Sigma Xi, Sigma Pi Sigma, the American Physi-

cal Society, and the American Association for the Advancement of Science.



M. Rettinger received in physics from the University of California at Los Angeles the B.A. degree in 1932 and the M.A. degree in 1934. Since 1936, he has served as an acoustic engineer for the RCA Manufacturing Company at Hollywood, California.



M. RETTINGER

D. B. Sinclair (J'30, A'33, M'38) was born on May 23, 1910, at Winnipeg, Manitoba, Canada. He attended the University of Manitoba from 1926 to 1929, and took the co-operative course in electrical engineering at the Massachusetts Institute of Technology from 1929 to 1932. He received the S.B. degree in electrical engineering from M.I.T. in 1931, the S.M.

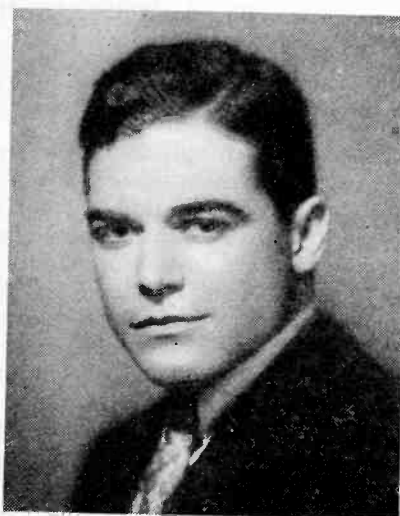

BROWDER J. THOMPSON

degree in 1932, and the Sc.D. degree in 1935. From 1932 to 1935 Dr. Sinclair was a research assistant at the Massachusetts Institute of Technology and research associate from 1935 to 1936. Since 1936 he has been an engineer with the General Radio Company. He is a member of Sigma Xi.



Browder J. Thompson (A'29, M'32, F'38) was born at Roanoke, Louisiana, on August 14, 1903. He received the B.S.



GILBERT S. WICKIZER

degree in electrical engineering from the University of Washington in 1925 and in 1926 he entered the General Electric Research Laboratory working on vacuum-tube research and development. From



D. B. SINCLAIR

1931 to 1940 Mr. Thompson was in charge of the Research Division, Research and Engineering Department, RCA Manufacturing Company, Harrison, N. J. At present he is Associate Director of the Research Laboratories of the RCA Manufacturing Company. In 1936 he received the Morris Liebmann Memorial Prize. He is a member of the American Physical Society.



Gilbert S. Wickizer (A'28) was born on August 20, 1904, at Warren, Pennsylvania. He received the B.S. degree in electrical engineering from Pennsylvania State College in 1926. During 1926 and 1927 he was with the Radio Corporation of America, Operating Division, and since 1927 he has been with the Receiver Research and Advanced Development Section of R.C.A. Communications, Inc. Mr. Wickizer is a member of Eta Kappa Nu.



For biographical sketches of T. Gilliland, S. S. Kirby, and N. Smith, see the PROCEEDINGS for January, 1940; for Heinz E. Kallmann, see the PROCEEDINGS for April, 1940.

"WE NOW HAVE MANY
450T's in service with nearly
ten thousand hours of
satisfactory service"

Says Mr. G. A. O'Reilly, ground station
radio engineer for Transcontinental &
Western Air, Inc.



TRANSCONTINENTAL & WESTERN AIR, INC.



10 RICHARDS ROAD

Kansas City, Mo.

March 7, 1940

Mr. J. A. McCullough
Eitel-McCullough, Inc.
San Bruno, California

Dear Mr. McCullough:

Our first Siebenthaler "individual radio frequency unit" transmitter was put in operation at the Kansas City TWA ground station eighteen months ago. Each radio frequency unit in the transmitter uses a pair of 450TL's in the output stage. The two tubes, which we operate at a plate potential of four thousand volts, deliver two and one-half kilowatts to the antenna with a surprising degree of ease.

During the early stages of the transmitter development, the use of inexpensive air-cooled triodes for power outputs of two or three kilowatts was the topic of considerable discussion. Various estimates of the tube life to be expected, most of which were not very encouraging, were made by interested persons. We were confident, however, on the basis of experience with your smaller tubes, that a pair of 450T's would handle this job. We now have many 450T's in service with nearly ten thousand hours of satisfactory operation.

TWA opened its fifth station of this kind a few days ago and, in so doing, placed the seventieth 450T in daily operation. Installation work will begin immediately on five more stations, and we are now completing plans for additional installations which will bring the total up to fifteen. I believe that this equipment program in itself expresses our opinion of Eimac tubes.

Very truly yours,

G. A. O'Reilly
G. A. O'Reilly

Ground Station Radio Engineer

EIMAC REPRESENTATIVES

California, Nevada
HERB BECKER, 1530 W.
104th St., Los Angeles, Cal.
Wash., Ore., Idaho, Mont.
GENERAL SALES CO.
Verner O. Jensen, 2605-07
Second Ave., Seattle, Wash.
Colo., Wyo., New Mexico,
Arizona, Utah
RICHARD A. HYDE,
4253 Quitman St., Denver,
Colo.

N. Caro., S. Caro., Georgia,
Tenn., Flor., Ala., Miss.
JAMES MILLAR, 316
Ninth St. N. E., Atlanta,
Georgia
N. Y., N. J., Penn., Md., Del.,
Dist. of Col., Maine, N. H.,
R. I., Conn., Mass.
ADOLPH SCHWARTZ,
14726 Elm Ave., Flushing,
New York

Texas, La., Okla., Ark.
J. EARL SMITH, 2821
Live Oak St., Dallas, Texas
Chicago, Illinois, Wisconsin
G. G. RYAN, 549 W.
Washington Blvd., Chicago,
Ill.
Ohio, Mich., Ky., Ind., Minn.
Mo., Kan., Neb., Iowa
PEEL SALES ENGINEERING CO., E. R. Peel
154 E. Erie St., Chicago, Ill.

Eimac
TUBES

EITEL & McCULLOUGH, INC.
SAN BRUNO, CALIFORNIA

R E S S

P A S S E N G E R S

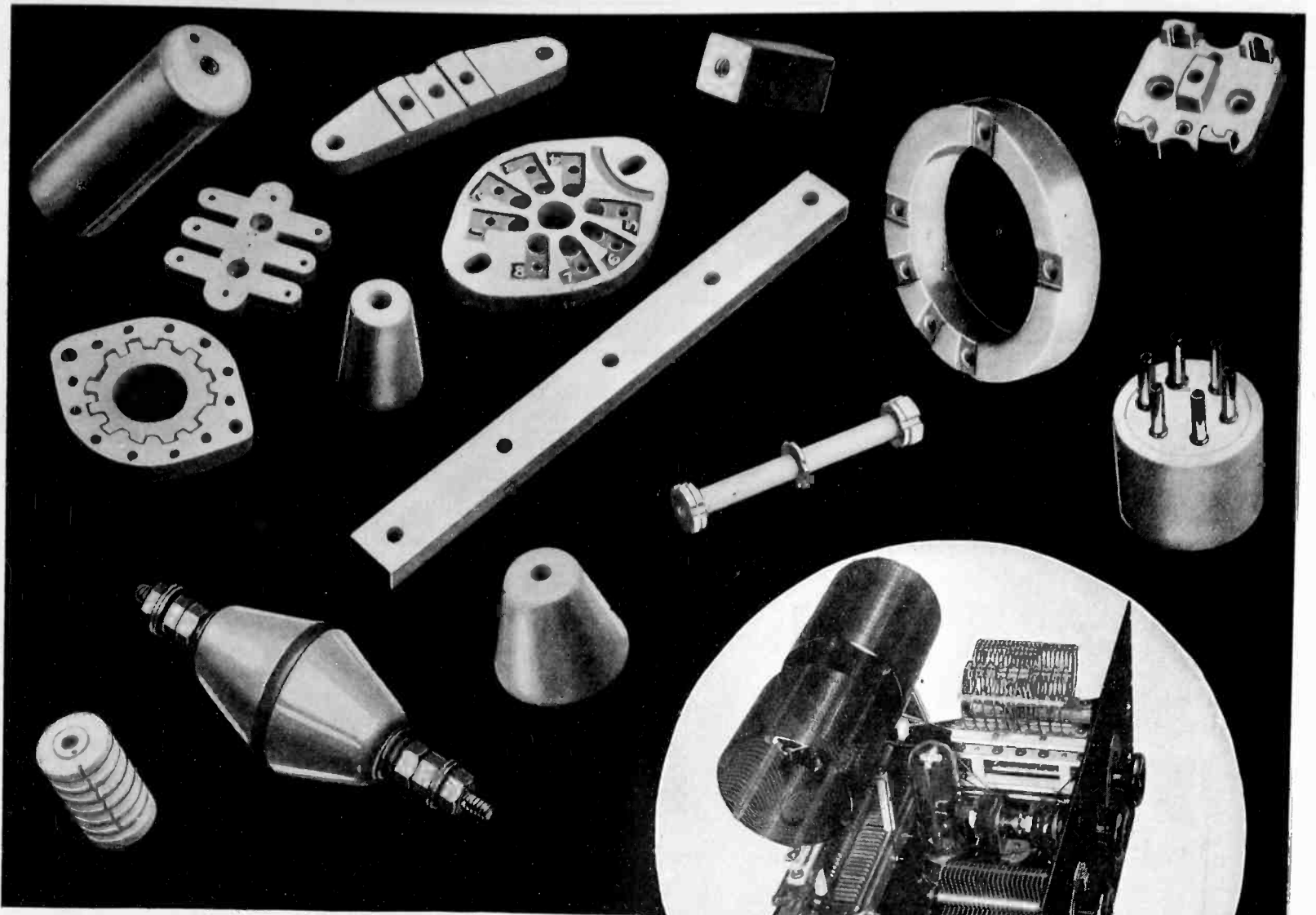

NO QUARTER!

AlSiMag inspection standards,
based upon rigid specifications, give no quarter to inaccuracy.

The percentage of our inspection cost is very high . . . perhaps the highest in the industry. We have taken every care to see that our inspections are as efficient as can be devised. Beyond that, we will not go. We gladly pay more for inspection because we know it results in greater economy in the long run . . . for us . . . for you . . . for your customers.

ALSiMAG

Trade Mark Reg. U. S. Pat. Off.

FROM CERAMIC HEADQUARTERS

AMERICAN LAVA CORPORATION • CHATTANOOGA • TENNESSEE

CHICAGO • CLEVELAND • NEW YORK • ST. LOUIS • LOS ANGELES • SAN FRANCISCO • BOSTON • PHILADELPHIA • WASHINGTON, D. C.

IRC

Scores Again!



A *New* POSITIVE PRESSURE BAND FOR ADJUSTABLE RESISTORS

✓ Prevents Oxidation and Corrosion at Point of Contact

✓ Eliminates Wire Damage and Breakage

✓ Cannot be Adjusted too Tightly

✓ Designed for High Temperatures

Heat-resistant, constant-pressure stainless steel spring spot-welded to band.

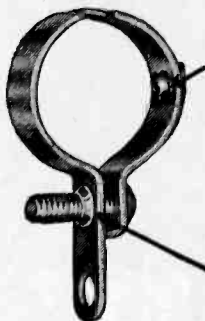
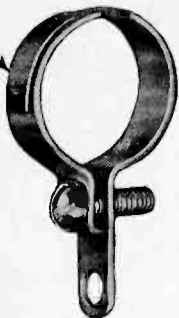

Positive pressure of contact button on wire never varies—never damages.

Thread on band—no nut required.

Flexible section permits easy bending for attaching band to resistor without disturbing radius.

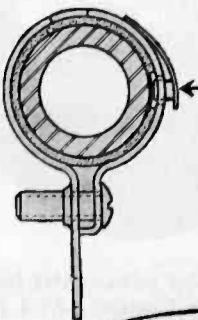
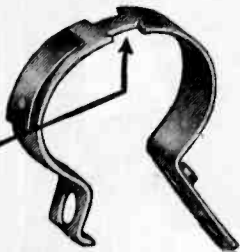

Silver contact button eliminates oxidation and open circuits.

It was a design engineer who classified adjustable resistors as a "necessary evil"—necessary because nothing can replace their convenience in adjusting resistance values to fit circuit requirements, evil because this adjusting so often results in damaged or broken windings. Furthermore, conventional-type bands with steel buttons provide opportunities for oxidation and corrosion.

The new IRC Positive Pressure Contact Band removes these troubles once and for all. No matter how much you tighten the band itself, the pressure of the silver contact button on the winding remains safe, constant and positive. No matter how often the bands are readjusted, there is no danger to the windings. The silver button prevents oxidation and corrosion, insuring good trouble-free contact at all times.

The band is cold-rolled steel heavily cadmium plated. The silver contact button is spot-welded to a heat-resistant stainless steel spring which assures constant pressure on the windings at all times. The units will not deteriorate under high operating temperatures or constant use. They are available in $\frac{9}{16}$ ", $\frac{3}{4}$ " and $1\frac{1}{4}$ " diameters for all IRC Cement Coated Adjustable Power Wire Wound Resistors from 25 to 200 watts inclusive.

FREE SAMPLE resistor with new band gladly supplied to manufacturers of original equipment or operating companies upon receipt of specifications. Write for IRC Bulletin No. IV describing all types, sizes and shapes of Power Wire Wound Resistors for every need.

INTERNATIONAL RESISTANCE COMPANY

431 N. Broad Street,

Philadelphia, Pa.



Cement Coated

POWER WIRE WOUND RESISTORS

PEAK PERFORMANCE...

PEAK ECONOMY... NOW...

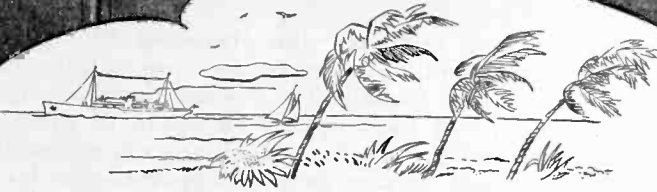

*with 5KW
Radiation Cooled
Transmitter*

The Western Electric 405B-1 Radiation Cooled transmitter assures broadcast quality and economy you never believed possible in a 5KW.

The Doherty Circuit doubles the efficiency of the power amplifier. Other features that interest any engineer are: improved stabilized feed-

back; automatic line voltage regulators and cathode ray oscillograph connections in all important circuits.

Both the 405B-1 air cooled and its companion 405A-1 water cooled transmitters were designed with an eye to the future. Ask Graybar for Bulletin T1632.

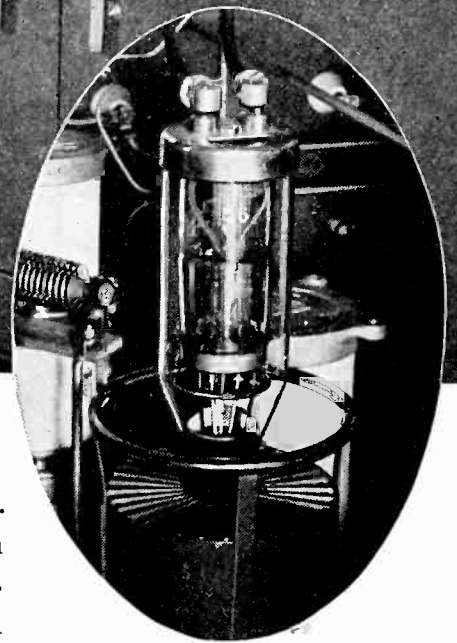

Here's the remarkable new Radiation Cooled 343AA tube—designed especially for use with Western Electric 405B-1 transmitter.

ASK YOUR
ENGINEER

Western Electric



DISTRIBUTORS: In U. S. A.: Graybar Electric Co., New York, N. Y. In Canada and Newfoundland: Northern Electric Co., Ltd. In other countries: International Standard Electric Corp.

IRE *membership offers many services to the radio engineer*

Proceedings—An outstanding publication in the radio engineering field. Over a quarter of a century of service to the world in publishing important radio engineering discoveries and developments, the PROCEEDINGS presents exhaustive engineering data of use to the specialist and general engineer. A list of its authors is a "Who's Who" of the leaders in radio science, research, and engineering.

Standards—Since 1914 our standards reports have stabilized and clarified engineering language, mathematics, graphical presentations, and the testing and rating of equipment. They are always in the process of revision and thus remain up to date.

Meetings—In twenty-two cities in the United States and Canada, meetings of the Institute and its sections are held regularly. Scores of papers on practically every branch of the field are presented and discussed. Several convention meetings are sponsored by the Institute and add materially to its effectiveness in distributing data of value to engineers.

The Institute of Radio Engineers

Incorporated

330 West 42nd Street, New York, N.Y.

To the Board of Directors

Gentlemen:

I hereby make application for ASSOCIATE membership in the Institute of Radio Engineers on the basis of my training and professional experience given herewith, and refer to the sponsors named below who are personally familiar with my work.

I certify that the statements made in the record of my training and professional experience are correct, and agree if elected, that I shall be governed by the Constitution of the Institute as long as I continue a member. Furthermore I agree to promote the objects of the Institute so far as shall be in my power.

.....
(Sign with pen)

.....
(Address for mail)

.....
(City and State)

.....
(Date)

SPONSORS

(Signatures not required here)

Mr.

Address

City and State

Mr.

Address

City and State

Mr.

Address

City and State

Associate membership affiliates you with the Institute and brings you the PROCEEDINGS each month as well as notices of meetings held near you.

(Typewriting preferred in filling in this form) No.....

RECORD OF TRAINING AND PROFESSIONAL EXPERIENCE

Name
(Give full name, last name first)

Present Occupation
(Title and name of concern)

Business Address

Home Address

Place of Birth Date of Birth Age

Education

Degree
(College) (Date received)

TRAINING AND PROFESSIONAL EXPERIENCE

(Give dates and type of work, including details of present activities)

Record may be continued on other sheets this size if space is insufficient.

Receipt Acknowledged Elected Notified

Requirements—For Associate membership, an applicant must be at least twenty-one years of age, of good character, and be interested in or connected with the study or application of radio science or the radio arts.

Sponsors—Three sponsors who are familiar with the work of the applicant must be named. Preferably these should be Associates, Members, or Fellows of the Institute. In cases where the applicant is so located as not to be known to the required number of member sponsors, the names of responsible nonmember sponsors may be given.

Dues—Dues for Associate membership are six dollars per year. The entrance fee for this grade is three dollars and should accompany the application.

Other Grades—Those who are between the ages of eighteen and twenty-one may apply for Junior grade. Student membership is available to full-time students in engineering or science courses in colleges granting degrees as a result of four-year courses. Member grade is open to older engineers with several years of experience. Information on these grades may be obtained from the Institute.

PRACTICAL DATA
for those who design and
build Transmitters . . .

Mica Capacitors

MEDIUM-DUTY BAKELITE-CASED TRANSMITTING CAPACITORS
TYPES 1100-1104-1110-1114-1118-1124

The medium-duty bakelite-cased transmitting capacitors are designed for use in the intermediate frequency and antenna circuits of transmitters. They are available in values from 100 p.f. to 1000 p.f. and in voltages from 500 to 1000 v. The bakelite case provides excellent insulation and protection against moisture and dust. The capacitors are individually tested and guaranteed to meet the specifications.

SPECIAL NOTES
TYPES 1100-1104-1110-1114-1118-1124

These capacitors are designed for use in the intermediate frequency and antenna circuits of transmitters. They are available in values from 100 p.f. to 1000 p.f. and in voltages from 500 to 1000 v. The bakelite case provides excellent insulation and protection against moisture and dust. The capacitors are individually tested and guaranteed to meet the specifications.

Individually Tested PRODUCTS

Continuous Service Rating Data
TYPES 1100-1110-1114-1118-1124

TYPE	1100	1104	1110	1114	1118	1124
Value (p.f.)	100	200	300	400	500	1000
Voltage (v.)	500	500	500	500	500	1000
Power (w.)	100	200	300	400	500	1000

Filter and By-Pass Capacitors

Rectangular-Can Hermetically-Sealed Oil-Filled Capacitors
TYPES 16 and 18

These capacitors are designed for use in the filter and by-pass circuits of transmitters. They are available in values from 100 p.f. to 1000 p.f. and in voltages from 500 to 1000 v. The rectangular can provides excellent insulation and protection against moisture and dust. The capacitors are individually tested and guaranteed to meet the specifications.

TYPE 16

TYPE 18

Filter and By-Pass Capacitors

Hermetically-Sealed Plug-In Type Paper Capacitors
TYPE 71

These capacitors are designed for use in the filter and by-pass circuits of transmitters. They are available in values from 100 p.f. to 1000 p.f. and in voltages from 500 to 1000 v. The plug-in type provides excellent insulation and protection against moisture and dust. The capacitors are individually tested and guaranteed to meet the specifications.

TYPE 71

TYPE	71	72	73	74	75	76	77	78	79	80	81	82	83	84	85	86	87	88	89	90
Value (p.f.)	100	200	300	400	500	600	700	800	900	1000	1100	1200	1300	1400	1500	1600	1700	1800	1900	2000
Voltage (v.)	500	500	500	500	500	500	500	500	500	500	500	500	500	500	500	500	500	500	500	500
Power (w.)	100	200	300	400	500	600	700	800	900	1000	1100	1200	1300	1400	1500	1600	1700	1800	1900	2000

Individually Tested

Transmitting
AEROVOX
Capacitor Catalog

Capacitors for the design, construction, testing and maintenance of radio transmitters, electronic devices, laboratory apparatus, line instruments and similar work.

● This new loose-leaf catalog and engineering manual is available to engineers, designers and builders of commercial-grade transmitters, P-A systems, electronic and allied equipment. It contains page after page of listings of extra-quality heavy-duty capacitors of such types as mica, paper, oil, and plug-in electrolytics, of particular interest to those who build to last and to safeguard enviable reputations.

Aerovox has extended its already outstandingly complete choice to include these extra-quality heavy-duty capacitors. What were special types yesterday now become standard Aerovox capacitors today, in taking care of the most critical buyers of radio components.

A copy of this limited-edition Aerovox Transmitting Capacitor Catalog is available only to professional engineers, designers or builders of radio or electronic equipment, writing us on their business letterhead.

AEROVOX CORPORATION
New Bedford, Mass.

Sales Offices in All Principal Cities



A New
W-I-D-E
R-A-N-G-E
Signal Generator

100 Kc
to 120 Mc

Dealer Net
Price
\$79.84



A Complete Range Signal Generator . . .
From 100 Kc to 120 Mc. (10 Bands) . . .
All frequencies fundamentals . . . Continuous
coverage of standard broadcast ranges
as well as the new high frequencies for
frequency modulated and television receivers.
Direct meter reading in microvolts.
Positive vernier dial tuning control—no back-
lash . . . Output available at end of
coaxial cable minimizes losses and distur-
bance to circuit under test . . . Operates
from AC line 50 or 60 Cycles . . . Hetero-
dyne detector incorporated . . . Provision
for external modulation at audio or radio
frequencies . . . Permeability adjustment
and tubular air-trimmer capacitors used
throughout, assuring excellent accuracy and
stability of dial scale calibration . . . Low
resistance copper shielding. Furnished in
Rolled edge metal case, 15" x 9" x 6 3/4"
. . . Dealer Net Price . . . \$79.84.

★★★
ONE OF THE LITTLE TRIPPLETS

Model 670 AC
Ammeter. Mold-
ed Case . . . Self-
contained Trans-
former. The little
tester with the
big 3" meter.
Dealer Net
Price \$9.00

(13 in the family)

Write for
Catalog —
Section 217
Harmon
Drive

TRIPPLET ELECTRICAL INSTRUMENT CO.
Bluffton, Ohio

DISPLAY ADVERTISERS

Aerovox Corporation	A	vii
American Lava Corporation		ii
American Telephone & Telegraph Company		ix
Bliley Electric Company	B	viii
Cornell-Dubilier Electric Corporation	C	x
Eitel-McCullough, Inc.	E	i
General Radio Company	G	Cover IV
International Resistance Company	I	iii
RCA Manufacturing Company	R	Cover III
Triplet Electrical Instrument Company	T	viii
Western Electric Company	W	iv

BLILEY

Precision Made

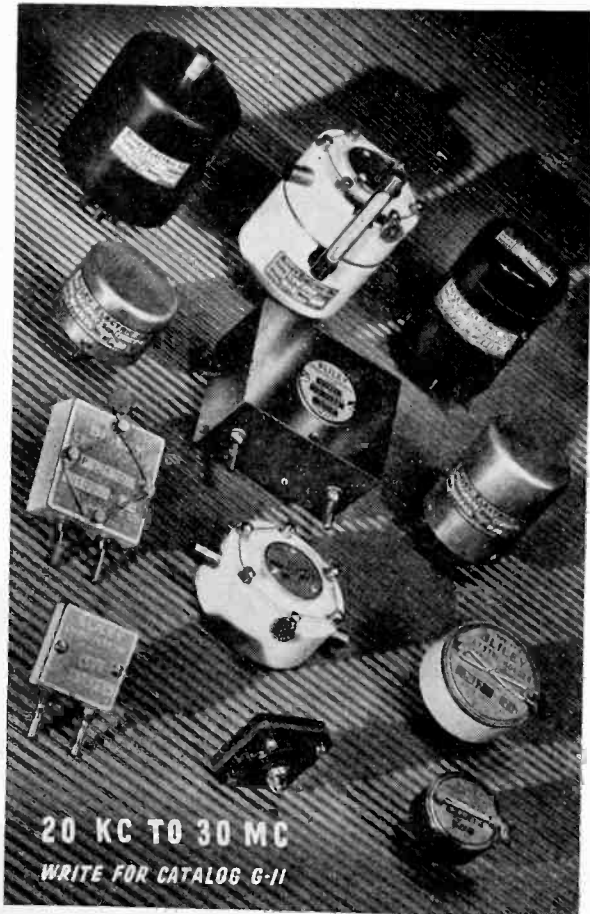

20 KC TO 30 MC
WRITE FOR CATALOG G-II

CRYSTAL UNITS

BLILEY ELECTRIC CO., Erie, Pa.



"IS IT FOR ME?"

You kind of hope it is — for a lot of good news and good times come your way by telephone.

Maybe it's a date for Sister Sue. Or a golf call for Dad. Or Bill asking if Jimmie can go to the movies. Or Grandma calling Mother to find out if things are all right.

And everything is more likely to be all right when there's a telephone in the home. In many, many ways, it is a real friend of the family.

BELL TELEPHONE SYSTEM



The Bell System cordially invites you to visit its exhibits at the New York World's Fair and the Golden Gate International Exposition, San Francisco.





they may
look alike

but what a difference
in performance!

Harness racing or capacitors...

THEY look pretty much alike dusting by—those tight-lipped "harness hoss" drivers. But behind the goggles of the men behind the horses, what a difference! Holding the reins on an eager, high stepping trotter, talking hoss sense at almost a mile-a-minute clip, coaxing home a winner—that takes experience.

And so it is with capacitors. They all look alike today. The test of performance... the difference between a winner and an "also ran" is deep down inside—in the ingredients. Knowing how to match these hidden ingredients to give you peak capacitor performance, real capacitor endurance and long-life dependability takes experience.

Cornell-Dubilier has specialized in capacitors for over thirty years. Combined with the fact that there are more C-Ds in "harness" today than any other make—this is proof that Cornell-Dubilier knows how.

CORNELL-DUBILIER ELECTRIC CORPORATION
1012 HAMILTON BLVD. • SOUTH PLAINFIELD, N. J.

*C-D ETCHED FOIL—NOT FABRICATED PLATE



Only Cornell-Dubilier
Electrolytics offer
all these REAL
features

Type UP*

These Features:

- Special high-voltage paper separator
- C-D etched plate
- Special C-D electrolyte
- Special high formation process

Result in:

- Minimum capacity change over wide temperature range.
- Great reduction in physical size—up to 40% for some types.
- Increased useful life.
- Reduced direct current leakage.
- Reduced equivalent series resistance.
- Higher breakdown voltage.
- Improved audio and radio frequency impedance characteristics.

The Type UP is the smallest can type capacitor available, and can be supplied in single, dual, triple and quadruple capacity combinations. Complete physical and dimensional data on request.

Remember! All C-D capacitors are union made and competitively priced.

specify **CORNELL-DUBILIER!**

THE WORLD'S LARGEST MANUFACTURER OF CAPACITORS

Emerson OK's Preferred Type Tubes Program



"A smart move to help the whole Radio Industry"

... says **BEN ABRAMS**

President of Emerson Radio and Phonograph Corporation, New York City

"It's the right answer to one of the most troublesome problems of the radio business. I see immediate benefits for manufacturers who will be able to insure more orderly and more economical production. Distributors, dealers, and service men can expect a more profitable and easier to operate tube business in the future. We, at Emerson, endorse this plan 100 per cent."

THEY'RE ALL FOR IT—manufacturers, distributors, dealers and service men. Never in history has a program received the immediate and enthusiastic support which is greeting the RCA Preferred Type Tubes Program!

The reason? Well—everybody benefits: the whole industry—and the consumer, too! It's sound all the way. Everybody has wanted it. Everybody is glad to get it. And RCA is doing all that can be done to see that every benefit for the industry will be realized as quickly as possible.



Less than one type in ten of the 470 types of radio receiver tubes now on the market is actually needed to design practically every type of radio receiver at the lowest ultimate cost. RCA has outlined a list of 36 RCA Preferred Type Tubes which adequately cover every function for any type of receiving set circuit.

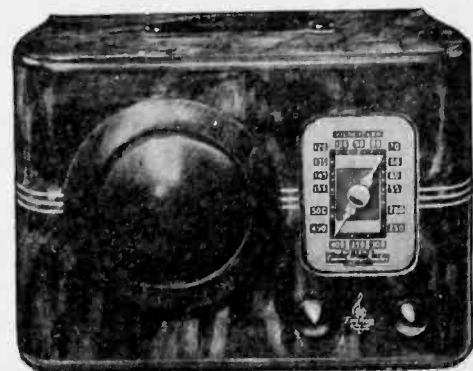

BRILLIANT EMERSON RADIO
Employs Preferred Tubes!

Emerson Model D.B. 315 with Re-Flex Miracle Tone Chamber. A fine example of the way a competent engineering staff can create great values with tubes in the Preference List.



Radio Tubes

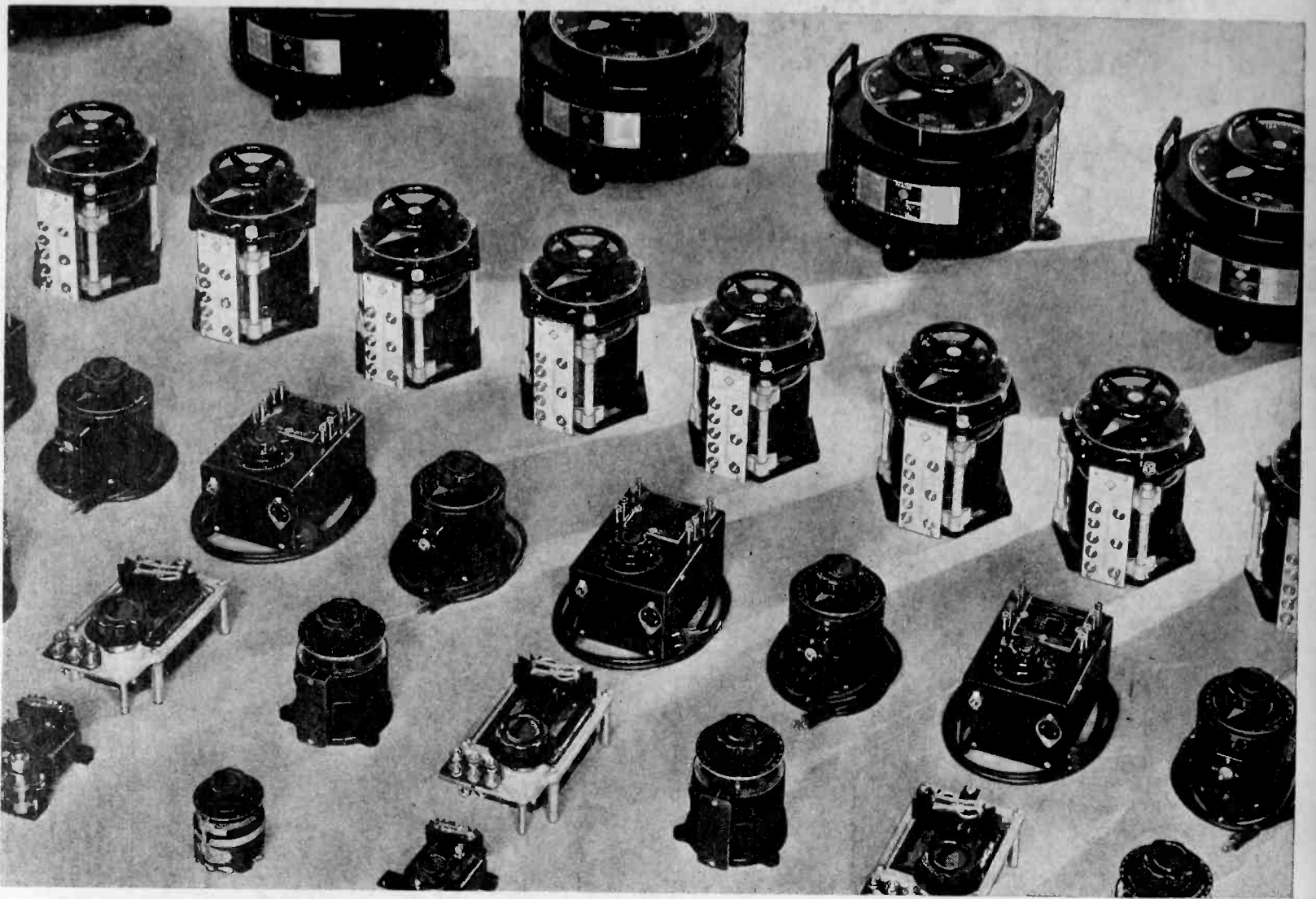

With the VARIAC . . . the *right* voltage every time

Thousands of enthusiastic users testify to the general usefulness of the VARIAC* *continuously adjustable* auto-transformer for use in hundreds of different applications where the voltage on any a-c operated device must be set *exactly right*.

The VARIAC is the original continuously-adjustable, manually-operated voltage control with these exclusive features found in no type of resistive control.

- **EXCELLENT REGULATION**—Output voltages are independent of load up to the full load rating of the VARIAC.
- **HIGH OUTPUT VOLTAGES**—VARIACS supply output voltages 15% higher than the line voltage.
- **SMOOTH CONTROL**—The VARIAC may be set to supply any predetermined output voltage with absolutely smooth and stepless variation.
- **HIGH EFFICIENCY**—Exceptionally low losses at both no load and at full power.
- **SMALL SIZE**—VARIACS are much smaller than any other voltage control of equal power rating.
- **LINEAR OUTPUT VOLTAGE**—Output voltages are continuously adjustable from *zero* by means of a 320 degree rotation of the control knob.
- **CALIBRATED DIALS**—VARIACS are supplied with reversible dials which read directly in output voltage from zero to line voltage or from zero to 15% above line.
- **SMALL TEMPERATURE RISE**—Less than 50 degrees C. for *continuous duty*.
- **ADVANCED MECHANICAL DESIGN**—Rugged construction—no delicate parts or wires, two or more units may be ganged on the same shaft to control several circuits simultaneously or to increase the total power rating.

VARIACS are stocked in fifteen models with power ratings from 170 watts to 7 kw; special units to meet the special requirements of individual users may be obtained promptly and economically in quantity. Prices on the stock models range between \$10.00 and \$100.00.

*Trade name VARIAC is registered at U. S. Patent Office. VARIACS are patented under U. S. Patent 2,009,013, issued to General Radio Company.

Write for Bulletin 613 for Complete Data

GENERAL RADIO COMPANY

Cambridge, Massachusetts

BRANCHES: NEW YORK • LOS ANGELES

MANUFACTURERS OF PRECISION ELECTRICAL LABORATORY APPARATUS

