

VOLUME 24

FEBRUARY, 1936

NUMBER 2

PROCEEDINGS
of
The Institute of Radio
Engineers



Application Blank for Associate Membership on Page XI

Institute of Radio Engineers

Forthcoming Meetings

JOINT MEETING

American Section, International Scientific
Radio Union and Institute of Radio Engineers

WASHINGTON, D. C.

May 1, 1936

CINCINNATI SECTION

February 6, 1936

CLEVELAND SECTION

February 27, 1936

DETROIT SECTION

February 21, 1936

LOS ANGELES SECTION

February 18, 1936

NEW YORK MEETING

February 5, 1936

March 4, 1936

PHILADELPHIA SECTION

February 6, 1936

March 5, 1936

TORONTO SECTION

February 10, 1936

WASHINGTON SECTION

February 10, 1936

The Institute of Radio Engineers

Board of Editors

ALFRED N. GOLDSMITH, <i>Chairman</i>	
R. R. BATCHER	K. S. VAN DYKE
H. H. BEVERAGE	H. P. WESTMAN, <i>ex officio</i>
F. W. GROVER	L. P. WHEELER
J. W. HORTON	L. E. WHITTEMORE
G. W. PICKARD	WILLIAM WILSON

CONTENTS

PART I

Institute News and Radio Notes.....	139
Retiring Address of Stuart Ballantine.....	139
Inaugural Address of Alan Hazeltine.....	140
Message from Valdemar Poulsen.....	144
Registration of Engineers.....	145
January Meeting of the Board of Directors.....	146
Committee Work.....	147
Institute Meetings.....	148
Personal Mention.....	157

PART II

Technical Papers

Preferred Numbers.....	ARTHUR VAN DYCK	159
A New Type of Gas-Filled Amplifier Tube.....	JAMES D. LEVAN AND PAUL T. WEEKS	180
Some Engineering and Economic Aspects of Radio Broadcast Coverage..	GLENN D. GILLETT AND MARCY EAGER	190
A New Tube for Use in Superheterodyne Frequency Conversion Systems	C. F. NESSLAGE, E. W. HEROLD, AND W. A. HARRIS	207
Design of Audio-Frequency Amplifier Circuits Using Transformers.....	PAUL W. KLIPSCH	219
An Experimental Study of Parasitic Wire Reflectors on 2.5 Meters.....	A. WHEELER NAGY	233
A Method for Determining the Residual Inductance and Resistance of a Variable Air Condenser at Radio Frequencies.....	R. F. FIELD AND D. B. SINCLAIR	255
Eddy Currents in Composite Laminations.....	E. PETERSON AND L. R. WRATHALL	275
Cathode-Ray Oscillographic Investigations on Atmospherics.....	HARALD NORINDER	287
Optimum Operating Conditions for Class B Radio-Frequency Amplifiers	W. L. EVERITT	305
A Network Theorem.....	J. G. BRAINERD	316
Discussion on "Parasites and Instability in Radio Transmitters," by G. W. Fyler.....	JAMES GREIG AND G. W. FYLER	328
Book Reviews: "A Fugue in Cycles and Bels," by John Mills.....	IRVING WOLFF	330
"Sound," by F. R. Watson.....	IRVING WOLFF	330
Booklets, Catalogs, and Pamphlets Received.....		331
Contributors to This Issue.....		332

The Institute of Radio Engineers

GENERAL INFORMATION

INSTITUTE. The Institute of Radio Engineers was formed in 1912 through the amalgamation of the Society of Wireless Telegraph Engineers and the Wireless Institute. Its headquarters were established in New York City and the membership has grown from less than fifty members at the start to several thousand.

AIMS AND OBJECTS. The Institute functions solely to advance the theory and practice of radio and allied branches of engineering and of the related arts and sciences, their application to human needs, and the maintenance of a high professional standing among its members. Among the methods of accomplishing this is the publication of papers, discussions, and communications of interest to the membership.

PROCEEDINGS. The PROCEEDINGS is the official publication of the Institute and in it are published all of the papers, discussions, and communications received from the membership which are accepted for publication by the Board of Editors. Copies are sent without additional charge to all members of the Institute. The subscription price to nonmembers is \$10.00 per year, with an additional charge for postage where such is necessary.

RESPONSIBILITY. It is understood that the statements and opinions given in the PROCEEDINGS are views of the individual members to whom they are credited, and are not binding on the membership of the Institute as a whole. Papers submitted to the Institute for publication shall be regarded as no longer confidential.

REPRINTING PROCEEDINGS MATERIAL. The right to reprint portions or abstracts of the papers, discussions, or editorial notes in the PROCEEDINGS is granted on the express condition that specific reference shall be made to the source of such material. Diagrams and photographs published in the PROCEEDINGS may not be reproduced without making specific arrangements with the Institute through the Secretary.

MANUSCRIPTS. All manuscripts should be addressed to the Institute of Radio Engineers, 330 West 42nd Street, New York City. They will be examined by the Papers Committee and the Board of Editors to determine their suitability for publication in the PROCEEDINGS. Authors are advised as promptly as possible of the action taken, usually within two or three months. Manuscripts and illustrations will be destroyed immediately after publication of the paper unless the author requests their return. Information on the mechanical form in which manuscripts should be prepared may be obtained by addressing the secretary.

MAILING. Entered as second-class matter at the post office at Menasha, Wisconsin. Acceptance for mailing at special rate of postage is provided for in the act of February 28, 1925, embodied in Paragraph 4, Section 412, P. L. and R., and authorization was granted on October 26, 1927.

Published monthly by

THE INSTITUTE OF RADIO ENGINEERS, INC.

Publication office, 450-454 Ahnaip St., Menasha, Wis.

BUSINESS, EDITORIAL, AND ADVERTISING OFFICES

Harold P. Westman, *Secretary*

330 West 42nd Street, New York, N. Y.

INSTITUTE SECTIONS

- ATLANTA—Chairman, I. H. Gerks; Secretary, Philip C. Bangs, 218 Red Rock Building, Atlanta, Ga.
- BOSTON—Chairman, E. L. Bowles; Secretary, Roland G. Porter, Northeastern University, Boston, Mass.
- BUFFALO-NIAGARA—Chairman, L. E. Hayslett; Secretary, E. C. Waud, 235 Huntington Ave., Buffalo, N. Y.
- CHICAGO—Chairman, H. C. Vance; Secretary, J. E. Brown, 2022 Engineering Building, Chicago, Ill.
- CINCINNATI—Chairman, C. D. Barbulesco; Secretary, R. L. Freeman, Crosley Radio Corporation, Cincinnati, Ohio.
- CLEVELAND—Chairman, R. Morris Pierce; Secretary, J. S. Hill, 3325 Beechwood Ave., Cleveland Heights, Ohio.
- CONNECTICUT VALLEY—Chairman, J. A. Hutcheson; Secretary, E. E. Schwarzenbach, 42 Northwood, Chicopee Falls, Mass.
- DETROIT—Chairman, E. C. Denstaedt; Secretary, Howard S. Gould, 214 Tuxedo Ave., Detroit, Mich.
- EMPORIUM—Chairman, Raymond R. Hoffman; Secretary, L. E. West, Hygrade Sylvania Corporation, Emporium, Pa.
- LOS ANGELES—Chairman, John F. Blackburn; Secretary, E. Pat Schultz, 1016 N. Sycamore St., Hollywood, Calif.
- NEW ORLEANS—Chairman, J. A. Courtenay; Secretary, C. B. Reynolds, Radiomarine Corporation of America, 512 St. Peter St., New Orleans, La.
- PHILADELPHIA—Chairman, Knox McIlwain; Secretary, R. L. Snyder, 103 Franklin Rd., Glassboro, N. J.
- PITTSBURGH—Chairman, Lee Sutherlin; Secretary, Branko Lazich, Union Switch and Signal Company, Swissvale, Pa.
- ROCHESTER—Chairman, E. C. Karker; Secretary, H. A. Brown, 89 East Ave., Rochester, N. Y.
- SAN FRANCISCO—Chairman, Robert Kirkland; Secretary, Henry Tanck, RCA Communications, Inc., Bolinas, Calif.
- SEATTLE—Chairman, Earl D. Scott; Secretary, Harold C. Hurlbut, 2633-11th Ave. N., Seattle, Wash.
- TORONTO—Chairman, L. M. Price; Secretary, R. Klingelhoefter, International Resistance Company, 187 Duchess St., Toronto, Ont., Canada.
- WASHINGTON—Chairman, Chester L. Davis; Secretary, Gerald C. Gross, Mt. Vernon Ave. and Carter's Lane, Oakcrest, Alexandria, Va.

GEOGRAPHICAL LOCATION OF MEMBERS ELECTED
JANUARY 8, 1936

Elected to the Associate Grade

California	Berkeley, 2510 Bancroft Way.....	Jones, C. B.
	San Diego, 1060 "C" St.....	Meloan, J. R.
District of Columbia	Bellevue, Naval Research Lab.....	Keeseey, E. R.
	Washington, 7218 Blair Rd.....	Cottrell, A.
	Washington, Radio Material School, Naval Research Lab.....	Nelson, J. D.
	Washington, 3342-18th St. N.W.....	Takase, R. H.
Illinois	Urbana, 606 W. Illinois St.....	Eddy, W. L.
Kentucky	Covington, Radio Station WCKY.....	Glatstein, H. B.
Michigan	Detroit, 16221 Sorrento.....	Shepley, L.
Missouri	Kansas City, 839 W. 50th St.....	Stevens, S. S.
	St. Louis, 4252 Maryland Ave.....	Boskamp, J. B.
New Jersey	Harrison, RCA Radiotron Division, RCA Manufacturing Co., Inc.....	Johnson, H. W.
New York	Hempstead, L.I., Cottage Pl.....	Pell, W. F., Jr.
	New York, Electrical Engineering Dept., Columbia University.....	Russell, J. B., Jr.
North Carolina	Durham, Radio Station, WDNC.....	Dalton, R. A.
North Dakota	Grand Forks, Box 102, University Station.....	Johnston, W. L.
Ohio	Cincinnati, 1885 Taft Rd.....	Gillette, A. D.
	Cleveland, Case School of Applied Science.....	Seletzky, A. C.
Oklahoma	Ardmore, Radio Station KVSO.....	Holaday, D. F.
Pennsylvania	Upper Darby, 5 E. Wilmot Ave., Llanerch.....	Kirk, W. C.
Virginia	Quantico, First Signal Co., Marine Barracks.....	Taylor, W. T.
Australia	Croydon, N. S. W., "Rockleigh," Lang St.....	Slade, C. W.
	Sydney, E. S. and A. Bank Bldg., Broadway and City Rd.....	Graham, L. B.
China	Shanghai, c/o Leede Engineering Corp., 395 Bubbling Well Rd.....	Chien, T. P.
England	Hayes, Middlesex, 16 Waltham Ave.....	Ferguson, R. A.
	Kingsbridge, Devon, Cliftonville, Belle Cross Rd.....	Pressler, W. C.
	Swanley, Kent, "Wayside," 11 Crockenhill Rd.....	Thwaites, H. J.
New Zealand	Pahiatua, Main St.....	Glassey, R. B.
South Africa	Johannesburg, 7 Kerry Rd., Parkview.....	Walker, G. D.

Elected to the Junior Grade

Michigan	Three Rivers, R.F.D. 3.....	Perkins, M. L.
----------	-----------------------------	----------------

Elected to the Student Grade

California	Pasadena, Dabney House, Calif. Inst. of Tech.....	Rector, E. M.
Georgia	Atlanta, 139 North Ave., N.W.....	Brown, J. G.
	Atlanta, 652 W. Peachtree St.....	Owens, W. B.
Indiana	Fort Wayne, Y.M.C.A.....	Conley, W. H.
	Fort Wayne, 1016 W. Washington Blvd.....	Jackson, W. C.
	Kendallville, 124 W. Grove St.....	Trowbridge, B.
	West Lafayette, 137 Cary Hall, E.....	Bernstein, J. R.
	West Lafayette, 227 E. Cary Hall.....	Spicer, F. D.
Iowa	Algona.....	Rising, V. K.
Massachusetts	Boston, 326 Bay State Rd.....	Angevine, O. L., Jr.
	Boston, 526 Beacon St.....	Rulon, M. C.
	Cambridge, Hayden 413, M.I.T. Dormitories.....	Laforge, L. H., Jr.
	Cambridge, 41 Linnaean St.....	Lewis, G. A.
	West Medford, 22 Vernon St.....	Ayer, J., Jr.
Michigan	Detroit, 13130 Lawton.....	Katz, L.
	Detroit, 2972 Garland Ave.....	Roggenbuck, R. A.
New York	Brooklyn, 281 Fountain Ave.....	Wolk, N. I.
	Troy, 2151-12th St.....	Adamson, A. A.
South Dakota	Brookings, Box 15.....	Rawlins, R. E., Jr.
Washington	Seattle, 4318 Brooklyn Ave.....	Larson, H. K.
China	Shanghai, Chiao-Tung University.....	Chang, C. H.
	Shanghai, Chiao-Tung University.....	Moo, C. Z.
	Shanghai, Chiao-Tung University.....	Ting, F.
	Shanghai, Chiao-Tung University.....	Chang, S. T.
	Shanghai, Chiao-Tung University.....	Wang, W. Y.
	Shanghai, Chiao-Tung University.....	Ye, C. Z.
England	Bristol 6, 25 Hampton Rd., Redland.....	Tozer, B. L.

APPLICATIONS FOR MEMBERSHIP

Applications for transfer or election to the various grades of membership have been received from the persons listed below, and have been approved by the Admissions Committee. Members objecting to transfer or election of any of these applicants should communicate with the Secretary on or before February 29, 1936. These applications will be considered by the Board of Directors at its meeting on March 4, 1936.

For Transfer to the Fellow Grade

New Jersey	Camden, RCA Manufacturing Co., Inc.....	Maloff, I. G.
Pennsylvania	Emporium, 104 W. 6th St.....	Carter, E. F.
	Mt. Airy, Philadelphia, 710 W. Allen's Lane.....	Holland, W. E.

For Transfer to the Member Grade

Minnesota	St Paul, St. Paul Hotel.....	Skifter, H. R.
New York	Tuckahoe, 240 Alpine Pl.....	Chinn, H. A.
Ohio	Dayton, Aircraft Radio Lab., Wright Field.....	Haller, G. L.
Pennsylvania	Philadelphia, 4300 York Rd.....	Robinson, H. A.

For Election to the Member Grade

Indiana	Fort Wayne, 901 Prange Dr.....	Cornell, J. I.
Australia	Sydney, N.S.W., Amalgamated Wireless Valve Co., Ltd., 47 York St.....	Smith, F. L.
England	London W.C. 2, Marconi Offices, Electra House, Embankment.....	Robb, J. G.
	Washford Cross, Somerset, British Broadcasting Corp.....	Humphreys, H. F.

For Election to the Associate Grade

Alabama	Selma, 114 Water Ave.....	Roberson, A. M.
California	Oakland, Boeing School of Aeronautics, Oakland Airport.....	Bainbridge, R. M.
	San Pedro, U.S.S. Oklahoma.....	Ryan, C. M.
District of Columbia	Washington, 1650 Harvard St. N.W.....	Bates, J. F., Jr.
Florida	Gainesville, University Station.....	Von Dohlen, H. W., Jr.
Illinois	Chicago, Commonwealth Edison Co., 2233 S. Throop St.....	Donaldson, R. J.
	Chicago, 501 E. 9th St.....	Gray, D.
	Chicago, 948 Edgecomb Pl.....	Rennick, J. L.
	Des Plaines, 524 Arlington Ave.....	Bottomff, P. A.
Kentucky	Ludlow, 272 Deverill St.....	Reynolds, D. J.
Maryland	Takoma Park, 219 Holly Ave.....	Morris, T. W.
Massachusetts	Fall River, 61 Forest St.....	Goldman, S.
	Marion, c/o RCA Communications, Inc.....	Backus, C. H.
	Rosindale, Boston, 30 Grandview St.....	Gross, F. A.
Michigan	Jackson, 701 W. Michigan Ave.....	Guyton, J. H.
Nebraska	Clay Center, c/o Radio Station KMMJ.....	Price, M. A.
New Jersey	Plainfield, 1406 W. 4th St.....	Siegelin, C. O.
New York	Brooklyn, 35-4th Pl.....	Patrone, E. F.
	Buffalo, 966 Lafayette Ave.....	Croysdill, W. T.
	Buffalo, 715 Amherst St.....	Neelon, W. J.
	New York, Pupin Physics Labs., Columbia University.....	Hughes, H. K.
	New York, Columbia Broadcasting System, 485 Madison Ave.....	Hutcheson, G. C.
	New York, 484 Convent Ave.....	White, F. E., Jr.
	Nyack, Oakwood Dr.....	Ames, J. T.
Ohio	Cleveland, 1895 E. 75th St.....	Roohk, H. V.
	Springfield, 634 Rice St.....	Ebert, H. J.
Pennsylvania	Emporium, 427 W. 6th St.....	Armstrong, W. M.
	Emporium, 4 W. 4th St.....	August, N. P.
	Emporium, Hygrade Sylvania Corp.....	Bateman, F. M.
	Emporium, 330 E. 3rd St.....	Bennett, R. G.
	Emporium, Stouts Tea Room, W. 4th St.....	Bloom, G.
	Emporium, 321 W. 5th St.....	Burns, M. D.
	Emporium, 126 E. 4th St.....	Carlson, R. F.
	Emporium, 314 W. 5th St.....	Cunningham, S. M., Jr.
	Emporium, Tube Application Dept., Hygrade Sylvania Corp.....	Cunningham, W. S.
	Emporium, 307 E. 4th St.....	Dehlinger, W.
	Emporium, 323 W. 5th St.....	Ehlers, H. A.
	Emporium, 203 E. 5th St.....	Elliott, W. A.
	Emporium, 100 W. 5th St.....	Erickson, P. W.
	Emporium, 108 E. 6th St.....	Fraenkel, V. H.

Applications for Membership

	Emporium, 36 W. 4th St.....	Gannon, T. P.
	Emporium, 417 Maple St.....	Gunnell, G. T.
	Emporium, 606 Vine St.....	Hoffman, M. C.
	Emporium, 315 E. Allegany Ave.....	Imboden, G. J.
	Emporium, 112 W. 5th St.....	Jordan, A. D.
	Emporium, 4 E. 6th St.....	Kahl, M. I.
	Emporium, Hygrade Sylvania Corp.....	Keen, A. W.
	Emporium, P.O. Box 292.....	Koontz, K. K.
	Emporium, 21 W. 2nd St.....	Larson, E. P.
	Emporium, 214 W. 4th St.....	Melzer, H.
	Emporium, 20 W. 6th St.....	Overmier, E. E.
	Emporium, 24 E. 6th St.....	Palmateer, R. E.
	Emporium, 220 W. 4th St.....	Pomfrett, J. M.
	Emporium, 308 E. 3rd St.....	Ratchford, H. L.
	Emporium, 211 E. 4th St.....	Raudenbush, C.
	Emporium, 513 Wood St.....	Welsh, W. T.
	St. Marys, 252 N. St. Marys St.....	Hoffman, E. J.
	St. Marys, c/o Speer Carbon Co.....	May, M. S.
Virginia	Alexandria, Luray and 3rd St.....	Beach, A. R.
Australia	East Brisbane, Queensland, Stanley Ter.....	Burmester, O. C.
Canada	Prince Rupert, B.C., Digby Island Radio.....	Mellor, S. J.
	Winnipeg, Manit., 327 Bannerman Ave.....	Zentner, A.
China	Hong Kong, 55 Wuhu St., Hung Hom, Kowloon.....	Chung, W. Y.
England	Barnsley, Yorks., 121 Racecommon Rd.....	Dyson, G. N.
	Coventry, 49 Waveley Rd.....	Sharp, S.
	London E. 4, 136 Cherrydown Ave., S. Chingford.....	Roberts, R. S.
	South Farnborough, Hants., Royal Aircraft Establishment.....	Williams, C.
	Surbiton, Surrey, 3 Berrylands.....	Jeffcock, J. P.
Italy	Napoli, Via G. Bonito 33.....	Valenzuela, E.
Japan	Hoten City, Manchukuo, M.T.T. Co., Hoten Central Tele- graph Office.....	Kurose, I.
	Shimizu-hososhio, Nr. Kumamoto, Radio Station JOGK.....	Ogata, T.
	Tokyo, 109 Naka-Negishi, Shitaya.....	Shoyama, M.
Straits		
Settlements	Singapore, c/o Messrs. Paterson, Siomons and Co. Ltd., Collyer Quay.....	Willoughby, E. O.
West Australia	Claremont, 14 Loftus St.....	Greer, N. C.

For Election to the Student Grade

California	Berkeley, 2417 Durant Ave.....	Hobrecht, J. P.
	Huntington Park, 3113 Broadway.....	Werner, W. K.
	Mill Valley, 74 Sycamore Ave.....	Behringer, D. S.
Connecticut	New Haven, Box 1390 Yale Station.....	Williams, E. M.
Illinois	Champaign, 209 E. John St.....	Stoddert, T. M.
Indiana	Fort Wayne, 608 W. Jefferson St.....	Erismann, R., Jr.
	Fort Wayne, 608 W. Jefferson St.....	Gilder, J.
	Fort Wayne, 121 E. Washington St.....	Toy, E. S.
Massachusetts	Cambridge, M.I.T. Dormitories.....	Campbell, J. A.
Minnesota	Owatonna.....	Hager, F. M., Jr.
New Jersey	Nutley, 49 Conover Ave.....	Barlow, W. A.
New York	Riverdale-on-Hudson, 5001 Goodridge Ave.....	Baum, D. C.
	St. Albans, L.I., 114-38-175th Pl.....	McDougall, J. A.
Ohio	Cleveland Heights, 1668 Eddington Rd.....	Weiss, H. M.
	Deshler.....	Brown, M.
	Yellow Springs, Xenia Ave.....	Carr, D.
West Virginia	Parkersburg, 1624 Lynn St.....	Kirk, J. W., Jr.
England	London N. 1, 6 Phillip St.....	Mercer, J. F. W.

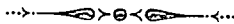

OFFICERS AND BOARD OF DIRECTORS

(Terms expire January 1, 1937, except as otherwise noted)

President

L. A. HAZELTINE

Vice President

VALDEMAR POULSEN

Treasurer

MELVILLE EASTHAM

Secretary

HAROLD P. WESTMAN

Editor

ALFRED N. GOLDSMITH

Directors

ARTHUR BATCHELLER

J. V. L. HOGAN

L. C. F. HORLE

C. M. JANSKY, JR., *Junior Past President*

C. B. JOLIFFE

A. F. MURRAY

H. M. TURNER

WILLIAM WILSON

SERVING UNTIL JANUARY 1, 1938

STUART BALLANTINE, *Senior Past President*

E. L. NELSON

HARADEN PRATT

L. E. WHITTEMORE

SERVING UNTIL JANUARY 1, 1939

E. H. ARMSTRONG

VIRGIL M. GRAHAM

H. H. BEVERAGE



INSTITUTE NEWS AND RADIO NOTES

RETIRING ADDRESS OF STUART BALLANTINE*

PRESIDENT, INSTITUTE OF RADIO ENGINEERS, 1935

As you know this is our Annual Meeting, which brings with it a change of administration in the Institute and a new President. My inaugural address lasted but thirty seconds and I should be very ungrateful indeed of the honor of being President of this society were I now to engage in a long valedictory harangue. In this connection I am reminded of Bliss Perry's reminiscence of a venerable Oxford don who, having reached a ripe old age without showing any signs of wishing to retire from teaching, had it said of him that he had all the Christian virtues except resignation. Now I shall try to avoid this criticism by stepping down promptly. First, however, somewhat in the spirit in which Thackeray liked to sit in the rear seat of the stagecoach facing backwards in order to survey the road over which he had passed, I should like to look back over 1935 and give you a very brief account of our stewardship of the affairs of the Institute during that period.

The apparent turn of the tide in the economic situation all over the world seems to be reflected in the affairs of the Institute, and although the changes are naturally only incipient, they nevertheless offer definite encouragement. The most significant of these is the favorable trend in our fiscal situation. Several years, 1932, 1933, and 1934 were lean ones and the Institute was faced with a deficit. In view of this the Board at the beginning of last year decided to make a serious effort to balance the budget by curtailing expenses in every possible way to conform with the expected returns. Fortunately, as a result of this policy and of the favorable upward trend, we now find at the end of the year that the revenues have exceeded our hopes and that in place of the usual deficit of several thousand dollars we are in the black by a small margin. A substantial part of this accretion will immediately be put into the PROCEEDINGS during the next four months, thus relieving some of the congestion in the publication of important papers.

There have been other favorable indications, in membership statistics, in the payment of dues, and in our activities on behalf of unemployed engineers, for the details of which I shall refer you to the annual report of the Secretary soon to be published in the PROCEEDINGS. A prodigious amount of work has been performed by our committees;

* Delivered before New York meeting of the Institute, January 8, 1936.

some seventy meetings of twenty-five committees were held during the year. These activities are of the greatest importance to the art and since the work goes on quietly behind the scenes are not as widely appreciated among the membership as they deserve to be. I would like to record my thanks to all those who have faithfully served the Institute by giving so unselfishly of their time and energy on these committees without hope of recognition or applause.

In retiring from this rostrum I would like to express to you again my deep appreciation of the honor of being President of this society and my pleasure in seeing the gavel pass into the competent hands of an esteemed friend.

And now, ladies and gentlemen, I have the honor of welcoming and presenting to you your next President, Professor Alan Hazeltine.

INAUGURAL ADDRESS OF ALAN HAZELTINE*

PRESIDENT, INSTITUTE OF RADIO ENGINEERS, 1936

THERE IS a tendency among young engineers (to whom my remarks are mainly addressed) to feel that the fundamentals of their field are settled, that for them is left only the improvement of details or, at most, the extension of the field in new directions. This is an error which has often been pointed out, but which is often repeated. It is an error into which I fell within the last year when, at a meeting of the New York Program Committee, I remarked that radio is not as interesting as it used to be. Then came Professor Armstrong's paper on frequency modulation that jarred us out of our rut. Instead of being settled, the accepted fundamentals of broadcasting seem to be all wrong. Let me outline the train of thought into which Professor Armstrong's work led me.

The technical basis of present-day broadcasting consists in varying the amplitude of a radio-frequency current linearly with respect to the audio-frequency current which is ultimately to be reproduced as sound. This is certainly the simplest way of doing the trick, and everyone (except Armstrong) seemed satisfied with it. But what does it entail? In the first place, it makes the game of modulation like that of tennis: the nearer you can come to the line of 100 per cent modulation the better, but you must not be over the line. Perhaps it is more like the friendly game of tennis as played in England, where it is considered sporting to call your opponent's ball "good" when it is not *too far* over the line, or too often. Obviously this sort of thing is interesting as a

* Delivered before New York meeting of the Institute, January 8, 1936.

game, but it is not characteristic of serious engineering, where factors of safety are the rule. Frequency modulation provides a way for removing this absolute restriction to 100 per cent modulation.

But what other undesirable features are characteristic of present-day broadcast technique, and are these removed by Armstrong's system? Noise, as always, is our greatest enemy. And noise, as we hear it, is mainly of rather high audio frequency. On the other hand, the musical tones that give the greatest amplitude to the audio-frequency currents are those of rather low frequency. Why do we not increase the modulation at high audio frequencies and then design our receivers to have less amplification at such frequencies, thus cutting down the noise without impairing fidelity and without exceeding modulation limitations at the transmitter? This expedient has been called *predistortion* and *restoring*. The studies of Fletcher¹ indicate that if the audio-frequency voltage at the transmitter is multiplied by the frequency, the peak modulation from a musical program may be expected to be roughly the same at all frequencies above about 200 cycles. This would indicate that the condenser-resistance correction system of Armstrong could better be placed in the receiver than in the transmitter, though possibly further studies would show that a somewhat less degree of predistortion would be preferable.

Furthermore, noise is obviously most objectionable during the playing of soft music. But present-day practice (as well as the Armstrong system) takes no account of this and leaves the noise level fixed independent of the loudness of the program. Why do we not use a *compressor-expander system*, in which soft music is amplified more than loud music in the transmitter, thus helping to bring it above the noise level, and is less amplified in the receiver?

Both the predistortion-restoring system and the compressor-expander system have been tried in practice and their value has been recognized. Both were referred to by my brilliant predecessor Mr. Ballantine in his paper on "High Quality Transmission and Reception."² With the addition of predistortion-restoring and compression-expansion, it is my belief that frequency modulation is highly useful *even in the standard broadcast band* of frequencies—not as a minor improvement, but as a means of making a five-kilowatt station, say, cover a greater area with less interference and noise than a fifty-kilowatt station of today.

With frequency modulation, the effect of excessive modulation is not of the sort to which we are accustomed. It does not distort the

¹ *Bell Sys. Tech. Jour.*, vol. 10, p. 349; July (1931).

² *Proc. I.R.E.*, vol. 22, pp. 564-629; May (1934.)

program transmitted, but does interfere on adjacent channels. We annoy our neighbors, not ourselves. Hence the maximum modulation permissible will depend on carrier-frequency allotment relative to the geographic location of the broadcast stations. To keep the side frequencies almost completely within the present ten-kilocycle channel, the peak half-swing in frequency might be of the order of four kilocycles. This is sufficient to give the noise reduction and the consequent decrease in required transmitter power that I have mentioned.

While it will probably be desirable to restore completely the pre-distortion (except perhaps for manual controls to reduce exceptional noise, as used at present), it will be a matter of study to determine how far the expander should go in counter-acting the compressor. At present we are using crude compression without expansion—the manual monitoring of the transmitter to minimize overmodulation; and it seems agreed that in our homes we do not find pleasing the enormous range in sound volume that we enjoy in a concert hall. Evidently these problems call for co-operative action on the part of broadcasters and receiver manufacturers. Presumably, frequency modulation will come into use first at high carrier frequencies. When receivers adapted to its reception are generally available, then it will be feasible to extend its use into the standard broadcast band.

The study of frequency modulation has carried me into two other lines of thought, which do not seem promising to me but which may be suggestive to some in the audience. The first is the possibility of obtaining the advantages both of frequency modulation and of single side-band transmission. Mathematically, I have found that if one side band is eliminated before frequency multiplication, it will not re-enter if no limiter is used subsequently in the transmitter, but it will be restored by the limiter in the receiver. This seems to solve the problem, but unfortunately the transmitted wave will have such high amplitude modulation, in addition to its frequency modulation, as to seem quite impracticable. Briefly, the mathematics is as follows: At low modulation (such as exists before frequency multiplication), the current vector moves around a small circle, whose center is the end of the unmodulated carrier; after frequency multiplication, the current vector moves over a locus whose extreme radii are the exponentials of the extreme angles (in radians) of phase swing. Thus, if the phase swing is plus or minus a half cycle (π radians), the extreme radii are the exponentials of plus or minus π , which are about 23 and $1/23$. This is only a moderate phase swing; and an increase in carrier amplitude of *twenty-three* times is certainly prohibitive.

The other thought, suggested by the results just described, is that

even with pure amplitude modulation we might avoid the absolute limit of 100 per cent modulation by modulating *exponentially* instead of *linearly*. The two forms would be substantially identical at low degrees of modulation; but at high modulation, the positive swing would *multiply* the carrier by a certain factor and the negative swing would *divide* it by that factor. When the factor is $\epsilon = 2.718$, we might say the modulation is 100 per cent, but neither this nor any other value would be a limiting one.

To return again to frequency modulation, this has an advantage that I have not seen mentioned; it permits of modulation at low power level followed by push-pull power amplification of the form which I described at the opening meeting of the Philadelphia section of the I.R.E. (under Mr. Ballantine's chairmanship) just sixteen years ago. With this system, the vacuum tubes would not be called upon (as they are today) to absorb power by reason of the differences in wave form of the input and output voltages; but the power losses would be determined only by the inherent characteristics of the vacuum tubes themselves. Most of the power input would then appear as output, not as tube loss. Naturally, the power tubes would be redesigned to take advantage of the low permissible losses; and perhaps might be of the type which I have disclosed in which a constant magnetic field prevents electrons from reaching the grids even when these are highly positive. With frequency modulation, we can therefore anticipate a great reduction in the cost of installing and operating a broadcast station, both by reason of the lessened power output required for a given coverage and because of the improvement in efficiency.

If we had to do it over again, I feel certain that we would use frequency modulation universally for broadcasting. Does not this indicate that it must force its way in eventually? It is particularly pleasing to me to endorse this latest work of Professor Armstrong; for it was his Institute paper on regeneration twenty-one years ago that started me in radio.

I have spoken of but a single element of radio engineering which has happened to engage my attention—modulation in broadcasting. I have suggested that present methods need complete re-examination, which will call for extensive investigation and development. Doubtless the same condition prevails in other parts of the radio field. There is ample opportunity for fresh minds to initiate and carry through important advances.

MESSAGE FROM VALDEMAR POULSEN*

VICE PRESIDENT, INSTITUTE OF RADIO ENGINEERS, 1936

First, I wish to express towards the retiring president and the Directors of the Institute of Radio Engineers my appreciation of the election as vice president for the year coming. The names of the personalities, who previously have been vice presidents of the Institute show clearly the honorary character of this title.

I very much regret that being too occupied with my experimental works I shall not be able to be present at the annual meeting of the Institute on January 8th next and to take part in the discussion of the many interesting problems on radio which accumulate all over the world.

On this occasion I shall confine myself to express the best wishes for the activities of the Institute in the coming year and to express the hope that the mighty factor, the radio, will succeed in fulfilling one of its most important cultural missions, which is to strengthen the collaboration and friendly bonds between the nations.

Copenhagen, the 23rd of December, 1935.

* Read by President Hazeltine before New York meeting of the Institute, January 8, 1936.

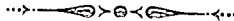

Special I. R. E. Committee Studying Registration of Engineers

At a meeting of the Board of Directors of the Institute on October 23, a Special Committee of the Board consisting of Messrs. A. F. Van Dyck, chairman; L. C. F. Horle, and R. H. Langley presented to the Board the results of its study of the question of engineering registration.

The Committee reviewed the state engineering registration laws for all states from which copies of the laws could be secured. It found that engineering registration laws are now in force in thirty-five states and in Hawaii, Porto Rico, and the Philippines. In no state does the law specifically mention radio engineers as those who must be registered. However, various organizations, particularly societies of professional engineers, are working actively to bring about an interpretation of the use of the appellation "engineer" as used in these laws in a way which may ultimately include the radio engineer. In addition, the Committee finds that seven large national engineering societies are supporting a nationally organized effort known as the Engineers' Council for Professional Development, to improve the status of engineers. A part of this effort is directed toward the establishment of unified and rational practices in the registration of engineers.

A review of the state engineering registration laws discloses that the question as to who may be registered is not clearly answered in most of the states nor is there more than a semblance of uniformity among the states. It appears to the Committee that in no states has the radio engineer been considered and in some instances the wording of the law is such as to exempt him from the scope of the statute.

The statutes in most of the states require the registration of "professional" engineers only. This term, in general, refers to those who advertise or "hold themselves out to be" practitioners of professional engineering. Additionally, in many states, the law provides that an engineer who is employed by a professional engineer or registered engineer, and who is not in responsible charge of work, need not be registered. Similarly, in many states, an engineer employed by a corporation, not in responsible charge of important work, need not be registered, provided that other employees who are in responsible charge of the work are registered engineers. Except in those states in which registration is restricted to civil or structural engineers, the laws permit any engineer to be registered who desires to be and can meet the requirements.

Most of the state laws specify the qualifications for registration, fees for examinations and registration and renewal thereof, and the penalties for infraction of the statutes. In general, there is so great a

divergence among the states that no generalizations of material significance can be made. However, substantially all of the statutes require several years of practical experience after graduation from an approved school, with provision also being made for the registration of those without any formal engineering schooling in which case considerably greater practical experience is required. Substantially all of the statutes require the passing of some form of examination.

The Committee came to the conclusion that no further effort at detailed interpretation of the statutes is warranted by the Board of Directors at this time in view of the divergence among the states and the lack of adequate adjudication of these laws.

The Committee calls the attention of the Board to the active work which is being carried on through the Engineers' Council for Professional Development mentioned above. This Council is undertaking a constructive program looking toward the improvement of the status of the engineer not only with respect to state registration laws but also in important educational, cultural, and social directions.

The Board feels that the work of the Engineers' Council for Professional Development is such as to be of great value to the radio engineering profession in the long run and plans to keep closely in touch with its activities.

January Meeting of the Board of Directors

The annual meeting of the Board of Directors was held on January 8 in the Institute office and attended by Alan Hazeltine, president; Melville Eastham, treasurer; E. H. Armstrong, Stuart Ballantine, Arthur Batcheller, Virgil M. Graham, C. M. Jansky, Jr., E. L. Nelson, L. E. Whittemore, William Wilson, and H. P. Westman, secretary.

Alfred N. Goldsmith was reappointed editor of the PROCEEDINGS, Melville Eastham was reappointed treasurer, and H. P. Westman was reappointed secretary for 1936.

Twenty-nine applications for Associate, one for Junior and twenty-seven for Student membership were approved.

An invitation from the Cleveland Section for the 1936 Convention of the Institute to be held in that city was accepted and K. J. Banfer designated chairman of the convention committee.

The requirement that a new entrance fee be paid by delinquent members applying for reinstatement was waived for 1936. Those who relinquished their membership in the past may now resume active membership by payment of current dues.

As a result of a ballot, J. V. L. Hogan, L. C. F. Horle, C. B. Jolliffe, A. F. Murray, and H. M. Turner were appointed to serve as directors for 1936.

An incomplete list of committee appointments was made up. It is anticipated that the final list will be completed at the February Board meeting and will be posted in the April issue of the PROCEEDINGS.

By resolution, the Broadcast Committee and the technical committees which previously served as subcommittees to the Standards Committee were made standing committees. The technical committees were those on Electroacoustics, Electronics, Receivers, Television and Facsimile, and Transmitters and Antennas. In matters pertaining to standards, these technical committees will report to the Standards Committee and the chairmen of these committees shall be ex officio members of the Standards Committee.

Institute representatives on other bodies will be included in committee lists published in the future.

A budget for operation during 1936 which provides for an increase in funds for PROCEEDINGS publication and based on a small deficit at the end of the year was adopted.

By resolution it was agreed that in interpreting Article II, Section 6 of the Constitution relating to Student members it is recognized that the giving of instruction involves the element of study and therefore a graduate student devoting approximately half his time to instructing and the remaining time directly to studies shall be considered as fulfilling the constitutional requirement of devoting "the major part" of his time to studies.

Committee Work

ADMISSIONS COMMITTEE

The Admissions Committee met on January 7 in the Institute office and those present were Austin Bailey, chairman; E. V. Amy, R. A. Heising, L. C. F. Horle, and H. P. Westman, secretary. Three applications for transfer to Fellow Grade were approved. Of six applications for admission to Member, four were approved and two denied. Four applications for transfer to Member were approved, one was tabled, and one denied.

TECHNICAL COMMITTEE ON ELECTROACOUSTICS

A meeting of the Institute Technical Committee on Electroacoustics was held on December 20 in the Institute office. Those present were H. F. Olson, chairman; Sidney Bloomenthal, Knox McIlwain, Hans Roder, V. E. Whitman, and H. P. Westman, secretary. Another meeting of this committee was held on January 10 with the same members present.

These two meetings were devoted to the completion of a report on definitions and the preparation of material on performance indexes and testing of electroacoustic devices.

MEMBERSHIP COMMITTEE

A meeting of the Membership Committee was held on January 8 in the Institute office and those present were F. W. Cunningham, chairman; J. M. Clayton, I. S. Coggeshall, H. C. Humphrey, and C. R. Rowe. A discussion of the personnel of the committee for 1936 was held and consideration given to the program of operation for the year.

TECHNICAL COMMITTEE ON RADIO RECEIVERS

Subcommittee on Test Procedures

D. E. Foster, chairman; L. F. Curtis, E. T. Dickey, J. F. Farrington (representing H. A. Wheeler), and H. P. Westman, secretary, were present at a meeting of the Subcommittee on Test Procedures operating under the Technical Committee on Radio Receivers. The committee devoted its time to an examination of the test procedures contained in the 1933 Report, and prepared a number of proposed modifications.

Institute Meetings

ATLANTA SECTION

A meeting of the Atlanta Section was held on October 24 at the Atlanta Athletic Club. It was presided over by I. H. Gerks, chairman. Nineteen were present and five attended the informal dinner which preceded it.

A paper on "Metal Tubes" was presented by H. A. Leighley, Manager of the Southeastern Division of the RCA Manufacturing Company. The paper covered constructional details of the metal tubes and their characteristics. Advantages of the new design over the glass tubes were fully shown. The paper was discussed by Messrs. Fowler, Gerks, Parkins, and Reesor.

BUFFALO-NIAGARA SECTION

A meeting of the Buffalo-Niagara Section was held at the University of Buffalo on November 13. L. E. Hayslett, chairman, presided and eight-four were present.

A paper on "The Manufacture and Application of Metal Tubes" was presented by Walter Jones of the Hygrade Sylvania Corporation. The paper was opened with a brief review of the metal tubes now be-

ing produced. Experience has shown that they are sufficiently different from glass tubes to require modifications in receiver design and the lack of this has been somewhat responsible for unsatisfactory results which have been obtained with metal tubes in a number of the earliest receivers to use them. It is anticipated that increased production will lower the cost of manufacture as fabrication tolerances can be reduced and maintained. Certain types of tubes have caused more trouble than others. The general difficulty with hard tubes has been in heating the elements sufficiently to drive off gases for complete exhaustion. Induction heating is not suitable where a metal envelope surrounds the electrodes and other methods of heating the electrodes have been developed. To reduce the temperature of the tubes, the interior surface of the metal envelope has been blackened so that it will absorb heat more readily and reflect less back to the elements. Some problems in connection with gas current, grid emission, and contact potential were discussed. General features of the design of receivers and factors requiring careful attention to produce satisfactory results were given. New developments in metal tubes which might be expected in the near future were outlined.

CHICAGO SECTION

The annual meeting of the Chicago Section was held on December 13 in the Hotel Sherman and attended by 400. There were twenty-five at the informal dinner which preceded the meeting. The meeting was presided over by Alfred Crossley, chairman. In the election of officers for 1936, H. C. Vance of the RCA Victor Company was named chairman; J. Kelly Johnson of the Wells-Gardner Company, vice chairman; and J. E. Brown, secretary-treasurer.

A paper on "Recent Advances in Television" was presented by P. T. Farnsworth, vice president in charge of research of Farnsworth Television, Inc. In it he outlined a system of image dissection employing cathode-ray tubes and image reproduction by similar devices having synchronized sweep circuits. Advantages of interlaced scanning over sequential scanning were discussed and the need for avoiding pull-in in scanning oscillators pointed out. A need for high amplification to permit satisfactory modulation of the transmitter was discussed. The use of the multipactor was given as a solution to the problem.

The development of the multipactor was described and the advantages and disadvantages of numerous types indicated. Beginning with the static type of two elements, the speaker described dynamic types which exhibit highly novel and useful characteristics. An early type driven by a high-frequency voltage in a range from 40 to 100

megacycles was described and its anode current-voltage characteristics described. Mechanical and electrical modifications were discussed. Another type consisting of a cylindrical cathode and a grid type anode capable of oscillation was analyzed and produced efficiencies of conversion from direct-current power to oscillatory current power close to one hundred per cent.

The paper was concluded with a demonstration of the operation of the multipactor as a modulated oscillator and amplifier. Many of those present participated in the discussion which followed.

CINCINNATI SECTION

The annual meeting of the Cincinnati Section was held on December 17 at the University of Cincinnati. A. F. Knoblauch, chairman, presided and thirty-one members and guests were present.

In the election of officers, C. D. Barbulesco of the U. S. Signal Corps Laboratories at Wright Field, Dayton, Ohio, was elected chairman; G. F. Platts of the technical staff of WLW was elected vice chairman; and R. L. Freeman of the engineering staff of the Crosley Radio Corporation was designated secretary-treasurer.

A paper on "The Quantitative Influence of Tube and Circuit Properties on Random Electron Noise" was presented by S. W. Seeley, an engineer for the RCA License Laboratories. This was the same paper which was presented at the recent Rochester Fall meeting.

CLEVELAND SECTION

A meeting of the Cleveland Section was held at the Case School of Applied Science on October 24 and attended by sixty-three. K. J. Banfer, chairman, presided.

A paper on "The Ionosphere and Propagation of Radio Waves" was presented by E. O. Hulburt, Superintendent, Division of Optical Physics, Naval Research Laboratories. Dr. Hulburt presented a brief history of ionosphere research and discovery from the first trans-oceanic communication by Marconi in 1902 to the pulse method of height determination developed by Breit and Tuve. Three layers have been located and are the E layer at approximately 100 kilometers, the F_1 layer at about 200 kilometers, and the F_2 layer which is about 300 kilometers high. The F layers are comprised of electrons while the E-layer composition is still undetermined. Continuous ionosphere records are being taken at Washington, D.C., and Huancayo, Peru. Graphs of virtual heights and electron density taken at these places were shown. The paper was closed with a description of diffraction and refraction of microwaves in the atmosphere.

The Cleveland Section met on November 21 at Case School of Applied Science. K. J. Banfer, chairman, presided and twenty-six members and guests attended.

A paper on "Continuous Recording of Radio Field Intensities" was presented by S. S. Kirby, Associate Physicist of the National Bureau of Standards. This paper reported on work to determine the best spacing by geographical location and frequency of broadcast transmitters, both sky and ground wave being taken into account. The results of measurements made near Washington, D.C., on the field strength of WLW with 50 kilowatts and 500 kilowatts power and on WCKY were shown. The recording equipment and its operation were described. Data on attenuation of transmitted waves from several stations were shown and an inverse distance curve developed from readings taken every twenty minutes over a period of months. This curve showed a peak at 500 to 600 kilometers from the station. In collaboration with the Columbia Broadcasting System, measurements were made on the transmissions from WBT at Charlotte, S. C. Seven recording stations were established at distances from twenty-five to five hundred miles from the transmitter. Continuous records were made during a summer and winter period. A comparison of a vertical radiator with a flat-top antenna showed the average night sky-wave field intensity to be higher with the former. The vertical radiator also increases the ground wave and decreased fading within a range of 150 kilometers. At greater distances the field intensity was increased with no increase in fading.

DETROIT SECTION

The annual meeting of the Detroit Section was held on December 20 in the Detroit News Conference Room and was presided over by A. B. Buchanan, chairman. Thirty-five members and guests were present and twelve attended the informal dinner which preceded the meeting.

A paper on "The Cathode-Ray Oscillograph as Used in the Study of Lightning Surges" was presented by F. M. Duff, an engineer for the Detroit Edison Company. He presented a short history of the work done in the study of lightning. Originally such discharges were thought to be unidirectional but there is now evidence to indicate that the stroke may be oscillatory in nature. The effects of lightning surges in power lines and methods for minimizing them were reviewed.

Four general types of surge recording apparatus are in use. One measures the size and number of holes punctured in a piece of paper by the surge current in the ground lead of a lightning arrester. Another uses the magnetizing effect of the surge current. These two employ

simple apparatus and can readily be installed in many places. Two others, the Clydonograph and the cathode-ray oscillograph are not easily portable and are used in particular locations where extensive studies are being made. The Detroit Edison Company at present mainly uses the oscillograph which was described in detail. The paper was discussed by Messrs. Buchanan, Holland and others.

The speaker described the artificial lightning generator used by the Detroit Edison Company.

New officers were elected to serve during 1936 and E. C. Denstaedt of the Detroit Police Department was elected chairman; R. L. Davis of Grand Rapids, vice chairman; and H. S. Gould, Detroit, secretary-treasurer.

NEW YORK MEETING

The annual meeting of the Institute was held in New York City on January 8 in the Engineering Societies Building.

Stuart Ballantine, the retiring president, opened the meeting with a short statement and introduced the incoming President, Alan Hazeltine. Their remarks appear elsewhere in this issue together with a message from Vice President Poulsen.

A paper on "Propagation and Characteristics of Frequency Modulated Waves" was presented by M. G. Crosby of RCA Communications. In it, the effects of multipath transmission with respect to distortion and diversity reception in the short-wave range were given in a description of frequency modulated transmissions from Bolinas, California, to Riverhead, N. Y. An analysis of the experimental results was given and the application of frequency modulation to ultra-short waves discussed.

Several of the 300 members and guests present participated in the discussion of the paper.

PHILADELPHIA SECTION

A meeting of the Philadelphia Section was held on November 7 at the Engineers' Club and presided over by Knox McIlwain, chairman. Two hundred and sixty were present and twenty attended the dinner which preceded the meeting.

L. M. Clement, vice president in charge of research and engineering of the Victor Division of the RCA Manufacturing Company, presented a paper on "European Radio Experiences, 1932-1935." It covered his experiences in Europe as chief engineer for European radio receivers for the International Standard Electric Company. He pointed out that radio in Europe has advanced very rapidly from 1932 to the present time. In most countries, broadcasting is supported by license.

fees and except for France, Ireland, and Luxembourg there is little advertising. In these countries, an English company presents advertising programs in English. For every thousand persons in 1934 there were thirty-five receivers in France, forty-eight in Mexico, seventy-three in Russia, eighty-two in Germany, one hundred and thirteen in Sweden, one hundred and thirty-six in England, one hundred and fifty-three in the United States, and one hundred and fifty-four in Denmark. It was pointed out that even though the labor rate was below that of the United States, the total labor cost was higher. Receiver prices abroad are higher than in the United States and in some countries this is due entirely to tube prices.

C. M. Sinnett of the Engineering Department of the RCA Manufacturing Company presented a demonstration of the latest type RCA receiving set and phonograph. He explained the volume expansion feature of the phonograph portion and stated that a volume range of an orchestra is seventy decibels. It is not practicable to record this range as the cutter would break through the adjacent groove and the record is limited to a range of about forty to forty-five decibels. By employing an expanding circuit, the range can be increased by twenty decibels.

The December meeting of the Philadelphia Section was held on the 5th at the Engineers Club with Chairman McIlwain presiding. Two hundred and seventy members and guests attended and twenty-four were present at the informal dinner which preceded the meeting.

Two papers were presented. The first by F. B. Woodworth of the Technical Staff of the Bell Telephone Laboratories was on "Harbor Craft Radiotelephone System of the Atlantic Communications Corporation." It described a radiotelephone communication system for tug boats on the Delaware and Schuylkill Rivers in the Philadelphia harbor area. The equipment operates at a frequency of 38.6 megacycles. The shore transmitter and receiver are installed at remote locations and connected by telephone lines to a central operating bay located at the Point Breeze Refinery of the Atlantic Refining Company. The transmitter is crystal controlled, employs voice control of the carrier output, and is rated at fifty watts. The receivers are of the superheterodyne type and are equipped with a device called the "codan" which prevents any audio output from the receiver passing over the lines to the control point until a signal is received. One receiver is installed on a pole over the refinery and the other on top of a grain elevator. The antennas are half-wave structures and a coaxial transmission line carries the energy to the receiver. The boat equipment comprises a crystal controlled five-watt transmitter, a crystal

controlled superheterodyne receiver, and a "codan" for regulating the voice output of the receiver. A selective ringing circuit is provided to actuate a delay in the pilot house when calling signals are dialed by the shore operator. The boat receivers are operated from a quarter-wave fish-pole antenna connected through a coaxial line to the receiver. The system is designed to be connected with the regular Bell Telephone System in the Philadelphia area. Three months of operation have indicated the service to be satisfactory.

The second paper was by P. T. Farnsworth, vice president of Farnsworth Television, Inc., and was on "Recent Developments in Multipactor Tubes." He described two types of electron multipliers, one a direct-current type and the other an alternating-current variety. The latter offers greater commercial possibilities in simpler form than the direct-current type. By suitable circuit arrangement, the multipactor could be made to multiply its current to the point where it will burn up any type of electrode used in the tube. This makes necessary the design of circuits to limit the multiplication of electrons in the tube.

A tube three inches in diameter and five inches long was used in a demonstration to represent a small broadcast station of fifty watts capacity. Its output was modulated by a phonograph and the radio waves operated a radio receiver on the opposite side of the lecture hall. A twenty-five-watt electric-light bulb in series with a few turns of wire was lighted to full brilliancy when brought into the field of the multipactor circuit. A cathode-ray oscillograph indicated how a high harmonic of the twentieth order can be controlled and varied from zero to twenty per cent. This feature will be useful in frequency multiplication.

PITTSBURGH SECTION

A meeting of the Pittsburgh Section was held on December 17 at the Fort Pitt Hotel and attended by twenty-four. J. G. Allen, vice chairman, presided and because of the resignation of R. D. Wyckoff as chairman, required by his removal to Texas, a special election was held to fill this office. This resulted in Lee Sutherlin of the Westinghouse Research Laboratories being elected chairman for the remainder of the term.

A paper on "Application of Vacuum Tubes to Automatic Train Control" was presented by L. R. Allison and R. K. Crooks of the Union Switch and Signal Company. Mr. Allison treated the general subject and pointed out various steps by which train control has developed to its present status. In the earlier system only two indications were

possible. Most present installations provide for four indications giving the locomotive crew continuous information as to the status of the right of way for three signaling blocks in advance.

Mr. Crooks discussed the design of amplifiers used for train control. They differ from ordinary audio and radio amplifiers in that they amplify a 100-cycle wave modulated at one and one third, two and three cycles per second. Three-cycle modulation provides clear signal indication, two-cycle is for restricting, and one and one third for approach indication. Unmodulated or absence of 100-cycle energy indicates a complete stop. It was pointed out that the copper-oxide rectifier is partly responsible for obtaining a Q in the neighborhood of five for the modulation frequency resonant circuits. The paper was discussed by Messrs. Lazich, Stark, and Upp.

SAN FRANCISCO SECTION

The San Francisco Section met jointly with the local section of the American Institute of Electrical Engineers on December 6. E. M. Wright, chairman of the electrical group, presided and 130 members and guests were present. Fifty-eight attended the informal dinner which preceded the meeting.

A paper on "Directive Antennas" was presented by L. F. Fuller, Chairman of the Electrical Engineering Department of the University of California. Dr. Fuller spoke chiefly on modern radio transmission and directive antennas. He outlined in considerable detail their history and brought out many points with which most of the audience were unfamiliar. Prior to his paper, short addresses were made by the Chairman, R. D. Kirkland, and Mr. Bartly, a student at the University of California, who spoke briefly on Maxwell and Hertz.

SEATTLE SECTION

R. C. Fisher, chairman, presided at the November 29 meeting of the Seattle Section which was held at the University of Washington and attended by thirty-six.

A paper on "Industrial Applications of Vacuum Tubes" was presented by L. B. Robinson of the General Electrical Company and described the application of the various types of vacuum tubes in the industrial field in and about Seattle. The use of sodium-vapor tubes for highway lighting, mercury-vapor lamps for interior lighting, and the thyatron controlled welder used extensively in airplane factories were featured in his talk. The paper was discussed by Messrs. Hoard, Libby, Willson and others.

TORONTO SECTION

L. M. Price, chairman, presided at the December 10 meeting of the Toronto Section which was held at the University of Toronto. Fourteen were present at the dinner which preceded the meeting and sixty-one attended the meeting.

A paper on "Circuit Applications for Metal Tubes" was presented by W. R. Jones of the Hygrade Sylvania Corporation. He discussed metal tube rectifier structures pointing out defects which showed up in initial designs and indicated how they were overcome. The difficulties of obtaining a definite analysis of power supply circuit failures when the transformer is destroyed were outlined and the desirability of suitable fusing emphasized. In considering metal tubes for every purpose, the problems of contact potential, grid emission, and gas were discussed and metal and glass tubes compared. The possibility of grid emission in current production metal tubes may be slightly greater than in comparable glass tubes and requires revision of resistance values in associated networks. Several compromise methods of obtaining satisfactory results were shown. The paper was discussed by Messrs. Bayley, Hepburn, Rogers and others.

WASHINGTON SECTION

The annual meeting of the Washington Section was held in the Potomac Electric Power Company auditorium on December 9 and presided over by E. K. Jett, chairman. There were seventy-four members and guests in attendance and twenty-seven were present at the informal dinner which preceded the meeting.

"A Symposium of Government Radio Activities for the Year" was presented by Raymond Asserson, Research Engineer of the Federal Communications Commission; J. H. Dellinger, Chief of The Radio Section of the National Bureau of Standards; H. G. Dorsey, Principal Electrical Engineer of the U. S. Coast and Geodetic Survey; and W. J. Ruble, Chief of the Radio Division of the Bureau of Engineering of the U. S. Navy Department.

Mr. Asserson outlined briefly the work of the Federal Communications Commission in exercising control in radio communication. Illustrations were presented showing the expansion of the useful radio spectrum and assignments made to different users since Maxwell's time. International control was touched on and many of the commissions related activities were outlined.

Dr. Dellinger reviewed the reasons leading to government control of radio. He described the work of the Bureau of Standards and men-

tioned among its activities the maintenance of standards and its service as a national physical laboratory. The Bureau maintains the national frequency standard, acts as a consultant for other departments of the government, studies wave propagation, is engaged in problems of ultra-high-frequency applications, and studies the relation between frequency and distance covered. Recent discoveries at the Bureau regarding short periods of fading at 55-day intervals were outlined.

Commander Ruble commented on the necessary restriction of his discussion of naval radio activities. He mentioned briefly the new 500-kilowatt transmitters at Annapolis, Honolulu, and the Canal Zone, the new receiving station for Washington, the experimental high-frequency radio keying circuit to Annapolis, and the emergency radio communication with Addis Ababa for the United States State Department. Mention was made of the use of radio direction finders to assist in the carrier location of survey vessels in off-shore mapping, of the development of improved depth finders working to 2000 fathoms, and of the campaigns to reduce the source of electrical noise at the Navy Yard. New Methods of procuring radio supplies, improved apparatus specifications, and methods of testing were outlined. Vacuum tubes are now bought on a life basis. It was stated that the trend in transmitters is now definitely away from crystal control.

Dr. Dorsey spoke briefly on the application of radio to the work of the Survey, including the use of time signals for the determination of longitude and gravity constant, the use of radioacoustic sound ranging for determining ships' positions in survey work, this method having been found superior to radio direction finding, and miscellaneous uses of sound applications including depth finding which have now been developed to give very accurate determinations at shallow depths.

The papers were discussed by Messrs. Bates, Burgess, Dingley, Jett, Ould, Perry, and Wheeler. In the election of officers, Chester L. Davis was named chairman; W. B. Burgess, vice chairman; and G. C. Gross, secretary-treasurer.

Personal Mention

Previously with the General Electric Company, A. C. Bartlett has joined the staff of the Electric Home and Farm Authority at Washington, D.C.

M. K. Goldstein formerly with Molded Insulation Company has become a development engineer for the Wright Field Aircraft Radio Laboratory at Dayton, Ohio.

Formerly with Amplivox Sound Laboratories, G. L. Haller has joined the staff of the Wright Field Aircraft Radio Laboratory at Dayton, Ohio.

Hugh Hamilton, Jr. has left the Hygrad Lamp Company to join the staff of Eclipse Aviation Corporation of East Orange, N. J.

H. W. Kozanowski has joined the engineering staff of RCA Manufacturing Company at Camden, N. J., having formerly been with the Westinghouse Electric and Manufacturing Company.

F. W. Kranz formerly with the Magnevox Company has joined the engineering staff of Consolidated Manufacturing Company, St. Louis, Mo.

G. A. Mathieu is now located at Polskie Zaklady Marconi in Warsaw, Poland, having formerly been located with Marconi's Wireless Telegraph Company in London, England.

I. A. Mitchell of Kenyon Transformer Company has been named president of that organization.

S. C. Milbourne has left the Wholesale Radio Company to become a service engineer for Supreme Instruments Corporation, Greenwood, Miss.

A. Z. Smith of RCA Communications has been transferred from Riverhead to 66 Broad Street, New York City.

C. N. Smyth has become a research engineer for Kolster Brandes, Ltd., of Sidcup, London, having formerly been with the General Electric Company.

H. C. Little previously with General Household Utilities Company has joined the engineering staff of Colonial Radio Company of Buffalo, N. Y.

J. R. Waugh, Jr., of the RCA Manufacturing Company has been transferred from Camden, N. J., to Detroit, Mich.

Eugene Wesselman is now with the Steward Warner Corporation in Chicago having formerly been with the Colonial Radio Corporation of Buffalo.

D. O. Whelan formerly with RCA Institutes has established the Dowca Engineering Service of Plainfield, N. J.

W. R. G. Baker has left the RCA Manufacturing Company to take charge of radio engineering and manufacturing for the General Electric Company at Bridgeport, Conn.

H. D. Cluff, Captain Royal Canadian Signals, has been transferred from Winnipeg to Camp Borden, Ontario.

W. F. Cotter has joined the Radio Engineering Department of the Stromberg Carlson Telephone Manufacturing Company having formerly been with the United American Bosch Corporation.

TECHNICAL PAPERS

PREFERRED NUMBERS*

BY

ARTHUR VAN DYCK

(RCA License Laboratory, New York City)

Summary—The history of preferred numbers in this country is given briefly and the present status of recommendations of the American Standards Association is described. The subject is explained, and advantages to design and manufacture which the system affords are outlined. Tables are given of preferred numbers recommended by the American Standards Association, in both decimal and fractional systems, and rules and suggestions for use of the tables in design work. Some possibilities for immediate use in radio design are suggested.

PURPOSE OF PREFERRED NUMBERS

PREFERRED numbers are certain numbers that have been selected to be used for standardization purposes in preference to any others. They should be used whenever possible for individual standard sizes and ratings, or for a series thereof, in applications similar to the following:

Important or characteristic linear dimensions, such as diameters and lengths.

Areas, volumes, weights, and capacities.

Ratings of machinery and apparatus in horsepower, kilowatts, kilovolt-amperes, voltages, currents, inductances, capacitances, speeds, power-factors, pressures, heat units, temperatures, gas or liquid-flow units, weight-handling capacities, etc.

Characteristic ratios of figures for all kinds of units.

HISTORY OF PREFERRED NUMBERS IN THE UNITED STATES

For about fifteen years past, various organizations in this country, interested in industrial standardization, have been working to develop a system of preferred numbers which would be suited to effective utilization by American industry. Under the procedure of the American Standards Association a system has now been developed which is thought suitable for wide application and therefore for widespread recommendation of the proposals. The object of this report is to make available to the members of the Institute of Radio Engineers a con-

* Decimal classification: R030. Original manuscript received by the Institute, September 26, 1935.

venient reference on the subject, with the recommendation that it be studied seriously by every member faced with design problems. The report is made up largely from the writings of numerous engineers who have been active in the work to date (see appended bibliography). These engineers have not only studied and worked in committee, but have promoted trials of the system in actual design, and have worked out the practical problems which have appeared, especially in the adaptation to the fractional system of measurement.

Proposed series of preferred numbers, recommended to be used by American industry, have been developed by sectional committee Z17 of the American Standards Association (ASA). These series, meant to supersede those informally recommended by the ASA in 1927 for a tryout in practice, are now published for general criticism and comment, before being submitted to the ASA for final approval. The proposal includes several tables of preferred numbers, in the decimal and binary systems. Comments on this proposal by the radio industry are invited, and may be sent to the writer for presentation to the Sectional Committee.

The decimal values given in the present proposal are identical with those contained in a proposed recommendation now under consideration by the International Standards Association (ISA), a federation of the national standardizing bodies, including ASA, in nineteen countries. (The ISA proposal does not give preferred numbers in the binary system.) Consequently, there is a fair chance that world-wide uniformity in this respect will be attained in the near future.

EXPLANATION OF "PREFERRED NUMBERS" SYSTEM

It is obvious that any line of machines, apparatus, or devices should be based, at least within certain ranges, on a geometric series, in regard to either dimensions or ratings, or both. This means simply that any rating in the line, within certain ranges at least, should be larger than the preceding one by a fixed percentage. However, if this practice were followed indiscriminately, with each designer independently choosing his own percentages, the consequence would be that a great number of different percentage figures, or ratios, would be used, and standardization and simplification would not be achieved.

The preferred numbers system is an attempt to bring about a standardization of these percentage figures. It establishes certain series of numbers increasing by these standardized percentages, giving a sufficient number of series so that some one of them will suit any but the most unusual design problems. These standardized percentage increases should always be used, in preference to other figures not contained in

these series. For example, this system provides the so-called "5 series," having five uniform steps of about 60 per cent each between 1 and 10;

TABLE I
BASIC PREFERRED NUMBERS--DECIMAL SERIES (10 TO 100)

5 Series 60% Steps	10 Series 25% Steps	20 Series 12% Steps	40 Series 6% Steps		
10	10	10	10		
		11.2	10.6		
			11.2		
			11.8		
			12.5		
12.5	12.5	12.5	12.5		
		13.2			
		14			
		14			
		15			
16	16	16	16		
		18	17		
			18		
			19		
		20	20	20	20
				21.2	
22.4					
25	25	25	23.6		
			25		
		28	25		
			26.5		
		31.5	31.5	28	
				30	
				31.5	
35.5	35.5	33.5			
		35.5			
		37.5			
40	40	40	40		
			42.5		
			45		
		45	45	47.5	
				50	
		50	50	50	
				53	
63	63	63	56		
			60		
			63		
		71	71	67	
				71	
80	80	75			
		80			
		85			
90	90	90			
		95			

Preferred numbers below 10 are formed by dividing the numbers between 10 and 100 by 10, 100, etc.

Preferred numbers above 100 are correspondingly formed by multiplying the numbers between 10 and 100 by 10, 100 etc.

Percentage steps in headings are approximate averages.

the "10 series," having ten steps of about 25 per cent; the "20 series," having twenty steps of about 12 per cent; etc. In addition many other related series are available, as will be described later. Table I shows

TABLE II
PREFERRED NUMBERS—BASIC FRACTIONAL SERIES

The use of the fractional system should be restricted to linear dimensions in inches where fractions are in common use and where therefore the decimal system is impractical. Percentage figures in headings are approximate averages.

1/8 to 1				1 to 10				10 to 40			
5 Series 60% Steps	10 Series 25% Steps	20 Series 12% Steps	40 Series 6% Steps	5 Series 60% Steps	10 Series 25% Steps	20 Series 12% Steps	40 Series 6% Steps	5 Series 60% Steps	10 Series 25% Steps	20 Series 12% Steps	40 Series 6% Steps
	1/8	1/8 9/64		1	1 1 1/4	1 1 1/4 1 3/8	1 1 1/16 1 1/8 1 3/16 1 1/4 1 5/16 1 3/8 1 7/16	10	10 12	10 11 12 14	10 10 1/2 11 11 1/2 12 13 14 15
5/32	5/32 3/16	5/32 11/64 3/16 7/32		1 1/2	1 1/2 2	1 1/2 1 3/4 2 2 1/4	1 1/2 1 5/8 1 3/4 1 7/8 2 1/8 2 1/4 2 3/8	16	16 20	16 18 20 22	16 17 18 19 20 21 22 23
1/4	1/4 5/16	1/4 9/32 5/16 11/32	1/4 17/64 9/32 19/64 5/16 21/64 11/32 23/64	2 1/2	2 1/2 3	2 1/2 2 3/4 3 3 1/2	2 1/2 2 5/8 2 3/4 2 7/8 3 3 1/4 3 1/2 3 3/4	24	24 32	24 28 32 36	24 26 28 30 32 34 36 38
3/8	3/8 1/2	3/8 7/16 1/2 9/16	3/8 13/32 7/16 15/32 1/2 17/32 9/16 19/32	4	4 5	4 4 1/2 5 5 1/2	4 4 1/4 4 1/2 4 3/4 5 5 1/4 5 1/2 5 3/4	40	40	40	40
5/8	5/8 3/4	5/8 11/16 3/4 7/8	5/8 21/32 11/16 23/32 3/4 13/16 7/8 15/16	6	6 8	6 7 8 9	6 6 1/2 7 7 1/2 8 8 1/2 9 9 1/2	Above 40 the fractional preferred numbers are the same as the decimal preferred numbers, see Table I. Below 1/8 the decimal series will be used. Below 3/16 the steps of the 40 series are omitted as finer gradations will seldom be used.			

The basic preferred numbers system, being an international system, is based on the use of decimals. But as the use of fractions has become so thoroughly established in the countries using the inch system as the unit of measurement, it was considered advisable by the American committee to devise a fractional system of Preferred Numbers, over the range between 1/8 inch to 40 inches, over which the use of fractions is most customary.

In order to make this system conform to well-established practices, the selected figures do not conform as closely to the theoretical values as the figures in the decimal system, the discrepancy being as much as 4 to 6 per cent in some cases. The maximum difference between values of the decimal and corresponding fractional system is 6.3 per cent.

the International System, which has been adopted also by the American Standards Association for the United States. Table II gives a fractional system of preferred numbers over a limited range. It is based upon the same general principle and may be used for linear dimensions in inches, where fractions are in such common use that decimals cannot be applied readily.

BASIC PREFERRED NUMBERS—80 SERIES

Series					TABLE III Decimal Series 10 to 100		TABLE IV Fractional Series 3/8 to 40 (Only for dimensions in inches)				
5	10	20	40	80	10	40	3/8	1 1/2	6	24	
			40	80	10.3	41.2	25/64	1 9/16	6 1/4	25	
			40	80	10.6	42.5	13/32	1 5/8	6 1/2	26	
			40	80	10.9	43.7	27/64	1 11/16	6 3/4	27	
		20	40	80	11.2	45	7/16	1 3/4	7	28	
			40	80	11.5	46.2	29/64	1 13/16	7 1/4	29	
			40	80	11.8	47.5	15/32	1 7/8	7 1/2	30	
			40	80	12.1	48.7	31/64	1 15/16	7 3/4	31	
	10	20	40	80	12.5	50	1/2	2	8	32	
			40	80	12.8	51.5	33/64	2 1/16	8 1/4	33	
			40	80	13.2	53	17/32	2 1/8	8 1/2	34	
			40	80	13.6	54.5	35/64	2 3/16	8 3/4	35	
		20	40	80	14	56	9/16	2 1/4	9	36	
			40	80	14.5	58	37/64	2 5/16	9 1/4	37	
			40	80	15	60	19/32	2 3/8	9 1/2	38	
			40	80	15.5	61.5	39/64	2 7/16	9 3/4	39	
5	10	20	40	80	16	63	5/8	2 1/2	10	40	
			40	80	16.5	65	41/64	2 9/16	10 1/4		
			40	80	17	67	21/32	2 5/8	10 1/2		
			40	80	17.5	69	43/64	2 1/16	10 3/4		
		20	40	80	18	71	11/16	2 3/4	11		
			40	80	18.5	73	45/64	2 3/16	11 1/4		
			40	80	19	75	23/32	2 7/8	11 1/2		
			40	80	19.5	77.5	47/64	2 15/16	11 3/4		
	10	20	40	80	20	80	3/4	3	12		
			40	80	20.6	82.5	25/32	3 1/8	12 1/2		
			40	80	21.2	85	13/16	3 1/4	13		
			40	80	21.8	87.5	27/32	3 3/8	13 1/2		
		20	40	80	22.4	90	7/8	3 1/2	14		
			40	80	23	92.5	29/32	3 5/8	14 1/2		
			40	80	23.6	95	15/16	3 3/4	15		
			40	80	24.3	97.5	31/32	3 7/8	15 1/2		
5	10	20	40	80	25		1	4	16		
			40	80	25.7		1 1/32	4 1/8	16 1/2		
			40	80	26.5		1 1/16	4 1/4	17		
			40	80	27.2		1 3/32	4 3/8	17 1/2		
		20	40	80	28		1 1/8	4 1/2	18		
			40	80	29		1 5/32	4 5/8	18 1/2		
			40	80	30		1 3/16	4 3/4	19		
			40	80	30.7		1 7/32	4 7/8	19 1/2		
	10	20	40	80	31.5		1 1/4	5	20		
			40	80	32.5		1 9/32	5 1/8	20 1/2		
			40	80	33.5		1 5/16	5 1/4	21		
			40	80	34.5		1 11/32	5 3/8	21 1/2		
		20	40	80	35.5		1 3/8	5 1/2	22		
			40	80	36.5		1 13/32	5 5/8	22 1/2		
			40	80	37.5		1 7/16	5 3/4	23		
			40	80	38.7		1 15/32	5 7/8	23 1/2		

While there are few applications requiring steps smaller than the six per cent steps of the 40 series such cases may nevertheless occur at times. Therefore the American Committee has adopted an 80 series, both decimal and fractional, as indicated in Tables III and IV. The numbers of this series should also be useful in many cases in actual practice where it is necessary to standardize two values which should be rather close together and where a difference of three per cent is suitable. One of the values can be chosen from one of the coarser series and the other can be the value of the 80 series immediately following.

Steps between numbers in Tables III and IV increase approximately three per cent on an average.

Tables III and IV give an "80 series" with 3 per cent steps.

Supplementary series can be constructed, using the same numbers as in the fundamental series but having steps increasing by 9, 18, 40, 100, 150, or 300 per cent, as shown in Tables V and VI.

Mathematically, the factor by which each figure is multiplied to obtain the next higher figure is

SUPPLEMENTARY SERIES OF PREFERRED NUMBERS

TABLE V Decimal Series—1 to 1000					TABLE VI Fractional Series—1/8 to 40				
5/2 Series 150% Steps	5/3 Series 300% Steps	10/3 Series 100% Steps	20/3 Series 40% Steps	40/3 Series 18% Steps	5/2 Series 150% Steps	5/3 Series 300% Steps	10/3 Series 100% Steps	20/3 Series 40% Steps	40/3 Series 18% Steps
1	1	1	1	1	5/32	3/8	1/8	1/8	13/64
2.5				1.18					
6.3				1.4					
16				1.7					
40				2					
100	2	2	2	2	1/4	1/4	1/4	1/4	
250	4	4	4	2.36	5/32	3/8	1/2	1/2	19/64
630				3.35					
				4.75					
				5.6					
				6.7					
	8	8	8	8	1/2	1	1	1	1
	16	16	16	9.5	40	2	2	2	1 3/8
				11.2					
				13.2					
				22.4					
				26.5					
	31.5	31.5	31.5	31.5	3/4	2	2	2	2
	63	63	63	37.5	16	8	4	5 1/2	4 3/4
				45					
				53					
				75					
				90					
	125	125	125	125	8	8	11	11	11
	250	250	250	150	16	32	16	22	16
				180					
				212					
				300					
				355					
	500	500	500	500	32	32	32	32	32
	630	630	630	600	16	38	16	19	22
				710					
				850					
				250					
				355					

Preferred numbers below 1 and above 1000 are formed by dividing the numbers between 1 and 1000 by 1000.
Preferred numbers above 1000 are correspondingly formed by multiplying the numbers between 1 and 1000 by 1000.

Supplementary series are selected from the basic series and are used, where percentage steps above 60 or between 60 and 25 or between 25 and 12 are necessary for some justifiable reasons.

Where it is desirable to have a nine per cent increase in steps, such a series may be constructed by using every third step in the 80 series.
Percentage figures in headings are approximate averages.

- for the 5 series $\sqrt[5]{10}$ or 1.5849
- for the 10 series $\sqrt[10]{10}$ or 1.2589
- for the 20 series $\sqrt[20]{10}$ or 1.1220
- for the 40 series $\sqrt[40]{10}$ or 1.0592

It therefore is clear that the system is a logical, simple method of arriving at the minimum necessary number of sizes for a given device

which will meet service requirements adequately. It insures that additional sizes may be provided later, where an incomplete range of sizes may at first be desired, with logical fitting in of the later sizes with first ones.

A knowledge of the theoretical basis is not essential for the practical use of the system. It has been mentioned above merely for the information of those interested. The theoretically exact values of series are obtained by starting with one and multiplying each number of the series by a constant factor to obtain the next higher number. However, the values selected for practical use (which are given in the Tables) are usually not the theoretically exact values, although they do not depart therefrom more than 1.3 per cent in any case. The theoretical values are not given here because they are of no value in the practical application of the system. A table of the exact numbers (five decimals) can be obtained from the American Standards Association.

APPLICATION OF PREFERRED NUMBERS

It should be emphasized that this method of standardization involves, as its name indicates, numbers which are *preferred*, but which do not have to be used where not efficiently suited. Many engineers who have considered the subject briefly, state that the system is "fine in theory, but impossible in practice," or "purely academic but sizes are determined by practical customer desires," or "useless because sizes needed have been determined by long practical evolution and industry can't stand for theoretically ideal changes."

Such objections are based on a misconception of the real nature of preferred numbers. It is quite evident that there are many cases in engineering design and industrial production where the application of the system, although possible in principle, is not practicable at the moment for reasons of economy. It cannot be expected that industry will scrap valuable tools or equipment merely for the sake of changing over to a new series of sizes which may be an ideal one. The important point is that there are many cases in which existing sizes are in process of revision, or new ones are being set up, where the series of preferred numbers can be followed without penalty or difficulty, and with greater economy. It is in such cases that its use is recommended.

Careful study in any drafting room will show that there are many cases in which the designer has latitude of choice of dimensions, ratings, etc., so that his decision with respect to them is arbitrary within certain limits, and quite often these limits are wide.

In view of this, it is obvious that if certain numerical values are universally accepted as preferred, and are used whenever they meet re-

quirements at least as well as any other arbitrary choices, there will be occasions where the identity of choices will develop later simplicities and usefulness because of logical relations existing, which were not in mind at the time of choices. Therefore, material savings should result, some of the obvious ones of which are:

1. Mill products which are used in the fabrication of manufactured articles could be made in a minimum number of standard sizes so chosen as to meet the needs of users who have adopted preferred numbers for the sizes of their wares.

2. Measuring equipment and production machinery might be simplified and cheapened, because it would be necessary to provide only for definite preferred dimensions instead of universal adjustment.

3. Odd sizes, manufactured through ignorance of real requirements or to meet the supposed, but really illogical, needs of a customer or industry, might be eliminated.

4. Operations would be simpler for both producers and users, because calculation, manufacture, commerce, catalogs, price lists, and human memory would deal only with certain easily memorized and widely used numerals.

One of practical turn of mind may think that there is much of theory and little of practical worth, in all this. Present sizes have been developed by a cut-and-try process, with commercial necessity acting as a brake on use of too many sizes. It might be assumed, therefore, that present-day industry is already using the minimum number of sizes consistent with meeting needs, and that these sizes are chosen most advantageously. Such arguments are weighty and worthy of serious consideration, of course, but it is the finding of those who have studied preferred numbers that the system can provide advantages over cut-and-try choices, which in many cases are distinctly worthwhile. Preferred number standards cannot always be used in a finally adopted design because it may be necessary to compromise with some of the many deeply rooted trade practices and customs, or with other uncontrollable requirements, but their application should always be studied.

A striking example of the use of preferred numbers and one which has been in use for seventy years, is the Brown and Sharpe wire gauge. The basis of its size variations is that of a geometric progression giving each increasing size a diameter greater than the preceding one by a constant percentage. It is probable that the popularity of this gauge is in large measure due to the utility inherent in the preferred number idea of which it has been for so many years—unwittingly, it is true—so successful an exponent. The system is nothing more than an intelli-

gent method of selecting sizes so as to afford the greatest utility and convenience, and to cover the full range with the minimum number of sizes.

Years of experience with incandescent lamps have developed a series of wattage ratings considered most useful. The application of preferred numbers in the beginning would have given the correct values at once as 10, 16, 25, 40, 63, 100, practically the same as determined by experience.

The "transmission unit" as used in telephone and radio practice is an example of existing preferred number application, and one using the "10 series."

It has been recommended¹ that the ratings of vacuum tubes for industrial applications be established according to preferred numbers.

Certain foreign countries have made considerable progress in utilization of the system. A German example in radio design is shown in Appendix I, applying to receiver control knobs.

RULES AND SUGGESTIONS IN USE OF PREFERRED NUMBERS

Basic Rules

Preferred numbers offer an excellent means to the individual manufacturer for standardizing parts and important internal dimensions of his products, but the principal and most important applications should be looked for in connection with figures of interest in purchasing materials and parts, such as gauge dimensions and sizes of materials, overall dimensions of machines and articles of all kinds, ratings, commercial capacities, speeds, etc.; in other words, preferred numbers should be used wherever the interchangeability of goods made by different manufacturers is of interest to the user.

While it is an essential feature of the preferred numbers system that it is based on geometric series; i.e., each number is a given percentage larger than the preceding number, the use of geometric series of numbers other than given here in the standard series should be avoided. *In order to further standardization, it is essential that the actual preferred numbers given in the tables be used.*

For a given line of articles or materials, the same series should be adhered to over as wide a range as possible, but a change from one series to another is frequently necessary in order to obtain the maximum utility and economy in the particular case involved. So far as possible, the numbers in the "5 series" should be given preference over those in the "10 series"; those in the "10 series," over those in the "20

¹ O. W. Pike and D. Ulrey, *Elec. Eng.*, December, (1934).

series"; and so on; but, again, such choice should be made subject to considerations of utility, economy, and the like.

If it is entirely impossible to adhere to the basic percentages of 6, 12, 25, and 60 of Tables I and II, other percentages can be obtained from the supplementary series of Tables V and VI. These latter tables are made up of numbers contained in Tables I and II, supplemented by an "80 series" (Tables III and IV).

Time of Application

When planning new designs, individuals and smaller industrial units should always use preferred numbers as a basis. If this practice is followed before standardization by larger bodies or before national standardizing agencies can function, it will greatly facilitate subsequent standardization by such bodies. When undertaking new work, standardizing agencies should always use preferred numbers as a basis. Where well-established and satisfactory standards exist, it is frequently not economical to make changes merely for the purpose of having the standardization conform to the preferred numbers system; however, if extensions are made to such existing standards or if changes are made for other reasons, preferred numbers should be used even though it can be done only to a limited extent.

Preferred numbers serve as a neutral ground in working out a revision of several standards of an article already in use that are either conflicting or too extensive to meet satisfactorily the demands of the industry. In "simplified practice," which is carried on in many industries and which usually consists in reducing the number of commercial sizes, preferred numbers can often be made use of by favoring those existing sizes that coincide with preferred numbers.

Application to Complete Machines, Devices, etc.

Preferred numbers should be applied to complete machines, devices, etc., in such a manner as will result in the maximum interchangeability to the user and also facilitate a comparison of the products of different manufacturers. This means that they should be applied primarily to the commercial ratings most commonly used, such as horsepower, speeds, etc. In the second place, they should be applied to important over-all and mounting dimensions or any other dimensions that will result in interchangeability to the user. Finally, the individual manufacturer may find it convenient to apply preferred numbers to characteristic dimensions, ratings, etc., that will facilitate standardization within his own sphere of activity.

Frequently certain devices have to be located within certain spaces with small clearances, and if in such cases preferred numbers cannot

be economically applied to both the devices and the clearances, they should preferably be applied to the devices proper.

Application to Parts

In the standardization of parts of apparatus, preferred numbers should preferably be applied to those parts with reference to which interchangeability is of importance to the user of the device. In addition, however, manufacturers whose products are made up of parts used in a multiplicity of combinations will find preferred numbers very advantageous in the standardization of such parts.

In the case of mating parts, such as bolts, studs, rotating bodies, etc., and the bore with which they are used, preferred numbers should be used for the internal members, and for the bore of the holes only if this can be done without economically handicapping results.

Application to Materials

Possible applications of preferred numbers to materials, hardware, etc., are innumerable. If both finished and raw material dimensions are involved, preferred numbers should be applied first to the finished dimensions, and to the raw material dimensions only if this can be done without economic waste.

Application to Interrelated Values

(a) *Values to be added or subtracted*—Generally speaking, two preferred numbers when added or subtracted will not result in a sum or a difference which is also a preferred number. This means that only two of any three such interrelated values can be preferred numbers, and in such cases preferred numbers should be applied to the more characteristic of the numbers and the ones most essential for interchangeability.

It often happens that two items which must differ from each other by a small amount are subject to standardization, such as a device or a part and the given space within which it is to be mounted, or possibly a given part and the raw material from which it is to be manufactured. In these cases it is often possible to standardize the finished device or part in line with one of the series of preferred numbers having large steps, such as the 10 series, and to use for the other dimension the numbers of the 40 series directly following those of the 10 series, or, if the numbers of the 40 series give differences that are too large, to use the numbers of the 80 series (Tables III and IV).

At times two equal standardized values combine into another value for which standardization is desirable. Unless exact doubling is required, this can easily be done by means of preferred numbers because each preferred number when doubled gives, at least approximately,

a preferred number. In the fractional series, each number when doubled gives an exact preferred number and therefore the fractional series may have to be resorted to where there is a necessity for exactness. (See Table II.)

(b) *Values to be multiplied or divided*—In the decimal series, the multiplication or division of two preferred numbers gives approximately a preferred number. This is frequently of great assistance. In many cases where two values and their product or quotient are all subject to standardization, desirable results can be obtained if the two values happen to be preferred numbers or can be chosen as such. In square or rectangular areas, for instance, the areas will be preferred numbers if preferred numbers are chosen for the sides. Even the area of a circle will be a preferred number if the diameter is, because π very closely approximates a preferred number. Again, in the case of an alternator, for example, both the kilowatt and the kilovolt-ampere can be preferred numbers if preferred numbers have been used for the standardization of the power factors.

If it is impossible to have all factors preferred numbers, as may be the case for instance in the unalterable specific weight of material, it is impossible to have both the volume and the weight preferred numbers. Here the more important value should be based on preferred numbers but the other values then cannot be such, though they will at least follow a geometric series.

Frequently the problem of standardization arises where certain devices or parts interrelated to others are used in such a way that the multiple of one device is operated by or used in conjunction with a single other device. In these cases it is not always possible to follow strictly a fundamental series for both types of devices, but a satisfactory arrangement can nearly always be worked out by resorting to the use of a supplementary series.

Rounding of Preferred Numbers

In standardization it may at times be desirable to use numbers that are more rounded than those given in Table I. This practice should not be followed by individuals or by smaller units, particularly where the use of an exact number by one party and of a rounded number by another would interfere with subsequent standardization and interchangeability.

If national or international standardizing bodies feel that for certain specific purposes more rounded numbers are essential, the rounding should in all cases be in accordance with the national rule for rounding.

The International Standards Association, although in principle opposed to rounding, has indicated some rounded numbers to be used when absolutely necessary; this has been done so as to avoid different rounding by various parties. The values suggested by the ISA are:

1.1 for 1.12	11 for 11.2
1.2 for 1.25	12 for 12.5
2.2 for 2.24	22 for 22.4
3.0 for 3.15	32 for 31.5
3.5 for 3.55	36 for 35.5
5.5 for 5.6	70 for 71
6 for 6.3	110 for 112
7 for 7.1	220 for 224

These numbers, with two exceptions, are in accordance with the adopted United States National rules for rounding.

Conversion of Inches to Centimeters

It so happens that the conversion factor of 2.54 for changing inches to centimeters is approximately a preferred number. Therefore, when converting inch values of the decimal preferred numbers system into metric units, the results will again be approximate preferred numbers (within 1.6 per cent). This approximation in many cases is satisfactory from a practical point of view. With the fractional system the discrepancies are much greater (up to about 5 per cent) and therefore standardization of linear dimensions that may become important internationally should preferably be by the use of the decimal series of preferred numbers.

Choice of Series and Size of Steps

The choice of the particular series and the corresponding size of step to be used will be governed by a number of factors, such as utility, economy, interrelation of products and parts, performance, and the like. If a small number of steps is used, it is necessary in many applications to use a size larger than actually needed for a particular case, which in turn represents a certain amount of waste. If the cost of the device increases but little with the size, that is, if the cost curve is relatively flat, such waste will not be appreciable. On the other hand, if the cost increases appreciably with the size, the use of too few steps is contrary to economy.

Against this, the use of few sizes will result in economies in such items as development costs, tools, setup costs during manufacture, stockkeeping, obsolescence of stock, etc., and if such costs are relatively high, certain economies can be accomplished by using larger

steps and a smaller number of sizes. The practical influence of the costs mentioned is of course determined largely by the quantity manufactured, that is by the activity of the particular article. In other words, with large production a great number of steps may be more economical than in the case of low activity.

In addition to the previously mentioned factors entering into the first cost of the device or material itself, other items of cost, such as that for installation and the like, may be of importance. Again, the size of steps may be influenced by considerations of performance, as, for example, the efficiency of a machine or the accuracy of measurement in the case of an instrument. Steps too large may result in unsatisfactory or uneconomical operation due to the fact that the devices would at times have to be used appreciably below their rated capacity.

All of these and numerous other factors will have to be taken into account in determining which of the available series should be used for any particular range of a given line. The best results will at times be obtained with the steps possible with the basic series, but in other instances some of the supplementary series may have to be resorted to. Since many of these factors, such as activity, cost relations, etc., will often change over the range of an entire line, it will naturally be necessary to change from one series to another for different ranges of a line.

Supplementary Series

Supplementary series of preferred numbers can be obtained by using, for instance, every third step in the 5 series, every second step in the 5 series, every third step in the 10 series, and so on. Such supplementary series should preferably, though not necessarily, start with one, going up and down. When starting with one, series shown in Tables V and VI will result. Such supplementary series, together with the basic series, result in the following possibilities:

Every 3rd step in the	5 series	results in	300% series
Every 2nd step in the	5 series	results in	150% series
Every 3rd step in the	10 series	results in	100% series
Every step	in the 5 series	results in	60% series
Every 3rd step in the	20 series	results in	40% series
Every step	in the 10 series	results in	25% series
Every 3rd step in the	40 series	results in	18% series
Every step	in the 20 series	results in	12% series
Every 3rd step in the	80 series	results in	9% series
Every step	in the 40 series	results in	6% series
Every step	in the 80 series	results in	3% series

(Percentages are approx.)

With this flexibility in the size of steps it should be possible to meet nearly every condition in practice and therefore there should be little occasion to resort to other geometric series not composed of preferred numbers.

The series having 150 per cent steps is often advantageous in standardizing new products having small activity, where in the beginning the 60 per cent steps of the 5 series are too small. By using the 150 per cent steps, the early conditions of development can be taken care of, with the possibility of filling in the missing steps of the 5 series later on when the activity increases.

The series having 100 per cent steps is suitable for quite a large number of conditions arising in practice where for some reason or other each size should be approximately a multiple of any other size.

The series giving 40 per cent steps meets conditions at times encountered in connection with sheets of paper, metal, etc., where it is desirable to cut smaller sizes by halving the larger sizes and at the same time to maintain the same ratio between width and length in order to facilitate photographic reductions of one size to another.

Calculations Based on Preferred Numbers

As preferred numbers have been so selected that they form a geometrical progression, any calculation based on such numbers becomes greatly simplified.

Mechanical calculations are often complicated and lengthy, particularly when they deal with parts of an irregular shape, as, for instance, the determination of the section modulus, center of gravity, moment of inertia, the cross section for figuring weights or similar values when the outline of the section varies from any of the customary geometrical shapes. If the factors of such an equation are preferred numbers, it is often sufficient to carry this calculation through for one member of a group of parts and then by means of a very simple calculation to arrive at the proportions of other members differing from the first one by certain percentages.

If a line of electric motors has diameters and lengths of armatures expressed in preferred numbers, it may be assumed that any work connected with the surfaces of these armatures will progress by preferred numbers; for example, time consumed for boring, turning, planing, or painting such surfaces, compared with the time needed for the same operation performed on an armature where the diameter and length are based on another of the preferred numbers in the same geometrical series. This process will also apply to the weight and the kilowatt output of these armatures.

Calculations Simplified by the Use of the Logarithms of Preferred Numbers

When preferred numbers are used as factors of an equation the figuring becomes very simple by using logarithms, as the mantissas of the Briggs' logarithmic system are round figures (see table below). When the logarithms of the factors of an equation are preferred numbers, the result will likewise be the logarithm of a preferred number and the final number will be found readily in the table of mantissas.

Examples

(a) *Required*—Circumferential speed (V) in feet per minute of a pulley having a diameter (D) = 8 inches, running at a speed (n) = 800 revolutions per minute.

$$\text{Formula: } V = \frac{D \times \pi \times n}{12}$$

$$\log V = \log D + \log \pi + \log n - \log 12$$

$$D = 8 \qquad \log D = 0.9$$

$$\pi = 3.14 \text{ (use 3.15)} \qquad \log 3.15 = 0.5$$

$$n = 800 \qquad \log n = 2.9$$

$$\text{Use 11.8 for 12} \qquad \log 11.8 = 1.075$$

$$\log V = 0.9 + 0.5 + 2.9 - 1.075 = 3.225$$

$$V = 1700.$$

The exact result would be, $V = 1675$, differing less than 1.5 per cent from a preferred number.

(b) *Required*—Torque (T) of a motor with an output (P) of 16 kilowatts and a speed of 2000 revolutions per minute.

$$\text{Formula: } T \text{ (foot-pound)} = 7040 \frac{P}{n}$$

$$\log T = \log 7040 + \log P - \log n$$

$$\text{Use 7100 for 7040} \qquad \log 7100 = 3.85$$

$$P = 16 \qquad \log P = 1.2$$

$$n = 2000 \qquad \log n = 3.3$$

$$\log T = 3.85 + 1.2 - 3.3 = 1.75$$

$$T = 56.$$

(c) Layout of a line of motors with output (P) based on the 10 series of preferred numbers from 10 to 50 kilowatts, and speed (n) on the 20 series from 2500 to 1120 revolutions per minute.

P = kw		n = rpm		T = foot-pound		T = foot-pound	
Pref. No.	Log	Pref. No.	Log	Log	Pref. No.	Calcu. from $7040 \frac{P}{n}$	% Differ. from Pref. No.
10	1.0	2500	3.40	$3.85+1.0-3.40=1.45$	28	28.2	0.71
12.5	1.1	2240	3.35	$3.85+1.1-3.35=1.60$	40	39.3	1.8
16	1.2	2000	3.30	$3.85+1.2-3.30=1.75$	56	56.3	0.54
20	1.3	1800	3.25	$3.85+1.3-3.25=1.90$	80	78.3	2.1
25	1.4	1600	3.20	$3.85+1.4-3.20=2.05$	112	110	1.8
31.5	1.5	1400	3.15	$3.85+1.5-3.15=2.20$	160	158	1.2
40	1.6	1250	3.10	$3.85+1.6-3.10=2.35$	224	225	0.45
50	1.7	1120	3.05	$3.85+1.7-3.05=2.50$	315	314	0.32

The result (*T*) is found to be part of the forty per cent supplementary series, Table V.

Preferred No.	Mantissa	Preferred No.	Mantissa
100	000	315	500
106	025	335	525
112	050	355	550
118	075	375	575
125	100	400	600
132	125	425	625
140	150	450	650
150	175	475	675
160	200	500	700
170	225	530	725
180	250	560	750
190	275	600	775
200	300	630	800
212	325	670	825
224	350	710	850
236	375	750	875
250	400	800	900
265	425	850	925
280	450	900	950
300	475	950	975

IMMEDIATE RADIO APPLICATIONS

It appears feasible to utilize preferred numbers in certain design matters of importance in radio production or service. The following examples are given as suggestions. Each must of course have thorough and expert study to determine whether it can be introduced with advantage, whether partial utilization only is economic, or whether use should await more favorable circumstances which may be brought later by changes in some associated factors.

Fixed resistors offer a splendid opportunity for benefit from utilization of preferred numbers. A large range of values is covered by these devices as used in radio, and permissible tolerances are so large that nominal ratings can readily be made by preferred number series. Choice of series is influenced by the fact that these units are sold with different standard tolerances, namely five, ten, and twenty per cent, and there is a desire to have every unit manufactured, regardless of what its value may be, fall into some standard size and tolerance. In other words three series are desired, with approximately five, ten, and twenty

per cent steps. A number of additional practical considerations are believed important by those studying the matter, but it should be possible without much practical penalty of the moment, to secure the long term advantages of preferred number sizes which would accrue from common standardization with other industries using resistors.

Other possible applications are fixed capacitors, electrolytic condenser can sizes, tubing diameters, coil form diameters and lengths, variable air condenser capacitance ratings, vacuum tube ratings, variable resistor ratings, mounting hole dimensions, control knob dimensions, and values for test frequencies in standard tests.

It is believed that very considerable benefits and economies can be had in industrial operations from the use of preferred numbers. The degree of benefits realized will increase as more and more kinds of industry and supply sources utilize them. Inasmuch as it is not practicable, or even economical, to obtain widespread use quickly, and use must grow gradually from small beginnings, it is recommended that opportunities for beginnings be not overlooked but on the contrary be sought, in order that growth may be encouraged.

It must be understood clearly, however, that choice of a random geometric series is not use of preferred numbers. The benefits to be derived come from use of the *same* series by many designers and producers, which means that choices must be made from the fundamental preferred numbers series shown in the tables appended to this report, or related ones derived therefrom.

CONCLUSION

Standardization of any kind is justified only if it brings about economies or other advantages and if it does not unduly interfere with progress. Vast economies could be accomplished by a great deal more standardization, but with the usual processes of arriving at standards so much time is consumed that the full value of such possible economies is never obtained. On the other hand, the instances where standardization has interfered with progress are extremely rare. These statements fully apply to standardization by preferred numbers, which should be used to a much greater extent than they have been in the past. They not only offer an excellent tool for working out standardizations, but their frequent and liberal use will materially speed up the establishment of standardizations. One reason why this useful tool, which in itself is so simple that it can be understood by a child in the fourth or fifth grade or by any laborer of ordinary intelligence, has not been used to a greater extent, is that it has been shrouded with a good deal of mystery by many mathematical discussions, by curves on logarithmic

paper, long drawn-out arguments on the merits of different systems, and the like. The reason why the engineering profession as a whole has not taken more interest in the system is that it and its utter simplicity have not been sufficiently advertised.

It cannot be emphasized too strongly that preferred numbers should be used very extensively but that considerations of utility, economics, and, above all, common sense should govern their application. In most cases the use of these numbers is an extremely simple procedure, and even where matters are somewhat involved it is usually not very difficult to find advantageous applications of the system.

APPENDIX I

German standard sheet DIN VDE 1525
Broadcast apparatus—knobs without scale

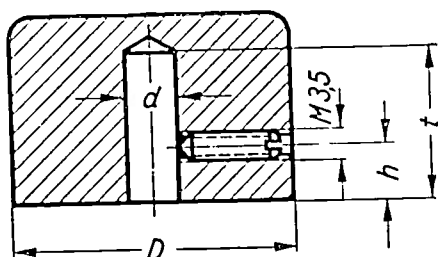

Instead of setscrews, other screws according to DIN standards may be used. The screws must be entirely embedded.

Designation of knob without scale, with a diameter $D=25$ millimeters: knob 25 VDE 1525.

Diameter D^1	Knob		h
	Depth t	Bore d Fit σ^2	
16 ²	10	3	4
20 ²			
25			
32	17	6	6
40			
50			

Dimensions not given may be freely chosen.

¹ For polygon knobs, D indicates diameter of circumscribed circle.

² For fine adjustment.

For knobs with scale, see DIN VDE 1526.

APPENDIX II

Method of "Rounding Off" Decimal Values

When a decimal value is to be rounded off to a lesser number of places than the total number available, the procedure should be as follows:

(a) When the figure next beyond the last figure to be retained is less than 5, the last figure retained should not be changed.

Example—1.12, if cut to one place, should be 1.1.

(b) When the figures beyond the last place to be retained amount to more than 5 in the next place beyond that to be retained, the last figure retained should be increased by 1.

Example—2.36, if cut to one place, should be 2.4.

(c) When the figure next beyond the last place to be retained is exactly 5, with only zeros beyond, the last figure retained, if even, should be unchanged; if odd, it should be increased by 1. This means that the last figure retained is always an even figure.

Example—4.25, if cut to one place, should be 4.2.

3.15, if cut to one place, should be 3.2.

(This method of rounding off even fives results, in the long run, in the same number of values being raised as are lowered, and thus the average value is correct, whereas if the even five were always retained or always discarded, the final value, in the long run, would be too large or too small.)

(d) For some applications, where the standard series prove entirely undesirable from the viewpoint of standard raw materials or special design features in accordance with the above, roundings may be used as follow:

In the 10 series, 31.5 may be rounded to 32

In the 20 and 40 series, 11.2 may be rounded to 11

22.4 may be rounded to 22

31.5 may be rounded to 32

35.5 may be rounded to 36

In addition, it is standard that

In the 20 and 40 series, 71 may be rounded to 70.

Bibliography

R. Rudenberg, "Ueber den Entwurf technischer Modellreihen" (Development of an ideal series of numbers for technical use), *Zeit. Vereins Deutscher Ingenieure*, p. 406, (1918).

C. F. Hirshfeld and C. H. Berry, "Size standardization by preferred numbers," *Trans. A.S.M.E.*, December 4 (1922).

J. I. Hommel, "Preferred numbers offer economies to electrical manufacturers," *Elec. Rec.*, December (1924).

F. J. Schlink, "A new tool for standardizers," *American Machinist*, July 12, (1923).

I. J. Gondriaan, "Considerations as to the most economical ratio of increase in a series of standardized main dimensions," The First World Power Conference.

Sidney Wilmot, "The possibilities of preferred numbers in civil engineering," *Engineering and Contracting*, February 25, (1925).

"German radio applications of preferred numbers," *Electrotech. Zeit.*, September 16, (1926).

Emil G. Bern, "Some engineering aspects of standardization," *Gen. Elec. Rev.*, October, (1926).

L. A. Hazeltine, "Preferred numbers," *Proc. I.R.E.*, vol. 14, pp. 785-787; December, (1926).

A. Herb, "Preferred numbers standardization based on calculation," *Mech. Eng.*, January, (1927).

"Table of Preferred numbers," *ASA Bulletin*, (1927).

R. E. Hellmund, "Experiences and suggestions relating to the preferred numbers system," *Mech. Eng.*, vol. 53, no. 3, April, (1931).

Abstract of "Experiences and suggestions relating to the preferred numbers systems," *ASA Bulletin No. 57*, January, (1931).

R. E. Hellmund and J. I. Hommel, "Standardization by preferred numbers," *Amer. Mach.*, November 5, (1931).

R. E. Hellmund, "Standardizing sizes and ratings by means of preferred numbers," *Commercial Stds. Monthly*, May, (1932).

R. E. Hellmund, "Fundamentals of standardizing sizes and ratings as related to preferred numbers," *Product Eng.*, vol. 3, September and October, (1932).

Abridged "Fundamentals of standardizing sizes and ratings as related to preferred numbers," *Elec. Eng.*, vol. 51, no. 1, January, (1932).

Translation by R. Germar, "Fundamentals of standardizing sizes and ratings as related to preferred numbers," *Zeit. Vereins Deutscher Ingenieure*, Band 77, Nr. 29, July, (1933).

R. E. Hellmund, "Standardization and profits aided by preferred numbers," *Elec. World*, August 18 (1934).

"Preferred numbers—a proposal of American standard series," *ASA Industrial Standardization*, October, (1934).



A NEW TYPE OF GAS-FILLED AMPLIFIER TUBE*

BY

JAMES D. LEVAN AND PAUL T. WEEKS

(Raytheon Production Corporation, Newton, Mass.)

Summary—The Raytheon Laboratories have had under development for several years a gas- or vapor-filled amplifier tube. This paper describes the general features of this type of tube and gives the detailed characteristics of some typical designs.

A distinctive feature of these gas-filled tubes is the introduction of an auxiliary grid-form electrode which serves as the anode for an ionizing discharge and at the same time as a cathode for the main electron stream which is controlled in the same manner as in an ordinary high vacuum tube. Due to the close spacing of the main electrodes and the relatively low gas or vapor pressure employed, the main electron stream or plate current can be continuously controlled by the voltage applied to the control grid, increasing as the negative bias on the control grid is decreased and decreasing to cutoff as the grid bias is made more negative. Within the voltage limits of each particular design of tube the presence of gas ions between the main electrodes only serves to neutralize partially the space charge, the general form of the characteristics being the same as for high vacuum tubes. The plate resistance however is characteristically low and the mutual conductance much higher than in high vacuum tubes of comparable size. Because of the low space-charge characteristic it also follows that high values of plate current and mutual conductance may be obtained at relatively low values of plate voltage, although normal characteristics are also obtained with plate voltages of several hundred volts.

This type of tube may be designed for use as a low-frequency or high-frequency amplifier or oscillator and as a triode or screen-grid tetrode. It has been made in sizes from a few watts to 50 watts rating, and has been used as an ultra-high-frequency oscillator delivering 20 watts at 100 megacycles.

CONSIDERABLE work has been done in the past few years in several laboratories on the general problem of developing a gas-filled amplifier tube. Among those working in this field have been Lubeke,¹ Schottky, Nienhold,² Seibt, Bley, and Hund.³ The general problem of controlling arc and glow discharges has also been under investigation in the Raytheon Laboratories for a number of years and some practical forms of gas-filled amplifiers have been developed which involve some important features not previously described. The

* Decimal classification: R330. Original manuscript received by the Institute, July 3, 1935. Presented before Tenth Annual Convention, Detroit, Mich., July 3, 1935.

¹ Ernst Lubeke and Walter Schottky, "Wall current amplifiers," *Wissenschaftliche Veröffentlichungen aus dem Siemens-Konzern*, IX Band, Marz, (1930).

Fritz Schroter, "Cold cathode amplifying tubes," *Electronics*, vol. 8, p. 131; April, (1935); *Telefunken, Rohre 1*, pp. 103-112, (1935).

² German Patents, (Nienhold), 345,276; 349,921; 331,029; and 319,806.

³ *Electronics*, vol. 6, p. 6; January, (1933).

purpose of this paper is to report on the results of some of these investigations, and in particular to describe the general features and give detailed characteristics of some of these tubes.

It has been felt from the beginning that gas-filled tubes might have certain advantages over high vacuum tubes, such as (1) lower impedance, (2) higher mutual conductance, and (3) higher cathode efficiencies. Our results show that these advantages can be obtained.

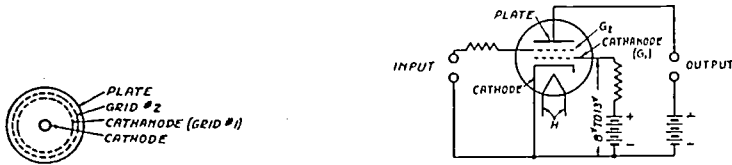
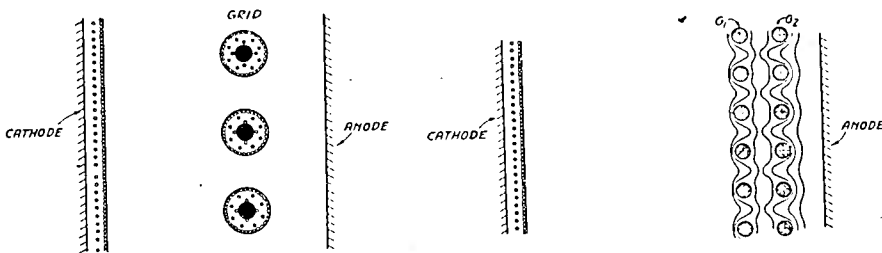

Fig. 1—End view of element structure.
Fig. 2—Typical circuit for RK-100 tube.

One of the distinctive features of these gas-filled tubes is the introduction of an auxiliary grid which acts as an anode for an arc discharge and at the same time as a "virtual" cathode for the main electron stream to the plate, which is controlled by a control grid as in an ordinary high vacuum tube.

An end view of the element structure is shown in Fig. 1 and a typical circuit in Fig. 2. As shown in Fig. 1, the "virtual" cathode or "cath-anode" and the grid are placed very near the plate. The resulting short electron paths, together with the small grid openings used (30 to 60



Figs. 3 and 4—Field in RK-100.

mesh) and the low gas pressure prevent cumulative ionization between G_1 and the plate. Enough positive ions are formed, however, to neutralize partially the space charge. These factors all combine to give a tube of low plate impedance and high mutual conductance and make the tube particularly useful on low plate voltages. However, as we shall later show, tubes of very high plate impedance can also be made.

The principle of operation of these tubes might be better understood by comparing them with the common grid-controlled mercury vapor rectifiers⁴ (Fig. 3). Here the grid acts as a kind of trigger, either

⁴ A. W. Hull and I. Langmuir, "Control of an arc discharge by means of a grid," *Proc. Nat. Acad. Sci.*, vol. 51, pp. 218-225, (1929).

allowing maximum current to flow or none at all. The grid is immersed in a space filled with electrons and positive ions in nearly equal numbers, and when negative, positive ions will be attracted to it, forming a definite sheath around the grid. The thickness of this sheath (x) can be determined from Child's space-charge equation, which when solved for x , gives

$$x = 0.622 \times 10^{-4} \frac{V^{3/4}}{I^{1/2}} \text{ cm}$$

where,

V = grid potential with respect to space just outside sheath

I = grid current in amperes per square centimeter.

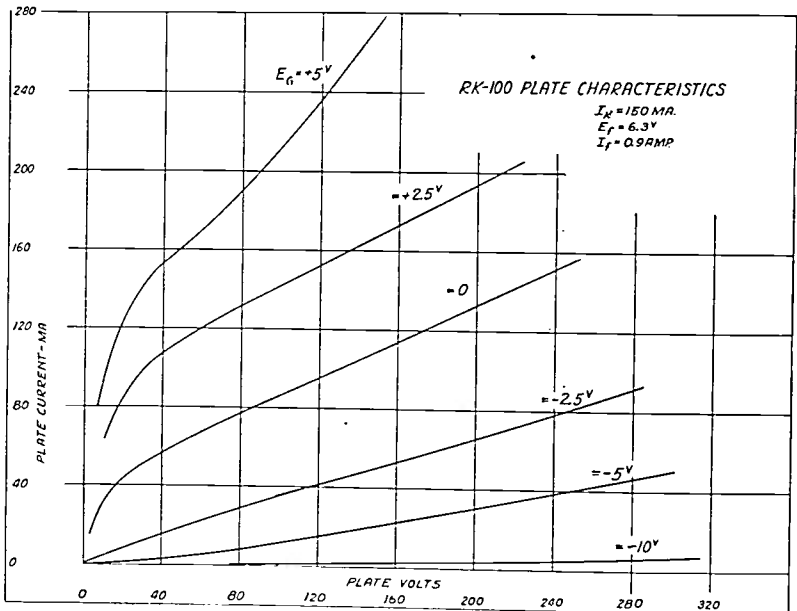

Fig. 5

With -10 volts on the grid and a current of 10 milliamperes per square centimeter flowing, this gives a sheath thickness of 0.0035 centimeter, which is very small compared to the openings in the usual grid. This thin sheath will, however, contain the entire voltage drop due to the grid and thus keep the grid from influencing electrons beyond the outer boundary of the sheath. Thus the region filled with highly ionized gas will project through the grid into the plate region.

From the space-charge equation it is apparent that the thickness of the positive ion sheath can be increased by decreasing the positive ion current to the grid. This can be done by shielding the grid from the highly ionized gas—as is done by G_1 in Fig. 1. In this way the sheath thickness can theoretically be increased until it extends beyond the adjacent elements, in which case, of course, no complete sheath really

exists, and we get a picture somewhat like Fig. 4, which gives an idea of what the equipotential lines might be like. The control grid (G_2) is thus enabled to control the shielded space between G_1 and the plate.

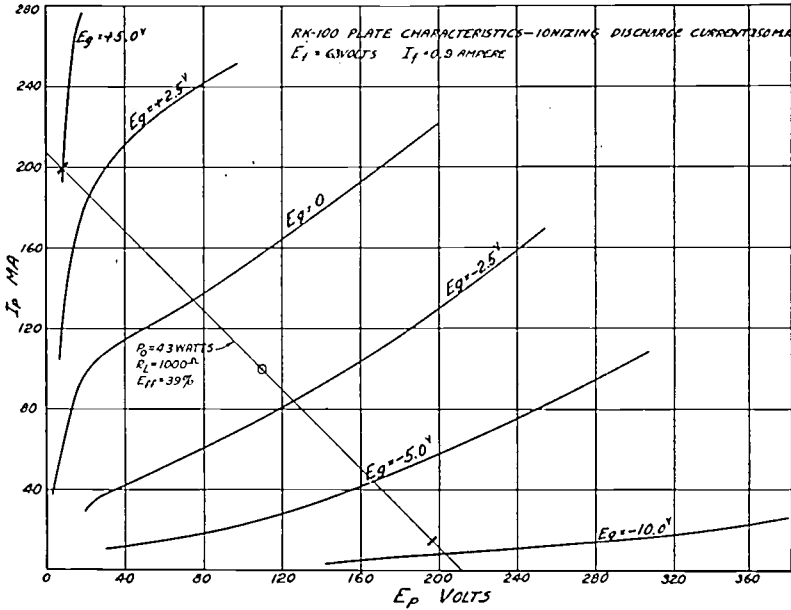

Fig. 6

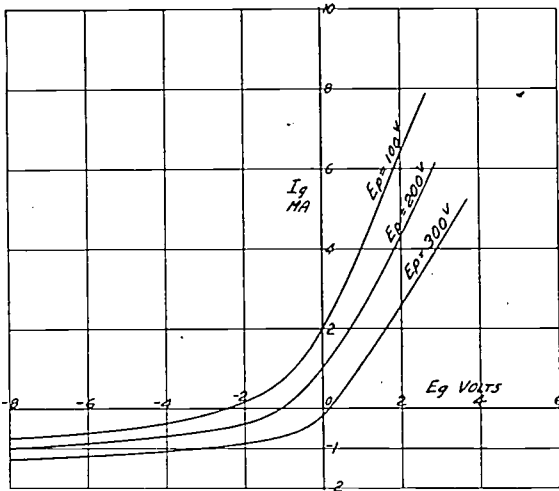
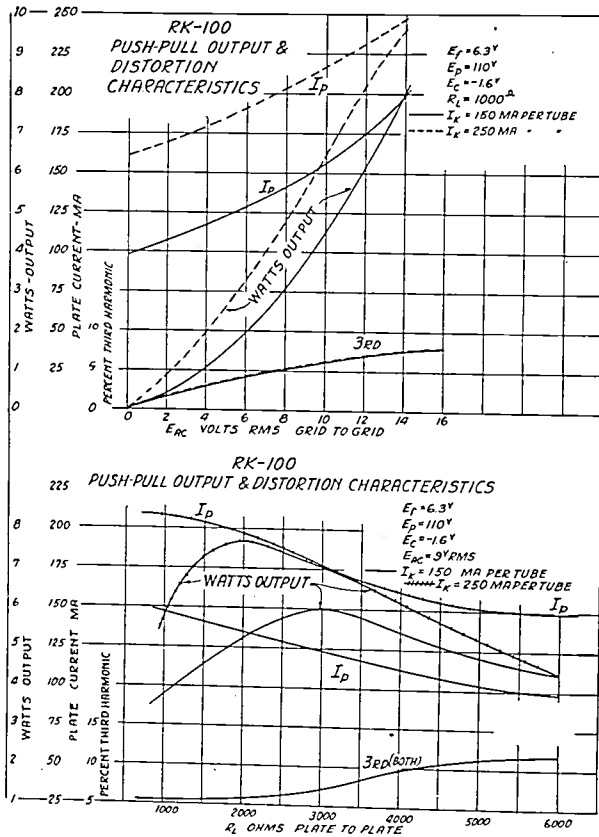

Fig. 7—RK-100 grid characteristics.
 $E_f = 6.3$ volts, $I_f = 0.9$ ampere, $I_k = 150$ milliamperes.

The characteristics of one type of tube (RK-100), with regard to the various parameters, are shown by Figs. 5 to 9 inclusive. This tube contains mercury vapor and was designed for 110-volt operation. Figs. 5 and 6 show the plate families for arc currents of 150 and 250 milliamperes. With 100 volts on the plate, 2.5 volts negative bias on the grid

(G_2), and an arc current of 150 milliamperes (to G_1), the amplification factor is approximately 50 and the mutual conductance 12,000 micromhos. With an arc current of 250 milliamperes the mutual conductance is increased to over 20,000 micromhos. The characteristics of these mercury-vapor tubes vary somewhat with temperature but this variation will be no material disadvantage in most applications. Tubes containing fixed gases, such as argon, have been made with similar char-



Figs. 8 and 9

acteristics and are independent of the temperature. Fig. 7 shows the grid characteristics for an arc current of 150 milliamperes and for plate voltages of 100, 200, and 300. While the grid draws current at all times, the operation in practical circuits is similar to that in conventional vacuum tubes. The grid impedance is reasonably high for negative values but decreases as the grid becomes positive.

Figs. 8 and 9 show push-pull output and distortion characteristics as a function of load resistance and input voltage for a plate supply of 110 volts and arc currents of 150 and 250 milliamperes per tube. Fig. 8 shows a maximum output of 9.5 watts with 7.5 per cent third harmonic and an input of 14 volts.

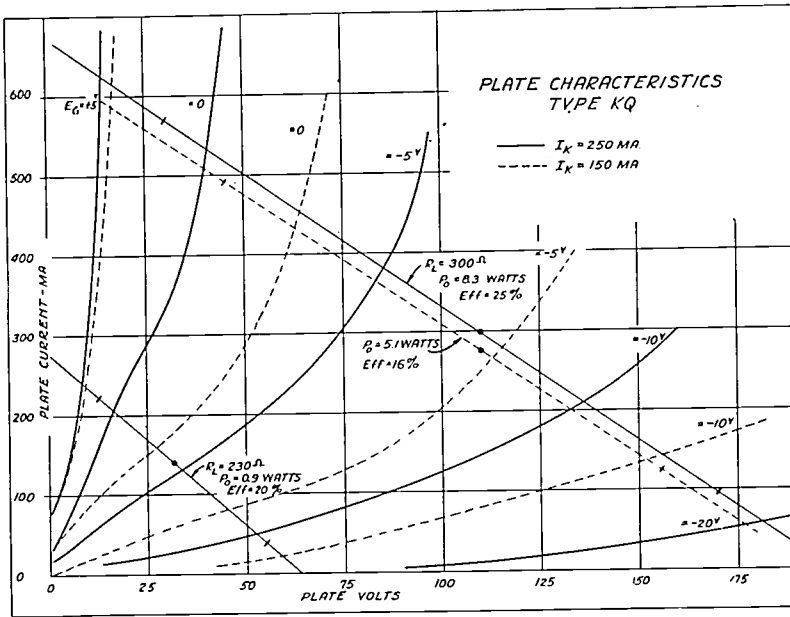
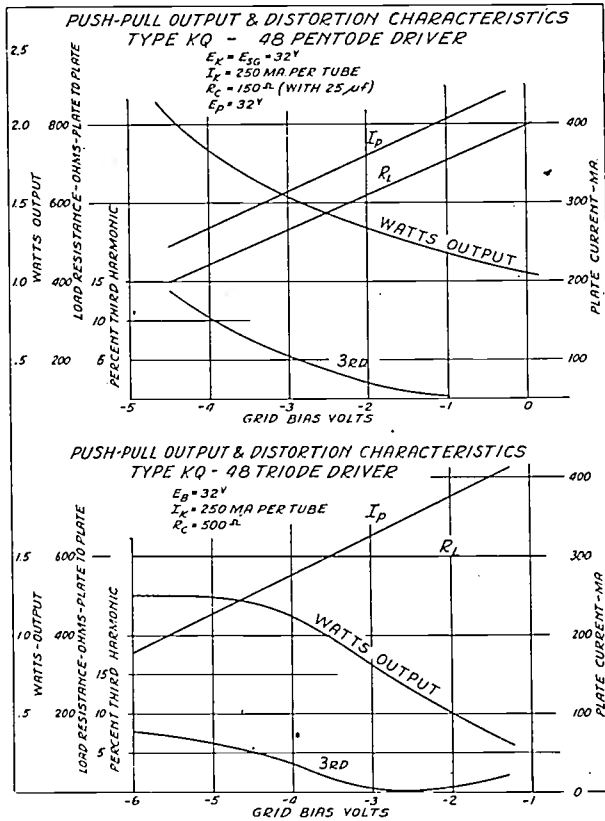

Fig. 10



Figs. 11 and 12

The characteristics of an experimental mercury-vapor tube, type KQ, designed to operate at very low plate voltages are shown by Figs. 10, 11, 12, and 13. Fig. 10 shows two plate families, for arc currents (I_k) of 150 and 250 milliamperes. The load line for 32 volts on the plate shows an output of 0.9 watt with 230 ohms load. With a plate voltage of 32 volts and an arc current of 250 milliamperes the amplification factor is about 9 and the mutual conductance 32,500 micromhos. Fig. 11 shows the output characteristics with a type 48 pentode used as a driver with 32 volts on the screen grid and plate. The cathanodes (G_1) were also supplied from the 32-volt source with a resistor in series to limit the current to 250 milliamperes per tube. The optimum load resistance was used for each value of grid bias and a resistance (R_c) of 150 ohms with 25 microfarads across it was connected in series with

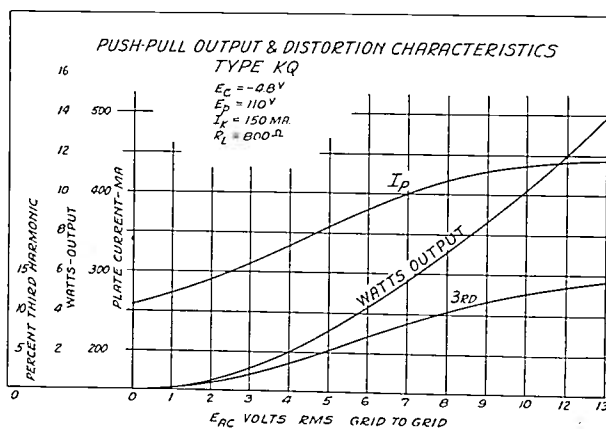

Fig. 13

each grid. A maximum output of two watts is obtained with 12 per cent third harmonic. A part of this distortion is due to the driving tube. The same characteristics are shown in Fig. 12 but with the type 48 driver connected as a triode; i.e., with the screen grid connected to the plate. The optimum load resistance was constant at 600 ohms for these curves. Fig. 13 shows a maximum output of 14 watts with a plate voltage of 110 volts, an arc current of 150 milliamperes, and an input voltage of 13 volts. For 110-volt operation this particular type is getting near the point of instability due to the sharp turning up of the plate-current characteristics, which in turn is caused by the ionization between G_1 and the plate increasing to a high value. The stability of this type increases with decreasing plate current.

When a screen electrode is incorporated in these gas-filled amplifier tubes in the same manner as in a vacuum tube the effect on the characteristics is similar to the effect in vacuum tubes, as would be ex-

pected. Fig. 14 shows the plate family of a mercury-vapor tube of this type connected as a tetrode. With a plate voltage of 200 volts and a

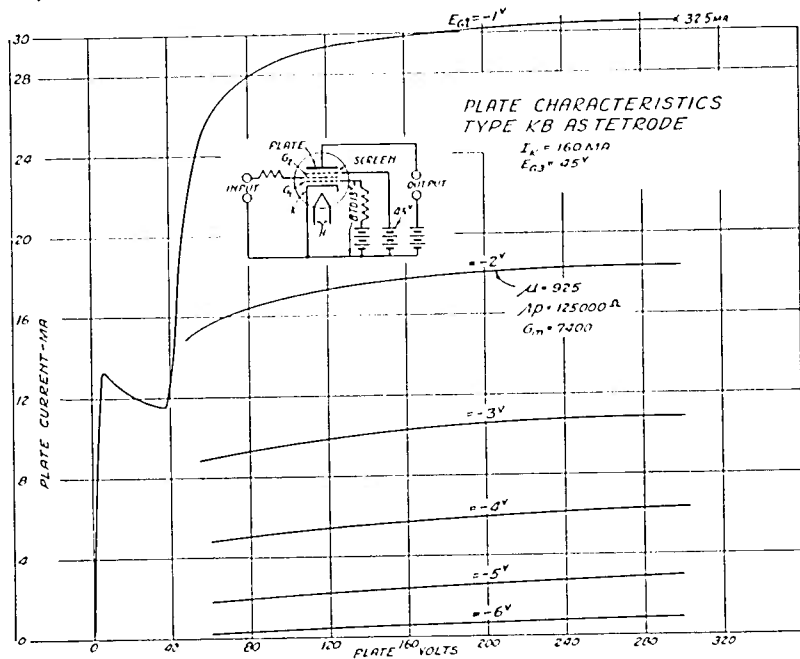

Fig. 14

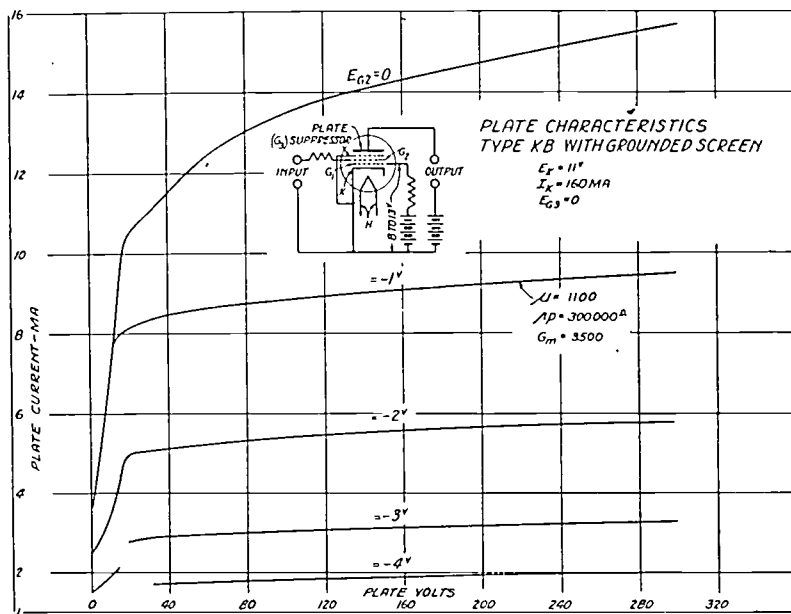

Fig. 15

grid bias of -2 volts the amplification factor is 925, the plate resistance 125,000 ohms, and the mutual conductance 7400 micromhos. Fig. 15 shows the plate family with the screen grid connected to the cathode

as a suppressor grid. With a plate voltage of 200 volts and a grid bias of -1 volt the amplification factor is 1050, the plate resistance 300,000 ohms, and the mutual conductance 3500. Fig. 16 shows the control grid characteristic of type KB as a tetrode for an arc current (I_k) of 160

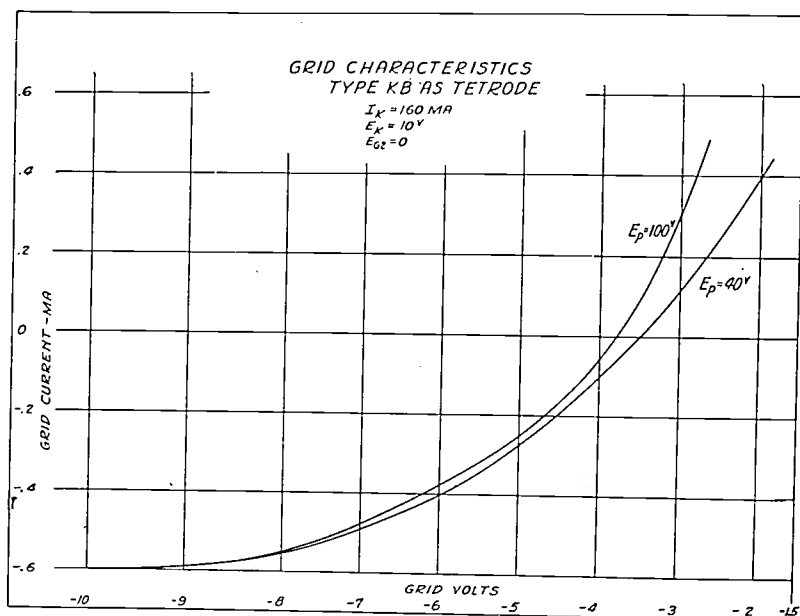

Fig. 16

milliamperes. The curve for $E_p = 200$ volts is essentially the same as for 100 volts. It is interesting to note that the grid-current change with respect to plate voltage below 100 volts is the reverse of that in the RK-100 and vacuum tubes. However, attention is called to the fact

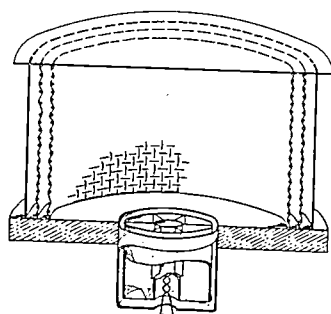

Fig. 17

that in tubes of this type the interelectrode capacities are several times those of comparable high vacuum tubes. These high capacities can be reduced considerably but for some applications especially designed circuits may be needed to realize the full possibilities of such tubes.

Fig. 17 shows how a highly efficient heat-shielded cathode may be

used in such tubes to obtain high emission limits. Such a cathode may easily be designed to give ten times the emitting area of the common type of cylindrical cathode and with no more energy consumption. The presence of the arc current between the cathode and G_1 makes it possible to locate the cathode at one end of the cylindrical structure and still obtain the full benefit of the large electron emitting area. Furthermore, the other elements are not heated as much by the cathode radiation as if it were centrally located.

The general types of tubes discussed in this paper have been used in self-excited Hartley oscillator circuits giving outputs around twenty watts with a plate voltage of 110 volts and at frequencies from 150 to four megacycles. The plate efficiency is around thirty per cent at 2.6 meters with a plate voltage of 200 volts and an output of twenty watts. At lower frequencies the efficiencies are higher; at thirty kilocycles one push-pull amplifier operating at 115 volts, class C, and giving forty watts output gave an over-all efficiency (including all arc and filament losses but no external resistor losses) of approximately seventy-five per cent. Tubes have been made which give 500 watts output on 110 volts. As high as 500 volts or so may be used on the plates, but such potentials exceed the present ratings of the tubes.



SOME ENGINEERING AND ECONOMIC ASPECTS OF RADIO BROADCAST COVERAGE*

BY

GLENN D. GILLETT AND MARCY EAGER

(Glenn D. Gillett, Inc., Washington, D. C.)

Summary—The results of a quantitative study of the major factors affecting radio broadcast coverage are given for a frequency range from 200 to 2000 kilocycles and for transmission conditions covering the range normally experienced in the United States

The effects of terrain, frequency, and antenna design in limiting the maximum nighttime service range of broadcast stations are discussed and it is shown that these limits are independent of the station power. The effect of terrain and frequency on the power required to deliver a 0.5-microvolt per meter signal at different distances is then shown in a series of curves, and the effect of atmospheric noise and interference considered.

The economic aspects of this coverage are next considered and the power per square mile required is shown and the total costs and costs per square mile are given for the same parameters as before. The economic aspects of the proper balance between transmitter and antenna costs are considered and curves given for the frequency range considered.

These studies show that it is economically unsound to attempt to cover large areas from a single station under unfavorable transmission conditions; i.e., high frequencies and high absorption. Also that for limited service areas the use of these high frequencies imposes no material hardships and that the lower frequencies should be reserved for stations of national and regional coverage while the lowest frequencies such as are now in use for broadcasting abroad are primarily suitable only for super-power stations of national coverage.

LONG experience in making field strength surveys of radio broadcast stations situated throughout the United States has sharply emphasized the desirability of undertaking a broad study to determine quantitatively the factors affecting broadcast coverage and their reaction on its economic aspects. In order to make the work more complete, the frequency range considered has been extended beyond the present broadcast band to include not only the low-frequency channels now in use abroad, and which have been considered for use here, but also the higher frequencies which have been suggested as offering a possible means of widening the broadcast band. The range of frequencies considered in this study comprises the band between 200 and 2000 kilocycles. The availability of the individual frequencies within this band for broadcast purposes has not been considered and the study

* Decimal classification: R270×R113.7 Original manuscript received by the Institute, March 30, 1934; revised manuscript received by the Institute, July 2, 1935. Presented before Ninth Annual Convention, Philadelphia, Pa., May 28, 1934.

has been confined to the consideration of the technical and economic aspects of the problem.

Three major factors determining the coverage of a radio broadcast station are ground conductivity, frequency, and power. The first is, of course, fixed for any given area and like the weather, while much discussed, nothing can be done about it. The second factor, frequency, must be considered not only in relation to its effect on attenuation but also in its relation to the intensity of static since we are concerned ultimately with the signal-to-noise ratio as well as the absolute signal strength received. An economic factor is interposed by the third since it costs more to radiate a given amount of power as the frequency decreases since the antenna structure for a given efficiency must be proportionately larger. Also, since the loss in efficiency may be balanced by an increase in transmitter power, the relation between transmitter cost and power output must be considered. Finally, the population density in a given area materially affects how much it is economically justifiable to spend in rendering a broadcast service to that area.

In making these studies it has been necessary to make certain fundamental assumptions in order to afford a quantitative basis of comparison. In considering the factors limiting the maximum service range of a station, it has been assumed that the limit of the daytime range was where the signal dropped to an intensity of 0.5-microvolt per meter, a value that has been generally accepted as reasonable. Since we are ultimately interested in the signal-to-noise ratio and since in the summertime the interference due to static becomes serious in most parts of the United States, we have also worked out the power required to give a constant signal-to-noise ratio for the various ground conductivities and frequencies considered. Careful investigations have shown that the intensity of this interference from static varies approximately as the inverse of the frequency. In order to get a basis of comparison it was assumed that a signal intensity of 0.5-microvolt per meter at 750 kilocycles would afford a satisfactory signal-to-noise ratio. This is in accord with the findings of the Dellinger report. The range of ground conductivity or attenuation used in these studies was based on the values determined by the engineering staff of the Federal Communications Commission to exist in the various sections of the United States as shown by their accumulated mass of transmission data. The radiating efficiency of the antenna system was assumed to be equal to that of a quarter-wave antenna with a good ground for the frequency under consideration.

In Fig. 1 there is shown the winter service range (0.5-microvolt per meter) for a radiated power of one kilowatt for a ground conductivity

range of $\sigma = 2 \times 10^{-14}$ to $\sigma = 3 \times 10^{-13}$ and a frequency range from 200 to 2000 kilocycles. It will be noted that the effect of ground conductivity is much more marked at the higher frequencies than at the low.

The power required to render a service at different distances has been computed for the range of frequencies and ground conductivities given above. The results of these studies are given in Figs. 2 and 3 which show the variations in radiated power required to serve any given distance for a number of discrete frequencies and ground conductivities for both winter and summer conditions; i.e., 0.5-microvolt meter limit and constant signal-to-noise ratio on the left and right,

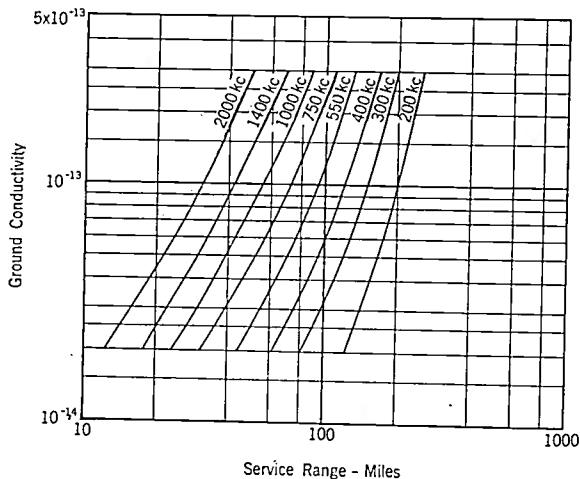

Fig. 1—Service range vs. ground conductivity and frequency for one kilowatt radiated and 0.5-microvolt per meter limit.

respectively. In the upper half of Fig. 2, the curves have been plotted for a ground conductivity of $\sigma = 3 \times 10^{-13}$ corresponding to conditions in Texas, while in the lower half the ground conductivity is $\sigma = 10^{-13}$ corresponding to conditions in Ohio and the middle west. In Fig. 3, the conductivities of $\sigma = 4 \times 10^{-14}$ and 2×10^{-14} for the top and bottom halves correspond to transmission conditions in Southeastern United States and New England, respectively.

It will be noted that the variation in coverage with frequency and terrain is tremendous. Thus in the wintertime in Texas a radiated power of but eight kilowatts on 200 kilocycles will serve a circle 1000 miles in diameter while in New England the same power on the same frequency will serve a circle but 380 miles in diameter and on 2000 kilocycles a circle only thirty-six miles in diameter. However, in the summertime when the relatively higher interference levels present on the lower frequencies tend to obscure the program, conditions are markedly different. Here the higher frequencies are more efficient for mod-

erate service ranges. In Texas the relatively low absorption does not overcome the handicap of the higher interference levels for service

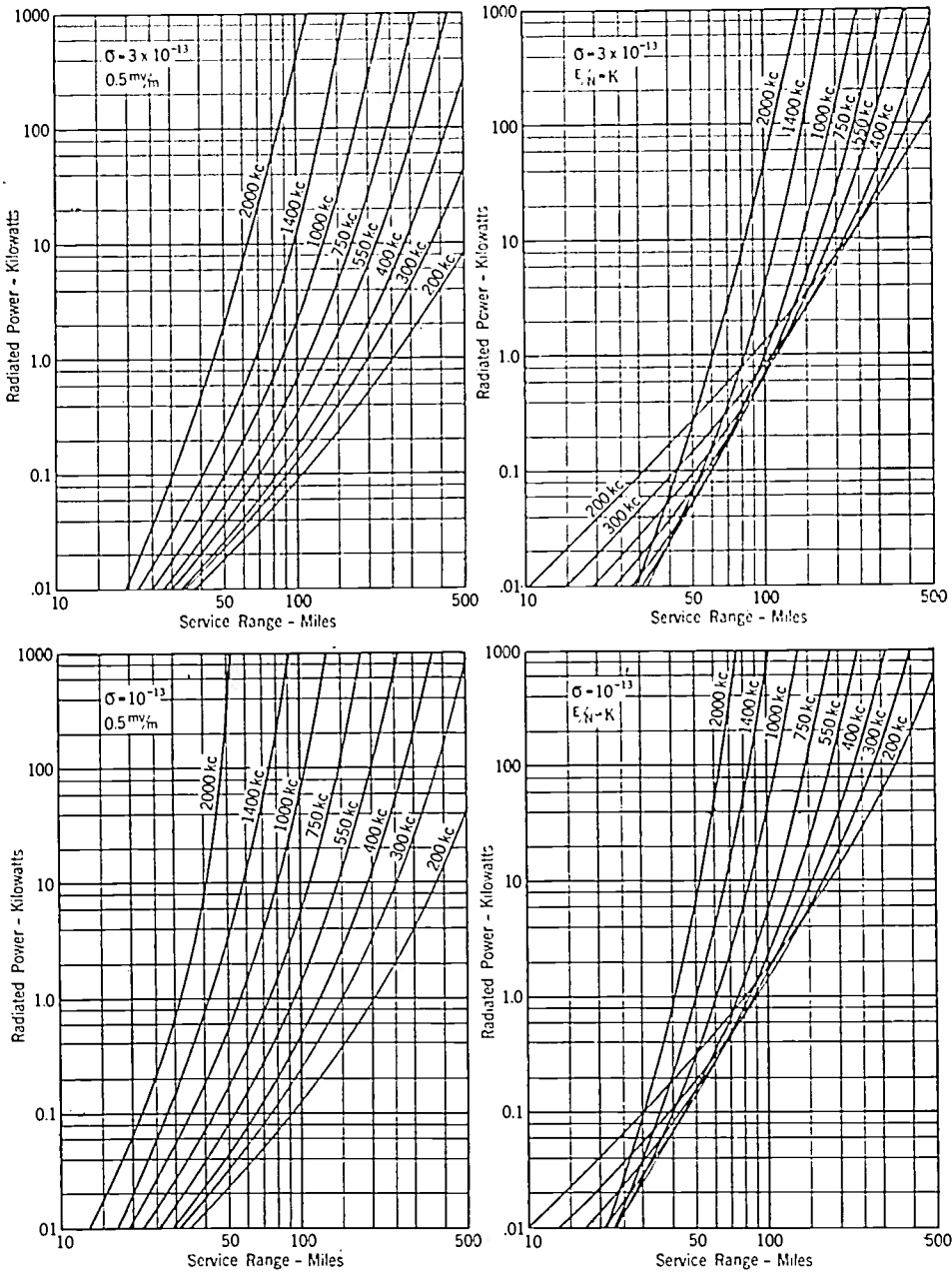

Fig. 2—Radiated power vs. service range for 0.5-microvolt per meter limit (left), and for constant signal-to-noise ratio (right) for conductivities of $\sigma = 3 \times 10^{-13}$ (Texas) and $\sigma = 10^{-13}$ (Ohio) for quarter-wave antenna.

ranges of less than about fifty miles while in New England, due to the high absorption, the higher frequencies hold their advantage only for service ranges of ten to fifteen miles. It is also interesting to note that

regardless of attenuation this advantage obtains only for stations of about a hundred watts power or less. These curves also bring out

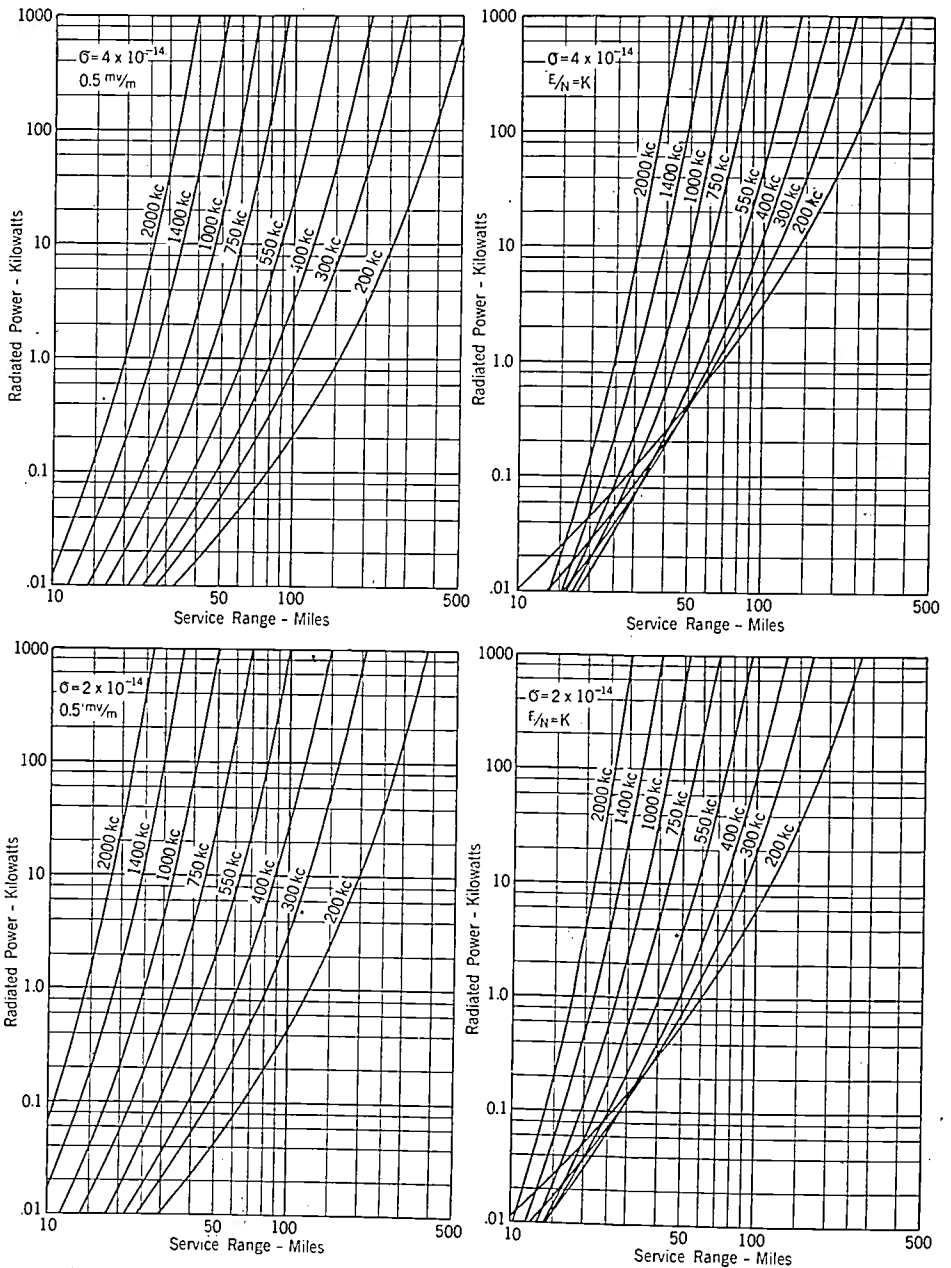

Fig. 3—Radiated power vs. service range for 0.5-microvolt per meter limit (left) and for constant signal-to-noise ratio (right) for conductivities of $\sigma = 4 \times 10^{-14}$ (Virginia) and $\sigma = 2 \times 10^{-14}$ (New England) for quarter-wave antenna.

very forcefully, particularly at the higher frequencies and in the terrains of high absorption, the fact that very small increases in service

range are obtained for relatively large increases in power. For example, doubling the power at 1000 kilocycles results in an increase in service range of 10 per cent or less.

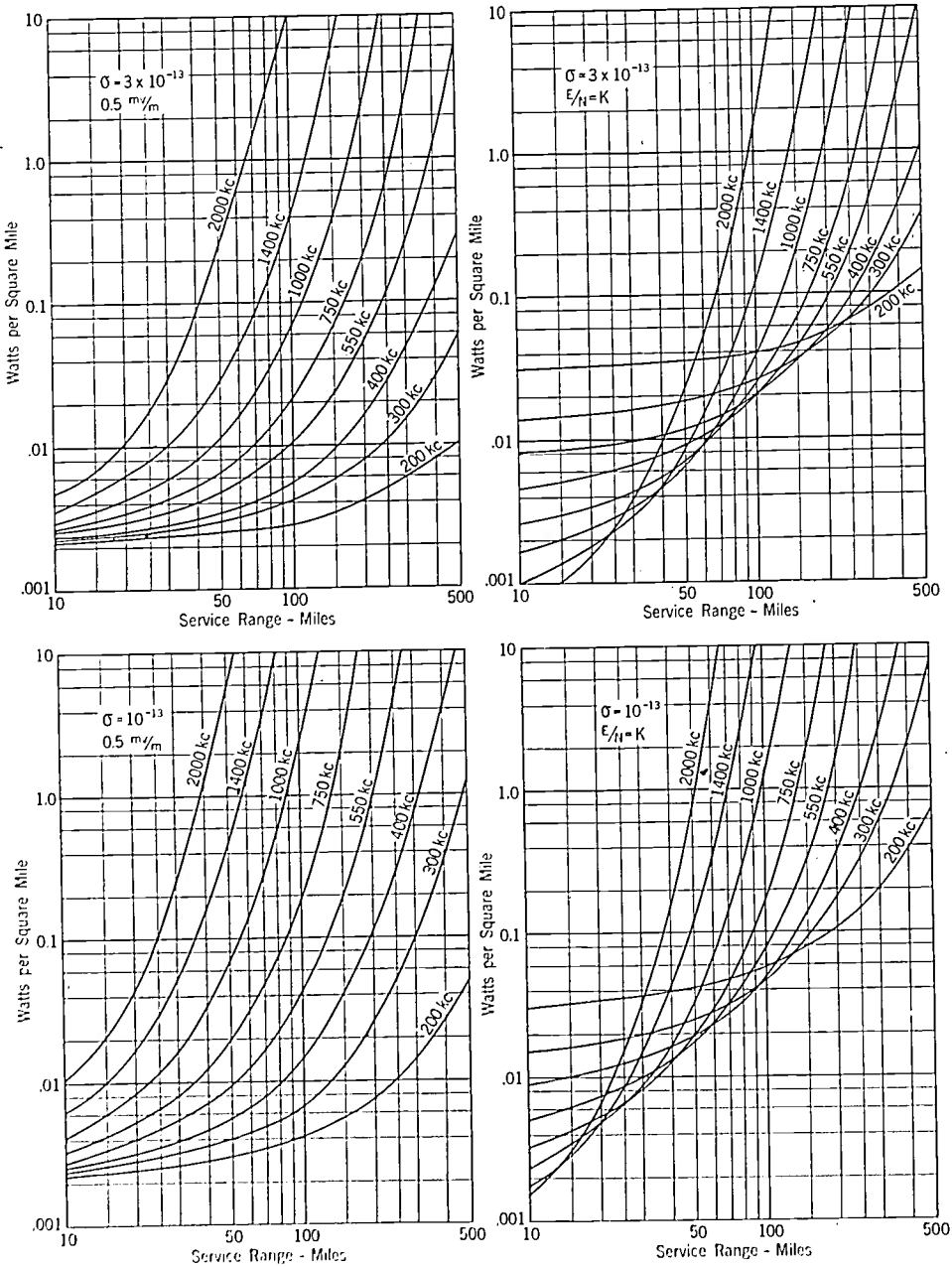

Fig. 4—Watts per square mile vs. service range for 0.5-microvolt per meter limit (left) and for constant signal-to-noise ratio (right) for conductivities of $\sigma = 3 \times 10^{-13}$ (Texas) and for $\sigma = 10^{-13}$ (Ohio) for quarter-wave antenna.

Since we are concerned not only with the total power but the power per unit area the curves in Figs. 4 and 5 were plotted to show the

variation in watts per square mile of service area for the same conditions as before. Here again it can be seen that in the winter the lower

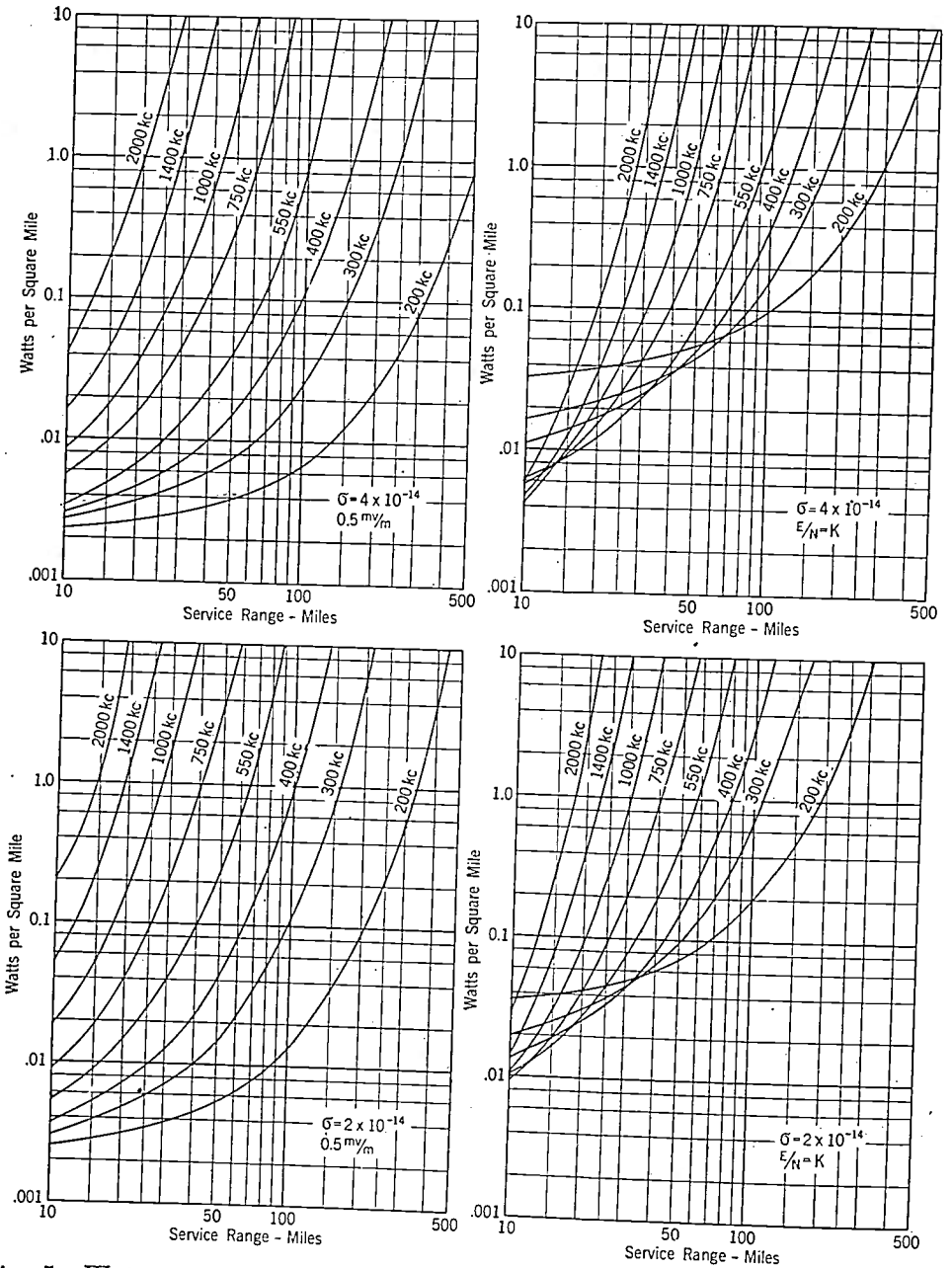

Fig. 5—Watts per square mile vs. service range for 0.5-microvolt per meter limit (left) and for constant signal-to-noise ratio for $\sigma = 4 \times 10^{-14}$ (Virginia) and $\sigma = 2 \times 10^{-14}$ (New England) for quarter-wave antenna.

frequencies always have the advantage though in the summertime for moderate ranges the conditions are reversed.

Through the kindness of Raymond Guy of the National Broadcasting Company and H. V. Akerberg of the Columbia Broadcasting System, the approximate annual operating costs of various powered stations were obtained. Using the actual costs thus obtained, the total annual operating cost for any given power was determined, and the preceding curves replotted in Figs. 6 and 7 in terms of the total annual operating cost involved for any given service range for the different

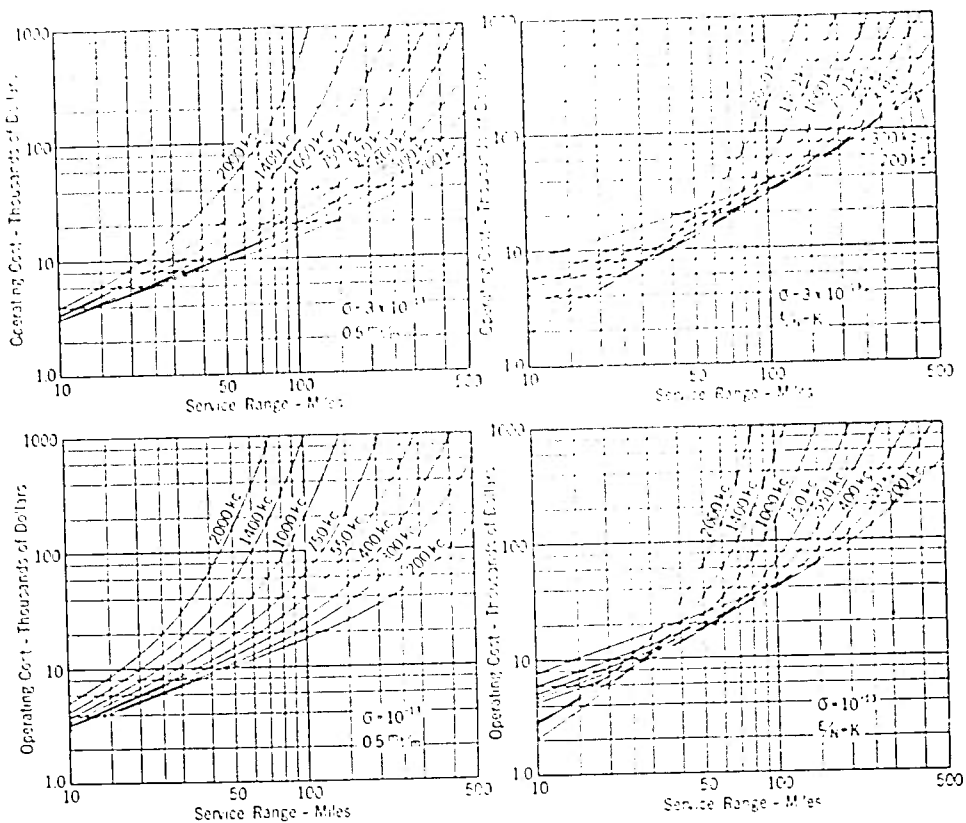

Fig. 6—Total annual operating cost vs. service range for 0.5-microvolt per meter limit (left) and constant signal-to-noise ratio (right) for conductivities of $\sigma = 3 \times 10^{-13}$ (Texas) and for $\sigma = 10^{-13}$ (Ohio) for quarter-wave antenna.

frequencies and conductivities considered before. It will be noted that in Texas in the wintertime a circle one thousand miles in diameter can be served at an operating cost of but eighty thousand dollars a year, while in the middle west the cost would be approximately a hundred and forty thousand dollars a year, in the southeast about five hundred thousand dollars, and in New England approximately two million dollars a year. Obviously the last figures approach economic absurdity, yet in the summertime the costs for the same service range on the low frequencies would be much higher. It will also be seen that for moder-

ate service ranges the higher frequencies are the most economical in the summertime.

Finally the annual cost per square mile of area served was determined for the same conditions and the results plotted in Figs. 8 and 9. Here it is emphasized that in areas of low attenuation such as Texas and Ohio the maximum economy is reached through serving large areas with high power on as low a frequency as possible, the optimum

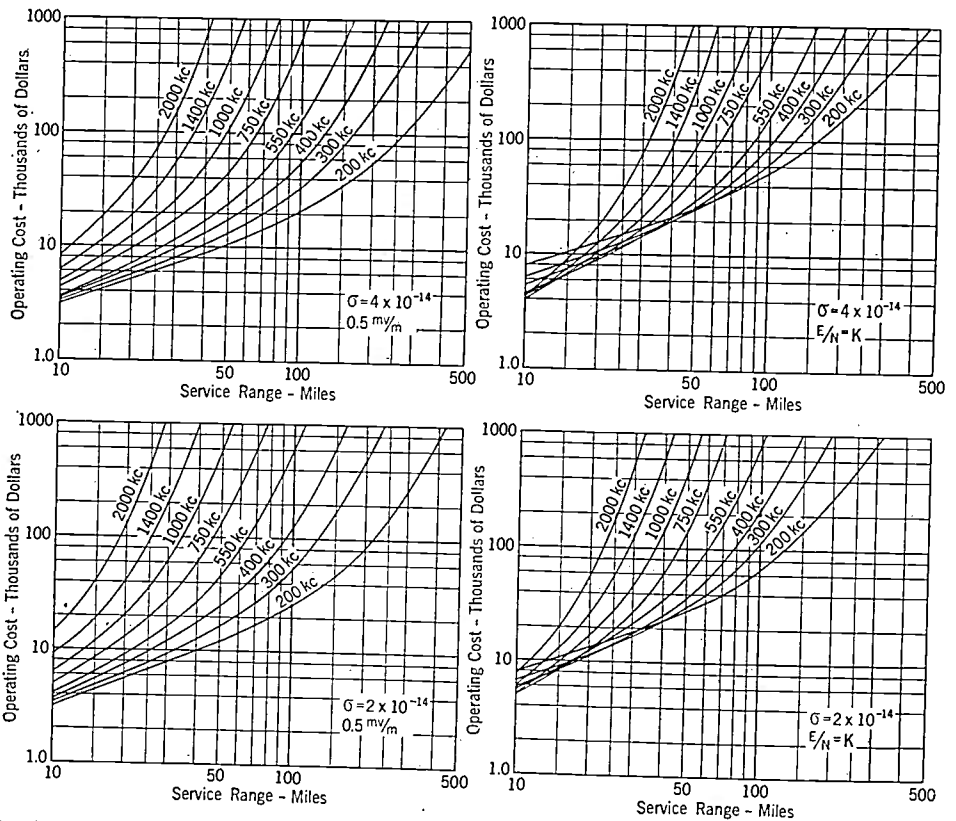

Fig. 7—Total annual operating cost vs. service range for 0.5-microvolt per meter (left) and constant signal-to-noise ratio (right) for conductivities of $\sigma = 4 \times 10^{-14}$ (Virginia) and $\sigma = 2 \times 10^{-14}$ (New England) for quarter-wave antenna.

distance for the lowest frequencies being in the order of five hundred miles or greater. Even in New England if the lowest frequencies were available it would be economically justifiable and desirable to serve areas only up to three to four hundred miles in diameter from a single station.

However on the higher frequencies in the areas of high attenuation the most economical range is both sharply defined and markedly limited so that any attempt to extend the coverage of a station beyond this limit in these areas by a mere brute force increase of power, be-

comes extremely costly and economically prohibitive before any material increase in range can be obtained.

Further it is quite important to note that for any given terrain there is, for each frequency, a definite service for optimum economy and that this is not materially different for summer and winter conditions. It is of course inevitable that the optimum service range should decrease rapidly as the absorption of the terrain increases and that

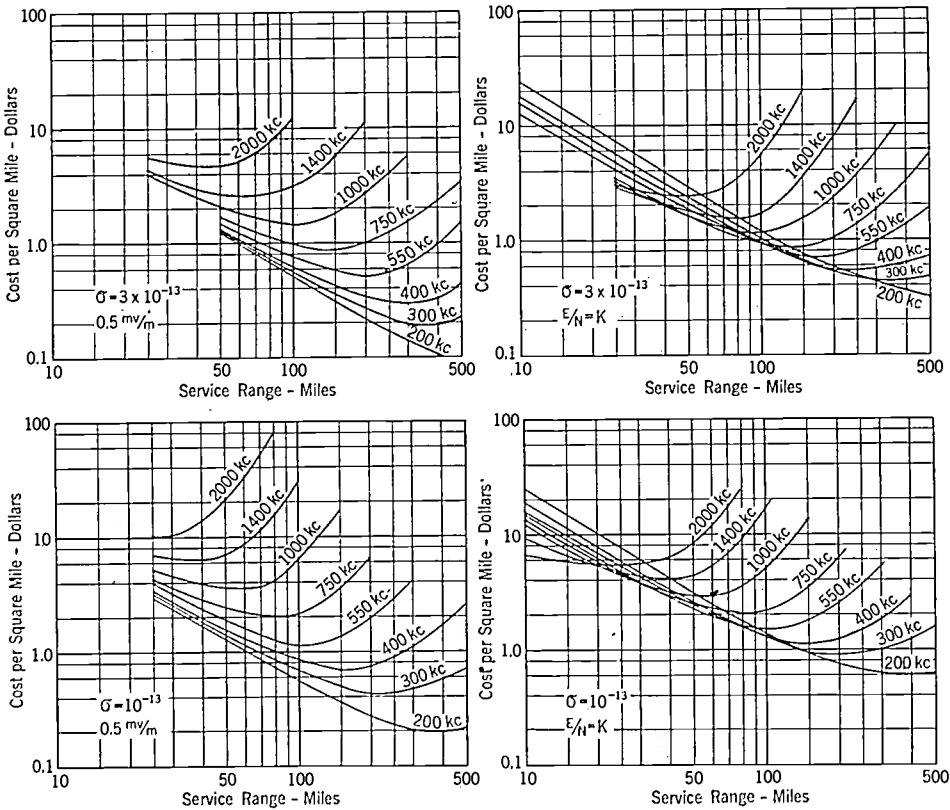

Fig. 8—Operating cost per square mile vs. service range for 0.5-microvolt per meter limit (left) and constant signal-to-noise ratio (right) for conductivities of $\sigma = 3 \times 10^{-13}$ (Texas) and $\sigma = 10^{-13}$ (Ohio) for quarter-wave antenna.

the cost per unit area should be highest in the areas of highest absorption. The absorption in transmission is essentially a matter of compound interest in which a certain percentage of the energy transmitted is absorbed per unit distance traversed. The magnitude of the amount of energy absorbed per unit distance depends directly upon the terrain and the frequency and varies between wide limits. In Texas for instance in the frequency range considered here the energy absorbed in transmission ranges from 0.4 to 8 per cent while for New England the range is from 2 to 37 per cent per mile. The problem of broadcast

distribution is essentially merely the balancing of high transportation costs against the economies accruing from volume production in larger units. Certainly no ice man faced with the fact that a third of his load would melt away for every mile traversed from the ice plant, would attempt to make any very distant deliveries, no matter how large the load with which he could start or how cheaply it could be produced, whereas if the loss per mile was but a fraction of a per cent, deliveries could economically be made over considerable distances.

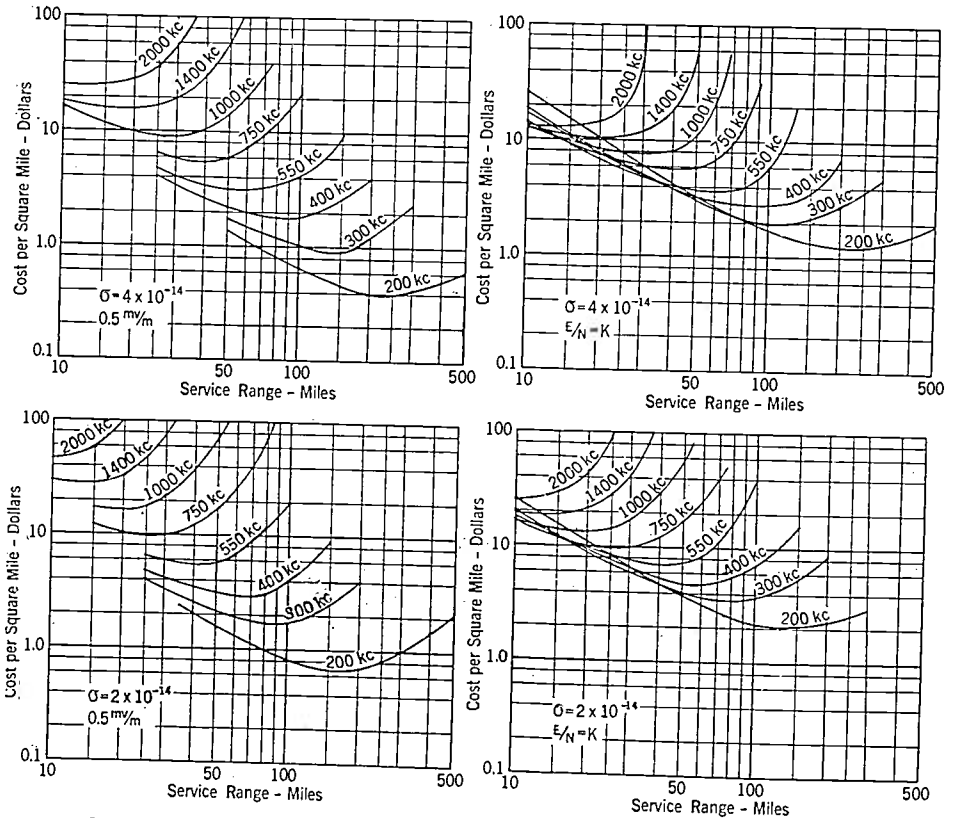

Fig. 9—Operating cost per square mile vs. service range for 0.5-microvolt per meter limit (left) and constant signal-to-noise ratio (right) for conductivities of $\sigma = 4 \times 10^{-14}$ (Virginia) and $\sigma = 2 \times 10^{-14}$ (New England) for quarter-wave antenna.

Ultimately the final economic question is the cost per capita or receiving set served but this cannot be determined without a detailed study of the specific conditions involved in each case. It is interesting to note that in general the highest attenuation areas are usually those of the highest population density and that vice versa the lowest attenuation areas such as Texas and the western plains are usually but sparsely settled. Specifically the population density in Texas is twenty-two people per square mile, while in Ohio and Massachusetts it is 163 and 528 people per square mile, respectively. Thus the cost per capita

in some cases may even be less in the high than in the lower attenuation areas and in general the cost per capita will tend to be much more nearly equal than the costs per square mile shown here. Since also the purchasing power per unit area tends to be highest in the high population density areas, the coverage in such areas may have a correspondingly high value per unit area.

From a study of these curves, it becomes clear that the use of the higher frequencies for local service is fully justified from both an engineering and economic viewpoint, though the handicap of terrain should be minimized so far as possible by the use of higher frequencies in the lower attenuation areas and the lower frequencies in the areas of highest attenuation. These curves show also that the superpowered stations for serving great areas are probably justifiable on only the lowest frequencies and that they are most beneficial in the central plains country where extreme coverage is most needed. This is fortunate since the cost of an antenna structure of maximum efficiency and service range is justifiable on the lowest frequencies only for stations of extreme power.

In all the preceding curves the costs have been computed for a station using a quarter-wave antenna. The use of a half-wave antenna will increase the radiation in the ground plane by an amount equivalent to approximately a sixty-five per cent increase in power. Since the cost of the station operation increases as about the two-fifths power of the station power for stations of the usual size, it works out that an annual expenditure of some twenty-five per cent of the total operating cost can be justified for increasing the antenna from a quarter- to a half-wave height. Thus a total capital expenditure of approximately one third the total transmitter cost may justifiably be made to secure a half-wave antenna. Since the cost of such an antenna increases approximately inversely as the square of the frequency, the use of a half-wave antenna structure for the lowest frequencies is prohibitive except for stations of extreme power. The approximate installed cost of such antennas versus frequency has been plotted in Fig. 10. Alongside the curve has also been noted the minimum frequency for which it is possible to justify economically a half-wave antenna for the power indicated. In many cases the added coverage obtained through the reduction in the nighttime fading may well justify it at even lower frequencies.

This is due to the fact that for all the high powered stations operating on individual channels as well as for many regional stations operating on shared channels without undue interference, the nighttime service range of a station is limited by fading and the concomi-

tant distortion and quality impairment of the receiving program which are caused by the interference between the ground and sky waves. It is interesting to consider the mechanism of this phenomenon.

Any simple antenna system suitable for broadcast purposes radiates energy not only in all directions about it in the ground plane but also in all directions in the vertical plane except the zenith. The distribution of the energy radiated in the vertical plane depends on the antenna conformation and the ground conditions. In the daytime nearly all of the energy radiated at an angle to the ground is absorbed in the upper atmosphere and lost except at great distances outside the scope of this study, so that in the daytime it is only the energy radiated parallel to the ground which performs any useful function; i.e., the so-called "ground wave."

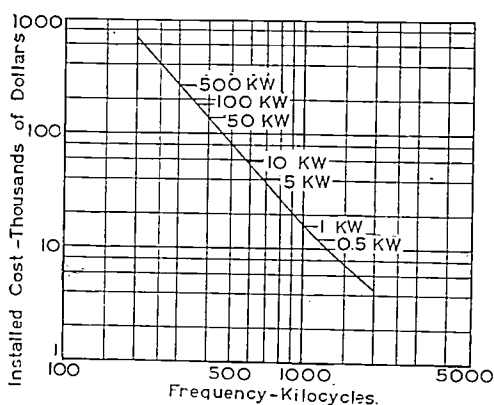

Fig. 10—Total installed cost for half-wave radiator vs. frequency. Frequencies and powers where additional cost over quarter-wave radiator can economically be justified are indicated on the curve.

At nighttime an ionized layer which forms in the upper atmosphere after sundown reflects a portion of the energy radiated at an angle to the ground and returns it to the earth's surface. The wave radiated at the higher angles is reflected back to the ground quite near the transmitter but since the intensity of the signal so radiated is usually low and the intensity of the direct signal radiated along the ground is high, the effect of the reflected sky wave adjacent to the station is not ordinarily noticeable. However, the intensity of the wave radiated at any angle increases markedly as the angle is decreased and it is returned to the ground at increasing distances from the transmitter where the intensity of the direct wave has been greatly attenuated so that the sky wave rapidly becomes more important. A point is soon reached where the sky wave approaches the ground wave in intensity and severe fading results. This is due to the fact that the reflecting

layer is unstable in height so that the length of the path traversed by the sky wave is constantly varying, hence the sky wave is continually shifting in and out of phase with the ground wave arriving at any point. The two waves add in turn to produce a loud signal and then cancel out to produce a weak signal so that the wide variations in signal intensity, known as fading, result.

Since the difference in the length of the paths traversed by the sky and ground waves is great and since each individual frequency component in the side bands differs from the others in wavelength, each component will differ in phase relative to the others and certain components will arrive in phase while other components are out of phase. This causes certain frequencies or frequency groups in the received program to appear unnaturally loud at the same time that others are eliminated, causing distortion in the received program which may be most distressing to the listener.

As the distance from the transmitter increases further, the ground wave disappears while the intensity of the sky wave radiated at relatively low angles from the antenna is still considerable. Here the rapid fading and quality impairment due to the interference between the ground and sky wave is absent and the program may be received with some satisfaction. This condition may exist over very considerable distances remote from a high power transmitter.

However the amount of energy in the sky wave fluctuates widely due to solar and terrestrial forces beyond our control and any reception involving the sky wave must be of a variable character and unreliable. It has been customary on this account to regard this secondary area served only by the sky wave as of limited commercial value and to consider the limit of the nighttime service range of a station to be where the sky wave becomes relatively strong enough to cause objectionable fading and quality impairment of the received program.

Briefly then, the daytime range is limited only by the amount of power which can be radiated in the ground plane while the maximum nighttime range is independent of the power radiated and is a function only of the ground-wave attenuation and the relative strength of the sky wave, which in turn is dependent on the antenna design.

Thus it is that the use of the half-wave vertical antenna in place of the more ordinary antenna of approximately quarter-wave form is very effective in increasing both the daytime and the nighttime service range of a station since it radiates more of the total energy in the ground plane and less at high angles so that the strength of the ground wave is increased and that of the near-by sky wave materially reduced.

In computing the sky wave, the assumptions originally promul-

gated by Eckersley¹ have been used; i.e., the sky wave is reflected with eighty per cent loss; the angle of reflection is equal to the angle of incidence; the signal strength is inversely proportional to the distance along the path traversed by the wave; the intensity of the signal induced in a simple receiving antenna is proportional to the cosine of the angle between the path of the wave and the ground; and the strength of the signal radiated at each angle is computed for the specific antenna used. The limit in the nighttime service range of a station as imposed by fading has been assumed to be where the sky wave is half as strong as the ground wave; i.e., a ratio of six decibels. Experience has shown this to be a reasonable limiting value. It is recognized that these assumptions can but represent the average conditions for a

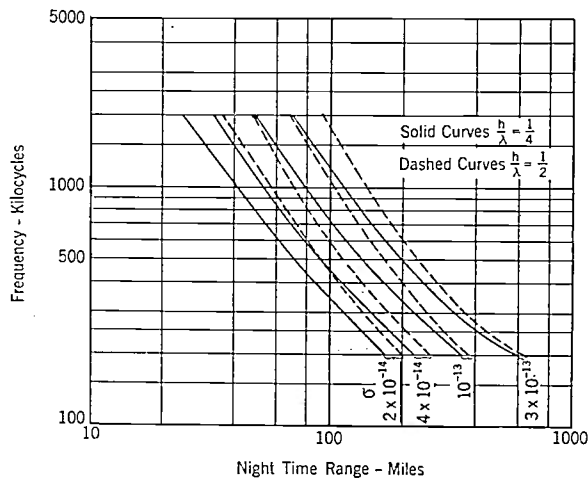

Fig. 11—Maximum nighttime fading-free range for half- and quarter-wave antennas.

phenomenon which varies over rather wide limits but they do yield results in accord with experience.

Using these assumptions the maximum fading-free range for a station using first a quarter-wave and then a half-wave antenna was computed for the various frequencies and ground conductivities considered above. Curves to show the results of this work have been plotted in Fig. 11. It will be seen that the use of the half-wave antenna is most beneficial at the higher frequencies, especially in the areas of higher attenuation. This is due to the ground wave being so rapidly attenuated that the sky wave, even though partially absorbed in reflection and traveling over a much longer path, quickly approaches the ground wave in strength. On the lower frequencies, especially in areas of low attenuation, the ground wave suffers so little attenuation that

¹ P. P. Eckersley, "The calculation of the service area of broadcast stations," Proc. I.R.E., vol. 18, pp. 1160-1193; July, (1930).

the sky wave radiated at the higher angles from the ground and but partially reflected, does not approach the ground wave in strength. It is only when the sky waves radiated at small angles approaching tangency to the ground, and hence of equal strength and traveling over paths of approximately equal length, are reflected back to the ground at very great distances that the sky wave approaches the ground wave in strength. It is natural that in such cases there should be little difference between the fading-free range for the quarter- and half-wave antennas. However within the present broadcast band and for the more usual attenuations, the improvement in the fading-free range of the station to be gained from the use of a half-wave antenna is marked. The use of the half-wave vertical radiator is probably justifiable on this basis alone for most of the present broadcast stations of any considerable power except where the limitation in the nighttime range is imposed by interference from other stations on the same channel, rather than by the fading itself.

CONCLUSIONS

These studies show that it is economically unsound to attempt to cover large areas from a single station under unfavorable transmission conditions; i.e., high frequencies in areas of high absorption. Since the cost of coverage per unit area rises so rapidly under any except the most favorable transmission conditions as the service range is increased, one is forced to the conclusion that for a great portion of the United States a broadcast service can be rendered most economically by a large number of stations of moderate power, each serving only the community and its immediate vicinity. Also for the limited service areas required for stations of but local interest and coverage, the use of these high frequencies imposes no material hardship. This is especially true when it is considered that for the low powered stations involved in such services, the actual operating costs directly proratable to power are but a small part of the total costs for studios, program production, etc. Thus it is both sound engineering and sound economics that these local stations of limited service area and interest should be placed on the highest frequencies.

The lower frequencies should be reserved for the use of higher powered stations of regional or national interest and service range. The lowest frequencies, such as are now in such successful use abroad for broadcasting, are pre-eminently suited for stations of national interest and coverage. On these frequencies only, does the coverage obtainable economically justify the large expenditures involved in the construction of such superpower stations. And on these frequencies only such stations are big enough to justify the expenditure

necessary to secure an antenna system of adequate physical dimensions to secure the radiation efficiency and pattern necessary for a rational utilization of these frequencies.

One is still left to face the problem of how best to serve adequately the rural population so unfortunate as to reside in these areas of high attenuation. Of course if the lowest frequencies become available in this country as in Europe, it should be possible to space the superpower stations so that all, even in these areas, should have access to one or two programs of high quality of national interest and scope. There still remains the problem of supplying these people with programs of but regional or local interest and, failing the ultra-low frequencies, of supplying a program of any sort with satisfactory conditions of reception. In some of these areas, the population density will be high enough so that while the cost per unit area may be extreme, the cost per capita may still be low enough to justify economically the high powered station which would be required.

For the rest of such country, there are several alternatives possible. One is to leave them dependent solely on such secondary service as may fall their way. The next is to use stations of high power which the area itself cannot justify economically but which may be easily justifiable on a social basis and which partially derive their support from subsidy. This may come either from governmental sources or through the station being a unit in a system of nation-wide service and being partially supported by the more favorably situated stations in other areas.

The success of synchronized stations properly separated geographically for the power involved, both abroad and more recently here, gives promise that therein may lie a solution for this difficulty as well as for the one of finding sufficient frequency allocations for the broadcast stations required. The use of a number of small synchronized stations should reduce the cost per square mile to a point sufficiently low to justify economically their operation. The operation of the individual units by remote or fully automatic control such as is now common use in substations of power distribution systems, might well effect sufficient economies to more than compensate for the cost of the frequency control equipment. Similarly since all would handle the same programs, the elimination of the individual station's studios, executive and program costs might well effect savings more than sufficient to support the wire-line charges for the distribution of the programs. An intermediate step may be the operation of such stations with the geographical separation sufficiently increased so that with synchronized carriers, separate programs of local scope can be broadcast in the daytime and a common program broadcast at night.

A NEW TUBE FOR USE IN SUPERHETERODYNE FREQUENCY CONVERSION SYSTEMS*

By

C. F. NESSLAGE, E. W. HEROLD, AND W. A. HARRIS
(RCA Manufacturing Company Inc., RCA Radiotron Division, Harrison, N. J.)

Summary—The major disadvantage of existing methods of frequency mixing is found in high-frequency operation with comparatively low intermediate frequencies, where serious coupling exists between oscillator and signal circuits in spite of electrostatic screening. Suppressor modulation of a radio-frequency pentode largely overcomes many of the defects but the oscillator voltage required is large and the low plate resistance limits the gain. For these reasons, a new tube has been developed (designated the 6L7) wherein the above disadvantages are largely overcome. The new tube contains five grids: the first grid is a remote cutoff signal grid, the second and fourth are screens, the third is used as the modulator grid controlled by a separate oscillator tube, and the fifth grid is a suppressor. The ideal characteristics of such a tube are derived. The actual characteristics of the tube developed are shown and a brief discussion of the results obtained is given. A discussion of the flow of electron current to a negative grid due to an unusual transit-time effect at high frequencies is given and it is shown that operation with sufficient grid bias reduces the phenomenon.

The characteristics of this tube also make it particularly suitable for use as a radio-frequency amplifier in receivers where the available automatic volume control or detector voltage is low; in this case the automatic volume control voltage is applied to both No. 1 and No. 3 grids.

Although not primarily intended for the purpose, the tube is also suitable for use in the volume expansion of recorded music. Such application provides for an effective means of emphasizing the crescendos and diminuendos of the music. A brief description of a method of accomplishing this is given.

INTRODUCTION

IN A previous discussion by one of the authors of this paper,¹ it was pointed out that with the present usual procedures for obtaining frequency mixing, considerable loss in gain at high frequencies was experienced because of space charge and other coupling between oscillator and radio-frequency signal circuits. It was also shown that suppressor modulation of a radio-frequency pentode largely overcomes these difficulties, but has the serious disadvantages of large oscillator voltage requirements and low plate resistance. It is the purpose of this paper to describe the development of a tube which overcomes these latter faults and yet retains the advantages of outer-grid modulation.

* Decimal classification: R330×R361. Original manuscript received by the Institute, August 5, 1935. Presented before Tenth Annual Convention, Detroit, Mich., July 3, 1935.

¹ W. A. Harris, "The application of superheterodyne frequency conversion systems to multirange receivers," Proc. I.R.E., vol. 23, pp. 279-294; April, (1935).

GENERAL DISCUSSION OF MIXER OPERATION

Referring to Fig. 1, it is seen that the tube consists of a cathode, an anode, and five grids having the following functions:

The first grid is the radio-frequency or control grid of the tube. It is of the remote cutoff type, thus minimizing radio-frequency distortion, cross modulation, and affording the conveniences of automatic volume control. The transconductance of this grid to the plate is made as high as possible without abnormal electrode spacings.

The purpose of the second grid is to accelerate the electrons similarly to a space-charge grid and also to provide screening between the first grid and the other electrodes of the tube.

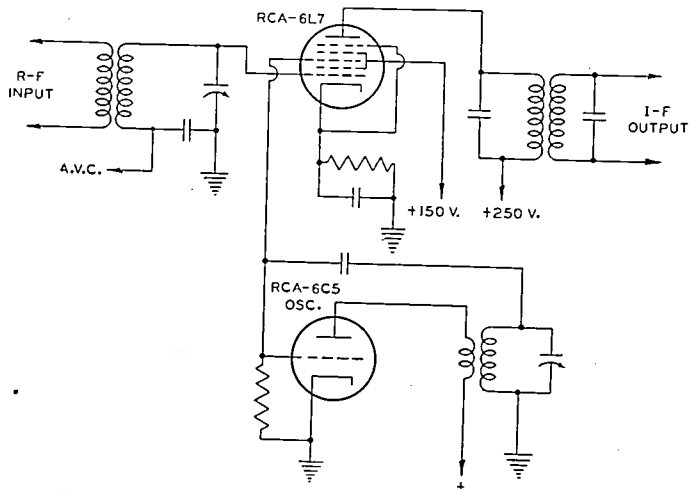

Fig. 1—Typical mixer circuit using 6L7 tube.

The third grid is modulated by the separate oscillator signal. In order to eliminate the disadvantages of large oscillator-signal requirements noted on existing pentodes, it has been made with a fairly high amplification factor.

The fourth grid is a screen internally connected to the second grid and serves as a means of securing high plate resistance to prevent the reduction in plate resistance noted in the case of the radio-frequency pentode with suppressor modulation.

The fifth grid is connected internally to the cathode and serves as a suppressor of secondary emission. This grid is included to assure high r_p and to permit operation at low plate voltages.

Since the No. 3, or modulator, grid is the most important element in overcoming the disadvantages of present pentodes in suppressor-modulation circuits, an analysis of its specific characteristics will be given at this point. To do so, it is necessary to review and analyze some converter theory.

Frequency conversion in a tube of the type considered may be regarded as a process of modulating the oscillator frequency by the signal frequency, the percentage modulation being very small in the usual case of large oscillator and small signal-frequency components in the plate current. Stated in other words, the amplitude of the oscillator-frequency component of the plate current is varied slightly at the signal frequency, one of the resulting side bands being the desired intermediate frequency. Because of the assumption that the modulation is small, high order nonlinear effects may be neglected. As is well known, the amplitude of one of these side bands is exactly one half the fractional modulation multiplied by the normal carrier amplitude (in this case the oscillator-frequency amplitude). Therefore, the intermediate-frequency component of the plate current is given by

$$I_{if} = \frac{m}{2} I_{osc}.$$

Now the change in oscillator-frequency amplitude is the product of the rate of change of this amplitude with signal voltage and the signal voltage, so that the change in oscillator-frequency amplitude is

$$\text{change in } I_{osc} = \frac{\partial I_{osc}}{\partial E_{c1}} eg_1$$

and hence the fractional change m is

$$m = \frac{1}{I_{osc}} \frac{\partial I_{osc}}{\partial E_{c1}} eg_1.$$

Thus,

$$I_{if} = \frac{1}{2} \frac{\partial I_{osc}}{\partial E_{c1}} eg_1.$$

Defining the conversion conductance as

$$s_c = \frac{I_{if}}{eg_1}$$

it is seen that

$$s_c = \frac{1}{2} \frac{\partial I_{osc}}{\partial E_{c1}}.$$

If the plate current of this tube be expanded by Fourier analysis, it can be shown that the amplitude of the oscillator-frequency component is

$$I_{osc} = \frac{1}{\pi} \int_{-\pi}^{+\pi} I_b \cos \omega t d(\omega t)$$

where ω is the angular velocity of the oscillator.

Taking the partial derivative of this with respect to the control-grid voltage, we have

$$\begin{aligned}\frac{\partial I_{\text{osc}}}{\partial E_{c_1}} &= \frac{1}{\pi} \int_{-\pi}^{+\pi} \frac{\partial I_b}{\partial E_{c_1}} \cos \omega t d(\omega t) \\ &= \frac{1}{\pi} \int_{-\pi}^{\pi} s_{m_1} \cos \omega t d(\omega t)\end{aligned}$$

where s_{m_1} is the transconductance between No. 1 grid and plate.

It is therefore seen that the conversion transconductance

$$s_c = \frac{1}{2\pi} \int_{-\pi}^{\pi} s_{m_1} \cos \omega t d(\omega t).$$

If the conversion conductance is required to be a maximum, the tube should operate only when $\cos \omega t$ is positive, that is, only when the oscillator swings from $-\pi/2$ to $\pi/2$. The s_m should be cut off during other angles because the change in sign of $\cos \omega t$ then would decrease

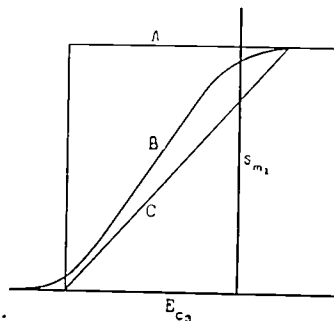

Fig. 2—First grid-to-plate transconductance as a function of third grid bias: A, ideal; B, actual; C, limiting case.

the integral. Again, during the interval $-\pi/2$ to $\pi/2$, s_{m_1} should remain at its maximum. Thus maximum conversion conductance

$$s_{c \text{ max}} = \frac{1}{2\pi} \int_{-\pi/2}^{\pi/2} s_{m \text{ max}} \cos \omega t d(\omega t) = \frac{s_{m_1 \text{ max}}}{\pi}.$$

This means that the conversion conductance of a mixer tube cannot exceed $1/\pi$ times the maximum s_m between the control grid and output element. In terms of the proposed mixer-tube parameters, it indicates that the shape of the s_{m_1} vs. E_{c_3} curve should be that of curve (A) of Fig. 2. Actually it is almost impossible to obtain a curve of this shape in a tube, but it is possible to obtain an S-shaped curve similar to (B) in the diagram. As a limiting factor, then, we may inspect the s_c in

the case where s_{m_1} varies directly with E_{c_3} as indicated in curve (C) of the same diagram. Applying the expression for s_{m_1} in this case to the above formulas for s_c , it can be shown that

$$s_c = \frac{s_{m_1 \max}}{4}$$

Assuming then that the oscillator voltage is sufficient to swing the No. 3 grid from cutoff through maximum s_{m_1} back to cutoff in the interval $-\pi/2$ to $\pi/2$, it will be found that the s_c of the tube will lie between

$$\frac{s_{m_1 \max}}{4} \text{ and } \frac{s_{m_1 \max}}{\pi}$$

it is desirable to keep this oscillator voltage requirement as low as possible, so that the No. 3 grid characteristic should have a high value of s_{m_1} at the maximum positive swing, be fairly saturated, and cut off as sharply as possible.

The tube embodying these refinements in outer-grid modulation has been designated as the 6L7. The characteristics of an average 6L7 together with typical operating conditions may briefly be tabulated:

6L7 CONVERTER OPERATION		
	$E_f = 6.3$	$I_f = 0.300$
E_{c_1}	-3	-6
$E_{c_2,4}$	100	150
E_{c_3}	-10	-15 (oscillator voltage superimposed)
E_b	250	250
Peak Osc. Volts	12	18
s_c	360 μ mhos	360 μ mhos
r_p	1 meg +	1 meg +
$I_{c_2,4}$	6.2 ma	8.3 ma
I_b	2.4 ma	3.2 ma

It will be noticed that one of the recommended screen voltages is 150 volts and is used with a normal bias of -6 volts. These values are higher than those usually employed. The reason for the choice of these voltages lies in an unusual phenomenon found at very high frequencies in the use of these tubes where a few microamperes positive grid current flows in the No. 1 grid circuit, even though this grid is biased negatively. This current was first observed by V. D. Landon of the RCA Victor Division in a typical converter circuit where 100 volts on the screen and -3 volts on the control grid were used. This effect is not to be confused with the space-charge coupling observed in pentagrid converters but is caused by forces acting on the electrons during their time of transit and may be explained as follows:

When the No. 3 grid is swinging slightly negative, part of the electrons approaching it is turned back towards the positive No. 2 grid. During their time of transit, that is, before they reach the No. 2 grid

on the way back, the No. 3 grid swings more negative. This increases the potential gradient in the No. 2 grid to No. 3 grid region, and an additional force is exerted on the returning electrons. When the frequency is high, this is sufficient to cause some of those electrons which pass through the No. 2 grid wires to overcome the retarding field near the No. 1 grid and flow through that circuit. When calculations are made on this additional imposed force on the electrons in terms of the No. 2 to No. 3 grid distance, the No. 3 grid frequency, and voltages

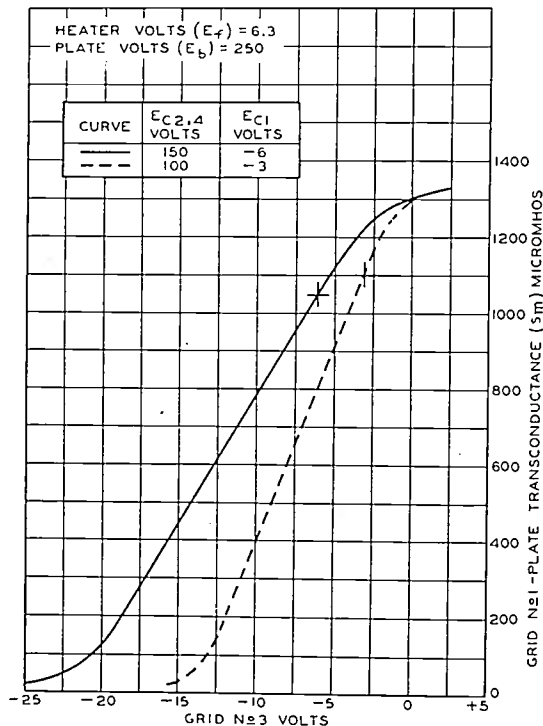

Fig. 3—First grid-to-plate transconductance characteristics for the 6L7. E_{c1} held constant.

under conditions resulting in grid current, it is found that the force imposed on the electrons during one trip is insufficient to overcome the retarding field near the No. 1 grid. It must, therefore, be assumed that the electrons make several trips through the No. 2 grid, those electrons which pass between the No. 2 grid wires picking up a small amount of energy each time until they acquire the amount necessary to enable them to reach the No. 1 grid. The additional force applied to the electrons by this effect is found to be proportional to the oscillator frequency, the transit time of the electrons, and the oscillator amplitude. Measurements at thirty megacycles using a fifteen-volt oscillator signal indicate that -6 volts bias on the No. 1 grid is sufficient to cut off the grid current. For this reason, it is recommended that for the use of the

6L7 in the short-wave bands a minimum bias of -6 volts be used on the No. 1 grid. When this bias is used, the screen voltage may be increased to 150 volts to increase the conversion gain. At still higher frequencies, grid current may be avoided by further increase in bias or by reduction of the oscillator voltage, but the screen voltage should not exceed 150 volts.

The characteristic curves of an average tube which are of importance in converter operation are the s_{m1} vs. E_{c3} curves, which determine

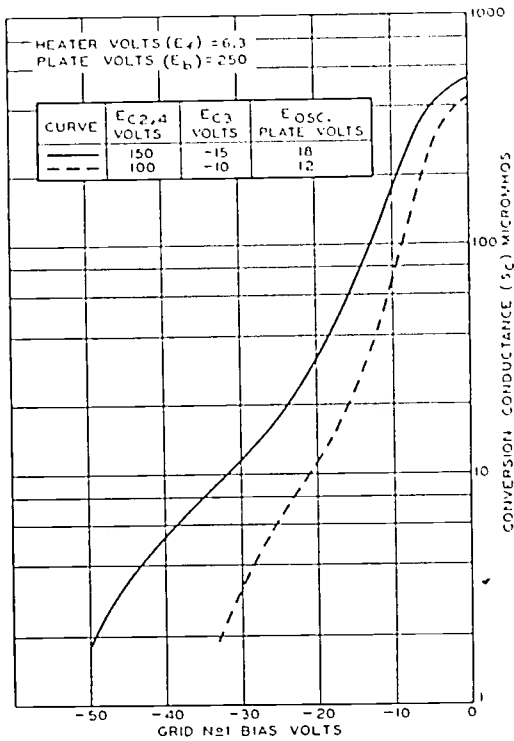

Fig. 4—Operation characteristics for type 6L7.

the s_c as outlined above, and the s_c vs. E_{c1} curve, which shows the control action and cross-modulation characteristics. The former curve is shown in Fig. 3 for a screen voltage of 150 volts and also for 100 volts. It will be observed that the latter voltage permits just as high s_c as the former (since the maximum s_m is about the same) and requires considerably less oscillator voltage. Inasmuch as the cathode current is also lower under this condition it may be advisable to use it when the upper frequency limit is twenty megacycles or less. For higher frequencies than this, enough advantage is usually obtained from the 150-volt screen operation to justify its use.

The s_c vs. E_{c1} curves of an average tube are shown in Fig. 4. This cuts off at approximately -50 for 150 volts on the screen and at -35

for 100 volts on the screen as shown. The curves are plotted semilog to illustrate the remote cutoff characteristics.

The performance of the tube with variation in oscillator voltage is shown on Fig. 5, where the s_c is plotted against E_{c_3} for various values of oscillator voltage. An inspection of the curves shows that the highest

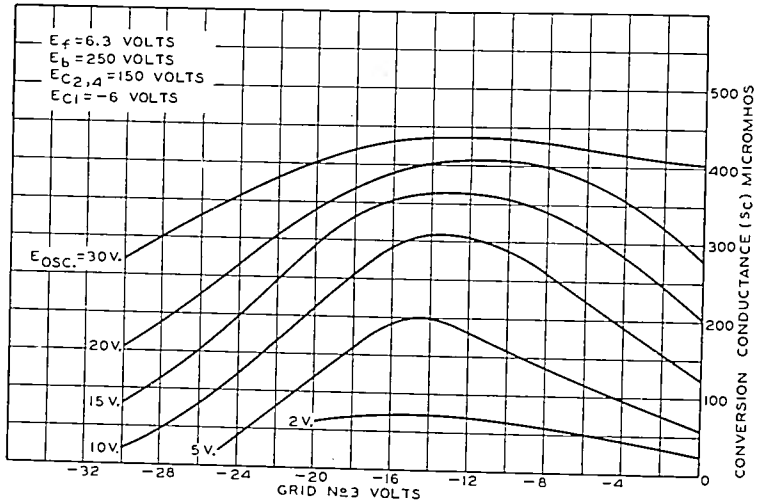

Fig. 5—Operation characteristics of type 6L7 as a mixer.

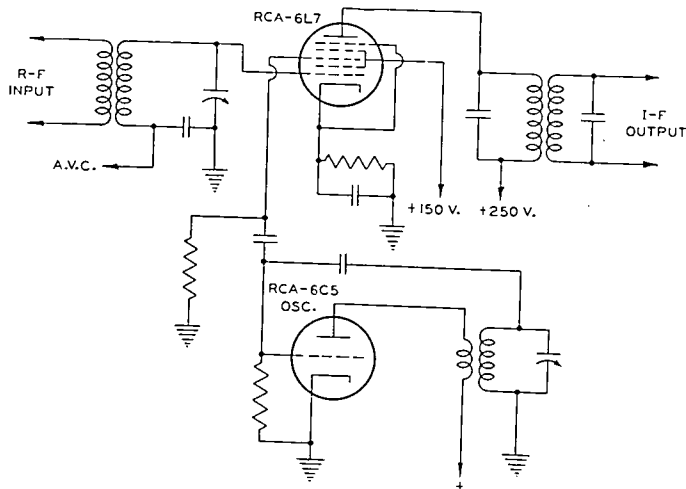

Fig. 6—Another typical mixer circuit for the type 6L7.

s_c is obtained by using a large oscillator signal. It will also be noted that for best results, the peak oscillator voltage exceeds the bias of the No. 3 grid, causing current to flow between this grid and cathode. This makes it convenient to obtain the biasing voltage E_{c_3} as the drop resulting from the flow of grid current through a grid-leak resistor. In Fig. 1, the bias is obtained by current through a grid leak common to the oscillator and 6L7 tubes. In Fig. 6, the bias is obtained by current

flowing through a separate leak for the No. 3 grid. The latter circuit permits connecting the No. 3 grid to any point in the oscillator circuit (for example, the plate) and is also helpful in reducing the effect of the No. 3 grid-to-ground capacitance of the 6L7 on the oscillator tuned circuit.

Some measured advantages² of the 6L7 over pentagrid converters in typical mixer circuits were found to be the following:

1. An increase in gain of between 5 and 8 to 1 at twenty megacycles.
2. Appreciably less required oscillator power, resulting in greater stability of the oscillator circuit.
3. Improved selectivity and increased gain in the first intermediate-frequency circuit because of the high r_p .
4. Easier alignment of tuned circuits due to less reaction between radio-frequency and oscillator components.
5. A greater range of operating frequencies. Good results have been obtained at 60 megacycles, whereas A7 type tubes will not operate well at frequencies above forty megacycles even when a separate oscillator is used. At forty megacycles, the improvement in sensitivity was measured as a 20-to-1 ratio over that of the pentagrid converter circuit.

The application of the 6L7 tube to radio receivers is not confined to converter operation alone, as the following discussion will show.

APPLICATION OF THE TUBE AS A RADIO-FREQUENCY AMPLIFIER

If a curve of s_m vs. E_{c1} is plotted for various negative potentials on the No. 3 grid, it will be noted that at more negative biases on the No. 3 grid, lower No. 1 grid-plate transconductance is obtained (Fig. 7). This phenomenon may be utilized in the circuit shown on the diagram. In this case, the tube is used as a radio-frequency amplifier with the automatic volume control voltage applied to the No. 1 grid and also to the No. 3 grid. The dotted line on the curves indicates the cutoff characteristic of s_m vs. automatic volume control voltage. It will be seen that, for a given automatic volume control voltage, a wide control of gain can be effected. This connection is particularly useful in midset sets where the voltage at the detector is limited, and affords a means of securing sharper automatic volume control action than is now possible with existing pentodes in these sets. Since the signal swings over the solid curves and operating points are determined by their intersections with the dotted curve, the cross modulation and

² We are indebted to the RCA Victor Division for these figures.

radio-frequency distortion are approximately the same as with conventional tubes. The extremely low No. 1 grid-plate capacitance is an

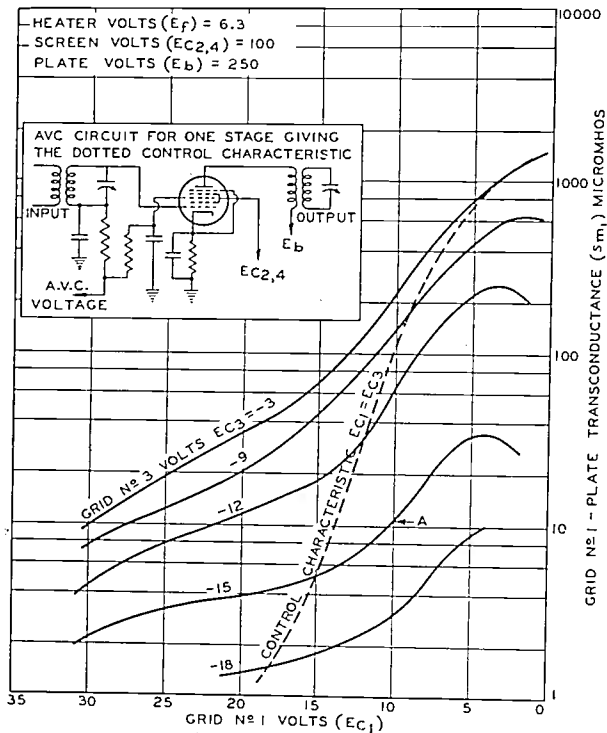

Fig. 7—First grid-to-plate transconductance characteristics of the type 6L7.

advantage in many applications. Typical operating conditions for the tube as a radio-frequency amplifier are shown below:

6L7 AS RADIO-FREQUENCY AMPLIFIER

Heater voltage	(E_f)	6.3 volts
Heater current	(I_f)	0.3 amperes
Plate voltage	(E_b)	250 max. volts
Control-grid voltage	(E_{C1})	-3 volts
Control-grid voltage	(E_{C3})	-3 volts
Screen voltage	($E_{C2,4}$)	100 volts
Transconductance	(S_m)	1100 micromhos
Plate current	(I_b)	5.3 milliamperes
Screen current	($I_{e2,4}$)	5.5 milliamperes
Plate resistance	(r_p)	0.8 megohms
Direct Interelectrode Capacitances:		
Input	8.0 μf	
Output	12.5 μf	
Grid-plate	0.0005 max. μf	

APPLICATION OF THE TUBE IN VOLUME EXPANSION CIRCUITS

Considerable interest has been shown recently in methods of compensating for the necessary contraction of volume range in practical systems for reproducing music. Although not primarily intended for the purpose, the 6L7 has been found adaptable to this application. The

simplest system for accomplishing this "volume-expansion" consists in increasing the gain of an amplifier tube in the audio system by means of a direct voltage proportional to the average level of the music.³ One method of effecting this with the 6L7 tube is to connect the signal to the No. 1 grid and to apply the volume controlling voltage to the No. 3 grid; the controlling voltage is obtained from a separate amplifier and diode rectifier whose input is connected to the signal (Fig. 8).

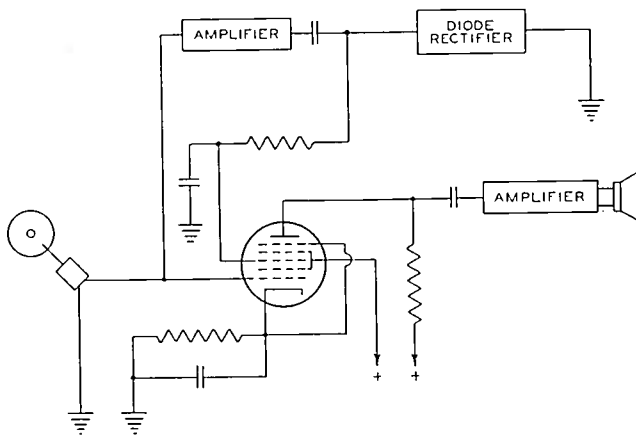

Fig. 8—Volume expander circuit.

The No. 3 grid of the 6L7 is initially biased to some low transconductance point as for example the point A on the s_m curves of Fig. 7. When the signal is applied, the diode raises the No. 3 grid potential so as to increase the gain over the zero value. The amount of increase in the gain is approximately proportional to the diode voltage and hence to the signal level.

The distortion of the audio signal by the curvature caused by the remote cutoff nature of the first grid is appreciable for large signals. The tube must therefore be used at small signal values such as are obtained from a phonograph pickup. Since the $s_{m_1} - E_{c_1}$ characteristic is nearly exponential in shape over small regions, the second harmonic distortion produced is approximately given by

$$\text{per cent 2nd} = (1/4)bE \times 100$$

where b is the slope of the s_{m_1}, E_{c_1} curve on semilog paper and E is the peak input voltage.

For the 6L7 operated at point A on Fig. 7, $\frac{1}{4}b \times 100 = 6$ so that about six per cent second harmonic per volt peak is encountered.

³ The pioneer work which led to the system described here was done by J. F. Dreyer, Jr.

CONCLUSION

The 6L7 tube provides a very efficient means of obtaining frequency mixing in superheterodyne receivers, particularly at high frequencies. The tube is also suited for use in radio-frequency amplification where a steep control characteristic may be obtained without sacrificing the advantages of remote cutoff tubes. In addition, the tube may be used in other circuits where a tube having two control grids is advantageous.

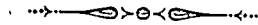

DESIGN OF AUDIO-FREQUENCY AMPLIFIER CIRCUITS USING TRANSFORMERS*

By

PAUL W. KLIPSCH

(Independent Exploration Company, Houston, Texas)

Summary—The computation of performance of a transformer at frequencies near resonance is simplified for the case in which the secondary is loaded with resistance. The information is presented in the form of a family of curves in which the generator and load resistances are the dependent and independent variables. The parameter, or third variable, held constant for a given curve, is the ratio of gain at resonance to the gain at some frequency at which resonance effects do not enter. It is referred to as the "resonance gain" and is expressed in decibels rise at resonance. Here the reference level of zero decibels is taken as either the gain at zero frequency for the equivalent circuit, which acts as a low-pass filter, or at infinite frequency for the case of a high-pass equivalent.

Frequency response curves are given to illustrate the use of the design charts and to show the effect of varying the ratio of load to generator resistance, keeping the gain parameter constant. A typical curve showing the effect of the ratio of load-to-generator resistance on the phase angle is also shown.

Use of the charts for design purposes is explained and numerical examples given.

INTRODUCTION

VARIOUS analyses are available for computing the performance near resonance of audio-frequency transformers in customary circuits,¹ but the case wherein the secondary is loaded with a resistor has apparently not been treated at length. It is the purpose of this paper to make available design data for transformer circuits with resistive loads, whereby the choice of value of the load resistance can be made so as to produce any desired frequency response curve.

ANALYSIS

The equivalent circuit of a transformer, used in a circuit with dissipative generator and load impedances, is shown in Fig. 1. R_1 is the equivalent generator resistance, consisting of the plate resistance of the driving tube, R_p , or the equivalent generator resistance, R_{gen} , and the transformer resistance in series. The transformer resistance is that which would be measured at the primary on an impedance bridge with the secondary short-circuited, or the sum of the primary winding

* Decimal classification: R363.2×R382.1. Original manuscript received by the Institute, March 6, 1935; revised manuscript received by the Institute, April 1, 1935.

¹ See for example, F. E. Terman, "Radio Engineering," McGraw-Hill, (1932).

resistance and the product of the impedance ratio with the secondary winding resistance. L is the leakage inductance of the transformer, which can be found at the same time as the transformer resistance if the latter is measured on an impedance bridge. C is the effective capacitance across the secondary winding, consisting of the self-capacitance of the winding, any stray capacitance, and the input capacitance of the stage into which the transformer works. It is not necessary to know the actual value of C since the resonant frequency is the only function of C that will be used in the final equations. The resonant frequency can be found by a frequency response test with R_1 as small as possible and R_2 infinite. R_2 is an externally connected load used to modify

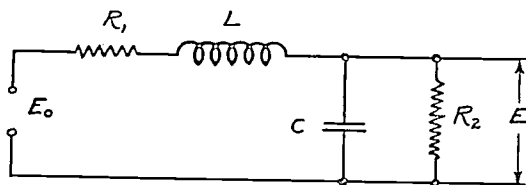

Fig. 1—Equivalent circuit of transformer coupled amplifier, valid for frequencies near high-frequency cutoff.

the frequency response. R_1 , L , C , and R_2 must all be referred to the same side of the transformer. The output voltage, E , and the equivalent generator voltage, E_0 , must also be referred to the same side of the transformer as that on which the constants are taken.

This equivalent circuit assumes that the capacitance between primary and secondary is negligible, a condition which is realized when an electrostatic shield is used between the two windings; the equivalent circuit under this condition is quite valid up to a frequency considerably above that of series resonance. Even when the interwinding capacitance is not negligible, experiments show that the use of an analysis based on this equivalent circuit can be made to yield approximately correct results.

The equivalent circuit is easily solved for its frequency response characteristic, given the various circuit constants. One method of solution would be to regard the circuit as a half-section filter terminated mid-shunt at the receiver and mid-series at the generator.² The solution by ordinary circuit analysis is simpler in this case and results in the following equations:

Let,

E = output voltage

E_0 = equivalent generator voltage

² T. E. Shea, "Transmission Networks and Wave Filters," D. Van Nostrand Co., (1929).

$$\omega = 2\pi f, \omega_0 = 2\pi f_0$$

f = frequency

f_0 = frequency at resonance, being defined as the frequency at which the inductive and capacitive reactances are numerically equal.

Then,

$$|X_0| = \omega_0 L = \frac{1}{\omega_0 C}$$

$$\frac{E}{E_0} = \frac{1}{1 + \frac{R_1}{R_2} - \omega^2 LC + j\omega \left(R_1 C + \frac{L}{R_2} \right)} \quad (1)$$

At zero frequency, (1) reduces to

$$\left(\frac{E}{E_0} \right)_{\omega=0} = \frac{1}{1 + \frac{R_1}{R_2}} \quad (2)$$

The ratio of output voltage at frequency f to the output at zero frequency will be called the gain of the circuit, G . Now by writing $\omega_0^2 = 1/LC$ and using reactance at resonance in place of terms containing L and C , and substituting f/f_0 for ω/ω_0

$$G = \frac{1 + \frac{R_1}{R_2}}{1 + \frac{R_1}{R_2} - \left(\frac{f}{f_0} \right)^2 + j \frac{f}{f_0} \left(\frac{R_1}{|X_0|} + \frac{|X_0|}{R_2} \right)} \quad (3)$$

At resonance, $f = f_0$ so that

$$G_0 = \frac{1 + \frac{R_1}{R_2}}{\frac{R_1}{R_2} + j \left(\frac{R_1}{|X_0|} + \frac{|X_0|}{R_2} \right)} \quad (4)$$

These equations are complete or vector equations from which both the absolute value and vector angle can be found.

An attempt to find values of R_1 and R_2 which will give a desired response at resonance involves a laborious cut-and-try method. To facilitate finding these values, a set of curves is offered, Fig. 2, which gives solutions, for the absolute value only, of (4), from which pairs of values of $R_1/|X_0|$ and $R_2/|X_0|$ may be found which will give a speci-

fied resonance gain. The resonance gain, G_0 , marked on the curves, is given in decibels instead of the actual ratio of (4), the relation being

$$N_{\text{db}} = 20 \log_{10} |G_0| \quad (5)$$

where,

$$|G_0| = \text{the numerical value of } G_0.$$

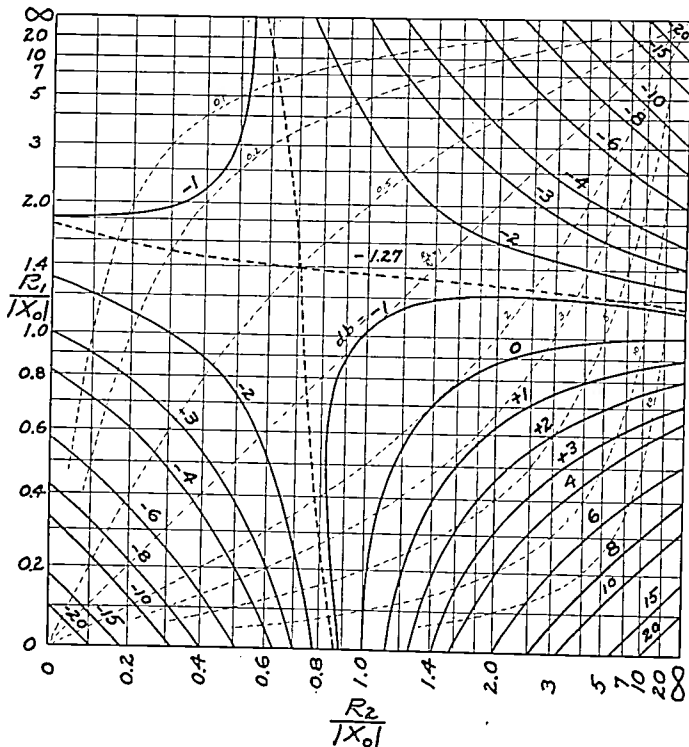

Fig. 2—Graphical solution of (4); heavy curves, contours of constant resonance gain G_0 (in decibels); dotted curves, contours of constant R_2/R_1 .

COMPUTATION OF THE CURVES OF FIG. 2

In order to arrive at the data for plotting Fig. 2, (4) was first plotted as a family of curves using $R_1/|X_0|$ as a parameter, $R_2/|X_0|$ as the independent variable, and G_0 as the dependent variable. Values of $R_1/|X_0|$ and $R_2/|X_0|$ were then picked off along lines of constant G_0 to replot in the form of Fig. 2.

The coordinate system used in Fig. 2 is interesting in that it represents all numbers from 0 to ∞ . It is laid out according to the relation

$$n = \tan x$$

where n is the number at any point and x is the distance out to that point.

TYPICAL RESPONSE CURVES

Figs. 3 to 6 show actual response curves computed from (3). Each figure gives a pair of curves for some selected value of gain at resonance, and is intended to show how the response curves vary for differ-

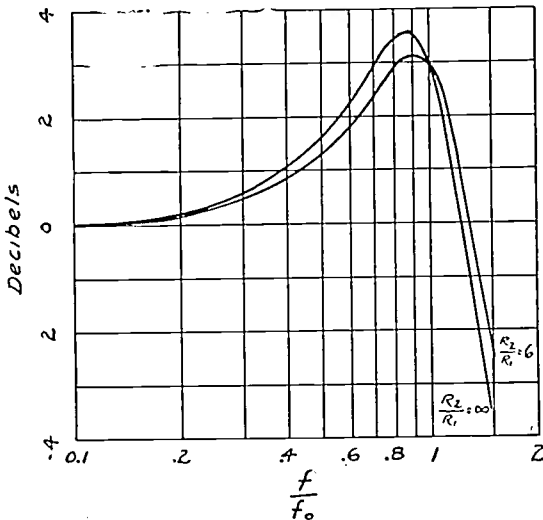

Fig. 3—Frequency resonance curve for maximum and minimum values of R_2/R_1 , resonance gain, three decibels. Any curve corresponding to any other possible values of R_2/R_1 must lie between the two curves shown, provided the resonance gain is the same.

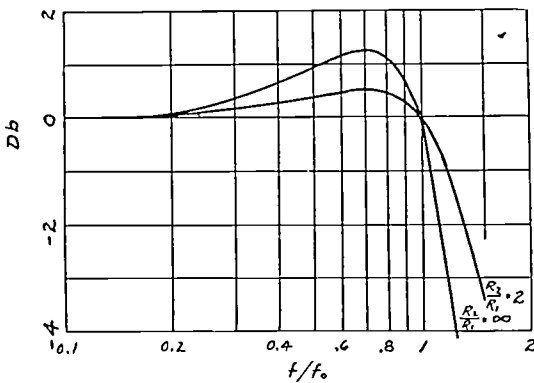

Fig. 4—Same as Fig. 3 but for resonance gain of zero decibels.

ent values of R_2/R_1 . The values of this ratio used for computing the curves shown are infinity and the minimum possible value when such a minimum exists.

In Fig. 5, the two curves are parallel, that is, the curve for $R_2/R_1 = 1$ is identical in shape to the curve for $R_2/R_1 = \infty$ but is moved over on the frequency axis by an amount which increases the apparent cutoff frequency by the factor $\sqrt{2}$. This shows that decreasing the ratio of

R_2/R_1 from the maximum to minimum increases the effective pass band by one-half octave, but of course at the expense of voltage amplification.

Fig. 7 shows how the phase angle varies with frequency for the circuit conditions corresponding to Fig. 4. The negative sign of the phase

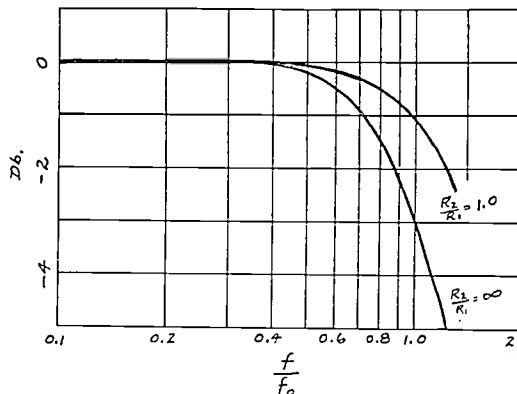

Fig. 5—Same as Fig. 3 but for resonance gain of -1 decibel for $R_2/R_1 = 1$ and -3 decibels for $R_2/R_1 = \infty$.

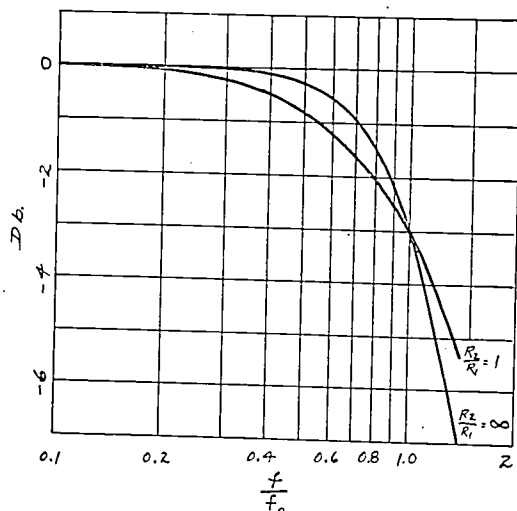

Fig. 6—Frequency response curve for resonance gain of -3 decibels for $R_2/R_1 = \infty$ and $R_2/R_1 = 1$. It should be noted that this last value is not a minimum in this case, no minimum existing for a resonance gain of less than -1.27 decibels.

angle implies that the output voltage lags the input, or that the phase angle of G is negative.

USE OF CHARTS

Fig. 2 makes possible and easy the determination of circuit constants necessary to produce a desired frequency response. With a given

transformer of known constants (leakage inductance, resonant frequency, and resistance) it is easy to choose R_1 and R_2 to give any desired response within the possible range.

For example, assume a transformer with the following constants

resistance, primary	2000 ohms
resistance, secondary	18,000 ohms
turn ratio	3:1
leakage inductance, referred to primary side	0.50 henry
resonant frequency, f_0	7500 cycles

(for the transformer leakage inductance, and all capacitances effective in producing resonance in the circuit).

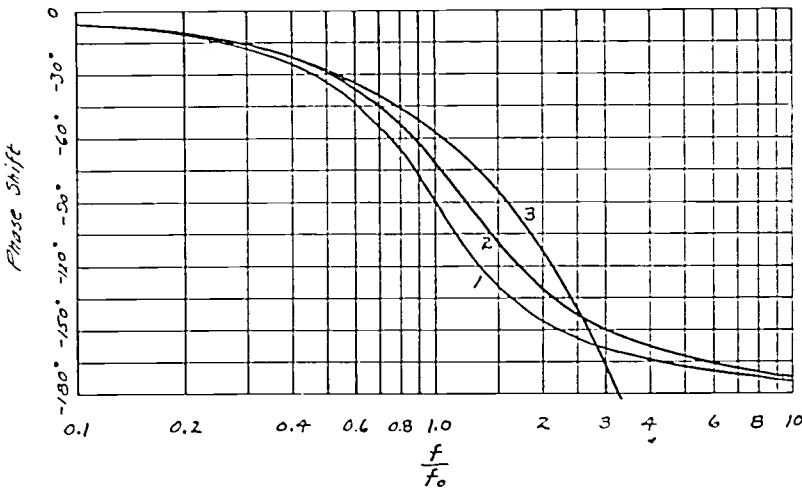

Fig. 7—Phase shift in degrees for conditions of Fig. 4.

Curve 1, $R_2/R_1 = \infty$

Curve 2, $R_2/R_1 = 2$

Curve 3, theoretically ideal phase shift for zero phase distortion where phase angle varies directly as frequency.

The part of R_1 made up by the transformer resistance is

$$2000 + \frac{18,000}{9} = 4000 \text{ ohms.}$$

At resonance, f_0 , the reactance is

$$|X_0| = 2\pi f_0 L = 23,600 \text{ ohms.}$$

Now if we want “flat” response from this transformer an examination of Fig. 5 indicates that a gain at f_0 of -1 decibel with $R_2/R_1 = 1$ will give flat response. If this value of R_2/R_1 is chosen, a glance at the chart of Fig. 2 shows that $R_1/|X_0| = R_2/|X_0| = 1$ so that

$$R_1 = R_2 = |X_0| = 23,600 \text{ ohms.}$$

The generator resistance must be

$$R_{\text{gen}} = 23,600 - 4000 = 19,600 \text{ ohms}$$

and the resistance shunting the secondary, referred to the primary, will be 23,600 ohms, or referred to the secondary, $23,600 \times 9 = 212,400$ ohms.

Or suppose, with this same transformer, that we have a driving tube whose plate resistance is known to be 9600 ohms. Then $R_1 = 9600 + 4000 = 13,600$ ohms.

$$\frac{R_1}{|X_0|} = 0.575.$$

Suppose we want a three-decibel rise in amplification at the high-frequency end to correct a corresponding loss in some other part of the circuit. It appears that a resonance gain of about 2.5 decibels will produce three decibels rise just before cutoff. The value of $R_2/|X_0|$ found from the chart for +2.5 decibels is 3.5 so that $R_2 = 3.5 \times 23,600 = 72,600$ ohms referred to the primary side, or 653,000 ohms load across the secondary. Any such solution must be checked if great accuracy is needed; the values may be put into (3) and a few points calculated just below the resonant frequency to see that the maximum value of G is near the value wanted.

Another convenient use is that of determining the change of constants necessary to vary an existing response curve by a predetermined amount. Suppose that the existing transformer and associated circuit give a rise just below resonance of five decibels as determined by test, there being no shunt on the secondary. If it is desired to flatten this response curve down to a total rise of one decibel, the chart is entered on the five-decibel contour at $R_2/|X_0| = \infty$, the line of constant $R_1/|X_0|$ is traced to the left until it intersects the zero-decibel line, at which point $R_2/|X_0|$ is read off. The choice of the zero-decibel value for the resonance gain is based on the fact that just before resonance there occurs a gain which is 0.5 to 1.5 decibels higher than the gain at resonance as shown in Fig. 4. Having found $R_2/|X_0|$, R_2 may be found by a measurement of the leakage inductance and the resonant frequency.

CASE IN WHICH THE INTERWINDING CAPACITANCE IS NOT NEGLIGIBLE

The equivalent circuit of a transformer in which an appreciable capacitance exists between windings is very complicated. A rigorous analysis of this condition has not been completed, but tests show that a reasonable approximation can be achieved by the use of Fig. 2 pro-

vided certain changes in methods of making the transformer measurements are made. The greatest inaccuracy encountered in comparing test and computed results was one decibel which occurred for values of external resistances, R_{gen} and R_2 , which are seldom met with in practice; for the usual values of resistance, the error was much less.

The value of L in Fig. 1 is usually found from a bridge measurement made at low frequency, say about 300 cycles. If this measurement is carried out at various frequencies up to 3000 cycles or higher and it is noted that L and R_7 , the leakage inductance and transformer resistance, change with frequency, it indicates that the interwinding capacitance is not negligible. In this case if the measurement is made at or as near the resonant frequency as possible and the value so found used to determine $|X_0|$ and R_1 , the charts may be used to obtain reasonably accurate results.

In making impedance measurements, it is well to remember that any interwinding or stray capacitances should be disposed in the same way in the test as in the amplifier circuit; thus if one side of the secondary, one side of the primary, and the transformer core and case are to be grounded as far as alternating-current potentials are concerned in the final amplifier, it is necessary to connect them the same way in making impedance measurements. Reversing the primary, or leaving the secondary ungrounded, has been found to change the leakage inductance as measured near cutoff by as much as twenty per cent. The measurement of the resonant frequency should be made using these same precautions. In one transformer, reversing the secondary changed the resonant frequency from 14,500 cycles to 12,500 cycles.

CASE OF FILTER TERMINATED WITH ITS CHARACTERISTIC IMPEDANCE

It was mentioned earlier that the circuit of Fig. 1 may be regarded as a half-section filter terminated mid-shunt at the receiver and mid-series at the generator end. If ideal terminal resistances are used, then

$$R_0 = \sqrt{\frac{L}{C}} = |X_0|$$

so that,

$$\frac{R_1}{|X_0|} = \frac{R_2}{|X_0|} = \frac{R_0}{|X_0|} = 1.$$

Using this relation, it is found from Fig. 2 that the resonance gain is -1.0 decibel (computation gives -0.97 decibel), and the frequency response curve is the one in Fig. 5 marked $R_2/R_1=1$. This is the re-

sponse curve which varies least within the range of pass frequencies, and represents a filter in which reflections between the section and its terminations are at a minimum.

TRANSIENT PERFORMANCE

The performance to transient excitation in the form of a "square" or "unit function" input voltage has been worked out for the half section with characteristic impedance terminations. The minimum of reflections which produces the flat frequency response curve under steady-state conditions also renders the transient response nearly non-

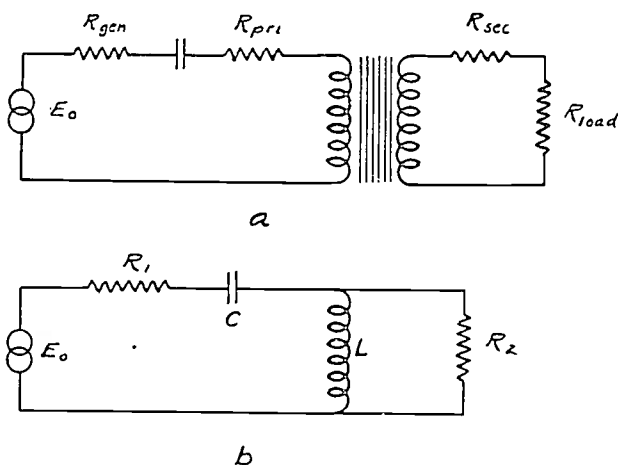

Fig. 8a—Transformer coupled stage, resonated primary to improve low-frequency response.

Fig. 8b—Circuit which for frequencies near low-frequency cutoff is equivalent to Fig. 8a.

oscillatory, the output rising to 104 per cent of its final value in an amount of time approximating one-half cycle of the cutoff frequency, then decreasing to the final value almost asymptotically. In general, it may be said that the amount of resistance necessary to give flat frequency response will give a response to transients which is nearly nonoscillatory, the steady state being closely approached in a time $t=1/2f_0$.

LOW-FREQUENCY RESPONSE

The resonated primary type of circuit which is occasionally used to improve the bass response is shown in Fig. 8a. The equivalent circuit at low frequencies is that of Fig. 8b. In this figure, L is the primary inductance which can be measured on various types of bridges and R_1 is the sum of the equivalent generator resistance and the resistance of the primary winding. R_2 is the sum of the connected load resistance and

the transformer secondary resistance. In the equations, in order to make them similar to those developed for the low-pass filter of Fig. 1, E , the output voltage, is taken as that across R_2 so that the terminal voltage is

$$E_{\text{sec}} = E \frac{R_L}{R_S + R_L}$$

$$R_S + R_L = R_2$$

R_S = transformer secondary resistance

R_L = connected load resistance.

C is an externally connected capacitor whose capacitance is selected on a basis of the lowest frequency which it is desired to transmit. This frequency may be loosely referred to as the low-frequency cutoff.

The performance of this circuit is given by the following equations, the notation being the same as for equations (1) to (4).

$$\frac{E}{E_0} = \frac{1}{1 + \frac{R_1}{R_2} - \left(\frac{f_0}{f}\right)^2 - j \frac{f_0}{f} \left(\frac{R_1}{|X_0|} + \frac{|X_0|}{R_2}\right)} \quad (6)$$

Since we want to compare the output at a given frequency with the output at some frequency at which the effects of resonance are negligible we set $f = \infty$;

$$\begin{aligned} \left(\frac{E}{E_0}\right)_{f=\infty} &= \frac{1}{1 + \frac{R_1}{R_2}} \\ G &= \frac{\frac{E}{E_0}}{\left(\frac{E}{E_0}\right)_{f=\infty}} \\ &= \frac{1 + \frac{R_1}{R_2}}{1 + \frac{R_1}{R_2} - \left(\frac{f_0}{f}\right)^2 - j \frac{f_0}{f} \left(\frac{R_1}{|X_0|} + \frac{|X_0|}{R_2}\right)} \quad (7) \end{aligned}$$

$$G_0 = \frac{1 + \frac{R_1}{R_2}}{\frac{R_1}{R_2} - j \left(\frac{R_1}{|X_0|} + \frac{|X_0|}{R_2}\right)} \quad (8)$$

The similarity of equations (7) with (3) and (8) with (4) show that the chart of Fig. 2 is applicable for low frequencies, or for the transformer acting as a high-pass filter, in the same way as for the high-frequency case where the transformer acts as a low-pass filter.

The charts may be used directly, but the sample performance curves of Figs. 3 to 7 must be reversed by substituting the reciprocals

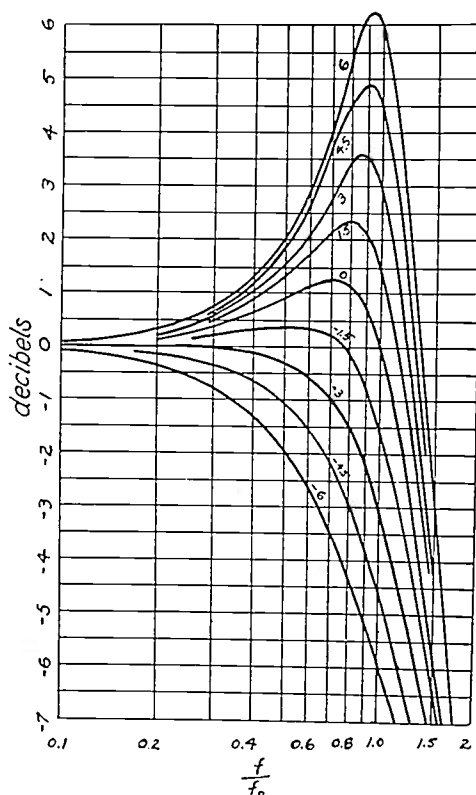

Fig. 9—Family of response curves for $R_2/R_1 = \infty$, resonance gain in decibels marked on curves.

of the frequency ratios shown. Also, the phase shift of Fig. 7 will be reversed in sign.

The constancy of the inductance with changes of direct-current saturation and alternating-current level will determine the accuracy obtainable. Usually this inductance varies so widely that the results will be only approximate, unless, of course, precautions are taken to hold the inductance constant. An air gap is useful for this purpose. It is the large air gap which is effective in determining the leakage inductance which makes the analysis very accurate for the high-frequency case.

DISCUSSION

A study of Fig. 2 reveals several interesting facts. For example, it is known that the driving tubes in an amplifier stage are subject to aging due to the change in plate resistance. As this resistance, R_p , is a part of R_1 , it is obvious that the resonance gain must change with time. But a part of any desired constant gain curve may be chosen such that considerable changes in R_1 produce only small changes in gain, the result being accomplished by proportioning R_1 and R_2 . This advantage of stability is gained at the expense of voltage amplification, but the loss in the latter may be kept down to six decibels or less.

Another interesting fact is that for every resonance gain value above -1.27 decibels there is a definite minimum value of R_2/R_1 .

The resonance gain in a simple circuit (Fig. 1 when $R_2 = \infty$) is numerically equal to Q_0 , or the ratio of resistance to reactance at resonance. Thus,

$$|G_0| = Q_0.$$

Figure 9 shows a family of frequency response curves for different values of resonance gain marked (in decibels) on the curves. Fig. 2 can thus be used to determine the Q at resonance when $R_2 = \infty$. One may consider that an equivalent Q_0 exists when R_2 is finite.

For the conditions of Fig. 9, where $R_2 = \infty$, the maximum amplification, if such a maximum exists ($G_0 > \sqrt{0.5}$ or -3 decibels), occurs at a frequency

$$f_m = f_0 \sqrt{1 - \frac{1}{2Q_0^2}}. \quad (9)$$

This equation bears a marked resemblance to the equation for the natural period of oscillation resulting from a transient impulse. This natural period is determined by

$$\begin{aligned} \omega_n = 2\pi f_n &= \sqrt{\frac{1}{LC} - \frac{R_1^2}{4L^2}} \\ &= \omega_0 \sqrt{1 - \frac{1}{4Q_0^2}} \end{aligned} \quad (10)$$

or,

$$f_n = f_0 \sqrt{1 - \frac{1}{4Q_0^2}}. \quad (10b)$$

Q ordinarily is considered a property of a coil or condenser alone. In this analysis it is seen to be useful as applied to the whole circuit. It

determines not only the steady-state response but the transient performance as well, in the one case determining the amount of resonance gain and in the other the persistence of oscillation after application of a transient impulse. In view of these important properties, it is proposed to name the parameter Q_0 the "persistence constant."³

ACKNOWLEDGMENT

The writer wishes to express his gratitude to Dr. F. E. Terman for the use of the laboratory facilities at Stanford University where this analysis was checked against measured performance.

³ A. B. Wood, "A Textbook of Sound," Macmillan Co., 1930, p. 160, uses the term "persistence." In the notation involving Q , his definition reduces to persistence = Q_0/π .

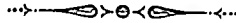

AN EXPERIMENTAL STUDY OF PARASITIC WIRE REFLECTORS ON 2.5 METERS*

BY

A. WHEELER NAGY

(Polytechnic Institute of Brooklyn, Brooklyn, New York)

Summary—This paper presents the results of an experimental investigation of the energy distribution in a horizontal plane due to the juxtaposition of a vertical antenna and parallel parasitic rod-shaped conductors. The reduction of spurious radiation to a minimum, through a special arrangement of the apparatus, results in symmetry of the polar radiation patterns and makes it possible to appraise accurately the dependency of the forward radiation, directivity, and backward radiation on the dimensions of the reflector system. Typical polar distributions of single, double, trigonal, trapezoidal, plane, and parabolic arrays are shown. The distance between antenna and reflector for optimum forward effect, for plane and other multiple-wire arrays, was found to depend, in general, on the number, length, and spacing of the reflector elements. The parabolic reflector is considered in greater detail and, while most of the results are seen to be in qualitative agreement with experiments reported abroad, it is evident that the aperture of a grid reflector is not always a consistent "figure of merit" of its performance. The results of the parabolic arrays are used, finally, to discuss a theoretical formula derived by Ollendorff.

1. INTRODUCTION

AMONG the various arrangements of multiple antennas employed in directional transmission, one may differentiate two systems: (1) the electrically coupled or directly excited system; (2) the radiation coupled or parasitically excited system. In the former all the wires comprising the transmitting array are physically interconnected by transmission lines, permitting direct control, thereby, over the phases and magnitudes of the currents in the radiators. In the latter, a secondary array (reflector wire or wires, metallic sheets, etc.) derives its energy through induction and radiation from a primary array (main antenna or antennas) excited directly by the high-frequency source. The phases and intensities of the induced currents in all the wires are determined, therefore, by the relative dispositions of the wires.

Both here and abroad, the directional characteristics of the electrically coupled system have been the subject of many investigations and the conclusions have been applied with success to commercial projects in short-wave transmission.¹

* Decimal classification: R325. Original manuscript received by the Institute, March 4, 1935; revised manuscript received by the Institute, May 20, 1935.

¹ Southworth, Proc. I.R.E., vol. 18, pp. 1502-1536; September, (1930), gives an extensive bibliography on the subject (parasitic systems included) up to 1930; Oehmann and Rein, *Hochfrequenz. und Elektroakustik*, vol. 42, July and August, (1933), discuss and list a bibliography of over 100 references.

Historically, the parasitic reflector was first employed by Hertz² (1885–1889) and about ten years later, by Marconi.³ In 1923, Dunmore and Engel⁴ reported some experiments with parabolic grid reflectors on a wavelength of ten meters, followed by Jones⁵ who worked with similar reflectors on three meters. More recently, the characteristics of solid metal and grid reflectors have been investigated by Gresky⁶ (298 centimeters), Köhler⁷ (16.8 centimeters), and Beauvais⁸ (15 to 17 centimeters), among others. Both Yagi⁹ and Uda¹⁰ obtained improved beam characteristics with the so-called “wave directors” used in conjunction with the reflector wires.

Although much of the work reported with this type of reflector seems to have been initiated from purely academic considerations, the trend toward directive communication with the ultra-short waves indicates favorably the use of radiation coupled reflector systems. The commercial possibilities of parasitic reflectors, moreover, have been amply demonstrated by the experiments of Meissner and Rothe,¹¹ Marconi and Franklin.¹² Clavier¹³ (18 centimeters), Esau and Hahnemann,¹⁴ Wolff, Linder, and Braden¹⁵ (9 centimeters), Kolster¹⁶ and others.¹⁷

In the experimental determination, however, of the radiation characteristics of parasitic wire reflectors in their dependence on the reflector dimensions, some of the work thus far reported brings into question the adequacy of the precautions taken in the experimental arrangements to minimize extraneous radiation. In a test, for example, of a vertical array of wires, if the field characteristics are to be attributed solely to the antenna-reflector combination, all idle and current-carrying elements not an integral part of the radiating unit, must be placed horizontally or at a distance from the reflector great enough

² Hertz, “Electric Waves” translated by D. Jones, Macmillan, (1900).

³ Marconi, Proc. I.R.E., vol. 10, pp. 215–238; August, (1922).

⁴ Dunmore and Engel, *Bur. Stand. Sci. Paper* 469, (1923).

⁵ Jones, *QST*, May, (1925).

⁶ Gresky, *Zeit. für Hochfrequenz.*, Bd. 32, p. 149; November, (1928).

⁷ Köhler, *Hochfrequenz. und Elektroakustik*, Bd. 39, p. 207; June, (1932).

⁸ Beauvais, *L'onde Electrique*, p. 484; October, (1930).

⁹ Yagi, Proc. I.R.E., vol. 16, pp. 715–739; June, (1928).

¹⁰ Uda, Proc. I.R.E., vol. 18, pp. 1047–1063; June, (1930).

¹¹ Meissner and Rothe, Proc. I.R.E., vol. 17, pp. 35–41; January, (1929).

¹² Marconi, Proc. I.R.E., vol. 16, pp. 40–69; January, (1928), and Franklin, *Electrician* (London), January 6, (1933).

¹³ Clavier, *Elec. Communication*, July, (1931), and July, (1933).

¹⁴ Esau and Hahnemann, Proc. I.R.E., vol. 18, pp. 471–489; March, (1930).

¹⁵ Wolff, Linder, and Braden, Proc. I.R.E., vol. 23, pp. 11–23; January, (1935).

¹⁶ Kolster, Proc. I.R.E., vol. 22, pp. 1335–1353; December, (1934).

¹⁷ The RCA 68-centimeter beam circuit, connecting Riverhead, L. I., and Rocky Point, L. I. (18 miles), is particularly demonstrative of economical point-to-point communication.

to ensure no contribution to the received energy. In most cases, in the absence of these precautions, the polar distribution of radiation shows dissymmetry.

This paper, from the results of an experimental investigation of various parasitic wire reflectors used in conjunction with a vertical antenna, discusses the dependency of the forward radiation, backward and lateral radiation, and the directivity on the dimensions of the reflector systems. The experiments were carried out through the facilities of stations W2XAC-XAQ (1933) on 2.5 meters, with an arrangement designed to eliminate the undesirable effect pointed out above.

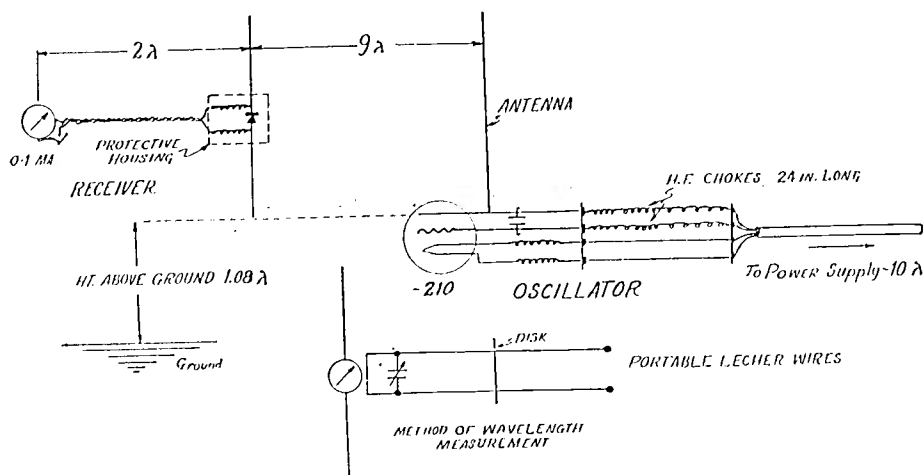

Fig. 1—Disposition of the apparatus. The portable Lecher pair permitted frequency determination at a distance of ten wavelengths from the antenna.

II. DESCRIPTION OF APPARATUS AND EXPERIMENTAL PROCEDURES

Fig. 1 and the photographs (Figs. 2 to 4) show the disposition of the entire equipment and the favorable characteristics of the environment. The terrain was uniform and flat and free from the disturbing effects of trees, underground circuits, etc. The soil was fairly moist and practically all the tests were carried out under equally favorable atmospheric conditions. The oscillator, with parallel-rod arrangement of inductance, was placed directly at the base of the main antenna in a horizontal position, and the direct-current leads were led out horizontally about ten wavelengths before dropping to the power supply. The receiver comprised a half-wave vertical rod broken at the center by a crystal detector which was housed in a suitable wrapping and box as protection against weather conditions. Following a pair of radio-frequency chokes, leads were carried horizontally from the detector to a 0-1 Weston milliammeter two wavelengths distant. The

distance between transmitting and receiving antennas was maintained constant at approximately nine wavelengths. With the main antenna removed from the oscillator, with or without the presence of the re-

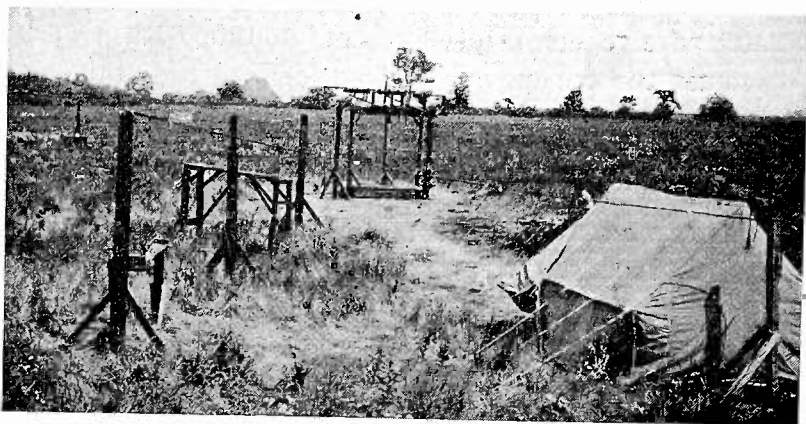

Fig. 2—General view of the field apparatus. The Lecher wires are shown in the left foreground.

flector wires, the receiver current was zero. The radiation of the antenna alone is seen, from the polar patterns, to be circular. The wooden structure at the transmitter was so designed as to permit 180 degrees

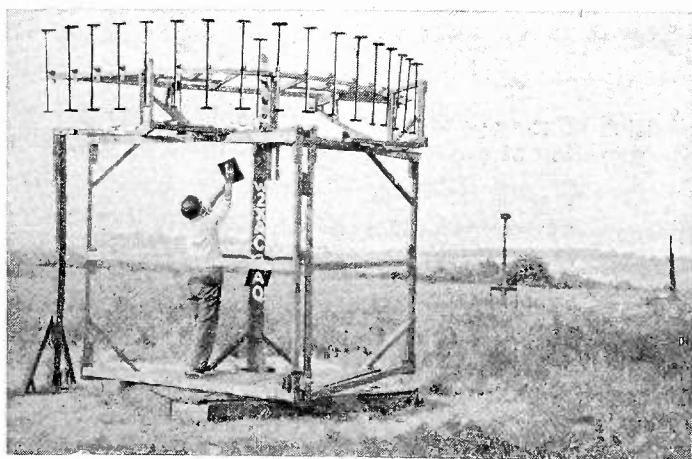

Fig. 3—Parabolic array of loaded elements. The receiver may be seen in the background on the right.

rotation, about the antenna, of any reflecting arrangements stationed behind or in line with it.

The reflector elements consisted of telescoping brass rods of 0.79 centimeter outside diameter, which, when loaded, carried one-millimeter copper disks on both ends, 12.57 centimeters in diameter. The rods were supported at the center by individual insulators and small

wood blocks which could be easily moved along the double track construction of the wood reflector forms.

The rectified receiver current from a square-law detector was recorded for reflector displacements in steps of fifteen degrees while the power input to the oscillator was kept constant by an observer. During each reading all observers retired to a distance of about ten wavelengths. Frequency was determined by the method depicted in Fig. 1. A portable Lecher pair was coupled to an antenna similar to the re-



Fig. 4—Close-up of transmitter structure showing single wire reflector. The main antenna is on the left.

ceiving unit, the entire arrangement being placed several wavelengths from the transmitting array. The distance between the two positions of the copper disk on the lines for which the current in the rod falls to zero or a minimum corresponds to one half the wavelength. The small input condenser was used to shift the current maxima in the lines in such a manner as to leave only a small length of free-line beyond the second current antinode.

III. LIST OF DEFINITIONS AND ABBREVIATIONS

The following symbols and definitions have been employed in this paper. By reference to Fig. 5 the various reflector dimensions may be appropriately identified.

- d = distance between the main antenna and the plane containing the reflector elements (wavelengths).
- S = separation of elements in plane and parabolic arrays (centimeters).
- S_1 = element antenna distance (wavelengths) see Fig. 5.
- S_2 = interelement spacing (wavelengths) see Fig. 5:
- f = focal length of parabola (wavelengths).
- a = aperture of parabolic reflectors, straight-line distance between the two outermost elements in an array (wavelengths).
- n = number of reflector elements in an array
- l = length of reflector element (centimeters)
- θ = angular displacement of reflector from the zero to 180-degree axis (degrees).
- I = rectified current in receiver for any value θ (milliamperes).
- I_0 = forward radiation, rectified receiver current for θ = zero degrees.
- μ = power amplification factor of reflector; i.e., ratio of rectified receiver current with reflector (I_0) to rectified receiver current without reflector (square-law detector).
- δ = total directivity; i.e., energy ratio of the area of a circle with radius I_0 to the area of the entire polar pattern (square-law detector).
- Δ = forward-sector directivity—ratio of the area of a semicircle with radius I_0 to the area of the polar pattern contained within the sector 270, 0, and 90 degrees.
- β = back radiation—the maximum value of receiver current in the sector 90, 180, and 270 degrees in per cent of I_0 .
- ρ = receiver current in sector 270, 0, and 90 degrees in per cent of I_0 .

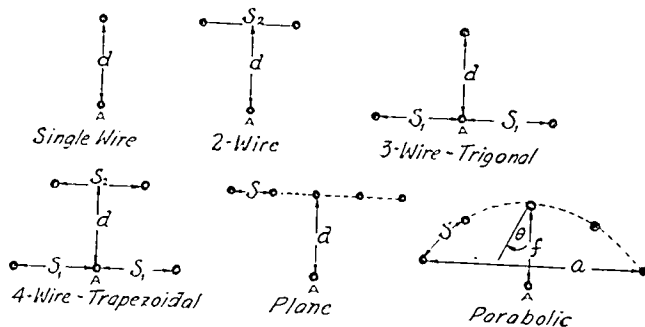

Fig. 5—Arrangement of reflector wires in parasitic arrays. A = antenna.

It will be shown later that specification of the forward sector directivity, in place of the conventional total directivity, assists in visualizing more exactly the distribution of the beam.

IV. DISCUSSION OF RESULTS

A. Miscellaneous Reflectors

In Figs. 6 to 9 are shown typical polar distributions, in a horizontal plane, of various wire arrangements. In some preliminary work on the optimum spacing of two lineal rods ($l=119$ centimeters) it was

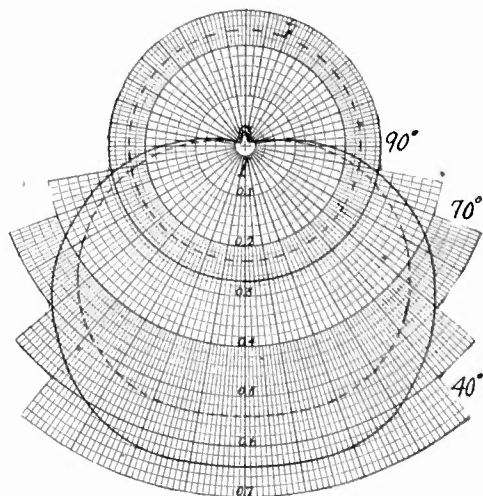

Fig. 6—Radiation diagrams of single wire reflectors with loaded elements.
 ————— $d=0.214\lambda$; $l=77$ cm
 - - - - - $d=0.234\lambda$; $l=77$ cm
 d =antenna-reflector separation; l =length of rods. Radiation of antenna (current in receiver) without reflector shown by circles.

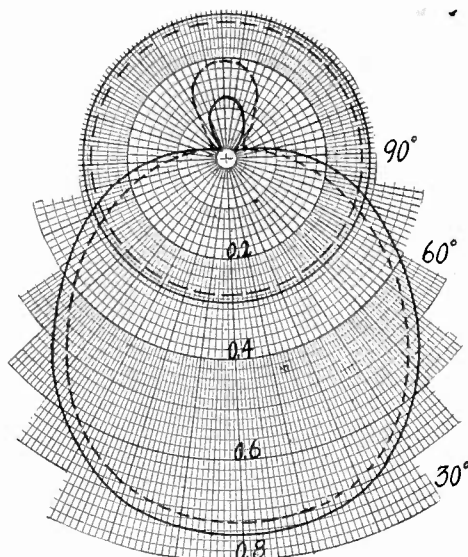

Fig. 7—Radiation patterns of two-wire reflectors.
 ————— $d=0.262\lambda$; $S_2=0.338\lambda$; $l=77$ cm (loaded)
 - - - - - $d=0.305\lambda$; $S_2=0.338\lambda$; $l=119$ cm (lineal)
 S_2 =separation between elements; I =receiver current. Circles show radiation from antenna alone.

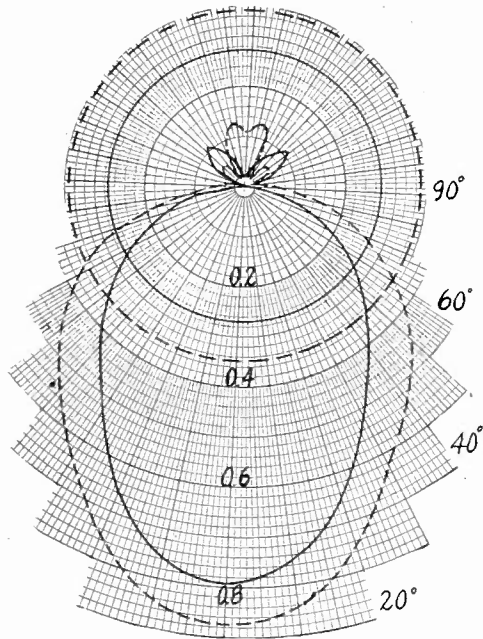

Fig. 8—Radiation patterns of three-wire (trigonal) reflectors.

—————	$d = 0.248\lambda;$	$S_1 = 0.535\lambda;$	$l = 119$ cm (lineal)
- - - - -	$d = 0.305\lambda;$	$S_1 = 0.520\lambda;$	$l = 77$ cm (loaded)
	S_1 =element antenna separation (see Fig. 5).		

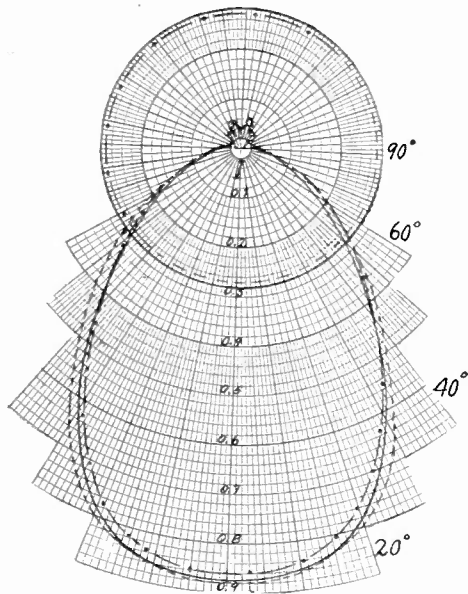

Fig. 9—Four-wire (trapezoidal) reflectors with loaded elements.

—————	$d(\lambda)$	$S_1(\lambda)$	$S_2(\lambda)$	l (cm)
- - - - -	0.262	0.52	0.339	77
-	0.264	0.52	0.244	77
—————	0.254	0.52	0.143	77

found that the energy distributions were practically of the same order for values of d ranging from 0.214λ to 0.33λ . Indeed, in many tests, as d (antenna-reflector distance) was varied in the neighborhood of optimum separation, the receiver current was found to be constant for changes in d as much as eleven centimeters ($\lambda = 250$ centimeters). This effect may be considered a "phase-amplitude equivalence" and represents a condition in which the partial destruction of the phase relations existing between the two fields necessary to establish optimum forward radiation, is compensated, as the reflector rod is brought nearer the antenna, by the stronger current induced in the reflector.

TABLE I
DEPENDENCY OF THE FIELD CHARACTERISTICS ON THE NUMBER, SEPARATION,
AND LENGTH OF ELEMENTS IN PARABOLIC ARRAYS

n	S	l	a	μ	δ	$\beta\%$
27	17.8	109	1.49	4.6	8.2	13.5
27	17.8	119	1.49	5.3	9.2	5.95
27	17.8	71*	1.49	5.6	6.9	18
27	17.8	77*	1.49	6.4	9.3	13.4
27	17.8	122*	1.49	9.7	10.7	0
27	10.2	119	0.982	4.3	6.7	10.3
27	10.2	109	0.982	4.5	7.2	19.5
19	25.4	109	1.47	4.4	7.7	17.2
19	25.4	119	1.47	4.3	7.1	8.9
17	30.5	119	1.47	6.3	10.9	2.63
17	30.5	73.6*	1.47	4.2	7.9	23.8
17	30.5	77*	1.47	3.5	6.9	19
17	15.3	73.6*	0.844	3.4	6.1	24.4
17	15.3	119	0.844	4.8	7.8	3.45
15	35.6	109	1.57	4.2	7.8	18.5
15	34.2	119	1.57	4.9	9.4	7.95
13	40.6	119	1.54	6.3	12.3	2.63
13	40.6	73.6*	1.54	3.9	7.5	25.0
13	40.6	77*	1.54	3.5	7.8	16.5
13	30.5	77*	1.25	3.3	7.2	20.5
11	40.6	119	1.34	5.8	9.8	2.86
7	81.3	119	1.53	6.3	9.6	2.63
7	81.3	73.6*	1.53	5	7.1	20
7	81.3	77*	1.53	3.7	7.8	11.4
7	81.3	119*	1.53	5.6	11.3	6.1
5	81.3	119	1.07	5.4	8.6	3.0
5	81.3	73.6*	1.07	4.5	6.2	12.2
5	81.3	77*	1.07	3.3	6.8	10
5	81.3	119*	1.07	4.6	9.4	10.9

* Loaded elements.

When two rods were introduced behind the antenna the value of d remained sensibly at 0.26λ as the separation of the elements was varied from 0.338λ to 0.092λ , the greater receiver currents obtaining, however, for the larger separations. It should be noted here that the value of d was separately maximized for each arrangement of the reflector array before the radiation pattern was determined; i.e., with any change in l , n , or S_2 , that value of d was determined which gave maximum forward effect.¹⁸

Fig. 9 shows the radiation patterns for a trapezoidal array of elements. The superiority of these reflectors over the plane reflectors used here may be due to the quasi-parabolic arrangement of the four wires in the former.

B. Plane Reflectors

The plane reflector diagrams obtained in these tests, of which Fig. 10 is typical, show the manner in which the number, spacing, and length of reflector rods affect the value of optimum d . The superiority of the 3- and 5-wire reflectors may be attributed to the relatively

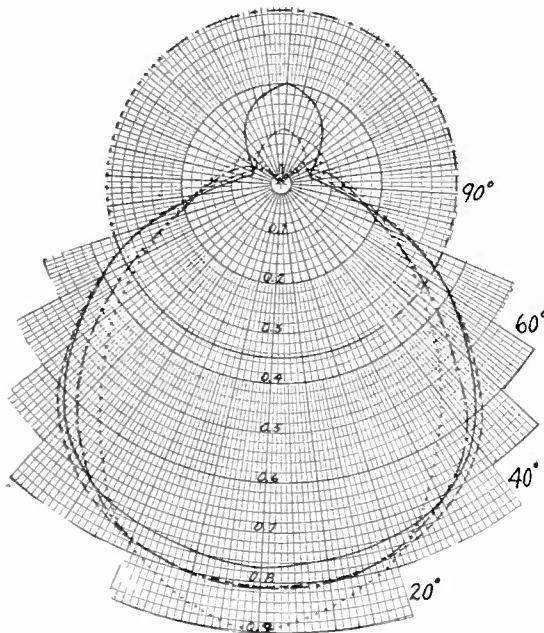

Fig. 10—Radiation patterns for plane arrays of reflector elements.

	n	S (cm)	$d(\lambda)$	l (cm)
—————	17	24.7	0.264	81.3
- - - - -	9	49.4	0.244	81.3
.....	5	96.5	0.204	81.3
.....	3	96.5	0.183	81.3

n = number of elements; S = element separation.

smaller mutual (loading) effects of the wires, in virtue of the larger values of S . The rods, for the larger separations, are permitted greater freedom to oscillate at resonant frequency with, consequently, more favorable effects. By proper selection of the wire length, the patterns may be considerably improved with closer spacing of a greater number of elements.⁶ It is evident from those curves and others which have

¹⁸ The separation for minimum backward radiation is not, in general, compatible with that for maximum forward radiation.

been omitted for economy of space that, in general, the optimum value of d for maximum forward radiation will vary with the number, spacing, and length of the elements. For many of the plane arrays, however the value of optimum d was found not to be critical within plus or minus 10 to 15 per cent. This may account for the value of $d = 0.20 \lambda$ prescribed by some investigators as the optimum distance for any plane reflector.^{19,6,7}

C. Parabolic Reflectors—Section 1

Figs. 11 and 12 show typical polar distributions for parabolic reflectors with loaded and unloaded (lineal) elements in relation to the reflector dimensions and characteristics. These data and those of the

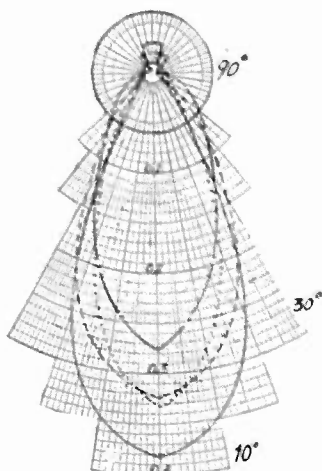

Fig. 11—Radiation characteristics for parabolic arrays of reflector elements.

	n	S (cm)	l (cm)
—————	7	81.3	119 (lineal)
-----	5	81.3	119 (lineal)
.....	7	81.3	119 (loaded)
— · — · —	5	81.3	119 (loaded)

Focal length of parabola (f) = 0.25λ .

unpublished patterns are arranged in the accompanying table, where the reflectors have been grouped according to the number of elements. Since the entire polar distribution is shown, and in order to facilitate comparison with previously reported values, the total directivity, δ , is here given.

The following conclusions may be drawn from these figures:

(1) The aperture of a grid reflector is not, in general, a "figure of merit" of its performance, since it is possible to alter the amplification, directivity, and back radiation of reflectors with constant aper-

¹⁹ Tartarinoff, *Jahr. der draht. Tel.*, vol. 28, p. 117, (1926).

ture, by varying the number, length, and separation of the elements.²⁰

(2) The amplification (μ), directivity (δ), and the backward radiation (β) vary in a complicated fashion with the length and spacing of the elements. For small values of S the beam characteristics are, on the average, better with the longer elements, and vice versa.

(3) Minimum backward radiation is not necessarily coexistent with maximum amplification and directivity.

These conclusions will be presently discussed in connection with the data of Figs. 16 to 21. At this point, however, it is interesting to compare the results obtained here with those of Gresky, in the previously cited work. Gresky ($\lambda = 298$ centimeters) found, using a re-

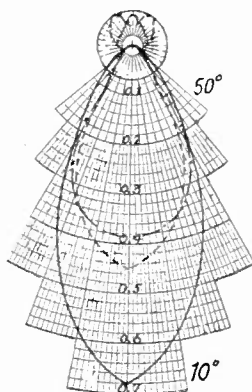

Fig. 12—Radiation diagrams for parabolic arrays showing the effect of reflector element length.

	n	S (cm)	l (cm)
—————	27	17.8	122 (loaded)
- - - - -	27	17.8	77 (loaded)
· · · · ·	27	17.8	71 (loaded)

$f = 0.25\lambda$; n = number of elements. Circle shows radiation of antenna without reflectors.

flector of $f = 0.27\lambda$, $l = 300$ centimeters, $n = 57$, $a = 1.48\lambda$, and $S = 10$ centimeters, the following maximum characteristics: $\mu = 12$, $\delta = 10.44$, $\beta = 1.68$ per cent.

The following optimum arrays selected from the table may be compared with these values.²¹

²⁰ It will be seen later, however, that with constant length and spacing of elements, the directivity and forward radiation are practically proportional to the aperture over a limited range, while the backward radiation varies inversely with the opening.

²¹ In the 27-wire array the loaded elements were equivalent to a length of about 180 centimeters, or 70 centimeters shorter than the full wavelength value. It is reasonable to expect, therefore, considerable improvement in the directivity and amplification with the use of 250-centimeter rods.

TABLE II

n	S	l	a	μ	δ	$\beta\%$
27	17.8	122*	1.49	9.7	10.7	0
17	30.5	119	1.47	6.3	10.9	2.63
13	40.6	119	1.54	6.3	12.3	2.63
11	40.6	119	1.34	5.8	9.8	2.86
7	81.3	119	1.53	6.3	9.6	2.63
5	81.3	119	1.07	5.4	8.6	3.00

* Loaded elements.

In connection with paragraph (2) above, it was found by Gresky that sharply defined minima in the amplification of parabolic arrays occurred when the length of the elements was approximately 0.50λ . From his curves, the amplification for a parabolic array, $a=1.48\lambda$ ($S=10$ centimeters) decreased about 26 per cent as the wire length was increased from 0.435λ to 0.50λ , increasing again about 28 per cent as the wires were further lengthened to 0.537λ . For a value of $S=40$ centimeters, over the same range, the amplification dropped first 25 per cent then increased 19 per cent. The directivity, however, for $S=10$ centimeters continued to increase, while the back radiation decreased. For plane reflectors, he observed similar variations in the neighborhood of $l=0.536\lambda$.

The relatively poor characteristics for the plane reflectors, and for the parabolic arrays comprising the loaded elements, 71.1, 73.6, and 77 centimeters, shown in the table, may, on the basis of these observations, be accounted for. The wavelength of a double end-loaded element may be computed, approximately, from the relation,²²

$$\lambda = 2.1l + 9d$$

l =length of loaded element, d =diameter of end plate. If we assume a proportionality factor (K) of 2.1 in the relation,

$$\lambda = Kl_0$$

l_0 =length of unloaded element, the equivalent resonant lineal length of the loaded element is, approximately,

$$l_0 = l + 4.285d.$$

For these tests, $d=12.57$ centimeters, therefore, $l_0=l+53.9$. This amounts to, for the 71.1-, 73.6-, and 77-centimeter rods, respectively, equivalent unloaded lengths of, 0.50λ , 0.51λ , and 0.52λ , values, all lying within the minima regions. It was found, on the other hand, that for two groups of parabolic arrays, having equal numbers and separation of elements, more favorable distributions obtained for $l=119$ centimeters (0.476λ) than for $l=109$ centimeters (0.435λ).

²² Nagy, *E.N.T.*, Bd. 11, p. 309; September, (1934).

Parabolic Reflectors—Section 2

Figure 13 shows a typical family of distributions in the sector, 270, 0, and 90 degrees, with variation of aperture and wire spacing for parabolic arrays of loaded elements. By plotting percentage values, as shown, the change in beam shape (forward sector directivity) may be readily noted. The conventional definition of directivity, δ , may result, in view of the many possible polar configurations, in the specification of an array wholly unfavorable for the requirements of a directive

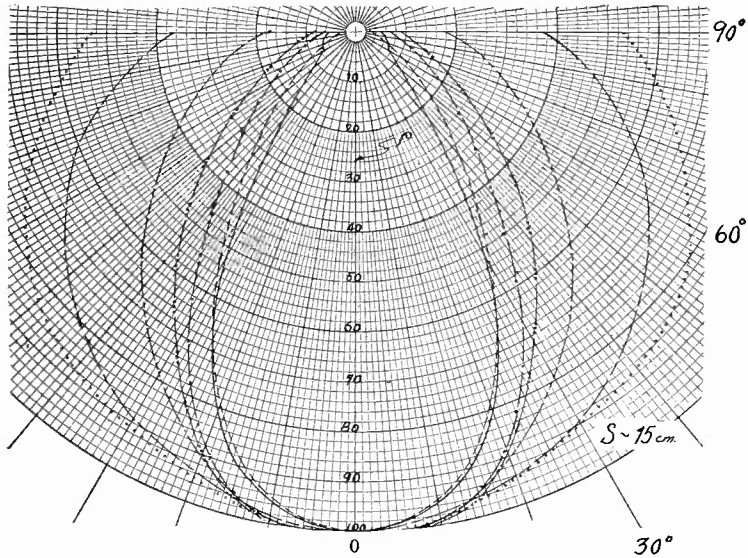

Fig. 13—Family of patterns for parabolic reflectors showing the effect on the forward sector radiation with variation of the reflector aperture.

	n	$a(\lambda)$
—————	25	1.120
-----	21	0.975
- - - - -	17	0.813
.....	13	0.635
-----	9	0.440
-----	5	0.228
.....	3	0.122

Focal length of reflector = 0.21λ ; separation of elements (S) = 15 cm; length of elements (l) = 119 cm (loaded); n = number of elements; a = aperture in wavelengths. ρ = receiver current in per cent of the maximum value (I_0).

system. In the table previously given, for example, the following may be found:

TABLE III

n	μ	δ	$\beta\%$
19	4.3	7.1	8.9
17	4.2	7.9	23.8
15	4.2	7.8	18.5
5	3.3	6.8	10
13	3.3	7.2	20.5

Comparing the first three arrays with practically equal μ 's, it is obvious that, if a minimum in the backward radiation is of prime importance, the directivity as commonly defined is no criterion.²³ Comparison with the last two shows, also, that the greater directivity is obtained for the array having the greater back radiation. Specifying the forward sector directivity, Δ , serves to delineate, on the other hand, the general shape of the beam effect quickly. The other portion of the pattern contained within the sector 90, 180, and 270 degrees (backward distribution) may then be specified, both as a ratio of the forward beam

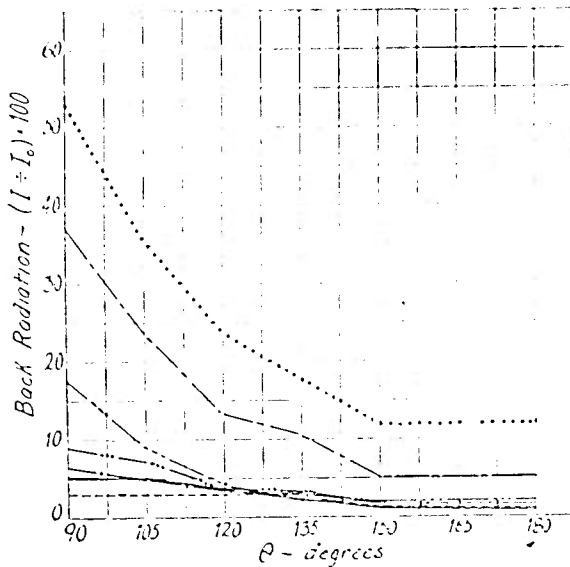

Fig. 14—Lateral and back radiation for the reflectors of Fig. 13. The ordinates are receiver current values in per cent of the maximum forward radiation (I_0).

	n	a
-----	25	1.12
-----	21	0.975
- . - . - .	17	0.813
.....	13	0.635
-----	9	0.440
-----	5	0.228
.....	3	0.122

$S = 15$ cms

All elements untuned end-loaded.

area to the area of the backward distribution, and another numeric expressing the maximum value of the backward distribution in per cent of the forward radiation; i.e., a number triplet.

Fig. 14 depicts the lateral and back radiation for the arrays of Fig. 13, while Fig. 15 shows, for a similar group of arrays with a thirty-centimeter separation of elements, the appearance of secondary beams

²³ Conclusion (3), Section 1.

or lobes of radiation. The curves were plotted on rectangular coördinates, apart from the corresponding polar curves, in order to permit a detailed inspection of the forward, lateral, and backward characteristics.

Finally in Figs. 16, 17, and 18 are shown, respectively, the forward radiation ($\theta=0$), backward radiation and the directivity for parabolic reflectors comprising lineal elements ($l=119$ centimeters; $f=0.25\lambda$); as a function of aperture with the element separation as parameter, while Figs. 19, 20, 21, show, similarly, the characteristics for parabolic

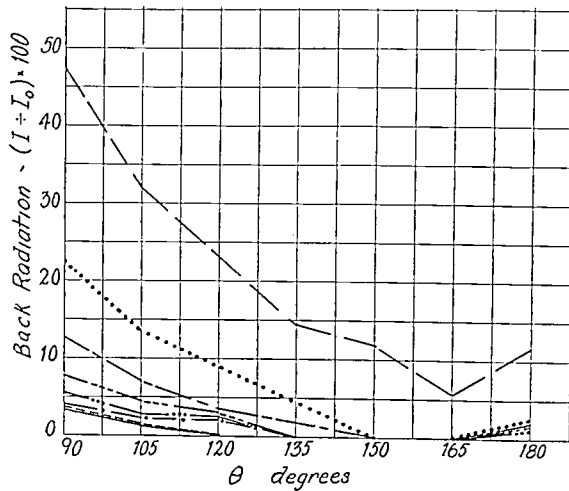

Fig. 15—Lateral and back radiation for parabolic reflectors showing the formation of diffraction fringes (radiation lobes) in the sector 120, 180, and 240 degrees. $f=0.21\lambda$; a =aperture; S =separation of elements. θ =angular displacement of reflector from zero to 180-degree axis.

	n	a
—————	17	1.38
— — — — —	15	1.26
· · · · ·	13	1.12
— · · · — · ·	11	0.975
— — — — —	9	0.813
— — — — —	7	0.635
· · · · ·	5	0.440
—————	3	0.228

$S=30$ cms

All elements end-loaded.

arrays of loaded elements ($f=0.21\lambda$; $l=119$ centimeters). The remainder of the paper is given over to their consideration.

The tests on these grid reflectors were carried out, not with the purpose of establishing optimum dimensions for the various arrays, but to examine the dependency of the beam characteristics on the aperture. The broken line curves of Fig. 16 show, for example, that the amplification affordable for various separations of the elements,

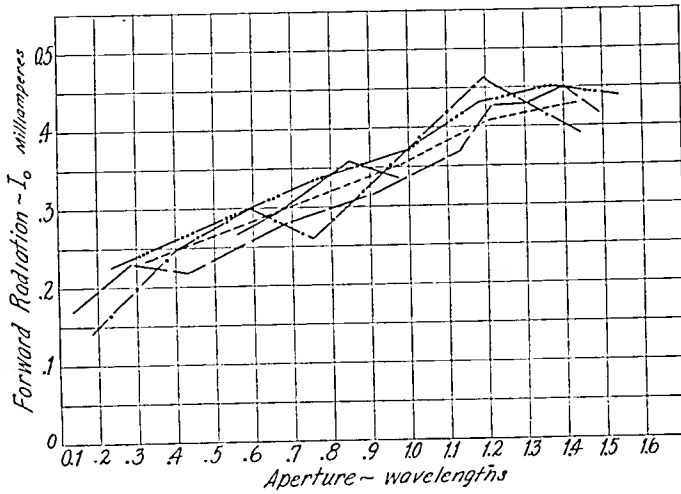

Fig. 16—Dependency of the forward radiation (receiver current I_0 , for $\theta = 0$ degrees) on the aperture of parabolic reflectors for various separations of lineal elements.

$f = 0.25\lambda$; $l = 119$ cm; $a =$ aperture.

- | | |
|-------|---------------|
| ————— | $S = 10.2$ cm |
| ----- | $S = 17.8$ cm |
| | $S = 25.4$ cm |
| | $S = 35.6$ cm |
| ----- | $S = 45.7$ cm |

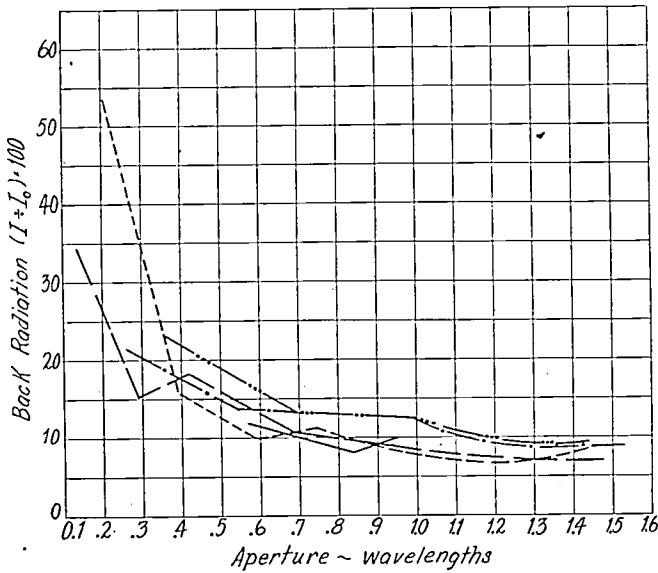

Fig. 17—Back radiation (β) in per cent of forward radiation as a function of aperture and wire separation for parabolic reflectors.

$f = 0.25\lambda$; $l = 119$ cm (lineal)

- | | |
|-------|---------------|
| ————— | $S = 10.2$ cm |
| ----- | $S = 17.8$ cm |
| | $S = 25.4$ cm |
| | $S = 35.6$ cm |
| ----- | $S = 45.7$ cm |

through increase of the aperture, may not be a simple monotone increasing function of the latter, but may actually show a diminution

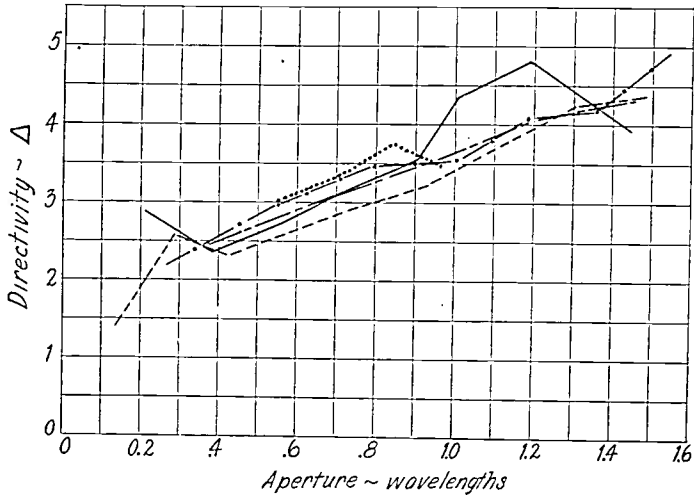

Fig. 18—Dependency of forward sector directivity on the aperture for the parabolic reflectors of Figs. 16 and 17.

- S = 10.2 cm
- S = 17.8 cm
- S = 25.4 cm
- · - · - S = 35.6 cm
- S = 45.7 cm

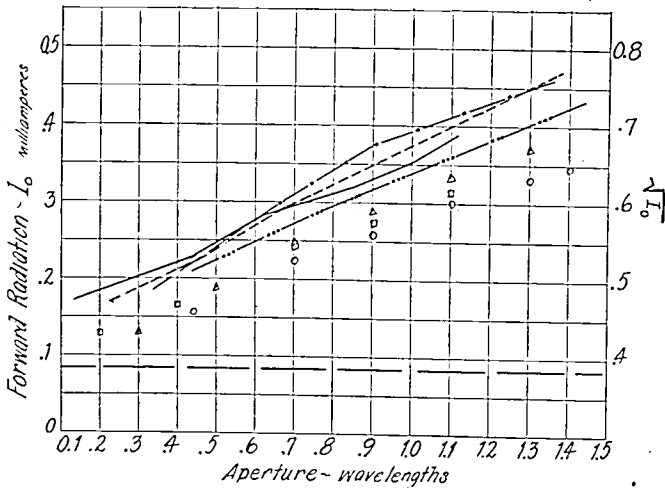

Fig. 19—Variation of forward radiation with the aperture and wire separation for parabolic reflectors comprising loaded elements.

$f = 0.21\lambda$; $l = 119$ cm. The unconnected traces plotted to the ordinates on the right indicate the variation of the field intensity with the aperture.

- S = 15 cm
- S = 30 cm
- · - · - S = 45 cm
- S = 60 cm
- Receiver current without reflectors.

for some increments of aperture.²⁴ Considerations of phase conditions indicate an explanation of this effect. When the aperture is increased by the addition of an element to each branch of the parabola, the phases of the fields due to the elements may be such that part of the forward radiation is nullified; i.e., the elements radiate unfavorably "into" the outgoing field due to the antenna and the elements in the vicinity of the vertex. Addition of more elements compensates for this decrease, until another unfavorable aperture value is obtained. The amplification, therefore, must approach a limit when, with the further addition of wires, the fields of the outermost members, in con-

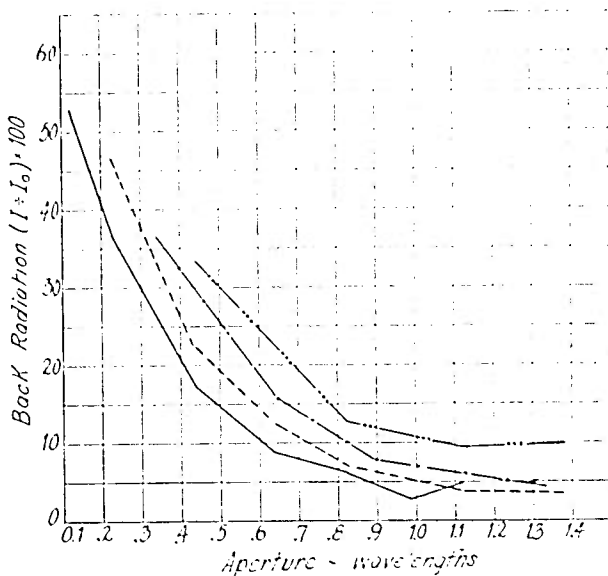

Fig. 20—Back radiation in per cent of forward radiation for the reflectors of Fig. 19.

—————	$S = 15$ cm
- - - - -	$S = 30$ cm
- · - · -	$S = 45$ cm
· · · · ·	$S = 60$ cm

sequence of weaker induced currents, contribute immaterially to the total radiation. The directivity (Figs. 18 and 21) must, likewise, fall off, while the back radiation, determined principally by the elements in the vicinity of the vertex, decreases only slightly for further increases of aperture.

Fig. 16 shows that the forward radiation is a maximum approximately in the region, $1.4-1.5\lambda$. Both Gresky and Köhler found no increase in the amplification for values of aperture greater than 1.5λ , although the latter, using cylindrical parabolic sheets, found improved

²⁴ Conclusion (1), Section 1.

characteristics with large apertures ($2\lambda-10\lambda$) by displacing the antenna from the focus ($f=0.27\lambda$) to positions given by the relations, $\lambda(0.27+k/2)$, $k=1, 2, 3, \dots$ For the reflectors with loaded elements (Fig. 19), no definite conclusions concerning a maximum can be drawn, since the value of aperture was not sufficiently extended.

In respect of the back radiation, Figs. 17 and 20 show that the greatest rate of change occurs up to approximately 0.8λ , with relatively small variation beyond this value. For lineal elements, over the greatest range of apertures, the amplification and directivity are seen to be most favorable for $S=35.6$ and $S=25.4$ centimeters, while minimum back radiation obtains for apertures greater than, about,

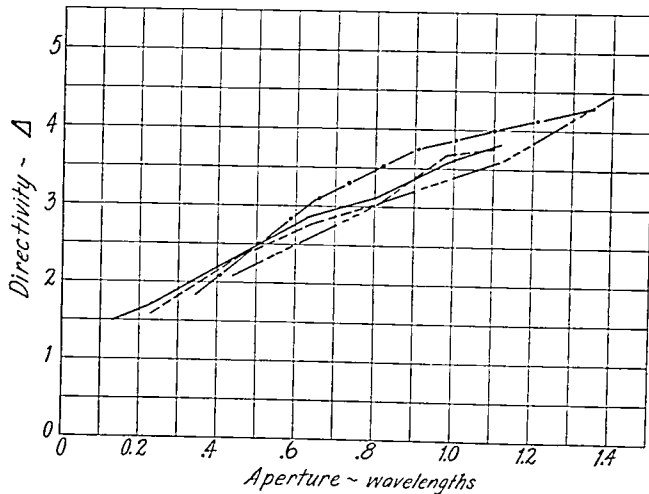
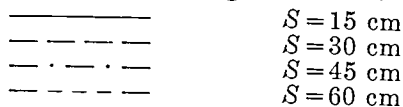

Fig. 21—Dependency of forward sector directivity on the aperture and wire separation for the reflectors of Figs. 19 and 20.



0.5λ , for $S=17.8$, and $S=25.4$ centimeters. For the loaded elements, $S=30$ and $S=45$ centimeters appear to be the optimum spacings over the greatest range; for minimum backward radiation (Fig. 20) the superiority of the smaller separations is in evidence.

From the foregoing it can be seen that a theoretical treatment, in view of the unknown phase and amplitude conditions in an array of parasitic wires, would lead to intractable mathematical relations. Since, moreover, experimental determinations on these arrays present no great difficulty, rigorous theoretical considerations of such systems would seem unwarrantable.

An interesting formula, however, has been derived by F. Ollen-

dorff,²⁵ for the field strength in a horizontal plane of a parabolic array of vertical elements. He replaces, mathematically, the effect of the reflector at the aperture by a sheet of electric intensity carrying a current of constant amplitude, i , and shows that the magnitude of the electric field is given by

$$\epsilon_{\max} = \frac{hi}{\pi\epsilon_0 ar} \left[\frac{\sin(2\pi b/\lambda \cdot b \sin \phi)}{\sin \phi} \right] \quad (1)$$

where,

h = length of reflector element

i = current density

ϵ_0 = dielectric constant of vacuum

r = distance from center of aperture to the receiver

a = velocity of light

b = half aperture of reflector

ϕ = angular displacement of reflector from zero-degree position.

To examine qualitatively the dependence of the forward radiation of the aperture, ϕ is made zero and ϵ_{\max} is expressed as a function of b . For $\phi = 0$, (1) becomes indeterminate. Writing K for $hi/\pi\epsilon_0 ar$ and differentiating numerator and denominator separately, there results

$$\epsilon_{\max} = K \frac{\cos(2\pi b/\lambda \cdot b \sin \phi) \cdot 2\pi b/\lambda \cos \phi}{\cos \phi} \quad (2)$$

which, for $\phi = 0$ and $k = 2\pi K/\lambda$, reduces to,

$$\epsilon_{\max} = kb. \quad (3)$$

Within the ranges of aperture shown in Figs. 16 and 19, this relation is qualitatively satisfied. Since the theory does not contemplate element-antenna phase relations, however, (3) fails to indicate a maximum in the neighborhood of $a = 1.5\lambda$. Equation (1) shows the field intensity to be proportional to the length of the reflector element. It was pointed out, however, that the amplification was a complicated function of (1), passing through a sharp maximum and minimum between $l = 0.403\lambda$ and $l = 0.536\lambda$.²⁶

From the table previously given, and the results in Figs. 16 and 19, it is evident that, for constant wire length, the amplification is a function, not only of the aperture, but with constant aperture, the separation of the elements. The formula should be most accurate for

²⁵ "Die Grundlagen der Hochfrequenztechnik," p. 600, published by J. Springer, Berlin, (1926).

²⁶ Gresky, *loc. cit.* Gresky also found about equal maximum effects for $l = \lambda$ and 1.5λ and minimum effects for $l = 2\lambda$.

those arrays, therefore, which produce effects simulated by metallic sheets; i.e., for $S = \lambda/30$,²⁶ $S = \lambda/40$.²⁷ On account of the assumptions involved in the derivation, the formula cannot be examined in respect of the back radiation ($\phi = 180$ degrees).

ACKNOWLEDGMENT

The writer takes this opportunity to thank Mr. James Nagy and Dr. E. Weber, research professor of electrical engineering at the Brooklyn Polytechnic Institute; the former, for his kind and able assistance throughout the field work, and for the design and construction of the transmitter structure; the latter, for timely suggestions and encouragement in the preparation of the paper.

²⁷ Blake and Fountain, *Phys. Rev.*, vol. 23, (1906).



A METHOD FOR DETERMINING THE RESIDUAL INDUCTANCE AND RESISTANCE OF A VARIABLE AIR CONDENSER AT RADIO FREQUENCIES*

BY

R. F. FIELD

(General Radio Company, Cambridge, Massachusetts)

AND

D. B. SINCLAIR

(Massachusetts Institute of Technology, Cambridge, Massachusetts)

Summary—When using a variable air condenser as a reactance standard at radio frequencies it is important to know the variation in effective capacitance and power factor with frequency. The procedure outlined in this paper furnishes a method for the measurement of the residual impedances causing such variations. A qualitative discussion of the sources of both residual inductance and resistance is presented. The residual inductance is largely localized in the leads and stack supports. The residual resistance may be considered as made up of a conductance caused by dielectric loss and a resistance caused by ohmic and eddy-current loss. It is pointed out that all these residual parameters tend to remain constant at a single frequency, irrespective of capacitance setting.

The procedure for determination of the residual parameters depends upon the measurement of a fixed condenser by a substitution method, using the variable condenser to be studied as standard. At a single frequency the residual inductance of the standard condenser causes a deviation in effective capacitance from the static value which depends upon the setting. The residual resistance caused by ohmic and eddy-current loss causes a variation in effective conductance which also depends upon the setting. If the capacitance and conductance components of the fixed condenser be measured over different ranges of the scale of the standard condenser there will therefore be an apparent variation in their values. Interpretation of these trends yields the magnitudes of the residuals causing them. Similar measurements with a series substitution method may be used to evaluate the residual conductance caused by dielectric loss.

Plots are included illustrating the procedure and giving typical values for the residual parameters. It is pointed out that error in the effective capacitance caused by inductance may reach ten per cent at six megacycles for a representative variable condenser set at 1100 micromicrofarads and that the metallic losses may be greater than the dielectric losses at a frequency as low as one megacycle.

INTRODUCTION

IN making electrical impedance measurements by comparison methods, it is of primary importance to know accurately not only the magnitudes of the standard impedances used but also the phase angles. While ideal resistance or reactance units, having exactly

* Decimal classification: R230×R240. Original manuscript received by the Institute, September 26, 1935. Presented before joint I.R.E.-U.R.S.I. meeting, Washington, D.C., April 26, 1935.

zero- or ninety-degree phase angles, are valuable theoretical tools, they are, of course, physically unrealizable. It is therefore necessary to examine any real standard for departure from perfection because of internal residual impedances.

This is particularly true when making measurements at radio frequencies, since the effects of residual inductances, resistances, and capacitances tend to increase with frequency for a given circuit impedance level. It is, in fact, the realization of the importance of these residual parameters that has led to the development of many special methods of measurement at radio frequencies not ordinarily used at audio frequencies and to a search for standards of maximum purity.

As a continuously adjustable standard, the air condenser probably approaches an ideal circuit element more closely than either inductance or resistance units. It has consequently been widely used in radio-frequency measurements, in some cases for the evaluation of unknown reactance components only, and in others as a basic standard for measurements of both resistive and reactive components.

In much of the early work in this field the residual components of a variable air condenser were considered negligible. With increasing demand for more accurate measurements at higher and higher frequencies, however, this assumption has become untenable. In recent years there has consequently been considerable interest in the measurement of phase defect of variable condensers. While much excellent work has been done in determining resistive components, there does not appear to have been a corresponding study of the residual inductance. Since this is of great importance in its effect on the apparent capacitance, a simple method of measurement is of value. The procedure outlined in this paper is believed to afford more comprehensive information regarding condenser residual impedances than any other of those which have appeared to date, in so far as it permits the separate evaluation, at a single frequency, of the residual inductance and of the two components of condenser resistance caused, respectively, by loss in the dielectric supports and by loss in the metallic stack structure.

ANALYSIS OF RESIDUAL PARAMETERS

Before proceeding to a consideration of the method of measurement used, it is desirable to attempt to isolate the sources of residual impedances in a variable air condenser. A typical assembly is sketched in Fig. 1.

Consider first the residual inductance. Charge enters at the binding post shown and flows down through the stator lead to the top stator plate. At this point the current divides, a portion of the charge

flowing out through the stator plate and back to the rotor and a portion passing on down the lead to the second stator plate. Here another division occurs and so on, the resultant current distribution in the stator lead and stack support being of the form illustrated. This current sets up magnetic flux in the plane of the plates, which, in turn, gives rise to an inductive reactance. A similar current distribution exists in the rotor shaft and lead, which also sets up magnetic flux in the

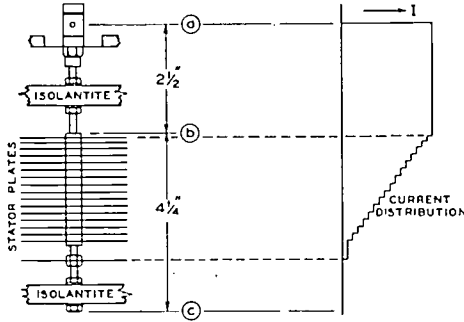

Fig. 1—Stator lead and stack support of General Radio type 222-M precision condenser and sketch of approximate current distribution for frequencies sufficiently low so that the effective capacitance does not differ from its static value by more than a few per cent.

plane of the plates. The current in and between the plates, however, sets up very little flux, since it is diffused over relatively large areas, and since the plates exert a shielding action. The major part of the residual inductance is therefore localized in the stator leads and supports, with the plates contributing only a small fraction. This means that, while presumably the current distribution in the plates changes radically as the rotor is turned, the over-all inductance remains relatively constant. On this assumption the condenser may be represented electrically by the circuit of Fig. 2.

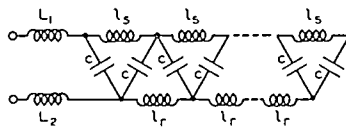

Fig. 2—Equivalent circuit for variable condenser including the residual inductance.

- L_1, L_2 = inductance of leads to stator and rotor.
- l_s = inductance of section of stator stack support between any adjacent pair of stator plates.
- l_r = inductance of section of rotor shaft between any adjacent pair of rotor plates.
- c = static capacitance between any stator plate and one adjacent rotor plate.

A recurrent circuit of this type has, of course, multiple resonances, the number of which depends upon the number of sections. For fre-

quencies low enough so that the effective input capacitance does not depart by more than a few per cent from its static value, however, the condenser may be approximated with sufficient exactness by the simple circuit of Fig. 3.

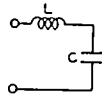

Fig. 3—Simplified equivalent circuit for variable condenser including residual inductance.
 L = total residual inductance.
 C = total static capacitance.

It follows that, for small deviations in effective capacitance from the static value, the law of variation is

$$C_e = \frac{C}{1 - \omega^2 LC} \quad (1)$$

where C_e is the effective capacitance, C the static capacitance, and L the total residual inductance. The action of the inductance is obviously to increase the effective capacitance over the static value by an amount which depends upon both the frequency and the capacitance setting.

Turning to a consideration of the losses in the condenser, it is clear that these may be considered as made up of two components, namely, the hysteretic loss in the dielectric supports and the joulean loss in the metal structure. These may conveniently be thought of as producing two dissipative components, the one a conductance caused by dielectric loss and the other a resistance caused by metallic loss.¹

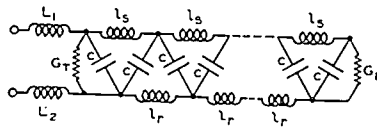

Fig. 4—Equivalent circuit for variable condenser including residual inductance and residual conductance caused by dielectric loss.

G_T , G_B = conductance components caused by loss in solid dielectric supports at top and bottom of stator stack.

In most variable condensers, the dielectric supports lie in an electric field which does not depend upon the position of the rotor but simply upon the voltage. The corresponding conductance component may therefore be safely assumed constant at any one frequency. In the particular condenser studied in this investigation there are six isolantite supports, three at the top and three at the bottom. Considering them as conductances the equivalent circuit of Fig. 2 may now be extended to take into account dielectric loss as shown in Fig. 4.

¹ R. M. Wilmotte, "The comparison of the power factors of condensers," *Wireless Engineer and Experimental Wireless*, vol. 6, p. 656; December, (1929).

For small deviations in effective capacitance this circuit may be simplified as before, and the condenser approximately represented as in Fig. 5.

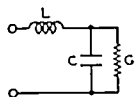

Fig. 5—Simplified equivalent circuit for variable condenser including residual inductance and residual conductance caused by dielectric loss.

G = total residual conductance.

The effective input resistance of the condenser then follows the approximate law

$$R_e = \frac{G}{(\omega C)^2} \quad (2)$$

where R_e is the effective resistance and G the residual conductance. The dielectric loss is seen to introduce an effective resistance component which varies inversely as the square of the capacitance. For solid dielectrics it has been experimentally shown that, in general, the loss per cycle is approximately constant, irrespective of frequency, at least up to 75 megacycles per second.² G/ω will therefore be constant and the resistive component will vary inversely with frequency.³

The metallic loss will, of course, occur in any portion of the metallic assembly in which current flows. There is reason to suppose, however, that it is largely caused by contact resistance at the washer-to-plate contacts in a bolted assembly and to sliding contacts at the rotor shaft.⁴ The change in series resistance with rotor displacement is therefore small despite the change in current distribution in the plates.

Assuming constant effective resistance components caused by metallic losses, the circuit of Fig. 4 may be completed by inserting in series with every inductance component the corresponding resistance component. As before, this circuit may be simplified for small deviations of effective capacitance. The approximate equivalent circuit for a variable condenser, when all internal residual impedances are considered, is illustrated in Fig. 6.

² J. G. Chaffee, "The determination of dielectric properties at very high frequencies," *Proc. I.R.E.*, vol. 22, pp. 1009-1020; August, (1934); H. Kessler, "Messungen an festen technischen Isolierstoffen bei $3 \cdot 10^6$ — $7, 5 \cdot 10^7$ Hertz," *Hochf. tech. und Elektroakustik.*, vol. 45, p. 91; March, (1935).

³ This is equivalent to the more common statement that $R_e \omega C^2$ is a constant where R_e is the effective input resistance. Cf. C. T. Burke, "Substitution method for the determination of resistance of inductors and capacitors at radio frequencies," *Trans. A.I.E.E.*, vol. 46, p. 482; May, (1927).

⁴ W. Jackson, "The analysis of air condenser loss resistance," *Proc. I.R.E.*, vol. 22, pp. 957-963; August, (1934).

The admittance of this circuit is given with sufficient exactness by the following formula:

$$Y = G_e + j\omega C_e = [G + R(\omega C)^2] + j \left[\frac{\omega C}{1 - \omega^2 LC} \right] \quad (3)$$

where R is the residual resistance caused by metallic loss, G the residual conductance caused by dielectric loss, L the residual inductance, and C the static capacitance.

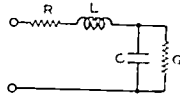

Fig. 6—Simplified equivalent circuit for variable condenser including all residual parameters.

R = total residual resistance caused by ohmic and eddy-current losses in the metallic structure.

The corresponding impedance is approximated by the expression

$$Z = R_c - j \frac{S_e}{\omega} = \left[R + G \left(\frac{S}{\omega} \right)^2 \right] - j \left[\frac{S}{\omega} - \omega L \right] \quad (4)$$

where S is the static elastance.

The residual inductance is seen to cause a fractional error in the effective capacitance and elastance which is dependent upon both frequency and rotor setting. The residual resistance caused by metallic loss introduces an effective conductance component $R(\omega C)^2$, which is a function of both setting and frequency; or conversely the residual conductance caused by dielectric loss introduces an effective resistance component $G(S/\omega)^2$, which is also a function of both setting and frequency. As may be seen from the equations, the dielectric loss component predominates at low frequencies, the metallic loss component increasing in relative significance with the frequency.

EFFECT OF RESIDUAL PARAMETERS IN MEASURING CIRCUITS

For precise measurements, a variable condenser standard is ordinarily used in substitution methods in which it remains permanently in circuit. The absolute magnitude of residual effects is therefore of less interest than the change with rotor setting.

Consider first the change in admittance, at a single frequency, when the rotor is moved from a position 1 to another position 2. In terms of the capacitance and conductance components this may be expressed as follows:

$$\Delta C_e = C_{e_1} - C_{e_2} = \frac{C_1}{1 - \omega^2 L C_1} - \frac{C_2}{1 - \omega^2 L C_2} \cong \frac{C_1 - C_2}{1 - \omega^2 L (C_1 + C_2)} \quad (5)$$

$$\Delta G_e = G_{e_1} - G_{e_2} \cong R [(\omega C_1)^2 - (\omega C_2)^2] = R \omega^2 (C_1 - C_2)(C_1 + C_2). \quad (6)$$

The percentage error in capacitance increment caused by the inductive residual, instead of being equal to the average error at the initial and final settings as might be surmised, is actually more nearly equal to the sum of the errors at the two positions. The variation in effective conductance depends directly upon the change in the square of the capacitance.

The corresponding change in impedance, when expressed in terms of its elastance and resistance components, becomes

$$\Delta S_e = S_{e_1} - S_{e_2} = S_1 - S_2 \quad (7)$$

$$\begin{aligned} \Delta R_e = R_{e_1} - R_{e_2} &\cong G \left[\left(\frac{S_1}{\omega} \right)^2 - \left(\frac{S_2}{\omega} \right)^2 \right] \\ &= \frac{G}{\omega^2} (S_1 - S_2)(S_1 + S_2). \end{aligned} \quad (8)$$

As regards the elastance increment, since the residual inductance is a constant series element, there is no error introduced in taking differences in static elastance. The variation in effective resistance depends directly upon the change in the square of the elastance.

In a parallel substitution method there may therefore be errors introduced into the measurement of both susceptive and conductive components. In a series substitution method there may be errors in evaluation of resistance. There is, however, no appreciable error in reactance measurements caused by internal residual parameters.

Because of parasitic circuit impedances inherent in any physical setup there will, of course, be other errors introduced. This is particularly true of the series substitution method. From a practical standpoint there will always be introduced a capacitance to ground by the unknown impedance to be measured or by its mounting. This capacitance, appearing across the standard condenser terminals, causes an error in elastance measurement of a similar nature to the error in capacitance measurement caused by the residual inductance. Thus, if δC be the residual shunt capacitance,

$$S_e = \frac{S}{1 + (\delta C)S}$$

and,

$$\Delta S_e = \frac{S_1}{1 + (\delta C)S_1} - \frac{S_2}{1 + (\delta C)S_2} \cong \frac{S_1 - S_2}{1 + \delta C(S_1 + S_2)}. \quad (9)$$

METHOD OF MEASURING RESIDUAL PARAMETERS

The errors formally expressed in (5), (6), (8), and (9) all depend upon the rotor setting at a single frequency. If a fixed condenser be measured by a substitution method, the apparent values of the capacitance and conductance, or susceptance and resistance components therefore vary with the initial setting of the continuously adjustable standard. In such measurements the foregoing equations take the following form:

(a) For a parallel substitution method, where C_x and G_x are the capacitance and conductance components of the unknown fixed condenser and ΔG_0 the change in circuit conductance with the fixed condenser in and out of circuit,

$$C_x = \Delta C_e = \frac{C_1 - C_2}{1 - \omega^2 L(C_1 + C_2)} \quad (5a)$$

$$G_x = R\omega^2(C_1 - C_2)(C_1 + C_2) - \Delta G_0 \cong R\omega^2 C_x(C_1 + C_2) - \Delta G_0. \quad (6a)$$

(b) For a series substitution method, where S_x and R_x are the elastance and resistance components of the unknown fixed condenser and ΔR_0 the change in circuit resistance with the fixed condenser in circuit and shorted,

$$S_x = \Delta S_e = \frac{S_1 - S_2}{1 + \delta C(S_1 + S_2)} \quad (9a)$$

$$R_x = \frac{G}{\omega^2}(S_1 - S_2)(S_1 + S_2) - \Delta R_0 \cong \frac{G}{\omega^2} S_x(S_1 + S_2) - \Delta R_0. \quad (8a)$$

Mathematically the various residual parameters may be determined from two parallel substitution measurements and two series substitution measurements. Practically, of course, since these measurements can only be made with limited precision, it is desirable to take several readings. With a number of measured values available, a convenient graphical analysis results if the data be plotted in the form of a straight line. Equations (5a), (6a), (9a), and (8a) are readily adapted to this form of analysis.

Taking $C_1 + C_2$ as independent variable for (5a) and (6a), a plot of $C_1 - C_2$ yields a straight line whose slope is $-\omega^2 L C_x$ and whose intercept with the ordinate axis is C_x . A plot of ΔG_0 yields a straight line whose slope is $R\omega^2 C_x$ and whose intercept is $-G_x$.

Taking $S_1 + S_2$ as independent variable for equations (9a) and (8a) a plot of $S_1 - S_2$ yields a straight line whose slope is $\delta C S_x$ and whose intercept is S_x . A plot of ΔR_0 yields a straight line whose slope is $G S_x / \omega^2$ and whose intercept is $-R_x$.

These plots permit rapid averaging of data which are not entirely self-consistent because of limited precision of measurement. They also serve as a check on the validity of the assumptions made, since any consistent variation in the residual quantities with rotor setting will cause a corresponding deviation from a linear relation.

The measurements themselves may be readily carried out by the various resonance methods developed for determination of total circuit resistance.⁵ The resonant settings of the standard condenser with the fixed condenser in and out of circuit determine C_1 , C_2 , S_1 , and S_2 . The measured change in circuit resistance yields values for ΔG_0 and ΔR_0 .

Measurements may also be made with a Schering bridge designed for high-frequency operation. In this case C_1 , C_2 , S_1 , and S_2 are determined from the balance settings of the standard condenser. Instead of resistance, however, the change in power factor, or more precisely in the ratio R/X , is read directly from a dial. When using such a bridge for measurement, (6a) and (8a) may be rewritten in the following form for the sake of convenience in interpreting data:

$$C_1\Delta D_0 = R\omega C_x(C_1 + C_2) - D_x C_x \quad (6b)$$

$$S_1\Delta D_0 = \frac{GS_x}{\omega} (S_1 + S_2) - D_x S_x \quad (8b)$$

where ΔD_0 is the change in ratio $R/X = G/B$ for the circuit when the fixed condenser is in and out and D_x is the ratio $R_x/(S_x/\omega) = G_x/\omega C_x$.

Plotting $C_1\Delta D_0$ as a function of $C_1 + C_2$ there results a straight line whose slope is $R\omega C_x$ and whose intercept is $-D_x C_x$. Similarly, plotting $S_1\Delta D_0$ as a function of $S_1 + S_2$ there results a straight line whose slope is GS_x/ω and whose intercept is $-D_x S_x$.

EXPERIMENTAL RESULTS

Typical plots of data taken by a resonance method at a frequency of 1.5 megacycles for a General Radio type 222-M precision condenser are shown in Figs. 7, 8, 9, and 10. The corresponding residual parameters found from these graphs are

$$L = 0.0604 \text{ microhenry}^6$$

$$R = 0.017 \text{ ohm}$$

$$\delta C = 2.4 \text{ micromicrofarads}$$

$$G = 0.210 \text{ micromho.}$$

⁵ E. B. Moullin, "The Theory and Practice of Radio Frequency Measurements," second Ed., pp. 259-285, Charles Griffin and Co., Ltd., London, 1931; S. L. Brown and M. Y. Colby, "Electrical measurements at radio frequencies," *Phys. Rev.*, ser. 2, vol. 29, p. 717; May, (1927).

⁶ This value compares with an estimated figure of 0.053 microhenry calculated from the dimensions of the leads, stator stack supports, and rotor shaft. The simple formula for a short wire in free space was used, assuming all current crowded to the surface of the conductors and distributed as shown in Fig. 1. Considering the crudeness of the assumptions made in the computations, the agreement with the measured value is remarkably good.

The only one of these quantities which can be directly compared with low-frequency measurements is the residual conductance. On the assumption of constant dielectric loss per cycle G/ω should be independent of frequency. The measured value of this quantity at a fre-

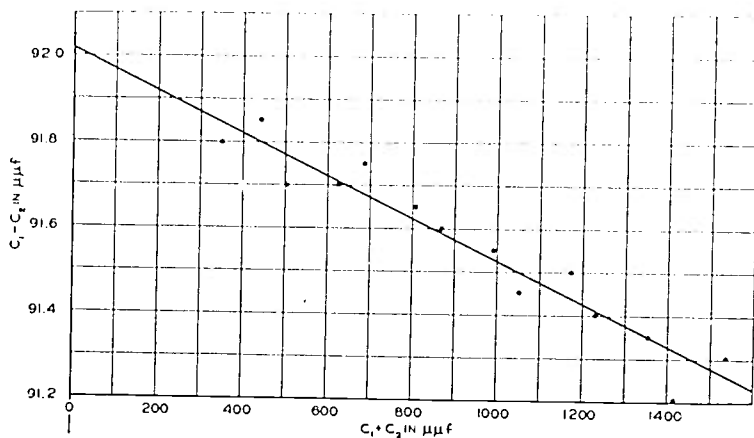

Fig. 7—Plot for determination of residual inductance of variable condenser at 1.5 megacycles.

$$L = \frac{1}{\omega^2} \cdot \frac{\text{slope}}{\text{intercept}} = 0.0604 \text{ microhenry.}$$

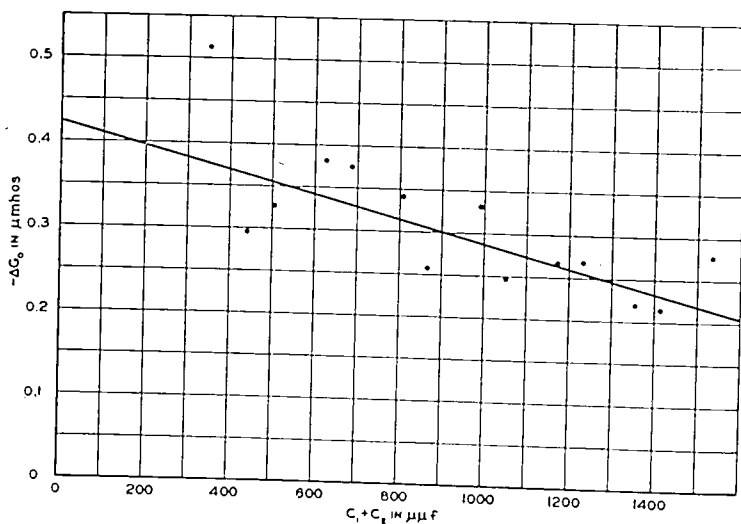

Fig. 8—Plot for determination of residual resistance of variable condenser caused by metallic loss at 1.5 megacycles.

$$R = \frac{1}{\omega^2 C_x} \cdot \text{slope} = 0.017 \text{ ohm.}$$

quency of 1000 cycles was found to check the 1.5-megacycle figure of 0.0223×10^{-12} within 0.5 per cent.

The closeness of this check is, no doubt, somewhat fortuitous because of the scattering of the points on the 1.5-megacycle plot. This scattering, noticeable in all these figures, is caused by the smallness of the residual errors at this frequency. More precise measurements of G

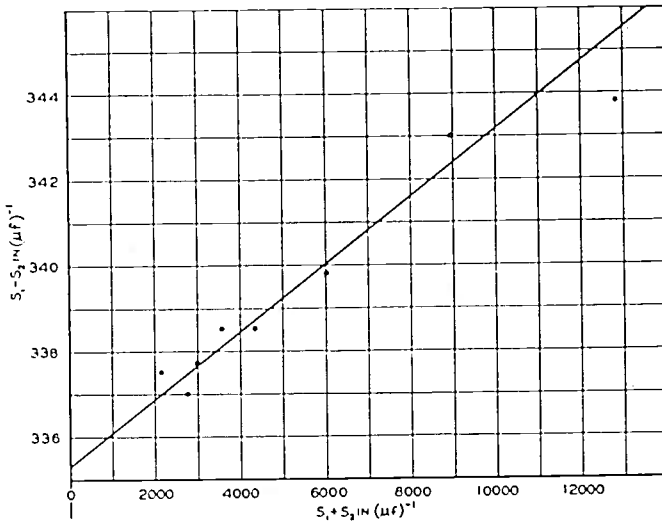

Fig. 9—Plot for determination of residual capacitance appearing across condenser terminals at 1.5 megacycles.

$$\delta C = \frac{\text{slope}}{\text{intercept}} = 2.37 \text{ micromicrofarads.}$$

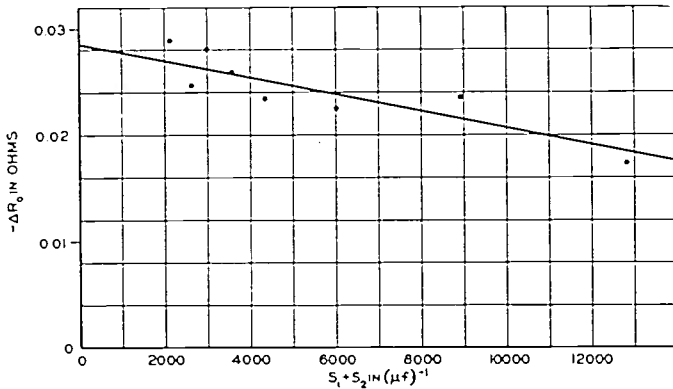

Fig. 10—Plot for determination of residual conductance of variable condenser caused by dielectric loss at 1.5 megacycles.

$$G = \frac{\omega^2}{S_x} \cdot \text{slope} = 0.210 \text{ micromho.}$$

may be made at lower frequencies, while measurements of L and R become easier as the frequency is raised. The increase of precision in the measurement of inductance, for instance, is forcibly illustrated in Figs.

11 and 12 which are plotted from data taken at frequencies of 3.0 and 5.0 megacycles.

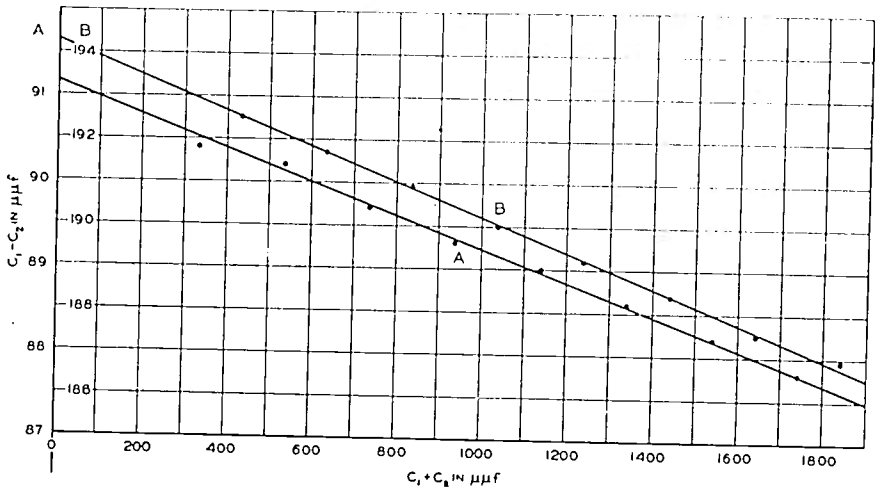

Fig. 11—Plot for determination of residual inductance of variable condenser at 3.0 megacycles.

Curve A: $C_x = 91.2$ micromicrofarads
 $L = 0.0593$ microhenry

Curve B: $C_x = 194.3$ micromicrofarads
 $L = 0.0591$ microhenry

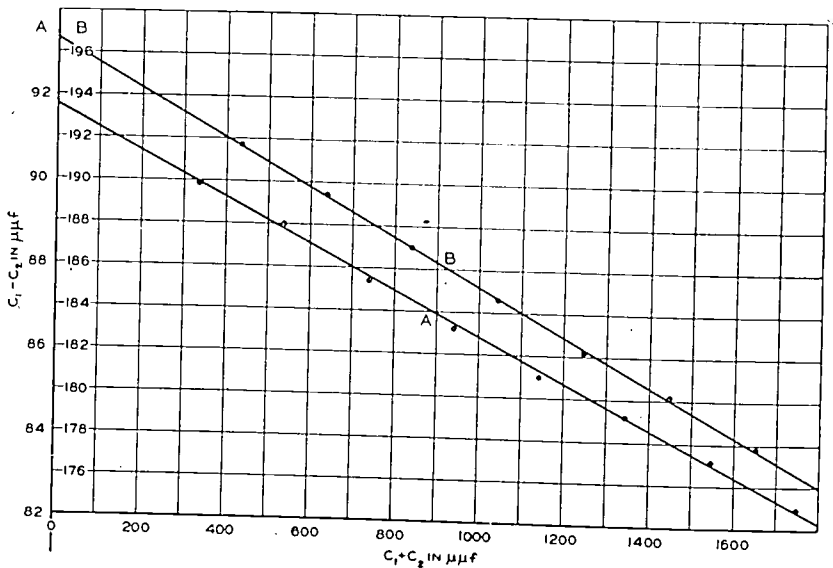

Fig. 12—Plot for determination of residual inductance of variable condenser at 5.0 megacycles.

Curve A: $C_x = 91.7$ micromicrofarads
 $L = 0.0589$ microhenry

Curve B: $C_x = 196.7$ micromicrofarads
 $L = 0.0593$ microhenry

Measurements taken at these two frequencies with different fixed condensers are seen to yield values of L which do not depart by more than ± 0.0002 microhenry from the average value of 0.0591 microhenry. Whether the difference between this figure and that obtained at 1.5 megacycles is real or simply a result of the lack of precision at the lower frequency has not yet been determined. There will certainly be a variation in inductance with frequency because of skin effect in the stator stack supports and rotor shaft, which might cause such a discrepancy.

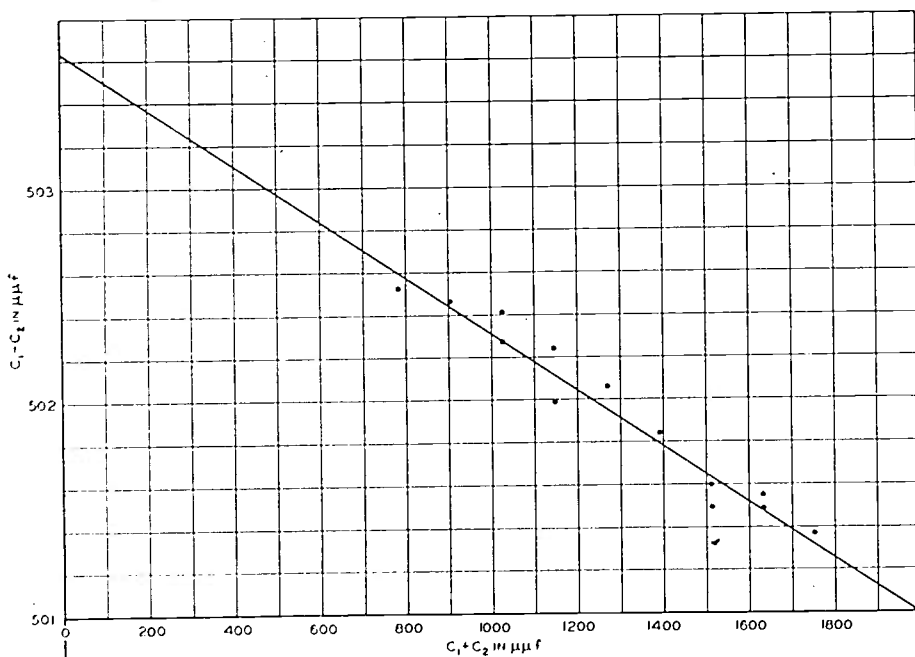

Fig. 13—Plot for determination of residual inductance of variable condenser at 1 megacycle. Data taken on radio-frequency Schering bridge.
 $L = 0.066$ microhenry.

In Figs. 13 and 14 are illustrated plots for the metallic resistance and residual inductance of a General Radio type 222-L precision condenser. The data for these curves were obtained from measurements made with a General Radio type 516-C radio-frequency bridge. The constants determined from the slopes and intercepts are

$$L = 0.066 \text{ microhenry}$$

$$R = 0.023 \text{ ohm.}$$

Both the inductive and resistive components are seen to be somewhat greater than those of the 222-M. This is presumably caused by the fact that the 222-L has a longer effective current path and more plates.

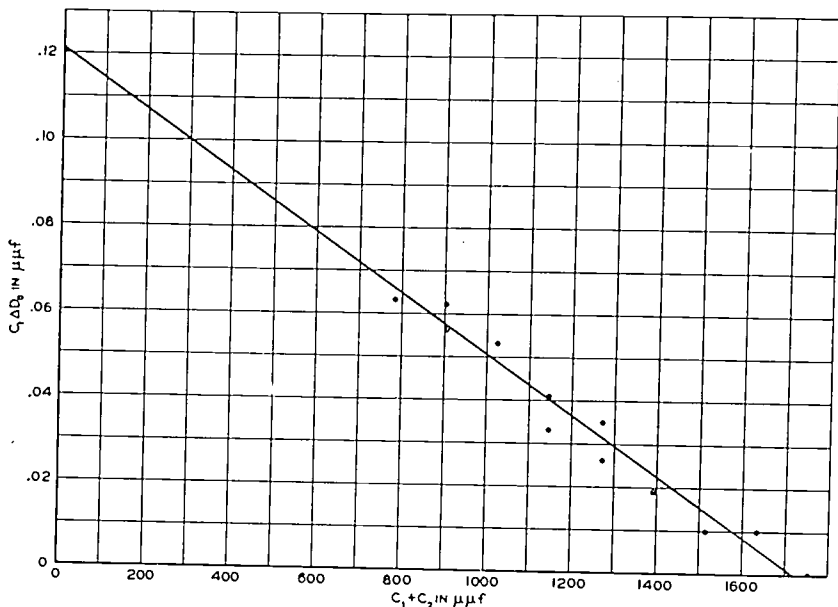

Fig. 14—Plot for determination of residual resistance of variable condenser caused by metallic loss at 1 megacycle. Data taken on radio-frequency Schering bridge.

$$R = 0.023 \text{ ohm.}$$

IMPORTANCE OF RESIDUAL EFFECTS

The variation in effective capacitance caused by a residual inductance of 0.0591 microhenry is plotted, for different frequencies and static capacitances, in Fig. 15. These curves are directly applicable to the type 222-M precision condenser. The measured inductance of this condenser is constant for the high-frequency region where the resultant

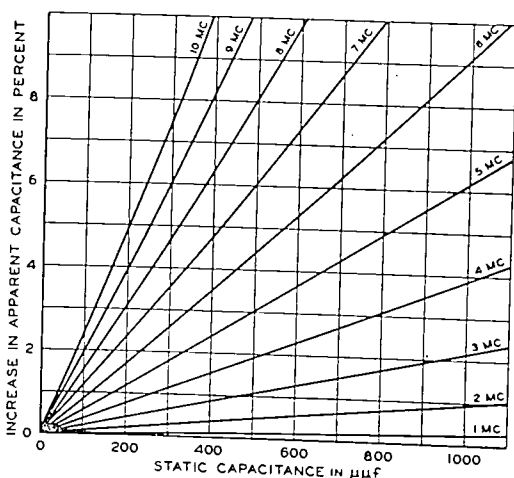

Fig. 15—Percentage variation in apparent capacitance from static value caused by residual inductance of 0.0591 microhenry.

increase in effective capacitance is large. Any small change in inductance at the lower frequencies will not appreciably alter the capacitance variation since the inductive effect is already small.

The maximum capacitance of this condenser is approximately 1100 micromicrofarads. For this setting, the variation in effective capacitance from its static value is about 0.25 per cent at one megacycle and about ten per cent at six megacycles. It is obvious that the condenser must be used with caution at frequencies as low as one megacycle if corrections are to be avoided. At higher frequencies it becomes essential to correct for the effect of inductance in precise work.

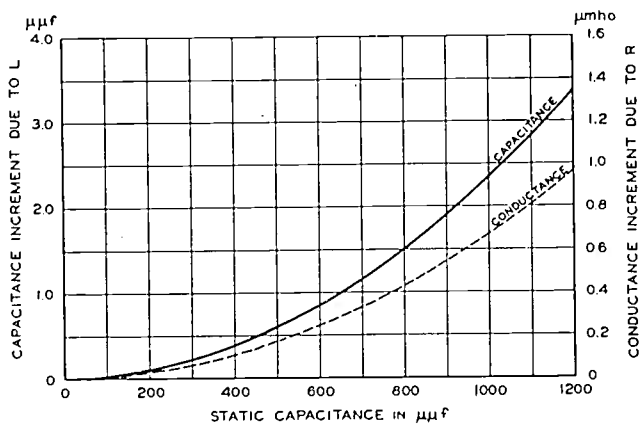

Fig. 16—Increments in capacitance and conductance components of variable condenser caused by residual inductance and by residual metallic resistance at 1 megacycle.

$$L = 0.0591 \text{ microhenry. } R = 0.017 \text{ ohm.}$$

The variation of input conductance is also of interest. At low frequencies, where the dielectric loss predominates, the effective input conductance is constant at a given frequency regardless of setting. At higher frequencies, as has been pointed out, there is a component of input conductance contributed by the metallic losses which varies as the square of the capacitance. For the type 222-M condenser the conductance component caused by dielectric loss at one megacycle was found to be 0.14 micromho. The component caused by metallic loss at maximum setting was about 0.8 micromho. Even at one megacycle, therefore, the assumption of constant input conductance is seriously in error. Fig. 16 shows the capacitance and conductance correction factors for the type 222-M condenser at a frequency of one megacycle as a function of static capacitance.

APPENDIX

Precision Calibration of a Variable Air Condenser
at Low Frequencies*Capacitance*

The measurement of the residual inductance of a condenser depends upon precise capacitance measurements. It is therefore of the utmost importance that the condenser to be tested be carefully calibrated for static, or, more strictly, low-frequency capacitance. With accurate, continuously adjustable capacitance standards available, such a calibration is most readily accomplished by a substitution method.

The capacitance of any variable condenser may be conveniently measured as the sum of two component capacitances; namely, the "zero capacitance" at some reference setting, and the "incremental capacitance" which must be added to the "zero capacitance" to obtain the total capacitance at any other setting. The measurement of the zero capacitance involves connecting and disconnecting the unknown condenser from the standard. It is sometimes difficult to do this without causing a significant change in the capacitance of the necessary wiring, with consequent error in the zero capacitance determination. The incremental capacitance, however, may be determined more accurately because the standard and unknown condensers may be left connected to one another at all times and capacitance simply transferred back and forth between them.

The type 222-M condenser used in this investigation is worm-driven with a 25:1 reduction. Ten turns of the worm therefore cover an angle of 144 degrees which is about the limit of the nearly linear range for a semicircular plate condenser. The condenser is built up with sufficient plates to give a capacitance increment of 1000 micromicrofarads through this angle. A dial on the worm shaft, divided into one hundred parts, and a dial on the condenser shaft, divided into ten parts, make the condenser direct reading in micromicrofarads with each worm division representing a one-micromicrofarad capacitance increment.

Proper alignment of the condenser assembly is sufficient to bring the capacitance characteristic within a tolerance of ± 1 micromicrofarad of linearity. It is not ordinarily feasible to attempt to decrease this tolerance to ± 0.1 micromicrofarad, although the dial reading may be estimated to this figure when it is desired to utilize the full precision of reading. It is therefore necessary to calibrate at even turns of the worm to determine the extent of the deviation of the capacitance characteristic from linearity.

For precise work it is usually found that there is another irregularity in the capacitance characteristic which must be taken into account. This is the deviation from constancy in the worm ratio as the worm goes through a complete turn. Such a variation may be caused by slight mechanical imperfection in the surfaces of the worm gear and the shoulder against which it bears, and usually causes a more or less sinusoidal deviation from linearity. The resulting capacitance deviation is ordinarily small, of the order of 0.1 to 0.3 micromicrofarad, but may be significant in work of high precision.

The calibration of the condenser used in this investigation was carried out at a frequency of 1000 cycles with two continuously adjustable standards known to an accuracy of 0.1 per cent. The zero capacitance and incremental capacitance for each complete turn of the worm were first measured by a substitution method with a standard of about the same maximum capacitance as the unknown. The variation of capacitance through a single turn of the worm was then measured by a substitution method with a standard of about one tenth the maximum capacitance of the unknown. The bridge arrangement was sufficiently sensitive so that the small standard could be set as closely as it could be read.

Plots of the "worm corrections" measured are illustrated in Fig. 17. At the ends of the scale the deviations from linearity are seen to be somewhat greater than in the middle. This is caused by the effect of fringing superimposed upon the mechanical worm correction. Over the major part of the scale the worm correction repeats itself within the limits of error, and subtraction of the average worm correction from the curves of capacitance deviation at the ends shows the smooth component caused by the nonlinearity of the condenser itself.

The final calibration of the condenser was self-consistent to 0.1 micromicrofarad at any point of the scale. This does not, of course, mean that the condenser was calibrated to an accuracy of 0.1 micromicrofarad at all points since this would require an accuracy of 0.01 per cent at the maximum setting. Specifying capacitance to 0.1 micromicrofarad simply means that incremental capacitances are accurate to 0.1 micromicrofarad or 0.1 per cent, whichever is the larger.

Conductance

While making capacitance measurements on the condenser, data were also taken on the conductive component. Measurements of conductance are ordinarily made under the assumption that the conductance of the standard is constant. This is certainly true as regards the conductance component caused by dielectric loss. The component caused by metallic loss is negligible at this low frequency. There may,

however, be a loss not previously considered. This occurs in dust layers on the plates and causes a conductance component which varies directly with the capacitance. If such a loss occurs in the standard, incorrect readings of conductance will be obtained.

It is interesting to note that, in measuring the conductance of a variable air condenser, only the differential dust loss can be deter-

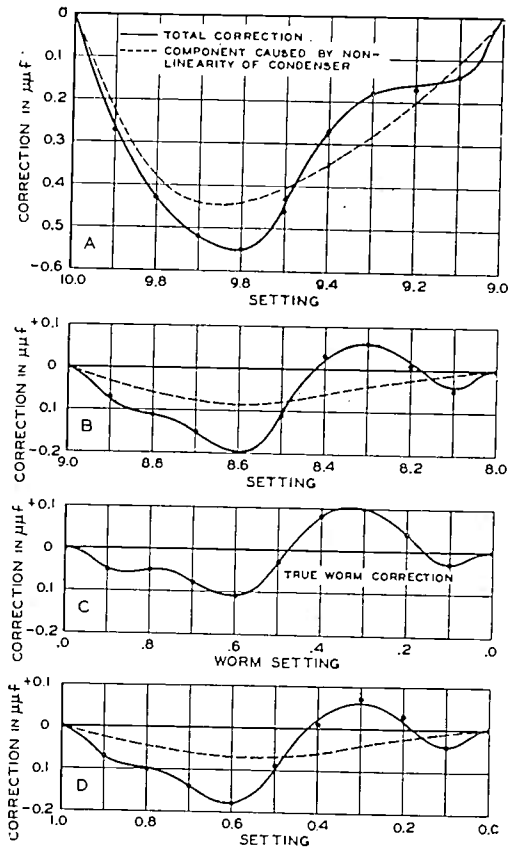

Fig. 17—Corrections for deviation from linearity in condenser calibration. Curve C is the average correction between a setting of 8.0 and a setting of 1.0.

mined. That is, if both the standard and unknown condensers are coated with equal layers of dust, the measured value of conductance of the unknown will be constant and equal to the component caused by the dielectric loss alone. If the standard be dusty and the unknown dustless, the apparent conductance will decrease linearly with the capacitance of the unknown. If the standard be dustless and the unknown dusty, the apparent conductance will increase linearly with the capacitance of the unknown.

The standards used in calibrating the 222-M condenser were clean and dustless. Fig. 18 shows the variation in the quantity G/ω for the 222-M before and after the plates were carefully cleaned. It will be observed that, within the limits of experimental error, the measured conductance is constant when the plates are cleaned. This does not show definitely that there is no conductance varying directly with the capacitance but merely that such a component is the same in both standard and unknown. There is, however, no reason to suppose that this component is appreciable when the dust has been carefully removed.

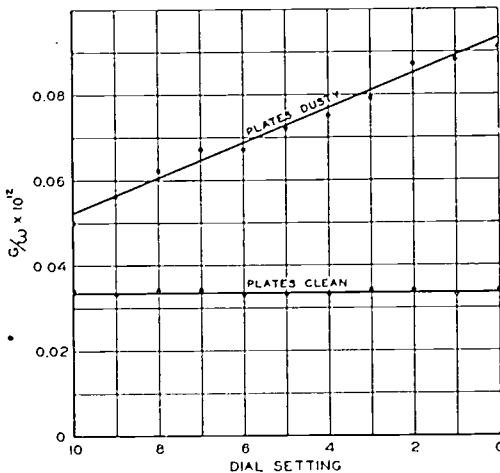
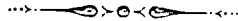

Fig. 18—Change in effective conductance of variable condenser at 1000 cycles caused by dust between the plates.

Bibliography

- (1) C. N. Weyl and S. Harris, "A method of measuring at radio frequencies the equivalent series resistance of condensers intended for use in radio receiving circuits," *Proc. I.R.E.*, vol. 13, p. 109-150; February, (1925).
- (2) C. D. Callis, "Measurement of the resistance of a condenser at radio frequency," *Phil. Mag.*, ser. 7, vol. 1, p. 428; February, (1926).
- (3) A. E. Maibauer and T. S. Taylor, "The variation of the resistance of condensers with dial setting at radio frequencies," *Phys. Rev.*, ser. 2, vol. 27, p. 251; February, (1926).
- (4) R. R. Ramsey, "The resistance of condensers at radio frequency," *Phys. Rev.*, ser. 2, vol. 27, p. 815; June, (1926).
- (5) R. R. Ramsey, "The resistance of high-frequency circuits," *Phil. Mag.*, ser. 7, vol. 2, p. 1213; December, (1926).
- (6) P. A. Cooper, "A new loss-measuring device and its application to high-frequency measurements," *Phil. Mag.*, ser. 7, vol. 3, p. 625; March (1927).
- (7) S. L. Brown, C. F. Weibusch, and M. Y. Colby "The high-frequency resistance of a Bureau of Standards type air condenser," *Phys. Rev.*, ser. 2, vol. 29, p. 887; June, (1927).
- (8) D. W. Dye, "Basic measurements of the resistance of condensers at radio frequencies," *Proc. Phys. Soc. (London)*, vol. 40, p. 285, (1928).
- (9) R. M. Wilmotte, "A quick and sensitive method of measuring condenser losses at radio frequencies," *Jour. Sci. Instr.*, vol. 5, p. 369; December, (1928).

- (10) G. W. Sutton, "A method for the determination of the equivalent resistance of air condensers at high frequencies," *Proc. Phys. Soc. (London)*, vol. 41, p. 126; February 15, (1929).
- (11) R. M. Wilmotte, "The comparison of the power factors of condensers," *Wireless Engineer and Experimental Wireless*, vol. 6, p. 656; December, (1929).
- (12) R. R. Ramsey and B. D. Morris, "Resistance of air condensers," *Phys. Rev.*, ser. 2, vol. 33, p. 1076; June, (1929).
- (13) R. R. Ramsey, "The variation of the resistance of a radio condenser with capacity and frequency," *Proc. I.R.E.*, vol. 18, p. 1226-1230; July, (1930).
- (14) E. B. Moullin, "A method of measuring the effective resistance of a condenser at radio frequencies and of measuring the resistance of long straight wires," *Proc. Royal Soc. (London)*, ser. A, vol. 137, p. 116; July 1, (1932).
- (15) W. Jackson, "The analysis of air condenser loss resistance," *Proc. I.R.E.*, vol. 22, pp. 957-963; August, (1934).



EDDY CURRENTS IN COMPOSITE LAMINATIONS*

BY

E. PETERSON AND L. R. WRATHALL

(Bell Telephone Laboratories, Inc., New York City)

Summary—The familiar theory of eddy current shielding leads to an expression for the impedance of a ferromagnetic core inductance coil in terms of the initial permeability and resistivity of the core material, the core geometry, and the measuring frequency. Measurements on a number of different core materials over a wide frequency range have revealed sizeable deviations from the theory in some cases. The discrepancies are especially marked in some specimens of chromium permalloy, the measured inductance over a certain frequency range being of the order of one tenth that specified by the theory.

It appears that discrepancies arise when the laminations are not homogeneous, a condition contrary to an assumption of the simple theory. The inhomogeneity takes the form of a thin surface layer which has a permeability much less than that of the interior. By etching off these surface layers, the initial permeability is increased, and discrepancies between the measured variations of impedance with frequency, and those calculated for a homogeneous sheet are removed almost completely.

The theory has been extended to take account of the surface layers, and agrees well with measurements on the original unetched laminations when plausible assumptions are made regarding the properties of the surface layer.

I

EDDY current shielding has been the subject of much study and investigation due to its importance in various fields of electrical engineering. The theory takes forms varying widely in complexity, depending upon the shape of the conductor in which eddy currents are induced, the nature of the impressed magnetic field, and the magnetic and electrical properties of the material itself. The theory assumes a comparatively simple form in the particular case of a homogeneous plane magnetic sheet having constant permeability, subjected to a sinusoidal magnetizing force.¹ The results for that case are applicable to the magnetic cores used in transformers and inductance coils, if the ratio of lamination thickness to lamination width is small. When the cores are made up of rings, an additional requirement for close approximation is that the ratio of lamination width to core radius be small. Finally, the assumption of permeability independent of magnetizing force is satisfactorily approximated in practice when the magnetizing force is sufficiently small.

* Decimal classification: R282.3. Original manuscript received by the Institute, July 22, 1935.

¹ Russell, "Alternating Currents," vol. 1, p. 491; Betz, *Jahrbuch*, vol. 26, no. 2, p. 29.

In several instances investigators² have found that the measured variation of inductance and resistance with frequency failed to check theoretical calculations, often by large factors. These discrepancies have been found in a number of different core materials. Since the theoretical analysis seems to be firmly grounded, explanations of these anomalies, advanced at different times, have taken the form of changes in the assumptions upon which the theory is based. These include the introduction of magnetic lag or viscosity, of nonlinear permeability at very low fields, and of nonhomogeneity of the core.

Each of these possibilities has been investigated in detail. The effect of magnetic lag appears upon analysis to be far too small to account for the observed results. To study the change in permeability with magnetizing force, measurements were made on several materials down to exceedingly low fields, at a frequency sufficiently low to render eddy currents negligible. In every case the variation of permeability with magnetizing force was found to be linear below a field characteristic of the material.³ The discrepancies existed, however, even when the field was taken so small that the permeability differed inappreciably from that corresponding to linear extrapolation to zero field. Finally the third possibility cited (nonhomogeneity) was definitely shown to be accountable for the discrepancies observed between the experiments and the theory formulated for homogeneous isotropic laminations.

In the section following we shall describe briefly the derivation of the expressions for inductance and eddy resistance of a coil having a homogeneous lamination as core. In the third section experimental findings are compared with these theoretical expressions and evidence is presented to support the idea that surface layers are responsible for the observed discrepancies. In the fourth section transmission line analogues for the simple and composite laminations are introduced to facilitate discussion of the phenomena involved in the composite lamination. The final section presents quantitative expressions for the inductance and eddy resistance of a coil having a composite lamination as core, and compares them with experimental results in specific cases.

² Discrepancies in the resistance at comparatively low frequencies, and in the inductance at higher frequencies, were pointed out by V. E. Legg and E. T. Hoch, respectively, in unpublished reports dating back a number of years. A comparatively recent publication dealing with the inductance discrepancy is that of Scott, *Proc. I.R.E.*, vol. 18, pp. 1750-1764; October, (1930).

³ The initial permeability is obtained by linear extrapolation to zero field of the curve relating permeability to magnetizing force. For this purpose the field is reduced to the region in which the initial rise of the curve is linear. Hydrogenized silicon steel exhibits a sudden drop in permeability at the low field corresponding to a flux density of 10 lines per cm², below which the curve again becomes linear. The other materials studied do not exhibit this effect, although data have been taken at flux densities as low as 0.1 line per cm².

II

With the simplifying assumptions mentioned in the first section, the properties of a ferromagnetic core coil may be deduced in a straightforward way. Setting up Maxwell's equations involving the magnetizing force H and electric gradient E in the magnetic core, and neglecting the displacement current, a linear differential equation of the second order is obtained for each of these two quantities. Taking E and H to vary sinusoidally with time, the equations then express the magnitudes of these vectors in terms of the distance " y " from the lamination center, as indicated in Fig. 1. The solution of either equation involves the sum of two exponential terms, each multiplied by an arbitrary constant. These two constants may be evaluated by reference to the boundary conditions that the magnetizing force at the two surfaces of the lamination is the same as that in the absence of a magnetic core.

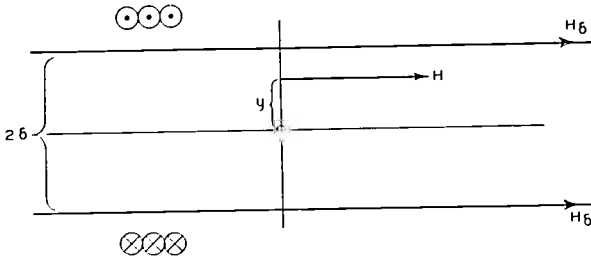

Fig. 1—Cross section of lamination of thickness 2δ , showing magnetizing forces H_δ at surface and H at distance y from lamination center. The vector H lies in the plane of the paper, and vector E (not shown) is perpendicular thereto.

The coil impedance due to iron reaction may then be deduced, since the electric gradient at the surface of the lamination is the same as the gradient in each turn encircling the lamination. The voltage across the coil due to the presence of the core is found by adding the gradients for the whole length of encircling winding and, since the current is known in specifying the magnetizing force, the impedance may be computed as the ratio of the two vectors. Carrying out the work, equations are obtained for the resistance R and inductance L at any frequency.⁴ For convenience these are expressed in terms of L_0 , the inductance at zero frequency. Thus,

$$A = \frac{1}{\theta} \frac{\sinh \theta \pm \sin \theta}{\cosh \theta + \cos \theta}, \tag{1}$$

⁴ The expressions for R and L include simply the components due to the presence of the ferromagnetic core. The resistance of the winding proper, the inductance of the air space within the winding, and the effects of shunt capacity are not included. Values of R and L are obtained from bridge measurements at sufficiently low fields by subtracting the winding resistance from the measured resistance, and by subtracting the estimated inductance due to the air space from the measured inductance.

where,

$A = L/L_0$ when the upper sign is used, and

$A = R/\omega L_0$ when the lower sign is used.

θ is conveniently expressed as

$$\theta = 2\pi \cdot 2\delta \sqrt{\mu\gamma f},$$

where 2δ is the lamination thickness in cm, μ is the initial permeability, γ the conductivity in micromhos/cm², and f the frequency in kilocycles, equal to $\omega/2\pi \cdot 10^3$.

The quantity θ is amenable to a simple physical interpretation inasmuch as it corresponds to the phase shift in radians, or the attenuation

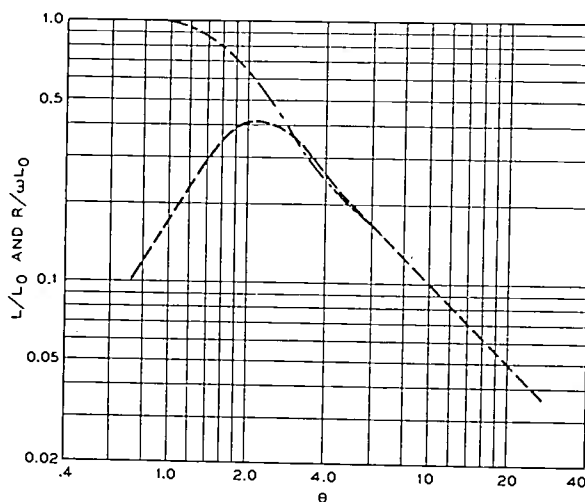

Fig. 2—Plot of (1), showing L/L_0 and $R/\omega L_0$ as functions of θ . The two curves practically coincide for θ greater than three where they approach the value $1/\theta$.

in nepers, which an electromagnetic wave encounters in traveling from one surface of the lamination to the other. By using this variable⁵ and the ratios L/L_0 and $R/\omega L_0$, it is evident that the performance of any coil satisfying the initial assumptions can be represented by (1). When the core is made up of a number N of similar insulated laminations, the distribution of flux density and magnetizing force in any one of them is independent of the presence of the others and (1) remains valid. The electric gradient, and the impedance corresponding, are N times that for a single lamination.

Plots of L/L_0 and $R/\omega L_0$ in terms of θ , obtained from (1), are shown in Fig. 2. It will be observed that the inductance varies but little up to θ equal to unity and then decreases, L/L_0 approximating $1/\theta$ for θ

⁵ The impedance is sometimes expressed in terms of the so-called skin thickness s , where $s = 2\delta/\theta$.

greater than three. The resistance curve ($R/\omega L_0$) increases linearly on the logarithmic scale at low frequencies, passes through a maximum, and practically coincides with the inductance curve when θ exceeds three. The phase angle of the coil passes through a maximum of about 47 degrees where the resistance curve passes above the inductance curve, and finally approaches 45 degrees.

III

To determine the extent to which the above theory applies, a number of different magnetic materials were used as cores of inductance coils. In agreement with previous investigators, deviations from the theory were found in some materials—larger resistance at small values of θ , and smaller inductance and resistance at large values of θ than specified by theory. Three classes of performance may be distinguished. In fourteen-mil specimens of silicon steel, hydrogenized silicon steel, nickel, permivar, and 78 per cent permalloy, the measured values of L/L_0 and $R/\omega L_0$ checked with the theory within experimental error up to θ equal to ten. In the next class, including specimens of soft iron, 45 per cent permalloy, and 3.8 per cent molybdenum permalloy, the measured inductances agreed with the theory at low values of θ , but were 30 per cent low at θ equal to ten. Deviations in the resistance curves were much smaller. Finally one material, 3.8 per cent chromium permalloy, exhibited much larger discrepancies; for example, the measured inductance shown in Fig. 3 is of the order of one fifth that given by the simple theory at θ equal to ten. Curves for the other deviating materials follows the same general course as those for chromium permalloy, but the deviations were much smaller, as indicated above.

The size of the deviation was found to depend upon the thickness of lamination, being larger for the thinner laminations at a given value of θ over the particular frequency range studied. In this connection it is of interest to see how the initial permeability of a given material is changed as the lamination thickness is progressively reduced by a factory rolling process, in which no particular care was taken in handling the material. For 3.8 per cent chromium permalloy the initial permeability was found to decrease as the sheet was rolled down and reannealed. The specific conductivity of the material, however, was found to be practically constant over the range of thicknesses. This suggests the presence of a low permeability skin which becomes more prominent as the sheet thickness is reduced.

To determine whether or not surface layers were responsible for the observed performance, the surfaces were etched off from some of the materials that showed deviations from the theory. In most cases two

mils or more were etched from each surface. In every case the permeability of the etched lamination was higher than it was before etching.

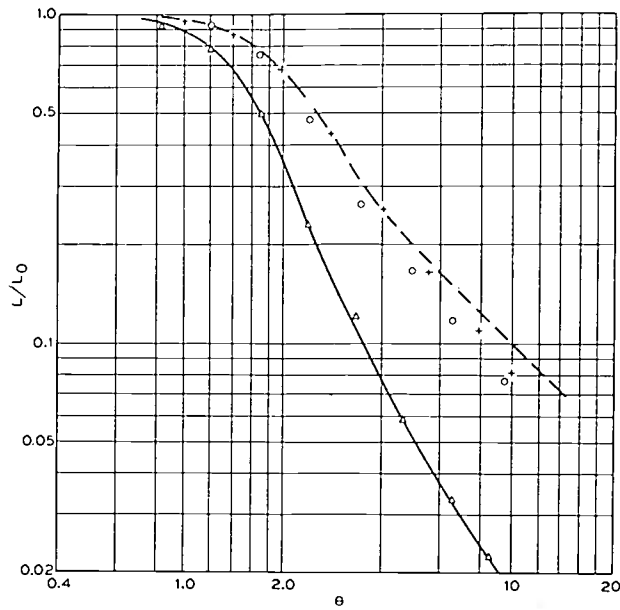

Fig. 3— L/L_0 as function of θ for 14-mil laminations of 3.8 per cent chromium permalloy (triangles). Dashed line gives theoretical values of (1). After etching two mils from each surface, values indicated by circles were obtained. Etching an additional half mil from each surface gave values (crosses) agreeing somewhat more closely with the simple theory.

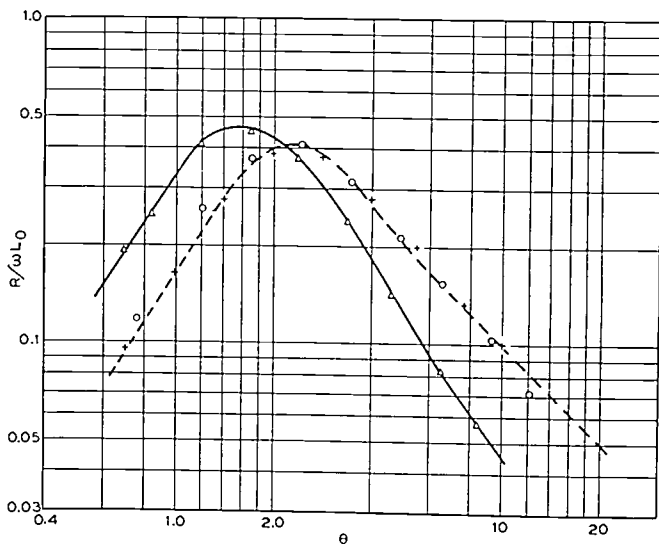

Fig. 4— $R/\omega L_0$ corresponding to the conditions of Fig. 3.

Further, in every case the deviations between theoretical and measured values of inductance and resistance over the frequency range were reduced substantially as illustrated by Figs. 3 and 4, and by Table I.

TABLE I

Material	2δ mils	μ ₀	Measured		Calculated
			L/L ₀	R/ωL ₀	L/L ₀ and R/ωL ₀
3.8% Cr. Perm.	14	4,400	0.0095	0.046	0.1
3.8% Cr. Perm.	9*	5,900	0.078	0.097	0.1
3.8% Cr. Perm.	101	13,300	0.0031	0.0067	0.01
Soft Iron	94*	14,500	0.0090	0.011	0.01
Soft Iron	32	260	0.071	0.094	0.1
45% Perm.	24*	325	0.100	0.102	0.1
45% Perm.	14	2,000	0.058	0.085	0.1
45% Perm.	10*	2,050	0.098	0.101	0.1

*Etched. Note that the measuring frequency was changed after etching to maintain the same value of θ.

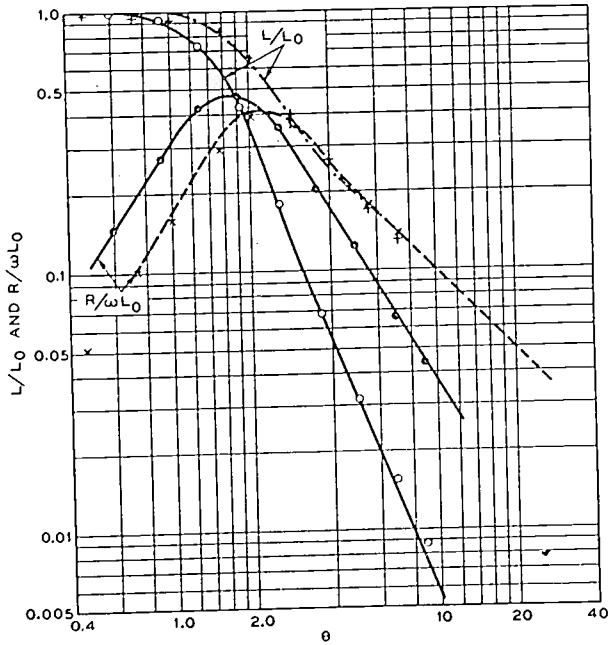

Fig. 5— L/L_0 and $R/\omega L_0$ as functions of θ for 28-mil silicon steel laminations. The dashed lines are theoretical values calculated from (1) and the crosses measured values. The dots are measured values after plating the laminations with 0.3 mil of copper. The solid lines are calculated for the plated material from (3).

This evidence supports the idea that a surface layer of low permeability exists, and that its presence leads to the observed deviations from the theory for uniform laminations. The processes of mechanical working and of heat treatment to which the laminations were subjected in their manufacture seem to be responsible for its presence.

Another experiment was performed to illustrate the surface layer effect. Starting with silicon steel laminations which follow the theory quite closely, a thin layer of copper was plated on the laminations. The resistance and inductance curves for the composite laminations, shown in Fig. 5, follow the same general course as those for unetched laminations of chromium permalloy shown in Figs. 3 and 4.

IV

Discussion of the phenomena connected with the flow of eddy currents is sometimes facilitated by reference to a physical picture of the propagation of electromagnetic waves in the lamination. Such a physical picture may be provided by simulating the propagation of electric gradient and magnetizing force in the lamination, to the propagation of voltage and current, respectively, in a transmission line.⁶ In this way the information available on transmission lines may be brought to bear upon the problems of propagation in the lamination.

The structure of the line equivalent in its propagation characteristics to those of the linear homogeneous lamination is shown in Fig. 6. There the series element has an inductance proportional to the initial permeability, and the shunt element has a resistance proportional to

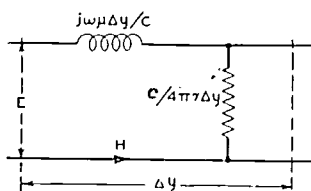

Fig. 6—Differential element of a transmission line, analogous in its properties to those of the magnetic lamination. Here the electric gradient E (e.s.u.) is taken as the potential drop across the element, and the magnetizing force H (e.m.u.) is taken as the line current. The series inductance is proportional to the initial permeability, and the shunt resistance is proportional to the specific resistivity of the lamination material. c represents the velocity of light (cm/sec).

the resistivity of the material. It may be verified readily that the equations corresponding to propagation along the uniform line, made up of these elements, are identical with those for the lamination, as they must be to provide similar characteristics. For this purpose not only the differential equations, but also the boundary conditions of the lamination and of the line must coincide.

To make the boundary conditions of the lamination coincide with those of the equivalent line, the two terminals of the line, which correspond to the two surfaces of the lamination, must be connected together in series so that the same current flows into each end and the same potential drop exists across the two terminals. (Fig. 7.) With this picture it is easy to see that when the frequency is so low that the series reactance is small compared to the shunt resistance, the impedance of the line is nearly that of a pure inductance equal in value to the sum of the individual inductance elements. When the frequency

⁶ Howe, *J.I.E.E.* (London), vol. 54, no. 258, (1916); Wolman und Kaden, *Zeit. für Tech. Phys.* vol. 13, no. 7, (1932).

is raised sufficiently to make the series reactance approach the shunt resistance, the attenuation through the line becomes appreciable and increases with frequency. At high attenuations there is no appreciable transmission from one end of the line to the other, so that we may regard the equivalent network as made up of two infinite lines with their

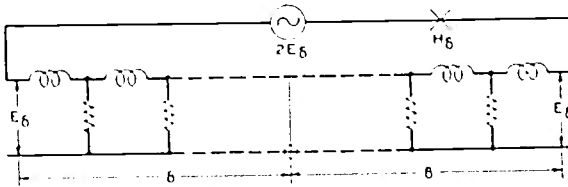

Fig. 7—Terminal conditions for the equivalent line. Here E_3 represents the electric gradient and H_3 the magnetic gradient at the lamination surface.

input terminals in series. In this case the input impedance, according to transmission-line theory, is proportional to the square root of the product of the series and shunt impedances. This yields a phase angle of 45 degrees, both resistive and reactive components being proportional to the square root of frequency. In this particular line it should be noted that the attenuation constant is equal to the phase constant. To take a particular value, when the phase shift through the lamination is 2π radians, the attenuation is 2π nepers (54.6 decibels) which corresponds to a reduction in amplitude to $1/537$.

The effect of the surface layer may now be discussed with the aid of the transmission-line analogue. The equivalent line shown in Fig. 8 is now made up of two types of sections,⁷ the section near the terminal of length δ_2 having low inductance series elements characteristic of the low permeability surface material (μ_2) and the inner section of length

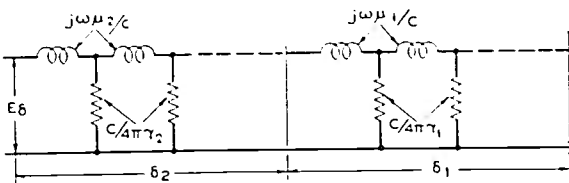

Fig. 8—Structure of transmission line equivalent to lamination provided with a surface layer. The structure is symmetrical about the origin, only one half being shown.

δ_1 having high inductance elements characteristic of the body of the material (μ_1). The shunt resistance elements are equal in the two sections. At low frequencies the surface material has comparatively little effect since its attenuation and phase shift are small. At higher frequencies, however, the attenuation and phase shift of the surface

⁷ Neglecting any possible transition region between them.

material are appreciable, the body of the material is screened, and an additional loss due to the mismatched impedances at the junction arises. For this reason the inductance at low frequencies starts out near the level characteristic of the high permeability material, but at high frequencies it descends to the much lower value which it would have if the whole lamination were constituted of the surface material alone.

V

These qualitative conclusions may be verified by calculations carried out on the equivalent transmission line,⁸ or by direct application of Maxwell's equations. When the appropriate boundary conditions are taken into account we get in place of (1)

$$A = \frac{\sinh \theta_2 \pm \sin \theta_2 + 2k(Y \cosh \theta_2 \pm X \cos \theta_2)}{\theta_2(1 + K) [\cosh \theta_2 + \cos \theta_2 + 2k(Y \sinh \theta_2 - X \sin \theta_2) + k^2(X^2 + Y^2)(\sinh \theta_2 \mp \sin \theta_2) + k^2(X^2 + Y^2)(\cosh \theta_2 - \cos \theta_2)]}, \quad (3)$$

where,

$A = L/L_0$ when upper signs are used, and

$A = R/\omega L_0$ when lower signs are used.

$$\theta_1 = 2\pi \cdot 2\delta_1 \sqrt{\mu_1 \gamma_1 f}, \quad \theta_2 = 2\pi \cdot 2\delta_2 \sqrt{\mu_2 \gamma_2 f}, \quad K = \frac{\mu_1 \delta_1}{\mu_2 \delta_2},$$

$$k^2 = \frac{\mu_1 \gamma_2}{\mu_2 \gamma_1}, \quad Y = \sinh \theta_1 / (\cosh \theta_1 + \cos \theta_1), \quad X = \sin \theta_1 / (\cosh \theta_1 + \cos \theta_1).$$

To test (3), calculations were carried out for the copper-plated silicon steel laminations previously mentioned. It will be observed that the agreement between theory and experiment shown in Fig. 5 is close.⁹ The equation was next applied to the measured results on chromium permalloy, assuming a surface layer one mil thick of per-

⁸ The transmission analogue has been of service in evaluating the effects of such complicating factors as magnetic hysteresis and magnetic viscosity. To account for hysteresis, the series arm must include in addition an inductance and a variable resistance proportional to frequency, the magnitudes of both varying linearly with magnetizing force. To account for magnetic viscosity, so called, a resistance proportional to frequency and independent of H must be included in the series arm. The presence of magnetic aftereffect, analogous to the dielectric aftereffect investigated by Debye, has been evaluated by R. R. Thompson by inserting a parallel combination of resistance and inductance in the series arm.

⁹ It should be noted that the values of θ used in plotting curves for composite laminations are obtained from the measured values of permeability and conductivity at low frequency. Thus,

$$\theta = 2\pi \cdot 2(\delta_1 + \delta_2) \sqrt{\mu \gamma f}$$

where,

$$\mu = (\mu_1 \delta_1 + \mu_2 \delta_2) / (\delta_1 + \delta_2)$$

$$\gamma = (\delta_1 \gamma_1 + \delta_2 \gamma_2) / (\delta_1 + \delta_2).$$

meability 250, and an inner layer with permeability high enough to give the observed average permeability. The results shown in Fig. 9 are in fair agreement with experiment, considering the approximations used. It appears hardly possible, in general, to deduce precisely the characteristics of the surface skin by means of measurements made on the lamination before and after etching, since etching may be expected to relieve strains in the body of the material and so change the permeability.

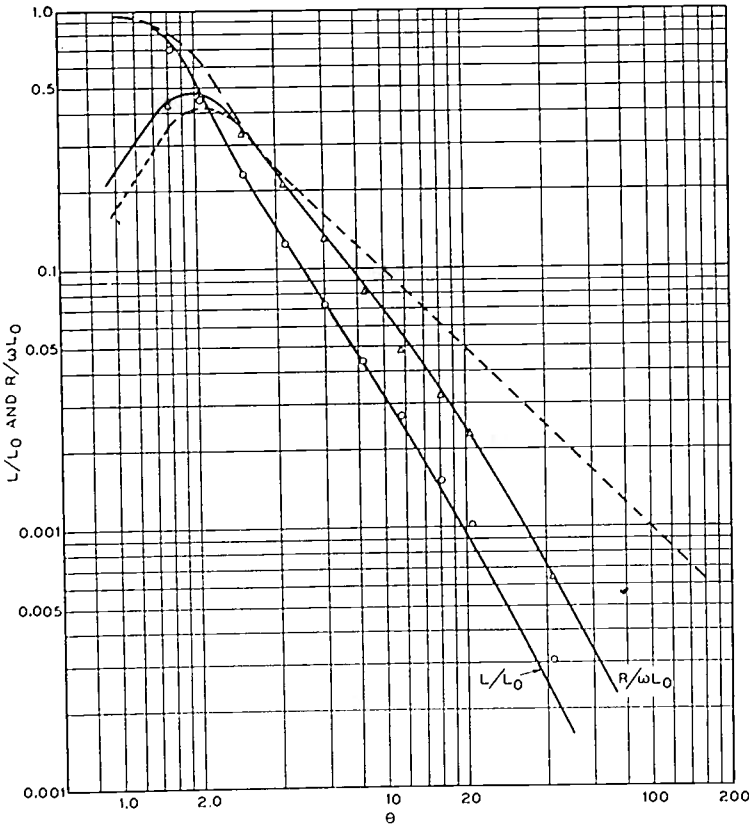

Fig. 9— L/L_0 and $R/\omega L_0$ as functions of θ . Dashed lines from (1). Solid lines from (3), for chromium permalloy lamination with $\delta_1 = 6$ mils, $\delta_2 = 1$ mil, $\mu_1 = 14,600$, $\mu_2 = 250$, $\gamma_1 = \gamma_2$. Circles and triangles represent measured values of 14-mil chromium permalloy tape with an initial permeability of 12,500.

In discussing the experimental results it was noted (Section III, Paragraph 2) that the magnitude of the deviation from the simple theory depended upon the thickness of lamination at a given θ . This effect is illustrated in Fig. 10, which shows L_1/L_0 in terms of θ plotted from (3). Four different composite lamination structures were assumed, the half thickness of the inner material (δ_1) being taken at 2, 6, 24, and 50 times the thickness of each surface layer (δ_2) which was fixed at one mil. Equal conductivities were assumed for the two

layers, and the permeabilities were taken as 16,000 for the body of the material, and 250 for the surface layers. It will be observed that the deviations are larger for the thinner laminations over the smaller values of θ , in agreement with experimental observations. At larger values of θ the curves all approach a straight line, having the

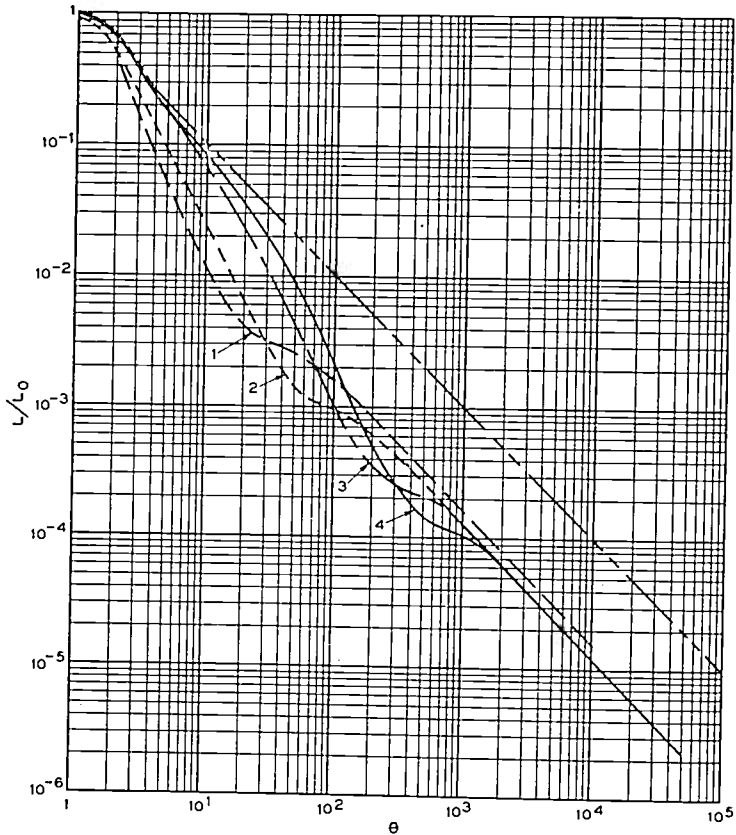
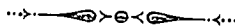

Fig. 10— L/L_0 as function of θ plotted from (3) for four composite laminations. $\delta_2=1$ mil, $\mu_2=250$, $\mu_1=16,000$, $\rho_1=\rho_2=56 \times 10^{-6}$ ohms/cm³ throughout. δ_1 is the parameter with values 2, 6, 24, and 50 mils for curves 1, 2, 3, and 4 respectively. Dashed line plotted from (1) from comparison.

same angle of 45 degrees as does the plot of the simple theory, but dis-

placed from it by the factor $\left[\frac{\mu_2}{\mu_1} \left(1 + \frac{\delta_2}{\delta_1} \right) \right]^{1/2}$. Equation (3) gives

$A = 1/\theta_2(1+k)$ when both θ_1 and θ_2 are much greater than unity. The above factor is then obtained by expressing θ_2 in terms of θ in the above limiting form for A when $\mu_1\delta_1$ is much greater than $\mu_2\delta_2$.



CATHODE-RAY OSCILLOGRAPHIC INVESTIGATIONS ON ATMOSPHERICS*

BY

HARALD NORINDER

(Institute for High Tension Research, University of Uppsala, Sweden)

Summary—An analysis of the true nature of the wave forms of atmospheric, when they show rapid time variations, can easily be obtained by using cathode-ray oscillographs with very high speed recording. The author describes the arrangement that he has used for recording and analyzing atmospheric, with his relay construction of high voltage cathode-ray oscillographs. These instruments were connected through amplifiers to horizontal aeriels having different heights above the ground.

A passing atmospheric produced voltage changes across a resistor inserted in the antenna system, which, provided that special precautions were taken, gave the dE/dt variations of the field E . By applying an integration procedure to the records, it was possible to obtain the true field curves $E(t)$ of the corresponding atmospheric. These observations were made at field stations located in the vicinity of the Institute of High Tension Research, University of Uppsala, Sweden. The results of observations made between February and August, 1934, are dealt with in this paper. About 7500 atmospheric were recorded, of which 600 were selected as typical, and have been integrated.

The total duration times of individual atmospheric that were most frequently observed lay between 100 and 150 microseconds. When periodic or quasi-periodic variations were observed, about sixty per cent of such atmospheric showed a periodicity of between five and ten kilocycles per second.

The atmospheric frequently occurred in groups composed of a number of separate and individual field variations. The time duration of about seventy per cent of such groups was within 5×10^{-2} seconds. The most preponderant value of the amplitude was 0.25 volt per meter, but values between 0.25 and 0.50 volt per meter were also frequent.

The wave front slopes most frequently observed during the winter and spring months lay between 5 and 10×10^{-3} volts per meter per microseconds. In June values up to 100 to 200×10^{-3} volts per meter per microsecond were very often recorded.

About 450 oscillographic records of visible lightning discharges occurring within twenty kilometers of the observation post gave characteristic wave forms in which several consecutive discharges, very often of similar discharge character, passed through the same lightning path. Wave form types of the same character were often observed in atmospheric occurring during typical thunderstorm conditions. Atmospheric of this thunderstorm type were found to have more complicated wave forms than those of atmospheric observed during undisturbed conditions.

Observations of the disturbing sounds occurring in ordinary radio receivers showed characteristic differences between the atmospheric which caused the clicks and those which gave rise to the grinders or hisses. The former consisted of a short wave form having a duration less than 200 microseconds. The grinders or hisses originated in groups of consecutive atmospheric, the duration of which sometimes extended over one thousand microseconds or more.

* Decimal classification: R114. Original manuscript received by the Institute, January 30, 1935.

INTRODUCTION

THE investigations of atmospherics which are described in this paper,¹ commenced with some earlier researches on the variation of the electric field set up by lightning discharges during thunderstorms. During our first experiments on this problem in 1921 we made use of ordinary sealed high voltage Braun tubes as indicating instruments. The deflecting plates of the tubes were connected across resistances joined between an antenna circuit and earth. During thunderstorms, lightning discharges occurring at suitable distances set up rather complicated but very characteristic voltage variations in this circuit. The general form of these variations could be observed visually on the screen of the cathode-ray tube. During these experiments the interesting and important observation was made, from a comparison between the observed disturbances in the form of atmospherics in the loud speaker of a radio receiving set and the observed voltage variations in the antenna circuit, that there was a possibility of employing the cathode-ray oscillograph to record the wave forms of atmospherics. In our first observations of this type, the atmospherics had been caused by discharges occurring in distant thunderstorms. It was then noted also that the wave forms of the voltage changes, arising from impulses passing over the antenna circuit system, were too complicated and rapid to permit of exact visual observation using a sealed cathode-ray tube of the usual pattern. Our efforts were thus from the beginning concentrated upon the construction of self-recording cathode-ray oscillographs sufficiently sensitive and rapid enough to record impulse wave forms of the order of microseconds in duration.

Our first experiments in the application of our specially constructed cathode-ray oscillograph to the problem of recording atmospherics were rather sporadic; and it was not until the beginning of 1934 that an opportunity arose of more extensive work on the subject. The first results are published in this paper.

Investigations of atmospherics by using a visual cathode-ray oscillographic method have, as we know, been executed in the English observations at Slough and other stations by Appleton, Watson-Watt, and Herd.²

The Scope of the Observations

Between February and August, 1934, we have recorded about 7500 atmospherics, and these records were extensive enough to permit of

¹ This paper covers with small additions the author's communication in the section of atmospherics at the Plenary Congress of the International Scientific Radio Union in London, September 11 to 19, 1934.

² E. V. Appleton, R. A. Watson-Watt, and J. F. Herd, "On the nature of atmospherics," I, II, III, *Proc. Roy. Soc. A*, London, vol. 103, p. 84 (1923), vol. 111, p. 615 (1926).

the detailed analysis of about 600 separate atmospherics which we have selected as typical for this observation period.

Atmospherics of the most common type occurred between February and June. During July and August thunderstorms were very frequent in Sweden, and this had a special influence on the type of atmospherics then prevalent. The usual types arising from these distant sources, became much mixed up with those which obviously had their origin in thunderstorms not very far away from the locality of the observations.

Method of Observation—The Recording Instrument

A specially constructed cathode-ray oscillograph, as has already been mentioned, was found to be necessary when we desired to record

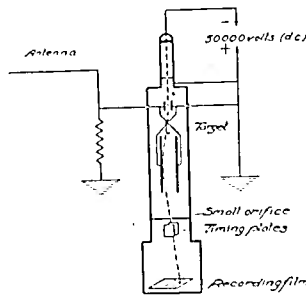

Fig. 1—Cathode-ray oscillograph with relay arrangement.

atmospherics; and this was arranged so that the electron beam in the instrument functioned as a relay. This arrangement, which is peculiar to the author's cathode-ray oscillograph construction, is illustrated in detail in Fig. 1.

The cathode-ray beam is stopped first by a small target. When a voltage impulse is applied to the upper pair of deflecting plates, the cathode-ray beam is bent away from the target. Below the target the beam is bent back again by the same voltage impulse which is applied reversed to a second pair of deflecting plates. The beam then passes through a small orifice below which are placed the deflecting plates of the timing circuit. The cathode-ray beam will thus fall upon the recording film only during the passage of the impulse, so that the target produces a characteristic zero line or band shadow in the oscillograms, which can be seen in those here reproduced. In the majority of cases there is no difficulty in interpolating to determine the path of the beam across this zero band.

This relay arrangement was found very convenient particularly as it was obviously not possible to know beforehand the time of arrival of the atmospheric. The often very complicated nature of the wave

forms of the atmospherics prevented the use, without great difficulties, of external relay arrangements utilizing electron tube circuits.

Field Stations and Antenna Arrangements

Horizontal antenna wire systems were used in our investigations, and the observations were made both in fixed and in movable field stations. One of the latter is depicted in Fig. 2, and the interior installation itself, with two cathode-ray oscillographs, in Fig. 3.

At the fixed station, two horizontal antenna wires, of different lengths, were used. The higher was 27 meters high, and had a length

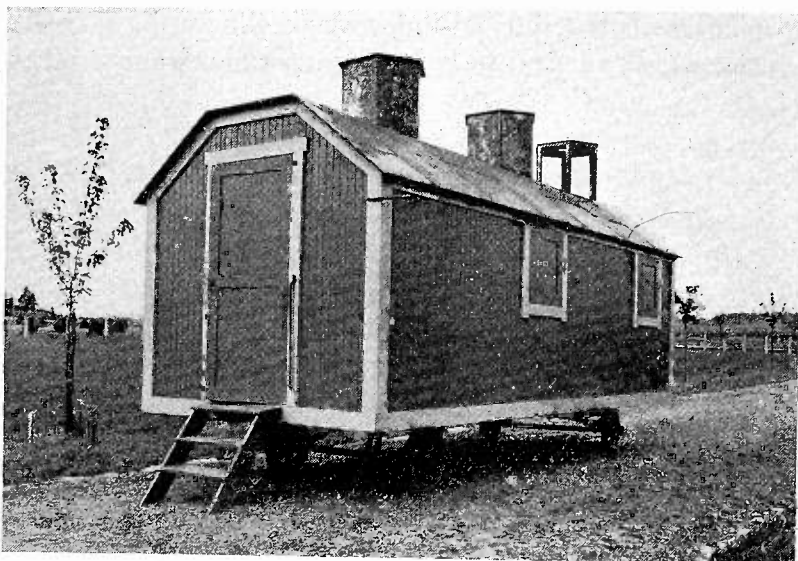

Fig. 2—A movable field station for recording atmospherics.

of 90 meters; the other was 7.2 meters high and 100 meters long. The movable station had an antenna length of 105 meters, with a height of 19 meters. From consideration of the capacities of the antenna systems and the values of the resistances used, the time constant was in most instances less than three microseconds.

Methods of Measurement and Calculation

The method used involved a measurement and a calculation. We observed the voltage variations across the ends of a resistor inserted between the aperiodically damped antenna and the earth. These voltage variations were obviously produced by the passage of an atmospheric within the field region of the antenna system, and this method gave a record in the cathode-ray oscillograms of dE/dt curves. In order to calculate the corresponding field curves $E(t)$ in volts per meter

it was necessary to apply an integration process. The fundamental formula used was³

$$E(t) = \frac{1}{fhRC} \int_0^t V dt \quad (1)$$

where f is the amplification factor, h is the height, R the resistance, C the capacity, and V the voltage variation in the circuit across R during the time of the record.

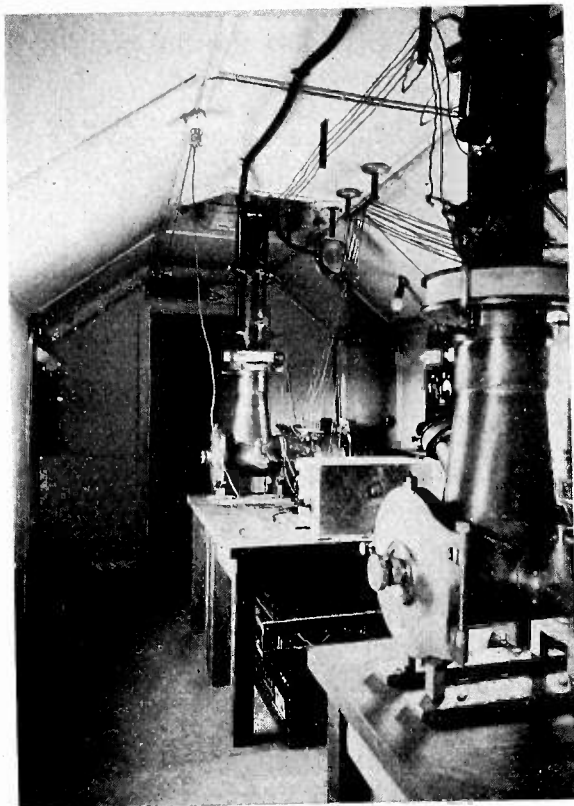

Fig. 3—Installation of cathode-ray oscillographs and amplifier in a field station.

The Amplifier

The atmospheric discharges gave rise to relatively small voltage variation across the resistance of the circuit, and it was then necessary to make use of an amplifier, connected between the antenna system and the oscillograph.

The short time of duration of the atmospheric discharges and their sometimes steep wave front necessitated taking some precautions in the

³ For derivation and discussion see Harald Norinder "On the nature of lightning discharges," *Jour. Franklin Inst.*, vol. 218, page 722; December (1934).

construction of the amplifier. In most of our tests, we used a two-stage amplifier with a gain which was usually adjusted to a value of 800. In some cases, and particularly when the thunderstorms were close, we used a separate single tube amplifier with a gain of seventeen.

The effect of the amplifiers on impulses having much steeper wave fronts than those encountered in atmospherics was investigated. The tests showed them to be very satisfactory as regards distortion within the limits of the observed wave form of atmospherics. Some check records taken simultaneously on the same atmospheric on the antenna systems with differing heights also showed good agreement.

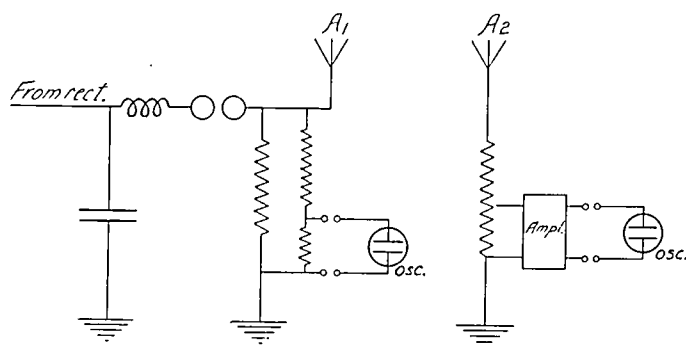

Fig. 4—Circuit diagram for control tests.

Direct Tests on the Reliability of the Recording Method

In order to verify the method of calculation we found it necessary to make a check on the observational method by means of some direct control tests. An impulse generator was set up which was adjusted so as to produce impulses having the same duration and wave form as for the common atmospherics. The impulse from this generator was impressed upon a horizontal aerial by means of which the impulse was radiated in free space. The effect of this impulse was observed using a receiving antenna connected to the movable field station, which included amplifiers and cathode-ray oscillographs. Fig. 4 gives a diagram of the arrangement. By using the movable field station it was also possible to record the impulse sent out on the transmitting antenna without using the amplifier. In this case a potentiometer was used as detailed in A₁ of Fig. 4. The two records so obtained are reproduced in Fig. 5.

The impulse wave form recorded directly across the resistance (see circuit A₁ in Fig. 4) is reproduced on a linear time scale in the dotted curve of Fig. 6, which shows also in the full curve the result of integrating the oscillograph record of the same impulse as received through the amplifier on the receiving antenna system (see circuit A₂

of Fig. 4). Comparing the curves in this manner shows a very good agreement. The small difference which can be seen between the two curves does not originate from distortion in the amplifier, as has been verified with much steeper wave fronts. This small difference is caused by a local field disturbance in the vicinity of the transmitting antenna system.

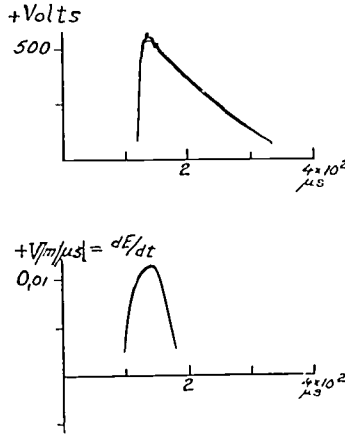

Fig. 5—Oscillograms of transmitted and received control test impulses.

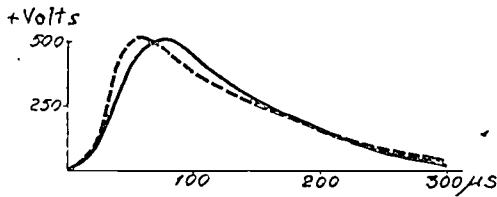

Fig. 6—Test impulse records from sending antenna (dotted curve) and corresponding impulse by integration (curve in full) from receiving antenna through amplifier.

RECORD WITH RAPID TIME SCALE

Some Common Types of Atmospherics

Before reproducing the most common types of atmospherics it is necessary to explain how the records were taken. While the records were being taken we used two oscillographs connected in parallel. One of these instruments was arranged for visual observations and the other for obtaining photographic records simultaneously. With this oscillographic system set up ready for use, when we noticed by visual observation a sufficient number of atmospherics, we made an exposure in the other oscillograph. The duration of the exposure time was controlled by the visual observations on the atmospherics appearing on the fluorescent screen of the oscillograph. The duration of the record could

thus be varied between a few tenths of a second up to about twenty seconds. In some of our earlier observations we used oscillators giving sinusoidal time axis. This type of time scale necessitated replotting the curves to a linear time scale. To avoid this inconvenient and laborious operation we developed oscillators to give a time base which should be linear within the accuracy of reading the curves. This time oscillator could be adjusted to give a time of sweep of the oscillograph beam which at the time proved most convenient for the type of atmospherics and the wave forms which were observed.

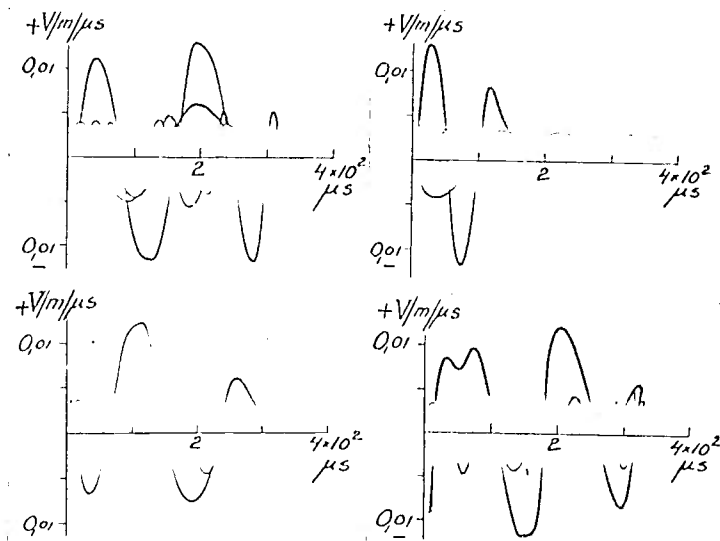

Fig. 7—Original oscillographic records of atmospherics.

In most cases the atmospherics were very numerous and followed one another with very small time intervals. In such cases the antenna system was obviously bombarded by consecutive sets of impulse groups frequently following very closely upon one another. When this occurred great care had to be taken when using the rapid time scale, otherwise oscillograms were obtained which were too difficult to follow and analyze in their details.

From about 7500 records of atmospherics which have been obtained in this way, we have selected 600 individual records which we have analyzed and integrated in order to determine the corresponding field or $E(t)$ curves as defined by (1). In the following statistical treatment of the atmospherics we have made use of these 600 typical records, and in consequence the results must be taken with some reservation on account of the number of the observations.

Characteristic Types of Wave Form

Some examples of atmospheric records are reproduced in Figs. 7 and 8 the curves of which are copied from the original oscillograms. In obtaining these records we have used for some years past with good results ordinary negative photographic film.

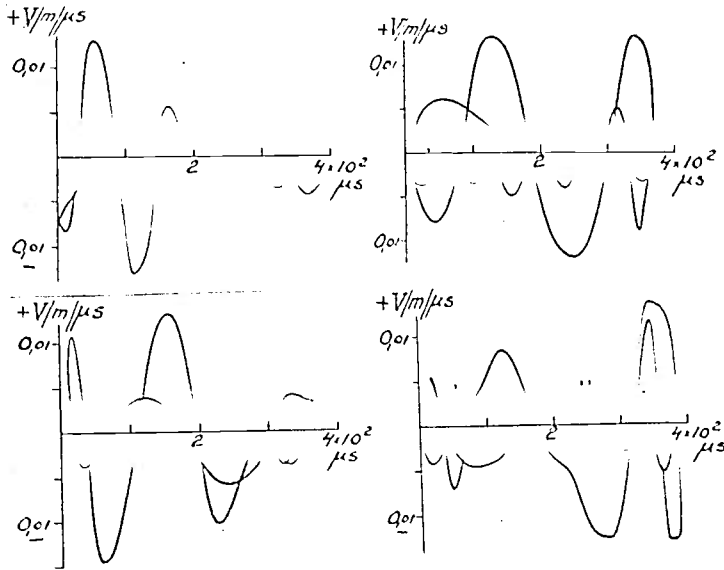

Fig. 8—Original oscillographic records of atmospherics.

A close examination of the recorded dE/dt curves showed sometimes very complicated wave forms, and it is easily understood that visual observations of such complicated wave forms must fail to give

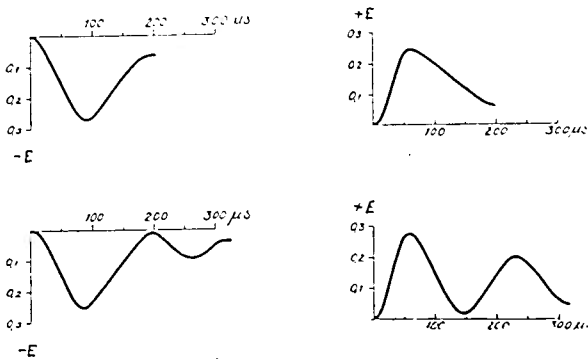

Fig. 9—Typical atmospherics as selected from 600 integrated curves.

exact reproductions of them. Such complicated wave forms are, as can easily be shown from the theoretical basis of our method, in some cases resultant from the dE/dt method. Voltage changes in the electric field of relatively small amplitude but great rapidity of change, are accentuated.

ated by the dE/dt method. We have sometimes observed that double or triple polarity changes in the recorded dE/dt curves do not occupy more than 100 microseconds, and it is obviously quite impossible to try to record such wave forms in true details by visual method.

Of the 600 typical atmospherics which have been integrated, we have selected some which we consider particularly typical. Some of these are reproduced in Figs. 9 to 12.

The wave forms of the atmospherics reproduced in Figs. 9 to 12 show in some cases very marked differences. Some of the types are similar to some which we have observed in connection with discharges during thunderstorms. Some, however, are not similar to such dis-

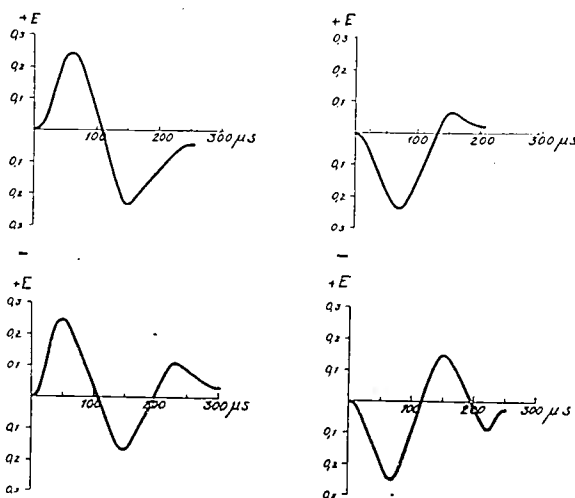

Fig. 10—Typical atmospherics as selected from 600 integrated curves.

charge types as were known from thunderstorm observations. At the present stage of our investigations it is not yet possible to give a full explanation of how these different wave forms originate from the discharges in the atmosphere. It will be necessary to extend our investigations in certain directions before we can hope to give any possible explanation with regard to the origin of these different types of atmospherics.

In some of the electric field curves we note that the initial and end values of the field are zero. With few exceptions such atmospherics arrive from very different sources. When, however, the source of the atmospherics is not very far away (see Fig. 12) we have often observed a very marked difference between the initial and end values of the electric field. Theoretical reasons can be advanced to explain such differences from near-by discharges.

The physical conditions for these different types of atmospherics

caused by primary electric discharge procedures in the atmosphere are intimately related to the possible current variation forms in the atmosphere. We are preparing for a study of such current variation forms and

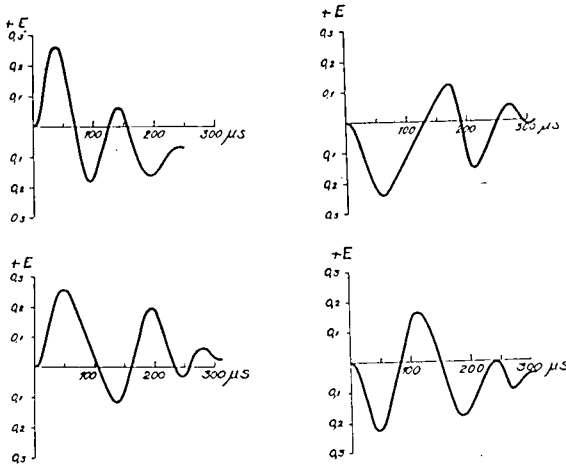

Fig. 11—Typical atmospherics as selected from 600 integrated curves.

intend to analyze the corresponding variation forms of the atmospherics in connection with this work.

As regards the time intervals between the atmospherics, our observations show that during certain periods the atmospherics occur very sporadically, but in others they arrive in fairly regular sequence. Thus it is easy to explain how such groups of atmospherics will be able

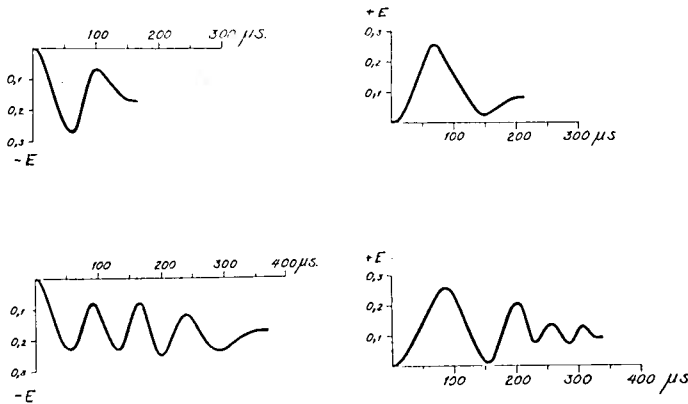

Fig. 12—Typical atmospherics as selected from 600 integrated curves.

to produce entirely different kinds of disturbances in radio receivers, and give rise to disturbances which are known under various typical designations. The general character of the sounds heard in the receiver obviously depends to a great extent upon the time periodicity of such atmospherics. The frequency with which the atmospherics pass the

aerial antenna is also of great importance in this respect and we hope to put forward an explanation based on this in another paper.

Considerable caution must thus be exercised in endeavoring to classify atmospheric in accordance with the different types of sounds which they give rise to in the radio receiver. Such methods can very easily lead to results which have only a quantitative classification value and no proper physical meaning.

The Total Durations of Selected Individual Atmospheric

The numerical distribution of atmospheric having different duration times is depicted by the curve in Fig. 13. The most frequent ones have duration times of 100 to 150 microseconds.

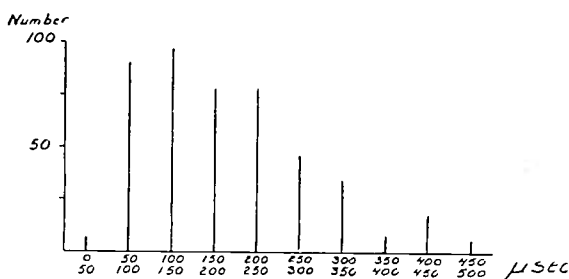

Fig. 13—Distribution of duration times of 600 atmospheric.

We have observed a seasonal tendency in the total duration times of atmospheric, which is illustrated by the curves of Fig. 14. Shorter

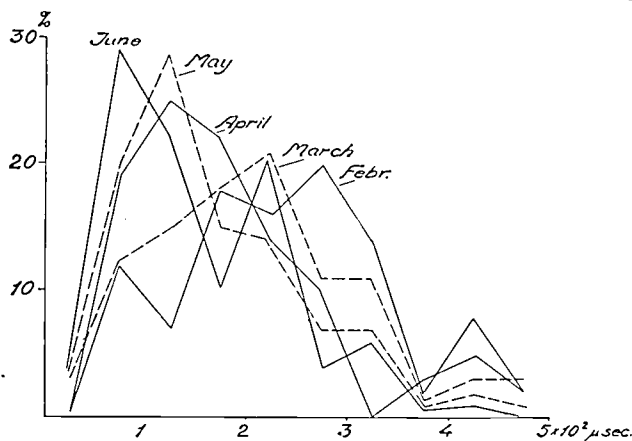

Fig. 14—Seasonal variations in time duration of atmospheric.

duration times are more frequent in the spring months than in the winter months; e.g., in February the most usual duration time was 300 microseconds, as compared with less than 100 microseconds in June. This we suppose may be due to variation in the distance of the source of the disturbances. The effect is also due to a seasonal variation in the damping of atmospheric.

Such periodic or quasi-periodic superimposed variations within atmospherics which are exemplified in the sample curves of Figs. 9 to 12 have been plotted with reference to the percentage occurrence of their frequency. During all the months (from February to June) the preponderant frequency of the selected 600 atmospherics was five to ten kilocycles per second. The average percentage distribution during this total period is depicted in Fig. 15.

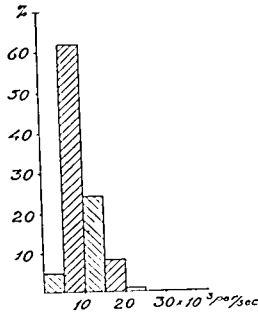

Fig. 15—Average percentage distribution of frequencies in atmospherics.

Number of Changes of Sign and Polarity Differences

By plotting the records of the field changes with the number of changes in their sign, Fig. 16 has been obtained. It is noted that atmos-

Number of half oscill	1	2	3	4	5	6	7	8	9
				etc					
Number	9	203	167	92	46	23	13	2	1

Fig. 16—Changes of sign in atmospherics.

		Number
Only +		151
Only -		174
+ and -		231

Fig. 17—Polarity distribution of atmospherics.

pherics with but one change of sign are the most frequent. If we select the atmospherics in terms of their polarity we achieve the result of Fig. 17.

The Absolute Amplitude in Volts per Meter

The maximum amplitude of the atmospheric was found, as was to be expected, to increase from February to June. This is shown in the curves in Fig. 18.

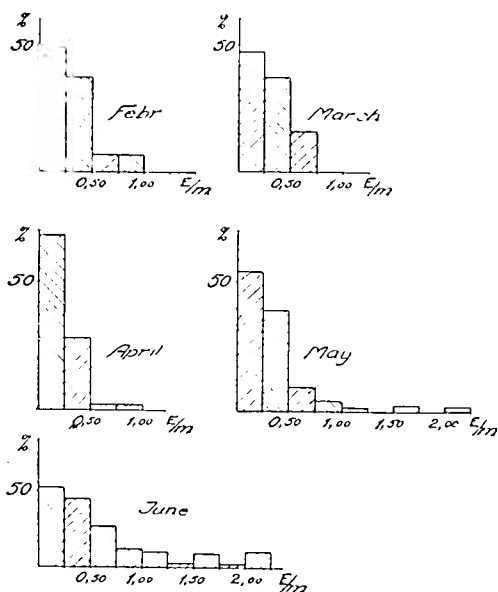

Fig. 18—Percentage distribution of voltage amplitudes of atmospheric in volts per meter.

The Slope of the Wave Fronts

It is a well-known fact that atmospheric are subject to a marked damping with increasing distance from the source of disturbance. A selection of the records of the atmospheric in terms of their maximum steepness of wave front should thus be found to result in less steepness for atmospheric arriving from distant sources of disturbance, as compared with those coming from less distant regions. The observations are in our case so uniform that we are able to observe this general tendency. From this it follows that the steepness of the wave fronts should be more pronounced during the spring months than during the winter. This is very marked, when we consider the percentage occurrence of the observed wave front slopes as plotted for different months. (Fig. 19.)

RECORDS WITH A SLOW-MOVING TIME AXIS

Occurrence of Atmospheric Groups

The atmospheric occurred, as we have already mentioned in another connection, sometimes in such unbroken succession that an analysis with the fast-moving time axis recording was impossible. In

such cases, we were forced to make use of a slow-moving time axis in which cases all rapid variations are recorded as vertical lines. This slow-moving recording was of interest in several respects. The method allowed more exact determinations to be made of the maximum ampli-

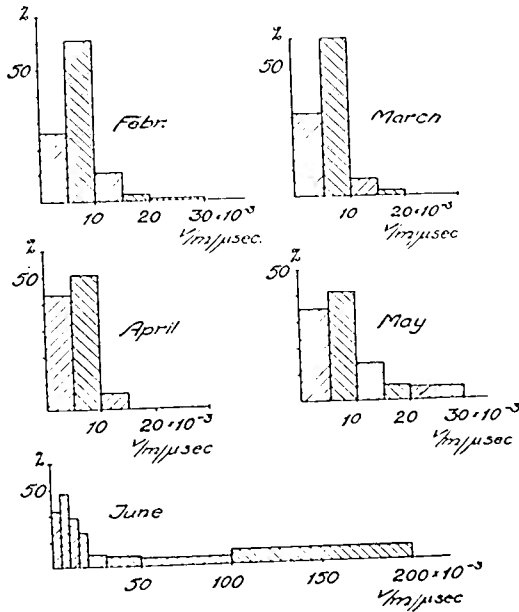
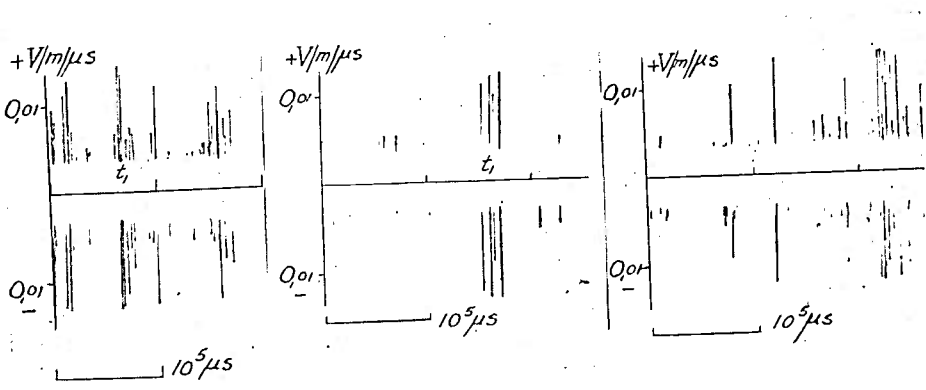

Fig. 19—Distribution of wave front slopes of atmospherics.

tudes and of the frequency of consecutive atmospherics. When using the slow-moving recording, the electron beam of the oscillograph passes through the maximum deflection points with reduced velocity, so that these turning points in the original oscillograms are thus well-



Figs. 20, 21, and 22—Records of consecutive atmospherics with a slow-moving method.

defined dots in the vertical lines. It is thus easy to distinguish one atmospheric from another.

The length of the time axis of the oscillograms when the fast-moving recording was used, was most often 3.8×10^2 microseconds and when the slow-moving method was used it was as slow as 2.8×10^6 microseconds.

Figs. 20 to 22 illustrate some of these records. The time t_1 in Figs. 20 to 21 is defined as the group duration time of an atmospheric. Fig. 23 results from plotting the percentage frequency of such duration groups, and shows a predominance of duration groups within 0.5×10^{-3}

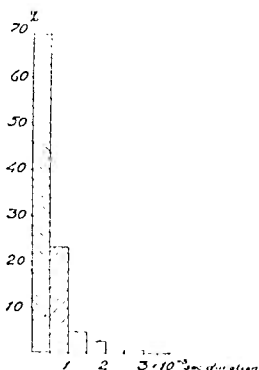

Fig. 23—Percentage duration time of groups of atmospheric.

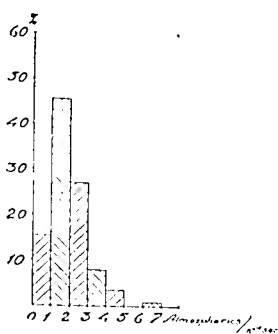

Fig. 24—Percentage number of individual atmospheric per 10^{-2} seconds.

seconds. The average time of occurrence density of individual atmospheric, which may be defined as the number of atmospheric per 10^{-2} seconds, shows the percentage distribution plotted in Fig. 24.

LIGHTNING DISCHARGES AND ATMOSPHERICS

It follows as a matter of course that we should devote special attention to the relation between lightning discharges and atmospheric. In the course of other investigations we had already gathered a very considerable number of observations of lightning discharges, recorded by means of cathode-ray oscillographs connected to horizontal antenna wires. For example, we have, during recent seasons,

recorded 450 lightning discharges which had taken place within a distance of twenty kilometers of our point of observation.³

These records show that the lightning discharges are very complicated. What we normally consider as one visible lightning flash consists of several consecutive discharges which in most cases follow the

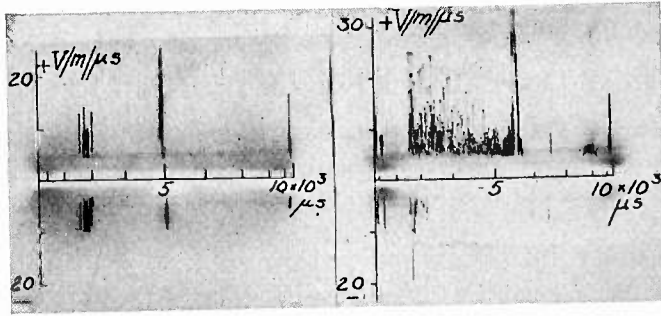

Fig. 25—Oscillograms of repeated lightning discharges.

same path. These partial discharges are very often developed under conditions which are similar from an electrical point of view. Some examples of such consecutive lightning discharges are illustrated in Fig. 25. In taking these oscillograms a sinusoidal time axis was used.

These lightning discharges show a variation structure quite similar to certain variation forms of atmospherics, and especially to those

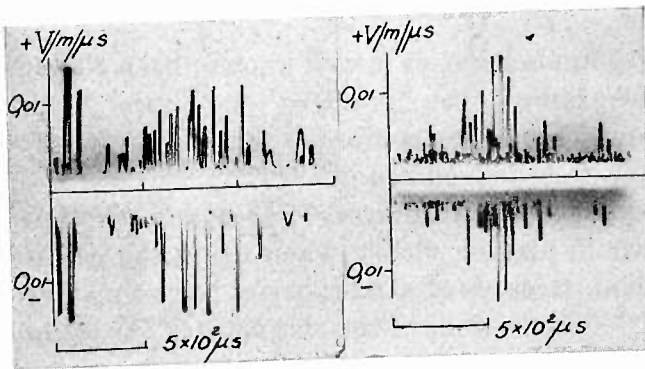

Fig. 26—Records of atmospherics of the lightning type.

types observed during atmospheric conditions which we generally characterize as thunderstorm conditions. This similarity in variation forms has led us to class certain atmospherics as "lightning discharge types." Some examples of these are reproduced in Fig. 26. With consideration to the difference in the time scale of Fig. 25 in comparison with Fig. 26 we are able to state a very marked similarity between the variation form in the two cases.

We have in all cases observed such lightning discharge types to be more complicated in their variation forms than atmospherics of the ordinary type. An explanation for this difference is to some extent found in the variation of the damping effect, since the most common types of atmospherics have their origin in most cases in very distant sources of disturbances, whereas the lightning discharge types originate in more near-by localities.

TYPICAL DISTURBANCE SOUNDS IN RADIO RECEIVERS

Since the early days of radiotelegraphy, atmospherics have been observed by the loud disturbing sounds that they produced in the re-

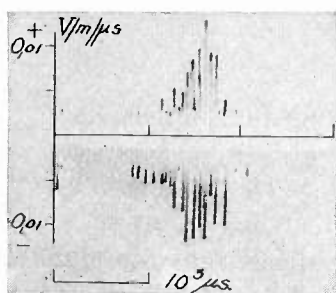

Fig. 27—Atmospherics producing typical sound disturbances in form of grinders or hisses.

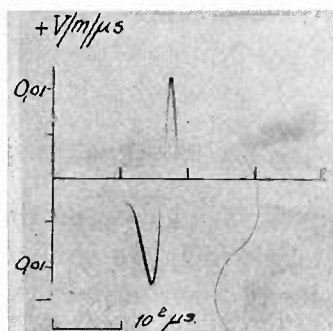

Fig. 28—Atmospherics producing disturbance sounds characterized as clicks in radio receivers.

ceivers. Such sounds have, as is well known, been classified into different types; for example, the “grinders” or “hisses” having a relatively long duration of sound, as compared with the “clicks” which have a very short and well-defined sound.

It seemed of particular interest to ascertain whether these typical differences would also be visible when using the cathode-ray oscillographic method. Records of atmospherics have thus been made simultaneously with observations of the character of the sounds occurring in radio receivers. The results obtained were very interesting. When grinders or hisses were heard in the radio receiver the oscillograms showed the types illustrated in Fig. 27. When clicks were observed in the receiver, we obtained the oscillograms of Fig. 28. The very marked difference observed between the clicks and grinders was what we were led to expect beforehand.

We have always observed that the clicks are produced by atmospherics of very short duration, less than 200 microseconds, with no or very few changes in their polarity. On the other hand grinders are caused by groups of consecutive atmospherics in which the duration times sometimes extended over a thousand microseconds or more.

OPTIMUM OPERATING CONDITIONS FOR CLASS B RADIO-FREQUENCY AMPLIFIERS*

By

W. L. EVERITT

(The Ohio State University, Columbus, Ohio)

Summary—A theoretical analysis of the efficiency and output of a triode operating as a class B radio-frequency amplifier is made.

It is shown that for a given tube, plate voltage, and plate loss there is a definite value of load impedance which will give maximum output. Design formulas are developed for determining this load impedance, the proper grid excitation, and the resultant efficiency and output.

IN A previous paper,¹ the author has described a method for the computation of the dynamic characteristics of amplifiers with tuned plate loads, in which the flow of current is confined to a fraction of a cycle. The equations there derived were applied to the problem of determining the optimum operating conditions of an unmodulated class C amplifier. In the present paper these same equations will be applied to the determination of the load impedance and grid excitation which will give the maximum output from a class B amplifier with a given tube, allowable plate dissipation, and plate voltage.

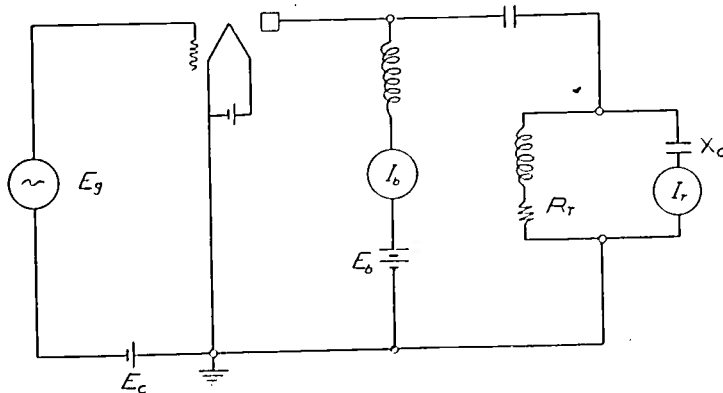

Fig. 1—Circuit for class B radio-frequency amplifier.

In a class B amplifier, due to the curvature near cutoff the tube should have a bias slightly less than E_b/μ so that current will flow in half-wave pulses. For purposes of approximation, the static grid-voltage—plate-current curve will be assumed as linear. The fundamental circuit is shown on Fig. 1. The following symbols and equations

* Decimal classification: R355.7. Original manuscript received by the Institute, March 29, 1935; revised manuscript received by the Institute, August 1, 1935.

¹ Proc. I.R.E., vol. 22, pp. 152-176; February, (1934).

from the previous paper will be required. In all cases the plate load is tuned to unity power factor at the frequency of the grid excitation.

E_c = absolute value of the negative grid bias

E_o = amplitude of the alternating grid voltage

E_b = voltage of direct-current plate supply

I_1 = amplitude of the fundamental alternating-current component of the plate current.

I_T = amplitude of the alternating current in each branch of the tuned plate circuit.

I_b = average or direct-current component of the plate current

Θ_1 = one half the angle during which plate current flows.

R_L = impedance of tuned load at the fundamental.

In the case of the class B amplifier, $\Theta_1 = \pi/2$ and the equations given in the previous paper are simplified.

For values of grid excitation where the maximum value of instantaneous grid voltage is less than the minimum value of instantaneous plate voltage,

$$I_1 = \frac{\mu E_o}{R_L + 2R_p} \quad (1)$$

$$\frac{I_1}{I_b} = \frac{\pi}{2}. \quad (2)$$

For values of excitation where the maximum grid voltage equals the minimum plate voltage the following equations hold:

$$\text{efficiency} = \frac{\pi\alpha}{4(\alpha + 2)} \times 100 \text{ per cent} \quad (3)$$

where,

$$\alpha = \frac{(\mu + 1)R_L}{R_p} \quad (3a)$$

$$\text{input} = \frac{(\mu + 1)E_b^2}{2R_p} \left[\frac{4}{\pi(\alpha + 2)} \right] \quad (4)$$

$$\text{output} = \frac{(\mu + 1)E_b^2}{2R_p} \left[\frac{\alpha}{(\alpha + 2)^2} \right] \quad (5)$$

$$E_o = \frac{\alpha + 2(\mu + 1)}{\mu(\alpha + 2)} E_b. \quad (6)$$

As the alternating-current grid excitation is varied, (1) shows that the fundamental component in the plate circuit is directly proportional

to this alternating-current grid excitation up to the point where the maximum grid voltage equals the minimum plate voltage. For values of grid excitation above this point the approximations used in computing (1) and (2) no longer hold and the curve breaks. The point at which the break occurs will be called the saturation point, and (3), (4), and (5) apply to this point. Since the output power equals both $I_1^2 R_L/2$ and also $I_T^2 R_T/2$ the tank current will be given by the relation

$$I_T = I_1 \sqrt{\frac{R_L}{R_T}} \quad (7)$$

where R_T is the sum of the resistances in the two branches of the tuned tank circuit, including any resistance which is introduced by coupling.

Equations (2) and (7) show that the tank current and direct plate current, since they are proportional to I_1 , will also be proportional to E_g . The input is equal to $E_b I_b$. Hence the efficiency is given by the equation

$$\text{efficiency} = \frac{I_1^2 R_L}{2E_b I_b}$$

By making use of (2) and (1),

$$\text{efficiency} = \frac{\pi}{4} \frac{I_1 R_L}{E_b} = \frac{\pi \mu E_g R_L}{4E_b (R_L + 2R_p)} \quad (8)$$

Therefore, the efficiency is also directly proportional to the grid excitation up to the saturation point, and reaches the maximum given by (3).

Fig. 2 shows an example of a comparison of values obtained experimentally and those computed by the theoretical equations. In the case of the theoretical curves, the saturation point is indicated by a horizontal break. The theory does not give values above saturation, but in actual practice this point is the upper limit of operation, and so no theory is needed for that part of the curve.

If a radio-frequency wave with a modulation ranging from zero to one hundred per cent is to be amplified by an amplifier showing the characteristics of Fig. 2, then the carrier amplitude applied to the grid should be adjusted to the middle of the straight-line portion of the $E_g - I_T$ curve. This middle point would be between forty-five and fifty per cent of the value at the computed saturation point to allow for the nonlinearity near saturation. Let K equal the ratio of the tank current at the operating point to that at the computed maximum. Then the

power output of the unmodulated carrier will be K^2 times the output at the saturation point, the direct-current power input to the plate circuit, and the plate efficiency will be K times that at saturation. Combine this relation and (3), (4), and (5) to obtain the values for the wave applied to the grid without modulation.

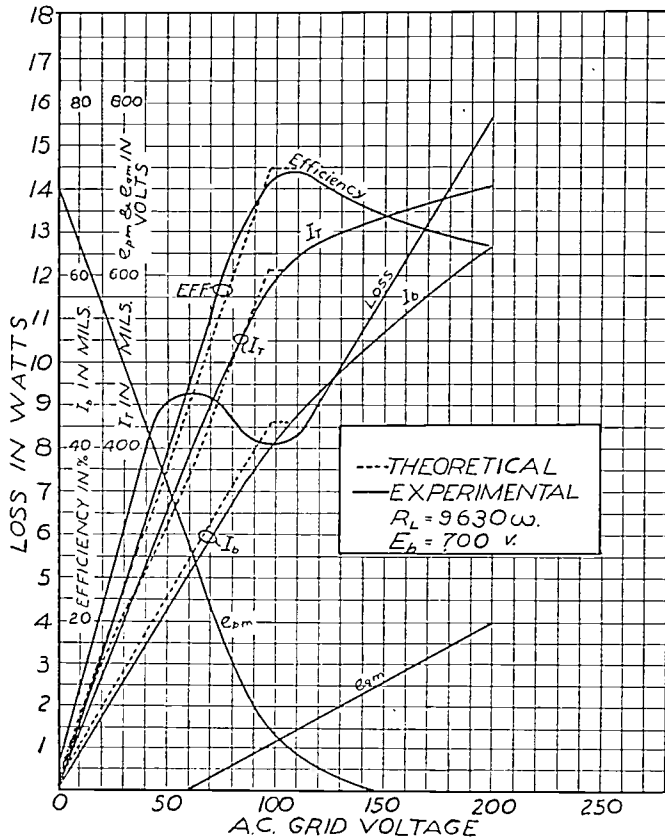

Fig. 2—Typical characteristics of UX210 as a class B amplifier.

$$\text{Efficiency} = \frac{\pi K \alpha}{4(\alpha + 2)} \times 100 \text{ per cent.} \tag{9}$$

$$\text{Input} = K \frac{(\mu + 1) E_b^2}{2R_p} \left[\frac{4}{\pi(\alpha + 2)} \right] \tag{10}$$

$$\text{Output} = K^2 \frac{(\mu + 1) E_b^2}{2R_p} \left[\frac{\alpha}{(\alpha + 2)^2} \right] \tag{11}$$

$$\begin{aligned} \text{Loss} &= (\text{Input} - \text{Output}) \\ &= \frac{(\mu + 1) E_b^2}{2R_p} \left[\frac{4K}{\pi(\alpha + 2)} - \frac{\alpha K^2}{(\alpha + 2)^2} \right] \end{aligned} \tag{12}$$

Since the $E_o - I_b$ curve is linear, the direct plate current will be unaffected by modulation of the grid excitation voltage. Hence the input to the tube would not be changed by this modulation. On the other hand the output will be increased by the amount of energy present in the side bands. In the case of one-hundred per cent modulation the output will be fifty per cent greater than that given by (11). Consequently the losses are less for a modulated excitation than for an unmodulated one. Since the circuit must be designed for the most severe conditions, (12) may be used for computing the loss for design formulas.

Let,

$$\Gamma = \frac{\text{loss} \times 2R_p}{(\mu + 1)E_b^2} \tag{13}$$

It will be observed that this Γ is a function of a tube, since the tube will determine the allowable loss, and also the plate voltage which may be used. μ and R_p are measured over the linear part of the characteristic. Equation (12) may be written

$$\Gamma = \frac{4K}{\pi(\alpha + 2)} - \frac{\alpha K^2}{(\alpha + 2)^2} \tag{13a}$$

Solve for α and obtain

$$\alpha = \frac{4K - \pi K^2 + \sqrt{\pi^2 K^4 + 16K^2 - 8\pi K^3 + 8\pi^2 K^2 \Gamma}}{2\pi \Gamma} - 2 \tag{13b}$$

Therefore, for a given value of Γ and K there is a value of α and hence a value of R_L which will give the allowable loss. This in turn will give a maximum output that can be obtained from the tube as a class B amplifier. For the special cases where $K=0.45$ and $K=0.50$, (13b) becomes, respectively,

$$K = 0.45 \quad \alpha = \frac{0.18523 + \sqrt{0.405000\Gamma + 0.034317}}{\Gamma} - 2 \tag{14a}$$

$$K = 0.50 \quad \alpha = \frac{0.19331 + \sqrt{0.500000\Gamma + 0.037371}}{\Gamma} - 2 \tag{14b}$$

Fig. 3 shows a plot of (14a) and (14b) and indicates that they represent almost identical curves. Since practical values of K would be intermediate between 0.45 and 0.50, these curves may be used to obtain the value of α and hence R_L necessary for optimum operation.

To obtain the required value of excitation, make use of (6) and re-

member that in the approximate curve $E_b = \mu E_c$ for class B operation. The unmodulated excitation must be K times that required for saturation.

$$E_g = \frac{K[\alpha + 2(\mu + 1)]E_c}{(\alpha + 2)} \tag{15}$$

$$= K \left[1 + \frac{2\mu}{\alpha + 2} \right] E_c.$$

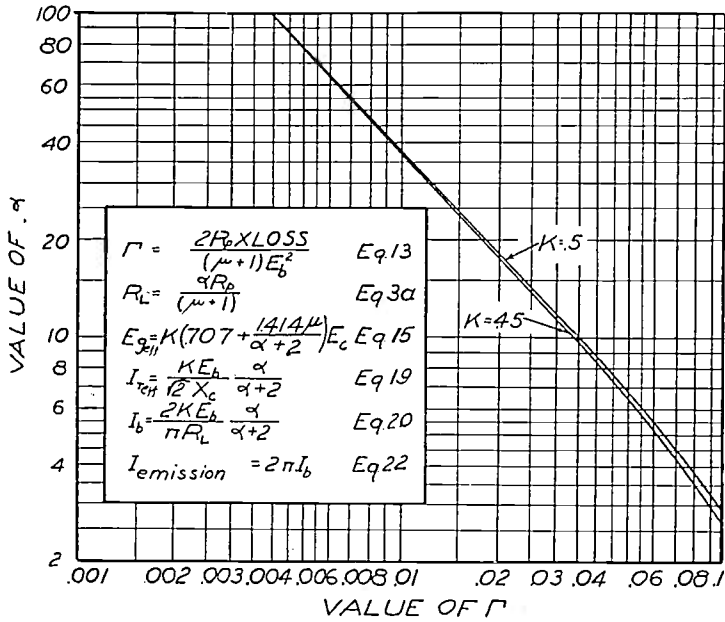

Fig. 3—Design plate for class B amplifiers.

The fundamental component of the plate current at the saturation point can be obtained by inserting (6) in (1).

$$I_1 = \frac{[\alpha + 2(\mu + 1)]E_b}{(\alpha + 2)(R_L + 2R_p)}$$

whence (3a) gives

$$I_1 = \frac{\alpha E_b}{R_L(\alpha + 2)} \text{ at saturation.} \tag{16}$$

At the operating point of the class B amplifier I_1 will be

$$I_1 = \frac{K\alpha E_b}{R_L(\alpha + 2)}. \tag{17}$$

The tank current can be found by applying (7) to (17),

$$I_T = \frac{KE_b\alpha}{\sqrt{R_L R_T}(\alpha + 2)} \quad (18)$$

But in an antiresonant circuit such as is used in the tank the approximate relation between R_L and R_T is

$$R_L = \frac{X_c^2}{R_T}$$

therefore, $\sqrt{R_L R_T} = X_c$

where X_c is the reactance of one branch.

Apply this to (19) and obtain

$$I_T = \frac{KE_b\alpha}{X_c(\alpha + 2)} \quad (19)$$

Equations (17) and (2) may be used to find the direct-current component of the plate current.

$$I_b = \frac{2}{\pi} \frac{KE_b}{R_L} \frac{\alpha}{(\alpha + 2)} \quad (20)$$

The emission requirements may be obtained by considering the maximum requirements. These can be obtained from (29) of the previous paper.¹ This equation for a class B amplifier gives

$$I_{\max} = \pi I_b \quad (21)$$

This is the value which would be obtained for an unmodulated excitation. In the case of one-hundred per cent modulation the maximum requirements would be twice this figure and the required emission would be

$$I_{\text{emission}} = 2\pi I_b \quad (22)$$

The various equations necessary for the complete design of the class B amplifier are grouped in Fig. 3 together with the plots of (14a) and (14b) from which the correct value of α and hence R_L may be obtained.

The penalty for not obtaining the optimum conditions may be determined from (10) and (11).

Let,

$$\Gamma_2 = \text{output} \times \frac{2R_p}{(\mu + 1)E_b^2}$$

then,

$$\Gamma_2 = \frac{\alpha K^2}{(\alpha + 2)^2}$$

In Fig. 4 the functions Γ and Γ_2 are plotted against α as the independent variable. These functions represent respectively the relative losses and output for any tube. If a value of α is used which is greater than the optimum value, the value of Γ_2 and hence the output will be less than that obtainable. The slope of this curve is quite steep and so shows that α should be selected quite carefully. On the other hand if too low a value of α is selected, then the losses will be too high. These losses might in turn be reduced by selecting a lower value of K , but

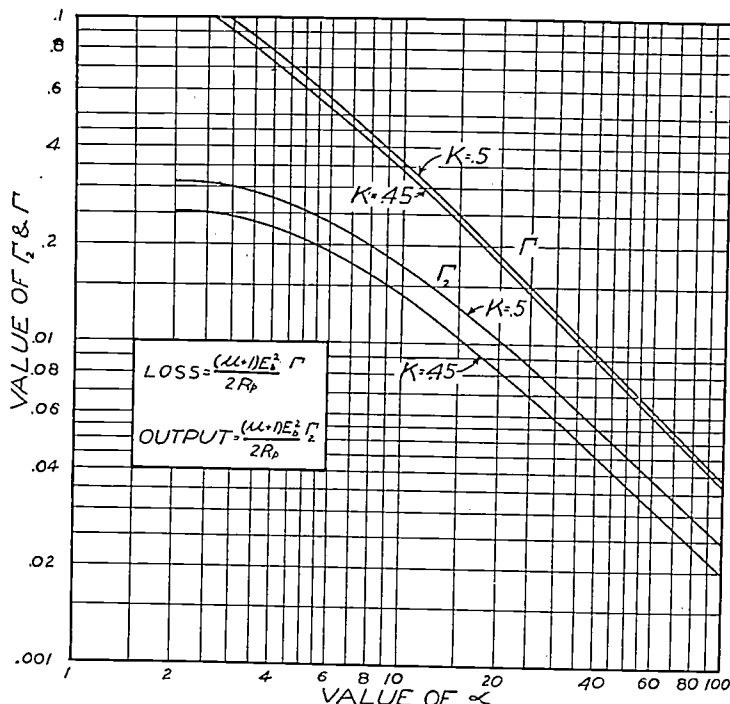

Fig. 4—Loss and output functions for class B amplifiers.

then the efficiency and output would be correspondingly reduced. The slope of the Γ curve is likewise quite steep and this also indicates the desirability of the accurate selection of load impedance.

In a class C amplifier, if the optimum value of load impedance is not chosen, a modification of operating angle will restore the loss to the permissible value with only a slight change in output. In the class B amplifier the operating angle is fixed and so the proper selection of load is more important.

The value of output/loss may be computed from (11) and (12). Since the tube determines the value of Γ as given by (13), this is used as the independent variable in the curves shown in Fig. 5.

Frequently the final stage of a transmitter is designed so that it can be operated either class B for a modulated amplifier or class C (un-

modulated) for telegraph signals. Since the value of Γ also determines the output possible in an unmodulated class C amplifier, as was demonstrated,¹ the ratio of the possible output as a class C amplifier to the output as a class B amplifier can be computed as a function of Γ . This ratio is also plotted in Fig. 5. It should be remembered that to obtain this possible output as a class C amplifier, the bias, grid excitation, and load impedance would all have to be changed when a transfer is made from the class B operation.

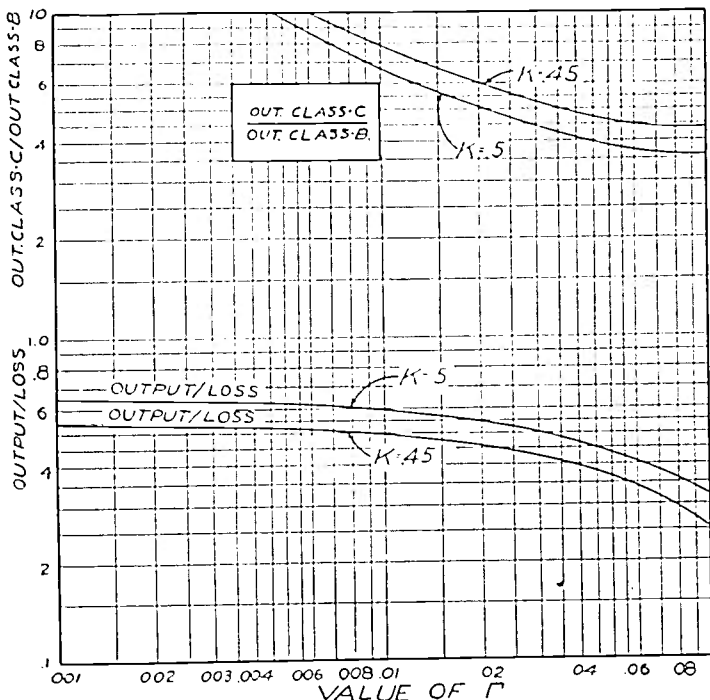

Fig. 5—Output functions for class B amplifiers.

APPENDIX

As an example of the application of these principles the computations indicated will be carried out for a UX 210 tube. The characteristics of the tube are

$$R_p = 4150 \text{ ohms}$$

$$\mu = 8.3$$

allowable loss = 15 watts

the value of plate voltage selected will be 700 volts

then,
$$E_c = \frac{700}{8.3} = 84 \text{ volts}$$

$$\Gamma = \frac{2 \times 4150 \times 15}{9.3 \times 700^2} = 0.0273.$$

Assume $K=0.45$.

From Fig. 3 $\alpha=13$

$$R_L = \frac{13 \times 4150}{9.3} = 5800 \text{ ohms}$$

$$E_{v\text{eff}} = 0.45 \left(0.707 + \frac{\sqrt{2} \times 8.3}{15} \right) 84 = 57 \text{ volts.}$$

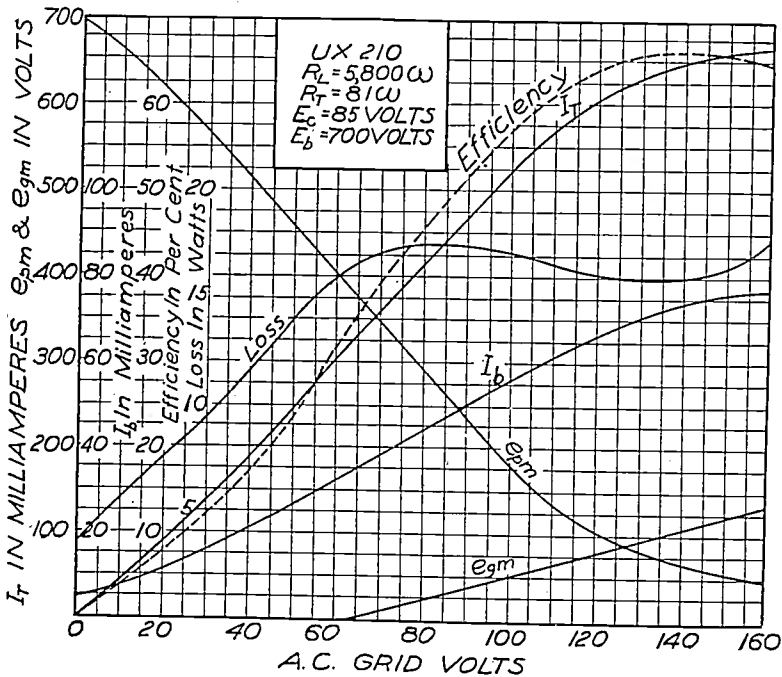

Fig. 6—Test run on design of class B amplifier.

In constructing the tank circuit a reactance of 687 ohms and a dissipative resistance of 81 ohms were selected to give the desired 5800 ohms. Then,

$$I_{T\text{eff}} = \frac{0.45 \times 700 \times 13}{\sqrt{2} \times 687 \times 15} = 0.282 \text{ ampere}$$

$$I_b = \frac{2 \times 0.45 \times 700 \times 13}{\pi \times 5800 \times 15} = 30.0 \text{ milliamperes.}$$

From Fig. 5 the output/loss will be

$$\text{output/loss} = 0.44$$

therefore,

$$\text{output} = 0.44 \times 15 = 6.6 \text{ watts}$$

$$\text{efficiency} = \frac{6.6}{15 + 6.6} = 30.5 \text{ per cent.}$$

A tube was set up and operated with the tank circuit described above and with the selected values of plate and grid voltage. The curves obtained are shown in Fig. 6. If an unmodulated wave of 57 volts is applied to the grid then the modulated wave would swing from zero to 114 volts, and it is seen that this is essentially the linear part of the $E_g - I_T$ characteristic. The measured values at

$$E_g = 57 \text{ volts are}$$

$$I_T = 0.288 \text{ ampere}$$

$$I_b = 31.5 \text{ milliampere}$$

$$\text{efficiency} = 29 \text{ per cent}$$

$$\text{loss} = 15.3 \text{ watts.}$$

These agree well with the computed values given above.

The alternating grid voltage at which the maximum grid voltage should equal the minimum plate voltage would be

$$E_g(\text{for } e_{pm} = e_{om}) = \frac{57}{0.45} = 127 \text{ volts.}$$

The value of the minimum plate voltage would be $2 E_b / (\alpha + 2)$.

$$e_{pm} = \frac{2 \times 700}{15} = 93 \text{ volts.}$$

These values check with the experimental results shown in Fig. 6.

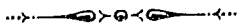

A NETWORK THEOREM*

By

J. G. BRAINERD

(Moore School of Electrical Engineering, University of Pennsylvania, Philadelphia, Pa.)

Summary—It is shown that any relation between any of the commonly used parameters of a linear passive network (of any complexity) with two pairs of terminals is the equivalent of some other equally true relation which, by a simple rule for symbol substitution, may be obtained from, but is not necessarily algebraically contained in, the original expression. This symbol substitution theorem applies not only to transducer parameters but also to those quantities which describe the action of the transducer with load, with one exception.

Distinguishing between the theorem and the rule for symbol substitution included in it, the rule may be used arbitrarily in cases where the theorem does not apply. By such a process it is shown that there is a closer relationship between certain structures than has heretofore been known. As an incidental to bringing the so-called general circuit parameters under the theorem, these have been expressed in terms of other parameters in such a way that certain minor theorems roughly analogous to Thevenin's theorem result.

IN THE general theory of steady-state conditions in linear passive networks with two pairs of terminals it is necessary to use three, and frequently convenient to use more, of those circuit parameters which may be utilized to specify the transducer. Since only three of the parameters can be independent, any parameter can be expressed in terms of any other three. Consequently there exists a large number of relations between the various parameters, many of which are of practical importance. In addition, the receiver impedance is arbitrary, and input impedance, current ratios, and other quantities specifying the action of the transducer with load can be expressed in terms of the transducer¹ parameters and the receiver impedance, thus increasing the number of relations associated with transducers.

It is the purpose of this paper (I) to show that any relation between any of the common parameters of a transducer is the equivalent of some other relation which may be obtained from the former by a simple substitution of symbols and to show that the same rule applies with one exception to the expressions which specify the over-all action of the transducer with load; (II) to use the rule of (I) to obtain new relationships between certain types of sections; and (III) to state several additional propositions in general network theory.

* Decimal classification: R140. Original manuscript received by the Institute, February 19, 1935.

¹ The term transducer is used throughout to indicate a linear passive network with two pairs of terminals.

The following is a list of some of the symbols used. References are to Fig. 1, where the currents I_1 , I_2 and the electromotive forces E_1 , E_2 are shown. All quantities are complex.

- z_r is the receiver impedance; $E_2 = -z_r I_2$ when an impedance z_r is connected at 22'.
- z_1 is the input impedance at 11' when $E_2 = -z_r I_2$.
- $z_{1s} = z_1$ when 22' are short-circuited ($z_r = 0$).
- $z_{10} = z_1$ when 22' are open-circuited ($z_r = \infty$).
- $z_{1s} = E_1/I_2$ when 22' are short-circuited (z_{1s} is the short-circuit transfer impedance).
- $z_{10} = -E_2/I_1$ when 22' are open-circuited (z_{10} is the open-circuit transfer impedance or the generalized mutual impedance).
- $\sigma_1 = I_1/I_2$ (z_r arbitrary).
- $\tau_1 = -E_1/E_2$ (z_r arbitrary).
- $\sigma_{1s} = \sigma_1$ when 22' are short-circuited ($z_r = 0$).
- $\tau_{10} = -E_1/E_2$ when 22' are open-circuited ($z_r = \infty$).
- A_y is a general circuit parameter ($= \sigma_{1s}$); see equation (23).
- A_z is a general circuit parameter ($= \tau_{10}$); see equation (23).
- z_{k1} is the iterative impedance at 11' ($z_1 = z_{k1}$ when $z_r = z_{k1}$).
- z_{I1} is the image impedance at 11' ($z_{I1}^2 = z_{10}z_{1s}$).

The reciprocal of any z above will be written y with the subscripts of the z . To every quantity containing a subscript 1 there is a corresponding quantity with subscript 2; thus z_{20} is the impedance measured at 22' when 11' are open-circuited, etc.

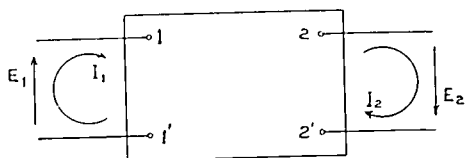

Fig. 1—Transducer.

I. SYMBOL SUBSTITUTION THEOREM

Theorem: Any relationship between any of the quantities given above (including those not listed, but implied in the preceding two sentences) can be converted into some other equally true relationship by making the following changes: change each z to y and vice versa, each subscript 0 to s and vice versa, each σ to τ and vice versa.

The proof of the theorem is given in the appendix.

As illustrations of the use of the theorem, consider the following equations, which are typical of those met in transducer theory.

$$z_{10} = \sqrt{z_{20}(z_{10} - z_{1s})} \tag{1}$$

$$z_{10}z_{2s} = 1/(y_{1s}y_{2s} - y_{ts}^2) \tag{2}$$

$$\sigma_1 = \frac{z_{20} + z_r}{z_{t0}} \tag{3}$$

$$z_1 = z_{10} - \frac{z_{t0}^2}{z_{20} + z_r} \tag{4}$$

$$z_{k1} = \frac{1}{2} [(z_{10} - z_{20}) \pm \sqrt{(z_{10} - z_{20})^2 + 4z_{10}z_{2s}}]. \tag{5}$$

Under the symbol substitution rule given above, these transform respectively into the following:

$$y_{ts} = \sqrt{y_{2s}(y_{1s} - y_{10})} \tag{1a}$$

$$y_{1s}y_{20} = 1/(z_{10}z_{20} - z_{t0}^2) \tag{2a}$$

$$\tau_1 = \frac{y_{2s} + y_r}{y_{ts}} \tag{3a}$$

$$y_1 = y_{1s} - \frac{y_{ts}^2}{y_{2s} + y_r} \tag{4a}$$

$$y_{k1} = \frac{1}{2} [(y_{1s} - y_{2s}) \pm \sqrt{(y_{1s} - y_{2s})^2 + 4y_{1s}y_{20}}]. \tag{5a}$$

All of these are true, and can be derived by network analysis or from the general theory of transducers.

Equations (1a) to (5a) express results which are not included in the corresponding equations of (1) to (5). It is seen that although the symbol substitution theorem here yields no result not obtainable by other methods, it serves to condense the entire general theory of transducers in that, in order to have the same total of information, many fewer relations need be explicitly expressed than are necessary without the theorem. Furthermore, it is shown in the following that the rule has a much wider significance than is evident from the statement of the theorem above.

Transducers in Series: If two transducers are in series (Fig. 2), then, denoting the parameters of the first by a prime and those of the second

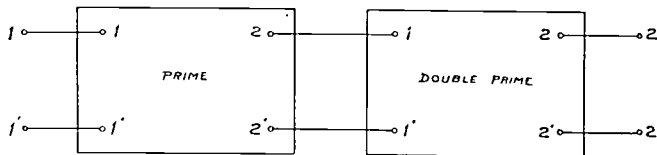

Fig. 2—Two transducers in series. Numbers within the rectangles represent terminal designations of subsidiary transducers, numbers at extreme ends are terminal designations of the major or over-all transducer.

by a double prime, the open-circuit parameters of the major transducer formed by the two subsidiary transducers in series are

$$\begin{aligned}
 z_{10} &= z_{10}' \left(\frac{z_{2s}' + z_{10}''}{z_{20}' + z_{10}''} \right) \\
 z_{20} &= z_{20}'' \left(\frac{z_{1s}'' + z_{20}'}{z_{10}'' + z_{20}'} \right) \\
 z_{t0} &= \frac{z_{t0}' z_{t0}''}{z_{20}' + z_{10}''}.
 \end{aligned} \tag{6}$$

The short-circuit parameters of the major transducer are

$$\begin{aligned}
 y_{1s} &= y_{1s}' \left(\frac{y_{20}' + y_{1s}''}{y_{2s}' + y_{1s}''} \right) \\
 y_{2s} &= y_{2s}'' \left(\frac{y_{10}'' + y_{2s}'}{y_{1s}'' + y_{2s}'} \right) \\
 y_{ts} &= \frac{y_{ts}' y_{ts}''}{y_{2s}' + y_{1s}''}.
 \end{aligned} \tag{7}$$

It is seen that equations (6) are related to (7) by the symbol substitution rule. Hence the theorem holds for all the parameters (and other quantities listed in the table of symbols) of the major transducer when expressed in terms of the parameters of the subsidiary transducers, the major transducer, and the receiver impedance. The argument can be extended to show that the theorem applies in the case of any number of transducers in series.

If at the junction of the prime and double prime sections corresponding impedances looking each way are equal ($z_{20}' = z_{10}''$ and $z_{2s}' = z_{1s}''$), then the major transducer is symmetrical (electrically) and

$$\begin{aligned}
 z_{10} = z_{20} &= \frac{1}{2}(z_{10}' + z_{1s}') = \frac{1}{2}(z_{20}'' + z_{2s}'') \\
 y_{1s} = y_{2s} &= \frac{1}{2}(y_{1s}' + y_{10}') = \frac{1}{2}(y_{2s}'' + y_{20}'').
 \end{aligned} \tag{8}$$

The parameters of the major transducer are now expressed in terms of the parameters, measured at one pair of terminals, of the subsidiary transducers or the half sections, in terminology customary in this case. It has been shown by Bartlett² and Brune³ that equations (8) hold when the prime and double prime sections are joined by more than two conductors. It is sufficient for the present purpose to note that the half-section parameters conform to the symbol substitution theorem.⁴

² Bartlett, "An extension of a property of artificial lines," *Phil. Mag.*, vol. 4, p. 902; November, (1927).

³ Brune, "Note on Bartlett's theorem for four-terminal electrical networks," *Phil. Mag.*, vol. 14, no. 93, p. 806; November, (1932).

⁴ The half-section parameters are intimately related to the image impedances.

II. APPLICATION OF THE RULE TO CERTAIN SECTIONS

The impedances of the arms of a T section (notation as indicated in Fig. 3) may be written

$$\begin{aligned} z_a &= z_{10} - z_{t0} \\ z_b &= z_{t0} \\ z_c &= z_{20} - z_{t0}. \end{aligned} \tag{9}$$

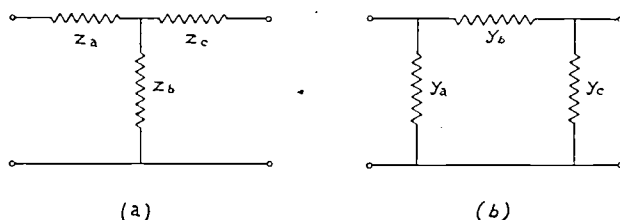

Fig. 3—T section (a) and Π section (b).

That is, (9) may be considered to give the open-circuit impedances of the T section in terms of z_a , z_b , and z_c or to give the conditions under which the T section will be equivalent to a transducer with parameters z_{10} , z_{20} , and z_{t0} .

Applying the symbol substitution rule to these,

$$\begin{aligned} y_a &= y_{1s} - y_{ts} \\ y_b &= y_{ts} \\ y_c &= y_{2s} - y_{ts} \end{aligned} \tag{10}$$

which are the equations for the admittances of the arms of the Π section shown in Fig. 3. There is thus a correspondence between any arm of the T section and the corresponding arm of the Π section. Either section, under the symbol substitution rule, contains in its equations those of the other section.

Furthermore, the complementary relationship applies not only to the impedances and admittances of (9) and (10) but also to other quantities. For example, the iterative impedance of the T section at 11' is

$$z_{k1} = \frac{1}{2}(z_a - z_c) \pm \sqrt{z_b(z_a + z_c) \left(1 + \frac{z_a + z_c}{4z_b} \right)}$$

and the y_{k1} derived by application of the symbol substitution theorem is

$$y_{k1} = \frac{1}{2}(y_a - y_c) \pm \sqrt{y_b(y_a + y_c) \left(1 + \frac{y_a + y_c}{4y_b} \right)}$$

which is the iterative admittance of the Π section at $11'$ terminals. Likewise the current ratio of the T section is

$$\sigma_1 = \frac{z_b + z_c + z_r}{z_b}$$

and the voltage ratio τ_1 derived by use of the symbol substitution theorem is

$$\tau_1 = \frac{y_b + y_c + y_r}{y_b} = \frac{1}{z_c z_r} (z_b z_c + z_b z_r + z_c z_r)$$

which is the voltage ratio of the Π section.

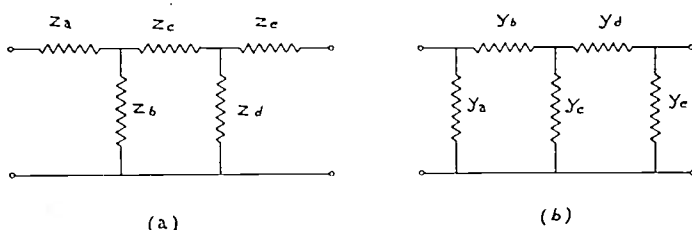

Fig. 4—Two complementary structures.

It can be concluded from these illustrations that a complete knowledge of one type of section gives, without algebraic manipulation, a complete knowledge of the other type of section. Thus it would appear that the symbol substitution rule points to a closer relationship between these two elementary sections than has heretofore been known.

The relationship between T and Π sections shown above can be extended to cover transducers composed of impedances connected only in series or in shunt with a line. For the first (a) section shown in Fig. 4

$$\begin{aligned} z_{10} &= z_a + \frac{z_b(z_c + z_d)}{z_b + z_c + z_d} \\ z_{1s} &= z_a + \frac{z_b \left(z_c + \frac{z_d z_e}{z_d + z_c} \right)}{z_b + z_c + \frac{z_d z_e}{z_d + z_c}} \end{aligned} \tag{11}$$

and z_{20} and z_{2s} are of similar form.

The second (b) section of Fig. 4 has parameters

$$y_{1s} = y_a + \frac{y_b(y_c + y_d)}{y_b + y_c + y_d}$$

$$y_{10} = y_a + \frac{y_b \left(y_c + \frac{y_d y_e}{y_d + y_e} \right)}{y_b + y_c + \frac{y_d y_e}{y_d + y_e}} \quad (12)$$

It is seen that (11) and (12) are related by the symbol substitution rule, that is, equations (12) are the result of applying the rule to (11) and vice versa. Hence either of the sections shown in Fig. 4 is the complement⁵ of the other, and the symbol substitution rule applies not only to z_{10} , z_{20} , y_{1s} , and y_{2s} , which is more or less evident by inspection,

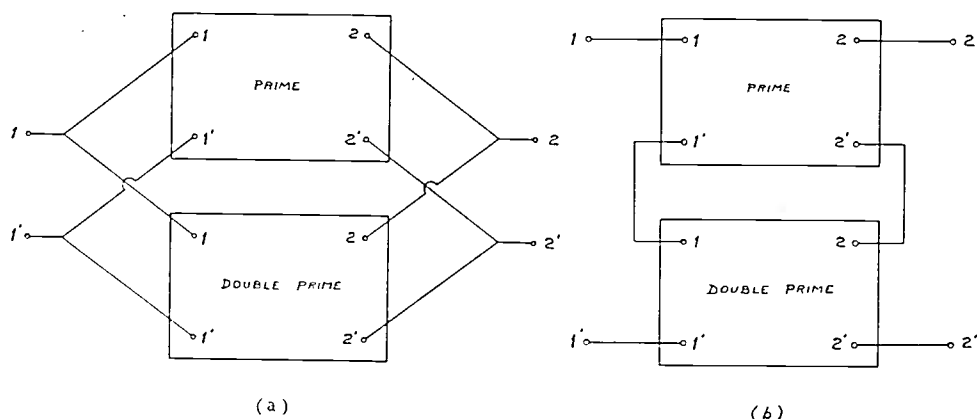

Fig. 5—Transducers in parallel (a) and side-series (b).

but also to z_{10} , z_{2s} and all the other parameters listed in the table of symbols. The equivalence, under the symbol substitution rule, of the basic equations of the sections is thus far more extensive than is evident on first sight. It should be emphasized that there need be no *numerical* relation between the impedances of (a) and the admittances of (b), Fig. 4; y_a is not necessarily $1/z_a$, for example. The only relation between the two sections is that wherever an impedance in series (shunt) with the line appears in (a), a shunt impedance or admittance has been inserted in shunt (series) with the line in (b). No numerical relations between corresponding impedances are implied.

Transducers in Parallel. If two transducers are in parallel (Fig. 5 (a)) the major or over-all transducer formed by the two has short-circuit parameters

$$\begin{aligned} y_{1s} &= y_{1s}' + y_{1s}'' \\ y_{2s} &= y_{2s}' + y_{2s}'' \\ y_{2s} &= y_{2s}' + y_{2s}'' \end{aligned} \quad (13)$$

⁵ The words "complement" and "complementary" are used to refer to sections or impedances related by the symbol substitution rule.

Applying the symbol substitution rule to these, there are obtained

$$\begin{aligned} z_{10} &= z_{10}' + z_{10}'' \\ z_{t0} &= z_{t0}' + z_{t0}'' \\ z_{20} &= z_{20}' + z_{20}'' \end{aligned}$$

which are the open-circuit parameters of two transducers connected in side-by-side series (not end-to-end, as is usually designated by "series"). Such an arrangement is shown in Fig. 5 (b). It is seen that there is a certain analogy between the interchange of impedances in the sections of Fig. 4 and the arrangements shown in Fig. 5.

The equivalence under the symbol substitution rule of the basic expressions for transducers in parallel and transducers in side-series can be extended to cover any number of transducers. The equivalence applies not only to open- and short-circuit impedances, but to all the quantities enumerated in the list of symbols at the beginning of this paper.

Other Types of Sections. Of the simple sections, other than the T and II sections, the most common are the bridged-T and the lattice types. Fig. 6 shows symmetrical forms of these sections to which the following is confined for simplicity.

For the bridged-T section,

$$1/z_b = y_b = y_{1s} + y_{ts} - 2y_a$$

and,

$$z_d = \frac{z_a z_{t0} - z_{10} z_{1s}}{z_a - 2(z_{10} - z_{t0})} \quad (15)$$

give z_b and z_d when z_a is arbitrarily chosen,

and,

$$\begin{aligned} z_b &= z_{10} + z_{t0} - 2z_d \\ 1/z_a = y_a &= \frac{y_d y_{ts} - y_{1s} y_{10}}{y_d - 2(y_{1s} - y_{ts})} \end{aligned} \quad (16)$$

give z_b and z_a when z_d is arbitrary. If z_b is chosen arbitrarily,

$$2y_a = y_{1s} + y_{ts} - y_b$$

and,

$$2z_d = z_{10} + z_{t0} - z_b. \quad (17)$$

Applying the symbol substitution rule to (15), (16), and (17) there are obtained

$$\begin{aligned} z_b &= z_{10} + z_{t0} - 2z_a \\ y_d &= \frac{y_a y_{ts} - y_{1s} y_{10}}{y_a - 2(y_{1s} - y_{ts})} \end{aligned} \quad (15a)$$

$$y_b = y_{1s} + y_{ts} - 2y_d$$

$$z_a = \frac{z_d z_{t0} - z_{10} z_{1s}}{z_d - 2(z_{10} - z_{t0})} \tag{16a}$$

$$2z_a = z_{10} + z_{t0} - z_b$$

$$2y_d = y_{1s} + y_{ts} - y_b$$

which are the equations of a bridge-T section similar to that shown in Fig. 6 (a) except that the symbols z_a and z_d are interchanged. Hence the complement of a bridged-T is another bridged-T. It can be seen that not all of (15) and (16) are necessary; given (15), the symbol substitution rule gives (15a), and these are for the complementary section the same as (16) for the original. Likewise only one of equations (17) is necessary. More important, if σ_1 is given for one section, τ_1 can be obtained for its complement which, since the forms of the original and the complement are similar, is the same as obtaining τ_1 for the original.

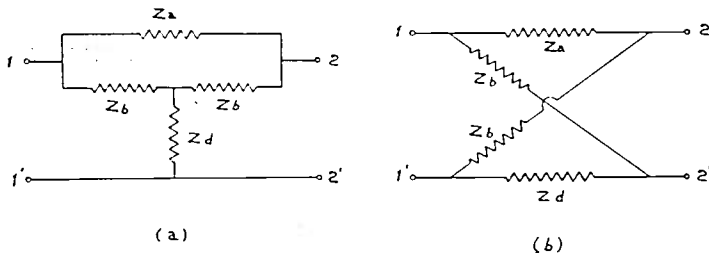

Fig. 6—Symmetrical bridged-T section (a) and symmetrical lattice section (b).

In the case of the lattice section, Fig. 6 (b), either z_a or z_d may be chosen arbitrarily. The equations for z_b and z_d in terms of z_a and the section parameters are

$$z_b = z_{10} + z_{t0}$$

and,

$$z_d = \frac{z_{t0}(z_{ts} - z_a)}{z_{t0} + z_a} \tag{18}$$

These transform, under the symbol substitution rule, to

$$y_b = y_{1s} + y_{ts}$$

and,

$$y_d = \frac{y_{ts}(y_{t0} - y_a)}{y_{t0} + y_a} \tag{19}$$

which are the equations of the same section with the 22' terminals reversed.

Hence in the cases of the bridged-T and lattice sections, networks

which cannot be built up by connecting impedances in series and in shunt with a line, the symbol substitution rule gives for each section results which are intimately related to the section itself. In each case a complementary section can be set up: for the bridged-T of Fig. 6 (a) another bridged-T with the symbols z_a and z_d interchanged on the diagram; for the lattice section another lattice section obtained by interchanging 2 and 2'.

III. SOME NETWORK RELATIONS

The so-called "general⁶ circuit parameters" are used rather widely in power work and but sparingly in the communication field.⁷ If E_1 and I_1 (Fig. 1) be written

$$\begin{aligned} E_1 &= AE_2 + BI_2 \\ I_1 &= CE_2 + DI_2 \end{aligned} \quad (20)$$

then A , B , C , D are called the general circuit parameters. If E_1 and I_1 are the load voltage and current, then a knowledge of the source electromotive force and current, together with A , B , C , D will enable the power delivered to the load to be computed. It is for this reason, among others, that the general circuit parameters have been useful in the power field.

In terms of the short-circuit parameters,

$$\begin{aligned} I_1 &= y_{1s}E_1 + y_{1s}E_2 \\ I_2 &= y_{2s}E_1 + y_{2s}E_2 \end{aligned} \quad (21)$$

and in terms of the open-circuit parameters

$$\begin{aligned} E_1 &= z_{10}I_1 - z_{10}I_2 \\ E_2 &= -z_{20}I_1 + z_{20}I_2 \end{aligned} \quad (22)$$

whence,

$$\begin{aligned} E_1 &= -A_z E_2 + z_{1s} I_2 \\ I_1 &= -A_y E_2 + A_v I_2 \end{aligned} \quad (23)$$

where,

$$A_z \equiv z_{10}/z_{1s} \quad \text{and} \quad A_y \equiv z_{1s}/z_{10}.$$

Equations (23) are in the form of (20), and by comparison it is seen that $B = z_{1s}$ and $C = -y_{10}$. A_z has been written for A and A_y for D . To interpret A_z and A_y it may be noted that

⁶ A misnomer. These parameters are no more general than the open- or short-circuit parameters.

⁷ Gewertz in "Network Synthesis," Williams and Wilkins, Baltimore, 1933, uses them and indicates where they have been used by others in communication problems.

$$A_z = \frac{z_{10}}{z_{t0}} = \tau_{10} = \frac{z_{ts}}{z_{2s}} = \sigma_{2s}$$

$$A_y = \frac{z_{ts}}{z_{1s}} = \sigma_{1s} = \frac{z_{20}}{z_{t0}} = \tau_{20} \quad (24)$$

hence,

$$E_1 = -\tau_{10}E_2 + z_{ts}I_2$$

$$I_1 = -y_{t0}E_2 + \sigma_{1s}I_2.$$

It is thus seen that the "general circuit parameters" are simply four of the short- and open-circuit parameters. For this reason none of the examples given above have been concerned with them.

However, equations (24) permit some interesting interpretations.

(1) The first of equations (24) states that the total applied electromotive force E_1 is always the sum of (a) the electromotive force which would have to be applied at 11' to produce an open-circuit voltage E_2 at 22' and (b) the electromotive force which would have to be applied at 11' to produce a short-circuit current I_2 at 22'.

(2) The second of equations (24) states that the total current I_1 entering the network is the sum of (a) the current which would have to enter to produce an open-circuit voltage $-E_2$ at 22' and (b) the current which would have to enter to produce a short-circuit current I_2 at 22'.

These two interesting theorems appear to be closely related to Thevenin's theorem, but whereas the latter states that $I_2 = -E_{20}/(z_{2s} + z_r) = z_{2s}I_{2s}/(z_{2s} + z_r)$, (E_{20} = e.m.f. at 22' when $z_r = \infty$; I_{2s} = current at 22' when $z_r = 0$) and hence gives I_2 and E_2 , the former give measures of E_1 and I_1 .

As an incidental it may be noted that the occurrence of y_{ts} twice in (21) is usually interpreted as the reciprocity theorem: E_1/I_2 when $E_2 = 0$ is equal to E_2/I_1 when $E_1 = 0$. I_2 in the former case and I_1 in the latter are short-circuit currents in the nomenclature used here. Corresponding to the reciprocity theorem for (short-circuit) currents is one for open-circuit voltages. It results from the occurrence of z_{t0} twice in (22): E_2/I_1 when $I_2 = 0$ is equal to E_1/I_2 when $I_1 = 0$. That is, the current I_1 required to produce an open-circuit voltage E_2 at 22' (Fig. 1) is the same as the current I_2 required to produce an equal open-circuit voltage at 11'.

APPENDIX

The following relations hold^{8,1}

$$\frac{z_{10}}{z_{1s}} = \frac{z_{20}}{z_{2s}} = \frac{z_{t0}}{z_{ts}} + 1 = \frac{z_{t0}z_{ts}}{z_{1s}z_{2s}} = \frac{z_{10}z_{20}}{z_{t0}z_{ts}} = \frac{z_{ts}^2}{z_{ts}^2 - z_{1s}z_{2s}} = \frac{z_{10}z_{20}}{z_{10}z_{20} - z_{t0}^2}$$

⁸ Brainerd, "Relations between the parameters of coupled-circuit theory and transducer theory with some applications," Proc. I.R.E., vol. 21, pp. 282-290; February (1933).

$$\begin{array}{ccccccc}
 y_1 y_2 & & y_{10}^2 & & \sigma_1 \sigma_2 & & \tau_1 \tau_2 \\
 y_1 y_2 = y_{10}^2 & & y_{10}^2 = y_1 y_2 & & \sigma_1 \sigma_2 = 1 & & \tau_1 \tau_2 = 1 \\
 \sigma_2 z_{10} & & \tau_1 \tau_2 & & z_{10} & & \sigma_1 z_{10} \\
 z_1 & & z_2 & & z_1 + z_2 & & \sigma_1 (z_1 + z_2) = h
 \end{array}$$

The quantity ρ is the filter factor $(z_{10} + z_{20} - 2z_{10}) / 4z_{10}$; frequencies which cause the ρ of a resistanceless section to fall between 0 and -1 lie in a transmission band, all others are in attenuation bands. The ratio $\sigma_1 (= \tau_1)$ is σ_1 when the receiver impedance is the iterative impedance. It may be shown by application to each term that h (and ρ , σ_1 , and τ_1) are invariant under the symbol substitution rule, and that each equality true before the theorem is applied yields a true result when transformed according to the theorem. Now if several equations obey the theorem; for example, if $a = b$ and $c = d$ obey it, then the equations $ac = bd$, $a + c = b + d$, and $a + c = b + d$ obey it, as well as all other equations which can be built up from the first two by algebraic processes. Since the group of equalities given above includes all quantities under consideration here, and is sufficiently comprehensive to allow any quantity to be expressed in terms of any three others by algebraic manipulation, the theorem is proved in so far as it relates to these quantities.

To prove that z_1 , σ_1 , τ_1 , z_{10} , z_{11} obey the symbol substitution theorem each can be expressed in terms of the transducer parameters, and z_1 when necessary, and tried. If the theorem holds for any given expression, it will continue to hold for any other expression for the same quantity, since the transducer parameters all obey the theorem.

There is one impedance which does not obey the theorem—the transfer impedance under load ($z_{11} = E_1 / I_1$ when $E_2 = -z_r I_2$). The reason can be seen from

$$-z_r \tau_1 = z_1 \sigma_1 = z_{11}.$$

Since z_r , τ_1 , z_1 , and σ_1 conform to the theorem, it is impossible for z_{11} to do so. For, applying the theorem

$$-y_r \sigma_1 = y_1 \tau_1 = y_{11}$$

or,

$$-z_1 \sigma_1 = z_r \tau_r = z_r z_1 y_{11} = z_{11}$$

which would require $z_{11}^2 = z_r z_1$ which is not true in general.

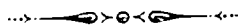

DISCUSSION ON "PARASITES AND INSTABILITY
 IN RADIO TRANSMITTERS"*

G. W. FYLER

James Greig:¹ It occurs to me in reading Mr. Fyler's very interesting and comprehensive study of radio transmitter instability, a subject which presents an almost endless variety of interesting phenomena and which may be approached from a number of different points of view, that a note on one or two points from personal experience may be of interest.

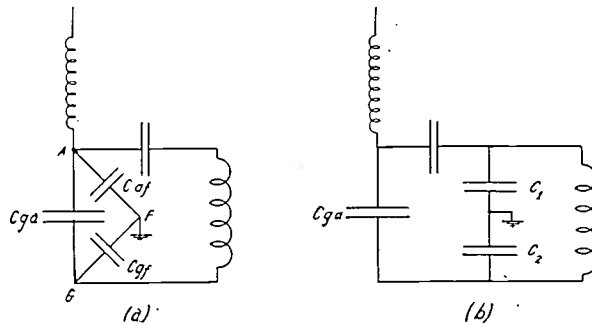

Fig. 1

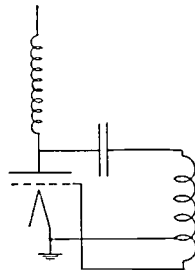

Fig. 2

I have found it helpful, in the case of the simple retroactive short-wave parasite, to regard the retroaction as having either the Colpitts or the Hartley mechanism. Consider first the case of a single valve circuit having an inductive connection between anode and grid but in which the only capacitances of importance are the internal valve capacitances, the external stray capacitances being negligible, Fig. 1(a). This is, obviously, a form of Colpitts circuit, the drive being provided by the capacitance potentiometer formed by C_{af} and C_{of} in series, which might be expected to self-oscillate if the ratio C_{af} to C_{of} is suitable. Alternatively, if the stray capacitances of the external circuit to ground are large compared with C_{af} and C_{of} , the circuit takes the form of Fig. 1(b), again a Colpitts circuit, with the drive determined by the ratio of C_1 to C_2 . The other extreme case would be one in which the capacitances to ground are negligible in comparison with C_{ga} and any capacitance paralleling it but in which a low impedance connection exists between the filament and some point on the inductance, as in Fig. 2, forming a Hartley circuit.

* Proc. I.R.E., vol. 23, pp. 985-1013; September, (1935).

¹ University College, London, England.

In the case of the Colpitts circuit, the addition of an antiparasitic capacitor between grid and filament may be regarded simply as reducing the drive by making C_2 large in comparison with C_1 , while, with the Hartley circuit, placing an antiparasitic capacitor as close to the valve as possible reduces the drive by reducing the ratio of grid inductance to anode inductance to its lowest value.

The fact that both grid and filament are inherently inaccessible and any paralleling capacitor is necessarily separated from both electrodes by a certain amount of inductance emphasizes the necessity for placing antishort-wave capacitors very close to the valve, but the importance of endeavoring to anchor the filament potential somewhere near the general ground potential at short parasitic wavelengths is, I believe, often overlooked. Standing waves have been observed even on filament bus bars where these were several feet long and connected to the general ground system at only one point. It has also been found that, with the antiparasitic capacitor mounted a little away from the valve, a standing wave can exist on the grid lead, utilizing the antishort-wave capacitor has a nodal point. In such cases subdividing the antishort-wave capacitance and distributing it at intervals along the grid conductor is sometimes effective.

With regard to the effect of plate and grid chokes in relation to short-wave parasites it has been found occasionally that a standing wave oscillation on a grid lead would be accompanied by a standing wave on the plate choke, the standing wave mode of the plate choke corresponding to this frequency, thus evidently presenting the requisite inductive reactance at the plate to enable oscillation to be maintained. Where chokes have been wound with less than a quarter wavelength of wire and efficiently by-passed to ground at the direct-current ends little trouble has been experienced with excessive voltages or currents at the fundamental frequency. Long-wave parasites in which plate and grid chokes in series resonated with the blocking capacitor in series with the output bank of high tension smoothing capacitors have been suppressed by the method of reducing the grid and increasing the plate choke inductances as described in the paper.

With reference to the single valve circuit shown in Fig. 5A in the paper, it has been found that, although parasites in this circuit can be suppressed by the usual methods, the circuit appears to be inherently unstable at a frequency close to the fundamental, while the corresponding circuit using a center-tapped grid capacitor is free from this trouble. A simple explanation of this effect is suggested in a paper entitled "Some Notes on the Stabilising of High-Frequency Power Amplifiers," *Jour. I.E.E.* (London), August, (1935).

G. W. Fyler:² Mr. Greig's discussion and recent paper present worth-while circuit considerations which should be helpful in the study of several transmitter parasites.

Regarding the filament bus standing waves of voltage mentioned, these have been known to cause abnormal sparking at the commutator of an associated filament motor-generator. I agree that grid-filament capacitors usually should be mounted very close to the tube to reduce the inductance of the grid-filament loop. This procedure helps greatly to prevent parasitic trouble with large water-cooled tubes, such as the General Electric Company 100-kilowatt tube (RCA 862). The grid and filament leads are brought out at one end of the tube. Development work on similar high power tubes where the grid lead was brought out at the opposite end from the filament indicated that the parasitic trouble was greatly increased because it was not possible to achieve a short grid-filament path.

² General Electric Company, Schenectady, New York.

BOOK REVIEWS

A Fugue in Cycles and Bels, by John Mills. D. Van Nostrand and Co., Inc., 250 Fourth Avenue, New York City. 264 pages. Price \$3.00.

Although it was evidently the author's primary purpose in writing this book to write for those whose main interest is in music, radio engineers will find its reading both profitable and interesting. The treatment is novel and descriptive, analogies to common experiences being frequently drawn upon. A historical approach to the discussion is used throughout. Perhaps it is natural in this phase of the writing that the author has overemphasized the contributions of the telephone engineers.

The book is divided into four parts, entitled: "From Pythagoras to Bell," "Telephonic Studies of Hearing," "An Electrical Future for Music," and "Plots and Graphs." In the first section of the book a brief discussion is given of the fundamentals underlying the perception of musical tones, simple electrical reproducing apparatus and musical scales; in the second section a very readable discussion is given of the limitations and range of the ear in the perception of sound. The third section discusses in simple terms such subjects as the power output of musical instruments, recording, noise, auditorium acoustics, electrical music, and teaching aids. In the discussion of disk recording the reviewer believes that the author has created a false impression by comparing the results obtained with a necessarily rather inexpensive form of lateral recording with a highly specialized form of vertical recording, and implying that these results give a fair comparison of the maximum attainable by these two methods.

*IRVING WOLFF

Sound, by F. R. Watson. Published by John Wiley & Sons, Inc., New York City. 219 pages. Price \$2.50.

As a subtitle the author has added "An Elementary Textbook on the Science of Sound and the Phenomena of Hearing." This expresses very well the scope and purpose of the book.

The treatment is physical throughout, mathematics having been avoided to as great an extent as is possible in a text on this subject. The emphasis is placed on the fundamentals of the science of sound rather than on the applications. A comprehensive list of problems is included at the end of each chapter.

In view of the successful experience of the author in the teaching of sound, this book should undoubtedly be of value to one who is desirous of learning some of the physical basis underlying the subject of acoustics, or as a classroom text for students who have only an elementary training in physics and mathematics. For those who are interested in proceeding with their studies, a complete bibliography of the important books on sound is included at the beginning of the text.

*IRVING WOLFF

* RCA Manufacturing Company, Inc., RCA Victor Division, Camden, New Jersey.

BOOKLETS, CATALOGS, AND PAMPHLETS RECEIVED

Copies of the publications listed on this page may be obtained without charge by addressing the publishers.

Broadside E on electrical measuring instruments for research, teaching, and testing, has been issued by Leeds and Northrup Company, 4902 Stenton Avenue, Philadelphia, Pa.

Bulletin No. 270 of the Rubicon Company of 29 N. 6th Street, Philadelphia, Pa., covers potentiometers.

Insulators made from lava, alsimag, alumina, beryllia, and magnesia are described in Bulletin No. 34 of the American Lava Corporation, Chattanooga, Tenn.

Doolittle and Faulkner, Inc., 1306 W. 74th Street, Chicago, Ill., have issued a leaflet describing their coaxial transmission line. Their antenna coupling units are described in another leaflet.

National Union Laboratories of 365 Ogden Street, Newark, N. J., has issued data sheets on the 6A8MG, self-excited electron-coupled converter; 6C5MG, medium- μ voltage amplifier; 6F5MG, high- μ voltage amplifier; 6F6MG, power amplifier; 6H6MG, twin diode; 6J7MG, sharp cut-off detector and amplifier; 6K7MG, remote cut-off radio-frequency and intermediate-frequency amplifier; 6L7MG, externally-excited electron-coupled converter; 6Q7MG, twin diode high- μ triode; 5Z4MG, full-wave rectifier; 6E5, tuning indicator; and inherent diode bias.

"Tantalum" is the subject of a booklet published by Fansteel Metallurgical Corporation of North Chicago, Ill.

Controlled rectifiers for uses requiring constant direct voltage under varying load conditions are described in Bulletin 8601 of the Ward Leonard Electric Company, Mount Vernon, N. Y.

RCA Manufacturing Company, Radiotron Division of Harrison, N. J., has issued Application Note No. 53 on the 6L7 as a volume expander for phonographs and application Note No. 54 on Class AB operation of Type 6F6 tubes connected as pentodes.

An Engineering News Letter is issued at irregular intervals by Hygrade Sylvania Corporation of Emporium, Pa., and covers developments in tubes and circuit applications. A technical manual supplement gives characteristics of nine metal tubes. Technical data sheets have been issued on the 6Q7, double-diode high- μ triode; 6E5, tuning indicator; ballast tubes; 1A4 and 1B4, radio-frequency amplifiers; 6X5 high vacuum full-wave rectifier; 1B5/25S, double-diode triode; and the 25A6 power amplifier pentode.

CONTRIBUTORS TO THIS ISSUE

Brainerd, John Grist: Born 1904, at Philadelphia, Pennsylvania. Police reporter, *Philadelphia North American*, 1923-1925. Instructor and assistant professor, Moore School of Electrical Engineering, University of Pennsylvania, 1925 to date. Received B. S. degree, University of Pennsylvania, 1925; Sc. D. degree, 1934. Associate member, Institute of Radio Engineers, 1933.

Eager, Marcy: Born April 16, 1898, at Brookline, Massachusetts. Received B. S. degree in electrical engineering, Harvard Engineering School, 1921; graduate work in communication engineering, 1922. Chief engineer's department, New England Telephone and Telegraph Company, 1922-1929; associated with Glenn D. Gillett, consulting radio engineer, 1933 to date. Associate member, Institute of Radio Engineers, 1933.

Everitt, William Littell: Born April 14, 1900, at Baltimore, Maryland. Received E. E. degree, Cornell University, 1922; M. S. degree, University of Michigan, 1926; Ph. D. degree, Ohio State University, 1933. Instructor in electrical engineering, Cornell University, 1920-1922; engineer in charge of laboratory and P. B. X. development, North Electrical Manufacturing Company, Galion, Ohio, 1922-1924; instructor in electrical engineering, University of Michigan, 1924-1926; assistant professor of electrical engineering in charge of communication courses, Ohio State University, 1926-1929; associate professor, 1929-1934; professor, 1934 to date. Department of development and research, American Telephone and Telegraph Company, summers, 1925-1930, inclusive. Associate member, Institute of Radio Engineers, 1925; Member, 1929.

Field, Robert F.: Born July 10, 1885, at Center Tuftonboro, New Hampshire. Received A. B. degree, 1906; A. M. degree, Brown University; 1907; A. M. degree, Harvard University, 1916. Instructor, Brown University, 1910-1915; Harvard University, 1917-1926; assistant professor, Harvard University, 1926-1929. Engineer, General Radio Company, 1929 to date. Member, Phi Beta Kappa, Sigma Xi, and American Physical Society; Fellow, American Association for Advancement of Science. Associate Member, Institute of Radio Engineers, 1918; Member, 1930.

Gillett, Glenn D.: Born April 14, 1898, at Sterling, Colorado. Studied at Pomona College; received A. B. degree, Harvard College, 1919; B. S. degree in electrical engineering, Harvard Engineering School, 1921. Southern California Edison Company, 1921-1922; department of development and research, American Telephone and Telegraph Company, 1922-1929; radio development group, Bell Telephone Laboratories, 1929-1932; consulting radio engineer, 1932 to date. Associate member, Institute of Radio Engineers, 1922; Member, 1927; Fellow, 1934.

Harris, W. A.: Born January 9, 1907, at Terre Haute, Indiana. Received B. S. degree in electrical engineering, Rose Polytechnic Institute, 1927. General Electric Company, 1927-1928; radio department, General Electric Company,

1928-1929; receiver development, RCA Victor Company, 1930; research and development laboratory, RCA Manufacturing Company, 1931 to date. Associate member, Institute of Radio Engineers, 1930.

Herold, E. W.: Born October 15, 1907, at New York City. Received B. Sc. degree, University of Virginia, 1930. Engineering department, Western Electric Company, 1924-1925; Bell Telephone Laboratories, 1925-1926; E. T. Cunningham, Inc., 1926-1929; research and development laboratory, RCA Manufacturing Company, Radiotron Division, 1930 to date. Associate member, Institute of Radio Engineers, 1930.

Klipsch, Paul W.: Born March 9, 1904, at Elkhart, Indiana. Received B. S. degree in electrical engineering, New Mexico College of Agriculture and Mechanic Arts, 1926; degree of Engineer, Stanford University, 1934. Testing department and advanced course in engineering, General Electric Company, 1926-1928; electric locomotive maintenance, Tocopilla, Chile, 1928-1931; Independent Exploration Company, Houston, Texas, 1934 to date. Member, Sigma Xi, Tau Beta Pi, and Society of Petroleum Geophysicists; associate member, American Institute of Electrical Engineers. Associate member, Institute of Radio Engineers, 1934.

LeVan, James D.: Born January 27, 1902, at Coffeyville, Kansas. Received B. S. degree in electrical engineering, University of California, 1925; M. S. degree, Harvard University 1927. Cutler-Hammer, Inc., 1928-1930; Raytheon Manufacturing Company, 1930 to date. Associate member, Institute of Radio Engineers, 1935.

Nagy, A. Wheeler: Born September 2, 1906, at New York City. Received E. E. degree, Polytechnic Institute of Brooklyn, 1930; M. A. degree in physics, Columbia University, 1932. Design and construction of ultra-short-wave apparatus, Graduate Research Laboratory, Polytechnic Institute of Brooklyn, 1933 to date. Junior member, Institute of Radio Engineers, 1926; Associate, 1927.

Nesslage, C. F.: Born June 23, 1909, at Union City, New Jersey. Received B. S. degree in electrical engineering, Princeton University, 1930. Research and development laboratory, RCA Manufacturing Company, Radiotron Division, 1930 to date. Associate member, Institute of Radio Engineers, 1934.

Norinder, Harald E.: Born March 3, 1888, at Norrköping, Sweden. Received Ph. D. degree, University of Uppsala, 1921. Manager of laboratory for lightning and high tension researches, Royal Board of Waterfalls, Sweden, 1922-1932; Docent of experimental electrophysics, University of Uppsala, 1928-1932; professor of electrophysics, 1932 to date; director, Institute for High Tension Research, University of Uppsala. Member, Swedish National Committee, International Radio Union. Nonmember, Institute of Radio Engineers.

Peterson, Eugene: Born August 26, 1894, at New York City. Cornell University, 1911-1914; Brooklyn Polytechnic Institute, 1917; received M. A. degree, Columbia University, 1923; Ph. D. degree, 1926. Electrical Testing Laboratories, 1915-1917; Signal Corps, U. S. Army, 1917-1919; member, technical staff, Western Electric Company, 1919-1925; Bell Telephone Laboratories, 1925 to date. Member, American Institute of Electrical Engineers and American Physical Society. Member, Institute of Radio Engineers, 1930.

Sinclair, D. B.: Born May 23, 1910, at Winnipeg, Manitoba, Canada. University of Manitoba, 1926–1929. Coöperative course in electrical engineering, Massachusetts Institute of Technology, 1929–1932. Received S. B. degree in electrical engineering, 1931; S. M. degree, 1932; Sc. D. degree, Massachusetts Institute of Technology, 1935. Research assistant, 1932–1935; research associate, Massachusetts Institute of Technology, 1935 to date. Research in radio-frequency measurements, General Radio Company, 1934–1935. Member, Sigma Xi. Junior member, Institute of Radio Engineers, 1930; Associate, 1933.

Van Dyck, A. F.: Born May 20, 1891, at Stuyvesant Falls, New York. Received Ph. B. degree, Sheffield Scientific School, Yale University, 1911. Amateur experimenter and commercial operator at sea, 1907–1910. National Electric Signalling Company, Brant Rock, Massachusetts, 1911–1912; research department, Westinghouse Electric and Manufacturing Company, 1912–1914; instructor in electrical engineering, Carnegie Institute of Technology, 1914–1917; expert radio aide, U. S. Navy, 1917–1919; Marconi Company, Aldene, New Jersey, 1919–1920; in charge, radio receiver design, General Electric Company, 1920–1922; Radio Corporation of America, 1922 to date. Charter Associate member, Institute of Radio Engineers, 1913; Member, 1918; Fellow, 1925.

Weeks, Paul T.: Born November 19, 1890. Received B. A. degree, Oberlin College, 1913; Ph. D. degree, Cornell University, 1917. Bureau of Standards, 1917–1918; U. S. Signal Corps, 1918–1919; Westinghouse Lamp Company, 1919–1928; Raytheon Manufacturing Company, 1929 to date. Associate member, Institute of Radio Engineers, 1919; Member, 1928.

Wrathall, L. R.: Born January 22, 1902, at Centerville, Utah. Received B. S. degree, University of Utah, 1927; graduate work, 1928. Member, technical staff, Bell Telephone Laboratories, 1929 to date. Nonmember, Institute of Radio Engineers.



★

SHE'S A PARTNER IN A GREAT AMERICAN BUSINESS



SHE is one of 850,000 owners of Bell System securities. They are typical Americans—some young, some middle age, some old. They live in every part of the nation.

One may be a housewife in Pennsylvania. Another a physician in Oregon—a clerk in Illinois—an engineer in Texas—a merchant in Massachusetts—a miner in Nevada—a stenographer in Missouri—a teacher in California—or a telephone employee in Michigan.

For the most part, Bell System stockholders are men and women who have put aside small sums for saving. More than half of them have held their shares for five years or longer. More than

650,000 of these 850,000 security holders own stock in the American Telephone and Telegraph Company—the parent company of the Bell System. More than 225,000 own five shares or less. Over fifty per cent are women. No one owns as much as one per cent of the stock of A. T. & T. In a very real sense, the Bell System is a democracy in business—owned by the people it serves.

Over 270,000 men and women work for the Bell System. One person out of every 150 in this country owns A. T. & T. securities or stock and bonds of associated companies in the Bell System.



BELL TELEPHONE SYSTEM

When writing to advertisers mention of the PROCEEDINGS will be mutually helpful.

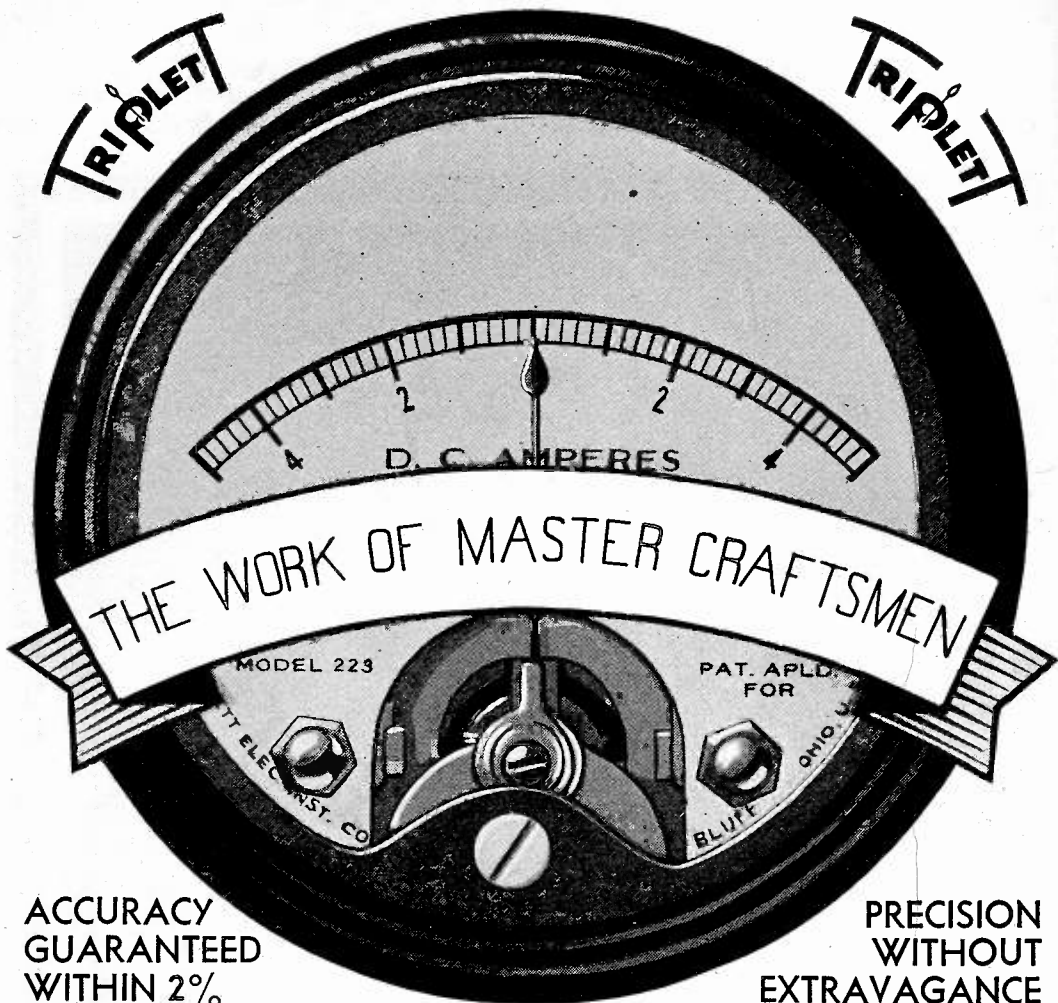

ACCURACY
GUARANTEED
WITHIN 2%

PRECISION
WITHOUT
EXTRAVAGANCE

MODEL 223 D.C.
5-0-5 AMMETER

Here is shown a 2" metal case clamp-on type Ammeter—just one of Triplet's large line of Instruments. Made in Bakelite and metal cases. D.C. instruments are the D'Arsonval moving coil type, A.C. are the movable iron repulsion type with an outstanding design.

TRIPLETT MANUFACTURES a complete line of all sizes and styles electrical measuring instruments for radio, electrical and general industrial purposes both standard and custom built. If you have an electrical instrument problem write to TRIPLETT.



MAIL THIS COUPON

Triplet Electrical Instrument Company
212 Harmon Drive, Bluffton, Ohio

Please send me your new 1936 Catalogue

Name

Address

City State

When writing to advertisers mention of the PROCEEDINGS will be mutually helpful.

The Institute of Radio Engineers

Incorporated

330 West 42nd Street, New York, N.Y.

APPLICATION FOR ASSOCIATE MEMBERSHIP

(Application forms for other grades of membership are obtainable from the Institute)

To the Board of Directors
Gentlemen:

I hereby make application for Associate membership in the Institute of Radio Engineers on the basis of my training and professional experience given herewith, and refer to the members named below who are personally familiar with my work.

I certify that the statements made in the record of my training and professional experience are correct, and agree if elected, that I will be governed by the constitution of the Institute as long as I continue a member. Furthermore I agree to promote the objects of the Institute so far as shall be in my power, and if my membership shall be discontinued will return my membership badge.

.....
(Sign with pen)

.....
(Address for mail)

.....
(Date)

.....
(City and State)

Sponsors:

(Signature of references not required here)

Mr. Mr.

Address Address

City and State City and State

Mr.

Address

City and State

The following extracts from the Constitution govern applications for admission to the Institute in the Associate grade:

ARTICLE II—MEMBERSHIP

Sec. 1: The membership of the Institute shall consist of: * * * (c) Associates, who shall be entitled to all the rights and privileges of the Institute except the right to hold any elective office specified in Article V. * * *

Sec. 4: An Associate shall be not less than twenty-one years of age and shall be a person who is interested in and connected with the study or application of radio science or the radio arts.

ARTICLE III—ADMISSION AND EXPULSIONS

Sec. 2: * * * Applicants shall give references to members of the Institute as follows: * * * for the grade of Associate, to three Fellows, Members, or Associates; * * * Each application for admission * * * shall embody a full record of the general technical education of the applicant and of his professional career.

ARTICLE IV—ENTRANCE FEE AND DUES

Sec. 1: * * * Entrance fee for the Associate grade of membership is \$3.00 and annual dues are \$6.00. •

ENTRANCE FEE SHOULD ACCOMPANY APPLICATION



—universal as radio itself

One of the cardinal principles of the Radio Corporation of America is that since radio is a universal medium, the Corporation must give universal service. . . . As the chief American factor in radio, this corporation consistently recognizes and assumes the responsibility of leadership. It maintains the country's foremost radio laboratories, to serve not only American manufacturers, but those in all other countries, where American genius, vision and progressiveness are freely recognized and eagerly sought. . . . To engineers of broadcasting stations, RCA offers RCA Radiotron Transmitting Tubes of all powers. . . . To manufacturing and service engineers, RCA offers a wide variety of laboratory, test and repair equipment and parts. To all the public, RCA offers inter-city,

marine and international radio communication; radio instruction in both its theoretical and practical aspects; products such as RCA Victor Receivers and Radio-Phonographs, RCA Radio Tubes, Victor Records, the finest broadcast programs through the National Broadcasting Company and associated stations, the enjoyment of sound motion pictures at their best as recorded and reproduced by RCA Photophone, and such devices as public address and educational systems. . . . RCA is the only American radio organization making everything from the microphone in the studio to the loud speaker in the home, every piece of apparatus coordinated with every other to work together for the maximum benefit of the public. . . . RCA is as universal as radio itself.

RCA MANUFACTURING CO., INC.

Camden, N. J. • A Subsidiary of the

RADIO CORPORATION OF AMERICA

When writing to advertisers mention of the PROCEEDINGS will be mutually helpful.

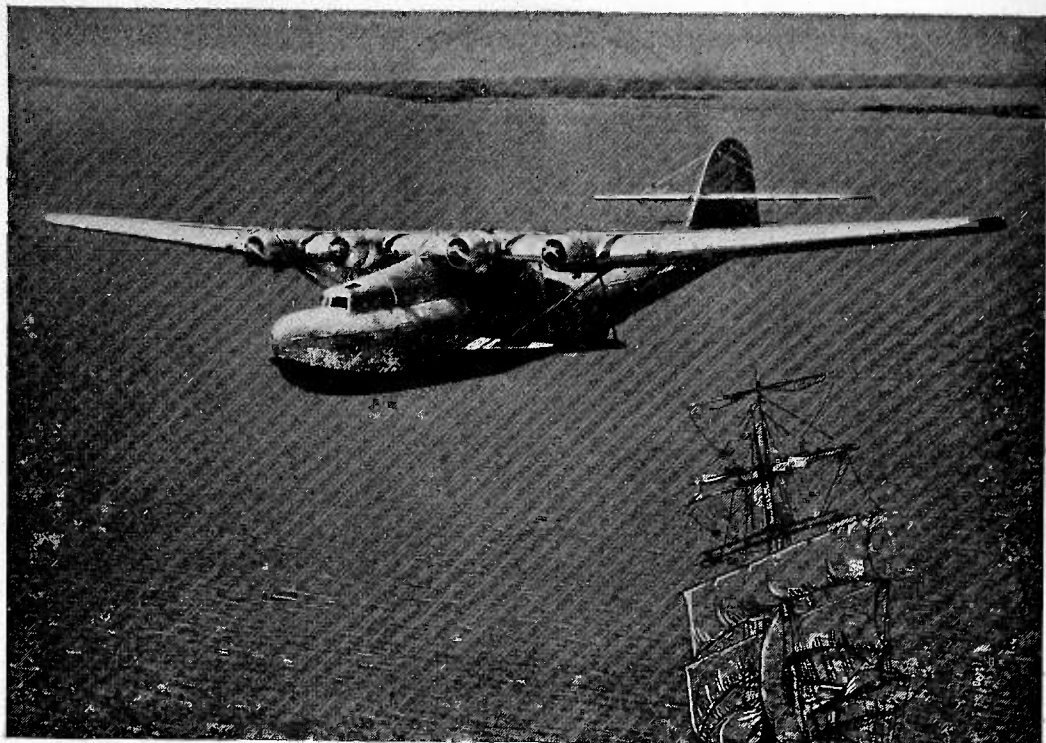

Flying Hours



THAT ONCE WERE SAILING WEEKS

Once more there are wings over the Pacific—not the wings of canvas on sailing boats—but the tireless wings of the "China Clipper," spanning 130 feet and capable of supporting a

load of twenty-five and a half tons. In the epic flight of the "China Clipper," Cornell-Dubilier capacitors played their part, as they have in practically every important pioneering achievement—in the first trans-atlantic flights, in the zeppelin exploits, in Arctic and



Antarctic expeditions—in fact, wherever reliable capacitors are a necessity.

Today, thousands of engineers are working on problems that hitherto have hindered progress. Radio beams mark highways through the sky! Earth inductor compasses point the way across the world! The "China Clipper" drones its tireless way across 2500 miles of the Pacific at almost 200 miles an hour! Cornell-Dubilier condensers are being developed and built to meet the requirements of this age! Cornell-Dubilier engineers and all the facilities of a great technical organization are yours to command wherever important capacitor installations are required!

Photo courtesy of Pan American Airways, Inc.

CORNELL-DUBILIER

CORPORATION

4379 BRONX BOULEVARD • NEW YORK

When writing to advertisers mention of the PROCEEDINGS will be mutually helpful.

VARIABLE CONDENSERS ...are no better than their INSULATION!

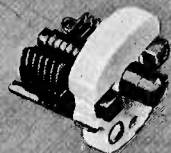
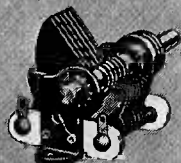
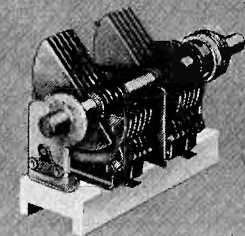
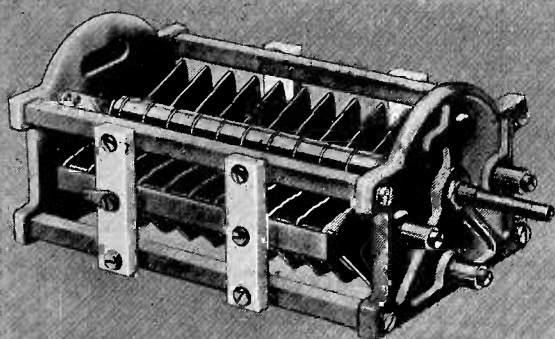

HAMMARLUND
MANUFACTURING CO.
NEW YORK

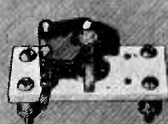

NATIONAL COMPANY
MALDEN, MASS.

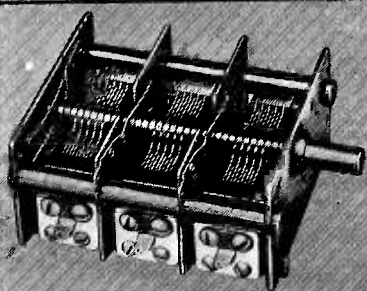
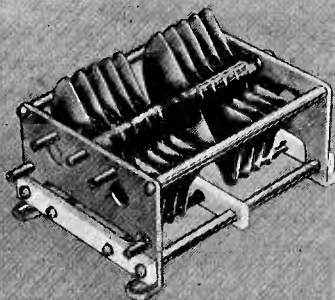
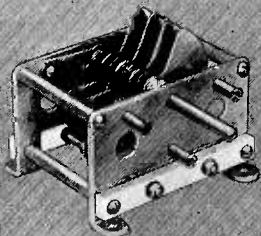

RADIO CONDENSER CO.
CAMDEN, N. J.

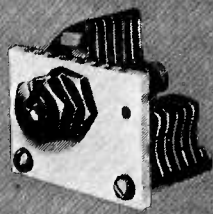
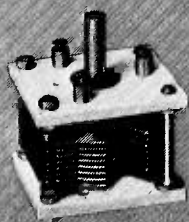

GENERAL RADIO CO.
CAMBRIDGE, MASS.

THE CAROWELL MFG. CORP.
BROOKLYN, N. Y.

RECOGNIZING this most important fact, these and many other manufacturers choose ISOLANTITE for insulating their quality products.

Insist on Condensers insulated with ISOLANTITE for maximum stability and dependability in your equipment.

Isolantite Inc., 233 Broadway, New York, N.Y. Factory at Belleville, N.J.

Isolantite

CERAMIC INSULATORS

When writing to advertisers mention of the PROCEEDINGS will be mutually helpful.

PROFESSIONAL ENGINEERING DIRECTORY

QUARTZ CRYSTALS

for Standard or Special
Radio Frequency Applications

Write for Catalog

BLILEY ELECTRIC CO.
230 Union Station Bldg.
ERIE, PENNA.

**Cathode Ray Tubes
and Associated
Equipment For All
Purposes**

*Write for Complete
Technical Data*

**ALLEN B. DUMONT
LABORATORIES**
UPPER MONTCLAIR, N.J.

PRACTICAL RADIO ENGINEERING

One year Residence Course
Advanced Home Study Course
Combined Home Study-Residence
Course

Write for details

**Capitol Radio Engineering
Institute**
Washington, D.C.

MICROPHONE APPLICATIONS

Our engineering department will co-
operate, without obligation, in the
selection of suitable microphones for
standard or special applications.

SHURE BROTHERS COMPANY
Manufacturers of Microphone Headquarters Telephone
Engineers Delaware 8383
215 WEST HURON ST. CHICAGO, ILLINOIS



GUTHMAN Coils

Radio Coils designed and
engineered to suit your re-
quirements by coil special-
ists. Correspondence is in-
vited.

EDWIN I. GUTHMAN and CO., Inc.
1036 West Van Buren St., CHICAGO, ILLINOIS

FOR MANY YEARS

the Professional Engineering Directory
has helped consulting engineers, design-
ers, and laboratory men make the right
contacts in the radio industry. Perhaps we
can help you with your problems too. For
further information write to

Advertising Department
**INSTITUTE OF RADIO
ENGINEERS**

330 West 42nd Street
NEW YORK CITY, N.Y.

*For the Engineering Consultant
who can handle a little extra business this year
For the Designer
who can manage some additional work*

we suggest the Professional Engineering Directory of the I.R.E. PROCEEDINGS. Manufacturers who need services such as yours and organizations with special problems come to our Professional Engineering Directory for information. Your name and special services announced here will put you in line for their business. For further information and special rates for I.R.E. members write to the Institute of Radio Engineers.

When writing to advertisers mention of the PROCEEDINGS will be mutually helpful.

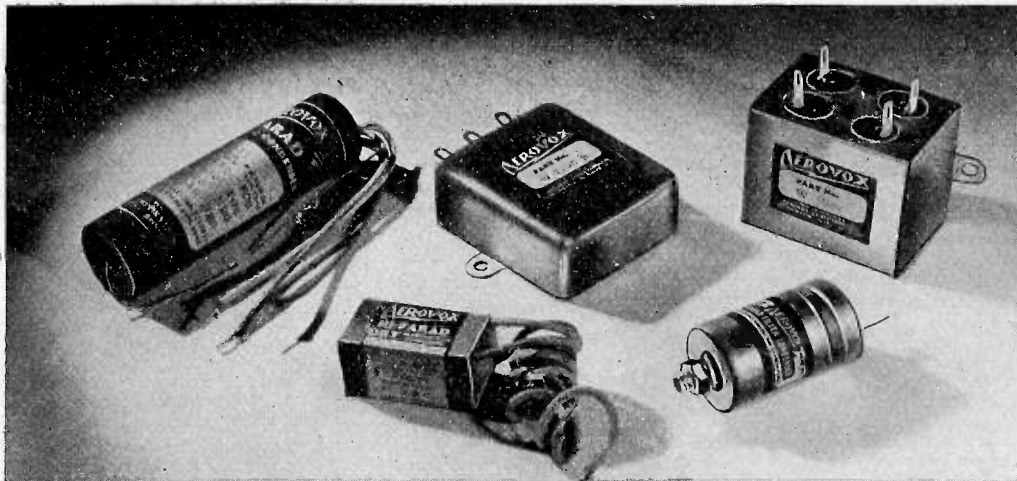

Condensers of Every Type

. . . Made to Your Specifications

Dry and wet electrolytics. Metal, cardboard and tubular casings.

High-capacity low-voltage electrolytics for A-eliminators and hum suppression.

Largest line of stamped metal case paper condensers . . . single and multiple sections.

Uncased paper-wound condensers for banking and other assembly purposes.

Complete line of Auto Radio condensers for initial components and noise suppression.

Oil-impregnated oil-filled transmitting condensers in round and rectangular cans.

Complete line of molded bakelite mica condensers. Also metal-cased mica units.

ALTHOUGH offering the greatest choice of standard and stock types, AEROVOX is always ready and anxious to build special condensers to your exact requirements. • We make all types—paper, oil, mica, electrolytic . . . in any container . . . all capacities, voltages, combinations. • Fully departmentalized, the AEROVOX plant assures you specialized engineering and production in any type condenser best suited to your needs. • Likewise with AEROVOX resistors . . . you will find them fit companions for our condensers.

DATA New 1936 Catalog covers AEROVOX line of standard condensers and resistors. Send for your copy. Meanwhile, please do not hesitate to submit condenser and resistor problems for engineering collaboration and quotations.



AEROVOX

C O R P O R A T I O N

71 Washington St.

Brooklyn, N. Y.

When writing to advertisers mention of the PROCEEDINGS will be mutually helpful.

Alphabetical Index to Advertisements

Aerovox Corporation	A	XVII
American Tel. & Tel. Company		IX
Central Radio Laboratories	C	XX
Cornell-Dubilier Corporation		XIV
Erie Resistor Corporation	E	XIX
General Radio Company	G	Cover IV
Institute of Radio Eng.	I	XI, XII, Cover III
Isolantite, Inc.		XV
Professional Engineering Directory	P	XVI
RCA Manufacturing Co.	R	XIII
Triplett Electrical Instrument Company	T	X

PROCEEDINGS BOUND VOLUMES

VOLUME 23 (1935) of the Proceedings is now available in bound form to members of the Institute. It may be obtained in Buckram or Morocco leather for \$9.50 and \$11.00 respectively. Foreign postage is \$1.00 additional per volume.

Bound copies of Volumes 18 and 19 (1930 and 1931) are also available at the same prices.

When writing to advertisers mention of the PROCEEDINGS will be mutually helpful.



In 1936

ERIE Insulated RESISTORS

*The outstanding resistor development
of 1935*

WILL CONTINUE TO BE

THE CHOICE OF LEADING

RADIO MANUFACTURERS

WHERE QUANTITY IS GIVEN

FIRST CONSIDERATION

ERIE INSULATED RESISTORS ARE AVAILABLE IN PRODUCTION QUANTITIES
IN $\frac{1}{4}$ AND $\frac{1}{2}$ WATT SIZES.

ERIE RESISTOR CORPORATION

ERIE, PA.

Factories in ERIE, PA. - TORONTO, CANADA - LONDON, ENG.

When writing to advertisers mention of the PROCEEDINGS will be mutually helpful.

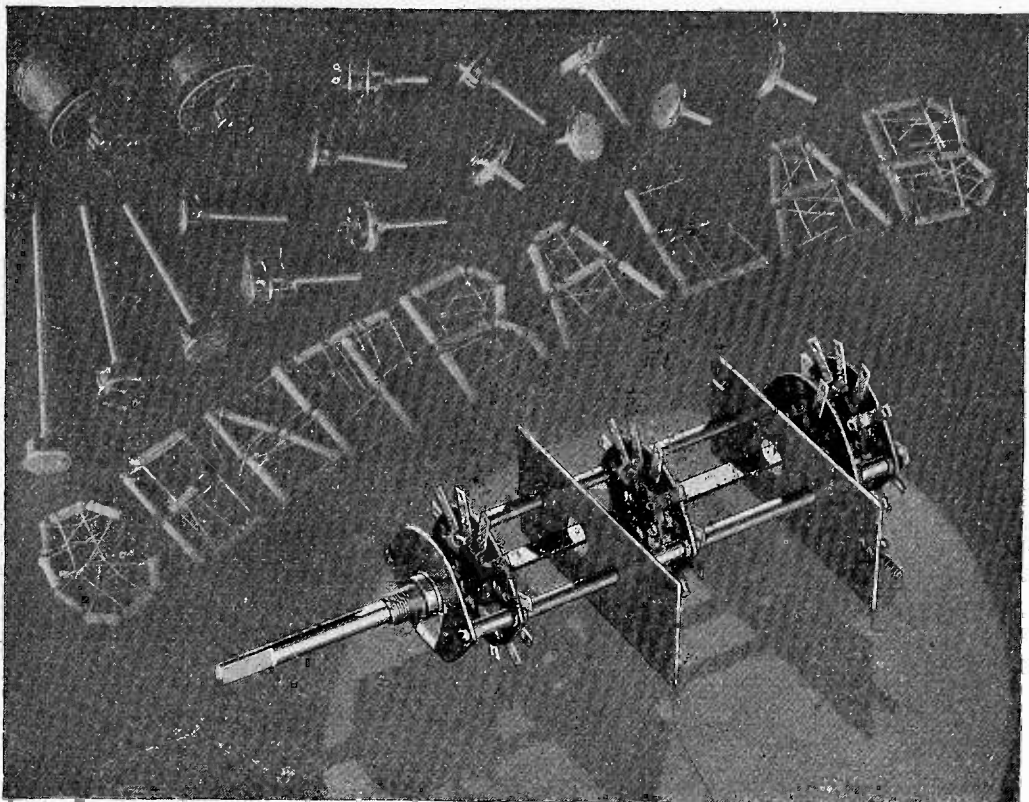

in The **SPOTLIGHT**

. . . a new Centralab Product

The Wave Change Switch, formerly made by PERFEX CONTROLS CO., of Milwaukee, Wis., is now a member of the famous CENTRALAB family. . . .

Leading manufacturers have "accepted" PERFEX Switches because of their positive biting contacts and their adaptability to all circuit requirements.

. . . and now under the CENTRALAB banner these wave change switches will, we believe, enjoy an even greater popularity. We welcome this new member to Centralab.

CENTRALAB: DIVISION OF GLOBE-UNION MFG. CO., MILWAUKEE

Centralab
CRL

Write Centralab for information on wave change switches, sockets, vibrators, controls and resistors.

When writing to advertisers mention of the PROCEEDINGS will be mutually helpful.

INSTITUTE SUPPLIES

EMBLEMS

Three styles of emblems are available to members of the Institute only. They are all of 14k gold with gold lettering on an enameled background, the color of which indicates the grade of membership. The approximate size of each emblem is as illustrated.



The lapel button is supplied with a screw back having jaws which fasten it securely to the coat. The price is \$2.75, postpaid, for any grade.

The pin which is provided with a safety catch may be obtained for any grade for \$3.00, postpaid.

The watch charm is handsomely finished on both sides and is equipped with a suspension ring for attaching to a watch chain or fob. Price for any grade, \$5.00, postpaid.

BINDERS

Binders are available for those who desire to protect their copies of the PROCEEDINGS with stiff covers. Each binder will accommodate the twelve monthly issues published during the year. These binders are of blue Spanish Grain Fabricoid with gold

lettering, and will serve either as temporary transfers or as permanent binders. They are so constructed that each individual copy of the

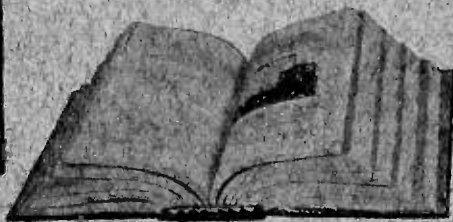

PROCEEDINGS will lie flat when the pages are turned. Copies can be removed from the binder in a few seconds and are not damaged by their insertion. They are priced at \$1.50 each, and the member's name or PROCEEDINGS Volume Number will be stamped upon the binder in gold for \$0.50 additional.

BACK ISSUES OF THE PROCEEDINGS

Complete volumes of back issues of the PROCEEDINGS are available in unbound form for the years 1918, 1921, 1922, 1923, and 1926 at \$6.75 per year (six issues) to members. Also complete unbound for 1931, 1932, 1933, 1934, and 1935 at \$7.50 per year to members. A list of the available miscellaneous copies published from 1913 on may be obtained from the Secretary. Single copies published prior to 1927 are sold to members at \$1.13 each, and those issued during and after 1927 are \$0.75 each. Foreign postage on single copies is \$0.10 per copy, making \$0.60 on unbound volumes before 1927.

Issues bound in blue buckram for 1930, 1931, and 1935 are priced at \$9.50 each to members. Foreign postage is \$1.00 additional per volume. Volumes for 1922 and 1926 bound in Morocco leather are available at \$10.25 each to members, volume for 1931 is \$11.00.

TWENTY-TWO-YEAR INDEX

An Index of the PROCEEDINGS for the years 1909-1930, inclusive, is available at \$1.00 per copy. It is extensively cross indexed. The earlier references are to the PROCEEDINGS of the Wireless Institute; the PROCEEDINGS of the Institute of Radio Engineers has been published since 1913.

When ordering any of the above, send remittance with order to the Secretary, Institute of Radio Engineers, 330 West 42nd Street, New York City.



**A SKELETON
BRIDGE FOR
MEASUREMENTS
OF**

INDUCTANCE

RESISTANCE

CAPACITANCE

Type 625-A Bridge \$65.00

An inexpensive skeleton bridge for the rapid measurement of any of these quantities. Designed for use with your own standards, an accuracy of 2% can be obtained over a considerable part of the following ranges:

- 1 microhenry to 100 henrys
- 1 milliohm to 1 megohm
- 1 micromicrofarad to 100 microfarads

WRITE FOR CIRCULAR 85-R FOR COMPLETE DETAILS

GENERAL RADIO COMPANY
30 State Street
Cambridge A Massachusetts



