

VOLUME 22

FEBRUARY, 1934

NUMBER 2

PROCEEDINGS  
*of*  
**The Institute of Radio  
Engineers**



Form for Change of Mailing or Business Title on Page VIII

---

# Institute of Radio Engineers Forthcoming Meetings

---

**CONNECTICUT VALLEY SECTION**  
February 23, 1934

---

**DETROIT SECTION**  
February 27, 1934

---

**NEW YORK MEETING**  
March 7, 1934

---

**PHILADELPHIA SECTION**  
March 1, 1934

---

**SAN FRANCISCO SECTION**  
February 21, 1934

---

**WASHINGTON SECTION**  
February 8, 1934

---

# The Institute of Radio Engineers

Board of Editors

ALFRED N. GOLDSMITH, *Chairman*

R. R. BATCHER  
 H. H. BEVERAGE  
 F. W. GROVER  
 G. W. PICKARD

K. S. VAN DYKE  
 L. P. WHEELER  
 L. E. WHITTEMORE  
 WILLIAM WILSON

## CONTENTS

### PART I

Institute News and Radio Notes.....	133
January Meeting of the Board of Directors.....	133
Radio Transmissions of Standard Frequencies.....	133
Institute Meetings.....	134
Personal Mention.....	143

### PART II

#### *Technical Papers*

Oscillators with Automatic Control of the Threshold of Regeneration....	JANUSZ GROSZKOWSKI	145
Optimum Operating Conditions for Class C Amplifiers... W. L. EVERITT		152
Magnetostrictive Alloys with Low Temperature Coefficients of Frequency	JOHN McDONALD IDE	177
A Compact Radio Field Strength Meter..... PAUL B. TAYLOR		191
On the Oscillations of a Circuit Having a Periodically Varying Capacitance	W. L. BARROW	201
Radiotelegraph Keying Transients..... REUBEN LEE		213
Note on a Multifrequency Automatic Recorder of Ionosphere Heights... T. R. GILLILAND		236
Radio Observations of the Bureau of Standards During the Solar Eclipse of August 31, 1932.	S. S. KIRBY, L. V. BERKNER, T. R. GILLILAND, K. A. NORTON	247
Development of Standard Frequency Transmitting Sets (Abstract)..... L. MICKEY AND A. D. MARTIN		265
A Continuous Recorder of Radio Field Intensities (Abstract)..... K. A. NORTON AND S. E. REYMER		266
Discussion on "Determination of Grid Driving Power in Radio-Frequency Power Amplifiers," by H. P. Thomas..... W. H. DOHERTY		267
Book Reviews: "Vocational Guidance in Engineering Lines," by American Association of Engineers..... F. W. GROVER		269
"A.S.T.M. Standards on Electrical Insulating Materials," American Society for Testing Materials..... L. E. WHITTEMORE		270
"Theory of Functions," by K. Polhausen..... K. S. VAN DYKE		270
"Differential Equations for Electrical Engineers," by Philip Franklin..... K. S. VAN DYKE		271
Radio Abstracts and References.....		272
Contributors to This Issue.....		277

# The Institute of Radio Engineers

---

## GENERAL INFORMATION

**INSTITUTE.** The Institute of Radio Engineers was formed in 1912 through the amalgamation of the Society of Wireless Telegraph Engineers and the Wireless Institute. Its headquarters were established in New York City and the membership has grown from less than fifty members at the start to several thousand.

**AIMS AND OBJECTS.** The Institute functions solely to advance the theory and practice of radio and allied branches of engineering and of the related arts and sciences, their application to human needs, and the maintenance of a high professional standing among its members. Among the methods of accomplishing this is the publication of papers, discussions, and communications of interest to the membership.

**PROCEEDINGS.** The PROCEEDINGS is the official publication of the Institute and in it are published all of the papers, discussions, and communications received from the membership which are accepted for publication by the Board of Editors. Copies are sent without additional charge to all members of the Institute. The subscription price to nonmembers is \$10.00 per year, with an additional charge for postage where such is necessary.

**RESPONSIBILITY.** It is understood that the statements and opinions given in the PROCEEDINGS are views of the individual members to whom they are credited, and are not binding on the membership of the Institute as a whole. Papers submitted to the Institute for publication shall be regarded as no longer confidential.

**REPRINTING PROCEEDINGS MATERIAL.** The right to reprint portions or abstracts of the papers, discussions, or editorial notes in the PROCEEDINGS is granted on the express condition that specific reference shall be made to the source of such material. Diagrams and photographs published in the PROCEEDINGS may not be reproduced without making specific arrangements with the Institute through the Secretary.

**MANUSCRIPTS.** All manuscripts should be addressed to the Institute of Radio Engineers, 33 West 39th Street, New York City. They will be examined by the Papers Committee and the Board of Editors to determine their suitability for publication in the PROCEEDINGS. Authors are advised as promptly as possible of the action taken, usually within two or three months. Manuscripts and illustrations will be destroyed immediately after publication of the paper unless the author requests their return. Information on the mechanical form in which manuscripts should be prepared may be obtained by addressing the secretary.

**MAILING.** Entered as second-class matter at the post office at Menasha, Wisconsin. Acceptance for mailing at special rate of postage is provided for in the act of February 28, 1925, embodied in Paragraph 4, Section 412, P. L. and R., and authorization was granted on October 26, 1927.

---

Published monthly by

**THE INSTITUTE OF RADIO ENGINEERS, INC.**

Publication office, 450-454 Ahnaip St., Menasha, Wis.

BUSINESS, EDITORIAL, AND ADVERTISING OFFICES

Harold P. Westman, *Secretary*

33 West 39th Street, New York, N. Y.

## INSTITUTE SECTIONS

- ATLANTA—Chairman, H. L. Wills; Secretary, Philip C. Bangs, 23 Kensington Road, Avondale Estates, Ga.
- BOSTON—Chairman, E. L. Chaffee; Secretary, G. W. Kenrick, Tufts College, Mass.
- BUFFALO-NIAGARA—Chairman, L. Grant Hector; Secretary, E. C. Waud, 235 Huntington Avenue, Buffalo, N. Y.
- CHICAGO—Chairman, R. M. Arnold; Secretary, Donald H. Miller, McGraw-Hill Publishing Company, 520 N. Michigan Ave., Chicago, Ill.
- CINCINNATI—Chairman, W. C. Osterbrock; Secretary, Helen Klein, Crosley Radio Corporation, Cincinnati, Ohio.
- CLEVELAND—Chairman, F. G. Bowditch; Secretary, C. H. Shipman, 14805 Ardenall Ave., East Cleveland, Ohio.
- CONNECTICUT VALLEY—Chairman, H. W. Holt; Secretary, C. B. De Soto American Radio Relay League, 38 La Salle Rd., W. Hartford, Conn.
- DETROIT—Chairman, Samuel Firestone; Secretary, E. C. Denstaedt, Detroit Police Department, Detroit, Mich.
- LOS ANGELES—Chairman, J. K. Hilliard; Secretary, N. B. Neely, 1569 Munson Ave., Los Angeles, Calif.
- NEW ORLEANS—Chairman, J. A. Courtenay; Secretary, C. B. Reynolds, Radiomarine Corporation, 512 St. Peter St., New Orleans, La.
- PHILADELPHIA—Chairman, W. F. Diehl; Secretary, G. C. Blackwood, 243 E. Upsal St., Mt. Airy, Philadelphia, Pa.
- PITTSBURGH—Chairman, Lee Sutherlin; Secretary, A. P. Sunnergren, West Penn Power Company, 14 Wood St., Pittsburgh, Pa.
- ROCHESTER—Chairman, Arthur L. Schoen; Secretary, Earl C. Karker, Mechanics Institute, 55 Plymouth Ave., Rochester, N. Y.
- SAN FRANCISCO—Chairman, G. T. Royden; Secretary, R. C. Shermund, 2300-16th Ave., San Francisco, Calif.
- SEATTLE—Chairman, H. H. Bouson; Secretary, Howard Mason, 2709-4th West, Seattle, Wash.
- TORONTO—Chairman, W. F. Choat; Secretary, G. E. Pipe, Rogers-Majestic Corporation, Toronto, Ont., Canada.
- WASHINGTON—Chairman, T. McL. Davis; Secretary, C. L. Davis, Washington Building, 15th and G Sts., Washington, D. C.

**GEOGRAPHICAL LOCATION OF MEMBERS ELECTED  
JANUARY 3, 1934**

**Elected to the Associate Grade**

California	Berkeley, 205 The Uplands . . . . .	Tonjes, V.
	Palo Alto, R.F.D. 1, Box 586 M. . . . .	Klipsch, P. W.
	San Pedro, NC Division, USS Chicago, c/o P.M. . . . .	Waldron, G. R.
Connecticut	Middletown, Box 369 Wesleyan Station . . . . .	Walstrom, J. E.
District of Columbia	Washington, 1112 Connecticut Ave. . . . .	Seccombe, W. T.
Massachusetts	Leominster, 9 Prescott St. . . . .	Cialdea, G. M.
	North Quincy, 37 Webster St. . . . .	Thomas, W. D.
Minnesota	Northfield, Radio Station WCAL . . . . .	Jensen, M.
New Jersey	Bloomfield, 198 Washington St. . . . .	Marsh, J. P.
	Cranford, 19 Adams Ave. . . . .	Fulmer, J. W.
	Harrison, RCA Radiotron Co., Inc. . . . .	Burnett, C. E.
	Harrison, RCA Radiotron Co., Inc. . . . .	Nesslage, C. F.
	Livingston, 20 Amherst Pl. . . . .	Charnley, R.
	Plainfield, 1441 Evergreen Ave. . . . .	Bucklin, K. G.
	Short Hills, 100 Hobart Ave. . . . .	Abel, W. K.
	Weehawken, 48 Hauxhurst Ave. . . . .	Dreyer, K.
New York	Brooklyn, 798 Myrtle Ave. . . . .	D'Agostino, V. F.
	Brooklyn, 93 Monitor St. . . . .	Graham, W.A.
	New York City, 195 Broadway, Rm. 2006. . . . .	Campbell, R. D.
	New York City, 215 W. 101st St. . . . .	Hartley, J. D.
	New York City, 150 W. 104th St. . . . .	Ryden, N. G.
Ohio	Cincinnati, 579 Terrace Ave. . . . .	Adams, R. F.
Texas	Dallas, Radio Station KRLD . . . . .	Peterson, D. A.
Australia	Sydney, N.S.W., c/o R. W. Reynolds, Ltd., 200 Chalmers St. . . . .	Cohen, L.
China	Shanghai, c/o Anderson Meyer & Co., P.O. Box 265 . . . . .	Chu, M. C.
England	Bristol, 6 Cotham Lawn Rd. . . . .	Pinto, C.
	Halifax, 7 Wade St. . . . .	Jackson, F. S.
	London N. W. 3, 39 Glenmore Rd., Belsize Park . . . . .	Jayasekara, D. P.
	London S. W. 17, 30 High St., Tooting . . . . .	Jones, S. L.
	Mayford, Woking, Mayford Villa . . . . .	Anderson, C. A.
	Portsmouth, Hants., 149 Eastney Rd. . . . .	Thomas, W. J.
France	Viarmes (S & O) 36 rue aux Fees . . . . .	Wybrands, K.
New Zealand]	Kaitia, North Auckland . . . . .	Snelgar, I. J.
	New Brighton, Christchurch, 174 Baker St. . . . .	Watkins, E. K. C.
North Wales	Colwyn Bay, Plas Cadnant, Woodland Park . . . . .	Parry, L.
Straits Settlements	Penang, 26 Kampong Kolam . . . . .	Hoe, T. G.
Sweden	Lidingo 2 . . . . .	Brigge, G. A.

**Elected to the Junior Grade**

New Jersey	Wildwood, 113 E. Young Ave. . . . .	Jimerson, O. J.
New York	Jackson Heights, 37-25 81 st St. . . . .	Zahn, K. W.
Utah	Salt Lake City, 177 E. 24th S. . . . .	Jones, R. F.

**Elected to the Student Grade**

California	San Francisco, 3773 20th St. . . . .	O'Brien, M. P.
	Stanford University, P. O. Box 544 . . . . .	Summerlin, W. T.
Georgia	Atlanta, 792 Techwood Dr. . . . .	Mohler, V. E.
Massachusetts	Cambridge, c/o Superintendent's Office, 69 Massachusetts Ave. . . . .	Maximoff, B. S.
Minnesota	Minneapolis, 3035 40th Ave. S. . . . .	Hauser, P. D.
	Minneapolis, 130 Arthur Ave. . . . .	Henrici, C. R.
	Minneapolis, 815 8th Ave. S. . . . .	Jacobs, M.
	Minneapolis, 3703 Washburn Ave. N. . . . .	Jensen, O. H.
	Minneapolis, 307 16th Ave. S. E. . . . .	Martin, C. A.
	Minneapolis, 516 Ontario St. S. E. . . . .	Newhouse, A. B.
	Minneapolis, 1219 University Ave. S. E. . . . .	Sather, O. J.
	Minneapolis, Pioneer Hall, Univ. of Minn. . . . .	Schott, O. A.
	Minneapolis, 2714 4th St. N. . . . .	Smith, M. R.
	Minneapolis, 621 Oak St. S. E. . . . .	Turnquist, A. G.
	St. Paul, 855 Edmund St. . . . .	Boese, W. C.
New York	Flushing, 4645 156th St. . . . .	McGirr, R.
Pennsylvania	Norwood, Del. Co., 308 Urban Ave. . . . .	Osterlund, J. A.
	Philadelphia, 6218 Catherine St. . . . .	Boghosian, W. H.
	Philadelphia, 2021 S. 7th St. . . . .	Hoffman, J.



## APPLICATIONS FOR MEMBERSHIP

Applications for transfer or election to the various grades of membership have been received from the persons listed below, and have been approved by the Admissions Committee. Members objecting to transfer or election of any of these applicants should communicate with the Secretary on or before February 28, 1934. These applications will be considered by the Board of Directors at its meeting on March 7, 1934.

### For Election to the Associate Grade

California	Alhambra, 700 N. Monterey St.	Gould, L. K.
Massachusetts	Belmont, 40 Upland Rd.	Norton, G. A.
	Beverly, 362 Cabot St.	Briggs, O. H.
	Beverly, 15 Ives St.	Carnahan, C. W.
	Cambridge, 26 Conant Hall	Kohler, H. W.
	Danvers, 45 B—Chase St.	Cox, J. L.
	Danvers, 45 A—Chase St.	McCarthy, H. J.
	Danvers, 43 Central Ave.	Swan, R. A., Jr.
	Everett, 59 Glendale St.	Kimball, C. N.
	Marblehead, 3 Pickwick Rd.	Haller, C. W.
	Salem, 31 Nursery St.	Henderson, F. C.
	Somerville, 8 Leon St.	Rockwell, S. A.
New Jersey	Great Notch, Box 6	Budelman, F. T.
New York	Brooklyn, 281 Carlton Ave.	Mercer, J. S.
	New York, 140 W. 77th St.	Chipp, R. D.
	New York, Rm. 212, 1 Madison Ave.	Ohno, S.
	Orangeburg, R. F. D.	Stafford, L. A.
	Rochester, 5 Wendall St.	Braman, P. U.
Ohio	Cincinnati, 1268 Michigan Ave.	Osmond, A. S.
	Columbus, 71 E. Lane Ave.	Spangenberg, K.
Pennsylvania	Media, 507 S. Orange St.	Richardson, F.
	Philadelphia, 5903 Wayne Ave.	Pearson, E. E.
Tennessee	Knoxville, P. O. Box 972	Epperson, J. B.
Australia	Dubbo, N.S.W., 263 Brisbane St.	Everett, F.
British India	Lahore, Punjab, D-96 Model Town	Handa, G. C.
Canada	Calgary, Alta., Suite 9, 1040 8th St. E.	Nielsen, K. D.
	Halifax, Nova Scotia, 4 Brenton Pl.	Egan, E. J.
	Halifax, Nova Scotia, T. Eaton Co.	Evans, J. W.
	London, Ont., 39 Lincolnwood St.	Little, R. W.
	Toronto, Ont., 50 Gloucester St., Apt. 209	Cuthbert, G.
England	Bradford, Yorkshire, 460 Harewood St.	Smith, F.
	Chelmsford, Essex, Russets Vicarage Rd.	O'Donovan, D. E.
	Coulsdon, Surrey, 466 Chipstead Valley Rd.	Hall, D. L.
	Guilford, Surrey, "Malvernian," Shepherds Lane	Perkins, A. C.
	Hounslow, Middlesex, 17 Kingsley Ave.	Hobbs, J. G.
	London, S.W. 15, 5 Clarendon Rd.	Whitehead, C. C.
	Sheffield 10, Yorkshire, 6 Clarkehouse Rd.	Walker, T. H.
	Tolworth, Surrey, 412 Ewell Rd.	Woods, G.
	Whiteley Bay, Northumberland, 70 The Broadway	Thew, C. L. A.
India	Cherat, N.W.F.P., Wireless Experimental Section	Peacock, J. W.
Japan	Aichi-ken, Nihon Musen Yosami-Mura, Hekikai-gun	Taki, I.
	Arimatsucho, JOCK, Okehazawa Hosojō	Keiji, S.
	Hiroshima, JOFK, Hiroshima Sending Station	Fujimoto, T.
New Zealand	Rotorua, 17 Amohau St.	Tapp, D. W. M.
West Africa	Monrovia, Liberia	Cooper, J. L.

### For Election to the Junior Grade

New York	Bayside, L. I., 40-19 219th St.	Roberts, R. H.
Turkey	Istanbul, Osmaniye Telsiz Telegraf Istasyonu, Telsiz Muamele Merkezi, Vasisiyle	Kerim, A.

### For Election to the Student Grade

California	Berkeley, 1443 Josephine St.	Randall, R. D.
Maryland	Linthicum Heights, East Hiltop Rd.	Brian, J. M.
New York	Troy, Clement Dormitory, Ave. B	Baluta, R. E.



## OFFICERS AND BOARD OF DIRECTORS, 1934

(Terms expire January 1, 1935, except as otherwise noted)

### *President*

C. M. JANSKY, JR.

### *Vice President*

BALTH. VAN DER POL, JR.

### *Treasurer*

MELVILLE EASTHAM

### *Secretary*

HAROLD P. WESTMAN

### *Editor*

ALFRED N. GOLDSMITH

### *Directors*

W. G. CADY, *Junior Past President*

O. H. CALDWELL

J. V. L. HOGAN

L. C. F. HORLE

C. W. HORN

E. L. NELSON

E. R. SHUTE

A. F. VAN DYCK

H. A. WHEELER

### Serving until January 1, 1936

R. A. HEISING

L. M. HULL, *Junior Past President*

F. A. KOLSTER

H. M. TURNER

### Serving until January 1, 1937

ARTHUR BATCHELLER

WILLIAM WILSON



## INSTITUTE NEWS AND RADIO NOTES

### Annual Meeting of the Board of Directors

The annual meeting of the Board of Directors was held in the Institute office in New York on January 3. Those present were: C. M. Jansky, Jr., president; Melville Eastham, treasurer; Arthur Batcheller, O. H. Caldwell, Alfred N. Goldsmith, R. A. Heising, C. W. Horn, E. R. Shute, H. M. Turner, William Wilson, and H. P. Westman, secretary.

The reappointment of Mr. Eastham as treasurer, Dr. Goldsmith as chairman of the Board of Editors, and Mr. Westman as secretary for 1934 was made.

Five directors to serve for 1934 were appointed and are Messrs. J. V. L. Hogan, L. C. F. Horle, E. R. Shute, A. F. Van Dyck, and H. A. Wheeler. The personnel of committees for 1934 was considered and recommendations presented by President Jansky approved. Certain committee appointments remain to be filled at the next Board meeting.

Thirty-seven applications for Associate membership, three for the Junior grade, and nineteen for the Student grade were approved.

The date for the regular New York February meeting was advanced to January 31 to permit our hearing a lecture demonstration on auditorium perspective to be presented by the Bell Telephone Laboratories. This demonstration involves the use of extensive equipment, a special orchestral program, and other things which require its being presented in conjunction with certain other meeting dates. Therefore it was not possible to have the meeting on February 7 as would be most desirable.

Permission was granted for holding the 1934 Rochester Fall Meeting on November 12, 13, and 14.

---

### Radio Transmissions of Standard Frequencies

The Bureau of Standards transmits standard frequencies from its station WWV, Beltsville, Md., every Tuesday except legal holidays. The transmissions are on 5000 kilocycles per second. The transmissions are given continuously from 12 noon to 2 P.M., and from 10:00 P.M. to midnight, Eastern Standard Time. The service may be used by transmitting stations in adjusting their transmitters to exact frequency, and by the public in calibrating frequency standards, and transmitting and receiving apparatus. The transmissions can be heard and utilized by stations equipped for continuous-wave reception through the United States, although not with certainty in some places. The ac-

curacy of the frequency is at all times better than one cycle per second (one in five million).

From the 5000 kilocycles any frequency may be checked by the method of harmonics. Information on how to receive and utilize the signals is given in a pamphlet obtainable on request addressed to the Bureau of Standards, Washington, D.C.

The transmissions consist mainly of continuous, unkeyed carrier frequency, giving a continuous whistle in the phones when received with an oscillating receiving set. For the first five minutes the general call (CQ de WWV) and announcement of the frequency are transmitted. The frequency and the call letters of the station (WWV) are given every ten minutes thereafter.

Supplementary experimental transmissions are made at other times. Some of these are made at higher frequencies and some with modulated waves, probably modulated at 10 kilocycles. Information regarding proposed supplementary transmissions is given by radio during the regular transmissions.

The Bureau desires to receive reports on the transmissions, especially because radio transmission phenomena change with the season of the year. The data desired are approximate field intensity, fading characteristics, and the suitability of the transmissions for frequency measurements. It is suggested that in reporting on intensities, the following designations be used where field intensity measurement apparatus is not used: (1) hardly perceptible, unreadable; (2) weak, readable now and then; (3) fairly good, readable with difficulty; (4) good, readable; (5) very good, perfectly readable. A statement as to whether fading is present or not is desired, and if so, its characteristics, such as time between peaks of signal intensity. Statements as to type of receiving set and type of antenna used are also desired. The Bureau would also appreciate reports on the use of the transmissions for purposes of frequency measurement or control.

All reports and letters regarding the transmissions should be addressed to the Bureau of Standards, Washington, D.C.

---

### Institute Meetings

#### CINCINNATI SECTION

A meeting of the Cincinnati Section was held on November 14 at the University of Cincinnati. W. C. Osterbrock, chairman, presided and forty members and guests were present.

"Vacuum Tube Universal Test Equipment" was the title of a paper presented by W. P. Koechel of the Kenrad Corporation. In it, the

speaker described many pieces of test equipment among which were a centralized control panel and voltage distribution system, an automatic monitoring device, a universal factory test set, which is readily adaptable to changing types of tubes, and a universal socket adaptor. The design of the universal laboratory test set capable of measuring a wide range of tube characteristics was discussed, and its flexibility which permits changes or alterations in wiring to be made without disturbing the operation of the set was pointed out. A method of utilizing isolated sources of voltage for various bias and plate supply requirements was outlined. There was also discussed a method of measuring any combination of tube element transconductances. Descriptions of miscellaneous adaptors, meter protection devices, and heating-time measuring devices were given.

Many of those present participated in the general discussion of the paper.

#### CLEVELAND SECTION

A meeting of the Cleveland Section was held on September 29 at Case School of Applied Science with Chairman P. A. Marsal presiding.

W. R. Veazy of Case School of Applied Science presented a paper on "Patents." In introducing his subject, Dr. Veazy pointed out that the purpose of the granting of patents is to promote the progress of science and the useful arts. The use of a patent or the withholding of it from use in such a way as to impede progress was given as grounds for court action against the owner of the patent.

No essential detail of an invention must be concealed. Although the patent office does not criticize specifications, it does check and edit the claims made for the invention. The fact that "imagination is not invention" was stressed with the further explanation that the inventor must first imagine, then actually make and show that the invention serves some human need. In the general discussion, the speaker related some of his own experiences in obtaining patents and defending them against infringement, in which case it was pointed out the inventor must prove first that his patent covers a real invention and second that it was infringed at a definite time and place and by a definite person or organization.

The November meeting was held on the 24th at Case School of Applied Science. Chairman Marsal presided and the attendance was eighteen.

L. N. Chatterton, chief engineer of WRBH, the Cleveland Police Radio Station, presented a paper on "Development and Use of Police

Radio." The speaker first discussed the use of radio broadcasts to police vehicles and the early developments in that field. The Cleveland installation was stated to be the first to be licensed in an exclusive police channel, and comprised a 1000-watt transmitter and six police cars at the time.

Interference with a neighboring city developed and its frequency was shifted to the present one. The change involved rebuilding of receiving equipment and certain new problems due to the original antenna towers resonating near the new frequency. The power was reduced to 500 watts to conform to Federal Radio Commission regulations, the towers were insulated at the base, and a new antenna system erected. This resulted in a more uniform field pattern and better overall field strength than had formerly been evident with twice the power. The present transmitting equipment is in duplicate with provisions for operation under practically all conceivable emergencies. The transmitter is remotely controlled by the operation of a single button. Broadcasts are also distributed through the wires of the police and fire signal system operating loud speakers in all precinct stations. About 180 mobile units are served which include suburban police and several pieces of fire apparatus to expedite the recall of fire trucks and tugs from false alarms to answer new alarms. About 80,000 messages were handled in 1932.

Reception problems in the mobile units and the elimination of electrical disturbances caused by ignition and other electrical systems were considered during the general discussion. Several cases were cited where radio was the determining factor in the apprehension of criminals or in meeting important emergencies.

The annual meeting of the Cleveland Section was held on December 21 at Case School of Applied Science and was presided over by P. A. Marsal, chairman. Forty-four members and guests were in attendance.

A paper on "Electronics in the Psychological Laboratory" was presented by J. M. Snodgrass, a professor at Oberlin College. The problem under consideration was that of measuring the electrical output of muscles under various conditions and the correlation of graphs showing electrical output and muscular tension. This curve was shown to be similar in shape and duration to that of the stimulus but followed it by a definite time interval. Oscillograms were shown of the electrical output of various muscles, and in one case the output of five sets of muscles from throat to lower abdomen were shown as a result of pronouncing simple single syllables. Some demonstration equipment permitted the

audible sounds produced by flexing the forearm and wrist muscles to be heard.

The use of thyratrons in synchronizing the stimulating currents and output measurements was discussed. High gain resistance coupled amplifiers operating from approximately minus ninety decibels and having an over-all gain of 70 to 80 decibels are employed. An additional power amplifier having a gain of 80 to 90 decibels follows it. Operation of the equipment from a motor-generator instead of directly from the alternating-current mains was considered necessary to avoid the effects of surges and other disturbances coming at relatively infrequent intervals. A general discussion followed the paper.

This being the annual meeting, officers for 1934 were elected. They are F. G. Bowditch, National Carbon Company as chairman; E. B. Snyder, Ohio Insulator Company as vice chairman; and C. H. Shipman, The Dodd Company, as secretary-treasurer.

#### CONNECTICUT VALLEY SECTION

The Connecticut Valley Section held a meeting at the Hotel Garde in Hartford on November 23. H. W. Holt, chairman, presided and the attendance was thirty-one.

"Noise Suppression in Automobile Radio Receivers" was the subject of a paper by L. F. Curtis who is chief engineer of United American Bosch Corporation.

His introduction of the subject divided the sources of noise interference in automobile radio receivers into four classes. The circuits in which the interference originated were outlined and the relative effects of changing voltages and currents, and producing transient sparks were considered. It was pointed out that the predominant noise frequencies were either very high or very low being in or near the audio-frequency range or in the very high radio frequency region. Methods of elimination by means of inserted resistance and by shielding were described and compared. The evils of improper shielding were pointed out. It was concluded that modifications in automobile design were necessary to solve the ultimate problem of suppressing entirely electrical interference to automobile radio receivers.

An interesting discussion followed in which B. V. K. French contributed some results of quantitative measurements to determine the frequencies at which the noise of representative systems peaked. Messrs. Cole and Lamb also participated in the discussion.

A Nominating Committee was appointed and election of officers will be held at the December meeting.

## DETROIT SECTION

G. W. Carter, chairman, presided at the December 15 meeting of the Detroit Section held in the Detroit News Conference Room. Thirty members and guests were present.

This meeting was devoted to a debate on the subject "Resolved that the British System of Radio Control be Adopted in the United States." On the affirmative were Messrs. Hastings, Kline, and Lee and for the negative, Messrs. Macomber and Willis, all of the Detroit City College. The debate was a no-decision affair and since all the points brought out were condemned, up-held, refuted, and substantiated both during the debate and discussion from the floor which was participated in by practically everyone present, a summary of it is not given. The consensus of opinion was that for America, the American system was preferable.

This was the annual meeting and officers for the next year were balloted upon. The new chairman and vice chairman are Samuel Firestone of the Detroit Edison Company and L. H. Larime of Station WJBK, respectively. E. C. Denstaedt of the Detroit Police Department was reelected secretary-treasurer.

## LOS ANGELES SECTION.

A meeting of the Los Angeles Section was held on September 17 in the Hotel Arcady. J. K. Hilliard, chairman, presided and forty members and guests were in attendance. Ten were present at the informal dinner which preceded the meeting.

"Naval Communications" was the subject of the paper by Lieutenant Myers, flag radio officer of the U. S. Navy. The speaker pointed out three major factors in the communication problem of the U. S. Navy. These are rapidity and secrecy of communication and the ability to cover an enormous area; namely, the entire world. He then outlined the general plan of the naval communications system covering the region between the Philippine Islands and the New England States. Next he discussed the various units which comprise our naval system indicating the tremendous task presented in providing adequate communication between all of them. The problems met in maintaining effective communication during heavy gun fire were also considered.

The second portion of the paper was a narrative history of the early portion of the World War. A detailed discussion was given of the evolution of naval communication, particularly in radio, and the part played by it in both the British and German Navies. Following this the meeting was open for general discussion which was participated in by many of those present.

The October meeting of the Section was held on the 17th at the Los Angeles Junior College. N. B. Neely, secretary-treasurer, presided and the attendance was 150.

The evening was devoted to a seminar on acoustics. The first speaker, Dr. V. O. Knudsen of the University of California, discussed the fundamental theory of vibration, harmonics, and overtone. Graphs were shown of the frequency-response characteristics of rooms to demonstrate certain points which were brought out. It was pointed out that contrary to common belief the absorption of sound in air was of considerable importance. Peculiarities of sound absorption of various gas molecules were explained as was the effect of humidity.

The second speaker, A. P. Hill of Electrical Research Products, discussed reverberation. Graphs indicating the reverberation characteristics of various rooms were shown and discussed with consideration of frequency-response, absorption, and reverberation and their effect on reproduced or original sounds. A recording reverberation register was operated and graphs of room noise were made and shown on the screen by means of the projector. Several sound-effect devices used in motion picture and radio broadcast work were demonstrated.

The third speaker was E. P. Schultz of the RCA Victor Company who concerned himself with the use of microphones and their placement under varying conditions. He pointed out the difference in acoustical characteristics at the place of origin and the place at which programs are reproduced, and discussed some experiments to determine the extent and the effect of this difference. Various methods of altering and controlling the reverberation characteristics of studios and auditoriums were discussed and the use of directional and nondirectional microphones considered. The directional qualities of the velocity microphone were discussed.

In November, J. M. Chapple, vice chairman, presided at a meeting held in the Los Angeles Junior College on the 21st.

At this meeting "Design Problems in Aircraft Radio" was the subject of a paper presented by Herbert Hoover, Jr. of Transcontinental Western Air, Incorporated. The subject was introduced with a general outline of the problems and transmission frequency assignments in aircraft radio. The various difficulties to be overcome in establishing effective communication between the aircraft and ground stations including radio range beacons and direction finders were discussed. The development of crystal control beat oscillators has resulted in increased operating efficiency.

The development and use of various types of antenna systems were

described. As it is necessary to operate on two or more transmission frequencies with a single antenna system, the problem is not simple. Disadvantages of the usual types of aircraft antennas were considered from the radio and aeronautical views. It was pointed out that the new Douglas transport planes are now using a nonretractable trailing wire attached to the tail of the plane. This results in greatly decreased drag, practically no ice accumulation, and several other desirable factors.

A block outline of the equipment used in modern transport planes and a brief description of the various units were given. It was pointed out that present demands upon the airplane electrical system may seem extreme in relation to the very slight drain of a few years ago and call for improved design of power supply systems for transport planes. The paper was closed with a discussion of the problems of airport control, the remote control of ground airway radio receivers and other problems in general. The attendance was 200.

#### NEW ORLEANS SECTION

A meeting of the New Orleans Section was held on November 14 in the X-ray laboratory of Tulane University.

L. J. Menville, head of the radiology department at Tulane University, and his associate J. N. Ane presented a paper on "The Physics of X-rays" and presented a demonstration of the latest apparatus. The paper covered the discovery and development of the principle of fluorescence and apparatus needs at the present time. In the demonstration, members attending the meeting were used as subjects and a series of slides were shown indicating the pioneer work done by the two doctors, who presented the paper, in their research on lymphatic glands. Eighteen members and guests were present and J. A. Courtenay presided.

A second meeting was held in November on the 29th at the Monteleone Hotel. C. B. Reynolds of the Radiomarine Corporation of America, who is also secretary of the section, presented a paper on "Automatic Alarm Systems" in which he covered the development and use of automatic alarm apparatus, and pointed out the advantages and disadvantages of such equipment. Receivers and relay circuits employed by the Norwegian Telefunken System were described in detail. A general discussion of the apparatus followed and was participated in by about fifteen of the forty members and guests who were present at the meeting. J. A. Courtenay, chairman, presided.

J. A. Courtenay, chairman, presided at the December 15 meeting of the New Orleans Section which was held at the Monteleone Hotel.



A paper on "Methods Used in Obtaining Evidence for Prosecution of Unlicensed Broadcast Stations" was presented by L. J. N. Du Treil, New Orleans Radio Inspector for the Federal Radio Commission.

Over one hundred unlicensed broadcast stations have been operating in Texas, Louisiana, Mississippi, and Arkansas chiefly because broadcast coverage is not reliable over the areas in which they have been located. Evidence must be secured proving that the station can be heard outside the state boundaries or causes interference with signals from outside the state. If neither of these two conditions exist on broadcast channels, a high-frequency receiver tuned to a harmonic of the station being investigated invariably does establish one or both conditions. Indictments and convictions in such cases has reduced the number so operating almost to insignificance.

In many cases, a network of such stations have been operated, advertising solicited and no attempt made to keep secret the location of the stations. However, in one particular case, a station was announced as being in Australia, South America and other remote places but was finally located in Mississippi. Photographs were shown of some of these stations. Many of the thirty-eight present participated in the general discussion of the paper.

#### NEW YORK MEETING

The annual meeting of the Institute held in the Engineering Societies Building on the evening of January 3, 1934, was attended by 300 members and guests.

In the absence of Dr. Hull, the meeting was called to order by Dr. Goldsmith who introduced President Jansky. In his address, President Jansky outlined the basis on which the Institute is operating. The organization and operation of the Board of Directors which is the governing body of the Institute was described and some of the problems which it has faced discussed.

The difficulty of defining a radio engineer in precise terms and the effect of this in industry was pointed out. The operation of certain Institute committees which assist in improving this condition was discussed. In closing Mr. Jansky extended his thanks not only for his own election but for the election of a Board of Directors composed of men of the highest caliber obtainable.

Although a paper on "Quality vs. Cost of Broadcast Receivers" was scheduled for presentation by R. H. Langley, it was not possible for Mr. Langley to be present. The summary of the paper was read and a general discussion was called for from the floor. This discussion examined various aspects and presented many informative viewpoints on this subject. It was participated in by Messrs. O. H. Caldwell, Alfred

N. Goldsmith, V. M. Graham, J. V. L. Hogan, C. W. Horn, E. L. Nelson and the chairman.

#### PHILADELPHIA SECTION

The Engineers Club in Philadelphia was the place in which the December 7 meeting of the Philadelphia Section was held. W. F. Diehl, chairman, presided and the attendance was 302.

A paper on "High Quality Radio Broadcast Transmission and Reception" which was given at the November 8 New York meeting was presented by Stuart Ballantine of the Boonton Research Corporation. The summary of this paper is given in the December, 1933, issue of the PROCEEDINGS.

#### SAN FRANCISCO SECTION

A meeting of the San Francisco Section was held on December 6 at the Bellevue Hotel. In the absence of the chairman, the meeting was presided over by A. Brolly and the attendance was fifty-five, twelve of whom were present at the informal dinner which preceded the meeting.

The subject of the meeting was "Modern High-Frequency Developments" and was discussed by Messrs. F. C. Jones, R. D. Kirkland, and Walter Bayha. It was chiefly a review of papers which have been published in the PROCEEDINGS and was supplemented by personal experiences, and observations. A general discussion followed and a display of modern high-frequency receivers and vacuum tubes was examined.

#### TORONTO SECTION

The November 16 meeting of the Toronto Section at which W. F. Choat, chairman, presided was held at the University of Toronto and attended by fifty-one.

"Development of Cathode Ray Tubes for Oscillograph Purposes" was presented by R. T. Orth of the RCA Radiotron Company. In it the speaker outlined the fundamental characteristics of these tubes with particular reference to the various types used for special classes of application. Focusing methods were considered and constructional diagrams of the tubes were presented and the function of each part discussed. Magnetic and electric field control of the cathode ray beam were described. It was pointed out that due to internal fields producing aberration of the fields due to external control coils, magnetic beam control was not desirable except in particular cases. Magnetic control also limits the picture fidelity to frequencies of 10,000 cycles or less. Electric field methods are suitable up to the limits of the electron speeds available. A useful system is to employ a magnetic control for the timing axis and an electric control for the actuating circuit.

A number of graphs were shown to illustrate the characteristic operating control factors and a demonstration of portable equipment provided. Various deflection and electron velocity formulas were given. Beam speeds of 600 inches per second are usually obtainable and photographed with ordinary Panchromatic film. Fluorescent materials such as calcium and cadmium tungstate, zinc sulphide and zinc orthosilicate have been used for the beam target but synthetic Willemite is now used generally and gives brilliant images between 5300 and 6150 Angstrom units which is between green and yellow. Some content around 4900 units results which is in the blue portion of the spectrum.

A general discussion was entered into by Messrs. W. F. Choat, C. Hepburn, W. Nesbitt, A. B. Oxley, G. E. Pipe, and V. G. Smith.

#### WASHINGTON SECTION

The attendance at the December 14 meeting of the Washington Section which was held at the Kennedy Warren Apartments was fifty-two, twenty-five of whom were present at the informal dinner which preceded the meeting. Dr. Dorsey, chairman of the section, presided.

This was the annual meeting of the section and C. M. Jansky, Jr., who was recently elected president of the Institute for 1934, attended as the guest of honor. The section expressed its pride in having for the fourth time one of its members elected to the presidency of the Institute. Mr. Jansky in an informal talk briefly outlined the activities of the Institute during the past few years. He discussed the work of various committees of the Institute particularly that of the Broadcast Committee and the Industrial Relations Committee.

The election of officers for the coming year was held and by unanimous vote the proposal of the Nominating Committee was accepted.

T. McL. Davis was elected chairman; V. Ford Greaves, vice chairman, and C. L. Davis continues as secretary-treasurer.

---

#### Personal Mention

Formerly with the DeForest Radio Company, D. W. Short is now radio transmitter engineer for Hygrade Sylvania Corporation at Clifton, N. J.

L. P. Williams of the Tropical Radio Telegraph Company has been transferred from Hingham, Mass., to New Orleans, La.

C. F. Wolcott is on the radio engineering staff of Noblitt-Sparks Industries of Columbus, Ind., having formerly been connected with the DeForest Radio Company.

Previously with Detrola Radio Corporation, H. M. Wood is now connected with Oak Manufacturing Company of Chicago.

Formerly with Bell Telephone Laboratories, J. D. Woodward has joined United Air Lines Communications with headquarters at Chicago, Ill.

Hidetsugu Yagi formerly at the Tohoku Imperial University has become Professor of Applied Physics at Osaka Imperial University.

Previously with Aeradio Corporation, Zolmon Benin is now on the engineering staff of Zenith Radio in Chicago.

L. V. Berkner has joined the Department of Terrestrial Magnetism of the Carnegie Institution at Washington, D. C., having formerly been connected with the Bureau of Standards Radio Section.

T. J. Boerner formerly with RCA Communications is now with the RCA Victor Company at Camden, N. J.

Previously with U. S. Radio and Television Corporation, D. E. Foster is now chief radio engineer of General Household Utilities Company, Chicago, Ill.

R. P. Glover formerly with the Clough-Brengle Company is now doing consulting work in Chicago, Ill.

A. E. Gray, assistant superintendent of communications of American Airways has been transferred from Robertson, Mo., to Chicago, Ill.

Previously with Arcturus Radio Rube Company, N. C. Hall is now connected with the Zetka Engineering Company of Nutley, N. J.

E. Harper has become managing director of Harken Electrical Company of Croyden, England.

Previously with International Telephone and Telegraph Laboratories B. B. Jacobsen is now a development engineer for Standard Telephones and Cables at North Woolwich, England.

W. W. Knight has joined the engineering staff of Electrical Research Products in Philadelphia having formerly been connected with the Naval Aircraft factory in that city.

A. W. Marriner, Captain, U. S. Army Air Corps, has been transferred from Chanute Field to Washington, D. C.

Previously with KGIR, R. D. Martin has become chief engineer of KFPY, Spokane, Wash.

Fred Muller formerly marine radio superintendent of the Tropical Radio Telegraph Company is starting a consulting practice in New York City.

J. H. Pressley previously with the U. S. Radio and Television Corporation has been appointed director of engineering for Zenith Radio of Chicago.

Formerly with the General Electric Company, W. E. Tucker has joined the RCA Victor Company as radio transmitter engineer.

TECHNICAL PAPERS

OSCILLATORS WITH AUTOMATIC CONTROL OF THE  
THRESHOLD OF REGENERATION\*

BY

JANUSZ GROSZKOWSKI

(State Institute of Telecommunications, Warsaw, Poland)

*Summary*—The frequency of an oscillator operating just on the threshold of the oscillation generation is determined—as is well known—by the constants of the circuit only; i. e., it does not depend on the operative conditions (supply voltages) of the system. The operation in this critical state for an ordinary dynatron oscillator as well as for a dynatron with back coupling can be continuously secured by means of an arrangement working automatically. Its principle is as follows: The oscillating circuit of the dynatron feeds a rectifier which, in turn, supplies the rectified voltage to the inner grid circuit of the dynatron tube (tetrode) in such a way that its bias becomes more and more negative when the oscillation amplitude increases. Owing to this arrangement the amplitude maintains itself continuously in the critical region for which the frequency stability is very high.

I. DYNATRON OSCILLATOR

THE frequency of an oscillator using negative resistance characteristics, when operated just on the threshold of the oscillation generation, is determined by the constants of the oscillating circuit only and is independent of the curvature of the character-

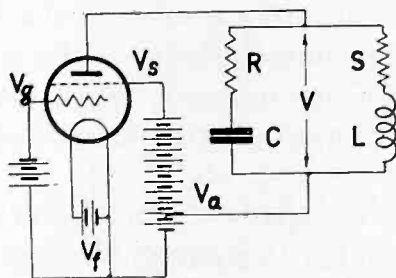

Fig. 1

istics.<sup>1</sup> Thus, for a dynatron circuit, shown in Fig. 1, the frequency of oscillation is given by the formula

\* Decimal classification: R 133. Original manuscript received by the Institute, September 1, 1933. Abbreviated résumé from the paper in Polish, *Wiadomości i Prace Instytutu Radjotechnicznego*, vol. 5, (1933).

<sup>1</sup> For example, see, J. Groszkowski, "Constant-frequency oscillators," Proc. R.E., vol. 21, no. 7, p. 960; July, (1933).

$$f = \frac{1}{2\pi\sqrt{LC}} \sqrt{\frac{1 - \frac{R^2C}{L}}{1 - \frac{S^2C}{L}}} \quad (1)$$

If we disregard the variations of the values of  $L, C, R$ , and  $S$ , the problem of the generation of constant frequency reduces itself to continuous maintenance of the generation system in the critical state of operation, i.e. on the threshold of regeneration. In this case, the variations taking place in the dynatron system and caused by the variations of the supply voltages,  $V_f, V_a, V_s, V_g$ , will exert no influence on the frequency of oscillation.

For a dynatron oscillator using the real nonlinear characteristics, such a critical state does not exist in the strictly mathematical mean-

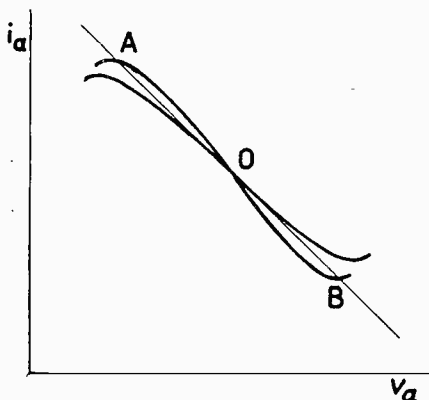

Fig. 2

ing. Practically, this state can be approached in a more or less accurate manner by causing the negative resistance characteristics to be more or less tangential to the characteristics of the oscillating circuit (Fig. 2). This can be attained, for instance, by varying the inner grid bias  $V_g$ , which, as it is well known, determines the dynatron negative resistance.

Assuming the simplest shape of the characteristics, having only three points of intersection with a straight line, we can consider that for the critical state the oscillation amplitudes are contained between zero (ideal critical state in the point 0) and a certain value given by the points  $A$  and  $B$  (practical conditions).

Evidently, (1) is applicable only to the ideal critical state, that is, to the oscillation amplitude near zero. When the amplitude increases, harmonics build up, causing the frequency to drift.<sup>1</sup> This drift, however, can be reduced considerably by limiting the region  $AB$ , or by maintaining the amplitude of the oscillation constant. This last-

mentioned manner of operation can be realized automatically by means of an arrangement, the principle of which is shown<sup>2</sup> in Fig. 3. First, let us suppose that the mutual inductance  $M$  is equal to zero.

In this case, the inner grid bias  $V_g$ , which determines the slope of the dynatron characteristics, is determined by the value of the voltage  $V_0$ . This voltage,  $V_0$ , is supplied by the rectifier, consisting of the valve  $K$  (a triode with grid and anode connected together may be used), of the load resistance  $r_2$  shunted by the condenser  $C_2$ , and of a polarizing battery  $V_p$ . The alternating voltage is supplied to the rectifier by the oscillating circuit  $LC$ . The rectifier is connected with the inner grid circuit in such a way that its potential  $V_g$  increases in the negative sense when the oscillation amplitude increases. Under these conditions, the operation of the oscillating system is determined by the

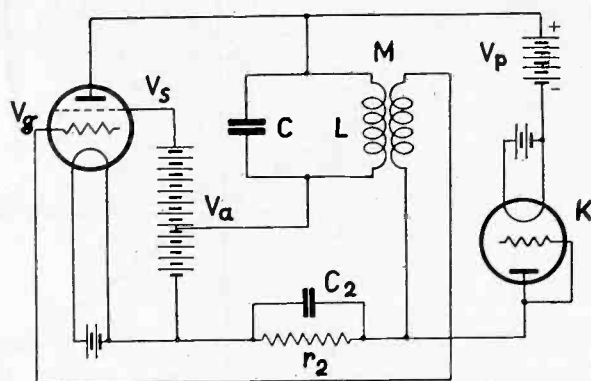

Fig. 3

solution of two equations. The first one determines the relation between the rectified voltage  $V_0$  and the output voltage  $V$  measured on the circuit  $LC$ ,

$$V_0 = \psi(V). \quad (2)$$

The second one determines the relation between the alternating voltage  $V$  and the inner grid bias  $V_g$ , which in this case is equal to  $V_0$ ,

$$V = \phi(V_g = V_0). \quad (3)$$

Fig. 4 represents graphically equations (2) and (3) for the circuit shown in Fig. 5. In the same figure, dotted curve (I) indicates the frequency variation as a function of the grid bias  $V_g$ .

If the resistance  $r_2$  be sufficiently high, the curve (II) is approximately a straight line; its position depends on the value of the polariz-

<sup>2</sup> The automatic control of the grid bias of a triode oscillator has been employed by Arguimbau, Proc. I.R.E. vol. 21, no. 1, p. 14; January, (1933), in order to secure linear operating characteristics of a generator; the author also points out that there is an increase in the frequency stability with this arrangement, but gives no numerical data.

ing direct-current voltage  $V_p$  in the rectifier circuit. By varying this voltage  $V_p$ , the intersection point  $P$  can be changed and the oscillation amplitude arbitrarily chosen and kept constant by the arrangement. The portion  $ab$  of curve (III) corresponds to the critical state of practical operation. This portion is usually very steep. (Sometimes, if the supply voltages are not suitably chosen, a loop can appear here.)

The frequency variation taking place when the oscillation amplitude is varying between points  $a$  and  $b$  (approximately from zero to 30 volts) is less than 0.01 per mille.<sup>3</sup> If it is assumed that the relative fre-

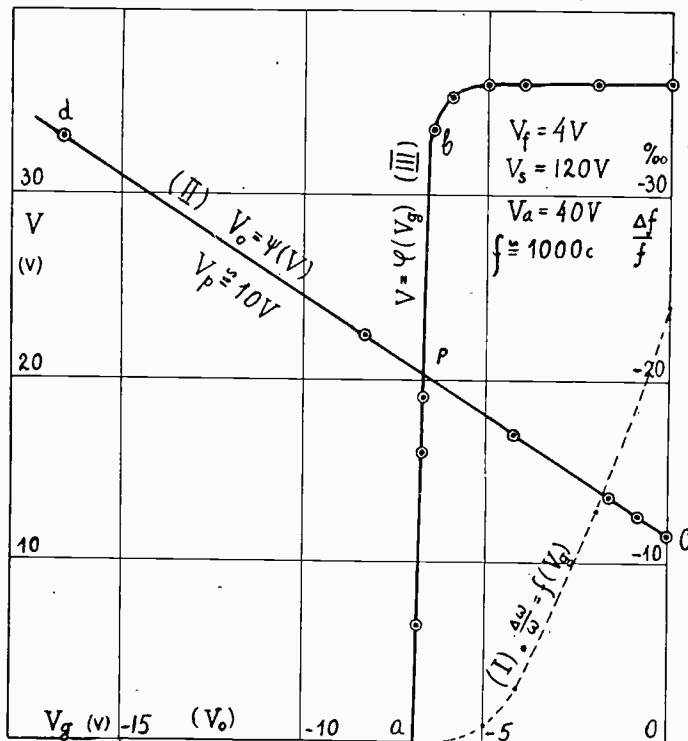

Fig. 4

quency drift  $\frac{\Delta f}{f}$  ( $f$  being frequency corresponding to the ideal critical state) is proportional to the amplitude  $V$ , this amplitude being maintained within 10 per cent, the frequency stability under the operating conditions of the dynatron will be of the order of 0.001 per mille; i.e., of one part in one million.

By suitably coupling the dynatron and the rectifier we can secure the automatic regulation of generation of the constant amplitude which is determined by the intersection of the curves (II) and (III) in Fig. 4. (There are several kinds of coupling suitable for this purpose; one of

<sup>3</sup> Correction. In the paper, "Constant-frequency oscillators," Proc. I.R.E., vol. 21, no. 7, pp. 977-978; July, (1933), Tables I and II, the symbol % (per cent) must be replaced by the symbol ‰ (per thousand or per mille), and "per cent" must be read "per mille." Indications in Fig. 14 are, however, right.



them is shown in Fig. 3. The curves of Fig. 4 correspond to the operating conditions of the circuit shown in Fig. 5.)

The operation of the system is as follows: If the shape (for example, the slope) of the characteristic of the dynatron is varying from any cause in such a way that the oscillation amplitude changes (increases or decreases), then the input alternating voltage changes also (increases or decreases). This change of alternating voltage causes a corresponding change of the output direct voltage of the rectifier. The inner grid negative bias follows these changes until the oscillation amplitude reaches the value corresponding to the equilibrium of the system.

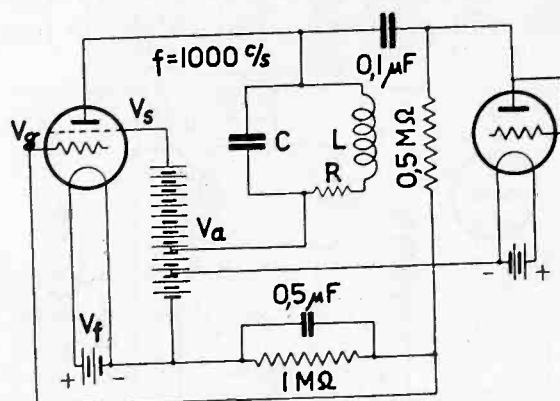

Fig. 5

The regulation ability of the system is seen from Table I. The values given in parenthesis show relative frequency variations caused by various changes occurring in filament voltage  $V_f$ , anode voltage  $V_a$ , and screen voltage  $V_s$  for an ordinary dynatron oscillator. Other values refer to an arrangement with automatic regulation of the critical state.

The frequency variations  $\frac{\Delta f}{f}$  expressed in per mille, correspond to the initial operating point given by the voltages  $V_f = 3.5$ ,  $V_a = 60$ , and  $V_s = 120$  volts.

TABLE I

Anode voltage $V_a$		50			60			70			
		140	120	100	140	120	100	140	120	100	
$\Delta f/f$ in ‰	Screen voltage $V_s$	4.0	(-30)	(-10)	(+1)	(-30)	(-3)	(+1)	(-5)	(-5)	(+3)
			-0.06	-0.07	-0.07	-0.02	-0.01	-0.01	-0.06	-0.02	-0.03
	Filament voltage $V_f$	3.5	(-6)	(-4.5)	(+2.5)	(-8)	(0)	(+2.2)	(+8)	(-3.3)	(+3.5)
			-0.06	-0.06	-0.07	-0.02	0	-0.01	-0.06	-0.02	-0.04
	3.0		(+4.5)	(+5)	(+5)	(+4)	(+5)	(+5)	(+5.5)	(+5)	(+5)
			+0.08	+0.10	+0.12	+0.05	+0.06	+0.10	+0.11	+0.11	+0.11

## II. DYNATRON WITH BACK COUPLING

Further improvement of the frequency stability of the arrangement described above can be attained by the supplementary back-coupling of the oscillating circuit  $LC$  with the inner grid (Fig. 6). Such a system can be considered, to some extent, as an ordinary triode oscillator with back coupling, but working with zero grid current, this condition, as is well known, is secured with difficulty in the case of an ordinary triode oscillator.<sup>4</sup>

The frequency stability of the system shown in Fig. 6 (for changes of supply voltages analogous to those shown in Table I) was better than 0.01 per mille. (The only case for which the frequency variation

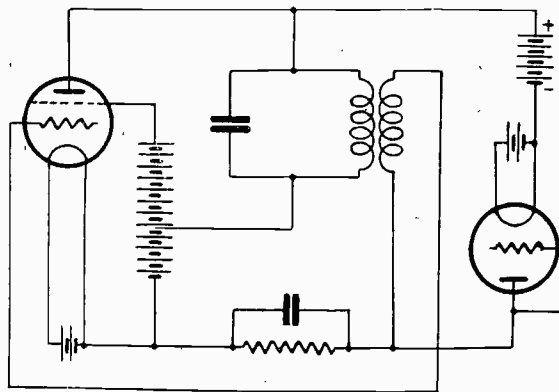

Fig. 6

came to 0.02 per mille took place for voltages:  $V_s = 140$ ,  $V_a = 60$ , and  $V_f = 3.5$  and 3.0 volts). In an ordinary back-coupled triode oscillator with grid leak, this frequency variation was between 0.01 and 1 per mille; without grid leak, the frequency variation was of the order of a few per cent.

## III. BINODE AS DYNATRON WITH AUTOMATIC CONTROL

The two valves which are necessary in the arrangements described above can be replaced by the binode, consisting of the tetrode and of the diode. The first one acts as a dynatron, the second as a rectifier for the automatic control of the threshold of regeneration.

The schematic diagram of the arrangement using an indirectly heated binode is shown in Fig. 7. The values of the various elements are as follows:  $L = 1.7$  mh,  $C \cong 300 \mu\text{mf}$ ,  $C_1 \cong 30 \mu\text{mf}$ ,  $r_1 \cong 1$  megohm,  $r_2 \cong 0.4$  megohm,  $B_p \cong 6$  volts. Frequency generated  $f \cong 200$  kilocycles. The

<sup>4</sup> The grid current can be considerably reduced by means of high grid leak resistance, but cannot be completely eliminated. Nevertheless, the presence of the grid leak always increases the frequency stability, as is well known from the papers by many authors.

operation of this arrangement is similar to that described above. Its frequency stability is seen from Table II, where, for comparison purposes, are tabulated results of the frequency drifts for two cases: namely, with automatic control and without it. As it is seen, the im-

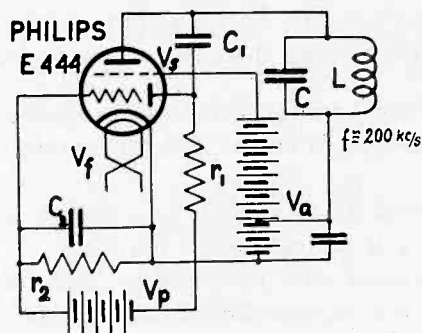

Fig. 7

provement of frequency stability is sufficiently good, especially for cases of filament and screen voltage variations.

TABLE II

Voltages main- tained constant		$V_s = 90 \text{ v}, V_a = 40 \text{ v}$				$V_f = 4 \text{ v}, V_a = 40 \text{ v}$					$V_f = 4 \text{ v}, V_s = 90 \text{ v}$		
		filament $V_f$				screen $V_s$					anode $V_a$		
Voltages varied		4.0	3.5	3.0	2.5	80	90	100	110	120	30	40	50
$\Delta f/f$ ( $\%$ )	without control	0	+0.06	+0.15	+0.3	0.14	0	-0.47	-1.25	-2.3	-0.03	0	-0.08
	with control	0	<0.01	+0.02	<0.01	—	0	+0.02	+0.06	+0.10	-0.02	0	-0.03

In these experiments for supply voltage variations not exceeding 10 per cent, the frequency stability was of the order of  $10^{-5}$ .

In conclusion I wish to thank Mr. Z. Jelonek for assistance in making measurements.



## OPTIMUM OPERATING CONDITIONS FOR CLASS C AMPLIFIERS\*

BY

W. L. EVERITT

(The Ohio State University, Columbus, Ohio)

**Summary**—A theoretical analysis of the plate efficiency and output of a triode operating as a class C amplifier is made. A linear amplifier with any desired operating angle is described.

Three cases in the operation of a triode as a class C amplifier are analyzed for the load impedance which will give maximum output.

It is shown that for a given tube, plate voltage, and plate loss, there is a definite value of load impedance, C bias, and grid excitation voltage, which will give maximum output. A rapid method of determining these optimum operating conditions is shown and checked experimentally.

IT IS a well-known fact that for the efficient operation of a radio-frequency power amplifier or oscillator, the flow of plate current must be confined to half a cycle or less. While the Institute definition of "class C" amplifier refers primarily to the operation of a modulated amplifier with varying plate voltage, it is also customary to use this term to apply to any amplifier where plate current flows for less than half a cycle, i.e., one which is biased beyond cut-off.

In the analysis of class C amplifiers, the customary method, as first outlined by Prince,<sup>1</sup> is to make use of the static characteristic curves of the vacuum tube under consideration. In this method the independent variables assumed are the alternating and direct grid and plate voltages. The conclusions which can be drawn are largely limited to the tube under consideration. Physically, one of the most important independent parameters is the load impedance, while the alternating plate voltage is a dependent variable. As a result, when the latter is made independent in the calculations, it is necessary to compute the corresponding load impedance, plot a number of points, and interpolate between them to find the best operating conditions.

The term "plate impedance" has a definite meaning when applied to a class A amplifier. This term is not quite so definite when applied to a class C amplifier. Since, however, primary interest lies in the impedance which will give maximum output, it is well to investigate what this impedance will be. Here again the conditions of operation must be definitely specified and the following three cases will be investigated.

\* Decimal classification: R132. Original manuscript received by the Institute, September 5, 1933.

<sup>1</sup> PROC. I.R.E., vol. 11, June, August, October, (1923).

*Case I.* Constant alternating voltage applied to grid. Angle during which plate current flows maintained constant.

*Case II.* Angle during which plate current flows constant. Grid bias and alternating grid voltage adjusted to the point where the maximum grid voltage equals the minimum plate voltage (or some specified fraction of it).

*Case III.* Loss maintained constant. Grid bias, alternating voltage, and operating angle adjusted for each change in load impedance so as to make the maximum grid voltage equal to the minimum plate voltage.

The impedance which gives maximum output under Case I is the one which comes nearest to the ordinary definition of internal impedance. The impedance obtained under Case II will generally result in excessive losses, while the impedance of Case III is, in general, the optimum operating condition for the tube, for it will give the highest output and plate efficiency possible to obtain with a given tube and plate loss. It is the purpose of this paper to show how this impedance, together with the required operating voltages may be quickly determined with a high degree of approximation for any triode, operating at any plate voltage and plate loss.

It is well to enumerate the independent variables which may be selected physically in the operation of any triode. They are as follows: (a) plate loss, (b) direct plate voltage, (c) load impedance, (d) grid bias, (e) alternating voltage applied to the grid.

The maximum values of plate loss and plate voltage are usually determined by the physical construction of the tube.

With so many independent parameters it is almost impossible to set up a quick, general method of determining optimum operating conditions from the experimental characteristic curves. Furthermore the method of Prince is not entirely free from approximations. A straight line composite characteristic will therefore be assumed for the tube. This may be written

$$\begin{aligned}
 i_p &= g_m \left( e_g + \frac{e_p}{\mu} \right) & e_g + \frac{e_p}{\mu} &> 0 \\
 i_p &= 0 & e_g + \frac{e_p}{\mu} &< 0
 \end{aligned} \tag{1}$$

In Fig. 1 is shown the actual and ideal characteristic for a '10 type tube, together with the actual and approximate instantaneous plate currents for a portion of a cycle, as determined for a sinusoidal excitation. It will be seen that the difference between the values of average

current as determined by the actual and approximate characteristics would be very small. The same statement is true for the fundamental component. It is common practice to evaluate the amount of fundamental component obtained from characteristic curves by an integration using the trapezoidal rule, and the latter approximation is of the same order as that obtained by neglecting the curvature at the lower values of  $e_g + e_p/\mu$ . A more serious objection for large power tubes to the use of (1) is that saturation is not taken into account, but a curve will be drawn showing the maximum plate current in terms of the

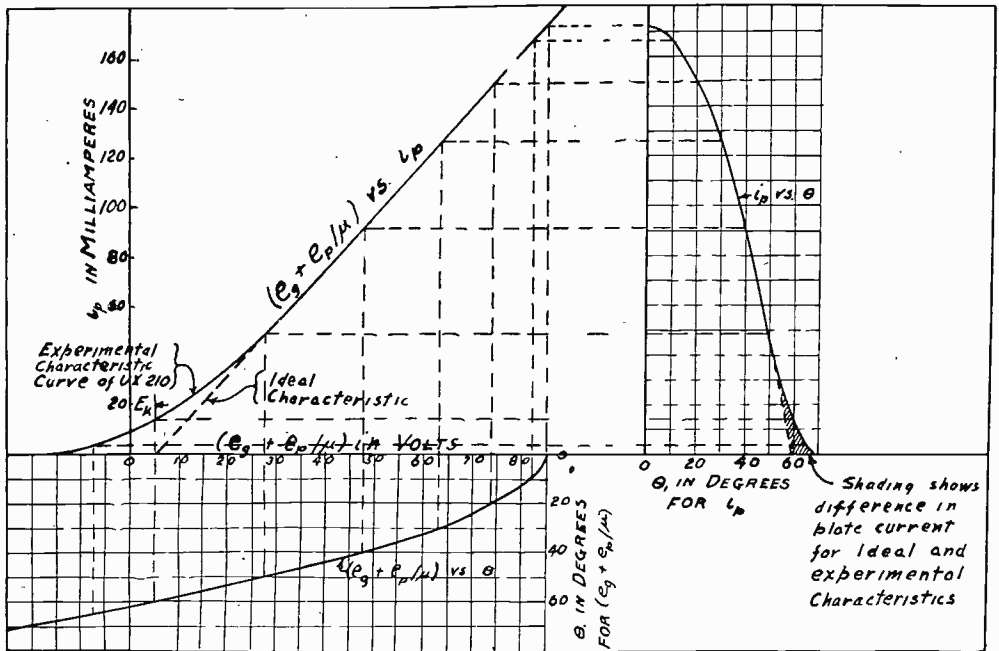

Fig. 1—Actual and ideal composite characteristic of '10 type tube.

average, and this maximum current may be compared with the saturation current in any actual case to determine the worth of the approximation.

Another justification for the use of the characteristic of (1), is that the linearity of both audio- and radio-frequency class B amplifiers depends upon the degree with which the actual curve approximates this ideal characteristic. The practical success in the use of class B operation as a linear amplifier is well known.

The composite voltage  $e_g + e_p/\mu$  will have an alternating- and a direct-current component. The following notation will be used.

Let,

$E'$  be the amplitude of the alternating-current component of the composite voltage

$E_a$  be the direct-current component of the composite voltage

$E_c$  be the absolute value of the *negative* grid bias (direct current)

$E_g$  be the amplitude of the alternating grid voltage

$E_b$  be the plate voltage

$I_1$  be the amplitude of the fundamental alternating-current component of the plate current.

$I_b$  be the average or direct-current component of the plate current

$2\Theta_1$  be the angle during which plate current flows.

The composite voltage will be assumed as symmetrical about the zero axis so that only cosine coefficients need be evaluated, i.e.,

$$i_p = g_m(E' \cos \Theta - E_a). \quad (2)$$

The tank circuit will be assumed to have an impedance  $R_L$  which is a pure resistance at the fundamental and a negligible impedance to direct current and all harmonics. The amplitude of the alternating-current component of the plate voltage will therefore be  $I_1 R_L$ .

$$E' = E_g - \frac{I_1 R_L}{\mu} \quad (3)$$

$$E_a = E_c - \frac{E_b}{\mu} \quad (4)$$

$$\Theta_1 = \cos^{-1} \frac{E_a}{E'} \quad (5)$$

$E_a$  will be equal to the amount by which the grid bias exceeds the cut-off value.

$I_1$  may be determined by evaluating the fundamental Fourier coefficient of the plate current

$$I_1 = \frac{2g_m}{\pi} \int_0^{\Theta_1} \cos \Theta (E' \cos \Theta - E_a) d\Theta.$$

Integrate and substitute the value of  $E_a$  obtained from (5)

$$I_1 = \frac{E' g_m}{\pi} \left( \Theta_1 - \frac{\sin 2\Theta_1}{2} \right). \quad (6)$$

Substitute the value of  $E'$  given in (3) and solve for  $I_1$ .

$$I_1 = \frac{\mu E_g}{R_L + \frac{\pi}{\Theta_1 - \frac{\sin 2\Theta_1}{2}} R_p}$$

This can be written

$$I_1 = \frac{\mu E_o}{R_L + \beta R_p} \quad (7)$$

where,

$$\beta = \frac{\pi}{\Theta_1 - \sin \Theta_1 \cos \Theta_1} \quad (8)$$

$\beta R_p$  is the apparent resistance of the class C amplifier and corresponds to the value mentioned in Case I. It has been checked experimentally for a '10 type tube, and a close agreement found with the values computed from (8).

The direct-current component of the plate current can also be obtained readily

$$I_b = \frac{g_m}{\pi} \int_0^{\Theta_1} (E' \cos \Theta - E_a) d\Theta.$$

Integrate and substitute the value of  $E_a$  obtained from (5).

$$I_b = \frac{E' g_m}{\pi} (\sin \Theta_1 - \Theta_1 \cos \Theta_1). \quad (9)$$

By taking the ratio of (6) and (9) it will be found that the ratio of direct current to the fundamental component of the plate current is a function of  $\Theta_1$  only.

$$\frac{I_1}{I_b} = \frac{\Theta_1 - \sin \Theta_1 \cos \Theta_1}{\sin \Theta_1 - \Theta_1 \cos \Theta_1} \quad (10)$$

Table I gives the values of  $\beta$  and  $I_1/I_b$  as a function of  $\Theta_1$ , computed from (8) and (10).  $\beta$  is plotted as a function of  $\Theta_1$  in Fig. 2 together with other functions to be derived later.

TABLE I

$\Theta_1$	90	80	70	60	50	40	30	20	10	0
$\beta$	2.000	2.564	3.489	5.115	8.262	15.271	34.681	113.530	891.735	$\infty$
$\frac{I_1}{I_b}$	1.571	1.651	1.725	1.794	1.854	1.905	1.946	1.976	1.996	2.000

An interesting conclusion may be obtained from (7). It shows that, if the operating angle is maintained constant, the fundamental component of plate current, and hence the radio-frequency tank current, will be directly proportional to the alternating grid voltage; i.e. the amplifier will be linear. This is the standard definition of a class B amplifier. If the bias is maintained constant the *only* value of bias which will



maintain a constant operating angle is the adjustment to cut-off. At cut-off  $E_a = 0$  and  $\Theta_1 = 90$  degrees irrespective of the value of  $E_g$ . Therefore the term class B has been applied to this adjustment. Equation (10) gives a clue to a method by which a radio-frequency amplifier may be made linear, i.e. satisfy the class B definition, and still operate with any value of  $\Theta_1$  desired, this value of  $\Theta_1$  being constant for all values of alternating-current grid excitation. If a constant operating

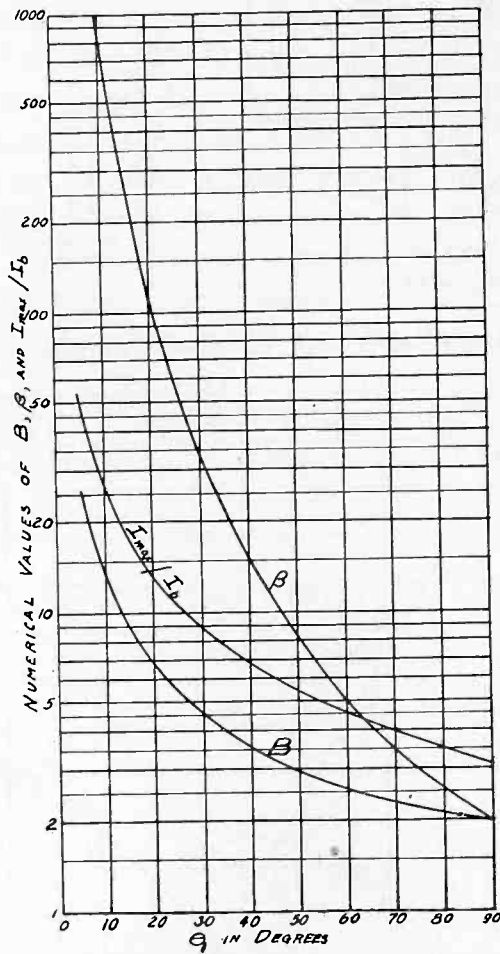

Fig. 2—Function of  $\Theta_1$ .

angle is maintained,  $I_b$  as well as  $I_1$  would be directly proportional to  $E_g$ , for a combination of (7) and (10) gives

$$I_b = \frac{\mu E_g}{R_L + \beta R_p} \left( \frac{\sin \Theta_1 - \Theta_1 \cos \Theta_1}{\Theta_1 - \sin \Theta_1 \cos \Theta_1} \right). \tag{11}$$

Now if the tube is biased to cut-off with a fixed voltage, and then a cathode resistor is used in addition, the extra bias provided by this resistor will be equal to  $E_a$ , proportional to  $I_b$  and hence to  $E_g$ . There-

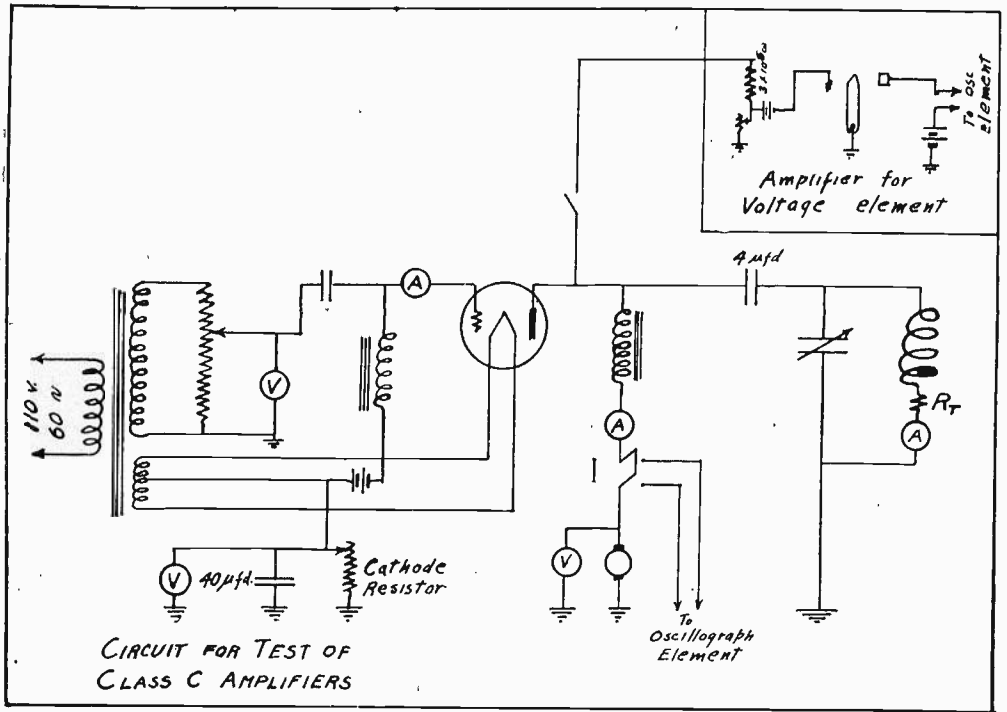

Fig. 3—Test circuit for class C amplifiers.

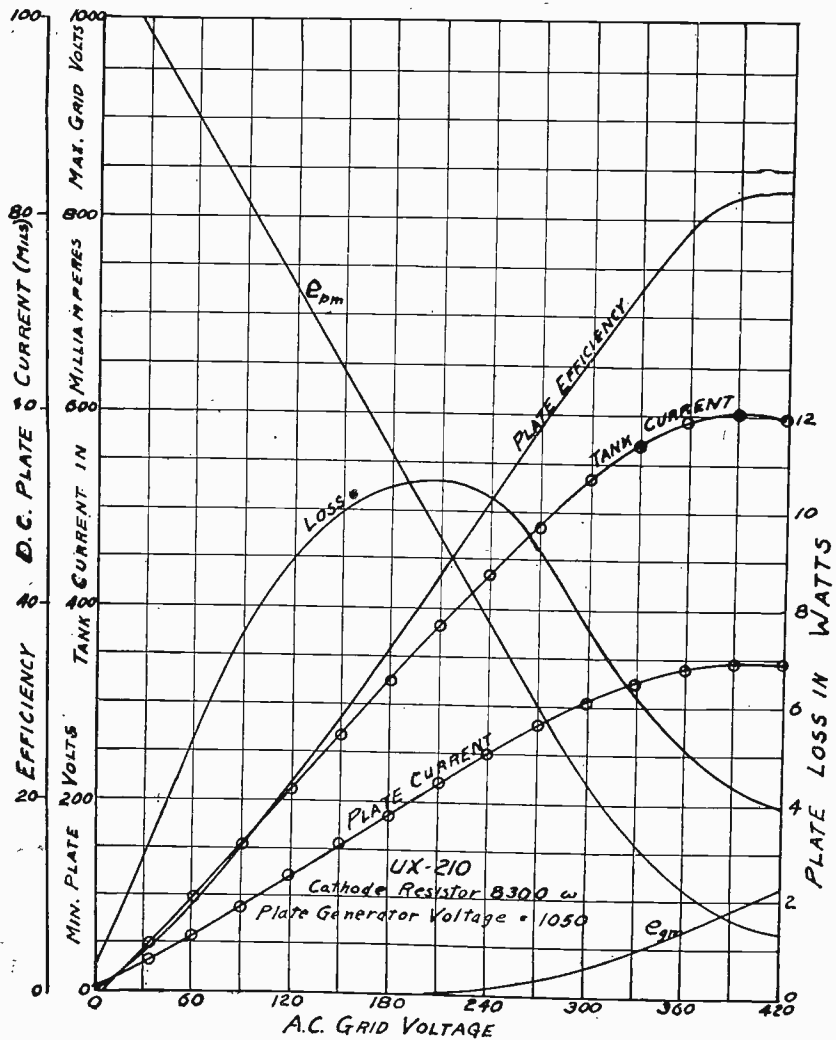

Fig. 4—Dynamic characteristics of linear amplifier with an operating angle  $\Theta_1 = 45$  degrees.

fore  $E_a/E_g$  will be a constant, which is a sufficient condition for a constant operating angle, as will be shown later. The circuit is shown in Fig. 3. This circuit was set up experimentally and tuned to 60 cycles, in order that oscillograms might be taken and the operating angle definitely determined. The available plate voltage drops as the grid excitation increases, due to the voltage lost in the cathode resistor, but as they are directly proportional the operating angle remains constant. Since the output is proportional to  $I_1^2$  and the input to  $I_b$ , the plate efficiency should also increase linearly with an increase in grid excitation. The plate efficiency is the ratio of output divided by the input to the plate, expressed in per cent. It neglects grid excitation losses and filament losses. Fig. 4 shows a set of dynamic characteristics thus obtained. The flattening-off of the curves occurs when the maximum grid voltage exceeds the minimum plate voltage and is a limiting condition which will be discussed later.

It is suggested that this type of linear amplifier be given the designation "class B'" to distinguish it from the standard class B where  $\Theta_1 = 90$  degrees.

It is possible to prove that  $\Theta_1$  is a function of the cathode resistor  $R_c$  and the mutual conductance alone. As explained in the previous paragraph

$$E_a = I_b R_c.$$

Substitute the value of  $I_b$  given by (11)

$$E_a = \frac{\mu E_g R_c}{R_L + \beta R_p} \left( \frac{\sin \Theta_1 - \Theta_1 \cos \Theta_1}{\Theta_1 - \sin \Theta_1 \cos \Theta_1} \right). \quad (12)$$

Now by (3) and (7)

$$\begin{aligned} E' &= E_g - \frac{E_g R_L}{R_L + \beta R_p} \\ &= \frac{\beta E_g R_p}{R_L + \beta R_p} \end{aligned}$$

Substitute the values of  $E_a$  and  $E'$  just obtained in (5).

$$\cos \Theta_1 = \frac{E_a}{E'} = \frac{\mu R_c}{\beta R_p} \left( \frac{\sin \Theta_1 - \Theta_1 \cos \Theta_1}{\Theta_1 - \sin \Theta_1 \cos \Theta_1} \right).$$

Introduce the value of  $\beta$  given by (8) and transpose.

$$R_c g_m = \frac{\pi \cos \Theta_1}{\sin \Theta_1 - \Theta_1 \cos \Theta_1}. \quad (13)$$

Since  $R_c$  is the physical independent variable this may be written<sup>2</sup>

$$\Theta_1 = f(g_m \times R_c). \quad (13a)$$

Table II shows values of  $g_m \times R_c$  for different values of  $\Theta_1$  and the results are plotted in Fig. 5. From this figure one may compute the proper value of  $R_c$  to obtain any desired operating angle.

TABLE II  
 $\Theta_1$  as a Function of  $g_m \times R_c$  in a Class B' Amplifier

$\Theta_1$	0	10	20	30	40	50	60	70	80	90
$g_m \times R_c$	$\infty$	1791.69	210.78	58.45	22.29	9.846	4.587	2.058	0.735	0.000

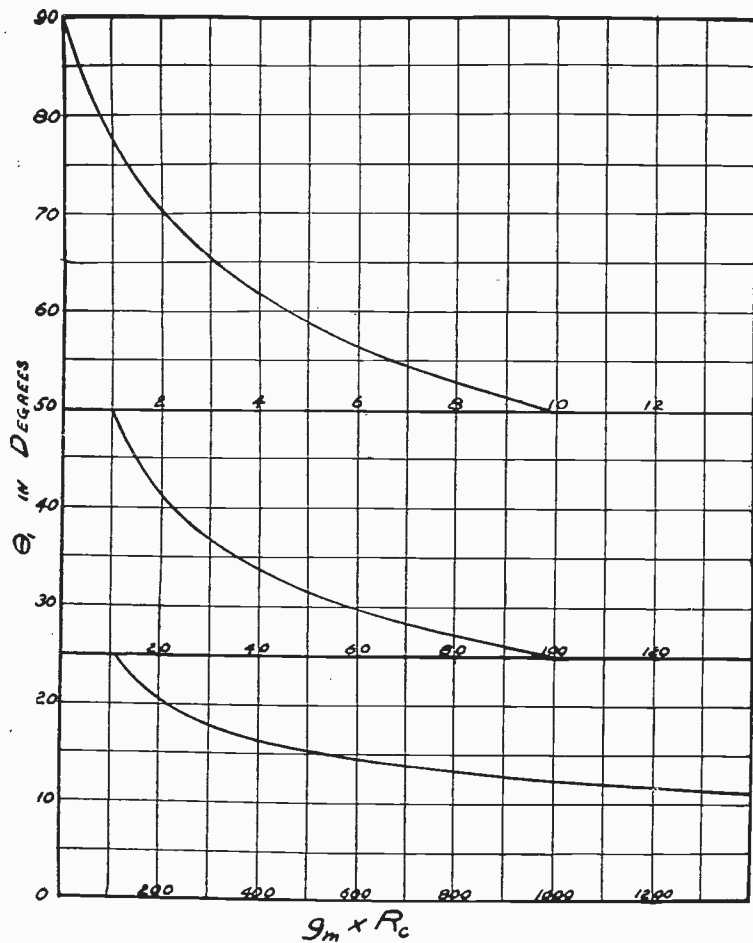

Fig. 5— $\Theta_1$  as a function of  $g_m \times R_c$  in a class B' amplifier.

In Fig. 6 is shown a set of oscillograms taken for different alternating grid voltages for the curves of Fig. 4 and shows that the angle does actually remain constant for this circuit. On tubes with a high

<sup>2</sup> Equation (13a) shows that the angle  $\Theta_1$  is independent of the excitation voltage and load impedance, when operated as a class B' amplifier. Hence this type of operation has important properties in the experimental determination of dynamic characteristics, as it is the only known way that  $\Theta_1$  can be kept constant while other parameters are varied.

amplification constant, where the loss in the cathode resistor would not be serious, this circuit results in increased values of maximum efficiency for a linear amplifier. In tubes with a lower value of  $\mu$  this circuit will result in a higher output from a given tube, at the expense of lower over-all efficiency, since there would be a considerable loss in the cathode resistor. In the lower level tubes of a transmitter, where plate resistors are normally used to drop the available voltage this loss in the cathode resistor would not be important. The circuit is also useful in the investigation of operating conditions where it is desirable to maintain  $\Theta_1$  constant.

As the grid excitation increases the grid becomes more and more positive (or less negative) at its peak, while the alternating voltage set up across the tank circuit makes the minimum plate voltage less and

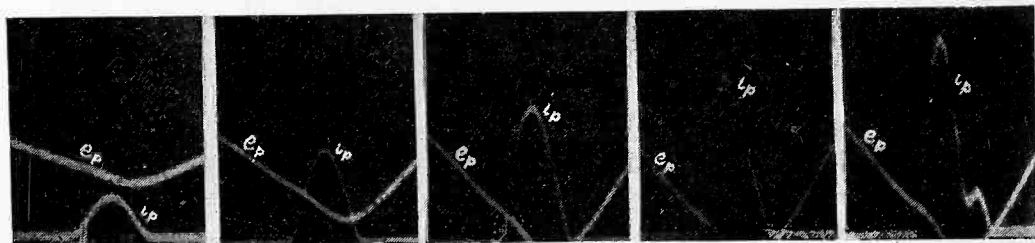

Fig. 6—Oscillograms of plate current in linear amplifier under conditions of Fig. 4.

less. If the tank circuit is a pure resistance at the fundamental, the maximum grid voltage will occur at the same instant as the minimum plate voltage. If the grid voltage exceeds the plate voltage at any instant the secondary emission of the plate will be drawn to the grid. This results in a flattening-off of the curves of tank current, direct plate current, and efficiency, and a rapid increase in grid excitation loss. This is shown in the curves of Fig. 4, and it is also demonstrated that this flattening commences when the grid and plate voltages meet. Prince has used a value of maximum grid voltage equal to 80 per cent of the minimum plate voltage as the optimum condition, but it will be seen that this represents only a small change in the values of Fig. 4 from the point where they are equal. Therefore the optimum condition used here will be assumed as that which makes the two values equal.

It will be of interest to determine what the efficiency will be at the saturation point.

Let,

$e_{gm}$  be the maximum value of grid voltage

$e_{pm}$  be the minimum value of plate voltage.

$$e_{pm} = E_b - I_1 R_L$$

$$e_{gm} = E_g - E_c$$

if,

$$e_{pm} = e_{gm} \quad (12)$$

then,

$$E_g - E_c = E_b - I_1 R_L. \quad (12a)$$

Substitute the value of  $I_1$  obtained from (7)

$$E_g - E_c = E_b - \frac{\mu E_g R_L}{R_L + \beta R_p}$$

$$E_g \left[ 1 + \frac{\mu R_L}{R_L + \beta R_p} \right] = E_b + E_c. \quad (13)$$

From (3), (4), and (5)

$$E_c - \frac{E_b}{\mu} = E_g \cos \Theta_1 - \frac{I_1 R_L}{\mu} \cos \Theta_1.$$

Substitute the value of  $E_c$  thus obtained in (13) and solve for the value of  $E_g$  which will satisfy the condition of (12). This gives

$$E_g = \frac{(\mu + 1)(R_L + \beta R_p)}{\mu[(\mu + 1)R_L + \beta(1 - \cos \Theta_1)R_p]} E_b. \quad (14)$$

Since  $I_1$  is the *maximum* amplitude of the fundamental component of plate current, the output power will be given by the equation

$$P_{\text{out}} = \frac{I_1^2 R_L}{2} = \frac{\mu^2 E_g^2 R_L}{2(R_L + \beta R_p)^2}. \quad (15)$$

Substitute in (15) the value obtained from (14). This gives

$$P_{\text{out}} = \frac{E_b^2 R_L}{2 \left[ R_L + \frac{\beta(1 - \cos \Theta_1) R_p}{\mu + 1} \right]^2}. \quad (16)$$

Let

$$B = \beta(1 - \cos \Theta_1) = \frac{\pi(1 - \cos \Theta_1)}{\Theta_1 - \sin \Theta_1 \cos \Theta_1}. \quad (17)$$

As  $R_L$  is varied in (16) the output power will be a maximum when

$$R_L = \frac{B R_p}{\mu + 1}. \quad (18)$$

Equation (18) specifies the load impedance which gives maximum output under the condition of Case II listed above. It is usually low in comparison with the plate impedance. The value of  $B$  as a function of  $\Theta_1$  is given in Table III below. If the impedance of (18) is connected as a tank circuit, the losses will usually exceed those allowable for the tube, and so Case II is not a useful conception of plate impedance.

The plate efficiency is given by the expression

$$\begin{aligned} \text{Plate eff.} &= \frac{\text{output}}{\text{input}} = \frac{I_1^2 R_L}{2E_b I_b} \times 100 \\ &= \frac{I_1 R_L}{2E_b} \times \frac{I_1}{I_b} \times 100 . \end{aligned}$$

Substitute the expressions of (7) and (10)

$$\text{Plate eff.} = \frac{\mu E_g R_L}{2E_b(R_L + \beta R_p)} \times \frac{\Theta_1 - \sin \Theta_1 \cos \Theta_1}{\sin \Theta_1 - \Theta_1 \cos \Theta_1} \times 100 .$$

Introduce the optimum value of  $E_g$  given by (14). The equation will reduce to

$$\text{Plate eff.} = \frac{100}{1 + \frac{BR_p}{(\mu + 1)R_L}} \times \frac{\Theta_1 - \sin \Theta_1 \cos \Theta_1}{2(\sin \Theta_1 - \Theta_1 \cos \Theta_1)}$$

This may be written

$$\text{Eff.} = \frac{A}{1 + \frac{BR_p}{(\mu + 1)R_L}} \tag{19}$$

where,

$$A = \frac{50(\Theta_1 - \sin \Theta_1 \cos \Theta_1)}{\sin \Theta_1 - \Theta_1 \cos \Theta_1} = 50 \frac{I_1}{I_b} . \tag{19a}$$

Table III also gives values of  $A$  as a function of  $\Theta_1$ . These values of  $B$  and  $A$  are plotted in Figs. 2 and 7.

TABLE III

$\Theta_1$	0	10	20	30	40	50	60	70	80	90
$B$	100	99.79	98.79	97.30	95.25	92.70	89.68	86.24	82.53	78.54
$A$	$\infty$	13.547	6.847	4.645	3.573	2.951	2.558	2.296	2.119	2.000

It will be seen that  $A$  represents the limit of plate efficiency for any given value of  $\Theta_1$ . Since  $B$  also increases with  $\Theta_1$  it does not neces-

sarily follow that a decrease in  $\Theta_1$  will increase the efficiency. As an example Fig. 8 shows a case where the load impedance was low and the maximum efficiency approximately the same for three different biases

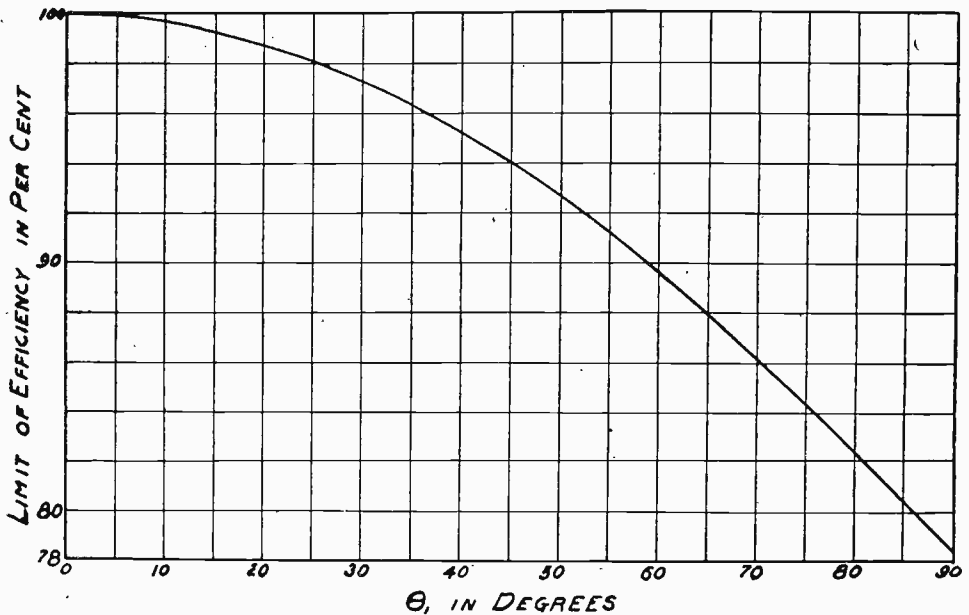

Fig. 7—Maximum possible efficiency as a function of  $\Theta_1$ .

and hence operating angles. The curves of Fig. 8 were taken with a fixed bias, and so a definite operating angle cannot be assigned to each curve. However the greater the bias, the smaller will be  $\Theta_1$ . It is shown

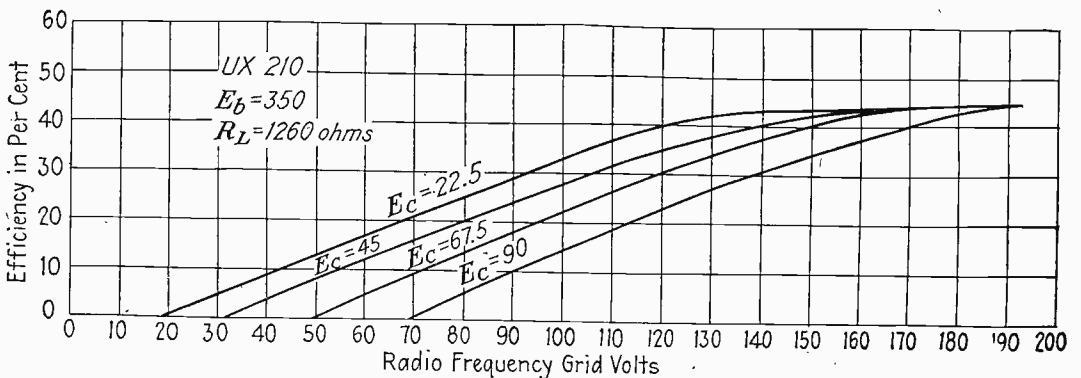

Fig. 8—Special class C amplifier characteristics where maximum efficiency does not increase with a decrease in  $\Theta_1$ .

that over a considerable range the maximum efficiency does not necessarily increase with smaller values of  $\Theta_1$ . The values for these curves are

$$R_p = 4150 \quad \mu = 8.3 \quad R_L = 1260.$$

For these values, the maximum efficiency for several angles was computed from (19) and the following results obtained:



$$\Theta_1 = 90 \text{ degrees} \quad \text{max. eff.} = 45.9$$

$$\Theta_1 = 50 \text{ degrees} \quad \text{max. eff.} = 46.9$$

$$\Theta_1 = 40 \text{ degrees} \quad \text{max. eff.} = 41.9$$

In order to make use of (19) it is necessary to know the value of  $\Theta_1$ . In radio-frequency operation it is not convenient to use an oscillograph, and an analytical method must be used.

From (3) and (7)

$$E' = E_g \left[ 1 - \frac{R_L}{R_L + \beta R_p} \right] = \frac{E_g \beta R_p}{R_L + \beta R_p}$$

Substitute this in (5)

$$\cos \Theta_1 = \frac{E_a}{E_g} \left( 1 + \frac{R_L}{\beta R_p} \right) \tag{20}$$

Let,

$$e = \frac{E_a}{E_g}$$

$$r = \frac{R_L}{R_p}$$

(20) becomes

$$r = \frac{\pi \left( \frac{\cos \Theta_1}{e} - 1 \right)}{\Theta_1 - \sin \Theta_1 \cos \Theta_1} \tag{21}$$

(21) can be written

$$\Theta_1 = f(r, e) \tag{21a}$$

This shows that with a given load impedance, a sufficient condition for  $\Theta_1$  being constant is that  $E_a/E_g$  should be a constant, as was stated previously without proof.

As (21) is not readily solved in the form of (21a) it has been computed and given in graphical form in Fig. 9.

In an actual computation  $E_a$  is not computed from (4), but an additional small value  $E_k$  is added to  $E_c$  to account for the fact that the extension of the straight-line portion of the composite experimental curve does not pass through the origin. As shown in Fig. 1 the value of this constant for a '10 type tube is about 5 volts. It may be neglected without serious error when the plate voltage is high. In application, (4) becomes

$$E_a = E_c - \frac{E_b}{\mu} + E_k. \quad (4a)$$

As a check on the accuracy of (19), the values for Fig. 4 will be computed. At the point of maximum efficiency shown in the figure the measured values of  $C$  bias, grid excitation, and plate voltage were:

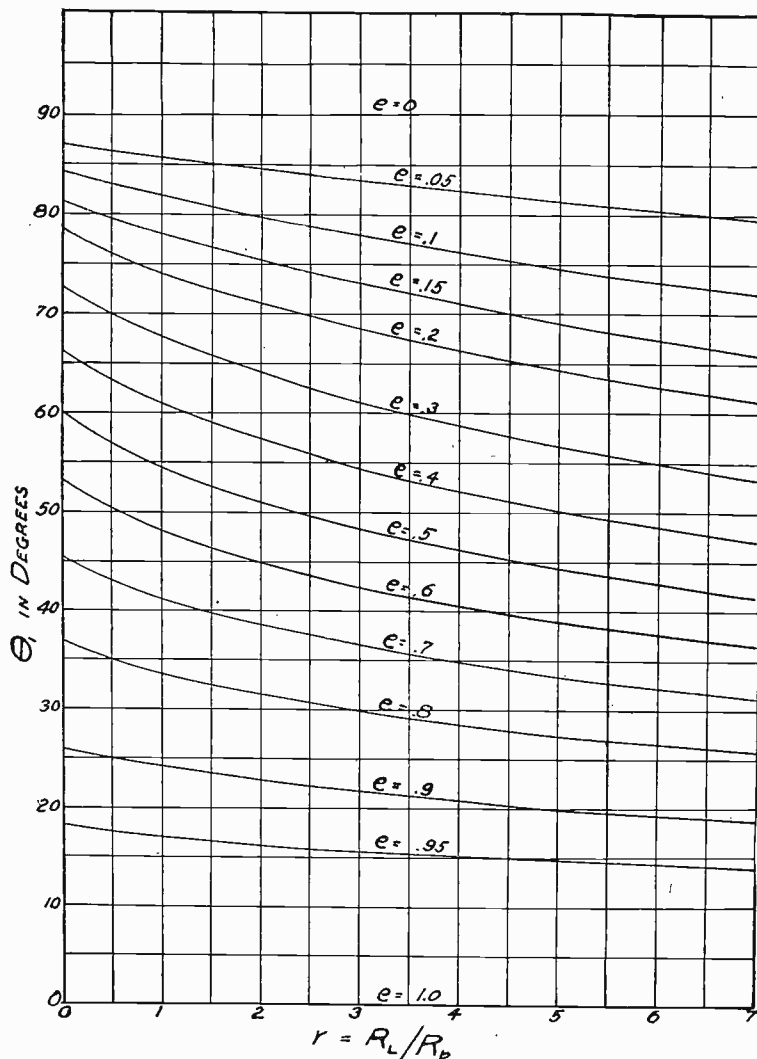

Fig. 9— $\Theta_1$  as a function of  $R_L/R_p$  and  $E_a/E_g$ .

$$E_c = 461$$

$$E_g = \sqrt{2} \times 390 = 551$$

$E_b = 700$  (the balance of the direct generated voltage is used in the cathode resistor)

The constants of the tube were:

$$\mu = 8.3$$

$$R_p = 4150$$

The characteristics of the load were:

$$R_L = 9630$$

$$R_T = 54.4 \text{ ohms}$$

The computation of  $\Theta_1$  and efficiency are then as follows:

$$E_a = 461 - \frac{700}{8.3} + 5 = 382 \text{ volts}$$

$$e = \frac{382}{551} = 0.694$$

$$r = \frac{9630}{4150} = 2.32$$

$$\Theta_1 = 39 \text{ degrees} \quad B = 3.66 \quad A = 95.4$$

$$\text{Max. eff.} = \frac{95.4}{1.169} = 81.6 \text{ per cent.}$$

The maximum output may be readily computed from (16). This may also be written

$$P_{\text{out}} = \frac{E_b^2}{2R_L \left[ 1 + \frac{BR_p}{(\mu + 1)R_L} \right]^2} \quad (16a)$$

For these data

$$P_{\text{out}} = \frac{1}{19260} \left( \frac{700}{1.1496} \right)^2 = 19.2 \text{ watts.}$$

Since the dissipative resistance in the tank circuit is 54.4 ohms the computed maximum tank current would be  $\sqrt{\frac{19.2}{54.4}} = 0.595$  ampere.

The input power should be  $\frac{19.2}{0.819} = 23.4$  watts.

This corresponds to a plate current of  $\frac{23.4}{700} = 33.5$  milliamperes.

The observed values in the run of Fig. 4 are

$$\text{Max. eff.} = 82.3 \text{ per cent}$$

$$P_{\text{out}} = 19.75 \text{ watts}$$

$$I_b = 34.5 \text{ milliamperes}$$

$$I_T = 0.601 \text{ amperes.}$$

It is also of interest to predetermine the loss, as this will permit the selection of optimum operating conditions.

The input is given by the equation

$$\begin{aligned} \text{Input} &= E_b I_b = E_b I_1 \times \frac{I_b}{I_1} \\ &= \frac{50\mu E_g E_b}{A(R_L + \beta R_p)} \end{aligned} \quad (22)$$

If the magnitude of the plate input is to be computed, when the output is a maximum, then the value of  $E_o$  from (14) may be substituted in (22). This will give the result

$$\text{Input} = \frac{E_b^2}{2R_L} \left[ \frac{100}{A \left( 1 + \frac{BR_p}{(\mu + 1)R_L} \right)} \right] \quad (23)$$

Let,

$$\alpha = \frac{(\mu + 1)R_L}{R_p}$$

Then (23) may be transformed into

$$\text{Input} = \frac{(\mu + 1)E_b^2}{2R_p} \left[ \frac{100}{A(\alpha + B)} \right] \quad (24)$$

$$= \frac{(\mu + 1)E_b^2}{2R_p} \gamma_1(\alpha, \Theta_1) \quad (24a)$$

where  $\gamma_1$  is a function of  $\alpha$  and  $\Theta_1$ .

In a similar way (16a) may be reduced to the form

$$\text{Output} = \frac{(\mu + 1)E_b^2}{2R_p} \left[ \frac{\alpha}{(\alpha + B)^2} \right] \quad (25)$$

$$= \frac{(\mu + 1)E_b^2}{2R_p} \gamma_2(\alpha, \Theta_1) \quad (25a)$$

where  $\gamma_2$  is also a function of  $\alpha$  and  $\Theta_1$ . The plate loss will be

$$\text{Loss} = \frac{(\mu + 1)E_b^2}{2R_p} [\gamma_1 - \gamma_2] \quad (26)$$

$$= \frac{(\mu + 1)E_b^2}{2R_p} \gamma_3(\alpha, \Theta_1). \quad (26a)$$

For a given tube and a given value of plate voltage the value of  $\frac{(\mu + 1)E_b^2}{2R_p}$  is a constant.  $\gamma_1$ ,  $\gamma_2$ , and  $\gamma_3$  are universal functions, applicable to all tubes. The problem presents itself of finding the load impedance and operating angle which will give maximum output for a given loss. This selection is best shown by Fig. 10. Here values of  $\gamma_2$  and  $\gamma_3$  have been plotted as functions of  $\alpha$  and  $\Theta_1$ . If the tube plate voltage and loss have been selected, then  $\gamma_3$  may be computed from (26a). By drawing a horizontal line on Fig. 10, corresponding to this

$\gamma_3$ , the values of  $\alpha$  which will give this loss for each value of  $\Theta_1$  are determined. By projecting vertical lines from the intersections with the  $\gamma_3$  family up to corresponding values of  $\Theta_1$  in the  $\gamma_2$  family, the resultant output will be ascertained. This will be a maximum for one and only one value of  $\alpha$  and  $\Theta_1$ . This value of  $\alpha$  then determines the

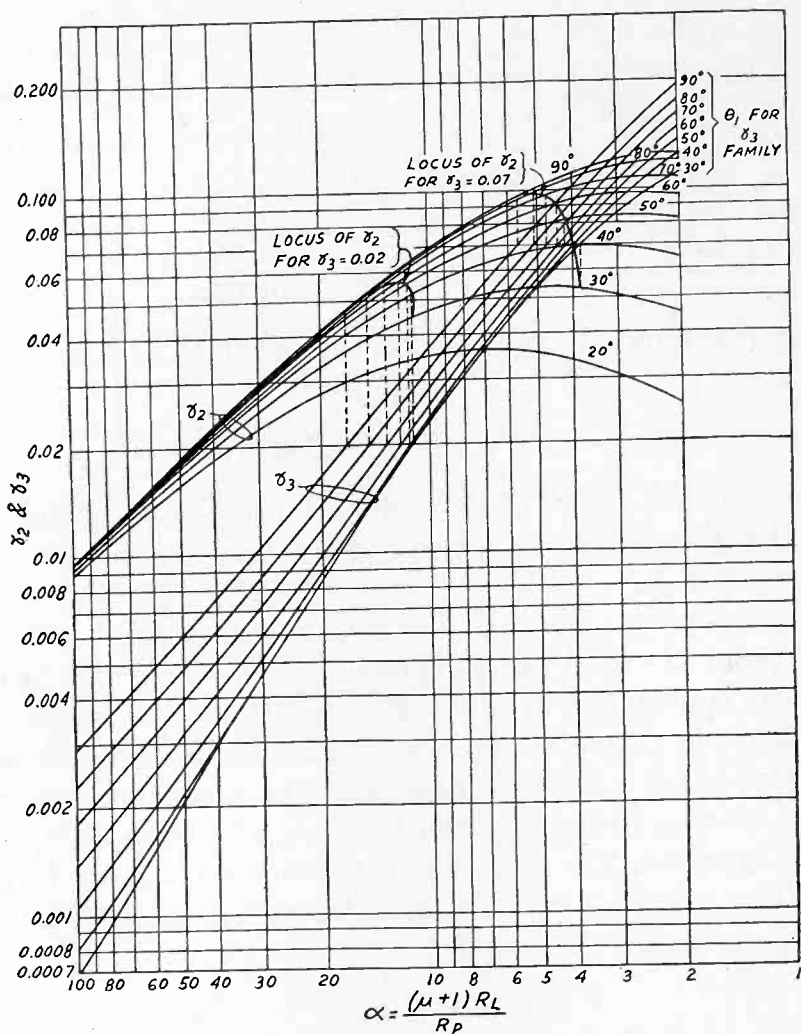

Fig. 10—Output and loss functions vs.  $\alpha$  and  $\Theta_1$ .

optimum value of load impedance for that tube, plate loss, and plate voltage. This corresponds to the load impedance specified in Case III.

The value of  $\Theta_1$  and  $\alpha$  determines the value of grid excitation voltage required as shown by (14). It is somewhat more convenient to reduce (14) to a form involving  $\alpha$ . Equation (14) then becomes

$$E_g = \frac{1}{\mu} \frac{\alpha + (\mu + 1)\beta}{\alpha + B} E_b.$$

In the optimum condition, for each value of  $\alpha$  there is a corresponding value of  $\Theta_1$  and hence  $B$ . It is convenient therefore to let

$$\alpha + B = C$$

and (14) becomes

$$E_g = \frac{\alpha + (\mu + 1)\beta}{\mu C} E_b. \quad (14a)$$

When the output has been computed the C bias may readily be computed as follows

$$\text{Output} = \frac{I_1^2 R_L}{2}$$

$$I_1 R_L = \sqrt{2R_L \times \text{output}}.$$

Apply (12a) and also subtract the constant  $E_k$  as described in (4a) above

$$E_c = E_g + \sqrt{2R_L \times \text{output}} - E_b - E_K. \quad (27)$$

The maximum values of the  $\gamma_3$  family correspond to the condition of Case II and (18). This equation can also be written

$$\alpha = B. \quad (18a)$$

The graphical use of Fig. 10 is cumbersome and its analytical solution is more convenient to apply. This will now be obtained.

If  $\gamma_3$  is made a constant in (26a) then  $\alpha$  becomes a function of  $\Theta_1$ . This expression for  $\alpha$  can then be substituted in the efficiency equation (19). This efficiency equation then becomes a function of  $\Theta_1$  alone and may be maximized. The operation is tedious but straightforward. As a result, the following equation is obtained for  $\gamma_3$  constant and the efficiency a maximum

$$\gamma_3 = \frac{4A'B + 2S(1 - A')}{(2A'B + S)^2} = f(\Theta_1) \quad (28)$$

where,

$$S = \frac{2\pi A' (\sin \Theta - \Theta)}{2 \sin^2 \Theta - \Theta^2 - \Theta \sin \Theta \cos \Theta} \quad (28a)$$

$$A' = \frac{A}{100}$$

and  $B$  has been previously defined.

Equation (28) gives a single value of  $\Theta_1$  for each value of  $\gamma_3$  and vice versa. This equation can most easily be solved by constructing a

table and plotting a curve. This curve is shown in Figs. 11 and 12. Now that the best value of  $\Theta_1$  is known for each value of  $\alpha$  the corresponding best value of  $\alpha$  may be computed from (26). The resulting

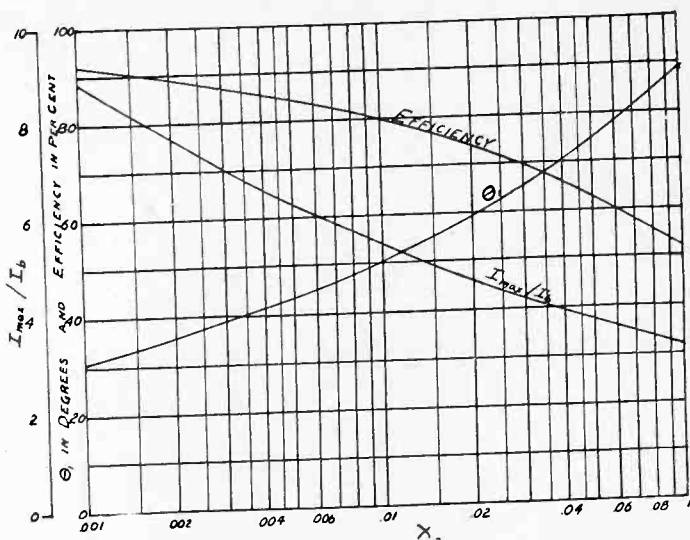

Fig. 11—Functions of  $\gamma_3$  under optimum operating conditions.

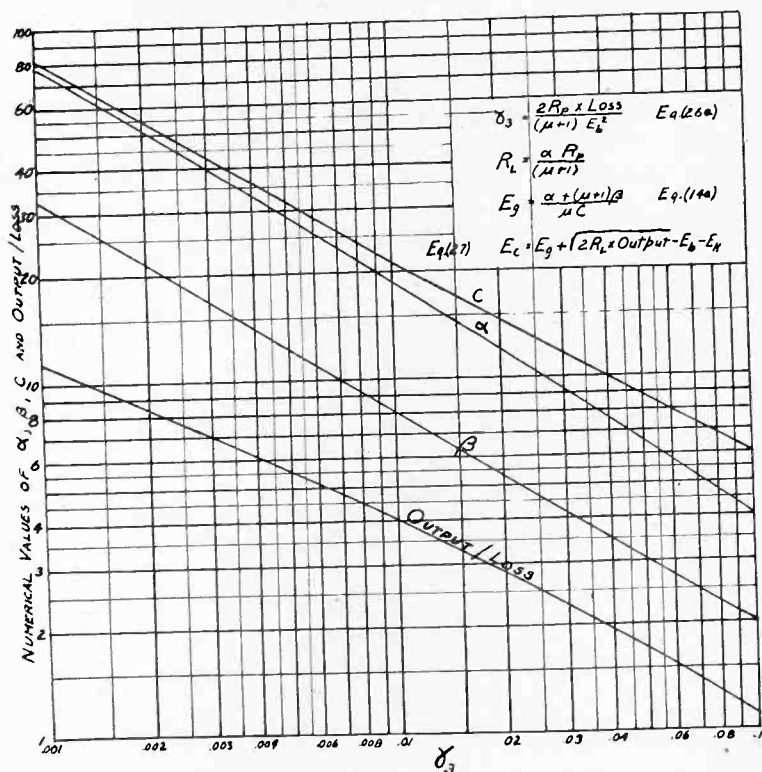

Fig. 12—Design data.

value of  $\alpha$  is plotted on Fig. 12. It is also possible to compute the efficiency, and ratio of output to loss for these optimum conditions. They are also shown in Table IV.

TABLE IV  
Optimum Operating Conditions for a Triode as Class C Amplifier

$\Theta_1$	30°	35°	40°	45°	50°	55°	60°	65°	70°	75°	80°	85°	90°
$\gamma_s$	0.00090	0.00187	0.00351	0.00606	0.00972	0.01474	0.0208	0.0290	0.0390	0.0533	0.0686	0.0833	0.1048
$\alpha$	83.1	53.6	36.2	25.2	18.87	14.50	11.70	9.33	7.70	6.19	5.21	4.57	3.87
Output/loss	12.00	8.65	6.54	5.17	4.05	3.31	2.76	2.34	1.97	1.652	1.417	1.249	1.071
Efficiency	92.31	89.62	86.72	83.8	80.2	76.8	73.4	70.0	66.4	62.3	58.6	55.5	51.7
$I_{max}$	9.02	7.76	6.80	6.06	5.48	4.98	4.58	4.246	3.960	3.710	3.492	3.306	3.142
$\frac{I_b}{C}$	87.1	57.6	39.8	28.4	21.82	17.23	14.26	11.74	10.00	8.39	7.33	6.62	5.87



Although the derivation of these relations has been somewhat involved the determination of the optimum operating conditions for a tube is a very simple matter. Fig. 12 gives the complete design formulas. As an example the computation will be made for a '10 type tube and a '59 tube.

$$\text{UX 210} \quad \mu = 8.3 \quad R_p = 4150 \quad E_b = 600$$

$$\text{Allowable plate loss} = 15 \text{ watts}$$

$$\gamma_3 = \frac{15 \times 8300}{9.3 \times 360,000} = 0.0372$$

With this value of  $\gamma_3$  the following operating conditions are obtained from Fig. 12.

$$\alpha = 7.8 \quad \beta = 3.49 \quad C = 10.1 \quad \frac{\text{output}}{\text{loss}} = 2.0$$

$$R_L = \frac{7.8 \times 4150}{9.3} = 3480 \text{ ohms}$$

$$\text{Output} = 2.0 \times 15 = 30 \text{ watts}$$

$$\text{Input} = 15 + 30 = 45 \text{ watts}$$

$$\text{Efficiency} = 66.7 \text{ per cent}$$

$$I_B = \frac{45}{600} = 75.0 \text{ milliamperes}$$

$$\frac{E_g}{E_b} = \frac{7.8 + 9.3 \times 3.49}{8.3 \times 10.1} = 0.479$$

$$E_g = 0.479 \times 600 = 284 \text{ volts.}$$

This is the amplitude or maximum value of the alternating grid voltage. The effective value will be

$$E_{g \text{ eff}} = \frac{284}{\sqrt{2}} = 201 \text{ volts}$$

$$E_c = 284 + \sqrt{6960 \times 30} - 600 + 5 \\ = 146 \text{ volts.}$$

The circuit of Fig. 3 was used in an experimental test with a tank circuit which had a dissipative resistance of 14.7 ohms to give the value of  $R_L = 3480$ . This would give an expected tank current of

$$I_T = \sqrt{\frac{30}{14.7}} = 1.43 \text{ amperes.}$$

The values of cathode resistor and plate generator voltage were adjusted to give the values  $E_b$ ,  $E_g$ , and  $E_c$  just computed. The result of the run is shown in Fig. 13. It will be seen that a good agreement with the computed maximum values of tank and plate currents and efficiency is obtained, and that these maximum values occur when  $e_{gm} = e_{pm}$

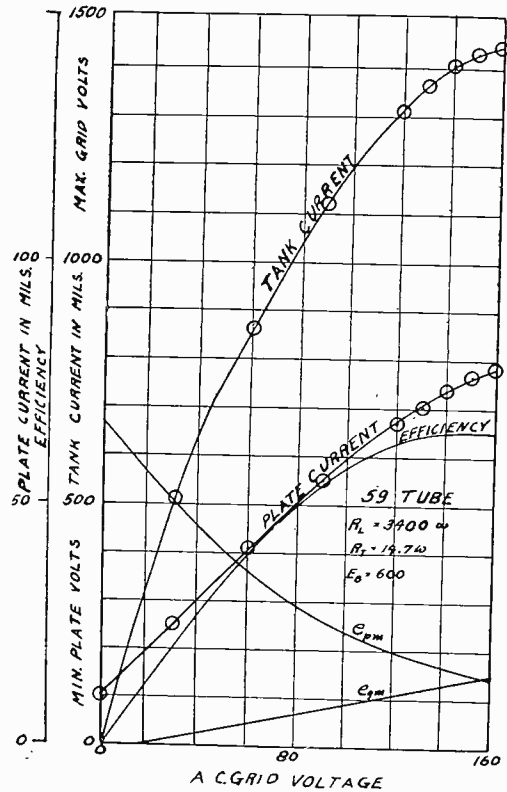

Fig. 13—Experimental check of tube circuit under optimum operating conditions using '10 tube.

and at the computed value of grid excitation voltage. The observed maximum values are

$$\begin{aligned} I_T &= 1.44 \text{ amperes} \\ \text{Output} &= 30.5 \text{ watts} \\ \text{Input} &= 45.9 \text{ watts} \\ \text{Loss} &= 15.4 \text{ watts} \\ \text{Efficiency} &= 66.5 \text{ per cent} \end{aligned}$$

A check was also made against a high- $\mu$  tube. The grids of a '59 were connected for class B operation and  $\mu$  and  $R_p$  measured. The values obtained were

$$\mu = 33.4 \quad R_p = 14,440 \Omega.$$

Assuming a loss of 15 watts and a plate voltage of 600 volts gave a  $\gamma_3$  of 0.0359. Computation of the optimum operating conditions gave the following values:

$$R_L = 3390$$

$$E_{g\text{ eff}} = 156$$

$$E_c = 79$$

$$\text{Output} = 30.8 \text{ watts}$$

$$I_B = 76.3.$$

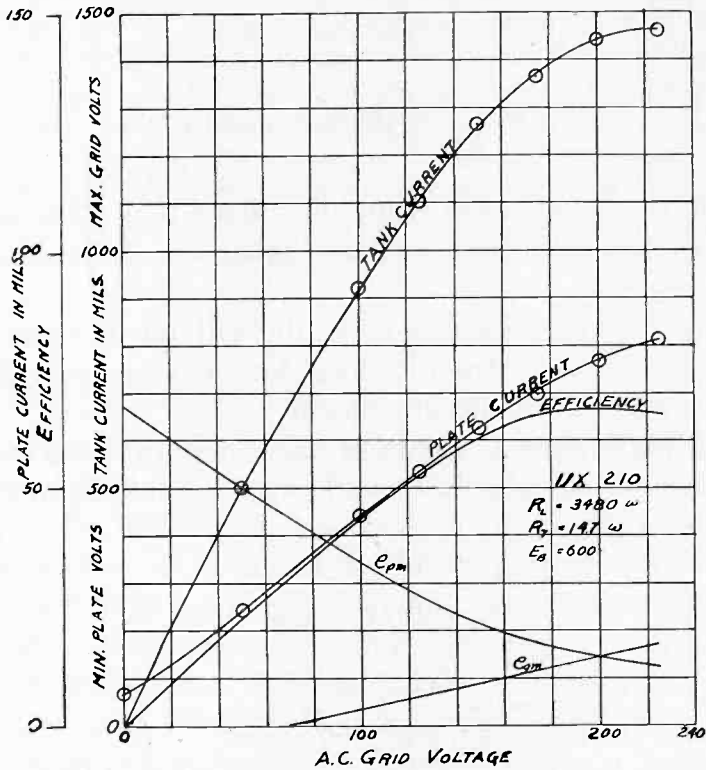

Fig. 14—Experimental check of tube circuit under optimum operating conditions using '59 tube.

In the experimental check a dissipative resistance of 14.7 ohms was used. The expected tank current would then be

$$I_T = \sqrt{\frac{30.8}{14.7}} = 1.45 \text{ amperes.}$$

The experimental curve is shown in Fig. 14 and is similar to Fig. 13. The observed maximum values are

$$I_T = 1.44 \text{ amperes}$$

$$\text{Output} = 30.5 \text{ watts}$$

$$\text{Input} = 47.0 \text{ watts}$$

$$\text{Loss} = 16.5 \text{ watts}$$

$$\text{Efficiency} = 65.0 \text{ per cent}$$

An examination of the curves and equations of Fig. 12 gives some interesting general conclusions. Some of these are well-known, but have not had adequate theoretical justification. It will be seen that the efficiency for optimum operating conditions is greater the smaller the value of  $\gamma_3$ . This indicates that the maximum possible value of  $E_b$  should be used. At low plate voltages the maximum output will be obtained with low efficiencies. The expression for  $\gamma_3$  can also be written

$$\gamma_3 = \frac{2 \times \text{loss}}{E_b^2 (g_m + g_p)}$$

where,

$$g_p = \frac{1}{R_p} = \text{plate conductance.}$$

Therefore the greater the value of mutual and plate conductance the less will be the value of  $\gamma_3$  and the higher the efficiency and output for a given loss.

Increasing the allowable loss in a tube will not increase the output by the same amount, for the increased loss will increase  $\gamma_3$  and result in a lower efficiency at maximum output.

The peak plate current required has a definite ratio to the direct plate current for each value of  $\Theta_1$  and hence  $\gamma_3$ . This ratio is computed as follows: From (2)

$$\begin{aligned} I_{\max} &= (E' - E_a)g_m \\ &= E'(1 - \cos \Theta_1)g_m. \end{aligned}$$

Divide by (9)

$$\frac{I_{\max}}{I_b} = \frac{\pi(1 - \cos \Theta_1)}{\sin \Theta_1 - \Theta_1 \cos \Theta_1} = \frac{2AB}{100} \quad (29)$$

This ratio is plotted in Figs. 2 and 11. When the value of plate current  $I_b$  is computed, the peak plate current can be checked against the emission of the tube.

Even when the tube has insufficient emission and resort must be made to characteristic curves, the use of the design formulas of Fig. 12 will give approximate values. These may be used in determining the values of voltage and operating angle originally assumed as independent variables and will facilitate the reaching of a final design. They will also give original values for use in an experimental approach to the problem, which will be much more accurate than those usually obtained by cut-and-try methods.



## MAGNETOSTRICTIVE ALLOYS WITH LOW TEMPERATURE COEFFICIENTS OF FREQUENCY\*

BY

JOHN McDONALD IDE

(Cruft Laboratory, Harvard University, Cambridge, Massachusetts)

*Summary*—Thirty-four magnetic alloys of iron, nickel, chromium, and cobalt were prepared and studied in order to find compositions which have substantially zero temperature coefficient of frequency of longitudinal vibration. Rods of these alloys were made to be used as secondary frequency standards, to stabilize the frequency of magnetostriction oscillators. The same alloys would be valuable for tuning forks. It was found that the temperature coefficient of frequency is a function of composition, heat treatment, temperature, and magnetization. Seven compositions were found which gave temperature coefficients of the order of one cycle in a million per degree centigrade, when properly heat-treated and magnetized. Five of these showed large dynamic magnetostriction, and gave good frequency stabilization when used with a magnetostriction oscillator.

### INTRODUCTION

MAGNETIC rods vibrating by magnetostriction can be used to stabilize the frequency of vacuum tube oscillators, in the audio range and above it up to about 100,000 cycles per second. Such circuits have been described by G. W. Pierce<sup>1</sup> and others. Quartz crystals may be used for the same purpose in the same and higher frequency ranges. Rods of the usual magnetic materials (nickel, invar, nichrome, Monel metal, stainless steel) are at a disadvantage in comparison with quartz crystals, since the temperature coefficient of frequency for such materials is of the order of 130 parts in a million per degree centigrade, whereas for Curie-cut quartz it is much smaller, of the order of 20 to 30 parts in a million per degree. The object of this research was to survey the field of magnetic alloys, with a view to finding compositions which have low temperature coefficients of frequency, and which are at the same time powerful magnetostrictive vibrators.

The writer has succeeded in making several practicable alloys with temperature coefficients from one to fifteen parts in a million per degree

\* Decimal classification: R282.3×538.11. Original manuscript received by the Institute, October 11, 1933.

<sup>1</sup> G. W. Pierce, "Magnetostriction oscillators," Proc. I.R.E., vol. 17, pp. 42-88; January, (1929). See also the following patents: U.S. patents No. 1,750,124; No. 1,889,153; No. 1,843,299; No. 1,882,393 to No. 1,882,401 inclusive. Also British patents No. 283,116; No. 311,004; No. 313,031; No. 314,891. Also German patents No. 554,399; No. 568,253. Also French patent No. 649,796, and additional Swedish, Japanese, Spanish, and Cuban patents on devices employing magnetostriction.

centigrade. Alloys of such composition should prove useful for the construction of tuning forks to serve as low audio-frequency standards, as well as for magnetostriction vibrators to stabilize higher frequencies. Some of these alloys are extremely powerful vibrators, having large magnetostrictive effects in addition to their relative independence of temperature.

The temperature coefficient of frequency was measured in each case at several points in the temperature range from 20 to 100 degrees centigrade, to see whether it varied with temperature in a useful manner. In a preliminary survey measurements were made on nickel, invar steel, two compositions of nichrome, Monel metal, cobalt-iron magnet steels, manganese nickel, an alloy of iron, cobalt, and tungsten (Fe 30%, Co 40%, W 30%), three specimens of stainless steel, and nickel tubes filled with aluminum and with lead. The temperature coefficient for nickel was found to decrease slightly above 100 degrees centigrade. For all the other materials the frequency versus temperature curves were straight lines, and the temperature coefficient was thus the same at all temperatures in the range covered. The values varied from  $-104 \times 10^{-6}$  cycles per degree in the case of the iron-cobalt-tungsten alloy, to  $-234 \times 10^{-6}$  cycles per degree for the filled nickel tubes. The values given by G. W. Pierce for the other materials were closely checked.

It was obvious that none of these materials promised anything in the direction of low temperature coefficients. A search of the literature on elastic constants showed that the only hopeful line of attack would be an investigation of the rather anomalous series of iron-nickel alloys between 30 and 50 per cent nickel. The work of Guillaume<sup>2</sup> and Chevenard<sup>3</sup> showed that the addition of chromium up to 12 per cent to the alloys of this series was effective in reducing the temperature coefficient of Young's modulus to extremely small values. I have made alloys of this type containing various percentages of chromium, and others with cobalt in place of chromium, and still others with both cobalt and chromium. The results described here were obtained with these alloys.

The relations between the various temperature coefficients should be explained before we proceed further. Let  $a$  be the coefficient of linear expansion,  $b$  the coefficient of Young's modulus  $E$ , and  $g$  the coefficient of frequency of longitudinal mode of vibration. By using the well-known equation for the velocity of sound in an elastic medium

$$v = 2lf = \sqrt{E/\rho}$$

<sup>2</sup> G. E. Guillaume, *Comptes Rendus*, vol. 170, p. 1433, (1920); also *Comptes Rendus*, vol. 171, p. 83, (1920).

<sup>3</sup> M. P. Chevenard, *Comptes Rendus*, vol. 171, p. 93, (1920).

and letting the temperature change slightly, it can be shown that

$$b = 2g - a \quad \text{or} \quad g = \frac{a + b}{2}.$$

It is obvious from this equation that one way to get a small temperature coefficient of frequency is to make alloys for which  $b$  is opposite in sign and nearly equal in magnitude to  $a$ . Since  $a$  is always positive and varies in value from  $1 \times 10^{-6}$  to  $12 \times 10^{-6}$  for alloys of iron nickel and chromium, we wish to make alloys for which  $b$  will be negative in sign and of this order of magnitude.

Guillaume found that for an alloy which he named "elinvar" (a contraction of "elasticity invariable"), containing 36 per cent nickel, 12 per cent chromium, and the balance iron,  $b$  was substantially zero, or could be made so by slight heat treatment. The writer has made alloys of this type, and finds that if Guillaume's composition is modified by using 8 to 10 per cent of chromium instead of 12 per cent, the value of  $g$  can be made vanishingly small, under suitable magnetic and thermal conditions. It is fortunate that the 8 and 10 per cent chromium alloys are very powerful magnetostrictive vibrators. The 12 per cent chromium alloy is relatively feeble, and becomes entirely nonmagnetic as the temperature rises above 60 degrees centigrade. We have found also that the addition of about 13 per cent of cobalt to the iron-nickel alloy containing 36 per cent nickel, reduces  $g$  to zero.

It is necessary to present the actual results in some detail, since it was found that the temperature coefficient of frequency  $g$  for any given alloy of this series, may vary with temperature, and with the steady magnetic field applied to the rod. For all these alloys  $g$  can be changed by heat treatment, such as quenching or annealing.

Thus, although  $g$  is primarily a function of composition, it is to some extent influenced by heat treatment, magnetization, and temperature.

#### PRODUCTION OF ALLOYS

The alloys made for this research were melted in a high-frequency induction furnace, in magnesia crucibles, which held about two pounds per melt. Each melt was poured into an iron mold, which produced an ingot an inch and a half in diameter and five or six inches long. These ingots were forged into bars five-eighths of an inch in diameter and about twenty inches long. The test rods were machined from the forgings, and were three-eighths of an inch in diameter and long enough to have natural frequencies in the neighborhood of 30,000 cycles per second (about three inches). All of the alloys contained about 1 per cent

of manganese as deoxidizer, which facilitated forging. The impurities should be low, since high grade materials were used, i.e., electrolytic nickel, cobalt, and chromium, and Armco iron.

I wish to acknowledge the coöperation of the Metallurgy Department of the Harvard Engineering School, and the able assistance of Dr. Bruce H. Rogers in the preparation of the alloys.

The following series of alloys were made and studied:

TABLE I  
ALLOYS STUDIED

Group 1.	5% Cr	5% Co	Ni 32, 34, 36, 38, 40%	Balance Fe
Group 2.	8% Cr	4% Co	Ni 36, 38, 40%	Balance Fe
Group 3.	8% Cr		Ni 25, 30, 32, 34, 36, 37, 38, 40%	Balance Fe
Group 4.	10% Cr		Ni 36, 38, 40%	Balance Fe
Group 5.	12% Cr		Ni 36, 38, 40%	Balance Fe
Group 6.		10% Co	Ni 34, 36, 38, 40%	Balance Fe
Group 7.		15% Co	Ni 34, 36, 38%	Balance Fe
Group 8.		Co 12, 13, 15, 20%	Ni 36%	Balance Fe

#### MEASUREMENT OF TEMPERATURE COEFFICIENTS

If we measure the natural frequency of vibration of a specimen rod, as a function of temperature, and plot frequency against temperature, the temperature coefficient of frequency is simply the slope of this curve.

The natural frequency of the rod was measured by placing it in the coils of a magnetostriction oscillator, whose frequency the rod was allowed to control. Some harmonic of this frequency (usually the seventh) was made to produce beats with some harmonic (usually the fifth) of the fifty-kilocycle output from a General Radio Class C-21-H standard frequency assembly. This standard frequency was accurate to at least one part in five million over considerable periods of time. The beat frequency (or difference frequency, as these are not true beats) was amplified and then measured by an audio-frequency meter. This audio-frequency meter is described in Pierce's paper referred to above. The natural frequency of the rod could then be computed with an accuracy of about one part in one hundred thousand, which was sufficient for the purpose of this research. It was necessary to use a high-pass filter to cut down unwanted frequencies picked up along the line from the standard frequency assembly.

The temperature of the rod was kept at any desired value between room temperature and 130 degrees centigrade by placing the magnetostriction coils containing the rod, inside a cubical box about a foot on a side, which had heating windings distributed evenly on the six outer sides. This box was in turn placed inside a somewhat larger insulating box lined with acoustolith blocks, with an asbestos board top. The de-



sired temperature was obtained by turning on a suitable heating current, and allowing equilibrium to be established. This was found to be just as satisfactory as using a thermostat, and far less trouble. It took four hours to reach equilibrium and the thermometer reading could then be depended on to give the rod temperature to within 0.1 degree centigrade.

The rods were magnetized by placing the magnetostriction coils inside a 25,000-turn coil which carried up to 200 milliamperes of direct current. This provided a maximum steady polarizing field of about three hundred oersteds.

Each rod was measured at four or five different temperatures, and a series of polarizing fields, so that I obtained curves of natural frequency against magnetic field, for each of several temperatures. From these curves temperature coefficients could be computed under various conditions of temperature and magnetization for each specimen. The amount of frequency variation with changing magnetic field is important to know in choosing rods for frequency standards.

The temperature coefficients, as finally computed, are accurate to about 1 per cent, for alloys whose frequency-temperature curves are straight lines. When this is not the case, or the coefficient is itself very small, 5 or 10 per cent would be a better estimate. This was considered sufficient accuracy for a survey of this type, in which there is a wide range of several variables.

#### RESULTS. TEMPERATURE COEFFICIENTS

The results of the temperature coefficient measurements appear in Table II. The complete composition of any alloy can be found in Table I. In Table II the alloys are arranged into their composition groups, and the nickel percentage (cobalt percentage is the variable in Group 8) is listed in the first column, to give each alloy its place in its group. Since  $g$ , the temperature coefficient of frequency, varies with temperature or magnetic field or both, there are listed in the second and third columns the smallest and largest values of  $g$  obtained for each specimen. In the last column is stated whether temperature or field (abbreviated to  $T$  and  $H$ , respectively) is the cause of the variation in  $g$ , and what the direction of the change is for both variables. The word "positive" signifies that  $g$  changes in the direction of positive values, That is, if it is negative, it becomes smaller, and if positive, it becomes larger. The word "negative" signifies that  $g$  changes toward negative values.

The data of Table II are plotted in Fig. 1, to show the range of  $g$  values as a function of nickel percentage, for Groups 1 to 7, and a function of cobalt percentage for Group 8. From these graphs one can

TABLE II  
 VARIATION OF  $g$  WITH COMPOSITION, TEMPERATURE, AND MAGNETIC FIELD

Per cent Ni	Range of $g$ Values Parts in a million		Nature of variations in $g$		Group No.
			As $T$ increases	As $H$ increases	
32	85.2	91.8	No variation with $T$	Negative	1
34	81.3	100.0	No variation with $T$	Positive	
36	29.5	42.6	Complex	Complex	
38	10.5	33.3	Complex	Complex	
40	-4.5	-20.0	Complex	Complex	
36	-3.6	23.2	Positive	Negative	2
38	-11.9	-18.4	Positive	Negative	
40	-31.3	-44.0	Positive	Negative	
32	15.0	39.0	Negative	Slightly negative	3
34	12.5	54.1	Negative	Slightly negative	
36	7.8	37.8	Positive	Negative	
37	-7.9	50.5	Decreases	Negative	
38	-8.0	8.3	Slightly positive	Negative	
40	-8.3	-20.5	No variation with $T$	Negative	
36	-9.0	29.6	Decreases	Negative	4
38	-10.0	-26.0	Slightly positive	Negative	
40	-25.8	-40.5	No variation with $T$	Negative	
36	-41.0	-96.0	Negative	No variation with $H$	5
38	-30.6	-59.5	Negative	No variation with $H$	
40	-48.9	-61.4	Slightly positive	Negative	
34	96.3	96.5	No variation with $T$	No variation with $H$	6
36	7.5	16.6	Positive	No variation with $H$	
38	-16.4	1.2	Positive	No variation with $H$	
40	-68.5	-68.5	No variation with $T$	No variation with $H$	
34	17.5	46.7	Positive	Positive	7
36	-14.0	-42.3	Positive	Positive	
38	-46.9	-63.9	No variation with $T$	Positive	
Per cent cobalt					8
10	7.5	16.6	Positive	No variation with $H$	
12	2.0	48.0	Positive	Little variation	
13	-13.8	10.0	Positive	Positive	
15	-14.0	-42.3	Positive	Positive	
20	-62.5	-73.9	Little variation	Positive	

interpolate between the alloys actually tested and determine what composition in each group would give the lowest temperature coefficient of frequency. It can be seen that there must be compositions in Groups 1, 2, 3, 4, 6, and 8 where the temperature coefficient changes from a positive to a negative value, passing through zero at some favorable temperature or field. These favorable alloy compositions are: Co 5%, Cr 5%, Ni 39%; Co 4%, Cr 8%, Ni 37%; Cr 8%, Ni 37%; Cr 8%, Ni 38%; Cr 10%, Ni 36%; Co 10%, Ni 37%; Co 13%, Ni 36%. The balance is iron in each case. Two groups of alloys, those with 15 per cent cobalt, and those with 12 per cent chromium, do not show any coefficients smaller than about  $-15 \times 10^{-6}$ .

It can be seen from the data and the graphs that the variations in  $g$  due to field and temperature cover an average range of about  $20 \times 10^{-6}$  cycles per degree. For the alloys in the three groups containing cobalt, 6, 7, and 8,  $g$  changes in the direction of positive values if temperature or magnetic field increases. That is, if  $g$  is negative, it be-

comes smaller in magnitude; if it is positive, it becomes larger. For the alloys in the three groups containing chromium, 3, 4, and 5, any changes which  $g$  undergoes with increasing field are in the direction of negative values, while no definite rule is followed for variations with temperature. For the alloys in Groups 1 and 2, containing both chromium and cobalt, the variations in  $g$  are complex, and no general trend can be seen.

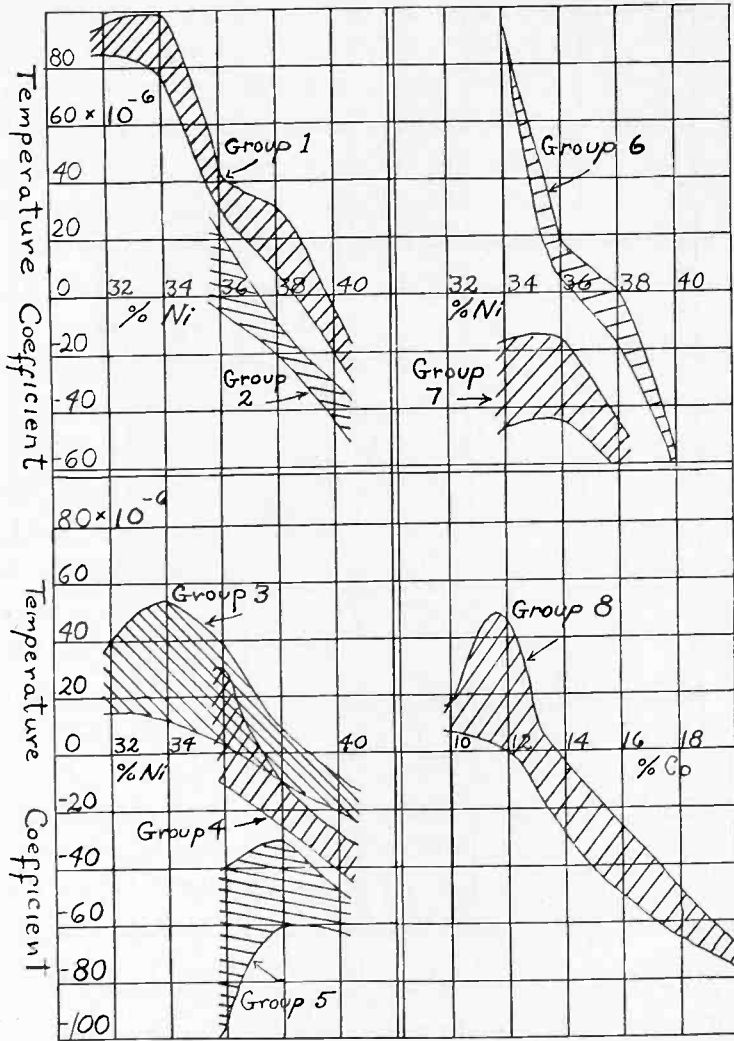

Fig. 1—Variation of temperature coefficient of frequency with composition for eight groups of alloys.

### VARIATION OF FREQUENCY WITH MAGNETIC FIELD

In Fig. 2 there is plotted frequency as a function of magnetic field for a typical alloy from each group. All the curves are for room temperature. In place of the actual frequency, which differed for different rods, the curves are made comparable with one another by plotting percentage change in frequency, or  $100 \times \Delta f / f$ .

The sample alloy for Group 3, (8% Cr, 37% Ni, balance Fe), is represented by three dashed curves, to show the effect of heat treatment on the variation of frequency with field. Samples cut from the same rod were measured in the quenched, annealed, and forged conditions. The annealed sample shows 0.6 per cent frequency change, the

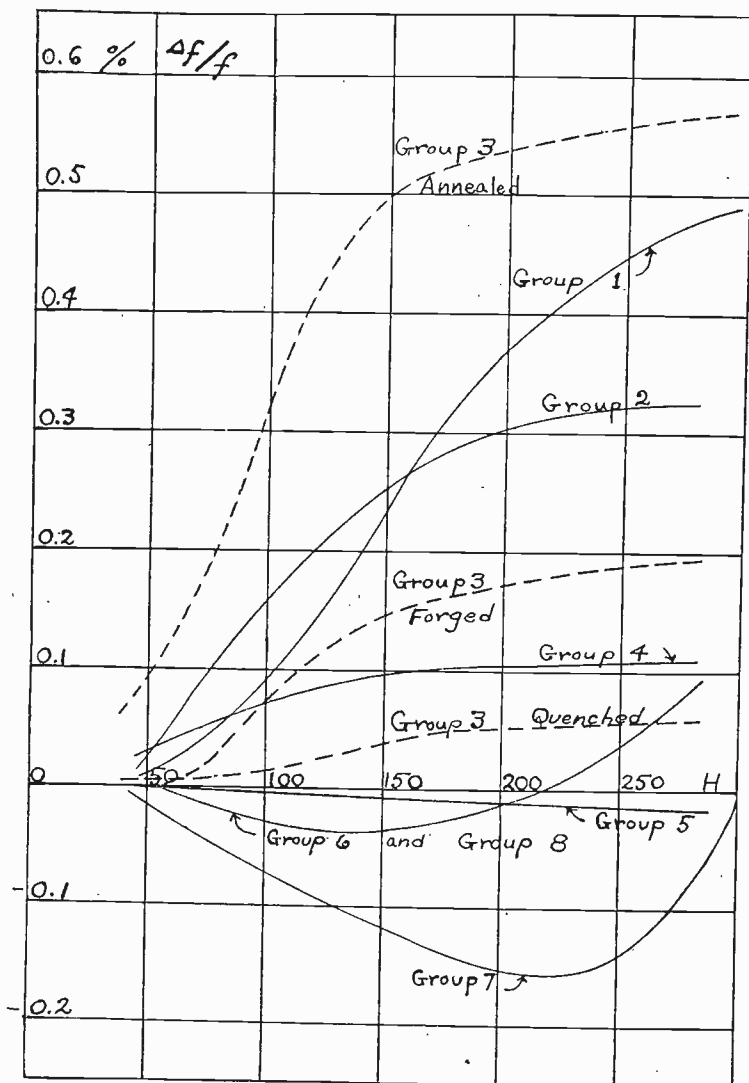

Fig. 2—Variation of natural frequency with magnetic field for eight groups of alloys.

forged sample 0.2 per cent change, and the quenched sample 0.1 per cent change, as the magnetic field increases to saturation. This behavior with heat treatment is typical of most of these alloys.

The effect of raising the temperature on the samples represented in Fig. 2, is to flatten all the curves and make them lower. There is thus less frequency variation with field as the temperature rises.

## MAGNETOSTRICTION EFFECTS IN THESE ALLOYS

There are no data for a quantitative estimate of the magnetostriction effects in these special alloys. But if we grade the rods as "Excellent," "Good," and "Fair," in accordance with the frequency stabilization produced by them, we can compare them roughly. The alloys in Groups 1, 2, 3, and 4 are in the "Excellent" class; those in Groups 6 and 7 can be labelled "good"; while those in Groups 5 and 8 are only "Fair." This leads to the conclusion that the addition of more than 10 per cent of chromium or cobalt to the iron-nickel series (30 to 40 per cent nickel) reduces the dynamic magnetostriction effects.

Another factor of some interest is the temperature at which the alloys become nonmagnetic, i.e., the Curie point. It is well-known that the addition of chromium to the nickel-iron series lowers the Curie point, and that enough chromium will lower it below room temperature, making such alloys completely nonmagnetic. The writer did not try to measure the transformation temperature, but it was obvious for some of the alloys that the magnetostriction effects faded out as the temperature rose. The alloys of Group 3 (8 per cent chromium) showed several effects. Those containing 25 and 30 per cent nickel were completely nonmagnetic at room temperature and above. The 32 per cent nickel alloy stabilized well up to 50 degrees centigrade, but the magnetostriction effects disappeared above 80 degrees centigrade. The 34 per cent nickel alloy stabilized well up to 70 degrees centigrade, and lost its magnetostriction entirely at about 100 degrees centigrade. The 36 per cent nickel alloy stabilized well up to 95 degrees centigrade, but was obviously nearing the transformation temperature. The other alloys of this series containing more than 36 per cent nickel showed no evidence of magnetic transformation below 100 degrees centigrade. The alloys of Group 4 (10% Cr, 36% to 40% Ni), showed a marked diminution of stabilizing power above 110 degrees centigrade. The alloys of Group 5 (12% Cr and 36% and 38% Ni) showed a complete loss of magnetostriction not far above 60 degrees centigrade. The addition of cobalt to the iron-nickel series raises the Curie point, so that the high cobalt alloys did not show any falling off of magnetostriction due to temperature.

It was found that the magnetic field at which the optimum magnetostriction effects are found in each case is the field corresponding to the beginning of saturation on the frequency versus field curves of Fig. 2. In most cases the rods stabilize very well with much smaller polarizing fields than this. Most of them do not stabilize well with their residual fields alone. A strong permanent magnet or a magnetizing solenoid,

preferably the latter, should be used to get effective frequency stabilization.

### EFFECT OF HEAT TREATMENT ON THESE ALLOYS

Heat treatment is another factor which may cause marked changes in the properties of these alloys. An alloy in Group 3 was chosen con-

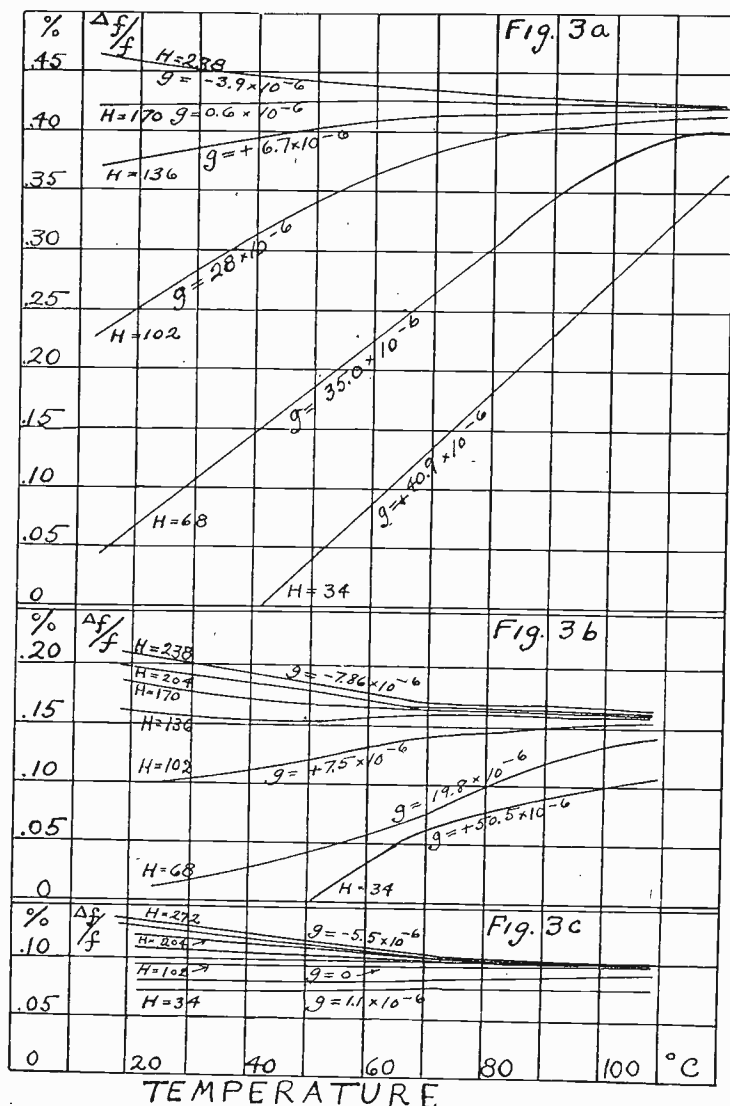

Fig. 3—Variation of frequency with temperature and magnetic field for an alloy containing 8% Cr, 37% Ni, balance Fe. (a) annealed; (b) forged; (c) quenched.

taining 8% Cr, 37% Ni, balance Fe, to illustrate the effects of heat treatment in a typical case.

In Fig. 3 frequency is plotted (in percentage change) against temperature, for a series of polarizing fields. Fig. 3 (a) shows these curves for an annealed sample. The annealing consisted in heating the sample to redness and allowing it to cool slowly in the furnace. Fig. 3 (b) shows

corresponding curves for a sample of the same rod which was left in the forged condition in which it was received. Fig. 3 (c) shows similar curves for another sample which was heated to redness and then quenched in cold water.

In each case the slope of any curve gives the temperature coefficient of frequency for the temperature and field represented by the portion of the curve where the slope is measured. Average values of  $g$  are marked on the curves. It is obvious that in each case there is a critical magnetizing field where the temperature coefficient changes from positive to negative values, passing through zero. This occurs when the frequency-

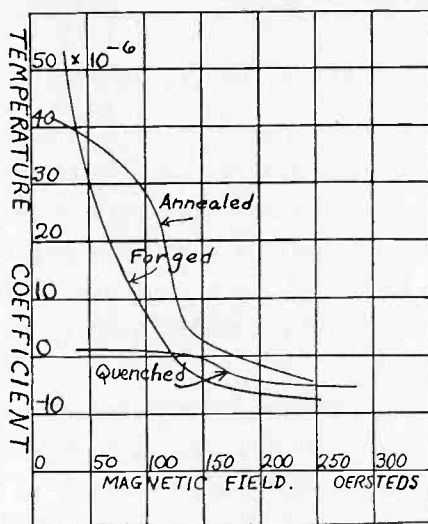

Fig. 4—Variation of temperature coefficient with magnetic field for an alloy containing 8% Cr, 37% Ni, balance Fe.

temperature curve is horizontal. For the quenched and forged samples this critical field is about 135 oersteds. For the annealed sample it is near to 170 oersteds. For larger fields  $g$  is negative, and for smaller fields it is positive. It can be seen from Fig. 3 and more clearly from Fig. 4 that the amount of change in the temperature coefficient, as the field varies, is large for the annealed and forged samples and very small for the quenched sample. Fig. 4 also shows the critical fields where  $g$  changes sign. We note also that if the magnetic field is larger than the critical value, the temperature coefficient remains small (less than  $7 \times 10^{-6}$ ) and does not vary much.

Referring to Fig. 2, the variation of frequency with field is shown for these samples on the dashed curves. These curves have already been discussed under "Variation of Frequency with Field." The relatively small change in frequency (0.1 per cent) for the quenched sample is the most noteworthy feature. This 0.1 per cent change is the whole change in frequency as the magnetic field increases from zero to saturation.

The average frequency variation for one oersted change in magnetic field is about three cycles in a million for this alloy. It is less than this for large fields, and greater for fields below saturation.

The magnetostriction effects are similar for the three samples. In each case there is optimum stabilization of frequency when the polarizing field is as large or larger than the critical field described above. The annealed and forged samples will stabilize fairly well with no external field, as they have considerable residual magnetism. The quenched sample has practically no residual field, and requires a polarizing field to make it vibrate. All three samples are extraordinarily powerful magnetostrictive vibrators when properly magnetized.

#### APPLICATION OF THESE RESULTS

Six groups of alloys were found by this research, in each of which there is one or more compositions with a low temperature coefficient of frequency. These low temperature coefficients can be made too small to measure, or less than one part in a million per degree, by careful adjustment of magnetic field and heat treatment. Without such adjustment, the coefficient may be counted upon to be less than  $20 \times 10^{-6}$  cycles per degree centigrade.

These temperature coefficients compare very favorably with those for quartz crystals. For X-cut crystals,  $g$  is 20 to 30 parts per million per degree centigrade; while for Y-cut crystals it may be two or three times as large. The smallest temperature coefficients ever obtained from crystals were about one part in a million per degree, using coupled modes of vibration in doughnut-shaped crystals.<sup>4</sup> Even this remarkably small coefficient is matched by our special alloys. Both crystal and rod require careful adjustment to find the conditions for minimum temperature coefficient.

This research shows that, while the temperature coefficient may be made negligible, the magnetic field applied to the rod may cause considerable variation of the rod frequency. This is due to the increase in Young's modulus with magnetization. It thus appears that variations in magnetic field may be more objectionable than temperature changes. When the frequency change with field is large, as for the annealed sample of alloy containing 8% Cr, 37% Ni, and balance Fe, there may be 50 parts in a million frequency variation for a field change of one oersted. It can be seen that the fluctuations of the earth's magnetic field would give a frequency variation of a few parts in a million. This is for the alloy which shows the largest effect of this kind, and the same

<sup>4</sup> W. A. Marrison, *Proc. I.R.E.*, vol. 17, p. 1103; July, (1929); also F. R. Lack, *Proc. I.R.E.*, vol. 17, p. 1123; July, (1929).



composition when quenched has this frequency variation reduced to about three parts in a million for one oersted field change. If fields larger than 170 oersteds are applied, the variation is further reduced to one part in a million per oersted.

There is now material at hand to discuss the relative merits of the low temperature coefficient alloys, with a view to their use as practicable frequency standards. The properties of seven such alloys are summarized in Table III. All the alloys are in the forged condition.

TABLE III  
LOW TEMPERATURE COEFFICIENT ALLOYS

Group	Composition				$\frac{\Delta f}{f\Delta H}$	Optimum field (Oersteds)	Stabilization
	Co per cent	Cr per cent	Ni per cent	Fe per cent			
1	5	5	39	Bal	$17 \times 10^{-6}$	220	Excellent
2	4	8	37	Bal	11	135	Excellent
3		8	37	Bal	7	135	Excellent
		8	38	Bal	4	120	Excellent
4		10	36	Bal	3	140	Excellent
6	10		37	Bal	7	170	Good
8	13		36	Bal	8	220	Fair

As was pointed out, the temperature coefficient varies somewhat with temperature, heat treatment, and magnetic field. Consequently by arranging the thermal and magnetic conditions it is possible to obtain practically zero temperature coefficient with any of the above compositions. Other compositions close to those in the table will have very small coefficients. For example, any composition in the range from 36 to 40 per cent nickel, 8 per cent chromium, and the balance iron in each case, should have a temperature coefficient less than ten parts in a million, under suitable conditions.

In Table III the column marked  $\Delta f/f\Delta H$  gives the frequency variation for one oersted change in magnetic field. It is thus the magnetic field coefficient of frequency, and is analogous to the temperature coefficient and of the same order of magnitude. The values in the table are averages computed from the curves of Fig. 2.

The desirable characteristics for frequency standards to control magnetostrictive oscillators are of course excellent stabilization and small magnetic field coefficient of frequency, in addition to low temperature coefficient. The alloys of Groups 6 and 8 are relatively poor vibrators, so that they would not be so suitable for magnetostriction applications, although they might be used for tuning forks. The other alloys are all excellent vibrators, and of these the two containing chromium without cobalt (Groups 3 and 4) have the smallest  $\Delta f/f\Delta H$ . On the whole these alloys are perhaps the most practicable compositions for applications requiring low temperature coefficient, low magnetic

field coefficient, and excellent stabilizing power (large dynamic magnetostriction). By quenching these alloys, the magnetic field coefficient can be still further reduced without affecting the other desirable properties, as is pointed out in the section devoted to heat treatment.

We conclude, therefore, that the best alloys indicated by this research for the purpose of magnetostrictive frequency standards are those containing from eight to ten per cent of chromium, thirty-six to thirty-eight per cent of nickel, and the balance iron, together with one per cent of manganese to facilitate forging. With such alloys, properly heat-treated and magnetized, we can expect to obtain temperature coefficients of frequency of the order of one cycle in a million per degree centigrade.



## A COMPACT RADIO FIELD STRENGTH METER\*

By

PAUL B. TAYLOR

(Formerly, Radio Engineering Department, Westinghouse Electric and Manufacturing Company, Chicopee Falls, Mass.)

*Summary*—This paper describes a compact portable field strength meter for frequencies in the broadcast band. The range of the instrument is from one volt per meter to one millivolt per meter. The theory of the resonant circuit is elaborated, and on the basis of the theory a novel method for calibrating the detector circuit is developed. A minimum of calibration is required for the instrument as a whole. The voltmeter may be calibrated on audio-frequency alternating current; and any loop used may be calibrated by the instrument itself in the field.

### FUNCTIONS OF FIELD STRENGTH METER

THE requirements exacted of a field strength meter are, in ascending order of precision: (1) That it shall indicate the order of magnitude of a radio field, for instance as to whether or not the field is sufficient to excite a receiver of given type, (2) that it shall give numerical values of field strength, which are comparative but not absolute, (3) that it shall measure the field absolutely in millivolts per meter. The meter here described has been developed with the intent that it should satisfy this third requirement, that there should be no question of its fidelity, and that it should be susceptible to being checked in the field with a minimum of auxiliary equipment. Other requirements were that it should be adapted to the broadcast band and be portable anywhere.

A field strength meter functions in two distinct stages: (1) As a receiver it must convert the radio field into a radio-frequency voltage with a known ratio between the voltage and the millivolts per meter of the field, (2) as a voltmeter it must measure this voltage on some sort of indicator. The two functions are independent except as the load of the voltmeter on the receiving circuit affects the properties of the latter.

### THE RESONANT RECEIVING CIRCUIT

The theory of the resonant receiving circuit frequently has received elementary treatment; but in order to explain certain refinements and modifications introduced into the instrument it is worth while to give it more careful attention.

Any tuned loop antenna may be represented by the circuit of Fig. 1.

\* Decimal classification: R270. Original manuscript received by the Institute, March 5, 1932. Released for publication, March 1, 1933.

$L$  represents the inductance of the loop,  $C$  the tuning capacity,  $R_o$  the series resistance of the loop, and  $G_o$  the normal conductance in parallel with the loop due to condenser dielectrics, voltmeter, etc. The radio field induces an electromotive force,  $E$ , in the loop, and the corresponding voltage,  $V$ , across the terminal points  $AB$ , is measured by a voltmeter of some sort.  $E$  and  $V$  are vector quantities not in phase, indeed at resonance they are 90 degrees out of phase. Due to the condition of resonance  $V$  is of the order of one hundredfold that of  $E$ .

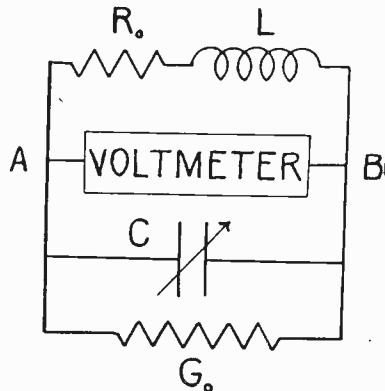

Fig. 1—Resonant circuit with parallel conductance.

We wish to determine the ratio between the tensor values of the induced electromotive force in the loop and the potential difference measured across its terminals when the circuit is in resonance. This ratio may be called the gain of the receiving circuit. Denote it by  $p$ .

$$p = \left| \frac{V}{E} \right| \text{ (resonance)}. \quad (1)$$

To evaluate  $p$  in terms of circuit elements consider the impedance,  $Z$ , offered to  $E$  by the circuit:

$$Z = j\omega L + R_o + \frac{-j\omega C + G_o}{\omega^2 C^2 + G_o^2}. \quad (2)$$

The voltage drop between  $A$  and  $B$  is given by

$$V = \frac{E}{Z} (j\omega L + R_o), \quad (3)$$

whence,

$$\frac{E}{V} = 1 - \frac{\omega^2 LC - R_o G_o + j(\omega L G_o + \omega C R_o)}{(\omega^2 L^2 + R_o^2)(\omega^2 C^2 + G_o^2)}. \quad (4)$$

Consideration is now restricted to the condition that  $R_o^2$  be negligible compared to  $\omega^2 L^2$  and  $G_o^2$  negligible compared to  $\omega^2 C^2$ . Under this restriction resonance may be defined by

$$\frac{\partial}{\partial C} \left| \frac{E}{V} \right| = 0, \quad (5)$$

that is, the tensor value of this ratio is a maximum. From this it readily follows that the real part of  $E/V$  vanishes, and that

$$\omega^2 LC = 1, \quad (6)$$

at least to the second order of small quantities. To the same order of precision we now have

$$\begin{aligned} \frac{E}{V} \text{ (resonance)} &= -j \frac{\omega LG_o + \omega CR_o}{(\omega^2 L^2 + R_o^2)(\omega^2 C^2 + G_o^2)} \\ &= -j(\omega LG_o + \omega CR_o), \end{aligned} \quad (7)$$

a pure imaginary. Hence the reciprocal gain is given by

$$\begin{aligned} \frac{1}{p} &= (\omega LG_o + \omega CR_o) \\ &= \frac{G_o}{\omega C} + \frac{R_o}{\omega L}, \end{aligned} \quad (8)$$

and the gain by

$$p = \left( \frac{G_o}{\omega C} + \frac{R_o}{\omega L} \right)^{-1}. \quad (9)$$

This is the desired expression for the gain of the circuit. Knowing  $V$  we may then find  $E$  from the relation,

$$|E| = |V|/p. \quad (10)$$

Frequently the term  $G_o/\omega C$  has been neglected in discussion on the ground that ordinarily  $R_o$  is small compared to  $1/G_o$ . This is insufficient justification as the following example will show. Take as elements of the circuit

$$\begin{aligned} \omega L &= \frac{1}{\omega C} = 500 \text{ ohms} \\ R_o &= 5 \text{ ohms} \\ \frac{1}{G_o} &= 100,000 \text{ ohms.} \end{aligned}$$

These are rather typical values and  $R_o$  is very much smaller than  $1/G_o$  to be sure. Yet

$$\frac{R_o}{\omega L} = 0.01$$

and,

$$\frac{G_o}{\omega C} = 0.005$$

so that the term  $G_o/\omega C$  is 50 per cent of  $R_o/\omega L$ . It reduces the gain of the circuit by 33 per cent and is not at all negligible. If  $G_o$  be of the magnitude of the average grid leak, say one reciprocal megohm, it still reduces the gain 5 per cent.

#### DETERMINATION OF CIRCUIT GAIN

We shall now develop a method for determining the gain,  $p$ , of the circuit, which does not require a knowledge of the circuit constants.

Let a known small resistance,  $R$ , be added in series with the inductive branch of the circuit. Corresponding to an induced electromotive force,  $E$ , in this branch let  $V_R$  be now the potential drop across  $AB$ , the circuit being at resonance.

$$\frac{E}{V_R} = -j \left( \frac{G_o}{\omega C} + \frac{R_o + R}{\omega L} \right) = -j \left( \frac{1}{p} + \frac{R}{\omega L} \right). \quad (11)$$

Similarly, let a known small conductance,  $G$ , be added in parallel across the capacitive branch and let  $V_G$  be the corresponding value of the potential drop.

$$\frac{E}{V_G} = -j \left( \frac{G_o + G}{\omega C} + \frac{R_o}{\omega L} \right) = -j \left( \frac{1}{p} + \frac{G}{\omega C} \right). \quad (12)$$

Elimination of  $p$  between (7) and (11) and between (7) and (12) yields, respectively,

$$\frac{V}{jE} \frac{1}{\omega L} = \left( \frac{V - V_R}{V_R} \right) \frac{1}{R} \quad (13)$$

$$\frac{V}{jE} \frac{1}{\omega C} = \left( \frac{V - V_G}{V_G} \right) \frac{1}{G}. \quad (14)$$

Multiplying corresponding members of (13) and (14),

$$\frac{V^2}{-E^2} = \left( \frac{V - V_R}{V_R} \right) \left( \frac{V - V_G}{V_G} \right) \frac{1}{RG} \quad (15)$$

or,

$$p = \left| \frac{V}{E} \right| = \sqrt{\frac{V - V_R}{V_R} \cdot \frac{V - V_G}{V_G} \cdot \frac{1}{RG}}. \quad (16)$$

The values of  $V$ ,  $V_R$ , and  $V_G$  may be read on a voltmeter placed across

AB. Thus (16) enables us to determine the gain of the circuit by means of two known resistors and three measurements of output voltage. None of the circuit elements nor the frequency need to be known.

This method of determining the gain of the receiving circuit has been adopted in the field strength meter because of its simplicity, the facility with which the only two calibrated elements necessary can be supplied, and the fact that the gain may be easily determined in the field. The method for calibrating the high resistance has been published.<sup>1</sup>

In terms of the inductance or capacity [cf. (13) and (14)] the gain of the circuit may be expressed also, of course, as

$$p = \frac{\omega L}{R} \left( \frac{V - V_R}{V_R} \right) \quad (17)$$

$$p = \frac{\omega C}{G} \left( \frac{V - V_G}{V_G} \right). \quad (18)$$

The first of these equations is well known, and is commonly derived for the circuit without consideration of conductance paralleling the capacity. It is now seen to be equally applicable whether or not conductance is present. This is indeed fortunate, since it means that neglect of the conductance term in the past has not lead to error in the use of the formula.

However, the statement sometimes made that the resistance of the loop is given by

$$R_o = R \frac{V_R}{V - V_R}$$

is not altogether correct. The value of  $R_o$  so found is the series resistance of a hypothetical circuit having the same gain as the actual circuit but with zero conductance across the loop. It is always larger than the true resistance of the loop, and will vary according to the circuit in which the loop is placed. Indeed it is not possible to evaluate  $R_o$  and  $G_o$  uniquely from measurements on the circuit at resonance, for there are an infinite number of pairs of values of  $R_o$  and  $G_o$  which give the equivalent circuit.

#### THE LOOP ANTENNA

The preceding treatment has been on the basis of lumped inductance and electromotive force in the loop. In the actual loop the in-

<sup>1</sup> P. B. Taylor: "Method for measurement of high resistance at high frequency, Proc. I. R. E., vol. 20, pp. 1802-1806; November, (1932).

ductance, resistance, and electromotive force are distributed, and there is present distributed capacity as well. This has the effect of reducing the apparent inductance of the loop and also, what is of most concern, the apparent electromotive force. The current in the loop is not uniform, and the effect of the added series resistor;  $R$ , when placed in circuit near the terminals of the loop is different from its effect when

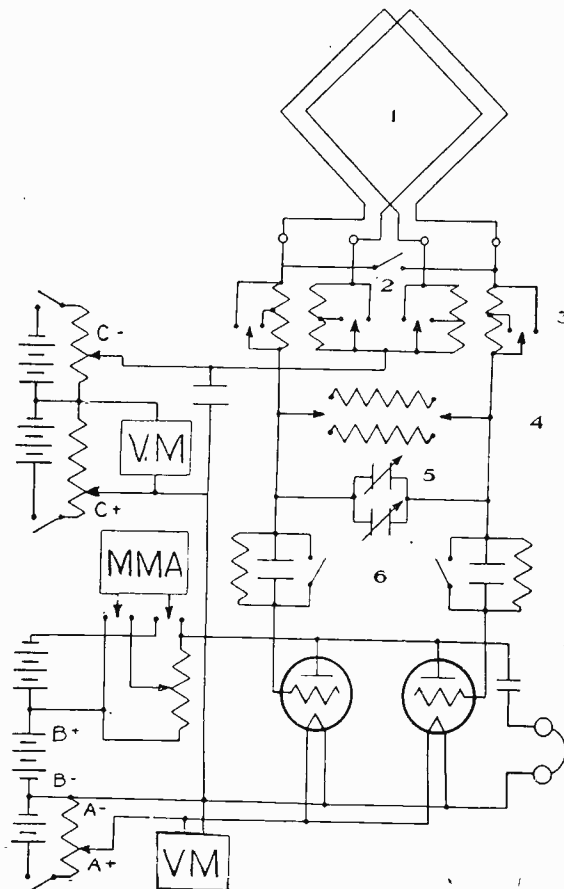

Fig. 2—Essential circuit of field strength meter.

1. Loop antenna.
2. Signal shorting switch.
3. Calibrating resistance,  $R$ . Two sets of four equal resistors are supplied, each set to accommodate a different loop. Of each set two resistors (combined value  $R$ ) are for insertion between loop and tuning condenser, two between loop and ground.
4. Calibrating conductance  $G$ , supplied in two values.
5. Tuning condenser.
6. Grid leaks.

placed in the middle of the loop. It may be shown that when the resistor is near the terminals the gain computed by the methods we have outlined is too small and when placed near the middle it is too large.

An analytical discussion of the loop with distributed constants has been worked out and will be published shortly. The nub of that discussion is a method for finding the true gain, which is remarkably



accurate and simple. It consists in inserting the series resistor,  $R$ , first in the middle of the loop and then in two equal halves at the terminals of the loop (that is, next the voltmeter). The apparent gain is computed in each case, and the true gain, as one might suspect, is given by their arithmetical average. By true electromotive force is meant the integrated electromotive force along the loop, or as given by

$$E = 2\pi nAF/\lambda$$

where,

$F$  = field strength of radiation

$\lambda$  = wavelength of radiation

$A$  = area of loop

$n$  = number of loop turns.

The true gain is then the ratio of the observed voltage,  $V$ , to this value of  $E$ .

The correction for distributed capacity has been found very necessary, as the gain computed without this correction may be in error several hundred per cent. Even in a loop of only two turns No. 18 wire spaced two inches apart a correction of 2 per cent was found and in a similar six-turn loop a correction of 20 per cent.

This device for determining the gain correctly has been made available in our field set by incorporating the proper resistors and switches. In order to meet certain theoretical requirements, which will be treated in a future paper, the loop is made square with a diagonal vertical. This disposition also lends itself well to a sturdy but light framework.

Another aspect of the loop which requires attention is the "antenna effect," that is, the electromotive force induced in the loop due to its capacity to surrounding objects. As this electromotive force is not to be calculated, it must be eliminated. This is accomplished by the common practice of dividing the loop into two symmetrical halves and grounding the center point, thus balancing the loop to ground. This balance is carried out systematically throughout the radio-frequency circuit. To preserve it the series resistors are divided in half and inserted with equal impedance to ground. The test for the elimination of antenna effect is the disappearance of received signal when the plane of the loop is turned parallel to the wave front. This instrument always meets this test except on the rare occasions when the wave front is not vertical.

#### THE VACUUM TUBE VOLTMETER

The voltmeter part of the instrument is a vacuum tube voltmeter. Two UX-864 tubes are used, and to preserve balance to ground the

input circuit is made push-pull, that is, the filaments are at ground and the grid-filament circuits are in series across the loop. The tubes are carefully selected from stock so as to have characteristics as nearly alike as may be. The plate circuits in parallel are in series with a high resistance microammeter, which constitutes the indicating portion of the field meter. By paralleling two tubes a better impedance match is obtained.

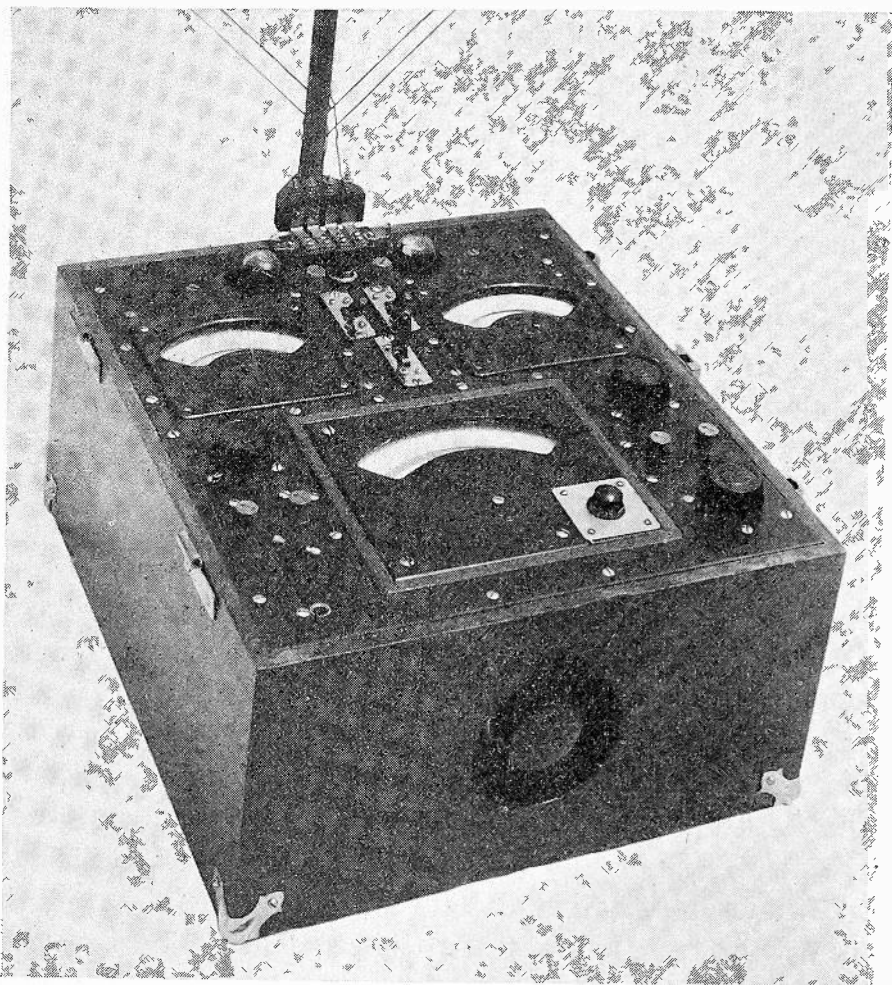

Fig. 3—Radio field strength meter—meter box showing electrical connections to loop.

The voltmeter may be used in three ways:

1. Fixed grid bias, total plate current being read.
2. Variable grid bias to give fixed plate current, bias voltage being read.
3. Grid leak, change in balanced plate current being read.

Each type of circuit is appropriate for a different range of signal. The combined range is from one volt per meter to one millivolt per meter.

For grid-bias use, a calibration of the voltmeter made at audio

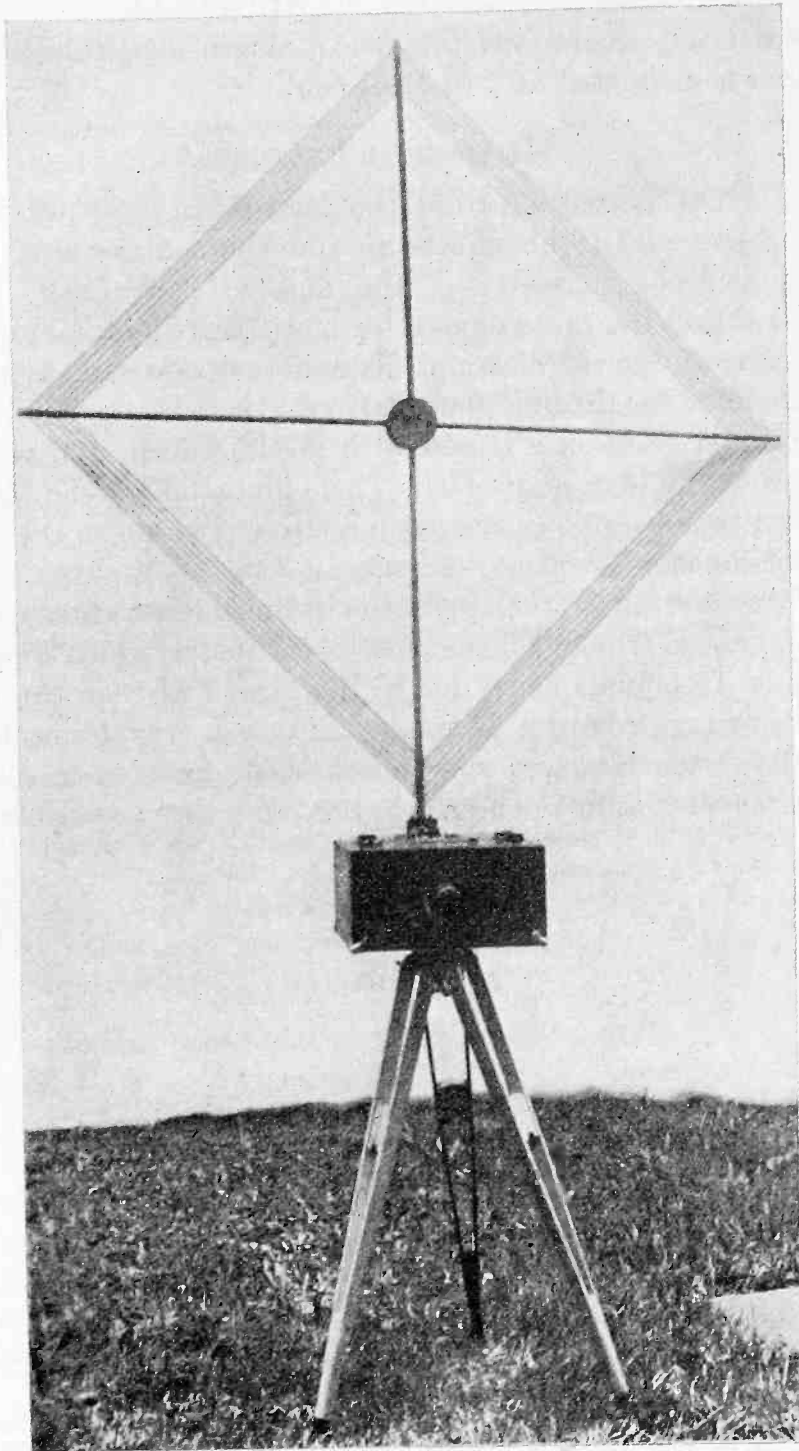

Fig. 4—Radio field strength meter set up for field measurement.

frequencies is reliable, and even for grid-leak use it is without serious error.

The over-all accuracy of this field strength meter under favorable conditions is estimated at 2 to 5 per cent.

#### MECHANICAL FEATURES

The layout of parts within the instrument case was made by Harold Roess, and to his efforts are due the compactness, lightness, and troubleproof character of the finished instrument. Dry cells mounted within the case are used for power. Auxiliary meters are provided for reading grid bias and filament voltages and a multirange microammeter for reading plate current.

The meter rests on a tripod with leveling head, and rotates as a whole when the loop is directed. This eliminates all sliding contacts and keeps the observer in the same relative position to the loop when taking readings.

For transportation, the apparatus is divided into three members—loop, meter, and tripod. The heaviest is the meter, which weighs about 40 pounds, 15 pounds being due to the case. Two men can carry the outfit over rough country. This portability is a very desirable feature, for it allows the observer very much wider freedom in selection of observation sites than when he is limited to places accessible by automobile.

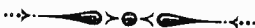

## ON THE OSCILLATIONS OF A CIRCUIT HAVING A PERIODICALLY VARYING CAPACITANCE\*

By

W. L. BARROW

(Round Hill Research Division, Department of Electrical Engineering, Massachusetts Institute of Technology, Cambridge, Massachusetts)

**Summary**—A previous theoretical study of a dissipationless oscillatory circuit having a periodically varying capacity predicted the existence of several interesting types of oscillations. An experimental investigation of such a circuit was therefore made. The results of this investigation are presented in this paper. The dissipation was reduced to a minimum by means of an associated vacuum tube in a regenerative connection. An auxiliary condenser and rotating commutator produced the periodic capacity variation. The nature of the oscillations was studied by means of oscillograph and meter measurements of the currents in the several parts of the circuit and by the use of headphones. A quite good agreement with theory was found, consistent with the deviations of the experimental conditions from the theoretically postulated ones. The oscillations were generally of a complicated nonsinusoidal character, but assumed a substantially sinusoidal form for certain adjustments of the circuit. The frequency of these sinusoidal oscillations was twice that of the capacity variation. Periodic oscillations were found to occur when, approximately,  $\alpha = 2\omega_0/n$ ,  $n = 1, 2, 3, \dots$ , where  $\omega_0$  is the natural angular velocity of the circuit for the mean capacity value and  $\alpha$  is the angular velocity of the capacity variation. Failure of all oscillations for certain circuit adjustments was related to the inherent loss of energy in the switching method employed for varying the capacity. The theory had predicted certain unstable conditions for which the amplitude should increase without limit. In the experimental circuit these unstable adjustments gave a large amplitude sinusoidal oscillation.

### INTRODUCTION

IN A previous paper<sup>1</sup> a mathematical study was made of the oscillations of a dissipationless oscillatory circuit having a periodically varying capacity. The existence of several very interesting phenomena was predicted from the analysis, and it was pointed out that their occurrence in any physically realizable circuit could not exactly follow the theory because of the absence of any form of dissipation in the idealized elements on which this study was based. Inasmuch as no experimental investigation of these effects was known to exist, one was undertaken<sup>2</sup> with the object of further determining the performance of

\* Decimal classification: R1400. Original manuscript received by the Institute, October 20, 1933.

<sup>1</sup> W. L. Barrow, "Frequency modulation and the effects of a periodic capacity variation in a nondissipative oscillatory circuit," *Proc. I.R.E.*, vol. 21, pp. 1182-1202; August, (1933).

<sup>2</sup> Mr. S. Sorkin and Mr. L. Jacobson, seniors in the electrical engineering department, communications option, Massachusetts Institute of Technology, were of material assistance in carrying out the experimental work.

the circuit in question. The present paper presents the most important results of this experimental study in which the theoretical analysis is corroborated.

### THEORETICAL DISCUSSION

For the details of the theory of the dissipationless resonant circuit with periodically varying capacity, reference may be made to the earlier paper,<sup>1</sup> as well as other citations given there. It is nevertheless of interest to review briefly the results of the theoretical analysis before proceeding to the experimental work.

Denoting the charge by  $Q$ , the mean frequency<sup>3</sup> of the circuit about which the variation takes place by  $\omega_0$ , the percentage change in frequency by  $h$ , the frequency of variation of the capacity by  $\alpha$ , and the time by  $t$ , the differential equation takes the form

$$\frac{d^2Q}{dt^2} + (\omega_0^2 + h \cdot \omega_0^2 \cos \alpha t)Q = 0 \quad (1)$$

provided a capacity variation is assumed in which

$$1/C(t) = \frac{1}{C_0} + \frac{1}{C_0} \cdot h \cos \alpha t,$$

which may be considered as a first approximation to the particular variation used in the experiment. It can be shown<sup>3</sup> that the solution of (1) is the real part of

$$Q = C_1 e^{-j\mu t} \cdot \sum_{n=-\infty}^{+\infty} b_n e^{jn\alpha t} + C_2 e^{+j\mu t} \cdot \sum_{n=-\infty}^{+\infty} b_n e^{jn\alpha t} \quad (2)$$

where  $C_1$ ,  $C_2$  are arbitrary constants determined by the initial conditions, and  $j = \sqrt{-1}$ . The summation is a Fourier series written in complex form, the coefficients  $b_n$  of which are to be determined from the recurrence relation:

$$\left[ \left( \frac{\omega_0}{\alpha} \right)^2 - (\mu + n)^2 \right] b_n + \frac{1}{2} h \left( \frac{\omega_0}{\alpha^2} \right)^2 [b_{n-1} + b_{n+1}] = 0. \quad (3)$$

The factor  $\mu$  in the exponent of (2) must also be determined from (3) and is called the "characteristic exponent." In general,  $\mu$  is a complex number  $u + jv$ , but for certain values of the parameters may be simply a real number. From a consideration of (2), this fact is seen to be of prime importance, for, when  $\mu$  is real, the solution takes the form

<sup>3</sup> For brevity in text and formulas the word *frequency* will be used throughout this paper to mean angular velocity  $= \omega = 2\pi f$ .

$$Q = C_1 \sum_{-\infty}^{+\infty} b_n \cos (n - \mu)\alpha t + C_2 \sum_{-\infty}^{+\infty} b_n \cos (n + \mu)\alpha t, \quad (4)$$

which is a steady state solution composed of several simultaneous (theoretically, an infinite number) sinusoidal oscillations of different frequencies and amplitudes. On the other hand, when  $\mu$  has an imaginary part different from zero, say  $\mu = u + jv$ , the solution becomes

$$Q = C_1 e^{+v\alpha t} \sum_{-\infty}^{+\infty} b_n \cos (n - u)\alpha t + C_2 e^{-v\alpha t} \sum_{-\infty}^{+\infty} b_n \cos (n + u)\alpha t. \quad (5)$$

The presence of the exponential factors in (5) causes the second term to become negligibly small compared to the first after a short interval

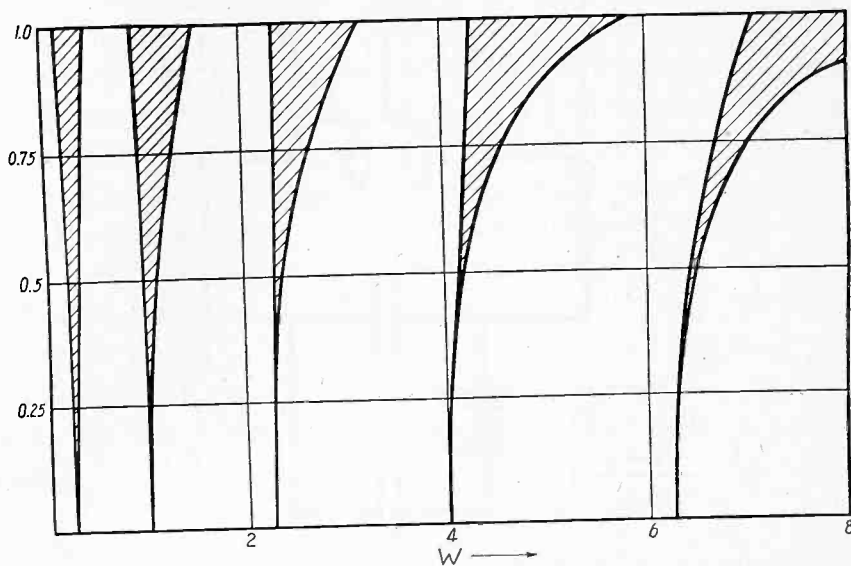

Fig. 1—Showing ranges of  $\omega_0$ ,  $\alpha$ , and  $h$  for which oscillations of stable (unshaded) and unstable (shaded) type are theoretically expected to occur. [Fig. 6, PROC. I.R.E., vol. 21, no. 8, p. 1195; August, (1933)]  $W = (\omega_0/\alpha)^2$ .

of time, leaving only the first term, which itself *increases in magnitude without limit*. This type of solution is called "unstable" and obviously cannot occur in precisely this form in any physically realizable circuit. The factors preventing such unstable oscillations depend, naturally, on the particular apparatus used in constructing the circuit; here, for example, the nonlinear characteristics of the associated vacuum tube are quite sufficient to explain a limited amplitude of oscillation, and thus a departure from the mathematical form of instability is to be expected. It is one of the purposes of this study to determine the nature of the oscillations in an actual circuit for an unstable adjustment. For stable adjustments, the solution (5) is closely related to that in (5); in fact, the elimination of the second term in (5), due to the rapid

for values of  $h$  up to 0.23 and  $(\omega_0/\alpha)^2$  up to 9.0 for a constant  $\omega_0 = 97.5$  c.p.s. Above  $h = 0.23$  no oscillations took place, due no doubt to the fact that the regenerative conditions for the vacuum tube were then too unfavorable to allow self-maintained oscillations to occur.

As  $h$  and  $\alpha$ , and thus  $(\omega_0/\alpha)^2$ , were varied, the character of the oscillations also varied, but certain critical points and regions were found where the nature of the oscillations was outstanding. Specifically, upon varying  $\alpha$  so as to approach one of these critical regions, rapid beats, i.e., waxing and waning, in the current were observed. These beats gradually became slower in period but larger in magnitude until the particular critical point was reached, whereupon the amplitude assumed a large value and the wave form became substantially sinu-

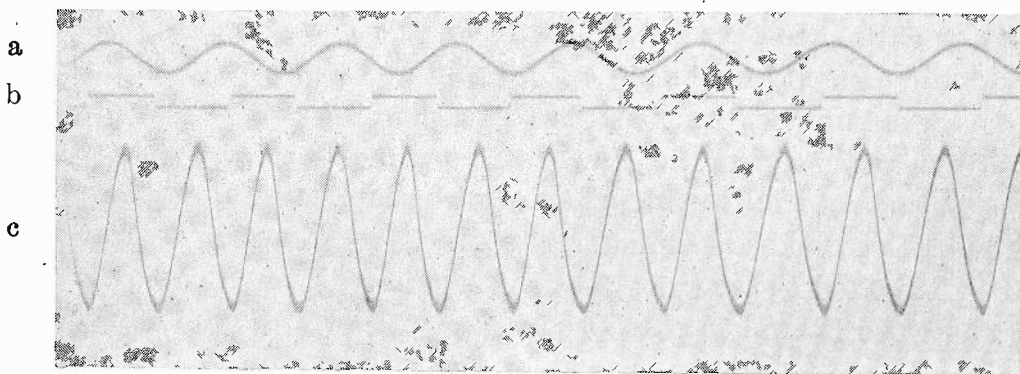

Fig. 3—Oscillogram of the current (the lower trace  $c$ ) of substantially sinusoidal wave form for a critical (unstable) adjustment of the circuit parameters;  $\alpha = 2\omega_0$ . The upper trace  $a$  is a 60-cycle per second timing wave. In the second trace  $b\Delta C$  is connected when the horizontal line is above and disconnected when it is below.

soidal. A series of such points or regions were located at values of  $\alpha$  of  $2\omega_0, \omega_0, 0.66\omega_0, 0.5\omega_0, 0.25\omega_0, \dots$ , corresponding to values of  $(\omega_0/\alpha)$  of 0.5, 1.0, 1.5, 2.0, 2.5,  $\dots$ , respectively. A glance at Fig. 1 shows that these are precisely the circuit adjustments for which either periodic or unstable oscillations were to be expected. It is thus concluded that instability of the ideal circuit is manifested in the actual circuit by an increase in amplitude and a wave form of substantially sinusoidal character. A typical oscillogram of the current in the oscillatory circuit for a critical adjustment is reproduced in Fig. 3 and shows plainly the character of the oscillation. When one considers the abrupt change in capacity occurring in the circuit once during each period, it seems quite remarkable that the oscillations should be of this simple sinusoidal form.

In passing, it is interesting to note that the unstable condition existing when  $\alpha = 2\omega_0$  was first noticed in connection with the vibrations



of a string whose tension was given a periodic variation, and was discussed theoretically by Lord Rayleigh<sup>6</sup> in 1887. If the capacity of the electrical circuit was varied at this rate by a method not involving a considerable loss of energy (for instance, by a rotating condenser),

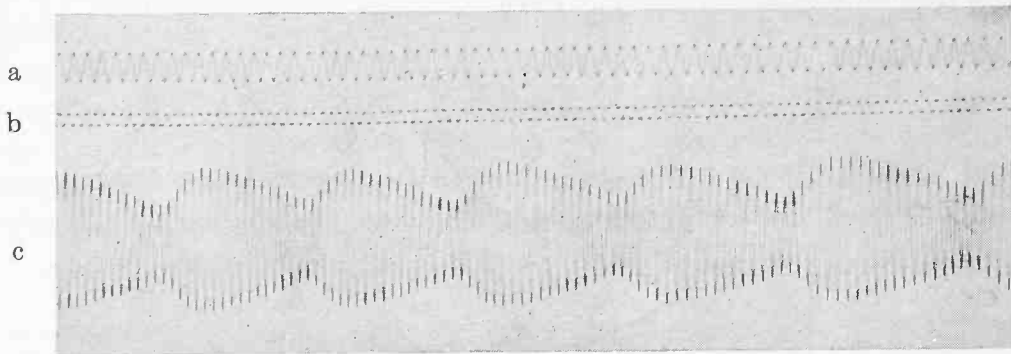

Fig. 4—Oscillogram of the beat type of oscillation occurring for a circuit adjustment differing only slightly from a critical (unstable) value.

self-maintained oscillations would be set up in the circuit without the help of a vacuum tube. Winter-Günter<sup>7</sup> has produced such oscillations by periodically varying the inductance instead of the capacity.

Fig. 4 shows a typical oscillogram of the current having the relatively slow beats just described above and Fig. 5 shows a more complex

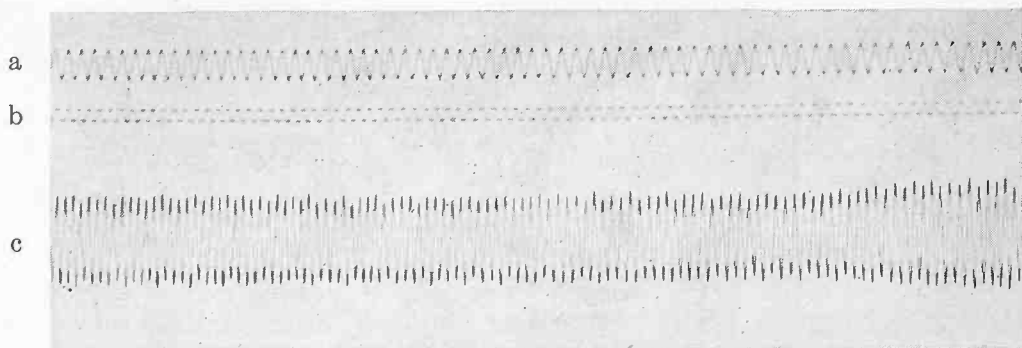

Fig. 5—Oscillogram of the complex wave form typical of an adjustment to the middle of a stable area of Fig. 1. Approximately  $h = 0.15(\omega_0/\alpha)^2 = 1.5$ .

wave form occurring about midway between two critical points. The occurrence of the beat phenomena may be explained from the theory, for the solution on the boundary between a stable and unstable region is known to be purely periodic, as  $\mu$  in (4) is either an integer or half integer. Further, it is practically sinusoidal for not too large values of  $h$  as the coefficients  $b_n$  then converge very rapidly. When the adjust-

<sup>6</sup> Scientific Papers, vol. III.

<sup>7</sup> *Jahr. der draht. Tel. u. Tel.*, vol. 34, p. 1, (1929), and vol. 37, p. 172, (1931).

ment is not quite that for a periodic solution,  $\mu$  differs only slightly from an integer or half integer, and components of current exist which differ only slightly in frequency, producing the beats observed. For example, if  $\Delta$  represents a number—small compared with unity—and  $\mu = 1 + \Delta$ , the frequencies as given by (5) are

$$[n - (1 + \Delta)]\alpha, \quad [n + (1 + \Delta)]\alpha, \quad n = \begin{cases} +1, 2, 3 \dots \\ 0, -1, -2, \dots \end{cases}$$

and beats having a lowest frequency  $2 \cdot \Delta\alpha$  occur. These beats vanish for  $\Delta = 0$  and become more and more rapid as  $\Delta$  increases. The observed

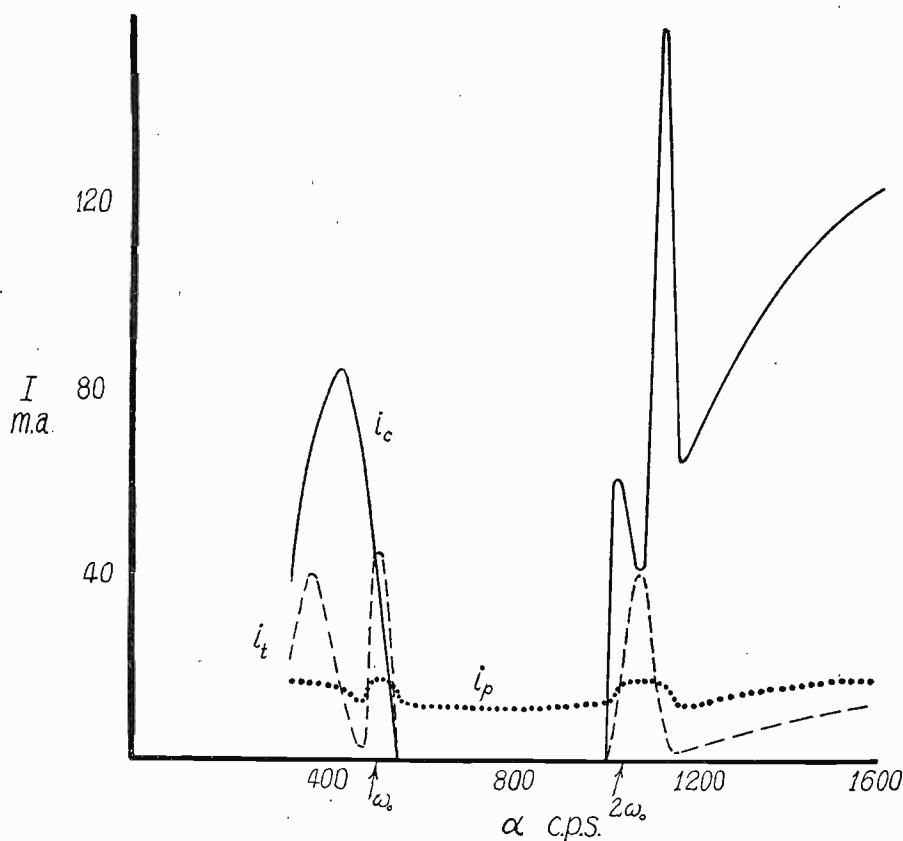

Fig. 6—Curves of currents in the oscillatory circuit  $i_t$ , between condensers  $i_c$  and in plate circuit of the vacuum tube  $i_p$  for  $C_0 = 2$  microfarads and  $\Delta C = 1$  microfarad.

increase in amplitude for the critical values may also be inferred from (5), which is pertinent to the case. The amplitude of the oscillation builds up as demanded by the positive exponential until the non-linearity of the vacuum tube characteristics causes a stable amplitude to be maintained; the wave form is then the same as that of the periodic oscillation just preceding instability.

The occurrence of periodic oscillations having a fundamental frequency different from  $\alpha$  or  $\alpha/2$  for other than these critical values was

predicted from the theory and such oscillations were actually observed. The wave form showed the presence of many simultaneous harmonic oscillations in each case, as contrasted with the substantially sinusoidal wave of the critical point oscillations.

When  $h$  was given a relatively large value greater than 0.16 and  $\alpha$  varied continuously from zero upward, it was found that for several ranges of values of  $\alpha$  the oscillations ceased altogether, even though sinusoidal oscillations of considerable amplitude took place in between these ranges. The ranges of  $\alpha$  in which oscillations cease have been located as the values of  $(\omega_0/\alpha)^2$  corresponding to the stable areas of Fig. 1. Curves showing the behavior of the currents in the oscillatory circuit and plate circuit of the vacuum tube for a typical run are given in Fig.

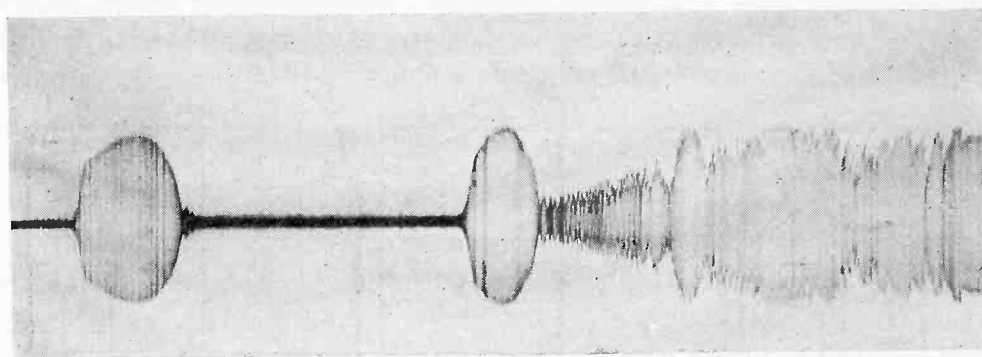

Fig. 7—Oscillograms showing the character of oscillations for  $C_0 = 1.7$ ,  $\Delta C = 1.0$  microfarad, and  $L = 1.3$  henrys. The speed of the motor was continuously changed during the taking of the oscillogram such that  $(\omega_0/\alpha)^2$  went from an infinite value at the right (i.e. zero r.p.m. of commutator) to about 0.5 at the left. Unevenness of paper accounts for the irregular blackening observable in the oscillogram.

6. The oscillogram of Fig. 7 makes this interesting phenomenon for relatively larger values of  $h$  even clearer. This oscillogram was made by registering the current in the tuned circuit (at a speed too slow to resolve the individual oscillations) as the frequency of capacity variation  $\alpha$  was continuously varied from zero to more than  $2\omega_0$ . Two regions within which oscillations ceased, the large amplitude sinusoidal oscillations in the critical (unstable) regions and the adjacent regions of beats with the highly complex wave forms in between, may all be distinctly seen. It is thought that the explanation of this interesting phenomenon lies generally in the fact that in the region of no oscillations the condensers  $C_0$  and  $\Delta C$  have large voltages of opposite polarity at the instant of connection resulting in a loss of energy when these voltages are equalized (a familiar proposition of electrodynamics and circuit theory), greater than the vacuum tube can supply. This explanation is supported by the observed fact that the current  $I_c$  between

condensers is zero in the critical regions and of considerable magnitude in between these regions.

An oscillogram similar to that of Fig. 7 is reproduced in Fig. 8. Here, the magnitude of  $h$  was only 0.13, and consequently oscillations continued for all rates of capacity variation. The several types of oscillations are again clearly discernible, particularly the strong beats

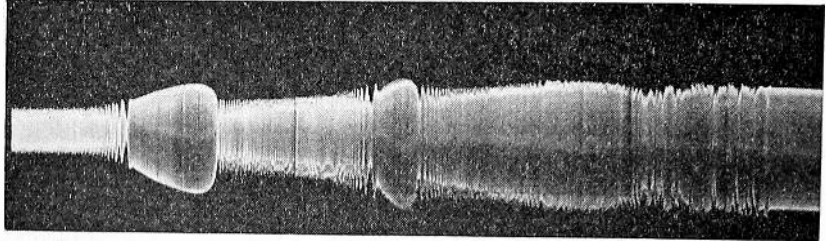

Fig. 8—Oscillogram showing character of oscillations for  $C_0 = 0.7$ ,  $\Delta C = 0.2$  microfarad, and  $h = 0.13$ .

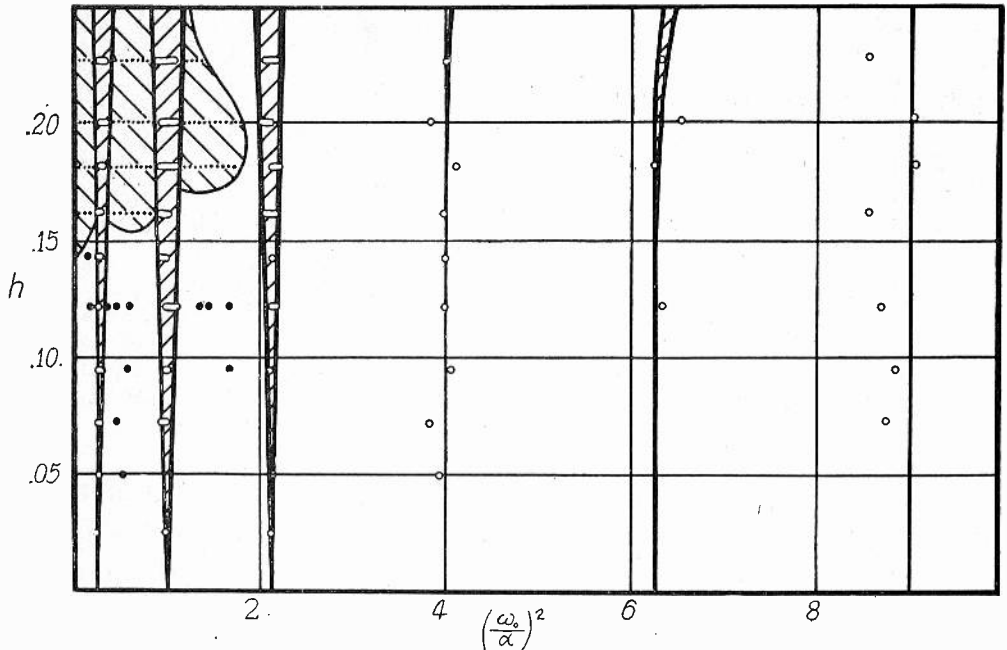

Fig. 9—Plot of the experimentally determined points, showing the character of the oscillations as a function of the several circuit parameters. Legend: white circles = substantially sinusoidal oscillations, black circles = periodic nonsinusoidal oscillations, small dots = no oscillations of any kind. A comparison should be made with the theoretically obtained curve of Fig. 1.

and large amplitude sinusoidal oscillations occurring for  $\alpha \cong 2\omega_0$  and  $\alpha \cong \omega_0$ , respectively, (the first and second prominent maxima of the oscillogram, counted from the left).

A graphical representation of the results of this study may be made in a form similar to Fig. 1. Such a plot is reproduced in Fig. 9. It allows a direct comparison between theory and experiment. It is seen at once

that the general agreement is quite good despite the approximations involved in the analysis and pointed out in the first section of this paper. The unstable oscillations of the theoretical case represented in Fig. 1 occur in the experimental curves of Fig. 9 for the same values of  $h$  and  $(\omega_0/\alpha)^2$ , but in the latter figure "unstable" is to be interpreted as an oscillation having practically sinusoidal form and a relatively large amplitude. For values of the circuit parameters bordering on an unstable adjustment large beats take place, while for values remote from an unstable region the wave form is quite complex. Other oscillations, periodic in character but of a nonsinusoidal wave form, may be located in the region of stable adjustment for certain parameter values. A third type of region is to be found in the experimental data, although absent in the theoretical one, in which absolutely no oscillations occur. This latter divergence from the theoretical predictions is the only prominent one found, and is the result of factors inherent in the actual physical circuit but not considered in the theoretical analysis.

#### CONCLUSIONS

The agreement between theory and experiment is quite good, despite the idealized circuit upon which this theory is based. Periodic oscillations of frequency  $\alpha$  or  $\alpha/2$  having a practically sinusoidal form and a relatively large amplitude occur when  $\alpha \cong (2\omega_0/n)$ ,  $n = 1, 2, 3, 4, \dots$ , although this phenomenon is most pronounced when  $n = 1$  or  $2$ . These sinusoidal oscillations correspond to an unstable condition of the circuit, for which the current amplitude would rise beyond all bounds were physical limitations not imposed by the apparatus, as energy is then fed continually into the electrical system from the mechanical one (i.e. the mechanical energy expended in varying the condenser is converted into electrical energy in the circuit). It is only for such an unstable adjustment that the wave form is sinusoidal. Oscillations of the stable type have, in general, a quite complex character which varies with the circuit parameters; they may be conveniently classified into three categories, namely; (1) periodic oscillations of nonsinusoidal form and of fundamental frequency different from  $\alpha$  or  $\alpha/2$ ; (2) oscillations of a beat type in which the amplitude periodically waxes and wanes; and (3) oscillations having no definite periodic properties and appearing as a continually transient phenomenon (periodicity may occur in this type, but the period is so long that the practical consequences are as though no periodicity existed).

The complete failure of oscillations for several ranges of parameter values was a phenomenon not directly explainable by the theory. It is believed that the explanation lies in the fact that the capacity variation

was secured by a switching method with its attendant loss of energy already discussed. The physical conditions were not all included in the differential equation, and consequently the solution would not necessarily contemplate every experimental observation; such is the case with this complete absence of oscillations for certain adjustments.

A circuit in which the inductance is periodically varied should behave in precisely the same manner as the one with periodically varying capacitance studied here. This follows from the symmetry in  $L$  and  $C$  of the differential equation (1).

It may be mentioned that the phenomena discussed in this paper represent what may ordinarily be thought of as a very exaggerated case of frequency modulation in which the degree of modulation and the modulation frequency are both of magnitude comparable with the middle frequency. Some of the observed effects are met with in the acoustical application<sup>8</sup> of frequency modulation, viz., the warble tone. They are not thought to occur in any radio-frequency case of present occurrence (this would mean a modulating frequency comparable to or larger than the carrier frequency) but could be produced by suitable apparatus if desired.

<sup>8</sup> W. L. Barrow, Proc. I.R.E., vol. 20, p. 1635; October, (1932).



## RADIOTELEGRAPH KEYING TRANSIENTS\*

BY

REUBEN LEE

(Westinghouse Electric and Manufacturing Company, Chicopee Falls, Massachusetts)

*Summary*—An investigation into the nature of transients occurring when keying takes place shows that objectionable features of these transients may be reduced by suitable precautions. In the usual form of low-pass plate-supply filter, high  $C$  or low  $L$  are essential preventives of transients, and poor voltage regulation sometimes reduces their harmful effects. The transient is a damped sinusoid causing an initial drop in plate voltage when the key is closed. Two-section filters produce a double-frequency transient, the low-frequency component being the more important. Theoretical deductions are confirmed by oscillographic measurements on both rectifier and generator plate supplies.

A CONTINUOUS-WAVE telegraph transmitter may be thought of as a generator of radio-frequency energy which is alternately switched on and off from its load. Whether the keying takes place in the grid circuit of the power amplifier or in a preceding stage, it produces the same effect upon the transmitted signal as would opening the antenna circuit or the power amplifier plate supply. Perhaps the latter analogy furnishes the best conception for visualizing keying phenomena.

In Fig. 1(a), an amplifier excited by a keyed source, receiving its plate power from a battery, and delivering its load into an antenna, may be represented by the battery, Fig. 1(b), having internal resistance  $R$  and delivering  $I_B$  amperes into load  $r$ , the current being interrupted at the keying rate by switch  $S$ . The plate current in this noninductive circuit follows the wave shape shown in Fig. 1(c); rectified antenna current has the same outline. Plate voltage has the outline of Fig. 1(d), where  $E_1$  is the no-load and  $E_B$  the full-load voltage. Such conditions produce absolutely square-wave signals.

When the power supply requires filtering, the switching no longer takes place in a noninductive circuit, and the signal wave shape is not square. The filter circuit is commonly composed of an inductive choke  $L$  having a direct-current resistance  $R$ , and a condenser  $C$  connected as in Fig. 2(a). If the plate supply is a generator, the inductance  $L$  may be the generator internal inductance and  $R$  the generator internal resistance. The original radio-frequency amplifier has been replaced by a circuit containing direct current only. Thus the transients

\* Decimal classification: R430×R385. Original manuscript received by the Institute, July 24, 1933.

are those which would exist in a direct-current circuit composed of the elements of Fig. 2(a).

When an amplifier having such a plate supply is keyed, transient voltages occur in the plate circuit, the amplitudes of which are determined by the circuit constants. In order to picture more readily the nature of these transients, we shall consider the action of the circuit constants  $L$ ,  $C$ ,  $R$ , and  $r$ .

Suppose, first, that the condenser is charged up to the full value of  $E_1$  while the key is up (switch  $S$  open). The physical phenomena occurring when the key is pressed are roughly as follows:

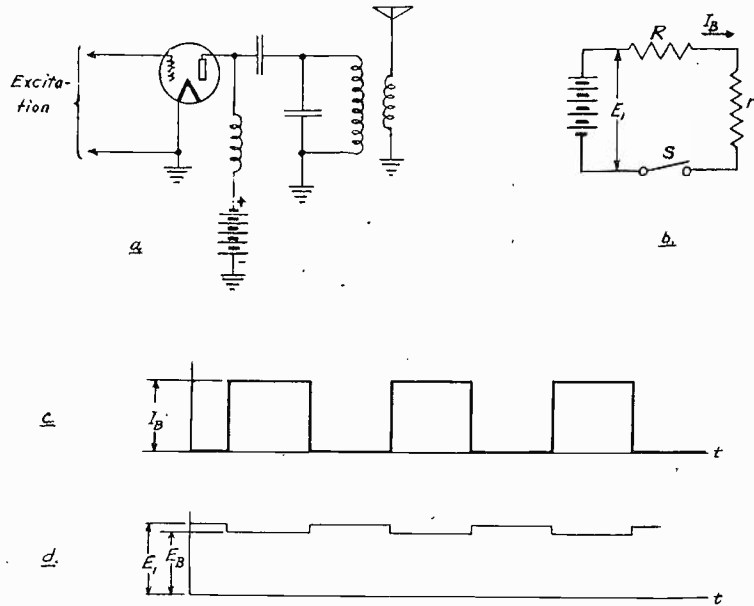

Fig. 1

1. The condenser  $C$  initially delivers full load current  $I_B$  into resistance  $r$ . The current then decreases at a rate depending upon the constants  $C$  and  $r$ . The higher the value of  $C$  or  $r$ , the slower is the decrease of load current.

2. Current through choke  $L$  supplies the difference between current through  $r$  and that delivered by  $C$ . Initially, the choke current is zero, and it rises slowly at first, because  $C$  is supplying most of the load current. The higher the values of  $r$  and  $R$  or the lower the value of  $L$ , the faster is the increase of choke current.

3. As current through the choke increases, it reaches a value equal to that delivered by the condenser at the same instant. Beyond this point, the load current rises again. Since the voltage  $e_B$  at any instant is  $ri_B$ , the plate voltage has a sag or dip when the key is pressed, the magnitude of the dip being smaller with lower values of  $L$  or higher values of  $R$ ,  $r$ , or  $C$ .



The combined action of  $L$ ,  $C$ ,  $R$ , and  $r$  produces a plate voltage variation  $e_B$  as shown in Fig. 2(b) if the circuit is oscillatory, which is the most important case. Fig. 2(c) shows the choke current for this case. Fig. 2(d) shows the plate voltage wave for a nonoscillatory circuit. The criterion for oscillations is given by (2) of the appendix. If  $R$  is very small compared to  $r$ , the circuit is oscillatory when  $r > \frac{1}{2}\sqrt{L/C}$ . A small value of  $R$  corresponds to good power supply regulation. As derived in the appendix, the equation (4) of the plate voltage is

$$e_B = E_1 \left( 1 - \frac{\epsilon^{mt}}{rCn} \sin nt \right),$$

where  $m$  is the decrement and  $n$  is  $2\pi$  times the frequency of transient

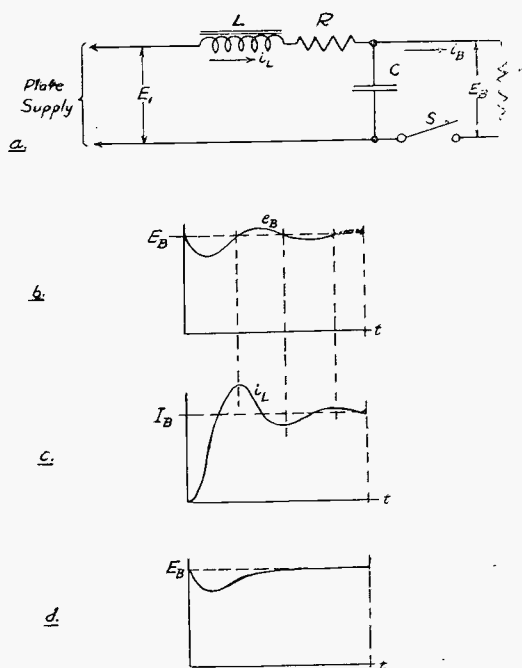

Fig. 2

oscillations. When  $m$  is small compared to  $n$  (usually true in radio transmitters) a good approximation for  $n$  is  $1/\sqrt{CL}$ .

This equation is based upon a pure direct-current supply voltage  $E_1$ , the effect of ripple being neglected. The ripple frequency is high compared to  $n/2\pi$ , and the amplitude is small, thus making it of negligible consequence as far as transients are concerned.

The variation in  $E_B$  produced by these transients results in the following undesirable effects on transmitter operation:

(1) *Modulation of the transmitted signal.* If the degree of this modulation be kept low enough, no difference in the note of the signal will appear in a receiver. A modulation of about 30 per cent is probably

the border line of this condition. Therefore, if the amplitude of the first dip in  $E_B$  is less than 30 per cent, all the succeeding dips and rises will be below this value also, and no difference in signal note will be detected.

(2) *Frequency variation in the master oscillator*, if the latter is connected to the same plate supply. The ultimate effect of this variation is a change in the signal frequency which is eliminated by reducing the transients as described under (1).

(3) *Greater tendency for key clicks*, especially if the transient initial dip is sharp. This tendency is less as the dip is reduced, or as the period of oscillation is increased. Increasing the value of  $C$  accomplishes both of these objectives, so that large  $C$  is an effective preventive of key clicks.

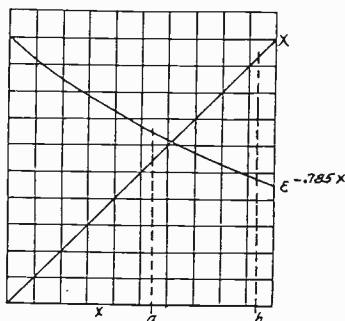

Fig. 3

(4) *Loss of signal power*. Since the first dip exceeds in amplitude any of the succeeding rises or dips, it causes a net loss of power in the transmitted signal.

If (4) is solved for the point of maximum dip, the latter will be found nearly at the first quarter period of oscillation. A relation can be established (equation (5)) between the maximum dip and the circuit constants, for negligibly small  $R$ , by maximum dip  $= x\epsilon^{-0.785x} = 0.30 E_B$  (for the limiting value of dip) where  $x = 1/rCn$ .

It will be noted that this relation for dip in  $E_B$  bears out the qualitative conclusions drawn above; namely, that increasing  $r$  decreases the voltage variation. For a given amplifier, the value of  $r$  is a fixed quantity which cannot be altered without upsetting the amplifier output or efficiency. Therefore it is usually possible for the designer to vary only  $L$  and  $C$  in order to keep the voltage dip down.

The equation for maximum dip is not readily solvable in terms of circuit constants. The relation,

$$x\epsilon^{-0.785x} = \text{some percentage of } E_B,$$

is the product of a straight line and an exponential curve, as indicated in Fig. 3, and a given percentage of  $E_b$  may be had at either of two points such as  $a$  and  $b$ . The lower value, to the left of the intersection, is the useful one.

For convenience in proportioning  $L$  and  $C$ , the product  $x\epsilon^{-0.785x}$  may be plotted for any given percentage of maximum dip. Fig. 4 shows such a group of curves for 20 per cent dip. It should be kept in mind that the damping effect of series  $R$  has been neglected; in other words, the curves are for a source having zero regulation. For any degree of regulation, the curves indicate somewhat higher values of  $C$  and lower values of  $L$  than those which produce a particular variation or dip in voltage.

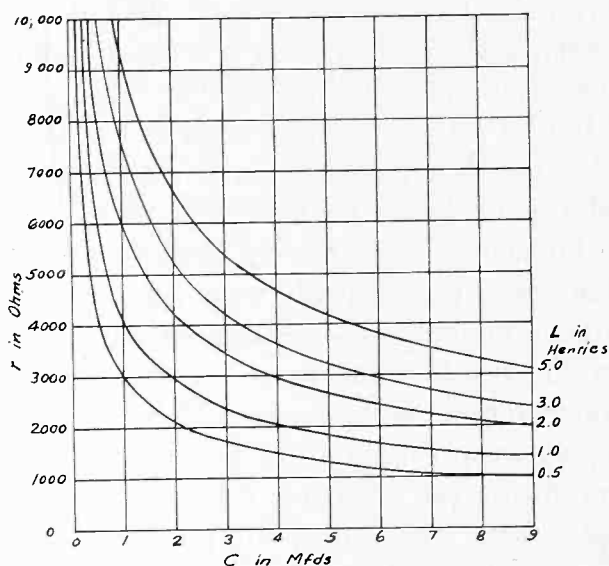

Fig. 4

It is possible, therefore, to predict the amount of transient dip in plate voltage for a given  $L$ ,  $C$ , and  $r$ . It is also possible to select  $L$  and  $C$  for a given  $r$  so that this dip will not exceed a given amount, although this process is more difficult, and the curves will be found helpful as first approximations.

High resistance  $r$  represents less load and a more highly oscillatory circuit. So while the oscillation amplitudes are small in cases where light loads are drawn from the source, the circuit is more oscillatory and the transients that are present persist for a longer time. Conversely attempting to damp these oscillations out is usually not a solution to the problem of removing plate voltage variations.

Instances where the circuit is damped to the nonoscillatory condition by load alone are rare in radio practice. Should they occur,

much larger  $C$  and smaller  $L$  would be required than for the oscillatory case, where  $r$  has higher values. Oscillatory plate supply circuits form the basis for the conclusions of this paper.

Often there is a fixed resistance or "bleeder" across the condenser, to drain off its charge when voltage is removed from the circuit. Another possible method of reducing transient effects consists in decreasing the value of this fixed resistance. The practical limitations of this method often render it of little importance. Where high resistance  $r$  occurs, the transient variations in voltage are of relatively small amplitude, and the effect of fixed  $r$  merely better that which may be already good enough. Where lower values of  $r$  prevail, the fixed  $r$ , in order to be of much effect, would be so low in value as to waste a great deal of power in heat. Economy of power and heat dissipation considerations may forbid the use of such a method, unless the fixed  $r$  is that of some useful device, such as another (unkeyed) amplifier.

The regulation of a power supply such as has just been considered is made up of two distinct components. One is the tendency of the condenser to charge up to the peak value of superimposed ripple while the key is up. This component merely elevates the front of the wave, and changes the first dip practically none when referred to the voltage  $E_B$ . The second component is the series resistance  $R$ , which also results in elevation of the front of the wave. It will be noted from the appendix that the decrement  $m$  increases with increased series  $R$ . In other words, poor plate supply regulation has the beneficial effect of decreasing the amplitude and duration of the transient oscillation. Sometimes efforts have been spent to obtain good regulation that were entirely unjustified in view of this factor.

#### TRANSIENTS OCCURRING WHEN THE KEY IS RELEASED

Thus far, the discussion has been confined to the plate voltage variations caused by pressing the key, assuming conditions were steady in the circuit before the instant of pressing the key. It was shown that the wave under this condition has a perfectly definite shape, determined by the circuit constants.

It is a demonstrable fact that oscillations also arise when the key is released, that these oscillations are usually of greater magnitude and duration than those caused by pressing the key, and that they may influence the latter to a marked extent.

When the key is released, the only damping elements left in the circuit are the series or supply source resistance  $R$ , and the fixed or "bleeder" resistance. These resistances permit the oscillations to reach a higher initial value and to continue for a longer time than the oscilla-

tions caused by pressing the key. The voltage rises initially, as would be expected from sudden cessation of load current. If the key is pressed again before the oscillations have died out, the shape of the next wave is affected. This is illustrated in Fig. 5, which shows the change in  $E_B$  when the key is pressed after steady conditions have prevailed, the

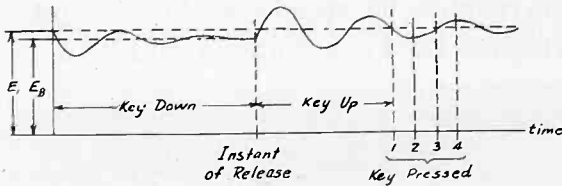

Fig. 5

transient oscillation when the key is released, and four comparative points of this oscillation at which the key may next be pressed: 1, 2, 3, and 4. In Figs. 6(a) and (b) are shown the wave shapes resulting when the key is pressed at instants 2 and 4. In Fig. 6(a), there is a phase shift which gives the appearance of a smaller dip; the dip is practically the same in amount as before, when taken with reference to the full load

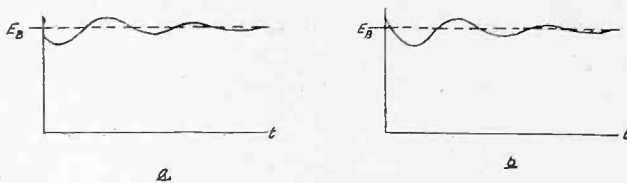

Fig. 6

voltage  $E_B$ . In Fig. 6(b) the oscillation appears to have moved in the opposite direction, and to have acquired a greater amplitude, but compared to  $E_B$ , the dip is about the same as before. If the key is pressed at instant 1, the two oscillations add in phase; that is, the amplitude of the oscillation with the key down is increased. Likewise, pressing the key at instant 3 results in decreased oscillation amplitude.

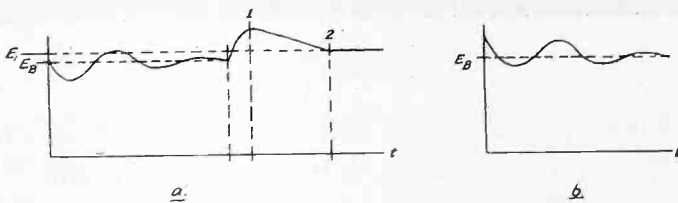

Fig. 7

The amount of plate-voltage variation, or irregularity in the transmitted wave is seen to be dependent to some degree upon the keying speed, unless the speed is so low as to permit the circuit to settle into a steady state during the time between dots.

If the source is a rectifier, the circuit starts to oscillate, but the oscillation becomes a surge having the shape shown in Fig. 7(a).

Transients with the key up produce an oscillatory current through the source but the tendency for current reversal is prevented by the rectifier. The slope of the surge between points 1 and 2 is determined by the time constant  $rC$  of the condenser discharging through the fixed resistance  $r$  (value of  $r$  with key up). At point 2 this slope ceases, and the plate voltage reaches its steady no-load value  $E_1$  again. Pressing the key at any instant between points 1 and 2 results in raising of the

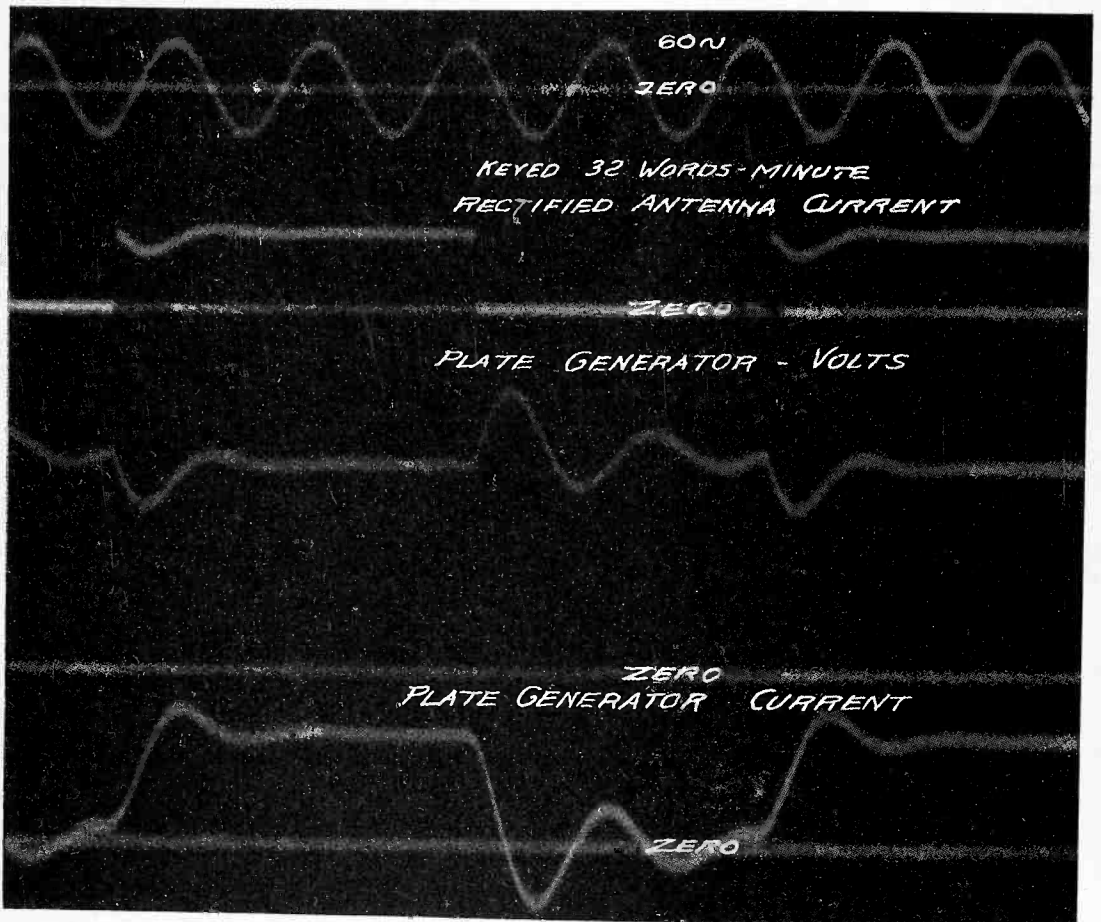

Fig. 8

front of the wave, in less first dip with reference to the steady full-load value  $E_B$ , and in greater "hump" following this dip. The wave shape is shown in Fig. 7(b).

Oscillograms shown in Figs. 8, 9, 10, and 11 bear out these conclusions. Fig. 8 shows a keying rate such that the key is pressed at an instant corresponding to point 4, Fig. 5, and Fig. 9 corresponds to point 2; these oscillograms show approximately the same amount of first dip with respect to the average  $E_B$ . Fig. 10 corresponds to point 3, and the first dip is reduced considerably. These oscillograms were all taken on the same generator plate supply. The general agreement between an-

tenna current and plate voltage wave shape will be noticed. The oscillogram of Fig. 11 was taken on a rectifier, and shows the cessation of rectifier (reactor) current when the peak of the surge is reached. The jagged form of reactor and condenser current represents alternating filter current (not voltage) while load power is being delivered.

As will be shown later, the transient resulting from releasing the key may be superimposed directly upon the dip which occurs when the

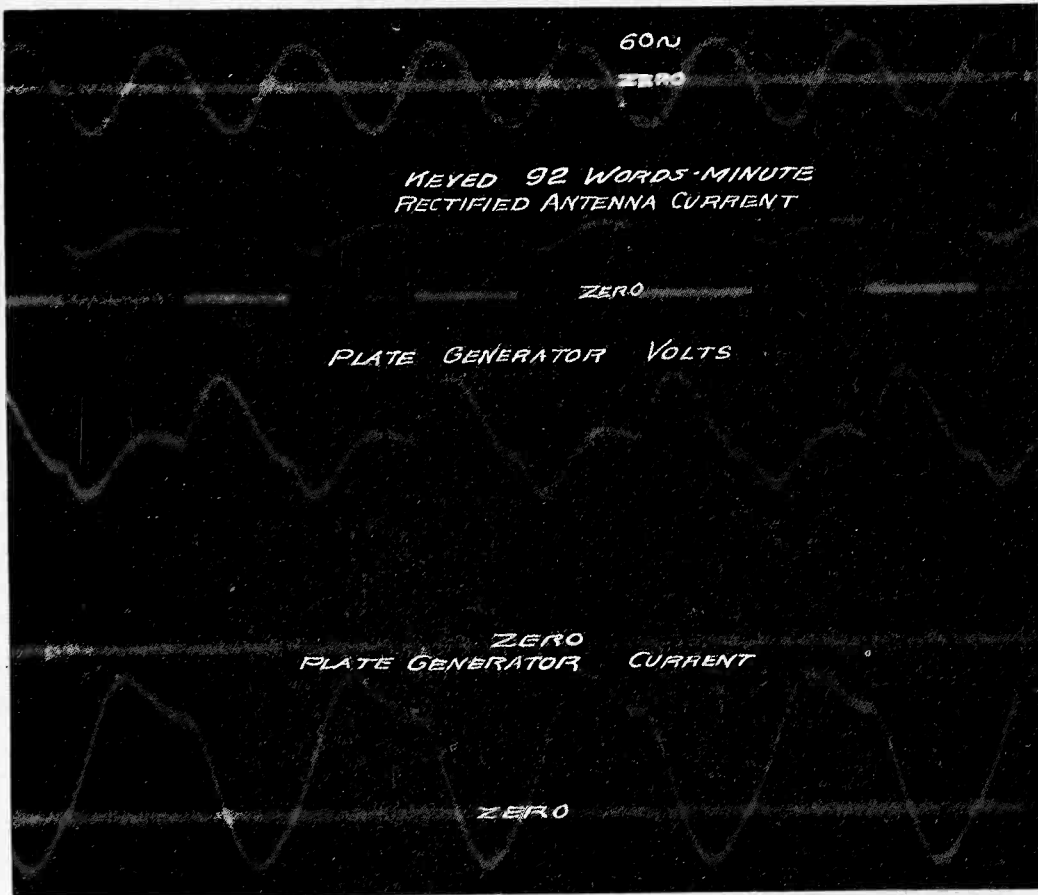

Fig. 9

key is pressed, with close approximation under certain conditions of slow keying speeds.

To illustrate the manner in which the plate-voltage dip is found, the following data applying to Figs. 8, 9, and 10, may be used in connection with equations (5) and (7).

- Plate supply, generator
- Internal inductance, 1.5 henries
- Internal resistance, 96 ohms
- Load resistance, 1920 ohms

Filter capacity, 3 microfarads

Bleeder resistance, 30,000 ohms

$$n = \sqrt{\frac{1}{LC}} = 470 \quad f = 75 \text{ cycles} \quad s = 1, \text{ practically}$$

$$x = \frac{1}{rCn} = \frac{10^6}{1920 \times 3 \times 470} = 0.369$$

$$\frac{R}{Ln} = \frac{96}{1.5 \times 470} = 0.136$$

$x\epsilon^{-0.785(x+R/Ln)} = 0.369\epsilon^{-0.785 \times 0.505} = 0.369 \times 0.670 = 25$  per cent dip at "make."

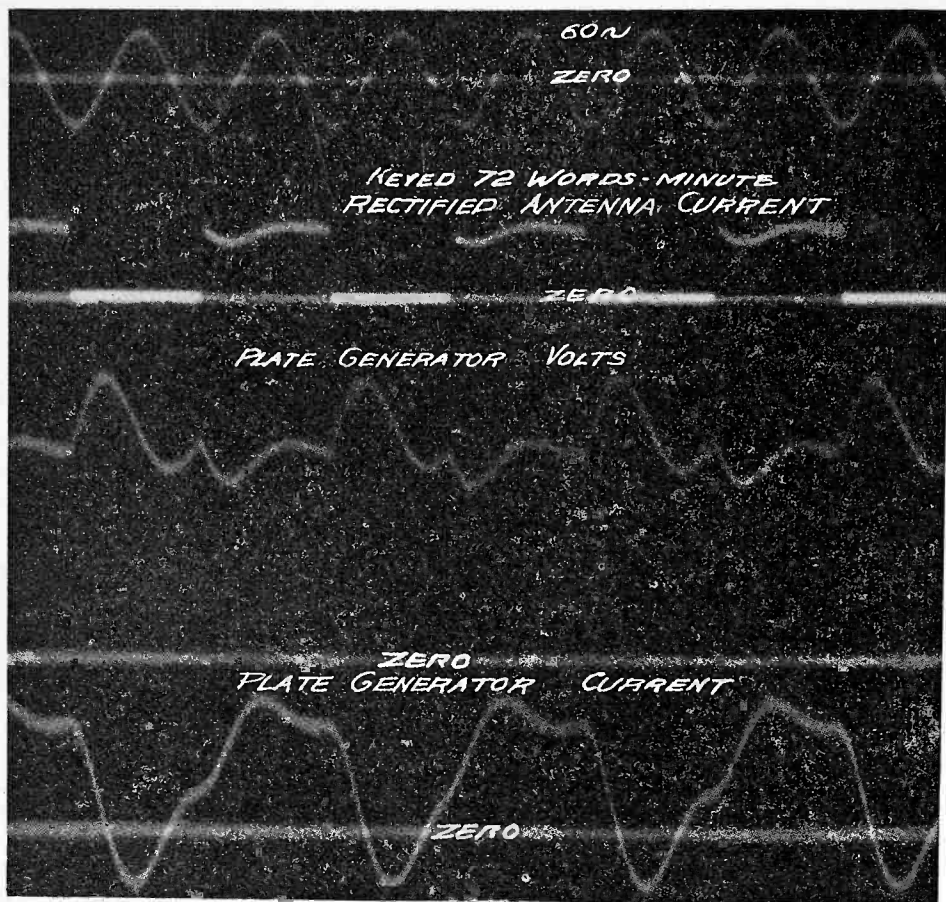

Fig. 10

$$\frac{x}{u} = \frac{0.369 \times 1920}{30,000} = 0.0236$$

$x\epsilon^{-0.785(x/u+R/Ln)} = 0.369\epsilon^{-0.785 \times 0.16} = 0.369 \times 0.88 = 32\frac{1}{2}$  per cent peak at "break."



At 50 words per minute, the space between dots is about 0.025 second. This is in the neighborhood of  $1\frac{1}{2}$  times the natural period, or

$$t = \frac{3\pi}{n} = \frac{9.42}{470} = 0.02 \text{ second} = 7 \text{ times a quarter period.}$$

Hence, the maximum dip resulting from the "break" that the succeeding dot encounters is

$$0.369e^{-7 \times 0.785 \times 0.16} = 0.369 \times 0.412 = 15.2 \text{ per cent.}$$

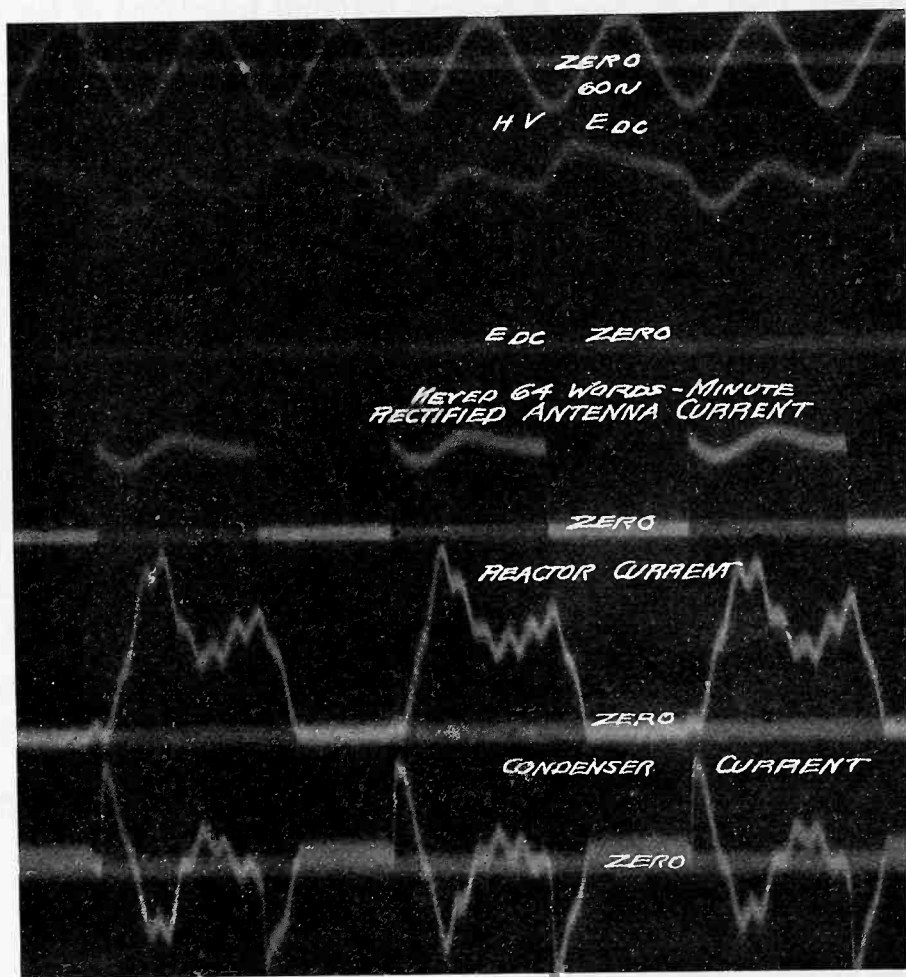

Fig. 11

Adding this to the previous value, we may expect a maximum dip of 40 per cent at 50 words per minute, and if undesirable effects are to be avoided, the transmitter should not be keyed at such a high speed, unless the value of  $C$  is increased. At lower keying speeds, the dip will be 25 per cent, with possible variations as the keying speed is decreased. These variations become less and less pronounced as the keying speed

is lowered. Note that if the keying speed is increased to 75 words per minute, the space between dots is four times a quarter period and a rise in the "break" transient occurs at the first quarter period of the succeeding dot. The value of this rise is

$$0.369\epsilon^{-5 \times 0.785 \times 0.148} = 0.369 \times 0.53 = 19.6 \text{ per cent.}$$

Subtracting this from 25 per cent leaves only 5.4 per cent dip, whereas Fig. 9, at 72 words per minute, indicates about 10 per cent. Adding the two waves directly is apparently not accurate at this keying speed.

The additional correction necessary is found from (8a) of the appendix. The last term requires that  $m_2$  and  $m_1$  be computed.

$$m_2 = -\frac{1}{2Cr_2} - \frac{R}{2L} = -37.5$$

$$m_1 = -\frac{1}{2Cr_1} - \frac{R}{2L} = -118.5$$

Hence,

$$\frac{\epsilon^{m_2 t} - \epsilon^{m_1 t + (m_2 - m_1)t_1}}{2r_1 C(m_2 - m_1)} = \frac{0.53 - \epsilon^{-118.5 \times 0.014 + 81 \times 0.011}}{2 \times 1920 \times 3 \times 10^{-6} \times 81} = 0.064.$$

This added to the 5.4 per cent just calculated brings the total dip to 11.8 per cent, comparing very well with the oscillogram. The other calculations check well with Figs. 8, 9, and 10, and confirm the preceding conclusions.

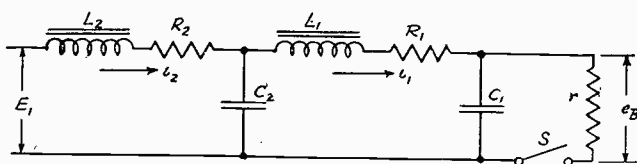

Fig. 12

### TWO-SECTION FILTERS

Often it is desirable, from a filtering standpoint, to use two sections or stages of plate supply filter, each having a series inductance element and a shunt capacity element, such as the circuit of Fig. 12. The keying transients occurring in this circuit are more difficult to predict, because of the increased complexity of the mathematics involved. [See (10) to (14).] Certain interesting facts are revealed by these relations which help in understanding the keying action.

The oscillations incident to keying are composed of two damped sine waves of different frequencies and amplitudes. The higher fre-

frequency component has the smaller amplitude, although it is less quickly damped out. If the two sections are alike ( $L_1 = L_2$ ,  $C_1 = C_2$ ,—the most effective filter) there is a definite ratio between the oscillation frequencies, no matter what their actual values may be. The resultant wave then has a characteristic shape, similar to that shown in Fig. 13. The higher frequency component reduces the initial dip to some extent because of its phase relation at the point of maximum dip.

Curves such as those in Fig. 4 cannot be readily constructed for two-stage filters, and finding the best combination of  $L$  and  $C$  is more a process of cut and try. It is usually possible to make a first approximation which is a great aid to the designer. In a filter having like sec-

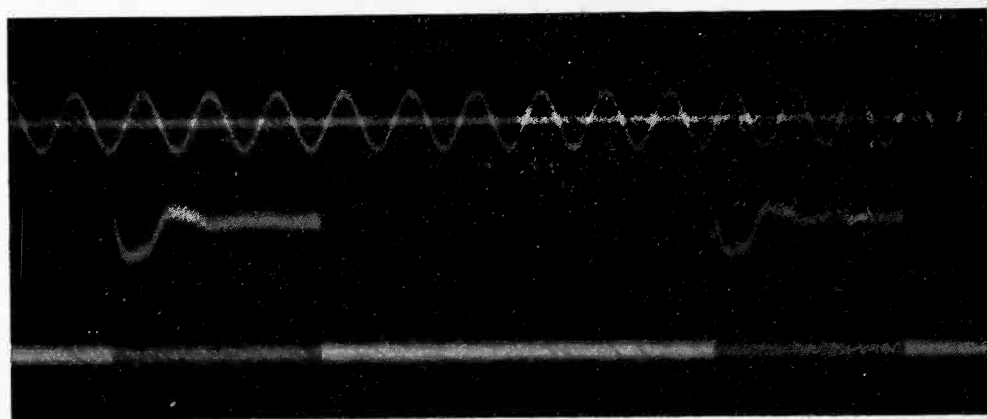

Fig. 13

tions, the small high-frequency component may be neglected for the approximation. The amplitude of the low-frequency wave is then found by (15), which is correct within a few per cent (of  $E_B$ ). This approximation has the advantage of being on the safe side, and further refinement often may be regarded as unnecessary in view of the laborious calculations thus avoided. Fig. 13 is an oscillogram for a plate supply of this type, where  $L_1 = L_2 = 2$  henries,  $C_1 = C_2 = 1$  microfarad,  $R_1 = R_2 = 100$  ohms,  $r = 5000$  ohms. Using (15) yields 33 per cent maximum dip, compared to 27 per cent as shown by Fig. 13.

The small amplitude of the high-frequency component can be attributed to the fact that the section of filter nearest to the plate supply source has less influence on the voltage variation than does the section nearest to the load. If the first section is removed completely, the maximum dip is not affected greatly. Therefore, if  $L_1 > L_2$  or  $C_1 > C_2$ , the approximation of (15) is nearer to the actual value of dip than in the case of like sections.

It will be observed that the same general factors contribute to keep down plate voltage variations as were enumerated for the single-stage filter. Likewise, the transients occurring when the key is released affect succeeding waves, if the keying speed is high enough, in a similar manner.

## APPENDIX

### Mathematical Derivations

#### A. Transients Caused by Pressing the Key

In this appendix  $p = d()/dt$ , the differential operator. Refer to Fig. 14 and denote the general load by  $r$ . Then<sup>1</sup> the current

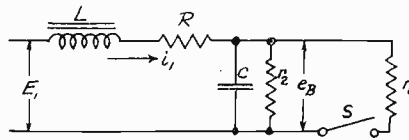

Fig. 14

$$i_1 = \left( Cp + \frac{1}{r} \right) e_B$$

$$E_1 = e_B + Lpi_1 + Ri_1$$

$$= e_B \left[ LCp^2 + \left( \frac{L}{r} + RC \right) p + \frac{R}{r} + 1 \right].$$

This is the relation between  $e_B$  and  $E_1$ . The steady value of  $e_B$  is  $E_B = E_1 r / (r + R)$ . The transient value is found by equating the bracketed portion [ ] to zero. The roots of this equation are

$$a, b = \frac{-\frac{L}{r} - RC \pm \sqrt{\left( \frac{L}{r} + RC \right)^2 - 4LC \left( \frac{R}{r} + 1 \right)}}{2LC}$$

$$= m \pm jn,$$

where,

$$m = -\frac{1}{2Cr} - \frac{R}{2L}$$

and,

$$n = \sqrt{\frac{1}{LC} \left( \frac{R}{r} + 1 \right) - m^2}$$

<sup>1</sup> See John Perry, "Calculus for Engineers," Arnold (London), p. 248.

The complete solution is, for the oscillatory case,

$$e_B = \frac{E_1}{\frac{R}{r} + 1} + \epsilon^{mt}(M \sin nt + N \cos nt). \quad (1)$$

The circuit is nonoscillatory (critically damped) if  $n=0$ , or

$$\left(\frac{L}{r} + RC\right)^2 = 4LC \left(\frac{R}{r} + 1\right),$$

whence,

$$r = \frac{L}{2\sqrt{LC} + RC} = r_n. \quad (2)$$

The constants  $M$  and  $N$  in (1) are evaluated by inserting the initial conditions. Let  $t=0$  when the key is pressed. At this moment,  $\epsilon^{mt}=1$ ,  $\sin nt=0$ ,  $\cos nt=1$ , and  $e_B=E_1$ . Therefore, since  $E_B = E_1 r / (r+R)$

$$E_1 - E_B = N = E_1 \left(\frac{R}{r+R}\right) = yE_1,$$

where,

$$y = \frac{R}{r+R}.$$

Also, when  $t=0$ , the condenser current

$$i_c = Cpe_B = -\frac{E_1}{r_1}, \quad (r_1 = \text{keyed load})$$

$$\begin{aligned} -\frac{E_1}{r} &= C[\epsilon^{mt}(nM \cos nt - nN \sin nt) + m\epsilon^{mt}(M \sin nt + N \cos nt)] \\ &= C[nM + mN]. \end{aligned}$$

Whence,

$$M = -\frac{E_1}{n} \left[ \frac{1}{r_1 C} + my \right]$$

and,

$$e_B = E_B \left[ 1 - \epsilon^{mt} \left\{ \left( \frac{1}{r_1 C n} + \frac{my}{n} \right) \sin nt - y \cos nt \right\} \right]. \quad (3)$$

For maximum dip in  $E_B$ ,  $e_B$  is a minimum, and  $pe_B=0$ , or

$$\frac{1}{r_1 C} \cos nt + \left( ny + \frac{m}{r_1 C n} + \frac{m^2 y}{n} \right) \sin nt = 0.$$

Whence,

$$\tan nt = - \frac{1}{r_1 C \left( ny + \frac{m}{r_1 C n} + \frac{m^2 y}{n} \right)}$$

If  $R=0$ ,  $y=0$ , and  $t = -\frac{\tan^{-1}\left(\frac{-n}{m}\right)}{n}$ . If  $r$  is large,  $\frac{n}{m} = -\frac{2rC}{\sqrt{LC}} = -\frac{r}{r_n}$ . Here  $r_n = \frac{1}{2} \sqrt{\frac{L}{C}}$  = critical damping resistance. Then  $t = \frac{1}{n} \tan^{-1}\left(\frac{r}{r_n}\right) = \frac{1}{n} \cdot \frac{\pi}{2} = \frac{1}{4f}$ , where  $f$  = frequency of natural oscillations. This means that, neglecting  $m$  in the expression for  $n$ , maximum dip occurs at the first quarter cycle of natural oscillation. If  $r > 5r_n$ , this will be accurate to within 2 per cent.

Note in (3) above that the regulation of the load is the coefficient of the cosine term, and this term is of zero value at the first quarter cycle. Hence, for computing maximum dip, we may write

$$e_B = E_1 \left( 1 - \frac{\epsilon^{mt}}{r_1 C n} \cdot \sin nt \right). \quad (4)$$

Put,

$$s = \frac{r_1 r_2}{r_1 + r_2} \text{ and } x = \frac{1}{r_1 C n}.$$

Then at  $t = \pi/2n$ ,  $e_B = E_1 [1 - x \epsilon^{-0.785(x/s + R/Ln)}]$ .

$$\text{If } r_2 = \infty, s = 1 \text{ and } e_B = E_1 (1 - x \epsilon^{-0.785x}). \quad (5)$$

For plotting curves such as Fig. 4, put  $x \epsilon^{-0.785x} = 0.20$  and find  $x$  by trial. Then  $C = x^2 / r_1^2 L$ .

### B. Transients Caused by Releasing the Key

When the key is released,  $r$  becomes  $r_2$ , which is usually very high:

$$e_B = E_1 + \epsilon^{mt} (M \sin nt + N \cos nt).$$

Now  $t=0$  is the instant of releasing the key. When  $t=0$ ,  $e_B = E_1$  and  $N=0$ ; also,  $i_c = C p e_B = E_1 / r_1$ .

Whence,

$$M = \frac{E_1}{r_1 C n}$$

and,

$$e_B = E_1 \left( 1 + \frac{\epsilon^{m t}}{r_1 C n} \sin n t \right). \tag{6}$$

Note  $e_B$  has an initial rise. Here

$$m = -\frac{1}{2Cr_2}; \quad n = \sqrt{\frac{1}{LC} - \frac{1}{(2r_2C)^2}}$$

Let  $u = r_2/r_1$ ; then  $1/r_2 C n = x/u$ , and at  $t = \pi/2n$ ,

$$e_B = E_1 [1 + x \epsilon^{-0.785 x/u}].$$

Note  $u$  affects damping rate only and not the undamped amplitude. Where series  $R$  is present,

$$e_B = E_1 [1 + x \epsilon^{-0.785(x/u + R/Ln)}]. \tag{7}$$

C. Overlapping Transients at "Make"

The action of overlapping transients may be analyzed by an artifice attributable to Bush.<sup>2</sup> Referring to Fig. 15, the circuit is the same as that of Fig. 2(a) with  $R$  omitted for the sake of simplicity. Switch  $S$

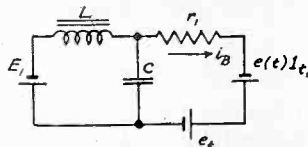

Fig. 15

is replaced by a fictitious voltage  $e(t)$  which has a value, at any instant prior to "make," determined by (6). At the instant of "make," or of pressing the key, an equal and opposite voltage  $e(t)1_{t_1}$  is suddenly inserted as shown. This is equivalent to closing the switch. In the following,  $t_1$  is the instant of "make" and  $t$  is any instant thereafter, both counted from the previous "break."

The indicial admittance of the circuit is

$$A(t) = \frac{LCp^2 + 1}{LCr_1 p^2 + Lp + r_1} \cdot 1 = \frac{1}{r_1} \left( 1 - \frac{\epsilon^{m_1 t}}{r_1 C n} \sin n t \right)$$

and,

$$e(t_1) = E_1 \left( 1 + \frac{\epsilon^{m_2 t_1}}{r_1 C n} \sin n t_1 \right),$$

<sup>2</sup> Vannevar Bush, "Operational Circuit Analysis," p. 314.

where,

$$m_1 = -\frac{1}{2Cr_1}$$

$$m_2 = -\frac{1}{2Cr_2}$$

The superposition theorem gives the plate current at any instant

$$i_B(t) = e(t_1)A(t - t_1) + \int_{t_1}^t A(t - \lambda)e'(\lambda)d\lambda$$

$$= \frac{E_1}{r_1} \left[ 1 + \frac{\epsilon^{m_2 t_1}}{r_1 C n} \sin n t_1 \right] \left[ 1 - \frac{\epsilon^{m_1(t-t_1)}}{r_1 C n} \sin n(t - t_1) \right]$$

$$+ \frac{E_1}{r_1} \int_{t_1}^t \left[ 1 - \frac{\epsilon^{m_1(t-\lambda)}}{r_1 C n} \sin n(t - \lambda) \right]$$

$$\left[ \frac{m_2 \epsilon^{m_2 \lambda}}{r_1 C n} \sin n \lambda + \frac{n \epsilon^{m_2 \lambda}}{r_1 C n} \cos n \lambda \right] d\lambda.$$

Making the substitution  $e_B = i_B r_1$ , and expanding and integrating the right-hand side of this equation yields

$$e_B = E_1 \left[ 1 + \frac{\epsilon^{m_2 t}}{r_1 C n} \sin n t - \frac{\epsilon^{m_1(t-t_1)}}{r_1 C n} \sin n(t - t_1) \right.$$

$$- \frac{\epsilon^{m_1 t + (m_2 - m_1)t}}{2r_1 C n} \{ \cos n(2t_1 - t) - \cos n t \}$$

$$+ \frac{m_2(m_2 - m_1) + 2n^2}{2r_1 C n \{ (m_1 - m_2)^2 + 4n^2 \}} \{ \epsilon^{m_1 t + (m_2 - m_1)t_1} \cos n(2t_1 - t) - \epsilon^{m_2 t} \cos n t \}$$

$$+ \frac{(m_2 + m_1)n}{2r_1 C n \{ (m_1 - m_2)^2 + 4n^2 \}} \{ \epsilon^{m_2 t} \sin n t - \epsilon^{m_1 t + (m_2 - m_1)t_1} \sin n(2t_1 - t) \}$$

$$\left. + \frac{\epsilon^{m_2 t} - \epsilon^{m_1 t + (m_2 - m_1)t_1}}{2r_1 C n(m_2 - m_1)} (m_2 \cos n t - n \sin n t) \right]. \quad (8)$$

The first three terms of this equation will be recognized as the equivalent of adding the transients directly.

The difference between  $\epsilon^{m_1 t + (m_2 - m_1)t_1}$  and  $\epsilon^{m_2 t}$  is small if  $t$  and  $t_1$  are not very different. Also, for points of maximum dip, the sine and cosine



multipliers of these factors cancel, except the sine in the last term. So while (8) is unwieldy for general use, simplifications can be made in most cases which produce the desired results. As an example, take the case of point 1, Fig. 5, where  $t_1 = 3\pi/n$ . The bottom of the next valley occurs at  $t = 7\pi/2n$ , and  $t_1 = 6t/7$

$$\begin{aligned} \sin nt &= -1 & \sin nt_1 &= 0 & \sin n(t - t_1) &= 1 \\ \cos nt &= 0 & \cos nt_1 &= -1 & \cos n(2t_1 - t) &= 0. \end{aligned}$$

Thus,

$$e_B = E_1 \left[ 1 + \frac{\epsilon^{m_2 t}}{r_1 C n} - \frac{\epsilon^{m_1(t-t_1)}}{r_1 C n} + \left\{ \frac{\epsilon^{m_2 t} - \epsilon^{m_1 t + (m_2 - m_1)t_1}}{2r_1 C(m_2 - m_1)} \right\} \right]. \quad (8a)$$

The last term in (8a) accounts for the change in damping of the first transient at  $t_1$ .

In every case the conditions must be carefully examined to see that they agree with those assumed above before the approximation is used.

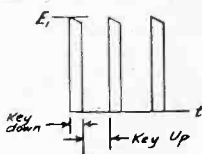

Fig. 16

If the conditions are different from those just outlined, similar reductions and approximations may often be made, in order to reduce the lengthy equation for  $e_B$ . For example, at very high keying speeds, all the exponential terms become nearly unity, with the result that the transient terms are negligibly small, and the keyed waves resemble those shown in Fig. 16.

Cases lying between the two keying speeds just considered may approach one or the other, or they may require different treatment, even to the point of accounting for every term in (8). Most transmitters are subject to a range of keying speeds, and the speed in this range likely to involve a maximum dip in the keyed wave is the point to consider in this connection. Very low keying speeds allow transients to die out before the next closing or opening of the key. Relatively high speed keying introduces an effect which has not been considered here at all; namely, the transient caused by closing the key does not die out before the key is next opened, and thereby influences the dip in the next wave. This effect is usually of minor importance compared to the overlapping which has just been analyzed.

## D. Two-Section Filters

From Fig. 12 may be written,

$$E_1 = (R_2 + L_2p)i_2 + (R_1 + L_1p)i_1 + e_B$$

$$i_1 = e_B \left( C_1p + \frac{1}{r} \right)$$

$$i_2 = i_1 + C_2p[e_B + (R_1 + L_1p)i_1].$$

Combining these yields

$$E_1 = e_B(A_0 + A_1p + A_2p^2 + A_3p^3 + A_4p^4) \quad (9)$$

where,

$$A_0 = \frac{R_1 + R_2}{r} + 1$$

$$A_1 = R_1C_1 + R_2C_2 + R_2C_1 + \frac{R_1R_2C_2}{r} + \frac{L_1 + L_2}{r}$$

$$A_2 = L_1C_1 + L_2C_2 + L_2C_1 + \frac{R_1L_2C_2}{r} + \frac{R_2L_1C_2}{r} + R_1R_2C_1C_2$$

$$A_3 = R_2L_1C_1C_2 + R_1L_2C_1C_2 + \frac{L_1L_2C_2}{r}$$

$$A_4 = L_1L_2C_1C_2.$$

To find  $e_B$  it is first necessary to solve the quartic (9). This may be done for highly oscillatory circuits, such as are used in most transmitter power supplies, by an approximation<sup>3,2</sup> based on the fact that the terms containing decrements ( $A_1$  and  $A_3$ ) play practically no part in determining the frequencies of oscillation. The roots of the quartic equation are

$$a = \alpha_1 + j\beta_1$$

$$b = \alpha_1 - j\beta_1$$

$$c = \alpha_2 + j\beta_2$$

$$d = \alpha_2 - j\beta_2.$$

For the purpose of evaluating the angular velocities  $\beta_1$  and  $\beta_2$ , the decrements  $\alpha_1$  and  $\alpha_2$  may be neglected, and likewise  $A_1$  and  $A_3$  in (9). Hence,

$$-\beta_1^2, -\beta_2^2 = -\frac{A_2}{2A_4} \pm \frac{1}{2} \sqrt{\left(\frac{A_2}{A_4}\right)^2 - \frac{4A_0}{A_4}}. \quad (10)$$

<sup>3</sup> C. P. Steinmetz, "Transient Electrical Phenomena and Oscillations," p. 164. Also see Bush, *loc. cit.*, p. 94.

Equating the quartic to zero,

$$\begin{aligned} f(p) &= (p - a)(p - b)(p - c)(p - d) \\ &= [(p - \alpha_1)^2 + \beta_1^2][(p - \alpha_2)^2 + \beta_2^2] = 0. \end{aligned}$$

Multiplying together the terms  $(p - \alpha_1)^2$  and  $(p - \alpha_2)^2$ , we find that the coefficient of  $p^3$  is  $-2(\alpha_1 + \alpha_2)$ . Also multiplying all terms gives  $-2(\alpha_1\beta_2^2 + \alpha_2\beta_1^2)$  for the coefficient of  $p$ , the higher powers of  $\alpha_1$  and  $\alpha_2$  being discarded. Thus we may write

$$\begin{aligned} -2(\alpha_1 - \alpha_2) &= \frac{A_3}{A_4} \\ -2(\alpha_1\beta_2^2 + \alpha_2\beta_1^2) &= \frac{A_1}{A_4}. \end{aligned}$$

Combining these results in

$$\alpha_1 = -\frac{1}{2} \left( \frac{A_1 - A_3\beta_1^2}{A_2 - 2A_4\beta_1^2} \right) \quad (11)$$

$$\alpha_2 = -\frac{1}{2} \left( \frac{A_1 - A_3\beta_2^2}{A_2 - 2A_4\beta_2^2} \right). \quad (12)$$

Equations (10), (11), and (12) enable us to find the decrements and angular velocities of oscillation. The amplitudes yet remain to be found. The complete solution is

$$\begin{aligned} e_B &= \frac{E_1}{\frac{R_1 + R_2}{r} + 1} + e^{\alpha_1 t} (M_1 \sin \beta_1 t + N_1 \cos \beta_1 t) \\ &\quad + e^{\alpha_2 t} (M_2 \sin \beta_2 t + N_2 \cos \beta_2 t) \end{aligned} \quad (13)$$

where  $M_1$ ,  $M_2$ ,  $N_1$ , and  $N_2$  are determined by the initial conditions:

- (1)  $e_B = E_1$
- (2) Current through  $C_1$  is  $-E_1/r$
- (3) Voltage across  $L_1$  is zero
- (4) Current through  $C_2$  is zero.

The last three conditions may be stated thus:

$$(2) \quad C_1 p e_B = -\frac{E_1}{r}$$

$$(3) \quad L_1 p \left( C_1 p e_B + \frac{e_B}{r} \right) = L_1 C_1 p^2 e_B + \frac{L_1}{r} p e_B = 0$$

$$(4) \quad C_2 p(L_1 p i_1 + e_B) = L_1 C_1 C_2 p^3 e_B + \frac{L_1 C_2}{r} p^2 e_B + C_2 p e_B = 0.$$

Now at  $t=0$ ,  $e_B = E_B + N_1 + N_2$

$$p e_B = \alpha_1 N_1 + \beta_1 M_1 + \alpha_2 N_2 + \beta_2 M_2$$

$$p^2 e_B = (\alpha_1^2 - \beta_1^2) N_1 + 2\alpha_1 \beta_1 M_1 + (\alpha_2^2 - \beta_2^2) N_2 + 2\alpha_2 \beta_2 M_2$$

$$p^3 e_B = (\alpha_1^3 - 3\alpha_1 \beta_1^2) N_1 + (3\alpha_1^2 \beta_1 - \beta_1^3) M_1 \\ + (\alpha_2^3 - 3\alpha_2 \beta_2^2) N_2 + (3\alpha_2^2 \beta_2 - \beta_2^3) M_2.$$

These relations inserted in the initial conditions (1) to (4) provide four simultaneous equations in  $M_1$ ,  $M_2$ ,  $N_1$ , and  $N_2$  from which these coefficients can be evaluated. The squares and cubes of  $\alpha_1$  and  $\alpha_2$  may be neglected to lessen the work of finding the coefficients.

Hence,

$$\left. \begin{aligned} N_1 + N_2 &= E_1 - E_B \\ \beta_1 M_1 + \beta_2 M_2 + \alpha_1 N_1 + \alpha_2 N_2 &= -\frac{E_1}{r C_1} \\ 2\alpha_1 \beta_1 M_1 + 2\alpha_2 \beta_2 M_2 - \beta_1^2 N_1 - \beta_2^2 N_2 &= \frac{E_1}{r^2 C_1^2} \\ \beta_1^3 M_1 + \beta_2^3 M_2 + 3\alpha_1 \beta_1^2 N_1 + 3\alpha_2 \beta_2^2 N_2 &= \frac{E_1}{L_1 r C_1^2} - \frac{E_1}{r^3 C_1^3} \end{aligned} \right\} \quad (14)$$

Besides being lengthy for practical purposes, these equations require unusually accurate calculations in order to give reasonable results. A useful and rapid approximation is had by neglecting the high-frequency oscillation, or putting  $M_2 = N_2 = 0$ . Also  $N_1 = 0$  at the first quarter period. By the second equation of (14) therefore,

$$M_1 = -\frac{E_1}{r C_1 \beta_1}. \quad (15)$$

In the case of like sections, further simplification is possible. If  $R_1$  and  $R_2$  are negligible,

$$A_0 = 1$$

$$A_2 = 3L_1 C_1$$

$$A_4 = L_1^2 C_1^2.$$

Whence,

$$\beta_2, \beta_1 = \sqrt{\frac{3 \pm \sqrt{5}}{2L_1C_1}}, \text{ or } \frac{f_1}{f_2} = \frac{1}{2.61}.$$

Also,

$$\alpha_1 = -\frac{1}{4C_1r} \left( \frac{1 + \sqrt{5}}{\sqrt{5}} \right) = -\frac{0.362}{C_1r}$$

$$\alpha_2 = -\frac{1}{4C_1r} \left( \frac{\sqrt{5} - 1}{\sqrt{5}} \right) = -\frac{0.138}{C_1r}.$$

So that,

$$\frac{\alpha_1}{\alpha_2} = 2.61.$$



## NOTE ON A MULTIFREQUENCY AUTOMATIC RECORDER OF IONOSPHERE HEIGHTS\*

BY

T. R. GILLILAND

(Bureau of Standards, Washington, D.C.)

*Summary*—A system is described which gives a curve of virtual heights of the layers of the ionosphere against frequency. The pulse method of Breit and Tuve is employed with modifications. Short pulses of radio-frequency energy are transmitted, and the time required for the energy to go up and return is recorded automatically by a galvanometer oscillograph of the type previously used for fixed frequency work. The transmitting and receiving sets are shifted in frequency from 2500 to 4400 kilocycles at the uniform rate of 200 kilocycles per minute.

Records are presented which show the characteristics for different times of day and night. In the daytime, during the period of these tests, three strata were usually indicated. For the lower range of frequencies, reflections come from the E layer with a virtual height of around 120 kilometers. As frequency is increased the waves pass through the E layer and are returned from the  $F_1$  layer with virtual heights of the order of 200 kilometers. The frequency for which this transition takes place varies with time of day and with season. In the middle of the day, during these tests, this critical frequency was in the neighborhood of 3000 kilocycles, while the critical frequency for passing through the  $F_1$  to the  $F_2$  layer was usually between 3800 and 4100 kilocycles. The  $F_2$  layer shows virtual heights of 280 kilometers or more. Of particular interest is the character of the change observed when passing from one stratum to another as the frequency is increased. Although, at times, when passing from E to  $F_1$  reflections may drop out completely for a short interval, frequently the curve is continuous and the time retardation will reach a high value just before the appearance of the  $F_1$  reflection. When passing from  $F_1$  to  $F_2$  the virtual height frequently reaches 800 or 900 kilometers. As evening approaches reflections no longer come from the E layer for these frequencies (2500 to 4400 kilocycles) and the long retardation between  $F_1$  and  $F_2$  becomes less pronounced. By sunset the curve is almost straight and there is little change of height with frequency. Later at night the highest frequencies cease to be returned and long retardations again occur. The phenomenon of double refraction is in evidence at this time.

The system described here offers a more convenient method than the manual methods previously employed, and greater economy is obtained in both time and personnel. It is possible to obtain records with much greater detail.

The results are presented with the idea of indicating the value of this method in the study of the physical properties of the upper atmosphere as well as in the study of radio transmission.

\* Decimal classification: R365.3 × R113.61. Original manuscript received by the Institute, August 31, 1933. Publication approved by the Director of the Bureau of Standards of the U. S. Department of Commerce. Presented in part at meeting of American Section, International Scientific Radio Union, at Washington, April 27, 1933. Presented at Eighth Annual Convention, Institute of Radio Engineers, Chicago, Illinois, June 27, 1933. Published in *Bureau of Standards Journal of Research*, October, (1933).

## I. INTRODUCTION

THE purpose of this note is to describe a system for automatically recording the virtual heights of the ionized layers of the upper atmosphere for a given band of radio frequencies and to show the type of record obtained. The system utilizes the pulse method of Breit and Tuve<sup>1</sup> with modifications which permit automatic recording and the shifting of the transmitting and receiving sets continuously over a desired band of frequencies.

Observers in previous work have recorded virtual heights manually where information was desired for more than one frequency. The frequency was varied by steps and readings of virtual height were made for each step. The disadvantages of this method are that it requires considerable time and labor and, since changes in the ionosphere are often quite rapid, important details are likely to be missed. Critical effects are often observed for very small changes in frequency so that a system that will give a continuous and rapid frequency variation is desirable.

The importance of the ionosphere in radio transmission has led to an intensive study of its characteristics both in this country and abroad. An investigation which gives fundamental information about its physical properties is of value in the general study of the atmosphere as well as in its application to radio transmission. The system originated by Breit and Tuve for making these studies consists of a radio transmitter, receiving set, and galvanometer oscillograph with photographic attachment. The transmitter is made to send out short pulses which arrive at the receiving set via the ionosphere as well as by a path along the ground. By passing the output of the receiving set through the oscillograph, a photographic record is made which gives a measure of the time required for the pulse to go up and back. This time interval is used to calculate the "virtual" height.

This method has been modified for automatic recording on a fixed frequency.<sup>2,3</sup> This is done by keying the pulses at the transmitter with a chopper driven by a synchronous motor. At the receiving station the oscillograph is provided with a revolving mirror also driven by a synchronous motor connected to the same power system. With this arrangement the pulse pattern is projected on to the oscillograph screen so that the ground-wave pulse remains stationary while the sky-wave

<sup>1</sup> Breit and Tuve, *Phys. Rev.*, vol. 28, p. 554, (1926); *Proc. I.R.E.*, vol. 16, p. 1236; September, (1928).

<sup>2</sup> Gilliland and Kenrick, *Bureau of Standards Journal of Research*, vol. 7, p. 783, November, (1931); *Proc. I.R.E.*, vol. 20, p. 540; March, (1932).

<sup>3</sup> Gilliland, *Bureau of Standards Journal of Research*, vol. 11 p. 141; July, (1933); *Proc. I.R.E.*, vol. 21, p. 1463; October, (1933).

pulses shift with respect to it as the virtual height of the ionosphere changes. In order to make a record of the changes taking place, photographic paper is passed over the pulse pattern in a direction parallel to the axis of the revolving mirror. The pattern is masked so that the paper is exposed to only the top portion of the pulses. The usual cylindrical lens of the oscillograph optical system is replaced by a spherical lens so that the light from the top part of the pulse is focused into a small spot on the paper. As the paper moves the ground pulse will

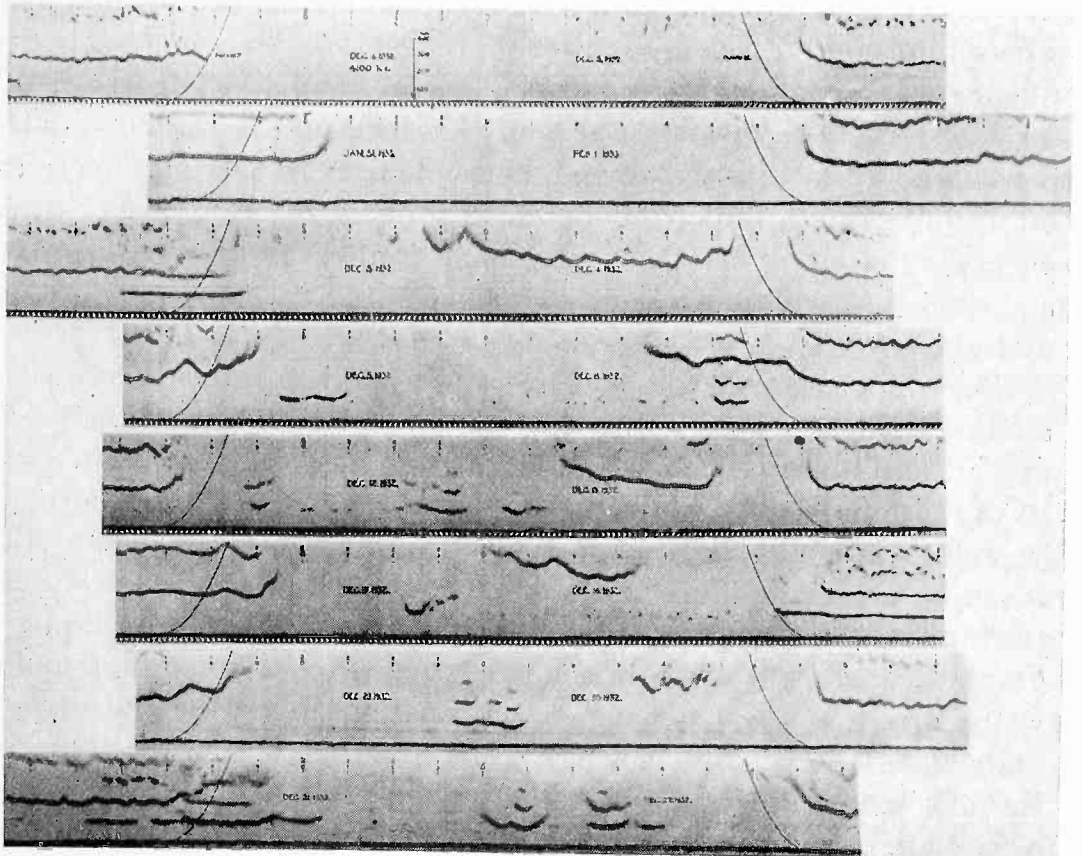

Fig. 1—Photograph showing type of record obtained on a fixed frequency of 4100 kilocycles. The first two records show almost no reflections at night. Third to seventh records inclusive show night reflections from both the E and F layers. The last record shows reflections from only the E layer at night.

trace a straight line since its path length is fixed. As the ionosphere shifts in virtual height, the time required for the other pulses to return will change and traces will be made which vary in distance from the ground trace. This distance gives a direct measure of the virtual height. In the present arrangement, the transmitting and receiving sets are placed in the same room and the chopper wheel and revolving mirror are attached to the same shaft. The placing of the complete equipment in one room adds greatly to the simplicity of operation, especially



with the multifrequency system. Troubles from phase shifts in the power system are eliminated.

Fig. 1 shows the type of record obtained on eight different days for a fixed frequency of 4100 kilocycles. Here reflections are shown from both the E and the F layers. During the daytime on these days reflections came more often from the F layer showing virtual heights of 240 kilometers and higher. Reflections from the E region at about 100 to 130 kilometers are shown to occur at irregular intervals.<sup>3</sup>

## II. DESCRIPTION OF MULTIFREQUENCY SYSTEM

The recorder for the multifrequency system is the same as that used for fixed frequency work. The receiving set is also the same except that a mechanism is introduced for tuning over the desired range of frequencies. A superheterodyne circuit is employed with a broad-

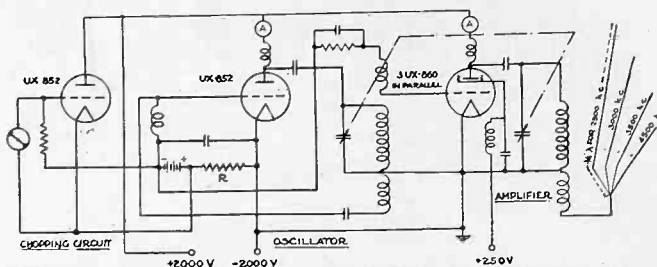

Fig. 2—Circuit arrangement of transmitter. With the chopper contacts open the oscillator grid is biased below the oscillation condition by the C battery. When the contacts are closed, current flows in the plate circuit of the chopping tube which includes resistance  $R$ . Current through  $R$  brings the oscillator grid up to the oscillation point and at the same time causes the bias on the amplifier grids to assume the proper operating value.

cast receiving set and high-frequency converter. The galvanometer oscillograph is connected in series with the moving coil of the loud speaker. The circuit arrangement of the transmitter is shown in Fig. 2. The oscillator circuit using one type UX-852 tube is followed by a single amplifier stage using three type UX-860 tubes in parallel. One UX-852 is employed as a chopping tube to avoid sparking at the chopper contacts which occurs when the oscillator is chopped directly. With the chopper contacts open the oscillator grid is biased below the oscillation condition by the C battery. When the contacts are closed current flows in the plate circuit of the chopping tube which includes resistance  $R$ . The current through  $R$  brings the oscillator grid up to the oscillation point and at the same time causes the bias on the amplifier grids to assume the proper operating value. The chopper is geared so that about 10 pulses per second are transmitted. The rotors of the oscillator and amplifier tuning condensers are attached to the same shaft.

The antenna system of the transmitter consisted of inverted L antennas of  $3/4$  wavelength for 2500, 3000, 3500, and 4500 kilocycles, all connected permanently together at the base. The receiving antenna was a single inverted L of  $3/4$  wavelength for about 4000 kilocycles.

The mechanical arrangement is shown schematically in Fig. 3. The transmitter tuning condensers are actuated by one cam while the receiving set condensers are actuated by another. Both cams are attached to a single shaft driven by a synchronous motor through a reduction gear. The cam lever of the transmitter is geared to the condenser shaft by spur gears with a step-up ratio of 4 to 1 so that the rotors turn through 180 degrees while the cam lever moves through 45 degrees. The rotors of the oscillator and detector tuning condensers of the re-

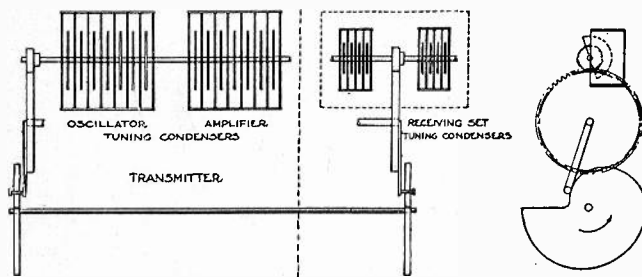

Fig. 3—Schematic diagram of mechanical arrangement. Transmitter condensers are actuated by one cam and receiving set condensers are actuated by another. Both cams are attached to a single shaft and are driven by a synchronous motor through a reduction gear.

ceiving set are also attached to a single shaft. For the desired range of frequencies these rotors turn through more than 180 degrees so that a slightly higher gear ratio is used.

It was found that one set of coils of the receiving set could be worked conveniently between 2500 and 4400 kilocycles without modification and since this is an interesting range for daytime work, the transmitter was designed to cover this range. The cam shapes were determined after the mechanism had been assembled. The transmitter cam shape was determined by changing the transmitter frequency in small steps. The distance from the cam roll to the center of the cam shaft was measured for each step with a caliper. Having chosen 200 kilocycles per minute as the rate of change of frequency, the angular position of the cam was known for each small step. With the radius known for each angular position it was then possible to lay out this cam. In order to lay out the other cam, the receiving set was tuned to the transmitter as the frequency was varied in small steps and the distance from the cam roll to the center of the cam shaft was measured for each step. With these measurements and the known rate of

rotation, this cam could be laid out. The cam was cut slightly large and then filed down to size after being installed. The tuning of the receiving set to transmitter frequency for each small step can be done conveniently while the transmitter is being pulsed. It was found advisable to keep the receiving set at low gain while tuning so that only the direct pulse was visible on the oscillograph screen. If tuning is done at high gain with reference to the sky wave pulses, inaccurate settings may be obtained at critical frequencies.

The system is adapted for sweeping automatically through the band either once each hour or each half hour. If switching is done manually

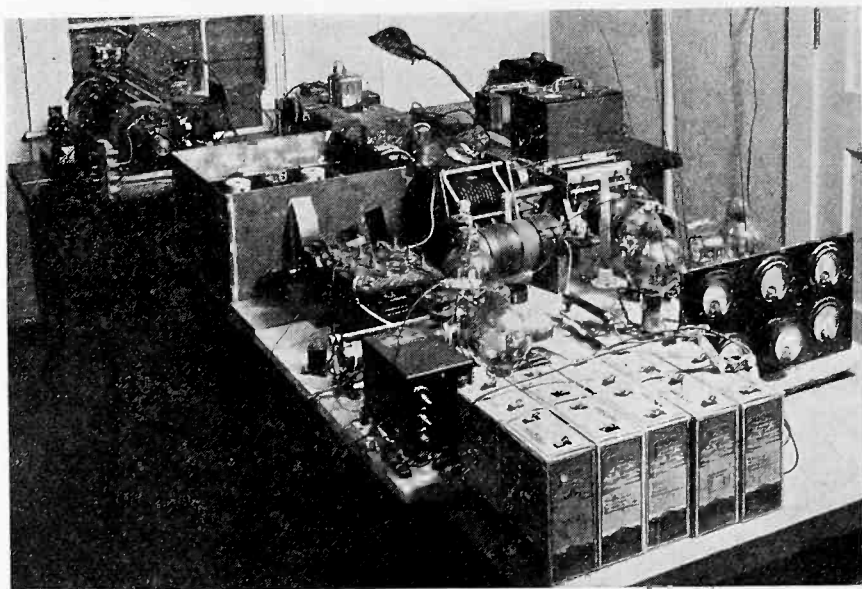

Fig. 4—Photograph showing preliminary arrangement. Transmitter in foreground, receiving set converter in box with cover removed, recorder in background at left.

at the end of each run, it is possible to sweep through the band almost six times per hour.

Fig. 4 is a photograph of the preliminary arrangement of the transmitter, receiving set, and recorder.

### III. RESULTS

The type of record obtained in the daytime is shown in Fig. 5. Here the notation followed is that adopted by Kirby, Berkner, and Stuart in a paper now in preparation. The single and double prime letters indicate extraordinary and ordinary rays, respectively, in accordance with the notation of Appleton and Builder.<sup>4</sup> Fig. 5 shows the changes in virtual height as the frequency is changed uniformly

<sup>4</sup> Appleton and Builder, *Proc. Phys. Soc.*, vol. 45, part 2, p. 208, (1933).

from 2500 to 4400 kilocycles at the rate of 200 kilocycles per minute. E layer reflections are noted at the left coming from a virtual height of about 135 kilometers for 2500 kilocycles. The virtual height increases gradually as the frequency is increased to about 2850 kilocycles. This is the critical frequency  $f_E$  for the E layer, and long retardations occur. As frequency is increased above this point, the virtual height drops rapidly to the level of the  $F_1$  layer. At about 3200 kilocycles, the virtual height reaches a minimum of 210 kilometers for the  $F_1$  layer. As frequency is increased the virtual height of the  $F_1$  layer for the ordinary ray ( $F_1''$ ) increases until another critical value

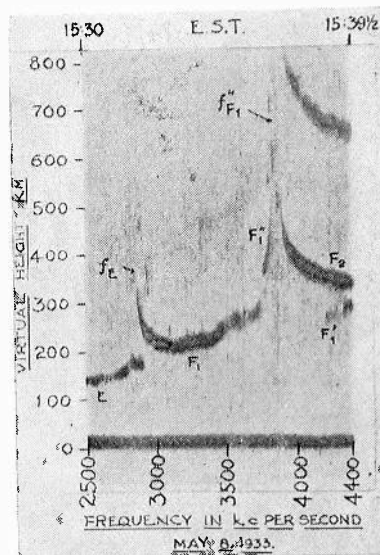

Fig. 5—Photograph showing type of record obtained in daytime.  $f_E$  denotes critical frequency for E layer.  $f''_{F_1}$  denotes critical frequency for ordinary ray in  $F_1$  layer.

$f''_{F_1}$  is reached at about 3850 kilocycles and the virtual height reaches 700 kilometers. This critical frequency is thought to be that for the ordinary ray as it passes through the  $F_1$  layer. As frequency is increased still farther, reflections for this ray come from the  $F_2$  region showing virtual heights of about 330 kilometers. The trace at the right marked  $F_1''$  is thought to be the extraordinary ray for the  $F_1$  layer. It is usually relatively weak and frequently does not appear at all. From observations on higher frequencies, Kirby, Berkner, and Stuart have noted that this ray becomes critical at a frequency approximately 800 kilocycles higher than for the ordinary ray during the daytime. It is likely that the critical frequency  $f_E$  noted for the E layer is for the ordinary ray and that the extraordinary ray is absorbed. The trace in the upper right-hand corner is a multiple of the  $F_2$  trace indicating that the pulse energy has gone up to the  $F_2$  layer and back twice. As evening ap-

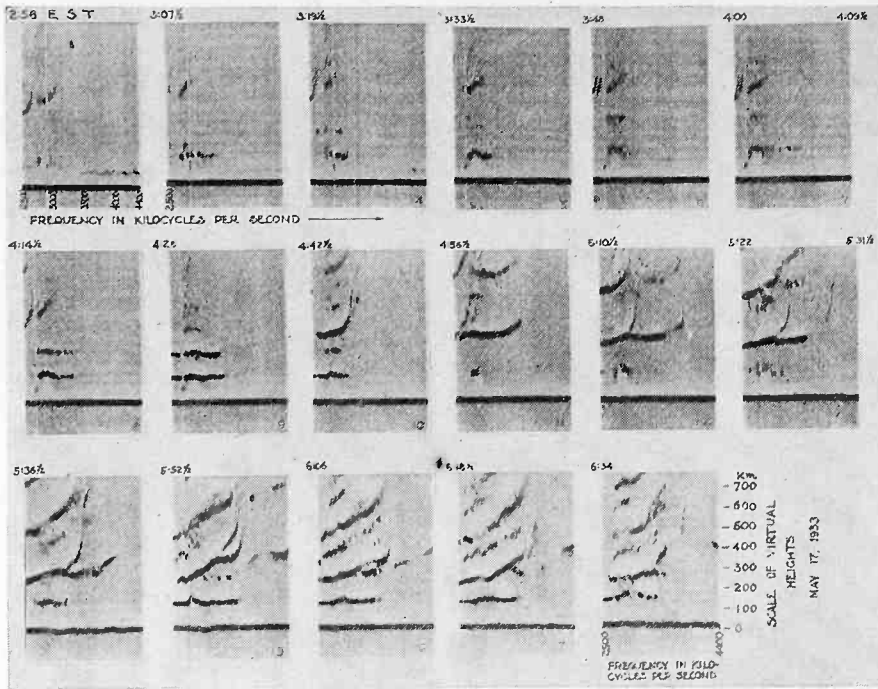

Fig. 6—Records of May 17. Each short section represents a frequency band from 2500 to 4400 kilocycles and requires 9 1/2 minutes. Last two records in second row show critical effects for ordinary and extraordinary rays.

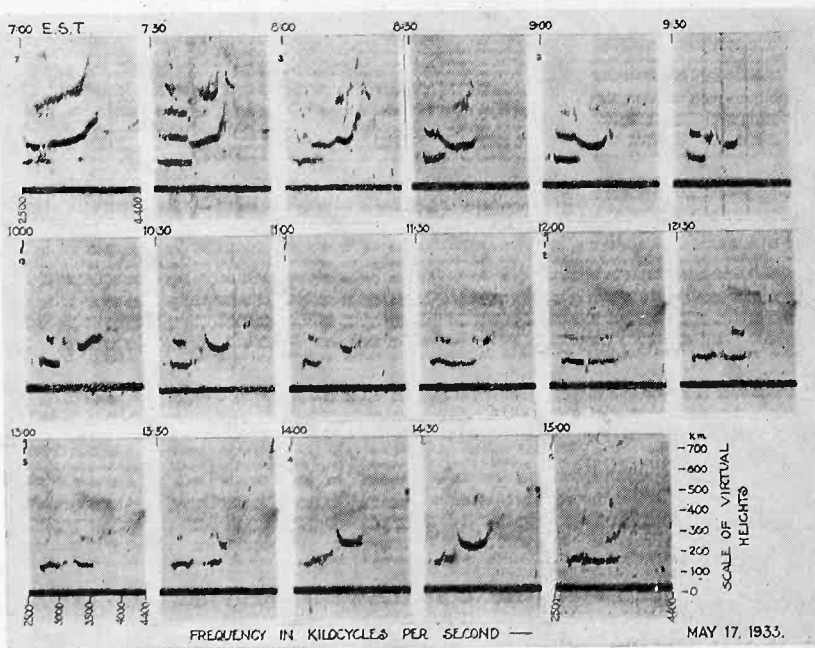

Fig. 7—Records for May 17 (continued).  $F_1$  reflections were very weak during this day.

proaches the stratification indicated in the F region disappears and it appears to become a single layer.

Figs. 6, 7, and 8 show records taken over a period of about 21 hours. Each short section of record represents the frequency band of 2500 to 4400 kilocycles and requires 9 1/2 minutes. In Fig. 6, weak reflections are recorded for both the E and the F regions until about 0415 when strong E reflections appear. By 0456, the E reflections have practically

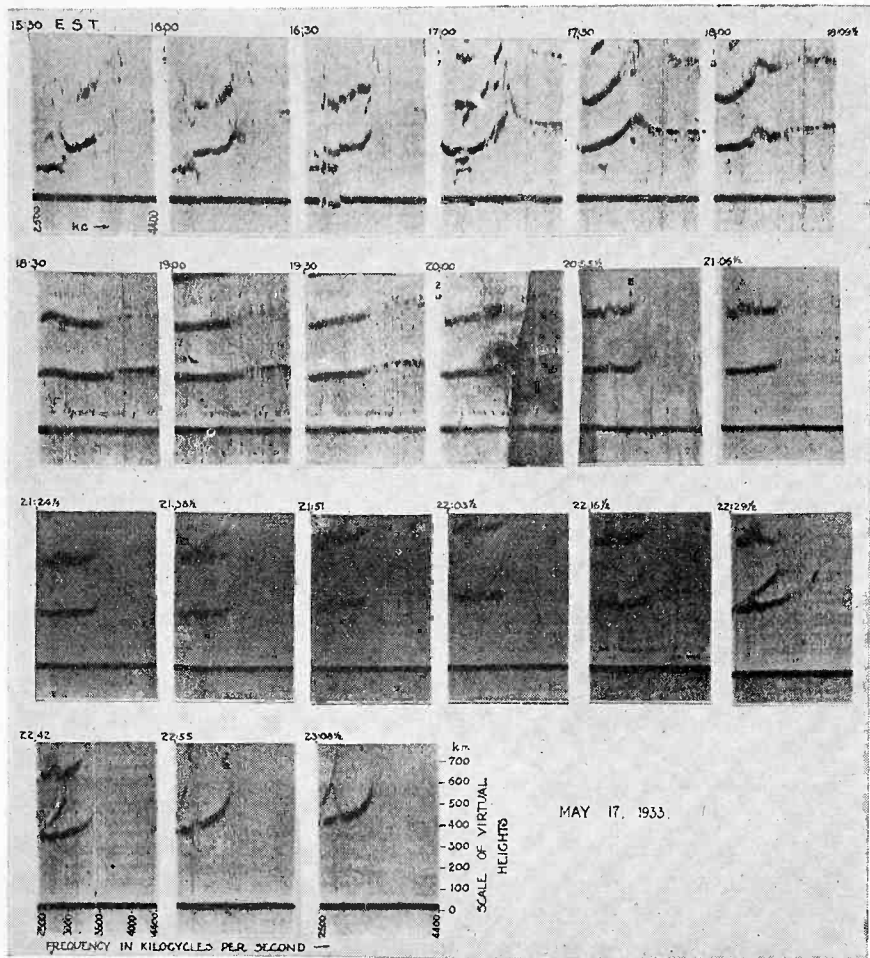

Fig. 8—Records for May 17 (continued). Note appearance of  $F_1$  stratification at 1700 which disappears later in evening. The ordinary and extraordinary rays become critical in this band again before midnight.

disappeared and strong F reflections are recorded. The records beginning at 0510 1/2 and 0522 show the critical effects for the two rays. It has been suggested that the frequency separation between these two rays, when critical, should under certain conditions give a measure of the strength of the earth's magnetic field at the layer.<sup>5</sup> Results during the remainder of the morning and the early afternoon should

<sup>5</sup> A theoretical discussion of this point is now in preparation by K. A. Norton.

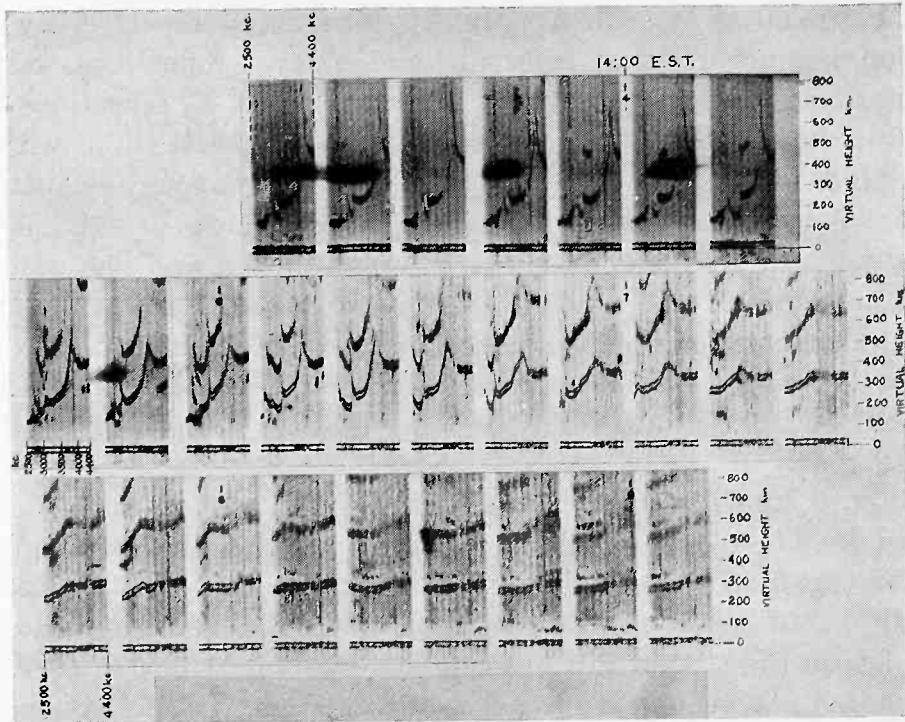

Fig. 9—Photograph of records taken during afternoon and evening of April 22. Note double critical effect between E and F<sub>1</sub> layer in first row.

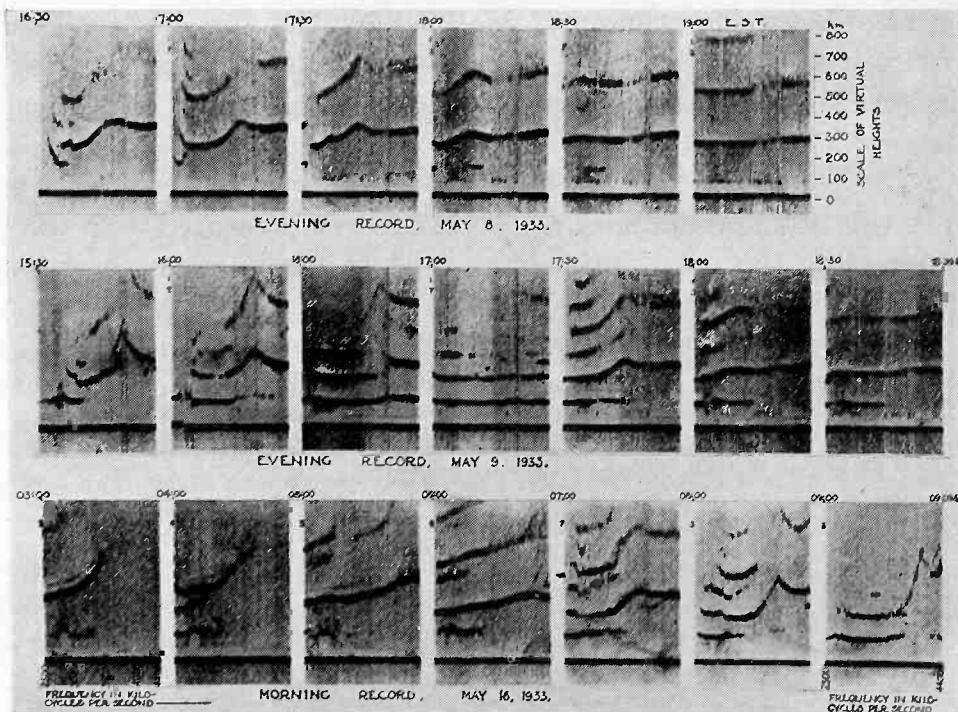

Fig. 10—Records showing changes during two evening runs and one morning run. Records for morning of May 16 show beginning of F<sub>1</sub> stratification.

not be taken as typical. Apparently abnormally strong E layer ionization was occurring at intervals, and F layer reflections were very weak at the higher frequencies. The absence of F<sub>1</sub> reflections during the middle of the day was checked by manual observations with other equipment. By 1700 (Fig. 8) the E critical frequency is just below 2500 kilocycles and F region stratification is now in evidence. The stratification gradually becomes less pronounced and has practically disappeared by 1830, which is 48 minutes before sunset at the ground. Critical effects for the two rays appear before midnight. The failure to record reflections between 3500 and 4000 kilocycles at times is caused by interference from the large number of amateur stations in this band.

Fig. 9 shows records taken during the afternoon and evening of April 22. The records in the first row show a double critical effect between the usual E and F<sub>1</sub> layers, indicating another stratum, making a total of four strata at this particular time. The changes indicated at the left in the second row are complex and very sharp critical effects are noted. As evening approaches the E layer critical frequency goes below 2500 kilocycles and the F region stratification gradually disappears.

Fig. 10 shows records taken during two evenings and one morning. The records for the evening of May 9 show the appearance of strong E reflections which obscure F reflections for a time. The morning records for May 16 show the beginning of the F region stratification.

#### IV. CONCLUSION

In this note, preliminary results have been presented with the view of indicating the possibilities offered by this method in the study of radio transmission and physical properties of the upper atmosphere. It is believed that records of the type shown give a more complete picture than it has been possible to obtain by methods previously used. It is hoped that it will be possible to continue these observations and to cover a wider band of frequencies.





## RADIO OBSERVATIONS OF THE BUREAU OF STANDARDS DURING THE SOLAR ECLIPSE OF AUGUST 31, 1932\*

BY

S. S. KIRBY, L. V. BERKNER, T. R. GILLILAND, AND K. A. NORTON

(Bureau of Standards, Washington, D. C.)

*Summary*—Radio observations of the heights of the several layers of the ionosphere were made at Washington, D. C., and Sydney, Nova Scotia, by the pulse method during the afternoon of the solar eclipse of August 31, 1932, and during the afternoons of several days preceding and following. At Washington three separate groups of determinations were made: (1) Measurements of the maximum ionization of the E layer during the afternoon; (2) continual series of measurements of virtual height during the afternoon at 4200 kilocycles which was ordinarily just above the  $F_1$  critical frequency for the ordinary ray; (3) measurements of the critical frequency of the  $F_2$  layer during the afternoon. At Sydney, determinations similar to (1) were made and continuous records of virtual height were obtained at 2400 and 3000 kilocycles. Separate equipment was used for each of these groups of determinations so that measurements could be made rapidly and continuously.

It was found that the ionization of the E layer decreased to about 30 per cent of its normal value at the time of the eclipse maximum, the variation taking place approximately in phase with the eclipse. The ionization of the  $F_1$  layer likewise decreased in almost exactly the same manner, reaching a value of about 40 per cent of its normal ionization at about the eclipse maximum. When analyzed by the method presented in this paper, observations of other investigators are found to agree well with these results. No unusual change was evident in the  $F_2$  critical frequency during the eclipse. No evidence of a corpuscular eclipse was found at either Washington or Sydney.

### I. INTRODUCTION

VARIOUS investigators have suggested that ultra-violet radiation from the sun is responsible for part, if not all, of the ionization in the upper atmosphere. However, the fact that more layers than one are present indicates the possibility that the source of the ionization of one layer may be different from that of the others. Some investigators believe that the ionization in the upper region is so great that most of the ultra-violet radiation is absorbed and that some other agency may be required to explain the ionization of the lower layers. It has been suggested by Professor Chapman<sup>1,2</sup> in England that

\* Decimal classification: R113.55. Original manuscript received by the Institute, October 23, 1933. Publication approved by the Director of the Bureau of Standards of the U. S. Department of Commerce. Published in *B.S.J.R.*, vol. 11, p. 829; December, (1933).

<sup>1</sup> Chapman, *Monthly Notices of R.A.S.*, March, (1932).

<sup>2</sup> Appleton and Chapman, *Nature* (London), May 21, (1932).

the lower region of ionization is caused by neutral corpuscles shot out from the sun. It has been shown that such corpuscles are likely to be emitted by radiation-pressure acting upon atoms and that a velocity of about 1600 kilometers per second away from the sun may be attained. At present there is no observational proof that such particles are present but if they exist and are responsible for any appreciable part of the ionization in the upper atmosphere, an eclipse of the sun should offer an opportunity to show just how important this agent is.

If ultra-violet radiation and particle bombardment were both important, we might expect the effect of one to be cut off before the other because of their different velocities, and changes during the eclipse to be much more abrupt and clear-cut than the changes noted from day to night. Calculations indicate that the particle eclipse should occur approximately two hours before the light eclipse. According to Chapman's calculations on the basis of a particle velocity of 1600 kilometers per second the corpuscular eclipse track would lie to the east of the optical eclipse track, and should be observed in northeastern North America.

In order to study this effect, observations were made in Washington, D. C., and Sydney, Nova Scotia, the latter lying within the area of the suggested corpuscular eclipse. As Washington was to the west and Sydney to the east of the optical eclipse, and both points were subject to approximately 90 per cent optical totality, the magnitude of changes at the two places due solely to ionizing sources traveling from the sun at the velocity of light should be of the same order.

An expedition comprising Messrs. Gilliland, Norton, and Carnes proceeded to Sydney. The equipment was taken in two laboratory trucks. Observations were made at Washington by Messrs. Kirby and Berkner.

In order to study possible optical and corpuscular effects, it was decided to make a series of determinations of the maximum ionizations of the various layers when facilities permitted, and lacking these, to make continuous records of virtual heights at frequencies so selected as to give as much information as possible regarding the changes of such maximum ionizations. The critical frequency of a layer has been defined as the lowest frequency which penetrates the layer. This frequency is a measure of the maximum ionization. These measurements, therefore, involved the determination of a series of critical frequencies, each determination requiring a series of from five to ten measurements. This procedure has been completely described elsewhere.<sup>3</sup>

<sup>3</sup> Kirby, Berkner, and Stuart, "Studies of the ionosphere and their application to radio transmission, *B.S.J.R.*, vol. 12, p. 15; January, (1934).

The general method used was that of Breit and Tuve<sup>4</sup> as adapted and described<sup>3,5,6</sup> in previous Bureau of Standards publications. For the somewhat specialized apparatus of the expedition, two types of oscillograph were employed for measurements. A cathode ray tube was used for visual work and manual measurements while a string oscillograph was used for continuous photographic recording.

A new method was employed for measuring the pulse retardation time on the cathode ray oscillograph. The sweep-circuit voltage was taken from the 60-cycle alternating-voltage supply and the pulses were shifted across the screen a known interval of time by means of a phase-shifting bridge similar to that described by Turner and McNamara.<sup>7</sup> The rheostats in the phase-shifting bridge which shifts the phase of the sweep-circuit voltage, were calibrated directly in virtual height, the relation between resistance and virtual height being almost linear. Pulse retardation time was measured as follows. The ground pulse was centered on the screen by means of an auxiliary bridge, preceding the calibrated bridge. Then the rheostats in the calibrated bridge were adjusted until the pulses corresponding to the various layers were centered on the screen. The corresponding heights were read from the rheostat dial.

In addition to the cathode-ray oscillograph at Sydney, the automatic recording equipment described by Gilliland and Kenrick<sup>8</sup> was used. At Washington a visual recorder with galvanometer oscillograph was used for measuring E-layer critical frequency and also for the measurements at 4200 kilocycles. A manually-operated photographic recorder was used to measure the F<sub>2</sub> critical frequency at Washington.

At Sydney the manual measuring equipment was designed to make a series of critical frequency determinations of the E layer, while the continuous recorder was used to make virtual height records at two frequencies which would show changes in the E layer if its critical frequency decreased. The rest of the apparatus consisted of a portable transmitter and receiver operating with each measuring equipment.

At Washington, three transmitters were located at the Bureau field station at Beltsville, Maryland, and two receivers were set up at

<sup>4</sup> Breit and Tuve, *Terr. Mag.*, vol. 30, p. 15, (1925); *Nature* (London), vol. 116, p. 357; September 5, (1925); *Phys. Rev.*, vol. 28, p. 554; September, (1926).

<sup>5</sup> Gilliland, *B.S.J.R.*, vol. 6, November, (1930); *Proc. I.R.E.*, vol. 19, p. 114; January, (1931).

<sup>6</sup> Gilliland, Kenrick, and Norton, *B.S.J.R.*, vol. 7, p. 1083; December, (1931); *Proc. I.R.E.*, vol. 20, p. 286; February, (1932).

<sup>7</sup> Turner and McNamara, *Proc. I.R.E.*, vol. 18, p. 1743; October, (1930).

<sup>8</sup> Gilliland and Kenrick, *B.S.J.R.*, vol. 7, p. 783; November, (1931); *Proc. I.R.E.*, vol. 20, p. 540; March, (1932).

Kensington, Maryland. One receiver was alternately tuned to a fixed frequency of 4200 kilocycles and to a series of frequencies near the E critical frequency, while the second was used for F<sub>2</sub>-layer critical frequency determinations. The measuring equipment has been described elsewhere.<sup>3,5,6</sup>

## II. EXPERIMENTAL RESULTS

In order to avoid ambiguity in reference to "critical" frequencies we shall discuss them from the point of view of experimental observations.<sup>3</sup> As the frequency is increased through a critical value for the E or F<sub>1</sub> layer, the ray penetrates the lower layer and is returned from the next higher layer. As the rise takes place, the signals are usually subject to long retardation and high absorption, so that high and rapidly changing virtual heights and small amplitudes are observed through a small range of frequency. The frequency corresponding to the greatest retardation (or sometimes complete absorption) at this virtual height change is interpreted as the critical frequency. The lower limit is the highest frequency at which reflections from the lower layer only are positively returned. The upper limit is the lowest frequency at which reflections from the upper layer are positively returned. These reflections are very much larger than those from the low layer which have a very small amplitude and usually occur above the critical frequency. The critical frequency for the F<sub>2</sub> layer is determined in a somewhat different manner. The greatly retarded signals at this critical frequency are often followed by scattered reflections of great virtual height and very small magnitude which have been shown to have no definite relation to the larger F<sub>2</sub> layer reflections. The critical frequency for the F<sub>2</sub> layer is taken as the frequency at which the slope of the frequency-height curve is a maximum, and above which the reflections are not of appreciable magnitude. The lower limit is considered as the beginning of the abrupt rise in the frequency-height curve, and the upper limit is indicated by the positive disappearance of any F<sub>2</sub> layer reflections.

The disappearance of reflections alone is not believed to be always an exact indication of this critical frequency because the high absorption often extending to frequencies well below the critical frequency as defined, would make the results depend somewhat upon the sensitivity of the receiver. The appearance of "scattered reflections" often through an extended range above the critical frequency might also have an influence.

In order to be sure of complete control, observations were made between noon and 6 P.M. on several days before and after the eclipse, as

well as on the day of the eclipse. The continuity of these experiments was interrupted only by adjustments of the apparatus and very severe atmospheric disturbances.

### III. OBSERVATIONS OF THE E-LAYER

The daily variations of the E-layer critical frequency ( $f_E$ ) are shown in Fig. 1 for days preceding and following the eclipse. Fig. 2 shows the variation of  $f_E''$  on the day of the eclipse at Washington and Sydney. The solid line graphs show the values at Washington, while the individual crosses show the values at Sydney for identical times. The break in the dip of the  $f_E$  graph taken at Washington occurred because the rapid change of  $f_E$  during this period made accurate determinations impossible. The data show that it is probable that  $f_E$  did not fall below 1600 kilocycles at Washington.

It may be shown from results of Pedersen<sup>9</sup> that the normal variation of  $f_E$  should follow the law  $f_E = f_{E0}(\cos \psi)^{1/4}$  where  $\psi$  is the angle which the sun's rays make with the zenith. The results shown in Fig. 1 agree well with this law when  $f_{E0} = 3265$  (obtained from an average of 81 determinations of  $f_E$  on August 29 and 30 and September 1, 3, and 4) for Washington and  $f_{E0} = 3170$  (an average of 10 determinations) for Sydney. Pedersen has also shown that the maximum electron density in the E layer is proportional to  $f_E^2$  so that it is possible to determine the percentage of the normal electron density on the day of the eclipse if it is assumed that the critical frequencies on that day followed the above cosine law with  $f_{E0}$  determined as above; i.e., the percentage of the normal maximum electron density in the E layer equals  $f_E^2/f_{E0}^2 (\cos \psi)^{1/2}$ . Fig. 3 shows the percentage of the normal electron density together with the percentage of the exposed disk of the sun at Washington, and Fig. 4 shows the same data for Sydney.

Fig. 5 shows the record of changes in virtual height at 2400 and 3000 kilocycles, respectively, for the day of the eclipse at Sydney, while Fig. 6 shows these changes plotted for the same period and compared with the two successive days. Fig. 7 shows the variations in virtual heights for a number of frequencies through which  $f_E$  decreased for the day of the eclipse and also for a succeeding day at Washington.

An examination of these curves brings out a number of points of interest:

(1) A marked decrease of the ionization of the E layer during the optical eclipse, reaching a minimum almost exactly at (not more than four or five minutes after) the maximum of the optical eclipse at both Sydney and Washington.

<sup>9</sup> Pedersen, "Propagation of Radio Waves," chapters V and VI.

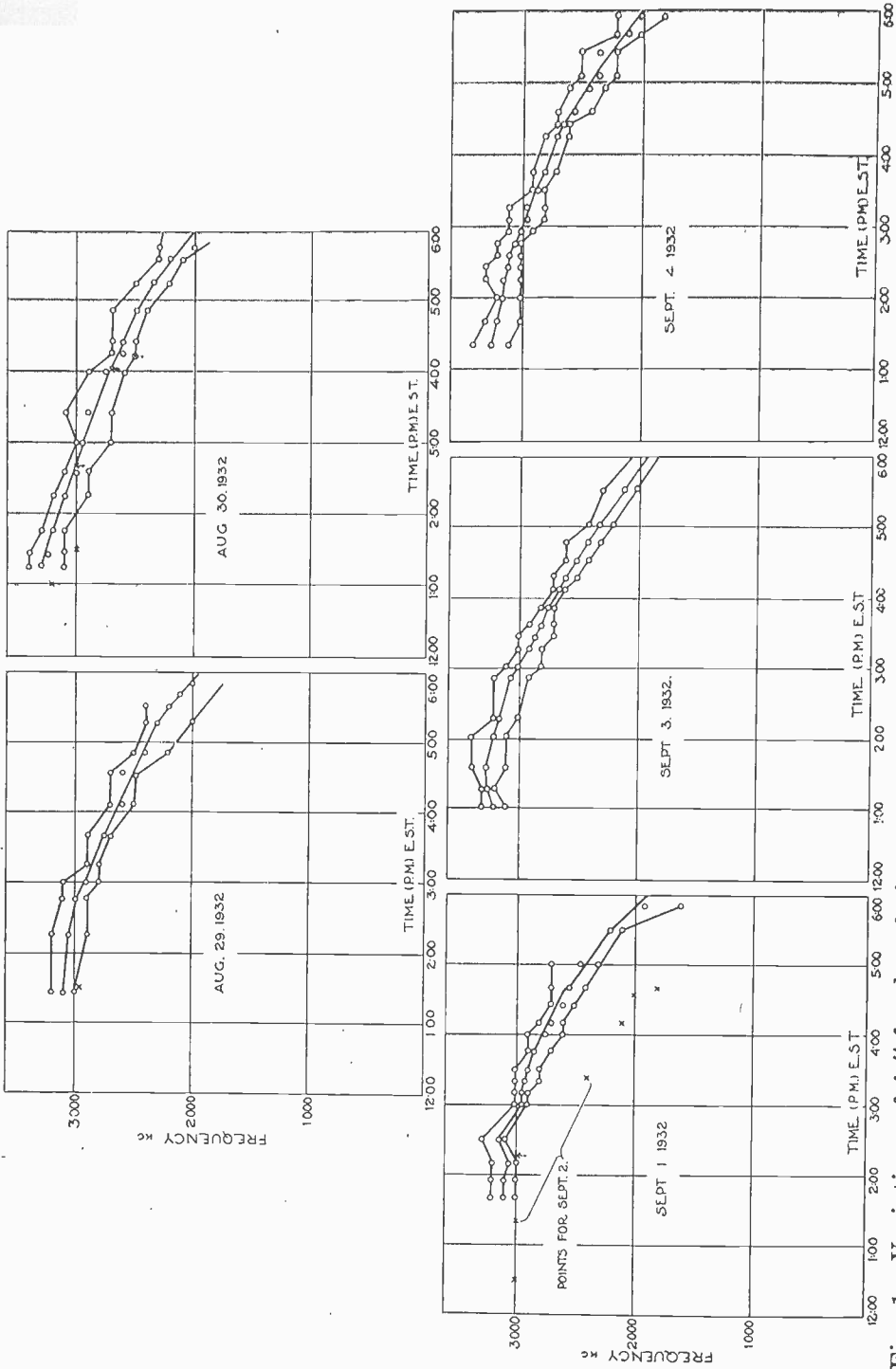

Fig. 1—Variations of  $f_E''$  for days before and after the eclipse. Curves for Washington, D. C., and for Sydney, Nova Scotia, for identical times.  
 $f_E''$  at Washington, limiting and mean values.  
 $f_E''$  at Sydney.

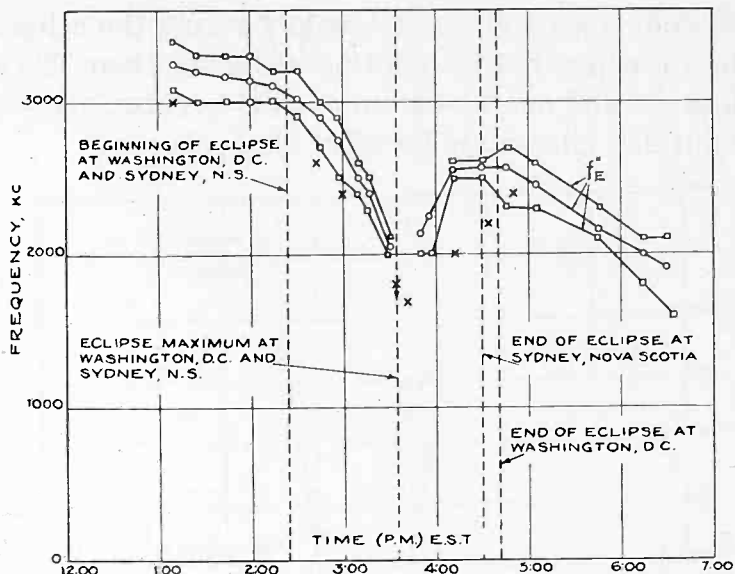

Fig. 2—Variations of  $f_{E''}$  during the time of the eclipse.  
 —○—  $f_{E''}$  at Washington, mean values. Squares indicate limiting values.  
 X  $f_{E''}$  at Sydney.

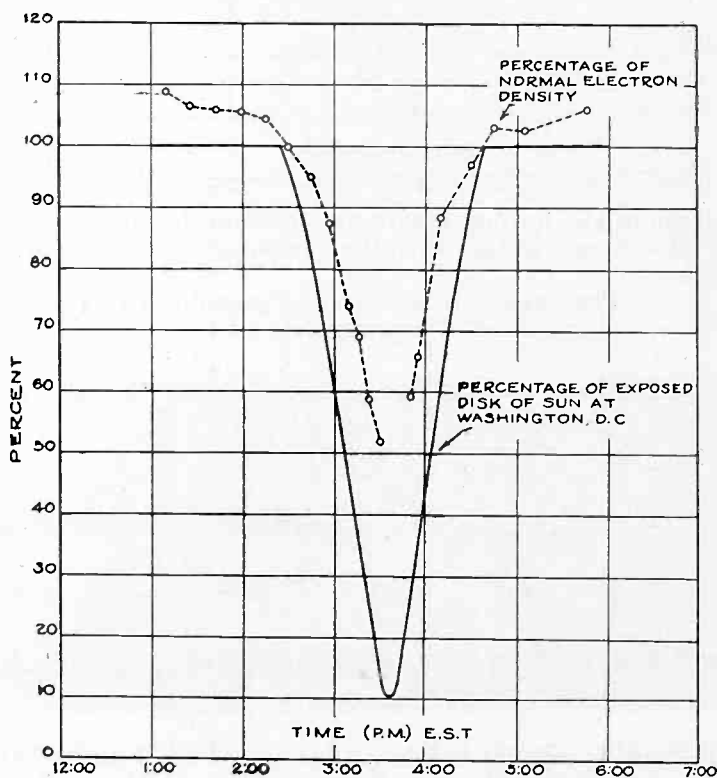

Fig. 3—Percentage of the normal maximum electron density in the E layer for the day of the eclipse together with the percentage of the exposed disk of the sun at Washington.  
 —○— Percentage of the normal maximum electron density.  
 ——— Percentage of exposed disk of the sun at Washington.

(2) At Sydney a greater virtual height during the eclipse of about 280 kilometers as compared with normal values of about 230 kilometers for 3000 kilocycles and nearly 400 kilometers as compared with normal values of about 220 kilometers for 2400 kilocycles.

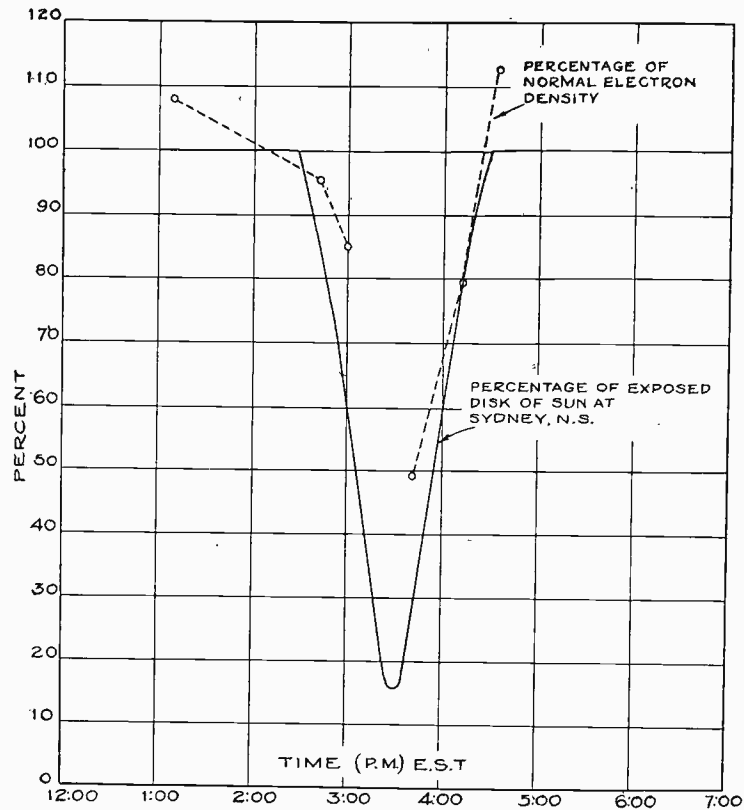

Fig. 4—Percentage of the normal maximum electron density in the E layer for the day of the eclipse together with the percentage of the exposed disk of the sun at Sydney.

○ — Percentage of the normal maximum electron density.  
 — — Percentage of exposed disk of the sun at Sydney.

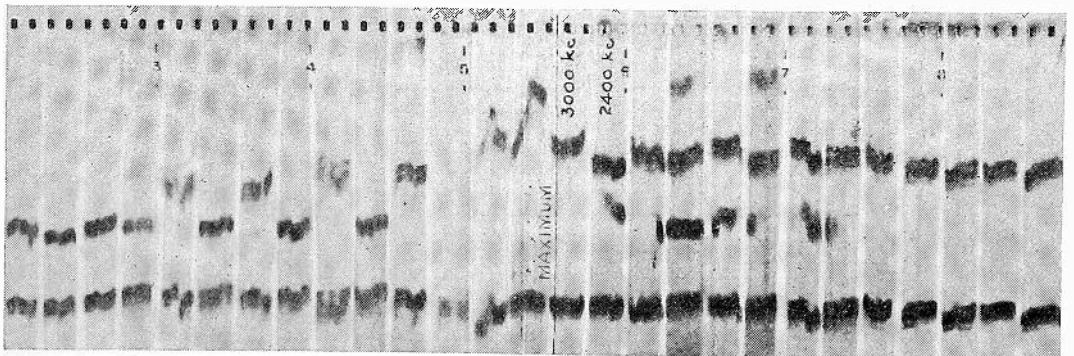

Fig. 5—Record showing virtual height variations of 2400 and 3000 kilocycles during the eclipse at Sydney, Nova Scotia.

(3) Similarly abnormally high values of virtual heights during the eclipse for frequencies just above  $f_E$  at Washington. These last two effects are discussed in the section: Investigations of the  $F_1$  Layer.



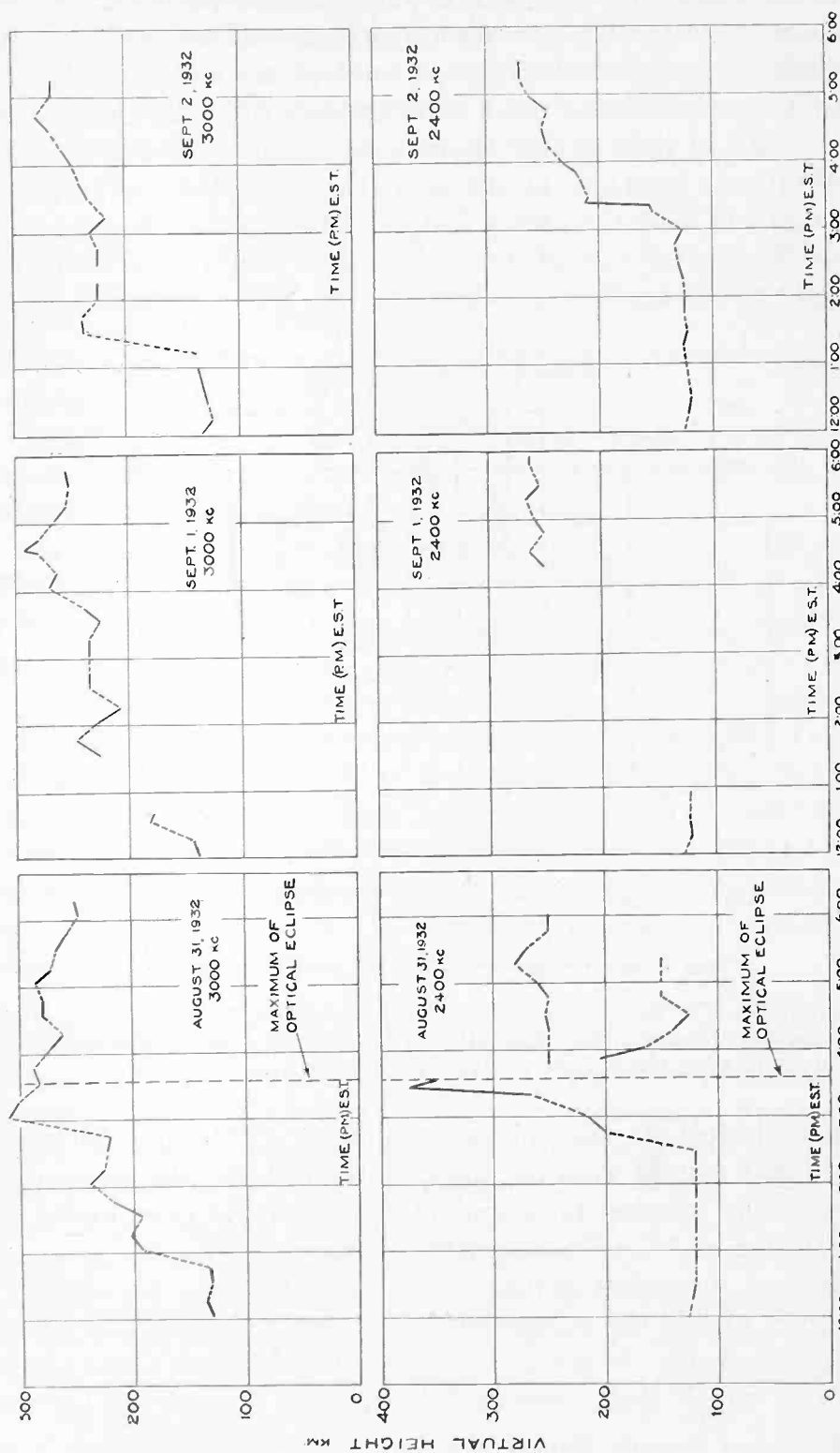

Fig. 6—Virtual heights of 2400 and 3000 kilocycles plotted for the day of the eclipse and succeeding days at Sydney, Nova Scotia.

Since the reduction and following rise in  $f_E$  at both stations coincided almost exactly with corresponding phases of the optical eclipse, we conclude that at least that part of the ionization of the E layer affected by the eclipse is due to an ionizing force from the sun traveling at the velocity of light rather than to corpuscular effects. It can be said qualitatively from an examination of the results that the magnitude of the ionization from the source just described seems adequate to account for the greater part of the ionization of the E layer in the daytime. Exact recombination rates have not yet been computed from the

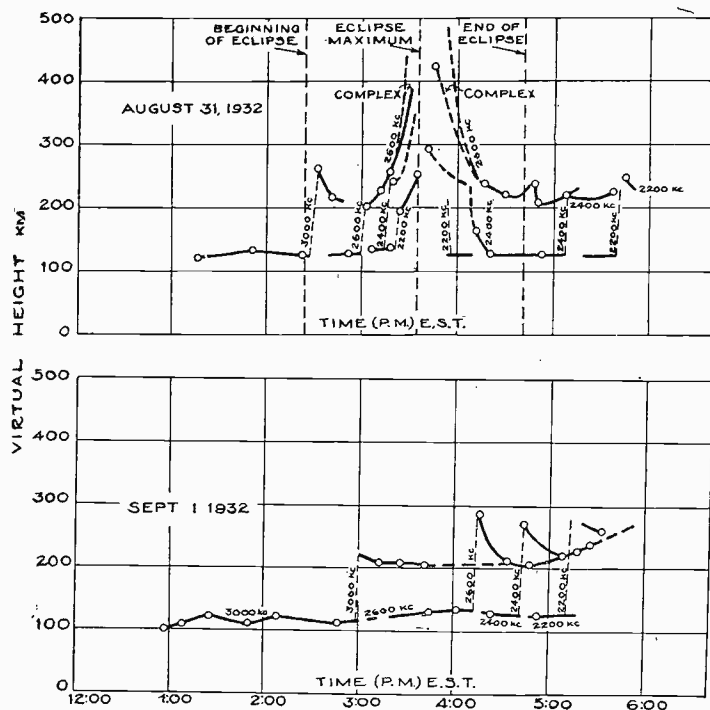

Fig. 7—Virtual height for a number of frequencies through which the E critical frequency decreased during the eclipse period for the day of the eclipse and the day following the eclipse at Washington, D. C.

data. An analytical discussion is in preparation with comparisons with ordinary night results with the view of determining the relative importance of this ionizing force and others known to exist under certain circumstances,<sup>3,10,11,12</sup> particularly at night.

A report of somewhat similar observations made by Canadian experimenters<sup>13</sup> during the eclipse period shows a very close correspondence with our results. It is noted that the slight increase above normal values of  $f_E$  which they observe following the eclipse has been at-

<sup>10</sup> Schafer and Goodall, *Proc. I.R.E.*, vol. 20, p. 1131; July, (1932); vol. 20, p. 1434; August, (1931).

<sup>11</sup> Gilliland, *B.S.J.R.*, vol. 9, July, (1933).

<sup>12</sup> Ranzi, *Nature* (London), vol. 130, p. 368; September 3, (1932).

<sup>13</sup> Henderson, *Canadian Jour. Research*, vol. 8, p. 1; January, (1933).

tributed to thunderstorm conditions which occurred at that time. Apparently identical increases in connection with the results at Sydney and Washington were observed during fair weather at both places, and it is believed that this increase must have been somewhat general and not the result of local meteorological conditions.

#### IV. INVESTIGATIONS OF THE $F_1$ LAYER

It has been shown<sup>14</sup> that the F region is divided into two layers during the daytime. These have been termed the  $F_1$  and  $F_2$  layers. The maximum ionization of the  $F_1$  layer is indicated by a critical frequency somewhat higher than  $f_E$ . At noon on the date of the eclipse, the critical frequency was about 4200 kilocycles

Facilities did not permit a continuous determination of the critical frequency of the  $F_1$  layer. Measurements were therefore made in Washington at a fixed frequency of 4200 kilocycles.

Fig. 8 shows the virtual heights for 4200 kilocycles on the days preceding and following the eclipse, and Fig. 9 shows the virtual heights for this frequency on the day of the eclipse. It has been shown<sup>3</sup> that retardations at this critical frequency for the  $F_1$  layer are frequently subject to a considerable variation during terrestrial magnetic disturbances and therefore the results for August 27, 29, and 30 cannot be considered as representative of normal conditions. Fig. 10, therefore, shows Fig. 9 superimposed on the envelope of the virtual heights for the undisturbed days of September 1, 3, and 4. The variations in virtual height are seen to be quite complex, and the characteristic phenomena associated with the  $F_1$  layer must be taken into consideration in the interpretation of the results.

It has been suggested that the maximum ionization of this layer may be manifest by two critical frequencies because of magnetic double refraction. For certain relations of the wave normal to the direction of the magnetic field of the earth, it has been determined that the second critical frequency for this layer should occur approximately 795 kilocycles above the first critical frequency.<sup>3,15,16</sup> Effects have been observed which appear to confirm this result.<sup>3,14,15</sup> At the first critical frequency, therefore, the reflection would consist of two components, reflected from different parts of the F region. The component for which the lesser reduction in refractive index occurs has been termed the ordinary ray designated here as  $F_1''$ , having a critical frequency of

<sup>14</sup> See footnotes 3 and 11. Also see Gilliland, *B.S.J.R.*, vol. 11, p. 561, (1933).

<sup>15</sup> Appleton and Builder, *Proc. Phys. Soc.*, vol. 45, part 2, no. 247, p. 208; March, (1933).

<sup>16</sup> This frequency separation has been determined by assuming a value of 0.52 gauss for the total earth's magnetic field at a height of 180 kilometers at Washington.

$f_{F_1''}$ . At a frequency just above  $f_{F_1''}$ , this ray will be reflected from the  $F_2$  layer, but will be subject to a retardation in the  $F_1$  layer and is then termed  $F_2''$ . The component for which the greater reduction in refrac-

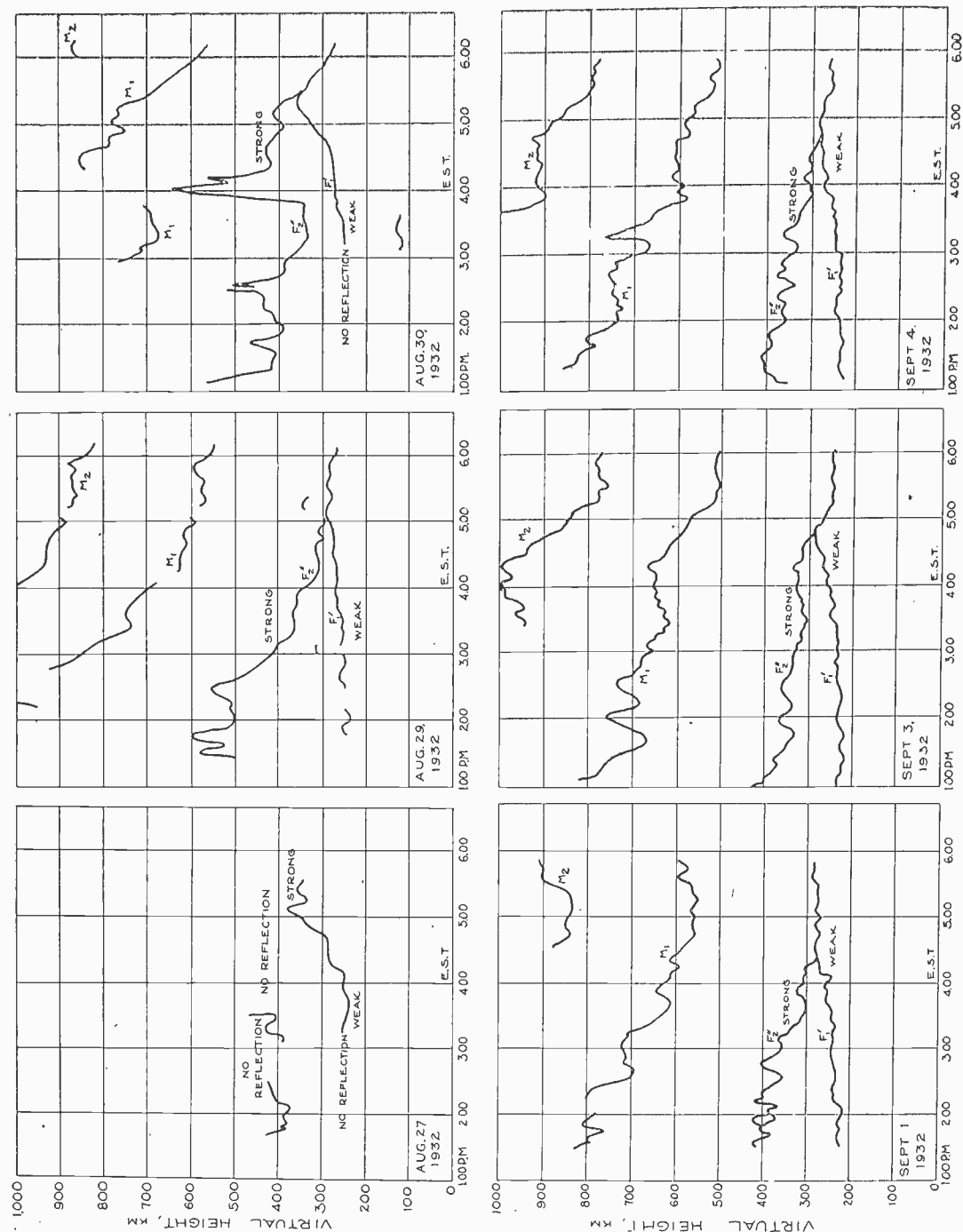

Fig. 8—Virtual heights for a frequency near the noon value of  $f_{F_1''}$  (4200 kilocycles) for days preceding and following the eclipse.

tive index occurs has been termed the extraordinary ray designated here as  $F_1'$  and having a critical frequency of  $f_{F_1'}$ . It can be shown that the component for which the greater reduction in refractive index

occurs ( $F_1'$ ) will be subject to the greater absorption at a given frequency.<sup>15</sup>

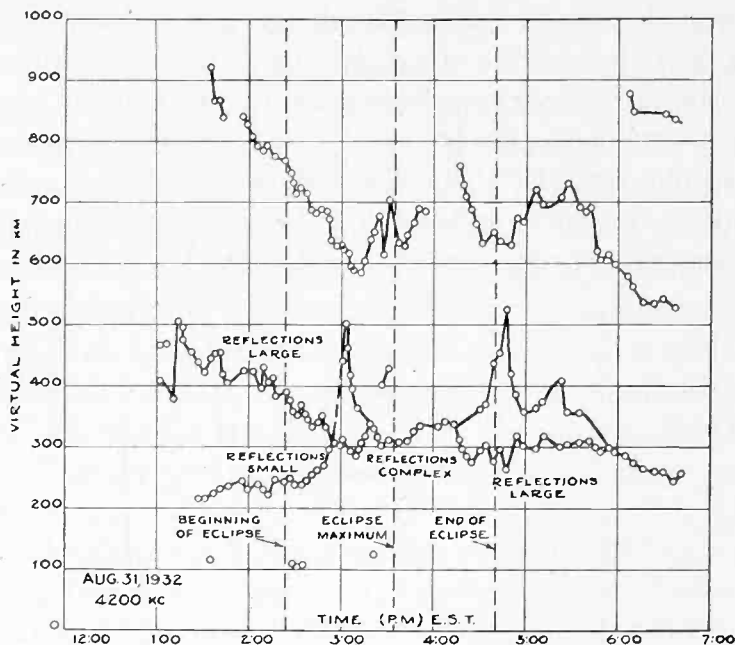

Fig. 9—Virtual heights for a frequency near the noon value of  $f_{F1}''$  (4200 kilocycles) for the day of the eclipse.

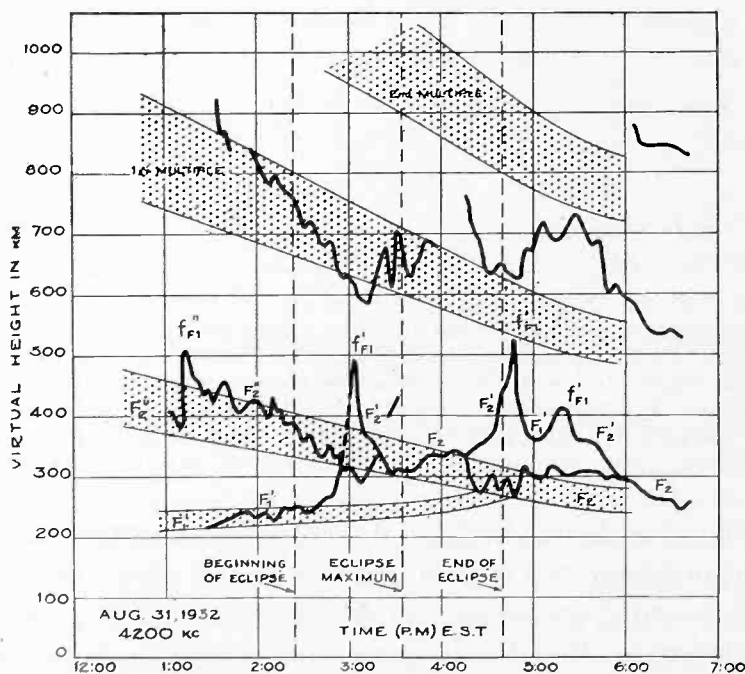

Fig. 10—Virtual heights for a frequency near the noon value  $f_{F1}''$  (4200 kilocycles) for the day of the eclipse superimposed on the envelope of the virtual heights for the undisturbed days following the eclipse.

Referring to Fig. 8, it is seen that on normal days two components are present. At noon at this frequency the amplitude of the upper re-

flection is about 1000 times as large as the lower reflection. It is probable that these two components are due to the double refraction effects just discussed. It is seen that 4200 kilocycles will lie between  $f_{F_1''}$  and  $f_{F_1'}$  during the course of the afternoon. In this case the upper reflection at noon is the ordinary ray reflected from the  $F_2$  layer, and suffering long retardation due to its proximity to  $f_{F_1''}$ . The lower reflection is the extraordinary ray,  $F_1'$ . It has been shown<sup>3</sup> that for magnetically undisturbed days the upper reflection will generally fall in height during the afternoon for two reasons: (1) the decrease in  $f_{F_1''}$ , and (2) the de-

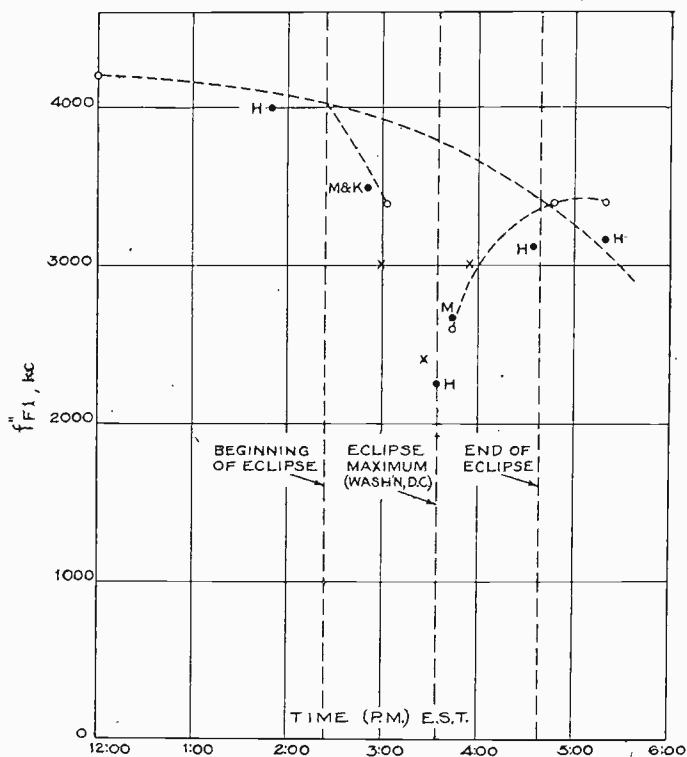

Fig. 11—Variation of  $f_{F_1''}$  for a normal day compared with that for the day of the eclipse including data plotted from the observations of other investigators. Unlabeled circles indicate Washington measurements. Points marked X indicates Sydney measurements. Circles marked H from Henderson. Circles marked M from Mimno and Wang. Circles marked K from Kenrick and Pickard.

crease in long retardation at  $f_{F_1''}$ . At the same time the virtual height for the extraordinary ray is seen to rise because of the decrease of  $f_{F_1'}$  toward the recorded frequency until the reflected ray joins the  $F_2$  reflection. It is known that the long retardations at  $f_{F_1''}$  and  $f_{F_1'}$  are not so great as the afternoon progresses, disappearing in the evening. This effect probably accounts for the fact that on the normal days long retardations accompanying the critical frequency of the second component ( $F_1'$ ) are not observed on 4200 kilocycles as recombination progresses.

During the day of the eclipse somewhat different effects were ob-

served as illustrated in Fig. 9. It seems that the rapid decrease in virtual height of the upper reflection after the commencement of the eclipse must have been due to a rapid decrease in  $f_{F_1''}$ . At the same time, since there was a corresponding decrease of  $f_{F_1'}$ , the lower reflection rose rapidly in virtual height and appeared to cross the other reflection, reaching a critical value at 3:03 P.M. It appears that 4200 kilocycles becomes the critical frequency at this time for the "extraordinary" ( $F_1'$ ) ray. The virtual height for this ray then fell, joining the other which was then returned from somewhat high  $F_2$  virtual heights. At 4:17 P.M. the reflection again split and it appears that  $f_{F_1'}$  again passed through 4200 kilocycles at 4:47 P.M. as it rose as reionization took place.  $f_{F_1'}$  finally again fell below 4200 kilocycles at 5:13 P.M. As might be expected this last critical effect is less distinct than the earlier effects. This was followed by the normal return of reflections from  $F_2$  layer heights. This analysis brings out certain points of interest. Ordinarily, it is not possible to use a single frequency for determining the decrease of  $f_{F_1''}$  and  $f_{F_1'}$  resulting from recombination, because these effects disappear toward evening. These observations therefore add confirming evidence of the existence of magnetic double refraction.

It has been shown that the difference in frequency between  $f_{F_1''}$  and  $f_{F_1'}$ , is a definite function of  $f_{F_1''}$  and the total magnetic field of the earth. When the value of  $f_{F_1'}$  is 4200 kilocycles,  $f_{F_1''}$  is 3405 kilocycles. Knowing the times at which the observed frequencies passed through  $f_{F_1''}$  and  $f_{F_1'}$  and using this separation, it is possible to obtain a series of points for  $f_{F_1''}$ , as plotted in Fig. 11.

It appears from the discussion of the data obtained during the investigations of the E layer that the abnormal virtual heights occurring at about 2500 kilocycles at the eclipse maximum were probably due to the decrease of  $f_{F_1''}$  to this frequency. This was shown in Fig. 7. The normal diurnal variation is also plotted.

From these data it is possible to estimate the magnitude of the decrease of ionization from the normal during the eclipse. The ratio of  $(f_{F_1''})^2$  at the eclipse maximum to the normal value is 0.40. Since this change in ionization took place practically in phase with the optical eclipse, we can therefore conclude that the portion of ionization represented by this drop in critical frequency was due, in this layer, also, to an ionizing agency traveling from the sun at the velocity of light.

At Sydney,  $f_{F_1''}$  was determined directly from the automatic records as shown in Figs. 5 and 6. These points seem reasonably consistent with the Washington data when it is considered that the eclipse occurred a few minutes earlier at Sydney.

The published reports of a number of observers<sup>13,17,18</sup> have been examined and it seems that the variation of virtual heights at frequencies through which  $f_{F_1''}$  and  $f_{F_1'}$  decrease can be interpreted in the same manner. From these data, a number of additional points are available, and are shown in Fig. 11. The variation of the points from the dotted curve is to be expected from the differences in latitude and per cent

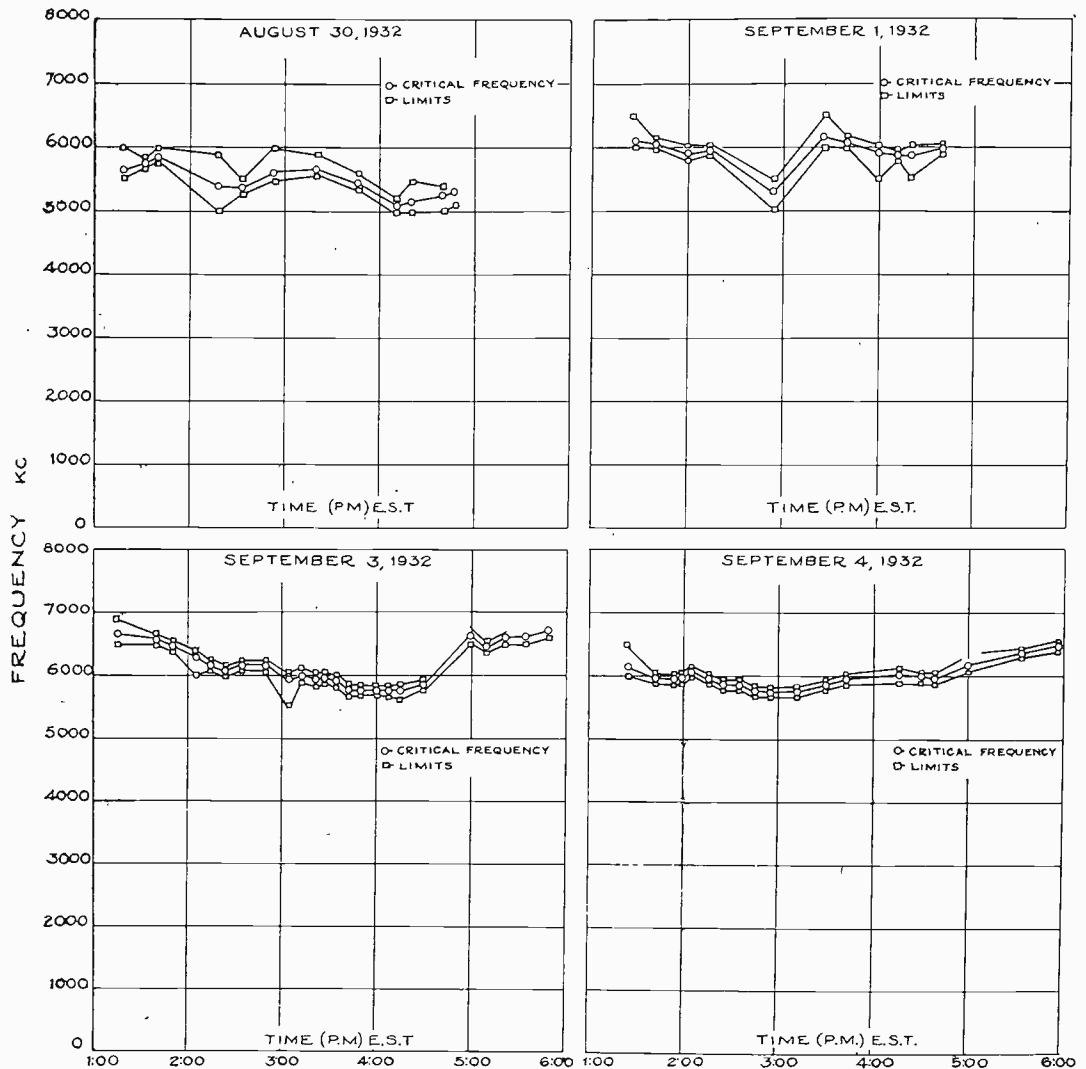

Fig. 12— $F_2$  critical frequency with limits for a number of days preceding and following the eclipse.

totality. It is striking that these points of various observers follow so closely the variation of ionization shown by this interpretation. The interpretation of these effects in terms of a corpuscular eclipse as suggested by Mimno and Wang does not seem to be necessary.

It is of particular interest that the retardations at  $f_{F_1'}$  remained long until very late in the afternoon. It has been mentioned that the

<sup>17</sup> Kenrick and Pickard, Proc. I.R.E., vol. 21, p. 546; April, (1933).

<sup>18</sup> Mimno and Wang, Proc. I.R.E., vol. 21, p. 529; April, (1933).



usual disappearance of these effects from the  $F_1$  layer during the afternoon might be due to an actual shifting of the layer. It is evident from the data obtained after the eclipse that the usual cause for disappear-

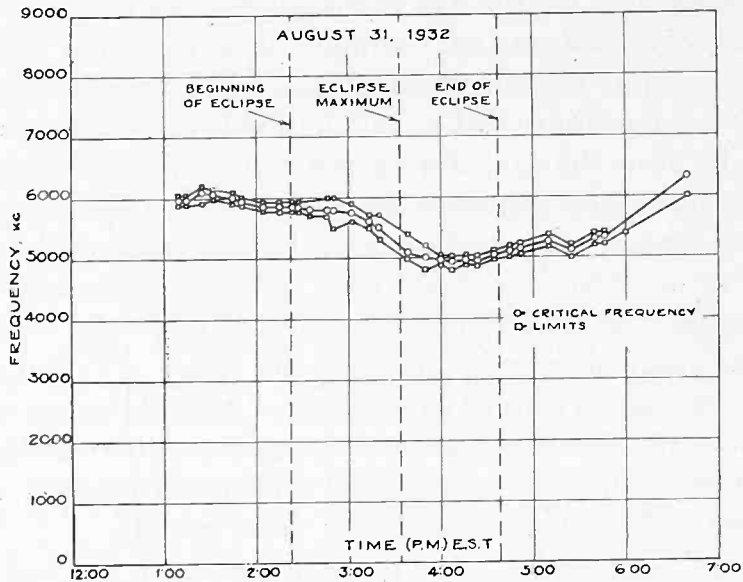

Fig. 13— $F_2$  critical frequency with limits for the day of the eclipse.

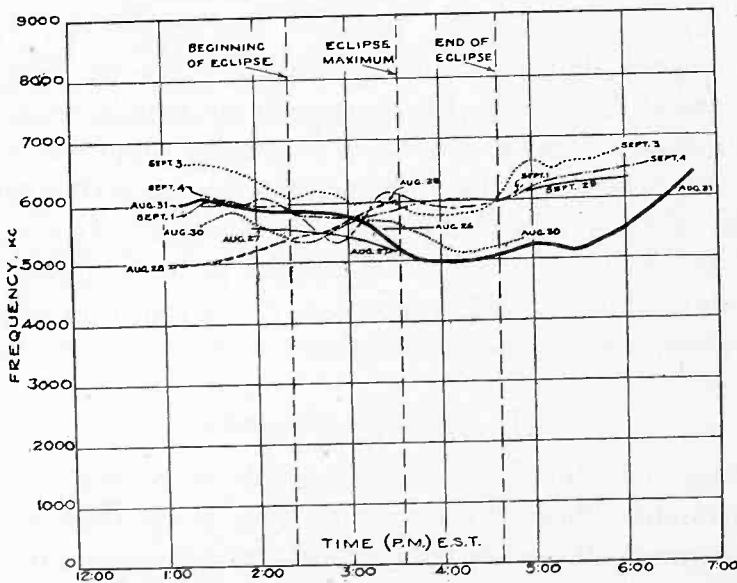

Fig. 14— $F_2$  critical frequency for the day of the eclipse superimposed on the curves of previous and succeeding days.

ance of these effects was not present during the eclipse. As a result, the physical aspects of the  $F_1$  layer appear to be about the same as during the early afternoon but with lower ionizations.

V. OBSERVATIONS OF THE  $F_2$  LAYER

Fig. 12 shows the  $F_2$  critical frequency ( $f_{F_2}$ ) plotted with known limits for a number of days preceding and following the eclipse. Fig. 13 shows the same data for the day of the eclipse, while Fig. 14 shows the comparison of the eclipse and "normal" data. It should be noted that because we are not certain whether this critical frequency is for the ordinary or extraordinary ray, no distinction in notations is made.

It will be seen that  $f_{F_2}$  during the eclipse period cannot be said definitely to have undergone any marked change. A decrease of  $f_{F_2}$  took place during the last phase of the eclipse, but decreases of the same order are found to occur on "normal" days, notably September 1, during about the same time. The values of  $f_{F_2}$  for August 27 and August 30 are, respectively, just below and just above the values of  $f_{F_2}$  for the eclipse day during this time. It must be recognized that these latter two days were magnetically disturbed, and though no direct correlation has been established between changes at  $f_{F_2}$  and such disturbances, it is possible that they may effect the results during these periods.

It appears, therefore, that no positive results on this can be stated. It can be said, generally, that any changes in  $f_{F_2}$  which might have been due to the eclipse were not large in magnitude, and were very small compared with the very large changes in  $f_{F_1}$  and  $f_E$ .

It has been shown by Kirby, Berkner, and Stuart<sup>3</sup> that  $f_{F_2}$  does not follow the normal characteristics of the lower layers. The possibility that this critical frequency does not indicate a maximum ionization has been discussed, and it has been suggested that the determining factor is absorption rather than ionization. It appears that the observed facts can be explained on this basis. It is possible that recombination occurred in the  $F_2$  layer in the same manner as in the lower layers, but that such changes did not directly affect  $f_{F_2}$ . From this point of view, the results obtained appear reasonable.

## VI. ACKNOWLEDGMENT

Operations at Sydney were made possible by courtesy of the Canadian Government. These arrangements were made through the U. S. State Department. We wish to acknowledge the assistance given by B. Haas, Carnegie Institution, Washington, D. C., P. N. Arnold, Harvard University, and a number of our associates in the Bureau of Standards during these measurements, and to acknowledge the loan of a receiving equipment by the Carnegie Institution during this period, all of which materially aided in obtaining the observations.

## DEVELOPMENT OF STANDARD FREQUENCY TRANSMITTING SETS\*

BY

L. MICKEY AND A. D. MARTIN

(Bureau of Standards, Washington, D.C.)

### ABSTRACT

Of the methods used by national laboratories to make generally available their standards of radio frequency, the most accurate, economical, and practicable method is the radio transmission of standard frequency signals. The paper describes the equipment used by the Bureau of Standards for such transmissions. The present equipment uses continuous waves; experimental work is under way for the transmission of modulated waves, with both the carrier and modulation frequencies serving as standard frequency sources. At first the signals were sent on various frequencies between 125 and 10,000 kilocycles. As elaborate working standards and monitoring stations developed, however, transmission over such a wide spectrum was found unnecessary. The demand became for the transmission of a single basic frequency of extreme accuracy. For this reason, the Bureau has more recently provided transmissions on 5000 kilocycles, a frequency which was selected as being most suitable for wide coverage of the United States. The transmitted frequency is accurate at all times within one in ten million.

Since 200-kilocycle piezo oscillators are used for control, a multiplication by 25 is necessary to obtain the output frequency. Synchronized oscillators and harmonic amplifiers, using both screen-grid and pentode tubes, were tried, the pentode harmonic amplifier being selected as the most satisfactory. In the final multiplier a distorting 200-kilocycle amplifier is used, followed by tuned 1000- and 5000-kilocycle stages. The development work led to the purchase and installation of a 30-kilowatt transmitter at Beltsville, Md., thirteen miles from the Bureau main radio laboratory. Marked improvement in the coverage and dependability of the signals has resulted.

\* Published in full in *Bureau of Standards Journal of Research*, January, (1934). Research Paper No. 630.



## A CONTINUOUS RECORDER OF RADIO FIELD INTENSITIES\*

BY

K. A. NORTON AND S. E. REYMER

(Bureau of Standards, Washington, D.C.)

An automatic recorder is described which is used to make continuous records of the received field intensities from radio transmitting stations operating on any frequency from 540 to 20,000 kilocycles. On account of the large variations (fading) in received field intensities, it was found necessary to make the scale of the recorder accommodate either a large range (e.g., 1 to 300,000 microvolts) or a small range (e.g., 100 to 300 microvolts) of radio-frequency voltages. This was accomplished by means of a special bridge arrangement in which one arm was the plate resistance of one of the vacuum tubes in the radio receiver used to amplify the received radio-frequency voltages. In order to eliminate the effects on the recorder of supply-voltage variations, the resistance of another vacuum tube was inserted in a parallel arm of the bridge, this latter tube not being affected by changes in the radio-frequency voltage. Several typical records made by the recorder are given in the paper. These records illustrate the flexibility of the recording method used. They also show several important characteristics of radio wave propagation. Steady daytime field intensities for near-by stations are shown, as well as fading daytime field intensities for the more distant stations, indicating the absence or presence of a sky wave of a magnitude comparable to that of the ground wave. At night, on all the records shown, the rapidity of fading may be seen to increase, the average value of the field intensity also increasing in some cases by a factor of about one hundred.

A number of these recorders are used in the Bureau's receiving station at Meadows, Md. They have given thoroughly satisfactory service during the past year. They operate with very little attention.

\* Published in full in *Bureau of Standards Journal of Research*, September, (1933). Research Paper No. 597.



DISCUSSION ON "DETERMINATION OF GRID DRIVING POWER IN  
 RADIO-FREQUENCY POWER AMPLIFIERS"\*

H. P. THOMAS

W. H. Doherty:<sup>1</sup> In Mr. Thomas's paper and an earlier and related paper by Mr. E. E. Spitzer<sup>2</sup> the complicated phenomena occurring in the grid circuit of a power amplifier have been very clearly treated. The simple formula given by Mr. Thomas for grid driving power, employing the useful relation that for narrow pulse widths a periodically recurring current pulse has a fundamental component of peak value twice the average value of the pulse and independent of its shape, is valuable not only in the computation of driving power but also in a study of grid heating, a consideration of importance in the use of large tubes.

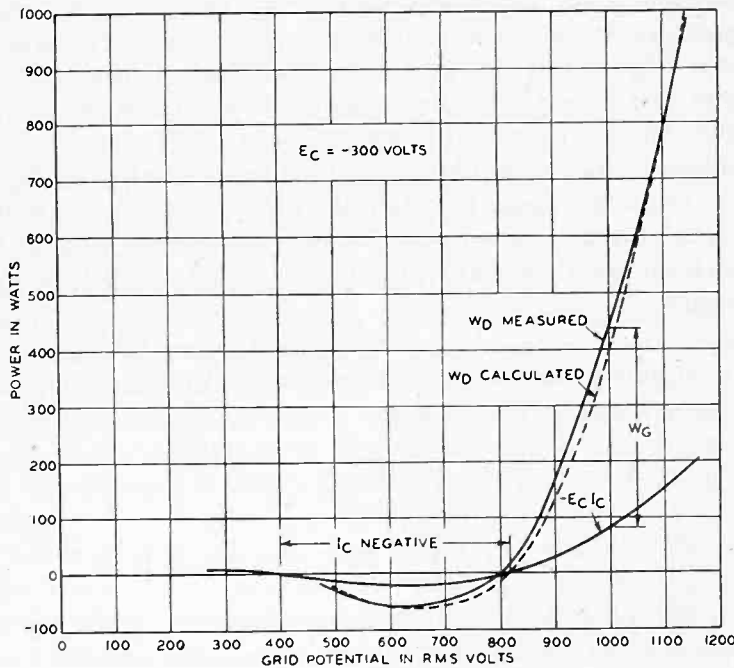

Fig. 1

I should like to present additional confirmation of Mr. Thomas's formula obtained in 1931 under somewhat different conditions, viz., with a higher-powered tube whose grid current was negative over a part of the range, and with the driving power measured at radio frequency, instead of at 60 cycles, by means of an electrostatic wattmeter. These tests were made on an experimental 100-kilowatt tube for use in the long-wave transatlantic radiotelephone system. The measured and calculated values of the total driving power  $W_d$  are shown in Fig. 1 as a function of excitation. The quantity  $-E_c I_c$ , the power delivered to the bias device, is also shown. For fairly heavy loads the calculated values of  $W_d$  are slightly lower than the measured values, instead of slightly higher as in Mr. Thomas's curves, because the approximate formula gives undue weight to the negative grid current occurring at a part of the cycle where the grid voltage is

\* Proc. I.R.E., vol. 21, p. 1134; August, (1933).  
<sup>1</sup> Bell Telephone Laboratories, Whippany, N. J.  
<sup>2</sup> Proc. I.R.E., vol. 17, p. 985; June, (1929).

considerably less than the maximum. At the highest excitation shown, the curves are crossing and the calculated value of  $W_d$  would be the greater if the excitation were further increased.

At moderate loads, where  $I_c$  is negative, the curves show the phenomenon of negative driving power mentioned in Mr. Spitzer's paper; the grid is feeding back power into the driving circuit. This power, of course, comes from the plate circuit through the electronic coupling established by the flow of secondary electrons from grid to plate.

The difference between  $W_d$  and  $-E_c I_c$  is the actual input power to the grid,  $W_g$ , and for heavy loads where secondary emission effects are negligible this may be taken as a measure of the heat generated by electron impact at the grid.

It is of interest to consider the application of Mr. Thomas's formula in the case of a modulated input, where insufficient power from the driving stage will result in distortion of the input wave. The radio-frequency driving power will usually be greatest at the peak of the envelope, and for a large percentage modulation the "direct-current" grid current existing at that instant—that is, the peak value of the audio-frequency grid current—will be many times the average value indicated by the grid-current meter, and may have to be determined by oscillographic means. This current is then multiplied by the instantaneous peak of the exciting voltage to obtain the peak driving power required. From the standpoint of dissipation we are of course interested only in the average value of  $W_d$  (from which we are to subtract  $-E_c I_c$  to get  $W_g$ ). Using Mr. Thomas's formula

$$W_d' = \sqrt{2} E_o' I_c', \quad (1)$$

where we now employ primes to indicate quantities varying at audio frequency, we have for the average driving power

$$\begin{aligned} W_d &= 1/T \int_0^T W_d' dt \\ &= \sqrt{2}/T \int_0^T E_o(1 + m \cos \omega t) I_c' dt, \end{aligned} \quad (2)$$

where  $T$  and  $\omega$  now refer to the modulation frequency,  $m$  is the degree of modulation, and  $E_o$  is the r-m-s value of the carrier alone. Recognizing now that most of the grid current comes at the peak of the envelope we may apply Mr. Thomas's approximation to the envelope as well as to the radio-frequency cycle, thus:

$$\begin{aligned} W_d &= \sqrt{2} E_o(1 + m)/T \int_0^T I_c' dt \\ &= \sqrt{2} E_o(1 + m) I_c, \end{aligned} \quad (3)$$

so that for calculating the approximate dissipation Mr. Thomas's method of taking the product of the direct grid current  $I_c$  and the peak value of the exciting voltage applies to a modulated wave as well as to an input of a pure cosine form.

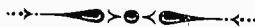

## BOOK REVIEWS

**Vocational Guidance in Engineering Lines**, elicited and edited by the American Association of Engineers. Editorial Committee: J. A. L. Waddell, chairman, Frank W. Skinner, Harold E. Wessman. 521 pages, 50 illustrations, The Mack Printing Co., Easton, Pa. Single copies, postpaid, \$2.50 and in lots of ten or more \$2.00 per copy, including transportation.

The purpose of this book, as is made clear in the Foreword, is to make available for young men planning to enter the engineering profession, and for their parents, authoritative information regarding the qualities of mind and character requisite for success in engineering, the real nature of engineering work, and some idea of the financial opportunities it offers.

Too often students, allured by the spectacular nature of engineering achievements and the prospect of travel, enter the engineering course in college, only to find out before the end of their freshman year that they have mistaken their calling and to be obliged to make a fresh start in some other line.

The wastefulness of this process of elimination, both in money and time, is evident. The sense of humiliation engendered in the youth who has been flunked out is altogether regrettable. The injury to the engineering profession due to the presence in its ranks of graduates who have made the grade in college, but who would be more successful in some other line is very real.

The recognition of these evils led, several years ago, to the appointment by the American Society of Engineers of a committee to consider remedies. The present book is a result of its studies of the questions involved, and is a first step in its program.

In the earlier chapters is given by the editors a general discussion of the nature of the work of the engineer, his duties and responsibilities. The fifty chapters which follow deal, first of all with the broad subdivisions of the engineering field, and in the later ones with the more specialized branches. Each is treated by an authority in the field in question, and covers a description of the nature of the work which has to be done, the problems which have to be solved, the preparation, mental and social qualifications of the engineer, and the average earnings he may expect at various points in his career. In these chapters much material is available which may be useful to members of engineering faculties who may be called upon to advise students as to the opportunities in other branches of engineering than their own.

It is interesting to note that, in spite of the wide range of subjects treated and the large number of different authors, they are practically unanimous in stressing the conclusions that the engineer should be interested in study and in reading, that he should be persevering, industrious, should be able to think analytically, and should be able to get along well with other people. All agree that a good grounding in mathematics and physics is necessary, together with the ability to write English clearly. All make clear their opinions that the engineer should choose his profession for the love of the work and for the opportunities for useful accomplishment, rather than with any idea of reaping rich financial rewards.

The book is illustrated with cuts of great engineering works, the style is clear and direct, and the whole work is well adapted to the performance of its object,—one in whose success all engineers should be interested.

\*FREDERICK W. GROVER

**A.S.T.M. Standards on Electrical Insulating Materials**, by Committee D-9 on Electrical Insulating Materials. Published by American Society for Testing Materials, 1315 Spruce Street, Philadelphia, Pa. 242 pages. Price \$1.25.

This pamphlet contains the current report of Committee D-9 on Electrical Insulating Materials in which various recommendations are made affecting certain standards, methods of testing and specifications, some of them tentative, which had been previously adopted.

The pamphlet contains the full text of 32 A.S.T.M. specifications and test methods applicable to electrical insulating materials. Some of these specifications and one of the testing methods were prepared by other committees but are included with the material prepared by Committee D-9 for the sake of completeness.

Among the materials which are the subject of testing methods and specifications included in this publication are, molded materials, porcelain, insulating oils, varnishes, tape and other fabrics, mica, paper, rubber, and asbestos.

†L. E. WHITTEMORE

**Theory of Functions as Applied to Engineering Problems**. Edited by R. Rothe, F. Ollendorff, K. Pohlhausen. Translated by Alfred Herzenberg. p. 189, 108 figures. Technology Press, The Massachusetts Institute of Technology, Cambridge, Mass., 1933. Price \$3.50.

This book is written primarily for the engineer whose study of mathematical methods has been definitely limited. It owes its existence to requests from practical engineers in Germany, which requests first bore fruit in two series of lectures at the Berlin Institute of Technology in the winter of 1929–1930 by the present authors. These lectures, the first group of them purely mathematical and the second engineering applications, were published by Julius Springer, Berlin in 1931 under the title "Funktionentheorie und ihre Anwendung in der Technik." The present volume is a rather literal translation.

Part I, "Mathematical Fundamentals, Introduction to Theory of Functions," written by R. Rothe, constitutes a brief course in function theory, treating, for the most part, the complex variable, but including one chapter on line-integrals in the real plane. In this Green's Theorem is developed and Potential Theory and Theory of Flow. In another chapter dealing mostly with miscellaneous theorems, a brief treatment of the Heaviside Operational Calculus is given.

Part II, "Applications," includes the following five treatments: "The Construction of Electric and Magnetic Fields by Means of Source-Line Potentials," by W. Schottky; "Two-Dimensional Fields of Flow," by K. Pohlhausen; "The Field Distribution in the Neighborhood of Edges," by E. Weber; "The Complex Treatment of Electric and Thermal Transient Phenomena," by F. Ollendorff; "Spreading of Electric Waves Along the Earth," by F. Noether. The first of

\* Union College, Schenectady, N. Y.

† American Telephone and Telegraph Company, New York City.



these is of particular interest to radio engineers in its calculation of the grid potential of an amplifier tube and the amplification factor and field within the tube. In the last of the five, Noether carries through a critical comparison of his development to previous treatments by Sommerfeld, Weyl, and Strutt.

In the second part of the book, particularly, bibliographical references are numerous and are a valuable part of the treatise. The translator has inserted footnotes here and there which are well chosen.

A review of the original German treatise may be found in the *Zeitschrift für Technische Physik*, vol. 13, p. 157, (1932).

\*KARL S. VAN DYKE

*Differential Equations for Electrical Engineers*, by Philip Franklin. 299 pages, 41 figures. John Wiley, New York City, 1933. Price \$2.75.

This text book was developed in connection with the author's course in the Mathematics Department at the Massachusetts Institute of Technology. Two introductory chapters treating the very useful tools, complex quantities and Fourier analysis, are followed by a standard chapter on linear equations with constant coefficients including electric circuit and network equations. There follows a group of chapters on partial differential equations with one of these chapters devoted to applications to physical problems. Here are developed the telegraph equations and the analagous one-dimensioned heat flow, streamline flow of liquids, a brief set of vibration problems and also the equations of heat flow in space. The following chapter introduces boundary conditions into several of these physical situations. The radio equations are derived without any clear indication of the physical situation.

The book is definitely a text book of mathematics and appears to be a very teachable one. The problems throughout are mostly mathematical exercises—even to a large extent those in the two chapters dealing with applications, the physical being only incidental.

There are finally two theoretical chapters on analytic functions and the convergence of Fourier series. A short bibliography arranged by chapters follows which should serve as a handy aid to an engineer using this or any other text book to review his mathematics. Answers to the problems in the various chapters are given in a special table at the end of the book.

\*KARL S. VAN DYKE

\* Scott Laboratory, Wesleyan University, Middletown, Conn.



RADIO ABSTRACTS AND REFERENCES

THIS is prepared monthly by the Bureau of Standards,\* and is intended to cover the more important papers of interest to the professional radio engineer which have recently appeared in periodicals, books, etc. The number at the left of each reference classifies the references by subject, in accordance with the "Classification of Radio Subjects: An Extension of the Dewey Decimal System," Bureau of Standards Circular No. 385, obtainable from the Superintendent of Documents, Government Printing Office, Washington, D. C., for 10 cents a copy. The classification also appeared in full on pp. 1433-1456 of the August, (1930), issue of the PROCEEDINGS of the Institute of Radio Engineers.

The articles listed are not obtainable from the Government or the Institute of Radio Engineers, except when publications thereof. The various periodicals can be secured from their publishers and can be consulted at large public libraries.

R000. RADIO (GENERAL)

R007 A. N. Goldsmith. North American broadcasting allocation. *Radio Eng.*, vol. 13, p. 15; November, (1933).

Constructive ideas bearing on the widely discussed problem of broadcast frequency allocations in North America are reviewed by the author.

R010 Les mesures radio-électriques au Laboratoire National de Radio-  
×R201 Électricité. (Radio measurements at the Laboratoire National de Radio-Électricité.) *Ann. des Postes Telegraphes et Telephones*, vol. 22, pp. 569-591, July; pp. 645-674, August; pp. 741-776, September; pp. 944-968; November, (1933).

The work of the Laboratoire National de Radio-électricité of France is described and measurements on the following treated: wave propagation, receiving sets, vacuum tubes, frequency, voltage, current, inductance, capacity, and resistance.

R051 The research work of the Marconi Company. *Marconi Review*, No.  
×R010 44, pp. 1-4; September-October, (1933).

A review of a new book "Wireless" by Dr. W. H. Eccles.

R070 J. Kaufman. The 20th birthday of a radio school. *Radio-Craft*, vol. 5,  
pp. 401, 422; January, (1934).

A review of the work done by the National Radio Institute, Washington, D. C.

R100. RADIO PRINCIPLES

R113 K. Fösterling and H. Lassen. Kurzwellenausbreitung in der Atmos-  
sphäre. (Short-wave propagation in the atmosphere.) *Hochfrequenz-  
technik und Elektroakustik*, vol. 42, pp. 158-178; November, (1933).

An extensive discussion of the properties of the upper atmosphere and the propagation of radio waves through it as affected by ionization and the earth's magnetic field.

R113.5 G. C. Southworth. Some earth potential measurements being made  
in connection with the International Polar Year. *Proc. I.R.E.*, vol.  
21, pp. 1740-1748; December, (1933).

R131 M. G. Scroggie. How to use valve load diagrams. *Wireless World*  
(London), vol. 33, pp. 362-364; November 3, (1933).

A simple explanation of preparing and using vacuum tube load diagrams.

\* This list compiled principally by Miss E. M. Zandonini and Mr. E. L. Hall.

- R131 F. M. Colebrook. Circle diagrams of valve input admittance and amplification factor. *Wireless Engineer & Experimental Wireless* (London), vol. 10, pp. 657-662; December, (1933).

The paper calls attention to the circle diagrams for amplification and input admittance for both audio and radio frequencies and demonstrates the more important practical conclusions. The discussion applies principally to triodes but it is equally applicable to screen-grid tubes for constant mutual conductance and internal resistance.

- R132 D. A. Bell. Harmonic distortion. *Wireless World*, vol. 33, pp. 378-379; November 10, (1933).

Why distortion is expressed in terms of harmonics, and why amplifiers sometimes give rise mainly to second harmonics, but in other cases third harmonics, is fully explained.

- R132 O. E. Keall. Noise as a limiting factor in amplifier design—Part II. *Marconi Review*, No. 44, pp. 5-12; September-October, (1933).

The second part of this paper deals with measurements taken on an actual amplifier.

- R133 E. C. S. Megaw. Note on the theory of the magnetron oscillator. *Proc. I.R.E.*, vol. 21, pp. 1749-1751; December, (1933).

- R140 S. I. Model. Operation of tube oscillators on a common load. *Proc. I.R.E.*, vol. 21, pp. 1722-1739; December, (1933).

- R140 Über parasitische Schwingungen beim ultrakurzen Oszillator. (On parasitic oscillations in short-wave oscillators.) *Hochfrequenztechnik und Elektroakustik*, vol. 42, pp. 155-157; November, (1933).

A discussion of parasitic oscillations of a relaxation nature occurring in an ultra-high-frequency oscillator when an inductance coil is placed in the anode circuit.

- R142 J. M. Borst. Electron coupling. *Radio News*, vol. 15, pp. 402-403; January, (1934).

The author explains the meaning of electron coupling.

- R170 Electrical interference with broadcast reception (editorial). *Wireless Engineer & Experimental Wireless* (London), vol. 10, pp. 645-647; December, (1933).

Some regulations on means to render electrical apparatus nondisturbing to broadcast reception drafted by the "Kommission für Rundfunkstörungen" of Germany are discussed.

- R170 G. Browning. Suppressing auto radio noise. *Radio News*, vol. 15, pp. 410, 427; January, (1934).

A study of the sources, means of distribution and overcoming ignition interference in automobile radio receiver installation.

### R300. RADIO APPARATUS AND EQUIPMENT

- R330 E. D. McArthur. Electronics and electron tubes—Part IX: Special tubes. *General Electric Review*, vol. 36, pp. 556-557; December, (1933).

The FP-54 a low grid-current vacuum tube, the PJ-11 the voltmeter vacuum tube, the FP-53 cathode-ray oscillograph tube, and the FP-126 ultra-high-frequency oscillator vacuum tube are described and their uses discussed.

- R331 H. E. Mendenhall. A 100 kilowatt vacuum tube. *Bell Lab. Record*, vol. 12, pp. 98-102; December, (1933).

Description of the 265A, water-cooled high-power transmitting vacuum tube which has an output of approximately 100 kilowatts is given.

- R331 The Catkin in the making. *Wireless World*, vol. 33, pp. 358-360; November 3, (1933).

Description of the processes involved in making the Osram "Catkin" metal vacuum tube.

- R331 B. J. Thompson and G. M. Rose, Jr. Vacuum tubes of small dimensions for use at extremely high frequencies. *PROC. I.R.E.*, vol. 21, pp. 1707-1721; December, (1933).
- R331 D. E. Replogle. Graphite anodes in transmitting tubes. *Electronics*, vol. 6, pp. 338-339; December, (1933).  
The advantages and disadvantages of carbon anode vacuum tubes are given.
- R331 F. J. Vosburgh. Electrodes—Carbon and graphite. *Electrical Engineering*, vol. 52, pp. 844-848; December, (1933).  
The history of carbon and graphite electrodes for vacuum tubes is outlined briefly, and the methods of manufacture and industrial applications are described.
- R331 D. E. Replogle. More power to your tubes. *Radio News*, vol. 15, p. 393; January, (1934).  
The use of carbon anodes for air-cooled types of transmitting vacuum tubes is discussed. Improved operating characteristics are claimed for this type of anode.
- R355  
×R355.8 J. C. W. Drabble and R. A. Yeo. High power pentode as an electron-coupled transmitter. *Wireless Engineer & Experimental Wireless* (London), vol. 10, pp. 648-656; December, (1933).  
Experiments are described on electron-coupled transmitters using a silica pentode vacuum tube capable of dealing with an input of 4 kilowatts. A method of modulating this pentode vacuum tube is investigated and it is found possible to modulate this 4-kilowatt pentode by means of a small receiving vacuum tube and transformer. The frequency limitations are discussed and found to be about 20,000 kilocycles.
- R355.7 G. Grammar. An amplifier for the universal exciter unit. *QST*, vol. 17, pp. 22-23; December, (1933).  
The amplifier described, for use with a low-power transmitting set, uses an RK-18 vacuum tube. Outputs of 35 to 50 watts can be expected on frequencies from 1750 to 14,400 kilocycles.
- R361 A. N. Goldsmith. Conditions necessary for an increase in usable receiver fidelity. *Radio Engineering*, vol. 13, p. 22; November, (1933).  
The author discusses conditions for high fidelity, circuit elements, channel separation, and harmonic distortion in relation to receiving set design.
- R361 R. H. Langley. Trends in radio receiver design. *Radio Engineering*, vol. 13, pp. 12-14; November, (1933).  
The author draws attention to various opportunities for betterment of the design of receiving sets.
- R361 J. H. Barron. Receiver design and development as affecting broadcast allocation problems. *Radio Engineering*, vol. 13, pp. 16-17; November, (1933).  
In order to arrive at a satisfactory solution of interference problems arising before the Federal Radio Commission, a thorough study was made of the selectivity characteristics of receiving sets with proper weighing of the different types of receiving sets purchased in order to determine a selectivity curve representing what is believed to be an approximate average receiving set. Upon such a basis a dividing line between objectionable and unobjectionable interference was determined.
- R361.2 J. J. Lamb and F. E. Handy. Pre-selection and image rejection in short-wave superhets. *QST*, vol. 17, pp. 9-12; December, (1933).  
Practical applications adapted to typical high-frequency receiving sets of the superheterodyne type for the suppression of image-frequency interference are given.
- R365.3  
×R113.61 T. R. Gilliland. Note on a multi-frequency automatic recorder of ionosphere heights. *Bureau of Standards Journal of Research*, vol. 11, pp. 561-566; October, (1933). Research Paper No. 608.  
A system is described which gives a curve of virtual height of the ionosphere against frequency. Records are presented which show the characteristics for different times of day and night.

- R388 C. W. Taylor; L. B. Headrick; R. T. Orth. Cathode-ray tubes for oscillograph purposes. *Electronics*, vol. 6, pp. 332-333; December, (1933).

The common faults of cathode-ray tubes are given and remedies to clear up these faults discussed.

- R388 The cathode-ray oscillograph—What it is and how it works. *Wireless World*, vol. 33, pp. 356-357; November 3, (1933).

The principle of operation of the cathode-ray tube and its use in television work are explained.

#### R400. RADIO COMMUNICATION SYSTEMS

- R423.5 L. C. Sigmon. Notes on propagation of ultra-short waves. *Radio Engineering*, vol. 13, pp. 20-21; November, (1933).

Reports on the results obtained on 60,000 kilocycles tests in the metropolitan district of Boston are given. Stationary, automobile and aeroplane reception was experimented with.

#### R500. APPLICATIONS OF RADIO

- R526 Capt. Mioche. Les radiophares à l'usage de la navigation aérienne. (Use of radiobeacons in air navigation.) *Annales des Postes Télégraphes et Téléphones*, vol. 22, pp. 841-873; October, (1933).

Uses of radio aids to air navigation with special reference to the Bureau of Standards 4- and 12-course visual type radio range beacons are given.

- R528 H. Diamond. Performance tests of radio system of landing aids. *Bureau of Standards Journal of Research*, vol. 11, pp. 463-490; October, (1933). Research Paper No. 602.

Performance data are given on the operation of a radio system for blind landing over an extended period of time, which indicates its complete practicability for commercial use.

- R566 J. Dunsheath. A two-way police radio system. *Radio Engineering*,  
 ×R423.5 vol. 13, pp. 25-26; November, (1933).

Description of the two-way mobile system for police work which is located at Bayonne, N. J. The frequency used is 34,600 kilocycles.

- R570 Controlling receivers from the broadcast transmitter. *Electronics*, vol. 6, p. 327; December, (1933).

The possibilities of radio receiving sets being put into operation by a suitable signal from a broadcast station are discussed with a brief report of such experiments.

- R583 N. Levin. The Kerr cell and its application to television. *Marconi Review*, No. 44, pp. 13-21; September-October, (1933).

The article deals with the general application of the Kerr effect to television reception, and, in particular, to a novel optical system as used by the Marconi Company in its latest type of television projector receiving set. Details of the multiple Kerr cell used by the Marconi Company are also given.

- R583 E. W. Engstrom. A study of television image characteristics. *Proc. I.R.E.*, vol. 21, pp. 1631-1651; December, (1933).

- R583 E. W. Engstrom. An experimental television system. *Proc. I.R.E.*, vol. 21, pp. 1652-1654; December, (1933).

- R583 V. K. Zworykin. Description of an experimental television system and the kinescope. *Proc. I.R.E.*, vol. 21, pp. 1655-1673; December, (1933).

- R583 R. D. Kell. Description of experimental television transmitting apparatus. *Proc. I.R.E.*, vol. 21, pp. 1674-1691; December, (1933).

- R583 G. L. Beers. Description of experimental television receivers. *Proc.*  
 ×R361 *I.R.E.*, vol. 21, pp. 1692-1706; December, (1933).

## R600. RADIO STATIONS

- R612.1 NBC's new studios in Radio City. *Electronics*, vol. 6, pp. 324-326; December, (1933).

Plans and facilities of the broadcast studios are given.

## R800. NONRADIO SUBJECTS

- 534 D. C. McGalliard. The decibel and its uses. *Radio Engineering*, vol. 13, pp. 28-29; November, (1933).

The use of the decibel is explained in simple terms.

- 621.313.7 C. Bradner Brown. A voltage doubling power supply for the cathode-ray oscillograph. *Radio Engineering*, vol. 13, pp. 27, 30; November, (1933).

Description of a 1200-volt plate power supply as developed for use with the cathode ray oscillograph.

- 621.375.1 M. W. Muehter. Vacuum tube delay circuits. *Electronics*, vol. 6, pp. 336-337; December, (1933).

Several time-delay circuit arrangements using vacuum tubes are shown and discussed.

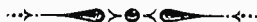

**CONTRIBUTORS TO THIS ISSUE**

**Barrow, W. L.:** Born October 25, 1903, at Baton Rouge, Louisiana. Received B.S. degree in electrical engineering, Louisiana State University, 1926; law student, Louisiana State University, 1926-1927; M.S. degree in electrical engineering, Massachusetts Institute of Technology, 1929; D.C. degree in physics, Technische Hochschule, Munich, Germany, 1931. Assistant, electrical engineering department, Louisiana State University, 1925-1926; instructor, communications division, electrical engineering department, Massachusetts Institute of Technology, 1928-1929; Redfield Proctor Fellow in physics, Technische Hochschule, Munich, 1929-1931; research and instructor, communications division, Round Hill, Massachusetts Institute of Technology, 1931 to date. Associate member, Institute of Radio Engineers, 1928.

**Berkner, Lloyd V.:** Born February 1, 1905, at Milwaukee, Wisconsin. Received B.S. degree in electrical engineering, University of Minnesota, 1927. Assistant radio engineer, airways division, Department of Commerce, 1927, to June, 1928; representing the Bureau of Standards with Byrd Antarctic Expedition, June, 1928, to June, 1930; associate radio engineer, Bureau of Standards, June, 1930, to July, 1933; associate physicist, Department of Terrestrial Magnetism, Carnegie Institution of Washington, July, 1933, to date. Associate member, American Institute of Electrical Engineers. Associate Member, Institute of Radio Engineers, 1926.

**Everitt, William Littell:** Born April 14, 1900, at Baltimore, Maryland. Received E.E. degree, Cornell University, 1922; M.S. degree, University of Michigan, 1926; Ph.D. degree, Ohio State University, 1933. Instructor in electrical engineering, Cornell University, 1920-1922; engineer in charge of laboratory and P.B.X. development, North Electric Manufacturing Company, Galion, Ohio, 1922-1924; instructor in electrical engineering, University of Michigan, 1924-1926; assistant professor of electrical engineering in charge of communication courses, Ohio State University, 1926-1929; associate professor, 1929 to date. Department of development and research, American Telephone and Telegraph Company, summers, 1925-1930, inclusive. Associate member, Institute of Radio Engineers, 1925; Member, 1929.

**Gilliland, T. R.:** Born March 16, 1903, at Danville, Illinois. Received B.S. degree in electrical engineering, California Institute of Technology, 1927; M.S. degree in communication engineering, Harvard University, 1931. Commercial radio operator, aboard ship for two years between 1923 and 1927. Radio Section, Bureau of Standards, 1928-1930, and June, 1931, to date. Associate member, Institute of Radio Engineers, 1928.

**Groszkowski, Janusz:** Born March 21, 1898, at Warsaw, Poland. Received Doctor of Technical Science degree, Warsaw Polytechnical High School, 1927; professor, Warsaw Polytechnical High School, 1929 to date. Director, Radio Institute, Warsaw, and State Institute of Telecommunications, Ministry of Post, Telegraph and Telephones, Poland. Member, Institute of Radio Engineers, 1931.

**Ide, J. M.:** Born August 17, 1907, at Mt. Vernon, New York. Received A.B. degree, Pomona College, 1927; M.S. degree, 1929; Sc.D. degree, Harvard University, 1931. Holder of Harvard Engineering School Prize Scholarship, 1927-1928. Assistant in physics, Harvard University, 1930-1931; instructor, 1931 to date. Junior member, Institute of Radio Engineers, 1928; Associate member, 1930.

**Kirby, S. S.:** Born October 27, 1893, at Gandy, Nebraska. Received A.B. degree, College of Emporia, Emporia, Kansas, 1917; M.A. degree, University of Kansas, 1921. Signal Corps U. S. Army, A.E.F., 1918-1919. High School teacher, 1919-1921; professor of physics, Friends University, Wichita, Kansas, 1921-1926; assistant physicist, Bureau of Standards, 1926-1930; associate physicist, Bureau of Standards, 1930 to date. Associate member, Institute of Radio Engineers, 1927.

**Lee, Reuben:** Born November 8, 1902, at Shirland, Derbyshire, England. Received B.S. degree in electrical engineering, West Virginia University, 1924. Westinghouse Electric and Manufacturing Company, 1924 to date. Student course, 1924; control engineering department, 1925-1928; radio engineering department, 1928 to date. Member, Tau Beta Pi. Associate member, Institute of Radio Engineers, 1932.

**Norton, K. A.:** Born February 27, 1907, at Rockwell City, Iowa. Received B.S. degree, University of Chicago, 1928. Inspection development laboratory, Western Electric Company, 1929. Columbia University, 1930-1931. Radio Section, Bureau of Standards, July, 1929, to September, 1930, and June, 1931, to date. Associate member, Institute of Radio Engineers, 1929.

**Taylor, Paul B.:** Born September 21, 1891, at Santa Monica, California. Received A.B. degree, 1913; M.A. degree, University of California, 1920; Ph.D. degree in physics, University of Pennsylvania, 1927. Assistant in mathematics, 1912-1914; assistant in physics, University of California, 1918. Served in Air Service, 1919. Junior physicist, United States Bureau of Mines, 1919-1920. Instructor in physics, Massachusetts Institute of Technology, 1920-1922. Associate physicist, Bureau of Standards and Frankford Arsenal, 1922-1924. Instructor in mathematics, Drexel Institute, 1925-1926. Physicist, Victor Talking Machine Company, 1927-1929; radio engineer, Westinghouse Electric and Manufacturing Company, 1929-1933. Member, Sigma Xi; associate member, Acoustical Society of America, A.I.E.E. Nonmember, Institute of Radio Engineers.

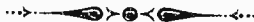



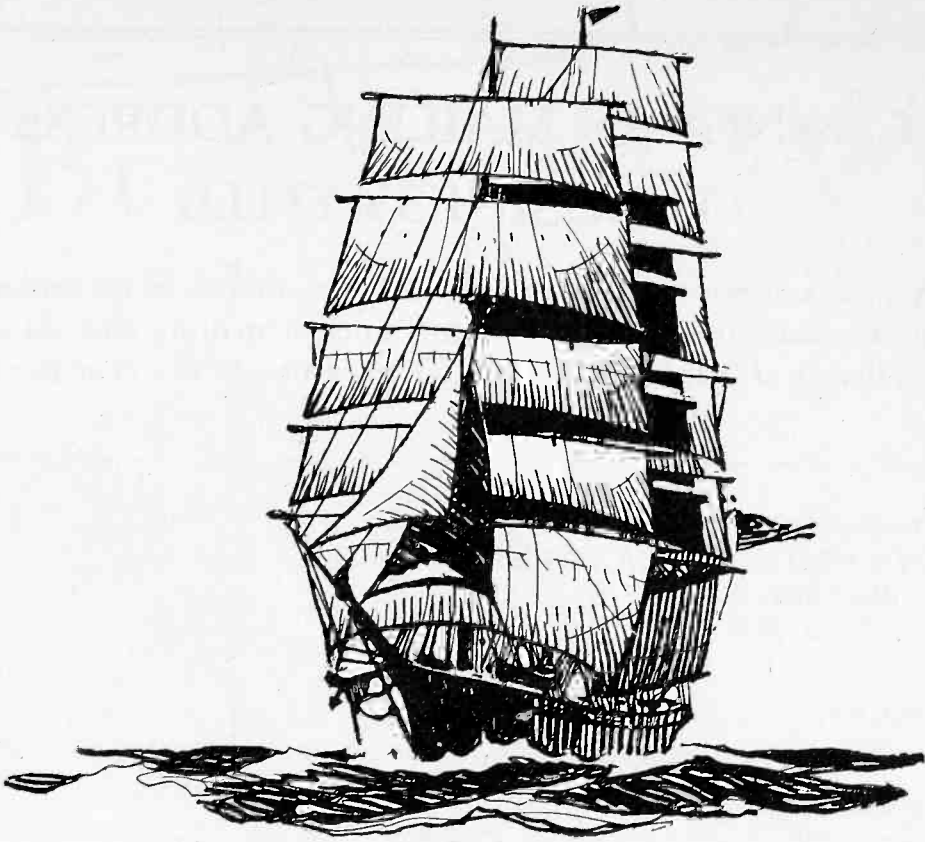

THESE MEN...

# STEER THEIR OWN SHIP

**T**HE majority of the stock of Hygrade Sylvania Corporation is owned by the same men who manage and control the business.

These men have skillfully steered their own ship through some of the most difficult years ever known in the radio industry. Today Hygrade Sylvania Corporation makes a major portion of the tubes installed as original set equipment.

Hygrade Sylvania engineers pioneered in the development of the more efficient 6.3 volt tube for automobile sets and general usage. These same engineers are always ready to help set manufacturers solve circuit and design problems . . . without charge or obligation.

Thus "management-owned" is more than a phrase. It is a guarantee of quality standards and full cooperation. Hygrade Sylvania Corporation, Emporium, Penna.

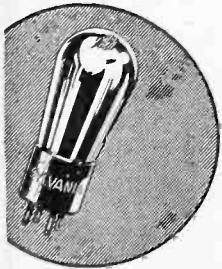

# Sylvania

(Reg. U S. Pat. Off.)

## THE SET-TESTED RADIO TUBE

*When writing to advertisers mention of the PROCEEDINGS will be mutually helpful.*

# CHANGE IN MAILING ADDRESS OR BUSINESS TITLE

Members of the Institute are asked to use this form for notifying the Institute office of a change in their mailing address or the listing of their company affiliation or title in the Year Book.

The Secretary,  
THE INSTITUTE OF RADIO ENGINEERS,  
33 West 39th Street,  
New York, N.Y.

Dear Sir:

Effective ..... please note change in my address  
(date)  
for mail as follows:

FROM

.....  
(Name)

.....  
(Street Address)

.....  
(City and State)

TO NEW ADDRESS

.....  
(Street Address)

.....  
(City and State)

Please note following change in my Year Book listing.

.....  
(Title)

.....  
(Company Name)

.....  
(Company Address)

# BUT IT'S FAIR AND WARM BY TELEPHONE!

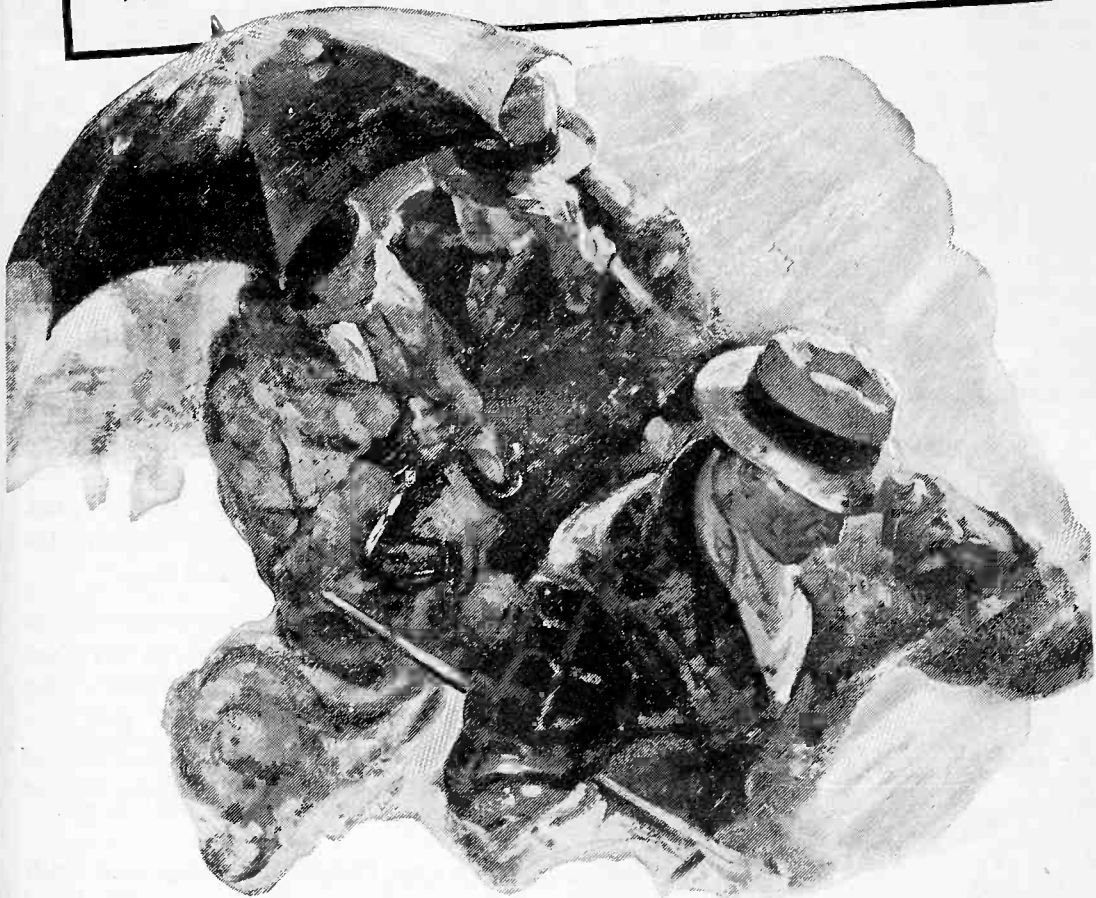

ALL outdoors may be frowning, the thermometer close to zero, street travel an exhausting task. Yet to your telephone it is as clear and fair as a day in June.

Without moving from your chair at home or in your office, you can send your voice across the snow-swept miles. Through all the days of the year, the telephone is your contact with the world beyond your door. It knows no season — no letting up when

the going gets hard. Through storm and flood, an army of trained employees works ceaselessly along the highways of speech. So that the service may go on. So that you may talk to almost anyone, anywhere, at any time.

*Make someone happy these winter days through a voice visit by telephone. A boy or girl at school, a mother or father in another city, or a good friend away on a visit. To most places 175 miles away, for example, the rate for a station-to-station call is 95c in the daytime, 85c after 7 P. M., and 55c after 8:30 P. M.*



**BELL TELEPHONE SYSTEM**

*When writing to advertisers mention of the PROCEEDINGS will be mutually helpful.*

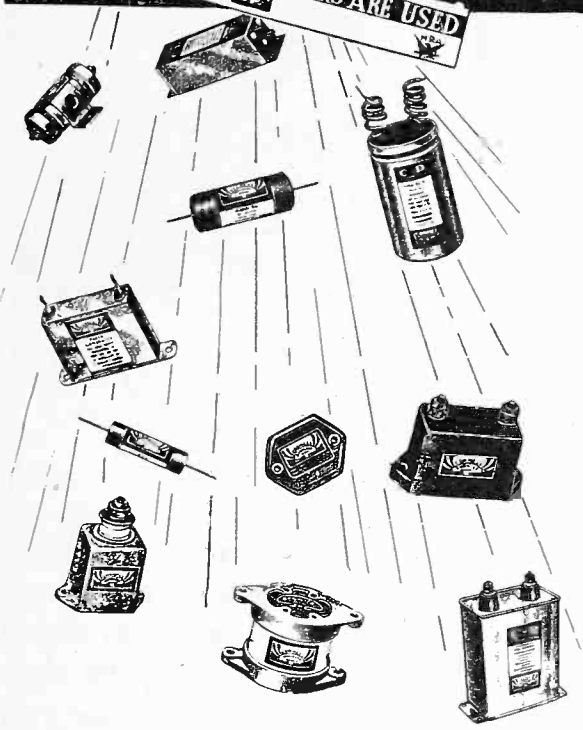
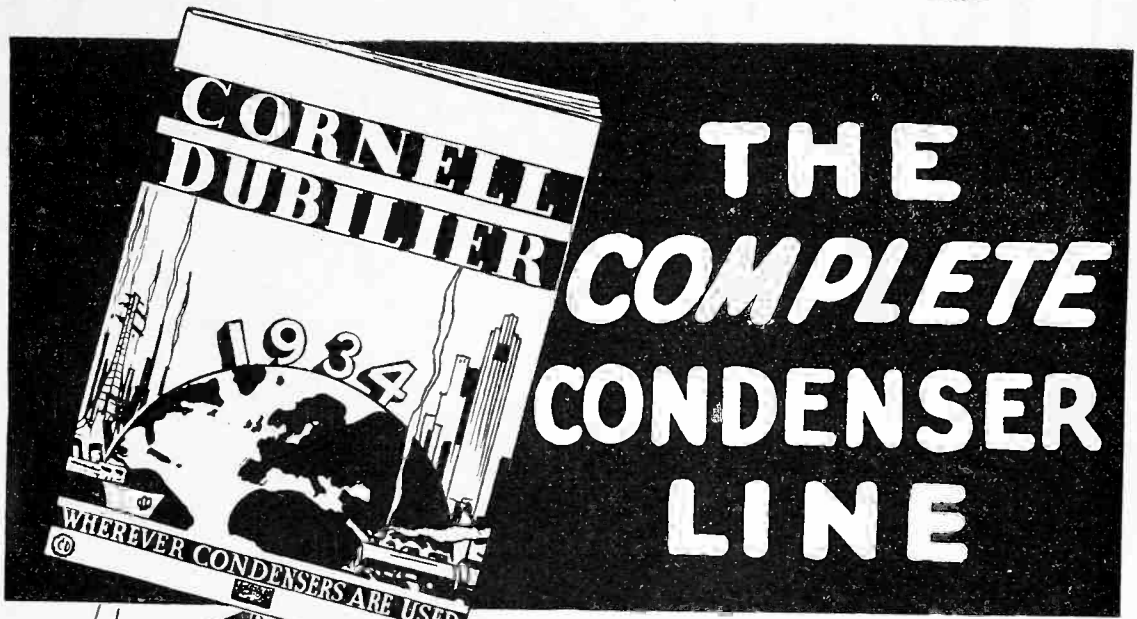

WITH the unification of the former Cornell and Dubilier lines, a single organization now offers you the only *complete* condenser line.

From tiny cartridge condenser of the paper or electrolytic type, to the giant mica capacitors for the world's most powerful radio transmitter, the Cornell-Dubilier organization is prepared to meet every need of the radio art and industry.

The new 1934 C-D catalog, now ready for distribution, covers the unified and complete line. Within its covers will be found every standard type, design and size of capacitor for receiving, transmitting, amplifying, power supply and allied purposes.

Send for Your Copy of the new 1934 C-D Catalog. And if you have capacitor problems or special requirements to be met, do not hesitate to enlist the collaboration of our condenser engineers.



CORNELL-DUBILIER CORPORATION

4377 Bronx Boulevard - - - New York City

When writing to advertisers mention of the PROCEEDINGS will be mutually helpful.

# The Institute of Radio Engineers

Incorporated

33 West 39th Street, New York, N. Y.

## APPLICATION FOR ASSOCIATE MEMBERSHIP

(Application forms for other grades of membership are obtainable from the Institute)

To the Board of Directors  
Gentlemen:

I hereby make application for Associate membership in the Institute of Radio Engineers on the basis of my training and professional experience given herewith, and refer to the members named below who are personally familiar with my work.

I certify that the statements made in the record of my training and professional experience are correct, and agree if elected, that I will be governed by the constitution of the Institute as long as I continue a member. Furthermore I agree to promote the objects of the Institute so far as shall be in my power, and if my membership shall be discontinued will return my membership badge.

.....  
(Sign with pen)

.....  
(Address for mail)

.....  
(Date)

.....  
(City and State)

### Sponsors:

(Signature of references not required here)

Mr. .... Mr. ....

Address ..... Address .....

City and State ..... City and State .....

Mr. ....

Address .....

City and State .....

The following extracts from the Constitution govern applications for admission to the Institute in the Associate grade:

#### ARTICLE II—MEMBERSHIP

Sec. 1: The membership of the Institute shall consist of: \* \* \* (c) Associates, who shall be entitled to all the rights and privileges of the Institute except the right to hold any elective office specified in Article V. \* \* \*

Sec. 4. An Associate shall be not less than twenty-one years of age and shall be a person who is interested in and connected with the study or application of radio science or the radio arts.

#### ARTICLE III—ADMISSION AND EXPULSIONS

Sec. 2: \* \* \* Applicants shall give references to members of the Institute as follows: \* \* \* for the grade of Associate, to three Fellows, Members, or Associates; \* \* \* Each application for admission \* \* \* shall embody a full record of the general technical education of the applicant and of his professional career.

#### ARTICLE IV—ENTRANCE FEE AND DUES

Sec. 1: \* \* \* Entrance fee for the Associate grade of membership is \$3.00 and annual dues are \$6.00.

*ENTRANCE FEE SHOULD ACCOMPANY APPLICATION*

(Typewriting preferred in filling in this form) No.....

**RECORD OF TRAINING AND PROFESSIONAL EXPERIENCE**

Name .....  
(Give full name, last name first)

Present Occupation .....  
(Title and name of concern)

Business Address .....

Permanent Home Address .....

Place of Birth..... Date of Birth..... Age.....

Education .....

Degree .....  
(college) (Date received)

**TRAINING AND PROFESSIONAL EXPERIENCE**

DATES

Record may be continued on other sheets of this size if space is insufficient.

Receipt Acknowledged..... Elected..... Deferred.....  
Grade ..... Advised of Election..... This Record Filed.....

# A Good Combination *for* Auto Radios

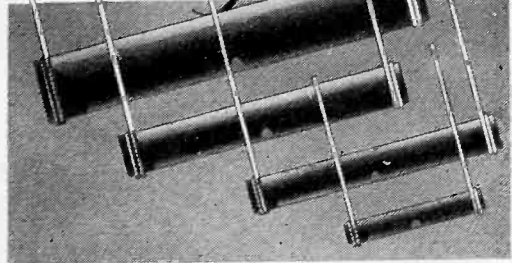

Erie moulded carbon resistors in the set . . . Erie Suppressor Resistors on the distributor lead and spark plugs . . . an unbeatable combination for automobile radios.

## *Erie Resistors*

The conservative rating of Erie Resistors permits the use of smaller size units, an important factor in auto radios where compactness is essential. Overloads of 50% of continuous rating produce no failures after 2,000 hours of testing.

Vibration holds no terrors for Erie Resistors. Leads are permanently soldered directly to the body of the resistor; there are no metal caps to work loose.

## *Erie Suppressors*

Exhaustive tests in our own laboratory and in actual use prove that Erie Suppressor Resistors change less than 5% in resistance value after 50,000 miles of service.

Durable Bakelite covers keep out engine heat, moisture and grease. Even at 120° C. and 100% relative humidity, they will not fail mechanically.

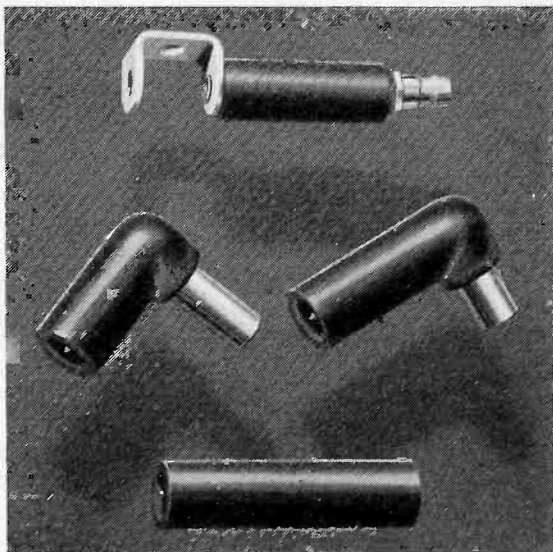

It will pay you to investigate the efficiency of these Erie products. Our engineering staff will gladly work with you on any problems you have.

# **ERIE RESISTOR CORPORATION**

▲ **ERIE, PA.** ▼

**Factories in ERIE, PA. - TORONTO, CANADA - LONDON, ENG.**

*When writing to advertisers mention of the PROCEEDINGS will be mutually helpful.*

# PROFESSIONAL ENGINEERING DIRECTORY

TO

CONSULTANTS

DESIGNERS

PATENT

ATTORNEYS

Cathode Ray Tubes  
and Associated  
Equipment For All  
Purposes

*Write for Complete  
Technical Data*

ALLEN B. DUMONT  
LABORATORIES  
UPPER MONTCLAIR, N.J.

## PRACTICAL RADIO ENGINEERING

One year Residence Course  
Advanced Home Study Course  
Combined Home Study-Residence  
Course

*Write for details*

Capitol Radio Engineering  
Institute  
Washington, D.C.

We

suggest

the use

of the

Professional  
Engineering Directory

## *Alphabetical Index to Advertisements*

	A	
American Tel. & Tel. Co. ....		IX
	C	
Central Radio Laboratories .....		XVI
Cornell-Dubilier Corp. ....		X
	E	
Erie Resistor Corp. ....		XIII
	G	
General Radio Co. ....		Outside Back Cover
	H	
Hygrade Sylvania Corp. ....		VII
	I	
I.R.E. ....		VIII, XI, XII, Inside Back Cover
	P	
Professional Eng. Directory .....		XIV
	W	
Weston Elec. Inst. Corp. ....		XV



AN  
*Accurate*  
INDICATOR  
OF  
CAPACITY  
VALUES

Here is another accurate indicator of radio's fundamentals—one of a complete line bearing the name Weston. To the dealer and service man this means that the instrument is the "last word" in test equipment . . . that it will prove a dependable and profitable partner in his business.

Like other Weston instruments Model 664 will not become obsolete because of its wide ranges and because it indicates in fundamental units—microfarads and volts. It can be furnished in a leatherette covered carrying case, or will fit into the Weston Standardized Service Kits along with other Weston standardized service units. All the facts are included in the Weston bulletin. Send for your copy. Use the coupon today . . . Weston Electrical Instrument Corporation, 589 Frelinghuysen Avenue, Newark, N. J.



**WESTON**  
*Radio Instruments*

WESTON ELECTRICAL INSTRUMENT CORPORATION  
589 Frelinghuysen Avenue, Newark, N. J.

Send Bulletin on Weston Radio Instruments.

Name \_\_\_\_\_

Address \_\_\_\_\_

City & State \_\_\_\_\_

When writing to advertisers mention of the PROCEEDINGS will be mutually helpful.

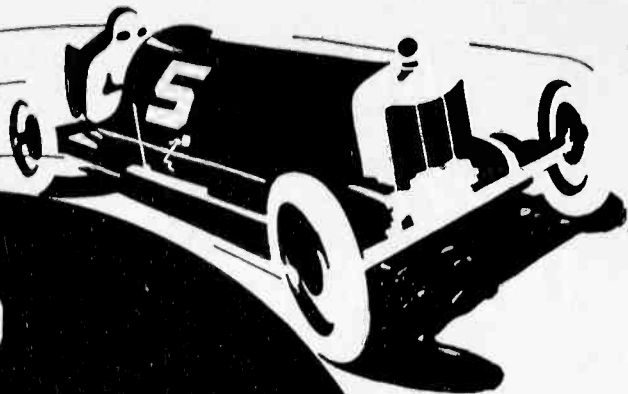

no  
"hugging the fence"  
with the *New*  
**Centralab**  
**radiohm**

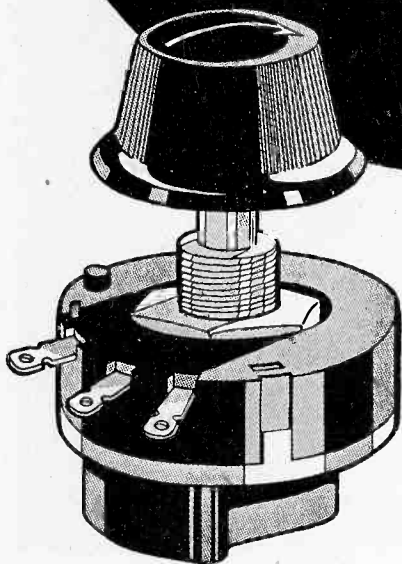

Unlike the old annular type resistors, there is no inner fence to hug in the new Centralab Radiohm.

Here is a resistor that distributes the load uniformly across its entire width. And because it is located on the inner circumference of the case, large resistor area is combined with small size.

**CENTRAL RADIO LABORATORIES**  
MILWAUKEE, WISCONSIN

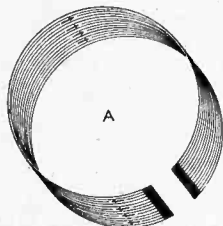

Resistor A used in the new Radiohm, has the same length path across its entire width, giving greater effective area for good volume control.

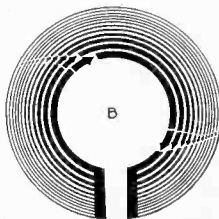

Resistor B of annular shape, has long been the standard type. Current concentrates around the INNER edge, i.e., the shortest path.

*When writing to advertisers mention of the PROCEEDINGS will be mutually helpful.*

# Take Your Choice

Every member of the Institute of Radio Engineers will want to wear one of these three attractive emblems. All of these emblems are appropriately colored to indicate the various grades of membership and each emblem is approximately the size of the following illustrations.



The Lapel Button is of 14k gold, with background enameled in the membership color, and with the lettering in gold. The screw-back on the back of this button fastens it securely to your coat.

\$2.75 postpaid—any grade.



The Pin is also of 14k gold. It is provided with a safety catch and is appropriately colored for the various grades of membership.

\$3.00 postpaid—any grade.



The Watch Charm, handsomely finished on both sides, is also of 14k gold. This charm is equipped with a suspension ring for attaching to a watch fob or chain.

\$5.00 postpaid—any grade.

*Orders, accompanied by checks made payable to the Institute of Radio Engineers, should be addressed to*

**THE INSTITUTE OF RADIO ENGINEERS**

33 West 39th Street  
NEW YORK CITY, N.Y.

*Send in your order now!*

---

---

## AUDIO FREQUENCY GAIN MEASUREMENTS SIMPLIFIED

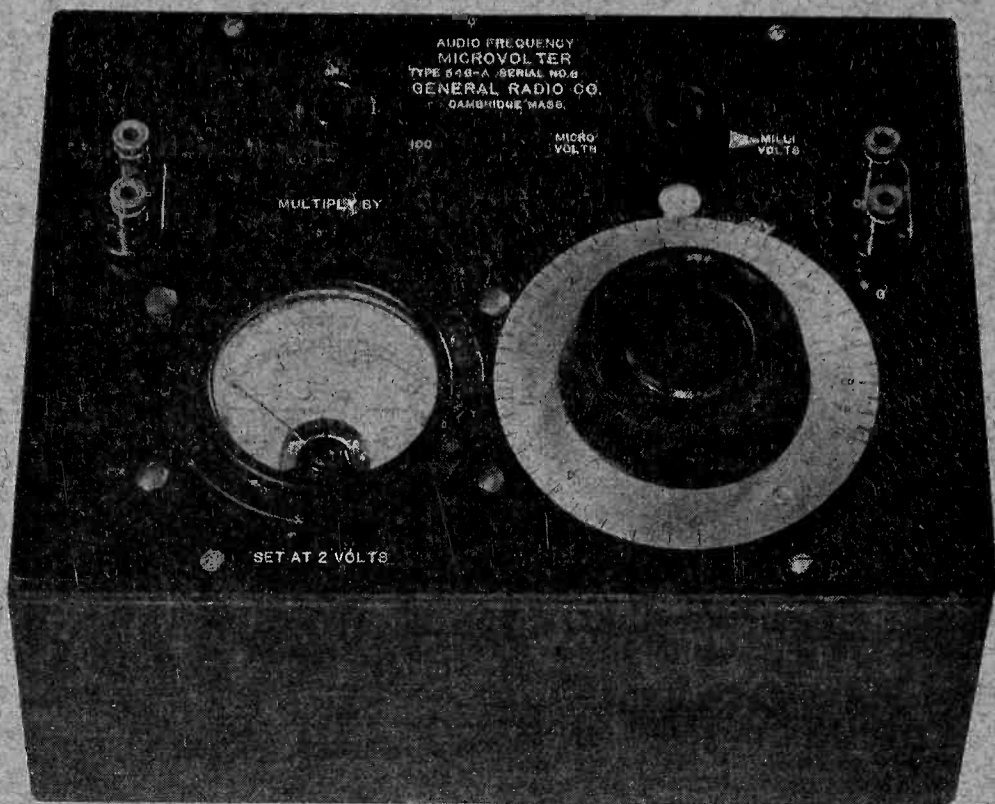

**T**HE familiar standard-signal generator technique is applied to audio-frequency testing by means of the Type 546-A Audio-Frequency Microvolter, which incorporates an attenuator and input voltmeter. Used with a voltage source and an output power meter, it provides all the equipment necessary for gain measurements.

Other uses include calibrations in low voltage ranges. The range of the microvolter is 1 microvolt to 1 volt.

Price: \$70.00

SEND FOR BULLETIN asking. Address a request for Bulletin  
A complete description of this Audio-Frequency Microvolter is yours for the EX-3306R to the General Radio Company, Cambridge, Massachusetts.

# GENERAL RADIO

---

---

GEORGE BANTA PUBLISHING COMPANY, MENASHA, WISCONSIN