

VOLUME 20

JANUARY, 1932

NUMBER 1

PROCEEDINGS
of
**The Institute of Radio
Engineers**



**Twentieth Anniversary
Convention**

**Pittsburgh, Pennsylvania
April 7, 8, 9, 1932**

Form for Change of Mailing Address or Business Title on Page XXXV

Institute of Radio Engineers

Forthcoming Meeting

CINCINNATI SECTION

January 19, 1932

DETROIT SECTION

January 15, 1932

NEW YORK MEETINGS

January 6, 1932

February 3, 1932

PROCEEDINGS OF

The Institute of Radio Engineers

Volume 20

January, 1932

Number 1

Board of Editors

ALFRED N. GOLDSMITH, *Chairman*

STUART BALLANTINE	G. W. PICKARD
RALPH BATCHER	L. E. WHITEMORE
W. WILSON	

CONTENTS

	Page
PART I	
Frontispiece, Convention Committee, Rochester Fall Meeting, 1931.....	2
Institute News and Radio Notes.....	3
December Meeting of the Board of Directors.....	3
Rochester Fall Meeting, 1931.....	5
Radio Signal Transmissions of Standard Frequency.....	6
Committee Work.....	7
Institute Meetings.....	11
Personal Mention.....	23
PART II	
<i>Technical Papers</i>	
The Optics of Radio Transmission..... ERNEST MERRITT	29
Ten Years of Transradio—A Retrospect..... E. QUACK	40
On the Use of Field Intensity Measurements for the Determination of Broadcast Station Coverage... C. M. JANSKY, JR. AND S. L. BAILEY	62
Effect of Shore Station Location Upon Signals..... R. A. HEISING	77
An Untuned Radio-Frequency Amplifier..... F. W. SCHOR	87
Historical Review of Ultra-Short-Wave Progress. WILLIAM H. WENSTROM	95
An Experimental Study of Regenerative Ultra-Short-Wave Oscillators... WILLIAM H. WENSTROM	113
An Experimental Study of the Tetrode as a Modulated Radio-Frequency Amplifier..... H. A. ROBINSON	131
Theory of Design and Calibration of Vibrating Reed Indicators for Radio Range Beacons..... G. L. DAVIES	161
Some Experimental Studies of the Vibrations of Quartz Plates (abstract). R. B. WRIGHT AND D. M. STUART	182
Book Reviews: "Experimental Radio Engineering," by John H. Morecroft S. S. KIRBY	183
"The Orfordness Rotating Beacon and Marine Navigation," by R. L. Smith-Rose..... S. S. KIRBY	183
"Données Numeriques de Radioelectricité," edited by R. Mesny..... S. S. KIRBY	183
"Radio in Advertising," by Orrin E. Dunlap. K. A. NORTON	184
"Radio Handbook," by Moyer and Wostrel... S. S. KIRBY	184
Booklets, Catalogs, and Pamphlets Received.....	185
Radio Abstracts and References.....	186
Contributors to this Issue.....	192

Copyright, 1932, by the Institute of Radio Engineers

The Institute of Radio Engineers

GENERAL INFORMATION

The PROCEEDINGS of the Institute is published monthly and contains papers and discussions thereon submitted for publication or for presentation before meetings of the Institute or its Sections. Payment of the annual dues by a member entitles him to one copy of each number of the PROCEEDINGS issued during the period of his membership.

Subscription rates to the PROCEEDINGS for the current year are received from nonmembers at the rate of \$1.00 per copy or \$10.00 per year. To foreign countries the rates are \$1.10 per copy or \$11.00 per year.

Back issues are available in unbound form for the years 1918, 1920, 1921, 1922, 1923, and 1926 at \$9.00 per volume (six issues) or \$1.50 per single issue. For the years 1913, 1914, 1915, 1916, 1917, 1919, 1923, 1924, and 1925 miscellaneous copies (incomplete unbound volumes) can be purchased for \$1.50 each; for 1927, 1928, 1929, 1930, and 1931 at \$1.00 each. The Secretary of the Institute should be addressed for a list of these.

Discount of twenty-five per cent is allowed on all unbound volumes or copies to members of the Institute, libraries, booksellers, and subscription agencies.

Bound volumes are available as follows: for the years 1922 and 1926 to members of the Institute, libraries, booksellers, and subscription agencies at \$8.75 per volume in blue buckram binding and \$10.25 in morocco leather binding; to all others the prices are \$11.00 and \$12.50 respectively. For the year 1929 and 1930 the bound volumes prices are: to members of the Institute, libraries, booksellers, and subscription agencies, \$9.50 in blue buckram binding; to all others, \$12.00. Foreign postage on all bound volumes is one dollar, and on single copies is ten cents.

The 1931 YEAR BOOK, containing general information, the Constitution and By-Laws, Standards Report, Index to past issues of the PROCEEDINGS, Catalog of Membership, etc., is available to members at \$1.00; to nonmembers, \$1.50.

Contributors to the PROCEEDINGS are referred to the following page for suggestions as to approved methods of preparing manuscripts for publication in the PROCEEDINGS.

Advertising rates for the PROCEEDINGS will be supplied by the Institute's Advertising Department, Room 802, 33 West 39th Street, New York, N.Y.

Changes of address to affect a particular issue must be received at the Institute office not later than the 15th of the month preceding date of issue. That is, a change in mailing address to be effective with the October issue of the PROCEEDINGS must be received by not later than September 15th. Members of the Institute are requested to advise the Secretary of any change in their business connection or title irrespective of change in their mailing address, for the purpose of keeping the Year Book membership catalog up to date.

The right to reprint portions or abstracts of the papers, discussions, or editorial notes in the PROCEEDINGS is granted on the express condition that specific reference shall be made to the source of such material. Diagrams and photographs published in the PROCEEDINGS may not be reproduced without making special arrangements with the Institute through the Secretary.

It is understood that the statements and opinions given in the PROCEEDINGS are views of the individual members to whom they are credited, and are not binding on the membership of the Institute as a whole.

All correspondence should be addressed to the Institute of Radio Engineers, 33 West 39th Street, New York, N.Y., U.S.A.

Entered as second class matter at the Post Office at Menasha, Wisconsin.

Acceptance for mailing at special rate of postage provided for in the Act of February 28, 1925, embodied in paragraph 4, Section 412, P. L. and R. Authorized October 26, 1927.

Published monthly by

THE INSTITUTE OF RADIO ENGINEERS, INC.

Publication office, 450-454 Ahnaip Street, Menasha, Wis.

BUSINESS, EDITORIAL, AND ADVERTISING OFFICES,

Harold P. Westman, *Secretary*

33 West 39th St., New York, N.Y.

SUGGESTIONS FOR CONTRIBUTORS TO THE "PROCEEDINGS"

Preparation of Paper

Form—Manuscripts may be submitted by member and nonmember contributors from any country. To be acceptable for publication, manuscripts should be in English, in final form for publication, and accompanied by a summary of from 100 to 300 words. Papers should be typed double space with consecutive numbering of pages. Footnote references should be consecutively numbered and should appear at the foot of their respective pages. Each reference should contain author's name, title of article, name of journal, volume, page, month, and year. Generally, the sequence of presentation should be as follows: statement of problem; review of the subject in which the scope, object, and conclusions of previous investigations in the same field are covered; main body describing the apparatus, experiments, theoretical work, and results used in reaching the conclusions and their relation to present theory and practice; bibliography. The above pertains to the usual type of paper. To whatever type a contribution may belong, a close conformity to the spirit of these suggestions is recommended.

Illustrations—Use only jet black ink on white paper or tracing cloth. Cross-section paper used for graphs should not have more than four lines per inch. If finer ruled paper is used, the major division lines should be drawn in with black ink, omitting the finer divisions. In the latter case, only blue-lined paper can be accepted. Photographs must be very distinct, and must be printed on glossy white paper. Blueprinted illustrations of any kind cannot be used. All lettering should be 3/16 in. high for an 8 x 10 in. figure. Legends for figures should be tabulated on a separate sheet, not lettered on the illustrations.

Mathematics—Fractions should be indicated by a slanting line. Use standard symbols. Decimals not preceded by whole numbers should be preceded by zero, as 0.016. Equations may be written in ink with subscript numbers, radicals, etc., in the desired proportion.

Abbreviations—Write a.c. and d.c. (a.c. and d.c. as adjectives), kc, μf , $\mu\mu f$, e m f., m.h., μh , henries, abscissas, antennas. Refer to figures as Fig. 1, Figs. 3 and 4, and to equations as (5). Number equations on the right in parentheses.

Summary—The summary should contain a statement of major conclusions reached, since summaries in many cases constitute the only source of information used in compiling scientific reference indexes. Abstracts printed in other journals, especially foreign, in most cases consist of summaries from published papers. The summary should explain as adequately as possible the major conclusions to a nonspecialist in the subject. The summary should contain from 100 to 300 words, depending on the length of the paper.

Publication of Paper

Disposition—All manuscripts should be addressed to the Institute of Radio Engineers, 33 West 39th Street, New York City. They will be examined by the Committee on Papers and by the Editor. Authors are advised as promptly as possible of the action taken, usually within one month.

Proofs—Galley proof is sent to the author. Only necessary corrections in typography should be made. *No new material is to be added.* Corrected proofs should be returned *promptly* to the Institute of Radio Engineers, 33 West 39th Street, New York City.

Reprints—With the galley proof a reprint order form is sent to the author. Orders for reprints must be forwarded promptly as type is not held after publication.

INSTITUTE SECTIONS

<i>Chairmen</i>	<i>Secretaries</i>
	ATLANTA
H. F. Dobbs	Philip C. Bangs, 23 Kensington Rd., Avondale Estates, Ga.
	BOSTON
George W. Pierce	Melville Eastham, 30 State St., Cambridge, Mass.
	BUFFALO-NIAGARA
L. Grant Hector	E. C. Waud, 235 Huntington Ave., Buffalo, N. Y.
	CHICAGO
Byron B. Minnium	J. Barton Hoag, Ryerson Laboratory, University of Chicago, Chicago, Ill.
	CINCINNATI
D. D. Israel	H. G. Boyle, Crosley Radio Corp., Cincinnati, Ohio.
	CLEVELAND
G. B. Hammon	P. A. Marsal, National Carbon Co., Inc., P.O. Box No. 400, Cleveland, Ohio.
	CONNECTICUT VALLEY
R. S. Kruse	George Grammer, 334 South Quaker Lane, West Hartford, Conn.
	DETROIT
Lewis N. Holland	Samuel Firestone, Room 615, 2000 Second Ave., Detroit, Mich.
	LOS ANGELES
T. E. Nikirk	L. Elden Smith, 345 N. Painter Ave., Whittier, Calif.
	NEW ORLEANS
Pendleton E. Lehde	Anton A. Schiele, 1812 Masonic Temple, New Orleans, La.
	PHILADELPHIA
G. W. Carpenter	G. C. Blackwood, 243 E. Upsal St., Mt. Airy, Philadelphia, Pa.
	PITTSBURGH
J. G. Allen	J. G. McKinley, West Penn Electric Co., 14 Wood St., Pittsburgh, Pa.
	ROCHESTER
H. A. Brown	M. A. Wood, 175 Winbourne Ave., Rochester, N. Y.
	SAN FRANCISCO
Ralph M. Heintz	Frederick E. Terman, Stanford University, Calif.
	SEATTLE
Abner R. Willson	L. C. Austin, 540 N. 82nd St., Seattle, Wash.
	TORONTO
F. K. Dalton	W. F. Choat, 355 King St., W., Toronto, Ont., Canada.
	WASHINGTON
L. P. Wheeler	Herbert G. Dorsey, U. S. Coast and Geodetic Survey, Washington, D. C.

GEOGRAPHICAL LOCATION OF MEMBERS ELECTED DECEMBER 2, 1931

Transferred to the Fellow Grade

New Jersey	Upper Montclair, 9 Bradford Way	DuMont, A. B.
New York	Flushing, 4360-170th St.	Farrington, J. F.

Transferred to the Member Grade

New Jersey	Haddonfield, 504 Avondale Ave.	Whelan, D. O.
------------	--	---------------

Elected to the Member Grade

Massachusetts	Watertown, 59 Bailey Rd.	Bareiss, M.
---------------	----------------------------------	-------------

Elected to the Associate Grade

Alabama	Birmingham, 8300 Division Ave.	Godwin, C. E.
Arizona	Phoenix, 914 N. 3rd St.	Grigg, J. W.
	Whiteriver	Mentor, E. L.
California	Fullerton, 230 W. Chapman St.	Mathewson, E. L.
	Hollywood, 1415 N. Fairfax Ave.	Kelch, M.
	Hollywood, 1337 N. Gardner St.	Ruggles, J. E.
	Los Angeles, 2419 S. Highland Ave.	Davis, H.
	Los Angeles, 1621-4th Ave.	Simonds, W. E.
	Oakland, 243-30th St.	Black, L. J.
	San Francisco, c/o KFRC, 1000 Van Ness Ave.	Baldwin, R. S.
	San Gabriel, 243 N. Bradbury Dr.	Henry, R. E.
	Tracy, P.O. Box 12	Kurth, W. O.
	Van Nuys, 6952 Vesper Ave.	Chesney, A. P.
Connecticut	Hartford, 64 Webster St.	Roach, J. C.
Dist. of Columbia	Washington, Saul Rd., Chevy Chase	Hodge, A. H.
	Washington, c/o Graybar Elec. Co., 714-12th St., N.W.	Whitten, L. H.
Florida	Palatka, Box 456	Peterson, T. R.
Georgia	Atlanta, 1533 Melrose Dr., S.W.	King, S. O., Jr.
Illinois	Chicago, 6548 Woodlawn Ave.	Oliver, M. J.
	Evanston, 2630 Prairie Ave.	Butow, A. J.
	Urbana, 208 N. Harvey St.	Abel, A. E., Jr.
Indiana	Goshen, 302 N. Main St.	Rieth, H.
Kansas	Fort Scott, 407 S. Holbrook St.	Hess, H. H.
Kentucky	Paducah, 210 N. 13th St.	Sims, C. G.
Louisiana	New Orleans, 202½ Bourbon St.	Hymel, L. F.
Maine	Rockland, 397 Main St.	Fickett, L. W.
Michigan	Detroit, 7626 Duncan Ave.	Lettich, M. M.
	Detroit, 12897 Woodward Ave.	Schall, R. C.
	Hastings, 213 W. State St.	Branch, R.
Minnesota	Rochester, 1225-1st St., S.W.	Biltz, F. J.
	St. Paul, 562 Holly Ave.	Skifter, H. R.
Missouri	Kansas City, 118 W. 47th St.	Sears, E. W.
	Kansas City, Radio Station WOQ, 917 Tracy Ave.	Winchel, H. T.
New Jersey	Atlantic City, 420 N. Massachusetts Ave.	Helmuth, C. F.
	Atlantic Highlands, R.F.D. 116	Eastmond, H. V.
	Jersey City, 220 Duncan Ave., Apt. 303	Hammerich, H. A.
	Keansburg, P.O. Box 111	Barrett, E.
	Rochelle Park, 91 Franklin Ave.	Gibson, R.
	Union City, 433 Bergenline Ave.	Krohn, R.
	West New York, 325-29th St.	Campbell, A. G.
New Mexico	Roswell, Box 421	Falconi, L.
New York	Brooklyn, 1670-58th St.	Babkes, E. A.
	Brooklyn, 594 Bedford Ave.	Culley, P.
	Brooklyn, 2130-59th St.	Jahlrl, E.
	Buffalo, 111 Virgil Ave.	Blinzler, R. F.
	Buffalo, 767 Bird Ave.	Tompkins, R. S.
	Kingston, 56 Crane St.	Kent, G. C.
	Long Island City, 451 Grand Ave.	Phoenix, Z.
	Maine	Lainhart, V.
	New York City, 18 Morningside Ave.	Alvarado, M. A.
	New York City, c/o Radiomarine Corp., 75 Varick St.	Caum, H. J.
	New York City, 430 E. 89th St.	Seichter, M.
	New York City, 867 Hornaday Pl.	Sklar, H. L.
	New York City, 925 Westchester Ave.	Stutz, M.
	New York City, 2061 Davidson Ave.	Weinhoeppel, K. L.
	Oakfield, R.R. 1	Howard, E. V.
	Rochester, 193 Shelter St.	Schifino, A. G.
	Rocky Point, P.O. Box 171	Goodfellow, D.
	Schenectady, 859 Hazelwood Ave.	Schwenker, A. H.
	Slaterville Springs	Bull, E. M.

Geographical Location of Members Elected December 2, 1931

Ohio	Akron, 662 Schiller Ave.	Kappus, P. B.
	Cincinnati, 4051 Clifton Ave.	Kemper, W. E.
	Cincinnati, 104 E. Auburn Ave.	Stocker, H. C.
	Dayton, c/o Walker & Dybvig, Reibold Bldg.	Dybvig, H. G.
	Uhrichsville.	Dempster, A. R.
Pennsylvania	Youngstown, 213 Holmes St.	Shaw, C. E.
	East Lansdowne, 155 Penn Blvd.	Michaelis, H. P., Jr.
	Harrisburg, 1616 N. 5th St.	Drumheiser, A. W.
	Keiser, 401 North St.	Coroniti, S. C.
	Philadelphia, 5752 N. Lawrence St.	Bell, G. D.
Texas	Philadelphia, 459 E. Wyoming Ave.	Miller, S. H.
	Pittsburgh, 3341 Latonia Ave., Dormont.	Goodboy, G. O.
	Verona, 5th St.	Sheaffer, C. T.
	Beaumont, 2535 Grand Ave.	Green, J. J.
	Galveston, 3719 Ave. Q.	Warren, A. J.
Virginia	Houston, 739 Yale St.	Archer, F. G.
	Tyler, c/o "Stephens".	Sawyer, T. M.
Washington	Norfolk, 604 Banker's Trust Bldg.	McFarland, D. C.
	Seattle, USGC Northland, c/o Postmaster	Bryan, E. O.
	Seattle, 218-10th Ave. N.	Martin, P. L.
	Seattle, 221 Belmont N.	Menard, A.
West Virginia	Seattle, 202 Burke Bldg.	Vincent, A. M.
	Buckhannon, 158 Pocahontas St.	Schreengost, J. C.
Wisconsin	Hinton, 110 Main St.	Criser, R. J.
	Ripon, 521 Liberty St.	Hoffman, O.
Australia	Mosman, Sydney, "Illalanda," Coronation Ave.	Persson, A. R.
Bermuda	Hamilton, P.O. Box 404	Gady, J. W.
Brazil	Rio de Janeiro, Cia Radio Internacional do Brazil, 50 Rua da	
	Alfandega	Andrade, M.D.
Canada	Wetaskiwin, Alberta, Box 535	Maggs, P. J.
	Moosejaw, Sask., 361 Coteau St., W.	Price, E. E.
	Prescott, Ont., King St., E.	Knight, L. F.
	Rouyn, P. Q., P.O. Box 822	Ouzounian, H.
	Sudbury, Ont., 135 S. Regent St.	Swezey, F.
Channel Islands	Guernsey, Bridge House, St. Sampson's	Wright, H.
Cuba	Calmanera, Oriente	Gelpi, J. B.
England	Burnley, Lancs., 10 Ightenhill Cross St.	Whitaker, H.
	Hornchurch, Essex, "Lynton," Hanes Park	Harvey, J. R.
	Lydd, Kent, North View	Craufurd, Q.
	Osterley, Middlesex, 51 Burlington Rd.	Dancker, J. A.
	Paignton, Devon, 8 Southfield Ave.	Maxey, H.
	Rugby, Engineering Research Lab., The British Thomson-	
	Houston Co., Ltd.	Maxted, R.
France	Rugby, Kingsley Ave.	Thomas, R. G.
	Paris VII, Frue Monsieur	de Baigneux, R.
Japan	Kobe, c/o The Kobe Wireless Telephone Station, Sakae-Machi	
	7	Tada, Y.
New Zealand	Epsom, 532 Manukau Rd.	Baxendale, J.
	Wellington, Box 1032	Smith, C.
South Africa	Durban, 202 Montpelier Rd.	Ford, W. S.
South India	Madras, Madras Fort Radio, Fort St. George	Fry, R.
Territory of Hawaii	Honolulu, 2737 Ferdinand Ave.	Walworth, L. A.

Elected to the Junior Grade

Illinois	Chester, 921 Sparta St.	Baronowsky, J.
Indiana	Hobart, c/o Phil Roper, Jr.	Barnes, H.
	Valparaiso, 703 Monroe St.	Lisor, D. J.
New York	Wolcott, Oswego St.	Harrison, W. M.



APPLICATIONS FOR MEMBERSHIP

Applications for transfer or election to the various grades of membership have been received from the persons listed below and have been approved by the Committee on Admissions. Members objecting to transfer or election of any of these applicants should communicate with the Secretary on or before February 1, 1932. These applicants will be considered by the Board of Directors at their February 3 meeting.

For Transfer to the Fellow Grade

New York New York City, 75 West St..... McCutchen, B. S.

For Transfer to the Member Grade

Missouri St. Louis, 1921 Telephone Bldg..... Fritz, H. R.
New Jersey Harrison, RCA Radiotron Co., Inc., 415 S. 5th St..... Thompson, B. J.

For Election to the Member Grade

Massachusetts Boston, 50 Oliver St..... Meader, R. B.

For Election to the Associate Grade

Alabama Birmingham, 711-8th Ave. W..... Grimmett, J. F.
California Alhambra, 835 N. Marguerita Ave..... Gilruth, M. T.
Los Angeles, 1100 W. 84th Pl..... Glassberg, L.
Los Angeles, 5862 S. Hoover St..... Hetzel, R. E.
Palo Alto, 717 Cherry St..... Goldrup, E. T.
Placentia, R.R. No. 1, Box No. 210..... Palmer, C. I.
San Francisco, 1362-8th Ave..... Besse, A. M.
Santa Barbara, Station KDB..... Moody, R. C.
Connecticut New Haven, Southern New England Tel. Co..... Millard, A. M.
Dist. of Columbia Washington, 2023 N. Capitol St..... Dunlap, W. J.
Florida Opa Locka, Box B..... Foley, D. H.
Idaho Boise, 2607 Woodlawn Ave..... Fletcher, H. H.
Indiana Marion, 114 E. 19th St..... Clark, R. R.
Scottsburg..... Manthei, L. F.
Topeka, 947 Winfield Ave..... Hart, H. T.
Kentucky Covington, 3513 Carlisle Ave..... Young, David L.
Maryland Cumberland, 604 Shriver Ave..... Bobo, J. W.
Massachusetts Roxbury, 7 Ottawa St..... Gilmore, T.
Michigan Detroit, 1740 Collingwood Ave..... Johnson, G. C.
Ishpeming, 205 Oak St..... Brozek, G. H.
Minnesota Duluth, 411 Exchange Bldg..... German, G. B.
Missouri Kansas City, 4726 Terrace St..... Burns, C. P.
St. Louis, 6543 Marmaduke..... Atchisson, C. H.
St. Louis, 1477 Engelholm Ave..... Castanie, W. F.
St. Louis, 5106 Cologne Ave..... Dungan, G. E.
St. Louis, 3642 Watson Rd..... Wood, P. E.
St. Louis, 3822 N. Grand Blvd..... Volk, J. A.
University City, 559 Melville..... Glaze, J. C.
University City, 7418 Liberty Ave..... Johnson, H. J.
New Hampshire Dover, 165 Payne St..... Watson, R. D.
New Jersey Camden, 206 Cooper St..... Ackerman, H.
Collingswood, 151 New Jersey Ave..... Hollahan, W. E.
Harrison, 415 S. 5th St..... Taylor, C. W.
Newark, 375 Clifton Ave..... Green, C. H.
Wayne, Box No. 67..... Donohoe, T. J.
New York Brooklyn, 365-14th St..... Morrissey, W.
Buffalo, 117 Newburgh Ave..... Huber, C. W.
New York City, 463 West St..... Atwood, J. B.
New York City, c/o Polymet Mfg. Co..... Clark, J. S.
New York City, 250 W. 99th St..... Cohen, A.
New York City, c/o G. Gulbenkian and Co., 225-5th Ave..... Rashduni, H. D.
Niagara Falls, c/o Schwegler Bros., Inc..... Fisher, H. F.
Schenectady, 1066 Gillespie St..... Miller, A. S.
Schenectady, 1270 Dean St..... Morey, D. P.
Stapleton, S.I., U.S. Coast Guard, Section Base 2..... Day, C. L.
N. Carolina Wilmington, 118 Red Cross St..... Grimes, J. S., Jr.
Ohio Cleveland, Radio Station WGAR, Hotel Statler..... Shipley, L.
Dayton, 510 Kenwood Ave..... Bonbright, C. F.
Pennsylvania Newberry, 1928 Lacomie St..... Morrison, R. L.
Pittsburgh, 14 Wood St..... Stickel, W. A.
Tennessee Nashville, 2506 Westwood Dr..... Woollard, J. R.
Texas Fort Worth, 915 Summitt Ave..... Kimzey, T. I.
Australia Sydney, N.S.W., 16 Stanley St., Waverley..... Duffy, J.
Sydney, c/o Mrs. C. Martin, 512 St. James Bldgs..... Martin, B.

Applications for Membership

Canada	Guelph, Ont., 34 Division St.	Robinson, C. A.
	Ottawa, Ont., 21 Butternut Terrace.	Merriman, H. O.
	Toronto, Ont., 601 Lansdowne Ave.	Clay, V. W.
England	Ramsgate, Kent, 17 The Paragon.	Jennions, A. E.
	Sherwood, Nottingham, 9 Osborne Grove.	Scotney, R.
Germany	Werder, Havel, 138 Hohewegstr.	Baumann, K.
Japan	Kokura City, Kokura Hosokyoku.	Kawakami, J.
Scotland	Markinch, Fife, 30 Commercial St.	Gibb, W.
South Africa	Johannesburg, Transvaal, c/o Kinemas, Ltd., Jeppe St.	Alexander, R. L.
Tanganyika Territory	Moshi, Post Office.	Barker, F. J.

For Election to the Junior Grade

Kentucky	Bellevue, 524 Lafayette St.	Werrmann, C. A.
Massachusetts	Boston, Army Radio Station, Army Base.	Clark, W. R.
Canada	Toronto, Ont., 71 Benson Ave.	Brown, N. E.



OFFICERS AND BOARD OF DIRECTION, 1931

(Terms expire January 1, 1932, except as otherwise noted)

President

RAY H. MANSON

Vice President

C. P. EDWARDS

Treasurer

MELVILLE EASTHAM

Secretary

HAROLD P. WESTMAN

Editor

ALFRED N. GOLDSMITH

Managers

ARTHUR BATCHELLER
J. H. DELLINGER

LLOYD ESPENSCHIED
HARRY HOUCK

C. M. JANSKY, JR.

Serving until January 1, 1933

J. V. L. HOGAN

R. H. MARRIOTT

Serving until January 1, 1934

L. M. HULL

A. F. VAN DYCK

Junior Past Presidents

A. HOYT TAYLOR
LEE DE FOREST

BOARD OF EDITORS, 1931

ALFRED N. GOLDSMITH, *Chairman*

STUART BALLANTINE

G. W. PICKARD

RALPH BACHER

L. E. WHITTEMORE

W. WILSON



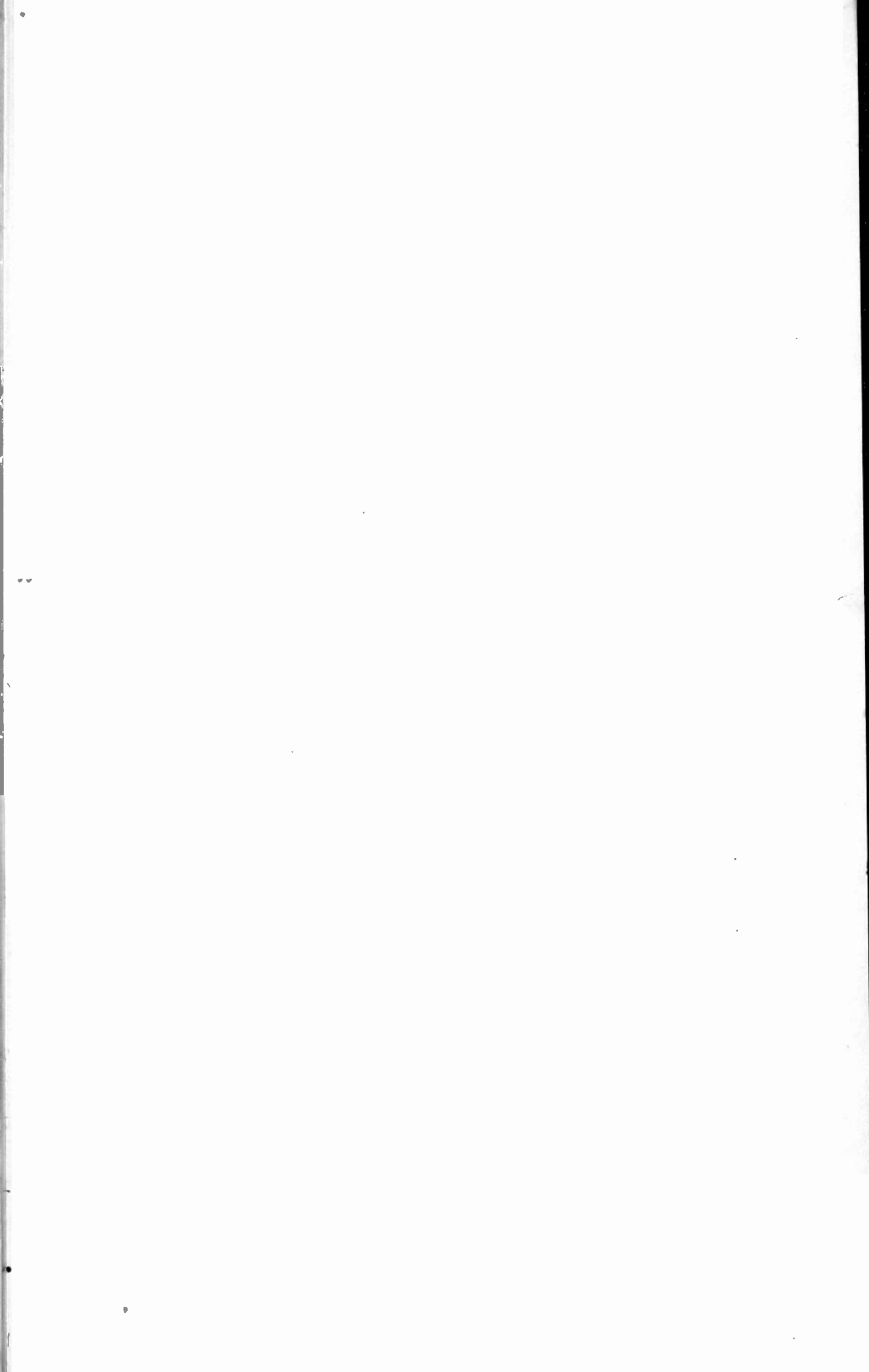



CONVENTION COMMITTEE
Rochester Fall Meeting, 1931

The success of the 1931 Rochester Fall Meeting was due in no small measure to the efforts of the above group. Those standing from left to right are: A. E. Soderholm, A. L. Schoen, E. C. Karker, R. A. Hackbusch, H. E. Gordon, and L. C. F. Horle. Those seated from left to right are: H. A. Brown, V. M. Graham, Chairman; C. P. Edwards, Vice President; R. H. Manson, President; H. J. Klumb, and O. L. Angevine.

INSTITUTE NEWS AND RADIO NOTES

December Meeting of the Board of Directors

The December meeting of the Board of Directors was held at the office of the Institute on the 2nd and was attended by R. H. Manson, president; Melville Eastham, treasurer; Alfred N. Goldsmith, editor; Arthur Batcheller, J. V. L. Hogan, Harry Houck, C. M. Jansky, Jr., R. H. Marriott, G. C. Southworth, (representing Lloyd Espenschied), A. F. Van Dyck, and H. P. Westman, secretary.

Allan B. DuMont and John F. Farrington were transferred to the Fellow grade and D. O. Whelan was transferred to the Member grade. Max Bareiss was admitted to the grade of Member. In addition, one hundred and nine applications for the Associate grade of membership and four applications for the Junior grade of membership were approved.

New blanks for membership applications were approved and a special blank for the new Student grade of membership established.

An Institute emblem having a green background with gold letters was agreed upon for the Student grade of membership. Its design is identical with the emblems now provided for the Junior, Associate, and Member grades except for the color of the background.

A Tellers Committee comprised of Messrs. Batcheller, Houck, and Van Dyck was appointed to oversee the counting of ballots for officers for 1932.

As a joint sponsor with the American Institute of Electrical Engineers of the Sectional Committee on Radio, the Institute was requested to consider for approval some dimensional standards on vacuum tube bases and sockets and some manufacturing standards applying to broadcast receivers. These standards were approved and upon their later approval by the American Institute of Electrical Engineers will be submitted to the American Standards Association for final approval as American Standards.

In discussing the subject of standards, the necessity of obtaining data on methods employed in the measurement of broadcast receiver performance which are not covered in the present standardization report of the Institute was pointed out. The effect on broadcast receivers of being "immersed in the fields" and subjected to the interfering effect of a large group of frequencies which is a condition not reproduced in the present used methods of determining selectivity characteristics was discussed in order that it might be brought to the attention of the Standards Committee. The necessity of establishing

satisfactory methods of testing and indicating the quality of transmission of broadcast stations to give some better index of the performance of the station than merely that it is maintained on its assigned radio frequency was thought desirable.

A report of the Broadcast Committee which was accepted appears under that committee heading.

C. C. Shangraw, communications engineer of the American Airways, Inc., was appointed representative of the Institute on the Liaison Committee on Aeronautic Radio Research.

An invitation to members of the Institute to be present at a meeting of the Society of Motion Picture Engineers on December 9 to hear a paper on vertical cut records by H. A. Frederick of the Bell Telephone Laboratories was accepted. Cards announcing this meeting were forwarded to all members of the Institute within a radius of fifty miles of New York City.

The secretary was instructed to have included in the 1932 YEAR BOOK for the information of the membership the proposed American standards which were approved by the Board of Directors.

The 1932 Convention which was originally set for May 12, 13, and 14 was changed to April 7, 8, and 9. This was considered advisable because the Radio Manufacturers Association Trade Show will be held in Chicago on May 23-26 which is only one week after the dates originally set for the Institute convention. It was deemed inadvisable to endeavor to hold these two conventions so close together. The place for the Institute convention is Pittsburgh, Pa., and as the Institute was founded in 1912, this convention will be known as the Twentieth Anniversary Convention.

A request from the Professional Engineers Committee on Unemployment, with headquarters in the Engineering Societies Building, for a list of Institute members residing within fifty miles of New York City so they may be solicited for funds to assist needy engineers was approved. Such members of the Institute in the New York area who are in need of assistance should enroll their names in the files of the Professional Engineers Committee on Unemployment.

Report of the Committee on Constitution and Laws on its consideration of the "Tentative Revision of a Recommended Uniform Registration Law for Professional Engineers and Land Surveyers" was approved. Further details of this report will appear under the heading of the Constitution and Laws Committee.

A report on the Rochester Fall Meeting held in November was approved. Permission was granted to hold the Fourth Rochester Fall Meeting in Rochester, N. Y., on November 7, 8, and 9, 1932.

J. V. L. Hogan, chairman of the newly established Technical Committee on Electro-Visual Devices which is to operate under the Standardization Committee submitted a list of proposed members for this committee which was approved.

A committee under the chairmanship of A. F. Van Dyck was appointed to consider material submitted by L. W. Wallace, chairman of the Subcommittee on Technological Studies which is operating under the Department of Labor. This committee will attempt to formulate some satisfactory answers to the questions asked on the subject of technological unemployment.

Rochester Fall Meeting, 1931

That the third Rochester Fall Meeting was even more successful than those that preceded it was undoubtedly evident to the three hundred and thirty Institute members and their guests who registered for the affair and to those who were present at the previous two meetings, it was apparent that there are many who are making a habit of attending these functions.

The two days of November 9 and 10 were given over entirely to technical sessions and eleven informal papers were presented. It is unfortunate that many of these will not appear in print as they would undoubtedly be of considerable interest to the membership. A number of these papers which discussed recent advances in radio could not be obtained for publication although it was possible for them to be presented orally.

An innovation was the "Engineering Sessions" at which representatives of the exhibitors were permitted to address those present on the products of their organizations. Seventeen of these addresses were made.

The meeting closed with an informal banquet held on the evening of November 10 which was under the direction of A. Hoyt Taylor as toastmaster. An interesting display of the versatility of some radio engineers was given by David Grimes and B. deF. Bayly and a lecture on "The Radio Business" was presented by O. H. Caldwell, editor of *Electronics*.

At the meeting there were representatives of eighty-two commercial organizations and twenty-four institutions of various types and of the total registration of three hundred and thirty, two hundred and thirty-one were from out of town.

We feel sure that all those who attended this meeting will look forward to greeting each other again in Rochester on November 7, 8, and 9, 1932, the dates set for the next Rochester Fall Meeting.

Institute Emblems

For the benefit of those members of the Institute who have transferred from one grade of membership to another, arrangements have been made whereby the Institute emblems either of the pin, lapel button, or watch charm type may be returned to the Institute for credit when ordering an emblem for the new grade of membership. A credit of \$1.25 is allowed upon the purchase price of a new emblem irrespective of the type of emblem returned.

Radio Transmissions of Standard Frequency; January, February, March, 1932

The Bureau of Standards announces a new schedule of radio transmissions of standard frequency. All transmissions are on 5000 kilocycles. This service may be used by transmitting stations in adjusting their transmitters to exact frequency, and by the public in calibrating frequency standards and transmitting and receiving apparatus. The signals are transmitted from the Bureau's station, WWV, in a suburb east of Washington, D.C., every Tuesday afternoon and evening. They can be heard and utilized by stations equipped for continuous-wave reception throughout the United States, although not with certainty in some places. The accuracy of the frequency is at all times better than a part in a million.

The transmissions are by continuous-wave telegraphy at 5000 kilocycles. They are given continuously from 2:00 to 4:00 P.M., and from 8:00 to 10:00 P.M., Eastern Standard Time, every Tuesday. The dates are January 5, 12, 19, 26; February 2, 9, 16, 23; and March 1, 8, 15, 22, 29.

The transmissions consist mainly of continuous, unkeyed carrier frequency, giving a continuous whistle in the phones when received with an oscillatory receiving set. The first five minutes of the transmission consist of the general call (CQ de WWV) and announcement of the frequency. The frequency and the call letters of the station (WWV) are given every ten minutes thereafter.

Information on how to receive and utilize the signals may be obtained by addressing a request to the Bureau of Standards, Washington, D.C. From the 5000 kilocycles any apparatus may be given as complete a frequency calibration as desired by the method of harmonics.

The Bureau is desirous of receiving reports on these transmissions, especially because radio transmission phenomena change with the season of the year. The data desired are approximate field intensity,

fading, and the suitability of the transmissions for frequency measurements. It is suggested that in reporting upon field intensities for these transmissions, the following designations be used where field intensity measurement apparatus is not at hand: (1) hardly perceptible, unreadable; (2) weak, readable now and then; (3) fairly good, readable with difficulty; (4) good, readable; (5) very good, perfectly readable. A statement as to whether fading is present or not is desired, and if so, its characteristics, such as whether slow or rapid and time between peaks of signal intensity. Statements as to type of receiving set used in reporting on the transmissions and the type of antenna used are likewise desired. The Bureau would also appreciate reports on the use of the transmissions for purposes of frequency measurement or control.

All reports and letters regarding the transmissions should be addressed to the Bureau of Standards, Washington, D. C.

Proceedings Binders

Binders for the PROCEEDINGS, which may be used as permanent covers or for temporary transfer purposes, are available from the Institute office. These binders are handsome Spanish grain fabrikoid, in blue and gold. Wire fasteners hold each copy in place and permit removal of any issue from the binder in a few seconds. All issues lie flat when the binder is open. Each binder will accommodate a full year's supply of the PROCEEDINGS and they are available at one (\$1.75) dollar and seventy five cents each. Your name, or PROCEEDINGS volume number, will be stamped in gold for fifty cents (50¢) additional.

Bound Volumes

The twelve issues of the PROCEEDINGS published during 1930 are now available in blue buckram binding to members of the Institute at nine dollars and fifty cents (\$9.50) per volume. The price to nonmembers of the Institute is twelve (\$12.00) dollars per volume.

1931 Index to the Proceedings

The 1931 Index to the PROCEEDINGS is issued as a supplement to this issue. The Institute will be glad to mail extra copies upon request.

Committee Work

ADMISSIONS COMMITTEE

A meeting of the Admissions Committee was held at 10 A.M. on December 2 at the office of the Institute and was attended by C. M.

Jansky, Jr., chairman; C. N. Anderson, R. A. Heising, A. F. Van Dyck, and H. P. Westman, secretary.

The committee approved one application for transfer to the grade of Fellow and two applications for transfer to the grade of Member. Of five applications for admission to the grade of Member, one was approved, one was tabled, and three were rejected.

The proposed new application blank for membership and the special blank for Student membership were reviewed by the committee which presented recommendations regarding them to the Board of Directors.

BROADCAST COMMITTEE

A meeting of the Broadcast Committee was held at 7 P.M. on December 1 at the office of the Institute. Those in attendance were E. L. Nelson, chairman; Arthur Batcheller, Harry F. Dart, Raymond Guy, J. V. L. Hogan, C. W. Horn, L. M. Hull, C. M. Jansky, Jr., Mr. Jones (representing B. R. Cummings), and R. H. Marriott.

The meeting was devoted primarily to a review of the unfinished business on hand and a discussion of plans for the coming year. It was the opinion of the committee that in view of the nature and scope of the subject matter with which it is concerned, consideration of the remaining questions which were submitted to it by the Federal Radio Commission should be merged into a general study of the system aspects of the broadcast problem. Plans were, therefore, formulated for the preparation of a memorandum outlining a proposed program for submission to the Board of Directors at its January meeting.

CONSTITUTION AND LAWS COMMITTEE

The Constitution and Laws Committee held a meeting at 2 P.M. on November 19 at the Institute office and those present were: R. H. Marriott, chairman; C. V. Amy, nonmember; Ralph Bown, nonmember; J. S. Dunham, nonmember; H. E. Hallborg, F. A. Hinnens, nonmember; R. H. Langley, nonmember, Donald McNicol, nonmember; E. R. Shute, nonmember, and H. P. Westman, secretary.

The objective of the meeting was a critical consideration of the "Tentative Revision of the Recommended Uniform Registration Law for Professional Engineers and Land Surveyers" upon which the Institute was requested to comment by the American Society of Civil Engineers. Because of the widespread effect and interest which this law would create the considerable number of nonmembers of the committee were asked to be present so that benefit of their opinions and advice could be obtained.

At the present time a number of states have laws requiring the

registration of Professional Engineers and Land Surveyers, and the American Society of Civil Engineers is sponsoring an effort to draft a uniform law for adoption by all states in the Union. It was the opinion of the committee that inasmuch as a very large number of engineers are employed in work that has no relation whatever to the safeguarding of life, health, and property which is the stated objective of this law, any attempt to make it applicable to all engineers would be highly undesirable. The committee, therefore, pointed out the necessity of defining as a "Professional Engineer" only those whose work does involve the safeguarding of the life, health, and property of the public. Its recommendations to the Board of Directors was in conformance with these thoughts.

NEW YORK PROGRAM COMMITTEE

Following an informal dinner, the New York Program Committee held a meeting at 7 P.M. on November 23 at the Institute office, Austin Bailey, chairman; M. C. Batsel, H. C. Gawler, J. L. Reynolds, R. M. Williams (representing R. H. Ranger), and H. P. Westman, secretary, being in attendance. The preparations being made for the December, January, February, and March New York meetings were reviewed and a substitute made for one program which could not be obtained as originally planned.

SECTIONS COMMITTEE

A meeting of the Sections Committee was held at the Hotel Sagamore in Rochester, N. Y., at 4 P.M. on Tuesday, November 10, which was during the Rochester Fall meeting. Those present were C. W. Horn, chairman; R. H. Manson, president; C. P. Edwards, vice president; O. L. Angevine, Rochester Engineering Society; G. C. Blackwood, Philadelphia; H. A. Brown, Rochester; A. B. Buchanan, Detroit; F. K. Dalton, Toronto; L. G. Hector, Buffalo-Niagara; D. D. Israel, Cincinnati; H. J. Klumb, Rochester; R. H. Langley, Cleveland; B. B. Minnium, Chicago; H. P. Westman secretary; and B. Dudley, assistant secretary.

Representatives of Atlanta, Boston, Connecticut Valley, Los Angeles, New Orleans, Pittsburgh, San Francisco, Seattle, and Washington were not present.

In considering the possibility of improving contact among the Sections and the Sections Committee, it was agreed that whenever an Institute meeting was held at which attendance by members of a number of Sections might be expected, an attempt should be made to hold a meeting of the Sections Committee. With the thought of permitting members of the various sections to arrange their plans to per-

mit their attendance at New York meetings of the Sections Committee, all notices of meetings of the Committee in New York will be forwarded at as early a date as possible.

The desirability of Sections submitting data on future meetings early enough to permit the inclusion of this material in the PROCEEDINGS was pointed out and possible methods of accomplishing this discussed.

Where Sections may desire to receive notices of meetings held by neighboring sections, the secretaries of the two Sections in question were requested to make the necessary arrangements.

The possibility of improving the present method of advising Sections of their membership and changes in mailing addresses was discussed, and a survey will be made of this situation to determine upon some more satisfactory method than that now employed.

The desirability of Section executive committees reviewing critically the list of names published in each issue of the PROCEEDINGS of those applying for admission or transfer in grade and the submission to the secretary of any objections to these applicants was agreed upon.

STANDARDIZATION

SECTIONAL COMMITTEE ON RADIO—ASA

A meeting of the Sectional Committee on Radio was held at 10 A.M. at the office of the Institute. Those present were Alfred N. Goldsmith, chairman; C. H. Sharp, vice chairman; Wilson Aull (representing J. V. L. Hogan), S. C. Bartlett (representing J. O' R. Coleman), R. D. Brown (representing W. E. Holland), E. T. Dickey (representing W. R. G. Baker), J. B. Dow, Lloyd Espenschied, E. B. Garland (representing J. A. Code), R. H. Langley, C. L. Thomas (representing J. J. Graf), L. E. Whittemore, William Wilson, B. Dudley, secretary, and H. P. Westman, nonmember.

The committee considered critically the proposed American standards on radio which were submitted to letter ballot and discussed such comments as were made on those portions of the report which were not approved by all voting. Votes were on hand representing the opinions of the entire committee.

It was agreed that that portion of the report under "Standard Vacuum Tube Base and Socket Dimensions" and "Manufacturing Standards Applying to Broadcast Radio Receivers" was satisfactory for adoption as American Standard. The Secretary was, therefore, instructed to forward this material to the two sponsor bodies (the American Institute of Electrical Engineers and the Institute of Radio Engi-

neers) for their approval and its subsequent submission to the American Standards Association for final approval.

The chairman was empowered to appoint a committee to review those unapproved portions of the report originally submitted by the Technical Committees to determine what disposition might best be made of the material. The Committee will cooperate with the Sectional Committee on Electrical Definitions in its consideration of that portion of the report dealing with definitions of terms used for radio.

TECHNICAL COMMITTEE ON VACUUM TUBES—IRE

A meeting of the Technical Committee on Vacuum Tubes operating under the Standardization Committee of the Institute was held on Tuesday, November 17, at the Institute office and was attended by J. C. Warner, acting chairman; R. R. Batcher, nonmember; F. H. Engel, V. M. Graham, nonmember; J. N. Hanley, M. J. Kelly, E. A. Lederer, L. M. Price, E. E. Spitzer, K. S. Weaver, P. T. Weeks, and B. Dudley, secretary.

A report of the Subcommittee on Letter Symbols was presented by Dr. Kelly and after considerable discussion it was agreed that the report should be circulated to the entire committee for further comment. Additional reports of the Subcommittee on Definitions by Dr. Weeks, Subcommittee on Phototubes by Mr. Lederer reporting for Dr. Ulrey, and Subcommittee on Methods of Measurement by Mr. Engel were considered. These reports are being circulated to the Technical Committee membership for further consideration.

Institute Meetings

ATLANTA SECTION

A meeting of the Atlanta Section was held at the Atlanta Athletic Club on October 30th and was presided over by Harry F. Dobbs, chairman.

A paper on "Modern Voice Amplifiers" was presented by Oliver Etheredge, an engineer for the Georgia Power Co. The author presented to those present a very clear conception of the modern audio amplifying circuits as employed today. The Loftin-White circuit was discussed in detail and many circuit drawings and diagrams were used to illustrate the material presented.

A lengthy discussion followed the presentation of the paper and was participated in by most of the fourteen members and guests who attended the meeting.

Twelve of those who attended the meeting were present at the informal dinner which preceded it.

BOSTON SECTION

A meeting of the Boston Section of the Institute was held at Cruft Laboratory, Harvard University on November 14.

The paper of the evening on "Recent Developments in Radio of the Naval Research Laboratory at Bellevue, Anacostia, D.C.," was presented by A. Hoyt Taylor and was of considerable interest to the ninety-six members and guests present judging from the discussion which it provoked.

BUFFALO-NIAGARA SECTION

A meeting of the Buffalo-Nigara Section was held on November 4th at the University of Buffalo, S. W. Brown, chairman, presiding.

The paper of the evening on "Present-Day Trends of Audio Amplifiers" was presented by George C. Crom, Jr., of the Colonial Radio Corporation.

The paper was discussed by Messrs. Hector, Huntsinger and several others of the twenty-four members and guests in attendance.

The Nominating Committee submitted its report and upon ballot the following officers were elected: Chairman, L. Grant Hector; Vice Chairman, George C. Crom, Secretary-Treasurer, E. C. Waud.

CHICAGO SECTION

The Chicago Section held a meeting on November 6th at the Western Society of Engineers Building which was presided over by B. B. Minnium, chairman.

The paper of the evening on "Electrolytic Condensers and their Use in Filter Circuits of Radio Sets" by R. O. Lewis and William Dunn of the Grigsby-Grunow Company was presented by Mr. Lewis.

The paper presented a report on tests made on electrolytic condensers during the past two years. Among the many factors tested, were capacity vs. frequency, leakage vs. temperature, life vs. temperature, effective capacity vs. temperature, power factor and resistance vs. frequency, maximum voltage, etc.

The discussion which followed the presentation of the paper was entered into by Messrs. Arnold, Clark, Dunn, Hoag, Lewis, McMaster, Miller, Minnium, O'Brien, and Tyzzer. The attendance totaled ninety members and guests.

CINCINNATI SECTION

The November meeting of the Cincinnati Section was held on the 17th at the Hotel Sinton-St. Nicholas, Chairman D. D. Israel, presiding.

The first paper of the evening on "Single Tube Inverter" was pre-

sented by Palmer C. Craig. The neon tube oscillator was pointed out as the most familiar of the simple two-element oscillators which might conceivably be used in the conversion of direct current into alternating current. The various uses to which such a converter could be put were outlined and the objections to such simple converters as had been set up in the past were discussed. An arrangement employing a Tungar bulb as an oscillator for the production of any desired frequency directly from a direct-current source was set up and operated.

The second paper of the evening by H. J. Loftis and H. C. Forbes on "Antenna Systems" was presented by Mr. Loftis. The problems confronting the installer of single or complex systems where antenna leads-in were in areas of high noise levels while the actual antennas were in comparatively quiet zones were discussed. A system was outlined whereby a double lead, with an antenna and counterpoise might be so connected that the induced noise in the down lead would balance itself out and the signal loss would be negligible. Curves were shown of noise-to-signal ratio in various localities and the improvement obtained by the system, a normal condition giving an 80-to-1 improvement in signal-to-noise ratio. Both simple and multiple installations were shown and three different types of commercial couplers were available for examination and comment.

The first paper was discussed by Messrs. Anderson, Glessner, and Kilgour, and the latter contribution discussed by Messrs. Felix, Israel, and Nichols.

A number of committee reports were made, among them being that of the Nomination Committee for 1932 officers. In addition the possibility of holding a future national convention of the Institute in Cincinnati was discussed. The meeting was attended by fifty-two members and guests, twenty of whom attended the informal dinner which preceded it.

CLEVELAND SECTION

A meeting of the Cleveland Section was held on September 25th at the WHK studios, G. B. Hamman, chairman, presiding.

The paper of the evening on "The New WHK Studios" was presented by E. L. Gove, chief engineer of WHK. In his paper he described and explained the constructional features of the studios, following which the sixty-five members and guests in attendance were escorted through the studios.

The October 30th meeting was held at the Case School of Applied Science, Mr. Hammon presiding.

"Solar Influences on Radio Reception" was the subject of a paper by Harlan T. Stetson, Director, Perkins Observatory, Ohio Wesleyan

University. Dr. Stetson pointed out the intensity of the sun spots, sinusoidally passing through a complete cycle of eleven years. At the present time these solar disturbances are approaching a minimum and such correlation as has been made between radio transmission and the sun spot cycle indicates radio transmission will be at its best in 1933. This statement was made with reference to the radio performance in the broadcast band. The effects of sun spots on short waves are under observation at Ohio Wesleyan in collaboration with Case School of Applied Science.

Some excellent slides were shown to indicate correlation between solar activity and radio reception.

Some transmitting and receiving equipment built at Case School of Applied Science to aid in the obtaining of correlation between sun spots and high-frequency transmission was described by S. McCuskey an instructor in astronomy at Case School.

This meeting was attended by forty-seven members and guests.

A November meeting was held on the 20th at Case School of Applied Science and was presided over by G. B. Hammon, chairman.

The paper of the evening was presented by Ray H. Manson, president of the Institute and chief engineer and vice president of the Stromberg-Carlson Telephone Manufacturing Company. He spoke on "Radio Broadcasting from the System Standpoint."

Requirements from microphone to loud speaker which are necessary to obtain high quality reproduction were pointed out and it was stated that transmitting equipment of the better type provides a higher quality transmission than the average broadcast receiver is capable of reproducing.

Some difficulties with regard to television were enumerated, the principal among which were the undivided attention required and the very close proximity necessary between studio and transmitter.

Prior to the presentation of his paper, President Manson explained the functioning of the various I.R.E. committees which regularly hold meetings in New York City.

The Nominating Committee reported its slate of nominations for officers for 1932 and the election will be held at the December meeting.

Attendance at this meeting totaled sixty-three.

CONNECTICUT VALLEY SECTION

The October 29th meeting of the Connecticut Valley Section was held at the Hotel Charles, Springfield, Mass., and was presided over by R. S. Kruse, chairman.

The paper of the evening on "Portable Radio Beacons" was pre-

sented by Carl J. Madsen, section engineer, Radio Communications Engineering, Westinghouse Electrical and Manufacturing Company, Springfield, Mass.

Mr. Madsen's paper described the design features and constructional details of a 100-watt portable beacon transmitter for use in blind landing of aircraft, including power supply and antenna equipment. The need for such transmitters was discussed, and their use in relation to fixed beacon transmitters was indicated. Photographs of the equipment both unmounted and in place on a motor truck were shown. The principles upon which beacon transmitters operate were discussed, and the actual operation of the beacon in guiding aircraft was illustrated by means of diagrams.

Mr. A. B. Bedrossyan, Superior Radio and Electric Company, Springfield, demonstrated a device of his own design and construction for obtaining "B" voltages for automobile radio receivers from the car storage battery. Much interest was evinced by those present in the operation of the device. The necessary "B" power for the receiver is obtained with a total consumption of about 12 watts from the storage battery. It is expected that higher efficiency will be obtained as the design is improved.

A number of the forty-one members and guests present entered into the discussion of the paper. Nine were present at the informal dinner which preceded the meeting.

DETROIT SECTION

A meeting of the Detroit Section was held on September 18th at the Detroit News Auditorium, L. N. Holland, chairman, presiding.

A paper on "The Installation of a Modern High-Frequency Beam Circuit" was presented by J. C. Hromada of the Airways Division of the Department of Commerce.

The speaker described the installation and operation of a high-frequency beam circuit between Cheyenne, Wyoming, and Washington, D. C. Communication on this circuit is being carried on principally on frequencies in the vicinity of 12,000 kc and the transmitters were designed and built particularly for this work. Many interesting developments and problems were described and practical solutions presented. A new method of coupling transmission lines to antenna systems was also shown and a simple method of solving such coupling problems outlined. The paper was illustrated by slides showing equipment used at both ends of the circuit.

The meeting was attended by fifty-five members and guests, a number of whom participated in the discussion which followed the presentation of the paper.

The November meeting of the Detroit Section was held on the 27th in the Detroit News Conference Room. As both the chairman and vice chairman were absent the meeting was presided over by A. B. Buchanan.

R. P. Wuerfel of the International Radio Corporation presented a paper on "Design of Modern Superheterodyne Receivers."

The integral parts of a superheterodyne receiver were outlined as comprising the radio-frequency preselector or amplifier, oscillator, first detector or mixer, intermediate-frequency amplifier, second detector, and audio-frequency amplifier. There then followed a description of several circuit arrangements in common use, each of which was explained and the relative advantages discussed. The importance of preselection was stressed and several types of undesirable response due to lack of preselection were explained.

A superheterodyne with a 175 kc i-f amplifier system was demonstrated. It was shown that if two carrier frequencies with a frequency difference of 175 kc reached the grid of the first detector, they would produce a beat frequency of 175 kc and be amplified, resulting in a distorted signal. This was easily demonstrated as the two most powerful local stations in Detroit, WWJ and WJR, have a carrier frequency separation of 170 kc and could be received with the oscillator tube removed from the circuit. The advantage of a high image frequency response ratio was explained and the possibility of double response or two-point tuning of a carrier frequency graphically shown.

A circuit analysis was made of how the response of the image frequency carrier might result in an undesirable heterodyne response at an audio frequency, again stressing the importance of sufficient preselection.

A number of the one hundred and two members and guests in attendance participated in the discussion.

LOS ANGELES SECTION

The Los Angeles Section held its October meeting on the 20th at the Mayfair Hotel. Chairman T. E. Nikirk, presided.

The paper of the evening by P. L. Johnson, a transmission engineer for the Southern California Telephone Company of Los Angeles, was "A Discussion of Television."

In his talk the author discussed the development of television from its inception, describing its relationship to wired picture transmission. Early scanning methods were described as well as the basic theories underlying present-day television. Brief descriptions were given of the latest developments in scanning disk design and in receiving methods,

including the cathode ray tube. Mr. Johnson illustrated his talk with an actual scanning system and with an operating cathode ray oscillograph. The talk was given as the first of a series to follow on various aspects of television and related developments.

Sixty members and guests attended the meeting.

LOS ANGELES SECTION

A meeting of the Los Angeles Section was held at the Mayfair Hotel on November 17th, T. E. Nikirk, chairman, presiding.

The paper of the evening on "The Acoustical Design of Broadcast Studios" was presented by A. P. Hill, acoustic consulting superintendent for Electrical Research Products, Inc.

Mr. Hill discussed the fundamentals of the work of the acoustical engineer, describing the materials with which his work was accomplished, the most recent methods of measurement, the importance and significance of the resonance properties of a studio, theater or other building, and related subjects.

The paper was followed by a rather lengthy discussion from the floor which was participated in by many of the fifty-five members and guests in attendance.

Reports of the Program, Membership, and Publicity Committees were given and a Nominating Committee was appointed.

NEW YORK MEETING

The December New York meeting was held on the 2nd in the Engineering Societies Building in New York City.

Three papers by members of Bell Telephone Laboratories were presented. These were "A Compact Alternating-Current Operated Speech Input Equipment," by W. L. Black, "Low Power Radiotelephone Transmitters for Broadcast Applications," by A. W. Kishpaugh and R. E. Coram, and "Application of Quartz Plates to Radio Transmitters," by O. M. Hovgaard.

It is anticipated that these papers will be published in an early forthcoming issue of the PROCEEDINGS and they are not, therefore, summarized here.

The attendance at the meeting totaled five hundred and ten.

PHILADELPHIA SECTION

The first fall meeting of the Philadelphia Section was held on October 22nd at the Engineers Club, G. W. Carpenter, chairman, presiding.

The paper of the evening "Radio City" was presented by Alfred N. Goldsmith, vice president and general engineer of the Radio Corpora-

tion of America. Dr. Goldsmith presented a very comprehensive description of the aims and purposes of this new center of radio activity and described the radio equipment that will be installed.

The meeting was attended by one hundred and seven members and guests.

New officers of the Section were introduced just prior to the presentation of the paper.

PITTSBURGH SECTION

The October meeting of the Pittsburgh Section was held on the 28th of the month at the Fort Pitt Hotel, Pittsburgh, J. G. Allen, chairman, presiding.

The speaker of the evening was Harold Roess whose subject was "The Modern High-Frequency Receiver."

The author covered the design of short-wave converters in general and he brought to the meeting several illustrations showing one particular type of converter applied to a standard broadcast receiver. A very interesting portion of the paper dealt with a converter which made possible reception below one meter. In the discussion which followed the paper Mr. Roess was able to give to the membership considerable information on constructional details, etc.

Twenty-two members and guests attended the meeting.

A meeting of the Pittsburgh Section was held on November 24 at the Fort Pitt Hotel, J. G. Allen, chairman, presiding.

A paper on "Methods of Measurement of Radio Interference" was presented by R. N. Stoddard.

The author briefly reviewed the events which led up to the formation of a joint National Committee to study the problem of radio interference standards and then outlined the tentative standards set up for field investigations. Following this, a considerable portion of the paper was devoted to reporting the progress made in the laboratory investigation of the causes of interference created by electrical equipment and the method used in the laboratory to measure the magnitude of such interference. Slides illustrated these points and in addition showed the various radio-frequency choke coils designed for filtration purposes.

A very thorough discussion of the subject ensued which was participated in by Messrs. Armstrong, Haller, Mag, McKinley, Nobel, Patterson, Roess, and Terven of the thirty members and guests in attendance.

SAN FRANCISCO SECTION

The San Francisco Section held a joint meeting with the San Francisco Section of the American Institute of Electrical Engineers at the Engineers Club on October 2nd.

An interesting paper on "Some Thoughts on Waves" was presented by O. B. Blackwell, a transmission development engineer for the American Telephone and Telegraph Company.

The meeting was attended by a large number of guests and members of the two societies.

The regular October meeting of the San Francisco Section was held on the 21st at the Bellevue Hotel, R. M. Heintz, chairman, presiding.

At this meeting Lieutenant C. Noble, U.S.N., presented a paper on "The Navy's Part in the Development of the Radio Art."

The chairman announced that arrangements had been completed for the holding of informal monthly meetings at which discussions of current literature would take place.

Of the forty-six members and guests who attended the meeting, thirty were present at the informal dinner which preceded it.

SEATTLE SECTION

A meeting of the Seattle Section was held on October 29th in Gugenheim Hall of the University of Washington, Seattle, Abner R. Willson, presiding.

A paper on "The Alaska Telegraph System" was presented by Captain Fred P. Andrews, U. S. Signal Corps.

The author who is in charge of engineering of the Alaska Telegraph System outlined its history from the time of the laying of the first cable to Alaska to the present time when radio has supplemented its operation. He discussed the operation and engineering problems connected with the cable and then covered the radio equipment, particularly from an operating and traffic handling standpoint. The transmitting and receiving equipment employed in Alaska was described and the problems of obtaining suitable power supply discussed. A large map showing the communications network in Alaska was exhibited.

Following the presentation of the paper, a six-reel motion picture taken on a round-the-world cruise of the cableship "Dellwood" was shown. Starting from Seattle, the "Dellwood" proceeded to the Panama Canal then on to London where she took aboard a cable manufactured for the Philippine Government which was to be laid in the Philippine Islands for interisland communication. From London the "Dellwood" proceeded to Oran, Algeria, Port Said, through the Suez Canal, Colombo, Singapore, and to Manila for the laying operations. On completion of this work the "Dellwood" proceeded to Seattle by way of Yokohama. The picture covered the scenic and general points of interest in cable manufacturing and laying operations.

Messrs. Libby, Lovejoy, and Tolmie of the sixty-five members and guests in attendance participated in the discussion of the paper.

On the following Sunday, at the invitation of Captain Andrews, members of the Section visited the traffic handling quarters of the Signal Corps in the Arcade Building, Seattle. After inspecting the control equipment the party proceeded to the transmitting plant in West Seattle and after inspecting that plant visited Fort Lawton where the receiving equipment is located.

The November meeting of the Seattle Section was held on the 19th at Guggenheim Hall, University of Washington, Abner R. Willson, presiding.

A paper by Oliver C. Smith of the Pacific Telephone and Telegraph Company on "Telephone Transmission Units" was presented.

Mr. Smith covered in minute detail the application of the decibel, noise, and cross-talk units to various types of equipment. Of unusual interest was the illustration of known powers being delivered to the loud speaker and by varying the frequency of the input current the response of the speaker and the hearing qualities of the membership were demonstrated.

Charts showing power level in decibels and current, voltage, and power ratios in decibels which were prepared for this meeting by Mr. Smith were distributed to each one in attendance. In his demonstration he employed two phonograph pick-ups which operated through a loud speaker, attenuator, and amplifier. In addition, a frequency generator covering from 40 to 8000 cycles was used.

At the close of the paper, T. M. Libby, transmission engineer for the Pacific Telephone and Telegraph Company, explained the advantages of those in the radio industry using such units as the decibel in their general work. He emphasized the fact that a greater change of ideas would be possible among those in the communication field through the use of noise units, cross-talk units, or transmission units. He pointed out ways of using the present visual indicating units calibrated in decibels for testing radio receivers and public address equipment.

Messrs. Anderson, Bouson, Eastman, Hackett, Libby, Pinkman, Renfro, Williams, and Willson of the forty-five members and guests entered into the discussion.

TORONTO SECTION

A meeting of the Toronto Section was held on October 28th at the University of Toronto, Chairman F. K. Dalton, presiding.

A paper by R. U. Clark of the engineering staff of Sprague Specialties Company of Cambridge, Mass., on "Filter Circuits in Radio Receiver Power Supplies" was presented.

The speaker outlined in general the problems involved in the filtration of the output of rectifier tubes and pointed out the economic desirability of using electrolytic capacitors for such purposes. Various combinations of inductance, resistance, and capacitance for filter purposes were shown diagrammatically, and various precautions to be taken in the use of electrolytic capacitors were outlined. Leakage current and ripple output were thoroughly discussed, and it was stated that dry electrolytic capacitors have a very limited life.

The paper was discussed by Messrs. Bayly, Burrill, Fox, Oxley and others of the fifty-four members and guests in attendance.

The November meeting of the Toronto Section was held on the 18th at the University of Toronto, F. K. Dalton, chairman, presiding.

The paper of the evening by R. F. Field of the General Radio Company was on "Radio-Frequency Measurements." The author discussed the problems of measuring the frequency of alternating current from 1 cycle to 100 megacycles, as well as the measurements of voltage, resistance, inductance, and capacitance. The various types of apparatus best suited for these measurements, their limitations and such precautions as need be taken in their operation were discussed fully. The paper was closed with the showing of a few slides illustrating various instruments developed by the General Radio Company for measuring purposes.

The paper was discussed by Messrs. Fox and Bayly of the fifty-nine members and guests in attendance.

President Manson who was present at the meeting made a few remarks outlining some of the activities of the New York headquarters.

WASHINGTON SECTION

A meeting of the Washington Section was held at the U. S. Bureau of Standards on October 8th, L. P. Wheeler, chairman, presiding.

The paper of the evening on "Television" was presented by Delbert E. Replogle, chief engineer of the DeForest Radio Company and vice president of the Jenkins Television Corporation.

The author pointed out that there were two general methods of illuminating the subject to be televised. The first employed flood lighting or daylight to illuminate the scene and then progressively project images of different portions of the subject on a photo-electric tube thereby obtaining suitable electrical response. In the second system, referred to as the indirect method or flying spot, an image of the entire scene is focused upon the photo-electric tube and the subject is illuminated by the moving spot of light, the light reflected causing the operation of the phototube. Since all the light is not effective in either case,

light filters are used to reduce the intensity of the light as seen by the eye without appreciably lowering the useful illumination as affecting the phototubes.

The variations in current produced by the photo-electric tubes are amplified, and employed to modulate the output of the transmitter. It is desirable that the amplifiers be capable of transmitting all frequencies between 15 cycles and 100,000 cycles. It has been found that series modulation although somewhat more complicated appears to give better wave form than the Heising modulation formerly employed at these high modulation frequencies.

It was pointed out that reflections from the Kennelly-Heaviside layer caused multiple images on the scanning screen which are worse in summer than winter and are much more damaging than static. Satisfactory results have been obtained at distances of 40 miles from the transmitters of the Jenkins Television Corporation. It has been found desirable to broadcast a sound program simultaneously with the picture program.

In an interesting demonstration, life-size pictures were projected upon a translucent screen and gave readily recognizable images. The receiving system consists of staggered tuned radio-frequency amplifiers, a detector, and two 445 tubes in parallel which operated a fifty-watt tube, the output of which supplied a Jenkins crater neon lamp. A lens disk driven by a synchronous motor operated from a 60-cycle a-c system was used for scanning.

Dr. Cohen, Dr. Gunn, and Messrs. Burgess and Mather among others entered into the discussion which was held after the paper was presented.

Thirty-nine of the ninety-five members and guests who attended the meeting were present at the informal dinner which preceded it.

Chairman Wheeler appointed A. Hoyt Taylor, F. P. Guthrie, and C. B. Jolliffe, the three last chairmen of the Section, to act as a Nominating Committee.

The November meeting of the Washington Section was held on the 12th at the Bureau of Standards, John B. Brady, presiding.

Lieutenant J. B. Dow, U.S.N., presented a paper on "Electron Coupled Oscillator Circuits" which paper is published in the December issue of the PROCEEDINGS and need not be summarized here. It was discussed by Messrs. Burgess, Robinson, White and others of the fifty members and guests who attended.

The informal dinner which preceded the meeting was attended by twenty-eight.

Personal Mention

At the Fifteenth Anniversary Convention of the Society of Motion Picture Engineers held at the New Ocean House, Swampscott, Mass., Dr. Alfred N. Goldsmith was elected president of that society. Dr. Goldsmith holds the distinction of being the only one who has been president of both the I.R.E. and S.M.P.E.

Quinton Adams, formerly with the RCA Victor Company at Camden has joined the staff of the National Broadcasting Company of New York.

Charles O. Baldwin left the DeForest Radio Corporation of Toronto to join the Engineering Department of Philco Products, Ltd., also of Toronto.

Frederick J. Baskett previously with the International Telephone and Telegraph Laboratories, London, has become an engineer for Standard Radio Relay Services, Ltd., of London.

Formerly with Freed-Esiemann Radio Corporation, S. H. Baum, has become chief engineer of the Empire Electrical Products Company of Brooklyn, N.Y.

Don G. Burnside previously with Atwater Kent Manufacturing Company is now in the Engineering Department of the RCA Radiotron Company at Harrison, N.J.

A. Cross has left the Broadcast Relay Service of Hull, England, to become engineer in charge of Northern Wireless Relay Company, Ltd., of Newcastle.

Previously with RCA Communications, Robert J. Davis has joined the staff of Wired Radio, Inc., at Newark.

J. P. Della Corte who was previously with the Sonora Phonograph Company has become a radio engineer for Amplex Instrument Company.

Porter H. Evans has become chief engineer of the Eastern Studios of Vitaphone Corporation in Brooklyn.

C. L. Farrand has become President of the United Research Corporation of Long Island City.

Dudley E. Foster has left the Case Electric Corporation to become assistant chief engineer of the United States Radio and Television Corporation of Marion, Ind.

H. C. Gawler, formerly with DeForest Radio Company, has become sales manager of the Federal Telegraph Company of Newark, N.J.

Walter E. Gilbert previously with the Atwater Kent Manufacturing Company has become engineer for the H. H. Eby Manufacturing Company of Philadelphia.

C. F. Harrington has left Station KFUL to do consulting work with headquarters at Little Rock, Ark.

Vernon D. Hauck, formerly chief engineer of Southern Radio Corporation, is now radio engineer for Wired Radio, Inc.

Formerly with the Patent Development Company of South Bend, Ind., C. C. Henry has become radio engineer for the Lear Development Company of Chicago, Ill.

L. S. Hillegas-Baird, formerly with High Frequency Laboratories is now with Radio Industries, Chicago.

V. E. Hollinsworth previously with Canadian National Telegraph Company has joined the engineering staff of DeForest-Crosley, Ltd., of Toronto.

Formerly with the Radio Valve Company, L. D. Irwin has become radio engineer and superintendent of Sparton of Canada at London, Ontario.

S. M. Kintner is now vice president of the Westinghouse Electric and Manufacturing Company, East Pittsburgh, Pa.

Previously a research engineer for Claude Neon National Laboratories, Paul A. Kober has become chief engineer of the Television Laboratories, Inc.

Lieutenant Walter B. Larew, U.S.N., has been transferred from Fort Shafter to Fort Monmouth, Oceanport, N.J.

James D. LeVan has become chief engineer of Raytheon, Inc., of Cambridge, Mass.

W. W. Macalpine, formerly with Communications Patents, Inc., has become a radio engineer for International Communications Laboratories, Newark, N.J.

Lionel S. Noel has become chief radio engineer of the Colonial Radio Corporation of Buffalo, N.Y.

Lieutenant L. W. Nuesse has been transferred from the U.S.S. Dobbin to the U.S.S. Milwaukee.

G. E. Oliver, formerly with the Southern Radio Corporation has joined the radio engineering department of the Short Wave and Television Corporation of Boston, Mass.

F. Murray Paret, formerly with the Gold Seal Manufacturing Company, is now head of the measurement department of Cable Radio Tube Corporation of New York.

S. Riccobono previously with Pacent Electric Company is now in the Engineering Department of the United Scientific Laboratories.

Hugo Romander, formerly in the Federal Telegraph Company, is now in the Engineering Department of the International Communications Laboratories, Inc., of Newark, N.J.

Previously with RCA Victor Company at Camden, M. G. Sateren is now section engineer of the Westinghouse Electric and Manufacturing Company at East Springfield, Mass.

E. G. Shalkhauser has become chief recording engineer of C. L. Venard Studios, Peoria, Ill.

Richard F. Shea, formerly with the Pilot Radio and Tube Manufacturing Company, is now doing consulting work at Arlington, Mass.

H. M. Smith, formerly radio engineer for Westinghouse Electric and Manufacturing Company, East Pittsburgh, Pa., is now engineer for Doolittle and Falknor, Inc., of Chicago, Ill.

W. L. Smith, formerly chief engineer of National Air Transport, is now development engineer of Transcontinental and Western Air, Inc., with headquarters at New York City.

David Sonkin previously with Jenkins Television Corporation is now affiliated with Polymet Manufacturing Company of New York City.

Harold Soule is now transmission engineer for Standard Sound Recording Company in New York City having previously been connected with General Recording Studios.

Lieutenant W. Arthur Steel, previously in the Department of National Defence, Ottawa, Canada, is now chief of the radio division, National Research Council of Canada with headquarters at Ottawa.

Formerly with Flint Radio Corporation, R. A. Stolle is now chief engineer of Jackson-Bell Company of Los Angeles, Calif.

Ellery W. Stone is now vice president of the International Telegraph Company of New York City formerly being president of the Federal Telegraph Company.

G. E. Stone, formerly with Radio Frequency Laboratories, is now radio engineer for Bludworth, Inc., of New York City.

W. T. Taber previously with Stevens Manufacturing Corporation is now an engineer of DeForest Radio Company at Passaic.

Lieutenant H. A. Tellman, U.S.N., has been transferred from the U.S.S. Arizona to the U. S. Naval Station at Key West, Fla.

Charles Travis has left the Atwater Kent Manufacturing Company to join the RCA Licensee Laboratories of New York City.

C. G. Turner, formerly with Sterling Radio Company, is now chief engineer of the Melodian Company of America, Kansas City, Mo.

D. C. Wallace, previously with General Motors Radio Corporation is now district manager of Kolster Radio, Inc., with headquarters at Long Beach, Calif.

William Waterman, previously with Radio System, Inc., is now radio engineer for Insuline Corporation of America of New York City.



PART II
TECHNICAL PAPERS



THE OPTICS OF RADIO TRANSMISSION*

By

ERNEST MERRITT

(Department of Physics, Cornell University, Ithaca, N. Y.)

IT WILL be remembered that the discovery of electric waves came as a result of the experiments undertaken by Hertz to test the electromagnetic theory of Maxwell. It is one of the cases where advance in theory definitely preceded the advance in experiment. For this reason perhaps physicists were interested in electric waves for a number of years after Hertz's discovery chiefly because of the confirmation that they gave of the electromagnetic theory of light. The older members of this audience will remember the large amount of interesting work that was done about thirty years ago in imitating the fundamental optical phenomena with electric waves several centimeters or several meters in length. Hertz himself showed that the waves were reflected and refracted like light waves. A little later their velocity of propagation was shown to be the same as that of light. They were found to show interference phenomena of various kinds. Then followed the demonstration for electric waves of diffraction by an aperture and by a grating, polarization, double refraction, rotation of the plane of polarization, total reflection, dispersion. In fact practically every important phenomenon that we think of as characteristic of light waves was found to be reproducible with electric waves. The last piece of work of this kind that I recall was published only a few years ago and used a model of the asymmetric carbon atom to give rotation of the plane of polarization of electric waves about 20 cm long.

It was while work of this sort was under way that Marconi began his efforts to utilize electric waves for radio communication—unfortunately in the beginning with only little encouragement from physicists. Naturally optical analogies were an important guide in this early work. In some of Marconi's first experiments a concave mirror was used to concentrate the rays; in a rough way his apparatus was the electric analogue of a searchlight. It is interesting to note that in recent years we have in the various methods of directed radio transmission an application in modern form of the same optical principles that were used by Marconi over thirty years ago.

* Decimal classification: R113. Presented by invitation at the Fifteenth Annual Meeting of the Optical Society of America held at the University of Virginia, October 31–November 1, 1930. Reprinted from the *Journal of the Optical Society of America*, February, 1931.

While Marconi used optical analogies as a guide so long as they were helpful, he did not allow himself to be hampered by such analogies. He was courageous enough to keep increasing the distance between his stations until he received signals at points far beyond that at which the curvature of the earth would prevent a searchlight from being seen. For a result like this no optical analogue could at that time be found. And when radio transmission across the Atlantic became a reality it seemed as though there was no possibility of treating radio as a branch of optics. It is true that in a half-hearted way diffraction was sometimes suggested as an explanation of how radio waves were able to bend around the earth. To some extent light waves bend around an obstacle: with the longer radio waves this bending would be much more marked. The inadequacy of this explanation was made clear by Larmor. If diffraction permits radio waves to follow the curved surface of the earth then if we reduce the wavelength to that of visible light and reduce the diameter of the earth in the same proportion, we should expect visible light to bend around the surface of this miniature earth. The wavelength ratio of ordinary radio waves and visible light is about 10^{10} to 1. If the diameter of the earth were reduced in this ratio we should have a sphere about a millimeter in diameter. We know that a sphere of this size casts a sharp shadow; the bending due to diffraction is too small to detect.

For a number of years after this optical methods played a very unimportant part in the development of radio. A satisfactory explanation of the bending of the waves about the earth was found by applying electromagnetic theory to a conducting sphere in much the same way that it had been used in treating the propagation of alternating currents along wires. So far as I know there is no optical phenomenon that corresponds to this. If there were we might guide light waves along wires in much the same manner that the carrier wave is guided in General Squire's "wired-wireless," and some of the problems of television would be greatly simplified!

The story of how optical methods came back into the radio field, to become more important than ever before, is both interesting and instructive. After the wartime restrictions were removed about ten years ago there was a rapid increase in the popular interest in radio. Its use as a commercial method of communication was greatly extended, broadcasting began, and an army of amateur radio enthusiasts established private stations not only for receiving but for sending. The interference between stations became so great that if radio was to survive at all as a useful method of communication some means of regulation and control became absolutely necessary. By national legis-

lation and international agreements a distribution of wavelengths was adopted by which a certain range of wavelengths was reserved for government stations; other wavelength bands were assigned to commercial stations, to broadcast stations, and so on. And after everything else was taken care of, what was left was assigned to the amateurs. The waves that the amateurs were left free to use were at the short-wave end of the radio spectrum, for these were the waves that were believed at that time to be the least useful for communication purposes. The theory which had accounted for the bending of radio waves around the earth when optical theories failed predicted that attenuation would increase rapidly with decreasing wavelength and that long range signaling could best be accomplished by longer waves than had previously been used. Up to that time experience had amply confirmed this prediction and the tendency was overwhelmingly toward the use of longer waves. The powerful stations that were built just at the close of the war used wavelengths as great as 30 km; and the belief was general that for long range communication waves shorter than one or two hundred meters were practically useless.

Since the amateurs were not allowed to use the longer waves they went ahead with undiminished enthusiasm to get what results they could with the wavelengths assigned to them. Presumably most of them were not familiar with the theoretical reasons for believing that work with short waves was not likely to prove successful; at any rate such knowledge of theory as they had did not deter them from trying experiments which the experienced radio engineer would have regarded as foredoomed to failure. When such experiments led to success with 100-meter waves they tried 50-meter waves and found the results still better. Gradually the wavelength was reduced still further until with a wavelength of about 20 meters it was found possible to signal over distances greater than had ever before been reached, and this with only a fraction of the power used by the long wave stations.

So large a part of the work was done by amateur experimenters, whose results were usually not published in the scientific and engineering journals, that it is difficult to get an accurate history of this development of short-wave radio. But as the result of the combined work of amateurs, radio engineers, and physicists we now know that the range of practical radio communication is a minimum for wavelengths of about 200 meters and that the range may be made greater either by increasing or by diminishing the length of the waves used.

What interests us particularly, however, is the fact that the only explanation offered for the long range reached by short radio waves is based upon ordinary optical principles. And the development of

modern radio is proceeding by the application of the same methods that would be used in the case of visible light.

The bending of short radio waves around the earth is now explained as the result of refraction by ionized air. Ions are known to be present in the air even at the surface of the earth. There is every reason to believe that their number increases with the height. As the density of the atmosphere becomes less the ions move more freely and at sufficiently high altitudes it is believed that free electrons are also present. These electrons and ions influence the propagation of radio waves in the same way that they influence the propagation of light in transparent media. If we take into consideration the different conditions to which the electrons are subjected and the different order of magnitude of the waves that we deal with we are able to apply to radio all the classical theories of the propagation of light. The difficulties that arise are due to our incomplete knowledge of the conditions in the atmosphere.

Of course the greatest difficulty is that of determining how the electron density varies with the height above the earth. To compute the electronic distribution we must make assumptions as to the agencies that produce ionization, the constitution of the atmosphere at different heights, and the rates of recombination of the different ions. But in spite of the uncertainty of these assumptions there is a remarkable agreement in essentials among the different estimates of the electronic distribution. All agree, for example, in predicting that at some height above the earth there is a very great increase in the number of free electrons, and that the increase is so rapid that we pass almost discontinuously from an atmosphere that may be treated as an insulator to a region that is a relatively good conductor. This region, whose existence was suggested independently by Kennelly and Heaviside, is known as the Kennelly-Heaviside layer. A simple way of picturing the propagation of radio waves is to think of this layer as a mirror which reflects the waves back to the earth. Since the earth also acts as a reflector, the waves are reflected back and forth in the space between two concentric spherical mirrors.

To make the picture more complete we must remember that ionized air causes absorption as well as refraction so that the medium between the two spherical mirrors is not perfectly transparent. Finally, since the reflecting layer is caused by the presence of ions, its reflecting power and also its height will depend upon the atmospheric conditions and upon the activity of the various agencies which produce ions. One of the most important of these ionizing agencies is undoubtedly sunlight so that it is to be expected that the Kennelly-Heaviside layer will be higher, and the absorbing power of the atmosphere less, at night

than during the day. Most of the well-known differences in the transmission of radio signals by day and by night are explainable as a result of this difference in the height of the reflecting layer and in the absorbing power of the air at lower levels.

Although extremely useful, and in its main features undoubtedly correct, this picture is of course much simpler than the reality. The boundary of the Kennelly-Heaviside layer can scarcely be sharp enough to permit true reflection. Probably what occurs is a continuous bending of the waves by refraction throughout their whole path, with the curvature greatest at the highest point. Theory indicates also that the index of refraction of ionized air is a function of the wavelength. The path followed by short waves will therefore be different from that taken by longer waves between the same two points, so that the apparent, or effective, height of the Kennelly-Heaviside layer will depend upon the wavelength used.

At moderate distances from the sending station we must assume that the waves reach the observer by at least two paths. One of these paths carries the waves up to the Heaviside layer and back. The other path follows the surface of the earth. When they meet at the receiving station the two wave trains interfere, and slight changes in the effective path lengths cause the interference to be sometimes additive and sometimes destructive. This is undoubtedly one of the chief causes of the changes often observed in the intensity of radio signals, in other words "fading."

It is customary to refer to the wave which follows the earth as the ground wave and that which follows the longer route the indirect wave or sky wave. The general belief has been that the ground wave is guided by the earth in much the same way that an alternating current is guided by a wire. In the immediate neighborhood of the sending station there seems to be little doubt that this view is correct. But to what distance this mode of propagation extends is still unsettled. It seems to me that there is a good deal of evidence in favor of the view that at greater distances the ground wave also is chiefly an optical phenomenon. Certainly there are some facts which are more readily accounted for if we think of the ground wave as proceeding according to optical laws along a curved path which rises to only a relatively small height above the earth.

The chief problems in which optics can help are, however, connected with the sky wave. From the optical point of view these problems would be perfectly straightforward if we knew the conditions in the upper atmosphere. But that is precisely what we do not know. And since the region in which we are most interested is far beyond the

heights that can be reached by balloons and airplanes, there is at present no direct way by which we can get the needed information. Almost the only way to attack the problem is to assume that radio transmission is an optical phenomenon and then by utilizing our knowledge of optical laws to try to deduce from the observed effects what the conditions must be that produce them. This is not a procedure with which we have had occasion to become familiar. It is as though we had the problem of determining from the flickering illumination of a sheet of paper what system of lenses and mirrors between us and the source would account for the observed changes in brightness. An excellent analogy to the radio problem is that offered by the shadow bands that are seen at the time of an eclipse.

To go into the optics of radio transmission in any detail would take us entirely too far. All I shall attempt to do is to point out some of the peculiarities and some of the complexities of the problem. We have to deal not only with refraction, reflection, absorption, interference, and diffraction effects, but also with magnetic double refraction and a Faraday rotation of the plane of polarization caused by the earth's magnetic field. The modern radio engineer must be familiar with the whole optical repertoire, and able to utilize his knowledge either in the design of apparatus—such for example as the radio beacon, or other directive antennas—or in interpreting observed phenomena.

The natural frequencies of the electrons in the molecule are so widely different from the frequencies used in radio work that we should hardly expect to find any of the effects which are explained in the classical wave theory by resonance of the bound electrons in the medium, such for example, as metallic reflection and anomalous dispersion. At high altitudes, however, where electrons are present in large numbers, and where their free path is long, another effect comes which gives results very similar to those of resonance. The electrons that are set in motion by the electric field of the wave will be deflected by the magnetic field of the earth and, if the direction of propagation is the same as that of the magnetic lines of force, will describe nearly closed curves. It can readily be shown that the time required for one complete rotation is independent of the speed of the electron, so that there is a resonant frequency at which the electrons will move in spiral paths of increasing radius and will continue to absorb energy from the waves until stopped by collision. The theory of wave propagation under these conditions has been developed by Nichols and Schelleng and shows that the effects to be expected, while in the highest degree complicated, are in the main such as would be anticipated from our knowledge of the phenomena of magneto-optics. The most obvious effect of the earth's mag-

netic field is a rotation of the plane of polarization of the radio waves. In the case of short waves this is very marked and often changes rapidly in amount as conditions change along the path of the ray. I have observed forty-meter waves from a station about three hundred miles away in which the electric vector rotated continuously, requiring from ten to twenty seconds for a complete rotation, for half an hour or more. In general the waves are elliptically polarized, but the polarization often remains nearly linear for long periods. In case the waves travel across the magnetic field, theory indicates that magnetic double refraction is also to be expected. I do not know of any observations in which this double refraction has been definitely detected. But there can be little doubt that it occurs, with results that are confused by the complexity of the phenomena.

Since the magnetic field of the earth varies from point to point, the critical or resonant frequency is not the same at different points in the path. It is as though we were dealing with a broad absorption band rather than a sharp line. The crest of the band corresponds roughly to a wavelength of two hundred meters. Undoubtedly that is the reason for the radical change in the behavior of radio waves when this critical frequency is passed.

In ordinary optical work the dimensions of the apparatus are usually large compared with the wavelength. Even the narrowest slit is several wavelengths wide. But the apparatus used in radio work is usually small compared with the wavelength. In a few cases antennas so long as to include several wavelengths are used. But this is the exception. The diameter of the coil used in the radio compass, or in any coil receiver, is often less than one per cent of the wavelength that it receives. This makes it possible to study the details of a radio wave pattern in a way which is hardly possible with visible light.

Recently I have been studying in this way what might be called the fine structure of a radio wave front.¹ The results are both interesting and puzzling.

The method was to use two coil receivers placed at two points on the wave front about half a wavelength apart, and by means of cables to bring the signals to a cathode ray oscillograph. The arrangement was such that one signal produced a horizontal vibration of the spot while the other produced a vertical vibration, the amplitude and phase relations between these vibrations being the same as between the original magnetic fields at the two receivers. One would naturally expect that at two points on the same wave front the phase and amplitude would

¹ The results of these experiments, which were supported by a grant from the Heckscher Foundation for Research at Cornell University, will be published in detail in the near future.

be the same. In this case the oscillograph figure would be a straight line inclined at an angle of 45 degrees. Sometimes this figure was observed. But usually it was not. Ordinarily the figure was an ellipse, and an ellipse which changed from moment to moment both in size and shape. At times the changes occurred so rapidly and so erratically that it was quite impossible to follow them. Unless the conditions were exceptionally steady the results were much the same whether the signals came from a great distance or from a station only fifty miles away.

The variations of phase and amplitude were less marked when the receivers were set so that the plane of each coil was directed toward the station. In this case the received signal was chiefly that carried by the ground wave. When the coils were turned at right angles to the station direction so as to receive the sky wave only the changes in the shape and size of the figure were much more marked. On numerous occasions the signal was strong at one station at the same time that it had faded out completely at the other station less than half a wavelength away.

Evidently the conditions in the wave front of a train of radio waves are not so simple as we have been accustomed to think. In fact they are so complicated and erratic that one is almost tempted to abandon the classical picture of a wave train and to attempt to build up a picture on the basis of the modern corpuscular theory. The quantity $h\nu$ is so small in the case of radio waves that even the weakest signal calls for an enormous number of photons. We might perhaps imagine an ordinary classical wave train as corresponding to an army of photons marching in regular array, each one keeping step and alignment with his neighbors. In the cases of radio reception which I have just described, where phase and amplitude vary from point to point in the same wave front, the photon army has become disorganized. Perhaps the hardships that it encountered in the upper atmosphere had weakened its morale and destroyed its discipline. The army had become a mob of photons, all marching in the same general direction, but made up of individuals and groups that acted independently.

Some picture more or less like this may ultimately take the place of the classical picture of wave propagation. But in the case of radio waves the necessity of such a change is not yet clearly in evidence. I am inclined to think that until the change is forced upon us it would be wiser to adhere to classical methods. To introduce a radio photon into the picture before we are forced to do so might create more difficulties than it avoids. How, for example, would we get our army of photons started? Where do the recruits come from? And when they reach the receiving station what is the process by which they set up the electric currents by which we detect them? It seems to me to be one of the cases

where it is "better to suffer the ills we have than flee to others that we know not of."

The observed variations of phase and amplitude along the wave front seem to me to be capable of a simple explanation along classical lines. If we assume that waves reach the receiving apparatus by several different routes it is to be expected that they will differ in amplitude, phase, and direction. An interference pattern will be formed at the receiver, which, if the conditions are steady, will consist of a fixed system of interference bands. It is quite possible that there would be additive interference at one receiver and destructive interference at the other. If we could investigate the conditions at different points in the interference pattern of a Michelson interferometer, or at the focus of a lens, we should not expect to find constancy of either amplitude or phase. If an interferometer were mounted above a hot stove the bands would probably disappear. At each instant there would still be a definite interference pattern—although probably a very complicated one. But the pattern would change so rapidly that in the case of light it could not be observed. In the case of radio waves everything is on a larger scale—even time—so that it is possible to follow the changes from instant to instant. When the conditions for radio reception are bad it seems probable, therefore, that something is going on in the upper atmosphere which is at least analogous to the convection currents in heated air. If we wish to make radio observations which involve any simple and predictable phase relations we must wait until the atmospheric conditions are favorable—just as we would have to do in the case of light.

Among the radio problems that are arousing a great deal of interest at the present time are those connected with so called "radio echoes," i.e. cases where two signals—or sometimes more than two—are received for each single signal sent. For example the dot of the Morse code is received as two dots. At points not far from the sending station this duplication of signals can be observed with suitable apparatus most of the time, the separation between the first signal and its "echo" being of the order of 0.001 sec. In such cases there can be little doubt that the first signal has followed the direct route from the station, while the second has been reflected from the Kennelly-Heaviside Layer. Observations of these echoes thus give an excellent means of determining the effective height of the layer. Sometimes more than two echoes are recorded, with such spacing as to suggest multiple reflection between the Heaviside layer and the earth. On other occasions when several echoes are observed the time intervals are such that the existence of two reflecting layers is suggested.

When signals are received from a powerful short-wave station capable of transmitting over great distances another type of echo is frequently observed in which the separation between the signal and its echo is of the order of one seventh of a second. The explanation seems to be that one signal has come by the shortest route while the other has traveled all the way around the earth and reaches the receiving station from the opposite direction. The time interval between the signals has been measured with such accuracy and consistency that very plausible estimates can be made of the height at which the waves travel. Sometimes however these round-the-world echoes are accompanied by echoes with a retardation considerably less than one-seventh of a second—sufficiently long to permit the waves to travel two or three thousand miles, but not much further. To account for these cases the suggestion has been made that the waves reached the observer after reflection from a hillside or possibly from the waves of the ocean. Evidently the continued study of these echo signals is likely to bring most interesting results.

About two years ago still another type of radio echo was observed which presents the most puzzling problem in the whole radio field. These echoes occur with a retardation ranging from three seconds to nearly thirty seconds. Traveling with the velocity of light radio waves would cover in thirty seconds a distance of over five million miles—two hundred times the circumference of the earth! Naturally one's first thought is that the observers must in some way have been deceived, possibly interpreting some accidental noise as an echo. But the observations were made by skilled observers and with such precautions and checks that this explanation seems to be ruled out. Signals were sent out at intervals of thirty seconds from Eindhoven in Holland and were received independently by three observers, two at different stations in Eindhoven and one in Oslo, Norway. In numerous cases, although not in all, when an echo was observed at one of these stations it was also observed at one of the others. Frequently it was observed at all three stations, and with nearly the same retardation.

These long-time echoes evidently call for very special conditions, for of the numerous attempts made to detect them only a few were successful. Two suggestions have been made to explain these echoes. One is that at times there is a stream of electrons from the sun at a distance of a million miles or so from the earth which is sufficiently dense to reflect the waves. Such an electron stream would be bent by the earth's magnetic field so as to have a tendency to reflect the waves directly back to the earth. Another suggestion is that the waves do not leave the

earth at all but travel in a region of the atmosphere where the conditions are such as to make the group velocity extremely small.

It is very much to be hoped that efforts to observe these long time echoes will be continued, for if they really occur—and it is hard to doubt that they do—their study seems likely to lead to results of great importance.



TEN YEARS OF TRANSRADIO—A RETROSPECT*

BY

E. QUÄCK

(Telefunkenhaus, Berlin, Germany)

Summary—This review of the development of the "Transradio" system includes a description of the transition from the manual operation of a single Berlin-New York radiotelegraph circuit to the operation of a system involving transoceanic radiotelegraph operation between Germany and fourteen other countries and localities. The development of the use of short waves is described and a tabulation is given of the frequencies and antennas employed with various transmitters for the several circuits. Figures are given showing the growth in traffic and the decrease in the time required for handling a telegram. References are given to papers which have been published covering the studies made of the propagation characteristics of short waves.

THERE are two reasons for reviewing what has been done in organization and technical work by the Transradio Gesellschaft during the last ten years. First, Transradio celebrated its ten years of existence on September 20, 1930. Ten years ago, in the presence of the President Ebert of Germany and of representatives from the Ministries, the large Nauen radio station was dedicated after its reconstruction, which started during the World War (Fig. 1). The other reason is that under the terms of the purchase of Transradio by the German Post Office, the operation will be transferred to the Post Office on January 1, 1932.

The sale must be regarded with some sorrow when we realize that the organization passes into other hands, but a certain satisfaction is derived in knowing that something great has been accomplished here, and that radiotelegraphy has developed from its initial stage and has become an important factor in world-wide communication. It can only be hoped that, in the future, German transoceanic radio will retain its present high position in world communication.

TRANSITION FROM MANUAL OPERATION TO MECHANICAL OPERATION

Ten years ago transoceanic radio communication, which was carried out with North America only at that time, was in its initial stage. This is shown by the low average word speed with which telegrams were sent. The telegrams were transmitted by means of a hand-operated key. The operator, who received through headphones the signals that frequently were weak and greatly affected by atmospheric

* Decimal classification: R610. Original manuscript received by the Institute, March 26, 1931. Translation received by the Institute, July 1, 1931. Published in *Telefunken-Zeitung*, February, 1931.

disturbances, wrote down the telegram slowly with a lead pencil, and at that time to a certain extent he had to have a sensitive artistic temperament. Nothing was allowed to disturb the operator because this would interfere with reception. What he had written was regarded necessarily as correct, because there was no checking. Atmospheric disturbances made reception difficult, particularly in the summer time. During this period the strain in the operating room was very great because reception was frequently impossible and because the customers complained of the mutilation and delay.



Fig. 1—Main operating building for the Nauen high power radio station.

Then a change was made, and a special machine transmitter was used instead of a key. Telegrams were converted into perforated tapes by means of a perforator, and the tapes were used to operate the transmitter through the mechanical sender. This method made possible better and more rapid transmission of signals than by hand. The first types of perforating machines made by Siemens and Halske were used. These made a large amount of noise and consequently had to be placed in a separate room so that nothing would interfere with reception. The perforated tapes were brought to the transmitter tables by messengers. The perforating machines were not perfect; they gave the wrong letters frequently and had to be watched constantly.

In order to improve reception, the signals as they were heard were recorded with a typewriter in order to make the receiving speed as rapid as possible. This necessitated overcoming a psychological resistance on the part of the radio operators who believed that reception would be retarded by the noise of the typewriters. But the attempt proved to be successful after the personnel had been trained in typewriting. At that time copies of the telegrams were prepared in the American way, by means of carbon paper. This method was soon replaced by using a copying machine that gave good dry copies from the original transcript, which is written in copying ink. These copies were necessary, in order that any inquiries from the receiver of the telegram at the operating office could be answered directly. The personnel had to learn to write with a typewriter and had to be trained in making perforations. The same keyboard was used on both machines. But as

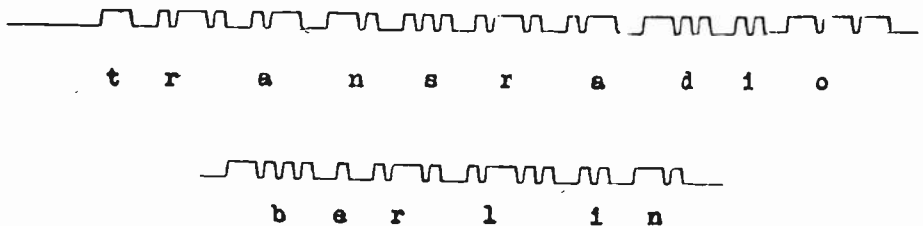

Fig. 2—Receiving record.

the Siemens and Halske perforating machine was not satisfactory, tests were made with other systems, such as the American Kleinschmidt type and the perforator developed by Creed. This we found to be excellent and it was introduced.

A visit to the Radio Corporation of America, in 1924, showed the superiority of reception with recording tape. In this method the signals picked up by the receiver are rectified and through a moving-coil system are recorded on a tape by means of a capillary stylus (Fig. 2). This method was immediately adopted from America and we bought several such recorders because there was no such German product, and in the fall of 1924 a change was made to recorder reception. Naturally the personnel again had to be trained to read the signals from the moving tape and to transcribe them on the typewriter in the usual form of telegram. This made possible a very great increase in the rate of reception and in the accuracy of the telegrams. Previously, with audible reception, a speed of only 30 words per minute was possible with a good operator, while with the new method telegrams could be sent at speeds as high as 300 words per minute. The average speed is now probably 100 words per minute with short-wave communication. Two operators

are necessary in order to transcribe the moving tape. Such speeds of telegraphy were impossible with long waves. Siemens and Halske then developed a new type of recorder that has important advantages in comparison with the recorder of the Radio Corporation, and this was then introduced in the central office.

Again the method of reception had to overcome a psychological difficulty. The value of the artistic quality in the ability of the operator to interpret the signals by ear was somewhat reduced, and in the case of errors in the telegrams, a comparison with the tape would show whether the operator had made a correct transcription. Then, as all



Fig. 3—Operating room of the Transradio operating central office, Berlin.

operating phases, such as perforators, senders, and receivers with typewriters, were placed in one large room (Fig. 3) in the central office, it was necessary to proceed systematically in order to reduce the mutual disturbances and influences. The transmitting and receiving table is shown in Figs. 4 and 5. This combination succeeded perfectly.

We see how organization measures caused repeated changes in the method of operation by the personnel, and these changes at times were very difficult. The operators at that time were government employees who in part were not familiar with quick and frequent changing of working methods in transoceanic radio communication. Only when the qualifications for radio operators were changed on May 1, 1925, so that training given in accredited schools owned by the companies was required, did it become possible to stimulate the personnel to a method of working with a good coöperative spirit and at present we take great

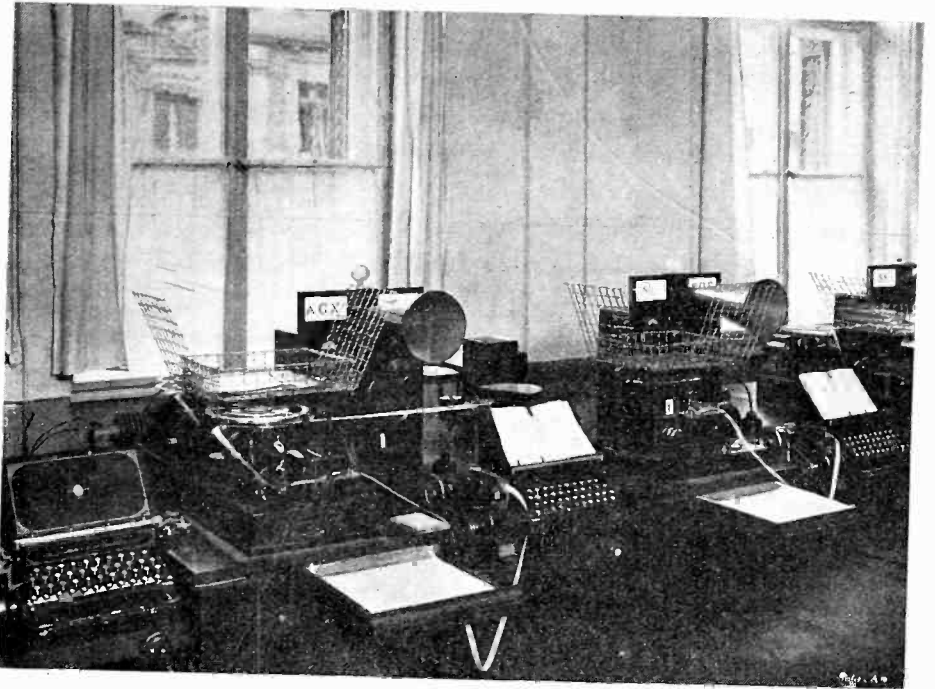

Fig. 4—Transmitting table in the Transradio operating central office with Creed perforator and machine transmitter.

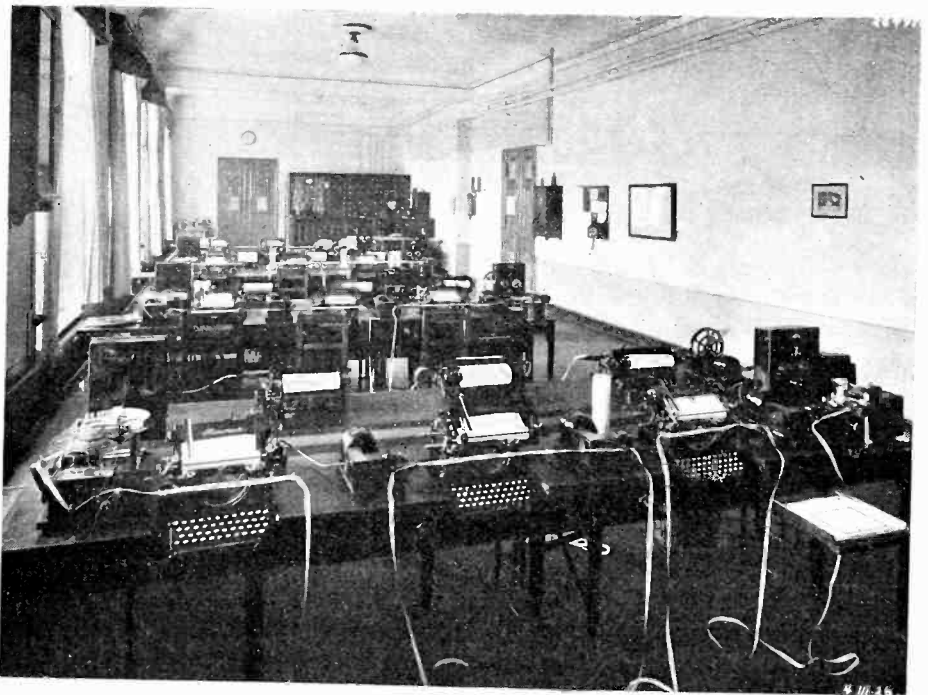

Fig. 5—Receiving table in the Transradio operating central office, Berlin, with recorder, typewriters, and tape movers.

satisfaction in stating that the personnel works excellently, because of this attitude, even under difficult conditions. At that time a successful attempt, the first after the revolution, was made to reach a wage agreement with the various employee associations, based on the principle of quality of the service, and although this wage schedule provided better payment for the employees than usual, it also aided the firm and its employees.

A proof of the improvement in the quality and reliability of communication is shown by statistics on errors made every month over a period of years in sending and receiving on the Berlin-New York line. The following table shows this:

TABLE I

Year	Transmitting		Reception	
	Errors Per Cent	Words Tested	Errors Per Cent	Words Tested
1925	0.31	45,200	0.95	56,177
1926	0.14	80,802	0.33	66,779
1927	0.1	78,853	0.32	49,595
1928	0.1	55,522	0.34	34,989
1929	0.16	71,341	0.29	5,463
1930	0.06	78,021	0.11	35,781

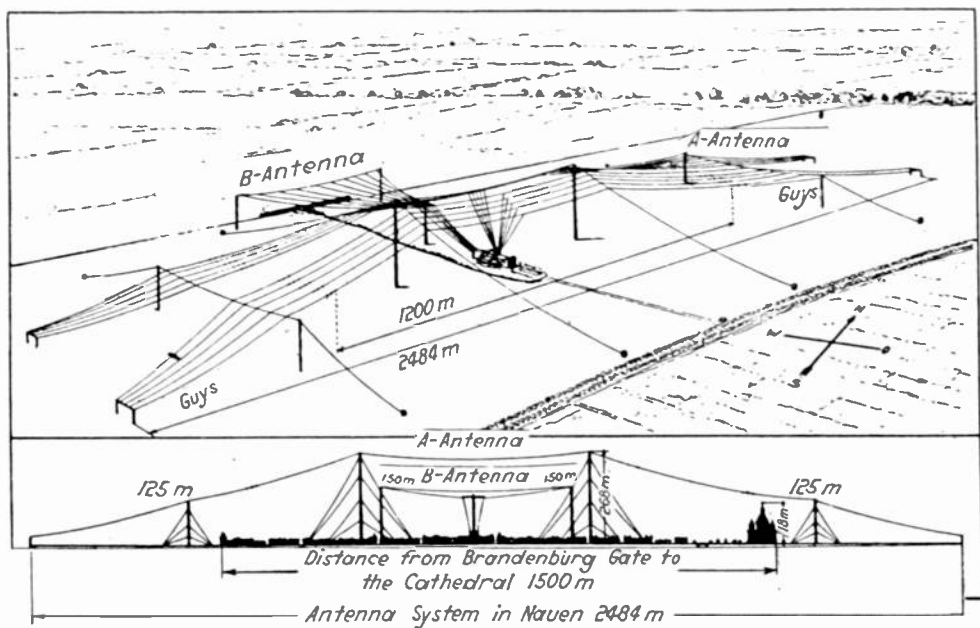

Fig. 6—Antenna system for the Nauen long-wave transmitter, 1920.

COMMUNICATION WITH SOUTH AMERICA

In 1920 Transradio took up the question of communication with South America because a large station was being erected in Buenos Aires. The power of the long-wave transmitting set in Nauen was increased. Instead of the usual antenna (Fig. 6) there was a new antenna

structure (Fig. 7) for long waves, and, as a matter of fact, the antenna areas A_1 and A_2 are used for 18,000-meter waves and antenna stages B and C are used for the 13,000-meter wave. The entire antenna structure is carried by two masts 258 meters high, 7 masts of 210 meters, and 4 masts 150 meters high.

This new construction was completed in 1924, the energy was increased and the method of operating the transmitter and regulating the speed of the machines was improved. For communication with

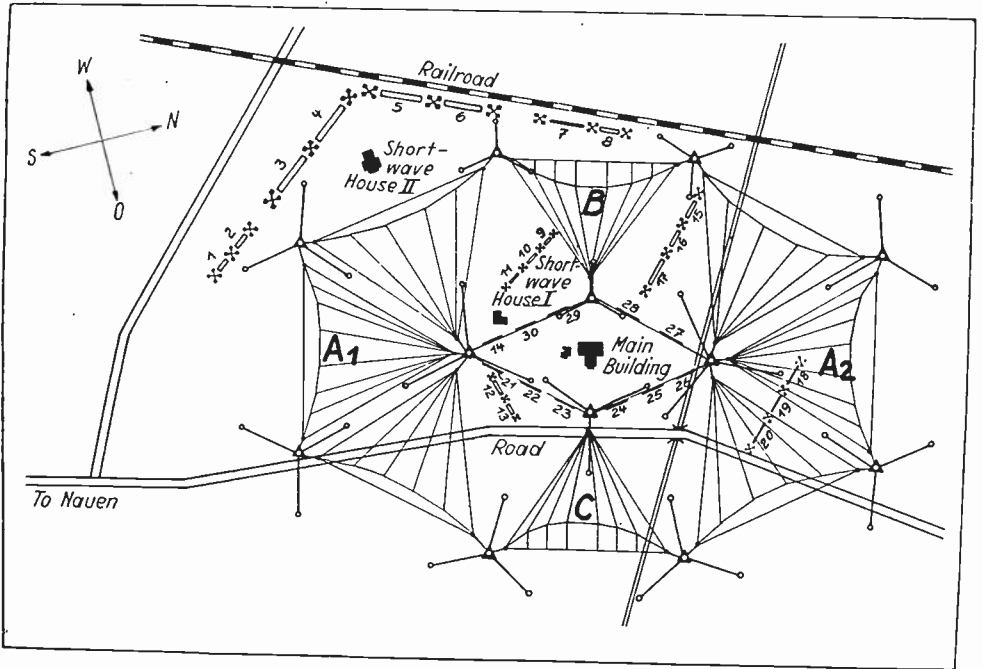

Fig. 7—Antenna installation for the Nauen long-wave transmitter since 1924, and location of the short-wave antennas and the short-wave transmitter house since 1930.

North America, the Eilvese station (Fig. 8) belonging to the Eilvese G.m.b.H., was operated by Transradio under an agreement. On April 15, 1929, this station suspended operation because, in the meantime, the Nauen station was able to take over the communication previously handled by Eilvese, because of the construction of the short-wave transmitting station. In 1924 a central office was established in Hamburg (Fig. 7) from which the radiograms to North America, taken in Hamburg, could be sent directly through the Eilvese transmitter. Today this branch office operates directly to North America through Nauen during hours of heavy traffic.

For receiving long waves from South America a new receiving station was built in Westerland. The location of this station on the sea

was much more favorable than inland because of fewer atmospheric disturbances.

Mutual operation with Buenos Aires was started in July, 1924. However, it was soon found that the atmospheric disturbances in

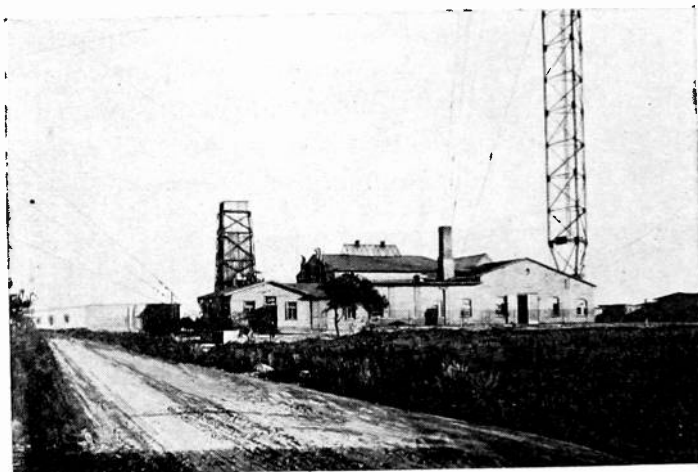

Fig. 8—Main operating building of the Eilvese high power radio station.

Buenos Aires had a very unfavorable effect on the incoming signal strengths, so that at times communication could not be carried on at all, or only very slowly.



Fig. 9—Operating room of the operating central office, Hamburg.

SHORT WAVES

Then short waves appeared as a friend in need. In July, 1924, communication was established with Buenos Aires by means of a laboratory short-wave transmitter of the Telefunken Gesellschaft in Nauen, using only 1 kw and a 70-meter wave, and during the night of July 17, the

long wave was not received but the signal of the small short-wave transmitter was very clear. This is due to the fact that the energy of the short waves is excellently conducted in a special layer, the Kennelly-Heaviside layer above the earth, and is brought down to the receiving location without any loss. In addition, atmospheric disturbances at the receiving station are very much less than with long waves. This led to the development of communication on short waves, and this was the first commercial transoceanic radio connection on short waves. Then very close connection was maintained with Telefunken, which led to the technical development of short waves.

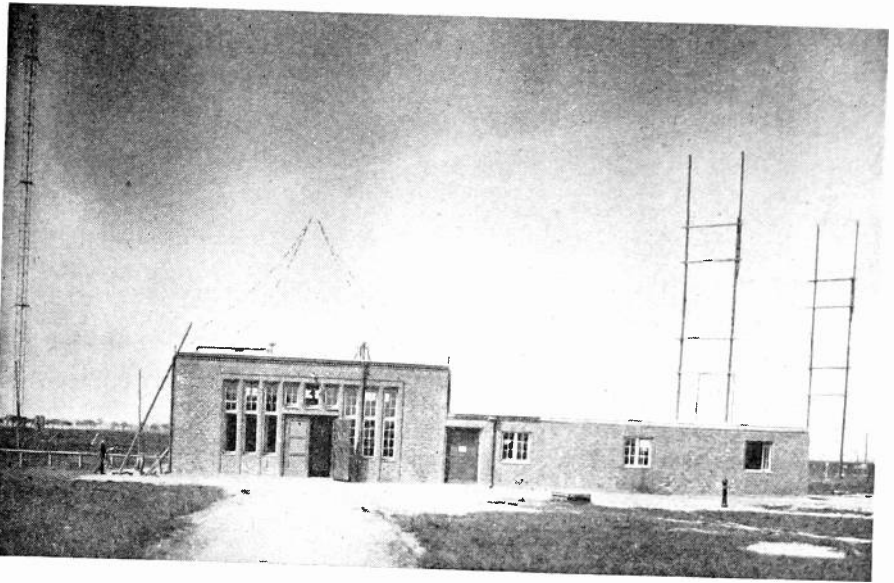

Fig. 10—Short-wave transmitter house I, Nauen, with temporary directive antenna. (See also Fig. 6.)

At that time the question arose whether a 100 per cent beam station, which had already been developed, should be purchased from Marconi for communication with South America. After a test of the English station it was decided that Telefunken would also develop such a set, and there resulted the first commercial short-wave transmitter with a power of 20 kw, in house I (Figs. 10 and 11) which was a small building erected at the side of the main building in Nauen. Later, another short-wave transmitter was installed.

In the meantime communication with South America was maintained by means of auxiliary short-wave transmitters using auxiliary antennas, installed in the old operating building in Nauen. At that time the short-wave transmitter was not controlled by crystals, and it was not believed practical to set up the transmitter in the main building because of the vibration of the large machines. This was the

reason for the special short-wave house I. This was lined on the inside with copper in order to act as a screen from induction effects that would be injurious to the constancy of the waves.

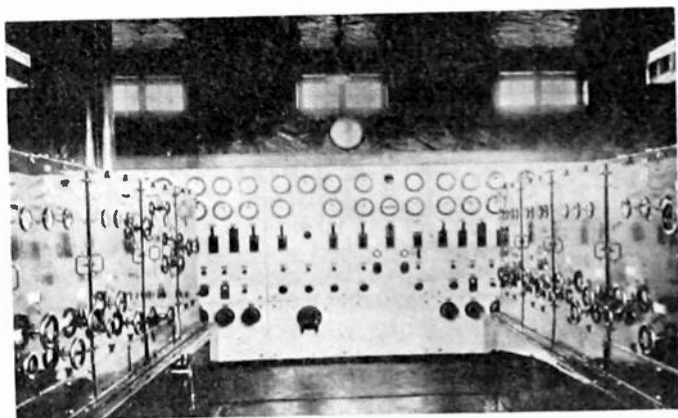

Fig. 11—Interior of the short-wave transmitter house I.

Telefunken developed practical antennas with horizontal dipoles based on their own work, and developed the beam antenna that was then built on a large scale. The next problem was the adaptation of the short-wave stations to the requirements of world communication so

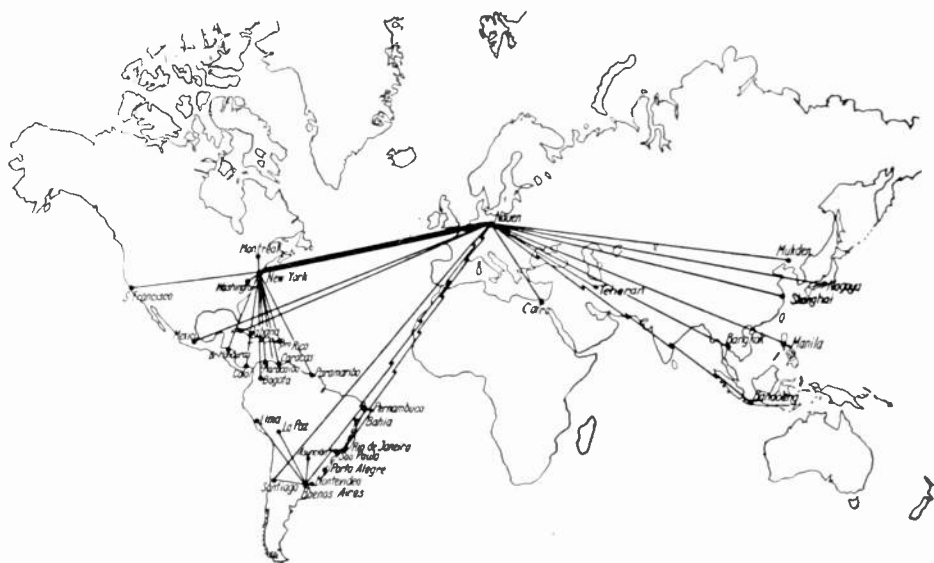

Fig. 12—World communication lines.

that they could work under all conditions. The map (Fig. 12) shows the various lines of communication for which the proper technique had to be devised. First of all there had to be a correct selection and allocation of waves suitable for communication.

The transmitters for North and South American communication were placed in house II (Fig. 13, 14, and 15) and the corresponding beam antennas were built outside the large antenna.

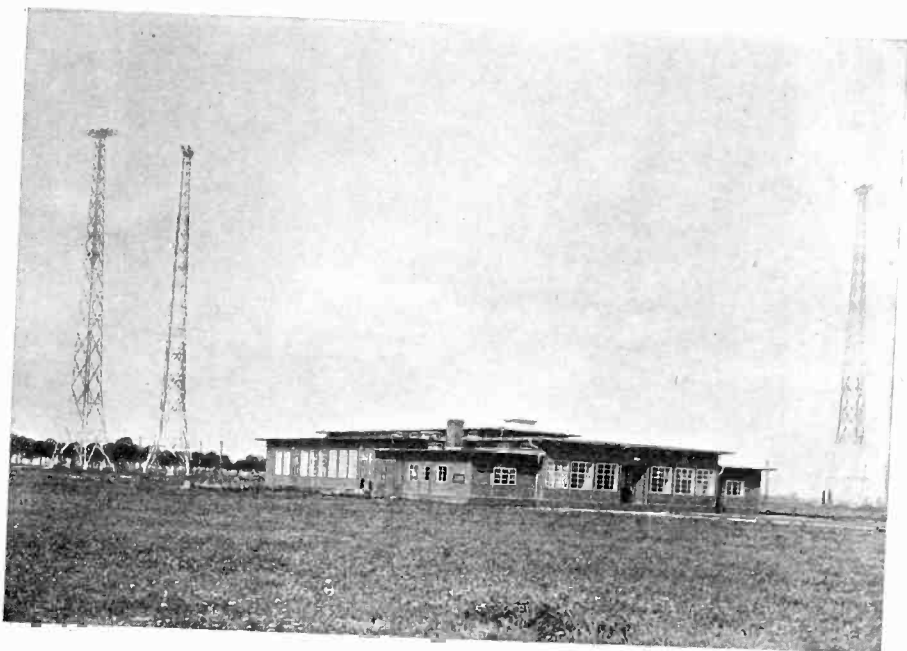

Fig. 13—Short-wave transmitter house II, Nauen, with large directional antenna. (See also Fig. 6.)

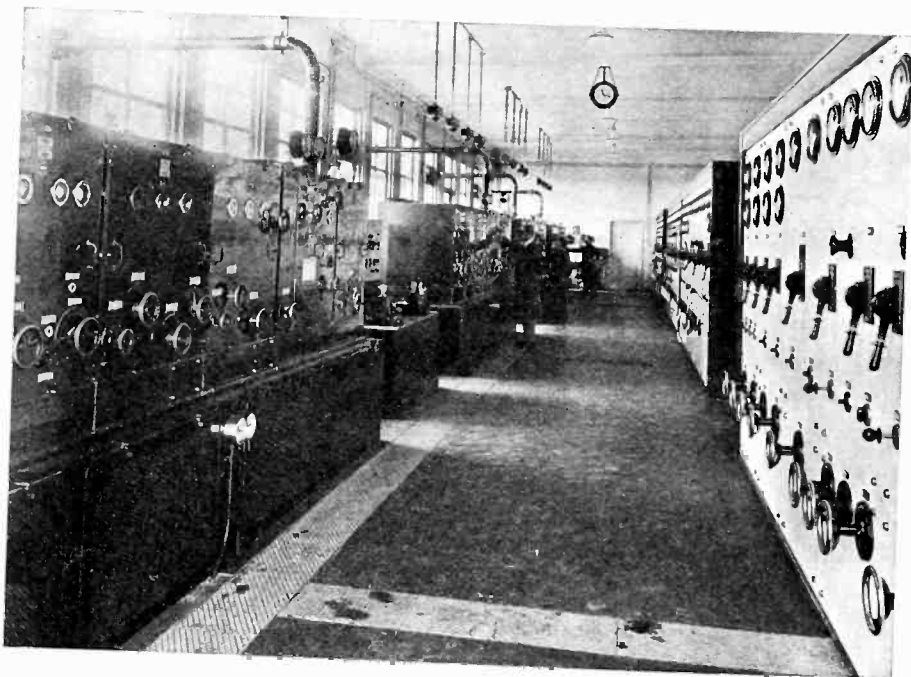

Fig. 14—Transmitting room in short-wave transmitter house II.

In the meantime the transmitters were equipped with quartz controls and on the basis of the tests that were made, it was felt justified in installing short-wave transmitters in the main building also, because, by the use of the crystal control, the harmful effect of the vibration of the large machines on the constancy of the oscillations was overcome. Four short-wave transmitters were placed in the main building. Two of them are used only for press communication. The installation of two more transmitters is planned. Press notices are sent daily at different times in different languages, such as German, English, French, and Spanish.

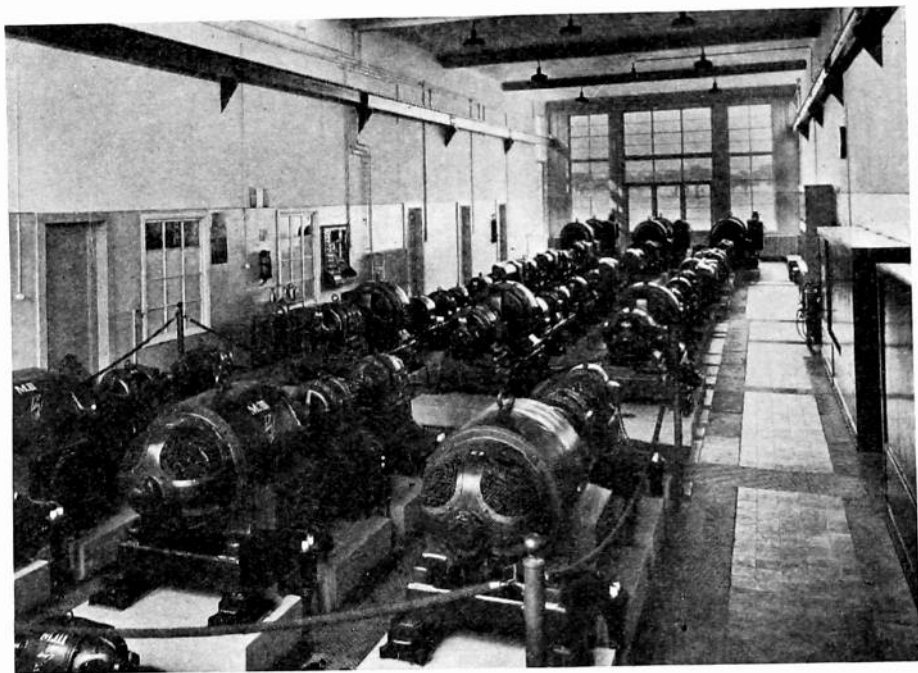

Fig. 15—Machine room of the short-wave transmitter house II.

FREQUENCIES AND ANTENNAS EMPLOYED

In Table II there are shown the various transmitters with their call letters and the wavelengths on which they operate, with the location and the antennas on which they work. In the antenna designation, as *H6/16R*, *H* means a horizontal dipole, 6 is the number of dipoles one under the other, and 16 the number of dipole series one beside the other. In addition, the tabulation indicates the communication circuit on which the transmitter operates. The numbering of the various antennas in the table may be found in Fig. 7. The energy for the transmitter at Nauen is supplied by the Märkischen Elektrizitätswerke and transmitted by overhead lines to the Dunkelfort substation, from

TABLE II
Short-Wave Transmitter, Nauen

At Present				After 1930 development								
Call letter	Kilo-cycles	Wave-length	Antenna		Transmitter location	Transmitter designation	Route	Call letter	Kilo-cycles	Wave-length	Antenna	
			Type	No.							Type	No.
dha	10,920	27.472	H6/2	14	KW1	K1 previously agb	Cairo Capetown	dha dpx dfd	10,920 20,060 14,665	27.472 14.955 20.457	H6/2 H4/4R H4/4R	14 13 12
dgx	20,060	14.955	H3/4R Slanting wire	Prov. 6 Prov. 8	KW1	K2 previously aga	Chile-Rio	dgb dgi dgc	20,420 13,375 9,880	14.691 22.429 30.364	H4/4R H2/4R H2/2R	9 11 10
dfa	19,240	15.592	H6/16R	5	KW2	K3	New York	dfa dfe	19,240 9,810	15.592 30.582	H6/16R H2/4R	5 8
dfe	9,810	30.582	H2/2R	Prov. 4	KW2	K4	Baires-Rio	dfr dfl	19,460 10,850	15.416 27.650	H6/16R H4/4R	3 2
dfr	19,460	15.416	H6/16R	3	KW2	K5	New York	dgg dgi dgv	13,180 20,140	22.762 14.896	H4/8R H2/4	6 7
dgi	13,375	22.429	H3/4	Prov. 3	KW2	K6	Baires-Rio	dho dgz dgd	20,020 14,605 10,210	14.985 20.541 29.382	H6/16R H4/4R	4 1
dgg	13,180	22.762	H3/4R	Prov. 5	KW3	K7	Transoceanic Press	dih dfo dih	19,947 9,730 7,332.5	15.040 30.832 40.918	H6/2	28 and 29
dgv	20,140	14.896	H6/16R	4	KW3	K8	Transoceanic Press	dis dfr dgv	10,150 15,595 20,500	29.557 19.237 14.635	H6/2	27 and 30
dho	20,020	14.985	H6/16R	28 and 29	KW3	K9	Cairo	dfr dfo dih	10,150 15,595 20,500	29.557 19.237 14.635	H6/2	27 and 30
dgd	10,210	29.382	H6/2	28 and 29	KW3	K9	Cairo	dfr dfo dih	10,150 15,595 20,500	29.557 19.237 14.635	H6/2	27 and 30
dih	19,947	15.040	H6/2	23	KW3	K10	Eastern Asia	dfr dfo dih	10,150 15,595 20,500	29.557 19.237 14.635	H6/2	27 and 30
dfo	9,730	30.832	H6/2	21	KW3	K10	Eastern Asia	dfr dfo dih	10,150 15,595 20,500	29.557 19.237 14.635	H6/2	27 and 30
dih	7,332.5	40.918	H6/2	22	KW3	K10	Eastern Asia	dfr dfo dih	10,150 15,595 20,500	29.557 19.237 14.635	H6/2	27 and 30
dis	10,150	29.557	H6/2	27 and 30	KW3	K10	Eastern Asia	dfr dfo dih	10,150 15,595 20,500	29.557 19.237 14.635	H6/2	27 and 30
dfr	15,595	19.237	H6/2	23	KW3	K10	Eastern Asia	dfr dfo dih	10,150 15,595 20,500	29.557 19.237 14.635	H6/2	27 and 30
dgv	20,500	14.635	H6/2	22	KW3	K10	Eastern Asia	dfr dfo dih	10,150 15,595 20,500	29.557 19.237 14.635	H6/2	27 and 30
dfq	18,700	16.043	H6/2	23	KW3	K10	Eastern Asia	dfr dfo dih	10,150 15,595 20,500	29.557 19.237 14.635	H6/2	27 and 30
dfo	12,985	23.103	H6/2	21	KW3	K10	Eastern Asia	dfr dfo dih	10,150 15,595 20,500	29.557 19.237 14.635	H6/2	27 and 30
dgu	9,650	31.088	H6/2	22	KW3	K10	Eastern Asia	dfr dfo dih	10,150 15,595 20,500	29.557 19.237 14.635	H6/2	27 and 30
dfb	17,520	17.123	H6/2	24	KW3	K10	Eastern Asia	dfr dfo dih	10,150 15,595 20,500	29.557 19.237 14.635	H6/2	27 and 30
dgh	10,440	28.736	H6/2	26	KW3	K10	Eastern Asia	dfr dfo dih	10,150 15,595 20,500	29.557 19.237 14.635	H6/2	27 and 30
dft	7,812.5	38.408	H4/2	25	KW3	K10	Eastern Asia	dfr dfo dih	10,150 15,595 20,500	29.557 19.237 14.635	H4/2	27 and 30
						K11	Mukden Shanghai Japan	dgy dhd dhe	17,880 9,910 7,325	16.778 30.272 40.965	H4/8R H2/4 H2/2	16 20 18
						K12	Mukden Shanghai Japan	dji djb djp	19,700 13,225 7,917.5	15.228 22.684 37.891	H4/18R H4/8R H2/2	15 17 19

Showing short-wave transmitters installed in Nauen, giving the call signal, wavelength, antenna, where installed, communication line.

which it is carried by cable at 15,000 volts to the main building. The erection of a suitable stand-by power plant operating by Diesel engines is contemplated for the short-wave transmitter.

Improvement in the short-wave receiving plant took place hand in hand with the short-wave transmitting sets. At first, because nothing else was available, very simple short-wave receivers were set up in a room in Geltow. The receiver had a tube detector, heterodyne, and low-frequency amplification, and operated with a simple dipole.

Then Telefunken developed an intermediate stage for short-wave receivers, which were worked with high-frequency stages with inter-

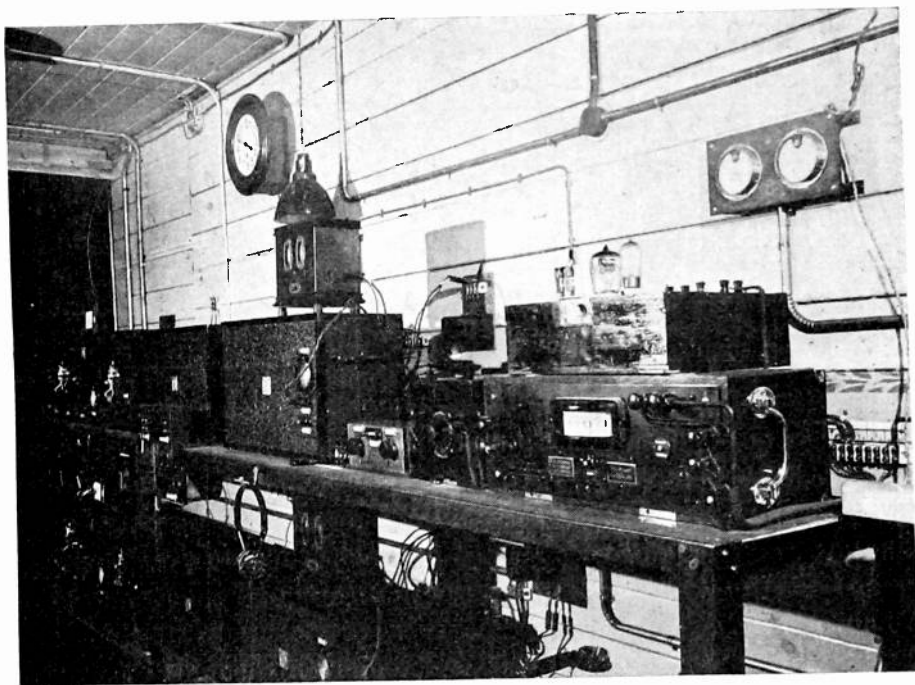

Fig. 16—Intermediate type of the Telefunken high-frequency short-wave receiver in Geltow.

mediate-frequency and low-frequency amplification. The receiver installation in Geltow can be seen in Fig. 16. Fig. 17 shows the auxiliary directive receiving antennas in Geltow.

Then Telefunken developed the so-called super-receiver for short-wave reception, which also operated with a relay so that the signals could be sent directly from the receiving station, with rectified direct current, to the central office.

In carrying out the large short-wave program for the different lines, the erection of a new receiving building had to be considered.

As early as January, 1928, the preliminary work and the construction of the receiving building (Fig. 18) for the Beelitz receiving station

45 km from Berlin, was started and it was completed in 1929. In the meantime the erection of the first large directive antenna was started (Fig. 19). This included:

One directive antenna A: $H4/12R$ for the 20-meter wave of the Radio Corporation of America of New York.

One directive antenna C: $H6/16R$ for the day waves in the region of the 15-meter band of the Companhia Brasileira, Rio de Janeiro (telegraph and telephone).

One directive antenna D: $H6/16R$ for the day waves in the 15-meter band region of the Transradio Internacional, Buenos Aires (telegraph and telephone).

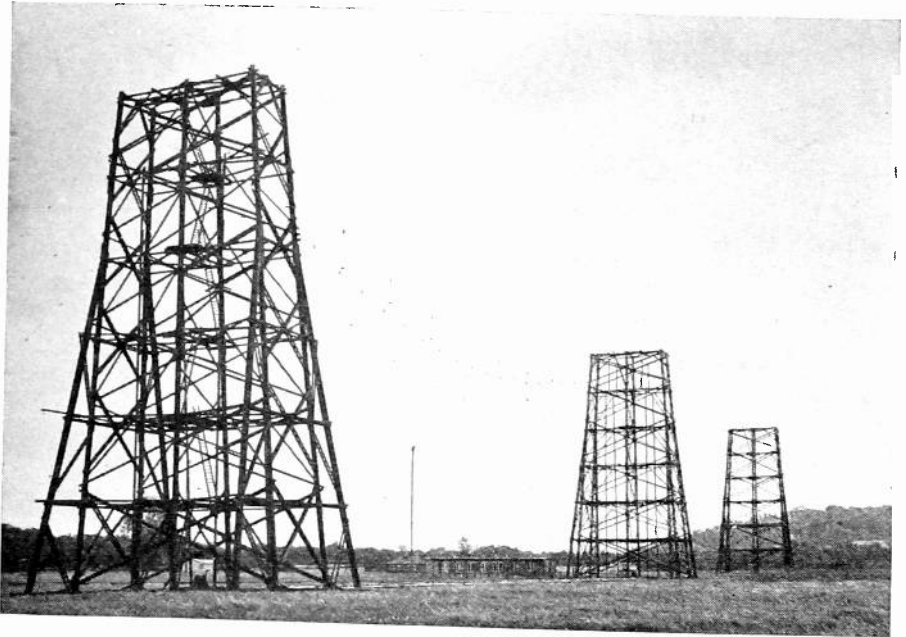

Fig. 17—Temporary directive receiving antenna in Geltow for reception from South America.

The leads to these antennas consist of concentric copper tubes. By changing antenna and reflector, the antennas at times can be used for reception from the Far East. The antennas necessary for the other lines are now being built. Their location, type of construction, and destination can be seen from the illustration. A Beverage antenna has also been built for purposes of comparison. All antennas with reflectors have switch connections so that antenna and reflector can be changed for receiving from opposite directions. In addition, 17 more directional antennas are available and, among other things, are used for receiving the night waves from New York and Buenos Aires, as well as for reception from Cairo, Manila, Japan, and Java. Fig. 19 shows a plan of the entire antenna arrangement. The data regarding the use of the

antennas are also indicated. For receiving the 15.89-meter wave from New York, and also the 16.8-meter wave from Java, two antennas of

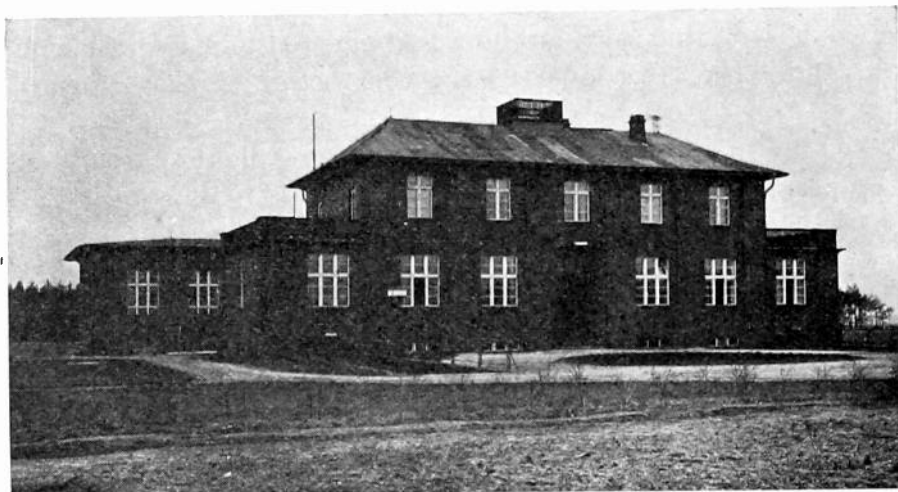

Fig. 18—Receiving building for short-wave reception in Beelitz.

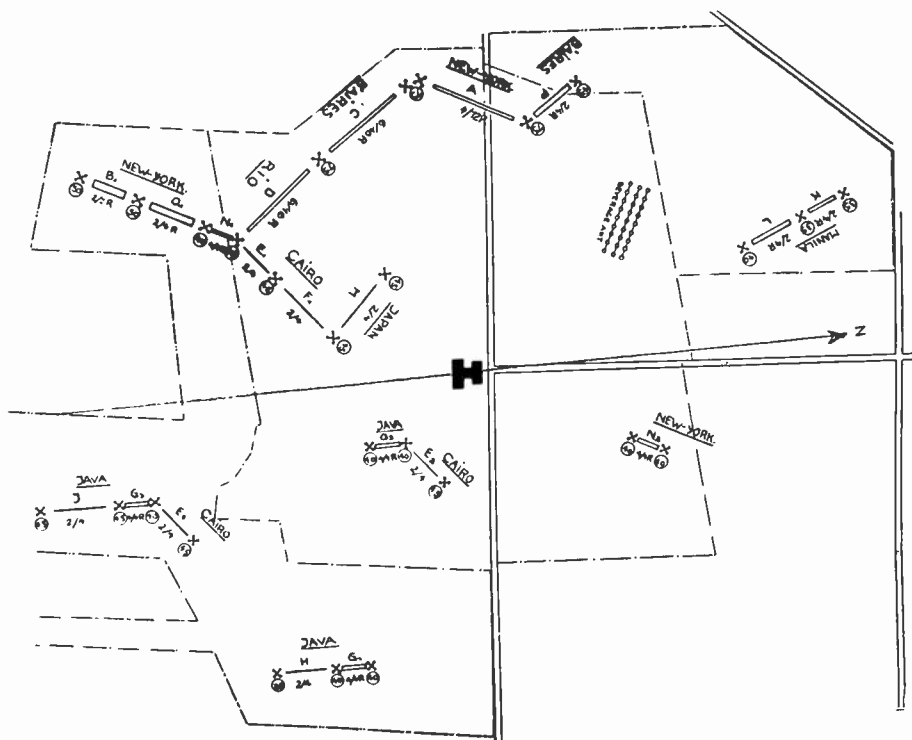

Fig. 19—Map of the short-wave receiving antennas in Beelitz, showing the communication lines and the type of antennas. Height of mast is given in circles.

the same size but separated in space were provided for the first time. For receiving the 25.2-meter wave from Cairo spacially separated an-

tennas were also provided. These multiple antennas are used primarily to overcome fading, which makes itself unpleasantly noticed on these routes and in these wave bands. The method of operation with these antennas is such that each antenna is connected to a receiver of equal output and these are connected together before transmission to the cable.

When the entire construction of the receiving plant, one of the noteworthy plants in the world, is completed, a total of 40 super-receivers will have been constructed for short-wave reception. By means of an

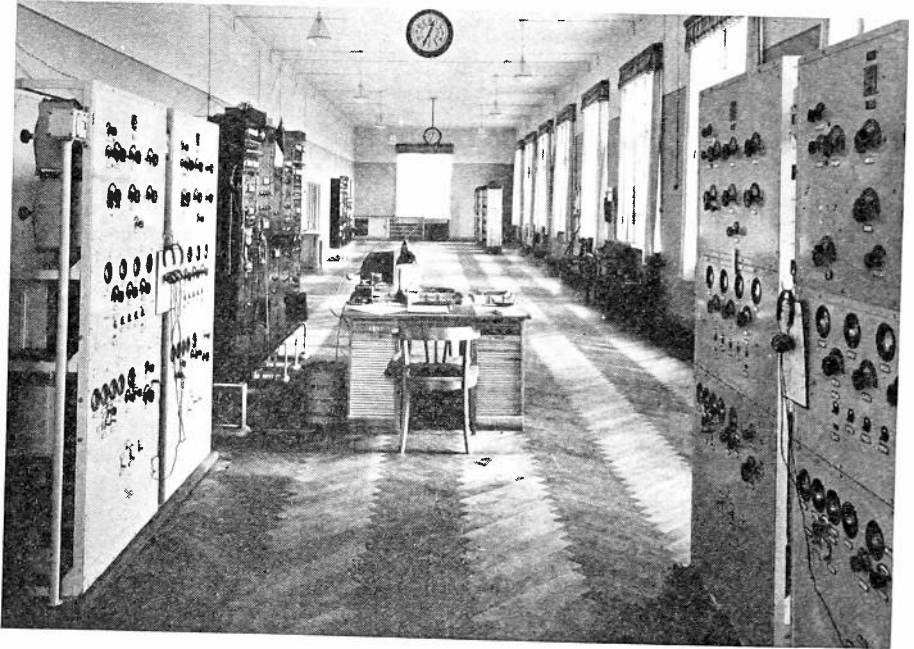

Fig. 20—Receiving room in the receiving building in Beelitz.

ingenious switch device it is possible to connect the receivers to the various antennas.

BUILDING ARRANGEMENT

The space distribution in the receiving building, which is made with thick massive walls and a flat roof, is as follows:

On the ground floor there are the administration, operation, clerical, and waiting rooms. At the end of the central corridor and running crosswise there is the large receiver room for the receivers and auxiliary telephone apparatus (Fig. 20). The basement contains an engine room (Fig. 21), a battery room, shop, storeroom, heating plant, garage, washroom, and the storage space for the personnel living in the building. Under the receiving room, only part of which is over the basement, there is an assembling room for various feed lines to the receiver.

In the upper story there is also a residence for the superintendent of operations and an overnight room for operators.

At present in Beelitz, four large receivers of the most modern type are in operation, and they can be connected as desired to the three antennas mentioned above. In addition, a receiver has been installed for the Reichsrundfunkgesellschaft, with which any transoceanic broadcasting can be picked up by the antennas for the Reichsrundfunkgesellschaft.

The current for operating the Beelitz receiving station is obtained



Fig. 21—Machine room of the Beelitz building for reception.

from the Märkischen Elektrizitätswerke as polyphase current at 15,000 volts. A supply which at first was provided at 50 kva, can be increased to 100 kva; the working voltage is 220/380 volts. Since there may be interruptions in the power line during thunderstorms, etc., which must not be permitted to interfere with reception, converters for supplying the receivers and other receiving devices are operated on 220-volt direct current. For this purpose there have been provided 30-kw alternating to direct current converters, as well as a storage battery of about 420 ampere hours (capable of being enlarged to 840 ampere hours). The arrangement is such that the battery is connected automatically if the alternating current fails. A 30-kw Diesel unit (Fig. 21) is provided in order to take care of rather long interruptions to service in the power line. The converters, each of which feed 10 to 15

receivers, consist of a 7.5-kw direct-current motor, direct coupled with a direct-current generator of 20 volts, 2.8 kw, and a direct-current generator of 220 volts, 2.5 kva.

The technical arrangements on the transmitting and receiving sides were not only developed for wireless telegraphy but have also been arranged in order to permit wireless telephony and phototelegraphy. At present Transradio operates 3 wireless telephone connections, with Buenos Aires, Rio de Janeiro, and Malabar (India). Further telephone connections with Siam and Mexico are under way.

Negotiations are being carried on in order to develop wireless telephone communication with Egypt and Japan.

In June, 1930, wireless transmission of pictures was started with Buenos Aires by the Transradio transmitting and receiving station.

Tests on the transmission of pictures with the Radio Corporation of America are being made now with prospects of excellent success.

CONNECTIONS FROM CENTRAL TERMINAL TO TRANSMITTING AND RECEIVING STATIONS

In order to use the transmitters for this purpose, high quality connecting lines had to be installed between the central office and Nauen. The lines from Beelitz to the central office had to meet the same requirements.

For this purpose, at our suggestion, good cable connections with Nauen and Beelitz were provided by the German Post Office, and the characteristics of these lines shall be discussed briefly. In laying these cables, which were each about 50 km long, there had to be considered not only the present properties for phototelegraphy, but also the future development and the future technical progress had to be anticipated. The object is faithful reproduction of pictures or text in the shortest time. Therefore the cables should have frequency bands of the same width, as far as possible, that can be sent by the transmitter.

A cable construction was provided with the following electrical dimensions:

1. *Special cable to Nauen* (50 pairs of wires)
 - 8 pairs for a limiting frequency of 36,000 cycles for picture transmission
 - 10 pairs for a limiting frequency of 3,500 cycles for transoceanic telephony
 - 16 pairs for a limiting frequency of 16,000 cycles for picture transmission and broadcasting.
 - 16 pairs for a limiting frequency of 2,700 cycles for high speed telegraphy.
2. *Special cable to Beelitz* (55 pairs)
 - 7 pairs for a limiting frequency of 36,000 cycles for picture transmission
 - 10 pairs for a limiting frequency of 3,500 cycles for transoceanic telephony
 - 10 pairs for a limiting frequency of 16,000 cycles for picture transmission and broadcasting
 - 28 pairs for a limiting frequency of 2,700 cycles for high speed telegraphy.

The cables were made by Siemens and Halske A. G., and they represent considerable progress in the manufacture of cables and coils, because especially high requirements were placed on the quality of transmission and on the other electrical properties.

CIRCUITS AND VOLUME OF TRAFFIC

There are given below the circuits operated by Transradio together with the distance and the date on which service was started.

1.	With North America	6349 km	started 1919
2.	" Mexico	9642 "	" 1929
3.	" Cuba	8360 "	" 1930
4.	" Argentina	11890 "	" 1924
5.	" Brazil	9975 "	" 1926
6.	" Chile	12350 "	" 1929
7.	" Japan (Tokyo)	8932 "	" 1926
8.	" China (Mukden)	7680 "	" 1924
9.	" Dutch Indies	10926 "	" 1925
19.	" Philippines	9650 "	" 1927
11.	" Siam	8630 "	" 1929
12.	" Egypt	2980 "	" 1923
13.	" Persia	3650 "	" 1930
14.	" China (Shanghai)	8340 "	" 1930

The plants and traffic stations operated by Transradio during the past can be seen in Fig. 22.

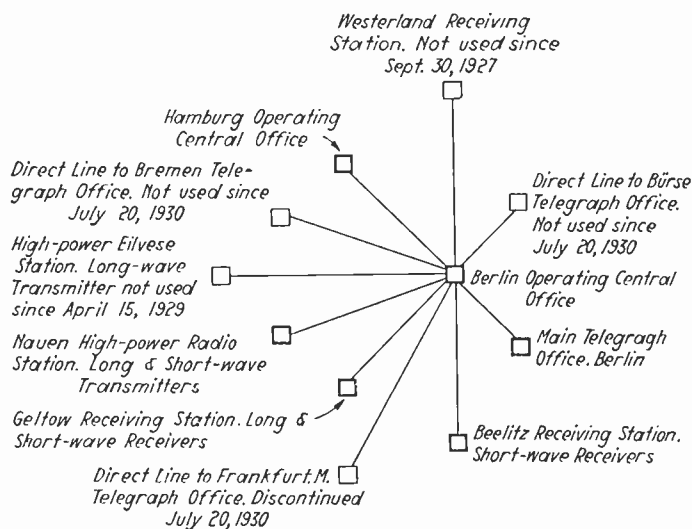

Fig. 22—Transradio operating installation 1920-1930.

The amount of traffic on the above lines has increased greatly from year to year. Thus the number of words sent in both directions on all of these circuits is as follows:

1919 (the year after the formation of Transradio, beginning with August).....	1,100,000	words
1920.....	2,800,000	"
1921.....	5,000,000	"
1922.....	6,500,000	"
1923.....	7,700,000	"
1924.....	10,700,000	"
1925.....	11,900,000	"
1926.....	12,700,000	"
1927.....	13,400,000	"
1928.....	16,300,000	"
1929.....	18,900,000	"

Thus we see that transoceanic radiotelegraphy has become a very important factor in world-wide communication in a very short time.

The way in which the rapidity in the evolution of telegraph communication, such as on the Berlin-New York line, has been increased by improving the technical devices, and particularly by using the short-wave system and the greater capability of the personnel, can be seen from the time taken by a telegram in the Transradio central station in the various years.

TABLE III

Average time taken by a telegram on the New York-Berlin line at the Transradio Central Operating Office		
<i>Year</i>	<i>Outgoing</i>	<i>Incoming</i>
1926	35.8 min.	15.3 min.
1927	22.1 "	11.6 "
1928	17.4 "	9.7 "
1929	15.8 "	5.5 "
1930 (Jan.-Oct.)	11.7 "	3.9 "

It should be mentioned that arrangements have been made in the short-wave plants permitting the measurement of the frequency of our own and distant transmitters with great accuracy on the transmitting side as well as on the receiving side. We have developed a method of measuring with illuminated quartz, which permits frequency measurements with an accuracy of 0.002 per cent. In addition, the transmitters are provided with quartz-controlled preliminary stages with thermostats, that make it possible to keep the transmitting frequency constant with an accuracy of 0.01 per cent.

STUDY OF WAVE PROPAGATION

Transradio has also been successful in analyzing the propagation of short waves. In Geltow the so-called double signals and echoes were determined for the first time by means of oscillograph pictures. Thus it was possible to prove that the short waves are propagated in a layer theoretically anticipated surrounding the earth, called the Kennelly-

Heaviside layer, and travel around the earth once or several times in the direction of sending or in a different direction. In order to avoid the effects of these interfering signals, special screening devices had to be used on the transmitting and receiving antennas. These are the so-called reflectors. This makes it possible to screen off the double signals which are directed backward, although it is not yet possible to make the direct double signals harmless.

It was also proved by means of oscillographs that certain signals apparently are reflected once or several times from the Kennelly-Heaviside layer at time intervals shorter than double signals, which go around the earth in one direction or another. These signals are called near-echoes.

A paper was published in volume 6, 1929, No. 2, of *Elektrotechnischen Nachrichten Technik*, on these double and multiple signals with short waves. This paper was read in January 1929, at the World Power Conference in Tokyo.

Another paper that appeared, and which is important in considering the propagation of short waves, was published in *Elektrischen Nachrichten Technik*, volume 5, 1928, No. 12, under the title "Audibility Limits and Optimum Transmission Time with Short Waves on Various Overseas Circuits." This paper contains observations made in Geltow over a number of years, and gives a picture of the short waves which can be used on various circuits over the earth and at what hours they are audible. It also gives the time of the appearance of the double signals in the various months.

This review of ten years of activity of Transradio shows how the technical and organization improvements in transoceanic radio communication have been made, and also how Transradio has contributed greatly to the important and tremendous questions in connection with the explanation of the propagation of short waves.

In conclusion, our thanks must be given to the German Post Office Administration for the aid that they have rendered in connection with the steps indicated above.



ON THE USE OF FIELD INTENSITY MEASUREMENTS FOR THE DETERMINATION OF BROADCAST STATION COVERAGE*

BY

C. M. JANSKY, JR. AND S. L. BAILEY
(Jansky and Bailey, Consulting Engineers, Washington, D. C.)

Summary—This paper discusses the importance of adopting uniform standards designed to express the coverage obtained by broadcast transmitters in terms of the field intensities produced, and discusses the methods used by the authors. Illustrations are given of the methods used to determine coverage, to predict the effect of changes where transmission constants are known, and to determine interference conditions on the basis of given receiving set characteristics. The importance in the field of radio regulation of the establishment of certain fundamental principles defining the area throughout which a broadcast station is entitled to protection against interference from other stations and the conditions under which a listener is entitled to interference free reception is particularly stressed.

A BROADCAST system may be said to consist of (1) a transmitting installation, (2) a transmission medium, and (3) the particular receiving installations which, at the time in question, are used for the reception of programs. Of these three parts, the one least subject to human control, the one concerning which the least knowledge is available, the one subject to the greatest variation in characteristics and yet the one involved in all problems of governmental regulation is the transmission medium.

The nonengineering problems of radio regulation in the broadcast field possess sufficient complexity to make the task exceedingly difficult, but these problems are comparatively simple as contrasted with those which result from the irregularities and the vagaries of radio transmission phenomena.

In any field of engineering the adoption of certain methods of measurement and the establishment of certain standards is essential before much real progress can be made. If a structural engineer orders a number of I-beams of certain lengths and cross-sectional dimensions to withstand certain loads, he knows that if he is reasonable in his demands it is possible to meet his specifications within a given degree of accuracy. Even a radio engineer can call for an audio-frequency amplifier designed to produce a given gain and to possess certain fidelity characteristics with the expectation that his specifications may be met and that he may determine whether or not the apparatus meets these specifications.

* Decimal classification: R270×R550. Original manuscript received by the Institute, April 23, 1931. Presented before Sixth Annual Convention of the Institute, June 4, 1931, Chicago, Illinois.

How different the situation where the idiosyncrasies of radio transmission phenomena are involved. Consider such basic questions as the following: How much power must a station radiate at a particular location and on a particular frequency to give satisfactory broadcast service to a given community? What will be the effect of assigning to the same and adjacent frequencies other stations in the same or in remote areas? What increase in coverage would be obtained by increasing the power a given amount? How would the situation be changed by changing the frequency assignment? Would the coverage be the same if the station were in Pennsylvania as it would be were the station in Kansas? Questions such as these cannot be answered without thorough and extensive studies in the field. Even then, the variable factors are so many and so involved that the results must be expressed carefully to prevent misinterpretation by those not fully understanding or not intimately acquainted with all of the conditions.

Before attempting to make a quantitative comparison between the coverage obtained by one station and that obtained by another, or to determine the effect of proposed changes in operating conditions, it is essential that there be some agreement among engineers with respect to what, from an engineering standpoint, constitutes coverage, and some agreement with respect to the methods of measuring such coverage. It is the purpose of this paper to present the standards of service at present in use by the authors and to give some of the results of their studies of coverage by the aid of field intensity measurements.

The sensitivity of receiving sets has been carried to a point where, assuming a given percentage modulation, the factor which determines whether or not reception from a particular station is satisfactory is the ratio of the electrical field intensity produced by that station to the intensities produced by other stations or other electrical disturbances. There may be present at the receiving location electric fields produced by the following:

- (1) Atmospheric electricity or "static."
- (2) The operation by man of nonradio electrical devices. (Referred to as inductive interference.)
- (3) Radio broadcast stations operating on the *same frequency assignment* as that used by the station from which reception is desired.
- (4) Broadcast stations operating on *frequency assignments* different from that used by the station from which reception is desired.

Unfortunately, there are wide differences of opinion among broadcast listeners with respect to what constitutes satisfactory reception conditions. The lay observer is likely to use as his standard of excellence

the strongest signal which happens to be available to him. However, different receiving conditions exist in different localities. Listeners in New York City have available high intensities from so many stations that they will not ordinarily listen to stations producing low intensities. On the other hand, listeners in some rural communities will accept and enjoy signals having intensities far lower than those demanded by listeners more fortunately situated.

Because of the conditions described above, reliance upon the opinions of broadcast listeners as a measure of broadcast coverage is almost certain to result in the accumulation of data incapable of satisfactory interpretation on the basis of any standard. Different listeners will not only not give the same opinion with respect to identical conditions but the same listener cannot be expected to preserve the same opinion with respect to the same conditions over a period of time. Something more accurate than the ears of listeners must be used if consistent results are to be expected.

For the past few years engineers have been using the field intensities produced by stations as a means of determining coverage. In the course of the development of the art there have been a number of expressions of opinion with respect to the intensities necessary for the delivery of the various grades of service. To illustrate, it has been said that 100,000 microvolts per meter are necessary for excellent service, 10,000 microvolts per meter for very good service, 1000 microvolts per meter for fair service and 100 microvolts per meter for poor service.¹ Another writer referring to city districts says, "50,000 to 100,000 microvolts per meter is as strong as one should ordinarily desire; 10,000 to 50,000 microvolts per meter, ordinarily free from interference and expected to give reliable year-round reception except for occasional interference from near-by thunder storms; 1000 to 10,000 microvolts per meter, from good to fair and even poor at times; below 1000 microvolts per meter, distinctly unreliable and generally poor in summer; 100 microvolts per meter, of some value for dissemination of useful information such as market reports, where the value of the material is not dependent upon high quality reproduction but practically out of the picture as far as reliable, high-quality entertainment is concerned."² On the other hand, there have been in the past and undoubtedly still are localities where, in the absence of anything better, field intensities as low as 100 or 200 microvolts per meter are considered

¹ A. N. Goldsmith, "Reduction of interference in broadcast coverage," *Proc. I.R.E.*, 14, 5, 575-603; October, 1926.

² Lloyd Espenschied, "Radio broadcast coverage of city areas," *Bell Sys. Tech. Jour.*, 6, 117-141; January, 1927.

usable by the people concerned.³ More recently there has been a tendency to classify broadcast service into three grades: high quality dependable, reasonably satisfactory, and useful at times but not always high quality or dependable. These have been referred to as Grade I, Grade II, and Grade III services. The outer limit of Grade I service has usually been taken as 10,000 microvolts per meter, while the limit of Grade II has been placed at values lying between 500 and 2000 microvolts per meter.⁴

It will never be possible to determine broadcast coverage to the same degree of accuracy as it is possible to measure the distance between two points. Nevertheless, field intensity measurements properly interpreted will give results far more accurate than those obtained by any other method of study yet developed. While the use of uniform standards is highly desirable, differences of opinion with respect to the intensities necessary for a particular grade of service are not of great importance so long as the same standard is consistently applied to the interpretation of a particular problem.

The smaller the number of grades into which broadcast service is divided, the greater the likelihood of agreement between various workers as to the requirements for each grade. The writers' method of studying broadcast coverage ordinarily makes use of only two grades.

The following is a brief description of the method used to determine what might be referred to as the "Good" broadcast coverage of a station for day conditions assuming that 500 microvolts per meter from a station using a high percentage of modulation will deliver this grade of service in a rural community, and assuming no interference from other broadcast stations. To avoid misinterpretation of the term "Good" the term "Grade A" will be used.

- (1) By means of a sufficiently large number of daytime observations, determine the field intensity pattern for the station with sufficient accuracy to permit drawing the 500, 1000, 2000, and 5000-microvolt-per-meter contours. It can be expected that except in unusual cases, the lower intensity contours will be farthest from the station.
- (2) Determine the population within the area circumscribed by the 500-microvolt-per-meter contour.
- (3) Within this area determine the minimum intensities necessary for Grade A broadcast service in all localities where conditions

³ C. M. Jansky, Jr., "Some studies of radio broadcast coverage in the middle west," *Proc. I.R.E.*, 16, 1356-1367; October, 1928.

⁴ J. V. L. Hogan, "Radio Facts and Principles," U. S. Government Printing Office. See also Testimony of other engineers in hearings before the Federal Radio Commission, re: Applications for 50-kw power on certain clear channels.

are such that more than 500 microvolts per meter are required.

- (4) Where the intensities produced in such localities are lower than the intensity necessary, subtract the population from the total population residing within the 500-microvolt-per-meter area.

The population remaining is the population receiving Grade A day-time broadcast reception.

If the results of the studies described above are to be applied to nighttime conditions, certain other factors must be considered. Although an intensity of 500 microvolts per meter may be present at the receiving location, there may also be present interfering signals from other stations operating on the same channel. The coverage area must, therefore, be reduced accordingly. This applies particularly to nighttime conditions on regional and local channels.

A second factor which must be considered is whether or not the signal intensity holds its value consistently at all times; that is, whether or not fading is present. The presence of fading may restrict the nighttime coverage obtained on clear channels as well as on regional and local channels.

When the course of procedure given above is followed there is obtained a summation of what was previously referred to as Grade I and Grade II coverage with the exception that consideration is given to differences in receiving conditions which may exist throughout the area under study. The consideration of receiving conditions renders less important subclassification of Grade A service beyond a distinction between Grade A night coverage and Grade A day coverage.

Service outside the Grade A coverage areas will be referred to as Grade B service. Grade B day service exists in rural districts where intensities are usable but are below 500 microvolts per meter and where in other areas the intensities are below those established as necessary for Grade A service. This, of course, assumes no radio interference present. In general, the same definition may be given to Grade B night service, but it must be noted that the factors which determine Grade B night service are far more complex than those which determine Grade B day service. Grade B night service depends largely upon sky wave phenomena and for this reason determination of the number of people receiving this grade of service will be exceedingly difficult if not impossible.

Percentage of time a signal is satisfactory is of importance in determining whether or not a service is to be classed as Grade A or Grade B. The mere fact that a listener at times may be able to receive without any interference a signal outside the Grade A coverage area does not raise the grade of service. It is for this reason that distant sky wave re-

ception from clear channel stations has been classified as a Grade B service, although the intensities frequently rise well above 500 microvolts per meter.

A rough distinction between Grade A and Grade B service is as follows: If a listener is within an area receiving Grade A service from several stations he will probably listen to the station transmitting the program which appeals to him most; while if he receives no Grade A

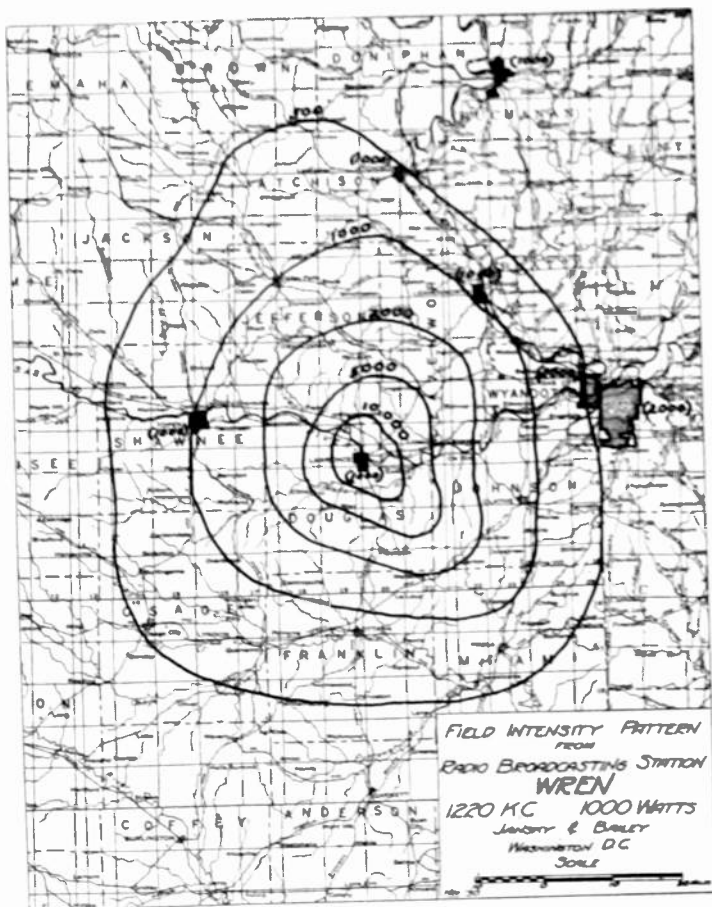

Fig. 1—Field intensity pattern 1000-watt station located in eastern Kansas.

service from any station but several Grade B services, he will probably select the station which, from a technical standpoint, produces the most acceptable signal.

Some examples of the methods of obtaining coverage described above are given in the accompanying diagrams. Fig. 1 shows the field intensity pattern used to determine the good coverage of WREN at Lawrence, Kansas. The population receiving good broadcast service was estimated at 253,500. This figure was obtained by subtracting the

populations of Kansas City, Kansas; Leavenworth, and Atchison, from the total population of the area within the 500-microvolt-per-meter contour. These cities do not receive an intensity sufficiently high to give a service equivalent to the service rendered by 500 microvolts per meter in a rural community.

Where transmission conditions are sufficiently uniform, transmission formulas may be applied to determine the attenuation factor and

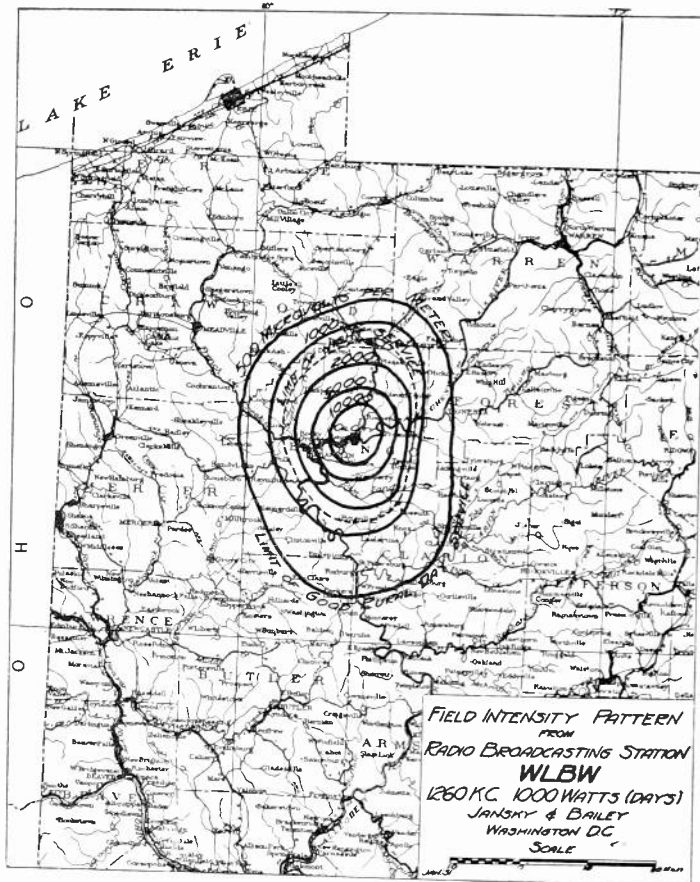

Fig. 2—Field intensity pattern 1000-watt station located in western Pennsylvania, antenna efficiency same as in Fig. 1.

the power radiated in the ground wave. In this case it was found that the attenuation factor was 0.01 and the antenna efficiency (ground wave power to antenna power) was about 11 per cent.

The great difference in transmission characteristics in different parts of the United States can be seen from a comparison of Fig. 1 with Fig. 2 which is the field intensity pattern for WLBW, Oil City, Pennsylvania. The difference in frequency assignments is only 40 kc, the power rating is the same (1000 watts), the antenna efficiencies are approximately the same, but the attenuation factor around Oil City

is approximately 0.025 to 0.035 as contrasted with 0.01 for the Kansas area.

The area within the 500-microvolt contour in Fig. 1 is 4735 square miles, while that within the 500-microvolt contour in Fig. 2 is 1483 square miles; that is, only 31 per cent as great.

No appreciable heterodyne interference was found at night within the 500-microvolt-per-meter contour around WREN. Neither was fading noticeable. Therefore, the conclusion is that Grade A night coverage is the same as the Grade A day coverage.

At WLBW an entirely different situation was found to exist at night. After sunset the power was only 500 watts but of greater importance is the fact that heterodyne interference was frequently experienced where the intensity fell below 1000 microvolts per meter. The 500-watt, 1000-microvolt-per-meter contour was therefore taken as defining the outer limit of nighttime service from WLBW. The area receiving good night service is only 400 square miles, 27 per cent of the cent of the area receiving good daytime service. The area receiving good nighttime coverage at WLBW is, therefore, only 8.5 per cent as great as that of WREN. The difference in power of the two stations at night is a minor factor. The nighttime coverage of a regional station is frequently less than the daytime coverage because of heterodyne interference.

The value of field intensity measurements as a basis for predictions may be shown by further reference to the Kansas situation. The attenuation factor and antenna efficiency obtained for WREN were used to predict the probable effect of a change from the present location on a flour mill in town to a suitable site in the country. It was assumed that at the proposed location the antenna efficiency could easily be made as great as 45 per cent. The attenuation constant was assumed to be substantially the same throughout the area. Both assumptions are entirely justified.

The predicted Grade A coverage areas at the new location for 1000 watts and 2500 watts are shown on Fig. 3. The area for 1000 watts at the present location (Fig. 1) is 4753 square miles while that predicted for 1000 watts at the new location (Fig. 3) is 10,220 square miles. The area predicted for 2500 watts is 16,380 square miles. These figures show that the contemplated move without any increase in power would give a Grade A service area more than twice as great as that at the old location. The population receiving good service would be increased from 253,500 to 950,000.

Increasing the power from 1000 to 2500 watts in the daytime at the new location increases the area served from 10,220 square miles to

16,380 square miles, an increase of 60 per cent. The gain in service area obtained by moving to secure greater efficiency is greater than the gain resulting from increasing the power by 2.5 times.

A transmission formula enables calculation of the area circumscribed by the 500-microvolt-per-meter contour for particular antenna efficiencies, frequencies, and absorption factors. Efficiencies

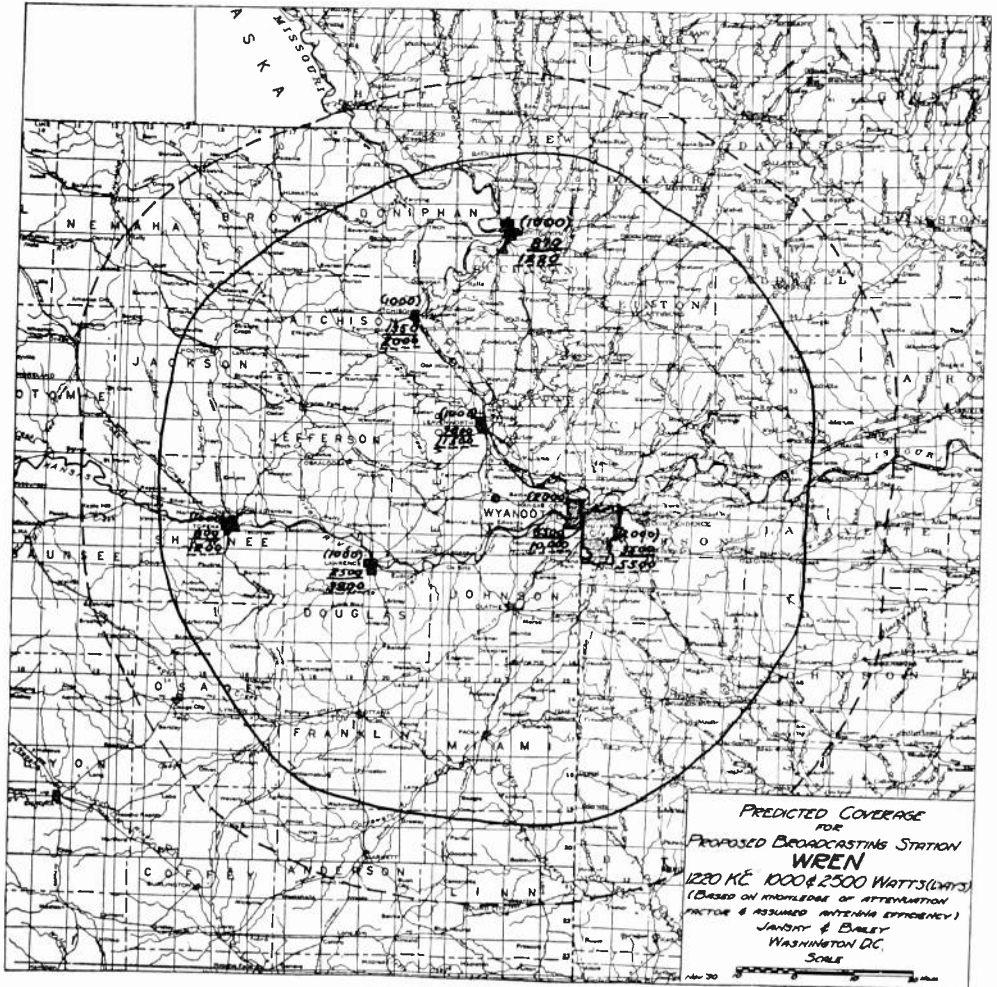

Fig. 3—Estimated coverage for a proposed broadcast transmitter installation, 45 per cent antenna efficiency, rural location eastern Kansas, 1000 and 2500 watts power.

as low as 10 per cent and as high as 70 per cent are not unusual. Illustrations of the wide range of absorption factors have already been given. A 1000-watt station having an antenna efficiency of 10 per cent operating on a frequency of 1450 kc in an area where the absorption factor is 0.035 would deliver Grade A day service over 660 square miles. On the other hand, a 1000-watt station operating with

70 per cent antenna efficiency on 550 kc in a territory where the absorption factor is 0.01 would deliver Grade A day service over 14,740 square miles. The latter coverage is 22 times as great as the former.

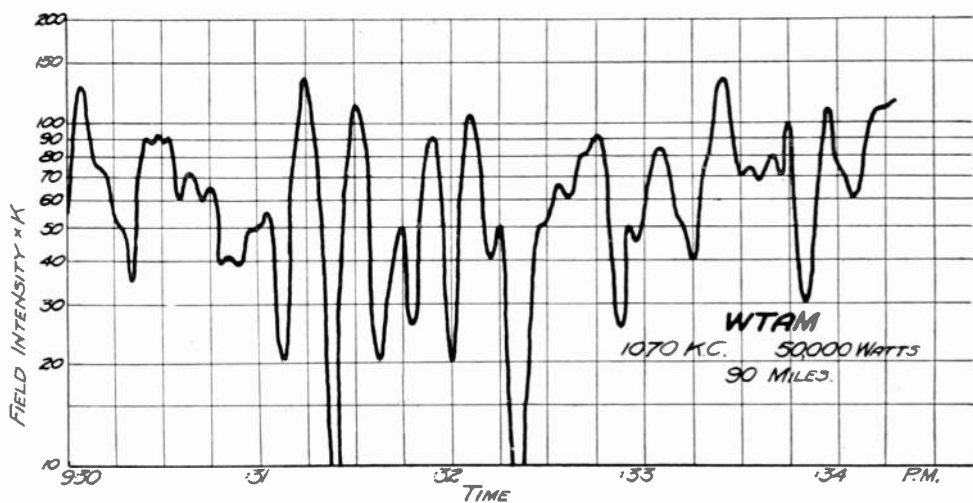
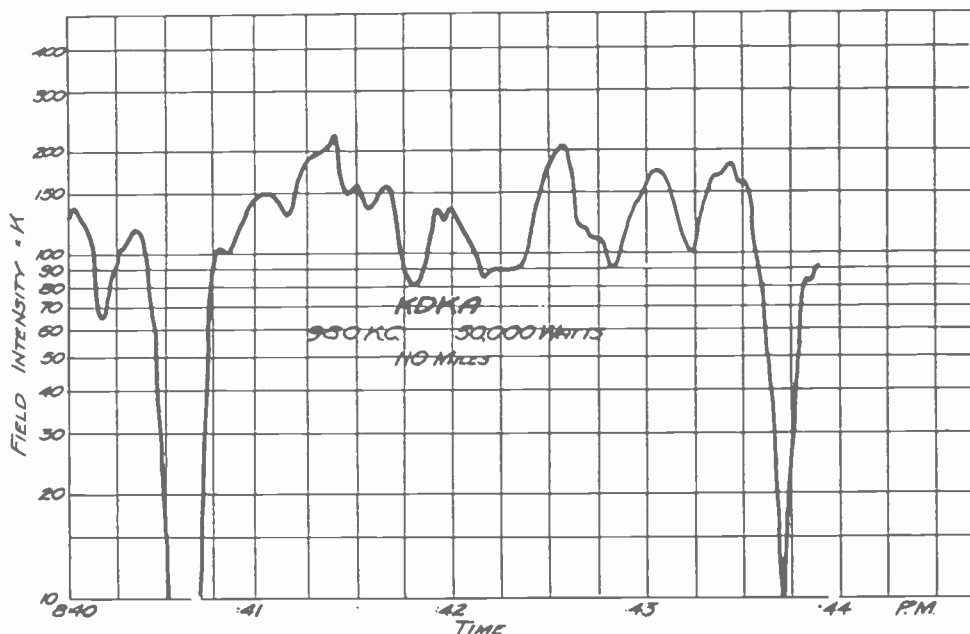

Fig. 4—Fading curves taken at Erie, Pennsylvania on signals from KDKA, 110 miles away and from WTAM, 90 miles away.

Inaccuracies of this order of magnitude may be expected if power and power only is taken as a measure of coverage.

The use of formulas to predict coverage must of course be limited to situations where the absorption constant possesses substantially the

same value throughout the entire area under consideration and where radiation from the antenna system is substantially the same in all directions in the horizontal plane. Where these requirements are not met the results obtained must always be considered in the light of conditions as they actually exist. To illustrate, the field intensities produced by transmitters located near large bodies of water usually show less attenuation in the directions along the shore than in directions directly away from the shore.⁵

Most regional stations have a smaller Grade A night coverage than Grade A day coverage due to the effects of heterodyne interference. This interference also eliminates the Grade B night service of the stations affected. Clear channel stations, however, at night have both Grade A and Grade B service. The Grade A night coverage area of a clear channel station may be less than its Grade A day coverage area due to fading. Fading is often most severe at distances 60 to 200 miles from the transmitter. For example, the City of Erie, Pennsylvania, is but 90 miles from WTAM at Cleveland and 110 miles from KDKA at Pittsburgh. Both stations are of 50-kw power and both occupy clear channels, yet neither gives good broadcast service in Erie at night due to rapid fading. Fig. 4 shows the observed variations of intensity. In this connection it is particularly interesting to engineers to note that the Court of Appeals of the District of Columbia has found: "It is generally accepted that a 50,000-watt broadcast station will deliver good service within a radius of 300 miles, and a fair service within a much greater radius."⁶

By no possible definition of the word "good" can nighttime reception at Erie from WTAM and KDKA be brought within this category; and no court decision will ever make this service good. As a matter of fact, the people of Erie obtain better nighttime reception from several clear channel stations of less than 50,000 watts power located at distances greater than 200 miles than they do from the two in question.

It would be interesting to trace the chain of events which resulted in the Court of Appeals arriving at the conclusion it did from the evidence before it, but such a discussion belongs elsewhere. The fact that the Court, in its endeavor to interpret a question of engineering fact, did arrive at this conclusion shows the necessity on the part of engineers of so circumscribing engineering conclusions that they cannot be misinterpreted or their use carried far beyond anything ever intended. Clearly, it is the duty of the engineer to resist the pressure of those who, because of their lack of knowledge of science, would have him carry his

⁵ See paper by S. W. Edwards and J. E. Brown in *Radio Service Bulletin*, March, 1927.

⁶ *W. O. Ansley, Jr. v F. R. C., D. C. C. of A. No. 5149*, p. 3.

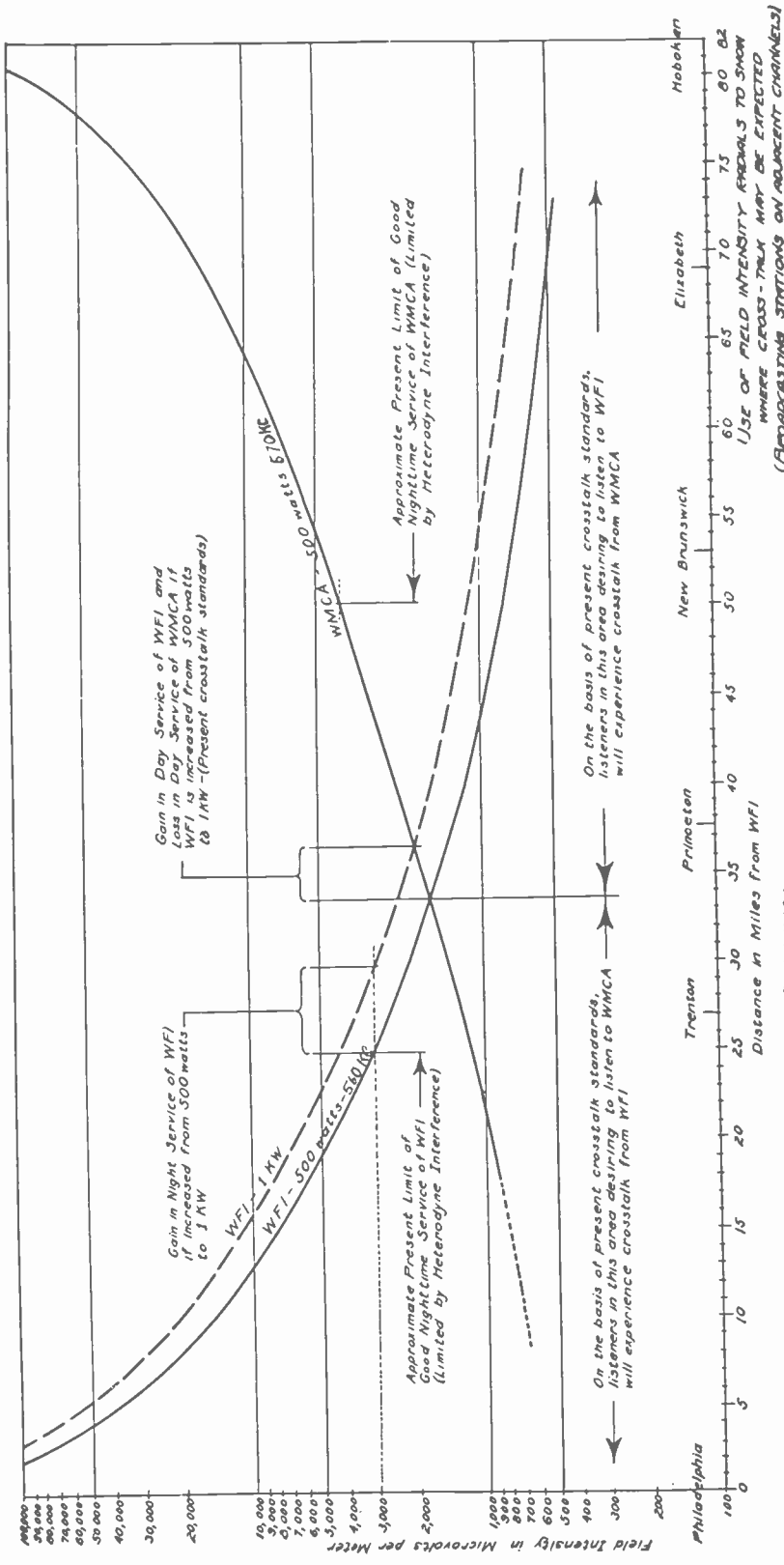

VERTICAL CROSS-SECTION OF FIELDS FROM WFI & WMCA

Fig. 5—Field intensity radials from broadcast stations WFI and WMCA along a line extending from Philadelphia to Hoboken.

(BROADCASTING STATIONS ON ADJACENT CHANNELS WHERE CROSS-TALK MAY BE EXPECTED)

conclusions beyond the limits of his knowledge. If he does not so limit himself, then both he and his profession will lose caste and cease to be factors in the regulatory development of an art for which he is fundamentally responsible.

No discussion of the factors limiting broadcast service would be complete without a consideration of that type of interference which is commonly referred to as cross-talk, a term which had its origin in the telephone industry. The term has been loosely applied in the radio field to all types of radio interference in the broadcast spectrum other than audible heterodyne interference. Where a listener on one telephone circuit (carrier telephony excepted) hears the conversation carried on over another circuit the term cross-talk is applied. Only the superposition of undesired other audio frequencies upon the desired is involved.

A somewhat similar situation exists when in listening to one station interference is experienced from another station on an assignment 10 or more kilocycles removed. While conditions are not identical with those in the telephone case described, the term "cross-talk" may be used. However, when the interfering station is operating on the same frequency assignment as the desired and audible heterodyne interference has been eliminated by reducing the beat note below audibility, the resulting phenomena are quite different. The only case which need be considered is the one in which the desired carrier and side frequencies impress voltages on the detector considerably in excess of those impressed by the unwanted carrier and side frequencies. There will then be produced in the output circuit of the detector audio frequencies due to a combination of the strong desired carrier and the weak undesired side bands. The result is quite different from that which would be obtained if the strong desired carrier were absent. This holds true even if the two carriers are of exactly the same frequency. If there is a slight difference in frequency between the carriers a mushy distortion exists.

The term "side-band noise" should be applied to the type of interference described above to distinguish it from cross-talk.⁷

The selectivity of receivers varies greatly, not only between those of different manufacture, but at different points of the spectrum as well. However, engineers today generally agree that an average receiver is one which will receive at will, without objectionable cross-talk, either of two stations operating on channels 10 kc apart when the field intensities produced at the receiving location by these stations are equal. If,

⁷ For complete discussion see Chas. B. Aiken, "Detection of two modulated waves which differ slightly in carrier frequency", *PROC. I. R. E.*, 19, 120-137, January, 1931.

in view of the lack of more detailed information, such a receiving set is taken as standard, then it is possible by means of field intensity measurements to determine whether or not in a particular locality cross-talk interference may be expected.

Fig. 5 shows receiving conditions along a direct line connecting WFI (560 kc) in Philadelphia and WMCA (570 kc) in the New York area. The field intensity curves are self-explanatory. The two stations are of equal power and separated by 10 kc. The field intensities produced are approximately the same at night as they are in the daytime. Due to the low frequencies used and the character of the terrain each station produces fairly strong signals at points 60 miles distant from the transmitter. The intensities of the two stations are approximately equal at a point 34 miles northeast of WFI and 48 miles southwest of WMCA. In the day-time, northeast of the point of equal intensity WMCA would be expected to interfere with reception from WFI; while southwest of this point WFI would be expected to interfere with reception from WMCA, assuming of course, that a receiver possessing the average characteristics defined above is in use. At night, however, heterodyne interference from other stations so limits the service areas of both WFI and WMCA that cross-talk does not exist within the good service area of either. The effect of doubling the power at WFI is shown by the dotted line.

It is probable that the conditions shown in Fig. 5 are not average conditions. Measurements by the authors in various parts of the country and on different frequencies show a wide variation in the factors determining whether or not cross-talk interference will occur. Enough material is at hand to show that each situation warrants individual consideration. Furthermore, as the art develops it may be desirable to adopt standards of receiver selectivity different from those in general use today as well as to take account of the fact that the average receiver may vary in selectivity in different parts of the broadcast spectrum.

Consideration of broadcast coverage and interference conditions on the basis of field intensity measurements is fundamental to consideration of the effect of such factors as power and distance. Field intensity measurements deal with conditions at the receiving location. Between the receiving location and the transmitting antenna lies the transmission medium—variations in transmission characteristics of which are as yet too little understood.

Interference in reception of one station due to the operation of others is too often considered only in the absolute. Emphasis is given to the presence or lack of interference in a particular instance and not to such matters as where interference exists and what listeners will ex-

perience it. Radio interference in the broadcast spectrum became possible the minute the second broadcast station began operation. In all probability the operation of the second station prevented reception of the first at points within a few hundred feet of the transmitting antenna of the second. The creation of additional stations merely augmented and brought to the fore a situation created by the simultaneous operation of the first two stations.

Reasonable consideration of the problems of radio interference requires definition of the area throughout which a given station is entitled to interference-free reception and definition of the circumstances under which a listener is entitled to expect freedom from interference in listening to a particular station. When there is general acceptance of some standards such as those proposed then and only then can there be laid down certain fundamental rules respecting coverage and interference necessary to the more equitable consideration of the rights of radio listeners and of stations. The establishment of these rules involves consideration of the more fundamental underlying principles of engineering, law, and economics. To illustrate, questions such as the following should be asked and answered:

Is a listener residing within the Grade A coverage area of one station entitled to interference-free reception of a Grade B service from a station operating on a frequency assignment adjacent to or close by the frequency assignment of the station delivering the Grade A service?

On the basis of present cross-talk interference standards is any station entitled to protection against cross-talk interference from channels other than the one on which it is operating at points which lie outside that station's Grade A coverage area?

Should a regional assignment be considered unsatisfactory if the Grade A night coverage area is less than the Grade A day coverage due to radio interference?

Should a clear channel station be expected to give consideration to its Grade B service?

Should a Grade B service be protected in areas which have available Grade A service from other stations?

When definite answers to questions such as these are made available to the engineer, then and only then will he be in a position to measure properly the effectiveness of the present broadcast structure and to suggest changes for improvement.

The authors wish to express their indebtedness to the managements and attorneys for Radio Stations WREN, WLBW, and WFI whose cooperation and assistance made possible the surveys described in part in this paper.

EFFECT OF SHORE STATION LOCATION UPON SIGNALS*

BY

R. A. HEISING

(Bell Telephone Laboratories, New York City)

Summary Experiments are described for ascertaining the attenuation suffered by the unreflected wave in traversing relatively small amounts of land between the sea-shore and hypothetical inland sites. The results show 8 to 12 db attenuation for 1 mile inland with greater attenuation thereafter for unfavorable terrain. Swampy ground produces small attenuation. The classical theory of wave transmission past a straight edge used in optics is applied to explain the reduction. Coexisting phenomena are mentioned.

INTRODUCTION

IT HAS long been known that transmission of radio waves over land is poorer than over water. This was one of the first radio phenomena observed. In certain short-wave investigations made a few years ago the phenomenon appeared as was to be expected but under conditions that rendered interpretation difficult. Signals originating at an experimental transmitting station at Deal, New Jersey, after traversing land and water to the south shore of Long Island, were observed to fall off very rapidly as the measuring set was moved inland. The extraordinary rapidity with which this decrease occurred in comparison with the attenuation observed over open water suggested that the small amount of land at the other end of the path, between Deal and the shore, might also have produced a reduction in signal comparable with that produced by passage over many miles of sea.

In the development of our ship-shore telephone circuit, this phenomenon became a matter of importance. The desire to keep down the power of the ship equipment necessitated reducing the radio transmission losses as much as possible. It appeared essential, therefore, to ascertain something of the magnitude of the attenuation that is produced.

PLAN OF INVESTIGATION

The information desired was not that of transmission over land alone. The phenomena observed involved signals traversing a path over both land and water. It was not known whether the attenuation was purely an overland transmission phenomenon or whether it was

* Decimal classification: R135. Original manuscript received by the Institute July 28, 1931. Presented before U.R.S.I., May 1, 1931, Washington, D.C.

in some way involved with the overwater path preceding. It was therefore decided to make tests with a path over both water and land where the length over land could be varied.

In order to give stable transmission for the ship-shore telephone circuit it was desirable to use the ground or unreflected wave for communicating over distances up to several hundred miles out to sea. It was desired also to use short waves. Representative wavelengths of 33 and 66 meters were therefore used in the tests.

In the investigation a portable transmitter was moved from point to point in New Jersey while receiving observations were made at Long Beach to give accurate ground wave information on short distance transmission, and at Nantucket to give information on medium distance ground wave transmission. The measuring equipments at these points were located in cottages facing the seashore. There were no structures between them and the water. The transmitter, consisting of a 500-watt telephone set, was operated at a number of points in New Jersey beginning at our Deal experimental laboratory and including locations right on the seashore in Elberon, as well as at various distances inland and with various types of surrounding terrain. Transmissions were made on 33 and 66 meters during parts of the day and night. A list of the transmitting locations is given herewith together with information concerning the surrounding terrain.

<i>Test. No.</i>	<i>Location</i>
0	Deal experimental station, in front of garage, with towers and some other antennas in the paths to Long Beach and Nantucket.
1	As near the shore at Elberon as a paved road leads. Distance to water probably 100 feet. No structures in paths.
1-B	60 yards inland from the location of test No. 1. No structures in paths of the waves.
1-C	120 yards inland from location of test No. 1. One house approximately in the path to Long Beach.
2	At Bayside with groves of trees about 200 yards from the transmitter in paths of the waves.
3	At Colts Neck Road, about 10 miles inland with clear unobstructed level field for $\frac{1}{2}$ mile from transmitter along paths.
4	Telegraph Hill near Redbank with unobstructed paths from the transmitter. The height was such that Long Beach was directly visible over all intervening land. In this location, there were unobstructed views to the water along both paths.
5	At Belmar near the old location of the Marconi receiving station. This site was at the water's edge of a lake with unobstructed views toward Nantucket and Long Beach for over $\frac{1}{2}$ mile across water.
6	Elberon $\frac{1}{2}$ mile inshore from test No. 1 location. Buildings, telegraph wires, and trees of the average inhabited town were quite close.

- 7 Same as above, but one mile inland.
- 8 A check measurement of location No. 1.
- 9 At Watertown on the west side of Barnegat Bay close to the water's edge with a clear unobstructed view towards Long Beach and Nantucket of several miles. The path to Long Beach, however, passed over a populated section of several miles while that to Nantucket passed over a partially settled sand bar $\frac{1}{2}$ mile wide.

RESULTS OF FIRST TESTS

The results are plotted in Figs. 1, 2, and 3. The first thing to be noticed from these curves is that the signal fell off rapidly as the trans-

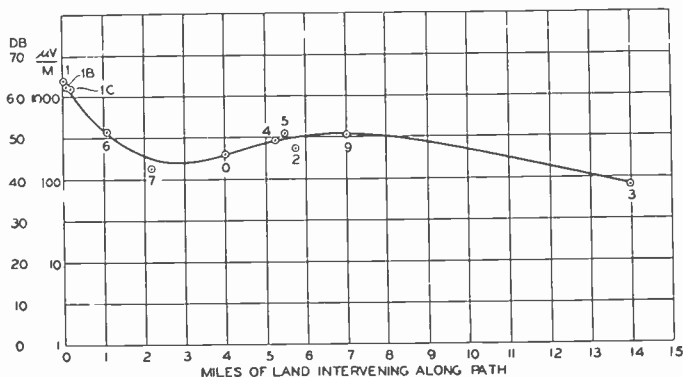

Fig. 1—Strength of signals received at Long Beach on 66 meters as a function of intervening land in path (Day or night.)

mitter was moved in from the shore. After the initial drop with intervening land, the signal then fell off at a much reduced rate. Fig. 1 shows a rise in signal at locations from 3 to 7 miles inland but the maxi-

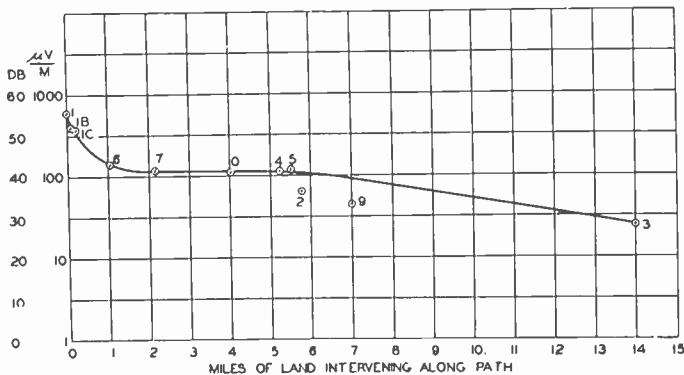

Fig. 2—Strength of signals received at Long Beach on 33 meters as a function of intervening land in path. (Day or night.)

mum is still 13 db below the seashore value. One mile of land reduced signals to Long Beach about 12 db and to Nantucket about 8 db. The signals at Long Beach on 66 meters appeared to suffer an attenuation of

25 db for a location 3 miles inland and on 33 meters they suffered 15 db attenuation.

SECOND INVESTIGATION

With such a definite indication of considerable attenuation of the ground wave being caused by intervening land, it appeared advisable to secure more information, and to check the measurements already made. In doing this it was decided to reverse the direction of transmission, put the transmitter at Long Beach and move from one possible site to another with the more easily transportable measuring set. The transmitting set was, therefore, moved to Long Beach and placed as near to the site which had been used for receiving as was possible without undue expense. The site chosen was at the end of a paved street

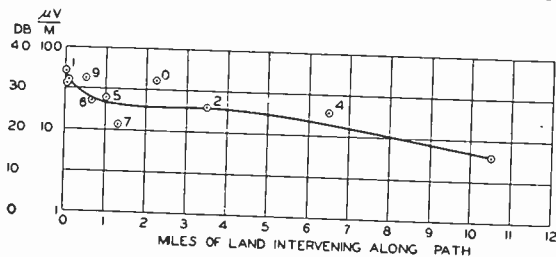

Fig. 3—Strength of signals received at Nantucket on 66 meters as a function of intervening land in path. (Day only.)

which was as near the previous location as possible but actually about 100 yards farther away from the water. It would have been necessary to have laid planks on the sand to get any nearer the water. In view of the size of the trucks in which the equipment was located this was not advisable. This location for the transmitter was naturally not as good as that used for the receiver when it was employed at Long Beach. However, there were no power, light, or telephone wires in the neighborhood and no metallic structures which would interfere with the waves. It was merely a question of greater distance from the shore. Subsequent measurements indicated that this greater distance reduced the signals by about 2 db to all points.

With the transmitter in this location, tests were again made on the same two frequencies. The measuring set was taken to all of the locations in New Jersey from which transmissions had previously been made and check measurements were taken. These checked exactly the previous measurements (except for the 2-db difference mentioned above). Incidentally, it might be said that these check measurements appear to substantiate the correctness of the "reciprocal theorem" as applied to radio transmission, and demonstrates the equal necessity for proper location of the receiving station as for the transmitting station.

Besides the check measurements, observations were made at a number of other points. A series of measurements were made along the south shore of New York Bay. Some of these were made with the specific object of finding the effect of the "shadow" caused by Sandy Hook, while others were designed to show the effect of moving inland from the shore in low, swampy, or marshy ground. Fig. 4 is a map

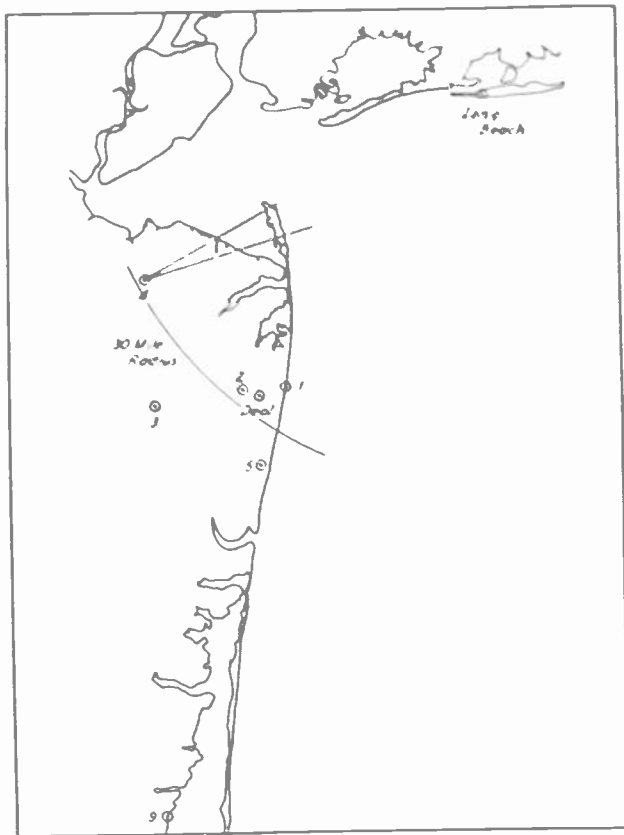

Fig. 4—Map showing principal transmitting and receiving points in New Jersey. The numbered points were used in plotting the curves. The lines extending out from Point 4 are paths toward Long Beach and Nantucket.

showing the locations at which these, as well as the other measurements, were made. The locations for these measurements are shown by a series of dots along the south shore of the bay and on Sandy Hook. The locations for the first group of observations are dots with circles around them, and are numbered.

GENERAL RESULTS

The second group of observations checked the first group in that they showed that serious signal attenuation occurs if a radio station is moved inland from the shore so as to have an inhabited region in the

line of travel. Further attenuation occurs with increased distance. The results also showed that land intervening some distance away can cause attenuation although of very much smaller amount. Sandy Hook, apparently, caused an attenuation of 2 db. The observations made by moving inshore over a mile from the south side of the Bay indicated that low and swampy ground produced very little attenuation.

THEORETICAL

The causes for greater attenuation of radio waves over land than over water undoubtedly lie in the conductivity and dielectric constants being different for soil than for sea water, and in the presence of irregularities including structures that extend above the surface of the ground. The amount by which ground conductivity and dielectric constants affect signal transmission has long been an object of search

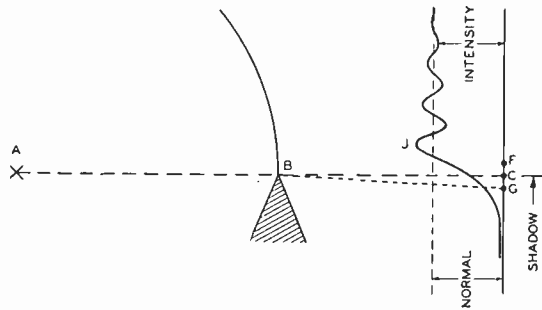

Fig. 5—Diagram showing interference fringes in intensity curve when a straight edge cuts off the lower part of a wave.

and its ascertainment can probably be helped little by the data presented. However, the large initial drop in signal for the first mile or two inland with reduced attenuation thereafter did not appear at first to result from a change in ground characteristics and led to a search for an explanation.

It was found possible to explain some of the phenomena observed by appropriating a classical optical picture and applying it to this case. It required pointing out certain physical and electrical characteristics that the ground could easily possess which would explain the phenomena to the general order of magnitude observed.

In Fig. 5, there is given the usual diagram showing the transmission of light past a straight edge.¹ At A is located a source of electromagnetic waves. At B is located an obstacle having a straight edge at the top which intercepts part of the radiation from A. Part of the wave front of an expanding spherical wave is shown above B. At C is located a vertical screen. A curve of intensity of incident radiation along the

¹ Woods, *Physical Optics*, p. 193.

screen is drawn with intensity plotted horizontally to the left. If the straight edge were not there, the intensity of arriving radiation along the screen would have a value represented by the dotted line labeled "Normal." The interposition of the obstacle cutting off the lower part of the wave alters markedly the shape of the intensity curve in the neighborhood of the edge of the shadow. Actually at the point C in line with the source A and the edge of the obstacle B , the intensity is 6 db lower ($\frac{1}{2}$) than the normal value.² It is suggested that this 6 db reduction in intensity is the larger part of the initial reduction in radio signals when moving inland from the shore.

In Fig. 6 is drawn a diagram representing the physical counterpart of the elements of Fig. 5, as they occurred in our transmission tests. Between A and B extend the conducting sea. At A is located the trans-

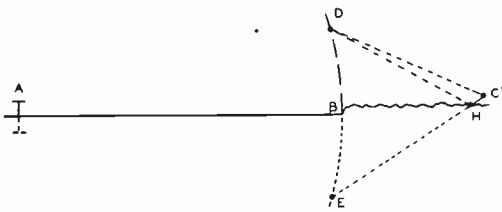

Fig. 6—Diagram representing transmitting path over water and land.

mitter which provides the radiation to be measured. At B is drawn an arriving wave front. Due to the presence of the conducting sea, any wave phenomena occurring between A and B and above the plane AB has all the attributes of a wave emanating from A and its image and moving in all directions in free space as though the conducting sea were not there. In other words, the wave from transmitter A moving toward B above the sea has an image moving beneath the sea. This results in the wave front BD having an image BE . At the shore is located the equivalent of the straight edge B . Between B and a receiving point C' , the land destroys the image of the wave front BD . At the point C' energy arrives from various parts of the wave front BD , such as along path DC' from point D . Energy from point D also travels path DH and would reflect toward C' , contributing to the field strength at C' if the ground were a flat conducting reflector. If we now make an assumption that the ground is a perfect absorber and produces no reflection contributing to field strength at C' , then the intensity of the wave as measured at various altitudes above ground level will follow the shape of the intensity curve of Fig. 5 and produce the phenomenon of a 6-db drop in signal strength on moving inland from the shore.

However, the ground is not a perfect absorber, and the 6-db drop

² Fig. 7 gives the shape of the curve more accurately.

in signal strength does not occur immediately upon moving inland. It occurs after moving inland almost a mile. The reduction in signal strength cannot be attributed to a perfectly absorbing ground. The situation can then be pictured about as follows.

When there is between B and C' considerable land which has a variegated surface, either in flatness or in electrical constants, the energy from various parts of wave front BD is not reflected regularly to reach C' and add properly, but it becomes scattered. The presence

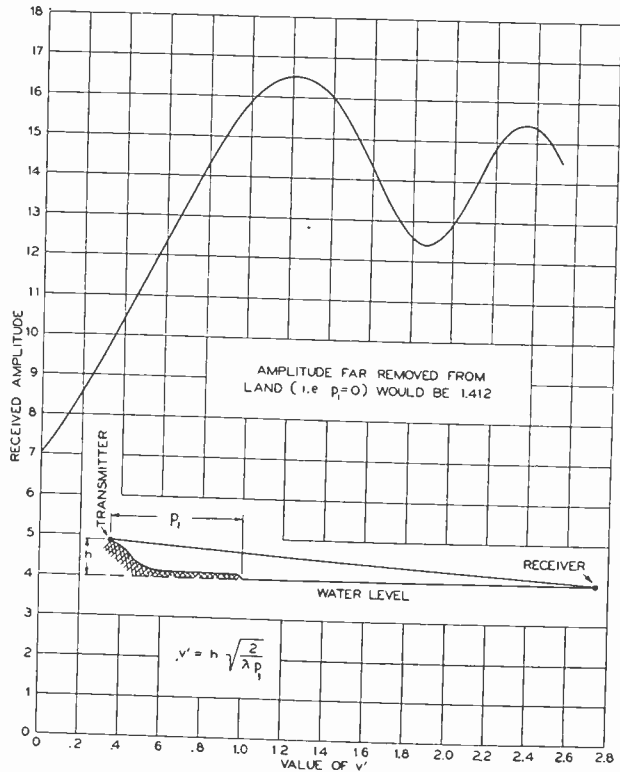

Fig. 7—Curve showing signal amplitude to be observed above the line of vision expressed as a function of height above and distance from the straight edge and of wavelength.

of land between B and C' which is irregular enough to scatter impinging radiation will, therefore, do the equivalent of a perfectly absorbing ground as regards reflecting useful energy toward C' , and the intensity curve should approach that of Fig. 5.

If there is also considered the case of land having primarily the characteristic of a dielectric instead of a conductor, a wave arriving at C' from a low angle direction will produce a reflected wave from flat ground that will tend to neutralize the directly received radiation. This may account for some of the attenuation observed of more than 6 db.

Deviation in attenuation from the 6 db value indicated by this picture can also be caused by variation in position of the receiver from the optical path that runs from *A* and touches *B* in passing. Position *G* in Fig. 5 would obtain in receiving when structures of various kinds such as buildings, trees, power lines, etc., that lie between the observer and the shore cause the effective height of the straight edge to be raised above the ground level. Position *F* can occur on the other side of the shadow line for such locations as observation No. 4 in these tests when the measuring location was at an altitude of about 300 feet above sea level on a hillside sloping sharply in the direction of Long Beach and

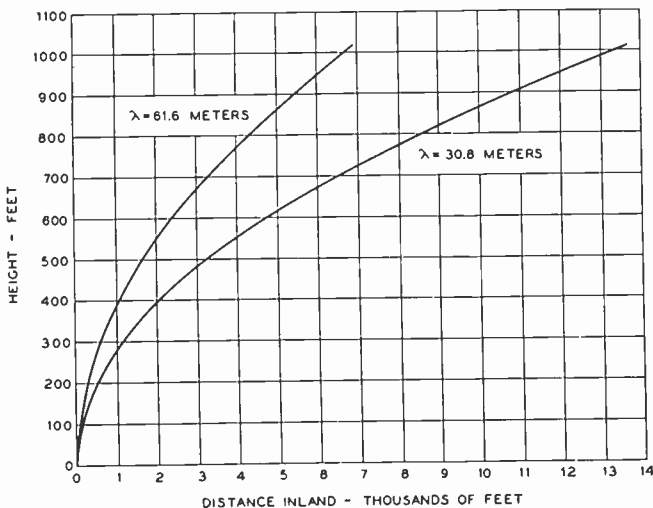

Fig. 8—Two typical curves giving required height of station as a function of distance inland from shore (or effective straight-edge location) in order that the radio signal will be a maximum.

where the optical path to the other station traveled 100 or more feet above all intervening land. However, at location No. 4 the altitude was not sufficient to give a pronounced increase in signal strength.

Concerning the attenuation with increased intervening land after the initial drop, there were an insufficient number of observations to ascertain the exact shape the curves should have considering all possible influences. The signals to Long Beach on 66 meters appeared to experience a minimum for about 3 miles inland, with a second maximum for about 7 miles inland while the same signals to Nantucket showed no such minimum and maximum but only a tendency to occur. The phenomenon was also absent on 33-meter signals to Long Beach. The amount of attenuation occurring for 3 miles inland also varied being greatest for Long Beach on 66 meters and least for Nantucket on the same wavelength. Due to the variety of man-made structures in the paths, at least part of the discrepancies may be at-

tributable to them. C. N. Anderson of the American Telephone and Telegraph Company has since made further observations in a less settled region and the results which he has in preparation for publication appear to bear out this last statement.

An interesting theoretical point in connection with this interpretation of the phenomenon is that at a certain distance above the line *ABC* in Fig. 5 there is to be found a signal strength *J* which is 16 per cent greater than it would be if the straight edge were removed. To secure this desirable condition requires that the station be elevated as a square-root function of the distance inland. Two sample curves of height against distance inland for this maximum signal intensity are shown in Fig. 8.

CONCLUSION

The results of the investigation indicate that when communicating with ships at high frequencies the attenuation of the ground or unreflected wave by land between the sea and the shore station is extraordinarily large for the first mile or two of intervening land. On simple theoretical grounds, attenuation of 6 db is to be expected, while attenuations of 8 to 12 db for one mile are observed. For greater distances, the attenuation per mile is very much reduced, though it is greater than over sea water. The initial attenuation is especially significant in that if interpreted in terms of equipment on ships or shore it indicates that stations one mile inland on the New Jersey shore would require transmitters both on ship and on shore of 6 to 16 times the powers that would be necessary to produce equivalent signals if the stations were located directly on the shore.

Appreciation is expressed for valuable assistance rendered by many men in this organization and in the American Telephone and Telegraph Company. Credit for most of the application of the optical theory is given to Dr. F. B. Llewellyn.

TABLE I

Test No.	Nantucket			Long Beach			
	Distance Miles	Amount Land Miles	<i>E</i> 66 M	Distance Miles	Amount Land Miles	<i>E</i> 66 m	<i>E</i> 33 m
0	212	2.25	32 db	28.4	4	46 db	41 db
1	210	0	34	27	0	64	55.7
1B	210 +	60 yards	31.2	27	160 yards	62.75	52.25
1C	210 +	120 yards	32	27	320 yards	62	51.5
2	213	3.5	26	29	5.75	47.5	36.25
3	222	10.5	16	34.5	11	38.5	28
4	218	6.5	25.8	28.	5.25	49.5	41.4
5	216	1	27.7	32.6	5.50	51	42
6	210	0.65	27	27	1.08	51.5	43
7	211	1.3	21.5	27	2.16	42.5	41.4
9	235	0.5	32.25	60	7	51*	33.25*

Table of observations giving distances in miles (unless otherwise noted) and field strengths in db above one microvolt per meter.

* Corrected for inverse distance only of 30 miles. Other readings not corrected in plotting since corrections would be negligible.

AN UNTUNED RADIO-FREQUENCY AMPLIFIER*

By

F. W. SCHOR

(Consultant, 6107 N. Glenwood Ave., Chicago, Ill.)

Summary—This paper outlines in brief a number of untuned radio-frequency transformers which have been used in the past. It discusses their characteristics and reasons for their limitations. It is pointed out that if the plate-load impedance of a tube can be increased at the high frequencies, the amplification will be increased. A method of doing this by closely coupling a circuit tuned to a high frequency is analyzed, and the equation for amplification is derived. The construction of a transformer embodying this principle is next described and amplification curves throughout the broadcast band are given for several varieties.

SINCE the popularity of band-pass tuning, the untuned radio-frequency amplifier has attracted the attention of many radio engineers. When used in a band-pass tuned radio-frequency system, it may be utilized to equalize the gain of the receiver over the broadcast range and at the same time save the cost of an additional

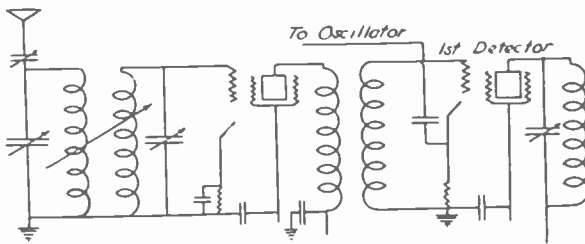

Fig. 1—R-F band selector circuit used in superheterodynes.

tuning condenser. Moreover, when the band-pass selector is used in a superheterodyne to eliminate cross talk, the second stage can be an untuned r-f transformer as shown in Fig. 1. This circuit can be easily designed to give equal amplification from the antenna post to the first detector.

In nearly all the present types of untuned amplifiers, the primary consists of a single winding of either resistance wire or of copper wire wound on an iron core. The voltage is transferred to the grid of the next tube by a coupling condenser and leak or by a closely coupled secondary. In such a system the greatest amplification occurs at the resonant frequency of the system. This frequency is determined by the inductance of either coil and the total capacity across both. If it should

* Decimal classification: R160. Original manuscript received by the Institute April 6, 1931.

be below 550 kilocycles, the amplification curve will resemble curve A, Fig. 2.

It will be noted that the gain at 1500 kc is only 2. This is due to high plate-to-ground capacity of the screen-grid tube, which together with the input capacity of the following tube and associated circuit and transformer capacities reaches in this case a value of about $30 \mu\mu\text{f}$. The reactance of this capacity at 1500 kc is 3500 ohms which is practically equal to the plate-load impedance. This value multiplied by the mutual conductance of the tube which may be 800 micromhos brings the voltage gain to 2.7.

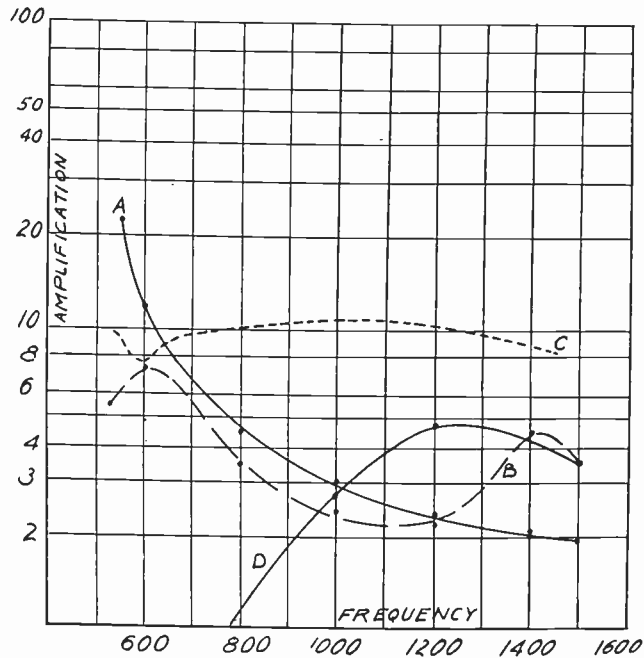

Fig. 2—Amplification curves of various untuned transformers.
 A—Two wires wound in parallel and resonated below 550 kc.
 B—Primary resonated at 600 kc and secondary at 1400 kc.
 C—Primary and secondary wound in single layers on opposite legs of a finely laminated silicon steel core.
 D—Primary and secondary resonated at the high frequencies.

By winding the primary so that its resonant period occurs at 600 kc, and the secondary so that it resonates at 1400 kc, the amplification at the high frequencies may be greatly increased as can be seen from curve B, Fig. 2. The gain at 1000 kc still leaves much to be desired and the gain at 550 kc is not as high as the transformer indicated by curve A.

By using a primary and secondary wound with No. 41 wire on opposite legs of a closed and very finely laminated silicon steel core, it has been possible to secure an amplification curve as shown at C. While such an excellent unit would be welcomed by experimenters, its high

cost does not attract the present-day engineers who are forced to use every possible economy.

The cheapest type of transformer would be one in which two parallel wires are wound on a simple cylindrical iron core. The iron is used to give the necessary resistance. Resistance wire on an air core could be used and it has the advantage of being more uniform but the disadvantage of being more expensive.

If such a transformer using an iron core has its resonant period below 550 kc, its amplification curve will resemble that of curve *A*, Fig. 2. If resonance occurs at 1400 kc, curve *D*, Fig. 2, will be the result with practically no gain below 800 kc. Where it is desired to compensate for an r-f amplifying system having a low gain at the low frequencies, the transformer indicated by curve *A*, Fig. 2 would be ideal.

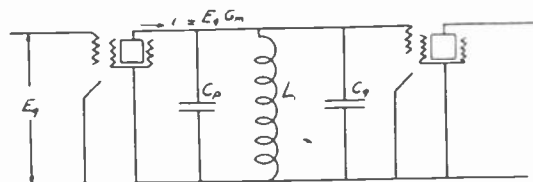

Fig. 3—Battery voltages are disregarded and only r-f potentials are shown.

Let us consider the case of a transformer with primary and secondary wires wound side by side, both coils being identical. Since two wires wound in parallel may be considered electrically as being a single winding, we may draw the simplified circuit as indicated by Fig. 3 showing the tube and circuit capacities.

C_p = Plate-to-ground capacity of tube.

C_g = Grid-to-ground capacity of tube.

L = Inductance representing transformer.

It is these capacities which lower the reactance across the transformer at the high frequencies and so limit our amplification. If we had some way of increasing this reactance our gain would increase proportionately.

It is a well-known fact that when a tuned circuit resonant at a frequency N is coupled to a second circuit, the reactance of this second circuit will be greater at this resonant frequency, N , than if the first circuit were not coupled to it. This is best illustrated by the ordinary tuned radio-frequency transformer having an aperiodic primary whose reactance is greatest at the frequency to which the secondary happens to be tuned, and of course the tube gives the greatest amplification at this frequency.

If it were possible to couple to the inductance L in Fig. 3, a circuit tuned to 1500 kc, the reactance across L would be raised and the gain

be below 550 kilocycles, the amplification curve will resemble curve A, Fig. 2.

It will be noted that the gain at 1500 kc is only 2. This is due to high plate-to-ground capacity of the screen-grid tube, which together with the input capacity of the following tube and associated circuit and transformer capacities reaches in this case a value of about 30 $\mu\mu\text{f}$. The reactance of this capacity at 1500 kc is 3500 ohms which is practically equal to the plate-load impedance. This value multiplied by the mutual conductance of the tube which may be 800 micromhos brings the voltage gain to 2.7.

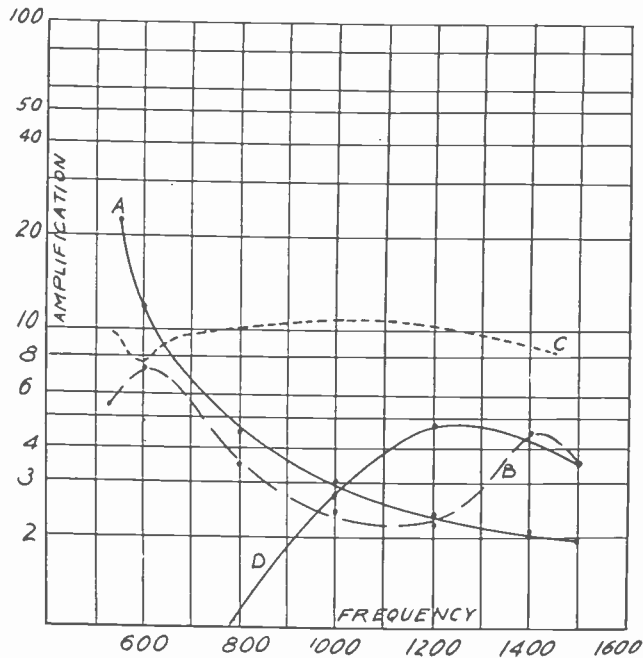

Fig. 2—Amplification curves of various untuned transformers.
 A—Two wires wound in parallel and resonated below 550 kc.
 B—Primary resonated at 600 kc and secondary at 1400 kc.
 C—Primary and secondary wound in single layers on opposite legs of a finely laminated silicon steel core.
 D—Primary and secondary resonated at the high frequencies.

By winding the primary so that its resonant period occurs at 600 kc, and the secondary so that it resonates at 1400 kc, the amplification at the high frequencies may be greatly increased as can be seen from curve B, Fig. 2. The gain at 1000 kc still leaves much to be desired and the gain at 550 kc is not as high as the transformer indicated by curve A.

By using a primary and secondary wound with No. 41 wire on opposite legs of a closed and very finely laminated silicon steel core, it has been possible to secure an amplification curve as shown at C. While such an excellent unit would be welcomed by experimenters, its high

cost does not attract the present-day engineers who are forced to use every possible economy.

The cheapest type of transformer would be one in which two parallel wires are wound on a simple cylindrical iron core. The iron is used to give the necessary resistance. Resistance wire on an air core could be used and it has the advantage of being more uniform but the disadvantage of being more expensive.

If such a transformer using an iron core has its resonant period below 550 kc, its amplification curve will resemble that of curve *A*, Fig. 2. If resonance occurs at 1400 kc, curve *D*, Fig. 2, will be the result with practically no gain below 800 kc. Where it is desired to compensate for an r-f amplifying system having a low gain at the low frequencies, the transformer indicated by curve *A*, Fig. 2 would be ideal.

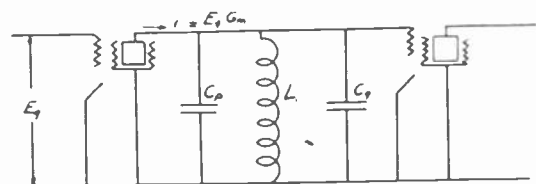

Fig. 3—Battery voltages are disregarded and only r-f potentials are shown.

Let us consider the case of a transformer with primary and secondary wires wound side by side, both coils being identical. Since two wires wound in parallel may be considered electrically as being a single winding, we may draw the simplified circuit as indicated by Fig. 3 showing the tube and circuit capacities.

C_p = Plate-to-ground capacity of tube.

C_g = Grid-to-ground capacity of tube.

L = Inductance representing transformer.

It is these capacities which lower the reactance across the transformer at the high frequencies and so limit our amplification. If we had some way of increasing this reactance our gain would increase proportionately.

It is a well-known fact that when a tuned circuit resonant at a frequency N is coupled to a second circuit, the reactance of this second circuit will be greater at this resonant frequency, N , than if the first circuit were not coupled to it. This is best illustrated by the ordinary tuned radio-frequency transformer having an aperiodic primary whose reactance is greatest at the frequency to which the secondary happens to be tuned, and of course the tube gives the greatest amplification at this frequency.

If it were possible to couple to the inductance L in Fig. 3, a circuit tuned to 1500 kc, the reactance across L would be raised and the gain

at the high frequencies materially increased. Fig. 4 shows the circuit of such an arrangement. Only the primary side of the winding is shown for the sake of clearness. It was found that by slightly altering the winding of the transformer that it was possible to incorporate this additional tuned circuit with a negligible increase in cost. Fig. 5 shows the construction.

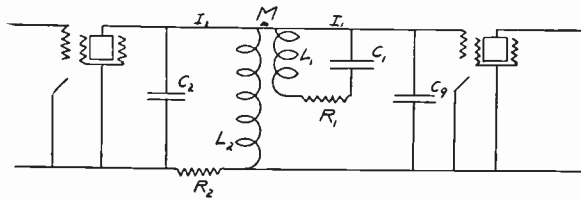

Fig. 4—Equivalent circuit of the r-f transformer.

A slit cylindrical soft iron core with a small bakelite washer over the center and a large one at each end is used as a winding form.

The primary is wound separately in the space *A-A*. At the same time, the secondary is wound in the space *B-B*. Both wires are next held together and wound in parallel in space *C-C*. Both primary and secondary are identical.

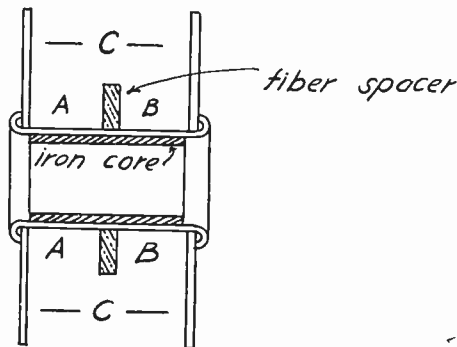

Fig. 5—Construction of aperiodic r-f transformer.

The characteristics of this transformer are shown in curve *A*, Fig. 6. The gain is fairly good at the high frequencies, excellent at the low frequencies, and still remains high at the middle.

That part of the primary winding in the space *A-A* can be considered as a separate coil tuned by its own distributed capacity. It is a part of the total primary inductance but we may consider it as being a separately tuned circuit coupled to the primary by that part of the primary inductance common to both windings. The same reasoning applies to the secondary and since practically the same voltages occur across the primary, it will only be necessary to consider one of these windings.

It was found by experiment that when the inner coils were wound very tightly and thoroughly impregnated with a wax having a high specific capacity, the amplification fell off rapidly at the high-frequency end and sometimes became less than unity as shown in curve *B*, Fig. 6. Various grades of iron were tried as cores but none of them gave results as satisfactory as ordinary commercial soft cold-rolled steel with the exception of iron dust indicated by curve *C*, Fig. 6. It is seen that the high-frequency resonance peak becomes very pronounced and the over-

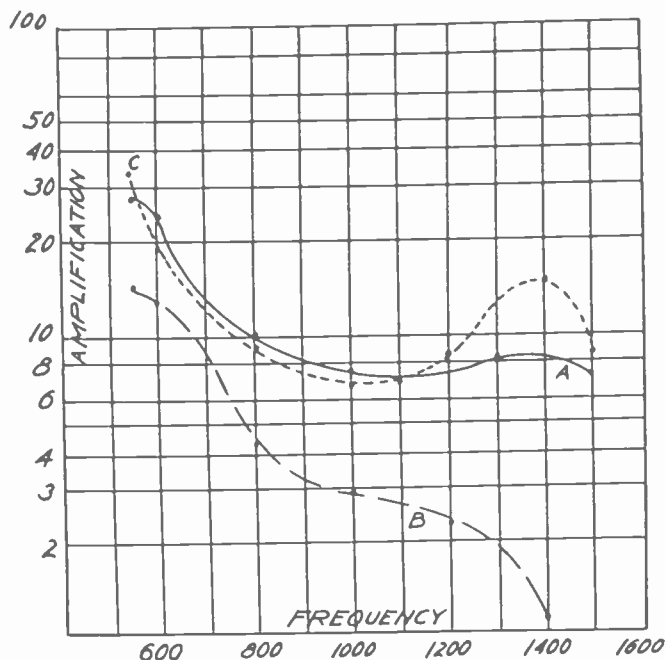

Fig. 6—Amplification curves of aperiodic r-f transformers using the double resonant primary and secondary.

A—Transformer described in Fig. 5.

B—Same transformer using coils with high self-capacity.

C—Same transformer as A using an iron dust core.

all amplification is slightly better. These results are largely due to the lowered high-frequency resistance of this core. Perhaps the reader may have wondered why an iron core is used at all. Eliminating the iron would double the amplification at the resonant points but cut in half the gain at 1000 kc, a condition which is not wanted.

The exact factors which govern the operation of this transformer may be deduced by a few simple equations.

Referring to Fig. 4, let I_1 be the current circulating in the circuit C_1 , L_1 , R_1 , and I_2 the current in circuit C_2 , L_2 , R_2 .

Then,

$$I_1 = \frac{\omega M I_2}{R_1 + jX_1} \quad (1)$$

where,

$$\omega = 2\pi \times \text{frequency}$$

$$M = \text{mutual inductance between } L_1 \text{ and } L_2 \\ = L_1$$

$$X_1 = \text{reactance of circuit } L_1 C_1.$$

The reactive drop across L_2 is $\omega L_2 I_2 - \omega M I_1$ and hence its reactance is,

$$X' = \frac{\omega L_2 I_2 - \omega M I_1}{I_2} \quad (2)$$

$$= \omega L_2 - \omega M \frac{I_1}{I_2} \quad (3)$$

From (1),

$$\frac{I_1}{I_2} = \frac{\omega M}{R_1 + jX_1} \quad (4)$$

$$X' = \omega L_2 - \frac{\omega^2 M^2}{R_1 + jX_1} \quad (5)$$

The series impedance of the circuit around C_2 , L_2 , R_2 is

$$Z_2 = R_2 + \frac{1}{j\omega C_2} + j\omega L_2 - \frac{\omega^2 M^2}{R_1} \quad (6)$$

The lower the series impedance of this circuit, the higher will be the parallel impedance and the greater will be the amplification.

The greatest amplification at the lower frequency end will occur at a frequency determined by the constants L_2 , C_2 , and will increase with an increase in L_2 and a decrease in R_2 . The curves show the gain at 550 kc to be about 25.

The amount of amplification at the high-frequency resonant point (determined by $L_1 C_1$) will depend upon the value of $\omega^2 M^2 / R_1$.

By using an air core, R can be made very small and $\omega^2 M^2 / R_1$ quite large, but, of course, the gain at the middle of the band will then suffer so we cannot do away with the iron. Since ω is already fixed by the higher end of the broadcast frequency spectrum, M is the only factor that can be used to increase the high-frequency amplification. Since M is equal to L_1 , we can best increase its value by winding the inner coils with as low a distributed capacity as possible. This means separating the turns as much as possible and using a thick insulation with low specific capacity. This fact was proved by curve *B*, Fig. 6, which shows what happened when the distributed capacity C_1 is high, causing L_1 to be low. The gain at 1300 kc is shown to be 1.8.

Above the high-frequency resonance period, the capacity C_1 and that part of L_2 between L_1 and ground (or $L_2 - L_1$) form a series resonant circuit whose period is only slightly higher. Its effect is practically to short-circuit the transformer and explains the reason for the sudden dropping off in gain of curve B , Fig. 6. This condition can best be avoided by making C_1 as low as possible.

If the constants of (6) are known, the performance of the transformer can be predicted in the following manner.

Let $Z_2 = R + jX$ when simplified; then the parallel impedance is

$$Z'' = \frac{R^2 + X^2}{R} - j \frac{R^2 + X^2}{X} \text{ and the numerical value is}$$

$$Z'' = \sqrt{\left(\frac{R^2 + X^2}{R}\right)^2 + \left(\frac{R^2 + X^2}{X}\right)^2}$$

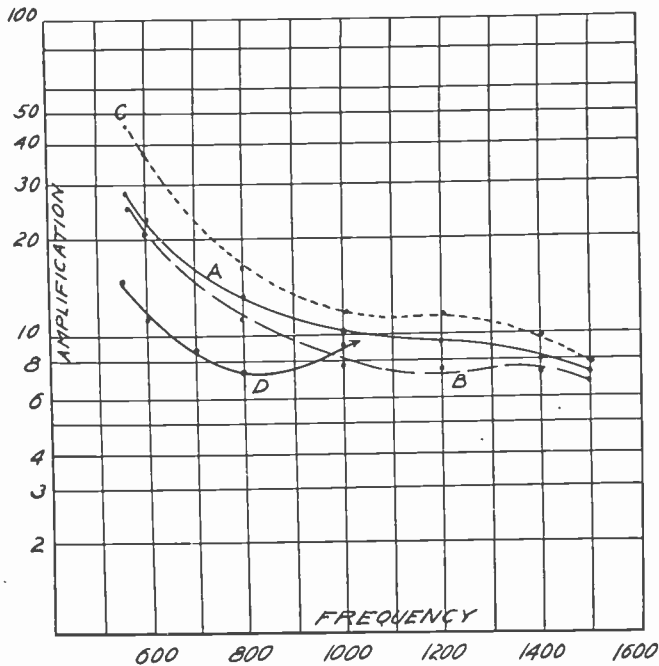

Fig. 7—Comparison of calculated performance with experimental results.
 A—Calculated amplification curve.
 B—Experimental curve of same transformer.
 C—High amplification transformer using extremely low self-capacity windings.
 D—Part of curve showing effect on low-frequency amplification of trap circuit.

The voltage across Z is $G_m E_o Z''$ and the amplification is this quantity divided by E_o or $G_m Z''$.

Using the following constants, the performance curve shown in A , Fig. 7, was calculated and checked experimentally by curve B .

Constants used,

$$\begin{aligned}R_2 &= 18,000 \text{ ohms} \\R_1 &= 4,000 \text{ ohms} \\C_1 &= 10 \mu\mu\text{f} \\C_2 &= 16 \mu\mu\text{f} \\L_1 &= 1.3 \text{ millihenries} \\L_2 &= 5.8 \text{ millihenries}\end{aligned}$$

A special transformer was next constructed using an extremely low distributed capacity in the winding and its curve is shown in Fig. 7, curve *C*. Note that the gain at the low frequencies rises very rapidly also. By making the primary winding larger than the secondary, the effect is to create an absorption circuit which lowers the gain at the low frequencies and gives the curve shown by curve *D*, Fig. 7.

Even though a random winding is used in the construction of these transformers, it has been possible to secure remarkable uniformity in quantity production combined with very low cost.

ACKNOWLEDGMENT

The author wishes to acknowledge the valued assistance of his former associate, Mr. I. Sveen.



HISTORICAL REVIEW OF ULTRA-SHORT- WAVE PROGRESS*

BY

WILLIAM H. WENSTROM

(Signal Corps, U. S. A., Fort Monmouth, N. J.)

Summary—This paper is a historical review up to the year 1931 of the more significant experiments with radio ultra-high frequencies and ultra-short waves. Developments are classified, in accordance with the type of oscillation generator employed, under four main heads: spark oscillators, regenerative oscillators of conventional type, electronic oscillators of Barkhausen-Kurz and Gill-Morrell type, electronic oscillators of the magnetron type. Within these four divisions arrangement is chronological.

INTRODUCTION

AMONG the significant and comparatively recent developments in electrical engineering is the efficient and dependable production of ultra-high-frequency oscillating currents. The applications of this technology, as yet largely unexplored, may ultimately lead to such widely diverse fields as human therapeutics and limited space transmission of electric power. Up to the present, however, the chief apparent utility of these oscillations has been in the communications field for the production of ultra-short electromagnetic waves.

Developments in the ultra-short-wave field have been so numerous and varied that direct study of them all entails for the nonspecialist a prohibitive expenditure of time and effort. For this reason a brief historical review of the entire subject appears desirable.

While the terms "ultra-high frequency" and "ultra-short-wave" are relative, the present discussion will be limited to currents oscillating at frequencies above forty megacycles and producing waves less than seven meters in length. In the ultra-short-wave region wavelength is a more convenient reference unit, and will be used in this paper.

Certain physical differences separate ultra-short-wave technology from that of ordinary radio. At ultra-high frequencies the electrical characteristics of a circuit are determined less by lumped constants than by distributed constants. At still higher frequencies the interelement travel time of an electron becomes appreciable.

For the efficient radiation of ultra-short waves, it becomes possible to employ directive radiator systems of convenient size. These may take the form of wave directors, wave reflectors, curved surfaces, or

* Decimal classification: R090×R133. Original manuscript received by the Institute, July 8, 1931. Bibliographic work done at Yale University in the course of preparing an essay for the degree of Master of Science.

outlined surfaces of various types, or even lenses. Such radiation, if continuous, can be readily modulated. The high carrier frequencies involved permit the use of high modulation frequencies such as those required for television.

Another significant difference between ultra-short waves and short waves in the ordinary sense concerns their propagation over the surface of the earth. It is well known that skip distance of short waves, corresponding to the nearest ground-strike of elevated rays after reflection or refraction from the ionized layer in the upper atmosphere, increases with frequency. As the wavelength approaches 7 meters (the critical wavelength depending upon the height and condition of the ionized layer) even a ray tangent to the earth's surface is above the limiting angle and passes through the layer into space. The result is that, although in exceptional cases ultra-short waves may be reflected earthward by some elevated object such as an airplane, in general their propagation along the earth's surface is restricted to the direct ray or ground wave and there is no sky wave in the ordinary sense. This limited range, largely a function of the transmitter height, is of some practical value. There is no long range interference between stations, and it becomes possible to operate many stations on the same wavelength if they are separated by a few miles. In military use long range enemy interception of the signals is an impossibility. Fading in the ordinary sense, as caused by sky wave variations, does not exist.

Finally, ultra-short waves in point-to-point propagation resemble light waves rather than the longer and more conventional waves of the radio spectrum. In accordance with the general law of wave diffraction, radio waves can bend around obstacles whose dimensions are small in relation to their wavelengths, but they leave pronounced shadows behind obstacles which are large in relation to their wavelengths. In the vicinity of 5-7 meters ordinary terrain obstacles such as small hills and even large buildings cause pronounced shadows, while at a wavelength of a few centimeters individual tree trunks or rocks have the same effect. This serious limitation of ultra-short waves in general places the same restrictions on station location as would obtain in the case of light signaling. Compared to the light beam, however, the radio beam has two advantages. It is produced in equal intensity with less power, and it penetrates readily mist, fog, smoke, dust, and other atmospheric obscurations involving particles of relatively small dimensions.

SPARK OSCILLATORS

The literature of ultra-high-frequency oscillations and ultra-short waves extends back to the discovery of the radiated waves by Hertz in

1887. Hertz and other early experimenters, as well as many later ones, used a spark as the source of oscillations. Hertz originated the half-wave antenna commonly used in short-wave transmission today, used reflectors to concentrate the waves into beams and prisms of pitch to refract them, observed standing waves in space, employed polarizers and analyzers similar to those used in optics, and performed many other experiments. He succeeded in producing, by means of a single spark gap, waves down to 50 cm in length.

In 1894 Righi, by using multiple spark gaps separated by small metal balls which themselves became the resonant circuits, succeeded in producing electromagnetic waves in the range between 20 and 125 mm.

In 1896-97 Marconi achieved radio communication over a distance of nearly two miles using waves of about 1 meter length. However, the phenomenal success of longer waves and their immediate applicability to marine needs soon caused him to abandon short waves for the time, and they were not again seriously considered as a means of communication for many years.

With modified Righi oscillators Lodge, Fleming, and others carried the short wave limit of electromagnetic oscillations further downward toward the infra-red spectrum. Other physicists, by producing longer heat waves, were extending the infra-red region upward. In 1911 Rubens and Baeyer obtained radiation from a quartz mercury arc lamp at 218 μ and 343 μ .

In 1923 Nichols and Tear⁶ succeeded in extending the short electric wave limit still further downward. They obtained waves between 1.8 and 4 mm long by means of the multiple spark oscillator system of Righi carried to extraordinary refinement. In place of Righi's isolated dipole consisting of two spheres, they employed tungsten cylinders from 0.2 to 5 mm in length and from 0.2 to 0.5 mm in diameter, immersed in kerosene. To reduce the temperature of the electrodes, which at best were soon burned away, a jet of kerosene played on the main gap and compressed air jets cooled the auxiliary gaps. The potential was 30,000 volts in series with a water resistance and an auxiliary 1 cm air gap.

In 1924 Glogowela-Arkadiewa⁶ devised apparatus of an entirely different type. As the wavelength limiting factor had been the size of electrodes, whose size in turn was limited by the fact that smaller electrodes were more quickly consumed, the Russian investigator decided to use electrodes which were constantly expended and renewed. A rotating wheel dipped into a continuously disturbed mass of brass and aluminum filings suspended in oil. Due to the viscosity of the oil,

the rotating wheel was constantly surrounded by an adhering ring of paste through which the spark discharge was made to pass. The metallic particles thus acted as miniature doublets. By this means Glagowela-Arkadiewa produced waves ranging in length all the way from 50 mm down to 82μ , and bridged the gap between the radio spectrum and the infra-red spectrum.

REGENERATIVE OSCILLATORS OF CONVENTIONAL TYPE

In 1916 White⁸ produced waves of 6 meters length with a pliotron tube. The grid was connected directly to filament without leak or condenser, and the anode was shunt fed through radio frequency chokes

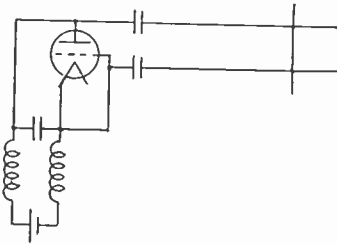

Fig. 1—Regenerative oscillator circuit, White, 1916.

(Fig. 1). As in all oscillators of the conventional regenerative type, the anode was strongly positive relative to the grid and cathode. Anode and grid were coupled through very small condensers to the two wires of a Lecher system. This appears to be the first recorded use of an electron tube for producing ultra-high-frequency oscillations.

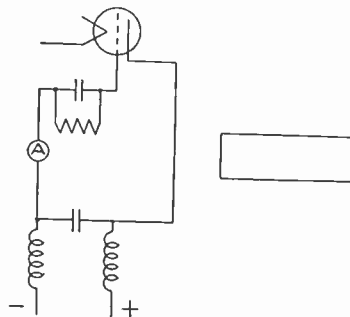

Fig. 2—Regenerative oscillator circuit, Gutton-Touly, 1916.

In 1919 Gutton and Touly⁹ reported results with a single tube oscillator which was the outgrowth of high-frequency experiments started during the war. It consisted of a single turn of wire between grid and anode, broken at the center by a relatively large condenser on each side of which, at points of low radio-frequency potential, the anode supply and grid bias leads were brought in. (Fig. 2). An alternative ar-

arrangement provided for a grid condenser and resistance in the grid lead. This circuit tuned down to 3 meters. By removing a meter from the oscillatory circuit, and inserting a very small variable condenser in the grid lead, next to the large stopping condenser, the wavelength was carried down to 2 meters. The arrangement of Gutton and Touly is fundamental in regenerative oscillator design; most of the single tube ultra-short-wave circuits of recent years have been patterned after it.

In the same year van der Pol¹⁰ constructed an ultra-short-wave oscillator of the tuned-plate type for use in determining the specific inductive capacities of liquids. With an ordinary high vacuum receiving tube he was able to produce waves as short as 3.65 meters, and obtained good output at 3.75 meters. Single turns of wire, in the form of thin rectangles about 30 cm long, served for grid coil and anode coil. A small variable condenser, placed near the filament end of the anode coil, tuned the anode circuit and varied the coupling coefficient between grid and plate circuits. The necessary reaction from the anode circuit on the grid circuit was obtained through the plate-grid capacity.

In 1919 also Eccles and Jordan¹¹ showed methods of connecting two triodes in parallel, using balanced circuits with both inductive and capacitive plate-grid coupling. These circuits have since been widely used in short-wave experiments.

In 1920 Southworth^{12,13} produced oscillations down to 1 meter with tubes from which the bases had been removed. The oscillating circuit consisted of a variable-length rectangle of brass tubing, about 8 centimeters by 13 centimeters for the shortest waves. The tube was connected in one end of this rectangle, the grid directly to one side and the anode to the other side through two series condensers, one fixed and the other variable. Thus the circuit may be classed as a tuned-grid arrangement, as opposed to the tuned-plate arrangement of van der Pol. Compared to the Gutton-Touly circuit both these arrangements had two disadvantages: the radio-frequency circuit was not symmetrical about a low potential axis, and the d-c supply leads were not brought in on this axis.

Southworth measured wavelength by means of variable-length Lecher wires terminating on pulleys behind a shield, and explored the harmonic region. He also developed a theory of parallel wire circuits and showed that measurements of L and C could be made in circuits having distributed constants. Where l is the length of a Lecher rectangle $\lambda = 2l$. Where L or C is added in one end of the Lecher rectangle and l' is the new length required to bring the Lecher system to resonance:

$$L = - Kl \tan \frac{l'}{l} \pi$$

$$C = - K'l \cot \frac{l'}{l} \pi.$$

These relations permit the rapid and accurate measurement of a small constant such as the interelectrode capacity of a vacuum tube.

In 1921 Holburn¹⁴ described some experiments with single-tube and two-tube oscillators producing waves down to 3 meters. He found that the single-tube arrangement of Gutton-Touly could be tuned to lower wavelengths by decreasing the blocking capacity, but that this adjustment decreased the intensity of oscillation. To overcome this difficulty he used two tubes in the balanced arrangement of Eccles and Jordan (Fig. 3). This design gave outputs of 1.5–2 watts, where E_p was 200–500 volts. It appears to be the first successful operation of more than one tube in an ultra-high-frequency oscillating circuit.

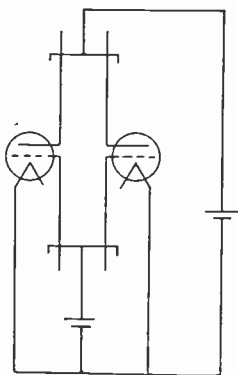

Fig. 3—Regenerative oscillator circuit, Holburn, 1921.

In 1924 Mesny¹⁶ reported experiments with a two-tube balanced circuit, using inverse inductive coupling between grid and anode coils (Fig. 4), and found that the wavelength varied directly as the coefficient of coupling. He obtained unstable oscillations as low as 1.2 meters and very stable oscillations at 1.5 meters. Grid modulation of the balanced oscillator was accomplished by a single modulator tube, the anode-cathode resistance of which served as the oscillator grid resistance. With a current of 80 ma in a $1/2\lambda$ antenna, without reflectors, this transmitter gave a radio-telephone range of 2 km through scattered trees and 500 meters through dense woods.

In 1925 Gutton and Pierret¹⁷ investigated the harmonics of short-wave oscillators. With a single oscillator tube giving a fundamental at 2.16 meters, the 2nd, 3rd, and 4th harmonics were detected. Two

tubes in parallel gave 2nd and 3rd harmonics at 20 per cent of the intensity of the fundamental. One balanced oscillator of fundamental 1.76 meters gave a 2nd harmonic of practically 100 per cent intensity, together with no detectable 3rd harmonic. Another balanced oscillator at 1.60 meters gave fairly strong 2nd and 3rd harmonics. These investigators concluded that circuit variations such as close coupling and lack of symmetry increase the intensity of harmonics.

In 1927 Kruse and Phelps^{19,20} built and described various oscillators ranging from 2.36 meters to 0.41 meter. All were of the Gutton-Touly type described above, with a comparatively large condenser connected by short leads between the grid and anode. The 2-meter wavelength was obtained with a standard tube and socket; other values were obtained with unbased tubes. The shortest wavelength was obtained by placing the condenser well up in the stem of the tube so as to make the leads as short as possible.

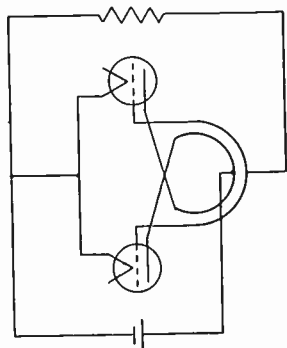

Fig. 4—Regenerative oscillator circuit, Mesny, 1924.

In 1927 also Englund²¹ reported experiments with various oscillators to determine the practical short-wave limit. Using standard tubes in balanced arrangements he reached 1.67 meters, and by unbasing the tubes reached 1.42 meters. By constructing a balanced pair of three-element groups within a single tube, λ 1.05 was reached. Englund's failure to reach the wavelength limits of Kruse is perhaps explained by two facts. Most of Englund's oscillators included a large metal socket which would tend to increase distributed capacity throughout the circuit, and in those oscillators using unbased tubes the lumped inductances were relatively large.

In 1928 Kohl,²² in the course of experiments chiefly concerned with the Barkhausen-Kurz effect to be described later, used in addition the conventional positive anode circuit. He produced waves down to 60 cm, and explained these oscillations, as well as those of the Barkhausen-Kurz type, on the basis of electronic oscillation inside the tube.

He found, like previous investigators, the wavelength varied as the length of connecting leads and the interelement capacity, and built special tubes which enabled him to reach the 60-cm limit.

In 1928 also Yagi²³ reported experiments with a balanced oscillator of the type used by Mesny. Waves as short as 60 cm were obtained, and stability was excellent at wavelengths shorter than 2.0 meters. Yagi also described some important and fundamental beam transmission experiments using wave reflectors and directors at 4.4 meters. Signals were found to increase rapidly as transmitter and receiver were raised clear of the ground.

In the same year Bergmann²⁴ reported tests with circuits of the Gutton-Touly type, using a special low capacity tube whose grid and anode leads were brought directly out at opposite sides of the glass bulb. This arrangement produced waves down to 80 centimeters with good output and stability.

In 1928 also Ritz²⁵ conducted 3-meter transmission experiments with a small portable radiotelephone set. A balanced Mesny oscillator was modulated by an additional tube, and a switching arrangement permitted the employment of the transmitting tubes and two additional ones in a super-regenerative receiver. Wide range variations, explained on the basis of absorption, were noted as follows: inside a tunnel scarcely 100 meters; over the surface of a lake 2 km; between isolated mountain peaks up to 130 km.

Further and more extensive experiments with the 3-meter wavelength were reported in 1930 by Esau and Hahnemann.²⁶ After many receiver difficulties the superregenerative principle was adopted. Transmitter circuits were not shown, but appear from photographs to be of conventional type. Powers up to 1 kw were used. Duplex telephone conversations were held with 2-cm channel separation at 3 meters. Some of the transmission results are rather conflicting, but it appears in general that for ranges greater than 2 km either the transmitter or receiver, or both, must be elevated at least 30 feet above the ground. This 2-km maximum ground-to-ground range of ultra-short waves was reported also in the experiments of Ritz and Mesny, and appears to be a fixed law of ultra-high-frequency transmission. Esau and Hahnemann carried out also some interesting airplane experiments, confirming the principle of increasing range with increasing altitude in accordance with familiar optical laws. With an airplane transmitter of 1 to 2 watts power, telephone transmission was accomplished over a range of 30 km and facsimile transmission was achieved over a somewhat shorter range.

In 1930 also Brown²⁷ reported results at 2 meters in general accord

with those mentioned above. He used an oscillator arrangement, similar to that employed by Scheibe in 1926 to produce Barkhausen-Kurz oscillations, which was in effect a balanced Lecher system with the tubes at the two ends and the supply leads brought in at the center. The entire transmitter could be covered by a cylindrical shield, divided at the center, which in itself formed the radiating dipole. This latter design provided unusual ruggedness.

In 1931 Diamond and Dunmore²⁸ reported the development of a 3-meter beam whose curved equisignal characteristic could be used as a safe gliding path for aircraft attempting to land during fog. The oscillator, of 500 watts power, was patterned in general on the circuit of Gutton and Touly.

During 1930 experiments with ultra-short-wave, limited-area broadcasting were carried out in Germany. They have been briefly described by Schwandt²⁹ and others. With a dipole radiating 1 kw elevated about 200 feet the range was about 25 miles, sufficient to cover the city of Berlin. The crystal-controlled transmitter (7.05 and 6.75 meters) employed five frequency-doubling amplifier stages. In reception, fading did not exist, electrical noise was less than 10 per cent of that encountered on conventional broadcast wavelengths, and absorption by metallic building fixtures was usually avoided by moving the receiver a few feet. It would be interesting to observe similar experiments in a typical American skyscraper city.

From the above review it appears that the practical lower wavelength limit, for efficient power conversion with oscillators of the conventional regenerative type, is in the neighborhood of 2 meters. While regenerative oscillators can be pushed down to 1 meter or even 0.5 meter by using special low capacity tubes and the shortest possible connecting leads, oscillations at these wavelengths are usually of low intensity suitable only for measurement purposes. The lower wavelength limit is imposed by the time of electron interelement passage, which becomes so appreciable as wavelength is reduced that conventional phase relations in the oscillating circuit can no longer be maintained. For the production of waves around 50 cm with even fair efficiency, an entirely different type of circuit is required.

ELECTRONIC OSCILLATORS OF BARKHAUSEN-KURZ AND GILL-MORRELL TYPE

In contrast to the regenerative oscillators described above, oscillators of the Barkhausen-Kurz type are distinguished by a grid potential strongly positive with respect to the anode and cathode potentials. As Hollmann⁴³ has pointed out, in a tube so connected four differ-

He found, like previous investigators, the wavelength varied as the length of connecting leads and the interelement capacity, and built special tubes which enabled him to reach the 60-cm limit.

In 1928 also Yagi²³ reported experiments with a balanced oscillator of the type used by Mesny. Waves as short as 60 cm were obtained, and stability was excellent at wavelengths shorter than 2.0 meters. Yagi also described some important and fundamental beam transmission experiments using wave reflectors and directors at 4.4 meters. Signals were found to increase rapidly as transmitter and receiver were raised clear of the ground.

In the same year Bergmann²⁴ reported tests with circuits of the Gutton-Touly type, using a special low capacity tube whose grid and anode leads were brought directly out at opposite sides of the glass bulb. This arrangement produced waves down to 80 centimeters with good output and stability.

In 1928 also Ritz²⁵ conducted 3-meter transmission experiments with a small portable radiotelephone set. A balanced Mesny oscillator was modulated by an additional tube, and a switching arrangement permitted the employment of the transmitting tubes and two additional ones in a super-regenerative receiver. Wide range variations, explained on the basis of absorption, were noted as follows: inside a tunnel scarcely 100 meters; over the surface of a lake 2 km; between isolated mountain peaks up to 130 km.

Further and more extensive experiments with the 3-meter wavelength were reported in 1930 by Esau and Hahnemann.²⁶ After many receiver difficulties the superregenerative principle was adopted. Transmitter circuits were not shown, but appear from photographs to be of conventional type. Powers up to 1 kw were used. Duplex telephone conversations were held with 2-cm channel separation at 3 meters. Some of the transmission results are rather conflicting, but it appears in general that for ranges greater than 2 km either the transmitter or receiver, or both, must be elevated at least 30 feet above the ground. This 2-km maximum ground-to-ground range of ultra-short waves was reported also in the experiments of Ritz and Mesny, and appears to be a fixed law of ultra-high-frequency transmission. Esau and Hahnemann carried out also some interesting airplane experiments, confirming the principle of increasing range with increasing altitude in accordance with familiar optical laws. With an airplane transmitter of 1 to 2 watts power, telephone transmission was accomplished over a range of 30 km and facsimile transmission was achieved over a somewhat shorter range.

In 1930 also Brown²⁷ reported results at 2 meters in general accord

with those mentioned above. He used an oscillator arrangement, similar to that employed by Scheibe in 1926 to produce Barkhausen-Kurz oscillations, which was in effect a balanced Lecher system with the tubes at the two ends and the supply leads brought in at the center. The entire transmitter could be covered by a cylindrical shield, divided at the center, which in itself formed the radiating dipole. This latter design provided unusual ruggedness.

In 1931 Diamond and Dunmore²⁸ reported the development of a 3-meter beam whose curved equisignal characteristic could be used as a safe gliding path for aircraft attempting to land during fog. The oscillator, of 500 watts power, was patterned in general on the circuit of Gutton and Touly.

During 1930 experiments with ultra-short-wave, limited-area broadcasting were carried out in Germany. They have been briefly described by Schwandt²⁹ and others. With a dipole radiating 1 kw elevated about 200 feet the range was about 25 miles, sufficient to cover the city of Berlin. The crystal-controlled transmitter (7.05 and 6.75 meters) employed five frequency-doubling amplifier stages. In reception, fading did not exist, electrical noise was less than 10 per cent of that encountered on conventional broadcast wavelengths, and absorption by metallic building fixtures was usually avoided by moving the receiver a few feet. It would be interesting to observe similar experiments in a typical American skyscraper city.

From the above review it appears that the practical lower wavelength limit, for efficient power conversion with oscillators of the conventional regenerative type, is in the neighborhood of 2 meters. While regenerative oscillators can be pushed down to 1 meter or even 0.5 meter by using special low capacity tubes and the shortest possible connecting leads, oscillations at these wavelengths are usually of low intensity suitable only for measurement purposes. The lower wavelength limit is imposed by the time of electron interelement passage, which becomes so appreciable as wavelength is reduced that conventional phase relations in the oscillating circuit can no longer be maintained. For the production of waves around 50 cm with even fair efficiency, an entirely different type of circuit is required.

ELECTRONIC OSCILLATORS OF BARKHAUSEN-KURZ AND GILL-MORRELL TYPE

In contrast to the regenerative oscillators described above, oscillators of the Barkhausen-Kurz type are distinguished by a grid potential strongly positive with respect to the anode and cathode potentials. As Hollmann⁴⁸ has pointed out, in a tube so connected four differ-

ent types of oscillations can occur, as follows: (1) oscillations within the cathode-anode space of the tube having a frequency independent of external circuit constants; (2) oscillations similar to (1) but governed in frequency by external circuit constants; (3) oscillations within the grid-anode space of the tube having a frequency independent of external circuit constants; (4) oscillations similar to (3) but governed in frequency by external circuit constants. Oscillations of types (1) and

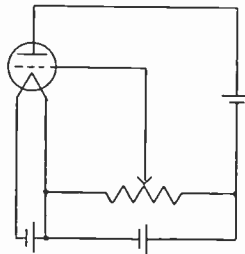

Fig. 5—Electronic oscillator circuit, Whiddington, 1919.

(3) are generally associated with the names Barkhausen and Kurz, while oscillations of types (2) and (4) are named after Gill and Morrell.

The first known investigation of oscillations in a triode having the grid positive with respect to the anode was reported by Whiddington³⁰ in 1919 (Fig. 5). He used "gassy" or "soft" tubes, and explained the observed feeble oscillation on the basis of rather complicated electron and ion oscillations about the grid. His theory also involved the ion

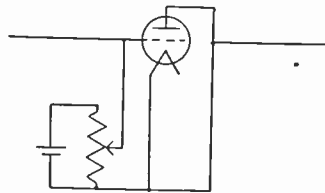

Fig. 6—Electronic oscillator circuit, Barkhausen-Kurz, 1920.

bombardment of sensitive spots on the filament, and ionization by collision. The frequency was determined by the grid potential and consequent particle velocities. Assuming polyatomic ions of mercury, calculations agreed closely with observed results. Due to the relative slowness of the comparatively heavy ions involved, the observed wavelengths ranged from 400 to 700 meters.

During 1919 also Barkhausen and Kurz³¹ discovered that high vacuum triodes, with grid strongly positive relative to cathode and anode (Fig. 6), gave oscillations of more practical significance than those observed by Whiddington. The radiated waves were in the general region of 1 meter, and ranged downward to 43 cm. These oscillations were explained as follows: Electrons emitted by the cathode

are attracted towards the grid. Some of them strike the grid wires, but most pass through the interstices toward the anode. Having passed the grid, however, they are subject to strong attraction from it, particularly if the plate is somewhat negative. Returning through the grid, some electrons are captured by it while others continue towards the cathode. Here they join electrons just emitted, again obey the grid attraction, and repeat the cycle. Thus continuous oscillations are produced, of wavelength dependent upon the element potentials and interelement distances. Neglecting space charge, these relations take the form:

$$\lambda = \frac{1000}{\sqrt{E_g}} \frac{d_a E_g - d_g E_a}{E_g - E_a}$$

where E_a and E_g are the respective anode and grid potentials and d_a and d_g are their respective diameters.

In 1922 Bergmann³² used a Barkhausen-Kurz oscillator for quantitative measurements of the radiated field about an oscillator, taking advantage of the extremely short continuous waves which the system afforded.

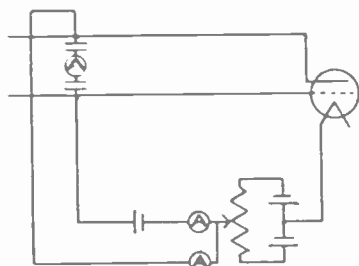

Fig. 7—Electronic oscillator circuit, Gill-Morrell, 1922.

In 1922 also Gill and Morrell^{33,35} reported new discoveries in experiments with Barkhausen-Kurz oscillators (Fig. 7). They found that in certain cases the wavelength was not independent of the external circuit constants, but varied directly with them in the familiar LC relation. Their results showed that a given grid voltage gave the strongest oscillations at a definite wavelength determined by the length of Lecher wires connected directly to grid and anode. They explained these observations by the following theory: Assuming cathode and anode at zero potential and grid positive, there is no work done on electrons leaving grid, coming to rest at anode, and returning to grid. If, however, there is an alternating potential of the form $V \sin pt$ between grid and plate due to oscillations, the work done on these electrons is not necessarily zero, and if negative it represents energy supplied to the external oscillating system. In their 1925 paper Gill and

Morrell also pointed out that the $I_p E_p$ curve showed a negative characteristic which in itself could explain oscillations, and they calculated that the oscillations could be maintained by secondary emission from the plate.

In 1924 Scheibe^{34,36} reported results, at variance with those of Gill-Morrell, confirming the conclusion of Barkhausen-Kurz that wavelength was a function of element dimensions and potentials alone, and was not influenced by external circuit constants. He obtained Barkhausen-Kurz oscillations in close agreement with theory, and in addition discovered an entirely new kind of oscillations of wavelength approximately one-half as great. It was established that these new waves were not harmonics of the longer ones; they depended upon some hitherto unnoticed interelement electronic effect. Hollmann ex-

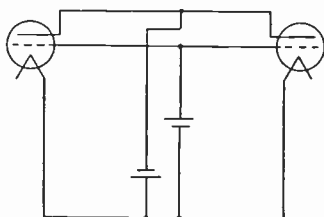

Fig. 8—Electronic oscillator circuit, Scheibe, 1926.

plained their origin a few years later. Scheibe also gave a complete formula for the “longer wave” oscillations, simplified by the assumption of zero electron escape velocity from the cathode.

All the above-mentioned oscillators employed a single tube. Oscillations were usually rather feeble, and they could be maintained at fair amplitude only by excessive electron emission from the cathode. As a result, tube life was short.

In 1926 Scheibe succeeded in connecting two tubes in parallel, using a symmetrical half-wave Lecher system with one tube at each end (Fig. 8). The tube elements were thus at points of high radio-frequency potential, while the supply leads could be brought in on the central low potential axis. Two tubes connected in this way gave five to seven times the output of a single tube. This system was later employed with positive-anode oscillators for 2-meter communication by Brown. Scheibe also showed that any number of tubes could be connected at half-wave intervals along a Lecher system, and this principle was carried out in practice in the same year by Grechowa.³⁷ She reached a lower wavelength limit of 18 cm.

In 1927 Kapzov and Gwosdower³⁸ worked out an improvement of Scheibe’s complete formula for Barkhausen-Kurz oscillations. Whereas

Scheibe had assumed an electron escape velocity of zero, they included a mean electron escape velocity in equivalent volts given by

$$V = \frac{v^2}{\frac{2E}{m}}$$

where v is mean velocity of escape.

In the same year Tonks³⁹ developed a mathematical theory of negative resistance in both anode and grid circuits as a basis for oscillations of the Barkhausen-Kurz type, furthering the earlier work of Gill and Morrell. He showed that negative resistance exists when a virtual cathode exists between grid and anode. In general, such a condition requires anode voltage low in relation to grid voltage, a minimum electron current density depending upon the voltages used, and proper electrode spacing. Output is greatest when the oscillating circuit of tube elements and leads has a period comparable to the relaxation period (or time between departure from and return to grid) of an electron. In 1927 also Kohl built Barkhausen-Kurz oscillators which radiated waves down to 30 cm, and further developed the negative resistance theory.

In 1928 Hollmann^{41,43} showed several designs for modulating Barkhausen-Kurz oscillators. In one, the secondary of the microphone transformer was connected in the anode (negatively biased) lead. In another, the anode of the modulator tube was connected to the grid (high positive) of the oscillator. With a receiver similar to the oscillator but having headphones connected in series with the anode (negative bias) circuit, telephone transmission was accomplished up to a distance of 500 wavelengths.

In his 1929 paper Hollmann presented a complete theory of the four positive-grid-connection types of oscillators, based on extensive experiments extending down to 20 cm. In general, shorter waves were produced by higher grid voltage. With a movable bridge Lecher system connected directly to the tube elements, Hollmann found that as the bridge distance increased, Barkhausen-Kurz oscillations increased slightly in wavelength. Then, at a critical point, the wavelength suddenly dropped by perhaps 20 per cent, and thereafter increased linearly as \sqrt{LC} , showing that Gill-Morrell oscillations had begun. The second type of oscillations was more intense; and it was shown that, as the external system approaches resonance with the Barkhausen-Kurz oscillations, these are built up and speeded up until they become Gill-Morrell oscillations entirely governed in frequency by the external circuit. Hollmann also observed the higher frequency oscillations re-

ported by Scheibe, but could not reproduce them with certainty until he built a special tube with about half the normal spacing between grid wires. As a result, he explained these higher frequency oscillations as follows: Ordinary Barkhausen-Kurz oscillations are caused by the to-and-fro oscillation of electrons about the grid. With a close mesh grid, however, most of the electrons cannot pass through it towards the cathode after leaving the vicinity of the anode. Their oscillations are thus confined entirely to the grid-anode space, and as this space is smaller than the cathode-anode space, the observed frequencies are higher.

In 1930 Uda⁴⁴ described telegraph and telephone transmission experiments with waves around 50 cm. He used an improved receiver comprising a Barkhausen-Kurz oscillator and two audio stages. Symmetrical parallel arrangements of tubes up to seven in number were employed as transmitters, together with reflectors and directive arrays. Telephone transmission was accomplished at a distance of 10 km, and telegraph at 30 km, using a 14λ director chain and antenna current of about 10–15 ma. In the same year Okabe⁴⁵ gave a theoretical explanation of Barkhausen-Kurz oscillator-detector action.

In 1930 also Beauvais⁴⁶ reported experiments with radiotelephone transmission at 15–18 cm. He used as transmitter a Barkhausen-Kurz oscillator with grid at +250 volts and anode at –40 volts. The receiver employed the superregenerative principle, with interruption frequency corresponding to a wavelength of 20 to 60 meters. Both transmitting and receiving antennas were placed in parabolic reflectors of 120 cm diameter and 20 cm focus. The audible beam was not over 20 degrees wide, and direction finding within 2 to 3 degrees was possible. With the transmitter on the Eiffel Tower, strong telephone signals were received at distances of 14 km and 23 km. A somewhat similar arrangement was later used for telephone transmission across the English channel; a small hemispherical reflector cut off scattering forward radiation and reflected all the energy back on the parabola, producing a substantially parallel beam.

ELECTRONIC OSCILLATORS OF THE MAGNETRON TYPE

Although the behavior of electrons in evacuated tubes under the influence of magnetic fields was investigated prior to 1895, magnetron oscillators involving a thermionic high vacuum diode or triode are a more recent development. In 1921 Hull^{47,48} developed the equations of motion for electrons starting from a cylindrical cathode and moving towards a coaxial cylindrical anode, in a uniform magnetic field parallel to the common axis. Experimental curves depicting, at constant

anode potential, anode current as a function of magnetic field strength, showed close agreement with theory. In his September paper Hull gave a physical explanation of his mathematical theory and described various low-frequency magnetron oscillators having power outputs up to 5 kw.

In 1924 Breit,⁴⁹ in the course of experiments with ultra-short-wave oscillators of the Barkhausen-Kurz type, placed them in magnetic fields. He noticed that the field exerted an effect on the anode voltage-anode current curve.

In 1928 Yagi²³ reported experiments with magnetron oscillators giving waves from above 1 meter down to 15 cm. He evolved a semi-theoretical formula for wavelength: $\lambda = 2ct$; where t is the time required by an electron for traveling across the space between cathode and anode (t in turn varies directly as interelement distance and inversely as anode voltage). The most intense oscillation occurred near a critical magnetic field strength, additional magnetization resulting in a decrease of output. The shortest waves were obtained with very small anodes operating in a strong field.

In 1929 Forro⁵² reported a study of magnetron oscillators. She found, as had Yagi, that increasing the magnetic field increased the output up to a critical value and thereafter decreased it. Field strength also appeared to have some effect on wavelength.

TABLE I
ULTRA-SHORT-WAVE PROGRESS

Regenerative Oscillators			Barkhausen-Kurz Oscillators			Magnetron Oscillators		
Name	Year	Wave-length (cm)	Name	Year	Wave-length (cm)	Name	Year	Wave-length (cm)
White.....	1916	600	Barkhausen and Kurz	1920	43-200	Breit	1924	60-150
Gutton-Touly...	1919	200-400	Gill and Morrell	1922	200-500	Yagi	1928	15-100
van der Pol.....	1919	375	Scheibe	1924	30-330	Forro	1929	30- 65
Southworth.....	1920	110-260	Grechowa	1926	18	Okabe	1929	5- 40
Holborn.....	1921	300	Hollmann	1929	20-140	Okabe	1930	3- 15
Mesny.....	1921	100-500	Uda	1930	50			
Gutton-Pierret...	1925	50-200	Beavais	1930	15-18			
Kruse.....	1927	41-500				<i>Spark Oscillators</i>		
Englund.....	1927	100-500	All wavelengths are listed in cm, and represent either the range investigated or the shortest wavelength reached.			Hertz	1887	50
Yagi.....	1928	60-200				Righi	1894	2-12.5
Bergmann.....	1928	80				Nichols and Tear	1923	0.18-0.4
Ritz.....	1928	300				Glagowela-Arkadiewa	1924	.008-0.5
Esau and Hahnemann...	1930	300						
Brown.....	1930	200						

In 1929 and 1930 Okabe^{53,54} reported further experiments with magnetron oscillators in which the lower wavelength limits were carried down to 5 cm and then to 3 cm. He found that the wavelength depended primarily on magnetic field strength, and that anode dimensions and voltage were secondary factors determining only the intensity of oscil-

lation. Okabe proposed a theory of magnetron oscillations as follows: The distribution of space charge in a magnetron is similar to that in a triode connected to produce Barkhausen-Kurz oscillations. By considering "virtual elements" one can prove the existence of negative resistance after the method of Tonks. When the magnetic field is greater than a critical value, the anode current is cut off and a space charge accumulates near the anode, producing a negative resistance characteristic. This in turn results in the dispersion of the space charge, upon which the negative resistance characteristic disappears until the space charge is built up again by emission from the filament. The cycle then repeats itself and the system oscillates.

Selected Bibliography

General

1. R. Mesny, *Les Ondes Electriques Courtes*, Presses Universitaires de France, 1927.
2. E. Pierret, "Les ondes electriques ultra-courtes," *L'Onde Electrique*, 8, 373; September, 1929.
3. R. Jouaust, "Les ondes tres courtes," *L'Onde Electrique*, 9, 5; January, 1930.
4. R. Jouaust, "Some details relating to very short waves," *Proc. I.R.E.*, 19, 479; March, 1931.
5. E. F. Nichols and J. D. Tear, "Short electric waves," *Phys. Rev.*, 21, 587; June, 1923.
6. A. Glagowela-Arkadiewa, "Short electromagnetic waves of wavelength up to 82 microns," *Nature*, 113, 640; May, 1924.
7. G. S. Field, "Methods of making lecher wire measurements," *Canadian Jour. Research*, 1, 516; December, 1930.

Regenerative Oscillators of Conventional Type

8. W. C. White, "The pliotron oscillator for extreme frequencies," *G. E. Review*, 19, 774; September, 1916.
9. C. Gutton and Touly, "Oscillations electriques non amorties de courte longueur d'onde," *Comptes Rendues*, 168, 271; February, 1919.
10. B. van der Pol, "The production and measurement of short continuous electromagnetic waves," *Phil. Mag.*, 38, 90; July, 1919.
11. W. H. Eccles and F. W. Jordon, "A method of using two triode valves in parallel for generating oscillations," *Electrician*, 83, 299; September, 1919.
12. G. C. Southworth, "Electron tube generators of alternating currents of ultra-radio frequencies," *Radio Rev.*, 1, 577; September, 1920.
13. G. C. Southworth, "Electrical measurements at ultra-radio frequencies," *Radio Rev.*, 2, 25; January, 1921.
14. F. Holborn, "Über versuche mit kurzen ungedämpften elektrischen wellen," *Zeits. für Physik*, 6, 328, 1921.
15. J. S. Townsend and J. H. Morrell, "Electric oscillations in straight wires and solenoids," *Phil. Mag.*, 42, 265, 1921.
16. M. Mesny, "Les ondes tres courtes," *L'Onde Electrique*, 3, 25; January, 1924.
17. C. Gutton and E. Pierret, "Sur les harmoniques des oscillateurs a ondes tres courtes," *L'Onde Electrique*, 4, 387, 1925.

18. W. S. Huxford, "Standing waves on parallel wires," *Phys. Rev.*, 25, 686; May, 1925.
19. R. S. Kruse, "Landmarks in the 1/2 to 5 meter region," *QST*, XI, 27; June, 1927.
20. B. Phelps and R. S. Kruse, "The 3/4 meter band officially opened," *QST*, XI, 9; August, 1927.
21. C. R. Englund, "The short wave limit of oscillators," *Proc. I.R.E.*, 15, 914; November, 1927.
22. K. Kohl, "Über kurze ungedämpfte elektrische wellen," *Ann. der Physik*, 85, 1, 1928.
23. H. Yagi, "Beam transmission of ultra-short waves," *Proc. I.R.E.*, 16, 715; June, 1928.
24. L. Bergmann, "Über einen röhrensender für kurze ungedämpfte wellen," *Ann. der Physik*, 85, 961, 1928.
25. M. Ritz, "Essais sur ondes tres courtes," *L'Onde Electrique*, 7, 488, 1928.
26. A. Esau and W. H. Hahnemann, "Report on experiments with electric waves of about 3 meters," *Proc. I.R.E.*, 18, 471; March, 1930.
27. W. J. Brown, "Ultra-short waves for limited range communication," *Proc. I.R.E.*, 18, 1129; July, 1930.
28. H. Diamond and F. W. Dunmore, "Blind landing of aircraft," *Proc. I.R.E.*, 19, 585; April, 1931.
29. E. Schwandt, "Ultra-short-wave broadcasting," *Wireless World*, XXVIII, 526; May 20, 1931.

Electronic Oscillations of Barkhausen-Kurz and Gill-Morrell Type.

30. R. Whiddington, "Ionic oscillations in three-electrode thermionic valves," *Radio Rev.*, 1, 53; November, 1919.
31. H. Barkhausen and K. Kurz, "Die kürzesten, mit vakuumröhren herstellbaren wellen," *Phys. Zeits.*, 21, 1; January, 1920.
32. L. Bergmann, "Messungen im strahlungsfelde eines Hertzschen und eines Abrahamschen ungedämpften erregers," *Ann. der Physik*, 67, 13; April, 1922.
33. E. W. B. Gill and J. H. Morrell, "Short electric waves obtained by valves," *Phil. Mag.*, 44, 161; July, 1922.
34. A. Scheibe, "Untersuchungen über die erzeugung sehr kleiner wellen mit gluhkathodenröhren nach Barkhausen und Kurz," *Ann. der Physik*, 73, 54; January, 1924.
35. E. W. B. Gill and J. H. Morrell, "Short electric waves obtained by the use of secondary emission," *Phil. Mag.*, 49, 369; February, 1925.
36. A. Scheibe, "Parallelschaltung von senderöhren sur erzeugung intensiver kurzer wellen," *Jahr. der Draht. Tel. und Tel.*, 27, 1; January, 1926.
37. M. T. Grechowa, "Weitere untersuchungen mit dem zweiröhren-und-vielröhrengenerator kurzen elektrischer," *Zeits. für Physik*, 38, 621; August, 1926.
38. N. Kapzov and S. Gwosdower, "Über die verschiedenen schwingungsarten, die von einer elektronröhre in scholtung von Barkhausen und Kurz erzeugt werden," *Zeits. für Physik*, 45, 114; October, 1927.
39. L. Tonks, "Space charge as a cause of negative resistance in a triode and its bearing on short wave generation," *Phys. Rev.*, 30, 501; October, 1927.
40. K. Kohl (see reference 22).
41. H. E. Hollman, "Telephonie auf extrem kurzen wellen," *Elek. Nach.-Technik*, 5, 268; July, 1928.

42. H. Hornung, "Messungen an Kurzwellenröhren," *Ann. der Physik*, **1**, 417; February, 1929.
43. H. E. Hollmann, "On the mechanism of electron oscillations in a triode," *Proc. I.R.E.*, **17**, 229; February, 1929.
44. S. Uda, "Radiotelegraphy and radiotelephony on half-meter waves," *Proc. I.R.E.*, **18**, 1047; June, 1930.
45. K. Okabe, "The amplification and detection of ultra short electric waves," *Proc. I.R.E.*, **18**, 1028; June, 1930.
46. G. Beavais, "Telecommunications avec les ondes ultra-courtes," *L'Onde Electrique*, **9**, 484; October, 1930.

Electronic Oscillators of Magnetron Type

47. A. W. Hull, "The effect of a uniform magnetic field on the motion of electrons between coaxial cylinders," *Phys. Rev.*, **18**, 31; July, 1921.
48. A. W. Hull, "The magnetron," *Jour. A.I.E.E.*, **XL**, 705; September, 1921.
49. G. Breit, "A method of producing short wavelength oscillations in electron tubes," *Jour. Amer. Opt. Soc.*, **9**, 708; December, 1924.
50. F. R. Elder, "The magnetron amplifier and power oscillator," *Proc. I.R.E.*, **13**, 159; April, 1925.
51. H. Yagi (see reference 23)
52. M. Forro, "Experimentelle untersuchungen über die Barkhausen-Kurzschwingungen in magnetischen feldern," *Ann. der Physik*, **1**, 513; February, 1929.
53. K. Okabe, "On the short wave limit of magnetron oscillations," *Proc. I.R.E.*, **17**, 652; April, 1929.
54. K. Okabe, "On the magnetron oscillation of a new type," *Proc. I.R.E.*, **18**, 1748; October, 1930.



AN EXPERIMENTAL STUDY OF REGENERATIVE ULTRA-SHORT-WAVE OSCILLATORS*

By

WILLIAM H. WENSTROM

(Signal Corps, U. S. A., Fort Monmouth, N. J.)

Summary—This paper gives a quantitative account of operating performance for two representative oscillator circuits, one of single tube type and the other of two-tube balanced type. Wavelength (approximately 3 meters) was measured by two independent methods. Efficiency and stability were measured under various plate, grid and filament voltage conditions. Normal efficiency values ranged from 20 per cent to 40 per cent. Under certain conditions the single tube circuit was more efficient, while under certain other conditions the balanced circuit was more efficient; under most conditions the efficiencies were about equal. In stability the two circuits were about equal; frequency variations were less than 1 per cent, while output variations rarely exceeded 2 per cent.

PRIOR experiments with ultra-short-wave oscillators have been reviewed in a previous paper¹ which includes an extensive bibliography. Many investigators have studied the performance of regenerative oscillators at wavelengths between 1 and 5 meters. It is noticeable, however, that most papers include only general and qualitative accounts of oscillator performance. It seems desirable, therefore, to make a quantitative study of typical oscillator performance in order to show how the dependent and independent variables of such performance are related. Of greatest practical importance among these variables are output, efficiency, and stability.

STATEMENT OF PROBLEM

The problem presented by a quantitative study of regenerative ultra-short-wave oscillators can be defined as follows:

- (1) To determine the best and most representative oscillator circuit types for operation in the vicinity of 3 meters.
- (2) Using ordinary commercial tubes and sockets, to build oscillators of all types chosen, as nearly alike as possible in mechanical construction and electrical performance, making certain that each oscillator embodies optimum design for its type.
- (3) To determine the general conditions for oscillation, and the

* Decimal classification: R133×R355.5. Original manuscript received by the Institute, July 8, 1931. Research work done at Yale University in the course of preparing an essay for the degree of Master of Science.

¹ W. H. Wenstrom, "Historical review of ultra-short-wave progress," Proc. I.R.E., this issue, page 95.

changes in plate current, grid current, and oscillating current which occur as a result of changes in plate voltage, filament voltage, and grid voltage.

(4) To determine the absolute efficiency of the oscillators under specified conditions, and the changes in efficiency caused by the changes listed above.

(5) To determine the stability of the oscillations with respect to output and frequency, and the manner in which it is affected by the changes listed above.

While the oscillation wave form is also of interest, harmonics are relatively feeble in well designed oscillators and have already been thoroughly studied.

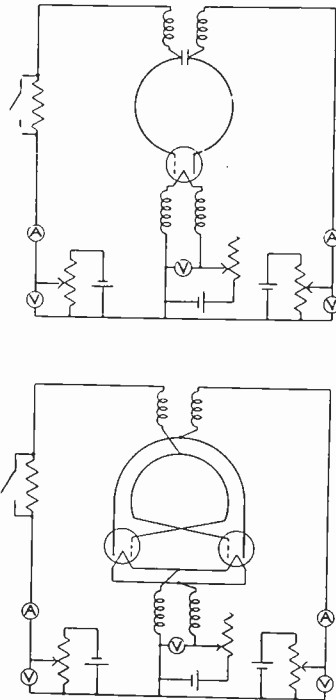

Fig. 1—(Above)—Experimental single tube oscillator.
(Below)—Experimental balanced double oscillator.

CHOICE AND CONSTRUCTION OF OSCILLATORS

The circuit originated by Gutton and Touly, in which a single turn of wire, broken by a large capacity, connects the grid and plate terminals of the tube, has been and still is used more than any other single tube arrangement. In addition, many apparently dissimilar circuits are variations of it, not excepting direct-coupled Lecher systems. It was therefore chosen as a representative type.

Among the parallel tube arrangements by far the most widely used

design is the balanced circuit of Mesny. All multitube circuits must be symmetrical, and variations of design became principally a matter of different degrees of coupling between the grid and plate coils. For most practical work Mesny used close coupling, the coils being inversely wound so that the voltages induced magnetically in the coils were in phase with those induced electrostatically across the tube capacities, although the system would also oscillate with the inductive coupling neutral, or opposing the capacitive coupling. The Mesny circuit was therefore chosen as the second representative type.

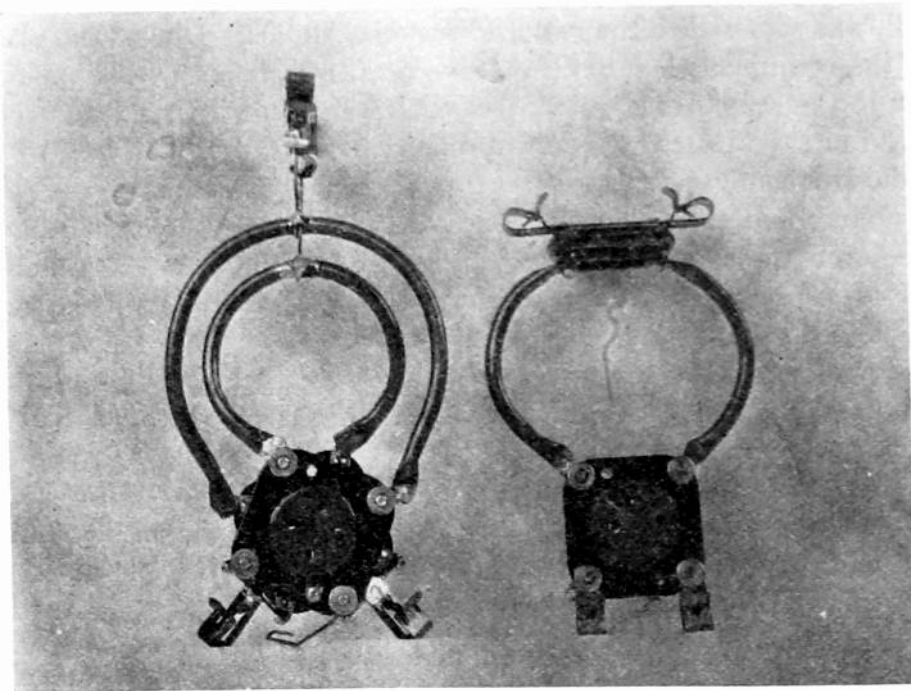

Fig. 2—Single oscillator (right) and double oscillator (left)

As most ultra-short-wave regenerative oscillators in use today differ slightly if at all from these fundamental designs, they were considered sufficient for the present investigation. Several oscillators of the two chosen types (Fig. 1) were built and tested in the search for optimum design.

The final Gutton-Touly oscillator (Fig. 2) consisted of a commercial spring socket, a single turn of 0.5-cm copper tubing about 8 cm. in diameter, soldered directly to the grid and plate socket terminals and broken midway in its circumference by a $.01 \mu\text{f}$ mica condenser moulded in bakelite. Wavelength was approximately 3.1 meters. Grid and plate d-c leads were brought in at the terminals of this condenser. Assuming that a line drawn through the condenser and midway between

the grid- and plate-socket terminals represents an axis of zero radio-frequency potential about which the system oscillates, the oscillating circuit should be symmetrical about it. There is thus a "virtual connection" between the midpoint of the condenser and the filament.

The final Mesny balanced oscillator (Fig. 2) consisted of two spring sockets fixed base-to-base so that short center-tapped wires connected the filament terminals. Filament supply was brought in to these center taps. Plate and grid coils were of 0.5-cm copper tubing. The plate coil, a single turn 9 cm in diameter, was soldered to the two plate socket terminals. The grid coil, 7 cm in diameter and directly inside the plate coil, was soldered to the two grid socket terminals. Due to the placing of the terminals, coupling was inverse although both coils appear to run in the same direction. Wavelength was approximately 3.2 meters. Plate and grid d-c leads were brought in on the central axis of zero radio-frequency potential.

Each oscillator, when in use, was mounted on porcelain stand-off insulators some distance above a wheel table. Filament, plate, and grid d-c leads were brought up to the oscillator through radio-frequency chokes. All d-c instruments, potentiometers, and other large high capacity objects were on a separate bench several feet away from the oscillator. Thus the radio-frequency circuit was isolated from the d-c circuit.

Filaments may be classified in descending order according to ruggedness as follows: tungsten, thoriated, oxide-coated. As no tungsten filaments are now available in small commercial tubes, thoriated filaments were used. Considering various practical factors such as tube availability and maximum ultra-short-wave transmitting range, the UX-210 tube was chosen for all experimental work.

WAVELENGTH

The conventional method of measuring the wavelength of ultra-short-wave oscillators makes use of standing waves on two parallel wires as demonstrated by Lecher in 1890. This method, as various writers have pointed out, is subject to inaccuracies due to such factors as distortion of wave front at the bridged end and reflections from the unmatched impedance of the open end.

For wavelength determinations in the present investigation, a Lecher system was built consisting of two brass tubes about 0.5 cm in diameter mounted about 5 cm apart on bakelite spreaders several cm above a wooden base. The total length of the system was about 2 meters. At one end a solid brass fixed bridge could be interchanged with current indicators, while another solid brass bridge was grooved to slide

along the tubes. The $1/2\lambda$ distance l was taken as the interbridge distance only without considering bridge dimensions.

In order to avoid the stray capacities of large instruments, a flashlight bulb was used as current indicator in the closed end for rough determinations. This introduced an error, however, as l was 148.8 cm with the bulb across the end and 154.4 with the solid bridge in place. In the latter case the resonance indicator was a small thermomilliammeter in series with a single turn of wire coupled to the oscillating circuit. As the movable bridge, lightly tapped with a long stick, slides through resonance, the milliammeter reading shows a decided drop. The degree of coupling between the Lecher system and the oscillator also influences the wavelength determination. With the closed end of the Lecher system directly above the nearest circumference of the oscillator coil, $l = 154.6$, while with a spacing of 20 cm between the two $l = 154.4$.

Considering the rather crude methods of moving the bridge and measuring its distance, excellent precision was attained. One series of three measurements on the single oscillator gave 157.5, 157.55, and 157.6, representing an actual creep of oscillator wavelength rather than measurement errors. The bridge was displaced after each measurement and the minimum again approached. Even assuming the oscillator constant, the probable error here was only about 0.006 per cent. Three measurements on the double oscillator gave 161.5, 161.5, and 161.55, with a probable error of 0.003 per cent. Corresponding wavelengths were 3.15 meters for the single oscillator and 3.21 meters for the double oscillator. The Lecher measurements were thus sufficiently precise.

In order to check the accuracy of the Lecher wavelength measurements, and to make the stability measurements detailed hereafter, it was decided to heterodyne against the ultra-short-wave oscillator some convenient harmonic of an autodyne receiver operating on longer wavelengths around 20 meters. Checked against a crystal over a ten-minute period, the receiver was found to have a frequency drift of less than 1 part in 4000. Beats were obtained between the 3-meter oscillators and the 6th, 7th, and 8th harmonics of the receiver. The 7th harmonic, being the strongest, was chosen for measurements. Receiver wavelengths were determined by the double click method using a General Radio type 224-L precision wavemeter.

For the single oscillator this comparison gave: Lecher measurement 3.15 meters; harmonic measurement 3.12 meters. The variation, about 1 percent, represents the probable accuracy of the Lecher measurement, as the wavemeter is accurate to 0.25 per cent. The double oscillator gave: Lecher measurement 3.21 meters; harmonic measurement 3.18 meters. The probable error of the Lecher measurement was again 1

per cent, and in the same direction as before. It appears, therefore, to be a constant error which should be common to all similar systems.

OSCILLATION CHARACTERISTICS

The oscillating circuits of the two experimental generators comprise extremely small distributed constants. For the single oscillator these are: the inductance of the single turn of copper tubing plus the inductance of leads from the grid and plate socket terminals to the tube elements, about $0.3 \mu\text{h}$; and the grid-plate capacity of the tube (about $8 \mu\text{mf}$) plus the distributed capacity of the leads (probably $1 \mu\text{mf}$). With its two plate-grid capacities in series, the double oscillator has about half as much total capacity as the single one; but because this circuit requires two turns of tubing instead of one, the inductance is about twice as great and the LC product and wavelength are about the same.

Conditions for oscillation of most conventional oscillating circuits have been derived by various writers. For the simplified tuned-plate or tuned-grid circuits, these become:

$$g_m = \frac{Cr}{M}.$$

All of these derivations, however, assume lumped constants, inductive coupling between grid and plate circuits, and grid and plate coils terminating in a filament connection. None of these conditions obtain in the Gutton-Touly or Mesny circuits. Inductance and capacity are distributed rather than lumped; the plate-grid capacitive coupling is more important than inductive coupling, and the filament connection is only a virtual one so far as high-frequency currents are concerned. It appears, therefore, that a mathematical treatment of conditions for oscillation in these circuits would involve so many false assumptions that it would be of questionable value. By analogy, however, the critical value of g_m for the single oscillator is given by an expression having r and C in the numerator, and L in the denominator. The condition for oscillation of the balanced circuit would involve added, though relatively unimportant, terms containing M .

Curves showing performance under varying grid bias are shown in Figs. 8 and 9. In each case as the grid bias is reduced and g_m reaches the critical value, oscillations suddenly start; and the plate and grid currents simultaneously jump from practically nothing to large values. The value of g_m necessary to maintain oscillations is less than the starting value, as shown by the fact that after oscillations are started the

negative grid bias can be increased to over twice the starting value without stopping oscillations.

Data on varying plate and filament voltages, though not included in the curves, show similar critical values for g_m . When operating with a grid resistance, oscillations start as increasing plate voltage reaches about 100. Assuming μ constant, the increase of E_p decreases R_p , thereby increasing g_m . With fixed plate voltage, oscillations start as the filament voltage reaches about 4.5. Here again, g_m is a function of the independent variable, in this case E_f .

When the single tube system is oscillating there is a current loop and voltage node at the center condenser, and voltage loops and current nodes at the grid and plate of the tube. Distribution is similar for the balanced system.

EFFICIENCY

Efficiency is usually defined as the ratio between the power supplied to the oscillation circuit and the power drawn from the source of plate voltage, expressed by the formula,

$$\text{Efficiency} = \frac{P_o}{P_p}$$

Where the maximum value of the alternating plate potential is not great enough to reduce the total plate potential to zero at the moment when the grid has its maximum positive potential, efficiency can be calculated from the formula:

$$\text{Efficiency} = \frac{e'_p i'}{2E_b I_b} \quad (1)$$

where e'_p and i' are peak values of alternating plate potential and peak oscillating current, respectively. In the more general case where e'_p is not limited as set forth above, it is necessary to use the formula:

$$\text{Efficiency} = \frac{\int E_p I dt}{\int E_p I dt + \int E_p I_p dt} \quad (2)$$

As (1) involves the assumption of lumped constants and (2) involves in addition the assumption of plate-current wave form, neither formula is conveniently applicable to ultra-short-wave oscillators. Efficiency was therefore determined experimentally.

The comparison of efficiency under different conditions, such as changes of plate voltage, involves the measurement of oscillating current and plate voltage and current. Assuming that the resistance of the oscillating circuit remains constant, a relative efficiency index is given

of the expression $I_0^2/E_b I_b$. While measurement of plate input power is of course simple, the measurement of oscillating current offers some difficulties. Inserting a meter directly in the oscillating circuit would unbalance the circuit symmetry, produce undesirable capacity effects, and disturb the normal efficiency.

It was decided, therefore, to place a thermomilliammeter in series with a single turn of constantan wire of relatively high resistance. Coupled inductively to the oscillator circuit, this loop provided an aperiodic current-measuring circuit and a predominantly resistive load (Fig. 3). During each relative efficiency run this coupling remained

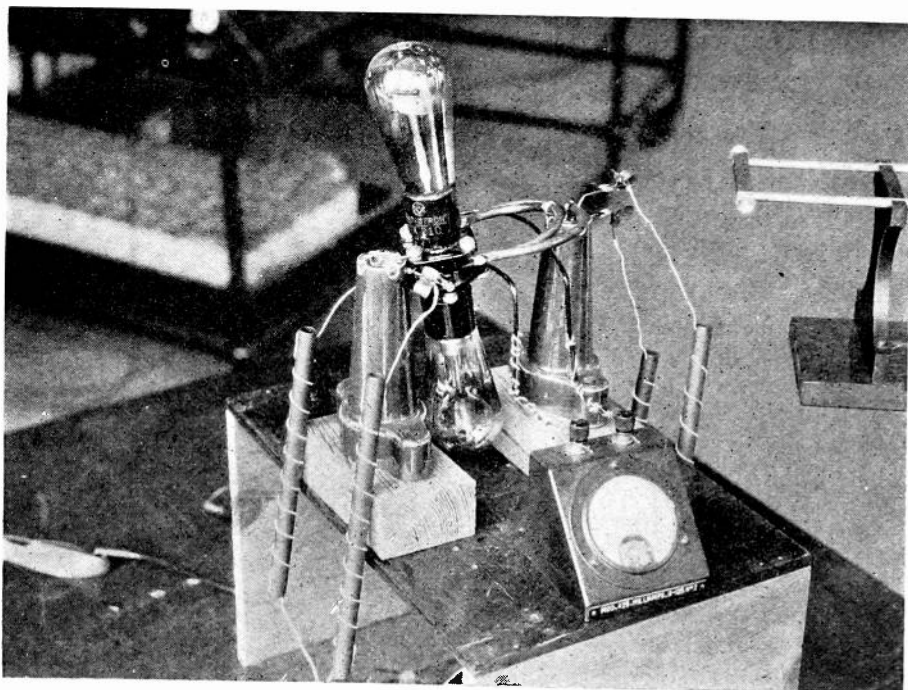

Fig. 3—Relative efficiency (double oscillator).

unchanged. Relative efficiency data were taken with both oscillators under varying conditions of plate voltage, filament voltage and grid voltage. Departures of individual points from smoothed curves indicate that the average precision of these measurements was about ± 3 per cent.

There remained the problem of determining the absolute efficiency or the value of the quotient P_0/P_p . If this could be found in the case of each oscillator at a set of simultaneous values for plate voltage, plate current, and oscillating current already included in the relative efficiency data, all relative values could be quickly converted to absolute values. Later results showed that neglecting grid losses in this conversion introduced an average error of less than 1 per cent.

At the suggestion of H. M. Turner of Yale University the writer tested a heat-radiation method of determining the absolute efficiency of the oscillators. Two small wires, one of constantan and the other of copper, were silver-borax soldered at their ends to form two thermocouples. One couple rested on the table in free air; the other was held by friction tape against the tube bulb, directly opposite the center of

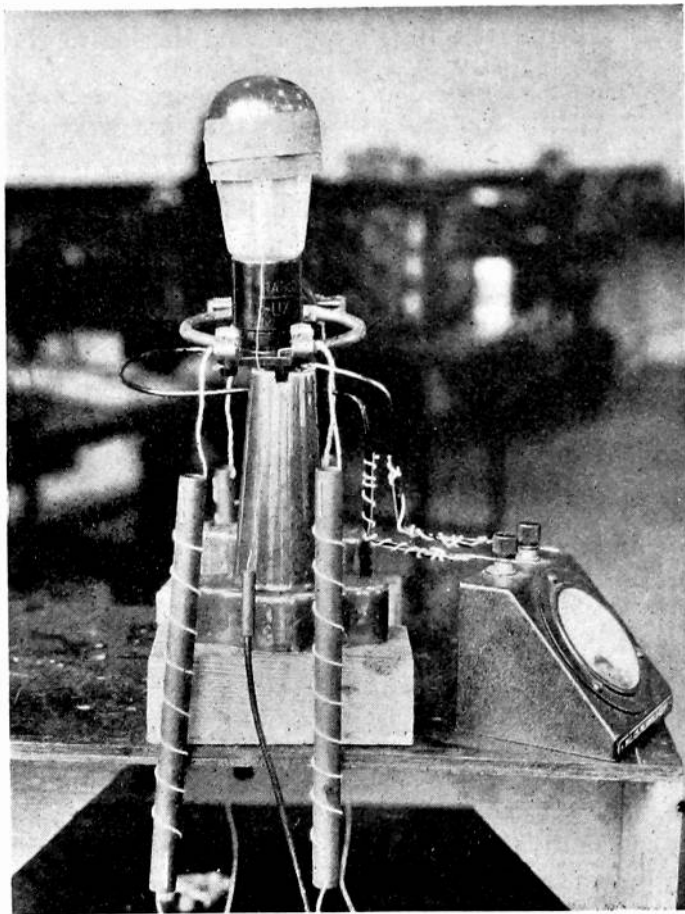

Fig. 4—Absolute efficiency (single oscillator).

the plate so as to receive greatest heat radiation from it (Fig. 4). A paper cylinder used to screen the oscillator and the hot thermocouple from stray air currents does not appear in the photograph. A microammeter was connected in series with the copper wire.

The measurement procedure was as follows: With plate voltage at 300 and the tube oscillating, grid voltage was adjusted to give currents corresponding to a set of values already recorded in relative efficiency—variable plate voltage data. The microammeter needle, which had indicated about $0.6 \mu\text{a}$ in response to radiation from the filament alone,

now moved upward at first rapidly and then more slowly, reaching a constant reading of about $4 \mu\text{a}$ in about 10 to 15 minutes. The tube was now stopped from oscillating by placing a $.01 \mu\text{f}$ condenser across the plate and filament socket terminals and the plate voltage was greatly reduced. After the tube had cooled sufficiently, as indicated by a low microammeter reading, plate and grid voltages were adjusted so that the plate input increased by steps at intervals until the microammeter reached the same reading as before. At this point the plate tem-

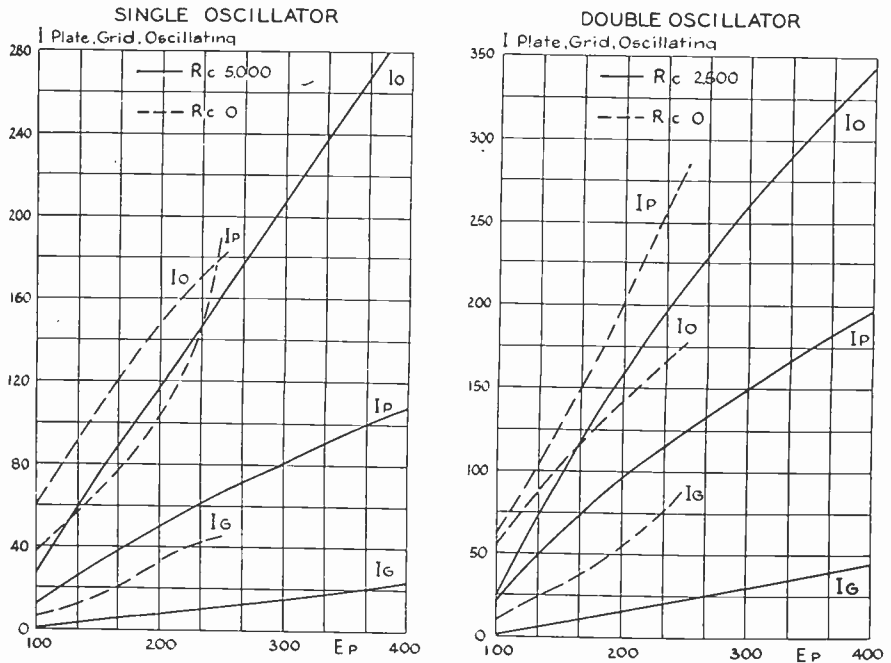

Fig. 5—Plate voltage vs. input, output.

perature was the same as it had been when the tube was oscillating, so that the plate power dissipation in the two cases was the same. As the total plate input and grid losses were known in each case, power delivered to the oscillating circuit and efficiency could be readily calculated by the following formula:

$$N = \frac{P_0}{P_{p0}} = \frac{P_{pc} - P_{pn}}{P_{p0}} = \frac{(P_{p0} - P_{g0}) - P_{pn}}{P_{p0}}$$

where,

P_0 = radio-frequency power delivered by tube.

P_{p0} = total power supplied to plate circuit when oscillating.

P_{g0} = power consumed in grid circuit when oscillating.

$P_{pc} = P_{p0} - P_{g0}$ = power consumed and converted in plate circuit when oscillating.

P_{pn} = power supplied to plate circuit when not oscillating.

The results of the method described above were as follows:

Single oscillator: 1st run 32.0 per cent, 2nd run 33.8 per cent, mean 32.9 per cent, probable error ± 1.8 per cent.

Double oscillator: 1st run 30.8 per cent, 2nd run (tubes interchanged under thermocouple) 32.3 per cent, mean 31.55 per cent, probable error ± 1.7 per cent.

Reduced to absolute efficiency percentages, the above probable er-

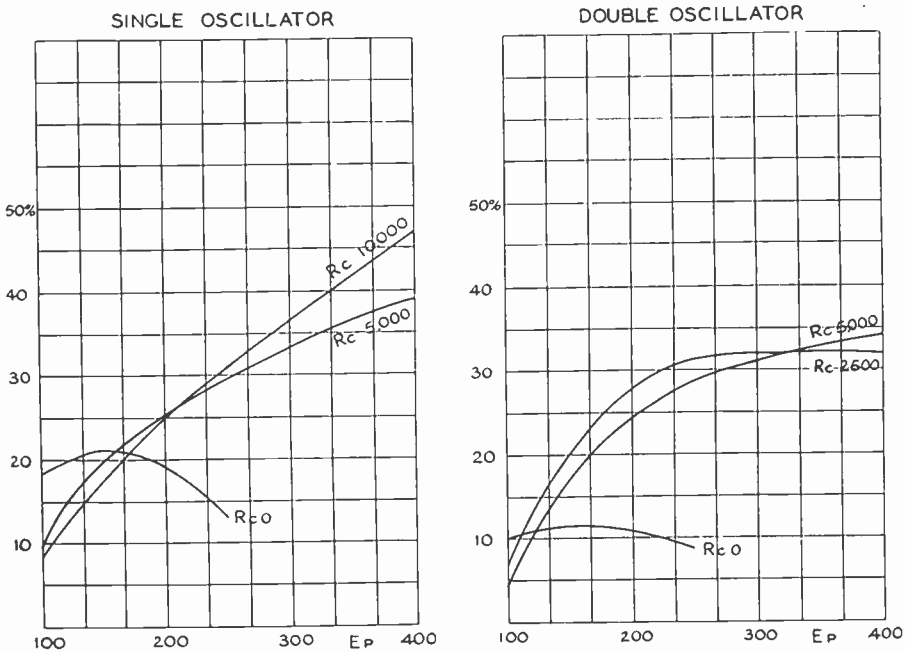

Fig. 6—Plate voltage vs. efficiency.

rors are less than 1 per cent. Thus the heat radiation method is simple and accurate.

Fig. 6 shows the efficiency of the single tube Gutton-Touly oscillator and the balanced Mesny oscillator over a wide range of plate voltages with various values of grid resistance. It is seen that, in general, the two circuits perform about equally at moderate plate voltages, while at high and low voltages the single circuit is more efficient. In the optimum grid resistance region (5000–10000 ohms per tube), a 2-to-1 variation of grid resistance has little effect on efficiency. Many investigators operate ultra-short-wave oscillators without grid leaks. The curves show that under this condition efficiency is very low—particularly so for the double circuit, although its efficiency is more uniform.

Fig. 7 shows the variation of efficiency with filament voltage. In the downward direction the voltage can fall about 20 per cent below

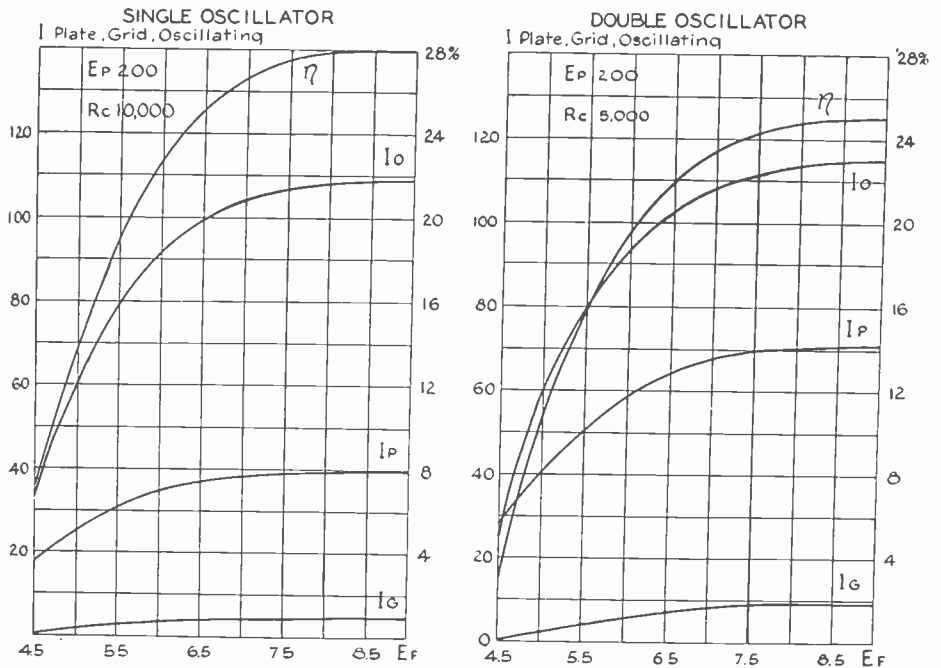

Fig. 7—Filament voltage vs. input, output, efficiency.

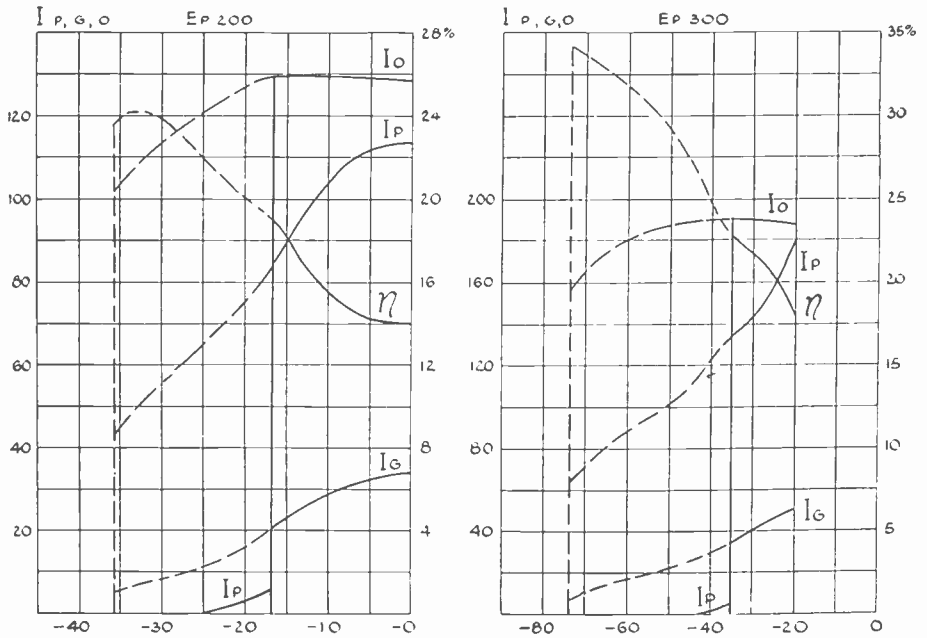

Fig. 8—Grid voltage vs. input, output, efficiency. (Single oscillator).

rated value (corresponding to a filament current decrease of about 10 per cent) without seriously impairing output or efficiency, and an equal variation upward has practically no effect on oscillator performance. This is of interest in view of statements that the performance of ultra-

short-wave oscillators depends on excessive filament emission, resulting in short filament life. It would appear that with proper design filament demands are not far from normal. In both circuits the tubes were run momentarily at three times rated plate current without apparent injury.

Figs. 8 and 9 show the variation of efficiency with grid voltage. In practically all cases efficiency increases with increasing grid voltage and decreases with decreasing grid voltage. The high efficiencies obtainable in the high grid bias region are not desirable in practice, however, be-

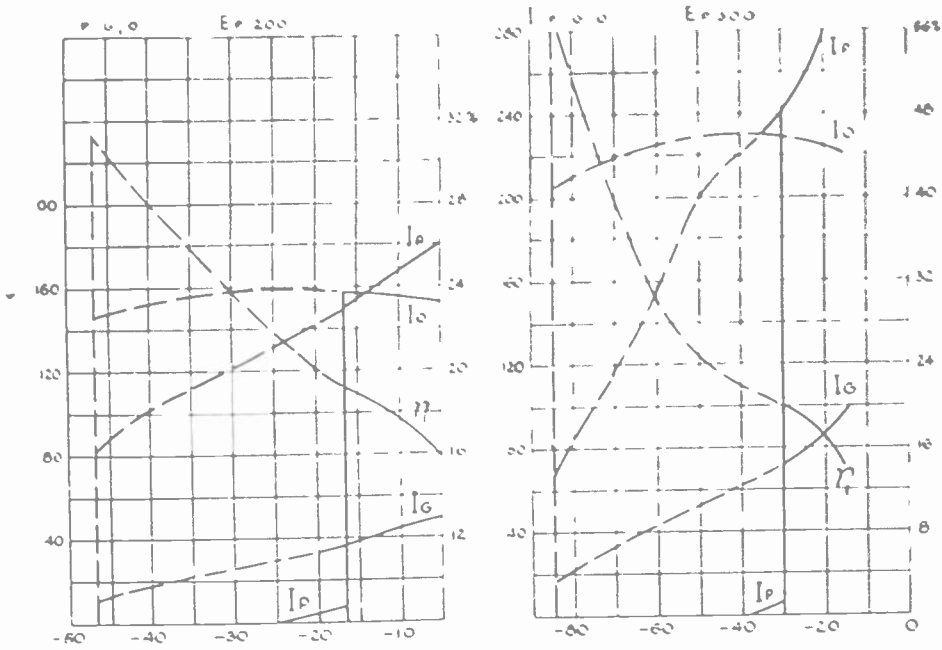

Fig. 9—Grid voltage vs. input, output, efficiency. (Double oscillator).

cause the output is falling off somewhat and, more important, the tube will go out of oscillation if small voltage variations occur. In general, a grid resistance appears to allow more stable and convenient operation than a grid battery.

STABILITY

In radio communication oscillators are chiefly useful in so far as they maintain constant frequency and, aside from purposive modulation, constant output. In view of the contradictory accounts of ultra-short-wave oscillator stability given in the literature, quantitative data are needed.

Fig. 10 shows variations in oscillating current, plate current, and grid current for each oscillator over a period of nine minutes. The vertical scale is exaggerated to show the slight variations which occurred.

Stability was somewhat better after 10 minutes operation when the tube had warmed up thoroughly, and no large power variations occurred during continuous runs up to an hour in length.

While none of these experiments were directed towards the radiation of energy for practical purposes, some mention of oscillator behavior when coupled to an antenna is of interest. A half-wave dipole about 1.5 meters long was used, with a small flash-light bulb in the center to give approximate current indications. Sufficiently close coupling was obtained by placing the center of the antenna near the high current

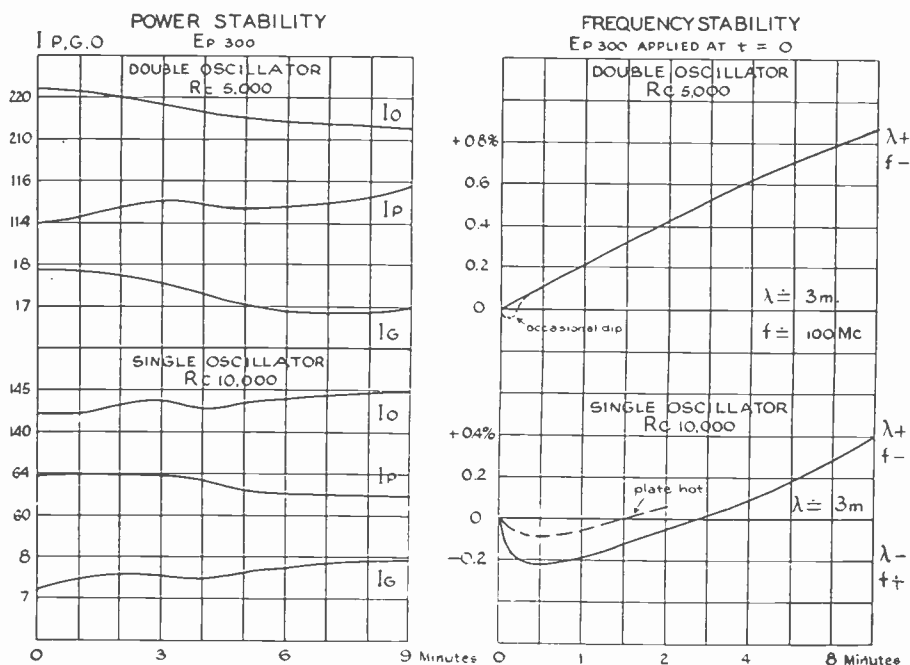

Fig. 10—Power stability and frequency stability vs. time.

part of the oscillator coil. With the single oscillator at E_p 300 and R_0 10,000, the antenna current was about 100–150 ma. Bringing the antenna up to the coil decreased the loop thermomilliameter reading from 150 to 124 ma. This would indicate that about one-third of the available oscillating energy was going into the antenna. With the double oscillator at E_p 300 and R_0 5,000 the antenna current was 150 to 250 ma, the antenna receiving about a third of the available power as before. With loose coupling, represented by moving the antenna 40 cm away from the oscillator coil, the antenna current was 30–40 ma.

The same 20-meter receiver used for harmonic wavelength measurement was used for the determination of frequency stability. At 3 meters the wavelength measurement error due to receiver drift was less than 0.75 mm. The 3-meter oscillator variations were so much larger than this

that the receiver served as a satisfactory reference standard, the probable error of frequency drift measurements being less than ± 5 per cent. On the main receiver dial each division represented a capacity change of $1.6 \mu\mu\text{f}$, while an electrical vernier dial gave $0.016 \mu\mu\text{f}$ per division. As the wavelength-capacity curve was substantially straight over a small range, the receiver could be calibrated directly in wavelength, each division of the vernier dial corresponding to a wavelength change of 0.2 mm at 3 meters . It was thus possible to follow quickly and accurately with the receiver any wavelength changes of the 3-meter oscillators.

Fig. 10 shows the variation of wavelength with time after closing the plate circuit. In the case of the double oscillator the wavelength usually increased steadily after the switch was closed. In a few instances a slight dip was observed, wherein the wavelength decreased about 0.05 per cent during the first 5 or 10 seconds, and then rose to join the usual upward curve. It is to be noted that time is plotted on a logarithmic scale, so that although the upward curves appear nearly straight they actually flatten out considerably at the later end. For both oscillators the wavelength change is only about 0.01 per cent per minute at $t = 10$ minutes.

In the case of the double oscillator this rise in wavelength can be accounted for in the following manner: When the plate voltage is applied the tube elements increase in temperature. Some relative motion between grid and plate, probably grid expansion, increases the two plate-grid capacities. As both of these are in series with the oscillating circuit, wavelength increases. When a condition of equilibrium is reached, as it is in about 10 minutes, there is practically no further temperature or wavelength increase. It is significant that 10 minutes was also the approximate time for reaching equilibrium in the tube temperature comparisons used in the determination of absolute efficiency, a coincidence which strengthens the theory outlined above.

The action of the single oscillator, after 2 or 3 minutes have elapsed, is similar to that of the double oscillator described above. However, the wavelength decreases quite sharply during the first 30 seconds by about 0.2 per cent; it then flattens out and starts upward, crossing the starting wavelength axis in one or two minutes and continuing upward in a manner explainable on the basis of plate heating. It is apparent that during the first part of the plate-grid capacity increase some other circuit element, either an inductance or a capacity, decreases. As no inductance change seems possible in this extremely rigid circuit, and the only added element here not included in the double oscillator is the large central mica condenser, it seems probable that this condenser, in response to local heating from the oscillating current, decreases rapidly

in capacity for thirty seconds or so, thereafter decreasing more and more slowly. Its continued decrease is sufficient, however, to hold the single oscillator wavelength increase well below that of the double oscillator. The probable heating curve of conductor and dielectric enclosed in a bakelite shell, which would retard the early escape of heat, is in accord with this theory.

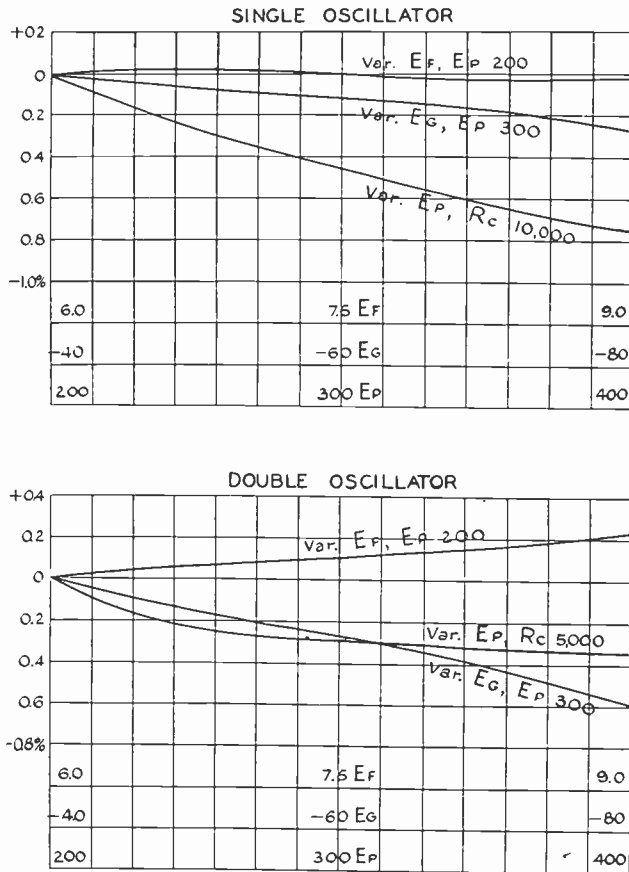

Fig. 11—Frequency stability vs. voltage changes.

Fig. 11 shows wavelength variations under changes of plate voltage, grid voltage, and filament voltage. It is probable that some time drift is included in these results, although the measurements were taken as rapidly as possible in an effort to exclude it. Changes of filament voltage did not greatly affect the wavelength of the double oscillator, and had practically no effect on the single one.

For both oscillators, increasing the negative grid bias lowered the wavelength. Apparently the cause-effect chain here was as follows: Higher grid bias decreased plate current, which decreased plate-grid temperature and capacity, which decreased wavelength. For both os-

oscillators also, increase of plate voltage, which should cause more heating and higher plate-grid capacity, somewhat paradoxically lowered the wavelength. This peculiar effect occurred uniformly on a large number of runs. It is barely possible that the grid-to-filament-to-plate capacity enters into the matter, and that the gradual removal of space charge by increasing plate voltage lowers this capacity enough to produce the observed effect; however, a more satisfactory explanation would be desirable.

CONCLUSIONS

As a result of the experiments described above certain general conclusions were drawn, as follows:

1. Carefully used, the Lecher system is a precise method of wavelength measurement (± 0.01 per cent), although somewhat less accurate (± 1 per cent).

2. Relative power output and efficiency of ultra-short-wave oscillators under various electrical conditions can be determined with about ± 3 per cent precision by means of a closely coupled high resistance loop in series with a thermoammeter.

3. Absolute efficiency can be determined by the heat radiation method with better than ± 2 per cent accuracy.

4. The absolute efficiency of ultra-short-wave oscillators operating under average optimum conditions is about 30 per cent to 40 per cent.

5. Operating with grid resistance, the single tube oscillator is more efficient than the balanced oscillator at low or high plate voltage, while at moderate plate voltage the two circuits are about equal in efficiency.

6. Operating with grid battery, the balanced oscillator is more efficient than the single tube oscillator at high negative grid bias, while with moderate grid bias the two circuits are about equal in efficiency.

7. In the optimum grid resistance region (5,000–10,000 ohms per tube), a 2-to-1 variation of grid resistance has little effect on output or efficiency.

8. With zero grid resistance the efficiency of both types of oscillators is low.

9. Considerable changes in filament voltage (± 20 per cent) have little effect on output and efficiency of oscillators employing thoriated filament tubes.

10. In properly designed circuits the filament emission demands are not far from normal.

11. The variations of oscillating current, plate current, and grid current in ultra-short-wave oscillators are less than 5 per cent during an hour of continuous operation.

12. The wavelength of an ultra-short-wave oscillator varies with time after plate voltage is applied due to the plate-grid capacity change caused by heating.

13. The wavelength of a balanced oscillator in general increases with time at a decreasing rate. The change is about 0.01 per cent per minute after 8 minutes operation.

14. The wavelength of a single tube oscillator at first decreases with time due to rapid capacity change in the external circuit condenser, then increases with time due to the predominant plate-grid capacity effect.

15. The wavelength of either type of oscillator varies only slightly with changes in filament voltage. It varies markedly, however, in response to plate or grid voltage changes.



AN EXPERIMENTAL STUDY OF THE TETRODE AS A MODULATED RADIO-FREQUENCY AMPLIFIER*

BY

H. A. ROBINSON

(Moore School of Electrical Engineering, University of Pennsylvania, Philadelphia, Pa.)

Summary—The advantages and limitations of the tetrode employed as a modulated radio-frequency amplifier tube are considered and the results of an experimental study made upon one type of screen-grid tube are given. Oscillograms and characteristics are presented from which the operation of the type UX-865 tetrode can be predicted under varied operating conditions and for several methods of modulation.

The method of graphical analysis is employed to determine the relative effects of the circuit parameters and electrode voltages upon the performance of the tetrode as a modulated amplifier.

A method of modulation is described in which the modulating signal voltage is introduced in both the screen-grid and plate circuits, eliminating the detrimental effects of secondary emission and permitting the complete modulation of the radio-frequency carrier with a negligible degree of distortion, the tetrode performing in a manner similar to that of a neutralized triode.

INTRODUCTION

MODULATION, as defined by the Committee on Standardization of the Institute of Radio Engineers, is the process whereby the frequency or amplitude of a wave is varied in accordance with a signal wave. Considering the alternating current undergoing modulation as the wave of carrier frequency, we shall confine ourselves in this paper to modulation systems in which only the amplitude of this carrier current is varied. In such a system of amplitude modulation, any frequency modulation, or variation of the carrier frequency accompanying the signal frequency, is undesirable and results in a widening of the frequency band required for the modulated transmission as well as other well-known objectionable effects in reception.

In the present state of the art, vacuum tube oscillators generating radio frequencies of the order of 500 kilocycles per second or higher, cannot be modulated directly without attendant frequency modulation because the introduction of the signal frequency in any of the well-known amplitude modulation methods results in a variation of the carrier frequency; a variation which is proportional to the amplitude of the signal current and hence becomes more objectionable when higher degrees of modulation are employed.

* Decimal classification: R132×R334. Original manuscript received by the Institute, May 6, 1931; revised manuscript received by the Institute, July 23, 1931.

For radio communication, the crowding of radio stations into narrowly defined frequency channels and ever increasingly stringent government regulations, necessitate the employment of every known means to insure the stability of the carrier frequency. Consequently, in modern radiotelephone transmitters the modulation of the radio-frequency carrier must be accomplished at some point intermediate to the master oscillator and the antenna. One of the radio-frequency amplifying stages thus becomes the logical point to modulate the carrier frequency and the vacuum tube and associated circuits in which the modulation takes place we will refer to as the modulated radio-frequency amplifier.

The use of the tetrode or screen-grid vacuum tube for amplifying radio-frequency currents of 500 kc and higher has very greatly simplified the construction and adjustment of such amplifiers through the elimination of the troublesome and critical adjustments associated with devices formerly employed for neutralizing the feed-back of energy from plate-to-grid circuits through the medium of the interelectrode capacity of the triode. This is particularly true in the case of radio transmitters which are designed for rapid changes of the carrier frequency over wide limits. In radiotelephone transmitters the triode is still largely employed as the modulated radio-frequency amplifier because of difficulty of securing complete modulation with the tetrode without the introduction of considerable distortion. This use of the triode as the modulated amplifier requires very critical adjustment of the neutralizing devices in order to permit complete modulation (100 per cent).

The advantages accruing from the use of a tetrode, capable of complete modulation, in the modulated amplifying stage are obvious and it is the purpose of this paper to present an experimental study of the tetrode in this application.

APPARATUS AND EXPERIMENTAL METHODS

In the mathematical theory of the tetrode as a modulated amplifier the plate current is considered as a function of the three-electrode voltages and an extension of the Carson series method, as employed by Llewellyn¹ and Brainerd,² permits the expansion of the plate current in an infinite series. For small values of the impressed voltages the contributions of the terms of higher order than the second may be neglected without introducing appreciable error. However, in the case of the modulated amplifier application, in practice we have alternating

¹ F. B. Llewellyn, "Operation of thermionic vacuum tube circuits," *Bell. Sys. Tech. Jour.*, 433, July, 1926.

² J. G. Brainerd, "Mathematical theory of the four-electrode tube," *Proc. I.R.E.*, 1006, June, 1929.

e.m.f.'s impressed on the grid of the order of 20 per cent of E_{p0} and in the case of plate modulation, to secure complete modulation the signal frequency voltage impressed in the plate circuit must have a peak value equal to E_{p0} . Thus for practical applications a very great number of terms of the expansion must be considered, resulting in a degree of

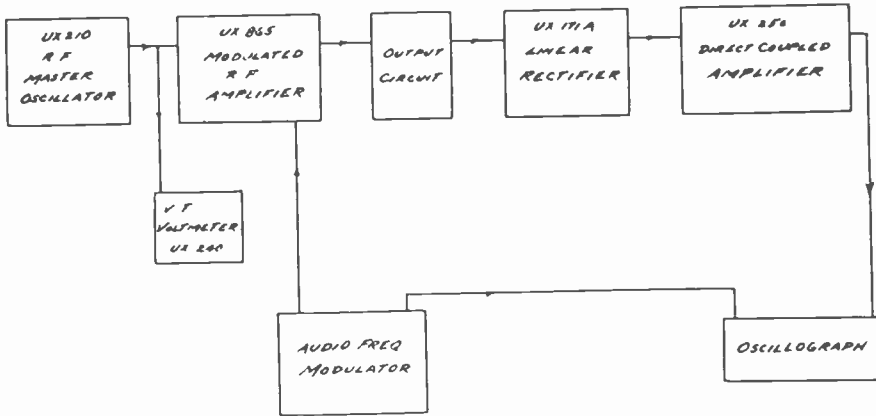

Fig. 1—Block diagram—tetrode modulated amplifier experimental set-up.

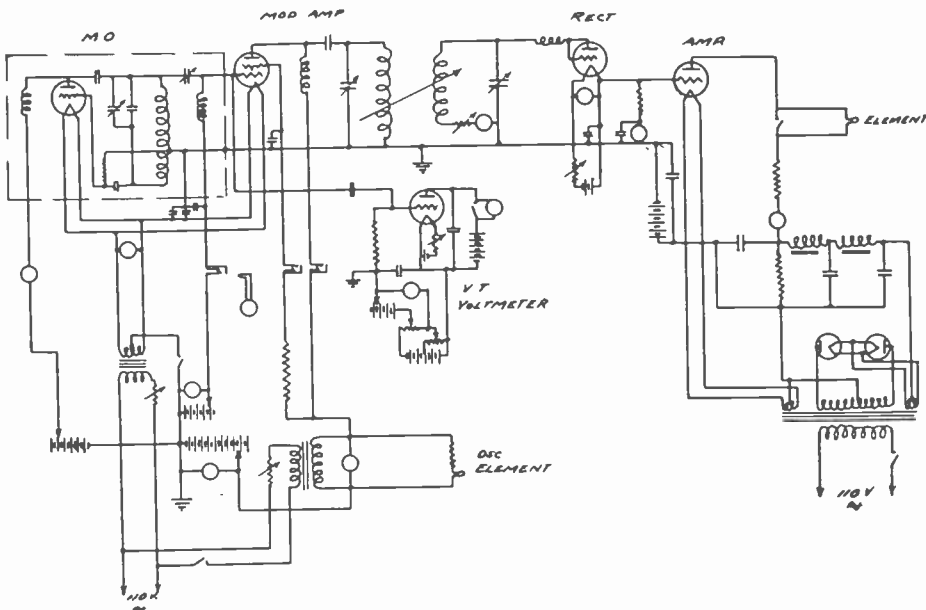

Fig. 2—Schematic diagram—tetrode modulated amplifier experimental set-up.

mathematical complexity that obscures the physical interpretation. For these reasons recourse to graphical analysis and direct experiment were the methods employed in this study.

The tetrode employed in these experiments was a Radiotron type UX-865 screen-grid tube. The average published constants for this type tube are given in Table I. A tube having average characteristics

was secured and the characteristics checked frequently throughout the period of the experiments. This type of tube was selected because of its general availability and wide usage, as well as for the convenience in obtaining proper power supplies and radio-frequency excitation.

The general arrangement of the experimental set-up is shown in the block diagram of Fig. 1 and the schematic diagram of the tetrode modulated amplifier and auxiliary equipment, is shown in Fig. 2. Photographs of the experimental set-up, Figs. 3 and 4, show the general arrangement of the modulated amplifier and the auxiliary equipment employed. The master oscillator which supplies the radio-frequency

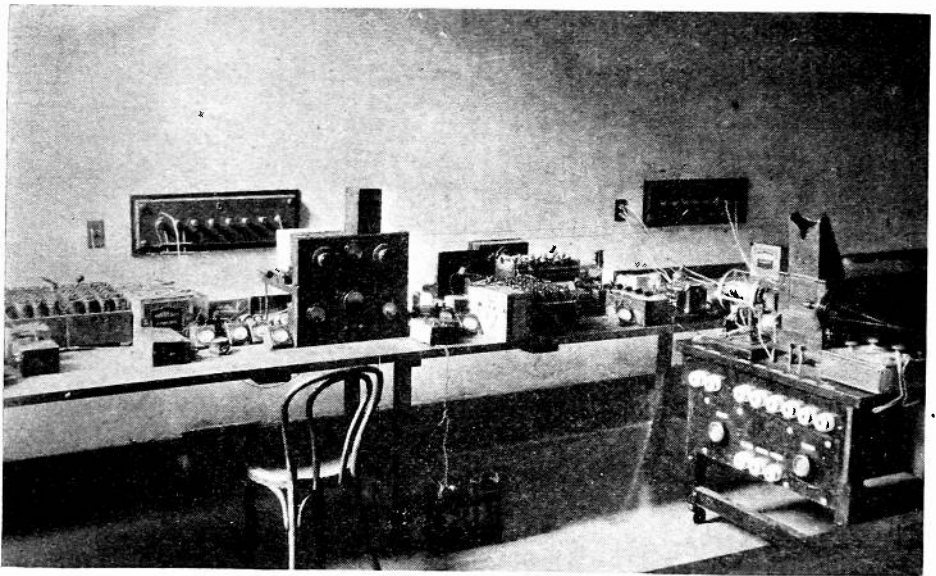

Fig. 3—Photograph showing the general arrangement of the laboratory set-up.

grid excitation for the modulated amplifier employed a type UX-210 tube in a Hartley oscillating circuit with parallel plate supply. A relatively low tuned circuit impedance was used in the oscillator tank circuit, to assure greater stability of frequency. The use of a power tube of this rating to supply the grid excitation for the UX-865, together with the separate plate supply and careful shielding, resulted in a master oscillator whose frequency was practically unaffected by wide variations in the plate or screen-grid potentials of the modulated amplifier tube.

The master oscillator was adjusted to a frequency of 3906 kc, and this frequency employed throughout the experiments. This frequency was selected in preference to a lower frequency because of the inherent advantage of employing the tetrode at high radio frequencies, and also

because a crystal with this frequency was available to check the reaction of the modulated stage upon the master oscillator. With this arrangement, under the conditions of excitation which placed the greatest load on the master oscillator, variation of the plate voltage of the modulated UX-865, from 0 to 500 volts produced a frequency shift less than 1 part in 20,000. Variation of the plate circuit tuning resulted in frequency shifts of the same order, while changing the screen-grid potential from 0 to 120 volts resulted in shifting the frequency 1 part in 10,000. The frequency modulation resulting during amplitude modulation may thus be neglected.

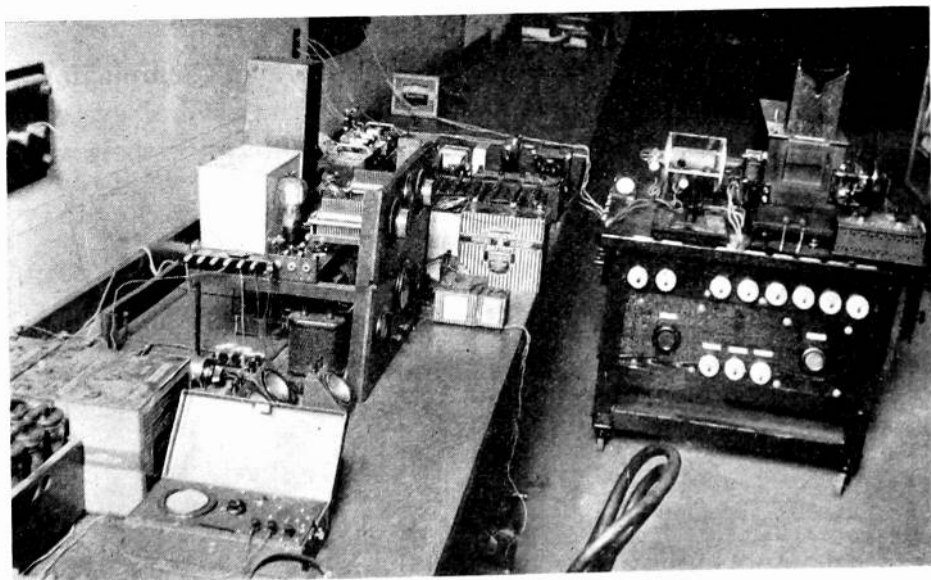

Fig. 4—Photograph showing the master oscillator compartment and the modulated amplifier stage.

A vacuum tube voltmeter was employed to determine the excitation voltage impressed on the grid of the UX-865. This voltmeter measures the peak voltage, and since the accuracy of its readings depends upon the sharpness of the cut-off of plate current as a function of grid voltage, a wide variety of tubes were tested in this region. The UX-240 with 90 volts on the plate was found to be the most satisfactory for this purpose. This type tube having a high plate impedance permits the use of a sensitive meter in the plate circuit without danger of burn-out resulting from insufficient grid bias. This advantage can be readily appreciated when it is considered that the plate current with zero bias is limited to 600 microamperes for the plate voltage stated. By employing a grid leak in the grid return the plate current cannot exceed this value at zero grid bias, even when an excessive input voltage is impressed

since the grid rectification and resulting bias built up across the grid leak is sufficient to limit the plate current.

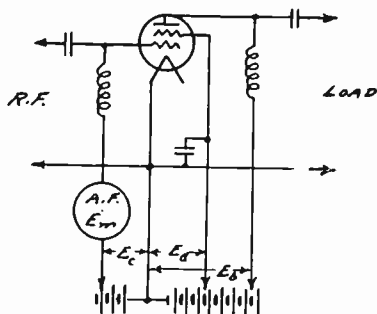

Fig. 5—Grid modulation; screen-grid return to E_d .

The modulated radio-frequency amplifier stage, employing the tetrode, was arranged to permit the use of the several systems of modulation shown in Figs. 5 to 11 in order to determine their relative

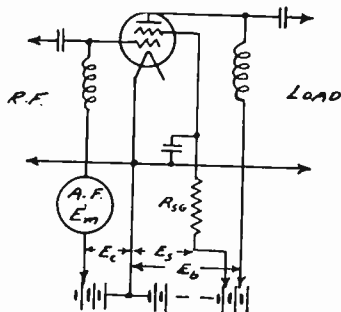

Fig. 6—Grid modulation; screen-grid return to E_s through R_{sg} .

advantages and limitations. The modulated radio-frequency output was supplied to an inductively coupled load circuit. The variable coupling and secondary load resistance permitted a wide range of values of

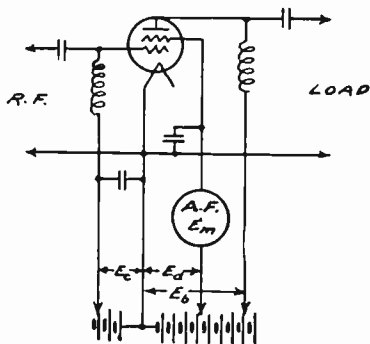

Fig. 7—Screen-grid modulation; screen-grid return to E_d .

transferred resistance being introduced into the tuned output circuit of the UX-865 giving data on the effect of the tuned circuit impedance upon the modulation characteristics.

A rather extensive series of operational characteristics was obtained showing the variation of the radio-frequency output current, as well as average plate and screen-grid currents, as functions of plate, screen-grid, and grid voltages, for varying conditions of excitation,

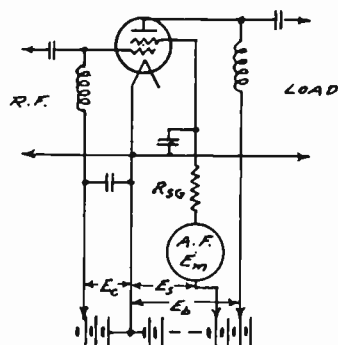

Fig. 8—Screen-grid modulation; screen-grid return to E_s through R_{sg} .

tuned circuit impedance, and electrode voltages. From these operational characteristics, hereinafter designated as r-f characteristics in order to distinguish them from the d-c characteristics, the operation of the tetrode as a modulated amplifier can be predicted over a wide range of

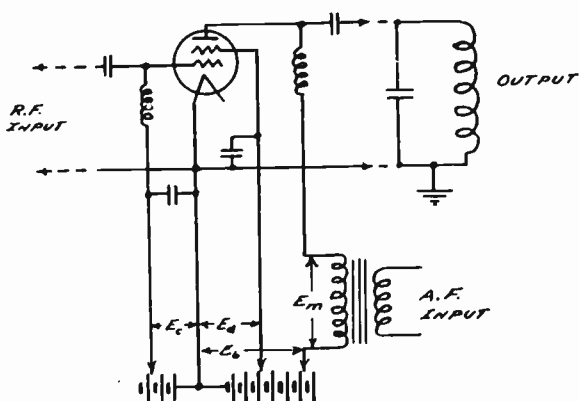

Fig. 9—Plate modulation; screen-grid return to E_s .

operating conditions and modulation methods. In order to verify the correctness of these r-f characteristics and the prediction of the form of modulated output obtained therefrom under actual conditions, the modulated output was rectified, amplified, and applied to the oscillograph, another element of which records the signal voltage input to the tetrode modulated amplifier. Analysis of the rectified output furnishes a measure of the distortion introduced in the modulated amplifier.

The linear rectifier in this set-up employs a type UX-171-A tube

age of peak value E_{gm} , impressed on the control grid. The radio-frequency current in the parallel tuned plate circuit was measured by means of a thermomilliammeter loosely coupled to the plate inductance, the relative value of the r-f current being observed as a function of the various electrode d-c potentials. The plate tuned circuit when tuned to the fundamental frequency (3906 kc) had an equivalent series resistance approximately 15,000 ohms. In the series of curves which follow this is the value of the tuned circuit impedance in all cases where no specific mention is made of other adjustments. Lower values of the tuned circuit impedance were obtained by directly adding resistance in the tank or by resistance transferred by close coupling of the secondary.

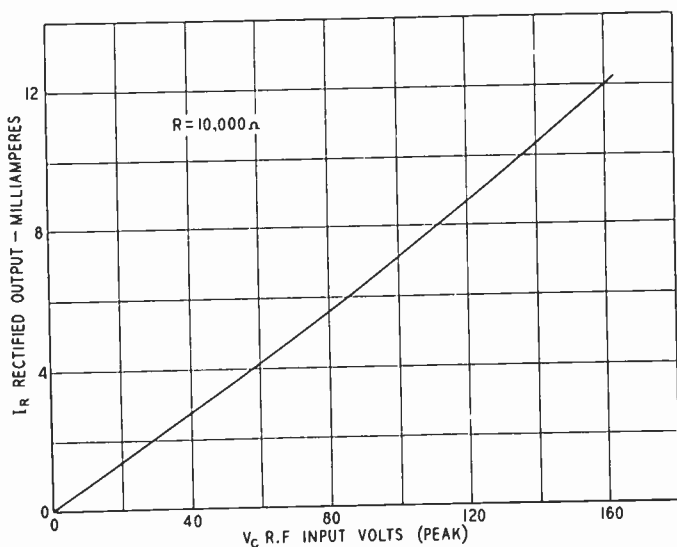

Fig. 12—Linear rectifier characteristic. A type UX-171-A tube as a diode with a load resistance of 10,000 ohms.

The r-f characteristics are grouped according to the method of modulation under consideration, and serve to indicate the relative effectiveness and limitations of the several methods.

GRID MODULATION

The variation of r-f output current with control grid voltage is shown by the curves of Fig. 13 for several values of screen-grid potential and r-f excitation. The region of linearity of r-f output current and grid voltage seems to be but slightly affected by the change of screen-grid and excitation voltages, being but slightly displaced towards the higher negative bias values for increasing values of these factors. These relations exist for low values of the tuned plate circuit impedance (less than 5000 ohms). Curves obtained under similar conditions but for higher values of tuned circuit impedance are shown by the curves of

Fig. 14. A flattening of the curves for lower negative bias voltages and a considerable reduction in the extent of the linear region is indicated while the screen-grid and excitation voltages evidence a pronounced degree of influence upon these curves.

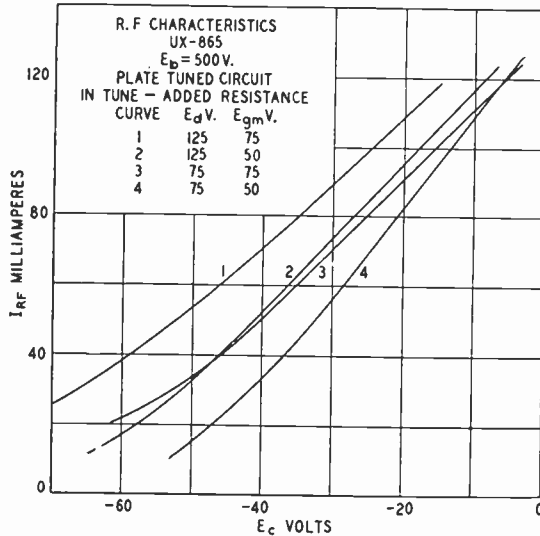

Fig. 13—R-F characteristics UX-865. Resistance added in plate tuned circuit.

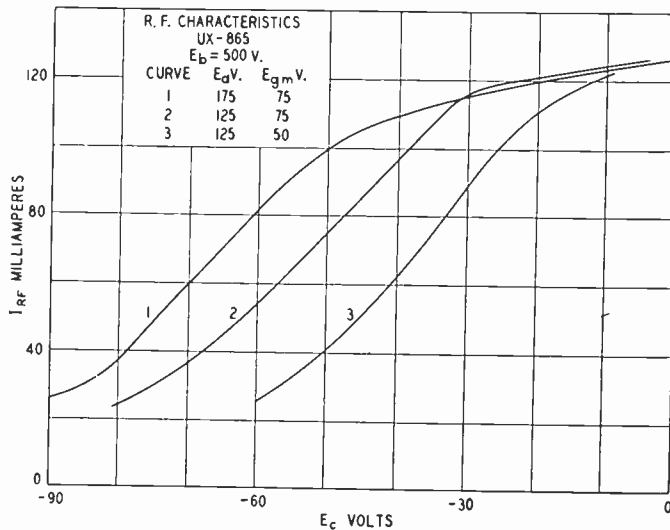

Fig. 14—R-F characteristics UX-865. No added resistance in tuned circuit.

SCREEN-GRID MODULATION

The relations between r-f output current and d-c screen-grid potential are shown by the curves of Fig. 15 for several values of the r-f excitation voltage. The ratio of the excitation voltage to the control grid

bias voltage is seen to be the major factor in determining the shape of the characteristics.

The curves of Fig. 16 again show the marked effect of the ratio of r-f excitation voltage to grid bias voltage in determining the shape of

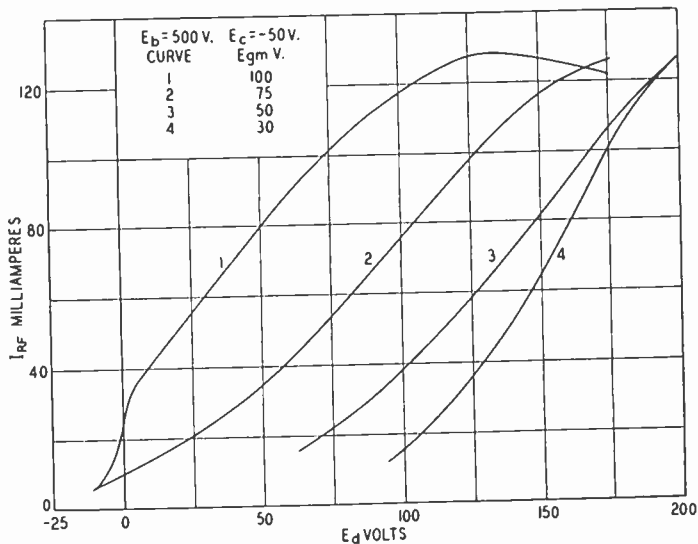

Fig. 15—R-F characteristics UX-865. Screen-grid modulation.

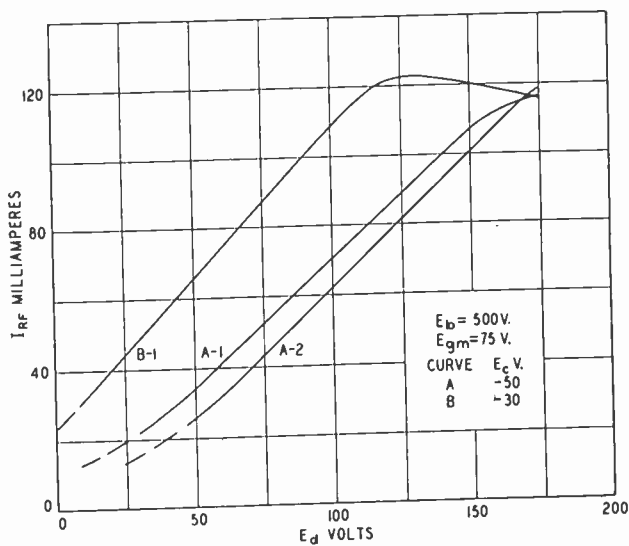

Fig. 16—R-F characteristics UX-865. Plate tuned circuit; 1—no added resistance; 2—added resistance.

the r-f output current characteristic. These curves also indicate that the decrease of the tuned plate impedance has a minor influence, tending to extend the linear portion of the characteristic for higher values for screen potential. Fig. 17 shows the corresponding variations in

average values of the plate and screen-grid currents under these conditions.

PLATE MODULATION

A. Screen grid directly connected to d-c supply E_d . The curves of Fig. 18 show the variation of r-f output current with plate supply

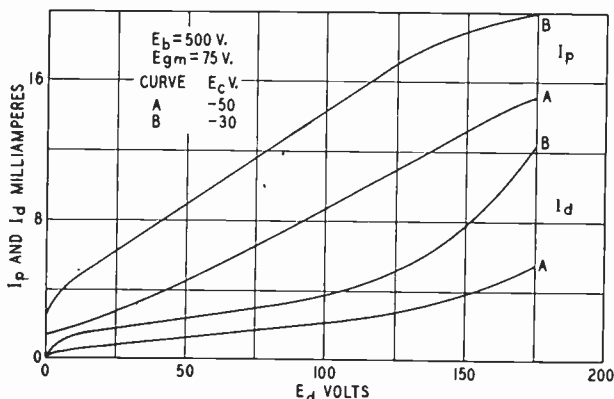

Fig. 17—R-F characteristics UX-865, for two values of control grid bias.

voltage for several values of control grid voltage. The primary importance of the ratio of r-f excitation voltage to grid bias is evidenced by these curves, the characteristic hump due to secondary emission when the plate potential falls below that of the screen is greatly reduced

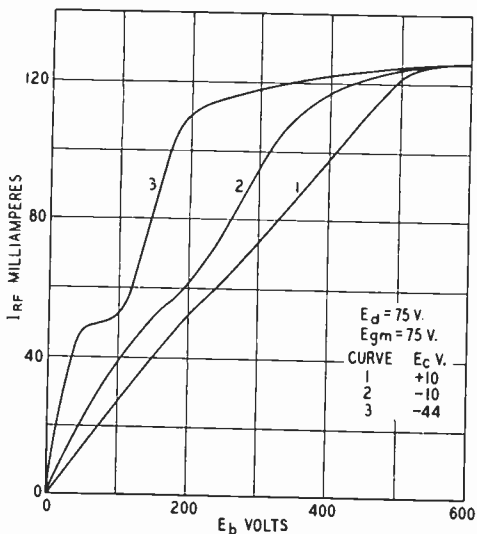

Fig. 18—R-F characteristics UX-865, for plate modulation with screen grid at constant potential.

for decreasing negative bias voltages. This same conclusion is drawn from the curves of the average value of plate and screen currents shown in Fig. 19. The curves of Fig. 20, show the effect of changing the r-f excitation voltage, and bear out the conclusion of the importance of the

ratio of the r-f excitation voltage to the control grid bias voltage in determining the shape of the characteristics. These curves were all taken for a high tuned circuit impedance. The effect of reducing the

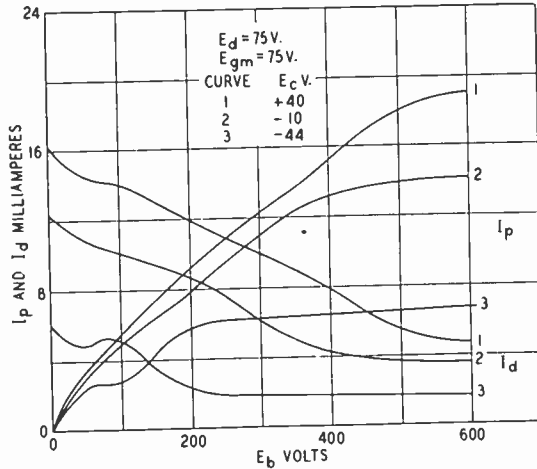

Fig. 19—R-F characteristics UX-865, showing variation of average values of plate and screen-grid currents.

tuned circuit impedance by the addition of resistance is shown in the curves of Fig. 21. Here all the radio-frequency currents have been reduced to the same scale. The decreasing of the tuned circuit impedance

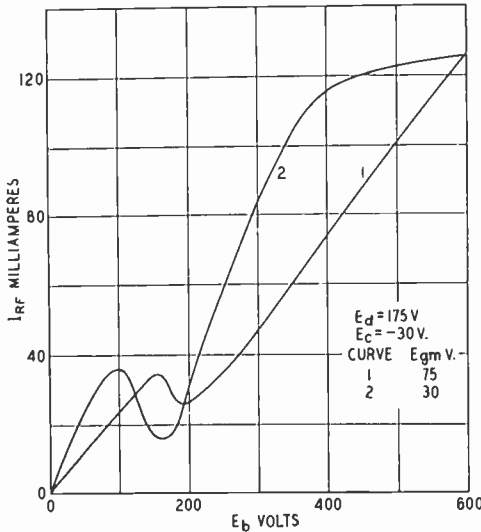

Fig. 20—R-F characteristics UX-865, showing the effect of the ratio of r-f excitation to grid bias voltage upon the output characteristic.

has the effect of greatly exaggerating the hump due to secondary emission and of shifting this region to lower plate potentials. The flattening of the curves at the higher values of plate supply voltage increases

at the same time. The curves of average plate current present these same relations as shown in Fig. 22.

B. Screen grid supplied through a series resistor R_{sg} . The effect of the secondary emission from the plate, when the plate potential falls

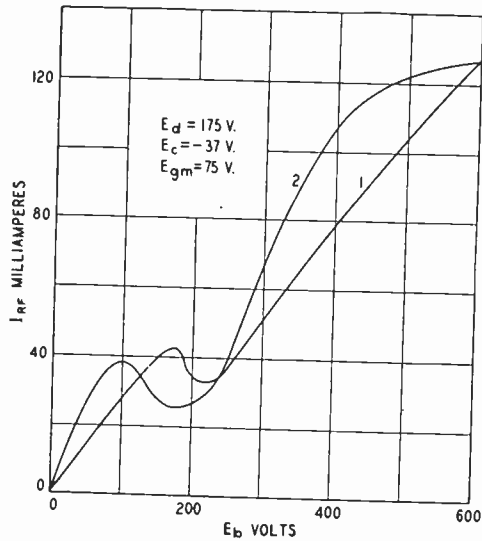

Fig. 21—R-F characteristics UX-865. Plate tuned circuit; 1—no added resistance; 2—resistance added, equivalent to heavy load.

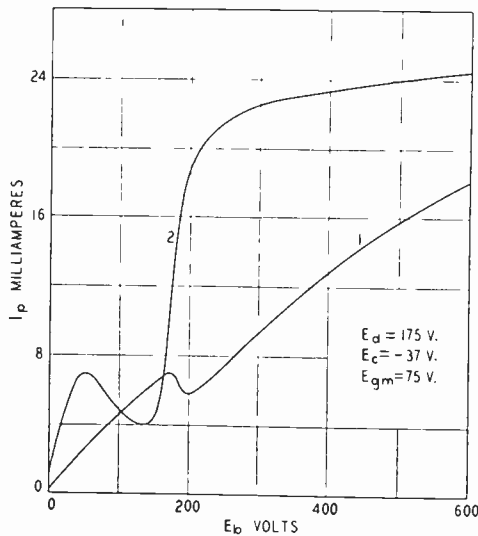

Fig. 22—R-F characteristics UX-865. Plate tuned circuit; 1—in tune; 2—off tune, tuned circuit impedance negligible at the fundamental frequency.

below that of the screen grid, and the resulting irregularity in the characteristic curves can be greatly reduced by supplying the screen-grid potential from a constant d-c supply of high voltage (E_s) and a series resistor (R_{sg}). The curves of Fig. 26 clearly show this improvement when compared to those obtained under conditions of fixed screen-

grid potential (Figs. 18 to 22). Here again the relative importance of the ratio of r-f excitation voltage to control-grid bias in determining the shape of the characteristic is in evidence. Fig. 24 supports the conclusion concerning the effect of the ratio of excitation to bias voltage

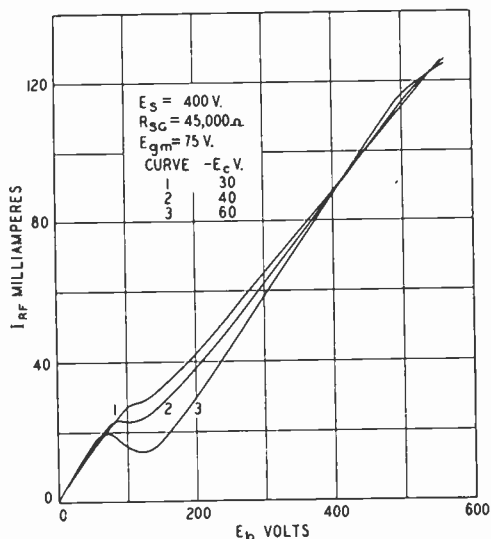

Fig. 23—R-F characteristics UX-865. Modulation method of Fig. 10. Screen-grid return to E_s .

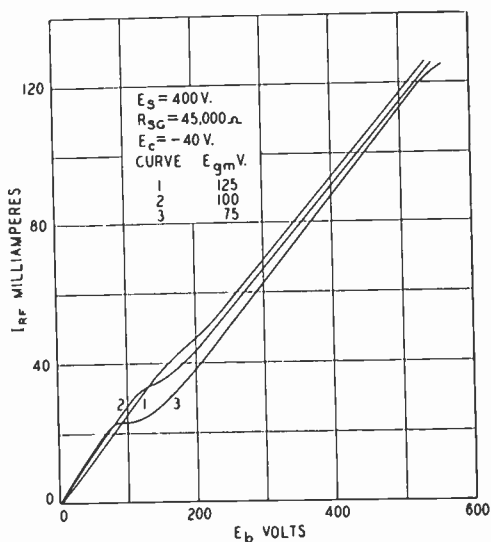

Fig. 24—R-F characteristics UX-865. Screen-grid return to E_s .

upon the resulting characteristic, the curve 1 being practically linear for a relatively high value of grid excitation. It would be expected that the higher the value of the series resistor the less pronounced would be the effect of the secondary emission. This conclusion is verified by comparison of the curves of Fig. 25 which were obtained for two values

of the screen-grid resistor. The effect of the tuned circuit impedance upon the r-f output current characteristic would be expected to be similar to the effect obtained when the screen grid was maintained at a constant d-c potential. That this conclusion is correct is evidenced by

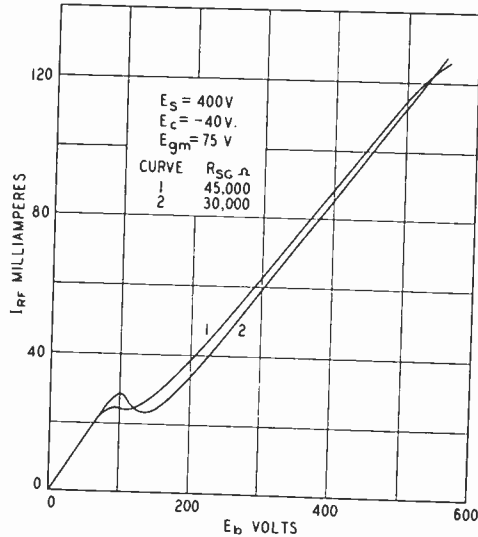

Fig. 25—R-F characteristics UX-865. Screen-grid return to E_s through R_{SG} , showing the effect of reducing the series resistance.

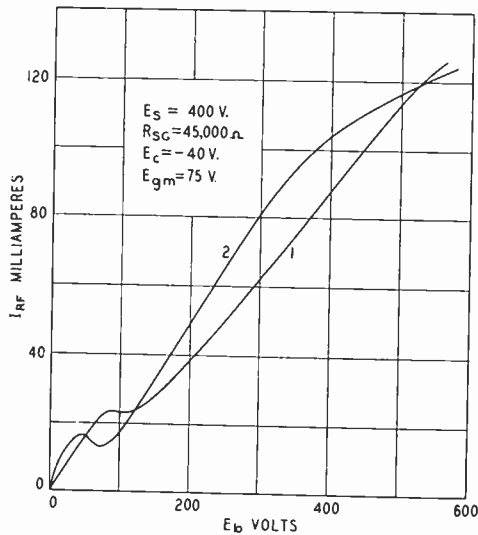

Fig. 26—R-F characteristics UX-865. Screen-grid return to E_s . Plate tuned circuit; 1—no added resistance; 2—added resistance.

the series of curves of Figs. 26, 27, and 28. Decreasing the tuned circuit impedance by the addition of resistance results in a more prominent irregularity in the characteristics resulting from secondary emission and a corresponding flattening at the higher values of plate supply voltage, just as was previously obtained with the screen at a fixed

potential though in a less pronounced degree. The series of plate current curves of Fig. 28 were obtained from several values of tuned circuit impedance. This suggests the possibility of a modification of this

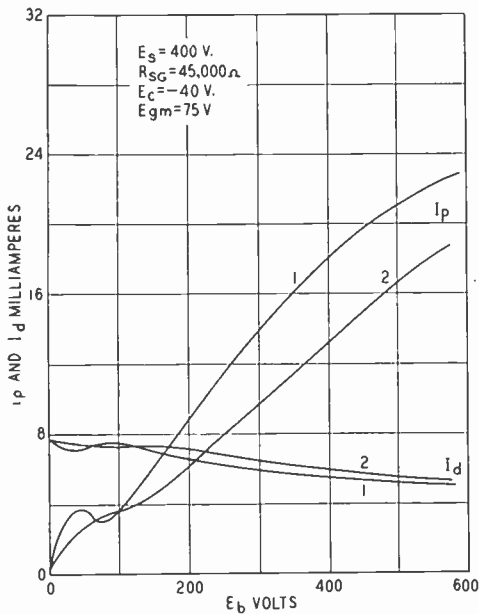

Fig. 27—R-F characteristics UX-865. Screen-grid return to E_s . Average values of plate and screen-grid currents. Plate tuned circuit; 1—added resistance; 2—no added resistance.

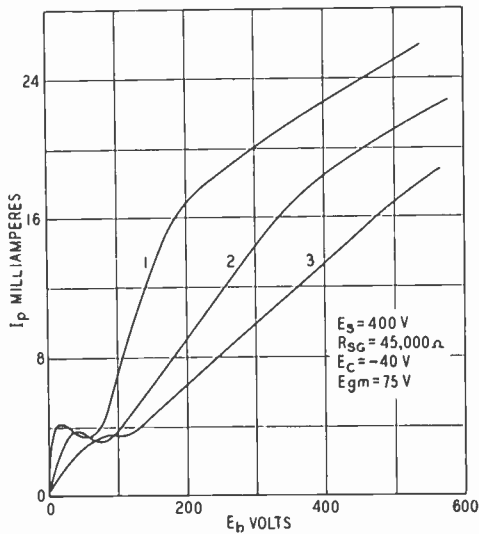

Fig. 28—R-F characteristics UX-865. Screen-grid return to E_s . Plate tuned circuit; 1—off tune; 2—in tune, added resistance; 3—in tune, no added resistance.

method for the purpose of measuring tuned circuit impedance at high frequencies. The great reduction in the characteristic hump with increasing value of tuned circuit impedance is quite marked.

PLATE AND SCREEN-GRID MODULATION

In order to eliminate the irregularities produced in the r-f output current characteristics by the secondary emission from the plate, when the plate potential falls below that of the screen grid, the possibility of

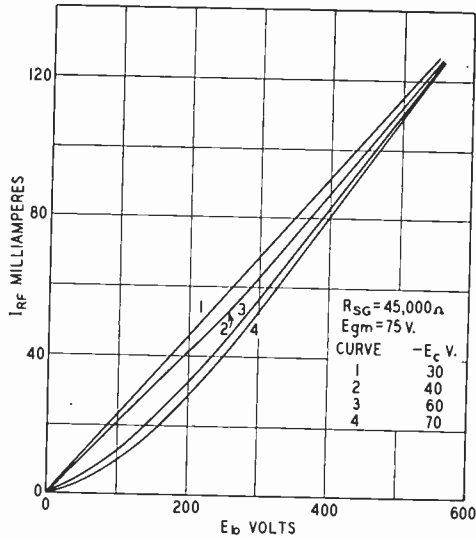

Fig. 29—R-F characteristics UX-865. Plate and screen-grid modulation, screen-grid return to E_b .

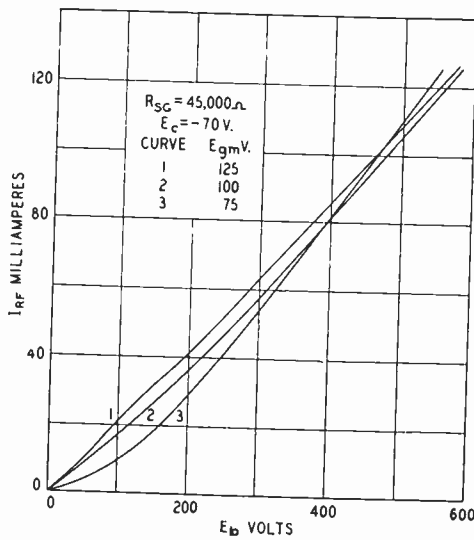

Fig. 30—R-F characteristics UX-865. Screen-grid return to E_b .

modulating in the screen-grid and plate circuits simultaneously was considered, thus reducing the screen-grid potential in the same proportion as the reduction in plate supply voltage. In these arrangements the screen grid was supplied from the plate voltage source through a series resistor. The curves of Fig. 29 indicate the complete elimination

of the secondary emission phenomenon as predicted. However, the ratio of r-f excitation voltage to control-grid bias is still seen to be a determining factor. The curves of Fig. 30 further illustrate the com-

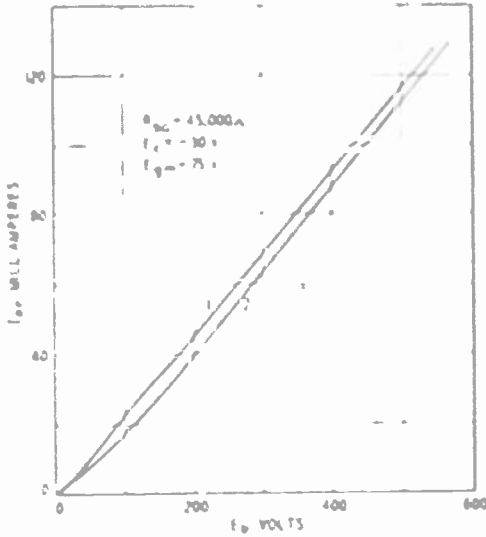

Fig. 31—R-F characteristics UX-865. Screen-grid return to E_b . Plate tuned circuit; 1—no added resistance; 2—added resistance

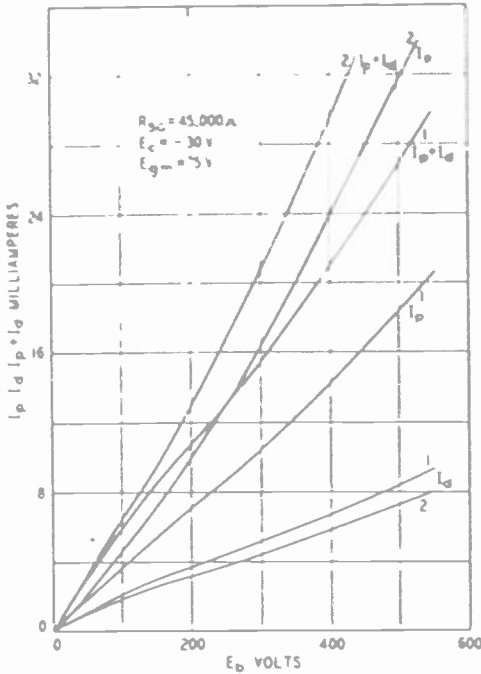

Fig. 32—R-F characteristics UX-865. Screen-grid return to E_b . Variation of plate and screen-grid currents and their sum. Plate tuned circuit; 1—no added resistance; 2—added resistance.

plete absence of secondary emission phenomena and the importance of securing the proper ratio of excitation to control-grid bias in order to secure a linear characteristic.

Since, as we shall see later, under these conditions of operation, in which the screen-grid potential is varied in proportion to the plate potential at the modulating frequency, the tetrode characteristics are similar in form to those of a neutralized triode, the effect of the tuned circuit impedance upon the r-f output characteristic would be expected to be greatly decreased. This conclusion is evidenced by the curves of Fig. 31 where the decrease in tuned circuit impedance results in only a slight curvature at the lower values of plate supply voltage. Fig. 32 shows the corresponding variation in plate- and screen-grid currents under these conditions. Since the impedance into which the modulator tube would work would be represented by the inverse of the slope of the curves of the sum of these two currents, it is desirable that they should be nearly linear, a condition which is closely fulfilled.

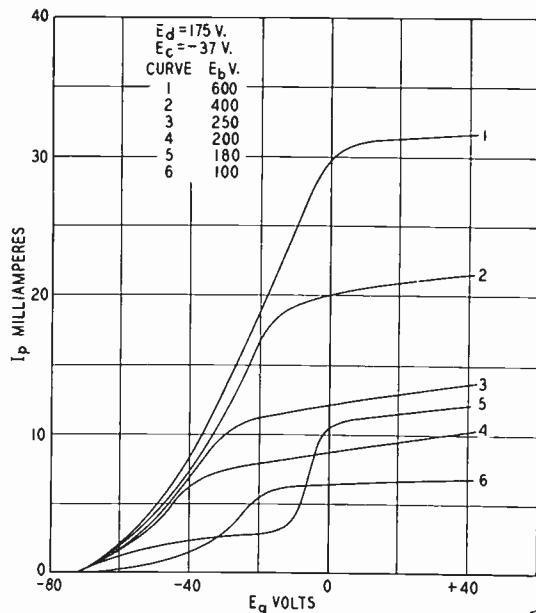

Fig. 33—Dynamic characteristics UX-865. Plate tuned circuit impedance $R_0 = 20,000$ ohms.

GRAPHICAL ANALYSIS

By employing a simple form of graphical analysis the performance of a tetrode can be visualized and the physical factors influencing the operating characteristics can be easily determined, in the case where the tube is working into a load impedance which presents a pure resistance at the frequency impressed upon the control grid.

To illustrate the value of this graphical method in interpreting and predicting the form of the characteristics, let us consider the application to the case of the tetrode in which the screen grid is maintained at a fixed d-c potential and the audio-frequency modulating voltage is to

be introduced in the plate circuit. Taking a value for the tuned circuit impedance (20,000 ohms in this case, corresponding to an inductance of $7.59 \mu\text{h}$; capacitance $218 \mu\text{f}$ and resistance 1.76 ohms) we proceed in a similar manner as with an audio amplifier, laying off on the d-c static plate characteristics for the required screen potential a series of load lines at several values of plate voltage, and for the control grid bias to be employed. The data thus obtained permit the plotting of the dynamic characteristics shown in Fig. 33. The peculiar effects result-

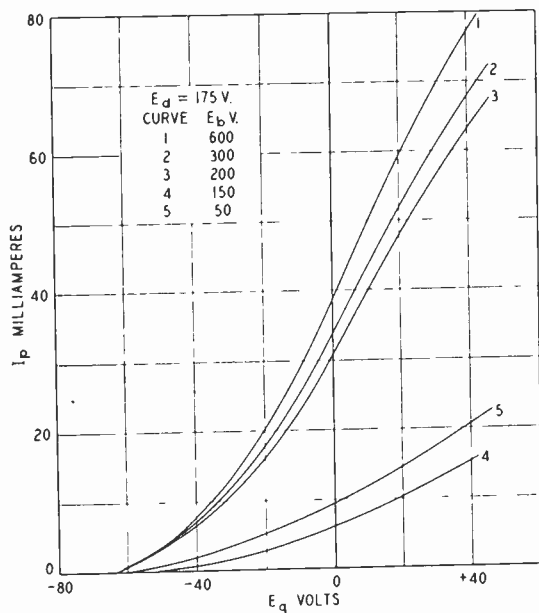

Fig. 34—D-C characteristics UX-865. Equivalent to dynamic characteristics for zero tuned circuit impedance $R_0 = 0$.

ing from the characteristic secondary emission are clearly shown in these curves. The comparison of Fig. 33 with the d-c static characteristics of Fig. 34, which would apply for the condition of zero tuned circuit impedance, shows the very great reduction of the effect of secondary emission for high values of the impedance. It now we apply graphically, a sinusoidal e.m.f. of predetermined value, to the control grid the resultant variations in plate current can be obtained by projection on the curves of Figs. 33 and 34 for several values of plate supply voltage. The curves of plate current can be analyzed and the average plate current and radio-frequency components plotted as functions of the plate supply voltage. Since it is the plate supply voltage which is varied at the modulating frequency, the curves thus plotted serve to predict the performance of the tetrode under these conditions when functioning as a plate modulated r-f amplifier. This is true only when the impedances involved in this d-c analysis present the same impedance (nec-

essarily resistive) to the modulating frequency. The resulting curves of average plate current and fundamental r-f component obtained by this graphical method are shown plotted in Figs. 35 and 36. Curve 1A of Fig. 35 shows the relation between average plate current and plate

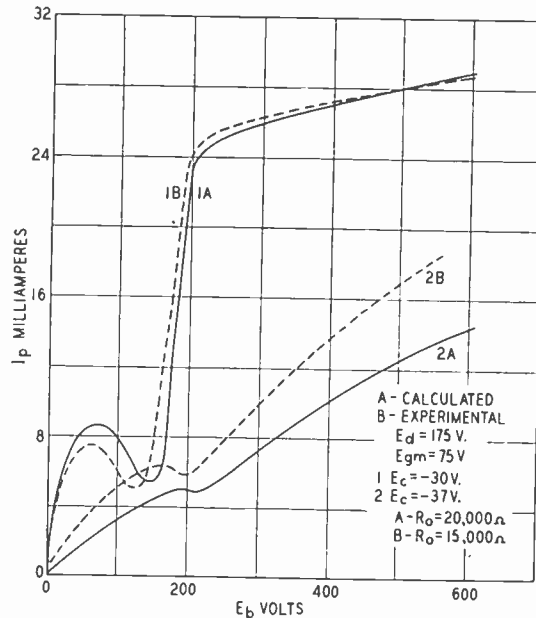

Fig. 35—R-F characteristics UX-865. Comparison of calculated and experimental curves. A—calculated; B—experimental. Note for curve 2A $R_0 = 20,000$ ohms while for 2B $R_0 = 15,000$.

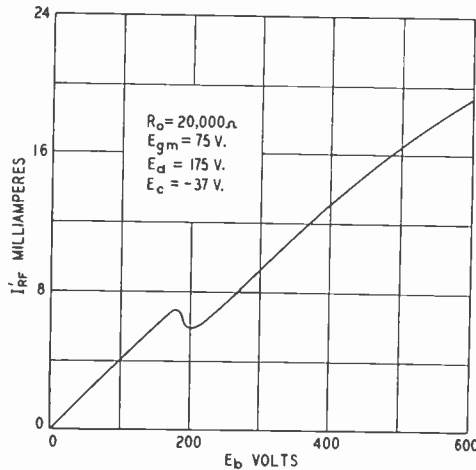

Fig. 36—Calculated r-f characteristics UX-865. Plate tuned circuit impedance $R_0 = 20,000$ ohms.

supply voltage when the plate tuned circuit is considerably off-tune so that the equivalent impedance at the fundamental radio frequency is practically zero. Curve 1B of this same figure shows the same relation as obtained by direct experimental measurements for the same condi-

tions of excitation and bias voltages. The close agreement is quite marked. The variation of the average plate current with plate supply voltage for the 20,000-ohm tuned circuit impedance, obtained by the graphical method is shown in curve 2A of Fig. 35 while an experimental curve for a somewhat lower value of tuned circuit impedance (15,000 ohms) is shown by 2B. Again the close agreement justifies the employment of this graphical method. The curve of r-f current of fundamental frequency as a function of plate supply voltage is shown in Fig. 36. This is the actual current to the tuned circuit, however, the r-f output current is directly proportional to it and hence this characteristic is directly comparable with the curves of output current previously obtained. The same general shape of characteristic is apparent though the irregularities due to secondary emission are reduced by the use of a high tuned circuit impedance. (Compare with curve 1 of Fig. 20.)

From these curves and the graphical analysis the effect of the increase of tuned circuit impedance upon the characteristic hump due to the secondary emission results in a proportionate decrease in the irregularity and a shifting of the same to higher values of plate supply voltage. The reasons for the former effect can be seen from the intercepts of load lines for several values of tuned circuit impedance upon the family of d-c static plate characteristics. The plate voltage variations about the d-c plate supply voltage, resulting from the r-f voltage developed across the tuned circuit impedance causes the instantaneous plate potential to fall below that of the screen grid, at values of the d-c plate supply voltage which would not produce the excessive secondary emission thus causing the progressive shifting of the irregularity in the plate and output current characteristics with increasing values of tuned circuit impedance (constant r-f excitation on the grid).

These examples serve to illustrate the usefulness of the graphical method in predicting the performance of the tetrode when functioning as a plate modulated radio-frequency amplifier with screen grid at a fixed potential. The application of these methods to other modulation systems is apparent. However, the cases where the screen grid is supplied through a series resistor, from a constant or a modulated high voltage supply, require an extensive series of approximations in order to allow for the drop in potential of the screen grid resulting from the average value of screen current flowing through the series resistor when the r-f excitation voltage is impressed on the control grid. The d-c characteristics obtained for the two methods of modulation in which the screen grid is supplied through a series resistor show some surprising comparisons. The curves of Fig. 37 show the d-c characteristics obtained by graphical means, for the modulation method of Fig. 11 in which the

screen grid returns to E_b , corresponding to the simultaneous modulation of the plate and screen-grid supplies. The uniformity, absence of all irregularities resulting from secondary emission, and similarity to the characteristics of a triode are quite apparent. An experimental r-f characteristic for a negligible value of tuned circuit impedance, is plotted for comparison showing the effect of the average plate and screen-grid currents resulting from the r-f grid excitation.

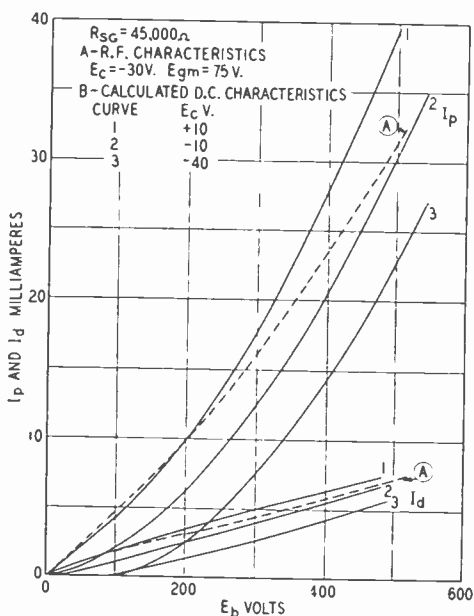

Fig. 37—D-C characteristics UX-865 for screen-grid return to E_b through R_s calculated from normal d-c characteristics. Curve A, an experimental r-f characteristic for a negligible tuned circuit impedance.

EXPERIMENTAL VERIFICATION OF THE MODULATION CHARACTERISTICS

From the series of r-f characteristics previously considered the performance of the UX-865 tetrode as a modulated radio-frequency amplifier can be predicted under various conditions and for several methods of modulation. The three oscillograms, showing the audio-frequency modulating signal input and the rectified modulated radio-frequency output, are typical examples of the experimental verification of the predicted performance.

The characteristic of the linear rectifier employed has been shown in Fig. 12. It was found that the direct current flowing through the power transformer supplying the 60-cycle modulating voltage resulted in a slight departure in the wave shape from a true sine wave and an apparent lag of the voltage behind the current of approximately 10 degrees. This was later corrected by sufficiently loading the transformer

or by keeping the direct current out of the windings; however, this slight distortion is present in the first two oscillograms.

In computing the effective percentage modulation of the carrier, the I.R.E. definition was employed, the percentage modulation being the ratio of half the difference between the maximum and minimum amplitudes of the modulated wave, to the average amplitude, expressed in per cent.

In all the oscillograms the voltage wave shows the modulating input voltage, the current wave being the rectified modulated output. The accompanying table lists the conditions under which the oscillograms were taken.

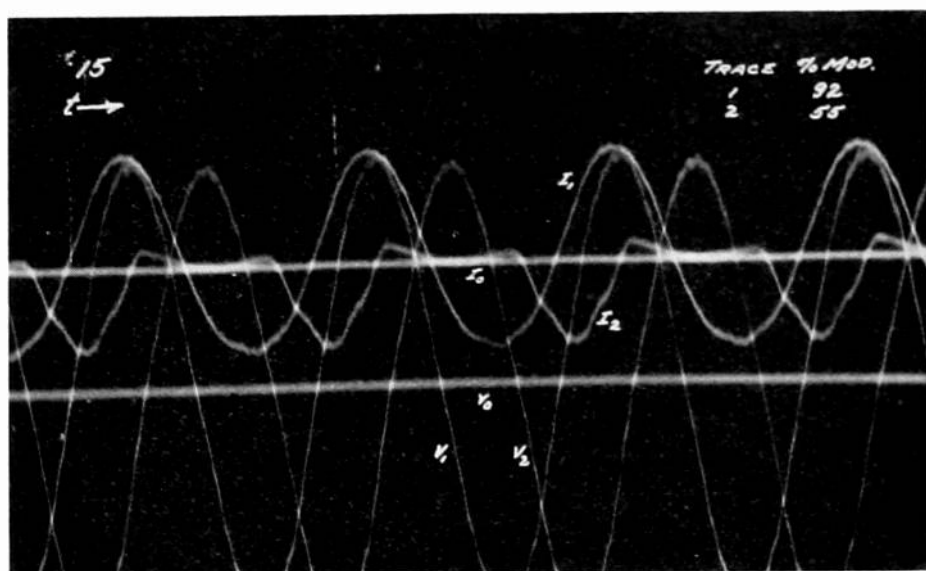

Fig. 38—Oscilloscope for screen-grid modulation method of Fig. 7.

Oscilloscope No. 15, Fig. 38, shows the results of modulation in the screen grid as indicated by Fig. 7, in which the screen grid returns to a constant voltage source E_d . Trace 1 of this oscilloscope corresponds to the conditions of the r-f characteristic of Fig. 16 A-2, except for a slightly higher excitation voltage. The resulting wave shape is in close agreement with this characteristic since the load of the rectifier effectively reduces the tuned circuit impedance straightening the r-f characteristic as shown. Trace 2 shows the result of increasing the ratio of r-f excitation to control-grid bias voltage. As would be expected from the curves of Fig. 15, allowing for the effect of the lowered tuned circuit impedance, the overexcitation would result in a characteristic similar to that of curve 1 of that figure. The positive modulation loops would be practically missing because of the flattening of the r-f char-

acteristic for values of the screen potential greater than the constant d-c value. The bending back of the characteristic upon itself accounts for the actual wave form obtained.

Modulation in the plate circuit with the screen grid at constant d-c potential as shown in the diagram of Fig. 9 resulted in the traces of oscillogram No. 11 of Fig. 39. The conditions under which these output wave forms were obtained correspond closely to those of the r-f characteristics of Fig. 18. Trace 1 shows all the irregularities and lack of positive modulation as expected from curve 3 of Fig. 18, and trace 2, for a slightly positive value of grid bias being in close agreement with the output as predicted from curve 1 of that figure.

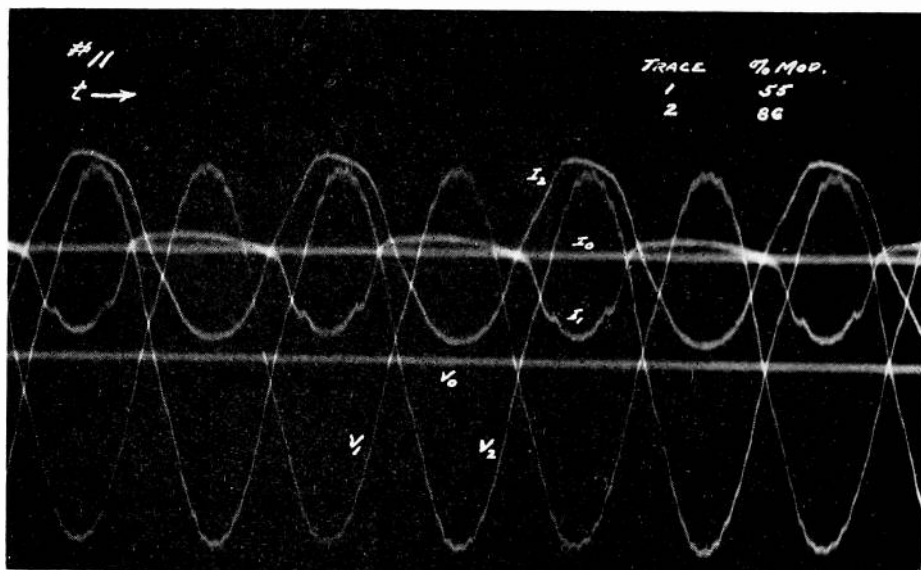

Fig. 39—Oscillogram for plate modulation method of Fig. 9.

The modulation method of Fig. 11, in which the screen grid is supplied through a series resistor and the modulating voltage introduced simultaneously in both the screen-grid and plate circuits, in phase, results in the complete elimination of the effects of secondary emission and a linear relation between r-f output voltage and plate voltage practically unaffected by the tuned circuit impedance and electrode voltages.

The traces of oscillogram No. 22, Fig. 40, show the output wave form for conditions corresponding to those under which the r-f characteristics of Fig. 31 were obtained. Trace 1 results from 100 per cent modulation of the carrier while trace 2 represents 85 per cent modulation. An appreciable 25th harmonic was present in the modulating voltage supply; the presence of the same in the rectified output, in the

same relative proportion, indicates an excellent frequency response characteristic. This nearly perfect reproduction for both 85 and 100 per cent modulation is evidence of the effectiveness of this method of simultaneous modulation of both the screen-grid and plate voltage.

CONCLUSIONS

The advantages of the use of a tetrode as the modulated radio-frequency amplifier in a radiotelephone transmitter at high frequencies are evidenced by the elimination of all neutralizing devices and the necessarily critical adjustments of the same. These simplifications are particularly advantageous in applications to aircraft and portable

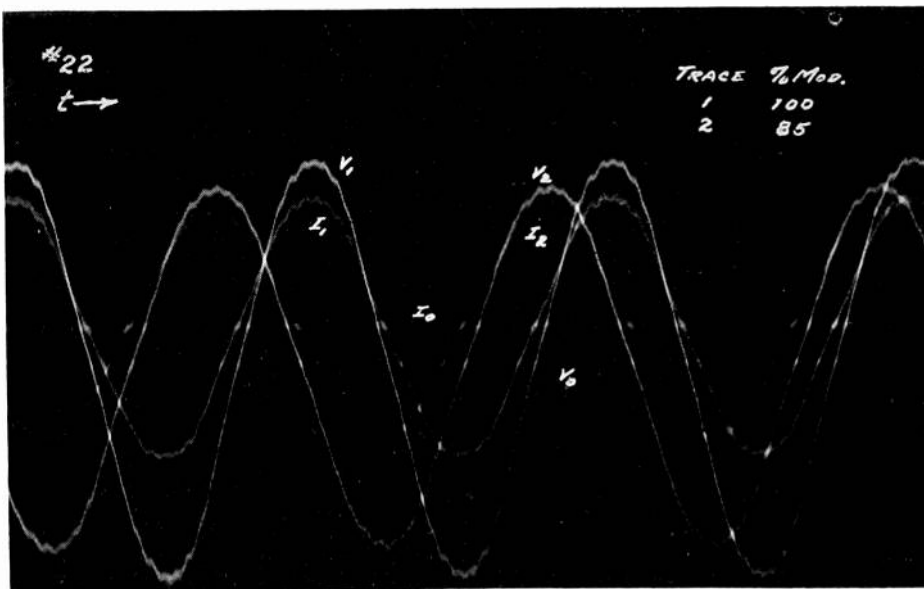

Fig. 40—Oscillogram for plate and screen-grid modulation method of Fig. 11.

transmitters requiring rapid changes of the operating frequency over wide ranges, and in signal generator equipment. The several methods of modulating the tetrode all have their advantages and limitations as have been shown by this experimental study.

The grid modulation method of Fig. 5 permits a modulation capability of the order of 60 per cent without excessive distortion, this degree of modulation being obtained with an audio grid swing of the order of but 20 volts r-m-s across an input impedance of 30,000 or 40,000 ohms. However, the adjustments to obtain this performance are somewhat critical and are greatly influenced by changes in the r-f excitation, electrode voltages, and tuned circuit impedance or load.

The screen-grid method of modulation of Fig. 7 permits a modula-

tion capability of the order of 75 per cent without excessive distortion. This degree of modulation can be secured by a modulating voltage of 50 volts r-m-s across an equivalent impedance of the order of 50,000 ohms. This method is also rather critical in adjustment and is greatly influenced by all the factors previously mentioned in considering the grid modulation method.

The screen-grid modulation method of Fig. 8 seems to be impractical because of the excessive distortion. Plate modulation by the method of Fig. 9 is seriously hampered by the effects of secondary emission and accompanying distortion, except for positive values of grid bias, an inefficient operating condition. The performance is also very greatly affected by all the factors previously mentioned. This method would seem to have little practical value.

Plate modulation by the method of Fig. 10 is capable of fairly complete modulation, nearly 100 per cent without excessive distortion, particularly when a high value of resistance is employed in series with the screen grid and when working into a tuned circuit of relatively high impedance. The performance is affected by these factors as well as by the ratio of r-f grid excitation to grid bias voltage, thus requiring careful adjustment.

The method of introducing the modulating voltage in the plate and screen-grid circuits, in phase, as shown in Fig. 11 is capable of complete modulation with a negligible degree of distortion. The effects of secondary emission are entirely eliminated since the screen-grid potential decreases proportionally with that of the plate. The tuned circuit impedance and ratio of r-f excitation to grid bias voltage have very minor effects upon the output characteristic thus avoiding critical adjustments. The tetrode under these conditions of modulation performs much like a neutralized triode with the added advantage of the elimination of the neutralizing devices. The effective input impedance of the screen grid and plate together, at the modulating frequency, is considerably higher than that of a triode of similar rating, an advantage from the standpoint of a vacuum tube modulator.

ACKNOWLEDGMENT

In conclusion the writer wishes to acknowledge his indebtedness to Dean Pender of the Moore School of Electrical Engineering, University of Pennsylvania, for the privilege of conducting this investigation in the well-equipped laboratories of the Moore School, and to Professor C. Weyl of the Moore School Faculty for his helpful advice and interest in this problem.

TABLE I

Constants and Rating of Radiotron Type UX-865.

Filament
Voltage 7.5 volts
Current 2.0 amperes
Average Characteristic Values
at $E_b = 500$ volts
$E_c = 0$ volts
$E_d = 125$ volts
$E_f = 7.5$ volts r-m-s.
Plate current 21 milliamperes
Plate resistance 200,000 ohms
Mutual conductance 0.75 milliamperes per volt
Amplification factor 150
Approximate Direct Interelectrode Capacities
Plate to grid (filament and screen grounded) $0.05 \mu\mu f$
Grid to filament and screen $10 \mu\mu f$
Plate to filament and screen $7.5 \mu\mu f$
R-F power amplifier—Class B
Maximum operating plate voltage 500 volts
Maximum nonmodulated plate current 30 milliamperes
Maximum plate dissipation 15 watts
Maximum screen dissipation 3 watts

TABLE II
DATA ON OSCILLOGRAMS

No.	Trace	E_{gm} v	E_b v	$-E_c$ v	E_d or E_s v	E_m v	$\frac{E_m}{E_{dc}}$ per cent	Per cent Mod.
15	1	90	500	50	100	100	100	92
	2	125	500	50	100	100	100	52
11	1	75	300	30	75	300	100	55
	2	75	300	-6	75	300	100	86
22	1	75	300	30	—	300	100	100
	2	75	300	30	—	254	85	85

LIST OF SYMBOLS

E_b	Plate supply voltage (direct current)
E_c	Control grid voltage (direct current)
E_{gm}	Maximum value of r-f control grid voltage
E_d	Screen-grid voltage (direct current)
E_s	Screen-grid supply voltage (direct current)
E_m	Maximum value of a-c modulating voltage
E_{dc}	D-C voltage in modulating circuit
I_d	Average d-c screen-grid current
I_g	Average d-c control-grid current
I_p	Average d-c plate current
I_R	Average d-c rectifier plate current
I_{RF}	R-m-s value of output r-f current
R_{sg}	Screen-grid resistor

Bibliography

1. B. C. Brain, "Approximate theory of screen grid valve," *Experimental Wireless and Wireless Engineer*, 179, April, 1928.
2. J. G. Brainerd, "Mathematical theory of the four-electrode tube," *Proc. I.R.E.*, 1006, June, 1929.
3. J. R. Carson, "Equivalent circuit of vacuum tube modulator," *Proc. I.R.E.*, 243, June, 1921.

4. J. R. Carson, "Notes on the theory of modulation," *Proc. I.R.E.*, 57, February, 1922.
5. C. A. Culver, "An improved system of modulation in radio-telephony," *Proc. I.R.E.*, 479, October, 1923.
6. R. A. Heising, "Modulation in radio-telephony," *Proc. I.R.E.*, 305, August, 1921.
7. C. E. Kilgour, "Graphical analysis of output tube performance," *Proc. I.R.E.*, 42, January, 1931.
8. G. F. Lampkin, "An analysis of high modulation transmission," *Electronics*, 326, October, 1930.
9. F. B. Llewellyn, "Operation of thermionic vacuum tube circuits," *Bell Sys. Tech. Jour.*, 433, July, 1926.
10. J. R. Nelson, "Circuit analysis applied to the screen-grid tube," *Proc. I.R.E.*, 320, February, 1929.
11. E. Peterson and F. B. Llewellyn, "Operation of modulators from a physical standpoint," *Proc. I.R.E.*, 38, January, 1930.
12. E. Peterson and C. R. Keith, "Grid current modulation," *Bell Sys. Tech. Jour.*, 106, January, 1928.
13. D. C. Prince and F. B. Vogdes, *Vacuum Tubes as Oscillation Generators*, General Electric Co., Chap. 3.
14. E. S. Purington, "Operation of the modulator tube in radio telephone sets," *Scientific Papers of the Bureau of Standards*, No. 423, 1921.
15. B. van der Pol, "Remarks in ultra-short-wave broadcasting," *Experimental Wireless*, 9, January, 1929.
16. J. C. Warner, "Some characteristics and applications of the four-electrode tubes," *Proc. I.R.E.*, 424, April, 1928.



THEORY OF DESIGN AND CALIBRATION OF VIBRATING REED INDICATORS FOR RADIO RANGE BEACONS*

By
G. L. DAVIES

Summary—This paper gives a general treatment of the theory of design of vibrating reed indicators, which was developed in connection with measurement and design work on the tuned-reed course indicator for the aircraft radio range beacon. The equations and conclusions may be readily adapted to apply to any similar vibrating system.

By assuming that a reed may be replaced by an equivalent particle, vibrating in the plane of the driving poles, the differential equation of motion is simplified greatly and becomes readily solvable for small vibrations. Equations are given for determining the constants of the equivalent particle from the dimensions and constants of the reed. The expression for the frequency of a loaded uniform reed, computed by a method equivalent to one given by Rayleigh, checks very closely with that obtained by Drysdale and Jolley for a similar reed. This theory for small vibrations is applicable when the amplitude is small enough so that its square may be neglected in comparison with the square of the air gap.

From an analysis of large vibrations of tuning forks by Mallett, the behavior of the reed at relatively large amplitudes of vibration is inferred, although an exact quantitative verification of the theory is difficult.

Design equations are given for uniform reeds and for the type used in the reed indicator. From the results of both theory and experiment, the effect of the various factors of design and operation upon the reed frequency is discussed, and the calibration procedure necessary to take account of these factors is outlined.

I. INTRODUCTION

THIS theory of reed indicator design has been developed in connection with a program of measurement and design work on the tuned-reed visual course indicator for the aircraft radio range beacon. The purpose of this work was to improve the sensitivity of the indicator, to standardize the design for production manufacture, and to develop apparatus and methods for laboratory and production calibration.

The theory of lateral vibrations of bars has been very completely developed by Lord Rayleigh.¹ However, his theory, while having the advantage of great generality, is somewhat complicated for practical use, and is not applicable to damped forced vibrations. Several investigators have developed simplifications of Rayleigh's theory, but these have not been found to be useful in connection with this problem.

* Decimal classification: R526.12. Original manuscript received by the Institute, June 1, 1931. Publication approved by the Director of the Bureau of Standards of the U.S. Department of Commerce. Published in *Bureau of Standards Journal of Research* 7, July, 1931.

¹ Lord Rayleigh, *Theory of Sound*, I, Ch. VIII, p. 255.

Mallett² has given a very thorough treatment of large vibrations of electrically driven tuning forks. With certain modifications, necessitated by differences in drives, his equations may be applied to vibrations of reeds, and are used to explain some of the properties of reeds when vibrating at large amplitudes.

Rayleigh derived an equation for the frequency of free vibration of a uniform bar, but none of the investigations include any equation for the frequency of a reed of nonuniform cross section, nor do they give any method for the calculation of the sensitivity of driven reeds. There is a definite need for these equations in indicator design, and they are developed in this work. The equation for frequency is obtained by Rayleigh's method, while an assumption that the reed is replaceable by an equivalent particle enables an expression for sensitivity to be derived.

The greatest problem encountered in production manufacture has been nonuniformity of indicators. This necessitated the expenditure of an inordinately large amount of time in calibration, thus increasing cost of manufacture. In order to minimize this time, it is necessary to determine and eliminate the causes of nonuniformity. Also, careful and exact design results in a simplification of calibration procedure which is of great value to a manufacturer.

It has also been necessary to develop apparatus and methods for calibration, which includes tuning the reed to the proper frequency and adjustment of its sensitivity and sharpness of resonance to the desired values.

II. THEORY FOR SMALL VIBRATIONS

A brief outline of the type of drive used in the reed indicator will give a clearer conception of what follows. Constructional details of the indicator are given in a publication by Dunmore,³ and a diagrammatic sketch is shown in Fig. 1. In this figure, *A* is the permanent magnet used to polarize the reed, *B* indicates the driving coils and pole pieces, and *C* is the reed. The magnetization of the permanent magnet is such that, with no current in the driving coils, both pole pieces have a polarity opposite to that of the reed and exert equal and opposite attractions upon the reed. The driving coils are connected in such a manner that when a direct current is passed through them, the ends of the coils nearest the reed have opposite magnetic polarities. Consequently, when a direct current flows in the coils, the attraction of one pole for

² E. Mallett, "Resonance curves of tuning forks," *Phys. Soc. Proc.*, 39, 334, 1927.

³ "Design of tuned reed course indicators for aircraft radio-beacon," *Bureau of Standards Journal of Research*, Research Paper No. 28, November, 1928.

the reed is increased while that of the other pole is decreased, and a force thus acts on the reed tending to displace it from its neutral position. If an alternating current flows in the coils, the attractions of the poles vary periodically with the current and the force on the reed varies correspondingly.

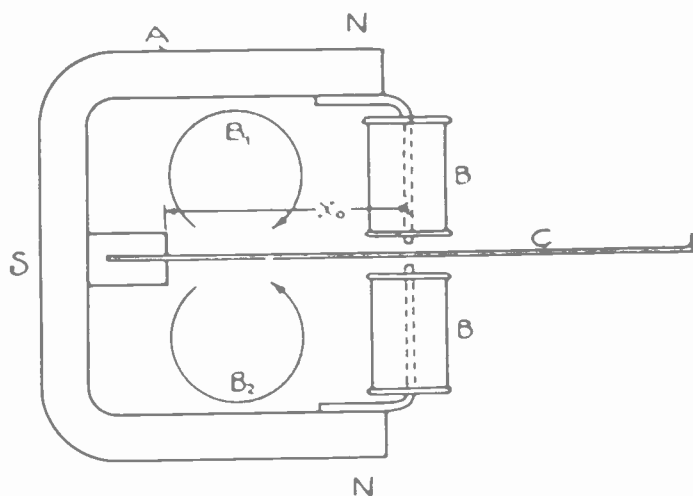

Fig. 1—Schematic diagram of drive used in reed indicator (side view).

It is obvious that, as soon as the reed moves from the neutral position, a second force due to the permanent magnet comes into play, inasmuch as the reed is then nearer to one pole than to the other. This force also tends to pull the reed away from its neutral position.

Fig. 2 shows a top view of the reed, with the damping vane attached at the narrow end.

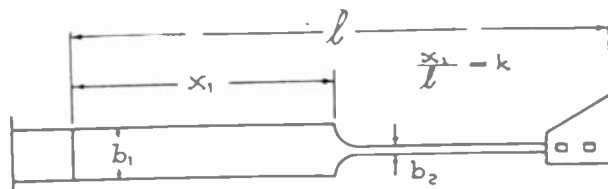

Fig. 2—Top view of reed used in reed indicator.

For small vibrations, the square of the deflection from the neutral position may be neglected in comparison with the square of the gap. If it is assumed that the entire reed may be replaced by an equivalent particle between the driving poles, that is, a particle of which the displacement at each instant is the same as that of a point on the reed between the driving poles, and which has the same kinetic energy, the same potential energy, and thus suffers the same loss of energy per unit of time as the reed, then the equation of motion may readily be written and solved. This assumption is the same as saying that the phase is the

same at every point on the reed. There is little but pragmatic justification for this assumption, although its success in numerous similar cases warrants its adoption here. The final justification, of course, lies in the experimental verification of equations dependent upon the assumption. If the mass of this hypothetical particle is m , the damping force per unit velocity is r , and the restoring force per unit of displacement is s , the equation of motion is

$$my'' + (r + A_1)y' + (s - A_2)y = BI \cos \omega t \quad (1)$$

where y is the displacement of that portion of the reed immediately between the magnet poles, B is the force per unit current, I is the maximum instantaneous value and ω the angular velocity of the current in the driving coils, and the primes over the y 's indicate differentiation with respect to the time, t . A_1 is a constant representing the increase in damping caused by magnetic and mechanical hysteresis, and A_2 is a constant denoting the decrease in stiffness caused by the permanent magnetic field. The quantities, $r + A_1$ and $s - A_2$, are replaced by r' and s' in the following. The solution of (1) for a steady state of vibration is

$$y = \frac{BI}{Z} \sin(\omega t + \theta) \quad (2)$$

where,

$$\left. \begin{aligned} Z &= \sqrt{\omega^2 r'^2 + (s' - \omega^2 m)^2} \\ \theta &= \tan^{-1} \frac{s' - \omega^2 m}{\omega r'} = \tan^{-1} \frac{X}{r'} \end{aligned} \right\} \quad (3)$$

X being written for $s'/\omega - \omega m$. The amplitude of this vibration is a maximum when Z is a minimum or

$$\omega = \sqrt{\frac{s'}{m} - \frac{r'^2}{2m^2}} \quad (4)$$

This equation shows that the reed vibrates with maximum amplitude when the frequency of the driving current is somewhat lower than the frequency of resonance of the damped reed outside a magnetic field because the quantity s' is less than the normal stiffness of the reed, and the quantity r' is greater than the normal damping force. The amount of this lowering of the frequency of resonance by the magnetic positional force is dependent upon the constants of the magnetic circuit and the position of the driving coils.

1. Equivalent Particle Constants

There remains the problem of determining the constants of the equivalent particle in terms of the dimensions and constants of the reed. For convenience the determination of the constants will be based on the average values of the kinetic energy, the potential energy, and the rate of dissipation of energy of the reed. The same final results are obtained as would be obtained by using the instantaneous values. If $Y=f(x)$ is the maximum value of the displacement at any point x on the reed (x being measured from the base of the reed), the r-m-s values of displacement, velocity, and acceleration at any point are $(1/\sqrt{2})Y$, $(1/\sqrt{2})\omega Y$, and $(1/\sqrt{2})\omega^2 Y$, respectively. The average kinetic energy of a small portion of the reed dx is

$$dT = \frac{1}{4}\omega^2 Y^2 A \rho dx, \quad (5)$$

A being the cross-sectional area of the reed and ρ its density. The kinetic energy of a load of mass M on the reed is $\frac{1}{4}\omega^2 M Y^2_M$, Y_M being the value of the displacement at the load. The total average kinetic energy is, then,

$$T = \frac{\omega^2}{4} \int_0^l A \rho Y^2 dx + \frac{1}{4}\omega^2 \sum M Y^2_M. \quad (6)$$

If this is divided by one-half the square of the r-m-s velocity at the driving point, the result will be the mass of the equivalent particle having the same velocity and kinetic energy as the reed and the same velocity as a point on the reed between the driving poles.

$$m = \frac{\frac{\omega^2}{4} \int_0^l A \rho Y^2 dx + \frac{\omega^2}{4} \sum M Y^2_M}{\frac{\omega^2}{4} Y^2_{x_0}} = \frac{\rho \int_0^l A Y^2 dx + \sum M Y^2_M}{Y^2_{x_0}} \quad (7)$$

Y_{x_0} is the value of Y at the driving point, and l is the length of the reed.

Similarly, the total energy dissipated per unit of time divided by the square of the velocity at the driving point gives

$$r = \frac{\int_0^l k_1 Y^2 dx + k_2 \sigma A_v Y^2_v}{Y^2_{x_0}} \quad (8)$$

and the potential energy of flexure divided by the square of the displacement at the driving point gives

$$s = \frac{q}{Y^2_{x_0}} \int_0^l I \left(\frac{d^2 Y}{dx^2} \right)^2 dx. \quad (9)$$

In these expressions k_1 and k_2 are constants depending upon the resistance of the air to the motions of the reed and the damping vane, respectively, A_v the area of the damping vane, Y_v the value of Y at the center of area of the damping vane, Y_{x_0} the value of Y at the driving point, E Young's modulus for the material of the reed, and I the moment of inertia of the reed cross section about its neutral axis. This use of the letter I will be readily distinguishable from its use to designate the current in the driving coils of the reed, as these two quantities appear in entirely different expressions in the following work, and the context will indicate which quantity is meant. The letters A in (7) and I in (9) are kept under the integral signs because the reed may not have a uniform cross section. Of course, if the reed were not of the same material throughout, ρ and E would also have to be placed within the integrals. This would be a rare case, however.

The above equations define the motion of the reed, provided that the square of the amplitude in the air gap is negligible in comparison with the square of the gap itself.

III. EFFECT OF LARGE VIBRATIONS

When the vibration becomes so large that the square of the amplitude becomes comparable in magnitude with the square of the gap, these equations no longer hold. The frequency of resonance becomes a function of the amplitude, and the resonance curve becomes unsymmetrical, tending to drop off more sharply on the low-frequency side than on the high-frequency side.

Mallett's treatment⁴ of large vibrations of tuning forks may be applied to the reed indicator, and admirably explains these effects. When properly transformed to conform to the conditions existing in the reed indicator and the notation used here, Mallett's solution becomes

$$\left. \begin{aligned} \left(\frac{s' - \omega^2 m}{\omega r'} \right) Y - CY^3 &= DI \cos \theta \\ Y + GY^3 &= DI \sin \theta \end{aligned} \right\}. \quad (10)$$

Here, ω , I , m , r' , and s' are the same as before, except that s' contains a small term depending upon the current in addition to the terms previously mentioned; Y is the amplitude of vibration of the equivalent particle; C , D , and G are constants depending upon the characteristics of the permanent magnet and coils and upon the dimensions of

⁴ See footnote 2.

the magnetic circuits; and θ is the phase angle of the current, referred to the phase of the vibration as standard.

Resonance curves plotted from graphical solutions of these equations show an increasing dissymmetry as the amplitude is increased. The equations also show that the damping increases with amplitude. The fact that the current amplitude enters into the quantity s' also indicates that the frequency of resonance varies slightly with the driving current at constant amplitude of vibration, the frequency decreasing as the current increases. Also the damping should change slightly with current at constant amplitude, but this effect is too small to be detectable.

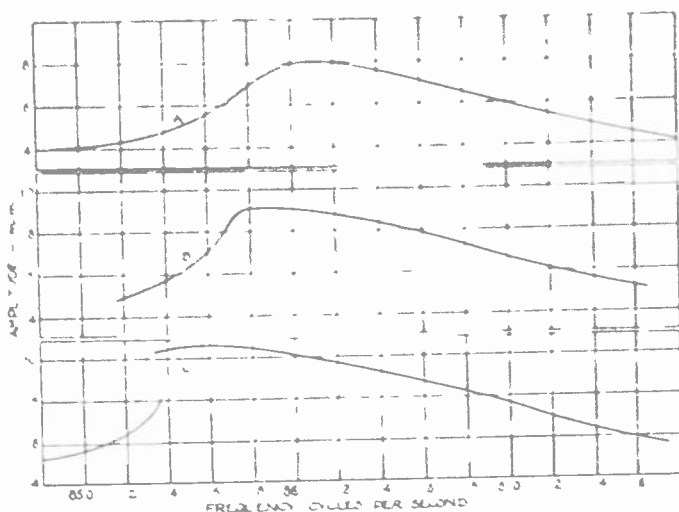

Fig. 3—Resonance curves taken with constant current, showing increasing distortion as amplitude is increased. A—0.70 ma; B—0.83 ma; C—0.98 ma.

Experimental resonance curves show all of the above characteristics, the upper portions of curves taken at constant current being displaced toward the low-frequency side and becoming broader as the maximum amplitude is increased (Fig. 3), while the upper portions of curves taken with variable current, the amplitude being held constant as the frequency is varied, are displaced toward the high-frequency side (Fig. 4). A sufficiently exact evaluation of the constants entering into (10) to permit a thorough quantitative check of these results has not yet been made.

It has been found desirable to sacrifice a certain amount of sensitivity in the indicator to eliminate the effects of large vibrations, since any change of the frequency of resonance with amplitude of either or both reeds in an indicator (inasmuch as such a change is nearly always different for the two reeds), will almost certainly result in a shift of the course as the operating amplitude of the reeds varies. Such variation of

operating amplitude is inevitable, since it is virtually impossible to maintain the output of an airplane radio receiving set constant under operating conditions. Therefore, the gaps between the reed and pole pieces are made so large that distortion of the resonance curve at normal operating amplitude is negligible. For the purposes of design, then, the vibration may be considered small, although an accurate calibration procedure must still take account of the large vibration effects.

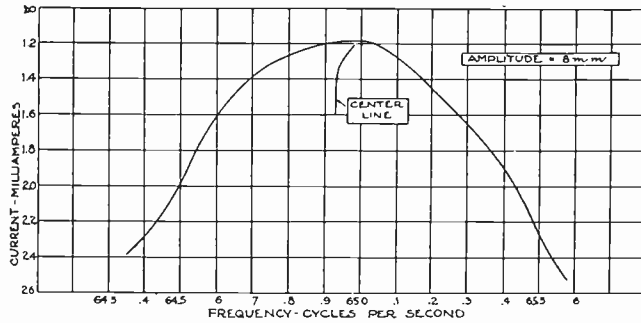

Fig. 4—Resonance curve at constant amplitudes, showing increase of frequency as current is decreased.

IV. APPLICATION OF THEORY TO REED DESIGN

In order that (7), (8), and (9) may be used for the design of reeds, the form of the function Y , which defines the curve of deflections assumed by the reed during vibration, must be determined. If the cross section is uniform, (provided the mass of the load is small in comparison with the mass of the reed, as is usually the case), Lord Rayleigh has shown theoretically that the curve assumed by a vibrating bar is very nearly the same as that which it would assume statically if deflected by a force acting at a distance from the base of three-fourths the total length. Later, however, Garrett⁵ showed by experimental methods that the curve assumed during vibration is more accurately approximated if the force is considered to be applied four-fifths of the length of the reed from the base. By use of these data, the curve assumed by a uniform reed vibrating freely is found to be

$$Y = \frac{\rho x^2}{30qI}(12l - 5x) \quad (0 < x < \frac{4}{5}l) \quad (11)$$

$$Y = \frac{8\rho l^2}{375EI}(15x - 4l) \quad (\frac{4}{5}l < x < l) \quad (12)$$

⁵ C. A. B. Garrett, "On the lateral vibrations of bars," *Phil. Mag.*, 8, 581, 1904.

where ρ is the force deflecting the reed statically. By substituting these expressions for Y in the formulas for m and s and carrying out the integrations, with $x_0 (< 4/5l)$ equal to the value of x at the driving poles and with the load at the free end of the reed, these constants are found to be as follows,

$$\left. \begin{aligned} m &= (12.40A\rho l + 49.5M) \left[\frac{l^3}{x_0^2(12l - 5x_0)} \right]^2 \\ s &= \frac{153.6EI}{l^3} \left[\frac{l^3}{x_0^2(12l - 5x_0)} \right]^2 \end{aligned} \right\} \quad (13)$$

Now, even though the damping of the reed is greatly increased by means of the air vane, the total damping still remains negligibly small. For example, in the case of a 65-cycle reed with $r'/2m$ equal to 3, which is about the largest value encountered in actual indicator reeds, the value of $r'^2/4m^2$ is approximately 5×10^{-5} times the value of s'/m , so that the effect of the damping upon the frequency of free vibration is less than 1 part in 20,000. Accordingly, the frequency of free vibration of a reed outside a magnetic field may be expressed

$$f = \frac{1}{2\pi} \sqrt{\frac{s}{m}} \quad (14)$$

Substituting for s and m the values given above,

$$f = \frac{0.1617cV}{(1 + 2R)l^2} \quad (15)$$

in which c is the thickness of the reed, $V = \sqrt{E/\rho}$ is the velocity of sound in the material of the reed, and R is the ratio of mass of load to mass of reed (this is assumed small). For a similar reed, Drysdale and Jolley⁶ give

$$f = \frac{0.1637cV}{(1 + 2.05R)l^2} \quad (16)$$

The agreement between these two formulas affords excellent confirmation of the correctness of the assumptions made regarding the shape of the curve of deflections, since in the derivation of their formula Drysdale and Jolley used entirely different assumptions and a method different from that used here.

It should be pointed out, however, that the validity of (15) does not confirm the equivalent-particle assumption. The expression for the

⁶ "Electrical Measuring Instruments," II, p. 261.

frequency may be obtained by equating the average kinetic and potential energies of the reed. Since the equivalent particle is assumed to have the same kinetic and potential energies as the reed, equating the average kinetic and potential energies of the particle necessarily gives the same frequency, as may be seen by substituting in (14) the values of s and m from (9) and (7). The method here given of computing the frequency, then, involves the determination of the form of the curve of deflections, $Y=f(x)$ and it is then equivalent to the approximate method of Lord Rayleigh.⁷

Frequencies computed by means of these formulas will be somewhat higher than those actually given by the reeds in the indicator because of the lowering due to the magnetic action. If all the factors entering into these frequency lowering effects are known accurately, they may be included in the formula, but their presence complicates the result considerably. Furthermore, these factors are very difficult to determine before the reed itself is made, so that, generally, it is far simpler to use the above formula and design the reed, considering R to be zero, to have a frequency sufficiently higher than the desired frequency so that, with the reed in the indicator, a certain amount of loading must still be added to bring the frequency down to the desired value. This permits adjustment of the load for accurate tuning.

Since Drysdale and Jolley have shown⁸ that their equation (16) for the frequency of a reed checks very closely with experimental results, either (15) or (16) may be used to determine the velocity of sound in the alloy used for reeds in the indicator. This alloy, known as "Allegheny electric metal," is used because of its high magnetic permeability and low thermoelastic coefficient. The value of Young's modulus of this material, which is necessary for the calculation of the velocity of sound in it, is not available at present. From observations on a reed made from sheet stock 0.020 inch thick cold-rolled to a final thickness of 0.015 inch, the value of V was found to be 4×10^5 centimeters per second. This can be considered as an approximation only, since experience shows that V varies appreciably with the thickness to which the 0.020-inch stock is cold-rolled, the thinner material having somewhat lower values of V .

To obtain an expression for the sensitivity of a reed, (2) is used. This equation gives the value of the displacement of the reed at the driving poles. It is necessary to multiply this displacement by the ratio of the amplitude at the tip of the reed to the amplitude in the gap in

⁷ See footnote 1.

⁸ See footnote 6.

order to determine the deflection of the free end of the reed. Thus, for the tip of the reed,

$$y = \frac{Y_1}{Y_{r_0}} \frac{BI}{Z} \sin(\omega t + \theta) \quad (17)$$

For values of ω near resonance, Z may be considered as approximately equal to $\omega r'$. Consequently,

$$y_1 = \frac{Y_1}{Y_{r_0}} \frac{BI}{\omega r'} \sin(\omega t + \theta) \quad (18)$$

or,

$$Y_1 = \frac{BI}{\omega r'} \frac{Y_1}{Y_{r_0}} \quad (19)$$

Now, r' is different for reeds of different frequencies, but since it is necessary that all reeds in the indicator have resonance curves of the same shape, the sharpness of resonance S_R must be constant for all reeds. Sharpness of resonance is here defined by the equation

$$S_R = \frac{f_R}{f_1 - f_2} \quad (20)$$

where f_1 and f_2 are the frequencies at which the amplitude on the resonance curve is 0.707 of the maximum amplitude, and f_R is the frequency at maximum amplitude. It may readily be shown that, defined in this manner

$$S_R = \frac{\omega_0 m}{r'} \quad (21)$$

where ω_0 is the angular velocity at resonance. On substitution of the value of r' obtained from (21), equation (19) becomes

$$Y_1 = \frac{BIS_R}{\omega_0^2 m} \frac{Y_1}{Y_{r_0}} \quad (22)$$

or, since $\omega_0^2 m = s'$

$$Y_1 = \frac{BIS_R}{s'} \frac{Y_1}{Y_{r_0}} \quad (23)$$

To a first approximation, s may be used in place of s' , since A_2 is rarely greater than 5 per cent of s .

Now in the case of a forced vibration it is possible that even a uniform reed does not conform to the curve of deflections already given,

unless the driving force is applied at a point four-fifths of the length from the base, which is not usually the case. Furthermore, reeds having other than uniform cross sections may be desirable in many instances, as in the reed indicator. In general, therefore, the curve of deflections must be determined experimentally and the corresponding equation developed. If it is possible to approximate to the curve of deflections by assuming the reed to be deflected by a single force at some point, the task of finding the equation of this curve may be simplified greatly. It should be pointed out here, however, that this method is useless in the case of a nonuniform reed unless the dimension (or dimensions) of the reed which varies with the distance from the base is expressible as a function of x which can be integrated. If this is not the case, it is necessary to fit a power series or other function of x to the observed curve. The equations for m , r , s , frequency, and sensitivity, will then have different forms from those given above. However, it may be shown, by suitable transformations of variables and functions within the integrals, that the occurrence, in the equations for m , r , s , frequency, and sensitivity, of all quantities independent of x is not affected by the form of the function representing the curve of deflections. Thus, these equations may be of some value even though the exact form of the function representing the curve of deflections is not known. For a reed of the type that is used in the reed indicator (Fig. 2), m and s may be written

$$m = \frac{\rho lc [f_1(b_1, b_2, k) + f_2(b_1, b_2, k)R]}{F_h^2} \quad (24)$$

$$s = \frac{c^3 E f_3(b_1, b_2, k)}{N_0 l^3 F_h^2} \quad (25)$$

Here, b_1 and b_2 are the widths of the wide and narrow portions of the reed, k is the ratio of the length of the wide portion to the total length, and N_0 is a numerical constant. F_h is a function derived from the equation of the curve of deflections and is equal to the value of F ,

$$F = \frac{Y}{Y_l} = F\left(\frac{x}{l}\right) \quad (26)$$

for $X = x_0$; that is

$$= F\left(\frac{x_0}{l}\right) = F(h). \quad (27)$$

From these values for m and s

$$f = \frac{N_1 c V}{l^2} \sqrt{\frac{f_3(b_1, b_2, k)}{f_1(b_1, b_2, k) + f_2(b_1, b_2, k) R}} \quad (28)$$

$$Y = \frac{B' I S_R}{E} \frac{l^3 F_h}{c^3 f_3(b_1, b_2, k)} \quad (29)$$

where N_1 is a numerical constant and B' is the constant B of (4) multiplied by the numerical factors arising from the substitutions and transformations made to obtain (29). In these equations, the manner of occurrence of the quantities c , l , ρ , E , and V is independent of the form of the function representing the curve of deflections. Therefore, if the values of b_1 , b_2 , and k are, or can be, fixed, and an approximate value for F_h obtained, either experimentally or mathematically, the equations have a certain field of usefulness as design equations. Thus, for the type of reed in use in the radio beacon course indicator, F_h is found to be very nearly proportional to h^2 , and the following relations are found useful, in connection with experimental data:

$$f \propto \frac{c}{l^2} \quad (30)$$

$$Y \propto \frac{l^3 h^2}{c^3} \quad (31)$$

An exact equation for f may be derived by fitting to the experimentally observed curve of deflections an empirical equation and using this equation to determine the values of N_1 and the functions of b_1 , b_2 , and k . This has been done in the present investigation as follows: the curve of deflections of the indicator reed was determined by measuring the double amplitude of the vibrating reed at a number of points along its length, by means of a traveling micrometer microscope. The distance from the base of the reed to the measuring point was determined in each case. The values for the double amplitude were then corrected for the thickness of the reed, divided by two, and plotted against the corresponding distances from the base of the reed. To fit this observed curve, it was found necessary to use three separate equations; the first, containing terms in x and x^2 , applied from the base to the end of the wide portion; the second, also quadratic in x , applied from the end of the wide portion to a point three-fourths of the length from the base; and the third, which was linear, applied to the remaining portion of the reed. By calculation from these equations, taking $b_1 = 0.794$ cm, $b_2 =$

0.127 cm, and $k=0.465$ (which are the standard values for all indicator reeds), the values of f_1 , f_2 , and f_3 were found to be as follows:

$$f_1(b_1, b_2, k) = 0.037$$

$$f_2(b_1, b_2, k) = 0.172$$

$$f_3(b_1, b_2, k) = 0.179.$$

Also,

$$N_1 = \frac{1}{2\pi}$$

Upon the introduction of these values, (28) becomes

$$f = \frac{0.35cV}{l^2\sqrt{1 + 4.65R}} \quad (32)$$

or, if R is small,

$$f = \frac{0.35cV}{l^2(1 + 2.33R)} \quad (33)$$

This equation and the relations (30) and (31) have been found to check very well with experimental data taken on a large number of indicators. Fig. 5 shows the current required to drive a reed at 8-mm total

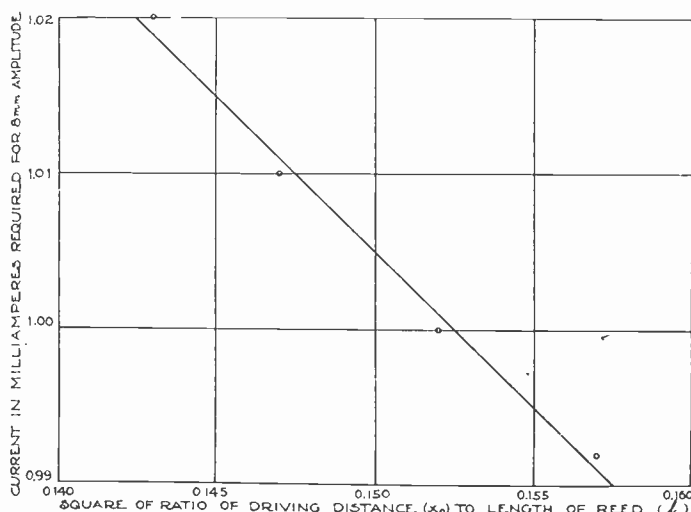

Fig. 5—Relation between current necessary to drive reed at 8-mm tip double amplitude and square of ratio of driving distance (x_0) to length of reed (l).

tip amplitude plotted against h^2 . Equation (32), of course, does not include the effect of magnetic action upon the reed frequency. As a consequence, frequencies calculated by this equation are consistently higher, by approximately 2 per cent, than the frequencies of the reeds in an indicator. In designing reeds, approximately five cycles per

second allowance is made for the effect of magnetic action and load; that is, the dimensions for a 65-cycle reed are calculated from (32) by using $f=70$ cycles per second. In special cases, when an unusually large load must be attached to the reed, greater allowances must be made.

An interesting application of these results occurs in the three-reed or twelve-course indicator. Because of space limitations in this type of indicator, it is not possible to set the driving coils at the proper positions to give equal reed sensitivities for equal gaps. In this case, the distance from the driving pole to the free end of the reed is considered constant and the reed sensitivity varied by moving the base of the reed, thus

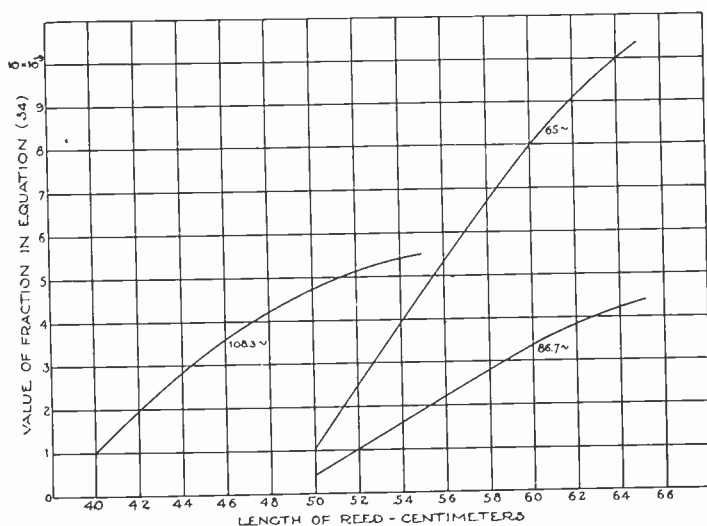

Fig. 6—Curves for determining length of reeds in twelve-course indicator.

varying the length and driving distance (x_0) simultaneously. As the length of the reed is varied, the thickness must also be changed to keep the ratio c/l^2 , and hence the frequency, constant. If d_1, d_2 , and d_3 represent the distances from driving poles to reed tips, and l_1, l_2 , and l_3 the lengths of the 65-, 86 2/3-, and 108 1/3-cycle reeds, respectively, the following equations are obtained from the given conditions:

$$\frac{\left(1 - \frac{d_1}{l_1}\right)^2}{27l_1^3} = \frac{\left(1 - \frac{d_2}{l_2}\right)^2}{64l_2^3} = \frac{\left(1 - \frac{d_3}{l_3}\right)^2}{125l_3^3} \quad (34)$$

Each of these fractions is proportional to the sensitivity of the corresponding reed, so that a graph of the value of each fraction against the corresponding length will show how the sensitivity of that reed changes as the length is varied under the prescribed conditions. Fig. 6 shows the values of all three of the fractions plotted against a common scale of

lengths for $d_1 = d_2 = 4.70$ cm, and $d_3 = 3.64$ cm. The intersections of any horizontal line with these curves give the lengths required for equal sensitivities. For actual design, the horizontal line is taken as high as possible to give maximum sensitivity. After the lengths are determined from these curves, the corresponding thicknesses can readily be calculated.

The damping of the reed is not so easily obtained. The air damping vane used on the reed introduces many factors the magnitudes of which have been difficult to control. Consequently, at the present time, no thorough experimental verification of theoretical expressions for damping is available, and the design of the air dampers continues to be mainly empirical. Equation (8) indicates that the value of r' , for a reed of fixed dimensions driven at a fixed point, should be a linear function of A_v , the area of the damping vane. The data available at present, however, when plotted against the area of the damping vane, give points that are too scattered definitely to determine the shape of the required curve. Further experimental work, perhaps accompanied by a more detailed theoretical analysis, will be necessary for a final determination of equations for the design of damping vanes.

V. CALIBRATION OF REED INDICATORS

The tuning of the reed is of the utmost importance, as the operating requirements are very exacting. Since the frequency of maximum response and the damping change with amplitude, a standard calibrating amplitude must be chosen and all measurements made at this amplitude. A very convenient method for determining the frequency and sharpness of resonance at a given amplitude Y consists in adjusting the driving source so that, as the frequency is varied, the maximum amplitude obtainable is equal to $\sqrt{2}Y$. If, then, the frequency alone is varied so that the reed vibrates with amplitude Y (which will occur at two frequencies), and the frequencies giving this amplitude measured, the frequency and sharpness of resonance may readily be computed. The measured frequencies are denoted by f_1 and f_2 , and S_R is found by means of (20), while the frequency of resonance f_R is given by

$$f_R = \frac{f_1 + f_2}{2} . \quad (35)$$

As noted above, resonance curves taken with constant current show a marked dissymmetry, the upper portions being displaced toward the low-frequency side. If the voltage across the indicator instead of the current through it is held constant, this dissymmetry is even more pronounced. Curves taken at constant amplitude, with vari-

able current, on the other hand, show only a slight dissymmetry, and here the displacement of the upper portions is toward the high-frequency side. The frequency and sharpness of resonance for the same reed will have different values when determined from these different resonance curves. Consequently, it is necessary to select as a standard one of the three possible methods of tuning a reed—at constant voltage, at constant current, or at constant amplitude. The proper choice obviously will depend upon the conditions under which the indicator is to be used.

Before this analysis is taken up, however, the cause of the difference between resonance curves at constant current and those at constant voltage should be considered. If the reed is held stationary in its neutral position and the impedance of the driving coils measured at various frequencies in the neighborhood of the frequency of resonance of

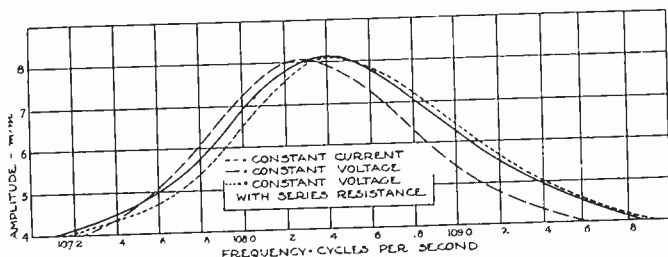

Fig. 7—Resonance curves showing effect of impedance variations upon frequency and sharpness of resonance.

the reed, this impedance will be found to be exactly the same as that of any impedance having the same constants. This is termed the damped impedance. If, now, the reed is allowed to vibrate, and the impedance again measured, at frequencies near the frequency of resonance of the reed the impedance will have values considerably different from the damped impedance. At frequencies slightly below resonance, the impedance is greater than the damped impedance, while at frequencies above resonance the impedance is less than the damped impedance. Consequently, when the voltage is held constant for measurement of a resonance curve, the current through the driving coils will vary with the frequency, being lower for frequencies lower than resonance than it is for frequencies higher than resonance. This explains the greater dissymmetry evidenced by curves taken at constant voltage. These impedance variations must be considered in tuning the reed if the indicator is to be operated under conditions such that its impedance variations will cause variations of the current through it. (see Fig. 7.)

Now, the reed indicator was developed for use in the output of a radio set as a visual course indicator for the radio range beacon. Fur-

thermore, pilots are instructed to use it at a fixed amplitude (8 mm). The volume control on the radio set may be either manual or automatic. If manual, the indicator may be considered to be operating in a series circuit comprising the indicator, a resistance equal to the output impedance of the set used, and a source of constant voltage but slightly varying frequency (because of slight variations in the modulating frequencies of the beacon transmitter). The conditions are the same if an automatic volume control operated by the received carrier wave is used. However, if an automatic volume control operated by the voltage across the indicator, such as that recently developed by the National Bureau of Standards, is used, the fluctuations of the voltage across the indicator caused by variations in the modulation frequencies will be corrected by the volume control and the voltage directly across the reed indicator, rather than that of the source in the series circuit mentioned above, will be maintained constant. Generally, the reed will be operated on a resonance curve with a maximum amplitude of 8 mm. (This includes the width of the tab on the front of the reed, the actual amplitude of vibration being only 6 mm.)

For use with a radio set having manual or carrier-operated automatic volume control, the indicator should be connected in series with a resistance equal to the output impedance of the radio set and a variable voltage of controllable frequency inserted in series with this circuit. This voltage is then adjusted so that the maximum amplitude obtainable, as the frequency is varied, is 8 mm, and for determination of f_R and S , the frequencies f_1 and f_2 giving 6.2 mm amplitude are measured, the voltage in the circuit being held constant. This value of 6.2 mm is obtained by taking 70.7 per cent of the actual amplitude of vibration, 6 mm, and adding the 2 mm width of the tab on the tip of the reed. The sensitivities of all reeds in the indicator are adjusted so that their amplitudes are the same for a given voltage impressed in the circuit described above.

For use with a radio set equipped with an automatic volume control operated by the indicator voltage, sensitivity adjustments are made as above, and tuning adjustments are made at the same amplitude. The voltage, during tuning adjustments, is maintained constant directly across the indicator terminals.

When tuned by either of these methods and operated under the corresponding conditions, the reeds show a minimum amount of variation due to the unavoidable causes pointed out in the above analysis of the operation of the reed.

In practical calibration work, the reed is driven by a vacuum tube oscillator and when this oscillator is adjusted to one of the "test fre-

quencies" (f_1 and f_2 of (20)) its frequency is determined by measuring with a stop watch the time required for ten beats between the driving oscillator and a standard frequency source. The standard frequency

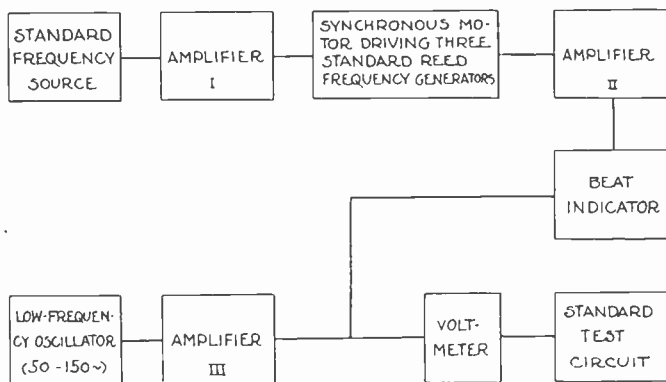

Fig. 8—Schematic diagram of reed calibrating equipment.

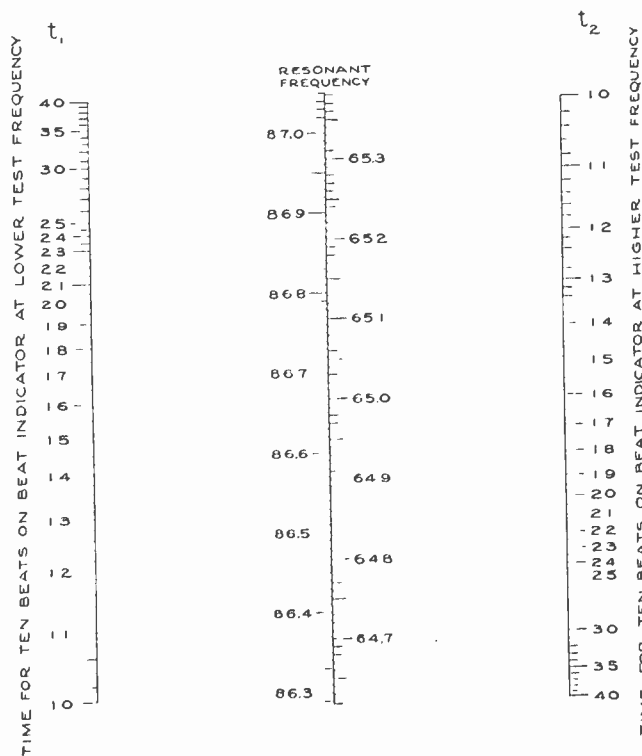

Fig. 9—Chart for determining frequencies of resonance of reeds.

source used at the National Bureau of Standards consists of three alternators, giving 65.000, 86.667, and 108.333 cycles per second, all mounted on the same shaft and driven by a 1000-cycle synchronous motor. The current to drive this motor is obtained from the primary

standard frequency equipment. Beats between the standard frequency and the driving oscillator are indicated by a vacuum tube beat frequency indicator. A schematic diagram of the complete calibrating equipment is shown in Fig. 8.

To eliminate the arithmetical work necessary to calculate the frequency and sharpness of resonance from the measured times for 10 beats at the test frequencies, two nomographic or alignment charts have been designed to facilitate the work. These charts are shown in

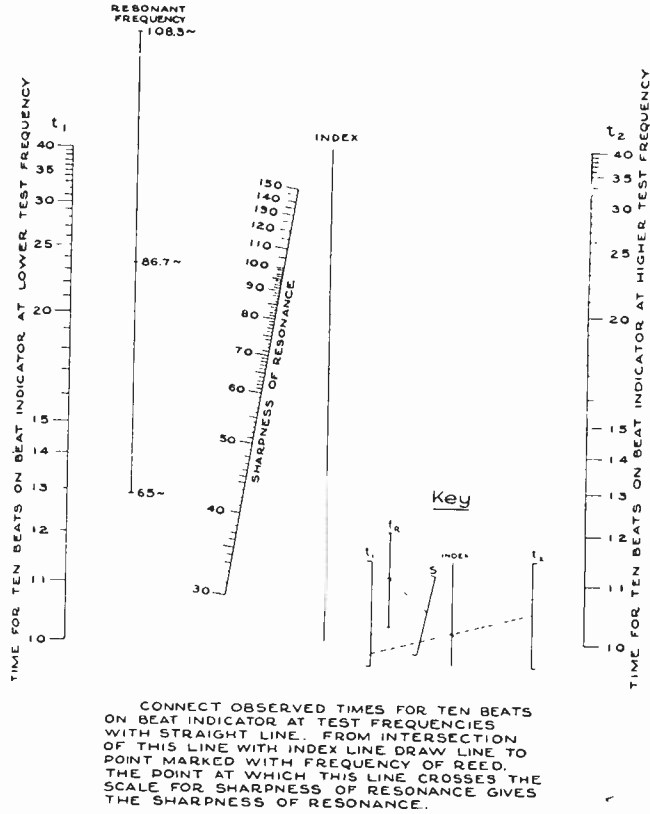

Fig. 10—Chart for determining sharpness of resonance of reeds.

Figs. 9 and 10, the former being used to obtain the frequency and the latter for sharpness of resonance. In the first figure, the two measured times are located on the scales indicated for them, and the straight line connecting these two points crosses the central line at a point which determines the frequency of resonance. The second figure is self-explanatory.

VI. CONCLUSION

By means of Rayleigh's approximate method, equations are obtained for the frequency of free vibration of a uniform reed and for a particular type of nonuniform reed.

To obtain an expression for the sensitivity of a driven reed, the entire reed is assumed to be replaceable by an equivalent particle located at the driving point. The equation thereby derived for the sensitivity of the reed checks very closely with results observed with the type of reed used in the reed indicator.

The theory also points out factors affecting the performance of the reeds which must be included in any consideration of procedures of calibration and adjustment, and it enables a method of calibration to be developed which will give the most desirable performance of the reeds in operation.

In conclusion, the writer wishes to express appreciation to F. W. Dunmore for much information regarding practical considerations in connection with the reed indicator, and to H. Diamond for many valuable suggestions.



SOME EXPERIMENTAL STUDIES OF THE VIBRATIONS OF QUARTZ PLATES*

BY

R. B. WRIGHT AND D. M. STUART

(Bureau of Standards, Washington, D. C.)

ABSTRACT

Numerous modes of vibration of zero- and thirty-degree cut circular and rectangular crystalline quartz plates were studied experimentally. Various methods were employed in studying these modes which are piezo-electrically excited. The behavior of lycopodium powder applied to the vibrating faces proved to be the most fruitful source of information. A number of photographs of the patterns thus formed are produced and described. Although of limited utility two mechanical devices also were employed in these studies.

The direction of maximum radial displacement was determined for the two active lower frequency modes of zero-degree circular plates. It was found that these directions are nearly parallel to directions of critical values of Young's modulus. Facts were disclosed concerning specially oriented rectangular plates and rods. Experimental values of Young's modulus based on vibration frequencies of the latter were found to agree closely with corresponding values computed from a known theoretically derived expression. Rough experimental verification of the direction of one of the critical values of Young's modulus was obtained.

Equations are derived for the modulus of rigidity and Poisson's ratio for crystalline quartz as functions of orientation, and graphs of these two functions as well as of Young's modulus are given.

Methods are indicated, which may prove advantageous, of rigidly mounting quartz plates.

* Published in full in *Bureau of Standards Journal of Research*, 7, 519—555; September, 1931.



CORRECTION

J. B. Dow has brought to the attention of the editors the following correction to his paper "A Recent Development in Vacuum Tube Oscillator Circuits," which appeared in the December, 1931, issue of the PROCEEDINGS. On page 2097 equality should read

$$C_n/C_t = C_a/C_p.$$

BOOK REVIEWS

Experimental Radio Engineering, by John H. Morecroft. Published by John Wiley and Sons, New York. 345 pages; 250 figures. Price \$3.50.

This is a textbook directed specifically to the teaching of radio principles in the laboratory, rather than to explaining the specific operation of radio apparatus. The author's viewpoint is that "The efforts of the radio engineer should be directed to mastering the relationships of the multitudinous factors which affect the performance of radio apparatus. Some one has the task therefore of dissecting into its simple constituents, receiving and transmitting apparatus, and laying out such tests as shall bring out the characteristics of these component parts. Then in so far as the performance of one part affects the operation of another, other tests must be laid out to show these mutual relationships."

There are 51 experiments covering a variety of radio subjects and in each of which the problem is analyzed and the experimental work outlined. This book may be considered as a laboratory companion book to the author's "Principles of Radio Communication."

*S. S. KIRBY

The Orfordness Rotating Beacon and Marine Navigation. Radio Research Special Report No. 10, by R. L. Smith-Rose. Obtainable from H. M. Stationery Office, Adastral House, Kingsway, London, or The British Library of Information, French Building, 5 East 45th Street, New York, N. Y. 14 pp. Price 6d net.

This report contains a description of the British rotating loop radio beacon and a description of the method of taking bearings with a radio receiver and stop watch and also with an automatic recorder. The results of a large number of observations made at sea are summarized. These observations showed that in 80 per cent of the cases the error in bearing was not over 2 degrees. Coastal deviations and night errors are also discussed.

*S. S. KIRBY

Données Numeriques de Radioélectricité, edited by R. Mesny. May be purchased from Secrétaire General Ch. Marie, 9 rue de Bagneux, Paris (VI^e). Representative in United States and Canada, McGraw Hill Book Co., N. Y. pp. XIX+17.

This is the radio chapter of Volume VII of "Tables Annuelle de Constantes et Données Numeriques" published by the International Council of Research. These data have been obtained by careful examination of the periodicals. Numerical data on the following subjects are given in this chapter: electronic tubes, propagation of waves, radiation measurements, atmospheric, high-frequency resistance, miscellaneous. References are given to all the original articles from which the data are taken. This material is indexed in German, English, French, and Italian, and explanatory notes given in English and French.

*S. S. KIRBY

* Bureau of Standards, Washington, D. C.

Radio in Advertising, by Orrin E. Dunlap, Harper and Bros., Publishers, New York. 383 pp.

This is a comprehensive book, treating of every phase of the art of radio advertising. The author points out the good and the bad methods of advertising, including many actual quotations from advertisers. He also shows the reaction of the public to various kinds of advertising by many quotations from listeners. Appendixes are added which contain data sufficient for planning a complete program of advertising. The latest information on the important subject of broadcast coverage is also included.

*K. A. NORTON

Radio Handbook, by Moyer and Wostrel. McGraw Hill. Flexible binding. 386 pp. Price \$5.00.

This book is a well-indexed, and accurate source of information on practically every subject pertaining to radio.

The first four sections are devoted to a discussion of elementary electrical theory and fundamental radio principles. The rest of the book consists of a detailed description of power supply systems, vacuum tubes and associated circuits, receiving equipment, commercial and broadcast transmitting equipment, laboratory apparatus and methods of high-frequency measurements, and photo-electric cells and their applications.

All of the material which is included has been carefully compiled and clearly presented. The book is evidently not addressed to the engineering profession but is rather intended as a source of information for the practical man and as such it should serve its purpose very well indeed.

*S. S. KIRBY

* Bureau of Standards, Washington, D. C.



BOOKLETS, CATALOGS, AND PAMPHLETS RECEIVED

Copies of the publications listed on this page may be obtained gratis by addressing a request to the manufacturer or publisher.

To enable broadcasters to meet the rigid requirements of General Order No. 116 of the Federal Radio Commission, a new frequency monitor has been developed by the General Radio Company of Cambridge, Mass., and is described in their 8-page catalog, supplement F-400. The essential element of the new monitor is a highly stabilized piezo-electric temperature controlled frequency standard which operates at a frequency differing from the assigned carrier frequency by exactly 1000 cycles per second. Voltages from this standard and from the unmodulated master oscillator of the transmitter are supplied to an audio-frequency meter which indicates the deviation of the transmitter frequency. The deviation of the transmitter carrier frequency from the assigned frequency may be read directly and continuously on a zero-center type of meter having a scale approximately five inches in diameter and calibrated in steps of 10 cycles per second from -100 cycles per second to $+100$ cycles per second from the assigned frequency. The absolute accuracy of this monitor may be expected to be within five parts in a million, with reasonable care and use.

Several types of resistor units are described in folders issued by Hardwick Hindle, Inc., Newark, N. J. Catalog No. 730 describes tubular rheostats having power ratings up to 750 watts. Catalog No. 630 lists enameled slide-wire resistors for use where the resistance needs be changed only occasionally. These units are available in stock sizes up to power ratings of 120 watts. Several types of fixed and tapped resistors are described in catalog No. 429.

An eight-page brochure, "Jewell Radio Instruments," describes the entire line of tube testers, set analyzers, test oscillators, output meters, resistance meters, and d-c and a-c meters manufactured by the Jewell Electric Instrument Company, 1640 Walnut St., Chicago, Ill.

Bulletin No. 18 of Jenkins and Adair, Inc., 3333 Belmont Avenue, Chicago, Ill., gives briefly the operating characteristics of three tubes designed for use in public address systems and audio-frequency amplifiers. The tubes are intended for use as a voltage amplifier, a small power amplifier, and a fifty-watt power amplifier. Bulletin No. 17 describes a portable amplifier for talking picture recording, phonograph recording, and broadcast purposes.



RADIO ABSTRACTS AND REFERENCES

THIS is prepared monthly by the Bureau of Standards,* and is intended to cover the more important papers of interest to the professional radio engineer which have recently appeared in periodicals, books, etc. The number at the left of each reference classifies the reference by subject, in accordance with the "Classification of radio subjects: An extension of the Dewey Decimal System," Bureau of Standards Circular No. 385, which appeared in full on pp. 1433-56 of the August, 1930, issue of the PROCEEDINGS of the Institute of Radio Engineers.

The articles listed are not obtainable from the Government or the Institute of Radio Engineers, except when publications thereof. The various periodicals can be secured from their publishers and can be consulted at large public libraries.

R000. RADIO

R007 P. G. Loucks. Radio legislation in the United States. *The Journal of Air Law*, 1, 572-580; October, 1931.

References to the most recent state legislation which is found in the 1931 Session Laws are given.

R007 W. Hoffman. The legal basis for broadcasting in Germany. *The Journal of Air Law*, 1, 491-498; October, 1931.
×R550

Eleven articles relative to broadcasting in Germany are included.

R007 H. M. Smith. The regulation of television. *The Journal of Air Law*,
×R583 1, 499-507; October, 1931.

The present legal status of regulation of television is reviewed. A list of the licensed television stations is given.

R100. RADIO PRINCIPLES

R113 Scattered radiation from short-wave beams (editorial). *The Wireless Engineer and Experimental Wireless*, 8, 579-580; November, 1931.

An effort is made to explain the secondary or diffused radiation as being caused by the passage of electromagnetic waves through the ionized layer.

R113.5 I. S. Bemis. Some observations of the behavior of earth currents and their correlation with magnetic disturbances and radio transmission. *Proc. I.R.E.*, 19, 1931-47; November, 1931.

Correlations between the abnormal earth currents noted during magnetic storms and transoceanic radio transmission on both long and short waves are presented. The radio transmission data were collected on the telephone circuits operating between New York and London and between New York and Buenos Aires. The earth current data were collected on two Bell System lines extending approximately 100 miles north and west from New York.

R113.6 S. Namba, E. Iso, S. Ueno. Polarization of high-frequency waves
×R125.31 and their direction finding. *Proc. I.R.E.*, 19, 2000-2019; November, 1931.

Results of experiments which were conducted during the past two years for the purpose of studying the high-frequency transmission phenomena are described. Some physical explanations are deduced. The measurement of polarization is taken up in connection with direction finding.

* This list compiled by Mr. A. H. Hodge, Mr. W. H. Orton, and Miss E. M. Zandonini.

- R113.6 S. Namba, Polarization phenomena of low-frequency waves. *Proc. I.R.E.*, 19, 1988-1999; November, 1931.
A cathode-ray oscillograph method of determining the state of polarization of a down-coming wave is described. A summary of results obtained with this method is given.
- R116 A. Mohammed, and S. R. Kantabet, Formation of standing waves on Lecher wires. *Proc. I.R.E.*, 19, 1983-1987; November, 1931.
With a short review of the work on Lecher wire methods of wavelength measurement, this paper describes in detail the wave form of current distribution along wires under a variety of terminal conditions of length and impedances.
- R132 K. Schlesinger. Der Widerstandsverstärker als Schwingungskreis. (The resistance-coupled amplifier stage as an oscillation circuit.) *Elek. Nachr.-tech.*, 8, 437-443; October, 1931.
The equivalent circuit of a resistance-coupled amplifier stage is shown to be a strongly damped oscillation circuit plus a fictional amplification. Phase relations and frequency or resonance curves for an n -stage amplifier are easily determined using this method.
- R132
× R141 K. Schlesinger. Einschaltvorgänge beim Widerstandsvertärker. (Transient phenomena in resistance-coupled, cascade amplifiers.) *Zeit. für Hochfrequenz.*, 38, 144-147; October, 1931.
The results of an oscillographic analysis of transient phenomena in the output of an n -stage resistance-coupled amplifier are compared with theoretical results previously obtained by the author. Measured time constants per stage are given.
- R132 W. I. G. Page. The voltage on the grid. *Wireless World and Radio Review*, 24, 489-490; October 28, 1931.
This article tells how the signal grows from stage to stage and discusses grid swing and negative bias.
- R133 E. B. W. Gill. Electrical oscillations of very short wavelength. *Phil. Mag.*, 12, 843-853; October, 1931
Very high-frequency oscillations are discussed. Methods of generating these waves and a theoretical explanation of their generation are given.
- R133 P. von Handel. Stabile und labile Schwingungen eines Zwei-kreis-Röhrengenerators bei überkritischer Kopplung. (Stable and unstable oscillations of a Meissner type vacuum-tube generator with close coupling between the two circuits.) *Zeits. für Hochfrequenz.*, 38, 129-136; October, 1931.
General conditions for oscillation stability are derived by reducing the system of a self-excited vacuum-tube generator to a simple equivalent undamped oscillating circuit. In the light of results thus obtained, the possible oscillating points of single and double-circuit generators are analyzed with reference to their stability.
- R133 E. D. McArthur and E. F. Spitzer. Vacuum tubes as high speed oscillators. *Proc. I.R.E.*, 19, 1971-1982; November, 1931.
The problem of tubes for generating power at wavelengths below five meters is discussed. The theory of the triode and split-anode magnetron is considered with particular reference to the limitations imposed by operation at short wavelengths. Essential data are given for examples of each type of tube, showing the power that can be obtained at various wavelengths.
- R134 J. R. Nelson. Grid circuit linear detection. *Radio Engineering*, 11, 32-34; November, 1931.
This article discusses briefly the operation of the screen-grid tube used as a grid circuit detector. Several graphs are included.
- R142.6 V. J. Andrew. The adjustment of the multivibrator for frequency division. *Proc. I.R.E.*, 19, 1911-1917; November, 1931.
In a multivibrator controlled by a voltage of another frequency having a harmonic relationship to the multivibrator frequency, the effect of varying the control voltage is analyzed, and a method for determining the best value of this voltage is described.

- R148 Z. Bouck. Counteracting acoustic feed back through the tuning condenser. *Radio Engineering*, 11, 21-22; November, 1931.
A solution for the distortion produced by reducing condenser dimensions is pointed out.
- R149
×R134 G. Ulbricht. Untersuchungen über Anodengleichrichtung. (A study of plate rectification.) *Zeits. für Hochfrequenz.*, 38, 111-115; September, 1931; 38, 136-144; October, 1931.
An exhaustive analysis of plate-rectifying action in three-electrode vacuum tubes is given.
- R191 C. B. Sawyer. The use of Rochelle salt crystals for electrical reproducers and microphones. *Proc. I.R.E.*, 19, 2020-2029; November, 1931.
A brief historical résumé of the development of piezo activity for acoustic uses and references are given. The principles involved in the use of Rochelle salt crystals as electrical reproducers are discussed. Microphones, pick-ups, and especially speakers are described, with some discussion of limiting conditions of load, temperature, and other operating conditions.
- R200. RADIO MEASUREMENTS AND STANDARDIZATION
- R241.5 J. A. C. Teegan. On the measurement of high resistance by the bridge method. *Phil. Mag.*, 12, 840-843; October, 1931.
A vacuum tube is used to replace the galvanometer in an adaptation of a bridge circuit.
- R254 J. Kammerloher. Neue Messmethode zur Bestimmung des Modulationsgrades von Telephoniesendern. (A new method of measuring percentage modulation of radiotelephone transmitters.) *Elek. Nach.-technik*, 8, 458-462; October, 1931.
An oscillographic method of measuring percentage modulation is described. The method is applicable for modulation frequencies from 10 to 5000 cycles per second.
- R262.9 E. N. Dingley, Jr. Development of a circuit for measuring the negative resistance of pliodynatrons. *Proc. I.R.E.*, 19, 1948-1950; November, 1931.
An adaptation of the Wheatstone bridge is used to measure the negative resistance of pliodynatrons.
- R270 K. Sohnemann. Feldstarkemessungen im Ultrakurzwellengebiet. (Field intensity measurements at ultra-high frequencies.) *Elek. Nach.-technik*, 8, 462-467; October, 1931.
Apparatus for making field intensity measurements at ultra-high frequencies is described. Super-regenerative reception is used and calibration is accomplished in the known field of a small auxiliary transmitter. Experimentally determined absorption coefficients and polarization conditions are given.
- R270 Lloyd Espenschied. Methods of measuring interfering noises. *Proc. I.R.E.*, 19, 1951-1954; November, 1931.
Various methods of measuring interference, particularly in radiotelephony, are outlined.
- R300. RADIO APPARATUS AND EQUIPMENT
- R330 C. W. Hough. A cold filamentless radio tube. *Electronics*, 3, 182-183; November, 1931.
A note accompanied by an editor's foreword in which an article describing the new tube is predicted.
- R339
×R133 D. Pollack. A neon-tube audio-frequency oscillator. *Radio Engineering*, 11, 24-25; November, 1931.
The discharge of a condenser through a neon tube is used to make the voltage across the tube first above then below ignition potential.

- R339 E. H. Hansen. Glow-lamp noiseless recording. *Electronics*, 3, 177-
×621.385.96 179; November, 1931.
The circuits and operating characteristics of the glow-lamp in sound recording are presented.
- R355.6 G. Grammar. More about economical crystal control. *QST*, 15,
22-31; November, 1931.
Efficient frequency doubling, clearing up of neutralization, and isolation of sources of trouble, are discussed.
- R355.6 J. W. Conklin, J. L. Finch and C. W. Hansell. New methods of
frequency control employing long lines. *Proc. I.R.E.*, 19, 1918-
1930; November, 1931.
The objections to crystal control for some transmitters operated on frequencies above 35,000 kc are given. Methods are described for meeting these objections through frequency control by long radio-frequency transmission lines, which have inherently large volt-ampere capacity and which make possible a considerable reduction in operating costs and improvement in reliability.
- R355.8 L. E. Barton. The class B push-pull modulator. *QST*, 15, 8-13;
November, 1931.
Description of an efficient system of complete modulation in amateur radio transmitters is given.
- R355.9 F. M. Colebrook. The dynatron oscillator. *The Wireless Engineer and Experimental Wireless*, 8, 581-584; November, 1931.
Practical details are given for the application of screen-grid tubes to the maintenance of oscillations by the dynatron method. An upper frequency limit of 15 megacycles is attained. By connecting the control grid through a high resistance to the filament and through a variable condenser to the plate, a new type of oscillation generator is obtained which can be used for frequencies up to 50 megacycles per second.
- R360 C. H. W. Nason. Radio reception from distant stations, with receiver located close to powerful transmitter. *Radio Engineering*, 11, 35; November, 1931.
A device which enables one to receive the signals of distant transmitting stations in the vicinity of local transmitting stations is described.
- R361 McM. Silver. A 200-2000 meter broadcast receiver design. *Radio News*, 13, 469-470; December, 1931.
Description of a receiving set which will combine broadcast and long wave reception, is given.
- R361.2 W. T. Cocking. Superheterodyne tendencies. *Wireless World and Radio Review*, 24, 460-464; October 21, 1931.
This article summarizes the salient features and gives valuable help on the practical details of design.
- R381 R. A. Lane. The electric condenser. *Radio Engineering*, 11, 17-20; November, 1931.
A technical presentation of the subject of condenser design and assembly is given. The condenser considered is the foil-paper type such as is used in telegraph, telephone, radio, and power factor operations.
- R383 W. A. Barclay. Choosing anode feed resistances. *Wireless World Radio Review*, 24, 472-474; October 21, 1931.
The object of the present article is to describe briefly an alignment chart which renders the process of choosing resistance values more or less automatic.
- R387.1 J. G. Ferguson. Shielding for electric circuits. *Bell Laboratories Record*, 88-92; November, 1931.
Various shielding arrangements for an impedance or a group of impedances are described.

- R388 V. K. Zworykin. Improvement in cathode-ray tube design. *Electronics*, 3, 188-190; November, 1931.

A new, hot-cathode, high-vacuum type cathode-ray tube is described. Focusing is accomplished electrostatically by means of a double anode structure. A special electrode is provided which gives undistorted control of the intensity of the spot.

R400. RADIO COMMUNICATION SYSTEMS

- R410 Die Anwendung des Ein-Seitenband-Systems in der Kurzwellentechnik. (Application of the single side band system in the field of high-frequency radio.) *Zeits. für Hochfrequenz.*, 38, 148-153; October, 1931.

After discussing difficulties and advantages of the single side band system, a detailed description is given of the equipment used in successful experiments recently carried out by French and Spanish interests.

- R412 A. A. Oswald. New overseas radio-telephone extensions. *Bell Laboratories Record*, 66-69; November, 1931.

Direct connections from New York to Rio de Janeiro, New York to Bermuda and San Francisco to Honolulu are now under construction. A new simplified type of antenna is briefly described.

- R490 E. E. Free. Telephony on a light beam. *Radio News*, 13, 466-467, December, 1931; 538-539; December, 1931.

A communication system which uses a modulated light beam as the transmitted energy is described. Reception is accomplished by means of a light sensitive tube.

R500. APPLICATIONS OF RADIO

- R533 I. J. Saxl. Controlling trains with light rays. *Radio News*, 13, 464-465; December, 1931.

×535.38

Apparatus employing an optical system and selenium cell is used to signal trains.

- R536 J. I. Heller. Methods used in electrical prospecting. *Electronics*, 3, 184-185; November, 1931.

Several methods of electrical prospecting are briefly reviewed.

- R550 F. Schröter. Zur Frage des Ultrakurzwellen-Rundfunks. (On the question of ultra-short wave broadcasting.) *Elek. Nach.-technik*, 8, 431-437; October, 1931.

×R423.5

The practicability of localized city-wide broadcasting at ultra-high frequencies is demonstrated by results of numerous experiments bearing on this plan.

- R555 Transmissions of wireless waves of standard frequencies from the National Physical Laboratory. *The Post Office Electrical Engineers' Journal*, 24, 237-238; October, 1931. (Call letters G5SW.)

The schedule of transmissions is announced. Instructions for calibrating a frequency meter are included.

- R583 R. W. Tanner. A new television system. *Radio Engineering*, 11, 27-28; November, 1931.

A system is described which has possibilities in throwing the received picture directly on the screen without employing a lens.

- R583 C. O. Browne. Technical problems in connection with television. *Jour. I.E.E. (London)*, 69, 1232-1234; October, 1931.

Two problems of television; namely, transmission and sufficient illumination on the receiver screen, are discussed.

R600. RADIO STATIONS

- R612.1 G. Lubszynski and K. Hoffmann. Die rundfunktechnischen Einrichtungen im neuen "Haus des Rundfunks" in Berlin. (The ar-

rangement and equipment of the "House of broadcasting" in Berlin.) *Elek. Zeits.*, 52, 561-566; April, 1931; *Proc. I.R.E.*, 19, 1955-1970; November, 1931.

A detailed description of the newly built broadcast center in Berlin.

- R612.1 J. Plebanski. Poland inaugurates long-wave super-power broadcasting. *Radio News*, 13, 484; December, 1931.

A powerful new transmitter constructed along the lines of Lt. Wenstrom's proposed single-coverage station for the U. S. has been giving Europe non-fading reception with simple sets.

R800. NONRADIO SUBJECTS

- 537.65 P. Vigoureux. Quartz resonators and oscillators (book). Noted in the *Wireless Engineer and Experimental Wireless*, 8, 602-603; November, 1931. Published by H. M. Stationery Office, London, price 7s 6d.
- The scope of the work covers the general physical properties of quartz; the theory, including optical and piezo-electric tests of the quartz; and some practical hints on the technique of production.
- 537.7 G. S. C. Lucas. Distortion in valve characteristics. *The Wireless Engineer and Experimental Wireless*, 8, 595-598; November, 1931.
- A simple arithmetical method for determining the amplitudes of the second, third and fourth harmonics with fair accuracy from the characteristic curve for the tubes is given.
- 621.314.3 G. E. Fleming. Power transformer design for the home experimenter. *Radio News*, 13, 480-481; December, 1931.
- Formulas for the design of a power transformer are given.
- 621.385 H. Jordan. Über die Beseitigung von Störgeräuschen in beeinflüssten Fernsprech Kabelleitungen. (On the prevention of inductive interference in telephone lines.) *Elek. Nach.-technik*, 8, 421-430; October, 1931.
- Conditions for eliminating disturbances in communication circuits due to inductive interference are discussed.



CONTRIBUTORS TO THIS ISSUE

Bailey, S. L.: Born October 7, 1905, at Minneapolis, Minnesota. Received B.S. degree in E.E., University of Minnesota, 1927; M.S. degree, 1928. Research in field intensity measuring apparatus. Assistant radio engineer, Airways Division, Department of Commerce, 1928; associate radio engineer, Airways Division, Department of Commerce, 1929; consulting engineer, Jansky and Bailey, 1929 to date. Associate member, Institute of Radio Engineers, 1928.

Davies, G. L.: Born November 24, 1905, at Scranton, Pa. Case School of Applied Science, 1929. National Carbon Company, June to October, 1929; Bureau of Standards, 1929 to date. Nonmember, Institute of Radio Engineers.

Heising, Raymond A.: Born August 10, 1888, at Albert Lea, Minnesota. Received E.E. degree, University of North Dakota, 1912; M.S. degree, University of Wisconsin, 1914. Technical staff, Engineering Department, Western Electric Company and its successor, Bell Telephone Laboratories, 1914 to date; connected with the development of transmitting apparatus, designed and operated the Arlington Transatlantic Telephone Transmitter, 1915; invented constant current modulation system used extensively in commercial broadcast work and by the United States Army and Navy. During the war, acted as instructor to technical men assigned by War Department to Western Electric Laboratories. Since the war, continued research and development work in connection with ship-to-shore operation, transatlantic tests, etc. Awarded Morris Liebmann Memorial Prize by the Institute, 1921. Associate member, Institute of Radio Engineers, 1920; Fellow, 1923.

Jansky, C. M., Jr.: Born at Delton, Michigan. Received B.S. degree in Physics, University of Wisconsin, 1917; M.S. degree, 1919. Instructor, in charge of University's broadcast and experimental station, associate professor, radio engineering, Department of Electrical Engineering, University of Minnesota, 1920-1929. Member of the four National Radiotelegraph Conferences. Consulting engineer, Jansky and Bailey, Washington, D.C., 1929 to date. Member, Associate member, Institute of Radio Engineers, 1918; Member, 1925; Fellow, 1928.

Merritt, Ernest: Born April 28, 1865, at Indianapolis, Indiana. Received M.E. degree, Cornell University, 1886; student, University of Berlin, 1893-1894. Associate professor of Physics, Cornell University, 1894; professor, 1904-1918; head of Physics Department, 1919 to date; Dean, graduate school, 1909-1913. Physicist, U. S. Naval Experimental Station, New London, working on anti-submarine devices, 1917-1918. Member, National Academy of Sciences, American Academy, American Physical Society. Member, Institute of Radio Engineers, 1915.

Quäck, Erich: Born July 27, 1890, at Bischofsheim bei Mainz, Germany. Studied at the Technical High School, Darmstadt. Served as volunteer at the Maschinenbau and Mühlenanstalt Luther, Darmstadt und Schuckert, Nürnberg. Entered the Telefunken Laboratory, 1905; chief engineer, Amalgamated Wireless Telegraph and Telephone Company, Berlin-London, (Poulsen system) 1907-1909; chief engineer, Telefunken Company, 1910; acting member of the manage-

ment of the Transradio A. G. für drahtlosen Überseeverkehr, 1921 to date. Non-member, Institute of Radio Engineers.

Robinson, Harris A.: Born November 13, 1907, at Philadelphia, Pennsylvania. Received B.S. degree in E.E., Moore School of Electrical Engineering, University of Pennsylvania, 1929; graduate work, Union College, 1929-1930; M.S. degree in E.E., University of Pennsylvania, 1931. Amateur radio operator and experimenter, 1921 to date; commercial radio operator, Radiomarine Corporation of America, summer, 1928; General Electric Radio Test Course, 1929-1930; student engineer, RCA Victor Company, Inc., 1931 to date. Associate member, Sigma Xi. Junior member, Institute of Radio Engineers, 1927; Associate, 1929.

Schor, F. W.: Born November 27, 1905. Received degree in E.E., Armour Institute of Technology, 1928. Standards Laboratory, Western Electric Company, 1924-1926; associate engineer, Temple Corporation, 1928-1929; engineering staff, United Air Cleaner Corporation, 1929-1930; chief engineer, K. B. Motoradio Corporation, 1930; engineering staff, Grigsby-Grunow Company, 1930-1931; consulting engineer, 1931 to date. Associate member, Institute of Radio Engineers, 1929.

Wenstrom, William H.: Born July 28, 1898, at Sala, Sweden. Graduate, United States Military Academy, 1918; postgraduate course, 1919; Cavalry School, 1920; Signal School, 1924. Regimental and brigade communications officer, 1921-1923, 1924-1926. Instructor, United States Military Academy, 1926-1930. Graduate student, Yale University, 1930-1931; instructor, The Army Signal School, 1931 to date. First Lieutenant, Signal Corps, United States Army. Associate member, Institute of Radio Engineers, 1925.



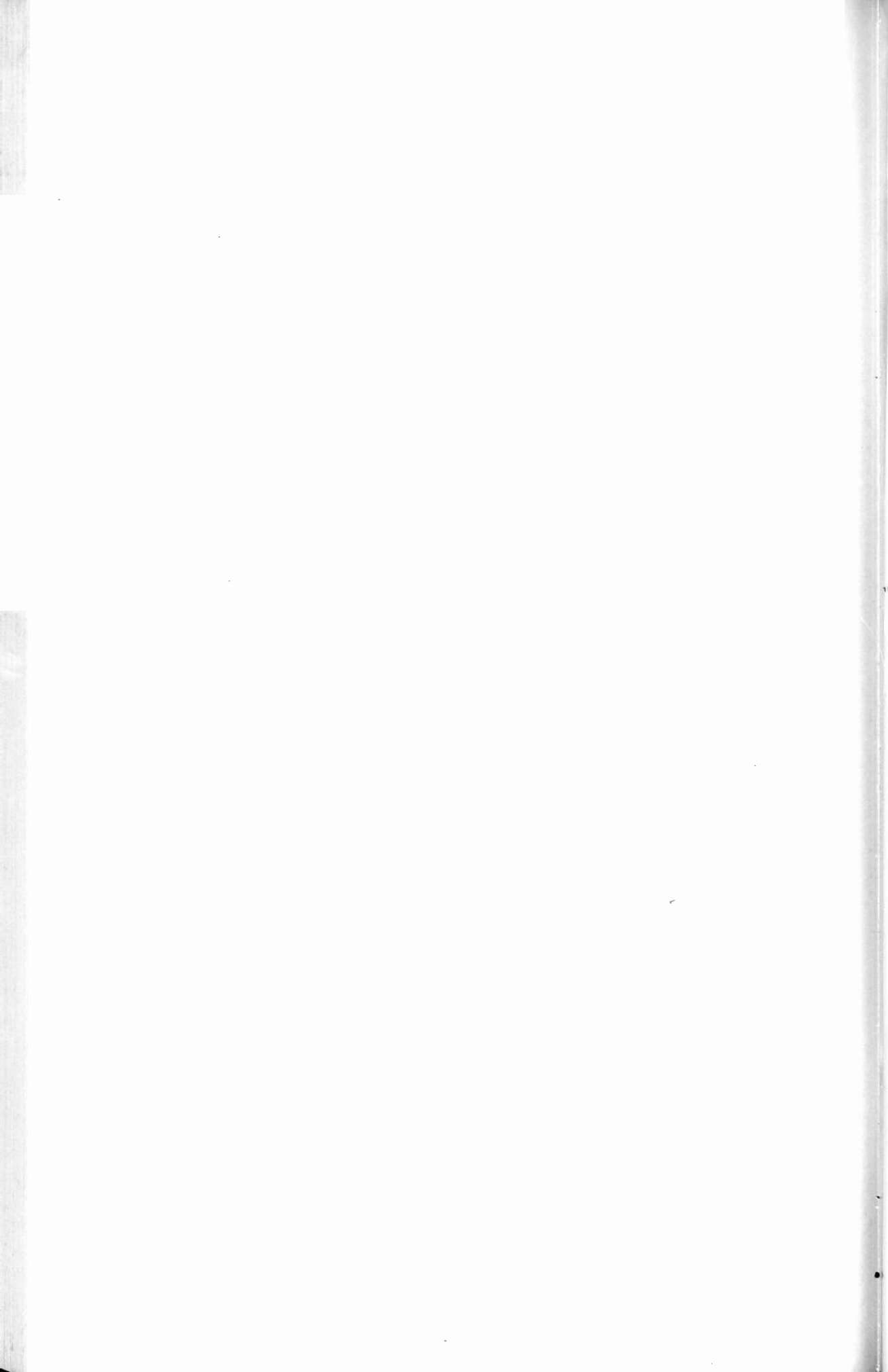

1932

WILL REQUIRE — MORE THAN EVER —

I. R. C. RESISTORS

RADIO set acceptance depends upon consistently high levels of performance. This means components of the highest quality.

Accuracy and permanence of resistance units will be of rising importance in 1932. The International Resistance Company, makers of Type "K" *Metallized* Resistors, pledges itself to uphold the standards set by millions of these resistors now in use.

1931 was the biggest year in our history. The growth of this company has been uninterrupted since its establishment in 1923—and we are prepared for continued growth in 1932. Sales, engineering and production facilities have been enlarged. New fields will be opened. We are ready to serve them.

Television occupies the minds of engineers. Standards of resistor performance in this field are more stringent.

I.R.C. engineers are keeping pace with the problem, and have a resistor ideally suited for television requirements.

To meet the needs for accurate Wire Wound resistors, we have developed Precision Wire Wound units which have found wide acceptance among engineers. These developments will continue with the growth of the vacuum tube industry.

Provision has been made to meet your resistor needs quickly. Manufacturing plants in Philadelphia and Toronto, Canada; branch offices in principal cities; and licensees and foreign agents in leading foreign countries assure prompt shipments. After making up your specifications for 1932, we suggest that you communicate with us. We welcome an opportunity to discuss your individual resistor problems.



INTERNATIONAL RESISTANCE COMPANY

PHILADELPHIA

--

TORONTO

DEVOTED EXCLUSIVELY TO THE MANUFACTURE OF RESISTORS

When writing to advertisers mention of the PROCEEDINGS will be mutually helpful.

ANNOUNCING A NEW TELETYPEWRITER SERVICE



THE BELL SYSTEM offers to the public a new Teletypewriter Service. Any subscriber to this service may be connected, through the teletypewriter "central," to any other subscriber, whether he be around the corner or across the continent. Subscribers can type back and forth by wire, for short or long periods, just as they now hold conversations by telephone.

This important development for the business world parallels the other progress which is constantly being made in the telephone art.

Messages, inquiries, reports — typed in one office — are instantly and accurately reproduced on the other subscriber's teletypewriter. Typewritten copies made by both sending and receiving machines are available for permanent records. The principal feature of this new service,

which distinguishes it from existing private line teletypewriter service, is that any subscriber may ask for any other subscriber and be connected immediately.

Further information about this new development in nation-wide communication will be furnished gladly by your local Bell Telephone Business Office.

Teletypewriter Service provides two-way communication.

Speed of connection is as fast as telephone service.

A typewritten record, one or more copies, is produced simultaneously by both sending and receiving machines.

Material transmitted may be recorded on forms if desired.

Teletypewriters are like ordinary typewriters in appearance.

Teletypewriters can be operated by any one who can operate a typewriter.

You can use Teletypewriter Service any time you need it.

A most economical form of record communication.

AMERICAN TELEPHONE AND TELEGRAPH COMPANY



When writing to advertisers mention of the PROCEEDINGS will be mutually helpful.

NEWEST and BEST IN AUTO SPEAKERS

Magnavox with the
**SINGLE STUD
MOUNTING**

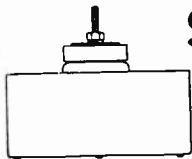

New tone quality, new practicality of design—these are the outstanding characteristics of these 1932-improved Magnavox Dynamic Speakers for automobile radio.

Never has such tone quality—full, true, rich—been possible with old-type speakers for automobile use. Magnavox has mastered this tone problem, the most difficult in radio, with these new Dynamic Speakers.

The *single-stud* mounting is important. This exclusive Magnavox feature renders installation easy on any dash. Bracket mountings also available. Rugged, dust-proof design makes these speakers a match for the punishment that automobile radios must stand.

These Magnavox-quality speakers are going to solve a big problem for more than one radio manufacturer. If they cost a few cents more they're worth it! Let us send models, with complete engineering data. No obligation.

Magnavox Company Ltd.

Executive and Sales
Offices

155 E. Ohio St.,
Chicago, Ill.

Factories: Fort
Wayne, Indiana



Subsidiaries:
The Magnavox
Company Electro
Formation, Inc.
Magnavox (Great
Britain) Ltd. Mag-
navox ((Australia)
Ltd.

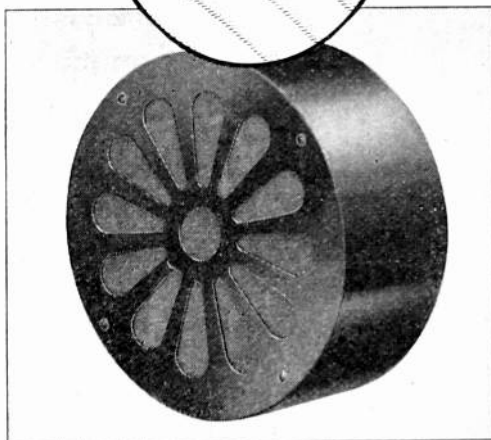
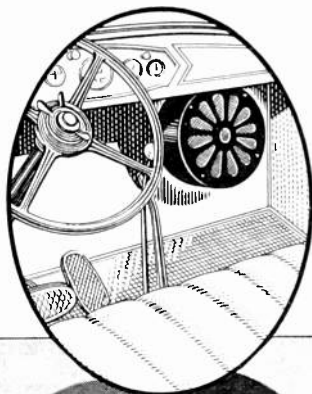

Magnavox Auto Speaker in heavy, non-resonant metal housing

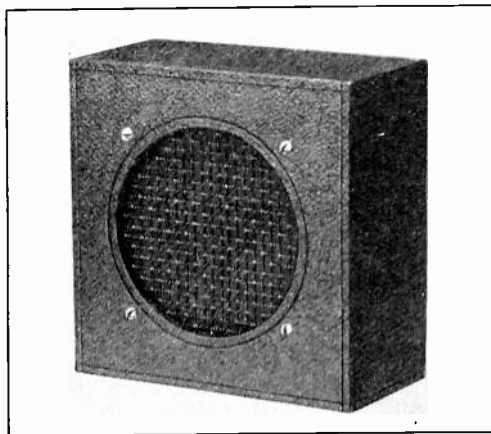

Magnavox Auto Speaker in attractive covered wood housing. Available in two sizes with Models 40 or 50 series speaker

Magnavox SPEAKERS

THE PRODUCT OF TWENTY YEARS' PIONEER RESEARCH

When writing to advertisers mention of the PROCEEDINGS will be mutually helpful.

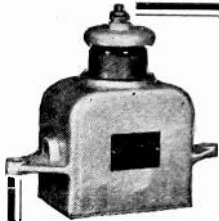

Faradon

Reg. U. S. Pat. Off.

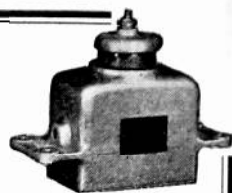

CAPACITORS

Superior Quality and Dependability

AMONG the many users of *Faradon* Capacitors are principal Radio Broadcast and Commercial Communication Companies.

THESE companies must render unfailing service under all conditions and have therefore selected *Faradon* fixed Mica Capacitors for superior quality and dependability.

Our capacitor engineering facilities are available to all users of both Mica and Paper capacitors.

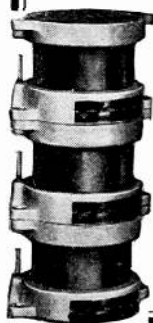

RCA Victor Company, Inc.

INDUSTRIAL PRODUCTS SECTION

(A Radio Corporation of America Subsidiary)

"RADIO HEADQUARTERS"

Camden, N. J.

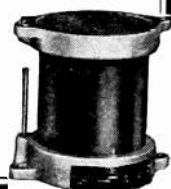

When writing to advertisers mention of the PROCEEDINGS will be mutually helpful.

Behind the Panel

A glance at the High Frequency devices, engineered and produced by leading Radio Communication and Broadcast Equipment builders discloses many significant applications of Isolantite.

A more obviously deserved endorsement could not be desired.

Isolantite Inc.

BELLEVILLE, NEW JERSEY

Sales Office: 75 VARICK STREET, NEW YORK CITY

When writing to advertisers mention of the PROCEEDINGS will be mutually helpful.



BAKED AT 2,500°

This is one of the specially-built furnaces which bake the spaghetti-like sticks of resistance material from which CENTRALAB FIXED RESISTORS are made.



This is but one of the many illustrations in the booklet just published, "A Baptism of Fire," which describes in detail the unique process of making CENTRALAB FIXED RESISTORS. It is yours for the asking. Send for it today.

Central Radio Laboratories: Milwaukee

Centralab

CENTRALAB FIXED RESISTORS

When writing to advertisers mention of the PROCEEDINGS will be mutually helpful.



DEPENDABLE

Public and engineering confidence in the quality of a product is a real *sales help*, at any time; it is a vital necessity in this *price market*.

POLYMET

Leading receiver manufacturers meet this situation by standardizing on Polymet Products — known throughout the world as *Dependable*.

PRODUCTS

ELECTROLYTIC CONDENSERS
PAPER CONDENSERS
MICA CONDENSERS
TRANSFORMERS
RESISTANCES
CHOKES
COILS

Inquiries and orders receive immediate attention

POLYMET MANUFACTURING CORP.

World's Largest Manufacturers of Radio Essentials

829 East 134th Street

New York City

BRITISH ISLES

CANADA

AUSTRALIA

A. H. Hunt, Ltd.
Tunstal Road, Croyden,
Surrey, England

Polymet of Canada, Ltd.
Catharine St., S.
Hamilton, Ontario

Eastern Trading Co.
155 Clarence Street
Sydney

When writing to advertisers mention of the PROCEEDINGS will be mutually helpful.

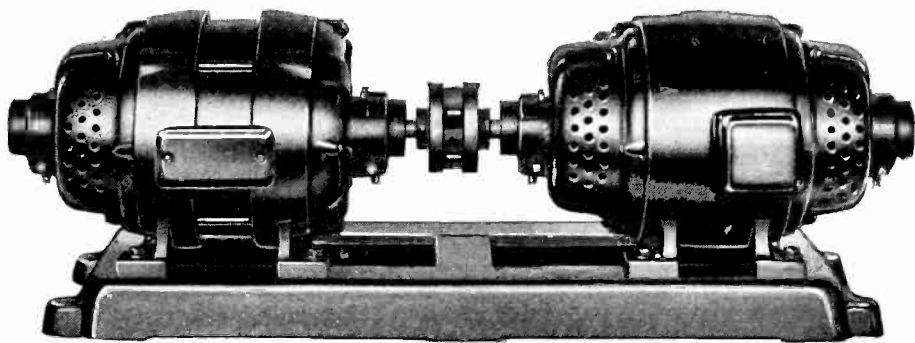

Do You Need Radio Power Supply?

Get in touch with "ESCO." For over twenty years "ESCO" has specialized in Electrical Power Equipment at reasonable cost.

ESCO RADIO PRODUCTS.

MOTOR GENERATORS Motors to fit any kind of power supply. Generators from four to ten thousand volts—double current, high and low voltage. Special units for battery charging, transmitters—plate and filament supply, alternator sets from 25 to 2,000 cycles. Furnished with ball-bearings, wool pack, or wick oil to suit your requirements.

DYNAMOTORS DC to DC for high voltage plate supply, grid bias, or battery charging.

DC to AC for transmitter supply, or for radio receivers.

AIRCRAFT Wind driven generators, double current, high and low voltage. Alternating current up to 1,000 cycles.

Dynamotors, 6 to 12 volts primary, and up to 1,500 volts secondary. Aluminum construction, enclosed.

AUTOMOBILE Efficient, rugged, battery operated dynamotors for receivers—wick oil, or ball bearing.

TELEVISION Synchronous motors, split phase or condenser types. Engineered to fit your individual requirements.

GASOLINE-ELECTRIC Portable and semi-portable power units. Generators for either alternating or direct current, high or low voltage.

ELECTRIC  SPECIALTY
COMPANY

300 South St.

Stamford, Conn.

When writing to advertisers mention of the PROCEEDINGS will be mutually helpful.

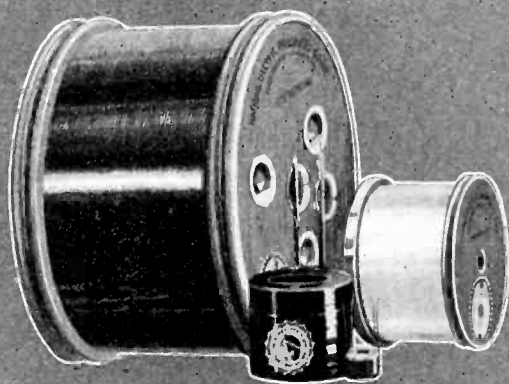

The
PREFERRED
SOURCE OF SUPPLY FOR
MAGNET WIRE & COILS

No electrical or radio product is any better than the magnet wire and coils used in its construction.

Inca products are engineered and manufactured by pioneers in the copper wire industry . . . products reliable in quality and uniformity, and dependable in service.

These are some of the reasons why many of the country's leading manufacturers have adopted Inca as their preferred source of supply.

INCA MANUFACTURING DIVISION
of National Electric Products Corporation
Fort Wayne, Ind.



INCA

SYMBOLIC OF THE
BEST IN COPPER
WIRE PRODUCTS



When writing to advertisers mention of the PROCEEDINGS will be mutually helpful.

Piezo-Electric Crystals

New Price List Effective Immediately

We are extremely pleased to announce **NEW REDUCED PRICES** for **HIGH GRADE CRYSTALS** for **POWER** use. Due to our **NEW** and **MORE EFFICIENT METHOD** of preparing these crystals, we are allowing you to share in the **LOWER COSTS** of producing these crystals.

We are proud of the confidence our customers have shown toward us, we extend to them our sincere thanks for their patronage thus making this reduction possible.

New prices for grinding **POWER** crystals in the various frequency bands, together with the old prices are as follows:

FREQUENCY RANGE	NEW LIST
100 to 1500 Kc	\$40.00
1501 to 3000 Kc	\$45.00
3001 to 4000 Kc	\$50.00
4001 to 6000 Kc	\$60.00

The above prices include holder of our Standard design, and the crystals will be ground to within .03% of your specified frequency. If crystal is wanted unmounted deduct \$5.00 from the above prices. Delivery two days after receipt of your order. In ordering please specify type tube, plate voltage and operating temperature.

Special Prices Will Be Quoted in Quantities of Ten or More

POWER CRYSTALS FOR AMATEUR USE

The prices below are for grinding a crystal to a frequency selected by us unmounted, (if wanted mounted in our Standard Holder add \$5.00 to the prices below) said crystal to be ground for **POWER** use and we will state the frequency accurate to better than a tenth of one per-cent. **IMMEDIATE SHIPMENT CAN BE MADE.**

1715 to 2000 Kc band.....	\$12.00 each
3500 to 4000 Kc band.....	\$15.00 each

LOW FREQUENCY STANDARD CRYSTALS

We have stock available to grind crystals as low as 13 Kilocycles. Prices quoted upon receipt of your specifications.

CONSTANT TEMPERATURE HEATER UNITS

We can supply a high grade heater unit which maintains a constant temperature **BETTER** than a tenth of one degree centigrade. These units have provision for two of our Standard Holders, (one used as a spare) and operate from the 110 V 60 cycle supply mains, entirely automatic and of excellent design. Price and description sent upon request.

PLEASE NOTE NEW ADDRESS

Scientific Radio Service

"THE CRYSTAL SPECIALISTS"

124 Jackson Ave., University Park

Hyattsville, Maryland

When writing to advertisers mention of the PROCEEDINGS will be mutually helpful.

de Forest

Announces

the manufacture of frequency monitoring and frequency control units as designed by the Radio Research Company of Washington, D.C.

These units, custom built to meet the individual requirements of the station, necessitate no changes in the transmitter. They are not stock items designed to meet General Orders 116 and 119. Rather, they are the outcome of many years of intensive research and engineering aimed at and anticipating and making possible those present General Orders.

Engineering data on these units has been placed in the hands of broadcasting and other station staffs. If you have not received your copy, please let us know.

DeForest Radio Company
PASSAIC » » » NEW JERSEY

After all There's No Substitute for 25 Years' Experience

When writing to advertisers mention of the PROCEEDINGS will be mutually helpful.

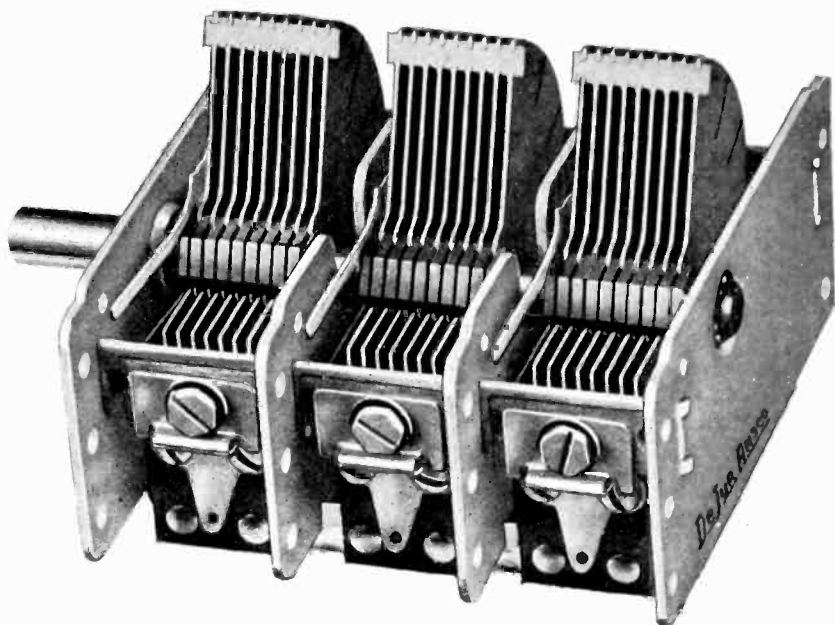

DeJur-Amsco

MIDGET CONDENSERS

For Midget T.R.F., Short Wave and Super-Hets

For ten years this organization has held a pre-eminent position in the radio industry as a parts manufacturer. Our customers are located throughout the civilized world and they constitute the blue book of international radio set manufacturers.

Because of our long and varied experience and the stability of our organization, it is our belief we are in a better position to meet the exacting present day requirements of set makers than any other parts manufacturer in the field.

If you have a condenser problem consult us. It incurs no obligation. Our entire organization is at your service. Why not come to headquarters? You will find our prices in line with present times.

DeJur-Amsco Corporation

95 MORTON ST., NEW YORK CITY

When writing to advertisers mention of the PROCEEDINGS will be mutually helpful.

The Institute of Radio Engineers Incorporated

33 West 39th Street, New York, N. Y.

APPLICATION FOR ASSOCIATE MEMBERSHIP

(Application forms for other grades of membership are obtainable from the Institute)

To the Board of Direction
Gentlemen:

I hereby make application for Associate membership in the Institute.

I certify that the statements made in the record of my training and professional experience are correct, and agree if elected, that I will be governed by the constitution of the Institute as long as I continue a member. I furthermore agree to promote the objects of the Institute so far as shall be in my power, and if my membership shall be discontinued will return my membership badge.

Yours respectfully,

.....
(Sign with pen)

.....
(Address for mail)

.....
(Date)

.....
(City and State)

References:

(Signature of references not required here)

Mr. Mr.

Address Address

Mr. Mr.

Address Address

Mr.

Address

The following extracts from the Constitution govern applications for admission to the Institute in the Associate grade:

ARTICLE II—MEMBERSHIP

Sec. 1: The membership of the Institute shall consist of: * * * (d) Associates, who shall be entitled to all the rights and privileges of the Institute except the right to hold the office of President, Vice-president and Editor. * * *

Sec. 5: An Associate shall be not less than twenty-one years of age and shall be: (a) A radio engineer by profession; (b) A teacher of radio subjects; (c) A person who is interested in and connected with the study or application of radio science or the radio arts.

ARTICLE III—ADMISSION

Sec. 2: * * * Applicants shall give references to members of the Institute as follows: * * * for the grade of Associate, to five Fellows, Members, or Associates; * * * Each application for admission * * * shall embody a concise statement, with dates, of the candidate's training and experience.

The requirements of the foregoing paragraph may be waived in whole or in part where the application is for Associate grade. An applicant who is so situated as not to be personally known to the required number of members may supply the names of non-members who are personally familiar with his radio interest.

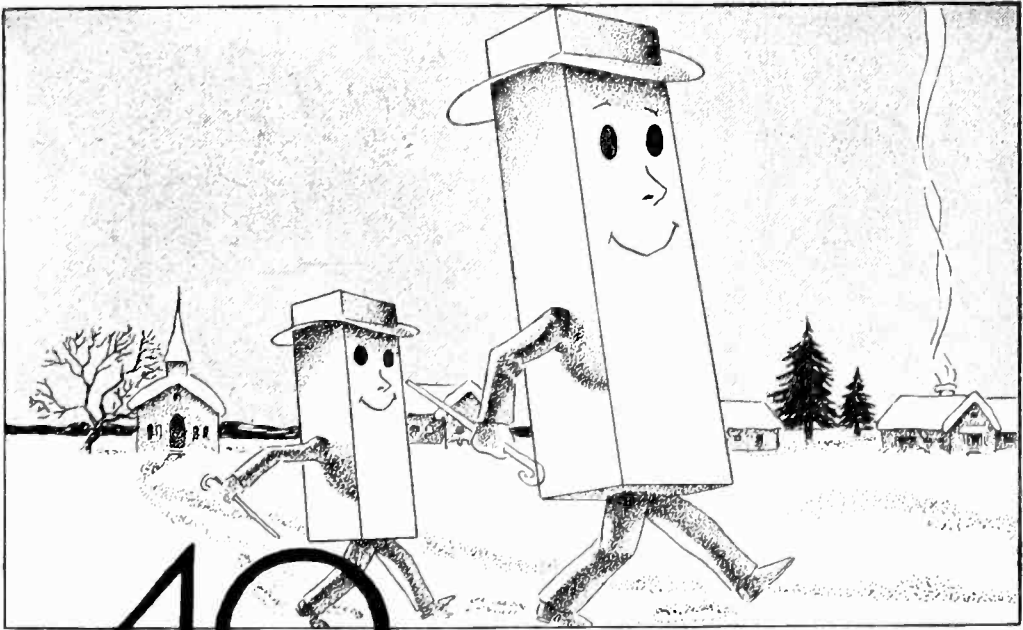

-40° F IN THE SHADE

IT doesn't matter how cold it gets, Elkon electrolytic condensers always perform at peak efficiency. If your sets are Elkon-equipped you don't need to worry about winter shipments. Because the Elkon is dry,* extreme cold does not interfere with its perfect operation as it would with aqueous electrolytic condensers. Yet it has all the advantages of this type—extremely compact—high filtering efficiency—long life—stability. Furthermore, Elkon has practically the same characteristics as paper condensers—but is lower in cost and much less bulky . . . and here's news—all of the above characteristics apply to our new By-pass condensers. 73 leading set manufacturers have standardized on Elkon. A request today will bring your sample tomorrow. Complete information will be sent to all members of your technical staff. Just send their names.

*—water of crystallization, of course—but no free water.

Elkon Division of P. R. MALLORY & CO., Inc., Indianapolis, Ind.

Sales Offices: New York · Cleveland

Detroit · Chicago · Los Angeles

ELKON — [E] — CONDENSERS

COST LESS TO BUY AND LESS TO INSTALL

When writing to advertisers mention of the Proceedings will be mutually helpful.

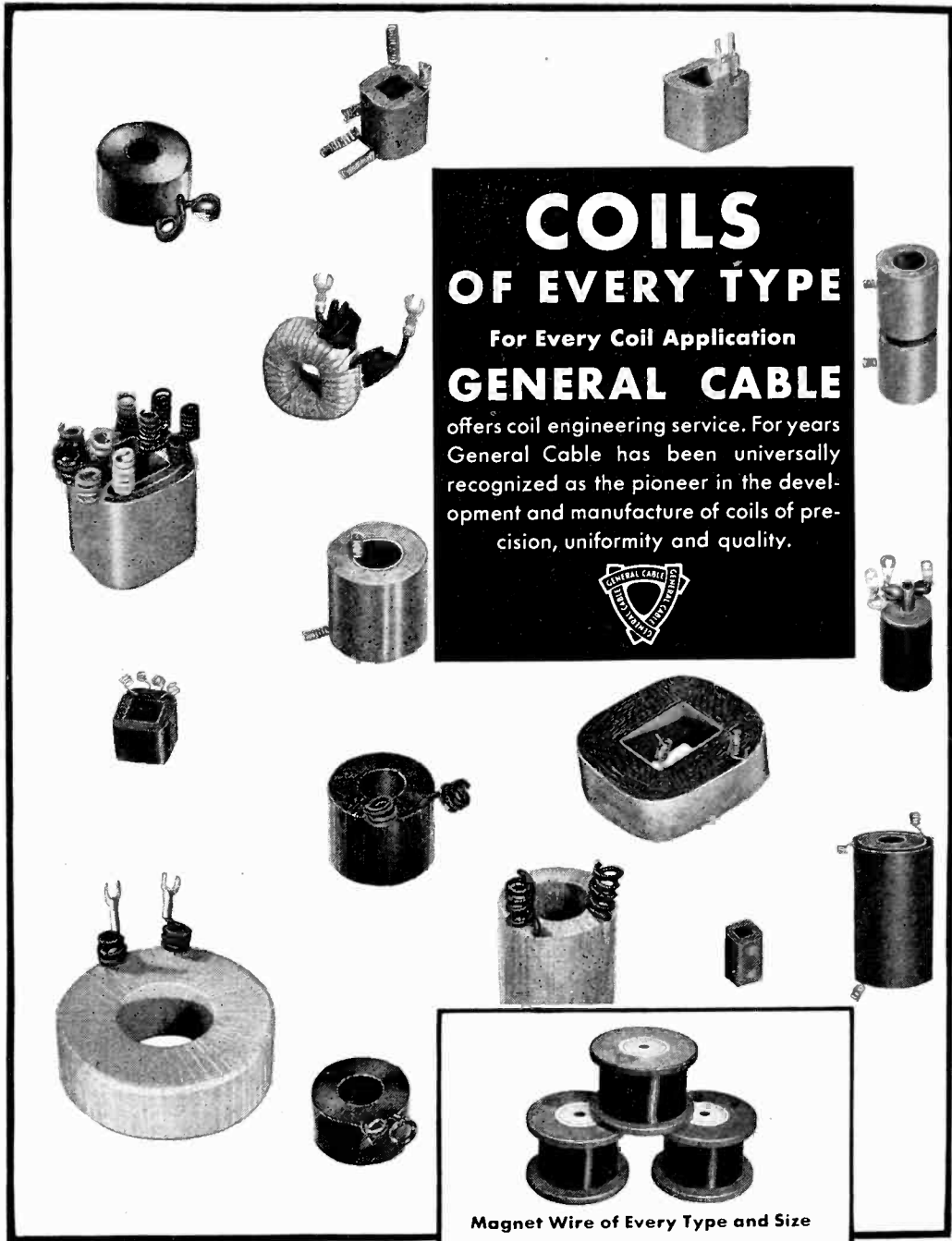

COILS OF EVERY TYPE

For Every Coil Application
GENERAL CABLE
offers coil engineering service. For years General Cable has been universally recognized as the pioneer in the development and manufacture of coils of precision, uniformity and quality.

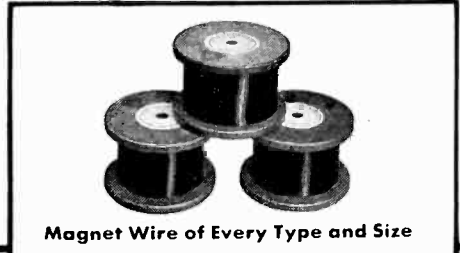

Magnet Wire of Every Type and Size

GENERAL CABLE CORPORATION

420 LEXINGTON AVENUE, NEW YORK • CONSULT OUR NEAREST OFFICE

When writing to advertisers mention of the PROCEEDINGS will be mutually helpful.

What Price Accuracy?

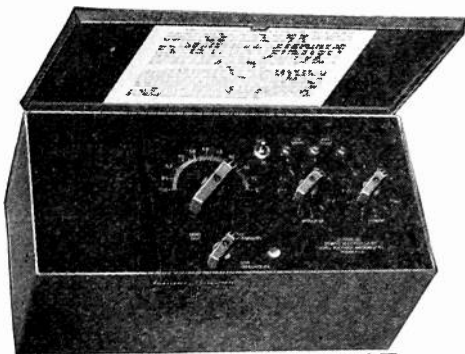

Though low in price, the Pattern 563 is complete in every respect.



Unusual simplicity of operation is achieved in the Pattern 444.

From the radio manufacturers' viewpoint, instruments for servicing radio receivers have one outstanding function—to assure the most accurate servicing of their products.

Jewell Radio Service Instruments embody every necessary quality of accuracy and dependability; yet remarkably low prices have been achieved by experienced design and large production.

The Pattern 444 Set Analyzer and Pattern 563 Test Oscillator are examples of Jewell's leadership in service instrument value.

Unusual Features of the Pattern 444 Set Analyzer

Heavy molded bakelite panel and over 50 other molded parts.

Indicating instruments accurate to 2% of full scale values.

Long meter scales and knife edge pointers. All wiring cabled.

Non-shatterable glass meter covers.

Socket test cord removable at the analyzer panel—easily replaced when worn.

Unusual Features of the Pattern 563 Test Oscillator

Entire instrument encased in metal for durability and effective shielding.

Oscillator coil separately shielded.

Rugged variable condenser with self-aligning, ball bearing supported rotor.

Adjustable to any point in three frequency ranges—550 to 1500 K. C., 125 to 185, K. C., and 175 to 300 K. C.

Write for literature describing Jewell Radio Service Instruments.

Jewell Electrical Instrument Company
1642-D Walnut Street, Chicago, Ill.

31 YEARS MAKING GOOD INSTRUMENTS
JEWELL

When writing to advertisers mention of the PROCEEDINGS will be mutually helpful.

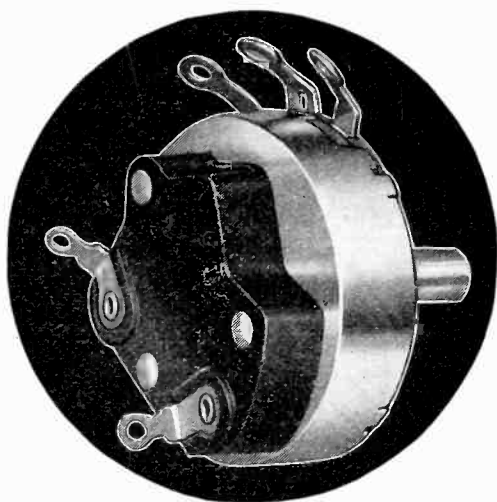

“Tailored” exactly to your requirements

WHEN we say that Frost Volume and Tone Controls are “tailored” exactly to your requirements we mean just that. Any receiver performs best with controls that suit its precise needs. From past experience we know that there are few cases where sets of different manufacture can successfully employ controls having identical characteristics. Accordingly, we prefer that you specify the characteristics you want, so that we may “tailor” the controls to conform to your specifications. Our Engineering Department will be glad to work out controls best suited to your set if you will send us a complete set with tubes and circuit diagram. This service is offered without charge, and any information sent us is held in the strictest confidence. . . . Write for Bulletin describing and illustrating our new Volume and Tone Controls, including our No. 70 Series Composition Element Type, No. 20 Series Wire Wound Type, and other Frost Units employing either principle of construction.

We invite inquiries from interested engineers, and are always glad to cooperate with them in working out the details of their Volume and Tone Control problems. Why not write us today?

CHICAGO TELEPHONE SUPPLY CO.

HERBERT H. FROST, Inc., Sales Division

GENERAL OFFICES AND PLANT

ELKHART, INDIANA

When writing to advertisers mention of the PROCEEDINGS will be mutually helpful.

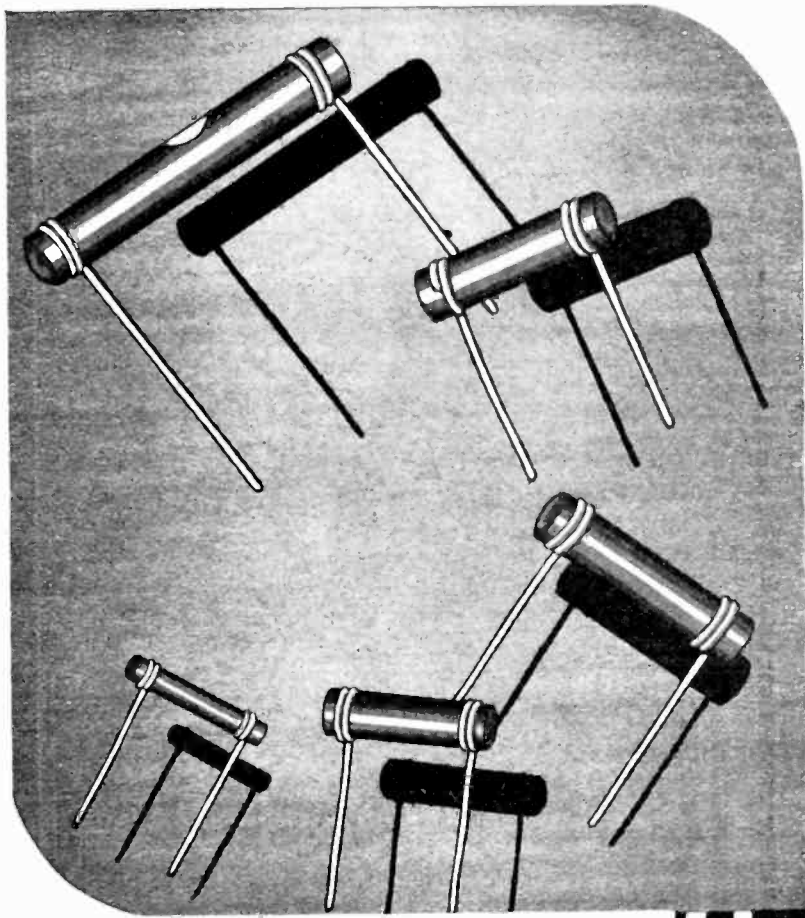

In the building of any product requiring moulded type resistors inefficient ones surely are reflected in the completed job.

The leading manufacturers know that **ERIE RESISTORS** give them dependable service under all conditions of use. Expert knowledge of how to make them plus triple inspection insures satisfactory performance.

May we send you samples and prices?



ERIE RESISTORS

Erie Resistor Corporation, Erie, Pa.
In the Center of the Radio Industry

FACTORIES IN ERIE, PA., AND TORONTO, CAN.

When writing to advertisers mention of the PROCEEDINGS will be mutually helpful.

PERCENTAGE MODULATION



A direct reading instrument which instantly indicates the percentage of modulation in relation to the CW carrier of a radio telephone transmitter. Operates in any position, loosely coupled to the antenna circuit—Standard range 1500 to 550 KC.—Very reasonably priced—

Ask for Cat. #286
Indicator

COMBINED OSCILLATOR and TEMPERATURE CONTROL BOX

Uniquely designed piezo crystal oscillator, combined with automatic temperature control box. A basic unit for precision controlling of radio transmitters. Will accurately hold frequency to within 50 cycles thus complying with the latest Federal Radio Commission rulings.



Built in well shielded aluminum case—Separately shielded oscillator compartment—Scientifically designed crystal temperature oven—Fitted with automatic thermostat, having a variable range between 40°C and 60°C—Special thermometer graduated in single degrees—Provisions for three crystals—Employing new rotor type crystal selector switch, which eliminates interference usually caused by having more than one crystal in the circuit—The unit is adaptable for table, rack or direct mounting into the transmitter—Also fitted for drawer sliding arrangement. When ordering specify the frequency of your crystal—Write for Cat. #285 bulletin, describing this apparatus.

RADIO ENGINEERING LABORATORIES, INC.

100 Wilbur Ave.

Long Island City, N. Y., U. S. A.

When writing to advertisers mention of the PROCEEDINGS will be mutually helpful.

Cornell

TRADE MARK REG.

DUAL "CUB" CONDENSERS

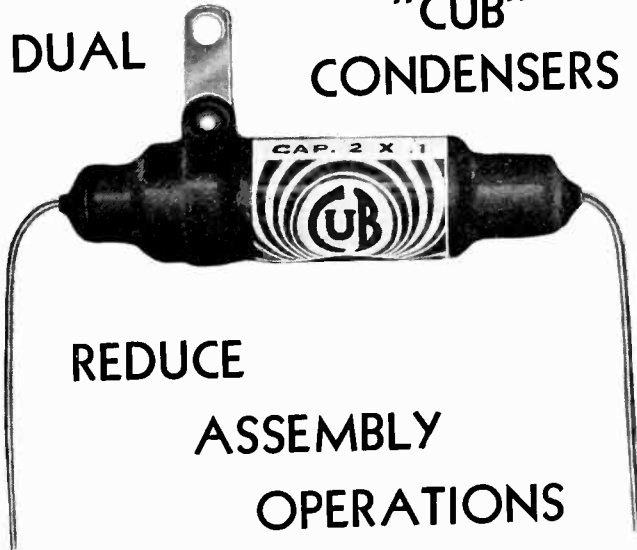

REDUCE ASSEMBLY OPERATIONS

Single mounting strap—can be attached to panel—initial cost is less—most flexible and easiest mounting—no loss in efficiency—reduces costs by cutting assembly operations—high insulation resistance—extraordinary dielectric strength—totally enclosed—hermetically sealed against exaggerated temperature and humidity—light weight and compact—capacities .00025 to .5 Mfd.—an exclusive development of Cornell Engineers.

*Write for samples and let us know your requirements.
We shall be glad to send you full particulars.*

CORNELL ELECTRIC MFG. CO., Inc.

*Manufacturers of
CORNELL "CUB" CONDENSERS
Filter and By-Pass Condensers, Interference Filters and
All Types of Paper Dielectric Condensers*

LONG ISLAND CITY, NEW YORK

When writing to advertisers mention of the PROCEEDINGS will be mutually helpful.

PERFECT BALANCE—

CARDWELL
LABORATORY
TYPE
BALANCING
CONDENSER

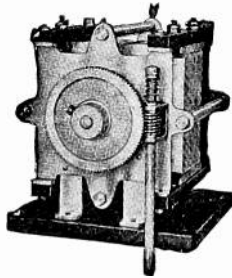

IN the scales of a chemical laboratory, perfect balance is imperative.

Important, too, in many cases, is a perfect electrical balance, such as between the many wires or circuits in the modern telephone cable consisting of thousands of separate conductors.

CARDWELL balancing condensers, because mechanically strong and electrically efficient, are utilized in the delicately attuned apparatus which makes possible absolute freedom from cross talk in your telephone circuit. Many other uses will suggest themselves to the engineer, but what we desire to stress is that when the need for special purpose condensers arises, you are more likely to find them here than elsewhere.

CARDWELL condensers, for transmitting on high or low power, and receiving condensers in many types and capacities have been, for a decade, "THE STANDARD OF COMPARISON."



To acquaint you with the scope of the CARDWELL Manufacturing Service a special folder has been prepared, describing special instruments and apparatus designed and manufactured by us and manufactured to customers' specifications. May we send it?

CARDWELL CONDENSERS AND MANUFACTURING SERVICE

The Allen D. Cardwell Mfg. Corp'n
93 Prospect Street, Brooklyn, N.Y.

“THE STANDARD OF COMPARISON”

When writing to advertisers mention of the PROCEEDINGS will be mutually helpful.

SPECIAL ITEMS FOR RADIO MANUFACTURERS

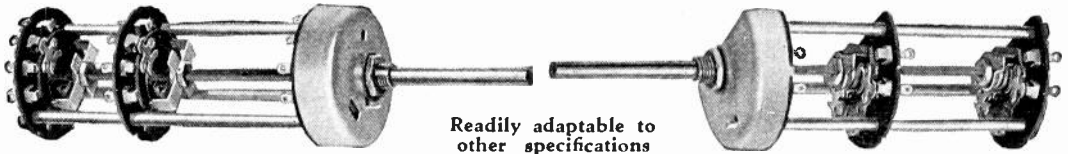

Readily adaptable to
other specifications

No. 7280A
3 gang, 4 positions
single circuit

No. 7260A
3 gang, 2 positions
2 circuits

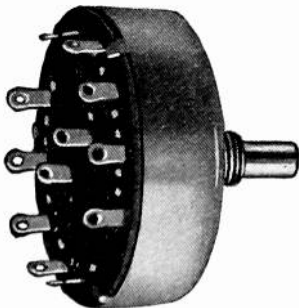

No. 7150A
5 positions, 2 circuits

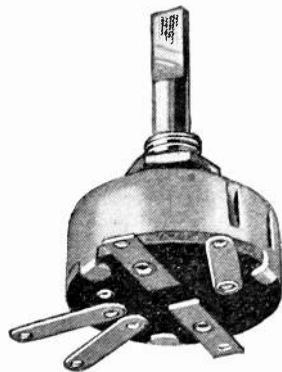

No. 7120A
Combined Acoustic and muting
switch 2 or 3 positions

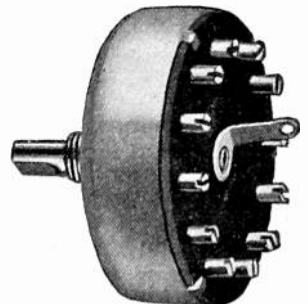

No. 7220A
12 positions, single circuit

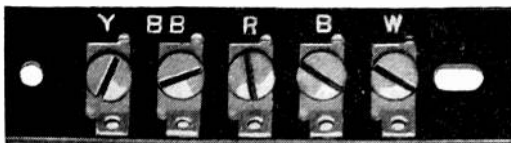

Terminal Strip
5 Lugs No. 6880A, 4 lugs No. 6990A



Terminal Strip
4 Clips, No. 6830A



Terminal Strip
5 Lugs, No. 6950A

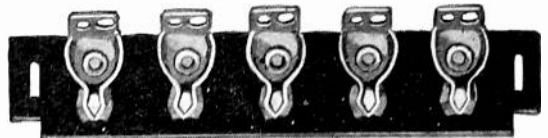

Terminal Strip
5 Clips, No. A6310AA, 4 Clips No. A6320AA

SORENG - MANEGOLD CO.

1901-9 Clybourn Avenue, CHICAGO, ILL.

1646 W. Adams St.
Los Angeles, Cal.

701 Stephenson Bldg.
Detroit, Mich.

245-5th Ave.
New York City

When writing to advertisers mention of the PROCEEDINGS will be mutually helpful.

Wait for The New

ACRACON

DRY Electrolytic
Condensers

THE Condenser Corporation of America will soon announce a new line of DRY electrolytic condensers companion to the famous Acracon wet electrolytic unit which is now specified by over 30 leading radio manufacturers.

News of the Acracon DRY unit has been withheld until exhaustive laboratory tests under all conditions have proved its design and construction are absolutely perfect.

The Acracon DRY unit meets the need of manufacturers for an electrolytic condenser that can be conveniently and successfully mounted horizontally or beneath the chassis. Several other exclusive features are incorporated in its design, which is as original in the DRY type as the Acracon wet unit was when it was introduced.

Wait for announcement soon of specifications and characteristics.

Acracon Features are Protected by Patents Pending

Condenser Corporation of America

259 Cornelson Ave., Jersey City, N.J.

Factory Representatives In:

Chicago Cincinnati St. Louis San Francisco Los Angeles Toronto

And Other Principal Cities

When writing to advertisers mention of the PROCEEDINGS will be mutually helpful.

CHANGE IN MAILING ADDRESS OR BUSINESS TITLE

Members of the Institute are asked to use this form for notifying the Institute office of a change in their mailing address or the listing of their company affiliation or title in the Year Book.

The Secretary,
THE INSTITUTE OF RADIO ENGINEERS,
33 West 39th Street,
New York, N.Y.

Dear Sir:

Effective please note change in my address
(date)
for mail as follows:

FROM

.....
(Name)

.....
(Street Address)

.....
(City and State)

TO NEW ADDRESS

.....
(Street Address)

.....
(City and State)

Please note following change in my Year Book listing.

.....
(Title)

.....
(Company Name)

.....
(Company Address)

Back Numbers of the Proceedings, Indexes, and Year Books Available

MEMBERS of the Institute will find that back issues of the Proceedings are becoming increasingly valuable, and scarce. For the benefit of those desiring to complete their file of back numbers there is printed below a list of all complete volumes (bound and unbound) and miscellaneous copies on hand for sale by the Institute.

The contents of each issue can be found in the 1909-1930 Index and in the 1931 Year Book.

BOUND VOLUMES:

Vol. 10 (1922), \$8.75 per volume to members
Vol. 18 (1930), \$9.50 to members

UNBOUND VOLUMES:

Vols. 5, 6, 8, 9, 10, 11, 12, 13, 14, and 18 (1917-1918-1920-1921-1922-1923-1924-1925-1926-1930), \$6.75 per volume (1917-1926) and \$7.50 per volume (1927-1930) to members

MISCELLANEOUS COPIES:

Vol. 1 (1913) July and December
Vol. 2 (1914) June and December
Vol. 3 (1915) December
Vol. 4 (1916) June and August
Vol. 7 (1919) February, April, August, and December
Vol. 15 (1927) January, April, May, June, July, October, November, and December
Vol. 16 (1928) February, March, April, May, June, July, August, October, November, December
Vol. 17 (1929) January, February, March, April, May, June, July, August, September, November, and December.
Vol. 19 (1931) January, February, March, April, May, June, July, August, September, October, November

These single copies are priced at \$1.13 each to members to the January, 1927, issue. Subsequent to that number the price is \$0.75 each. Prior to January, 1927, the Proceedings was published bimonthly, beginning with the February issue and ending with the December issue. Since January, 1927, it has been published monthly.

MEMBERS will also find that our index and Year Book supplies are becoming limited. The following are now available:

INDEX

The Proceedings Index for the years 1909-1930 inclusive is available to members at \$1.00 per copy. This index is extensively cross indexed.

YEAR BOOK

The 1931 Year Book is available to members at \$1.00 per copy. This Year Book includes the 1931 Report of the Committee on Standardization,—an "up to the minute" report on the most recent standardization information available.

Make remittances payable to the Institute of Radio Engineers and send orders to:

THE INSTITUTE OF RADIO ENGINEERS

33 West 39th Street
NEW YORK CITY, N. Y.



AMERTRAN DYNAMIC FIELD SUPPLY (TYPE P-108)

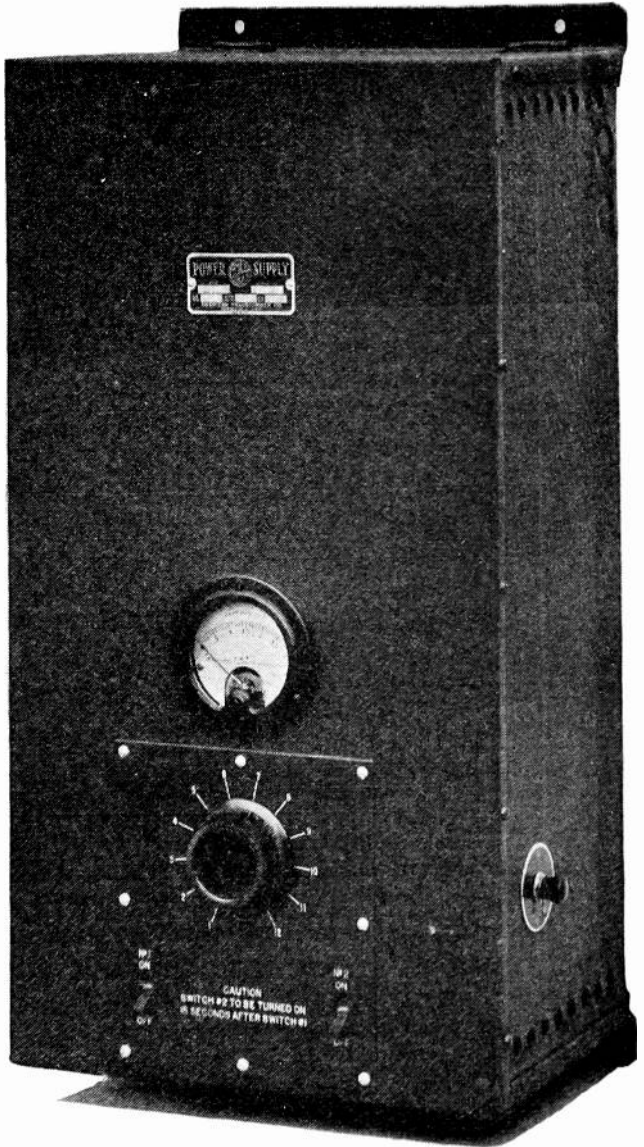

AmerTran offers a new addition to their line of power supply units—the Dynamic Field Supply. This rectifier unit is designed to supply filtered d c of the proper value to energize the field windings of dynamic type loud speakers used in large installations. It is unusually flexible supplying as many as nine dynamic fields or may be quickly and accurately adjusted to the number of speakers actually in use.

Write for complete descriptive list of power supply units with technical data.

American Transformer Company

Factory and Main Office—
178 EMMET STREET
Newark, N. J.

New York Office
HUDSON TERMINAL
Room 1963, 50 Church Street

When writing to advertisers mention of the PROCEEDINGS will be mutually helpful.

NOT 400 VOLTS —
NOT 450 VOLTS —
BUT 500 VOLTS!



The advanced processes and features in design, combined with the special electrolyte employed in Hi-Farad DRY Electrolytic Condensers make possible a condenser which will continually withstand 500 VOLTS PEAK, a rating considerably higher than other types of electrolytic condensers. A condenser whose characteristics limit it to 400 or 450 volts peak cannot be used at higher voltages because at slightly higher voltages its leakage current becomes excessive.

AEROVOX

**HI-FARAD
DRY ELECTROLYTIC
CONDENSER**

AN AEROVOX CONDENSER AND RESISTOR FOR EVERY USE

The Aerovox line includes the most complete line of condensers and resistors in the radio and electrical industries. No matter what your requirements are for fixed and tapped condensers or resistors, you are sure to find Aerovox units suited to your needs. In addition, we are equipped to supply special types and sizes of condensers and resistors to meet individual requirements.

Write for our 1931 catalog. Also ask to receive the Aerovox Research Worker, a monthly periodical which will be helpful and interesting to you.

AEROVOX WIRELESS CORP.
70 Washington Street, Brooklyn, N. Y.

When writing to advertisers mention of the PROCEEDINGS will be mutually helpful.

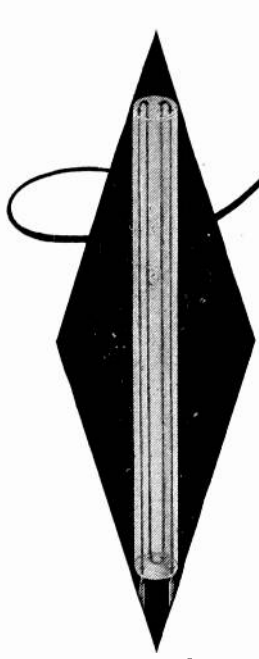

Now . . .

ANOTHER ACHIEVEMENT BY **ARCTURUS**

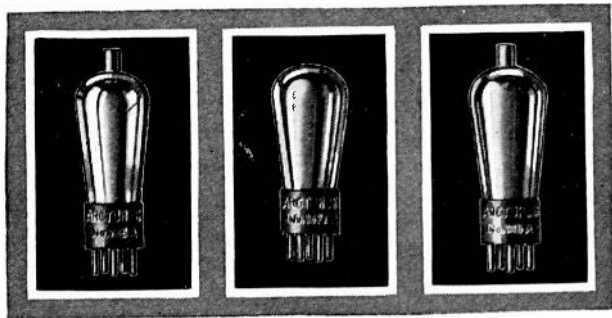

Exclusive Advantages of Arcturus Types

136A, 137A, 138A Tubes

1. An "M" filament is used instead of a coiled filament, providing a more rugged and dependable element.
2. The Arcturus "M" filament is non-inductive and reduces hum to a negligible factor, permitting these tubes to be used efficiently with a.c. as well as d.c. filament voltages.
3. Many of the failures in other types were due to the breaking down of the insulator because of the extremely high temperature of the coiled filament. The insulator used in these Arcturus Tubes withstands higher temperatures than 2600° centigrade, although maximum operating temperature is less than 1700° centigrade—providing a generous safety factor.
4. While the filament current varies appreciably with coiled filaments and fluctuates if the tubes are jarred (because of variable contact between the insulator and the filament) this condition is obviated in the "M" filament tubes. This filament is held securely in position throughout its length by a rugged insulator, which prevents shorts and leakages and insures uniform filament current that will not fluctuate even when the tubes are jarred. (This is of special importance when tubes are connected in series, as for 110 volt d.c. operation.)
5. The variable contact between the insulator and the coiled filament was responsible for noises in reception due to scraping. These noises are entirely eliminated by the new Arcturus construction.
6. Because of the uniform filament temperature insured by the "M" filament (elimination of "hot spots") the life of this filament is appreciably longer than coiled filament.
7. The 136A, 137A and 138A are interchangeable with the corresponding '36, '37 and '38 types and, like all Arcturus Tubes, these three types are quick-acting.

New improvement in automobile tubes permits use with **A.C. or D.C.**

Engineers and automotive set manufacturers have long felt the need for improved, more dependable automobile radio tubes.

Now—Arcturus meets that need with the Types 136A, 137A and 138A—utilizing a new non-inductive "M" filament. This is the *first* time an "M" filament has been used in indirectly heated cathode receiving tubes as a heater—*another Arcturus achievement*. These tubes are interchangeable with corresponding types.

In uniformity, serviceable life and performance these new Arcturus automobile tubes establish advanced operating standards. Besides permitting their use with a.c., the non-inductive filament eliminates fluctuations in current draw and banishes noisy reception.

The rugged design and compact size of these tubes, make the 136A, 137A and 138A especially fit the specifications for a universal receiver to operate on either a.c. or d.c.

We have already cooperated with a few set manufacturers in employing these tubes and will gladly send reliable manufacturers complete specifications and characteristics on request.

ARCTURUS RADIO TUBE COMPANY, NEWARK, N. J.

ARCTURUS

"The Blue TUBE with the LIFE-LIKE TONE"

When writing to advertisers mention of the PROCEEDINGS will be mutually helpful.

TWO-SPEED

33 $\frac{1}{3}$ and 78 r.p.m.

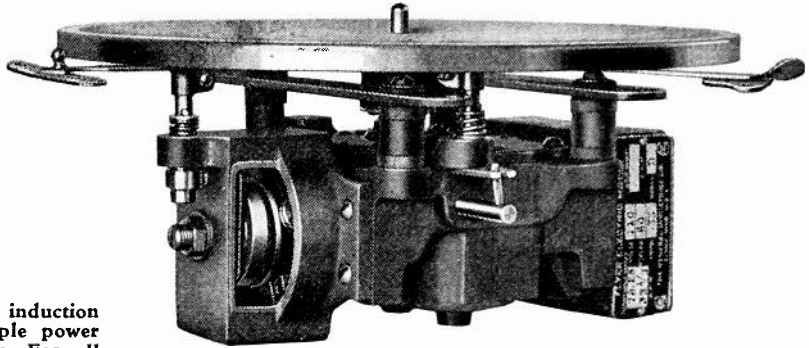

Self-starting induction type, with ample power for all records. For all voltages and frequencies; also supplied for direct current, either 110 or 220 volts. Furnished complete with turntable, speed regulator dial and speed change escutcheon. Automatic stop is optional.

Stroboscope disc, for showing correct 33 $\frac{1}{3}$ and 78 r.p.m., sent free on request.

The *NEW* Model D **Green Flyer** *with Governor-Control*

THIS newest development in the 17-year-old Flyer family of phonograph motors is still another proof of the value of Flyer simplicity of design and Flyer phonograph motor-building experience. Once again it is a Flyer Motor that promptly and successfully meets a new demand from the radio-phonograph industry and trade.

Pushing a handy lever shifts the speed. Furnishes dependably uniform speed under severe variations of voltage and record drag. Governor control permits 10% range of speed adjustment. All gears are laminated Bakelite, spiral-cut, and completely enclosed, running in oil. Long oversize self-lubricating bearings.

Order a sample **NOW** and learn at once how perfectly it serves for both the present standard and popular new long-playing records.



*In ordering,
please specify
voltage and fre-
quency you re-
quire.*

The **GENERAL INDUSTRIES CO.**

3246 Taylor Street, Elyria, Ohio

When writing to advertisers mention of the PROCEEDINGS will be mutually helpful.

PROFESSIONAL ENGINEERING DIRECTORY

For Consultants in Radio and Allied Engineering Fields

Greenleaf Whittier Pickard

Consultant

59 Dalton Road,
Newton Centre, Mass.

JENKINS & ADAIR, INC.

Engineers

Designers and manufacturers of apparatus essential to broadcasting, sound recording and sound measurement work.

3333 Belmont Ave., Chicago, U.S.A.

Cable Address: *Jenkadair*

Telephones: Keystone 2130

The J. G. White Engineering Corporation

Engineers—Constructors

*Builders of New York Radio
Central*

43 Exchange Place New York

For EXPORT of Material Manufactured
by:

American Transformer Co.
Allen D. Cardwell Mfg. Co.
Cornell Elec. Mfg. Co., Inc.
Corning Glass Works
P. R. Mallory
Radio Engineering Labs.
Ward Leonard Electric Co.
Weston Elec. Inst. Co.

Apply to

AD. AURIEMA, INCORPORATED
116 Broad St.
New York City, N.Y.

ALLEN B. DU MONT

Consulting Engineer

Television Transmission and Reception
Vacuum Tube Manufacture, Development
and Application

Phone
Montclair
2-2176

Office and Laboratory
9 Bradford Way
Upper Montclair, N.J.

FOR ADVANCED TRAINING

in:

Practical Radio Engineering
Practical Television Engineering

write to

**CAPITOL RADIO ENGI-
NEERING INSTITUTE**
Riggs Bank Bldg.
Washington, D.C.

ELECTRICAL TESTING LABORATORIES

Tests of Inductances.
Condensers. Transform-
ers etc. Life and charac-
teristics of Radio Tubes

80th Street and East End Ave.
• • NEW YORK, N.Y. • •

BEN J. CHROMY

Attorney at Law

Patents and Patent Causes

National Press Bldg.

WASHINGTON, D.C.

"Radio Patent Service"

Weekly

When writing to advertisers mention of the PROCEEDINGS will be mutually helpful.

Alphabetical Index to Advertisements

A

Aerovox Wireless Corp.XXXVIII
Allen-Bradley Co. . . Inside Back Cover
American Tel. & Tel. Co.XII
American Transformer Co. . . XXXVII
Arcturus Radio Tube Co. . . . XXXIX

C

Cardwell, Allen D., Mfg. Corp. XXXII
Central Radio Corp.XLVI
Central Radio LaboratoriesXVI
Chicago Telephone Supply Co. XXVIII
Condenser Corp. of America . . XXXIV
Cornell Electric Mfg. Co.XXXI

D

DeForest Radio Co.XXI
DeJur-Amsco Corp.XXII

E

Electric Specialty Co.XVIII
Employment PageXLIII
Erie Resistor Corp.XXIX

G

General Cable Corp.XXVI
General Electric Co.XLV
General Industries Co.XL
General Radio Co. . . Outside Back Cover

I

Inca Division National Elec. Prod.
Corp.XIX
International Resistance Co.XI
I.R.E.XXIII, XXIV, XXXV,
.XXXVI, XLIV
Isolantite Inc.XV

J

Jewell Elec. Instr. Co.XXVII

M

Magnavox Co., Ltd.XIII
Mallory, P. R., & Co., Inc.XXV

P

Polymet Mfg Co.XVII
Professional Eng. DirectoryXLI

R

Radio Engineering Labs.XXX
RCA Victor Co., Inc.XIV

S

Scientific Radio ServiceXX
Soreng-Manegold Co.XXXIII

When writing to advertisers mention of the PROCEEDINGS will be mutually helpful.

EMPLOYMENT PAGE

Advertisements on this page are available to members of the Institute of Radio Engineers and to manufacturing concerns who wish to secure trained men for positions. All material for publication on this page is subject to editing from the Institute office and must be sent in by the 15th of the month previous to the month of publication. (November 15th for December PROCEEDINGS IRE, etc). Employment blanks and rates will be supplied by the Institute office. Address requests for such forms to the Institute of Radio Engineers, 33 West 39th Street, New York City, N.Y.

MANUFACTURERS and others seeking radio engineers are invited to address replies to these advertisements at the Box Number indicated, care the Institute of Radio Engineers. All replies will be forwarded direct to the advertiser.

COLLEGE STUDENT desires design and development work on vacuum tube applications, sound reproduction, or as broadcast station engineer. Experience includes four years ship and some broadcast operating. Holds first class operator's license. Instructor in laboratory work two summer sessions and also worked as laboratory assistant on photo-electric cell and vacuum tubes in college. Will receive B.S. in E.E. January, 1932. Available for position February, 1932. Age 26. Will travel. Box 100.

SERVICE MAN with one year's experience in charge of assembly and inspection for manufacturer desires work as factory foreman or as service man. Service experience includes five and one half years work on radio receivers and sound distributing systems. H.S. Graduate. Age 24. Will travel. Box 101.

COLLEGE GRADUATE employed two years as laboratory assistant for well known manufacturer, with one year's experimental work on vacuum tubes and with two years work as field engineer handling installation and inspection of theatre sound apparatus. Interested in engineering work or in traveling for concern dealing in commercial applications on radio or electrical devices. E.E. 1929. Age 27. Married. Will travel. Box 102.

COMMERCIAL OPERATOR desires work operating or installing radio equipment or designing radio apparatus. Experience includes seven years as chief engineer and operator for various radio stations. Holds commercial first class operator's license. Normal School and U.S. Naval Academy training. Age 32. Married. Will travel. Box 103.

BROADCAST OPERATOR holding first class commercial operator's license wishes work on the construction and maintenance of radio apparatus. Experience includes two years broadcast operating, one and one half years marine operating, and one year's work on installation and operation of equipment for radio communications concern. High school graduate. Married. Age, 23. Box 92.

COLLEGE GRADUATE with six years experience in research and development work desires new connection in radio field. Interested in college teaching position or in work as sales or technical field representative for New York vicinity. B.S. 1925. Single. Age, 30. Box 94.

STUDENT ENGINEER desires position as instructor, operator, or in aviation or police radio systems. Experience includes two years test and development work on transmitters, transmitting tubes, and facsimile equipment. B.S. in E.E. 1929. Single. Will travel. Age, 23. Box 95.

BROADCAST OPERATOR with two and one half years college training desires new position. Two and one half years experience in operation and maintenance and three years in charge of broadcast station. Married. Will travel. Age, 26. Box 97.

FOREMAN of testing department with five years experience in inspection and production testing of radio receivers, public address systems, and related equipment, desires position where past experience will be valuable. High School Graduate. Age 26. Married. Box 104.

When writing to advertisers mention of the PROCEEDINGS will be mutually helpful.

Take Your Choice

Every member of the Institute of Radio Engineers will want to wear one of these three attractive emblems. All of these emblems are appropriately colored to indicate the various grades of membership and each emblem is approximately the size of the following illustrations.



The Lapel Button is of 14k gold, with background enameled in the membership color, and with the lettering in gold. The screw-back on the back of this button fastens it securely to your coat.

\$2.75 postpaid—any grade.



The Pin is also of 14k gold. It is provided with a safety catch and is appropriately colored for the various grades of membership.

\$3.00 postpaid—any grade.



The Watch Charm, handsomely finished on both sides, is also of 14k gold. This charm is equipped with a suspension ring for attaching to a watch fob or chain.

\$5.00 postpaid—any grade.

Orders, accompanied by checks made payable to the Institute of Radio Engineers, should be addressed to

THE INSTITUTE OF RADIO ENGINEERS

33 West 39th Street

NEW YORK CITY, N. Y.

Send in your order now!

When writing to advertisers mention of the PROCEEDINGS will be mutually helpful.

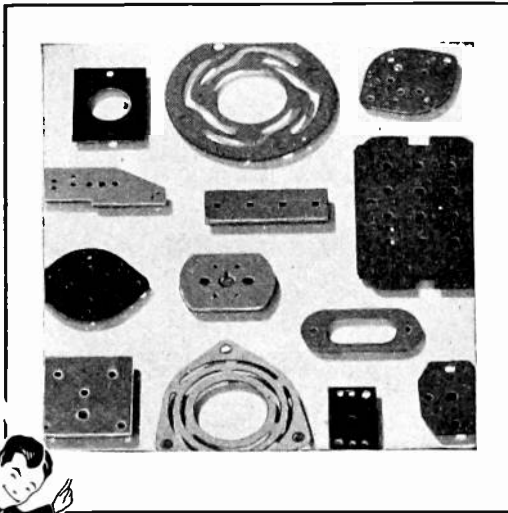

*A few representative pieces
of Textolite laminated pre-
pared for application to
radio receivers*

MEET — the
Radio-frequency
Family of

TEXTOLITE LAMINATED

General Fabricating Co.
37 East 18th Street
New York City

Electrical Insulation Corp.
308 W. Washington St.
Chicago, Ill.

JOIN THE "G-E CIRCLE"—
SUNDAYS AT 5:30 P.M., E.S.T.,
ON N.B.C. NETWORK OF 54
STATIONS — WEEK-DAYS (EX-
CEPT SATURDAY) AT NOON

EXHAUSTIVE tests show that in the radio-frequency grade of Textolite laminated the power-factor is so slightly changed by wet or dry conditions that humidity ceases to be a problem. This distinguishing quality, combined with characteristics of easy machinability and mechanical strength, accounts for the use of Textolite in leading radio receivers.

Ask the Textolite specialist at the G-E office in your vicinity, or representatives of the eastern or western fabricators, to outline the properties of this insulating material which make it desirable for application to the set you manufacture.

SHEETS RODS TUBES
FABRICATED PARTS

831-4D

GENERAL ELECTRIC

SALES AND ENGINEERING SERVICE IN PRINCIPAL CITIES

When writing to advertisers mention of the PROCEEDINGS will be mutually helpful.

XLV

THE CRC SOCKET LINE Includes

THE "500" SERIES —

For extremely economical production — unique design permits almost unlimited size and shape possibilities with acceptable electrical characteristics.



THE "600" SERIES —

The quality socket of the CRC line — unusually rugged, reinforced contacts providing accessibility for fast and accurate production — mechanically and electrically correct.

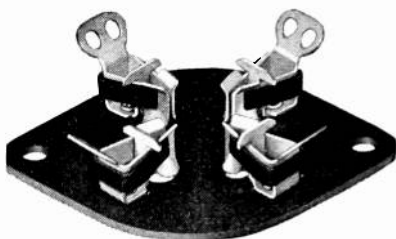

THE "800" SERIES —

providing the same kind and amount of spring reinforced contact as the 600 series and with the same mechanical and electrical correctness, all in a more economical form.



SPECIAL DESIGNS —

Whether your problem calls for mogul sockets, special contacts, odd sizes, shapes and terminal arrangements or for the creation of an entirely new idea CRC will solve it.

CENTRAL RADIO CORPORATION
BELOIT, WISCONSIN

When writing to advertisers mention of the PROCEEDINGS will be mutually helpful.



In the Bradleyometer approximately 50 solid resistance disks are interleaved between metal disks, forming a resistance column that will produce any form of resistance-rotation curve, as shown to the right

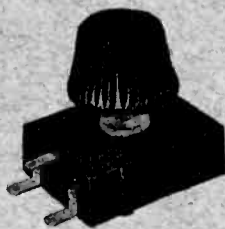
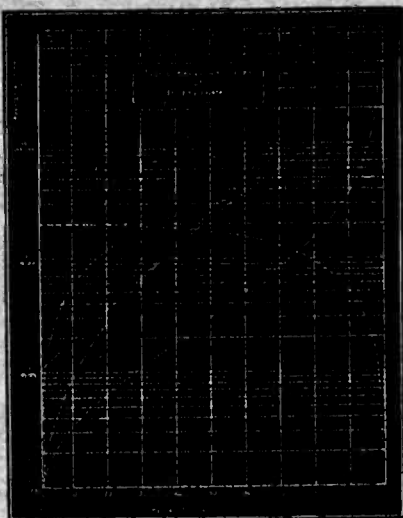

The Bradleyometer is a "stepped" potentiometer for volume level control and tone control. Can be furnished with one to six units operated by one knob. Ideal for sound recording, telephone lines, etc.

Every Radio Engineer should have the latest data on these remarkable resistors

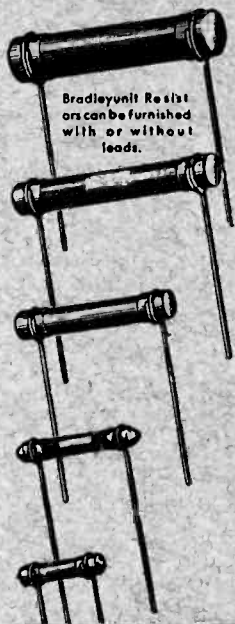

Bradleyunit Resistors can be furnished with or without leads.

Bradleyunit Resistors are made in five sizes, with or without leads. All Bradleyunits are color-coded to meet set manufacturers' specifications. These solid molded resistors are accurately calibrated and have great mechanical strength. They are used by the world's largest radio manufacturers for providing correct C-bias, plate voltage, screen grid voltage, and for use as grid leaks. Get an Allen Bradley quotation on your next order.

Bradley Suppressors are special solid molded resistors which minimize the disturbing oscillations in the ignition circuit of cars equipped with radio resistors. They resist the destructive effects of heat, moisture, and age. They are the last word for motor car radio. Send for complete data.

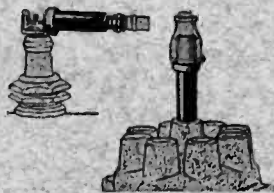

Bradley Suppressors installed on spark plugs and distributor of radio-equipped car.

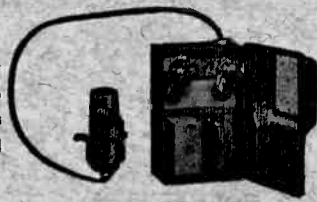

Allen-Bradley Bulletin 880 Photo-electric Relay used with Allen-Bradley Bulletin 875 Light Source. Can be furnished in water-tight enclosures for outdoor service. Send for Bulletins 875 and 880 today.

Allen-Bradley Co.

116 W. Greenfield Ave.



Milwaukee, Wisconsin

ALLEN-CO. BRADLEY RESISTORS

Produced by the makers of Allen-Bradley Control Apparatus

FOR THE NEW ± 50 -CYCLE LIMIT

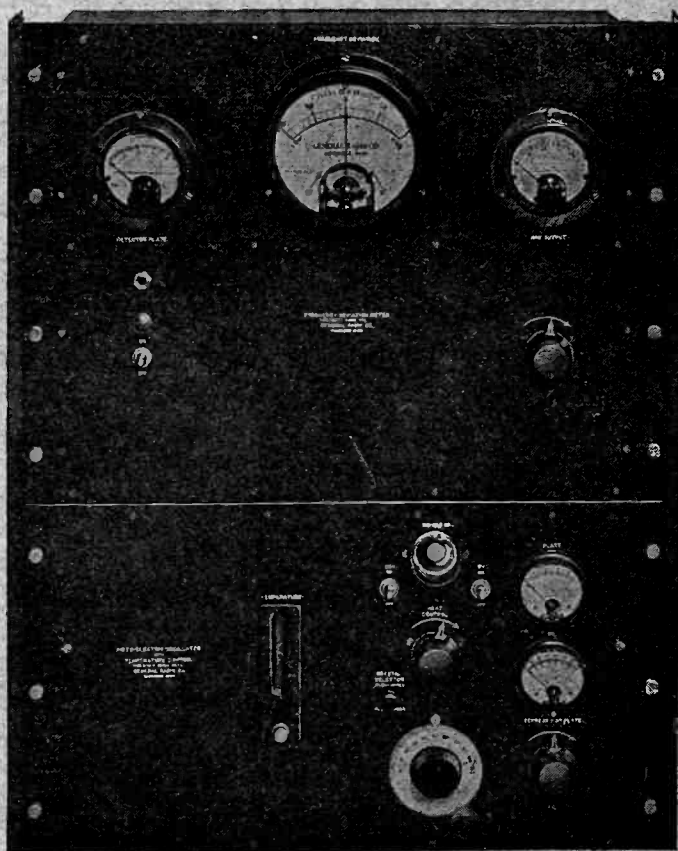

THE General Radio frequency monitor more than meets the exacting requirements of General Order No. 116 of the Federal Radio Commission. It affords a *continuous visual* check on the station frequency and shows both the amount and direction of the drift.

The monitor consists of two units: a piezo-electric frequency standard stable to within ± 5 cycles in a million, and a frequency deviation indicator which operates on the beat between transmitter and standard.

FEATURES

- 1) Continuous monitoring
- 2) Approval by F.R.C. guaranteed
- 3) Direction of drift shown on scale
- 4) Complete instrument (except ground-to-order crystal) can be shipped from stock
- 5) Price: \$550.00, complete with crystal but without tubes

ORDER NOW

GENERAL RADIO COMPANY
OFFICES :: LABORATORIES :: FACTORY
CAMBRIDGE A, MASSACHUSETTS