

# FM-TV

Price 25 Cents

Mar. '50

# RADIO COMMUNICATION

★ ★ Edited by ★ ★  
Milton B. Sleeper

*Induct-tuner Page 9*  
*Craftsman RC100-A TV Page 12*  
*GBN6 Applications Page 14*  
*AEI-AM-FM tuner Page 22*

REFERENCE COPY  
Not to leave Library  
Under LIBRARY

CHECKING SITE FOR  
MICROWAVE RELAY



10th Year of Service to Management and Engineering





The new Type 1023-A Amplitude Modulator, while designed particularly for use with the G-R Type 1022-A F-M Generator, may be used equally as well with other standard-signal generators at frequencies between 5 Mc and 220 Mc. It produces an amplitude-modulated signal with no appreciable incidental f-m. A feature of this modulator when used with the Type 1022-A Generator is the i.f. operating range switch which provides a gain of 10 at the 10.7 Mc standard f-m receiver intermediate frequency. Output voltages up to 3 volts can be obtained without serious envelope distortion. The output impedance is exceptionally constant.

**TYPE 1023-A AMPLITUDE MODULATOR \$250.00**



For measurements of  $\sim$ f sensitivity on balanced lines for f-m and tv bands, the Type 1000-P5 V-H-F Transformer plugs into a standard-signal generator having a 50-ohm unbalanced output and supplies an equal balanced open-circuit voltage behind a 300-ohm balanced impedance. Its frequency range is 50 Mc to 250 Mc.

**TYPE 1000-P5 V-H-F TRANSFORMER . . . . \$27.50**

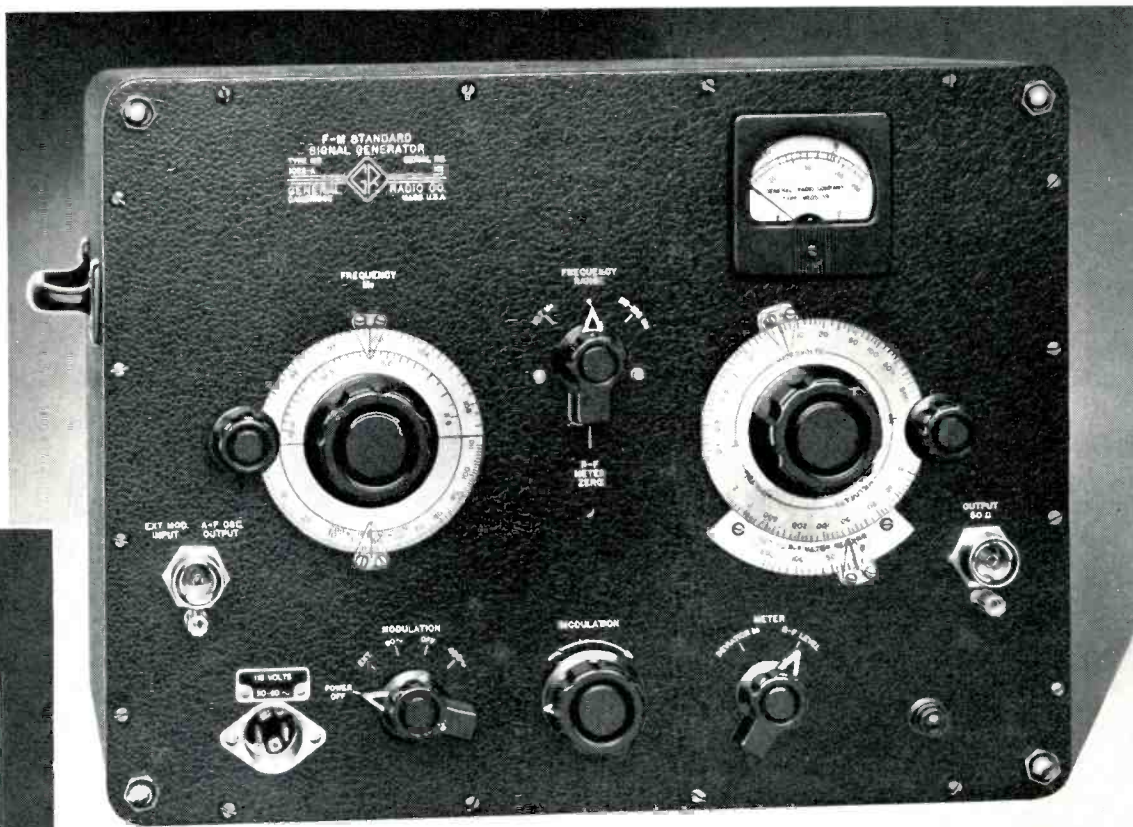

## FOR TESTING F-M BROADCAST RECEIVERS

**SIMPLE • INEXPENSIVE • NO SPURIOUS SIGNALS**

**T**HIS new G-R Standard-Signal Generator is designed especially for testing f-m broadcast receivers. All unessentials have been omitted in order that it can be moderately priced. Its features include:

- **Carrier Frequency Ranges** — 10-11.5 Mc and 88-108 Mc
- **Very Low Incidental Amplitude Modulation** — less than 5%
- **F-M Noise Level Very Low** — more than 50 db below 75 kc deviation
- **Slow Drift** — less than 0.005% after 20 minutes operation
- **High Output Voltage** — 88-108 Mc from less than 0.1 mv to more than 1 volt; open circuit; 10-11.5 Mc from less than 0.1 to 0.25 v
- **No Spurious Signals in Output System** — generates only one frequency
- **Extra-Low Generator Leakage** — undetectable on high-grade commercial f-m receiver
- **Semi-Logarithmic Meter Scale** — easier to read low deviations
- **Constant and Purely Resistive Output Impedance** — 50 ohms nominal
- **Auxiliary Tuning Scale** — for easy interpolation, 200 kc intervals on 88-108 Mc range and 20 kc on 10-11.5 range

**TYPE 1022-A F-M STANDARD-SIGNAL GENERATOR . . . \$625.00**

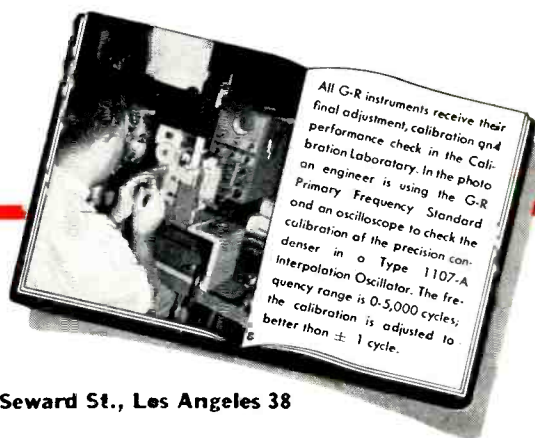

  
**GENERAL RADIO COMPANY**  
 Cambridge 39, Massachusetts

90 West St., New York 6    920 S. Michigan Ave., Chicago 5    1000 N. Seward St., Los Angeles 38



# COMPARE FACTS!

UP-TO-DATE FEATURE	YOUR CAMERA	DU MONT
Dual Purpose Equipment (Studio or remote)		✓
Electronic View Finder		✓
Tube Interchangeability		✓
Turret Lens Plate with Remote Iris Control		✓
Breakaway Chassis for Accessibility		✓
Automatic Lap Dissolve and Fade		✓
Single-Unit Sync Generator		✓
Single Jiffy Connectors		
White Peak Limiter		
Fingertip Controls		
Adequate Cooling		
Panhandle Focus		✓

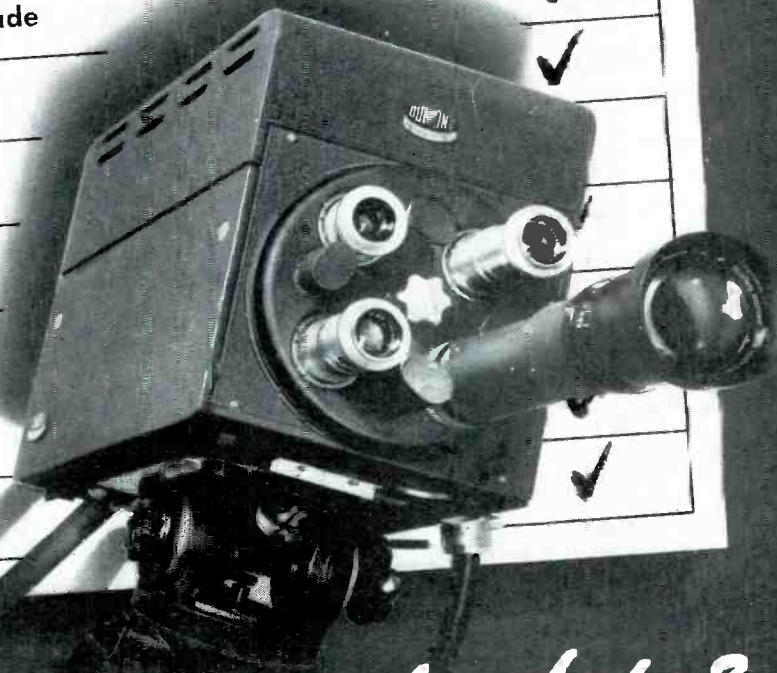

*Are your cameras up-to-date?*

© ALLEN B. DU MONT LABORATORIES, INC.

**DU MONT**

*First with the Finest in Television*

ALLEN B. DU MONT LABORATORIES, INC. • TELEVISION TRANSMITTER DIVISION, CLIFTON, N. J. • DU MONT NETWORK AND WABD, 515 MADISON AVE., NEW YORK 22, N. Y. • DU MONT'S JOHN WANAMAKER TELEVISION STUDIOS, NEW YORK 3, N. Y. • WTTG, WASHINGTON, D. C. • STATION WDTV, PITTSBURGH, PA. • HOME OFFICES AND PLANTS, PASSAIC, CLIFTON, ALLWOOD, AND EAST PATERSON, N. J.

# 1950 Zenith "Black" Tube Television With New "Super-Range" Chassis

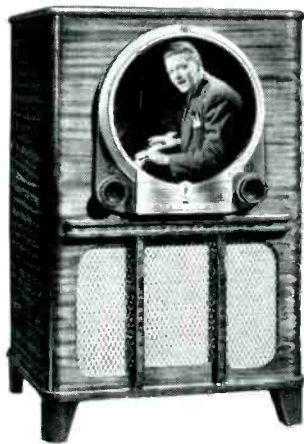

**\$269.95\***

*Plus Federal Excise Tax*

## New Zenith "Adams"

An unprecedented value in television entertainment. With new Glare-Ban "Black" Tube—television's greatest picture improvement! Has "Big B" Giant Circle Screen and sensational new "Picturemagnet" built-in aerial. Plus Zenith's exclusive One-Knob Automatic Tuning and convenient Duo-Picture Control Switch. In handsome cabinet of genuine mahogany veneers.

**Of course, Zenith Has a Built-In Antenna—  
the Amazing "Picturemagnet"—Plus the New  
Super-Sensitive Circuit—Giant-Picture Screen  
and Many Other Zenith "Firsts"**

Never before have there been such amazing television improvements available to you as in these new Zeniths! Zenith gives you pictures with great depth and detail—photographic realism. Sensational Zenith Glare-Ban "Black" Tube (Blaxide) increases picture clarity—eliminates objectionable blur and glare. And now in many locations, no need for a separate aerial inside or out with Zenith television... just plug in, and Zenith's exclusive "Picturemagnet" does the rest.

**Yes, of course Zenith has a Built-In Antenna—**

## **PLUS These Sales-Proven Zenith Features**

- ★ **One-Knob Automatic Tuning**—one twist brings in station, picture, sound. Does automatically what on many other sets takes up to 5 or 6 manual tuning operations.
- ★ **"Gated" Automatic Gain Control**—Zenith's exclusive, automatic protection against "picture flutter."
- ★ **Genuine Armstrong FM Sound**—the FM of the experts. Glorious toned, static-free, even in worst storms!
- ★ **Giant Circle Screen with Picture Control**—gives you a choice of circular or rectangular pictures at the flick of a finger!

## ZENITH TELEVISION

### New Zenith "Lincoln"

Quality television at its finest! New Zenith Glare-Ban "Black" Tube—gives greatly improved picture clarity in lighted rooms. With "Giant C" Giant Picture Screen and Zenith's exclusive built-in "Picturemagnet" aerial. Simplified One-Knob Automatic Tuning and convenient Duo-Picture Control Switch. An exquisite console in genuine mahog-

**\$359.95\***

*Plus Federal Excise Tax*



## ZENITH TELEVISION

**Zenith has the great values**



**ZENITH RADIO CORPORATION**

6001 West Dickens Avenue, Chicago 39, Illinois

### New Zenith "Van Buren"

Television FM-AM Radio-Phonograph Combination. With new Glare-Ban "Black" Tube and "Big B" Giant Circle screen. Has Zenith's new built-in "Picturemagnet" aerial plus exclusive Duo-Picture Control and Simplified One-Knob Automatic Tuning. Matchless radio reception with Zenith's new Super-Sensitive FM and famous Long-Distance AM. Revolutionary new 3-Way Cobra Tone Arm and Record Changer plays all records, all sizes, all speeds—automatically! All exquisitely combined in a superb "Queen Anne" cabinet of genuine mahog-

**\$489.95\***

*Plus Federal Excise Tax*



*\*Suggested retail prices. West Coast prices slightly higher. Prices subject to change without notice.*

FM-TV, the JOURNAL of RADIO COMMUNICATIONS





Formerly, FM MAGAZINE, and FM RADIO-ELECTRONICS

VOL. 10

MARCH, 1950

NO. 3

COPYRIGHT 1950, by Milton B. Sleeper

## CONTENTS

### INDUSTRY NEWS

<b>TV-FM-AM Set Production</b> Compiled from figures released by the RMA .....	4
<b>Spot News Notes</b> Items and comments about people and companies .....	5
<b>What's New This Month</b> FCC Commissioner Jones' address to the AMA, Part 2 .....	16

### TELEVISION EQUIPMENT

<b>Continuous Tuning for TV Sets</b> B. K. V. French .....	9
<b>Optimum Big-Picture Quality</b> Edward Miller .....	12
<b>TV Applications of the 6BN6</b> Richard O. Gray & Walter J. Stroh .....	14

### FM COMMUNICATIONS

<b>Mobile Radio News &amp; Forecasts</b> Jeremiah Courtney .....	18
<b>Radio Relays vs. Wire Lines</b> Frederick T. Budelman .....	19
<b>Low-Cost Mobile Fleet Control</b> Jack Kulansky .....	20

### FM BROADCAST RECEIVERS

<b>The AEI FM-AM Tuner</b> Fred E. Behrley .....	22
---	----

### AUDIO SECTION

<b>Notes and Observations</b> Milton B. Sleeper .....	24
--	----

### SPECIAL DEPARTMENTS

<b>Professional Directory</b> .....	6
<b>Special Services Directory</b> .....	7
<b>News Pictures</b> .....	17
<b>Advertisers Index</b> .....	35

THE COVER DESIGN AND CONTENTS OF FM AND TELEVISION MAGAZINE ARE FULLY PROTECTED BY U. S. COPYRIGHTS, AND MUST NOT BE REPRODUCED IN ANY MANNER OR IN ANY FORM WITHOUT WRITTEN PERMISSION

**MILTON B. SLEEPER, Editor and Publisher**

ROY F. ALLISON, Associate Editor  
CHARLES FOWLER, Business Manager  
LILLIAN BENDROSS, Circulation Manager  
SOPHIE FORTY, Production Manager  
Published by: FM COMPANY

Publication Office: 264 Main St., Gt. Barrington, Mass. Tel. Gt. Barrington 500  
Chicago Office: Louis Reinig, 176 W. Adams St. Tel. Andover 3-5585

FM-TV Magazine is issued on the 10th of each month.

Single copies 25c—Subscription rate: \$6.00 for three years, \$3.00 for one year in the U. S. A.—Canada, add 50c per year postage—foreign, add \$1.00 per year postage.

Contributions will be neither acknowledged nor returned unless accompanied by adequate postage, packing, and directions, nor will FM-TV Magazine be responsible for their safe handling in its office or in transit.

Entered as second-class matter August 22, 1946, at the Post Office, Great Barrington, Mass., under the Act of March 3, 1879. Additional entry at the Post Office, Boston, Mass. Printed in the U. S. A.



# DEPENDABLE



# and TROUBLE FREE VIBRATORS

Select your replacement vibrators wisely... and you, too will choose Radiart! Laboratory tests and customer reports prove that Radiart Vibrators give LONGER LIFE and trouble-free performance BECAUSE THEY ARE BUILT TO WITHSTAND RUGGED SERVICE! These extra hours of dependable performance are one of the factors that has made Radiart the leader. Superior engineering and design have made them THE STANDARD OF COMPARISON.

At All Good Radio Parts Jobbers. Ask for the Special Service Group — 5500 and 5600 Series.



IT'S RIGHT WHEN IT'S RADIART

**THE RADIART CORPORATION**  
CLEVELAND 2, OHIO



- ROTATORS
- VIBRATORS
- TV ANTENNAS
- AUTO AERIALS
- POWER SUPPLIES



CIRCULATION AUDITED BY  
HENRY R. SYKES,  
CERTIFIED PUBLIC ACCOUNTANT  
SYKES, GIDDINGS & JOHNSON  
PITTSFIELD, MASSACHUSETTS

For the Best in . . .

**TWO-WAY  
RADIO  
COMMUNICATIONS**  
always specify

*Link*

DESIGN LEADER IN THE FIELD  
SINCE 1932 WITH EQUIPMENT

"Preferred the  
World Over!"



**FM**

- 25-50 MC • 72-76 MC
- 152-162 MC • 450 MC
- BAND • 960 MC BAND



**AM**

- 25-50 MC
- 1500-3000 KC



**Portable Units**



**Vetric Motorcycle  
Radio Equipment**

**Link Radio Corporation**

125 W. 17th St., New York 11, N. Y.

*Link*



**Y**EAR-END figures on home radio production show that the industry prospered in 1949. RMA estimates that TV sets totaled something more than 2,800,000, taking into account the production of non-member companies. This is 3.2 times the '48 figure.

FM sets, plus the rapidly-growing sale of chassis not included in RMA figures, amounted to about 1,000,000. While that is one-third below the '48 total, it actually represents a gain in the manufacture of sets capable of giving creditable FM reception. Also, some 500,000 TV receivers built during the year had FM tuning, so that the effective FM total added up to about 1,500,000 capable of giving their owners substantially more enjoyable performance than from AM broadcasting.

The 1949 figure for AM was 6,391,000, down almost one-half from '48. To be exact, it dropped 5,300,000. Last month, we said that the November figure, a record for the year, might not be reached again. As the Barometer shows, December was down again, and a very substantial further drop can be expected as the monthly figures come out for the new year. Only 2,784,000 home-type AM sets were produced in '49, of which nearly

one-half were billed at less than \$12.50. AM consoles dropped to 4,286.

Looking ahead, it is difficult to anticipate TV sales in 1950 because there is no likelihood that the VHF band will be opened up before a decision is reached on UHF allocations. Of course, the market in the present VHF areas is far from saturation. However, there will not be any spectacular increase in TV production until UHF models can be brought out. Therefore, current TV figures will run at about the present level, with seasonal variations, until the nationwide allocations can be released.

Despite all dire predictions by those who wish it weren't, FM is firmly and permanently established. In addition to Zenith's big production, General Electric is readying a low-price model of excellent performance. It is probable that FM sets will reach the 2 million mark in '50, not counting TV models with FM tuning.

Manufacturers are dropping AM models already. Auto sets and portables will far exceed home sets during the coming year. It's only an opinion based on the postwar figures, but it looks as if the 1950 AM total may not exceed 3 million. If that is the case, the net drop of AM sets in use will be about 5 million.

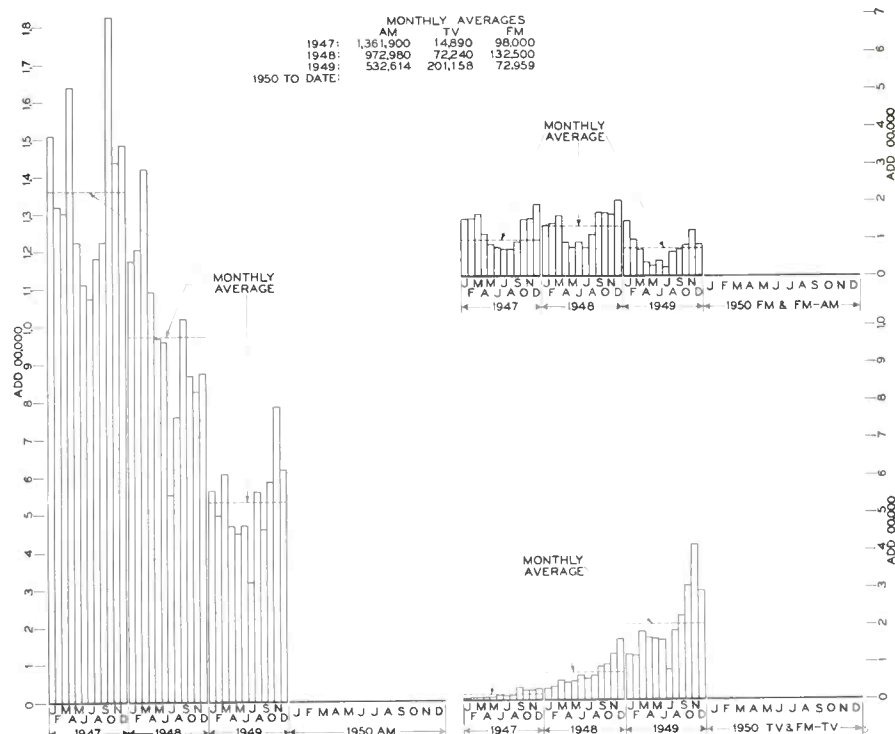

TV, FM, and AM Set Production Barometer, prepared from RMA figures



## THIS MONTH'S COVER

The Bell System's FM microwave relay which has proved so successful between New York and Boston is now being extended to Chicago, and will ultimately reach San Francisco. This month's cover shows a test installation used for checking relay locations. A portable, guyed tower, 200 feet high, is used for this purpose. Then the transmitter or receiver is cranked up to the required height, as indicated by measurements made on the ground. Such elaborate tests are necessary because of the high cost of multiplex relay installations.

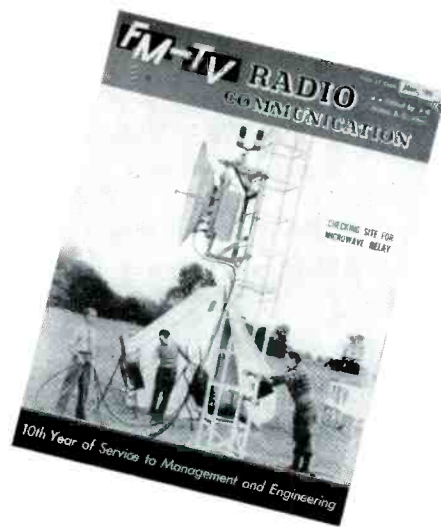

## SPOT NEWS NOTES

ITEMS AND COMMENTS, PERSONAL AND OTHERWISE, ABOUT PEOPLE AND COMPANIES CONCERNED WITH RADIO COMMUNICATIONS

### December 12, 1901:

Next year we shall celebrate the 50th anniversary of Marconi's first transmission of radio signals across the Atlantic. Certainly our Post Office should recognize this historic event by issuing a commemorative stamp. If you agree, it's none too early to write Postmaster General Jesse M. Donaldson about it.

### Leroy A. Wilson:

AT & T president to the supervisory staff at Bell Laboratories: "I would emphasize that although technology must come before service, the service *idea* comes before the technology. The great success of the Bell Telephone Laboratories in advancing the art of telephony has come out of a continuous underlying motive of providing service—more service, more dependable and improving service, . . ." Strikes us that radio broadcasting needs more of that kind of thinking at management level.

### Equipment and Components:

A catalog of 144 pages has just been issued by the Radio Shack, 167 Washington Street, Boston 8, listing equipment for broadcasters, manufacturers, laboratories, and custom set-builders. This is the only parts jobbing concern east of New York that carries a full stock of cataloged items.

### Melville Eastham:

Founder of General Radio Company, and its president until 1944, retired on February 15, in accordance with the Company's retirement plan. For the past six years, he has held the position of chief engineer; now he has been appointed honorary president. Charles C. Carey and Arthur E. Thiessen, both of whom are vice presidents, have been elected directors.

### Low Temperature in TV Freezer:

FCC Chairman Coy, testifying on January 30 at a closed hearing of the House Appropriations Committee on Independent Offices: "I have no clear idea how long that [allocations hearing] is going to take. I do not see how we can possibly get out of the freeze before the latter part of the summer. I cannot even say we will get out of it." If, as is widely held, the time depends upon progress in developing and field-testing UHF transmitters and receivers, and setting UHF standards, it seems as if the FCC should say so, frankly and explicitly.

### R. L. Grove:

Appointed Chief Engineer of Cornell-Dubilier's ceramic division at New Bedford, Mass. Previously, he was ceramic engineer at the Westinghouse plant in Derry, Pa., and more recently with Centralab in Milwaukee.

### Color TV Report:

A complete report on FCC tests and a discussion of the present status and future prospects of color television will appear in the April issue of *FM-TV*. Important factors, not covered by the press, will be considered in detail.

### Now It's SMPTE:

The word "Television" has been added to the name of the Society of Motion Picture Engineers. Explaining this, president E. L. Sponable said that this is in recognition of "the fact that in certain regions the interests of the television and motion picture engineers coincide. Each can learn much from the other." Information concerning membership in the SMPTE, and the Society's excellent monthly Journal can be obtained from Boyce Nemec, executive secretary, 342 Madison Avenue, New York.

**NOT JUST A PRODUCT\***

**Bliley**  
THERMOSTABILIZED  
TYPE TCO-1  
55000 KC  
6.31.85 M125 °C  
BLILEY ELECTRIC CO.  
ERIE, PA.  
U.S.A.

BLILEY  
T86  
CRYSTAL

FREQUENCY RANGE  
1.00 MC

WITHOUT TEMPERATURE CONTROL, BND CRYSTAL UNITS (SHOWN IN PHANTOM) CAN BE BUILT TO STABILIZE WITHIN  $\pm 0.023\%$  FROM  $-55^{\circ}\text{C}$  TO  $+90^{\circ}\text{C}$ . WITH TEMPERATURE CONTROL INSTALLED IN TYPE TCO-1 OVEN, STABILITY CAN BE  $\pm 0.003\%$  IF DESIRED. IT PAYS TO CONSIDER THE RATIO OF COST TO IMPROVED STABILITY.

\* BUT . . . A COMPLETE APPRECIATION OF END USE COST FACTORS AS APPLIED TO FREQUENCY STABILITY.

Always Specify Bliley!

**Bliley**  
CRYSTALS

BLILEY ELECTRIC COMPANY  
UNION STATION BUILDING  
ERIE, PA.

## Professional Directory

### Jansky & Bailey

Consulting Radio Engineers

EXECUTIVE OFFICES:  
970 National Press Bldg.,  
Washington 4, D. C. ME 5411

OFFICES AND LABORATORIES:  
1339 Wisconsin Ave. N.W.,  
Washington 7, D. C. AD 2414

Member AFCEE

### GARO W. RAY

CONSULTING RADIO ENGINEERS

Standard, FM and Television Services

HILLTOP DRIVE  
STRATFORD, CONN. Tel. 7-2466

### ANDREW ALFORD

Consulting Engineers

ANTENNAS & RF CIRCUITS

Laboratory and Plant:  
299 Atlantic Ave., Boston 10, Mass.  
Phone: HAncock 6-2339

### DALE POLLACK

FREQUENCY MODULATION

development and research  
transmitters, receivers  
communications systems

352 Pequot Avenue New London, Conn.  
New London, 2-4824

GEORGE C. DAVIS

Consulting Radio Engineers

501-514 Munsey Bldg.—Sterling 0111

Washington 4, D. C.

### AMY, ACEVES & KING, Inc.

Specialists in the  
Design and Installation of

HIGH-GAIN  
AM, FM, and TELEVISION  
ANTENNA SYSTEMS

LOngacre 5-6622  
11 West 42nd St., New York 18, N. Y.

## SPOT NEWS NOTES

(Continued from page 5)

### New Equipment Manufacturer:

Standard Electronics Corporation, Providence, R. I., has been organized with private capital to manufacture audio and video broadcast station equipment, and communications equipment. Products will be distributed by Graybar, which formerly handled a similar Western Electric line. President is Edwin M. Martin, former board chairman of American Bosch. Sales manager is John Ganzenhuber, formerly in charge of Western Electric's radio sales.

### New Propagation Laboratory:

Bureau of Standards will spend \$4.5 million on a propagation laboratory at Boulder, Colo. Plot of 210 acres is adjacent to the University of Colorado. Most of the staff of 300 will be moved from Washington. Research will cover propagation, systems, and measurement standards.

### Antenna Sales Promotion:

Philco's January service-dealer bulletin listed FM turnstile and single-dipole receiving antennas with the comment: "A recent survey has revealed that many of the millions of FM receivers in the United States are located in low signal-strength areas, and that the sets are not performing at peak efficiency because they have no outside aerials. That, of course, means that owners of these sets are in the mood to buy one of the new Philco FM aerials. What a market."

### New Plant Construction:

Motorola is doubling the capacity of its Locust Avenue plant at Quincy, Ill. Corning Glass is proceeding with two buildings, one for TV tube development, and the other for mechanical development. Admiral has purchased the General Mills building, of 64,000 square feet, at Bloomington, Ill. Hytron is adding space for TV tube production, adjacent to its factory at Salem, Mass.

### More AM Licenses Deleted:

Use of figures showing a great number of "FM station deletions" is just another example of efforts to discredit FM broadcasting. It is true that some 189 construction permits for FM stations were turned back to the FCC, along with 60 AM construction permits. However, CP's do not represent operating stations. Some applications for CP's amounted to much more than expressions of wishful thinking. Of the licensed stations that were on the air and then closed down in 1949, twenty were AM, compared with six FM stations!

## Professional Directory

### McNARY & WRATHALL CONSULTING RADIO ENGINEERS

906 National Press Bldg. DI. 1205  
Washington, D. C.

1407 Pacific Ave. Phone 5040  
Santa Cruz, California

### KEAR & KENNEDY

Consulting Radio Engineers

1703 K St., N.W. STerling 7932  
Washington, D. C.

### GEORGE P. ADAIR

Consulting Engineers

Radio, Communications, Electronics

1833 M St., N.W., Washington 6, D.C.  
EXecutive 1230

### —McINTOSH— & INGLIS

Consulting Radio Engineers

710 14th St. N.W., Wash. 5, D. C.  
METropolitan 4477

### RATES FOR PROFESSIONAL CARDS IN THIS DIRECTORY

\$12 Per Month for This Standard  
Space. Orders Are Accepted  
for 12 Insertions Only.

### LYNNE C. SMEBY

Consulting  
Radio Engineers

820 13th St., N.W. EX 8073  
WASHINGTON 5, D. C.



## Professional Directory

### RAYMOND M. WILMOTTE Inc.

*Consulting Engineers  
Radio & Electronics*

1469 Church St. N. W. Decatur 1232  
Washington 5, D. C.

### WELDON & CARR CONSULTING RADIO ENGINEERS

Washington, D. C.

1605 Connecticut Ave. MI. 4151

Dallas, Texas

1728 Wood St. Riverside 3611

### RUSSELL P. MAY

CONSULTING RADIO ENGINEERS

★ ★ ★

1422 F Street, N. W. Wash. 4, D. C.

Kellogg Building Republic 3984

Member AFCEE



CONSULTING  
RADIO  
ENGINEERS

**Andrew**  
CORPORATION

263 EAST 75th STREET • CHICAGO 19

### RATES FOR PROFESSIONAL CARDS IN THIS DIRECTORY

\$12 Per Month for This Standard  
Space. Orders Are Accepted  
for 12 Insertions Only

Paul W. Klipsch  
Professional Engineer  
Acoustic development  
and consulting

Klipsch and Associates  
building the authentic  
KLIPSCHORN  
world's finest sound reproducer

Hope, Arkansas

Tel. Hope 995

## SPOT NEWS NOTES

(Continued from page 6)

### Phonevision Tests Set:

With FCC authorization, Zenith is preparing to start Phonevision tests on channel 2 in Chicago. A contract was signed with Illinois Bell Telephone Company on February 2 under which 300 families, equipped with test receivers, will be charged \$1. on their phone bills if they ask central for a Phonevision connection.

### Extra Dividends from Taxi Radio:

Radio dispatching has doubled the business of the Checker Taxi Company of Madison, Wis., according to general manager Robert L. Bender. And he adds the interesting side-light that, despite the added revenue-miles, deadhead mileage has been cut so drastically that the cabs only average 30,000 miles travel per year. Before radio, cabs were traded in each year. Now they run two to three years.

### 1,449 Feet High:

Both WPIX and WABC-TV have contracted with NAB for transmission from the new antenna to be erected on the Empire State Building, New York City. WABD will probably use this tower later.

### Harold J. Adler:

Appointed chief television engineer for Hallicrafters. For the past sixteen years, he has been Sentinel's chief engineer.

### Maybe It's Retribution:

When WMCA president Nathan Straus decided to close down WMCA-FM, he went to great pains to explain in detail that FM was only a snare and a delusion. His letter, published in *The New York Times*, stated: "FM is a service which, for the ordinary listener in the average location, has no advantages over AM." But he has never referred publicly to the fact that his AM transmission is being practically ruined by a squeal from Cuban interference. Nor did he shut down WMCA-FM, because he received several offers to buy the station!

### Car Radio Production Dropped:

Although auto sets have represented \$20 million volume at Zenith Radio, the Company will give up this business in order to devote its facilities to increased production of TV and FM sets. Alternative would be expensive plant expansion which, in Commander McDonald's conservative judgment, is not warranted.

### More Transit Radio Sponsors:

Transit Radio, Inc., reports a 22 per cent increase in number of sponsors during the last two months of '49. Current list shows 459 companies using time on 14 affiliated stations.

## Special Services Directory

### METHODS ENGINEERS

Materials & Methods engineers in America's leading manufacturing plants use Topflight's Printed Cellophane, Self - Adhesive Tapeto meet A-N specs. - assembly line - follow through - instruction labels. Easy to Apply.

TOPFLIGHT TAPE CO. YORK PA.

### RANGERTONE

TAPE RECORDERS

HIGH-FIDELITY EQUIPMENT FOR  
BROADCAST & RECORDING STUDIOS

RANGERTONE, INC.

73 Winthrop St. Newark 4, N. J.  
Tel. Humbolt 5-2550

### THE WORKSHOP

ASSOCIATES

INCORPORATED



*Specialists in  
High-Frequency  
Antennas*

66 Needham St., Newton Highlands, Mass.  
Bigelow 4-3330

### MEASUREMENTS CORPORATION

*Research &  
Manufacturing  
Engineers*

Specialists in the Design & Development  
of Electronic Test Instruments

BOONTON, N. J.

### HAROLD M. HEIMARK

Communication Engineers

Specialists in the design of low  
power portable & mobile two-  
way radio equipment.

MANUFACTURING FACILITIES

734 N. Austin Blvd. Chicago phone  
Oak Park, Illinois Estebrook 8-7047

**16mm  
maurer**

16-MM Professional Motion Picture  
Production Equipment

J. A. MAURER, Inc.

37-07 31st Street, Long Island City 1, N. Y.  
Tel. Stillwell 4-4601

# TV FEATURES

OF THE

## MAURER

### 16 MM. CAMERA

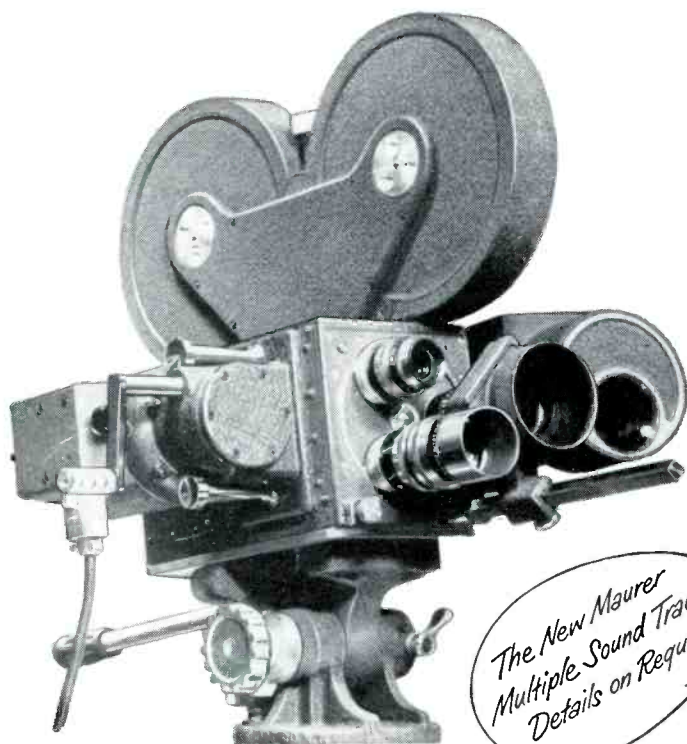

*The New Maurer  
Multiple Sound Track  
Details on Request*

The Maurer 16 mm. camera is the answer to your exacting TV production requirements. Designed *specifically* for professional use, it produces steadier, sharper and more accurately composed pictures under all conditions. Ease of operation, combined with many other unique features make the Maurer Professional tops in performance and dependability.

**The 16 mm. Camera Designed  
Specifically for Professional Use!**

*For details on these and other exclusive  
Maurer features, Write:*

**J. A. Maurer, Inc.**

37-01 31st Street, Long Island City 1, N.Y.

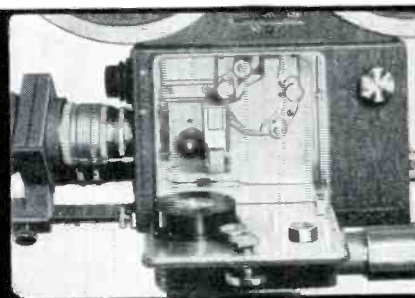

In the exclusive Maurer intermittent movement the functions of the pulldown claw and registration pin are combined, giving accurate registration in old or new film. Because it depends to a minimum extent upon the accuracy of 16 mm. perforations, this movement provides the most accurate registration obtainable.

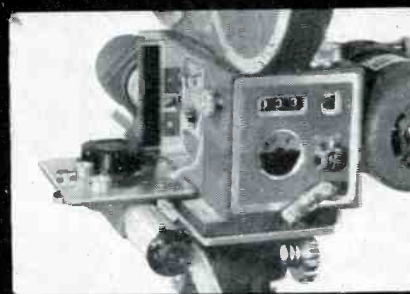

The unique Maurer focusing system provides full field composition through the taking lens. The image seen through the clear glass reticle permits the greatest magnification ever obtained in a motion picture camera for critical focusing, therefore obtaining the greatest accuracy.



The Maurer variable shutter has a 235° open segment . . . allowing use of a smaller aperture with the same lighting . . . giving greater depth of field. Calibrated in 1/2 lens stops, it permits quick and accurate change of exposure while shooting. The additional light transmission permits you to shoot your originals in color easily, a factor which is valuable now and may become much more important.



# CONTINUOUS TUNING FOR TV SETS

DETAILS AND PERFORMANCE DATA ON THE NEW DUMONT 4-SECTION HEAD END, DESIGNED TO TUNE CONTINUOUSLY FROM 54 TO 216 MC.—By B. K. V. FRENCH\*

INPUT tuning systems for television receivers can be broadly classified, according to the method of channel selection, as step-tuning or continuous-tuning types.

The step-tuning types employ rotary switches or a detent-positioned turret to allow a discrete jump from one television channel to the next. Fine tuning over a limited frequency range at each channel position is usually provided by means of auxiliary vernier control of oscillator frequency. Step tuning systems are applicable to receivers designed for television reception alone, and do not take advantage of the fact that the standard FM broadcasting band, 88 to 108 mc., is located in the portion of the spectrum between television channels 6 and 7.

## Purpose of Continuous Tuning:

A continuous tuning input system, in conjunction with the dual IF channel type of television receiver, makes it possible to provide high quality FM reception as an added feature without the inclusion of any other circuit elements than those required for television reception.

\*Electronic Parts Division, Allen B. Du Mont Laboratories, Inc., 2 Main Avenue, Passaic, N. J.

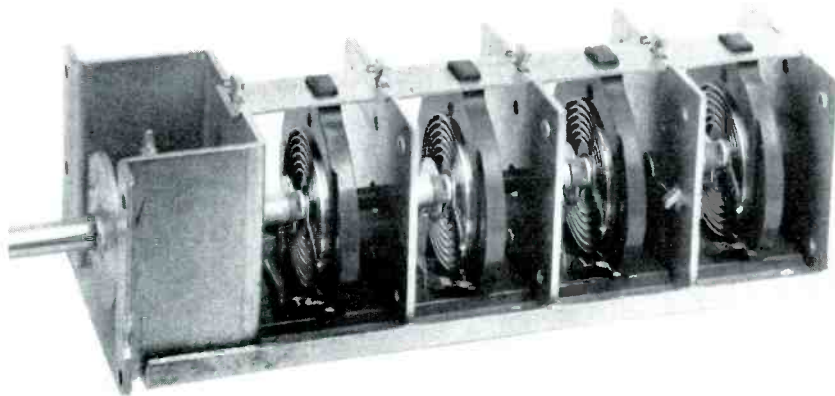

Fig. 2. Spiral design of coils increases linearity at high end of tuning range

Since television broadcasting at present is confined to a short operating day, especially in sections of the country not served by coaxial or relay network service, this dual function of TV and FM reception by the same entertainment device is of value.

Another advantage of continuous-tuning systems is the fact that optimum picture and sound tuning can be realized at all times, whereas any drift in tuning due to the aging of carrier tuning elements of a step type system can be corrected only by a service adjustment.

Continuous tuning can be accomplished by the use of either a variable capacitor, a variable inductor, or a combination element embodying simultaneous variation of inductance and capacitance (butterfly tuning). Since it is desired to cover the entire range from television channel 2 at 54 mc. to channel 13 at 216 mc. with a single variable tuning element, the variable inductance type of tuning appears to be the most practical method because of its wide-range capabilities.

## Variable Inductor Development:

The perfection of a reliable and efficient variable inductor for this range of frequencies has been a continuing development of more than twelve years.<sup>1, 2, 3, 4, 5</sup> Fig. 1 shows the latest Du Mont 4-section Inputuner<sup>6</sup> model T4A at the right, and the preceding 3-section design.

In common with previous designs, the new series T4A Inputuner employs a sliding-contact, variable gang inductor known as the Inductuner.<sup>7</sup> This miniature version allows a tuner design in which four tuning sections occupy less space than the three sections of the older type, making possible a completely shielded unit with an additional tuned

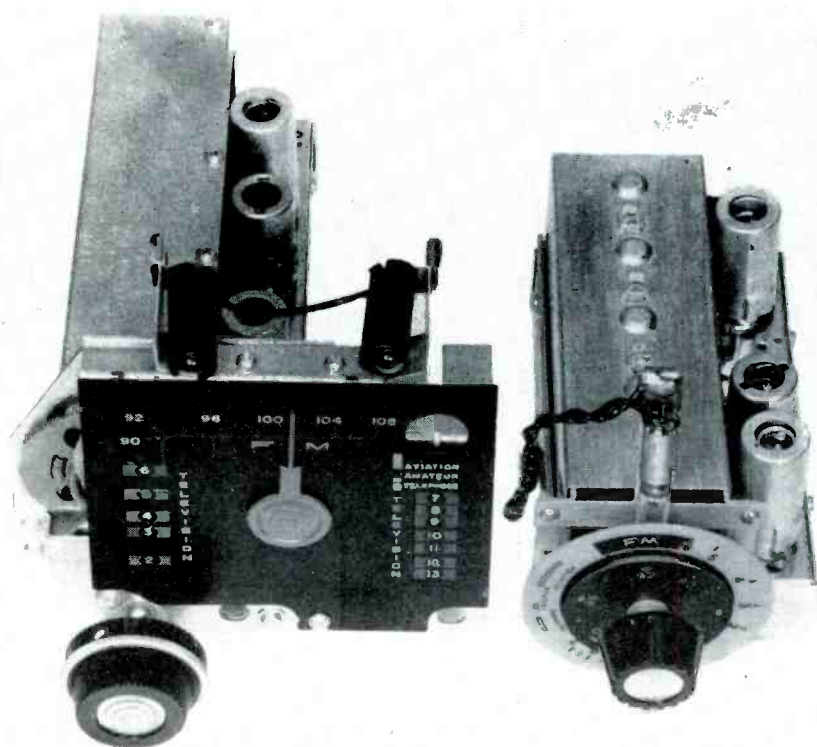

Fig. 1. Old and new Inputuners. New model, right, has added section but is smaller

<sup>1</sup>"A New System of Inductive Tuning," Paul Ware, *Proc. I.R.E.*, March, 1928.

<sup>2</sup>"A New Inductive Tuning System," Paul Ware, *Proc. Radio Club of America*, February 1938.

<sup>3</sup>"Inductive Tuning at Ultra High Frequencies," B. V. K. French, *Electronics*, April 1941.

<sup>4</sup>"Inductive Tuning System for FM-Television Receivers," Paul Ware, *Proc. Radio Club of America*, May 1946.

<sup>5</sup>"Two New Television Tuners," Myron F. Melvig, *Proc. National Electronics Conference*, November 1949.

<sup>6</sup>Trademark, Allen B. Du Mont Labs., Inc.

<sup>7</sup>The Inductuner is manufactured by P. R. Mallory & Co., Inc. Inductuner is the registered trademark of that company.

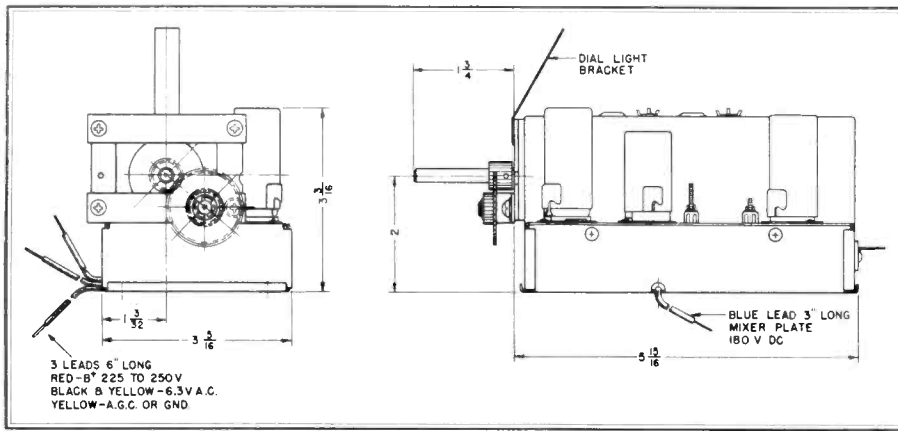

Fig. 3. Dimensions of the improved Inputuner, showing power supply requirements

circuit which gives superior performance but occupies less chassis space.

The earlier type of Inductuner employed rotating cylindrical coils mounted on a ceramic shaft with a sliding contact riding trolley-fashion on the wire to short out the unused portion of the inductor. End rings on the inductor forms permitted circuit connection to both ends of the inductor. The mechanical requirements of spacing the units and providing a rear bearing for the shaft resulted in a three section unit which was 7-1/4 ins. long.

#### The Miniature Unit:

The new miniature type, shown with the shield removed in Fig. 2, has an overall length of only 6 ins. for a four-gang unit. In this design, the inductors take the form of flat spirals. The silver conductor is supported by grooves molded accurately in a mica-filled, low-loss bakelite plate.

In addition to the reduction in size, the spiral type possesses several other mechanical and electrical advantages as compared with the earlier design. Since the new design has one less contact per section, fewer moving parts, and a single bearing, the average torque required has been reduced. The original Inductuner employed 10 turns of primary tuning motion but its range included the old TV channel 1. In the spiral tuner, it has been found possible to obtain the desired inductance range for 51 to 220 mc. with less than 6 turns of tuning motion. The spiral form of the inductor, with the high-frequency end of the tuning range employing the inside turn, produces a reduction of the slope of the tuning curve as compared with that of the cylindrical type. This results in an improved curve which simplifies the tuning of the upper seven channels. The overall size and mounting dimensions are illustrated in Fig. 3.

#### Tuning Dial Design:

The dial scale illustrated in Figs. 1 and 4 consists of a small dial mounted directly

on the tuner shaft and a large dial scale which is driven through a gear train. Both dials are made of translucent, peach-colored lamacoid, screened with a dark brown pattern. The television channel positions, as well as other short wave services such as the amateur and aviation bands, are indicated by calibra-



Fig. 4. Tuner has a separate dial for FM

tion points on the large dial which makes less than one revolution for the entire range of tuning.

The small dial mounted on the tuner shaft covers the FM broadcasting band from 88 to 108 mc. in approximately 3/4 turn of the tuning knob. This dial is

directly calibrated in megacycles, with the calibration markings translucent against an opaque background. As the FM band is reached, the FM dial is illuminated. During television tuning, the FM dial is darkened.

#### Inputuner Performance:

The desirable features of an input tuning system for a television receiver are:

1. High, stable RF gain,
2. A high order of rejection of spurious responses due to transmissions outside the desired television channel,
3. Uniform band pass shapes, with low peak-to-peak and peak-to-valley ratios, and adequate oscillator tracking to keep the video and sound carriers placed within the pass band,
4. A high order of oscillator frequency stability with time and temperature,
5. Low oscillator radiation which would interfere with neighboring TV receivers,
6. Low noise figure,
7. Freedom from microphonism, and
8. Provision for operation with either a 300-ohm balanced or a 75-ohm unbalanced input system.

The performance data shown in Fig. 5, taken on a typical tuner, indicates the extent to which certain of these requirements have been met in the T4A unit.

The voltage-gain figures and the value for oscillator radiation require some explanation as to method of measurement. The gain figures shown are for the 75-ohm input condition. Input tuning system gains are measured from the antenna terminals to the first IF grid. It has become standard to refer such gains to a normal mixer plate transfer impedance of 1,000 ohms. The gain is expressed as the ratio of output voltage at picture carrier IF, which appears at the grid of the first IF amplifier tube, to the antenna input terminal voltage at RF picture carrier. The gain measurement is made with the mixer plate load normally used, the value of the mixer plate transfer impedance determined, and then the gains are extrapolated to determine the gain per 1,000 ohms of transfer impedance. Such a gain figure allows comparison of input tuning systems without reference to a particular complete IF system.

PERFORMANCE DATA ON TYPICAL 4-SECTION INPUTUNER												
CHANNEL	2	3	4	5	6	7	8	9	10	11	12	13
GAIN (VOLTAGE RATIO)	44	45	44	40	38	22	22	23	23	22	22	21
GAIN (db)	32.8	33	32.8	32	31.6	26.8	26.8	27.2	27.2	26.8	26.8	26.4
I. F. REJECTION RATIO	5K	6.2K	6.5K	7K	10K	12K	12K	14K	20K	22K	24K	25K
I. F. REJECTION (db)	74	75.8	76.2	76.9	80	81.6	81.6	82.9	86	86.3	87.6	87.9
IMAGE REJECTION RATIO	10K	10K	10K	8.5K	7K	1K	1K	900	830	600	550	400
IMAGE REJECTION (db)	89	80	80	78.6	66.9	60	60	59	53.3	55.6	34.3	52
NOISE FIGURE (db)	14	13	14	13	13	15	15	15	15	16	16	15
OSCILLATOR RADIATION	1.9K	1.2K	1.4K	1.2K	1.6K	720	826	792	1K	1.1K	1.1K	1.1K

Fig. 5. Data from tests on the Inputuner. Note low oscillator radiation figures



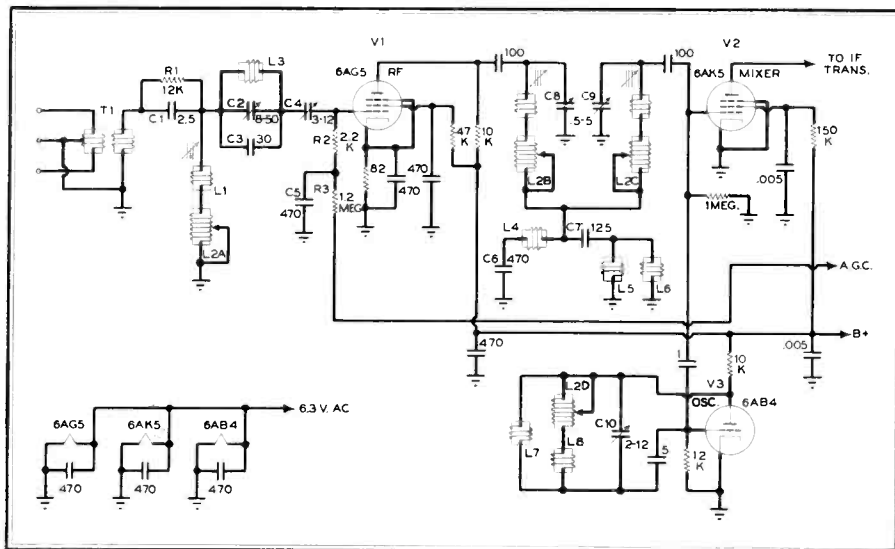

Fig. 7. Schematic of Model T4A. Added section permits double-tuning of RF plate

The voltage gain figures for the 300-ohm input terminals are not shown in the table, but are approximately one-half the values given for the 75-ohm input. The input transformer in the Inputuner provides a voltage step-up of 2 to 1 from the 75-ohm terminals, as compared to the 300-ohm terminals. Since, under identical field strength conditions, and neglecting lead-in losses, a 300-ohm antenna system provides twice the voltage of a 75-ohm system, the overall sensitivity is the same for either type of antenna.

The oscillator radiation values given in Fig. 5 were taken with a dummy load across the input terminals equal to the nominal antenna system impedance. Interference with television reception due to oscillator radiation from nearby receivers is fast becoming a serious industry problem. Like the earlier Inputuner models, this unit is completely shielded, it employs an interstage shield between the input circuit components and the rest of the tuner, and utilizes a pentode RF stage. These expedients, as well as careful parts placement, have resulted in the extremely low figures of oscillator radiation indicated.

The advent of more and higher-power television transmitters in the metropolitan areas is imposing the problem of providing sufficient selectivity against signals in nearby channels. The present design provides a high order of selectivity, as shown by the curves in Fig. 6.

#### Details of the Circuit:

A description of the circuit employed with reference to the schematic diagram, Fig. 7, and the bottom view in Fig. 8 will serve to elaborate the means of meeting the balance of requirements previously listed.

The tube complement consists of a 6AG5 RF amplifier, a 6AK5 mixer, and a 6AB4 oscillator. Transformer T1

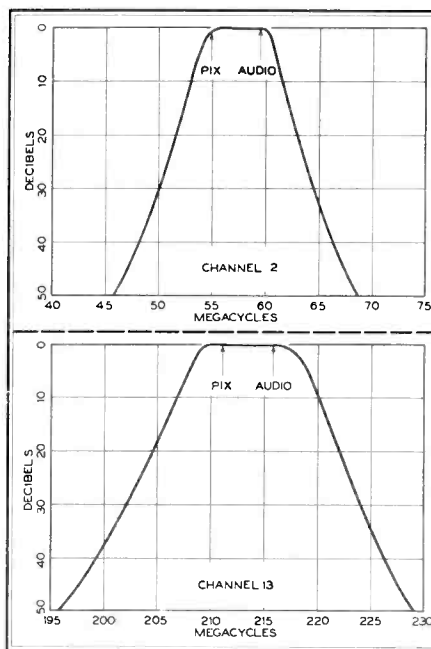

Fig. 6. Selectivity is uniform and sharp

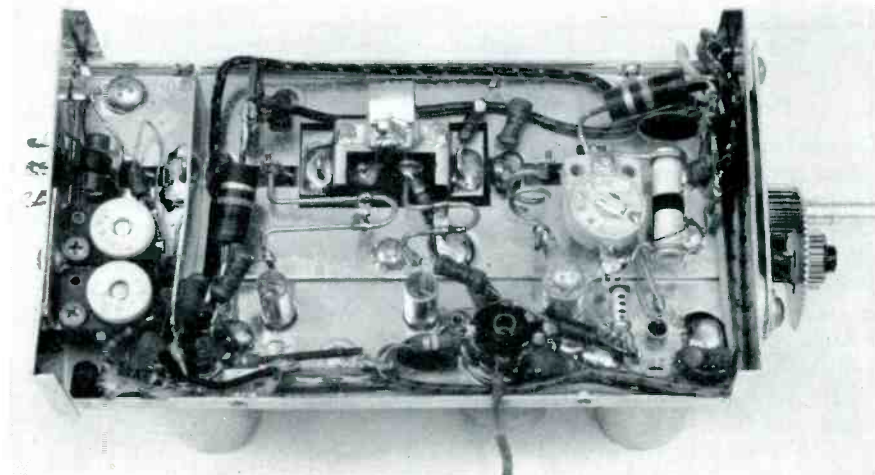

Fig. 8. Bottom of chassis. RF section at left is shielded to prevent radiation

allows the use of either 75-ohm unbalanced or 300-ohm balanced antenna systems. This transformer can be seen immediately behind the terminals at the upper left of Fig. 8. Connection is made to the center or grounded terminal and to one of the outside terminals for 75-ohm input, while the outside terminals are used for 300-ohm input. In addition to its normal function of matching the antenna impedance to the circuit, the transformer rejects strong low-frequency signals such as those from AM broadcasting stations.

The secondary of input transformer T1 is loosely coupled to the tuned input circuit through capacitor C1. This input circuit comprises the adjustable end-inductor L1 and the variable tuning element L2A, resonated by the network of capacitors C1, C2, with C3 and L3 in parallel, C4, and the input capacitance of the RF tube V1. In this circuit capacitor C4 and C2 are made adjustable for factory alignment. They can be seen at the lower left hand corner of Fig. 8. C4 is used to adjust the circuit-tracking at channel 6, while C2 adjusts at channel 2. End-inductor L1 is used to set the high frequency end at channel 13. Damping of the circuit for proper bandwidth is accomplished by resistors R1 and R2.

The grid return of V1 is filtered by the decoupling network R3, C5, and is connected to the AGC circuit of the receiver for gain control.

A double-tuned bandpass circuit couples the plate of the RF tube V1 to the grid of mixer tube V2. It will be noted that this bandpass circuit does not employ any top-side coupling, but rather uses a compensated system of bottom-side coupling comprising circuit elements L4, C6, L5, L6, and C7 to provide correct bandwidth and signal transfer over the entire tuning range. C8 and C9 ad-

*(Concluded on page 33)*

# OPTIMUM BIG-PICTURE QUALITY

A CUSTOM TV RECEIVER EMPLOYING CIRCUITS DESIGNED TO REDUCE VIEWING DISTANCE, AND PROVIDING FOR HIGH-QUALITY SOUND — *By* EDWARD MILLER\*

BECAUSE the Craftsmen RC100A television receiver is designed for custom installations, the cost of cabinet furniture and the attendant expenses of handling and shipping have been eliminated. Thus the RC100A could be designed for optimum big-picture performance, high-quality sound reproduction, and extreme sensitivity without raising the price to an extravagant level.

The result is to assure fine TV reception in noisy metropolitan locations and in fringe areas where signals may drop at times to the point where picture quality is unsatisfactory on conventional receivers.

Figs. 1 to 3 show the mechanical construction of the receiver. No power amplifier or loudspeaker is provided, since it is anticipated that they will be available in associated audio receiver and record-playing equipment. Either a glass or metal picture-tube can be used, with a long or short neck. A 16-in. tube is supplied as standard equipment, but a 19-in. tube can be used.

be about the right viewing distance. In the case of this set, that would be 14 ft.

Probably the most important factor of big-picture performance, and one which has led to mistaken ideas as to limitations of picture quality on the present 525-line standard, is the attainment of perfect interlace. An investigation of this factor will reveal that, in the average set, perfect interlace is not available. Instead, the lines comprising the two fields overlap slightly or, at best, are paired.

Any departure from perfect interlace results in deterioration of the picture, and increases the viewing distance. When the interlace is perfect, i.e., the spacing between the horizontal lines is exactly uniform, a remarkable improvement is obtained in detail and resolution, and the proper viewing distance is reduced to about 5 times the picture height, or one-third the distance it is necessary to sit back from most 16-in. receivers.

## How Interlace is Improved:

Perfect interlace can be guaranteed, even



Fig. 1. Mounting takes 16- or 19-in. tubes

tical and horizontal synchronization, as used in the RC100A, employ this fly-wheel effect, thus giving the full advantage of large-size images.

By reference to the block diagram, Fig. 4, it can be seen that similar systems are used for both the vertical and horizontal synchronization systems. These systems operate by first adding and then subtracting a portion of sweep voltage to an equivalent amount of synchronizing pulse, comparing the resultants in a discriminator circuit, and finally utilizing the derived DC output voltage to control the sweep oscillators.

The circuits differ in that the horizontal system phase reversal for the sweep voltage is provided by a transformer, while in the vertical system the synchronizing pulse is inverted by a 12AU7 phase inverter. Also in the first system the DC output voltage controls a 6AH6 reactance modulator which determines the frequency of a sine-wave oscillator, while in the latter system the DC control voltage is amplified directly and then applied to the grid of a blocking oscillator.

## Keyed Automatic Gain Control:

One other important consideration in a custom TV receiver is simplification of operating controls. This has been attained by the inclusion of a keyed, automatic gain control whose operating characteristic is nearly flat. With its use, the video output is practically constant for any input from 25 microvolts to over .25

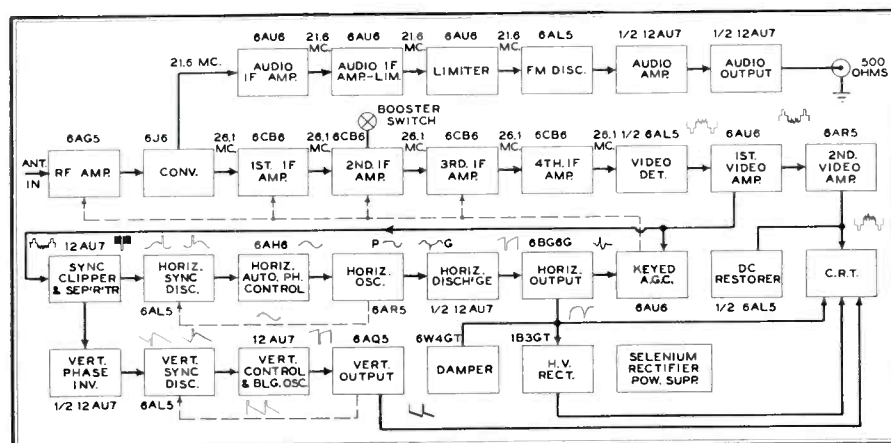

Fig. 4. The RC100A circuits. Note 500-ohm audio output, keyed AGC, booster switch

## Better Big Picture Quality:

The most common complaint against big-picture sets, as compared to those using smaller tubes, is that they offer little advantage to the viewer because, as picture size is increased, it is necessary to move back from the tube. It has become a generally accepted rule that the viewing distance should be 10 to 12 times the diameter of the tube.

Relating this distance to the picture height, which is the most critical dimension, 15 times the picture height would

under conditions of noise, by utilizing synchronizing circuits employing the fly-wheel effect on both the horizontal and vertical sweeps. The automatic phase and frequency control systems for ver-

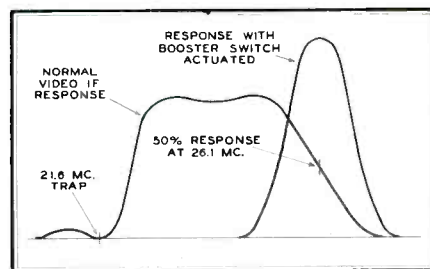

Fig. 5. Booster shifts video response

\*Chief Engineer, The Radio Craftsmen, Inc., 1617 South Michigan Avenue, Chicago 17, Ill.



volts, even if the input were to vary as fast as 100 cycles. Thus the keyed, automatic gain control, operating instantaneously, eliminates all noticeable picture flutter usually caused by airplanes overhead. Picture contrast is similarly stabilized, despite other disturbances caused by windblown antennas and transmission lines, or persons moving near indoor antennas. The use of horizontal retrace pulses for keying results in a short duty-cycle of approximately 5 per cent of time of operation, and this AGC circuit is consequently immune to noise occurring during 95 per cent of the time.

Other operational benefits of this circuit are a remarkable improvement in synchronization circuit operation, and automatic contrast adjustment when

and full 4-mc. bandwidth throughout the video IF and video amplifiers with negligible phase distortion.

#### Sequence Selector:

The RF tuner is of the turret-type, using replaceable coil cartridges for the 12 TV channels. For easier front-panel channel selection, these cartridges can be interchanged so that local stations are grouped together. It is also possible to replace any unused channels with units especially designed for UHF reception or FM broadcast stations.

#### Fringe-Area Booster Switch:

Although the chassis was originally designed to give excellent fringe area reception, a tube change incorporated in later

in video sensitivity. Since this action is accomplished after the sound take-off coil, sound reception is not disturbed. It is obvious that the boost action is identical on all channels since there is no effect on the RF tuner. The switch mechanism is controlled by shifting the fine tuning control so that the boost is readily available at all times. This latter feature is important for fringe-area use because of the wide variation in signal strength often encountered during the day. For example, reception at sundown might require use of all available boosting action. Three hours later strong signals, producing high-definition pictures free of snow, would make wide-band reception possible.

In conjunction with the booster switch, the excellent control offered by the AFC

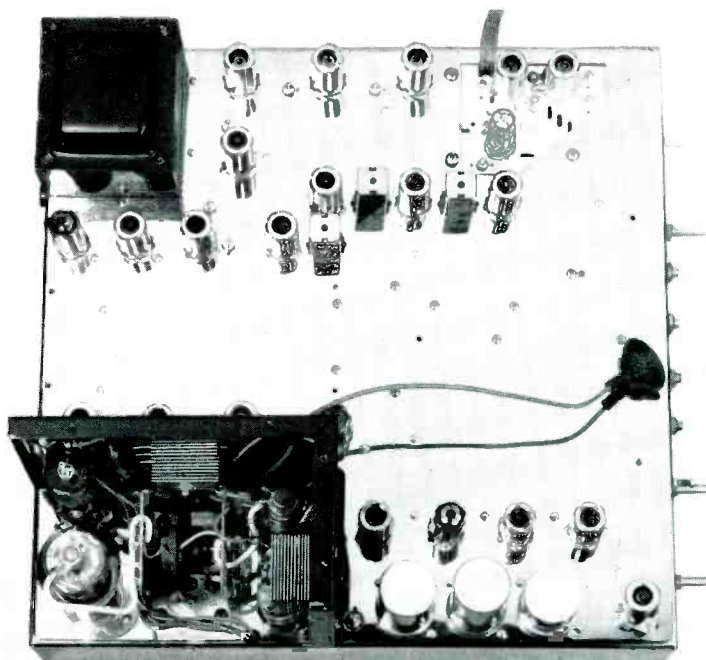

Fig. 2. Top view, kinescope and high-voltage shield removed.

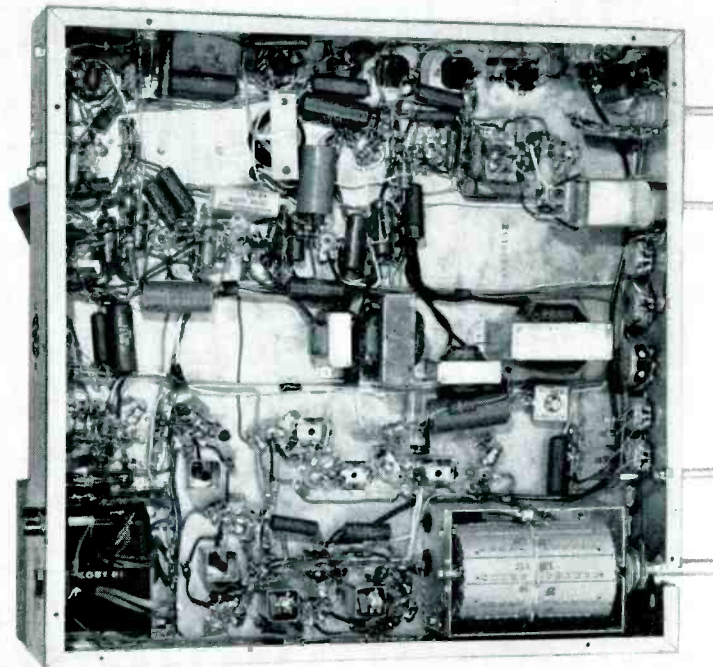

Fig. 3. Turret tuner at lower right has replaceable cartridges

switching from channel to channel. Due to this automatic contrast feature under all types of signals, coupled with the automatic-brightness control action of the video DC restorer, it is not necessary to include the brightness adjustment with the main operating controls.

#### Automatic Retrace Erase Circuit:

An annoying effect often noticed on some receivers is the appearance of the vertical retrace lines, either when there is no picture being sent during a broadcast or with a dimly lighted scene. These retrace lines are completely eliminated, even in the absence of a video signal, by providing a blanking pulse on the cathode of the picture tube during retrace intervals.

Other requirements for good, large-picture performance are the use of 13 kv. or more for the picture-tube potential,

production (RC100A) has doubled the video sensitivity of the receiver to 25 microvolts for 1 volt at the detector. In addition to the use of the new 6CB6 high Gm video IF amplifiers, a switch has been incorporated which gives a booster action in fringe areas enabling performance equivalent to that obtained with the use of most separate boosters.

In operation, this switch shifts the response of the video IF curve, Fig. 5, so that advantage is taken of the partial double side-band transmission of a TV station. At the same time, the IF gain is increased and the video bandwidth is narrowed to 1.5 mc., resulting in improved signal-to-noise ratio. It should be noted that the loss in bandwidth is not noticeable where pictures include the disturbance of "snow." The overall result of the switch action is a 10 db boost

action of the horizontal and vertical synchronization circuits and the keyed AGC delivers extremely stable pictures with very weak signals.

The sound system has even greater sensitivity, and provides 30 db quieting at 15 microvolts input.

#### High-Fidelity Audio:

One particularly disconcerting practice in popular television receivers has been the inclusion of inadequate sound systems, in spite of the excellent potentialities of the FM sound transmitted by TV stations. By taking advantage of possible consolidation with existing audio equipment, the entire RC100A audio system provides for high-fidelity performance without adding unnecessary expense. The separate sound IF incorporates a double limiter and

(Continued on page 33)

# TV APPLICATIONS OF THE 6BN6

ADVANTAGES OF USING THE GATED BEAM TUBE AS AN AUDIO LIMITER-DISCRIMINATOR AND VIDEO SYNC CLIPPER—By RICHARD O. GRAY & WALTER J. STROH\*

THE 6BN6 gated beam tube developed by Dr. Robert Adler<sup>1</sup> of Zenith and produced by General Electric Company has proved to be well adapted for application in television receivers. The tube is simple, though highly unconventional in structure and characteristics.

## Operation of the 6BN6:

Fig. 1 shows a cross section of the unique structure which fits into a miniature tube envelope. The operation of the tube is based on electron-optical principles. The focus electrode surrounding the cathode in conjunction with the first accelerator slot forms an electron gun which projects a thin sheet-like beam upon the first grid. The lens slot and screen together with the second accelerator slot form a convergent lens system which re-focuses the beam and projects it onto the second grid. This second grid and anode are enclosed in a shield box.

The characteristic of the first control grid resembles a step-like function. The plate current rises steeply from zero to a sharply-defined maximum level in response to a positive signal applied to the grid. The plate current remains constant at this maximum level no matter how far positive the grid is driven. The second control grid also has a step-shaped characteristic similar to the first and controls the level to which the plate current rises. These characteristics are shown in Fig. 2A.

Whenever an alternating voltage in excess of 1 volt RMS is applied to grid No. 1, the plate current becomes substantially a square wave of constant amplitude as shown in Fig. 2B. If the control grids are driven positive, they will draw current but they cannot draw more than a proportionate share of the total beam current. The current to either control grid levels off at about 500 microamperes. This feature is very useful. It is permissible to drive the grids positive without overloading the tube or damping the driving circuits too much.

Such a tube may serve as a clipper or square wave generator, or it can be used as a limiter followed by a conventional discriminator. In these applications the second control grid is not used, and can be connected to the plate to obtain the largest output amplitude, or to ground

to obtain limiting at the lowest input signal. In its application as a straight limiter, it rejects amplitude modulation better than a conventional grid bias limiter. Limiting occurs instantaneously,

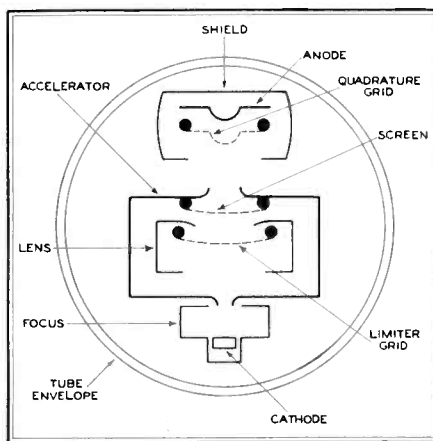

Fig. 1. Physical structure of the 6BN6

and no energy is stored from one cycle to the next. The improvement is most marked for short pulses such as ignition interference.

The step-shaped characteristics or clipping action of the 6BN6 makes it ideally suited as a sync clipper in television receivers, performing the task of separat-

ing the sync pulses from the composite video signal. This function will be described in greater detail later in this paper. Perhaps the most interesting application of the gated beam tube is that of a limiter-discriminator for frequency-modulated signals. The FM detector circuit used in this connection goes back to a circuit invented by Zacharias<sup>2</sup> in 1936, in which was proposed the use of a converter tube for FM detection. The signal was applied to the first control grid and a resonant circuit was connected to the

## Use as a Limiter-Discriminator:

The intercarrier sound system is being used in present day television receivers for many reasons, the most important of which is economy consistent with good performance. The 6BN6 gated beam tube makes possible an intercarrier system requiring a minimum number of components.

Fig. 3A shows the schematic diagram of an intercarrier sound system of a conventional commercial receiver. The 4.5-mc. beatnote is selected at the second detector, amplified in the 6BA6 pentode stage, and fed to the second amplifier which is operated as a grid-bias limiter. The amplified and limited signal is fed into a conventional ratio detector circuit.

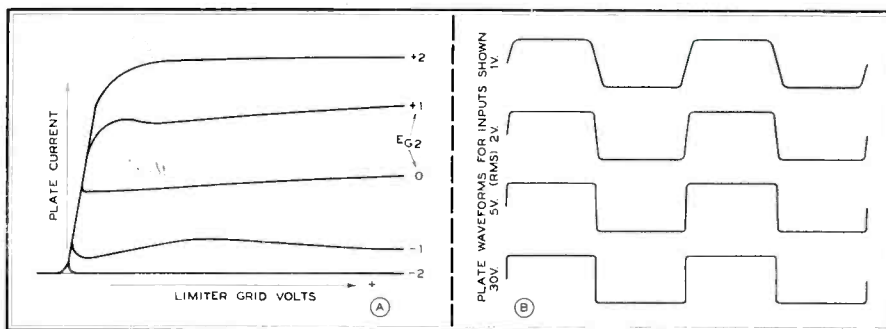

Fig. 2A. Step-like grid characteristics of 6BN6 give square-wave output. Fig. 2B

ing the sync pulses from the composite video signal. This function will be described in greater detail later in this paper.

Perhaps the most interesting application of the gated beam tube is that of a limiter-discriminator for frequency-modulated signals. The FM detector circuit used in this connection goes back to a circuit invented by Zacharias<sup>2</sup> in 1936, in which was proposed the use of a converter tube for FM detection. The signal was applied to the first control grid and a resonant circuit was connected to the

The detected audio is first fed to an amplifier stage and then to a conventional power output stage, such as the 25L6, to drive the speaker. The portion of the circuit enclosed by the dashed line can be replaced by the gated beam limiter-discriminator.

Fig. 3B shows the gated beam tube functioning as the limiter-discriminator. Here the 4.5 mc. signal is selected at the second detector, amplified in a single pentode stage, and fed directly to the

\*Engineering Department, Zenith Radio Corporation, 6001 Dickens Avenue, Chicago 39, Ill.

<sup>1</sup>Robert Adler—"The 6BN6 Gated Beam Tube" *Electronics*—February 1950.

<sup>2</sup>Zacharias—U. S. Patent No. 2,208,091.

<sup>3</sup>H. P. Kalms—U. S. Patent No. 2,233,706.



limiter grid of the 6BN6. The level of the signal at the grid is approximately 5 volts RMS, depending upon the detector output and the gain factor of the amplifier stage. The tube will limit and provide constant audio output down to an input signal as low as 1 to 1.5 volts RMS.

Whenever an alternating voltage in excess of 1 volt is applied to the first control grid, a square wave electron beam of nearly constant amplitude is passed during each half-cycle through the second accelerator slot and projected onto the

damping resistor, 20 to 25 volts RMS audio output can be obtained with 3 to 5 per cent harmonic distortion for 25-ke. deviation.

The audio output level is sufficiently high that the usual audio amplifier stage can be eliminated, and the detector output fed directly into the power tube. A 6V6 or 25L6 power tube could be driven to full output with 30 per cent modulation of the sound carrier. A 6AG7 power output tube, because of its high power sensitivity, can be used to assure good

the video amplifier, and applied directly to the limiter grid of the 6BN6, through a suitable coupling transformer. By the use of good circuitry to separate the intercarrier signal from the video signal, and by avoiding AM modulation of the 4.5-mc. beatnote due to overloading the video stage, a satisfactory two-tube audio system is possible.

#### Use as Sync Signal Clipper:

The gating characteristic of the 6BN6 can be used to advantage in slicing a

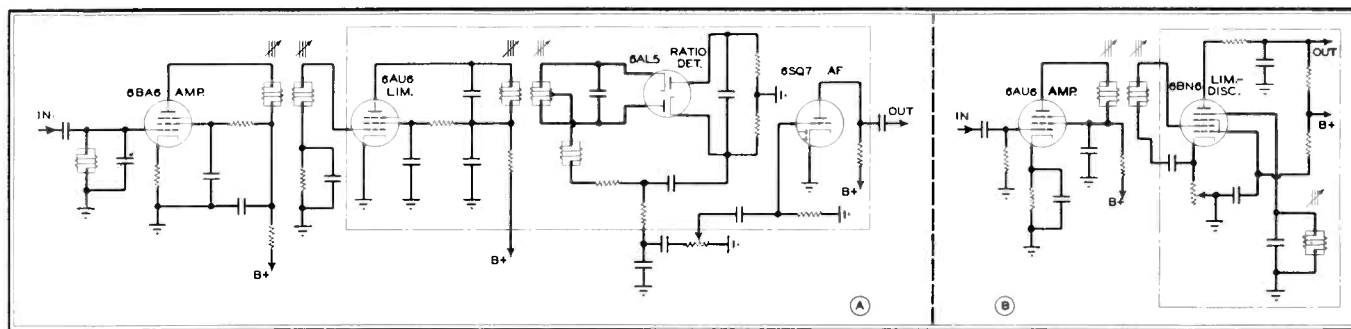

Fig. 3A. Conventional ratio-detector circuit. Fig. 3B. 6BN6 functioning as limiter-discriminator replaces three tubes

second control grid (quadrature grid). The periodic variation of the space charge in front of this quadrature grid produces about 5 volts of a signal across a resonant circuit connected to it, which lags the signal frequency by 90 degrees. The quadrature grid clips the leading portion of each half-cycle pulse and passes on to the plate periodic pulses of about one quarter-cycle length. Modulation of the signal frequency affects the phase lag between the half-cycle pulse and the quadrature grid voltage, and correspondingly affects the length of the plate current pulses. Across the plate load resistor a voltage drop appears which is proportional to this pulse length and, therefore, to the original modulation.

The curve of output voltage vs. frequency differs from that of a conventional discriminator or ratio detector. It is shaped like a long flat S, and has no negative slope within several hundred kilocycles of center frequency, as indicated in Fig. 4.

The bandwidth of the discriminator curve is proportional to the bandwidth of the quadrature circuit. Insertion of a small resistor in the plate lead between the plate and the bypass condenser affects the quadrature circuit in a manner which results in increased bandwidth as well as good audio output and improved AM suppression.

The audio output which can be obtained is largely a function of the plate supply voltage. In the circuit shown, with 170 volts supply voltage, 15 volts RMS is normal output with about 2 per cent distortion for 25-ke. deviation. With higher supply voltage and a smaller

audio power output even when the percentage modulation of the sound carrier is extremely low.

An adjustable resistor is placed in the cathode of the 6BN6 for the purpose of nulling the response to AM for low signal-input levels. With correct adjustment, the AM suppression compares favorably with other FM detectors in commercial use.

Not only has the gated beam tube made possible this extremely simple and

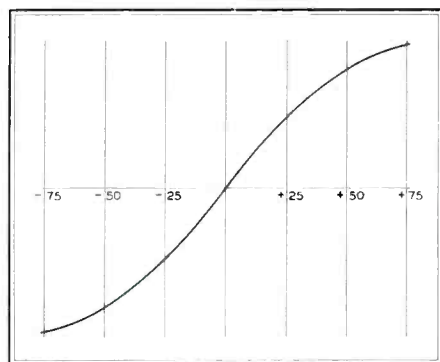

Fig. 4. 6BN6 discriminator output curve

economical intercarrier system, but its alignment also is simple. The 4.5-mc. amplifier transformer is tuned for maximum signal at the limiter grid. The quadrature circuit is tuned for maximum undistorted audio output, and the bias control in the cathode of the 6BN6 is adjusted for maximum AM rejection.

The circuit described has been designed for use in receivers of highest quality. For receivers where cost is a major factor, the 4.5-mc. amplifier stage can be omitted, the signal extracted from

small segment of the synchronizing impulse from the composite video signal in a television receiver. A limit of acceptability in television receivers in areas where signals are weak and impulse type of noise is abundant is the partial or total disappearance of synchronizing impulses. The impulse noise manages to bias one tube or another sufficiently to put the synchronizing signals in the non-conducting region. The period during which the signals disappear is a function of the time constant of the grid coupling element.

In Fig. 5A a typical synchronizing signal separator is shown, using familiar tube types. The system utilizes two tubes, or four tube functions. The first half-tube is used to clip roughly most of the picture from the composite video for reasons to be explained later. The grid of this tube is driven with 12 volts peak-to-peak of composite video, which has had most of the impulse noise clipped in a previous stage. This tube is biased in such a manner that most of the picture is clipped off and the impulse noise does not drive the grid positive. The second half-tube is strictly an amplifier with some low frequency boost in its plate circuit. The third half-tube is a sync clipper. The grid of this tube is coupled through a small time-constant circuit, composed of a 200-mmf. condenser and a 2.2-megohm resistor.

The grid of this tube acts as a diode plate, drawing grid current on the sync signal peaks and biasing the grid such that the picture component of the signal is beyond grid cut-off. The voltage across the plate load of this tube is

(Concluded on page 30)

# WHAT'S NEW THIS MONTH

## A VERY SIGNIFICANT STATEMENT OF FCC POLICY WITH RESPECT TO THE FUTURE OF FM AND TV BROADCASTING — *By* THE HONORABLE ROBERT F. JONES\*

EDITOR'S NOTE: *Part 1 of Commissioner Jones' address appeared in our February issue. The conclusion follows. Only a few brief comments on this address have appeared in the press. However, as a detailed account of FCC thinking, it deserves careful reading and thorough study by both broadcasters and manufacturers, for it probably indicates the direction of future actions with respect to FM and television broadcasting, and the plan of allocating VHF and UHF television frequencies.*

PEOPLE were suggesting that the VHF frequencies were to be the clear channels of television, and the UHF the local channels. History was repeating itself. What had happened in AM as a result of non-regulation was happening in television with regulation.

The stations are going again to where the dollar is located. The immediate market for television receivers is in the same congested areas — in the 140 metropolitan areas. Marketing to areas not densely populated is unprofitable. Therefore, these areas don't have television and won't have reliable television service for a long time to come if the industry is permitted to follow its present course.

### Conditions in Smaller Cities:

Where does that leave the smaller cities of the United States? Let's go back to Lima in the twenties. Towns and people change. Towns have come closer together, with better transportation. Outside papers from the big metropolis invaded the compact county seat. People feel the urge for the great metropolitan papers to supplement — bear in mind I said supplement — the local newspapers' information. While it is true, as in many communities its size, a fourth newspaper was added in 1915 to the three I've mentioned, by 1920 two had merged, by 1924 two more had merged, and by 1933 there was one remaining newspaper.

Up to this time I have not mentioned radio in Lima. As these papers were merging, something new was added to Lima. In 1922, a radio station was constructed. The licensee was no slouch. He had been a successful merchant. He saw his piano and musical instrument market dwindling before your electronic device

that would bring music into the homes of his market area. He wasn't going to repeat the mistake of the carriage and wagon manufacturers with the automobile. In short, he wasn't going to be caught running a horse-collar factory in an automobile world. His power was 100 watts, his range 50 miles (so the license stated). In October, 1922, he started to operate this little station a few hours a week, weekday nights, with composite equipment of every make and description, to broadcast the unsponsored home-talent, bearing the expenses as institutional advertising.

But by December, 1925 he apparently had had enough. Then for ten long years there was no radio station in Lima.

In July 1935 a new application was filed for radio facilities. After a recitation of the business concerns in Lima, the applicant stated: "Advertisers are compelled to look to outside stations located at Fort Wayne, Indiana (65 miles distant by road), Dayton, Ohio (72 miles by road), Toledo, Ohio (89 miles by road). For this reason, both the general public and the Lima merchants desiring to use radio advertising are deprived of the means of so doing."

Let's see what he said further: "Day-time radio reception in Lima during the hot summer months is very poor. Some families pay a monthly fee to the local telephone company in order to have radio programs transmitted over telephone lines."

The applicant got his station, 100 watts of power. Later it was sold and power was increased to 250 watts. In 1947 two FM stations and in 1948 another AM station were granted to Lima.

What was the effect of having but one local station in Lima until 1948? True enough, Lima heard its local station and got one reliable network service. But for all the rest, the population in and around Lima had to listen to radio service of a sort from Pittsburgh, Cincinnati, Fort Wayne, Dayton, and Toledo. That service was first of all subject to all the infirmities widely associated with reception of distant stations, and, second, the programs radiated from these powerful clear channel stations were certainly not beamed with the interests of Lima in mind. Where the problems and interests in Lima coalesced with the national interests and problems, Lima was satisfied. But where Lima's problems were different or where the citizens of Lima wanted

an opportunity to assert themselves, they found that radio was completely inadequate. When all the newspapers were in Lima, any one could get his side of the story told in at least one of the papers. Now, with but one local station on the air, the radio facilities in Lima were just not capable of handling all the radio needs of that city. Very fortunately in this instance the Commission was able to assign additional channels to Lima, both AM and FM. However, many other cities have not been so fortunate because of the existing assignments of not only clear channels but also regionals and locals to the large metropolitan areas. Many of the smaller cities still wait for their first assignments.

### The Radio Industry's Record:

To what extent can the Commission rely, then, upon the radio industry — the broadcast licensees, the networks, and the equipment manufacturers — to advise the Commission in the fulfillment of its statutory duty, to provide a fair and equitable distribution of radio facilities to all the people and both small and large communities of this country? Unfortunately we must look at the record. This is the same industry that built clear channels in the congested areas. It's the same set manufacturers who, by and large, have refused to build FM sets without the AM combination. It's the same networks who have refused AM sound to FM stations when it wouldn't cost them a cent to get the FM coverage. It's the same industry that promised to network high-fidelity FM service. It's the same industry that pays for 5,000-cycle tie lines with its affiliates, and when it serves an FM station across the land with a network program, that affiliate is just broadcasting another standard signal from his FM station. May I say that 15,000-cycle lines are available on demand from the telephone company, and there is no shortage of such facilities except in some very few areas, and even in these areas 8,000-cycle lines are available.

So who cares if people all over the country bought expensive high fidelity FM receivers to capture this wonder sound of aural broadcasting? Certainly not the networks; certainly not the equipment manufacturers. People in the service areas of some high fidelity FM stations can't even buy FM sets.

*(Concluded on page 29)*

\* Commissioner, Federal Communications Commission, Washington, D. C. An address before the American Marketing Association, Hotel Commodore, New York, January 17, 1950.



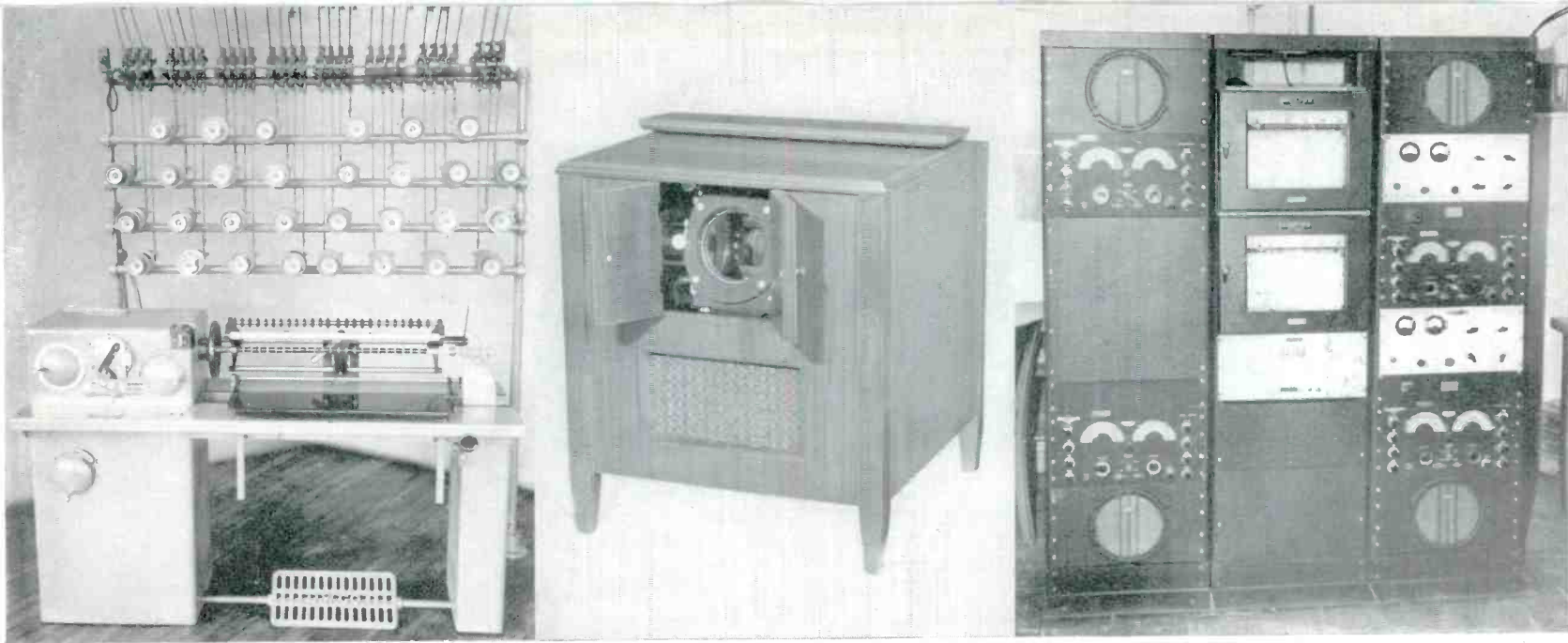

## NEWS PICTURES

**N**EARLY every mail brings information on new services, machinery, and instruments for the radio industry. Typical examples are illustrated here.

**TOP ROW:** A job-shop type of multiple winding machine for low-cost production of paper-insulated coils. Design features quick setup and automatic stop when the preset number of turns has been reached. Speed range is 400 to 2,200 RPM, with lead-screw accuracy of .003 in. This type 108 winder is manufactured by Universal Winding Company, Providence, R. I.

Hi-Par Company, Fitchburg, Mass., is producing the home-type TV projection receiver illustrated, a commercial unit for public installations, and a conversion unit which can be used with any receiver. Picture 3 by 4 ft. is projected on a beaded-surface screen.

The Bureau of Standards operates this automatic recorder in its continuous study of the ionosphere. Also, this data, correlated with other observations, is used to give the advance warning of disturbances affecting high-frequency radio transmission. The report is transmitted on WWV at 19 and 49 minutes past each hour.

**CENTER:** Here is a miniature VT voltmeter with a large scale, produced by Simpson Electric Company, Chicago, 44.

It has 5 voltage ranges on DC, 5 on AC, and 3 on AF; 5 resistance ranges, 5 db ranges from -20 to +63; center-zero galvanometer; a 20-volt RF range flat from

to 15 kc. Internal modulation at 60 and 400 cycles is provided, with a deviation range of 0 to 200 kc. containing less than 5% incidental AM. Output is continuously variable from .1 microvolt to 1 volt, at 50 ohms impedance.

Development and ultimate production of UHF TV sets has prompted the design of a sweep frequency oscillator for 470 to 890 mc. output, and a sweep range of 0 to 30 mc. Output level is adjustable from 100 microvolts to 2 volts at 50 ohms. This is a product of Polytechnic Research & Development Corporation, 202 Tillary Street, Brooklyn.

The final illustration shows a General Radio 1022-A amplitude modulator for use with the 1022-A FM signal generator or other types used for receiver tests where AM is required, with negligible FM. It modulates the signal generator output after attenuation. RF range is 10 to 150 mc. with a gain of .1, and 10.1 to 11.3 mc. with a gain of 10.

Of course, these illustrations represent only a few of the machines and instruments being bought to meet the new requirements of the radio industry. They do serve, however, to show the depth of support that is required behind each new use of radio communications and the utilization of higher frequencies, in development, production, testing, operation, and maintenance.



20 kc. to 100 mc.; and 30,000-volt probe. **BOTTOM ROW:** General Radio has a new type 1022-A FM standard signal generator for testing FM equipment in the broadcast band. Range is 88 to 108 mc., plus IF range of 10 to 11.5 mc. The modulation system is flat from 20 cycles

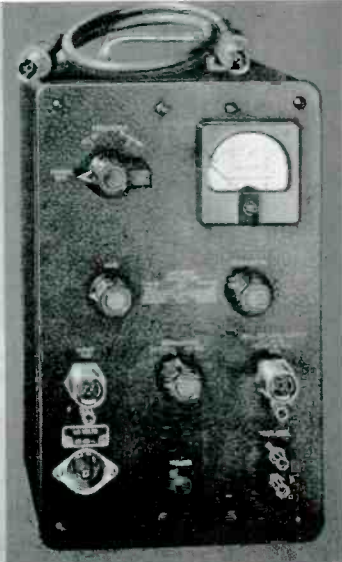
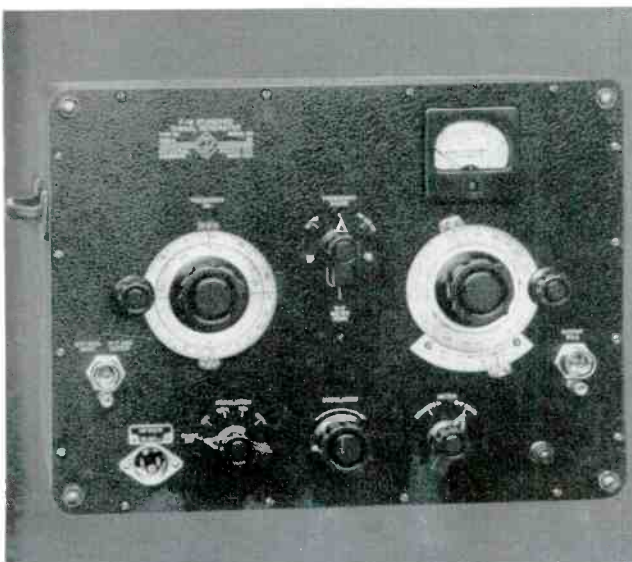

# JEREMIAH COURTNEY'S MOBILE RADIO NEWS and FORECASTS

YOU can take it on the authority of an eminent Yale anthropologist: government bureaucrats are here to stay.

Not only may we count on that, but family strains may soon be recognized in our favorite bureaus and bureaucrats. For according to Dr. Ralph Linton of Yale, a succession of "hereditary bureaucrats" is gradually beginning to develop in Washington, D. C., which will find our Government run, from generation to generation, by the sons and daughters of the parents who did the job before them.

## Faster Processing Needed:

With such dire consequences up-coming, it is refreshing to note that the FCC at least proposes a look-see at its own status quo. It has a staff management counsellor analyzing its work load and making recommendations on how to handle it. Unfortunately for the mobile radio sector, where applications processing delays have mounted astonishingly, the first departmental analysis is apparently being made of the Commission's common carrier activities.

Out of this critical re-examination of its work load and methods for handling it, a substantial reorganization may be expected.

Most probably, four Director positions will be set up intermediate the Commission and its four principal staff departmental activities which are broadcast, mobile radio, common carrier, and field work. These four Directors would be charged with seeing that the policies established by the Commission were carried out.

The importance to the mobile radio services of the re-examination under way is perhaps best indicated by the addition of 13,000 non-broadcast stations during 1950, as compared to a broadcast growth of only 43 additional authorizations.

Without intruding upon the FCC management counsellor's sphere of activity, it has always seemed to this department that there is no good reason why an application that is in perfect order and requires a total of ten minutes for review should take three months to be granted. This happens principally because a number of troublesome or de-

\*1707 H Street, N. W., Washington, D. C.

fective applications, requiring extended correspondence or Commission presentation, happen to be filed ahead of the application that is filled out properly. Probably 80% of the Commission's processing drag in the mobile relay sector could be eliminated by the simple expedient of dividing the work day into two equal parts: morning, for review and grant of all applications properly filed; afternoon, for dealing with the defective or questionable applications which were laid aside in the morning.

About three months of this procedure should clean out 80% of the applications now hanging fire. After that, the present three-month processing lag in some services (four months in Industrial Radio Service) should be reduced to two or three weeks at most for an application filed properly.

With the great majority of applications breezing through as they should, time now spent in dealing with the inquiries of applicants and their Congressmen with respect to applications that should have been granted months ago could be devoted to the one application in five that requires extended consideration. The conservation of this time now wasted would inevitably result in faster processing applications in both categories.

Even supposing that the processing delay on the difficult applications were not reduced, this procedure would operate to put the pressure on applicants to file their applications correctly.

At present there is little or no reward for filing applications in proper form. However, a few months of the suggested procedure should produce a substantial reduction in the number of defective or incomplete applications, enabling the FCC's staff to give more attention to such really difficult problems such as increased frequency utilization through individual exceptions to the present system of nation-wide frequency allocations.

## National Frequency Resources:

Commissioner E. M. Webster followed up his analyses of taxi and petroleum industry communications problems with a sweeping review of the unsolved national policy questions in the radio field. Speaking before the New York Chapter of the

Armed Forces Communications Association, he outlined the six major questions facing the country in shaping national policy with respect to our frequency resources, as follows:

1. Shall the government operate communications systems for the purpose of carrying their own communications?
2. Shall the military agencies operate communications systems in peacetime which can be expanded to meet their needs in wartime?
3. Shall the military agencies look to the commercial communications systems for their basic communications needs in wartime?
4. Can we find a method to finance VHF (line of sight) throughout the American hemisphere and in Europe so as to release the long-distance frequencies for vital communications services?
5. Can we find a method to finance a stratovision systems for relaying general communications over the North Atlantic, and relieve the strain of existing high frequency radio circuits?
6. Shall we have competitive private overseas communications systems or shall we have a regulated monopoly?

## Miscellaneous Notes:

In a unique action, the Commission has authorized the Department of Forests and Waters of the Commonwealth of Pennsylvania to construct 62 fixed stations to be used for determining water levels throughout the Susquehanna River basin in connection with flood forecasting. The system, comprising a control center at Harrisburg, 11 automatic relay points, and 50 reporting units, will operate on nine frequencies in the 170-mc. Government band, with the concurrence of the Interdepartment Radio Advisory Committee.

The Diamond State Telephone Company has been granted authority to set up a special direct-dispatching operation at Wilmington, not connected with public message telephone system. First application of its kind by a Bell System operating company, the grant was protested by National Mobile Radio System, the association of limited common carriers.

The theatre television hearing, instituted by FCC, may affect microwave assignments of land mobile radio services if the FCC decides that this new service requires and should have frequency allocations in microwave bands.

Plans to use channels from 450 to 460 mc. for point-to-point service have bogged down. This use was contemplated when the new rules went into effect last July. Equipment is available for delivery, and is much less expensive than that for higher frequencies, but the Commission has not seen fit to process applications.



# RADIO RELAYS VS. WIRE LINES

WHY THE USE OF RADIO RELAYS IS EXPANDING, METHODS OF MULTIPLEXING, COMPARATIVE COST OF RELAYS AND WIRE LINES—By FREDERICK T. BUDELMAN\*

IN many countries outside the USA, FM radio relays offer a practical means for extending communications circuits to communities and areas where new wire circuits cannot be run because of copper shortages, lack of production, mountainous or wooded terrain, or high costs. In our own country, although we have a highly integrated wire and cable system, radio relays offer an attractive solution to the physical and financial problems of additional facilities, transmission over geographical barriers, or more economical or reliable circuits.

## Relays Go Where Wires Can't:

The most obvious use for fixed radio services is as a substitute for or extension to telephone lines. The use of radio in providing economical public communication where it cannot be established by wire facilities is steadily increasing all over the world to an extent that is not generally realized. Radio very often can bring outside communication to whole communities where the cost of erecting and maintaining wire lines prohibit their installation. Natural barriers such as rivers, bays, lakes, and swamps can be easily spanned by radio.

Many other less obvious uses for fixed radio circuits are very much in the public interest. Among these are point-to-point circuits for oil and gas pipe lines and public utilities to handle the multiplex transmission of supervisory controls, load controls, telemetering, and voice, teletype and facsimile services. Another interesting example is the 150-mc. relay system recently installed over the entire length of the island of Cuba, about 750 miles, to handle the network operation of a series of broadcast stations.

## Modulation Methods:

Two different forms of radio communication can be used for point-to-point and relay systems. These are frequency or phase modulation, and pulse modulation. The former can be applied successfully at any frequency, but the latter must usually be used at microwave frequencies because of its wide bandwidth requirements.

Although the VHF and lower UHF frequencies are quite crowded in the United States, and frequency assignments for fixed and relay systems difficult to obtain, the same situation does not exist in

most other countries. In most applications, the use of VHF or the lower UHF frequencies permits large savings in initial cost and maintenance as compared to microwaves.

Any of the various forms of pulse modulation, on the other hand, is comparatively wasteful of radio frequency spectrum, and must be confined to higher frequencies where broadband operation is permissible at present. Past history has shown that, as the higher frequencies are utilized more and more, there will be heavy pressure to make more economical utilization of the radio frequency spectrum than is accomplished with pulse

binning several channels of intelligence on a single transmission circuit. The process in either case is called multiplexing, but the methods used fall into the two general classes of time-division and frequency-division multiplexing.

In the former, the various signals to be transmitted are sent sequentially, so that only one of the channels uses the transmission medium at a time. In order to get the illusion of continuous signals on all channels, however, each signal is chopped up into small segments and then the small samples of each channel are combined in a prearranged sequence. In this way, samples of each

APPROXIMATE COST PER CHANNEL-MILE OF BASIC DUPLEX COMMUNICATION SYSTEM (BELOW 450 MC.)									
Number and Type of Stations	Length of System	NUMBER OF AUDIO CHANNELS							
		1	2	3	4	5	6	7	
Between 2 terminals only	45 miles	\$3730	7100	8460	9880	11200	12560	13980	System cost
		\$ 83	158	188	220	249	279	311	Per mile
		\$ 83	79	63	55	50	47	44	Per channel-mile
2 terminals 1 repeater	90 miles	\$7460	12625	13985	15405	16725	18085	19505	System cost
		\$ 83	141	156	172	185	201	217	Per mile
		\$ 83	71	52	43	37	34	31	Per channel-mile
2 terminals 2 repeaters	135 miles	\$11190	18150	19510	22930	22250	23610	25030	System cost
		\$ 83	135	145	155	165	175	186	Per mile
		\$ 83	68	48	39	33	29	27	Per channel-mile
2 terminals 3 repeaters	180 miles	\$20305	23675	25035	26455	27775	29135	30555	System cost
		\$ 113	132	139	147	155	162	170	Per mile
		\$ 113	66	46	37	31	27	24	Per channel-mile
2 terminals 4 repeaters	225 miles	\$25830	29200	30560	31980	33300	34660	36080	System cost
		\$ 115	130	136	142	148	154	161	Per mile
		\$ 115	65	45	36	30	26	23	Per channel-mile
2 terminals 5 repeaters	270 miles	\$31355	34725	36085	37505	38825	40185	41605	System cost
		\$ 116	129	134	139	144	149	154	Per mile
		\$ 116	65	45	35	29	25	22	Per channel-mile

Fig. 1. Cost of point-to-point radio systems is appreciably less than wire lines

modulation, and pulse modulation will be forced to still higher frequencies in a continuing evolution.

Finally, exhaustive comparisons show that single-sideband subcarriers on a phase-modulated RF channel provides the best performance factors of any of the presently available systems of multiplexing, even considering bandwidths up to 10 mc. These factors indicate that better signal-to-noise ratios can be obtained with less power and less bandwidth than from other methods.

## Multiplexing Methods:

It is particularly fortunate that the use of single-sideband subcarriers should prove so advantageous, because that type of channeling equipment has been used for many years as the standard method of providing multiple circuits over telephone lines and cables.

There are two basic methods of com-

channel occupy the entire transmission medium one at a time. The sampling procedure must be fast enough so that at least three samples are taken of each wave at the highest audio frequency transmitted. Under this condition, the original wave can be reconstructed at the receiving end of the system with reasonable accuracy. The samples of each channel can be transmitted by phase, frequency, or amplitude modulation, but most systems utilize some form of pulse transmission at microwave frequencies. A radio-frequency carrier is turned on and off in short bursts of energy called pulses, and the intelligence is transmitted by varying in some manner the pulse rate, width, time-position, or amplitude.

The second basic method of multiplexing is frequency-division. In this method, all the channels are transmitted continuously and simultaneously, but each is

(Continued on page 27)

\*Vice President and Chief Engineer, Link Radio Corporation, 125 W. 17th Street, New York 11.

# LOW-COST MOBILE FLEET CONTROL

SIMPLE CONTROL UNITS LIMIT CAR RECEPTION TO MESSAGES FROM ITS OWN TRANSMITTER, OR IMPROVE RELAY RELIABILITY. PART 1—By JACK KULANSKY\*

WITH the increased use of radio telephone communication, the operational need of limiting reception to the associated transmitter or transmitters is becoming more urgent. When the number of systems in the USA assigned to a particular frequency was small, skip-distance reception was more of a novelty than an annoyance. Today, however, operators are not only confronted with skip reception of nuisance proportions but, in many areas, the added confusion of hearing messages from other local transmitters on the same channel.

Two methods of eliminating this source of operational difficulty are now available. The first is selective calling, whereby all speakers in a mobile system are muted, except when a car receiver picks up its particular code number signal. Then the speaker is turned on for the duration of the message. The second system is fleet-control, whereby all speakers are muted except when the car receivers pick up a particular audio frequency note. Then the speakers in every car in the fleet are turned on for the duration of the message.

The use of fleet-control units can be applied to the actuation of point-to-point and relay systems, also, and to talk-back operation so that the operator at a headquarters station hears only his own cars.

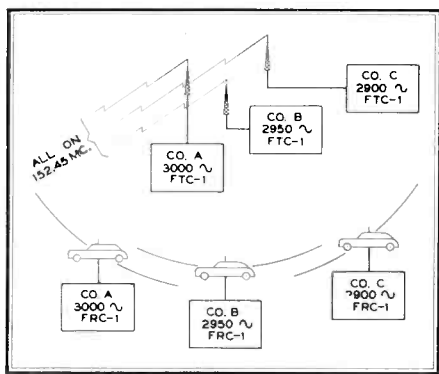

Fig. 1. Three systems on same frequency

It can even be expanded to use with groups of cars, as in the case of a police system serving two or more adjacent towns.

It is the purpose of this paper to explain the applications of the fleet control system developed by the Hammarlund Manufacturing Company, and the operation of the control units.

\*Mobile Systems Engineer, Hammarlund Manufacturing Company, Inc., 460 West 34th Street, New York City.

## Basic Method of Operation:

The fleet-control system employs very simple units which can be connected readily to radio telephone transmitters and receivers of any type. Simply stated, the transmitter unit develops an audio-frequency tone which is transmitted for 200 milliseconds each time the press-to-talk button on the microphone is actuated. Thus, the short tone-signal automatically precedes each message.

At each associated receiver, the loud-speaker is muted. However, if the receiver picks up a tone signal from an associated transmitter, the receiver control unit turns on the speaker and holds it for the duration of the message.

The idea of using such a control is so simple as to be obvious. The development of the units into commercial designs involved the perfection of circuits that would assure positive lock-and-key functions, operating dependably upon transmission of the actuating signal, and rejecting all impulses and random noise picked up by the receiver. Such equipment has been produced, put through exhaustive field tests, and is now in commercial use for several different types of communication systems. Typical examples of these are described in this paper.

## Shared-Channel Operation:

In order to attain maximum use of the frequencies available for communications, the FCC has found it necessary to assign one channel to two or more users in many areas. This is particularly true of the taxi service. Each driver, then, hears every call, and must listen carefully to distinguish between the calls from his own transmitter, and all the calls made by the other transmitters. Such a situation is illustrated in Fig. 1.

Resulting confusion is tiresome, annoying, and distracting. It often causes drivers to miss their own calls. During busy hours, efficiency drops sharply, since the calls are speeded up to 15 to 20 per minute!

Other services, on lower frequencies, may not have as much traffic, but they may have serious skip-reception trouble from the distant stations on the same frequency.

By the use of fleet control units, reception at any receiver of signals other than from the associated transmitter can be eliminated. Fig. 1 shows the operating plan for three independent systems using

the same frequency in one area. This is not an uncommon situation.

Each transmitter has an FTC-1 control unit, set respectively at 2,900, 2,950, and 3,000 cycles. All Company A's cars have FRC-1 receiver controls, set at 3,000 cycles. Controls in Company B's cars operate at 2,950 cycles, and Company C's, at 2,900 cycles.

When the operator at transmitter A has a call to put out, he presses the push-to-talk button in the usual manner, but even before he can start to speak, the control unit automatically sends out a 3,000-cycle tone for just 200 milliseconds.

Normally, all the speakers in the cars operated by the three companies are muted. When transmitter A goes on the air, however, the speakers in all Company A cars are turned on by the receiver control units. The message is not heard by Company B and C cars. The same degree of privacy is afforded to messages from the B and C transmitter to their cars.

Similar protection for headquarters receivers can be obtained by adding FRC-2 units to the receivers, and FTC-1 control units to the mobile transmitters. Then the dispatcher will hear only his own cars. When this is done, a different audio frequency is used for the mobile control units in each system. Otherwise, transmission from one car would turn on the speakers in all cars operated by the same company.

## Multiple Service Operation:

A variation of the method just described is ideally suited to use at a single transmitter which serves two or more groups of cars. For example, several small fleets of taxicabs might join in the use of one main station. Or, as is the case in many areas now, one transmitter may serve the police and fire departments, the county sheriff's office, and the city hospital. In other localities, several adjacent towns may join in the use of one headquarters station. This practice is encouraged by the FCC, and is provided for in the Rules, in order to attain maximum channel utilization.

The drawback to such a plan is that messages intended for one group of cars are heard by all the other cars. Taxi fleet owners object to this, naturally. Many police departments operate individual transmitters not because their traffic warrants it, but because the chiefs



do not want their messages to be picked up by other cars.

These objections can be overcome by a modification of the setup illustrated in Fig. 1. By using three FTC-1 control units, set to different audio frequencies, at one transmitter, the dispatcher can turn on the speakers of any particular group of cars.

For example, cars in group A would have receiver control units adjusted to 3,000 cycles, in group B cars, 2,950 cycles, and in group C, 2,900 cycles. Additional frequencies can be used for a larger number of groups.

The actual method of dispatching is very simple. The operator has a control box with as many buttons as there are groups of cars. If he wants to call the cars in group C, he presses button C, and transmits his message in the usual manner. Button C remains depressed, keeping control unit C connected to the transmitter and ready for use. Later, if he wants to reach group A cars, he presses button A, which automatically releases button C.

#### Fully Automatic Control:

It will be seen from the foregoing that the advantages of fleet-control operation are obtained without modifying or complicating the established dispatching procedure. The operation is fully automatic, and no time is lost in handling messages. Even when traffic is heavy, the operator is not conscious of the 200-millisecond interval during which the actuating signal is transmitted.

In the multiple-service system just described, it is only necessary for the operator to push the group-selector button once. It is not touched again until he is ready to give a message to a different group of cars.

#### Relay System Operation:

Quite a different way of using the same control units is shown in Fig. 2. This is a relay system for operation with vehicles traveling on a highway, or service cars patrolling an oil or gas pipe line. It is designed to receive messages from any car, pass them along the microwave relay in both directions, and to transmit them to all other cars in the system, no matter how far away.

Installations of this sort are now in use, but their operation is seriously impaired because the relay links can be turned on as readily by noise, random impulses and skip-distance reception as by the associated mobile units. Thus, any interference picked up at any point is repeated throughout the system. Experience has shown this to be a serious disadvantage, for the whole installation may be tied up for long periods. Volume controls are turned down, and calls may be missed.

The method of operation with the FTC-1 transmitter control and FRC-1 receiver controls is as follows:

Each mobile unit operating, for example, on 158.46-mc. has a transmitter control unit set at 3,000 cycles. There is a 158.46-mc. receiver, with a control unit adjusted to 3,000 cycles, at each relay point. Also, each relay has a VHF link to a 153.05-mc. transmitter so located as to cover one section of the area traveled by the cars.

When any mobile transmitter goes on the air, the initial 3,000-cycle pulse is

pepper transmitters, so that the message from the initiating car is heard at every other car. As soon as the message is completed, and the carrier of the car transmitter goes off the air, the entire system is released.

Noise or transmissions from any other system have no effect, however, for the relays can be put in operation only by the initial 3,000-cycle tone.

Modifications of the three basic plans described can be worked out to meet any number of special operational requirements.

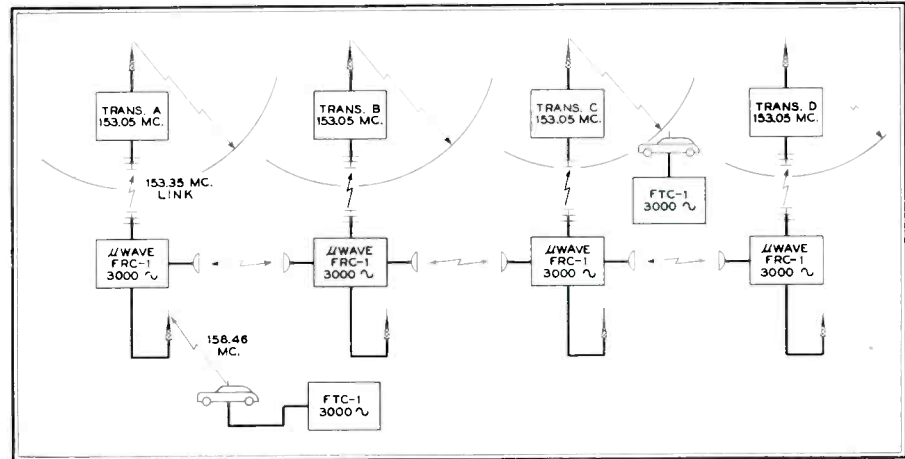

Fig. 2. Relay system is actuated only by 3,000-cycle pulse from car transmitter

picked up by the receiver at the nearest relay. This switches on the relay transmitters in both directions, and they, in turn, switch on the succeeding relays over the length of the system.

The link transmitters turn on the re-

*Editor's Note: Concluding Part 2, to be published in a forthcoming issue, will describe the transmitter and receiver control units in detail, and explain the method of connecting them to any transmitter and receiver now in use.*

## BUREAU OF STANDARDS' NEW PROPAGATION LAB

APPROVAL has been given for the development of a site at Boulder, Colorado, for additional Bureau of Standards laboratory facilities. The site, to be used by the Bureau's Central Radio Propagation Laboratory, consists of about 210 acres, directly south of the city and close to the campus of the University of Colorado.

The National Bureau of Standards expects to erect laboratory facilities at Boulder for research in radio propagation, at a cost of about \$4,500,000. It is expected that actual construction work on the radio laboratory will begin at Boulder during the summer of 1951. A research staff of about 300 will be employed. Most will be transferred from the staff in Washington.

In addition to its normal research duties, the laboratory renders many advisory and consulting services to other agencies of the Government.

The Bureau's radio work is carried on in three distinct categories: The ionospheric research laboratory, the systems

research laboratory, and the measurement standards laboratory.

The ionospheric research laboratory performs basic research on the nature of the upper atmosphere and its ability to reflect radio waves. It maintains a network of 14 field stations extending over the American continents and throughout the Pacific area.

The systems research laboratory applies radio propagation information to the practical problems of communication, and publishes a series of monthly charts predicting the best frequencies for long-distance radio communication throughout the world. It also conducts research on propagation in the VHF and UHF bands, to help determine the most efficient allocation of frequencies to FM, television, and other services.

The measurement standards laboratory is largely concerned with improving the methods and standards of measurement at radio frequencies. Advances in recent years have carried this work to higher and higher frequencies, and have opened up whole new fields of study. The new laboratory will permit even more comprehensive studies.





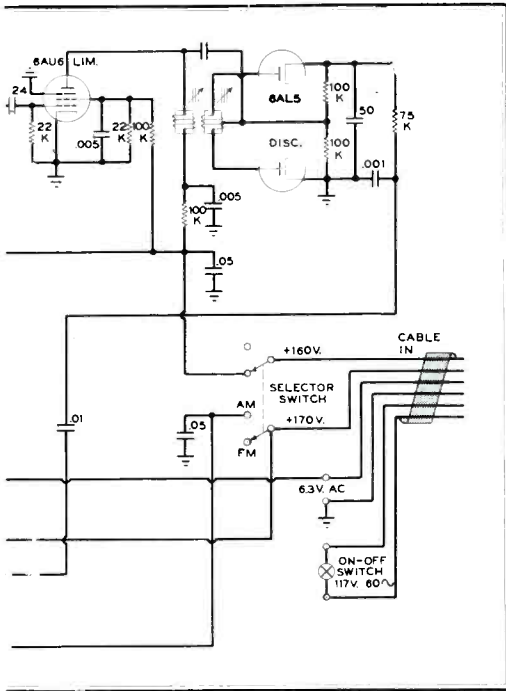

drift. Same audio stage is used for FM & AM

unit. However, completely separate RF, oscillator, and IF circuits are employed.

The front-end FM tubes and coils are located at the left of the tuning capacitor. A 6AG5 is used as an RF amplifier, capacitively coupled to a 6BE6 mixer, with a separate 6J6 oscillator.

All three FM sections of the tuning capacitor are shunted with temperature-compensated trimmers to minimize initial drift. It has been the writer's experience that no FM broadcast receiver meets the claim of "absolute freedom from drift." With all the compensating devices, there is still enough initial drift to invalidate such claims. The important point about drift is that it must cease after a short

warm-up period. That has been accomplished in the A-710 to the extent that if the set is used in the evening and is turned off, it will be exactly at resonance with the same station next morning, after it has been turned on for five minutes, assuming that the ambient temperature is approximately the same. However, after the set has warmed up, a center-zero DC vacuum-tube voltmeter across the discriminator shows complete frequency stability. That is what counts.

#### FM IF Amplifier:

Two 6AU6 tubes are used as IF amplifiers. The double-tuned, low drift miniature transformers are of the K type, operating at 10.7 mc., with a bandwidth of 200 kc. Silver ceramic condensers and Allen-Bradley resistors are employed in these circuits.

A limiter-discriminator circuit was chosen in preference to a ratio detector for better all-round performance. Type 6AU6 tubes are used for the cascade limiter, feeding a 6AL5 discriminator. No AVC is required.

#### FM-AM Switching:

The simplest method possible is used to switch from FM to AM. No signal circuits are switched. Instead, a two-position, two-pole switch connects the B supply to the FM or AM section of the tuner. So little current is drawn by the filaments that they are left on all the time the set is in use. This has the advantage of keeping the FM tubes warm and ready during AM reception.

#### The AM Section:

All AM components are located at the right of the tuning capacitor. The cir-

cuit is conventional, using a high-gain 6BA6 RF stage with a 6BE6 mixer-oscillator followed by a 6BA6 IF amplifier operating at 456 kc. The output feeds the diode section of a 6AT6, while the triode section is common to both the FM and AM circuits. Sensitivity is 10 microvolts, and the IF bandwidth 8 kc. AVC is used on the RF and IF stages.

#### Audio Amplifier:

Because most custom set-builders have their own ideas about audio amplifiers, no amplification is provided beyond the triode section of the 6AT6. As Fig. 3 shows, the 75-microsecond de-emphasis network from the FM section is connected in parallel with the output of the AM section across the volume control.

#### Special Notes:

An unusual mechanical feature has been incorporated in this tuner for the benefit of custom set-builders. In some cases, with the front panel mounted vertically or horizontally, it may be more convenient to mount the chassis so that the scale can be read from the side of the panel. Accordingly, the scale shown in Fig. 1 can be replaced with another that has calibrations reading at right angles to the length of the escutcheon.

A 3-ft., coded power cable is wired into the chassis for connections to the power supply.

Power requirements are as follows:

All filaments, 6.3 volts, 4 amperes AM B supply, 170 volts, 20 milliamperes DC.

FM B supply, 140 volts, 37 milliamperes DC.

Overall dimensions of the tuner illustrated are: 8¼ ins. wide, 8 ins. deep, and 5¾ ins. high.

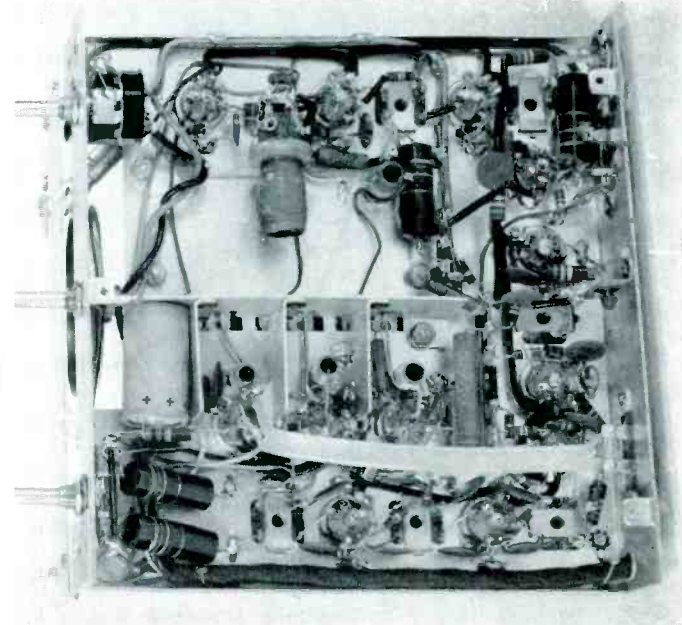
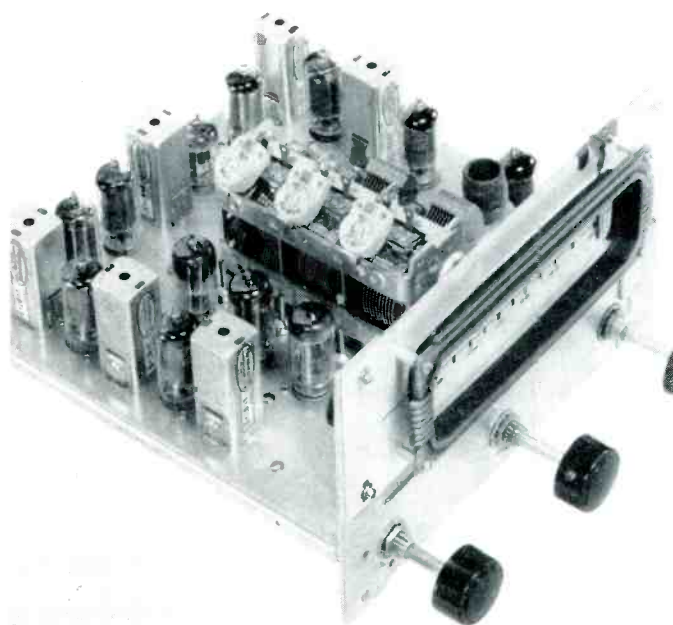
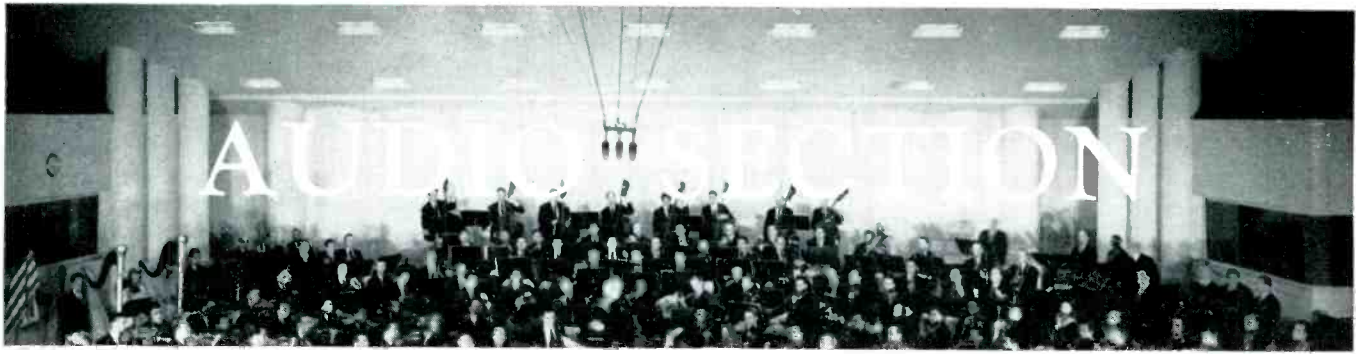

Fig. 1. Top of chassis. 6-section tuning capacitor is used for both AM & FM. Fig. 2. Bottom view reveals extensive shielding



## AUDIO NEWS & NOTES

### BACKGROUND NOISE, FM VS. AM AND RECORDINGS. A NEW FILM RECORDER — *By* MILTON B. SLEEPER

AT the time Nathan Straus, president of New York station WMCA, thought he would close down the affiliated FM transmitter, he had this to say about high-fidelity broadcasting: "The advantage seems to me theoretical rather than actual. The human ear, except in the case of a few trained musicians, is not especially sensitive to the absence of frequencies at the extremes of the listening range. More important, most radio programs are such that a slight loss of fidelity does not at all affect the listener's enjoyment."

to have well-informed opinions. That is the matter of background noise. We are particularly conscious of it because, during the past ten years, we have become so conditioned to a background of silence on FM that we cannot accept the noise behind AM reception, or the needle-scratch on wide-range recordings. Also, we know that recognition of the difference between live-talent and network programs comes from listening experience, and is not limited to "a few trained musicians."

We're not prepared to argue the point with Howard Chinn of CBS, or the Eng-

that networkers will be forced to provide it.

3. Those interested in serious music, whose source is now wide-range recording, will come to depend more and more on FM live-music programs unless needle-scratch can be virtually eliminated.

Of course, we do not think that these changes will occur overnight. Habits, in general, are quite resistant to displacement. There is no reason to suppose that listening habits are different from others. Opposing the change, also, is the fact that it would involve replacement of existing equipment.

But we are only interpreting the trend in the light of our own experience and those of others we have spoken to. It seems to us that the change has begun.

ANOTHER film recorder is illustrated in Fig. 1. It is a 16-mm. portable model, from Movie-Mite Corporation, 1105 Truman Road, Kansas City 6, Mo. Frequency response is rated flat within 1 db from 50 to 10,000 cycles at a speed of 72 ft. per minute, which corresponds to 14.4 ins. per second. Reel capacity is 2,000 ft.

Associated amplifiers provide 500 ohms output at 8 dbm level for rerecording, or 6 watts with 4, 8, 15, and 22 ohms output to drive a speaker. An interesting feature is the use of a REHEARSE position on the control switch which bypasses the heads, and makes it possible to check microphone placement, and level settings during rehearsal without using film. A separate playback head permits the recorded signals to be monitored with a time lag of only .2 second.

THIS month, Reeves Soundcraft Corporation will enter the magnetic tape field. Production facilities have been set up at 35-54 36th Street, Long Island City, and the present sales office at 10 East 52nd Street, New York, will be moved to that address. Reevesound photosound and magnetic film recorders will also be manufactured at the new plant. In addition, sales offices for two subsidiaries, Tele-Video Corporation and Airdesign, Incorporated, will be located there.



Fig. 1. This film recorder has flat response 50-10,000 cycles, with 28-minute reels

Some such remark is always made in any group-discussion of FM. On this other hand, there is an increasing demand for phonograph records with extended upper-range response. That can be seen in the increased sale of English records, and in the improvements already achieved in domestic long-playing records.

But there is an aspect of listening preference that is generally neglected in discussions by those who are in a position

lish expert J. Moir, but purely on the basis of habits acquired from FM listening, it does seem that, as an increasing number of people become conditioned to noise-free reproduction, the following effects will be noted:

1. Radio audiences will forsake interference-afflicted AM and will shift to FM entirely, except for those in the immediate vicinity of AM transmitters.

2. The demand for 15,000-cycle program quality will become so insistent



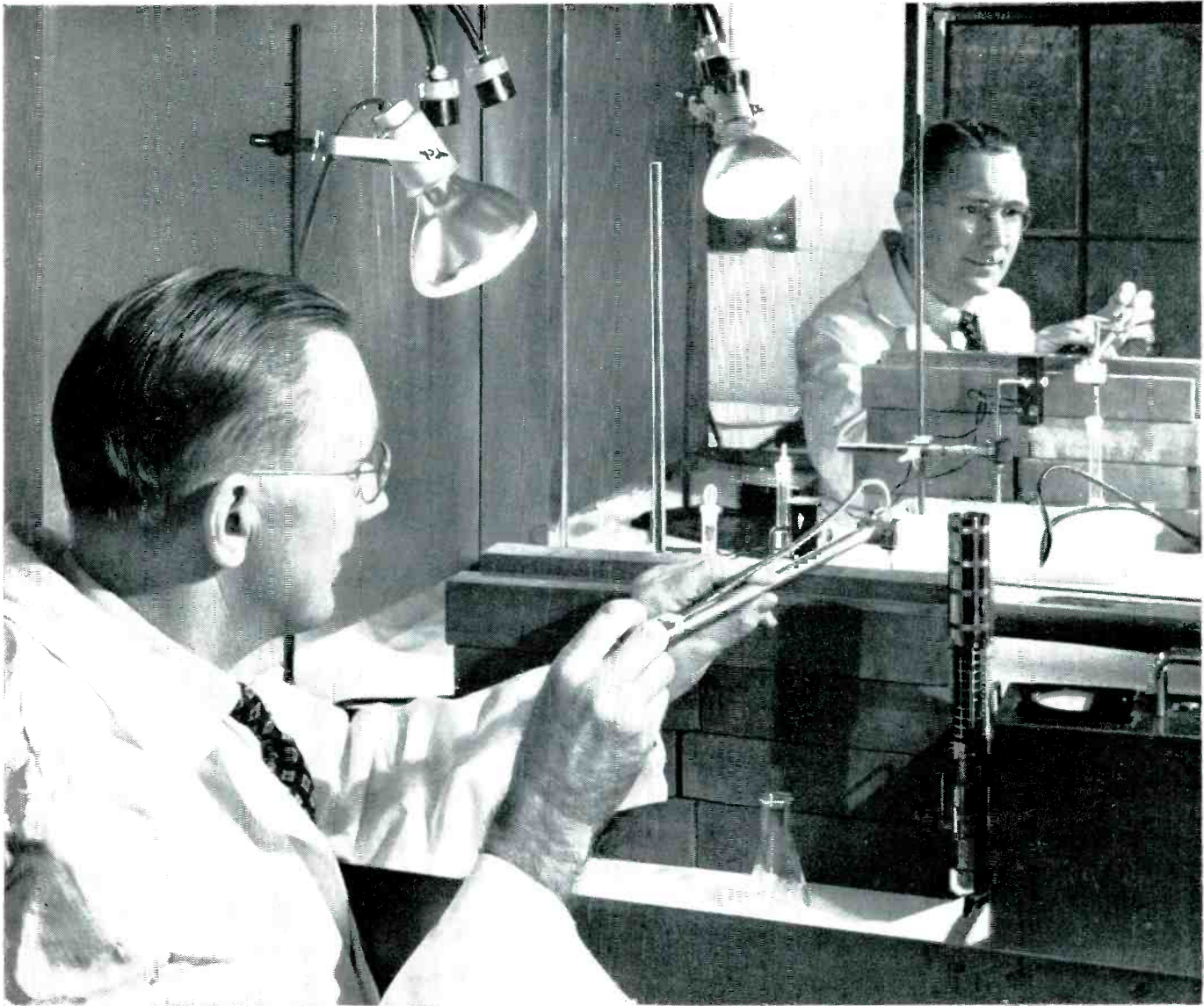

## IT'S **DONE WITH MIRRORS!**

Protected by a wall of lead bricks and using a mirror to guide his instruments, this Bell Laboratories scientist is preparing a solution of a radioactive isotope, for use as a tracer to study materials for your telephone system.

Bombardment by neutrons turns some atoms of many chemical elements into their "radioactive isotopes"; these are unstable and give off radiation which can be detected by a Geiger counter. Chemically a "radioactive isotope" behaves exactly like the original element. Mix the two in a solution or an alloy and they will stay together; when the Geiger counter shows up an isotope, its inactive brother will be there too. Minute amounts beyond the reach of ordinary chemical methods can be detected—often as little as one part in a billion.

The method is used to study the effect of composition on the performance of newly developed germanium transistors—tiny amplifiers which may one day perform many functions which now require vacuum tubes.

It enables Bell scientists to observe the behavior of microscopic impurities which affect the emission of electrons from vacuum tube cathodes. It is of great help in observing wear on relay contacts. And it may develop into a useful tool for measuring the distribution and penetration of preservatives in wood.

Thus, one of science's newest techniques is adopted by Bell Laboratories to make your telephone serve you better today and better still tomorrow.



### **BELL TELEPHONE LABORATORIES**

EXPLORING AND INVENTING, DEVISING AND PERFECTING, FOR CONTINUED IMPROVEMENTS AND ECONOMIES IN TELEPHONE SERVICE.

# All Sound by **ALTEC**

## MICROPHONES

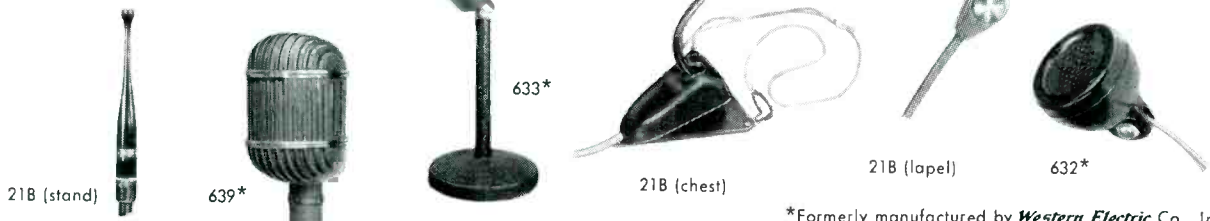

21B (stand)

639\*

633\*

21B (chest)

21B (lapel)

632\*

\*Formerly manufactured by *Western Electric Co., Inc.*

## AMPLIFIERS



Pre-amplifiers and Mixers

Portable P.A. Amplifiers

Power Amplifiers

AMPLIFIERS AND SPEAKERS ILLUSTRATED ARE A FEW OF THE WIDE SELECTION AVAILABLE

## LOUDSPEAKERS

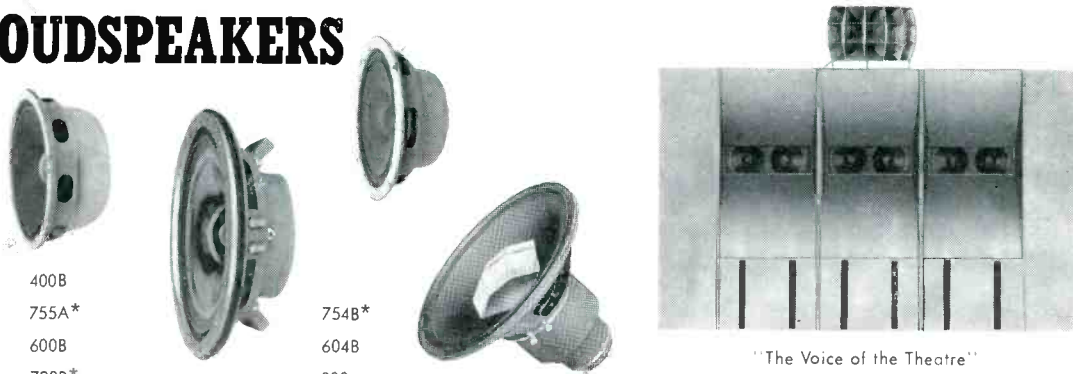

400B  
755A\*  
600B  
728B\*  
603B

754B\*  
604B  
800  
757A\*

"The Voice of the Theatre"

\*Formerly manufactured by *Western Electric Co., Inc.*

## REPRODUCERS



9A\* and 9B\*

109 Reproducer Group\*

\*Formerly manufactured by *Western Electric Co., Inc.*

1161 N. VINE ST., HOLLYWOOD 38, CALIFORNIA  
161 SIXTH AVENUE, NEW YORK 13, NEW YORK



Also **PEERLESS TRANSFORMERS**



• Sun Radio MONTHLY MAILER keeps you posted on timely radio-electronic parts, accessories, assemblies, tubes, instruments. Real technical dope. We tell you everything we know about the products—pictures, descriptions, specs, prices. But no high-pressure selling. You do your own deciding—and buying, if you wish. If you're interested in superlative sound reproduction, there's our 68-page manual-catalog "Audio Equipment". It's chock full of practical, economical, hard-to-find data. Both "musts" ABSOLUTELY FREE! Nothing to buy! No strings!

"Audio Equipment"—a gold mine of practical dope on high-fidelity sound.

**Sun Radio**  
**& ELECTRONICS CO. INC.**  
 122-F DUANE ST. • NEW YORK 7, N.Y.  
 2 Blocks North of Chambers St.  
 BARCLAY 7-1840

... for quality sound, say

*"All-Tech!"*

In every field there is an outstanding leader whose prices may be higher than some, but whose quality is second to none. ALTEC LANSING is proud of the position it holds in sound reproduction. Now, with the inclusion of selected Western Electric audio products, ALTEC offers the most complete high quality audio line and sound service for every application, with stocks and service near at hand.

**DEALERS EVERYWHERE**

SPEECH INPUT  
 PUBLIC ADDRESS  
 INDUSTRIAL SOUND  
 VOICE REINFORCEMENT  
 HOME MUSIC

1161 N. VINE ST., HOLLYWOOD 38, CALIFORNIA  
 161 SIXTH AVENUE, NEW YORK 13, NEW YORK

**ALTEC**  
 LANSING CORPORATION

**RADIO RELAYS VS. WIRES**

(Continued from page 19)

carried by separate, narrow bands which, combined, comprise the total bandwidth transmitted. At the receiver, the composite signal is put through band-pass filters which separate the individual channels and reconvert them to their original forms. Frequency-division multiplexing of voice-frequency channels has been highly developed in the telephone industry in a form calculated to give not only the maximum possible utilization of frequency spectrum, but to give the maximum signal-to-noise ratio for the least power. This form of multiplexing is known as suppressed-carrier, single-side band carrier telephone. Standard equipment of this type is readily available.

**Operational Requirements:**

Many uses of multiple-channel point-to-point and relay radio systems require the use of both radio and wire facilities. In those cases, the ability of the wire circuits to transmit the multiple modulation must be considered. The large bandwidths required for time-division systems of multiplexing in general and pulse modulation systems in particular prevent their use over normal telephone facilities. Single-side-band frequency-division channeling equipment, on the other hand, provides the maximum possible usage of available bandwidth and is the accepted method of multiplexing on wire or cable circuits. In a trunk system, then, to be composed of terminal circuits over wires and interconnecting radio links, it is imperative that this latter type of equipment be used. A typical commercial application may be visualized in the use of radio in a telephone trunk circuit as a link to span a natural barrier such as a large river or bay. In this case, the radio must accept the complex intelligence on the wire or cable line, reproduce it faithfully at the other end of the radio link, and pass it on again to wire circuits. If the radio equipment is designed around time-division methods of multiplexing and pulse modulation, the intelligence on the wire line would have to be demodulated in carrier terminal equipment to the original voice-frequency channels which would then be reapplied to the time-division modulation circuits. The reverse process would be required at the receiving terminal. The added terminal and channeling equipment would not only add enormously to the first cost, but would greatly increase the cost of maintenance and add to the distortion, noise, and crosstalk levels of the resulting circuit.

The widespread use of radio relay-equipment during the past war and the

(Continued on page 36)

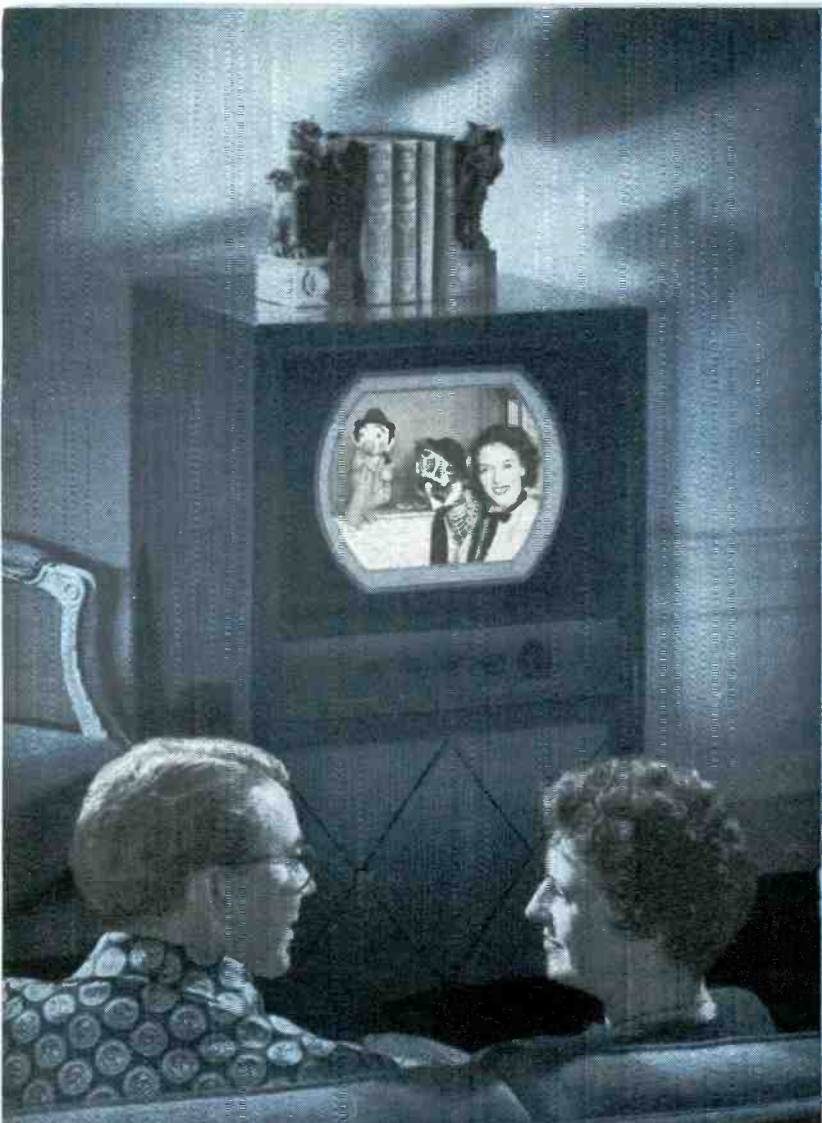

**"We have a much better picture than the neighbors. I think the serviceman was right when he said it's all because of our Amphenol INLINE\* Antenna."**

**This is the antenna they are talking about. It assures you the Best TV PICTURE**

© 51, '64 EHT MC 74744FC

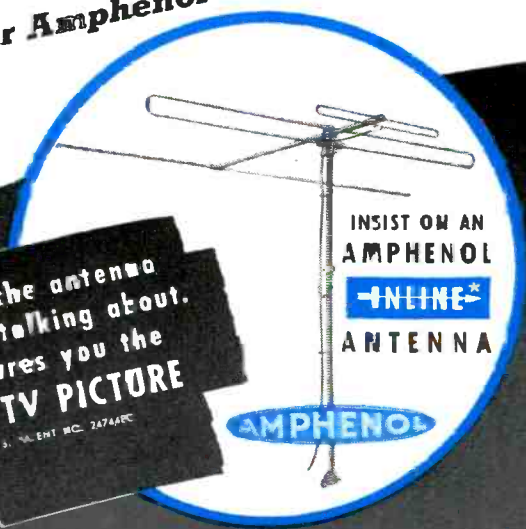

**INSIST ON AN AMPHENOL INLINE\* ANTENNA**

**AMERICAN PHENOLIC CORPORATION**  
1830 SO. 54TH AVENUE · CHICAGO 50, IL. INDIS

**NOW**

**STABILIZED and REGULATED**

**VARIABLE DC VOLTAGE**

FROM 0-30 VOLTS

**FROM AN AC SOURCE**

**ALL IN ONE UNIT**



The VARICELL, a product of The Superior Electric Company, meets today's demand for a stabilized and regulated source of variable D-C voltage. It operates from a 95-135 volt, 60 cycle, 1 phase ALTERNATING CURRENT line; delivers a DIRECT CURRENT output settable to any value from 0-30 volts. Maximum output current at any voltage setting is 15 amperes.

The D-C output is stabilized — held to the set value regardless of line variations. Output is also regulated — the unit automatically compensates for load fluctuations. Stabilization and regulation: 0.25% for an output setting between 6 and 30 volts. R.M.S. ripple voltage does not exceed  $\pm 0.1$  volts.

Only the VARICELL offers stabilized and regulated variable D-C voltage from A-C lines. One unit — built to give long, trouble-free service — gives you the flexibility of several. There are no extras to buy — no accessories or special parts are needed. One unit gives you completely variable D-C voltage — from 0 to 30 volts.

WRITE TODAY FOR COMPLETE INFORMATION  
903 MEADOW STREET, BRISTOL, CONNECTICUT

**THE SUPERIOR ELECTRIC CO.**  
BRISTOL, CONNECTICUT



POWERSTAT VARIABLE TRANSFORMERS • VOLTBOX A-C POWER SUPPLIES • STABILINE VOLTAGE REGULATORS



## WHAT'S NEW THIS MONTH

(Continued from page 16)

Of course, the answers are obvious. Why pay more and profit less if the sales can be made for the sponsor with a cheaper service? In other words, merchandising is not only the life blood of the radio industry but apparently also the whole blood; and I don't distinguish between sponsors, radio equipment manufacturers, licensees, or networks when I refer to the radio industry. True enough, the industry has distinguished scientists. But what stands out in bold relief to me is that these scientists, men of great reputation in the electronics field, have distinguished themselves more by solving merchandising and economic problems than they have by providing an adequate broadcasting service to the people of America.

Let me state the question again with specific reference to television: the VHF freeze, opening UHF, and color. To what extent can the Commission rely upon the same radio industry to advise the Commission in the fulfillment of its statutory duty to provide television — black-and-white and color — to all the American people? Again, unfortunately, we'll have to look at the record. The Commission's original allocation of television proposed 4 stations in New York City. The industry — the Television Broadcasters Association — recommended seven. The Commission accepted the industry's advice and gave New York City seven stations. Who suffered? First the smaller cities close to New York and, next, all the smaller communities east of the Mississippi River.

In fact, because of this VHF concentration, the Commission now finds it is able to propose only one VHF station to the entire state of Connecticut.

What happens to these communities like Lima that are left out of the VHF channel assignment plan? Bridgeport, Connecticut, is a good example. It sought a Hartford VHF channel and lost. Now, years later, it gets a UHF experimental station, not primarily to provide service to Bridgeport but to collect data on UHF propagation characteristics and equipment tests. What happens to the other Bridgeports? They get nothing yet, and four years have passed since VHF was opened for commercial operation.

Now it seems to me the scientists in the industry should have been aware of the fallacy of assigning seven stations to New York City, and the lack of a chance to serve the smaller communities. And to the mind of a scientist, the course should have been clear that it was necessary to start an immediate search for the propagation and equipment answers to UHF commercial operation. Keeping

their eyes on the merchandising interests of their bosses, the scientists of the industry just could not give their attentions to UHF, the means by which all the American people would get television.

And they didn't solve their merchandising problem even in the VHF since it has been found that the service areas are suffering from assignments too close together — these very same assignments they had recommended. The scientists were willing to get away with as much as they could so long as their employers could get the stations going where they wanted. It is natural, then, that the scientists did very little to study the use of UHF until the Commission actually proposed the use of UHF, because they were kept so busy finding solutions to problems the industry had created in the scramble for the valuable metropolitan assignments in VHF.

### Color Television:

We are on the eve of a new development of the art. By that I mean color. The Commission is engaged in the quasi-legislative process of finding a home for this fine broadcast service. I approach the problem here just the same as I did a bill when I was a Congressman. The criteria I use at the Commission is the same as I used on the Hill: Is this proposal in the public interest?

Now let's look at the industry's color record. In 1941 when the black-and-white standards were being adopted, the industry, through its National Television Systems Committee, thought great things about color. It felt that color television should be encouraged and field tested at once. On April 30, 1941, the Commission asked for field tests and for proposed standards for color. Of course a war has intervened, but the war has been over for four and one-half years and now, eight years later, the color tests have just started. And they aren't off to a good start yet, either.

The Radio Manufacturers Association produced a series of about thirty tests which is said it felt would have to be conducted before any of the color systems proposed in the present hearing could be adopted. So far as I know, however, no one other than the proponents has as yet taken any steps to conduct any of these tests. The television set manufacturers have not been exactly bankrupt or financially embarrassed these last four and one-half years. In fact, some of them, while operating on a shoestring, and before a receiver had been sold, conducted extensive tests to help write black-and-white television standards.

It's strange to me that some of these manufacturers who have made phenomenal profits from the sale of black-and-

white receiving sets have spent little or nothing on color research of their own, or in the field-testing of systems proposed by others. Instead of offering us the results of field tests, we are offered new forms of advisory committees, committees which are but a part of a general scheme which frequently reminds me of the interlocking directorates the public utilities used in the heyday of that industry. No matter where the Commission turns to get advice to help solve its engineering problems, the same large industry interests are represented in one form or another. These industry advisory committees could serve a wonderful function if they did the job they purport to do. But I am afraid that frequently the record establishes not the advancement of the art, but the suppression of the art. I need not remind you that the Justice Department has taken steps to use the anti-trust laws where it appeared that an art was being suppressed for the advancement of private interests, and to the prejudice of the interest of the American people. Concerted action by these industry groups to delay, if not to prevent, the establishment of color television might well lead to the same type of action.

When private enterprise seeks out the most profitable market for the installation of clear channels and regionals in highly congested areas, I find no fault with such action. That is the kind of enterprise I have defended all my public and private life. But, when private industry attempts to use Government processes to accomplish the same thing in television, or when I think it attempts to use the Commission to eliminate the natural forces of competition between established black-and-white and infant color, I draw the line. Likewise, when the industry tries to use the Commission to thwart or delay reliable television service for towns like Lima, that calls for some noise and infield action.

While it may be true that the radio interests I have referred to are primarily concerned with protecting existing investments and systems including black-and-white television, you people represent advertisers who long ago abandoned black-and-white labels for more colorful advertising. They must be interested in the full and immediate introduction of color television. To that extent your interests and the statutory duty of the Commission coincide.

Since the advent of all phases of broadcasting, many mistakes have been made by all concerned. But let us hope that we profit by the wrong roads that have been taken, to build a broadcasting service that we may look back upon, ten years from now, with pride and satisfaction.

## GATED BEAM TUBE

(Continued from page 15)

clipped sync with random noise on the peaks if the signal is weak. The impulse noise also drives this grid positive, backing off the sync pulses. The syncs recover in a few milliseconds because of the small time constant of the grid coupling element. The low-frequency component is re-inserted by virtue of the small time-constant, with the grid drawing current on sync tips only. This form of re-insertion works satisfactorily only if the major portion of the low-frequency component has been eliminated. This is the reason for the first tube function, called the picture clipper. The random noise remaining on the sync tips is clipped off by the fourth half-tube. The output of this circuit is 60 volts peak-to-peak of positive-polarity sync.

Fig. 5B shows an equivalent circuit using a single gated beam tube, or one tube function. The circuit is capable of operating with a variation of composite video, positive polarity, from 12 to 120 volts input to the first grid. This produces 35 volts negative sync signal output. In a television receiver, the input to the 6BN6 is adjusted to a nominal value of 70 volts peak-to-peak with a strong signal. The sensitivity of the receiver and the automatic gain control action normally maintain this voltage

The grid resistor is chosen to produce the best clipping level on weak signals where the random shot noise is in evidence as in Fig. 6. One horizontal period of composite video is shown with shot noise and impulse noise superimposed on the desired signal. With proper choice of the grid bias resistor, the high Gm region of the grid characteristic occurs during the portion of the sync pulse most free of random noise. The impulse noise is clipped to the same level as the clipped sync pulse, as shown. Impulse noise can

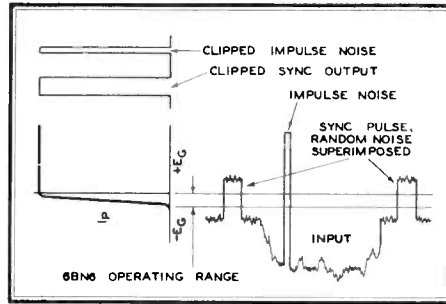

Fig. 6. Sync separator clipping action

change the grid bias only by a limited amount because of grid current saturation. Although the grid time-constant is large, the limited grid current prevents the syncs from biasing beyond cut-off except for extremely heavy-duty cycle impulse noise in which the loss of picture is the limiting factor of acceptability.

When the composite video input to the

automatic gain control voltage is modulated by the beat frequency of the horizontal oscillator and the horizontal sync pulses. This beat note appears as sinusoidal modulation of the composite video, shortening the period in which the sync signals are in proper phase relation with the horizontal oscillator, and thus reducing the capability to pull into synchronization.

### TUBE COMPARISON TABLE

	CONVENTIONAL 6BN6 CIRCUIT	
	CIRCUIT, FIG. 5A	FIG. 5B
TUBES	2	1
FUNCTIONS	4	1
RESISTORS	15	4
CAPACITORS	8	2

In using the 6BN6, a satisfactory compromise is made between AGC time-constant, horizontal AFC time-constant, and horizontal synchronization lock-in range. In a superior synchronizing circuit employing the 6BN6, another tube function is added ahead of the 6BN6 to remove most of the picture content of the composite video. This makes possible the use of a smaller time-constant in the 6BN6 grid.

As pointed out by Dr. Adler, positive sync pulses can be derived from the accelerator of the 6BN6, and the second control grid can be utilized for applying a gating pulse. The gating characteristic would make the sync signal output even more immune to noise.

### Credits:

The authors wish to express their indebtedness to Dr. Robert Adler, Research Department of Zenith Radio Corporation for his valuable assistance in adapting the 6BN6 to the applications described, and to Mr. Louis Metevier, Engineering Department, for his engineering and field test work that proved the circuits to be adaptable to mass production.

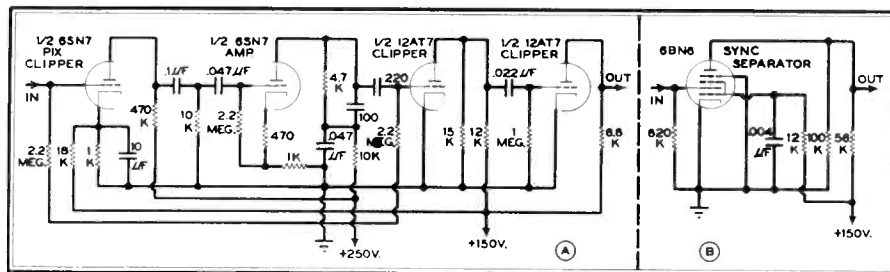

Fig. 5. Use of 6BN6 as sync separator saves components, space, and wiring time

relatively constant. In some receivers this voltage may drop to 25 or 30 volts with weak signals. The variation in input to the gated beam tube grid may be 25 to 70 volts.

The operation of the 6BN6 is best explained by the use of Fig. 6. The grid-voltage, plate-current characteristic of the tube is shown to resemble a step function. At a negative value of grid voltage, the plate current cuts off sharply and is zero for more negative grid potentials. If the grid voltage is increased, the plate current rises from 10 to 90% of saturation for a change of the order of 2 to 3 volts. For more positive grid potentials the plate current saturates. The grid current begins to flow at a slightly negative grid potential, and increases to a saturation level at a small, positive grid voltage.

6BN6 increases, as it will with stronger signals, sufficient grid current is drawn to readjust the grid bias for proper clipping of the increased composite video.

A rough analysis of the simplification of the sync circuit by using the 6BN6 is shown by the following chart. The 6BN6 circuit has proved to be more immune to impulse noise than the conventional circuit. The conventional circuit as shown is more capable of handling low-frequency distortion and hum modulation of the composite video by virtue of the DC re-insertion in the grid of the third tube function, Fig. 5A. This characteristic is desirable in circuits employing short time-constant, gated automatic gain control wherein the gating signal comes from the synchronized horizontal scanning circuit. When the horizontal oscillator is out of synchronization, the au-

## RADIO RELAYS VS. WIRES

(Continued from page 27)

expanded studies since that time indicate that single-sideband sub-carrier on a phase-modulated radio link is in many cases the preferred method of radio-relay multiplexing, considering first cost, maintenance, power requirement, flexibility and reliability.

### Cost of Relays vs. Wires:

In order to illustrate the order of magnitude of costs involved in systems of the type to be described, the accompanying table was prepared to show approximate costs for systems having from one to seven channels and from one to six links.

(Concluded on page 32)



# HAMMARLUND: *Perfected System of* SELECTIVE CALLING

**Approved**—Approved by manufacturers and users because it is technically sound and has been successfully field tested over a period of years.

**Specified**—Specified by leading manufacturers of two-way radio for all of their selective calling applications because of guaranteed customer satisfaction.

**Used**—Used in large and exacting installations because of its economy, versatility, and reliability.

**Available**—Available to fill your needs for privacy, speed, safety, and convenience. Add it to your existing system or specify it for your new systems.

**RCA**—Business and Professional Telephone Exchange, Los Angeles, Cal. 2 Hammarlund SCPB Push Button Central Station Coders and 20 SCM-30 Mobile Control Unit, Audio Mute Type.

**LINK**—Republic of Cuba National Police, Havana, Cuba. 1 Hammarlund SCPB Push Button Central Station Coder, 3 SCF-30-C Dial Central Station Coders and 50 SCM-30-T Mobile Control Units, Bell Ringer Telephone Type.

**G. E.**—Philadelphia Suburban Transit Company, Philadelphia, Pa. 1 Hammarlund SCF-30-C Dial Central Station Coder and 25 SCM-30-T, Bell Ringer Telephone Type.

**PHILCO**—Geneva Telephone Company, Geneva, Ohio. 1 Hammarlund SCF-30-C Dial Central Station Coder and 10 SCM-30-T, Bell Ringer Telephone Type.

**MOTOROLA**—Greenwood Telephone Company, Greenwood, N. Car. 1 Hammarlund SCF-30-C Dial Central Station and 25 SCM-30, Mobile Control Units, Audio Mute Type.

**LINK**—City of Saint Paul Police and Fire Departments. 2 Hammarlund SCPB Push Button Central Station Coders and 80 SCM-30-T Mobile Control Units, Bell Ringer Telephone Type.

**RCA**—State of Pennsylvania Flood Control. 1 Hammarlund SCF-30-C Dial Central Station Coder and 24 SCM-30-T Mobile Control Units, Bell Ringer Telephone Type.

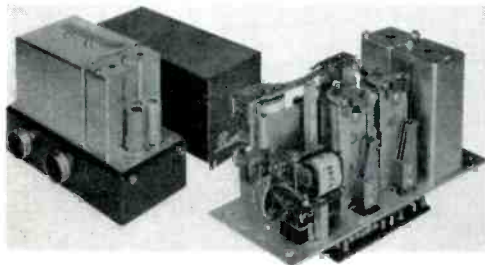

Inquiries are invited on radio, carrier or land line control requirements. Systems for remote supervisory control, radio telemetering and fault alarms for microwave relays supplied to your specification needs.

## HAMMARLUND MFG. COMPANY, INC.

460 West Thirty-fourth Street, New York 1, N. Y.

March 1950—formerly FM, and FM RADIO-ELECTRONICS

**INSURE**  
*Proven Quality*  
with **JONES**  
**PLUGS & SOCKETS**

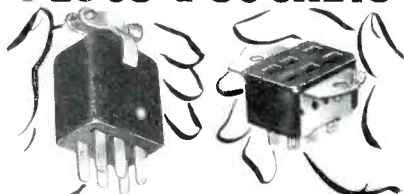

P-306-CCT — Plug,  
Cable Clamp in cap.

S-306-AB — Socket  
with Angle Brackets.

**Series 300 Small Plugs & Sockets for 1001 Uses**

Made in 2 to 33 contacts for 45 volts, 5 amps, for cap or panel mounting. Higher ratings where circuits permit. All plugs and sockets polarized. Knife switch socket contacts phosphor bronze, cadmium plated. Engage both sides of flat plug—double contact area. Bar type plug contacts hard brass cadmium plated. Body molded bakelite.

Get full details in Catalog 17. Complete Jones line of Electrical Connecting Devices, Plugs, Sockets, Terminal Strips. Write today.

**HOWARD B. JONES DIVISION**  
CINCINNATI MANUFACTURING CORPORATION  
CHICAGO 24, ILLINOIS  
SUBSIDIARY OF UNITED-CARR FASTENER CORP.

**RADIO RELAYS VS. WIRES**

(Continued from page 30)

These figures are given only as representative costs to indicate factually the low cost of radio channels compared to physical wire circuits. A recent analysis by the United States Independent Telephone Association shows that the current cost for a single-channel pole line is approximately \$878 per mile, and for a three-channel pole line is \$1,080 per mile or \$360 per channel mile. Current maintenance expense for the single-channel line is given as roughly \$46 per mile, and for the three-channel line as \$66 per mile or \$22 per channel mile.

The table shows approximate costs in dollars for all equipment including radio equipment, channeling equipment, antennas, transmission line and towers but not including the land and buildings. The availability of 115-volt AC or 24-volt DC power at each point is assumed. The table is based on presently available equipment operating below 450 mc. At higher frequencies, costs per mile are progressively higher because of increased costs of radio equipment, the necessity for higher towers, and the shorter jumps required between the transmitters.

**BIG-PICTURE QUALITY**

(Continued from page 13)

Foster-Seelye discriminator with an overall bandwidth of 250 kc. This is wide enough for full modulation from standard, wide-band FM broadcasts. A bass-compensated volume-control precedes a 12AU7 audio-amplifier and cathode-follower output with a 500 ohm output impedance, capable of delivering up to 3 volts at less than 1 per cent distortion over a range of 20 to 20,000 cps.

**Custom Installations:**

Many requirements are imposed by the variations necessary for custom installations. For example, in order to accommodate some installations, the picture tube mounting assembly has been designed as a complete unit, removable from the chassis by simply unplugging the electrical connectors and removing five machine screws. This mounting is also adjustable to accept all available types of 16-in. or 19-in. metal or glass picture tubes. Especially necessary for wall installation is easy access to the secondary controls, made possible by their location on the chassis front, immediately behind a removable escutcheon plate for the tuning controls.

Also necessary for installation in wall enclosures is low heat dissipation which, in this chassis, has been minimized by the low power consumption of 175 watts, roughly one-half of the usual big-set re-

(Concluded on page 33)

**HIGH FIDELITY**  
AM • AM-FM  
**TUNING**  
WITH  
*Approved*  
**PRODUCTS**

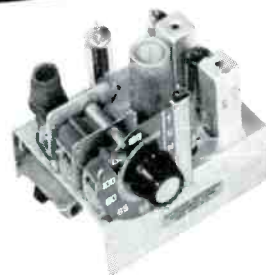

**MODEL**  
A-600  
(AC-DC)  
ONLY  
**\$12.85**

**BROADCAST SUPERHET TUNER**

Tubes used are as follows:  
1 — 12BE6 — Converter; 1 — 12BA6 — High gain IF stage; 1 — 12AT6 — Diode detector, and 1st audio; 1 — 35W4 — Rectifier.  
Permeability tuned IF transformers. Approximately 10 Volts audio output (high impedance). Maximum output adjustable in 3 steps or 10 volts, 5 volts, 1 volt. Self contained 115 Volts AC-DC power supply. Air tested and aligned. Output cable 2 1/2 feet shielded. Attached 5 ft. antenna. Size 4 x 4 x 5". APPLICATIONS: Public Address Systems, Record players, Wire Recorders, etc.

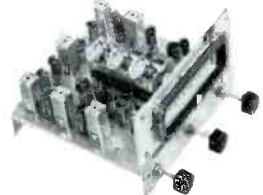

**MODEL**  
A-710  
FM-AM  
TUNER  
**\$57.50**

For the first time in radio history, there is really available a high quality FM-AM tuner, designed for drift-free, realistic high fidelity reception AT A PRICE THAT PLACES IT WITHIN EASY REACH OF THE CUSTOM BUILDER, SERVICEMAN, MANUFACTURER, EXPERIMENTER, ETC.

**12-TUBE MINIATURE FM-AM TUNER**  
TUBES USED ON FM: 1 — 6AG5 RF Amplifier; 1 — 6BE6 Mixer-Detector; 1 — 6J6 Oscillator; 1 — 6AU6 IF Amplifier; 1 — 6AU6 IF Amplifier; 1 — 6AU6 Limiter; 1 — 6AU6 Limiter; 1 — 6AL5 Discriminator. TUBES USED ON AM: 1 — 6BA6 RF Amplifier; 1 — 6BE6 Converter; 1 — 6BA6 IF Amplifier; 1 — 6AT6 Diode (audio amplifier common to AM-FM).

Chassis dimensions: 8 1/2" x 5 3/8" high, 8" deep. Net weight: 5 1/2 lbs. Power requirements: 170 V DC 20 MILS and/or 140 V DC 37 MIL. 6.3 V. 4 AMP.  
Write Dept. F for New 1950 Edition 12-Page Catalogue & Jobber Net Prices

**APPROVED ELECTRONIC INSTRUMENT CORP.**

142 Liberty St., Dept. P  
New York 6, N. Y.

**Get both FREE**  
1. NEW BOOK ON  
**CUSTOM HIGH FIDELITY**  
RADIO PHONOGRAPHS



"High-Fidelity Guide"  
prepared by David Randolph,  
noted Musicologist and Music  
Consultant for Lafayette  
Radio and by the Lafayette  
Technical Staff.

"The best collection of ideas for professional builders of custom radio and phonograph installations we have seen so far" — says FM-TV Magazine.

2. New 1950 LAFAYETTE CATALOG  
The most famous catalog in the field for 29 years. 164 pages filled with "everything in radio" including these well-known makes of high-fidelity equipment: Altec-Lansing, Bell Bogen, Brook, Browning, Cinaudagraph, Espey, G. E., Hallicrafters, Jensen, Lafayette, Leak, Masco, Meissner, National, Pickering, RCA, Radio Craftsmen, Scott, Stephens, Thornderson, UTC, University, Webster-Chicago and many others.



**Lafayette**  
RADIO

100 Sixth Avenue, New York 13, N. Y.  
901 W. Jackson Blvd., Chicago 7, Ill.

Mail the Coupon NOW to Get Both Books FREE

LAFAYETTE RADIO, Dept. HC-50  
100 Sixth Avenue, New York 13  
or 901 W. Jackson Blvd., Chicago 7

Rush me FREE copy of  
 New "High Fidelity Guide"  
 1950 Lafayette Catalog. (Please do not request if you have already received a copy.)

Name .....  
Address .....  
City ..... Zone ..... State .....

PASTE ON PENNY POSTCARD



## BIG-PICTURE QUALITY

(Continued from page 32)

quirements. This simplifies the ventilation problem. One means for accomplishing this is the use of selenium rectifiers in a bridge circuit to supply 350 volts at 140 milliamperes, in addition to 175 volts at 180 milliamperes from a full-wave connection available at the center tap of the power transformer secondary. Also contributing to low power consumption is the use of a combination PM-EM focusing unit which also gives excellent regulation of focus with variation in line-voltage.

Interconnections with other audio equipment are provided by the audio output receptacle and switched AC power outlet for direct connection to any audio system. The low output impedance permits long-line connection to remote units.

## CONTINUOUS TV TUNING

(Continued from page 11)

just the circuits for the lower end of the band. The end-inductors are in the form of a silver-plated loop or "trombone" with an adjustable bridge. They can be seen at the center of Fig. 8.

The oscillator circuit requires the most careful choice of components and method of mounting to assure stability with change of temperature, and to provide correct compensation for frequency drift with temperature. Ceramic posts are used to mount the components rigidly, and the oscillator tube socket is of the ceramic type. The drift of oscillator frequency from its value at room temperature to its stable value after a temperature rise of 45° C. is less than 100 kc. at any point in the tuning range. This order of stability is required to preclude the necessity of retuning the sound channel after initial warm-up of the receiver. Components of the oscillator circuit can be seen in the lower right hand corner of Fig. 8. The oscillator tuned circuit comprises variable inductor L2D with series end inductor L8 and shunt inductor L7, this combination being resonated by adjustable capacitor C10. L7 serves as the tracking element to reduce the oscillator range with respect to the tuned input circuit range. End-inductor L8 is used to adjust the high-frequency end of the range, while capacitor C10 is for the low-frequency end.

The various alignment and tracking adjustments described are performed only in manufacture of the unit. Readjustment in the field is not necessary or desirable.

Over a half million television receivers employing the Inductuner are in use. The reliability and trouble free record of these sets attest the soundness of its design.

# IMMEDIATE DELIVERY!

No delays — Same-day shipment from stock on these essential, precision-type television test instruments



APPROVED ELECTRONICS MODEL A-460  
FIELD STRENGTH METER.  
NET PRICE **\$79.50**

## SWEEP SIGNAL GENERATOR

Clever and conservative design has provided all essential features for precision TV alignment. Frequency range 2 to 60 mc., 20 to 120 mc., and 168 to 227 mc. without switching. Sweep frequency of 60 cycles, variable in width from 0 to 12 mc. Internal marker, 5 to 250 mc., eliminates need of extra generator. Ample output for stage-by-stage alignment. Tubes: 6J6 variable oscillator, 6J6 fixed oscillator, 6AU6 mixer, 6C4 cathode-follower, 6C4 variable marker oscillator, 6C4 crystal oscillator, 7Y4 rectifier. Built-in power supply for 115 volts, 60 cycles.



APPROVED ELECTRONICS MODEL A-400  
SWEEP SIGNAL GENERATOR.  
NET PRICE **\$79.50**



APPROVED ELECTRONICS MODEL A-450  
MARKER GENERATOR.  
NET PRICE **\$59.50**

## MARKER GENERATOR

A precision oscillator to provide modulated or unmodulated markers, when used with a sweep generator and scope. The tunable oscillator, crystal oscillator, or both spot audio and video pips for checking bandwidth, and locating sound or adjacent-channel traps. With a 4.5-mc. crystal, inter-carrier systems can be aligned. Tubes: 6C4 variable oscillator, 6AU6 mixer, 6C4 cathode follower, 6SJ7 AF oscillator, 6C4 crystal oscillator, 6C4 AF buffer amplifier, VR150 regulator, 7Y4 rectifier. Built-in power supply for 115 volts, 60 cycles.

You Can Be Certain That Any Of These Instruments Will Be Shipped The Day Your Order Is Received

**GENERAL APPARATUS CO.**  
SOUTH EGREMONT, MASSACHUSETTS

## ACKNOWLEDGED STANDARD OF FM PERFORMANCE

# Customers Who Require the Finest FM Receiver Performance

**W**HEN you buy an ordinary radio set, you take it for granted that the butcher, the baker, and perhaps the candlestick maker may have exactly the same make and model.

But when you make up your mind that you aren't going to be satisfied with anything less than the superlative performance of an REL 646-B FM receiver, it may occur to you to wonder who else has bought sets of this type.

There's no secret about the purchasers of this model. Here are the names of a few customers, taken from recent sales records:

Mary Hardin-Baylor College  
Belton, Texas

Paramount Pictures, Inc.  
New York City

Radio Station WJER  
Dover, Ohio

Sanford Laboratory Products  
New York City

Presto Recording Corp.  
Hackensack, N. J.

Skyland Broadcasting Corp.  
Dayton, Ohio

Radio Station WMMW  
Meriden, Conn.

Radio Station WPAQ  
Mount Airy, N. C.

Sonograph Corp.  
New York City

A great number go to dealers who handle custom-built installations. Our sales records don't show the names of these owners, but we have become acquainted with many of them through letters telling how surprised and delighted they are to discover the completely new kind of radio entertainment that the REL model 646-B provides. And they have the added satisfaction of owning the same type of receiver selected by broadcast stations and laboratories which require the finest performance, regardless of price.

Production on the 646-B is now at a level where we can ship orders within 48 hours. Not every dealer can handle

this model, of course. But many can. Quite a number are doing so very successfully right now. These are dealers who are experienced in custom work. They know how to mount and install speakers, turntables, and tape recorders which are generally specified in 646-B installations. Also, they know how to put up FM antennas.

If you are handling business of this sort, write for technical data on the 646-B, and information as to the trade discount. You'll find it an exciting experience to demonstrate and sell an FM receiver of such distinctive performance that listeners exclaim: "I had no idea that radio reception could sound like that!"



**\$345** WITH 19-IN. RACK PANEL, OR IN METAL CABINET, AS ILLUSTRATED



**RADIO ENGINEERING LABORATORIES, Inc.**

35-54 36th STREET,  
LONG ISLAND CITY 1, N. Y.



# ZOPHAR



## WAXES COMPOUNDS and EMULSIONS

FOR  
INSULATING and WATERPROOFING  
of ELECTRICAL and  
RADIO COMPONENTS

Also for  
CONTAINERS and PAPER  
IMPREGNATION

FUNGUS RESISTANT WAXES

ZOPHAR WAXES and COMPOUNDS  
Meet all army and navy  
specifications if required

Inquiries Invited

**ZOPHAR MILLS, INC.**  
FOUNDED 1846  
122-26th ST., BROOKLYN, N. Y.

## BACK ISSUES OF FM-TV

Here is your opportunity to complete your files. The following issues are available at 25c each, postpaid:

- 1940: sold out
- 1941: except Feb. issue
- 1942: all issues available
- 1943: all issues available
- 1944: except Jan. & Feb.
- 1945: except Nov.
- 1946: except June
- 1947: all issues available
- 1948: except Jan.
- 1949: all issues available

There are only two or three copies of some months. If any issue is sold out, your remittance will be returned.

**FM-TV Magazine**  
Great Barrington, Mass.

## Advertisers' Index

Adair, George P. ....	6
Alford, Andrew .....	6
Altec Lansing Corp .....	26, 27
American Phenolic Corp. ....	28
Amy, Aceves & King Co., Inc. ....	6
Andrew Corp .....	7
Approved Electronics Inst. Corp....	32
Bell Telephone Labs. ....	25
Bliley Electric Co. ....	5
Browning Radio Labs., Inc. ....	Inside Back Cover
Davis, George C. ....	6
Du Mont Laboratories .....	1
Eitel-McCullough, Inc. ....	36
FM-TV .....	35
General Apparatus Co. ....	33
General Radio Co....	Inside Front Cover
Hammarlund Mfg. Co., Inc. ....	31
Heimark, Harold M. ....	7
Jansky & Bailey .....	6
Jones, Howard B., Division .....	32
Kear & Kennedy .....	6
Klipsch and Associates .....	7
Link Radio Corp. ....	4
Maurer, Inc., J. A. ....	7, 8
May, Russell P. ....	7
McIntosh & Inglis .....	6
McNary & Wrathall .....	6
Measurements Corp. ....	7, 35
Motorola, Inc. ....	Back Cover
Pollack, Dale .....	6
Radiart Corp .....	3
Radio Engineering Labs. ....	34
Radio Wire Television, Inc .....	32
Rangertone, Inc. ....	7
Ray, Garo W. ....	6
Smeby, Lynne C. ....	6
Sun Radio & Electronics Co., Inc....	27
Superior Electric Co. ....	28
Topflight Tape Co. ....	7
Weldon & Carr .....	7
Wilmotte, Raymond M. ....	7
Workshop Associates, Inc. ....	7
Zenith Radio Corp. ....	2
Zophar Mills .....	35

## MEASUREMENTS CORPORATION Model 59

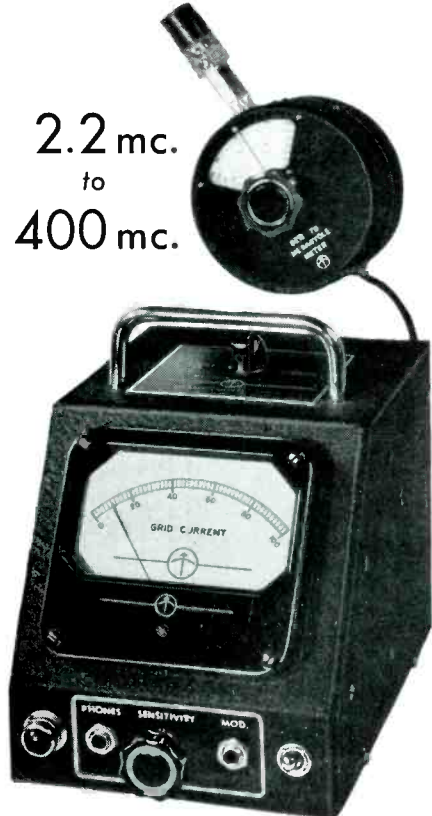

2.2 mc.  
to  
400 mc.

## MEGACYCLE METER

Radio's newest, multi-purpose instrument consisting of a grid-dip oscillator connected to its power supply by a flexible cord.

Check these applications:

- For determining the resonant frequency of tuned circuits, antennas, transmission lines, by-pass condensers, chokes, coils.
- For measuring capacitance, inductance, Q, mutual inductance.
- For preliminary tracking and alignment of receivers.
- As an auxiliary signal generator; modulated or unmodulated.
- For antenna tuning and transmitter neutralizing, power off.
- For locating parasitic circuits and spurious resonances.
- As a low sensitivity receiver for signal tracing.

### TELEVISION INTERFERENCE

The Model 59 will enable you to make efficient traps and filters for the elimination of most TV interference.

Write for Special  
Data Sheet. 59TV1

**SPECIFICATIONS:**  
Power Unit: 5 1/8" wide;  
6 1/8" high; 7 1/2" deep.  
Oscillator Unit: 3 3/4"  
diameter; 2" deep.

**FREQUENCY:**  
2.2 mc. to 400 mc.;  
seven plug-in coils.

**MODULATION:**  
CW or 120 cycles; or  
external.

**POWER SUPPLY:**  
110-120 volts, 50-60  
cycles; 20 watts.

**MEASUREMENTS CORPORATION**  
BOONTON NEW JERSEY

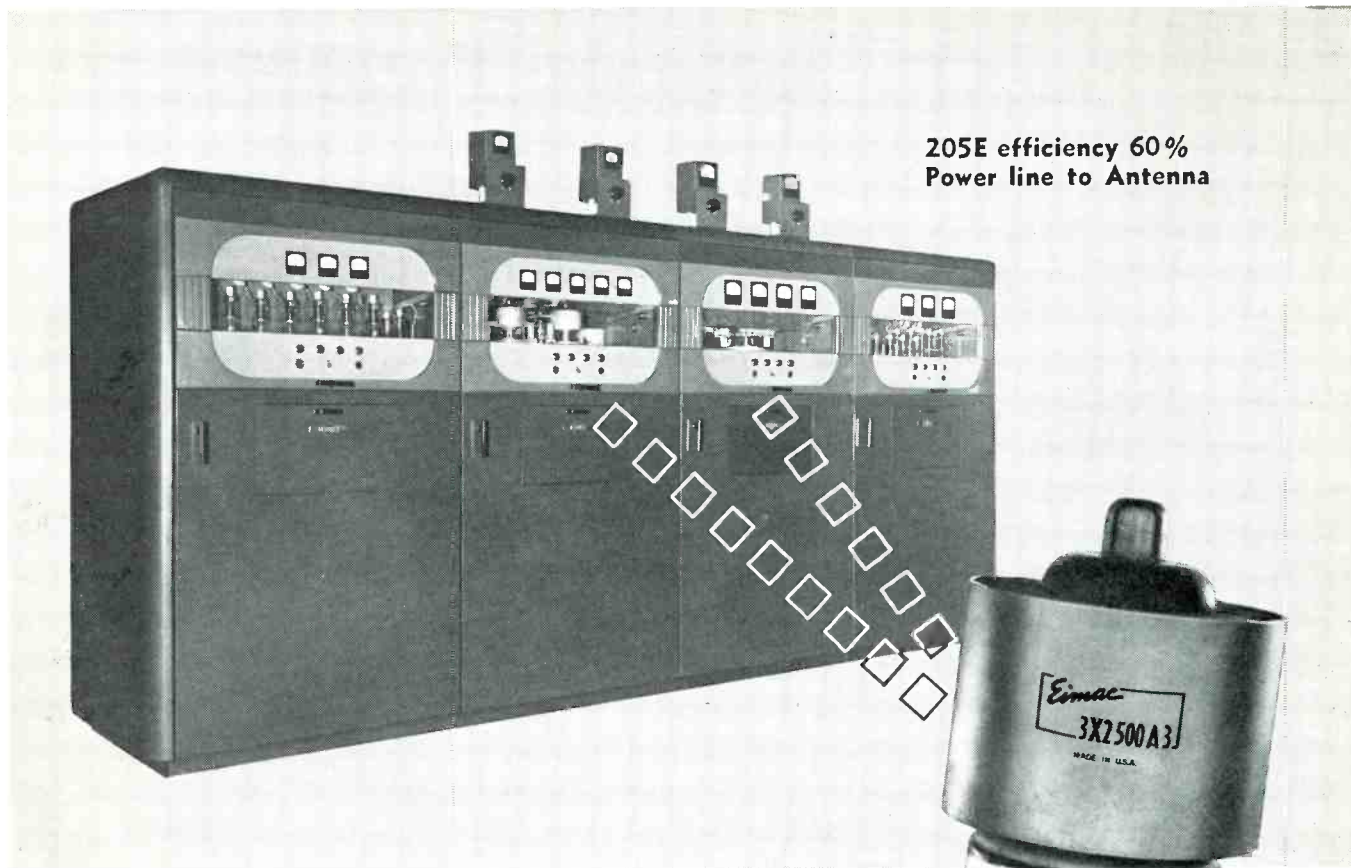

## EIMAC TUBES CHOSEN FOR COLLINS' 50 KW CW TRANSMITTER

CW communications transmitter type 205E is an outstanding example of engineering craftsmanship by Collins Radio. Designed for military and civilian service between 4 and 26 Mc. the 205E will provide 50 kw CW output with remarkable economy from the standpoint of both power consumption and tube cost.

**Overall efficiency of the transmitter through all stages, from the 230 volt power line to the antenna, is 55% to 60%.**

Collins engineers say, "We can attribute the largest percentage of this performance to our use of Eimac tubes. The 3X2500A3 triodes operate with low filament-power, and their high power-gain and high efficiency permit economical exciting equipment. Further power saving is effected because of the simple air-cooling requirement."

You, too, can take advantage of Eimac tubes' functional design, economical operation, and higher performance.

Complete catalogues covering operational data and characteristics on all Eimac tubes are available without charge . . . write today.

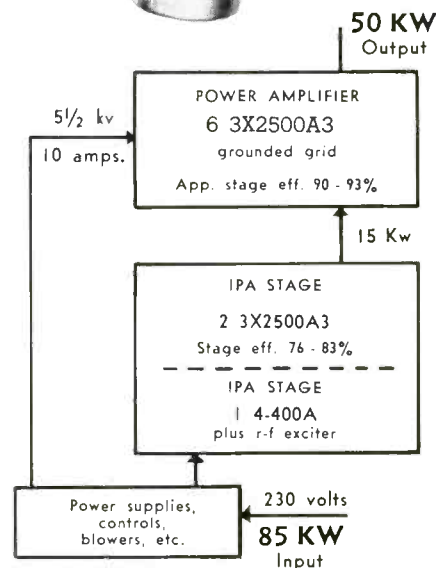

**EITEL-McCULLOUGH, INC.**  
San Bruno, California

Export Agents: Frazar & Hansen, 301 Clay St., San Francisco, California

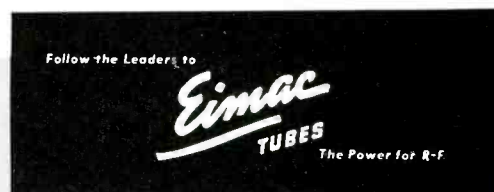



*... for the best reception of both FM and AM*



#### **BROWNING RV-10 FM TUNER**

High-sensitivity FM reception can be added easily to any AM receiver. The moderately-priced BROWNING RV-10 tuner is designed for that purpose. A tuned RF stage with an Armstrong dual limiter and discriminator produce complete noise limiting with signals of less than 10 micro-volts. This is the same FM section as in the RJ-12A and RJ-20. Controls: phono switch, radio-phono volume, and tuning. Tubes: three 6AU6, one 7F8, two 6SJ7, one 6H6, one 5Y3 rectifier, and 6AL7 tuning eye. As illustrated, or on a 19-inch rack panel.

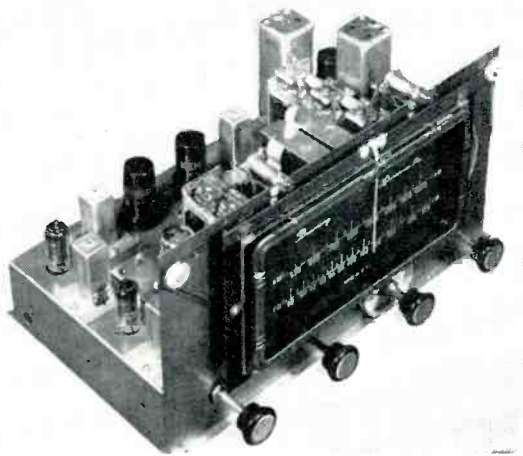

#### **BROWNING RJ-12A FM-AM TUNER**

This model combines high-sensitivity FM reception from an Armstrong circuit that limits noise completely on signals of less than 10 microvolts, with the best reception of AM broadcasting. FM and AM circuits are completely separate. FM audio response is flat within 1½ db from 20 to 15,000 cycles. No drift after 2-minute warming. AM is flat within 3 db from 20 to 6,600 cycles. Front phono switch and combined radio-phono volume control. Tubes: three 6AU6, one 7F8, one 6SK7, one 6SG7, two 6SJ7, one 6H6, one 6SA7, one 1N34 detector, one 6AL7 tuning eye. Operates from separate PF12 power supply with one 5Y3GT. As illustrated, or on a 19-in. rack panel.

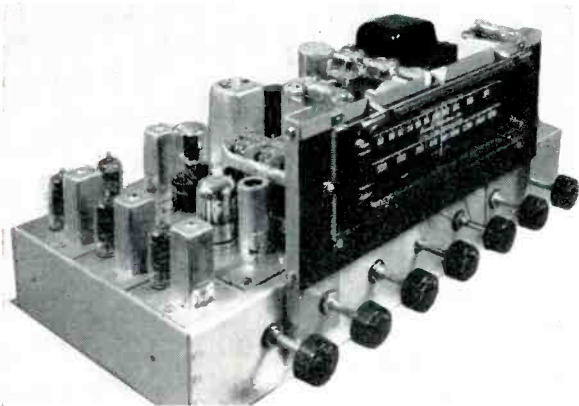

#### **BROWNING RJ-20 FM-AM TUNER**

The RJ-20 is intended particularly for those who require superlative reproduction quality on both radio and records. Armstrong circuits, incorporating every refinement, deliver the full promise of FM's interference-free performance with maximum receiving range. Variable IF bandwidth allows AM selectivity adjustment from 4 to 9 kc. A 2-stage audio system is built in to provide separate treble and bass boost up to 20 db for record reproduction. Tubes: Five 6AU6, one 7F8, one 6SG7, one 6SA7, one 6SK7, two 6AL5, one 6NS7, 6AL7 tuning eye, 5Y3GT rectifier. As illustrated, or on a 19-in. rack panel.

*For Complete Technical Data on These FM and FM-AM Tuners, Address:*

**BROWNING LABORATORIES, Inc.**

700 Main Street, Winchester, Massachusetts

# MOTOROLA "RESEARCH" LINE OF F.M. 2-WAY RADIO

# Chosen again

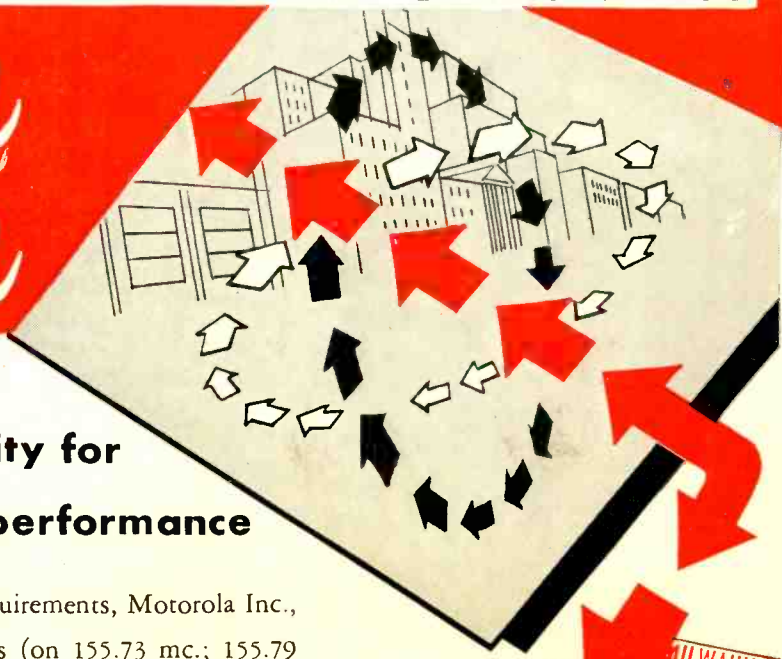

and again by city after city for  
superior adjacent channel performance

**TYPICAL REPORT:** "In compliance with test requirements, Motorola Inc., installed three 250-watt fixed station transmitters (on 155.73 mc.; 155.79 mc.; 155.85 mc.). The Motorola mobile equipment selected the 155.73 mc. station in all conditions with good results. No reception of the adjacent channel station was noted even when the mobile unit was operated in the immediate vicinity of the other transmitter."

- MILWAUKEE
  - ROCHESTER
  - CITY OF MEMPHIS
  - LAKE COUNTY
  - VALLEJO, CAL.
  - ILLINOIS
  - CITY OF BUFFALO
- REPORT (CONTINUED)

## "RESEARCH" LINE OF F.M. 2-WAY RADIO

with revolutionary new developments engineered at Motorola—the World's largest laboratories devoted exclusively to the development of radio communications systems—specialists in this field for over twenty years.

COMPARE Motorola with any other equipment. Write today for complete details.

### protection

... of your long-term investment. PROTECTION against obsolescence for many years to come.

Specify Motorola "Research" Line for permanence in FM 2-way radio operation.

GOOD  
POLICY



# Motorola