



AND TELEVISION

DEC. 1947

★ ★ Edited by Milton B. Sleeper ★ ★



N. Y. — BOSTON FM RELAY
CARRIES TELEVISION PROGRAMS

(See pages 3 and 36)

**From this package
come the finest recordings
in the world**

Presto

GREEN LABEL DISCS

You have heard about Presto Brown Label discs. They're one-side perfect . . . with a flaw on the other side you probably couldn't find. Perfect for one-side recordings, reference recordings and tests, and at greatly reduced cost.

FREE! Presto will send you free of charge a complete bibliography of all technical and engineering articles on disc recording published since 1921. Send us a post card. Address Dept. A.



RECORDING CORPORATION
242 WEST 55TH STREET
NEW YORK 19, N. Y.



THE NATIONAL EMBLEM ON PARTS IS YOUR GUARANTEE OF QUALITY

For over 25 years, hams, engineers and radio technicians have agreed that National parts were thoroughly reliable in manufacture and performance.

That reputation is your guarantee of quality when ordering National parts for new equipment.

If you need parts that will fit as they're supposed to, that will give you long hard service, then National's your best bet — as any radio veteran can tell you.

Send today for your copy of the new 1947 National catalog, containing over 600 parts.



Type AR-16 (Air-Spaced) Exciter Coils and Forms

These air-spaced coils are suitable for use in stages where the plate input does not exceed 50 watts and are available for the 6, 10, 20, 40 and 80 meter bands. All have separate link coupling coils and all include the PB-16 plug, which fits the XB-16 Socket.

AR-16 Coils, End Link, Center Link or Swinging Link.
Net price.....\$1.15 (Include PB-16 Plug)
PB-16, Plug in Base Only.....Net price...\$.27
XB-16, Plug-in Socket Only.....Net price...\$.33

The HRT is a new plastic tuning knob with a chrome plated appearance circle. The HRT knob fits a 1/4" diameter shaft and is 2 1/8" in diameter. Available in Black or Gray.

HRT Knob...Net price...\$.75



The HRS Knobs are a new series of plastic knobs with a 1 1/8" diameter chrome-plated skirt. They all fit 1/4" diameter shafts. Three types are available in Black or Gray.



HRS-1 Knob...ON-OFF through 30° rotation.....Net price.....\$.51
HRS-2 Knob...5-0-5 through 180° rotation.....Net price.....\$.51
HRS-3 Knob...0-10 through 300° rotation.....Net price.....\$.51

National Company, Inc. Malden, Mass.

Please write to Department 14
National Company, for further information

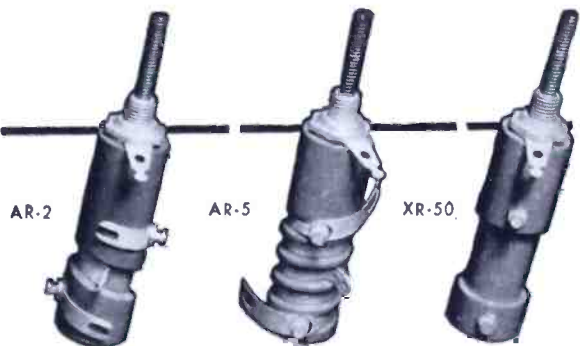

The AR-2 and AR-5 coils are high Q permeability tuned RF coils. The AR-2 coil tunes from 75 mc to 220 mc and the AR-5 coil tunes from 37 mc to 110 mc with suitable capacitors.

XR-50 coil forms may be wound as desired to provide a permeability tuned coil. The form winding length is 11/16" and the form winding diameter is 1/2". The iron slug is 3/8" diameter by 1/2" long.

AR-2 High Frequency Coil.....Net price.....\$1.71
AR-5 High Frequency Coil.....Net price.....\$1.46
XR-50.....Net price.....\$1.01

MAKERS OF LIFETIME RADIO EQUIPMENT

READY NOW

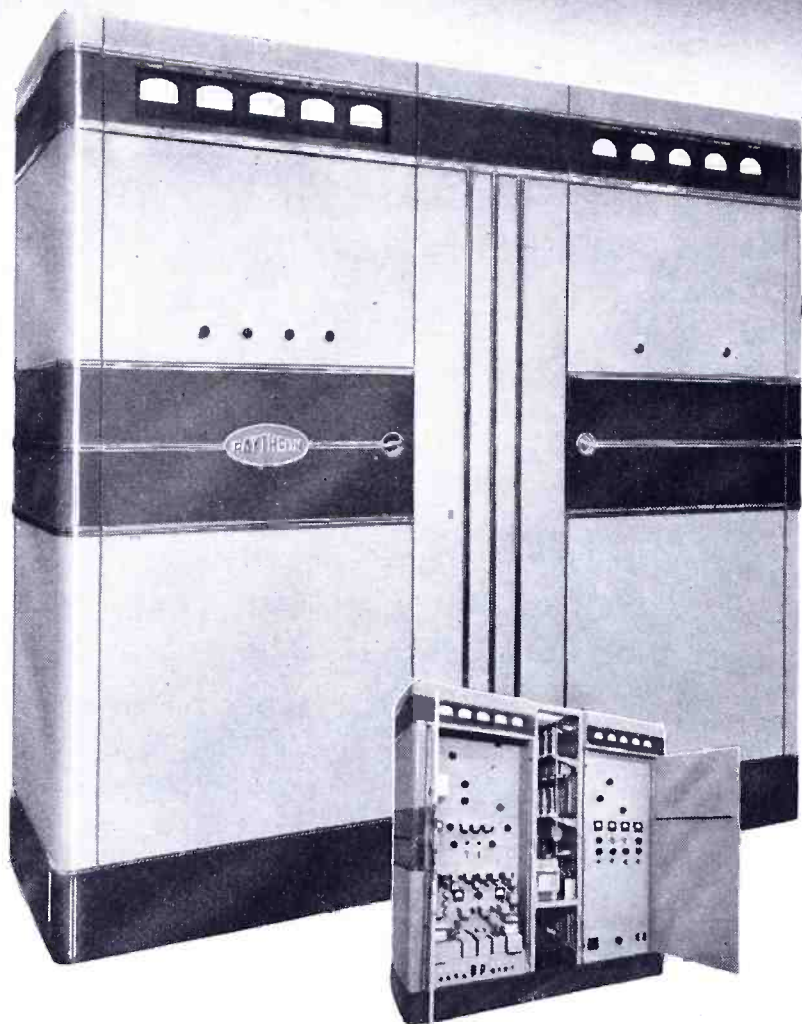

Front view shows arrangement of controls for tuning driver and amplifier. Center lift-off panel has been removed to show accessibility of power supply.

It's a RAYTHEON *Responsibility*

Backed by Raytheon's *complete* manufacturing and service facilities . . . when you specify *Raytheon* not only for FM or AM transmitters but for speech input and station equipment — you are teaming up with Raytheon's huge organization devoted to research and manufacture for the Broadcast Industry.

Look ahead with RAYTHEON

Raytheon's *Integrated Design* Policy lets your station grow with the industry. Start as low as 250 watts . . . step it up with the new 3KW-FM Amplifier and Transmitter . . . use it later as a driver for a 10 KW unit. You're set for the future with no fear of obsolescence.

Write today for complete information and technical details

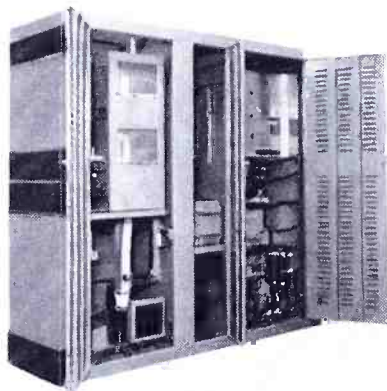

Rear view showing accessibility of chassis, terminal boards, etc.

A New **3 KW-FM** TRANSMITTER by **RAYTHEON**

Ask WLAW-FM about **RAYTHEON SERVICE**

Marked "OK for shipment" at Raytheon, Waltham, on Thursday, equipment for WLAW's new FM transmitter began feeding programs into their antenna at Burlington, Mass., on Saturday. That's evidence of Raytheon super service made possible by dependable, easy-to-install Raytheon quality equipment.

You'll like its LOOKS

It's clean as a whistle, modern, streamlined — a handsome addition to any up-to-the-minute station. It's true, but hard to believe, that the new Raytheon 3KW-FM Transmitter is the lowest cost reliably made equipment of its class that you can buy.

You'll like its PERFORMANCE

It's easy and quick to tune — requires a minimum of special testing equipment . . . delivers a high quality, stable, hi-fidelity signal . . . operates at an inherently lower noise level. Features *Raytheon* direct crystal control and simplified Cascade Phase Shift Modulation.

You'll like its EASE OF MAINTENANCE

Simple, conservatively rated circuits . . . easy accessibility . . . *the use of standard, readily obtained, easily replaced parts* — make this Raytheon 3KW-FM Transmitter the easiest, most economical equipment to service and operate.



Excellence in Electronics

RAYTHEON MANUFACTURING COMPANY

COMMERCIAL PRODUCTS DIVISION

WALTHAM 54, MASSACHUSETTS

Industrial and Commercial Electronic Equipment, Broadcast Equipment,
Tubes and Accessories

Sales offices: Boston, Chattanooga, Chicago,
Dallas, Los Angeles, New York, Seattle



AND TELEVISION

★ ★ Edited by Milton B. Sleeper ★ ★

FORMERLY, FM MAGAZINE and FM RADIO-ELECTRONICS

VOL. 7

DECEMBER, 1947

NO. 12

COPYRIGHT 1947, Milton B. Sleeper

CONTENTS

WHAT'S NEW THIS MONTH	
Report on 44- to 50-Mc. Hearing.....	4
FM RELAY OUT-PERFORMS COAX	
Milton B. Sleeper.....	15
FM MONITOR HAS COUNTER DISCRIMINATOR	
Charles A. Cady.....	18
AUDIO RANGE CHART	
Voices and 31 Musical Instruments.....	24
TRUCKING COMPANY REPORTS ON FM	
Howard Willett, Jr.....	28
RATIO DETECTORS FOR FM	
Stuart Wm. Seeley.....	26
TELEVISION FIELD EQUIPMENT	
R. J. Smith.....	30
WHAT KPFM IS DOING	
S. Goard.....	33
INDEX OF ARTICLES AND AUTHORS	
Cross Index for January to December, 1947.....	37
SPECIAL DEPARTMENTS	
Telenotes.....	6
Products & Literature.....	8
Spot News Notes.....	22
News Pictures.....	23
Advertisers' Index.....	54

THE COVER DESIGN AND CONTENTS OF FM AND TELEVISION MAGAZINE ARE FULLY PROTECTED BY U. S. COPYRIGHTS, AND MUST NOT BE REPRODUCED IN ANY MANNER OR IN ANY FORM WITHOUT WRITTEN PERMISSION

★ ★ ★ ★ ★

MILTON B. SLEEPER, *Editor and Publisher*

RICHARD H. LEE, *Advertising Manager*
STELLA DUGGAN, *Production Manager*
LILLIAN BENDROSS, *Circulation Manager*
Published by: FM COMPANY

Publication Office: 264 Main St., Great Barrington, Mass. Tel. Great Barrington 500
New York: 511 Fifth Avenue, New York 17, Tel. VA 6-2483

Pasadena: MILO D. PUGH, 35 S. Raymond Ave., Pasadena 1, Calif. Tel. Madison 6272
FM Magazine is issued on the 20th of each month.

Single copies 50¢ — Yearly subscription in the U. S. A. \$5.00; foreign \$6.00. Subscriptions should be sent to FM Company, Great Barrington, Mass., or 511 Fifth Avenue, New York 17, N. Y.

Contributions will be neither acknowledged nor returned unless accompanied by adequate postage, packing, and directions, nor will FM Magazine be responsible for their safe handling in its office or in transit. Payments are made upon acceptance of final manuscripts.



THIS MONTH'S COVER

This month's cover presents the only photograph taken on the memorable occasion, November 13, when Walter S. Gifford, president of AT & T, put in the first official call over the New York-Boston FM relay. With him in this picture are Frank P. Lawrence, left, vice president in charge of long lines, and Carl Whitmore, president of the New York Telephone Company. Cameraman is Robert S. Daniels.

Performance of the relay system was so perfect that television images originating in New York were transmitted to Boston, back to New York, to Boston, and to New York again without loss of picture quality. This was equivalent to transmission over 900 miles, through 31 relays.

Entered as second-class matter, August 22, 1945, at the Post Office, Great Barrington, Mass., under the Act of March 3, 1879. Additional entry at the Post Office, Concord, N. H. Printed in the U. S. A.

MEMBER, AUDIT BUREAU OF CIRCULATIONS



NEW HYPER-MAG LOUD SPEAKERS

featuring the NEW PARABOLIC PROJECTOR coupled with the HYPER-MAG MAGNET

for high quality plus efficient performance

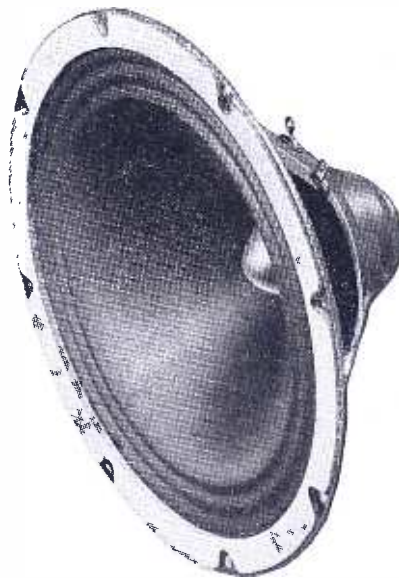

The new RMC Hyper-Mag Speaker represents an outstanding advance in the art of Speaker design and development. The center dome with its parabolic projector, and the special magnet design provides a high quality, efficient unit for FM and wired music installations. The result of many years' research and skillful engineering, the RMC Hyper-Mag Speaker offers a linearity of response from 98 to beyond 8500 cycles and an extremely low distortion. Naturally, RMC quality and fine workmanship are plus advantages.

Write for Speaker Bulletin HS 1

Sold through local jobber

Export: Rocke International Corporation:
13 East 40th Street, New York 16, New York

RADIO-MUSIC CORPORATION

PORT CHESTER

NEW YORK

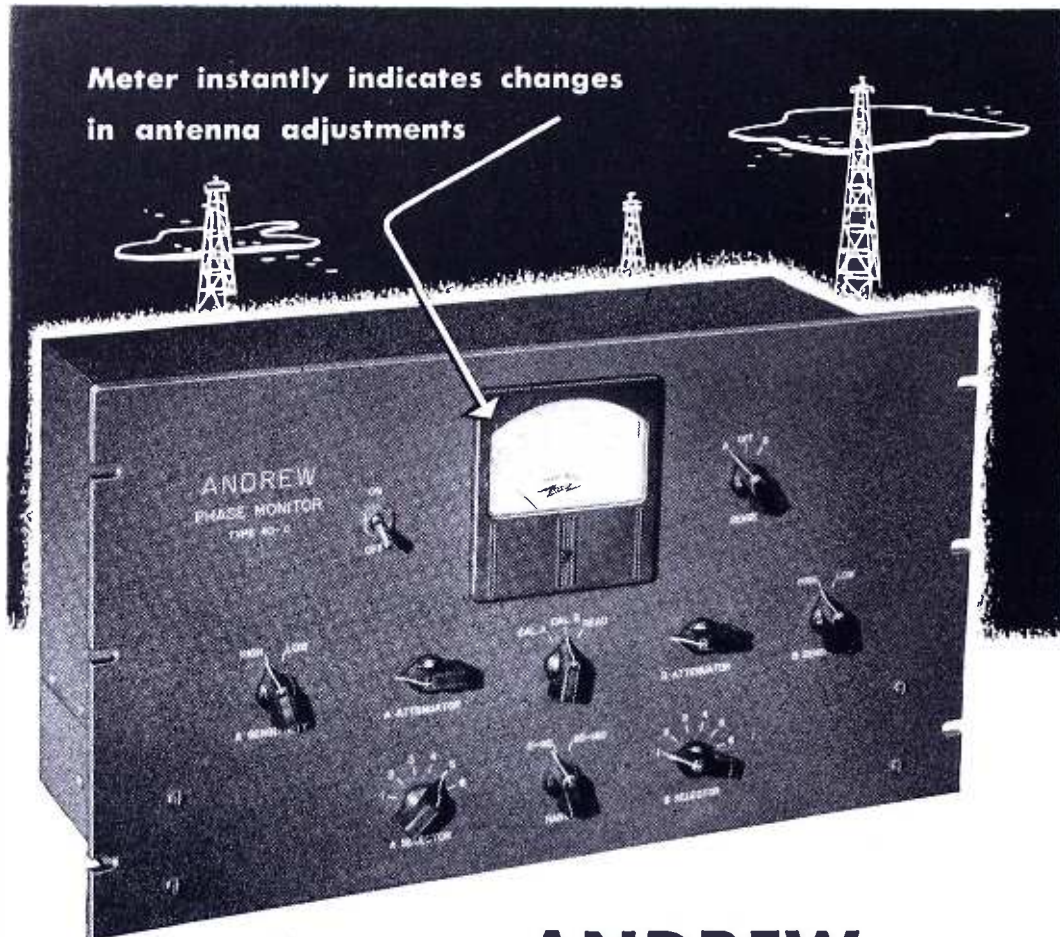

Meter instantly indicates changes
in antenna adjustments

New
MODEL 40-C

ANDREW

PHASE MONITOR

The ANDREW Type 40-C Phase Monitor is a modern, new instrument, designed to facilitate adjustment and maintenance of broadcast directional antenna arrays. Accurately measuring both angle of phase difference and ratio of antenna current amplitude, it provides a quick, direct check on antenna system adjustment.

An exclusive Andrew feature permits measurement of current ratios and phase angles in degrees on a single meter. This affords immediate observation of the effects of small antenna circuit adjustments.

Sensitivity is high—better than one volt from 550 to 1600 KC.

Six individual input circuits accommodate directional systems utilizing as many as six towers.

Write for Bulletin 47 for full details. Prompt placement of your order will assure delivery when needed.

Many stations already have purchased this new Phase Monitor; among them are:

CJCA	KJAY	WBOC	WKBZ
CKCH	KLOU	WBTM	WKOW
KCBC	KOGT	WDEV	WKVM
KCRG	KOLO	WGAD	WRGA
KDSH	KSBW	WGIO	WROW
KFSA	KSEL	WGTM	WRWR
KGFM	KVGB	WHHT	WSAV
KGHI	KVOH	WHIS	WTMC
KGIL	KVVC	WINZ	WVIS
KGNC	KXOA	WJLS	WWOK
KGO	WAGF	WJMS	WWXL
KITO	WBBC	WJRD	



ANDREW CORPORATION

363 EAST 75TH STREET · CHICAGO 19, ILL.

Pioneer Specialists in the Manufacture of a Complete Line of Antenna Equipment

13,503 TV TABLE
10,181 TV CONSOLES & PHONO. COMB.

656 FM CONSOLE
49,319 FM TABLE
100,714 FM PHONO.

SEPT. TOTAL
TV- 23,693
FM- 151,244
AM- 1,827,366

1947 TOTAL
TV- 125,081
FM- 830,016
AM- 13,409,121

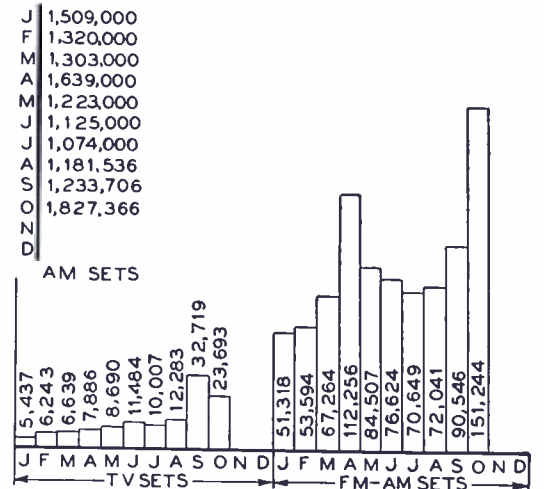

FM, AM, AND TELEVISION PRODUCTION
BAROMETER, BASED ON RMA REPORTS

WHAT'S NEW THIS MONTH

1. 44- TO 50-Mc. HEARING
2. NORTON-ALLEN PAYOFF

1. The FCC hearing on the reallocation¹ of services in the 44- to 50-mc. band, November 17 to 21, was attended in full force by representatives of the communications groups and FM and television broadcasters.

There is no question but what additional channels must be found for the various mobile communications services. New systems are being installed at an astonishing rate. The exact extent of this expansion will be shown next month in our Communications Directory.

Opinions from industry representatives, expressed at the hearing, can be summarized in this manner:

TELEVISION: While television broadcasters are reluctant to give up 44 to 50 mc., now assigned as channel No. 1, they agree that they will be better off to give it up in exchange for eliminating the sharing of channels with communications services.

COMMUNICATIONS: These services are in dire need of additional channels. They agree that the assignment of 44 to 50 mc. will be only a stop-gap measure, since it

¹For table of proposed allocations, see *FM & TV*, Oct. 1947, pg. 18.

(CONTINUED ON PAGE 12)

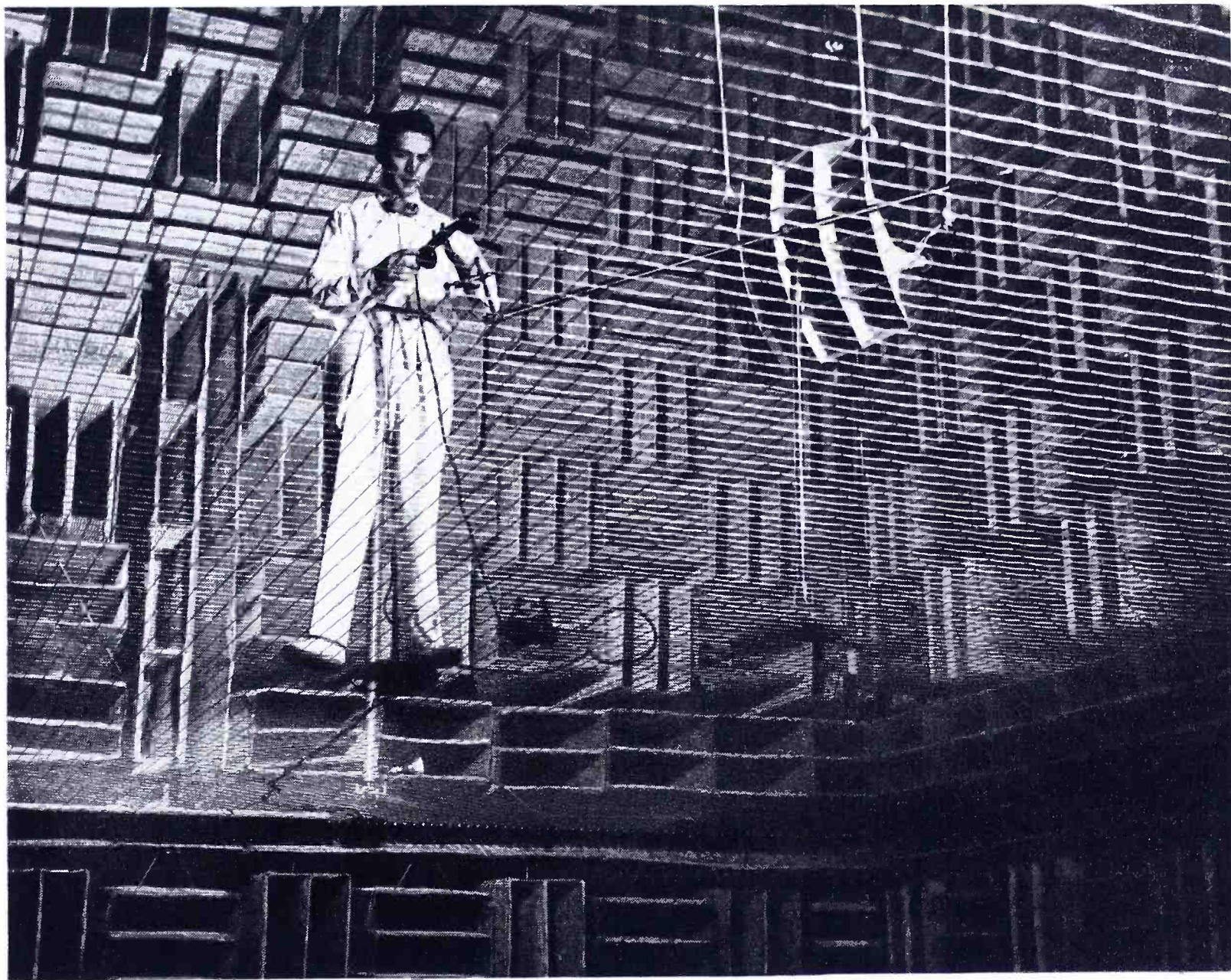

A telephone listens to a loud speaker in the new "free field" acoustic test room at Bell Telephone Laboratories. The sound-transparent "floor" is built of steel cables.

Test-tube for Sound

This giant "test-tube" is actually an echoless sound room at Bell Telephone Laboratories. Here engineers seek new facts about sound which will help them make telephone service still better and more dependable.

Bell scientists know a great deal about what happens to sound in electrical systems. This new room will give them a powerful tool to find out more about what happens to sound in the air.

In an ordinary living room, most of the sound addressed to you comes by way of reflections. At 10 feet less than 10% reaches you directly.

Sound that bounces at you from walls, ceilings, furniture, and your body is all right for hearing—but it poses questions for scientists who would study it uncontaminated by reflections.

The Bell Laboratories "test-tube" gives telephone people the chance to produce pure sound and analyze it reliably with respect to intensity, pitch, and direction. The entire room is lined with glass wool, contained in wire-mesh cases, wedge-shaped to give maximum absorbing area. Sound bounces along the sloping surfaces, sifts into the soft glass wool, and is gradually stifled.

This is one more example of Bell Laboratories' constant work to learn more about everything which can extend and improve telephone service.

BELL TELEPHONE LABORATORIES

Exploring and inventing, devising and perfecting for continued improvements and economies in telephone service.



All Kinds of OPPORTUNITY Now!

The availability of precision production-made facsimile recorders at a low cost by Alden opens all kinds of opportunities. These opportunities are in home broadcasting, emergency fields, communications, impulse recording and experimentation.

The Alden Products Company engineers are receiving unusual praise from all quarters for the simplicity, interchangeability, and precision qualities of the Alden "four." This recorder is producing the most beautiful pictures in black and in the pleasantly toned Sepia paper manufactured for Alden by Alfax Paper and Engineering Company.

The low frequency requirements of the Alden "four" simplifies the problem of operation over ordinary telephone lines and with existing communication sets, making the recorder capable of universal adoption.

In the home recording field, FM stations are ordering this equipment as a promotional means to increase their listening audience and call attention to their FM stations. That this publicity can be effective and accomplished with a small number of machines, programs are planned for the use of recorders located in semi-public places. A portion of the programs are to be over wire circuits and in addition to the small recorder, the same program is transmitted to the master size recorders. On the Master Bulletin type recorder the program appears four times enlarged with four feet of the program visible for easy reading.

In the communication and emergency field it is being found that the Alden "four" is well-suited to work with existing equipment.

In the impulse recording field its simplicity and high speed of recording are catching the imagination of engineers who find they have an inexpensive way of recording phenomena not readily found in the previous types of conventional recording equipment.

We have literally thousands on our mailing list, some of whose interest is speculative and casual; but who tell us they enjoy our mail releases. If you are in this category and wish to be added to the list, please mail a dollar so that you may receive all mailings automatically, including the immediate mailing of "Questions and Answers Regarding Facsimile."



PRODUCTS COMPANY
Brockton 64FM, Massachusetts

TELENOTES

Opportunity: It's still easier to get a television transmitter than to find capable men to operate it.

Philadelphia Conventions: Set manufacturers, under the chairmanship of WFIL's Roger Clipp, have agreed to install receivers in the Commercial Museum next June and July to permit 15,000 to view the Republican and Democratic Conventions.

Low-Priced Set: Motorola is producing a 7-in. television table model, with FM and AM tuning, priced at \$179.95. Switch selects any 8 channels. Also coming is a 10-in. console model.

New York: Daily News has placed orders with RCA for its television transmitter, and with G. E. for studio equipment.

TV Survey: DuMont survey of 64 New York dealers indicates that 63% of the television sets bought in 1948 will be table models, 37% consoles. Of these, 57% will have television only, 21% will have FM and AM tuning also, and 22% will have FM, AM, and record players. Also, survey shows that 61% of the customers will do their buying after 7:00 P.M.

CBS Net: Columbia's WABC-TV is now exchanging programs via coaxial cable with WMAR Baltimore and WMAL-TV Washington. Later, WPEN-TV will be added. According to Leonard Hole, the CBS net will be extended to Boston and on south of Washington when facilities are available.

Philadelphia: Third station, WPEN-TV, should be in operation on channel No. 10 by the end of December.

WRGB: Went commercial on December 1. Rate is \$210 per hour. One-minute features will be accepted as participations in variety programs only, at the 5-minute rate of \$53. Until April, 1948, a 50% discount will be allowed on all time purchased from this station.

Transmitters: RCA has delivered 5-kw. television transmitters to 10 stations. These are WBNW and WMAL Washington, KSD St. Louis, WFIL Philadelphia, WTMJ Milwaukee, WLW Cincinnati, WBZ Boston, KOB Albuquerque, WBEN Buffalo, and WMAR Baltimore. Shipments are now being made at the rate of three a month.

Pittsburgh: Westinghouse Radio Stations has filed an application with the FCC for channel No. 6.



CAN SAVE YOU MONEY

without sacrificing Quality!

DRAKE Lighting Assemblies are specially designed for your requirements. Check up particularly on our new, low cost, compact U.L. approved 110v Light Socket. You've probably never seen one like it. Your engineers will be thankful for its development.

The units illustrated show varied styles of Sockets. Send your prints for specific Mounting Brackets, and electrical characteristics.

MINIATURE SOCKETS



117H



217H

CANDELABRA SOCKETS



409AH



632U-A1
(SINGLE CONTACT)

DECORATIVE AND ILLUMINATING LIGHTING — 110 Volt



A950G Complete with Lamp (Double Contact)

JEWELS AND JEWEL PILOT LIGHTS



Plus
every-
thing
in
between

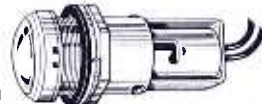

No. 5-6 volt No. 975-110 volt

Delay may be costly. Write us about your needs, today! Ask for our latest Catalog, too.

Socket and Jewel LIGHT ASSEMBLIES

DRAKE
MANUFACTURING CO.
1713 W. HUBBARD ST., CHICAGO 22

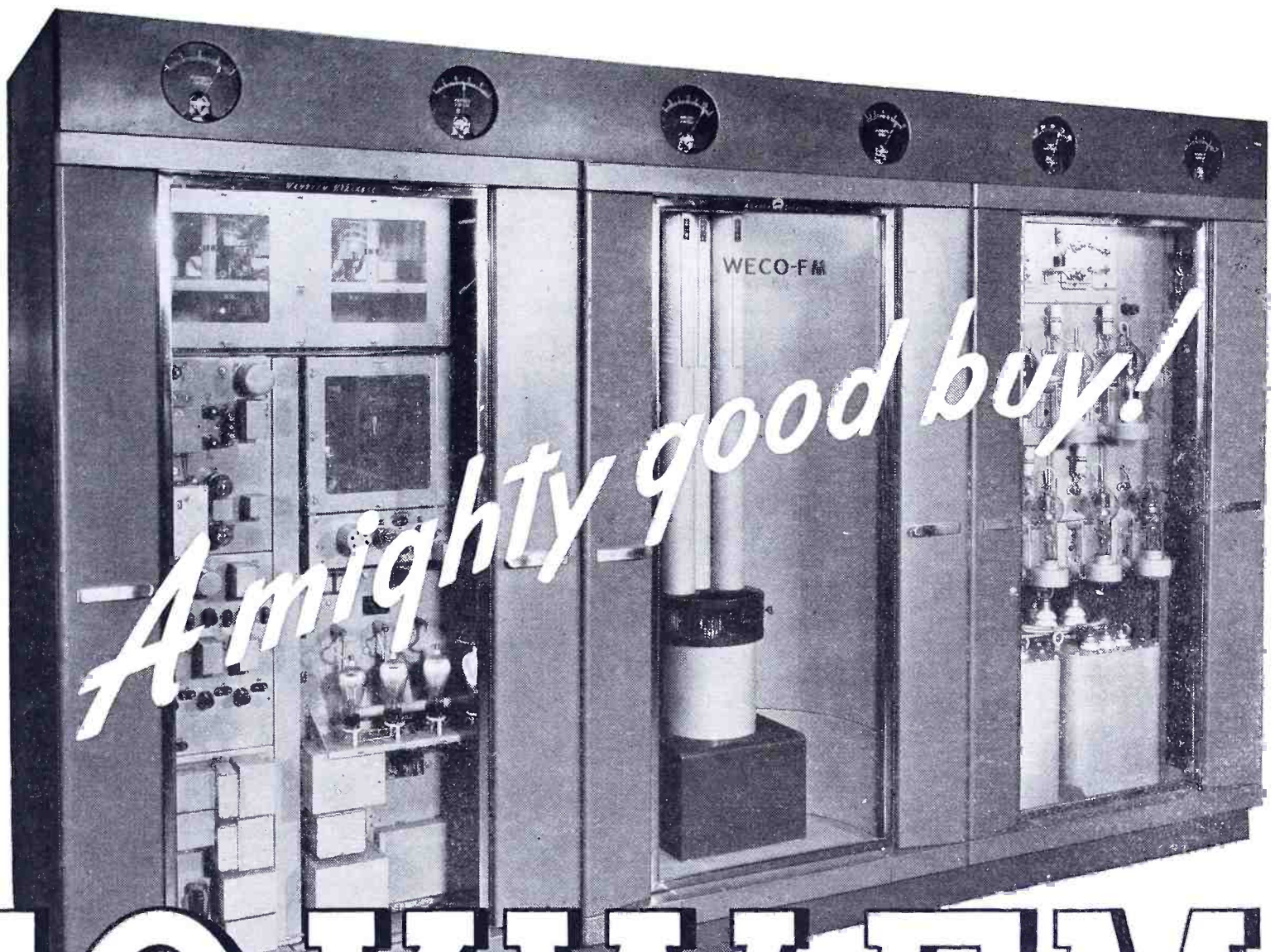

A mighty good buy!

10 KW FM

by

Western Electric

BECAUSE its exclusive feature, the RF Power and Impedance Monitor, gives you an accurate, direct measurement in kilowatts of the actual RF power fed to the antenna system and also provides a method of measuring standing wave ratio under full power output.

BECAUSE its exclusive feature, the Arc-Back Indicator, spots faulty mercury vapor rectifier tubes surely—instantly—enabling you to get back on the air in a fraction of the usual time.

BECAUSE its exclusive feature, the Frequency Watchman, keeps it on frequency at all times.



BECAUSE its exclusive Bell Laboratories' design holds inter-modulation and harmonic distortion down to a new low.

BECAUSE its exclusive feature, TRANSVIEW design, gives you striking appearance coupled with maximum visibility and accessibility.

Only in 10 KW FM by *Western Electric* do you get all these outstanding features. For full details, call your local Graybar Broadcast Representative, or write to Graybar Electric Company, 420 Lexington Avenue, New York 17, N. Y.

— QUALITY COUNTS —

PRODUCTS & LITERATURE

So many new instruments, components, and materials are being brought out that space does not permit us to publish illustrated descriptions of them all. Accordingly, rather than selecting a few each month, we have established this new department of Products & Literature so that a great number of brief descriptions can be published. From these, you can select items which interest you, and send for catalogs or bulletins. We'll appreciate it if you will mention FM and TELEVISION in your requests.

Relays in a wide range of types and characteristics for AC and DC operation. Long telephone types, intermediate sizes, and miniature designs are illustrated in a new folder. — American Relay and Controls, Inc., 2555 Diversey Ave., Chicago 47.

Catalog Supplement: A 32-page supplement devoted to new FM, television, and high-fidelity sound equipment.—Catalog K10, Radio Wire Television, Inc., 100 Sixth Ave., New York.

Microphone Stands: Two new floor stands for studio use, with noiseless clutch action to adjust height up to 72 ins. Either 3-legged or round base.—Bulletin 112, Universal Microphone Co., Inglewood, Calif.

Midget Ratio Detector Coils: Extremely small size achieved by the use of a new design with iron-core tuning. Polystyrene bases and mica condensers are used for high Q and stability. Unit measures $\frac{3}{4}$ by $\frac{3}{4}$ by $\frac{3}{4}$ in.—Bulletin 19, Stanwyck Winding Co., Newburgh, N. Y.

Polar Recorder: For plotting aircraft antenna radiation patterns. Permanent ink record, rapid writing speed, low pen overshoot, and precise angular position are features of the design.—Bulletin MB, Airborne Instruments Lab., Inc., Old Country Road, Mineola, N. Y.

De-Reeling Tension: Mounting a spool of magnet wire, this device reduces wire breakage by maintaining smooth, even tension. Can be mounted on any single or multiple winding machines. There are two types, one for 44 to 38 and one for 40 to 20 AWG wire.—Bulletin 14, Paper Machinery & Research, Inc., 1014 Oak St., Roselle, N. J.

FM-TV Signal Generator: To align FM and television RF, IF, and video amplifiers. FM sweep is adjustable from 40 kc. to

9 mc., with an output from 0 to .5 volt. Center-frequency range is 2 to 226 mc. Synchronization of associated oscilloscope is at power line frequency or at a selected multiple or sub-multiple. Price \$48.50—Bulletin FG, McMurdo Silver, Inc., 1240 Main St., Hartford, Conn.

Oscilloscope: New model for research applications has a variety of sweep lengths, highly accurate delay circuits, crystal-controlled markers, variable internal trigger generator, and wide band video amplifier.—Model 256-D, Bulletin 11F, DuMont Labs., Inc., Passaic, N. J.

Television Transmitter: Video output 5 kw., audio output 2.5 kw. on any low-band channel from No. 1 to 13. The two transmitters are housed in three adjacent cabinets, with a total length of 16 ft. by 3 ft. deep and 7 ft. high.—Technical Specifications EP, General Electric Co., Electronics Dept., Syracuse, N. Y.

Knobs: Of all types and sizes for radio equipment are listed in a new catalog which also contains information on reducing tool costs and on deep-relief branding.—Bulletin 214, Rogan Bros., 2500 W. Irving Park Blvd., Chicago 18.

400-Watt Tetrode: Small, rugged design is radiation cooled with reduced air flow volume. Two tubes operated conservatively will give 1 kw. at 4,000 plate volts on 88 to 108 mc.—Type 4-400A, Bulletin 92, Eitel-McCullough, Inc., San Bruno, Calif.

Dial Cord Guide: Contains 552 dial cord stringing diagrams of receiving sets built from 1938 to 1947. Reference index lists approximately 2,300 different receiver models. Price 75¢—Howard W. Sams & Co., Inc., 2924 E. Washington St., Indianapolis, Ind.

Feed-through Terminals: Turret-lug design, insulated for voltages up to 8,000 at 60 cycles. Two lengths are available, with bushings for $\frac{1}{4}$ - and $\frac{3}{8}$ -in. holes.—Bulletin MF, Cambridge Thermionic Corp., Dept. 11, 445 Concord Ave., Cambridge 38, Mass.

Wheatstone Bridge: Portable type for laboratory or production use, complete with batteries or with Murray and Varley loops. Galvanometer has 15 1-millimeter divisions each side of zero, with a sensitivity of 1 microampere per division. The instrument can be used also as a resistance decade.—Bulletin RS, Industrial Instruments, Inc., 17 Pollock Ave., Jersey City 5, N. J.

Co-Spiral Speaker: Designed for reproduction from 40 to 14,000 cycles, 15 watts, with 8- or 16-ohm voice coil. Diffuser is rated at approximately 100% spherical pattern over 90°. Either 12- or 15-in. diameter,

with 2½-lb. Alnico V magnet.—Bulletin 109-X, Stephens Mfg. Corp., 10416 National Blvd., Los Angeles 34.

FM Tuner: Comprises parallel tuning lines and sliding shorting loops for the FM band from 88 to 108 mc. Unit includes scale, pointer, and tuning knob.—Bulletin H, Edwards FM Radio Corp., 168 Washington St., New York 6.

Pickup: Variable reluctance type, rated velocity-responsive to 15,000 cycles. High-impedance cartridge has 60 millivolts output at 1,000 cycles with .001-in. lateral displacement.—Bulletin 32G, Clarkstan Corp., 11927 W. Pico Blvd., Los Angeles 34.

Casting Resin: NBS resin, developed by the Bureau of Standards, for potting radio components and assemblies. Has low power factor and dielectric constant, small shrinkage and moisture absorption, high impact strength and dimensional stability. Used during the war for proximity fuses.—Bulletin WAM, Mathieson Alkali Wks., Inc., 60 E. 42 St., New York.

Foreign Plugs: New circular lists a complete line of male plugs to fit European and South American types of electrical receptacles. For use on line cords supplied with export radio sets.—Bulletin XF, Bardon Mfg. Co., 1415 Augustine Blvd., Far Rockaway, N. Y.

Diamond Reproducer: For home record-players similar to types used at broadcast stations. Sold under life-time guarantee.—Bulletin EP, General Electric Co., Electronics Dept., Syracuse, N. Y.

Automatic Welder: Bench-type machine for welding tube parts or attaching leads to components. Accessories and attachments can be furnished to perform special operations.—Bulletin 9, Tweezer-Weld Corp., 1060 Broad St., Newark, N. J.

Pulse Generator: Output consists of rectangular voltage pulses from $\frac{1}{2}$ to 1,000 cycles, with pulse duration of 25 to 950 microseconds. Ranges of 1, 5, and 50 volts output into a 10,000-ohm load are provided. Operates from 115 volts, 60 cycles. Price \$432.50—Bulletin EC, Electrodyne Co., 899 Boylston St., Boston.

Adjustable Dipole: Folded type, with telescoping loops which can be locked at any length for tuning to 85 to 150 mc. Horizontal mounting plate is insulated for receiving or low-power transmitting use.—Bulletin 750, Heintz & Kaufman, Ltd., 50 Drum St., San Francisco.

Photo Cell: Self-generating barrier-layer type, 1½ ins. square, produces several hundred microamperes in strong light.—Bulletin RD2, American Scientific Co., 137 Marcy Place, New York 52.

AMPHENOL
RF CABLES AND CONNECTORS



**Efficient Connecting Links
 for Electrons at Work . . .**

Write today on your business letterhead for your free copy of the new D-1 catalog. Amphenol will serve you well as a dependable source of supply. Catalog D-1 is today's guide for the engineer and purchasing agent in the selection of highest quality cables and connectors.

Amphenol radio frequency cables, connectors and cable assemblies assure lasting, low-loss continuity on highly critical circuits.

Available—from stock—to makers of electronic equipment and to amateurs, they are produced in several types. Each is designed to meet the requirements in a specific field of application.

To simplify your selection, the new Amphenol D-1 Catalog of radio frequency cables, connectors and cable assemblies includes decibel loss and power rating data of all cables. Functional illustrations and tabular matter quickly show which connector is needed for each cable. Installation dimensions are shown, as are instructions for the proper assembly of cables to connectors. Included is a cross-index of army-navy and Amphenol type designation numbers.

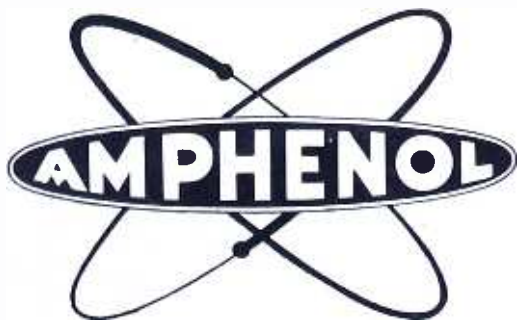

AMERICAN PHENOLIC CORPORATION
 1830 South 54th Avenue, Chicago 50, Illinois

COAXIAL CABLES AND CONNECTORS • INDUSTRIAL CONNECTORS, FITTINGS AND CONDUIT • ANTENNAS • RADIO COMPONENTS • PLASTICS FOR ELECTRONICS

December 1947 — formerly FM, and FM RADIO-ELECTRONICS



**..AS DISTINCTIVE
 AS YOUR**

Fingerprint!



Surprenant's improved SPIRALON is just that! SPIRALON is a thinwall plastics insulated wire with one, two or even *three* spirally inlaid solid color stripes. These, in turn, provide a total of up to four colors per wire . . . or a maximum of 1120 distinctively coded combinations to make wire identification easy — even in the most complex installations.

Non-inflammable, non-corrosive, flexible and tough, SPIRALON is obtainable with or without a thin jacket of transparent Dupont nylon to further preserve every electrical property and resist oils, dilute acids, alkalis, abrasion and fungus attack. SPIRALON is approved under specification JAN-C-76 type WL . . . it will not fray, crack or rot — and offers a higher rupture point than braid or lacquers. These superior features are available at no extra cost in all standard wire types and sizes — or to your most exacting specifications. Write today for samples and technical data.

SPIRALON "O"
 (with nylon jacket)

SPIRALON
 (without nylon jacket)

Surprenant
MFG. CO.



"Pioneers in
 Plastics Extrusions"

Write
 DEPT. D

199 Washington St. • Boston 7, Mass.

© 1947 S. MFG. CO.

Already chosen to bring

Deliveries of RCA's 5-kw "All Channel" television transmitter now being made to 26 top stations

Here's the transmitter that is putting television on the map now . . . in many of the nation's key cities.

Announced only ten months ago, 26 leading broadcasters have already recognized its design advantages with orders. Sixteen transmitters have already been shipped . . . and it is expected that others will be shipped this year. The combined radiated power of these stations will blanket approximately 75,000 square miles . . . bring *clear, high-definition* television pictures within reach of 42,486,000 people.

Stage-by-stage, this transmitter has everything you might want for your new station. Here are the highlights:

FINGER-TIP CONTROL for all operating and monitoring functions. Monitoring facilities permit observation of the picture and its waveform. New RCA console handles both sound and picture signals—simplifies getting transmitter on the air and keeping it there.

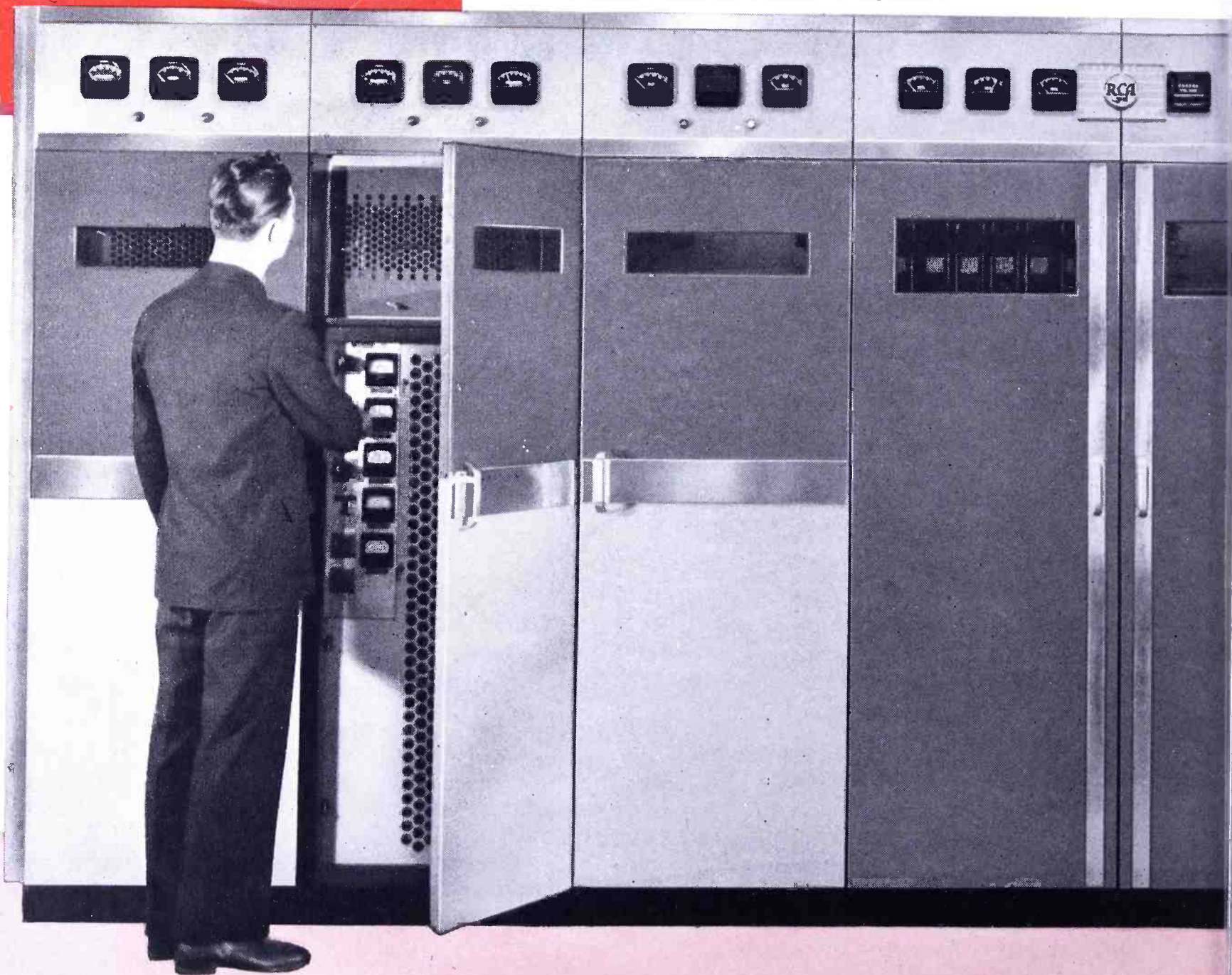
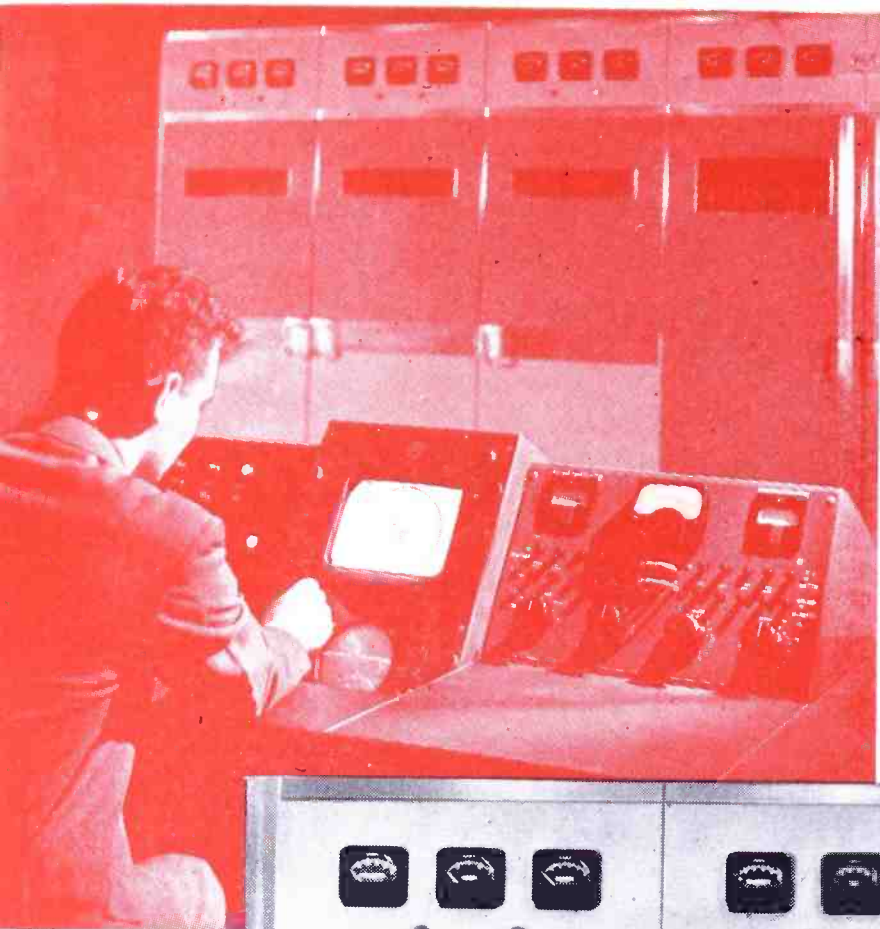

television to 42,000,000 people

- Covers all 12 metropolitan channels and assures a full 5-kw signal on each channel
- Divides into eight relatively small, lightweight units (25 by 36 by 80 inches) for easy handling and installation and flexible station layout
- Facilitates inspection and servicing with its "walk-in" type construction
- Simplifies transmitter operation due to similarity in design between the sound and picture transmitters
- Eliminates complicated tuning adjustments — a high-level modulation system permits the use of meter-tuned, narrow-band drivers . . . *only one* modulated stage to adjust
- No neutralization of modulated PA stage
- Employs radically new tubes in the output stages — RCA 8D21 twin tetrodes — permitting unusually small r-f drivers
- Requires fewer spare tubes — only 15 types.

From every standpoint, the RCA TT-5A is comparable in convenience, performance, and operating economy with today's finest AM transmitters.

Be sure to see the transmitter in the RCA exhibit. Ask a representative to describe its many advantages to the station engineer, manager, owner, and audience. Write Dept. 35-L.

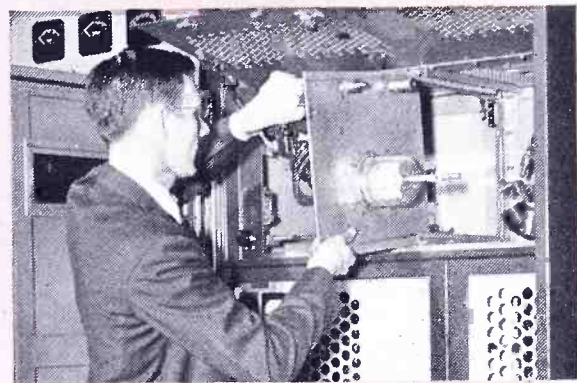

SIMPLIFIED TUBE CHANGING—When a PA tube change is necessary, the tube and special mounting plate can be removed as a unit and a spare assembly slid into place and connected in a matter of minutes.

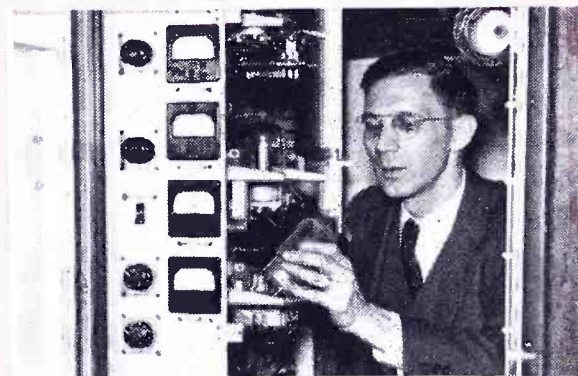

WALL-MOUNTED UNITS afford easy access to all tubes and wiring. Rear doors further increase ease of reaching all components. Illustration above shows portion of the aural transmitter's r-f driver unit.

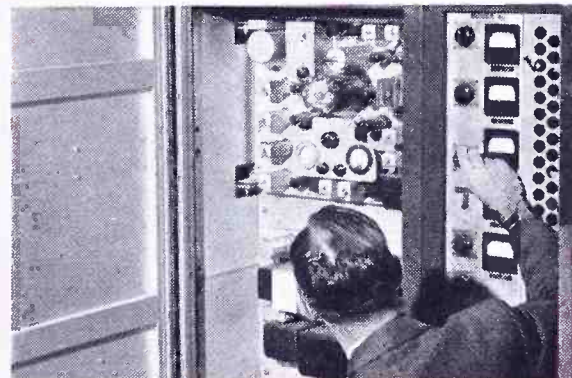

THE "DIRECT FM" EXCITER for the sound channel. Uses only four r-f tubes; does not involve phase multiplication. Inherently capable of lower noise and distortion than any exciter yet developed.



TELEVISION BROADCAST EQUIPMENT
RADIO CORPORATION of AMERICA
ENGINEERING PRODUCTS DEPARTMENT, CAMDEN, N.J.

In Canada: RCA VICTOR Company Limited, Montreal

Professional Directory

Jansky & Bailey

AN ORGANIZATION OF
Qualified Radio Engineers
 DEDICATED TO THE
SERVICE OF BROADCASTING
 National Press Bldg., Washington, D. C.



ANDREW CO.

Consulting Radio Engineers
 363 EAST 75th STREET, CHICAGO 19
 Triangle 4400

• TELEPHONE BRIDGEPORT 5-2055 •

GARO W. RAY

Consulting Radio Engineers

991 Broad Street, Suite 9-11
 Bridgeport 3, Conn.

LABORATORY: Hilltop Drive
 Stratford, Conn. — Phone 7-2465
Instruments and Measurements

RATES FOR PROFESSIONAL CARDS IN THIS DIRECTORY

\$10 Per Month for This Standard
 Space. Orders Are Accepted
 for 12 Insertions Only

DALE POLLACK

FREQUENCY MODULATION

development and research
 transmitters, receivers
 communications systems

352 Pequot Avenue New London, Conn.
 New London, 2-4824

THE WORKSHOP ASSOCIATES

INCORPORATED

*Specialists in
 High-Frequency Antennas*

66 Needham St., Newton Highlands, Mass.
 Bigelow 3330

WHAT'S NEW THIS MONTH

(CONTINUED FROM PAGE 4)

would only meet their immediate needs. They would prefer a wider band in the vicinity of 152 to 162 mc. There is a strong feeling that the Government should release some of the frequencies it has reserved, but is using to a limited extent.

Furthermore, it was suggested, and quite logically, that if Government frequencies are released now for commercial use, equipment will be developed which could be modified readily for military communications.

FM BROADCASTING: Under the original plan worked out by the pioneer FM broadcasters, high-power, mountain-top stations were to furnish wide rural coverage, and, serving as relay points, supply programs to local and regional stations. As the result of the FCC's acceptance of the Norton testimony at the original allocations hearing, that plan was broken down, and allocations were based on assigning low power in the 88- to 108-mc. band.

Now FM broadcasters, on the basis of operating experience on both FM bands, want to keep 44 to 50 mc. for network operations and wide-range, rural coverage.

Major Armstrong, at the conclusion of his testimony, summed up the situation in this way: "As near as I can see, the only people who really want the 44- to 50-mc. band are the FM people. The police, emergency services, and so on say, 'Well,' in effect, 'we'll take it if we have to, but we would much prefer to be up around 150 mc.'"

"Now, we had a situation like this in Chairman Fly's time, following the March, 1940 hearing. It was resolved to give FM the low band, making an arrangement with IRAC to give television a space further up in the spectrum. If such an arrangement could be worked out this time, I am sure everybody would be very happy about it."

Then Mr. McIntosh asked: "Under that situation, Mr. Armstrong, would FM broadcasting still require the band 88 to 108 mc.?"

Mr. Armstrong: "Yes, I am not suggesting that the FM band be moved down. It is too late for that. I suggest that be continued and supplemented with 44 to 50 as an area rebroadcast service. That is the suggestion I make."

The Chairman: "Confined to recarry a broadcast service?"

Mr. Armstrong: "Yes, I think so, Mr. Chairman. What will come out of it in territory where you need wider coverage will develop from experiment and progress, but at the present time the great need is to get some push behind FM and some competition with the AM networks to get this thing rolling. I think that is the best way to do it."

2. What the outcome of this hearing will be, no one seems prepared to
 (CONTINUED ON PAGE 13)

Professional Directory

RAYMOND M. WILMOTTE, Inc.

*Consulting Engineers
 Radio and Electronics*

PAUL A. DEMARS, Associate
 1469 Church St., N. W., Washington 5, D. C.
 Decatur 1234

RUSSELL P. MAY

CONSULTING RADIO ENGINEERS

★ ★ ★

1422 F Street, N. W. Wash. 4, D. C.
 Kellogg Building Republic 3984

OUR
 19th
 YEAR

Herbert L. Wilson

*Consulting
 Radio Engineers*

1025 Conn. Ave., N.W. NA. 7161
 Washington 6, D. C.

1000 No. Seward St. HO. 6321
 Hollywood 38, Calif.

CONSULTING
 RADIO ENGINEERS

**DIXIE B. MCKEY
 &
 ASSOCIATES**

1730 CONNECTICUT AVE. N.W.
 WASHINGTON 9, D.C. ADAMS 3711

**NATHAN
 WILLIAMS**
Consulting Engineer



20 Algoma Blvd.
 Oshkosh, Wis.
 Phone: Bl'khawk 22

FREQUENCY MEASURING SERVICE

Exact Measurements - at any time



RCA COMMUNICATIONS, INC.
 64 Broad Street, New York 4, N. Y.

Professional Directory

**FRANK H.
McINTOSH**

Consulting Radio Engineers
710 14th St. N.W., Wash. 5, D. C.
MEtropolitan 4477

Preliminary surveys, management and operational consulting service based on practical experience with AM, FM and Facsimile.



Phone: EXecutive 3929

RADIO CONSULTANTS, Inc.
1010 VERMONT AVE., WASHINGTON 5, D. C.

**ANDERSON &
MERRYMAN**

Consulting Radio Engineers

715 American Bank Bldg. Tel. RAymond 0111
New Orleans 12, Louisiana
Suite 1726-28, 33 W. 42nd St. Tel. Wis. 7-9391-2
New York City



*Radio Engineering Consultants,
Frequency Monitoring*

Commercial Radio Equip. Co.

International Building • Washington, D. C.
603 Porter Building • Kansas City, Mo.

Custom-Built
SPEECH INPUT EQUIPMENT
U. S. Recording Co.

1121 Vermont Avenue
Washington 5, D. C.
District 1640

**WINFIELD SCOTT MCCACHREN
AND ASSOCIATES**

Consulting Radio Engineers
TELEVISION SPECIALISTS

PHILADELPHIA: 410 BOND BUILDING
809B Windemere Ave. Washington, D. C.
Drexel Hill, Pa. District 6923
Sunset 2537-W

WHAT'S NEW THIS MONTH

(CONTINUED FROM PAGE 12)

hazard a guess. It seems likely that the Commission will be reluctant to take an arbitrary stand against Major Armstrong's recommendation in view of the bomb shell he exploded on the final day of the hearing.

It had been expected that Major Armstrong would again challenge the Norton testimony on high-band vs. low-band transmission. The opportunity came while Kenneth Norton was on the stand during the final day. Under cross-examination, Mr. Norton knocked the props from under the Commission when, upon being asked, "But you were wrong?" he answered nonchalantly: "Oh, certainly."

Following is the official transcript of the cross-examination:

MR. ARMSTRONG: "Mr. Norton, in your first appearance in the allocations hearings on October 28, 1944, on page 3767, you made this statement:

"If high-power VHF transmitters had been operating in South America or in Australia at or near 80 mc. during the maximum of the last sun spot cycle, then it seems to me quite likely that they would have been intercepted for many hours with intensities sufficiently strong to cause serious interference to an FM or television broadcast service."

We are now in the peak of the highest sun spot cycle that we know of, and I would like to ask you if that prediction has been borne out.

MR. NORTON: "Well, I haven't heard whether signals have been heard from Australia, but it is my understanding, although I do not have direct knowledge of it, that signals have been received from South America."

Q. On 80 mc.?

A. No, Not on 80 mc., no.

Q. Well, I will read the statement again, if you would like to have me do so.

A. I have the statement here. And as regards to that, why, certainly not.

Q. Now, some of us questioned that, Dr. Beverage, Dr. Burroughs, Dr. Pickard, Dr. Stetson, and we filed a memorandum. At the oral argument in the early part of 1945, you declined cross examination on the ground that it was a classified matter, and suggested that a secret hearing be held under the auspices of the military.

Mr. Denny, who was then general counsel of the Commission said, after arrangements had been made to hold this hearing, or agreement had been entered into to hold the secret hearing:

"I would like to ask one question. I do not know whether you would want to go this far on the record. I want to ask a question; but if there is any doubt about it, do not answer it. It has been suggested in the course of these hearings when you presented your Exhibit 380 that the curves

(CONCLUDED ON PAGE 44)

Professional Directory

McNARY & WRATHALL
CONSULTING RADIO ENGINEERS

★ ★ ★

983 National Press Bldg. DI. 1205
Washington, D. C.

KEAR & KENNEDY

Consulting Radio Engineers

1703 K St. N.W. REpublic 1951
Washington, D. C.

GEORGE P. ADAIR

Consulting Engineers

Radio, Communications, Electronics
1833 M St., N.W., Washington 6, D.C.
EXecutive 1230

RATES FOR
PROFESSIONAL CARDS
IN THIS DIRECTORY

\$10 Per Month for This Standard
Space. Orders Are Accepted
for 12 Insertions Only

WATKINS 9-5310

S. A. Barone Co.

Consulting Engineers

MECHANICAL—RADIO—ELECTRONIC
PRODUCT DEVELOPMENT & RESEARCH

Development Specialists in Circuits, Part
Lists, Models, Manufacturing Drawings.

143-145 W. 22ND STREET, NEW YORK 11

AMY, ACEVES & KING, INC.

*Specialists in the
Design and Installation of*

**HIGH-GAIN
AM, FM, and TELEVISION
ANTENNA SYSTEMS**

LONGacre 5-6622
11 West 42nd Street, New York 18, N. Y.

You get all these features **ONLY** in the *Western Electric 5A Monitor* for FM Broadcasting

CENTER FREQUENCY MONITOR:

Accuracy—better than ± 500 cycles. (± 200 cycles if occasionally adjusted to agree with a primary standard)
Meter Range— $\pm 3,000$ cycles
Terminals for connecting remote meter

MODULATION PERCENTAGE MONITOR:

Accuracy—better than 5% for all readings
Modulation Range Capability—up to 133% (± 100 kc)
Terminals for connecting remote meter

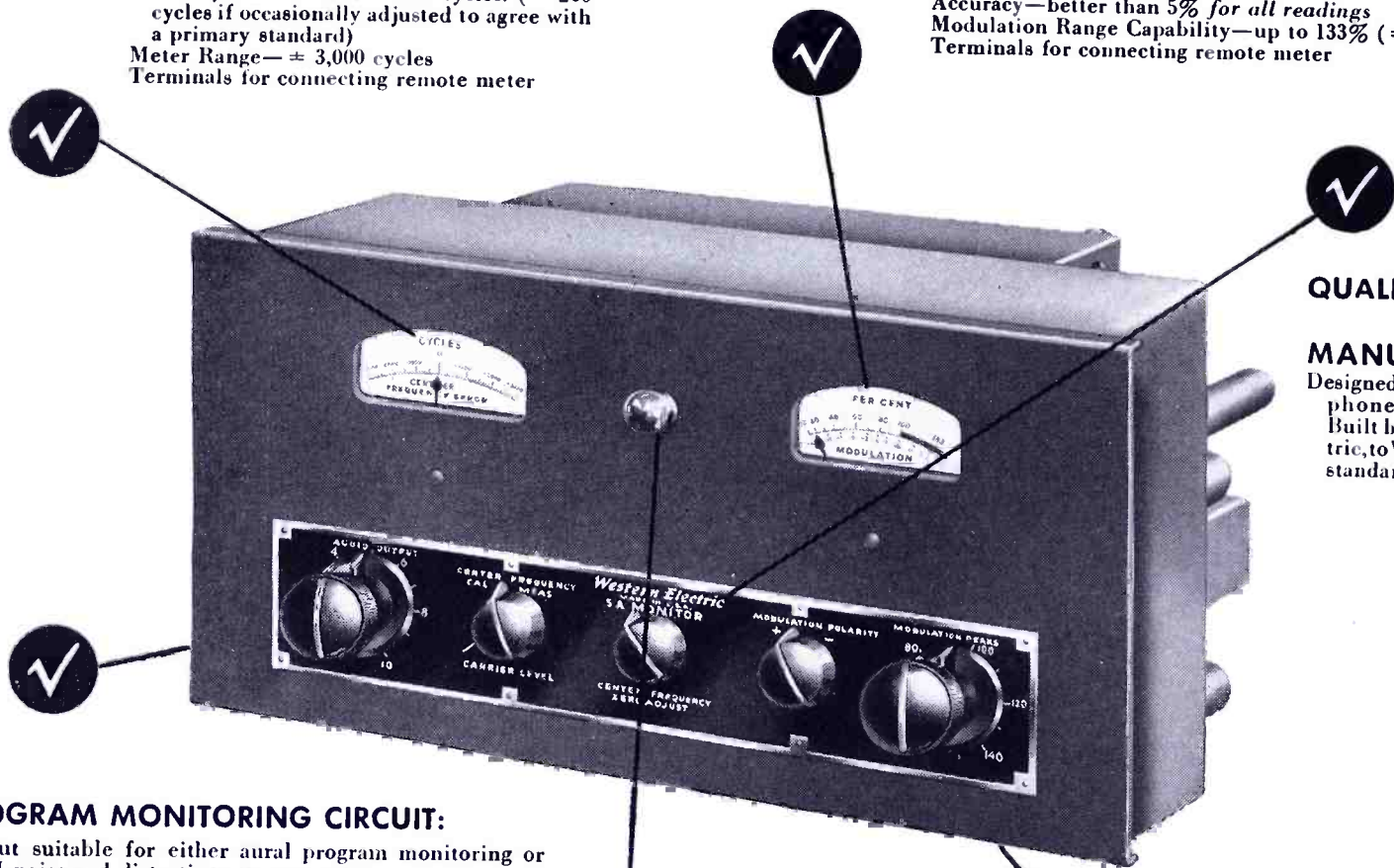

QUALITY DESIGN AND MANUFACTURE:
Designed by Bell Telephone Laboratories.
Built by Western Electric, to Western Electric standards of quality.

PROGRAM MONITORING CIRCUIT:

Output suitable for either aural program monitoring or FM noise and distortion measurements
Frequency Response— ± 0.25 db, 30 to 30,000 cycles, without de-emphasis; with de-emphasis, response is within ± 0.5 db of the standard 75 microsecond de-emphasis curve
Audio Output Power—output level adjustable up to +12 dbm—permits direct switching of program monitor from transmitter input to 5A Monitor output
Harmonic Distortion—less than 1/4 of 1% from 30 to 15,000 cps
Output Noise—at least 75 db below signal at 100% modulation

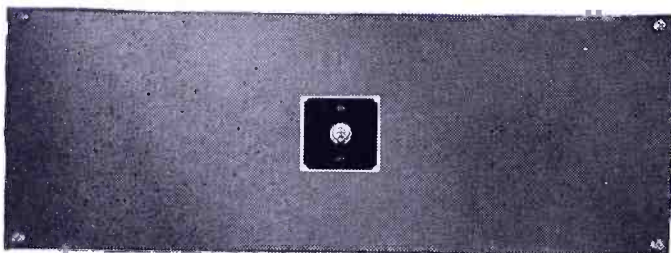

POWER SUPPLY: Newly designed 20C Rectifier (furnished as a part of the 5A Monitor) provides electronically regulated d-c with less than 1 millivolt ripple from 105-125 volts a-c 60 cycles. May be remotely located if desired.

MODULATION PEAK INDICATOR:

Indication Lamp—flashes when a selected level of modulation is exceeded
Peak Limit Range—continuously adjustable between 40% and 140% modulation

AM NOISE DETECTOR:

An exclusive feature in the 5A Monitor. The output of this detector—which may be read directly on an electronic voltmeter or noise meter—is automatically referred to 100% amplitude modulation, thus simplifying measurement of transmitter AM noise.

The 5A Monitor includes numerous other valuable features such as: dual thermostats and dual heaters for each crystal—means for checking the inherent noise level of the monitor from its input to output terminals—requires only a low RF input level (1 watt) which can vary from 0.3 to 3.0 watts; i. e., a 10 to 1 variation without affecting the performance of the monitor. To get the complete story on this outstanding monitor value, call your Graybar Broadcast Representative or mail the coupon below.

Western Electric

Distributors: In the U. S. A.—Graybar Electric Company.
In Canada and Newfoundland—Northern Electric Company, Ltd.

—QUALITY COUNTS—



Graybar Electric Company
420 Lexington Avenue, New York 17, N. Y. FMT

Please send me Bulletin T-2437, including curves, schematics and block diagram of the 5A Monitor.

NAME _____

STATION _____

ADDRESS _____

CITY _____ STATE _____

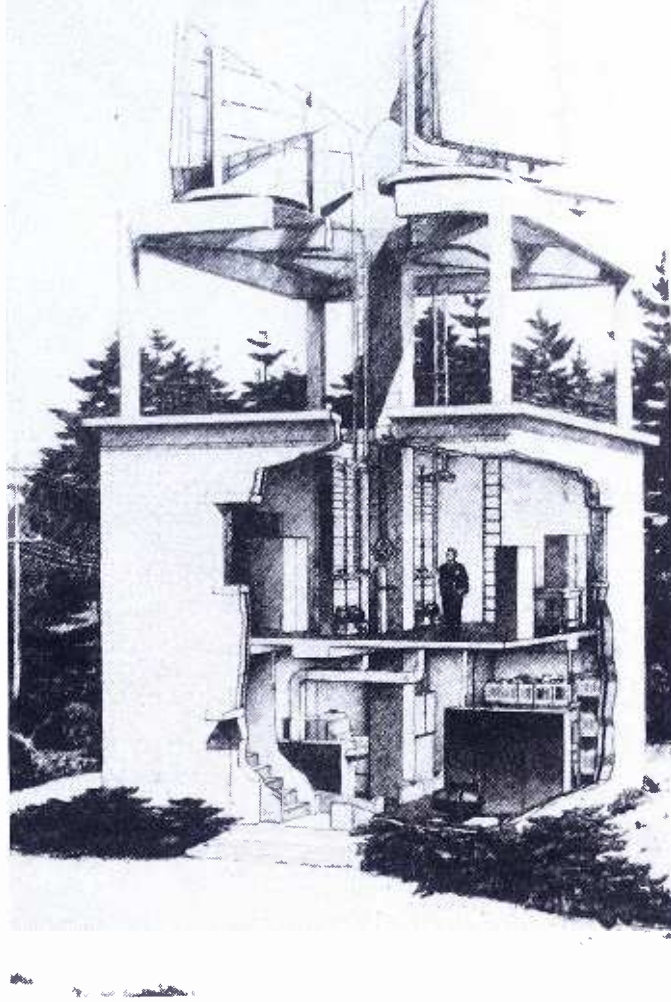
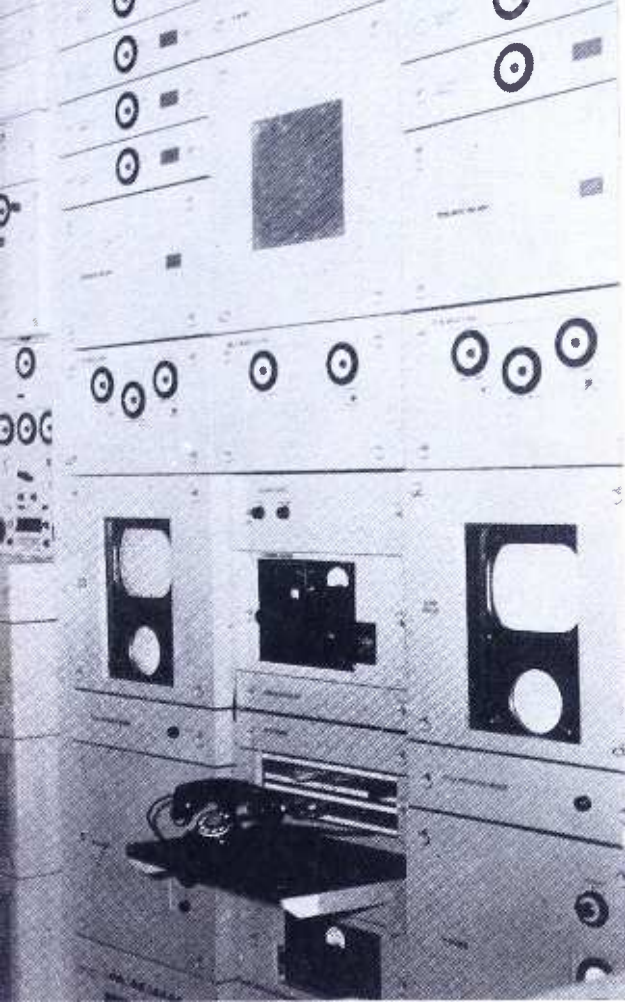

LEFT: TERMINAL MONITORING POSITION. CENTER: CUT-AWAY VIEW OF RELAY. RIGHT: LENS ANTENNAS FOR TERMINAL AT N. Y.

FM RELAY OUT-PERFORMS COAX FOR TELEVISION

AT & T Boston-New York Relay Amazes Audience at First Demonstration

BY MILTON B. SLEEPER

FREQUENCY Modulation made another outstanding contribution to radio communications and specifically to the expansion of television broadcasting when, on November 13, the American Telephone & Telegraph Company opened its Boston-New York relay system by carrying video and audio signals between those two points.

Taking part in this event, witnessed by broadcast executives and engineers and press representatives, were AT & T president Walter S. Gifford, vice president Frank P. Lawrence in charge of long lines, N. Y. Telephone Company president Carl Whitmore, Bell Telephone Laboratories president Dr. Oliver E. Buckley, and Dr. Ralph Bown, director of research at Bell Laboratories.

The demonstration was staged at 32 Avenue of the Americas, New York. Cameras were set up to televise the participants, and a number of standard commercial receivers were provided for the audience, numbering about 200.

Radio vs. Coaxial Cable ★ After an introduction by Mr. Lawrence, Mr. Gifford called Joe E. Harnell, president of the New England Telephone & Telegraph Company, in Boston, and we saw and heard Mr. Harnell's answer. The picture quality, according to present standards, was per-

fect. In fact, it was better than anything we have seen coming directly from a broadcast station.

That part of the program included out-of-the-window views of Boston, and a televised talk about early telephone instruments in the State Street museum.

Then the scene shifted to Washington, D. C., with the signals coming over the coaxial cable. We saw and heard H. Randolph Maddon, president of the Chesapeake & Potomac Telephone Company, and acting FCC Chairman Paul A. Walker.

Since signals by radio relay and coaxial cable were received on the same sets, with similar cameras at both ends, we could get a direct comparison of results with the two methods of transmission. The FM radio relay, as might be expected, was definitely superior. Checking with other observers, there was agreement that while reception from Boston was virtually perfect, images from Washington were distorted, and lacked brightness and contrast. Knowing Mr. Walker, we could see very considerable distortion when the camera was turned on him.

Television Network ★ This demonstration program, which also included a story of the relay told by Tom Shirley in person and by movies, was carried by what was prob-

ably the largest number of stations ever joined in a network. They were WABD, WCBS, and WNBT New York; WFIL-TV and WPTZ Philadelphia; WMAR-TV Baltimore; WMAL-TV, WNBW, and WTTG Washington; and WRBG Schenectady.

If there had been television stations in Boston and at such intermediate points as New Haven, Hartford, Springfield, and Worcester, they, too, could have taken the program from the relay. This may become a reality in 1948. In fact, it is quite possible that the Westinghouse station in Boston will be in operation when the Republican and Democratic conventions are held in Philadelphia.

Operation of the Relay ★ The combined coaxial cable and relay circuits totaled 500 miles, of which the relay covered 220 miles. New York terminal of the relay is at 32 Avenue of the Americas. One of the accompanying photographs shows the receiving and transmitting antennas there. Similar antennas are mounted on the Bowdoin Square Building in Boston. Intermediate relays are located at:

Jackie Jones Mt., Near Haverstraw, N. Y.
 Birch Hill, near Pawling, N. Y.
 Spindle Hill, near Waterbury, Conn.
 John Tom Hill, Glastonbury, Conn.
 Bald Hill, near Stafford Springs, Conn.

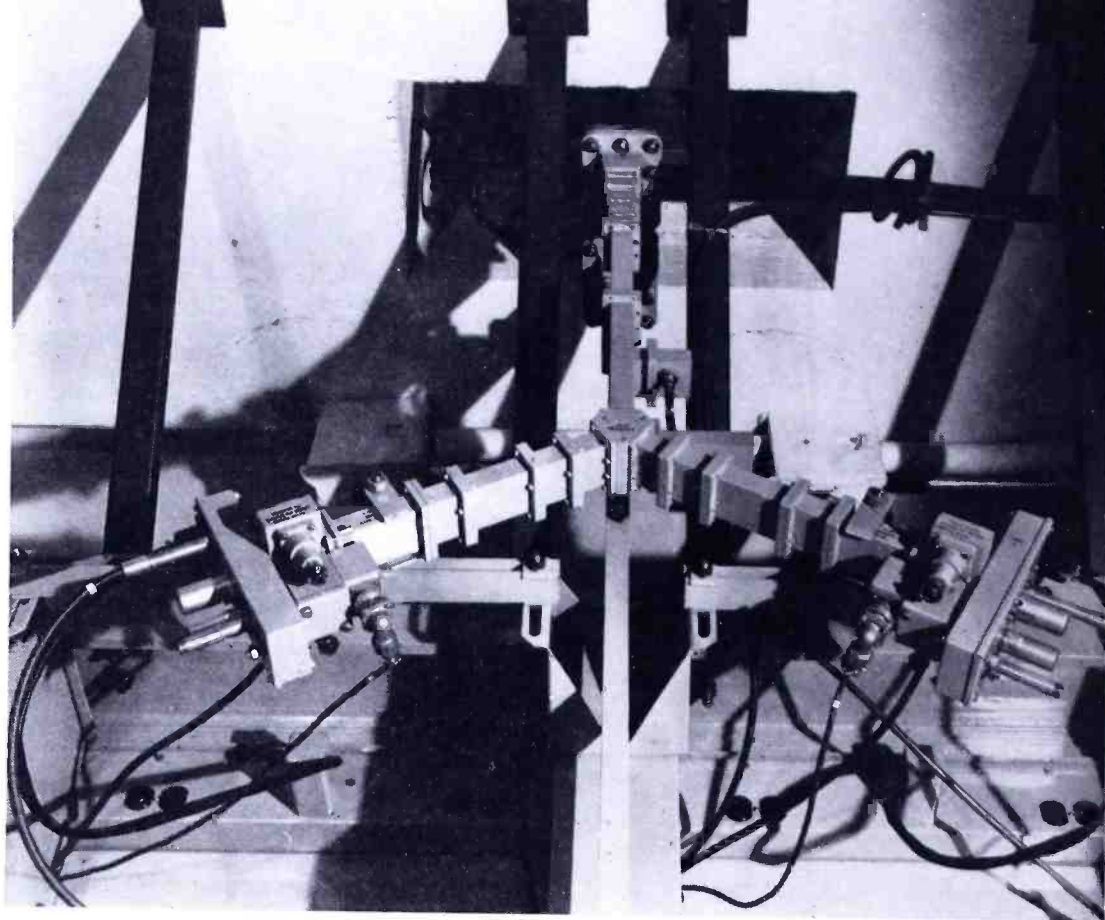
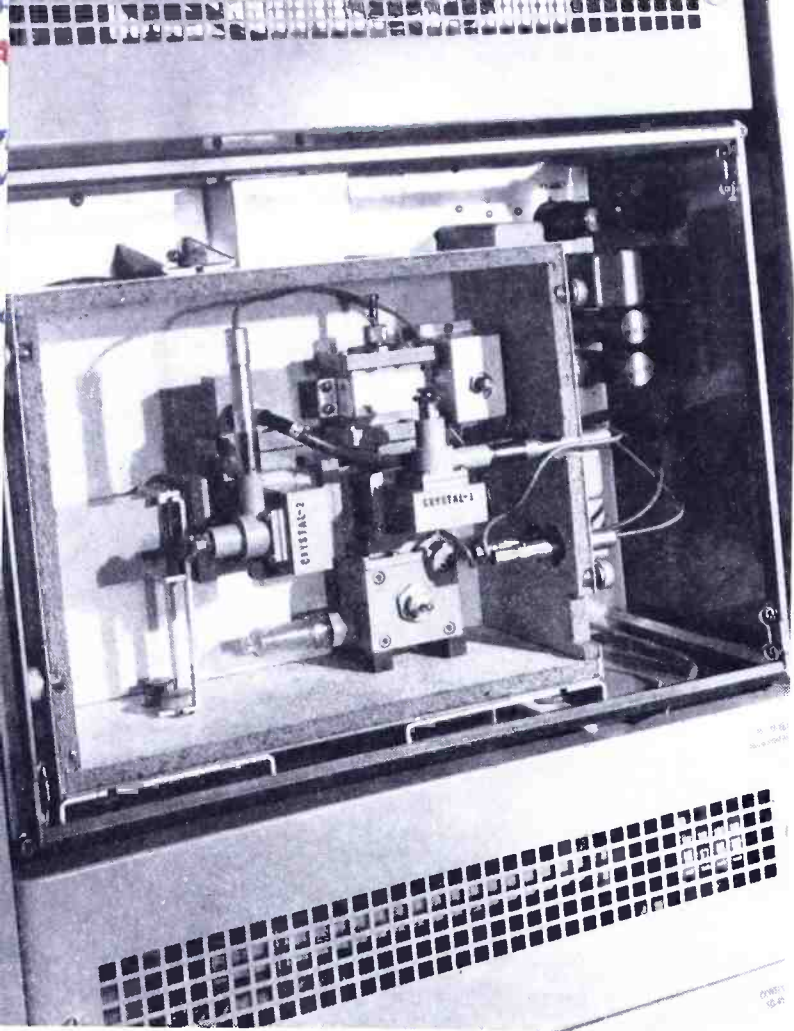

ABOVE, LEFT: AFC UNIT OF MICROWAVE RELAY IN INSULATED CASE. RIGHT: WAVE-GUIDE INPUT, BRANCHING FILTERS, CONVERTERS, AND PREAMPLIFIERS FOR 2 CHANNELS. BELOW, LEFT: REPEATER AT JACKIE JONES. RIGHT: CHANNEL-COMBINING TRANSMITTER FILTERS BELOW, RECEIVER FILTERS ABOVE

Mt. Asnebumskit, near Worcester, Mass.
Bear Hill, Waltham, Mass.

These jumps range from 11 to 35 miles, a 27.5 miles average.

Detailed photographs show the exterior appearance and interior equipment, with a cut-away drawing of a typical building. Two lens-type antennas, one for transmitting and one for receiving, face in each

direction. Each antenna, 10 ft. square, is faced with reinforced glass cloth to keep out birds, insects, and snow.

The two circuits, N. Y.-Boston and Boston-N. Y., operate in the band from 3,700 to 4,200 mc. Dr. Bown did not give details of the system of transmission and reception, but he said that "we think this gives room enough for at least 6 two-way

broad-band channels on a route. Each of these can be made wide enough for color television if required."

The ground floor of the relay stations contains heating and ventilating equipment to maintain constant temperature under all conditions. In addition, there are emergency storage batteries and an emergency gasoline-driven generator, for use

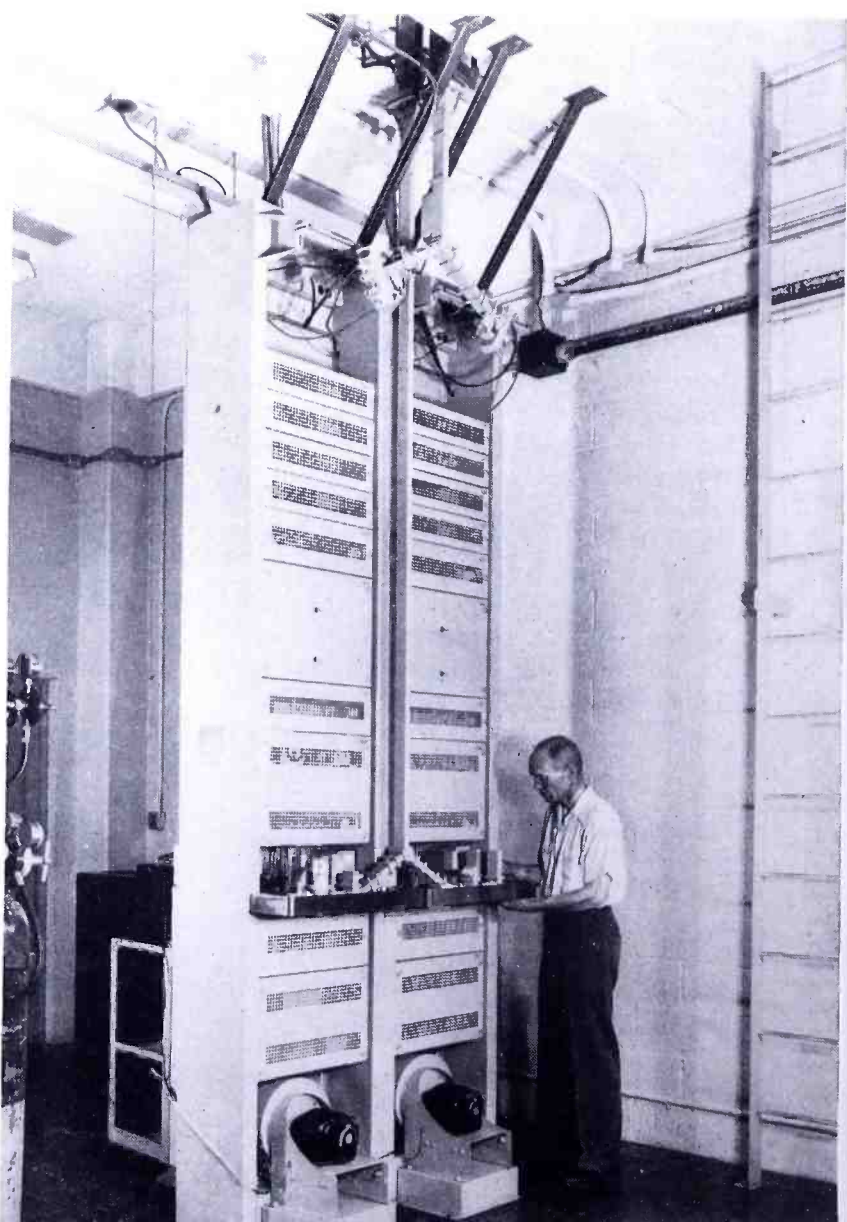

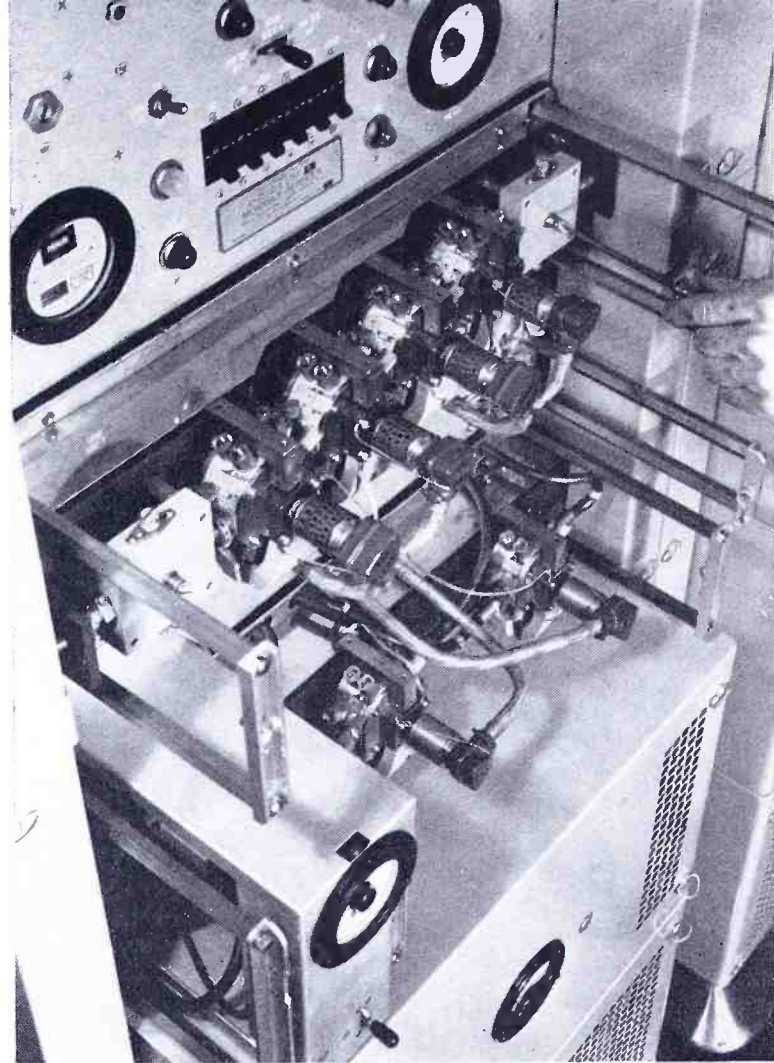
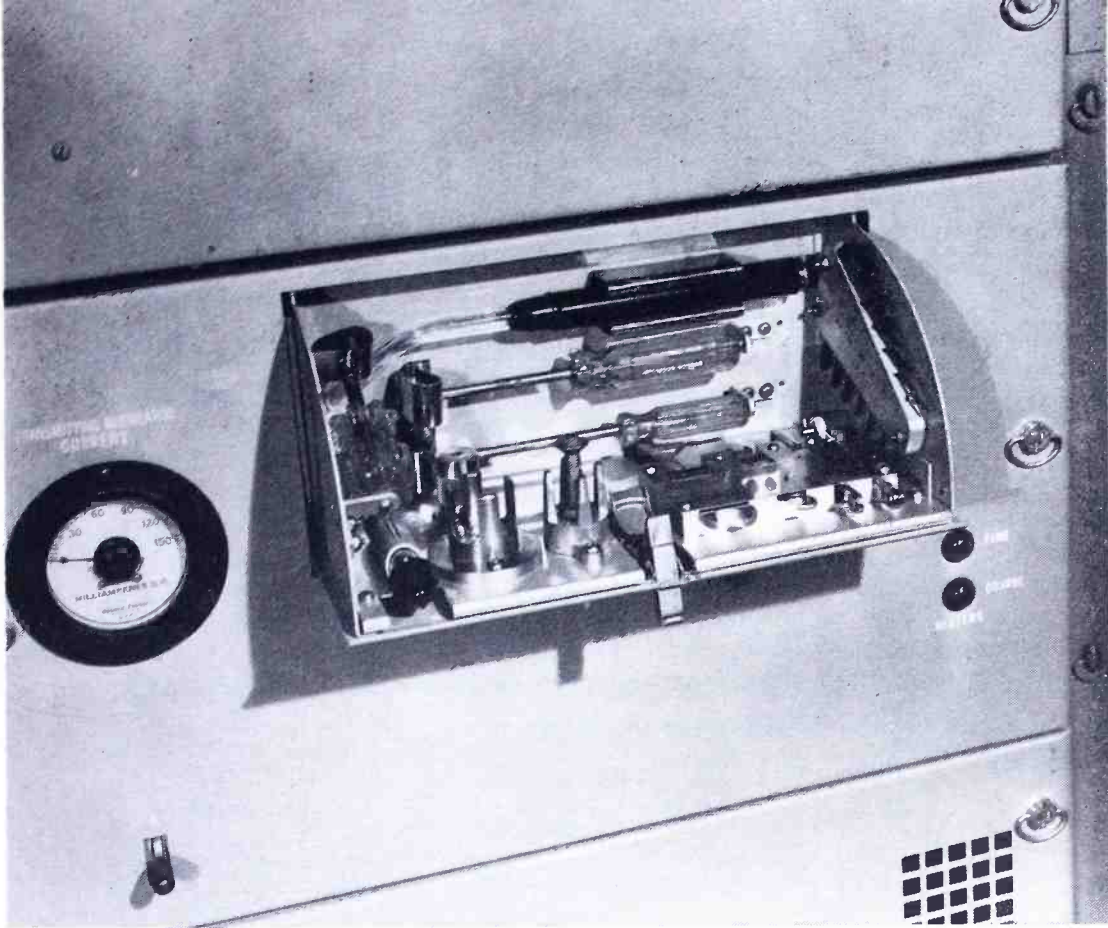

ABOVE, LEFT: TOOL BOX RECESSED INTO EQUIPMENT RACKS. RIGHT: OUTPUT CAVITY OF MICROWAVE AMPLIFIER. BELOW, LEFT: CHECKING THE OPERATION OF THE MICROWAVE REPEATERS. RIGHT: INSTALLATION OF REPEATER RACKS. CANNISTER MAINTAINS NITROGEN UNDER PRESSURE IN WAVE GUIDES

in case of power line failure. Above are the FM repeaters, comprising regular and spare circuits in each direction. These and the associated equipment are shown in the accompanying illustrations.

Dr. Buckley said of this system: "Now we are going to use radio as an entirely new type of communication facility to carry a great volume of communications

between any major cities. . . . Such a system actually becomes a work-horse, if you will, a means of providing communications circuits in great numbers—hundreds, eventually thousands of telephone circuits and, if necessary, dozens of television channels. Eventually, we may have numerous radio relay routes binding cities together to any extent necessary. Even as

we open the system between New York and Boston today, work is well advanced on a second system between New York and Chicago." It is expected that this route, via Philadelphia, will be in service in 1949.

900 Miles by Relay ★ At the conclusion of the
(CONCLUDED ON PAGE 35)

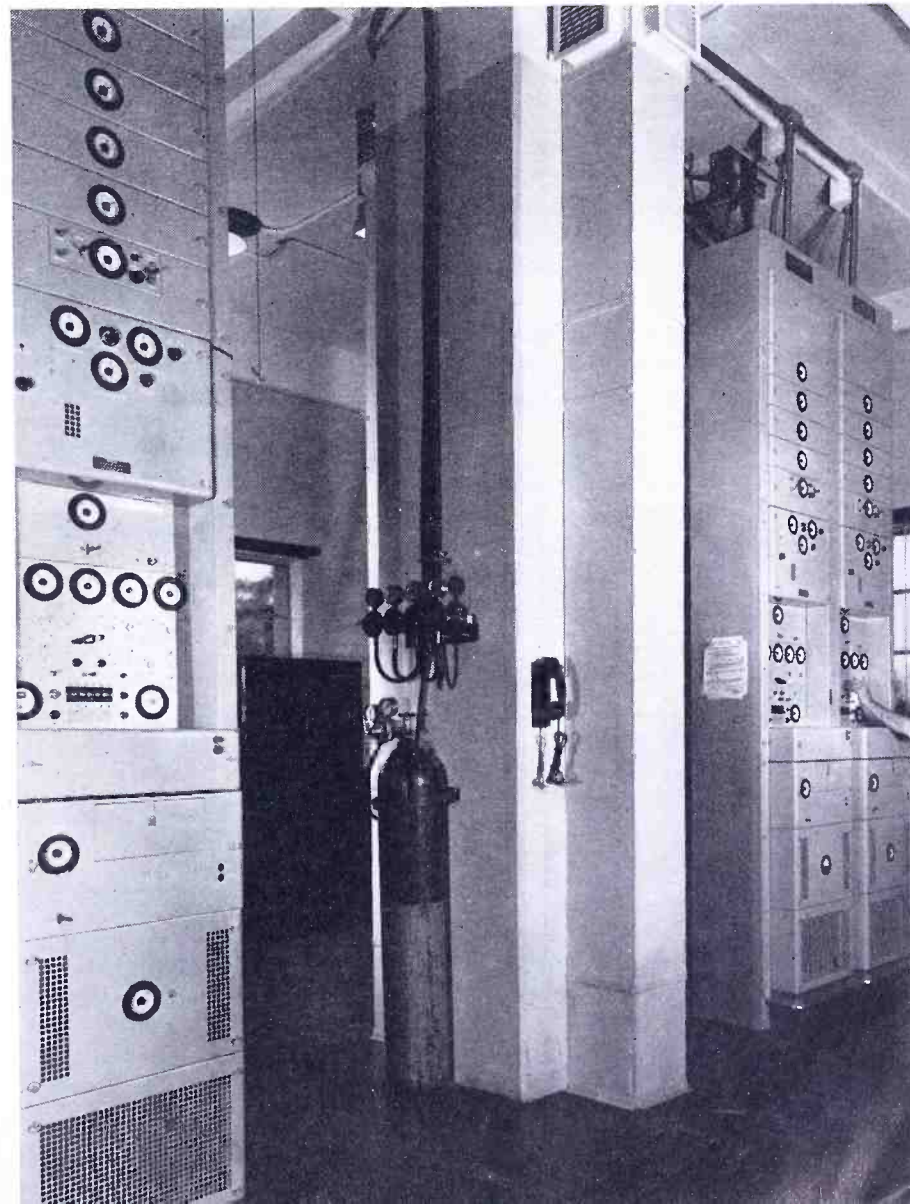
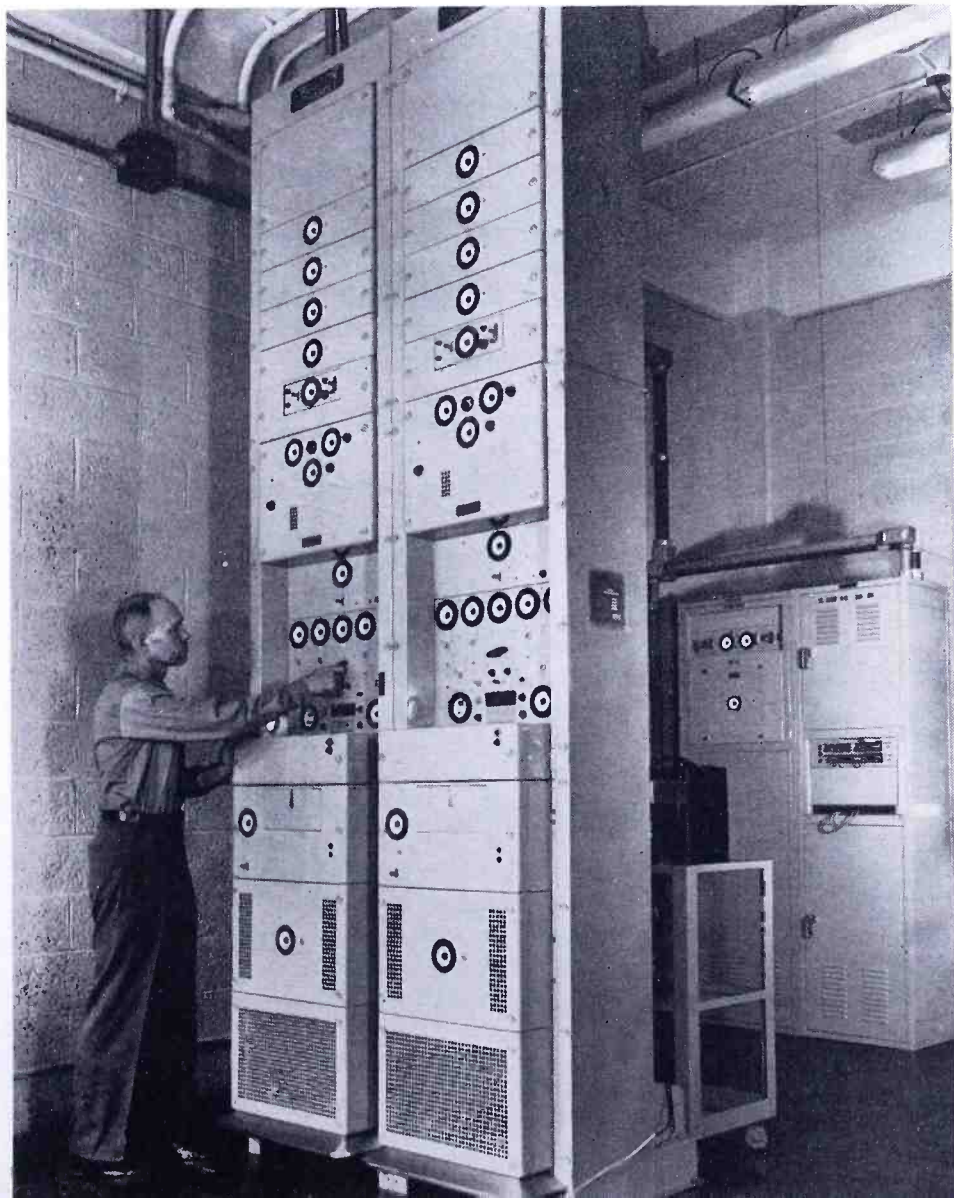

FM MONITOR HAS PULSE-COUNTER DISCRIMINATOR

General Radio FM Monitor for FM Broadcast and Television Sound Transmitters

BY CHARLES A. CADY*

ous indications of center-frequency deviation, modulation percentage, and over-modulation peaks are available at all times, without the need of calibration adjustments during the operating day.

able with characteristics as uniform as those of vacuum tubes, for tests on both types of diodes showed that only with vacuum tubes could the desired stability be achieved in this application.

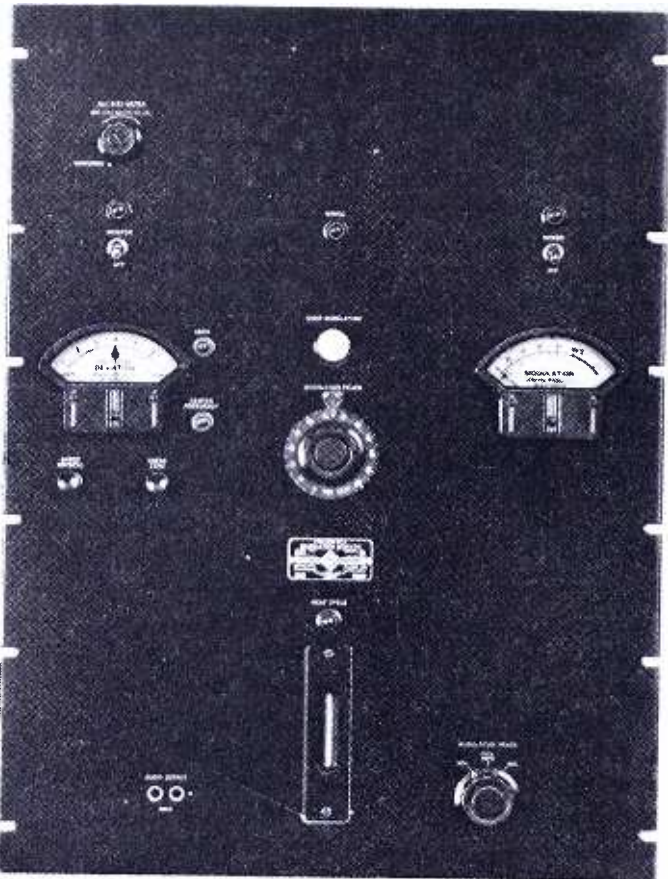

FIG. 1. FRONT PANEL OF THE MONITOR

THE General Radio Company has provided monitoring instruments for AM broadcast transmitters for many years. Their outstanding characteristics are ease of installation, reliability in operation, and stability of indication. These features were also the objectives for the new General Radio 1170-A FM monitor to be described here.

In this design, Figs. 1, 2, and 11, continu-

* Engineer, General Radio Company, Cambridge 39, Mass.

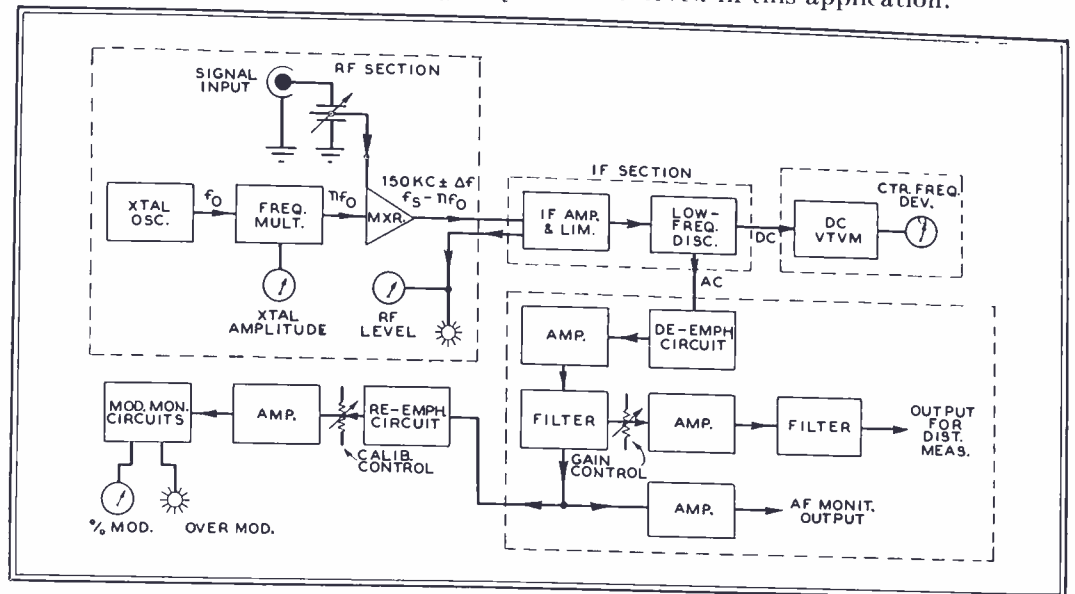

FIG. 3. THIS BLOCK DIAGRAM SHOWS THE CIRCUIT ELEMENTS OF THE FM MONITOR

When remote indicators are used, the operator need not leave his position at the transmitter desk for the purpose of making any adjustments or calibrations. Without this feature, remote indicators are nearly useless.

Input power requirements are very low; only 1 volt into a high-impedance circuit is needed. This greatly simplifies the coupling problem and facilitates installation. The assembly is designed to dissipate the heat generated by the tubes and to make all parts accessible, as can be seen in Fig. 2. All circuits have undergone tests to prove their reliability and suitability for long-period service.

With one exception, vacuum-tube diodes are used rather than crystal rectifiers. Our experience indicates that crystals are not yet commercially avail-

Design Considerations ★ The problems of flexibility were considered in the initial design stage of the new FM Monitor. It was planned for television audio service as well as FM broadcasting, and as a measuring device for the laboratories of transmitter manufacturers. These services require a high degree of adaptability to suit the many changing requirements. For example to shift the operating frequency with a minimum of effort, the tuning adjustments have been made readily accessible, and they cover a wide range without the necessity of removing components. Further, as the same calibration for the modulation swing is not employed in all FM services, a single adjustment is provided to permit rapid changes in this setting.

The RF sensitivity of the monitor is high enough to permit remote monitoring over short distances. Most transmitters are provided with a direct connection to the monitor, but the high impedance RF input and the 1-volt RF sensitivity of this instrument indicate that, with tuned RF amplifiers, remote installations are possible.

Two of the most important features of any monitor are the accuracy and stability of the center frequency indication. The first of these can be readily obtained through the use of crystal oscillators and precision metering circuits. However, the overall stability of an FM monitor is very closely dependent on the characteristics

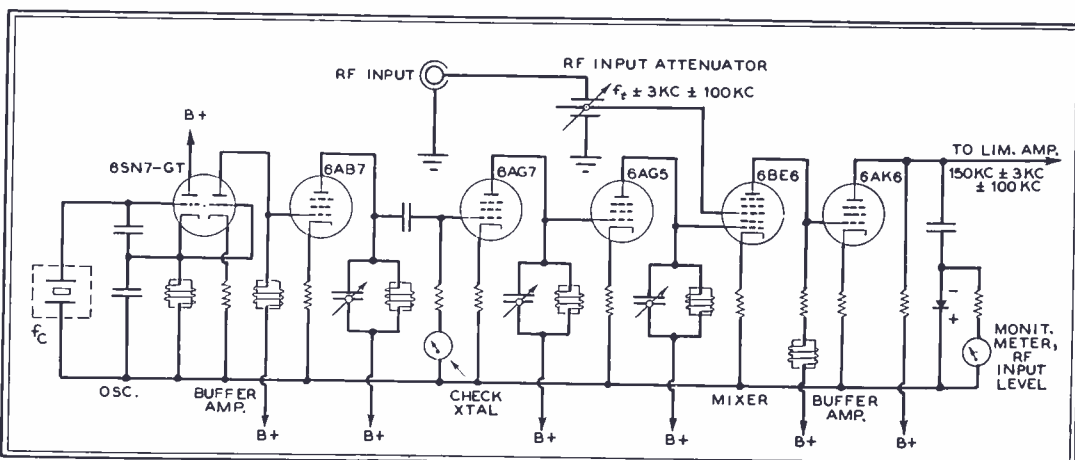

FIG. 4. SCHEMATIC DIAGRAM OF THE CRYSTAL OSCILLATOR AND THE RF SECTION

of the discriminator employed. Early attempts to design a suitable tuned-circuit type of discriminator involved a frequency of several megacycles in order to obtain a linear characteristic. Operations at these frequencies resulted in a relatively unstable discriminator and required the use of a second, or calibrator crystal, in order to provide the required overall accuracy. While this arrangement might simplify the design, the result would be more of a measuring device than a true monitor, since continuous calibration checks would be necessary.

By employing a pulse-counter type of discriminator, it was found possible to

components are simple, and the freedom from critical adjustments justifies a larger instrument. The second factor to be overcome was noise produced in the square-wave amplifier and discriminator. Extraneous signals resulting from beats between the crystal oscillator and harmonics of the square-wave intermediate-frequency are eliminated through judicious selection of the crystal operating frequencies. High-frequency noise, resulting from the pulse-type waveform of the discriminator output, is removed by low-pass filters. A high signal-to-noise ratio is achieved by operating the discriminator at a high input level.

noise meter, and 3) a third amplifier system includes a standard pre-emphasis characteristic to restore the flat frequency response for the modulation metering circuits. These provide for indicating positive and negative modulation peaks simultaneously, or either one alone as selected on a panel switch. Also, an over-

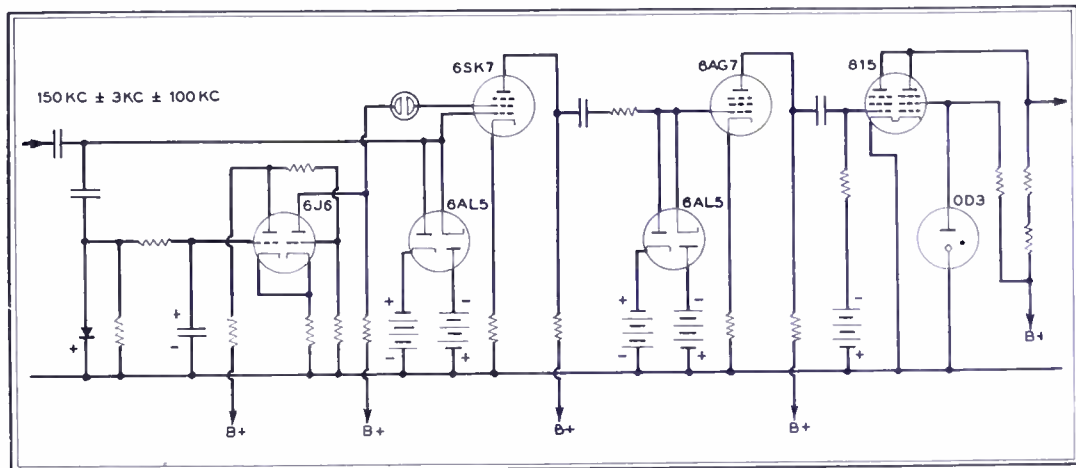

FIG. 5. MIXER OUTPUT SIGNAL GOES TO DIODE CLIPPERS AND LIMITING AMPLIFIERS

operate at the relatively low frequency of 150 kc. This resulted in a considerable improvement in the ratio of desired frequency stability to discriminator center-frequency. In the case of the tuned-circuit discriminator operating at 10.7 mc., with the required stability of the center-frequency indicator arbitrarily chosen as 100 cycles, the ratio is $100/10,700,000$ or .001%, while in the case of the pulse-counter discriminator the ratio is $100/150,000$ or .066% for the same stability.

In order that the center frequency of the discriminator remain within 100 cycles of its nominal value for long periods, and thus eliminate auxiliary crystal calibrators, the choice was decidedly in favor of the low-frequency discriminator operation. With standard circuit components, a stability of .066% in center frequency of the discriminator can be far more readily obtained than the .001% figure.

Pulse counters are inherently linear devices, with circuit simplicity a direct result. Distortion measurements made with this type of discriminator do not depend upon critical adjustments, which may exhibit serious ageing effects or drift with changes in climatic conditions.

The pulse-counter type of discriminator is not without limitations, but these are more readily overcome than their counterparts of the tuned-circuit type. The inherent lack of sensitivity of the pulse-counter discriminator made additional amplification necessary. This increased the size of the monitor, but the added

Operating Circuits ★ Fig. 3 shows the operation of the monitor in simple block form. A crystal oscillator is used to drive a series of simple tuned-circuit amplifiers to produce a signal at the mixer which differs from the transmitter channel frequency by 150 kc. This 150-kc. signal is the center frequency of the IF system. A series of diode limiters and limiting amplifiers convert the signal into a high-level square wave that operates the pulse-counter discriminator. The DC output of the discriminator actuates a meter that indicates shift in the center frequency of the transmitter from the assigned frequency. The AC output of the discriminator is de-emphasized and passed

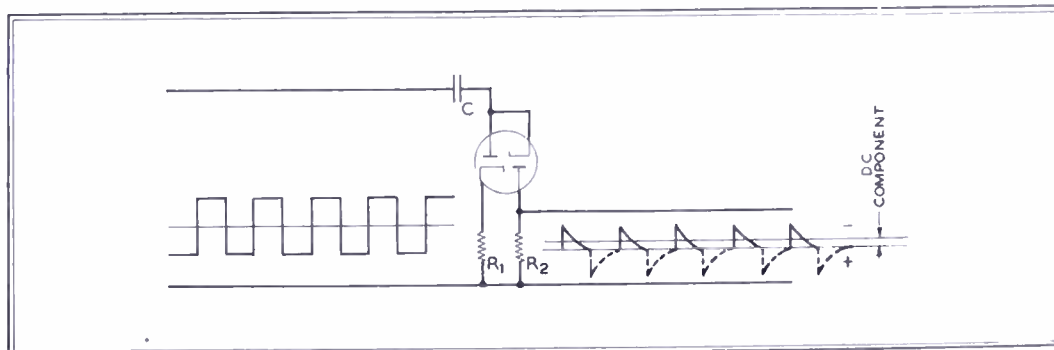

FIG. 6. THIS DRAWING SHOWS THE PRINCIPLE OF THE PULSE COUNTER DISCRIMINATOR

through filters to remove unwanted high-frequency components. At this point, the audio signal divides into three systems: 1) a simple amplifier provides an output for local aural monitoring, 2) a second amplifier, with adjustable gain, provides a signal to operate an external distortion and

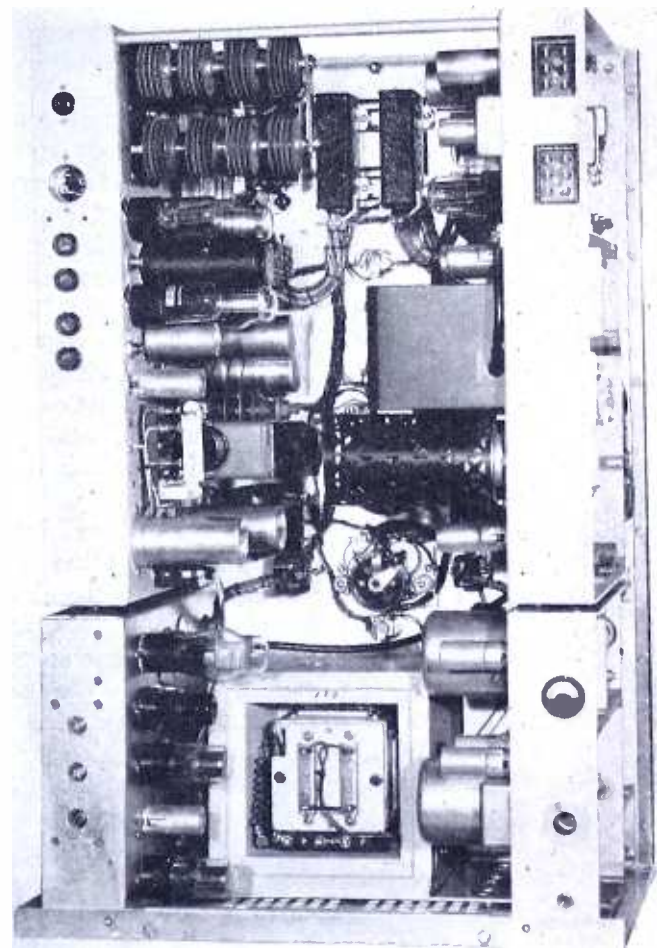

FIG. 2. REAR OF THE MONITOR CHASSIS

modulation lamp flashes whenever the dial setting has been exceeded.

Auxiliary circuits are provided for checking monitor operation. These include:

1. An indication of crystal oscillator output level,
2. An indication of the RF input level,

3. A monitoring signal lamp to indicate normal transmitter input.
4. A heat-cycle pilot lamp to show the action of the crystal oven thermostat.
5. A panel switch to check the electrical zero-setting of the center frequency indicator, and

6. Connections for external meters and an external over-modulation lamp.

Crystal Oscillator & RF Section ★ The crystal oscillator is one developed at General Radio specifically for frequency monitoring. There are no tuning inductances, and the crystal operates very close to its true resonant frequency. High stability is obtained without critical circuit adjustments. Crystals can be interchanged with ease. The oscillator circuit is shown at the left of Fig. 4.

Circuit capacitance can be changed by as much as 4% before the frequency will change by 1 part per million. The crystal has a temperature coefficient of less than 2 parts per million per degree Centigrade, and is enclosed within a temperature-controlled oven operated at $60^\circ \pm 0.15^\circ \text{C}$. For maximum stability, low-frequency crystals are used, with fundamentals between 1.4 and 2.2 mc. Amplitude of the crystal oscillator output is indicated on a panel meter when a panel switch is depressed.

The crystal oscillator is followed by an aperiodic buffer amplifier and 3 harmonic multiplier stages. Fig. 4 shows the circuit arrangement.

The crystal frequency is chosen so as to result, after passing through the multipliers, in a 150-ke. offset from the assigned transmitter frequency. The multipliers are operated at high levels to minimize phase-shift effects which would appear in the monitor output signal as residual FM noise. Because these stages are individually tunable over a considerable range, it is a relatively simple matter to change the operating channel frequency of the monitor. It is merely necessary to insert the new crystal and make three simple tuning adjustments of the multiplier stages.

It is possible to extend the RF range of the monitor down to 30 mc. by replacing one or more of the fixed inductances in the

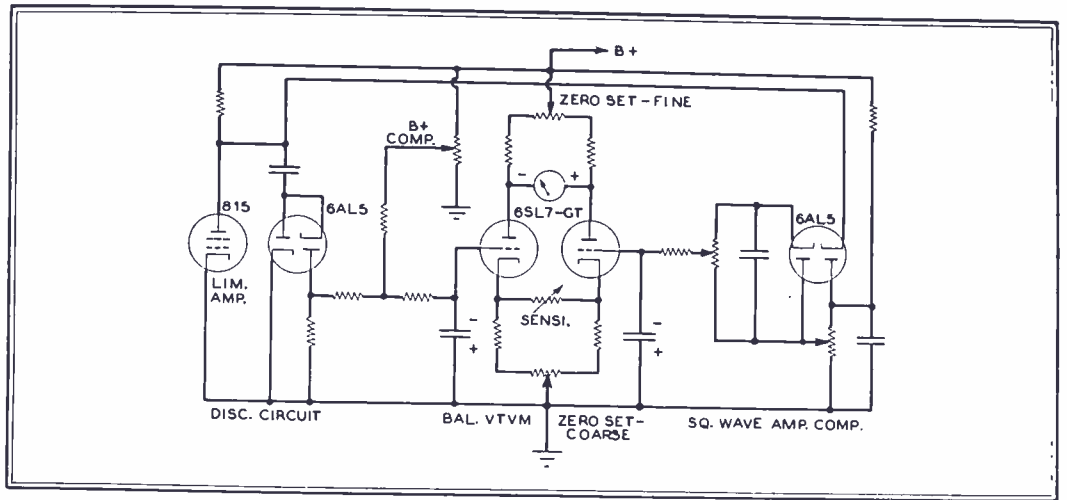

FIG. 7. CIRCUIT OF THE PEAK-RESPONSE DIODE VOLTMETER AND ZERO ADJUSTMENTS

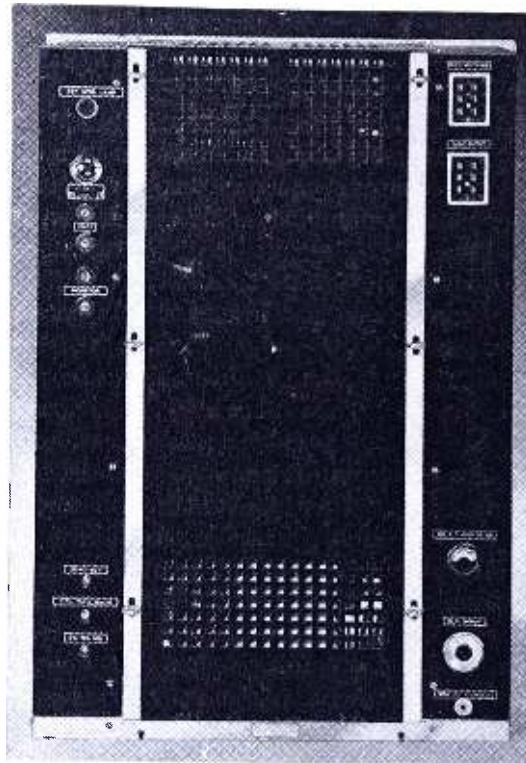

FIG. 11. VIEW OF THE REAR PANEL

RF input from the transmitter is fed to the mixer stage through an adjustable capacitive attenuator. This is a high-impedance circuit, operating with a nominal signal level of 1 volt. No appreciable power is taken from the transmitter, and there are no loading resistances subject to burnout. The RF input level is continuously indicated by a small meter at the rear of the monitor. This meter is operated by the IF signal, which is proportional to the RF input over the normal operating range. The amplifier saturates at higher levels, making it impossible to burn out the meter through overloading. Since the RF level is not critical, this meter is normally used only during the initial installation procedure. A panel pilot lamp provides a continuous indication of the required minimum transmitter signal level.

Limiter-Amplifier ★ The mixer output signal is amplified and passed through a series of diode clippers and limiting amplifiers to convert it into a square wave. These are shown in Fig. 5. To operate the limiters, a minimum input voltage level is required. A control tube keeps the final amplifiers inoperative until the output of the mixer is sufficient to provide a saturation signal to the limiters. Erratic behavior at low RF input levels is thus avoided, since the monitor automatically ceases operation when the signal level falls below a critical value.

The pulse-counter type of discriminator depends for its operation upon a uniform charge and discharge of a condenser through a series resistance during each half-cycle. For this reason, those characteristics of the square wave which influence the condenser charges must be rigorously controlled. Anode and limiter-bias potentials in the clipper-limiter sections are closely regulated. A power tube, operating as a limiter, is used to drive the discriminator at a high level.

Discriminator Operation ★ Fig. 6 illustrates the principle of the pulse counter discriminator. The series condenser is alternately charged through the left diode, and discharged through the right diode.

multiplier system. The high-frequency operation can be extended above 162 mc. by replacing a removable section of the multiplier assembly with a VHF unit.

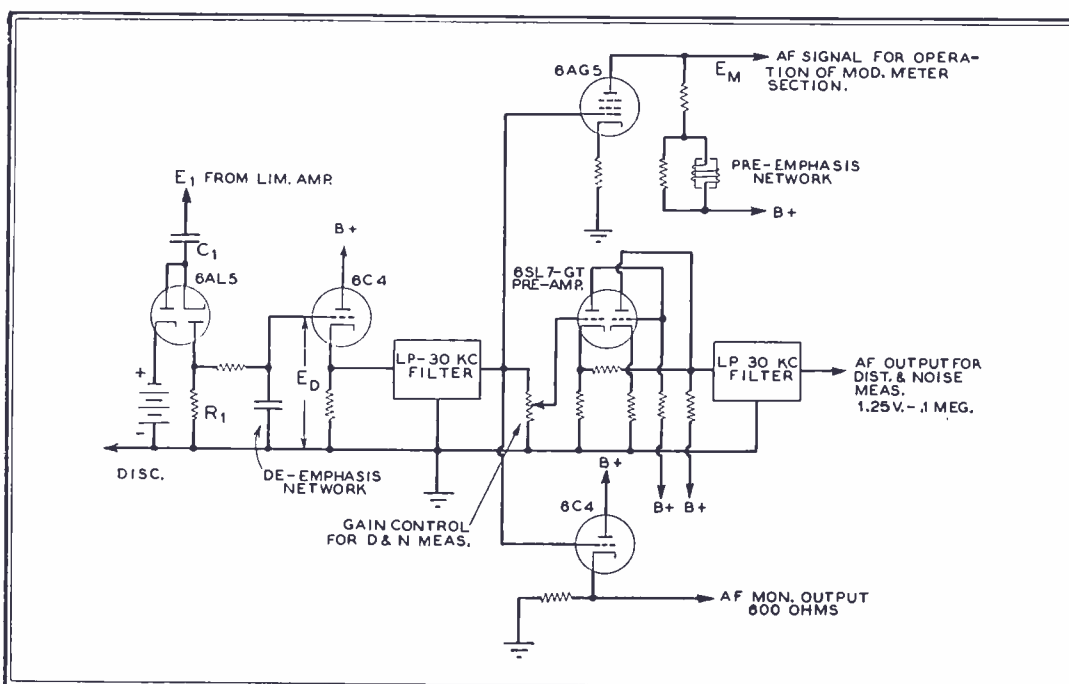

FIG. 8. THE AUDIO SYSTEM IS DIVIDED INTO 3 SEPARATE CIRCUITS, AS SHOWN HERE

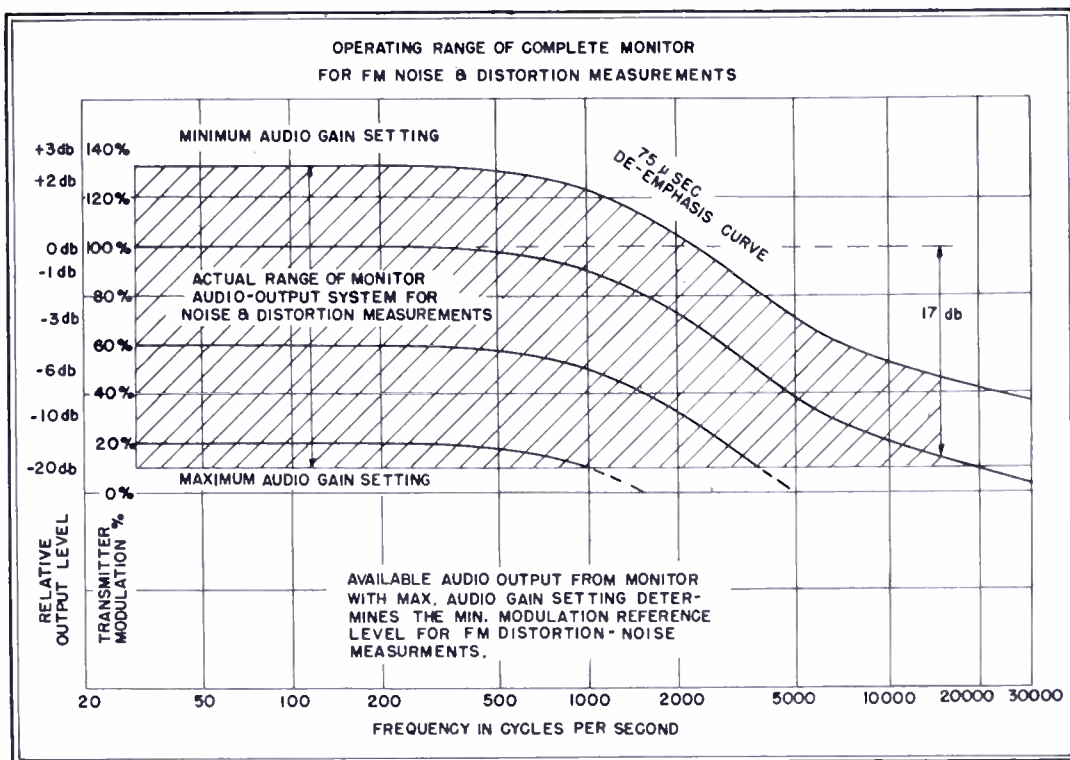

FIG. 9. OPERATING RANGE FOR MAKING FM DISTORTION-NOISE MEASUREMENTS

Thus a series of short, uni-directional current pulses flow through the resistance at the rate of 1 per IF cycle. When the transmitter is unmodulated, these pulses occur at a uniform rate. When modulation is applied, the pulses occur at a varying instantaneous rate, dependent upon the modulation signal. A DC potential is developed across the resistance which is proportional to the average rate of the pulses. This is used to operate a balanced DC vacuum-tube voltmeter, calibrated to read average center-frequency-shift from the assigned transmitter channel frequency.

To minimize the effects of minor variations in the amplitude of the discriminator input signal, a compensating circuit is used. This consists of a peak-response diode voltmeter, whose output is applied to one side of the balanced DC vacuum-tube voltmeter. Amplitude changes affect

age appearing across the discriminator resistance contain the modulation signal, the fundamental pulse repetition frequency, and a series of harmonics. The high frequencies are above the upper limit of the audio measurement band (i.e., 30 kc.), and a high-pass filter is used to separate the desired modulation signal.

Audio System ★ The entire audio system is coupled to the discriminator by a standard 75-microsecond de-emphasis network. This reduces the reactance load across the discriminator to improve the linearity, and is an effective low-pass filter which attenuates the pulse repetition frequency and its harmonics. This is followed by an impedance-transforming amplifier and a low-pass filter section which provides a uniform frequency-response up to 30 kc. At this point, the audio system divides into three separate circuits, as in Fig. 8.

input gain control. This is intended for fidelity measurements, and has been designed for very low residual noise and distortion. It has a low-pass filter section on the output to reduce further the noise resulting from IF and RF interference. The residual distortion level is less than .1% with a noise level of approximately -80 db, and is intended for use with an external distortion and noise meter such as the GR 1932-A. Input gain control permits the output of the amplifier to be set for a constant level of 1.2 volt with transmitter modulation swings ranging from ± 100 kc. to ± 6 kc. In the standard FM broadcast band, this corresponds to a range of 133% to 8% modulation. For television aural transmitters, the range is 133% to 24% modulation. Due to the de-emphasis characteristic, the available signal level for a given modulation swing decreases at the higher audio frequencies. This limits the minimum modulation swing, or percentage modulation, at which measurements can be made when the audio frequency approaches its upper limit. Fig. 9 shows the operating range for these measurements.

The third audio circuit comprises the modulation measuring system. An amplifier with a standard pre-emphasis characteristic is used to restore a flat frequency-response, since the modulation swing must be measured without de-emphasis. Following this is an amplifier with continuously adjustable gain. To change the calibration of the entire modulation system it is only necessary to reset this one control. It has a range slightly in excess of 3 to 1. Hence the instrument can be shifted readily from a calibration level of 100% modulation for ± 75 -kc. swing to a value of 100% modulation for ± 25 kc. swing, as required for monitoring television aural transmitters.

The output of this amplifier feeds two modulation indicating circuits. One of

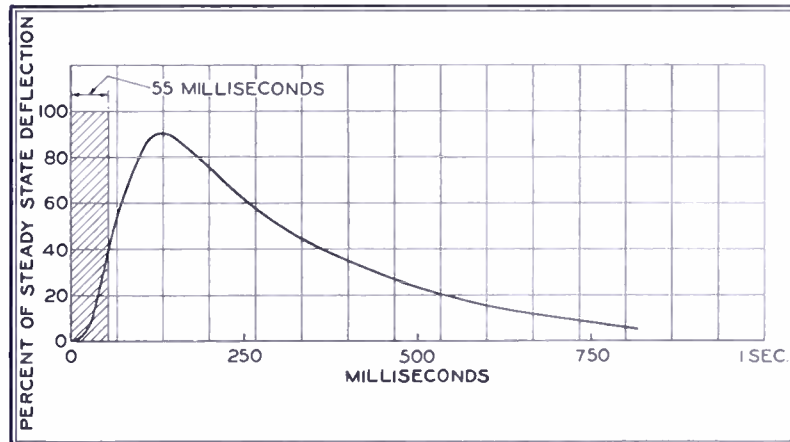
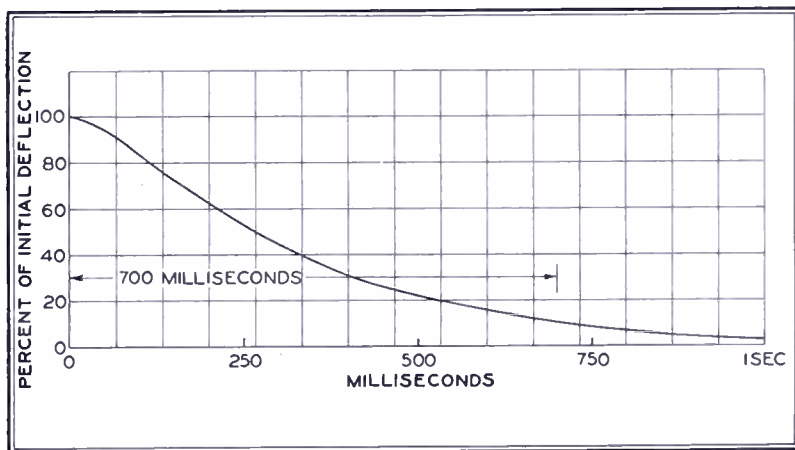

FIG. 10. PERCENTAGE OF INITIAL DEFLECTION AND STEADY STATE DEFLECTION ARE IN ACCORDANCE WITH FCC REQUIREMENTS

both circuits equally, and hence do not affect the meter indication. Frequency changes are detected only by the discriminator, and hence appear as deflections on the meter. The metering circuit is shown in Fig. 7.

The AC components of the pulse volt-

A cathode-coupled amplifier provides an audio signal for direct connection to aural monitoring lines at a level of 0 dbm for a modulation swing of ± 75 kc. The image impedance is 600 ohms, and has one side grounded.

A second amplifier is provided with an

these consists of an over-modulation peak indicator, which flashes a panel lamp whenever the instantaneous modulation peaks exceed a given setting of a dial indicator. A thyratron tube is employed to flash a lamp connected in its anode

(CONCLUDED ON PAGE 36)

SPOT NEWS NOTES

Items and comments, personal and otherwise, about manufacturing, broadcasting, communications, and television activities

Trade-ins: Following the Federal Trade Commission's crack-down on prizes for retail salesmen, the Better Business Bureau has called for an end to advertised trade-in allowances which are allowed even though there's no set to trade in. This is a good time to straighten out that situation because, before long, smart dealers will find it profitable to take in expensive FM and TV sets as a means of selling newer models. The trade-ins can then be sold to people of moderate means who could not otherwise own such sets.

Chicago Parts Show: Will be held at Hotel Stevens during the week of May 9. Information about the Show can be obtained from S. I. Neiman, 1 N. LaSalle Street, Chicago.

Railroad Radio: Union Switch & Signal Company is handling Sperry railroad radio equipment. General Railway Signal Company has a similar arrangement with General Electric.

New FMA Members: Are WLWA, Crosley Broadcasting Corp., Cincinnati; WSIX, Nashville, Tenn.; WLOB, Claremont, N. H.; Charleston Gazette, Charleston, W. Va.; KMUS, Muskogee Broadcasting Co., Muskogee, Okla.; WHFB-FM, Palladium Publishing Co., Wyandotte, Mich.

TV Stations: As of December 1, FCC records show that there were 6 licensed stations, and 11 others operating under temporary authority. These are: Hollywood 1, Washington 3, Chicago 2, Baltimore 1, Detroit 1, St. Louis 1, New York City 3, Schenectady 1, Cleveland 1, Philadelphia 2, and Milwaukee 1.

Another FM Net: An all-relay net, using no wire lines, is operating in North Carolina. The 13 stations are: WBBB-FM Burlington, WGTM-FM Wilson, WGBR-FM Goldsboro, WRAL-FM Raleigh, WMFR-FM High Point, WHPE-FM High Point, WSTP-FM Salisbury, WAYS-FM Charlotte, WAIR-FM Winston-Salem, WMIT Mt. Mitchell, WGNC-FM Gastonia, WSIC-FM Statesville, and WGBG-FM Greensboro.

General Roger B. Colton: After a brilliant 36-year career in the Army, nearly half of which was devoted to the Signal Corps, Major General Colton, now retired, has been elected a vice president of Federal Telephone and Radio Corporation.

Corrections: In our October directory of FM broadcast stations, WAFM Birmingham was listed only as holding a CP. Chief Engineer Norman S. Hurley protested at having such an indignity visited upon a station that started in July, 1945, and moved to the high band last January.

Also, the Eitel-McCullough station KSBR was not shown as being on the air. Sales director O. H. Brown reminded us that KSBR San Bruno has been putting out 200 kw. of effective power since it started operation on April 23. Schedule is 3:00 to 10:00 P.M. weekdays, on 100.5 mc. Our apologies to both these stations.

Paul Weathers: New vice president and chief engineer of Airdesign, Inc., transformer manufacturers at Upper Darby, Pa. He was formerly with RCA at Camden and Indianapolis.

More Dollars: Ex-RMA president Ray Cosgrove expects that more dollars will be spent in 1948 for television receivers than for AM broadcast sets. Since Mr. Cosgrove should know, we can presume that inventories of AM set components must be in good shape. Otherwise, there's some trouble ahead.

WENA: Detroit FM station operated by the *Evening News* has changed its call letters to WWJ-FM, and is now on a 10-hour schedule from noon to 10:00 P.M.

AC-DC FM Sets: New series of FM-AM phonographs paralleling their AC line has been introduced by Freed Radio Corporation, 200 Hudson Street, New York City. Prices are about 10% higher. Considerable demand for FM is developing in the DC areas of New York City, Chicago, Boston, and Washington.

Here's an Opportunity: DuMont station WABD New York will institute an apprentice training program the first of the year to meet the demand for television station personnel. This should be a rare opportunity for those accepted. Information can be obtained from John McNeil, general manager of WABD.

Kansas City: KSBS has their new station on the air from 1:00 to 10:00 P.M. at 105.9 mc. President is Harry Butler; chief engineer is C. O. Simmons. Studios at 30 S. 18th Street are open daily for public inspection.

Peter N. Tsokris: Appointed chief engineer of Colonial Television Corporation, 2139 Harrison Avenue, New York 53, N. Y.

New York City: Although its FM application was finally rejected by the FCC, the *Daily News* has by no means abandoned its plans to erect an FM station. This may well develop into a scrap that will set or upset some precedents.

No Training: Limiting factor of both FM and TV set sales is lack of sales ability on the part of retail stores. Lack of factual

knowledge and sheer indifference to progress are common faults in all areas. As a result, a relatively small number of dealers are getting the bulk of the business on FM and television receivers. This shift has been forced by the increasingly technical aspect of radio equipment.

Even servicemen can't bluff their way when confronted by the new models. The industry has finally reached the point where lack of training shows up sharply in both sales and service work. Amateurs who taught themselves and know mostly things that aren't so are going to be a real headache to set manufacturers in 1948. Right now, the number of poor FM set installations, explained away with "You'll be able to hear FM when they get it perfected," is appallingly large.

Edward E. Lewis: Newly-elected president of Colonial Radio Corporation, Buffalo. This company, a wholly-owned subsidiary of Sylvania Electric, is the principal source of radio receivers for Sears. Mr. Lewis has served as treasurer of Bijur Motor Appliance Corporation, economist for G.E., treasurer and works manager of Eclipse Aviation, and vice president in charge of accounts and finances at RCA.

Expansion: DuMont Laboratories are completing a brick addition to their tube plant. New facilities will triple production of 12-in. cathode-ray tubes.

San Bernadino: Station KBMT, one of the exclusive FM stations, is now operating on 99.9 mc. This brings to 28 the number of FM's in southern California.

Promotion: Westinghouse officials recently exhibited to the press a most elaborate plan of promotion which will be furnished to purchasers of FM station equipment. Worked out to the last detail, it is set up to build an FM audience quickly.

Surprising: The FM Association paid Congressman Carroll D. Kearns \$50 for attending a meeting on October 1 with the president of the American Federation of Musicians. Well, the AFM should have paid him more than that for the heroic, though unconvincing, public relations effort he made on their behalf at the FMA Conference in New York City.

Wheeling: New West Virginia station is WTRF-FM, putting out 20 kw. at 100.5 mc. from 6:00 A.M. to 10:30 P.M. daily. R. W. Ferguson is station manager, and George Cowen is chief engineer.

New Ownership: Airadio, Inc., Stamford, Conn., founded by J. B. Cobrain, has been sold to Jay Sullivan and his associ-

(CONCLUDED ON PAGE 42)

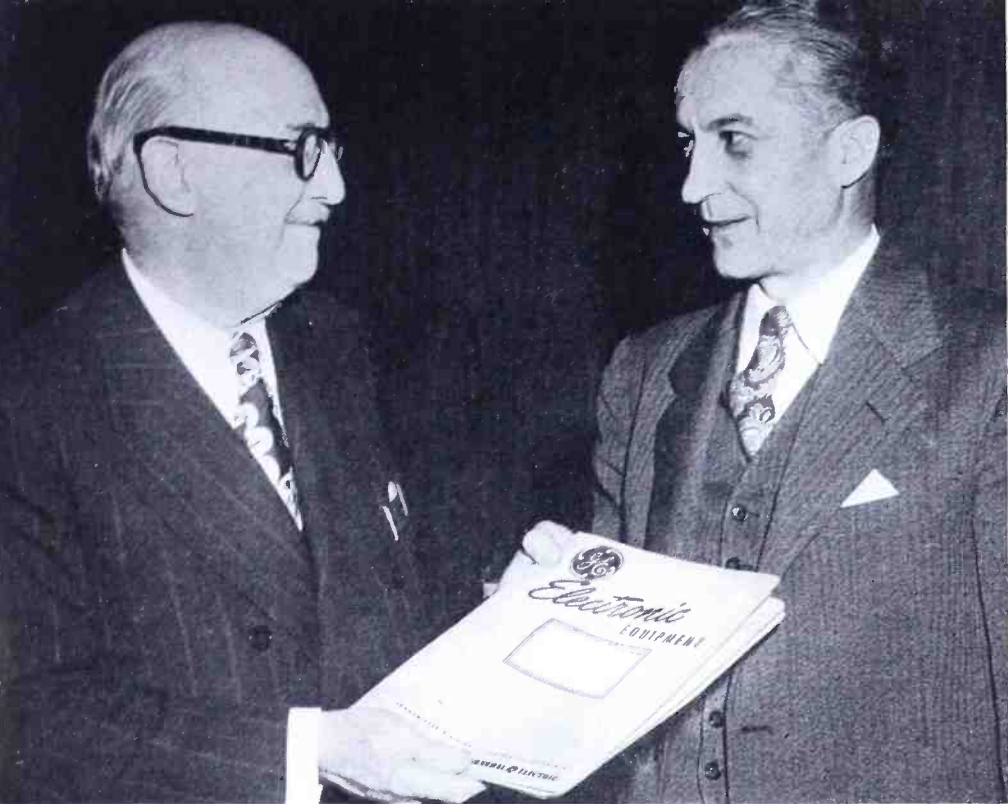

1: YANKEE NET TO ENTER TELEVISION

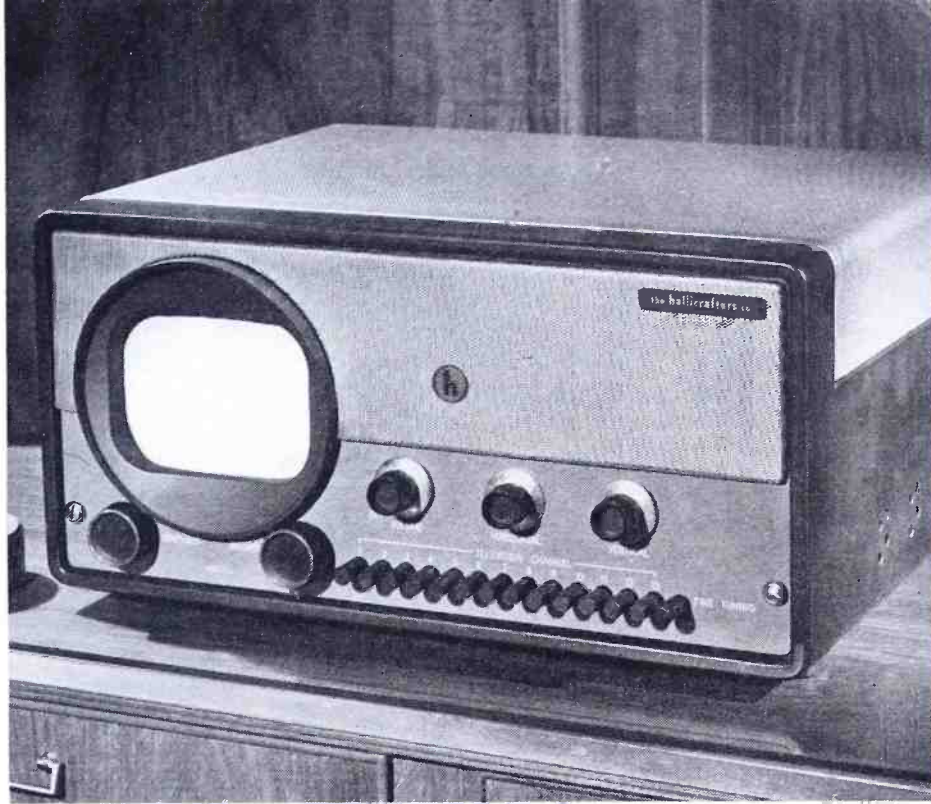

2: TELEVISION SET HAS METAL CABINET

NEWS PICTURES

1 John Shepard, 3rd, pioneer broadcaster and chairman of the board of the Yankee Network, is going into television, too. He is pictured here, left, with R. L. Hanks, New England manager of G. E.'s electronics department, after signing a contract for the installation which will be WNAC-TV. The transmitter, scheduled to start operation next summer, will be at Medford, Mass., outside Boston.

2 Hallicrafters, having proved that metal cabinets of functional design are acceptable in the best living rooms, has now set a new style in television receivers. This cabinet, designed by furniture stylist Raymond Loewy and produced by Karp Metal Products, is finished in gray and silver. Substitution of metal for wood, a practice long championed by this publication, has made it possible to price this 7-in. model at the amazingly low price of \$169.50.

3 Stromberg-Carlson's Radio City, at Rochester, N. Y., is nearing completion. Started in November, 1945, this most modern studio and office building will be dedicated on February 14, 1948. Planned and constructed under the direction of general manager William Fay, the building is truly the last word in design, equipment, and studio facilities.

4 If you listen to the Stromberg-Carlson program over the Continental Network on Friday nights from 8:30 to 9:00, you'll be interested in this picture of conductor Guy Frazier Harrison. The Rochester Civic Orchestra, under his direction, is giving listeners to 33 FM stations what is unquestionably the finest music ever heard on the air.

3 Stromberg-Carlson's Radio City, at Rochester, N. Y., is nearing completion. Started in November, 1945, this most modern studio and office building will be dedicated on February 14, 1948. Planned and constructed under the direction of general manager William Fay, the building is truly the last word in design, equipment, and studio facilities.

4 CONDUCTOR, 33-STATION FM PROGRAM



3: WHAM-WHFM BLDG. NEARS COMPLETION

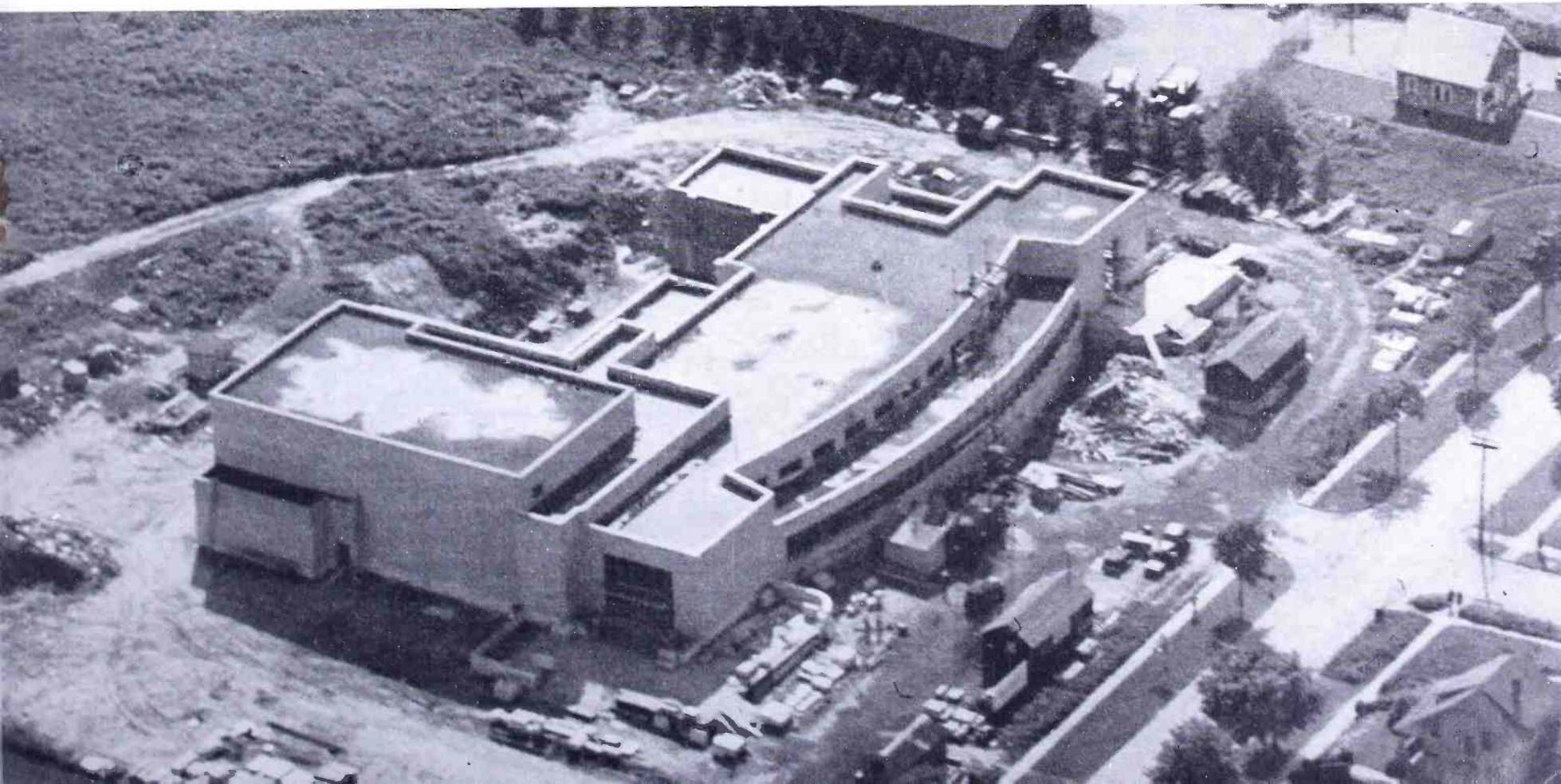

AM IS LIMITED TO THIS RANGE

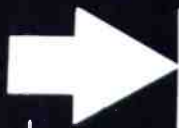

FM ADDS THIS RANGE

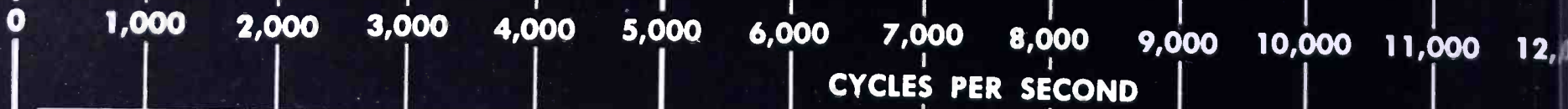

FEMALE VOICE: 170 TO 10,000

MALE SPEECH: 100 TO 8,300

BASS CLARINET: 80 TO 15,000

CASTANETS: 500 TO 15,000

CELLO: 65 TO 15,000

CHIMES: 523 TO 15,000

FLUTE: 261 TO 15,000

GLOCKENSPIEL: 784 TO 15,000

GONG: 300 TO 15,000

OBOE: 283 TO 15,000

ORGAN: 29 TO 15,000

PICCOLO: 587 TO 15,000

SNARE DRUM: 80 TO 15,000

SOPRANO SAXOPHONE: 200 TO 15,000

TAMBOURINE: 500 TO 15,000

TRIANGLE: 500 TO 15,000

VIOLIN: 190 TO 15,000

XYLOPHONE: 130 TO 15,000

BASS SAXOPHONE: 55 TO 14,500

CLARINET: 146 TO 14,500

BASSOON: 58 TO 14,000

CYMBALS: 300 TO 14,000

VIOLA: 130 TO 11,000

CELESTA: 261 TO 10,000

DOUBLE BASS: 40 TO 9,500

TRUMPET: 164 TO 9,500

ENGLISH HORN: 164 TO 8,500

FRENCH HORN: 61 TO 8,200

TROMBONE: 80 TO 8,000

TUBA: 41 TO 7,500

PIANO: 30 TO 6,500

BASS DRUM: 52 TO 5,500

TYMPANI: 45 TO 5,000



NOTE: Frequencies below 4,000 cycles contribute ENUNCIATION, clarity, intelligibility, and emotion in the individual characteristics of

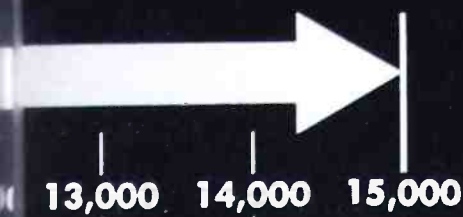

Frequency Modulation Means: Freedom from Static, Interference, and Fading **PLUS** Clear. Natural Speech, Music, and Sound Effects

W

ILL a high-quality amplifier and speaker give me enough added listening pleasure to justify the extra cost? We have had so many letters on this subject that the following summary from an extensive study of listener reactions¹ is offered to help clarify this very important point:

1. When listeners conditioned to AM reception first hear the natural reproduction of live-talent FM programs, their first impression is one of relief from the irritating, distracting background noise of AM reception.

2. Then, almost invariably, they become conscious of the clarity of FM. That is due partly to the presence, against a background of silence, of the high frequencies which supply definition to individual sounds and instruments, and partly to the freedom from intermodulation distortion. There is none of the rasping and blurring characteristic of nearly all AM receivers.

3. Usually, the next reaction is the discovery of "presence effect" which draws the comment: "It sounds as if that orchestra (or speaker) is right in this room!" There's a reason for that impression. If you stand at the back of a theatre, you hear the low frequencies, but very little of the high frequencies because they are attenuated rapidly in space. In the front row, you are conscious of being near the sound source not as much because the sounds are louder, but because you hear the higher frequencies clearly. That is why natural (full-range) FM reproduction makes you feel that you are in the presence of the performers. Turning down the tone control to cut off the high frequencies seems to move the loudspeaker back to some indefinite distance.

4. Sometimes listeners complain at first that full-range reproduction is harsh. That is because they have been conditioned to AM reception and phonograph records. Invariably, those same people, after listening to full-range reproduction of live talent on FM remark, if the tone control is turned down: "Now the music sounds flat. It has no life!"

It is difficult to discuss the differences between simulated (limited-range) tone quality and natural (full-range) reproduction unless those taking part are listening to the same sound source. However, the chart opposite tells a complete story.

Notice that 27 out of the 31 instruments, and both male and female voices, employ frequencies of 8,000 cycles or more. Female voices and 22 instruments employ frequencies of 10,000 cycles or more. And 20 instruments range from 14,000 to 15,000 cycles!

If you will be satisfied to sacrifice all sounds above 4,500 to 5,000 cycles, then most any amplifier and cheap speaker will give you what you want. But if you want natural reproduction, free of intermodulation blurring, to recreate in your home exactly what you would hear at the broadcast studio, then you will never be satisfied until you have an amplifier and speaker capable of delivering 30 to 15,000 cycles.

¹This discussion assumes live-talent broadcasting. While many FM programs are now made up of recordings, the amount of live talent is increasing steadily, and the use of recordings will be cut drastically by the settlement of the AFM union controversy, permitting the full expansion of live-talent FM networks.

cycles contribute
ies above 4,000
provides personal-
tech, and bring out
musical instruments.

RATIO DETECTORS FOR FM RECEIVERS

Explaining the Principles Involved, and the Performance Characteristics

BY STUART WM. SEELEY*

UNTIL a few years ago, most Frequency Modulation receivers used detector circuits which were sensitive not only to frequency deviation but also to amplitude variation of the applied signal. The slope, or deviation sensitivity, of such detectors was usually directly proportional to the strength of the received wave and thus

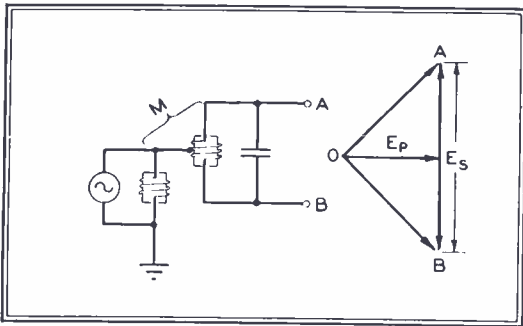

FIG. 1. BASIC DISCRIMINATOR CIRCUIT

allowed incidental amplitude modulation to be reproduced as distortion or noise.

To obviate this difficulty, it was general practice to remove as much as possible of the incidental amplitude variations before applying the signal to the FM detector. This was usually accomplished by passing the signal through one or more limiter stages, which were operated beyond saturation, and thus produced nearly uniform

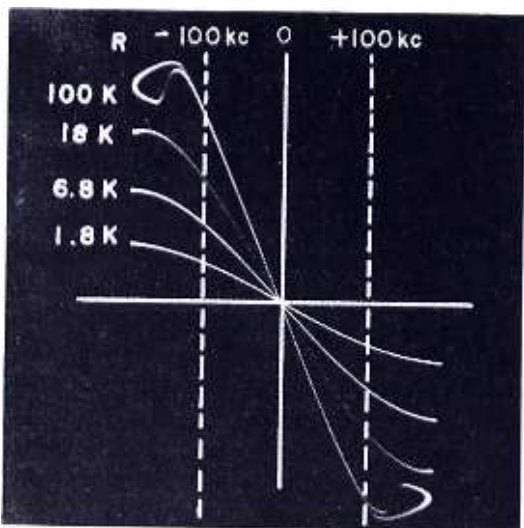

FIG. 4. DEVIATION SENSITIVITY OF FIG. 3

output regardless of input signal variations.

It was obvious that limiter stages were necessary only to counteract the inherent amplitude sensitivity of early types of detectors, and that if the detector were sensitive to frequency deviation alone, all of the advantages of capture effect, low distortion, freedom from noise, etc.,

* Director, RCA Industry Service Laboratory, 711 Fifth Ave., New York City.

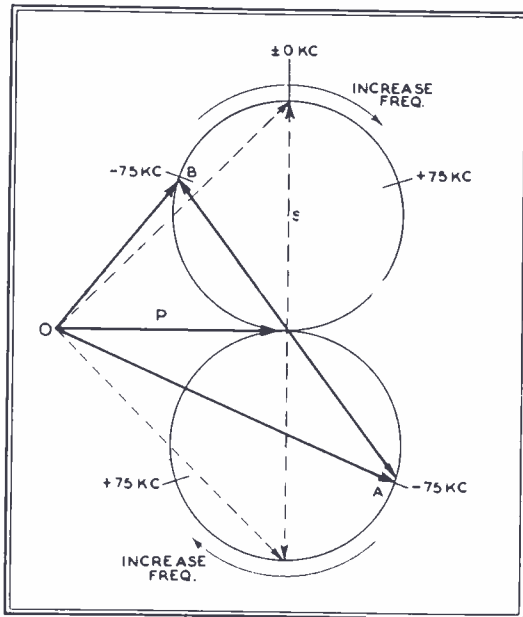

FIG. 2. DOTTED LINES SHOW ZERO DEVIATION

would result without the necessity for amplifying the signal to a high enough level to saturate a limiter.

Principle of the Ratio Detector ★ In the last few years several types of detectors with a high degree of immunity to amplitude variations have been developed. One of these, which has recently come into rather wide use, is called the Ratio Detector. This circuit has many variations and has been applied in many different ways, but the most common application utilizes the phase-shift discriminator network. The description which follows is devoted to that form of the circuit.¹

The basic connections of a phase-shift type of discriminator network are shown in Fig. 1. In this circuit a single-ended primary and a balanced secondary are loosely coupled and the voltage end of the primary is connected to the midpoint of the secondary. If the frequency of the voltage impressed upon the primary is equal to the resonant frequency of the secondary, two potentials of equal magnitude are developed. The voltage between ground and the end of the secondary marked A, consisting of the primary voltage and one half the secondary voltage, will be equal in amplitude to the voltage between ground and the point marked B, made up of the primary voltage plus that of the other half of the secondary. The vector relations are shown in Fig. 1.

If the frequency of the generator is decreased by, say, 75 kc. below the resonant frequency of the secondary, the secondary

¹ For a more detailed discussion, see "The Ratio Detector" by Stuart Wm. Seeley and Jack Avins, *RCA REVIEW*, June, 1947.

voltage will no longer be in exact quadrature with the primary. The vector voltages will then be as indicated by the solid lines of Fig. 2. Notice that the length of the vector O-B, which consists of the primary plus one-half of the secondary, is less than that of O-A, which is made up

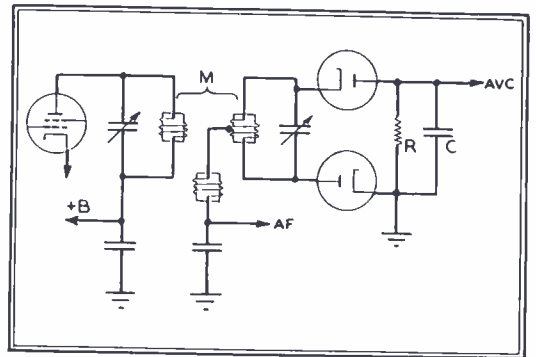

FIG. 3. RATIO DETECTOR CIRCUIT

of the primary plus the other half of the secondary.

If the frequency of the generator of Fig. 1 were raised above the resonant frequency of the secondary, the secondary vector A-B of Fig. 2 would swing in the opposite direction so that O-B would be longer than O-A. Notice that the loci of the ends of the secondary vector form perfect circles. As the frequency of the applied energy is varied either above or below the secondary resonant frequency, the magnitude of the total secondary

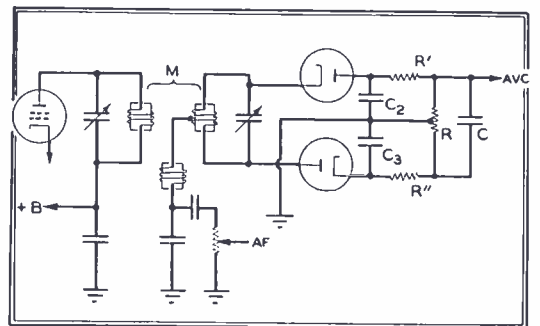

FIG. 5. PHASE-SHIFT DISCRIMINATOR

voltage is altered at the same time that its phase is shifted.

In the description so far, we have assumed that the primary voltage is constant regardless of the frequency. This has been done in order to emphasize the fact that it is the phase shift of the resonant secondary voltage which produces the variations in the magnitude of the voltages between ground and the two ends of the secondary. If, instead of being delivered by a constant voltage generator, the primary energy is derived from a tuned circuit in the plate circuit of an amplifier stage, that energy may also have

variations in amplitude with frequency. However, those amplitude variations will in no way affect the vector relations as shown in Fig. 2 as long as the secondary Q remains constant. The secondary voltage will grow and diminish in exact con-

secondary is loosely coupled to the primary and develops the resonant quadrature voltage. Half of this is added to the tertiary voltage for the upper diode, the other half being added to the same tertiary voltage for the lower diode.

created diode load resistor which will cause a decrease in the Q of the resonant center-tapped secondary. This decreased Q will, in turn, decrease the phase shift sensitivity of the circuit and thus momentarily provide a detector of less devia-

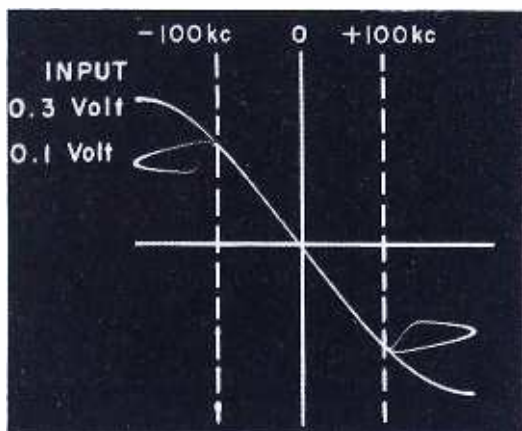

FIG. 6. CHARACTERISTIC OF CORRECTLY DESIGNED RATIO DETECTOR CIRCUIT

formity with the primary changes, while always maintaining the *relative* magnitude and angular phase position as shown.

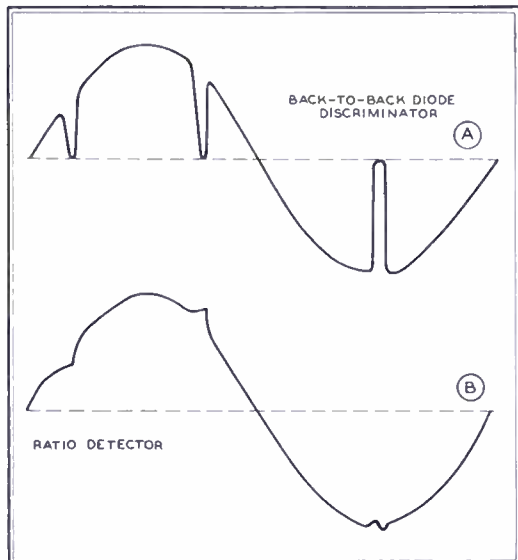

FIG. 7. RATIO DETECTOR, B, TENDS TO SMOOTH OUT LOSS OF SIGNAL

In other words, we might say that the only effect of primary amplitude changes would be to enlarge or reduce the vector diagram of Fig. 2 exactly as though by photographic processes. This again emphasizes the dependence of the ratio of the lengths of O-A and O-B upon the phase shift of the secondary. Then, since we know that the phase of the secondary voltage in coupled tuned circuits is a function of the Q of the secondary, it is easy to see that the higher the Q of the secondary, the more the ratio of O-A to O-B will depart from unity with a given departure of the applied frequency from resonance.

A basic ratio detector circuit is shown in Fig. 3. Here the primary voltage is derived from a small winding tightly coupled to the tuned primary in the plate circuit of an IF amplifier stage. The voltage across this auxiliary or tertiary winding is always directly in phase with, and proportional to, the voltage developed across the tuned primary. The center-tapped

Effects of Loaded Rectifiers ★ Before proceeding further it is well to review the effects of loaded rectifiers on resonant circuits. If a diode with an RF bypassed load resistor is shunted across a tuned circuit, and the diode has 100% rectification efficiency, the damping produced by the combination will be exactly equivalent to that which would have been produced if a resistor of one-half the value of the diode load resistor had been shunted directly across the resonant circuit. In the circuit of Fig. 3, the diode load resistor is not only by-passed for RF energy, but also for variations which might otherwise occur at an audible rate. In other words, the condenser C (usually an electrolytic) is sufficiently large so that if any signal amplitude variations occur at an audible rate, the voltage across the condenser is not altered. However, the rectified current flowing into the R-C combination will increase materially with increases in signal level and will decrease, even to zero, if the applied voltage is materially decreased. If the DC voltage across the R-C combination remains fixed, but the direct current flowing into that circuit is increased, the effect is exactly as though the value of the load resistor had been decreased insofar as its effect on the resonant secondary is concerned. Conversely, if the voltage remains fixed and the current decreases, the action simulates an increased value of load resistance. From this step it is easy to see that the effective resistance shunted across the resonant circuit will vary as an inverse function of the amplitude of the applied voltage, and by the same token the Q of the secondary will be altered as the amplitude is varied.

If there is a momentary increase in the signal amplitude applied to a ratio detector circuit such as that of Fig. 3, the diode current will increase, but the large condenser will prevent the diode load voltage from increasing. This will simulate a de-

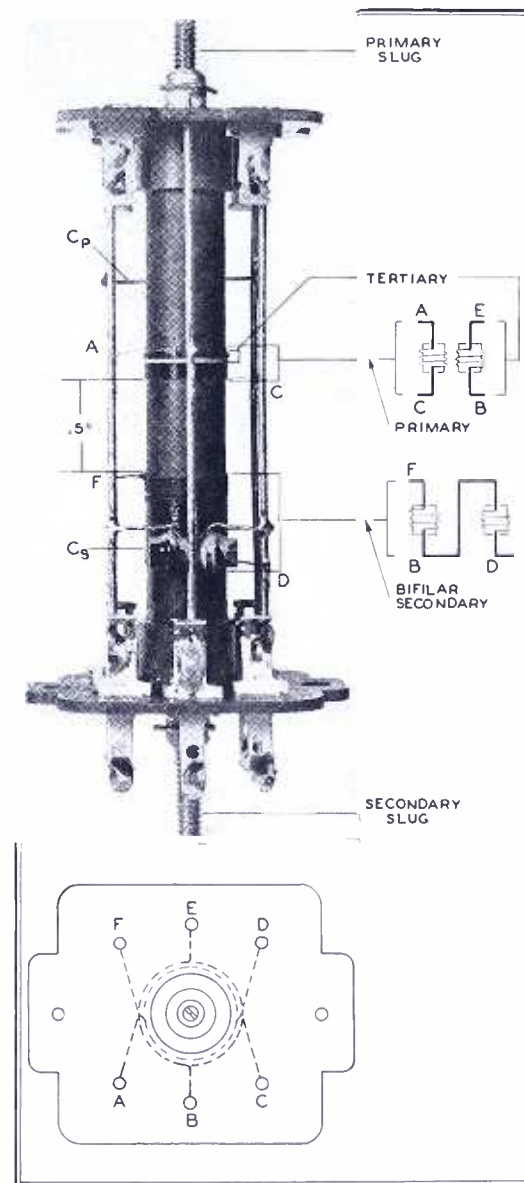

FIG. 8. DETAILS AND CONNECTIONS OF A RATIO DETECTOR TRANSFORMER

tion sensitivity during the period of the increased amplitude.

Other Effects ★ Other effects take place at the same time. The ratio of primary to secondary voltage is increased and the series resistive component of the imped-

(CONTINUED ON PAGE 46)

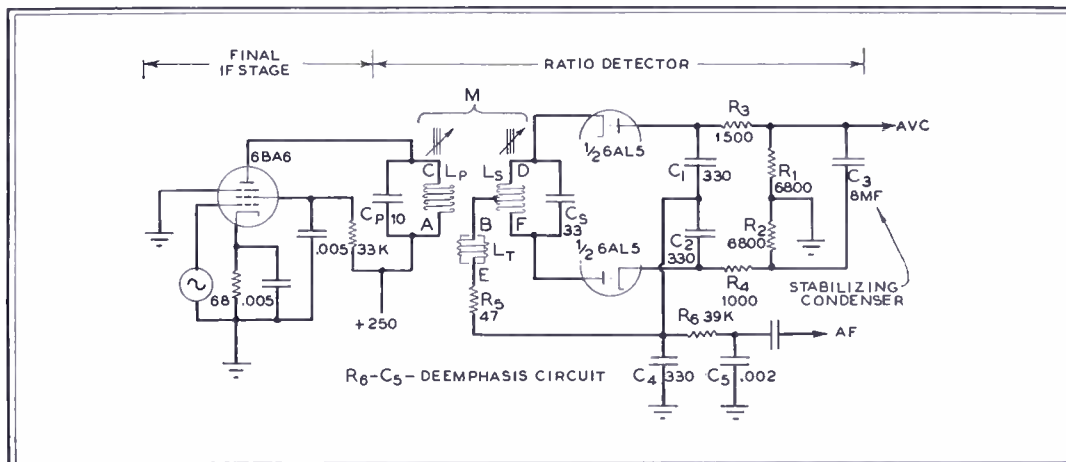

FIG. 9. RATIO DETECTOR WITH BALANCED PHASE-SHIFT TRANSFORMER, FEEDING A 6AL5



FIG. 1. TYPICAL ANTENNA MOUNTING ON A POWER UNIT.



FIG. 2. BELMONT MOBILE INSTALLATION IN ONE OF THE WILLETT BUSES

A TRUCKING COMPANY REPORTS ON 2-WAY FM

Summary of a Year's Experience with FM Communications by The Willett Company of Chicago

BY HOWARD WILLETT, JR.*

ALITTLE over one year ago, The Willett Company of Chicago, and Raytheon's subsidiary, Belmont Radio Corporation, announced completion of the first two-way mobile radiophone system for trucks. The results of the year's operation have been so gratifying, and we believe of such value to the industry as a whole, that this report, covering the highlights of our operation, has been prepared for the benefit of communications engineers and other trucking companies.

Like every other company, at the end of the war we were concerned with rising costs right down the line, not only in wages but in the cost of vehicles, supplies, gasoline and replacement parts.

We were also confronted with a man-hour problem. Formerly, when we had worked 8½ to 9 hours per day, 6 days a week, there was adequate time to handle all work. When we cut our working day to 8 hours and a 40-hour week, we had to find new ways to increase our operating efficiency.

Two-way radio was one possible means. This had been the subject of discussion in our organization for several years. When the FCC opened suitable frequencies experimentally, we decided to test out the use of two-way radio.

Belmont was already doing considerable research in this field, and we approached them with our problems. Their cooperation and experience did much to meet our initial difficulties, and to set up

a system suited to our needs and capable of further expansion.

Now that we have 49 mobile units installed and operating, we are convinced that it is one of the most valuable aids to our business since the advent of the motor vehicle, and we are installing additional units as rapidly as conditions permit.

Scope of Operations ★ Throughout the eighty years our Company has been in business, it has pioneered many improvements in equipment and techniques.

Back in the early days, we were first trucking concern to use the ball-bearing axle in wagons instead of the old type journal, the first to double-deck roll paper out of box-cars, and to offer customers the choice between horse-drawn and motorized equipment. We initiated the use of aluminum, and it is interesting to note that we are still operating some aluminum vehicles built 17 years ago.

In more recent years, we pioneered the extensive use of the shuttle-system in operating tractors and trailers in railroad and boat line transfer, the use of trailers in distribution of loads in the Chicago Loop and City areas, the establishment of a comprehensive scheduled maintenance system, and were first to put in a driver-testing, training and safety program.

One of the largest trucking organizations in the Country, we operate 1,130 vehicles, of which 300 are trailers. The 830 power units consist of 60 motor buses

operated by Willett Motor Coach, 250 vehicles leased out in conjunction with the National Truck Leasing System, and 520 vehicles operated in the general business of the Company in Chicago. We average 1,500 store-door deliveries daily, make approximately 800 pick-ups from the Pennsylvania freight terminal alone, and haul all oil for Socony Vacuum and Phillips Petroleum. This information is offered as an explanatory background of our entry into mobile communications.

Equipment and Coverage ★ The transmitter-receiver units on our trucks measure 6 by 6½ by 15 ins., and are installed out of sight under the seat, in a trunk or in the cab, depending upon the type of truck. The power supply is an integral part of the control unit which mounts under the dash in the front seat. It measures 4½ by 6 by 6 ins. These can be seen in Fig. 2.

The standby drain for the entire installation is only 4.8 amperes, or 18 amperes while transmitting. The mobile antenna, Fig. 1, is about 18 ins. long, and mounts in the center of the truck or car roof, using the roof itself as the other half of the antenna system.

A complete unit can be installed or removed quickly, since all wiring connections are made with separable connectors. When a unit requires service, it is taken from the truck to our service department, and another substituted at once. Thus we never have trucks tied up during repairs on the radio equipment.

* Vice President, The Willett Company, Chicago, Ill.

Our headquarters transmitter and receiver, Fig. 3, are located in our main garage, operated by remote controls in our two dispatchers' offices. One of these installations is shown in Fig. 4. The antenna is mounted on the top of a nearby smokestack.

The original installation comprised the central station and 6 sets on trucks and tractors engaged in different types of work. Soon after the initial installation, we increased the test vehicles to 17 in order to determine the worth of radio communications more accurately and rapidly.

It has become a generally accepted conclusion that while a single, well-located headquarters transmitter will give workable coverage over large cities, no single receiver can do an adequate job of picking up the vehicles over the same area. This was confirmed by our experience.

Our single headquarters receiver gave us about 60% reliability. While unsatisfactory, this was deemed sufficient to permit evaluation of the economics of dispatching motor trucks by radio. After 6 months of experimentation, having determined that certain of our services could be operated more profitably when radio equipped, we then commissioned Belmont to expand the system to a degree of reliability as nearly comparable to wire telephone as possible.

Extensive field tests showed that, although satellite or repeater transmitters would increase the reliability in the secondary coverage area (suburbs), the benefit in the primary area (city limits) would be small and did not justify the cost.

Tests with additional receivers, however, disclosed important advantages. Using two receivers with antennas separated by only 50 ft., we frequently found a good signal in one and none in the other. Likewise, receivers separated by 10 miles often had the stronger signal at the point farther from the vehicle, and in a great number of transmissions the signals shifted back and forth from one receiver to the other. Unfortunately, most of the transmissions were strong enough to open the squelch on both receivers. The resultant double signal created a bad phase distortion, and the noise level was always that existing at the receiver having the poorer signal.¹

While it was possible to select the better receiver manually, this would mean an operator on duty continuously, as the dispatchers are generally much too busy to perform this added work. Obviously, an automatic means of choosing the better signal was indicated. An automatic receiver selector that far surpassed any manual selector in both speed and ac-

curacy, operating without manual control, was developed by Raytheon. It monitors three receivers continuously, silencing all three until a signal is received, at which time it instantaneously evaluates the signal level in each receiver and selects the best one. This evaluation is continuous so that if, during a transmission, the signal in the receiver selected deteriorates below a predetermined value and is better in another receiver, the selector switches to that receiver so quickly that the change is completely inaudible.

This equipment is now in service with one receiver at our headquarters station, one receiver 6 miles south, and a third 3 miles to the north. Reliability of the system has been thus increased to 99%.

Now our area of prime coverage includes all of Greater Chicago, from the Gary steel mills on the south to Joliet and LaGrange on the west and Arlington and Waukegan on the north.

Operation ★ Acquainting our dispatchers and drivers with this improved method of communications, and teaching them to make the most efficient use of it proved easier than we had expected. While we borrowed much of our methods from procedures established already in the emergency services, we found it necessary to adopt some radical departures. For example, our drivers do not attempt to use the radio while their trucks are in motion. Accordingly, the dispatcher waits 30 seconds after calling a truck to allow time for the driver to stop. Similarly, and we have found this very important, our drivers park their vehicles before attempting to call headquarters.

Our first driver to use a radio-equipped truck became so proficient in handling the radio that we made him a dispatcher. Now he is using his experience as a driver to improve operations on all radio-equipped trucks.

One of the interesting aspects of this new installation has been the increase in the drivers' morale on the radio-equipped trucks. The drivers have seen the advantages to them to the extent that they have arranged that seniority dictates assignment to a truck with radio communications!

We estimate the cost of the radio equipment, plus operation, maintenance, depreciation, and other miscellaneous charges to be approximately \$1.00 per day per vehicle. The current minimum rate per vehicle is \$4.00 per hour, so that a 15-minute saving in operating time per day will pay for an installation. A half-hour saving per day will give us a 100% return on our investment. Our operation so far has convinced us that a half-hour saving per day is easy to attain. The by-product benefits, although difficult to measure in dollars, are more important.

Advantages ★ Benefits could be foreseen to



FIG. 4. THE AUTHOR GETS A QUICK ANSWER TO A REQUEST FOR INFORMATION

almost all of our services, but test reports from various category emphasize the effectiveness of our communications system.

Our greatest return on the investment in radio has been in day-to-day dispatching. Specifically, our dispatchers now have an up-to-the-minute picture of the constantly changing disposition of the vehicles at their disposal. Trucks regularly assigned for a full-day's work on deliveries are now frequently radiophoned en route and given pick-ups on or near their routes. Time saved in avoiding parking and searching for public telephones enables such pick-ups to be made during the same working day. This is a very great saving when measured by hundreds of calls. Immediate contact with trucks late in the afternoon makes

(CONTINUED ON PAGE 32)

FIG. 3. TRANSMITTER-RECEIVER INSTALLATION AT THE MAIN GARAGE. SYSTEM ALSO HAS TWO REMOTE RECEIVERS



¹ This conclusion presents an interesting difference from that reported in "Dual Diversity Transmission on 75-Mc." by Lieut. Basil Cutting, *FM and TELEVISION*, Feb. 1947.

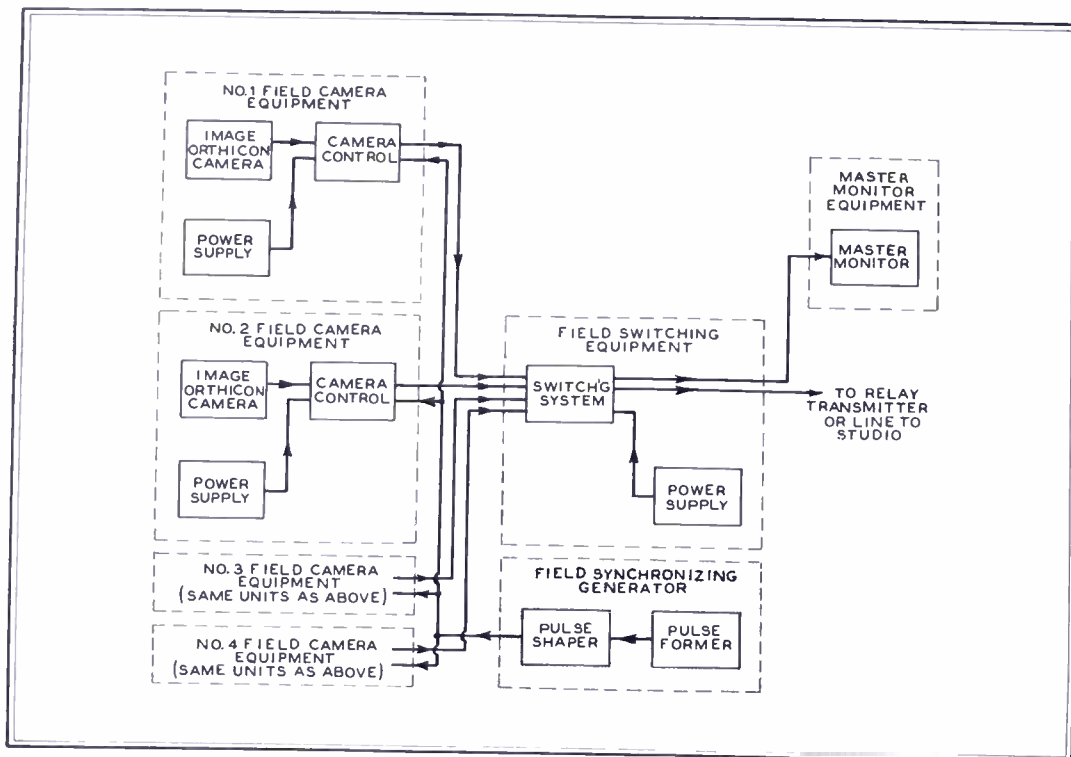

FIG. 17. SHADED AREA SHOWS POSITION OF EQUIPMENT DESCRIBED IN THIS ARTICLE

TELEVISION FIELD EQUIPMENT

The Synchronizing Generator and Its Functions

BY J. R. SMITH *

THE synchronizing generator furnishes all the timing impulses required to operate one or more television cameras. Its position in the circuits of a television field equipment setup are shown by the shaded

area in Fig. 17. Detailed views of the RCA sync generator units are shown in Figs. 18 to 22. One unit, at the left in Fig. 18, contains the pulse forming, frequency control, and regulated power supply cir-

FIG. 20. FRONT OF THE PANEL CARRYING THE CIRCUITS OF THE PULSE-SHAPER UNIT

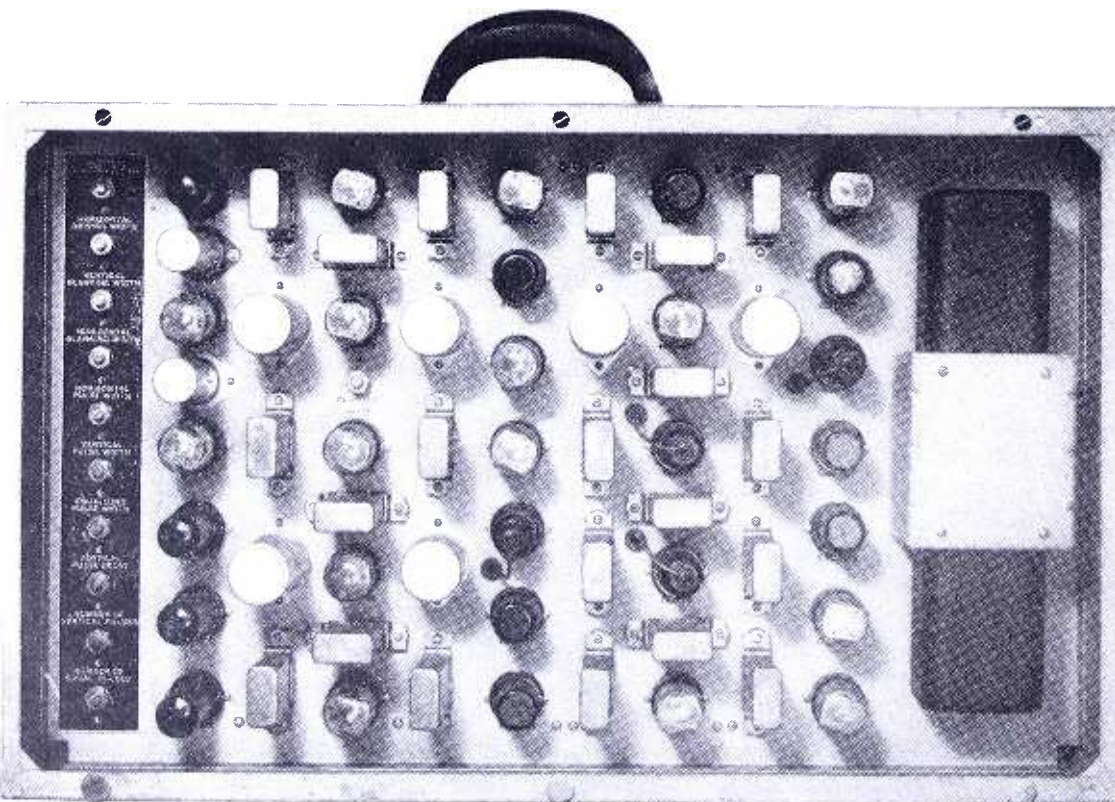

cuits, while the other contains the pulse-shaping and output circuits. Four types of pulses or output signals, accurately related in timing, are generated. They are carefully controlled to conform with RMA wave-form standards, and locked as to timing frequencies with the 60-cycle line frequency. However, when conditions make it necessary, the frequencies can be established by a built-in crystal oscillator. The four types of signals generated are:

1. Horizontal Driving Signal ★ The horizontal scanning frequency is supplied to the camera in the form of square-wave pulses at the rate of 15,750 cycles. These are the pulses which trigger off the saw-tooth generator in the camera itself. In this manner, the horizontal scanning voltage is supplied to the pickup tube.

2. Vertical Driving Signal ★ Vertical scanning frequency, at 60 cycles, is established by the power line frequency. The vertical driving pulses, also of square-wave form, trigger the saw-tooth generator in the camera which supplies the vertical scanning voltage for the pick-up tube.

3. Synchronizing Signal ★ In order to synchronize the scanning action of the picture tubes in television receivers, synchronizing signals must be transmitted along with the actual picture signals generated in the camera.

The synchronizing signals are made up of 3 different types of pulses which perform 3 different control functions in the receivers, just as the first 2 types of signals described above control the operation of the camera tube. It should be noted that the first 2 are only fed to the camera tube, while the synchronizing and blanking signals are actually transmitted by the television broadcast station, together with the picture signals.

The composite sync signals are made up of 1) short-duration, 15,750-cycle pulses which time the horizontal scanning in the receiver, 2) longer, 60 cycle, serrated pulses which time the vertical scanning at the receiver, and 3) a series of 6 short pulses preceding and following each vertical scanning impulse. The exact shape of these pulses and their timing are established by RMA standards.

4. Blanking Signal ★ In order to blank out the return trace at the end of each horizontal scanning line in the receiver picture tube, it is necessary to transmit blanking signals. These are square-wave pulses at the 15,750-cycle horizontal scanning frequency, transmitted at approximately the black level. They are the pedestals to which the synchronizing signals are added.¹ In other words, the synchronizing

*Television Engineering Department, RCA, Camden, N. J.

¹For a more complete explanation, see "Television Handbook" by Madison Cawein, *FM AND TELEVISION*, pg. 27, Dec. 1946.



FIG. 18. PULSE-FORMING UNIT, LEFT, AND PULSE-SHAPING FIELD UNITS

signals are transmitted at maximum power output, so that they are at the blacker-than-black level.

Pulse-Forming Circuits ★ Tied-in frequencies of 60 and 15,750 cycles are obtained through the use of a Potter-type of master oscillator operating at 31,500 cycles. The frequency of the master oscillator is stabilized by locking it in with the 60-cycle power supply, or by the use of a crystal control.

Frequencies of 60 and 15,750 cycles are actually obtained by applying the master oscillator output to a series of counter stages which divide the 31,500 cycles in steps, down to the operating frequencies required. One is a 2-to-1 counter circuit, followed by a buffer amplifier delivering 15,750 cycles. The other has four stages, 7-to-1, 5-to-1, 5-to-1, and 3-to-1, also followed by a buffer amplifier, delivering 60 cycles.

Each amplifier is biased in such a manner as to operate as a clipper stage. That is, the negative half-waves are cut off, and also the peaks of the positive waves. Thus the output voltages are approximately square-wave, all in the positive direction.

As it is desirable to lock the timing impulses of the system to the power line frequency, a sample of the 60-cycle frequency generated by the counter circuits is fed to a 60-cycle locking circuit. In this circuit, samples from the two 60-cycle sources are compared. Any phase difference between them causes a DC voltage to be applied to the grid of a reactance tube. Since the plate circuit of the reactance tube is a part of the master oscillator timing circuit, any change in the output of the reactance tube alters the frequency of the oscillator by the amount necessary to bring the 60-cycle output derived from the oscillator back into phase with the 60-cycle line voltage.

In cases where the power line operating

the field equipment comes from a system not tied in with the system at the transmitter, the built-in crystal oscillator can be used to drive the master oscillator.

A 2-in. cathode-ray indicator, Fig. 19, is built into the pulse-former unit for use in adjusting the counter stages. For checking purposes, a 5-position switch, just below the tube, switches in the stair-step voltage wave of the corresponding counter circuit, and applies the voltage to the horizontal plates of the cathode-ray tube. As the number of steps corresponds to the ratio of division, operation of a counter circuit can be checked by counting the dots appearing on the face of the tube. By switching in each stage in succession, the overall performance can be checked quickly.

The two knobs below the 5-point switch adjust the focus and brightness of the tube. Controls on the center panel, Fig. 19, are for 60-cycle or crystal frequency control, phase shift, AFC time constant, and counter circuits at 60, 180, 900, 4,500, and 15,750 pulses.

Pulse-Shaping Circuits ★ Circuits of the pulse-shaping unit are more complex. Their job is to produce the relatively complicated form of the transmitted synchronizing signals from the pulses supplied by the pulse-former circuits. Those pulses must be broadened or narrowed, the leading edges advanced or retarded, and they must be combined in the proper number and sequence to produce the final pattern to operate the camera tube and to perform the functions of synchronizing and blanking at the television receiver.

Simplest of the output signals are the horizontal and vertical driving pulses

supplied to the camera tube. The horizontal driving signals, consisting of square-wave impulses at the horizontal line frequency of 15,750 cycles, are obtained by applying the 15,750-cycle signals from the pulse-former to a 2-stage multi-vibrator circuit, where they are modified to the correct height and shape. A delay network in the input of the multi-vibrator establishes the leading edges of these pulses at the right timing with respect to the other output signals.

The vertical driving signals are also simple square-wave impulses, but they occur at the frame frequency of 60 cycles, and are broader than the horizontal driving pulses. They are obtained by applying the 60-cycle pulses from the pulse-former unit to a multi-vibrator circuit which broadens them and squares them off to the required shape.

The blanking signals, added to the picture signals, comprise two sets of square-wave pulses. One, at horizontal line frequency, is transmitted after each scanning line to remove the return line trace. The other, at frame frequency, removed the trace from the top to the bottom after each frame.

To form these pulses, the 60-cycle and 15,750-cycle inputs from the pulse-former are used to drive separate multi-vibrators, the outputs of which are combined in a clipper stage. The cutoff point of the clipper is so adjusted that it cuts off the several horizontal-frequency pulses that are formed during the longer vertical frequency pulses. This prevents the amplitude of the former from being added to the amplitude of the latter.

Now, the complete RMA standard series of receiver synchronizing pulses

FIG. 19. INTERIOR OF THE PULSE-FORMER, SHOWING THE OSCILLOSCOPE AND CONTROLS

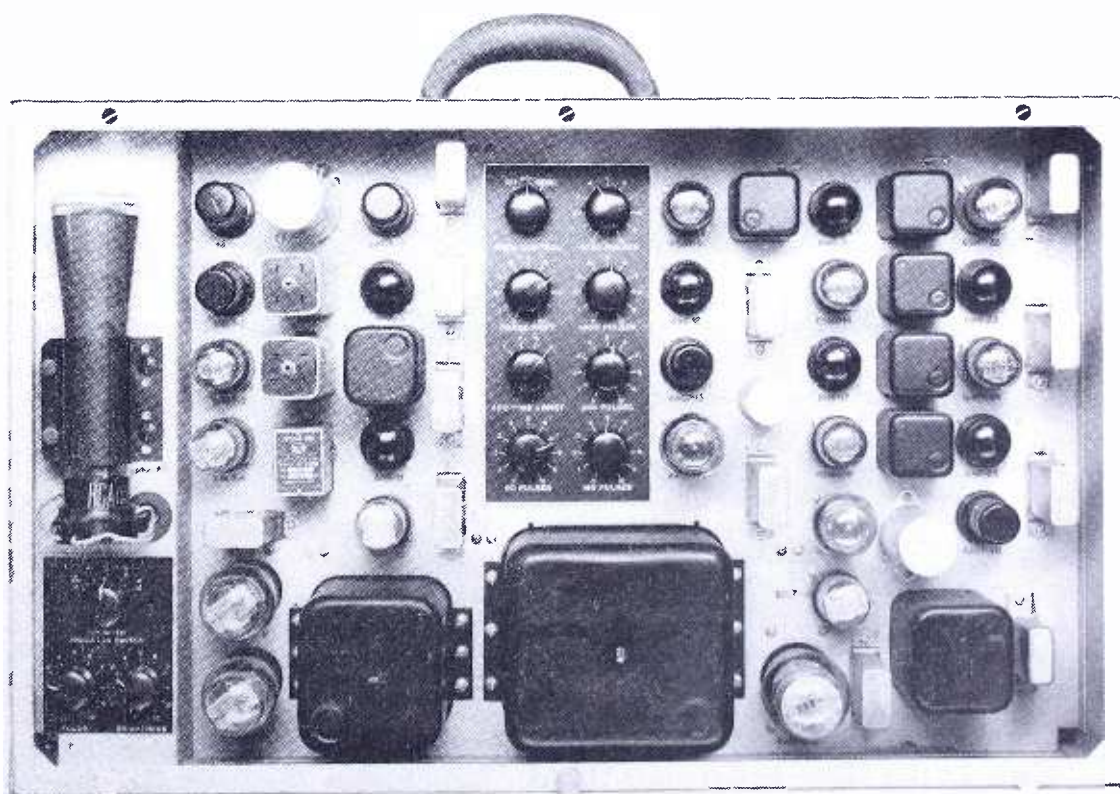



FIG. 21. REAR OF PULSE-FORMER UNIT

forms a complicated sequence comprising 1) short, square-wave pulses at the horizontal line frequency, 2) special pulses, each made up of 6 separate pulses, at the frame frequency, and 3) two short sets of equalizing pulses at double the line fre-

quency. These occur just before and just after the vertical-frequency pulses. These separate signals are combined by using the three pulse input signals of 60, 15,750, and 31,500 cycles to drive a succession of multi-vibrators, the outputs of which are combined in special clipper and mixer stages to produce the complete series of impulses required to keep the receivers in synchronism with the transmitter.

Outside Connections ★ The RCA pulse-former and pulse-shaper units are 24 ins. long, 8 ins. wide, and 15 ins. high. They weigh 67 and 52 lbs., respectively. Each is made up with a vertical panel, Figs. 19 and 20, carrying the principal components on the front, and the wiring on the rear.

A separate power distribution box, fitted with 9 twistlock sockets, provides connections to these units and up to 4 cameras from a single-phase, two-phase, or three-phase AC power line.

Figs. 21 and 22 show the outlet terminals. One cable connects the two units. The pulse-former, Fig. 21, has connections for the AC power input, and a separately-fused convenience outlet for a soldering iron or auxiliary light. The center connector on the pulse-shaper is for a 75-ohm concentric line to carry the synchronizing signals to the switching unit or to the camera control unit, if only one camera is used. The bottom connector is for a cable with 3 coaxial lines to carry driving and blanking pulses to camera controls.



FIG. 22. REAR OF PULSE-SHAPER UNIT

The first article of this series, describing the camera and its power supply, appeared in the November issue. The third, describing the switching system, will appear in a subsequent issue.

2-WAY RADIO FOR TRUCKS

(CONTINUED FROM PAGE 29)

rush pick-ups entirely practical now. This was never feasible before because trucks working their way back through heavy traffic could not stop to telephone for last minute calls.

Night spotting of trailers at the team track in the railroad yard is greatly facilitated by radio dispatching. Another convenient use is to have a radio-equipped truck or car drive through the freight house and read off trailer numbers so that the exact location can be recorded for the morning dispatcher. A single man can do many more times the work in a radio-equipped vehicle, and in the morning the tractors go directly to the trailers, making them first at most of the loading docks for morning deliveries.

Here is a typical example of time saving: A dispatcher received an order to pull an empty trailer at one of our large accounts. He ordered a tractor at 14th and Michigan Avenue to come across the Loop to remove the empty trailer. A returning tractor, about to leave our customer, overheard the dispatcher and called in to report his location. The dispatcher ordered him to pull out the empty and reassigned the 14th Street tractor before he had made the trip. We estimate the time saved as at least one-half hour.

As all trucking organizations know, frequent irregularities in the number of bills, pieces, markings, etc., are encountered. We have found it possible to save valuable time by having the driver call in immediately upon encountering any discrepancy. The dispatcher generally knows the correct party to reach and the book-keeping can be straightened out in a matter of minutes.

Good will, an invaluable asset of any business, is a by-product of our radio installation that we feel cannot be measured in dollars and cents. Typical of the extra service that radio has enabled us to render was our handling of a request from the Peter Hand Brewery. A rush order had come in for 150 additional cases of beer to be shipped that evening to the Chicago Stadium, where the Graziano-Zale fight was scheduled. It was almost closing time, and speed was essential. While the shipping clerk was placing the order with our dispatcher, another dispatcher called a nearby tractor. It was at the brewery within a few minutes after the call. The shipping clerk at the brewery was so surprised and, needless to say, pleased with this service that he recommended to his superiors that all their own trucks be radio equipped.

Radio has greatly facilitated our maintenance operations. The drivers can call the shop and consult with the foreman on an unusual performance of their vehicles

or mechanical difficulties, thus preventing breakdowns before they occur. We found it necessary and desirable to install loud speakers and microphones in the Maintenance Department so that service calls could be handled direct by that department. In addition, this department, which works on a 24-hour basis, handles calls after the regular dispatching office closes.

Not long ago our trucks were the target of an organized gang of hi-jackers. The driver of one of our tractors noticed a suspicious looking car following him. He immediately radioed the dispatcher who in turn telephoned the police. Within a few minutes a police car was paralleling the truck, giving protection against any attempt at robbery. It is our policy, as well as that of the Cartage Theft Division of Chicago Police Department, to report any suspicious cars following trucks. Obviously, without two-way radio, this would be impossible.

Our radio-equipped trucks were of public service from the day they went on the road. Typical of the everyday uses that are made of our two-way radio was an accident observed by one of our drivers involving a linen truck operated by a local firm. The driver of this vehicle was seriously injured and rushed to a hospital. Our driver radioed the dispatcher who promptly notified the linen supply company, which was able to protect its

(CONCLUDED ON PAGE 36)

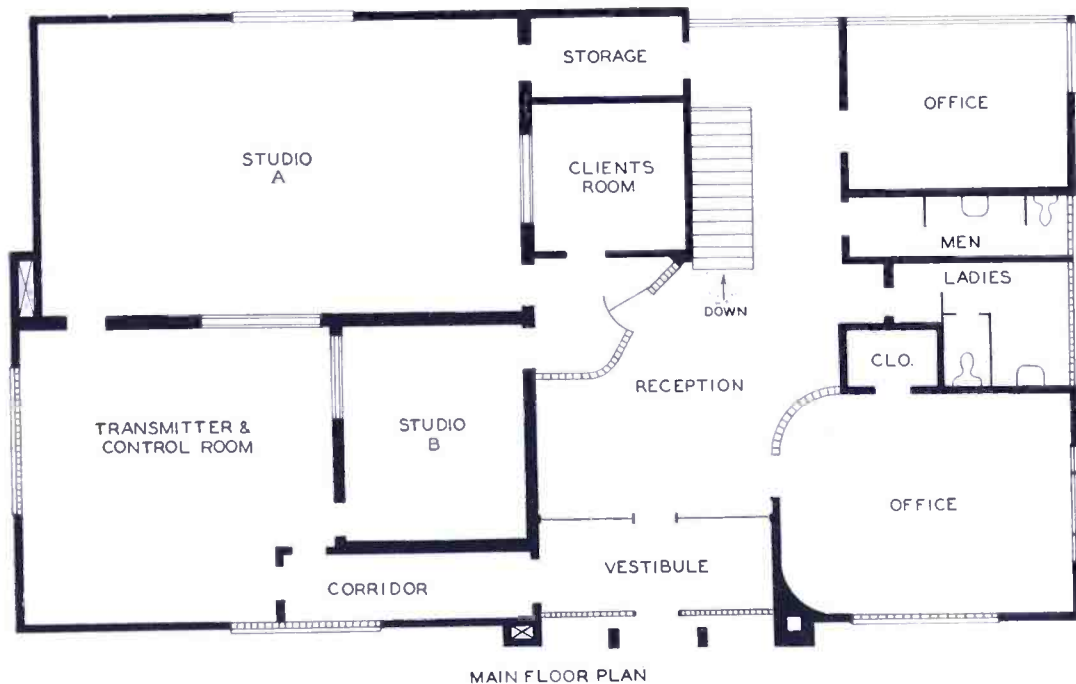

MAIN FLOOR PLAN
LAYOUT OF THE MAIN FLOOR GIVES EFFICIENCY AND A VERY ATTRACTIVE APPEARANCE

WHAT KPFM IS DOING

Plans and Policies Designed to Build an FM Listening Audience

BY S. M. GOARD*

MOST things seem to start with an idea, and that's how KPFM started. Back in 1941, Stromberg-Carlson gave an FM demonstration to their distributors and dealers, using a portable transmitter and an FM-AM receiver. It sold the writer on the tremendous possibilities of this new and better system of broadcasting. The idea that later became KPFM was a direct result. The way it developed may interest others who are planning to start FM stations.

First Steps ★ Of course, the first step was to find a suitable piece of property on a high ground, close to the City of Portland. Topographical maps were studied with the thought of locating as high as possible near the city, and yet remaining outside the city limits because of building restrictions and zoning problems. A 4-acre plot was found within 400 ft. of the city boundary and within 2 miles airline of the center of the business district. At an altitude of 1,020 feet, it overlooks about 95 per cent of the city area.

The property was involved in a legal tangle, but a Supreme Court decision was handed down in October, 1943, and the purchase was consummated. Trees from brush size to firs 3 to 4 ft. in diameter had to be cut down. Their removal provided 80 cords of wood.

Realizing that it would require considerable capital, and that it would be desirable to have close associates in the venture, the writer and three intimate friends formed Broadcasters Oregon, Ltd., and an application was submitted to the FCC in February of 1944. The partners, each owning 25 per cent interest, are George W. Phillips, insurance broker;

*Manager, FM Station KPFM, Portland, Ore.

James L. Murray, office equipment specialist; Robert T. Zabelle, Muzac franchise holder for Portland; and the writer.

The Building ★ In the summer of 1945, application was made to WPB for authorization to erect a building. This was denied as unessential to the war effort. Application was again made in the fall, and permission was granted. A lumber strike developed the next day.

It appeared that the best way to determine the minimum requirements for an FM installation would be to visit a few FM and AM stations. This was done, and the conclusion reached was that at least 2,000 sq. ft. of floor space would be required for two studios, offices, and transmitter equipment. We therefore constructed a building with 3,000 sq. ft. of floor space and have an additional 3,000 sq. ft. in the lower floor for expansion. Some of the additional space will be re-

quired for facsimile, which we plan to add.

The building is of concrete; outside walls, the roof, and the studio walls are insulated with 2-in. Fiberglas. Windows are of Thermopane and glass brick. The building is equipped with a heating and air conditioning system. Great care was taken to keep the entire space now used on the upper floor bright and cheery. Plans contemplate using the upper floor until such time as more space is required, and then everything is in readiness to finish the lower floor.

The reception and waiting room are at the center of the building, with the offices along one side on the main floor. The transmitter room and studios are on the other side.

A Western Electric speech input console is mounted in the corner of the transmitter room facing the operator when he is looking into the main studio. To his right are two Presto turntables, both mounted into a solid table of 1½-in. plywood. This also provides space for two recorders. The 23C will be replaced with a Western Electric 25B speech input console, as the dual channels are needed to record in the studios while other material is on the air. Microphones are Western Electric Cardioid and Salt-Shaker types. The piano is a Steinway concert grand.

The studios are not fastened solidly to the building except where they are attached to the exterior concrete walls. The floor joists were made to rest on blocks which, in turn, rest on pads of Firtex. The floors and walls are built on the joists, and the ceilings are attached to the walls. The studio dimensions were based on the regular cube-root-of-two formula.

Heating and ventilating ducts run to the furnace individually so as to isolate the sounds. They were wrapped with air-cell asbestos, and the cold air ducts, which were joist spaces, were lined with Firtex for sound absorption. Where the conduits pass in or out of the studios, special flexible connections keep the studio from rigid contact with other parts of the building.

Having read about polycylindrical sound diffusion, we investigated the

LATER, AS BUSINESS EXPANDS, THE BASEMENT WILL BE PUT TO USE AS THIS PLAN SHOWS

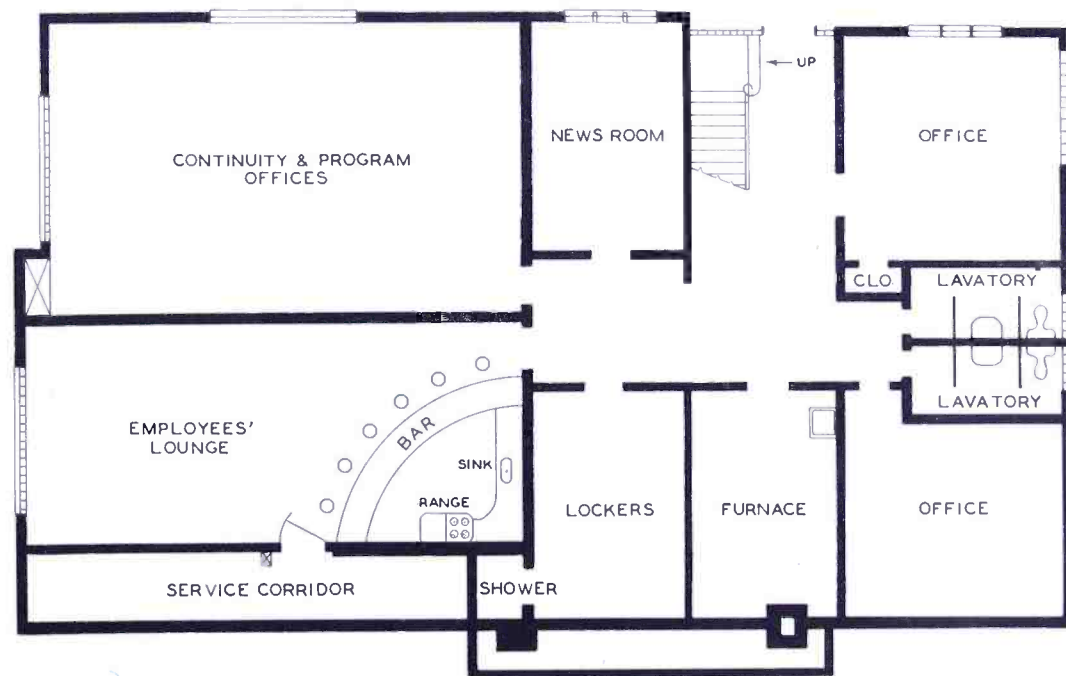

BASEMENT PLAN



TOP: CURVED SURFACES AND PROFUSE USE OF GLASS BRICK HIGHLIGHT RECEPTION ROOM. BELOW: EXTERIOR VIEW

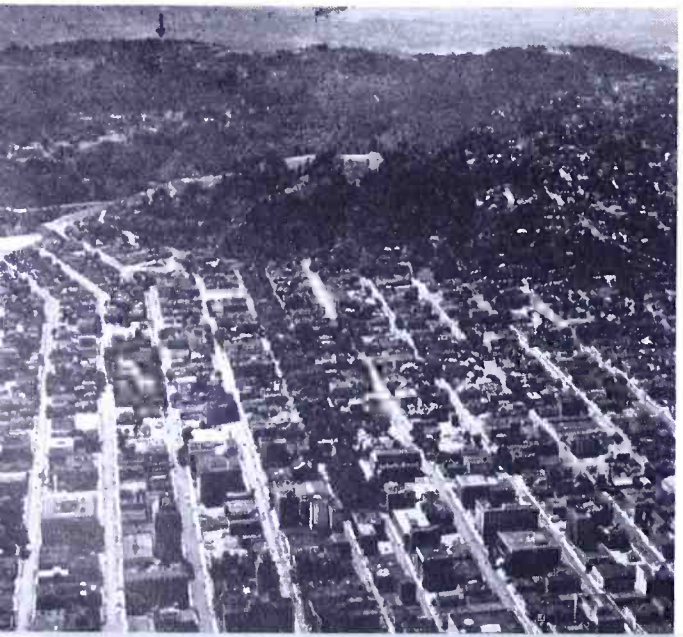
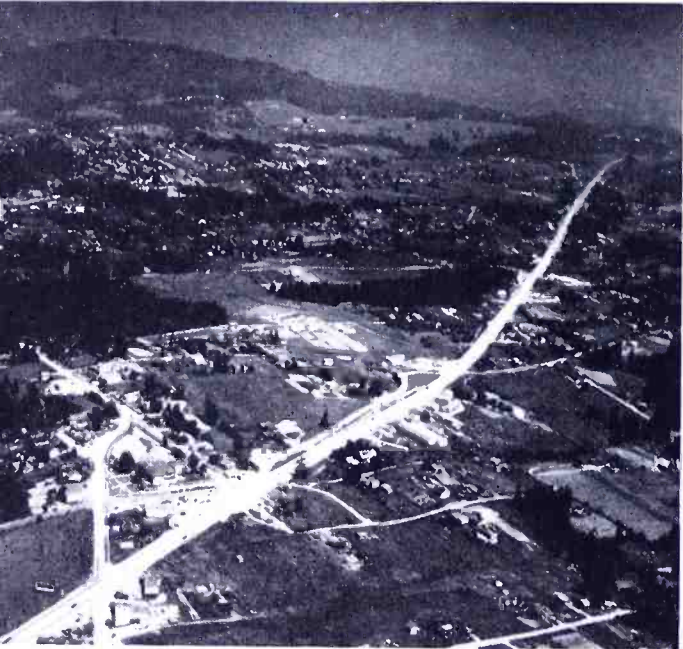

method and built 30-in. columns in the large studio and 16-in. columns in the smaller. These were bent over ribs of 1-in. stock, faced with strips of Firtex to dampen the vibration of the panels. The panel material is 1/8-in. Masonite. Back of the polycylindrical walls are pads of 2-in. Fiberglas insulation.

The floors are of 3/4-in. plywood over regular sub-floors, and are finished with asphalt tile. The studios were a little too live until about 50 per cent of the floor space was covered with rugs. They seem to be about right now, as they are live without undue reverberation.

The recreation and lounge room shown on the lower floor is for the employees' comfort. It will contain an electric range, refrigerator, and sink for that lunch or snack that all employees require during the day.

Considerable difficulty was encountered in obtaining building materials. The Thermopane, of which there are several panes 6 by 10 ft., was ordered in October, 1945. The glass brick, which is used quite profusely, was obtained just in time. It was the last in the city. Many friends and considerable effort were needed to obtain building items such as nails, plumbing, hardware, wiring, conduit, and plywood. Finally, the building was completed in September, 1946, the Thermopane having arrived in that month.

On the Air ★ The Western Electric transmitter was delivered in the Spring of 1946, tested in August, and went into program tests, 8 hours a day, in October, 1946. Operation commenced with commercial accounts on November 1. It was estimated that there were some 3,000 sets in the service area, which includes approximately 6,000 sq. miles and better than 700,000 people.

We plan to add a Western Electric 10-kw. amplifier in 1948, using our 1-kw. transmitter as the driver. At present, we have a temporary antenna of the slotted cylinder type on a 75-ft. wooden pole. It will be replaced with a high gain Clover-Leaf antenna located on a tower 150 ft. high.

Although line of sight is 42.6 miles from our location, we have received many reports from twice that distance and farther. The greatest distance from which reports have been received (and there have been several from this location) is the city of Eugene, Oregon, 105 airline miles from KPFM. There have been many reports from places that are considerably shadowed or beyond line of sight, and the station is beginning to receive some good

ABOVE: LOOKING NORTHEAST TOWARD TRANSMITTER SITE. CITY IS BEYOND HILL. BOTTOM: CITY LIES BELOW KPFM

reports from make-shift mobile receivers that have been constructed for listening in different parts of the service area. Some of these points are well shadowed by tunnels or bridges and beyond line of sight. Although it is not expected that this coverage will be exceeded greatly when we go to full power (KPFM will eventually have 100 kw. effective radiation compared to the present 1,600 watts), we do believe that it will be easier for those in the service area to receive the station with less concern about antennas or perfect receiver performance.

Time Rates ★ Rate structure was set up in line with most of those used by other FM stations, and in line for a station serving an area of about 10,000 radio homes. In order to make the set-up equitable for advertisers who started when we first went on the air, a two-for-one plan was instituted, giving the purchaser twice the time he contracted for until there were 10,000 FM radios in the service area.

It is now estimated that they are in excess of this number, and more are coming in at a very fast rate. Many of the sponsors have indicated their desire to purchase the extra time they have been given, in order to keep their appearance on the air as regular as it has been. Some very unusual results have been obtained for some of the sponsors.

Programs ★ A friendly feeling towards the station has been evinced by many letters and telephone calls, both local and long distance. Many have indicated that they tune in the station when it goes on the air each day at noon and stay with it until it goes off the air at 10:15. It has been the policy of the station not to use cow-catchers or transcribed announcements or singing commercials; to incorporate all spot announcements into regular programs, not to exceed four spot announcements in any one hour; to limit the commercial time; not to use phonograph records, but only transcriptions with full fidelity; to limit dance music to the melodic type rather than jive; and not to overdo the long-hair classical music.

KPFM does not use soap operas or quiz programs, and we change the trend of music throughout the day very slightly so there is no sudden change in type of music. Most of the mail comments on our solid hour of dinner music, a program called "Candlelight and Silver," which has very little voice appearing on it. Three numbers are usually announced at a time.

The announcing staff is comprised of top men, who do announcing only. The continuity department does an especially fine job of writing interest-catching items into the commercials, with a little humor and enough solid information to get the advertiser's message over. We try to give listeners a desire to listen, rather than to

close their ears to commercials. We work on the premise that a station that pleases the public with its broadcasting will have the listeners, and so it will have the advertisers.

We have instituted several small innovations in operation which have worked out very well. The library of high quality transcriptions, vertically cut on vinylite by the Associated Music Producers, is handled like live talent. Following concert-hall custom, we put a soloist into orchestral programs where the talent fits. For example, when a band is featured, we spotlight an artist as a guest soloist on this particular program. We allow a little pause between programs, a matter of seconds, so the audience can hear that startling quietness which is characteristic of FM. Of course, we use as much live material as can be obtained.

Promotion ★ As to the business side of the venture, our FM station has required considerable promotion. During the month of April, 1947, KPFM was on the air 15 minutes early each day with a sound effects demonstration, to allow the dealers to demonstrate the new and finer FM receivers. This created a good impression both with the dealers and with the public. Dealers cooperated by inserting advertisements in the newspapers, inviting the public to come in for FM demonstrations each day. They put signs in their stores and show windows, calling attention to the demonstration programs. Some dealers made it a point to call their accounts personally.

We have cooperated with FM set distributors by putting on special broadcasts. We have given talks to their personnel, and conducted them on tours of the station. In the month of June, we originated two broadcasts per day from downtown store windows, first from the corner win-

TOP: POLYCYLINDRICAL TREATMENT IN MAIN STUDIO. BELOW: OFFICE OCCUPIED BY JERRY HARTSHORN AND THE AUTHOR

dow of the largest furniture store, and then from the largest stationery and book store in the city. These used live talent and the programs were sent to the transmitter over 15,000-cycle lines; the broadcasts were received over radios placed around the stores. This proved very effective both for the extra business created, and for the publicity it gave FM. Advertising agencies have been visited and invited to inspect the station. The public is being educated rapidly by owners of FM receivers. FM set owners have proved to be boosters through and through. The majority of people in the KPFM area have heard FM and ask their dealers about it when they inquire about purchasing new radios.

Promotional material used by KPFM includes printed weekly program schedules mailed to set owners; stamped, printed postal cards for dealers to give FM set buyers to send us so they can be put on our mailing list, and an attractive brochure describing some of FM's advantages and giving information about the station, its service area, and its personnel. A mimeographed newsletter, the "KPFM Discriminator," is published twice a month.

Progress ★ So KPFM has grown from an idea to a reality. It is now established as a definite service to the Portland area. In response to the usual question as to how business is, we usually say, "Pretty good; we're not losing as much money as we were." Now, with a whole-hearted industry support of this new and better medium, it appears that it will not be too long before the business will become a profitable venture.

FM RELAY SYSTEM

(CONTINUED FROM PAGE 17)

demonstration program, Dr. Bown announced that a special experiment would be made. Connections were then set up to transmit television signals to Boston and back to New York, giving the effects of relay transmission over 440 miles.

As far as we could observe, the picture quality was the same as over the one-way circuit.

Then new connections were set up, this time to carry the signals from New York to Boston and back, and to Boston and back again, representing nearly 900 miles of relay transmission.

Some of the observers remarked that they thought there was a slight difference, but it seemed to us that there was no loss of picture quality.

Future Networks ★ If a conclusion can be drawn from this demonstration, it seems to confirm our belief that the coaxial cable

will not be a permanent means for setting up television networks. The cable has served a useful purpose in carrying programs between Washington and New York, but it is far from being the equivalent of the FM radio relay.

What effect the success of the relay may have on AT & T's projected nation-wide cable system was not disclosed. Without knowing all the details involved, it appears to us quite likely that the cable, with its extremely high installation cost and maintenance expense, and its limited capabilities, may be abandoned in favor of the radio relay system.

To an outside observer, the cable seems to be an extreme extension of prewar methods, perhaps old-fashioned, not in point of time but in terms of applying radio techniques now available to communications.

ABOVE: OPERATING POSITION IS BETWEEN STUDIOS. BOTTOM: CHIEF ENGINEER NELSON AT W. E. TRANSMITTER.



FM MONITOR

(CONTINUED FROM PAGE 21)

circuit. The thyatron is tripped by a triggered amplifier tube which has the modulation signal impressed on its control grid, together with a given amount of negative bias voltage as determined by the dial-potentiometer setting. Whenever a modulation peak exceeds the applied DC bias, a pulse of plate current is generated in the amplifier, which is then used to trip the thyatron. The lamp operates on positive modulation peaks. This is not significant, except when asymmetrical modulation is present, at which times the agreement between the modulation meter and the over-modulation lamp will depend upon the meter polarity used.

The second modulation indicator consists of a semi-peak response meter circuit, which can be set to respond to negative or positive modulation swings, or both simultaneously. There are two semi-peak response diodes, each used to operate an independent VT voltmeter tube. An R-C network is placed in the grid circuits of each of these tubes. This permits a rapid rise in the grid potential with increasing modulation amplitude, and a slow response to decreasing amplitudes. During modulation, the meter indications appear to float along the peaks of the modulation signal. This dynamic-response characteristic meets FCC requirements. It is illustrated by Fig. 10.

For FM applications, there is no preference for monitoring any one polarity of the modulation signal, as is the case in an AM transmitter. Operators are mainly interested in the maximum modulation swing regardless of polarity. Hence, the ability to monitor both simultaneously is advantageous. This is especially true when asymmetrical program material is encountered. The maximum modulation peaks may shift from one polarity to the other as the program changes, thus requiring continual shifting of the meter polarity to assure an indication of the true maximum peak swing. By setting the meter to respond to both polarities simultaneously, this operating complication can be avoided.

Center-Frequency Indicator Characteristics ★ The stability and accuracy of the center-frequency indications are dependent upon several circuits. The monitoring crystal affects the center frequency meter directly. After the initial installation and the usual frequency check and adjustment, it has been found that long-term stabilities in the order of 1 part per million can be expected. This will account for a change in the center-frequency indicator of 100 cycles.

A second factor to be considered is the discriminator center-frequency stability. This includes the discriminator, com-

pensating circuits, and associated diodes. These circuits will not cause an effective shift in discriminator center frequency greater than .066%, or an indication of 100 cycles on the center frequency indicator.

These account for errors in the center-frequency indicator, and will amount to only 2 parts per million, or 200 cycles.

Changes in meter circuit sensitivity can be neglected, since they are proportional to the full-scale deflection of the meter, and are negligible by comparison with other factors.

Since a balanced DC vacuum-tube voltmeter is used to drive the center-frequency meter, any change in the zero setting will affect the meter directly. This has been reduced to a value of less than 200 cycles for extended periods. A panel switch has been provided so that this zero setting can be checked (once a day is adequate), and hence drift in the zero does not influence the ultimate accuracy of the center-frequency indicator. If this check is not made, the overall instability will approach a maximum of 400 cycles. Continuous recordings of the center frequency are feasible, a feature which is not possible without this high overall stability, regardless of the ultimate accuracy.

The extreme linearity of the discriminator results in a negligible shift in indicated center frequency under full modulation conditions. Therefore, the monitor can be used to test transmitters for this characteristic.

External Indicators ★ Arrangements are provided for connecting to remote indicators. The meters used are currently available types, with a minimum of special requirements, and can be connected without affecting the calibration. The remote over-modulation-peaks indicator is a standard 3- to 6-watt, 115-volt Mazda lamp.

Test Equipment ★ One of the most difficult problems associated with the development of the monitor was that of determining the overall performance characteristics in the absence of a perfect test source. Each component was first tested separately. The discriminator was checked statically, using a precisely calibrated potentiometer. A characteristic was obtained which indicated a maximum of .05% departure from linearity over a range of ± 100 kc.

The audio fidelity measuring system was considered satisfactory when overall tests resulted in a residual distortion below 0.1%, and the residual noise measured less than -80 db.

Other portions of the instrument were given long-term calibration tests. To ascertain its stability characteristic for extended periods, the discriminator was operated from a 150-kc. signal derived from our primary-frequency standard.

By operating the IF system from a stable, noise free, 150-kc. source, the

residual equivalent FM noise level was measured to be less than -80 db for the combined IF, discriminator, and audio output systems.

Overall tests of the complete monitor were made with a specially developed phase-modulated FM test-source, operated from the 50-kc. output of the primary frequency standard, multiplied to 102.4 mc. This provided a source of extremely stable FM signals, and was very useful for determining the shift in the indicated center frequency of the monitor with applied transmitter modulation. It further served as a comparison test source for fidelity measurements. A second test source employed a local FM oscillator for overall tests of residual noise and distortion. It was obviously impossible to construct a perfect test source, and there were practical limits imposed upon the two test units. By comparing the results obtained from each of these two different types of modulators, a relative measure of the monitor performance was obtained. Consistent results showed a measured distortion level of 0.25% over a wide range of modulating frequencies and transmitter modulation levels for both test sources. The modulating oscillator was known to have 0.1% distortion. On the basis of the tests on the monitor, made by insertion of an IF signal, it was adjudged that most of the remaining distortion was actually generated within the test sources. While these tests cannot be used to define rigorously the residual distortion within the monitor, they are indicative of the results that may be expected.

The same is true for the noise measurements, where the results indicated a noise level of -70 db for the entire system, with the conclusion that the FM test sources were again the limiting factor.

2-WAY RADIO FOR TRUCKS

(CONTINUED FROM PAGE 32)

valuable cargo and look after the welfare of the injured employee.

The installation of more sets in buses was rushed to handle the Machine Tool Convention in Chicago, when we transported 30,000 people per day between the Chicago Loop and the new Tucker plant.

One of our services is to transport some 3,000 handicapped children to and from their homes to special schools. Our two-way radio is enabling us to take better care of these children. In case of illness en route, we can get in immediate touch with the school and the child's family.

In the evening, after school hours, the radio enables us to dispatch buses promptly on special runs. Also in case of a breakdown, the dispatcher can quickly send out an alternate bus.

In summary, we should like to reiterate that we consider the installation of mobile radiophone the most progressive step in our business since the adoption of motor vehicles.

INDEX OF ARTICLES AND AUTHORS

From January 1947 to
December 1947

INDEX OF ARTICLES

	1947 Issue Page		1947 Issue Page
ALLOCATIONS, FREQUENCY		COMMUNICATIONS, FM TRUCK & BUS	
Opportunity for a "free radio" through		Greyhound, 3,000-mc. repeater	29
FM, C. M. Jansky, Jr.	Feb. 28	Trucking company report on FM, H.	
New FM allocations spread stations	May 29	Willett, Jr.	Dec. 35
Govt. vs. com. communications, J. Courtney	June 30	COMMUNICATIONS, SYSTEMS	
Interference between television and com-		Report on FM communications, M. B.	
munications	July 37	Sleeper	July 21
More FM channels	July 38	Proposed revision on 44-50 mc.	Oct. 18
44 to 50 mc. for FM broadcast develop-		COVERAGE, FM	
ment, E. H. Armstrong	Nov. 21	Practical considerations of FM coverage,	
AMPLIFIERS, AUDIO		P. de Mars	Apr. 21
Plug-in studio amplifiers, W. M. Dallin	May 24	Practical considerations of FM coverage,	
ANTENNAS, FM BROADCAST		P. de Mars	May 30
Station WJMR, New Orleans, La.	Mar. 27	FM for tropical and mountainous coun-	
Station WTCN, Minneapolis, Minn.	Mar. 40	tries, C. M. Jansky, Jr.	Sept. 21
Antenna uses waveguide principle, G. G.		DEMONSTRATIONS	
Greene	July 38	R.E.L. FM clinic, M. B. Sleeper	Mar. 23
FM antenna at WMRC-FM	Aug. 24	Demonstration at E. S. auditorium,	
Station KERA-FM, Dallas, Texas	Aug. 29	M. H. Fogel	Aug. 20
Station WMRC-FM, Greenville, S. C.		FCC demonstration for Int'l. Tele.	
Front Cover	Sept. 34	Comm. Conference, C. M. Jansky, Jr.	Sept. 21
Station WBT, Charlotte, N. C.	Nov. 23	FM relay out-performs coax, M. B.	
ANTENNAS, FM COMMUNICATIONS		Sleeper	Dec. 17
Ont.-Minn. pulp & paper station	Aug. 29	DESIGN, FM RECEIVERS	
ANTENNAS, FM RECEIVING		Hallcrafters all-purpose FM-AM, Nelson	
Facts of life about FM, M. B. Sleeper	Jan. 30	Case	Jan. 34
Dimensions for folded dipole, 88-108		Browning FM-AM tuner, F. A. Spindell	Feb. 34
mc.	Feb. 36	High-fidelity designs at mass-market	
Multiple antennas, F. A. Klingenschmitt		prices, W. Buehr	Mar. 31
Don't blame FM — put up an antenna!		Discussion of FM set designs	June 4
J. C. Morgan	May 40	Harvey double superheterodyne, B. J.	
BROADCASTING, FM		Cosman & A. W. Richardson	June 21
Opportunity for a "free radio" through		Set designs are changing, M. B. Sleeper	Aug. 22
FM, C. M. Jansky, Jr.	Feb. 28	A. E. I. FM tuner, F. E. Berhley	Aug. 35
FM wins listeners, M. B. Sleeper	Apr. 19	FMI railroad receiver, F. A. Mesch &	
WEAW-FM taps local talent, G. Gruen-		L. H. Morse	Sept. 30
wald	Apr. 30	Ratio detector, Stuart Wm. Seeley	Dec. 26
Lea act upheld	July 28	DESIGN, FM TRANSMITTERS	
More FM channels	July 38	Cascade phase-shift modulator, M.	
FM for the tropics	Aug. 4	Marks	Jan. 43
FM for tropical & mountainous countries,		48-channel phone transmitter, A. Van	
C. M. Jansky, Jr.	Sept. 21	Weel	Mar. 28
FM and television problems, M. B.		Phasitron modulation, L. O. Krause	June 31
Sleeper	Sept. 24	R. E. L. quadriline amplifier, J. R. Day	
New pattern for industry, M. B. Sleeper	Oct. 17	& M. H. Jennings	Aug. 43
Review of radio progress, C. R. Denny,		FMI railroad transmitter, F. A. Mesch	
Jr.	Oct. 19	& L. H. Morse	Sept. 30
New deal for listeners, Paul A. Walker	Oct. 21	DESIGN, TELEVISION RECEIVERS	
Planning an FM station, R. S. Lanier	Oct. 34	Details of the DuMont RA-101, J. H.	
Planning an FM station, R. S. Lanier	Nov. 28	Ruiter	May 35
FM broadcast stations in the U. S.	Oct. 39	DIRECTORIES	
44-50 mc. for FM broadcast develop-		FM stations on the air Jan. 25, 1947	Feb. 43
ment, E. H. Armstrong	Nov. 21	List of cities where FM stations are au-	
What KPFM is doing, S. M. Goard	Dec. 29	thorized	July 27
BROADCASTING, TELEVISION		U. S. communications systems, Part I	July 40
Interference between television and com-		FM broadcast stations in the U. S.	Oct. 39
munications	July 37	EQUIPMENT, COMMUNICATIONS	
FM and television problems, M. B.		Sperry installation for C. R. I. & P.	Jan. 33
Sleeper	Sept. 24	Bendix portable pack set	Apr. 29
Review of radio progress, C. R. Denny,		G. R. S. installation for M.-P.	July 35
Jr.	Oct. 19	152-162-mc. mobile equipment, B. J.	
Philco-RCA television relay	Oct. 20	Cosman	Nov. 36
G.E. New York-Schenectady relay	Oct. 20	EQUIPMENT, TELEVISION FIELD	
FM relay out-performs coax, M. B.		Television field equipment, J. H. Roe &	
Sleeper	Dec. 17	N. S. Bean	Nov. 30
BUILDINGS, TRANSMITTER		EQUIPMENT, TEST	
Plan of WMRC-FM, transmitter build-		Television signal generator, J. Fisher	Oct. 24
ing	Aug. 26	FACSIMILE	
Planning an FM station, R. S. Lanier	Oct. 35	Miami Herald newspaper, E. H. Felix	Apr. 36
Planning an FM station, R. S. Lanier	Nov. 28	Philadelphia Bulletin tests	May 34
What KPFM is doing, S. M. Goard	Dec. 29	Facsimile is ready for home use, M. B.	
CAMERAS, TELEVISION		Sleeper	June 19
Television field equipment, J. H. Roe &		New pattern for industry, M. B. Sleeper	Oct. 17
N. S. Bean	Nov. 31	Discussion of facsimile standards, M.	
COMMUNICATIONS, FM FORESTRY		Alden	Nov. 4
153 mc. for forestry, R. L. Atkinson	July 23	FEDERAL COMMUNICATIONS COMMISSION	
Directory of forestry systems	July 55	Television color hearing, Dec. 12, 1946	Jan. 4
COMMUNICATIONS, FM POLICE		How the FCC views FM, C. R. Denny,	
Dual-diversity on 75 mc., B. Cutting	Feb. 26	Jr.	Feb. 24
Directory of police radio systems	July 40	Discussion of television color hearing	Mar. 4
Motorcycle installation	Nov. 23	FMA request to substitute AM for stand-	
COMMUNICATIONS, FM PUBLIC UTILITY		ard	Mar. 70
System for power utility, G. H. Under-		Decision on color television	Apr. 4
hill	Jan. 25	New allocations to spread stations	May 28
COMMUNICATIONS, FM RAILROAD		Govt. vs. Coml. comm., J. Courtney	June 30
Sperry installation for C. R. I. & P.	Jan. 33	Cities where FM stations are authorized	July 27
G. R. S. installation for M.-P., R. Max-		FM demonstrations for Int'l. Comm.	
well	July 35	conference	Sept. 21
Directory of railroad radio systems	July 40	Proposed revision of assignments on	
Bendix installation for W.M., J. M.		44-50 mc.	Oct. 18
Sitton	Aug. 32	FCC's review of radio progress, Charles	
FMI railroad radio, F. A. Mesch & L. H.		R. Denny, Jr.	Oct. 19
Morse	Sept. 30	Chairman Denny resigns	Oct. 22
COMMUNICATIONS, FM SPECIAL		FM broadcast stations in the U. S.	Oct. 39
FM for logging camps, R. L. Wasley	Sept. 38	44 to 50 mc. for FM broadcast develop-	
		ment, E. H. Armstrong	Nov. 21
		FM ASSOCIATION	
		FMA girds for big job ahead	Jan. 23
		Organizers of FM association move fast,	
		M. B. Sleeper	Feb. 21
		Address at Washington, C. R. Denny,	
		Jr.	Feb. 24
		Address at Washington, H. D. Lavery	Feb. 25
		Request to substitute AM for standard	Mar. 70
		Receiver production, H. C. Bonfig	May 4
		Address at N. Y. by Paul A. Walker	Oct. 21
		FREQUENCIES, AUDIO	
		Range of musical instruments	Dec. 24
		GENERATORS, TELEVISION SIGNAL	
		Television signal generator, J. Fisher	Oct. 24
		INSTALLATIONS, FM RECEIVER	
		High-fidelity designs at mass-market	
		prices, W. Buehr	Mar. 31
		Multiple antennas, F. A. Klingenschmitt	
		May	May 21
		Don't blame FM — put up an antenna!	
		J. C. Morgan	May 40
		INSTRUCTION	
		R.E.L. FM clinic, M. B. Sleeper	Mar. 23
		INSURANCE, RADIO STATION	
		Insurance for radio stations, Part 1	Jan. 48
		Insurance for radio stations, Part 2	Feb. 32
		Insurance for radio stations, Part 3	Apr. 44
		LENSES, TELEVISION CAMERA	
		Zoomar lens	May 27
		MODULATION	
		Cascade phase-shift modulation, M.	
		Marks	Jan. 43
		Phasitron modulation, L. O. Krause	June 31
		MONITORS	
		General radio monitor, C. R. Cady	Dec. 19
		NETWORKS, FM BROADCAST	
		Continental network starts	Apr. 28
		Continental network map	May 19
		FM can cut AM rates, M. B. Sleeper	May 19
		Bell system sees FM network demand,	
		L. G. Woodford	Aug. 19
		Continental network programs	Sept. 4
		FM demonstration for Int'l. Tel. Comm.	
		conference	Sept. 21
		FM-AM duplication	Nov. 17
		NETWORKS, TELEVISION	
		Review of radio progress, C. R. Denny, Jr.	Oct. 19
		Philco — RCA television relay	Oct. 20
		G. E. New York-Schenectady relay	Oct. 20
		New television relays	Nov. 17
		FM relay out-performs coax, M. B.	
		Sleeper	Dec. 17
		PERSONALITIES	
		Anderson, Iannes, E.	Front Cover
		Armstrong, Major E. H.	Aug. 20, Aug. 22
		Feb. 21, Front Cover	Aug. 20, Aug. 22
		Feb. 23	Feb. 23
		Baker, Dr. W. R. G.	Feb. 31, Nov. 23
		Braun, Cyril	Feb. 22
		Bray, W. Ennis	Aug. 25
		Buehr, Walter	Front Cover
		Carl, Larry	Sept. 29
		Chapman, Oscar	Sept. 29
		Claire, Marion	Nov. 23
		David, W. R.	Feb. 22
		Denny, Charles R. Jr.	Front Cover
		Jan. Feb. 24, Sept. 22, Oct. 19	Jan. Feb. 24, Sept. 22, Oct. 19
		Dillard, Everett L.	Feb. 21, Sept. 29, Oct. 17
		Fairbanks, Jerry	May 27
		Freed, Arthur	Feb. 21, Feb. 31
		Gatewood, W. Frank	Sept. 29
		Gray, Gordon	Feb. 22
		Gunther, Frank A.	Feb. 23, Mar. 35, Aug. 21
		Hanson, O. B.	May 27
		Hofheinz, Roy	Feb. 21, 22, Oct. 17
		Hogan, John V. L.	Feb. 23
		Jansky, C. M. Jr.	Front Cover
		Feb., Aug. 22	Feb., Aug. 22
		Jett, F. K.	Sept. 22
		Jolley, R. A.	Aug. 24
		Lavery, Hugh D.	Feb. 25
		Lawrence, Walter L.	Front Cover
		Nov. 29	Nov. 29
		Mandernach, Howard	Sept. 29
		Manson, Dr. Ray H.	Feb. 23, Feb. 31
		McDonald, Comdr. Eugene F.	Feb. 31
		Norman, Nathaniel	Aug. 20
		Perdieu, Howard L.	Sept. 29
		Poppele, Jack R.	Sept. 29
		Reilley, John A.	Sept. 29
		Runyan, C. R. Jr.	Mar. 24
		Runyan, C. R. 3rd	Mar. 24
		Russell, Gordon	Aug. 21
		Samuelson, Cyrus D.	Sept. 29
		Tate, George	Aug. 27
		Walker, Paul A.	Oct. 21
		PROPAGATION	
		Practical considerations of FM coverage,	
		P. de Mars	Apr. 21
		Practical considerations of FM coverage,	
		P. de Mars	May 31
		WWV standard frequency broadcasts,	
		W. W. George	June 25
		FM for tropical and mountainous coun-	
		tries, C. M. Jansky, Jr.	Sept. 21
		RECEIVERS, COMMUNICATIONS	
		152-162-mc. mobile equipment, B. J.	
		Cosman	Nov. 36
		RECEIVERS, FM BROADCAST	
		Hallcrafters all-purpose FM-AM, Nelson	
		Case	Jan. 34
		Browning FM-AM tuner, F. A. Spindell	Feb. 34
		High-fidelity designs at mass-market	
		prices, W. Buehr	Mar. 31
		Production problems, H. C. Bonfig	May 4
		Harvey double superheterodyne, B. J.	
		Cosman and A. W. Richardson	June 21
		A. E. I. resonant line tuner, F. E. Berhley	Aug. 34
		Pilot FM tuner	Sept. 37
		C. A. P. FM-AM tuner, W. H. Collins	Nov. 18
		RECEIVERS, PRODUCTION OF	
		Problems of production, H. C. Bonfig	May 4
		Monthly barometer of set production	Sept. 4
		This appears on page 4 of each subse-	
		quent issue	
		Production methods vs. circuit designs,	
		hallicrafters photos	Oct. 29
		RECEIVERS, TELEVISION HOME	
		Details of Du Mont RA-101, J. H. Ruiter	May 35
		RECEPTION, FM	
		Facts of life about FM, M. B. Sleeper	Jan. 30
		RELAYS, TELEVISION	
		Review of radio progress, C. R. Denny, Jr.	Oct. 19
		Philco — RCA television relay	Oct. 20
		G. E. New York-Schenectady relay	Oct. 20
		New television relays	Nov. 17
		G. E. relay installation	Nov. 23
		FM relay out-performs coax, M. B.	
		Sleeper	Dec. 17

(Continued on page 38)

YOUR SALES STORY

Will Be HEARD By More "Interested People" * If You Put It On

WCFC in BECKLEY

* People With FM Sets . . . Interested In Keeping Abreast With The Times . . . Want New Products . . . New Facts About The Old

★ Beckley, the "Smokeless Coal Capital," can be one of your richest markets with the help of WCFC, pioneer FM station in West Virginia. WCFC programming is geared to the needs of the community and is thus able to serve the advertiser better. Write for rate card and complete market data.

The SMOOTH Voice Of The "Billion Dollar" Smokeless Coal Fields
3000 WATTS • 101.3 Mcs. • CHANNEL 267

WCFC

305 Reservoir Road
 Beckley, West Va.

1947 Issue Page

Characteristics of the quadriline amplifier, J. R. Day & M. H. Jennings	Aug.	43
Federal installation at WMRC-FM, E. W. Bray	Aug.	23
Federal installation at WMRC-FM, E. W. Bray	Sept.	34
Collins FM broadcast transmitters, N. H. Hale	Oct.	32
152-162-mc. mobile equipment, B. J. Cosman	Nov.	36
AT & T FM relay, M. B. Sleeper	Dec.	17
TRANSMITTERS, TELEVISION		
Television field equipment, J. H. Roe & N. S. Bean	Nov.	31
Television field equipment	Dec.	32
TUBES, MAGNETRON		
Magnetrons, Part 4, J. B. Fisk, H. D. Hagstrum, & P. L. Hartman	Jan.	50
Magnetrons, Part 5	Feb.	44
Magnetrons, Part 6	Mar.	46
Magnetrons, Part 7	Apr.	40
Magnetrons, Part 8	May	42
Magnetrons, Part 9	July	30
TUNERS, See RECEIVERS		
ALDEN, MILTON		
Discussion of facsimile standards	Nov.	4
ARMSTRONG, EDWIN H.		
44-50 mc. FM broadcast development	Nov.	21
BEAN, NORMAN S.		
Television field equipment	Nov.	31
BERILEY, FRED E.		
Tuning without condensers	Aug.	35
BONFIG, H. C.		
Problems of FM receiver production	May	4
BRAY, W. ENNIS		
48.6-kw. installation at WMRC-FM	Aug.	23
48.6-kw. installation at WMRC-FM	Sept.	34
BUEHR, WALTER		
High-fidelity FM designs at mass-market prices	Mar.	31
CADY, CHARLES R.		
General radio monitor	Dec.	19
CASE, NELSON		
All-purpose FM-AM receiver	Jan.	34
CAWEIN, MADISON		
Television Handbook	Jan.	39
Television Handbook	Feb.	38
Television Handbook	Mar.	38
Television Handbook	Apr.	31
Television Handbook	June	37
Television Handbook	Aug.	39
Television Handbook	Sept.	41
COLLINS, WILLIAM H.		
C.A.P. FM-AM tuner	Nov.	18
COSMAN, BERNARD J.		
Harvey double superheterodyne FM receivers	June	21
152-162-mc. mobile equipment	Nov.	36
COURTNEY, JEREMIAH		
Government vs. commercial communications	June	30
CUTTING, LIEUT. BASIL		
Dual diversity transmission on 75 mc.	Feb.	26
DALLIN, WILLIAM M.		
Plug-in studio amplifiers	May	24
DAY, JAMES R.		
Characteristics of the quadriline amplifier	Aug.	43
DE MARS, PAUL		
Practical considerations of FM coverage, Part 1	Apr.	21
Practical considerations of FM coverage, Part 2	May	30
DENNY, CHARLES R., JR.		
How the FCC views FM	Feb.	24
FCC's review of radio progress	Oct.	19
FELIX, EDGAR H.		
Miami Herald transmits newspaper	Apr.	36
FISK, J. B.		
Magnetrons, Part 4	Jan.	50
Magnetrons, Part 5	Feb.	44
Magnetrons, Part 6	Mar.	46
Magnetrons, Part 7	Apr.	40
Magnetrons, Part 8	May	42
Magnetrons, Part 9	July	30
FOGEL, MORTIMER H.		
FM demonstrations: 1935, '47	Aug.	20
GEORGE, W. W.		
WWV standard frequency broadcasts	June	25
GOARD, S. M.		
What KPFM is doing	Dec.	29
GREENE, GARDINER G.		
FM antenna uses waveguide principle	July	38
GRUENWALD, GEORGE		
WEAW-FM taps local talent	Apr.	30
HAGSTRUM, H. D.		
Magnetrons, Part 4	Jan.	50
Magnetrons, Part 5	Feb.	44
Magnetrons, Part 6	Mar.	46
Magnetrons, Part 7	Apr.	40
Magnetrons, Part 8	May	42
Magnetrons, Part 9	July	30
HARTMAN, P. L.		
Magnetrons, Part 4	Jan.	50
Magnetrons, Part 5	Feb.	44
Magnetrons, Part 6	Mar.	46
Magnetrons, Part 7	Apr.	40
Magnetrons, Part 8	May	42
Magnetrons, Part 9	July	30
HERZOG, L. W.		
Plans for television at WTMJ-TV	Nov.	24
ING, GEORGE		
Field service of mobile equipment	Apr.	27
JANSKY, C. M., JR.		
Opportunity for a "free radio" through FM	Feb.	28
FM for tropical and mountainous countries	Sept.	21

(CONCLUDED ON PAGE 40)

SERVICE, DATA ON		1947 Issue Page
Hallcrafters SX-42 receiver, Nelson Case	Jan.	34
Browning FM-AM tuner, F. A. Spindell	Feb.	34
Field alignment of mobile equipment, G. Ing	Apr.	27
Harvey double superheterodyne, B. J. Cosman and A. W. Richardson	June	21
A.E.I. resonant-line tuner, F. E. Berhley	Aug.	35
Pilot FM tuner	Sept.	37
C.A.P. FM-AM tuner	Nov.	18
SPEAKERS		
Western electric dual speaker	Mar.	35
Klipsch reproducer, P. W. Klipsch	Sept.	25
STANDARDS, FREQUENCY		
WWV broadcasts, W. W. George	June	25
STATIONS, FM BROADCAST		
Stations on the air, Jan. 25, 1947	Feb.	43
Station WJMR, New Orleans, La.	Mar.	26
Installation at WMRC-FM, W. E. Bray	Aug.	23
Installation at WMRC-FM, W. E. Bray	Sept.	34
Planning an FM station, R. S. Lanier	Oct.	35
Planning an FM station, R. S. Lanier	Nov.	28
What KPFM is doing, S. M. Goard	Dec.	29
STATIONS, TELEVISION		
Status of U. S. television stations	Sept.	24
Television at radiolympia	Nov.	23
Plans for WTMJ-TV, L. W. Herzog	Nov.	24

TELEVISION, COLOR		1947 Issue Page
FCC color television hearing, Dec. 12, 1946	Jan.	4
Discussion of television color hearing	Mar.	4
FCC decision on color television	Apr.	4
TELEVISION HANDBOOK		
Madison Cawein, (1st part appeared Dec., 1946)	Jan.	39
Madison Cawein	Feb.	38
Madison Cawein	Mar.	38
Madison Cawein	Apr.	31
Madison Cawein	June	37
Madison Cawein	Aug.	39
Madison Cawein	Sept.	41
TIME SALES		
How time-buyers view FM, H. D. Lavery	Feb.	24
TRANSMISSION, FM COMMUNICATIONS		
Dual-diversity on 75 mc., B. Cutting	Feb.	26
TRANSMITTERS, FM		
Cascade phase-shift modulator, Part 2, M. Marks	Jan.	43
48-channel phone transmitter, A. Van Weel	Mar.	28
Phasitron-modulated transmitters, L. O. Krause	June	31
50-kw. RCA FM transmitter	Aug.	29

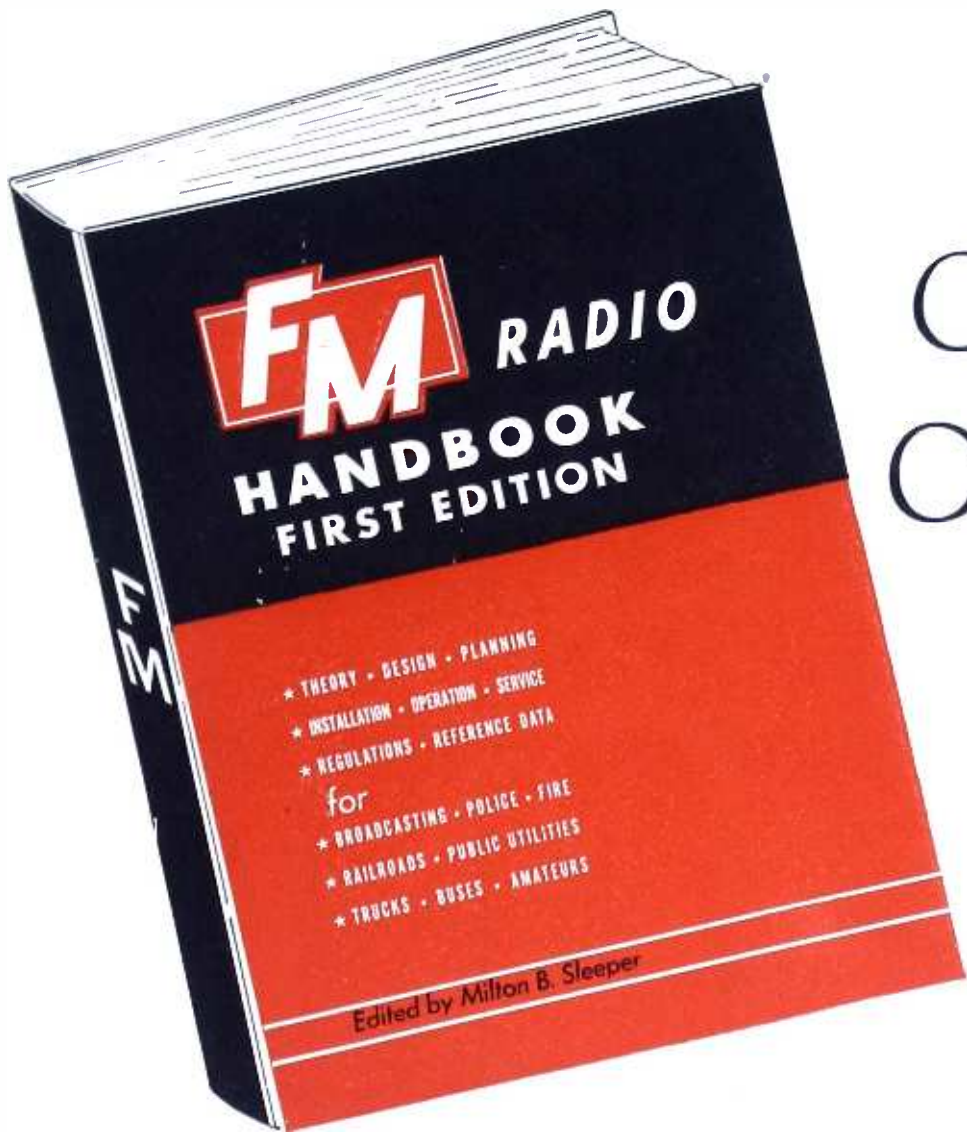

Order Your
Copy Today!

\$2 postpaid in U. S.
elsewhere \$2.25
in the Paper Bound Edition

the Industry's Most-Needed Source of Information

The STANDARD FM HANDBOOK

THE 15 chapters of the FM HANDBOOK were written by 14 outstanding FM engineers. This book, of 174 pages, 8¾ by 11½ ins., is equal to 300 pages of the ordinary handbook size. There are 218 photographs, wiring diagrams, and charts to illustrate the latest FM equipment and circuits. Here is a resume of the chapters:

1. Background of FM: as told by Major Armstrong to the Senate Interstate Commerce Committee in December, 1943. Also, excerpts from his log in 1934, '38, and '39.
2. Theory of FM: by Rene Hemmes. This is the most complete and understandable explanation of FM theory ever written. By using charts and diagrams, the functions of FM circuits are shown clearly, without recourse to mathematics. This chapter explains all the special features of receiver design, including AFC; and transmitter design, including the Armstrong dual-channel modulator.
3. Business of FM Broadcasting: by Milton B. Sleeper. Answers questions from those planning to enter FM broadcasting.
4. FM Studio Techniques: by D. W. Gellerup. Explaining fundamental differences between AM and FM techniques.
5. Coaxial Lines for FM Transmitters: by C. Russel Cox. A complete exposition, with working charts and mechanical layouts.
6. Audio Distortion and Its Causes: by Jerry Minter. A study of cross-modulation and its effect on tone quality.
7. High-Fidelity Reproduction: by John K. Hilliard. Describing the operation and design of coaxial speakers and high-fidelity amplifiers.
8. Antennas for Communications Frequencies: by James A. Craig. Covering all types of antennas for 30 to 44, 72 to 76, and 152 to 156 mc.
9. Selective Calling Methods: by Milton B. Sleeper. Explanation includes a call-number chart for individual and group calling.
10. Maintenance of Communications Systems: by Frank Bramley. How Connecticut State Police handles the maintenance of 332 cars and 11 main stations.
11. Alignment of FM Receivers, by Bernard J. Cosman. The fast, visual method for aligning FM broadcast and communications receivers.
12. WWV Signals for Frequency Checking, by Arthur Fong. Describing a receiver for checking circuits, meters, and modulators from WWV transmissions.
13. Railroad Radio Installations: by Arnold Nygren. Presenting factual data on their operation and performance.
14. Notes on Facsimile Equipment, by Frank R. Brick. Outline of progress for commercial and broadcast services.
15. FCC Standards of FM Engineering Practice, corrected to January 1, 1947.

NO OTHER BOOK LIKE IT

This is the first and ONLY Book ever written on FM which covers BOTH theory and practice. It answers questions for those engaged in manufacturing, broadcasting, communications, sales, and maintenance. Whatever your connection with the industry, you'll find that it contains the largest amount of practical useful information you have ever bought in any one book!

ORDER YOUR COPY NOW!

FM and TELEVISION

200 Main Street
Great Barrington, Mass.

Please send me by return mail a copy of the Standard FM Handbook.

Enclosed are \$2.00 (paper edition)
 \$4.00 (cloth edition)

Name.....

Street.....

City.....

Postpaid in U.S.A. — Add 25¢ foreign postage

WASH—FM— WASHington, D. C.

ORIGINATING STATION
FOR THE

Continental Network

The "exclusively-FM" station, featuring
live-talent shows that "sell FM" in the
Nation's Leading FM receiver market

On the air with 650 watts
in Downtown Washington
2:45 to 11:05 Daily

15000 watt installation under construction

EVERETT L. DILLARD, General Manager

JENNINGS, M. H.	Aug.	43
Quadriline amplifier		
KLINGENSCHMITT, F. A.	May	21
Multiple antennas		
KLIPSCH, PAUL W.	Sept.	25
Klipsch sound reproducer		
KRAUSE, L. O.	June	31
Phasitron modulation		
LANIER, R. S.	Oct.	35
Planning an FM broadcast station		
Planning an FM broadcast station	Nov.	28
LAVERY, HUGH D.	Feb.	31
How the time-buyers view FM		
MAXWELL, RAY	July	35
Engine-to-caboose FM		
MESCH, F. A.	Sept.	30
FMI railroad radio		
MORGAN, JOHN CARL	May	40
Don't blame FM — put up an antenna!		
MORSE, LEW H.	Sept.	30
FMI railroad radio		
PENCE, WILLIAM P.	Dec.	28
Television in the southeast		
RICHARDSON, ARTHUR W.	June	21
Harvey double superheterodyne		
ROE, JOHN H.	Nov.	31
Television field equipment		
RUITER, J. H.	May	34
Details of the DuMont RA-101 teletest		
SEELEY, STUART Wm.	Dec.	26
Ratio detector		
SITTON, JOHN M.	Aug.	32
FM increases terminal efficiency		
SLEEPER, MILTON B.	Jan.	30
Facts of life about FM		
Organizers of FM association move fast	Feb.	21
REL FM clinic	Mar.	23
FM wins listeners and worries AM'ers	Apr.	19
FM can cut AM rates	May	19
Facsimile is ready for home use	June	19
Report on FM communications	July	21
Set designs are changing	Aug.	22
FM and television problems	Sept.	24
New pattern for industry emerges	Oct.	17
CCBS plans — TV relays — FM-AM	Nov.	17
duplication	Dec.	17
FM relay out-performs Coax		
SPINDELL, F. A.	Feb.	34
Data on the Browning FM-AM tuner		
UNDERHILL, G. H.	Jan.	25
Mobile system for power utility		
VAN WEEL, A.	Mar.	28
48-channel FM phone transmitter		
WALKER, PAUL A.	Oct.	21
New deal for listeners		
WASLEY, ROBERT L.	Sept.	38
FM for logging camps		
WOODFORD, L. G.	Aug.	19
Bell system sees FM network demand		

STATEMENT OF THE OWNERSHIP, MANAGEMENT, CIRCULATION, ETC., REQUIRED BY THE ACTS OF CONGRESS OF AUGUST 24, 1912, AND MARCH 3, 1933

Of FM AND TELEVISION, published monthly at Great Barrington, Massachusetts, for October 1, 1947

State of Massachusetts }
County of Berkshire } ss.

Before me, a Notary Public in and for the State and county aforesaid, personally appeared Milton B. Sleeper, who, having been duly sworn according to law, deposes and says that he is the owner, publisher, and editor of the FM AND TELEVISION Magazine and that the following is, to the best of his knowledge and belief, a true statement of the ownership, management, etc., of the aforesaid publication for the date shown in the above caption, required by the Act of August 24, 1912, as amended by the Act of March 3, 1933, embodied in section 537, Postal Laws and Regulations, to wit:

1. That the names and addresses of the publisher, editor, managing editor, and business managers are: Publisher, Milton B. Sleeper, Great Barrington, Massachusetts; Editor, Milton B. Sleeper, Great Barrington, Massachusetts; Managing Editor, none; Business Manager, none.

2. That the owner is: Milton B. Sleeper, db/a FM Company, Great Barrington, Massachusetts.

3. That the known bondholders, mortgagees, and other security holders owning or holding 1 per cent or more of total amount of bonds, mortgages, or other securities are: None.

4. That the two paragraphs next above giving the names of the owners, stockholders, and security holders, if any, contain not only the list of stockholders and security holders as they appear upon the books of the company but also, in cases where the stockholder or security holder appears upon the books of the company as trustee or in any other fiduciary relation, the name of the person or corporation for whom such trustee is acting, is given; also that the said two paragraphs contain statements embracing affiant's full knowledge and belief as to the circumstances and conditions under which stockholders and security holders who do not appear upon the books of the company as trustees, hold stock and securities in a capacity other than that of a bona fide owner; and this affiant has no reason to believe that any other person, association, or corporation has any interest direct or indirect in the said stock, bonds, or other securities than as so stated by him.

(Signed) MILTON B. SLEEPER, Owner.

Sworn to and subscribed before me this Seventh day of October, 1947.

(Seal) LILLIAN BENDROSS, Notary Public
Commission expires July 1, 1954.

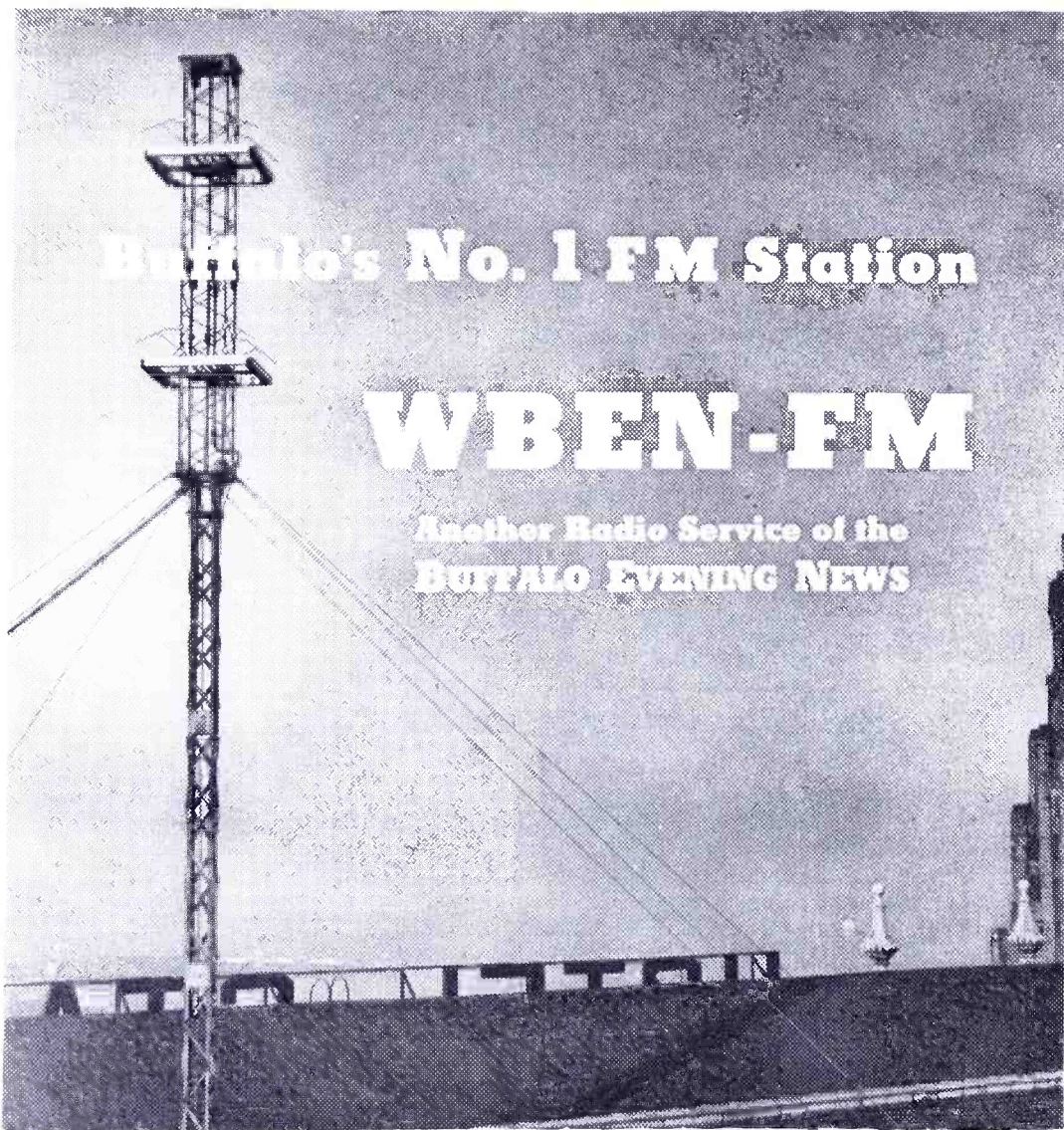

SANGAMO CAPACITORS

the Line you can
Buy with Confidence--Use with Confidence



Sangamo Capacitors are available to meet almost any paper, mica or silvered mica capacitor requirement of the electronic industry, in either the transmitting or receiving types. Designed to conform to the exacting requirements of the joint Army-Navy specifications, high inherent quality and performance is assured.

A quarter of a century of experience in building better capacitors, with

new and more exacting requirements and greater accuracy demanded each year, give Sangamo Capacitors—of all kinds—a reputation for quality.

Discriminating users have learned to rely on Sangamo Capacitors for excellent design and construction, honest characteristics and conservative ratings. There is a Sangamo Capacitor to fill your every post-war capacitor need.



Investigate the Sangamo line today. Send for our new Capacitor Catalog No. 23. Your copy is ready and will be mailed upon request.

SANGAMO

ELECTRIC COMPANY

SPRINGFIELD • ILLINOIS



SC474A

WMRC-FM GREENVILLE, S. C.

Building the Largest FM Audience in the Carolinas, by Giving the Finest FM Service

With 48.6 kw. of effective radiation on 93.3 mc., WMRC-FM has taken the lead in providing fine programs with powerful signals over the western and central Carolinas and east to Rocky Mount, Goldsboro, Fayetteville, Myrtle Beach, and Charleston, and extending to Bristol and Danville, Va., Knoxville and Johnson City, Tenn., and Atlanta and Athens, Ga. Daily schedule, noon to 9:00 p.m.

Textile Broadcasting Co.
WMRC and WMRC-FM

WE WISH YOU AND YOURS
Season's Greetings

- The Holiday Season is Short ...
- BUT the Selling Season is Long.
- Remember, If You Want Your
- Message HEARD
- WELD Is Your *Buy-Word!*

WRITE FOR RATE CARD

WELD

Ohio's First FM Station

COLUMBUS



SPOT NEWS NOTES

(CONTINUED FROM PAGE 22)

ates. Under the new setup, Mr. Sullivan, formerly vice president, has become president and treasurer, with Kenneth M. Piper as the new vice president. Other executives will continue in their previous positions.

Equipment Sales: There has been a recent general drop in the volume of broadcast equipment sales. Best opinion holds that the FCC was successful in discouraging some of those preparing to enter AM broadcasting, and that orders for FM equipment are being held up pending the AFM settlement at the end of January. These are reasonable opinions. The mad rush to get into AM was unsound, for it was based on an unrealistic notion of easy money.

Watchful waiting for AFM developments is a different matter. Except for a few die hards, broadcast operators realize that agreement on FM-AM program duplication will sound the gun for the inevitable and eventual change over from AM to FM. Perhaps the American Federation of Musicians realizes that it will also be the turning point in the revival of live talent shows, and the most effective means of regaining employment for many members. At least, Mr. Hooper could tell the AFM that however acceptable recordings may sound on AM-sets, FM listeners want to hear the musicians in person.

Full Power: Independent FM station WFMZ, Allentown, Pa., has upped its output to full power of 1 kw. and has shifted to its permanent frequency of 95.9 mc. New antenna is a 6-bay G.E. design, installed by Frederick Tower Erection Company.

Servicemen's Meeting: A 3-day town meeting for servicemen will be held at the Bellevue-Stratford Hotel, Philadelphia, on January 11 to 13. The program is sponsored by the RMA, Sales Managers Club, NEDA, Electronic Parts and Equipment Manufacturers, and The Reps. Plan is to bring the servicemen up to date on FM and TV receiver techniques. Chairman is Harry Ehle of I.R.C.

Actually, the meeting represents belated recognition of the fact that, under wartime restrictions, servicemen were cut off from contact with developments in the radio art from 1941 to 1945. If the Philadelphia meeting proves to have worthwhile results, similar sessions will be held in other cities. For details of the program, address: David Krantz, 2109 S. 7th Street, Philadelphia.

Communications Systems: You will be astonished to see from our January issue the enormous growth of taxi, bus, truck, and public utility systems.

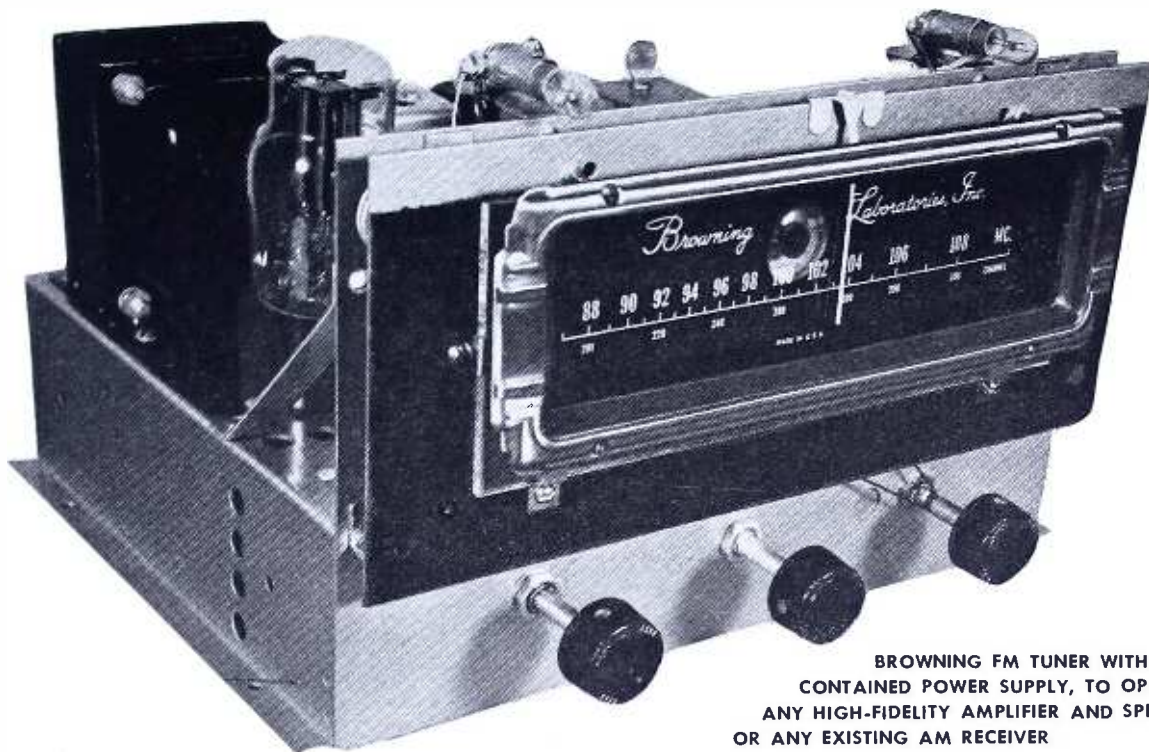

BROWNING FM TUNER WITH SELF-CONTAINED POWER SUPPLY, TO OPERATE ANY HIGH-FIDELITY AMPLIFIER AND SPEAKER OR ANY EXISTING AM RECEIVER

The Experts Who Have Tested All Types Prefer

BROWNING FM and FM-AM TUNERS

IF YOU look inside the newest studio equipment and the latest custom-built receivers, the chances are you'll see BROWNING FM or FM-AM tuners.

Experts, who have built their reputations on performance, have come to prefer BROWNING tuners on the basis of comparative tests. In the installations they design, price is not a factor. Only performance counts with them.

You'll also find BROWNING tuners in very modest installations, too. When price must be very carefully balanced against results to determine maximum performance per dollar, BROWNING tuners win again.

There are two reasons: 1. These tuners

employ genuine Armstrong dual-limiter-discriminator circuits, giving the most complete noise suppression of any FM circuit yet devised.

2. As the largest manufacturers of Armstrong-circuit tuners, we have set up production methods which maintain uniform, peak performance more precisely than if each tuner were made in a model shop, and tested with the finest laboratory instruments.

You can pay more for an FM or FM-AM tuner, but you can't buy finer performance. If you pay less, you'll be sorry.

The coupon attached will bring you complete technical information and prices on the instruments you check.

Browning Labs., Inc.

750 Main Street, Winchester, Mass.

In Canada, Address:

MEASUREMENT ENGINEERING, Ltd.

Arnprior, Ontario

BROWNING LABORATORIES, Inc.
750 Main St., Winchester, Mass.

Please send me technical details and prices on the following Browning precision products:

- | | |
|---|---|
| <input type="checkbox"/> FM Tuners | <input type="checkbox"/> WWV Frequency Calibrator |
| <input type="checkbox"/> FM-AM Tuners | <input type="checkbox"/> Laboratory Oscilloscope |
| <input type="checkbox"/> Frequency Meters | <input type="checkbox"/> Capacity Relay |

Name

Address

Company Connection

wghf
101.9 MC.

THE FINCH FM-FACSIMILE STATION

Presenting more and more live-talent shows for listeners within 70 miles of New York City. Now operating on 2 kw., soon on full power of 7.2 kw. Hours of operation: 3:00 to 12:00 m.

FREQUENCY 101.9 MC.

Studios and Transmitter: 10 E. 40th St., New York City

Telephone Lexington 2-4927

*A New ERA
in the Great Southwest!*

WFAA-FM

(formerly KERA)

First FM station in the Southwest's Biggest Billion Dollar Market — Dallas and Fort Worth — operating nine hours daily with 14,000 watts radiated power.

97.9 Mc.

WFAA-FM Channel 250

A RADIO SERVICE OF THE DALLAS MORNING NEWS

Dallas, Texas

WHAT'S NEW THIS MONTH

(CONTINUED FROM PAGE 13)

contained in that exhibit indicated much greater F2-layer reception than had heretofore been anticipated and briefs and oral presentations that have been made have suggested you made certain fundamental errors in the computation of those exhibits. I would like to know whether if such a closed session as has been suggested is held, you would expect to be in a position to substantiate the conclusions set forth in Exhibit 380."

That concludes Mr. Denny's question. And you answered him and you said:

"Yes, I certainly will be able to substantiate those conclusions at such a session."

Now, did you substantiate them, Mr. Norton?

A. Yes, sir, I did substantiate them.

Q. On 80 megacycles?

A. The conclusions I had reference to were the conclusions as to the presence of long-distance high signal-intensity F-layer transmissions in the band up to 50 megacycles, which was the band then proposed for FM broadcasting.

Q. But you said 80 megacycles, Mr. Norton.

A. I said 80 megacycles relative to what I would have expected, yes, that is right; at that time, based on the available information I had at that time.

Q. But you were wrong?

A. Oh, certainly. I think that can happen frequently to people who make predictions on the basis of partial information. It happens every day.

MR. ARMSTRONG: "That is the point I would like to make, Mr. Chairman, the type of engineering advice this Commission has been given, and that has resulted in chaos to those of us who have been trying to do an engineering job."

One point is still unsettled. Major Armstrong produced, in support of his testimony, photostats of his signal-strength recordings. Mr. Allen, however, offered only an analysis of the recordings he had made. There is some question as to whether the analysis reflected accurately the conditions represented by the recordings.

Accordingly, Major Armstrong requested and received permission to examine the original Allen recordings, and to file a brief after he has checked the analysis offered at the hearing by Mr. Allen. We expect that this supplementary material will be ready in time to discuss it in our next issue.

In this connection, it should be noted that recordings can be analyzed on either the instantaneous or median basis. The former method shows the total time signals are below usable intensity. In the latter method, complete drop-outs are not disclosed, as they merely reduce the figure of average intensity.

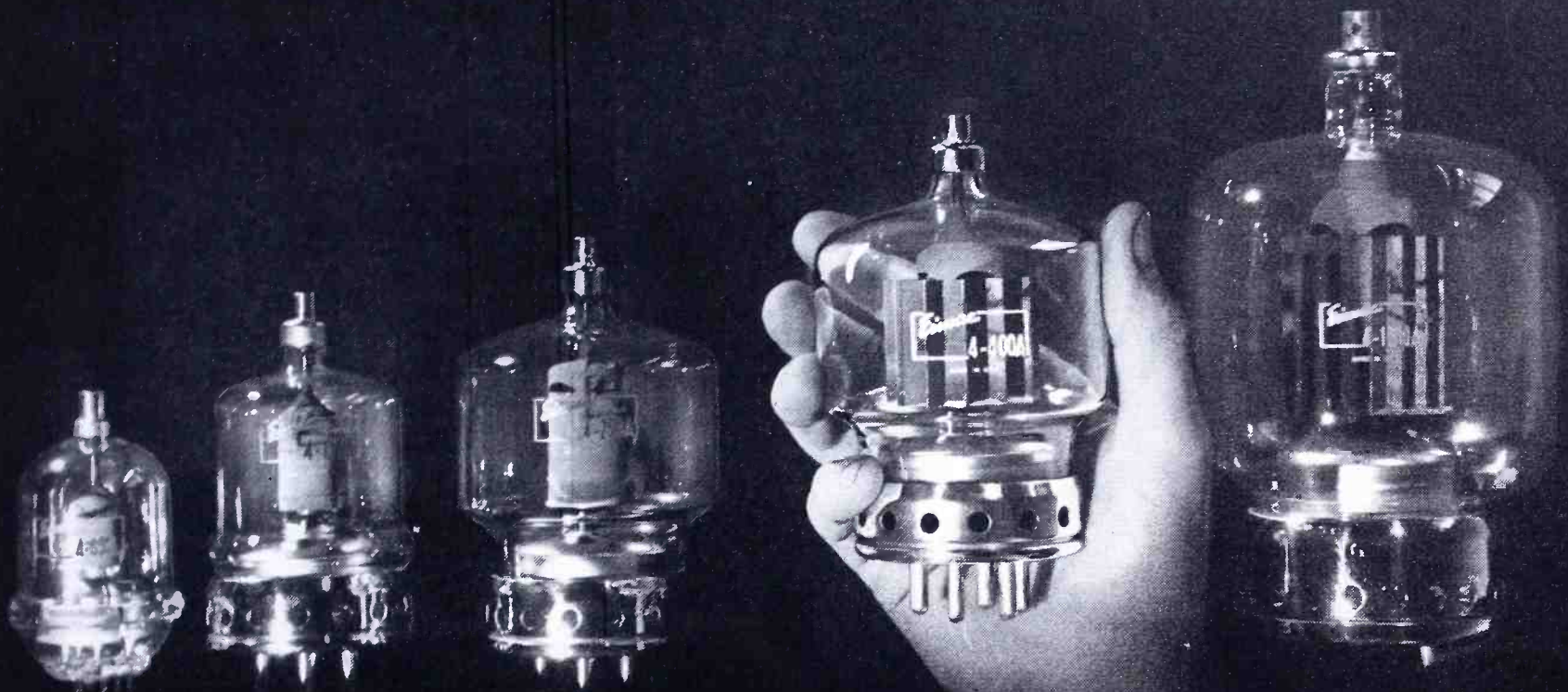

FOR 1 KW FM . . . A NEW RADIATION COOLED TETRODE

ANOTHER in the Eimac line of power tetrodes . . . Type 4-400A embodying stability, high performance, and economy characteristics familiar to all Eimac tetrodes.

PROVEN DESIGN

The 4-400A was created to fill the established need for a tetrode of the internal anode type capable of providing 1 kw FM-broadcast output per pair at low driving power, while operating well below maximum ratings. Type 4-400A inherits the Eimac know-how of tetrode design, it incorporates maximum shielding of the tube input—output circuits, processed non-emitting grids, low-inductance leads, thoriated tungsten filament and a rugged plate contributing to exceptionally long tube life.

AMPLE POWER

In typical operation, at frequencies in the 88-108 Mc FM broadcast band, two 4-400A tetrodes provide over 1000 watts of useful power output, operating at 4000 plate volts, while the plate dissipation is considerably under the maximum rating of 400 watts per tube. Complete operational data and characteristics are available by writing direct.

UNIQUE FEATURE

To assure adequate cooling and extended tube life, the 4-400A must be used in the special Eimac socket and air control chimney. This unique socket makes maximum use of a small amount of air by directing it first on the terminals, around the base seals, through the socket, around the envelope, and then on the plate seal and lead. The socket housing

is of cast aluminum and conveniently mounts below the chassis deck while spring clips on the deck support the pyrex chimney.

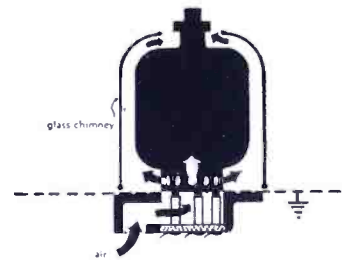
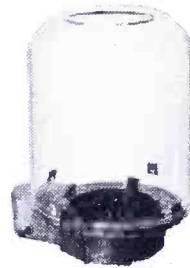

LOW COST

Type 4-400A tetrodes are priced at \$50.00 each, an exceptionally low price considering their power performance capabilities.

DESIGN ASSISTANCE

Let Eimac engineers assist you in your vacuum tube application problems. A letter to the Application Engineering Department will bring you up-to-the-minute data and application suggestions on the 4-400A and other Eimac tube types.

EITEL-McCULLOUGH, INC.

186 San Mateo Avenue
San Bruno, California

Follow the Leaders to

Eimac
TUBES
The Power for R-F

EXPORT AGENTS: Frazar & Hansen—301 Clay St.—San Francisco, Calif.

MR. RADIO RETAILER

A MUST for NOISE-FREE STORE DEMONSTRATION . . .



PURATONE* SIGNAL BOOSTER

CARRIES AM, FM and TV ANTENNAS ALL ON THE SAME MAST

Increase your radio sales by bringing home-like reception to any AM, FM and TV set in your showroom . . . eliminating all interference and bothersome noises.

HERE'S HOW: The Puratone Signal Booster System is easily installed on the roof of your building. A shielded coaxial cable runs directly from the mast to the concealed amplifier on the display floor.

From the amplifier a radiating wire is placed inconspicuously around the display space. No direct wire connection to radio sets required. One system serves any number of floor models. Dual wave traps in the video-type AM-FM amplifier bring in all stations at an average tone-level. 30-40 DB gain on FM; 40-60 DB gain on AM. Effective for any radio department layout.

Write for illustrated circular.

L.S. BRACH MFG. CORP.
200 CENTRAL AVE., NEWARK 4, N. J.

WORLD'S OLDEST AND LARGEST MANUFACTURERS OF RADIO
ANTENNAS AND ACCESSORIES

RATIO DETECTORS

(CONTINUED FROM PAGE 27)

ance introduced into the primary by the mutual coupling between the circuits is decreased. This latter effect would, of itself, tend to increase the grid-plate gain of the IF driver tube, and thus enhance the increase in signal amplitude. However, part of the increased diode current is derived from the tertiary winding voltage, so there is increased damping of the primary which tends to counteract that effect.

The curves of Fig. 4 were taken with an oscilloscope by applying the audio sine wave modulating voltage of an FM signal generator to the horizontal plates, with a

ratio detector output voltage applied to the vertical plates. The signal from the generator to the ratio detector driver tube was held constant and the diode load resistance adjusted to the several values indicated. These curves demonstrate the dependence of detector sensitivity upon the value of the diode load resistance.

The simulated inverse load-resistance variation with amplitude, in a correctly designed ratio detector, might be somewhat in excess of the amount necessary to provide amplitude variation immunity. In other words, the simple circuit of Fig. 3 might give decreased output with increased input. This would be almost as objectionable as a corresponding increase

in sensitivity with amplitude. The resistors R' and R'' of Fig. 5 may be added to the diode load outside the heavily bypassed portion to allow some variation in diode load voltage with signal amplitude changes, and thus make the detector deviation sensitivity a true inverse ratio of the instantaneous signal amplitude. If there is inherent circuit unbalance, the values of R' and R'' may be slightly dissimilar to obtain balance.

Other circuit parameters may be varied to accomplish these results. For instance, if the condensers C_2 and C_3 , Fig. 5, are small enough to have measurable impedance at the operating frequency, it will be found that they can be adjusted to affect the amplitude variation sensitivity. A small resistance of the order of 100 ohms, added in series with the tertiary winding, will alter the operational characteristics.

Performance Characteristics ★ Correct design of these factors will produce a ratio detector which will have the same deviation-output characteristic over its operating range in the presence of rather wide changes in signal amplitude as shown in Fig. 6.

Incidentally, it is well to point out that in order to obtain an oscillogram of dual characteristics such as those of Fig. 6, it is necessary to measure the DC voltage across the load resistor when the mean, or average, signal is applied, and then stabilize it at that voltage by connecting a battery or other DC source across the load during the tests. The electrolytic condenser will stabilize the voltage against changes at an audible rate, but will not hold it constant while a signal generator is varied from one level to another.

The fact that the DC load voltage adjusts itself to the average level of the signal being supplied to the detector means that the negative end of the load resistor becomes a good source of AVC voltage. The use of AVC will prevent the IF amplifier stages from overloading with a strong signal, and thus losing their selectivity characteristics.

The loops at the ends of the 100,000-ohm diode load resistance curves of Fig. 4 and those at the ends of the 0.1-volt curve of Fig. 6 have special significance which deserves explanation.

Examination of the circuit in Fig. 3 will show that in the absence of conduction in the diodes, the center-tapped secondary and the auxiliary or tertiary winding are completely isolated from ground and will "float" at any potential at which they may be left if diode conduction is momentarily stopped. Therefore, if the peak applied signal is momentarily decreased below the DC bias voltage supplied by the stabilized resistor-condenser load combination, the output audio potential tends to remain at whatever value it had assumed at the instant conduction ceased. The only restoring tendency is that supplied by the

(CONCLUDED ON PAGE 47)

CO-AX CONNECTORS



**AVAILABLE FOR
IMMEDIATE
DELIVERY**

We carry all popular standard and British type coaxial cable connectors in stock. These connectors are brand new and were produced for the Government by the leading manufacturers in this field. Our inventory contains sufficient quantities for the largest users at prices well below the market. Write or wire for special Coaxial Cable and Connector Listing 100A or send us your requirements.

Manufacturers and Distributors

Wells maintains one of the world's largest inventories of highest quality radio-electronic components. Our new catalog, now ready, will be mailed upon request.



320 N. LASALLE ST.
Dept. TV, Chicago 10, Illinois

NEXT MONTH

COMMUNICATIONS DIRECTORY, Part 2

SHOWING:

Operating Companies

Street Addresses

Call Letters

Frequencies

Number of Mobile Units

Make of Equipment

for over 5,000 taxi, truck, bus, and public utility communication systems. — In the January issue of

FM and TELEVISION

RADIO DETECTORS

(CONTINUED FROM PAGE 46)

small conduction (high resistance) of the audio volume control which, together with the RF bypass condenser, forms a relatively long time-constant network.

The loops in Figs. 4 and 6 are due to the high secondary selectivity dropping the peak signal below diode conduction outside the normal operating range of deviation. This happens only when the secondary Q is high, due to a high load resistance in Fig. 4 and to low signal in Fig. 6.

The net result of this characteristic is illustrated in Fig. 7A and 7B. In these curves, interfering impulses of sufficient amplitude and proper phase to produce the so-called "pop" effect are applied to the receiver during different portions of an audio modulating cycle. A "pop" is normally produced when the interference, in effect, heterodynes out a complete cycle of the received wave and thus causes the signal to go to zero momentarily.

In Fig. 7A the interfering impulses are shown applied to a balanced, back-to-back diode phase-shift discriminator. In Fig. 7B the same impulses are applied to a ratio detector. Notice that in Fig. 7B the instantaneous audio potential tends to ride at whatever value it had assumed at the instant the signal is removed until it is again applied. For the sake of illustration, de-emphasis was omitted in taking both of these characteristics. In some receivers strong interfering impulses may actually cause momentary blocking due to grid current charges on bypass condensers in early amplifier or converter stages. Much can be done by proper design to obviate that condition, but the ability of an FM detector to ride over such holes in the signal, without undue disturbance, is a real advantage.

Design ★ The design of a ratio detector is not easily accomplished without proper laboratory equipment and instrumentation. The ability to reproduce characteristics such as those of Fig. 4, in order to provide proper compensation, is almost a necessity. However, having determined the correct value for all parameters, a ratio detector is not critical to normal manufacturing tolerances.

Fig. 8 shows a typical ratio-detector transformer of commercial design, used in the circuit illustrated in Fig. 9.

Advantages ★ A properly engineered ratio detector receiver has several distinctive characteristics. It is relatively quiet between stations, is easy to tune, and maintains its full degree of selectivity in the presence of strong signals. It is less susceptible to crosstalk and adjacent-channel interference than other types of circuits, and provides full capture-effect for co-channel transmissions. Side responses are very much subdued or entirely absent.



**first in facsimile
for broadcasting and point-
to-point communication!**

FINCH TELECOMMUNICATIONS

INCORPORATED

SALES OFFICE:

10 EAST 40th STREET, NEW YORK

FACTORIES: PASSAIC, N. J.

Crystals for the Critical



JK STABILIZED H18

Frequency Range 80 kc to 2 mc.
8-prong octal base. Hermetically sealed, can be evacuated or gas filled.

Separate pin for grounding shell.

Will stand maximum vibration and changes of temperature.

Crystal is plated and wire mounted.

As many as three crystals may be mounted in this holder.

Write For Illustrated Folder

The JAMES KNIGHTS CO.
SANDWICH, ILLINOIS

**VALUABLE
EASY-TO-BUY
ELECTRONICS**

Authorized WAA Electronics Distributors

EASTERN

Automatic Radio Mfg. Co., Inc. 122 Brookline Ave. Boston, Mass.	Johanns & Keegan Co., Inc. 62 Pearl St. New York, N. Y.
Carr Industries, Inc. 1269 Atlantic Ave. Brooklyn, New York, N. Y.	Newark Electric Co., Inc. 242 West 55th St. New York, N. Y.
Tobe Deutschmann Corp. 863 Washington Street Canton, Mass.	Radio Parts Distributing Co. 128 West Olney Road Norfolk, Va.
Electronic Corp. of America 353 West 48th Street New York, N. Y.	Smith-Meeker Engineering Co. 125 Barclay Street New York, N. Y.
Emerson Radio & Phonograph Corp. 76 Ninth Ave. New York, N. Y.	Standard Arcturus Corp. 99 Sussex Ave. Newark, New Jersey
General Electric Co. Bldg. 267; 1 River Road Schenectady, N. Y.	Sylvania Electric Products, Inc. Emporium, Pa.
General Electronics, Inc. 101 Hazel Street Paterson, N. J.	Technical Apparatus Co. 165 Washington St. Boston, Mass.
Hammarlund Mfg. Co., Inc. 460 West 34th Street New York, N. Y.	Tung-Sol Lamp Works, Inc. 95 Eighth Ave. Newark, New Jersey
Hytron Radio & Electronics Corp. 76 LaFayette Street Salem, Mass.	W. & H. Aviation Corp. Municipal Airport Rochester, New York

MIDWESTERN

American Condenser Co. 4410 N. Ravenswood Ave. Chicago, Ill.	Electro-Voice, Inc. Carroll & Cecil Streets Buchanan, Michigan
Belmont Radio Corp. 3633 S. Racine Ave. Chicago, Ill.	E. F. Johnson Co. 206 Second Ave., S. W. Waseca, Minnesota

SOUTHERN

Navigation Instrument Co., Inc. P. O. Box 7001, Heights Station Houston, Texas	Southern Electronic Co. 611 Baronne St. New Orleans, La.
--	--

PACIFIC

Cole Instrument Co. 1320 S. Grand Avenue Los Angeles, Calif.	Hoffman Radio Corp. 3761 S. Hill Street Los Angeles, Calif.
--	---

large stocks...

wide selection...

quick delivery, too!



MANUFACTURERS

WHOLESALE — JOBBERS

See these WAA Authorized Distributors for *your share!* Their inventories include many types of unused electronic devices, tubes and equipment.

Purchasing of surplus electronic tubes, devices and equipment has been simplified to a high degree. These WAA Approved Distributors were selected on a basis of their ability to serve you intelligently and efficiently.

Write, phone or visit your nearest Approved Distributor for information concerning inventories, prices and delivery arrangements. Fill your needs—NOW—while inventories still permit large purchases and wide selection. You'll find you can "Save with Surplus."



Offices located at: Atlanta • Birmingham • Boston • Charlotte
Chicago • Cincinnati • Cleveland • Denver • Detroit • Grand Prairie,
Tex. • Helena • Houston • Jacksonville • Kansas City, Mo. • Little Rock
Los Angeles • Louisville • Minneapolis • Nashville • New Orleans • New
York • Omaha • Philadelphia • Portland, Ore. • Richmond • St. Louis
Salt Lake City • San Antonio • San Francisco • Seattle • Spokane • Tulsa

1377

Customer Service Centers in these and many other cities.

FM AND TELEVISION

Collins 37M
FM Ring Antenna



a package of top F.M. Performance



Collins 733A
3 kw FM
Transmitter

Collins can furnish all equipment and accessories for your new FM station, and it's smart to buy that way. Consider these advantages:

1. Collins engineering sees your station as an integrated whole, each part of which is designed, assembled and tested to uniformly high standards.
2. By reposing all responsibility for equipment in one company well known for its engineering skill and manufacturing integrity, you assure maximum FM performance and a minimum of maintenance and outages.
3. In addition to its complete line of broadcast equipment, Collins designs and makes special audio control equipment, when necessary, to meet a customer's individual operating methods.

Consult us about your needs, studio to antenna, for an FM station from 250 to 50,000 watts.



Collins 212A
Speech Input Console

FOR THE BEST IN FM, IT'S . . .



COLLINS RADIO COMPANY, Cedar Rapids, Iowa
11 West 42nd Street, New York 18, N. Y.

458 South Spring Street, Los Angeles 13, California

Take a page from the book of the Masters

For the finest FM transmission ...install an REL QUADRILINE!



THIS IS THE QUADRILINE—QUADRILINE is the name of the REL FM TRANSMITTER that has delivered a smashing performance from one end of the country to the other. Heart of this transmitter is the QUADRILINE 10 KW final amplifier that provides economy of operation previously impossible at 100 megacycles. Basically, this amplifier consists of four tubes with short sections of four wire line comprising the resonant circuit. This unique four wire, four tube circuit simplifies mechanical design; easily permits economical mass production; obsoletes costly "block building" methods of achieving high FM power. Important, too, failure of one power tube reduces power output only 15%—service is uninterrupted.

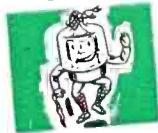

WITH ECONOMICAL TETRODES—The REL QUADRILINE is powered with 4 Eimac internal anode tetrodes. These tubes were selected for low first cost, ready availability and proven capacity to deliver required power for thousands of hours. Having high gain, the tetrode amplifier requires far less drive power; effectively reducing first and operating costs.



SHIPPED READY TO OPERATE—The QUADRILINE TRANSMITTER is an operating reality when you receive it. There is no costly field assembly; no factory engineers will swarm through your transmitter room for weeks chasing bugs. Actually, REL pre-shipment tests are so complete that it has become the REL policy to invite customers to have their engineers present during the factory test of their own equipment.



PROVEN PERFORMANCE—We feel that the REL QUADRILINE is by any standard the best 10 KW FM Transmitter on the market today. We feel, too, that actual performance records in the field substantiate this claim irrespective of the terrain or climatic conditions. But don't take our word for it—ask the opinion of the present users!

THESE FM STATIONS NOW OPERATE THE REL 10 KW QUADRILINE

WRAL-FM: RALEIGH, N. C.—FRED FLETCHER, MGR.; STANLEY BROWN, CHIEF ENGINEER
WMNE: MOUNT WASHINGTON, N. H.—YANKEE NETWORK; L. B. ROBINSON, CHIEF ENGINEER
WNBF-FM: BINGHAMTON, N. Y.—CECIL D. MASTIN, MGR.; LESTER H. GILBERT, CHIEF ENGINEER
WHKX: CLEVELAND, OHIO—K. K. HACKATHORN, GEN. MGR.; R. H. DE LANY, CHIEF ENGINEER
WMFR-FM: HIGH POINT, NORTH CAROLINA—FRANK S. LAMBETH, GEN. MGR.; ROBERT MOORE, CHIEF ENGINEER



AN INVITATION TO YOU—REL cordially invites any one interested to visit the REL plant. Here you will see the QUADRILINE in all stages of production and under actual test. Visits to operating installations can also be arranged. **WRITE FOR COMPLETE QUADRILINE LITERATURE**—To obtain the complete Quadriline story, write today to RADIO ENGINEERING LABORATORIES, 36th ST., LONG ISLAND CITY 1, N. Y.

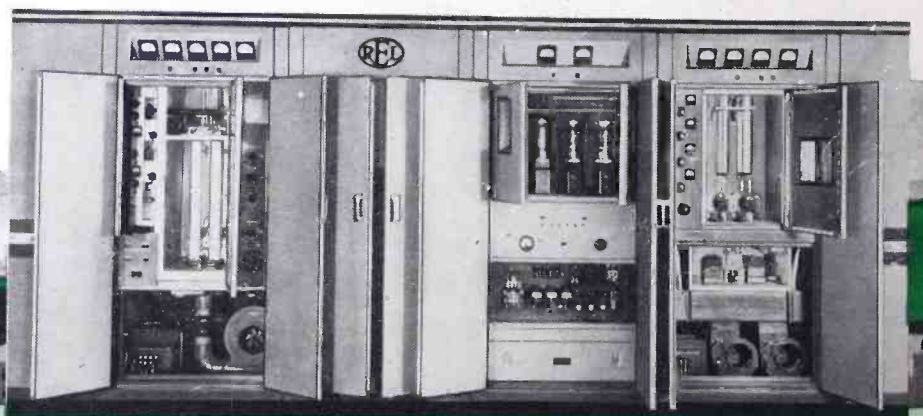

DESIGNERS & MANUFACTURERS OF FM EQUIPMENT EXCLUSIVELY
RADIO ENGINEERING LABORATORIES · INC

REL