

FMM

NOVEMBER

1941

PRICE—TWENTY-FIVE CENTS



W2XMN ALPINE —
FM BROADCASTING STARTED HERE

**RADIO BROADCAST, COMMUNICATIONS & TELEVISION ENGINEERING
AND DESIGN PRACTICE** ★ ★ *Edited by M. B. SLEEPER*

REG. U. S. PAT. OFF.

www.americanradiohistory.com

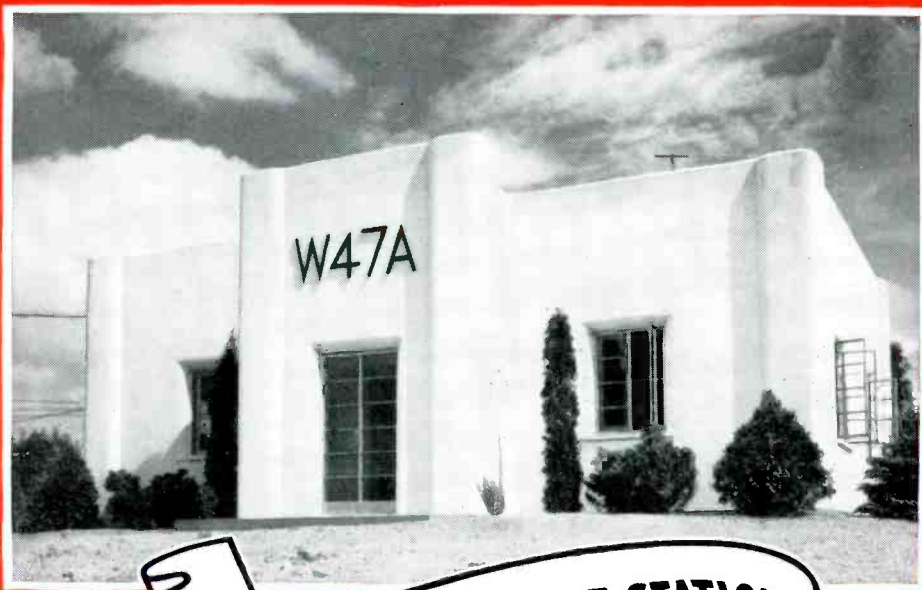

FM's FIRST INDEPENDENT STATION
on-the-air
with a G-E 1-kw transmitter

Proof That the Public Regards "FM" as More than a Strange Radio Symbol

W47A started operation July 17 with 36 sponsored programs, none less than 15 minutes long. It serves the Capitol district of New York State—covering 6589 square miles—16½ hours daily, 18½ hours Saturdays.

Owned and operated by the Capitol Broadcasting Co., Inc.—devoted solely to FM—it is the first commercial FM station unaffiliated with any broadcast interest.

W47A is also the first station in the country to get a construction permit from the F.C.C. for STL equipment. It will operate on 331 megacycles with W2XEO as the call letters. This studio-to-transmitter equipment is being built by G.E. and will soon be installed.

General Electric offers the only comprehensive line in FM today—broadcast and relay, transmitters, receivers, tubes, frequency and modulation monitors, high-gain turnstile antennas, and crystals. G.E. is the only manufacturer of FM broadcast transmitters and receivers operating an FM station as a proving ground. To benefit from actual operating experience look to General Electric for all your FM needs. Just get in touch with the nearest of our 80 offices.

Dwelle S. Hoag, Chief Engineer of W47A, takes readings on the 1-kw FM transmitter

Free!

**HOW TO PLAN AN FM STATION
HINTS ON OPERATING FM TRANSMITTERS
HOW TO MAKE MEASUREMENTS
IN FM TRANSMITTERS**

Three valuable guides, written by G-E engineers, to help you in the FM field. Get them from your G-E representative, or write General Electric, Sec. D160-16, Schenectady, N. Y.



GENERAL ELECTRIC

160-16B-6914

Who Reads *FM* Magazine?



6. That's a fair question for advertisers to ask: "Who reads *FM* Magazine?" We have detailed information available for those who want to study it, but a quick way to present the picture is to select some of the well-known names from the current subscription lists which are made out each day. Among them are:

MARCONI'S WIRELESS COMPANY
London, England
G. J. MOREY, Manager
WNLC, New London
MILWAUKEE PUBLIC LIBRARY
Milwaukee, Wis.
KAAR ENGINEERING COMPANY
Palo Alto, Calif.
JOHN V. L. HOGAN, Pres.
WQXR, New York City
LEEDS & NORTHRUP COMPANY
Philadelphia, Pa.
NAVAL RESEARCH LABORATORIES
Washington, D. C.
BELL TELEPHONE LABORATORIES
Library, New York City
13 BROADCAST ENGINEERS
WGN, Chicago
6 ENGINEERS
Freed Radio, N. Y. C.
SUPPLY DIVISION, Office of
Chief Signal Officer
Washington, D. C.
PERRY LIND, Chief Engineer
KOL, Seattle, Wash.
K. R. SWINTON, Dept. Ntl. Defense
Ottawa, Canada

RCA MFG. Co., Service Division
Camden, N. J.
5 ENGINEERS
Wells-Gardner Co., Chicago
9 ENGINEERS AND EXECUTIVES
WJAR, Providence, R. I.
HAZELTINE SERVICE CORP.
New York City
DAYTON POWER & LIGHT COMPANY
Dayton, O.
ELECTRONIC APPLICATIONS, INC.
Southern Pines, N. C.
W. A. WILSON, Chief Engineer
KBUR, Burlington, Ia.
SCHWEIZERISCHE BANKGESELLSCHAFT
Berne, Switzerland
GEORGE DRENEL BIDDLE
Byrd Mawt. Pa.
FEDERAL COMMUNICATIONS COMMISSION
Washington, D. C.
W. J. SCRIPPS, General Manager
WWJ, W45D, Detroit
WAR PLANS & TRAINING DIVISION
Office of Chief Signal Officer
Washington, D. C.
WAR OFFICE, Whitehall
London, England

These names of recent subscribers, picked at random, give a cross-section of the circulation of *FM* Magazine. A detailed examination shows that *FM* Magazine gives complete coverage of the executive and engineering heads of the broadcast and communications companies, the manufacturers of transmitters and receivers, components, and associated apparatus, and the officials of police and public utility emergency radio systems.

We believe that, among radio engineering papers, *FM* Magazine has the highest concentration of circulation in these groups, and is the most complete.

M. B. SLEEPER, *Editor and Publisher*

Motorola

2-WAY F-M RADIO SYSTEM EXPEDITES HANDLING OF ST. LOUIS STREET CAR AND BUS EMERGENCY SITUATIONS



With the aid of Motorola F-M 2-Way Radio Communication System, the Public Service Company of St. Louis is now able to speed up the handling of street car and bus emergency situations . . . This modern installation of Motorola equipment was made under the direct supervision of Motorola engineers.



In front of central dispatcher is a map showing car and bus routes and the reverse side shows the radio districts into which the system is divided. A mobile supervisor with radio cruises each district. Headway recorders check up on the spacing of street cars. Impulses generated by cars passing over regularly spaced trolley contactors are transmitted by telephone lines to recording instruments. Delays or disruption to service are immediately apparent.

The map shows the dispatcher the radio district in which emergencies arise. 2-way radio contact is established with the supervisor who is instructed to investigate the emergency and report details. Trouble trucks dispatched to the emergency are equipped with 2-way radio.



The Public Service Company of St. Louis has 3 trouble trucks all equipped with Motorola F-M 2-Way Communication Equipment.



The Public Service of St. Louis has 15 cruising supervisor's cars all equipped with Motorola F-M 2-Way Radio Equipment.



WRITE FOR COMPLETE DESCRIPTIVE LITERATURE AND TECHNICAL DATA

GALVIN MFG. CORPORATION ★ CHICAGO, ILL.

MAKERS OF THE FAMOUS MOTOROLA AUTO AND HOME RADIO



W2XMN ALPINE

THIS month's front cover reproduces a photograph of a corner in the transmitter room at Major Armstrong's FM experimental station at Alpine, New Jersey.

Major Armstrong was kind enough to have this picture taken specifically for *FM Magazine*. We wanted such a photograph because, in years to come, it will unquestionably have as great historical value as such treasured pictures of Brant Rock and Wellfleet as may be in existence still. Those stations were abandoned and dismantled long ago. They served their purpose, and were important to the early progress of the radio art. But theirs was a part in a passing show.

W2XMN Alpine occupies a different position in the march of the radio art. This station is a monument to the successful conquest of static, marking the beginning of a new era in radio communication, from which radio will move forward to more and wider fields of service.

Frequently the question is heard: "When will Alpine go commercial?" No official answer has been made. However, it seems likely that Major Armstrong will want to continue the station on an experimental basis, as it is the only high-power FM transmitter available for purposes of further research.

In the meantime, at the Major's expense, it carries most of the load of furnishing FM entertainment to listeners in the New York area.



THE RADIO ENGINEERING NEWS JOURNAL OF BROADCASTING, COMMUNICATIONS & TELEVISION

VOL. 2 NOVEMBER, 1941 NO. 1

COPYRIGHT 1941 M. B. SLEEPER

CONTENTS

WE MUST ALL REMEMBER!	4
<i>from a speech by Dr. James Bryant Conant</i>	
FM STATION SURVEY	5
<i>by Dick Dorrance</i>	
TELEVISION CAMERA EQUIPMENT	7
<i>by Klaus U. Landsberg</i>	
WHAT THE FM BROADCASTERS HAVE TO SAY:	15
<i>A Statement by Roger W. Clipp</i>	
HIGH-POWER S.W. EQUIPMENT	16
<i>by H. G. Towson</i>	
ZENITH ENGINEERS BUILT STATION W51C	24
<i>by J. E. Brown</i>	
FM SPOT NEWS	30
NEWS PICTURE	31
<i>W45CM sets construction record</i>	
FM COMMUNICATIONS TRANSMITTER	32
<i>by Donald G. Beachler</i>	
HANDY FIELD STRENGTH METER	34
<i>by Samuel Curtis, Jr.</i>	
RADIO DESIGN PRACTICE	35
SINGLE CHASSIS CONSTRUCTION	36
<i>REL emergency equipment</i>	
COMMENTS	38
<i>from readers of FM Magazine</i>	

THE COVER DESIGN AND CONTENTS OF FM MAGAZINE ARE FULLY PROTECTED BY U. S. COPYRIGHTS, AND MUST NOT BE REPRODUCED IN ANY MANNER OR IN ANY FORM WITHOUT WRITTEN PERMISSION

★ ★ ★ ★ ★ ★

M. B. SLEEPER, *Editor and Publisher*

Published by: FM COMPANY

Editorial and Advertising Office:
112 East 36th Street, New York City, Tel. LE 2-8070

FM Magazine is issued on the 20th of each month. Single copies 25¢ — Yearly subscription in the U.S.A. \$3.00; foreign \$4.00. Subscriptions should be sent to FM Company, 112 East 36th St., New York City.

The publishers will be pleased to receive articles, particularly those well illustrated with photos and drawings, concerning all phases of FM developments. Manuscripts should be sent to the publication office, at New York City. Contributions will be neither acknowledged nor returned unless accompanied by adequate postage, packing, and directions, nor will FM Magazine be responsible for their safe handling in its office or in transit.

Advertising correspondence, copy, and cuts should be addressed to the advertising office at New York City.

PLEASE NOTE FM MAGAZINE'S NEW ADDRESS: FM COMPANY
112 E. 36 ST., NEW YORK CITY

We Must All Remember!



SINCE THE 15TH CENTURY, three major developments in human society have gone hand in hand — the rise of modern capitalism, the development of science, and the evolution of free institutions. There are a multitude of striking interconnections between these three paths of development of the Western race.

“Without science, neither a business civilization nor the social philosophy of liberalism could have come to pass. And, conversely, without liberalism, science could not have blossomed and endured.

“If we consider the effect on science of the form of society in which the scientist lives, we cannot fail to realize the debt that both science and industry owe to that political movement which gave us our present degree of personal freedom.

“It is hard indeed to appreciate how much we owe to this release of human energy — the release made possible by the growth of free institutions in every Western nation.

“We must not let the momentary triumph of the totalitarian states fool us, nor let our eyes be diverted from the fact that three paths of development — political freedom, free enterprise, and science — run parallel.

“The world’s present travail makes their brief history an ever more precious heritage. We have learned that we cannot lose one without suffering the loss of all.

“Science may temporarily appear to bloom under a totalitarian dictatorship, but no one who has known the history of science can fail to prophesy the ultimate withering of the scientific tradition in a totalitarian state.

“If we value a continuation of scientific advance, either in pure science or in technology, I do not see how we can fail to be concerned for the preservation of both free initiative and free institutions.”

— JAMES BRYANT CONANT, *President of Harvard University, and Chairman of National Defense Research Committee*

FM STATION SURVEY

Facts and Figures Taken from Questionnaires Sent to FM Broadcasters by FMBI

BY DICK DORRANCE *

NEARLY 40,000,000 potential listeners today live within the assigned service areas of 17 commercial FM stations actually on the air as of October 15.

These 17 stations provide a program service averaging 13½ hours a day, and in some cases as long as 20 hours.

Programs are designed primarily for FM and not duplicated in the same area over any AM transmitter. Fourteen of the 17 stations offer a schedule that is 89.6% exclusively FM programming.

At least nine commercial FM stations maintain completely separate staffs from those of their parent AM organizations.

These are some of the encouraging facts revealed in a recent survey conducted by FM Broadcasters, Inc., the national trade association of FM broadcast stations.

Two types of questionnaires were circulated among the 58 FM licensees approved by the FCC up to October first. One was intended for stations already operating; the other for those stations which are in process of construction.

The 17 stations actually on the air were gratifyingly prompt to respond—far more so than CP holders, one quarter of whom failed to provide information requested concerning their specific plans. FMBI sought data on equipment, operating set-ups, programming, and local public reaction to FM. More than three-quarters of the 58 licensees were heard from within two weeks after the questionnaires had been sent out.

In the first group—those now operating—it was found that REL transmitters outnumber other makes, with six in use. General Electric has three units operating commercially, Western Electric

and RCA two each. Four stations engineered their own transmitters on a composite basis.

Only eight stations are now using the full operating power authorized by the Commission and therefore covering their entire assigned service areas. REL has put two 50-kw. and two 10-kw. units on the air, plus a three and a one. Two 3-kw. and a one are reported for G-E. Western Electric's score seems to be a one and a 10-kw. installation, while the RCA units are both 1-kw.

It must be remembered that this survey concerns itself only with stations operating on a regular commercial footing, without regard for some 14 experimental outlets still on the air. Consequently, in addition to the above all four manufacturers may lay claim to a number of additional 1-kw. transmitters running experimentally.

The combined operating power of all 17 commercial FM stations—nine of them still using temporarily reduced power—totals 115,000 watts. Complete installations, when finished, will have a capability in excess of 400,000 watts.

Horizontal polarization is universally accepted as standard for antennas. Only four verticals, all of the coaxial type, were reported. At least three are makeshift units, with plans calling for a change to horizontal as soon as delivery can be made on proposed arrays.

Multi-element turnstiles are most popular, ranging in complexity from two-bay to ten-bay combinations, depending on the desired amount of gain. One folded turnstile is listed, while two stations volunteer the information that they are considering use of an Alford squared array.

The questionnaires revealed that special FM staffs, devoting their efforts solely to FM, are not unusual. All but two of the

DICK DORRANCE OF THE FMBI



*General Manager, FM Broadcasters, Inc., 52 Vanderbilt Ave., N. Y. C.

17 stations are offshoots of AM interests, yet nine declare that FM is looked upon as a separate enterprise. Eight maintain partial FM staffs. The number of commercial programs signed up to date by FM stations, while not epochal, is unusual in view of the discovery that only five have salesmen devoting their time to FM.

Card rates for a night-time hour (after 6 p.m.) range from \$35 to \$100. The average is between \$50 and \$75. Two stations have not established rates, a third tacitly skipped the question.

Nine declare that they air regular announcements on AM calling attention to FM. Four say they don't. Announcements are scheduled from 15 times a day to only once. The degree of FM promotion varies in different cities from rampant enthusiasm to quiet apathy.

Most FM stations maintain a full-time program schedule. The larger FM outlets operate at least 15 hours a day, although some keep to a bare minimum of eight, with 20 as the other extreme. Group figures average about 13½ hours daily.

Particularly encouraging was the high percentage of special programming on FM, amounting to 99.6%. Four of the 17 failed to answer this query, but the efforts of the other 13 indicate realization on the part of broadcasters that a suitable, planned program service is a necessity in developing a large listening audience.

The trend is evidenced, for example, in the exclusive FM broadcasts of the Pittsburgh Symphony over W47P, in unusual special features of local interest, such as the Detroit mid-gt auto races on W45D and talks by well-known speakers at the New York Advertising Club, heard over W71NY. Local football games, not otherwise aired, are being broadcast by some FM stations, special musical groups for live, full-fidelity programs are featured over others (W59C, W55M, W65H, W43B, etc.).

Listener mail shows a steady

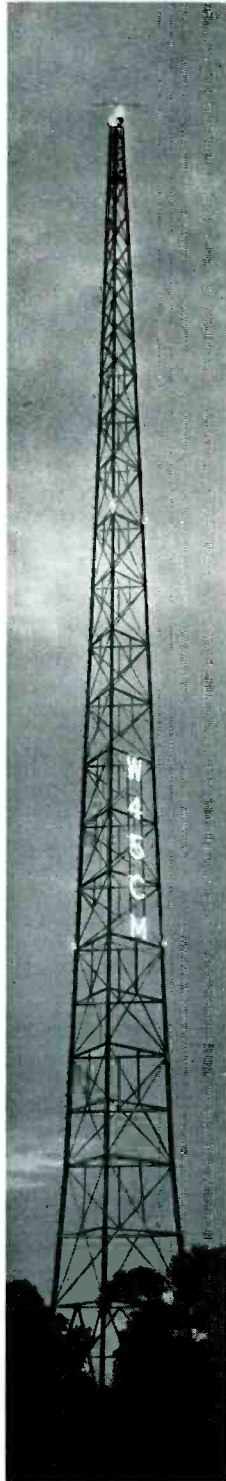

increase during recent months, keeping pace with the mounting sale of FM receivers. Most frequently requested are programs of "good music," meaning both classical selections and old favorites. A lesser demand has been voiced for news, local sports and network highlights.

Public reaction on FM, according to questionnaire answers, is either "enthusiastic" or "promising" in every case. The widest distribution of FM sets is attributed to General Electric, Stromberg-Carlson, Zenith and Philco.

Although figures are not yet complete on the activities of 41 non-operating CP holders, sufficient questionnaires have been returned to indicate that factory production of transmitters, antennas and other essential equipment is proceeding at snail's pace. Only REL and General Electric seem to have made any deliveries worthy of note.

At least seven stations admit having in sight dates when they may begin operation, and six of these expect to use temporary low wattage pending completion of higher power installations at some unpredicted date. In ten cases actual delivery dates have been named, but these are counterbalanced by more than twice as many instances where manufacturers are promising nothing. The attitude of some broadcasters to this situation is reflected in the reply of one station to FMBI's query on the manufacturer's promised date of delivery:—"They change it every month."

One or two stations holding commercial CP's but currently on the air with experimental transmitters hedged warily when asked about completion of their commercial installations. Their answers seemed to indicate that they consider experimental operation with its limited range and program service ample excuse for delaying completion of commercial outlets authorized in some cases as long as eight months ago.

Horizontal polarization will
(CONTINUED ON PAGE 44)



COMPLETE 2-CAMERA EQUIPMENT IS CARRIED IN THIS 3/4-TON TRUCK. THE CAMERAS CAN BE OPERATED FROM THE ROOF PLATFORM, OR SET DOWN ON THE GROUND

TELEVISION CAMERA EQUIPMENT

Design and Operation Features of the DuMont System of Dividing Video Apparatus into Individual, Portable Units

BY KLAUS U. LANDSBERG *

THE equipment to be described in this article was designed to fill the ever increasing demand for television camera chains which will perform equally well under all conditions encountered in field or studio use.

An attempt was made to make this apparatus of greatest portability without affecting the simplicity of operation and maintenance.

To fulfill these requirements, each camera chain has been divided into several units of about suitcase size. Furthermore, an operating dolly was designed to carry all units required

for the operation of two complete camera chains.

Fig. 1 shows a complete dual chain set-up and gives an indication of its mobility in operating condition.

Functional Layout ★ The iconoscope camera equipment functionally divides itself into four groups:

1. The scanning and synchronizing system.
2. The video system.
3. The monitoring system.
4. The power supply.

By splitting each group further into several

* Chief Engineer, Television Productions, Inc. (Subsidiary of Paramount Pictures Inc.), Hollywood, California.

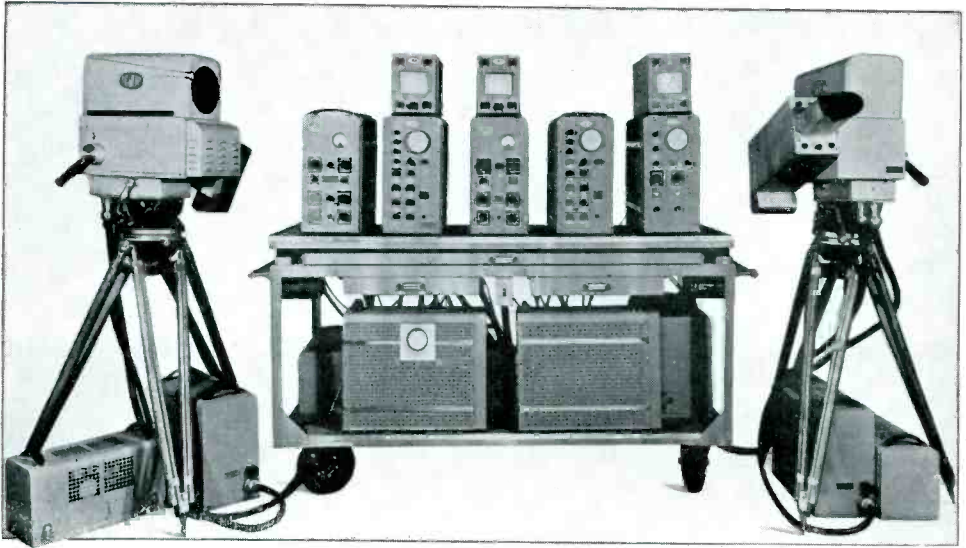

FIG. 1. COMPLETE DUMONT SET-UP, INCLUDING TWO CAMERAS AND THEIR VARIOUS SUPPLY UNITS

units, as it seemed logical according to their electrical functions, the weight of each unit was reduced so it can easily be handled by one man, and cramping of circuit components and wiring, which would highly complicate servicing of the equipment, was avoided.

1. Scanning & Synchronizing ★ The block diagram Fig. 2 and the photograph Fig. 3 show the two units which are used for the generation of the composite synchronizing signal, the sweep and blanking voltages.

This synchronizing generator is of the all-electronic type. Its master oscillator, through a frequency divider consisting of transformer-coupled relaxation oscillators, interlocks the synchronizing signal with the 60-cycle power line.

FIG. 2. SCANNING AND SYNCHRONIZING

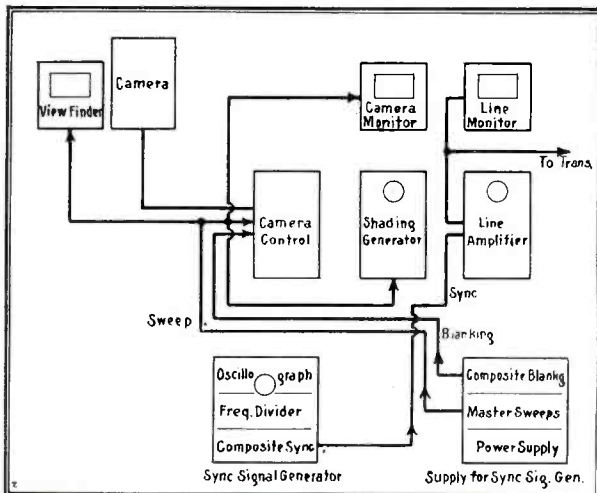

The master oscillator, oscillating at a frequency of 31,500 cycles per second for a horizontal line frequency of 525 lines, is also coupled into a divider stage, oscillating at half-frequency to provide the required horizontal pulse frequency of 15,750 cycles per second. This pulse is then shaped in an amplitude clipper, amplified and mixed with the vertical synchronizing signal. The vertical synchronizing signal is of the 500-kc. type¹ and is generated in a conventional oscillator circuit which is keyed by the 60-cycle pulse delivered by the frequency divider. After mixing the horizontal and vertical synchronizing signals, and clipping the composite signal, it is fed through a cathode-coupled output stage into the line amplifier unit, to be combined there with the video signal.

In the synchronizing generator a wave switch is provided for selection of line and frame frequencies other than those now standardized for black and white picture transmission.

To facilitate adjustment of the master oscillator, the frequency divider stages, and the sweep and blanking voltages, a 3-in. cathode ray oscillograph is built into this unit.

The second unit of this group contains the horizontal and vertical sweep oscillators. The sawtooth voltages generated in this unit are distributed to the various units as shown in Fig. 2. In the camera control unit they are further amplified and shaped before they are fed to the iconoscope deflection circuits in the

¹ Goldsmith, Campbell and Stanton: "A new method of synchronization for television systems." Journal of the Society of Motion Picture Engineers, Vol. XXXV, pages 254-99 and 40.

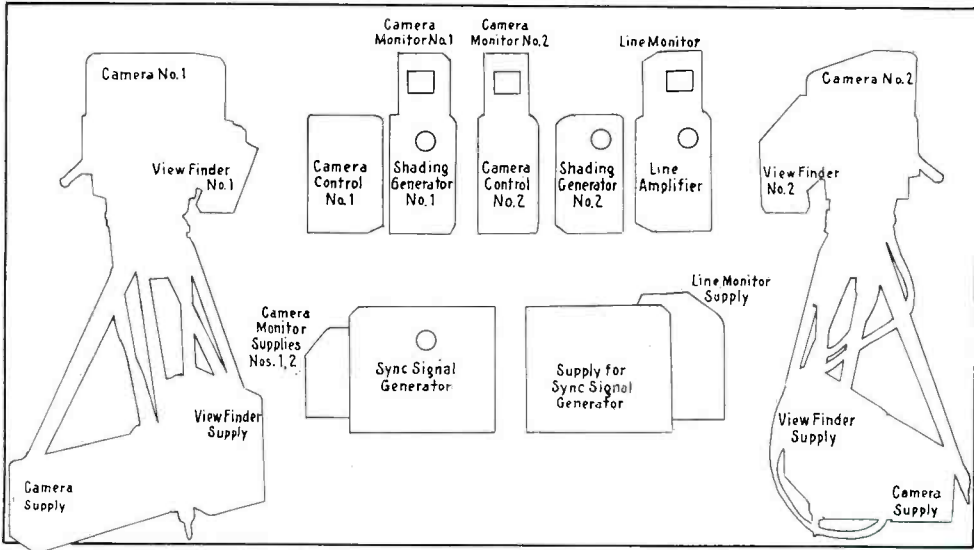

FIG. 1-A. IDENTIFICATION SKETCH OF THE CAMERA CHAIN UNITS ILLUSTRATED IN FIG. 1

camera. All adjustments such as deflection amplitude, keystoneing, balance and positioning are provided in the camera control. The horizontal and vertical sawtooth voltages are also carried into the shading generator, the camera monitors and electronic view finders, which units will be described later.

To produce the blanking signals, the sweep signals are furthermore shaped by distorting networks and clippers. These shaping circuits are also contained in the sweep generator unit and fed through a blanking mixer and cathode follower stage into the video amplifier of the camera control.

2. Video System ★ To produce a video signal suitable for transmission, various signals in addition to the actual picture signal must be generated for each individual camera chain. A considerable complexity of circuits is required.

As is shown in Fig. 4, the video system of each camera chain is divided into three units:

The camera, the camera control, and the shading generator. In addition, a fourth unit serves as a line amplifier for both camera chains.

The video signal developed in the iconoscope output resistor is preamplified in the camera and the loss of higher frequencies due to the capacitance in the iconoscope output circuit is compensated for in a peaking stage of this amplifier. A cathode-coupled output stage feeds the video signal through the camera cable into the camera control or blanking amplifier, where its level is raised further and the blanking signal is impressed upon it. In the camera control, the video gain as well as the blanking level or pedestal is regulated before the signal is carried into the camera monitor and into the switching and line amplifier unit. In the latter unit, the signal from either camera can be selected and is mixed with the synchronizing signal. The composite video and synchronizing signal is then amplified and made available through four electronically

FIG. 3. LEFT, THE SYNC SIGNAL GENERATOR AND, RIGHT, THE SUPPLY UNIT FOR THE GENERATOR. THESE TWO INSTRUMENTS ARE CARRIED ON THE LOWER SHELF OF THE DOLLY, FIG. 1

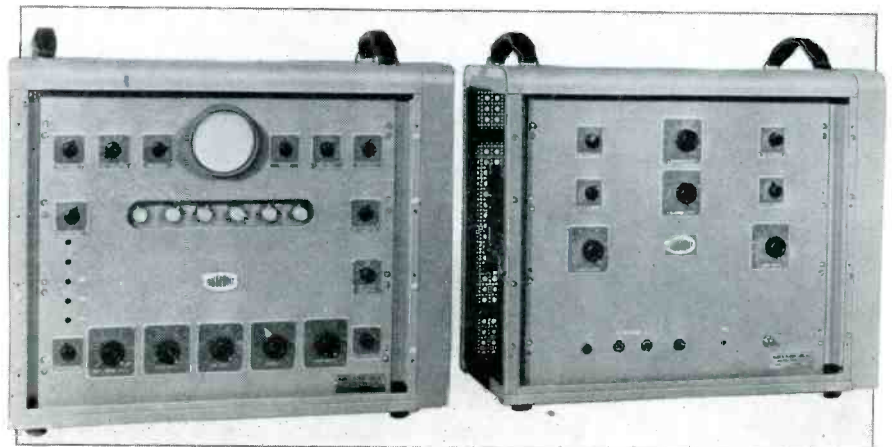

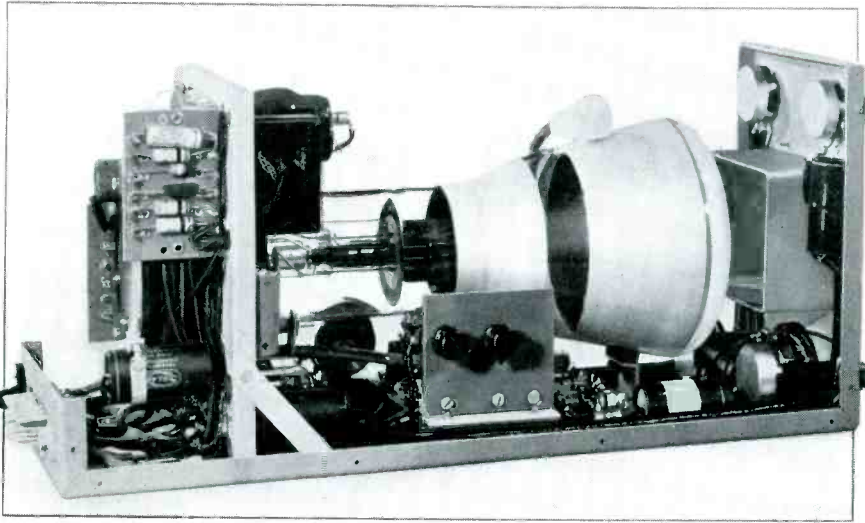

FIG. 6. CHASSIS OF THE DU MONT CAMERA MONITOR, WITH THE COVER REMOVED

controlled at the camera control by the operator.

For protection of the iconoscope, relays are installed in the camera deflection output circuits. In case of deflection failure, these relays will shut off the iconoscope beam and prevent it from burning a spot into the photo-sensitive mosaic.

3. Monitoring System ★ In the design of television camera equipment, the provision of adequate monitoring facilities is an outstanding task. It is not only important that the camera control operator be given all possible help in monitoring every operation he must perform, but a high quality view finder must be provided for the cameraman. The view finder is the first and possibly most important part of the monitoring system. Special consideration was, therefore, given to the two types of view finders which can be used, the optical (second lens) and the electronic type.

Several disadvantages of the optical view finding system are apparent. It is most difficult and expensive to obtain two lenses of the type used in television cameras with exactly the same optical characteristic. Furthermore, quick changing of lenses during a program is required and it can be seen readily that changing and lining up two lenses would delay and complicate this operation. Another problem was found in the low light-intensity of the picture given by the optical view finder, thus causing a great strain on the camera operator who must continually and over long periods of time observe his camera action and proper focus.

For these reasons an electronic view finder

was developed for the camera chains. The construction of this device and its arrangement on the side of the camera can be visualized best from Fig. 1. It is a small and extremely light unit which can be adjusted in its position to best suit the camera operator.

The 5-in. picture tube shown in Fig. 6 was specially designed with regard to smallest possible dimensions, and to give a particularly fine and brilliant trace. Self-contained in the view finder unit are the video and deflection output amplifiers, and their gain, the positioning of the picture, and both brightness and focus can be controlled by the cameraman.

As is shown in Fig. 7, the deflection voltages are carried into this unit direct from the camera, while the video signal is first fed from the camera control into the view-finder supply

FIG. 7. BLOCK DIAGRAM OF THE MONITORS

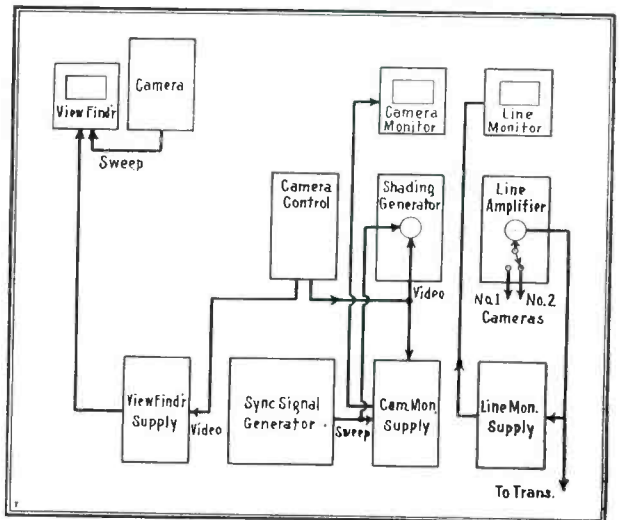

unit for further amplification. By arranging the two video amplifier stages in the supply unit, the finder unit gained in compactness, and the best shielding of the video circuit against feedback into the camera preamplifier was accomplished.

Aside from the view finder, each camera chain requires a picture monitor for the ob-

monitor. It is provided for each dual chain and shows whatever picture is selected for transmission.

In contrast to the other monitors described here, the line monitor must give an indication not only of the video adjustments but also of correct synchronization. The scanning voltages for the monitor are, therefore, generated

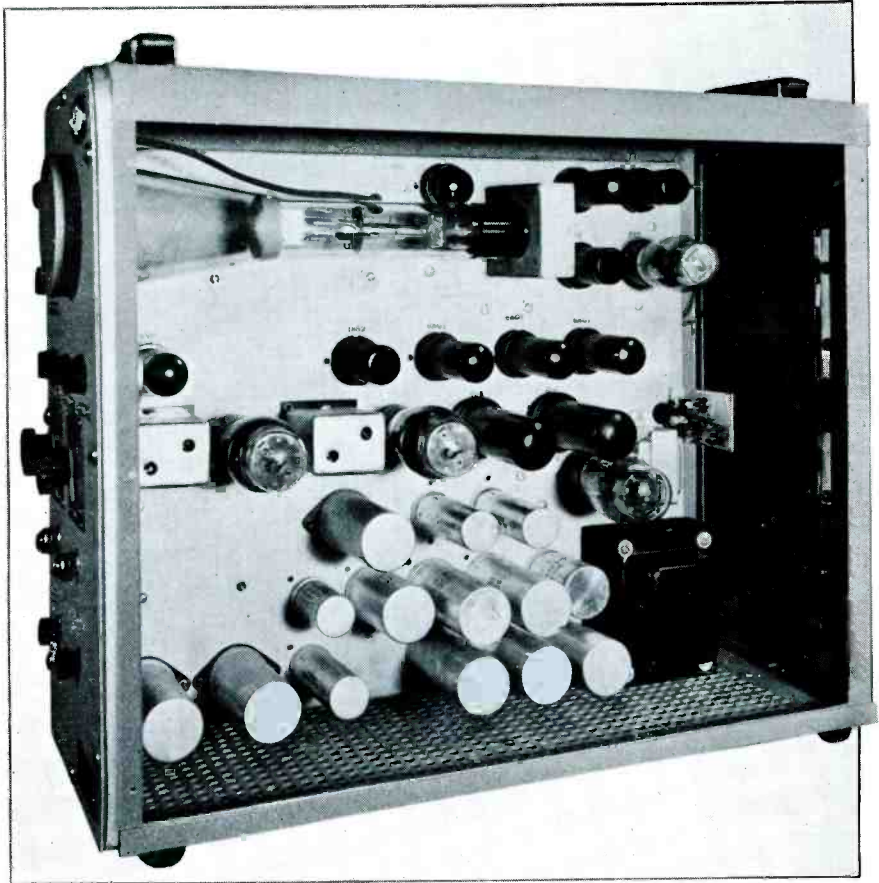

FIG. 8. LINE AMPLIFIER, WITH COVER REMOVED TO SHOW THE TYPE OF MECHANICAL DESIGN EMPLOYED TO REDUCE EFFECT OF HEAT ON COMPONENTS

servation of all camera control and shading adjustments. This camera monitor is almost identical in mechanical and electrical design with the view finder. The only difference in design is the supply unit, which contains amplifiers for the vertical and horizontal sawtooth voltages. Although the amplitude furnished by the sweep generator would be sufficient to drive the monitors, the provision of these amplifiers makes available about twice the required deflection voltage, and allows spreading of the picture to aid various adjustments.

The third type of picture monitor is the line

in separate blocking oscillators which are tripped by the synchronizing pulses selected in separator circuits from the composite signal supplied by the line amplifier. The oscillator and separator circuits were built into a small additional chassis which is arranged on top of the monitor supply unit in a common case. Uniform design and interchangeability of all monitor units was maintained thereby.

These three types of monitors are essential but not sufficient for proper operation of television camera equipment. All generated signals must be monitored not only as an optical

picture, but most of all as an electrical composition.

This equipment was, therefore, provided with several indicating instruments, the most outstanding of which are the cathode ray oscillographs contained in the synchronizing generator, the shading generator, and the line amplifier.

The monitoring of the various signals in the synchronizing generator oscillograph has been described already. The equipment is shown in

milliamperemeter. It is mounted in the camera control unit above the controls and is provided with a switch which connects it to the individual video amplifier stages. By measuring their plate currents, the camera control operator is in a position to locate a bad tube quickly. It may seem that the monitoring system has received almost too much attention, but it is well known to anyone operating television transmitter equipment that for operation and maintenance, the best monitoring facilities can

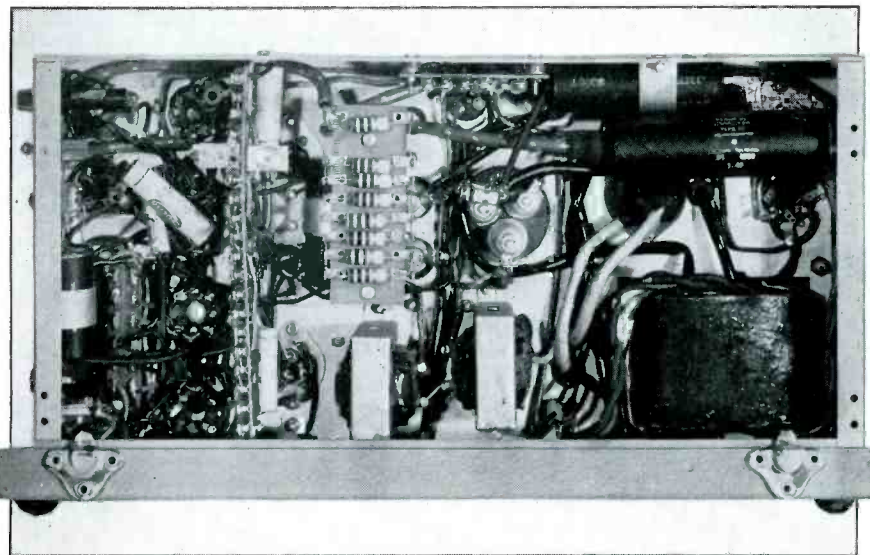

FIG. 9. ONE OF THESE POWER SUPPLY UNITS IS USED FOR EACH CAMERA MONITOR UNIT, AS IS SHOWN IN THE BLOCK DIAGRAM OF THE MONITOR SYSTEM

Fig. 3. The arrangement of the 3-in. cathode-ray tubes in the line amplifier and the shading generator can be seen clearly in Fig. 8.

The deflection for the shading oscillograph is provided through the sweep voltages carried into this unit from the sweep generator. The switch allows the operator to select vertical or horizontal frequency for the horizontal deflection of the electron beam. This simple operation greatly facilitates the quick adjustment of the vertical and horizontal shading signals.

In the line amplifier, the horizontal deflection is generated in a gaseous triode, the discharge of which is controlled by the synchronizing impulses. The vertical deflection amplifier input for this oscillograph can be connected in parallel to any signal entering or leaving the line amplifier. During a broadcast, however, it is usually kept in parallel to the line amplifier output feeding the transmitter.

In addition to these oscillographs, use was made of a more conventional instrument, the

never be valued highly enough because of their practical usefulness to the operator.

4. Power Supply ★ After discussing all actual control apparatus, mention must be made of the power supply for this equipment. Again, the weight problem had to be considered in the mechanical design, and this particularly as the power supply contains the heaviest circuit components, such as transformers and chokes. Therefore, and to minimize the danger of hum pick-up, only two units, the sweep and the shading generator, contain their own power supplies. All other units are powered from small individual supply units such as the monitor supply shown in Fig. 9.

In planning their design, special care was taken that no supply would operate close to its full capacity. Stability and wide range of regulation as well as adequate filtering were other objectives. All high-voltage leads and connections are carefully dressed to prevent breakdowns or injury to those working with them.

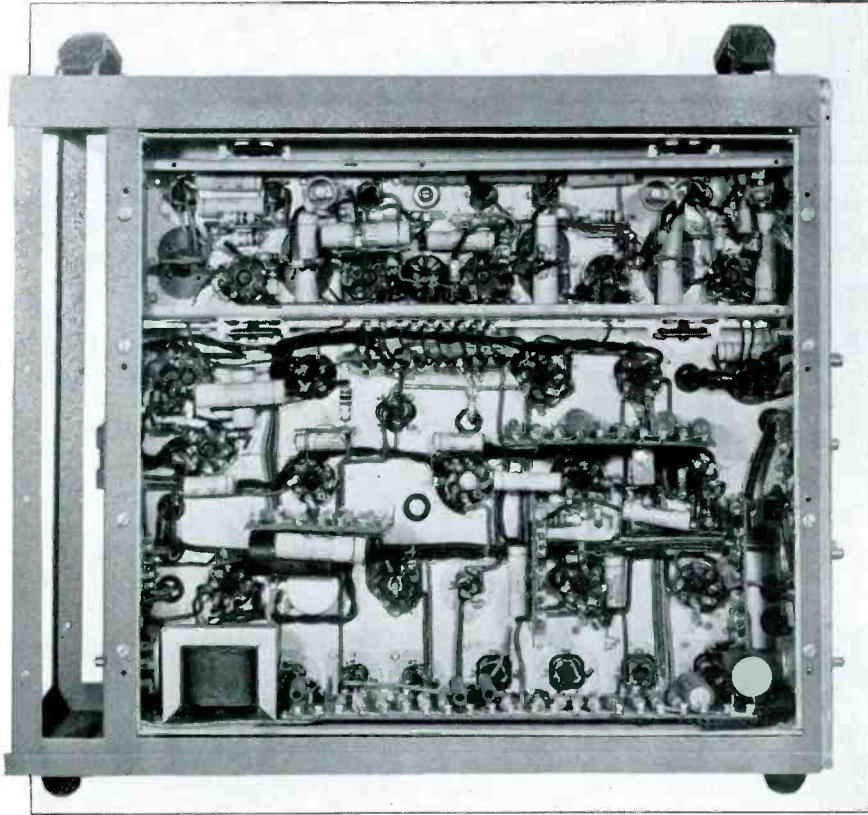

FIG. 10. THE CAMERA CONTROL HAS A SHOCK-MOUNTED CHASSIS, TO PREVENT OUTSIDE VIBRATION FROM SETTING UP MICROPHONIC DISTURBANCES THROUGH THE TUBES

Jacks are provided on every supply to allow frequent checking of voltages and current. The total power consumption of the two complete camera chains is about 3 kw., distributed over the different units as shown in the following table:

Blanking and sweep generator.....	280 watts
Camera power supply ¹	225 "
Camera control power supply.....	345 "
Shading generator.....	180 "
Line amplifier supply.....	325 "
View finder supply.....	205 "
Camera monitor supply.....	230 "
Line monitor supply.....	240 "

¹Two of these units are used for each dual camera chain.

Mechanical Design ★ All units are built in chassis form, as can be seen from Figs. 8, 9, and 10. The chassis are placed in their cases in such a way that, by removing the side covers, the tubes are exposed on one side, while all circuit components and the wiring can be reached from the other.

The electrolytic condensers are mounted below the tubes to prevent their exposure to

heat radiation which might change their characteristics if not cause breakdown.

It was also considered that high temperature deteriorates the iconoscope mosaic, and tubes with high heat dissipation were arranged on a separate little chassis in front of the camera. All cases are perforated to allow sufficient air circulation.

The video amplifier chassis in the camera and the camera control are shock mounted, Fig. 10, to prevent microphonic disturbances. For the same reason the camera walls were treated with a sound absorbing material.

The average weight of the units is 40 pounds. The dimensions of the cameras are 10 by 20 by 18 ins., while the control units measure 8 by 20 by 16 ins., the monitors 6 by 18 by 8 ins., and the power supplies are 9 by 18 by 10 ins.

Control Dolly ★ To combine all the individual units into an operating console which can be moved from studio to studio or, in a truck, to remote pick-up locations, a special dolly table was designed.

(CONTINUED ON PAGE 45)

WHAT THE FM BROADCASTERS HAVE TO SAY:

A Statement Concerning the First FM Station on the Air in Philadelphia, W53PH, by Roger W. Clipp, Vice President and General Manager



SINCE the eighties William Penn has stood high on City Hall looking out and down on Philadelphia. The ever heightening skyline of the city has climbed slowly upward but Billy Penn has always remained supreme. Now frequency modulation has come and the beacon light on the top of the transmitting tower of W53PH sends its warning flashes over the head of the founder of the City. This slender shaft, thrusting into the sky at the crossroads of Philadelphia, has brought great interest in FM among people who have never heard a note of high fidelity, static free transmission.

On November 10, W53PH, WFIL's frequency modulation station will make its bow as the pioneer FM station in the Philadelphia area. With an antenna towering 552 feet above the heart of Philadelphia and a 10-kw. transmitter, the station will cover an area of 9,300 square miles in four states: Pennsylvania, New Jersey, Delaware and Maryland. In the north, the 50-microvolt area extends 51 miles to include Allentown, Bethlehem and Easton. The area extends northeast for 60 miles in the direction of New York. To the south, east, southeast, and southwest the 50-microvolt contour reaches the Atlantic coast and well down into Delaware Bay. Because of the higher elevations encountered in the west and northwest, the contour falls to 48 and 50 miles respectively.

The 1-millivolt contour extends from 20 to 60 miles from Philadelphia, with the minimum coverage towards the north and west where again higher elevations are encountered. Within this 1-millivolt pattern there are, in addition to Philadelphia, such cities as Camden,

Wilmington, Norristown, Chester, Phoenixville and countless smaller towns and communities.

Our program plans have been carefully considered and we are about to go on the air with a definite formula. With an initial operation of 6 hours a day, from 2 to 8 p.m., we shall have five minutes of news before each hour and good music practically all the rest of the time. Present plans call for no duplication of AM program material with the exception of a few outstanding features from time to time. Our music, almost entirely classical and semi-classical, will be made up of some live music, but mostly high fidelity transcriptions. We also plan to include some outstanding sports events, and are working on a regular schedule of civic and public service features. Some of the fine musical programs on NBC will be duplicated on FM and some of the better programs that we have been unable to release locally on WFIL will be fed to W53PH. As our program hours increase, some changes will be made of course in this basic setup.

We have already begun an intensive educational and promotional program for FM in general and W53PH in particular. We have held meetings with dealers and service men to announce our plans, and more meetings are set.

(CONTINUED ON PAGE 45)

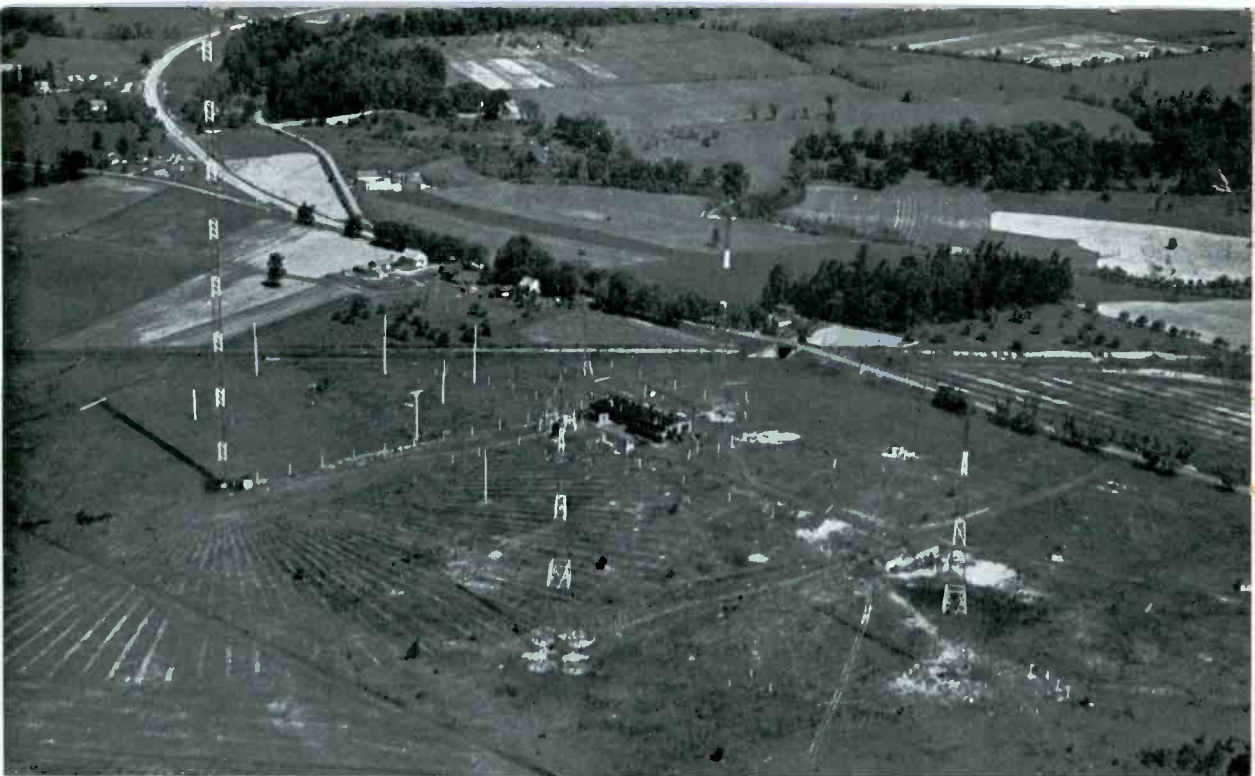

FIG. 1. AERIAL VIEW OF SOUTH SCHENECTADY LOCATION OF S.W. TRANSMITTERS

HIGH-POWER S.W. EQUIPMENT

A description of the Technical Facilities at General Electric International Broadcast Stations WGEA, WGEO and KGEI

BY H. G. TOWLSON *

THE events of the past months have emphasized the importance of engineering developments in the field of high-power, short-wave broadcast station equipment, now performing highly useful service in international broadcasting.

Original Purpose ★ The General Electric Company has been active in this field since February, 1925, when W2XAD was licensed. At first it was intended that shortwave broadcasting should serve as a means of facilitating radio development and research. This was, in fact, the prime purpose behind its being licensed by the Department of Commerce as an "Experimental Relay Broadcasting Station."

As the technical problems of high-frequency operation became fewer, however, program activities increased, until, in May, 1939, the Federal Communications Commission recog-

nized shortwave as highly developed, removed it from the experimental class, and placed it on a par with standard broadcasting. As a result of this, the transmission of programs for the benefit of listeners in foreign countries increased. Early program experiments showed that here was an opportunity, through these international stations, to improve the relations between peoples and reduce the misunderstandings existing in the world. The programs have since been tailored with this object in mind.

S. W. Service ★ A large, especially capable program staff at the G. E. stations devotes full time to the achievement of the purpose outlined above. Programs are prepared after a study of listener preference as indicated by a mail response totalling some 30,000 pieces per year, and after consultation with persons qualified to give worth-while opinions.

* General Electric Company, Schenectady, N. Y.

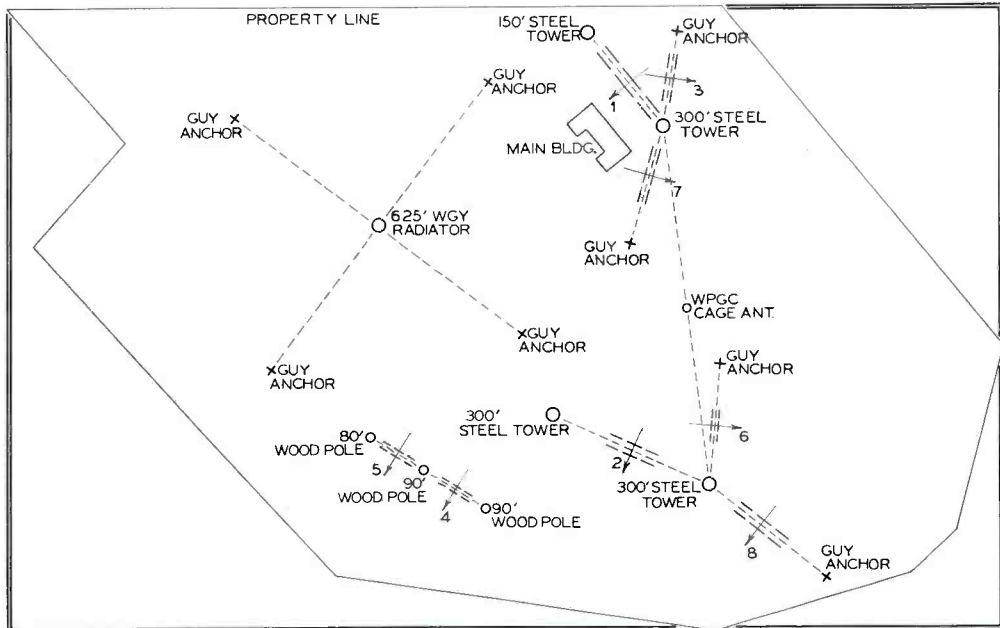

FIG. 10. MAP OF THE PROPERTY, CORRESPONDING TO THE VIEW IN FIG. 1

Regular program schedules are maintained in Spanish, Portuguese, French, Dutch, Czech, and Chinese, as well as in English, with program schedules published in advance. Announcers are employed who are native to the country for which the program is prepared. They are selected with particular reference to their clarity of enunciation, pleasing voice quality, and high personal character.

Service programs in addition to news reports include daily market reports, sports results, special time signals, and question-and-answer sessions in science and agriculture. Programs portraying phases of life in the United States are of special interest to our foreign audience. The service most appreciated at present is the broadcasting of news. This is given in uncolored, factual, and accurate fashion, and has won wide praise in Latin America, Europe, and the Far East.

Transmitter Facilities ★ The international broadcast facilities of General Electric now in service comprise three transmitters. Two of these, the new WGEA 50-kw. transmitter, and the new WGEA 100-kw. transmitter, are located near Schenectady, N. Y., and are particularly well situated to deliver programs to Europe and to South and Central America. The third unit, KGEI, is at Belmont, near San Francisco, California. This location is particularly favorable for transmission to Asia, Alaska, Mexico, and the western coast of

South America. The power of KGEI was recently increased from 20 to 50 kw.

South Schenectady Plant ★ The South Schenectady broadcasting plant, an aerial view of which is shown in Fig. 1, is located on a 68-acre site about 5 miles from the city of Schenectady. Here there are, beside the two international transmitters, the 50-kw. WGY standard broadcast transmitter, a 50-kw. auxiliary WGY transmitter, and the 5-kw. New York State police transmitter, WPGC.

Primary power is received at 13,200 volts and can be fed to the stations from two directions from any of several sources. This feature assures continuous operation.

General Data ★ The transmitter installations at WGEA, WGEA, and KGEI are essentially alike as indicated by the similarity of the block diagrams of Figs. 2, 3, and 4. The main difference is in the use of additional power amplifier, modulator, and audio-driver tubes for WGEA. Fig. 5 is a view of the new WGEA transmitter, taken during the initial stages of installation.

In the past, in international broadcasting, much attention has been given to the strength of the signal, sometimes with little concern for other considerations such as transmitter noise level, distortion, and frequency response. This attitude is not without some justification, as it is seldom that the received signal will

have an intensity sufficient to produce a noise level better than 35 DB down at the receiver, and interference and fading generally take some toll of quality. However, it is desirable to set the goal high. The same rigid specifications were set for these transmitters as would be deemed mandatory for a transmitter operating in the standard broadcast band. That these standards are achieved is indicated by the typical performance as measured on WGEA and shown in Table 1.

transmitters, because of economy of operation and freedom from critical tuning adjustments when changing frequencies.

The choice of high-power RF tubes was likewise made easy by the recent appearance of the GL-880. This tube, which is shown in Fig. 6, was originally developed for high power FM and television. To this development, international broadcasting owes its sister arts a debt of gratitude, as it made available for the first time a truly high-frequency,

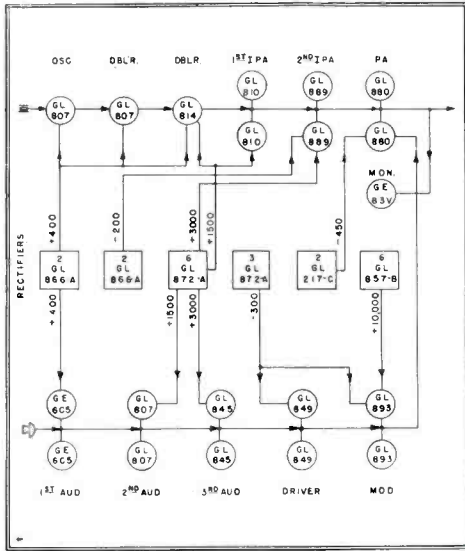

FIG. 2. 50-KW. KGEA TUBE ARRANGEMENT

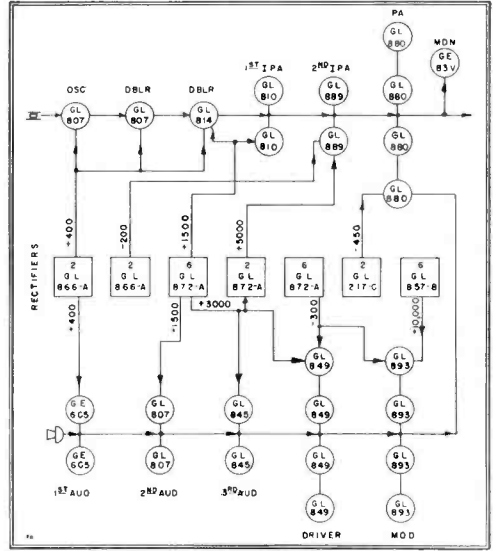

FIG. 3. 100-KW. KGEA TUBE ARRANGEMENT

WGEA Power Amplifier ★ Since the General Electric Company at various times used both high-level and low-level modulation systems in international broadcasting, it was easy to choose the high-level system for the new

TABLE I. TRANSMITTER PERFORMANCE OF WGEA

Carrier-Frequency Range	6,000-22,000 KC.
Carrier Power	50,000 Watts
Transmitter Efficiency (at 22,000 KCO)	72% plus
Modulation Capability	100%
Audio-Frequency Response (1,000 cps reference)	±1 DB
50 — 15,000 cps	
Total Harmonic Distortion (50 — 7,500 cps)	Less than 5% at 85% modulation
Unweighted Carrier-Noise Level (below 100% Mod.)	
Below 100 cps	- 50 DB
Above 100 cps	- 60 DB
Carrier Shift, 0 to 100% Mod.	Less than 3%
Carrier-Frequency Stability	Within 0.0025%

high-power transmitting tube. Due to the unique "folded anode" construction, this new tube, with an overall height, including glass and connection pins, of less than 12 inches, has a power capability such as would require tube structures of twice the length with conventional type construction. This feature, resulting in short internal leads, is particularly emphasized as it makes possible an amplifier design which is stable and trouble-free, especially when the equipment must be operated on different frequencies. A transmitter afflicted with parasites is always a source of trouble.

Each 50-kw. power amplifier uses two GL-880's in push-pull. The variable plate tank capacity is obtained by meshing the cast aluminum cylinders mounted on the movable carriage (operated from the front panel by a worm and gear system) into the upper cylinders which house the tube jackets and neutralizing capacitors. The neutralizing capacitor construction also employs concentric cylinders, the inner cylinder being so arranged as to

telescope within itself to give ample variation for neutralizing adjustments. This form of construction has several important advantages:

1. Due to its compactness, circuit elements are kept lumped—an important consideration in causing an amplifier to operate in the desired manner.
2. The lead inductance between tube anode, tank capacity, and tank inductance is practically nil. This is especially important at the highest frequencies at which the transmitter is to be operated (in this case 21.5 mc. with a tank current of 114 amperes) as any appreciable inductance will prevent proper operation of the circuit.
3. The use of concentric cylinders gives an optimum design, since concentric spheres are impractical, from the standpoint of giving maximum capacitance and maximum flashover strength for a given size and spacing. The movable cylinders will unmesh completely, giving a high ratio of maximum-to-minimum capacity.
4. The smooth outer surface of the assembly gives freedom from corona and flash-overs which could readily occur with modulation peaks producing voltage of the order of 40,000.

The tank inductance is conventional, as it was considered unnecessary, at frequencies up to at least 26 mc., to go to the linear type. This contention is substantiated by the fact that, even at 21.5 mc., the transmitter efficiency is over 72%, 51.15 kw. being fed into the transmission line with 70.7 kw. input. The method of changing inductance by shorting turns for different frequencies is evident from Fig. 7, and is simple, effective, and quick. The heat developed in the copper-bar shorting links is readily conducted into the anode cooling water, which also flows through the inductance.

Because of the ever increasing occupancy and importance of the ultra-high-frequency end of the radio spectrum, it is no longer possible to disregard the emission of harmonics. Although the antenna systems themselves discriminate against harmonic radiation, and considerable success has been achieved with the use of linear reactances shunted across the transmission lines at suitable points, it is still desirable to keep as low as possible the harmonic content at the sending end of the transmission lines. For this reason, inductive coupling is used, the coupling coil itself being relatively small to keep the capacitive coupling to the tank coil low. The coupling coil then feeds an impedance-matching network of the low-pass filter type which gives further

attenuation of harmonics. The position of the coupling coil can be varied from the front of the panel, giving an excellent control of output.

Audio Channel ★ The audio channel was designed around the use of two GL-893 tubes as Class B modulators. These tubes are particularly well adapted to this service due to their moderate driving power requirements, use of multi-phase filaments to give low residual hum,

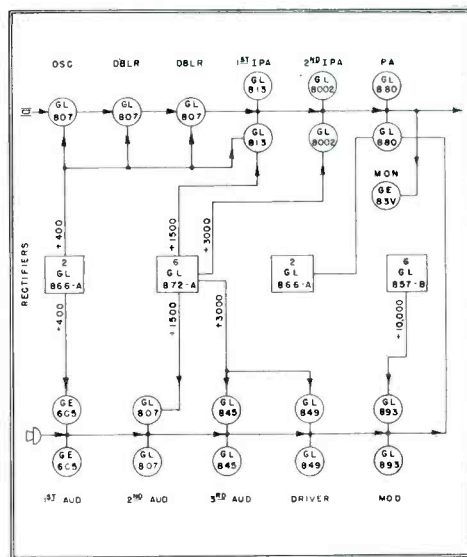

FIG. 4. 50-KW. KGEI TUBE ARRANGEMENT

and their comparative freedom from grid emission effects. Two GL-849 tubes operating in push-pull, class A prime, are used as drivers. Preceding this stage are three push-pull class A stages using GE 6C5's, GL-807's, and GL-845's. A simple, effective feedback system is used from the GL-893 modulator anodes to the GL-807 grids to materially aid in maintaining a low noise level. The entire audio channel for WGEA is mounted in a single frame excepting, of course, the modulation transformer and modulation reactor located out of doors.

Exciters ★ The WGEA and WGEO exciters are identical despite the grid drive requirement of 1.8 kw. for WGEA and 3.6 kw. for WGEO. The exciter output stages use push-pull GL-889 tubes. These tubes, while capable of 20-kw. output if operated at full ratings, are physically small and sturdy, and are specially designed for high frequency use. Their conservative operation makes it possible to operate at considerably reduced filament voltage with an appreciable increase in tube life. To

¹ Sterba & Feldman, Proceedings of the IRE, 1932, Vol. 20, p. 1163.

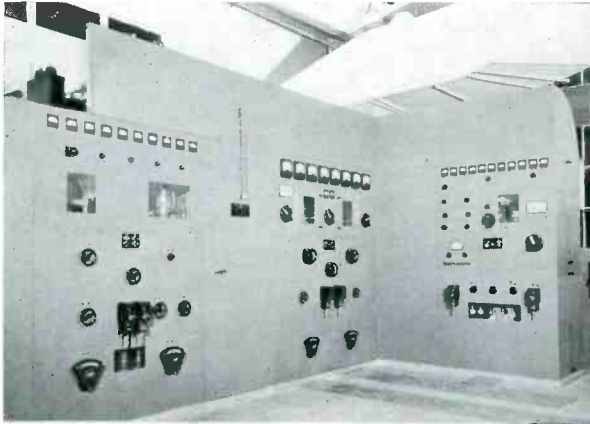

FIG. 5, LEFT. 100-KW. TRANSMITTER IN COURSE OF INSTALLATION AT SCHENECTADY, FOR SERVICE TO EUROPE AND SOUTH AND CENTRAL AMERICA. FIG. 7, BELOW. FREQUENCY IS CHANGED BY SHORTING TURNS OF THE TANK INDUCTANCE

take advantage of this, each tungsten filament tube (GL-880, GL-893, GL-889) has been equipped with individual filament control and is being so operated.

Low-power RF stages include a GL-807 crystal oscillator, a GL-807 doubler, used as tripler on 21.5 mc., a GL-814 doubler, and push-pull GL-810's. All crystals are low temperature-frequency units which are mounted in the new G31 individual heat control chambers. The oscillator plate circuit is tuned by a tapped inductor to eliminate the human re-set error which exists with the usual variable capacitor. Frequency bands are changed in the exciter by means of tap switches on the various inductors.

Main Rectifiers ★ Each of the three transmitters employs six GL-857B mercury vapor tubes in a 3-phase, full-wave circuit to supply the 10,000 volts DC required. Although, in the case of WGEA and KGEI, three tubes in a half-wave circuit would have sufficed, the full wave connection has been standardized because of low-ripple amplitude and high-ripple frequency, giving easy filtering, and because of the high transformer-utilization factor with this type circuit.

Safety to Personnel ★ Before installation of these transmitters, considerable thought was given to assurance of safe operation. The conventional door interlock type of switch, causing all plate contactors to be de-energized, was employed as a matter of course. However, an additional safety system, entirely independent of the regular system, was desired. A simple, effective scheme was finally evolved around the safety switch shown in Fig. 8. This switch is so connected that, in the UP position, it shorts the two high voltage DC busses to ground and also opens the primary supply to the high voltage transformers. The switch is

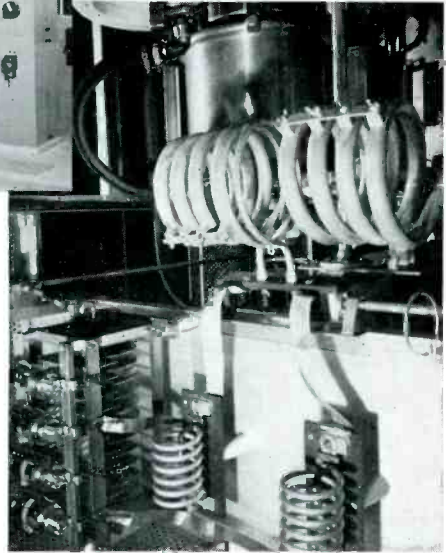

installed above the entrance door to the transmitter enclosure, Fig. 5, and must be manually operated before the door can be opened. In the case of KGEI, this switch is sufficient in itself, as this installation has but the one access door, all tubes being changed from within the enclosure. With WGEA and WGE0, however, the layout was different. It was necessary to employ access doors for changing certain tubes. So as not to circumvent the main safety switch, a solenoid-operated door-latch was devised, and mounted and connected so that all access doors remain locked until the main safety switch is thrown to the UP position. The latch and method of mounting are shown in Fig. 9.

Antenna Systems ★ The South Schenectady plant presents an impressive sight with its eight directive antenna arrays, 625-ft. vertical radiator for WGY, and 300-ft. cage antenna of WPGC. Fig. 10 shows the layout of the various antennas. It will be noticed that all arrays are so located that they do not shoot through any other array. This feature is important, as early tests made with a continuous recording of field intensity at a European receiving site demonstrated that as much as 10

FIG. 9. RIGHT. DOOR-LATCH SAFETY SWITCH ON TUBE ENCLOSURES

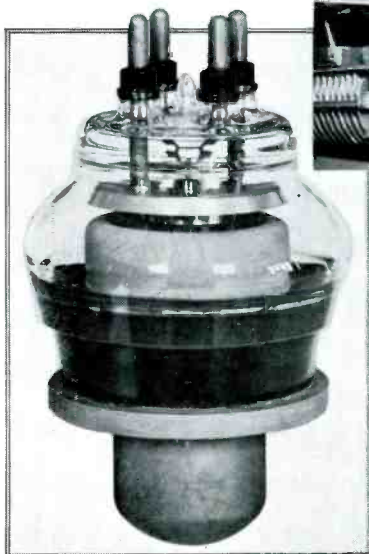

FIG. 6. FOLDED ANODE TYPE OF POWER TUBE FOR HIGH-FREQUENCY CIRCUITS

DB attenuation could readily occur when an array 500 ft. in front of the one transmitting was raised or lowered. It will be noticed that most of the towers and poles of this system are used to support more than one antenna. In the case of antennas Nos. 4 and 5, the center 90-ft. wooden pole supports both. The same scheme is used at KGEI where three 125-ft. steel towers support the two arrays. Antennas 3, 6, 7, and 8 are supported between a 300-ft. tower and a guy wire attached between the tower top and a guy anchorage. Both of these methods have been very satisfactory, both electrically and mechanically.

Table II gives pertinent antenna data supplementary to Fig. 10.

The type A array is the original Alexanderson panel antenna, which was developed by Dr. E. F. W. Alexanderson for facsimile experiments. It was found ideal for international broadcasting and, after 13 years of use, still enjoys high popularity and is widely used in either the original or a modified form. The array employs 3 co-linear, horizontal half-wave elements with a similar section stacked a half-wavelength above, all elements being excited in phase. A similar curtain is suspended a quarter-wavelength to the rear and parasitically excited as a reflector. The height of these arrays above ground varies from a half

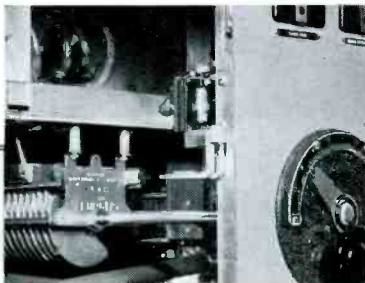
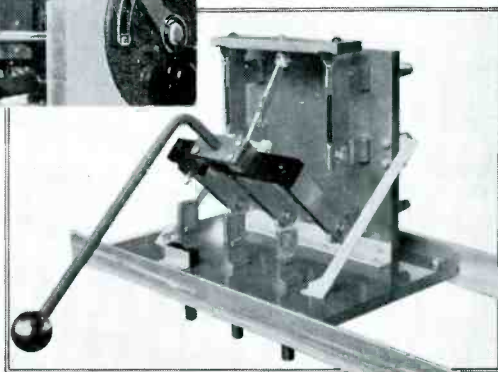

FIG. 8, BELOW. ADDITIONAL SAFETY SWITCH MUST BE OPERATED MANUALLY BEFORE OPENING TRANSMITTER ENCLOSURE DOOR



to a full wavelength to the lowest element, with our preference for the higher figure. The major vertical lobe makes an angle of about 18 degrees with the ground. The total width, horizontally, of the transmitted beam is 45 degrees at the point of 6DB below peak field intensity.

The Type B array, which is shown in Fig. 11, consists essentially of two type A arrays stacked vertically. The horizontal pattern remains the same, but the gain is increased approximately 3 DB due to suppression of the higher angle radiation. The major vertical lobe makes an angle with the ground of about 9 degrees. This remains our favorite array, but it is evident that it requires considerable space.

Transmission Lines ★ Two-wire balanced transmission lines are used. The wire used is No. 6 B & S hard-drawn copper with a center-to-center spacing of 12 inches. The insulators used are of mycalex, $\frac{3}{4}$ in. in diameter, with an overall length of $13\frac{3}{4}$ ins. Each end is fitted with a corona ring $2\frac{3}{4}$ ins. in diameter. Although the corona rings admittedly add lumped capacitances along the line—approximately 5 mufd between rings—they were found essential at the power used. Early lines employing glass insulators, while satisfactory up to about 15 kw., were unusable at the higher powers. Due to the high potential gradient in the glass eyelet at the point of contact with the wire, the insulator would reach incandescence and fail.

During power output measurements on WGEA, the resistive component of the line impedance was measured and found to vary from

610 ohms to 790 ohms over the range 6 mc. to 22 mc., calculated $Z_0 = 600$ ohms. It should be noted that when using the conventional RF ammeter for measurements of this type, normally calibrated on DC, it is absolutely essential that the meter be calibrated at the frequencies at which it will be used. It is also desirable to use a meter shield.² As an example of the correction factor to be expected, the conventional 3-in. internal thermocouple meters used in these measurements carried multiplying factors varying from about .8 at 6 mc. to about .6 at 22 mc. The need for the correction factor appears to be mainly due to the increased RF resistance of the thermocouple with increasing frequency. It is suspected that the low impedances sometimes claimed for lines of this type may be due to failure to appreciate the magnitude of the correction to the RF instrument readings.

It is necessary, at the powers used at these stations, to terminate the lines carefully, since a high degree of reflections will produce standing waves which will build up the line voltage

² G. D. Wallace, Proceedings of the IRE, January, 1941, P. 1.

FIG. 11. THE TYPE B ANTENNA HAS TWO TYPE A ARRAYS STACKED VERTICALLY

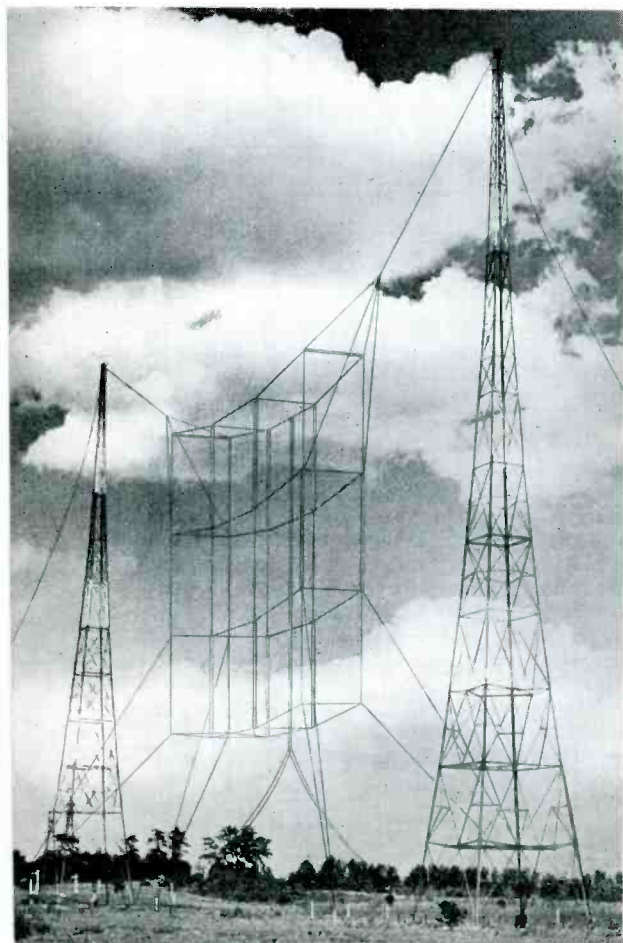

enough to sustain a 3-ft. streamer of flame between the transmission line and the ionized surrounding atmosphere. A technique has been evolved which permits the termination to be adjusted to give a standing wave ratio of 1.1/1 or less, depending on the patience of the engineer doing the adjusting. Although operation of the lines has been entirely successful and the indicated efficiency per 1,000 ft. is approximately 88% at our highest frequency, our preference for this type of service is for a 4-wire type of line because:

1. The surge impedance is more nearly constant over a range of frequency.
2. Efficiency is higher due to lower line voltages, resulting in decreased dielectric losses in the insulators and freedom from corona effects.

Transmission Line Switching ★ As the number of operating frequencies grew and the transmitter power increased, the problems of transmission-line switching became more acute. With transmitters of moderate power, and with but a few incoming transmission lines, a simple system of knife switches had been adequate. This was definitely not the answer to our problem, however, where it was desired to:

1. Switch to either of two transmitters any one of at least eight transmission lines with provision for future increase of this number.
2. Introduce no irregularity in the line sufficient to cause reflections and necessitate retuning when changing antennas on the same frequency.
3. Maintain a high degree of reliability, simplicity, and freedom from flashovers.

After a study of various arrangements including those in use by others³ confronted with the same problem, the system illustrated in Fig. 12 was adopted. Here, a movable section of transmission line is moved in an arc from one pole to another. Connection is made by a sturdy, semi-flexible "Hook Switch." Wherever a transmission line is used on only one transmitter, it is connected directly to the proper pole on the switching bay for that transmitter. If the line is occasionally used on either transmitter, as is sometimes the case with the 9.5-mc. antennas, it is connected to the blades of a disconnect-type switch mounted on the switching frame so as to essentially become a portion of the line itself, the clips then feeding each switching bay.

This switching system has been highly successful. Antennas can be switched at station breaks without loss of time. During two years of operation the system has required very little maintenance.

³ L. W. Hayes and B. N. MacLarty, Empire Broadcasting Service, Daventry, England.



FIG. 1. THE 50-KW. TRANSMITTER, LOCATED ON THE 45TH FLOOR OF THE FIELD BUILDING. FIG. 2, CENTER, TRANSCRIPTION TURNTABLES AND

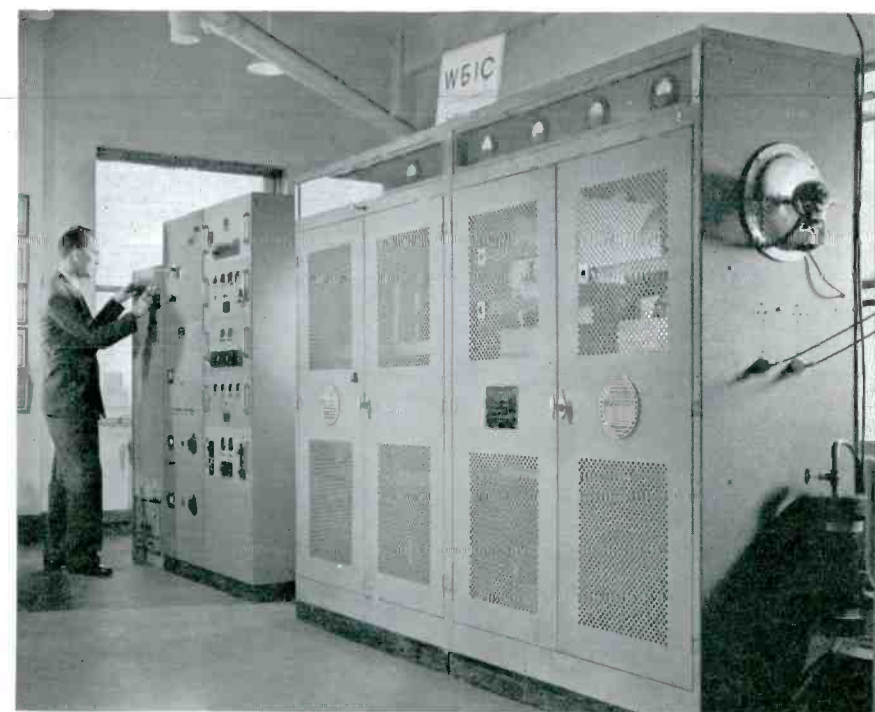

SPEECH INPUT EQUIPMENT. FIG. 3, LEFT, THE FM MODULATOR UNITS. RIGHT, THE INITIAL AMPLIFIER STAGES AND THE 5-KW. DRIVER FOR THE FINAL STAGE

FIG. 7. THE RECTIFIER PORTION OF THE HIGH-VOLTAGE POWER SUPPLY TO THE FINAL POWER AMPLIFIER STAGE



ZENITH ENGINEERS BUILT STATION W51C

Engineering Details of Chicago's Pioneer FM Transmitter, Installed on the Field Building

BY J. E. BROWN *

THE Zenith Radio Corporation first made application for a Frequency Modulation transmitter to be erected in Chicago during the summer of 1939. Authorization for the construction of the station was received early in the winter of that year, and experimental transmissions under the call W9XZR were started from the Zenith factory in February, 1940.

Very soon thereafter, the installation was moved to a tall building in the downtown section of Chicago, where greater antenna height was obtainable.

During all this time, a power of 1 kw. was employed. Later in 1940, authorization for the use of 5 kw. was received, and the output increased accordingly.

Regular schedules were started in February,

1940, on a basis of 16 hours per day, 7 days per week. These have been maintained continuously since the time of their inception.

In the fall of 1940, W9XZR was moved to its present and final location on the Field Building, in downtown Chicago. This is one of the largest office buildings in the Loop section, and one of the very few operating entirely on AC.

Although its roof construction lends itself admirably to the installation of high-power FM broadcasting equipment, we had a few unusual problems. These, however, only serve to emphasize the fact that broadcast station engineering calls for ingenuity in many directions which have no connection with the radio equipment itself.

For example: It was decided to put the water pumps on the roof of the building, some 150 ft. from the transmitter in order to pre-

* Engineer, Zenith Radio Corp., Chicago, Ill.

FIG. 4. LEFT, THE 50 KW. POWER AMPLIFIER STAGE. AT THE RIGHT IS THE HIGH-VOLTAGE RECTIFIER



TABLE II. GENERAL ELECTRIC INTERNATIONAL ANTENNAS

<i>Call Letters</i>	<i>Ant. No.</i>	<i>Freq. KC</i>	<i>Type</i>	<i>Gain DB</i>	<i>Bearing</i>	<i>Directed On</i>
WGEA-WGEO	1	6190	A	10 25	190°	Central America
WGEA-WGEO	2*	9550	B	13 25	151½°	Brazil
WGEA-WGEO	3	15330	A	10 25	50°	Europe
WGEA-WGEO	4	15330	A	10 25	160°	Argentina
WGEA	5†	21500	A	10 25	160°	Argentina
WGEA	6	21590	A	10 25	50°	Europe
WGEO	7	9530	A	10 25	63½°	North Africa
WGEA-WGEO	8*	9530	A	10 25	167°	Argentina
KGEI	1	15330	A	10 25	126°	South America
KGEI	2	9670‡	A	10 25	306°	Asia

* Operates on 9530 or 9550 kc.

† Operates on 21500 or 21590 kc.

‡ Operates on 9530 or 9670 kc.

Scope of Operation ★ For 22 hours out of the 24, at least one of the three General Electric international stations can be heard, and much of the time all three are on the air. The time of each program service, and the frequency band on which it is to be transmitted, are subjects requiring knowledge of listeners' habits in the interested areas and study of information regarding propagation characteristics. The predictions published monthly by the National Bureau of Standards in the Proceedings of the IRE have been of great value. These predictions are supplemented by reception reports received from various agencies and short wave listeners. In general the conclusions drawn are remarkably consistent, and aid us greatly in maintaining dependable service to our foreign audiences.

A MODERN MIRACLE INDEED!

Sometimes FM's reputation as a modern miracle gets a little out of hand, and people begin to attribute sheer supernatural powers to Major Armstrong's latest invention.

On the outskirts of Milwaukee, for example, W55M is completing the installation of its new 50-kw. transmitter. The turnstile antenna is carried on a mast atop a tall steel tower.

Recently, according to an account given to us on good authority, a local farmer, looking aloft while the antenna was being adjusted, switched his chewing tobacco reflectively to the other cheek and remarked to his friend: "I understand as how that there riggin' is goin' to stop the thunder showers in these parts!"

FIG. 12. ANTENNA SWITCHING FOR QUICK CHANGES DURING STATION BREAKS

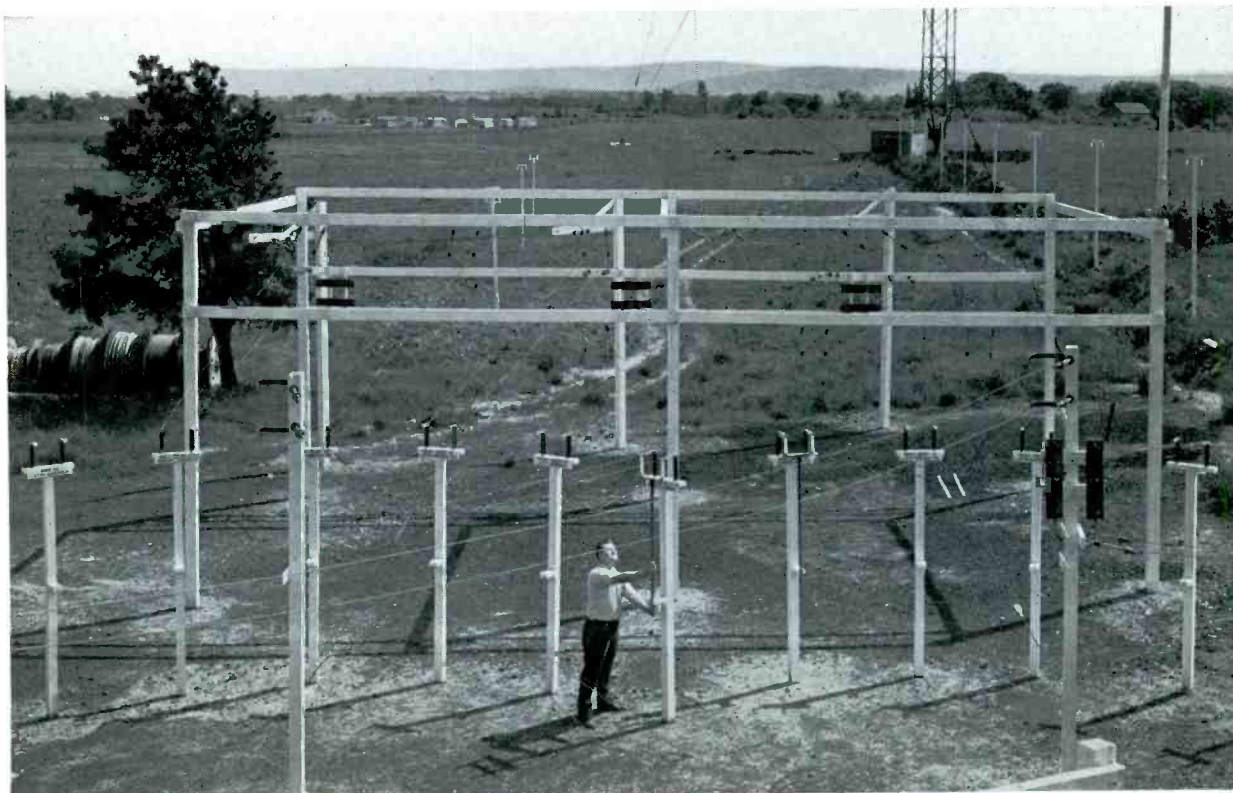



FIG. 6. FINAL STAGE, WITH THE GL-880'S, AS SEEN FROM THE FRONT OF THE CABINET

vent the communication of vibrations to the radio apparatus. The erection of a housing for the pumps, and for the transformers also, on the roof of the building gave us a few headaches. Chief among these was the matter of getting the steel beams up from the street.

This was finally done by cutting the beams in two on the ground, so that we could hoist them in the elevators to the roof. Once up, they were welded together again!

The entire transmitter was built by Zenith Radio Corporation, with the exception of the high-voltage supply which was purchased from Westinghouse, and the spare modulator which was manufactured by REL.

Several views are shown here of the transmitter. This room is on the 45th floor, 540 feet above the street level, and amply sepa-

rated from the water-cooling system, and the power supply and voltage regulator on the roof above.

A general view of the transmitter room is given in Fig. 1. The transcription equipment, to be seen at the far end of the room in Fig. 1, is shown in detail in Fig. 2. This consists of dual RCA turntables of current design, with Western Electric 9A pick-ups. Equalization circuits have been arranged so as to obtain the maximum fidelity.

The speech input equipment is of RCA manufacture. A peculiarity of this installation is that the speech input gear is located in the same room with the 50-kw. transmitter. Some troubles from radio frequency feed-back were experienced at first, but these were eliminated by the use of adequate filtering. Thus, special

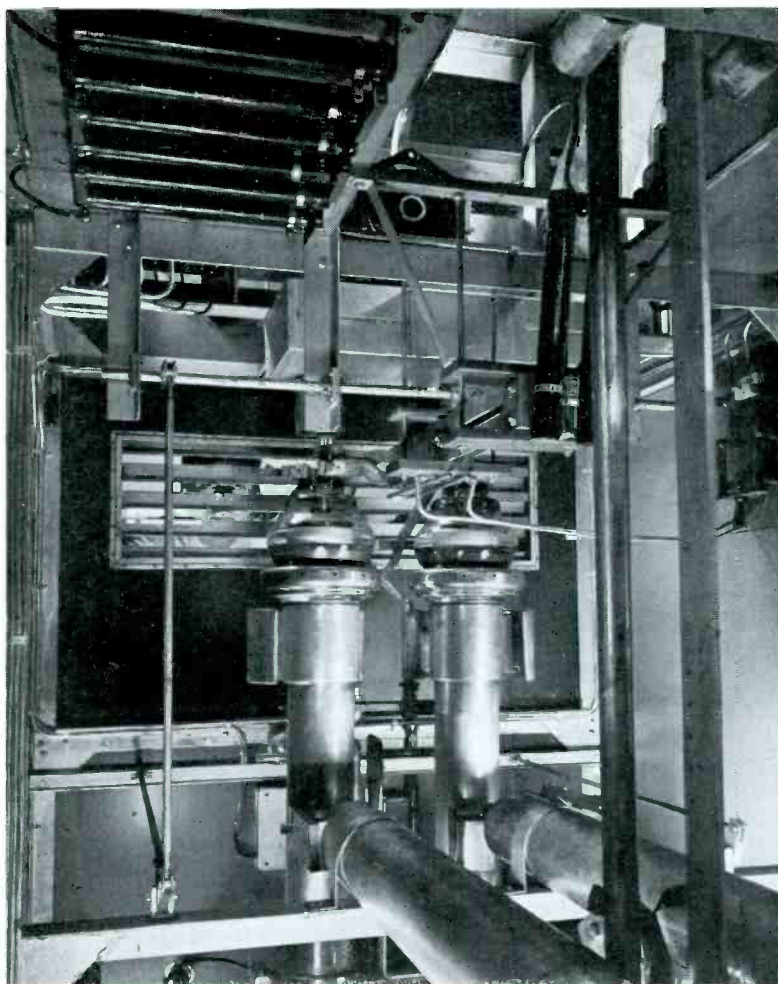

FIG. 6. REAR VIEW OF THE FINAL STAGE SHOWING SOME ADDITIONAL DETAILS

shielding was not found necessary, even though strong fields are present throughout the top of the building.

Fig. 3 is a view of the FM modulator and the 5-kw. intermediate stage of the transmitter. Eimac 2000-T tubes are used in the power stage of the intermediate amplifier. These are driven by two lower-powered stages, using Eimac 35-T and Eimac 250-TH tubes, respectively.

In the final stage of the transmitter, Fig. 4, we have two GL-880's. We believe that this is the first commercial use of the GL-880 high-power vacuum tubes, and considerable interest attaches to this design.

An inside view of the final stage, looking from the front, is given in Fig. 5. The GL-880's can be seen here, and also in Fig. 6, the

view of the final stage from the rear. This also illustrates the final tank circuit, the transmission line, the antenna coupling, and other details.

Should any trouble develop in the high-power stage or in the antenna system, the transmitter is so arranged that almost instantly the 5-kw. output of the last driver stage can be switched to an auxiliary antenna. This, I believe, is novel in FM station design so far.

The rectifier portion of the high-voltage power supply is located adjacent to the final stage. This is shown in Fig. 1, at the extreme right. There is also a detailed view in Fig. 7.

The special building which we constructed on the roof of the Field Building is shown in Fig. 8. Of brick and steel construction, this

FIG. 8. A VIEW INSIDE THE PENTHOUSE, WHERE THE WATER CIRCULATING PUMPS AND STORAGE TANKS ARE LOCATED. THE ANTENNA MAST CAN BE SEEN AT THE LEFT

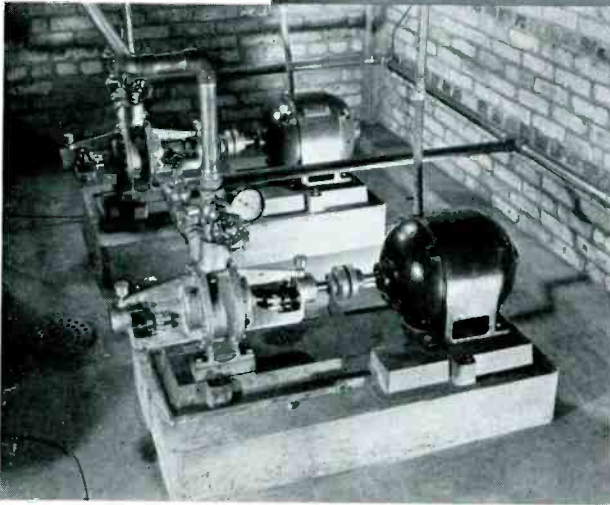

FIG. 9. CONSTANT CIRCULATION OF WATER FOR COOLING PURPOSES IS A VITAL NEED. FOR SAFETY, DUAL WATER PUMPS ARE PROVIDED, EITHER ONE OF WHICH CAN KEEP THE WATER FLOWING

houses the water-circulating and storage system, and serves as a base for the antenna mast.

For reasons of safety, dual water pumps, Fig. 9, were provided. Their location with respect to the storage tanks can be seen in Fig. 8.

The antenna system of W51C is carried on a 60-ft. steel pole, 14 ins. in diameter at the base. This is mounted through the roof of our penthouse. It can be seen in Fig. 8, at the left, and in detail in Fig. 10. The transmission lines run down from the antenna to the necessary junctions, where they are consolidated into the two main lines which connect to the transmitter. The illustration shows various details of the phasing sections and the line transformer.

Fig. 11 is a view of the special antenna at W51C. This is a development of the Zenith laboratories. It consists of four bays, spaced one-half wave apart. A power gain of nearly 3 is realized from this antenna. A distinguishing characteristic of this design is the ease and simplicity of feeding the bays, as is clearly indicated in Fig. 11.

For our schedule of 16 hours per day, 7 days a week, we have developed a type of program using electrical transcriptions which has been accorded rather remarkable acceptance in the Chicago area. The good service range of the transmitter with 5 kw. is known to be over 75 miles, and its range with 50 kw. is expected to exceed 100 miles. The actual service area specified by the Federal Communications Commission in the case of this station is 10,800 square miles. This covers a population of nearly 5,000,000, the second largest retail market in the U. S. A.

In addition to the service performed by W51C for listeners who have purchased FM receiving sets, this station has been of great value in introducing to the listening public the advantages of this new kind of broadcasting, since we have put on many special demonstration programs for the benefit of various clubs and organizations. At the same time, we have made programs available to dealers, so that they could give FM demonstrations in their stores.

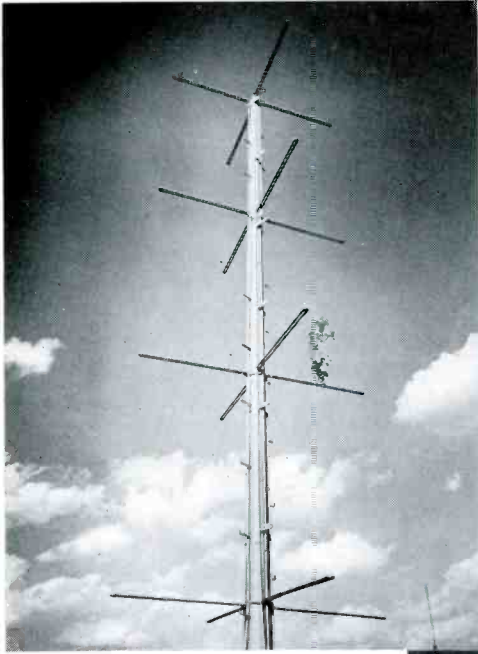

FIG. 10. TRANSMISSION LINES WHICH FEED THE ANTENNA BAYS COME DOWN THE STEEL MAST AND ARE CONSOLIDATED INTO TWO MAIN LINES

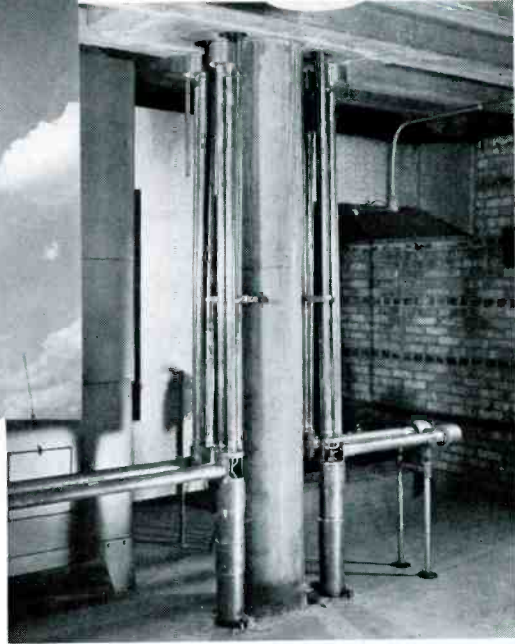

FIG. 11. THE 4-BAY ANTENNA IS CARRIED ON A 60-FT. STEEL MAST, MOUNTED THROUGH THE ROOF OF THE NEWLY-CONSTRUCTED PENTHOUSE

AMERICAN NETWORK ACTIVITIES

THE prospect of improved program service for New York's FM listeners came closer this week with the announcement that The American Network, FM's first chain organization, will shortly file its application for a key outlet in New York City.

The new station, if approved by the Federal Communications Commission, will be located in the Lincoln Building, 60 East 42nd Street, with transmitter and radiating antenna at the same site.

Simultaneously with filing of its official application, The American Network will ask permission to make temporary use of a 10-kw. FM installation, now idle, until such time as the Commission has had an opportunity to consider the granting of a regular license. This special transmitter could be ready to go on the air with a daily program schedule 60 days after approval, if so authorized.

The American Network plans the eventual establishment of a coast-to-coast FM web

having outlets in more than 40 principal cities, with approximately 75% of the national population living within the proposed service areas.

Already operating are two of the network's stations in New England—W43B and W39B—which have a combined coverage capable of reaching 93% of the population in those six states. As soon as W53PH, Philadelphia, makes its debut as that city's first FM station, it will be another outlet of The American Network. Establishment of a New York station would provide a valuable link, giving continuous FM network coverage along the entire northeastern seaboard.

Decision to file the new application as soon as routine data can be amassed was reached by The American Network's directors at a recent meeting in New York.

Other stations of the chain already on the air with daily schedules, but not as yet linked up for program exchange, are W47NV Nashville, W55M Milwaukee, W45D Detroit, W51R Rochester, and W45CM Columbus. In addition, W41MM will be operating shortly.

FM SPOT NEWS

Notes and comments, personal and otherwise, about frontline radio activities

Over 1,000: FM sets are being produced per day by Armstrong licensees. Next milestone will be reached when one manufacturer attains this rate. With reasonable deliveries of materials and components, that goal should be reached early in 1942.

American Network: Has applied for a C.P. to erect its key station on the Lincoln Building, East 42nd Street, New York City. They ask for 47.9 mc., one of the three class B channels not yet assigned. This makes 10 applications for these three channels.

Finch: Recent statement that he will have New York station W55NY on the air soon after November 1st does not check with present status of equipment. No antenna has been erected, and the 1-kw. Western Electric transmitter is conspicuously missing.

Button, Button: Who's got the FM transmitters? It seems to be a game between the FCC and those to whom the FCC, with its dubious wisdom, has granted CP's. Sometimes it seems as if the Commissioners must have given the CP's to those it could be sure wouldn't be able to get transmitters on the air.

Big Business: Meanwhile, New York dealers, believe it or not, are selling all the A-FM sets they can get so fast that some of the licensee manufacturers are deliberately holding back on deliveries in that area, so as to give other cities their fair share of production, and in that way equalize distribution on a national basis.

Larry F. Hardy: Is now manager of Philco's Home Radio Set Division. With Philco since 1932, he will have charge of merchandising all home radio sets, both large and small.

Help for the Deaf: Tests made by W59C show that people with impaired hearing can understand and enjoy speech and music by FM reception to a far greater extent than AM at the same volume level. This is due to full reproduction of low frequencies, and greater definition provided by highs on FM, both of which are missing on AM reception. This indicates that people with normal hearing who can't find any improvement in FM over AM either bought the wrong kind of receivers or else they don't want to hear any difference.

Concord, N. H.: First man to buy an FM set at Rumford Press, where *FM Magazine* is printed, is Warren Fuller. With a Meissner set he hears Paxton, Worcester, and Mt. Washington, with best signals from Paxton. This is one of the very worst spots in all New England for AM, even with the very best receivers. Says Fuller: "We only listen to FM now. The only time we use AM is to hear Lowell Thomas."

E. F. McDonald, Jr.: "Television's basic problems are no longer technical but economic." Giving the figure of 23¢ as the average movie show admission, or 9¢ per hour cost to the public, the Zenith president expresses strong doubt that television can gain wide public acceptance until it can compete in quality and cost with motion pictures.

Frank Thorpe Vreeland: Producing a series of dramatic plays on Philco's WPTZ, says, "Television, because of its spontaneity, lends itself as a medium to talented actors whose art would be hindered by the limitations of the theatre and motion pictures."

Philadelphia: I.R.C. has added 30 per cent to its
(CONTINUED ON PAGE 40)



"TITANS OF INFORMATION" WINNING TEAM FROM G.E. RESEARCH LABORATORY, ON W2XOY QUIZ PROGRAM. L. TO R.—DR. LEWI TONKS, DR. FRANCIS J. NORTON, DR. RALPH P. JOHNSON, E. F. HENNELLY, DR. LOUIS NAVIAS. THEY OUT-SCORED 21 TEAMS, INCLUDING INTERNATIONAL G.E. GROUP

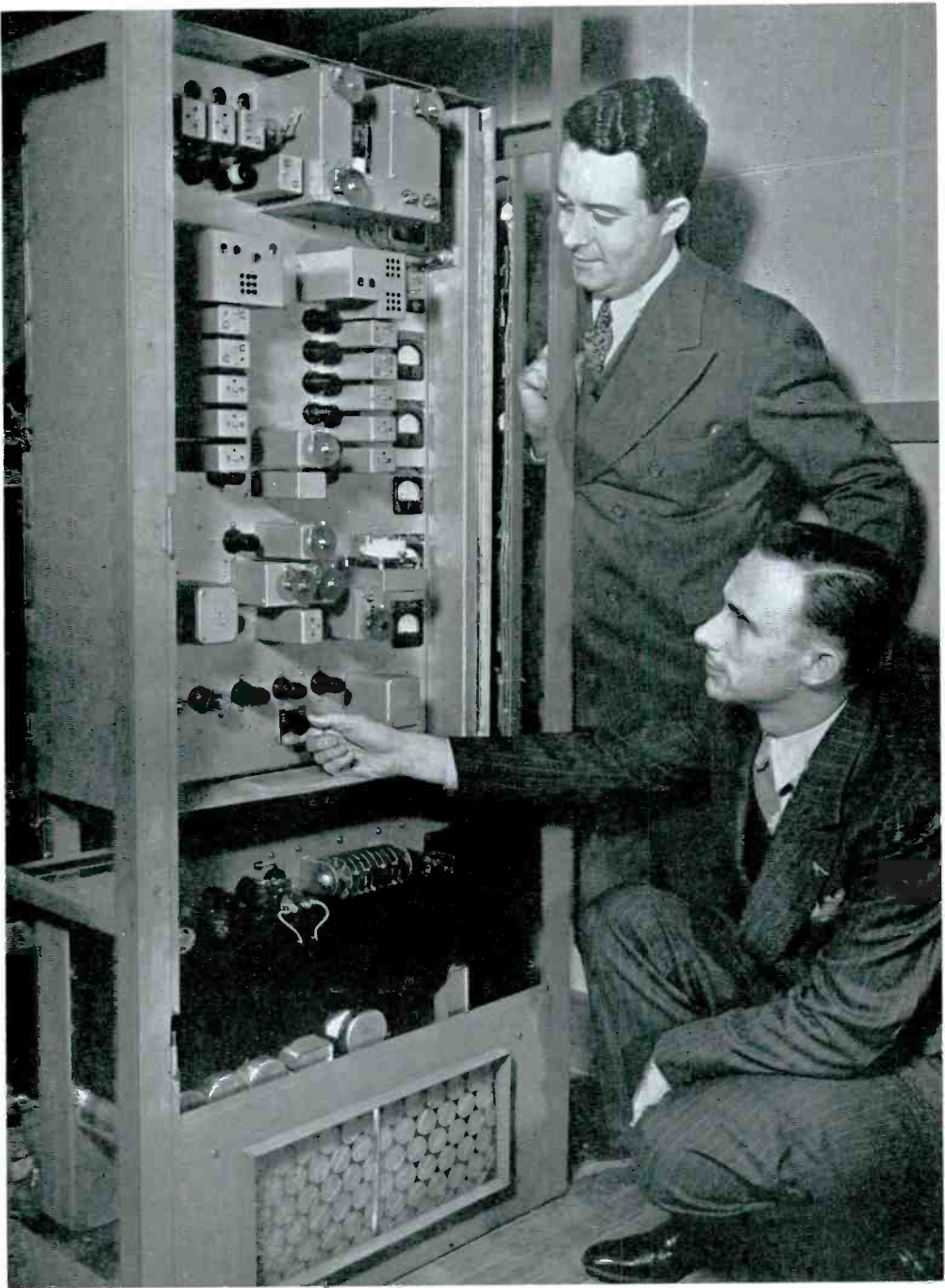

NEWS PICTURE

W45CM Sets Construction Record: Lester Nafzger, standing, chief engineer of WBNS and W45CM, Columbus, and Frank Gunther, chief engineer of REL, are feeling happy over the record they made in completing the installation of a 10-kw. REL FM transmitter 30 days after the order for the equipment was signed. Shown here is the new Armstrong phase-shift modulator, similar to that illustrated on the front cover.



FIG. 1. THESE COMPACT FM TRANSMITTERS MEASURE ONLY 46 INS. HIGH BY 21 INS. WIDE

FM COMMUNICATIONS TRANSMITTER

Compact 250-Watt Link Design Is Suitable for Semi-Portable Use

BY DONALD G. BEACHLER*

IN STEP with the increasing demand for FM communications equipment for the regular services and for many new applications, F. M. Link has brought out a 250-watt model of very compact mechanical design. This type 250-UFS-X is only 21 ins. wide, 18 ins. deep, and 46 ins. high, making it suitable for use under conditions where space requirements would not accommodate greater dimensions.

A standard Link FM receiver is also housed in the cabinet. This can be seen in the rear view, in Fig. 2, mounted directly above the power transformer.

Electrical Data: Designed for any frequency in the 30- to 40-mc. band, this transmitter is nominally rated at 250 watts output, but it can be operated continuously with 500 to 600 watts input to the final stage. At the 500-watt figure, the radio frequency output is approximately 350 watts into a 70-ohm coaxial cable.

The phase-shift method of modulation gives a frequency deviation of at least 15,000 cycles at a modulating frequency of 500 cycles and a signal input of 6 milliwatts (zero level) into the 500-ohm input.

High frequency pre-emphasis is employed so that, with constant-amplitude audio input, the frequency deviation increases linearly to

3,000 cycles, representing an increase of 15 DB over the frequency deviation at 500 cycles. Filter networks attenuate all modulating frequencies above 3,000 cycles, to cut off excessive high frequency side bands.

The design of the modulator system provides an inherent peak-limiting action at levels corresponding to the rated deviation of the transmitter. This action is inherent, and requires no adjustment.

The use of the phase-shift method of modulation permits direct crystal control of the carrier frequency. This makes possible a guaranteed frequency tolerance of .01% under ambient temperature variations from -18° F. to 110° F. Crystals used have a coefficient of not more than 1 cycles per mc. per degree Fahrenheit. They are temperature-controlled to within 3° F., and can be matched to within 50 cycles at their operating frequencies.

Thirteen tubes, including the rectifiers, are required. Following are the types and functions:

- 1—7C7 crystal oscillator
- 2—7A8 balanced modulators
- 1—7C7 1st frequency quadrupler
- 1—7C5 2nd frequency quadrupler
- 1—6L6 frequency doubler
- 2—807 intermediate power amplifier

* Engineer, F. M. Link, 125 W. 17th St., New York City.

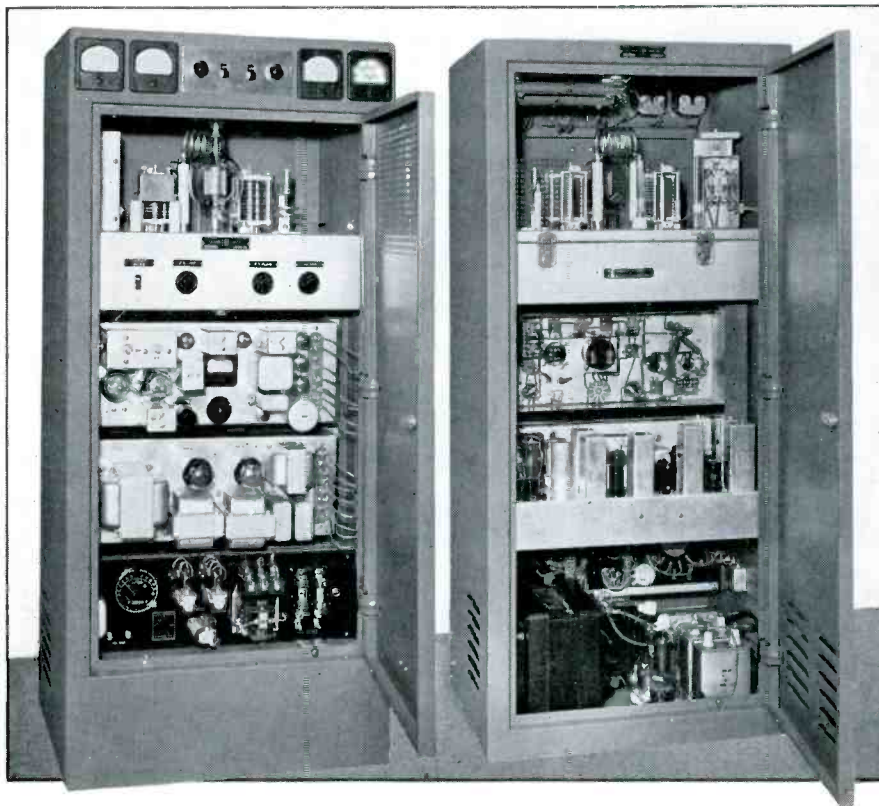

FIG. 2. POWER AMPLIFIER AT THE TOP, THEN 50-WATT DRIVER, 50-WATT SUPPLY, AND HIGH-VOLTAGE SUPPLY AT BOTTOM. IN REAR VIEW, RECEIVER IS ABOVE HIGH-VOLTAGE SUPPLY

- 1—250-TH Eimac final amplifier, or 454H Gammatron
- 2—866A or 249B high-voltage rectifiers
- 2—866Jr. intermediate voltage rectifiers

Control Functions ★ The 250-UPS-X is designed for full remote control over a 2-wire metallic circuit. Time delay and overload relays protect the tubes and circuit components in case of overload or breakdown. The circuit is so arranged that the overload relay can be reset from the remote control point, using the single pair of wires.

An antenna transfer relay in the transmitter allows the use of the main antenna for reception during standby periods, while a keying relay disables the receiver during periods of transmission. The output of the headquarters receiver contained in the cabinet is normally fed to the remote control point over the same two wires which are used for the transmission control and speech input.

Thus, when the operator is ready to talk into the microphone, the application of the control voltage on the 2-wire line causes the

receiver to be disabled, the antenna transmission line to be transferred from the receiver to the transmitter, the power tube filament to be raised from 80% to full operating voltage, and all plate power to be applied. The line connections are also transferred from the receiver output to the transmitter input.

If this equipment is used in a system which calls for the reception of two different frequencies, another receiver can be added at the point where the transmitter is installed, and its output carried to the remote control point over the same 2-wire circuit.

Remote Control ★ The remote control unit designed for use with this transmitter gives complete 2-way operation. It can be installed at any distance up to about 20 miles from the transmitter. The remote control equipment includes the following:

1. Receiver line amplifier, volume control, and loudspeaker
2. Push-to-talk handset with crystal microphone

(CONTINUED ON PAGE 44)

HANDY FIELD STRENGTH METER

Simple Method for Using G.E. JFM-90 Converter to Check Field Strength

BY SAMUEL CURTIS, JR.*

SINCE the introduction of FM into the New England area, the Yankee Network has had occasion to make a great many experimental receiver installations. Due to the marked changes in field strength sometimes encountered, it was deemed advisable to have some sort of inexpensive measuring equipment at hand.

We solved the problem in a very simple way. The method we used may be interesting to readers of *FM Magazine*.

Briefly, the procedure is to take a G.E. model JFM-90 translator and equip it with a 0-1 milliammeter, a small loudspeaker, a D.P.-D.T. toggle switch, and an extra stage of audio amplification.

One of the little 2- or 3-in. permanent magnet loudspeakers, mounted in one end of the translator cabinet is just right for this purpose. Mount a

Weston model 301 or equivalent 1-mil. meter in the other end of the cabinet. Install a D.P.-D.T. toggle switch on the rear apron of the chassis, and wire it into the circuit as explained on the accompanying diagram. It will be a good idea to have the JFM-90 wiring diagram¹ before you when doing the wiring.

We used a single audio stage with a 6F6, which was mounted horizontally underneath the chassis. More gain can be had by using one of the newer 6AD7 dual triodes instead of the 6F6. This is a larger tube, but it can be mounted on top of the chassis in place of the can type filter condenser. The filter condenser is then mounted horizontally beneath the chassis by means of a clamp.

In biasing the output triode section of this tube, care should be taken to keep its plate current down to a minimum in order to avoid unnecessary overload on the power transformer.

The reason for transferring the meter from one circuit to the other is on account of the

saturation characteristic of the limiter. We therefore switch the meter into the 2nd I.F. stage to read strong fields, and on weak fields shift it over to the 1st limiter stage to take advantage of the added gain.

Calibration of this instrument is helpful, although not at all necessary. If you happen to have access to an ultra high frequency signal generator, calibration is easy. Otherwise, you can keep a record of measurements taken in known good spots, and use those as approximations in other locations.

Here are some typical fields, as they might appear on your 0-1 milliamper scale. These readings will vary somewhat between one translator and another, due to differences in alignment for sensitivity, but for practical purposes in the field, and for making comparisons, the following calibration charts will

be found sufficiently accurate.

With meter cut into first limiter circuit:

<i>Microvolts</i>	<i>Milliamperes</i>
200	.98
100	.82
50	.46
20	.18
10	.08
5	.04

With meter cut into second I.F. circuit:

<i>Microrolts</i>	<i>Milliamperes</i>
10,000	.8
5,000	.58
2,000	.25
1,000	.14
500	.08
200	.06

This equipment will facilitate the installation and adjustment of antennas for A-FM sets, and serve as a most useful check in cases where there are complaints about reception.

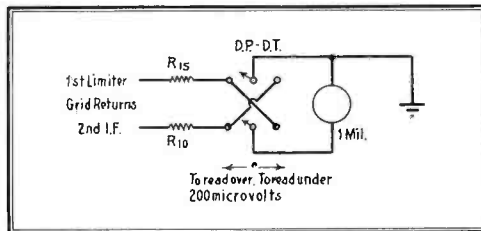

SWITCHING CIRCUIT FOR DOUBLE RANGE

* Technician, The Yankee Network, 21 Brookline Ave., Boston, Mass.

¹ Published in *FM Magazine*, March, 1940, page 45.

RADIO DESIGN PRACTICE

Items about New Designs
and News about Designers

Stromberg-Carlson: Advertising points out that if a radio receiver is designed correctly, it has no "tone" of its own. This is a most important point, and one which radio engineers must come to recognize in making comparisons of audio performance. The only thing that an audio system or a loudspeaker can add to an FM program is distortion. The public is just beginning to find this out. As more listeners make this discovery, there will be some vast changes in radio receiver design.

RCA: Tests on the first production model of their 10-kw. transmitter FM-10A are said to show 0.9% or less distortion at frequency deviations up to 100 kc. for power of 3 to 10 kw. at 30 to 15,000 cycles. First delivery of this model may go to WCAU's FM station.

A-FM-Phono: Knight "16" is a new 3-band A-FM receiver of 10 watts output, with a Garrard mixer-changer. Tunes 540-1,650 kc., 4.8-17 mc., and 40-50 mc. Separate tuner chassis has 6SG7 RF, 6AB7 FM modulator, 6SA7 AM modulator, 6J5 oscillator, two 6SG7 IF's, two 6SJ7 limiters, 6H6 discriminator, 6SR7 2nd detector and 1st audio, 6SR7 inverter, and 6U5 indicator. Rectifier-amplifier unit has 5Z3 rectifier and two 6K6GT push-pull output tubes. Cabinet size 40 ins. wide, 38 ins. high,

18 ins. deep. Operates on 105-125 volts, 60 cycles. Produced by Allied Radio Corp., 833-F West Jackson Blvd., Chicago.

I. J. Kaar: Now managing engineer of receiver division of G.E.'s Bridgeport radio and television division. He is responsible for both engineering and manufacturing in the receiver division, and reports to Dr. W. R. G. Baker.



I. J. KAAR, OF G.E.

Armored Rheostat: To withstand hard use in exposed positions, Clarostat has brought out a new line of power rheostats. A $\frac{3}{8}$ -in. bushing provides one-hole mounting. Values range from 1 to 5,000 ohms, 25 watts. Other values are obtainable on special order. Further specifications are available from Clarostat Mfg. Co., Inc., 285-7 N. 6th Street, Brooklyn, N. Y.

New A-FM Models: Freed-Eisemann catalog just out lists six automatic phono combinations and a table model. One of the big sets has the Garrard turn-over changer. These sets are AC operated, but two of the combinations and the table model are also available with AC-DC circuits. Combinations list at \$260 to \$1,250, with the new table model at \$99.50. Freed Radio Corp., 39-F West 19th Street, New York City.

WABC Interference: New transmitter will undoubtedly benefit many listeners, but it's causing a lot of interference in homes where listeners were satisfied before, while others have noticed no difference. This all heads up to the fact that public interest, convenience, and necessity will be better served only when the number of AM stations is reduced, and the overloaded channels relieved by shifting the burden to the FM frequencies where there is room for several hundred new stations.

20-In. Oscillograph: New DuMont type 233 oscillograph has 2532A20 intensifier teletron with medium persistence screen, 20 ins. in diameter, for lecture-demonstration purposes. Final accelerating potential of 6,000 volts gives high-intensity trace. X- and Y-axis amplifiers are identical. Time base generator is variable from 8 to 30,000 cycles. Complete instrument, with power supply, mounts on a rolling table 28 ins. wide, 36 ins. deep, 60 ins. high. Weight is

(CONTINUED ON PAGE 42)



A-FM KNIGHT "16"
PHONO COMBINATION
FROM ALLIED RADIO
CORP.



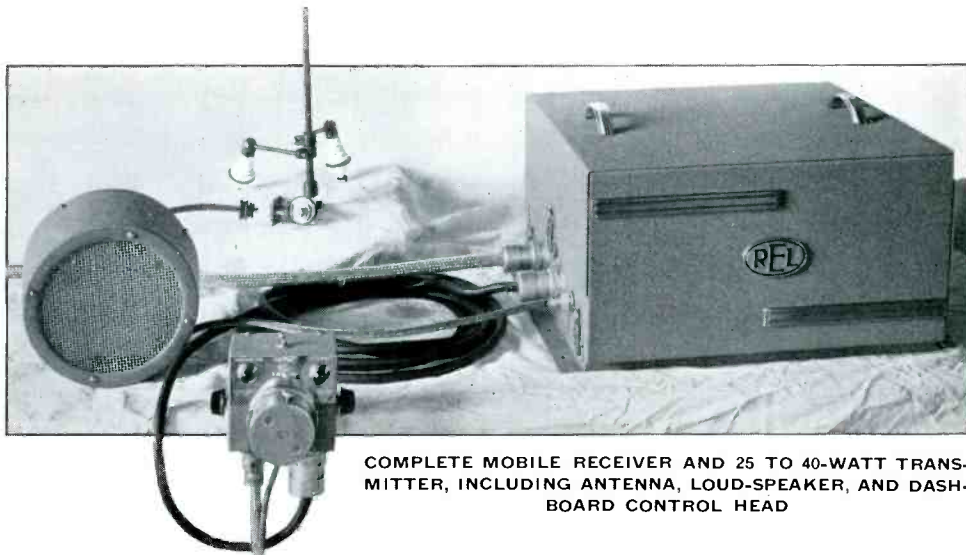

COMPLETE MOBILE RECEIVER AND 25 TO 40-WATT TRANSMITTER, INCLUDING ANTENNA, LOUD-SPEAKER, AND DASHBOARD CONTROL HEAD

New REL Emergency Equipment of SINGLE-CHASSIS CONSTRUCTION

Interesting Features Are Built Into This One-Piece Chassis Design

UP TO the present time, it has been almost standard practice to build mobile emergency equipment in two units—one for the receiver, and another for the transmitter. There are both faults and advantages in that type of construction.

To correct those faults, and to provide additional advantages, REL has recently put into production a single-chassis type of mobile equipment, shown in the accompanying illustrations.

Among the first of these units to be delivered is a considerable quantity purchased by the Canadian Marconi Company for use by the Royal Air Force in Canada.

One of the purposes of this new construction is to reduce the overall dimensions and the weight. Also, greater efficiency is obtained by making use of the receiver dynamotor for the transmitter as well as the receiver, thus eliminating the necessity for dropping the high voltage usually supplied by the transmitter dynamotor to furnish power to the smaller tubes in the transmitter circuits.

This equipment, identified by REL as No. 565, is designed to operate on any predetermined frequency between 30 and 40 mc. Both transmitter and receiver are crystal controlled.

Transmitter Details ★ By using a new circuit-arrangement, the number of tubes ordinarily used in transmitters of this sort has been re-

duced greatly. There are only five tubes in the 565 transmitter, although the power output is in excess of 25 watts when 6 volts are applied to the battery end of the battery cable.

The tube complement is as follows:

- 1—6F7 crystal oscillator and phase modulator
- 2—7V7 frequency quadruplers
- 1—6V6 power doubler
- 1—815 push-pull power amplifier

This combination of tubes gives an output of 25 to 40 watts.

The transmitter employs a total frequency multiplication of 32 times, and incorporates a crystal oscillator and phase modulator in a single tube envelope.

The phase shift produced by this modulator is equivalent to or greater than most phase modulators which use a greater number of tubes. The phase shift is in excess of 40° with good linearity, and retains a characteristic of phase modulators in that it is completely crystal controlled.

Modulator and audio circuits are set up specifically for communication purposes, with pre-emphasis on the higher frequencies up to 3,000 cycles. Beyond 3,000 cycles, the response is deliberately attenuated to prevent noise effects introduced by carbon microphones.

There is, of course, a de-emphasis network in the audio circuit of the receiver, so that the

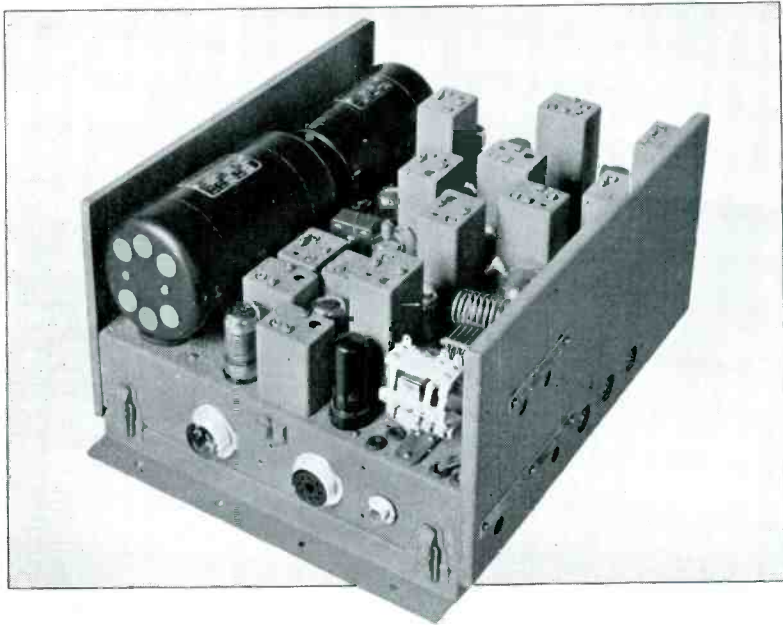

ONLY FIVE TUBES ARE USED IN THE TRANSMITTER, WITH 11 TUBES IN RECEIVER. NOTE THE TWO DYNAMOTORS, USED IN A NEW ARRANGEMENT FOR POWER ECONOMY

overall response is fairly flat from 500 to 3,000 cycles.

Total drain by the transmitter tubes and tube control is 3.63 amperes at 6 volts.

Receiver Details ★ The receiver is a double-IF superheterodyne, designed to operate at any frequency within the 30- to 40-mc. range. Crystal controlled, it is locked to the predetermined frequency.

One quartz crystal is used both on its fundamental frequency for the second IF injection voltage, and also on its fourth harmonic for the first IF amplifier injection voltage.

Audio volume can be adjusted at the remote control unit. A stop is provided so as to prevent the audio level from being set down to zero. The squelch control is also adjusted from the remote control at the dashboard. Squelch operation can be secured from signals of the value of less than .5 microvolt. Essentially complete limiter action is effected on signals of less than 1. microvolt.

The audio amplifier is designed to pass the proper band of frequencies for speech transmission, and to suppress extraneous noise outside the speech spectrum.

Following is the tube complement of the receiver:

- 1—7H7 RF amplifier
- 1—7H7 1st mixer
- 1—7H7 oscillator and multiplier
- 1—7H7 1st IF mixer
- 1—7H7 2nd mixer

1—7H7 2nd IF amplifier

1—7C7 1st limiter

1—7C7 2nd limiter

1—7A6 discriminator

1—7F7 Squelch control and 1st audio amplifier

1—7C5 audio output tube

It is interesting to note that only five different types of tubes are used in the receiver, and only four types in the transmitter, a considerable factor of convenience in simplifying service and replacements.

The accompanying illustrations show the equipment furnished for a complete installation. This includes the transmitter-receiver unit, cables and plugs, remote control head, and antenna.

The antenna is of the two-piece type, with a tripod mounting that conforms to any car body shape. Connection to the antenna is made by means of a flexible 70-ohm transmission line, fitted with plugs at both ends. The battery cable furnished with the standard equipment is 15 ft. long, and the control cable, running to the dashboard unit, is 20 ft. long.

The remote control unit is provided with an ON-OFF switch, pilot lights to indicate that the receiver and transmitter are operating, and controls for the receiver squelch and volume adjustment.

Mechanical details and the wiring have been planned to suit the widest variety of conditions without requiring any modification of the apparatus.

COMMENTS

From Readers of FM Magazine, As Expressed in Letters Written to the Editor

Major Armstrong: In your issue of October under the heading "The Manufacturers Say" there is a statement by David Grimes, Chief Engineer of the Philco Corporation, which calls for comment by me.

Mr. Grimes announces that the Philco Company is "pioneering" in the development of a low-priced FM-AM set, that the great burst of public interest in FM in the last few months coincided with the introduction of this set and that there is a parallel between the growth of the automobile industry from the period of its early days and what is now about to happen in this new field of broadcasting.

May I first, in the name of all those men who contributed to the real pioneering work, protest the right of the Philco organization to claim any credit whatsoever for the development of the public interest in FM. The adventurous spirits among the broadcasters with their mountaintop stations, the designers of the high quality transmitting equipment, the manufacturers of real FM receivers, and the distributors and dealers in radio merchandise who painstakingly demonstrated to the public the merits of this system are those to whom the credit for building this public demand is due. They did it at a time when there was no financial reward for their efforts and they did it in the face of an organized opposition which endeavored, without success, to "talk down" the performance and the future of the FM system.

Second, may I point out the misleading fallacy in Mr. Grimes' statement that:

"Philco's decision to pioneer in the making and selling of low-priced FM-AM receivers is . . . sound from the point of view of the best interests of the radio art—"

and that this decision has made it

"possible for large numbers of people to enjoy this improved kind of radio reception."

Philco's decision to sell at a low price what it calls an FM receiver has no relation to the purpose of enabling more people to enjoy "this improved kind of radio reception." "This improved kind of radio reception" obviously refers to the genuine FM reception which has been demonstrated for several years and which the public understands FM to mean. The Philco receiver does not give this type of reception because certain elements essential to its production are not incorporated in the Philco set.

The outstanding characteristic of an FM receiver is that it is made substantially immune to amplitude disturbances and responds fully only to the wide swing modulations of the characteristic FM wave. The consequences of

this are that great immunity from all forms of static and great freedom from heterodyning by other stations on the same wave length are obtained. It is no contribution to the new method of broadcasting to reduce the price of a set, but omit the means for effectively achieving these results. Nor is it a contribution to the reputation of an industry for integrity to represent as an FM set a receiver which in fact does not contain the means for wiping out the amplitude disturbances so that genuine FM performance may be obtained.

Now referring specifically to Mr. Grimes' statement about the growth of the automobile industry, we find no instance of any company doing in that industry what Philco is now doing in the radio industry. No manufacturer endeavored to obtain an unfair advantage over its competitors by omitting the differential or the transmission or some equally important part and presenting his product for sale at lower cost as a complete automobile. On the contrary, each manufacturer made the best product he could and left it to the resulting increased demand and mass production to reduce the cost for each succeeding year.

No one can object to the soundness of the proposition that low-priced FM receivers are in the public interest; no one can doubt that such receivers are on the way. Nor can one object to Philco's advertising that its sets will receive the programs of FM stations. Any amateur knows that his short-wave AM, or his superregenerative receiver will do this. No one can object to the offering for sale of any type of set whatsoever for the reception of the signals of these stations, but—the purchaser must be informed what he is getting. Objection must be made to Philco's representation to the public as an FM set of a receiver which does not give FM performance. No one should be permitted to do this.

EDWIN H. ARMSTRONG

Palmer E. Fry, W45D: You asked for it, friend—and we didn't miss it—October issue of *FM*, page 44, "Football." We have been broadcasting all Wayne University football games this fall from Keyworth stadium here in Detroit. The pickups are remarkable and the color given to sound as we never heard before. Crowd background noise and band pickups are truly realistic in clarity and superior to any AM broadcasts we have heard. And we predict now it's going to be a "must" as more FM listeners are aware of the service. At 15,000 cycles the frequency response curve is down

(CONTINUED ON PAGE 46)

Eimac 75T

Eimac 304T

4 TRIODES IN 1

LOW VOLTAGE TUBE...LOW INTERNAL RESISTANCE with a 10 to 1 safety factor

More than a year ago, Eimac announced these Multi-Unit tubes to the industry under the statement "A Revolutionary Change in Vacuum Tube Design." They were developed in the Eimac laboratories for the precise purpose of providing a high power, low voltage (1000 to 2500 volts) tube having an extremely low internal resistance which would operate efficiently up to 200 megacycles. In actual operation Eimac 304T tubes are seeing service with as much as 20,000 volts on the plates...10 times the rated voltage. Where else is there a tube offering such a safety factor? It's just typical of Eimac's leadership... another reason why Eimac tubes are to be found in the key sockets of most of the important radio transmitters throughout the world.

FOLLOW THE LEADERS TO



Eitel-McCullough, Inc. San Bruno, California

EIMAC REPRESENTATIVES

California, Nevada
HERB BECKER, 1530 W.
104th St., Los Angeles, Cal.
N. Y., N. J., Penn., Md., Del.,
Dist. of Col., Maine, N. H.
R. I., Conn., Mass.
ADOLPH SCHWARTZ,
262 Grayson Place, Teaneck, New
Jersey.

Wash., Ore., Idaho, Mont.
GENERAL SALES CO.,
Verner O. Jensen, 2605-07
Second Ave., Seattle, Wash.

Colo., Wyo., New Mexico,
Arizona, Utah
RICHARD A. HYDE, 4253
Quitman St., Denver, Colo.

Chicago, Illinois, Wisconsin
G. G. RYAN, 549 W
Washington Blvd., Chicago,
Ill.

N. Caro., S. Caro., Georgia,
Tenn., Flor., Ala., Miss.

JAMES MILLAR, 316 Ninth
St. N. E., Atlanta, Georgia.

Texas, La., Okla., Ark.
J. EARL SMITH, 2821 Live
Oak St., Dallas, Texas.

Ohio, Mich., Ky., Ind., Minn.,
Mo., Kan., Neb., Iowa
PEEL SALES ENGINEER-
ING CO., E. R. Peel, 154
E. Erie St., Chicago, Ill.

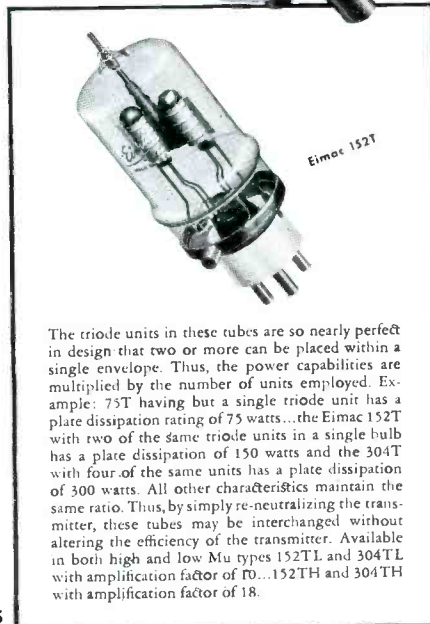

Eimac 152T

The triode units in these tubes are so nearly perfect in design that two or more can be placed within a single envelope. Thus, the power capabilities are multiplied by the number of units employed. Example: 75T having but a single triode unit has a plate dissipation rating of 75 watts...the Eimac 152T with two of the same triode units in a single bulb has a plate dissipation of 150 watts and the 304T with four of the same units has a plate dissipation of 300 watts. All other characteristics maintain the same ratio. Thus, by simply re-neutralizing the transmitter, these tubes may be interchanged without altering the efficiency of the transmitter. Available in both high and low Mu types 152TL and 304TL with amplification factor of 70...152TH and 304TH with amplification factor of 18.

Export Agents: FRAZAR & CO., LTD. • 301 Clay Street, San Francisco, Calif.

FM SPOT NEWS

(CONTINUED FROM PAGE 30)

floor space to accommodate new production facilities needed for National Defense orders.

W. R. G. Baker: Under new setup at General Electric, the Company will have four major operating departments. These are appliance and merchandising, radio and television, lamps, and apparatus. Radio and television will head up to Dr. W. R. G. Baker, recently elected a vice president. He has been with G.E. since 1917, with the exception of the years from 1929 to 1935, when he was at RCA-Victor.



H. VERNON ANDERSON, V.P. OF W45BR AND WJOB GETS HIS FIRST FM CONTRACT FROM T. J. DAIGRE, OF BATON ROUGE COCA-COLA

Milwaukee: The Journal's W55M has been stepped up from 1 kw. to 3 kw., giving substantial increase in coverage. After December, when the 50-kw. transmitter, 22 miles outside Milwaukee, goes on the air, the 3-kw. equipment in the City will not be dismantled, but will be retained as a spare.

Sign of the Times: Henry Heins, of Heins and Bolet, New York's largest independent radio store, seen leaving 570 Lexington Avenue. Questioned, he said: "I'm trying to get more Stromberg A-FM sets from Ben Gross."

C. H. Wesser: Reports from W45D, Detroit: We are on full power permitted by our C.P., namely 13.3 kw. in the radiator, or a plate input to the final stage of 23 kw. Results have been most gratifying, with very fine reception reports from Cleveland, Canton, and Toledo, Ohio; Erie and Sharon, Pa.; and many reports from cities in Michigan up to 100 miles and better away from Detroit.

James S. Knowlson: President and board chairman of Stewart-Warner has been granted a leave of absence, without pay, to enable him to act as deputy director of priorities on the Supply Priorities and Allocation Board at Washing-

ton. His duties at S-W will be handled by Frank A. Ross, senior vice president, during his absence.

Presence Effect: Hazel Sims, staff musician at W59C, remarked: Because of the fidelity of FM transmission, I feel as if I am giving a personal concert for each person whose radio is tuned to W59C.

A-FM Promotion: Under a cooperative arrangement, Freed Radio advertising is being run in New York papers by Sloane, Center Music, Wurlitzer, Haynes-Griffin, and Wanamaker. Copy is running in the *Tribune*, *Times*, *Sun*, and *Telegram*. Other schedules are starting in Detroit, Boston, Los Angeles, Hartford, Philadelphia, Milwaukee, and Chicago.

Baton Rouge: First commercial FM contract in the deep South was signed by Baton Rouge Coca-Cola Bottling Company, which will sponsor all Tulane University football games this season, over W45BR.

George C. Conner: Speaking as toastmaster at the Radio Club of America banquet: Radio is the only electrical appliance that gives off gas.

Hartford: Very handsome weekly FM program bulletin issued by W65H lists commercial programs sponsored by Watkins Brothers and Tuckel Radio. Former features Otto Neubauer who plays the piano and Solovox; latter is all-request program which is proving very successful. Excellent cooperation has been given W65H by the Hartford Courant, pioneer in crystal detector days, and now carrying considerable FM set advertising.

Once Upon a Time: The Tuckel brothers gave your Editor their first order for an FM receiver—a Pilot table model A-FM. They sold it promptly to none other than Major Doolittle, of W65H, but they refused to order another to replace it. They just couldn't see FM, particularly at the high cost compared to straight AM sets. They said, "People here in Hartford just won't spend that money." More power, now, to the Tuckel brothers for changing their minds—and the minds of their customers!

Pittsburgh: Frank R. Smith, general manager of W47P and WWSW, has made arrangements to broadcast concerts of the Pittsburgh Symphony Society, through Edward Specter, manager of the Society. Special telephone lines have been installed to carry the music to the station. Several all-orchestra programs will be heard, and others featuring soloists whose contracts permit radio appearances. This series will give Pittsburgh FM broadcasting at its best.

Your Opportunity
to Own Two Important

REFERENCE VOLUMES

If You Act Promptly!

**1ST BOUND VOLUME
OF FM MAGAZINE
15 COPIES AVAILABLE
NOVEMBER 1940 TO APRIL 1941**

**2ND BOUND VOLUME
OF FM MAGAZINE
85 COPIES AVAILABLE
MAY 1941 TO OCTOBER 1941**

These two bound volumes of **FM** Magazine comprise a 600-page record of the most important developments in modern radio progress, invaluable as a reference source to engineers, patent attorneys and radio executives.

We have been able to make up an additional 15 copies of the First Volume, and 85 copies are available of the Second Volume.

The binding, of three-quarter pigskin, was done by Eggeling, and is of the finest workmanship, designed to last a lifetime.

The cost is less than you would pay to have a single set of copies bound.—
Send your order at once!

\$5.00

EACH, POSTPAID, IN THE U. S. A.

FM COMPANY

112 EAST 36th STREET
NEW YORK CITY



MONITORING

*for efficiency,
quality, coverage*

- DuMont Type 213-A Cathode-Ray Modulation Monitor is a "must" piece of equipment in safeguarding today's high broadcasting standards. Permits monitoring and study of radio-frequency transmissions, while eliminating necessity for connecting deflection plates of cathode ray tube to bulky externally-provided tuned circuits. Entirely self-contained with its own resonant circuit tuned to transmitter frequency and coupled by means of low-impedance link to source of modulated radio frequency.

Modulated envelope or trapezoidal modulation patterns. Tuned circuit frequency range of from 400 kc to beyond 40 mc per second. Horizontal deflection effected either by externally-provided linear sweep circuit for modulated envelope study, or by audio-frequency voltage taken from transmitter modulator circuit.

- Write for Literature . . .

DU MONT

ALLEN B. DU MONT
LABORATORIES, Inc.

Passaic ★ New Jersey

Cable Address: Wespexlin, New York

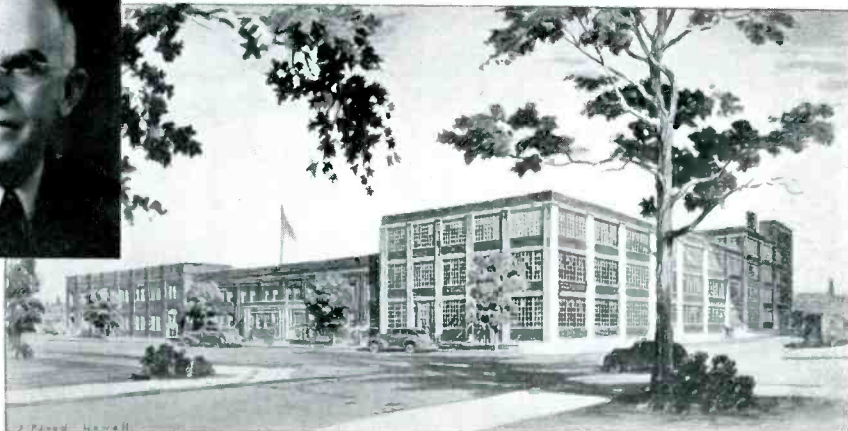

ISOLANTITE PLANT UNDER CONSTRUCTION AT BELLVILLE, N. J., SCHEDULED FOR COMPLETION EARLY NEXT YEAR. INSERT, W. D. WALTMAN, PRESIDENT OF ISOLANTITE, INC.

RADIO DESIGN PRACTICE

(CONTINUED FROM PAGE 35)

250 lbs. Operates on 115/230 volts, 40 to 60 cycles.

Frozen: Yankee Network's driven well on Mt. Washington. Water supply for FM station W39B has disobligingly turned to ice 700 ft. down. Usual ingenuity of Paul de Mars and Al Sise will undoubtedly persuade the water to flow again, however.

Clarostat: Will show a complete line of standard and special resistors at the I.R.E. Rochester convention. Sales engineers Jimmy Youngblood and Eddie Trefz will be in attendance, along with George Mucher, chief engineer and Vic Mucher, sales manager.

Isolantite: New million-dollar plant expansion at Belleville, N. J., will step up production ten times over output of a year ago, according to W. D. Waltman, president of Isolantite, Inc. Three-story building, shown here, will add 80,000 sq. ft. New machinery, with individual motor drive, will handle intricate ceramic shapes. Added equipment includes presses, machine tools, and kilns. Tool room will be enlarged for production of dies for presses and extrusion machines. K. D. Hamilton, vice president and general manager, will continue in direct supervision of the plant.

Gates: Announces a new 250-watt AM transmitter, type 250C, with immediate delivery guaranteed. Design features the mounting of all components on a single vertical panel, with the tubes on shelves. Motor tuning of condensers, through speed reducing gears, is used for

smooth and easy adjustment. Gates American Corp., Quincy, Ill.

FM Antenna: Dr. Andrew Alford, of the Federal Telegraph Company, Newark, N. J., has designed a special high-gain antenna for W67C, the FM outlet of WBBM, Chicago. The antenna tops the 1 North La Salle Building, 621 ft. above the street level. W67C is designed to cover the Chicago area, of 10,800 square miles, with 10 kw. output.

Radio Age: The first issue of a new RCA house organ, Radio Age, has just been published. It is intended to present the news of RCA services, research, manufacturing, communications, and broadcasting. Contributors to the first issue are Thomas F. Joyce, vice-president of RCAM; Ralph Beal, research director of RCA Laboratories; John Elwood, manager of the NBC International Division; and Alfred H. Morton, vice president in charge of NBC television.

National SCR-2: New National AM receiver, of single-frequency design, is carried on a panel $3\frac{1}{2}$ ins. high, suitable for rack mounting. Range of frequencies within which this set can be supplied has not been announced, but it will probably be furnished for any channel covered by the HRO. The circuit has two RF stages preceding the detector, and a crystal oscillator. To allow for drift at the transmitter, the IF circuits are designed to have band pass characteristics with a width of 4 kc. for 2 times down, but only 19 kc. for 1,000 times down. Power supply is built in. At signal input of 2.5 microvolts, signal-to-noise ratio is rated better than 10 DB. This is an ideal receiver for standard frequency signal reception at broadcast stations. National Company, Inc., Malden, Mass.

ARMSTRONG MEDAL AWARDED TO HARRY WILLIAM HOUCK

MEMBERS of the Radio Club of America cheered with vigorous approbation when, at their 32nd annual banquet in New York, the Armstrong Medal was awarded to Harry Houck who, for so many years, has had an active part in radio development and research.

The citation read: "The Armstrong Medal of The Radio Club of America is awarded to Harry William Houck for his outstanding contributions to the radio art.

"After assisting at the birth of the Superheterodyne in Armstrong's wartime laboratory in Paris, he designed the second harmonic superheterodyne, the first type to be placed in large commercial production.

"Radio receivers operating from alternating current power lines, from their very inception, leaned heavily on the technique, the designs, and the inventions of the medalist. His researches on capacitors—paper, mica, and electrolytic—made practical the filter systems used in all modern receivers.

"His studious, detailed, careful experimental attack on any radio problem, with results always worth while, should be an inspiration to younger men."

Major Armstrong gave an interesting account of Harry Houck's work in France during the War, and told of an incident which very nearly had a fatal conclusion. In 1918, Houck was very seriously ill in a French hospital. In fact, his condition was such that the doctor, after examining him, told the orderly to arrange for his burial the next day, since he could not last through the night.

Next morning, accordingly, two orderlies came to carry him out. Houck managed to ask: "Where are you going to take me?"

"To bury you," one of the orderlies said. "You're practically gone now."

"To hell I am!" said Houck, more vigorously. And it's a good thing for radio that Harry Houck won that argument!

During the World War, said Major Armstrong, there were just three superheterodynes in use. Those original models had 32 adjustments, but there would have been fewer if they hadn't stopped the War so soon.

Much of the work of simplifying the superheterodyne was done by Harry Houck. In 1922, this circuit required nine tubes, although it was generally considered that three were the limit for a radio receiver. Houck boiled the super down to six tubes, and made it practical for home radio reception.

"Why we had so much trouble with the superheterodyne in those days I don't know," the Major said. Then he added, "It's always hard to understand why we had problems after they have been solved."

It's Meissner again

WITH A BRAND NEW

F-M ★ A-M

3-BAND COMBINATION



TABLE MODEL RECEIVER

that has everything!

- ★ Two-tone, hand-rubbed walnut cabinet
- ★ 12¼" high — 22¾" wide — 11" deep
- ★ FM and AM in two separate channels
- ★ Covers Broadcast & Short Wa. on AM
- ★ Full coverage of 42-50 mc FM band
- ★ Calibrated glass scale, edge-lighted
- ★ Tuning indicator, accurate adjustment
- ★ Includes seventeen latest type tubes
- ★ High-gain RF stage on all three bands
- ★ Wide-band I-F chan. on both AM bands
- ★ 3-stage I-F channel on FM at 4.3 mc
- ★ Audio system common to both channels
- ★ Response flat from 30 to 15,000 cycles
- ★ Push-pull output, 6½ watts undistorted
- ★ Heavy-duty 8" PM Hi-Fidelity Speaker
- ★ Operates on 105-125 volts, 50-60 cyc.

Complete Receiver, as shown, with tubes,
Model 9-1053 List Price **\$108.00**

Chassis Only, with tubes **\$95.00**
Model 9-1054 List Price

**WRITE TODAY FOR FREE 48-PAGE
COMPLETE CATALOG**

ADDRESS DEPT. F-9

Meissner MT. CARMEL,
ILLINOIS
"PRECISION-BUILT PRODUCTS"

FM
 Frequency Modulation First in Michigan

Michigan's pioneer F.M. station is now on the air. Independent programming 10 hours daily. Owned and operated by The Detroit News, associate station WWJ.

Rate Card on Request

W 4 5 D
 4500 Penobscot Bldg.
 DETROIT, MICHIGAN

Radio Engineer's BOOK SHELF . . .

*Selected Volumes Obtainable
from FM's Book Department*

- RADIO ENGINEERING**, by *F. E. Terman*
 A comprehensive treatment covering all phases of radio communications. Written for both students and engineers. 813 pages, 475 illustrations. 2nd edition. \$5.50
- ELEMENTS OF RADIO COMMUNICATIONS**, by *Prof. J. H. Morecroft*
 By the author of the well-known "Principles," this book treats the subject of communications in a more elementary fashion. Mathematics are limited to simple algebra. 286 pages, 170 illustrations. 2nd edition. \$3.00
- COMMUNICATION ENGINEERING**, by *W. L. Everitt*
 A general text book for both first year and advanced courses. Presents complete treatment of network theory, including mathematical analysis of radio circuits and vacuum tubes. 727 pages, 411 illustrations. \$5.00
- ENGINEERING ELECTRONICS**, by *Donald G. Fink*
 Covers the field of electronic tubes and their applications, including not only radio but other fields where vacuum, gas-filled, and photo-sensitive tubes are being used. Includes theory, but mathematical treatment is relatively simple. 358 pages, 217 illustrations. \$3.50
- EXPERIMENTAL RADIO ENGINEERING**, by *Prof. J. H. Morecroft*
 An excellent laboratory text, directed particularly to the principles involved in the operation of radio apparatus. It is intended as a supplementary volume to "Elements of Radio Communications." Of particular interest is Prof. Morecroft's list of 51 experiments. 345 pages, 250 illustrations. \$3.50

Prices include postage in the U. S. A.

FM COMPANY

112 East 36th Street New York City

FM STATION SURVEY

(CONTINUED FROM PAGE 6)

continue its popularity in FM transmission, according to indications. Only three stations under construction have shown a preference for vertical antennas, and two of these are in small communities where high gain is not imperative.

If nothing else, this particular FMBI survey—conducted almost one year after the first commercial construction permits were granted at Washington—gives hint of steady progress despite obstacles and discouraging delays. The 58 licenses granted to October 15 postulate the outlay of much money, engineering skill, and faith in a field of superior broadcasting, founded upon a desire to serve the public more fully than has ever before been possible. Frequency Modulation needs time above all, and patience; the progress is taking care of itself.

FM COMMUNICATIONS TRANSMITTER

(CONTINUED FROM PAGE 33)

3. Handset hang-up box to cut off speaker and energize handset earpiece when handset is lifted
4. Microphone pre-amplifier and gain control
5. Relay circuits and remote power supply control for transmitter
6. 2-stage RF amplifier, detector, and vacuum-tube voltmeter to indicate relative field strength when transmitter is in operation

This equipment is housed in a sloping-front console, to be mounted on the operator's desk.

Antenna ★ The output of the transmitter is intended for connection to the usual 70- to 80-ohm load, although the output circuit will readily match any other impedance if necessary.

The antenna system recommended is a half-wave vertical radiator, matched to a concentric transmission line by a quarter-wave, two-wire matching transformer, or a concentric antenna utilizing concentric transmission line.

This equipment is planned so that, when it is used for fixed service, the transmitter and antenna can be located at the most advantageous spot for maximum operation, even though the control and operating point is at a considerable distance. No attendance is required at the transmitter for, in case of any trouble, the condition will be known at the control point immediately through the failure of the field strength indicator to show normal field intensity. Occasional routine inspection of the transmitter is enough.

TELEVISION CAMERA EQUIPMENT

(CONTINUED FROM PAGE 14)

As seen from Fig. 1, this arrangement makes it possible to leave the equipment in operating condition while moving it. Built into this control table is a power distribution system which can be connected to either a single- or a three-phase line to supply power to the complete dual chain set-up. Also, an interphone system enables the operator to communicate with either of the cameramen or the transmitter operator.

Pneumatic tires are used, and the top shelf holding all the sensitive control apparatus is mounted on shock absorbers to isolate the equipment mechanically against vibration. Another shelf serves as an arm rest and to hold scripts and operating logs and, to make it complete, two drawers are provided for tools, spare tubes and parts.

The over-all dimensions of the equipment dolly are: 66 ins. long, 28 ins. deep, and 36 ins. high. With all the equipment placed on it, it is easily moved through a standard size door.

REAR-ADMIRAL S. C. HOOPER

As guest speaker at the 32nd Annual Banquet of the Radio Club of America, at New York City, Rear-Admiral Hooper recalled facts about the status of the radio art in 1916 which, in the light of present progress, seem almost startling.

In 1916, he said, the Navy was hoping to replace flags with radio for inter-fleet communication, and it was about that time that he personally set about adjusting many of the transmitters on the ships so that the operators could shift to any one of five different frequencies. For checking purposes, he used a Pierce wave-meter.

The principal manufacturers of commercial apparatus at that time were Wireless Improvement Company, Wireless Specialty, Marconi Company of America, Telefunken, Lowenstein, Federal, and Emil J. Simon. With the exception of Federal Telegraph, all these names have disappeared.

Because of limited space in shipboard radio shacks, the Navy backed William Dubilier in the development and manufacture of small, high-voltage mica condensers, to replace the huge Leyden jars required for transmitters.

Similarly, said Admiral Hooper, it was the Navy's need for direction-finding equipment that prompted them to give encouragement and aid to Dr. Kolster in the development of the Kolster radio compass.

These and many other interesting facts recalled by Admiral Hooper made his very enjoyable talk of greatest interest to the record number of engineers who attended the Radio Club dinner.

Complete

YOUR FILE OF

Back Numbers

Check your file of back copies against the list below, and order those you are missing while we can still supply them. There are only a few copies of some issues.

- | | |
|---|--------------------------------------|
| <input type="checkbox"/> November, 1940 | <input type="checkbox"/> April, 1941 |
| <input type="checkbox"/> Out of Print | <input type="checkbox"/> May |
| <input type="checkbox"/> December | <input type="checkbox"/> June |
| <input type="checkbox"/> January, 1941 | <input type="checkbox"/> July |
| <input type="checkbox"/> February | <input type="checkbox"/> August |
| <input type="checkbox"/> Out of Print | <input type="checkbox"/> September |
| <input type="checkbox"/> March | <input type="checkbox"/> October |

Back issues of "FM" are a source of important reference material and engineering data, available from no other source. As time goes on, these issues are proving to be of increasing value. Complete your file of back numbers while you have the chance.

\$1.00 for SIX ISSUES

Any six issues, from March to October, 1941, will be sent postpaid for \$1.00, provided the copies you want are still available when your order is received.

FM COMPANY

112 EAST 36th STREET
NEW YORK CITY

WHAT THE BROADCASTERS SAY:

(CONTINUED FROM PAGE 15)

Advertising agency executives and newspaper men have been given an FM preview in our studios. Window cards are being distributed to 1,400 radio dealers in the area and 275 service men will deliver 35,000 pieces of literature to homes each month. A film is in preparation for showing before the public, private, and parochial schools, and before clubs and service organizations. On the day of our opening, a 10-page supplement will appear in two newspapers and there will be special pages in two others.

Although the tremendous improvement in tonal quality has received great acclaim within the industry, we are not stressing this quality of FM so heavily in our promotion. Generally, the public has been satisfied with the tonal range of AM, and converts on the basis of quality will be difficult to make. We are bearing down most heavily on the static-free, noise-free characteristics of FM, and on the absence of fading and interference. In our area, where there are so many transmitters, interference has been a constant source of complaint and annoyance to listeners. We feel that stressing the elimination of these nuisances will do the most effective selling job for FM.

We are stimulating interest in FM before it comes, and we shall double our efforts after it is here. If our promotion can bring people to W53PH, we are sure that the quality of FM and the programs we are planning can substantiate all we are saying.

COMMENTS

(CONTINUED FROM PAGE 38)

only 1.7DB, while at 50 cycles the curve is down .6DB while over all the line is flat.

Since our formal opening October 17, we have stepped up our program schedule to 18 hours daily from 6:00 A.M. to 12:00 P.M. and 8:00 A.M. to 12:00 P.M. Sundays. This obviously has proved gratifying to dealers who

now can demonstrate FM any hour of the day.

In addition to our regular program features we will, beginning November 3, pick-up programs originating in Ann Arbor from the University of Michigan broadcasting service and will have the programs exclusively over FM for one year. Because of the variety of program material we believe it worthy to list for you some samples from a week's schedule beginning Monday, November the third.

Monday

3:30- 4:00 Folk songs and folk tales

Tuesday

11:15-11:45 University Choir

7:00- 7:15 The World Today: News Comments, by Professor R. H. McDowell

7:15- 7:30 Faculty and students of the School of Music

Wednesday

5:00- 5:30 Fries Memorial Organ

Thursday

3:30- 4:00 Madrigal Singers

7:00- 7:15 Sports and Health

7:15- 7:30 Faculty from University School of Music

Friday

3:30- 4:00 University Symphony Orchestra

For the purpose of demonstrating FM to various clients, local brass hats and a choice invitational list of folks, we have engaged a parlor in the Book Cadillac hotel and have asked dealers to install every FM model receiver available in this area. We intend to keep a steady file of visitors in and out that want to hear FM under normal conditions from whatever receiver they like and under pleasant circumstances that will not have attendant sales pressure. We ourselves will handle the demonstrations and have scheduled them for several weeks.

Very truly yours,

PALMER E. FRY,
Sales & Promotion



SUPPORTED BY SPECIAL FM PROGRAMS, TOM STEWART OF W47NV, NASHVILLE, HAS DEMONSTRATED THE NEW RECEPTION TO OVER 50,000 PEOPLE ATTENDING FAIRS IN TENNESSEE CITIES. TWO TRUCKS CARRIED THE EQUIPMENT 1,600 MILES, ALL WITHIN 100-MILE RADIUS OF W47NV

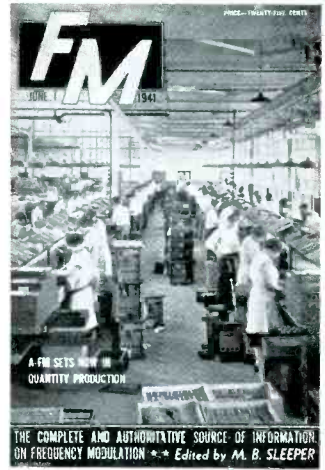

NOW IN ITS SECOND YEAR OF PUBLICATION, "FM" HAS REACHED FIRST PLACE IN THE FIELDS OF RADIO ENGINEERING AND DESIGN PRACTICE, COVERING BROADCAST, COMMUNICATIONS, AND TELEVISION EQUIPMENT.

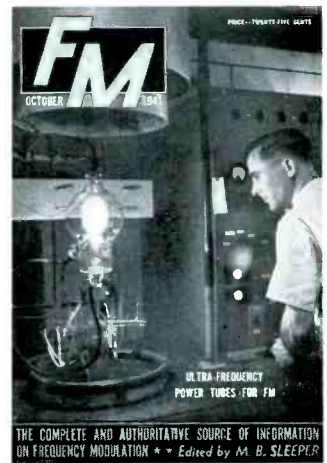

Partial List of Police Departments, Public Utilities, and other purchasers of Browning Monitors

Police Departments

- Arlington, Mass.
- Atchison, Kansas
- Big Spring, Texas
- Bloomington, Indiana
- Bremerton, Washington
- Centralis, Washington
- Coffeyville, Kansas
- Columbia, Missouri
- Crawfordsville, Indiana
- Emporia, Kansas
- Fitchburg, Mass.
- Fond du Lac County, Wisconsin
- Great Bend, Kansas
- Klamath Falls, Oregon
- Leominster, Mass.
- Marathon County, Wisconsin
- Milton, Pa.
- Nampa, Idaho
- Sharon, Mass.
- Shelby County, Indiana
- Sidney, Ohio
- St. Charles, Missouri
- Twin Falls, Idaho

- General Electric Company
- Graybar Electric Company
- Burdick Corp., Milton, Wis.
- Cleveland Railway Company
- Cleveland, Ohio
- Water Supply Commission
- Belchertown, Mass.
- Hygrade Sylvania Corp.
- Salem, Mass.
- San Antonio Public Service
- San Antonio, Texas
- San Diego Gas & Electric
- San Diego, California
- Southern California Edison
- Los Angeles, California
- Toledo Edison Company
- Toledo, Ohio
- Transmitter Mfg. Company, Inc.
- New York City
- United Electric Light Company
- Springfield, Mass.
- United Illuminating Company
- New Haven, Connecticut
- University of Maryland
- College Park, Md.

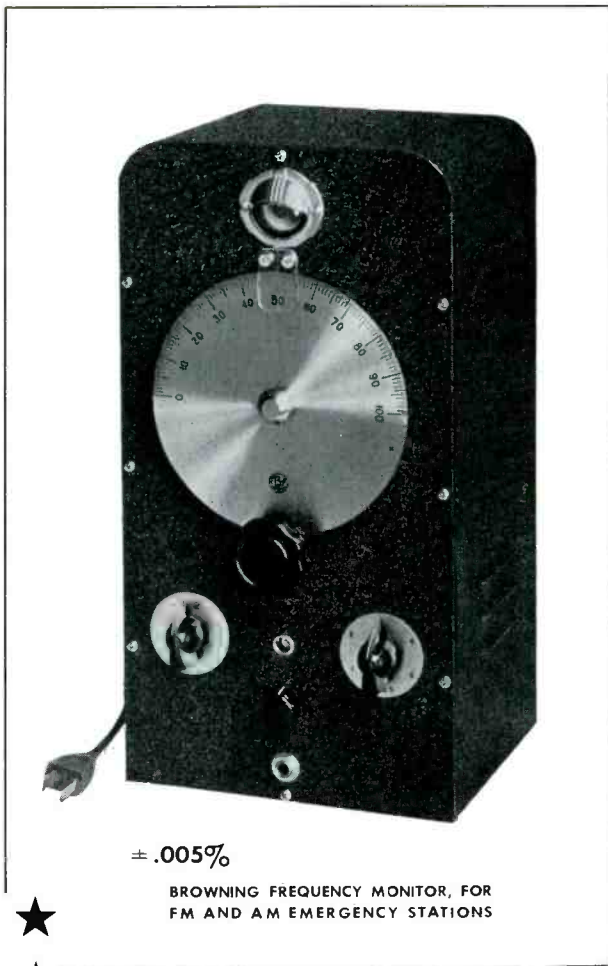

$\pm .005\%$

BROWNING FREQUENCY MONITOR, FOR FM AND AM EMERGENCY STATIONS



**Increased Accuracy to Meet New
FCC REQUIREMENTS
For All Emergency Transmitters**

The new Type S-2 Browning Frequency Monitor provides the greater precision now required by the FCC for all emergency transmitters. Suitable for both FM and AM, the Browning Monitor is built with one to four bands, for any frequencies between 1.5 and 60 mc. Prices:

1 Band	\$125.00	3 Bands	\$165.00
2 Bands	145.00	4 Bands	185.00

BROWNING LABORATORIES, INC.
755 MAIN STREET WINCHESTER, MASSACHUSETTS

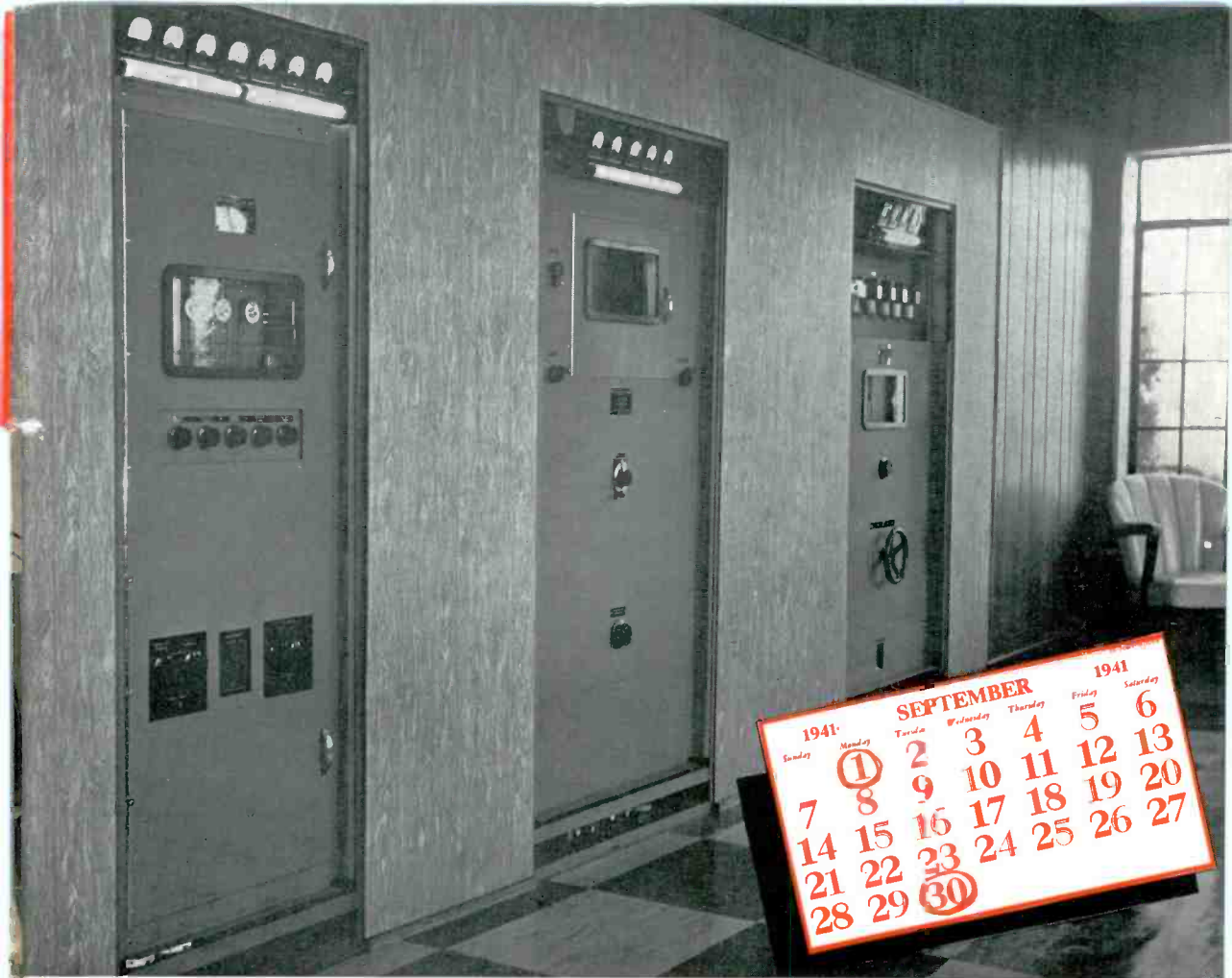

10-KW FM TRANSMITTER AT W45CM, COLUMBUS

30 Days from Order to Completed Installation

HERE'S proof again that there is no need to accept indefinite postponement of FM transmitter deliveries.

In this instance, **REL** delivered and installed a 10-kw. FM transmitter at W45CM (WBNS) Columbus within 30 days after the purchase order was signed!

How can **REL** accomplish what no other manufacturer can do? The answer is clear when you consider the facts:

Based on the experience of having produced all the high-power FM equipment now in operation, **REL** is building standard production units of 1- to 50-kw. These are perfected designs of proven performance, requiring no further experi-

mentation in the course of manufacture or after delivery to customers.

Equally important is the demonstrated performance of **REL's** Armstrong phase-shift exciter, the only type of exciter known to be unaffected by stray fields from high-power amplifiers, and used exclusively by the larger FM stations.

The **REL** factory is now completing another 50-kw. transmitter, a 10-kw. transmitter, and several of smaller capacity, along with a quantity of the new No. 558-DL Armstrong phase-shift exciter units.

Among the transmitters completed recently are 10-kw. in-

stallations for W45CM (WBNS) Columbus, W53PH (WFIL) Philadelphia, and W39B Mt. Washington. The new 50 kw. for W55M (WTMJ) Milwaukee will be installed and on the air before the end of December. No wonder radio engineers and executives say: "There's no conjecture about **REL** equipment."



RADIO ENGINEERING LABS., Inc.
Long Island City New York

Pacific Coast Sales Offices:

5334 Hollywood Blvd., Hollywood, Calif.
420 Market Street, San Francisco, Calif.

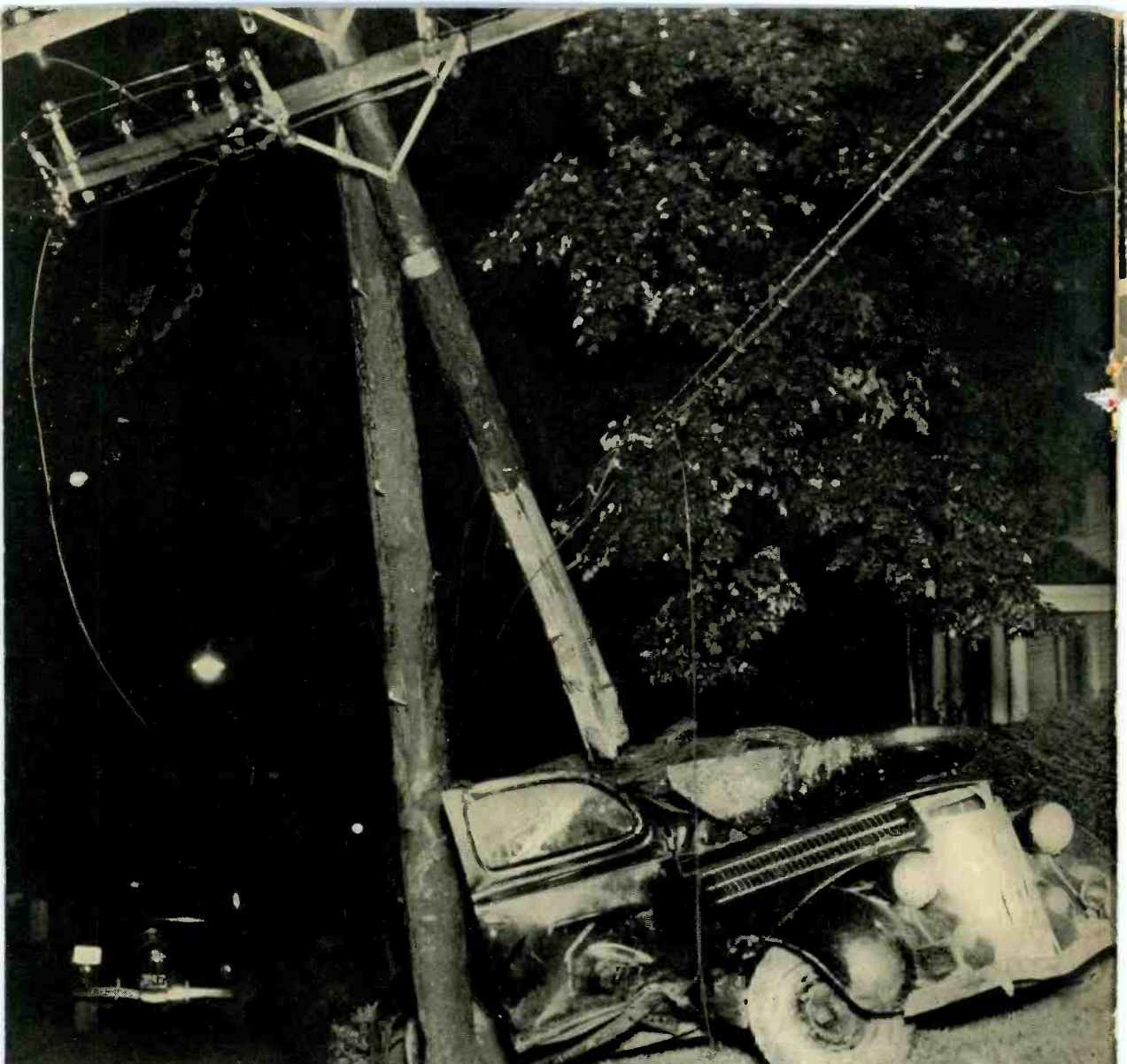

**LINK FM and AM
RADIO COMMUNICATIONS SYSTEMS**

serve in such emergencies as
this actual case with speed
and dependability. Operat-
ing costs are negligible.

**ENGINEERS and MANUFACTURERS of FM and AM EQUIP-
MENT for GOVERNMENT, PUBLIC UTILITY, POLICE and FIRE**



Fred M. Link 125 WEST 17th ST., NEW YORK, N. Y.

Engineer • Manufacturer

Telephone: CHELSEA 2-3838