

FM

JUNE

1941



A-FM SETS NOW IN
QUANTITY PRODUCTION

THE COMPLETE AND AUTHORITATIVE SOURCE OF INFORMATION
ON FREQUENCY MODULATION ★ ★ *Edited by M. B. SLEEPER*

REG. U.S. PAT. OFF.

FM

ON THE TOP
OF
MT. WASHINGTON

■
**YANKEE NETWORK
STATION W39B**

using

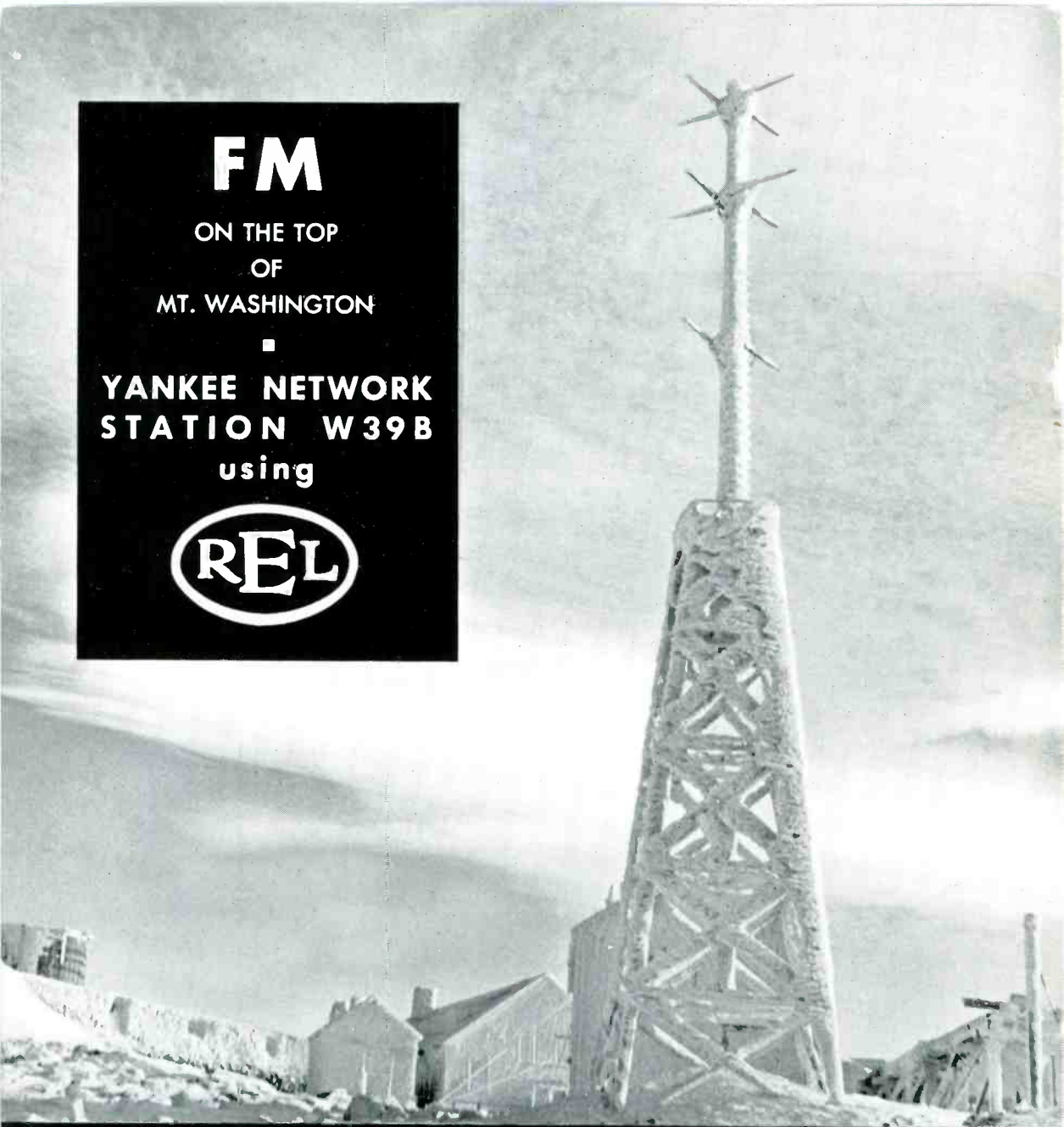

GRUELLING WEATHER CONDITIONS PROVE REL FM TRANSMITTERS ARE DURABLE AND RELIABLE

Despite sub-zero temperature, average 72 mile wintry gales, blizzards, snow, sleet and rain, Yankee Network's Mt. Washington FM station, using a 1 kw REL transmitter,* maintained its remarkable performance record of 16 hours daily throughout the past winter. REL's transmitter met what Dr. C. Brooks of Harvard's observatory describes "as the worst weather in the world", without any impairment,

proving beyond a doubt REL's durability and reliability in FM manufacture.

No wonder, then, the majority of FM broadcasters now in actual operation use REL transmitters. If you want to protect your FM investment, by all means check your FM needs with REL, the pioneer name in FM manufacture, Long Island City, N. Y.

**As soon as weather conditions permit, Yankee's W39B will install a 10 kw REL FM transmitter.*

Interesting Facts about

FM MAGAZINE



2. Who are the readers of *FM MAGAZINE*? This question, of great importance to advertisers, can be answered accurately from the subscription records.

In a few words, *FM MAGAZINE* is read by the "Management Group" in the radio broadcasting and communications fields.

This is no accident! Indeed, every article in *FM MAGAZINE* is used (1) because it contains news of specific interest to the men who comprise this Management Group, (2) because it presents information of direct usefulness to them, or (3) because it answers questions they are asking.

Who are the men in the radio Management Group? They are the executives and engineers of companies which manufacture home receivers, broadcast station and communications equipment, component parts, or associated equipment.

They are the broadcast and radio communications executives and engineers at AT & T, Bell Laboratories, and at the associated companies.

They are the executives and engineers of the standard AM broadcast stations, the FM broadcast stations, and the television stations.

They are the officials of the FCC and other Government departments concerned with radio, and the officers and civilian engineers of the U. S. Army and Navy.

They are the radio engineers and technicians of state, county, and municipal police departments, and of the public utilities.

They are the buyers, technicians, and service managers of the radio distributing companies, the department and chain stores, and the large retail radio and phonograph shops.

These, the radio Management Group, are the readers of *FM MAGAZINE*.

M. B. SLEEPER, *Editor and Publisher*

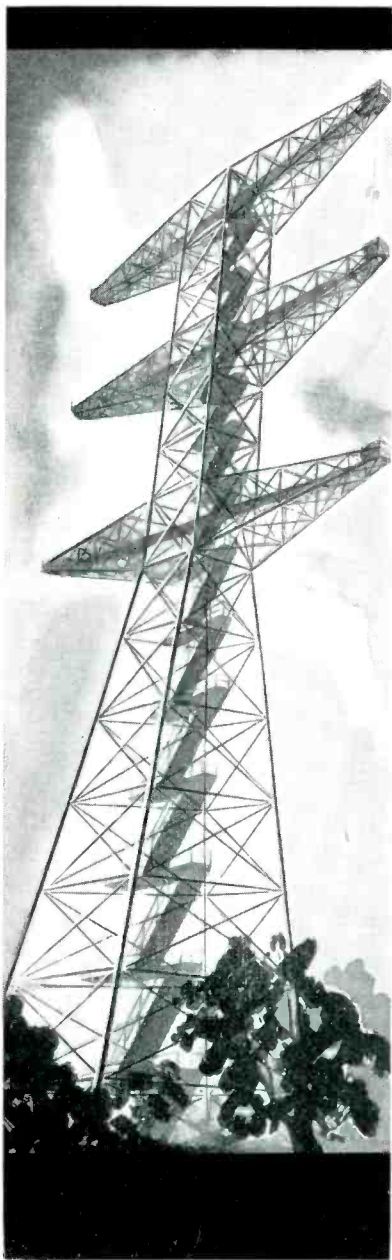

Write for literature and engineering bulletins describing CENTRALAB FM applications for Fixed Resistors . . . Ceramic CAPACITORS, and Ceramic TRIMMER Capacitors.

For

FM

specify

Centralab

Fixed Resistors

Ceramic Capacitors

Ceramic Trimmer Capacitors

FM and other ultra-high frequency bands demand ultra-precision parts not affected by the vagaries of these fickle frequencies. Because CENTRALAB Ceramic Capacitors, Ceramic Trimmer Capacitors and Ceramic Fixed Condensers maintain CONSTANT characteristics under ALL sorts of unusual operating conditions they are ideally suited for FM and other high frequency circuits. The CENTRALAB heritage of unflinching performance so typical of all of the products bearing this famous name is also true NOW that FM has placed new and more stringent demands upon it.

For every FM use . . . specify CENTRALAB.

Centralab

Div. of Globe-Union, Inc.

900 E. Keefe Ave., Milwaukee, Wis.

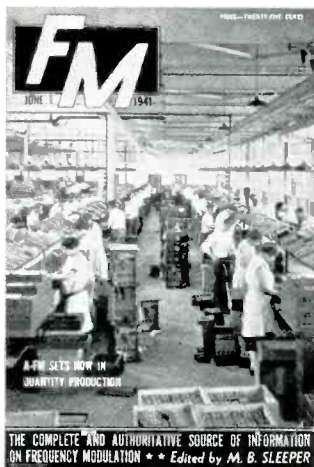

A-FM PRODUCTION

AS each new FM broadcast station goes on the air, a new market is created for A-FM receivers, and further impetus is given to the swing from one-way sets to those which include FM tuning.

This month's cover shows one of the assembly bays at the Stromberg-Carlson factory where their A-FM models are assembled.

Stromberg production of A-FM receivers and phonograph combinations is hard-pressed to keep up with a constantly increasing volume of orders. Their new advertising campaign, explaining the advantages of FM and featuring Stromberg tone quality, is proving highly effective at a time when, in recent years, most radio manufacturers have been inclined to limit their sales promotion to portables.

With priority headaches worrying the radio manufacturers, Frequency Modulation may prove a boon to those who are licensed for the use of FM circuits.

An expensive A-FM set requires little more of the scarce materials than a cheap midget. Therefore, if numerical production is cut, the FM licensees will undoubtedly put their sales pressure on the higher-priced A-FM models in order to maintain dollar volume of business.

By fall, when dealers turn from refrigerators and sporting goods to radio again, additional FM stations will afford practically a national market for A-FM receivers.



THE COMPLETE AND AUTHORITATIVE SOURCE OF INFORMATION ON FREQUENCY MODULATION

VOL. 1 JUNE, 1941 NO. 8

COPYRIGHT 1941 M. B. SLEEPER

CONTENTS

AIRCRAFT BATTERY MAY REVISE PORTABLES	5
ILL-ADVISED FCC RULES <i>by M. B. Sleeper</i>	7
OFFICE BUILDING FM STUDIO	8
WHAT THE BROADCASTERS HAVE TO SAY <i>by J. R. Poppele</i>	12
NEW REL TRANSMITTERS <i>by Frank A. Gunther</i>	13
THE MANUFACTURERS SAY: <i>A Statement by G. V. Rokeye</i>	22
2-WAY LINK FM EQUIPMENT DATA <i>by Frederick T. Budelman</i>	24
FM HANDBOOK <i>by G. H. Browning</i>	29
FM SPOT NEWS	32
NEWS PICTURE <i>Western Electric FM Transmitters</i>	33
MEASUREMENT OF H.F. IMPEDANCES	34
COMMERCIAL FM STATIONS	41

THE COVER DESIGN AND CONTENTS OF FM MAGAZINE ARE FULLY PROTECTED BY U. S. COPYRIGHTS, AND MUST NOT BE REPRODUCED IN ANY MANNER OR IN ANY FORM WITHOUT WRITTEN PERMISSION

★ ★ ★ ★ ★

M. B. SLEEPER, *Editor and Publisher*

Published by: FM COMPANY

Editorial and Advertising Office:

41 Washington Street, Newton, Mass. Tel. Lasell 0808

FM Magazine is issued on the 20th of each month. Single copies 25¢ — Yearly subscription in the U.S.A. and foreign countries \$3.00. Subscriptions should be sent to FM Company, 41 Washington St., Newton, Mass.

The publishers will be pleased to receive articles, particularly those well illustrated with photos and drawings, concerning all phases of FM developments. Manuscripts should be sent to the publication office, at Newton, Mass. Contributions will be neither acknowledged nor returned unless accompanied by adequate postage, packing, and directions, nor will FM Magazine be responsible for their safe handling in its office or in transit.

Advertising correspondence, copy, and cuts should be addressed to the advertising office at Newton, Mass.

Aircraft Type Battery May Revise

PORTABLE RADIO DESIGNS

G.E. Uses Up-Side-Down Storage Battery to Cut Weight and Operating Cost

BY WAY of returning the many services that radio has performed for aviation, the airplane now contributes to radio the up-side-down storage battery which was originally developed for aircraft use.

The resultant saving of weight and operating cost may bring about a general revision in the design of portable radio receivers, except in the very low-priced brackets.

Operating Cost ★ Figs. 2 and 3 show the new type of portable developed by General Electric Company at their Bridgeport, Conn., plant. In the rear view, the back plate of the storage battery compartment has been removed, and the battery moved out so that it can be seen more clearly.

Using this new power supply system, operating cost has been cut to the vanishing point. It amounts to approximately 2½ cents per 100 hours of use, as compared to \$1.50 per 100 hours for operation from A and B batteries.

Thus the list price of \$39.50 is, in effect, less than sets selling at a considerably lower, original price.

Power Supply System ★ In the space ordinarily occupied by dry cells, the G.E. set has a metal box, also serving as a shield, which contains:

1. Up-side-down storage battery
2. Vibrator type B voltage supply
3. Copper oxide charging rectifier

This unit can be seen in Fig. 2. Note that a flexible fabric tube fits over the vent of the storage battery, and runs to a small hole in the side of the case. This is to carry off fumes from the battery.

On the panel of the set, the battery switch provides the following adjustments:

1. All power circuits are open, and the set is switched off completely.
2. The set operates from the battery, as would be the case when the set is used out doors, or is not plugged into the AC line.
3. With the set plugged into the AC line, the circuits operate from the battery, but a trickle charge flows into the battery sufficient to bring the battery up to full charge, slowly, if it is down.
4. In this position, the battery is charged from the AC line, but the radio circuits are switched off.
5. The battery can be charged by connecting it to a 6-volt automobile battery. Terminals

for this purpose are located just above the rectifier disc, on the left hand side of the battery compartment, Fig. 2. A cable plugs into the dash-board light of the car. The vibrator B supply, which is readily replaceable, has a life of 1,000 to 1,500 hours or more.

Up-Side-Down Battery ★ The storage battery in this set is a 2-volt Willard No. 20-2 type. The transparent case is of Polystyrene, a molded material which combines resistance to acid with great mechanical strength. Actually, there is no danger of damage to the battery, for it is much more rugged than the radio set.

Fig. 2 shows the wide space between the electrolyte and the top of the case. The free liquid amounts to hardly more than a tablespoonful, and the vent extends down from the top of the case a considerable distance. Consequently, there is no possible way for the liquid to get into the vent hole. This battery may be described as being thoroughly house-broken!

A 90-day blanket guarantee is given on this battery. In addition, there is an 18-month warranty which provides for a pro rata allowance, within 18 months, toward the cost of a new battery.

FIG. 2. REAR VIEW, WITH BATTERY COMPARTMENT COVER REMOVED. NOTE ARRANGEMENT OF RECTIFIERS, BATTERY, AND B VIBRATOR



FIG. 4. CURVE SHOWING VOLTAGE DROP OF THE STORAGE BATTERY. VOLTAGE CAN BE CONSIDERED CONSTANT OVER 18 HOURS OF USE. THUS SENSITIVITY VARIES LESS THAN WHEN DRY BATTERIES ARE USED

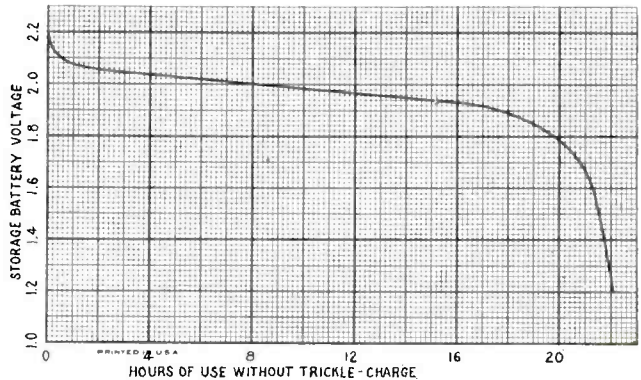

Battery Drain ★ Fig. 4 shows the discharge curve of the battery over a period of 22 hours. When the battery has been charged fully, the voltage drops quickly to 2.1 volts, and for the following 18 hours, drops only to 1.9 volts. This furnishes much more stable operation than can be obtained from dry cells and, thereby, keeps the radio circuits at maximum efficiency at all times.

This overcomes the complaint heard of dry-cell sets that the sensitivity falls off considerably after a new set of batteries have been used for a few days.

In summer camps, if no AC is available, there is certain to be an automobile at hand. In that case, the radio battery can be plugged into the car, using a special cord, provided as an accessory, which has a limiting resistor built into it. The charging rate in that case is 1.4 amps.

Although the specified AC voltage is 110

FIG. 3. FRONT VIEW. RAISING COVER BRINGS ANTENNA INTO OPERATING POSITION

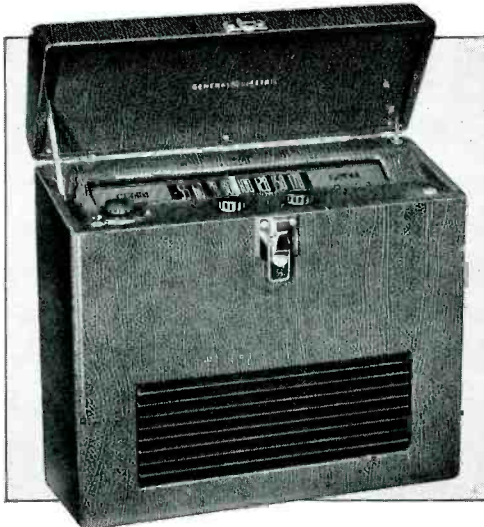

to 125, this set will operate and maintain the battery at 105 volts.

Antenna ★ Because of the steel plate which closes the battery compartment at the rear of the set, it was not practical to locate the loop antenna on the back of the case.

This made necessary a different antenna arrangement which resulted in a considerable increase in efficiency.

In this set, the antenna is fastened inside the hinged top. Thus, it is entirely clear of the metal parts on the chassis, giving a Q for the loop of well over 100, and a sensitivity of 20 to 40 microvolts per meter at 50 milliwatts output. Expressed in terms of practical operation, the loop arrangement in this set gives greater pick-up and higher signal-to-noise ratio than could be obtained from a similar chassis, operating on batteries, with the loop on the back of the case.

Specifications ★ Following are the specifications for the G.E. model LB-530 portable:

Dimensions ★ Height 13 ins.; width 13 ins.; depth 4¾ ins. Weight, with battery, 16 pounds.

Electrical Rating ★ Charging from an AC line, 110-125 volts, 50-60 cycles—6 watts

110-125 volts, 25-60 cycles—10 watts

Charging from a storage battery, using the LM-1 charging cable, 6.3 volts DC—1.4 amps.

Receiver power consumption, 2.1 volts DC—1.3 amps. or 2.7 watts

Tuning Range ★ This set has one tuning band, covering 550 to 1,750 kc.

Power Output ★ The maximum power output is 225 milliwatts

Tubes ★ Tubes used in this set are
 1A7GT Converter-oscillator
 1N5GT 1st IF amplifier
 1N5GT 2nd IF amplifier
 1H5GT Detector and 1st audio
 1Q5GT Power output

(CONTINUED ON PAGE 43)

Reorganization of FCC May Result from ILL-ADVISED NETWORK RULES

BY M. B. SLEEPER

THERE are, undoubtedly, certain aspects of network operations which call for revision. The whole art of broadcasting has undergone a great change in the last few years, and it is quite possible that the business end of network activities has not kept pace with technical advancement.

Essentially, however, our American system must be right, for it is furnishing the citizens of this Country the finest service available anywhere in the world.

No government owned and operated system in other countries can compare with it in public service. Experience over a period of years has shown conclusively that such programs as some individuals think listeners should have do not meet the requirements of public interest, convenience, and necessity as those which are gauged by audience surveys.

The status of American broadcasting has been achieved under a competitive system which requires that programs be acceptable to the public to the extent that the broadcasting of those programs shows a profit in terms of advertising effectiveness.

Actually, the revenue from sponsored time is sufficient to cover the cost of thousands of station-hours from which no revenue is derived.

Without this support, stations would have to give up some of the best music now available to listeners. They could not devote countless hours to the interests of the Army and Navy, the Treasury Department, and many government agencies now asking for, and receiving, free time.

Now, our American system of broadcasting is more than a public service. It is more than an essential part of our national economy. It is a vital element of our national safety and defense.

In planning any revision of the present set-up, not merely the first, but all three of these factors must be considered! Any change that does not take this into account is a disservice to public interest, convenience, and necessity, and must be greeted with sharp and immediate protest.

The manner in which the Federal Communications Commissioners have acted shows these men to be ungrounded in the principles of conducting business for profit—because they forgot to consider the advertisers whose money pays the bills for American broadcasting to the extent of some \$90,000,000 annually.

Expenses of such magnitude may not seem important to lawyers, reformers, and disciplinarians, but no business man in his right mind would fail to give consideration to the source of revenue required to meet such tremendous obligations.

But the Commissioners, in formulating the new regulations, gave no thought to their effect upon the relations between stations and the advertisers.

The fact is that the Commissioners have introduced new complications into the business of selling time. The effect of the regulations is to engender uncertainty, doubt, and lack of confidence, on the part of advertisers. Thus, in their way of correcting one set of conditions, the Commissioners may well find that they have created a new situation different, but worse, than that now prevailing.

If advertisers do not want what, under the new regulations, the broadcasters are able to give them, they are free to turn to other mediums of advertising. The sponsors who have been paying the bills for broadcasting are not responsible to the Commissioners. They are not *obliged* to use radio for sales promotion purposes. Magazines, newspapers, and billboards are available to them.

The men at the FCC can regulate and discipline the broadcasting stations until the cows come home, but when these men start to antagonize the advertisers, the Commissioners will find that they are only shadow-boxing.

No. Regulation and discipline, the Commissioners should be shown, are not an end in themselves. When the exercise of authority fails to foster trust and confidence, those to whom it is delegated cease to be useful in public office.

Commissioners Case and Craven ★ In fairness to Commissioners Norman S. Case and T. A. M. Craven, it should be pointed out that these two men recognized the dangers of the course taken by the other five members.

These two commissioners, in a minority report, dissented vigorously. (CONTINUED ON PAGE 38)

Basic Plan for an

OFFICE BUILDING FM STUDIO

Suggestions for Arrangement Suitable for a Metropolitan Station

WHAT facilities and equipment are essential to an FM broadcasting station, aside from the transmitter and the antenna? This question is being asked from time to time by individuals and organizations interested, but not experienced, in the business of broadcasting.

This is a broad question, the answers to which will probably vary considerably with each person to whom it is addressed. Indeed, standard AM stations range from accommodations for one small studio and a control room which provides space for a turntable and record racks, up to elaborate and beautiful buildings which cost hundreds of thousands of dollars.

However, as a starting point from which to cut down or build up, the layout shown in Fig. 3 may prove highly useful.

This plan, suggested by R.C.A., is suitable for an office building location where:

1. The transmitter is located in the tower of the building, if it is sufficiently high.
2. The transmitter is located at the top of a high building nearby, so that the studio can be connected to the transmitter by wires.
3. The transmitter is several miles distant, so that a studio-to-transmitter radio link is required.

In the latter case, the link transmitter and antenna would be installed on the roof of the building where the studio is located.

The facilities provided for in this plan are quite complete. There are accommodations for the management and commercial staff, the program department, announcers and chief engineer, and for a shop and equipment storage.

Then, in a compact group, centered around the control room, there are the large and small studios, an audition room, and a client's booth and viewing room, both with sound-proof windows opening upon the larger studio.

Loudspeakers, 6 and 7 in the plan, connected to the control room, can be cut in so that programs from either studio or from an outside source, can be heard at any point. Also, transcriptions played in the control room can be piped around to these speakers.

Studio A has two program microphones, 1, and an announcer's microphone, 2. In addition, there is a loudspeaker, 5, from which the control room operator can talk to those in the studio during rehearsals, by using microphone 4, at the right of his chair. Studio B has one program and one announcer's microphone.

The plan of the control room is highly compact and convenient. All the operating controls are located in the console, 10, between the double windows opening onto both studios.

At the left is microphone 3, for making announcements on the air, and the studio talk-back microphone, 4, at the right. A monitor speaker, 7, enables the operator to hear, at all times, how the program is going out on the air.

There are two turntables, 11, for playing transcriptions, and transcription storage racks, 13, where recordings are kept ready for use.

Control Console ★ Heart of the entire sound system is the console, 11, illustrated in Figs. 1 and 2. This operates in conjunction with the amplifier rack 9, details of which are shown in Figs. 4 and 5. These units comprise the R.C.A. 78-B1 studio equipment.



FIG. 1. ALL THE STUDIO EQUIPMENT CONTROLS ARE LOCALIZED IN THIS CONTROL ROOM CONSOLE. THE ASSOCIATED AMPLIFIERS AND RELAYS ARE MOUNTED IN A SEPARATE RACK

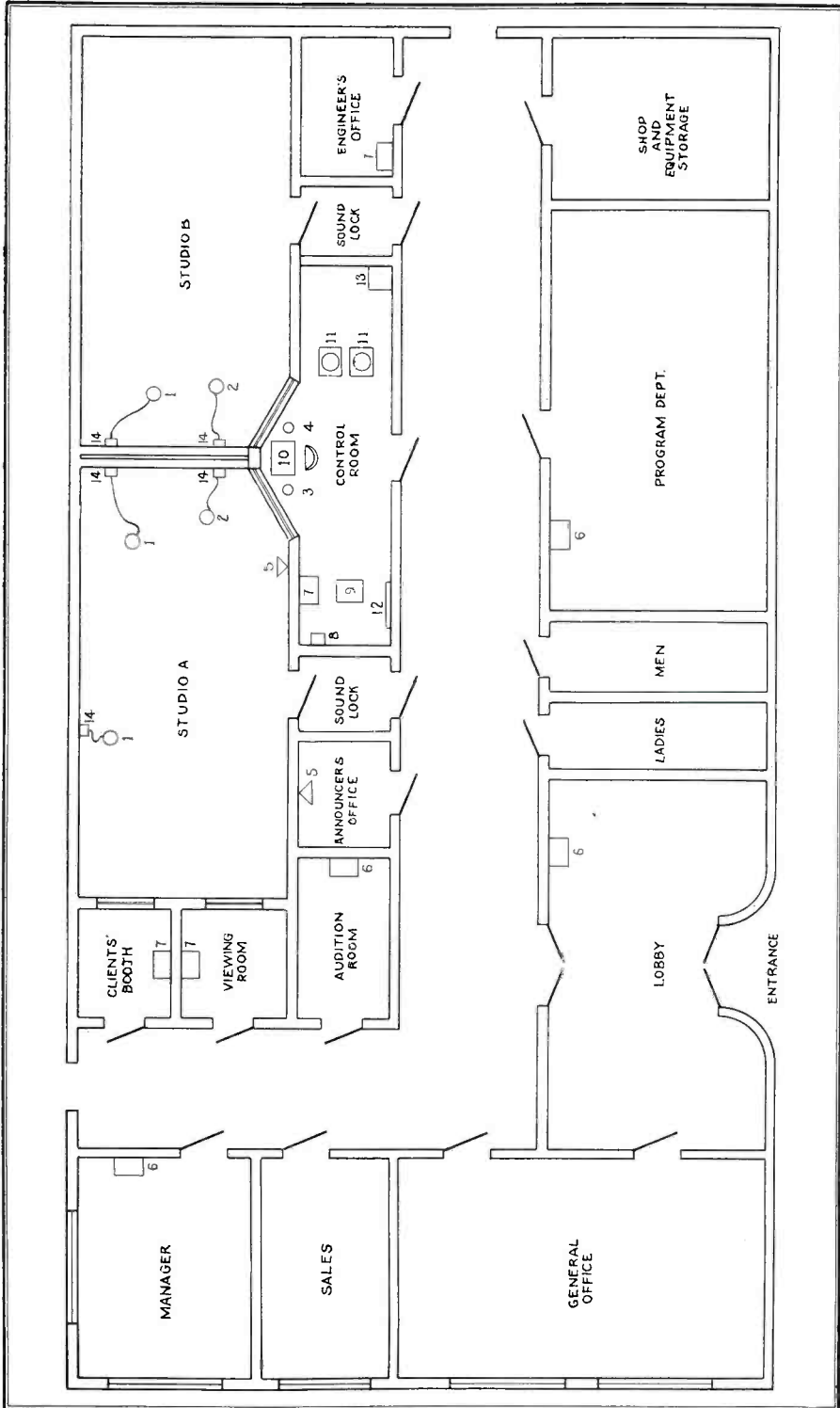

FIG. 3. BROADCAST OFFICES AND STUDIOS. 1, Studio program microphones — 2, Studio announce microphones — 3, Control room announce microphone — 4, Control room talk-back microphone — 5, Studio cue speakers — 6, Audition and office speakers — 7, Monitoring speakers — 8, Rectifier — 9, R.C.A. 7-N-B1 Rack — 10, Console — 11, Turrtables — 12, Telephone terminal box — 13, Record rack — 14, Microphone connectors



FIG. 6. HIGH FIDELITY R.C.A. SPEAKERS FOR BROADCAST STUDIO MONITORING PURPOSES

An account of the various functions performed by the console gives a general picture of the manner in which the studio is operated.

Six microphones can be handled at the console, by means of the three pairs of switches on the upper left hand plate. The microphones can be divided equally between the two studios, or between the studios and the control booth. In the up position, for example, these key switches would connect the microphones in studio A, or in the down position, those in studio B.

These three microphone keys are connected to three independent amplifiers, mounted in the rack 9. Thus, three microphones can be used simultaneously for any separate or combined purposes.

Of the six mixer controls across the lower front section of the console, three are to regulate the three microphone circuits.

The fourth mixer controls the input from the transcription pick-ups, either one of which can be selected by a 2-position switch. This arrangement, with a separate transcription mixer, makes it possible to use the turntables for the radio program while, at the same time, the three microphone channels are used for rehearsals or auditioning.

Another mixer, with a 2-position switch, controls either of two lines coming into the studio from outside. These might be for bringing in network programs or for picking up programs originating at remote points.

At the extreme right is a master gain control, through which all circuits must pass if they are to be fed into the program amplifier and on to the radio transmitter. The volume indicating meter, at the center of the console, shows the volume level at the output of the program amplifier and, therefore, the level at which program signals are fed to the transmitter.

Since the operator must listen at all times to his own program through the monitoring speaker, 7, a gain control for the monitoring amplifier is required. This is located at the right of the meter. Other monitoring speakers are also connected to this special amplifier.

If speakers are provided in both studios, the operator's talk-back microphone, 4, can be connected to either one, by means of a 2-posi-

FIG. 2. VIEW OF THE CONSOLE WITH THE FRONT PANEL RAISED FOR INSPECTION. ALL PARTS ARE MARKED CLEARLY AND ARE DESIGNED FOR QUICK REPLACEMENT IN CASE OF ANY FAILURE

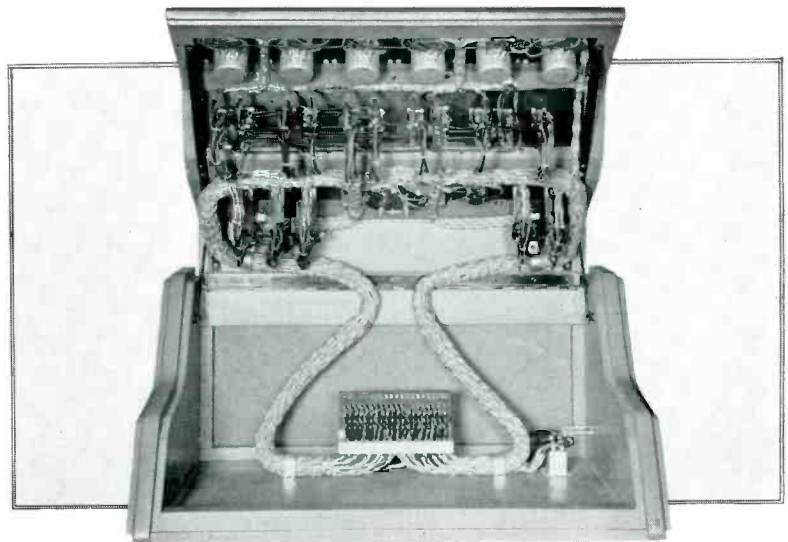

tion switch. However, circuit provisions are made so that, if the studio microphones are set up for a program, the operator is automatically prevented from cutting in on that studio. Otherwise, his voice from the speaker δ might get into the studio microphones, and so out on the air.

When the studio talk-back microphone or the booth microphone for making announcements is in use, the monitoring speaker, 7, in the control room, is automatically cut out. If that were not done, the feed-back from the speaker to the booth microphone would set up a shrill howl.

Amplifier Rack ★ Three amplifier panels, with their respective power supplies, are mounted on the rack shown in Figs. 4 and 5. These are the 3-channel pre-amplifier, the program amplifier, and the monitoring amplifier which oper-

FIG. 5. HERE ARE THREE AMPLIFIERS AND THE NECESSARY RELAYS

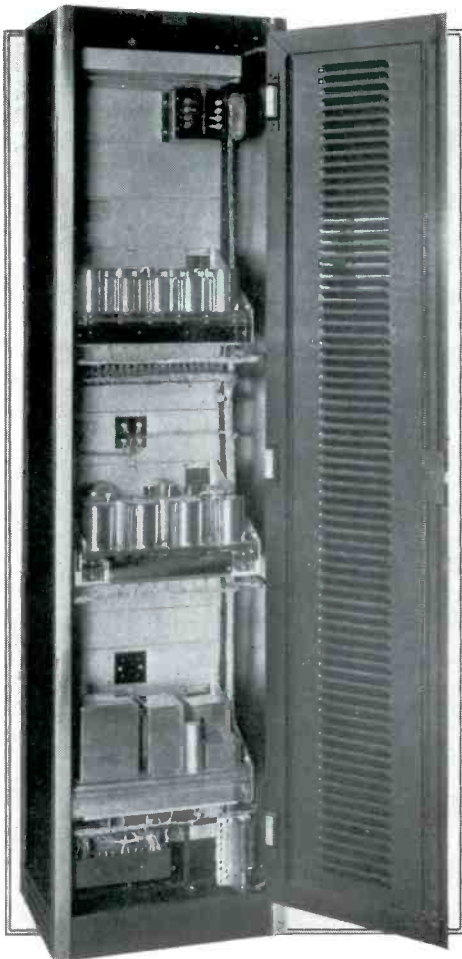

FIG. 4. EXTERIOR OF THE AMPLIFIER RACK

ates the speakers at various points in the studio. This unit also carries the relays which perform various automatic functions, chiefly to prevent interference between different parts of the equipment and circuits.

Direct current to operate the relays is furnished by a separate relay rectifier, 8, which is mounted on the wall of the control room. This is required because all the studio equipment is designed to use alternating current.

FM Audio Requirements ★ The requirements as to audio fidelity are much higher for studio equipment used in FM stations than in standard AM broadcasting stations.

For that reason, apparatus was selected for discussion here which is intended for FM station use, although it is also used in AM studios.

WHAT THE FM BROADCASTERS HAVE TO SAY:

A Statement Concerning W71NY,
by J. R. Poppele, Chief Engineer,
Bamberger Broadcasting
Service, Inc., New
York City

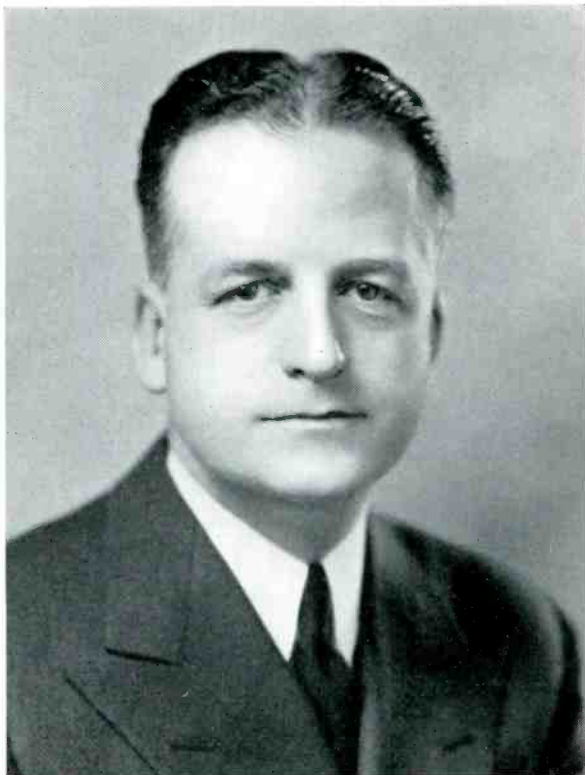

THE operation of an FM station, with its many technical and programming problems, constitutes a new and exciting adventure in broadcasting. FM is a shiny horizon that has opened up at a time when we were all beginning to believe that there weren't many promising frontiers left in the business of radio as we knew it. Television, facsimile, it is true, were new developments. But their path appears to be a thorny one.

Now, in the space of a year, we find FM has magically arrived. We find that it answers so many of the problems confronting modern broadcasters. We find that the public likes FM. And, most of all, we find that FM has the power to revitalize this industry with new talent, engineering ability, and improved service to the listener.

Here at WOR we have watched with lively interest the growth of frequency modulation. It was this interest that impelled us to install an experimental FM transmitter in February, 1940, many months before FM received its commercial go-ahead. We did this because we had faith in FM, like many other pioneer broadcasters throughout the nation. Today that experimental station, W2XOR, has grown to become W71NY, New York's first commercial FM outlet. It operates on a full-time schedule that is 95% different in program material from its parent station, WOR.

The commercial aspects of FM are today

limited. We have sold several programs, but are reconciled to the fact that it will be a number of years before we realize any substantial returns from our investment. But *there will be returns*. We are so confident of this fact that we have ordered a 10,000-watt Western Electric installation to be on the air by about the middle of this summer.

We are encouraged by the brisk sale of A-FM combination receivers around New York City, where some 10,000 sets are already in use. We find a mounting interest on the part of advertisers who, in many cases, are waiting only for further growth of the listening audience before buying air time. It is up to W71NY and its fellow FM stations to give their best in programming so that this audience may increase. Then, with the beginning of substantial revenue, we must make that programming service even better.

FM, as we view it today at W71NY, is an unparalleled opportunity to serve the public better with a finer product. And only by doing so, in our eyes, shall we be able to fulfill that fundamental tenet of broadcasting—to operate freely and intelligently, dispensing education and entertainment in the "public interest, convenience and necessity."

NEW REL TRANSMITTERS

Five Transmitters, Comprising Coordinated Units and New Modulator, for 250 w. to 50 kw. Make up DL Line

BY FRANK A. GUNTHER*

THE first commercial FM transmitter produced was manufactured by Radio Engineering Laboratories, and was installed at station W2XAG, Yonkers, N. Y., in 1935. It is still performing satisfactorily after six years of operation.

Since that time, REL has built and installed ten complete FM broadcasting stations, of 1 to 50 kw., all of which are in daily service. Notable among these installations is the 50-kw. station at Paxton, Mass.,¹ and the 1-kw. transmitter atop Mt. Washington, N. H.² The latter, incidentally, will be replaced with a 10-kw. equipment as soon as the roads up the Mountain are open.

From the knowledge thus gained through experience, REL has now completed the development and design of an entirely new group of FM transmitters, known as the DL line, which will supersede current models.

* Vice President in Charge of Engineering, Radio Engineering Laboratories, Long Island City, N. Y.

¹ Gateway to Finer Entertainment, by Paul A. de Mars, FM Magazine, Nov. 1940, and W1XOJ Exceeds Expectations, by Paul A. de Mars, FM Magazine, March, 1941.

² More FM Service for New England, by A. F. Sise, FM Magazine, April, 1941.

FIG. 2. THE TYPE 558 MODULATOR PANEL SWINGS OUT OF ITS STEEL CABINET

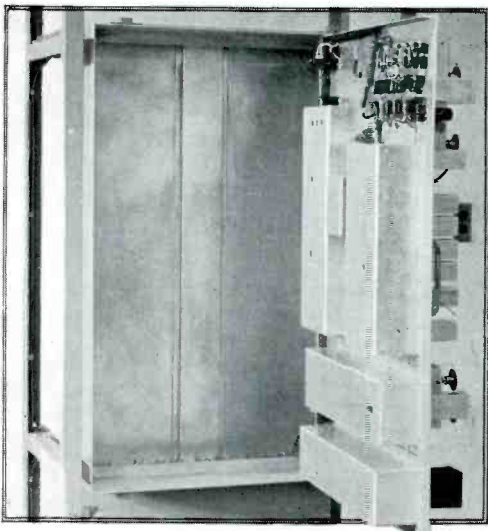

No. 558 Modulator ★ The new designs incorporate an improved version of the Armstrong phase-shift method of modulation. This unit, type 558, is built directly into the transmitter cabinets, and is not furnished as a separate unit. However, it is arranged so as to be readily accessible for adjustment and maintenance, as will be seen from Figs. 1 and 2.

This modulator is built into the rear of the 250-w. and the 1-kw. basic transmitters, so that any of these units can be used as drivers for amplifiers of higher power.

Access to the modulator unit is provided through a door at the rear of the transmitter.

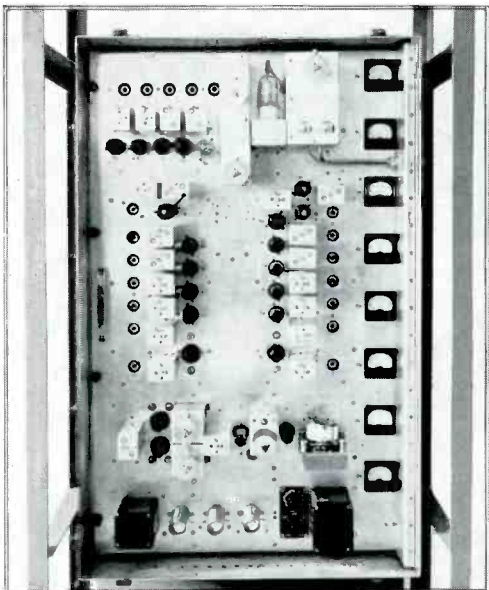

FIG. 1. IMPORTANT NEW DEVELOPMENTS ARE NOW AVAILABLE IN THE PHASE-SHIFT MODULATOR TYPE 558, SHOWN ABOVE

When the door is opened, all tubes and tuned circuits are exposed, Fig. 1. Then, in turn, the complete modulator unit can be swung out, if it is necessary to get at the rear, Fig. 2.

The audio line from the studio enters the cabinet at the bottom portion, and the RF output passes through two concentric lines at the top right. This single, compact unit con-

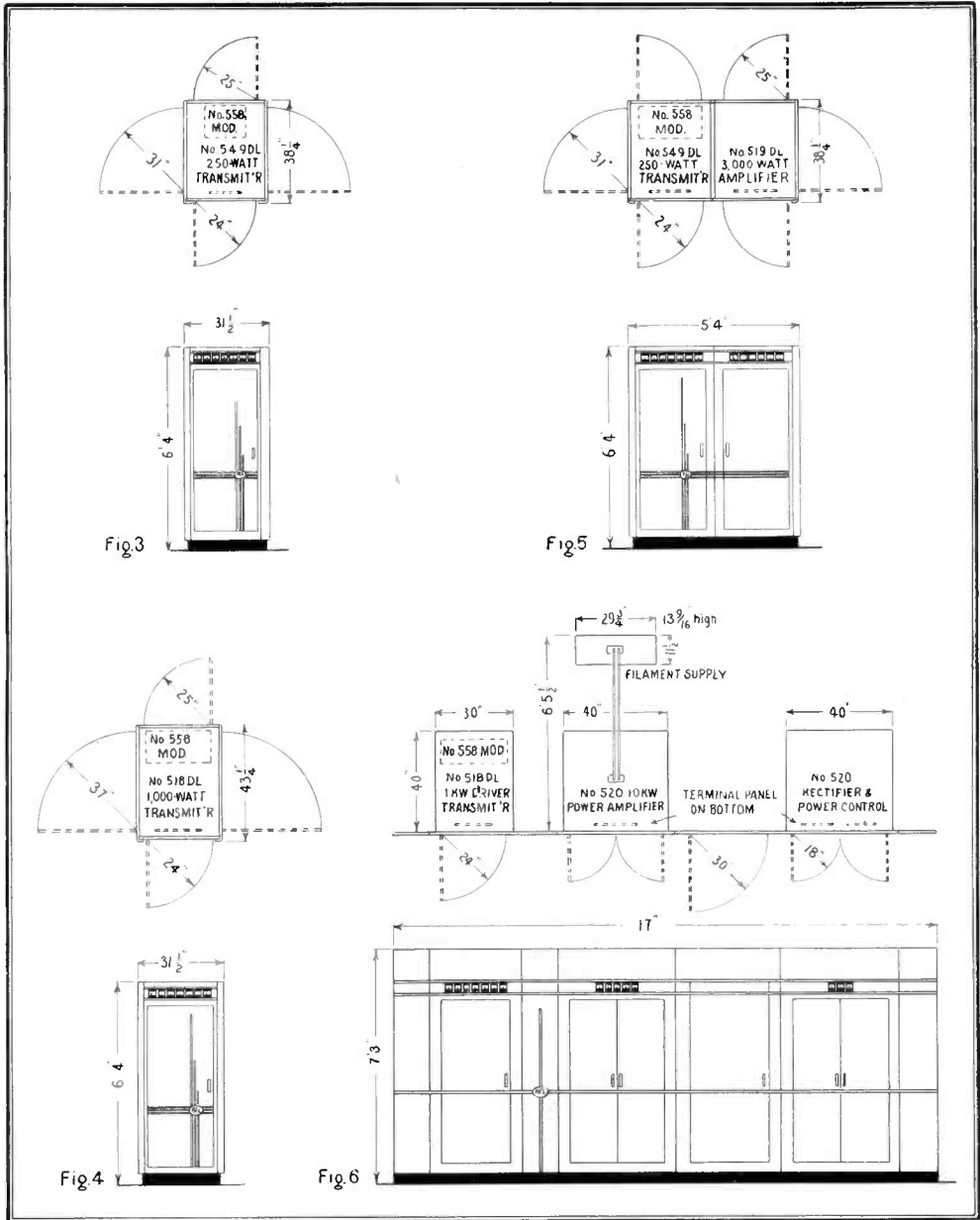

FIG. 3. TYPE 549DL 250-W. TRANSMITTER—FIG. 4. TYPE 518DL 1-KW. TRANSMITTER—FIG. 5. THE 549DL IS USED AS A DRIVER FOR THE 3-KW. AMPLIFIER—FIG. 6. THE 518DL DRIVES THE 10-KW. AMPLIFIER. SEPARATE FILAMENT SUPPLY AND RECTIFIER ARE ADDED

tains the entire modulator and multiplier, which has an output of 20 watts at the operating frequency.

Power Ratings ★ The DL line comprises transmitters of the following ratings:

- No. 549DL—100 to 250 watts
- 518DL—250 to 1,000 watts
- 519DL—1,000 to 3,000 watts
- 520DL—3,000 to 10,000 watts
- 521DL—12,500 to 50,000 watts

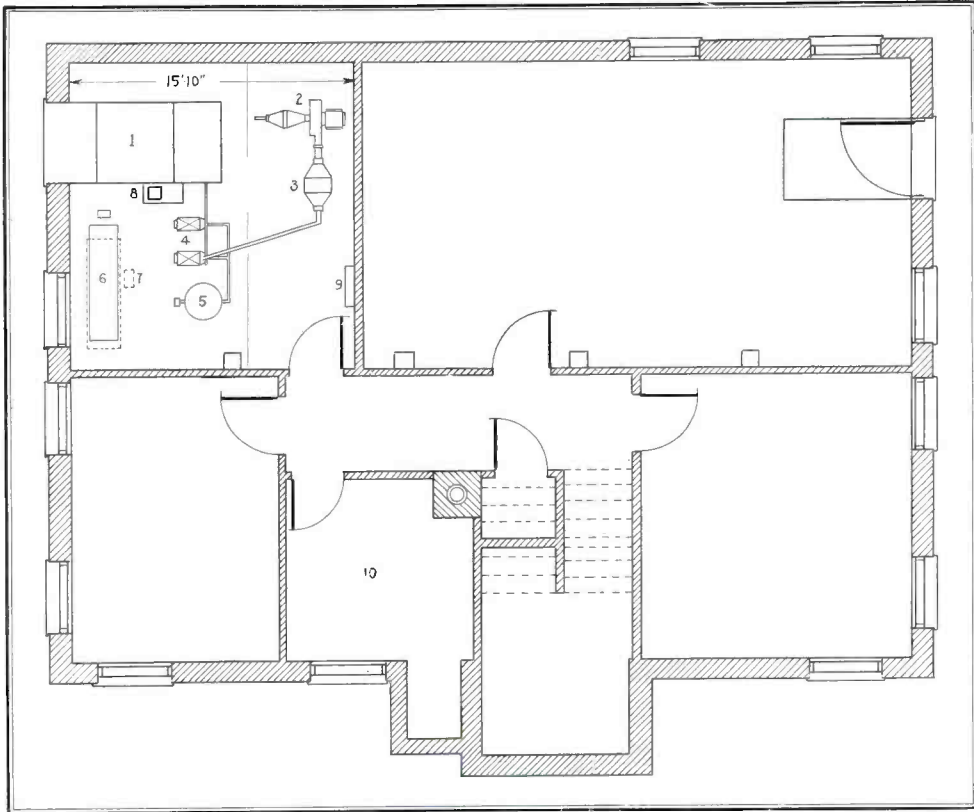

FIG. 7. PLAN OF THE BASEMENT OF W55M'S FM TRANSMITTER BUILDING. THIS SHOWS THE ARRANGEMENT OF THE COOLING EQUIPMENT, REQUIRED BECAUSE OF THE HEAT GENERATED BY THE HIGH-POWER TRANSMITTING TUBES. BOILER ROOM IS MARKED 10 ON THE PLAN

The 250-w. transmitter can be used as a driver for the 3-kw. amplifier, and this, in turn, is planned to drive the 50-kw. amplifier. In the same manner, the 1-kw. transmitter is intended for use as a driver for the 10-kw. amplifier.

The general overall characteristics of these transmitters are:

Operating Frequency ★ Available to operate on any predetermined frequency from 40 to 50 mc. The exact frequency must be specified when the order is placed.

Frequency Stability ★ These transmitters are guaranteed to maintain their frequency within less than 200 cycles of the assigned frequency. The frequency is directly controlled by a single crystal employing a multiplication of only 72 times from the crystal to the operating frequency.

Fidelity ★ The overall response is within plus or minus 1 db from 30 to 15,000 cycles.

Distortion ★ The measured r.m.s. harmonic dis-

ortion is less than 1% for all signal frequencies between 50 and 15,000 cycles at ± 75 kc. swing.

Noise Level ★ The signal-to-noise ratio is 70 db, measured at the output of a monitor receiver. This is an unweighted measurement, with 150 kc. maximum swing, and includes hum.

Input ★ The audio input to the transmitters is zero level, 500 ohms, 6 milliwatts.

Finish ★ All metal cabinets are finished in two-tone grey, with chrome trim.

250-Watt FM Transmitter ★ An outline drawing, to show overall dimensions, is given in Fig. 3. This is the complete unit, including the built-in ventilating system and air filters. The 558 modulator is mounted at the rear. The output of the modulator drives the final amplifier, a pair of HK-257 tubes. A step type of regulator controls the plate voltage to the final amplifier, by means of which the power output can be adjusted from 100 to 250 w.

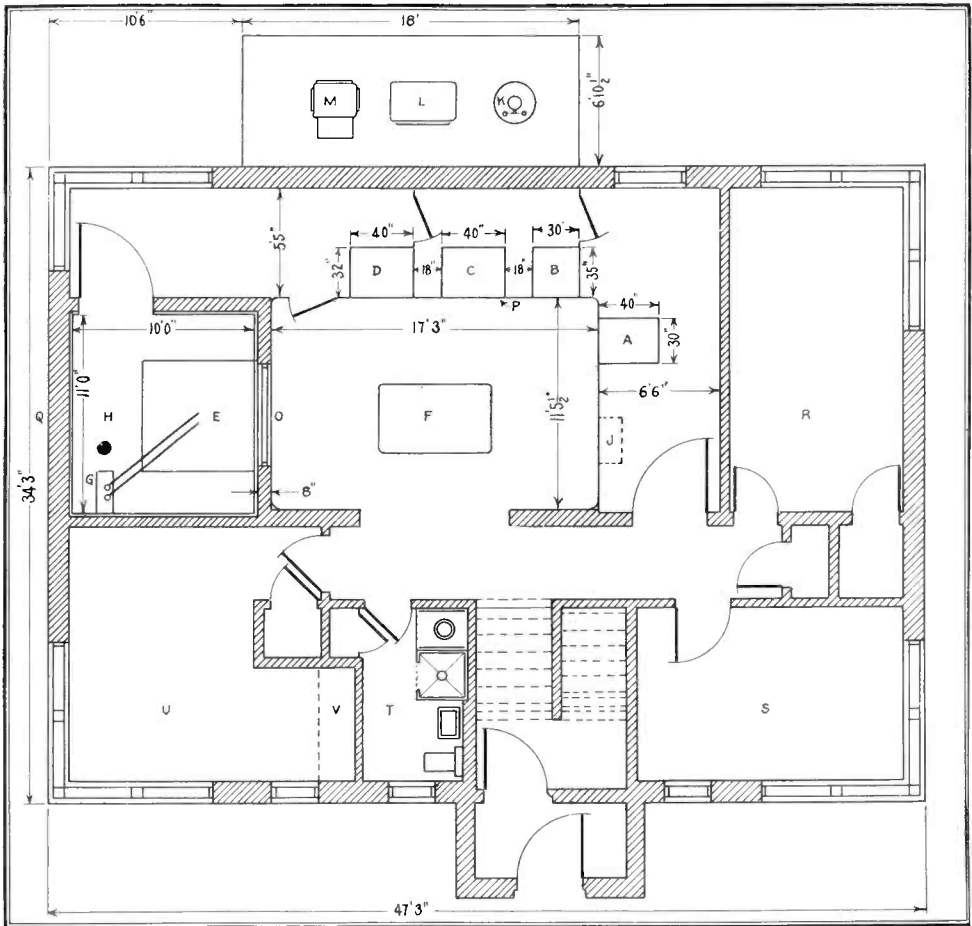

FIG. 8. GROUND FLOOR PLAN OF TRANSMITTER BUILDING AT W55M, ACCOMMODATING RADIO EQUIPMENT AS WELL AS PROVIDING QUARTERS FOR OPERATING CREW. POWER CONTROLS ARE MOUNTED ON REAR OUT-DOOR PLATFORM. TRANSMITTER UNITS ARE GROUPED AROUND CONTROL DESK F. AMPLE SPACE IS ALLOWED FOR WORKSHOP R, AND SPEECH EQUIPMENT ROOM S

Primary power requirements are 205 to 230 volts, 60 cycles, single-phase at 1,200 w. for maximum output.

The output connection from the transmitter is designed to operate into a single 7/8-in. concentric line at 72 ohms.

1,000-Watt FM Transmitter ★ This is also a completely self-contained unit, including the ventilating system and air filters, of dimensions given in Fig. 4. It is the same in width as the 250-w. unit, but slightly deeper. The 558 modulator, mounted at the rear, drives a pair of HK257 tubes as an intermediate amplifier. These, in turn, drive the final amplifier, with two Eimac 304TL tubes. Power output can be adjusted from 250 to 1,000 w. by means of a

step type regulator controlling the voltage to the final amplifier.

Primary power requirements are 205 to 230 volts, 60 cycles, single phase at 3,200 w. for maximum output.

The output connection from the transmitter is designed to operate into a single 7/8-in. concentric line at 72 ohms.

3,000-Watt FM Transmitter ★ This equipment is contained in two cabinets with a common front panel, as shown in Fig. 5. Interconnections are made above the floor, thus eliminating any need for wiring under the floor.

At the left is the 250-w. transmitter, No. 549DL, with the 3-kw. final amplifier at the right. The final amplifier employs two Eimac

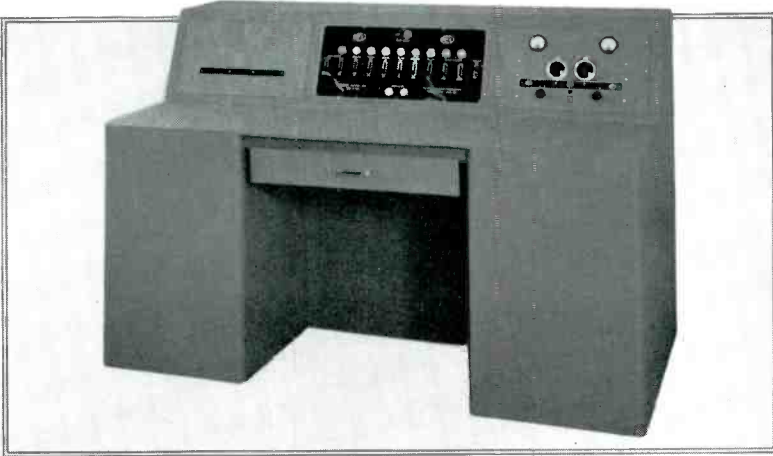

FIG. 13. FM CONTROL CONSOLE LOCALIZES ALL THE TRANSMITTER CONTROLS AND MONITORING EQUIPMENT FOR CHECKING AUDIO, MODULATION, AND FREQUENCY

type 1500T tubes which use lines in the plate circuit. Output is adjustable from 1 to 3 kw. by means of a step type regulator which controls the plate voltage to the final amplifier.

Primary power requirements are 205 to 230 volts, 60 cycles, 3-phase at 7.5 kw. for maximum output.

Output connections from the transmitter are designed to operate into two $\frac{1}{8}$ -in. concentric lines at 72 ohms.

10,000-Watt FM Transmitter No. 520DL ★ Three units, mounted with a common front panel, comprise the 10-kw. transmitter, as shown in Fig.

6. When the transmitter room is planned, it should be arranged so that the ceiling will be furred down to the top of the transmitter panel. Similarly, the side walls should be built out to meet this panel.

The three units comprise the 518DL 1-kw. transmitter with the 558 modulator, a 10-kw. power amplifier, and the rectifier and power control. In addition, there is a filament supply unit, located directly behind the power amplifier. Fig. 14 shows the 10 kw. amplifier.

Forced air cooling is provided for the two 889R's in the power amplifier. The intake to



FIG. 9. THIS ARRANGEMENT AT PAXTON, MASS. IS SIMILAR TO W55M LAYOUT, SHOWN IN FIG. 7

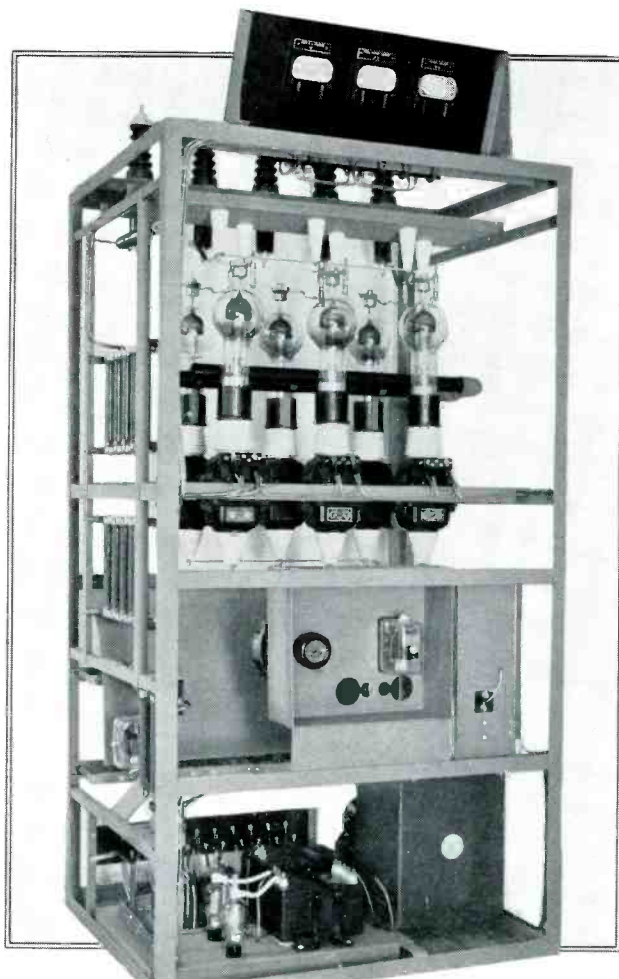

FIG. 10. THE 15,000-VOLT RECTIFIER, SUPPLYING THE 50-KW. AMPLIFIER. THIS UNIT IS MARKED C IN THE FLOOR PLAN, FIG. 8

this cooling system should be connected by a duct either to the outside of the building or to an existing air-conditioning system. In either case, the ambient temperature at the air intake must not exceed 45° C. at any time. Since considerable heat is dissipated in cooling these tubes, a means for exhausting the air in the transmitter room must be provided.

This involves installing an exhaust ventilator capable of moving approximately 2,000 cubic feet per minute.

The 889R tubes are mounted on the top of the tubular plate lines, through which air is forced for cooling purposes. These tubular plate lines also serve as the plate tank circuit.

This transmitter is so designed that, in case of failure in the power amplifier, the 1-kw. driver can be connected directly to the an-

tenna. Thus, the driver alone can be used as an emergency transmitter.

By means of a step type voltage regulator, controlling the plate voltage of the final amplifier, the power output can be varied from 3 to 10 kw.

The primary power requirements are 205 to 230 volts, 60 cycles, 3-phase, at 24 kw. for maximum output.

The output connections from the transmitter are designed to operate into two 1½-in. concentric lines at 72 ohms.

50,000-Watt FM Transmitter No. 521DL ★ The 50-kw. transmitter is comprised of several separate units. If a new transmitter building is being constructed, these units can be used as the nucleus around which to plan the structure.

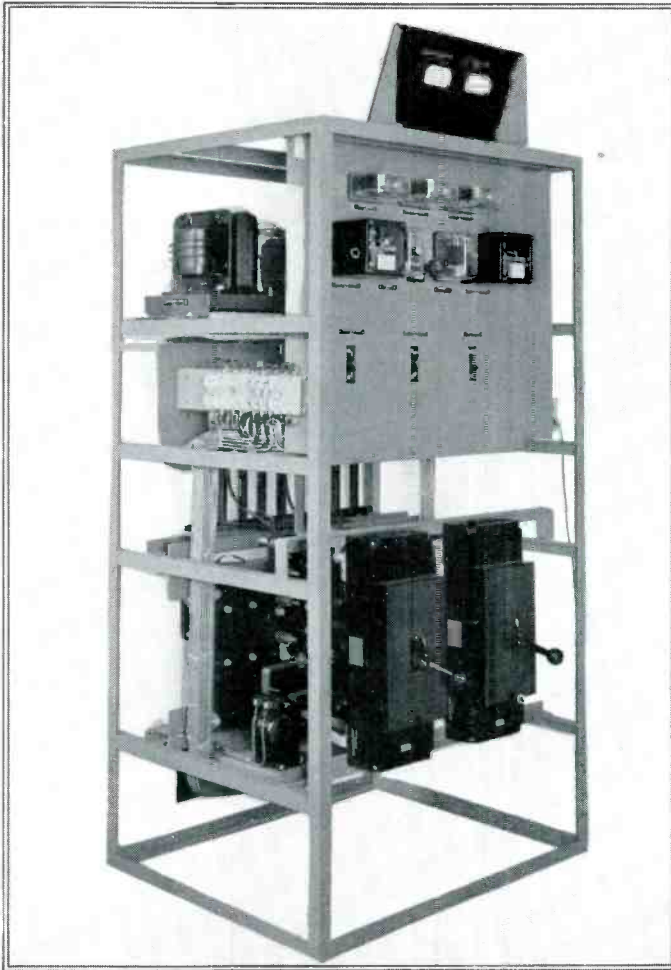

FIG. 11. POWER CONTROL AND RELAY RACK FOR THE 50-KW. FM TRANSMITTER. THIS UNIT IS MARKED D IN THE FLOOR PLAN, FIG. 8

On the other hand, this unit design has great advantages when the equipment must be fitted into an existing structure.

A typical installation is the Yankee Network station at Paxton. This was the first 50-kw. FM transmitter ever built.

Another mountain-top installation is The Milwaukee Journal's station W55M, at Richfield, Wis.³ Floor plans of this station are shown in Figs. 7 and 8.

In the basement of this structure, besides the heating plant and other appurtenances required for the maintenance of the building, there is housed the rotating machinery required for the operation of the transmitter. By

³ FM Featured in \$500,000 Plant, FM Magazine, February, 1941; and photographs of construction, page 37, FM Magazine, April, 1941.

referring to Figs. 7 and 9, it will be noted that this apparatus is located in a room 16 ft., 2 ins. by 15 ft., 10 ins. It includes the following items:

- 1—Evaporative cooler, provided with fresh air intake and discharge ducts connected to the outside.
- 2—Pressure blower necessary for the cooling of the 50-kw. tube seals.
- 3—Air cooler installed in the power blower discharge line. This utilizes circulating cold water for reducing the temperature of the air supplied to the seals of the tubes.
- 4—Water circulating pumps. Two are provided, one of which is a spare.
- 5—100-gallon copper water storage tank.
- 6—Motor generator used to supply DC to the

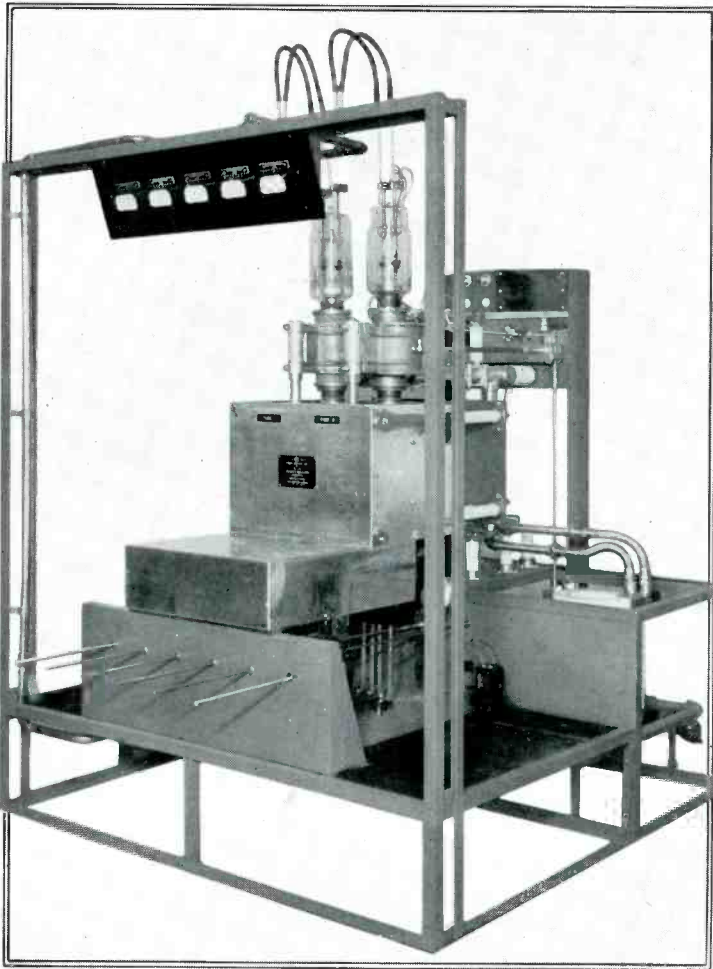

FIG. 12. THE 50-KW AMPLIFIER. SIX SHAFTS AT THE FRONT EXTEND THROUGH THE WALL OF THE AMPLIFIER ROOM H, SHOWN IN THE FLOOR PLAN FIG. 8

filaments of the two 899A power amplifier tubes.

- 7—Motor generator wiring connection box.
- 8—Spray pump used in connection with the evaporative cooler.
- 9—Sub-control panel which houses the various motor starters and other associated equipment required for operating this rotating machinery.

The first floor includes space for the various activities of the operating personnel:

- R—Workshop.
- S—Shielded speech equipment room.
- T—Wash room.
- U—Operators' quarters.
- V—Kitchenette.

Units of the transmitter are arranged as follows:

- A—250-w. basic transmitter, No. 549DL.
- B—3-kw. intermediate amplifier, No. 519DL.
- C—15,000-volt rectifier, shown in Fig. 10.
- D—Power control rack, containing circuit-breakers, relays, and overload protective devices, Fig. 11.
- F—Centralized operator's desk, from which position full control of the entire transmitter is obtained. The audio, frequency, and modulation monitors are incorporated in this desk. This is shown in Fig. 13.
- E—50-kw. power amplifier stage, Fig. 12.
- G—Filament cabinet.
- H—Copper-shielded room for the 50-kw. amplifier.
- J—Proposed location for a spare modulator or 250-w. basic driver.
- O—Double glass window providing a full view

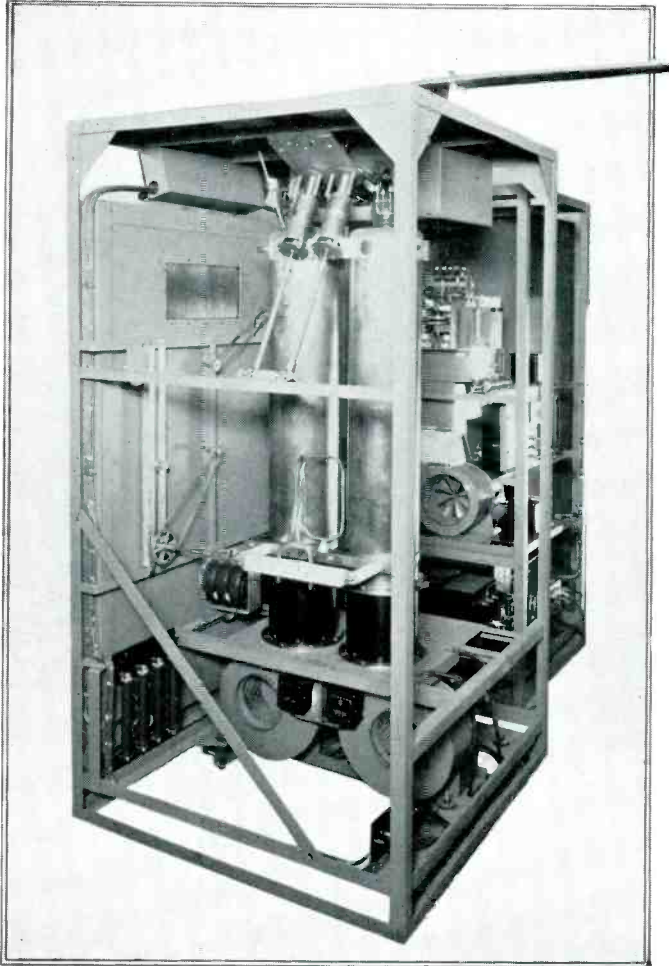

FIG. 14. THE 10-KW. AMPLIFIER WITH THE SIDE PLATES REMOVED. THE 1-KW. DRIVER CAN BE SEEN BEHIND THE AMPLIFIER ASSEMBLY. DIMENSIONS ARE GIVEN IN FIG. 6

of the power amplifier. Fig. 12 shows 6 shafts which project through the wall at O. These are centralized controls for adjusting all the variable tuning circuits.

Q—Two $3\frac{1}{8}$ -in. concentric transmission lines enter room H at Q. They feed the output of the final stage to the phasing and matching unit at the base of the antenna tower.

A sheet metal enclosure forms three walls of the room where the operator's desk is located, and serves as a front panel for the transmitter units. This enclosure, 7 ft., 3 ins. high, is finished in two-tone grey and chromium.

At the rear of the building is the out-door equipment, mounted on a concrete slab, and surrounded by a chain-link fence. It includes:

K—Filter reactor.

L—High-voltage plate transformer.

M—Motor-driven voltage regulator.

The high-voltage leads from K and L are carried through the wall of the building in high-voltage insulators, to the rectifier unit C. The low-voltage lines from L and M run under ground to the power control rack D.

By means of the motor-driven regulator, the plate voltage on the final amplifier can be adjusted to vary the power output from 12.5 to 50 kw.

Under actual test, a similar installation, at Paxton, Mass., an output of 57 kw. was attained with two Westinghouse 899A tubes in the final stage.

In case of failure in the final output stage,

(CONTINUED ON PAGE 45)



G. V. ROCKEY

BOSS MAN AT MEISSNER PLANT, PRODUCING A COMPLETE LINE OF PARTS, ALSO BUILDS THESE PARTS INTO NEW EQUIPMENT, IN STEP WITH TECHNICAL PROGRESS

THE MANUFACTURERS SAY:

A Statement by G. V. Rockey, Vice-President and General Sales Manager, Meissner Manufacturing Co., Mt. Carmel, Ill.

YES, we believe in the future of FM! Just a little over a year ago, the Meissner Manufacturing Company produced its first frequency modulation receivers. Today, we are in production on four models, with three others receiving finishing touches in the laboratory.

In a very few words—that is what we, at Meissner, think of the present and near future of FM!

It is difficult for us to conceive of any of the better combinations being sold this year without having frequency modulation incorporated as an integral part of the radio receivers, regardless of whether there is an FM station in the customer's immediate vicinity or not. Certainly, a customer's investment of a hundred dollars or more should be protected by including the FM band which, in the next two years, will become more and more important.

The dealers who are preaching this policy are accomplishing two things—a nice step-up in sales volume—and the assurance of a satisfied customer, both now and within six months or a year—or two!

Many dealers, in areas where FM is now available, are doing a real favor for their customers of the past two years who purchased expensive receivers by having representatives call on them with FM converters under their arms. In this way, otherwise impossible prospects can be sold units costing \$40 or more with resultant mutual satisfaction to both the customers and the dealer! It is by exerting this rather obvious—but extra—sales effort that many dealers are making sales grow where none would grow otherwise for at least a year or two.

In addition, through this procedure, the customers are strongly impressed by the dealers' evident concern and effort to enable them to obtain full value from the fine receivers which they purchased a short while ago—and which were so soon in danger of becoming obsolete! Such effort will not go unrewarded when the time comes for those same customers to buy their next, bigger and better, receivers.

As we look at FM—and you must remember that we can sit back and observe from the quiet tranquility of a sleepy little town on the banks of the Wabash—its future remains in the hands of the men on the firing line. These are the men who will SELL Mr. and Mrs. American Public on the fact that there is such a thing as stateless radio reception and that there actually are tones above 3,500 cycles! True, Mr. and Mrs. American Public may have to learn to appreciate and enjoy programs that do not sound like radio (as they knew it before) but in time they will.

If they insist on having more bass, they can always twiddle a knob, but they should at least be exposed to the pleasure of listening to genuine music.

We men in the factories, the engineers in the laboratories, are working night and day to bring to the radio distributors and dealers of America the opportunity to make larger unit sales, greater profit margins, and more satisfied customers than it was ever possible to have before. It has cost the industry millions of dollars in pioneering effort to back the only really forward step in radio since the introduction of the superheterodyne!

The summer season is just ahead—the season of noise and interference. This is the time for dealers to get their feet wet by selling FM converters now, so as to follow up this fall with the larger, more expensive, FM combinations.

Yes, we at Meissner firmly believe in the future of FM. We are investing substantial sums and a majority of our Engineering Department's time in that belief. We can manufacture a satisfactory product—we can present it to the distributors—we can help by national advertising—we can even tell dealers how to sell it—but we can't sell the consumers. That's the job for dealers, and as more and more dealers get the idea of material extra profits for a little additional effort, the future of FM will not only be assured but will become another of the monuments to the enterprise of one of the world's leading scientists—Major E. H. Armstrong!

2-WAY LINK FM EQUIPMENT DATA

Circuit Analysis of 25-UFM Transmitter and 11-UF Receiver, Part 1

BY FREDERICK T. BUDELMAN *

ALTHOUGH the demonstrated success of 2-way FM equipment dates back only to the completion of the F. M. Link system installed for the Connecticut State Police, hardly more than a year ago, the use of 2-way FM installations has increased at a rate that is phenomenal, even in a business that is full of surprises.

As a result, radio engineers and service experts are encountering this kind of equipment in the most unexpected places, and under unusual circumstances.

A great many of the 2-way FM units are going into services connected with National Defense, for use right here in the United States. For obvious reasons, no further details can be given here. It is sufficient to say that a great number of such installations are already in operation, and many more will go into use in the near future.

Public utilities are buying 2-way FM systems not only for emergency maintenance but for patrolling their lines.

New police systems are specifying 2-way FM, and many others, including some of the largest cities, are replacing 1-way AM apparatus at a rate which is only limited by the present rate of making deliveries.

All this activity adds up to the need for information concerning circuits, maintenance, adjustment, and service. To this end, since a very large part of the 2-way FM equipment is the F. M. Link 25-UFM transmitter and 11-UF receiver units, data is offered here which has not been public before.

25-UFM Transmitter Data ★ The 25-UFM transmitter is a 25-watt frequency-modulated unit designed especially for mobile use. Its more salient characteristics may be listed as follows:

Power output—25 watts (nominal).

Frequency range—30–40 mc.

Frequency deviation—±15 kc.

Audio range—300–3000 cycles with high frequency pre-emphasis.

Weight—29 lbs.

Overall size—9 by 17 by 8¼ ins. high.

Power supply—Self-contained dynamotor.

Power input—6.0 v. at 2.25 amps. stand-by, 13.5 watts; 6.0 v. at 23 amps. transmitting, 138 watts.

Output impedance—Any—usually fed into concentric line.

*Chief Engineer, F. M. Link, 125 W. 17 St., New York City.

This transmitter utilizes the phase shift method of obtaining the desired deviation. This permits the use of direct crystal control of the carrier frequency, and a simple circuit design with no critical tuning adjustments. The transmitter is entirely self contained and utilizes a dynamotor to convert the 6-volt input to high voltage for plate supply of the tubes. Eight tubes are included on the chassis, seven of which are of the low drain receiving type. The tube types and their uses are as follows:

1-7C7—Crystal oscillator.

1-7C7—RF amplifier.

2-7A8—Balanced modulators.

1-7C7—Frequency quadrupler (first).

1-7C7—Frequency quadrupler (second).

1-7C5—Frequency doubler.

1-807—Final or power amplifier.

From the above list it is seen that the crystal frequency is multiplied thirty-two times in order to obtain the final operating frequency. Metering jacks are provided in the grid circuit of each stage for convenience in making adjustments. All tuning adjustments are straightforward and small errors in making them will not affect the output frequency, quality, or modulation level in any way.

Transmitter Circuit Analysis ★ Crystal oscillator V1 is a pentode receiving tube 7C7 connected as a triode and operating as a conventional triode crystal oscillator. The crystal in its grid circuit is of the low drift AT-cut type and operates at the 32nd sub-harmonic of the output frequency. Since the output frequency range is 30–40 mc., the crystal frequency will lie between 937.5 kc. and 1250 kc. The plate tank circuit of the crystal oscillator is entirely contained in transformer T1 or T1A. These transformers have been used interchangeably and perform in exactly the same manner. In T1 the electrical centertap of the tank circuit is a capacity centertap, while in T1A it is a coil centertap.

Balanced Modulator ★ T1 also contains the phase shift network R16, C4 which feeds the amplifier V2 (7C7) and the balanced modulators V7 (7A8) and V8 (7A8). The injection grids of these latter tubes are driven from opposite ends of the oscillator tank circuit through coupling condensers C3 and C5. Their grid voltages and plate currents are, therefore, 180

degrees out of phase. The amplifier V2 is driven thru coupling condenser C6 from the junction of R16 and C4. By making R16 equal to the reactance of C4 at the operating frequency, roughly 1100 kc., the voltage applied to the grid of V2 is 90 degrees out of phase with the voltages applied to V7 and V8. The plate current of V2 will likewise be 90 degrees out of phase with the plate currents of V7 and V8. Since the plates of V2, V7 and V8 are connected in parallel into the common tank circuit T2, their plate currents will add. However, the plate currents of V7 and V8 are equal and exactly out of phase and will cancel each other leaving a resultant plate current in T2 from V2 alone.

The control grids of the balanced modulators V7 and V8 are connected to the secondary of the push-pull audio transformer T6. This transformer is driven directly from the microphone and microphone current is taken from the six volt primary source through the filter network R1, C30. C30 is a non-polarized electrolytic condenser so that no reconnection is necessary when the transmitter is changed from a primary source with the positive grounded or vice-versa. The modulator grids are fed through the frequency correcting networks R25, C31 and R26, C33. These RC combinations attenuate the audio frequency range (above 2000 cycles) so that excessive frequency deviation is not obtained. Resistors R30 and R31 are terminating resistors for the secondary of the microphone transformer T6. Cathode bias and screen voltages are obtained in a conventional manner.

As audio voltages are applied in push-pull to the control grids of the modulators V7 and V8, their plate currents are varied about mean values, and as one increases the other decreases. Thus their values no longer cancel in T2 and an out of phase component of varying magnitude and sign is added to the constant plate current of V2. The resultant current in T2 is shifting in phase (and frequency) with the audio frequency fed into the microphone circuit. Some amplitude variations are also introduced, but these may be neglected since they are wiped out by the limiting action of the succeeding stages.

Frequency Multipliers ★ The frequency deviation which may be produced in a balanced modulator such as described above is relatively small, usually not more than a value equal to the modulating frequency without encountering severe distortion. To get sufficient deviation (± 15 kc.) the frequency of the modulated wave must be multiplied considerably, in this case by a factor of 32. This is accomplished by two quadruplers V3 (7C7) and V4 (7C7)

and a doubler V5 (7C5). All three tubes act as "Class C" radio frequency amplifiers with grid leak bias. The grid drive in each case is well above saturation so that slight changes in tuning or reduction in tube emission can have little effect on succeeding stages. Up to this point, all stages use receiving type tubes working at relatively low plate and filament currents.

Power Amplifier ★ The power amplifier V6 utilizes an 807 beam transmitting tube as a Class C amplifier. Grid leak bias is used and, as in the preceding stages, a jack is provided to meter

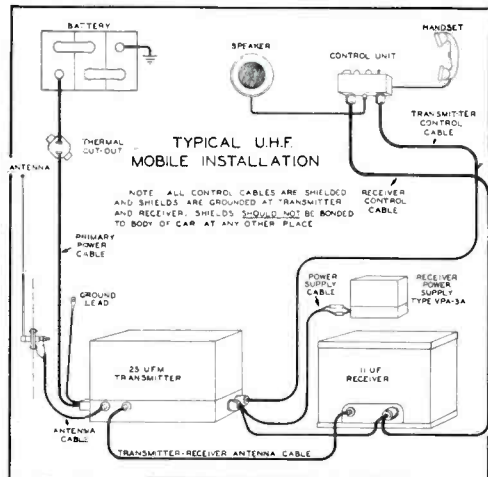

COMPONENTS OF COMPLETE 2-WAY LINK FM EQUIPMENT FOR MOBILE USE

the grid current for alignment and testing. The plate tank and antenna circuit is of the Pi type for harmonic suppression and ease of adjustment. This circuit consists of the plate tuning condenser C40, the tank coil L3, antenna loading condensers C41 and C46. The output is fed through the blocking condenser C44 to the antenna relay RL C.

Control and Power Circuits ★ The 25-UFM transmitter has sufficient relay circuits for complete remote control and in addition is designed to provide all necessary relay and control functions for the 11-UF receiver. The normal operating sequence is as follows:

1. Relay A is energized by applying "hot" 6 volts to contact 3 on the control plug. This is accomplished in the remote control unit by turning on the volume control switch.
2. Relay A energizes transmitter filaments, receiver filaments through contact 5 on the receiver plug, and the receiver power supply

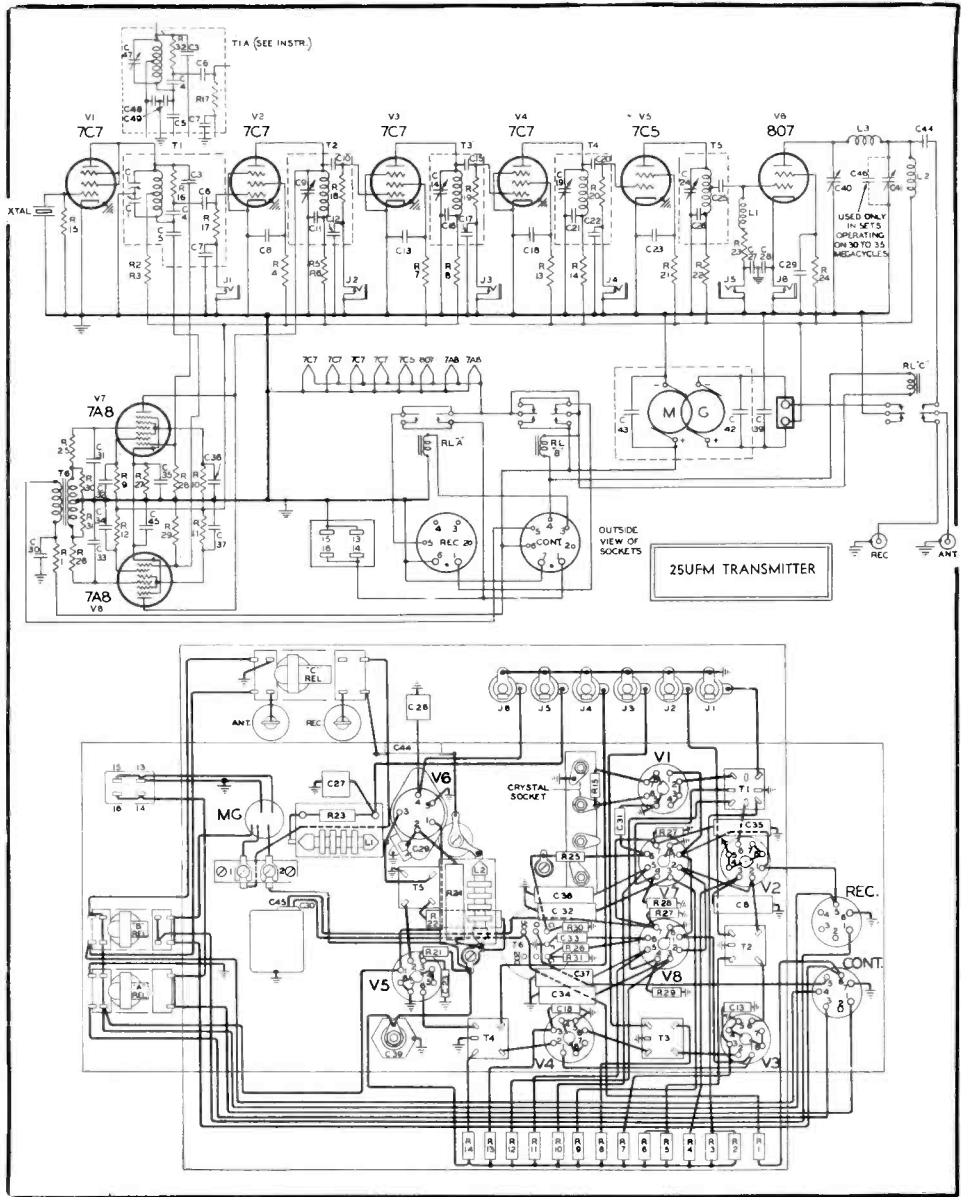

ABOVE, LINK 25-UFM SCHEMATIC, WITH PICTURE WIRING DIAGRAM BELOW

3. In order to transmit, Relays B and C are energized through contact 4 on the control plug and the microphone push-to-talk button.
4. Relay B breaks the receiver power supply voltage, thus muting the receiver. It also applies primary energy to the dynamotor MG which supplies the entire transmitter with high voltage.
5. Relay C transfers the antenna from receiver to transmitter and closes the + B circuit from transmitter dynamotor to the transmitter circuits. This high voltage break is necessary to key the transmitter rapidly

and allow rapid transfer from transmit to receive. The dynamotor MG is hash filtered by condensers C42 and C43. C39 is a high voltage, high capacity condenser to reduce ripple to a satisfactory level.

Tuning the 25-UFM Transmitter ★ When shipped from the factory the 25-UFM transmitter is equipped with the proper tubes and crystal and is tuned correctly to the specified operating frequency. In addition, the approximate positions of the tuning adjustments are marked in red to facilitate tuning. The tuning meter jacks appearing on the front of the chassis are numbered to correspond with the numbers on the tops of RF transformers. Jacks one to five meter grid currents of the respective stages, and jack six is used to meter the cathode current of the final amplifier. For initial tune-up it can be assumed that all the circuits are in proper tune except the P.A. and antenna tuning adjustments. The transmitter is energized by holding down the push-to-talk button on the handset at the remote control unit.

In order to tune the output circuit of the transmitter, disconnect the antenna cable from the transmitter chassis, place the antenna tuning condenser at maximum capacity, and adjust the P.A. tuning condenser for minimum cathode current as metered in jack six. This current should be approximately forty milliamperes. Connect the antenna and re-resonate the P.A. tuning adjustment for minimum current. Now decrease the antenna tuning condenser capacity in small increments, retuning the P.A. tuning each time for minimum current. Continue this process until the P.A. current is one hundred milliamperes on the minimum adjustment of the P.A. tuning. Lock nuts are provided to maintain these adjustments. On the higher frequencies in the band it may be necessary to remove the antenna padding condenser C46 in order to load the P.A. stage to a sufficiently high value. This condenser is located under the antenna tuning condenser C41.

Maintenance of 25-UFM Transmitter ★ Six test meter jacks are located on the front of the transmitter chassis. They afford a complete check-up on the condition of the unit. Those numbered from 1 to 5 read the grid currents of the amplifier, first quadrupler, second quadrupler, doubler, and P.A. respectively. The sixth jack reads the P.A. cathode current and is used to adjust the P.A. plate and antenna loading circuits. A 0-1 DC milliammeter is used to read the currents in jacks 1 through 4, a 0-5 or 0-10 DC milliammeter for jack 5, and a 0-250 DC milliammeter for jack 6. The numbering of the jacks and RF transformers is so coordinated that the meter is plugged into jack one to tune transformer T1, etc.

All tuning adjustments except for the output circuit are made for maximum grid current in each successive stage, and the following table will act as a guide to normal readings. The values given are average at a battery supply voltage of 6.3 volts. Higher or lower voltages will, of course, slightly alter readings.

Jack	Transformer	Circuit	Current
1	T1	7C7 Amplifier Grid	0.1 ma.
2	T2	7C7 1st quadrupler Grid	0.6 ma.
3	T3	7C7 2nd quadrupler Grid	0.8 ma.
4	T4	7C5 Doubler Grid	0.3 ma.
5	T5	807 P.A. Grid	2.5 ma.

A substantial decrease below any of these values will indicate a weak tube, probably in the stage whose plate circuit is being tuned, and that tube should be replaced.

25-UFM Service and Tests ★ Maintenance of the 25-UFM transmitter will consist primarily of routine tube replacements when necessary. All components are operated under conditions which insure long life, and failures have proven rare in field service. Since every stage is metered, nearly all possible conditions will be reflected in the meter readings, and servicing is reduced to simple deduction.

VOLTAGE CHART — 25-UFM TRANSMITTER

Pin No.	V1	V2	V3	V4	V5	V6	V7	V8
	7C7 Csc.	7C7 Amp.	7C7 Quad.	7C7 Quad.	7C5 Doub.	807 P.A.	7A8 Mod.	7A8 Mod.
1	6.0	6.0	6.0	6.0	6.0	6.0	6.0	6.0
2	*250	*250	*300	*280	*225	†125	*250	*250
3	250	100	100	150	160	—	100	100
4	250	0	0	0	0	0	—	—
5	0	0	0	0	0	0	75	75
6	—	—	—	—	—	—	0	0
7	0	0	0	0	0	0	4	4
8	0	0	0	0	0	0	0	0

By comparison with the table of currents given therein, or by comparison with values known from experience to be normal, trouble may be quickly isolated in a particular tube or stage. The procedure already outlined will readily check the condition of all tubes except the 7A8 balanced modulators. These tubes and the entire modulator circuit may likewise be checked by the same meter readings. Referring to the previous description of the balanced modulator, it is seen that if we remove both modulator tubes and retune T2, the amplifier tube T2 will deliver the carrier voltage to the tank circuit T2 in the normal fashion, and the grid current measured in jack 2 should be about normal for that stage. Any variation should be on the high side since removing

* Plate Supply measured at "cold" end of tank coil.
 † This reading is taken with Plate Circuit tuned to resonance. Varies with tube.
 — No readings to be taken on these pins.
 Plate voltage of 807 P.A. should be approximately that read on terminals of dynamotor, 400 V.
 20,000 ohms-per-volt meter used for all readings. Taken between pin and ground.

V7 and V8 causes the plate voltage on that stage to rise somewhat. If either one of the modulators is plugged in and T2 again tuned to resonance, the grid current on the following stage, as measured in jack 2, should rise since the output of that modulator adds vectorally with the output of the amplifier. A normal change would be from 0.8 ma. to 0.9 ma. when one modulator is put in the circuit. Removing the modulator tube and placing the other modulator tube in the other modulator socket should give approximately the same result.

The foregoing test, if normal, indicates several things. First, it shows that the modulator tubes are both in normal condition. Second, it shows that the modulator circuit is balanced. Third, it shows that the phase shifting circuit is functioning normally. If the test does not show a normal reaction, the modulator tubes may be reversed in their sockets or new tubes tried until the trouble is localized in the tubes or circuit.

When both modulator tubes are placed in the circuit and T2 is properly retuned, the current from one modulator should cancel the current from the other modulator and the grid current of the following stage should be the same as it was with neither modulator in the circuit. Actually, it will be slightly lower due to the increased drop in plate voltage caused by the additional drain of the two modulators.

If a loud shout or whistle is directed into the microphone, the current as read at jack 2 should flicker upward when the modulators are working normally. This is caused by the fact that as the modulators are brought into play, some small amplitude changes are present in the modulated output and these register to give a meter flicker. As previously explained, this amplitude modulation is subsequently removed by the limiting action of the succeeding stages.

The condition of the tubes in all the low power stages may readily be observed by the appropriate grid current readings. In the P.A. stage, however, another simple method may be used to detect tube deterioration long before replacement is necessary. Do not rely on tube tester readings to give the full story on whether or not a tube is suitable for service. Tube testers will commonly show a poor tube to be good and vice versa simply because they do not test the tube under its operating conditions in the actual set. The equipment under discussion has been designed to have an ample factor of safety, and tubes need not necessarily be replaced at the first sign of weakening. Many more hundreds of hours of service may still be left in the tubes without causing any drop in performance of the set. Furthermore, it has now been well established that there is no sound reasoning behind replacing a tube merely

because it has served a certain number of hours. In the case of the 807 P.A. stage, tube deterioration can usually be detected long before loss of output is imminent and replacement justified.

This deterioration may be detected by operating the transmitter at normal primary voltage and detuning completely the P. A. tank circuit. The 807 cathode current will normally rise to 125-150 ma. with a new tube. As the tube deteriorates, this off-resonance current will approach closer and closer the on-resonance current of 100 ma. and the dip will accordingly become less. When the off-resonance current becomes so close to the on-resonance current, say 110 ma., that only a slight dip is observable, the RF output will start to decrease and the need of a new 807 is indicated. All these tests assume, of course, that the preceding stages have been checked and found normal.

Changing Frequency ★ In tuning the 25-UFM, each transformer is tuned for maximum current in the like numbered jack. In some cases, however, there may be more than one maximum in the tuning range of the condenser, since the necessary range will permit the quadruplers to tune to other than the fourth harmonic. The transmitter tuning adjustments when made to the original frequency at the factory are marked in red so that no mistake can normally be made in making routine adjustments. When changing to a new frequency, however, care should be taken to insure the proper selections of harmonics.

Transformers T1 and T2 are on the crystal frequency and have only one tuning point. T3 will very often show two tuning points corresponding to the fourth and either the third or fifth harmonics. These may readily be separated by observing the position of the tuning condenser. Some condensers have stops limiting the rotation to 180 degrees. In this case maximum capacity is fully clockwise. Those condensers not equipped with the stops are marked at the maximum capacity point by red lines on the side of the tuning shaft. These marks line up when the condenser is fully meshed. Since the tuning range corresponds to only 30-40 mc., reference to the desired operating frequency will fix approximately the position of the condenser.

A number of small maximum current points can be found on T4 but the proper one will be that one giving the largest peak current when the condenser is near the position judged to be proper.

EDITOR'S NOTE: *Part 2, appearing in the July issue of FM Magazine, will present similar data on the 11-UF receiver and the receiver power supply.*

FM HANDBOOK

Chapter 5: FM Service Instruments and Alignment Procedure

BY GLENN H. BROWNING

THE minimum instrument requirements for servicing FM receivers are as follows:

- (1) A 0 to 1 milliamper DC current meter.
- (2) A center-scale DC microammeter converted into a high-resistance voltmeter by adding a 1-megohm resistor in series with the meter. It is suggested that this microammeter have a sensitivity of 50 microamperes either side of the center zero. A more sensitive meter is preferable but not essential. A good vacuum tube voltmeter which will measure DC can be employed instead of the high-resistance voltmeter. When a VTVM is employed, a switching arrangement will be convenient, for it is necessary to read both positive and negative DC volts at the output of the detection circuit.
- (3) An unmodulated signal generator is essential. Although it would be advantageous to have the signal generator cover the FM band of frequencies, from 42 to 50 mc. on fundamentals, the second harmonic of a signal generator covering from 21 to 25 mc. can be employed satisfactorily in most cases. It is most essential that the signal generator have a considerable band-spread at the intermediate frequency of FM receivers. This varies from 2.1 to 5 mc., according to the manufacturer. The band-spread on the signal generator throughout this range should be such that accurate readings can be made to at least 50 kc. and preferably 25 kc.

The above apparatus is for alignment only. For fault location, a volt-ohm milliammeter which is found in every service laboratory can be employed as well as signal tracers and similar pieces of apparatus, as will be pointed out later. For checking the condition of component parts, a tube checker and a condenser analyzer are almost indispensable.

Alignment of FM Receivers ★ The service man is to be cautioned against changing alignment in FM receivers until he is definitely sure that the poor quality, low gain, or other fault in the receiver is due to alignment. Furthermore, a serviceman should be experienced in FM alignment work before he hangs out his shingle for repairing and aligning FM receivers. Although the alignment procedure is not difficult, a certain amount of understanding based on experience is required. It would be advantageous for service men who wish to specialize in FM serv-

icing to build FM receivers, as this not only gives them a knowledge of alignment procedure but the troubles encountered in building the receiver will bring out many construction details which will be valuable in locating faults. For instance, the location and lead length of various condensers and resistors are critical for high gain without regeneration.

Alignment of FM receivers may be divided into three parts — the IF amplifier, the detection transformer and the RF amplifier. The detection transformer must be aligned after final adjustments have been made on the IF amplifier, consequently the following order is preferred.

Aligning the IF Amplifier ★ With the receiver in an operating condition, a voltage from the signal generator should be fed into the signal grid of the mixer tube. In case the mixer tube is a 6K8, the signal is fed into the top cap, while if a 6SA7 is employed, the signal is fed into terminal 8. The ordinary RF lead to the signal grid can be left connected, but in this case the RF tuning coil is between this grid and ground, which tends to short the IF signal from the signal generator. Thus, in some cases, it may be necessary to remove the connection from the RF coil and connect between the signal grid and chassis a resistor of between 20,000 and 100,000 ohms, and feed the signal from the generator directly to the signal grid. The object of the resistor between the signal grid and ground is to supply the ordinary bias to the signal grid of the tube. The service man should know from the manufacturer's specifications whether the broad-band of the IF amplifier has a single or double-peak characteristic, and the intermediate frequency employed. If the IF curve is of the single-peak variety, the following procedure will result in proper alignment: Connect a 0 to 1 millimeter in series with the grid return of the limiter tube at X as shown in Fig. 1. If two limiters are employed in the receiver, it is advisable to use the tuning meter in the grid return of the second limiter and keep the signal from the generator at as low a value as possible consistent with reading the limiter current meter. Set the unmodulated signal generator, connected as above, at the center IF frequency. Starting with the IF transformer which feeds the grid of the limiter tube, adjust the secondary and primary of each IF transformer in turn for maximum limiter

FM SPOT NEWS

Notes and comments, personal and otherwise, that have to do with FM activities

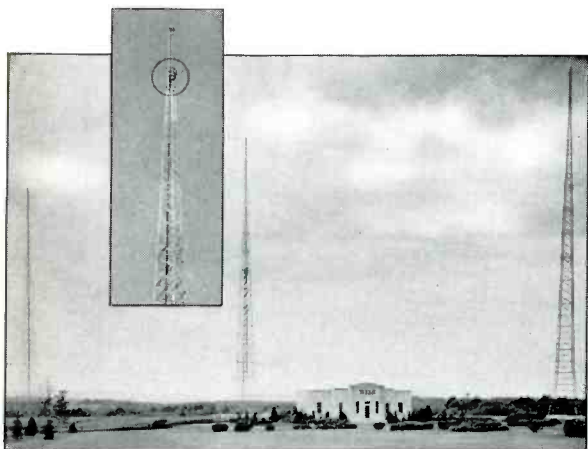

WTAG, WORCESTER, MASS., HAS FM TURNSTILE DI-POLES AT TOP OF CENTER MAST, INDICATED BY CIRCLE IN INSET

WIXTG ★ FM affiliate of WTAG, Worcester, Mass., is the first FM station to rebroadcast BBC news as it is sent out from England at 4:45 P.M., eastern daylight saving time. Oddly enough, Earl Mullin reports that NBC's listening post heard of this in an announcement from GSC. Concluded the English announcer: "We are very flattered, and we hope our American listeners have enjoyed hearing the news through WIXTG."

GORDON GRAY ★ And some of his boys from WSJS, Winston-Salem, took a truck with a mobile AC power plant as far up Mt. Mitchell as they could drive it. Then they ran wires the remaining distance to the summit. At this point, they hooked up a G.E. Translator and audio system, and tuned in W47NV, Nashville, over 350 miles away. Antenna was a simple di-pole.

R.E.L. ★ Just awarded contract for new FM station for New York City's Board of Education. This new equipment will replace the AM set-up which has been used for the public schools.

W51R ★ On May 8th, Stromberg-Carlson's 1-kw. experimental FM station W8XVB became 3-kw. commercial FM station W51R. Featured on inaugural program was Dr. Howard Hanson, composer and Director of the Eastman School of Music, at Rochester, N. Y.

A-FM TELEVISION ★ All receivers for commercial television reception, OK'd to start July 1st, must have AM circuits for video, FM for audio. This combination is required by FCC regulations.

JOHN V. L. HOGAN ★ Filed the 19th FM application for New York City. He plans to replace his experimental transmitter, W2XQR, with a 7-kw. installation capable of covering 8,550 square miles at 48.7 mc.

PROVIDENCE, R. I. ★ The Outlet Company, to speed FCC action on their proposed FM station, has modified their application, reducing area to 4,480 square miles, population to 1,556,495.

FM INTERFERENCE ★ Answer to question about interference between FM police stations on same frequency comes from Ohio, where Connecticut's state police signals sometimes come in strong. As soon as local cars go on the air, distant signals are blocked out.

\$1,500,000 RADIO PLANT ★ Being erected by the International Telephone & Radio Mfg. Company at Newark, N. J. This new factory will produce telephone and radio equipment and selenium rectifiers.

MUSIC TRADES SHOW ★ Interest of music stores in FM receivers is responsible for a larger number of radio exhibitors this year than ever before. Show will be held at Hotel New Yorker, N. Y. C., July 29th to August 1st.

LINK ★ No. 2 state-wide 2-way FM system goes to F. M. Link as Delaware throws out AM equipment to purchase 5 FM main stations and, as a starter, 50 car installations. This installation, like Connecticut's, is really 3-way, as it provides car-to-car communication, also.

PILOT ★ Goes overboard in delivering long-distance FM reception. Models just announced, using new Conqueror chassis, pick up Paxton, Mass., at New York City. Pilot's Conqueror chassis has, in addition to other important innovations, two RF amplifier stages—one tuned and one untuned. Result, extra sensitivity and higher signal-to-noise ratio.

DON LEE ★ FM is getting under way in California at last, as Don Lee pushes construction of mountain-top station near Los Angeles. FCC has given permission to go on the air with reduced power, pending completion of the installation which will cover 6,944 square miles and 2,600,000 population. Frequency is 44.5 mc.

DETROIT ★ FM transmission from The Evening News station W45D started May 19th. Reduced power is being used until 50-kw. REL installation is completed. However, the station is delivering a beautiful signal right now.

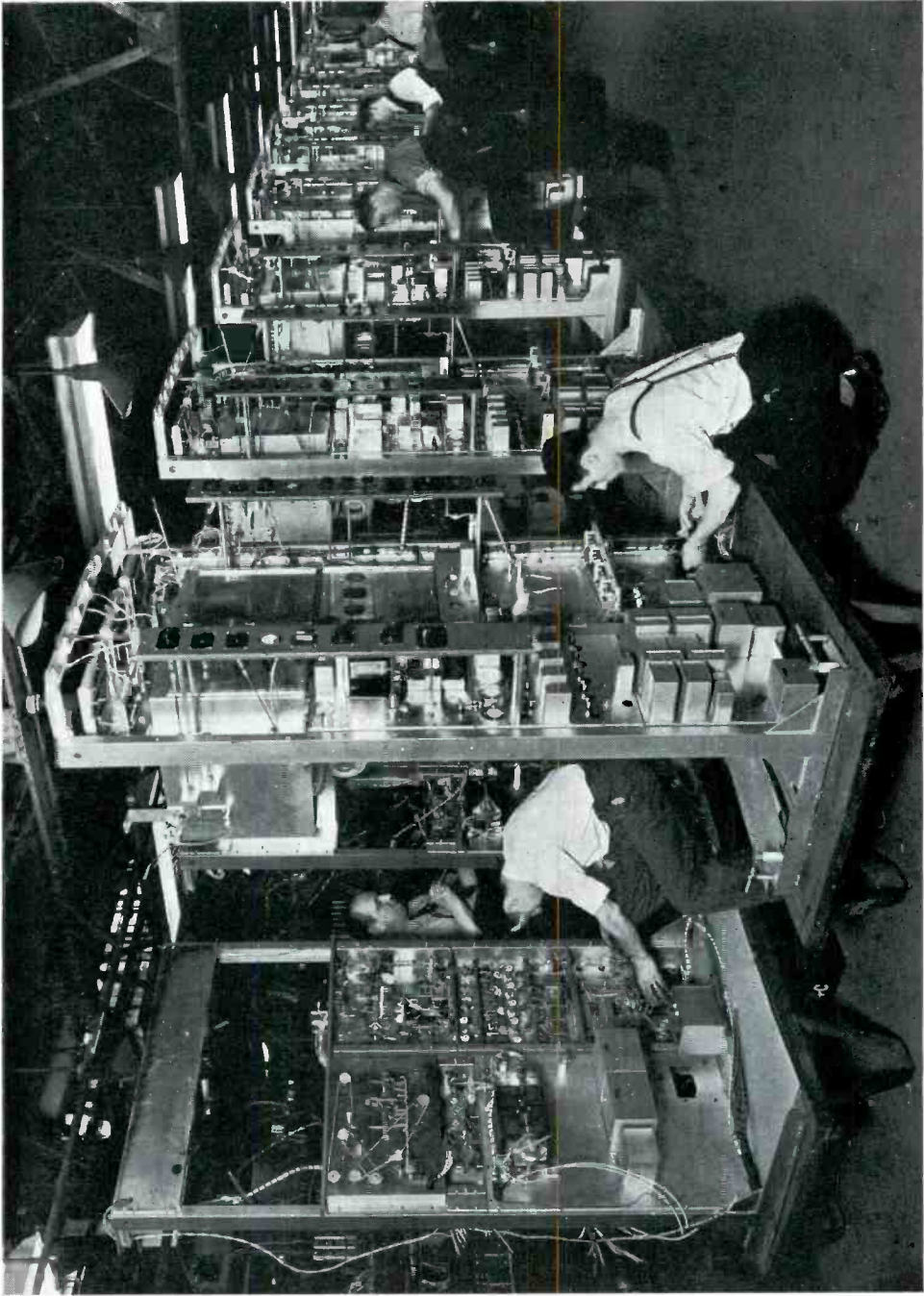

NEWS PICTURE

1-kw. FM Transmitters: This production line of 1-kw. FM transmitters seems to be Western Electric's answer to the question: "Do you expect that FM broadcasting is going to forge ahead during the summer?" These units can be used as transmitters or as drivers for amplifiers up to 50 kw. Probably Western Electric Company knows where they will sell these units. Certainly it is not intended that the engineers should eat them.

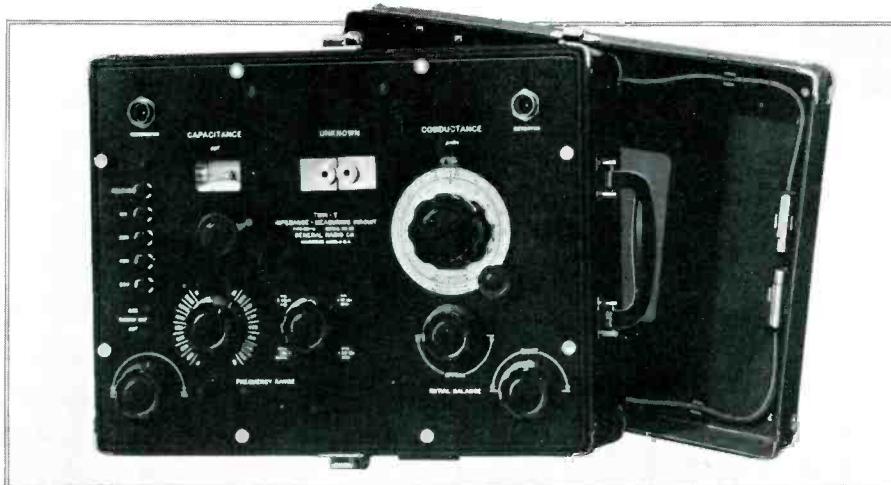

FIG. 2. TWIN-T IMPEDANCE MEASURING CIRCUIT, WITH COVER REMOVED

MEASUREMENT OF H.F. IMPEDANCES

How G. R. Twin-T Circuit Is Used for Measurements at High Frequencies

BY C. E. WORTHEN*

IN order to facilitate and to increase the accuracy of many measurements at high frequencies which are required in radio research and development work, General Radio Company has designed the type 821-A Twin-T measuring circuit. A null instrument for measuring impedance at 460 kc. to 30 mc., it is intended for:

Admittances having small conductive components, such as—

- Small condensers
- Coils
- Dielectric samples
- Parallel-tuned circuits
- High-resistance units
- Antennas and unterminated transmission lines

Admittances having large conductive components, such as—

- Series-tuned circuits
- Terminated transmission lines and matching sections
- Antennas and unterminated transmission lines near quarter-wave resonance.

The direct-reading capacitance range is 110 to 1100 $\mu\mu\text{f}$, and direct-reading conductance, 0 to 100 $\mu\mu\text{mho}$ at 1 mc.; 0 to 300 $\mu\mu\text{mho}$ at 3 mc.; 0 to 1000 $\mu\mu\text{mho}$ at 10 mc.; and 0 to

3000 $\mu\mu\text{mho}$ at 30 mc. For other frequencies, the range of the conductance dial varies as the square of the frequency.

1.0 DESCRIPTION

1.1 General Description ★ This instrument is used basically with a parallel-substitution method for measuring unknown impedances in terms of their parallel admittance components, namely susceptance, B , and conductance, G .¹ The susceptance is obtained from capacitance increments, read from a dial directly calibrated in capacitance (in $\mu\mu\text{f}$), by means of the relation:

$$B = \omega \Delta C \quad (1)$$

The conductance is obtained from a dial directly calibrated in conductance (in μmho). Conversion from the parallel admittance components, G and B , to series impedance components, R and X , can be made, if desired, through the relations:

$$R = \frac{G}{G^2 + B^2} \quad (2)$$

$$X = \frac{-B}{G^2 + B^2} \quad (3)$$

¹ The convention $Y = G + jB$ is used throughout so that capacitive susceptance is considered positive, inductive negative.

*Engineer, General Radio Company, Cambridge, Mass.

FIG. 1. BASIC CIRCUIT OF THE TWIN-T IMPEDANCE MEASURING INSTRUMENT. THIS IS A NULL INSTRUMENT

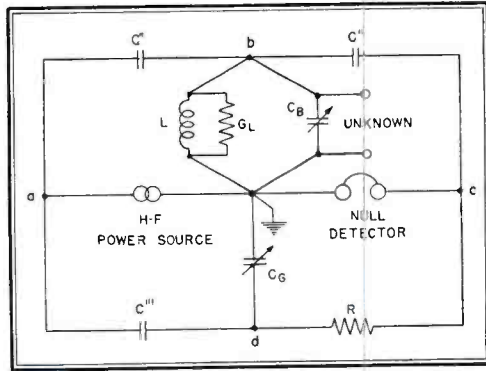

FOR MAKING MEASUREMENTS AT HIGH FREQUENCIES, UP TO 30 MC. ITS USES ARE DESCRIBED IN DETAIL

1.2 Circuit and Balance Conditions ★ The circuit used consists of two T networks connected so that they furnish parallel transmission paths, a-b-c and a-d-c, from a high-frequency generator to a null detector as shown in Fig. 1.

Zero energy transfer from the generator to the detector occurs when the transfer impedances² of the two T networks are made equal and opposite, and a null balance is obtained. The circuit conditions for which this occurs are expressed by

$$G_L - R\omega^2 C' C'' \left(1 + \frac{C_G}{C'''} \right) = 0 \quad (4)$$

$$C_B + C' C'' \left(\frac{1}{C'} + \frac{1}{C''} + \frac{1}{C'''} \right) - \frac{1}{\omega^2 L} = 0 \quad (5)$$

1.3 Method of Measurement ★ In measuring an unknown admittance, $Y_X = G_X + jB_X$, the circuit is initially balanced to a null. The unknown admittance is then connected to the UNKNOWN terminals and the circuit rebalanced by adjusting the conductance condensers, C_G , and the susceptance condenser, C_B . From the initial capacitance values, C_{G1} and C_{B1} , and the final capacitance values, C_{G2} and C_{B2} , the unknown admittance components are found as follows:

$$G_X = \frac{R\omega^2 C' C''}{C'''} (C_{G2} - C_{G1}) \quad (4a)$$

$$B_X = \omega(C_{B1} - C_{B2}) \quad (5a)$$

These relations show that each of the components is proportional to a capacitance increment. Since the unknown conductance component is always positive, the capacitance of the conductance condenser, C_G , must always be increased when an unknown impedance is connected to the UNKNOWN terminals and a single scale can be provided reading incremental conductance from 0 μ mho, at the

minimum capacitance value, to a value determined by the capacitance range. The susceptance component, on the other hand, may be either positive or negative. For direct readings, therefore, two scales would be necessary, one reading from 0 μ mho at maximum capacitance and the other from 0 μ mho at minimum capacitance. To avoid confusion from the use of two scales, reading in opposite directions, a single scale of absolute susceptance can be substituted, the unknown susceptance being found from the difference between the two absolute susceptances at balance, as indicated in equation (5a).³

1.4 Conductance Range ★ For a given conductance value the capacitance increment, $C_{G2} - C_{G1}$, varies inversely as the square of the frequency, as shown in equation (4a). The conductance dial, therefore, reads directly only at a single frequency and, at all other frequencies, the reading must be multiplied by the square of the ratio of the operating frequency to the frequency at which the dial was calibrated.

In the Twin-T Impedance-Measuring Circuit the use of a single conductance scale is not feasible because of the very large change in conductance range that results from the wide frequency band covered. To prevent this excessive variation of conductance range the multiplying factor $\frac{R\omega^2 C' C''}{C'''}$ in equation (4a)

is changed by adjustment of the condensers C' and C'' . By switching these condensers, for instance, a single scale could be made direct-reading at several different frequencies and the variation in conductance range at frequencies between these could be made reasonably small. Some increase in range, as the frequency increases, seems desirable, however, from a consideration of the frequency characteristics of

² Defined as the ratio of the input voltage to the output current when the output terminals are short-circuited.

³ For the reason outlined in paragraph 1.5 the dial used with the Twin-T is calibrated in absolute capacitance, rather than susceptance.



FIG. 4. SIDE VIEW OF THE TWIN-T, WITH THE COVER REMOVED

THE GROUND CLAMP CAN BE SEEN ON THE LOWER SIDE OF THE CASE

common types of circuit elements.⁴ The Twin-T has, therefore, been provided with a four-position switch that establishes linearly increasing conductance ranges at successively higher frequencies, as follows:

Nominal Switch-Position Frequency	Conductance Range
1 mc.	0 to 100 μ mho
3 mc.	0 to 300 μ mho
10 mc.	0 to 1000 μ mho
30 mc.	0 to 3000 μ mho

To accommodate these on the dial, two scales are provided, one reading from 0 to 100 μ mho and one from 0 to 300 μ mho. The first scale is read directly at 1 mc., the second at 3 mc. The first is again used, with a multiplying factor of 10, at 10 mc. and the second, with a multiplying factor of 10, at 30 mc. At other frequencies the dial reading corresponding to a given nominal switch-position frequency must be multiplied by the square of the ratio of the operating frequency to the nominal switch-position frequency.

1.5 Susceptance Range ★ For a given susceptance value, the capacitance increment, $C_{B_1} - C_{B_2}$, varies inversely as the frequency, as shown in equation (5a). A susceptance dial, therefore, would read directly only at a single frequency. Since, in many cases, the effective parallel capacitance is as convenient a quantity to measure as the susceptance, and since capacitance does not vary with frequency, the Twin-T has been provided with a dial calibrated in capacitance rather than susceptance. For the reasons outlined in paragraph 1.3 it reads directly the absolute capacitance, rather than incremental capacitance. It has a range from 100 $\mu\mu$ f to 1100 $\mu\mu$ f and can therefore be used directly to measure effective parallel

capacitances from - 1000 $\mu\mu$ f to + 1000 $\mu\mu$ f. At the nominal switch-position frequencies, this range of effective parallel capacitance corresponds to the following susceptance ranges:

Nominal Switch-Position Frequency	Susceptance Range
1 mc.	- 6,280 to + 6,280 μ mho
3 mc.	- 18,840 to + 18,840 μ mho
10 mc.	- 62,800 to + 62,800 μ mho
30 mc. ⁵	- 188,400 to + 188,400 μ mho

1.6 Auxiliary Controls ★ Equation (4) shows that the setting of the conductance condenser, C_G , for the initial conductance balance is determined by the effective conductance, G_L , of the tuning coil, L . Since this conductance does not, in general, vary as the square of the frequency⁶ the initial setting of the conductance condenser will change with the frequency. In order to avoid this variation and to take full advantage of the calibrated conductance scale, an auxiliary condenser is connected in parallel with the conductance condenser. By making the initial conductance balance with this auxiliary condenser it is possible to set the conductance dial at zero at all frequencies and thereby obtain direct conductance readings on the dial.

Equation (5) shows that for any given tuning inductance, L , the setting of the susceptance condenser, C_B , for the initial susceptance balance also varies with frequency. In order to make it possible to set initially at any point on the scale, an auxiliary condenser in parallel with the susceptance condenser is therefore necessary. In addition, because of the limited

⁵ Because of errors caused by residual parameters, discussed in Section 3.2, the full range of the condenser cannot be used above 20 mc. At 30 mc. the actual usable capacitance increment is about 300 $\mu\mu$ f and the corresponding susceptance range from - 56,500 to + 56,500 μ mho.

⁶ In terms of the series resistance, R , and inductance, L , the conductance is given by $\frac{R}{R^2 + (\omega L)^2}$. For values of the storage factor, Q , over 10 this is practically equal to $\frac{1}{RQ^2}$.

⁴ For instance, the conductances of coils that are tuned with the same variable condenser over different wave bands and that have similar values of Q will increase with frequency as will those of condensers and dielectric samples having reasonably constant power factors.

tuning range that can be obtained with a single coil, several different coils are necessary to cover the frequency range. These are selected by a switch.

1.7 Panel Layout and Circuit ★ A panel view of the Twin-T is shown in Fig. 2. The controls, plainly marked on the panel, are:

(1) A precision-type variable condenser (CAPACITANCE) used to measure susceptance components and having a dial and drum combination calibrated from 100 to 1100 μmf .

(2) An auxiliary condenser (AUX. TUNING CAP.), consisting of a bank of fixed condensers, controlled by push buttons, and a small variable condenser. This combination is in parallel with the precision condenser and is used to establish the initial susceptance balance at any chosen dial setting.

(3) A coil switch, marked with the frequency range covered by each tuning coil.

(4) A variable condenser (CONDUCTANCE) used to measure conductance components and having a dial that carries two scales, one from 0 to 100 μmhos and one from 0 to 300 μmhos .

(5) A 4-position switch used to establish scales on the conductance dial as described in paragraph 1.4. The nominal switch-position frequencies (1, 3, 10 and 30 mc.) are marked in large characters while the frequency limits between which the setting is usable are marked in smaller characters. The 4-position switch and the coil switch are jointly identified by the panel marking FREQ. RANGE.

(6) Two small variable condensers (INITIAL BALANCE), in parallel with the conductance condenser, used as coarse (APPROX.) and fine (EXACT) controls to establish the initial conductance balance at a dial reading of zero.

The complete circuit diagram of the Twin-T, showing the switches and auxiliary condensers, is illustrated in Fig. 3. The resistor-condenser combinations associated with the tuning coils are used to modify the tuning-coil conductances so that their variations with frequency do not exceed the adjustment range of the auxiliary condensers used to establish the initial conductance balance.

2.0 OPERATION

2.1 Generator ★ Any well-shielded radio-frequency oscillator having an output voltage of the order of 1 to 10 volts and adequate frequency stability will serve as generator.

2.2 Detector ★ Any well-shielded radio receiver having a sensitivity of the order of 1 to 10 μv will serve as detector. It is recommended that the receiver used be provided with an adequate r-f sensitivity control and a local oscillator to give a heterodyne note at the intermediate frequency, and a switch to cut out the

ave. Most so-called communications receivers fill all these requirements.

2.3 Cables and Terminals ★ Two single-conductor coaxial cables are supplied with the instrument for connection to the generator and detector. One of these is provided with General Radio Type 774-M Cable Jacks at each end and is intended for use with a General Radio Type 605-B Standard-Signal Generator as generator. The other is provided with a Type 774-M Cable Jack at one end and spade terminals at the other. It is intended for use with any receiver having machine-screw terminals for antenna and ground. If possible, however, it is recommended that this second cable also be terminated in a Type 774-M Cable Jack and that a Type 774-G Panel Plug, into which it can be plugged, be installed at the receiver.

A special coaxial adapter (Type 774-V) is available for the Type 684-A Modulated Oscillator that will receive the Type 774-M Cable Jack and it is recommended that this be used, rather than the Type 138-V Binding Posts normally provided, if this instrument is to be used as generator.⁷

2.4 Grounding ★ The instrument should, in general, be grounded at a single point, through as low reactance a connection as possible. To facilitate making this connection a ground clamp is provided on the instrument case, as shown in Fig. 4.

The ground lead should preferably be made with a short length of copper strip, say 1 inch wide. In laboratory setups a satisfactory "ground" can be obtained by covering the top of the bench with copper foil, even though the bench is physically far removed from ground. If the foil area is large enough, it will usually be found that a connection from it to ground, say through a steam radiator system, will make no appreciable difference in results.⁸ In field setups the best "ground" is usually found to be some large metal structure, such as a relay rack.

If the grounding is not adequate it will usually be found that the panel of the instrument is at a different potential from the hand of the operator and that the balance can be changed by touching the panel, and erroneous results will be obtained.

⁷ It has been found that a low-reactance connection between the outer conductor of the coaxial cable and the generator panel is very important. On this count, the combination of a Type 274-ND Shielded Plug and Type 138-V Binding Posts has been found inadequate at frequencies over about 15 mc. even though the shielding is satisfactory. If another type of oscillator is to be used as generator it is strongly recommended that a Type 774-G Panel Plug be installed to receive the Type 774-M Cable Jack.

⁸ The foil area should be at least great enough so that generator, Twin-T, and detector can all be placed upon it.

(CONTINUED ON PAGE 40)

(CONTINUED FROM PAGE 7)

They stated emphatically that neither they nor any of the other commissioners condoned "any form of monopoly which concentrates power contrary to the public interest, or which constitutes unreasonable restraint of competition." "But," their report continues, "we fear that the proposals of the majority will result in impaired efficiency of the existing broadcast system of the country."

Commissioner Wakefield ★ Although Commissioner Ray C. Wakefield of California was not appointed to the FCC until March 22nd, long after the records had been closed in the network investigation, he voted with the majority in favor of the new regulations.

This has caused considerable indignation on the part of some of the other Commissioners. To say the least, there is a question as to whether, in hardly more than a month's time, he was in a position to be adequately informed, and if it would not have been in better taste if he had refrained from voting.

FCC Authority Needs Restatement ★ As Mr. Niles Trammell, president of NBC, pointed out in a recent statement, "Laws are made by Congress, and the Congress created the FCC not to make laws but to administer them."

It now appears that the Commissioners have so definitely over-stepped the authority they were intended to exercise that a complete investigation and reorganization must be made before public confidence in the FCC can be restored.

This is not merely opinion outside the offices of the FCC. Commissioners Case and Craven, in their minority report stated, "In broadcasting, Congress evidently intended to apply the constitutional doctrine of a 'free press.' In so doing, Congress recognized that the advantages of a 'free radio' were more important than the advantages of the type of regulation considered necessary in the public utility field. As evidence of their intent, Congress specified that radio broadcasting should not be classed as a common carrier even though licensed by the Government to operate as a form of monopoly in the public domain. The type of regulation specified by Congress for broadcasting clearly envisioned that the Communications Commission should not regulate the programs, the business practices, or business policies of broadcast station licensees. Congress specified a type of regulation designed to maintain its policy of a 'free radio.'

This type of regulation differs from that applied to other private business operations in the public domain."

About 500 broadcasting stations are affected by the new network regulations. To require 70% of the nation's stations to revise their relations with advertisers, and to do it within 90 days, can be done only at a tremendous loss of revenue. The time salesman cannot call on his clients and make them like the new set-up. The devastating effect of wholesale regimentation is recognized by the Case-Craven minority report:

"If some form of monopoly exists in radio broadcasting which is contrary to the best interests of the public, it should be remembered that the Commission has licensed all broadcasting stations in the United States after finding time and time again that each of the licensees was operating his station in the public interest. Therefore, if the Commission has erred in the past, it can now correct the mistake by exercising in individual cases the licensing power delegated to it under the Communications Act of 1934. . . . However, as has been stated elsewhere in this report, no abrupt changes should be attempted without positive indication that such changes will result in improved service to the public. The record in this instant investigation does not justify sweeping proposals to change the developments resulting from practical experience. . . . It must be admitted that imperfections exist. No human institution is free from error. It is significant, however, that this record fails to disclose any important abuses. Moreover, no information is available to the Commission which justifies an invasion of the business practices of the licensees of this Commission."

When such reasonable doubt can be cast on the new network regulations by two of the members of the Commission, action by Congress is definitely indicated. If the Commissioners are right, they still need a vote of confidence. If they are found to be assuming authority which is not theirs to exercise, or to be acting in an arbitrary and capricious manner, then the radio industry and the public should have relief from their interference.

In either case, everyone connected with the industry will serve a useful purpose by asking for Congressional action in what seems to be a serious condition of maladministration, contrary to public interest, convenience, and necessity.

FM and Eimac Tubes are old friends

EIMAC 250T
Recommended for
250 to 500 watt
stations

EIMAC 450T
Recommended for
1KW stations

EIMAC 1500T
Maximum power
and efficiency for
2KW and over

EIMAC 2000T
Maximum power
and efficiency up
to 10KW

All through the development of the frequency modulation principle and on into the leading Commercial FM transmitters Eimac tubes have been first choice. The Yankee Network, Stromberg Carlson, Zenith, The Milwaukee Journal Co. . . these and many other leaders in the field use Eimac tubes for FM work.

Why take chances on untried tubes . . . select Eimac tubes and *know* in advance that you can expect vastly superior performance, greater dependability and complete freedom from failures which are caused by gas released internally . . . plus the assurance that Eimac tubes are thoroughly tested in actual FM performance.

Follow the leaders to

Eimac
TUBES

Eitel-McCullough, Inc.
San Bruno, California

EIMAC REPRESENTATIVES

California, Nevada
HERE BECKER, 1530 W.
104th St., Los Angeles, Cal.

Wash., Ore., Idaho, Mont.
GENERAL SALES CO.,
Verner O. Jensen, 2605-07
Second Ave., Seattle, Wash.

Co. S., Wyo., New Mexico,
Arizona, Utah

RICHARD A. HYDE, 4253
Quemar St., Denver, Colo.

Ohio, Mich., Ky., Ind., Minn.,
Mo., Kan., Neb., Iowa

PEEL SALES ENGINEER-
ING CO., E. R. Peel, 154
E. Erie St., Chicago, Ill.

N. Y., N. J., Pens., Md., Del.,
Dist. of Col., Maine, N. H.
R. I., Conn., Mass.

ADOLPH SCHWARTZ,
14726 Elm Ave., Flushing,
New York.

Texas, La., Okla., Ark.
J. EARL SMITH, 2821 Live
Oak St., Dallas, Texas.

Chicago, Illinois, Wisconsin
G. G. RYAN, 549 W.
Washington Blvd., Chicago,
Ill.

N. Caro., S. Caro., Georgia,
Tenn., Flor., Ala., Miss.
JAMES MILLAR, 316 Ninth
St. N. E., Atlanta, Georgia.

Export Agents:

Frazar & Co., Ltd., 301 Clay St., San Francisco

NUMBER OF FM STATIONS ACTUALLY ON THE AIR MOUNTS STEADILY

Months of investigation, construction, and experimentation are now beginning to bear fruit as commercial FM broadcasting stations begin to spring up with accelerating speed in all parts of the United States.

Among the latest to operate on a full commercial basis are W65H, Hartford, Conn.; W51R, Rochester, N. Y.; W45D, Detroit; and W45RG, Baton Rouge, La.

The entire list, in the sequence that these FM stations were authorized to start commercial operation, includes:

- W45NV — Nashville, Tenn.
operated by station WSM
- W71NY — New York City
operated by station WOR
- W51C — Chicago, Ill.
operated by Zenith Radio Corp.
- W39B — Mt. Washington, N. H.
operated by The Yankee Network
- W55M — Milwaukee, Wis.
operated by The Milwaukee Journal
- W43B — Paxton, Mass.
operated by The Yankee Network
- W51R — Rochester, N. Y.
operated by Stromberg-Carlson
- W65H — Hartford, Conn.
operated by station WDRC
- W45D — Detroit, Mich.
operated by Detroit Evening News
- W45CM — Columbus, O.
operated by station WBNS
- W45RG — Baton Rouge, La.
operated by station WJBO
- W45V — Evansville, Ind.
operated by WGBF-WEOA

The FCC has authorized the Don Lee Broadcasting System of California to operate its K45LA on a temporary commercial basis with a power of 1 kw. This will serve the Los Angeles area, pending the completion of a 10-kw. transmitter which is already under way.

Similar permission has been granted to WJLB of Detroit to put its W49D station on the air commercially for 60 days. These stations bring FM's commercial tally up to 14, while another 14 experimental transmitters are on with scheduled programs.

In the realm of educational FM, the Board of Education at Chicago has made application for a transmitter to operate on 42.5 mc., 1 kw., with unlimited time.

As of May 15th, the FCC has issued 46 FM station construction permits. Meanwhile, the number of applications on file has increased to 61. In other words, there are now 105 FM stations in operation, under construction, or waiting FCC permission to start. This compares with 700 AM stations now on the air.

In a Hurry for F-M?



Use the Meissner F-M RECEPTOR for immediate satisfaction!

The Meissner F-M Receptor is a complete, self-powered, 8-tube converter, designed to add F-M reception to any regular receiver — feeds directly into the input of the audio system! With this inexpensive unit you can have all the advantages of F-M — hi-fidelity, staticless, noise-free and interference-free reproduction — right on your own radio set! Power output and tone quality are limited only by your present audio system.

RF stage provides maximum reception range and noise rejection — tuning indicator for accurate adjustment — only two controls. Extremely compact — only 13" wide, 7" high and 6³/₄" deep — beautiful, hand-rubbed walnut cabinet. For 110-volt AC operation only; also available without cabinet if desired. List price, ready to operate, only \$39.95!

Write for Free General Catalog Today!

ADDRESS DEPT. F-6



"PRECISION-BUILT PRODUCTS"

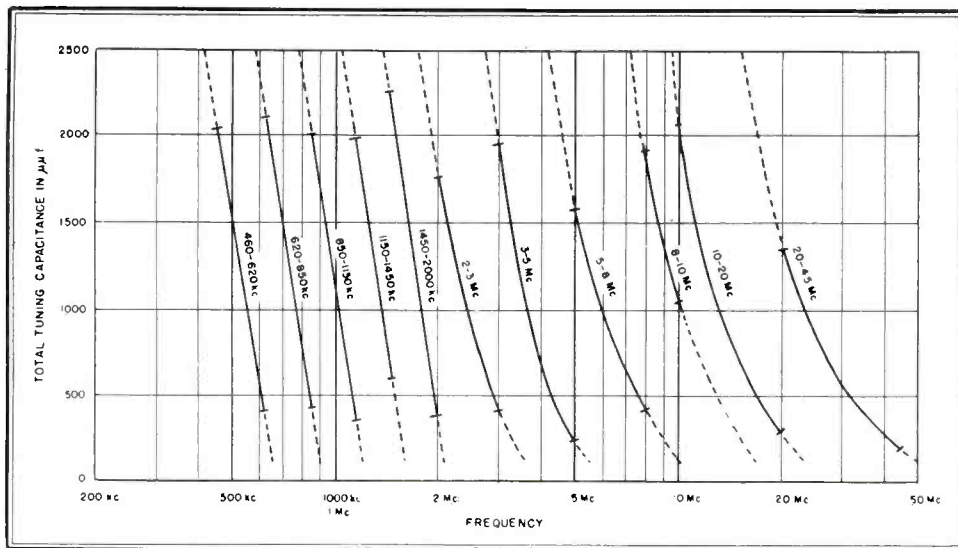

FIG. 5. PLOT OF THE FREQUENCY VARIATION OF THE TOTAL TUNING CAPACITANCE

Fig. 5 is a plot of the frequency variation of the total tuning capacitance (sum of capacitance of auxiliary condenser combination and susceptance condenser) required for the initial susceptance balance for the different coils. The plot will be found useful both in estimating the approximate initial settings and the capacitance range over which the precision condenser can be varied. At the low-frequency end of each coil range the precision condenser cannot generally be set at initial low-capacitance readings, and at the high-frequency end of each coil range it cannot generally be set at initial high-capacitance readings. By selecting the proper coil, however, it is possible to set at both minimum and maximum capacitance at any frequency in the operating range.⁹

For the detector it is particularly desirable to use a receiver that has a good r-f sensitivity control and a switch to disconnect the a.c. If the receiver gain is set too high there is a tendency for the receiver output to increase as balance is approached, and if the conductance balance is not set approximately correctly it becomes quite difficult to find the susceptance balance, or vice versa. When the r-f sensitivity control is set to minimum sensitivity, and the a.c. is disconnected, no difficulty should be found in making the initial balance. As balance

is approached, the receiver sensitivity can be increased to improve the precision of setting. For the first rough balance the generator signal can be modulated and the receiver beat oscillator turned off. The precise balance, however, should be made with the generator signal unmodulated. The a.c. should be left disconnected at all times. If an adequate r-f sensitivity control on the receiver is not available it is sometimes possible to accomplish the same general results by reducing the generator output, rather than the receiver sensitivity. For the precise balance the generator output should preferably be set at maximum so that the ratio of useful output to leakage is as great as possible.

Once the initial balance has been obtained, the setting of the precision condenser can be changed to any desired value and the susceptance balance reestablished by varying the auxiliary condenser combination. The choice of the initial setting depends upon the sign of the unknown susceptance that is to be measured. If it is capacitive, the initial setting should be high so that a decrease in setting can be observed when the unknown admittance is connected to the instrument; if it is inductive, the initial setting should be low so that an increase in setting can be observed when the unknown admittance is connected to the instrument.

2.7 Measurement of Unknown Admittance ★

2.71 UNKNOWN ADMITTANCE COMPONENTS WITHIN DIRECT-READING RANGES OF TWIN-T. Since a parallel-substitution method is used, the Twin-T is generally adapted to the measurement of high impedances or, specifically, to

⁹ Because of errors caused by residual parameters, discussed in Section 3.2, the full range of the condenser cannot be used at frequencies above 20 mc. (Footnote 4). At the highest frequencies it will be found that the inductance in the leads to the auxiliary condensers causes their effective capacitances to increase above their nominal values. Since they play no part in the measurement process other than to establish an initial balance, however, this variation has no bearing on accuracy of measurement.

(CONTINUED FROM PAGE 6)

Electrical Constants ★ The following list gives the values for the various component parts, shown with corresponding reference numbers in Fig. 1:

C-1, 2	Tuning condenser and trimmers
C-7	47 mmf., mica
C-8, 9	100 mmf., mica
C-10	.05 Mfd., 200 V. paper
C-11	0.1 Mfd., 200 V. paper
C-12, 13	.005 Mfd., 600 V. paper
C-14	.01 Mfd., 600 V. paper
C-15	0.1 Mfd., 200 V. paper
C-16	.05 Mfd., 200 V. paper
C-17	.006 Mfd., 100 V. paper
C-18	100 mmf., mica
C-19, 20	0.5 Mfd., 120 V.
C-21A, 21B	15 Mfd., 150 V. dry electrolytic
C-21C	1200 Mfd., 2 V. dry electrolytic
C-22	0.5 Mfd., 120 V. paper
C-23	.05 Mfd., 600 V. paper
R-1	0.5 megohm volume control
R-2	220,000 ohm, $\frac{1}{2}$ W. carbon
R-3	47,000 ohm, $\frac{1}{2}$ W. carbon
R-4	2.2 megohm, $\frac{1}{2}$ W. carbon
R-5	27,000 ohm, $\frac{1}{2}$ W. carbon
R-6	47,000 ohm, $\frac{1}{2}$ W. carbon
R-7	4.7 megohm, $\frac{1}{2}$ W. carbon
R-8	1.0 megohm, $\frac{1}{2}$ W. carbon
R-9	2.2 megohm, $\frac{1}{2}$ W. carbon
R-10	1,000 ohm, $\frac{1}{2}$ W. carbon
R-11, 12, 13	8.2 ohm, $\frac{1}{2}$ W. carbon
B-1	5.0 V. bias cell assembly
L-1	Loop antenna assembly (inside cover)
L-2	Oscillator coil
L-5	B choke
L-6	Vibrator choke
L-7	External loop antenna
L-8	Filament supply choke
SW1	Power selector switch
T-1	Output transformer
T-2	Vibrator power transformer
T-3	50-60 cycle rectifier step-down transformer
T-4	1st IF transformer
T-5	2nd IF transformer
V-1	Power supply synchronous vibrator
X-1	Copper oxide rectifier
Spkr	P M speaker

A Few Back Numbers of FM MAGAZINE

ARE AVAILABLE TO THOSE WHO
SEND THEIR ORDERS AT ONCE

January, 1941, featuring:

Connecticut Police FM System
Tests of W2XOR Reception on Long Island
G.E. Police Radio Equipment
Service Data on Zenith and Scott Sets
G. H. Browning's FM Handbook, Chap. 3

February, 1941, featuring:

Practical Ideas for FM Antennas
Planning an FM Station
W.E. Speech Input Equipment
Data on Stromberg-Carlson & Meissner Sets
G. H. Browning's FM Handbook, Chap. 4

March, 1941, featuring:

List and Map of FM Stations
RCA 1 and 10 Kw. Transmitters
Details of Paxton FM Station
Police FM Success in Nebraska
Data on Stromberg-Carlson & G.E. Sets
G. H. Browning's FM Handbook, Chap. 4

April, 1941, featuring:

FM for Cleveland Schools
Details of Mt. Washington Station
Complete List of FM Stations
S-C Coaxial Speaker
Motorola Emergency FM Equipment
G. E. FM Frequency Monitor

May, 1941, featuring:

2-Way FM for Power Maintenance
FCC Order No. 79
How A-FM Sets Are Being Sold
Review of A-FM Receivers, 40 Models
W. E. Level-Governing Amplifier
James S. Knowlson, on Defense Production

PRICE, 25c PER COPY, SUBJECT
TO PRIOR SALE. ADDRESS:

FM COMPANY, NEWTON, MASS.

the measurement of admittances having small conductive components. In this class fall, generally, the admittances of such elements as coils, condensers, dielectric samples, antennas and unterminated transmission lines near half-wave resonance, parallel-resonant circuits and high-resistance units.

To measure admittances of this class, first establish an initial balance as described in paragraph 2.6. Then connect the unknown admittance and rebalance with the susceptance condenser, C_{B_1} , (CAPACITANCE) and the conductance condenser, C_G , (CONDUCTANCE). If C_{B_1} and C_{B_2} are the initial and final readings of the susceptance condenser, the effective parallel capacitance, C_{P_x} , of the unknown admittance is given by

$$C_{P_x} = C_{B_1} - C_{B_2} \tag{5b}$$

and the susceptance, B_x , is given by

$$B_x = \omega(C_{B_1} - C_{B_2}) \tag{5a}$$

If the final capacitance setting, C_{B_2} , is greater than the initial capacitance setting, C_{B_1} , the effective parallel capacitance is negative and the susceptance is inductive. If the final capacitance setting, C_{B_2} , is less than the initial capacitance setting, C_{B_1} , the effective parallel capacitance is positive and the susceptance is capacitive.

The unknown conductance, G_x , is determined from the final setting of the conductance dial, G_2 .¹⁰ If the measurement is made at a frequency of 1, 3, 10 or 30 mc., where the dial is direct reading, the unknown conductance is directly given by the final dial reading. If it is made at any other frequency, the dial reading must be multiplied by the square of the ratio of the frequency used to the nominal switch-position frequency corresponding to the setting of the 4-position conductance range switch (see paragraph 1.4).

The result, when measured in this way, is of course in terms of the admittance, $Y_x = G_x + jB_x$. In many cases it is preferable to express it in terms of the impedance, $Z_x = R_x + jX_x$. This can be obtained from the relations

$$R_x = \frac{G_x}{G_x^2 + B_x^2} \tag{2}$$

$$= \frac{1}{G_x} \frac{1}{1 + \left(\frac{B_x}{G_x}\right)^2} = \frac{1}{G_x} \frac{1}{1 + Q_x^2} \tag{2a}$$

$$X_x = \frac{-B_x}{G_x^2 + B_x^2} \tag{3}$$

¹⁰ It is actually determined by the difference between the final and initial settings. The initial setting, G_1 , however, is made at a setting calibrated as zero. (See paragraph 2.6.)

$$= -\frac{1}{B_x} \frac{1}{1 + \left(\frac{G_x}{B_x}\right)^2} = -\frac{1}{B_x} \frac{1}{1 + D_x^2} \tag{3a}$$

For coils, the result is conveniently expressed in terms of the effective parallel inductance,¹¹ L_{P_x} , and the storage factor, Q_x , which can be found from

$$L_{P_x} = -\frac{1}{\omega B_x} = -\frac{1}{\omega^2 C_{P_x}} \tag{6}$$

$$Q_x = \left|\frac{B_x}{G_x}\right| \tag{7}$$

For condensers, the result is conveniently expressed in terms of the effective parallel capacitance, C_{P_x} , and the dissipation factor, D_x , given by

$$C_{P_x} = C_{B_1} - C_{B_2} \tag{5b}$$

$$D_x = \left|\frac{G_x}{B_x}\right| \tag{8}$$

2.72 UNKNOWN ADMITTANCE COMPONENTS OUTSIDE DIRECT-READING RANGES OF TWIN-T. At the sacrifice of the direct-reading features of the Twin-T, measurements can also be made of low impedances or, specifically, admittances having large conductive components. In this class fall, generally, the admittances of such elements as terminated transmission lines, antennas and unterminated transmission lines near quarter-wave resonance, series-resonant circuits and low-resistance units.

Measurements of admittances of this class are made by connecting in series with the unknown admittance an auxiliary condenser of such reactance that the net admittance of the combination falls within the direct-reading ranges of the Twin-T.¹² From measurements of the net admittance components and a separate

¹¹ This is the inductance that has a reactance equal to that of the tuning capacitance in a parallel-resonant circuit. For a coil having a storage factor, Q_x , of 10 or greater it is within 1% of the value of the effective series inductance, L_{S_x} . The relation between them is

$$L_{S_x} = \frac{L_{P_x}}{1 + (1/Q_x)^2} = \frac{L_{P_x}}{1 + D_x^2}$$

¹² The conductance and susceptance of the combination are found, by rearranging equations (2a) and (3a), to be:

$$G = \frac{1}{R} \frac{1}{1 + Q^2} \tag{2b}$$

$$B = -\frac{1}{X} \frac{1}{1 + D^2} \tag{3b}$$

As the auxiliary condenser is made smaller and smaller, X and Q increase and D decreases. In the limit, therefore, as X_x approaches infinity,

$$G \rightarrow \frac{1}{RQ^2} = \frac{R}{X^2}$$

$$B \rightarrow -\frac{1}{X}$$

measurement of the reactance of the auxiliary condenser it is then possible to determine the unknown impedance.

To determine the proper auxiliary capacitance to use, first establish an initial balance as described in paragraph 2.6. Next connect a small fixed condenser in series with the ungrounded lead of the unknown admittance, connect the combination to the UNKNOWN terminals of the Twin-T, and rebalance with the susceptance condenser (CAPACITANCE) and the conductance condenser (CONDUCTANCE). If the auxiliary series capacitance is too large the balance will be found to be outside the range of one of the Twin-T condensers, usually that of the conductance condenser. If it is too small, the settings for balance will not change by a sufficient amount to yield adequate precision of measurement.

Editor's Note: The conclusion of Mr. Worthem's article will appear in the July issue of FM Magazine.

(CONTINUED FROM PAGE 21)

the antenna can be connected directly to the 3-kw. driver, making it available as a spare, in the case of emergency.

50-Kw. Transmitter at W45D ★ The 50-kw. REL installation for The Detroit Evening News, station W45D, is located on two floors of a typical skyscraper building. The units of the transmitter are the same as those described above, however, except that their relative positions have been changed to meet the space requirements.

This gives further emphasis to the advantages of designing transmitting equipment of this power in several independent units, so as to facilitate erection. Many installations are planned for the upper floors of tall buildings where adequate space is not available on one floor. Furthermore, in many cases, elevators capable of carrying large units are not available.

FM Antennas ★ Practical radiating systems for use on these frequencies and capable of carrying 50-kw. of power have not been commercially available to the purchaser of a 50-kw. transmitter. REL, therefore, has undertaken to furnish complete turnstile antennas for FM broadcasting stations such as the two-bay antennas at station W55M, Milwaukee and station W45D, Detroit. These employ the proven and successful design developed by Paul A. deMars and in use at the Yankee Network station, Paxton, Mass.

(CONTINUED FROM PAGE 31)

FM receivers are equipped for doublet operation, and therefore have two antenna terminals. The two output terminals of the signal generator covering frequencies from 42 to 50 mc. should be connected to these antenna terminals. The 0 to 1 ma. meter should be inserted

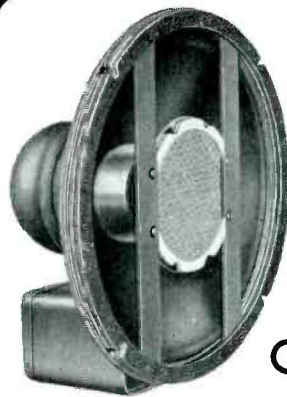

for
FM
a new
**Cinaxial
Speaker System**

For absolute fidelity of response in FM and other high fidelity uses.

CINAUDAGRAPH SPEAKERS offer this model FM-12 designed to fit any standard 12-inch baffle mounting.

All transformers and condensers neatly contained in a single unit compactly mounted on the speaker.

List only..... **\$42.50**

Write for special FM bulletin

CINAUDAGRAPH SPEAKERS, Inc.
921 W. Van Buren Street
CHICAGO, ILLINOIS

BROADCAST STATION

Executives and Engineers

A great volume of special information comes to the Editorial office of *FM Magazine*, concerning broadcasting activities and equipment.

We shall welcome the opportunity of answering questions and supplying information required by engineers and executives concerning any application of Frequency Modulation.

Letters should be addressed to the Editor:

FM MAGAZINE

41 Washington St., Newton, Mass.

in the grid return of the limiter tube so as to indicate limiter grid current. If the service man is sure of the frequency calibration of his signal generator, the oscillator trimmer should be adjusted so that the dial calibration is substantially in accordance with the frequency of the received signals. To make this adjustment, set the signal generator at a frequency of about 48 mc. and adjust the tuning dial of the receiver for maximum response (maximum limiter grid current). If this maximum is obtained when the receiver dial indicates 48 mc., no adjustments on the oscillator trimmer condenser will be necessary. However, if such is not the case, the dial should be set so as to read 48 mc., and the trimmer on the oscillator set so that maximum response is obtained at this point. Having set the oscillator trimmer correctly, the antenna and RF trimmers are adjusted for maximum signal strength (maximum limiter current). During this process, the output of the signal generator should be reduced as the circuits are brought to adjustment, so that the final adjustment is made with a weak signal.

To check the tracking of the high-frequency portion of the circuit over the FM band, the signal generator should be set consecutively at 48, 45, and 43 mc., the receiver tuned to maximum response, and the output, as indicated by the limiter current, noted. If there is a marked difference in output, this may be due to either poor tracking of the HF tuner or to incorrect adjustments of the antenna and RF circuits.

Some manufacturers prefer to operate the oscillator on the low-frequency side of the signal. That is, the oscillator frequency will be lower than the signal frequency by the amount of the intermediate frequency. In such cases, the image will be lower in frequency than the signal by twice the intermediate frequency. Although, as a rule, the intermediate frequency used in FM receivers are so high as to make it impossible to align the antenna and RF systems on the wrong side of the oscillator, this could be done in rare cases and would account for the poor tracking over the FM band. If there is any question as to whether the oscillator should be on the high or low frequency side of the signal, the tracking over the FM band should be carefully noted and, if poor, an attempt made to adjust the oscillator to the opposite side of the signal frequency.

To do this, the signal generator and the limiter current meter are connected as before. The output of the signal generator is increased. The oscillator trimmer is rotated, whereupon two response points should be obtained, one with the oscillator trimmer at some small value of capacitance and one at a considerably larger value of capacitance. In some cases, it would be better to connect the input of the signal generator to the signal grid feeding the mixer tube,

rather than trying to feed the signal through the tuned antenna circuits and RF stage for this adjustment. In this latter case, the response as indicated by the limiter current meter would be substantially the same at both of the oscillator settings. If there is a limited adjustment on the oscillator trimmer condenser or if the IF is too high a frequency, it may be impossible to set the oscillator frequency on both sides of the signal frequency. When the oscillator has been set either above or below the signal frequency, the signal generator is connected to the antenna input circuit and the tuned antenna system and the RF oscillator is adjusted for maximum output in the high-frequency portion of the FM band and tracking over the band is checked again.

IF Alignment with Oscilloscope and FM Generator ★ If the service man has available or has constructed a frequency-modulated signal generator, the fundamental frequency of which can be varied over the range of frequencies encountered in the IF amplifiers, and the frequency swing of which can be varied from a few kc. to 75 kc. either side of the center, IF alignment can be made by means of this apparatus and a cathode ray oscilloscope. The signal generator should be frequency-modulated at the rate of 60 cycles per second in order that the cathode ray oscilloscope sweep circuit can be locked in with the generator. The generator is connected to the signal grid of the mixer tube and the cathode ray oscilloscope is connected between point B and ground, Fig. 1. The amplitude of the frequency modulation is set at say 50 kc. either side of the intermediate frequency whereupon, if the cathode ray oscilloscope is swept at the correct rate and in phase with the frequency modulation of the generator, the response pattern of the IF amplifier as a whole will be depicted on the screen of the cathode ray oscilloscope, and alignment can be made for the most symmetrical and flattest-nose curve. This procedure is quite similar to aligning amplitude IF systems by means of a frequency modulated signal generator and a cathode ray oscilloscope, a process familiar to most service men. This procedure would be particularly advantageous in over-coupled IF amplifier circuits with double-response peaks. By varying the amount of the frequency-modulated signal from 75 to 25 kc., these portions of the response curve can be inspected visually. The essential thing about the IF amplifier curve is that it should be as symmetrical as possible, and the response characteristics should not vary more than 10 to 1 at 75 kc. either side of the center frequency.

Editor's Note: The next article of this series, describing the construction of a frequency-modulated oscillator, is scheduled for the August issue.

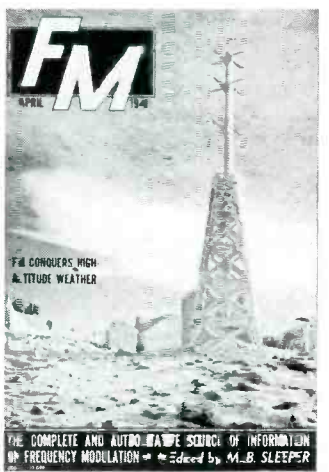
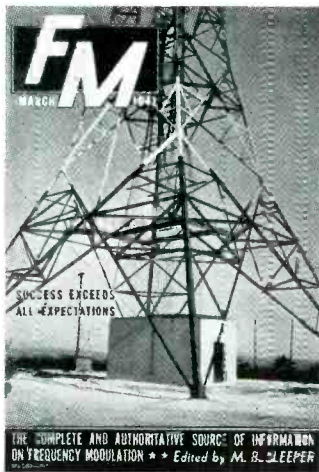

Because of the importance of its editorial contents, FM Magazine has been accorded first place in "reader attention" and usefulness to engineers and executives in the radio manufacturing, broadcasting, and communications fields, as well as to those in charge of public utility and police radio systems, and to radio officers and engineers of the U. S. Army and Navy—Circulation over 5,000



THE RADIO ENGINEERING NEWS JOURNAL OF COMMUNICATIONS AND BROADCASTING

Meets

FCC REQUIREMENTS

for both

FM and AM Police,
Fire, Public Utility,
and other Emergency
Transmitters

Complete,
any two bands

\$97.95

any three bands

\$122.50

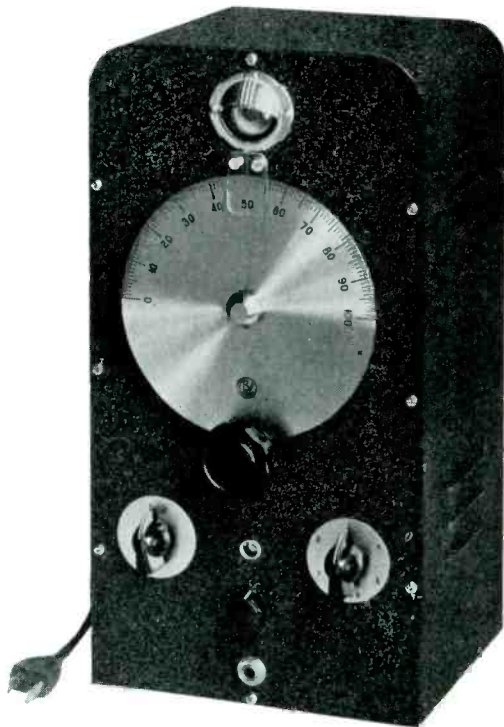

BROWNING FREQUENCY METER

More Accurate—because it is Easier to Read

1. Scale can be read with precision because of wide spread of the dial calibrations.
2. Designed for use by operators of police, fire and emergency radio transmitters.
3. Checks frequencies within any two or three bands specified at time of purchase. Each band is 50 to 1000 kc. wide, depending upon position in the 1.5 to 60 mc. spectrum.
4. Complete stability of standard crystal oscillator and electron-coupled oscillator.
5. Cathode ray indicator for accurate visual check against crystal standard as well as against transmitter.
6. 100-kc. crystal oscillator provides at least two check-points within each band.
7. Fast operation. Less than one minute required to check transmitter frequency exactly.
8. Light in weight — easy to carry — plugs into any 115-volt AC or DC supply.
9. Each instrument precision-built on order, hand-calibrated to better than .01% for each band.

Fast Operation: the simplified and improved design of the Browning Frequency Meter saves time in checking emergency transmitters. **Easy Reading:** no need to use a magnifying glass and flashlight to read the clearly calibrated scale. **Accurate:** exceeds the FCC requirements of .01% on each band. **Rugged:** not a delicate instrument, but a sturdy piece of emergency service equipment. **Universal:** the same instrument can be used for checking both FM and AM transmitters. — For additional details, write

BROWNING LABORATORIES, Inc.
755 MAIN STREET **WINCHESTER, MASSACHUSETTS**

Growing FM Acceptance

with
G-E
Simplified
Circuit
Design

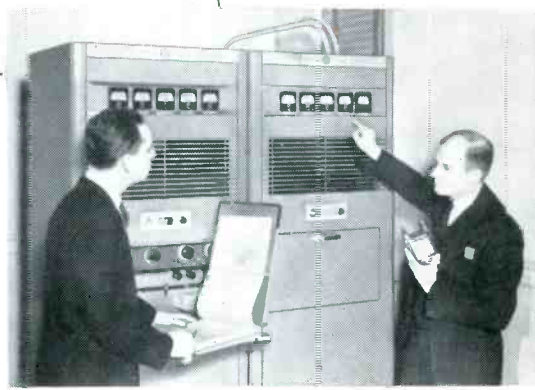
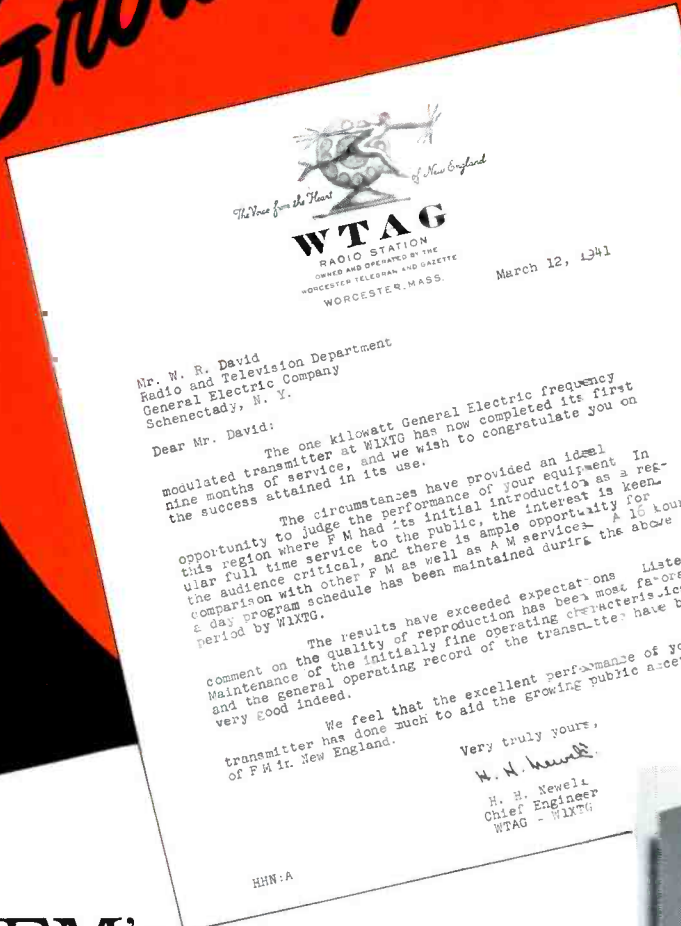

FM's toughest job is audience building and the trend in W1XTG's area shows that G-E simplified FM is doing more than its share in winning listener approval. General Electric FM broadcast transmitters give full fidelity, real dependability, extra economy. Ask to see the figures on G-E performance.

G.E. for Complete Service

General Electric offers the only complete line in FM today—broadcast and relay transmitters, tubes, receivers, antennas, crystals, and the new station monitor. Speech equipment will be announced soon. FM audience building is a specialty with G.E., through co-ordination of the work of our receiver and transmitter sales divisions. Get an early start in FM. Your copy of "How to Plan an FM Station," and full information on the G-E complete service, are available through any of our 80 offices, or from Radio and Television Dept., General Electric Co., Schenectady, N. Y.

Chief Engineer H. H. Newell (right) compliments G.E.'s S. H. Magruder on the excellent life of the G-E tubes at W1XTG. A complete set of tubes for W1XTG's 1-kw G-E transmitter costs less than \$290!

FOR TOP PERFORMANCE
Use G-E Transmitting Tubes

GENERAL ELECTRIC

160-13B-6914

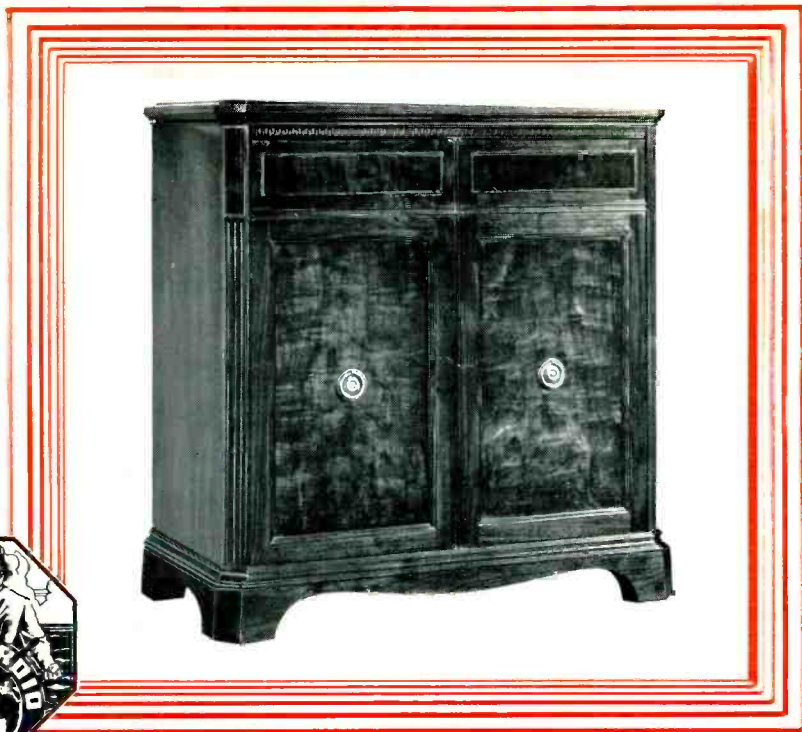

PILOT Phono Combination tunes broadcast, short waves, and FM. The same "Conqueror" chassis available in console and table cabinets. 17 tubes, 45 watts output, 2 RF stages

"THE ADAM"



PILOT engineering looks years ahead . . .

to produce the A-FM "Conqueror" . . . new from antenna coil to voice coil . . . embodying advanced FM and AM developments disclosed for the first time . . . engineered by PILOT with such consummate skill that your customers will be set agog by such superior performance. . . . Here, truly, is PILOT'S engineering leadership reaffirmed. Write or wire for detailed information, prices, discounts:

PILOT RADIO CORPORATION, Long Island City, New York

"The Standard

Pilot
RADIO

of Excellence"