

# Communication Engineering

July-Aug. 1953

MILTON B. SLEEPER, Publisher

Price 65 Cents

Established as

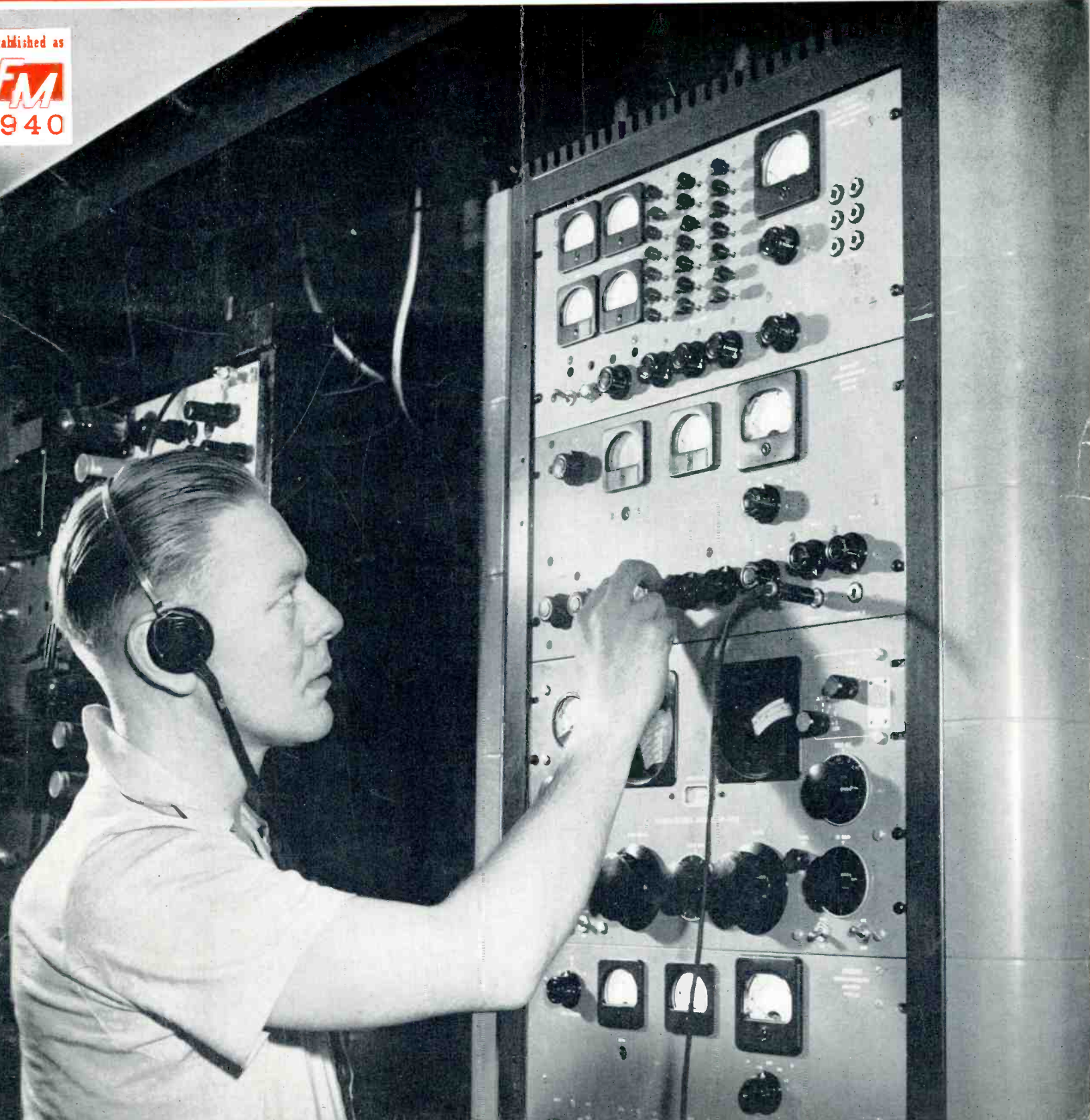



**FIRST WITH 450**

**CLASS "A" CITIZENS EQUIPMENT  
IN USE FOR OVER 3 YEARS**

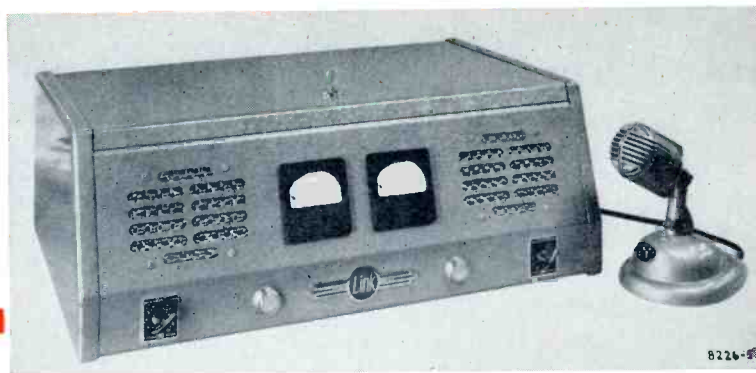

**RECEIVER-TRANSMITTER TYPE 2975-20AC-D2  
CHARACTERISTICS & SPECIFICATIONS**

- 15 Watt Transmitter Output
- 1 Microvolt Receiver Sensitivity
- .0005% Frequency Stability
- Low Spurious Responses
- Up to Four Channel Operation
- Low Cost Tube Complement

**ASSOCIATED MOBILE EQUIPMENT**

- 10 or 20 Watt Models
- Multi-Channel Operation—
- Up to 4 Frequencies
- Optional 6-12 Volt
- Universal Wiring

**PLUS**

- A COMPLETE GROUP OF  
ACCESSORIES INCLUDING:—**
- High Gain and Directional Antennas
  - Local and Remote Control Units
  - Dispatching Turrets

*For Additional Information  
Write*

**LINK RADIO CORPORATION**

125 W. 17th St., New York 11, N. Y.





**"REPORTER" PTC 116/117  
MOBILE RADIO-TELEPHONE  
FOR ENGINEERING  
COMMUNICATIONS**

Ranking high among the benefits derived from V.H.F. radio-telephone communication is the control of mobile vehicles and personnel. The Pye "Reporter" fulfils this function in admirable and versatile fashions.

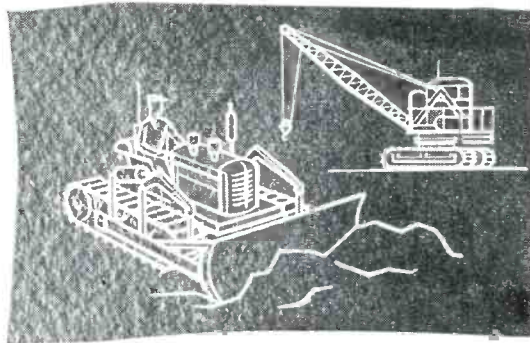
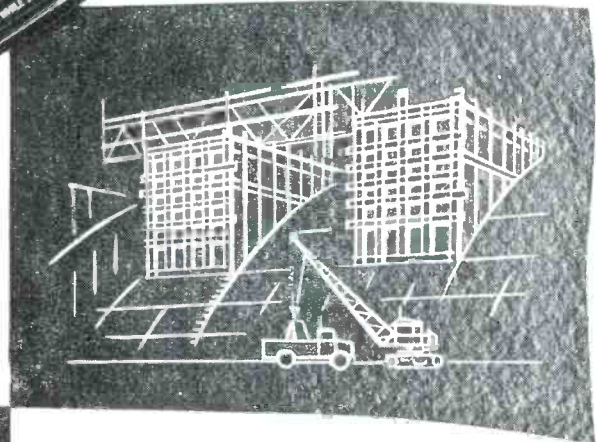

A compact and economical equipment, it is designed to fit neatly under vehicle dashboards but is also available in transportable form. Reason enough that it should feature so prominently in over two-thirds of the V.H.F. schemes in the United Kingdom.

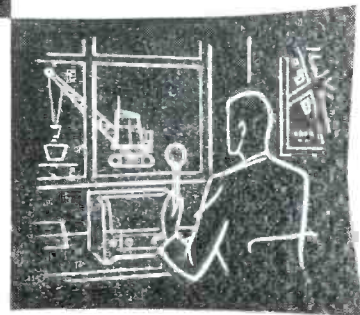

PYE LIMITED • CAMBRIDGE ENGLAND

formerly *FM-TV* RADIO COMMUNICATION

# RCA MICROWAVE

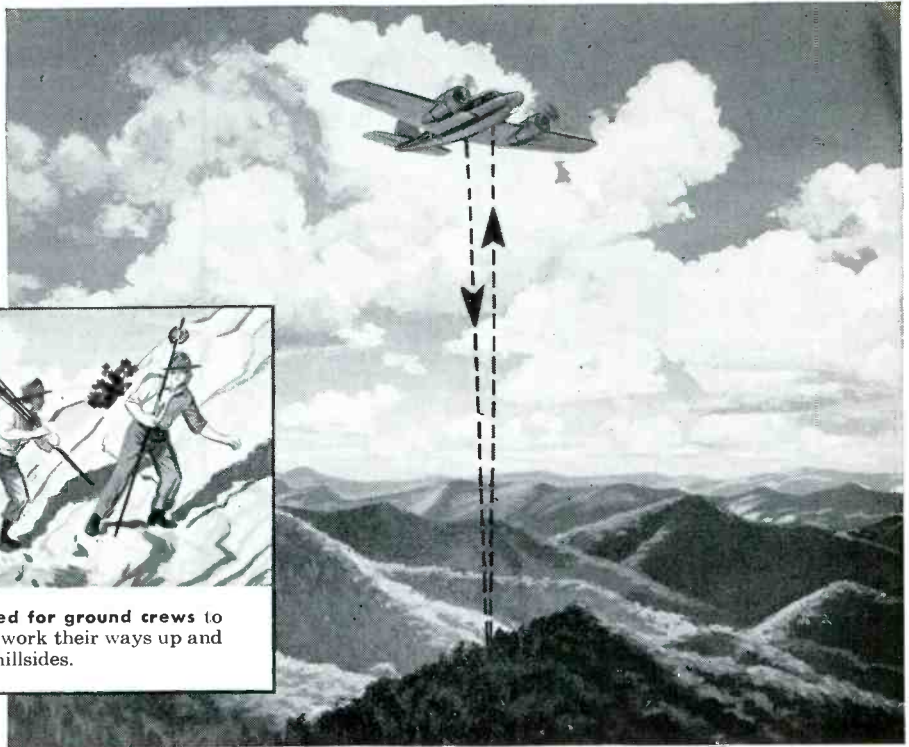
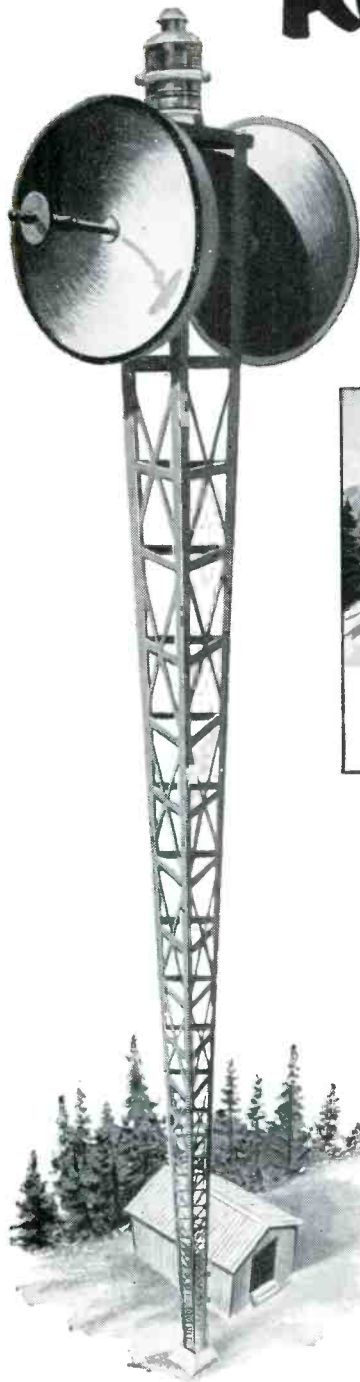

No need for ground crews to slowly work their ways up and down hillsides.

Radar signals provide precise data on contour of earth beneath proposed path of a microwave beam.

## RCA AERIAL SURVEY speeds installation ... insures accuracy

FOR the ultimate in microwave planning, RCA offers the important advantages of fast, accurate aerial survey.

Flying a simulated path of the microwave beam, ground elevations are charted by continuous readings from a vertical radar system. Recording instrumentation enables the survey team to plot an accurate route—and an *alternate route*—at high speed. By direct observation and aerial photography these experts select the most economical, easily accessible sites. An unobstructed microwave route is plotted in a fraction of the time nor-

mally required—without the premature publicity that often results from surveyors' operations.

For dependable communication, proved on existing systems, call an RCA Microwave Specialist at the nearest Regional Office, or MAIL COUPON.

• • •  
Check RCA 2-way radio for proved dependability in mobile communications.

And remember, only RCA can provide the nationwide service facilities of the RCA Service Company.



**RADIO CORPORATION of AMERICA**  
COMMUNICATIONS DIVISION CAMDEN, N. J.

Communications Division  
Radio Corporation of America  
Dept. 132S, Building 15-1  
Camden, N. J.

Please send me your free booklet on:

- RCA Microwave
- RCA 2-Way Radio
- Send an RCA Communication Specialist

Name \_\_\_\_\_

Title \_\_\_\_\_ Company \_\_\_\_\_

Address \_\_\_\_\_

City \_\_\_\_\_ Zone \_\_\_\_\_ State \_\_\_\_\_



# Communication Engineering

Formerly FM-TV and RADIO COMMUNICATION

VOL. 13 JULY - AUGUST, 1953 No. 4

COPYRIGHT 1953, by RADIOCOM, INC.

## DEPARTMENTS

<b>Systems Data</b>	
Breakdown of new application information	4
<b>Product Information</b>	
New components, equipment, and literature	6
<b>Companies and People</b>	
Expansions, activities, appointments, awards	12
<b>Meetings and Events</b>	
Schedule of important shows and conferences	12
<b>Communication Review</b>	
General news of the industry	17

## ARTICLES

<b>Helical-Beam Antenna Performance</b>	
Edward F. Harris	19
<b>FCC Assignment Philosophy, Part 1</b>	
Edwin L. White	21
<b>Los Angeles County Radio System</b>	
Stephen D. Sykes	22
<b>450-Mc. Mobile Equipment Design</b>	
John F. Byrne and Angus A. MacDonald	26
<b>Single-Sideband Diversity Units</b>	
Murray G. Crosby	29
<b>Long-Life Rectifier Power Supply</b>	
Leo G. Sands	31
<b>The SP-600 Communication Receivers</b>	
J. C. Whitehead	32
<b>Radio Control for Railroads</b>	
Remote switching and signaling by radio	36

THE COVER DESIGN AND CONTENTS OF COMMUNICATION ENGINEERING MAGAZINE ARE FULLY PROTECTED BY U. S. COPYRIGHTS, AND MUST NOT BE REPRODUCED IN ANY MANNER OR IN ANY FORM WITHOUT WRITTEN PERMISSION

ROY F. ALLISON, *Editor*

MILTON B. SLEEPER, *Publisher*

FRED C. MICHALOVE <i>Eastern Manager</i>	CHARLES KLINE <i>Western Manager</i>	EDWARD BRAND <i>West Coast Manager</i>
CLAIRE EDDINGS <i>Production Manager</i>	LILLIAN BENDROSS <i>Accounting</i>	
WARREN SYER <i>Promotion Manager</i>	ELEANOR GILCHRIST <i>Art Director</i>	

*Publication Office:* The Publishing House, Great Barrington, Mass. Tel. Great Barrington 1300.

*Chicago Office:* 426 North Pine Avenue, Tel. Columbus 1-1779.

*New York Office:* 6 East 39th Street, Room 1209, Tel. Murray Hill 5-6332.

*West Coast Office:* 1052 West 6th Street, Los Angeles, Tel. Michigan 1732.

COMMUNICATION ENGINEERING MAGAZINE is mailed on the 20th of January, March, May, July, September, and November.

*Subscriptions:* Should be sent to Publishing House, Great Barrington, Mass. Single copies 65c. Sub. rates: 3 years—\$6.00; 2 years—\$5.00; 1 year—\$3.00.

Contributions will be neither acknowledged nor returned unless accompanied by adequate postage, packing, and directions, nor will COMMUNICATION ENGINEERING Magazine be responsible for their safe handling in its office or in transit.

Entered as second-class matter August 22, 1946, at the Post Office, Great Barrington, Mass., under the Act of March 3, 1879. Additional entry at Post Office, Boston, Mass. Printed in the U. S. A.



Specifically Designed For  
Rugged Mobile Communications Service

**DEPENDABLE**  
and Trouble-Free  
**VIBRATORS**



Select your replacement vibrators wisely... and you, too, will choose Radiart! Laboratory tests and customer reports prove that Radiart Vibrators give LONGER LIFE and trouble-free performance BECAUSE THEY ARE BUILT TO WITHSTAND RUGGED SERVICE! These extra hours of dependable performance is one of the factors that has made Radiart the leader. Superior engineering and design have made them THE STANDARD OF COMPARISON.

At all good radio parts jobbers. Ask for the new Form F781 listing the latest replacement recommendations.



IT'S RIGHT WHEN IT'S RADIART

**THE RADIART CORPORATION**  
CLEVELAND 13, OHIO



• VIBRATORS • AUTO AERIALS  
• ROTORS • TV ANTENNAS • POWER SUPPLIES

CIRCULATION AUDITED BY  
HENRY R. SYKES  
CERTIFIED PUBLIC ACCOUNTANT  
SYKES, GIDDINGS & JOHNSON  
PITTSFIELD, MASSACHUSETTS





# RADIO ENGINEERING LABS., Inc.

PIONEERS IN THE CORRECT USE OF  
ARMSTRONG FREQUENCY MODULATION

## FOR FM NETWORKING OR MONITORING

### The REL 722 Relay Receiver

All kinds of public service and special events programs can be handled over local FM and FM-AM networks with REL 722 Crystal-controlled FM receivers.

Model 722 is a fixed-frequency type of receiver, furnished for operation on any channel in the 88 to 108-mc. band. It is intended for picking up FM programs, and rebroadcasting them from FM or AM stations. This receiver is widely used to provide additional audience coverage for baseball, basketball, and football games, boxing matches, and other sporting events. It is also used for the reception of such programs over public address systems in public halls, theatres, and at outdoor gatherings.

Built to the highest standards of commercial performance and long-time stability, the 722 receiver has a frequency response flat to 1/2 db from 50 to 15,000 cycles, with less than 1/2% distortion. Sensitivity is such that the sputter point is under 2 microvolts, and spurious response more than 70 db below the desired signal.

The complete receiver and power supply are mounted on a standard rack panel 19 ins. wide by 12 1/4 ins. high. For engineering data, price, and delivery schedule, write:

Engineers and Manufacturers of  
Broadcast, Communication, and  
Associated Equipment since 1922

# RADIO ENGINEERING LABORATORIES, Inc.

TEL.: STILLWELL 6-2100 TELETYPE: N. Y. 2816  
36-40 37th Street, Long Island City 1, N. Y.

## SYSTEMS DATA

FIGURES in the accompanying table, compiled from COMMUNICATION ENGINEERING's Weekly Reports of applications filed with the FCC during the months of May and June, show that new records were set for mobile as well as low-power hand-carried units. If the May-June figures are projected on an annual basis, they would show that mobile equipment is up to 96,000 units per year, and portables up to 7,200 per year. From those figures there must be deducted some estimated difference between units actually bought and the numbers shown on license applications.

The table shows the number of new base stations practically unchanged from the March-April report, although the ratio of mobile and base stations on 30 to 50 mc. to those on 152 to 174 mc. is now 1.5 to 1. However, use of the upper-band portables is 4 times that of those designed for the lower band.

Use of 450 to 460 mc. is showing a steady increase. Applications totalled 1,260 mobile and 23 base transmitters in this period. These appeared in filings by the highway maintenance, power utility, taxicab, auto emergency, and miscellaneous common carrier services. This is up from 325 mobile and 10 base transmitters reported for the previous 2-month period. In addition, a number of 450-mc. transmitters were specified for relay and control stations.

Following is a list of transmitters for

which applications were filed in May and June *not included* in the Table because they will be operated outside the 30 to 50-mc. and 152 to 174-mc. bands:

**POLICE:** 24 speedmeters on 2,445 mc.; 10 interzone CW transmitters on 1,634 to 7,935 mc.; 1 relay on 73 mc., 8 on 154 mc., 1 on 454 mc.; 3 control transmitters on 73 mc., 1 on 154 mc., and 2 on 454 mc.

**FIRE:** 1 base station on 1.63 mc.

**FORESTRY CONSERVATION:** 1 relay on 172 mc.

**HIGHWAY MAINTENANCE:** 12 speedmeters on 2,445 mc.; 350 mobile units and 10 base stations on 454 mc.; 6 relays on 73 mc., 4 on 160 mc., and 1 on 458 mc.; 1 control station on 73 mc., 4 on 160 mc., and 1 on 453 mc.

**SPECIAL EMERGENCY:** 1 base station on 3.19 mc.

**POWER UTILITY:** 220 mobile units and 5 base stations on 456 mc.; 1 relay on 37 mc., 4 on 73 mc., 1 on 156 mc., 2 on 450 mc., 2 on 1,985 mc., and 4 on 6,700 mc.; 1 control station on 37 mc., 7 on 73 mc., 2 on 456 mc., 1 on 954 mc., 2 on 1,935 mc., 5 on 2,000 mc., and 8 on 6,625 to 6,725 mc.

**PIPELINE PETROLEUM:** 12 mobile units on 1.614 mc., and 15 base stations on 1.614 to 2.292 mc.; 10 relays on 73 mc., 1 on 456 mc., and 33 on 6,785 mc.; 3 control stations on 73 mc., 1 on 456 mc., 1 on 1,980 mc., and 14 on 6,484 to 6,785 mc.

Concluded on page 44

TABLE OF APPLICATIONS FILED MAY 1 TO JUNE 30, 1953

	TOTAL		—30 to 50 mc.—			—152 to 174 mc.—			
	MOBILE	BASE	PORT.	MOBILE	BASE	PORT.	MOBILE	BASE	PORT.
Police .....	3,131	160	74	1,894	88	35	1,237	72	39
Fire .....	1,902	92	53	1,522	51	27	380	41	26
Special Emergency.....	322	99	—	237	90	—	85	9	—
Highway Maintenance..	420	26	10	400	24	10	20	2	—
Forestry Conservation....	171	54	53	146	27	53	25	27	—
Power Utility.....	1,058	131	14	706	87	9	352	44	5
Pipeline Petroleum.....	877	146	—	716	114	—	161	32	—
Special Industrial.....	3,399	255	54	2,680	201	36	719	54	18
Low-Power Industrial....	—	—	948	—	—	106	—	—	842
Relay Press.....	16	2	—	—	—	—	16	2	—
Motion Picture .....	—	—	—	—	—	—	—	—	—
Forest Products .....	477	45	3	440	36	3	37	9	—
Taxicabs .....	2,403	166	—	—	—	—	2,403	166	—
Railroads .....	523	48	—	—	—	—	523	48	—
Highway Trucks .....	410	36	—	410	36	—	—	—	—
Intercity Busses .....	10	5	—	10	5	—	—	—	—
Transit Utilities .....	—	—	—	—	—	—	—	—	—
Auto Emergency.....	52	12	—	52	12	—	—	—	—
Radio Paging .....	—	15	—	—	15	—	—	—	—
Common Carrier.....	175	3	—	175	3	—	—	—	—
Misc. Common Carrier..	656	19	—	—	—	—	656	19	—
<b>TOTALS .....</b>	<b>16,002</b>	<b>1,314</b>	<b>1,209</b>	<b>9,388</b>	<b>789</b>	<b>279</b>	<b>6,614</b>	<b>525</b>	<b>930</b>

COMMUNICATION ENGINEERING July-August, 1953



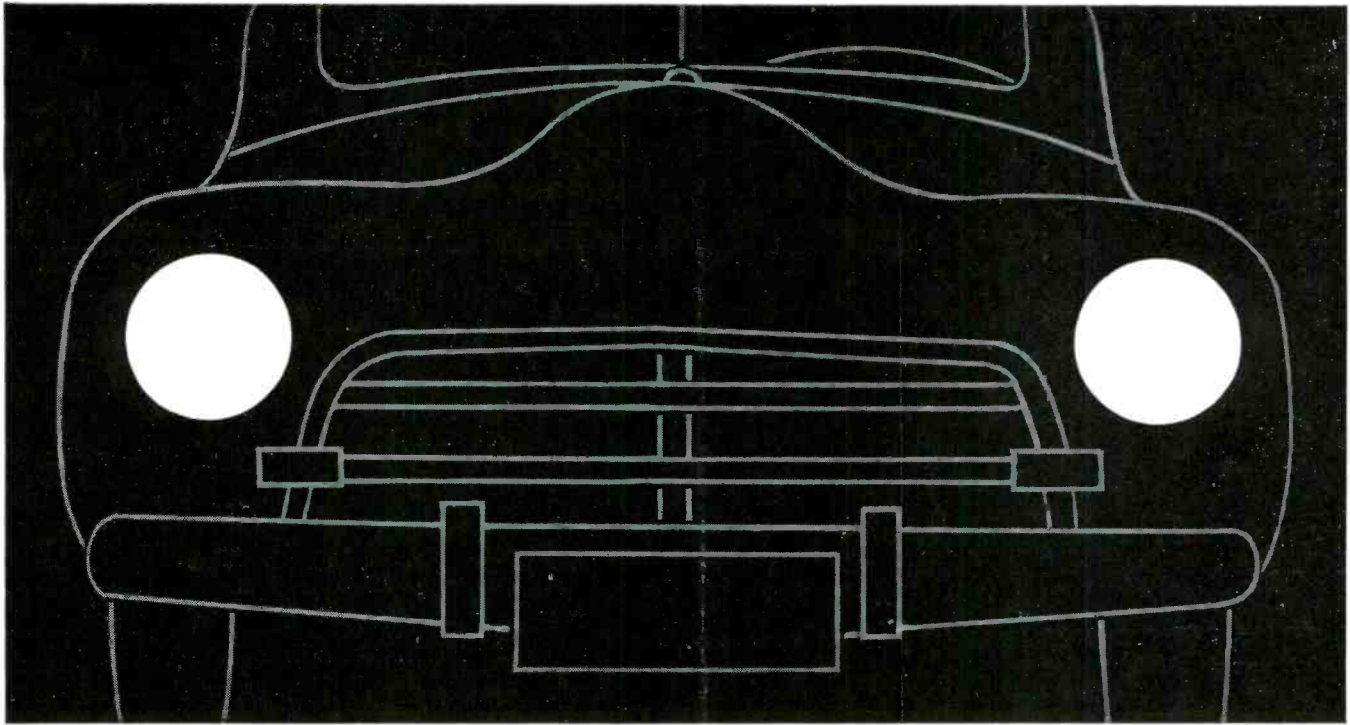

# Revolutionary 2-Way Mobile Radio Pulls No More Amps Than A Headlight!

... 15 great features, including a new electronic squelch that gives you *all of the signal, none of the noise.*

This new Bendix 2-way radio is called the Traffic-master. It's a clean and rugged, compact unit. Let's look at some of the advantages it has over ordinary mobile units.

## A new electronic squelch

It's a Bendix developed squelch that eliminates chopped up messages in fringe areas. It has a delaying action that screens out all the noise. It gives you only the voice message. True and sharp like in a home radio from 20 miles and farther out.

## From Hand Sets to Land Stations

In addition to the latest type of mobile equipment ... Bendix offers a complete line of fixed stations from 21½ to 250 watts. As well as accessories from hand sets to speakers, antenna to shock mounts ... plus all technical help in obtaining license and complete system engineering.

\*Reg. U. S. Pat. Off

## BUY ON INSTALLMENT PLAN

Bendix has developed with local banks, what has been called one of the finest financial plans anywhere. You pay for your new Bendix 2-way radio ... as you use it and as it makes money for you. Write for details.

Write today ... because you too can now afford the best in 2-way radio. Bendix costs you no more than ordinary equipment. Get all the information.

## Longer life

Your new Bendix Traffic-master has been field tested under the most difficult conditions. Longer life of tubes and components is assured. Another big feature is that Bendix uses Selenium stacks ... instead of rectifier tubes. They almost never wear out!

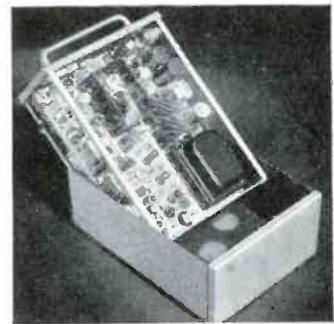

**BENDIX\* RADIO**  
BALTIMORE 4, MD.

DIVISION OF  AVIATION CORPORATION

EXPORT SALES: Bendix International Division, 72 Fifth Avenue, New York 11, N. Y.

*Bendix* THE MOST TRUSTED NAME IN *Radio*

# NEW...

**POWER BOOSTER**

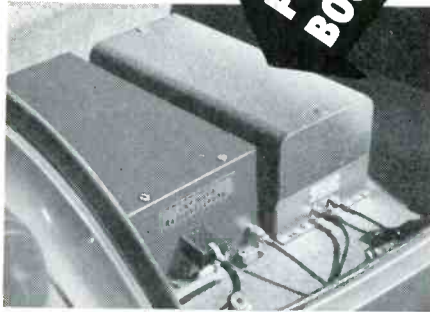

## NEW POWER BOOSTER Boosts Power instantly!

Stronger signals and greater transmission range even in hilly country are now possible through use of the new Kaar Power Booster, which increases by six times the power output of any 8 to 10 watt mobile transmitter, without adding to standby battery needs—a recent, outstanding engineering achievement of the Kaar research laboratories.

**DEPENDABLE  
MOBILE  
COMMUNICATION**

**RADIOPAK**



Rugged construction... simplicity of design... lowest possible battery drain... exceptional voice quality—these are the features that make the Radiopak the most dependable single unit mobile radiotelephone available today. Furnished for both the 25 to 50 mc band and the 152 to 174 mc band, the Radiopak is ideally suited for use in police cars, taxis, fire department vehicles, trucks, and three-wheeled motorcycles.

- WRITE FOR SUMMARY CATALOG ON ALL KAAR MOBILE EQUIPMENT

**DEALERS!**

Kaar is the only major radiotelephone manufacturer selling through authorized dealers. Write for complete information.

**KAAR**  
**ENGINEERING CORP.**  
MIDDLEFIELD ROAD • PALO ALTO, CALIF.

# PRODUCT INFORMATION

**Cordless Switchboard:** Especially suited to dispatching in MCC services, a new cordless switchboard unit has been developed for

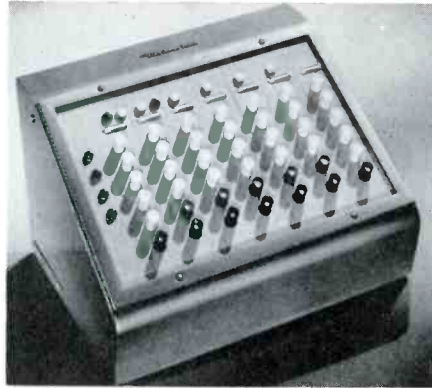

inter-connection of a telephone system with a mobile 2-way radio, microwave, or power-line carrier system. Any one of five telephone lines can be connected to an RF system by pressing a button; simultaneous conversations can be carried on over four independent talking channels. Any number of switchboards can be paralleled, and more than one radio channel can be used. Tally lights are provided. Motorola, Inc., Communications and Electronics Division, 900 N. Kilbourn Ave., Chicago 51, Ill.

**Compression-Molded Toroids:** Types 206, 848, 930, 671, 395, and 269 toroids can now be obtained in compression-molded plastic, uncase. Mounting is accomplished by means of bushing, threaded for 6-32 screw or drilled for 6-32 bolt. Complete data can be obtained from Communication Accessories Company, Hickman Mills, Mo.

**UHF Grid-Dip Meter:** Model 101B grid-dip meter covers frequency ranges from 300 to 425, 425 to 650, and 650 to 1,000 mc. by using three plug-in coils. Dial is calibrated individually to accuracy of  $\pm 2\%$ . Can be used as auxiliary signal generator with internal or



external modulation, as well as absorption-type frequency detector. Boonton Electronics Corp., Boonton, N. J.

**Tool Guide:** A wide assortment of tools for the repair and maintenance of radio and electronic equipment is to be found in a 36-page catalog just released. Included are detailed illustrations, specifications, technical data, and prices on tools made by 17 manufacturers. Copies can be obtained from United Catalog Publishers, Inc., 110 Lafayette Street, New York 13, N. Y.

**Impulse Recorder:** A versatile new magazine recorder accepts on-off information from two sources, and records each separately along with a time-base trace on electro-sensitive paper tape. Marking power supplied by recorder is controlled by on-off switch connected to action to be recorded. Very small, efficient, rugged, and inexpensive, the unit can be furnished with widely varying speed range. Maximum resolution is about 1/6 second. Alden Electronics and Impulse Recording Company, Westboro, Mass.

**Modulation Monitor:** A number of design refinements are incorporated in the MD-33 modulation monitor, illustrated here. successor to the original type MD-25. Modulation swing to 20 kc. can be read on either of two



RF ranges, 25 to 70 and 70 to 174 mc. It is only necessary to tune the meter to resonance with the incoming signal, and then the modulation can be read directly. A back-of-chassis adjustment permits accurate readings of narrow-band modulation also. Browning Laboratories, Inc., Winchester, Mass.

**Varistors:** Comprehensive data on voltage-current characteristics, current ratings, temperature performance, typical applications, and dimensions for a new line of varistors is contained in 6-page bulletin SR-3, available from International Resistance Company, Special Products Division, 401 North Broad Street, Philadelphia 8, Pa.

**Vibrator Converter:** Recently developed for telephone, communication, and stand-by use is a vibrator-converter supply capable of delivering continuous power up to 350 watts at 115 volts, 60 cycles from an input of 48 volts DC. This unit, model 3494, can be activated externally by a voltage-sensing circuit, and is capable of picking up a full load 50 milliseconds after the start relay is energized. Output voltage, waveform, and frequency are relatively insensitive to input and load changes. A standby vibrator with automatic changeover is supplied. Suitable for rack mounting. Bulletin No. EB-3494 can be obtained from Cornell-Dubilier Electric Corp., South Plainfield, N. J.

*Continued on page 8*



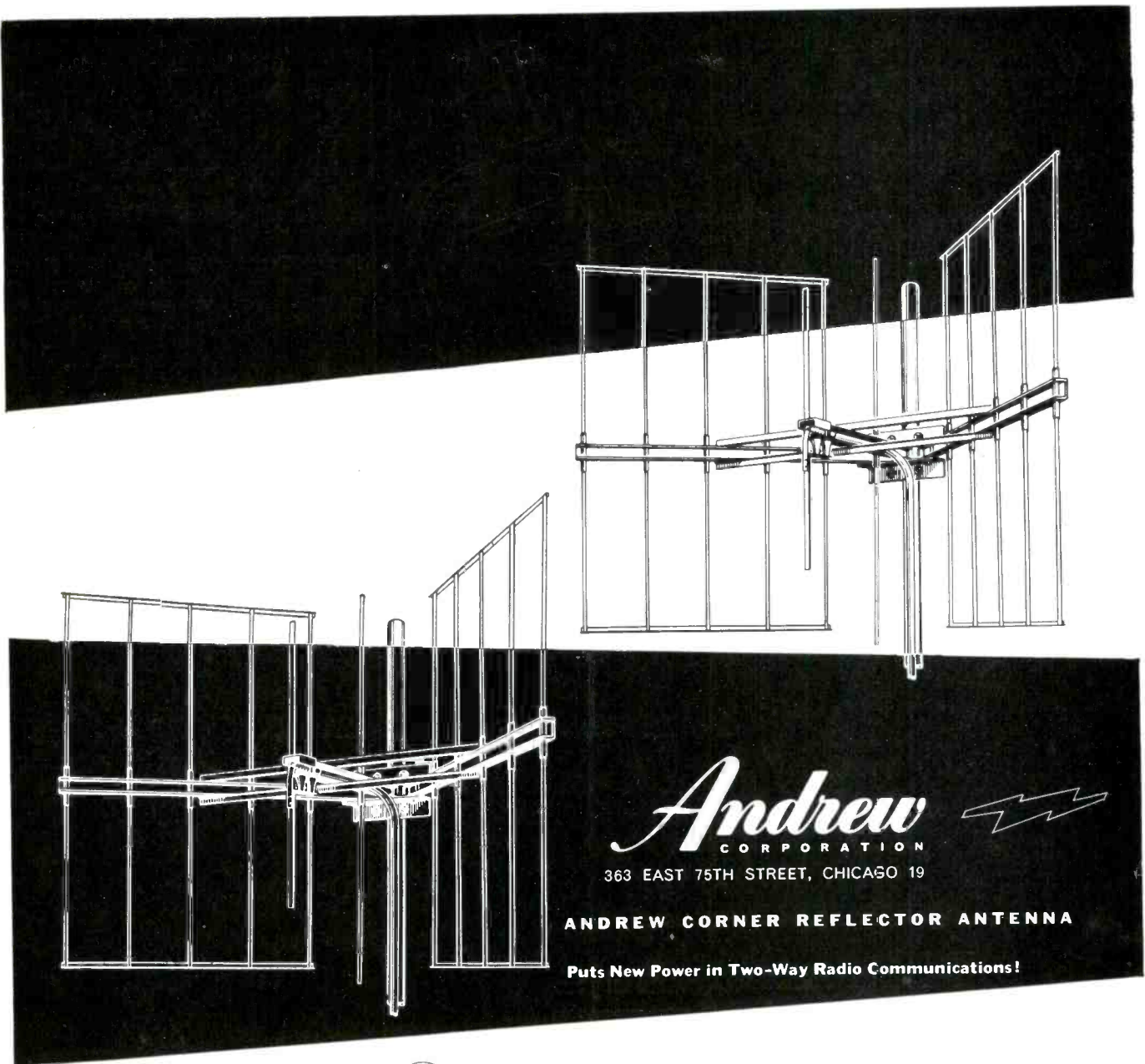

*Andrew*  
CORPORATION

363 EAST 75TH STREET, CHICAGO 19

**ANDREW CORNER REFLECTOR ANTENNA**

**Puts New Power in Two-Way Radio Communications!**

**S**tronger signals at greater distances are **BUILT-IN** this new narrow-angle antenna. Ideal for serving long stretches of highway, rail or pipe lines, it is equally effective for point-to-point communications, or back-to-back with other services. Gains up to 12 DB can be achieved by stacking. Vertically polarized, uni-directional, Andrew Corner reflector antennas are available in all mobile communications bands. Put them to work for you to **INCREASE** and **IMPROVE** your radio coverage. For more information, write us today.

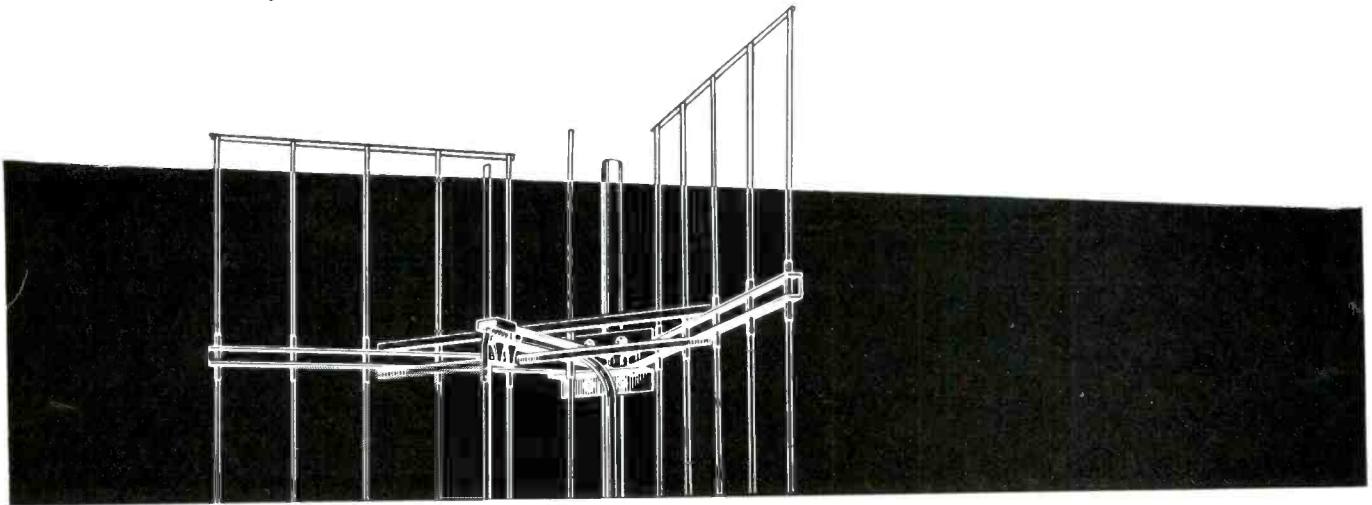

formerly *FM-TV* RADIO COMMUNICATION

You Replace with  
the Best when  
you Buy **RCA**



More RCA-2E26 tubes are used in mobile transmitters than any other transmitting tube type.

**W**HEN YOU REPLACE TUBES in your communications equipment, you want the best tubes you can obtain. That's why it pays to insist on RCA Tubes.

RCA's engineering leadership, production experience, and rigid standards of quality control assure you of tube *Performance Security* in the operation of your mobile communications equipment. As evidence of this, more RCA tubes have been performance-proved under field operating conditions than any other make.

**Call your local RCA Tube Distributor for efficient service and fast delivery.**



**RADIO CORPORATION of AMERICA**  
**ELECTRON TUBES HARRISON, N.J.**

## NEW PRODUCTS

(Continued from page 6)

**Tower Bulletin:** Various types of guyed and self-supporting towers for all types of antennas are described in a 20-page bulletin entitled "Blaw-Knox Towers." RTMA standard specifications are given. Obtainable free on request to Blaw-Knox Company, Tower Dept., Farmers Bank Bldg, Pittsburgh 22, Pa.

**Sound Catalog:** General catalog No. 44 lists complete information on microphones, microphone parts and accessories, cartridges and pickups, wire and tape recording heads. Available from Shure Brothers, Inc., 225 West Huron Street, Chicago 10, Ill.

**Subminiature Tube Clamps:** A new clamp for subminiature tubes has been developed for use under conditions of extreme heat, vibration, and shock. Heat transfer is optimized by use of alloy containing 99.5% silver. Models for top and end insertion or end insertion only are available. Where maximum heat transfer is not important, clamps of silver-plated beryllium copper can be obtained. The Bircher Corp., Valley Blvd., Los Angeles 31, Calif.

**Heavy-Duty AF Amplifier:** Model 101-D amplifier is designed for long, continuous operation with a minimum of maintenance. for use in railroad, warehouse, and depot paging systems, and communication applications. Delivers 50 watts with less than 3% harmonic distortion from 100 to 8,000 cycles; frequency response is flat within 1 db from 30



to 15,000 cycles; voice band filter available. Load impedance from 1 to 1,000 ohms, balanced or grounded. Rack or cabinet mounting. Langevin Mfg. Corp., 37 West 65th Street, New York 23, N. Y.

**Selenium Rectifiers:** Type K Magamp selenium rectifiers, for all magnetic amplifier circuits and sensing devices, are described completely in 8-page booklet TD-52-650. Tables, formulas, and examples are provided. Westinghouse Electric Corp., Box 2099, Pittsburgh 30, Pa.

**Nylon Cap Connectors:** Tube cap connectors with nylon insulation are now available in quantity. Nylon operating temperature limit, 300°F., lies between that of polyethylene and Kel-F. Since cost is substantially less than that of Kel-F, these caps should be of value for many applications in which temperature requirement exceeds polyethylene limit but does not approach Kel-F limit. Caps are furnished with leads integrally molded into cap insulation;

Continued on page 10



# FREQUENCY CONTROL FOR MILITARY APPLICATION



MIL CRYSTAL UNIT	BLILEY CRYSTAL HOLDER	FREQUENCY RANGE MEGACYCLES	OPERATING TEMPERATURE RANGE (Centigrade)	FREQUENCY TOLERANCE OVER OPERATING RANGE
CR-15	AR23W	0.080 - 0.19999	-40° to +70°	± .01%
CR-16	AR23W	0.080 - 0.19999	-40° to +70°	± .01%
CR-18	BH6A	0.8 - 15.0	+70° to +90°	± .005%
CR-19	BH6A	0.8 - 15.0	-55° to +90°	± .005%
CR-23	BH6A	10.0 - 75.0	-55° to +90°	± .005%
CR-24	BH7A	15.0 - 50.0	-55° to +90°	± .005%
CR-27	BH6A	0.8 - 15.0	+70° to +80°	± .002%
CR-28	BH6A	0.8 - 15.0	+70° to +80°	± .002%
CR-29	AR23W	0.080 - 0.19999	+70° to +80°	± .002%
CR-30	AR23W	0.080 - 0.19999	+70° to +80°	± .002%
CR-32	BH6A	10.0 - 75.0	+70° to +80°	± .002%
CR-33	BH6A	10.0 - 75.0	-55° to +90°	± .005%
CR-35	BH6A	0.800 - 20.0	+80° to +90°	± .002%
CR-36	BH6A	0.800 - 15.0	+80° to +90°	± .002%
CR-37	BH9A	0.090 - 0.250	+70° to +80°	± .02%
CR-42	BH9A	0.090 - 0.250	+70° to +80°	± .003%
CR-44	BH6A	15.0 - 50.0	+80° to +90°	± .002%
CR-45	BH6A	0.455	-40° to +70°	± .02%
CR-46	BH6A	0.2 - 0.500	-40° to +70°	± .01%
CR-47	BH6A	0.2 - 0.500	+70° to +80°	± .002%

**BULLETIN NO. 43 CONTAINS A QUICK REFERENCE INDEX FOR MILITARY TYPE CRYSTAL UNITS---SENT UPON REQUEST**

**Bliley CRYSTALS**

**BLILEY ELECTRIC COMPANY  
UNION STATION BUILDING, ERIE, PA.**



# Speeding Electronic Progress

through

crystal  
research



JK STABILIZED G-12 CRYSTAL

The JK G-12 is a precision 100 kc G-T cut crystal intended for operation in Meacham Bridge and similar oscillators. Available for operation at series resonance or into large load capacities. Resistance approximately that of usual lamp used for amplitude stabilization, simplifying bridge circuit design. The JK G-12 is vacuum sealed. Equipped with octal base it is more convenient than usual "soldered-in" type of precision standard crystal. Suitable for transistor oscillators. Will fit JK 07EH temperature control unit. Consult us on specific applications.

## Did you know?

Surgical cleanliness during manufacture is an important reason for the unequalled stability of JK Crystals. In an airconditioned, dust-free plant crystal blanks are repeatedly cleaned with chemicals, washed in distilled water and spun dry — plain tap water or even a fingerprint would impair stability. The final crystal, vacuum sealed in a glass holder, provides stability equal to a watch that would remain accurate to within three seconds over a year's time. Creative research combined with today's most modern production facilities brings you today's finest — JK "Crystals for the Critical".

THE JAMES KNIGHTS COMPANY, SANDWICH, ILLINOIS



## NEW PRODUCTS

(Continued from page 8)

lead length to specification. Alden Products Company, 117 North Main Street, Brockton 64, Mass.

**Tube Picture Book:** An educational picture booklet of photographs, cutaway drawings, and exploded views showing structural details of typical glass, metal, and miniature tubes; subminiature, power, and super-power triodes; thyratron, high-voltage rectifier, and pencil-type tubes; TV picture, studio camera, and industrial camera tubes, and multiplier phototubes has just been published at 25 cents per copy. Commercial Engineering RCA Tube Department, Harrison, N. J.

**Miniaturized Capacitors:** The TWM series of high-temperature metal-cased miniaturized tubular capacitors has been added to the Demicon line. These new units employ extended-foil construction and du Pont Mylar polyester film as a dielectric. Throughout the temperature range of  $-55$  to  $+130^{\circ}$  C. no derating is required; up to  $+165^{\circ}$  C., derating only to 75% is necessary. Complete engineering information is given in bulletin NB-151, available from Cornell-Dubilier Electric Corp., Industrial Division, South Plainfield, N. J.

**Pulse Transformers:** A miniaturized line of pulse transformers for blocking oscillator applications has been announced. Three styles are available: plug-in octal base construction hermetically-sealed MIL-T-27 construction, and an encapsulated version with built-in solder seal for chassis mounting. Raytheon Mfg. Company, Waltham Mass.

**Phenolic Terminal Blocks:** For electronic and communication equipment, four types of phenolic terminal blocks providing 40, 60, 80, or 100 pre-tinned double-notched terminals have excellent electrical characteristics, structural stability, and low water absorption. Specifications and prices given in bulletin B1-P2, from Lenkurt Electric Company, County Road, San Carlos, Calif.

**Communication Receiver:** The new dual-conversion SX-88 communication receiver is said to have a very high degree of usable



selectivity, an audio system of near high-fidelity quality, and maximum obtainable control of selective fading. The Hallicrafters Company, 4401 West 5th Avenue, Chicago 24, Ill.

**Operating Manual:** A comprehensive 24-page illustrated reference and operating manual on the machining of glass-bonded mica has just been published. Entitled "From One Machinist to Another", the booklet is available from Mycalex Corp. of America, Clifton, N. J.

**Sealed Transformers:** A new line of her-



metically sealed transformers, designed to MIL-T-27 specifications, includes specific types chosen by ASES for universal military applications and cover a wide type range. All are readily available. Described in a bulletin from Ferranti Electric, Inc., 30 Rockefeller Plaza, New York City.

**Small Tower:** New addition to the Rohn tower line is the No. 5, inexpensive 9-inch triangular tower for low-height applications. These are of heavy steel tubing, self-supporting up to 40 ft., and can be climbed. Rohn

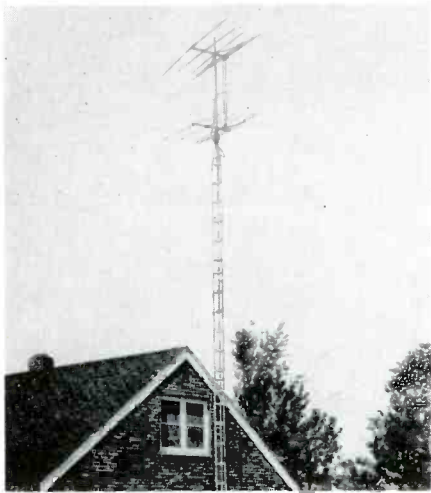

Mfg. Company, 116 Limestone, Bellevue, Peoria, Ill.

**Variable Tubular Capacitor:** Type CST-50 tubular ceramic variable capacitor has capacity range from 1.5 to 12 mmf., can be locked securely with no change in capacity. Dimensions 19/32 in. long by 1/4 in. diameter. Cambridge Thermionic Corp., 445 Concord Avenue, Cambridge 38, Mass.

**Frequency Meter:** Model 5570 is a direct-reading frequency meter with an accuracy of 1 part in 10 million,  $\pm 1$  count, from 0 to 42 mc. Can be attached to digital recorder for drift measurement. Simple means for internal adjustment to WWV frequency is provided. Suitable for use up to 160 mc. with accessories. Display time 1 to 5 seconds, continuously variable. Berkeley Scientific Division, Beckman Instruments, Inc., 2200 Wright Avenue, Richmond, Calif.

**Junction Diodes:** A new line of germanium diodes utilize small-area junctions rather than point contacts as electrical connections. It is claimed that this produces more rugged and stable diodes which will operate at higher currents and/or higher voltages than point-contact types; at the same time, because the junctions are small in area, high-frequency performance is not affected. Bulletin 1002, giving complete information, can be obtained from Transistor Division, National Union Radio Corp., Hatboro, Pa.

**Pulse Generator:** Model 618B signal generator is intended for use in the range from 3,800 to 7,600 mc., which it covers continuously. Frequency and voltage are set and read directly. External or internal pulse modulation from 40 to 4,000 pps. can be obtained. Pulse width is variable from 3 to 300 microseconds. Synchronization with external sine wave or pulses is possible. Hewlett-Packard Company, 395 Page Mill Road, Palo Alto, Calif.

## Had we but world enough and time

no one would need monitors but speed in communication is economy and often a life and death matter.



MODEL PR9 FOR 152-174 MC BAND

If you have a police, fire, forestry, pipeline, civil defense, taxi or any other vital 2-way radio system, here is how monitors pay off.

Says Chief McMurtry—of the Sheridan, Indiana, Volunteer Fire Department:

"In the past, the largest obstacles for our Volunteer Fire Department to overcome has been the method of determining the exact location of the fire and beating the traffic there. Speed of course is essential for the efficient operation of any Fire Department. Now, with the Town Police Radio Base Station located in the Department and with the use of 18 PR9 Receivers in the homes of our members we not only learn of the fire before the Town Siren is blown, but we in many cases arrive at the fire before the equipment....*We do not hesitate to recommend this Receiver to any Department.*"

Franchises available, write for information.

**RADIO APPARATUS CORPORATION**  
FACTORY—55 NORTH NEW JERSEY STREET  
INDIANAPOLIS 4, IND., PHONE: ATLANTIC 1524  
SALES OFFICE: 1604 WEST 92ND STREET  
CHICAGO 20, ILL., PHONE: BEVERLY 8-7770

**MONITORADIO**



Chief McMurtry and members of Sheridan, Indiana, Volunteer Fire Department with John Oakley Vice-President of Midwest Fire and Safety Equipment Co. who supervised monitorradio installation.



burton browne advertising

# ONLY PLATT 2-WAY RADIO gives you ALL these IMPORTANT ADVANTAGES



Model 30-TRM-31

## 1. COMPACTNESS

Platt Mobile Radio Equipment incorporates a transmitter and receiver mounted on a single chassis which is installed under one cover with a vibrator power supply affording 30 watts of R-F output in the 152-174 mc band. 24 tubes. Dimensions: 14 $\frac{1}{4}$ " x 9 $\frac{3}{4}$ " x 5 $\frac{3}{4}$ ". Cabinet opens from either side for easiest servicing.

## 2. DEPENDABILITY

Laboratory and comparative field tests have shown Platt 2-way radio to be the most dependable equipment available today! Satisfied users report its performance to be unmatched under the severest conditions.

## 3. EASIEST INSTALLATION

Brackets are supplied for front mounting under dashboard, glove compartment, or driver's seat. Controls and loudspeaker are incorporated as an integral part of the cabinet. Only one short lightweight cable and antenna assembly are required for complete installation.

## 4. COMPETITIVELY PRICED

Platt Mobile Equipment is comparatively low priced, making it an ideal choice for taxi fleets, police, fire departments, forestry, railroads, trucks, civil defense, etc.

## 5. GUARANTEED

Platt equipment is fully guaranteed against defective materials and workmanship for 90 days.

GET ALL THE FACTS ON THIS ADVANCED EQUIPMENT. WRITE FOR LITERATURE TODAY!

**PLATT Manufacturing Corp.**

489 BROOME STREET, N. Y. 13, N. Y.  
PHONE: WORTH 4-0827

## THE COVER PICTURE

Almost unappreciated during the scramble of the TV networks to get films of the Coronation was the fact that radio and newspaper coverage was solid, in spite of magnetic storms; radiophotos and detailed accounts of the proceedings come uninterrupted over the facilities of Press Wireless and RCA Communications. Anthony Hilferty of Press Wireless is shown on the cover operating Crosby single-sideband triple-diversity equipment which was used at Baldwin, Long Island to pick up the transoceanic broadcasts. This setup is described in detail beginning on pages 29 and 32.

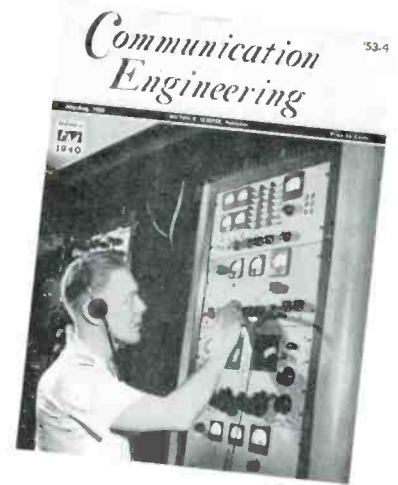

# COMPANIES & PEOPLE

**The Truce in Korea:** Some military contractors started to prepare for the possible effects of a Korean truce long before it became more than a highly speculative possibility. Others, among them companies previously warned by terminations, have not taken action to anticipate the alternatives of going out of business or tapping civilian markets. At this time, the only certainties are that 1) there will be no immediate change in the international climate, 2) taxes will be lowered by reducing military expenditures just as soon and as much as the President and Congress feel that this can be done without impairing national security, and that 3) the Administration will fix a target date for such action somewhat in advance of the 1954 elections.

**West Coast Office for RTMA:** Will be opened immediately in Los Angeles, with Joseph J. Peterson, newly appointed member of the engineering department, in charge. In Washington, Jean A. Caffiaux has been appointed assistant to RTMA chief engineer Ralph Batcher.

**Communication Aids:** Union Switch & Signal division of Westinghouse Air Brake has formed new engineering and sales departments to handle the special apparatus requirements of its customers in aviation, electronic components and systems, and electro-mechanical devices. E. G. Agnew has been appointed manager of general apparatus engineering, and Allan S. Robertson manager of sales.

**John S. Brown:** Appointed director of engineering at Andrew Corporation, in charge of the company's engineering and development program. Lawrence R. Krahe has been named to head the advance development group at Andrew's

420-acre antenna development center, Orland Park, Ill.

**Baltimore Civil Defense:** Sixteen base stations will be installed, two at the main control center, and the remainder at public library buildings. Fixed and mobile equipment will be supplied by Bendix Radio.

**Freshmen Engineers Increase 29%:** Louis M. Stark of Westinghouse, in an address at MIT: "In 1951, some 40,000 freshmen enrolled in engineering, and this group will produce about 22,000 graduates in 1955. In 1952, the enrollment of first-year engineering students rose to about 52,000, justifying an estimate of 29,000 graduates in 1956. . . . This is proof that the efforts of engineering societies, industries, universities, and high school science teachers have had a marked effect in steering young people into careers in technical fields. . . . Of primary importance is the need for high school science teachers to keep the

*Continued on page 13*

## MEETINGS and EVENTS

- AUGUST 19 - 21,  
WESTERN ELECTRONIC SHOW  
San Francisco Auditorium, San Francisco
- SEPTEMBER 1 - 3,  
INT'L SIGHT AND SOUND EXPOSITION  
Palmer House, Chicago
- SEPTEMBER 21-25,  
8TH NATIONAL INSTRUMENT EXHIBIT  
Hotel Sherman, Chicago
- SEPTEMBER 28 - 30,  
9TH NATIONAL ELECTRONICS CONFERENCE  
Hotel Sherman, Chicago
- OCTOBER 14 - 17,  
AES CONVENTION, AUDIO FAIR  
Hotel New Yorker, N. Y. C.
- OCTOBER 19 - 21,  
RTCM FALL MEETING  
Edgewater Beach Hotel, Chicago
- OCTOBER 20 - 22,  
COMMUNICATIONS SECTION, AAR  
Hotel Plaza, San Antonio, Texas
- OCTOBER 26 - 28,  
RTMA-IRE RADIO FALL MEETING  
Toronto, Ontario, Canada



## COMPANIES & PEOPLE

(Continued from page 12)

science curriculum up to date. . . . There is also a need, in addition to modern curricula, for informed guidance and for the teaching of science as a part of general education."

**Dr. Wilbur A. Lazier:** Elected vice president and technical director in charge of research and engineering at Sprague Electric Company, North Adams, Mass. Dr. Preston Robinson, a director and former head of research and engineering, will continue as a consultant.

**Lloyd A. Hammarlund:** Elected to the executive board of the Electronic Manufacturers Association. Principal function of EMA is to handle relations with IUE and CIO groups on behalf of New York and New Jersey radio manufacturers. Mr. Hammarlund is also employer-trustee of the District Welfare Plan.

**NCUR Officers:** Dale Schreiner, manager of Woodbury Electric Cooperative, Morville, Ia., has been elected chairman of the National Committee for Utilities Radio, with R. W. Lewis, Boston Edison Company, vice chairman, and T. G. Humphreys, Alabama Gas Corporation, Birmingham, secretary. This committee handles frequency coordination problems for the public utilities, working in cooperation with the Edison Electric Institute, American Gas Association, National Rural Electric Cooperative Association, and other sponsoring organizations.

**450 to 460-Mc. Allocations:** Although a hearing is scheduled for this fall, the FCC has finalized the proposal on allocations in this band, released June 29, to the extent that applications are being accepted only in accordance with the following plan:

**INDUSTRIAL SERVICE:** 10 channels from 451.05 to 451.95 mc. for base and mobile transmitters; 10 channels from 456.05 to 456.95 mc. for mobile transmitters only.

**TAXICABS:** 5 channels from 452.05 to 452.45 mc. for base and mobile transmitters; 5 channels from 457.05 to 457.45 mc. for mobile transmitters only.

**AUTO EMERGENCY:** 1 channel at 452.55 mc. for base and mobile transmitters; 1 channel at 457.55 mc. for mobile transmitters only.

**RAILROAD & TRANSIT UTILITIES:** 4 shared channels from 452.65 to 452.95 mc. for base and mobile transmitters; 4 shared channels from 457.65 to 457.95 mc. for mobile transmitters only.

**PUBLIC SAFETY:** 10 channels from 453.05 to 453.95 mc. for base and mobile

Continued on page 14

# Covering the Coronation

## Despite Magnetic Storm

**PRESS WIRELESS, INC.**  
CANTIAQUE ROAD (WEST SIDE)  
P. O. 248 HICKSVILLE, L.I.  
HICKSVILLE, N.Y. 11700

VIA WIRE

June 1954

Crosby Laboratories, Inc.  
Box 233  
Hicksville, New York  
Gentlemen:-

The importance of your Crosby Triple-Diversity Single-Sideband Receiver, Model 155, in our covering the British Coronation ceremonies cannot be over-emphasized. We depended on this remarkable receiver, as well as Model 154H, for both precision performance and complete reliability under the most severe conditions of interference and fading.

Very truly yours,  
RCA COMMUNICATIONS, INC.  
E. J. Murphy  
Engineering Manager  
Riverhead Station

Very truly yours,  
W. A. Hilforty  
Chief Engineer

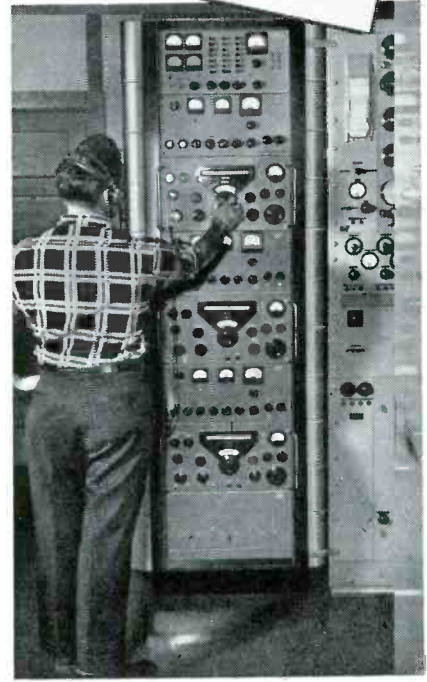
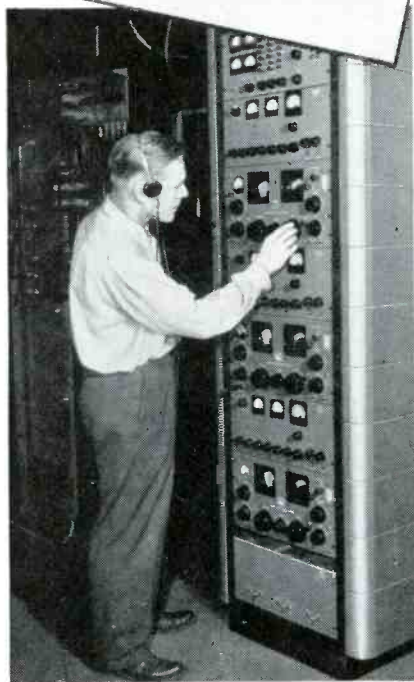

SINGLE-SIDEBAND AND EXALTED CARRIER DIVERSITY RECEIVERS • BROADCAST AND COMMUNICATIONS APPARATUS • MULTIPLEX TRANSMITTING AND RECEIVING EQUIPMENT  
COMPLETE ENGINEERING SERVICE

Founded in 1948, Crosby Laboratories, Inc. is an engineering, development and production firm whose accomplishments include many original contributions to the science of long-range radio communications. The organization is staffed by electronics engineers with more than twenty-five years' experience in the fields of radio communications and applied electronics.

For complete, interesting literature, write to—

**CROSBY LABORATORIES, INC.**

Robbins Lane • Hicksville, N. Y.

# NEW!

## RG/LOW TEMPERATURE CABLE

for SIGNAL CORPS  
and AIR FORCE

- Full Electrical and Mechanical Efficiency at  $-40^{\circ}$  C.
- Non-Contaminating Black Jacket.
- Identification by Ink Marking to Eliminate Thin Spots on the Jacket.

For several years the Signal Corps has been looking for a cable jacket compound that meets the requirements listed above. In addition, the cable must be capable of being bent around a mandrel ten times the diameter of the cable at  $-40^{\circ}$  C. without cracking. AMPHENOL's new low temperature cable, now on a production basis, not only fully meets all of these requirements but also provides a large safety margin.

### CONNECTORS for RG/ CABLES

Because AMPHENOL has complete laboratory and engineering facilities, research on RF Connectors is a constant development. New connectors are constantly being added to the list of cataloged items. As a result, AMPHENOL offers the most complete selection of quality RF Connectors available from a single manufacturer.

For complete information on the entire line of AMPHENOL manufacture, write today for your free copy of the AMPHENOL B-2 General Catalog.

AMERICAN PHENOLIC CORPORATION  
1830 SOUTH 54TH AVENUE • CHICAGO 50, ILLINOIS



**AMPHENOL**

## Professional Directory

**FRANK H. McINTOSH**

Consulting Radio Engineer

1216 Wyatt Bldg., Washington 5, D. C.  
MEtropolitan 8-4477

**JOHN D. TRILSCH CO.**

TOWERS for

RADIO • TELEVISION  
COMMUNICATION

1310 McKinney Ave., Houston, Texas  
Phone: ATwood 9351

### General Electric TWO WAY RADIO

- Systems Engineering
- Installation
- Contract Maintenance

#### Communications Engineering Co.

900 Dragon St.  
Dallas, Tex.  
PR 7508

6422 Long Dr.  
Houston, Tex.  
OL 8501

## COMPANIES & PEOPLE

(Continued from page 13)

transmitters: 10 channels from 458.05 to 458.95 mc. for mobile transmitters only.

**REMOTE PICKUP BROADCAST:** No details were announced on the 20 channels assigned for remote pickup broadcast transmitters, base and mobile, on 450.05 to 450.95 and 455.05 to 455.95 mc.

**DOMESTIC PUBLIC:** No details were announced for the base and mobile transmitters to be operated on 20 channels from 454.05 to 454.95 and 459.05 to 459.95 mc. Purpose of assigning separate mobile-only bands in the safety and special services is to take care of the larger number of mobile transmitters, a plan that can give the effect of doubling system capacity to handle incoming calls. It is also proposed to assign the 4 taxi channels on 152.27 to 152.45 mc. to fixed and mobile transmitters, and the 4 channels from 157.53 to 157.71 to mobile transmitters only.

**New Appointments:** Walter W. Watts has been elected vice president in charge of technical products at RCA, and Theodore A. Smith has been elected vice-president in charge of engineering prod-

Concluded on page 15



## Professional Directory

### Jansky & Bailey, Inc.

Consulting  
Radio & Electronic Engineers

Suite 970 National Press Bldg.  
Washington 4, D. C. ME 8-5411

Engineering Building  
1339 Wisconsin Ave., N.W.  
Washington 7, D. C. AD 4-2414

### WELDON & CARR

Consulting  
Radio & Television  
Engineers

Washington, D. C. Dallas, Texas  
1605 Connecticut Ave. 4212 So. Buckner Blvd.

### MICROWAVE SERVICES, INC.

"Architects of Modern Communications"

Independent Consultants,  
Engineers, Constructors

Wire, Carrier, Radio — Transmission, Distribution  
— Inside and Outside Plant Facilities —  
Appraisals, Surveys, Specifications, Design,  
Construction

Circle 7-4953 45 Rockefeller Plaza, New York 20



SINCE  
1931

Professional 16mm Sound-On-Film Motion  
Picture Cameras for Television Newsreels,  
Commercials and other Television Filming.

Write for free illustrated catalog.

### BERNDT-BACH, Inc.

7349 Beverly Blvd., Los Angeles 36, Calif.

### RUSSELL P. MAY

CONSULTING RADIO ENGINEERS

★ ★ ★

1422 F Street, N.W., Wash. 4, D. C.  
Kellogg Building Republic 3984

Member AFCCE

### WORKSHOP ASSOCIATES DIVISION



THE GABRIEL COMPANY

Specialists in  
High-Frequency  
Antennas

Endicott Street Norwood, Massachusetts  
NORWOOD 7-3300

## COMPANIES & PEOPLE

(Continued from page 14)

ucts. Mr. Watts assumes the post previously held by L. W. Teegarden, who became RCA's executive vice president last February.

**Consolidation:** Chicago Transformer Division of Essex Wire has been consolidated with Standard Transformer Corporation. The new name is Chicago Standard Transformer Corporation. Under this arrangement, Addison Holton is president, and Arni Helgason, J. J. Kahn, and L. S. Racine are vice presidents. No changes in personnel or plant locations are contemplated.

**E. M. Boykin:** Former head of field engineering at Hughes Research & Development Laboratories has been named director of the field service and support division of Hughes Aircraft at Culver City.

**High-Frequency Transistors:** RCA has developed experimental transistors capable of oscillating at frequencies as high as 425 mc. According to transistor engineers F. L. Hunter and B. N. Slade, *p*-type point-contact transistors are capable of oscillating at substantially higher frequencies than *n*-types.

**J. Harvey Pickett:** Appointed chief engineer of the Aerovox capacitor division, New Bedford, Mass. Mr. Pickett joined Aerovox Canada, Ltd. in 1935, and served as chief engineer there until he was transferred to headquarters. At the same time, Abraham G. Kalstein was advanced to the post of assistant chief engineer.

**Silicon Junction Diode:** Bell Laboratories has developed a silicon alloy junction diode with a ratio of resistances rated at 100 million to 1, capable of apparently indefinite life, and operation at high temperatures. It uses high-purity silicon produced by a method which DuPont developed under Bell Laboratories sponsorship, opening up an unlimited source for this material.

**Vincent C. O'Donnell:** Appointed communication engineer for Bendix Radio, to handle sales in northern New Jersey.

**Last Issue:** On page 17 of our July-August issue, there was a photograph of the telephone engineers who attended the 3-day symposium at RFL's Long Island City plant on point-to-point multiplex microwave equipment. The names of the engineers were given, but not of their companies. These were: AT&T, Bell Telephone Laboratories, Chesapeake & Potomac Telephone, and New England Telephone Company.

## Professional Directory

### KEAR & KENNEDY

Consulting Radio Engineers

1302 18th St., N. W. HUDSON 3-9000

Washington, D. C.

### GEORGE P. ADAIR

Consulting Engineers

Radio, Communications, Electronics

1610 Eye St., N.W. EXECUTIVE 3-1230

Washington 6, D. C.

antenna

specialists

MANUFACTURERS OF RADIO COMMUNICATIONS ANTENNAS

12415 EUCLID AVENUE  
CLEVELAND 6, OHIO  
RAndolph 1-9575



16-MM Professional Motion Picture  
Production Equipment

### J. A. MAURER, Inc.

37-07 31st Street, Long Island City 1, N. Y.  
Tel. 5Tillwell 4-4601

### MEASUREMENTS CORPORATION



Research &  
Manufacturing  
Engineers

Harry W. Houck Jerry B. Minter  
John M. van Beuren  
Specialists in the Design and  
Development of Electronic Test Instruments  
BOONTON, N. J.

### RATES FOR PROFESSIONAL CARDS IN THIS DIRECTORY

\$12 Per Issue for This Standard  
Space. Orders Are Accepted  
for 6 Insertions Only

# Motorola uses

## *Eimac* 2C39A's

In the First 460 Mc  
Type-Approved Equipment  
For Operation in the  
Class-A, "Citizen's Band"

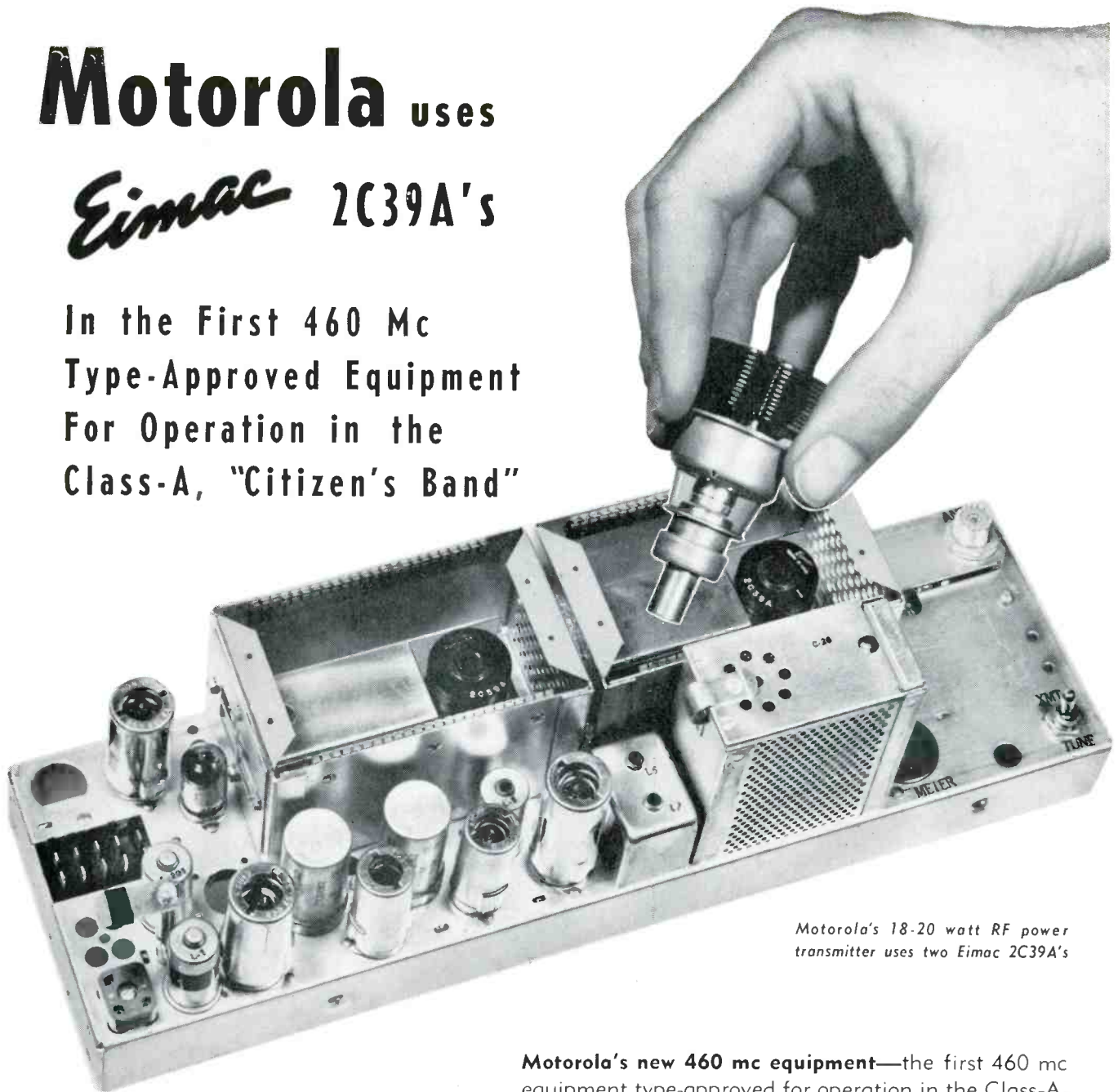

Motorola's 18-20 watt RF power transmitter uses two Eimac 2C39A's

FOR INFORMATION ABOUT THE  
2C39A WRITE EIMAC'S APPLICATION  
ENGINEERING DEPARTMENT

**Motorola's new 460 mc equipment**—the first 460 mc equipment type-approved for operation in the Class-A, "Citizen's Band" employs Eimac 2C39A's as tripler-drivers and power amplifiers in its mobile and base station transmitters. In the Eimac 2C39A, Motorola utilizes a highly efficient, domestically available tube that has been JAN accepted and proved in rugged and exacting military service. Motorola, through the use of Eimac 2C39A's and other late electronic developments, makes available a UHF two-way radio system designed to meet the demands of individuals, industry and emergency services.

FOLLOW THE LEADERS TO

*Eimac*  
REG. U. S. PAT. OFF.  
TUBES

**EITEL - McCULLOUGH, INC.**  
S A N B R U N O , C A L I F O R N I A

Export Agents: Fräzar & Hansen, 301 Clay St., San Francisco, California



---

# COMMUNICATION REVIEW

---

**T**HE Committee on Manufacturers' Radio Use has filed a statement of intent to appear before the FCC with a petition setting forth the reasons and need for establishing a manufacturers' radio service, separate from the present special industrial service, which is of a somewhat catch-all character.

Three major problems now confront manufacturers who use or plan to use radio communication. These are listed in the CMRU statement as:

1. Constant uncertainty regarding free and uninterrupted use of existing mobile systems. Caused by the belief that the limited number of frequencies available to them, and the rate of growth will soon combine to produce the most severe and destructive interference in their established radio systems.

2. Uncertainty regarding the availability of microwave frequencies for point-to-point communications. The microwave applications of manufacturing companies are presently treated on a case-to-case basis. In consequence no company is in position to know, prior to filing, whether a particular application will or will not be granted. The planning and establishment of a microwave system of communications by any manufacturing company involves several serious factors, namely feasibility, comparative economics, and physical surveys. When these factors must be evaluated in a climate of uncertainty with respect to the Commission's action upon the applications to be filed, the result is often the postponement or the abandonment of the company's plans for microwave use.

3. Uncertain conditions surrounding multiple-frequency mobile use. The Commission's "one-to-a-customer" rule for mobile frequency assignments, which is adhered to unless a special showing of need is made, introduces a factor of inflexibility in the planning of radio systems, especially by the larger, highly departmentalized users. The operating facts that enter into a consideration of the need for multiple frequency usage are varied and complex; it is necessary to state here only that the element of uncertainty injected by the requirement of a special showing, that may or may not be accepted, should be relieved in order to facilitate the establishment of new radio systems and the continued growth of all systems on a sound basis.

Herbert E. Markley, of Timken Roller Bearing Company, Canton, Ohio, is chairman of the CMRU, and Jeremiah Courtney is counsel for the Committee.

**M**ICROWAVE communication, for all its technical progress, has only now been recognized by the FCC as requiring a revised status in the Commission's rules and standards. This situation was detailed in a notice of proposed rule making issued by the FCC on May 15:

"Until recently, because of the scarcity and experimental nature of equipment designed for operation on frequencies above 890 mc., as well as uncertainty as to the ultimate usage and capabilities of such equipment, it has not been considered appropriate to standardize on the specific frequencies to be assigned in the bands above 890 mc., or to establish uniform technical standards for the stations operating on those bands. Within the past year, however, this situation has changed to some extent, and suitable equipment has become available and is finding sufficiently wide usage to indicate a need for some degree of standardization in the bands in which the majority

of operation is taking place. With respect to the band 952 to 960 mc., particularly, it now appears appropriate that specific frequencies be designated for assignment, and that minimum technical standards be established for the purpose of promoting orderly and efficient utilization of that band under conditions which, in any given area, may be expected to result in the minimum possibility of interference between stations operated by different licensees. Such action also appears reasonable in view of the degree of technical uniformity already attained by the manufacturers and users of equipment in this band, with respect to both the equipment and its operation."

**O**NE very important action was taken by the FCC with respect to the special industrial service when, on May 15, an order was issued making an important change in the Rules. Originally, eligibility in this service was limited to operations conducted in "a remote or sparsely settled region."

This excluded many potential users who could qualify in all other respects. While there are other problems under consideration at the FCC related to this service, the Commission decided to amend that restriction to read: "Each station will be located and/or operated at all times in areas *other than* Standard Metropolitan Areas of 500,000 or more population, as the term is defined in the 1950 Census of Population, Series PC-9, No. 6, released November 24, 1952, by the Bureau of the Census, United States Department of Commerce."

The effect, as the Commission pointed out, will be to "expedite the processing of many applications currently on file, and permit the expansion of an important use of radio by industry." No action, however, was taken on other problems related to the special industrial service because there are "difficulties which must be given further study, along with the other matters left unsolved."

**M**ANY times, during the course of our travels, executives of radio manufacturing companies and development laboratories have remarked: "How fortunate you are to operate your business out in the country. I wish we could move from the city to some pleasant New England town, but of course

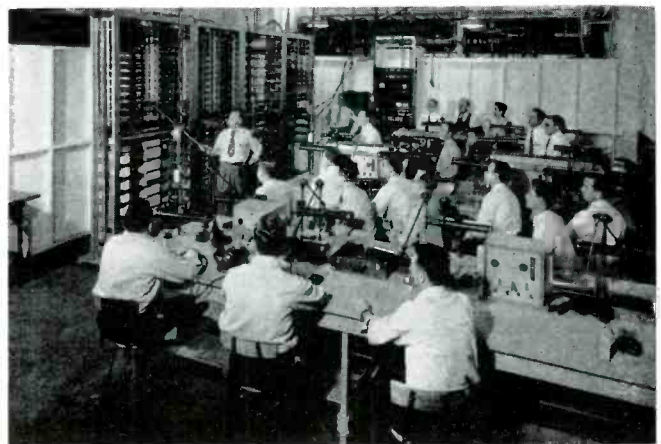

MORE AND MORE PHONE EQUIPMENT IS GOING INTO RADIO SYSTEMS. HERE ARTHUR SIGO CONDUCTS A STUDY OF KELLOGG SWITCHING UNITS

it wouldn't fit our kind of operation. We just can't do it."

Can't do it? Why not? From Dover, N. H., where Clarostat is now located, to Ampex at Redwood City, Calif., more and more companies in our industry are thriving on country air in the uncrowded space available in rural communities.

A recent article in *Fortune* about the exodus of business from big cities and highly industrialized areas concluded with the dim view that arguments for or against such a move can be weighted to tip the scales either way, depending upon the preference of top management for living in the city or the suburbs.

*Fortune*, however, missed the main point of the to-move-or-not question, by concerning itself principally with the relative merits of urban and suburban locations. From our experience and observation, to gain important advantages it is necessary to move to a place well beyond commuting distance to any large city.

For the benefit of executives who know our part of the Country as a vacation area, we offer the following information about its advantages to industry, quoted from the monthly *New England Letter*, published by the First National Bank of Boston:

"In little more than a decade, New England has accomplished a major readjustment in its industrial set-up. This development is highly significant but little known outside this region. What has taken place in a comparatively short period of time is a profound shift in its basic industries from a textile-based economy to one in which the metals industries predominate. Since 1939, employment in the metal-using industries has increased twofold, from 342,000 to 680,000, while employment in textiles declined 18% during this period. Textiles and apparel industries now account for less than 20% of total factory employment in New England as against one third in 1919. The number of persons employed in the New England metals industries is nearly twice as much as total employment in all textiles and shoes combined. Electronics and allied lines have shown the most pronounced gains and account for 138,000 persons, as compared with 55,000 in 1939. This young and rapidly expanding industry furnishes excellent employment opportunities since, by its nature, it provides the basis for the expansion of many industries. Another fast-growing industry in New England is plastics. This region accounts for around 30% of the national output of plastics products.

"New England enjoys distinct advantages because of its highly concentrated industrial economy. There are more di-

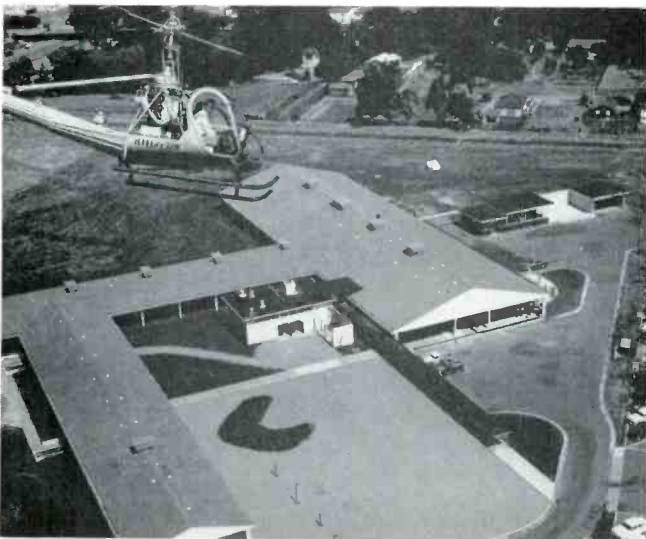

HELICOPTER VIEW OF THE NEW RESEARCH, DEVELOPMENT, AND ADMINISTRATION BUILDING ERECTED BY VARIAN ASSOCIATES AT PALO ALTO

versified industries per square mile in New England than anywhere else in the world. It has around 24,000 manufacturing establishments, representing more than 400 separate industries. New products and new lines have more than filled the gaps made by the retreat or disappearance of old industries.

"With a density of population per square mile of 148, as against 51 for the country as a whole, New England provides a concentrated market, quick and relatively cheap transportation, and an abundant labor supply. In many instances, the skill of labor has been passed on from one generation to another, developing unexcelled craftsmanship. Adequate, dependable, and economical power facilities are available to practically all communities.

"New England is blessed with a healthy and invigorating climate. One of the leading authorities of geography and its effects upon civilization has said that the New England states have the most stimulating climate in the country.

"New England has been in the forefront in research development. As a matter of fact, organized research has been defined as 'Yankee ingenuity gone scientific.' About one sixth of the nation's research laboratories are within our borders, and a large proportion of the foremost scientists hail from this region. It has been said that in the Boston-Cambridge area is found the greatest concentration of scientific brains and ideas in all America. New England firms are using research as the best means to meet the challenge of changing conditions. In addition to the development of new products, the principles of research are being used in all phases of business operations such as reducing costs through new processes and methods, improving the quality of products, and providing for diversity of output.

"Total assets of New England financial institutions aggregate around \$33 billion and represent a 2.4-fold increase since 1939. Of these institutions, the investment trust has had the most phenomenal record, with a fivefold gain in little more than a decade.

"In order to extend financial services, New England has pioneered in the creation of credit development corporations. Already these institutions are operating in Maine, New Hampshire, and Rhode Island, and are in the process of being established in Connecticut, Massachusetts, and Vermont. These corporations are sponsored by commercial banks and other financial institutions which pool a small percentage of their resources to provide venture capital to firms that might not be able to obtain it through other channels."

**D**URING the year ending May 30, there were sixteen failures among the radio manufacturers. According to RTMA, five produced components, 4 assembled radio and TV sets, 3 manufactured military equipment, 2 sound equipment, 1 test instruments, and 1 hearing aids.

H. A. Pope, chairman of the RTMA credit committee, attributed the failures to lack of adequate accounting methods and records. This was revealed by the fact that the companies were reporting profits, but actually losing money. The companies manufacturing military equipment were found to have accepted contracts at prices on which they could not show a profit, or those which were beyond their production facilities or engineering experience.

At this time, there is some uncertainty as to the future credit risks involved among companies organized in recent years for the purpose of handling military contracts exclusively. This applies specifically to those which have never entered the civilian market, and would be expected to encounter difficulty in replacing Government contracts with sufficient volume of sales on non-military products quickly enough to stay in business.

*Concluded on page 41*



# Helical-Beam Antenna Performance

CHARACTERISTICS AND PERFORMANCE INFORMATION ON THE HELICAL-BEAM ANTENNA FOR POINT-TO-POINT APPLICATIONS — By EDWARD F. HARRIS\*

POINT-to-point communication systems represent a large percentage of the applications for the 450 to 470, 890 to 960, and 1,750 to 2,110-mc. bands. Certain interference considerations have reduced the value of 72 to 76-mc. point-to-point installations so that most new users are being forced to investigate the possibilities of the higher frequencies. It is apparent, therefore, that unidirectional antennas must be relied on in the attempt to achieve system performance equivalent to that obtained at the lower frequencies.

The helical beam antenna developed by Kraus<sup>1</sup> possesses all the gain, pattern, impedance, and bandwidth properties found to be desirable in unidirectional applications and, in addition, has some advantages from a propagation standpoint. Until recently, a practical commercial design for the helical beam configuration was not available; however, advances in the technique of Fiberglass-polyester resin molding have now made feasible the production of a helix design capable of meeting the most rigid commercial strength requirements.<sup>2</sup>

**Helix Properties:** The primary advantage of the helix design over linearly-polarized radiators is evident on consideration of

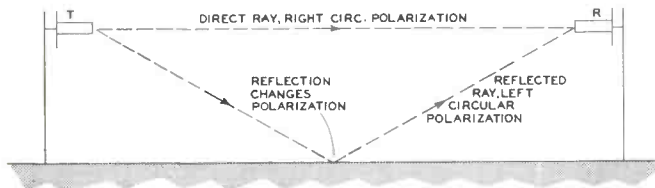

FIG. 1. HOW HELICAL ANTENNA DISCRIMINATES AGAINST REFLECTED RAY

the factors which are involved in point-to-point propagation. It is well known that the helical beam antenna affords rather high gain for its size. In addition, it has an important property in that a right-hand helix responds to right circularly polarized waves only. Fig. 1 shows a simplified presentation of the path of propagation. As in normal linear polarization, there is a direct and a reflected wave. In this case, however, the reflected ray is of the opposite sense from that of the direct ray, and the receiving helix does not respond to it.

Tests have shown that helices of opposite senses discriminate by about 20 db between correctly and incorrectly-

\*Chief Engineer, Mark Products Company, 3547-49 Montrose Avenue, Chicago 18, Ill.

<sup>1</sup>Kraus, John D., "Helical Beam Antennas for Wide-Band Applications"; *Proc. of the IRE*, October, 1948.

<sup>2</sup>Harris, Edward F., "A Helical Beam for Citizen's Radio"; *Electronics*, March, 1953.

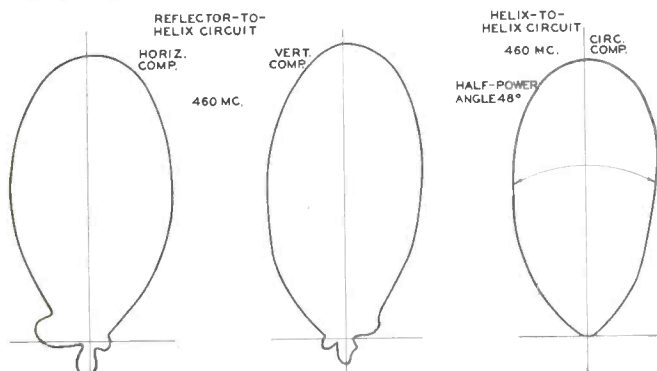

FIGS. 2, 3, AND 5. RECEIVING PATTERNS FOR 460-MC. HELICAL ANTENNA, WORKING WITH A REFLECTOR AND THEN A HELIX. FIG. 4. SINGLE 450-MC. HELIX

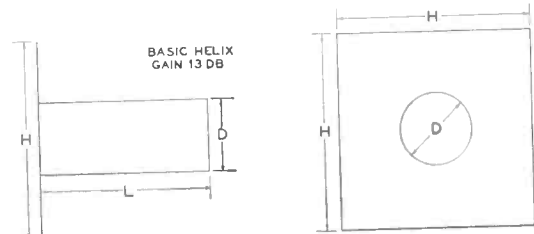

FIG. 6. DIMENSIONS OF SINGLE HELICAL BEAM AND GROUND PLATE

polarized waves. In the linear polarization case, the reflected ray normally causes large variations in received signal strength, especially over water paths. The two-helix system tends to provide more uniform levels because the reflected ray does not energize the receiving antenna. Of course, the discrimination is not complete because perfect reflection is never obtained; but the gain is appreciable, especially in regard to reduced fading.

Since a rather small helical beam antenna is capable of gains of 10 to 12 db, it performs well in comparison with other arrays available. Also, a significant extra gain is achieved because circular rather than linear polarization is employed.

The helix is characterized by its lack of critical dimensions or critical electrical adjustment. This property permits operation under conditions of severe ice and snow accumulation with no measurable change in pattern or impedance characteristics. The high radiation resistance, approximately 130 ohms, affords good operating efficiency.

Another important advantage of helix properties manifests itself in the operation of adjacent systems or back-to-back systems. In these cases helices of opposite sense can be employed, thus bettering by some 20 db the effective front-to-back ratios of the antennas, so far as separation is concerned.

**Radiation Patterns:** Experimental pattern measurement work on helical antennas has proceeded along conventional lines. One experimental setup consisted of a linear polarized transmitting antenna illuminating the helical antenna. Figs. 2 and 3 show the horizontally and vertically-polarized field components of the 450-mc. helix, which can be seen in Fig. 4. These patterns were obtained by changing the polarization of the transmitting antenna. During the tests, the helix was re-

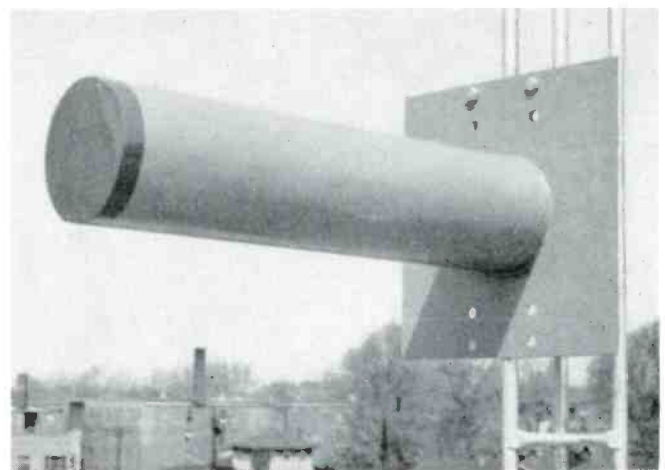

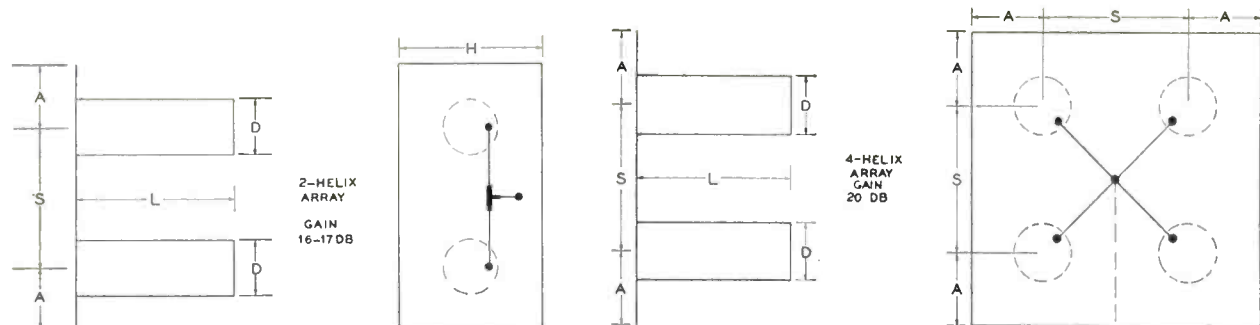

FIGS. 7 AND 8. PHYSICAL DIMENSIONS FOR THESE TWO AND FOUR-HELIX ARRAYS ARE GIVEN FOR VARIOUS FREQUENCIES IN THE ACCOMPANYING TABLE

tated about its longitudinal axis; an axial ratio of 1.2 was measured. This represents a very small deviation from circular polarization, for practical purposes.

There are small back and side lobes present in Figs. 2 and 3. In order to check the operation of a helix-to-helix system, another helical beam antenna was substituted for the linear transmitting antenna. Fig. 5 shows the measured pattern of the receiving helix under conditions of circularly-polarized transmission. An extremely smooth pattern is obtained, and there is a total lack of any spurious lobes. Since all reflected radiations are of the opposite sense the receiving helix does not respond to them, and the pattern measured is more nearly the

order to attain still higher gain. Figs. 6, 7, and 8 have been prepared to show the overall dimensions of the single helix, the two-helix array, and the 4-helix array at 450, 960, and 2,000 mc. The accompanying table gives these figures. At 960 mc. the two-helix array, Figs. 9 and 10, has a forward gain of 16 db while the 4-helix unit provides 20 db. In the multiple-helix units either left-hand or right-hand circular polarization, as well as linear polarization, can be obtained. These gain figures compare favorably with those attainable with standard parabolic dishes at such frequencies. Mechanical and cost advantages are obtained as well.

Pattern measurements used in the development of helical arrays for the 890 to 960-mc. band are shown in Figs. 11 and

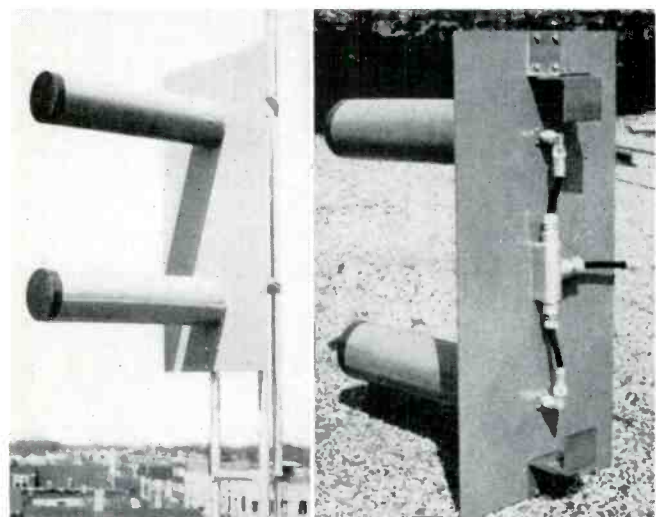

FIGS. 9 AND 10. FRONT AND BACK VIEWS OF 960-MC. TWO-HELIX ARRAY

free-space pattern only. It is significant that the increase in field strength measured when the helix was substituted for the linear transmitting antenna was about 10 db greater than that which can be explained simply by the greater gain of the helical beam and the extra 3 db provided by circular rather than linear polarization. The only satisfactory explanation lies in the lack of interference from a ground-reflected ray.

**Multi-Helix Arrays:** In the 960 and 2,000-mc. regions several helices can be arrayed upon a common ground plate in

DIMENSIONS FOR FIGS. 6, 7, AND 8, INCHES

TYPE	FREQUENCY	A	H	S	D	L	GAIN, DB
SINGLE HELIX							
	460 mc.		16		6.4	28	13
	900 mc.		12		4.0	18	13
	2,000 mc.		10		2.2	11	13
TWO HELICES							
	460 mc.	8	16	28	6.4	28	16.5
	900 mc.	6	14	16	4.0	18	16.5
	2,000 mc.	5	10	10	2.2	11	16.5
FOUR HELICES							
	460 mc.	8		28	6.4	28	20
	900 mc.	6		16	4.0	18	20
	2,000 mc.	5		10	2.2	11	20

12. Fig. 11 is a set of measured patterns for the single 890 to 960-mc. helix when illuminated by a helix of the same sense. The patterns are figures of revolution, because the orientation of the helix about its longitudinal axis does not change the measured pattern. In this particular antenna, the design was scaled so as to produce maximum gain at 960 mc. The beam mode is still in existence through 1,000 mc.; however, operation is limited beyond that point. This unit operates at frequencies as low as 700 mc., but with reduced gain and a broader radiation pattern.

Continued on page 44

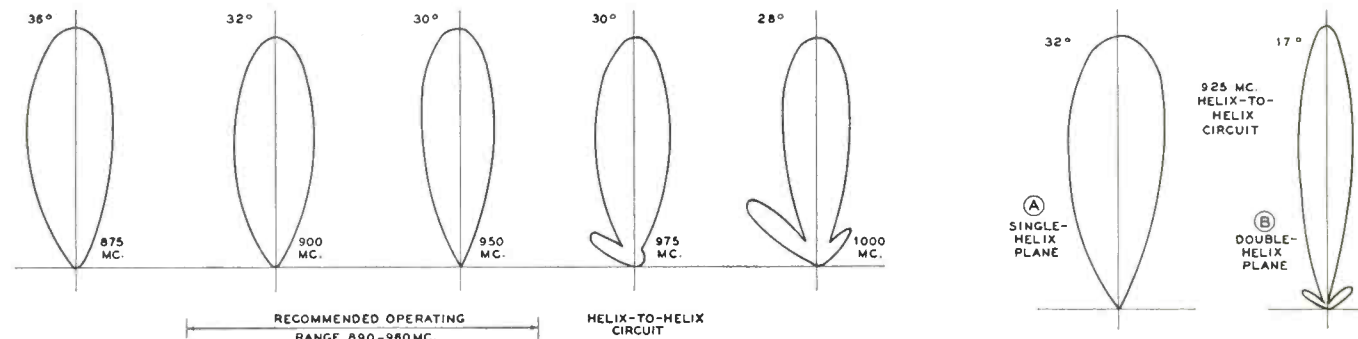

FIG. 11. FIELD PATTERNS FOR A SINGLE 960-MC. HELIX OVER A WIDE FREQUENCY RANGE. FIG. 12. PERPENDICULAR PATTERNS FOR A TWO-HELIX ARRAY



# Safety and Special Radio Services

**PART 1: WHILE POLICIES REFLECT PAST EXPERIENCE, THEY ANTICIPATE GREAT EXPANSION AND TECHNICAL PROGRESS — By EDWIN L. WHITE\***

THE philosophy underlying the regulation of the safety and special radio services differs in many respects from that underlying the broadcast and common carrier services, for reasons which will be outlined hereafter. In order to discuss this subject, I would like to call attention to certain basic facts.

First, it must be realized that communication is a service, whether it be by mail, air transport, surface transport, wire, or by radio. It never exists for itself alone. It is merely a vehicle for the exchange of goods or intelligence which in turn facilitates the carrying out of some basic function.

Generally, in the broadcast and common carrier fields those conducting communications do so for direct personal profit. Nonetheless, the communications rendered are a service. The common carriers transmit messages to serve the desires of the general public. The broadcaster caters to the entertainment and education of all. On the other hand, with a very few exceptions, notable among which are coast stations, the safety and special radio services are licensed to those who are in some kind of a business other than communications and the communication system is to them one of the tools of business. This communications tool either permits them to do something hitherto impossible or to carry on their business more efficiently, safely, or at less expense. In most cases communication has become as essential in their business as a squad car to the policeman, and the drill to the oil-well driller.

For various reasons, radio frequencies cannot be used indiscriminately by everyone. Their characteristics differ and, therefore, they are suitable for different tasks. Uncoordinated use would result in uncontrollable interference. Even with coordinated use, interference exists to varying degrees.

The allocation-of-frequencies process begins with international conferences. The necessity for international allocation stems from the fact that the number of frequencies that can be used for communications is strictly limited, and the characteristics of those frequencies are such that their use by any nation will inevitably affect the radio operation of other nations, sometimes adjacent and sometimes many miles distant. There is a further reason for international agreement in the use of certain frequencies. In the aviation and marine services, for example, our ships and aircraft operate in all parts of the world. Without international coordination of frequency use it would be extremely difficult if not impracticable to provide equipment that would meet all possible requirements. This situation also applies to certain other mobile service, such as the public telephone, wherein automobiles and trucks cross our land borders.

At international frequency allocation meetings, the delegates divide up the spectrum and provide for the use of portions of that spectrum by broad segments of industry, such as aviation, marine, broadcast, and common carrier. Inevitably, such sub-division calls for compromise, and the best that can be achieved is to have each nation equally dissatisfied. For example, a nation having no maritime industry but having a strong aviation industry might feel that, in the final distribution, frequencies could well be taken

from the marine service and given to the aviation service. Similarly, a nation very strongly interested in propaganda might feel the necessity for increasing the broadcast bands at the expense of other services which they consider less important.

Similar negotiations are conducted within the U. S. Since the assignment of frequencies to Federal Government radio stations is a function of the President, and the assignment to other stations a function of the FCC, agreement must be reached as to how the available frequencies are to be divided between these two classes of stations. Quite obviously these negotiations are difficult since agreement has to be reached on such controversial matters as, for example, the relative importance to the general public of the civilian police radio service and military requirements for similar frequencies in a very restricted band.

The divergence between the treatment of broadcast and common carrier services and the treatment of safety and special radio services stems from the facts previously outlined. In the first two of these services the bands available are established by international agreement. The applicants for frequencies desire to render service for their own profit. Under such circumstances, it is inevitable that there be contests between individual applicants and it is necessary to determine which applicant can best render to the public the service intended. This determination may be difficult and sometimes can be resolved only after a hearing.

In the case of the safety and special radio services, with the exception of marine and aviation and amateur, there is no specific international service allocation as such. Therefore, the Commission must enter into allocation proceedings which are very much akin to the proceedings carried out in the international frequency allocation meetings. They can become very long and complicated and can involve the taking of hundreds of pages of testimony. In the last major proceeding conducted by the Commission there were requests to use frequencies aggregating several times the number available. In view of those circumstances, the Commission could not grant all of the requests, and was forced to evaluate the services proposed to be rendered by the various witnesses.

In proceedings of this nature, reaching a final decision involves three phases: a) the establishment of the relative importance to the needs of the general public for the services of applicant groups proposing to make use of radio; b) the benefits to be obtained by the applicant groups by the proposed radio operation, and the degree to which these benefits would be passed to the general public in better service, reduced charges, or otherwise; and c) in view of the two determinations just mentioned, what proportion, if any, of the frequencies available in which bands should be devoted to carrying out the proposals.

It is no easy matter to reach a determination on these points. The importance of the police and fire services is readily apparent to the general public. It is not difficult to show how the benefits of radio would be passed on to them. But if both police and fire need the same frequencies and cannot share them, it is impossible to establish categorically

*Continued on page 38*

\*Chief, Safety and Special Service Bureau, Federal Communications Commission, Washington, D. C.

# Los Angeles County Radio System

MICROWAVE-VHF SYSTEM OPERATED FROM AN UNDERGROUND HEAD-QUARTERS CONTROL STATION  
By STEPHEN D. SYKES\*

IF the population of Connecticut were suddenly doubled, and all the houses, utilities, highways, public services, and means of livelihood increased accordingly, the result would be exactly comparable to the present status of Los Angeles County, which has an area of 4,084 square miles, and over 4½ million population! The focal point of civil administration and industrial activity is the City of Los Angeles, where one-half the county population is concentrated in an area of only 440 square miles.

These brief statistics are sufficient to indicate to police communication engineers the magnitude of the problems involved in handling the routine functions of the County Sheriff's Department, and in meeting the situations that would arise from such a disaster as would make it necessary to evacuate the City. It should be explained further that, while California has a Highway Patrol organization, the County Sheriff's Department performs many functions of the state police organizations of other states.<sup>1</sup>

**Plan of System Operation:** Basically, the communications system must provide 2-way contact with each of the 250 vehicles and 2 airplanes operating within the county, since criminal and civil actions in all the unincorporated areas are

\*Radio Engineer, Sheriff's Department, Los Angeles County, Room 238, Hall of Justice, Los Angeles 12, Calif.

<sup>1</sup>In this respect, the California Highway Patrol and County Sheriff's Departments are comparable to the state organization in Wyoming. See "How Wyoming Uses Radio communication," by Thurman D. Sherard and John T. Roberts. COMMUNICATION ENGINEERING, Jan.-Feb. 1953.

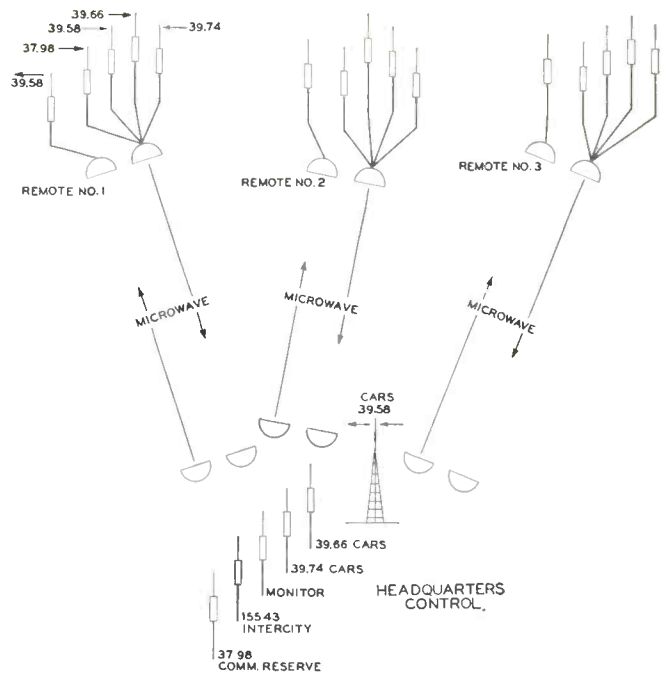

FIG. 1. PLAN OF THE LOS ANGELES COUNTY SHERIFF'S RADIO SYSTEM

the direct responsibility of the Sheriff's Department. In addition, this Department cooperates with the Highway Patrol, the police departments of the cities and towns within the county, and with Sheriff's Departments in the adjoining counties of Orange, Riverside, San Bernardino, San Diego, and Ventura.

Our County Sheriff's radio system was planned not only to provide the necessary radio coverage, but to include special operational and administrative features which will be described. Some of these features are of particular interest because they can be adapted to other, and totally different, kinds of systems.

Fig. 1 shows the elements of the headquarters control installation at Los Angeles. VHF equipment provides for FM transmission to the cars on 39.58 mc., with talk-back on 38.74 mc. from the patrol cars and on 39.66 mc. from the

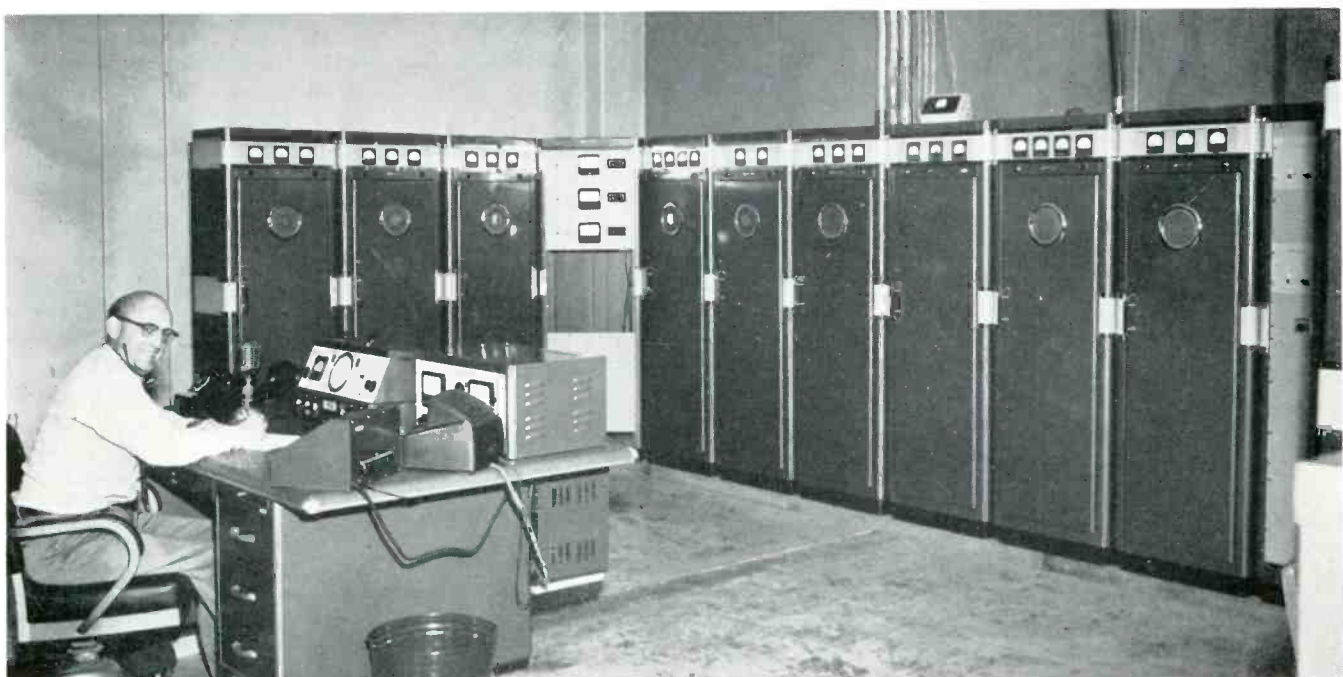

FIG. 4. THE AUTHOR AT THE CONSOLE UNDERGROUND. CABINETS CONTAIN MULTIPLEXING CIRCUITS, MICROWAVE CONTROLS, VHF TRANSMITTERS



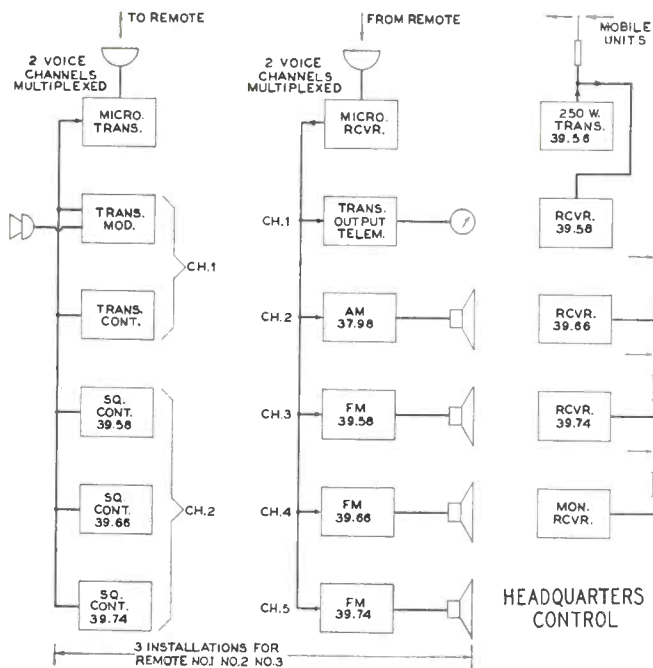

FIG. 2. HEADQUARTERS HAS THREE MOTOROLA 2-CHANNEL MICROWAVE TRANSMITTERS AND THREE 5-CHANNEL RECEIVERS, PLUS VHF EQUIPMENT

special vehicles. All mobile transmitters operate on 39.58 mc., also, for emergencies. In addition, the control station handles intercity traffic on 155.43 mc., and traffic with the communication reserve organization on AM at 37.98 mc.

To provide extended coverage throughout the county, there are three remote repeaters connected to headquarters by microwawe circuits, as indicated in Fig. 1. The operator can talk out over the microwawe links to one or all the repeaters, to reach the vehicles on 39.58 mc. Remote FM pickup receivers on 39.58 mc., 39.66, and 39.74 mc., and AM receivers on 37.98 mc., are connected to headquarters by multiplexed voice channels.

Headquarters facilities are shown in greater detail in Fig. 2, and those at each of the remote points in Fig. 3. Each microwawe transmitter at headquarters has two multiplexed voice channels. One is used to modulate the remote VHF

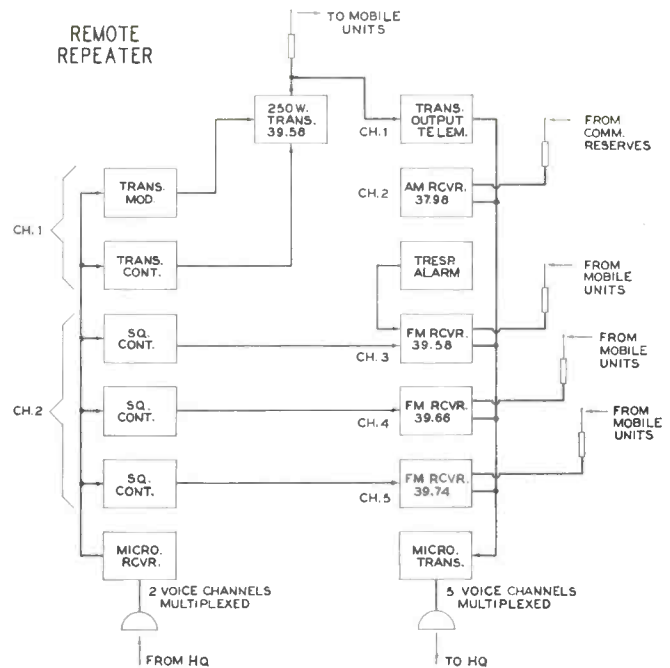

FIG. 3. THIS DIAGRAM SHOWS THE FUNCTIONS OF MOTOROLA MICROWAVE TRANSMITTER AND RECEIVER INSTALLATION AT EACH REMOTE STATION

transmitter and turn it on or off, while the other channel carries audio-frequency impulses which adjust the squelch controls of the three remote VHF receivers.

At each remote installation, the microwawe transmitter has five multiplexed voice channels. Three are required for the FM pickup receivers and another for the AM pickup receiver.

The fifth is a telemetering channel, by which the output of the remote VHF transmitter can be indicated at headquarters. In addition, an alarm at the remote station signals the approach of a trespasser over one of the FM receiver channels.

An unusual feature of the headquarters installation is an emergency VHF antenna. If, for any reason, the main tower is damaged, a 50-ft. tower and antenna can be run up from under ground by hydraulic pressure. Thus, in a matter of

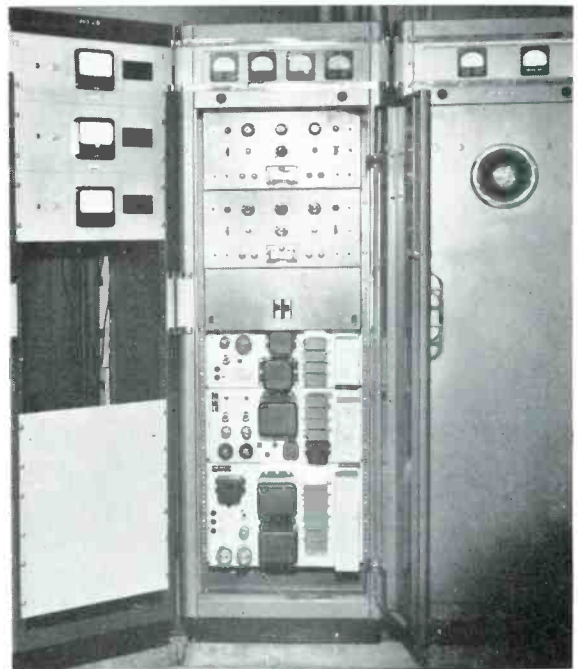
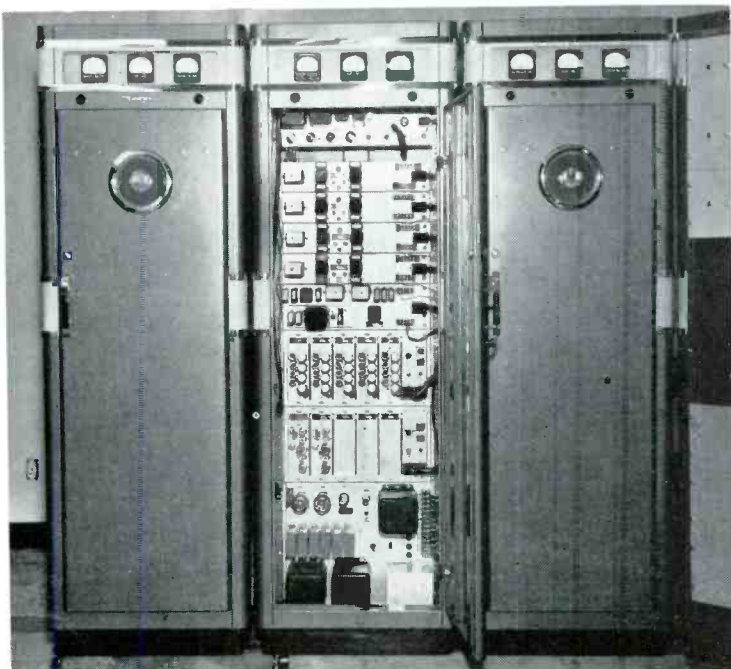

FIG. 5. EACH CABINET CONTAINS MULTIPLEXING CIRCUITS FOR ONE MICROWAVE TRANSMITTER-RECEIVER. FIG. 6. REMOTE MICROWAVE CONTROLS



FIG. 7, ABOVE: MAST IS ASSEMBLED FROM SECTIONS CARRIED IN LONG COMPARTMENT UNDER THE TRUCK. TWO MEN CAN PUT IT TOGETHER QUICKLY. FIG. 8, RIGHT: SIMPLE FIXTURES ON THE TRUCK HOLD THE ANTENNA SECURELY. THE LEAD PLUGS INTO A COAXIAL CONNECTOR



minutes, the VHF transmitter can be back on the air again.

**Headquarters Control Installation:** For security reasons, certain details of the headquarters station cannot be shown, although some of the facilities are illustrated in the accompanying pictures. Most of the station is underground,<sup>2</sup> built of very heavy reinforced concrete construction. Complete and comfortable provisions have been made for the staff, so that they can carry on at the station for an extended period without leaving, if that should be necessary.

One part of the building serves as a disaster communication center, where reports can be received and reviewed by

<sup>2</sup> Although there was no rock formation at the site of this building, a considerable amount of blasting was necessary because of the enormous petrified trees encountered below the surface of the ground.

administrative officials responsible for coordinating relief work. Telephone circuits are brought in for this purpose, so that the radio dispatching facilities will not have to carry all the load under such emergency conditions.

Other sections are devoted to space for the radio operating room, a very complete drive-in service and repair shop, an emergency engine-driven generator, and offices for the staff.

**Radio Equipment:** Fig. 4 shows the underground room in which the radio equipment is installed. The three cabinets at the left, shown closeup in Fig. 5, contain the multiplexing circuits for the three microwave transmitters and receivers. The next two cabinets to the right carry the remote controls for the microwave transmitters and receivers which are located at the foot of the tower, above ground. Farther right are

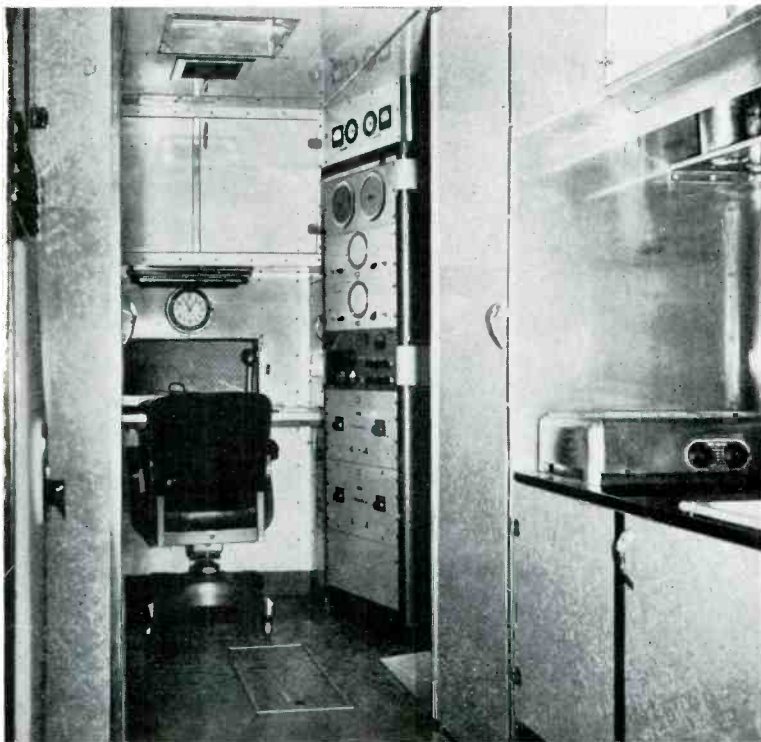

FIG. 9, LEFT: RADIO OPERATOR'S POSITION IS DIRECTLY BEHIND THE DRIVER. THIS VIEW, TAKEN FROM THE GALLEY, SHOWS THE ELECTRIC STOVE AND SINK. FIG. 10, ABOVE: COMPARTMENTS ON EACH SIDE AT THE REAR HOUSE THE 3-KW. ONAN ENGINE-DRIVEN GENERATORS



standard VHF transmitters. All the radio equipment is of Motorola manufacture.

In Fig. 5, one of the multiplex circuit assemblies can be seen, with the power supply below. By the use of audio pulses of different frequencies, the squelch controls on the

on the rack was provided for three microwave frequency monitors, although they had not been installed when the photograph was taken.

Remote controls for the headquarters microwave transmitters and receivers are located in two racks, Fig. 6. The

FIG. 11. PERMANENT SETUP ON THIS BENCH INCLUDES CONTROL HEADS, SPEAKERS, WATTMETER WITH DUMMY LOAD, AND STORAGE BATTERIES, SO THAT A MOBILE UNIT CAN BE PLUGGED IN QUICKLY AND CHECKED UNDER OPERATING CONDITIONS

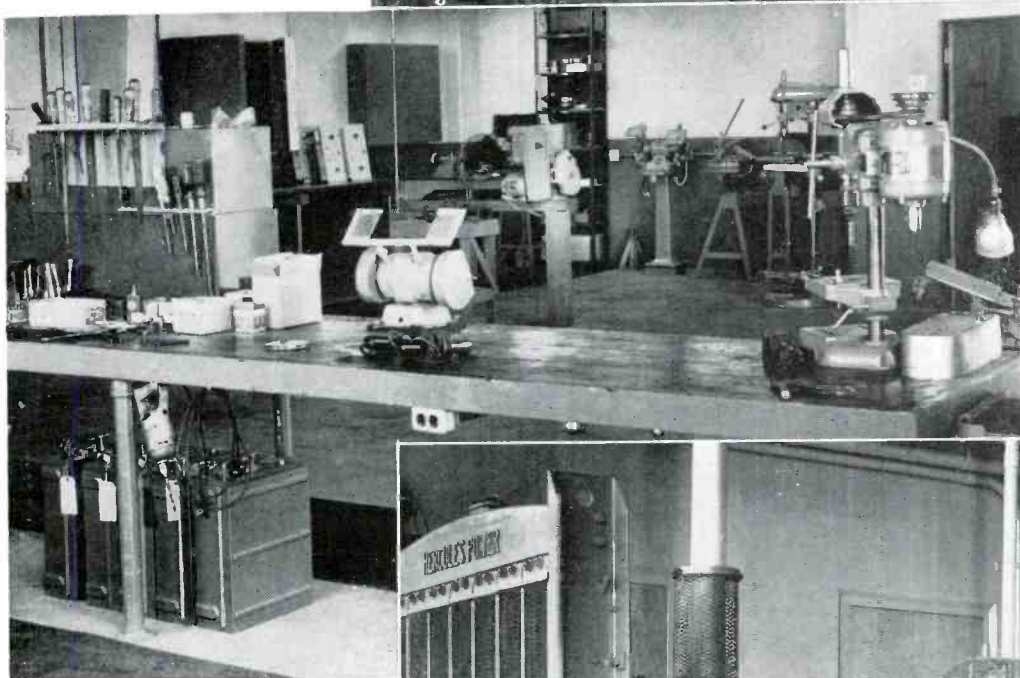
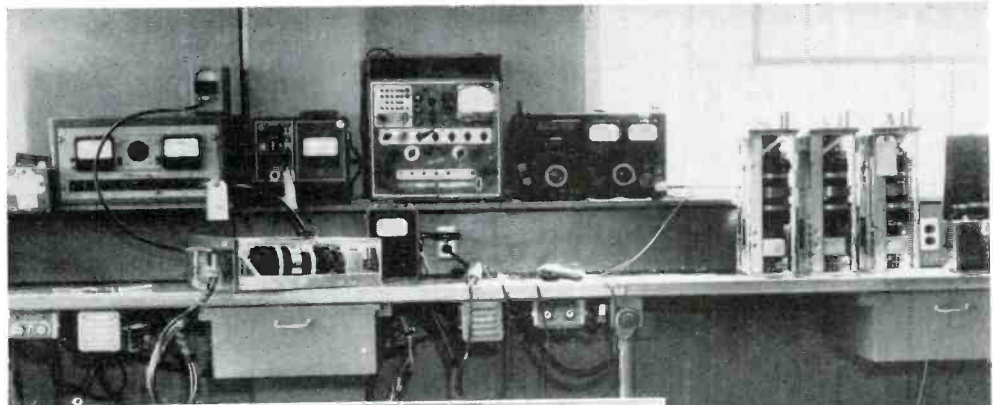
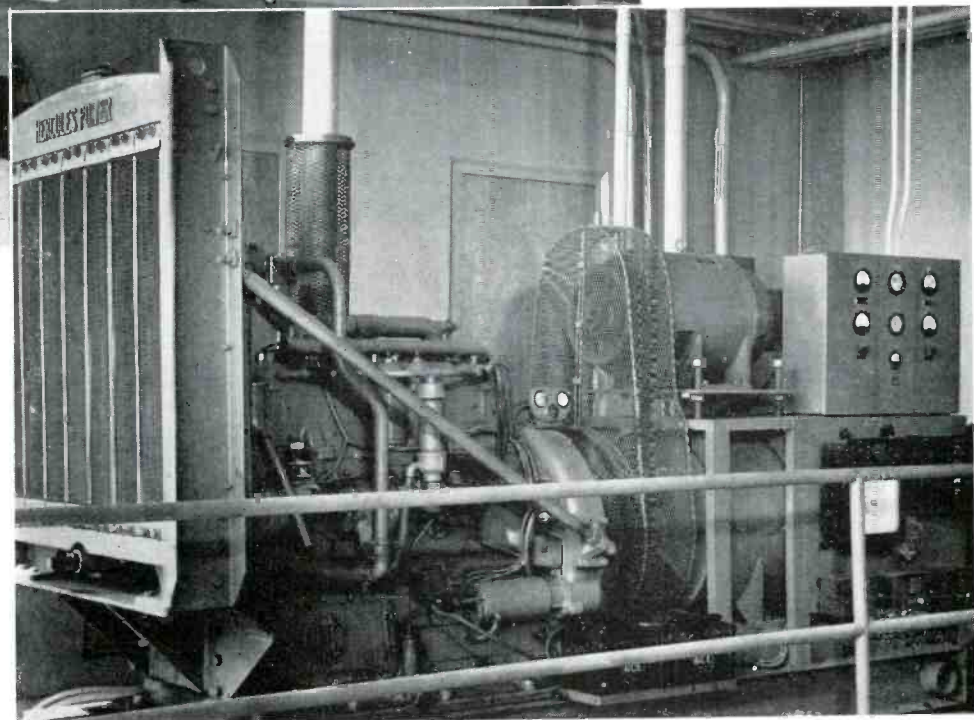

FIG. 12. OPPOSITE END OF THE DRIVE-IN SERVICE SHOP IS DEVOTED TO MACHINE TOOLS FOR HANDLING SPECIAL WORK AND MECHANICAL REPAIRS

FIG. 13. IN CASE OF THE OUTSIDE POWER LINE FAILING, THIS POWER PLANT WILL TAKE UP THE ENTIRE LOAD OF THE LIGHTS AND RADIO EQUIPMENT IN A MATTER OF SECONDS. THE GASOLINE ENGINE DRIVES BOTH THE 2-PHASE AND 3-PHASE GENERATORS. A HEATED MANIFOLD IS USED TO START THE ENGINE MORE QUICKLY.



three FM receivers at any of the remote stations can be adjusted while the operator listens to the signals coming in at headquarters from that transmitter.

The rack partly seen at the right of Fig. 5 is in full view in Fig. 6. The three meters, each operated by an incoming telemetering channel, show the VHF transmitter output at the corresponding remote point. Additional space

left hand cabinet, shown with the door open, has two sets of controls above, with the power supplies mounted below. The other cabinet has the third set of controls. Adjustments are provided at the left of the panel for the local oscillator, and at the right for the output. With the frequency monitors installed, a transmitter can be adjusted remotely.

*Concluded on page 42*

# 460-Mc. Mobile Equipment Design

UNIQUE DESIGN PROBLEMS ENCOUNTERED AT 460 MC., AND HOW ONE MANUFACTURER HAS MET THEM — By JOHN F. BYRNE AND ANGUS A. MacDONALD\*

IN 1949 the FCC provided 100 additional channels for the land mobile services by opening the UHF band from 450 to 460 mc. for developmental purposes. Channel spacing in this band was set at 100 kc.

Many operators who decided to use the new band did so out of desperation. They had to have radio, and the new channels were the only ones available. Their initial hesitancy has been supplanted, in most cases, by wholehearted endorsement of the new band. The two unknowns, untried equipment and new propagation characteristics were found, as is often the case, to be not troublesome at all.

This paper outlines the special properties required of receivers and transmitters operating in the 450 to 460-mc. band. Overall system performance is then discussed, with reference to both propagation data and field experience.

The specific equipment used as an example was designed to cover the complete frequency range from 450 to 470 mc. This was done so that it could also be used in the 40 Class A channels allocated at the edges of the so-called Citizen's band, which extends from 460 to 470 mc. Citizen's radio is defined as a fixed and mobile service intended for use in private or personal radio communication, radio signaling, control of objects or devices by radio, and other purposes not specifically prohibited. Any citizen of the United States, eighteen years of age or over, is eligible for a station license in this class of service.

**460-Mc. Receiver:** In order to operate effectively in a 460-mc. system, a receiver must meet several very stringent requirements. First, for reasons that will be explained later, it should remain within  $\pm 2.5$  kc. or  $\pm 0.00055\%$  of the transmitter frequency. Second, it should have a sensitivity of 1 microvolt or better. Third, it must reject intermodulation products to the greatest possible extent. Finally, it must have sufficient selectivity to provide good rejection of adjacent-channel signals and all spurious signals.

The relative frequency stability between the receiver and the transmitter at 460 mc. is an important design consideration. Exhaustive laboratory and field tests have shown that the relative drift between the receiver and transmitter cannot exceed 1/12th of the receiver bandwidth, if good system performance and ignition suppression are to be maintained. For a bandwidth of 30 kc., then, the relative drift should not exceed 2.5 kc. If the allowable drift is divided evenly between the receiver and transmitter, only  $\pm 1.25$  kc. or  $\pm 0.00027\%$  can be permitted each unit. This degree of stability is a little beyond that obtainable with reasonably-priced crystals and ovens.

\*Communications and Electronics Division, Motorola, Inc., 4545 West Augusta Blvd., Chicago 51, Ill. This material was adapted from a paper presented at the 1953 National IRE Conference.

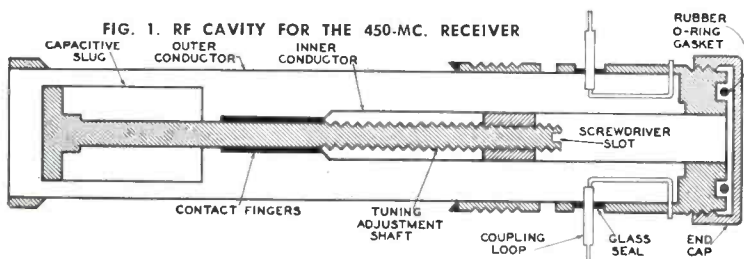

The problem of relative frequency stability has been solved in this equipment by applying automatic frequency control to the receiver high-frequency crystal oscillator. The transmitter frequency is controlled by means of an oven-mounted crystal to within  $\pm 2.3$  kc. The receiver crystal is not oven-mounted, and the receiver's natural frequency is permitted to drift a maximum of  $\pm 13.7$  kc. Therefore, the maximum natural drift is about 16 kc. The correction ratio of the automatic frequency control circuit is better than 8 to 1. Under the worst possible conditions, therefore, the relative receiver detuning will not exceed 2 kc., which is well within the allowable limit of 2.5 kc. The automatic frequency control is designed to correct the tuning of any signal within 30 kc. of the receiver frequency. Precautions are taken in the design to prevent tuning to the next channel.

The second basic consideration is that of receiver sensitivity. From field experience and from data on solar and man-made noise levels in this band, it is found that a sensitivity of one microvolt would be useful. Sensitivities of 0.45 microvolt have been obtained in this frequency range; however, a practical figure for the production receiver with a minimum of tube selection is 0.6 to 0.8 microvolts for 20 db quieting. This

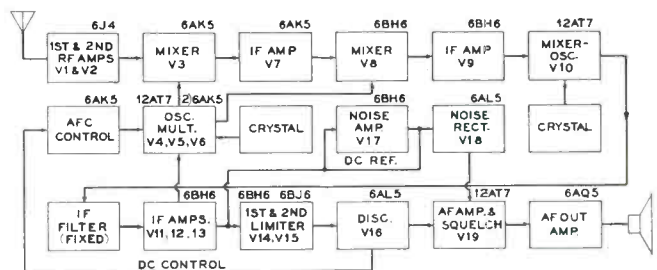

FIG. 2. THIS 450-MC. RECEIVER EMPLOYS TRIPLE CONVERSION AND AFC

corresponds to a noise figure of 8.5 to 11 db. In order to provide sufficient safety factors to allow for tube aging and test equipment variations, the receiver sensitivity is advertised to be 1 microvolt. All the sensitivity figures mentioned are in closed-circuit microvolts, or the signal voltage across the receiver terminals.

The closed-circuit microvolt mentioned above is better known as the advertising microvolt, since it is usually half the IRE or RTMA standard open-circuit microvolt. The advertising microvolt is commonly used in competitive sales literature and sales talk. Since receivers are power-operated devices, it would seem sensible to rate sensitivities in decibels below 1 watt. This rating would eliminate the confusion in everyone's mind concerning the big and little microvolt. On a power basis, the receiver in question would be rated at -137 dbw. Because of its frequency advantage, a good 160-mc. receiver would have a sensitivity of about -143 dbw.

The receiver sensitivity depends upon several factors. First is the choice of the RF amplifier tube (or tubes) and circuit. The use of disc-seal tube types in the RF amplifier would render a good noise figure, but the tube cost would be high. It was felt that the use of more conventional miniature tubes would provide adequate sensitivity and reasonable tube cost. Many tube types were tested carefully for noise figure and gain. Of the miniature tubes tested, the 6J4 provided the best noise figure and uniformity, and was selected for use in a grounded-grid circuit for production.



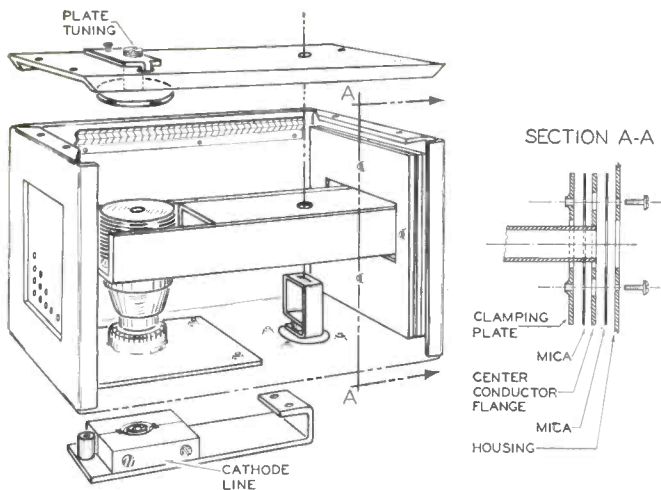

FIG. 4. PLATE CAVITY CIRCUIT FOR THE 2C39A DRIVER AND PA STAGES

The second important factor in receiver sensitivity is RF gain. If a good noise figure is to be obtained, sufficient RF gain must be provided to override the noise generated in the first mixer stage. In order to achieve this result, it was necessary to cascade two grounded-grid 6J4 RF stages.

Related to the problem of achieving good receiver sensitivity is that of designing compact, high-*Q* tunable resonators for use in the grounded-grid circuits. After rather extensive theoretical and experimental work, during which time everything that would tune the frequency range was tried, from gold tie clips to cavity tuners, an extremely satisfactory coaxial cavity tuner was finally developed.

Fig. 1 shows a cross-section of the tuner, which is about  $4\frac{1}{2}$  ins. long and  $\frac{7}{8}$  in. in diameter. The unit is tuned by unscrewing the end cap and inserting a standard metal screwdriver into the tuning slot. Contact is made between the movable center conductor and the stationary center conductor by silver-plated contacts. Smooth tuning adjustment is accomplished by careful design of the capacitive end slug. Temperature compensation is provided for the center conductor assembly by using two types of metal with different thermal coefficients.

Input and output coupling loop leads are supported and brought out of the tuner through glass seals. Soldering the loops into the correct position is done with assembly fixtures

which permit accurate control of input and output impedances.

The removable end cap compresses a circular neoprene ring to make a hermetic seal in the cavity. The contact fingers are protected further against corrosion by a small amount of DC-4 Silicone.

Three of these tuners are used in conjunction with the two 6J4 grounded-grid amplifiers, and a fourth is used to filter the injection voltage fed to the first mixer tube.

Fig. 2 is a block diagram of the receiver, which employs triple conversion. The first IF is variable from about 71 to 75 mc.; the second IF from 8 to 8.9 mc. It should be noted that the injection voltages for first and second conversions are derived from the same crystal oscillator, which operates

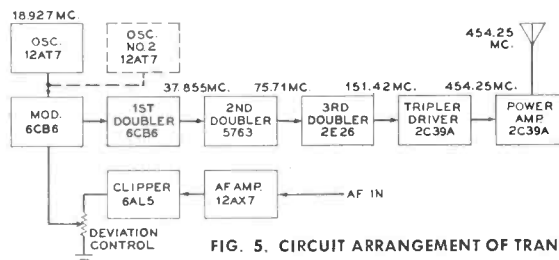

FIG. 5. CIRCUIT ARRANGEMENT OF TRANSMITTER

from about 31.5 to 33 mc. Automatic frequency control is applied to this oscillator.

The use of grounded-grid RF amplifiers makes the control of intermodulation more difficult than in a low or high-band VHF set, because biasing a grounded-grid RF amplifier increases the intermodulation. Therefore, intermodulation control must be attained by other means. In this receiver, it is achieved by reducing the injection voltage to the first mixer, and therefore the receiver gain, as the desired signal strength increases above the sensitivity threshold.

In the final conversion the desired signal is converted to 455 kc. Again, the injection voltage is obtained from a crystal-controlled oscillator, whose frequency ranges from 8.5 to 9.4 mc.

Triple conversion makes it possible to attain the same selectivity at 460 mc. as in the low or high VHF band. At the same time, all spurious responses including images are attenuated by more than 85 db. Selectivity is achieved at 455 kc. by means of the same type of packaged filter as is used in other Motorola receivers.

Low standby drain is secured in the receiver by biasing

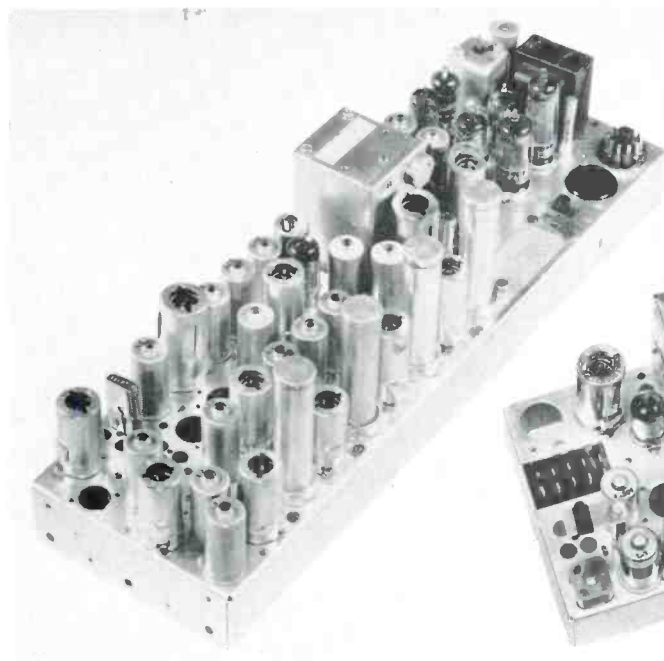
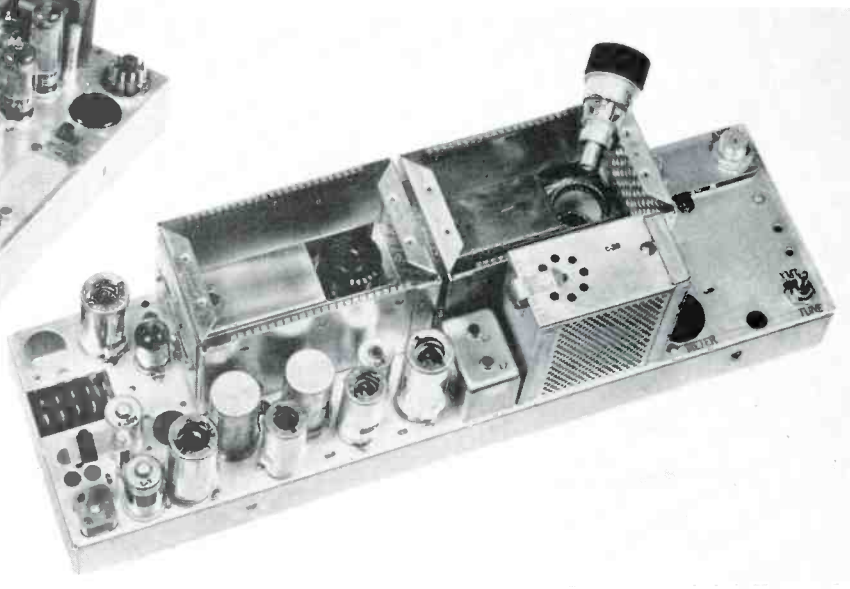

FIG. 3, LEFT: RECEIVER CHASSIS. NOTE RF FILTERS ON RIGHT EDGE  
FIG. 7, BELOW: TRANSMITTER CHASSIS WITH 2C39A CAVITIES AT TOP



the audio stages to cutoff when the receiver is squelched, and by omission of the receiver crystal oven.

Fig. 3 is a top view of the complete receiver. The coaxial cavity tuners can be seen on the lower edge of the chassis at the right. Specifications for the receiver are listed below:

- Sensitivity — 1 microvolt for 20 db quieting.
- Selectivity —  $\pm 15$  kc., 6 db down;  $\pm 60$  kc., 85 db down.
- Spurious Responses — all better than 85 db down.
- Stability — with AFC, better than .0005%,  $-30^\circ$  to  $+60^\circ$  C.
- Squelch Sensitivity — better than .3 microvolt.
- AF Output — 1 watt, less than 10% distortion.
- Weight —  $7\frac{1}{2}$  lbs.
- Size —  $16\frac{1}{2}$  by  $4\frac{7}{8}$  by  $4\frac{9}{16}$  ins.

**The Companion Transmitter:** The mobile transmitter should have a power output of at least 20 watts. This should preferably be accomplished using tubes which have long life, for low maintenance; and high efficiency; for minimum battery drain. In order to operate successfully with the receiver automatic frequency control, the transmitter frequency stability must be  $\pm 0.0005\%$  or better.

The problem of all transmitter engineers is that of attaining a desired power output at reasonable efficiency and tube replacement cost. This is particularly difficult in the 460-mc. frequency range. In addition, the fact that the transmitter must be mobile imposes the requirement that the tubes used be rugged enough to withstand vibration and hard knocks.

After tests of the various tube types available which would serve as power-output stages in the 460-mc. range, it was apparent that the Eimac 2C39A disc-seal triode would best meet the requirements.

As used in the new transmitter, the 2C39A has a plate efficiency of about 65%. An understanding of the importance of this efficiency can be gained by a comparison between it and the plate efficiency of a more conventional tube at these frequencies. A good conventional tube of a type suitable for use at 160 mc. has a plate efficiency of only about 25% when operated in the 460-mc. band. This difference in plate efficiency in a 20-watt transmitter represents a difference in drain from a 6-volt battery system of approximately 12 amperes. Of course, the savings in power-supply size and cost with high plate efficiency are obvious.

The 2C39A is rugged and is operated well within its ratings. Maximum plate dissipation rating is 100 watts; in the mobile transmitter, its plate dissipation is only about 10 watts.

The initial cost of a 2C39A is higher than that of conventional tubes designed for use at lower frequencies. However, since it is used at a small percentage of its maximum rating, it has a life expectancy many times that of a cheaper tube used up to the limit of or in excess of its rating; and the cost of tube replacement in dollars per hour is less for the expensive tube than for the conventional tube.

Design of a stable, highly-efficient tank circuit to work with the tube is another unconventional engineering job. Fig. 4 is a drawing of the plate cavity circuit designed for use with the 2C39A driver and grounded-grid power amplifier stages in the 20-watt transmitter strip.

In the power amplifier the grid is bypassed to ground by means of a metal plate to which the grid connector is soldered. This plate is DC-insulated from ground by means of a sheet of silvered mica. The center conductor of the cavity consists of a piece of rectangular pipe to which the plate connector is soldered. The end of this pipe opposite the tube is flared out into a rectangular flange, forming one plate of a bypass capacitor which connects the center conductor to the outer cavity for RF. Dielectric insulation in this condenser consists of two sheets of silvered mica. The rectangular center conductor serves a dual role, both as a portion of the RF circuit and also, in the case of the 40-watt unit to be discussed later, as an air duct through which cooling

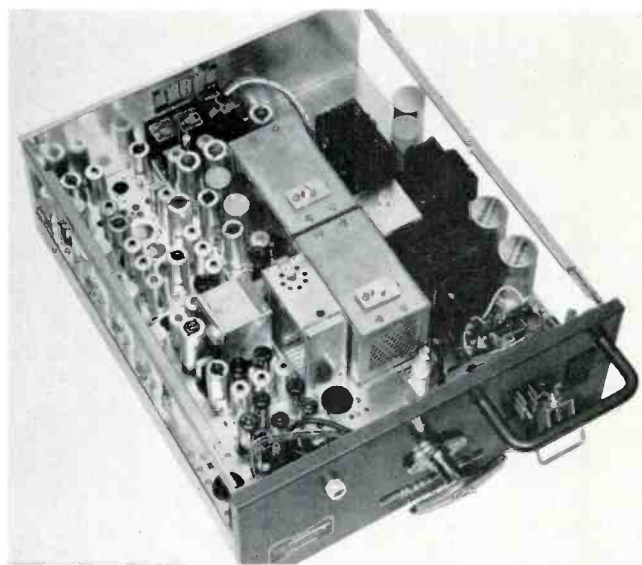

FIG. 8. COMPLETE RECEIVER, TRANSMITTER, AND POWER SUPPLY ASSEMBLY

air from a blower is directed at the anode fins on the tube. The heater and cathode connections underneath are equipped with heavy heat-radiating connectors to conduct heat away from the heater seal.

The tripler-driver stage is operated as a conventional grounded-cathode frequency multiplier. This arrangement is employed so that a good thermal path to the chassis can be provided, thereby reducing cathode seal temperatures in the absence of a blower. No blower at all is required for the 20-watt mobile unit.

RF drive for the final amplifier is injected directly into the fixed-tuned cathode circuit, consisting of a heavy alum-

*Continued on page 46*

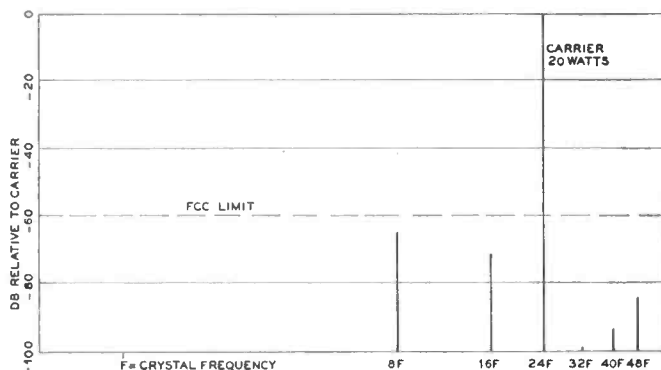

FIG. 6. SPECTRAL DISTRIBUTION OF TRANSMITTER RADIATIONS WITHOUT MODULATION.

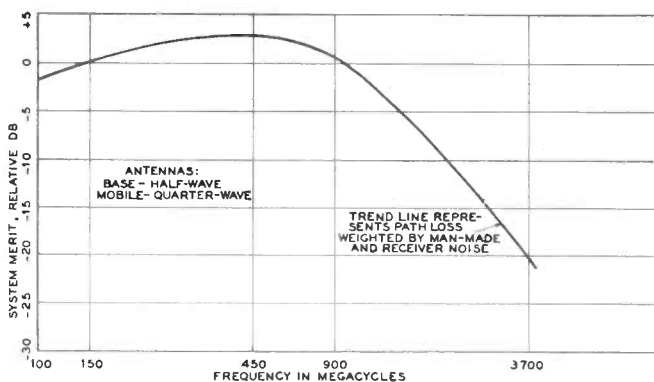

FIG. 9. SYSTEM QUALITY VS. OPERATING FREQUENCY RANGE



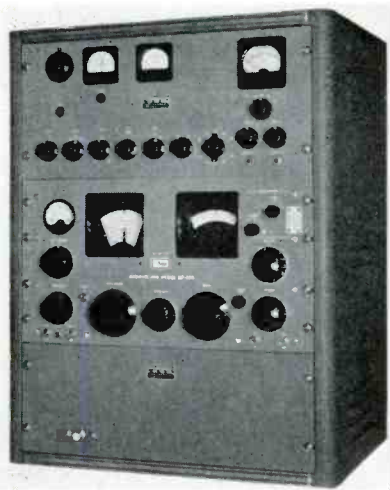

FIG. 2, LEFT: SINGLE-SIDEBAND RECEIVING UNIT WITH POWER SUPPLY. FIG. 6. DIVERSITY COMBINER

## Long-Range Communication With

# Single-Sideband Diversity Units

TRANSOCEANIC COMMUNICATION CAN BE ACCOMPLISHED DEPENDABLY WITH SINGLE-SIDEBAND DIVERSITY EQUIPMENT — By MURRAY G. CROSBY\*

ONE of the heaviest long-range communication traffic loads in history occurred during the time of the recent coronation ceremonies in England. Wide use was made of single-sideband equipment, which performed very creditably. Dependable transoceanic reception of standard traffic and photo transmissions was achieved with Crosby triple-diversity single-sideband systems, used by RCA Communications and Press Wireless. This relatively new equipment is described in the following pages.

**Advantages of Single-Sideband:** A primary reason for the increased use of single-sideband systems is that they yield an important saving in frequency bandwidth requirements. This is of great importance because of the rapid growth in international radio communication, which is worsening the already-severe congestion in the short-wave channels.

In addition to the basic advantage of economical frequency utilization, single-sideband systems permit a 9-db effective power gain as compared with double-sideband AM systems. This improvement factor is of considerable significance, particularly in multi-channel communication circuits and in international broadcast services where quality of signal must be preserved in order to meet basic performance requirements.

Single-sideband receiving techniques have significant value in eliminating certain types of interference even when employed with double-sideband transmission systems. A single-sideband receiver can operate in the presence of interference which may fall within the range of one sideband, but not in the range of the other. Sideband selection in such a case can get rid of the interference completely. This, of course, is a real advantage in view of the present severe band overcrowding and international jamming. At the present time, as a receiver is tuned to various signals in the HF frequency range, it is a very rare occurrence to find one signal free from interference on both sidebands, and which could not be improved by using one sideband alone. Thus, there is an obvious advantage in the use of single-sideband receivers in

any communication system, even though the receiver may not be utilized in receiving signals transmitted by the single-sideband method.

**Single-Sideband Adaptor:** In a single-sideband system, a conventional short-wave communications receiver is employed to select and amplify the desired radio-frequency carrier and its modulation components. Fig. 1 is a block diagram of the adaptor for converting such a receiver to single-sideband operation; a view of the combined receiver (in this case, a Hammarlund SP-600JX) and adaptor is given in Fig. 2.

By means of a coaxial-cable connection with the IF output circuit of the receiver the selected carrier signal, at intermediate frequency, is fed to the converter of the adaptor. Here the carrier is heterodyned with a second signal from a high-frequency oscillator, under precise automatic frequency

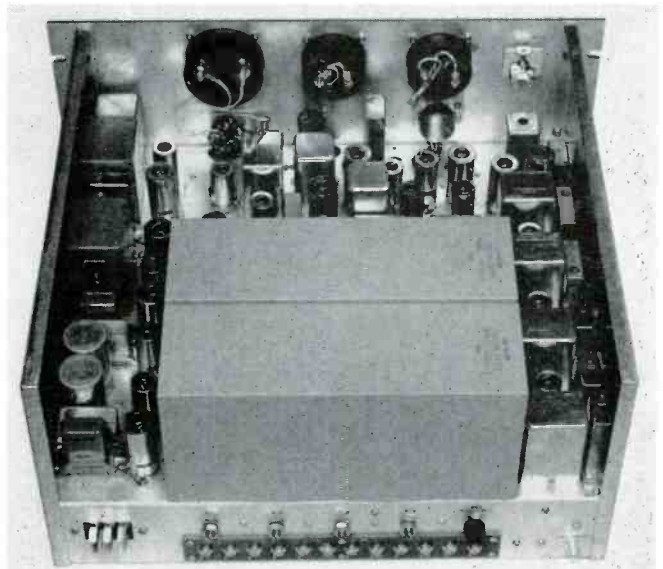
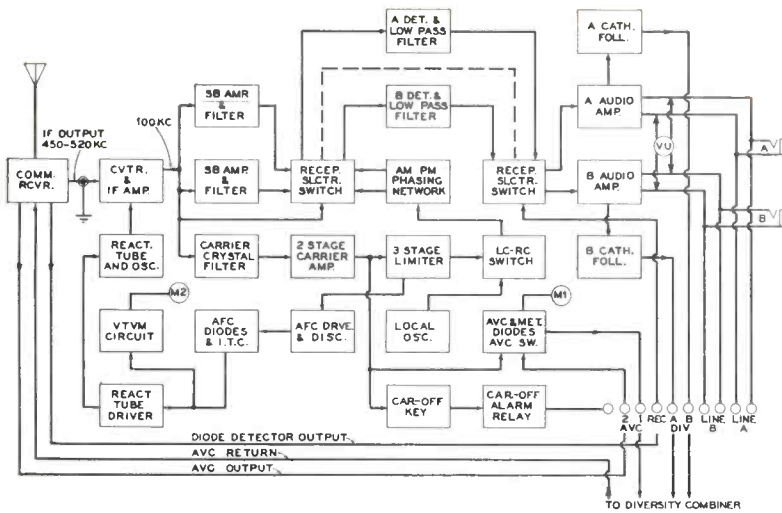

FIG. 3. SINGLE-SIDEBAND RECEIVER ADAPTOR. NOTE CRYSTAL FILTERS

\*President, Crosby Laboratories, Inc., Hicksville, Long Island, N. Y.



FIGS. 1 AND 7. FUNCTIONAL DIAGRAMS OF THE ADAPTOR AND COMBINER UNITS

control, to produce a new intermediate frequency of 100 kc.

The 100-kc. IF signal, with modulation components, is amplified and applied to upper and lower sideband filters having pass-bands from 100 kc. to 106 kc. and from 94 kc. to 100 kc., respectively. These filters can be seen in Fig. 3, which is a rear view of the adaptor. Responses of the filters are shown in Fig. 4. The 100-kc. signal is applied also to a sharply-tuned crystal filter with a passband of 20 cycles, which removes the sidebands as shown in Fig. 5. This is fed to a two-stage carrier amplifier, in which the carrier amplitude is adjusted to an optimum level, as required in compensating for carrier reduction at the single-sideband transmitter. From this point, the amplified carrier is applied to a three-stage limiter, a pair of diodes which supply AVC and carrier meter voltages, and a keying amplifier which forms a part of a carrier-off alarm circuit.

From the three-stage limiter the carrier, reconditioned and exalted by the filter, carrier amplifier, and limiter, is applied to one side of a Reconditioned Carrier-Local Carrier selector switch identified as the LC-RC switch in Fig. 1. A

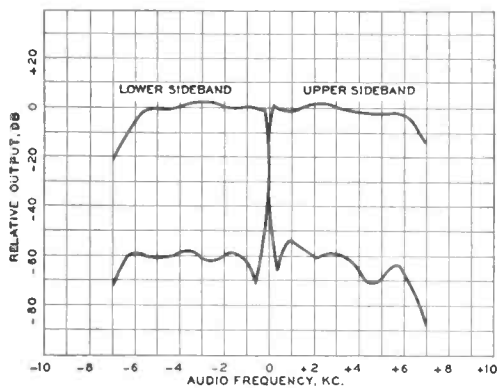

FIG. 4. COMPLEMENTARY RESPONSES OF SIDEBAND FILTERS IN AN ADAPTOR

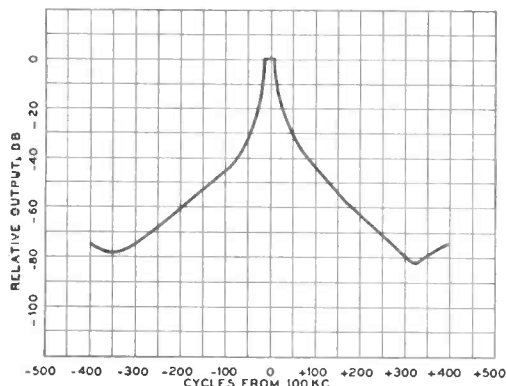
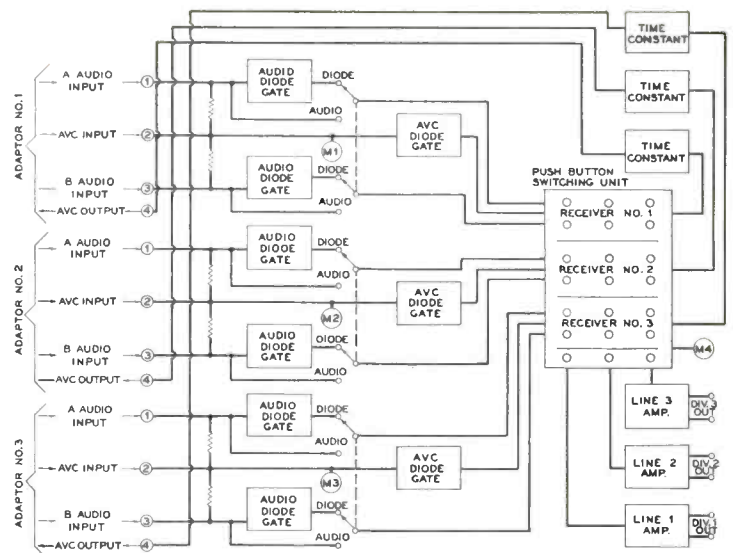

FIG. 5. PERFORMANCE OF THE CARRIER SEPARATION CRYSTAL FILTER



locally-generated 100-kc. carrier from a crystal oscillator is applied to the opposite side of the LC-RC switch. Thus, a choice of reconditioned exalted carrier or local carrier for single sideband reception is available. From the LC-RC switch, the selected carrier is fed to an AM-PM phasing network. This is used in establishing the proper phase relationship between the sidebands and the selected carrier in amplitude-modulated double-sideband signal reception and in phase-modulated double-sideband signal reception.

The reconditioned or local carrier and the sideband signals from the two sideband filters are applied through a reception selector switch to individual detectors for channels A and B. Here, exalted-carrier detection is provided by a triple-triode product-type detector; this unique circuit eliminates harmonic and cross-modulation distortion caused by selective fading of the carrier component. The audio signals in each channel are then applied, through low-pass filters, to separate audio amplifiers associated with the two channels.

The reception selector switch provides for operation with virtually any method of reception. When the sideband filters are switched into the circuit, single-sideband exalted-carrier reception is provided. Either the upper or lower sideband of a conventional double-sideband AM transmission can be selected individually, and the signals applied to separate detectors and audio amplifiers, or both sidebands of a twin-channel multiplex transmission can be received concurrently, with the individual signals being applied to the respective detectors and audio amplifiers. When the signals are selected directly from the 100-kc. IF amplifier and the AM section of the phasing network, exalted-carrier double-sideband AM reception is obtained. When the PM section of the phasing network is used, exalted-carrier reception of phase modulated double-sideband signals is provided. When a connection is made directly to the diode output of the communication receiver, conventional double-sideband AM reception as provided by the basic receiver is possible.

100-kc. carrier voltage from the first stage of the three-stage limiter is applied to an amplifier driving a crystal discriminator, which produces an output voltage proportional to small frequency deviations from the mean frequency of 100 kc. This voltage is rectified by the AFC diodes. The DC error voltage obtained is impressed on the grid circuit of a reactance-tube driver, which contains a storage capacitor for Infinite Time Constant (ITC) operation. In the event that the IF carrier falls below a predetermined level in the ITC circuit, the AFC diodes are disabled. When the carrier reappears, normal AFC action is restored. This protects the reactance tube and oscillator from spurious control by un-

*Continued on page 39*



FIGS. 1 AND 2. ENTIRE POWER SUPPLY IS HERMETICALLY SEALED IN THIS SMALL CONTAINER



# Long-Life Rectifier Power Supply

HERMETICALLY-SEALED POWER CAPSULE, CONTAINING COMPLETE AC TO DC SUPPLY, CAN BE SOLDERED IN PLACE AND FORGOTTEN — By LEO G. SANDS\*

IN order to meet an increasing demand for individual rectifier units suitable for use as local or line batteries, and capable of operating telegraph circuits, instruments, and printers, Bogue has developed a line of hermetically-sealed rectifiers called Power Capsules. These components, shown in Figs. 1 and 2, are designed for extremely long life; solder terminals are utilized as connections. Because of the relatively low price no provision has been made for repairing the Capsules. Instead, they are simply replaced with new units and discarded. They can, therefore, be considered as virtually zero-maintenance devices.

**Design Considerations:** Specifications which were set up by the AAR communications section were used as a basic guide in the development work. These specifications list minimum requirements for an acceptable rectifier power supply to be used for telegraph applications. By meeting but not exceeding

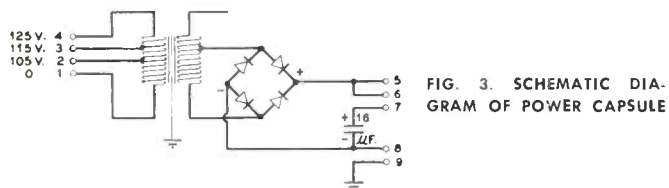

FIG. 3. SCHEMATIC DIAGRAM OF POWER CAPSULE

these requirements, it is possible to build an inexpensive but adequate power supply. However, our engineers concluded that a very good rectifier could be manufactured at a cost not excessively greater than one meeting only the basic minimum requirements, and it was decided to follow the latter course. Fig. 3 gives a schematic diagram of the final model. This fur-

nishes 120 volts DC at 150 ma., with an input of 105 to 125-volt single-phase 50 to 420-cycle AC.

After due consideration, it was decided to include an input transformer. This has two main advantages: first, it provides protection against accidental grounding of the hot side of the AC line; second, the primary taps permit adjustment of output voltage for various values of line voltage. An electrostatic shield was incorporated. The transformer is derated 100% in power from normal rated load.

A full-wave selenium rectifier was employed in preference to a half-wave rectifier so that less filtering would be required. This component is also operated at 50% normal rating. Although the electrolytic capacitor is usually considered to be a reliable component, it does require replacement at long intervals. For that reason, a 16-mfd. metallized-paper capacitor, rated at 400 volts DC, was specified. This gives a ripple of approximately 15 volts at 150 ma. output, and a DC output of better than 120 volts — quite adequate performance for the purpose.

The AAR specification suggested plug-in contacts. This was not followed, for two reasons: first, plug-in contacts are occasionally troublesome over long periods; second, because of the extremely long life expectancy of this unit, plug-in contacts are unnecessary. Instead, solder terminals are provided. Polarity reversal can be effected by transposition of output leads or by means of an external toggle switch.

In order to protect the line-isolation transformer, the selenium rectifier, and the filter capacitor from moisture and dust, these components are sealed hermetically inside a metal can with a moisture-proof ceramic terminal header.

**Accessories:** The rectifier supply itself is identified as type PC-1. PCA-1 is an adapter for mounting one of these units on

*Concluded on page 45*

\*Formerly president, Bogue Railway Equipment Division, Bogue Electric Mfg. Company, Paterson 3, N. J. Now with Langevin Mfg. Corp., 37 W. 65th Street, New York 23, N. Y.

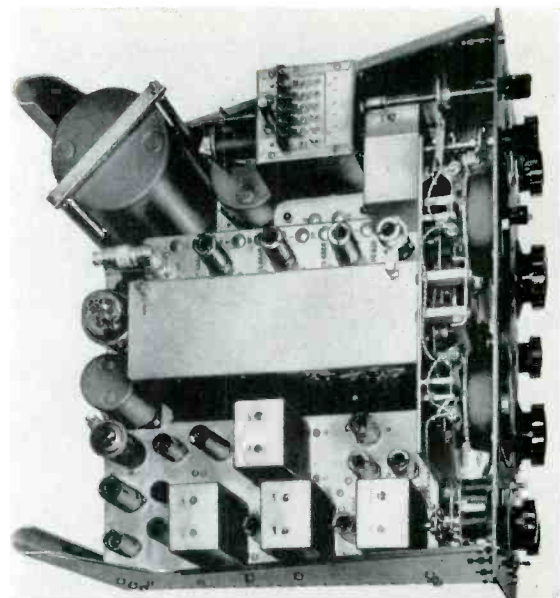

FIG. 1. SP-600JX RECEIVER IN TABLE-MODEL CABINET. SET CAN BE RACK-MOUNTED ALSO. FIG. 2. CHASSIS WITH SECTION COVER PLATES IN PLACE

# The SP-600 Communication Receivers

LATEST ELECTRICAL AND MECHANICAL DESIGN TECHNIQUES ARE TYPIFIED IN THIS GENERAL-PURPOSE MF-HF-VHF RECEIVER — *By J. C. WHITEHEAD\**

THE Hammarlund SP-600 sets were developed to meet the need for general-purpose communication receivers of professional performance, dependability, versatility, and stability. That they fulfill all these requirements is attested to by their immediate acceptance and use in a wide range of government, commercial, and amateur applications.

Because of their unique design, which makes use of the best features of older models and incorporates several ingenious mechanical and electrical innovations, these receivers should be of general interest. They are described in the following pages.

**General Information:** The receiver is made in two basic models, the SP-600J and the SP-600JX. They are identical except that the latter is supplied with circuits and controls by means of which the high-frequency oscillator can be continuously variable or set to any of six crystal-controlled frequencies, and the former has the variable high-frequency oscillator only. The suffix J indicates that, insofar as possible, components are used which have characteristics meeting military specifications.

Mounting for the basic chassis can be either a standard rack panel 10½ ins. high or a ventilated steel cabinet with rubber feet, shown in Fig. 1. Rack models have top and bottom cover plates. Views of the chassis are given in Figs. 2 and 3.

The power supply is completely self-contained, and is suitable for operation on any 50 to 60-cycle single-phase AC power source from 90 to 270 volts. Power consumption is 130 watts.

Headphone and loudspeaker reception of AM radiotelephone, CW telegraph, and AM MCW telegraph signals is provided. The receiver is also well adapted to diversity reception applications. Coverage from 540 kc. to 54 mc. is obtained in six bands. In addition to changing band circuitry, the band switch changes the band indicator visible through

a front-panel window and aligns the dial frequency indicator with the proper dial scale. The main dial has an arbitrary scale also which, in conjunction with the vernier dial, furnishes a continuously-expanded scale in each frequency band for very accurate logging and resetting.

The single tuning control is large and of unique design to permit maximum traverse speed as well as precise adjustments. It controls both main and vernier dials. An anti-backlash gear train is used with a ratio of 50 to 1 for the main dial and 300 to 1 for the vernier dial. Positive locking without frequency shift is obtained with the tuning lock mechanism.

Two stages of RF amplification are provided on all bands. Single conversion is used for signal frequencies up to 7.4 mc. and double conversion, by means of a crystal-controlled second oscillator, for signal frequencies above 7.4 mc. Four stages of IF amplification, as well as separate detector, AVC rectifier, noise limiter, meter rectifier, beat-frequency oscillator, BFO buffer, IF output, AF amplifier, and AF power amplifier stages are employed.

The frequency control unit supplied with JX models can be seen at the upper right-hand corner of the front panel, Fig. 1. This provides for fixed-frequency crystal-controlled operation on any six frequencies within the range from .75 to 54 mc. A front-panel control permits selection of any of these fixed-frequency channels or normal variable-frequency tuning. It is necessary first to set the dial to the rough frequency desired and then switch to the proper crystal. Very precise tuning can be obtained then with the delta frequency control, which is part of the frequency control unit. Crystals are not supplied with the receiver, but can be obtained on special order.

Frequency drift after a 15-minute warming period ranges between .001 and .01% of the signal frequency. This is unusually good for a variable-tuned HF oscillator, and approaches crystal stability closely.

Six degrees of selectivity are available from .2 kc. to 13 kc., determined by a front-panel selector switch. In three

\*Receiver Engineer, the Hammarlund Mfg. Company, Inc., 460 West 34th Street, New York 1, N. Y.



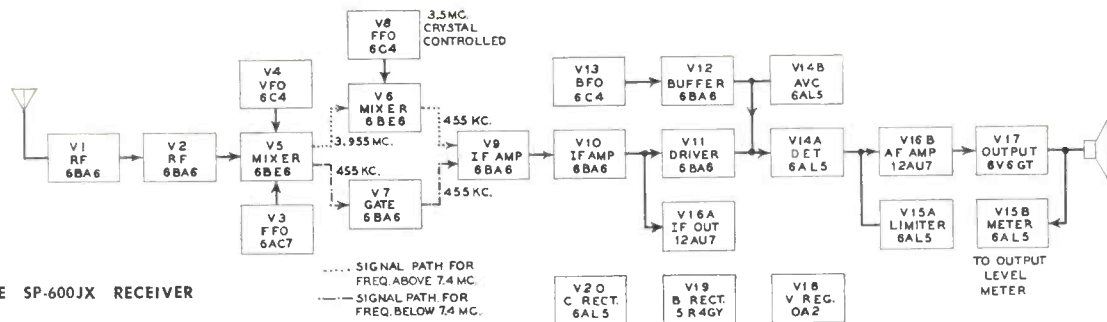

FIG. 4. CIRCUITS OF THE SP-600JX RECEIVER

of these positions a crystal-filter circuit is employed.

An effective noise-limiter circuit, which can be switched in or out independently of other controls, is included for suppression of interference from ignition or other types of impulse noise. A send-receive switch is provided also; this desensitizes the receiver but leaves the power on so that the set is ready instantly to operate when the transmitter is turned off. Remote relay operation of this switch is possible.

Although the input circuit is designed for a balanced 95-ohm line, a single-wire antenna can be used. Radiation is negligible, well within requirements for shipboard operation and multi-receiver installations.

The audio output circuit impedance is 600 ohms for a high-impedance loudspeaker or audio line. Maximum power output is about 2 watts to this load. The headphone output circuit, when terminated in an 8,000-ohm load, provides a signal attenuated about 15 db from that at the 600-ohm output terminals.

**Circuitry:** A block diagram, Fig. 4, shows the arrangement and functions of the various circuit sections.

The input impedance at the antenna socket, which is visible at the rear of the RF platform in Figs. 2 and 3, is intended to match a 95-ohm transmission line. An angle plug adaptor and connector plug is supplied for RG-22/U cable, which should be used in a balanced antenna installation. If it is desired to operate with a single wire antenna it can be connected to one terminal of the plug, and a ground lead connected from the other plug terminal to the ground terminal at the rear of the tuning unit.

A rotary turret assembly is used to change frequency bands. RF, mixer, and first oscillator coil assemblies are

mounted on the turret, and they are rotated into place directly adjacent to the 4-gang tuning capacitor and the tubes as the bands are changed. This turret can be seen at the center in Fig. 5, which shows the bottom of the receiver with the turret section shield cover removed. RF amplifier tubes V1 and V2, variable high-frequency oscillator tube V4, and mixer tube V5 are mounted on the RF platform situated at the left of the tuning condenser, Fig. 3. A detailed view of this platform is given in Fig. 6. Mechanical construction of this sort provides for short, direct connections on all bands and assures maximum sensitivity as well as minimum radiation throughout the frequency range covered by the receiver.

The six frequency bands are from .54 to 1.35, 1.35 to 3.45, 3.45 to 7.4, 7.4 to 14.8, 14.8 to 29.7, and 29.7 to 54 mc. On the first three bands the incoming signal is heterodyned directly to 455 kc., the IF frequency, and is passed through the gate tube V7 to the first IF amplifier stage. On the higher three bands, however, the gate is closed and the first oscillator frequency is such that the signal is heterodyned to 3.955 mc. in the first mixer. This is fed to V6, the second mixer, where it beats with a 3.5-mc. signal from crystal-controlled oscillator V8. The difference frequency of 455 kc. is fed to the first IF amplifier, V9.

As explained before, the first oscillator stage may be variable in frequency or crystal-controlled on any of six fixed frequencies (in JX models). In all fixed-frequency positions a front-panel control marked DELTA FREQUENCY provides adjustment of the crystal oscillator over a  $\pm .005\%$  range.

Selectivity is varied by control of the IF section band-pass. A six-position switch gives 6-db bandwidths of .2, .5, 1.3, 3, 8, and 13 kc., as shown in Fig. 7. In the three narrow-band positions of the switch a crystal filter is used. A crystal phas-

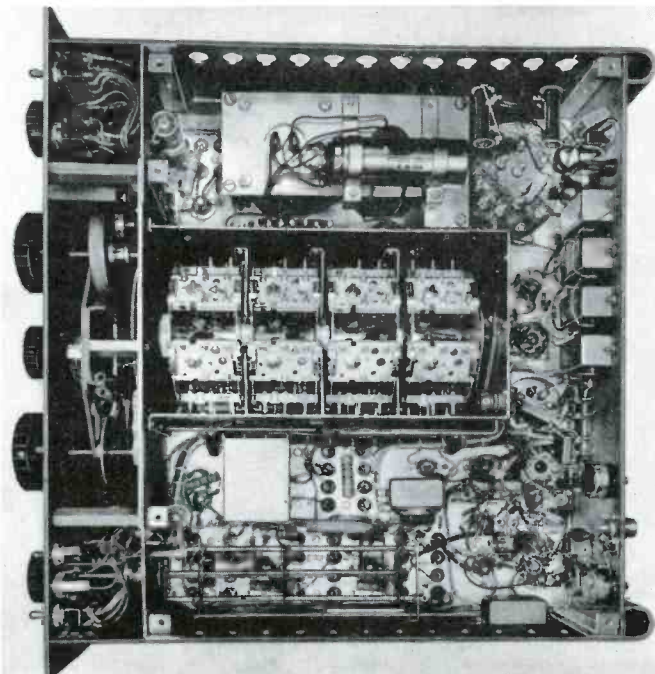
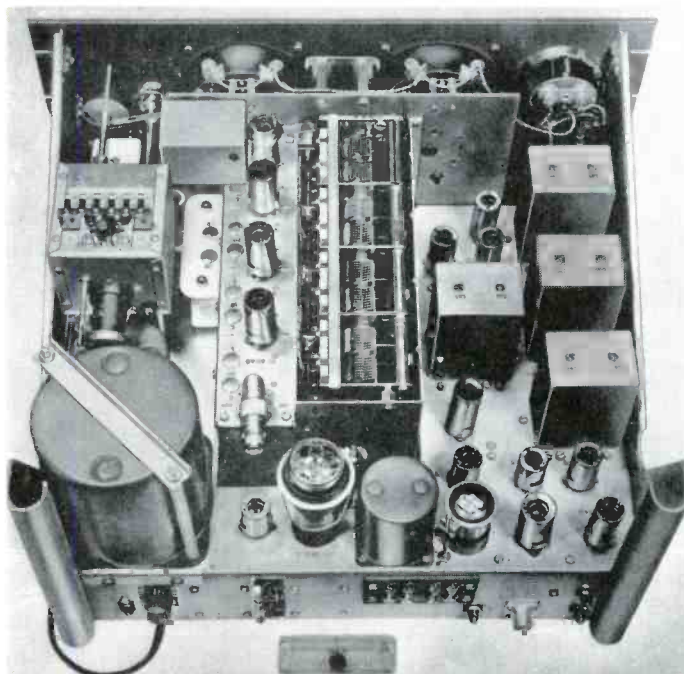

FIGS. 3 AND 5. RF PLATFORM AND GANG TUNING CAPACITOR ARE ABOVE THE CHASSIS AT CENTER, AND ROTATING COIL TURRET IS JUST BELOW THEM



Complete transmitter and receiver in a single easy-to-carry case. 152-174 Mc

*Most versatile*  
**medium-range radio station...  
 RCA Carfone Station Unit "15"**



IT'S EASY TO CARRY as your traveling bag. The case is only 19 3/4" long, 10 3/4" high, and 9 1/4" deep.



IT CAN BE SET UP ANY PLACE where there's 115-volt, a-c supply—for taxis, forestry, utilities, construction projects.



IT'S IDEAL for 2-way operation (police, fire, etc.) in small and medium-size municipalities requiring medium-range communication equipment.

FOR ALL-AROUND USE . . . for portable or fixed-stations, here's your best buy . . . the RCA Carfone 2-Way Radio Station Unit "15."

It is complete with transmitter, receiver, power supply, portable antenna, handy microphone, and loudspeaker . . . all in a single package.

Easy to carry and easy to set up, this portable unit can be operated wherever there is a 115-volt, a-c outlet.

For fixed station use, place the unit on the operating desk, hook up the antenna, plug in the power cord, and you're set to go. For portable station use, simply connect the quarter-wave, whip antenna (supplied) and plug in the power cord. No extra components to carry around. No installation expense involved.

Greatly improved receiver selectivity reduces adjacent channel signals well below interference levels. A newly designed transmitter modulation control enables you to transmit the full signal potential of the transmitter and maintain one-hundred-per-cent modulation at virtually all voice levels—whether you shout or whisper into the microphone.

**For complete information,  
 MAIL COUPON TODAY.**

Communications Section, Dept. —  
 Building 15-I  
 Radio Corporation of America  
 Camden, N. J.

Please send me complete details  
 on the RCA Carfone Station Unit "15."

NAME \_\_\_\_\_ TITLE \_\_\_\_\_  
 COMPANY \_\_\_\_\_  
 ADDRESS \_\_\_\_\_  
 CITY \_\_\_\_\_ ZONE \_\_\_\_\_ STATE \_\_\_\_\_



**RADIO CORPORATION  
 of AMERICA**  
 COMMUNICATIONS EQUIPMENT  
 CAMDEN, N. J.



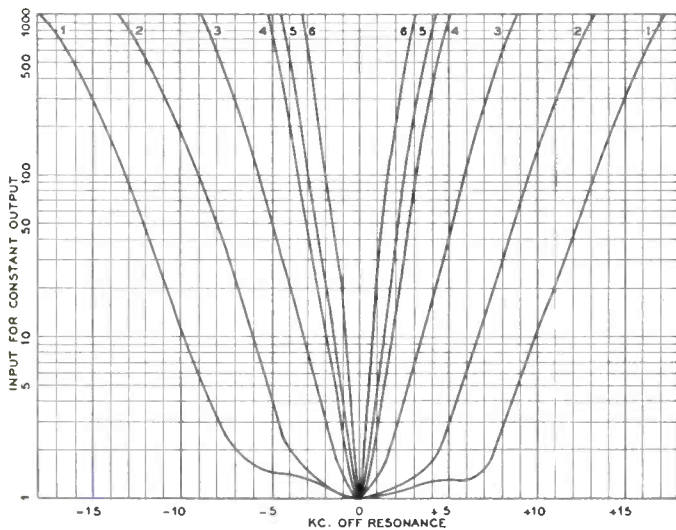

FIG. 7. IF BANDPASS FOR VARIOUS POSITIONS OF SELECTIVITY SWITCH.

ing control operative in these switch positions provides precise control of the skirt for discrimination against very close interfering signals.

Cathode-follower tube V16A couples the IF signal to a socket at the rear of the chassis for diversity and teletype applications. Output impedance is 70 ohms. About 200 millivolts are available to a matched load with 2 microvolts input signal.

The two halves of V14 operate as a high-level detector and a separate AVC rectifier. Different time constants are used in the AVC circuit for AM and CW operation. As can be seen in Fig. 8, output terminals are provided at the back of the chassis for AVC and detector voltages; these are intended for diversity applications. Shunt connection for AVC and series connection for the detector loads are employed. When the external connections are not made, a jumper is used to short the detector output terminal.

V13, the beat frequency oscillator, is a high-capacity Colpitts circuit which has good stability and low harmonic content. Buffer amplifier V12 is used to eliminate oscillator lock-in and to permit variation of the oscillator injection. The control for that purpose is at the rear of the chassis. On the front panel, however, is a control by which the oscillator frequency can be varied from zero beat to  $\pm 3$  kc.

Signals from the detector are fed to audio amplifier V16B across a noise limiter, V15A, which can be switched in or out of the circuit as desired. The audio gain control is also in the grid circuit of V16B. Audio output tube V17 delivers a maximum of 2 watts to a 600-ohm load through a split-balanced output transformer. This provides DC balance in

FIG. 6, BELOW: PLATFORM HAS CIRCUITS FOR V1, V2, V4, AND V5 STAGES  
FIG. 8, RIGHT: CIRCUIT CONNECTIONS ARE AVAILABLE AT CHASSIS REAR

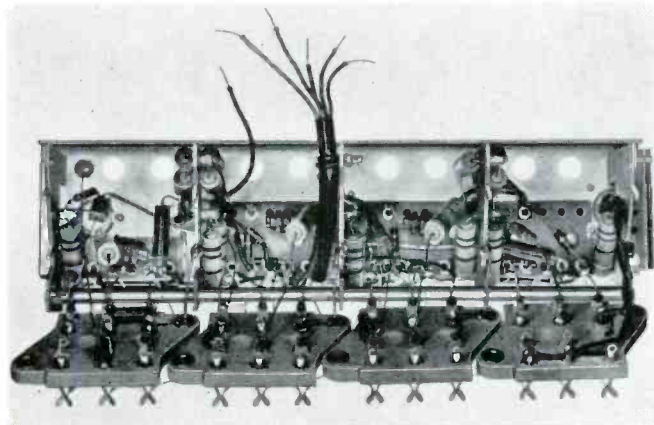

formerly *FM-TV* RADIO COMMUNICATION

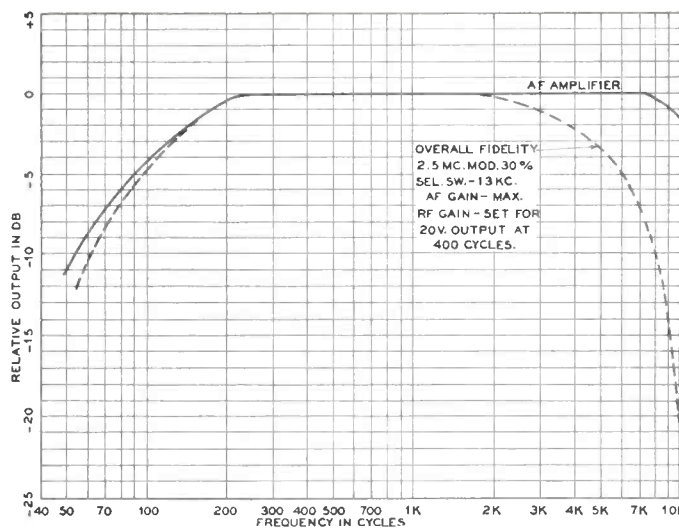

FIG. 9. FIDELITY CURVES FOR AF AMPLIFIER AND OVERALL RECEIVER

the output circuit, as required for teletype and similar applications. Where the insertion of DC control or indicating devices is required, the jumper connecting the two sections of the 600-ohm winding can be removed and the auxiliary circuit, such as a low-resistance balancing potentiometer, connected in its place.

The speaker should be of the PM type, and should be of 600 ohms impedance or used with an impedance-matching transformer. If the 600-ohm output is not used, then a 600-ohm 2-watt resistive load should be connected to the output terminals. A separate secondary winding delivers 15 milliwatts to an 8,000-ohm load when the 600-ohm load receives  $\frac{1}{2}$  watt. High or low-impedance headphones can be used, but the high-impedance type is recommended. Audio fidelity is unusually good for a communication receiver, as the curves in Fig. 9 show.

An RF gain control is furnished, primarily to prevent overloading on strong signals when the AVC is rendered inoperative by the AVC-MANUAL switch. However, the control is in the circuit also when the AVC is functioning. The AC ON-OFF switch is operated in the extreme counterclockwise position of the RF gain control.

A front-panel meter is furnished to indicate accuracy of tuning and relative received signal strength. When the meter switch is depressed, the circuits are changed so that the meter reads audio output level in db above 6 milliwatts. V15B is used as a rectifier for this purpose.

The power supply is an integral part of the receiver. This section includes the high-voltage rectifier V19 and the bias

*Continued on page 43*



# Radio Control for Railroads

HOW TWO-WAY TRAFFIC WILL BE CONTROLLED ON 90-MILE SINGLE-TRACK RAILROAD BY ONE DISPATCHER USING SIGNALS CARRIED BY VHF RADIO

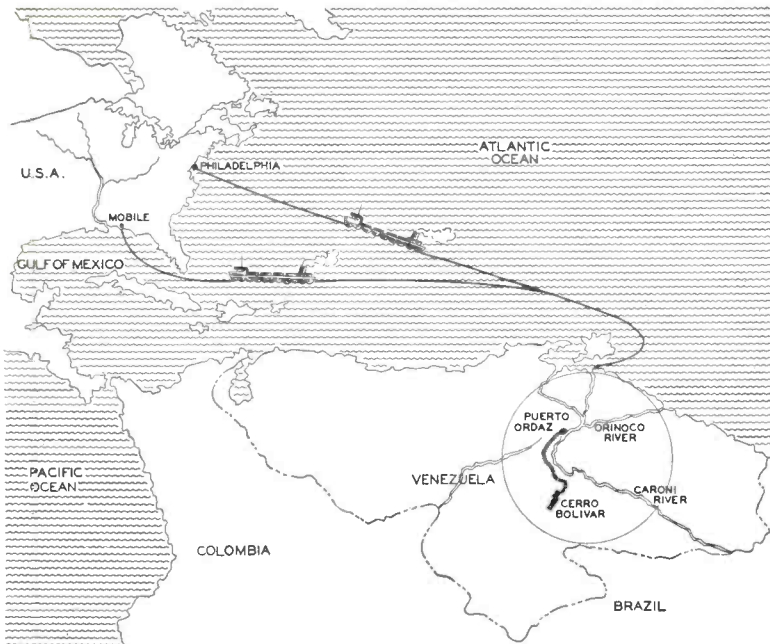

FIG. 1. LOCATION OF RAILROAD WHICH WILL BE CONTROLLED BY RADIO

NOW being installed on a 90-mile stretch of railroad track in Venezuela is the first VHF radio system for remote control of switches, signals, and interlocks. The single-track right-of-way will be used to transport iron ore from U. S. Steel's Cerro Bolivar mine to Puerto Ordaz, Fig. 1, where it will be loaded on barges for shipment to the United States.

As in all single-track systems, sidings will be provided at intervals so that train service can be obtained in both directions at the same time. When trains traveling in opposite directions are scheduled to meet, one is shunted to a siding until the other has passed. In this particular installation eight sidings are contemplated, as shown in Fig. 2. Switches for four of these will be controlled by radio from the central dispatching point at Puerto Ordaz.

Voice-frequency coded carrier control equipment for centralized traffic control (CTC), manufactured by Union Switch & Signal, will be used in conjunction with VHF transmitters and receivers from RCA. The complete system will be capable of handling five telephone and two teletype channels, in addition to the traffic control signals, over one full duplex circuit. Dr. Paul F. Godley was consulting engineer on the project.

**System Operation:** The plan of the 90-mile system is shown in Fig. 2. Two main towers are to be used, each equipped with two transmitters, two receivers, two transmitting antennas, and two receiving antennas. The higher tower will be located at Puerto Ordaz, since it will be only 100 ft. above sea level, and land lines will connect it to the control point. The other main tower will be fairly short, because the terrain at Cerro Bolivar is about 2,000 ft. above sea level. It will be connected to headquarters at the mine via land lines.

A tower for transmitting and receiving VHF signals is to be employed at each of the controlled sidings. Each siding and the five-track yard at the mine will be equipped with standard US & S signals and switch machines; in addition, each siding will have a CTC line coding unit for switch and

signal control, and an extension unit to handle indications of power failure and transfer from normal to standby carrier equipment. These extensions will also be used to furnish indication of transferral from normal to reserve RCA equipment. At Puerto Ordaz will be installed two sets of coded carrier control equipment (one for standby) and a CTC panel. Holding signal units will be at both yards.

Under normal conditions, with a train leaving Cerro Bolivar and one leaving Puerto Ordaz at the same time, the operator at the control panel will operate panel levers to transmit coded pulses which will release the signal holding the train at Puerto Ordaz. Release impulses for the holding signal at the mine will be sent over the land line to the Puerto Ordaz main tower, relayed by radio to the mine tower, and sent by land line to the mine yard.

To control the two sidings nearest Puerto Ordaz, the panel will transmit coded pulses over the cable to the radio tower location. These pulses will key a 2.9-kc. US & S transmitter which, in turn, will modulate the VHF transmitter. Receivers located at the sidings will pick up the code indications and operate the signals and switches accordingly.

The two sidings near Cerro Bolivar will also be controlled from the panel at the port. In this case, however, the signals will be carried by RF channel to the main tower at Cerro Bolivar, where the demodulated 2.9-kc. code will modulate another VHF transmitter, sending the signals to the towers.

Tower locations at the four sidings will be capable of transmitting as well as receiving code indications. Only seconds will elapse between the time the Puerto Ordaz operator throws the appropriate lever and the switches at the siding nearest the mine complete their movements. Codes indicating a train has cleared a siding will be flashed back to the operator.

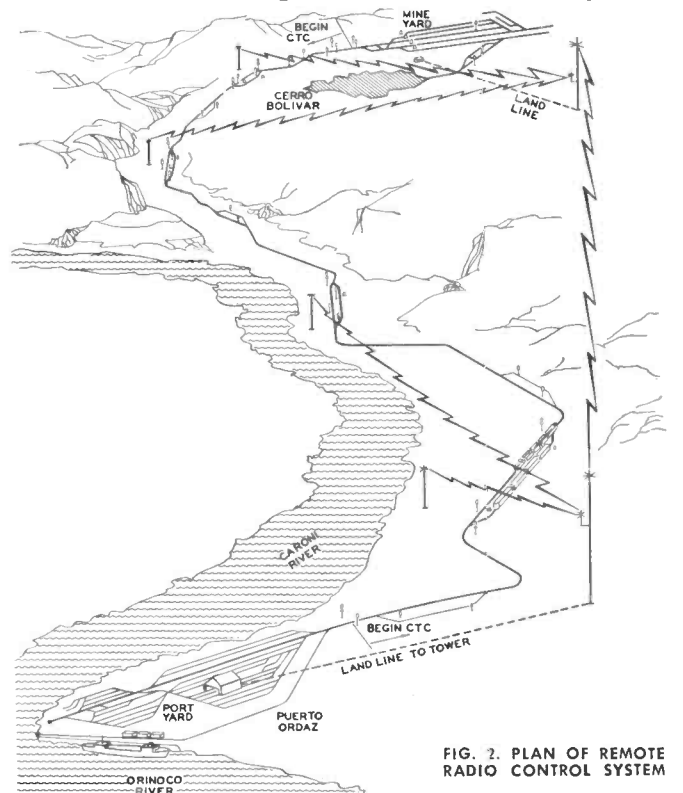

FIG. 2. PLAN OF REMOTE RADIO CONTROL SYSTEM



Just off the Press:

## Registry of Public Safety Systems

The new edition of the Registry of Public Safety Communication Systems, revised directly from records in the FCC files at Washington, lists over 7,000 systems operated by

- Municipal, County, State Police
- Zone and Interzone Police
- Fire Departments
- Special Emergency Services
- U. S. and State Forestry Departments
- Highway Maintenance Departments

Each listing shows the mail address of the licensee, location of the transmitter, number of mobile units, operating frequencies, and call letters, and indicates special purpose transmitters used as relays or controls.

This is the only source of such information, and is published by permission of the Federal Communications Commission.

### FCC APPROVED TRANSMITTERS

As an added feature of great value, this Registry also contains the complete list of transmitters approved by the FCC for use in the Safety and Special Services, with additions and revisions up to May 1. This list is not available from the FCC. Over 700 approved transmitter types are listed, from 38 manufacturers.

**SEND FOR YOUR COPY NOW!**  
\$1.00 Per Copy, Postpaid, from

REGISTRY DEPARTMENT  
**Communication Engineering**

The Publishing House  
Great Barrington Massachusetts

## For Every Microphone Need in Two-Way Radio

# SHURE

## Has a "Field-Proved" Model

Here is the world's most popular fixed-station all-purpose microphone. Outstanding because of its high speech intelligibility, extended frequency range, high output and reduction of feedback. Prevents the transmission of distracting station noises.



Model 55s  
"Small Unidyne"  
Ultra-Cardioid  
Dynamic  
Microphone

This is the original "old faithful" mobile hand microphone. Used for rugged field and car duty more than all other makes combined! Features high speech intelligibility and ruggedness. Stands up under heavy use and abuse.



The  
"100 Series"  
Carbon  
Hand-Held  
Mobile  
Microphone

This Controlled Reluctance Microphone Cartridge is an ideal service replacement for the Model 520SL Dispatcher and for use in special hidden microphone applications. Practically unaffected by heat and humidity.



Model R5  
"Controlled  
Reluctance"  
Microphone  
Cartridge

This dispatching unit handles the most severe field requirements of paging and dispatching systems. Supplied with 2-conductor shielded cable, and wired to operate both microphone and relay circuits. Features "Grip-to-Talk, Slide-to-Lock" long-life switch.



Model 520SL  
"Dispatcher"  
Complete  
Dispatching  
Unit

Designed for use with small portable and mobile transmitters. Only 2" in diameter and 1 1/2" thick. Has 3-conductor coiled cord, metal-spring strain relief, and Push-to-Talk switch. Has same operating characteristics as "100 Series" Carbon Microphones.



Model 115  
Carbon  
"Pack"  
Microphone

A Controlled Reluctance Microphone and desk stand assembly—ideal for mobile and fixed-station use in all types of communications work. Has a built-in switch for controlling both the microphone circuit and an external relay or control circuit.



Model 510MD  
"Controlled  
Reluctance"  
Microphone  
Assembly

## SHURE BROTHERS, INC.

Manufacturers of Microphones  
and Acoustic Devices



225 W. Huron St. • Chicago 10, Ill.  
Cable Address: SHUREMICRO

# 6 YEARS PROOF ON 2-WAY RADIO!

## Leece-Neville

### ALTERNATORS END BATTERY TROUBLES

#### BATTERY USED FOR STARTING ONLY

Since 1946, L-N Alternators have been eliminating battery troubles on 2-way radio vehicles... or wherever needs for current are high. Replace conventional generators with the L-N Alternator System and get

25 TO 40 AMPERES IDLING

ENTIRE ELECTRIC LOAD  
CARRIED BY THE ALTERNATOR

BATTERY KEPT FULLY CHARGED

Let us arrange a demonstration of the L-N Alternator for your fleet. Or



write for all the facts. The Leece-Neville Company, Cleveland 14, Ohio. Distributors in principal cities... Service Stations everywhere.

HEAVY-DUTY ELECTRIC EQUIPMENT  
FOR OVER 43 YEARS



Be Sure to Specify Leece-Neville

ALTERNATOR SYSTEMS • GENERATORS  
STARTING MOTORS • REGULATORS • SWITCHES  
FRACTIONAL HP MOTORS



#### RADIO SERVICES

(Continued from page 21)

an appropriate division. At best, the division has to be based on the judgment of the Commission, according to the allocation hearing record. The same situation applies in every category of service. How can one judge between railroads, highway transport, and air transport in making the first determination, although air transport has an easy time compared to the other two? In the taxi field, radio makes it possible for a far larger number of people to have the benefit of the services of a fleet of cabs than would be

possible without communication with cabs in the street. To the taxi company, revenues increase and costs decrease. In the utility field, the use of radio reduces the frequency and length of interruption to service, reduces the cost of service with consequent reduction in rates, and makes the maintenance of service safer for the personnel of the utility.

To summarize, in making frequency allotments the paramount consideration is the provision for safer, more efficient or more economical service rendered directly or indirectly to the general public by the licensees.

In the aviation service, the Interna-

tional Civil Aviation Organization, one of the specialized agencies of the United Nations, formulates international policy with respect to the aviation matters, including aviation communications. Within the U. S. the CAA and the CAB have the responsibility for the control of air safety and, therefore, have a major role in the establishment of aviation communication policies. The function of the Commission, therefore, is to assist in the formulation of policies by these organizations in order that the frequencies provided may be used realistically, and in order that the Commission's rules and regulations for the aviation communications service may realistically meet the problems of aircraft operation.

The aviation communications service is restricted to the handling of communications essential to aircraft operation. It may not be used for the handling of public message traffic. Essentially, aviation communications must be interference-free. As a matter of safety policy, only one licensee is permitted at any one location to render any one aviation service. In rendering that service, the licensee is required to serve all users on an equal and cost-sharing basis.

There is as yet no organization in the international marine service comparable to that in aviation. The International Convention for the Safety of Life at Sea covers communications with a host of other matters involved in the safety of life at sea. Under domestic law, the FCC, in cooperation with the Coast Guard, is responsible for the use of radio in promoting safety of life at sea. The marine radio service is, from the point of view of governmental philosophy, established primarily for the protection of lives and property. The use of stations in the service for the handling of commercial messages between ship and shore and between ships is merely incidental, and is subject to interruption should safety require. It is for this reason that, although the stations in the marine service have common carrier functions, they are classified as safety stations.

Since these stations handle commercial messages, there is an opportunity for operation of coast stations as commercial ventures. Therefore, there is occasional contest between applicants desiring to operate coastal stations which must be decided first as to whether safety would be achieved by the establishment of an additional coast station (increased sharing of frequencies may outweigh increased coverage), second, if another coast station is warranted, which of the applicants' plans would make the greatest contribution to safety, and finally, does the public need additional coastal service.

Leaving the question of these two specialized services and returning to the



general case, the Commission, after setting forth in its rules the frequency bands to be used by the various industries to perform specific services, must first, in its rules, describe in detail the service to be rendered and insure the prohibition of all unintended activities. Second, the Commission must specify the qualifications to be met by those wishing to render the services. Thereafter, all applicants that meet the general criteria of eligibility obtain authorizations to perform the specified communications service. The problem of living together and sharing the frequencies is to be met through cooperative action by these licensees.

The situation creates certain responsibilities which licensees in these services must assume. There are others that the Commission has asked them to assume. In the latter category falls the making of recommendations to the Commission as to which frequencies, among those available to the service, might best be assigned to a prospective licensee. These recommendations are usually prepared by groups of licensee representation all operating in the same service in the same area. The recommendations of industry groups, while bearing great weight, are considered with other information.

*(To be concluded)*

## DIVERSITY UNITS

*(Continued from page 30)*

desired signals or noise during intervals when the desired radio carrier drops below a designated threshold strength. At the same time, while the AFC voltage is removed, the residual charge on the storage capacitor of the reactance-tube driver remains at a substantially constant potential over periods of several minutes, thus holding or freezing the high-frequency oscillator at a frequency in close proximity to its last-corrected frequency. In normal operation, when carrier is present, the AFC circuit is relatively immune to high noise peaks or interference from jamming signals because of the protection afforded by the crystal filter, limiter, and crystal discriminator.

The 100-kc. signal voltage, after passing through the crystal carrier filter and the carrier amplifier, is rectified by an AVC diode. Normally, it is then applied to the AVC circuit of the communication receiver to provide protection against interference which might otherwise gain control of the AVC system. When used in a diversity system, the AVC voltage is applied to the diversity combiner, described below, and is afterward fed back to the communication receiver. A switch permits the AVC system to be controlled either from the filtered and rectified carrier alone, as above indicated, or from the total rectified signal and sidebands,

# C-D and

## Faradon\* CAPACITORS

*They earn their leadership  
every day, in the laboratory  
and in the field!*

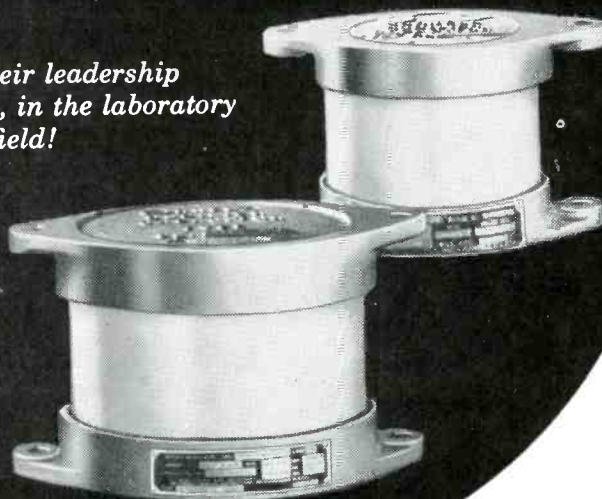

C-D transmitting capacitors and Faradon\* capacitors manufactured exclusively by Cornell-Dubilier, available through all Authorized C-D Distributors. Write for Catalog to: Dept. TV 73, Cornell-Dubilier Electric Corp., South Plainfield, N. J.



CONSISTENTLY DEPENDABLE  
**CORNELL-DUBILIER**  
CAPACITORS

Plants in South Plainfield, N. J.; New Bedford, Worcester, and Cambridge, Mass.; Providence, R. I.; Indianapolis, Ind.; Fuquay Springs, N. C.; and subsidiary, The Radiart Corp., Cleveland, Ohio

which is advantageous for tuning purposes. The carrier meter furnishes visual indications of signal level and proper tuning.

**Diversity Combiner:** The operating principle of the diversity combiner, shown in Fig. 6, is that of a diode gate controlled by the rectified signal so that the gate selects automatically the audio output from the receiver having the strongest rectified carrier or total signal.

The audio signal from each channel of each receiver, Fig. 7, is fed through its individual diode gate to a common load resistor, incorporated in a push-button

switching unit. DC voltage from the AVC circuit of each receiver is fed to the respective audio diode gates of each channel through isolating resistors, as shown in the diagram, and directly to an AVC diode gate. The diode gates act as controlled resistances, each of which has a low value when the bias from the rectified signal is high, and a high value when the bias is low. The audio voltage fed through the controlled resistance to the common load resistance, therefore, is selected primarily from the receiver with the strongest rectified carrier or total carrier at any given moment.

*Continued on page 40*

*Simplifying HF Power Measurement*  
**Model 67 TERMALINE**  
**DIRECT-READING R-F WATTMETER**

30 mc to 500 mc  
 (to 1000 mc if specified)

50 ohms

Triple Range 0-25 watts  
 0-100 "  
 0-500 "

Type N Input Connector  
 (Adaptor for PL-259 supplied)



● Model 67 is a larger type Wattmeter than the well-known AN-ME-11/U (our Model 611) R-F Wattmeter. Specifically designed for fixed station transmitters to 500 watts output, it may be used nicely on low range for mobile gear. Provided with an aluminum cased, shock-mounted meter, Model 67 is as simple to use as a DC voltmeter. Now in general use throughout the industry, TERMALINE Wattmeters may be depended upon for fast, accurate and repeatable power readings.

**NON-RADIATING**  
 ... Accuracy - 5%  
**RUGGED CONSTRUCTION**  
 ... Size - 17" x 9" x 6"  
 Wght. - 30 pounds



**BIRD**  
**ELECTRONIC CORP.**  
 1800 EAST 38<sup>TH</sup> ST., CLEVELAND 14, OHIO  
**TERMALINE Coaxial Line Instruments**

NEELY  
 ENTERPRISES  
 Hollywood • San Francisco  
 Albuquerque  
 EARL LIPSCOMB  
 ASSOCIATES  
 Dallas • Houston

## MOBILE RADIO HANDBOOK

Practical Working Data on Mobile and Point-to-Point Systems

EDITOR: MILTON B. SLEEPER — ASSOCIATES: JEREMIAH COURTNEY, ROY ALLISON

**PLANNING:** How to plan a mobile or point-to-point communications system. This chapter covers the overall problems of power and topography, interference, city ordinances, public liability, operation, maintenance, expansion, and interconnection.

**FREQUENCIES:** FCC rules and allocations which became effective in July, 1949 provided for many new services. Complete details are presented on every service in the common carrier, public safety, industrial, and transportation groups.

**LICENSES:** How to apply for a construction permit, license, and renewal for a communications system. Complete FCC forms, filled out in the correct manner, are shown. This is of the utmost importance; incorrect forms may cause months of delay.

**EQUIPMENT:** Three chapters are devoted to the problems of selecting the right equipment for a particular system, specifications on transmitters and receivers of all makes, selective calling and fleet control and adjacent-channel operation.

**ANTENNAS, TOWERS:** The problems of planning antenna installations are covered very thoroughly in two chapters which explain the various special-purpose types of radiators, and the correct method of erecting a standard guyed, steel antenna tower.

**MAINTENANCE:** How to keep a communications system at peak performance. Methods and record forms that have been perfected by years of experience are described in detail. Proper balance between essential and superfluous maintenance is explained.

**OPERATORS:** The FCC is becoming increasingly strict about the observance of rules relating to operator requirements at communications systems. Official information is given, with a detailed explanation from FCC Secretary T. J. Slowie.

**HOW FM WORKS:** Advantages of FM over AM, coverage, interference, and static elimination, and circuit functions are explained pictorially in 83 illustrations. The use of mathematics has thus been avoided in this clear, practical presentation.

An elaborately illustrated reference book for executives, communications engineers, system supervisors. 190 pages, 8¾ by 11½ ins.

\$4.00 Cloth Bound - \$2.00 Paper Cover Postpaid in the U.S. Elsewhere, 25c Postage

Published by **RADIOCOM, INC.**

THE PUBLISHING HOUSE, GREAT BARRINGTON, MASS.

## DIVERSITY UNITS

(Continued from page 39)

The selected audio voltage in each audio channel is applied to one of the audio amplifiers in the combiner, and the DC voltage from the strongest signal is fed back to the individual receivers through selected time-constant networks to apply common AVC. Direct addition of the audio outputs of each receiver can be obtained in lieu of diode-gate selection when the DIODE-AUDIO switch is in the AUDIO position.

The AVC voltages in the receiver channels are applied to vacuum-tube voltmeters, shown in Fig. 7 as M1, M2, and M3, to provide indications of signal strengths. VTVM M4 is furnished to indicate logarithmically the combined signal strength. Audio signal level in any channel can be measured by means of VU meter incorporated in the combiner but not shown in the diagram.

**Conclusion:** By means of the push-button switching unit, which contains

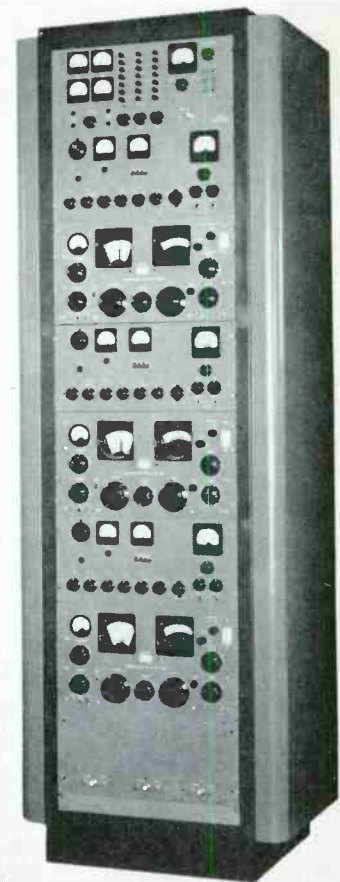

FIG. 8. COMPLETE TRIPLE-DIVERSITY SYSTEM

the common-load resistors and dummy-load resistors, any receiver channel can be connected individually to its dummy load to feed any of the three audio line amplifiers; alternatively, signals from any combination of two or three receivers connected in a diversity arrangement on

Concluded on page 43



## REVIEW

(Continued from page 18)

**F**ILING by Petroleum Communications, Inc., of an application for VHF and microwave facilities will bring out certain aspects of FCC policy hitherto unexplored, which may have an important bearing on future developments.

Petroleum Communications, Inc., of Lafayette, La., was formed recently as a non-profit organization, established to provide mobile and relay service on a cost-sharing basis to companies associated with the oil, gas, and mining industries. Initial plans call for operation in the bands from 152 to 162 mc., 890 to 940 mc., and 6,575 to 6,875 mc.

Presumably, the organizers of this project expected that it would qualify under FCC eligibility rules as a non-profit organization formed for the purpose of furnishing a radio communication service solely to persons who are engaged in the petroleum industry.

That was Commission thinking when the present eligibility rules were put into effect July 1, 1949. However, on June 26, 1953, Petroleum Communications was told that its application had raised a substantial question as to whether the proposed service rendered to members would be a communications common carrier service. Further, the FCC said that, on the basis of facts submitted, it did not appear that a grant would serve public interest, convenience, and necessity. Also, it was pointed out that "the microwave frequencies which you seek to use to tie together the mobile portion of your system, and for such point-to-point communication as your subscribers might require are available on a developmental basis only."

Finally, before granting such an application, it will be necessary to determine "the extent to which common carrier facilities are, or would be, made available upon request to perform the same function that the cooperative system seeks to perform."

The last limitation on the eligibility of a non-profit organization formed to share radio facilities does not seem to have been contemplated in 1949. It is surprising, therefore, to learn that the FCC may now find that Petroleum Communications would be a common carrier service and, as such, "would be precluded by the Commission's rules from operating in the petroleum radio service." Presumably, the FCC will reach a decision that will explain when facilities shared on a non-profit basis do and don't constitute common carrier service, and also under what circumstances an organization without profit as an objective can qualify as a common carrier. — M. B. S.

formerly *FM-TV* RADIO COMMUNICATION

# SINGLE-INSTRUMENT FM MODULATION CHECKING



— from  
**25 to 174 megacycles with the NEW Browning MD-33**

The MD-33 Frequency Modulation Monitor is a completely new instrument, for precision performance in critical work. No plug-in units of any kind are required.

The unique peak-flasher circuit permits the operator to select either of two pre-set values for flasher indication of transient overmodulation, adjustable to 20 kc.

*Remember:* the best costs less—in the long run.

*Coverage . . .* 25 to 174 megacycles, continuous, in two bands.

*Sensitivity . . .* better than 1 mv to 140 mc, and better than 2 mv to 174 mc.

*Panel meter . . .* 20 kc maximum, on linear scale.

*Flasher . . .* indicates peaks in excess of either of two pre-set values, from 1 to 20 kc.

*Audio output . . .* adjustable, 5 volts RMS maximum, flat from 100 cps to 15 kc.

*Phone jack . . .* on front panel.

*Drift . . .* obviated by AFC applied to local oscillator.

*For detailed information, write for data sheet*

ENGINEERED  
FOR  
ENGINEERS



**BROWNING**

Laboratories, Inc.  
Winchester, Mass.

The NEW

*Custom*  
**DC-AC CONVERTER**  
by **Carter**



**Delivers MORE Power for PROFESSIONAL Use**

These latest-of-all Carter DC to AC Converters are specially engineered for professional and commercial applications requiring a high capacity source of 60 cycles AC from a DC power supply. Operates from storage batteries or from DC line voltage. Three "Custom" models, delivering 300, 400, or 500 watts 115 or 220 V. AC. Wide range of input voltage, 12, 24, 32, 64, 110 or 230 V. DC. Unequaled capacity for operating professional recording, sound movie equipment and large screen TV receivers. Available with or without manual frequency control feature.



**HOW LEADING NETWORKS USE CARTER CONVERTERS**

Photo shows Tommy Bartlett, star of NBC "Welcome Travellers" program, aboard N.Y.C. R.R. "Twilight Limited." His Carter "Custom" Converter makes recording possible on board the train, from regular train current converted to 110 V. AC. Radio networks, stations, program producers use Carter Converters for all sorts of on-the-spot recording.

MAIL COUPON FOR CATALOG

**Carter MOTOR CO.**  
2641 N. Maplewood Ave.  
Chicago 47

Carter Motor Co.  
2641 N. Maplewood Ave., Chicago 47

Please send new catalogs containing complete information on Carter "Custom" Converters and other Rotary Power Supplies.

Name \_\_\_\_\_  
Address \_\_\_\_\_  
City \_\_\_\_\_ State \_\_\_\_\_

**COUNTY SYSTEM**

(Continued from page 25)

**Mobile Emergency Communication Center:** If, for any reason, it should be necessary to abandon the control center, or if an emergency anywhere in the county calls for setting up a temporary radio dispatching point, the Sheriff's Department has a radio-equipped truck ready to go into service on a moment's notice. This is illustrated in Figs. 7 to 10. Directly behind the drivers cab is the radio operator's position, Fig. 9. Part of the equipment is at his right, while the 250-watt VHF transmitter is at his left. The latter can be seen through the door in Fig. 10. Fig. 9 shows one end of the galley. There are complete cooking facilities, and sufficient provisions are carried for 30 days. Sleeping quarters and a sizable conference space occupy the rear section.

Power for the radio equipment, lights, and stove is supplied by two 3-kw. Onan engine-driven generators, carried in separate compartments at the rear on each side.

The 30-ft. antenna, assembled in sections, fits into two small compartments, the covers of which can be seen on each side of the towing eye, Figs. 7 and 8. After the sections have been put together, Fig. 7, and the mast secured at the rear of the truck, Fig. 8, it can be extended to full length by cranking up a light cable. Finally, the lead is plugged into a coaxial connector at the rear of the truck.

**Shop and Power Plant:** A very important part of the headquarters station is the service and repair shop, which is illustrated in Figs. 11 and 12.

A driveway leads to the outside doors of the shop, so that Sheriff's cars and special vehicles can be driven in for the installation or repair of radio equipment. Machines are available to handle practically all work required at the station, making it unnecessary to call on outside sources, and effecting savings in time and expense which amply justify the cost of providing the space and equipment.

The emergency power plant, Fig. 13, is comprised of a gasoline engine, a 3-phase generator of 35 kva. output, and a single-phase, 75-kva. generator. Rated time from start to full output is 45 seconds, but the actual time is only 10 seconds, for the engine is equipped with a heated manifold.

At this time of writing, some work remains to be completed on the remote stations, but the system is performing its principal functions to an extent that we are assured of its successful performance when, by early fall, the last of the new equipment will be in operation.

**24 HOUR DELIVERY FROM STOCK!**

**RELAYS**

Our stock of more than a million relays — in over a thousand different types — is the world's largest. Don't delay your production for want of large or small quantities of relays of any type.

Telephone, wire or write for quotations.

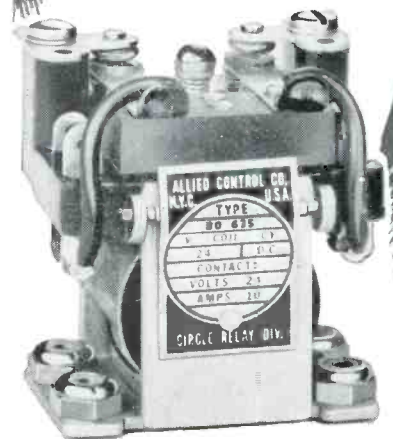

NEW AND MORE COMPREHENSIVE

**1953 RELAY SALES CATALOG**

NOW READY

Be sure to send for your copy



Telephone

**5Eeley 8-4146**



**833 W. CHICAGO AVE.**

DEPT. 12, CHICAGO 22, ILL.



## DIVERSITY UNITS

(Continued from page 40)

a common load can be fed to any one of the audio amplifiers. This provides full flexibility of interconnection between the various receiver channels and the three audio amplifiers, so that they can be set up in any conceivable arrangement of triple-diversity, dual-diversity, or single-receiver systems with a choice of either sideband from any receiver or combination of receivers. Such flexibility ensures dependable operation under virtually any combination of operating requirements

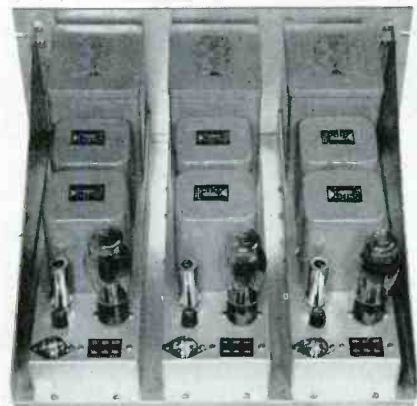

FIG. 9. POWER SUPPLIES FOR THREE ADAPTORS and atmospheric conditions. Fig. 8 shows a complete triple-diversity equipment rack: the diversity combiner occupies the top space; under it are three groups of adaptors and receivers; finally, at the bottom, a power supply panel furnishes power for the adaptors. A rear view of this panel is given in Fig. 9.

## SP-600 RECEIVERS

(Continued from page 35)

rectifier V20, together with individual filters, and a voltage regulator V18. Power transformer primary taps are furnished for single-phase supply voltages of 95, 105, 117, 130, 190, 210, 234, and 260 volts. Input power required is 130 watts. Power transformer and filters are protected by fuses.

In order to desensitize the receiver during periods of transmitter operation, a SEND-RECEIVE switch is furnished by which the RF, gate, second mixer, and 3.5-mc. oscillator stages are cut off in the SEND position. Power is not cut off, however, so that the receiver is ready for operation instantly when the switch is returned to the RECEIVER position. If external relay operation is desired, connection can be made to this switch by soldering a cable to the terminals.

**Other Specifications:** In addition to the performance figures given previously, mechanical and electrical specifications are as follows:

*Concluded on page 44*

formerly FM-TV RADIO COMMUNICATION

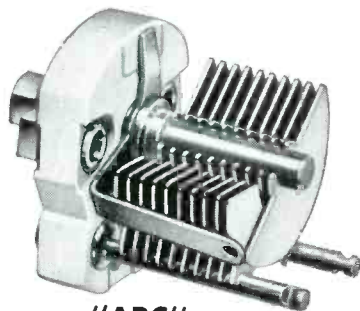

"APC"

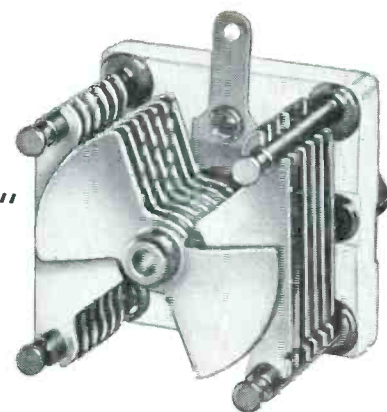

"BFC"

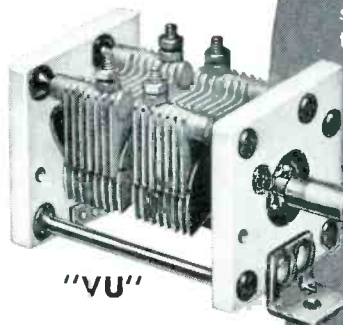

"VU"



"MC"

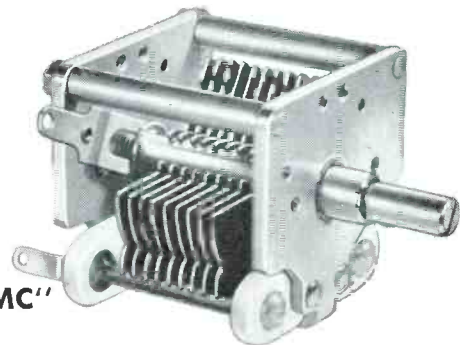

"RMC"

*When design considerations are critical—Put in*  
**HAMMARLUND CAPACITORS**

Consider these facts about Hammarlund Capacitors when selecting components for your electronic equipment:

- Plates are of brass and soldered, not staked, to their supports to insure perfect contact and prevent loosening.
- Precision soldering fixtures and assembly jigs used during fabrication assure uniformity of plate spacing.
- Rotor and stator assemblies are nickel-plated to minimize corrosion.
- Rotor contact springs are beryllium copper or phosphor bronze, and nickel or silver plated, for positive contact.

These are some of the features that make Hammarlund Capacitors your best choice for use in quality electronic equipment.

**HAMMARLUND**

HAMMARLUND MANUFACTURING CO., INC.  
460 WEST 34th ST. • NEW YORK 1, N. Y.



# When designing any plug-in unit REACH FOR THIS BASE

**ALDEN**

Molded boss to hold mounting cards.

Holes to take brackets or bail, kept well away from corners.

**20-PIN**

Also 11-pin & MIN. 7 & 9-pin



All prongs numbered.

Tapped side holes.

DESIGNED SPECIFICALLY FOR PLUG-IN UNIT CONSTRUCTION

## TREMENDOUS FLEXIBILITY

Bases are complemented by standard Alden components: handles, brackets, housings, terminal cards to lick almost any problem.

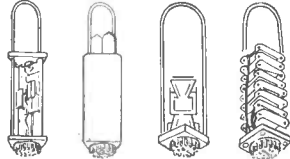

## NON-INTERCHANGEABLE COLOR CODED

Choice of variable pin patterns guarantees against mismatching. Color coding directs plug-in to its correct socket.

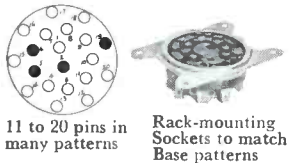

11 to 20 pins in many patterns

Rack-mounting Sockets to match Base patterns

Also 20-pin, 11-pin, 9-pin, 7-pin MATING SOCKETS Request free samples and free 226-page "Alden Handbook" of Plug-in Unit Construction.

143 N. Main St., Brockton 64, Mass.



**ALDEN PRODUCTS CO.**



## AVOID THESE TROUBLES OF USING TUBE BASES FOR PLUG-IN PACKAGES



LONG PINS BEND EASILY

RIGID BRITTLE BOSS BREAKS



LEVERAGE OF LONG PINS CRACKS BASE

Are you tired at throwing away perfectly good units because of broken bases?

## START RIGHT WITH ALDEN BASES Bases specifically designed for Plug-in Unit Construction

Ruggedly designed for specific purpose

Mounting holes well away from edges



Short, stubby prongs will not bend or break out

No center boss to break or crack base

Standardize on Alden Bases and Sockets and your Design Problems vanish.

## SP-600 RECEIVERS

(Continued from page 43)

Rack model — 19 by 10½ by 16½ ins., 66 lbs.

Table model — 21¾ by 12¾ by 17½ ins., 87½ lbs.

All models: Sensitivity — 2.3 microvolts or better throughout the range for a signal-to-noise ratio of 10 db, at 20 milliwatts output and RF gain control at maximum.

Image rejection — better than 74 db. throughout range.

IF rejection — 2700 to 1 at 600 kc.

AVC action — output constant within 12 db for inputs from 2 to 200,000 microvolts.

## SYSTEMS DATA

(Continued from page 4)

SPECIAL INDUSTRIAL: 44 mobile units and 2 base transmitters on 2.292 mc.; 4 relays on 74 mc. and 2 on 456 mc.; 1 control station on 73 mc., and 2 on 451 mc.

FOREST PRODUCTS: 2 relays on 72 mc., and 2 on 954 mc.; 1 control on 75 mc., and 2 on 956 mc.

TAXICABS: 450 mobile units and 6 base stations on 450 mc.

RAILROADS: 2 relays on 161 mc., and 1 on 453 mc.; 1 control on 453 mc.

AUTO EMERGENCY: 40 mobile units and 1 base transmitter on 453 mc.

MISCELLANEOUS COMMON CARRIER: 200 mobile units and 1 base transmitter on 454 mc.

## HELICAL ANTENNAS

(Continued from page 20)

Two 900-mc. helices have been arrayed on a common ground plate and fed in phase in order to produce greater gain. Fig. 12 shows the measured patterns of this unit at 925 mc. in the single-helix plane and also the plane of the two helices. Arraying two units produced a beam width of 17°, increasing the gain appreciably. If the array is mounted as shown, with the helices stacked one above the other, Fig. 12A is the horizontal pattern and Fig. 12B is the vertical pattern. Either orientation can be employed, depending on requirements.

**Conclusion:** It is felt that helical beam unidirectional antenna meets the requirements for these services as well as or better than most linear arrays. The circularly-polarized radiation which it produces provides operating advantages from the propagation standpoint as well as the system-separation standpoint. It is doubtful that a more rugged antenna structure is available at the present state of the art. If the comparatively small ground plate is considered as a portion of the tower, the cylindrical Fiberglass structure offers rather low wind loading.

# FM SIGNAL GENERATOR



## For testing Mobile Radio receiving equipment

TYPE 202-C  
RF range 54-216 mc.

The 202-C FM Signal Generator has been designed for use with mobile communications receivers or other narrow band high sensitivity equipment. Its features include:

- Very low leakage and spurious signal components.
- Switched electronic tuning for rapid selectivity measurements.
- Narrow band continuous electronic tuning.
- Internal calibration of switched electronic tuning.
- FM or AM from either internal or external audio frequencies.
- RF range 54 to 216 mc accurate to 0.5%.

### SPECIFICATIONS

#### RF SPECIFICATIONS:

Frequency Range: 54 to 216 mc in two ranges. Accuracy ±0.5%.  
Fine tuning range: ±20 kc in 108-216 mc range; ±10 kc in 54-108 mc range.  
Switched Tuning Range: ±5, ±10, ±15, ±20, ±25, ±30, ±50, ±60 kc in upper RF range; one-half these values in lower range.  
Output Voltage: 0.1 to 200,000 microvolts with standard cable connected.  
Output Impedance: 26.5 ohms looking back into standard cable.

#### MODULATION:

Frequency Modulation Deviation: 0.24 kc, 0.80 kc, 0.240 kc continuously adjustable.  
Amplitude Modulation: Meter calibrations at 30% and 50%.  
Distortion: FM—Less than 2% at 75 kc, 10% at 240 kc. AM—Less than 3% at 30% and 6.5% at 50%.  
Internal Modulating Voltages: 50, 100 and 400 cps, 1, 5, 7.5, 10, and 60 kc.  
Simultaneous FM and AM available using external and internal audio frequency.  
Spurious Output: All spurious RF output at least 30 db below desired fundamental.  
Signal to Noise ratio: 60 db below 10 kc deviation.  
PRICE: \$1090.00 FOB Boonton.

**BOONTON RADIO**

BOONTON · N · J · U · S · A

Corporation





Design of the helix has been developed taking into consideration the rather high dielectric constant of the surrounding Fiberglas structure, so that snow and ice have only a secondary effect on the electrical performance of the antenna. Ice formation does not occur on the conductor, but only upon the dielectric which surrounds the conductor. Since the bandwidth of the helix is large, the slight shifts which varying amounts of ice may cause do not affect adversely the performance.

These facts point toward the conclusion that the helical beam antenna will find wide application for all types of point-to-point communication.

## RECTIFIER SUPPLY

*(Continued from page 31)*

a wall or desk; the adaptor has an on-off switch, line and load fuse holders, a pilot light assembly, and a line cord and plug.

PCP-4 is an aluminum rack panel 7 by 19 ins., with standard Western Electric notching and drilled holes for mounting four power supply units.

PCAP-4 is an applique rack panel 3½ by 19 ins., with standard notching and drilled holes for mounting on-off switches, line and load fuse holders, and pilot light assemblies for four power supplies. PCAP-8 is the same except that it is 5¼ ins. wide and has holes for eight sets of power-supply control apparatus.

PCK-1 is a kit containing an on-off toggle switch, fuse holders, and a pilot light assembly.

**Operation:** The pilot lamp assembly, with a built-in lamp resistor, is usually connected across the DC output terminals of the power supply unit concerned. As the telegraph circuit that particular power supply is connected to is keyed, the lamp flickers, thus indicating normal operation.

Neither side of the DC output is grounded to the can, as Fig. 3 shows. The user can ground either side himself by making appropriate terminal connections. For polarized circuits, in which both positive and negative voltages are required, two power supplies can be used.

Output voltage can be adjusted by external selection of transformer primary taps. Also, the filter capacitor can be removed from the circuit to permit the use of an external filter, which can be either choke or capacitor-input in configuration.

The Power Capsule, although rated at 150 ma., can be used to supply up to 250 ma. without overload. For that reason these units, while designed for telegraph applications primarily, can be used for a wide variety of other purposes wherein dependability is of importance.

# Communication Engineers

with  
experience  
in  
the  
fields  
of

**Systems  
Engineering**

**Information  
Theory**

**Circuit  
Development**

**Electro-  
mechanical  
Development**

**Equipment  
Engineering**

*Advancements in the fields of wave propagation, translation of information, communication theory, circuit techniques and equipment miniaturization have created a number of new openings for qualified engineers in the Hughes Advanced Electronics Laboratory.*

### THE COMPANY

Hughes Research and Development Laboratories, located in Southern California, form one of the nation's leading electronics organizations. The personnel are presently engaged in the development and production of advanced electronics systems and devices.

### AREAS OF WORK

The communication group is concerned with the design and development of unique radio communication systems and with exploiting new radio communication techniques. Specialists in propagation phenomena, antenna sys-

tems, network theory, magnetic recording, wide-band amplification, and intricate electromechanical devices are active in this program.

### THE FUTURE

Engineers who enjoy a variety of problems requiring originality and ingenuity find the proper environment for personal advancement in these activity areas. Widespread future application of advanced communication techniques will enable the Hughes engineer to take full advantage of his experience as the Company expands commercially.

*How to apply*

*Write today, giving details of qualifications and experience. Assurance is required that relocation of the applicant will not cause disruption of an urgent military project.*

**Hughes**  
RESEARCH AND DEVELOPMENT LABORATORIES

Scientific  
and  
Engineering  
Staff

CULVER CITY,  
LOS ANGELES  
COUNTY,  
CALIFORNIA

# Communication Registries

WHATEVER information you need about any U. S. communication system in any service group, you will find it in one of the Registries of Communication Systems listed below. These Registries, revised annually from data contained in the original license files at Washington by permission of the FCC.

Each system listing shows the name and address of the licensee, location and type of each transmitter, number of mobile units, call letters, frequencies, type of modulation, and make of equipment used.

Systems are grouped by services in accordance with FCC practice, and are listed alphabetically by states. Currently, facilities added since the previous Registry are so identified.

## REGISTRY OF TRANSPORTATION SYSTEMS

Listing all mobile, base, relay, mobile relay, and point-to-point transmitters licensed in the following services:

TAXICABS	HIGHWAY TRUCKS	TRANSIT UTILITIES
RAILROADS	INTERCITY BUSES	AUTO EMERGENCY

Most active services in this group are the taxicab, railroad, and auto emergency systems.

REGISTRY OF TRANSPORTATION SYSTEMS, postpaid.....\$1.00

## REGISTRY OF INDUSTRIAL SYSTEMS

Listing all mobile, base, relay, mobile relay, control, and point-to-point transmitters licensed in the following services:

POWER UTILITIES	PIPELINES & PETROLEUM	FOREST PRODUCTS
RELAY PRESS	LOW-POWER INDUSTRIAL	MOTION PICTURE
	SPECIAL INDUSTRIAL	

This Registry has the largest number of new listings, because it includes the relay and point-to-point stations installed by the public utilities and pipe lines. Many listings have been added for the special industrial, forest products, and low-power industrial services, also.

REGISTRY OF INDUSTRIAL SYSTEMS, postpaid .....\$2.00

## REGISTRY OF PUBLIC SAFETY SYSTEMS

Listing all mobile, base, relay, mobile relay, portable, control, and point-to-point transmitters licensed in the following services:

MUNICIPAL & COUNTY POLICE	STATE POLICE	FORESTRY CONSERVATION
ZONE & INTERZONE POLICE	FIRE DEPARTMENTS	HIGHWAY MAINTENANCE
	SPECIAL EMERGENCY	

A large number of new police, fire, and special emergency systems are listed in this Registry. State police systems have been expanded greatly. Interzone police networks now cover practically all the U. S. This is the only CW telegraph service listed in any of the Registries.

REGISTRY OF PUBLIC SAFETY SYSTEMS, postpaid .....\$1.00

## AIR-GROUND AND COMMON CARRIER SYSTEMS

Listing all mobile, base, relay, mobile relay, portable, control, and point-to-point transmitters licensed in the following services:

CARRIER AIRCRAFT	AIRDROME ADVISORY	MOBILE UTILITY
AIR OPERATIONAL	FLYING SCHOOL	COMMON CARRIER
OPERATIONAL FIXED	FLIGHT TEST	COMMON CARRIER RELAY
AIRDROME CONTROL		MISC. COMMON CARRIER

This Registry lists all transmitters operated in commercial aircraft, and all those used for air-ground communication. Also included are the AT&T relay stations which carry television network programs.

AIR-GROUND & COMMON CARRIER SYSTEMS, postpaid .....\$1.00

RADIOCOM, Inc., Dept. 104, The Publishing House  
Great Barrington, Mass.

Please send me the following Registries of Communication Systems, for which I enclose —

\$1.00 Registry of Transportation Systems     \$1.00 Registry of Public Safety Systems  
 \$2.00 Registry of Industrial Systems     \$1.00 Registry of Air-Ground, Com. Car. Systems

Name .....

Address .....

## 450-MC. DESIGN

(Continued from page 28)

inum strap. This furnishes the necessary thermal path to the chassis and a large radiating surface to reduce seal temperatures of this cathode. The plate cavity circuit is tuned capacitively by means of a single disc capacitor located directly over the end of the line. Power is taken out by means of a rotatable loop coupled into the cavity near the current maximum.

The transmitter block diagram is given in Fig. 5. A harmonic-mode crystal is employed in the oscillator, operating at about 19 mc. This is multiplied 24 times to obtain the final frequency. The techniques employed are similar to those used in 160 mc. equipment, except for the 2C39A tripler-driver and the 2C39A final stage. Standard instantaneous deviation control circuits are used in the audio amplifier. Basic transmitter specifications are:

RF power output—20 to 40 watts.

Spurious Emissions—In-band, -85db. Others, -60 db.

Stability—±.0005%, -30° to +60° C.

AF input—.2 volt for 100% modulation at 1 kc.

Weight—7½ lbs.

Size—16½ by 4⅞ by 5¼ ins.

Spectrum distribution of the transmitter spurious radiations is shown in Fig. 6. It is interesting to note that there are no significant radiations within the band. All spurious radiations are at least 60 db. below the carrier level. The only significant spurious radiations are at one third the final frequency, its second harmonic, and the second harmonic of the final frequency. Even these are significantly below the 60-db down level specified by the FCC.

Fig. 7 shows the complete transmitter. Note that the tripler and final amplifier cavities are placed end to end. This is done so that in the base-station applications, this basic unit can be provided with a blower to cool the 2C39A's, and a power supply used that will produce 40 watts output.

The complete mobile receiver, transmitter, and 6-volt power supply can be seen removed from the mobile housing in Fig. 8. Complete, the assembly is about 16 ins. wide by 17 ins. long by 6 ins. high, and weighs 58 lbs. Battery drain is 14 amperes standby and 39.5 amperes transmitting.

**System Performance:** First, it must be said that the performance of the equipment described has lived up to expectations. Field experience has shown that the design aims of ruggedness, dependability, long life, and low maintenance.

Concluded on page 48



INDEX  
OF



ADVERTISERS

FOR YOUR CONVENIENCE, TELEPHONE NUMBER OF EACH COMPANY IS SHOWN HERE

Adair, George P. Washington, D. C.: Executive 3-1230	15
Alden Products Company Brockton, Mass.: Brockton 160	44
American Phenolic Corp. Chicago: Bishop 2-1000	14
Andrew Corp. Chicago: Triangle 4-4400	7
Antenna Specialists Cleveland, Ohio: Randolph 1-9575	14
Bendix Aviation Corp. (Radio Div.) Baltimore, Md.: Hopkins 3411	5
Berndt-Bach, Inc. Los Angeles, Cal.: York 8294 (Webster 8-6963)	15
Bird Electronic Corp. Cleveland, Ohio: Express 1-3535	40
Bliley Electric Company Erie, Pa.: Erie 2-2287	9
Boonton Radio Corp. Boonton, N. J.: Boonton 8-3200	44
Browning Laboratories, Inc. Winchester, Mass.: Winchester 6-3700	41
Carter Motor Company Chicago: Humboldt 6-1289	42
Communications Company, Inc. Coral Gables, Fla.: Coral Gables 4-0846	48
Communications Engineering Co. Dallas, Texas: PR 7508	14
Cornell-Dubilier Electric Corp. South Plainfield, N. J.: Plainfield 6-9000	39
Crosby Laboratories, Inc. Hicksville, N. Y.: Hicksville 3-3191	30
Eitel-McCullough, Inc. San Bruno, Cal.: Juno 8-1212	16
General Apparatus Corp. Gt. Barrington, Mass.	47
Hammarlund Mfg. Co., Inc. New York, N. Y.: Longacre 5-1300	43
Hickok Elect. Inst. Company Cleveland, Ohio: Liberty 1-8060	Inside Back Cover
Hughes Research & Dev. Labs. Los Angeles, Calif.: Texas 0-7111	45
James Knights Co. Sandwich, Ill.: Sandwich 2141	10
Jansky & Bailey Washington, D. C.: Me 8-5411	15
Jones, Howard B., Division Chicago: Nevada 2-2000	48
Kaar Engineering Co. Palo Alto, Calif.: Davenport 3-9001	6
Kear & Kennedy Washington, D. C.: Hudson 3-9000	15
Leece-Neville Company Cleveland, Ohio: Henderson 1-0740	38
Link Radio Corp. New York, N. Y.: Chelsea 2-1100	Inside Front Cover
Master Mobile Mounts, Inc. Los Angeles, Calif.: York 5221	48
Maurer, Inc., J. A. Long Island City, N. Y.: Stillwell 4-4601	15
May, Russell P. Washington, D. C.: Republic 3984	15
McIntosh, Frank H. Washington, D. C.: ME 8-4477	14
Measurements Corp. Boonton, N. J.: Boonton 8-2131	15
Microwave Services, Inc. New York City: Circle 7-4953	15
Motorola, Inc. Chicago: Spaulding 2-6500	Back Cover
Platt Manufacturing Corp. New York City: Worth 4-0827	12
Pye, Limited Cambridge, England	1
Radiart Corp. Cleveland, Ohio: Melrose 1-6660	3
Radio Apparatus Corp. Indianapolis, Ind.: Franklin 1052	11
Radiocom, Inc. Gt. Barrington, Mass.: Gt. Barrington 1300	37, 40, 46
Radio Corp. of America (Eng. Products) Camden, N. J.: Woodlawn 3-8000	2, 34
Radio Corp. of America (Tubes) Harrison, N. J.: Harrison 6-8000	8
Radio Engineering Labs Long Island City, N. Y.: Stillwell 6-2101	4
Relay Sales Company Chicago: Seeley 8-4143	42
Rohn Manufacturing Co. Peoria, Ill.: Peoria 4-9156	48
Shure Bros. Chicago: Delaware 7-4450	37
John D. Trilsch Company Houston, Texas: Atwood 9351	14
Weldon & Carr Washington, D. C.: Michigan 4151	15
Workshop Associates, Div. of Gabriel Co. Norwood Mass.: Norwood 7-3300	15

formerly FM-TV RADIO COMMUNICATION

# Air-Coupler Performance

*"Can you send me a performance curve on the Air-Coupler? I listened to one briefly some time ago, and I thought it was the finest quality I have ever heard. But when I consulted a friend of mine who is an audio expert, he advised me against buying an Air-Coupler. He said it is obvious to anyone familiar with audio theory that it cannot give satisfactory bass reproduction."*

WE didn't send a performance curve on the Air-Coupler in response to that letter. Nor do we want to argue with anyone who pre-judges speakers without hearing them. We have never published curves made in an anechoic chamber or in free air, because we have never heard of anyone who listens to music in his own home under such conditions!

However, we did answer that letter with some very specific information on what we believe to be the most conclusive way so far devised to test bass reproduction—and under home listening conditions, with your own ears. Simple as it is, *this is the most severe test that can be made on loudspeakers.* It is also a method of obtaining from an Air-Coupler such magnificent musical reproduction as you have never heard from phonograph records. As far as we know, only the Air-Coupler can pass this test. Here is the way to make it:

Get permission from your church organist to make a tape recording of organ music during a choir rehearsal. Do it with the very best recorder you can obtain, and use a broadcast studio type of microphone. Set the gain just below the point of overloading on the lowest frequencies, and leave it there. Then feed that tape into your audio system, and listen to the speaker you want to test.

Why use organ music recorded on tape? Because the full dynamic range is recorded on tape made in the manner described, while the dynamic range of phonograph records is usually severely limited to keep the grooves from running into each other. You will be absolutely astounded to hear how speakers fail to reproduce low frequencies from such a tape. Some just quit. Others make a fluttering sound like a startled partridge.

But the Air-Coupler will give you perfect reproduction of every note you heard from the organ *when you were making the tape.* We recommend this test because we believe you will find it the most striking demonstration of speaker performance you have ever heard. It is the simplest, most conclusive way to settle any doubt you may have about the amazing capabilities of the standard Dual Air-Coupler, or the new Compact Air-Coupler.

## PRICES OF AIR-COUPPLERS, SPEAKERS, TWEETERS

**DUAL AIR-COUPLER, COMPLETELY ASSEMBLED.** The original design, 72 ins. long, 16 ins. wide, 6 ins. thick. Can be mounted on edge behind a sofa, used to form part of a low seat or table, or it can be built under the floor. Ready for you to mount your own 12-in. speaker. Immediate delivery ..... \$47.50

**DUAL AIR-COUPLER, KNOCKED DOWN.** As described above, all parts precision-cut from high-quality 3/4-in. plywood. Only screwdriver needed to assemble. Opening cut for mounting your own 12-in. speaker. Immediate delivery.....\$34.50

**NEW, COMPACT AIR-COUPLER.** A more convenient shape for many purposes, 42 ins. high, 18 ins. wide, 7 ins. thick. Completely assembled, ready for you to mount your own 12-in. speaker. Immediate delivery from stock. Formerly \$49.90. Now only .....\$39.95

**AIR-COUPLER SPEAKER.** The 12-in. Altec 600-B is recommended for the Dual or Compact Air-Coupler, and as an intermediate speaker. Impedance is 8 ohms. Immediate delivery from stock.....\$46.50

**TWEETER.** When the Air-Coupler is combined with an intermediate speaker and a tweeter, the University 4408 tweeter is recommended. Impedance is 8 ohms. Immediate delivery from stock.....\$16.50

**NETWORKS FOR SPEAKER SYSTEMS.** General Apparatus can supply crossover networks from stock for speakers of all standard impedances, and 14 different crossover frequencies from 85 to 2,200 cycles. We furnish either the inductances only, or complete parts comprising the inductances, variable resistors, and condensers.

Send 10c for the G. A. Network Data Sheet and circuit diagrams, from which you can determine your exact requirements, and the price. Or, if you prefer, tell us the impedances of your speakers and the crossover frequencies you want to use. We will send you the specifications and price by return mail.

**SHIPPING CHARGES.** Air-Couplers are shipped by Railway Express, FOB Great Barrington. Other items are shipped FOB unless 75c is included to cover parcel post and insurance. No COD's, please.

# General Apparatus Co.

240 State Road, Great Barrington, Mass.

## Master Mobile MASTERPLANE

**GROUND PLANE ANTENNA—Model 300—Master De Luxe**... NEW!... brings in that DX for you. Outperforms any type of vertical dipole. "Drooping" Type Ground Plane plus four straight radials to give a low angle of radiation for general coverage. It gives an almost perfect circle radiation pattern. Ideal for CD and defense nets. Covers complete Amateur Band with excellent Broad Band characteristics. Other frequencies as specified. Matches 52 ohm coaxial cable through threaded coaxial fitting at end. Straight radials are adjustable (up or down) for purpose of eliminating standing waves on transmission lines. For medium or low-powered transmitters. Sturdily-built of finest alloys to withstand corrosion, high winds and extreme icing. With 36" length of 3/4" pipe for mounting purposes. Standard mounting facilities can be secured locally.

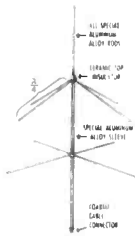

**TWO METER COAX ANTENNAS**  
**NO. 214—MASTER DELUXE**—ruggedly-constructed, vertically polarized, frequency range 140 to 170 MC. Completely waterproofed. Highly polished chrome enhances appearance of any vehicle. Furnished with 10' of 72 Ohm Coax Cable. **MOUNTING TYPES:** Type 1—on side with 2 brackets furnished—NET: \$15.95. Type 2—**MASTER MOUNT** (No. 132X or 140X). Mounts sold separately. Complete \$17.45. Adjustable mounting—adjusts to 17".

**MODEL 300 — AMATEUR'S NET: \$12.95**  
**2 METERS — 140 to 162 MC**  
**Model GP-4.** Four "Drooping" Radials for perfect match to 52 ohm coax cable. Complete amateur band coverage. Specify other frequencies. Attaches to Mast with U-Bolts. (U-Bolts and Mounting Brackets furnished.) Also attachable to side of building. Sturdy, with special alloys, to withstand corrosion and extreme weather. **Model GP-4 AMATEUR'S NET: \$5.95**  
**2 METERS — 140 to 162 MC**  
**SOLD BY LEADING JOBBERS**

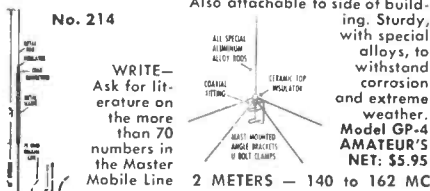

**WRITE—** Ask for literature on the more than 70 numbers in the Master Mobile Line  
**MASTER MOBILE MOUNTS, INC.**  
 P. O. BOX 1817 • LOS ANGELES • CALIF.  
 Warehouse & Shipping Address: 1306 Bond St.

## 450-MC. DESIGN

(Continued from page 46)

nance have been achieved successfully in this equipment.

Transmitter tube life has been particularly satisfactory. A mobile unit on life test has run over a million transmissions, with a duty cycle of 33%, on the same set of tubes. In general it has been found that maintenance is no more troublesome for this equipment than for 160-mc. mobile transmitters and receivers.

The most outstanding performance characteristic was that of propagation. It was thought for some time that users of the 460-mc. band would suffer an appreciable loss in system performance relative to a 160-mc. system. This has turned out to be false. In a range test on smooth earth with equal powers and antenna gains, the 160-mc. system would at first appear to be about 6 db or 1.5-to-1 better in range than the 460-mc. system, particularly in rural areas. However, the level of man-made noise even in suburban areas is about 9 db higher in the 160-mc. band than in the 460-mc. band. Therefore, for most systems, the 460-mc. band is about 3 db better.

Fig. 9 is a summary of propagation data from 100 to 3,700 mc.<sup>1</sup> The abscissa is frequency and the ordinate is relative system merit, in db, for suburban coverage. It can be seen from the curve that the 460-mc. band has a slight edge over other bands even before high-gain antennas are used. Of course, a high-gain antenna for the base station is much smaller and cheaper at 460 mc. than it is at 160 mc.

In urban areas also, the 460-mc. band has proved itself superior to any other. This is due primarily to the fill-in of holes obtained at the higher frequencies. Coverage can be obtained in tunnels and cuts which are not covered at the lower frequencies. The largest part of urban coverage is not line-of-sight, and is dependent upon multi-path reflection, which is materially increased at the higher frequencies. In addition to this advantage, man-made noise is greatly reduced in urban areas at 460 mc.; Young found the noise level to be about 12 db less at 460 mc. than at 150 mc. The results of these exhaustive field tests serve to corroborate field experience and other comparative field tests made in the 160 and 460-mc. bands. It can be expected that rapid expansion of service in the UHF channels will occur.

Credit should be given to James Clark and Frederick Hilton, who were responsible for the receiver and transmitter developments respectively.

<sup>1</sup>Data for this curve was published in COMMUNICATION ENGINEERING for January-February, 1953, under the title "150 to 3,700-MC. Performance tests," by W. Rae Young, Jr.

## COMCO

"FLIGHTCOM"  
**TWO-WAY VHF**  
**RADIO FOR AIRCRAFT**

FREQUENCY MODULATED  
 25-50 MC — 152-174 MC.



Provides communication between ground FM communication systems and executive or utility aircraft  
**COMPACT**—mounts in smallest planes  
**LIGHT**—total weight only 23 lbs.  
**LOUD**—full watt audio to speaker  
**POWERFUL**—10 watts 30-50 mc. band  
 7½ watts 152-174 mc. band  
**LOW BATTERY DRAIN**  
**PERFORMANCE**—identical with ground station equipment.  
 For details contact your nearest COMCO dealer



Manufacturers of Radio and Electronic Equipment  
**COMMUNICATIONS COMPANY, INC.**  
 CORAL GABLES 34, FLORIDA

## INSURE Proven Quality with JONES PLUGS & SOCKETS

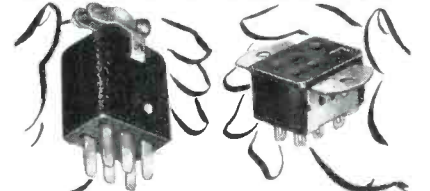

P-306-CCT — Plug, 5-306-AB — Socket  
 Cable Clamp in cap. with Angle Brackets.  
**Series 300 Small Plugs & Sockets for 1001 Uses**

Made in 2 to 33 contacts for 45 volts, 5 amps, for cap or panel mounting. Higher ratings where circuits permit. All plugs and sockets polarized. Knife switch socket contacts phosphor bronze, cadmium plated. Engage both sides of flat plug—double contact area. Bar type plug contacts hard brass cadmium plated. Body molded bakelite.

Get full details in Catalog 18. Complete Jones line of Electrical Connecting Devices, Plugs, Sockets, Terminal Strips. Write today.

**Jones** **HOWARD B. JONES DIVISION**  
 CINCH MANUFACTURING CORPORATION  
 CHICAGO 24, ILLINOIS  
 SUBSIDIARY OF UNITED-CARR FASTENER CORP.

# ROHN

"Superior Design"

## COMMUNICATION TOWERS

**Proved in Construction, Design, and Operation.**  
 Truly the finest tower of its kind. Made of heavy-duty tubular steel, electric welded throughout. In 10-ft. sections for easy erection, 14-in. triangular design. Can be used non-guyed to 60-ft.—guyed up to 150-ft.  
**Get the full facts today!**  
 Call your Rohn representative or write, phone or wire:  
 "Pioneer designers and manufacturers of all type towers."

**ROHN MANUFACTURING CO.**  
 DEPT. CE • 116 LIMESTONE, BELLEVUE  
 PEORIA, ILLINOIS • PH. 4-9156



# Laboratory Model

# HICKOK



**PORTABLE  
TUBE TESTER**

Model 539A

Electronic Development Engineers . . . you men who create and build today's electronic miracles, depend heavily on the keystone component—the vacuum tube.

HICKOK pioneered the first commercial tube testers with Dynamic Mutual Conductance circuits. This circuit, long recognized as the true evaluation of a vacuum tube, is available only in equipment bearing the HICKOK trademark. The laboratory portable shown is one of eleven models available . . . all expertly engineered with specific features for every specialized need.

**THE HICKOK ELECTRICAL INSTRUMENT COMPANY**

10514 Dupont Avenue

Cleveland 8, Ohio

24 HOURS A DAY—YEAR IN AND YEAR OUT

# Motorola Microwave

is speeding operations for many industries

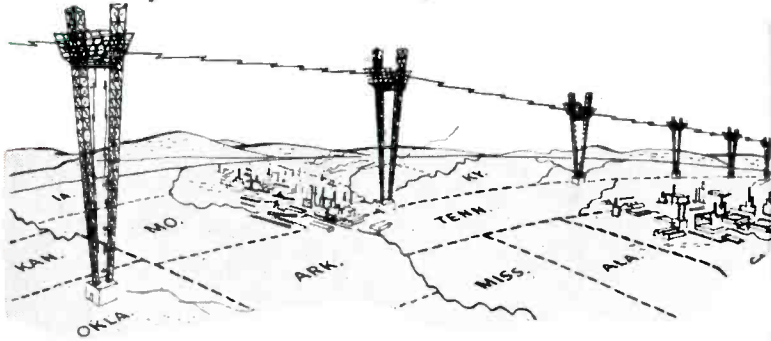

## Full Load Operations Prove MOTOROLA'S WORKING RELIABILITY

Thousands of miles of multi-channel Motorola microwave systems—with hundreds of operating stations—have been designed, installed and put in daily, non-stop operation for leading companies throughout the country. Eight of these systems, in use over four years, have been in continuous service, 24 hours a day.

Motorola systems provide dependable, job-proven communications for industry, transportation, utilities and public services. Microwave and VHF radio tie-ins blanket plant areas, railroads, pipelines and entire cities. Write today! Discover how you can cut communications costs, save man hours and speed operations with Motorola Microwave.

### Motorola Systems Are In and Working for These Companies

Below is a partial list of systems installed and operating, and those under construction (\*) or under contract (\*\*).

Pacific Power and Light Co., Portland, Ore.	La Fourche Telephone Co., Golden Meadow, La.
Brazos River Electric Transmission Cooperative, Waco, Texas	Greenwood Telephone Co., Greenwood, So. Carolina
Illinois Power Co., Decatur, Ill.	*Middle South Utilities, Pine Bluff, Ark.
Central Illinois Public Service Co., Springfield, Ill.	*Bonneville Power Administration, Chehalis, Wash.
Pan American Pipeline Co., Houston, Texas	*Sinclair Pipeline Co., Independence, Kans.
Shell Pipeline Co., Houston, Texas	Freeport Sulfur Co., New Orleans, La.
Panhandle Eastern Pipeline Co., Kansas City, Kans.	*West Coast Telephone Co., Everett, Wash.
Mid-Valley Pipeline Co., Longview, Texas	U. S. Atomic Energy Commission
Southern Counties Gas Co., Los Angeles, Calif.	*Dayton Power & Light Co., Dayton, Ohio
	Southern California Edison Co., Los Angeles, Calif.

— with 20 additional systems under construction

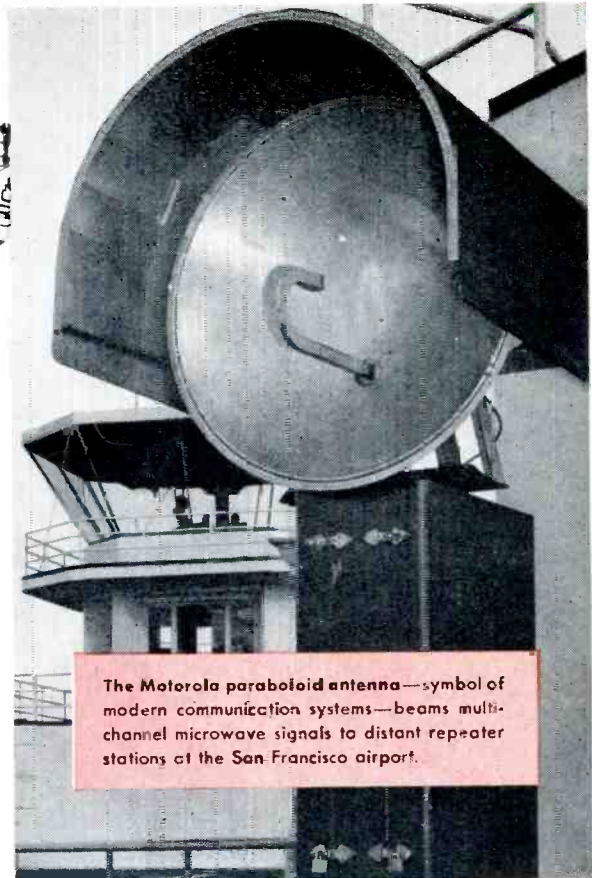

The Motorola paraboloid antenna—symbol of modern communication systems—beams multi-channel microwave signals to distant repeater stations at the San Francisco airport.



Simultaneous transmission of numerous (1) voice, (2) telemetering, (3) teleprinting and (4) industrial control signals over one radio frequency carrier allows positive, fail-safe control of widely separated, remote system facilities.

Job-Proven Microwave... by the Leaders of the 2-Way Radio Industry

For Full Details—Write Dept. 2286CE

Job-Proven Microwave

# Motorola

Communications & Electronics, Inc.

A SUBSIDIARY OF MOTOROLA, INC.

900 N. Kilbourn Ave., Chicago 51, Illinois • Rogers Majestic Electronics Ltd., Toronto, Canada

IN ANSWERING THIS ADVERTISEMENT, PLEASE MENTION "ITEM 5348"