

Everyday Mechanics

TRADE MARK REGISTRATION APPLIED FOR

"It Tells You How to Make and How to Do Things"

VOL. 1

MAY, 1916

No. 4

IMPORTANT TO OUR FRIENDS

EVERYDAY MECHANICS is to its founders the realization of an ideal. Not in the full sense of the word, perhaps, for its life has been too short and too full of pitfalls and obstacles. Nevertheless, the little magazine has come into being overnight, as it were, and, in its short span of life, has found its way into the most astonishingly remote quarters of the civilized world.

With this number that is now in your hands, your little magazine has performed the rather startling feat of trebling its circulation with the fourth number. This issue is in an edition of 32,000 copies; if we could have procured the additional paper required on such short notice, the edition would have been 47,000, for the newsstand orders exceed that figure at this writing.

When EVERYDAY was started its founders had practically no capital, but they had what is perhaps better—an absolutely overwhelming faith in the soundness of the idea and abundant confidence in their own ability to carry it through. The response of the first loyal subscribers furnished all the capital that was required under normal conditions. But this limited capital could not be expected to hire lawyers, secure expert advice and testimony, and pay the thousand and one incidental expenses of a suit in equity brought by a powerful contemporary.

Added to that financial burden comes the rise in the price of paper. When EVERYDAY was started, the paper in each single copy of the magazine cost 1.4 cents. Today the very same paper from the same mill costs 2.9 cents. Please keep that figure in mind.

Then, on April 1, the engraver who makes all of the line and halftone cuts used so profusely to illustrate the

articles, sent us the following ultimatum, not in these words but to this effect: "Hereafter you will pay \$1 for each little line cut and \$2 for each little halftone you use in your magazine, instead of an average of 22 cents for line and \$1.25 for halftone minimum cuts, as heretofore." Now, EVERYDAY is as full of little cuts as a comb is of teeth, and you, kind reader, may judge for yourself. To add insult to injury, the cost of the larger cuts has increased from 5 to 7½ cents per square inch for line and from 12 to 15 cents per inch for halftones.

I think I have said pretty nearly enough. EVERYDAY, in point of actual mechanical cost per copy, has practically doubled with its fourth number. With regard to receipts, I need not say that the newsdealer, the chap who sells the magazine, has a living to make, and he cannot pay five cents for it and sell it at that price. Then, again, the express companies who carry the magazines to the dealers throughout the country demand and receive a certain stipend for their services. So, it is not a great problem to figure how much more the magazine costs than the figure we receive for it.

The source of greatest revenue for a magazine is the advertising section. EVERYDAY has been made first and foremost for the reader on the theory that the advertiser would naturally follow. Some few of the many firms solicited have placed their copy and pledged their support with this issue. Others, firms that owe their very existence to the magazines I have been associated with, have either ignored my letters entirely, or else have indifferently declined to come in with EVERYDAY until "its circulation is greater."

If your little magazine is to live and improve under the burden it is carrying and despite the obstacles thrown in its path, it must be supported either by the reader or the advertiser—or both. The founders of the magazine have given it all they possess and the response from the readers is conclusive evidence that it has made good.

I have said that EVERYDAY would start and continue as a five-cent magazine and I mean it—notwithstanding all of the weight it is carrying. But what am I to do? There seems to be but three ways out of the difficulty: Lower the quality—or, raise the price to 10 cents—or,

vastly increase the circulation and the amount of business done by the Company. I prefer the third, will only resort to the second if the readers tell me to do so, and will not under any circumstances consider the first. There you are.

In the back of this issue you will find reproduced a letter that I have sent to subscribers. It states our position and asks each reader to do his little bit to get a subscription or to place a book order for us. If each one who feels that the magazine is worth its price to him will take the initiative and tell one friend about it, there is no doubt that we shall succeed. When you need parts, materials or apparatus, or books, if you will patronize our advertisers and mention EVERYDAY, you will give it just that little boost that is necessary to carry it through the storm with colors flying. And, just to let me know whether I am giving you what you want, write to me and tell me what you think of your new magazine, what you would suggest to help it over its rocks, and how, when our legal troubles are over, I can make the magazine better or more to your liking.



YOUR EDITOR.

Owing to the unforeseen difficulties EVERYDAY MECHANICS has had to contend with in the past three months, its publication date has been uncertain and its schedule upset. In order to "catch up" in its dating, the current number has therefore been dated "May" with the serial number "4" retained. The June number will mark the appearance of the magazine on its regular publication date of the 20th of the month preceding date of issue.

CONSTRUCTION OF A MODEL SUBMARINE WITH WIRELESS CONTROL*

PART III.—MOTOR, PROPELLER AND RUDDER CONTROL.

BY THE LABORATORY STAFF

IN the design of this model, the endeavor has been to use only such standard parts and materials as might be readily obtained by the amateur builders throughout the country. Up to this time no castings have been required, and the principal items of stock have been brass rod, tubing and sheeting. The same requirements obtain in the construction of the details covered in this installment.

The Rudder and Control. The rudder is not difficult of construction, and the principal requisite is care and patience rather than skill. The blade is of sheet brass about 1/32 in. thick. The general shape and appearance of the part is shown in the halftone, Fig. 1. For a detailed illustration of the rudder the builder is referred to Fig. 2, which gives a drawing of the control device as well. Figs. 3 and 4 show the control installed in the hull of the submarine; the former view omits

the propeller shaft for the sake of clearness.

With reference to Fig. 2, the builder may note that the rudder blade, 1, is inserted in a slot cut in the post and securely soldered in position. This operation requires merely care for its successful execution. The post, which consists of a length of 5/32-in. diameter brass rod, is first placed in the lathe chuck and the slight shoulder turned on one end while the other is threaded 8/32 for 3/8 in. The post is then placed in the vise with the end to be slotted projecting an inch and a half. Filing a nick to start the saw, the builder may proceed to cut the slot with a fine-tooth hacksaw, taking great care to keep the saw-cut parallel with the center of the post. This may appear difficult, but if the precaution is taken to place the post in the vise at an angle so that the saw blade cuts at an angle of about 45 deg. with the post, no difficulty will be experienced. It is obvious, however, that the work must proceed cautiously, not only to keep the cut straight but to prevent bending the post as well.

When the slot is finished the

*This model is being constructed under the personal supervision of Mr. Curtis. Owing to his enforced absence from the laboratory in connection with the litigation in which EVERYDAY MECHANICS is involved, the present installment is not as complete as was originally planned. Interested readers in New York City may call at the office to see the Submarine on Saturday afternoons between the hours of three and four.

rudder blade may be inserted and the shoulder portion of the post bound with a bit of enameled wire. Laying the post and blade upon a piece of asbestos, the builder may apply soldering acid made by "killing" muriatic acid with zinc (place a few pieces of sheet zinc in the acid and wait

for the solder to flow or "sweat" quite through the union until it comes out on the opposite side. When this occurs the builder may rest assured that his rudder is so firmly secured to the post that the blade will bend double before it becomes detached from the post.

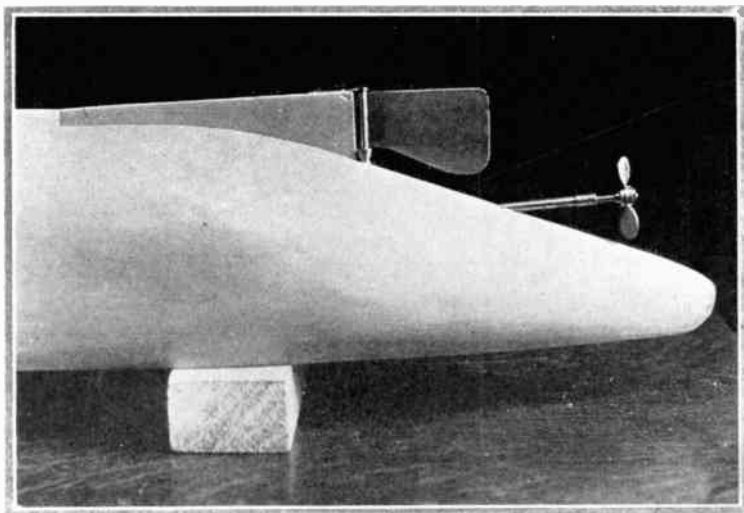

Fig. 1. Showing the rudder and propeller in place

until bubbling ceases before using). Care should be exercised to see that the acid finds its way well in between the blade and post on both sides. With a good, hot copper, well tinned, the solder may then be applied in small quantities, holding the copper well up against the union and watching

The soldering job completed on both sides, the enameled wire may be removed and the surplus solder scraped and filed away from the shoulder. The object of using enameled wire is now seen. The solder does not include it in the union and the wire therefore serves well its mission of clamping the split

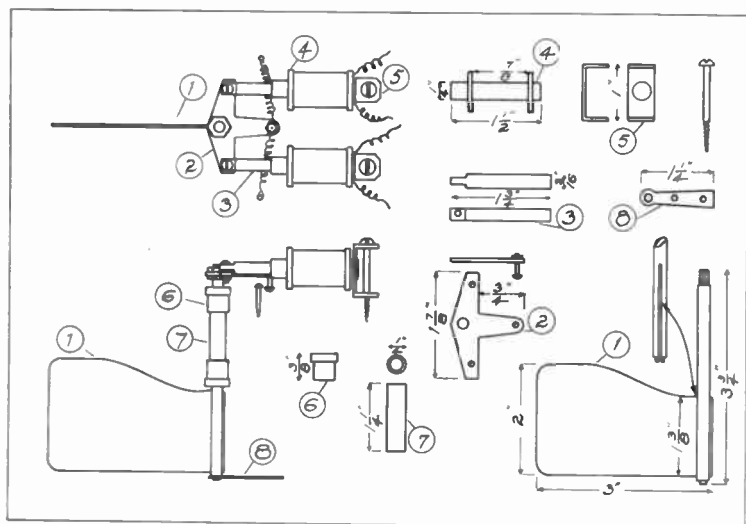

Fig. 2. Detail of the rudder and the rudder control

sections of the post. If care has been used to apply the solder sparingly and to use a sufficiently hot copper, there will be very little solder to clean away from the union; what little there is can be scraped away and the job cleaned up with fine sandpaper. In our model, the rudder and propeller are left in the bright brass; while this color will soon tarnish in the water, the appearance, while the model is on exhibition, is very attractive in contrast with the battleship grey of the hull.

The rudder post passes through a piece of brass tubing fitted at either end with a water-tight gasket inclosed

within a simple cap turned up from brass rod. This cap is merely forced over the end of the tubing and held in place by friction. A better way would be to thread the tube and cap, but it scarcely seems necessary in our experience. The gasket is of lamp-wick rubbed in grease. The strands are separated and packed into the cap around the rudder post before the caps are forced on the tube. The latter is $\frac{1}{4}$ in. in outside diameter and it therefore is a nice force fit into a hole bored through the stern with a $\frac{1}{4}$ -in. bit. The tube was covered with white lead before being placed in position.

The rudder control is by means of two solenoids which draw iron plungers attached pivotally to a cross-arm attached to the top of the rudder post. The rudder is normally held in the "straight ahead" position by the tension of the two coiled springs. The pull of one of these springs counteracts that of the other, and the net result is that the rudder is held in the neutral position except when current is sent through one or the other of the solenoids. The action is therefore to the right or the left according to which solenoid is energized.

The solenoids are constructed as shown at 4 in Fig. 2. A 1½-in. piece of ¼-in. brass tubing is fitted with heads of fiber, which may well be the fiber washers used in hot-water faucets. The brass is then covered with paper and the space wound full of No. 28 D.C.C. magnet wire. This winding should then be saturated with shellac. Before the winding is done the solenoid pivot piece, 5, should be soldered to the end of the tube. This piece is bent up from 1/16-in. brass strip, drilled in the center to take the tube and in either end to take the long wood screw that forms the pivot.

The coiled springs should be of comparatively fine brass or phosphor bronze wire. Our springs were originally of No.

22 brass, but this was found to be so stiff that the solenoids would not draw the plungers. A substitution of No. 30 proved a solution of the difficulty.

The plungers may be made from pieces of large wire nail placed in the chuck and made perfectly smooth with a fine file and finished with fine sandpaper or emery cloth and oil. The dimensions are given at 3 in Fig. 2.

The Propeller and Motor.
The propelling mechanism has been re-designed to provide for a single propeller instead of the twin as shown in the first installment. The object of this was to simplify the connection with the motor shaft and to obviate the necessity for friction or gear drive. The coupling, as it stands, is the acme of simplicity; the coiled spring connection is so clearly shown in Fig. 4 that no comment is necessary on that score.

The propeller is shown in Fig. 1 and in detail in Fig. 5. The screw is formed from a single piece of 1/16-in. thick sheet brass, marked off as shown in Fig. 5 at 1 and filed to shape. The hole in the center is tapped 8/32 to engage the thread on the end of the propeller shaft. The propeller is securely held between collars and nuts on the shaft, the final nut acting as a lock-nut. The propeller is given

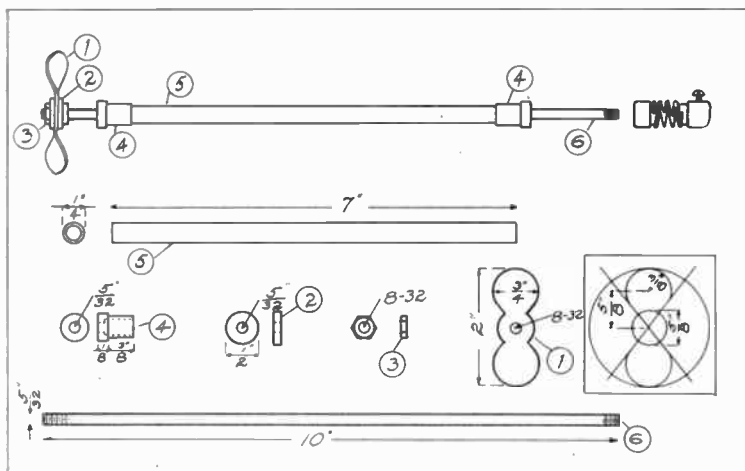

Fig. 5. Detail of propeller, shaft and coupling

its "pitch" by bending the blades very carefully after the whole combination is assembled. The screw must be so bent that the boat will move forward when the propeller shaft is turned to the right or clockwise when the builder looks toward the stern from the bow. This is essential as the flexible coupling employed to connect the motor shaft to the propeller shaft incorporates an ordinary right-hand thread which, of course, will not unscrew so long as the power is applied in a clockwise direction.

The propeller shaft is a piece of 5/32-in. brass rod, 10 in. long. It is threaded on one end a distance of 1/2 in. and on the other

end 1/4 in. with an 8/32 die. The tube through which the shaft runs is made in a similar manner to the tube for the rudder post. The difference is found in the greater length of the water-tight gaskets and caps. These are packed in the same manner, however, and as the drawing shows their construction so clearly, further description is deemed unnecessary.

The task of boring the hole through the stern is one that requires care and patience. The hole is started from within the hull, and in our model the 1/4-in. bit was gripped in the chuck of a hand drill as we could not operate even a ratchet brace in the limited space available. The

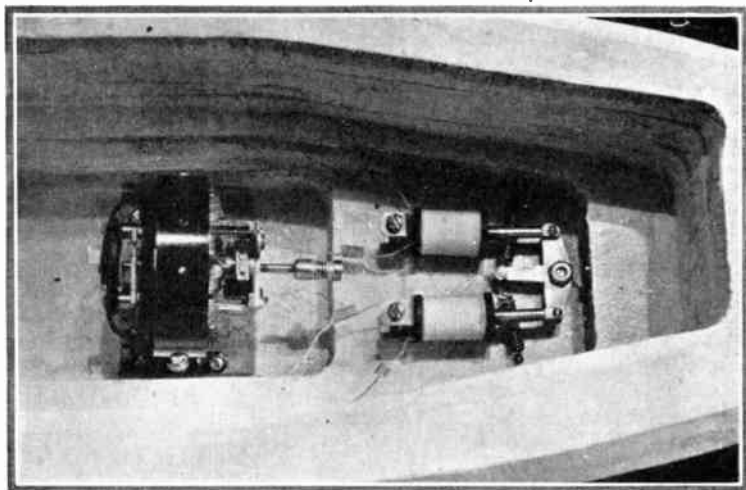

Fig. 3. Rudder control in place

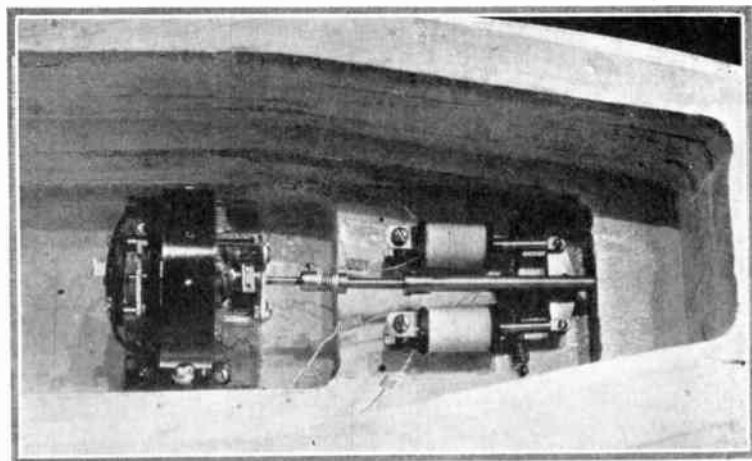

Fig. 4. Propeller shaft coupled to motor

bit was constantly sighted for angle, and to keep it accurately centered we marked a pencil line down the center inside the hull. It would be useless to give the exact angle for the propeller shaft as the next builder, in all probability, could not adhere closely



Fig. 6. The driving motor

to it. Therefore, let it suffice for us to say that the bit was started $\frac{1}{4}$ in. below the upper edge of the No. 3 plank of the hull and it came out at exactly the center of this same plank. If the reader will closely observe first Fig. 1 and then Fig. 4, he will understand this seemingly complex explanation.

The tube for the propeller shaft is a close drive fit in the

hole made by the bit. However, to insure that no leaks will develop, the tubing may be coated with white lead after it has been started in the hole. This coating, be it ever so thin, will serve to seal the entrance.

The motor used in our model was selected after a number of tests with various types. It is a very diminutive affair, measuring only $2\frac{3}{4}$ in. over the field ring that forms the frame of the machine. Fig. 6 gives a good idea of the appearance of the motor, and the reader will note that the armature is of the drum type, commutator mica insulated and accurately turned, brushes of copper gauze with coiled spring tension, and that in many other respects, the little machine is as perfectly built as one of its big brothers.* No attempt will be made to describe the construction of the motor, as it is a standard product that may be purchased at a lower price than it can be made by the amateur.

The motor must be mounted at an angle to correspond with that taken by the propeller shaft in its passage through the hull. This is readily accomplished through the medium of a shim or tapering block of wood upon which the motor is

*The Service Department of this magazine will supply manufacturers' names and tell you where you may buy any part or machine specified in an article.

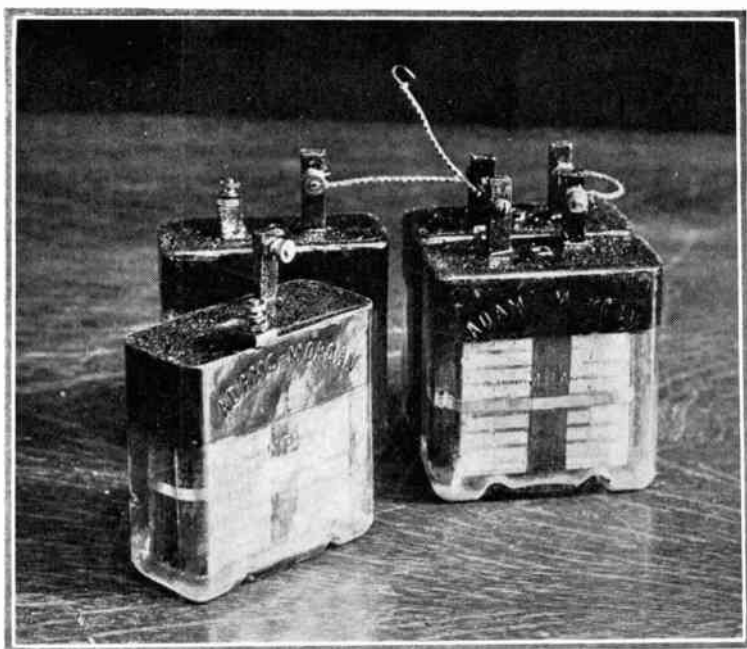

Fig. 7. The storage battery which consists of four small cells

mounted. The flexible coupling is merely two collars of brass, one of which is threaded to fit the propeller shaft while the other is secured to the motor shaft with a setscrew. The collars are connected with a coiled spring of No. 22 brass wire soldered at either end. So effective is this coupling that the motor may be operated at an angle of some 35 deg. with the shaft before appreciable friction is developed. This is an important

point, as it relieves tension on the motor bearings should the motor and propeller shafts be slightly out of alignment.

The storage battery, Fig. 7, consists of four standard miniature cells of 10 ampere hours capacity. The cells are sealed with an ingenious vent that permits the gases to escape but totally eliminates the leakage of the electrolyte. The outside dimensions of each cell are $1\frac{3}{4}$ in. thick, $3\frac{3}{4}$ in. high

and $3\frac{3}{4}$ in. wide. The lugs are too high when left as the cell is supplied, and in order to make them fit within the deck

starting from left to right, the relay, controller, storage battery, driving motor, propeller shaft and rudder control device

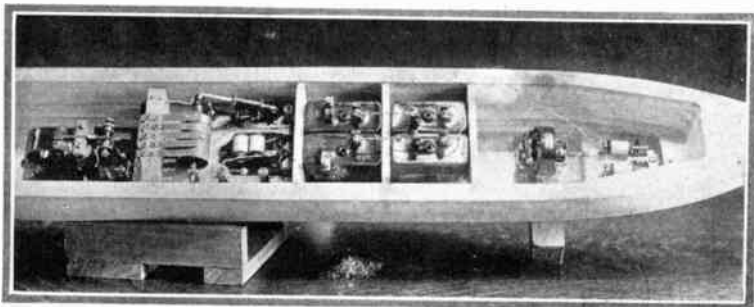

Fig. 8. Showing relay, controller, storage battery, driving motor and rudder-control installed in hull

of the hull we bent them over as shown in the illustration, Fig. 7. The cell at the extreme left has had its positive lug bent. This operation is not difficult of accomplishment, as the lugs are of lead.

In Fig. 8 is shown a portion of the interior of the hull with,

in position. The storage battery fits nicely within the hull and the cross pieces or partitions serve to hold the cells securely in place. The jars, of course, rest upon the No. 1 plank of the hull. The wiring plan will be given in the next issue.

(To be continued)

CONSTRUCTION OF A SIMPLE WAVEMETER

BY THE STAFF ENGINEER

NOT a few radio amateurs are under the impression that a wavemeter is more or less of a luxury—a desirable adjunct to the equipment of a modern amateur radio station but not necessarily an essential

factor. That this idea is a fallacy is admitted by most amateurs after they have installed and used the important instrument that makes it possible accurately to determine not only the wave length of their own

stations but those of their friends, as well.

Given the design and curve or table of wave lengths of a simple meter, the amateur may readily construct the instrument in his home shop without great expenditure of time or money. The wavemeter, in fact,

are refinements in the more expensive instruments that make for convenience and greater accuracy, still the principle is exactly the same.

The first requisite is a variable condenser which may be of the standard amateur type having a maximum capacity of

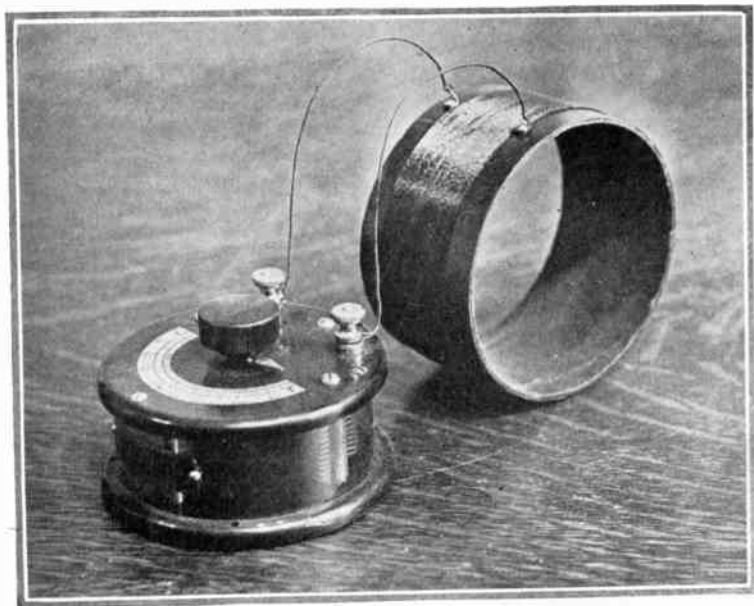

The winding is connected to the terminals of the condenser

consists merely of a standard variable condenser and an inductance comprising a few turns of insulated wire wound upon a form of wood or perhaps cardboard tubing. While there

0.0005 mfd. There are a number of suitable condensers on the market, and the one chosen for the model herein described was selected merely because it happened to be in stock. This ex-

planation is given in order to dispel any impression that its use in our model is an indication of partiality of indorsement. The instrument is, in our estimation, no better or worse than many others available to the amateur.

The condenser shown in the illustration is known as a Murdock No. 368 with sixteen stationary and fifteen rotary plates of standard amateur size. The capacity is 0.0005 mfd., and upon this capacity and scale the curve reproduced has been made. If a condenser having a different capacity or size and shape of plates is used, the wavemeter must be calibrated by comparison with a standard instrument.

The inductance coil is the only

in. in outside diameter and $2\frac{1}{4}$ in. long. The ends of the winding are left exactly 7 in. too long when the coil is finished. A brass screw placed as shown in the photograph holds each end of the winding in place while the 7-in. leads are left free to go to the terminals of the condenser. It is quite essential that the length of leads, diameter of cylinder, size of wire, etc., be adhered to in the event that the builder has no means for re-calibrating the instrument when it is finished. Outside of this precaution, no particular care or skill will be required.

In the table which follows, the wave lengths with the fixed inductance and variable condenser described are given:

Condenser Degrees	Wave Length in Meters
0	118
20	185
40	237
60	285
80	328
100	345
120	395
140	435
160	470
180	485

part of the instrument that requires specific description from the builder's standpoint. It is composed of 34 turns of No. 20 D.S.C. magnet wire wound in a single smooth layer upon a cylinder of cardboard tubing $4\frac{1}{2}$

In an early issue will appear a comprehensive article on the calibration and use of the wavemeter. While this second article will be complete in itself, it will refer specifically to the instrument described herewith.

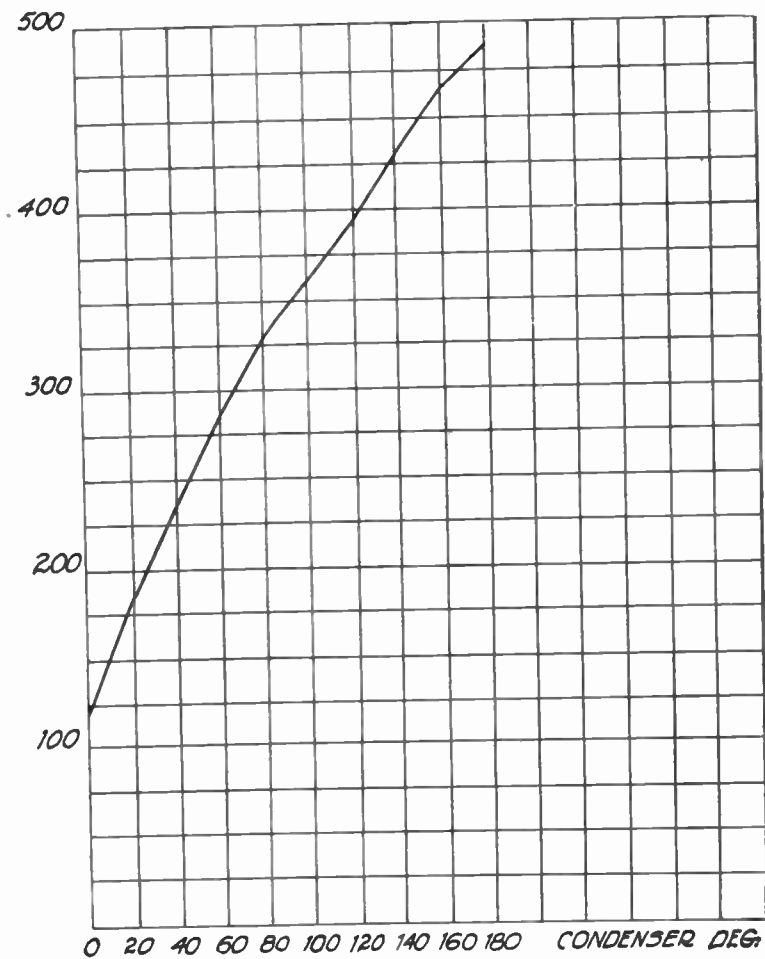

The wavemeter curve

THE WOODWORKER

BY RALPH F. WINDOES

Instructor of Manual Training, Davenport High School,
Davenport, Iowa

Editor's Note: This series, under the heading of "The Woodworker," will run for several issues, and will be devoted to the interests of the home craftsman and the student of manual training. Its principal theme will be cabinet making, and it will endeavor to teach the veriest beginner the essentials of tool using and how they may be applied in the construction of handicraft furniture for the home. The first article is devoted to the selection of tools, and the equipment of a home workshop.

HOMECRAFT woodwork-
ing is no longer an exper-
iment. Ever since its incep-
tion, a few years ago, countless men
have taken it up as an avoca-
tion, and as a result our Amer-
ican homes have come to possess
an air of originality in furnish-
ings not to be found in any age

since the frontier days. It has
offered an outlet for the pent-
up physical energies of the of-
fice man and teacher. A little
shop wherein he can fashion a
desired article for his home,
wherein he can spend the few
minutes between his supper
hour and bed time in the most

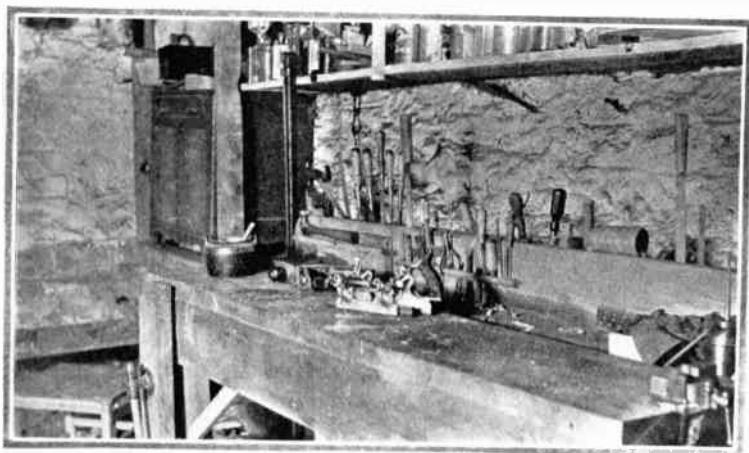

Fig. 1. A section of a home craft shop

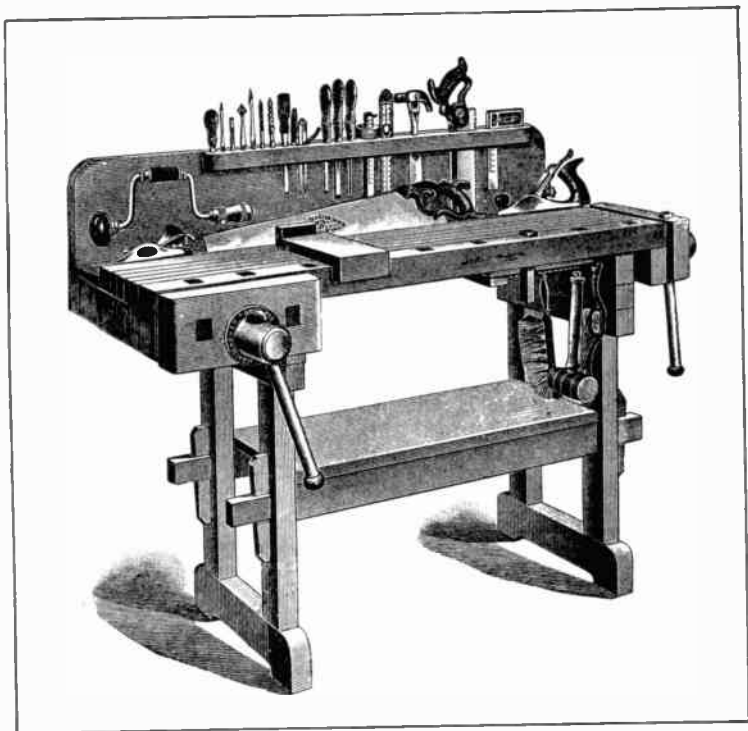

Fig. 2. A small bench with tool equipment

profitable of occupations, wherein he can take his growing son and give to him that power of expression in actual materials that the boy so longs for in dreams—these are the things that appeal to the worth-while man, and these are the demands that are creating homecraft shops all over the country.

Many men have followed this development, and have longed to

join the ranks, but the fear that they will be unable to do the work has prevented them from starting. Many have thought themselves incapable of handling the tools correctly, as they have tried some time to do a difficult job, and failed because of improper training. Many others would be willing to try if they could be taught in a logical and sequential manner.

This course will start at the beginning, will be profusely illustrated, every new step will be carefully explained, and we have no fear when saying that any earnest and conscientious worker, with absolutely no experience, can successfully make creditable pieces of furniture if he will follow it faithfully.*

buy them. When selecting your tools, go to a responsible dealer—one you have faith in—or take with you a man who, in your judgment, knows good tools from his experience with them. You may be able to find good tools in second-hand stores, but if you consider them, look for the name of the maker and

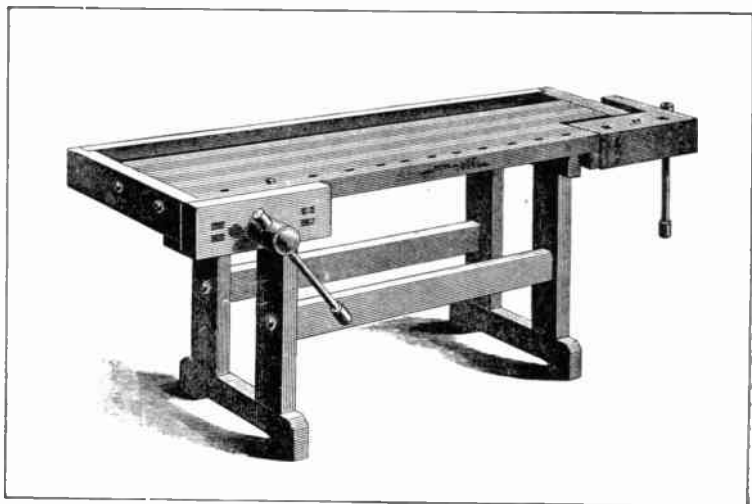

Fig. 3. A large bench, particularly adapted to cabinet work.

THE SELECTION OF TOOLS

To begin with, you must have a *good* set of tools. Cheap tools are an expensive luxury that none can afford. Under no circumstances is it advisable to

assure yourself that he is one of the best.**

The tools we recommend to begin the work with are as follows. A few more will be needed later, but these are almost

*The author will be glad to answer any questions on woodworking submitted through the "Technical Adviser" of EVERYDAY MECHANICS.

**EVERYDAY MECHANICS Service Dept. will furnish catalogs of reliable dealers. See inside front cover.

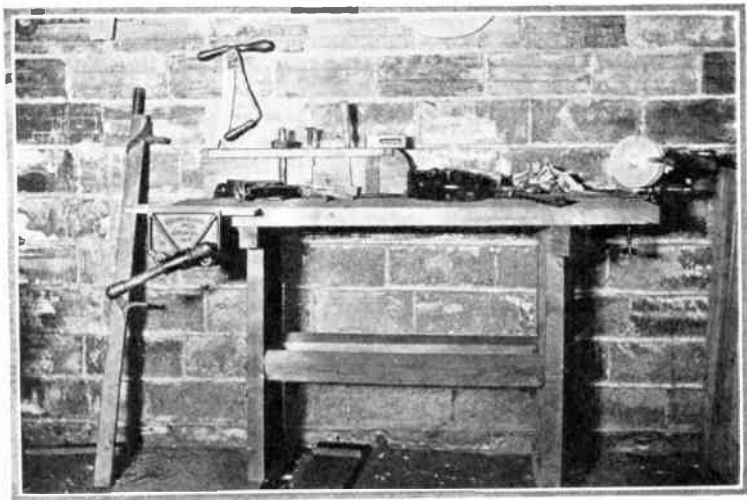

Fig. 4—A home craft shop and some of its tool equipment

necessary to start, and it will be cheaper to purchase them in one group such as this, than to buy one or two at a time.

- One firmer chisel $\frac{1}{4}$ in.
- One firmer chisel $\frac{1}{2}$ in.
- One firmer chisel 1 in.
- One firmer gouge $\frac{3}{8}$ in.
- One back saw 12 in.
- One 10-pt. hand saw 22 in.
- One 8-pt. rip saw 24 in.
- One iron pad keyhole saw.
- One 13-oz. adz eye hammer.
- One 14-in. jack plane, 2 in. cutter.
- One $7\frac{1}{2}$ -in. block plane, $1\frac{3}{4}$ -in. cutter.
- One No. 6 ($\frac{3}{16}$ in.) bit stock drill.

One No. 4 ($\frac{1}{8}$ in.) bit stock drill.

One No. 4 ($\frac{1}{4}$ in.) auger bit.

One No. 8 ($\frac{1}{2}$ in.) auger bit.

One No. 12 ($\frac{3}{4}$ in.) auger bit.

One expansive bit, $\frac{7}{8}$ in. to 3 in.

One ratchet brace 8 in.

One $\frac{5}{8}$ -in. countersink.

One 8-in. try square.

One 8-in. T-bevel.

One 16-in. carpenter's square.

One 10-in. marking gage.

One 6-in. screw driver.

One $\frac{3}{8}$ -in. screw driver bit.

One brass-bound 2-ft. rule.

One hickory mallet, $2\frac{1}{2}$ -in. face.

One pegging awl.

One winged dividers 6 in.
 One bench duster.
 One nail set.
 One iron spoke shave 10 in.
 One draw knife 8 in.
 One oil stone, medium cutting.
 One coppered-steel oiler.
 One bench grinder.
 One steel cabinet scraper 3 in.
 by 6 in.
 One combination pliers 7 in.
 One half-round bastard file 8 in.
 One flat, smooth-cut file 8 in.
 Six wooden hand screws 18-in. jaw.
 Six wooden hand screws 10-in. jaw.
 Six iron clamps opening 6 in.
 To these may be added a number of home-made tools, such as cabinet clamps, saw

horses, miter box, bench hook, etc. Directions for their making will be given in future issues.

WORK BENCH.

With the tools purchased, the craftsman must provide himself with a bench to work upon. Single benches may be purchased at a reasonable price, and, though usually small, are satisfactory. Fig. 1, from a photograph of a homecraft shop, shows such a bench in use, and Fig. 2 illustrates a similar type with tool equipment in place. This bench, complete with the tools illustrated, is listed by a reliable firm at \$22.50, making the price of the bench alone about \$10. A larger bench is

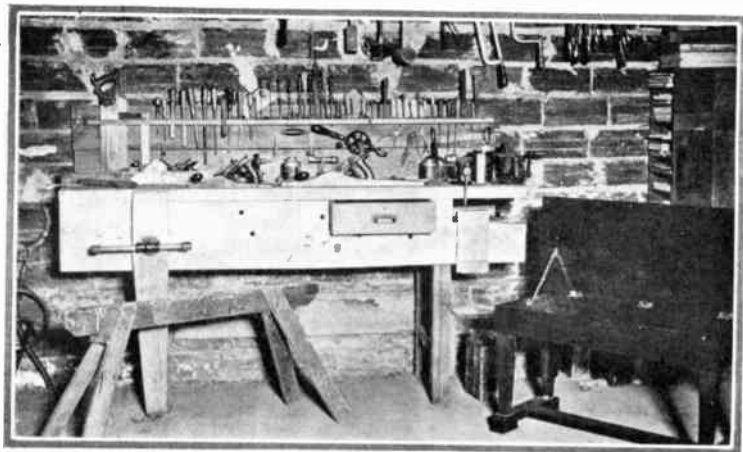

Fig. 5. A shop with a large tool equipment and a piano bench made by the owner

shown in Fig. 3. It is especially adapted to cabinet work, and sells for about \$12, complete with vises.

Fig. 4 shows a section of a homecraft shop and some of its tool equipment. The bench was made by the craftsman who had had no previous tool experience. In the next installment of this series we will give directions for the making of a similar bench.

Fig. 5 illustrates a very complete and well-equipped shop, together with a sample of the craftsman's handiwork — the piano bench on the right. More small tools are here illustrated than will be found absolutely necessary, but they do become very useful and time-saving. The larger tools are stored in a cupboard, not seen in the picture. Some men find an old dresser of great value for the storage of such tools.

LOCATION OF SHOP

If possible the shop should be located above the basement, as the latter is bound to be more or less damp—sometimes wet—and few basements have good light. The first or second floors are best—if a secluded room can be obtained—while the attic, if easily accessible, will do very nicely. The three shops illustrated are all basement shops, and their owners are well pleased with them. If a little oil is rubbed on the exposed

parts of the tools, and the stock and unfinished pieces are kept off the floor and away from the outside walls, but little trouble from dampness is experienced.

TO BE CONTINUED.

CURTAIN RINGS OF CANE

Once, when a country school needed some curtain rings, a man who was known to be "handy" was asked to make some. The rings he sent were merely pieces of cane sawed off

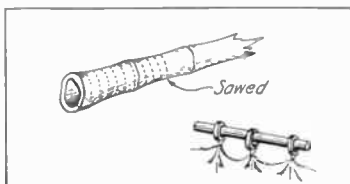

The home-made cane rings slide easily

in quarter-inch lengths. These the pupils sewed with coarse thread to the curtains, and it was found that the cane rings slipped with much greater ease on the wire than did the home-made wire rings they had at first tried to use.

Contributed by LORA ROBERTSON.

To Make a Fire Draw.—If the fire in your grate refuses to draw, hold a piece of paper for a minute over the entire opening between the top of the grate and the top of the fireplace.

CONSTRUCTION OF A TRANSATLANTIC RECEIVING SET

PART II.—THE WING OR GRID INDUCTANCES AND AUDION CABINET.

BY LOUIS GERARD PACENT

THE opening instalment of this series in the last number gave constructional details of the long-wave receiving transformer. The next important element is the construction of the two-wing or grid inductances calculated to work properly with the remainder of the instruments. These inductances are, essentially, loading coils arranged so that connection may be made to any one of three places on the winding of each.

While only one coil is illustrated and described, the builder should make two identical coils. The illustration, Fig. 1, shows well the appearance of one of the inductances. The winding is of No. 31 S. S. C. magnet wire closely wound in a smooth layer on a cylinder of cardboard 4 in. in diameter and 30 in. long. The winding is started at one end of the cylinder, leaving about an inch of the tube clear of the wire. The winding is carried for a distance of 8 in., when approximately 680 turns of wire will have been placed. Without cutting the conductor at this point, its insulation is scraped for half an inch and the copper held beneath

the socket of a plug connector, or, if this form of tap is not conveniently accessible, the worker may employ an ordinary binding post of the screw or even the spring type. Leaving an inch of space at this point, the worker proceeds to wind another 8 in. of the coil when the second tap is made. Another inch of space, then the third section of 8 in. of winding and the coil is complete. Of course, a third plug connector or binding post surmounts the coil as shown in the illustration.

To aid in making a firm and stable winding, the worker may paint the surface of the cardboard cylinder with first a thin coat of shellac and then, when that is dry, he may add a second coat of thicker fluid. This second coat should have become "tacky" or about half dry before the winding was started. The result of this procedure is a firm, smooth coil the surface of which is not marred with the usual uneven coating of shellac applied after the winding is done. The latter course is good only in that it prevents, to a certain extent, the absorption of moisture by the insulation. If this is deemed of sufficient im-

portance, depending, of course, upon the climate of the locality, the builder may give the final coat of shellac after the primary or "sticking" coat has dried thoroughly.

When the two coils have been finished in the winding, they may be fitted with neat wooden bases and turned wooden tops if an attractive and business-like finish is desired.

THE AUDION CABINET

The design presented for the audion cabinet offers many points of advantage that may be termed unique. While the illustration shows the cabinet lying on its base, in use it is placed vertically in the usual manner. Among the several points of vantage to be found in this cabinet may be mentioned the fact that the batteries are almost instantly accessible for replacement or testing. The connection to the batteries is made through a series of brass springs which press against the spring connectors on the flashlight cells when each group of three of the latter is placed in the case. No wires or other loose and troublesome connections are employed.

Dimensions of Cabinet.—The cabinet is of oak or mahogany and of such a size that it will inclose 12 pocket flashlight batteries of the No. 703 size. Each



Fig. 1. One of the loading coils. Two coils are to be wound. Each consists of a single layer of wire on a cardboard cylinder

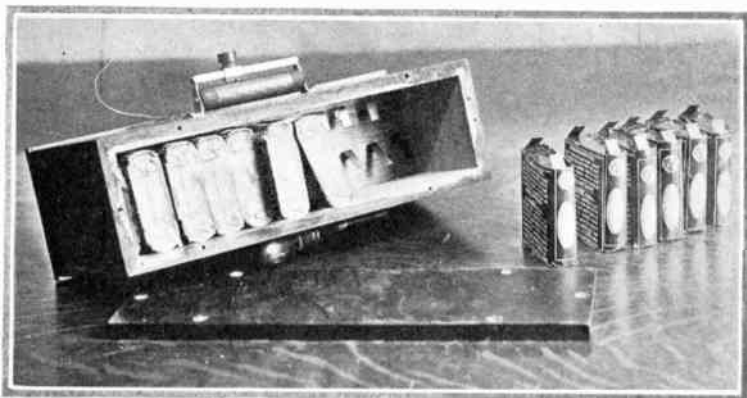

Fig. 2. The cabinet opened, showing cells and spring contacts

of these batteries comprises three cells sealed up and fitted with spring terminals. The unit of three cells measures $2\frac{1}{2}$ in. wide by $2\frac{5}{8}$ in. high by $\frac{3}{4}$ in. thick. The twelve units, therefore, nicely fill the interior of the cabinet if it be made $2\frac{1}{2}$ in. wide by 10 in. long. The depth is 3 in. to provide space for the spring contacts with which the battery terminals make connection when the units are placed in position. These spring contacts are secured to the underside of a partition placed near the upper edge of the cabinet. The partition and the springs are clearly visible in the illustration, Fig. 2.

To accommodate the batteries, connectors, and the partition, the cabinet has been made $4\frac{1}{4}$ in. deep in all. The parti-

tion is secured in such position that the depth of the battery space is 3 in. The back of the cabinet is secured with flat-head brass wood screws.

Above the partition in the cabinet the reader will notice the flexible leads from the batteries. While the illustration, Fig. 3, does not show the actual method of connection, this will be readily understood when we state that the contact springs beneath are secured to the partition with brass machine screws and hexagon nuts; the spring is held beneath the head of the screw while the nut secures the flexible wire above the partition.

Taps are made at nine points in the series of batteries. The flexible wires lead to contact points of a nine-point switch on

the hard-rubber cover; the switch lever is connected with one of the binding posts. Connections are so made that when the switch lever rests on the first point of the switch, there are four units of the battery in the circuit. Each of the eight remaining units of battery is connected with a contact of the switch.

The top of the cabinet is of hard rubber. It is secured with countersunk screws at suitable points. The cover carries the audion bulb which may well be

of the new tubular variety. The fixture for this purpose is so clearly shown in Fig. 4 that detailed description seems unnecessary. The manufacturer of the audion supplies with the bulb an adapter that makes it possible to use a standard candleabra base receptacle attached to a miniature wall fixture.

On the side of the cabinet is placed a small rheostat of simple but good design. This rheostat consists essentially of a single layer of 70 spaced turns of bare No. 22 climax resist-

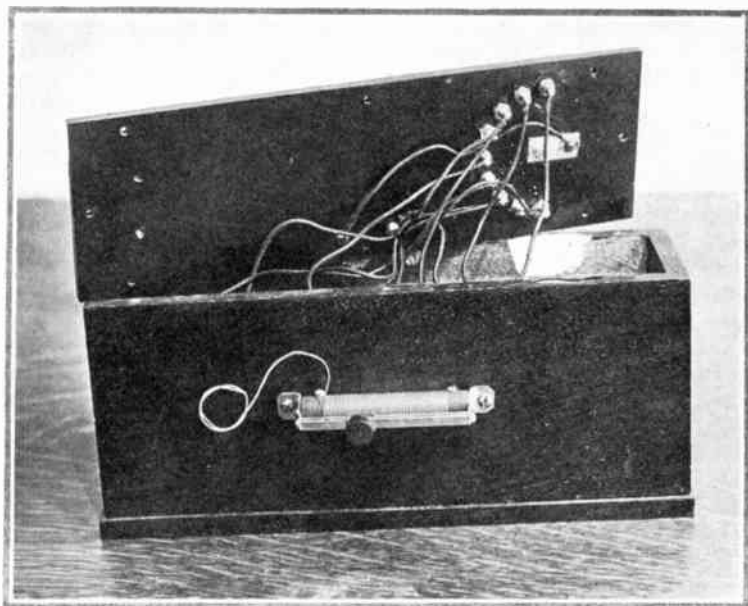

Fig. 3. Flexible wires lead to the contact points of a nine-point switch

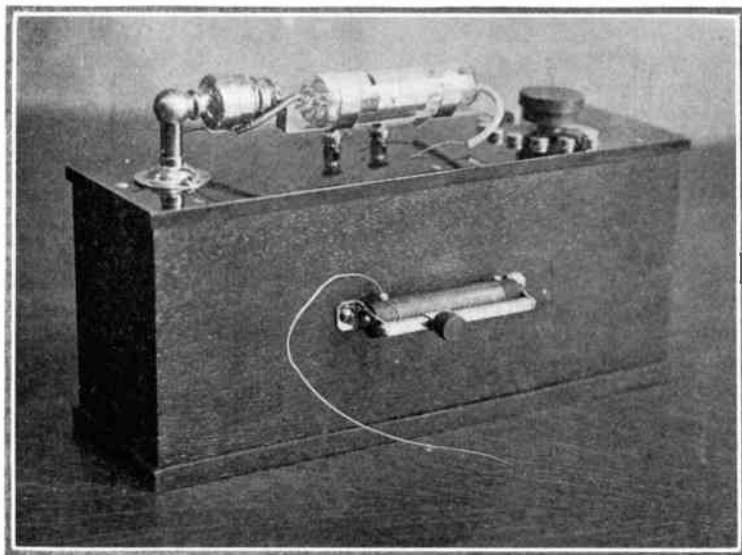

Fig. 4. The cabinet complete, showing audion bulb

ance wire wound upon a rod of black fiber $\frac{1}{2}$ in. in diameter and 3 in. long. The variation of resistance is accomplished by means of a conventional sliding contact familiar to nearly every radio builder.

The instructions for connecting up and using the apparatus will be given in the next instalment, as the work outlined in this one will probably keep the readers busy for the month.

If you have trouble, let *The Technical Adviser* help you.

Removing Grease Spots from Wall Paper.—To remove grease spots from wall paper, put a thin piece of blotting paper over the spot and hold a hot flatiron against it. The iron should be as hot as possible without scorching the paper. Repeat the operation until the spot disappears.

In very obstinate cases that fail to yield to this treatment, get a little washed sulphuric ether and dab it on the spot with a fine, clean sponge. Don't do this at night, however, as the ether is very inflammable.—F. H. SWEET.

CONVERTING THE KITCHEN STOVE FOR OIL BURNING WITH KEROSENE

BY S. H. SAMUELS

THE oil burner herewith described will manifest itself as one of the present-day items toward the elimination of manual labor, which gives rise to so much trouble in firing the coal stove, and removing the ashes from the ash pit.

The burner is very easy to construct, and has, at the same time, the property of cheapness.

Briefly stated, the operation of the burner is as follows: Kerosene oil is fed from a tank into the feed pipe, where the vaporizer *F* converts the liquid fuel into a gaseous state, combined with the air supplied through the proper regulation of the damper. Here the oil begins to burn, the heat currents passing through the pipes *C* and *D*, thus thoroughly circulating the hot air within the fire-box.

The entire outfit is composed of standard malleable pipe fittings, thus the parts are easily obtained and assembled.

The main part of the burner, which rests upon the grate bars within the fire-box, consists of the following fittings: Nipples *A*, *B*, *C* and *D*, size 2-in.; two 2-in., 90-deg. elbows; one T 2-in. x 2-in. x 1½-in.; one 1½-in. nipple *E*.

These fittings are then assembled as shown in the drawing, making the nipples *A* and *B* of such length that the union shall then result into the inside length of the fire-box. The length of the fire-box will vary from 15 to 24 in., depending upon the shape, size and type of kitchen stove. This distance shall allow the friction of the 90-deg. elbows against the inside back and front of the fire-box to produce enough pressure to secure the burner in a permanent position. The burner, by means of the pipe nipples *C* and *D* resting on the grate, aids in fixing the burner in a firm position. Not all grate bars are straight, some being convex, others concave; therefore due allowance must be made for the burner to rest upon. This is readily done by shaping the ends of the nipples *C* and *D* to coincide with the surface of the grate. The lengths of nipples *C* and *D* are such that distance *Y* will be equal to approximately two-thirds the height of the fire-box, which varies from 12 to 14 in., according to the type of stove.

The next step is to construct the vaporizer which consists of

a 2-in. x 2½-in. reducer, ½-in. x ⅜-in. bushing, ⅜ pipe to the proper length and a pipe cap for the same as shown in the cross-section view of the complete vaporizer. The vaporizer rests upon the grate. The lengths of nipples as shown in the sketch, and is

in diameter, leaves a clearance of ¼ in. around the nipple *E*, this space being due allowance for the passage of free air to be combined with the vaporized oil. The ⅜-in. pipe projects above and inside the reducer, allowing a ⅜-in. cap to be fitted on. The

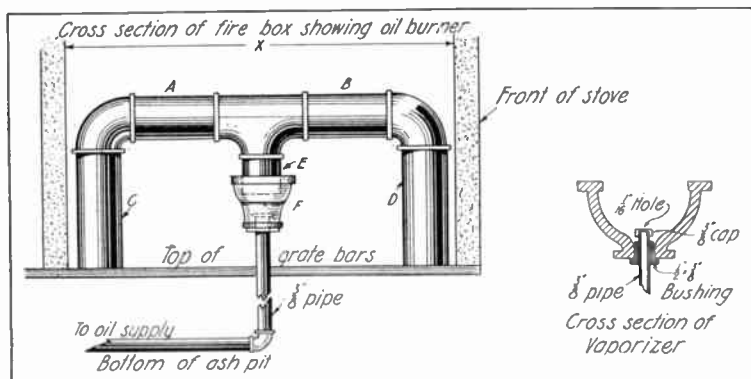

This arrangement converts the stove to an oil-burner, and does away with much work.

held in a vertical position by the ⅜-in. pipe running clearly through the center of grate and down to the bottom of the ash pit. The ⅜-in. pipe is fastened to one of the grate bars by means of a piece of wire wound around the pipe and its nearest grate-bar. The pipe running to the ash pit meets a 90-deg. elbow resting upon the surface of the ash pit. The other outlet of this elbow contains the feed pipe of oil supply. The reducer or vaporizer proper, which is 2 in.

latter has a 1/16-in. hole drilled in the center.

The feed pipe runs to a tank having a minimum capacity of 2 gal. The method in which the feed pipe will be constructed depends entirely upon the shape of the stove, and here the mechanic must use his own judgment. The shape of the tank is optional and should be placed or fixed at least 6 ft. away from any external part of the stove. Regarding the height of the tank, the higher the better, since

a greater height results in a greater pressure of the oil, which will produce better vaporizing qualities, thus saving fuel.

The flow of oil can either be controlled by a regular brass globe valve or a Lunkenheimer sight feed valve which provides a means of experimenting for the proper amount of drops of oil flowing per minute best suited for the burner. This valve should be placed in the feed line and as near as possible to the outlet in the kerosene tank.

The damper of the stove is an important factor in the economical operation of this oil burner and also in the elimination of any smoke. The damper should undergo a close examination in order to insure close regulation of the air supply.

GALVANOMETER SUSPENSION WIRE

Here is a method by means of which galvanometer suspension may be made without the use of any very elaborate equipment. The suspension consists of a piece of very thin and narrow metal ribbon, seemingly almost as fine and delicate as a hair.

The device to be described is for use in a small bench lathe. A piece of steel rod is turned up and polished. This is held

between centers. A piece of $\frac{1}{8}$ -in. steel bar is then fitted to the cross feed table and clamped. The far end of the steel bar, which overhangs the table, is fitted with a toolmaker's clamp and beneath this clamp a piece of No. 38 copper wire is secured. The other end of the wire is held under the head of a bolt which passes through the steel bar.

It is obvious now that if the steel roller is of such a diameter that it bears heavily upon the steel bar as the latter is fed in by the cross feed, the piece of copper wire stretched across the bar will become flattened beneath the roller. The latter should be securely held between

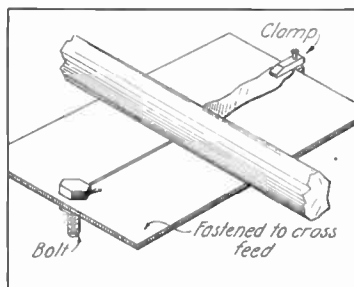

The roller is held in the lathe spindle, and flattens the wire.

centers, just sufficient play being allowed to permit of its turning upon the centers.

Contributed by

M. F. VAN ORSDALE.

TURNING A SQUARE PIANO INTO A HANDSOME DESK

BY WILLARD HOWE

THE latest novelty is turning a "white elephant" into a useful household article, as found in a home in the National Capital, where a magnificent desk has been created out of an old square piano.

neat manner directly facing the person sitting at the desk. To the right, where a large, un-gainly, hollow space was left, additional divisions of varying sizes were created, and back of these a trough-like receptacle



The convenience of a roll-top is combined with the elbow room of a flat top desk

The harp, keyboard, etc., were taken out and shelves for paper, and cubbyholes and niches for envelopes, letters, etc., were substituted in a convenient and

forms a convenient depository for waste paper. On top of these niches is a convenient place for an electric or gas lamp.

On the left side of the writing space, the solid structure is retained, forming another location for a light or article of art. The space for correspondence is 40 in. by 19 in., which is ample for writing and a typewriter, as well as for current periodicals.

A conspicuous feature of this desk is that the original out-

lines of the piano are not disguised. The heavy picturesque legs are there, the solidity of the structure itself, and even the lid is retained intact. When closed it has all the appearance of the musical instrument. This piano desk is not only unique, but it is artistic and useful. Its cost is purely nominal.

A GARBAGE AND LITTER INCINERATOR

BY T. H. LINTHICUM

THE best way to get rid of garbage, waste paper and other litter is to burn it. But

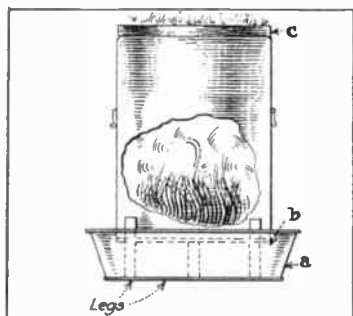

Fig. 1. An old pan receives the ashes

before you start your fire be sure it will not endanger the surrounding property.

The illustration shows a safe incinerator made from an old ash can, three sheet-iron hoops (off an old barrel), two pieces of wire netting, three strips of

iron and a few rivets. An old dish pan, *a*, Fig 1, serves as an ash receiver.

Remove the bottom from an old ash can and rivet in its place a bottom made of a piece of net wire and an iron hoop, as shown at *b*, Fig. 1. The removable cover *c*, Fig. 1, fits over the outside edge of the can. To make this, fit a hoop *d*, Fig. 2, over the upper edge of can, put over this hoop a circular piece of wire, *e*, 2 in. larger in diameter than the hoop, bend down the projecting edge all around,



Fig. 2—Construction of the removable top

fit a little larger hoop, *f*, over the wire and rivet the two hoops together.

Then rivet three strips of iron, about 6 inches long to the lower edge of the can for legs.

This device may be used with perfect safety in windy weather. The ash receiver not only

prevents live coals from blowing about, but saves the trouble of scraping up the ashes and does away with the ugly burnt spots in your yard. It is cleanly, safe and convenient.

A CAMP HAMMOCK

BY LORA L. ROBERTSON

IF you go camping this year, take a barrel hammock with you for your bed. It beats sleeping on the cold, damp ground along with the snakes and the toads. Of course, no one can sleep comfortably in an ordinary, soft hammock, which has the habit of folding its victim up in a shapeless, contorted mass in the middle of the hammock, but a barrel hammock, because of its stiffness, is different. There is another difference, namely, about \$3, in cost.

The material for one of these ideal beds is two common barrels and about 65 ft. of half-inch rope. If you happen to have on hand a generous supply of strong baling wire, for lacing the staves together, 25 ft. of rope may be enough to buy. By placing the staves far apart, one barrel is sufficient, but the hammock is more comfortable when the staves are placed close together. These staves are laced together near the ends, with the rope or the wire, by

passing the rope over the first stave and under the second until the end is reached. Then bring the rope back, passing it over staves number two, four, etc., and under one, three, etc. The staves, of course, run cross-wise and ropes for hanging are attached at each end.

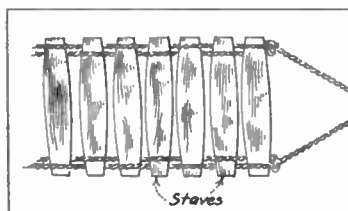

Lace the staves as shown above with half inch rope

A good mattress for the hammock is made by taking an old comforter or thick quilt, folding it once and tacking. This hammock is not very sightly, but the most restful bed imaginable, and is just the thing for a shady back yard or that nook in the woods at camp.

TIN CAN UTILITIES

BY MARIUS VAN REMLAR

EVERY household to-day buys some kind of canned foodstuff, which when used leaves an empty tin can. Such cans are ordinarily thrown away as waste, though they can be used for many purposes.

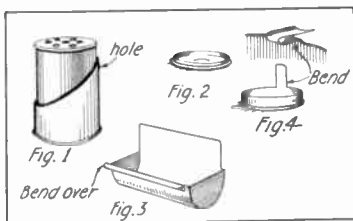

Holders may be made for the scouring powder can, soap, cigar ashes, etc.

To be made available, tin cans should first be thoroughly cleaned, the "crumbs" scrubbed out with a test-tube brush, a thing which should be at every modern kitchen sink. Then the can should be permitted to drain dry; this is best done by placing the can on a top shelf of the pantry open end down.

Clean tin cans, with a pair of scissors (and every household has an *old* pair of scissors which can be used for cutting tin) can be made into match-boxes, soap dishes, sugar scoops, ash-trays, covers for bottles and cans, book racks, and many things, including toys

of various kinds. Boys will enjoy making things from cans, so both boys and tin cans can be made useful.

By merely cutting the can into the right shapes, many things can be made without first melting apart the tins. By cutting away the larger part of the side as shown in Fig. 1, a holder for tin cans, or for scouring powder is made. This can also serve as a holder for a drinking glass. It is hung upon a nail or hook through a hole near the top. By using the same pattern, and attaching at the center of the base, preferably by a bolt, a spool or other handle, there is formed a sugar scoop, Fig. 6.

By cutting away practically all of the side, leaving but a narrow edge, a stand for pots and pans is formed, as shown in Fig. 2. This can also be used as a smoothing-iron stand. It is not as noisy as the conventional stands and does not absorb as much heat if the iron is placed on the remaining edges (it should not be used otherwise, for then the lead might melt and trouble ensue). By cutting the can so as to leave a strip about $\frac{1}{2}$ in. wide standing, and an attached strip about $\frac{3}{4}$ in. wide along the seam of

the can (but not including the seam), and bending this strip perpendicular to the $\frac{1}{2}$ -in. strip that is parallel to the base of the can and then bending it back on itself about $\frac{1}{2}$ in. from the edge and cutting it off half an inch from the other side, and slightly "scooping" the sides, there is formed an individual ash tray, a thing very convenient for card games and a device saving of much labor in sweeping up the ashes otherwise scattered about in the effort to place all in a communal tray. See Fig. 4.

By simply cutting the sides of cans of the correct diameters, covers can be made for

If the can be opened along the side, instead of the customary way at the end, and the tin cut to the correct shape, soap dishes or match boxes can be made. (See Fig. 3.) In these it is best to fold back an edge so that there will be no danger of cutting the fingers as one reaches into the box for the contents.

Match-boxes and soap trays can be more elegantly made by a little more effort. By melting the can apart and leaving only the hollow cylindrical sides, and cutting this along the seam, a flat piece of tin is obtained. By cutting this along the heavy lines, as shown in Fig. 5, and folding along the dotted lines a substantial box like the completed one in Fig. 5 is made.

If the tin be cut as shown in Fig. 8 (along the heavy lines) and folded as shown, (along the dotted lines) a book block or support is made. This article is very convenient in small libraries.

In melting the cans apart, if they have been opened the conventional way, there remains the base of the can in two parts, the outer ring and the inner. This is really the top of the can, for, it is through the small opening that the can is filled. The outer ring makes a delightful toy. A number of these, used with a peg made on a

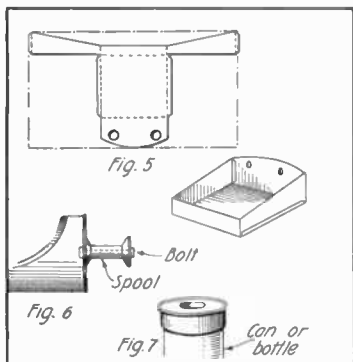

Match boxes, scoops and bottle covers are a few of the things to be made.

other tin cans. Small condensed milk cans make excellent covers for milk bottles. See Fig. 7.

small slab of wood, make the necessary equipment for "indoor quoits," the circles having a wonderful "sailing" quality. The smaller disks are good for toy money for the children.

If a little more diligence is taken in the melting apart of the can, and these ends are not melted apart, but come away from the cylindrical sides of the can intact, there is a pretty little wheel made, four of which make an attractive wagon for the child. These are always "true" by tacking them to the axle through the point at the center which is always present in these.

Excepting for the toys listed, it would be better that the cans used be opened through the labelled base, the real top, *i. e.* through the end which has two parts and the soldered circle showing. When this end is opened, the soldered parts will not show in the device made from the can, and the reason is that inasmuch as cans are packed with the soldered end down, and are placed on the store shelves with the same end down, the food-contents naturally become thicker at that end, and it is more easily emptied.

As tin cans are not "of tin," but merely thin sheet iron coated with "tin," they readily rust. To prevent this, all articles

made which will come in contact with water or moisture should be painted. If asphaltum is handy, it will make an excellent black covering, nicely

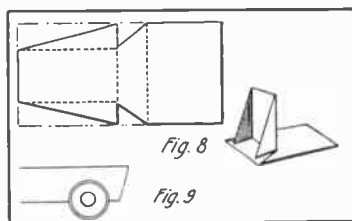

Toys made from the cans are both attractive and cheap.

filling in the crevices. This makes an excellent coating for the covers for milk bottles, or food containing cans, though, of course, paint will do as well for general purposes. If brilliancy of color is desired, in the natural tin, the tins can be coated with ordinary paraffine wax; the metal will show the natural silver-like color through the coating of this substance and also be waterproof.

The following recipe for waterproof glue has the advantage that it contains no water. The parts are measured by weight.

- Four parts ordinary glue.
- One part iron oxide.
- One part boiled oil.

FOUNDATION WASHERS OF OLD STEEL ANGLES

BY ANDREW E. HOLLAND

It does not appear to be generally appreciated among erection men that they can, in a pinch, make foundation bolt washers out of almost any kind of scrap metal. The function of a foundation washer, where the foundation is not pocketed, is merely to prevent the withdrawal of the bolt from the masonry. Where the foundation is of concrete, if a round bolt is set in the concrete to a depth equal to twenty of its diameters and the concrete is thor-

rectively serve the function of a washer.

Structural steel angles are often very conveniently applied for this service as suggested, for instance, in Fig. 1. A length of angle used as shown not only prevents the withdrawal of the foundation bolts, but it retains the lower ends of the bolts the specified distance apart, and thereby assists the template in holding the bolts where they belong while the concrete is being poured.

Lengths of angle used for setting the foundations can be drilled in the shop before they go out on the job. Where this procedure is followed, an accurate spacing between the bolt holes is assured. The fact that the spacing is correct also serves as a check on the carpenter who makes the template out on the job.

Fig. 2 shows a case where short angles used instead of the standard foundation bolt washer were found particularly convenient. The distance between the centers of each of the bolts of either pair was so small that there was no room to accommodate the standard foundation bolt washers, hence a short length of 2 in. x 2 in. x $\frac{1}{4}$ steel angle was used for each

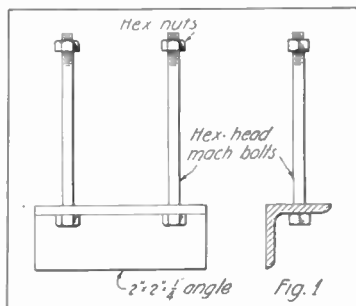

The angle retains the lower ends of the bolts, the specified distance apart.

oughly tamped around the bolt while it is wet, the rod will break before the adhesion of the concrete fails. It is evident then, that almost any object that will provide some enlargement on the lower end of the foundation bolt will ef-

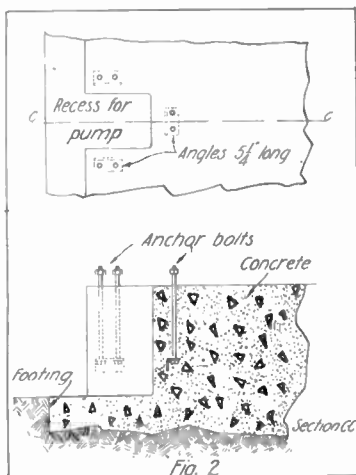

Fig. 2
Short angles used instead of bolt washers were found convenient in this case.

pair of bolts instead of two washers. The angles maintained the proper spacing between the bolts while the foundation was being poured and rendered their withdrawal impossible after the concrete had set.

ATTACHMENT PLUG FROM FUSE

Remove the alloy wire from a burned-out fuse plug, solder the bare tips of a length of flexible cord respectively to the shell and the centre contact of the plug, and fill the plug with the tar and pitch compound removed from an old dry cell. The result will be a serviceable attachment plug for use on the bench where the 110-volt cur-

rent is used at various places and under varying conditions.

FOR THE DRAWING BOARD

The arrangement here illustrated may seem rather cumbersome, but it has many distinct advantages over the T-square. Unlike the latter, it cannot slip and may be used on boards regardless of edges that are not straight. The device consists of a straight stick—a ruler will do nicely—near the ends of which two grooved wheels have been fastened, and two pieces of cord. Tack one end of a string to a "top" corner of the board, pass it under the wheel below, over the other wheel and fasten it to the corner diagonally opposite the starting point. From the

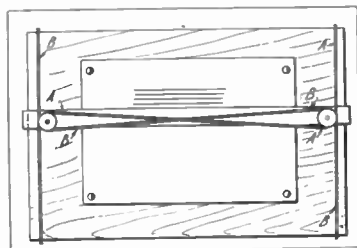

If the string is taut the rule will not "slip."

other "top" corner, draw a cord under the wheel below, over the other wheel to the remaining corner.

If the string is taut, or wire used in its place, the accuracy of the work done with this arrangement may be relied upon.

MAKING CONCRETE FLOWER BOXES

BY GEORGE E. WALSH

CONCRETE flower boxes and stands are the most durable, and in some respects the most artistic, for the piazza, house, or lawn. They are practically indestructible, and consequently it pays to make them carefully, giving an amount of attention to their construction that would hardly pay with less durable flower holders. With stucco and concrete houses, a few plant boxes of the same material give to the front piazza a finish that is in perfect harmony with the surroundings.

Concrete is one of the most plastic and easily worked of all materials, and any one can mix and mold it in desirable forms. But in making flower boxes and stands, the difficulty met in building molds for the liquid concrete or cement is rather discouraging. Yet everything depends upon these molds, and unless a simple way of designing and making them is in mind the results will be far from satisfactory.

For flower stands and boxes the best and simplest molds are made from old boxes. To begin with, go to your grocer and get an ordinary wooden box, a trifle larger than the measurements of the flower box wanted. Then

choose another that will fit inside of this, leaving a margin all around of about two inches. It may be necessary to cut the latter down at the ends to make a good fit.

Purchase a bag of cement and some fine sand, and mix them together in the proportion of one part cement to two parts sand. Add water and stir steadily until the mass is about as thick and consistent as mud. Pour this in the bottom of the larger box until it is 2 in. thick. Then place your smaller box on top of this layer, taking care that it is exactly in the middle. Pour cement in the spaces left between the two boxes until it is even with the tops. Tamp down by pushing with the fingers or a small stick. When the cement hardens for a few days you can remove the inner box and strip off the outer one. Your simple flower box is complete.

To work well, it may be necessary to smear the sides of the boxes that come in contact with the concrete with lard or oil to prevent sticking. After you have turned out the plainest form of concrete box, you can begin making molds of a more elaborate nature. The principle is the same in all. An in-

side space is formed in which to pour the cement or force it in with the hand.

A box with cement legs is made by cutting boards in the form desired, and joining them together. Any old box boards will do for this. Make your side and end boards any shape desired, and then make duplicates

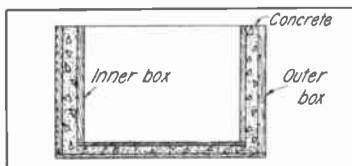

Fill the space between the two boxes with concrete.

exactly 2 in. wider on all sides. The bottom part of the mold can be closed up with thin pieces of cigar-box wood or tin. The mold thus made is only temporarily joined together. It can be tied instead of nailed. The objects are to have channels formed between the outside and inside boards of the mold to receive the concrete, and a simple way of removing the mold when the concrete hardens.

A flower box with wooden legs and wooden partitions embedded in the concrete sides, is very effective, and the mold is not difficult to make, as may be seen by the illustration. Two boxes are necessary. First, a large one through the bottom of

which holes have been cut at the corners. Thrust the legs in place. Get these perfectly upright, and fasten temporarily with wire nails. Next place your other strips of wood in position, as shown, fastening them lightly in position so they will not move. When all the woodwork is adjusted, place your smaller box inside, on the 2-in. layer of concrete at the bottom. By filling the spaces between the boxes with concrete, the legs and side strips of wood will be embedded in the whole mass.

It is usually necessary to reinforce the wooden legs. This can be done by joining the hard wood frame together with nails, and then inserting the legs in the holes of the bigger box, or joining the framework together by running stiff pieces of wire in the bottom from side to side. When the concrete is put in the mold this wire will be embedded in it and entirely concealed from view. When the concrete has hardened, the boxes can be removed, and the flower stand will be ready for any further finishing off needed.

For this type of box, hardwood susceptible of a fine polish should be used for the legs and ornamental partitions. When taken out of the mold, the legs can be polished or stained any color desired. A most unique and ornamental flower stand can be made in this way.

Flower boxes and stands of concrete can be made of different shades and colors by using colored sand. A reddish, gray or green sand can be obtained at any building supply company, and when mixed with the cement beautiful shades are obtained.

All flower boxes can be finished off roughly and decorated

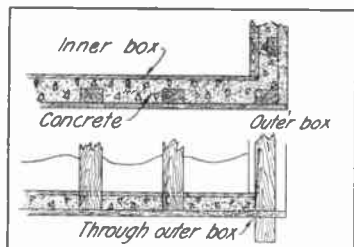

Wooden legs make the concrete box more presentable.

with bits of colored glass, stones, bricks and pebbles. To do this, the front board of the mold is removed while the concrete is still plastic. After it has set for a few hours the bits of glass, bricks or pebbles can be pushed into the side after any desired pattern. If the concrete is too hard, add a little water, and perhaps a little fresh cement. There is little difficulty in handling it—far less than many suppose.

One can go even further by carving or cutting into the plastic surface, flowers or con-

ventional patterns. These may be cut in easily with a knife and smoothed out with a spoon. When the concrete is dry the pattern can be painted or bronzed. Your initials or the name of the house may be cut into the flower box instead of a conventional design.

Here is a chance for those who have hammered brass and iron to put their skill to profitable use. Concrete boxes and stands with the edges and corners finished off with brass or iron are very artistic. The metal strips can be fastened to the sides of the boxes by nails or brass-headed tacks. If driven in while the concrete is soft, they will remain in place permanently after the material hardens.

More pretentious flower stands and holders can be made in proportion to the time and labor one is willing to devote to the construction of the molds. In making molds the question of removing them simply without breaking or cracking the concrete must be considered carefully. For this reason it is always better to use screws instead of nails in putting the molds together. One can then unscrew them easily. If nails have to be withdrawn or knocked out, the concrete may be cracked.

A flower stand of concrete placed on a base of some hard

wood, which can later be polished, with round balls of concrete for legs, is simply made, and very attractive when finished. The base board is used for the bottom of the mold, and an outside box with the bottom removed placed on top. Then a smaller inside box is used. The concrete balls for legs are made

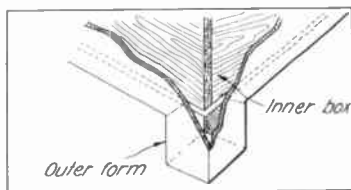

Special forms must be made for pouring boxes with legs.

by rolling the plastic material in shape with the hand. Place them in the sun to dry. Then drive a nail in the wooden baseboard at each corner, leaving about an inch sticking out. This is forced into the concrete ball and when the latter hardens, the nail holds it firmly to the bottom of the baseboard.

A TEST OF GOOD WATER

Many of you live where you have access to both well and city water and more than once, perhaps, you have wondered which of the two had the greater claim to purity.

The accompanying illustration represents the end of a broom handle (*a*) with a shingle nail driven in the end of it (*b*). To this nail is fastened a piece of string with a small weight (*c*) such as lead, at the bottom. Now take a pencil and draw lines (*d*) on one side of the broom handle about $\frac{1}{4}$ in. apart, as shown in the illustration, and you are ready for the experiment. The two kinds of water can be put in ordinary water pails—one pail full of city water and the other full of well water.

Now drop the instrument which you have constructed into each of the pails of water and you will notice at once by the lines which you have drawn on the broom handle that the instrument will sink lower into



Drop the device in the water, and watch how deep it sinks.

one pail than it does in the other. The water in which the instrument sinks the deeper is the lighter and therefore the best and most wholesome for drinking. The experiment is a simple test of the specific gravity of water.

Contributed by—

H. A. BRODERICK.

THE CONSTRUCTION OF A PRIVATE LIGHTING PLANT

BY THE LABORATORY STAFF

PART II.—CONSTRUCTION OF THE GENERATOR—(Continued)

EDITOR'S NOTE: *The aim of this series will be to describe in detail the construction of a complete electric lighting plant suitable for a country house, a small hotel, or for the workshop and laboratory. The present instalment describes the direct current generator and the instructions are given in the words of the designer, A. E. Watson, E.E., Ph.D., who is Professor of Electrical Engineering in Brown University. Later articles will cover the storage battery, gasoline engine, control devices, etc.*

Commutator. The construction of a commutator is often a Waterloo to an amateur, but the one here described is compact, durable and well insulated. A comparatively small lathe and easily obtained materials will suffice for its construction. There are sixteen divisions, or "segments," made of smooth copper, drawn wedge-shaped, or of filed castings to fit around into a complete circle; or a ring may be turned to the right size and then split into sixteen parts. The latter may be the more available method.

Procure a piece of copper tube, or gun metal casting, that in the rough measures about $1\frac{1}{2}$ in. outside diameter, $\frac{15}{16}$ in. inside, and $\frac{7}{8}$ in. long. Bore

out the inside to 1 in. in diameter, mount it on an arbor and turn the outside to the dimensions shown at *A* in Fig. 7. While still on the arbor, place it in a milling machine, slotter, or gear cutter, and saw it into sixteen segments. Let the saw be thin and cut within $\frac{1}{32}$ in. of the arbor. Fit strips of mica to the saw cuts, then finish cutting the segments apart. File off the burrs and assemble the segments and insulations into a circle. Secure them with a string or rubber band, and prepare the rest of the structure.

A piece of seamless brass tubing $1\frac{3}{8}$ in. long, $\frac{3}{4}$ in. outside and $\frac{9}{16}$ in. inside diameter is to be threaded for a short distance at each end. Use a fairly fine thread, say 20 to the inch. File a slot $\frac{1}{8}$ in. wide in one end to fit the pin that was located in the shaft. Tap two iron or brass nuts to match. Drill two

*Dr. Watson's book "How to Build a One-Fourth Horse Power Dynamo" gives the data for winding this machine for 7 volts, 25 volts, 50 volts and 110 volts. The book may be obtained from our Book Department at 75 cents.

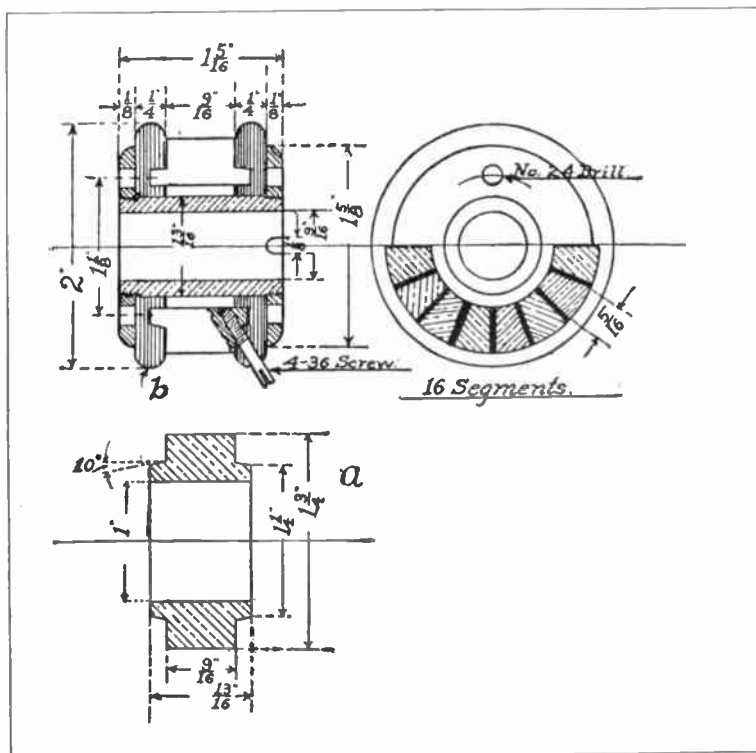

Fig. 7. Details of commutator.

holes in these thin nuts to allow the use of a spanner wrench. Screw one of these on tightly. Turn two vulcanized fiber discs as shown at *B* in Fig. 7 and slide one on the brass tube; set the segments into the groove; put on the other disc, and screw on the other nut, but be careful not to let the segments get "skewed" or strained into a spiral.

Provision must now be made for getting electrical connection between the segments and the wires that are to be wound on the armature. Insert an arbor in the commutator and tilt it on a wooden jig or frame to an angle of about 15° . Prick-punch into the fiber in sixteen places opposite the centers of the segments, and drill through

the fiber with a No. 32 drill; then continue through the segment with a No. 40 drill, and thread with a 4-36 tap. Brass rods, threaded 4-36, *E*, Fig. 4, may be screwed into these holes, care being taken not to let them extend through the segments and touch the tube. Bind some copper wire tightly around the segments to hold them in place, and remove the nut from the end farthest from the connection screws; take off the disc and clean out the chips of copper that may have col-

lected. Reassemble the parts, remove the binding wire, and turn the surface of the segments even, finishing with a piece of fine sand paper.

Brushes, Holders and Yokes. Two kinds of brushes are commonly used, copper and carbon, with appropriate holders. The same supports called "yoke and studs" will fit either. For the former, "planished" or hard-rolled leaf copper about five one-thousandths inch thick is to be cut in strips $7/16$ in. wide and 2 in. long. Enough to equal $1/8$ in.

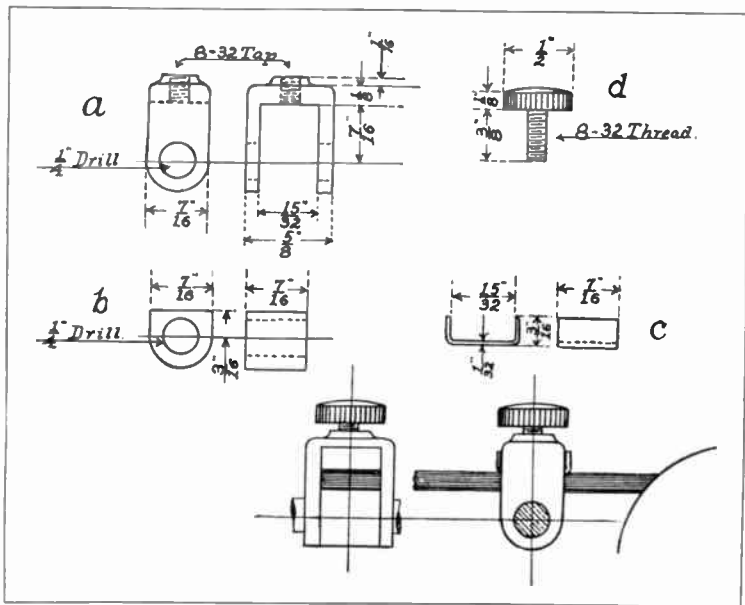

Fig. 8. Details of the brushes, holders, and yokes.

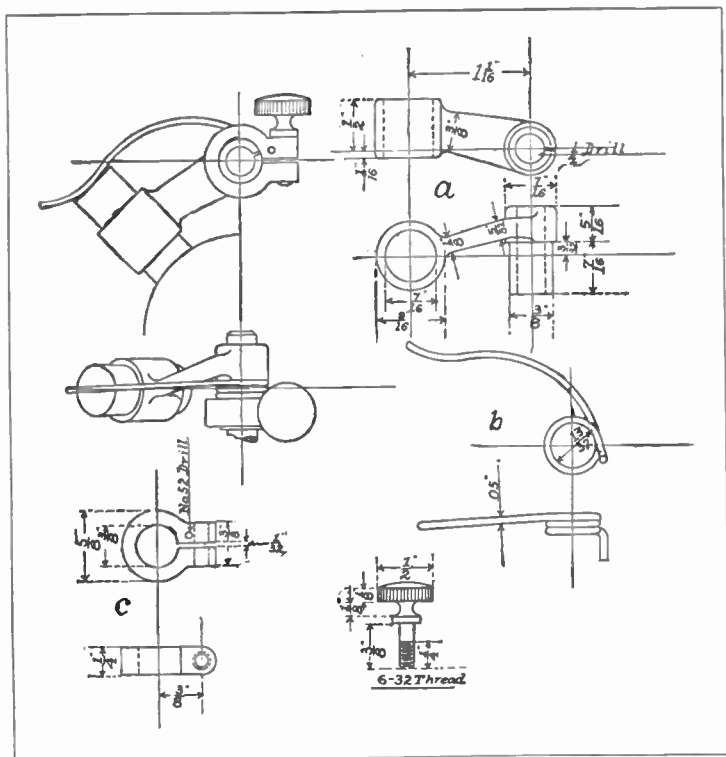

Fig. 9. A suitable carbon-brush holder.

thickness should be grouped together and soldered at one end, the other being beveled to an angle of 45 deg. to fit the commutator. The holder is shown assembled and in detail in Fig. 8. There are two brass castings, a body *A* and shoe *B*, a clamp *C* of sheet copper, and thumb screw *D* of brass. The construction is such that the pres-

sure of the screw binds both the brush and the holder securely. A slight loosening of the screw will allow the holder to be tilted, and remove the brush from the commutator, without changing the adjustment. If the 20-volt winding is adopted, the copper brushes should by all means be used.

A suitable carbon brush hold-

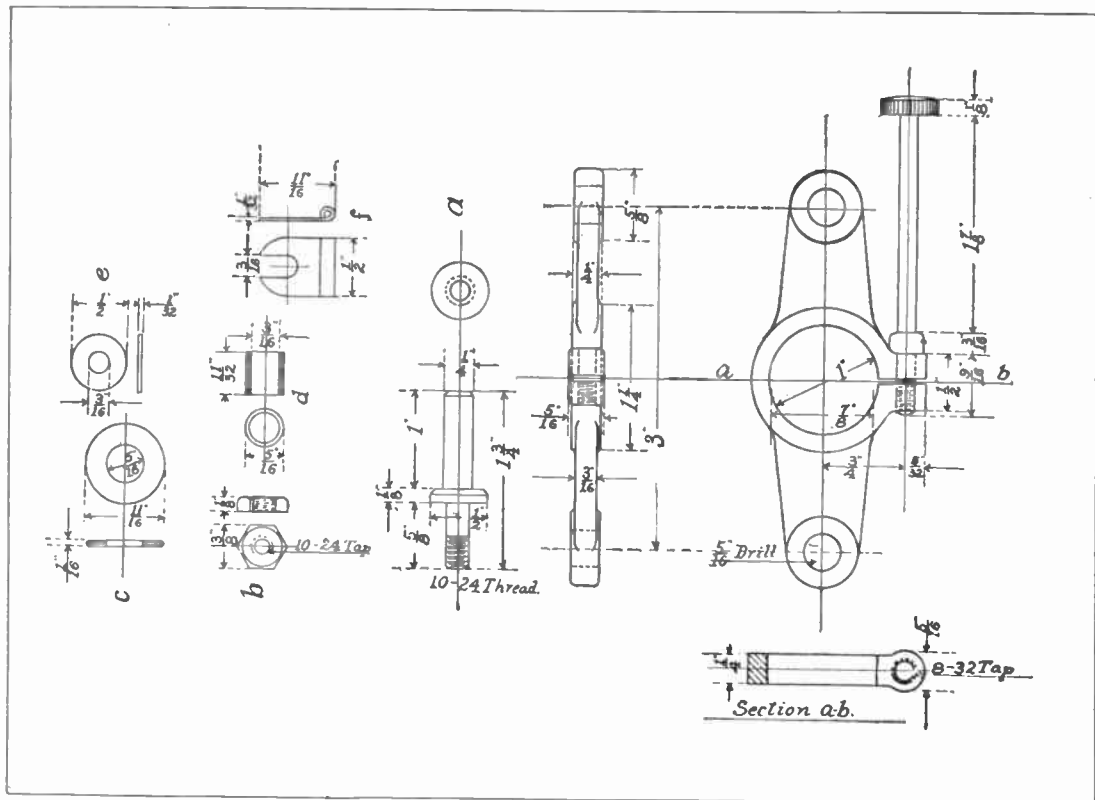

Fig. 10. Brush holder studs, yoke and lugs.

er is given in Fig. 9. The brass body casting *A* is drilled at one end $\frac{1}{4}$ in. in diameter, the same as the copper holder, but the other end is drilled $\frac{7}{16}$ in. A presser *B* is made of steel or brass wire about five one-hundredths inch in diameter. The clamp *C* is also a casting, and serves to retain the short end of the spring. By turning the clamp one way or the other, a variation of tension on the spring may be obtained, and the screw binds it and the holder in any desired position in the stud. The brush is itself a short piece of standard electric light carbon, with one end filed to fit the commutator, and the other with a groove for keeping the presser in place.

Make the brush holder "studs" of 4-in. brass rod. See *A*, Fig. 10. One end is turned to $\frac{3}{16}$ in. diameter and threaded 10-24. For the flange, a brass washer may be slipped on the $\frac{3}{16}$ -in. portion, soldered and turned true. The nut *B* and the lug *F* are brass, the washers *C* and bushing *D* are hard rubber; terminal clip *E* is sheet copper.

It is necessary to provide some means of adjusting the position of the brushes. This is accomplished by attaching the studs to a rocker or "yoke." The construction is shown also in Fig. 10. Bore out the center of the casting to fit on the turned

portion of the bearing as previously noted; drill and tap for the thumb screw, and then saw the slot. The rounding ends should be so as to allow the studs to be firmly held and kept parallel with each other.

(To be continued)

GOOD SOIL FOR POTTED PLANTS

There is hardly a better mulching material than the leaves of our trees and shrubs, and no better soil can be found in our woods and forests than where the leaves have fallen and decayed.

The soil, called leaf mold, is one of the best soils for your potted plants, especially for your ferns, and is listed in florists' catalogs at a dollar a bushel. It is usually mixed with about one-half part of good garden loam and a little sand and gives not only a rich soil in humus and plant food, but also a potting soil which is porous, light, retains moisture well and will not crack or bake, especially valuable for plants with many fibrous roots and for seedlings.

Leaves also form an excellent mulching material around your trees and shrubs and hardy borders, as they retain the moisture, prevent the soil from cracking open, and the freezing dry of the roots of your trees and shrubs.

ART AS APPLIED TO AMATEUR CRAFTSMEN

A Straightforward Discussion of the Elementary Principles of Decoration and Design

BY WM. P. LANGREICH

Editor's Note: In this timely article, Mr. Langreich gives a simple and lucid explanation of the basic principles which govern the successful application of color and design to products of the amateur craftsman's handiwork. The article should carry a message to the worker who feels that his ability is solely mechanical and not artistic.

OF the many practical things made by the amateur, few are used, because they seem to lack what is broadly termed "attractiveness." Too often do the fruits of our labors find

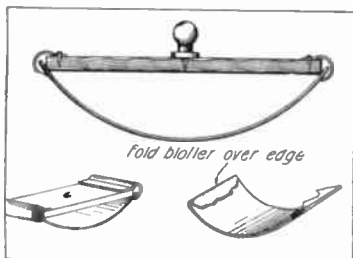

Fig. 1. The beauty of this device may be increased in many ways.

their way to the attic or the wood-pile solely because their ungainly appearance would mar the beauty of the home. A simple analysis of the basic principles of art, as it affects the amateur craftsman, may serve to deviate the home-made product from the downward path, to a treasured spot within the family circle.

Let us take, for illustration, the rocking blotter shown in Fig. 1. It is a simple affair and one that is easily made from a block of wood and a few pieces of tin. The utility of this device cannot be questioned, but the appearance of the object would not warrant a place on the desk. Let us see how many simple expedients we may employ to enhance its beauty.

The first natural step would be to take the object as it is, and find out what can be done to it. The block could be stained, or a design burned on its surface with a pyrographic outfit. The blotter would not yet have a presentable appearance. A great step toward our goal would be to substitute sheet brass or copper for the tin. The craftsman might now think it good enough to occupy a corner of the desk, but in the case of a larger object, where a surface of metal seems rather to spoil than improve its appearance, the metal itself may be

improved. There are many ways of doing this, among them to paint it, to etch it, to hammer designs into it with a pointed tool, to cut some of the metal away, leaving only a framework arranged in a simple design, or to hammer a design by placing the sheet on a block of wood, and using a nail with a rounded point or a similar tool.

So far we have learned two things, the first is to choose the

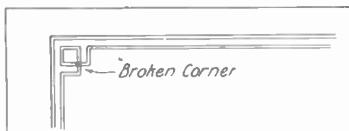

Fig. 2. The "broken corner" gives beauty to straight lines.

proper material, that most suited to the needs of the object to be built. The other is to treat that material in such a way that it will improve the appearance of the whole object, and not only a portion thereof. There is another point which, if fully explained, would be the topic for several volumes, but we will "wade" through it as best we can. That point is the selection of designs.

While the individual has his or her own ideas on this matter it may be said that to please the majority it would be well to adhere to the policy of simplicity. Let "simplicity" be the pass-

word to the satisfaction of the "particular." Another important point is that of harmony—not only in design, but

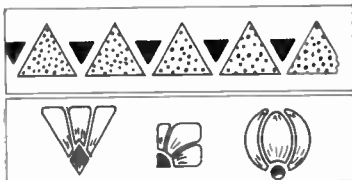

Fig. 3. Geometric forms are easily adapted.

in construction and color. Harmony in design is a rather difficult problem to master. The colors must match the motifs and at the same time improve the appearance of the whole object. There are various ways of applying design to a surface; one of them the border, another the all-over or "repeat," and a third, a single design made to cover a given area. Often two or more means are combined in one pattern.

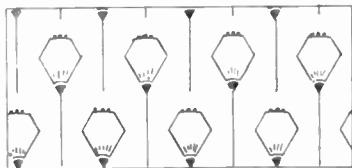

Fig. 4. An "all over" design.

Too many craftsmen fear their lack of ability as an artist. This ability might be an asset, but not a necessity. Effec-

tive and beautiful borders can be made by running parallel lines of varying width. Monotony might be avoided by breaking the corners (Fig. 2). Borders of the "repeat" or alternating type can be made by tracing a single picture, or the outline of a leaf, or using simple geometric forms as motifs (Fig. 3). Flowers may be conventionalized or altered to fit certain geometric forms, and are rather effective (Fig. 3). Where a large surface remains uncov-



Fig. 5. Color should be balanced in "black and whites."

ered the "all over" is used (Fig. 4). This may be the repetition of a single unit, or two or more units may be alternated. The repeating should be done in such a way that the form of the spaces left between the units is attractive. The "all over" can be used to good advantage on walls, in place of wall paper, by using a stencil. Where a surface is limited it is a good plan to use a border—if only a hair-line—where an "all over" is used.

The single design made to fit a given space is easy to apply. The most difficult thing is to choose one suitable and easy to

"match." In all cases avoid the intricate or "rich" designs. The windmill is an easy subject. It can be cut to fit almost any geometric form. Silhouettes of animals are often used, as it is easy to trace the outline of one, but use only profile or "side" views of them. The three steps in the craftsman's "beauty course" are:

1. Choose the materials suitable to the needs and appearance of the object to be made.
2. Decorate that material in an appropriate manner, adhering to the policy of simplicity.
3. In decorating choose designs that are in harmony with the object and pleasing to the eye.

A SAFETY GUARD FOR THE PEN

A safety guard to keep the pen from being dipped too far into the ink-well or rolling over the paper may be made from a

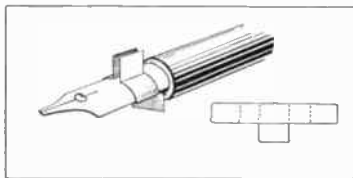

Bend the tin as shown by the dotted lines.

piece of tin cut and bent to fit over the pen-point as shown in the illustration.

Contributed by A. L. ROAT.

SALVAGING SALT-WATER-SOAKED HARDWARE

BY J. E. KING

HARDWARE dealers of Galveston, Texas, have devised a novel scheme for salvaging tools, knives, nails, staples and other iron articles that were soaked with salt water from the Gulf of Mexico during a recent Texas coast storm.

The president of a hardware company which was perhaps the heaviest loser among the city's hardware men, reports that through the work of the devices which his firm is now employing an apparent loss of nearly \$100,000 will be reduced to not more than \$2,000.

The most interesting device is a sand blast which is directed against the articles being cleaned with such force that the rust is not only taken off, but the article is actually given a high polish. For the sand blast, a gasoline engine, air pump, sand tank and piece of rubber hose to which a small nozzle is attached are used. The gasoline engine operates the air pump by which a pressure of 100 lb. is maintained in the tank. A small stream of fine, sharp sand is allowed to trickle into the hose just in front of the small iron nozzle, and this is driven against the article being cleaned by the air stream from the tank. The operator is forced to cover face,

hands and arms and wear leather aprons which the grains of sand will not penetrate. Several nozzles can be operated from one air tank, and thus the work of cleaning is hastened. Once cleaned the articles may be wrapped in paraffine paper and laid away, practically as good as new.

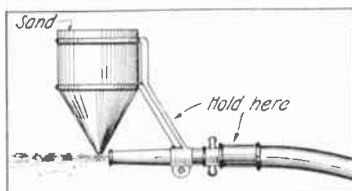

Sand is fed from a tank, and blown on by the air.

For tools having a sharp edge that must not be turned, a fine steel brush, attached to an electric motor and driven at high speed, should be used.

For nails and staples which were water-soaked in the kegs and rusted into apparently solid masses, an ordinary concrete mixer is employed. The masses of rusty iron are dumped into the mixer, together with a shovel of coarse, sharp sand, and the mixer is turned for a few minutes. The load is dumped onto a screen and the sand and rust fall through.

HOME-MADE DYES AND DYEING

BY F. H. SWEET

DYES and dyeing are subjects of more or less interest to every housewife, and in some of its phases, to every houseman also.

The era of homespun was also the era of home dyes. Dye-stuffs were supplied by orchard, field and woodland. They still abound there, ready to the hand of whoever knows how to make use of them.

In dyeing, it is essential to understand that different textiles have different susceptibilities to coloring matter. That is to say, it is one thing to dye wool and silk, and quite another to dye cotton and flax. Old-time cloth makers almost never undertook the dyeing of tow. For one reason, its natural tint was pleasing; for another, it made only rough fabrics; for still another, it had such a trick of bleaching out in use, losing thus even its soft native neutrality.

INDIGO AND THE HOME-BLUE

A hundred years back, growing indigo was a great industry, both in lower Carolina and in Louisiana, but it is doubtful if the plantations produced crops greater than the aggregate of the indigo patches planted strictly for home use. It was tedious and troublesome

to dye blue thus directly from the plant, still those fine economists, our great-grandmothers, did not shrink from it, even though the results, to their minds, fell far below the blue of the commercial article. But their descendants would hardly agree with them—the home-blues were so deliciously soft, and varied. They ran the whole gamut of what we call art tones. So it might be worth the while of ambitious experimenters to plant indigo patches, and see what they could achieve. The plant is easily grown, though it requires a rich soil and a warm and sunny situation. It was cut at a little past blossom, broken up, steeped in rain water for several days, then at a stage of fermentation that only practice could decide, wrung out hard, and thrown away, leaving the coloring matter to settle in a cake at the bottom of the vessel. These cakes were used the same as the purchased stuff. Setting a blue-dye pot of any sort was a serious matter—so serious that its proper elucidation is far beyond the scope of this paper. Suffice it to add that, in the hands of a past mistress, the blue-dye pot colored wool, cotton, linen and silk. Each fiber required some small differentiation.

THE CLOUDED DYE

A great triumph was dyeing things clouded—especially stocking yarn. To dye clouded, the thread was first reeled into hanks, then the hanks were bound round about, at about two handbreadths apart, with layer on layer of stout cornhusks, tightly wrapped and tied. When they went into the dye the free strands took up color while the lengths underneath the husks, which were impervious to water, remained white. The resultant fabric, either knitted or woven, was sure to be nicely clouded. Clouding, of course, was possible with any kind of dye, but was rarely resorted to, except with indigo blue and madder red.

BARK DYES FOR COTTON

To dye cotton, either in yarn or woven, aside from the super-serviceable copperas, which gave a fine tawny tint with very little trouble, the main reliance was upon either swamp maple bark, red oak bark, or full-grown peach leaves. The best bark came from youngish trees of such quick and vigorous growth that they had reached a good size. First the bark-gatherer's ax skelped away the rough outside, then cut long strips and shavings of that next the wood. But if he knew his business, or had a woodsman's soul, he took

bark but half way round, choosing rather to maim two trees or even three, than to kill one outright. Still there were vandals and vagabonds who girdled trees and destroyed them. That is, however, beside the mark. Bark-gathering could be done at any time, but the best bark was stripped in September and October, when the new wood was forming, and the bark itself rich with sap. Properly cut, and dried in the shade, it kept good for years. The teeming and plenteous forest, however, made such providence rare.

LIGHT GRAY TO SLATE-PURPLE

Swamp maple bark dyes anything from light gray to slate-purple, the difference lying in the strength of the infusion. To make it, boil the bark three hours, preferably in an open iron kettle. Dip a shred of the stuff to be colored—if it comes out too dark add water; if too light, put in more bark and boil afresh. A peck of new-cut bark to five gallons of water gives a dye of average strength. After boiling, skim out the bark and drop in a little alum—say a lump the size of a nutmeg for each two gallons of dye. Stir until well dissolved, then put in the things to be dyed—which must be clean, and wet all through with clear hot water. Push them quickly under, head and ears, so they may take color

equally. Keep the dye boiling for ten minutes, then dip out the fabrics, hold them to air half a minute, above the pot, drop them back, boil ten minutes longer, then hang them out to drain and cool before washing. Maple dye is very bad about smutting, no matter how well washed, so it is not recommended for garments, but for floor and wall coverings, or the cotton warp of half-wool weaves it is an excellent thing.

GRAYISH-BROWN TO BURNT ORANGE

Red oak bark requires the same treatment, except that the alum for setting is less—about half. Set with alum it gives a distinct and distinguished color—light grayish-brown with the barest hint of green. Set with copperas—green vitriol—the color may approximate what is known as burnt orange. Use the copperas sparingly—a tablespoonful is enough for a big pot of dye. See that it is all dissolved before putting things in the dye. If lighter shades are wanted, put in half the dyeing first, then let the other half go in the partly spent solution.

PEACH LEAVES FOR YELLOW

Peach leaves dye yellow. Take them at the beginning of September, or even the end of August, when they are green, glossy, oily looking, and give

out a scent of almonds at the least bruising. Fill the pot cramful, cover the leaves with soft water, bring it to a slow boil, and simmer for an hour, then skim well, and put in a little alum—about half as much as for the bark dyes. Fill up as the water boils away. When the leaves are all in, stir the dye very hard, then put in what is to be dyed, having it sopping wet with boiling water. If a special depth of color is desirable, test the dye before putting in the main bulk. Be sure also to keep what is dyeing well beneath the surface, upon pain of having it come out spotty.

DYEING WOOL AND SILK

To dye wool and silk, use oak bark, hickory, walnut, cherry, walnut hulls, walnut roots, sumac berries and yellow puccoon root. There is a rare Indian art of dyeing red, the finest soft shade, with red puccoon root, but the process is so intricate it requires Indian patience. Oak bark set with a very little alum or copperas, dyes wool a brilliant tawny color neither brown nor yellow, but with tones of both. Hickory bark, especially from shellbark or pignut trees, well boiled, set with a trace of alum, and skimmed clean, gives a pure lemon yellow. Wild cherry bark requires expert handling—its ruddy-brownish tones are apt to

come out muddy in any but expert hands. Black walnut bark and ripe black walnut hulls may be used together. Their color-gamut is from tobacco to seal-brown. A bushel of hull nuts is equivalent to half a bushel of bark. The fresher they are the better. If they have dried and turned black they have lost half their strength. White walnut bark, especially if mixed with

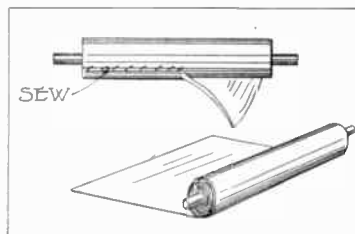

After rolling the goods on a beam, sew tight and hit the roll with a mallet.

unripe nuts, thoroughly cracked, gives a hard, clear color, brown with tones of red. Walnut roots chipped up and boiled half a day yield a fine yellowish brown, quite unlike that furnished by the bark and hulls. None of the walnut dyes require other setting than to have what is dyed in them dipped up several times and thoroughly exposed to air in course of the dyeing. But in all sorts of dyeing one must not forget to dye wet nor to make certain that there is no soap left in anything which

goes into the pot. A soaped substance takes color differently, so almost infallibly makes a spot or a streak.

A GOOD FAST BLACK

Black walnuts, cracked and mixed, hulls and all, with their own bulk of sumac berries, dye an excellent fast black that can be washed until it will not smut. To set such a dyepot, put a little water in a clean iron vessel, add a layer of sumac berries not stemmed but pulled into little clumps, and over them a layer of walnuts. Next put in a layer of fabric, then more berries, nuts and still more fabric, repeating the layers until all your stuff is in. Have a layer of nuts on top, and upon them lay a board well weighted, then pour in water to stand just level with the board. Boil undisturbed for about two hours, then turn the pot on its side, take out the dyed things, air them a bit, and wash while still warm.

To color lock-wool, pick it clean of trash, wet it, squeeze it very dry, then lay it lightly in an open basket, and plunge the basket in a pot of hot strained dye. Keep it there half an hour, stirring the wool about every little while. Do not mat nor felt it, but keep it as open as possible. It must be very well washed and thoroughly dried before it goes to the cards. Yellow

puccoon root, which gives a canary yellow, is so much in request as a medicine that dyeing with it is an extravagance. Big wild-rose hips are said to yield up their fine red color, but they are suggested merely as subjects for experiment.

GENERAL DYEING HINTS

Soft water is indispensable—if pond or rain water is not at hand, add a cupful of clear lye, or a small lump of washing soda, to each gallon of water that goes in the dye-pot. In washing dyed things, remember to give the color time to set before water touches it, also to wash in suds, rather than to rub on soap. In dyeing piece-goods, baste selvages together, right side in, also baste across the open end of the bag thus formed. This protects the surface and helps to even dyeing. After washing well, take out the bastings, stretch the goods carefully straight, and let it half-dry. Then begin at one end and roll it tight and smooth around a stout wooden beam, pinning or sewing the lap fast at the finish. Lay the roll upon something solid and beat it all over with a heavy mallet, after which let it stand until dry.

For a Smoking Fireplace.—

If you have a smoking grate, try burning charcoal in it instead of coal. Coke smokes

much less than coal, but is much more difficult to burn in an open fireplace than is charcoal.—LORA L. ROBERTSON.

HOW TO READ WORNOUT INSCRIPTIONS ON COINS

Take an ordinary piece of chalk and rub it over the old inscription with a slight pressure. Be sure that you rub it into all the crevices of each character, then rub your finger over it briskly in order to remove the chalk from around the letters and you will be able to read the inscription as though it had been inscribed two minutes before. This scheme will be of use to people who have fountain pens that need to be repaired but whose trade mark is indistinct. White chalk should be used on all dark articles. Blue chalk is suited to bronze. Pink and yellow chalk show up admirably on silver, while white should be used on gold.

Contributed by ANDREW W. J. GALLAGHER.

Enameled Iron Bedsteads.—Kerosene will remove dirt and finger marks from enameled iron bedsteads as if by magic. Apply with a soft cloth that has been but slightly moistened with the oil.—F. H. SWEET.

HOW TO CONVERT A ROLLER TO A FLAT TOP

BY RICHARD B. BENNETT

MANY office people find that, whatever may be the advantages of a roll-top desk, it is not a thing of beauty, and, once one has become accustomed to the flat-top, the latter will, in nine cases out of ten, be found not only more convenient, but many times more handsome. The flat-top does not block off the view of the rest of the room, with an unsightly bulwark of pigeon holes, its occupant has a full and free view of the office around him, and more actual desk space.

Having reached these conclusions, in which he has become confirmed during several months of experience with the flat-top, the writer decided to adopt the latter form, and with half an hour's work and very small expense made the change as follows:

For a desk with a top 31 x 54 in., he procured 2 yd. of the best Spanish moroccoline leather at \$1.10 a yard, and two boxes of upholstering tacks with covered heads. The whole top of the desk, with pigeon-holes, curtain, and all was unscrewed and taken to the attic, where it has been gathering dust ever since. The two holes left in the table of the desk, through which the

rods for locking the drawers ran, were stopped with wooden plugs, cut to fit snugly and flush with the level of the table. The moroccoline was then cut to cover the top of the desk and run 2 in. beyond all around to admit of fastening. It was then stretched taut and evenly over

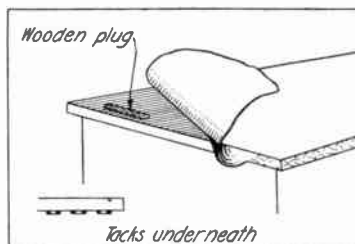

The holes were stopped with wooden plugs.

the table; the overlapping edges, folded neatly in at the corners, were drawn under the table, and secured every 2 in., with the tacks driven in front below the ledge.

The result was a change to a richly finished office desk—for two dollars and a quarter.

A soldering acid dauber can be made of a bone-handled tooth brush by cutting off about half the bristles. It serves the purpose well.

PRACTICAL MECHANICS FOR EVERYDAY MEN

PICTURE FRAME OF BARK

At a very small cost, a beautiful picture frame can be made from the rough bark of a well seasoned young hickory tree; the deep furrows in the bark giving the effect of artistically carved wood.

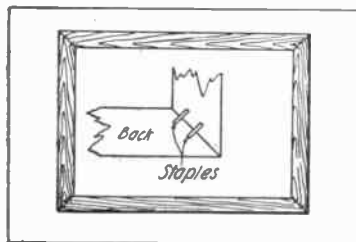

The pieces may be joined with corrugated fasteners, staples, or nails.

The timber should be cut down in the winter so that the bark will adhere to the wood.

Cut the log the length desired and saw or split it into pieces of suitable width. Rip off the outer edge, leaving the bark and enough wood to hold the bark in shape, and dress off the edges with a plane. A home-made miter-box may be used to make the angles for the corners. Use corrugated-fasteners and small wire nails to join the pieces.

It is not necessary to varnish

or paint, as the natural bark gives a dark rich color. However, if a thin coat of varnish is used, the faint green of the growing tree would probably be preserved.

Contributed by H. G. WOOD.

CONTINUOUS RINGING BELL CIRCUIT

The illustration shows how the amateur mechanic may improve a continuous ringing electric bell. The arrangement really comprises two separate circuits, the one being a relay for the other. To the left is shown the circuit which goes to the door, for instance, and the reader will note that the contact on the vibrating arm of the bell has been displaced by an L-shaped bit of metal soldered to the arm. This provides a catch to hold the contact of the second circuit open. The ends of the magnet windings are connected with the first circuit direct. It is quite apparent that when the first push button or, in the case of a burglar alarm, the window or door contact, is closed, the magnets will draw the armature thus permitting the second contact to fall and close the continuous

ringing circuit. A switch to the right permits the circuit to be opened, thus stopping the

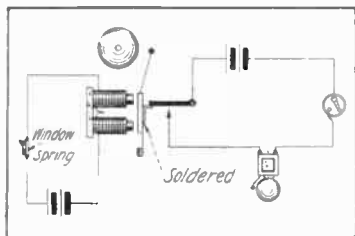

Opening the door or window will set the bell ringing.

operation of the bell until such time as the relay can be re-set.

A DOOR BAR

Wide and heavy house doors, especially front portals with a northern exposure, will mock all ingenuity of latches and weather stripping to make them wind-tight in blustery weather. The accompanying sketch shows a refrigerator bar adapted to meet the situation. The device is a complete success, and it has attracted unusual attention as a clever idea, saving its cost many times over in the whistling wind and cold it keeps out.

One hardware store in a town of a hundred thousand people had about forty such second-hand bars in stock, for sale cheap. The shank *A* is a bolt which should be cut off to fit the jamb of the door. If the nut is concealed in the jamb it

cannot be reached when the door is closed; then the contrivance defies the jimmy of a burglar.

All exposed parts may be nicked before being placed. The socket *B* is so shaped that, as the bar is brought down, the door is forced firmly up against the rebate and weather stripping—a feat that can never be satisfactorily achieved by making the usual lock bolt and latch a tight fit.

As a wind-defier, an extra burglar protection, and a real ornament, this applied device has interested and pleased all

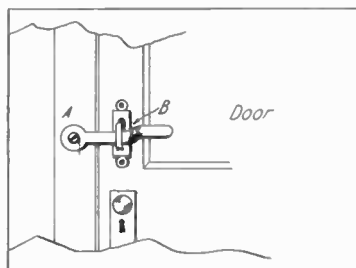

The refrigerator bar is fastened to the casing.

who have seen it. To pick up a few of these bars, nickel them and convert owners of country houses to their use ought to put a penny or two into the pockets of an enterprising young mechanic.

Contributed by—

JAMES WILLIAM JACKSON.

HOLDING BRAKE-PEDAL DOWN

Here is a device with which the brake-pedal can be held in the "on" position.

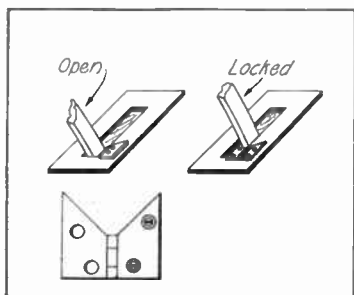

The device is made by sawing a V-shaped piece out of one end.

As shown in the accompanying sketch, this is merely a large iron hinge with a V-shaped piece sawed out of one end. It is screwed to the floor board in such a way that when folded it does not interfere with the use of the pedal. But when the pedal is depressed and the hinge opened up, it will be retained in its depressed position.

Contributed by T. LANSING.

UTILIZING OLD CASINGS

Here is an idea that should be of value to every motorist who wishes to economize in the upkeep of his automobile casings and obtain full and satisfactory service from them as long as there are any wearing qualities left in them.

Take, for example, a casing

with an ugly blowout wound in it. Its service may be increased without expensive vulcanization by inserting in it the fabric from another apparently worn-out casing. But here is the point I wish to emphasize: First trim the sides of the blowout gash off smoothly with a sharp knife. Then, when stripping the fabric to be used for the interliner from the worn-out casing, leave on it a portion of the rubber corresponding to the position of the wound in the casing of a size large enough to fit tightly into the wound when the interliner is in place. A casing thus fixed will run from 500 to 3000 miles farther, the distance covered depending on the quality of the rubber in the casing.

A tight fitting joint prevents sand and water from working into it. This joint may then be vulcanized with any small home vulcanizing outfit, if desired, which further increases the efficiency of the casing.

Contributed by J. L. JUSTICE.

DARK ROOM LAMP

This handy ruby lamp may be moved around from place to place in the dark room. It is particularly useful when one loses something on the floor; should such an incident occur, the worker is helpless unless he has some portable form of ruby lantern to aid in the search.

To make the lamp, procure an ordinary two-quart fruit jar, break out the porcelain lining in the cover, and cut a hole through the metal just large

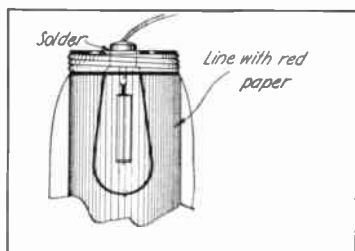

The socket is soldered to the cover.

enough to fit over the socket. Solder the cover to the socket. Line the inside of the jar with a double thickness of orange "postoffice" paper. Insert a four-candle power lamp in the socket and screw the cover on the jar.

The lamp is now complete. The connecting cord should be of sufficient length to permit of using the jar at any part of the table or in any corner of the room.

Contributed by H. FRANK.

A CLOSET DARK-ROOM

An amateur photographer sometimes had occasion to use a plate camera, as films in the large sizes were too expensive. He had no dark room or developing tank, but used a small

closet made light-proof by tacking strips of cloth over the cracks and keyhole.

After putting the plate into the tray and agitating for a moment to make sure it was well covered by the liquid, he inverted a shallow baking pan over the tray and went outside. He always took the precaution to darken the room into which the closet opens as much as possible, but has never had a plate injured by the light.

He rocked the tray a few times at intervals during the twenty minutes. At the end of this time, a tray of hypo was taken into the closet and the plate placed therein, after which light would not affect it.

Contributed by—

T. LANSING.

A POLISHING KINK

When polishing the door-bell or door-knob, the woodwork

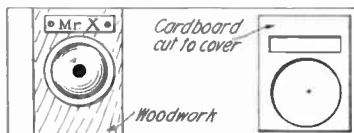

The openings should be large enough to fit about the metal-work.

around the metal fixtures may be protected in this manner: Cut a strong piece of cardboard and make an opening in it just large enough to fit snugly about the fixtures; then, by holding

this shield in place, you can use any polish on the metal without any injury to the wood.

Contributed by—

J. W. WOLFE.

USE FOR OLD HEADLIGHT REFLECTORS

The junk heaps of most garages have dozens of "done-for" electric headlights that

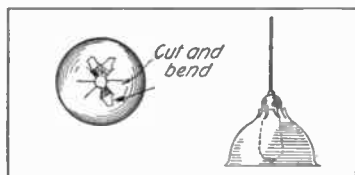

Cut the slits from the socket hole.

would make dandy reflectors for the lights at the work bench. Remove the reflectors and sock-

HOW TO MAKE A SIMPLE GUN

The illustration shows in detail how a piece of tubing and a scrap of wood may be converted into a weapon that would delight any boy.

The tubing is $\frac{3}{4}$ in. in diameter and about 20 in. long. Cut a $\frac{1}{8}$ -in. slot along it, within 2 in. of the ends, by drilling a series of holes close to each other. Run a chisel along the row and file the edges smooth. At one end, cut a "trigger catch" at an angle of less than 90 deg. to the slot.

The chamber *A* is made from a broom stick cut down to less than the inside diameter of the tubing.

D is but a nail, bent to hold one end of a $\frac{1}{8}$ -in. elastic. The other end is fastened to the trig-

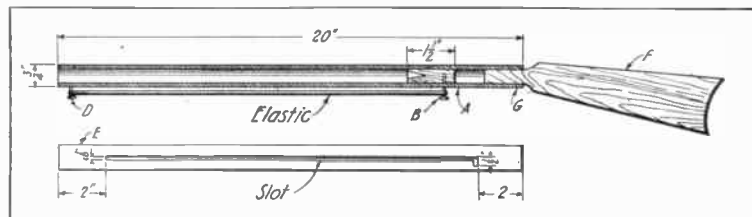

To shoot, the trigger is disengaged from the notch.

ets, cut slits from the socket hole, and pass over the drop-light. The surfaces of these reflectors are highly polished, and serve their purpose well.

Contributed by—

H. E. MOWER.

ger. The stock, *F*, should be cut to fit snugly at *G*.

To load, the trigger is drawn back and slipped on the "catch," and the "shot" (beans, putty, peas, etc.) is dropped into the barrel. Then aim and

disengage the trigger from the notch. The best feature of a gun of this kind is its harmlessness.

Contributed by JAMES MCINTYRE.

TELEPHONE MAY BE USED IN EITHER ROOM

By placing a swinging shelf in an opening cut through the

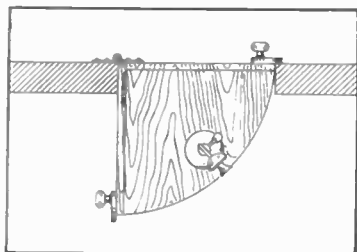

Privacy is assured when one instrument is used by two offices

wall between rooms, a telephone instrument may be made available for use in either room at a moment's notice. The illustration suggests, in a plan view, how this may be accomplished with a minimum of labor. The opening may already be found in the form of a window. The scheme is particularly adaptable in shops where the office of the foreman is a rough inclosure with thin walls in the main room of the shop.

Contributed by WM. G. MANY.

SAVING BOOK CORNERS

In shipping books, the corners of the binding can be prevented from breaking by bending triangular pieces of tin as shown in the cut, and slipping the pockets so formed on the corners. To prevent scratching, a piece of paper may be folded over the corners before the pocket is put in place.

TYPEWRITING ON TRACING CLOTH

When typewriting on tracing cloth from which blue-prints are to be made, the characters on the print can be made sharp and clear by placing a sheet of carbon paper under the cloth. Then, when a key is struck, an impression will be made on both sides

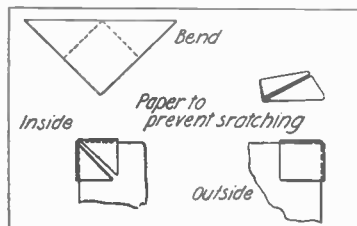

Paper under the tin will prevent scraping

of the cloth. Make sure, however, that the carbon sheet is inserted so as to face the cloth.

SIMPLE BAROMETER

Partially fill a long necked bottle with water and invert it into a quart jar almost full of

water. Mark an arbitrary scale upon a piece of paper pasted to the bottle and note changes in

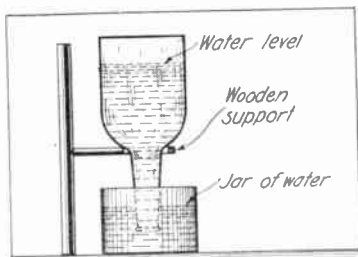

The inverted bottle should not touch the bottom of the jar

the height of the water in the bottle with changes of the weather. The experience of ten days or two weeks will enable the builder to mark notations that will prove to be a fairly reliable weather barometer for future use.

Contributed by A. L. ROAT.

HOW TO MAKE PAPER BASKETS

To make durable and artistic work baskets, fruit baskets, etc., braid $1\frac{1}{2}$ in. strips of brown crêpe paper, cut across the bolt. The heavier and stronger the basket is to be, the tighter the strips should be braided. Form the braids into a basket of the desired shape, beginning at the center of the bottom, and sewing them in place. A handle may be made of a heavy braid. A coat of shellac will make the finished

product almost as hard and durable as a twig basket, but much prettier.

Contributed by LORA ROBERTSON.

FLAME IS HOLLOW

Pour a little wood alcohol onto a spoon and touch a match to it. A blue flame will be seen to rise from all edges of the spoon. Have someone take a thread and hold it in the flame near its base. To your surprise, the thread will burn only at the edges of the spoon—the rest will fall uninjured into the spoon and remain there until the alcohol is consumed. This proves that flame is hollow.

Contributed by—

H. A. BRODERICK.

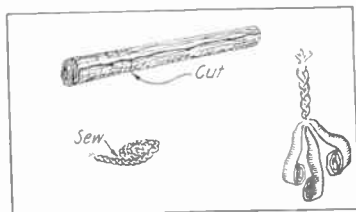

Start the basket by sewing the braid spirally

A CONVENIENT CEMENT

To mend a crack in the range, or to fill holes in the floor of the fireplace, use a cement made of equal parts of sifted ashes and salt, mixed with just sufficient water to form a paste.

Contributed by LORA ROBERTSON.

AN EASILY FILLED MATCH SAFE

I use the penny-a-box matches, and, in order to provide an easily filled match holder, I fixed the device shown in illustration.

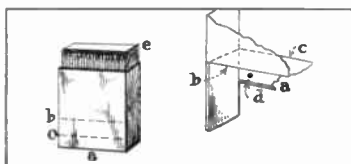

The device will last a long time

I slit the cover of a box about $1\frac{1}{4}$ in. on either side as from *a* to *b* (illustration, Fig. 1), folded the flap inward along *cc*, then tore off the projecting end *e* of box, and fastened the then completed safe to the wall by means of two large-headed tacks at *d*.

To refill, I first remove empty box from the holder, then slipping cover half way from a new box, I insert box in holder, remove cover entirely, and tear off head of the box.

This device is easy to make, very convenient, and, if not abused, lasts a long time.

Contributed by T. H. LINTHICUM.

AN ELECTROLYTIC INTERRUPTER

It is believed the interrupter described below will prove of

considerable value to amateurs who use spark coils.

Fill a glass gravity battery jar to within an inch or so of the top with an electrolyte of 20 per cent nitric or sulphuric acid; into this put a small glass jar (an olive bottle will do nicely), which has a small hole cut through its side near the bottom. The cutting can be done with an ordinary file. Into this bottle place a strip of lead for one electrode and another strip of lead into the main jar for the other electrode. Hook the interrupter in series with the primary of the spark coil, making sure that the interrupter on the end of the coil is screwed down.

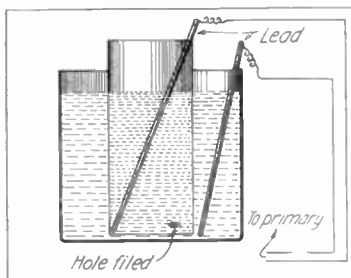

Two strips of lead will do for electrodes

This interrupter will give excellent results on 110-volts with a 1-inch spark coil. For lower voltages, the electrolyte may be made up as high as a 30-per cent nitric acid solution, which

is the limit for low resistance in electrolytes. This interrupter is not satisfactory on low voltages.

Contributed by E. R. EDGE.

A HOME-MADE DOORMAT

A very good doormat can be made from a piece of sheet iron or heavy tin, a number of bottle caps and as many small rivets.

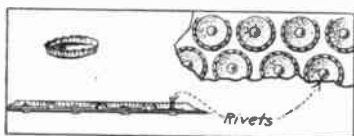

Rivet the caps to a sheet of tin

Save up the tin caps removed from bottles of "soft" as well as "hard" drinks, and rivet them to a piece of stiff sheet metal of suitable size, as shown in the illustration.

This makes an efficient and durable foot wiper.

Contributed by T. H. LINTHICUM.

A CELLAR ENTRANCE HOTBED

Anyone having an outside entrance to the basement or cellar of the house which faces to the south can make a very efficient hotbed without employing any other means than that of a glass covering. It will serve admirably to raise plants in the spring for the home garden and also to raise vegetables throughout the winter season. This method utilizes the heat from a cellar

in which is located a furnace.

Obtain a single heavy sash large enough to fit snugly into the frame of the top of the cellar entrance and hinge it to the end of the frame next the house so that it may be lifted up at the outer end. A foot below the sash can be built a permanent or removable frame on which to put boxes of dirt in which the seeds are planted. In case entrance to the cellar must be made at frequent intervals one may build a permanent bed in half of the entry way, leaving the other half open. Neither plan will necessitate the removal of the steps.

When this method is adopted in winter or very cold weather the upper cellar doors may be let down at night to offer fur-

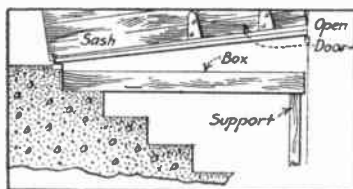

Rest the box as shown

ther protection against cold. If the lower cellar door is left open two or three inches on dark days and cold weather there will be sufficient heat from the cellar to keep the plants growing, though on sunshiny days it will be unnecessary.

Contributed by J. L. JUSTICE.

TO BEND PIPE WITHOUT BUCKLING

Make the attachment shown in the illustration, fill the pipe with sand, and you will have no difficulty in forming a perfect bend without a trace of buckling. The bending device consists merely of a large and a small block secured to the bench and a double arm swinging on a pivot and carrying a pulley which swings in the same radius as the curved corner of

that the inner portion of the hole is a little larger than at the surface. Then place a lump of clay around the outer end of bolt and firmly press it against the wall. At the top leave an opening for pouring in the melted lead, or, if only a light load is to be placed on the bolt, melted stick sulphur may be used. After the lead or sulphur has been poured in and has hardened, the clay may be knocked off, and the bolt will

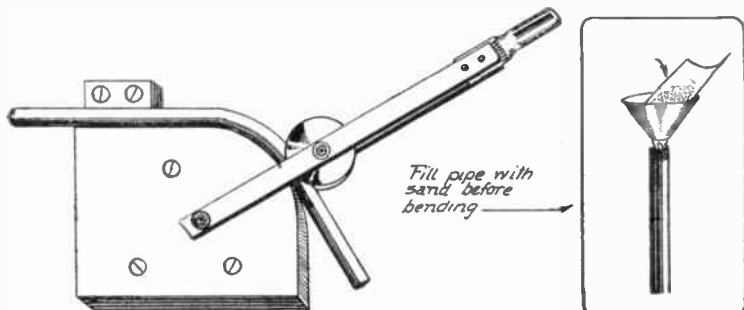

First fill the pipe with sand, then bend

the larger block. The pipe is plugged at its lower end, filled with sand packed hard, and the upper end plugged. The pipe is then inserted between the blocks and the lever brought slowly around while an assistant aids by pressing on the free end of the pipe in the direction of the proposed bend.

TO FASTEN BOLTS IN MASONRY
Drill a hole in the wall so

be found firmly embedded in the wall.

Contributed by F. H. SWEET.

COAT HANGERS MADE OF MAGAZINES

In a small home, where every bit of room counts, there is often no place for the old household magazines, which, however, one may want to keep. Roll these magazines, tie each in the middle with a strong cord

leaving a loop by which to hang it up, and use it as a coat or dress hanger.

This suggestion will prove to be of value to the traveling man



Roll the magazines and then tie them

who dislikes to carry a coat hanger in his already heavy grip.

Contributed by LORA ROBERTSON.

A GOOD HOME-MADE CEMENT

A very good, quick-setting cement which will answer almost every requirement, such as uniting small pieces of iron, setting wooden handles into tools, etc., may be made by dissolving orange shellac in enough alcohol to form a paste. This will keep indefinitely if tightly corked so the alcohol will not evaporate. When wanted for use put as much of the paste as will be required into a small vessel and set over the fire. The alcohol will soon burn out and the cement should be used before it has time to cool. This cement is very strong and is waterproof.

Contributed by F. H. SWEET.

HANDY COFFEE STRAINER

Cut a piece of copper or nicked wire screen to fit the inside of the tea or coffee pot with a flap to extend above the rim. Bend the flap out over the rim so that the lid fits down upon it. As the liquid is poured, it is strained. The strainer is easily removed for washing and returned to its place in a moment.

Contributed by A. L. ROAT.

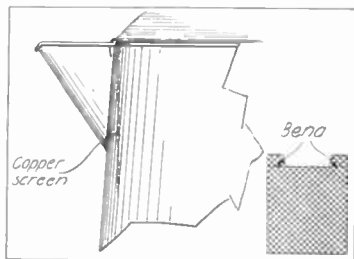

Hang the wire behind the spout

Pan Cover Handles often come off by burning or rusting out; a small wood screw and a cork form a serviceable handle which is always cool, never heating up from steam or fire.—C. H. BIRON.

Dust Collections Between Switch Points and on detector minerals may be removed by using a small bicycle pump. This method does not necessitate any disturbance of the layout.—C. H. BIRON.

THE OBEDIENT MATCHES

Take five matches and break in half, and place in the position shown by *A*. By dropping water in the center of the group, they will assume the position shown by *B*.

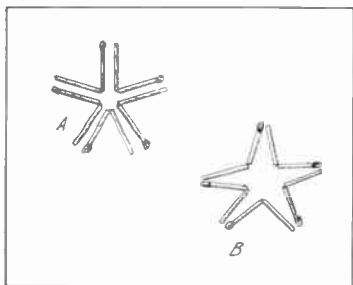

Drop the water in the centre of "A"

Break a match in half and place over the mouth of a bottle. On this, place a dime and request some one to put the coin into the bottle without touching it. This can be done by dropping water on the break, thereby causing the match to spread.

Contributed by J. McINTYRE.

INNER-TUBE REPAIR

Motorcycle quick-repair patch ("gasoline patch") applied and left under pressure over night will serve as strong as vulcanizing. If a suitable clamp is not handy, lay the tire on the floor with a small piece of flat board on top and stand one post of the bed on it, or lay it on the floor with the board on top and slip

it under a half-open door well back near the hinge and drive a small wedge between the board and the bottom of the door. Either way will give a good pressure.

Contributed by C. H. BIRON.

To Clean Painted Woodwork

—Cover the soiled places with kerosene oil, after first brushing off the dust, and let it remain for a few minutes; then wipe off with a soft cloth. It is as effective as it is simple.—
F. H. SWEET.

Cleaning Windows.—Wash in clear, warm water to which a little kerosene has been added. You will be surprised to see how much the labor is lightened by the addition of the kerosene.—
F. H. SWEET.

TO MEND ENAMELED IRON WARE

Purchase several sizes of copper rivets, such as are used for

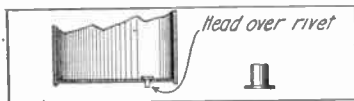

The rivet seals the hole

mending harness; insert one of these in the hole, place the kettle or basin over some solid surface, and with a hammer flatten out the rivet.

Contributed by—

J. W. WOLFE.

THE TECHNICAL ADVISER

The object of this department is to answer the questions of readers who may experience difficulty in the construction or use of apparatus described in the magazine. The columns are free to all readers whether they are subscribers or not, and questions pertaining to matters electrical or mechanical will be answered in the order in which they are received. If the reader cannot wait for an answer to be published he may secure an immediate answer by mail at a cost of 25 cents for each question.

In order to insure prompt attention, readers should adhere closely to the following rules which have been formulated with a view to expediting the handling of the mass of correspondence. Questions should be written on one side of the paper, enclosed in an envelope addressed to The Technical Adviser, care of Everyday Mechanics, Eolian Hall, New York City. The letter should state plainly whether answer is to be published or sent by mail; in the latter case the fee of 25 cents per question should be enclosed in coin, one-cent stamps, check or money order. The envelope enclosing questions should not contain matter intended for any other department of the magazine.

13. L. M. R., New York City, writes that he has built a kicking coil high frequency apparatus from the description given in the March number and obtains excellent results on the city lighting circuits. He wishes to know whether the same apparatus may be made to operate with greatly increased power by means of a rotary contact breaker and if the operation will be as satisfactory on alternating current as it is on direct. Ans.—We have in our Laboratory just such a coil as you are interested in. It draws about seven amperes from the line and produces a 10-in. spark of very good quality on the 110-volt direct current circuit. It is absolutely useless, however, on alternating current, as the speed of the rotary breaker cannot be made even to approximate the frequency of the current or any multiple thereof. The result is an unsteady and very feeble spark. When we retard the

speed by means of a brake, a point is reached for an instant where the spark is good, but we cannot seem to hold the speed at the synchronous point. Of course, the motor in use is one that is supposed to operate on either alternating or direct current, but it is rather a failure on the former. While a true alternating current motor would undoubtedly answer the purpose and produce a period of interruption that would coincide with the frequency of the current, this motor would not be worth while. It would be better to use the same weight of metal in a transformer and condenser, combining the latter instruments with the kicking coil outfit.

The coil we are using has a rotary contact breaker consisting of a heavy wheel of brass out of the periphery of which two segments have been cut. These segments are replaced with built-up mica. The whole

is then turned off to present a smooth periphery to the copper gauze brush. The wheel turns at about 4000 r.p.m. and the speed of the motor is adjustable by means of a rheostat.

We are working on a combined A. C. and D. C. outfit to give a 10-in. spark. The apparatus comprises a kicking coil for D. C. and a transformer of very small proportions for A. C. The rotary contact breaker also carries a series of studs that serve as a rotary gap for the transformer. The entire outfit has been designed for portable use on any voltage and any frequency that may be found in road work. The article will appear in an early issue.

14. E. C., Tampa, Fla., asks: Where can cardboard cylinders for the primary and secondary of the long wave receiving transformer described in March be obtained? Ans.—Your inquiry has been referred to our Service Department. If the firms suggested cannot supply you, write to advertisers whose names appear in this issue.

15. H. E. J., Galveston, Tex., writes: I note that you specify silver contacts for both the induction coil and the kicking coil interrupters; what is the object? I have always heard that platinum is the only substance that will hold up. Ans.—Platinum is undoubtedly superior if one can afford it, but small platinum contacts are not as good as large silver ones. In actual service we have found silver to be admirably adapted to this purpose, and so satisfactory and so cheap has it been that we have not used platinum in the shop for a long while except for very small contacts.

16. G. F. C., Chelsea, Mass., asks: What is the effect upon the body of a high frequency current? That is, what diseases are cured by it and in what manner does the current prove of such great importance to physicians? Ans.—Your question is one that is difficult to answer in the space of these columns. However, we will do our best. The general effect of the current is a tonic one. That is to say, a person treated is given a feeling of energy and vigor and this invigoration is not followed by a period of depression as is the case when a stimulant is administered. The high frequency current increases nutrition by increasing the blood supply to the parts under treatment. Possibly the most important application of the current is in cases of arteriosclerosis or "hardening of the arteries." In this class of treatment the current is used to reduce the blood pressure of the patient. Other interesting and important applications are in cases of various skin diseases, scalp diseases, goitre, articular rheumatism, neuralgia, etc. Cures have been reported in many cases of bad scalp affections. Gray hair has been restored and partially bald heads rejuvenated. We cannot hope to go into the detail your question would imply you desire, but would suggest that you obtain copies of "High Frequency Apparatus," Curtis, \$2, and "High Frequency Manual," Eberhardt, \$2.50, from our Book Department. The former book deals with the construction of the apparatus, while the latter tells of its use in therapeutics.

If you wish further information, write us again.

A CHAT WITH THE EDITOR

WHAT THE READERS THINK

THIS little magazine was conceived, designed and produced exclusively for the readers by one of them. Therefore, when what appears to be a crisis in its career has approached, it seems but fair and logical that the readers as a class should be placed in possession of the facts. To this end, the following form letter was mailed to subscribers on April 12th:

Everyday Mechanics MAGAZINE

"It Tells You How to Make and How to Do Things"

AEOLIAN HALL, 35 WEST 42ND STREET, NEW YORK

My Dear Friend:

Our "EVERYDAY" is facing a situation that threatens to be serious. Not satisfied alone with placing the little magazine under the ban of a suit in equity, the Publishers of Popular Mechanics have entered interference proceedings at the Patent Office in Washington in an effort to prevent the issue of a certificate of Registration for our trademark.

When "EVERYDAY" was started, its backers had practically no capital; the magazine was the realization of an ideal that I, as an amateur mechanic, have cherished for years—ever since I wrote my first article in the old "Electrician & Mechanic." The little magazine has grown by leaps and bounds and, were it not for the fact that the litigation in which we are involved will cost thousands of dollars, the April issue would actually carry the Company past the critical point where profit and loss are in the balance.

In all of my editorials and announcements, I have tried to be as frank and open as possible. My first circular told of what I hoped to do; three issues of the magazine have given the reader an opportunity to judge whether or not I have succeeded. When the action was started against us, I made a frank statement to my readers telling them what we were up against, for I felt that they had a right to know what was happening to the paper they made possible; made possible because of the support they have given it.

Now when "EVERYDAY" is in a measure up against it hard, I feel that the reader is the man to tell my story to. The time has come when, if young "EVERYDAY" is to weather the storm and retain its birthright, it must have financial help. I, personally, have given it everything I possess and hold valuable—my reputation, the soundness of the idea I have proposed, what earthly possessions I have, day and night work for months—all have gone into the melting pot. I am face to face with the problem of holding together the structure that I have worked hard to build. Two alternatives present themselves: One, to sell out to large capital or some one of the half-dozen publishers who are anxious to get hold of "EVERYDAY"; the other to appeal to my loyal readers, each one to do his bit in sending me a single subscription or an order for a book or something that will give his new magazine the little boost that it must have if it is to live.

In no case will a pure and simple contribution be considered, for I am not begging for "EVERYDAY." For whatever we receive, we must give something of value in return. The point is this: "EVERYDAY" must have two thousand dollars to pay attorneys'

fees, cost of securing testimony, railroad fares from New York to Chicago and Washington, etc. Now, the subscription list numbers considerably over two thousand names. Suppose each subscriber were to induce a friend to subscribe at 50 cents; there is a thousand dollars. Suppose in answer to my appeal, you and your friends were to look over your copies of "EVERYDAY" and see a book or two that you need; your order coming in addition to the current business being done, even though it were only for a 25 cent book, would swell into hundreds of dollars if multiplied by the number of subscribers.

I hope I have made myself clear. "EVERYDAY" will not take one cent from a purely charitable point of view, but it needs a little lift from each one of its loyal friends in what manner he can afford. If each reader who feels that he has been given his money's worth will devote one hour to the cause and make an effort to secure one or more subs. for one year or a period of years, or to get an order, no matter how small, for a book or books, "EVERYDAY" will weather the storm with flying colors.

Your recent letter makes me feel that I can ask you to do whatever you can; that you are with me in my fight to give the amateur worker and experimenter his first recognition by devoting the first how-to-make-it magazine solely to him; and, further, that you are just as anxious as I am to hold the control of "EVERYDAY" in the hands of those who have grown up as amateur mechanics perhaps as you have.

I do not want you to work any hardship upon yourself. All I ask is that you do something; your order for a ten cent Bubler Book will be just as welcome as one for a ten dollar library or a ten-year subscription. Just remember that no matter how small your result may seem, if it is multiplied many times the aggregate will furnish the lifeboat for your little magazine.

Please use the enclosed envelope for your reply and also tell me whether I may publish your name as that of one of the loyal supporters of "EVERYDAY." If you object, your wishes will be respected, but I want the readers at large to know the friends who came to the rescue in our time of need.

Sincerely yours,

THOMAS STANLEY CURTIS.

We do not feel justified in taking sufficient space to publish even a fair percentage of the replies. The few letters which follow are characteristic of all. The response has put new life into us and we feel certain that before another month has passed, we shall have had at least a letter from each of those to whom we mailed letters. Our appreciation of the help that these loyal readers have given can best be expressed in the better magazine we plan to give them, when our troubles are over. In the next number, a list of names of the loyal friends, who have so generously come to the rescue of their little magazine, will be published.

*Thomas Stanley Curtis,
New York.*

Hamilton, Ohio, April 12th, 1916.

Dear Sir:—

We are very sorry to see your fine little magazine in trouble. You have our subscription for two years, and we are enclosing, as per your request providing it meets with your approval, a check to cover two (2) years more.

I believe that you have for sale a book on "Construction of Induction Coils" for twenty-five cents; also a book on "Storage

Batteries" for fifty cents. You will find an additional seventy-five cents added to our check, for which please mail us a copy of these books.

Wish to say that the writer has gotten so much good out of you and your efforts that if there is anything else we can do, please advise us. Trusting that you will be able to continue giving us the good things in the future that you have in the past, we remain

Yours for success.

(Signed)

CHAS. PFOTZER.

St. Louis, Mo., April 13, 1916.

Thomas Stanley Curtis,
New York.

My Dear Mr. Curtis:—

I am forwarding you my check for \$5.00 for which please enter my subscription to EVERYDAY MECHANICS Magazine for ten years.

Yours very truly,

(Signed)

TERRELL CROFT.

Bangor, Maine, April 11th, 1916.

Thomas Stanley Curtis,
New York.

Dear Sir:—

You may publish my name as a loyal supporter of EVERYDAY MECHANICS. As a proof of this statement you will find enclosed \$1.00, for which please send me the books entitled "Storage Batteries," by J. T. Niblett, and "House Wiring," by Thomas W. Poppe. At some early date I'm in hopes to send you two new subscriptions for your wonderful little magazine. I certainly shall feel bad if anything should happen to our little magazine. The more I read it the better I like it, and we have grown to be good friends and we must not part now; if I can do anything to prevent it I wouldn't hesitate to act.

Yours respectfully,

(Signed)

HARRIS E. MOWER.

Jefferson Barracks, Mo., April 13th, 1916.

Thomas Stanley Curtis,
New York.

Dear Sir:—

Your letter in reference to the need of funds received. I enclose check for \$1.25 for the following books * * *

With reference to the suit against you by Popular Mechanics I desire to say that I am taking both magazines, and fail to see wherein your magazine is in any way an infringement of Popular Mechanics. The magazines are not at all alike in appearance nor in the treatment of the subject matter.

Wishing you success, I am

Very sincerely,

(Signed)

C. R. STRODLER.

Captain 7th Cavalry.

Wilkesburg, Pa., April 8th, 1916.

Thomas Stanley Curtis,
New York.

Dear Editor:—

I have at hand your March issue of EVERYDAY MECHANICS, which was addressed to me at Derby Line, Vt. My former home was at Derby Line, but since taking up my new duties as motor tester with the Westinghouse Co. I expect to make Pittsburgh my future home.

I like your little magazine very much and would like to see it succeed and grow, as I am sure it will, because it fills a want which is a wonder to me why it has not been filled before.

At present I am a subscriber to "The Electrical Experimenter"

and "Popular Science Monthly," but neither of these magazines devote the entire space to the idea of construction, which is of great interest to me and the vast army of experimenters.

My idea of the suit entered upon you by Popular Mechanics is exactly expressed in a letter appearing in the March issue, written by Mr. W. T. Gevrez, so I will not enlarge upon that idea. I used to buy "Popular Mechanics," but I found it did not fill my need as well as the two magazines which I am now taking, so I discontinued buying it.

I am enclosing sixty cents, for which please send me EVERYDAY MECHANICS for one year, beginning with the April, 1916, issue, and also please send the first two numbers which have appeared before the March issue which I have before me. I want to get every number from the first, as I deem it a too valuable book to afford to miss even a single copy. I have enjoyed your articles which have appeared in Popular Science Monthly very much, and hope you will continue to give us the same class of articles in your new magazine.

Wishing you every success with your new publication,
Sincerely yours,

(Signed)

H. TILTON.

Thomas Stanley Curtis,
New York.

Dear Mr. Curtis:—

It seems impossible that such a great (?) mechanical publication as "Popular Mechanics" should bring suit against such a small competitor, if EVERYDAY MECHANICS may be called a competitor for using material, facts and a name that Popular Mechanics never found itself able to use for the reason that it never was given a chance to do so.

Popular Mechanics, that profusely illustrated magazine, greatly akin to a child's story book, must indeed be envious, and not without reason, for EVERYDAY MECHANICS more than fills the void left by the merging of the Electrician & Mechanic with other magazines.

From the experimenter's point of view EVERYDAY MECHANICS is a marvel. It is not only neat and printed on good quality paper, but contains facts, not the fabrications of a disordered brain.

I sincerely hope EVERYDAY MECHANICS will have a long and useful life, and to that end find enclosed \$1.00, for which please send EVERYDAY MECHANICS to Charles O. Yaple, 16 Kellogg Street, Erie, Pa., for one year, and send me a copy of EXPERIMENTAL HIGH FREQUENCY APPARATUS in cloth binding.

Hoping that the best and only magazine of its kind comes into its own, I am

Yours respectfully,

(Signed)

M. F. VAN ORSDALE.

Cleveland, Ohio, April 17th, 1916.

Thomas Stanley Curtis,
New York.

Dear Sir:—

I heard you were in need of money, so I send you 50 cents for a subscription. I think those Popular Mechanics people are "nuts," and about the only way to settle them is with a brick.

Hoping you will get through all right, I am

Your interested reader,

(Signed)

PHILIP MORSE.

Frohna, Mo.

Thomas Stanley Curtis,
New York.

Kind Str:—

In reply to your request I will say that I must admit that I am only a man in the woods and know only a little more about law than a pig knows about Sunday, and what I know is that Thomas Paine was about right when he said law is only a necessary evil,

but I am from the "show me" state, and I don't believe that Windsor, or any one living, can show me where there is any justice, if there is law, for the suit you claim he is bringing.

I see nothing in the name, size or general appearance of your little how-to-make magazine that would cause any sane man to buy it thinking he was buying the Popular, or what might be called a how-things-look or picture album of a magazine. The Popular Science and the Popular Mechanics are both pretty good catalogs of advertisements, and pretty good picture albums, and that is about all there is to them; however, I consider the Popular Science the better journal of the two. This is the reason I have quit the Popular Mechanics but still take Science.

It seems to me that if the laws of this country are going to give every journal a cut and dried case against every other journal that uses a single word in its name that is the same as theirs, then certainly there will be litigation enough to fatten all the jackleg lawyers out of jail, and little journals like the Mechanical Digest of Grand Rapids, Mich., will get the "stuffers" knocked out of them on the one side by the great big Popular, because it tries to claim something that belongs to the mechanical world, and at the same time they will have a rear-end collision with some other large journal like the Literary Digest because they use in its name the word Digest, and all the little fish of the editorial world will either be gobbled up or their lives will be chaos; all chaos inhabited and cultivated by the ghosts of dead ambition.

Yours truly,

W. B. CLINE.

(Signed)

P. S.—A man in the woods fits nowhere else, but if he does, use him.

St. Louis, Mo., April 13th, 1916.

Thomas Stanley Curtis,
New York.

Dear Sir:—

Enclosed please find 50 cents in stamps, for which please enter the name of Mr. Scofield Kappel, 8110 North Broadway, St. Louis, Mo., on your subscription list.

You may use my name as one of your readers who thinks the proceedings of the Popular Mechanics Magazine are selfish and unjust. It is just another case of the "Big Guy" trying to monopolize everything in sight by squeezing out the smaller competitors. Whatever you do, hold on, and if there's such a thing as justice in this country of ours, you'll win out, because I know you're right. So for the "love of Mike" don't sell out to those grasping publishers.

Yours truly,

W. H. SCHEER, JR.

(Signed)

Cleveland, Ohio, April 15, 1916.

Thomas Stanley Curtis,
New York.

Dear Sir:—

In response to your letter I hasten to enclose 50 cents for a subscription to your magazine.

I have succeeded in getting one other person in sending you a subscription. I also want you to quote me prices on fifty copies of your book, "Construction of Induction Coils and Transformers" for resale in our catalog.

The above constitutes "my little mite" to help put EVERYDAY MECHANICS on its feet. Your magazine is exactly the type of publication that is needed to-day among experimenters and among busy business men who are live enough to desire information on the "why" of things.

I should feel very badly indeed if your little magazine should be unable to weather the storm.

Being personally a writer on similar topics, I can appreciate in full measure the splendid quality of the articles appearing in EVERYDAY MECHANICS. I like 'em. I know that if you can

hold your head above the water for a short time more you will make every one else like 'em.

Here's hoping once again for the success of EVERYDAY MECHANICS.

Use this letter any way you want.

Very truly yours,

THE ELECTRO-SET CO..

J. S. NEWMAN, PRES.

(Signed)

Edwardsville, Ill., April 15, 1916.

Thomas Stanley Curtis.

New York.

Dear Sir:—

Your circular letter just received. As a slight "boost" am enclosing 90 cents in stamps, for which please extend my subscription another year from the time of expiration, and also send me a copy of Watson "How to Make a 1/4-Hp. Dynamo."

Also wish to say that EVERYDAY MECHANICS is the first magazine that to my mind reaches nearly the ideal magazine for the experimenter. I read Electrician & Mechanic for a number of years, still read Popular Science Monthly and Popular Mechanics, and cannot see any similarity between your magazine and the others mentioned. Your article on "Kicking Coils" in last month's issue is one that I have been looking for for some time, and am sure it cannot be found in any other publication.

I trust that you will be enabled to continue the magazine as planned, and if the use of my name will be of assistance in attaining this result, you are at perfect liberty to use it.

Yours very truly,

E. W. FREDERICK.

(Signed)

Union Hill, N. J., April 17, 1916.

Thomas Stanley Curtis.

New York.

Dear Sir:—

Your recent letter regarding the jealousy suit of the Popular Mechanics magazine was received a few days ago.

Just at present I can only send you an order for one book, "Amateur's Wireless Handybook." While I purchase wireless and electrical books from time to time, I regret that the above is the only book that I need at present. I am, however, making a canvass of my friends and trust I will be able to send you a few subscriptions.

If the suit were to be tried before a jury and if the jury's mind was the same as mine, you would win "hands down."

If my name can be of any help to you use it as you see fit.

Sincerely,

J. G. HAUSSMANN.

(Signed)

Long Island City, N. Y., April 11th, 1916.

Thomas Stanley Curtis,

New York.

Dear Mr. Curtis:—

I was very sorry to receive your letter stating that Popular Mechanics has brought suit to stop the patent office from granting you your trademark. While we appreciate that they can do nothing in this matter, it certainly is a serious proposition to finance the defence of both suits which they have brought.

In accordance with your general suggestion I have enticed 50 cents from an interested reader. A check for this amount is enclosed. Please send EVERYDAY MECHANICS for one year, commencing with the March, 1916, issue, to Mr. R. E. Leonard, 318 West 57th St., New York City.

I have no objection to your using my name or the previous letter I wrote you; in fact, almost anything you can do to get even with Popular Mechanics would be a source of personal joy to me.

Very truly yours,

H. B. RICHMOND.

General Vehicle Company.

(Signed)

Thomas Stanley Curtis,
New York.

Alpaugh, Cal., April 19th, 1916.

Dear Sir:—

The party that would mistake EVERYDAY MECHANICS magazine for Popular Mechanics magazine would not have sense enough to know the difference.

Respectfully yours for justice,
PROF. W. M. H. THOMPSON.

Thomas Stanley Curtis,
New York.

Amarillo, Texas, April 21st, 1916.

Dear Sir:—

I must say that I am very glad to help what I can in keeping our little magazine just as it is. I prize the copies I have received very highly, and have benefited greatly by making use of its articles.

Enclosed photos show large Tesla coil built according to description in EVERYDAY MECHANICS, also my wireless apparatus built entirely by myself.

Find enclosed two dollars (\$2.00), for which please send me a copy of your book, "High Frequency Apparatus."

Hoping that EVERYDAY MECHANICS will steer past all obstacles in the near future and the best of success to the editor, I am
Very sincerely yours.

(Signed)

BRENT DANIEL,
Pres. Amarillo Radio Club.

Thomas Stanley Curtis,
New York.

Lacey, Wash., April 18th, 1916.

Dear Sir:—

I have with the greatest pleasure and interest perused two copies of your very worthy little magazine, and think it something quite out of the ordinary and very desirable for the mechanically inclined reader. I am professor of sciences here at St. Martins College and also conduct a very efficient radio station, for which reason your magazine holds a great deal of real interest for me.

I am enclosing 50 cents for a year's subscription but would like to have you send me the back numbers if possible, that is, beginning with Vol. 1, No. 1.

Yours for further success.

(Signed)

REV. S. RUTH.

Thomas Stanley Curtis,
New York.

Pinckncyville, Ill., April 14th, 1916.

Dear Sir:—

Please send me a copy of "House Wiring" by Poppe, and "Making and Fixing Electric Bells and Batteries," for which find enclosed money order for sixty cents (60c.).

I fail to see wherein EVERYDAY MECHANICS is an infringement of Popular Mechanics, for it seems to me that a high power microscope even would not find any resemblance between the two, and I certainly would not mistake one for the other in size, shape or make-up and further. Popular does NOT tell me "How to do things" as the little "EVERYDAY" DOES, and I am perfectly willing that everybody knows I say so.

I am 78 years of age, but frequently I want to know how to make or repair some mechanical device.

(Signed)

Yours truly,
S. WALTER REYNOLDS,
Captain U. S. Vols.

Pawtucket, R. I., April 17th, 1916.

Thomas Stanley Curtis.
New York.

Dear Sir:—

Received your letter of the 10th and am sending you nine subscriptions and will send you more in a few days. I would like, if possible, for you to start them all from the first issue, as they are all enthusiastic about it and think it is the best nickle's worth on the market. You will find money order for \$4.50 enclosed and I hope you will get 9000 more. and furthermore, I hope you beat the sharks. as it is the old story of the sharks trying to eat the little fishes up. Wishing you success, and hope you beat the sharks.

Yours,

(Signed)

B. BRADLEY.

West Reading, Pa., April 19th, 1916.

Thomas Stanley Curtis.
New York.

My Dear Sir:—

Your appeal for subscriptions to help weather the storm now besetting EVERYDAY MECHANICS has caused me to wake up and do some hustling in behalf of the best little magazine it has ever been my privilege to read. I have succeeded in landing four subscriptions, which I am enclosing with the two dollars to pay for one year for each. You will surely pull through if each of your subscribers send in as many. I sincerely hope you do, for I do not want to see the magazine go under. If you have all the back numbers you may start each one from the beginning, as I used my back numbers to show what they were like and each man saw enough to interest him to want the complete volume.

I may add that I expect to try for more subscriptions and will send them in promptly if I succeed.

Yours very truly,

(Signed)

LEWIS AIRHART.

Quincy, Mass., April 10th, 1916.

Thomas Stanley Curtis.
New York.

Dear Mr. Curtis:—

You may depend upon me for the support asked for in your circular letter. I think EVERYDAY MECHANICS in no way resembles any magazine I know of and that it would be a shame if we had to lose it.

Yours truly,

(Signed)

T. LINDALL WILLIAMS.

San Francisco, Cal., April 6th, 1916.

Thomas Stanley Curtis.
New York.

Dear Sir:—

I wondered what was the reason I did not get the February number of your little magazine. The boys in my class in the Humbolt Evening Technical High School kept asking for it. They all like it and I think it fills a place among such magazines that has not been filled by any other. There is no justification in the claim of Popular Mechanics that you are infringing on their rights. It is entirely different in size, price and substance. I believe it is far superior for the purpose of instruction.

It encourages personal experiment on the part of the reader, which is a very desirable purpose. In fact, to develop originality and personal effectiveness is the end and object of education. You have my best wishes for the success of your magazine, and I hope you will be able to overcome unjust and malicious action by any of your competitors.

I am enclosing a check for 50 cents for one year's subscription for one of my boys who wants it entirely for himself. He wants the subscription to commence with the first issue. His address is: Christ. Banzet, 510 Brannan Street, San Francisco, Cal.

Respectfully,

(Signed)

G. W. CUTHBROTSON.

Chcster, Pa., April 17th, 1916.

Thomas Stanley Curtis,
New York.

Dear Sir:—

Your letter received. How Popular Mechanics can be so selfish and jealous I cannot understand. There is certainly room for all. I wish you every success in your troubles and am sure you will come out on top. As I want to do my "bit" I am enclosing \$1.00 for two books as follows: Electrician's Handy Manual, by Curtis; cloth, 50 cents, and House Wiring, by Poppe; cloth, 50 cents.

Yours respectfully,

GEO. D. BOWERS.

(Signed)

Chicago, Ill., April 18th, 1916.

Thomas Stanley Curtis,
New York.

Dear Sir:—

Enclosed please find money order for 70 cents, for which extend my subscription to the magazine one year and also send me one copy each of * * *

The test to which you and your magazine are subjected to cannot do more than to finally establish it as the best and only one of its kind.

Wishing you success in this fight, I remain,

Yours truly,

HAROLD A. LUTTERLOH.

(Signed)

San Francisco, Cal., April 15th, 1916.

Thomas Stanley Curtis,
New York.

Dear Sir:—

In answer to your letter which I received this morning, I enclose 50 cents (in stamps) for which kindly extend my subscription for another year.

I do not like to see our little magazine suffocated at this time and I do hope all the subscribers chip in and help.

Wishing you and your little magazine the best of success, I remain,

Yours very truly,

J. P. SWANSON.

Enginer, Bank of Italy.

(Signed)

Lincoln, N. H., April 18th, 1916.

Thomas Stanley Curtis,
New York.

Dear Sir:—

Your letter received suggesting each subscriber either buy books or try to get subscriptions to your magazine. Will say I have succeeded in getting three subscribers, and will get a few 10-cent books to help out all I can. Would like to do more if I could, as I'd hate to see your magazine go under now. That last copy—March—was great. Keep it up—that struck me as all right. It remained me more of the old Electrician and Mechanic, and that was sure one grand magazine. Wish it was still going now. * * *

I hope this will help you out a little; if everyone does as much, as you say, then you ought to weather the storm all right.

Hoping you come out all right and to see more issues like the March one, I am

Yours very truly,

H. L. DEARBORN.

(Signed)

Oak Park, Ill., April 18th, 1916.

Thomas Stanley Curtis,
New York.

Dear Sir:—

I received your letter this day and was very much pleased for you to call on me to help you in your suit with the Popular Mechanics, and I heartily hope you will win. Please find enclosed 50 cents