

# EVERYDAY ENGINEERING MAGAZINE

AUGUST 1920  
Vol. 9 No. 5

Twenty Cents  
a Copy



*air tool Page 46*



INDUSTRIAL NIAGARA (See Page 396)



# Prices of McGraw-Hill Home Study Courses Must Go Up

**Now is the Time to Get Ready for Bigger Pay** Industrial America is teeming and throbbing with the greatest activity in its history. Every day hundreds of men in small positions are raised to bigger responsibilities and bigger pay. A search is being made everywhere for men who have the necessary training to assume these new responsibilities.

**A McGraw-Hill Home Study Course Will Prepare You Quickly** The McGraw-Hill Home Study Courses are founded on actual work as it is done in the great fields of engineering which they cover. No space is wasted with higher mathematics and theory. Only facts, written so that you can understand them. About one hundred thousand men are now using them as a daily guide. They are equally valuable to the expert and the beginner.

## Not One Cent in Advance Small Monthly Payments If You Are Satisfied

No matter what your age is, where you are located, or how limited your means, you can succeed through one of the McGraw-Hill Home Study Courses. Everyone contains a complete education on the subject covered. No matter how much you might pay for books or courses you cannot acquire knowledge that will advance you more rapidly and surely than a McGraw-Hill Home Study Course.



### Power Plant Library

Power plant practice complete, including mathematics, boilers, engines, electricity, turbines and refrigeration. Now the most used engineers' library in existence. Has enabled thousands of men to pass the most rigid examinations. 2,500 pages, 1,500 illustrations. Eight handsome volumes, bound in the tough T pattern of cloth, as durable as leather. Price \$16, payable \$2.00 per month.

### Factory Management

A set of books written by leading authorities, to help men fit themselves to take complete charge of the shop or factory. Covers industrial organization, administration, purchasing, manufacturing costs and accounts, engineering of shops, factories and power plants. 6 volumes, 2,300 pages, fully illustrated. Bound in semi-flexible karatol. Price \$20, payable \$2 in ten days and \$3 per month.

### Croft Library of Practical Electricity

Without question of more practical value than anything of the kind ever attempted in the world of electricity. Enables you to know electricity as experts know it. Mathematics, practical electricity, electrical machinery, central stations, wiring for light and power, wiring of finished buildings, illumination. 8 flexible volumes, pocket size, 3,000 pages. Price \$20, payable \$2 in 10 days and \$3 per month.

### Iron and Steel Library

The high positions in the great iron and steel world are now attainable through this library, which is written by authorities actually engaged in this work. Metallurgy, foundry work, blast furnaces construction, operation and products, refractories. A complete iron and steel library. Seven volumes, over 3,000 pages. Fully illustrated. Price complete \$24, payable \$3 per month.

### Machine Shop Library

Machine shop practice complete. Written by eight practical men, well known in the machine shop world. Now the standard in America. No other set of books on the subject ever equalled it in popularity. Mathematics, drawing and design, composition and heat treatment of steel gears, tool work, grinding, jigs and fixtures, screw machines, dies, etc. 9 volumes, 3,000 pages. Price \$20, payable \$2 in 10 days and \$3 per month.

### Metal Mining Library

Herein is brought together in nine flexibly-bound volumes the very meat of metal mining practice in America. Examinations, principles of mining, timbering, thousands of working details, ore dressing, surveying, accounting, costs. All the information you need to reach the high positions in the mining world. The most intricate problems solved by plain words and illustrations. Price \$24, payable \$3 per month.

### Coal Mining Library

Coal mining and colliery practice complete, including outside and inside work—both mechanics and engineering. Of assistance to every man in the business, from the lowest paid man to the operator. It is now looked upon as a necessity, and as containing the secrets of success in coal mining. 8 volumes, 3,000 pages, 1,700 illustrations. Price \$20, payable \$2 in 10 days and \$3 per month.

### Radcliffe's Electricity

A three-volume compact set of books on the practical side of electricity. In question-and-answer form, for quick reference. This course is somewhat condensed, and will be found of special value to those interested in electricity as used in power plants. 700 pages of facts, illustrated and carefully indexed. Price \$6, payable \$1 per month.



## Any Library Shipped on Ten Days' Trial— At Our Expense. Merely Return the Coupon

Look at the illustrations of the libraries at the left and right of this page. Then refer to the coupon, check the library you want, fill out the blank spaces carefully and return to us. After receiving the books, go over them carefully. Keep them ten full days. See how much knowledge you can gain from them within ten days. If then you decide you cannot afford to be without them, send us the small monthly payments called for. Paper has advanced 300% and is still going up. This is your chance to procure a McGraw-Hill study course at the old price.

Pay only  
\$1 to \$3  
per  
month  
if you are  
satisfied

## Free Examination Coupon

McGraw-Hill Book Co., Inc., 239 W. 39th St., N. Y.  
Gentlemen: Send for ten days' free inspection the Library I have checked below:

- Croft's Electricity, \$20—payable \$3 per month.
  - Machine Shop Library, \$20—payable \$3 per month.
  - Iron and Steel Library, \$24—payable \$3 per month.
  - Mining Library, \$24—payable \$3 per month.
  - Coal Mining Library, \$20—payable \$3 per month.
  - Power Plant Library, \$16—payable \$2 per month.
  - Factory Management, \$20—payable \$3 per month.
  - Radcliffe's Electricity, \$6—payable \$1 per month.
- If satisfactory I will send first payment in ten days and the same amount each month until paid. If not wanted I will return the books at your expense.

Signature .....

Residence address .....

City and State .....

Your employer .....

His address .....

Your occupation .....

# C O N T E N T S

VOL. 9

AUGUST, 1920

NO. 5

HEAT TREATING ALLOY STEELS—PART 4.....	391
<i>By Victor W. Pagé, M.S.A.E.</i>	
ELECTRONS AND THE CONSTITUTION OF THE CHEMICAL ATOM—PART 2.....	394
<i>By Prof. T. O'Connor Sloane</i>	
INDUSTRIAL NIAGARA .....	396
<i>By Raymond Francis Yates</i>	
SPARK TEST FOR STEEL.....	400
COMMON CAUSES OF AUTOMOBILE NOISES— PART 2 .....	402
<i>By Victor W. Pagé, M.S.A.E.</i>	
SHOP PRACTICE .....	405
Increasing Range of Milling Machine—Flanging Copper Tubes—Resistance of Steel to Cutting— Device for Small Drills—Extemporized Air Compressor.	
MODEL STEAM ENGINE AND BOILER CONSTRUCTION— PART 2 .....	407
<i>By Wm. A. Helms</i>	
A Double-Acting Oscillating Engine—Stationary Boiler.	
EVERYDAY MOTORIST .....	411
A New Lapping Compound—A Quenched Gap as a Spark Intensifier—Simple Spring Oiler—A Bush- ing Extractor—Testing Inner Tubes of Automob- ile Tires—Extension Pads for Ford Pedals— Clogged Muffler.	
HOW THE AUTOMATIC TELEPHONE WORKS....	413
<i>By Kenneth Altan</i>	
A FOUR-CYLINDER AIR MOTOR FOR MODEL AIR- PLANE .....	416
<i>By Clifford A. Butterworth</i>	
USEFUL AND INTERESTING INVENTIONS.....	418
Scheme for Air Cooling—Stump Sawing Machine —New English Valve Designs—New Fuel Feed Device—Two-Piece Piston.	
ELECTRICAL PROGRESS DIGEST.....	420
Determination of Minute Length Changes in Bridge Members—Electric Lighting Increases Efficiency of Laying Hens—Hand Instrument for Measuring Angles—Electricity Applied to Agr- iculture in Germany—Losses in Car Generators.	
THE PROCESS OF NICKEL PLATING.....	422
<i>By L. M. Blakey</i>	
CHEMICAL NOTES, RECIPES AND FORMULAS....	423
HOW TO GET MORE MILEAGE.....	424
<i>By Victor W. Pagé, M.S.A.E.</i>	
AEROMARINE AIR YACHT.....	426
SIMPLE KITE PHOTOGRAPHY.....	427
<i>By L. B. Robbins</i>	
COMMUTATION AND WHAT IT MEANS TO A MOTOR .....	428
<i>By N. M. Ferris</i>	
HOW TO MAKE A HORIZONTAL SUN DIAL.....	430
THE UTILITOR GARDEN TRACTOR.....	431
AVIATION BRIEFS .....	432
Fishing from a Blimp—A French Aviette—Record Parachute Jump—Completely Enclosed Airplane Fuselage for High Altitude Flights—Experimental Multiplane.	
MANUAL ARTS AND CRAFTS.....	434
<i>By Chas. E. Muller, M.A.E.</i>	
Electric Boudoir Lamp—Magazine or Dictionary Stand—A Simple Balance—How to Make a Small Lift Truck.	
EVERYDAY SCIENCE NOTES.....	438
<i>By Prof. T. O'Connor Sloane</i>	
THE DESIGN AND USE OF LOOP ANTENNAS....	440
<i>By M. B. Sleeper</i>	
EQUIPMENT FOR THE RADIO STATION.....	442
<i>By Stuart D. Dimond and John A. Hall</i>	
THE RADIO DEPARTMENT .....	444
A NEW DEVELOPMENT IN TUNING INDUCTANCES	446

# EVERYDAY ENGINEERING MAGAZINE



2 West 45th Street

New York City

A Dependable, Instructive Digest of Current Mechanical,  
Scientific, Automotive and Radio Progress.

<i>Managing Editor</i>	<i>Science Editor</i>	<i>Radio Editor</i>
VICTOR W. PAGÉ	PROF. T. O'CONNOR SLOANE	M. B. SLEEPER

*Contributing Editors*

L. M. CLEMENT  
*Radio Engineering*

CHAS. E. MULLER  
*Manual Arts and Crafts*

*Advertising Manager*  
STEPHEN ROBERTS

*Branch Advertising Office*  
SEARS & IRVING, Peoples Gas Building, Chicago, Ill.

Published Monthly by  
EVERYDAY MECHANICS COMPANY, Inc.  
New York, N. Y.

Entered as second-class matter November 20, 1915, at the post office  
at New York, N. Y., under the Act of March 3, 1879.

Subscription price \$2.00 a year in the United States and possessions;  
Canada, \$2.25; Foreign, \$2.50 a year.

Copyright, 1920, by Everyday Mechanics Co., Inc.

## What Is Engineering?

WE are frequently called upon to define the functions of an engineer, and to explain the term "ENGINEERING" by outlining its scope and its limitations. The report submitted by one of the committees of the American Society of Civil Engineers gives definitions that are worthy of general adoption because they answer the questions so often asked.

ENGINEERING is the science and art of directing the great sources of power in Nature to the use and convenience of man. Engineering is an art and a science. It is a science in so far as physical laws are its base, and an art in so far as in the application of these laws the things designed and constructed develop the spirit of progress, the creation of wealth, and the well-being of all peoples. Engineering is generally divided into four divisions: civil, mechanical, electrical and mining. The practice of engineering requires knowledge of physical laws, forces, and the materials of Nature. The professional engineer is one who by reason of special training, education and experience is qualified to design and direct the construction of engineering work in one or more of the major divisions of engineering.

ENGINEERING is the creative science and art of applying economically the materials and forces of Nature to the use and convenience of man. Engineering is the science of industrial effort, and the science and art of applying this effort for the welfare of the public. An engineer is one versed in the science and art of industrial effort made for the purpose of public welfare.

NONE of these definitions state that an engineer must be trained only in a special technical school or institute, or that a successful engineer must have a degree from some seat of learning. Engineering can be learned in the school of practical experience, but the great value of preliminary education is that the student becomes familiar with what has been done, and why, without the inevitable waste of time that always accompanies an education obtained solely by experience.

THE engineering world demands that anyone who wishes to practice in any of the branches of this profession must combine a good theoretical knowledge of basic principles with a practical appreciation of how things are done. The former can be obtained by study, the latter only by doing. The engineer taught in both schools is the one who succeeds best, and who accomplishes great things.

# Useful Books on Mechanical Subjects

## Electro-Deposition of Metals

By George Langbein  
and  
William T. Brant

The new eighth edition of this volume, which has been completely revised, considerably enlarged and entirely reset, is now ready. It is a complete and comprehensive treatise, written from a scientific as well as practical standpoint and especially intended for the practical workman, wherein he can find advice and information regarding the objects to be plated while in the bath as well as before and after electroplating. This volume is the foremost book on the subject in the English language and covers electroplating and galvanoplastic operations, the deposition of metals by the contact and immersion processes, the coloring of metals, lacquering, and the methods of grinding and polishing as well as descriptions of the voltaic cells, dynamo-electric machines, thermopiles, and of the materials and processes used in every department of the art. Particular attention has been paid to all important innovations, and it has been endeavored to include all of the latest practical methods of plating, as well as the most recent machinery and apparatus. It is a ready book of reference and a practical guide to the workshop. Octavo, 875 Pages, 185 Illustrations.

Price \$7.50

## Complete Practical Machinist

By Joshua Rose

One of the best-known books on machine shop work, now in its twentieth edition, and written for the practical workman in the language of the workshop. It gives full practical instructions on the use of all kinds of metal-working tools, both hand and machine, and tells how the work should be properly done. It covers lathe work, vise work, drills and drilling, taps and dies, hardening and tempering, the making and use of tools, tool grinding, marking out work, machine tools, etc. Throughout the entire classic the explanations are as clean-cut as the tools they describe, and the earnest mechanic or machinist seeking greater efficiency will be helped toward using both head and hands to better advantage. No machinist's library is complete without this volume.

547 Pages. 432 Illustrations

Price \$3.00

## Metal Worker's Handy-Book of Receipts and Processes

By William T. Brant

This volume is a valuable work of reference and instruction for all engaged in the working of metals. It is a collection of formulas and practical manipulations for the working of all the metals and alloys including the decoration and beautifying of articles manufactured from them. The utmost pains have been taken to insure the accuracy and efficiency of the recipes so that with ordinary care as to quantities and manipulation the results may be implicitly relied upon.

It treats on alloys and amalgams; hardening, tempering, annealing; bronzing and coloring; casting and founding; cements; cleansing, grinding, pickling, polishing; decorating, enameling, engraving, etching; electro-plating, brasing, coppering, galvanizing, gilding, nickeling, silvering, tinning, etc.; fluxes and lutes, lacquers, paints and varnishes; solders and soldering; welding and welding compounds. To the new edition has been added several new chapters on die-casting, thermite and oxyacetylene welding, etc.

582 Pages. 82 Illustrations

Price \$3.00

Send for our new 48-page descriptive catalogue mailed free on request.

**HENRY CAREY BAIRD & CO., Inc.**

Publishers of Mechanical  
and Industrial Books

2 West 45th Street, New York, N. Y.

# LEARN DRAFTING

## At Home—In Spare Time as you would in actual practice

Get into this constructive branch of industry where big salaries are paid. No previous training is necessary to become a capable draftsman with the help of the Columbia School of Drafting. You can master the practical lessons of our famous home study course, at home, in spare time. You will be personally coached and instructed, by mail, by Roy C. Clafin, president of the school, whose long experience as a draftsman and teacher, especially qualifies him to give you the training you need to become a successful Draftsman.

### Become a Specialist

We not only give you thorough and practical training in Mechanical Drafting, teaching you to make actual drawings as you would in any drafting room, but the additional benefit of a post-graduate course in some special branch of drafting. A big field of opportunity is thus opened to you as a trained specialist in this profession.

Draftsmen are needed in greater numbers, and receive better salaries than ever before.



**Draftsmen Get \$35 to \$100 a Week**

Because of the importance of his work the draftsman is paid a big salary and is always in line for advancement. The draftsman's pay is from \$35 to \$100 a week. A knowledge of drafting is the stepping stone to big technical positions in the industrial field paying as high as \$50,000 a year.



### How "Columbia" Students Succeed

Students of the Columbia School of Drafting often secure positions at \$2,000 or more a year to start before completing the course. Hundreds of men and women with "Columbia" training are now making good with big concerns all over the country. Many more are needed for splendid positions now open. Here is what "Columbia" training is doing for some of our graduates: Laurence Johnston, over \$5,000 a year; George Murray, \$45 a week to start; G. Tangorra, \$2,800 a year; A. L. Gash, \$140 a month to start; W. S. Burfoot, \$150 a month to start; T. R. Brown, \$2,860 a year; R. Fowkes, \$3,700 a year. These are only a few of a great number of similar cases.

### This Complete Drafting Equipment Furnished

to students of our school. The instruments are of standard American make of the best quality, fully guaranteed, and become your property on completion of the course. Every instrument needed for the course is included.



### Big Concerns Employ "Columbia" Graduates

The best concerns in America employ Columbia graduates in their drafting departments because of the thorough practical training we give which enables them to step right into important drafting positions. Our diploma is the entering wedge into big drafting rooms everywhere. As a Columbia graduate you are recognized as an experienced draftsman, not as a mere apprentice. Why be satisfied with a grinding, underpaid position when there are hundreds of promising positions open to you in the big field of Drafting. We are called upon to place trained draftsmen more rapidly than we can produce them.

### Send This Coupon Today

Let us tell you the fascinating story of Drafting and how you can master this lucrative profession of big salaries and steady advancement through our help. Write today to

### COLUMBIA SCHOOL OF DRAFTING

Roy C. Clafin, President  
Dept. 1152, 14th & T Sts., N. W., Washington, D. C.

### COLUMBIA SCHOOL OF DRAFTING

Roy C. Clafin, President  
Dept. 1152, 14th & T Sts., N. W.  
Washington, D. C.

I am interested in your practical training in Mechanical Drafting. Please send me Free, your illustrated book of particulars, featuring the course checked below: (Mechanical Drafting, or Machine Drafting, is the foundation course and is complete in itself.)

- Architectural Drafting.....
- Automobile Drafting.....
- Electrical Drafting.....
- Aeroplane Drafting.....
- Special Machinery Drafting.....
- Sheet Metal Drafting.....
- Structural Drafting.....
- Highway Drafting.....
- Patent Drafting.....
- Topographical Drafting.....
- Ship Drafting.....
- Statistical Drafting.....
- Radio Drafting.....
- Automotive Drafting.....
- Hydrographic Drafting.....
- Machine Design.....
- Tool Design.....
- Shop Mathematics.....
- Builders' Course.....

Name.....  
Age..... Address.....  
City..... State.....



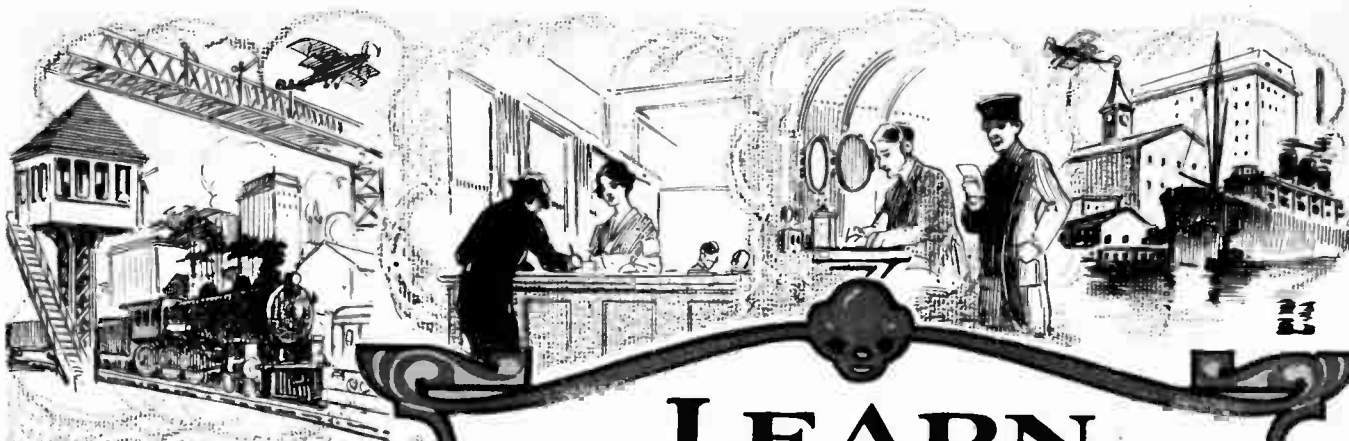

# LEARN WIRELESS

## At Home Quickly and Easily

**W**IRELESS is the hinge upon which swing the doors to success. It is the very foundation of the road which leads to many professions vast in scope, big in responsibility, satisfying in progress and salary.

A trained Wireless Operator with initiative and ambition can easily fulfill his ideals for a successful future; one including a position filled with vital enterprise, adventure, and financial success.

## Attractive Work — Alluring Salaries

Radio offers interesting work in pleasant environment, besides substantial salaries. Radio Operators' salaries start at \$125 a month with all living expenses—board, lodging, laundry, etc.—paid. When totalled and added to salary, it means \$200 or more a month, at the very start. Advancement to higher positions with bigger pay is readily accomplished.

## Travel Without Expense

If you are eager to travel, anxious to visit foreign countries and increase your knowledge of world affairs, wireless offers unequalled opportunities. On shipboard you are rated as an officer, living and eating with the officers, and mingling with the passengers. All without one cent's expense to you! Land Wireless positions are just as attractive if you prefer them.

## Send for Free Booklet

Our booklet "Wireless The Opportunity of Today" contains much interesting and valuable information. We have helped hundreds of ambitious men and women; the booklet explains how we did it, and how we can give you a thorough Wireless training, in your spare time, at home, by mail, and help you secure a worthwhile position.

## NATIONAL RADIO INSTITUTE

Dept. 263 14th & U Sts., N.W.  
WASHINGTON, D. C.

*Send This Coupon Today*

NATIONAL RADIO INSTITUTE  
Dept. 263, 14th & U Sts., N. W., Washington, D. C.  
Send me your FREE book, "Wireless the Opportunity of Today." Tell me about your Home Study Course in Wireless Telegraphy and Telephony—the free post graduate course and your Special Instrument offer.

Name .....  
Age..... Address.....  
City..... State.....



# A SPECIAL OFFER TO OUR READERS

ANY ONE OF THESE BOOKS WILL BE SENT FREE FOR EACH NEW OR RENEWAL SUBSCRIPTION WHEN SENT DIRECT TO US AND NOT THROUGH AN AGENT

**HOME MECHANIC'S WORKSHOP COMPANION**



TELLS HOW TO DO MANY USEFUL ELECTRICAL AND MECHANICAL THINGS INCLUDING NUMEROUS SHOP KINKS

By  
ANDREW JACKSON JR.

①

EVERYDAY ENGINEERING SERIES  
NORMAN W. HENLEY PUBLISHING CO  
1 WEST 45 TH STREET, NEW YORK

**For the Handy Man in the Home or Shop**

There has always been a demand for a hand book of mechanical instruction that would help the average everyday man to do the many small jobs of repair work that are found around the home and shop.

**HINTS AND TIPS FOR AUTOMOBILISTS**

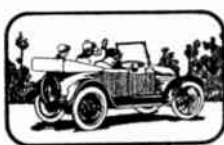

MONEY SAVING HINTS OF CARE AND OPERATION ALSO LOCATION AND REPAIR OF ROADSIDE TROUBLE

By  
VICTOR W PAGE

②

EVERYDAY ENGINEERING SERIES  
NORMAN W. HENLEY PUBLISHING CO  
1 WEST 45 TH STREET, NEW YORK

**For the Automobile Owner or Driver**

The book is ideal for the busy man or woman who wants to know about car operation and upkeep because of the economies possible when an automobile is intelligently operated. It contains many money saving hints.

**HOW TO MAKE & USE A SMALL CHEMICAL LABORATORY**



AN INTRODUCTION TO THE STUDY OF INORGANIC CHEMISTRY WITH DIRECTIONS FOR THE CONSTRUCTION OF A SMALL LABORATORY

By  
RAYMOND FRANCIS YATES

③

EVERYDAY ENGINEERING SERIES  
NORMAN W. HENLEY PUBLISHING CO  
1 WEST 45 TH STREET, NEW YORK

**For the Student Chemist and Experimenter**

This book gives all the necessary information for a well-grounded understanding of chemistry. It will not only be a help, but an inspiration to study further into this fascinating realm of science.

**SOLDERING & BRAZING**



A USEFUL HANDBOOK FOR MECHANICS

By  
RAYMOND FRANCIS YATES

④

EVERYDAY ENGINEERING SERIES  
NORMAN W. HENLEY PUBLISHING CO  
1 WEST 45 TH STREET, NEW YORK

**For the Mechanic and Model Maker**

This treatise gives all the necessary "kinks" that will enable one to accomplish successful soldering. If a mechanic has not succeeded in his soldering, this book may tell him just what he needs to produce good work.

**RADIO HOOK-UPS**



A BOOK OF THE MOST ADVANCED CIRCUITS OF RECEIVERS AMPLIFIERS AND TRANSMITTERS FOR DAMPED AND UN DAMPED WAVE WORK:

By  
M. B. SLEEPER

⑤

EVERYDAY ENGINEERING SERIES  
NORMAN W. HENLEY PUBLISHING CO  
1 WEST 45 TH STREET, NEW YORK

**For the Radio Experimenter and Amateur**

In this book, the best circuits for different instruments and various purposes have been carefully selected and grouped together. The result is a comprehensive summary of radio circuit diagrams for every purpose. A special feature of this book is the explanations which accompany each circuit, giving construction or operating details.

ALL of these Books are written in Simple Non-technical Language and contain Information of Real Value on Subjects of Timely Interest.

TRY TO SEND US FOUR NEW SUBSCRIBERS— WITH YOUR OWN— SO WE CAN SEND YOU THE SET OF SIX BOOKS

Fill Out the Special Blank Below  
Check Off the Title Desired and Mail with Your Remittance

Special Circular Describing These Books Sent on Request

The Experience and Knowledge of Experts Condensed and Simplified for the Handy Man—the Mechanic and the Radio Experimenter.

**DESIGN DATA FOR RADIO TRANSMITTERS & RECEIVERS**



SIMPLE METHODS FOR DESIGNING APPARATUS ACCORDING TO APPROVED AND PROVED PRACTICE

By  
M. B. SLEEPER

⑥

EVERYDAY ENGINEERING SERIES  
NORMAN W. HENLEY PUBLISHING CO  
1 WEST 45 TH STREET, NEW YORK

**For the Radio Engineer and Student**

In Design Data, radio experimenters are given such information, readily accessible, as to make it possible for them to have modern and highly efficient equipment and to get the best possible results from the instruments they make or buy.

<p><b>EVERYDAY ENGINEERING MAGAZINE</b> 2 WEST 45TH STREET NEW YORK CITY</p> <p>You may enter my subscription to EVERYDAY ENGINEERING MAGAZINE for ..... years at \$2.00 per year (Canada, \$2.25; foreign, \$2.50). Please let this start with the ..... issue. I enclose \$....., and according to your special offer send me copy of book checked off.</p> <p>Name .....</p> <p>Street .....</p> <p>City .....</p> <p>State .....</p> <p>TEAR OFF AND MAIL THIS NOW</p>		<p>EVERYDAY ENGINEERING SERIES OF HANDBOOKS Check off title desired here</p> <table border="1"> <tr> <td>1</td> <td>HOME MECHANIC'S WORKSHOP COMPANION</td> <td></td> </tr> <tr> <td>2</td> <td>HINTS AND TIPS FOR AUTOMOBILISTS</td> <td></td> </tr> <tr> <td>3</td> <td>HOW TO MAKE AND USE A SMALL CHEMICAL LABORATORY</td> <td></td> </tr> <tr> <td>4</td> <td>SOLDERING AND BRAZING</td> <td></td> </tr> <tr> <td>5</td> <td>RADIO HOOK-UPS</td> <td></td> </tr> <tr> <td>6</td> <td>DESIGN DATA FOR RADIO TRANSMITTERS AND RECEIVERS</td> <td></td> </tr> </table>	1	HOME MECHANIC'S WORKSHOP COMPANION		2	HINTS AND TIPS FOR AUTOMOBILISTS		3	HOW TO MAKE AND USE A SMALL CHEMICAL LABORATORY		4	SOLDERING AND BRAZING		5	RADIO HOOK-UPS		6	DESIGN DATA FOR RADIO TRANSMITTERS AND RECEIVERS	
1	HOME MECHANIC'S WORKSHOP COMPANION																			
2	HINTS AND TIPS FOR AUTOMOBILISTS																			
3	HOW TO MAKE AND USE A SMALL CHEMICAL LABORATORY																			
4	SOLDERING AND BRAZING																			
5	RADIO HOOK-UPS																			
6	DESIGN DATA FOR RADIO TRANSMITTERS AND RECEIVERS																			



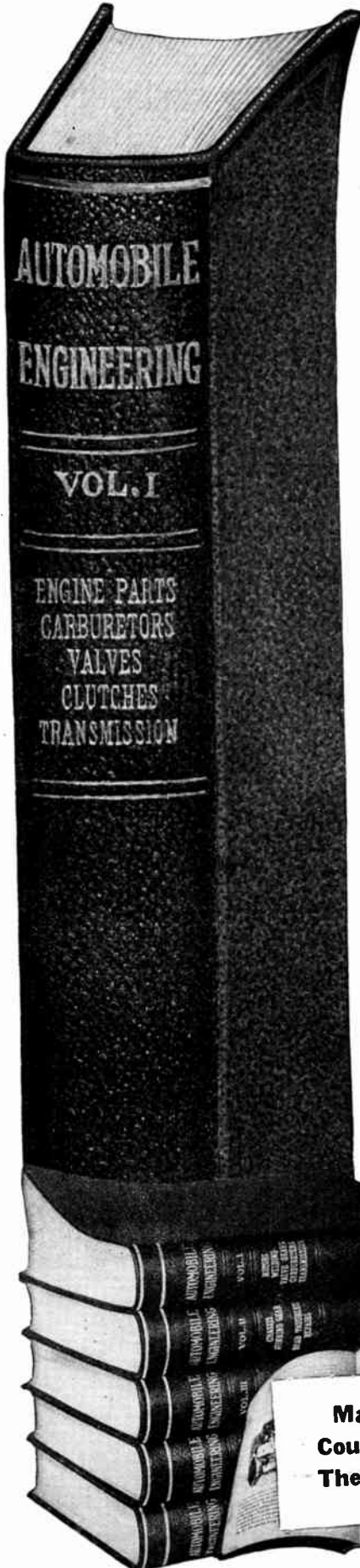

NAME	POSITION	SALARY
John	AUTOMOBILE ENGINEER	\$125 A WEEK
	REPAIR MAN	\$50 A WEEK
	CHAUFFEUR	\$30 A WEEK



## PUT YOUR NAME ON THIS PAY-ROLL

Men like you are wanted for big-pay positions in the fascinating field of automobile engineering. We have made it easy for you to fit yourself for one of these positions. You don't have to go to school. You don't have to serve an apprenticeship. Fifteen automobile engineers and specialists have compiled a spare time reading course that will equip you to be an automobile expert without taking any time from your present work.

## AUTO BOOKS

6 Volumes Shipped Free

Now ready for you—an up-to-the-minute six-volume library on Automobile Engineering, covering the construction, care and repair of pleasure cars, motor trucks and motorcycles. Brimming over with advanced information on Lighting Systems, Garage Design and Equipment, Welding and other repair methods. Contains everything that a mechanic or an engineer or a motorcyclist or the owner or prospective owner of a motor car ought to know. Written in simple language that anybody can understand. Tastefully bound in American Morocco, flexible covers, gold stamped, 2,600 pages and 2,300 illustrations, tables and explanatory diagrams. A library that cost thousands of dollars to compile but that comes to you free for 7 days' examination.

### ONLY 7cts A DAY

PARTIAL LIST OF CONTENTS
More than 100 blue prints of wiring diagrams
Explosion Motors
Motor Construction and Repair
Carburetors and settings
Valves, Cooling
Lubrication
Fly-wheels
Clutch
Transmission
Final Drive
Steering Frames
Tires
Vulcanizing
Ignition
Starting and Lighting Systems
Shop Kinks
Commercial Garage Design and Equipment
Electrics
Storage Batteries
Care and Repair of Motorcycles
Commercial Trucks
Glossary

Not a cent to pay in advance. First you see the books in your own home or shop. Just mail coupon and pay express charges when books arrive. You can read them and study them for seven whole days before you decide whether you want to keep them or not. If you like the books send only \$2.80 in seven days and \$2 a month until the special introductory price of \$24.80 has been paid. (Regular Price \$36.00.) Along with the set goes a year's consulting membership in the American Technical Society. (Regular price \$12.) This great bargain offer must soon be withdrawn.

### SEND NO MONEY NOW

Don't take our word for it. See the books without cost. There is so much profit in this offer for you, that we urge you to waste not a moment in sending for the books. Put the coupon in the mails today. Send no money—Just the coupon.

American Technical Society,  
Dept. A35c  
Chicago, Ill.

Mail The Coupon For These Books

Dept. A35c  
American Technical Society  
Chicago, Illinois.

Please send me the 6-volume set, Automobile Engineering for 7 days' examination, shipping charges collect. If I decide to buy, I will send \$2.80 within 7 days and the balance at \$2 a month until \$24.80 has been paid. Then you send me a receipt showing that the \$36.00 set of books and the \$12 Consulting Membership are mine and fully paid for. If I think I can get along without the books after the seven days' trial I will return them at your expense.

Name .....

Address .....

Reference .....

# Get Bigger Pay through ELECTRICITY

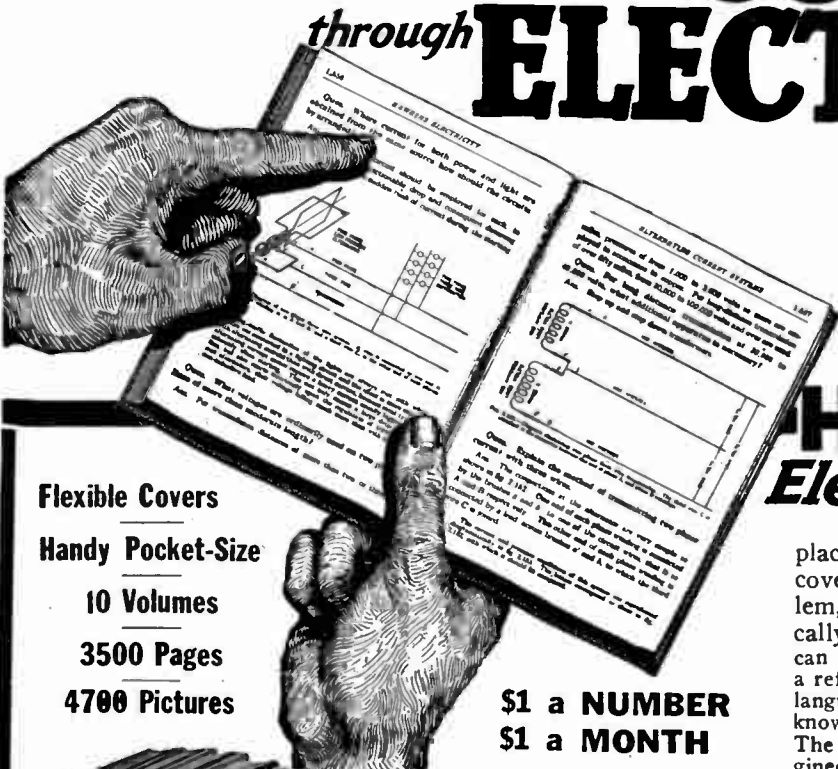

by using your set of **HAWKINS Electrical Guides Every Day.** They tell you just what you need to know.

## HAWKINS Electrical Guides

- Flexible Covers
- Handy Pocket-Size
- 10 Volumes
- 3500 Pages
- 4700 Pictures

**\$1 a NUMBER**  
**\$1 a MONTH**

place electricity at your fingers' ends. They cover every subject, principle, theory, problem, trouble, and way of doing things electrically. Every subject is indexed so that you can turn right to it. They are a study course and a reference guide in one, written in plain every day language—no wasted words—only what you need to know—full of up-to-the-minute electrical knowledge. The guides are a complete course in electrical engineering.

They will help you in every detail of the day's work. You can't ask an electrical question that Hawkins Guides can't give you help on.

### The **WHOLE SET** sent **FREE** for your inspection

The books are small enough to slip into your coat pocket—handsomely bound in flexible black covers.

You can carry each volume with you until you have mastered its contents. 3,500 pages of actual information and 4,700 illustrations. Once you see these books and put them into actual use you will never again want to be without them. Try it at our expense.

### TO EARN MORE—LEARN MORE

It will cost you nothing to receive these books—to look them over—ask them all the questions you can think of—use them in your work—study them—pick up some information that will increase your earning ability. We will ship you the entire set of 10 volumes entirely **FREE**.

This is a sign of our confidence in the guides. Pure gold does not object to being tested. Keep them for seven days and if you do not decide that you can't get along without them, return them to us and owe us nothing.

When you decide to keep them you only have to pay \$1.00 down and remit the balance of \$9.00 on the easy payment of \$1.00 a month till paid for.

Use the coupon to get the books. It will pay you many times over.

#### What Users Say:

Become a Superintendent  
Hawkins Guides are worth double their price. I have been able to secure higher pay and a better position with their aid.  
K. W. Monard,  
Supt. Erskine Light & Power Plant,  
Erskine, Minn.

\$5,000 Saved  
The ten dollars I invested in Hawkins Electrical Guides netted the company by whom I am employed somewhere around \$5,000.

The knowledge gained from your books enabled me to save a transformer house, whereas a year ago I should have thought myself in great danger and have run.

Use this letter as you please as I am truly thankful for having the little wonders.  
A. L. Foster, Opher, Colo.  
Handy to Carry  
The great beauty of them is that you can carry them in your pocket. That suits me for I never want to be without them.  
F. S. Collins,  
Richardson Engineering Co., Hartford, Conn.

**THEO. AUDEL & CO.**  
72 Fifth Ave., New York, N. Y.

THIS COUPON BRINGS THE GUIDES

**SEND NO MONEY**

THEO. AUDEL & COMPANY  
72 Fifth Avenue, N. Y.

Please submit me for examination Hawkins Electrical Guides (price \$1 each). Ship at once, prepaid, the 10 numbers. If satisfactory I agree to send you \$1 within seven days and to further mail you \$1 each month until paid.

Signature .....

Occupation .....

Employed by .....

Residence .....

Reference .....

#### READ THIS PARTIAL LIST OF CONTENTS

- No. 1 Contains 348 pages, 388 illustrations. Electrical signs and symbols—static and current electricity—primary cells—conductors and insulators—resistance and conductivity—magnetism—induction coils—dynamo principles—classes of dynamos—armatures—windings—commutation—brushes, etc.
  - No. 2 Contains 348 pages, 594 illustrations. Motor principles—armature reaction—motor starting—calculations—brakes—horse-power—selection and installation of dynamos and motors—galvanometers—standard cells—current measurement—resistance measurement—voltmeters—wattmeters—watt-hour meters—operation of dynamos—operation of motors, etc.
  - No. 3 Contains 300 pages, 423 illustrations. Distribution systems—wires and wire calculations—inside, outside and underground wiring—sign flashers—lightning protection—rectifiers—storage battery systems, etc.
  - No. 4 Contains 270 pages, 379 illustrations. Alternating current principles—alternating current diagrams—the power factor—alternator principles—alternator construction—windings, etc.
  - No. 5 Contains 320 pages, 814 illustrations. A. C. Motors—synchronous, and induction motor principles—A. C. commutator motors—induction motors—transformers: losses, construction, connections, tests—converters—rectifiers, etc.
  - No. 6 Contains 293 pages, 472 illustrations. Alternating current systems—switching devices—current breakers—relays—lightning protector apparatus—regulating devices—synchronous condensers—indicating devices—meters—power factor indicators—wave form measurement—switch boards, etc.
  - No. 7 Contains 316 pages, 379 illustrations. Alternating current, wiring power stations—turbines: management, selection, location, erection, testing, running, care and repair—telephones, etc.
  - No. 8 Contains 332 pages, 436 illustrations. Telegraph—simultaneous telegraphy and telephony—wireless—electrolysis bells—electric lighting—photometry, etc.
  - No. 9 Contains 322 pages, 627 illustrations. Electric railways—electric locomotives—car lighting—trolley car operation—miscellaneous applications—motion pictures—gas engine ignition—automobile self-starters and lighting systems, electric vehicles, etc.
  - No. 10 Contains 513 pages, 599 illustrations. Elevators—cranes—pumps—air compressors—electric heating—electric welding—soldering and brazing—industrial electrolysis—electro-plating—electro-therapeutics—X-rays, etc.
- Also a complete 128 page ready reference index of the complete library. This index has been planned to render easily accessible all the vast information contained in the 10 electrical guides. There are over 13,500 cross references. You find what you want to know instantly.

**SEND NO MONEY—USE THE COUPON**

Please mention **EVERYDAY ENGINEERING MAGAZINE**



PRACTICAL MECHANICS  
FOR EVERYDAY MEN

# EVERYDAY ENGINEERING MAGAZINE

IT TELLS YOU HOW TO  
MAKE AND DO THINGS

VOLUME 9

AUGUST, 1920

NUMBER 5

## Heat Treating Alloy Steels

*A Series of Simplified Articles Detailing the Various Methods of Heat Treating Modern Alloy Steels. This Installment Explains the Methods of Making Microscopic and Chemical Analysis in Determining Carbon Content of Steel*

By Victor W. Pagé, M. S. A. E.

### PART IV.

IT will be apparent to the reader that in a series of this nature it is not possible to cover the broad field of the metallurgy of iron and steel but before dealing with the heat treatment of alloy steels it will be well to describe briefly the influence of various percentages of carbon on the steel and also to explain how it is possible to determine the chemical composition of the steel by microscopic analysis which is done as shown in Fig. 1 and chemical analysis which is carried on by means of either of the combustion trains shown at Figs. 2 and 3.

The combustion method is a very good way of determining the carbon content by chemical means. Different tests are necessary to detect other alloying elements, such as nickel, chromium, etc. Steel is a generic term applied to a large variety of iron alloys which range from wrought iron, which is nearly carbonless at one extreme and cast iron, which is very high in carbon at the other extreme. Steel differs from either wrought or cast iron in that its nature may be changed by heat treatment and various internal structural modifications will take place either upon the application or abstraction of heat. Metal that contains less than .03% of carbon is not known as steel but is termed wrought iron or ingot iron, while a metal that has over 1.80% of carbon is cast iron. It will then be apparent that the material we know as steel, ranges, as far as its proportions of carbon are

concerned, within the limits mentioned above.

#### *Microscopic Analysis of Steel*

The use of the microscope in determining the amount of carbon and other alloying elements in iron and steel is of comparatively recent development. The pioneer work was done by Dr. Clifton Sorby, about fifty years ago, and it is due to the researches of this scientist that we know of the micro-structure of steel. At the present time

scratches. This polishing process is followed by etching the steel with various kinds of acid, depending upon the micro-constituent that is to be looked for and finally the small piece is mounted on a glass slide or in a special holder so it may be easily manipulated for inspection under the microscope.

It is not necessary to go into details regarding the polishing process, suffice it to say that this must be very carefully done, the piece being ground on a fine emery wheel and then polished by successive stages in which a start is made by using a piece of medium coarse emery cloth on an absolutely flat surface and then worked down by using finer grades of cloth successively and performing the final polishing operation by holding the specimen against a revolving block covered with a damp canvas cloth charged with a fine polishing medium such as crocus, tripoli powder or rouge.

After the piece has been polished it is

ready for etching. This is done by using various etching fluids, the one best adapted for general use being a saturated solution of picric acid in alcohol. The etching operation consists of moving the polished surface of the specimen in the acid for a period of time depending upon the nature of the material tested. This can only be determined by experience. The usual time for a plain carbon steel is about thirty seconds. If deeper etching is desired it may be necessary to immerse the polished surface for a longer period.

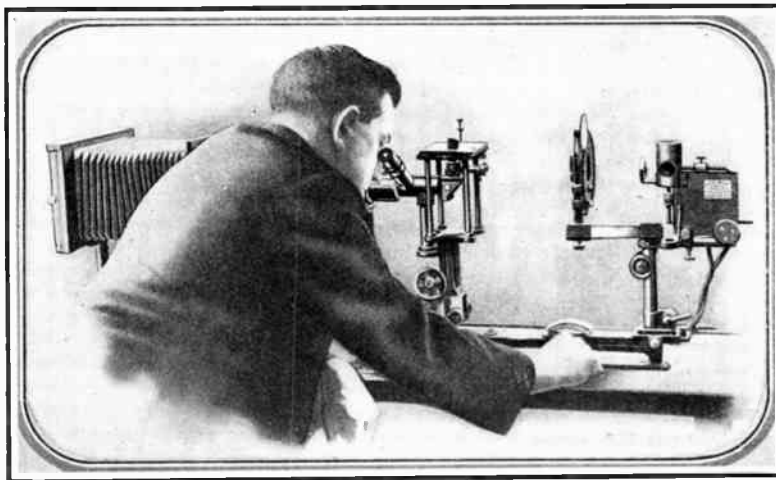

Fig. 1—Method of examining steel specimens under the microscope to determine micro-constituents

thirty different micro-constituents of steel are known. The micro-structure, which is produced by various heat treatments, enables one to determine very accurately if the heat has improved the metal or if it has damaged it as regards to strength, endurance, and other physical characteristics.

Before a piece of iron or steel can be examined under the microscope a small piece must be cut off the bar, then this must be ground to an absolutely level surface after which the piece must be polished so as to remove all

During the etching process, the lines of demarcation between the various crystals are intensified as these cannot be detected on the polished surface unless it is etched.

Care must be taken that the scratches made by the abrasive do not run always in the same direction when polishing.

After the etching process, the crystals of which the metal is composed are more sharply defined and are apparently bounded by walls. The etched specimen is illuminated by a powerful and concentrated light which does not illuminate the walls or spaces between the crystal but yet brings out the surface so that when viewed through the microscope, the illuminated crystals are marked out by black lines. The effect of increasing the carbon content of iron is to produce gradually augmenting areas of a compound known as pearlite, and when the proportion of carbon is about .90%, all of the ferrite or pure iron has been replaced by this new substance, known as pearlite. If the carbon proportions are augmented further, some of the pearlite is in turn replaced by another constituent known as cementite, and this material outlines the pearlite which tends to arrange itself into a triangular form.

The accompanying illustrations at Fig. 4, which are reproduced from the *Scientific American*, show clearly the appearance of pure iron after various percentages of carbon have been added to it. In a future installment, actual reproduction of photo-micrographs will be shown so that the reader will readily

understand how the name pearlite was given on account of the appearance of that material which is similar to mother of pearl under strong illumination. It is possible to detect other elements in steel and impurities in iron by the microscope, for example: sulphur and manganese forms manganous sulphide,

carbon steels and at that point if the steel is in a soft or annealed condition the structure shows no ferrite of cementite but the mixture of pearlite.

The changes in the structure of steel and the action of the iron and carbon it contains may be stated about as follows: To start with we have pure variety of iron, then by adding a little carbon we add a little cementite. At this point we have neither free cementite nor toally free ferrite, but a partial mixture of both known as pearlite and so on up to the point where sufficient carbon has been added so there is complete mixture of cementite, and iron and there is no free ferrite or cementite and only pearlite is shown.

When the carbon content exceeds .90% we have the pearlite stage and some excess of cementite. If the carbon should reach 6.06% we would have only cementite in the mixture, but it is not available commercially as either cast-iron or steel. The carbon content of a steel may be estimated by the metallurgist trained in this work by the relative percentage of the micro-constituents. As has been previously pointed out, if .90% steel will show all pearlite, one having half of that amount or .45% will show half ferrite and half pearlite, while a steel of 1.50% carbon will show .90% pearlite and .10% cementite. The micro-constituents of annealed simple carbon steel containing various percentages of carbon can be readily approximated, by the simple chart presented at Fig. 5, showing ferrite, pearlite and cementite.

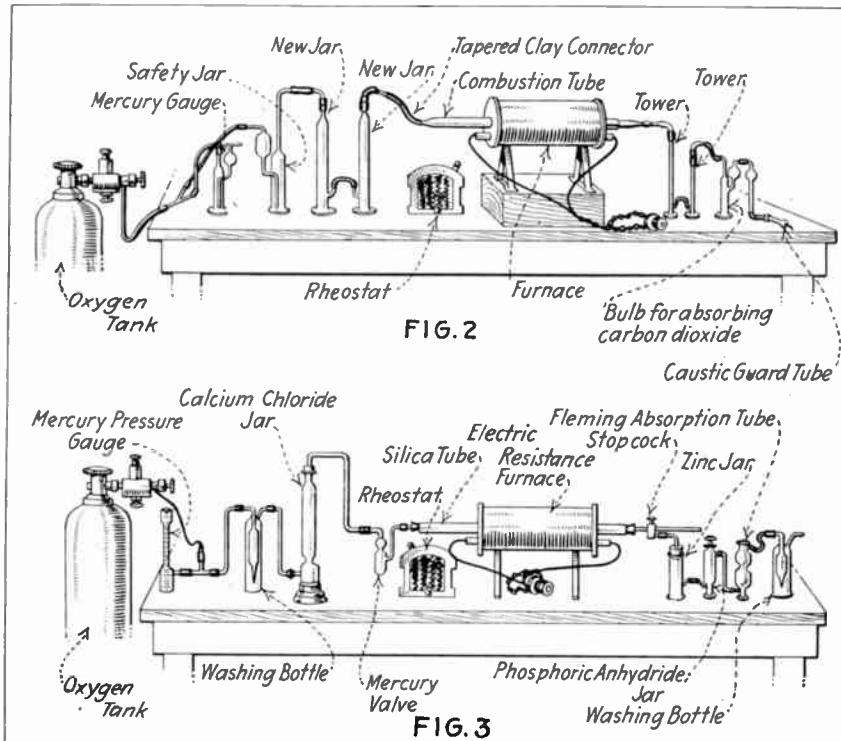

Figs. 2 and 3—Typical combustion trains for determining carbon content of steel by chemical analysis

which shows up a dove gray under the microscope.

**Composition of Simple Carbon Steel**

Steel is composed of pure iron or variety of iron carbide ( $Fe_3C$ , containing 6.06% carbon, 93.04% iron) together with various impurities in solution. A certain amount of the carbide will dissolve in iron and when that definite amount is exceeded there will be precipitated free carbide which is known as cementite. As previously stated the point of complete saturation is reached at .90% carbon in simple

carbon content of a steel may be estimated by the metallurgist trained in this work by the relative percentage of the micro-constituents. As has been previously pointed out, if .90% steel will show all pearlite, one having half of that amount or .45% will show half ferrite and half pearlite, while a steel of 1.50% carbon will show .90% pearlite and .10% cementite. The micro-constituents of annealed simple carbon steel containing various percentages of carbon can be readily approximated, by the simple chart presented at Fig. 5, showing ferrite, pearlite and cementite.

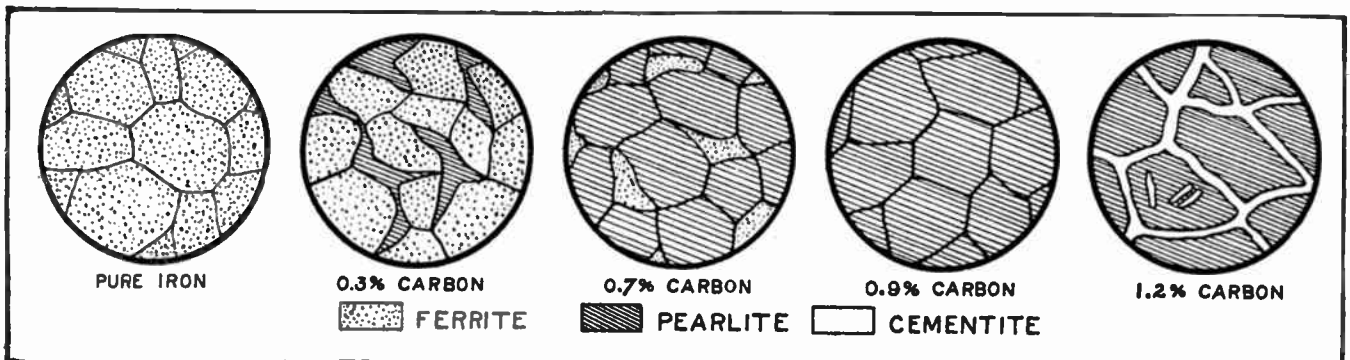

Fig. 4—Sketches of photo-micrographs showing how various percentages of carbon change the structure of steel when examined under a powerful microscope



**Chemical Analysis of Steel**

Having explained in a simple way how it is possible to determine the carbon content of steels by micro-analysis, an attempt will be made to show how the carbon content of steel is determined by the chemist using analytic methods. It is believed that the reader who is interested in the subject of heat treatment will be better able to understand the discussions which are to follow, if he has some idea of how it is

amount of carbon contained in the steel is determined.

The steel is divided into very fine chips or coarse filings and is placed in a small shallow "boat" or tray of clay and then put into a combustion tube. Various chemicals used in the train of apparatus are for removing impurities and moisture from the oxygen gas and also from the carbon dioxide gas given off by the combustion of the carbon contained in the steel.

and there is no longer any guess work in determining the amount of carbon or any of the alloying elements ordinarily used in connection with iron and steel manufacture. In the next installment the various critical points in plain carbon steels will be described and the effect of heat treating steel at points other than those indicated to be best will be considered.

(To be Continued)

**UNUSUAL MONOPLANE DESIGN**

RATHER radical ideas on airplane design are embodied in a machine under construction by the Stout Engineering Laboratories from designs of William B. Stout, and reported in *Automotive Industries*. It is called the Stout bat-wing monoplane and its chief characteristic is that all the machinery, trussing, etc., is in the wing. The engine is set into the leading edge, the passengers are enclosed between the surfaces of the wing and every part exposed to the air is designed to lift. Central part of wing is thick and of long chord, the tips are thin and narrow. For this reason and on account of the peculiar trussing inside, all formed of plywood, the plane is said to be exceptionally light. Not only the frame, but the surface of the wing, as well, is of strong, waterproof veneer, the surfacing being only 0.05 inch thick and three-ply.

Each wing is supported on either side by nine spars, and two of which are said to be strong enough to support the ship should the others be shot away. The longest spars, with a spread of 20 feet, weigh only 7½ pounds and supported in test over a ton per pair without breakage. The radiators pull into the wings when cold altitudes are reached, and the heat from them is utilized to warm the passengers and pilot. In the large type even the landing gear is pulled into the wing when the ship is off the ground.

A new ship of this type being laid down has a span of 100 feet, a wing depth of 7 feet at the center, and has within it a compartment for mail, bombs or passengers, as the case may be, this cabin being 30 feet long, 6 feet high and 8 feet wide.

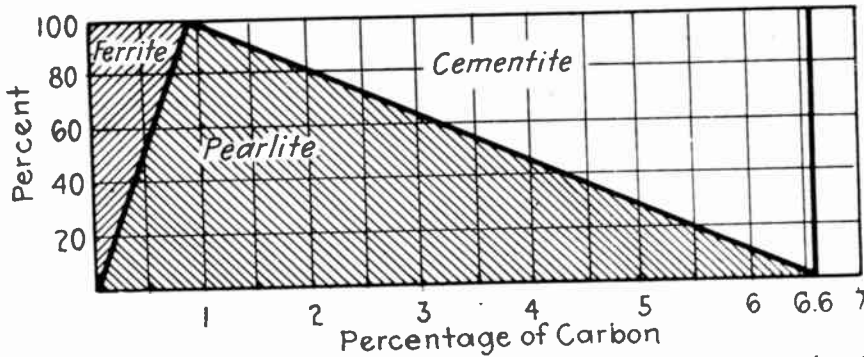

Fig. 5—Chart showing influence of carbon percentage on character of micro-constituents of annealed steel

possible for the chemist to determine accurately how much carbon or other alloying elements are in combination with the iron to form steel.

The arrangement of chemical appliances at Fig. 2 shows a combustion apparatus designed by C. N. Johnson, and supplied by the Scientific Materials Company. It is used for determining the amount of carbon in iron or steel by direct combustion and it is stated that the elimination of all rubber stoppers reduces the liability of gas leaks. The electric furnace is of the resistance type and can be supplied for either 110 or 220 volt circuits. It can be used with either alternating or direct current. The mercury gauge is used to detect gas loss and stoppages in the apparatus. The next is a safety jar which is filled with a potassium hydrate solution. Then we have a new jar, one-half of which is filled with anhydrous calcium chloride and the other half with granulated soda lime. The next new jar is provided for lump caustic potash.

The combustion tube, which is inside of the furnace, is made of vitrified clay and is provided with taper connectors for the rubber sleeves which join one end of the combustion tube to the new jar and the other end to the tower. The rheostat is used for the regulation of the furnace temperature. The first tower is used for granulated zinc, the second tower is used for phosphoric anhydride. The bulb for absorbing the carbon dioxide gas, which is produced by burning out the carbon from the steel specimen in the combustion tube in the presence of oxygen, is used for weighing and it is from this that the

The outfit shown at Fig. 3 is known as a Fleming combustion apparatus, and while it operates on practically the same principle as Johnson's combustion train shown at Fig. 2, it differs from it in some respects. It is stated that only five minutes are required to make a combustion test and that a feature of the absorption tube is that there is no possibility of the CO<sub>2</sub> or moisture escaping even though the oxygen current passes through the combustion tube at the rate of 600 cubic centimeters per minute. The apparatus consists of a mercury pressure gauge to detect leaks by falling pressure and stoppage by rising pressure. Next is a washing bottle, then a calcium chloride jar which is joined to a mercury valve. The combustion tube is of silica and varies from twenty-four to thirty inches long and from three-fourths of an inch to seven-eighths of an inch inside diameter. The furnace is the same type as shown at Fig. 2, as is the current regulating rheostat. The remainder of the apparatus performs the same functions as in the outfit illustrated above it.

It is not within the province of this series to go into the methods used for carbon determination because this can be found in detail in text books devoted to the subject. The reason for presenting these combustion trains in this article is to make clear to the reader how it is possible to test the steel and determine its composition as relates to alloying elements accurately by chemical analysis and the type of apparatus that can be employed for that purpose. The chemical test can be checked up by a microscopic analysis

**COMPOUNDS OF LEAD**

Red lead, litharge, and white lead are all compounds of lead. Litharge and red lead are oxides of lead, except that the red lead contains more oxygen than the litharge. A still higher oxide of lead called the peroxide is brown. White lead is a basic carbonate of lead. It will be appreciated, therefore, that the compounds of lead are quite varied in color.

# Electrons and the Constitution of the Chemical Atom

By Prof. T. O'Connor Sloane

IT is fair to say that the constitution of the atom is still unsettled and is a subject for theorizing and investigation. Perhaps the best conception of it as it is now generally accepted is to start with the hydrogen atom. All atoms are supposed to be made up of a nucleus which is charged with positive electricity and holds within the limits of the atom one or more electrons charged with negative electricity. It is something like the solar system in which the sun would represent the nucleus and the planets the electrons. The electron carries a charge of negative electricity. Every electron carries precisely the same charge, so that we here have in nature a fundamental unit of electric quantity. The positive charge of the nucleus of an atom is equal to the sum of the charges of the electrons of that atom. Returning now to our hydrogen atom

under the earth's surface. A very convenient way to think of an atom is to figure it as a sphere with the nucleus in the center.

In the case of helium we may place an electron at the North and South Poles. We now may think of the surface of this sphere as divided into eight equilateral spherical triangles whose bases are  $90^\circ$  in angular measurement and lie upon the equator and the apex of each of which is at the North or South Pole. Now in addition to the North and South Pole electrons, place an electron in the center of each of these triangles and we will have eight additional symmetrical points indicated on the sphere. Such points may be picked out easily on a terrestrial globe. The atom we have just described would have ten electrons and the nucleus would possess ten unit charges of positive electricity. This

This is the atom of argon, another element absolutely without affinity. The seventeenth of the elements in numerical order is sodium and argon is the eighteenth. Between hydrogen and argon there come in sixteen elements in numerical order, giving a total of eighteen, including sodium and argon; the numerical order of each element expresses its number of electrons. If we double the electrons of the argon atom we double of course the positive charges in the nucleus and we will have a 36 electron atom, also perfectly balanced and incapable of combining with anything. This is the 36th element in the numerical order and is called krypton. Between argon and krypton come in thirty-four elements one for each additional electron, so as to make an even series of numbers. Next adding eighteen electrons to krypton we get xenon with fifty-four electrons, and finally by adding thirty-two electrons to the fifty-four xenon we get the niton atom with eighty-six electrons. These are the six perfectly balanced atoms which can combine with nothing. Approximately the half of the atomic weight of an element gives the number of the electrons of its atom in the series. There are a very few vacant spaces counting each space as if we had discovered the element to fit it. Assuming the missing elements to exist we find there is a total of ninety-two elements. It will be evident that there is a relation of the number eight to atomic properties. As long ago as 1864 Newlands had the idea of chemical octaves and the number eight appears in the modern table of atoms very definitely.

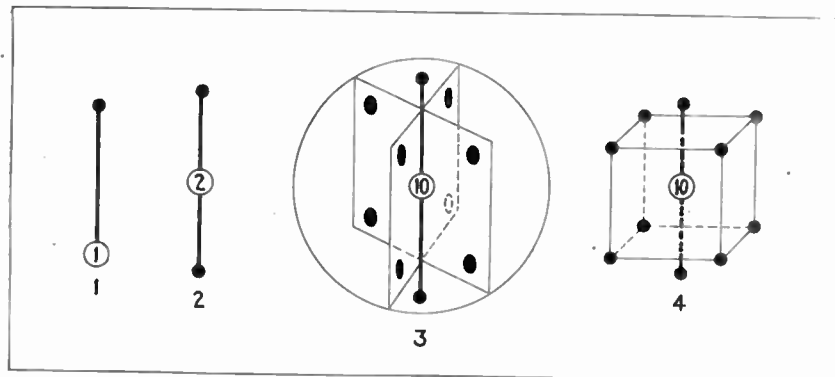

we must think of it as consisting of a nucleus with a unit positive charge and a single electron with a unit negative charge. This makes a one sided structure. There is no balance or equilibrium about it, therefore it cannot exist alone, but must combine with another atom so that the vacant space, as we may term it, shall be taken care of. We find, therefore, that hydrogen has very high chemical affinities. Now suppose that another electron is added to the atom and that another positive charge is added to the nucleus. Here we have a perfectly balanced atom; it is like a balance-beam with equal weights at each end. This atom takes care of itself, it combines with nothing and cannot be forced into any combination. Chemically speaking it is found to be absolutely neutral and without any affinity. It cannot enter into any chemical compound. This substance is helium. It is a very light gas and exists in considerable quantities

atom would be in perfect balance and would be perfectly symmetrical. It would combine with nothing, as there is no vacant place upon it for another atom to attach itself, and this describes the atom of the element neon, a second element without any affinity whatever.

If we examine the list of elements we will find that from hydrogen to neon inclusive there are precisely ten elements taking them in the order of their atomic weights. We shall give later the list of the elements in their order, one set of figures expressing their numerical position as well as the number of electrons in the atom of each element, while the other row of figures expresses their atomic weight. Suppose now that we add eight more electrons to our atom. These we may suppose to lie in a sphere concentric with the other and they involve the possession by it of eight more unit charges of positive electricity by the nucleus. Again we have perfect equilibrium.

The valency of an element indicates the number of vacant electron spaces in its atom. This is a general way of putting it and from the popular standpoint it is perhaps as good as any. We have seen that the hydrogen atom has one vacant place where an electron might fit. Hydrogen, therefore, has only a valency of one or is a monad element. The element oxygen has eight electrons in its atom. We have seen that a ten electron atom is perfectly balanced and neutral; if we subtract eight from ten we have two, so that oxygen is an element whose atom is two electrons out of balance and is therefore a dyad or of twofold valency. We may go right through the list in this way and find that the vacant electron spaces correspond very

closely to the old time bonds, which latter are still used in chemical formula.

Thus if an atom of oxygen combined with hydrogen one atom of hydrogen would take care of each vacant space. A molecule would be formed containing two atoms of hydrogen and one of oxygen, which would be properly expressed by the formula  $H^2O$ , and that is, as our readers know, the formula of water.

But the most interesting thing about the electron theory of the constitution of atoms is that we have an almost complete list of elements found by chemists and physicists successively increasing in atomic weight by almost even additions, so as to lead to the conclusion that starting with single electron hydrogen, then with two electron helium, we can go right down the list, each element having one more electron than its predecessor. Thus the numerical position of an element in this list tells us the number of electrons which it contains and tells us the charge of its nucleus.

We have said that the atom is comparable in structure to the planetary system with the sun to represent the nucleus. Whether the electrons have independent motion within the limits of the atom, and if so what such motion is, we do not know.

Various illustrations have been given of the relations of nucleus and electrons. One authority says that if an atom were ten meters in diameter the electron would not exceed one-tenth of a millimeter in diameter. This is one one-hundred-thousandths of ten meters. On this conception the atom is principally empty space, and its mass which gives it weight and inertia is taken as concentrated in the nucleus and this leads to a very extraordinary conclusion. If it were possible to fill a cubic inch with a nuclei of gold atoms in close contact with each other the weight would exceed three million tons.

The absolute size of an atom is roughly estimated from various considerations, among others by observing the interference colors of a soap bubble film. Its thickness can be calculated. When it is on the point of breaking and the film on the top is at its thinnest, showing black, it is taken as being approximately a molecule in thickness. The color of gold films deposited on glass, which also may be made extremely thin and the thickness of the oil films floating on water all give an idea of the possible size of a molecule. A crude way to get at this figure is by the use of the microscope, to determine the smallest quantity of dye that can be seen by man. From these and other considerations one conclusion reached is that the diameter of a molecule is less than a millionth of a millimeter.

If a molecule is composed of the smallest number of atoms compatible with its valency we may get from the above some idea of the size of an atom.

An electron is defined as a corpuscule of electricity. The possession of the property of producing self induction is taken as showing that electricity possesses inertia or mass. It is taken as almost certain that the mass of an electron is entirely due to its charge of electricity. This brings us to the electric theory of matter, which states that all matter is composed of electricity coming pretty close to the old doctrine of subjective ideality, and bring us perilously near the point where the words of Milton apply, and we will "find no end in wandering mazes lost."

We have no exact knowledge of the constitution of the nucleus. We know that it is the seat of intense force, so intense that chemical methods cannot affect it. In radio-active emission electrons are detached from the atom forming beta and alpha particles; the latter are found to be helium gas, the first of the six saturated or neutral elements, with atomic weight of four. This is taken as indicating a grouping of positive electrons in the nucleus in groups of two.

gine is effected by means of compressed air. As the boat in question, together with other similar boats, has been entered for most of the coming season's motor boat races, it may be confidently expected that the above-mentioned speed will be still further improved upon. The accompanying illustration shows how our own Liberty engine has been installed in a very fast motor boat of American design that made speeds in the neighborhood of one mile per minute in its trials. American racing craft fitted with two Liberty motors have attained speeds of over 75 miles per hour.

#### SYNTHETIC FUEL OIL

It is reported from Germany that wartime experiments showed that the distillation of lignite at a high temperature gave a liquid coal tar which contained certain ingredients suitable as a substitute for gasoline, kerosene, and lubricating oils. Through a new process benzene and kerosene can be obtained from liquid coal tar, which has been distilled from lignite at a lower temperature, and all industries using lignite are urged to set up facilities for generating this liquid coal tar and thus secure synthetic products to supply the lack of the natural products. It is

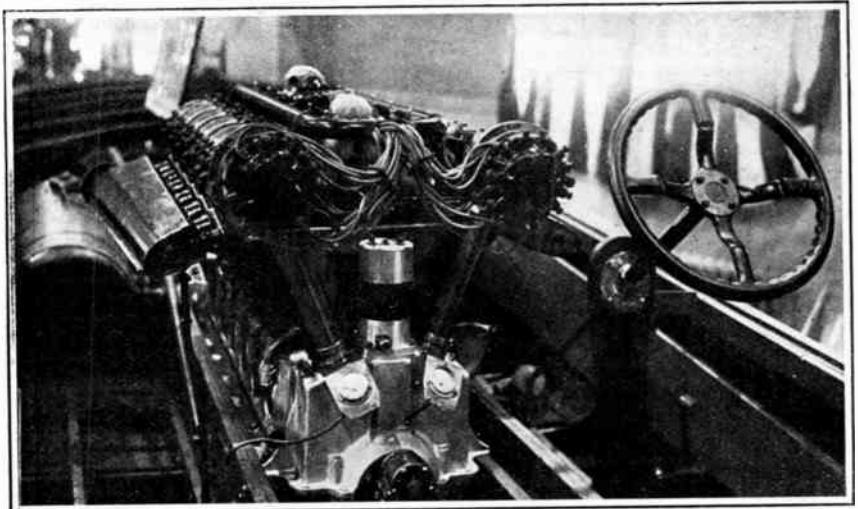

How the 400 H.P. U. S. Standard or Liberty motor is installed in a speed boat hull

#### AIRPLANE ENGINES FOR RACING BOATS

**T**HE new motor boat built by M. Despujols in Paris, which succeeded in attaining a speed of 75 miles per hour, is fitted with a Sunbeam-Coatalen engine of the "Matabele" type, suitably modified for use in motor boats. For motor boat purposes the engine is fitted with an exhaust manifold of special design, which acts as an efficient water-cooling arrangement. The engine is mounted on special resilient mountings and the drive is through a flexible coupling to a gear box by which the speed of the propeller is geared up to 3,000 r.p.m. The starting of the en-

gine is effected by means of compressed air. As the boat in question, together with other similar boats, has been entered for most of the coming season's motor boat races, it may be confidently expected that the above-mentioned speed will be still further improved upon. The accompanying illustration shows how our own Liberty engine has been installed in a very fast motor boat of American design that made speeds in the neighborhood of one mile per minute in its trials. American racing craft fitted with two Liberty motors have attained speeds of over 75 miles per hour.

interesting to remark that at this time when there is a shortage of fats in central Europe, German newspapers are advertising a liquid soap containing a percentage of alcohol for shaving purposes. This is undoubtedly a by-product.

Bismuth subnitrate has been a favorite medicine for treatment of stomach troubles. During the early part of the war all sources of bismuth became exhausted and now it is said that kaolin, the pure white clay used in making fine porcelain, can act as a substitute and has been demonstrated to be efficacious in the treatment of stomach complaints. It certainly will be an innocent medicine operating by its porosity, as it is quite insoluble in the gastric juices.



# Industrial Niagara

*How a Small Part of the Energy of the River Producing This Great Waterfall Is Made To Do Useful Work*

By Raymond Francis Yates

AS we view the titanic waterfall of Niagara we are inspired by its terrible thunder, entranced by its omnipotence. We are indeed under a spell—the spell of some inconceivable yet ever-existing spirit—the “Spirit of Niagara.” It toys with the soul strings of the

power. He cared not for its grandeur, for in it he saw a spirit—he felt the “Spirit of Niagara.” To satisfy his superstition the fairest maiden in the tribe, in a flower-bedecked canoe was willingly sacrificed to the “Great Spirit.” The red man’s wigwam has vanished. Vanished is the smoke from his campfire, for now, in ever-changing measures, the smoke of a hundred industries mingles with the mist of the mighty waterfall. Gone are the red man’s pathways where now wind great highways of traffic. This mighty waterfall has run relentlessly for countless centuries. But when the white man came he invaded the realm of the “God of Waters” and wrested the secret from him; bade the waters to dash and roar to a purpose.

## *Birth of the Project*

It was in the year 1852 that the first power project in Niagara Falls saw its birth in the starting of the Hydraulic Canal. The canal which now plays a very momentous part in the

Niagara power development extends from the upper river to the banks of the lower river, which gives its water the same drop as the falls. With the digging of the canal the Niagara Falls Hydraulic Power Company was incorporated. At the outbreak of the Civil War, operations on the canal and power equipment were suspended, and for years the water gushed over the cliff unused. In 1877, new life was put into the movement and four years later the first electrical energy ever furnished by the waters of Niagara was generated. From that period the canal has been enlarged and deepened many times, for the men associated with the movement realized that the harnessing of Niagara was no longer a venture but a reality.

The two generating stations of the Hydraulic Power Company stand huddled in the shadow of the towering cliff within the roar of the mighty Niagara itself. It is from these two sturdy structures of stone and steel that nearly 200,000 electrical horsepower is launched, by a network of wires, to meet the needs of the many industries all of which contribute to make Niagara Falls a potent factor in the commercial world. Many patrons of the Hydraulic Power Company are situated on the bank directly above the generating stations, and, being so close, it is possible for the company to supply the different industries with power that is fitted to their needs without the use of an elaborate transmitting system.

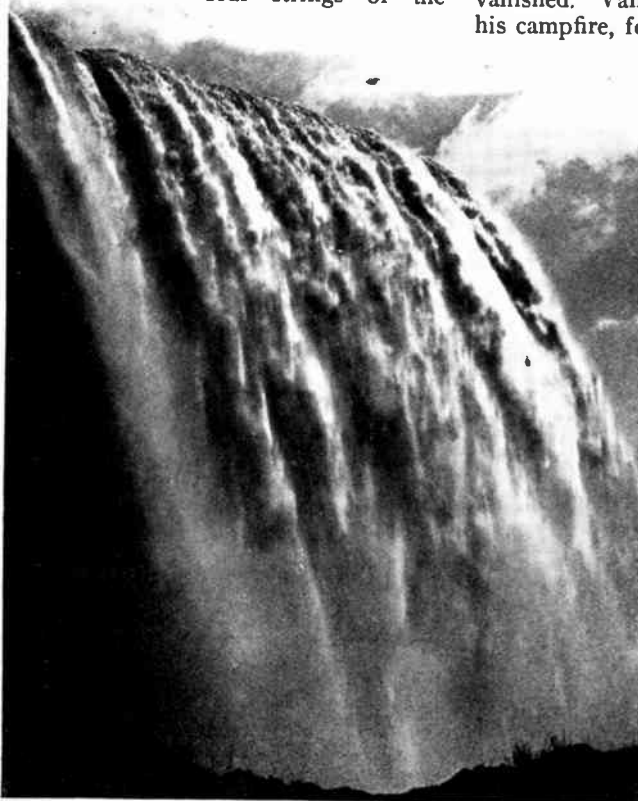

*Niagara Falls, one of Nature's marvels, is being harnessed by man and some of its titanic power diverted to useful work*

most mundane observer, and the strongest minded are powerless to withstand its aesthetic appeal. We look into the awful depths below and watch the crystal waters, as if beckoned by some unseen force, glide off the apex and leap into the terrible abyss. In the stream below the waters again become peaceful and move with a sluggish current on down the gorge with growing calmness to again be churned into turbulence by the witchery of the rapids below.

Back in the dim past, the illiterate red man gazed at this mighty waterfall. He thought not of its immeasurable

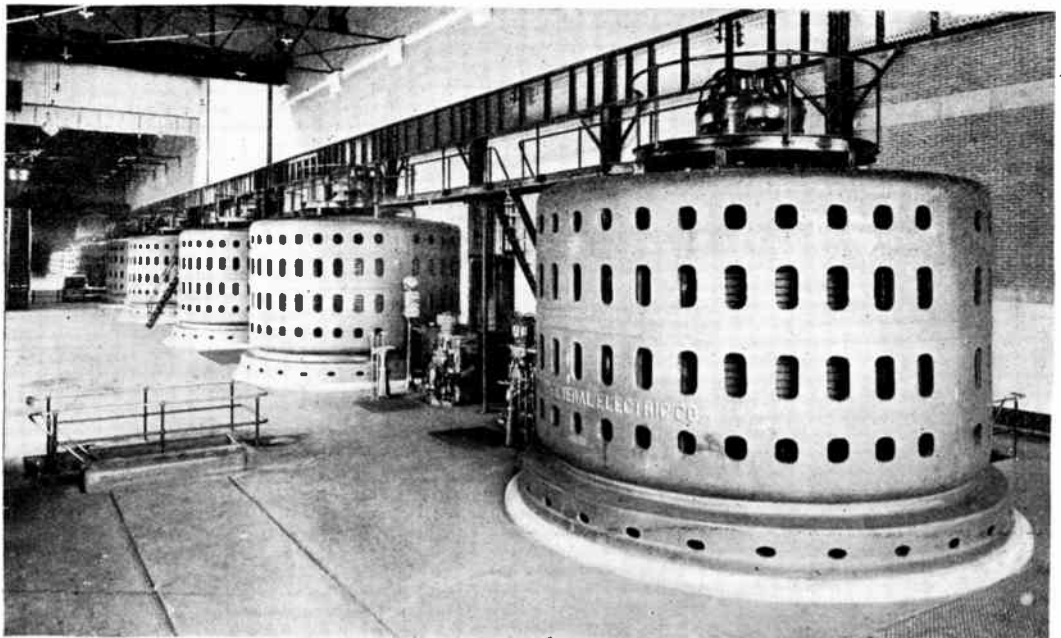

*View in one of the power houses, showing the long line of generators driven by turbines far below them*

A few years ago the Hydraulic Power Company installed 13,000 H.P. units and it was then thought that this was the limit of engineering. In fact, it

water passes into the power houses located on each side of the canal and thence on to the penstocks. The penstocks, which are seven feet in diameter,

imparted its energy at a pressure of 55 pounds to the square inch to the turbine, it is discharged into a large tunnel which carries it off under the city of Niagara Falls for a distance of 7,000 feet, where it discharges into the lower river almost directly under the famous Steel Arch Bridge. This tunnel is 18 feet in diameter and the largest of its kind in the world.

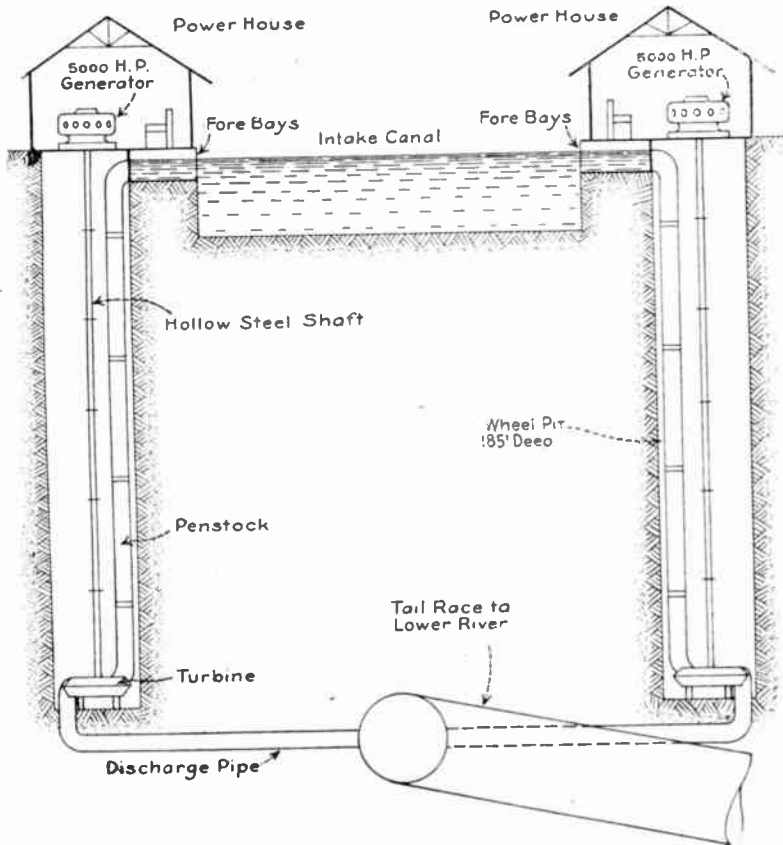

Sectional plan view showing placing of generators and turbines and how the penstocks supply water from the intake canal to the water wheels below

was at that time. The penstocks feeding turbines were but nine feet in diameter and a solid column of water this diameter was passing through the penstocks at a speed of three miles per minute.

The latest units to be installed by this company have a capacity of 37,500 H.P.; nearly three times as large as their forerunners. The penstocks feeding these gigantic turbines are fourteen feet in diameter.

*How Power is Utilized*

Situated on the upper river about a mile above the falls are two power houses owned by the Niagara Falls Power Company, and which, if judged by the engineering problems that were met with in their construction, are two of the greatest man-made wonders of the age—veritable castles of volts and amperes. They stand out rather boldly with the slowly moving river in the background, and as the setting sun casts its rays on the crystal waters, our thoughts are for an instant returned to the humble red man—to think these modern creations of science stand on his very hunting grounds.

The water from which these stations operate is drawn from the river by a short intake canal. From the canal the

extend vertically for 180 feet below the surface into a long, narrow pit over which the building stands. At the end of each penstock is adjusted a large turbine with a long, vertical, steel shaft which is connected to the generators in the station above. After the water has

In Power House No. 1 of the Niagara Falls Power Company, which was the first to be built, are ten generators of the revolving field type, each with its respective turbine and connecting shaft. These machines have a capacity of 5,000 horsepower each and generate alternating current of 2,200 volts, two-phase, twenty-five cycles running at 250 revolutions per minute. At the side of each generator is located a governor which automatically operates the large valves on the turbines below and thereby controls the amount of water flowing through the turbines. This keeps the generators running at a very uniform speed, which is imperative. The total weight of the revolving parts of each machine is about 240,000 pounds.

This would naturally make the problem of lubrication a difficult one. It is accomplished in a very unique manner. At the extreme end of each shaft is fastened a large metal disc which is enclosed in a compartment of the turbine wheel case. Into this compartment water is forced at a great pressure upward against the disc. This method avoids hot bearings and reduces friction to a minimum. A few feet beneath the generators is placed another large bearing. This is a thrust bearing and consists mainly of two discs, one stationary and the other connected to the shaft. Between these two discs oil is forced

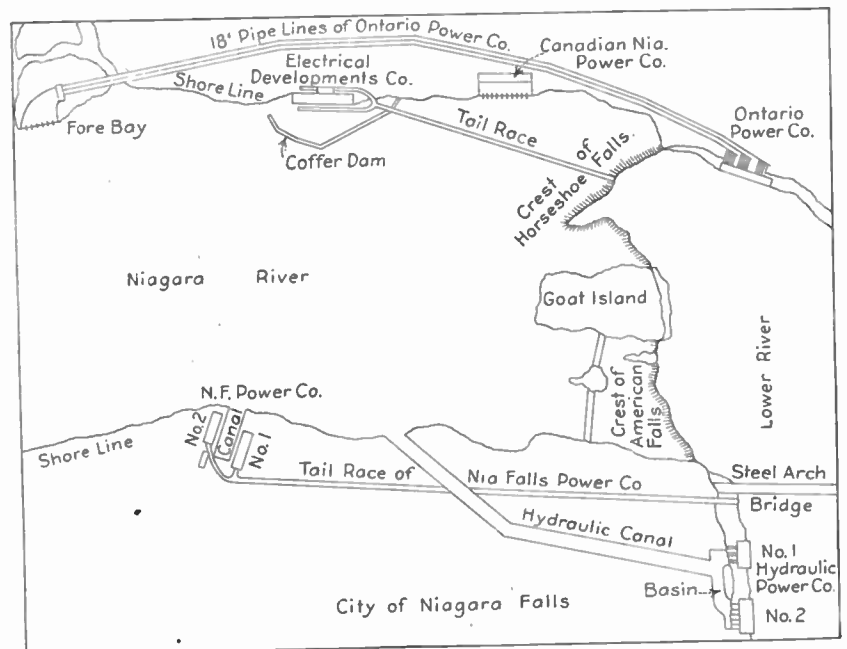

Plan of power plant development for utilizing some of the potential power of the Niagara River on both American and Canadian sides of the falls

under a very heavy pressure.

Power House No. 2 of the Niagara Falls Power Company, which was completed in 1904, is very similar to Power House No. 1. The main difference is in the last five machines which are of the internal field construction. The capacities of these machines are the same as those of the revolving field type. There are eleven generators in this plant which makes the total output 55,000 horsepower. This combined with the 50,000 horsepower of Power House No. 1 makes an output of 105,000 horsepower for the Niagara Falls Power Company on the American side of the river.

The company supplies local service directly from the generator bus-bars at generator cycle and voltage. The electro-chemical processes operating in the upper river district and calling for direct current, operate their own rotary converter stations. The factories in the immediate neighborhood of the power house are supplied by a system of underground cables. For long-distance transmission the current is taken from the generator bus-bars and fed to air-blast, step-up transformers. It leaves the transformers at 22,000 volts and is distributed by a three-phase system overhead to Buffalo, Tonawanda and Lockport.

Companies generating power on the Canadian side of the river are: Canadian Niagara Power Company, the Electrical Development Company of Ontario and the Ontario Power Company.

The Ontario Power Company employs a novel system for converting the power of Niagara. This is probably one of the most interesting and carefully planned hydro-electric systems in use today. About a mile above the Horse Shoe Falls, at the beginning of the rapids, is a large forebay and screen house through which the water passes into three large pipes that lead to the power house located in the gorge directly across from the American Falls. These pipes, which measure 6,200 feet in length and 18 feet in diameter, are the largest used for hydro-electric purposes in the world. At the top of the cliff, directly

above the generating station, the pipes are each divided into eight smaller penstocks. Six of these are 9 feet in diameter and two are 30 inches in diameter. Just before the larger penstocks enter the twin wheel turbines which they drive, they are divided into two separate branches, one for each wheel of the turbine. The wheels of the turbine revolve on a horizontal shaft which is directly connected to a

more than 350,000 horsepower can be generated on the American side of the river. In other words, not more than 20,000 cubic feet of water can be used per second. At the present time only 15,600 cubic feet is being used. The companies on the Canadian side are, however, granted 36,000 feet per second. Of the power generated from this, 160,000 horsepower may be brought into the United States.

The above is only a puny fraction of the amount of power it would be possible to produce from the waters of Niagara. The flow in the river is approximately 222,000 cubic feet per second. This great amount of water falling 300 feet in five miles, as it does, would theoretically be equivalent to 7,500,000 horsepower!

Niagara was America's greatest industrial ally in the world war. It was an absolute necessity to the development and maintenance of our war machine. It was responsible for the whirr of a myriad of wheels and nearly every industrial establishment in the country was dependent upon it to a greater or less extent.

Every great battleship in our navy that cut its way through the blue waters of the sea, every shell that whistled through the air from her guns, every torpedo that rushed to its mark, every submarine that glided unseen beneath the surface, and every airplane that soared aloft carried with it one or more products made possible by Niagara.

#### *Niagara as One of the Allies*

Without steel, modern warfare as we understand it, would be impossible, as we could have no battleships, artillery, shells, submarines, railroads, automobiles or warplanes. Steel is no longer a simple mixture of iron and carbon. The great armor-piercing shells of today would pass through such steel with ease. Modern steel is extremely hard, resistant and tough. This is made possible by the addition of certain alloys that alter the physical properties of steel, making it more tenacious. Niagara and its abundant hydro-electric power, through the medium of the wonderful

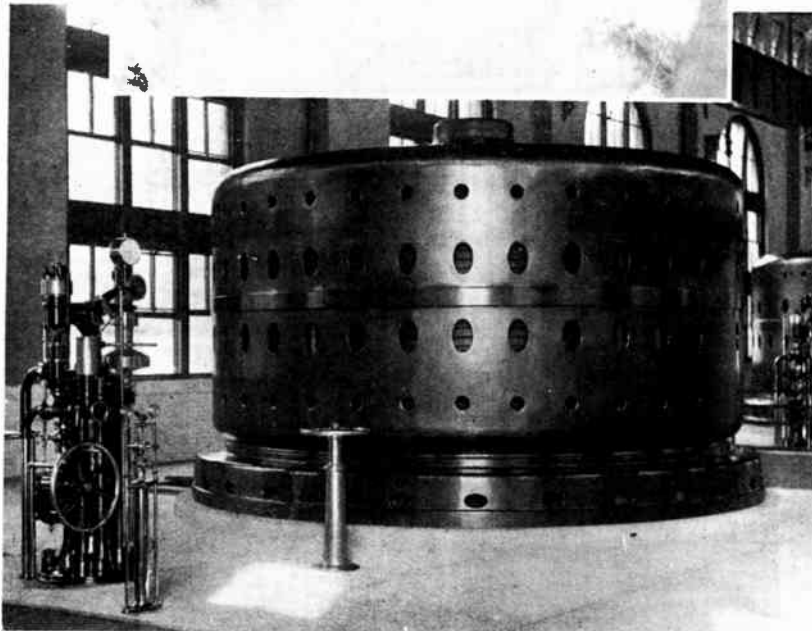
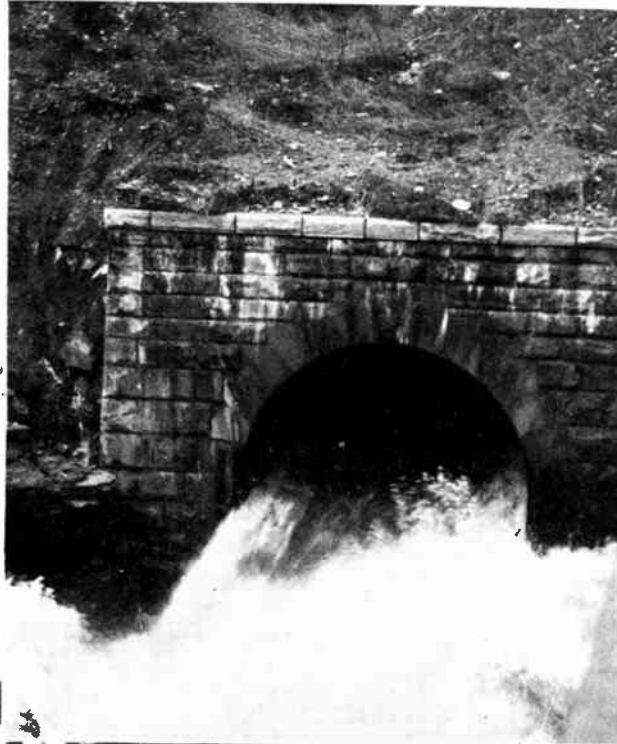

*The upper view shows one of the tail race outlets. The lower illustration is that of a 5,000 H.P. generator and its driving turbine control apparatus*

10,000 horsepower generating unit of the revolving field type. These machines run at  $187\frac{1}{2}$  revolutions per minute and produce alternating current of 25 cycles, 3-phase, at a potential of 12,000 volts.

#### *Power Obtained Limited*

As a result of the International treaty, the Burton Act, between the United States and Great Britain not



electric furnace, is providing ferro-alloys for 85 percent of the 28,000,000 tons of basic open-hearth steel produced annually in the United States. Ferro-silicon is very necessary in the production of certain grades of steel and Niagara at present supplies the entire demand of America. Every battleship in our navy has many tons of ferro-chromium in its armor, as this is the essential hardening element in the manufacture of armor-plate as well as armor-piercing projectiles.

A prominent English scientist calculated that a modern 12-inch shell, with a velocity of 1,700 feet per second, has twice the striking force of an express train traveling 45 miles per hour, yet the shell has but 1/8000 the bulk of the train. Such shells pass through the 12-inch armor-plate of a battleship with ease. This is made possible by the extreme hardness of the steel in the nose of the shell. When the metallurgist was called upon to produce steel with such wonderful hardness, he accomplished it only by the use of ferro-chromium. America's entire supply of this invaluable product is produced within the fiery radiance of Niagara's electric furnaces.

#### *Production of Ferro-Silicon*

A few years ago, metallic silicon was a rare element. Today it is a common commercial article of inestimable value to the steel industry. Tons and tons of this material are produced annually in the furnaces at Niagara. Ferro-silicon, which is produced by the chemical union of iron and silicon within the high heat of the electric furnace, is practically indispensable in the production of high-grade castings by eliminating blow holes. It is said that the greatly increased use of steel as building material during the past twenty years is chiefly due to ferro-silicon, which insures complete deoxidation of the steel. This important alloy also enters into the production of sound iron castings. Silicon is also used in the manufacture of a

special steel known as silicon-steel, and this product is invaluable to the electrical industry. Silicon-steel is used in all alternating-current apparatus and it has figured greatly in the development and perfection of such apparatus during the past fifteen years. It has entirely replaced transformer iron in the manufacture of electrical transformers. Silicon-steel saves many millions of dollars annually in the United States through the conservation of our electrical energy, especially in alter-

Niagara could not supply these vital products, we would be at the mercy of the world, for without them we would have no hard steel, and without hard steel we would have no navy or coast defense. Carbon steel is no longer used in metal cutting, as it is not hard enough and cannot cut if it becomes heated. The ferro-alloy steels have entirely replaced carbon-steel cutting tools, not only because of their superior hardness and cutting power, but because they can stand up under red heat, which is essential for fast work in steel cutting.

In passing through the large Government munition plants we can see 16-inch guns being turned to diameter in the great lathes while the ferro-alloy cutting tool is peeling off curls of steel that are red hot as they fall. In fact, the point of the tool itself is at red heat, but it continues to cut just as efficiently as if it were cool. Ferro-alloy cutting tools have tripled the output of every machine shop in the country!

#### *Abrasives an Important Product*

Of all the valuable products of Niagara's electric furnaces, the artificial abrasives, aloxite, carborundum, alundum and crystallon probably enter into our daily life most intimately, as they form an indispensable part in every manufacturing establishment in the land—in the world in fact. These modern artificial abrasives, with their unprecedented hardness and wonderful cutting power, are largely responsible for the present-day automobile in its great perfection

and moderate cost. Modern machines and instruments are intricate and delicate, and the lathe, with its steel cutting tool, can no longer be relied upon to work with sufficient accuracy. The grinding wheel has superseded the steel cutting tool and is capable of great accuracy—an accuracy figured in the five-thousandths of an inch. In the tannery we find it buffing leather; in the stone-working industry we find it

*(Continued on page 470)*

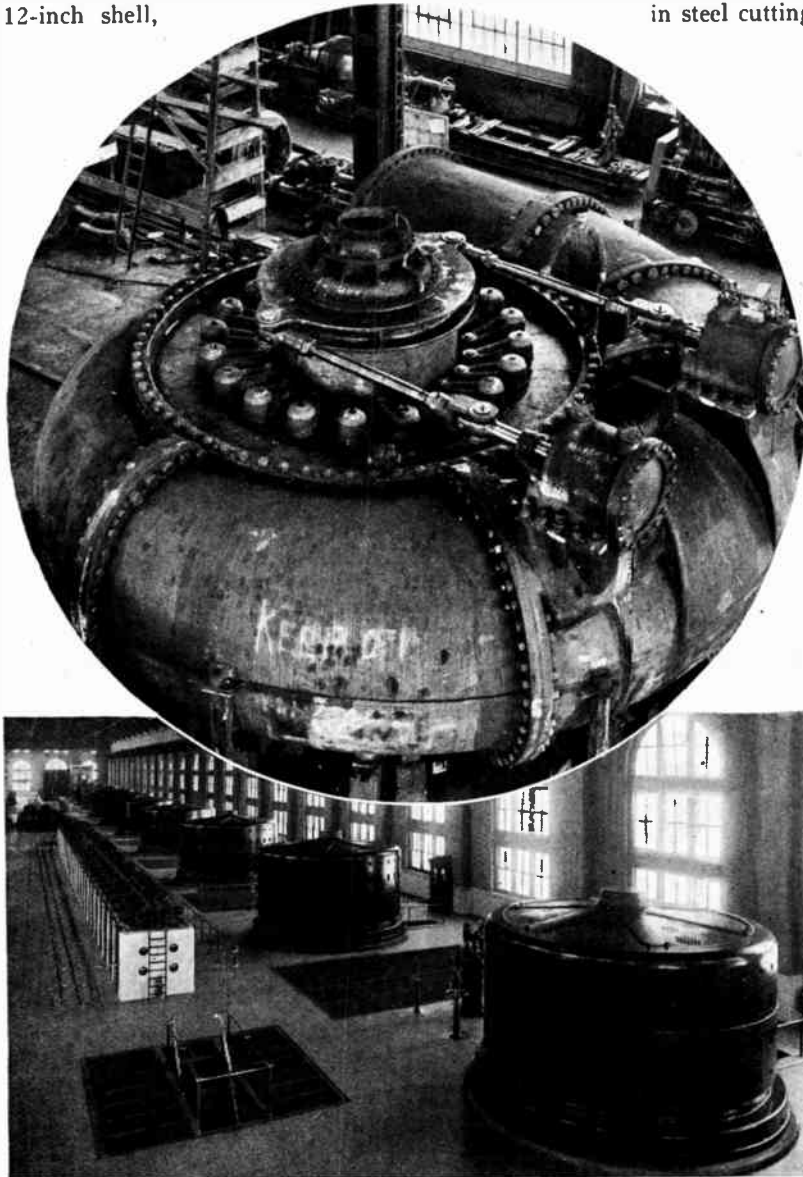

*One of the gigantic turbines that is placed down in the wheel pits is shown above the row of generators that are driven by duplicates of this power producing unit*

nating current transformer stations.

It can be said with absolute confidence that Niagara is the backbone of the steel industry of the United States. A cessation of the production of ferro-silicon alone would result in nothing less than a calamity to the steel industry of America. The War Department's specifications for shell steel in munition contracts called for 0.20 to 0.30 percent silicon, with a corresponding percentage of ferro-chromium. If

# Spark Test For Steel

**I**T is rather difficult to determine the exact nature of a bar of steel unless microscopic or chemical tests are made to give some index to its chemical composition and the nature of the alloying elements used. John F. Keller, in a paper read before the Indiana Section of the S. A. E., describes some interesting tests by which some approximation of the nature of the steel may be determined.

If a piece of steel is touched with some pressure to an emery wheel revolving at high speed it will throw off a great number of sparks, characteristic of the combustible elements in the metal. If we could distinguish the different sparks by their quantity or characteristics as caused by the different elements in the metal, we might be able to identify with a reasonable degree of accuracy iron or steel that throws a characteristic spark.

Much time and money has been spent in attempting to photograph the sparks from different metals, but we have been unable to get anything worth while; therefore, we have resorted to the pen (Figs. A to H, inclusive) in order to furnish an illustration of the sparks from different steels. While it is not absolutely correct, nevertheless, it will furnish some idea of what to look for.

In making spark tests the following conditions are essential: (1) Clean-cutting emery wheel running at a speed of about 7,000 feet per minute; (2) enough pressure on the wheel to throw a few sparks only.

Suppose a piece of wrought iron (a) almost free from carbon is held against an emery wheel revolving at high speed; the small heated particles thrown from the wheel will follow a straight line, which becomes broader and more luminous some distance from its source of heat. If the particles are not all consumed, they fall to the floor, just as do those from the meteorite or shooting star. The broadening of the streak of light is probably due to the action of the oxygen of the air, requiring some time to act. All commercial iron contains a small percentage of carbon; this will be indicated by a branching or forking of the luminous streak.

In the manufacture of steel, carbon is added to iron; therefore, if we touch a piece of mild steel (b) that contains a small percentage of carbon, the effect is at once noted by a division or forking of the luminous streak. This is probably due to the presence of carbon, which is acted upon by the maximum heat of the iron spark; this burns ex-

plosively, causing several breaks in the original heavy line.

With increase of carbon from 0.50 to 0.85 per cent, the iron spark lines (c) diminish, becoming less conspicuous in proportion to the increase of carbon content; the forking of the luminous streak occurs much more frequently, being subdivided by re-explosions from the smaller particles. The lower the percentage of carbon, the less will be the forking of the heavy lines of light and the farther the sparks will be thrown from their source of heat.

In the higher grades of carbon tool steel (d) the iron lines are practically eliminated with increase of the explosions and subdivisions, causing a beautiful display of figures. This is probably due to the iron and carbon becoming united in such a manner that they are easily attacked by the oxygen of the air. Hence the danger of burning carbon tool steel on the emery wheel and in the fire. It would be well to state here that the higher the percentage of carbon, the more profuse are the explosions, and the shorter is the distance from the sparks to the source of heat.

The spark shown at (e) is thrown from high-speed steel. Practically all

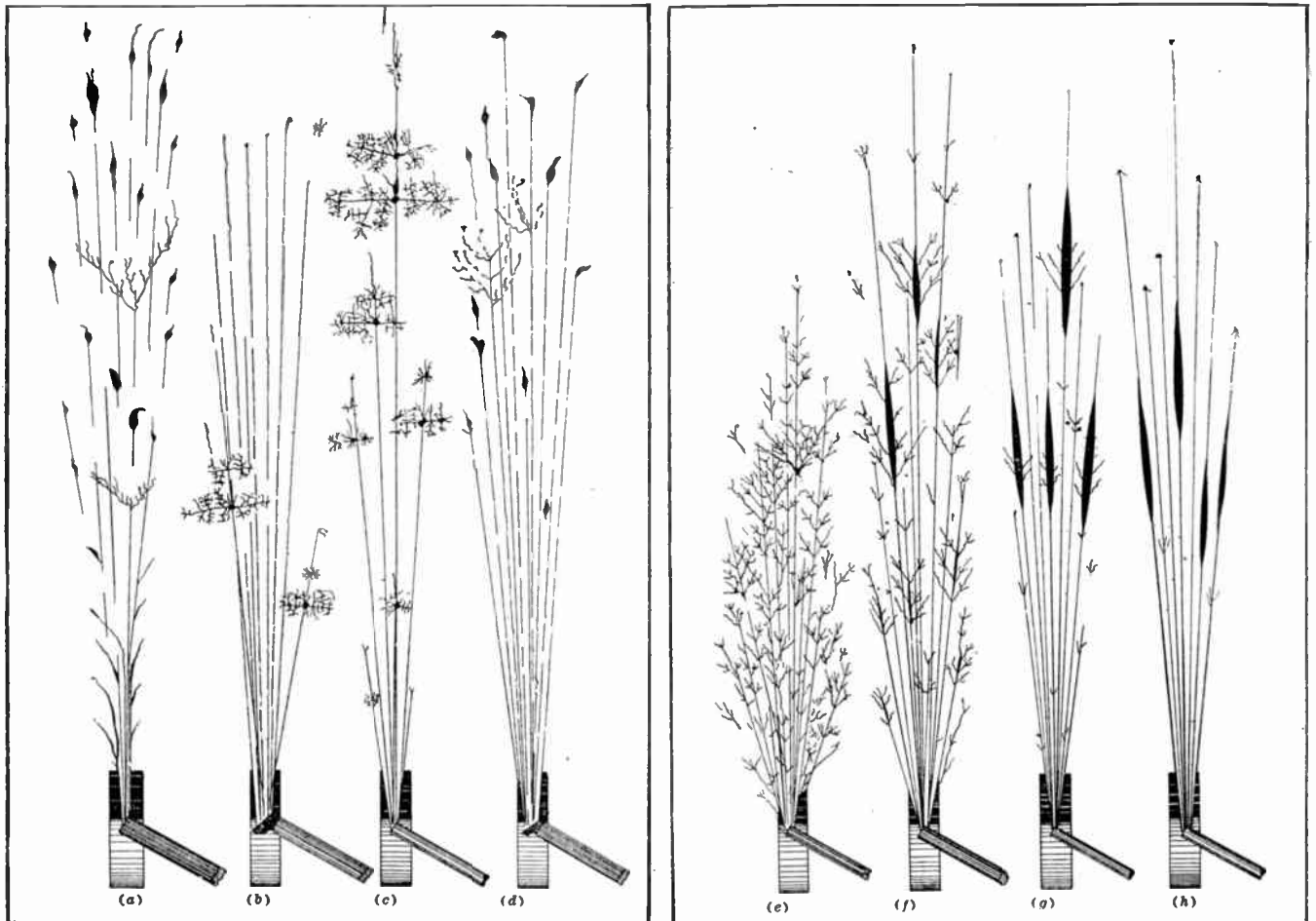

Diagrams showing various types of sparks produced by different grades of steel when brought in contact with high speed emery wheel

high-speed steel contains, in addition to carbon, other alloying elements, chiefly tungsten and chromium. This steel contains about 65 per cent carbon, but the particles show no trace of a carbon spark whatever. It is probable that the alloying are so thoroughly combined with the carbon that they prevent its explosion or burning. The metal being much more refractive than carbon steel, will endure high temperature without scaling or burning, and the temper is not drawn so easily as in carbon steel. Considerable pressure on the emery wheel is required to ignite a spark. Its color is a dark yellow owing to the chromium and tungsten. The spark follows a straight line similar to iron, except that the broad streak of light is more abrupt, with an occasional branching spark that is probably due to manganese.

At (f) is represented a manganese spark. This differs widely from the carbon spark in that it seems to explode at right angles to the direction in which it is moving. Each spark is divided and sub-divided into a number of re-explosions which are very distinct. An illustration of this spark can be found in cast iron high in manganese; the spark from manganese steel is not so distinct, yet to the trained eye it is easily recognized by its branching appearance, as indicated at (e) and (h). This is probably due to the manganese and other elements becoming so united or combined as to prevent the free explosion of the manganese.

The spark thrown from the oil grade of "Mushett" steel (not the modern high speed) is shown at (g). This steel usually contains about 16 to 17 per cent tungsten, about 2 per cent carbon and 2 per cent manganese. A remarkable fact is that it shows no trace of a carbon spark and only an occasional manganese spark. This steel is easy to detect owing to the fact that it requires considerable pressure on the wheel. The particles follow a broken line, and the color is a very dark red with an occasional manganese spark. The old "Mushett" steel is not in general use since the introduction of the modern high-speed steels, but we found a great quantity of it among old tools not in service, especially in old-established factories. The steel companies are glad to have such material at this time, owing to its high percentage of tungsten.

At (h) is represented the spark thrown from a special steel manufactured especially for magnets and, therefore, known as magnet steel. This is similar to the spark from high-speed steel, except that it is of a lighter color with a more profuse quantity of abrupt luminous explosions and an occasional branching manganese spark. The explosions, however, occur at a shorter distance from the source of heat than

do those of high-speed steel. We find by this test that many of the permanent magnets in service today are made from carbon steel rather than from the more expensive magnet stock.

**NEW ENGLISH SIDE CURTAINS**

**I**N really bad weather, the ordinary Cape cart hood offers little protection unless side curtains are fitted. The usual drawbacks to side curtains are the difficulty of fitting them and the problem of storing them when not in use. To overcome these difficulties, Mr. F. H. Hall, of Claverdon, Warwick, England, has designed and patented side curtains which are permanently attached to the hood when not in use. The top edges of the curtains are preferably sewn to the sides of the hood, and the bottom edges fasten to the body in the ordinary way when the

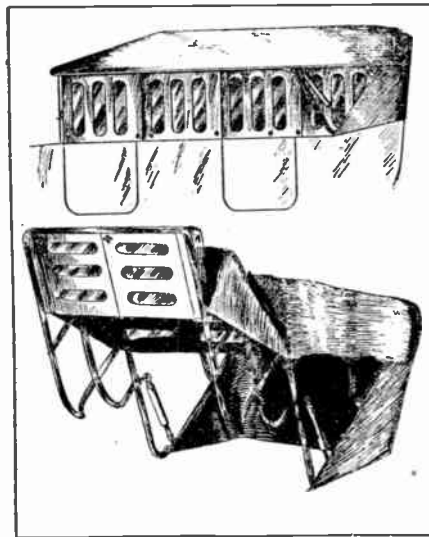

*New English side curtains*

curtains are in use. When the side curtains are not required, the fasteners on the body are released and the curtains swung up to the roof of the hood and buttoned there. The curtains may be swung up on to the outside of the hood, but are preferably kept on the inside. When the hood is put down, the curtains fold up with the hood, and, being of thin material, do not make the hood bulky, the same hood envelope being employed. By splitting the curtain into four sections, a separate section is left over each door, and thus does not interfere with the ease of exit or entrance. In this country, curtains that are part of the top are common, these sliding along wires strung from one top bow to the other and are carried at the back of the top in special pockets when not in use. The English idea is not as slightly because the curtains are visible in the top when not in use but it has the advantage of permitting almost instant use of the curtains in case a sudden shower comes up.

**SCREWING DOWN GREASE CUPS**

**T**HERE is a right and wrong way of doing even such a simple thing as screwing down a grease cup. A very common mistake is made in filling grease cups by not squeezing the grease down in the top of the cup. When the cup is not properly filled, the first few turns do not force the grease into the bearings but simply compress it in the grease cup. Figure 1 shows grease cup not properly filled. The first few turns

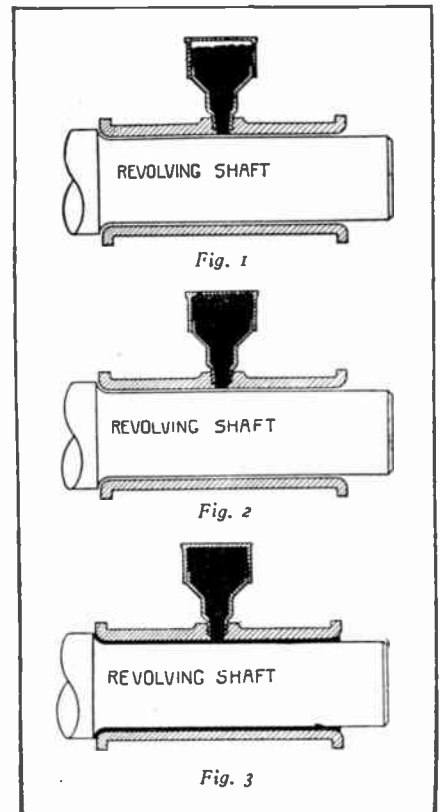

*Screwing down grease cups*

will not send the grease into the bearing—but will compress it into the cup. No part of the bearing is lubricated. Because of this fact the man may think he has done his part and greased the bearings when in reality he has not. Figure 2 shows another thing that happens when the grease cup is carelessly used. The bearing is only partially supplied with grease. The illustration at Figure 3 shows the right way to handle the grease cup. Screw the top down until the bearing is well filled or until it can be plainly seen that the grease has reached both ends of the bearing.

The United States Bureau of Standards has been investigating the mixing of concrete. Cement and water were mixed for a long period, 15 to 30 minutes, and to this mixture were added the sand and stone constituents of the concrete. The usual way is to mix all the constituents together for a few minutes and then to put the mixture in place. It was found that there was no advantage by this preliminary mixing of cement and water.



# Common Causes of Automobile Noises

*A Simplified Exposition for the Man Who Runs His Own Car  
Describing What Various Noises in an Automobile  
Are Due To and How To Eliminate Them*

By Victor W. Pagé, M. S. A. E.

## PART 2

### Wear in Front Axle Parts

The points to inspect in the front axle after that member has been jacked up so that the weight of the car is off of the wheels, are: first, make sure that the wheels are properly adjusted. If the front wheel bearings are insufficiently tight, the wheel will move back and forth on the steering spindle, and this will not only cause noise because of loose bearings, but will also result in the entire front end of the car vibrating and any looseness in various link joints will result in rattling. The amount of play between the steering knuckle and the steering knuckle bolt should also be noted and if this is more than a few thousandths of an inch, the movement will produce rattling.

There are a number of joints in the tie-rod and drag link that will cause rattling as soon as they are worn. The tie-rod, which is the member that is parallel with the front axle and that joins the steering arms of the steering knuckles together, has two joints, one on each steering arm. The drag link, which is the part that usually runs parallel with the frame member and which joins the steering arm at the lower end of the steering gear with the arm on the steering knuckle, also has two joints, and as these four joints are exposed to dirt and dust in most cars, as well as being subjected to considerable strain, it is not unusual to find that most of the rattling at the front end is due to wear on these points. On most cars the drag link members have ball ends so that a certain amount of take-up is possible for wear. This is not true of the tie-rods of most cars, which have points somewhat limited in bearing surface and which can only be adjusted by the substitution of new bushings and new bolts.

One of the most prolific sources of noise is a dry spring. The leaves of which these are composed should move relative to one another all the time that the car is in use, so that if there is considerable rust or lack of oil between the springs, noise due to the rubbing of dry metals will be evidenced. Properly lubricated springs not only make for noiseless operation, but also contribute materially to the easy riding qualities of a car.

### How to Lubricate Springs

The best method of lubricating a spring is to remove it from the car and to take it apart. This enables one to clean off the rust deposits with emery cloth or sandpaper and also makes it possible to insure that grease can be put on the working surfaces of the leaves before they are reassembled. There is a trick in connection with taking a spring apart that the average car owner might not know. This is to hold the spring parts together with a heavy C clamp while the bolt or rivet that passes through all of the leaves to hold them together is removed.

oil can. Some repair men use a mixture of paraffine wax and graphite for spring lubrication but this can only be applied properly when the springs are taken apart and the leaf surfaces well cleaned of all rust.

### Spring Shackles and Bolts

The spring shackles and spring shackle bolts are also common offenders against quiet operation. Any lost motion in the spring shackle will result in rattling. The lubrication of these shackle bolts and spring eyes is apt to be neglected because of the inaccessible position of the grease cups. In any event, they are not screwed

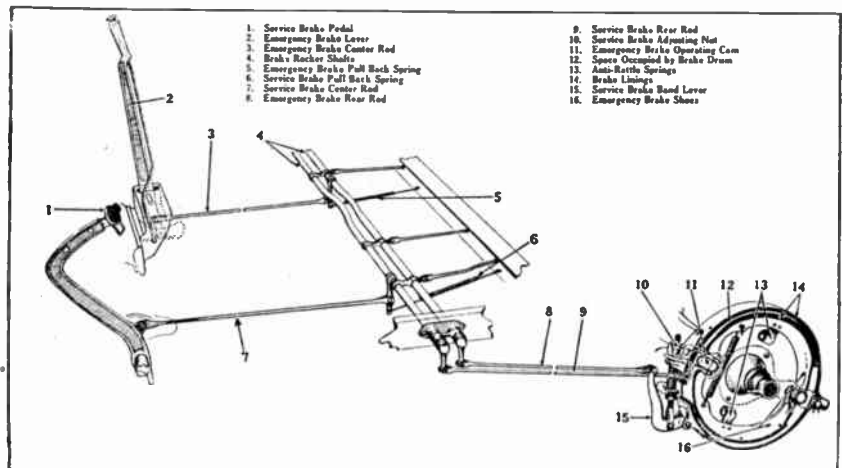

Typical brake operating linkage with actuating rods outside of frame. This is used on some Overland models

This C clamp is also used on reassembling to bring all parts of the spring back together before the bolt or rivet is reinserted. A graphite grease is much better than oil for use between spring leaves as it will fill minute spaces in the surface of the metal. Even if the oil finally works out, the graphite remaining between the leaves is an excellent lubricator.

A quick method of lubricating springs is to pry the leaves apart with a screw driver or a special tool made for that purpose and insert oil or graphite in the space provided in this way. This does not insure as thorough distribution of lubrication as the method previously described and does not remove the rust. It is sometimes possible to clean out the space between the spring leaves by spreading the leaves apart and allowing kerosene to penetrate the space. This kerosene can be applied with a squirt gun or a hand

down with the regularity that is required to prevent abnormal depreciation.

The majority of car owners do not take the trouble to lubricate the car properly until it begins to be noisy, at which time it is really too late as the damage has been done. The only remedy for worn spring shackles and shackle bolts is replacement with new ones. Whenever depreciation in the front or rear axle is found, the point should be made clear that looseness will not develop unless the various parts are relieved of their share of the car weight. If this is done, parts that appear to be tight when examined with the weight of the car holding them together will be found to be quite loose as soon as the car weight is lifted off. It is only when operating on smooth roads that these parts are uniformly loaded as when running on rough roads, the car frame and load is con-



windshield frame so that the glass will be a tight fit therein.

Loose registration number plates are also a common cause of trouble. In many cars, the plates are fitted directly to the carrying brackets and as they are of thin metal, and are usually supported only at one end or the top, it will be apparent that considerable noise will be caused by the other end striking the metal parts attached to them. A simple way to prevent this trouble is to make sure that the plate is held between leather or rubber washers and to pack the metal part of the supporting bracket where the plate hits with ordinary friction tape, using enough to make sure that the noise will be deadened. If the car is provided with shock absorbers, it is well to note that any loosening in the parts themselves or in the brackets by which these are attached to the frame, will be instantly audible.

wheel with water so as to swell the wood and then tightening the nuts that hold the flanges together. Poorly adjusted and worn brake bands, especially those used on external brakes cannot fail to produce a rattling noise by striking the brake drums and care should be taken that the brakes are always properly adjusted.

If the brakes squeak when applied, it is because the brake lining has become impregnated with particles of sand and grit and these get into the brake lining and of course cause a loud squeak as they bear on the metal drum. The only real remedy is to remove the brake bands and clean off the lining so that all of this noise making material will be removed. A temporary expedient is to put a few drops of oil on the brake drum, but this should not be done carelessly because if too much oil is applied the brakes will slip.

## PRODUCER GAS FOR VEHICLES

**S**OLID fuels offer the only method whereby the high price of liquid fuels can be countered. An English engineer gives the distillation of coal in the process of making coal gas as an example and goes on to say that 1 ton of coal would propel a 5-ton steam wagon about 160 miles, the fuel then being completely destroyed. If subjected to distillation the 1 ton of coal would give 13,000 cubic feet of coal gas, and taking 250 cubic feet of this gas as equal to 1 gallon of gasoline, this would propel a 5-ton internal-combustion-engined vehicle 312 miles. But after allowing for the fuel use for the retort about 10 hundredweight of coke would still remain, and at 3 pounds of coke per mile, a 5-ton producer gas vehicle would run a further 373 miles on this, or a total of 685 road miles, as against 160 miles on 1 ton of coal burned directly.

## A SIMPLE HORSE POWER FORMULA

**O**NE of the automotive publications describes simple horse power formulas that are remarkably simple and that are claimed to have a low limit of error. In fact, they are sufficiently accurate for making approximate calculations when comparing one engine to another quickly. The formulas are:

$$\frac{\text{H.P.} = B^2 S}{3} = \text{for four cylinders.}$$

$$\frac{\text{H.P.} = B^2 S}{2} = \text{for six cylinders.}$$

$$\frac{\text{H.P.} = B^2 S}{1.5} = \text{for eight cylinders.}$$

$$\text{H.P.} = B^2 S = \text{for twelve cylinders.}$$

The formula is not intended to be used for extremely high speed engines or for engines having special power producing elements such as multiple valves, special timing and refinements of that nature. In the above formulas, initial B is the bore of the cylinder in inches and S the stroke of the piston in inches. Care should be taken in each case to use the proper divisor, depending upon the number of cylinders.

"Keep the motor cool" is not a good tractor maxim, if kerosene fuel is used. Both the motor and radiator water should be kept hot because the fuel, which is thicker than distillate, needs much heat for good combustion; needs also more needle valve opening, though too rich a mixture means carbon, as with lighter fuels. The trick is to start with gasoline and continue with it till the engine is thoroughly warmed for smooth, economical running with kerosene or distillate.

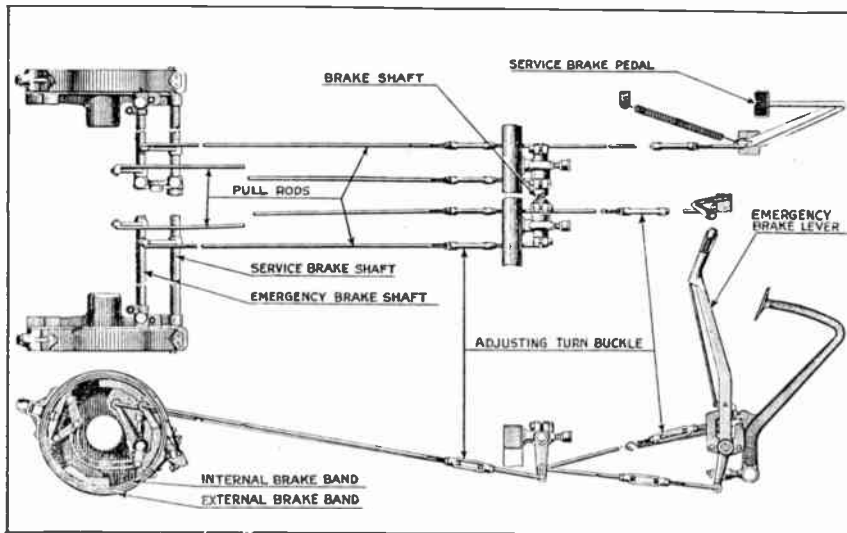

Buick brake operating linkage using turnbuckle adjustment and brake rods inside of the frame

### Wheels and Wheel Lugs

One of the most annoying squeaks and one that is the hardest to locate by the motorist is due to poorly-fitting, rim retention lugs. There are twenty-four of these on the average automobile, six being used on each wheel and looseness of any one will cause a constantly, re-occurring squeaking noise every time the wheel turns. It is sometimes impossible to prevent this squeaking even if the lugs are screwed in as tightly as possible. This is because the wedge portion of the lugs has worn and the only remedy is to use new lugs that will have wedges of the proper size to take up the space between the rim carrying the tire and that of the felloe of the wheel.

Wood wheels sometimes squeak if the spokes become small and are not a good fit between the hub flanges. This is a rare case and is produced by the wood drying out or the flanges bedding into the spoke butts. It can sometimes be cured by soaking the

In conclusion, it may be stated that knocking and rattling noises are usually caused by considerable lost motion between two parts which should be firmly held together. Squeaking sounds are generally produced by limited movement of dry parts against each other. In most cases a knocking or rattling may be taken care of by tightening the retention means, while squeaks may be eliminated by the liberal use of properly applied lubricants or by various rubbing strips and packings of sound-proof material, such as wood, leather or rubber.

Zinc, it is found, can be reduced from its oxide by carbon in an atmosphere of nitrogen. A temperature from 762° to 1100° C. is required. The easier and more general reduction by carbon monoxide requires only 350° C. and the production of the carbon monoxide from carbon and dioxide requires a temperature of 450° C.





# SHOP PRACTICE

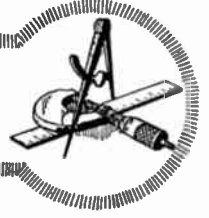

## INCREASING RANGE OF MILLING MACHINE

**A** VERY useful kink for the machinist was described in a recent issue of the *American Machinist* by O. F. Kuhlman, and is illustrated here-with: Recently there came to his shop the job of repairing a shaft and pinion, the object being to use the same shaft but to make a new pinion smaller in diameter. The old pinion was next to impossible to remove from the shaft, so

a strip of sheet steel or brass about 1/32nd inch thick between them. The four holes should be drilled and countersunk for the various sizes of tubing the fixture is intended to handle. In the most popular sizes the range of size is 1/4 inch, 5/16 inch, 3/8 inch, and 1/2 inch. The two parts may be held together by suitable bolts.

After the holes are drilled, the small pieces that are left of the spacer member are taken away, because the only

tween the jaw pieces, the tube will be flared out to correspond to the bevel on the shoulder of the punch. The rod inserted in the end of the punch is to facilitate its removal and to steady it while it is being driven into the tube. The smaller diameter or pilot member of the punch is to be a good fit in the inside of the tube so that the tube will not be closed in when the vise jaws are clamped around it. It is a very simple matter to make flanges on tubing with this device and this can be done in any ordinary form of vise.

The clamp bolts are loosened so that the tube can be inserted, allowing enough to project above the surface to insure that the flanged portion will be of sufficient length. After the clamp bolts are tightened and the tubes securely held between the vise jaws, the device is placed in a vise to hold the tube and the suitable sized punch is driven down the required distance to form the flange.

Hard brass tubing should be annealed before an attempt is made to form a flange on it as it is apt to give trouble by cracking at the ends unless this precaution is taken. Ordinary grades of copper tubes such as used on fuel and oil lines are soft enough so that flanges can be easily formed without annealing.

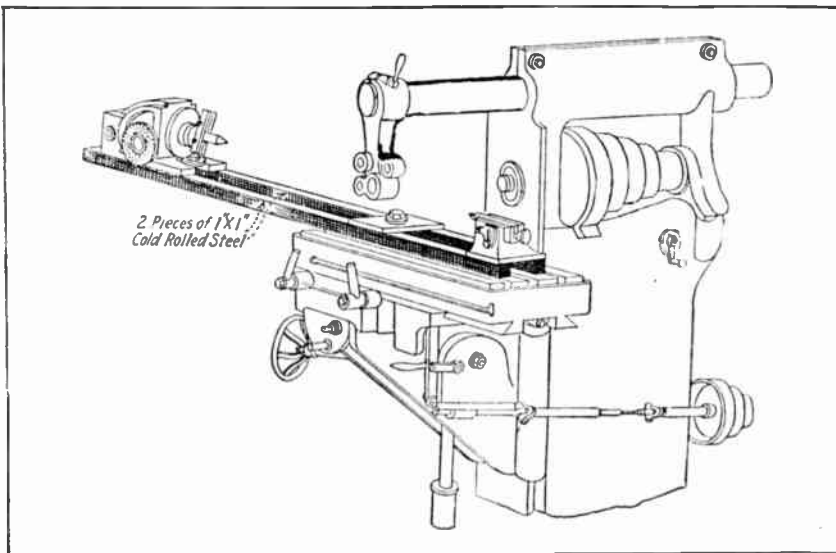

Increasing range of milling machine

he decided to turn it down while in place, to the new blank diameter and cut the teeth without removing it. There was no milling machine available to handle a shaft 6 ft. long, so a Brown & Sharpe miller was rigged as shown in the sketch by putting long steel parallels on the platen, and attaching the index centers to them. Two blocks are set into the T-slot to keep the parallels in line.

function of these is to insure enough clearance between the tube clamps while drilling so that the tubes to be flanged will be securely held between them. Punches are made as shown,

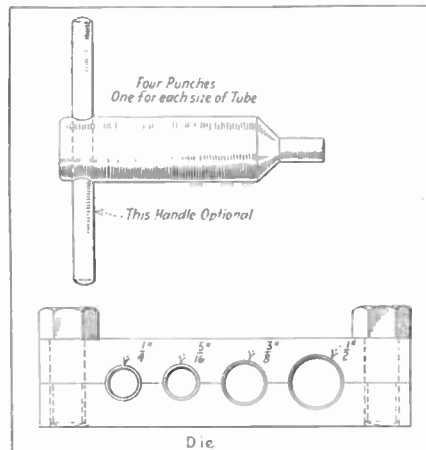

Simple device for flanging copper tubes

## RESISTANCE OF STEEL TO CUTTING

**A**T a recent meeting of the Academy of Sciences in Paris, a memorandum was presented from M. Ch. Fremont giving some interesting explanations regarding the phenomena attendant upon the cutting of metals, as follows: For example, a steel having a tensile strength of 107,000 lbs. per sq. in., when calculated according to the conventional rule universally used, that is to say by dividing the maximum stress by the original section, will wear away and dull the cutting tool quite rapidly, when another steel having a tensile strength of 166,000 lbs. per sq. in. can be cut easily and will not wear the faces of the tool. The explanation of the paradoxical phenomenon is to be found by measuring the final resistance obtained in a tensile test of the two steels.

## FLANGING COPPER TUBES

**I**N automobile practice and in motor boats, the fuel supply and oil lines are usually made of copper tubing and the joints where the tubing is attached to the fittings are generally of the simple tapering flange form. In this construction the flat end of the tube fits against a suitable tapered piece which is the male member while the female member or nut, screws against the flange and keeps it steady.

It is not difficult to make a simple fixture for flanging various sizes of tubing ordinarily used, if the suggestion given in the accompanying illustration is followed. Two flat pieces of steel or iron are clamped together with

these having a pilot member which is the size of the inside diameter of the tube. The large portion of the punch has a 45 degree shoulder or bevel so that as the punch is driven into the tube after it is properly clamped be-

By "final resistance" is meant that which is obtained by dividing the resistance of the test piece at the moment of rupture by the actual section at the point of fracture, that is to say, the reduced section of the test piece. This

final resistance or stress is less than the maximum stress which just preceded it, but the final resistance per square inch, on the other hand, is higher than the resistance is ordinarily calculated, because the actual reduced section at the point of fracture is less than that of the original section.

#### DEVICE FOR SMALL DRILLS

WHEN using an ordinary hand or precision drill in connection with small drills, it is very difficult to drill a hole without breaking the drill several times unless great care is taken in the operation. The simple fitting shown in accompanying illustration may be made by any man handy with tools and is a tool that will make it possible to drill holes in hard material with small twist drills without break-



Steadying device for small drills

ing them from the pressure needed to insure penetration of the drill point. The device is a simple clamp which has a slot at its upper end in which the steadying handle of the drill press is inserted. At the lower end, a screw clamp fitting is mounted that just fits above the chuck. A rod that slides in a sleeve or bearing member is attached to the clamp, the movement of this rod being controlled by a stiff spring within the sleeve.

It will be evident that a tool of this nature will prevent the drill from breaking because it will be difficult to press too hard on the drill press and the vibration that is evident with a tool of this kind when using small drills is prevented and another cause of breakage is eliminated.

#### EXTEMPORIZED AIR COMPRESSOR

ONE of our readers, Mr. William B. Hunt of Montgomery, Alabama, sent in the accompanying sketch showing how he has extemporized a motorcycle engine that had outlived its usefulness for its legitimate purpose, as an air compressor. While all details are clearly shown in the drawing, a few words of description may be of value to those of our readers who would like to make up a similar outfit. The engine was a single cylinder type about two horsepower and formerly served as the propelling mechanism of an Indian motorcycle. It is attached to a wood bed, which is bolted to a work bench and braced by  $\frac{1}{4}$  inch by 1 inch strap iron extending from the motor support plates to the bench. A new head was made from a piece of solid stock tapped with two holes, one of

which receives the intake ball check fitting, the other the outlet ball check fitting from which the pipe extends to the air tank under the bench. The air in the tank was directed to the air hose by another length of pipe in which a gauge was placed to indicate the pressure in the tank. A shut-off valve was interposed between the gauge and the air hose coupling.

When it is necessary to blow up a tire, this shut-off valve is opened, allowing the air to flow through from the tank to the air hose. Even if an automatic coupling is fitted at the air hose, it is advisable to use the shut-off valve because this will prevent air leaking through at the joints in the air pipe or hose. The same oil pump and oil tank that served to lubricate the motor when it was installed in the cycle frame also serves to supply lubrication to the engine in its new role. This as attached to the wall in a convenient place. A few strokes of the pump will supply sufficient oil for an extended period of operation. The oil level is clearly shown in the oil sight glass on the bottom of the motor crank case. The pump is driven by any suitable means at a speed of about 300 r. p. m.

If an electric motor is used for power

Mr. Hunt states that the provision of a new solid head reduced the combustion space sufficiently so that an adequate working pressure is provided to blow up most sizes of automobile and motorcycle types. When air is pumped in this way, it is advisable that a filtering device to be interposed in the air line to remove any oil that may be present and that would tend to deteriorate the rubber of tire tubes. If the piston rings are carefully fitted to the cylinder, then very little oil will go by the piston and it may not be necessary to supply the filtering fitting.

The inclusion of such a filter is recommended by many manufacturers of commercial tire inflating outfits, so it would seem that it would be a valuable addition to the scheme suggested by our correspondent. The suggestion illustrated should be easily followed by any mechanical man and will supply quantities of air for experimental work or tire inflation purposes. A special fitting is necessary to carry the driving pulley on the engine crank shaft, this being turned from a piece of steel or brass and adapted to fit the end of the shaft instead of the driving sprocket or the clutch assembly ordinarily attached at that point.

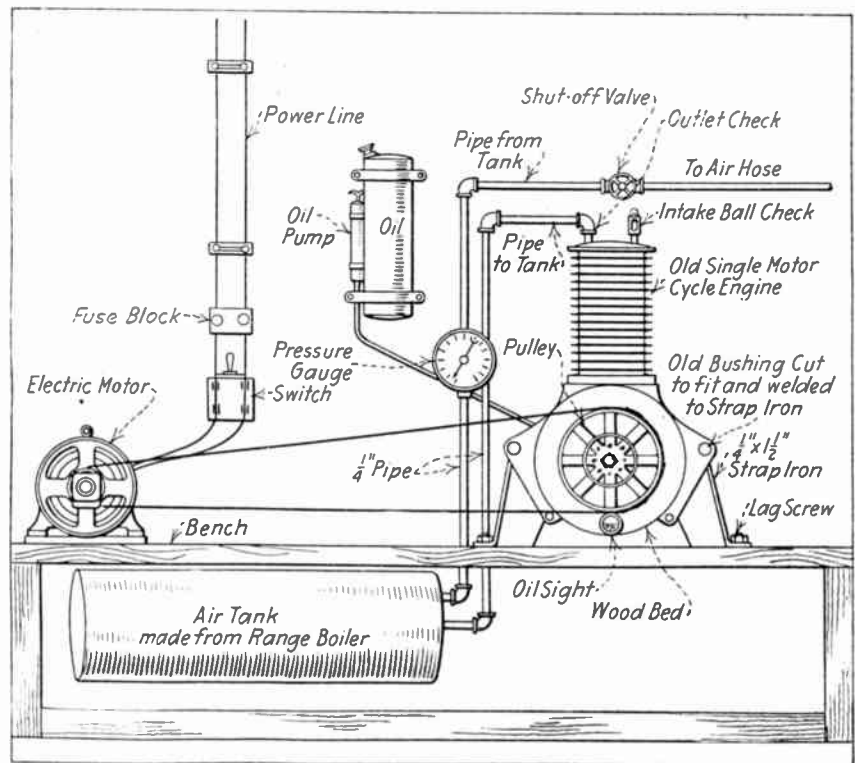

Details of an extemporized air compressor outfit made from an old single cylinder motorcycle engine and a range boiler

as indicated in the sketch, it should be provided with an automatic, or other adjustable belt tension device and should be fitted with a small enough pulley so it can be run up to speed without driving the air compressor too fast. It will be evident that the air compressor may be driven from a line shaft.

Medallions, coins and the like can be cast from the following alloy which will reproduce all of the very finest details: Tin 3 parts, lead 13 parts and bismuth 6 parts. Another which is more suitable for certain work contains less lead but more bismuth, as follows: Tin 6 parts, lead 8 parts, bismuth 14 parts.

# Simple Model Steam Engine and Boiler Construction

By Wm. A. Helms

## PART II

### A DOUBLE-ACTING ENGINE

**I**N the first article I have described the single acting oscillating engine and have started the construction of a boiler suitable to run those engines. I conclude the latter in this article, as it is also employed to generate the steam for the double acting engine described in this instalment.

We come now to the double acting oscillating cylinder. It requires only a little more than half the momentum of the single acting, as the only dead points are those when the piston is at the extreme ends of the stroke. The double acting engines have therefore almost twice as much power for the

same size of cylinder as the single acting ones and are less likely to stop at reduced speed. This type of engine economizes space and weight. They are especially adapted for propelling small power boats. The entire machine is built low which is an important factor in small boats. It is important to use a rather heavy flywheel, as experiments have shown that it is required on an engine which has the constant drag of a propeller to overcome.

The dimensions of the cylinder described here are  $\frac{5}{8}$  in. stroke by  $\frac{1}{2}$  in. bore (see Figs. 1 and 5). As is usual on engines of that kind it is made out of a brass casting. The length with-

out covers is 1 in., allowing  $\frac{1}{4}$  in. for the thickness of piston,  $\frac{1}{32}$  in. for each of the spigots of the cover, and the same distance left vacant at each end. The diameter of the cylinder over the flanges is  $\frac{7}{8}$  in. One of the most difficult jobs to be accomplished by a model engineer is the boring and facing of the cylinder of a model engine, as accurate work is required to make a successful running model. This is especially the case with beginners. As there are several ways of doing it I will describe the method I believe to be the easiest. In describing this I presume the model engineer to be in possession of a lathe, and drilling machine. A shaper would also be very useful, but is not necessary as the surface work can be finished on a lathe.

### Machining Cylinder Casting

We take the casting and start with the bore. To do this, we clamp the casting on the saddle of the lathe and use a boring bar. The cylinder flanges being round are easily faced by using a chuck. The bearing surface on the cylinder is faced by using a small and accurate angle plate. It is fastened to the face plate and on this is placed the cylinder, which is securely held by a clamp. In order that the facing tool can finish the face level, it is necessary to first drill the hole for the cylinder-trunnion (see Figs. 4 and 6). The utmost care should be used in setting up the cylinder on the angle plate and I recommend using a piece of smooth and thin paper between the angle plate and cylinder and other touching parts, so as to keep the finished parts from being burred. Then drill the steam ports and drill and tap the flanges for the bolts which hold the cylinder covers. The latter are fastened to the cylinder by six hexagon headed bolts of  $\frac{1}{10}$  in. diameter. The cover on the bottom side of the cylinder is equipped with a stuffing box for the piston rod. The gland is screwed direct into the boss of the cylinder cover (see Figs. 1 and 5). The boss is filled with lamp cotton and compressed by the gland so as to make a steam tight fitting for the piston rod.

### Piston and Piston Rod.

The piston rod is made out of a piece of  $\frac{1}{8}$  in. steel rod, truly centered to make sure that it is perfectly straight. A thread is cut on both ends, one to fit into the piston and the other into the cross head. A small lock nut

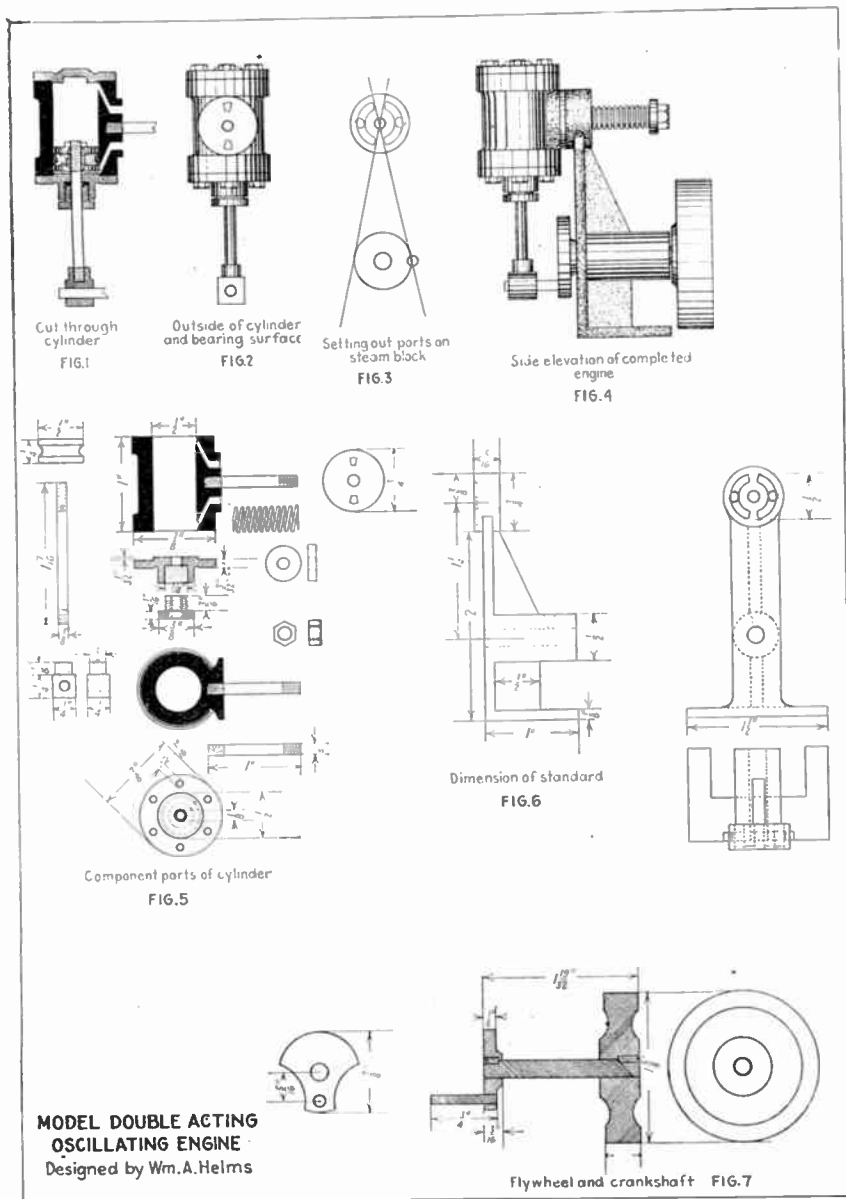

MODEL DOUBLE ACTING OSCILLATING ENGINE  
Designed by Wm. A. Helms

Flywheel and crankshaft FIG. 7

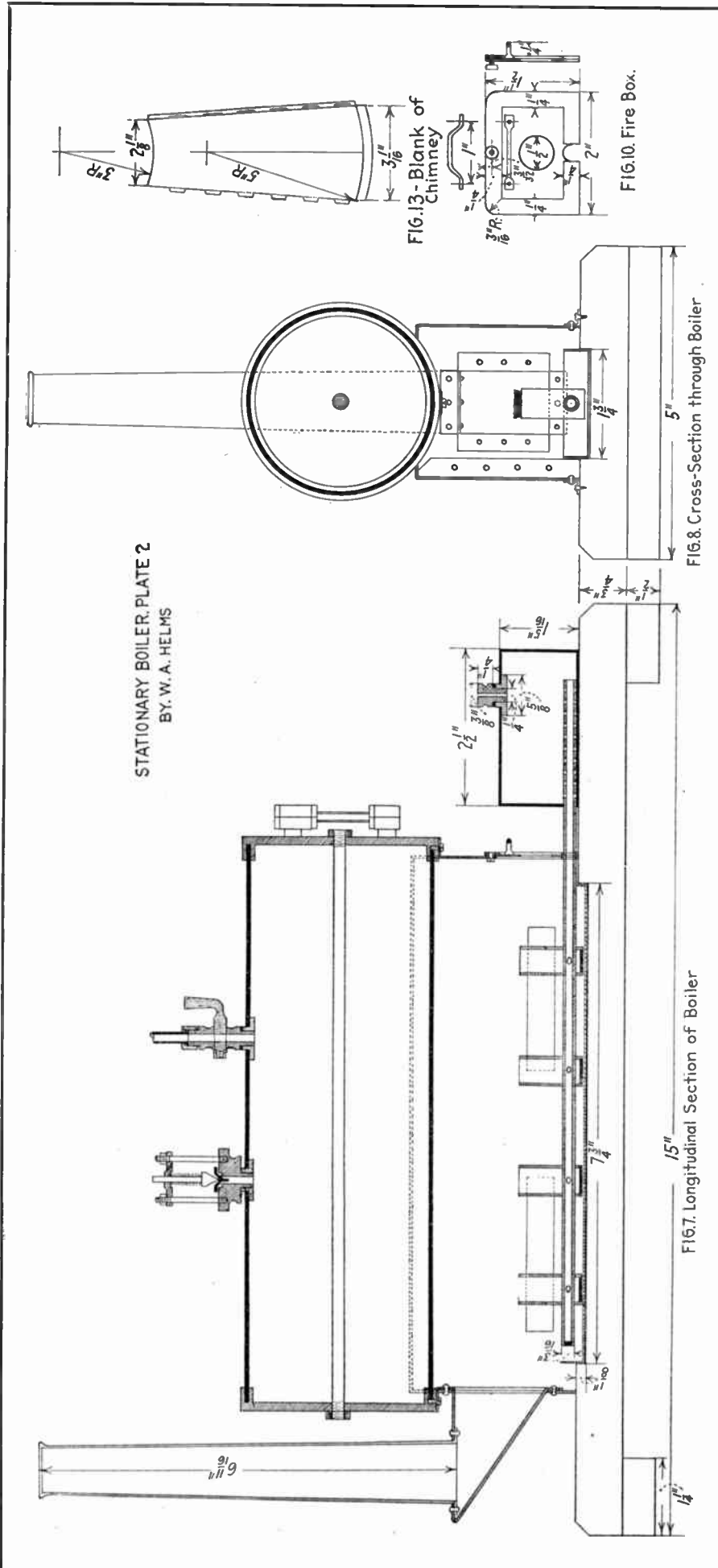

is employed to fasten the piston securely to the piston rod. The cross head is simply screwed into the lower end. The piston itself is turned out of a solid brass bar or out of a casting, and is provided with a groove for the packing to make a steam tight fitting with the cylinder wall.

The cross head is turned out of a 1/4 in. square brass rod. In the drawing it is shown in one piece, but it is better to cut the head horizontally to the diameter of the crankpin and secure the cap with two screws. This is done to obtain a good bearing for the crankpin, as the double acting cylinder exerts the same strain at both the up and down movement of the piston.

*Crankshaft and Flywheel*

The crankpin is made out of 1/8 in. steel rod and is riveted into the balanced crank arm (see Fig. 7). The latter is fitted into the crankshaft by a small set screw. The crankshaft is turned out of a 3/16 in. steel rod and is fitted into the bearing of the standard. It has been previously bored and carefully riemed, parallel to the trunnion bearing in the steam block and vertical to the center line of the cylinder (see Fig. 6). A small hole should be drilled for the lubrication of the crankshaft. The bearing is a long one to insure a smooth running engine and keep the crankshaft from troublesome vibration.

The flywheel is turned out of a casting either iron or brass. The latter is preferred as it is softer and makes a better finish. It has a diameter of 5/8 in. and is 5/16 in. wide on the rim. It is secured to the crankshaft with a small set screw.

The bearing surface on the steam block of the standard (Fig. 6) must be made perfectly level and at right angles to the boring of the crankshaft and trunnion bearing. This is done in the lathe by fastening the standard to the face plate, using the trunnion bearing to center it. At the same time cut the circular grooves, which form the steam and exhaust posts respectively.

*Engine Action Explained*

The action of a double acting oscillating cylinder is easily explained by a close study of the drawings. The steam block, which forms part of the standard contains two ports, drilled from the back, one to receive the steam pipe, the other the exhaust pipe. These ports run into the circular grooves. When the cylinder is placed in position and fastened to the standard with the aid of the trunnion, as illustrated in Fig. 4, and the cylinder is in vertical position the port holes of the cylinder are opposite the solid parts of the steam block. As soon as the steam enters the groove, the cylinder is moved and steam



enters the port of the cylinder and presses against the piston. By the same motion the other port opens into the second groove and discharges the used steam. Reaching a vertical position the steam ports are closed once more and

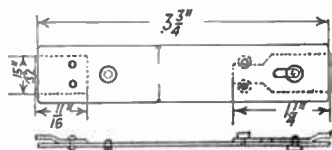

FIG. 11. Inspection Door

the momentum of the flywheel carries it over the dead center and the position of the ports is reversed. In this way the steam is admitted alternately at both ends of the cylinder.

**STATIONARY BOILER**

**H**AVING finished the boiler tube and fittings as described in the last issue of the magazine, we start now with the construction of

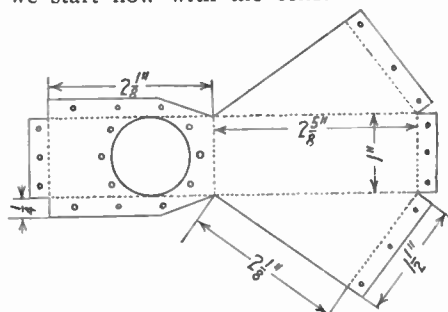

FIG. 14. Blank of Chimney-Support.

the baseboard, the flame guard, spirit lamp, etc. The baseboard is made out of a piece of hardwood 15 in. long, 5 in. wide and 3/8 in. thick. Having it planed and the edges chamfered, to give it a finished appearance, we screw crosswise to the grain of the upper piece two pieces of wood, 5 in. long, 1 1/4 in. wide and 1/2 in. thick, to form feet and keep it from warping. This being done, mark out the position of the drip tray and recess the part to a depth of

1/8 in. as indicated in Figs. 7 and 8, showing sectional cuts of the complete boiler.

*Boiler Support and Flameguard*

Next we take the boiler support and

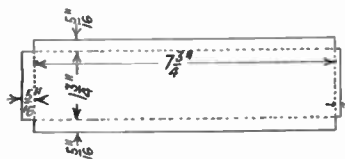

FIG. 12. Blank of Drip Pan

flameguard in hand. It is made out of a piece of tin plate or Russian iron about 1/32 in. thick, the latter being preferred. Having obtained a suitable piece, cut a strip about 24 in. long and 3 in. wide, mark out the developed plan as shown in Fig. 9. Having this done carefully we start by cutting out the ventilation holes, a; the inspection door, b; and the chimney support hole, c. The firebox door opening, d; do not cut out until after having bent the guard to shape. Having cut the holes, cut out the whole piece and smooth the cuts with a file, special attention being paid to the curved parts forming the boiler saddles and slots for the screws to hold the boiler in place. The keyhole slot for the firebox door is made by drilling two holes, a 3/16 in. one and below it a 3/32 in. one and finish up with a small round file. Next we drill the 1/16 in. rivet holes, f; and bend the guard to shape.

The flameguard is fastened to the baseboard by two angle pieces 8 in. long. They can be made out of strips of brass and bent to shape and are riveted to each side of the boiler support. Before doing this drill four holes in each for securing it to the baseboard. The ventilation holes may be covered on the inside with fine copper gauze.

*Firebox Door*

The firebox door is made out of No.

16 gauge sheet brass cut and filed to the size shown in Fig. 10. Drill a 1/2 in. hole in the position indicated for ventilation purposes and drill and file the slot for the alcohol supply tube of the lamp. The 1/4 in. edge piece is also cut out of a piece of No. 16 sheet brass and sweated to the door, after which it is necessary to carefully clean the edges. The door handle is made out of a piece of No. 14 gauge brass wire, the ends of which are flattened out and riveted to the door, after having been previously bent to shape. For rivets we use copper wire. To insure the heads against splitting it is very good to first anneal the wire. We finish the door by drilling and tapping a 1/16 in. hole to receive a small screw, which is intended to fit into the keyhole of the flameguard, to hold the boiler in place.

*Inspection Door*

Now we come to the inspection door, the dimensions of which are shown in Fig. 11. It is provided to light the lamp and adjust the wicks, etc., without removing the lamp. Like the firebox door it is made out of No. 16 gauge sheet brass. It is held in place by two catch-pieces. One is riveted into place, the other one is free to slide. The latter is kept in place by a screw which travels in a special slot and the tail piece, which slides under the heads of two screws. Before attaching the catch-pieces to the door it is necessary to bend them as shown.

*Drip Pan and Chimney Support*

This brings us to the drip pan. It is cut out of the same material as the boiler support, to the size shown in Fig. 12. The ends are bent up and the joints are soldered on the inside. In Figs. 7 and 8 the pan is shown in position. It is provided to protect the baseboard against the heat of the flame and against fire, should any spirit overflow and become ignited.

Our next step is the construction of the chimney and its support. They are made out of stout tin plate, by carefully marking and cutting out the developed planes shown in Figs. 13 and 14. Then drill the rivet holes and bend them to shape. It is advisable to first rivet the chimney onto the support before riveting the latter to the flameguard. Copper wire rivets are being employed.

*Details of Spirit Lamp*

The spirit lamp which is shown in place in Figs. 7 and 8 and in plan in Fig. 15, is the last part to be finished. For its construction we require two lengths of brass tubing—one 3/16 in. diameter and 10, 11/16 in. long, and the other 1/2 in. diameter and 5 in. long. The latter is cut into four 1, 1/4 in. pieces. Into each one drill a 3/16 in. hole 7/32 in. from each end to take

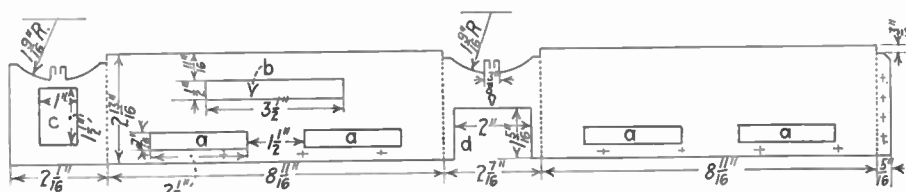

FIG. 9. Developed Plan of Flameguard

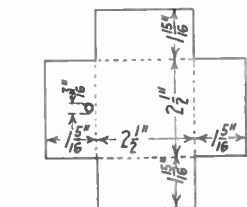

FIG. 16. Blank of Bottom and Sides of Spirit Tank (half-size)

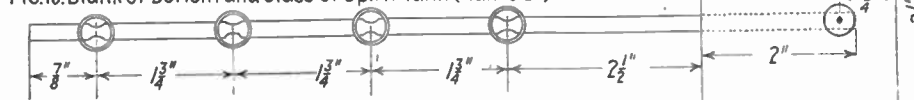
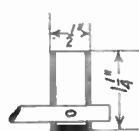

FIG. 15. Plan of Spirit Lamp. (half size)

the supply pipe. Having done this take the small tube and file a small hole at each side in the place designated, with a small round file, to allow the spirit to flow into the wick tube. Then we slip the latter into position, having previously plugged the bottom of the tubes with brass discs, well soldered into place. After having the wick tubes carefully lined up, we solder the joints, taking care to make a good job. The end of the supply pipe must also be closed by sweating a  $\frac{1}{4}$  in. brass plug into it. The bottom and sides of the spirit tank are made of tin plate cut to the dimensions shown in Fig. 16. After having drilled the hole for the supply pipe we bend the sides up and solder the joints on the inside. Next we put the supply pipe into place, allowing 2 in. of it to project into the reservoir and solder it to the bottom. The top is made out of the same material and soldered into place after having the filler boss sweated into place. A hole to act as ventilator is drilled into the filler plug, to allow the escape of vapor, which would otherwise create a pressure which would cause an overflow in the wick tube.

#### TESTING LEATHER

ONE of the most useful of the many bureaus established by the Government is the Bureau of Standards. One of the important functions of this bureau is making investigations of various materials and collating data that is of great value to industry and to all branches of engineering. As an example of the work that is done and the various forms of machinery that are exploited, we present herewith views of two special leather testing machines. One of these is a tensile testing machine that measures the elongation and ultimate strength of various grades of harness, shoe and belting leather.

As will be apparent, specimens from various parts of hides and from various forms of hides may be measured and those having the best physical characteristics recommended to the industry using such leather.

Another interesting and simple machine is that developed to determine the durability and endurance of sole leather. This machine subjects the material tested to a strain similar to that obtained in actual service. The mechanism is relatively simple. The operating wheel is driven by a chain drive and suitable reduction gearing from a small electric motor. The leather or composition material to be tested are attached to the rim of this wheel, which bears upon a disk covered with abrasive material. A hand brake keeps the disk from moving too freely and the leather is called upon to rub over the surface of the disk as it rotates with an action similar to that a shoe sole receives on a pavement.

A brush is provided to loosen up particles of leather from the abrasive material and a suction blower draws the dust down into a bag. The general construction of both machines may be readily ascertained from the accompanying photographs.

The tensile machine consists of two carriages moving on the machine bed, one of these being attached to a spring balance, the other to a threaded rod, which passes through the tail stock of the machine and which is screwed up automatically by a small electric motor placed on the machine bed. Each one of the carriages is provided with a suitable clamp or chuck to receive the leather specimens and the ultimate strength is indicated by the dial of the machine, while the elongation may be easily measured with calipers.

#### CRUCIBLES OF REFRACTORY MATERIALS

DURING the past month the making of crucibles from highly refractory oxides and minerals has been investigated by the Bureau of Standards. It has been found possible to make such crucibles without the use of clay or binder, which would tend to reduce the refractoriness of the finished product. One method is to make the crucible with the use of water by tamping the plastic mass inside of a fire clay mold lined with plaster-of-paris. When the mold and crucible are fired to a red heat, the plaster-of-paris disintegrates and permits the crucible, which is then fairly strong, to be removed from the mold. The crucible is then fired to a high temperature in order to give it the necessary density and strength. The other method is to mix linseed oil with a refractory oxide and then to shape the crucible inside a detachable metal shell; the crucible is then baked in the shell in a core oven, a similar process to that employed in the baking of cores for castings. After the baking, the shell is removed and the crucible fired to a high temperature, which results in a burning out of the temporary carbonaceous binder and a sintering of the refractory oxides, thus forming a dense, strong, and highly refractory crucible. Working in this way, crucibles have been produced from titanium dioxide, zirconium dioxide, and carborundum fire sand.

In casting brass in sand, if the gate breaks off in the mold, it usually indicates that the metal is not good. Such a breakage shows that the metal is red, short and breaks while cooling. The difficulty may be caused by the presence of sulphur, antimony, arsenic or other foreign elements in the metal. Bronze or composition acts in the same manner as brass.

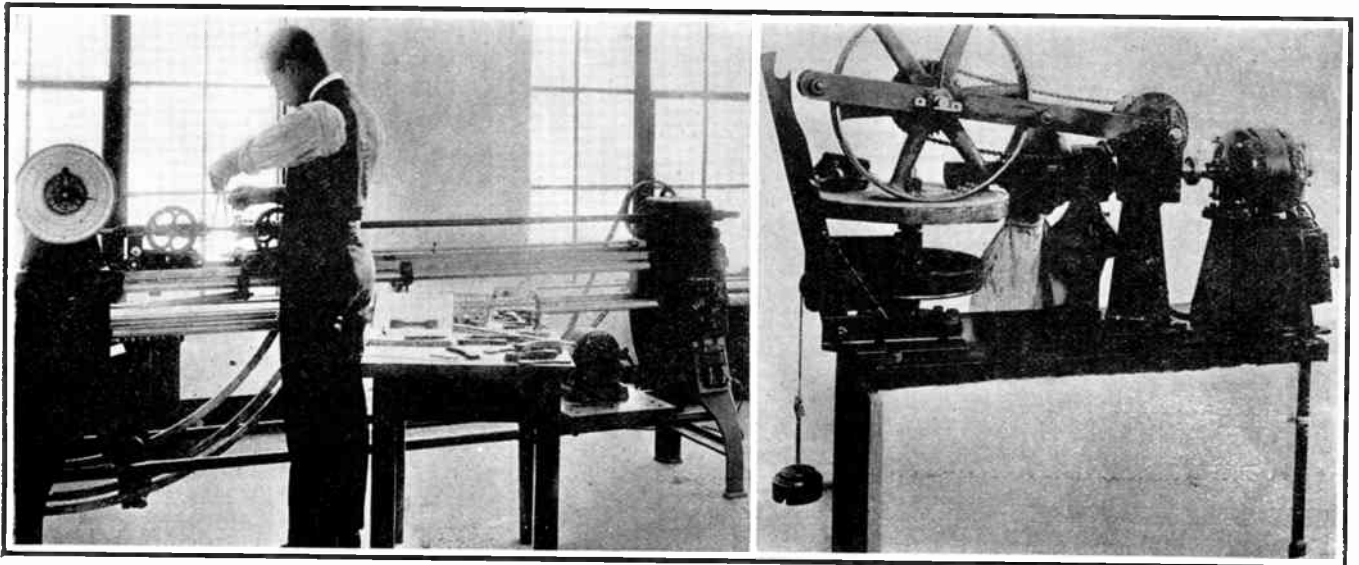

Special machinery developed by the U. S. Bureau of Standards for testing harness and shoe leather



# EVERYDAY MOTORIST

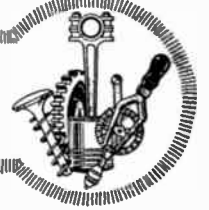

**A NEW LAPPING COMPOUND**  
**F**OR securing good fits in iron, steel and other hard metal parts, the lapping process is often used. Lapping of main and connecting rod bearings, however, has been practically out of the question because of the tendency for the hard abrasive to stick in the soft bearing material, or the shaft, and continue to grind after the lapping operation has been completed. It is practically impossible to wash the shaft or bearing free of these lapping or grinding compounds and consequently carborundum and emery have not been used.

Recently a new type of compound

scrape the usual bearing. It is soluble in oil, or it can be removed with gasoline or kerosene after the lapping operation is completed. It cannot be used in grinding valves, or lapping in pistons and rings, as it does not work on iron or steel and carborundum and emery compounds are best for such use.

The method of using this compound is to bore or cast the solid bearings or bushings to a light driving fit on the shaft and grind in Timesaver. This is applied very thinly and with plenty of oil. It is ground or lapped with a turning motion. After a few twists have been given, the shaft is cleaned and fresh compound applied. A num-

Fig. 2 shows crankcase, upper half and cylinder block inverted. Place on stand or box, crankshaft roughly fitted to main bearings and compound applied, cap bolted in place lightly, shaft rotated to belt connection with a line shaft or electric motor, then caps screwed down a little tighter and shaft rotated until bearings show a good surface. Several applications may be necessary.

Fig. 3 shows rods being fitted to the crankshaft. The crankshaft is held in a vise or special holder, rod bolted on with compound applied to bearing. Rock back and forth a few minutes, tighten up as babbitt grinds out, removing shim if necessary until fit is obtained.

It is claimed that bearings produced in this manner do not have to be assembled as tightly as a scraped bearing, so there are no high spots to wear off and the bearing if properly done, is a finished job. There is no abrading action on the steel shaft.

Fig. 4 shows a crankshaft in a lathe, all rods assembled on shaft, one shim removed at a time and assembled so as to turn free, but not tight, and bearing compound put in the bearings with oil, small end connecting rods resting and free to slide on sheet metal plate or board, clamped to the lathe bed with C clamps. The crankshaft is rotated by a lathe dog fitting face plate slot and is supported so it rotates freely on the lathe centers. The lathe is rotated at moderate speed and all rods are fitted at the same time. Shims removed and nuts tightened as the babbitt grinds out, until a perfect fit is obtained.

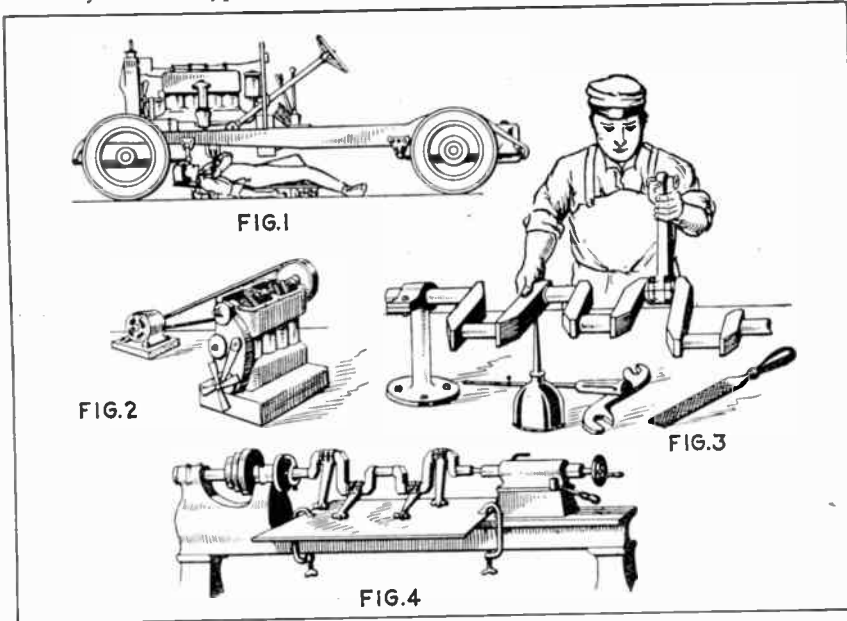

Diagrams showing how new bearing metal lapping compound may be used

has been brought out, especially adapted to soft metals, which breaks down after it has been in use for a short time. It is composed of large and small crystals, the cutting surface being the large crystal, and the small crystal being a neutralizing substance. When the large crystal has been worn down so that the short crystals are in contact with the rubbing surfaces, these are broken up and due to their neutralizing action, destroy the cutting qualities of the entire compound. This action generally requires about 10 minutes.

This product is sold under the name of Timesaver, and does not contain any form of emery, carborundum, or glass. It is stated that an 80 or 90 per cent bearing can be secured with it in about one-fourth of the time required to

ber of other methods can be utilized. Fig. 1 shows car with engine in place and the bottom half of crankcase removed. The connecting rods being fitted to the crankshaft are in the reverse position, that is, hanging down. Obviously, the only types of engines on which this can be done are those in which the heads are detachable so the pistons and rods may be removed without dismantling the engine or removing the crankshaft.

Enough shims are removed and connecting rods bolted up, just snug with bearing compound and oil in the bearing, and rocked back and forth a few minutes, tightening the nuts as the babbitt grinds out. If one application does not produce the desired surface, repeat operation. A few minutes will generally produce desired results.

## A QUENCHED GAP AS A SPARK INTENSIFIER

**F**OR some time past it has been known that the insertion of an auxiliary gap in the secondary circuit leading from the coil or magneto to the spark plug would result in the spark overcoming any obstacles in its path that ordinarily would prevent sparking. The sparko-gap is similar in construction to the quenched gap used in radio work and is a simple device that can be used with any spark plug and which is said to permit a plug to spark even if it is short-circuited with oil or carbon.

These claims are supported by Government tests and trials that have been made with this device applied to internal combustion engines, used on all

forms of automotive vehicles, running from motorcycles to airplanes. These tests have indicated that the device has merit and that plugs that would be inoperative without it will function under disadvantageous conditions if equipped with a device of this nature.

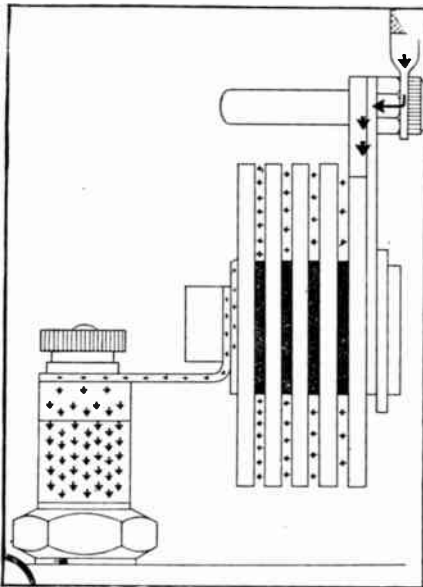

Quenched gap spark intensifier

The device is inexpensive and may be easily applied by any motorist, as it calls for no electrical or mechanical knowledge. There is nothing about the device to give trouble after it is once installed because of its simple and strong construction.

#### SIMPLE SPRING OILER

THE importance of keeping the springs of an automobile lubricated is not realized by the average motorist and it is often neglected because of the trouble involved in getting the oil in between the leaves. The spring oiler shown affords a simple and easy method of having oil flow between the

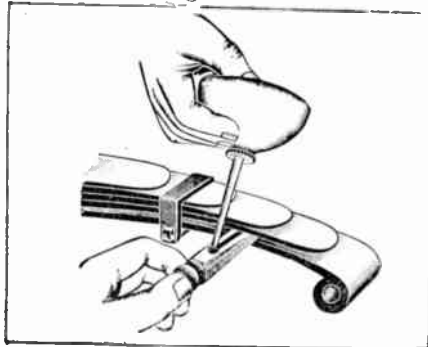

Device for oiling spring leaves

leaves. To use the device, the car weight is taken from the springs by lifting the car frame directly with a jack so that there is no strain on the springs except the hanging load of the axles. The wedge portion of the spring oiler is driven in the spaces between the leaves by a few taps of a hammer, and any oil that is supplied to the groove on the wedge of the device by a hand oil can will naturally flow to the points requiring lubrication.

#### A BUSHING EXTRACTOR

THE simple tool illustrated quickly and easily removes the steering knuckle, spindle arm and spring bushings in a Ford front axle. It is made of steel and nicely finished. It may also be used for Dodge, Dort, Chevrolet and Overland cars. It is valuable to the repairman and the owner who does his own work. When removing the steering knuckle bushings it is not necessary to remove the wheel. The way the tool works is obvious. The forked end has sufficient spring so it can be inserted in the knuckle through the hole in the other bushing, then the ends spread out as shown and bear on both sides of the bushing so that the

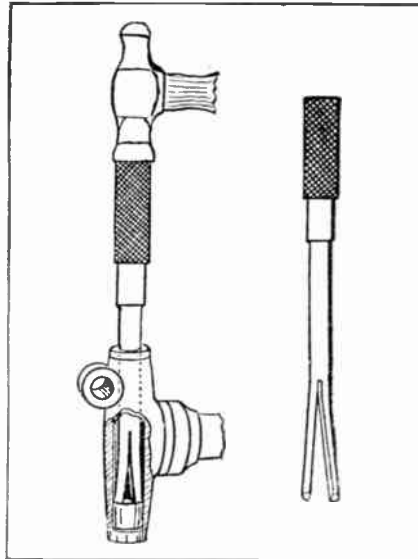

An effective bushing extractor

force of the hammer blows is directed equally on all sides of the metal, preventing cramping or binding due to a one-sided thrust, as is the case if an ordinary punch is used to force it out and thus making for easier removal.

#### TESTING INNER TUBES OF AUTOMOBILE TIRES

WE illustrate in the cut a simple method of rapidly testing the inner tube of a tire. The tube is blown up to a sufficient pressure to hold its shape,

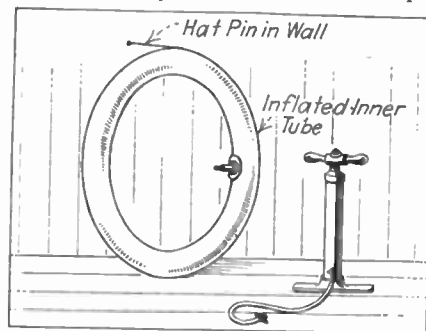

How to test inner tubes for minute leaks

when set up resting against a wall as shown. A hatpin is stuck into the wall above it so as to just touch the rubber at the highest part of the tube.

The smallest possible leak will show in five minutes by the tube sinking away from the pin. It is far more sensitive and a much quicker way of testing a tire than the method of hanging it up over night. It is fair to say that, if it does not sink from the pin in five minutes, it is airtight.

#### EXTENSION PADS FOR FORD PEDALS

THE pedal control group of the Ford car was evidently designed for persons with very small feet because the pedal pads are placed so close together that an ordinary man-sized foot

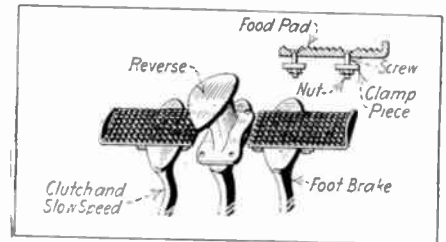

Extensions for Ford control pedals

covers at least two of them. It is somewhat disconcerting to put on the slow speed and reverse at the same time and does not enable one to make much progress. Extension pedals or rather foot pads which are shown in accompanying illustration make this control group a really practical one that can be operated without confusion. The center or reverse pedal has an extension which raises the foot pad above the level of the other two. For the clutch and brake pedals, special wide foot pads that are corrugated and that furnish a good firm grip for the foot are provided. The ends of these pads are bent up so that it is impossible for the foot to slip off of the foot pad. A number of accidents that have occurred in the past happened because the operator's feet slipped off of the control pedals at the critical time or from not being able to get the reverse pedal down far enough without applying the slow speed pedal at the same time. These new appliances are sold at a low price and can be easily applied by any one and have considerable value for operators of this popular machine. The extensions are attached to the foot pads by the clamping members illustrated, which are fitted to the pad and which firmly clamp the pedal.

#### CLOGGED MUFFLER

A CLOGGED muffler is a distinct cause of loss of power. When the constricted passages inside the muffler become clogged with carbon or soot, a back pressure is set up and the engine has to work against this pressure. Tap the muffler several times lightly with a hammer, then start the engine and blow out the loosened carbon. Occasionally the muffler should be taken apart and thoroughly cleaned of carbon and the small holes in the baffle plates opened up with a pointed tool.



# How the Automatic Telephone Works

*A Simplified Exposition Defining the Principles Involved in Mechanical Switching and How the Needs of a Large City Can Be Met Adequately*

*By Recently Developed Mechanism*

By Kenneth Alton

**I**N its elements a mechanical switch-board is nothing more or less than a combination of apparatus in which a mechanically propelled cord associates itself with the terminals of your line when you remove the receiver from the hook, and then, under the control of the electrical impulses sent out by your calling dial, automatically associates the other end of this connecting cord with the terminals of the line with which you wish to connect. In other words, we substitute a machine for the operator, who now picks up a cord and inserts one plug in the jack of your telephone line, and upon learning the number required plugs the other end of the cord into the jack of the line you are calling.

your own. It then becomes necessary for this mechanical switchboard, and the manual as well, to perform an intermediate operation, which consists of selecting a trunk line leading to the exchange in which your wanted subscriber is located. The difference here is that your mechanical operator, instead of connecting you direct to your subscriber, picks out an idle trunk to the exchange wanted, and another mechanical operator at that point picks up your connection and through its mechanical connecting cord associates it with the line you want.

The calling dial of a simple instrument which is illustrated in Fig. 1 is located at the subscriber's station. In the case of a desk-stand, it is mounted on the base as shown, and in the case of a wall set, on the face of the set itself, as outlined at Fig. 2.

It is so designed that by manipulating a finger wheel electrical impulses are sent out over your line corresponding with the numerals or letters appearing in the holes. When used in the larger cities, the dial will bear certain letters of the alphabet, in addition to the numerals, and in the smaller centers numerals only may be employed. A dial suitable for use in a large city is shown at Fig. 3. In making a call the subscriber will, of course, refer to the telephone directory, and he will find in the new directory that the central office name is printed somewhat differently from heretofore. Typical examples of the new form of listing telephone numbers are shown below:

Argentine Naval Commission,  
2 W. 67.....COLumbus 5623  
Argentine Quebracho Co., 80  
Maiden La.....JOHN 1652  
Argentine Railway Co., 25  
Broad .....BROAd 1383  
Argentine Trading Co., 1164  
Bway. ....MAD Sq 1871  
Argeres Bros., Restrnt., 86 6th  
Ave. ....SPRING 5337

These conform to the present manual listings, except that the first three letters of the office names are set out prominently. Simple as this change in the form of listing appears, until it was developed by the Bell System experts, no satisfactory system of designating telephone numbers for machine switching systems for large cities, such as New York, Chicago, Boston and Philadelphia, was known.

One advantage of this plan is that it does not necessitate the abandonment of all the existing manual designations. For manual operation it leaves them substantially as at present. For machine switching operation the same form of listing is used in the directory, a clear indication being given as to the portion of the listing which should

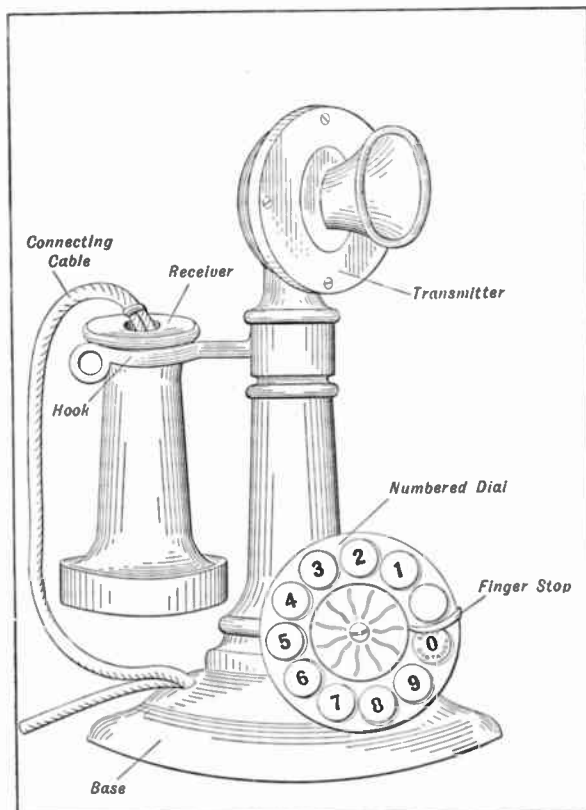

Fig. 1—Desk telephone for automatic exchange system

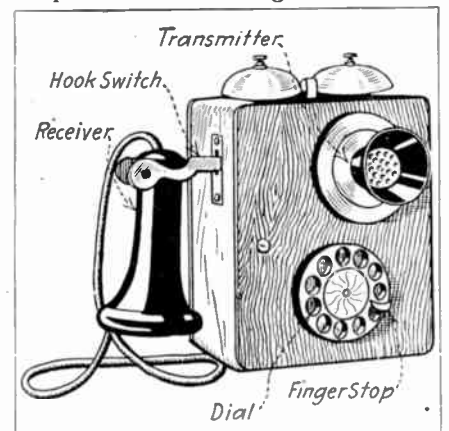

Fig. 2—Arrangement of dial on wall set

The above is a fair pen picture of what takes place in the small town where there is no exchange. When we come to the larger places, however, where there are a number of central offices, the chances are that the majority of your calls will be for subscribers connected to exchanges other than

Argent Co., 1400  
Bway....GREley 5513  
Argentina, Brazil &  
Chile Shipping Co., 70 Wall,  
HANover 0307  
Argentine Genl. Consulate, 17  
Batory Pl.....RECTOR 6946  
Argentine Impt. & Expt. Corp.,  
Prod. Ex.....BROAd 1768  
Argentine Mercantile Corp., 42  
Bway. ....BROAd 5066

be dialed in making an automatic call.

The maze of connections and duplications of detail of the latest systems is apt to be confusing to the reader not entirely familiar with modern telephone switchboard practice, but the basic principles of mechanical selection involved can be easily understood by following the description given and studying the diagrams of a simple system consisting of only a few subscribers and a correspondingly few parts of

the mechanism. The more complicated systems used in large cities are a refinement and logical development of the system described which will suffice to bring out enough of the basic principles so the reader can obtain an idea of the way the system works.

#### Function of Calling Dial

The automatic systems must have some arrangement at each end of the line so the subscriber can call any party desired without any other aid, and suitable mechanism must be provided so connection will be established with the desired party at a central station. The arrangement at the subscriber's end was formerly a series of push-buttons, but at the present time a much more satisfactory and positive device does the calling. This is a numbered dial, previously explained, attached to the base of a desk telephone of the usual form. The numbers around the edge of the dial range from 0 to 9

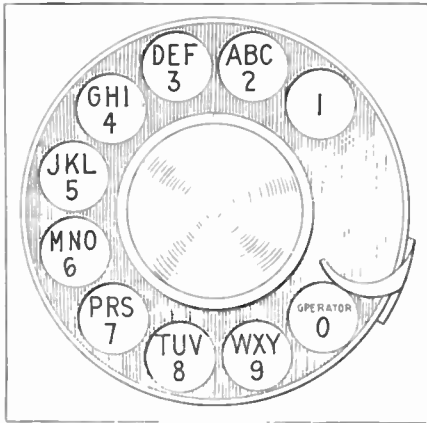

Fig. 3—Calling dial for large city exchanges

and may also have letters adjacent, as in Fig. 3, thus enabling any combination of figures to be selected. The neat dial is all that is visible at the outside of the instrument, but some very ingenious mechanism is hidden inside the telephone base and is actuated by the dial. At the edge of the dial there is a little fixed hook or finger stop. In calling a number, the finger is placed in one of the openings in the upper dial, directly above a specific number, then the dial is rotated in a clockwise direction toward the fixed stop, until its motion is arrested when the finger is removed. Then the dial, which has been turned against the resistance of a torsion spring, is returned to its starting place, but in so doing a toothed segment rotating with the dial makes a certain number of electrical contacts corresponding to the number at which the dial was released. Thus, if the dial was released when the finger in hole No. 7 came against the finger stop, the contacts would send seven distinct impulses over the line to the central exchange, where a special electromagnetic selective device moves contacting fingers over suitable

connections arranged so the desired circuit is brought in action. The calling of any number composed of more than one figure is accompanied by inserting the finger in the dial, rotating it to the fixed stop and releasing it for each number in succession, as shown in Fig. 4.

#### What the Automatic Selector Does

The operation of an automatic selector at the exchange will be understood by referring to Fig. 5, which is a simple selector or circuit finder for an exchange of ten subscribers. The subscriber's lines, or circuits, terminate in ten pairs of plates or "bank contacts" arranged on the arc of a circle and numbered from 1 to 10, respectively. A ratchet wheel, R, is arranged with its center at the center of the arc formed by the contacts and carries a pair of springs. W, technically termed a wiper, is arranged with its center at the center of the arc formed by the contacts and carries a pair of springs. W, technically termed a wiper. The line for subscriber No. 1, for instance, by whom it is supposed this instrument will be used, is represented as being connected not only to the first pair of "bank contacts," but also to the wiper, to the rotary magnets and to the release and rotary push-buttons.

Suppose that subscriber No. 1 wishes to connect to line No. 2. To do this he presses twice (theoretically speaking) the rotary button (Rot. B) in the drawing, located at his telephone. This closes the circuit from the battery through the rotary magnet. Every time the circuit is completed the rotary magnet is energized and attracts an armature (A). This armature, which carries a pawl or finger (P), at its end, which engages the ratchet wheel (R) and moves it, as well as the wiper (W), one step each time the armature is attracted. Consequently, when A has been attracted and released twice in succession, the wiper, W, will have been moved from its normal position at the left of the first pair of contacts and will rest on pair No. 2 of the bank contacts, thereby bridging the gap between the terminals of lines No. 1 and No. 2. By means not shown in the diagram, subscriber No. 2 will be signaled and called to answer his telephone. The arrangement of the apparatus is such that when the conversation is finished and calling subscriber No. 1 hangs up his receiver, the release magnet (Rel. Mag. in cut) will be momentarily energized and so attract its armature. This will pull the retaining dog (D) out of engagement with the ratchet wheel, which is then returned to its normal position by

a clock spring. In a similar manner, subscriber No. 1 could call any one of the other nine subscribers of the system, and they, in turn, could call any other party by using their instruments in the manner indicated. The proper sequence of electrical impulses for the actuating rotary control magnet is automatically sent by the spring-propelled drum and dial at the subscriber's instrument.

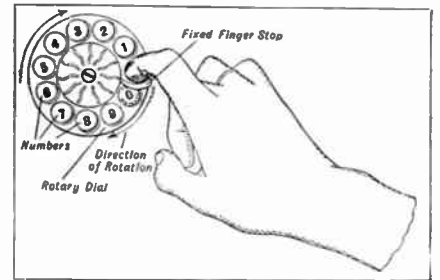

Fig. 4—How calling dial is worked

#### How a Complex Selector Switch Works

Let us consider next the action of a selector switch suitable for a 100-subscriber exchange. The details of this selector mechanism are illustrated at Fig. 6. The line terminals to the number of 100 pairs will now fill ten "bank rows," with ten pairs of contacts in each row. The ten rows are superposed as shown. The number of the line connected to the first pair of contacts in the lower row would be 11; the number of the line connected to the second contact in this row would be 12; the next 13, etc. The number of the line connected to the second pair of contacts in the second row from

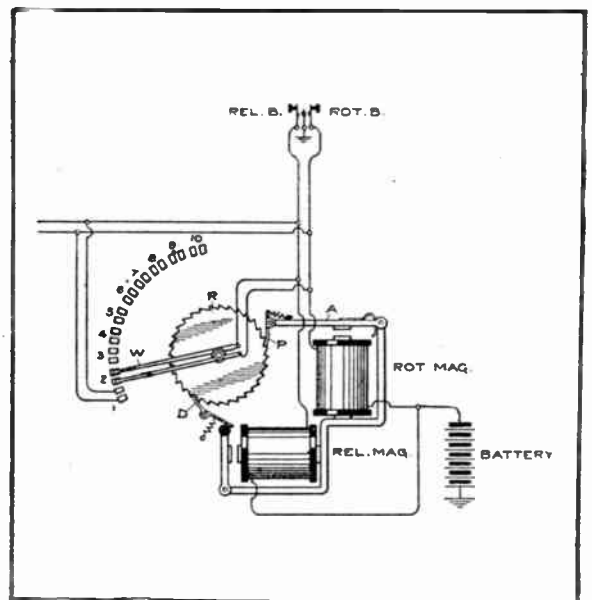

Fig. 5—Operation of automatic telephone selector

the bottom would be 22, that immediately above it would be 32, etc. It is evident that by this arrangement in a system of 100 lines each subscriber's number would contain two digits; the first digit would indicate in which horizontal row of bank contacts his line terminals could be found and the

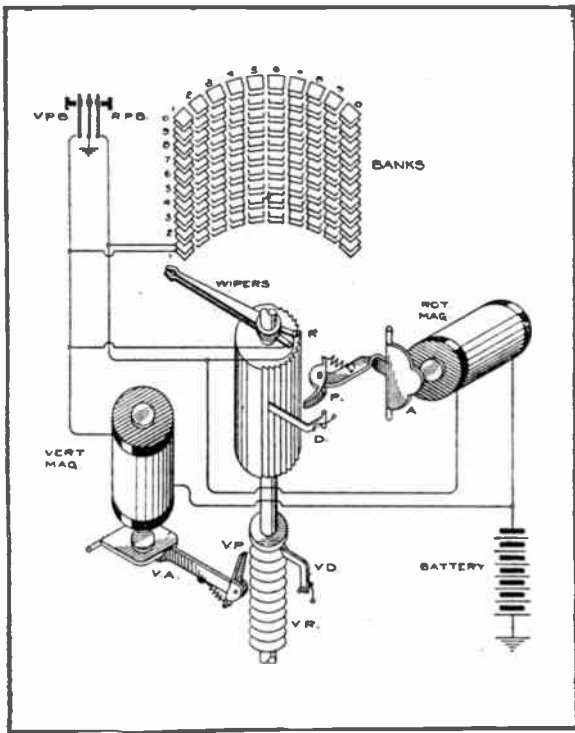

Fig. 6—Diagram showing automatic selector for 100 subscriber exchange

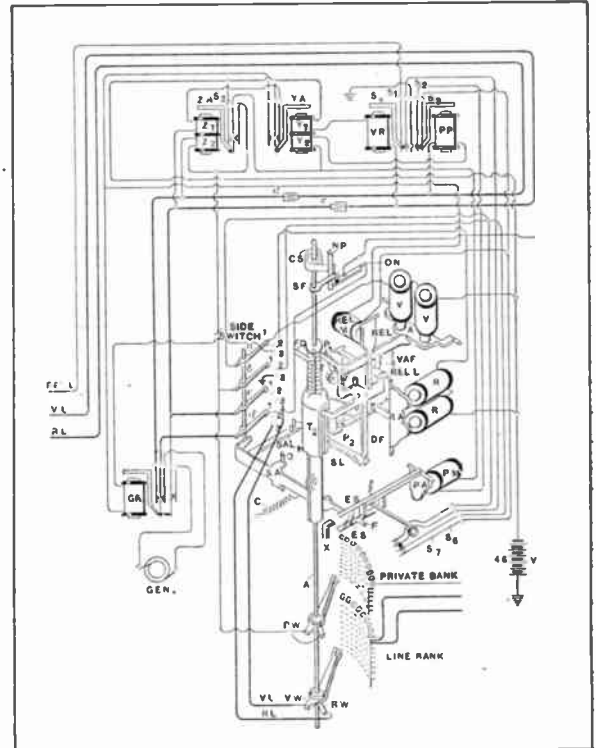

Fig. 7—Diagram showing all connections of 100 subscriber Automatic Exchange

second figure would indicate the exact pair of contacts in this row.

An idea of the method pursued in obtaining a certain connection in a system of this capacity (100 subscribers) may be had by considering that each subscriber circuit or line of two wires is connected to a pair of the "bank contacts" and to a connecting machine, technically termed a "connector switch," somewhat after the method depicted in the cut, which shows the connection for station 11. The important feature of the connector switch is the ratchet wheel or hub (R), which carries the wiper (W), already described in connection with the simple diagram at Fig. 5.

The actuating rotary magnet is represented by Rot. Mag. with its armature at (A) and pawl (P), also the dog (D), for the retention of the ratchet after each rotary step. The shaft upon which the ratchet is mounted is extended and carries another ratchet (VR), called the "vertical ratchet." The vertical magnet is adapted to attract the vertical armature (VA), which carries on its end the pawl (VP), arranged to engage the vertical ratchet and raise the shaft. By means of it the wiper is raised automatically one step whenever the magnet attracts its armature. The vertical dog (VD) is adapted to drop into place each time the ratchet is raised one step and thus retain the wiper in position. It is thus evident that by means of the vertical pawl and ratchet the wiper may be raised to a point opposite to any one of the ten horizontal rows of "bank contact" pairs and then, by actuating

the rotary pawl and ratchet, the shaft may be rotated until the wiper rests on any desired pair of bank contacts in that horizontal row. Thus, if the vertical magnet should be intermittently energized three times and the rotary magnet intermittently energized five times, the wiper should be raised to the third horizontal row of bank contacts and rotated five steps, thus connecting line No. 11 to line No. 35. The apparatus, of course, is so arranged that subscriber No. 11 may intermittently energize the vertical and rotary magnets and control the movements of the wiper so that he can talk to any of the other ninety-nine subscribers at will by turning the dial on his telephone, as has been previously explained.

In a commercial telephone exchange of the automatic type there are several connector switches capable of serving each subscriber, the operation of one being intermittent upon that of the preceding one. If it were desired to have the lines so arranged that all the subscribers could talk at once it would be necessary to have fifty connector switches, which would provide for fifty separate conversations between 100 parties. In general, it may be said that in the average automatic exchange it is not necessary to have connector switches for every subscriber, but just sufficient to handle the calls at the busiest period of the day. Usually 20 per cent of the number of subscribers is taken as the proper number of connector switches to employ, but these may be augmented according to the demands made upon the exchange. The

actual wiring in connection with a typical selector switch is shown at Fig. 7, and the various circuits may be easily followed by the student. The principles of operation should be well understood, in view of the explanations previously given. Obviously, a complete presentation is not within the scope of a magazine of this character, as it would call for specialized knowledge that few of our readers possess.

### INCANDESCENT LAMP WITH DUAL BASE

A NEW double-base lamp by means of which household appliances and fixtures may be used simultaneously from the same outlet without the use of double plugs or adapters has been developed by E. O. Schweitzer, chief testing engineer of the Commonwealth Edison Co., of Chicago. The lamp may be made up in any style and capacity. The lead-in wires are those used for the standard 500-watt lamp and continue through the bulb from base to base, the lamp filament being tapped off from them. The lead-in wires, which are formed into an expansion loop to eliminate strain due to unequal contraction and expansion of the lamp elements, are made with a quarter twist to provide clearance for the filament anchors. Exhaustion is carried out through a concealed tube within one of the bases, continues *Electrical World*, thus making a tipless lamp. By the addition of a light brass shell beaded at each end any standard shade holder may be used. The extra attachment to the lamp may be made by using a socket screwed to its tee base.

# A Light Four Cylinder Air Motor For Model Airplanes

By Clifford A. Butterworth

**A** FOUR cylinder, light-weight compressed air motor for use in a model airplane is shown in the accompanying drawings. When properly made this motor should weigh about 4½ ounces, and will have sufficient power to drive a 12 or 14 inch diameter propeller. It is ⅜ inch bore by ½ inch stroke, with overhead rotary valves. This type of valve is the only kind that can be used on an engine of this size. Furthermore it is very simple in construction, and there are no flat surfaces to be finished as with the ordinary slide valve.

The cylinders are turned from ⅝ inch cold rolled steel. They should be finished as smooth as possible by reaming and polishing. Drill the lower exhaust holes before doing the polishing. When drilling the inlet and exhaust ports in the top of the cylinder care must be taken to drill them at the exact angle indicated. The best way to do this is to mount a ⅜ inch pin in a

block at an angle of 45 degrees, as detailed in Fig. 6, and hold the cylinders on this when drilling the ports. The lower end of the cylinder is threaded with a forty thread to take the ring shown in Fig. 1.

The connecting rods are made from ⅛ inch steel or brass. The lower half of the big end is riveted on carefully after the rod has been put in place on the crankshaft.

The plate to which the cylinders are fastened is made of 1/16 inch steel bent over at the edges to increase the stiffness. The cylinders are held on by means of the ring, Fig. 1. Another method of fastening them is shown in Fig. 5. They are clamped down with small steel strips and screws.

The crankshaft is of the built-up type. The shaft is ⅜ inch drill rod, the crank webs are made from ¼ to 3/16 inch steel, pinned on with 1/32 inch pins. The bushings are brass, the design for the two end ones is shown in

Fig. 2. The center bushing is only ⅜ inch in length, and is split to permit its being placed on the shaft.

The bearing supports, Fig. 3, are made of ¼ by 1/16 inch flat steel, bent on the forming die shown in Fig. 4. The center support is made only ⅞ inch across the tcp instead of 1⅝ inches, and must also be bent over to clear the cylinder clamping rings. The bushings are clamped in place with No. 2-56 screws as shown. The same size screws are also used to fasten the supports to the plate.

The valve shaft is turned from ¼ inch steel rod. It should fit the holes in the cylinders as tightly as possible without undue friction. The packing grooves are wound with oil-soaked thread or soft string before it is put in place. It is driven by bevel gears at one-half the crankshaft speed. The large gear is ¾ inch in diameter, the smaller ones ⅜. The bracket supporting the gear shaft is made from ¼ by 1/16 inch steel. The air pipes are brass tubing of ⅜ inch outside diameter. A ball thrust bearing can be mounted at the front end of the crankshaft if desired.

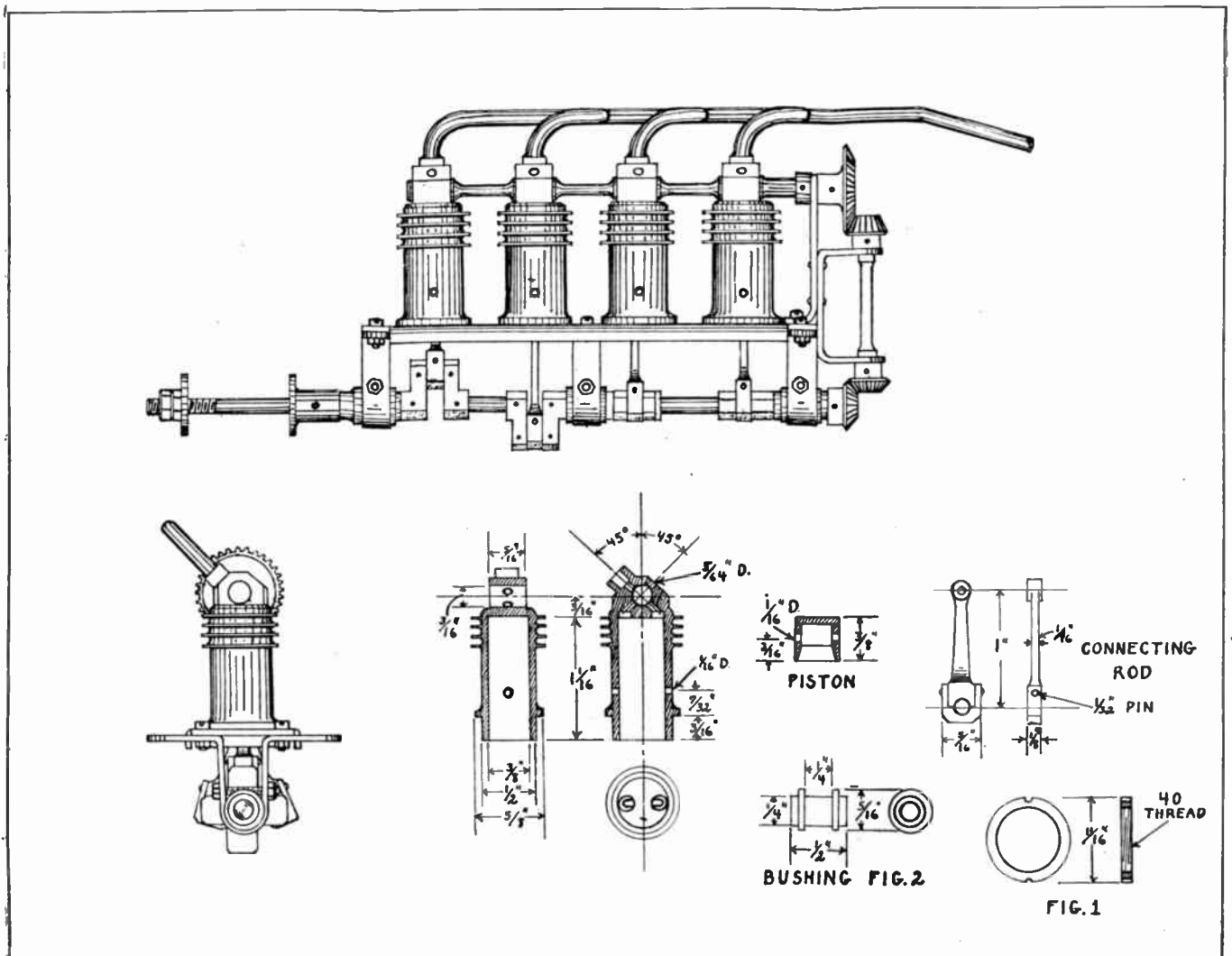

Assembly view of very light four-cylinder air motor using rotary overhead valve at top and details of cylinder, piston, and connecting rods below



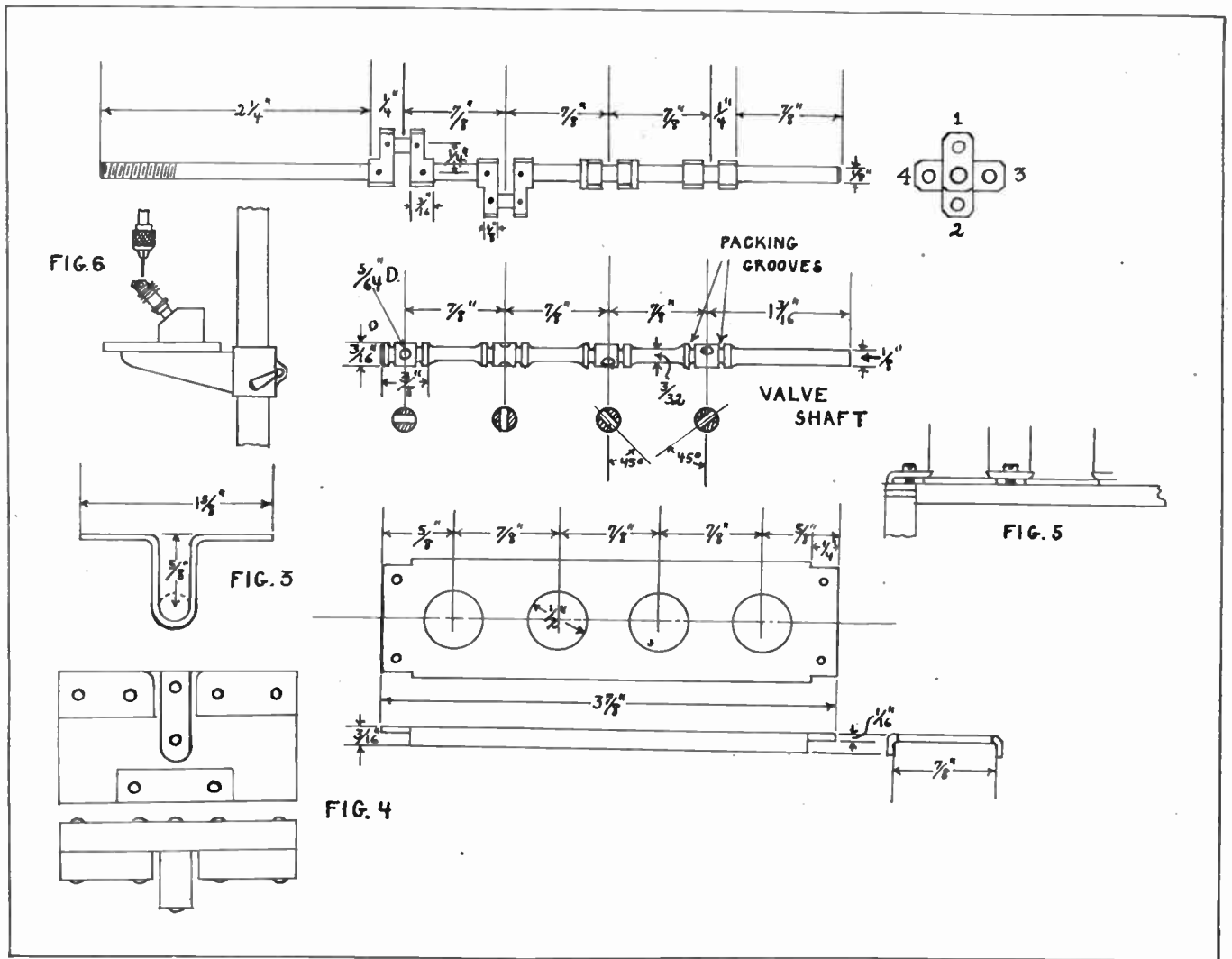

Details of crankshaft, valve shaft and engine base of four-cylinder air motor

COMMERCIAL AVIATION IN GERMANY

**D**IE *Deutsche Luft-Rederei* has now published its first annual report of flying activities. According to the figures, 13 twin-engined and 71 single-engined mail aircraft transported 3,000 passengers and 100 tons of mail and other cargo on the six regular lines: — Berlin - Leipzig - Weimar (opened Feb. 5th, distance, 250 km.; mean flying time, 2 hr. 18 min.; number of flights, 893). Berlin-Hamburg (March 1st, 260 km., 2 hr. 10 min., 571 flights). Berlin-Rhineland-Westphalia (April 15th, 490 km., 4 hr. with intermediate landings at Hannover and Braunschweig, 402 flights). Berlin-Warnemünde (April 15th, 220 km., 1 hr. 55 min., 159 flights). Berlin-Swinemünde (July 5th, 175 km., 1 hr. 15 min., 132 flights). Hamburg-Westerland, Island Sylt (July 5th, 175 km., 1 hr. 15 min.); besides 1,389 other flights. Ninety-five per cent of all flights were completed.

With the Government gasoline supply ceasing all flights except occasional ones stopped on Aug. 1st. In July flights were made over the sea sur-

roundings of Berlin each Thursday in G class aeroplanes, and week-end trips to the Swinemünde sea resort. During the fairs in Leipzig a service to Berlin was maintained and numerous other flights carried out with single and twin-engined aircraft to all parts of Germany. Exhibitions in connection with passenger flights were arranged at the aerodromes of Dresden, Leipzig and Gelsenkirchen.

SOFT WOOD PROPELLERS

**I**T is reported that German airplane constructors, instead of using mahogany and walnut for propellers, are using softer woods of different kinds laminated together. Experiments made to determine the strength of these propellers show that with the wood skillfully compacted together these propellers are as difficult to break as the best hardwood propellers. It must be remembered that the extreme strain necessarily makes the life of even the best propeller comparatively short, and there is something to be said for the view that efficient and durable propellers may be made from comparatively cheap timber so easily obtained.

HOW TO DISTINGUISH MAHOGANY AND WALNUT FROM RED GUM

**I**N the manufacture of furniture and cabinets a great deal of red gum is used as an imitation of mahogany or Circassian walnut. When red gum is properly finished it can be made to look so much like either of these woods that only by very careful observation can the true be distinguished from the substitute. There is a very distinct difference, however, between red gum and mahogany or walnut. This difference lies in the size of the pores. In mahogany, Circassian walnut, and black walnut the pores are so large that they can be seen very distinctly, on a smoothly-cut surface of the end grain, where they appear as minute openings smaller than pin holes but visible without magnification. On surfaced faces the pores appear as fine grooves, running parallel with the grain. They are even visible through the varnish, appearing as dark lines. In red gum the pores are much smaller and can be seen only with a magnifying glass.

# USEFUL AND INTERESTING INVENTIONS

## AUTOMOTIVE - MECHANICAL - ELECTRICAL

**SCHEME FOR AIR COOLING**  
**T**HE accompanying illustration depicts a scheme for air cooling small engines which depends on the ejector action of the exhaust gases to draw air around the cylinders. The inventor believes that this scheme will save the power that is used by the usual form of cooling fan which runs from one-half to one horsepower with the engine running at high speed. The advantage

of a wheel element and the cylinders are provided with vertical instead of horizontal flanges. It is doubtful if the exhaust gases issuing from the silencer would have sufficient speed to induce much of an air draft through the cooling cowl. This is an English invention.

**STUMP-SAWING MACHINE**  
**A** STUMP-SAWING machine, invented by Arthur Hamilton of

eration of a cross-cut saw. Not the least of the advantages of the device is that it may be operated very close to the ground—Lester L. Sargent.

**NEW ENGLISH VALVE DESIGNS**

**W**HENEVER inventors try to make improvements in internal combustion engines, the point of attack is nearly always the valves or their operating mechanism. Two new British patents were recently reported in *Engineering*, of London, that should be of interest to those of our readers who are following internal-combustion engine design progress. The object of the invention of S. S. Guy of Wolverhampton, shown at the left in accompanying illustration, is to provide for adequate and automatic lubrication of enclosed, valve-operating mechanism and its associated parts. The invention consists in providing the casing enclosing the valve mechanism with openings communicating with the crank-case and outer atmosphere. The openings already provided in the top of the crank-case to accommodate the valve rocker arms may be sufficient to allow of the oil mist entering the casing. The top of the crank-case 2, to which the casing 3 enclosing the valve-operating mechanism is secured, is formed with holes 4, in addition to the openings for the rocker arm 6. The breather orifices 7 are formed in the upper part of the casing 3, and are fitted with gauze caps easily detachable for cleaning purposes. By this arrangement the aspiratory effect produced by the action of the piston on the oil mist in the crank-case causes the said mist to pass through the casing 3 so that while the engine is

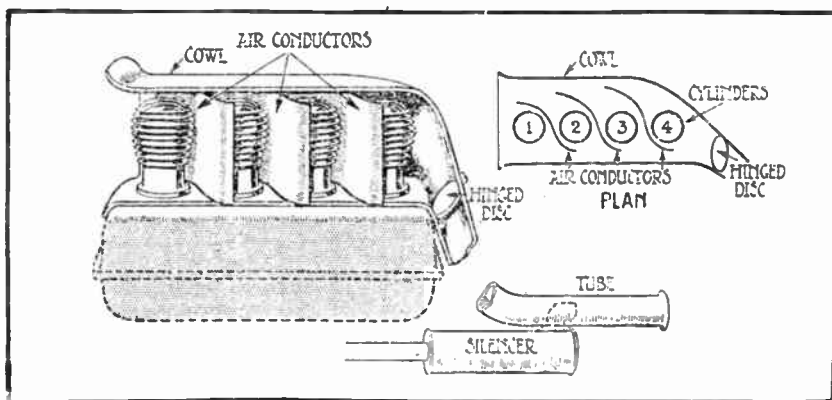

*New system of air cooling auto engines*

advanced by the inventor is that there are no moving parts in the cooling system other than the moving gases, and that the waste gas is made to do more useful work instead of being discharged into the air after it leaves the cylinders.

The scheme is a simple one, the cylinders being enclosed by a sheet metal cowl having partitions to deflect air around each one of the cylinders. This is a modification of the well-known Franklin system of air cooling used in this country, with the exception of that on that type the air is drawn through the cylinder jackets by a blower fly-

Harrisburg, Ark., is portably mounted so that it can be readily drawn across a field and brought into proper position for operating upon any desired stump. The saw is reciprocally operated by cables which are run over rollers on arms depending from an overhead frame. The cables are attached to a reciprocating cross-head, which is driven back and forth by a pittman and drive wheel, which is driven by a gas engine. The machine is operated by one man, with the saving of all the back-breaking work incident to the op-

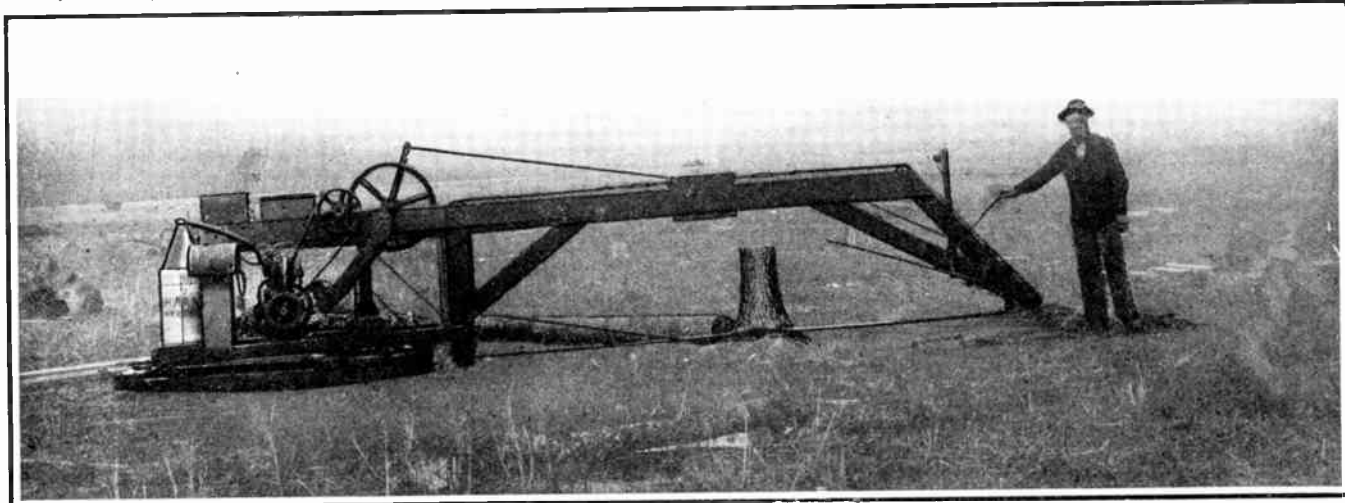

*Recently devised stump-sawing machine*

running there is a constant circulation of the oil mist in the said casing.

Messrs. D. E. Turner of London and E. B. Ware of Tottenham have devised an oscillating valve as shown at the right of illustration herewith. The invention relates to valvular arrangements for internal-combustion engines of the kind in which an oscillating spherical or part spherical valve is mounted to oscillate in a head in the cylinder by means of cams. According to the invention, the valve is actuated in its essential movements by cam mechanism through the medium of tappet

**NEW FUEL FEED DEVICE**  
**T**he Sparton Fuel Feeder introduces a principle thus far never commercially applied to a fuel feed—positive force generated in the combustion chamber so applied as to pump fuel in direct proportion to the motor's needs. Instead of employing a vacuum created by suction from the intake manifold, the Fuel Feeder pumps direct from the supply tank the moment cylinder compression takes place.

The mechanism is housed in a small cylindrical tank, which is to be mounted under the hood. It has few moving

forced into the tank. As soon as the fuel rises enough to lift the float, it closes off the pressure pipe and the pump is inoperative until the level becomes low enough to allow the float to drop and again open the control valve.

Simple compression furnishes the pumping power, the action of the Fuel Feeder is not only positive but it varies directly with the engine load. Reference to the mechanical drawing will make clear how the float and cut-off mechanism maintains a constant fuel level and thus insures a full fuel supply that is under automatic control.

**TWO-PIECE PISTON**

**T**he accompanying illustration shows an internal combustion engine piston that has been devised in England. It is composed of two distinct parts, the upper part or piston proper which takes the thrust of the explosion and the lower slipper or guide member to take the thrust of the connecting rod. The slipper member is securely fastened to the wrist pin but the piston member has a certain degree of movement and can adjust itself to the bore of the cylinder. It is claimed that the separation of the two members assists in materially reducing the

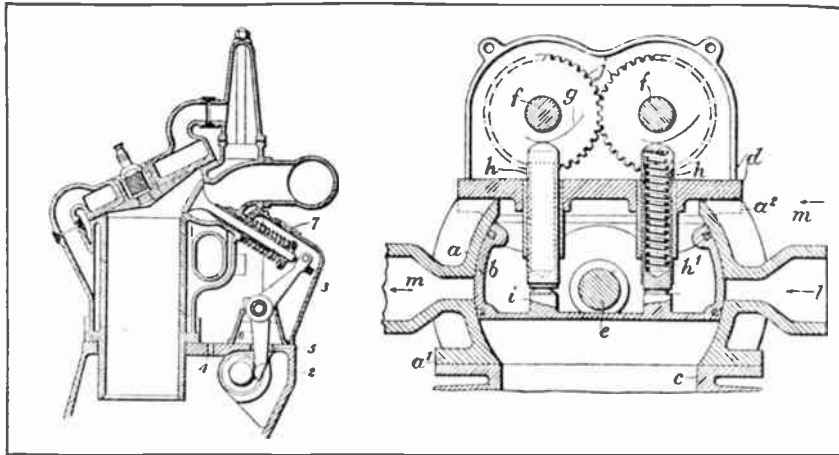

*New English valve designs*

rods adapted to bear thereon so as to control the admission of fuel to, and the exhaust of the products of combustion from the cylinder. The hollow spherical casing a, carrying the valve b, is flanged at a<sup>2</sup> and at a<sup>1</sup>, where it is secured to the cylinder c. To the flange a<sup>2</sup> is secured a suitable casing d, to contain the cam-actuating mechanism. The valve b is mounted on trunnions e. The oscillating movements of the valve b are effected by cams g mounted on spindles f, f, passing through and supported by the casing d enclosing the cam-actuating mechanism. Each cam spindle f, f, is provided with a cam g adapted to act on a tappet rod h supported by the cam casing and interposed between the cam g and a projection i on the oscillating valve b. The tappet rods are telescopic, and the two tubular portions thereof are kept extended by a spring h<sup>1</sup>, which is always under compression. The cams g, g, are arranged centrally of their spindles f, f, and effect the movement of the valve. The valve spindles f, are geared together as shown at j. The valve b, when moved upward on one side of the supporting trunnion e, will admit fuel through the inlet port i, and when raised on the opposite side will uncover the exhaust port m.

To remove ink marks, such as writing, from celluloid, light rubbing with a rag moistened with acetone is effectual. After removal of the ink marks, it may be necessary to polish the surface with a dry cloth.

parts, and should be strong and durable. The compression pressure pushes a small piston down against a spring and on the up-stroke of the piston it acts just as any plunger pump does

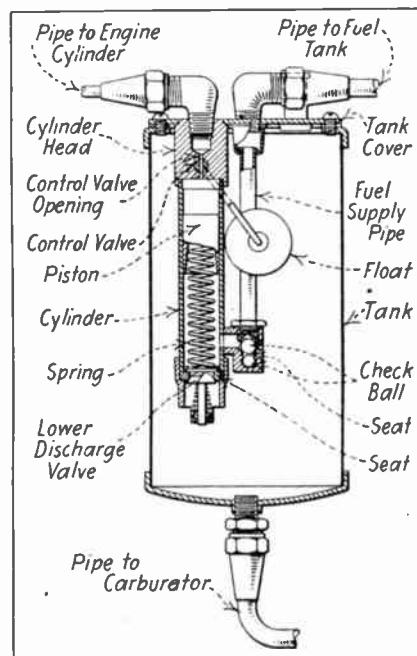

*Fuel feed device*

and draws in gasoline through the check valve which opens to give access to the main fuel container. On the down-stroke the discharge check valve leaves its seat and the gasoline previously pumped into the cylinder is

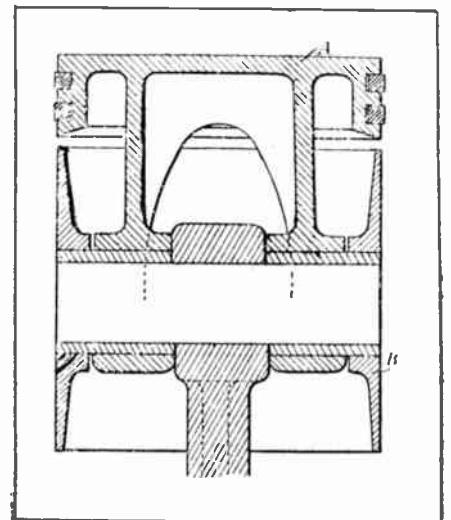

*Two-piece engine*

temperature of the guide member and results in improved lubrication of the part that is subject to the greatest side thrust.

Both sections are held together by the wrist pin which passes through wide bushings extending through bosses on both parts of the piston. As should be expected, the larger part of the bearing area is on the portion of the piston subject to the explosion pressure.

A cement for mending hard rubber and similar materials is made by melting one part of rosin and adding to it one half of its weight of india rubber cut into small pieces, slowly with constant mixing, taking care to do it at as low a heat as possible. To use it melt and apply keeping the parts under strong pressure for several hours.

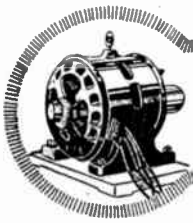

# ELECTRICAL PROGRESS DIGEST

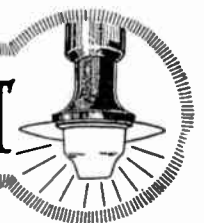

## DETERMINATION OF MINUTE LENGTH CHANGES IN BRIDGE MEMBERS

THE note given by a vibrating wire, whose ends are absolutely secured, will vary greatly for a change in the distance between the ends which may be brought about by any cause. In a wire a yard long, a change of distance between its points of attachment of as little as 1/100th of an inch may change the note nearly one-fifth. This shows how exceedingly delicate a base is given

The fundamental note of this wire being known, the number of its vibrations per second is also known. The observer moves the bridge back and forth until the notes given by the two wires are of exactly the same pitch. This is done while the bridge member or strut is loaded and unloaded. Each time a different note will be given, the member of vibrations is noted, and by application of a simple formula the change in length of the wire,  $f$ , is determined with extreme accuracy. The

## ELECTRIC LIGHTING INCREASES EFFICIENCY OF LAYING HENS

ELECTRIC lighting is being utilized to increase the efficiency of the laying hen, according to a writer in *Edison Current Topics*, published by the Southern California Edison Company. For several years experiments have been made and the results obtained have been so satisfactory that almost all the poultry breeders are now increasing their egg production from 35 to 70 per cent during the off season by lighting the chicken pens in the early morning hours before daylight. Some of the poultry journals make the statement that in some parts of the Middle West there has been such a large increase in the egg production in what was the off season, that during the past year the off-season production exceeded the regular supply during the regular laying season.

Beginning about the fifteenth of October, the lights are turned on in the chicken houses at 3:30 A. M. to get the hens off the roosts; they are immediately fed. The egg production depends on the amount of warmth and food supplied to the hens in the early part of the day. As soon as the hen is properly warmed and properly fed, she goes on the nest. If the stock is left to get off the roosts after daylight during the winter, the egg production drops off after the days grow shorter. This lighting is continued, if the chickens remain in good physical condition, until about the fifteenth of February. After that time, the lights are not turned on until about 4:00 A. M. and a month later the artificial lighting is discontinued altogether for the season. The amount of light used per square foot varies and seems to be a matter of the individual opinion of each rancher. The average, however, is about one watt for every fifty square feet of floor surface.

In Norway, a great deal of interest is being excited by the use of electric smelting. It is believed by some that this is a clue to the future development of the iron industry there. It is proposed in one place to construct electric works capable of producing 80,000 tons of iron per annum, as far as possible from Norwegian ores and utilizing water power for the purpose.

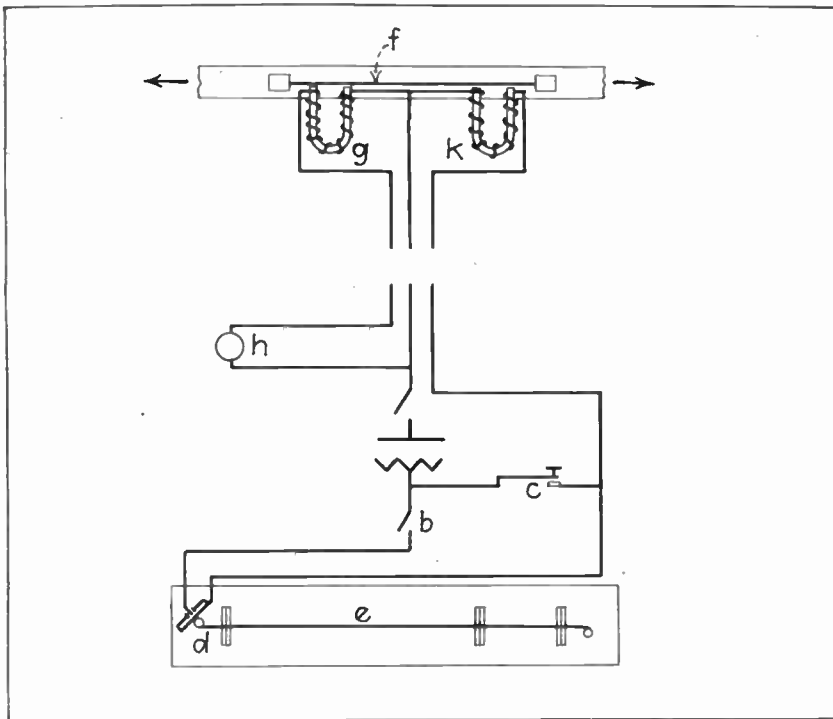

Method of determination of minute length changes in bridge members

for length measurements. In the diagram,  $f$  represents the wire secured to a member of a bridge-truss, which in stress of wind or of load, changes in length. The diagram illustrates the connections clearly.

A source of direct current is supposed to be somewhere in the system. If the key,  $c$ , is depressed and released it will set the wire,  $f$ , into vibration as the electromagnet,  $k$ , acts upon it just as if it had been mechanically vibrated. By listening with the telephone receiver,  $h$ , the note of the vibrating wire will be heard as it reproduces by induction its vibration in the circuit of the electromagnet,  $g$ . For perfect quietude, the hearer may be stationed in a distant place. Alongside him is a second stretched wire,  $e$ , with a movable bridge,

above method implies a more or less musical ear. This qualification is dispensed with by introducing a microphone at  $d$ , and closing the switch,  $b$ . The string,  $e$ , is then plucked by hand and if, by proper placing of the bridge, it is in tune with  $f$ , the latter will be thrown into vibration by the action of the current passing through the coils of the magnet,  $k$ , and by the magnet,  $g$ , and the note will be reproduced in the telephone. The bridge of the wire,  $e$ , is shifted back and forth until the induced note is at its loudest. This point gives the number of vibrations of the wire,  $f$ . The formula is a simple one, except that certain constants, such as the specific gravity and the coefficient of elasticity of the wire have to be known with great exactness.



**HAND INSTRUMENTS FOR MEASURING ANGLES**

**T**HIS apparatus, which compares with the sextant or other reflecting instrument of that type, is based upon the use of reflecting prisms. They are mounted upon a circular plate whose periphery carries a scale of angular measurements. The prism,  $P_2$ , consists of two right-angle pieces secured face to face as shown, with reflecting surfaces of silver deposited upon the two faces in contact. This prism is mounted so as to rotate freely, the angular scale, T, turning with it. The spindle is received by the handle A, of the instrument. This is shown clearly in Fig. 2. The prism,  $P_1$ , has a silvered face and the dotted lines indicate

line with the first one. The angular reading is then taken giving the angle between the two objects. The instrument can be used for vertical or horizontal angles and as made is remarkably compact.

**LOSSES IN CAR GENERATORS**

**O**NE of the most popular systems of regulating current generation in small dynamos of the automobile type used for storage battery charging is the third brush system and while the practical value of this system cannot be questioned it appears that dynamos regulated by this means are not as efficient at all speeds as those having other methods of control, such as speed governors. The matter was considered by

1. Poor connection in the charging line increases the amperes output.
2. Increasing the main brush or third brush width, decreases the output.
3. Setting the third brush to give higher output than normal is dangerous because the trailing edges of the main brushes will be burned away, resulting in still higher output.
4. Setting the main brushes ahead of the manufacturer's position is dangerous because a larger field current will be drawn for a given output.
5. Setting the main brushes back of neutral is dangerous because it will cause heavy short circuit currents to flow through the main brushes, eating away the trailing edge.
6. Setting the brushes on neutral by finding the position of "no rotation," with only armature current flowing, is correct only with generators having symmetrical pole faces; that is, equal airgaps at the entering and trailing edges.

The third brush regulating system is very simple and even if it does not permit of maximum efficiency, it gives much less trouble than centrifugal governors or voltage regulators of various types incorporating vibrators and contact points and its use on the greater part of the product of American manufacturers is proof of its practical merit and reliability.

**ELECTRICITY APPLIED TO AGRICULTURE IN GERMANY**

**S**UMMING up an article in the *Journal of the Royal Society of Arts* on the use of electricity in agriculture, with special reference to its development in Germany, a writer in the *Journal of the Franklin Institute* says that there has been an astonishing increase in the application of electricity to agricultural operations in Germany. In Saxony, at least, electricity was thus employed to a larger extent by small or moderate holders rather than by large farmers. Rural co-operative societies are common. In 1901 there was one; in 1913 more than 600. Some societies develop electrical current themselves, while others merely distribute it.

- (1) The British farmer feeds from 40 to 50 persons; the German farmer feeds from 70 to 75 persons.
- (2) The British farmer grows 15 tons of corn; the German farmer grows 33 tons.
- (3) The British farmer grows 11 tons of potatoes; the German farmer grows 55 tons.
- (4) The British farmer produces 4 tons of meat; the German farmer produces  $4\frac{1}{4}$  tons.

A chief factor in favor of the German farmer is his increased use of artificial fertilizers.

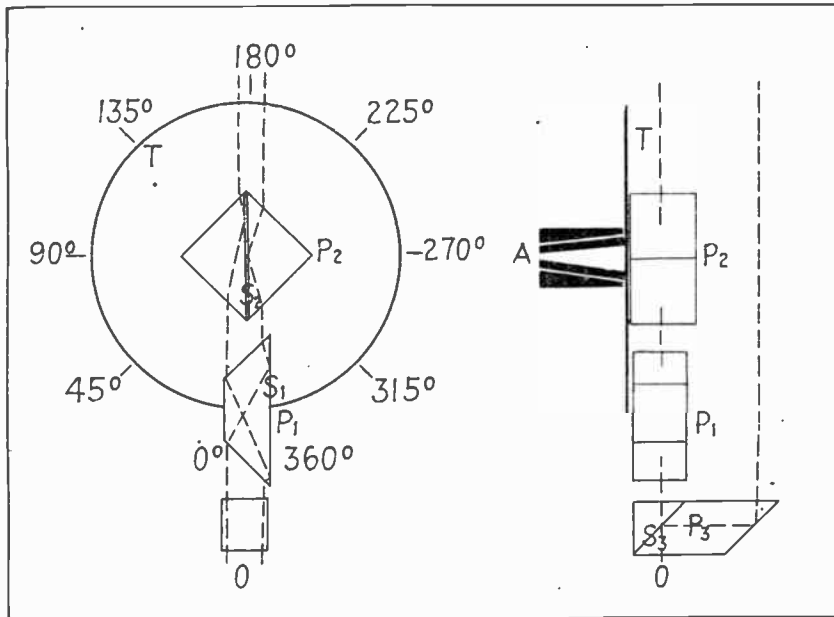

Diagrams defining principles of instruments for measuring angles

the course of rays from a distant object when the scale is set at zero. The rays are reflected from the silvered surfaces,  $S_2$  and  $S_1$ , and are brought by refraction back into line.  $P_3$ , represents another prism also with reflecting surfaces, the one at  $S_3$ , being very thin so that it can be seen through by the observer. With his eye at 0 the observer by direct vision looking through the prisms  $P_3$ ,  $P_1$  and  $P_2$ , sees a distant object. By turning the prism  $P_2$ , different objects are brought into the field of view, and the reading of the angular displacement on the scale gives the angular distance of the object.

Looking at Fig. 2, it will be seen that by reflection the observer sees the object directly opposite to him. Rays from it strike the oblique face on the right of the prism,  $P_3$ , are reflected from that face to the face,  $S_3$ , and hence the observer's eye. To determine the angle between two distant objects one of them is brought into the direct field of view by double reflection in the prism,  $P_3$ . The prism,  $P_2$ , is then rotated until the other distant object is brought into

a writer in *Automotive Industries* in a recent issue. He cites the current output of a typical shunt wound machine running at 1200 r.p.m. as 110 amperes, at 8 volts potential, if the only loss to be considered was armature winding resistance.

Brush loss brings the current down to 75 amps; reactance to 55 amps; field distortion to 32 amps; and then changing the excitation from shunt to third brush reduces it to the final rate, 14 amps.

In ordinary non-interpole generators, commutation is improved by shifting the brushes forward under the tip of the leading pole; thereby bringing the coils undergoing commutation into an assisting field. But in the third brush machine under load condition, shifting either forward or back of neutral, brings the coils into an unfavorable field. This indicates why the output of this class of machine may change 50 per cent after being installed on the car in case the brushes are not well ground in.

From the theory that was given the following operating points are deduced:

# The Process of Nickel Plating

*How the Amateur Can Do Good Work With Simple Apparatus*

L. M. Blakey

**M**ANY amateurs and experimenters, and others for that matter, have small articles they wish to nickel plate, or probably have tried to plate with little or no success. It is for these I have prepared this article. Also for the benefit of the experimenter that has not had the advantages of a chemical education, I have omitted all chemical formulas. The formula given here is, at the present time, in use by a number of commercial houses and is giving good results.

For the average experimenter, a one or two-gallon glass or crockery jar is of sufficient size. To each gallon of water, add nine ounces of nickel sulphate, one tablespoon of boracic acid and about one-half pound of salt. The latter is used to make the solution a better conductor of electricity.

in the plating solution. Wherever possible a small buffer should be used and objects should be highly polished, if a bright, smooth surface is desired in the end. Next a strong solution of lye water should be prepared in a metal bucket or pan—other than aluminum—placed over a fire and allowed to approach the boiling point. Also a solution of potassium or sodium cyanide should be prepared in a glass or crockery jar. The potassium cyanide is more desirable than the sodium, because it is more active, but the latter is very satisfactory. *Caution—Do not breathe the fumes or get any of the solution in your mouth, because it is a deadly poison.* Always keep the jar covered when not in use.

Now the polished screws or objects—if small—should be fastened on a

should be copper plated before nickel plating, as copper will fasten itself to iron, etc., much more readily than nickel can. For this purpose use a copper sulphate solution.

After plating remove objects and wash immediately in clear cold water, then place in hot water for a minute. This prevents streaking and the objects will dry at once. They are now ready for the final polishing and use. If the above has been carefully followed there is no reason why you should not be rewarded with a perfect and lasting job.

## FLAT PANELS AND NO SURFACE CHECKS BY MAXIMUM-HUMIDITY METHOD

**I**f panels are over-dried their tendency toward warping and twisting is greatly increased. The lower the moisture content the more the warp. The short time required for drying panels, varying from a few hours for thin panels to a few days for thick ones, makes it impracticable to make actual determinations of moisture content to decide when the material has reached the desired degree of dryness.

An automatic method of insuring the proper moisture content in dried panels is proposed by the Forest Products Laboratory. This is what may be called the "maximum-humidity method," in which the relative humidity of the air in the kiln or drying room is regulated so as to remain at the highest level which will permit the wood to dry to the desired degree (and no further) in a reasonable length of time. By this method checking of face veneer is also prevented.

The maximum-humidity method lends itself to the most convenient and economical handling of the panel-drying operation. As there is little danger of over-drying, the stock may be left in the drying chamber for any reasonable length of time beyond the minimum required. Thus, thin panels and thick panels may be taken from the press and placed in the kiln at the same time and removed at the same time, even though the thin panels dried much quicker.

For panels made up of normally dry veneer, a kiln temperature of 120 degrees F. throughout the drying period is a good schedule to follow. If with this temperature the humidity is maintained at 46 per cent, the panels will come uniformly to a final moisture content of about 8 per cent within a reasonable drying period.

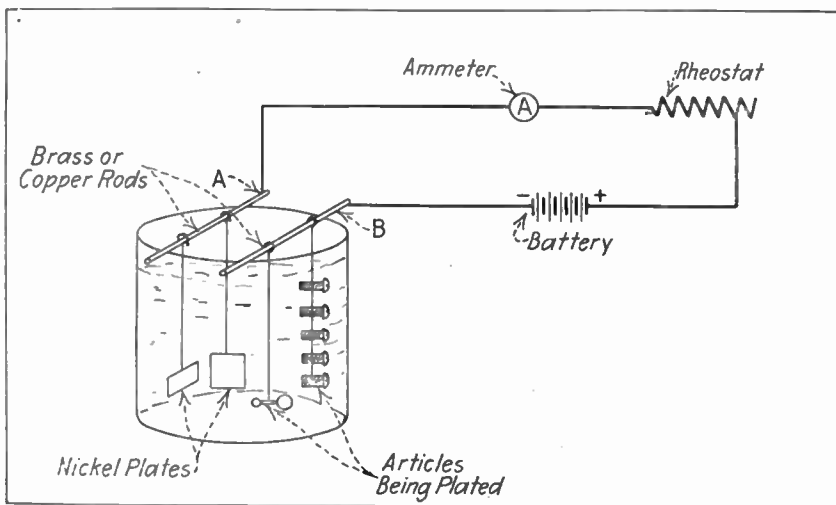

Fig. 1. How small articles may be electro-plated by the amateur

The electricity may be supplied by one, two or three dry cells, but a storage battery is more desirable. The rate of plating may vary from three to ten amperes, according to the size of the objects to be plated. For best results an ammeter and simple battery rheostat (Fig. 1) should be used to gauge and regulate the flow of current, but these are not absolutely necessary. Ten to thirty minutes will be required to plate an object, depending on the thickness of the layer of nickel desired. It is advisable to plate at a slow rate, for if a high rate is used, there is a tendency to "pile" the nickel on, causing a rough brownish surface. It is also desirable to keep the solution in motion while the current is on.

The reason so many fail to plate objects successfully is because the metal is not properly prepared before plating

wire or placed in a wire basket and immersed in the hot lye solution for two or three minutes. When removed, they should be thoroughly washed in clear cold water and placed in the cyanide solution for the same length of time, after which they are again washed and placed in the plating solution. Do not touch the articles with the hands after the washing is begun, for the oil from the body will probably cause the nickel to peel. All objects to be plated should be placed on rod B—(Fig. 1) and the nickel plates—which may be secured from some chemical house, or maybe some old heavily plated article found around the shop, on rod A. The rods should be separated three or four inches. After a few minutes, if a dull brownish or whitish color is noticed you must reduce the flow of current.

Metals other than brass or copper



# CHEMICAL NOTES, RECIPES AND FORMULAS



## NICKEL PLATING SOLUTION

A GOOD nickel plating solution follows:  
 Nickel Sulphate .....100 parts  
 Ammonium Tartrate, neutral.. 72 parts  
 Tannin .....0.5 parts  
 Dissolve the nickel salt and the tartrate in half a quart of hot water and add the tannin, previously dissolved in a little ether; mix and dilute with water to a volume of two quarts.

## OXIDIZING COPPER

CLEAN the piece with caustic soda solution, then treat with weak nitric acid. Finally immerse in a solution of antimony chloride in hydrochloric acid. It gives a tint bordering on violet.

## TO REMOVE RUST SPOTS FROM CLOTH

PLACE the part, on which the spot is, in a saucer, containing a mixture of one part of hydrochloric acid and three parts of water. After the spot disappears the goods must be thoroughly rinsed out with abundant water and washed. If the spot is of long standing or if someone has used Javelle Water on it, a 15 per cent solution of tin salt (stannous chloride) is recommended applied as above and followed by thorough rinsing and washing. No acid or salt must be left in the goods.

## BLUE-PRINT PAPER

The two following solutions are separately prepared.

1  
 Ammonio-citrate of Iron..... 25 parts  
 Distilled Water.....100 parts

2  
 Potassium Ferricyanid..... 45 parts  
 Distilled Water .....100 parts

The two solutions are mixed, filtered and immediately spread on paper free from all sizing. It is to be dried before use and all the operations should be conducted in the absence of actinic light. After the paper has been exposed under the negative, it is washed until the yellow tint completely disappears. To accelerate the operation the prints may be placed for a few seconds in a bath composed of:

Chloride of Lime (bleaching powder) 1 part  
 Hydrochloric Acid ..... 10 parts  
 Distilled Water .....200 parts

The prints are finally thoroughly washed and dried.

## SEALING WAX FOR BOTTLES

Melt together the following:

Rosin .....160 parts  
 Lanoline ..... 40 parts

To remove it from the bottles when they are to be opened it may be melted in a flame and wiped off with a cloth.

## ABSORPTION OF CARBON MONOXIDE

Satisfactory results in the absorption of this very dangerously poisonous gas have been obtained by the use of the following mixture:

Manganese Binoxide.....50%  
 Cobalt Oxide.....15%  
 Copper Oxide.....30%  
 Silver Oxide..... 5%

It may be used in gas masks wherever there is danger of its evolution. The mixture loses in efficacy by the absorption of humidity from the air.

## ENAMELED LETTERING ON GLASS

The following process may be used for lettering glass bottles in chemical laboratories and the light.

Red Lead .....15 parts  
 Zinc Oxide .....15 parts  
 Borax .....10 parts  
 Cryolite .....10 parts

The letters are painted on the glass with varnish. The mixture is dusted on with a bit of waste and it is then placed in a muffle and the enamel brought to fusion and the bottle allowed to slowly cool. Many laboratories have their own muffle furnaces.

A much simpler process is to use a solution of sodium silicate (water glass) in which there is rubbed up some very finely powdered red lead. The inscription is painted on with this mixture, and it is said that after a few days it becomes very firmly adherent.

## CLEANING METAL SURFACES

TO remove oxides from metallic surfaces, a weak solution of sulphuric acid followed by rinsing and drying in saw-dust may often be used. Another method is to plunge the object into a solution of perfectly neutral stannous chloride leaving it there for two hours, wash and dry as above. The stannous chloride may be made by dissolving tin in hydrochloric acid until the acid is saturated. Pure tin such as is used for wrapping chocolate may be employed.

## ALUMINUM SOLDER

Zinc .....70 parts  
 Tin .....30 parts  
 Silver ..... 3 parts  
 Copper ..... 8 parts

The zinc and tin are first melted and the silver and copper are then added, preferably melted together as an alloy.

## CEMENT FOR ATTACHING INDIA RUBBER TO METALS

Shellac .....10 grams  
 Ammonia, 22° .....100 (u. centimeters)

This solution requires long standing, several weeks being necessary; it should be perfectly limpid at the end of this time. Parts by weight may be substituted for the above.

## CASEIN GLUE

Casein .....35 parts  
 Slaked Lime in Powder.....30 parts  
 Sodium Silicate (water glass)...20 parts  
 Ammonia, 22° ..... 5 parts  
 Water .....10 parts

Rub up the casein with the sodium silicate, add the lime previously moistened with the water and then add the ammonia.

## CEMENT FOR PHOTOGRAPHIC FILMS

WHILE sealing wax will serve as an expedient for this purpose, the following is a formula for home-made cement. Some old photographic films may be used to supply the celluloid. They are to be thoroughly washed in warm water to remove every trace of gelatine. They are then dried and dissolved in acetone to which it is well to add some amyl acetate. The formula is given as follows:

Acetone .....50 cu. centimeters  
 Amyl Acetate.....50 cu. centimeters  
 Celluloid from old films.....2 grams

If the above are all taken as parts by weight the formula will work perfectly.

## PREPARING CANVAS FOR OIL PAINTING

THE canvas is first stretched on its frame in the regular way. It is next sized; for this purpose a solution of glue may be applied or a solution of starch. The latter is made by stirring 25 parts of starch with 1,000 parts of cold water, which is then brought to boiling. When the canvas thus treated is perfectly dry it is smoothed off with ground pumice applied with a bit of cotton. After this it is given a coat of oil color, white or slightly yellow; the oil color should have two thirds of its volume of turpentine mixed with it.

## REMOVING PAINT FROM WOOD

CAUSTIC soda solution, while very effective in removing paint raises the grain of the wood and also soaks into it so that it is almost impossible to remove it. The following formula is recommended for removing paint:

Kerosene ..... 25 parts  
 Acetone .....150 parts  
 Ordinary Alcohol.....300 parts  
 Benzine .....550 parts

The kerosene is dissolved in the benzine. The acetone is then added and last of all the alcohol. It is said that it works very rapidly. It is brushed over the paint and allowed to stand for a little while when the latter can be scraped off easily.

## CEMENT FOR ATTACHING COPPER TO PORCELAIN

Caustic Soda..... 40 parts  
 Water .....50 parts

When dissolved, add to the above little by little, 30 parts of resin. When the cement is to be used mix with it its own weight of plaster of paris and apply at once.

## OXIDIZING COPPER

Water .....1,000 parts  
 Powdered Orpiment (Arsenious Sulphide) ..... 2 parts

Crystallized Sodium Carbonate..20 parts  
 Boil for a few minutes and immerse in it the object to be oxidized or bronzed, constantly moving it about. When darkened sufficiently, wash and dry.

Remember that the bath is very poisonous.

## BRONZING ZINC

Prepare the two following solutions:  
 Potassium-Sodium Tartrate... 30 parts  
 Caustic Soda..... 40 parts  
 Warm Water.....250 parts

In another vessel dissolve 35 parts of copper sulphate in 250 parts of warm water.

The second solution is slowly poured into the first with constant stirring with a glass rod or stick of wood, until any precipitate, which forms, is redissolved.

A brush, free from all metal winding, is used to apply the solution to the zinc surface; the first color which shows is violet but it soon develops a brown color, and must be immediately washed copiously the instant the desired tint is attained. It is well to varnish the metal after it is absolutely dry.

For liquid glue soak good glue in cold water for twelve hours and then liquefy by heat. Add to the solution one tenth of its volume of water glass solution.

# How to Get More Mileage

*A Concise Exposition of Some of the Factors Governing Fuel Consumption of Automobile Motors and Points to Observe to Secure Most Economical Use of Gasoline*

By Victor W. Pagé, M. S. A. E.

**O**LD timers in the automobile business can remember the time when gasoline was a drug on the market and when it could be procured for a few cents a gallon. For a number of years the best gasoline could be bought for ten and eleven cents, even after automobiles began to be used in quantities. The automobile, however, is not the only piece of automotive apparatus that uses liquid fuel, nor is it the only one that has increased greatly in numbers during the past decade. In addition to the demands made upon the fuel producers by the automobile, we have an additional demand created by the increasing use of motor boats, farm tractors, small farm power plants, isolated electric lighting plants, and even the airplane, all of which use the more volatile constituents derived from fuel oil in their engines. In addition to the consumption of the refined products, we find a greatly increased consumption of the fuel or burning oil due to the use of oil burning locomotives and ship boilers and naturally any oil burned in this way cannot be refined or become available for use by the engines requiring a more volatile fuel.

A careful study of the statistics in a memorandum issued by the American

Petroleum Institute, shows that the amount of crude oil available during the period of very low-priced gasoline was so great as to excuse for the time being any expenditure of effort on the part of the automotive engineer to conserve fuel. That time is past. Today, we are facing a problem both from the automotive engineer's and the oil man's aspect of an insufficient production of crude oil to meet with the great demands being made upon it. It would seem that at the present time, the problem of the automotive engineer is to build engines and so design the cars they are to drive that instead of going from 7 to 12 miles on a gallon of gasoline, the car will go from 20 to 30 miles on the same amount. Another problem is not only to construct engines to burn refined oil produced from petroleum but also to contrive power plants that will work efficiently on alcohol or certain synthetic or manufactured fuels that have been broached as substitutes for petroleum.

It is not possible, however, to do this designing overnight and meanwhile there are several million automobiles and other pieces of automotive apparatus that were designed initially for the purpose of utilizing volatile liquid fuel. The owner of such machinery

cannot throw an investment representing thousands of dollars in some instances, into discard, even if a new engine and fuel suitable for it were developed in the near future. All such people can do is to do the best they can with the equipment they have and to try and conserve the available supply of fuel that their engines will operate on.

It is possible for a careful car owner to off-set the augmenting cost of gasoline in many cases, if he will make sure that all parts of his car, which contribute to the fuel consumption, are working properly. There are various factors that contribute to the waste of gasoline that has been almost universal in times past and which, of course, was largely due to the low cost at which it could be obtained. It is possible for any motorist to reduce the fuel cost per mile by eliminating various sources of waste that make a demand on the motor. Illustrations are presented to show a few of the common points about an automobile that demand attention if the motorist wishes to conserve gasoline.

Obviously, one of the most common causes of waste is in poor carburetion and even in cars of recent development, we find manifold designs and carburetors that use more gasoline than they

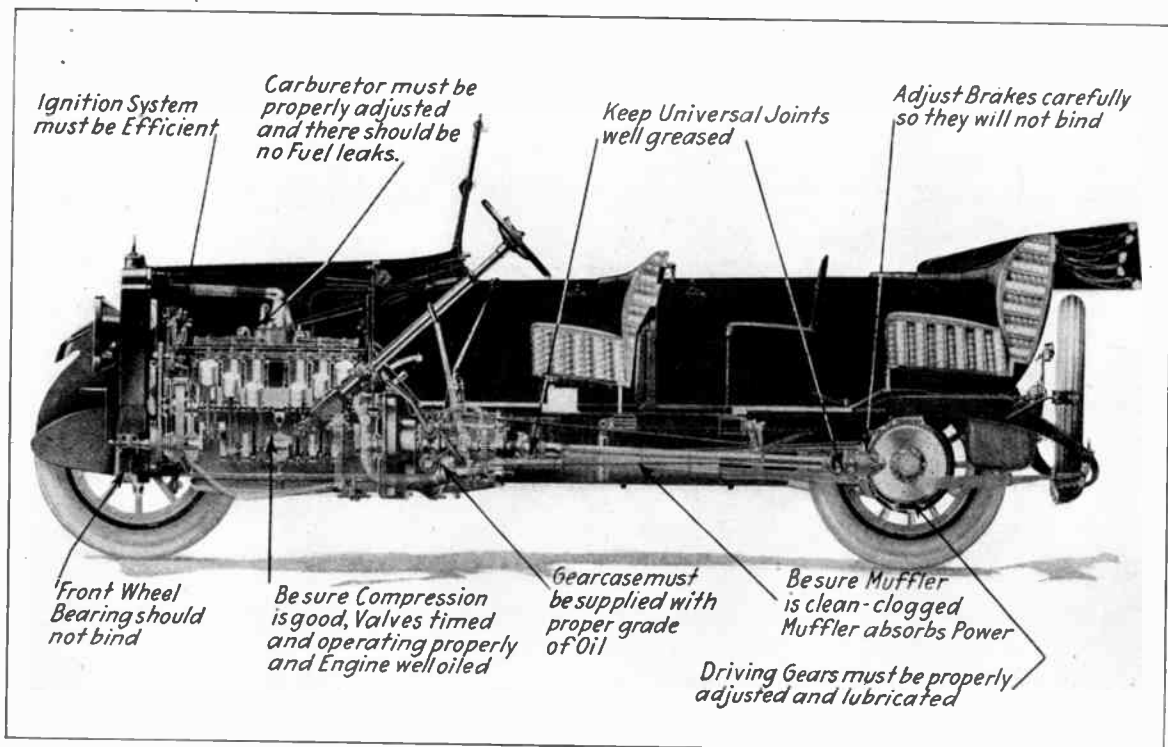

Sectional view of Packard Twin Six automobile showing parts needing inspection in endeavoring to save gasoline

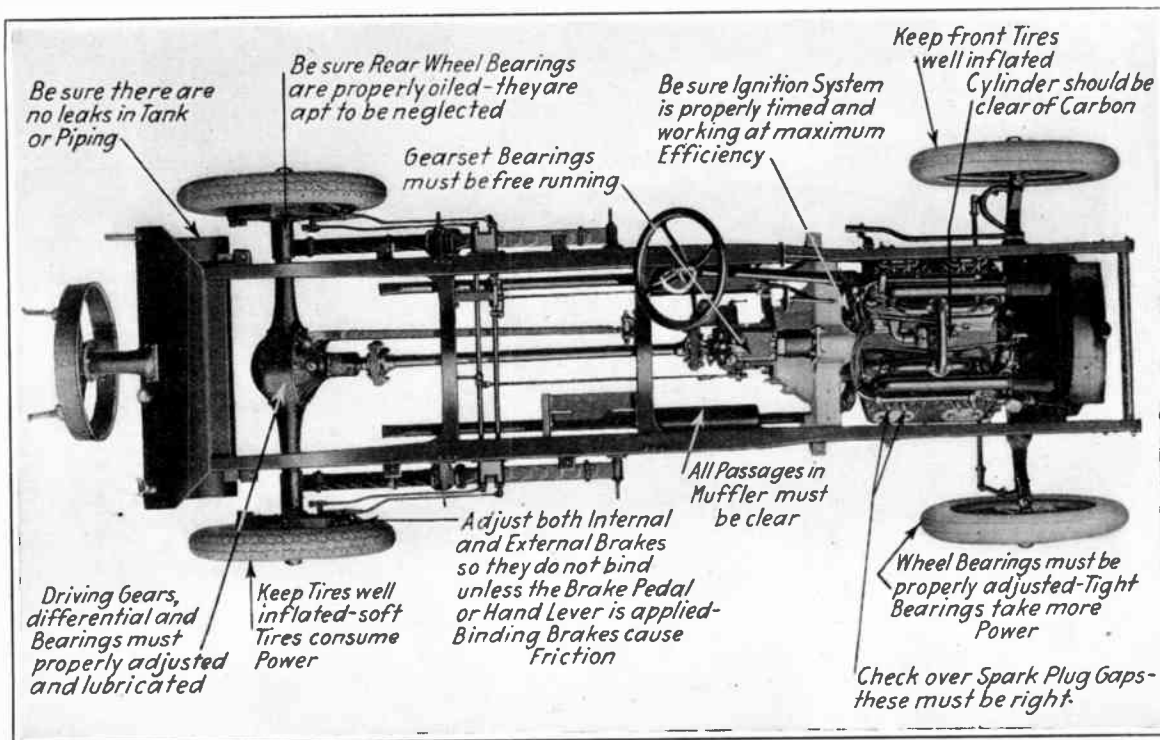

Plan view of King eight-cylinder chassis showing location of parts to inspect in the search to eliminate wasted power

should. Changing a manifold is a problem that requires the services of an expert engineer but it is not a serious matter to provide heating means by which either cooling water or exhaust gases may be supplied to heating elements attached to the unheated manifold. Motor fuels of today are not as volatile as those marketed several years ago, so a man who owns a type of car dating back more than a few years, should be careful to see that all precautions are taken to not only supply warm air to primary air intake of the carburetor but also to heat the manifold to assist in vaporization. The carburetor should be carefully inspected to see that there is no leakage at the float control needle valve which will permit a slow flooding to take place and a loss of gasoline from the mixing chamber.

One should be sure that the carburetor is properly adjusted. If it is of the non-adjustable, spray nozzle type of carburetor, an expert should be engaged to try and see if a smaller size of jet will not give adequate results. If the carburetor has an air adjustment, it should be remembered that after the motor gets started and heats up that it is possible to supply more air to the mixture than can be used advantageously with a cold motor.

This mistake made by most men in adjusting a carburetor is to supply a mixture that is too rich in order to permit rapid acceleration and easy starting. The point that should be considered, is to set the carburetor with maximum economy because there should be no difficulty in starting the

engine and instead of depending on a rapid acceleration or pick-up of the motor and adjusting the carburetor to supply a rich mixture, the motorist should use the change speed gearing which has been provided for a specific purpose and shift to a lower speed when it is desired to make a quick get-a-way in traffic instead of having the carburetor set "rich" so that the car will accelerate on the high gear.

Even if the carburetor is adjusted properly, if the ignition system is not functioning as it should, or if for any reason the spark occurring in the cylinders is not of sufficient intensity, or properly timed, it will require a wider throttle opening and consequently a greater consumption of gasoline to obtain sufficient power from the motor to drive the car at the desired speed. In other words, one must supply a rich, easily ignited mixture to compensate for a weakened ignition spark. As most cars are now equipped with self-starters, there is no excuse for running an engine idly when the car is not in motion so this cause of waste is easily eliminated.

To get the maximum amount of power from an internal combustion engine, it is evident that it must be in proper working order. If any of the bearings are fitted too tightly, or if lubrication is inadequate, there will be considerable friction that must be overcome by burning an extra amount of gasoline. Valves should be ground in and properly timed, there should be no carbon in the cylinder head or on the piston top. The piston rings must be in good condition because it is essential that the

compression pressure be maintained to the point of maximum efficiency.

The working pressure obtained by burning combustible gas in a cylinder depends upon the amount of compression prior to ignition. If the engine is designed to operate on seventy pounds compression, a leakage by the pistons, piston rings, or because of score marks in the cylinder walls, will reduce its compression and in some cases even cut it in half. Obviously this will reduce the efficiency of the engine because there will be diminished force to the explosion and it will call for a greater throttle opening and a larger amount of gas to produce anywhere near the amount of power needed for average running conditions.

It is important to inspect all parts of the ignition system, making sure that the spark plugs have the proper gap between the electrodes and also that points in the timing device are clean and in correct adjustment. Positive and energetic ignition has a very great bearing on gasoline economy. This is not usually understood. In examining the various parts of the transmission system, the clutch spring tension should be such that there is no slipping and the various portions of the clutch that transmit power must be functioning properly because a slipping clutch always means power wasted.

Various bearings on the running gear, especially those in the rear axle, are apt to be neglected as far as lubrication is concerned. Tight bearings or binding brakes hold the car back and increase the amount of frictional

(Continued on page 429)



### AEROMARINE AIR YACHT

ALTHOUGH the yacht has a wing spread of 104 feet, there have been larger flying boats used in the American and British navies, and it is not in size that the Aeromarine yacht is most noteworthy. It is in features that make the big ship a yacht rather than a boat—refinements like wind and waterproof cabins, large ports screened with curtains, electric lights, comfortable wicker chairs, ventilators and furnishings—that the new craft excels.

In the bow of the big yacht, which is painted pure white, is a cockpit which is used for observation purposes. It affords an unobstructed view. Just behind this in the top of the hull is a sliding door. This leads into the main passenger cabin, beautifully furnished, roomy, and comfortable. This compartment contains six wicker chairs arranged two by two with an aisle between. Each passenger has a circular window of celluloid eighteen inches in diameter to himself. A sliding door connects with the front cockpit, so that passengers need not go up the stairs to reach it.

To the rear of the big cabin but ahead of the front wing beam is a space for baggage or mail. Behind that is another compartment corresponding to the chart room of a yacht, in which pilot and mechanic sit together. The roof of their compartment is raised above that of the main cabin so that they have a clear view ahead. Beneath this compartment are the gasoline and oil tanks. The pilot and mechanic are located under the upper wing close to the two Liberty motors, which are set a short distance on either side of the hull in the gap between the wings. The propellers are set in front of the wings. From the pilot's compartment a door opens direct to the lower wing so that the mechanic can reach the motors while in flight. A dual control system is used to enable a pilot and pilot-mechanic to alternate in handling the "ship" in long flights.

Behind the pilots, and also behind the great wings, is another commodious cabin in the hull. This is not quite so large as the main cabin, for it is designed to seat four passengers. Large windows enable the voyagers to watch the earth or clouds passing by. The great plane deserves the description of air yacht or cruiser not only on account of its size and beauty, but because of the distance which its large gasoline-carrying capacity enables it to cover in a single flight. The boat has a high speed of 85 miles an hour and a low or landing speed of 50 miles. Fuel

gasoline-carrying capacity is 230 gallons and her oil capacity twenty gallons. Fully loaded she weighs 12,823 pounds. Without passengers, fuel, etc., she weighs 8,456 pounds.

### SEWING MACHINE OILS

THE best oil for lubricating sewing machines and other delicate mechanism is composed of 3 ounces rectified benzoline, 1 ounce foreign oil of lavender and 9 ounces pale oil of almonds, which are well mixed together and filtered. A good mixture is 3 ounces petroleum, 9 ounces pale nut



View of Aeromarine air yacht hull, showing cabin and location of power plants

and oil supply for four hours may be carried in addition to the full load of twelve persons each of an estimated weight of 180 pounds and 620 pounds of mail, freight or baggage.

The air yacht has an upper wing spread of 104 feet and a lower wing of 75 feet, giving her a total of 1,397 square feet of supporting surface, not including that of elevators and stabilizer. Her height is 18 feet 9 inches and length 50 feet. Two Liberty twelve-cylinder motors totalling 660 horse power drive her through the air. Her

oil, 40 to 50 drops essential oil of almonds, all of which are mixed together and filtered. A very good light oil is made of 2 parts sperm oil and 1 part petroleum. Another method is to take a light oil, mix it with eight times its weight of absolute alcohol and put it in a retort. This mixture is boiled for ten minutes, poured off and allowed to cool. It is then evaporated until it is reduced to 1/5 of its original volume, at which time it is ready for use. It should be kept in well-stoppered bottles and is suitable for the finest work.

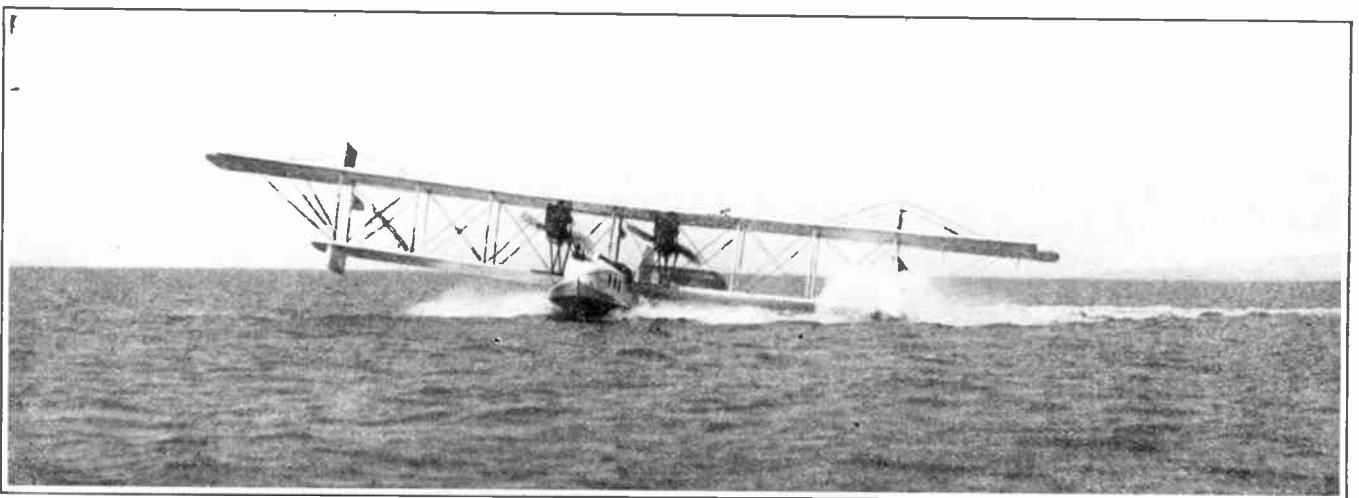

Aeromarine air yacht under way on the surface of the water preparatory to taking off

# Simple Kite Photography

By L. B. Robbins

MUCH interest has been aroused regarding aerial photography since the war. Remarkable pictures were taken from airplanes and observation balloons, but as the general public does not own either one of these things, we can confine our efforts to photographing from kites. All the essentials of aerial photography can be enjoyed with a common kodak, either the folding or the box kind, and a good kite capable of lifting four or five pounds will be sufficient to carry all the apparatus you will require.

As the modern kite is capable of lifting about 3/10 of a pound to each

shows a good way to suspend the camera. Lash a smooth ring to the kite string just in front of the bridle. Then make a harness of heavy cord so the camera will hang lens down and tie the top of the harness to a second ring. This ring is then attached to a light but stout line which passes through the ring on the kite string. After the kite is flying the desired height, pull gently on the free end of the camera string and raise the camera to the ring on the kite string. Then lash the camera string to the place where the kite string is fastened or held.

The methods of releasing or snap-

the camera is ready to raise to the kite the string is touched with a drop or two of strong acid. Then in the course of a few moments, the acid will eat through and rot the string so that the pull from the spring will break it and pull the shutter lever over and make the exposure.

The other method is one that will enable one to estimate the duration of time a little closer. Arrange a spring the same as just explained. Then lead a string in the opposite direction, through an eye and hang a vial or other container which will hold an ounce or two of water. Drill a small hole in the bottom. When filled this should hold the shutter closed against the tension of the spring. A certain quantity of water will drip away in a certain length of time so when the balance between the weight of the water and the spring tension has been reversed, the shutter will be snapped. Other methods may be suggested to the experimenter which can be adapted to his own case.

Of course, the camera will have to be lowered after each exposure and a fresh film turned in place. Films are preferred to plates because of their not being liable to breakage if the camera receives a shock in flight or in lowering to the ground.

## NEW TRIANGLE

THE triangle illustrated will certainly be appreciated by draftsmen and others who have occasion to use tools of this nature, because it combines in one simple piece of apparatus the usual form of triangle and also a protractor. The protractor scale is riveted to the movable piece of the tri-

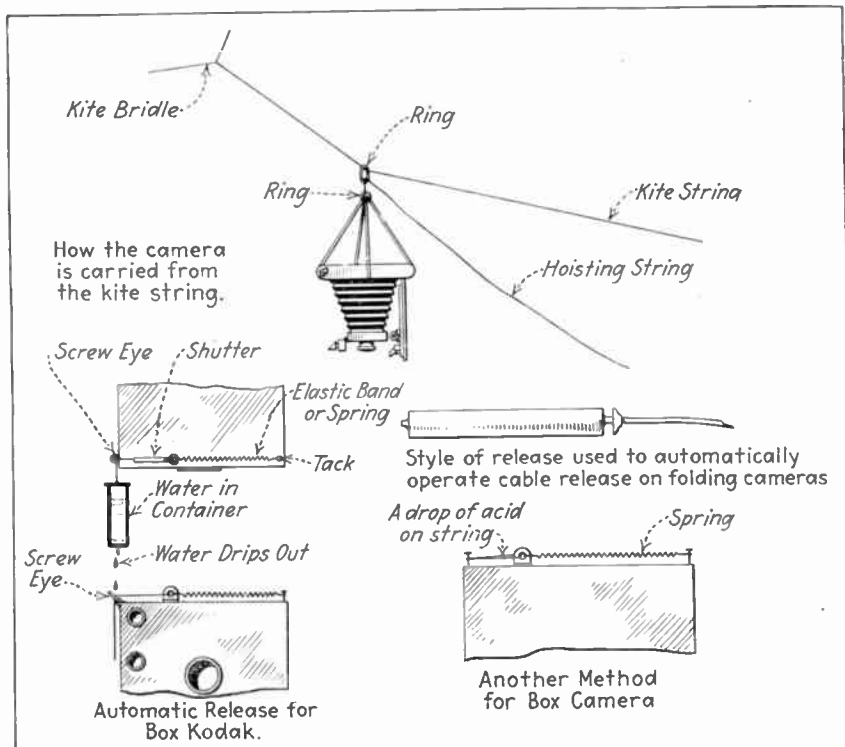

How camera may be operated for simple kite photography experiments

square foot of surface, a kite of 20 sq. ft. area will do the trick. Use a tailless or box kite if possible, otherwise be sure the one you do use is as steady as it is possible to make it.

The whole trick in kite photography is to raise the camera to the desired height and then release the shutter of the camera at a time when all possible scenery is within range of the lens. The higher the camera is raised above the ground the shorter the exposure it will be necessary to give the film or plate. Also, with a short exposure, there will be less liability to blur the picture by sudden whirling of the camera or lurching of the kite.

Choose a bright day and a time when the sun rides high so it will not shine in the lens. This will also make your pictures sharper with the short exposure it is necessary to give them. The sketch

ping the shutter are many, but the most simple for our use are illustrated in the sketch. There is an attachment on the market which will operate the shutter of a folding kodak having what is termed a "cable release". This is set to work from 10 seconds to more than a minute. By using this you can set it for the greatest length of time possible and then hoist the camera to the kite in ample time for the shutter to open and make the picture. By a little ingenuity, this can be adapted to operate the shutter on a box camera.

Two other methods for working the box camera shutter are also shown. One is to tie the shutter over with a piece of cotton string to a tack in that corner of the camera. A second tack is then driven in the opposite corner and an elastic band or light spiral spring run from the shutter to it. When

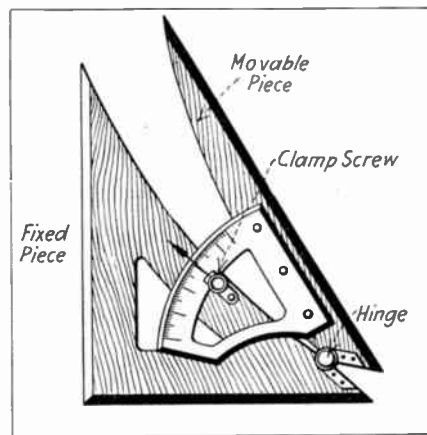

New English triangle and protractor combination

angle, which is hinged to the lower end of the fixed piece. A clamp device is attached to the fixed piece so that the scale may be locked in any desired position. Any desired angle from zero to 90 degrees may be obtained by this tool, which means one device will do the work of several fixed side triangles and a protractor.

# Commutation and What it Means to the Electric Motor

By N. M. Ferris

**T**HE successful operation of any direct current dynamo depends very extensively upon good commutation. The commutator and brushes on a dynamo are its most troublesome parts, so if a motor could be designed to operate without these features a big improvement would be made in the design of dynamo-electric machinery. When motors do not commute properly there is sparking between the commutator and brushes. Continued sparking is destructive to the commutator and brushes in that it burns them badly and causes them to wear unevenly which, in turn, makes the matter worse as this condition continues.

To simplify the explanation of the operation of a commutator it might be said that its function is the same as that of a switch; to make and break a circuit. Now, when the brush leaves contact with one segment and passes to the next, the brush endeavors to draw the current to segment 2, but the current which had been passing through segment 1 to the brush refuses to be interrupted so suddenly. This is due to the inertia of the current. As a result when the brush has left the first segment, the current continues to flow, but not through a metallic or carbon medium but through air in the form of a spark (just as it does when you open a knife switch).

At some moment the brush short-circuits a coil and it is at this time that the current in the coil is reversed and this should be done without sparking if the machine is to run efficiently and for a long term of years. The success of this operation depends upon whether the current in the short-circuited coil has been reversed or not before the brush leaves the first segment of the coil. If the current has changed its direction of flow all well and good, but if not, sparking will result.

Due to the fact that the short-circuited coil is carrying a current, a mag-

netic field is set up which tends to prevent the reversal of the current by generating a counter electromotive force. This reverse voltage is caused by the changing field surrounding the coil under commutation. The field is made to vary in magneto motive force by the reducing of the current flowing through the coil which takes place as the commutator moves from the position in which the coil carries the greatest current, as shown in Fig. 1, to that in

even if the coil is cutting lines of force of a different polarity it will take some time for the current to change its direction of flow.

Referring to Fig. 3, we see that coil F has passed the neutral plane and is beginning to cut more lines of force which tends to set up a flow of current in such a direction as to come out at the segment 2, but the self-induction of the coil prevents this from taking place, consequently the current in the

coil is at zero. A current then commences to flow in the opposite direction to which it did before, but just as the brush is about to leave segment 1, the current is but small compared with that flowing in the other coils, so it will divide at S, part going through the coils (as indicated by the arrows in Fig. 4) and the remainder through the lead to segment 1.

It can readily be seen that if the brush is to break connection with segment 1 under these conditions, that the coil F will be thrown into series with the other coils on the

right of the armature. At once the current will rise from almost nothing to a maximum, which cannot take place as quickly as the machine requires and as a result some of the current jumps across the air gap between segment 1 and the brush, causing the spark. The greater the speed at which the coil undergoes commutation, the greater the effect of induction.

In a machine of slow speed and low voltage the commonest way to remedy this trouble is by means of the "resistance method", as it is called. To obtain sparkless commutation by this method the current in the coil is caused to reverse by the variation of the contact resistance between the brushes and the commutator. Carbon brushes are always used in this method because their resistance is very great compared with that of the individual coil.

The second method is by generating a counter electromotive force in the

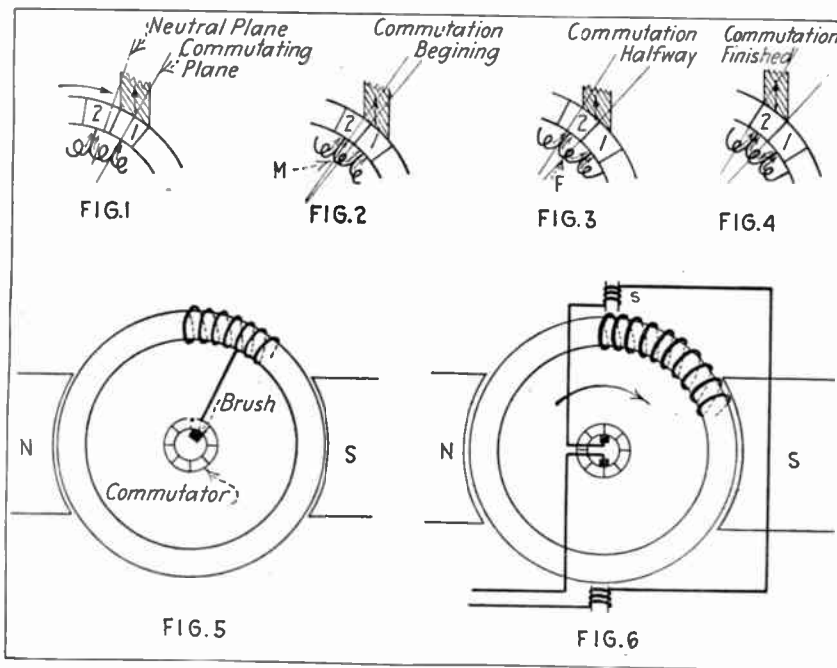

Diagrams explaining commutation and showing its influence on motor action

which it carries much less current, shown in Fig. 2, because, as can be seen by the arrows, the current divides at M, part going through the coil and the remainder through the segment 2 to the brush. The self-induction resists the quick change of direction of the current in the short-circuited coil as, we might say, momentum resists the quick stopping of the motion of a heavy body such as a heavy ocean liner.

As an analogy we can say that the different directions of revolution of the propeller represent the field poles; the motion of the ship can be compared with the direction of current flow in the coil. Now if we rotate the propeller in a clockwise direction the ship will move forward, but when we suddenly stop the propeller from rotating in this direction and cause it to revolve in a counter-clockwise direction, it will take some time for the ship to stop and change its direction of motion. Thus,

short-circuited coil which will assist in reversing the current in that coil. This opposing voltage must be as great as that which is generated by self-induction. This method is well adapted to high speed machines carrying considerable current. There are two ways of producing a counter electromotive in the coil under commutation. Until recently the only method of generating an opposing voltage in the short-circuited coil of a machine was to shift the brushes slightly in the opposite direction to that of rotation. In a generator the brushes are shifted forward or in the same direction of rotation.

known as the "interpole" or "commutating pole" method. Principally, it consists of a very narrow magnetic pole placed between each of the main field poles. The interpoles are wound with heavy copper wire and are in series with each other and with the armature as illustrated in Fig. 6. If the load increases, causing a greater current to flow into the armature it must also pass through the interpoles, thereby increasing their strength which would, in turn, tend to generate a greater voltage in the short-circuited coil to counteract the excessive flow of current in this coil, which would result in sparking.

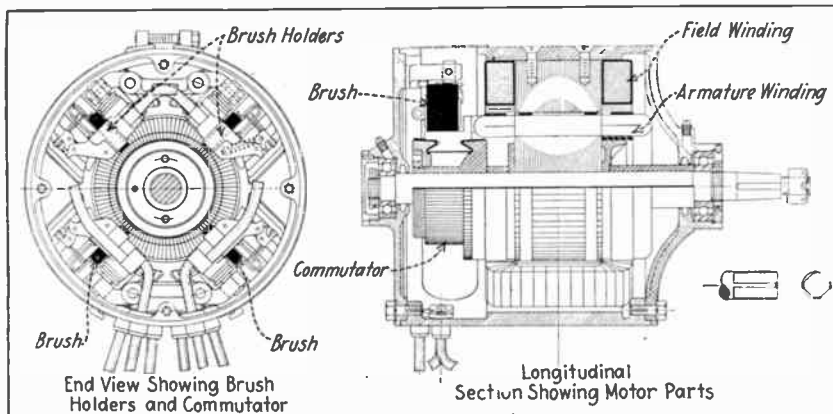

Sectional views of typical vehicle motor showing commutator and brushes

This is done so that the coil under short circuit will be cutting the lines of force of the trailing pole as shown in Fig. 5. In this way a voltage is generated opposing that which has been forcing current through the coil, which in turn aids in reversing the current.

The angle through which the brushes are shifted depends upon the load of the machine and is found by trial. The greater the load, the greater the shifting angle. The brushes must not be shifted too far because this also will cause sparking owing to the fact that the opposing voltage will have to drop to normal value before the brush leaves the segment, which is impossible.

In a machine which is subject to quick and great changes of load, it is impossible to place the brushes in such a position as to obtain sparkless commutation, at all times. When confronted with this obstacle the brushes are placed in the mean load commutating plane. That is to say, they are so placed that no sparking takes place when the machine is running at the average load. If the load is greater or lesser than average, sparking will result. The brightness of the spark and its destructive ability will be greatest when operating at the farthest from average load in either direction, i.e., above or below average.

During the past few years a much better means of generating a counter electromotive force in the short-circuited coil has been developed. It is

These poles work automatically, always neutralizing the effect of self-induction. The number of ampere turns in these interpoles are determined by the manufacturer according to the H.P. of the machine and thereafter adjustment is unnecessary. A greater range of speed and load can be had with this type than with a machine without interpoles.

#### HOW TO GET MORE MILEAGE (Continued from page 425)

resistance that the engine power must overcome. The rear axle, differential housing and change speed gearing should be filled with a medium weight, special transmission lubrication and not a heavy fibrous grease because a heavy grease at these points will cause a certain amount of friction and contribute its small quota to the total power loss.

Improperly inflated tires will make for greater power consumption. A motorist can easily tell this by noting the amount of effort it takes to move a car by moving it with even one tire partly deflated and how easily a car moves when all the tires are blown up to the proper point. If a car is driven in a district where there are some hills, it is always well to stop the motor while the car is going down the hill and allow the car to coast down by relieving the clutch. Some motorists have a mistaken idea that they are saving gaso-

line if they keep their clutch in and cut out the ignition. Positively, this is not making one iota of saving because the pistons are drawing in a charge of gas through the carburetor all the while that the engine is turning over, even though this gas is not exploded. This practice is a valuable one in cooling an over-heated engine, but is not of any value in saving gasoline. In order to determine if brakes are adjusted properly, or if there is undue friction in the axles or power transmission parts, the car should be tested from time to time by having it coast down a slight grade and seeing how far it will run without power.

Even such a trivial thing as driving with the top down and wind-shield open will have material influence on the fuel consumption, especially on a long trip or if the car is running against the wind. By proper attention to the details enumerated, it is often possible to make a material saving in fuel consumption.

#### LITMUS TEST PAPERS

LITMUS test papers are widely used in the chemical industry for indicating acid or alkaline reactions. Litmus paper may be prepared by rubbing good litmus with a little hot water in a mortar, pouring the mixture into an evaporating basin; add water until the proportion is half pint water to 1 ounce litmus; cover up so as to keep warm for an hour, then filter the liquor and pour fresh hot water on the residue. This is boiled, covered as before, and allowed to stand. The operation is repeated a second time and if much color comes, a third time. The first solution is kept separate from the second and the third, which may be mixed together. The first one will not require evaporation, but the others may be so far reduced in quantity that when a piece of blotting or filtering paper is dipped into them and dried they will impart a blue color of sufficient intensity for use. Blotting paper or any unsized paper of good color and moderate thickness may be used. The paper is cut into convenient size and dipped into the solution. The paper used should be free from earthy matter or carbonate of lime. Pour the litmus solution in a plate and draw the slips of paper through it so the liquid will coat both sides, allow excess liquid to drip and hang across lines to dry. The tint should be a distinct blue. When the paper is dry it should be tied up in bundles and preserved from both air and light. A glass stoppered bottle is best suited for the purpose of holding test papers, and if a piece of black paper is pasted around the outside of the bottle the light will be excluded.

# How to Make a Horizontal Sundial

By James W. Bulman

**A**LTHOUGH sundials are not used for indicating the time, they are of great interest to those who are scientifically bent, and in this short article the writer gives some simple instructions for making a circular horizontal dial.

First of all procure a piece of soft white wood about 1/2-inch thick, and about 10 inches square. Draw on this a circle 9 inches diameter with a pencil compass, and cut round along this line with a fretsaw, the resulting circular piece of wood being shown at A in Fig. 1. Now scribe a circle 7 inches diameter with an old pair of dividers, on this, as shown in Fig. 3. Cut out a slot 3 1/2 inches long and 1/8 inch wide with a fretsaw, which is to take the gnomon or style Fig. 2.

This gnomon, or style, should next be fitted to the circular wooden base by inserting the bottom into the slot B and gluing well into place as shown in Fig. 4. Care must be taken to ensure that the style is fixed exactly at right angles to the dial board. This can be done by testing it with a setsquare, first one side and then the other.

Now the dial is practically finished, excepting the markings to record the time.

The two lines representing noon can be scribed with a sharp penknife, as shown in Figs. 3 and 4 on the north side of style, i.e., the direction to which the style is pointing. The reason for these two lines 1/8 in. apart, is to allow for the thickness of the style. The lines for 6 a.m. and 6 p.m. can be scribed as shown. The intervening hours had better be found by trial, although if those shown in Fig. 3 be transferred they will be approximately correct.

The best way to do this is to place the dial perfectly level with the aid of a spirit level, on a suitable support in the garden where the sun shines all day, so that the noon

marking is pointing to the north. Select a sunny day and with the aid of a

good watch showing meantime, (i.e., one hour slower than summer time) and adding or subtracting so many minutes to allow for the equation of time, endeavor to mark the half-hours, and hours. Supposing you wish to calibrate this sundial on August 1, you would have to add 6 minutes to the time shown on the watch.

The dial being temporarily fixed as before stated, a mark should be made every half-hour with a fine pointed pencil, and when all the hours and half hours between 4 a.m. and 8 p.m. are obtained they can be scribed on with a penknife and the figures put on as shown in Figs. 3 and 4.

The sundial is now complete and should be given a thin coat of any good transparent varnish and left to dry for at least two days. When dry it can be permanently fixed on the top of a stout wood pole or fancy pillar in a sunny position, care being taken to get it exactly level and pointing to the north. Fig. 4 shows the finished dial on a wooden pole.

The following table gives the approximate equation of time for the first of every month throughout the year:—

	Min.
Jan. 1st	+ 3
Feb. 1st	+ 13 1/2
March 1st	+ 12 1/2
April 1st	+ 4
May 1st	- 3
June 1st	- 2 1/2
July 1st	+ 3 1/2
August 1st	+ 6
Sept. 1st	- 0
Oct. 1st	- 10
Nov. 1st	- 16
Dec. 1st	- 10

The plus sign indicates that the equation of time is to be added to the meantime and the minus sign that it is to be subtracted. Times for intervening dates can be found in any nautical almanac.—*Junior Mechanics and Electricity, London.*

It is interesting to note that American Sperry gyroscopic compasses are to be installed in two steamships being built in Great Britain.

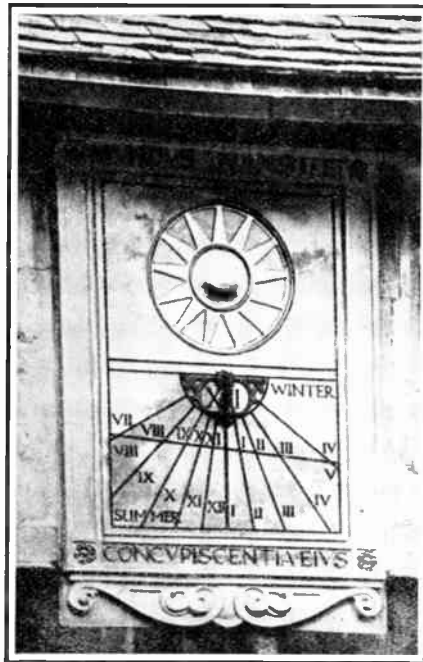

A vertical sundial of English design that indicates both summer and winter time.

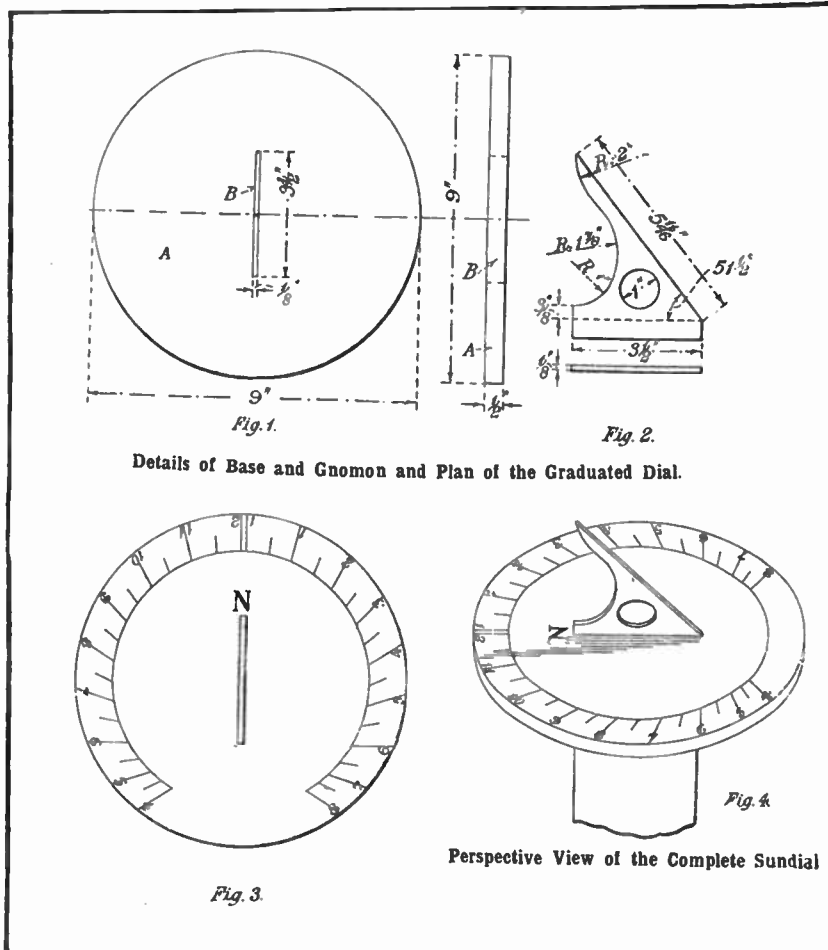

Details of Base and Gnomon and Plan of the Graduated Dial.

Perspective View of the Complete Sundial



# The Utilitor Garden Tractor

**T**HERE is considerable interest at the present time on the part of gardeners and owners of small estates in small-sized tractors that may be used for work where one of the ordinary, medium-duty tractors could not be employed profitably. The utilitor machine, which is shown in accompanying illustration, is a good example of this type of light machine. It is controlled by an operator walking behind it or riding a light cultivator through the medium of control levers mounted on grips that in turn are carried on extended handle-bars that resemble those used on various types of agricultural implements that must be guided by an operator. The machine is exceptionally compact in construction and of light weight. The sectional view at Fig. 1, which is a longitudinal part section, and that at Fig. 2, which is a cross section taken from the end, shows the arrangements of the various parts of the mechanism very clearly. The engine is a single-cylinder, four-cycle type having a detachable cylinder head.

The bore is  $3\frac{1}{2}$  inches, the stroke  $4\frac{1}{2}$  inches and the normal speed 1,200 revolutions per minute. It is rated as delivering from 2 to 4 horsepower at the belt and  $1\frac{1}{2}$  to 2 on the drawbar. It is fitted with a Kingston Model Y carburetor, and is intended to be operated on gasoline fuel. Ignition is by Eisemann high-tension magneto. Another feature is the use of detachable

rims. These rims are fitted with different kinds of lugs, according to the work to be done, and when it is desired to change the lug equipment, the complete rim is changed by means of a few bolts rather than by the tedious process of bolting and unbolting each lug individually.

There are standard types of rims, for cultivating, plowing and lawn-mowing, respectively. Other departures from garden-tractor construction are found in the use of heavier fly-wheels and the use of more weight and strength generally. It is claimed, also, that the hitching of implements to the utilitor has been simplified to a marked degree. The transmission is fitted with Fafnir bearings, while the axle bearings are of the company's own make. Final drive is by internal gear, the gear ratio between the motor and the wheels being 35 to 1. The drive wheels are  $23\frac{3}{4}$  inches high and are so spaced that the overall width is  $17\frac{1}{2}$  inches. A belt pulley  $4\frac{5}{8}$  inches in diameter is furnished. The weight of the utilitor is 700 pounds.

The fuel tank is carried above the engine, while the usual form of water-cooling radiator is carried at the front end of the tractor. A gear on the engine crankshaft drives a spur gear, which transmits power to the clutch casing. This spur gear forms an intermediate reduction of speed, the final reduction being obtained between the pinions on the ends of the clutch cross

shaft and the large internal gears that are attached to and drive the traction wheels. The clutch is controlled by handles at the right and left of the machine, there being two clutching effects provided, so that either wheel may be driven independently of the other, or both driven together. This handle clutch control is obviously necessary to make for easy steering of the tractor, as it renders the machine straight steering and does not require the operator to exert any strength in attempting to swing it around by the leverage obtained by the long handle-bars.

The tractor will run in a straight line when both clutches are engaged and will turn in one direction or the other depending upon which clutch is engaged. Ignition is by high-tension magneto, and the engine is easily started with a starting handle that forms part of one of the engine fly-wheels. Engine cooling is by the thermo-syphon system, and there are very liberal water spaces provided around the cylinder and cylinder head. While this machine is light in weight, it has been proportioned with due regard to continuous duty, and it is stated that it will have a drawbar pull equivalent to one horse. A belt pulley is attached to the crankshaft end and will enable the machine to be used for stationary power purposes within its capacity. Obviously, it could be coupled up to any other form of machine that did not require more than 4 or 5 horsepower in the same manner.

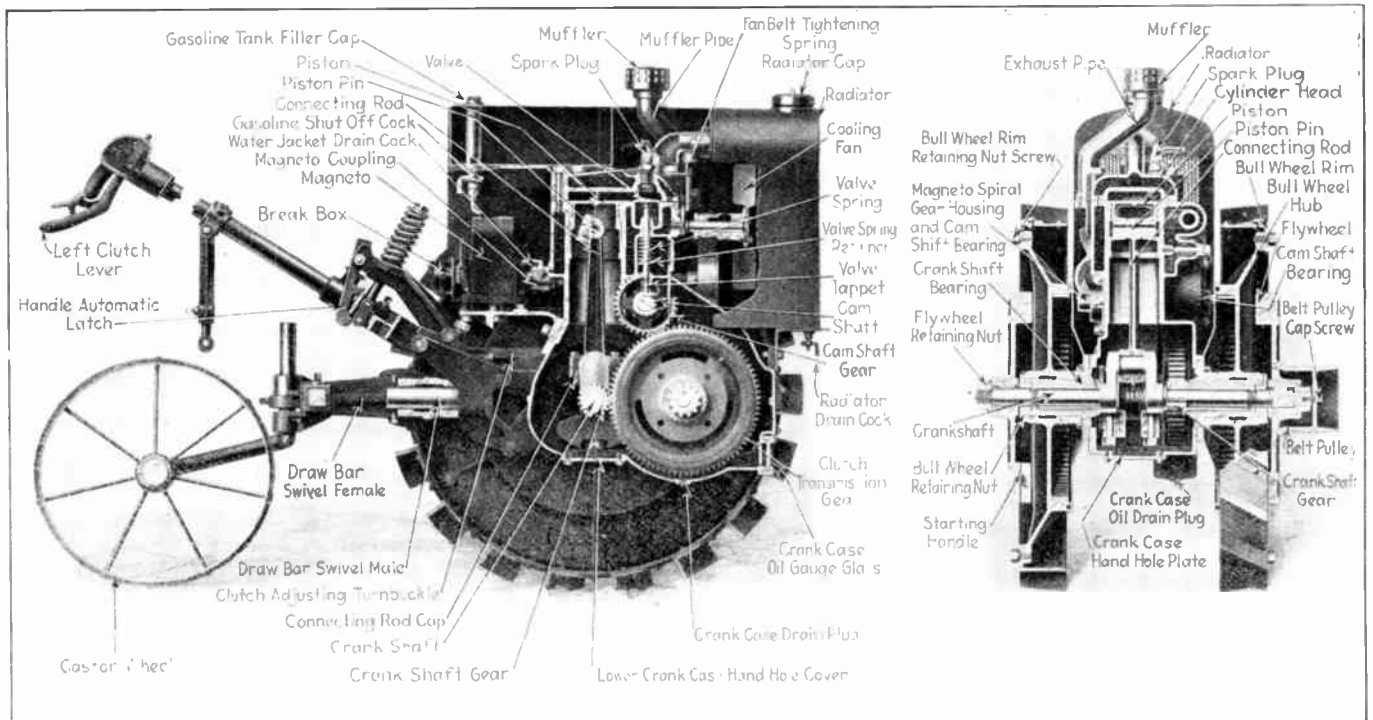

Sectional views showing arrangement of parts of typical small garden tractor driven by a one-cylinder engine. Fig. 1. Longitudinal part section. Fig. 2. Sectional end elevation

# AVIATION BRIEFS

## FISHING FROM A BLIMP

ONE of the features of the dirigible balloon is that it is possible to balance the load carried by the gas bag so accurately that the balloon may be readily moved to any desired level. As is well known to balloonists, the lifting power of the gas contained in the bag may be balanced so accurately by using ballast that may be easily disposed of, such as water or sand, that a balloon may be made to rise by

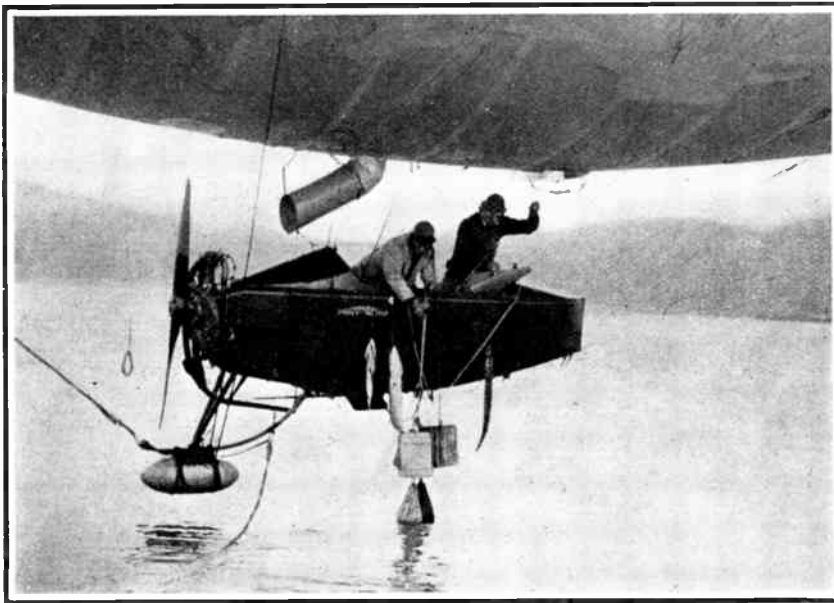

Expert aeronauts fishing from nacelle of Blimp type dirigible

disposing of such a small quantity as a few ounces of the ballast.

The expert aeronauts in charge of the blimp depicted in the accompanying illustration finally succeeded in making an accurate enough balance so that the bag remained suspended just far enough above the surface of the water so the car carrying the aviators was near enough to the surface to permit of casting out the lines and making a reasonably good catch of fish, if one is to believe the evidence presented by the photograph. Those of our readers who are not interested in fish stories will surely appreciate the intimate view afforded of the three-cylinder, air-cooled power plant and general arrangement of the car and its relation to the gas bag.

For drilling holes in glass hardened steel drills can be employed which are supplied with a solution of camphor in turpentine. It is recommended to work the drills back and forth; this, of course, would apply only to flat drills.

## A FRENCH AVIETTE

AT various times we have published short items detailing experiments that are being carried on in France with small airplanes intended to be propelled by man power. Inasmuch as a prize of some value has been offered by one of the Paris newspapers for flights with machines of this kind, there is considerable activity on the part of French experimenters in devising these light aircraft. One of these, which is shown

and from this a round leather belt runs over pulleys to the two four-blade tractor screws mounted on a light framework at the front end of the bicycle. When pedaled briskly enough, in addition to the degree of movement produced by the tractive effect of the bicycle wheel on the ground, there is an added thrust obtained from the rotating air screws. The advantage claimed for this dual driving system is that it is easy to secure sufficient speed to lift the machine from the ground. Reports indicate that machines of this nature have made short flights under favorable conditions of a few yards.

Anyone who is familiar with the principles of aerodynamics will not believe that the limited amount of power produced by a man will be enough to keep a machine off the ground a sufficient length of time so that practical flights can be made by this means. As a continual power-producing proposition, the average man is able to exert one-eighth of a horsepower. For short periods a human being may exert two or three times this amount.

Even the maximum amount that a man can exert, and it makes no difference what kind of mechanical gearing is employed, will not be sufficient to propel an airplane of even the lightest form through the air for any distance. A machine of the type illustrated must always remain a scientific plaything,

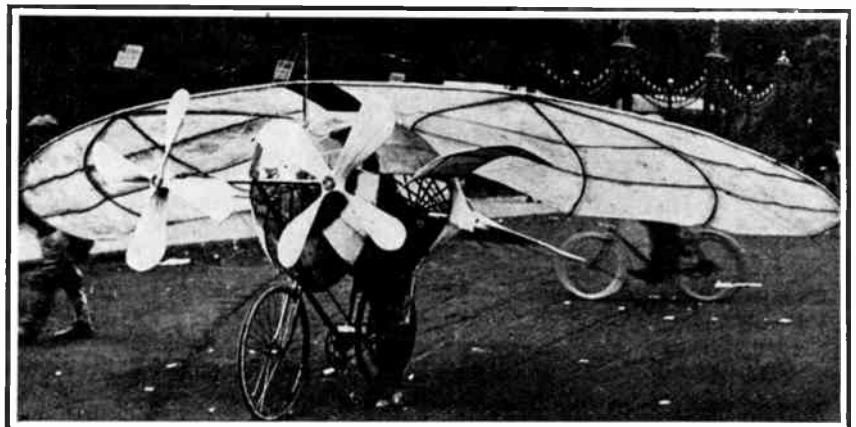

Typical French aviette or flying bicycle

in the accompanying illustration, is stated to have made short hops of a few yards several feet above the ground.

As will be apparent, an ordinary safety bicycle forms the basis of the device, and to this a light monoplane wing structure has been fastened. A belt pulley is secured to the rear wheel

rather than becoming a device having any real value.

**RECORD PARACHUTE JUMP**  
SERGEANT BOTTRIELL of McCook Field recently made a record parachute descent from an aeroplane at 19,500 feet. The aeroplane, piloted

by Sergeant Madan, climbed to an altitude marked by the indicator as 19,500 feet. Bottriell climbed out on the fuselage to make his jump. The wind caught his parachute and pulled him through the tail of the machine, tearing the rudder. He bruised the muscles of his arm and strained the ligaments.

Bottriell landed safely near Germantown, ten miles west of there, with his parachute ripped where it had been in contact with the tail wires of the plane.

**COMPLETELY ENCLOSED AIRPLANE FUSELAGE FOR HIGH ALTITUDE FLIGHTS**

**I**N an interesting article in our French contemporary, *Le Génie Civil*, an eminent French scientist, describes a type of airplane having completely enclosed power plants and passenger compartment as shown in accompanying illustration. The air plane is a modified Bréguet passenger-carrying type provided with a completely enclosed fuselage, within which the passengers, the crew and the engines are accommodated, and within which the air pressure at all altitudes is maintained at that of the ground level value by means of a pump. With this arrangement it is claimed that not only are the occupants of the machine practically unaffected by the rarefaction of the air at very high altitudes, but the engines are likewise supplied with their full quantity of oxygen at all heights, while as an additional advantage the compression and decompression reaction on the passengers and crew resulting from a rapid descent or ascent are avoided. The fuselage, it will be seen, is, so far as the conditions prevailing in its interior are concerned, quite comparable with the body of a submarine, except that whereas the latter may have to withstand an external pressure of three or four atmospheres the fuselage skin has to withstand an internal pressure of not more than half an atmosphere.

The Bréguet high-altitude biplane fuselage is equipped with four Bréguet-

Bugatti motors B on the system exhibited at the Paris Aeronautical Salon last December. The total horsepower developed is 950. All four motors drive the one screw A, and should one or other of them develop a defect it is automatically cut out by a clutch C. The radiator is shown at D, the oil tanks at E, and the fuel tank at F. A turbo-compressor G, presumably of the Rateau type, driven by the exhaust gases of the engines, draws in air from

wings, and various wing arrangements have been tried to get more lifting surface than it is possible to obtain with the usual biplane or triplane arrangement and without having too great a wing spread.

The latest multiplane machine to be constructed full size is now being exhibited at Langley Field, Va., preparatory to a series of flying tests. It is a unique affair, as will be seen from accompanying illustration. The main

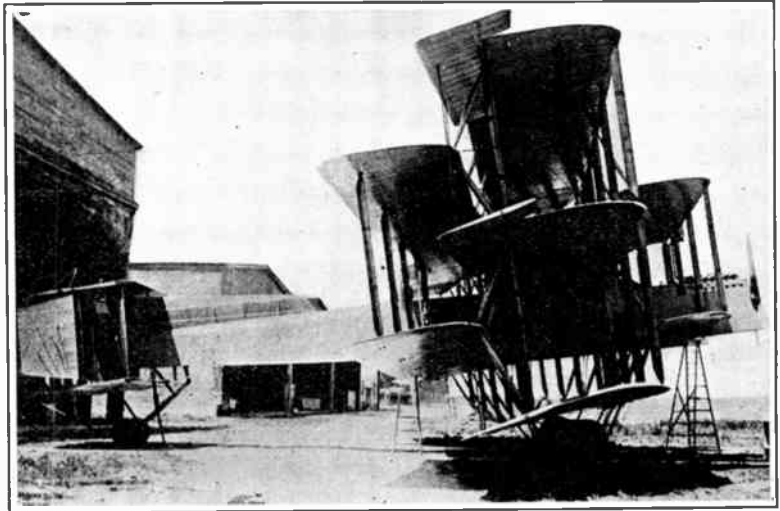

Unusual multiplane design having three sets of lifting surfaces

the outside and supplies it both to the engines and the compartment in which the pilot and passengers are placed. The usual expedient of supplying oxygen, if breathing becomes difficult, can be utilized just as required if the supercharger could not supply air enough for the four engines and the passengers.

The physiological effects of ascents to high altitudes are now fairly well understood, and in their aeronautical bearing have been made the subjects of considerable research by the medical officers attached to the air services of this and other countries.

**EXPERIMENTAL MULTIPLANE**

**F**OR some time past some aeronautical designers have favored airplanes having more than three sets of

part of the machine consists of a triplane arrangement, but right behind this and arranged midway between the triplane wings is a biplane arrangement. Evidently the designer of this machine has endeavored to get more wing surface with a minimum of interference. Whether he has succeeded or not remains to be proved. The fact is that this machine has plenty of power—two engines for propellers and one engine for a tractor screw, so there is no question of its ability to fly, even though its efficiency may be in doubt.

To preserve the softness and flexibility of india rubber coats, overshoes, and the like, it is recommended to immerse them in water which has been boiled, so as to be free of dissolved air, and to keep the whole in a dark place without extremes of temperature.

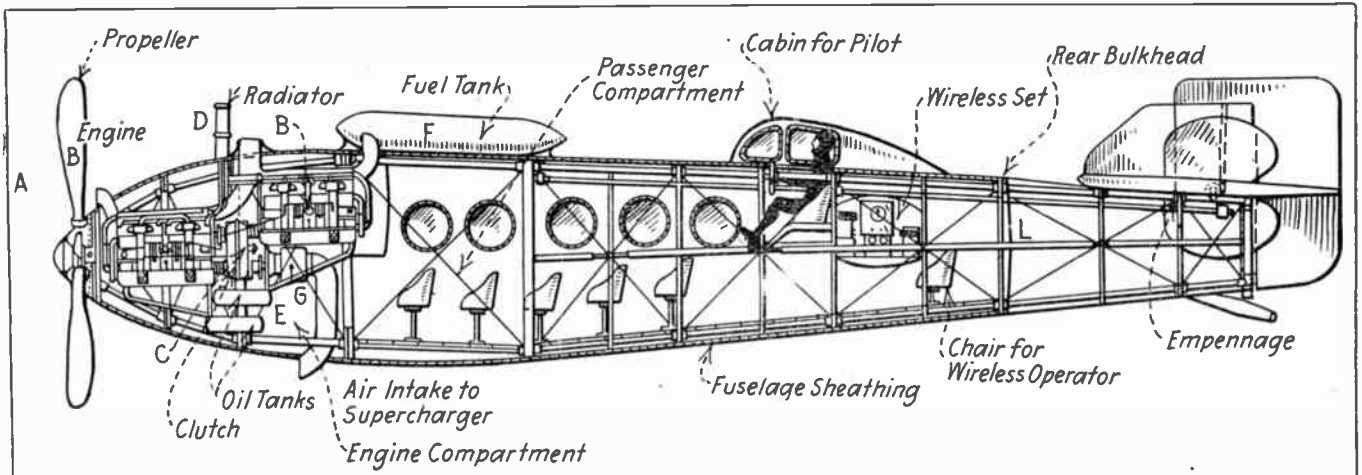

Completely enclosed airplane fuselage for high altitude flights designed by Bréguet



# MANUAL ARTS AND CRAFTS

PROJECTS FOR THE SCHOOL, HOME OR SHOP



## ELECTRIC BOUDOIR LAMP

**T**HIS lamp has been designed for the average novice to make. It is extremely simple in construction and requires very little knowledge of electricity, and that may be learned by inquiring of the party selling the electric fixture, how to connect the wires to the proper terminals within the socket fixture. The important consideration being to keep the wires well insulated and from coming into contact with one another.

The bracket A is best laid out by taking a sheet of paper (drawing paper or light card board)  $6\frac{3}{4}$  wide by 14" long folding it thru the center lengthwise to  $3\frac{3}{8}$  x 14, then draw one half the design on it. Now cut out the pattern folded and when opened it is sure to be symmetrical with the center line well defined and true. Tack this pattern to, and trace its shape carefully on "A". It is essential that the bracket A and two brackets B are cut to the correct length, 14 inches, and should have one straight edge with both ends square at 90 degrees to the true edge.

The pattern is slightly changed by laying off  $\frac{1}{2}$  the thickness of the material used, on each side of the center line (the crease made by folding). This allowance is made so that when the brackets B are nailed or glued on to A all four sides will be approximately the same from the centerline. Suggestions are offered for three different contours for the brackets. These will suggest others. It is very gratifying to design one's own. The principal dimensions are given in all cases. Contour No. 1 requires an expansive bit, set to  $1\frac{1}{2}$ " dia., the holes bored as indicated, and using a fret or turning saw.

No. 2 requires a 1" bit. The centers may be located by counting the squares, each one represents  $\frac{1}{4}$  of an inch. The rest of the contour may be made with a cross cut saw if a rip saw is not convenient. No. 3 is made with a saw only and may be hollowed as shown with a chisel (bevel side in) or a spoke shave. Coarse sandpaper or file will smooth the edges. The whole project should be sandpapered with No. 1 followed by No. 10 carefully dusted

before staining or finishing.

A saw-kerf or groove is made in A along the center line to permit the two wires to be concealed before B is attached. Care must be taken if B is nailed to A not to pierce the wire insulation. It is therefore safer to glue B to A, or depend on nailing the base C and the cap D to the brackets A and B.

The base C is then laid out. Cut  $2\frac{7}{8}$  x  $\frac{7}{8}$  or thereabouts x 8" long, half lap them at the center making a cross, figure C, then shape them as shown. A sketch of the half lapped joint is shown. This is easily made by notching each piece C so that one part crosses the other at 90 degrees or at right angles.

Bisect the 8" lengths, lay out  $\frac{1}{2}$  the thickness of the stock on each side of the center. Place the piece that crosses over the lines thereby checking up the lines. If correct, gauge the depth of the cut out  $\frac{1}{2}$  the thickness of the stock. If this joint is made first it eliminates any possibility of making the common mistake of having one side upside down. Keeping them in position, lay out the recessed bottoms. This

ELECTRIC BOUDOIR LAMP	
DESIGNED FOR THE AMATEUR BY C. E. MULLER MAE	
MANUAL TRAINING INSTRUCTOR NYC SCHOOLS	
A	1 BRACKET $6\frac{3}{4}$ x 14
B	2 " " " " " "
C	2 BASE $2\frac{7}{8}$ x $\frac{7}{8}$ x 8
D	1 CAP $4\frac{1}{4}$ x $4\frac{1}{4}$
E	1 SOCKET BASE
F	1 BULB (40-WATT)
G	1 SHADE
H	1 FRAME (WIRE)

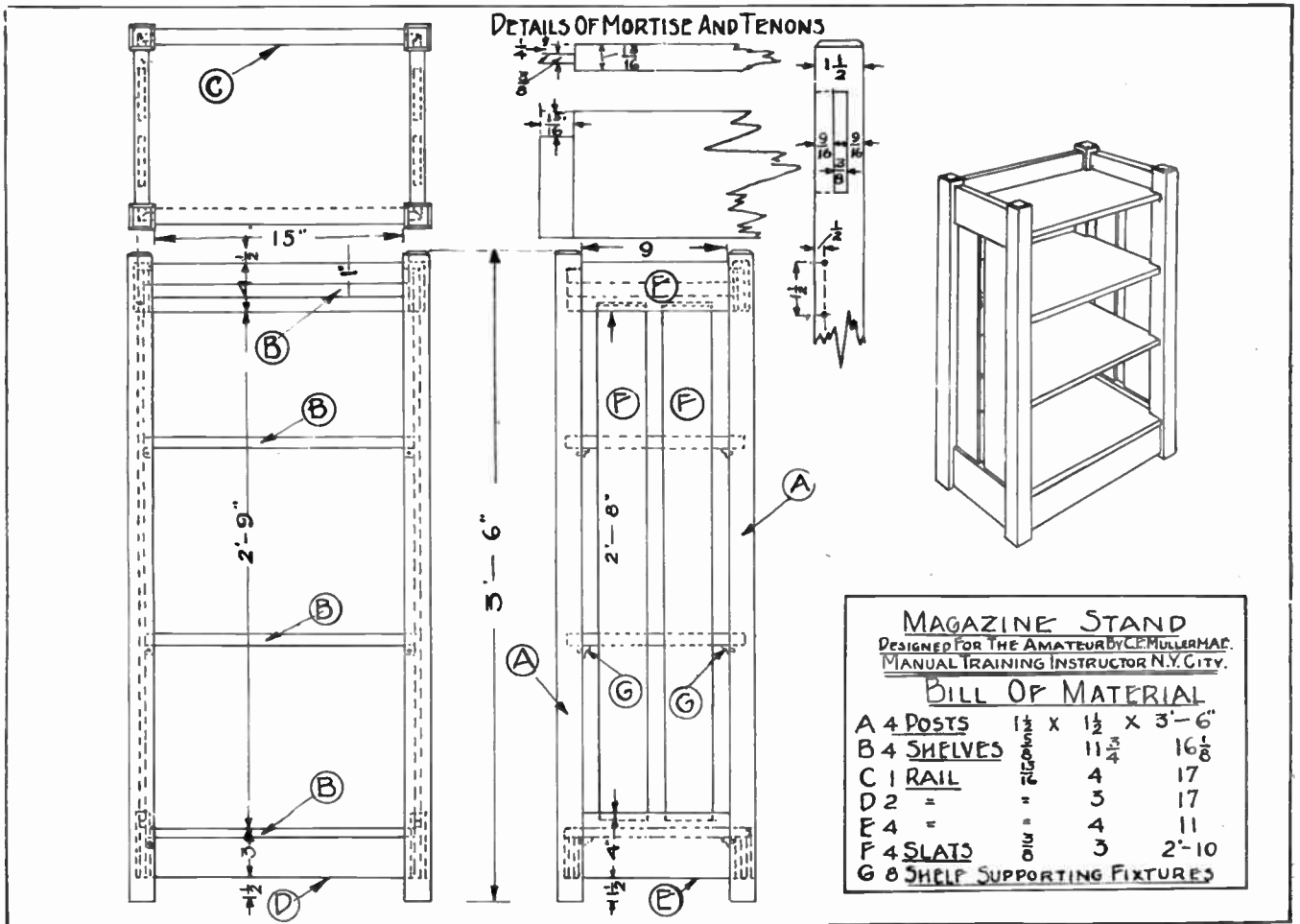

is made by measuring 1" from each end, then sawing 1/4" deep, tapering from O at the center to 1/4" near the ends. The reason for this is that the surplus material may easily be chiselled out with a slicing cut. After the model is assembled, it is then advisable to pare a slight clearance at this point so that only the four outer pads or feet may rest on any surface such as a table top. A 1/4" hole must be drilled at this place and thru the cap for the wire to lead thru.

The cap D and the base C are nailed to the brackets A and B with 8 1 1/2" No. 18 wire brads carefully centered so that they will not protrude thru the sides. The socket base E is then located and fastened with two oval-headed 1" No. 12 wood screws. The wires are fastened each to their respective binding posts, properly tightened. It will be found convenient to always make the loop end turn in the same direction as the nut of the binding post tightens, as this tends to draw in the ends of the wire, especially when flexible cord wire (multi-strand wire) is used. The opposite end of this cord or wire must have a socket plug to fit into the wall or chandelier socket.

The bulb is inserted, of any candle power desired up to 100-watt. The shade frame may be a lateral ring at the top of the fringe with three or four braces of 3/32nd round wire clamped

between the socket E and the cap D. The double loop arrangement as shown may be purchased for 15 cents or easily made of 1/16" brass wire.

The shade G may be made of silk, cretonne or crepe paper of an infinite number of designs. If fringed with beads it will surely commend itself to anyone. The stand may be stained to suit ones fancy, left a dull stain or waxed with a floor wax to a polish. A small can of colored varnish, such as Japalac, will give a fair finish with two coats. Allowing the first coat to dry thoroughly, then sandpaper carefully. Dust well before applying the second coat. Keep the project in a dry place free from dust when varnishing it.

See the second article for other methods of finishing.

### MAGAZINE OR DICTIONARY STAND

**T**HIS project was designed for the advanced worker and handy boy. It looks particularly well in chestnut, whitewood, redwood, cypress, oak or ash. It may be used for a magazine stand, book rack or dictionary rest. The construction is of the conventional type using mortised and tenoned posts and rails with the three lower shelves adjustable. An extra shelf may be added if desired. The shelves in the latter case may be spaced 4" for the upper one to lay the magazines or cur-

rent newspapers flat, the next 6 1/4" for small text books, another 8 1/4" for an ordinary text book and the last 12 1/2" for books the size of the standard dictionaries.

The rail tenons are shown in the detail. They will be mitered at 45 degrees as indicated when they come in contact with each other. Three-eighths of an inch dowels may be used instead of the mortise and tenon joint. Many cabinet makers use this method especially where single pieces of furniture are made mostly of handwork.

When gauging the mortises care should be taken not to scratch beyond the shoulders, so that no gauge marks will show after assembling the parts. Bore a series of holes with an augur bit that just fits the width of the mortise. A Stanley bit jig is surely worth the price, and will positively insure excellent results. It may be also used to employ the dowel method of construction. Many cabinet makers and practical carpenters use the dowel method, using two or three 3/8-in. dowels 2 in. long instead of the tenons. The centers of the dowels may be located by driving in small brads, cutting off the heads with nippers, then pressing the adjoining surfaces accurately against these brad joints. Using the intersection of the lines produced by the gauges and a squared penciled line is the common method. The slats are usually



housed into the back rails their full thickness width about  $\frac{1}{2}$ " deep.

The mortises are shown  $\frac{3}{8}$ " wide but may be increased  $\frac{1}{16}$ " to  $\frac{1}{8}$ " to accommodate a  $\frac{1}{2}$ " bit. It is advisable to gauge these mortises on two adjacent corners of each post, taking care not to gauge beyond where the rail cover, as the scratch marks are disfiguring in the finished product and are always more prominent when stained and varnished. A series of holes bored carefully within the gauge lines will facilitate the removal of the desired material.

The slats are usually housed into the rails for  $\frac{1}{2}$ " to 1" deep. A housed joint differs from a tenoned joint in the fact that it has no shoulders. In other words, it is mortised into its component its full thickness and usually its full width. The reader will observe that the rail is omitted in the front at the top. Also that the lower rails at the front and back butt up to the lower shelf.

The upper and lower shelf corners are cut out to fit the posts and will butt the rails, thus will be approximately  $15\frac{3}{4}$ " long. The other shelves are also cut out at the corners to fit the posts so that they will butt up to the side slats. All shelves should be uniformly back  $\frac{1}{8}$ " from the front edge of the posts, front and rear. Sand-paper carefully with the grain, removing all surplus glue at the joints.

The June edition of this magazine gives a number of suggestions for making different, very inexpensive stains with turpentine, kerosene, gasoline, water and vinegar. Diamond dyes mixed with alcohol or shellac will also produce stains that will prove satisfactory on chestnut, whitewood and basswood.

The following method of finishing is one of the very best to be recommended: Stain the project with a bicromate of potash diluted with water followed by an application of Wheeler's No. 7 filler for mahogany. This will develop a wonderful mahogany red especially on whitewood. Let this dry for 24 hours. 2. Then apply a coat of white or orange shellac. Let this dry for 6 hours. Smooth carefully with No. 0 steel wool. 3. Dust thoroughly, apply a coat of Glidden's varnish (Glidden's hard oil finish varnish). Let this dry for 48 hours. 4. Rub down with crude oil and fine pumice thoroughly, wipe clean and dry. 5. Apply second coat of varnish, allowing it to dry for 48 hours or more. 6. If a brilliant lustre is desired, rub down well with crude oil and pumice. If a smooth, dull finish is wanted, rub down with pumice and water. Remove all pumice and moisture with a dry flannel cloth. The method of fuming oak with ammonia will be described in a subsequent article.

## A Simple Balance

A USEFUL scale for weighing mail or other very light things may be easily made from odds and ends that can be found in any experimenter's work-shop. Any wide-mouth glass jar, such as a water tumbler, jam or pickle jar, is used to hold the water in which the balance floats. A small glass test tube is weighed with a little lead or with iron filings so that it will float vertically in the water. The test tube is fitted with a cork and a piece of light cardboard about three or four inches square is attached to the cork by means of glue or sealing wax, but care should be taken to center the cork in the middle of the cardboard scale.

The scale is a sheet of paper which is pasted up the length of the test tube. The test tube is floated in the water with the scale pan or cork in place and a mark is made to indicate the flotation level with waterproof drawing ink, this mark being indicated by a figure 0. The rest of the scale is marked by procuring weights of known value and placing them on the cardboard scale pan. For example, a weight of one ounce will sink the test tube a certain amount. The figure one is placed opposite the line that indicates this new level. The amount of weight is increased and new markings are made at the various levels to show the amount of weight supported by the scale.

After the main indications are made, the intermediate marks that indicate  $\frac{1}{2}$ - and  $\frac{1}{4}$ -ounce subdivisions can be put in by dividing the main lines

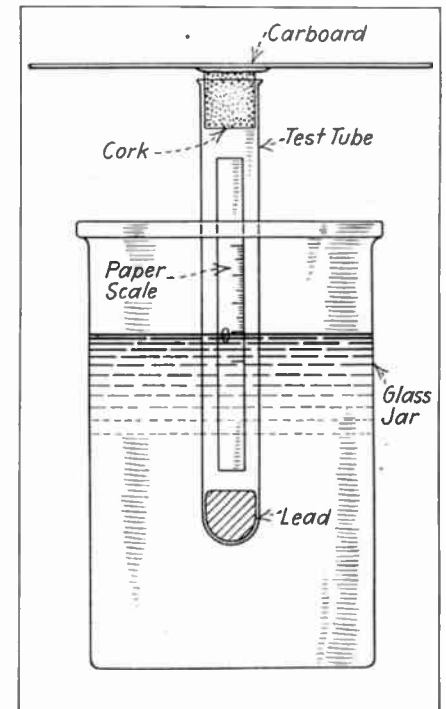

equally. After the balance is finished and properly calibrated, one or two coats of white shellac varnish is applied to preserve the scale against the action of the water.

## How to Make a Small Lift Truck

By Harry A. Mount

THE small lift truck of unique but simple design illustrated can be quickly and cheaply constructed by anyone handy with tools. It will prove serviceable in the small shop or factory. The truck will lift and carry weights up to a ton. In addition to its extreme simplicity, it has the added advantage over most of the commercial models of lift trucks of being able to turn within its own length, making it particularly adaptable to crowded quarters. The truck described was for use in a small printing establishment and the dimensions could be altered to meet other conditions.

The "sliding wedge" principle was employed to obtain the "lift." Two 2x4 pieces 40 inches long were used in making the two sets of bearing surfaces. These pieces were sawed, as is indicated in Fig. 1, so that there was a "pitch" of two inches. The two inclined surfaces were then planed down until they were perfectly smooth. Two pieces of 2x4 20 inches long were then cut and the undercarriage of the truck assembled, as in Fig. 2. Screws were

used in assembly and where they were driven through the thin edges of the wedges the heads were countersunk below the surface to prevent scratching the upper member. It will be noticed that the 2x4 on the heavy end of the wedges was set upright and mortised into the ends two inches to allow a projection equal to the thickness of the cross-member on the other end.

Two tongue supports were made of strap iron, as shown in Fig. 3. Each support consisted of two pieces, one a V-shaped piece, fastened to the 2x4 by a bolt passing through both ends and through the timber. The other part was a longitudinal brace, anchored to the wood by a bolt and riveted to the V. An upright projection was drilled to receive the tongue bolt. It is desirable that the two tongue supports be made of rather heavy material and that they be bolted rigidly in place to the front upright 2x4 of the truck undercarriage, as considerable strain is imposed on them.

The tongue may be of hardwood,  $1\frac{1}{2}$ "x $1\frac{1}{2}$ ", or be made of a section of

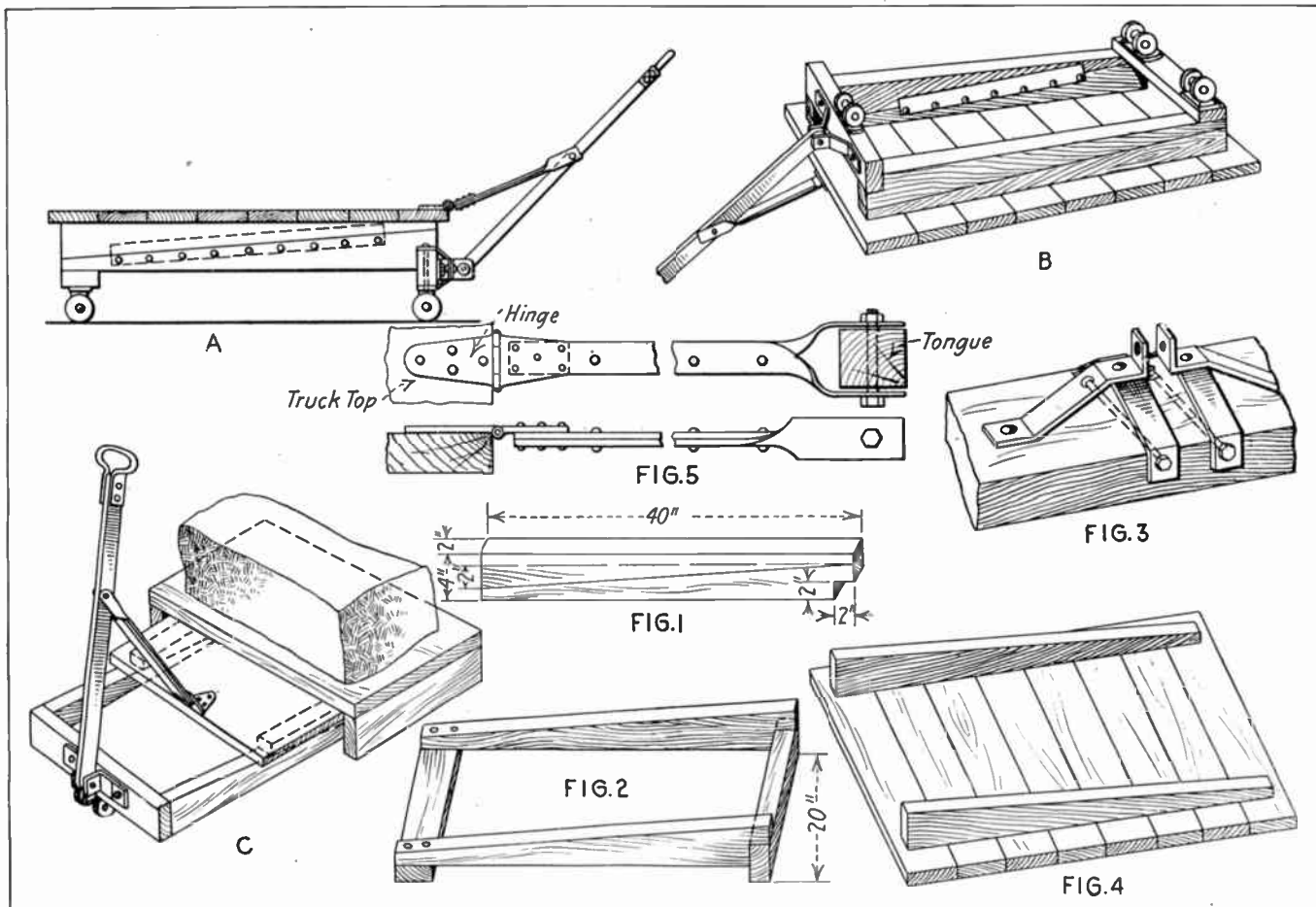

Details of easily made shop truck

iron pipe about 36 inches long. In either case a hand hold of heavy strap iron should be made and bolted to the end. The other end should be bolted between the two tongue supports, allowing as little side-play as possible.

Next the top may be constructed. This is done by nailing boards to the two top wedges, as shown in Fig. 4, taking care that the wedges are spaced exactly as the lower ones and are kept parallel. Two small boards are then nailed or screwed to the inside of each of the top wedges (Fig. 4) to serve as guides. The top may then be placed on the base. If there is any tendency toward "binding" between the two parts this must be corrected by planing. The four wedge surfaces should then be greased with axle grease so that there is perfect freedom of movement between them.

A strip of strap iron long enough to reach from the front edge of the truck top to a point about two-thirds up the handle is now required. One end is drilled and riveted to a door hinge (Fig. 5). The other end is split with a cold chisel, the two ends twisted at right angles and drilled so that they can be bolted to the tongue.

The truck is now complete excepting for wheels. Large castors with double wheels, of very heavy construction, such as are obtainable at any hardware store, were used. Four castors were employed, arranged as shown at B. The two

rear castors were placed on the extreme corners of the truck so that the weight of the load bore directly on them, with little strain on the thin ends of the bottom wedges. The front castors were placed side by side in the center of the truck, which was permitted by the heavier construction of this end of the undercarriage. Each of these castors was rated at 500 pounds capacity, making a combined capacity of a ton

The use of castors, rather than wheels, saved the complication of a movable axle for guiding the truck and made it possible to move the truck in any direction or to turn it within its own length. This was found to be a decided advantage.

In operation the tongue was pushed back, sliding the top back about half its length. The truck was then pushed under a platform, built according to standard practice, just high enough off the floor to allow the truck to get under. The platform carries the load. Then the tongue is pulled forward until the wedge action causes the top to engage the platform. Then a quick pull of the tongue shoves the bottom of the truck back under the load, raising it clear of the floor. In lowering the load, a quick pull should be given to the bottom of the tongue.

It was found that the end of the tongue moved about twenty inches in raising the top an inch, so that a pull of 50 pounds on the tongue would raise

a load of 1,000 pounds (not allowing for loss by friction). It can readily be seen that the truck can be made much more substantial if sheet metal and angle iron are used instead of wood in the construction.

### PRACTICE IN ASSEMBLING AUTOMOBILE WORM-GEAR DRIVES

**I**N the assembly of worm-gear drives for automobiles it is the custom to offset the wheel relative to the worm a few thousandths of an inch sidewise. The object of this is to counteract the inevitable looseness which there is in the ball or roller bearings, not only of the differential but of the worm itself. There necessarily must be a very slight looseness in any bearing, otherwise it could not run freely. According to an engineer well versed in the design of worm drives, this sidewise assembly is of little importance in ordinary commercial truck work, but in gears for electric vehicles where the elimination of noise is an important factor, this sidewise assembling has to be very carefully done. It is generally supposed that worm-gears run quietly, and compared with internal gear drives they do, but they produce enough noise so that this factor must be considered in the design of drives for electric pleasure cars, which must run almost noiselessly.—*Machinery*.



# EVERYDAY SCIENCE NOTES

BY PROF. T. O'CONOR SLOANE



## SIMPLE SPANNER WRENCH

WE have already had occasion to illustrate a couple of adjustable spanners and in the accompanying article we show another form. In this a hexagonal hole at the end receives the nut and a screw actuated

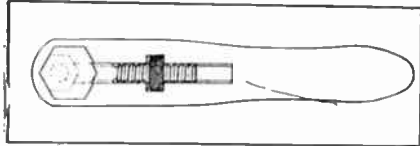

by a knurled nut and with a notch in its end of 60° opening, is screwed back and forth so as to grip the nut as clearly shows in the cut. A feather and groove device is provided to prevent the screw from turning.

In Arizona there is a small perfectly circular lake, called the Meteor Crater, which is supposed to have been formed by the fall and explosion of an aerolite. Fragments of meteoric iron are scattered around it. It is taken as being what may be called a lunar crater, as the craters on the moon are undoubtedly in large part due to the fall of meteorites.

Experiments which have shown that the presence of carbon dioxide gas is favorable to plant life have been carried out in Germany. The exhaust gases from an internal combustion engine plant at a blast furnace were caused to act upon vegetation, and the result was a great increase in yield. It actually suggested a way of regenerating burned coal. It in a sense established a reproduction of the carboniferous era. It was calculated that a blast furnace producing 1,000 tons of pig iron per day could supply gas for the cultivation of 4,000 tons of potatoes. Tomatoes yielded three times the normal, cucumbers twice the normal, and equally good results were obtained by supplying the gas through perforated pipes traversing the plot. The first tests were done in a sort of cold frame with a mixture of the gases with an equal volume of atmospheric air.

It has been found that ostrich eggs last for many weeks without any particular care. Eggs sent from Africa to France were edible after more than three months. The volume of one egg is put at about three pints.

A snow storm made it possible to determine the weight of soil transported as dust by the wind. It was in Madison, Wis., that the snow was observed to be colored a brownish red. By collecting the snow, melting it and evaporating the resulting water, it was a simple matter to determine the dust in any given quantity. It amounted to nearly seventy-five grains of dust to the square yard. The mineralogical characteristics and chemical composition of the dust pointed to New Mexico and Arizona as the place of origin, involving a transfer of fifteen hundred miles. The weight of soil thus transported over this great distance in the one storm was put at a million tons.

Petroleum has been found in Greece, and this time by the engineer officers of the French army, certainly a more beneficial operation than fighting. One of the wells bored gives 50 barrels of oil a day.

In the cuts are shown two simple methods of filtering lubricating oil which in service gets charged with bits of brass and steel so as to greatly impair its value for a second use. In the first one charcoal is placed in a special wire basket and below it is a bag or diaphragm of cloth and the oil is shown as it pours through the two and drips into lower compartment. It is so pure as to be available for a second use. In the next cut the oil is syphoned through a heavy wick which may be plaited or twisted out of a ball of lamp wick. As long as one end of the wick is longer than the other and a difference of level is maintained between the two vessels of wire, the fluid will pass through the pores of the wick from the higher to the lower level and be perfectly purified in such passage.

The soaring flight of birds which is most frequent in the tropical regions has been examined by scientists lately and it has been found that the air has a vertical ascending component in the regions where this flight is mostly observed. In other words, the wind blows vertically upwards hard enough to keep the birds in suspension, as in the case of a parachute. The conclusion is new that the wind in these regions nearly always has a vertical component in places; to find and use it the birds seem to be limited to the zones having these ascending components. Of course, the object of the bird is to keep in the rising zone and if its flight enters a descending zone it will turn its course and recover its zone of supporting air. This accounts for their apparently unaccounted for turns, and the old idea expounded by Langley, that the soaring can be accounted for by the sudden changes in velocity of the wind is pretty definitely abandoned by these observers.

## GAS METER

AN interesting meter for registering the flow of gas is shown in our illustration. The level of water in the two tanks, A and B, when gas is passing through the diaphragm lying in the pipe directly above the tank, the course of which gas is indicated

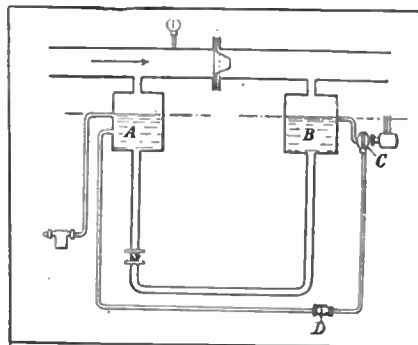

by the arrow, will vary with the amount of gas passing. The water in A will be depressed and that in B will rise. A pump in C keeps the level invariable in the two tanks pumping out of B into A through a water meter D. The reading of the water meter will vary with the difference of pressure exerted by the gas upon the two tanks and will give the measure of the gas flowing.

## FLUID LEVEL INDICATOR

THE apparatus shown in the cuts is designed to show the level of water or of other fluid in a tank by the use of a floating ball. The point involved is that a stuffing box with its attendant friction is dispensed with. A magnet of the shape of an approximate circle is attached to the axle of the floating ball. A soft iron partition cuts off the interior of the tank, as shown on the right of the section of the tank, and

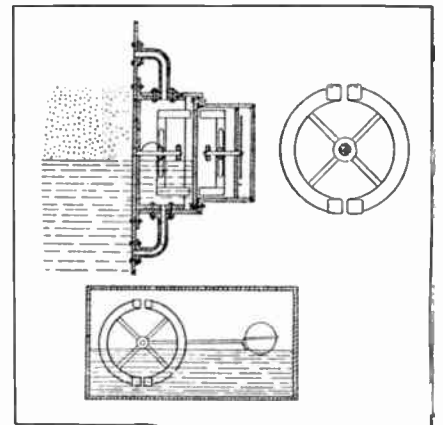

the magnet on the shaft of the floating ball has its poles close to it. An identical magnet is mounted on a shaft in line with the other shaft and carries a second magnet with its poles also close to the iron diaphragm. The effect of this is that the outer magnet follows with great accuracy the motions of the interior one and thus the position of the float is given free from all inaccuracy which might be occasioned by friction. Especially bad would be the friction of a stuffing box, which this construction dispenses with. It contains a hint which might be utilized in other appliances.

A catalyzer of good power is made by precipitating silver on a base of asbestos or similar inert substance. At the temperature of 250° C. this will effect the oxidation in air of many organic substances. Calcined alum has also been found quite powerful.

In Germany the great gas holders are cheaply protected from rusting by putting a layer of oil less than half an inch thick on the water in the tank. As the holder rises it carries up with it a coating of the oil which protects it perfectly. The expense is a small fraction of that of painting. Of course, the part which does not descend into the water must be painted.

The Czecho-Slovak Republic by the Peace Treaty after the world war has been awarded free transit on the Elbe and Oder Rivers to Hamburg and Stettin. It has now been decided by the Prague Government to canalize the middle Elbe and to connect it with the Danube and the Oder. This waterway will connect three great seas, the North Sea, through the Elbe by Hamburg, the Baltic by the Oder through Stettin, and the Black Sea through the Danube. This, it will be seen, gives waterway from the Mediterranean to the waters in the North of Europe.

Armco iron, made by the American Rolling Mill Co., has been elaborately reported on in France. It was found to be 99.8 per cent pure, with only traces of impurities. It was found to weld easily, to resist corrosion, and to be of good electric conductivity. Of French home products electrolytic iron approaches it in characteristics. One of the products made from electrolytic iron is weldless tubing. Electrolytic iron is so pure that it answers for the manufacture of crucible steel, where Swedish iron has long been employed. Success has not yet been attained in the manufacture of electrolytic sheets.

By cutting a wedge-shaped piece out of a cork which is too large for a bottle, the

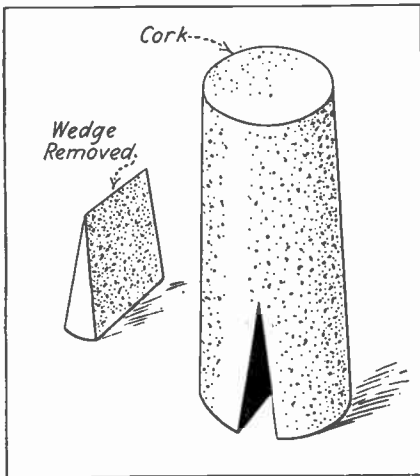

cork in question can be made to fit perfectly. It is the upper end which is supposed to be thus treated and the reversed cork can then enter the neck of the bottle.

Of 100 horses in the United States 82 are of the heavy order, 53 Percherons, 12 Belgian and 5 or 6 English. This type of almost giant horse is said to fail in the United States in a few generations, so that importations of new stock are constantly needed. The Percheron and two or three other breeds are said to have suffered but little in the war; other kinds were badly reduced in number.

From New Caledonia comes the tale of the utilization of the deer. It seems that these animals have increased until they have become a plague, just as the rabbits in Australia have. Now they are being utilized as material for canned food products. One provision house is cited as using them to supply canned venison. The hunters are paid 25 francs apiece and the carcasses are brought in by the truck load.

The use of a spectroscope with quartz prisms for the study of the ultra-violet spectrum has been quite successful in the hands of Drs. L. and Eugene Bloch. The spectra were produced by the electric spark between electrodes of the metal to be studied. As an advance on this method the same investigators are using fluorite prisms and to avoid the slight absorption of the ultra-violet rays by the air are conducting the work in a vacuum. An exposure of five to ten minutes is given and aluminum or mercury lines are used as the standard or basis of work.

The death of a French scientist is noted. He was engaged in the investigation of the effects of war gases on the human system and fell a victim to his work. The soil of the earth was found to possess an absorbing power for the gases in question, so that by a proper disposition it is sometimes possible to dispense with gas-masks. The best way to dispense with them and the most obvious would seem to be not to go to war.

Iron has long been protected from rusting by various processes based on the formation on the surface of an oxide, usually or always the magnetic oxide. The well-known Bowers-Barff process, in which the treatment with steam at a high temperature is utilized, effects the deposition of such an oxide. From Italy comes the description of an electrolytic method of giving a protective coating to iron. A bath of sodium ferrite is employed. The piece to be coated is the anode. The passage of a current gives it a surface very sensitive to oxidation. The current after a while is reversed and the iron then receives a firm coating of oxide, so as to be protected from rusting. The sodium ferrite is produced and maintained in the bath by the normal action of the current. Black magnetic oxide of iron,  $Fe_3O_4$ , is the form of protective coating produced.

The action of air on the funnels of steamships has been investigated and it has been found that the air is in compression over only about  $78^\circ$  of the front portion of the smoke stack. There is a slight depression on other parts of the smoke stack so that a component reverse in direction to the wind results.

Synthetic pig iron is now being produced in the electric furnace. Steel turnings are melted along with charcoal and basic slag. The composition of the resulting pig iron, which may run up approximately to 4% carbon, can be greatly modified by the ingredients of the charge. One furnace produces from 80 to 100 tons per 24 hours, using 675 kilowatt-hours per ton; 5 kilograms of electrode and 80 kilograms of coke per ton are used. Charcoal in small pieces of about the fineness of the turnings, works very well and it is advisable to treat the melted charge in a mixer before casting. It is found to give excellent material for malleable iron castings.

An odd instance of the change of view is reported from Sumatra. Normally the tiger is not a favorite neighbor, but on this island a palm tree is cultivated, whose fruit is a favorite with the wild pigs, and the result has been a plague of wild swine. Now it is considered good policy to protect, for a while at least, the tiger, until he kills off the too numerous porcine population.

The maximum theoretical flight and the speed which is theoretically possible for aeroplanes has been investigated by M. Rateau. He finds that it is extremely difficult to establish the possibility of a flight of 4,300 miles without descent to earth. The flight would have to be at an elevation of five miles for ten hours. As maximum theoretical limit of speed he gives a little less than 300 miles an hour. These figures are of only theoretical interest.

The French are giving much attention to the finding of substances fit for the manufacture of paper pulp. Pine tree needles have been suggested, and waste products of the wine press have been tried; the latter is to be exploited on the large scale in Spain. In the French colonies, notably in Algiers, it is believed that paper pulp can be made and exported as such, to be made into paper in the mother country. Alfalfa is produced in great quantities in Africa, and it is possible to increase the area devoted to it. Hitherto England has been the principal consumer of this crop.

It is claimed that radioactive substances have a fertilizing value for plant life. The residues from the manufacture of radium preparations have been used as fertilizers with beneficial results. It is believed that they increase the root development, activate the nitrating ferments, and favor the chemical reactions of the soil and of ordinary fertilizers, playing the rôle of stimulants

Animals fed with food sterilized at a high temperature die of starvation with definite symptoms, which have received the name of avitaminosis. This fact has led to the theory that vitamins are formed in the intestinal tract by the action of bacteria. It has long been known that bacteria played an important rôle in the life of animals, human and others. A completely sterilized animal would soon die.

The French have long been famous for their artificial cultivation of oysters. During the war this industry suffered severely. Now attention has been directed to the natural beds, and it is claimed that there is to be found in them a source of large revenue. It is stated that hitherto nine-tenths of the possible oyster harvest has been lost by neglect of the natural beds.

The pressure produced by the blow of a whip lash has been investigated by a French humanitarian. By receiving the blows of a whip lash on a surface of soft clay and measuring the depth of penetration, it was a simple matter to determine how many kilograms or pounds were required to effect the same result by simple pressure. The force of the blow was found to be far higher than supposed; it varied from 72 to over 300 pounds. The plea is made to spare the uncomplaining servant of man and to practise kindness and restraint in the use of the often brutal whip.

The action of ultra-violet rays on vitamins has been recently studied. The vitamins required for growth of immature beings, such as infants, are destroyed by eight hours exposure to the light. It is therefore asked if the sterilization of milk by the ultra-violet light may not impair its value as a food, especially for infants, who depend so largely upon it for their growth and nourishment.

X-rays have been applied to the disclosure of ancient paintings. In old times a painting was often obliterated by a coat of ground color and a second painting made on the new surface. Now by the use of the X-ray some of these ancient paintings have been photographed through the overlying and more recent picture with interesting and important results. In one case an absolutely invisible picture has been radiographed and in another case numerous restorations and changes in a painting by an old master have been disclosed. It is believed that the same method may prove of value for the study of palimpsests, manuscripts which have been erased so as to permit the parchment to be used for other writing. Often it happens that the old erased matter can be brought to the light of day, and in this way priceless finds are possible.

Australia has long been pictured as in great part a desolate area surrounded by a margin of fertile country. Preliminary operations for extensive irrigation work are now in progress. The water which it is proposed to utilize flows between two cliffs, several hundred feet high which approach each other until they are only separated by about 150 yards. By closing the gap with a concrete dam the water will be impounded and a great reservoir will be formed. The first section of the work will be sufficient to provide water for the irrigation of 10,000 to 12,000 acres. It is at least a beginning of what may become a very extensive development. The operations are in the state of Queensland and in the same district, the Government is investigating the development of the great magnetic iron ore deposits at Mount Biggenden. There is also an enormous coal field there and other iron deposits.



# RADIO

## TELEPHONE AND TELEGRAPH APPARATUS



## The Design and Use of Loop Antennas

*A Discussion of the Problems Involved in the Design and in the Operation, at Maximum Efficiency, of Loop Antennas*

By M. B. Sleeper

**A** LOOP, or coil antenna, or, as the British call it, a frame aerial, is not merely a solenoid or pancake arrangement of wire. The loop has very definite characteristics, controlled by the mechanical dimensions, the frequency at which it is used, and the circuits connected to it. Experimenters may know that these things are true, but few understand the process of actually designing a loop, or how to use it.

In the first place, let us see for what purposes a loop can be used. Below are the most common ones:

1. Short-distance reception.
2. Long-distance reception.
3. Direction finding.
4. Directional transmission.

1. A properly designed loop is good for short-distance reception, particularly on 200 meters, for, as will be shown later, the efficiency is higher at short wavelengths. This type of work calls for a small loop, 2 or 3 feet square, which can be mounted over the operating table. An audion detector will permit reception over several miles from a spark coil.

In cities and harbors a great deal of receiving can be done on a small loop from ships and 200-meter stations. The directional effect helps to reduce interference.

2. Long-distance reception requires a multi-stage amplifier or a very large loop, 10 to 15 feet square. If possible, a loop should be set up indoors, as moisture and dust tend to reduce the insulation between the turns. In general, a straight antenna of the single-wire type is much better because it is easier to erect and is more efficient. On the other hand, local interference, if not in the line of direction of the loop, is reduced.

3. Loops used as direction finders, like those for other purposes, must be designed for the wavelength range over which they are to operate.

4. For transmitting, the loop is not

as good as a straight antenna because of its low resistance. However, it is well adapted to vacuum tube transmitters, and extremely interesting experiments, either in telegraphy or telephony, can be conducted with it. Spark coils have also been used in the loops, and quite successfully.

In the following paragraphs we shall consider the design factors which influence the inductance, natural period and resistance of a loop.

### HIGHER EFFICIENCY AT SHORT WAVES

In order to set up a current in a loop there must be a difference in potential between the two sides. If equal potentials are set up in both sides of the loop at the same time, no current will flow. In a loop this difference is brought about by the time which elapses between the cutting of the near side and the cutting of the far side by the lines of force radiated from the transmitter. Increasing the size of the loop increases the time difference and the potential difference.

Also, since the speed of the waves is constant, the shorter the wavelength, the greater is the fraction of a cycle through which the wave will pass while it is travelling from the near side to the far side of the loop.

To make this more clear, suppose we have a loop the vertical sides of which are 4 feet apart, receiving a 200-meter wave. The difference in phase of the approaching alternating current wave as it cuts the two sides is only 2.5 degrees. If the wavelength is increased to 2,000 meters, this difference is only 0.25 degrees.

This does not mean, however, that any loop operates more efficiently as the wavelength is decreased, for each loop has its own maximum response frequency, but the overall efficiency of a short wave loop is greater than that of a long wave loop. At the same time the peak of a curve of the reception factor plotted against wavelength oc-

curs at the short wave end of the curve.

In actual practice it is found that a loop should not be operated at less than 1.5 to 2.0 times its natural wavelength.

### THE RECEPTION FACTOR

In experimenting with loops some measure of efficiency is necessary. This is called the reception factor, given by the expression

$$\text{Reception Factor} = \frac{NaL}{\lambda^2 R}$$

N = Number of turns on the loop,

a = Area enclosed by a turn,

L = Inductance of the loop,

$\lambda$  = Wavelength of the incoming signals,

and R = Effective resistance of the loop at  $\lambda$ .

To determine the efficiency of a loop over a range of wavelengths the reception factor is determined at a number of wavelengths and plotted against those wavelengths.

### TESTS MADE ON LOOPS

In the EVERYDAY ENGINEERING Laboratory a series of tests on 2-, 4-, 6- and 8-foot loops were made to find the correct size, number of turns and spacing for various wavelengths.

It was necessary to work backwards, building the loops first and then determining their characteristics. A complete summary of the data taken will not be given here, for, while it would be interesting, the purpose of this article is to give a method of designing loops for maximum efficiency.

First of all, experiments were made to find out what effect, if any, the spacing had upon the reception factor. Obviously, a larger number of turns were required, when the spacing was increased, to keep the inductance constant. This increased the value of N, but it also increased R very rapidly. An average of the results showed that,



for the square solenoid type loop, which was used in all tests, the best spacing was that given in Table 1.

**TABLE 1.**  
SPACING OF TURNS.

Loop	Spacing
2 ft.	0.1 in.
4 "	0.3 "
6 "	0.5 "
8 "	0.6 "

Turns	4-foot loop Wavelength	Reception Factor
5	250	2,500
10	450	3,100
15	800	3,700
20	1,200	4,300
25	1,450	4,700
30	1,600	5,000
35	1,800	5,300
40	2,000	5,500
45	2,140	5,650
50	2,220	5,750

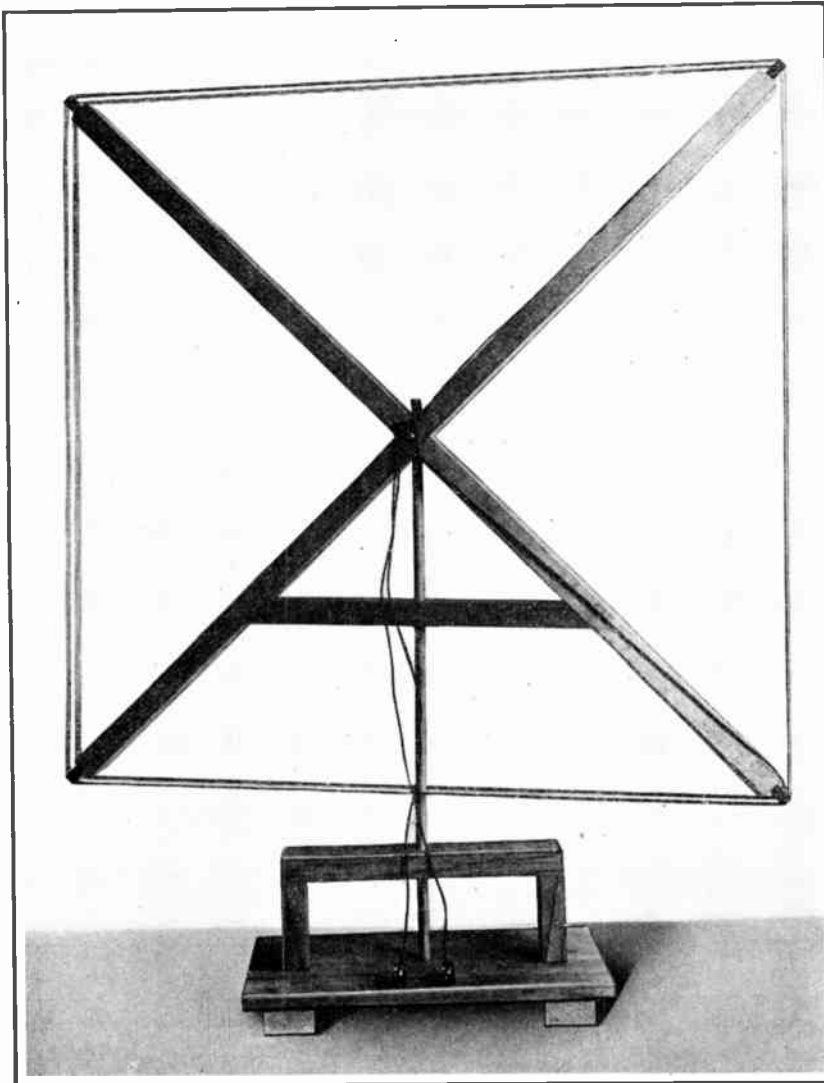

A loop and mounting used in the Everyday Engineering Laboratory

Next, loops of the sizes listed were wound with fifty turns, using the spacing values in Fig. 1. Then, taking off five turns at a time, the wavelength was determined at which the reception factor was maximum. The results are given in Table 2.

**TABLE 2.**  
WAVELENGTHS FOR MAXIMUM RECEPTION FACTOR

2-foot loop			6-foot loop			8-foot loop		
Turns	Wavelength	Reception Factor	Turns	Wavelength	Reception Factor	Turns	Wavelength	Reception Factor
5	200	1,200	5	400	4,500	5	500	4,500
10	250	2,000	10	600	5,000	10	900	5,800
15	425	3,100	15	950	5,400	15	1,300	6,300
20	550	4,500	20	1,400	5,900	20	1,700	6,900
25	700	5,000	25	1,700	7,000	25	2,100	7,600
30	850	6,000	30	2,000	8,200	30	2,500	8,200
35	975	6,500	35	2,150	8,700	35	3,000	8,100
40	1,080	6,100	40	2,300	9,000	40	3,500	8,000
45	1,230	5,000	45	2,700	9,100	45	3,800	7,500
50	1,320	2,200	50	3,000	9,000	50	4,000	6,700

The foregoing tables show, with quite a degree of accuracy, the wavelength at which a loop of given size and number of turns, with the spacing indicated in Table 1, will operate at maximum efficiency. All these loops were made with No. 20 bare copper wire. Different physical conditions in the laboratory or operating room will, of course, bring about variations in the results obtained, but Table 2 is a very safe guide. Space limitations made it impossible to make tests on larger loops, but few experimenters are so fortunately situated that they can have more than an 8-foot loop. The efficiency decreases rapidly below the maximum efficiency wavelength given in Table 2. Above these values the efficiency drops off slowly, the curve being much more steep for loops of few turns.

To determine the size of loop for receiving a given wavelength, determine the reception factor for that wavelength with the different sized loops. Select the loop that shows the maximum reception factor for the required wavelength.

**SIZE OF WIRE**

Although tests were not made to determine the advantage gained by the use of high-frequency cable over solid wire, the results obtained with ordinary inductances will hold for loops as well. These show that, at wavelengths below 1,000 meters, the cable gives a lower resistance. Above 1,000 meters, the resistance is about the same until, above 2,000 meters, solid wire is superior to cable, even though a size as large as 3 x 16 No. 38 is used.

**TUNING CIRCUITS FOR RECEIVING**

During these tests all tuning was done with only a variable condenser shunted across the loop. The circuit for ordinary reception should be that used for the secondary of a loose coupler, replacing the secondary coil by the loop. The condenser should be of the 0.0005 mfd. type, certainly not over 0.001 mfd.

The insulation of the condenser is of particular importance in loop reception, for a leaky, low-resistance condenser reduces the efficiency of the loop, the sharpness of tuning, and the voltage applied to the grid, which reduces the signal strength.

For uni-lateral direction finding a small coil should be put in series with one lead from the loop to the condenser. This is for coupling with a coil connected to a regular antenna and ground, as explained in the November-December issue of EVERYDAY.

**BALANCING OUT DISTORTION**

Because of the interference from buildings and other objects, a loop does not always give a true directional reading. This is also due to the antenna

(Continued on page 451)

# Equipment for the Radio Station

*A Standardized Panel Receiver, and an Interesting Type of Transmitter for 200-Meter Work*

By Stuart D. Dimond and John A. Hall

THE receiving set shown in the accompanying photographs was constructed along lines suggested by articles which have previously appeared in EVERYDAY ENGINEERING. The builder has followed certain suggestions which appeared in several editorials to the effect that all raw materials, parts, and instruments used, be those regularly carried in stock by most dealers in radio goods. This idea, it is argued, if generally followed by amateur experimenters would benefit both the dealer and the buyer. The advantages of standardization are self-apparent.

## GENERAL

The units shown in the pictures were built one at a time and each section, beginning with the tuner, was put into service as soon as completed. This immediately demonstrated the value of the standardized panel idea. The only radio apparatus the writer had when the set was started was a crystal detector, single slide tuner and head phones, so upon completion of the tuner panel it was immediately connected up and used. The condenser panels were then completed and put into service, the sec-

panels has been made into an audion detector unit, very much like that shown in the June number for use with the Heterodyne Wavemeter. It differs from the one mentioned in that the knob of the Paragon rheostat was

The connections between panels are made with No. 14 bare copper wire as can be plainly seen in Fig. 2.

The set has been in use since last December with very satisfactory results.

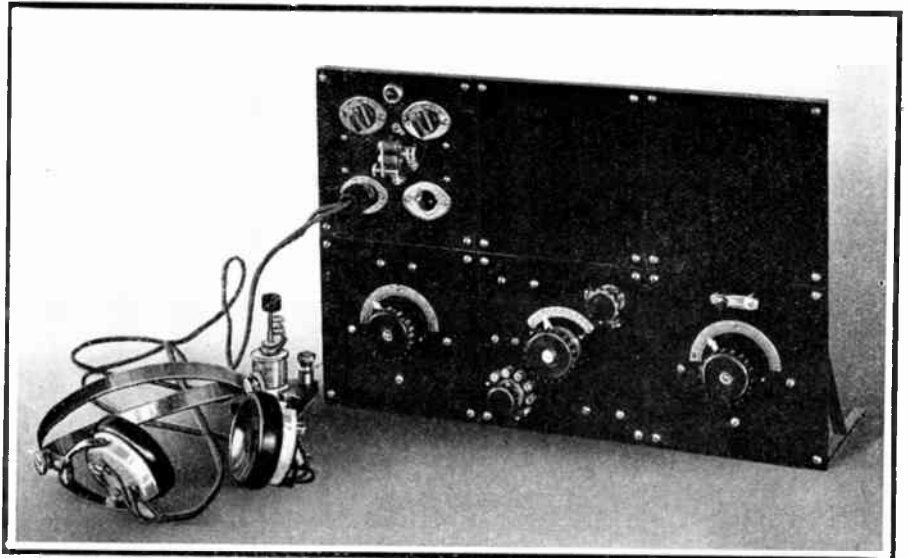

Fig. 1—The two blank panels are to be used later for an audion detector and amplifier

## THE PANELS AND METHOD OF MOUNTING

The standardized panel idea is that already set forth in previous numbers of this Magazine, with a slight change in the method of joining the units. The panels are all 5 x 5 x  $\frac{1}{8}$ " bakelite. The holes for the supporting screws are drilled  $\frac{1}{4}$ " from each edge at the corners. The drilling was done accurately by means of a small template of sheet brass.

Pieces of heavy sheet brass exactly one inch square, with four holes all drilled the same distance from the corners, are used to join the panels. The holes were drilled with the same template used in drilling the corner holes in the bakelite panels. This insures accurate alignment with no spaces between the panels, making for neat appearance. These pieces show clearly in the photograph. They are interchangeable and can be used at either the center or edge of a group or panels No. 6-32 R. H. brass machine screws,  $\frac{1}{4}$ " long, are used to bolt the panels together.

The supports are made of bus bar copper  $\frac{3}{8}$ " wide soldered together to form an angle, and braced and bent as shown. Holes are drilled and tapped at the proper points to coincide with those in the panels. Number 6-32 screws are used.

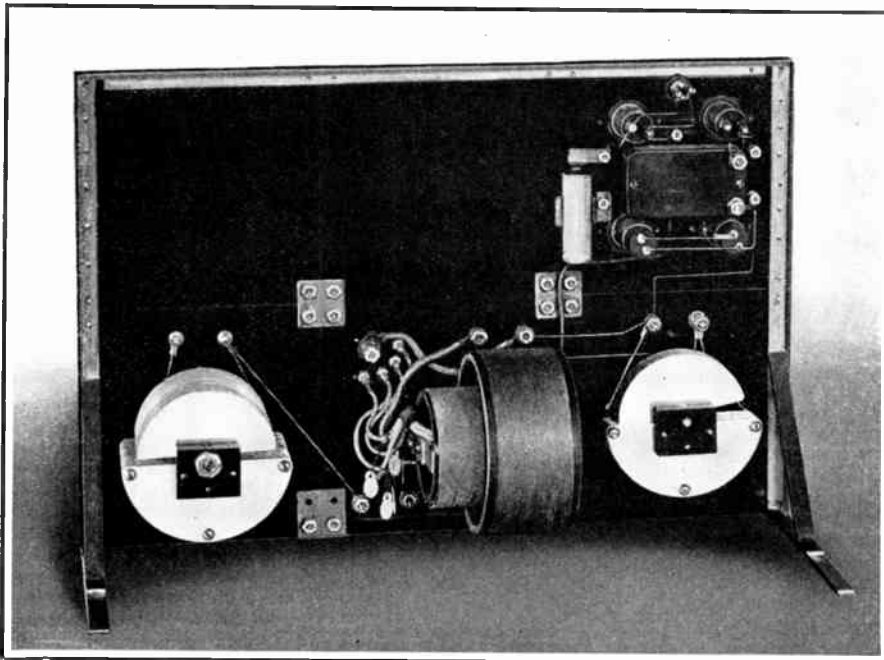

Fig. 2—A view of the instruments mounted at the rear

tion with the buzzer test, phone connections, and fixed condenser being completed last. It was thought that six panels would be enough for some time to come so supports were made to take care of this number. Since the photos were taken one of the blank

and the window for the audion is a vertical slot about an inch long by an eighth wide having an oval brass plate over it with a slot in it coinciding with that in the panel. This plate is fastened to the bakelite with two 2-56 R. H. brass machine screws.

### TUNER PANEL

The tuner is the popular de Forest Signal Corps type of coupler, and the primary and secondary switches are of the same make. No further description will be given, as these parts are familiar to all experimenters.

### CONDENSER PANEL

The secondary condenser is an eleven plate Illinois variable. This condenser comes with the shaft drilled and tapped for a 6-32 machine screw making it an easy matter to use either an Army or Navy type of knob in place

the rotor of this instrument, so that a knob similar to the others used in the set could be applied.

The condenser dials are those usually furnished with unmounted condensers and are fastened to the bakelite with 2-56 R. H. brass machine screws. The stops for the pointers are brass furniture nails driven into holes in the bakelite a trifle smaller than the nails themselves.

### PHONE CONNECTION AND BUZZER TEST PANEL

The details of this unit may not be

as the plug and jack arrangements used in expensive sets but give as good service as any others. Above the buzzer are two switches, companions of the plugs and sockets. One of these is turned on to close the buzzer circuit continuously while locating the required sensitive spot on the crystal; the other is to connect and disconnect the small fixed condenser, mounted on the rear of the panel, connected in parallel with the head telephones. The small push button above the switches is for the usual buzzer test during operation of the set. A small flashlight cell is mounted on the rear of the panel in spring brass clips. This cell furnishes the current for the buzzer test.

The connections used with the crystal detector are of the usual sort, but it is understood, of course, that the panels shown can be connected in whatever manner the builder chooses, this being one of the advantages of the standardized panel type of construction.

### THE 200-METER TRANSMITTER

The 200-meter transmitter, shown in Fig. 4, will be of interest to those who are considering the construction of a set which is semi-portable, compact, and which requires a minimum of table or floor space. This set recently took first prize in the amateur apparatus building contest held by the St. Paul Radio Club at the local Y. M. C. A.

The frame is made, with the exception of the top cross pieces, entirely of angle iron, enameled black. The legs or corner pieces are of 3/16- x 1-in. angle iron about 26 in. in length. The square in the bottom is of 1/8- x 1-in. angle iron, bent into a 15-in. square, after sawing three-cornered pieces out of one side to enable it to be bent. The corners were then welded and the square drilled and bolted to the legs. 1/4-in. machine bolts were used throughout. The square top of the frame is made of hard wood with a cross section of 7/8- x 2-in. It is needless to remark that a closed iron circuit here would absorb a great deal of the energy in the primary circuit.

The transformer used is a 1 k.w. Acme, type H 1, which gives a secondary voltage of approximately 15,000. There is a cross piece in the bottom of the frame on which two of the legs of the transformer rest, the other two resting on the side of the frame.

A Thordarson oil-immersed, bakelite dielectric condenser is used. It is held by straps made of 1/16- x 1/2-in. copper, in the rear left hand corner of the frame.

The rotary gap motor used is one which the writer believes is the best for this use which can be had. It is an Emerson variable speed universal motor, 1/25 h.p., 110 volts, 4,500 r.p.m. At highest speed this motor is slight-

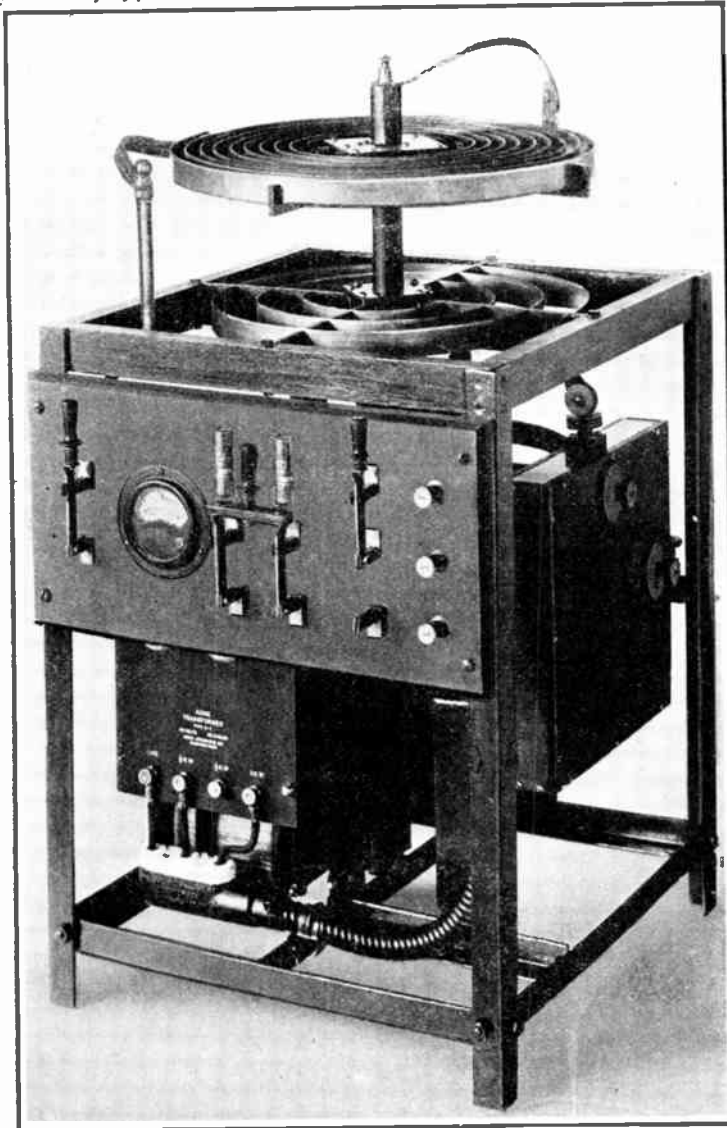

Fig. 3—There is very little about this set to suggest the old home-made apparatus experimenters used to make

of the one regularly furnished with the condenser. A condenser of larger capacity was at first used across the secondary of the tuner, but as the set is only used on amateur wavelengths the smaller condenser is now used with better results.

The primary condenser is a 42 plate Murdock of the panel mounting type and is provided with a Midget switch so placed that closing the switch short-circuits the condenser. It was necessary to drill and tap the shaft of

of interest to the majority of readers who are probably using audions, but the amateur using the crystal detector may find points of interest.

The buzzer is the Century type, removed from its base and fastened directly to the panel. Below the buzzer are two sockets taking bayonet plugs of the type used on the lighting systems of automobiles. These plugs and sockets are for the head-phone connections, and have proven very satisfactory. They do not cost as much

ly overloaded as it draws 1.3 amperes on test, being rated at one ampere, but does not heat appreciably until it has run continuously for fifteen or twenty minutes. The disc used is an 8-tooth Thordardson, with the electrodes widened out to  $\frac{5}{8}$  in. by riveting  $\frac{1}{4}$ -in. pieces of aluminum on both sides and filing to the shape of the electrodes. Since the bore of the disc was only  $\frac{3}{8}$ -in., and could not be enlarged due to the construction of the brass hub, the motor shaft which was originally  $\frac{1}{2}$  in. was turned down to fit. The disc is enclosed in a case made of  $\frac{1}{4}$ -in. black sheet bakelite. The inside dimensions are 9 x 9 x-1  $\frac{1}{4}$  in. The case is mounted on the pulley end housing of the motor, by machine screws which pass through the back of the case, then through spacers made of  $\frac{3}{4}$ -in. fibre rod  $\frac{3}{4}$ -in. long, and into threaded holes in the motor housing. A hole in the back of the case is made a driving fit on the bearing box of the motor which projects conveniently about one inch from the housing. The fixed electrodes are of  $\frac{1}{8}$ - x  $\frac{5}{8}$ -in. copper bus bar and slide in slotted bakelite blocks which, in turn, are screwed on the sides of the case, 90 degrees apart. A set screw in the side of these blocks clamps the electrode in any desired position. The fixed electrodes are each fitted with four copper cooling flanges, and are tapped at the end for a machine screw which clamps the connection strip between 1-in. copper washers. Directly opposite the sparking points, a 2-in. hole is cut in the front of the case. These inspection holes are normally closed with bakelite discs which are clamped in place by threaded knobs on projecting studs.

The oscillation transformer is wound with 7/8- x 1/32-in. brass ribbon on  $\frac{1}{4}$ -in. bakelite supports, with a spacing of 1  $\frac{1}{2}$  in. in the primary and  $\frac{3}{4}$ -in. in the secondary. The primary has three turns and the secondary eight. The secondary slides on a 1-in. hard rubber rod and may be clamped to any desired coupling by a large bakelite knob carrying a threaded stud which passes through a block in the secondary hub.

The leads are of 1-in. Belden copper braid in the primary, and  $\frac{3}{4}$  in. in the secondary circuit. Where they connect to condenser, spark gap, and oscillation transformer, 1-in. copper washers are used.

The radiation ammeter was originally a Roller Smith 0 to 2  $\frac{1}{2}$ -ampere hot-wire instrument with a suitable shunt enabling the meter to indicate up to 5 amperes. While satisfactory, it has since been replaced with a meter having a scale reading to 10 amperes. It is a model 425 Weston thermammeter which came to hand after the

set had been completed. It is of practically the same size so the panel needed no altering.

The switchboard is of  $\frac{3}{4}$ -in. slate with a dull black finish. It is mounted on the front of the frame with machine screws. It carries a single-pole, single-throw knife switch for shorting out the radiation meter when no reading is desired, a radiation ammeter as described above, a double-pole, single-throw switch with 20-ampere cartridge fuses for the main a. c. line, a single-pole, double-throw switch for changing

from  $\frac{1}{4}$  to 1 k. w., and three binding posts for power and key connections.

The wiring for the motor circuit is of No. 14 lead-covered duplex, with the lead covering grounded. Leads from switchboard to transformer are No. 10 rubber-covered wire in  $\frac{1}{2}$ -in. flexible metallic conduit, with suitable condulets at the terminals. The conduit is also grounded.

Such a combination of transmitter and receiver makes an excellent equipment for 200-meter communication.

## The Radio Department

### *A Discussion of Current Topics of Interest to Manufacturers and Experimenters*

**C**OL. W. A. BISHOP, lecturing to the Cadets in one of the American typing schools, said, "Get all you can from what others teach you. When you go on the other side, you will forget it all, and learn for yourselves."

This is applicable as well to the process of developing new devices or methods. The successful man, after learning the principles involved, studies the work of others. Then, putting that aside, he starts on a new course, basing his work on the fundamentals, and guiding his course by the results of other investigators.

The inventor of the linotype machine, for example, studied typesetting methods to learn what was required. Then, instead of making a new sort of composing stick, or working out an improvement in type cases, he envolved a new principle, a system of casting type to order, it might be called.

Altho it is far more difficult, the latter method of inventing is generally more successful than attempts to improve the results of others. Experimenters will increase the net value of their work if they bear this principle in mind.

**T**ELEPHONE jacks and plugs are coming into very wide use. So much so, in fact, that it is time for someone to bring out a less expensive type of plug than those now on the market. If a man pays five dollars for a pair of telephones, and excellent ones can be bought at that price, he does not like to spend nearly three dollars for a plug and jack to connect them.

The fact that the ordinary types have been used for many years, does not mean that a less expensive and equally good type cannot be made. One dollar is enough to pay and the company that markets a plug and jack at this price will find the demand enormous.

Some departure from the usual design will probably be necessary. The great difficulty in making the ordinary

plug is due to the concentric construction of the terminals. This can be overcome by a change in design. If this is done, a different style of jack will be required, but one operating on the same general principles.

Experimenters are rapidly learning that many circuits can be used and operated by changes effected by the insertion or removal of the telephone plug. The A. H. Grebe Company has gone farther than the others in this respect. They not only control the plate circuits of their amplifiers but the filament circuits as well by the plug and jack method.

**T**WO months ago, there appeared an article in EVERYDAY on the standardization of apparatus design. A number of companies wrote, in response, that they were interested in the idea, and would like to be informed regarding any developments.

That is rather characteristic of radio men. The appeal of the article was for ideas, and not simply interest. Perhaps the experimenters can help, for they are the ones to be pleased, ultimately.

Consider the binding post. There are innumerable ways of making connections, but 99 percent of them have outstanding disadvantages. They turn when the thumb nut is tightened, or the thumbnuts are lost, or they do not grip the wires, or do not hold more than one wire securely. Posts which do not have these faults are extremely expensive. Is there no one who can submit a design which will be labelled "OK" by experimenters, and which the manufacturers will not veto as being too difficult to make? The switch, such as is used for inductance control, is another detail that has never been worked out in a satisfactory manner. Someone must have a solution.

Other parts need the same treatment. EVERYDAY would like to publish some of the ideas which its readers must have if they will only submit them.

# A Radio Telephone Operating On Six Volts

*The De Forest Company Calls This a Buzzer Radiophone, Tho the Name Seems Misleading Until You Understand the Set*

**T**HE elimination of the B battery has been the dream of many an experimenter who has gone thru the usual hardships which accompany the use of a high-potential battery for the plate supply of an audion. Tests made on the buzzer radiophone seem to indicate that still another step forward has been made. And there will be many a radio man who will reproach himself for not having thought of it before.

the wavelength of the set. It is interesting to note that ordinary three-element tubes are employed as rectifiers. The grid and plate of each tube are connected together to form one side, while the filament serves as the other.

The grid condenser, on the lower part of the panel, is adjusted for maximum modulation, or the clearest speech. A hot-wire ammeter indicates the radiation.

In operation, after the preliminary

out of the question, this method of supplying plate voltage offers no disadvantages. A high potential can be obtained from the buzzer with a correspondingly heavy plate current, yet only a small storage battery is needed. The weight and space of the buzzer are, of course, much smaller than of a motor-generator.

One of the great objections to radio apparatus on motor boats has been that no current supply was available on board, or that only low-voltage direct current was obtainable from the generating system. With this equipment, however, batteries can be carried aboard readily, or the ship's current can be used to charge the batteries.

For portable work, also, the buzzer radiophone is well adapted, and can be employed under many conditions where other types of equipment would be out of the question.

A suggestion given in connection with this set will be helpful for other portable installations, too; namely, that a heavy spike, driven into the trunk of a green tree, makes an excellent ground for radio apparatus when used in the field.

## CONCRETE RADIO MASTS

Believed to be the highest concrete masts in the world, the towers of the new Japanese stations are 660 feet high. They are being made at Tomicka-cho, where the stations for which they are to be used will operate with the United States. The estimated daily capacity of these stations is 8,000 words each way.

Within the next two years, if all the present plans for commercial radio are carried out, an amount of traffic never dreamed of ten years ago will be handled by the high-powered stations.

## USING VARIOMETERS

Variometers are rapidly increasing in popularity, especially for short wave receivers. Experimenters do not seem to understand, however, that, as a method of varying inductance, the variometer is quite limited, unless the usual proportions are greatly increased.

It is not practical, for example, to replace a tuning condenser by a variometer to give the close adjustments between taps on a coil, unless the taps are taken off at very short intervals.

With the ordinary methods of construction, the variation of inductance obtained does not exceed the inductance of one of the variometer coils.



*No motor-generators or high potential batteries are needed to operate this set*

In a few words, this new set is fitted with a buzzer transformer, operating on 6 volts, which gives a very high voltage on the secondary. The alternating current produced in this way is rectified by means of two tubes, smoothed out thru choke coils and applied to the transmitting tube.

The set is shown in the accompanying illustration. At the top, the tuning inductance is barely visible behind the panel. In the left-hand corner the transmitting tube, marked OSC, is mounted. Two tubes, indicated by RECT, are located on either side of the antenna condenser which controls

adjustments have been made, the switch at the right is pushed up to talk. This connects one battery to the buzzer, which vibrates at a low and steady pitch as long as the transmitter is in use. To listen-in, the switch is put down, stopping the buzzer and changing the antenna and ground to the receiving apparatus.

With two 6-volt storage batteries, this complete set weighs only 60 pounds.

Many advantages of this set will appeal to those who use radio for other than purely experimental work. Under conditions where a motor-generator is



# A New Development in Tuning Inductances

*Designed on a New Principle, the G. A. Standardized Inductances Represent a Distinct Advance in Coil Construction*

By K. H. Stark

**I**T is very doubtful if Faraday or Henry would recognize the inductances now used for radio reception. Many men have contributed to the development of these coils, carrying them thru from the long, single-layer types to the present low resistance, low capacity, concentrated coils.

There are certain factors which must be considered in designing coils for radio receivers. The most important are listed below in the order of their value, looking at the subject from the

The new coils, described in this article, were designed to meet, as fully as possible, the various requirements, with particular reference to efficiency, because radio experimenters are rapidly developing an extreme fastidiousness in the selection of their equipment.

The first problem is to get a maximum inductance from a given length of wire. Decreasing the size of the wire makes the turns per inch larger, and increases the inductance, but it also makes the resistance higher. Wind-

them. On this basis, the attempt was made to put a 2-ft. solenoid in a 1-in. space without sacrificing the electrical efficiency, and gaining the mechanical advantages of a small, self-supporting coil.

How this was done can be seen from the accompanying illustrations. This coil is merely a telescoped solenoid, the sections of which are separated by an air dielectric. This means that, with the turns of each section close together, the inductance per section is

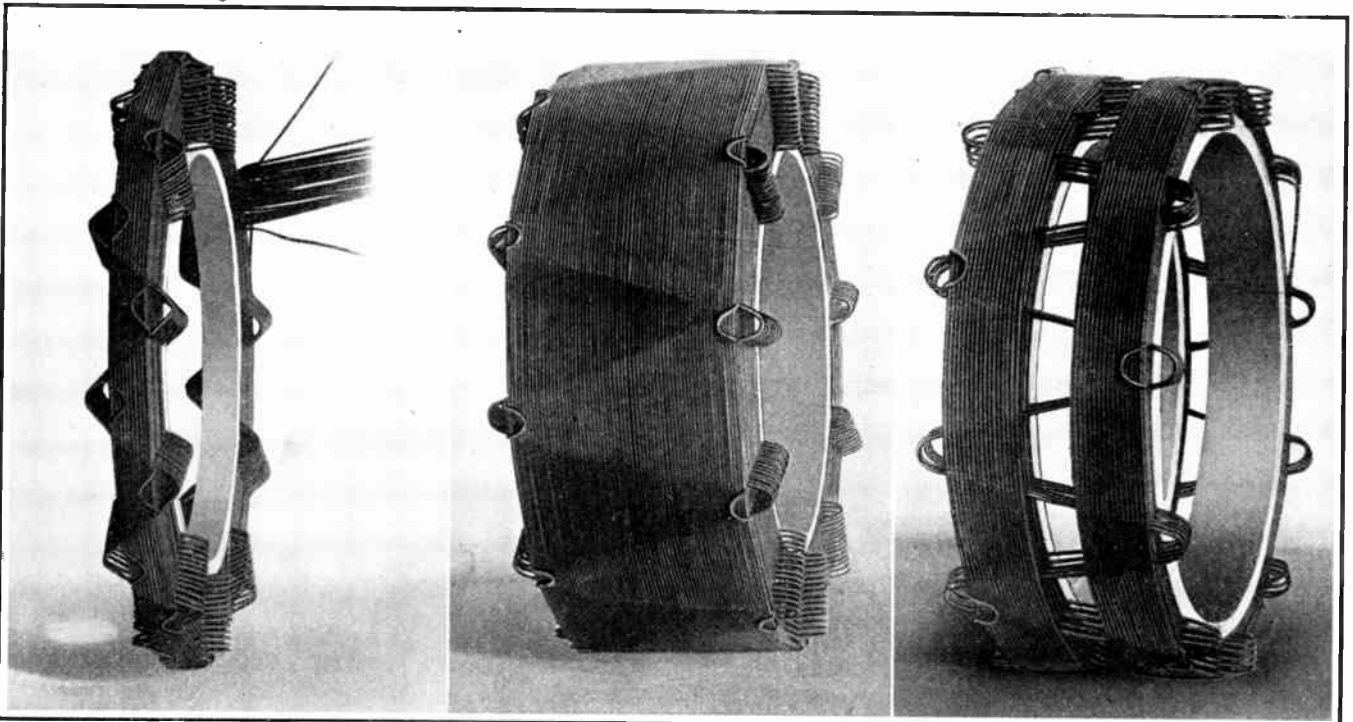

Fig. 1—A coil only 0.2 in. wide, tapped at every layer

Fig. 2—A high inductance coil, not tapped

Fig. 3—This type can be fitted with a shaft to rotate it

point of view of the manufacturer of radio equipment for experimenters.

1. Price.
2. Possibility of quantity production.
3. High frequency resistance.
4. Mechanical dimensions.
5. Distributed capacity.
6. Ease of mounting.
7. Novelty of appearance.

Others, possibly, would put them in a different order. Certainly price and quantity production come first. Then the popularity of a coil will depend upon its efficiency, its adaptability to various uses, and its general appearance.

Thus it can be seen that the development of a new inductance of commercial value is no small problem. In any coil all the factors cannot be met entirely, but an average must be struck.

ing coils in a multilayer form makes the inductance large, and the resistance and capacity as well. Spacing the turns, as is done in the different types of cross-wound coils, brings down the capacity—and the inductance, while the resistance goes up, for a given inductance, because more wire is needed. Another source of loss is due to the insulation and binding varnish. A perfect coil would be one in which the layers are separated entirely by air.

It seems like an affair which is best settled by shaking it up and taking out what comes to the top. Here, however, is a solution.

The G. A. Standardized inductances are a development of the ordinary single layer solenoid, which, in electrical efficiency, is equal to any of the other types, and superior to most of

high. The total inductance, because of the close interlinking of the fields of the sections, is many times greater than that of an equivalent single-layer solenoid. There is practically no capacity, because of the spacing between sections, and because of the low dielectric constant of air. However, since air is a perfect insulator, there is no loss, indicated by an increased high frequency resistance, as in the case of coils wound with paper between the layers, or unspaced coils where the bare wires are separated only by silk or cotton insulation. Moreover, the losses due to varnish are greatly reduced because only the outer surfaces are coated lightly. The crossing of one wire over another is reduced to eleven times per turn, making a further decrease in electrical losses, and also in the possibility of short circuits. This

latter defect is guarded against, too, by using double silk covered wire.

The actual method of winding these coils is as follows:

First the supporting tube is slipped on a mandrel, in the winding machine. Then, by the manipulation of a lever on the machine, two sets of pins, one on each side of the tube, are sprung out, fitting snugly against the ends of the tube. When the end of the wire has been fastened, and the machine started, the mandrel is rotated for one turn, during which time the wire is wound back and forth around the pins. Next, the mandrel is revolved at a higher speed, and one layer of wire wound across the tube, over the cross winding. Subsequent sections are wound

tion is that less space is required when the coil is rotated on a shaft, than when it is swung from a support at the side.

Several ways of mounting the coils are employed. The simplest, when rods are used as supports, is to set a wooden disc inside the tube. Another method is to set two bakelite discs, of a diameter equal to that of the tube, at each end of the tube, and draw them together with machine screws. The discs fit inside the loops of the cross winding. Other means, not ready for publication, are also employed.

THE SELECTION OF INDUCTANCE AND CAPACITY VALUES

ACCOMPANYING this article is a table showing the wavelengths

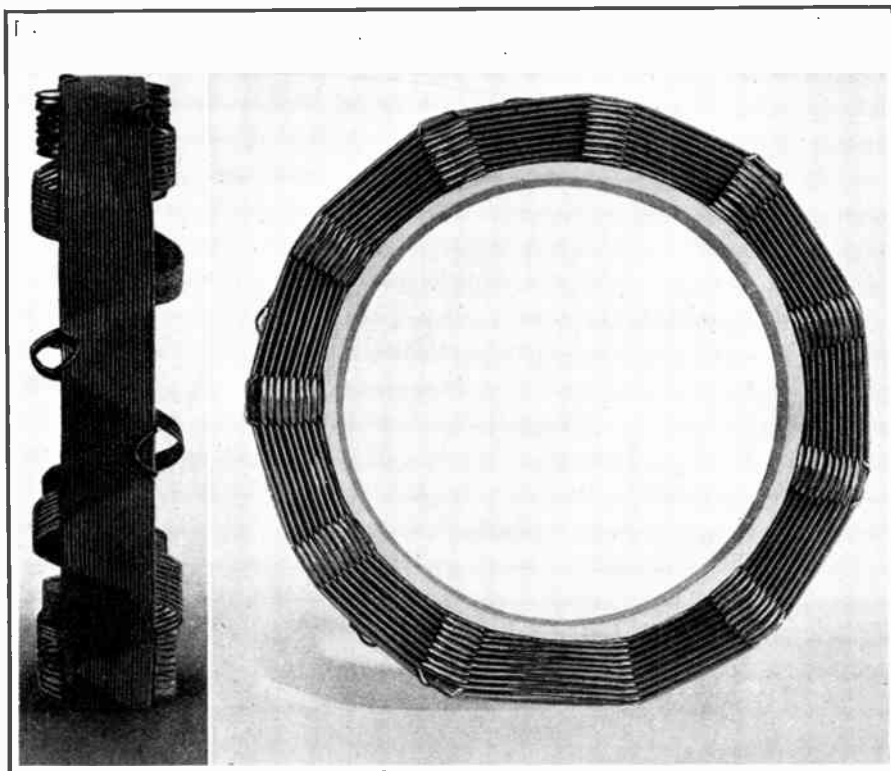

Fig. 4—Front and side views of the "telescoped solenoid" inductance

in a similar manner, first the cross, and then the straight winding. Upon completion, the pins are drawn in, and the coil removed from the mandrel.

The illustrations show the projecting cross wires where they were put around the pins, and make clear the method of spacing the sections by means of the cross windings. Due to the binding effect of each section upon those beneath, these coils possess great mechanical strength. By turning over the loops under the outside section, the turns are effectively prevented from becoming loose. A coat of thin varnish, on the outer surfaces of the coil, completes the work.

In the patent application a modification is described, of the type shown in Fig. 3. This is to take a shaft, so that the coil can be rotated, as in the case of a loose coupler secondary or a variometer. An advantage of the construc-

tion obtained with various capacities from 0.00001 to 0.002 mfd., and inductances of 0.02 to 200 millihenries. This is very useful in determining the inductance and capacity required for a given wavelength.

It should be noted that coils for radio work, unless it is otherwise stated, are rated at their effective inductance, and allowances must be made, in accurate calculations, for the distributed capacity. With these new coils, for all ordinary design purposes, this effect can be disregarded. To determine the distributed capacity of a coil, the following procedure will be found simple, tho for small capacity measurements the instruments must be very accurately calibrated.

1. Connect the coil to a small capacity, about 0.0002 mfd., and measure the wavelength of the circuit.
2. Increase the condenser to about

0.001 mfd., and measure the wavelength.

3. Substitute the wavelength and condenser capacity found in 2 in the equation  $\lambda^2_2 = 3552L C_2$ .

4. Substitute the wavelength and condenser capacity found in 1 in the equation  $\lambda^2_2 = 3552L C_2$ .

5. Subtract the equation in 4 from the equation in 3.

6. Solve for L. This gives the true inductance of the coil.

7. Substitute the value of L in the equation

$$C = \frac{\lambda^2_2}{3552L} - C_2,$$

and solve for C. This gives the value of the distributed capacity.

For example, a coil, connected with a condenser of 0.0002 mfd., gives a wavelength of 7,299 meters. With 0.001 mfd., it gives 13,380 meters. Substituting in 3,

$$195,440,400 = 3553 \times L \times 0.001$$

$$\text{or } 195,440,400 = 3.552L$$

$$\text{Substituting in 4}$$

$$53,245,401 = 3552 \times L \times 0.0002$$

$$\text{or } 53,245,401 = .7104L$$

$$\text{Subtracting 4 from 3}$$

$$195,440,400 = 3.5520L$$

$$53,245,401 = .7104L$$

$$142,194,999 = 2.8416L$$

$$\text{Then } L = 50,000,000 \text{ cms.}$$

To find the distributed capacity, substitute the value of L in 7. Then

$$C = \frac{7,299^2}{3552 \times 50,000,000} - 0.0002,$$

$$C = \frac{53,245,401}{177,600,000,000} - 0.0002,$$

$$C = 0.0003 - 0.0002,$$

or  
 $C = 0.0001,$   
 which is the distributed capacity of the coil.

When inductance is measured by the wavemeter method, the capacity across the inductance being measured should be large. Otherwise, the distributed capacity will make a considerable error in the inductance value found. To show this, let us use the foregoing example. With the coil described above, the wavelength, with a condenser of 0.0002 mfd., was found to be 7,299 meters. The apparent inductance would be

$$L_{app} = \frac{\lambda^2_1}{3552C_1}$$

$$= \frac{7,299^2}{53,245,401}$$

$$= 3552 \times 0.0002$$

$$L_{app} = 75,000,000 \text{ cms.}$$

which shows an error of 50% in the apparent inductance. With the larger capacity value, however,

$$L_{app} = \frac{195,440,400}{3552 \times 0.001}$$

$$L_{app} = 55,000,000 \text{ cms.}$$

which is an error of only 10%.

# Wavelength, Inductance,

C	0.02	0.025	0.03	0.04	0.05	0.06	0.07	0.08	0.09	0.10	0.12	0.14	0.16	0.18	0.20
0.00001	27	30	33	38	42	46	50	53	57	60	65	71	75	80	84
0.00002	38	42	46	53	60	65	71	75	80	84	92	100	107	113	119
0.00003	46	52	57	65	73	80	86	92	98	103	113	122	131	139	146
0.00004	53	60	65	75	84	92	100	107	113	119	131	141	151	160	169
0.00005	60	67	73	84	94	103	112	119	126	133	146	158	169	179	189
0.00006	65	73	80	92	103	113	122	131	139	140	160	173	185	196	207
0.00007	71	79	86	100	112	122	132	141	150	158	173	187	200	212	223
0.00008	75	84	92	107	119	131	141	151	160	169	185	200	213	226	238
0.00009	80	89	98	113	126	139	150	160	170	179	196	212	226	240	253
0.00010	84	94	103	119	133	146	158	169	179	189	207	223	238	253	267
0.00012	92	103	113	131	146	160	173	185	196	207	226	244	261	277	292
0.00014	100	112	122	141	158	173	187	200	212	223	244	264	282	299	315
0.00016	107	119	131	151	169	185	200	213	226	238	261	282	302	320	337
0.00018	113	126	139	160	179	196	212	226	240	253	277	299	320	339	358
0.00020	119	133	146	169	189	207	223	238	253	267	292	315	337	358	377
0.00025	133	149	163	188	211	231	249	267	283	298	326	353	377	400	421
0.00030	146	163	179	206	231	253	273	292	310	326	358	386	413	438	462
0.00040	169	188	206	238	267	292	315	337	358	377	413	446	477	506	533
0.00050	188	211	231	267	298	326	353	377	400	421	462	449	533	565	596
0.00060	206	231	253	292	326	358	386	413	438	462	506	546	584	619	653
0.00070	223	249	273	315	353	386	417	446	473	499	546	590	631	669	705
0.00080	238	267	292	337	377	413	446	477	506	533	584	631	674	715	754
0.00090	253	283	310	358	400	438	473	506	536	565	619	669	715	759	800
0.00100	267	298	326	377	421	462	499	533	565	596	653	705	754	800	843
0.00110	280	313	342	395	442	484	523	559	593	625	685	740	791	839	884
0.00120	292	326	358	413	462	506	546	584	619	653	715	772	826	876	923
0.00130	304	340	372	430	481	526	569	611	645	680	744	804	859	912	961
0.00140	315	353	386	446	499	546	590	631	669	705	772	834	892	946	997
0.00150	326	365	400	462	516	565	611	653	690	730	800	864	923	979	1,032
0.00160	337	377	413	477	533	584	631	674	715	754	826	892	954	1,011	1,062
0.00170	348	389	426	491	550	602	650	695	737	777	851	920	983	1,042	1,099
0.00180	358	400	438	506	565	619	669	715	759	800	876	946	1,011	1,073	1,131
0.00190	367	411	450	520	581	637	687	735	780	822	900	972	1,041	1,102	1,162
0.00200	377	421	462	533	596	653	705	754	800	843	923	997	1,066	1,131	1,192

C	2.5	3.0	4.0	5.0	6.0	7.0	8.0	9.0	10.0	12.0	14.0	16.0	18.0	20.0	25.0
0.00001	298	326	377	421	462	499	533	565	596	653	705	754	800	843	942
0.00002	421	462	533	596	653	705	754	800	843	923	997	1,066	1,131	1,192	1,333
0.00003	516	566	633	730	800	864	923	979	1,032	1,131	1,221	1,306	1,385	1,460	1,632
0.00004	596	653	754	843	923	997	1,066	1,131	1,192	1,306	1,410	1,509	1,599	1,686	1,885
0.00005	663	730	843	942	1,032	1,115	1,192	1,264	1,333	1,460	1,577	1,686	1,788	1,885	2,108
0.00006	730	800	923	1,032	1,131	1,221	1,306	1,385	1,460	1,599	1,727	1,846	1,959	2,065	2,308
0.00007	789	864	997	1,115	1,221	1,320	1,410	1,496	1,577	1,727	1,866	1,995	2,116	2,230	2,493
0.00008	843	923	1,066	1,192	1,306	1,410	1,509	1,599	1,686	1,846	1,995	2,133	2,262	2,384	2,665
0.00009	894	979	1,131	1,264	1,385	1,496	1,599	1,696	1,788	1,959	2,116	2,262	2,399	2,529	2,827
0.00010	942	1,032	1,192	1,333	1,460	1,577	1,686	1,788	1,885	2,065	2,230	2,384	2,529	2,665	2,980
0.00012	1,032	1,131	1,306	1,460	1,599	1,727	1,846	1,959	2,065	2,262	2,443	2,612	2,770	2,920	3,264
0.00014	1,115	1,221	1,410	1,577	1,727	1,846	1,995	2,116	2,230	2,443	2,639	2,821	2,992	3,164	3,526
0.00016	1,192	1,306	1,509	1,686	1,846	1,995	2,133	2,262	2,384	2,612	2,821	3,016	3,199	3,372	3,770
0.00018	1,264	1,385	1,599	1,788	1,959	2,116	2,262	2,399	2,529	2,770	2,992	3,199	3,392	3,576	3,998
0.00020	1,333	1,460	1,686	1,885	2,065	2,230	2,384	2,529	2,665	2,920	3,154	3,372	3,576	3,770	4,214
0.00025	1,490	1,632	1,885	2,108	2,308	2,493	2,665	2,827	2,980	3,264	3,526	3,770	3,998	4,214	4,713
0.00030	1,632	1,788	2,065	2,308	2,529	2,732	2,920	3,097	3,264	3,576	3,863	4,129	4,379	4,617	5,161
0.00040	1,885	2,065	2,384	2,665	2,920	3,154	3,372	3,576	3,770	4,129	4,460	4,768	5,057	5,331	5,960
0.00050	2,108	2,380	2,665	2,980	3,264	3,526	3,770	3,998	4,214	4,617	4,987	5,331	5,654	5,960	6,663
0.00060	2,308	2,529	2,920	3,264	3,578	3,863	4,129	4,379	4,617	5,057	5,462	5,840	6,192	6,529	7,299
0.00070	2,493	2,732	3,154	3,526	3,863	4,172	4,460	4,731	4,987	5,462	5,900	6,306	6,693	7,052	7,885
0.00080	2,665	2,920	3,372	3,770	4,129	4,460	4,768	5,057	5,331	5,840	6,306	6,741	7,152	7,539	8,429
0.00090	2,827	3,097	3,576	4,000	4,379	4,731	5,057	5,364	5,654	6,192	6,693	7,152	7,587	7,996	8,940
0.00100	2,980	3,264	3,770	4,214	4,617	4,987	5,331	5,654	5,960	6,529	7,052	7,539	7,996	8,429	9,423
0.00110	3,125	3,424	3,953	4,420	4,842	5,230	5,591	5,930	6,251	6,848	7,396	7,909	8,386	8,810	9,880
0.00120	3,264	3,576	4,129	4,617	5,057	5,462	5,840	6,192	6,529	7,152	7,724	8,261	8,761	9,233	10,320
0.00130	3,398	3,722	4,298	4,805	5,264	5,685	6,109	6,449	6,796	7,444	8,040	8,594	9,119	9,611	10,750
0.00140	3,526	3,863	4,460	4,987	5,462	5,900	6,306	6,693	7,052	7,724	8,344	8,922	9,459	9,973	11,150
0.00150	3,650	3,998	4,617	5,161	5,654	6,109	6,529	6,902	7,299	7,996	8,637	9,233	9,794	10,320	11,540
0.00160	3,770	4,129	4,768	5,331	5,840	6,306	6,741	7,152	7,539	8,261	8,922	9,536	10,110	10,660	11,920
0.00170	3,885	4,256	4,915	5,495	6,020	6,502	6,949	7,373	7,771	8,511	9,196	9,828	10,420	10,990	12,290
0.00180	3,998	4,379	5,057	5,654	6,192	6,693	7,152	7,587	7,996	8,761	9,459	10,110	10,730	11,310	12,640
0.00190	4,108	4,500	5,196	5,809	6,365	6,872	7,384	7,796	8,215	9,000	9,721	10,410	11,020	11,620	12,990
0.00200	4,214	4,617	5,331	5,960	6,529	7,052	7,539	7,996	8,429	9,230	9,973	10,660	11,310	11,920	13,330

# and Capacity Table

0.25	0.30	0.40	0.50	0.60	0.7	0.8	0.9	1.0	1.2	1.4	1.6	1.8	2.0	C
94	103	119	133	146	158	169	179	189	207	223	238	253	267	0.00001
133	146	169	189	207	223	238	253	267	292	315	337	358	377	0.00002
163	179	207	231	253	273	292	310	326	358	386	413	438	462	0.00003
189	207	238	267	292	315	337	358	377	413	446	477	506	533	0.00004
211	231	267	298	326	353	377	400	421	462	499	533	565	596	0.00005
231	253	292	326	358	386	413	438	462	506	546	584	619	653	0.00006
249	273	315	353	386	417	446	473	499	546	590	631	669	705	0.00007
267	292	337	377	413	446	477	506	533	584	631	674	715	754	0.00008
283	310	358	400	438	473	506	536	565	619	669	715	759	800	0.00009
298	326	377	421	462	499	533	565	596	653	705	754	800	843	0.00010
326	358	413	462	506	546	584	619	653	715	772	826	876	923	0.00012
353	387	446	499	546	590	631	669	705	772	834	892	946	997	0.00014
377	413	477	533	584	631	674	715	754	826	892	954	1,011	1,066	0.00016
400	438	506	565	619	669	715	759	800	876	946	1,011	1,073	1,131	0.00018
421	462	533	596	653	705	754	800	843	923	997	1,066	1,131	1,192	0.00020
471	516	596	666	730	789	843	894	942	1,032	1,115	1,192	1,264	1,333	0.00025
516	566	653	730	800	864	923	979	1,032	1,131	1,221	1,306	1,385	1,460	0.00030
596	653	754	843	923	997	1,066	1,131	1,192	1,306	1,410	1,509	1,599	1,696	0.00040
666	730	843	942	1,032	1,115	1,192	1,264	1,333	1,460	1,577	1,686	1,788	1,885	0.00050
730	800	923	1,032	1,131	1,221	1,306	1,385	1,460	1,599	1,727	1,846	1,959	2,065	0.00060
789	864	997	1,115	1,221	1,320	1,410	1,496	1,577	1,727	1,866	1,995	2,116	2,230	0.00070
843	923	1,066	1,192	1,306	1,410	1,509	1,599	1,686	1,846	1,995	2,133	2,262	2,384	0.00080
894	979	1,131	1,264	1,385	1,496	1,599	1,696	1,788	1,959	2,116	2,262	2,399	2,529	0.00090
942	1,032	1,192	1,333	1,460	1,577	1,686	1,788	1,885	2,065	2,230	2,384	2,529	2,665	0.00100
988	1,083	1,250	1,398	1,531	1,654	1,768	1,875	1,977	2,165	2,339	2,500	2,652	2,795	0.00110
1,032	1,131	1,306	1,460	1,599	1,727	1,846	1,959	2,065	2,262	2,443	2,612	2,770	2,920	0.00120
1,075	1,177	1,359	1,520	1,665	1,798	1,922	2,039	2,149	2,354	2,543	2,718	2,883	3,039	0.00130
1,115	1,221	1,410	1,577	1,727	1,866	1,995	2,116	2,230	2,443	2,639	2,821	2,992	3,154	0.00140
1,154	1,264	1,460	1,632	1,788	1,932	2,065	2,190	2,308	2,529	2,732	2,920	3,097	3,264	0.00150
1,192	1,306	1,509	1,686	1,846	1,995	2,133	2,262	2,384	2,612	2,821	3,016	3,199	3,372	0.00160
1,229	1,346	1,554	1,737	1,904	2,056	2,198	2,332	2,457	2,692	2,908	3,108	3,297	3,475	0.00170
1,264	1,385	1,599	1,788	1,959	2,116	2,262	2,399	2,529	2,770	2,992	3,199	3,392	3,576	0.00180
1,299	1,423	1,643	1,837	2,012	2,174	2,321	2,465	2,598	2,846	3,074	3,286	3,485	3,674	0.00190
1,333	1,460	1,686	1,885	2,065	2,230	2,384	2,529	2,665	2,920	3,154	3,372	3,576	3,770	0.00200
30.0	40.0	50.0	60.0	70.0	80.0	90	100	120	140	160	180	200	C,	
1,032	1,192	1,333	1,460	1,577	1,686	1,788	1,885	2,065	2,230	2,384	2,529	2,665	2,795	0.00001
1,460	1,686	1,885	2,065	2,230	2,384	2,529	2,665	2,920	3,154	3,372	3,576	3,770	3,960	0.00002
1,788	2,065	2,308	2,529	2,732	2,920	3,097	3,264	3,576	3,863	4,129	4,379	4,617	4,843	0.00003
2,065	2,384	2,665	2,920	3,154	3,372	3,576	3,770	4,129	4,460	4,768	5,057	5,331	5,596	0.00004
2,308	2,665	2,980	3,264	3,526	3,770	3,998	4,214	4,617	4,987	5,331	5,654	5,960	6,250	0.00005
2,529	2,920	3,264	3,578	3,862	4,129	4,379	4,617	5,057	5,462	5,840	6,192	6,529	6,850	0.00006
2,732	3,154	3,526	3,863	4,172	4,460	4,731	4,987	5,462	5,900	6,306	6,693	7,052	7,390	0.00007
2,920	3,372	3,770	4,129	4,460	4,768	5,057	5,331	5,840	6,306	6,741	7,152	7,539	7,900	0.00008
3,097	3,576	4,000	4,379	4,731	5,057	5,364	5,654	6,192	6,693	7,152	7,587	7,996	8,380	0.00009
3,264	3,770	4,214	4,617	4,987	5,331	5,654	5,960	6,529	7,052	7,539	7,996	8,429	8,850	0.00010
3,576	4,129	4,617	5,057	5,462	5,840	6,192	6,529	7,152	7,724	8,261	8,761	9,233	9,680	0.00012
3,863	4,460	4,987	5,462	5,900	6,306	6,693	7,052	7,724	8,344	8,922	9,459	9,973	10,460	0.00014
4,129	4,768	5,331	5,840	6,306	6,741	7,152	7,539	8,261	8,922	9,536	10,110	10,660	11,190	0.00016
4,379	4,057	5,654	6,192	6,693	7,152	7,587	7,996	8,761	9,459	10,110	10,730	11,310	11,870	0.00018
4,617	5,331	5,960	6,529	7,052	7,539	7,996	8,429	9,230	9,973	10,660	11,310	11,920	12,510	0.00020
5,161	5,960	6,663	7,299	7,885	8,429	8,940	9,423	10,320	11,150	11,920	12,640	13,330	14,000	0.00025
5,659	6,529	7,299	7,996	8,637	9,233	9,794	10,320	11,310	12,210	13,060	13,850	14,600	15,330	0.00030
6,529	7,539	8,429	9,233	9,973	10,660	11,310	11,920	13,060	14,100	15,090	15,990	16,860	17,700	0.00040
7,299	8,429	9,423	10,320	11,150	11,920	12,640	13,330	14,600	15,770	16,860	17,880	18,850	19,790	0.00050
7,996	9,233	10,320	11,310	12,210	13,060	13,850	14,600	15,990	17,270	18,460	19,590	20,650	21,640	0.00060
8,637	9,973	11,150	12,210	13,200	14,100	14,960	15,770	17,270	18,660	19,950	21,160	22,300	23,380	0.00070
9,233	10,660	11,920	13,060	14,100	15,090	15,990	16,860	18,460	19,950	21,330	22,620	23,840	24,990	0.00080
9,794	11,310	12,640	13,850	14,960	15,990	16,960	17,880	19,590	21,160	22,620	23,990	25,290	26,520	0.00090
10,320	11,920	13,330	14,600	15,770	16,860	17,880	18,850	20,650	22,300	23,840	25,290	26,650	27,950	0.00100
10,830	12,500	13,980	15,310	16,540	17,680	18,760	19,770	21,650	23,390	25,000	26,520	27,950	29,290	0.00010
11,310	13,060	14,600	15,990	17,270	18,460	19,590	20,650	22,620	24,430	26,120	27,700	29,200	30,630	0.00120
11,770	13,590	15,200	16,650	17,980	19,220	20,390	21,490	23,540	25,430	27,120	28,830	30,390	31,890	0.00130
12,210	14,100	15,770	17,270	18,660	19,950	21,160	22,300	24,430	26,390	28,210	29,920	31,540	33,150	0.00140
12,640	14,600	16,320	17,880	19,320	20,650	21,900	23,080	25,290	27,320	29,200	30,970	32,610	34,340	0.00150
13,060	15,090	16,860	18,460	19,950	21,330	22,620	23,840	26,120	28,210	30,160	31,990	33,720	35,560	0.00160
13,460	15,540	17,370	19,040	20,560	21,980	23,320	24,570	26,920	29,080	31,080	32,860	34,750	36,740	0.00180
13,850	15,990	17,880	19,590	21,160	22,620	23,990	25,290	27,700	29,920	31,990	33,720	35,760	37,700	0.00180
14,230	16,430	18,370	20,120	21,740	23,240	24,650	25,980	28,460	30,740	32,860	34,850	36,740	38,630	0.00190
14,600	16,860	18,850	20,650	22,300	23,840	25,290	26,650	29,200	31,540	33,720	35,760	37,700	39,540	0.00200

# The Uni-Control Receiver

*A Set, Built By the Wireless Improvement Company, Which Is Controlled By a Single Adjustment*

**T**HERE is an inherent disadvantage in the usual type of radio receiving apparatus in that, while listening in, only such stations are heard as may be transmitting on the wavelength to which the receiving is tuned. To overcome this difficulty, Mr. Roy E. Thompson of the Wireless Improvement Co. designed the uni-control set described in this article.

As may be implied from the name the uni-control receiver is designed to be operated by the adjustment of a single handle, shown in Fig. 1, at the lower left-hand corner of the panel. For listening in, this handle is continuously revolved by a motor connected thru a worm gear and flexible shaft to the single adjustment. When the motor is started the set is slowly tuned over a range of 300 to 3,000 meters. When a station is heard, the operator merely switches off the motor and makes a close adjustment of the tuning by means of the handle.

This summarizes the operation of the uni-control receiver.

There are several distinct advantages in the use of a set of this type. In the first place, it assures the reception of any call which is transmitted at a wavelength in the range of the receiver. If equipment of this sort were generally

call on a wave which another station, also sending, was not using and the calling operator could depend upon the

receiver are shown in Figs. 2, 3 and 4. Fig. 2 shows the front of the set with panes removed; Fig. 3 is a top view,

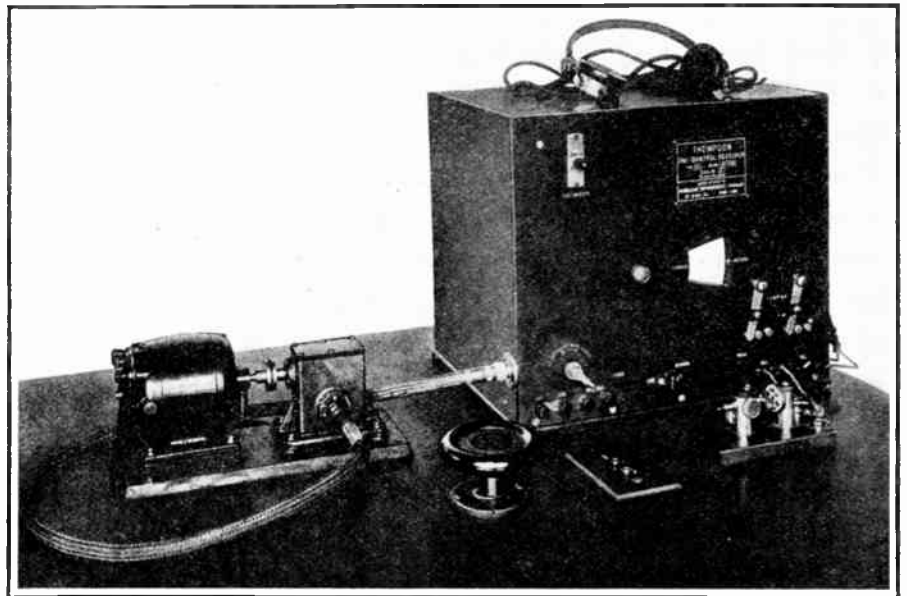

Fig. 1. A complete Uni-Control Receiver installation, with motor switch and speed control

reception of his signals. While it may not be advantageous to reduce the responsibility of the radio operator to too great an extent, it is certain that

and Fig. 4, the front, with the wavelength indicating dial removed.

The circuit employed with the set is of the untuned secondary type. The primary inductance is divided into two sections, one with twenty-six taps brought off at short intervals and the other with nine larger steps. The latter coil is broken by four dead-end switches. A coupling control is provided between the secondary and the primary coils, so that the signal's strength can be varied.

On the shaft which carries the wavelength indicating dial there is a switch which moves over two concentric sets of segments which are connected to the large steps on the inductance. A small sector of the inner circle goes to the variable condenser and on to the small step switch mounted at the rear lower left-hand corner of the sub-panel. Both the condenser and small step switch are continuously rotated as long as the wavelength indicated dial shaft is being turned. The condenser, however, is only used for short wave reception when the switches are in a position for minimum inductance. When this point has been passed—that is, the wavelength increased from the minimum to the maximum value obtainable with the full capacity of the condenser—the inductance is increased by cutting in more turns of the small section. The wavelength is still further increased until the end of the small step

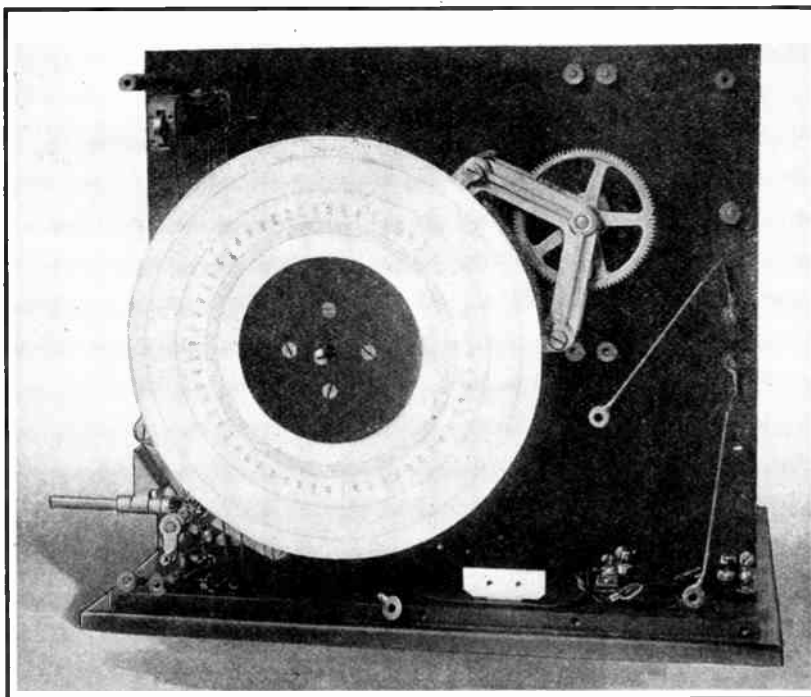

Fig. 2. The main panel removed, showing the arrangement on the sub-panel

adopted, the disadvantage of a single calling wave would be overcome, with the result that interference would be greatly reduced, as a station could

this type of set would increase the effectiveness of an operator inclined to be indifferent in carrying out his duties.

Detailed views of the uni-control re-



switch is reached. At this point it moves on to zero, but the first large step of inductance is cut in. Again the small step switch is rotated until it passes from maximum to minimum

ordinary antenna, as well as electromagnetically, due to the true loop action.

This effect can be overcome, except in extreme cases, by the use of a con-

**TRANSMITTING WITH A LOOP**

The usual sending apparatus can be used with a loop. The primary of the oscillation transformer should be in series with the condenser and spark gap, with the spark coil across the gap. The secondary of the oscillation transformer goes to the terminals of the loop, with a small condenser in one of the leads. This should be adjustable, by some means, for sharp tuning. A satisfactory method is to make up a variable air condenser having a large separation between the plates and heavy insulation. This can be shunted around the fixed condenser.

When an audion transmitter is employed, the loop can be tapped at the middle and connected in a manner similar to that employed for the heterodyne wavemeter, described in the June, 1920, issue of *EVERYDAY ENGINEERING*. Other circuits are shown in "Radio Hook-Ups," by M. B. Sleeper.

Heavy wire is needed for the loop winding. Using two or more wires in parallel has been found satisfactory.

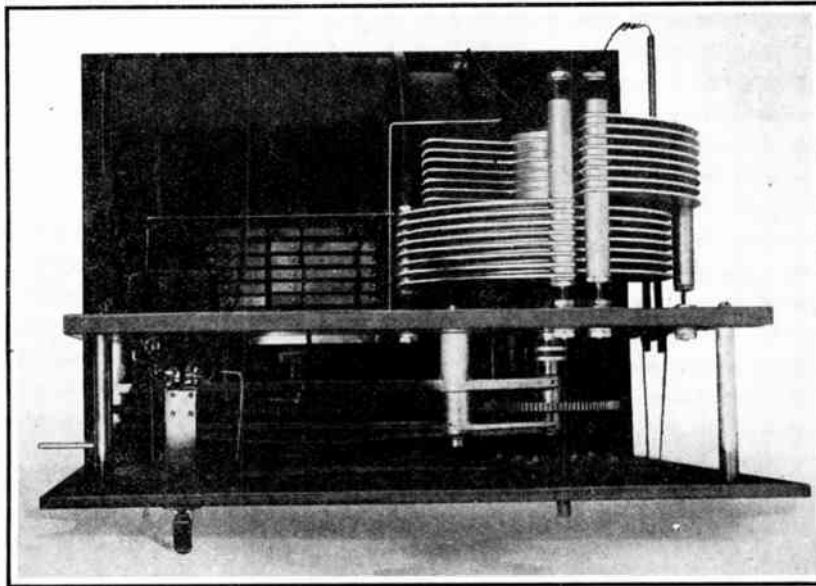

Fig. 3. Looking down on the top of the set, the inductance, dead-end switch, and condenser can be seen

as another large section of the coil is brought into circuit. In this way a continual variation from the low wavelength obtained by the use of the series condenser is slowly accomplished until all of the small steps and all the large steps of inductance are in use.

In Fig. 4 the large gear is clearly shown. At the upper right-hand corner is the gear which rotates the variable condenser. Down in the left-hand corner there is a set of beveled gears, to one of which is secured the flexible shaft from the motor. The other beveled gear is on the shaft which drives, thru a spur gear, the large controlling gear. On this shaft, also, is the switch arm for the small step switch, the points of which are just visible below the beveled gear.

Fig. 3 illustrates the tuning inductance and dead-end switches; it also makes more clear the relation of the driving gears.

Fitted to the shaft carrying the large gear is a dial divided into 300 sections, opposite which a calibration can be made after the receiving is set up with a particular antenna.

The manual control of the wavelength adjustment is rather interesting; by pushing in the handle, the beveled gear is disengaged from that on the flexible shaft, so that the motor is not rotated when the adjustment is controlled by hand.

**LOOP ANTENNAS**

(Continued from page 441)

effect of the loop; that is, signals are received electrostatically, as with an

denser made with two opposite semi-circular plates and one semi-circular movable plate. By turning the shaft, the movable plate is brought over either stationary one. The movable

**THE RADIO REGISTRY**

All kinds of opportunities are coming up in radio work, not only in the United States but in foreign countries as well. Men to fill these positions cannot be located readily, but they will be found through the Radio Register. The fol-

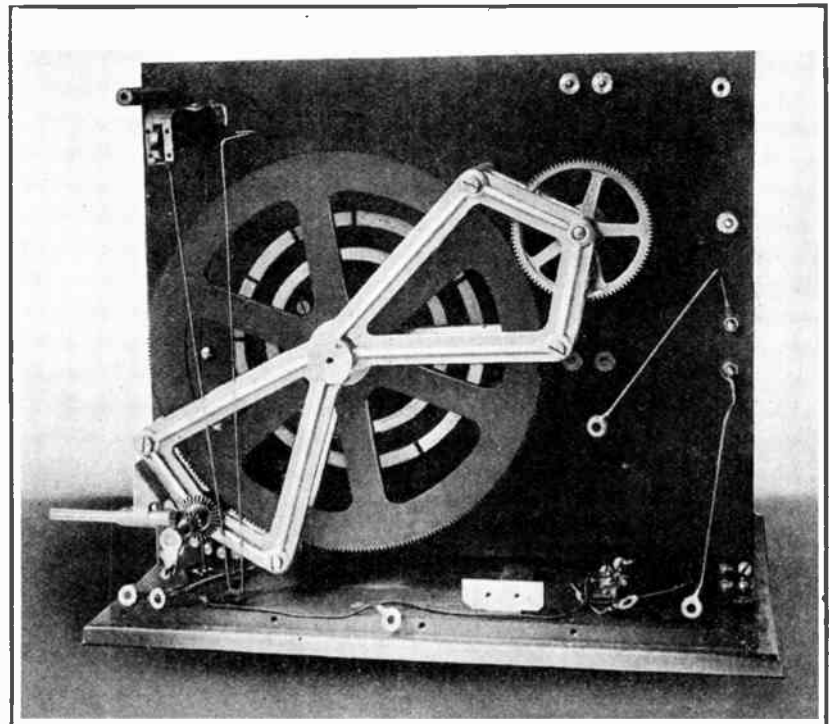

Fig. 4. With the indicating dial removed, the switch segments are visible

plate is connected to the ground, one fixed plate to one terminal of the loop and the other plate to the other loop terminal. By adjusting the position of the movable plate with respect to the fixed ones, the antenna effect and resulting distortion can be balanced out.

lowing information, clearly written, is needed for proper registration:

Name. Address. Engineer or Experimenter. Age. Experience. Special qualifications. Radio station owned, if any.

Address your letters to the Radio Department, *EVERYDAY ENGINEERING*.

# An Interesting Type of Pneumatic Drill

THE immense value of model making to engineering development was probably never better illustrated than in the case of the designing of the very novel and interesting type of pneumatic drill illustrated herewith and described in a recent issue of the *Model Engineer and Electrician* of London. The inventor and patentee is Mr. Charles Desoutter, whose name will be remembered as the constructor of several successful compressed air and CO<sub>2</sub> power driven model aeroplanes just before the war. It was from experience gained in making the small single and two cylinder engines for these models that Mr. Desoutter realized the possibilities in the improvement of the design of the pneumatic drills in general use.

The power of these small motors was remarkable, bearing in mind the small bore of the cylinders and light weight. The same characteristics apply to this new drill. It weighs only one pound, fourteen ounces, and the cylinders, of which there are five, are 7-16th in. bore, yet there is sufficient power to enable one to penetrate a 1/2-in. mild steel plate with a 1/4-in. drill in 28 seconds.

The machine takes the form of a cylinder 4 ins. long by 1 5/8 ins. diameter, from which the chuck protrudes. This is grasped in the palm of the hand and the air is controlled by a press button placed in the head of the drill. Being so light and operated by one hand it proves to be an enormous time and labor saver for all types of constructional work where it is inconvenient or impossible to employ a bench drilling machine or the usual form of breast drill. For the same power, the electric or usual type of pneumatic drills generally require two hands to operate and consequently a second man is often needed on the job to hold and adjust the work being drilled.

The drill is wonderfully efficient where the consumption of air is concerned, taking only four cubic feet per minute at a pressure of 80 lbs. per sq. in. It requires only a small diameter feed tube and is practically vibrationless.

The drill essentially consists of the casing, control, actuating mechanism, bearing and drill chuck. The casing is a steel tube within which the parts are assembled, leaving only the control button, the air connection and the chuck protruding. This casing is knurled for convenience of handling. The control consists of a slide valve actuated by a press button, which has automatic return to the off position.

The actuating mechanism consists of a block of five cylinder of 7-16th in. bore and 1 5/8th in. stroke, disposed

symmetrically with respect to a central axis, and with their bores parallel to one another (see Fig. 1). Within each cylinder is a hollow piston, which has two working faces on the lower end. These fit a specially shaped cam, to be described later. The working faces or slides are cut spirally on a special machine. The design of these pistons is shown in accompanying plate.

The cam, shown at 3, is machined from one piece of steel; incorporated with it is the conical extension for the



Cut showing small size of pneumatic drill

chuck; the central members of the ball bearing; the double spiral working face which produces the rotary motion; a groove, the purpose of which is explained later, and a keyed drive for the valve. The cam is mounted so as to rotate about the central axis, partly inside the recessed portion of the cylinder block. The pistons are operated in succession, and controlled by a distributing valve. It will be seen that on the down stroke (which takes place whilst the pistons are on the left-hand spiral side of the cam) the cam will be given a rotary motion in the usual direction for drills. The pistons on the other, or right-hand, spiral face will be pushed upwards, the exhaust being operated by the distributing valve.

This valve is of the rotary type and is illustrated at 6. It works on the circular valve face in the centre of the cylinder head shown at 11. As each piston reaches the top and then the bottom of its stroke, the valve automatically admits air in the first case, and permits the exhaust to take place when the bottom of the stroke is reached. This occurs with each cylinder in succession. There being five cylinders and pistons, a continuous motion is thus given to the cam. At the bottom of each stroke two small ports are exposed in each cylinder, which allow oil to be blown on to the cam face and ball race. The purpose of the groove previously referred to is to accommodate a pin protruding from the

extension of each piston. If the drill is rotated by hand these pins cause the pistons to follow the contour of the cam. If the pins were not there the pistons would be left at the top of the stroke.

The cylinder heads, valve face, inlet and exhaust ports are all in one piece, shown at 11. As previously mentioned the valve is of the rotary type, thus doing away with the loss of time inseparable from reciprocating valves. The only working parts of this rotary valve are the actual distributing faces, and the wear on these parts is minimized by the special device described later. As explained, the valve works in the cylinder head, and uneven wear is prevented by making it integral with a long stem reaching the length of the cylinder block. The lower end of the center stem is a sliding fit in a sleeve which is keyed to the center of the cam. The drive from the sleeve to the valve stem is through a mechanical lifting device which is balanced by the pressure on the valve. This practically eliminates friction on the valve face and consequent wear.

The cam rotates in a large ball bearing of which it forms the central member. Two large diameter outer races fitted with balls of ample size complete the essentials of the bearing, which hard practical testing has proved to have an ample margin of strength and wearing qualities for the work demanded of it. The thin steel ring shown at 5, is a distance piece clamped between the outer races and forms the only adjustment required. These are in varying thickness by .0005 in. and if the bearing requires adjustment a thinner or thicker one is put in as the case may be. Thus it will be seen that the race can be taken apart and put together again with a minimum of trouble and no risk of mal-adjustment.

The internals of the drill are kept in place by the screwed control valve housing, 9, and the screwed disc, 10. These screw at the top and bottom of the steel casing respectively. The conical end of the cam protrudes from the lower end of the drill and is fitted with a No. 1 Jacob's chuck. This is kept on by a taper-fit and screw.

A very important factor in the efficiency of the drill as far as air consumption is concerned is the arrangement of employing one valve to control five cylinders, thus reducing leakage to a minimum. Loss of air is also prevented by having the valve parts directly on top of each cylinder. Friction on the valve face is reduced to an insignificant amount because a balancing device is provided. Another important point is the fact that the specially shaped cam gives a longer effec-

tive piston stroke than can be produced by a crank.

It will be observed that the form of construction of the cylinder block presents a means of getting the maximum power in the smallest space practicable. As they lie together, the cylinders of course do not occupy anything like the space of a motor of the projecting cylinders type, nor is there any wasted space. The original arrangement of the cylinders gives great strength for a minimum of metal, and the fact that the cylinder heads, valve pockets, and inlet and exhaust parts, are all in one part, together with the employment of hollow

waste air when it is laid down.

Wear on the distributing valve and valve faces is negligible, due both to the balancing device and the combination of metals used. The foregoing description is of one particular machine incorporating the Desoutter Patents in pressure fluid operated drills and other rotary tools. We understand that drills of a larger capacity are now under construction and it is intended to apply the principle to such other tools as pneumatic spanners for motor car erection (with reduction worm drive in the head and reverse), tapping machines, reaming machines, etc.

exists due to the great weight of the water above them.

The diving armor illustrated is made of steel and bronze and is so very heavy that a derrick is required to raise and lower this massive bulk into the water. An eye is provided in the top of the headpiece which engages the hook at the end of the fall line.

With the ordinary form of diving armor the water pressure is resisted by internal air pressure inside of the suit, but as there is a limit to the amount of air pressure that a man can resist, it will be apparent that the depth to which he can go depends entirely upon

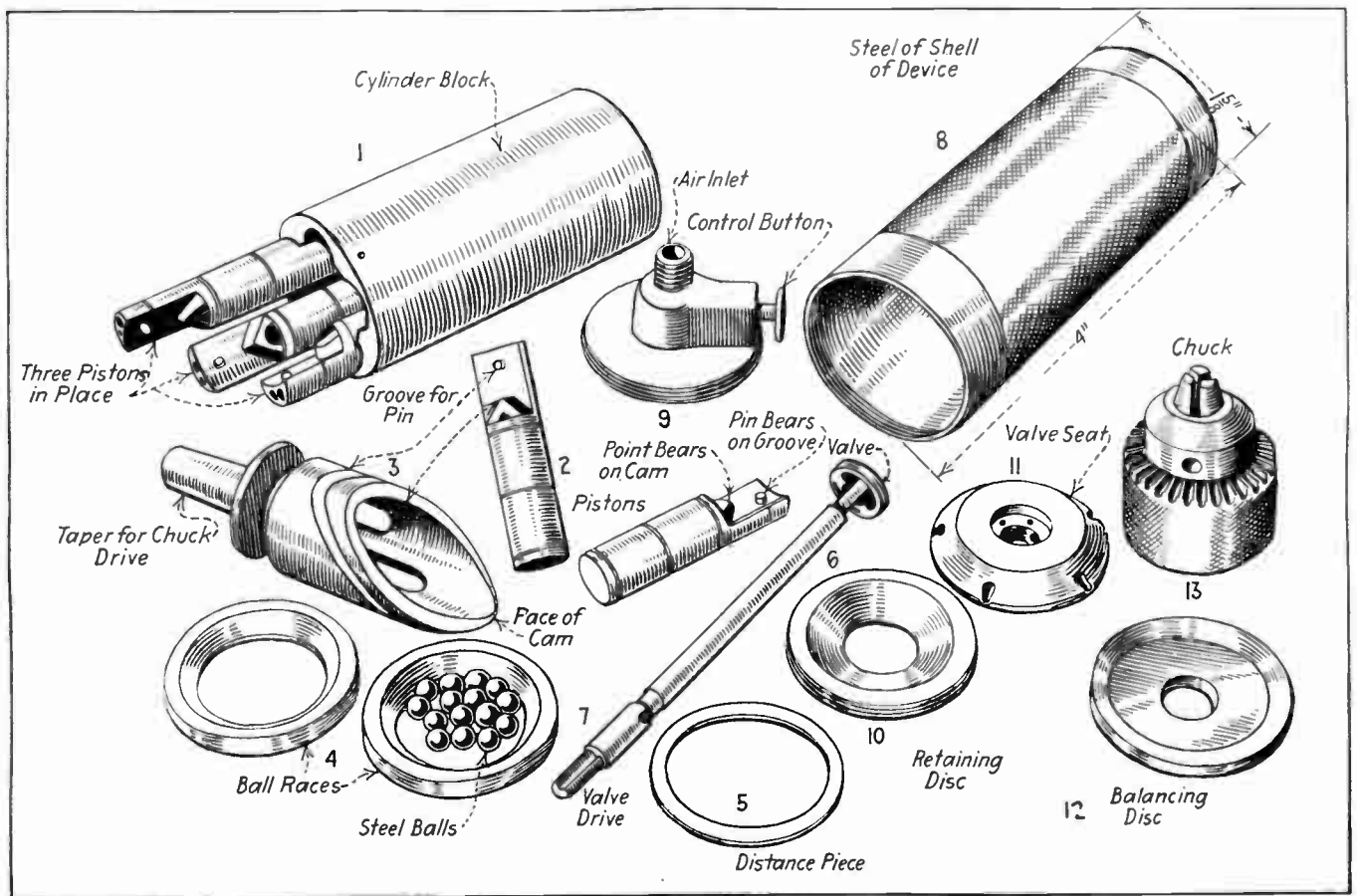

The Desoutter pneumatic drill mechanism shows how experience gained in model-making was applied in developing a practical tool

pistons, contributes to this end. Vibration is practically eliminated by using five instead of an even number of cylinders.

Experience has proved that wear is practically negligible. The first experimental model, after two years' hard use, showed no signs of wear on the cam or piston slides, and the circumferential wear on the pistons was not discernible. The control valve is of the slide valve type, controlled by a push button. There is no spring in the control mechanism. The rod of the press button acts as a piston, working through a small leather gland, the working pressure being used to force this outwards, and thus automatically closing the control valve. The drill cannot therefore continue to work and

### DEEP-SEA DIVING ARMOR

THE ordinary form of diving armor generally used limits the diver's work to depths where the water pressure will not be great enough to crush the diver's body, which receives but little reinforcement from the rubber material of which the ordinary suit is composed, unless it is distended with compressed air. Many ships carrying rich cargoes have been sunk in water that is much too deep to be invaded by a diver in the usual form of armor, because he cannot work under too high air pressure. New forms of diving armor are being constantly invented which give the operator more protection and which enable him to reach ships that are so far down that a terrible water pressure

his powers of resistance to the air pressure. If the diving armor itself is structurally strong and can resist the pressure, the diver can be supplied with air at a very slight pressure, not much above normal, that will permit him to work to much better advantage.

The armor shown was invented with the main object in view of permitting salvaging operations on the numerous vessels that were sunk during the war in water too deep to be reached by ordinary means. Special clamps are provided at the ends of the arm containers which are worked from inside of the armor. These are shaped so that ordinary tools may be held and some work done. At each side of the headpiece, above the breast, are two electric lights which are intended to assist

in illuminating the parts of the vessel on which the diver is to work.

The armpieces and legpieces are movable, special joints being provided for permitting some movement and at the same time to keep out the water. The suit is ribbed in order to increase its stiffness without correspondingly

concentrated formaldehyde solution, commercially known as formalin, to a pint of water. Similarly, the proper concentration of sodium salicylate may be obtained by dissolving three teaspoonfuls of the pure chemical (a powder) to a pint of water.

An ordinary thin-walled drinking

lavishly even on the table linen. The odor is very disagreeable to flies but refreshing to most people.

Geranium, mignonette, heliotrope and white clover are offensive to flies. They especially dislike the odor of honeysuckle and hop blossoms.

According to a French scientist, flies have intense hatred for the color blue. Rooms decorated in blue will help to keep out the flies.

Mix together one tablespoonful of cream, one of ground black pepper and one of brown sugar. This mixture is poisonous to flies. Put in a saucer, darken the room except one window and in that set the saucer.

To clear the house of flies, burn pyrethrum powder. This stupefies the flies, but they must be swept up and burned.

Borax is especially valuable around farms and out of doors. One pound of borax to twelve bushels of manure will be found desirable as a poison without injuring its manurial qualities or farm stock. Scatter the borax over the manure and sprinkle with water.

Lyre, chloride of lime, or copperas (sulphate of iron) dissolved in water, crude carbolic acid, or any kind of disinfectant may be used in vaults.

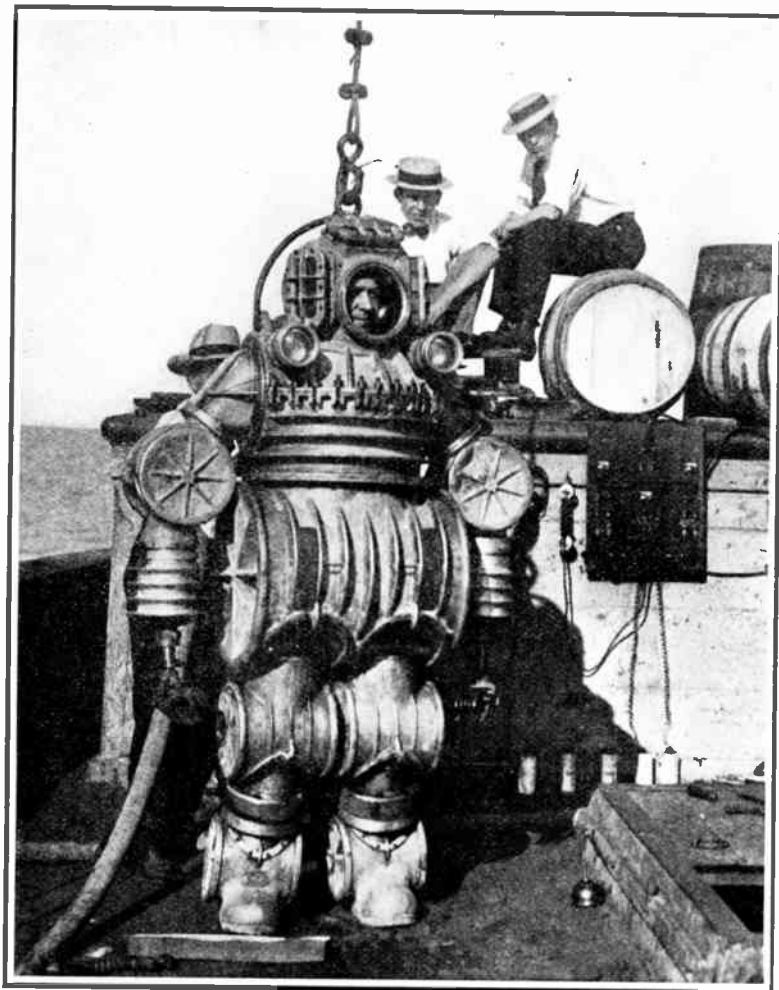

*Diving armor of great strength makes deep-sea diving practical*

increasing the weight. As is usual, a telephone is carried inside of the armor with which the diver communicates with the persons above in charge of the air machinery or other apparatus.

### SOLUTIONS FOR KILLING FLIES

**T**HE United States Government makes the following suggestion for the destruction of house flies: Formaldehyde and sodium salicylate are the two best fly poisons. Both are superior to arsenic. They have their advantages for household use. They are not a poison to children; they are convenient to handle, their dilutions are simple and they attract the flies.

A formaldehyde solution of approximately the correct strength may be made by adding three teaspoonfuls of the

glass is filled or partially filled with the solution. A saucer, or small plate, in which is placed a piece of white blotting paper cut the size of the dish, is put bottom up over the glass. The whole is then quickly inverted, a match placed under the edge of the glass and the container is ready for use. As the solution dries out of the saucer the liquid seal at the edge of the glass is broken and more liquid flows into the lower receptacle. Thus the paper is always kept moist.

#### *Other Simple Preventives*

Any odor pleasing to man is offensive to the fly and vice versa, and will drive them away.

Take five cents worth of oil of lavender, mix it with the same quantity of water, put in a common glass atomizer and spray it around the rooms where flies are. In the dining room spray it

In Milwaukee, advantage was taken of the heavy ice formation in shallow water for driving piles for port improvement. In the place where they were to be driven, the water was so shallow that to float pile drivers into position dredging would have been required, but in winter the water froze, and where it was but a foot in depth, the ground beneath it also froze. Timbers 12 inches square were laid upon the ice and on these the pile drivers and appurtenances were rolled out into position. A hole for each pile was started through the ice and frozen ground by a steam jet, this operation taking about 6 minutes. The piles were then driven with complete success and with perfect alignment. It is considered that the work done took half the time that would have been required with floating derricks. Some of the piles were driven with a batter of 30°.

Among the German "ersatz" or substitution experiments some of the most valuable were those involving the use of steel for copper or brass. Promising results are expected for some uses from nitrogenized iron. If iron is exposed at a proper heat to a current of ammoniacal gas, the hydrogen of the ammonia reduces any oxide of iron which may be present and the nitrogen combines with the iron, producing a metal of distinctive properties which, it is thought, may prove available for steam turbine vanes.

Experiments have been conducted in England with the Brikett regenerative propeller for vessels. Naturally, a propeller imparts a whirl to the water in which it is rotating and the regenerative propeller is a fixed one, which, not rotating, and placed behind the main propeller, takes much of the whirl out of the water, thereby increasing the useful axial thrust of the rotating propeller. The largest vessel it has been tried on so far is of 600 h. p. and it is claimed that as much as 20 per cent of the indicated h. p. may be saved by its use. The regenerative propeller may be somewhat less in diameter than is the main propeller.

**HARDENING FILES AND RASPS**

**T**HE hardening of files is an interesting operation. Files are hardened only, not drawn. They are heated in a lead pot, and in reality there is a certain amount of letting down the temper, for the files are removed from the cooling bath before they are cold. The files before hardening are coated with some preparation to keep the lead from sticking to the teeth. Whiting and wood alcohol is one of the commonest preparations though, due to the present high cost of the latter, water is now used extensively for the mixture—the water dries a little slower. Helpers or boys dip the files in the mixture and stand them up to dry, standing them against heated racks. It is highly important for the safety of the hardeners that there be no trace of moisture on the files when dipped. One of the most efficient arrangements for this work is a conveyor using a wire mesh belt, power driven, with the loading position close to the coating tank and the delivery at the lead pot. During its travel the belt passes through a gas or steam heated oven that is kept at a predetermined heat for the assumed drying of the coating; the speed of travel is also variable if necessary.

The files are suspended in the lead by driving them in handles that in turn are suspended from cross pieces over the pot. The hardener always has a sufficient number ahead to give all a chance to heat thoroughly and slowly. Under the best systems two men work in a team and harden in the neighborhood of 300 dozen medium sized files in a day, one man doing the dipping and the other the straightening. The old fashioned way was for one man to do both these operations, and while he did them well and rapidly the production was far less, due to the extra movements he must make.

The lead, of course, is kept at a red heat. Its surface is covered with pulverized charcoal or other substance to keep it from oxidizing. In connection with the conveyor scheme detailed above, a saving of fuel was discovered in the files being so warm as they were plunged—a file as warm as could be held in the hand would not chill the lead to the extent that one of atmospheric temperature would—the heat required to raise the file to a drying temperature was saved and utilized, making the process one of pre-heating as well as drying.

Salt water is used for quenching the heated files. It is a medium that has not yet been superseded. The brine is made very heavy; salt added to the water until it will absorb no more. This heavy quenching bath cools better than water alone because it does not fly away from the plunged file as does  
(Continued on page 456)



It takes but a moment—to mark the career of your choice, sign your name, clip out and mail.

Yet that simple act has started more than two million men and women toward success.

In city, town and country all over the world men are living contented lives in happy, prosperous homes—because they clipped this coupon.

In every line of business and industry, in shops, stores, offices, factories, in mines and on railroads, men are holding important positions and receiving splendid salaries—because they clipped this coupon.

Clerks have become sales, advertising and business managers, mechanics have become foremen, superintendents and engineers, carpenters have become architects and contractors, men and boys have risen from nothing at all to places of responsibility—because they clipped this coupon.

You have seen it in almost every magazine you have looked at for years. And while you have been passing it by more than ten thousand men and women each month have been making it the first stepping stone to real success in life.

Will you still turn away from opportunity? Can you still go on, putting in your days at the same grind, getting the same pay envelope with the same insufficient sum, trying to keep up the constant fight against a soaring cost of living, when such a little thing can be the means of changing your whole life?

You can have the position you want in the work you like best, a salary that will give you and your family the home, the comforts, the little luxuries you would like them to have. No matter what your age, your occupation, your education, or your means—you can do it!

All we ask is the chance to prove it. That's fair, isn't it? Then mark and mail this coupon. There's no obligation and not a penny of cost. It's a little thing that takes but a moment, but it's the most important thing you can do today. Do it now!

**INTERNATIONAL CORRESPONDENCE SCHOOLS**  
Box 6088-B, SCRANTON, PA.

Explain, without obligating me, how I can qualify for the position, or in the subject, before which I mark X.

- |  |   |
|--|---|
| <input type="checkbox"/> ELECTRICAL ENGINEER       | <input type="checkbox"/> CHEMICAL ENGINEER                            |
| <input type="checkbox"/> Electrician               | <input type="checkbox"/> SALESMANSHIP                                 |
| <input type="checkbox"/> Electric Wiring           | <input type="checkbox"/> ADVERTISING MAN                              |
| <input type="checkbox"/> Electric Lighting         | <input type="checkbox"/> Show Card Writer                             |
| <input type="checkbox"/> Electric Car Running      | <input type="checkbox"/> Outdoor Sign Painter                         |
| <input type="checkbox"/> Heavy Electric Traction   | <input type="checkbox"/> RAILROADER                                   |
| <input type="checkbox"/> Electrical Draftsman      | <input type="checkbox"/> ILLUSTRATOR                                  |
| <input type="checkbox"/> Electric Machine Designer | <input type="checkbox"/> DESIGNER                                     |
| <input type="checkbox"/> Telegraph Expert          | <input type="checkbox"/> BUSINESS MANAGEMENT                          |
| <input type="checkbox"/> Practical Telephony       | <input type="checkbox"/> Private Secretary                            |
| <input type="checkbox"/> MECHANICAL ENGINEER       | <input type="checkbox"/> BOOKKEEPER                                   |
| <input type="checkbox"/> Mechanical Draftsman      | <input type="checkbox"/> Stenographer and Typist                      |
| <input type="checkbox"/> Toolmaker                 | <input type="checkbox"/> Cert. Pub. Accountant                        |
| <input type="checkbox"/> Ship Draftsman            | <input type="checkbox"/> Traffic Management                           |
| <input type="checkbox"/> Machine Shop Practice     | <input type="checkbox"/> Commercial Law                               |
| <input type="checkbox"/> Gas Engineer              | <input type="checkbox"/> GOOD ENGLISH                                 |
| <input type="checkbox"/> CIVIL ENGINEER            | <input type="checkbox"/> Common School Subjects                       |
| <input type="checkbox"/> Surveying and Mapping     | <input type="checkbox"/> CIVIL SERVICE                                |
| <input type="checkbox"/> MINE FOREMAN OR ENGINEER  | <input type="checkbox"/> Railway Mail Clerk                           |
| <input type="checkbox"/> ARCHITECT                 | <input type="checkbox"/> STATIONARY ENGINEER                          |
| <input type="checkbox"/> Architectural Draftsman   | <input type="checkbox"/> Textile Overseer or Supt.                    |
| <input type="checkbox"/> PLUMBING AND HEATING      | <input type="checkbox"/> AGRICULTURE <input type="checkbox"/> Spanish |
| <input type="checkbox"/> Sheet Metal Worker        | <input type="checkbox"/> Tailry <input type="checkbox"/> Italian      |
| <input type="checkbox"/> Navigator                 | <input type="checkbox"/> Automobiles <input type="checkbox"/> Italian |

Name \_\_\_\_\_

Present Occupation \_\_\_\_\_ 7-20-10

Street and No. \_\_\_\_\_

City \_\_\_\_\_ State \_\_\_\_\_

**WIRELESS MANUAL** No. K-12 Ready May 25

We make a charge of 25c for it issuing a coupon receipt redeemable on a purchase of \$5 or more.

You cannot get satisfaction from wireless instruments unless they are absolutely perfect. The slightest imperfection in construction destroys their efficiency. We catalog and offer for sale wireless apparatus of the highest quality, guaranteed to be mechanically and electrically perfect.

Get a copy of our complete wireless catalog and order all of your radio material from one source of supply and save trouble.

Our 180 page combined Manual and Catalog illustrates and accurately describes the uses of standard radio instruments.

**MANHATTAN ELECTRICAL SUPPLY CO., INC.**  
New York—17 Park Place  
Chicago—114 So. Wells St.  
St. Louis—1106 Pine St.  
San Francisco—604 Mission St.



## We're Prompt!

You don't have to wait from three weeks to three months, for the apparatus you order. On everything except apparatus specially constructed to order, you'll have the benefit of



**Shipment Guaranteed Within Twenty-Four Hours**

### Audions and Amplifiers

- Audion Control . . \$22
- Without bulb or B batteries:—
- 1 Step Amplifier
- Without Detector. \$28
- With Detector . . . \$33
- 2 Step Amplifier
- Without Detector. \$45
- With Detector . . . \$50

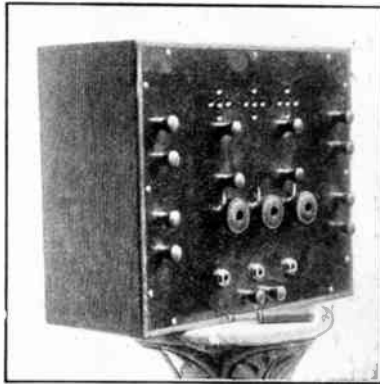

### 10-Ampere Reco Key

Mounted on Italian marble base, with solid silver bar contact points, finished in brushed brass or nickel. Absolutely no side play in this Key. A great big special at \$6.50 postpaid.

If you want a bright, snappy, monthly bulletin that means something; send us 6c in stamps. NEW! An Adaptor for Tubular Bulbs—fits any socket; is rugged—simple and 100 per cent. efficient, and positively vibration-proof—Immediate Delivery **\$1.50**

Radisco Agents for the South  
C. D. BLAIR  
P. O. Box 859  
Richmond, Va.

**The Radio Engineering Co.**  
Baltimore, Md.

614  
North Calvert Street

## ATTENTION AMATEURS

The only practical adapter

Price \$1.50

## RADISCO AGENCY

We make up sets to specifications

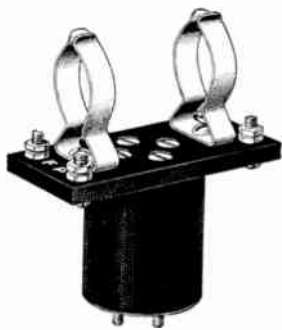

Made by the

**AMATEUR WIRELESS EQUIPMENT CO.**

1390 Prospect Ave., Bronx, N. Y.

Catalogue sent on receipt of 10c, which may be deducted from first order.



Dealers write for proposition

## PACENT ELECTRIC COMPANY

Builders and specialists in Electrical, Radio and Laboratory equipment.

SALES AGENTS

for

DUBILIER CONDENSERS,  
DUO-LATERAL COILS,  
GREBE APPARATUS,  
MAGNAVOX PRODUCTS,  
RAWSON METERS,  
STANDARD VT BATTERIES,  
and other first class equipment.

Telephone Beekman 5810

150 NASSAU STREET, NEW YORK CITY

Recognized as the largest and best



INCORPORATED

Send ten cents for descriptive catalogue to  
Dept. E, 900-902 Penna. Ave., N. W.,  
Washington, D. C.

the lighter medium; it makes better contact with the file just as the liquid lead in the heating pot makes a far better contact than would the coals of a fire.

Files are subject to bending or warping in the cooling bath just as other articles of carbon steel and for the same reasons, though system and quantity production and supervision have eliminated to an extent many of the causes of warping, against which the hardener of a few odd pieces must battle. The straightener has been mentioned and his duties are to correct the worst of the crookedness which occurs after due precautions have been taken in manufacture, delivering a file that is commercially straight.

To the blacksmith, the idea of straightening a piece which is glass hard and not drawn seems an impossibility. It is a trick of the file trade, and so well acquired that the straightener rarely breaks a file. While the file is yet warm, before it entirely ceases to sizzle it is withdrawn and quickly inspected; if a crook shows up, the file is bent the required amount and cooled in a way that will fix this shape permanently. For this purpose the workman uses a flat brush which he dips in a tank of water and applies to the side of the file that he wishes to contract.

Half round files are the most troublesome in hardening because of the unequal area of surface and the back. To overcome this the hardener bends the file slightly before he dips it in the brine, an amount which his experience tells him will be needed to counteract the "draw" of the greater cooling surface on the back. The hardening process leaves a very slight oxidization and there is a little grit left from the coating, all of which must be removed to make a neat appearing file. Stiff brushes are used for some of this work but the great volume of files are cleaned in a steam cleaning device, which shoots a spray of steam, water and a little of the finest sand against the surface of the files.

Rasps are made of a low grade of steel, primarily because steel of higher carbon will not stand the bending and compression which a rasp tooth must without breaking. So low in carbon is this steel that only the thin points of the teeth harden at all, but this is sufficient for the work rasps have to do. They are cut with a round nose chisel—this leaves a half round gouge in the flat surface of the blank and the metal thus thrown up forms the tooth, the end of the chisel making the straight side.

Formerly rasp teeth were cut by hand by the workman, who sat before a bench on which the rasp was strapped down and who used a hand chisel which he drove by a short-handled hammer hav-

(Concluded on page 457)

ing a peculiar bludgeon-shaped head weighing several pounds. The workman spaced the teeth by eye, a wonderfully regular piece of work. The rasp cutting machine now entirely replaces the handwork. In finishing, the tops of the teeth are evened off by a grinding machine, which passes across the surface of the rasp.—*Canadian Blacksmith.*

**ARTIFICIAL GLACIERS IN THE HIMALAYA MOUNTAINS**

**T**O secure a permanent supply of water in the form of a glacial stream, the inhabitants of the Karakorum Range of the Himalayas proceed as follows: A high point in a valley is selected and a species of dam is built across it. Alternate layers of straw, pine tree needles, charcoal and the like are laid across the valley in the summer and just before snow is to be expected a lot of coarse gravel is put on top. The snow which accumulates back of the structure is covered in the early spring with straw and on this a layer of earth is placed. This is kept up for five or six years, and eventually a glacier is formed, which will last for forty years, giving a constant stream all summer long as well as in the winter months, if it is not too cold.

**STRANGE USE FOR SHEARS**

**O**NE of the strange aftermaths of the war is noted in a request recently received by an American shear-maker from a firm in Korea for quotations on shears to be used in cutting the tusks of hippopotamus, with the added injunction from them that, as the shears were to be used while the animals sleep, they must be really sharp ones and capable of quick action. The general conclusion of the man in the street would seem to be that the average maker would prefer to manufacture the shears than be called upon to use them.

**TESTING THERMOMETERS WITH MOLTEN METAL**

**A**NEW thermometer comparator has been devised by the U. S. Bureau of Standards that is electrically heated and that utilizes stirred molten metal to secure uniformity of temperature.

The distribution of temperature is uniform to an infinitely small calculation of 0.1 degree C over a length of approximately 35 centimeters, from a point 10 centimeters below the top of the bath.

The thermometers are encased in thin closed-end steel tubes which are dipped into the molten metal. Scientists have pronounced the newly designed comparator as quite efficient for the testing of thermometers in the interval 300 to 550 degrees C. The Bureau of Standards contemplates frequent use of the machine in the pointing and testing of thermometers by manufacturers.

# AUDIOTRON

*The Original Tubular Vacuum Detector, Amplifier, Oscillator*

**NOW FREE FROM ALL RESTRICTIONS**

*Dealers and Amateurs!—*

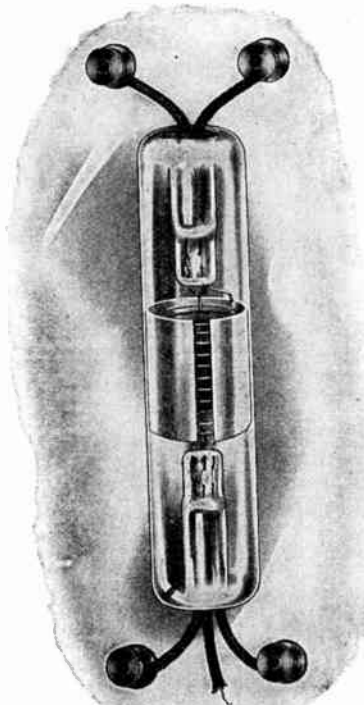

AUDIOTRONS, recognized as the most sensitive detectors ever produced, are now licensed under Fleming Patent No. 803684 to be used only for amateur and experimental uses in radio communication. They are no longer limited to audio frequency and can now be used as detectors and oscillators as well as amplifiers.

All patent questions have been definitely settled. Vacuum tube patents are basic and have been sustained by the Federal Courts. Be sure to get genuine AUDIOTRONS. They outclass any other form of detector and are absolutely free from all legal restrictions or difficulties. These new uses make it even more necessary to insist on the genuine. You can always tell a real AUDIOTRON by the name stamped plainly on the glass.

Insist on the name AUDIOTRON on every tube you purchase. Fully guaranteed by the AUDIOTRON Mfg. Co. (*Read the guaranty below.*)

**Your last chance for an AUDIOTRON or double filament DETECTOR**

Manufacturing reasons make it impossible to continue the present hand made AUDIOTRON. This type has a double filament of special thorium tungsten and the operating life is over 2,000 hours. No special socket is required. The electrical and mechanical dimensions result in a heavy plate current and corresponding signal strength. Plate voltage under 40.

The few thousand that will still be produced, will be of the same standard of excellence that has characterized every AUDIOTRON. Already recognized as the most sensitive detector on the market, these few that still remain, with all restrictions on amateur use lifted, are undoubtedly the greatest opportunity ever offered to amateur radio operators. See your dealer at once or order direct. Be sure to benefit by this last opportunity to secure a hand made super-sensitive double filament AUDIOTRON Detector, Amplifier, Oscillator. **\$6.00 each**

*No increase in price*  
**The AUDIOTRON Exclusive Guaranty:** Each and every AUDIOTRON is guaranteed to arrive in good condition and to prove fully satisfactory. Replacement of unsatisfactory tubes will be made free of charge. The only tube satisfactory enough to stand a guarantee.

**AUDIOTRON MFG. COMPANY**  
*(Successors to the AUDIOTRON Sales Co.)*

**Dealers—**

Get in touch with the AUDIOTRON Mfg. Co. at once. We will give you full information about settlement of all patent difficulties. *You will also be interested in our new proposition for wide awake dealers.*

After the present supply is exhausted, new types of AUDIOTRON, manufactured entirely by machinery, will be offered for sale. Our extensive advertising during the Fall will establish definitely the superiority of the AUDIOTRON and will create new sales for you. Be sure to take advantage of our full co-operation at once. Prepare to cash in on the AUDIOTRON reputation, established since 1915.

*Write us today for full details.*

Dept. V Lick Building  
San Francisco, California

**MAKE YOUR OWN REGENERATIVE RECEIVER USE WILCOX VARIOMETER PARTS**

SET NO. ONE contains carefully turned wooden parts as illustrated.

Price \$2.50 Postpaid

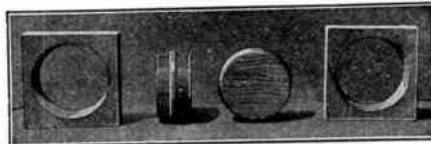

SET NO. TWO contains all parts for variometer including a 3" dial.

Price \$5.00 Postpaid

**THE WILCOX LABORATORIES, - - LANSING, MICH.**

**ALL READERS OF EVERYDAY ENGINEERING MAGAZINE KNOW THE REAL WORTH OF THE DISTINCTIVE RADIO ARTICLES WE PUBLISH. WHY NOT TELL OTHERS WHO MAY NOT BE FAMILIAR WITH THEM?**

# RADIO Mail Order Service

Our claim of "Personal Service to the Consumer" has been more than upheld and we have pleased our many clients by our prompt and courteous attention to their wants.

Our early success along these lines, has prompted us to establish a Mail Order Department, so that out-of-town Radio Men can realize and feel the strength of our service and know that when they order a piece of apparatus they can get it at once and not have to wait until it is manufactured or otherwise secured. We carry a complete stock and list some of the more important instruments below:

### AUDION CONTROL PANELS

Radio Craft detector unit	\$15.00
Radio Craft 2 step amplifier	50.00
Radio Craft detector and 2 step amplifier	70.00
RORA Grebe detector unit	11.00
RORH Grebe detector unit with batteries	17.00
P 400 De Forest Unit	12.00
P 401 De Forest Unit, with oak finished cabinet	14.75
P 402 De Forest Unit with 40 Volt "B" Battery	22.00
P 500 De Forest Audion, Ultra Audion, complete with 40 V. "B" Battery	25.00

### DETECTORS (Crystal)

RPDB Grebe Single	\$2.75
D101 De Forest with crystal	2.80
AMCO Crystal Detector	1.75
Tested galena crystals mounted ready for use	.25

### GRIDLEAKS

Mareoni complete with holder and leak	\$1.00
ROCA Grebe Condenser and leak	1.60

### LOOSE COUPLERS

Arnold 3000 meter loose coupler	\$22.50
CE P673 3000 meter coupler	14.00
Signal No. R21 3000 meter coupler	18.50

### OSCILLATION TRANSFORMERS

International TXL-100A	\$16.75
Signal R13	16.00

### ANTENNA SWITCHES

463 Murdock switch stands up to 1 K.W.	\$4.50
F658 Clapp Eastham, three pole with bakelite antenna post	12.50

### AMPLIFIERS

RORE Grebe single step audio frequency amplifier	\$23.00
RORJ Grebe 2 step amplifier with cam switch control	45.00
RORG Grebe detector and one step amplifier	43.00
RORD Grebe detector and two step amplifier	65.00
Radio Craft Co. two step amplifier	50.00
Radio Craft Co. detector and two step amplifier	70.00
P200 De Forest two step amplifier with "B" Battery	70.50

### HONEY COMB COILS

L. 25	\$1.40	L. 100	\$1.70	L. 300	\$2.10	L. 750	\$2.80
35	1.45	150	1.80	400	2.25	1000	3.00
50	1.52	200	1.90	500	2.40	1250	3.35
75	1.60	250	2.00	600	2.65	1500	3.60

Instruments and parts listed above will be sent postpaid to any part of the United States.

Our word of honor to you is our guarantee. Let us prove it.

## CONTINENTAL RADIO AND ELECTRIC CORP.

J. DI BLASI, Secretary  
Dept. F-6

6 WARREN STREET

J. STANTLEY, Treasurer  
NEW YORK

### BUZZERS

55 Mesco Buzzer	\$2.25
Century Buzzer	2.25
251 Nickelplated	.80

### CONDENSERS

General Radio 182A	\$12.00
C. V. 500 De Forest	6.25
366 Murdock	4.75
367 Murdock	4.75
368 Murdock	3.75
F800 Clapp Eastham	7.50
F800 A Clapp Eastham	9.50

### SOCKETS

156 General Radio	\$1.75
350 Murdock	1.00
S.I. Radio Service	1.20
R300 De Forest	1.50

### HOT WIRE AMMETERS

General Radio No. 127 0-1 or 0-2½ Amp. peres	\$5.00
Roller Smith 0-2½ Amperes	7.00
Extra Shunts .05 Amp	.75

### "B" BATTERIES

766 Amer. Eveready 22½ V. 10 Amp.	\$3.50
7623 } Standard 22½ V.	1.35
7625 } "B" Batteries	2.40
7650 } Variable	3.25
9280 Cyclone 22½ Volts 5 Amp.	1.00
9281 Cyclone 22½ V. 10 Amp.	2.00

### AMPLIFYING TRANSFORMERS

Acme—specially mounted	\$5.00
Acme—unmounted	4.50
Federal 226V	7.50

### DUO LATERAL COILS

U. S.	\$ .90
25	1.00
35	1.10
50	1.20
75	1.30
100	1.40
150	1.50
200	1.60
250	1.80
300	2.00
400	2.20
500	2.50
600	2.70
750	2.90
1000	3.50
1250	3.90
1500	4.00

## MAKING PAINT LOOK LIKE ENAMEL

To make white paint look like enamel; take a piece of caustic soda, the size of marble and dissolve thoroughly in half a wineglassful of spirits of turpentine, and add this to a 2-lb. tin of white zinc paint; stir well, and it is ready for use. When dry, it will be found to have a glossy surface which almost equals enamel.

## COMPARATIVE VALUE OF TIMBER CUT FROM LIVE AND DEAD TREES

PREJUDICE exists in certain quarters against the use of timber cut from dead trees, and some purchase specifications insist that only timber cut from live trees will be acceptable. As a matter of fact when sound dead trees are sawed into lumber, and the weathered or charred outside is cut away, there is no method known to the Forest Products Laboratory by which the lumber can be distinguished from that cut from live trees, except that the lumber from dead trees may be partly seasoned when sawed.

All the information available at the laboratory indicates that timber cut from insect or fire-killed trees is just as good for any structural purpose as that cut from live trees of similar quality, providing the wood has not been subsequently injured by decay or further insect attack. If a tree stands on the stump too long after it is killed, the sapwood is likely to become decayed or badly infested by wood-boring insects; and in time the heartwood also will be similarly affected. The same thing is true of logs cut from live trees and not properly cared for. Until the wood becomes affected by these destructive agents, dead tree wood should be just as strong and just as durable as sound live tree wood.

In considering the subject it may be useful to remember that the heartwood of a living tree is entirely dead, and in the sapwood only a comparatively few cells are living. Most of the wood cut from trees is dead, therefore, regardless of whether the tree itself is living or not. Such being the case, purchase specifications, instead of providing that material must not be from dead trees, should state that material showing evidence of decay or insect infestation exceeding a specified limit will not be accepted.

## EASY METHOD OF CLEANING A CLOCK

WHEN a clock stops it is a mistake to suppose that it must at once be taken to the workshop for repairs. In most cases clocks cease running because of the accumulation of dust particles which clog the bearings. It is not even needful to take



No. 7623—Price \$1.35

## Ask Your Dealer for these "Standard Products"



Miniature Jack and Plug—Price \$1.50 Per Dozen

**RICHTER & BYRNE, Manufacturers**

198 Roebling St., Brooklyn, N. Y.

Pacnet Electric Co., Inc., Sole Eastern Agents  
150 Nassau St., New York, N. Y.

Should you know of a worthy young man desirous of obtaining a good technical education and making a good future for himself refer him to our announcement on page 474 of this number.

Please mention EVERYDAY ENGINEERING MAGAZINE

the clock to pieces to clean it if a simple plan outlined in the *Scientific American* is followed which will be found to work very well. Soak a piece of cotton wool in kerosene and place this in a small saucer, a canister lid, or anything similar. Then put this in the case of the clock under the works. Close up, and at the end of twenty-four hours, examine the cotton wool. It will be found to be covered with black specks; these are the dust particles brought down by the fumes of the kerosene. Wind the clock up and it will start away again. Where the works of the clock are in an enclosed case a few drops of kerosene should be poured through the small hole which is present in the metal covering. Turn the clock about a while so that the kerosene is distributed and after an interval, it is extremely likely that the works will commence their normal operations again.

**A NON-REMOVABLE SCREW**

A SIMPLE suggestion is given in the cut for holding a screw in a place inaccessible for the hand. The screw is stuck through a piece of cardboard, such as a strip of a visiting card, and held thus in any corner or other awkward place; it is started with a screw-driver, and the instant it has taken

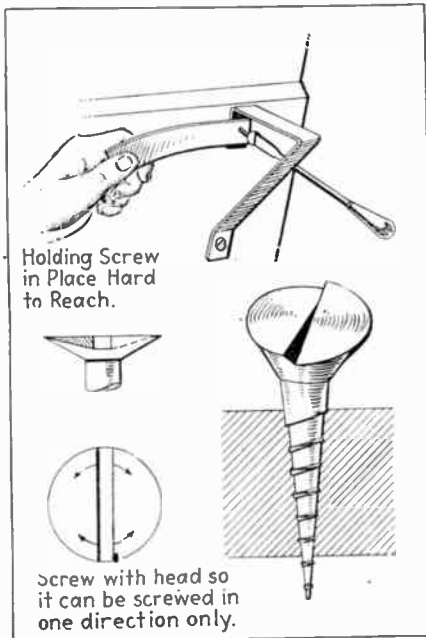

A simple method of starting a screw shown in upper illustration and a non-removable screw depicted below it

hold the paper is pulled away and the screw is driven home by turning it as usual. Another clever idea is shown in the next cuts, it is a screw which cannot be unscrewed. The slot is filed away, as shown, so that the screw-driver can only take hold in one direction, as shown, this direction is the driving one. An attempt to withdraw it will fail, because the screw-driver will slip around, as it evidently cannot get any grip on the angular faces.

# RADIO PROGRESS

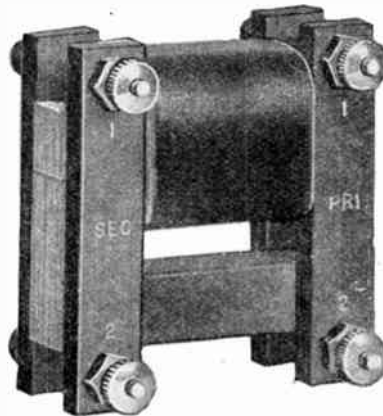

Progress in Radio means the efficient elimination of unnecessary, old and inefficient apparatus and in producing instruments full of life and vigor, quality, workmanship and service; something necessary to the modern station of today; something that is an improvement over the old methods: —the

**A. R. Co.**

**Amplifying Transformer**

is distinctly a step forward, a step toward the goal of efficiency. In designing this piece of apparatus, particular reference was given to the correct ratio of impedance and turns between primary and secondary.

Another feature which makes this transformer a desirable piece of apparatus, is the simple but very effective

mounting of bakelite strips, supporting the laminated closed core and coil, which allow for quick mounting in case or on panel.

The primary and secondary leads are indicated by engraving on the bakelite mounting strips.

The price does not do justice to the reliability and high service quality of this product.

**A-4 Amplifying Transformer, list price \$5.00**

does not include carrying charges on one pound or duty paid for use in Canada. RADISCO AGENTS carry only apparatus of proven merit. Look for the Radisco trade mark on all parts you buy and be sure of getting efficient apparatus. Below are listed a few of the reliable firms who carry Radisco products; A. R. Co. Amplifying Transformers and are our agents for all other standard apparatus of merit.

**COMMUNICATE YOUR WANTS TO THEM**

- ALBANY, N. Y.**  
E. L. Long,  
21 Magnolia Terrace.
- ATLANTIC CITY, N. J.**  
Independent Radio Supply Co.,  
118 South New Jersey Ave.
- BALTIMORE, MD.**  
Radio Engineering Co.,  
614 North Calvert St.
- BEINVILLE, QUEBEC, CAN.**  
Canadian Radio Mfg. Co.
- BOSTON, MASS.**  
Atlantic Radio Co.,  
88 Broad Street.
- BROOKLYN, N. Y.**  
Kelly & Phillips Electric Co.,  
312 Flatbush Avenue.
- BRONX, NEW YORK**  
Amateur Wireless Equipment Co.,  
1390 Prospect Ave.
- CHICAGO, ILL.**  
Chicago Radio Laboratories,  
1316 Carmen Avenue.
- EUREKA, ILLINOIS**  
Klaus Radio Co.
- KANSAS CITY, MO.**  
McCreary Radio Supply,  
Fourth and Delaware Sts.
- LOS ANGELES, CALIF.**  
The Wireless Shop,  
511 West Washington St.
- MONTREAL, CAN.**  
J. B. Miller,  
1600 Hutchison St.
- McKEESPORT, PA.**  
K. & L. Electric Co.,  
427 Olive Street.
- NEW ORLEANS, LA.**  
L. A. Rose,  
121 Camp Street.
- NEWARK, N. J.**  
A. H. Corwin & Co.,  
4 West Park Street.
- NEWCASTLE, PA.**  
Pennsylvania Wireless Mfg. Co.,  
507 Florence Ave. "8HA"
- PHILADELPHIA, PA.**  
Philadelphia School of Wireless  
Telegraphy,  
Broad and Cherry Streets.
- PROVIDENCE, R. I.,**  
Rhode Island Elec. Equip. Co.,  
45 Washington Street.
- PITTSBURG, PA.**  
Radio Electric Co.,  
3807 Fifth Avenue.
- SEATTLE, WASH.**  
Northwest Radio Service Co.,  
609 Fourth Avenue.
- SCRANTON, PA.**  
Shotton Radio Mfg. Co.,  
P. O. Box 3  
Branch 8 Kingsbury St.,  
Jamestown, N. Y.
- SPRINGFIELD, MASS.**  
Electric Service Co.,  
585 Armory Street.
- ST. LOUIS, MO.**  
The Benwood Specialty Co.,  
3424 Olive Street.
- TORONTO, ONT., CAN.,**  
The Vimy Supply Co.,  
585 College Street.
- WASHINGTON, D. C.**  
National Radio Supply Co.,  
808 9th St., N. W.
- WICHITA, KAN.**  
The Cosradio Co.,  
1725 Fairmount Ave.

Responsible Dealers: Write for interesting sales proposition on Radisco apparatus

If none of the above agencies are in your vicinity, communicate with  
**RADIO DISTRIBUTING COMPANY : Newark, New Jersey**

# RADIO APPARATUS

Distributors of reliable Radio apparatus for experimenters in every branch of the Radio field!



## Honey-Comb Coils

LITZENDRAHT WIRE. (While they last.)

LL-75	330-1030 meters	\$1.60
LL-100	450-1460 "	\$1.70
LL-150	660-2200 "	\$2.00
LL-200	930-2850 "	\$2.10
LL-250	1300-4000 "	\$2.30
LL-300	1550-4800 "	\$2.50
LL-400	2050-6300 "	\$2.80
LL-600	4000-12000 "	\$3.00
LL-750	5000-15000 "	\$3.20
LL-1000	6200-19000 "	\$3.50
LL-1250	7000-21000 "	\$3.90

Note:—These are the genuine DeForest Iltz coils.

## Transmitting Condensers

(Dubilier)

Type	Watts	Cap	Price
D-100	250	.007	\$19.00
D-101	500	.007	\$30.00
D-102	1000	.007	\$45.00
D-103	1000 Spec.	.007	\$50.00
D-150	For C. W. or spark coil transmitters, .0024 MF., 8000 volts		\$ 5.00

## F. D. Pitts Co. Boston, Mass. Transmitting Transformers

(New Type Acme)

Acme	Watt	mounted	Price
"	250	unmounted	\$16.00
"	250	unmounted	\$13.00
"	500	mounted	\$22.00
"	500	unmounted	\$18.00
"	1000	mounted	\$33.00
"	1000	unmounted	\$28.00

## F. D. Pitts Co. Boston, Mass. Continuous Wave, Power Transformers

(For Wireless Telephone)

Acme	Watt	C. W. Power trans.	Price
"	200	unmounted	\$16.00
"	200	C. W. Power trans. mounted	\$20.00
"	50	C. W. Power trans. mounted	\$15.00
"	50	C. W. Power trans. unmounted	\$12.00

## F. D. Pitts Co. Boston, Mass. Modulation Transformers

(For Wireless Telephone)

Acme	A-3	unmounted	Price
"	A-3	semi-mounted	\$5.00
"	A-3	mounted	\$7.00

## F. D. Pitts Co. Boston, Mass. Quenched Gaps

Amrad	G-1	1/2 K. W. type	Price
"	G-2	1/4 K. W. type	\$18.85
"	G-3	1/4 K. W. type	\$13.50

## F. D. Pitts Co. Boston, Mass.

Important! Every article sent to any part of the U. S. A. Postage prepaid. We want your business. Send 6 cents in stamps for new catalog.

**F. D. PITTS CO., Inc.**  
12 Park Square Dept. F.  
BOSTON, MASS., U. S. A.

# Indicating QUALITY



## The Corwin Indicating Dial

recognized by Radio Men as a popular and needy addition to any set, has been further improved and now comes in two sizes, three inches and three and seven-eighth inches in diameter. This larger dial (3 7/8 in.) fills the general demand for an indicator to fit the standard one-quarter inch shaft; quality and workmanship better than ever.

3 in. dial only, 75c.  
With knob \$1.30  
3 7/8 in. dial only, \$1.00  
With knob \$1.70  
Sent postpaid anywhere.

## For sale at all Radisco Agencies

Ten cents brings our latest catalog to you, describing the above dial and all standard radio apparatus.

**A. H. CORWIN & CO.**  
Dept. F5, 4 West Park Street  
NEWARK, N. J.

## ADJUSTING SPRING DIES

A READER has had difficulty in adjusting spring dies. That is to say, from his description, he tightened up only one of the adjusting screws and so broke the die. He assumes that the adjusting screws should be only tightened up sufficiently to hold the die in collet or stock. There is, however, considerably more in the matter than this, and perhaps a note on how to adjust such dies will be of help to not a few.

There are several types of circular die capable of a fine adjustment, of which the most general is the spring die. This type of die is not an adjustable die so-called. An adjustable die is a spring die having a self-contained adjustment which is generally the subject of a patent. These usually are made so that, when free of adjustment, they spring to under size, and have, therefore, some kind of grub screw, set screw, or bolt, which opens them out to size and maintains them at that size. The device is part of the die. To use such dies it is only necessary to fasten them in a collet, stock, or even a chuck, which in all cases prevents them springing open further under cut, and they can then be removed from the holder and put back again, with the assurance that they will cut to the set size again without any readjustment. This is because they cannot be closed in any further on account of the locking action of their self-contained adjustment.

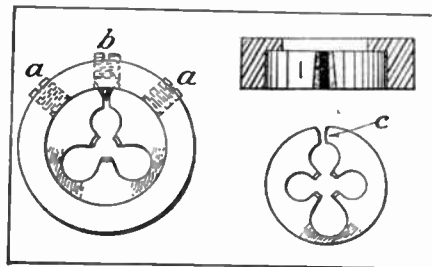

Fig. 1. Diagram showing method of adjusting spring dies

The spring die relies for its means of adjustment on several screws (usually three), which are part of the holder and may be therefore part of a collet, or stock. It is one of these which is under consideration. Fig. 1 is a sketch showing this kind of adjustment wherein, at the top, a section of the collet, stock, or other kind of holder is given, in which the die is shown in edge elevation. The centre view is on the face of a spring die, which is in its holder. This die has three cutting edges, whereas the view at the bottom shows a similar die having four cutting edges, to which the same particulars as to adjustment apply. These dies are made split, as at C in the bottom view, and are hardened and tempered all over to a degree necessary

(Continued on page 462)

# "POROX"

"Trade Mark"

High grade Batteries made up in single transparent Celluloid and Pyralin cells for model and radio work.

Special Batteries made to order also duplicating of foreign batteries.

Prices on request.  
**ALBERT MULLER**  
8758 Queens Boulevard  
Jamaica, Long Island, N. Y.



# THE G. A. TIME RECEIVER

Has a wave length range from 200 to 2500 Meters

A complete portable crystal receiver furnished in a satin Flemish oak-finished cabinet, with hinged cover, snap catch and carrying handle.

Very sharp tuning for a set of this type is obtained on all wavelengths by using a single layer solenoid type inductance with taps divided to eliminate dead end effects and yet secure selectivity. A nifty universal adjusted detector with a standard Army-Navy type Arlington tested galena crystal puts the signals in the head set with the highest intensity and a permanency of adjustment that is appreciated. A hynote buzzer with push allows detector setting to be easily obtained when set is used in the field. Additional binding posts for a key incorporates the advantage of buzzer code practice. A set that comes to you complete in itself and with materials for a G. A. standardized long range antenna as well as a pair of 2,000-ohm Murdock No. 55 Telephones for

**\$25.00**

SEND 3c STAMP FOR G. A. BULLETIN OF RADIO AND MODEL SUPPLIES

BUY YOUR  
SUPPLIES AT  
THE G. A.  
STORE



OPEN UNTIL  
NINE O'CLOCK  
EVERY  
EVENING



Shipping Weight, 10 lbs.

THE GENERAL APPARATUS COMPANY  
4310-A BROADWAY AT 183rd STREET NEW YORK CITY

## Q. S. T. de ACE

LET'S SING

(TUNE, Battle Hymn of the Republic)

Mine ears have heard the signals  
From a dozen different lands,  
From Greenland's icy mountains  
To Sahara's burning sands;  
From the land of cherry blossoms  
To where Mount Sorata stands.  
And I've learned a thing or two.

CHORUS

Q. R. X., I'm going to tell you.  
Q. R. X., I'm going to tell you.  
Q. R. X., I'm going to tell you.  
How you can get them, too.

This spasm continued next month. Watch our ads, they are "different." So are our instruments. It's to our mutual advantage to get acquainted. "You may pay more, but you can't buy better."

DEALERS: If you don't stock Ace equipment you are missing a good line.

THE PRECISION EQUIPMENT COMPANY  
2437 Gilbert Ave., Dept. B Cincinnati, Ohio

## That Radio Instrument

When you are looking for some distinct part of a radio station and you have been unable to locate it elsewhere, come to us and you will find it here, anything in radio that is a necessity, we have it.

Apparatus of all responsible manufacturers, whose quality and service have been proven.

Here are some of the Instruments kept in stock:

- |  |  |  |   |  |   |   |   |   |                            |                                      |                            |                             |  |   |                                   |  |                                   |
|--|--|--|---|--|---|---|---|---|----------------------------|--------------------------------------|----------------------------|-----------------------------|--|---|-----------------------------------|--|-----------------------------------|
| Filament Ammeters for Radio Work, made by Roller Smith, 0-1, 0-2 Amperes. List Price \$8.20, Special \$6.90. | Loose Couplers, \$5.00, \$10.00, \$15.00, \$19.00. | Tuning Coils, 4,000 Meters \$4.75; 1,250 Meters, \$3.50. | Murdock Variable Condensers, .001 Mfd. \$4.75; .0005, \$3.75. | DeForest Variable Condensers Always On Hand. Fixed Condensers, .002 Mfd. 70c; .003, 90c. | Oscillation Transformer (Murdock Type), \$5.00. | Lightning Switch, 600 V-100 Amp., \$6.94. | Switch Points, 3/16"x3/16", Threaded Shank with Nut, 3c Ea. | Switch Points, 3/16"x3/16" with Machine Screw, 20c Per Doz. | White Metal Dials 3", 50c. | Binding Posts, 9c, 10c, 12c and 20c. | Paragon Rheostats, \$1.75. | DeForest Rheostats, \$1.00. | All the Wireless Press Books, Marconi VT Bulbs, \$7.00; Socket for Same, \$1.50. | Murdock VT Socket, \$1.00; DeForest Type, \$1.50. | Western Electric Phones, \$12.00. | Complete Stock of DeForest, Murdock and Grebe Manufacture. | Loads of other Apparatus on Hand. |
|--|--|--|---|--|---|---|---|---|----------------------------|--------------------------------------|----------------------------|-----------------------------|--|---|-----------------------------------|--|-----------------------------------|

The above list does not do justice to our complete stock and it cannot be appreciated unless you send for our catalog, which will be sent to all who wish it upon receipt of 10c.

AMERICAN ELECTRO TECHNICAL APPLIANCE COMPANY  
DEPT. EM., 235 FULTON STREET NEW YORK CITY

## Federal Radio Accessories

Are the Recognized STANDARDS for Their Respective Uses.

BULLETIN 102 W.A.

Gives full description. Besides it contains valuable information on

### AMPLIFICATION

of Radio Signals

Send 6c in Stamps today and receive this Bulletin.

FEDERAL TELEPHONE AND TELEGRAPH CO.

1756 Elmwood Avenue  
BUFFALO, N. Y.

## REWINDING A. C. MOTORS

And all methods for connecting and reconnecting are clearly shown in the ELECTRICAL WORKERS FRIEND. 66 diagrams with detailed explanations solving every rewinding and reconnecting problem. Electricians and Experimenters will find this book exactly what the name implies. "The Electrical Workers Friend." Price \$4.00 Cash with order or (C.O.D.—U.S.A. only).

HENRY F. BOSSHART  
P. O. Box 68 Homewood Sta. Pittsburgh, Penna.

## A NEW DETECTOR

That can either be used as a Panel Unit, as advocated by this magazine or "on the table," and only one knob is used for Position and Pressure. Instantly adjustable to any spot on the crystal. Price includes tested galena. Base 5 ins. by 2 1/2 ins. \$2.50. Base 5 ins. by 5 ins. 3 cups \$5.00.

Just write for information and list  
THE BARWICK RADIO SUPPLY CO.  
69 Britannia Ave. Hamilton, Ont., Can

# C W ACME APPARATUS

**POWER TRANSFORMERS  
MODULATION TRANSFORMERS  
FILAMENT HEATING TRANSFORMERS  
1½ HENRY CHOKE COILS**

ACME C. W. POWER TRANSFORMERS are designed for use with rectifying tubes for supplying D. C. voltage and current and for heating filaments.

- 200 Watt C. W. Power Transformer, Mounted .....\$20.00
- 200 Watt C. W. Power Transformer, Core and Coil Assembled ..... 16.00
- 50 Watt C. W. Power Transformer, Mounted ..... 15.00
- 50 Watt C. W. Power Transformer, Core and Coil Assembled ..... 12.00

The ACME A-3 MODULATION TRANSFORMER is correctly designed for Radio Telephony without distortion of speech and for maximum modulation.

- A-3 Fully mounted with engraved bakelite panel..... \$7.00
- A-3 Assembled with supports ..... 5.00
- A-3 Core and Coil Assembled..... 4.50

The ACME FILAMENT TRANSFORMER is designed for 110 volts 60 cycles and to deliver current at two voltages of 8 and 10 volts each.

- Acme Filament Heating Transformers, 50 watts, Fully Mounted.....\$12.00
- Acme Filament Heating Transformers, 50 watts, Core and Coils Assembled. 9.00

ACME 1½ HENRY CHOKE COILS are designed for use in the D. C. circuit when modulating.

- 1½ Henry Choke, 500 milampere capacity, Semi-mounted..... \$6.00
- 1½ Henry Choke, 150 milampere capacity, Semi-mounted..... 4.00

With two separate coils \$2 extra in each case.

**DISTRIBUTED BY ALL LEADING DEALERS  
PRICES ON LARGER SIZES ON APPLICATION**

**ACME APPARATUS COMPANY**  
24 WINDSOR STREET CAMBRIDGE 39, MASS.  
*Up-To-Date Transformer and Radio Engineers and Manufacturers*

## To the Radio Engineer Radio Manufacturer Radio Amateur

You cannot afford to do without the  
**PROCEEDINGS OF THE INSTITUTE OF RADIO ENGINEERS**

In it, you will find all the latest information on **Transmitters, Receivers, Bulbs, Radio Telephony, Elimination of Strays,** and every other important radio topic.

Subscription per year { \$9.00 (in U. S.)  
9.60 (abroad)

Address

Secretary,

**INSTITUTE OF RADIO ENGINEERS**  
COLLEGE OF THE CITY OF NEW YORK

### ADJUSTING SPRING DIES

(Continued from page 460)

for cutting. In addition to this the temper is drawn to a blue or spring temper at the points shown shaded in both views, in order that they may be the more flexible at the springing points, and therefore less likely to snap. The temper colors are not usually preserved, but are polished away to give the die a finish. As shown in the bottom view, the edges of the split are beveled at the outside of die to an angle corresponding to the point of the opening screw (shown at b in the middle view). If, therefore, this screw is driven down, it opens the die out. To check this opening out, two screws, a, are provided on either side of the opening screw. These screws are usually flat on point and only bear against the flat edge (or periphery) of the die. All the screws are usually hardened. The die can be held, therefore, to the extent it is necessary to open it out by means of b up to the point that the edges come into contact with a, a on either side, and it is there held rigid.

Putting such a die in its holder, it will be found that, as made and tempered, it stands, unsprung either way, at about correct size. First, draw all the screws slightly (not right out, of course), but so that the points of a, a are drawn below the inner surface of holder, and the point of b in such position that the die will slip in without being opened out. When it is right home, the screw, b, is first driven until it just holds the die and no more. The screws a, a are then driven till they just hold the die, taking care that both are on its surface with about even pressure. In this position the die should cut to size, but if a test cut shows it cutting oversize, the screw, b, should be drawn slightly and the screws, a, a, set down evenly till they both again bear on the die. This closes it and another test can be made. If, on the other hand, it cuts under-size, the two screws, a, a, are first withdrawn an even distance and the screw, b, driven until it just holds the die rigid, which will result in opening it out.

In the better class of spring die they are made with a taper bevel at the edges of the split, as shown in the top view of Fig. 1. These dies should only be put in the holder one way, and are often polished only on one side, and that the outside, in order readily to distinguish which way they go in. It will be noticed that the smaller end of the bevel goes in first, so that, when the screw, b, is driven to just hold the die, it cannot drop out of the holder unless it be sprung out to allow the inner ends of bevel to clear the point of b. When, therefore, the screws, a, a, are duly adjusted the die can neither turn nor

(Concluded on page 464)

**Arnold** Loose Couplers  
Combination Loose Coupler Parts and accessories.  
Send 4c stamp for literature which is sure to interest you.  
J. F. ARNOLD 2082 Lexington Av., N.Y. Established 1910

**RADIO APPARATUS**  
on the  
**INSTALLMENT PLAN**  
Full particulars and the RYA BULLETIN each month sent on receipt of ten cents—stamps or coin.  
**J. DONALD VANDERCOOK**  
LOMBARD Box 443 ILLINOIS

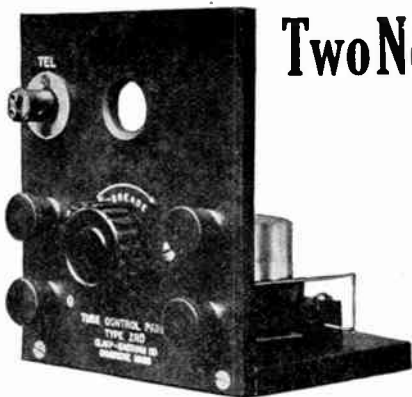

**DETECTOR UNIT**  
PRICE \$12.00

## Two New Vacuum Tube Units

Both units are designed to incorporate the Standard "4-prong" Vacuum Tube. Beautifully engraved Bakelite Panel, Oak Base. Ready for immediate delivery.

### WE TAKE PLEASURE

In announcing the opening of a branch store of the Atlantic Radio Co., at 15 Temple Street, Portland, Me., under the management of Mr. H. W. Castner. Northern New England amateurs will welcome this opportunity for expedited shipments.



**1-STAGE AMPLIFIER**  
PRICE \$18.00

### READ THIS LETTER:—

*Atlantic Radio Co.*

*Gentlemen:—I wish to thank you for the very prompt service which you gave me on my last order and for your ability to deliver at once just what was wanted. Such service as I received is so unusual that I cannot refrain from thanking you. The goods you sent were all perfect and the best of the kind I have yet seen.*

*Very truly yours,*

*(Name on request.)*

*Rochester, N. Y., June 30, 1920.*

"BULLETIN 14"—108 pages—over 100 illustrations—sent upon receipt of ten cents. A Rebate Certificate good for 10 cents on first dollar order is inclosed.

## ATLANTIC RADIO COMPANY

88 Broad St.,  
Boston 9, Mass.

Incorporated

Portland Branch—  
15 Temple St., Portland, Me.



## A More Comprehensive WICONY SERVICE

The Radio Art has long known *Wicony* to stand for *perfection* as applied to Navy, Army and Commercial radio apparatus.

The Radio Art will now know *Wicony* to stand for *perfection* as applied to specially designed amateur and experimental radio apparatus.

*Radio Dealers, amateurs and experimenters* have been freely consulted. Therefore, this new service is really yours—outlined by men who would consider the matter from *your* point of view.

*Watch for further announcements in Radio periodicals.*

**DEALERS:** It will pay you to write us now.

### WIRELESS IMPROVEMENT COMPANY

*Radio Engineers, Manufacturers and Distributors.*

47-B West Street

New York City

"Ask anyone who has used it"  
**Users Are Provers**

"I have also asked some of my friends all of whom say, 'BRANDES? Sure, get them: They will positively pay for themselves'". (Name on request.)

### Brandes Wireless Headset



"Superior," 2000 ohms, \$7

**TRIAL OFFER** Test out Brandes Wireless Receivers against any other make. Test them for sensitivity, clearness and distance. If within ten days you're not only satisfied but enthusiastic over them—back comes your money without a question. Prove for yourself the fine quality, the "matched tone." The two diaphragms, toned exactly alike, strengthen the signals and prevent blurring. Used by many U. S. Government experts and experts abroad; by colleges and technical schools; and by professionals and amateurs everywhere.

SEND 4c FOR CATALOGUE M  
**C. BRANDES, 32 Union Square, INC.** Room 822, New York

*Wireless Receiver Specialists*

# DE FOREST

## An Inexpensive Radio Receiving Set for Amateurs

FOR the beginner in Radio work or the experienced Amateur, this DeForest Audion-Unit Radio Receiving Station offers an easy and inexpensive way to secure accurate, efficient and expertly designed apparatus of usual DeForest superior quality. The set is complete; Aerial and Ground connections, "Honey Comb" Tuning Coils, Audion Detector, Tuning and Grid Condensers, Head Telephones, all necessary wire, insulators, back-board, base mounting, etc. Full instructions for installing and operating accompany the apparatus. The beginner can secure no better apparatus and with this set will gain practical knowledge and experience.

Our booklet, "How to Set Up an Amateur Radio Receiving Station" explains this and other sets and gives much information for the Amateur. Sent postpaid for 10 cents a copy.

DE FOREST RADIO TEL. AND TEL. CO.

Inventors and Manufacturers of  
High Grade Radio Apparatus  
1415 Sedgwick Avenue, New York City

Lee DeForest Inc., 451 Third St., San Francisco  
Western Distributors



# DE FOREST

## TUBE CONTROL PANELS

of unit size, 5½" High 4½" Wide



Tube Control Detector Panel Z. R. D. \$13.00  
One Stage Amplifier Panel Z. R. A. 18.00

Beauty and convenience have been incorporated in the design of these Panels to an unusual degree. The detector panel has a plug connection for the telephones which takes your regular phone tips. The amplifier panel has binding posts making it very easy to connect two of these together as a two stage amplifier. Both instruments will give you the utmost value for your money and the name Clapp-Eastham Co. engraved on the bakelite panel carries with it almost 13 years development experience in the Radio Field. Catalogs mailed for 6c stamps.

Order one or both panels  
from your dealer to-day

## CLAPP-EASTHAM COMPANY

131 Main Street

Cambridge, Mass.

## No Seals—No Secrets —BUT SERVICE!

Inspection of the interior of any Radio apparatus bearing the mark:



reveals design and workmanship fully in keeping with its outward appearance.

GREBE RADIO apparatus is licensed under the original Armstrong and Marconi patents.

Our guarantee is absolute and unconditional. Each instrument must give satisfactory service. Our interest in the purchaser does not terminate with the sale.

Ask your dealer to show you our line of super-grade apparatus. If he doesn't carry it as yet write us for catalogue, mentioning his name.

A. H. GREBE & CO., Inc.  
71 Van Wyck Blvd., Richmond Hill, N.Y.

## RADIO MEN

THE

Mutual Purchasers Association  
will save you money on all  
WIRELESS APPARATUS

Write Dept. E10 for details.

Mutual Purchasers Association  
2-4 Stone Street, New York

## TELEGRAPHY

(Both Morse and Wireless and RAILWAY ACCOUNTING taught thoroughly and quickly. Big salaries now paid. Great opportunities for advancement. Oldest and largest school; established 46 years. Endorsed by Telegraph, Railway, Radio, and Government officials. Expenses low - opportunities to earn large portion. Catalog free.

DODGE'S INSTITUTE 749 C Street, Valparaiso, Ind.

## ADJUSTING SPRING DIES

(Continued from page 462)

come out. It will be clear now that the use of any two, or only one, screw to hold a spring die is a source of danger, and may easily result in the die splitting. All three screws must be in action, otherwise the contrivance is unsuitable, and the cutting strain of the die put on its spring, which is obviously a mistake.

Some dies, which are usually expensive patterns, are made self-adjusting and locked both ways, so that they could be used in hand without any injury resulting, but spring dies must never be so used. And indeed most of the ordinary patterns of adjustable dies require a holder, as they tend to open out when set to work unconfined. Never put a spring die in a chuck and trust to the holding power of the chuck, as this is likely to result in fracture, the setting not being rigid like that which has been described.—*Model Engineer and Electrician, London.*

## GUIDING AIRPLANES BY WIRELESS

IT has been known for some years past that stronger wireless signals could be received when the top and bottom wires of a rectangular aerial were pointed in a direct line toward the sending station, whereas the signals were very much weaker when the aerial was placed so that the top and bottom wires were at right angles, or broadside on to the sending station. At intermediate positions of the rectangle the signals varied in strength from practically nothing, when at right angles, to the maximum strength when directional to the sending station.

The rapid turning about of large aerial in that manner is not practicable; therefore, the Marconi Company erects two independent triangular or rectangular aerials fixed with their planes at right angles, and connects them to the direction-finder box, which may be said to reproduce the external conditions in a small space. Inside the box there are two fixed "field" coils mounted in planes at right angles and connected to the aerial wires. Within these fixed coils is a rotatable "search" coil. This portion of the apparatus combines the signals received on the two aerials so that the movable "search" coil is influenced by them when in a plane directed toward the sending station, but is unaffected when it occupies a position in a plane that is located at right angles to that direction.

The dial of the finder is calibrated from 0 degrees to 360 degrees, and is arranged so that the direction of the incoming signals is due north when the direction-pointer is at 0 degrees. When signals have been obtained, the apparatus is tuned to the proper wavelength as in ordinary wireless reception.

By rotating the handle of the direction-finder, the strength of the signals in the telephone headgear will be heard to vary. The maximum strength will be heard at points diametrically opposite on the scale, and between these positions the sound gradually decreases until at two other opposite points, midway between the maximum positions, there is silence.

Since at the present time it is not possible for one direction-finding station to determine from the received signals alone the distance of their origin, but only their direction, it is necessary to make use of two or more stations separated by a considerable distance. Such stations having obtained the directions of the transmitting station, in this case, the airplane, it is only necessary for the control station to plot these directions on the map, when the point of intersection will give the position required.—*Illustrated London News.*

**REMOVING BROKEN TAP**

**T**HE extraction of a broken tap bolt is a problem occurring sometimes in the machine shop. One way of extracting the piece is to drill a hole in it and to back it out with a left-handed tap. We illustrate a much simpler way. A hole is drilled in the broken bolt

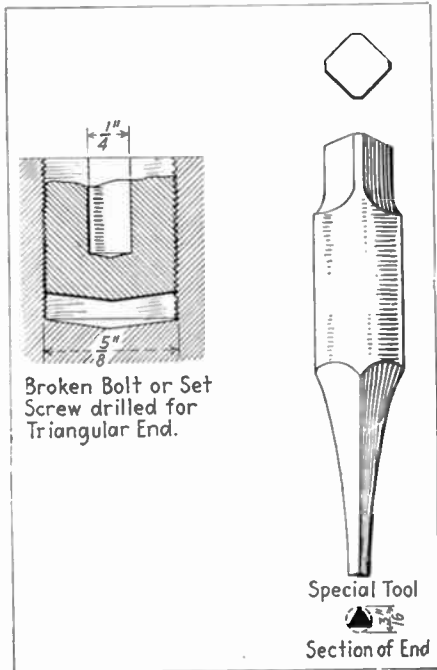

Broken Bolt or Set Screw drilled for Triangular End.

Special Tool

Section of End

Details of special drift pin or punch for removing broken stud bolts

and to turn it out, a three-cornered punch, such as shown, is employed. This must be well tempered, so as to cut into the sides of the hole and give a good grip. A hole one-third of the diameter of the bolt will suffice. The extracting tool can be made from an old tap or reamer, whose square head gives the hold for a wrench or spanner.



“—That’s why I say he knows his trade.”

“Look at his tools spread out on that planer bed. Every one’s got the Starrett trade mark on it. It’s a pretty safe guess that a man with Starrett Tools, knows how to use ’em.”

“Guess you’re right. I’ve worked around considerable, and everywhere I’ve been, I’ve noticed that the high-class men use Starrett Tools. It’s easy to see why. You’ve simply got to have good tools for first-rate work.”

“Starrett’s name on a tool is enough for me. I’ve been using them since I was an apprentice, and I know I can depend on ’em. When I’m on a high-grade job—or just an ordinary one, for that matter—give me a Starrett Tool.”

**THE L. S. STARRETT COMPANY**

*The World’s Greatest Toolmakers*

*Manufacturers of Hack Saws Unequaled*  
ATHOL, MASS.

There are 2100 tools listed in the Starrett Catalog—tools of the highest quality. Write for Catalog No. 21 “MB.”



42-68

**Starrett Tools**

**Richardson’s Polyphase Slide Rule**

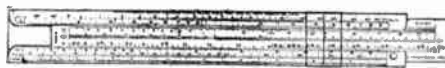

has the regular A, B, C and D scales; also a CI or Polyphase Scale, Logarithm, Sine and Tangent Scales. All graduations are printed on white coated steel from engine divided plates. These Scales are accurate and will retain their accuracy indefinitely. They are not affected by acids, alkalis, water or grease. Length of rule 16". A 100 page Instruction Book, which teaches all there is to know about slide rules, is sent with each order.

Price of the Richardson’s Polyphase Slide Rule, in case, with a 100-page Instruction Book, \$2.00.

An ideal slide rule. It is low priced and an equal to any other rule in appearance, accuracy and durability. Be convinced. Your money will be promptly refunded if you are not satisfied.

Send for our 40 page catalogue of supplies. It describes rules ranging from 50c to \$10 each. Instructions in Logarithms and Trigonometry free with every catalogue. **GILSON SLIDE RULE CO., Niles, Mich.**

**L A S T I N G**



THAT’S THE ECONOMY of owning a Union Tool Chest—it outlasts the ordinary chest so many years. The garage man, the auto machinist, the car owner will find the right “house” for his tools in this Union Garage Chest

175 tools can be conveniently packed, carried and locked in it. Don’t you want a tool chest that is durable, compact, neatly arranged and of the finest workmanship? Let us tell you more about Union Tool Chests—sold on “Satisfaction or Money Back” guarantee—24 styles to choose from.

**WRITE FOR FREE CATALOG**  
**UNION TOOL CHEST CO., Inc.**  
34 MINN Street  
**UNION** Rochester, N. Y.  
TOOL CHESTS

**EVERYDAY ENGINEERING MAGAZINE**

**Is the Only Publication That Meets the Needs of the Experimenter and Home Mechanic. It Tells How to Make and Do Things, and Why Things Are Done. Subscribe Now.**





**DUCK'S** No. 14  
264 Pages

**Electrical and Wireless Catalog**

**JUST OFF THE PRESS**

175 Pages of Wireless Instruments

Any radio amateur will tell you there is no catalog to take its place, and that it is a *Beacon Light* to guide you in the selection of your apparatus.

**THIS UNRIVALLED CATALOG MAILED TO ANYONE UPON RECEIPT OF 12c IN STAMPS OR COIN, which may be deducted on first dollar purchase.**

Great cost of catalog and low prices prohibit distribution otherwise

**What This Big Catalog Contains**

175 pp. Wireless Apparatus for Commercial and Experimental use;	42 pp. Motors and Dynamos;
10 pp. Raw Material;	8 pp. Flashlights;
2 pp. Transformers;	2 pp. Medical Batteries;
9 pp. Auto and Sig. Batteries;	3 pp. Ammeters and Voltmeters;
8 pp. Telegraph Instruments;	20 pp. Electrical and Mechanical Books.

**THE WILLIAM B. DUCK CO.**  
244-246 Superior Street, Toledo, Ohio

# THE RADIO REVIEW

A MONTHLY RECORD OF SCIENTIFIC PROGRESS IN RADIO TELEGRAPHY AND TELEPHONY

Monthly - Half-a-Crown

Single copies, post free 2s. 9d. Annual Subscription, post paid, 30/- post free.

THE RADIO REVIEW, a new monthly magazine, devoted entirely to the technical side of radio communication.

Edited by Professor G. W. O. HOWE, D.Sc., M.I.E.E., assisted by PHILIP R. COURSEY, B.Sc. A.M.I.E.E.

THE RADIO REVIEW is the Authoritative Journal of Wireless Research. Contributions from the pens of the World's leading Radio Scientists are a special exclusive feature.

Editorial and Publishing Offices  
12-13, HENRIETTA STREET  
LONDON, W.C. 2

## METALS WITH RADIOACTIVE PROPERTIES

IN addition to the ordinary radioactive substances, which are all closely related to uranium and thorium, two elements of the lightest atomic weights known, only two of the light metals of relatively small atomic weights, potassium and rubidium, seem to be radioactive to a certain extent. The nature of this latter radioactivity is by no means understood, while a great deal is known as to the character of the ordinary radioactivity. In case of the radium and the other radioactive elements there is certainly a decay of atoms. As regards potassium and rubidium, we have no definite evidence of any decay. In discussing these problems in the *Physikalische Zeitschrift* some time ago, Otto Hahn and the late Martin Rothenbach point out that, while several investigators are convinced that these alkali metals emit beta rays, alpha rays have not been discovered; it is, on the other hand, striking that the potassium suit deposits of Strassfurt are rich in helium.

The radioactivity of the alkali metals might be due to some impurity; but no impurity has been traced, and the radioactivity observed is always proportional to the potassium percentage; e. g., the intensity of the radiation from potassium, which was first observed by N. Campbell at Cambridge in 1906, is very small; yet it was considered to be at least ten times stronger than that from rubidium. Hahn and Rothenbach made their experiments especially on the sulfates of potassium, rubidium and caesium, with the aid of electrosopes of unusually large dimensions. The following are the conclusions at which they arrived: There is no indication of the presence in rubidium of some isotope; the beta rays from rubidium to uranium as 1:15, and rubidium to thorium as 1:10; the life period of potassium would probably be from three to seven times longer than that of rubidium. Speculations have been made by others as to a possible production of strontium from rubidium, calcium from potassium and barium from caesium; but such speculations appear to be quite arbitrary for the present.

Much disappointment has been experienced in the use of caustic soda (concentrated lye) for cleaning out obstructed sewer pipes. It is recommended to use a hot solution instead of the usual cold one; this will dissolve much which the cold solution will not affect. It may be kept hot in a stopped pipe in many cases by pouring boiling water over the outside of the pipe. This especially may be taken as applying to the cleaning out of a trap.

To attach mica to cast iron, as in stove doors, a cement made of slaked lime mixed with a saturated solution of borax in water is recommended. It should be given plenty of time to dry before being exposed to heat.

## YOUR FUTURE IS ON THE SEAS



Be a Ship Officer

### Join America's Mighty Merchant Marine

Hundreds of first, second and third mates, masters and captains are needed by the big shipping companies and America's great merchant marine.

**Salaries up to \$412 per month and living expenses.**

Ships flying the American flag pay the biggest salaries of any in the entire world.

Learn Navigation at Home or on Board Ship.

Captain Warren Sheppard's Course on Ocean, Coast and Lakes Navigation is now ready. It is a life time of practice placed before you for quick mastery. Captain Sheppard was instructor for the United States Shipping Board during the war. All of his students received licenses—from third mate to master. Not one failed. He offers this same sure method to you at a very low price. You cannot fail.

Valuable Booklet FREE

Fill out the coupon below and return to us. A 36-page booklet telling how you may become a ship officer at a big salary will be sent you free. Don't delay. Officers urgently needed.

FREE COUPON

World Technical Institute  
Dept. 102 Fuller Bldg., Jersey City, N. J.

Gentlemen:—Send me free booklet, "Your Future is on the Seven Seas." (Write Plainly)

Name \_\_\_\_\_  
Address \_\_\_\_\_



**SCHNOTER'S SUSPENSORIES**

YOU can enjoy perfect comfort and freedom. Schnoter's Suspensories and Jock Straps have gained their wide-spread popularity by quality, wear, fit and low price.

If your druggist does not carry Schnoter's, Accept No Substitutes. Sent direct upon receipt of \$1.00.

Send for booklet of other styles and prices.

**J. C. SCHNOTER CO.**  
628 SIXTH AVE. Dept. (E) N. Y. CITY

**IF YOU NEED SPECIAL INFORMATION WRITE OUR SERVICE DEPT., EVERYDAY ENGINEERING MAGAZINE**

**MORE ABOUT THE HANDLEY PAGE WING DISCOVERY**

THOSE who realize the importance of the discovery in wing forms made recently by the Technical Department of Handley Page, Ltd., will be interested to hear that the Aircro D. H.-9, fitted with an experimental set of the new wings, has been flown with apparent success. No official account of the experiment has been issued, nor has any information been received from anybody connected with the firm, but as Cricklewood Aerodrome (England) is an air port, and is open to the road, intelligent observers are occasionally able to obtain a glimpse of what is occurring there. According to the account of an eye-witness writing in the *Aeroplane*, the D. H.-9, which, as is generally known, normally leaves the ground at a high speed after a reasonably long run, lifted at about 30 miles an hour with the new wings, and only travelled a few yards before lifting. Also, it seemed to continue climbing at about the same speed. So far as could be seen, it handled quite normally when in the air. Presumably, the experimental flights were made with the machine dead light, but, even so, the low lifting and climbing speed was abnormal. Thus one is led to believe that the initial tests were successful.

**A NEW PARACHUTE**

RECENTLY tests were carried out at Villacoublay, France, with a new parachute, designed to allow light, delicate and valuable articles to be dropped from aircraft without damage. It has been designed by M.M. Bourgeois and Debreuil, and the experiments carried out under Lieut. Robin (of the S. T. Ae.) from a Breguet biplane were perfectly successful.

The parachute in being dropped from the aeroplane falls at its normal speed to about 15 meters from the ground. At this point an antenna, carrying at its extremity a weight of 500 grammes, comes in contact with the ground, thereby relieving the parachute of most of the weight and allowing the actual load to land with the minimum of bump.

**TEST IN VACUUM TANK.**

AN interesting test was carried out by Lieut. Casale at St. Cyr, near Paris, France, recently by way of preparing for an attack on the altitude record. Entering an insulated cylindrical chamber, the air was gradually exhausted until the atmospheric conditions, as indicated by the barograph, were similar to those at a height of 12,000 meters (39,300 feet). The "ascent" was made in 47½ minutes and the "descent" in 20 minutes. Lieut. Casale started to inhale oxygen at 4,600 meters. During the experiment 1,000 liters of oxygen were consumed.

**This is not a Real Machine but a Wading River 4-Foot Scale Model NC-4**

With a Wading River outfit, you, too, can build this perfect exhibition and experimental model. It is equipped with complete controls, dummy Lib-



erty Engines, Paragon Propellers—every detail a perfect reproduction of the original. It is easy to build with Wading River parts.

**BUILD AND FLY A MODEL NIEUPOORT SCOUT BIPLANE**

You can make it from our complete unassembled outfits. What this builder says stands good with all others who build this perfect model.

Feb. 9, 1919.  
Have had fine success with my Nieuport Biplane. It has flown 181 feet.  
E. Waterhouse, 521 W. Mo. St., El Paso, Texas.

**SET OF 11 SCALE DRAWINGS OF BEST KNOWN MACHINES FOR \$1.50**

This set includes the Nieuport monoplane, Bleriot, Curtiss Hydroplane, Antionette, Langley Tandem, German Taube, Deperdussin, Wright biplane, White Racer, White Flyer, and Champion Racer. Send 5c for our latest catalogue containing illustrations of models of Curtiss J.N.-4-B, S.P.A.D. Scout, De Havilland 4, Caproni Biplane, Handley Page, Sopwith Triplane and others.

**WADING RIVER MANUFACTURING CO.**

672-D Broadway

Brooklyn, N. Y.

**NOW YOU CAN FLY!**

A REAL AEROPLANE AT LOW COST



**THE DELERAY D-5 SPORT PLANE**

Wing Span 17 ft. Speed 39-65 m.p.h.

Planned by men with many years' experience in designing successful U. S. Government planes. Equipped with 15 H.P. engine (practical engineering made it possible for this biplane to be flown with only 8 H.P.) Use your own motorcycle engine if you wish.

Send \$6.00 for complete set of 25 large detailed blueprints, actual duplicates of our shop drawings, showing exactly how each part is made and fitted.

**DELERAY AIRCRAFT WORKS**

AEROPLANES ENGINES PARTS  
FREEPORT, LONG ISLAND, N. Y.

**AVIATION INFORMATION FREE**

Send us your name and address for full information regarding the Aviation and Airplane business. Find out about the many great opportunities now open and how to prepare you at home, during spare time, to equality. Our new book "Opportunities in the Airplane Industry" shipped free if you answer at once.

AMERICAN SCHOOL OF AVIATION  
Dept. 749C 431 S. Dearborn St. CHICAGO

**Telegraph Pictures**

BY ELECTRICITY

A complete set of two machines of this marvelous equipment for only \$19.50. Instructive, mystifying and useful. This picture of President Wilson was telegraphed by these machines. Picture telegraphing is the coming science. Write today.

J. LEISHMAN CO. Dept. L. Ogden, Utah



**Umakem Club**

You send \$5 for instructions, designs, blueprints then you Make Umakem Money running Umakem Community Shops or form your own Umakem Club with the \$5 outfit. You can make Bleriot, Curtiss, Spad and other Flying Planes; also real Work Benches, Sewing Stands, Stationary Backs, Baskets, Book Trays, Arks, Cans, Wagons, War Tanks, Action Toys, Dogs, Birds, Squirrels, Elephants, Rabbits, Goats, Toads, Giraffes, Ostriches, Numbers, Letters, 19 Jointed Animals, Doll Furniture and Doll Houses. Principal dealers buy all their toys and novelties now for Christmas. Get your Umakem shop started quick and coin Umakem Money.  
W. R. PRICE, Inc., Dept. 17 Umakem Bldg., 127 5th Ave., N. Y.

**CLEARSTONE PHONOGRAPHS**

\$4.00 to \$200.00 Retail  
Our Sundry Dept. offers Needles 80c per thousand, in lots of 500,000. Motors \$1.75 to \$14.75 each. Tone Arms and Reproducer \$1.30 to \$5.75 per set. Main Springs 20c to 90c each. Records, Needles, Sapphire Points and Parts at reasonable prices.  
Write for our 34-page catalogue, the only one of its kind in America, illustrating 3 different styles of Talking Machines and over 600 different Phonograph Parts.

LUCKY 13 PHONOGRAPH COMPANY  
Export Dept. 46M, E. 13th St., N. Y., U.S.A.



**Compressed Air Motors**

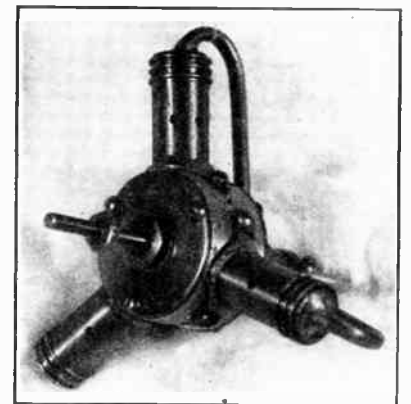

THE new and improved method of propelling your model aeroplane. Manufactured of the finest materials. Workmanship guaranteed. Special propellers for the above motors. Send stamp for descriptive circular of these wonderful motors. We manufacture everything for the model aeroplane builder. Give us a trial and be convinced.

**HEC AEROPLANE CO.**

302 East 49th St. New York City

**Mathematics Made Easy**

The Aracscope—the Combination Triangle with a Brain—will multiply, divide, figure percentage and proportion, solve all problems in trigonometry and geometry, draw symmetrical figures, plot arcs, etc. Superior to any slide rule. Simple to operate. Also includes a TRANS-PARENT TRIANGLE, PROTRACTOR and THREE RULES. Used at Columbia University, West Point, U. S. Aeronautic Schools, etc. Only \$1.00 postpaid. Order today before you forget.  
Dept. U. L. J. LEISHMAN CO., Ogden, Utah



**Umakem Airplanes**

Curtis Model J.N.-4 can be made complete ready to fly from Umakem No. 17 (price \$3.00), which includes blueprints, wood, metals, rubber and special tools necessary. Send for this set quick and Make Money Making Umakem Flying Airplanes for sale. Enormous demand. Profits big. Completed Plane sells at \$10 and can be made in 6 hours from Umakem No. 17 Set. Ask about our 40 other Umakem sets for making Airplanes, Toys, Novelties, Work Benches and practical Screw Cutting and Milling Lathes.

W. R. PRICE, Inc., Dept. 17, Umakem Bldg., 127 5th Ave., N. Y.

## It is One Thing to Desire—and Another to Determine

Almost everybody WANTS a good job—but not so many have the WILL TO DO what is necessary to get it.

### Ask Yourself These Questions:—

Are you ambitious? Do you like machinery? Do you want an opportunity to qualify for a better job—with prospects of earning MORE MONEY? Would a position with shorter hours interest you? IF YOUR ANSWER IS YES—

We would advise you to see us at once.—  
Don't be a misfit

THINK BIG—You can get what you want if you go after it the right way.

KNOWLEDGE—Is the BIG answer to your chance to earn BIG MONEY.

SUCCESS—Is the result of knowing how.

THINK THIS OVER—This is your opportunity.

WE TEACH YOU THE HOW—Of the biggest industry the World has ever known.

AUTOMOBILISM—has no limit as to how BIG an amount of money you can earn.

TAKE THIS OPPORTUNITY—to start yourself on a career of usefulness—make up your mind to BECOME AN AUTO EXPERT—and make yourself what you would like to be—A BIG SUCCESS—If you know how you cannot fail.

If your present occupation offers you no chance of promotion our advice to you is—come at once and LEARN THE AUTOMOBILE BUSINESS.  
Yours for a big success

BUFFALO AUTO SCHOOL

Buffalo, New York

P.S.—If you cannot call send us your name for full particulars.

## SAVE MONEY!

A High Grade  
INNER TUBE FREE

6000 MILES Guarantee

Economy Reconstructed Tires made by our new special process are guaranteed to give good service because the best materials are used in their construction. Our tires are guaranteed for 6,000 miles and we give a FIRST quality inner tube free with every tire ordered from us. Our tires are reinforced with extra piles of fabric making them strong so they resist punctures and blowouts.

RELINER IS FURNISHED WITH EACH CASING AT NO EXTRA COST.  
THESE PRICES INCLUDE CASING, RELINER AND TUBE.

30x3	\$7.15	33x4	\$11.00	35x4 1/2	\$13.15
30x3 1/2	8.25	34x4	11.25	36x4 1/2	13.50
32x3 1/2	9.00	32x4 1/2	11.75	36x5	14.50
31x4	10.10	33x4 1/2	12.25	37x5	14.50
32x4	10.45	34x4 1/2	12.80		

State with your order whether a straight side or clincher, plain or non-skid tread. Send a deposit of \$2 for each casing ordered. Balance C. O. D. subject to examination. 7% discount if full amount is sent with order. References furnished if desired.

UNITED ECONOMY TIRE CO.

205 West 48th Street New York City

## SHIP BY TRUCK

Motor Cartage.

One to Five-ton Trucks.

Hauls made to any point in United States and Canada.

Rates by hour, day or contract.

W. H. SQUIRES

1561 Woodward Avenue  
Detroit, Mich.

## You Can Save \$50.00

By recovering your old auto top frame yourself. We make these covers to fit all makes and models of cars. Any person that can drive a car can put it on. We furnish instructions. Roof and quarters sewed together with rear curtain, fasteners, and seats. All complete. Give us the name, year and model number of your car and we will send you our catalogue with samples and quote you exact price.

LIBERTY TOP & TIRE CO., Dept. E3, Cincinnati, O.

## Airplane Instruments on a Car

THE accompanying illustration, which is reproduced from an English motoring print, *The Autocar*, shows a car dash-board that has a collection of instruments not usually found on an automobile, yet which serve their owner's purpose of carrying on various experiments in connection with engine and car performance while the car is in use. In other words, the tests and determinations can be made under actual operating conditions on the road and can be depended on to be of real practical value. The owner of the car so fitted, Captain W. Gordon Aston, is an ardent experimenter and writer on technical subjects, so his reasons for the use of two instru-

presence solely to the fact that the dials really look rather nice and "set off" the dash-board very handsomely. They are quite surprised when I tell them that I find these two almost as interesting as the rest of the other things put together, for they cannot see what possible use they can be. This attitude is so general that I am in hopes that this short article may not be out of place.

### Estimating Gradients

Dealing first with the barometer, this is employed simply as a means of accurately measuring gradients. Since it performs this function very capably, it is to most people extremely disap-

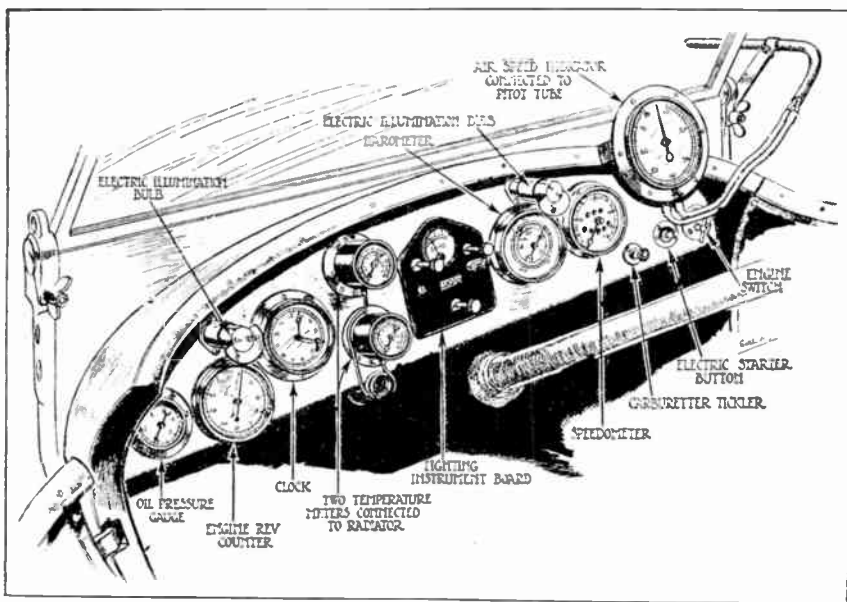

Cowlboard of English aviation and automobile enthusiasts' car shows practical use of several airplane instruments

ments usually associated only with aircraft should be of particular interest to those of our readers who have an inquiring turn of mind.

The dash-board equipment is unusually complete and some of the instruments are of real value in the everyday operation of the car as well as for research work. There is an oil pressure gauge, a revolution counter, a clock, an electric switchboard with ammeter, a voltmeter, a discharge ammeter, a telethermometer for the top of the radiator, a telethermometer for the bottom of ditto, a road speed indicator, an aneroid barometer and, finally, an air speed indicator.

"Most of the people whose eyes are caught by any accessory showroom in the garage seem to be able to understand all the instruments with the exception of the barometer and the air speed indicator: these, for the most part, they look upon as owing their

pointing, because it notably fails to record the "miles of one in six" that one hears so freely talked of. The dial is marked with the usual "Inches of Mercury," so that it can be used to confirm one's opinion of the weather, and outside of these figures are calibrations reading down to 20 ft. As a matter of fact, with a little practice one can read down to 10 ft. quite easily, and a closer approximation than this is rarely required. Outside the main dial is a movable annular dial, also finely calibrated, and bearing a zero mark. On one side of this the figures and spacings are red, showing descent; on the other black, showing ascent.

The modus operandi is as follows: At the foot or top of a hill (the car need only be slowed down for this purpose) the speedometer trip and the barometer are both set to zero. The former reads in tenths of a mile, and a certain amount of judgment has to be

used in connection with it. For instance, .6 may be shown whilst the car is on the hill, whilst .7 would not be put up until its foot or its crest had been passed by fifty yards or so. Hence it is necessary, at the top or the bottom of the hill, as the case may be, to go on running until the higher figure is shown, and then make a suitable deduction. In the meantime, the aneroid barometer, having been started at zero, has shown the vertical height traversed, so that the calculation is a very elementary one. As an instance, the hill outside Henley (White Hill, I think it is called) is .65 mile long, and rises 220 ft. The gradient is, roughly, therefore, 1 in 16, though as a rule I have heard it described generally as 1 in 12, frequently as 1 in 10, and once or twice as 1 in 8. This shows how deceptive the eye may be.

*Importance of Wind Resistance*

Now for the air speed indicator. The real reason why it is on the car I am not for the moment going to disclose. I will merely say that it is a scientific reason in connection with which research has not yet been started. The air speed indicator being in position, however, I find it so interesting for a secondary reason that, even if I were not going to put it to other uses, I should still consider it well worth dash-board room; although it is somewhat large in dimensions, it is amazingly light in weight. It reads from 10 m. p. h. to 70 m. p. h. It is almost superfluous to say that it is dead accurate. I tried it very early one morning when there was not a breath of air stirring and smoke from a cigarette went up vertically, and found that from ten to fifty (and just over!) it read mile for mile with the speedometer (previously checked and adjusted).

*Air Speeds and Car Speeds*

It is almost a truism that at low and moderate speeds, the atmospheric resistance of a car can be dismissed from serious consideration, but these speeds are air speeds and not road speeds, and it is desirable to have, therefore, a straw or two to show which way the wind blows. How often one is apt to think, "How nicely the car is going," when the fact of the matter is that it has got a twenty-mile wind smack on the back panel, and, conversely, "She does not seem to be pulling so well to-night; never had to change gear so early before on this hill!" when all the time the little engine is battling with a stiff head wind. Now, the air speed indicator tells you the truth about these things. I have not had it on very long, but I have already seen it show fifty when the road speed indicator would only bid twenty-five, and I have seen

*(Continued on page 472)*

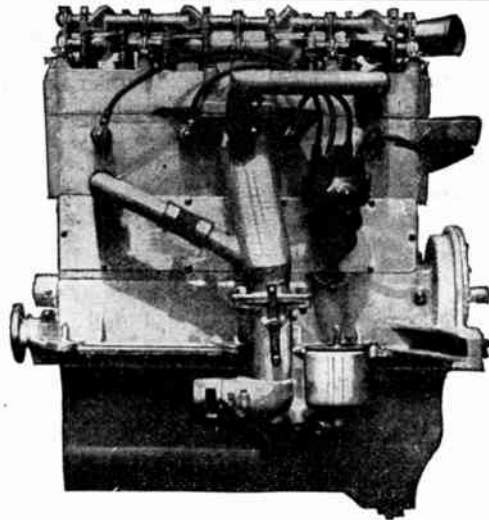

**"ACE" MOTORS**

**Are Powerful, Light, Reliable and Economical**

**Weight 126 Pounds**

**Forty B. H. P.**

These motors embody all the features of engineering that an extensive series of tests proved necessary, and are the product of ripe judgment of practical airmen. The ideal power plant for the man building his own plane.

Descriptive Literature on Request.

**HORACE KEANE**

*Aero*  *Planes*

Sales Office  
280 Madison Ave.  
New York

INC.

Factory  
North Beach  
Long Island



**Fits Bearing Surfaces Without Scraping**

**T**IMESAVER Compound is the modern bearing abrasive that turns to a lubricant after a few minutes' cutting. Produces perfect surfaces in any size or type of babbitt, brass or bronze bearing. Contains no emery, carborundum or glass, will not cut or scratch iron or steel and will not injure any part of the motor or machinery. Effects savings of from 500% to 3000%. Send \$1.50 for trial can. Money back if not satisfied.

**M. T. K. SALES CORPORATION**

296 Andrews St.

Rochester, N. Y.

Manufacturers, M. K. T. Products Co., Seattle, Wash.

**FOR SALE**

Rotary-Spark-Gap, with 4 to 6 volt. high speed, compound wound D. C. motor, rotary disc being made of bakelite. \$8.00. One unground transformer with laminations. .80. One-inch spark coil, practically new. \$5.00. Ten Edwards buzzers; some high tone, at .50 each. One large buzzer at .35. 12-volt colored bulbs with sockets at .11 each.

**JOSEPH F. MATIS**  
316 E. 89th St. New York City

**DRAFTING**

**Inventions and Ideas Developed!**

Mechanical, Electrical, Patent Office and Engineering Drawings of Every Description. **COMPETENT DRAFTSMEN AT YOUR SERVICE**

**A. G. HAGSTROM**  
116 Nassau St. New York City  
Telephone Bookman 4589

## INDUSTRIAL NIAGARA

(Continued from page 399)

cutting marble and granite; in the machine shop we find it accomplishing a hundred tasks; in the steel plant we find it grinding rails, armor-plate and armor-piercing projectiles; in the glass factory we find it cutting glass, and even in the dentist's chair we feel it whirring against our teeth as it cuts into them. Of all the wheels of industry, the grinding wheel is probably the busiest. It fulfills a thousand tasks. It is hard for one to realize its importance—its absolute necessity.

Modern industry owes to the grinding wheel what transportation owes to steam and electricity. Without Niagara we would have no modern abrasives. The diamond would still hold its own, and emery, with its poor abrasive qualities, would still be in use. The automobile, as well as the airplane, to which we attached so much importance in the late war, would still be in the embryo state. The modern high-powered gas engine, with its perfect-fitting pistons and high compression, would be an unattainable dream. Ferro-manganese is so extremely hard that it cannot be cut with steel tools, and were it not for the grinding wheel we would not be able to use this valuable material which is employed in many industries.

### Aluminum Production

Before the pulsating might of Niagara had been lashed to the service of mankind, aluminum was a metallic rarity. Today aluminum is one of the most common metals and plays an important part in our daily life. The automobile owes much to aluminum. It is used in castings of every description where lightness is sought without any sacrifice in mechanical durability. This makes it particularly adaptable for use on the airplane and it is destined to play a very important part in the development of aircraft. In fact, aluminum is employed on the present-day airplane wherever possible.

Vanadium steel bears the distinction of being the hardest alloy steel known to commerce. Without it our armament would suffer considerably. This material was made possible by a process which employs aluminum as its oxidizing agent. It is fast replacing copper as a conductor in high-voltage transmission lines and it is found to be much more economical. The wonderful welding mixture of thermit would be utterly impossible without aluminum as one of its constituent ingredients. Fifty-five thousand horsepower is used in the electrolytic production of aluminum at Niagara Falls.

### Artificial Graphite

A few years ago the world obtained its supply of graphite by mining it. The

natural product is very impure and entirely unsuitable for many processes that involve the use of graphite. Today artificial graphite is being produced in electric furnaces at Niagara Falls. Being created under a chlorific influence of 7,500 degrees Fahrenheit, this man-made graphite has a purity that closely approaches 100 per cent, as all the elements which would contaminate it are vaporized in the terrific temperature necessary for its production. Artificial graphite finds many uses and its part in the military establishment of the nation is an important one. One of its important uses at the present time is in the manufacture of smokeless gunpowder, where it is absolutely necessary. The granular product also finds broad use as paint pigment and dry-cell filler. In fact, artificial graphite brought the dry cell from an undependable makeshift to a reliable commercial commodity. Due to its wonderful purity and its unapproachable unctuousness, Niagara-made graphite, when blended with oil, makes a lubricating grease that is one of the most efficient anti-friction compounds ever originated. Graphite finds its most important uses when it is moulded into electrodes for electro-chemical and electrothermic processes. One of the foremost electro-chemical authorities in the United States once said that the development of electro-chemistry would have been as impossible without artificial graphite electrodes, as the perfection of electric lighting would have been without the dynamo. This is a very true statement and it is extremely difficult for one to realize what it means to the country.

Nearly all of our metals are refined electro-chemically and numerous other elements that are absolutely necessary are products of electrolysis. Before the advent of artificial graphite, platinum was largely used for electrodes, but it is now possible to dispense with it, owing to the great adaptability of graphite. Graphite is employed in most every electrolytic cell in America and previous to the war, it was used in every electro-chemical process in continental Europe.

### Chemicals Produced Economically

Benzol is another important product of Niagara. One of the derivatives of benzol is toluene. When toluene is treated with sulphuric and nitric acids, trinitrotoluene is produced. This substance has a much more restless molecule than nitro-glycerine and is far more violent as an explosive. Benzol is an important substance in the aniline dye industry.

Chlorine is produced abundantly at Niagara and can be compressed and stored under pressure in steel bottles in the liquid state. Chlorine has far more

humane uses than the suffocating of men on the battlefield. It is important to the arts and sciences, and is also the most powerful bleaching agent known. Without chlorine we would have no white paper to write upon and our white clothes would come back from the laundry a tinted yellow. Chlorine is used in the production of many chlorites and chlorates that are indispensable to the country. Hypochlorite is used in sterilizing the water supply of every city. Carbon tetrachloride is one of the most efficient fire extinguishers ever discovered. Chlorine products are also used in the sterilization and bleaching of surgical cotton.

Niagara produces more alkaline products than any other community in the world. These alkaline substances are used in the manufacture of mercerized cotton, explosives, medicines, dyes and in the refining of oils. Metallic sodium is a Niagara-made product of great importance. Sodium cyanide is necessary in gold and silver refining, and sodium peroxide is used to purify air and increase the oxygen content, especially in submarines. Phosphorus which is produced abundantly at Niagara is used in the manufacture of phosphorus bronze, and it is also used as a deoxidizer in other non-ferro alloys.

A great manufacturer of automobiles contemplated an output of 1000 cars per day during the year of 1917, and it was estimated that if he had been deprived of carborundum, aluminum, high-speed tool steel and oxy-acetylene, which are products of Niagara, that he could not have produced 100 cars per day with the same force of men he employed in making 1000 cars per day. This is a vivid illustration of Niagara's importance to the industry of the country.

Among the other important chemical products manufactured at Niagara Falls are sodium, caustic soda, chlorates of potash and soda, chloroform, carbon tetrachloride, bleaching powder, phosphorus, hydrochloric acid, sodium peroxide, formaldehyde, titanium, ferromanganese and caustic potash.

### STERILIZING AIR BY ELECTRICITY

We have already had occasion to note the removal of dust from gases by the use of a highly charged system of conductors hanging vertically in tubes through which the current of gas went. Recent experiments in drawing air through a copper tube in whose axis a wire was maintained at a negative potential of 50,000 volts referred to the potential of the tube showed that the air thereby could be rendered absolutely sterile, so that absolutely no bacteria could be found in it.



## Useful Electrical Appliances for the Household

ONE of the greatest time and labor savers ever introduced in the household is the electric current and its uses are manifold. Numerous and practical devices are marketed for performing almost any desired household task by the aid of the electric current. The accompanying illustration shows some recently developed appliances that seem to have advantages warranting their use. The insert heater for range boilers permits of obtaining a supply of hot water when it is too warm to operate the coal-burning range, to which such a boiler is usually

capacity. This development is along the lines noted in these columns where electric current has been used for generating steam for various purposes by heating boilers, this development being especially notable in Switzerland.

Sometimes only small quantities of hot water are needed and they are required at once, so that the instantaneous electric water heater, which can be put in any ordinary cold water pipe line, should be valuable. The main portion of the heater is a cylinder of porcelain and the body is provided with a series of tubular passages which are connected

heating elements is connected to the current supply sources by a simple switch which is operated simultaneously with the faucet. As soon as the faucet is opened to the hot water position, contact is established and the metal coils quickly become heated and impart their heat to the water passing through them.

Another appliance that will be voted for enthusiastically by the younger members of the family is the combined ice cream freezer and ice-cracking machine illustrated. The entire mechanism operates by a small electric motor and both the cream freezer and ice-cracking machine are installed on a solid base so that the device will remain rigid in operation. Simple gearing is provided for turning the freezer and ice cracker and a clutch arrangement is incorporated so that either machine may be driven independently of the other. Electric motors supplied can be built to operate on either alternating or direct current, and while the freezer shown is one of larger capacity than would be needed in the ordinary family it can be made in smaller sizes suitable for family use. One of the advantages is that no belts are used, the motor being directly connected to the main power shaft through a series of reduction gears which are well protected.

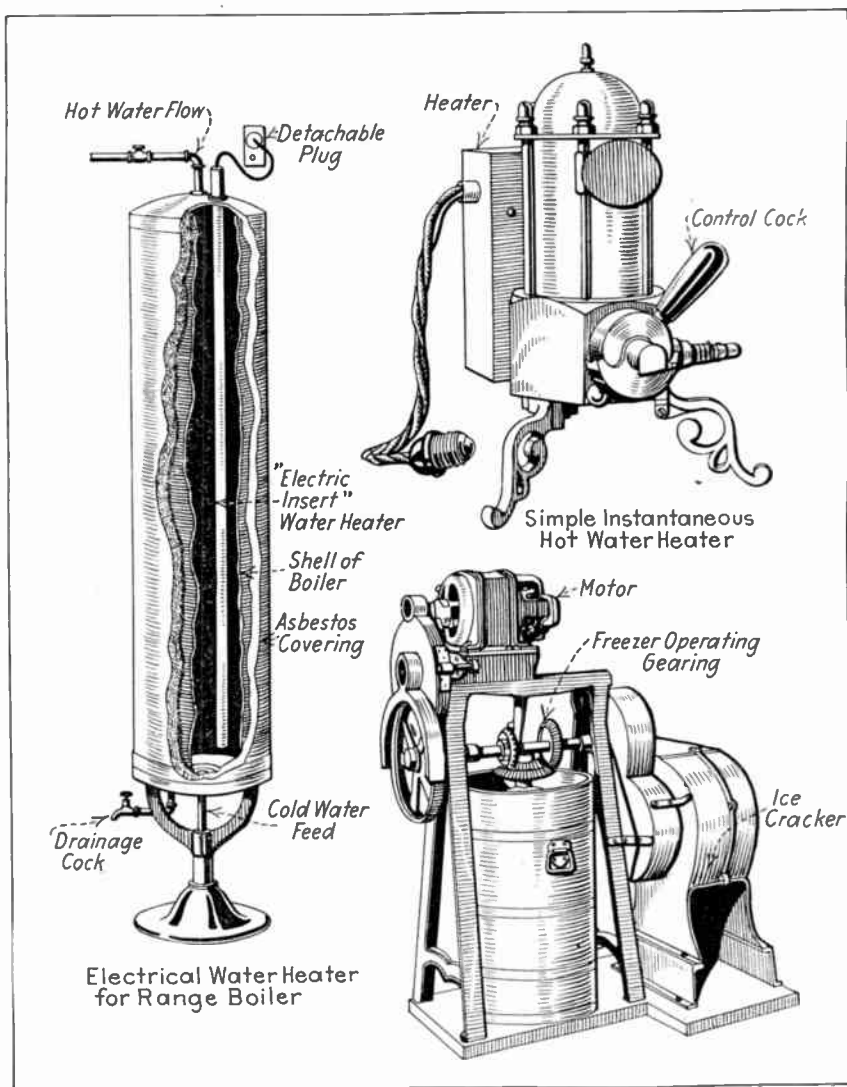

Useful electrical appliances for the household

### PREVENTING INFECTION OF SMALL WOUNDS

A SMALL cut or scratch on the hands, if not properly cared for, may become infected and cause serious trouble. If the wound, after being thoroughly cleansed, is sealed with pyroxyline, which may be obtained in liquid form in any drug store, a film is formed over it which prevents infection. Great care should be taken that no dirt or foreign substance is left in the wound.

### DO NOT USE STEAM IN AIR BAGS

ONE repair man has asked if it would be all right to use steam instead of air pressure in bags used for sectional repairs to eliminate the necessity of curing on an inside vulcanizer.

It is not advisable to use an ordinary air bag for this purpose for the reason that it is not constructed for use as a steam container. As it has no outlet, condensation would result and water would form in the bag. Never apply the section to an inside patch vulcanizer to finish the cure. The time specified gives 40 pounds steam pressure with Goodyear repair material without the aid of the inside patch vulcanizer.

connected. As there is a tendency in many kitchens to use electric stoves to the exclusion of those burning either solid or gaseous fuel for cooking purposes, the insert heater, which is a small and modified form of resistance heater, would, of course, be used as a permanent installation. As will be apparent, it is a simple matter for the makers to supply heaters suitable for any kind of current or of any desired

in series with each other by suitable caps placed at the top and bottom of the pipe. The cold water enters the first passage either from the water pipe or any suitable hose connection, flowing through the different passages where it is heated, and from the last passage it goes to the faucets. All of the passages are provided with metal resistance coils made of non-corrosive material. These are connected in series and the group of

# NEW MOTORS

**FACTORY GUARANTEED ALL SIZES PROMPT DELIVERY**

<p><b>Polyphase Motors</b> 9 and 3 phase, A. C., 220 v. 60c., 1750 R.P.M. Complete with base and pulley.</p> <p><b>Charging Generators</b> Suitable for all lighting, Battery Charging and Power Requirements.</p> <p>8 v., 10 amp. . . \$19.50 15 v., 10 amp. \$26.50 40 v., 6 amp. . . \$31.50 110 v., 2 1/2 amp. \$31.50 110 v., 5 amp. . . \$52.50 40 v., 12 amp. . . \$52.50 110 v., 9 1/2 amp. \$67.50 40 v., 25 amp. . . \$67.50 110 v., 18 amp. \$116.50 40 v., 50 amp. . . \$116.50 110 v., 26 amp. \$156.50 110 v., 50 amp. \$238.50 Moving Picture Arc Generator 90 v., 55 a. \$116.50</p>	<p><b>Direct Current Motors</b> 110 or 220 volts, D. C., shunt wound. 1750 R. P. M. With base pulley and starting box.</p> <p>1/4 H. P., Washing Machine Motor - \$28.50 1/4 H. P., 22 v. Washing Machine Motor - \$28.50 1/2 H. P. . . . \$58.50 1 H. P. . . . \$82.50 2 H. P. . . . \$124.50 3 H. P. . . . \$142.50 5 H. P. . . . \$218.50</p>	<p><b>Single Phase Motors</b> 110-220 volts, A. C., 60 cycle, 1750 R. P. M. with pulley.</p> <p>1/4 H. P., 220 v. Induction Washing Machine Motor - \$28.50 1/4 H. P., 110 v. grinding balling motor - \$28.50 1/2 H. P. Induction, full load start - \$46.50 1/2 H. P. repulsion induction For compressor service - \$54.50 1 H. P. repulsion induction, Special Storage Motor - \$74.50 2 H. P. repulsion induction with sliding base - \$126.50 3 H. P. repulsion induction with sliding base - \$146.50 5 H. P. repulsion induction with sliding base - \$188.50</p>
---	--	--

WRITE FOR CATALOG. BARGAINS IN MOTORS AND GENERATORS

**SPECIAL**  
1/4 H.P. 110 volts  
S. P., 1750 R.P.M.  
Complete, cord, plug and pulley

**WASHING MACHINE MOTORS**  
Suitable for operating small Washers, 4 office Washers, Etc.  
**\$26.50** Each  
Reg. Val. \$34.50

**GUARANTEE**  
25% deposit required on all orders. Balance C. O. D. by Express. Sight draft with Bill of Lading attached by freight.

MANUFACTURERS' DISTRIBUTOR  
**CHAS. H. JOHNSTON, Box 10, West End, Pittsburgh, Pa.**

## AIRPLANE INSTRUMENTS ON A CAR

(Concluded from page 469)

it at twenty or so when I was doubling the legal limit. It also indicates very clearly that, if you are wind jamming and you want to save petrol, a good way is to give the road to a big limousine, and then hang on behind as close as you dare. It further shows why sometimes you come in with the radiator very hot, whereas after the same run on other occasions the water is quite cool.

The air speed indicator is of the usual aircraft type employing a pilot head coupled up to the instrument with rubber tubes. The head has to be fixed a little out-board of the car so as not to be subject to interference of air flow caused by radiator, mudguards, and so on, but need not be so far out as to be unsightly, owing to the comparatively low speeds that have to be dealt with. Strictly speaking, of course, the speeds shown on the air speed indicator should be corrected for atmospheric temperature and pressure; but the changes in these are relatively so small that they do not matter, especially as the road speed indicator only shows the rotational speed of the wheel, and not the translational velocity of the car."

## OVERHEATING REDUCES STRENGTH OF ANIMAL GLUE

**T**HAT long continued heating reduces the strength of animal glue solutions is demonstrated by the following test made at the Forest Products Laboratory. Solutions of a high grade joint glue and a veneer grade glue were heated for 48 hours at 104, 140 and 176 degrees Fahrenheit, and tested every few hours during this period for strength and viscosity.

In the first 7 hours of heating at 176 degrees the veneer glue lost approximately one-half its joint strength, and the high grade glue joints weakened almost as much. The greatest loss in the strength of the glue joints occurred at this temperature. In the solutions kept at 104 degrees there was a sudden drop in the strength of the joints made with the high grade glue after 31 hours of heating, due possibly to a combination of bacterial and chemical action. The veneer glue joints showed a more gradual decrease at this temperature. The most favorable of the three temperatures tried was 140 degrees, but even at this temperature an appreciable weakening in both glues was noted at the end of 7 hours, and longer heating caused greater loss.

The viscosity of the high grade glue declined more rapidly than that of the veneer glue, but at the end of the heating test the viscosity of the high grade

## BIG PROFITS for YOU in HB BATTERY CHARGING

Profits of \$100 to \$300 a month are easy—hundreds of letters from HB users everywhere prove it. Cost 10c to 15c per battery—customer pays 75c to \$2.00. There is a sturdy, reliable, economical HB Charger to fit any size battery business.

Mark a cross (X) on the outfit suited to your needs. Then tear out this ad and mail TODAY for complete information. Small cash payment—balance easy monthly terms. Get busy.

**HOBART BROTHERS COMPANY**  
Box EE 87 Troy, Ohio

### Barometrical Determination of Heights

A practical method of barometrical levelling and hypsometry. By F. J. B. Cordelro. Second edition, revised and enlarged, 6 x 4 in., limp cloth, 50 cents.

### Buchanan's Tables of Squares

Containing the square of every foot, inch, and sixteenth of an inch between one-sixteenth of an inch and fifty feet. These tables will be found to be of great value to all classes of Engineers, \$1.25.

### French Measure and English Equivalents

By John Brook. Giving equivalents in inches and decimals of an inch and inches and fractions of an inch (to the nearest 64th + or -) or from 1 to 1000 millimetres, and 1 to 100 metres, and table of fractional parts of an inch with corresponding decimals. 80 pages. 4 x 3 ins., limp cloth, 50 cents, net.

### Metrical Tables

By Sir Guilford G. Molesworth.  
Fourth Edition, Revised and Enlarged  
VIII + 95 pages, 5 x 3 in., limp cloth, 75 cents, net.

## SPON & CHAMBERLAIN

120E Liberty St. New York

### AGENTS AND DISTRIBUTORS WANTED

Sparko-Gap is a nationally advertised automobile and motor boat accessory—almost essential with present-day power gas—tested and proved by United States experts, the French Government, electrical engineers and users everywhere.

Can be installed in two minutes without tools or adjustments. Demonstrates its merit in the first five minutes of driving.

Universal market, big profits and chances to establish own business without any investment. Still a few territories open.

We want the right man and don't ask for any guarantee or stock order. Hustle and enthusiasm the only requirements. Write at once for territory still open.

**SPARKO-GAP COMPANY**  
54 West 39th Street, New York City

### ALUMINUM CAN BE SOLDERED with SUPREME BRAND ALUMINUM SOLDER

FLOWS AT 500° FAHRENHEIT REQUIRES NO FLUX

Used by General Electric Company, Worthington Pump Company, Hale & Kilburn Company, Bethlehem Shipbuilding Corp., National Lead Company, and hundreds of other manufacturers and repair shops.

Instructions\* for using with each bar.  
Price \$3.00 per Pound in Half Pound Bars.  
Send Fifty Cents for 2-Ounce Sample Bar.

**VANDAM SPECIALTY COMPANY**  
Grand Central Palace, Dept. EE, New York City

## TWO GOOD BOOKS

### Designs for Small Dynamos and Motors

By Cecil P. Poole

186 pages containing designs for machines ranging from 1/6 h.p. to 2 kw. Fully illustrated, cloth.  
Price \$2 postpaid

### Model Making

By Raymond Francis Yates

400 pages, 301 illustrations, cloth  
Price \$3 postpaid

A postcard puts you on our mailing list.

**SWANSON BROS.**  
Technical Book Service  
186 No. La Salle St., Chicago, Ill.

**THE SEPTEMBER NUMBER OF EVERYDAY ENGINEERING MAGAZINE WILL MAKE SPECIAL APPEAL TO AVIATION ENTHUSIASTS**

Please mention EVERYDAY ENGINEERING MAGAZINE

glue still averaged higher than that of the veneer glue. Covered glue pots were used in this experiment. When open glue pots are used the loss in strength caused by the heat is less apparent, since the loss is compensated to some extent by evaporation of the water. On the other hand, the concentration of the glue solution through evaporation is an expensive means of gaining strength.

**TO PREVENT RUSTY RIMS FROM DAMAGING CASINGS**

**I**RON rust eats into canvas very quickly and for this reason the rims should be examined and cleaned a few times each season. Assuming that the rim is clean, as it should be when the tire is attached, it may be kept so indefinitely if proper attention is given to keep the rims straight, and if the locking nut on the valve stem is drawn tight so that no water can work in through the hole in the rim. If, on inspection, the rim is found to be rusty, even though merely in small spots, the rust should be sandpapered off and the rim given a coat of graphite or thin shellac. Ordinarily, stove polish, which contains graphite, is also excellent for preventing rust and making it easy to remove a tire in case of an emergency. Any dent or bent in a rim should be corrected as soon as discovered, for if the bend is inward a great strain is brought on the bend and side of the casing. If the bend happens to be outward, there is a fine chance for water, oil and dirt to work in between tire and rim.

**RECORDING INSTRUMENT FOR CARS**

**A** DETROIT inventor has patented an instrument to be installed in a motor vehicle that provides a continuous record of every period of use of a car. In brief, it consists of a strip of ruled record paper moved by clock-work. A suitable marking device is attached to the speedometer of the combination. The mark left on the record sheet shows the speed at which the car was travelling at any indicated time, as the paper strip is divided into days, hours and minutes. This device is believed to be of value to operators of taxicabs where meters are not required by local ordinances and also to owners of expensive automobiles driven by chauffeurs, not to mention the possibilities in the motor truck field.

Directional wireless stations are being erected in various places along the Pacific Coast from San Diego to Alaska and others are being established to carry ships through the Delta of the Mississippi River to the port of New Orleans.



**WE BUILT IT** for fellows who want something new and better. We found a way to give you two wagons in one. When you want to haul, you need a box wagon. The Auto-Wheel Convertible Roadster is ready. Swing sides outward and there's a roomy wagon bed that will carry 1,000 lbs. Fold the sides toward the center and there's the new model roadster—long, low and built for a race. The only one of its kind made.

**Auto-Wheel Roadster** has the same chassis as the Auto-Wheel Coaster—the old stand-by. On both these Auto-Wheel models you'll find the same smooth-running roller-bearings and the same substantial steel tires and axles that have made Auto-Wheels the standard for boys. Get "Auto-Wheel Spokesman" A monthly magazine that tells all about Auto-Wheel wagons. Gives details of the Auto-Wheel Prize Contests (they are worth entering.) Send names of three coaster dealers telling which handle the wagon with the name "Auto-Wheel" on sides. We'll put your name on mailing list.

In Canada: Preston, Ont.  
Export Office: 365 W. 23rd St., New York City.  
**The Buffalo Sled Co.,**  
159 Schenck Street,  
N. TONAWANDA, N. Y.

**EASY to LEARN at HOME**

**ELECTRICITY TAUGHT BY A PRACTICAL MAN**

This Home Study Course, based on the years of practical experience of Yorke Burgess, who gives personal attention to each student, has trained hundreds of men and boys in better positions. Beginners get employment after taking the Burgess course a short while—over 85% of students now engaged in electrical work.

**For BEGINNERS and EXPERIENCED MEN**

**What You Should Learn and The Way You Should Learn It**

Why the Burgess method is best for you—Read what I. E. Walkins, E. E. M. E., of Brockton, Mass., one of the foremost Electrical Engineers in the U. S. and a pioneer in electric railway work, writes of the Burgess school: "It is indeed good that there has been established a school of Electricity on so practical lines Free From The Frills of the general run of correspondence schools."

**You TAKE NO CHANCE—so confident are we of your success that YOUR PAYMENT'S CASE IF YOU ARE NOT SATISFIED—EASY TO LEARN etc., are included in the course. "ELECTRICITY" every person interested in electricity or employed in any branch of electrical work should have. Contains valuable information and scores of letters from men and boys who are making a success by the Burgess method.**

**ELECTRICITY TAUGHT BY A PRACTICAL MAN**

**SEND for this Remarkable Book N-8 IT COSTS YOU NOTHING**

**BURGESS ELECTRICAL SCHOOL**  
YORKE BURGESS, Supt.  
151 E. 42nd St., Chicago, Illinois

**Umakem** Outfit No. 8 includes 16 good tools, designs, 3 ply wood, hardware, mechanical parts and everything to make a \$30 Toy Circus drawn by two large jointed animals with Clown Riders, 19 Wild and Domestic Animals, kicking and jumping Donkeys with riders and other Circus Things. This set is a red hot Money Maker and several people can work with Umakem No. 8 at the same time. Fine for families, toy clubs and schools. Send \$10 for this set. Dealers buy Christmas toys now.

W.R. PRICE, Inc., Dept. 17, Umakem Bldg., 127 8th Ave., N. Y.

**Tycos-**

It will be obviously safe for you to follow the lead of prominent engineers in the use of Tycos Temperature Instruments—Indicating, Recording and Controlling.

There are Tycos:

- Indicating Thermometers
- Recording Thermometers
- Controlling Thermometers
- Pyrometers
- Pressure Gauges
- Time Controls
- Hygrometers
- Hydrometers
- Barometers
- Vacuum Gauges
- Thermographs
- Oil Testing Instruments
- Laboratory Glassware
- Compasses
- Household Thermometers
- Altimeters
- Actinometers

Details regarding any instruments in the Tycos line gladly furnished.

**Taylor Instrument Companies**  
ROCHESTER, N. Y.  
There's a Tycos and Taylor Thermometer for every purpose

**Be a Draftsman!**  
**Make \$30 to \$75 a Week**

Your name and address on the coupon brings this great Cyclopaedia of Drawing without a penny down. Pay only net shipping charges when books arrive. With these books and a low price "school set" of drawing instruments, obtainable at any store, a man can become master of drawing and earn \$30 to \$75 weekly.

**LEARN AT HOME**—Good paying positions open everywhere. Intense activity in manufacturing, railroading, building, etc., calls for more draftsmen.

**Shipped on 7 Days' FREE Trial**  
**CYCLOPEDIA OF DRAWING**  
4 Volumes. 1650 Pages. Thousands of Illustrations. Bound in genuine American morocco. Pages 5 1/2 x 8 1/2 inches. Covers all branches of Drafting—Architecture, Electrical, Structural Steel, Sheet Metal, etc. Teaches pen-and-ink rendering, lettering, free-hand, perspective, shades and shadows, working shop drawings, machine design, etc., etc.

**50c a Week**—Only \$2 a month if you keep the good books. Coupon explains offer, good only within borders of U. S. and Canada. **Free Membership in This Society.**—A Consulting Membership given free with each set—worth \$12.00.

**AMERICAN TECHNICAL SOCIETY**  
Dept. L-35C Chicago  
AMERICAN TECHNICAL SOCIETY  
Dept. O-35  
Chicago, U.S.A.

Please send Cyclopaedia of Drawing for 7 days' examination, shipping charges collect. I will send \$2.80 within 7 days and \$2 a month until \$14.80 is paid, or notify you and hold books subject to your order. Title not to pass until fully paid.

Name .....  
Address .....  
Reference .....

# BURGESS ELECTRICAL HAND-BOOK

(called THE BURGESS BLUE BOOK, originally in blue-print form)

## SHORT CUTS AND TIME SAVERS

Prepared in pocket size especially for practical men and those taking up the study of electricity. Contains drawings and diagrams of electrical machinery—over 200 formulas for calculation and problems worked out showing how formulas are used. From the personal note book of Yorke Burgess while on all different kinds of electrical work covering a period of nearly a quarter of a century.

Electrical laws, formulas, methods of calculation, etc. Simplified and made easy to under-

stand and remember. Easy to apply in practical work. Many valuable stunts not to be found in any other book. Of value to any electrical man, whether Technical Graduate, Electrical Engineer, Student or Practical Man.

Electricians all over the world are sending for this book. The most complete and valuable book of its kind published. Nothing else like it. If you have never seen this book it is impossible for you to realize what you have missed.

Price \$1.00

Send dollar bill, money order or check. You take no chance—money back ANY TIME if not satisfactory.

### THE BURGESS COMPANY

Consulting Electrical Engineers  
YORKE BURGESS, President

Engineering Division (Department 109) 750 E. 42nd Street,  
CHICAGO, ILLINOIS, U. S. A.

## Discover Your Talents

What Are You Best Fitted For?

Personal, Mental and Vocational analysis, by Dr. S. S. George, M.A., Ph.D., former U. S. Army expert. Will help you know your mind and what you are best fitted for. Complete course of tests and analysis, with 1,500 vocations classified, will be mailed to you on approval. Send \$3.00 for the course post-paid. If it is not satisfactory return it in five days and we will refund your money. Address

The Vocational Guidance Institute  
2255 Broadway, New York City



\$110 A Month To Start As  
Railway Traffic  
Inspector

ONLY THREE MONTHS spare time study will equip you for responsible position with a good salary from the start. Railway Traffic Inspectors advance rapidly—they work right with railway officials who are constantly seeking capable men. A pleasant position—you become broad minded—you travel and see country, expenses paid S.B.T.I. instruction is very interesting—it's easily assimilated. We arrange for position; no age limit. Those who started studying a few months ago fill positions today and they're on the road to still further advancement, so write immediately for Booklet D-68 before you turn this page. Standard Business Training Institute, Buffalo, N. Y.

WE ARRANGE  
FOR A  
POSITION

## Are You Going to Give Up a College Education BECAUSE YOU CAN'T AFFORD IT?

Will you allow yourself to go through life handicapped by the lack of technical education, knowing that you can never attain the success that would have been yours if you had gone to college?

**NO!**

If you have the stuff in you of which success is made you need not think of the cost of going to college, for EVERYDAY ENGINEERING MAGAZINE will pay your expenses at any University, College, Trade School or Correspondence School in the United States.

### *Everyday Engineering Will Finance Your Education*

in return for all or a portion of your spare time. It may seem too good to be true, but it is no less a fact—Four years at college with all the opportunities of learning, with the social life, which, in itself, is of tremendous importance in the life of every man.

To make arrangements for starting this coming fall, write immediately to the "Circulation Department", EVERYDAY ENGINEERING MAGAZINE, stating the name of the University to which you want to go, the course you are desirous of taking and the approximate cost for the scholastic year.

Here is your chance. It is up to you to take this opportunity now.

**EVERYDAY ENGINEERING MAGAZINE**

2 West 45th Street

New York City, N. Y.

### BE SURE AND ORDER YOUR SEPTEMBER COPY OF EVERYDAY ENGINEERING MAGAZINE EARLY

IN ADDITION TO ALL THE USUAL FEATURES AND DEPARTMENTS THERE WILL BE SEVERAL SPECIAL ARTICLES DETAILING RECENT DEVELOPMENTS IN EXPERIMENTAL AND COMMERCIAL AVIATION, IN EUROPE AS WELL AS AMERICA. WHY NOT SUBSCRIBE AND BE SURE OF RECEIVING EVERY COPY AS ISSUED? SEE OUR SPECIAL OFFER ON PAGE 388. VALUABLE BOOKS GIVEN AWAY.

**WHAT A MODEL AERO CLUB DOES**

BY BERTRAM POND  
Corresponding Secretary

THE war is over, at least for a while, and the war-time crimp put into the model aeroplane world is fast straightening out. As evidence to this fact, let me tell you of a few things which the Illinois Model Aero Club has accomplished in the short space of one year.

A banquet was given last March, a year ago, as a "send off" and to the success of the contests to come. The summer was marked by a world's record passing from Mr. Pease to Mr. Sweitzer, who made a flight R. O. G. of 4029 feet. The usual annual series of contests for the handsome Laird Weaver Trophy was won by Mr. Wm. Sweitzer. Mr. R. Jaros won the amateur duration prize. The prize for amateur distance was won by Mr. J. Kroviak. The famed Villard Trophy, muchly polished and lacquered, is now a permanent part of the I. M. A. C. collection of trophies. The Aerial Age Medals were all won by I. M. A. C. members, and medals formed an important part of the time keeping equipment of the lucky ones.

The winter has been marked by some very important events for the Club. A scale model contest, Aero Show exhibit, exhibitions at Marshall Field & Co. on various occasions, a series of contests for 10" models, a series of lectures on "Model Designing," and a show of a few of our models before a Pathe camera man were the winter's most notable activities.

The annual scale model contest was held Dec. 5th, 1919. Among the models entered were an "Ansaldo 1" and an S. E. 5 and an Albatross C. V. The model making the best duration flight was given 50% and the other models in proportion. The best workmanship was given 25% and the others in proportion. The model constructed most nearly like the drawing or plan of the original machine, which the contestant was required to furnish, received 25% and the others proportionately. S. E. 5 took first in workmanship and following the original design, the Albatross flew longest, but the "Ansaldo 1" judged a close second in all three characteristics—won a handsomely engraved shield given by Mr. Brock by having the highest average for the three points considered. Had these models been constructed in time, I am sure the Aerial Age Cup, for scale models would have had a fine chance of seeing Chicago.

A big boost was given the model game by the Chicago Aero Show, where the models created more of a sensation than the big machines. Members of the I. M. A. C. kept slow flying indoor

tractor models circling in the air above the crowds most of the time during the show. The outdoor models and the scale models were hung around above the Club's booth and a large case of accessories of all sorts stood across the booth. New members were secured, and many orders for models were taken.

A series of indoor contests for 10" R. O. C. duration machines, with two prizes for each contest was held from January to April. Along with these contests a series of lectures was given on model designing by as many old flyers as could be found. The last talk, which was a very good one, on the "General Design of Flying Models" will be printed in a later issue.

The Club gave several exhibitions of flying models at Marshall Field & Co. during the Holidays and was rewarded by a fine feed and several new members were attained. The more enthusiastic members of the Club waded out to the flying field some time ago to have a Pathe man make some pictures for Reel Twenty-Six to be shown all over the country. The pictures were quite good considering the mire.

With many of the old members gone, the success of the Club during a very hard year is nothing short of remarkable. The Club remains unchallenged as the foremost model club in the country and the holder of 9/10ths of all the world's records and another cup.

**VULCANIZATION OF RUBBER AT VARIOUS TEMPERATURES**

IT is found possible to calculate and apply a series of rising temperatures such that the vulcanization time curve for any rubber-sulphur mixture may be made a straight line, the slope of which is dependent on the temperatures employed and the amount of catalyst present (compare this J, 1916, 643). To obtain the best physical properties by vulcanization at constant temperature, sulphur must be present in the mixture in such amount that its active mass is not decreased sufficiently to diminish the rate of reaction appreciably before the desired vulcanization coefficient is attained. With rubber-sulphur mixtures containing 5 per cent or less of total sulphur, the physical properties of the mixture after vulcanization at a series of rising temperatures are inferior to those given by vulcanization at constant temperature; this is true particularly for vulcanization coefficients of 2.8 or more. For Hevea rubber the optimum vulcanization coefficient probably lies between 1.7 and 2.8. The coefficients recommended by various authorities are found to be excessive, and unless the history of the vulcanization phenomenon is fully known it is unsafe to judge samples solely on the basis of their sulphur content.—*Jour. Soc. Chem. Ind.*

# BOYS



## Learn Drafting

Employers everywhere are looking for skilled draftsmen. They are offering good salaries to start with splendid chances for advancement.

Drafting offers exceptional opportunities to a young man because drafting itself not only commands good pay, but it is the first step toward success in Mechanical or Structural Engineering or Architecture. And drafting is just the kind of work a boy likes to do. There is an easy delightful way in which you can learn right at home in spare time. For 29 years the International Correspondence Schools have been giving boys just the training they need for success in Drafting and more than 200 other subjects. Thousands of boys have stepped into good positions through I. C. S. help, but never were opportunities so great as now.

Let the I. C. S. help you. Choose the work you like best in the coupon, then mark and mail it. This doesn't obligate you in the least and will bring you information that may start you on a successful career. This is your chance. Don't let it slip by. Mark and mail this coupon now.

TEAR OUT HERE  
**INTERNATIONAL CORRESPONDENCE SCHOOLS**  
BOX 6089-B, SCRANTON, PA.

Explain, without obligating me, how I can qualify for the position, or in the subject, before which I mark X.

- |  |   |
|--|---|
| <input type="checkbox"/> ELECTRICAL ENGINEER       | <input type="checkbox"/> CHEMICAL ENGINEER                            |
| <input type="checkbox"/> Electrician               | <input type="checkbox"/> SALESMANSHIP                                 |
| <input type="checkbox"/> Electric Wiring           | <input type="checkbox"/> ADVERTISING MAN                              |
| <input type="checkbox"/> Electric Lighting         | <input type="checkbox"/> Window Trimmer                               |
| <input type="checkbox"/> Electric Car Running      | <input type="checkbox"/> Show Card Writer                             |
| <input type="checkbox"/> Heavy Electric Traction   | <input type="checkbox"/> Outdoor Sign Painter                         |
| <input type="checkbox"/> Electrical Draftsman      | <input type="checkbox"/> RAILROADER                                   |
| <input type="checkbox"/> Electric Machine Designer | <input type="checkbox"/> ILLUSTRATOR                                  |
| <input type="checkbox"/> Telegraph Expert          | <input type="checkbox"/> DESIGNER                                     |
| <input type="checkbox"/> Practical Telephony       | <input type="checkbox"/> BUSINESS MANAGEMENT                          |
| <input type="checkbox"/> MECHANICAL ENGINEER       | <input type="checkbox"/> Private Secretary                            |
| <input type="checkbox"/> Mechanical Draftsman      | <input type="checkbox"/> BOOKKEEPER                                   |
| <input type="checkbox"/> Ship Draftsman            | <input type="checkbox"/> Stenographer and Typist                      |
| <input type="checkbox"/> Machine Shop Practice     | <input type="checkbox"/> Cert. Pub. Accountant                        |
| <input type="checkbox"/> Toolmaker                 | <input type="checkbox"/> Traffic Management                           |
| <input type="checkbox"/> Gas Engineer              | <input type="checkbox"/> Commercial Law                               |
| <input type="checkbox"/> CIVIL ENGINEER            | <input type="checkbox"/> GOOD ENGLISH                                 |
| <input type="checkbox"/> Surveying and Mapping     | <input type="checkbox"/> STATIONARY ENGINEER                          |
| <input type="checkbox"/> MINING ENGINEER           | <input type="checkbox"/> CIVIL SERVICE                                |
| <input type="checkbox"/> ARCHITECT                 | <input type="checkbox"/> Railway Mail Clerk                           |
| <input type="checkbox"/> Architectural Draftsman   | <input type="checkbox"/> Textile Overseer or Supt.                    |
| <input type="checkbox"/> PLUMBING AND HEATING      | <input type="checkbox"/> AGRICULTURE <input type="checkbox"/> Spanish |
| <input type="checkbox"/> Sheet Metal Worker        | <input type="checkbox"/> Penmanship <input type="checkbox"/> French   |
| <input type="checkbox"/> Navigator                 | <input type="checkbox"/> Automobiles <input type="checkbox"/> Italian |

Name \_\_\_\_\_ 7-28-19  
Present Occupation \_\_\_\_\_  
Street and No. \_\_\_\_\_  
City \_\_\_\_\_ State \_\_\_\_\_

# EXPERIMENTAL SCIENCE

CHEMISTRY • PHYSICS •



All that its name implies

THE scientific magazine of experimental and practically applied science. Subscribe NOW. \$1.50 yearly. 15c a copy at most newsstands. Literature on request.

Experimental Science Publishing Company, 710 14th St., Washington, D. C.



# THE H. E. BOUCHER MFG. CO.

150 Lafayette Street  
NEW YORK CITY

**GENERAL MODEL MAKERS**  
*Marine Models a Specialty*

## BUILD and FLY YOUR OWN MODEL AIRPLANE



Dia.		PROPELLERS Weight Propeller	Pitch	Price
6"		1½ oz.	8"	\$0.40 each
7¼"	Racing	2½ oz.	11"	.45 each
7½"	Heavy Load	4 oz.	11"	.50 each
8"	Racing	2 to 2½ oz.	18"	.55 each
9"	Racing	3½ oz.	16"	.60 each
9½"	Heavy Load	6 to 8 oz.	12"	.65 each
10"	Racing	3½ oz.	22"	.70 each

Prices include postage.

We can supply propellers either right or left constructed on scientific basis by specially constructed machinery. Guaranteed to work. A trial will convince. Send five cents for catalogue of finished airplanes and parts.

**MODEL MAKERS SUPPLY COMPANY**  
Everyday Engineering Magazine  
Box HDH 2 West 45th Street  
New York City

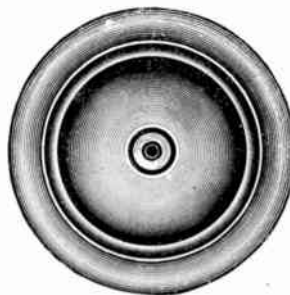

WHEELS

No. 22. Aluminum with imitation rubber tires, weight one-third ounce, diameter 1¾". Price—\$0.50 pair.

No. 23. Aluminum with real rubber tires, weight one ounce, diameter 2". Price—\$0.75 per pair.

## NEW BOOKS

**TIN, SHEET-IRON AND COPPER PLATE WORKER.** A Practical Workshop Companion by Leroy J. Blinn, Master Mechanic; New, Enlarged Edition. 334 pages, 5 x 7¾ inches; cloth binding. 207 illustrations. Published by Henry Carey Baird & Co., Inc., 2 W. 45th Street, New York City.

This volume is a new and enlarged edition of one of the most popular books on metal-plate work ever published in this country. It has helped many to solve their everyday problems in that line and should be within reach of every metal worker for ready reference. With it you need never be at a loss to describe a pattern, to solve a point in practical geometry or to know the right varnish or cement to use, or the strength of any material.

The present edition has been enlarged by the addition of many new pattern problems which deal more particularly with triangulation and modern skylight work. As a result, that department of the book, valuable heretofore, is now considerably improved. As geometrical problems never become obsolete and as pattern cutting is based on that science, the original problems are as correct and useful as ever and have therefore been retained. The following brief summary gives a good idea of the scope of the work:

Rules for Describing Patterns. Practical Geometry. Mensuration of Surfaces. Mensuration of Solids and Capacities of Bodies. Tables of Weights, etc. Tables of Circumferences of Circles to the Nearest Fraction of Practical Measurement; also the Areas of Circles in Inches and Decimal Parts; Likewise in Feet and Decimal Parts, as may be Required. Practical Receipts. Varnishes—Miscellaneous. Lacquers. Miscellaneous Cements. Important Metallic Alloys. Miscellaneous Receipts. Strength of Materials. Tables of Strength of Materials. Supplementary Pattern Problems. Index.

A noteworthy feature is the treatment of metallic alloys and solders which gives to the worker just the information he very often needs; the more important seams or joints used in plate work and the various ways of making them are illustrated and described. There are hints for tempering and for other operations and manipulations for everyday use in the workshop, also numerous useful tables which furnish ready aid and save much time. Valuable receipts of all kinds round out a most complete work. The publisher states that experts have carefully gone over the receipts and tables to insure their accuracy. The book covers a wide field and covers it exceptionally well.

# THE AMERICAN MODEL SALES AND MFG. CO.

601 Broadway

New York City

**PATTERNS  
MODELS  
CASTINGS**

**SHIP FITTINGS  
RAW MATERIALS  
BOILERS**

MAIL ORDERS ONLY

**PROMPT  
SERVICE**

**TELEPHONE  
SPRING 3337**

## WILLIAM VOGEL

INVENTIONS DEVELOPED  
MODELS, EXPERIMENTS  
Absolute Secrecy Guaranteed

**CONSULTATION**

Phone Barclay 9134 96 Warren Street  
New York City

## CELLULOID

SHEETING, PRINTING, MOULDING,  
TURNING, DIE CUTTING  
EXPERIMENTAL WORK, ETC.

**NAPIER BROWNING CO.**

105 W. 40th ST. NEW YORK CITY

## BOOK REVIEW

**EXPERIMENTAL WIRELESS STATIONS, THEIR THEORY, DESIGN, CONSTRUCTION AND OPERATION.** By P. E. Edelman, E. E. 390 pages, 5 x 7. 167 illustrations. Published by Norman W. Henley Publishing Co., No. 2 W. 45th Street, New York City.

The new 1920 revised and enlarged edition of this book gives the theory, design, construction and operation, including Wireless Telephony, Vacuum Tube and Quenched Spark Systems. This book tells how to make apparatus to not only hear telephoned and telegraphed radio messages, but also to make simple equipment that works for transmission over reasonably long distances. Then there is a host of new information included. The first and only book to give you all the recent important radio improvements, some of which have never been published.

This volume anticipates every need of the reader who wants the gist of the art, its principles, simplified calculations, apparatus dimensions and understandable directions for efficient operation, as it contains special chapters on: Nature of Wireless Transmission, Aerials, Coil and Sub-Service Systems, Grounds and Lightning Protection, The Transmitter and Resonance, Wavelength, Capacity and Oscillation Circuits, Transformers and Spark Coils, Construction Details, Auxiliary Apparatus, Condensers and Capacities, Inductances, Spark Gaps, Radiation Indicators and Measurements, Advanced Systems, Vacuum Valves and Circuits, Tube Radiotelephones, The Receiving Station, Detectors, Sensitive Indicators for Receiving Sets, Tuning and Interference Prevention, Special Receiving Sets, Receiving Condensers, Construction of Receiving Inductances, Making the Wireless Set Work, Miscellaneous Applications, Time and Weather Signals, Radio-communication, Patent Rights of the Experimenter.

One of the features evident on inspection of this book is the clarity of presentation. The amateur is told how things are done without recourse to abstruse and confusing mathematics and all types of apparatus are illustrated without limitation to any special company types as in non-independent publications. It is a complete understandable treatise of modern radio practice and is especially recommended to those of our readers who are experimenters rather than engineers.

**AUTOMOBILE STARTING, LIGHTING AND IGNITION SYSTEMS.** By Victor W. Pagé. 815 pages, 5 by 7½ inches; 425 illustrations. Published by the Norman W. Henley Publishing Co., 2 W. 45th St., New York City.

This is a revised and enlarged edition of a book on automobile starting, lighting and ignition system practice, written with special reference to the requirements of the reader desiring

## MODEL AIRPLANE ENGINES

3 Cylinder Rotary Compressed Air Engines.

¾ in. bore, ½ in. stroke  
 ½ in. bore, ½ in. stroke  
 ¾ in. bore, ¾ in. stroke

6 Cylinder rotary steam engines, steel cylinders, tobisn bronze pistons, aluminum crank case.

¾ in. bore, ½ in. stroke

Send stamp for descriptive circular.

**MODEL MACHINE SHOP CO.**  
 415 East 71st St. New York City

## OH—Just What I Wanted Real Model Racing Yachts

Sails Faster Than You Can Walk



**New York Model Boat & Mfg. Corporation**  
 Dept. EM, 18 Broadway New York City

Sport for men and boys. Construction Set—complete—30 in. long, with Rigging, Fittings and HEAVY LEAD KEEL, ready to assemble. 5 screws, 20 brads and Yacht is built. Also same Model finished ready to sail. Send 25 cents and your dealer's name and address for book "Model Yacht Sailing," just printed, giving full instructions of the Sport; How to sail, rig, nautical terms, etc., etc.

## MODEL ELECTRIC MOTOR YOU

can build this working model. All parts furnished complete with Blue Prints. No Extras required. \$2.00. Blue Prints only 25c.

A. F. CASSEL

52 W. 130th Street, New York City



Small Steam Engines & Boilers, Gas & Gasoline Engines ¼ H.P. and Up, Tanks, Pumps, Model Makers' Supplies. Get our big Catalogue sent Postpaid for 15c (coin preferred) or Stamps. Refunded first order. 192 Pages, over 200 illustrations.

**MODERN ENGINE & SUPPLY CO.**  
 364 Monadnock Bldg., Chicago, Ill.

Speed Lathe \$7 Complete Swing 7 ins. 24 in. metal bed Head has a three step cone. Spindle is hollow. Centers are No. 1 Morse taper shank. Tail stock has a screw feed spindle and No. 1 Morse taper shank center. Spur center is furnished for wood turning. Bearings are of high grade bearing metal and are adjustable to wear. Rest is adjustable to all positions. Lathe is complete at the above price. Longer bed \$1.00 per additional foot.

M. & J. SPECIALTY CO.  
 252 S. Parke St., Pontiac, Mich.

## UmakeM Lathe You make a High-grade Screw Cutting and Milling Lathe from UmakeM outfit No. 18

and 13 detail blueprints. Complete outfit \$25. Next following dimensions: Length over all, 3 ft. 11 ins.; Breadth, 13 ins.; Approximate weight, 105 lbs.; Dimensions of working surface of milling table, 4 ins. by 6 ins. This lathe has been designed to meet the wants of Model Makers who require a tool capable of very varied and accurate work. It is self-setting and self-cutting. With it all plain milling work can be done, as well as making it easy to do a great many boring jobs otherwise very difficult. Address W. R. PRICE, Inc., Dept. 17, UmakeM Bldg., 127 8th Ave., N.Y.

## Earn \$35 to \$100 a Week

BECOME A PROFESSIONAL PHOTOGRAPHER

Big opportunities NOW. Qualify for this fascinating profession. Three months' course covers all branches:

**MOTION PICTURE—COMMERCIAL—PORTRAITURE**  
 Cameras and Materials furnished free

Practical instruction; modern equipment. Day or evening classes; easy terms. The School of Recognized Superiority. Call or write for complete catalog No. 20.

**N. Y. INSTITUTE OF PHOTOGRAPHY**  
 141 W. 38th St., N. Y. 505 State St., Bklyn.

## A Necessity for Every Shop

"The Samsen No. 3 Bench Punch," with a powerful leverage of 24 to 1, is intended for work beyond the capacity of the "Samsen Hand Punches," and will punch holes from ¼ to ¾ in. in soft metal up to 12 Gauge. Extra sets punches and dies size ¼, 3/16, ¼, 5/16, and ¾ in. easily inserted and removed, (maximum punching capacity 3/16 in. through 12 gauge soft metal.)



Equipped with 3-16-inch Punch and Die unless Otherwise Specified. F.O.B. Factory  
 Price \$15.00

Catalog of Complete Line Sent on Request.

**The Machine Appliance Corporation**  
 351 Jay Street, Dept. Eng. BROOKLYN, N. Y.

## THE EXPERIMENTER'S SHOP

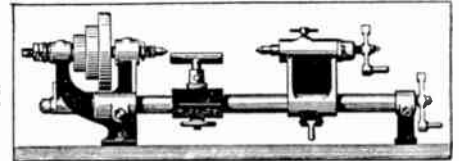

## SHOP TOOLS AND EQUIPMENT

Rough and machined castings for 6" lathes  
**DESIGNS FOR MODEL BOATS**  
 Drawings of famous ML-80 British Destroyer  
 Send stamp for catalog

**HUHN MFG. CO., 550 Elm St., ARLINGTON, N. J.**

## "RICHARDS' MADE"

Boys, you can build and race them. So can "Dad"—Complete construction sets of SAILING MODEL YACHTS. Circular tells the rest.

**WM. RICHARDS**  
 747 Tremont Ave., New York City

## Mechanical Drafting

EXPERT SERVICE—REASONABLE INQUIRIES INVITED  
**E. W. HEANEY & CO.**  
 2105 Monterey Avenue New York City  
 Telephone Fordham 6249

## Your Prospective Customers

are listed in our Catalog of 99% guaranteed Mailing Lists. It also contains vital suggestions how to advertise and sell profitably by mail. Counts and prices given on 9000 different national Lists, covering all classes; for instance, Farmers, Noodle Mfrs., Hardware Dirs., Zinc Mines, etc. This valuable reference book free. Write for it.

Send Them Sales Letters

You can produce sales or inquiries with personal letters. Many concerns all over U. S. are profitably using Sales Letters we write. Send for free instructive booklet, "Value of Sales Letters."

**Ross-Gould**  
 Mailing Lists St. Louis

# PATENTS

**To the Man with an Idea**

I offer a comprehensive, experienced, efficient service for his prompt, legal protection and the development of his proposition.

Send sketch, or model, and description, for advice as to cost, search through prior United States patents, etc. Preliminary advice gladly furnished without charge.

My experience, and familiarity with various arts, frequently enable me to accurately advise clients as to probable patentability before they go to any expense.

Booklet of valuable information and form for properly disclosing your idea, free on request. Write today.

**RICHARD B. OWEN**  
PATENT LAWYER  
144 Owen Building, Washington, D. C.

## PATENTS

EVIDENCE OF CONCEPTION

Before disclosing your invention to anyone, send for blank form, "Evidence of Conception," to be signed and witnessed. Form and information concerning patents FREE.

**LANCASTER AND ALLWINE**  
225 Ouray Building, Washington, D.C.  
Originators of the form "Evidence of Conception"

**WILLIAM C. LINTON**  
Consulting Engineer and Patent Attorney  
"Inventor's Adviser" mailed free on request. Gives full information as to Patents, Trade Marks and Their Cost.

Offices

364 University St. Montreal, Canada      920 F St., N. W. Washington, D. C.

**Competent Patent Service**  
By a Former Examining Official of the U. S. Patent Office

**NORMAN T. WHITAKER**  
Lawyer and Engineer

580 Whitaker Bldg. Washington, D. C.  
Branch Office, 87 Nassau St., New York City  
INQUIRIES INVITED

## Free Book on PATENTS

Contains valuable information and advice to inventors on securing Patents. Send model or sketch of your invention for Free Opinion of its patentable nature. Prompt service. 20 years experience. Write today

TALBERT & TALBERT 4850 TALBERT BLDG., Washington, D.C.

### Professional Assistance and Consultation

We solicit the patronage of inventors and will give prompt, confidential service in the perfection of ideas Complete drawings and plans prepared. Specialists in steam and gas engine appliances.

Correspondence Invited.  
Let Us Know Your Problem

**Bell & Hoyt**  
366 Madison Ave. New York, N. Y.

## BOOK REVIEWS

easily understood explanatory matter relating to all types of automobile electrical systems. Elementary electrical principles are considered before an attempt is made to discuss the features of the various systems. The basic principles are clearly stated and illustrated with simple diagrams. Over 200 wiring diagrams are presented. All the leading systems of starting, lighting and ignition have been described and illustrated with the cooperation of the experts employed by the manufacturers. Complete data are given for locating troubles in all systems, and full directions are given for making repairs. Various accessories operated by electric current, such as electrical gear shifts, brake actuation, signaling devices, vulcanizers, etc., are also described. An idea of the material presented in the book will be obtained from the chapter heads which are as follows: Elementary Electricity; Battery and Coil Ignition Methods; Magneto Ignition Systems; Elementary Electric Starter Principles; Typical Starting and Lighting Systems; Starting System Faults and Their Systematic Location; Miscellaneous Electrical Devices; Late Ford and Maxwell Electrical Systems; the Hudson-Delco and Two-Unit Delco Systems; The Dodge Brothers' Ignition-Starting-Lighting System; The Stutz-Remy and Mitchell-Remy Systems; Bijur-Roamer Electrical Systems; Design of Electrical Measuring Instruments and Use in Testing; 1917-1918 Wiring Diagrams of Popular Cars; 1919-1920 Wiring Diagrams of Popular Cars, Electrical System Details—1920 Cars. This is a standard work on this subject by a recognized authority and the new edition shows that the author keeps pace with all new developments in the great industry and branch of engineering he represents. This book should be in the hands of anyone interested in automobile repairing, as the diagrams alone are invaluable and worth the cost of the book.

### TO PRESERVE FISHING LINES

To preserve fishing lines and the like impregnation with copper stearate is recommended. First soak the line in a five per cent solution of Castile soap in rain water or in distilled water. Rub off the surplus and immerse in a two per cent solution of copper sulphate. The effect is to precipitate the copper stearate in the pores of the fibre and the treatment is said to have a high degree of permanency.

The following is the formula for a metal-cleaning liquid, which has had considerable popularity.

Water .....	500 parts
Ammonia .....	50 parts
Castile Soap in Powder.....	100 parts
Tripoli .....	250 parts

It may be perfumed with 5 parts essence of mirbane.

*the national joy smoke*

# PRINCE ALBERT

Our exclusive patented process cuts out bite and parch.

*You can be quickly cured, if you*

# STAMMER

Send 10 cents coin or stamps for 70-page book on Stammering and Stuttering. "Its Cause and Cure." It tells how I cured myself after stammering for 20 years.

Benjamin N. Bogue, 911 Bogue Bldg., Indianapolis

# THE Wireless World

The Official Organ of the Wireless Society of London

Commencing with April 3d, will be published fortnightly in order to adequately deal with the increasing amount of Wireless Experimental and Research Work.

Full of Practical hints and useful information for Wireless Amateurs.

Extensive reports of the Wireless Societies of Great Britain.

**Annual Subscription 17s, Post Free**  
Single Copies 9d, Post Free

To be entirely up-to-date in your knowledge of Wireless you must be a subscriber to The Wireless World.

---

To the Publisher,  
The Wireless World,  
12-13 Henrietta St., London, WC2, England.

Please enter me as a subscriber to the Wireless World for the period ..... to ..... for which I enclose.....

Name .....

Address .....

Please write distinctly.

# CLASSIFIED ADVERTISING COLUMNS

## HAVE YOU ANYTHING TO BUY, SELL OR EXCHANGE?

Automobile owners, mechanics, model makers, motor boat owners, radio and electrical experimenters and students read these classified columns every month, looking for advertisements of things they need. Are you telling them what you have? The cost is but 7c a word; about 7 words per line. Advertisements should reach us by the first of the month to insure proper classification.

### Agents Wanted

**MAKE \$30.00 NEXT SATURDAY.** Speederator for Fords selling like wildfire. Used by Ford Motor officials. Makes any Ford run like a Packard. Stops stalling and bucking. Put on quick—Instant satisfaction. No holes to bore. Sell ten to twelve a day easy. Splendid profits and exclusive territory. Write quick for information. Address Perrin Co., 1047 Hayward Bldg., Detroit, Mich.

**AGENTS MAKING \$200 WEEKLY** selling Bull Dog Inner Tires. Double life of tires, eliminate blowout and punctures. Big repeater. Wonderful opportunity to establish independent, permanent, growing business. Write at fish independent, permanent, growing business. Write at Eastern Auto Specialty Co., Dept. 5, Utica, N. Y.

**WANTED—Men with Ford cars** to work home territory or travel; earn \$10 to \$25 daily. Write for particulars. Barrett Motor Starter Mfg. Co., 1777 Broadway, New York City.

**WOULD YEAR ORDER** quick seller interest you? Dept. 51. Martinek Company, 405 Lexington Avenue, New York.

**BIG MONEY** and fast sales. Every owner buys gold initials for his auto. You charge \$1.50; make \$1.35. Ten orders daily easy. Write for particulars and free samples. American Monogram Co., Dept. 72, Glen Ridge, N. J.

### Automobile Accessories

**VULCANIZE RUBBER** without heat or tools. Whirlwind seller to every Auto Owner. Further particulars free. Muscatine Agency, E402, Muscatine, Iowa.

**STORAGE BATTERIES FOR AUTOMOBILES.** We furnish all parts and moulds for making them. Sample Plate 40c. Foreign Countries 50c. Windsor Specialty Co., 5419 Windsor Ave., Chicago, Ill.

### Aviation

**CONSULTING AERONAUTICAL** and Automotive Engineers. Inventions analyzed and developed. Designs prepared. Tests. Expert advice. Van Huffling & Marx, City College, New York.

### Books

**BOOKS DELIVERED FREE.** Write today for Illustrated Guide to the Latest Books. Wesley Mills Co., Dept. A, 500 Fifth Avenue, New York, N. Y.

### Business Opportunities

**FREE information** regarding large earnings, Raising Canaries for pastime. Birdland, Lynnhaven, Virginia.

**SUBSTANTIAL Manufacturing corporation** wants capable men to establish branch and manage salesmen. \$300 to \$1,500 necessary. Will allow expenses to Baltimore as explained. Address, Treasurer, 416 N. Howard St., Baltimore, Md.

**AMBITIOUS MEN—Grasp this opportunity** to make money. You can make \$5.00 to \$10.00 every day in your spare time at home. Not a cheap scheme, agency or soliciting proposition, but substantial business plus. Investigate this today. Address, Business, Box 175, Fredonia, N. Y.

**START a business of your own.** 24 plans, \$1.00. Joel Tillberg, Proctor, Vermont.

**SUBSTANTIAL MANUFACTURING CORPORATION** wants capable men to establish branch and manage salesmen. \$300 to \$2000 necessary. Will allow expenses to Baltimore as explained. Address, Mr. Clemmer, 603 N. Eutaw St., Baltimore, Md.

### Cameras

**SEND favorite negative** and 50 cents for a beautifully mounted enlargement, guaranteed to please you or your money refunded by return mail. Western Portrait Co., 2118 Kendall St., Chicago, Ill.

### Chemicals

**EXPERIMENTAL LABORATORIES**, fully equipped—\$11.00 to \$100.00. Pack-out 14 in or Cash. Descriptions and actual photographs free. Write Dept. E-27, Lions Scientific Institute, "Laboratory Outfitters," Mt. Oliver, Pittsburgh, Pa.

**CHART OF CHEMICAL SOLUBILITIES.** 375 chemicals listed. Hang it in your laboratory. Useful. Wallc. 3118 14th Street, Washington, D. C.

### Dogs

**SPORTSMEN—Trained beagles, rabbit, fox, coon, skunk, squirrel and opossum dogs, bird dogs, pet and farm dogs, wine, rabbits, pigeons, pheasants, goats.** 100 varieties blooded stock. Circulars 10c. Violet Hill Kennels, York, Pennsylvania.

### Electrical

**INSTANTANEOUS Hot Water Heater**, attachable any faucet, valuable hospitals, physicians, and dentists' offices, barbers, and home use. Retail \$60. Dealers \$45. Victor O. Ford Company, 250 West 54th St., New York.

### Ford Owners

**FORD SPEED-POWER EQUIPMENT** stocked; 4 Speed Forward Auxiliary Transmissions, Doubles Pulling power. Increases speed 40 or 20%; 16 Valve Overhead Cylinder-head; speed carburetors; camshaft, piston rings; light pistons, crankshaft counterbalances; high tension magnets; underslung fixtures; speed power bevel gears; foot accelerators; steering wheels; wirewheels; disc wheels; metal wheel discs; Ford Fire Chemical Hook and Ladder; 15"-30" Double Universal Wheelbase Extension; 1 1/2 ton Side Spring Additional Frame Work Units; Complete Lane 1 1/2 ton Shaft-Chain Drive Units; Racing Body; Complete Racing Cars \$500.-\$1750. E. V. Ford Speed-Power Equipment Manufacturers, 250 West 54th St., New York.

### Formulas

**EXPERT CHEMIST** will furnish Formulas, Processes and Trade Secrets. All lines. Lists free. W. L. Cummings, Ph.D., 228-230 Gordon Ave., Syracuse, N. Y.

### For Sale

**MOTOR BOAT POWER PLANT COMPLETE—Four cylinder, Liteson H.P. Motor; Rear Starter; Magneto and Carburetor; Clutch and Reverse Gear; Enclosed Type; Spicer Universal Joint. Must sacrifice. Practically New. Price \$100.00 F.O.B. New York. Box 10, Everyday Engineering Magazine.**

### Guinea Pigs

**WANTED—5,000 baby guinea pigs** 3 to 4 weeks old 60c each. Who will raise them for us? Breeding stock supplied at moderate prices. Western Reserve Animal Industries, Drawer B, Station E, Cleveland, Ohio.

### Help Wanted

**WRITE for newspapers and magazines.** Big pay. Experience unnecessary, details free. Press Reporting Syndicate, 534 St. Louis.

### Inventors

**INVENTORS—Write for our free illustrated guide book** and Evidence of Conception Blank, seen model or sketch and description of invention for our opinion of its patentable nature free. Highest References. Prompt Service. Reasonable Terms. VICTOR J. EVANS & CO., 748 Ninth, Washington, D. C.

**INVENTOR'S MANUAL, HOW TO MAKE A PATENT PAY** is a work of special interest to inventors in perfecting their inventions, taking out their patents, and disposing of them. It is not in any sense a Patent Solicitor circular nor a Patent Broker's advertisement. No advertisements of any description appear in the work. It is a book containing a quarter of a century's experience of a successful inventor, together with notes based upon the experiences of many other inventors. 120 pages. Price \$1.25 postpaid. The Norman W. Henley Publishing Co., 2 West 45th Street, New York.

**TWO VOLUMES on MECHANICAL MOVEMENTS** by G. D. Hiscop are works every inventor should have for reference. If the thing you want has been invented, it is illustrated in these volumes. If it hasn't been invented, then you'll find in it the nearest things to what you want, some movement or device that will apply in your case, perhaps, or which will give you a key from which to work. No books ever published are of more real value to the inventor, draftsman or practical mechanic than this set of books. Price per volume each \$4.00 prepaid. The Norman W. Henley Publishing Co., 2 West 45th Street, New York.

### Male Help Wanted

**SALESMEN—City or Traveling.** Experience unnecessary. Set for list of lives and full particulars. Prepare in spare time to earn the big salaries—\$2,500 to \$10,000 a year. Employment services rendered members. National Salesmen's Training Association, Dept. 157-K, Chicago, Ill.

**DETECTIVES EARN BIG MONEY.** Travel, unusual opportunity. Write Johnson's Detective Correspondence School, Deck 17, 232 Stuyvesant Ave., Grand Rapids, Mich.

**DETECTIVES EARN BIG MONEY.** Excellent opportunity. Travel Experience unnecessary. We train you. Particulars free. Write, American Detective System, 1968 Broadway, N. Y.

**RAILWAY TRAFFIC INSPECTORS** earn from \$110 to \$200 per month and expenses. Travel if desired. Unlimited advancement. No age limit. We train you. Position furnished under guarantee. Write for Booklet, CM-36. Standard Business Training Institute, Buffalo, N. Y.

**FIREMEN, Brakemen, Baggage-men** \$140-\$200; Colored Foremen by Railroad, everywhere. Experience unnecessary. 898 Ry. Bureau, East St. Louis, Ill.

### Miscellaneous

**FIVE MASTER KEYS** and Novel Key Chain \$1.00. Open hundreds of different locks and replace hundreds of different keys. Recommended by locksmiths, real estate men, and detectives. Master Key Co., 33 Manhattan Building, Milwaukee, Wis.

**SUPERIOR SANITARY CUSHIONS.** Sell at baseball parks, race tracks, fairs, circuses, etc. Sample 15c postpaid. Superior Sanitary Cushion Company, 419 Boston Block, Minneapolis.

**1000 LETTERHEADS, envelopes, cards, etc., \$3.50.** Samples. E. M. Orvis, Hackensack, N. J.

**I WANT \$200.00 to complete model and patent same.** This is not a charitable loan, but a strictly business proposition with good returns. A. C. Backer, P. O. Box 97, South Coventry, Conn.

### Motion Picture Plays and Supplies

**\$25-\$300 PAID ANYONE** for ideas, suggestions suitable for photoplays. Experience unnecessary; complete outline free. Producers League, 530, St. Louis, Mo.

**PHOTOPLAYS WANTED.** Big prices paid. You can write them. We show you how. Free particulars. Rex Publishers, Box 175A-10 and 175A-11, Chicago, Ill.

### Motorcycles

**\$25.00 UP, GUARANTEED REBUILT MOTORCYCLES.** Henderson, Excelsior, Indian, Harley-Davidson, Bicycles, \$5.00 up. Tires and accessories at wholesale. Illustrated Bulletin free. Ash Motor Corporation, 162 N. Clinton Ave., Rochester, N. Y.

### Opportunities

**AUTOMOBILE OWNERS' FRIEND,** labor, money saver \$1 guaranteed. Kautch Sales Co., Stockton, Cal.

### Patents

**PATENTS—Herbert Jenner,** Patent Attorney and Mechanical Expert. 622 F St., Washington, D. C. I report if a patent can be had and its exact cost. Send for circular.

**PATENTS.** Over 70 years' practice; all communications strictly confidential; handbook on patents free on request; special facilities for office consultations. Munin & Co., Patent Attorneys, 641 Woolworth Building, New York. 625 F Street, Washington; Tower Building, Chicago; Hobart Bldg., 582 Market Street, San Francisco, Calif.

**PATENTS.** In all matters pertaining to invention consult National Institute of Inventors, 118 Fulton St., New York City, having three thousand members. Booklet free. "INVENTORS RECORD" and "Bulletin" sent without charge. My free blank form for disclosing your invention simplifies procedure. Send sketch or description for preliminary advice. Wm. H. Mulligan, Registered Attorney, 384 Woodward Building, Washington, D. C.

**PATENT** what you invent. It may be valuable. Write me. No attorney's fee until patent is allowed. Etab. 1882. "Inventor's Guide" Free. Franklin H. Hough, 510 Loan & Trust Bldg., Washington, D. C.

**PATENTS—Fees in installments.** Frank T. Fuller, formerly Lieutenant, Engineer, Washington, D. C.

**PATENTS—Prompt, personal, efficient service** by an attorney-at-law, skilled in all branches of Patent Practice. Over 12 years actual experience; full information upon request. B. P. Fishburne, 322 McGill Bldg., Washington, D. C.

**DON'T LOSE** your rights to patent protection, before disclosing your invention to anyone send for blank form "Evidence of Conception" to be signed and witnessed. Form and information concerning patents free. Lancaster and Allwine, 237 Ouray Building, Washington, D. C. Originators of the form "Evidence of Conception."

### Phonographs

**BUILD YOUR OWN PHONOGRAPH—Big saving.** We furnish parts and cabinets. Write today for free instructions. Associated Phonograph Supply Co., Dept. V, Cincinnati, Ohio.

### Photo Developing

**MAIL US 20c** with any size film for development and six velvet prints. Or send six negatives any size and 20c for six prints. Or send 40c for one 8 x 10 mounted enlargement. Prompt, perfect service. Roanoke Photo Finishing Co., 283 Bell Ave., Roanoke, Va.

### Short Stories Wanted

**SHORT STORIES, Poems, Plays, Etc.,** are wanted for publication. Literary Bureau, 166 Hannibal, Mo.

### Stammering

**ST-STU-T-T-TERING** and Stammering cured at home. Instructive booklet free. Walter McDonald, 103 Potomac Bank Building, Washington, D. C.

**STAMMERS.** My course of private lessons is inexpensive and will correct your impediments. Samuel E. Robbins, 246 Huntington Avenue, Boston.

### Stamps

**APPROVAL 60% discount.** Reference, please. Stamp bought. Lang, 1433-J 59th, Cicero, Illinois.

**HAVE YOU SEEN THE STAMP HERALD?** Finest monthly stamp paper published. Subscription 50c a year. 3 months trial for 10c. Stamp Herald Publishing Co., Dept. E, Indianapolis, Ind.

**STAMPS FREE—60** all different for the names of two collectors and 2c postage. 30 Sweden stamps 10c. 20 Denmark stamps 10c. Toledo Stamp Co., Toledo, Ohio, U. S. A.

### Telegraphy

**TELEGRAPHY** (both Morse and Wireless) and Railway accounting taught quickly. Tremendous demand. Big salaries. Great opportunities. Oldest and largest school; established 46 years. All expenses low—can earn large part. Catalogue free. Dodge's Institute, P. St., Valparaiso, Indiana.

### Toys

**AMERICAN MADE TOYS NEEDED.** Homemakers on small scale and manufacturers on large scale wanted to manufacture Toy Soldiers, Army, Navy, Machine Guns, Cannons, War Ships, Indians, Cow-boys, Wild Animals, Whistlers and other toys and novelties. Greatest chance for industrial people to have an independent business. Enormous demand gives an unlimited field and great future all over the United States, Canada and foreign countries. Experience or tools not necessary. Hundred and more made complete per hour. Casting forms, complete outfit from \$3.00 up. We buy these goods all year paying fixed prices. For painted goods we offer attractive prices. Contracts made with reliable parties. We have connections all over the United States and goods made with these casting forms are badly needed by all wholesale and retail dealers on account of the scarcity in these lines. Greatest opportunity is offered manufacturers of American Made Toys. A strictly business proposition and no one need apply unless he means business. In this case write for booklet and information, furnished free. Toy Soldier Mfg. Co., 32 Union Square, New York City.

### Wireless

**WIRELESS PARTS, PROMPT DELIVERY.** Standard 1 1/2" switch knob-lever complete 35c. Switch points with screw 25c dozen. State panel thickness. Novotoy Electric, Charlotte, N. C.

# New Patent of Sherwin Cody's Makes Perfect English Easy In 15 Minutes a Day

An amazing new method that corrects bad habits in speech and writing at once

**T**HE tremendous value of good English in everyday life cannot be overestimated. Today the ability to speak and write correctly and forcefully has come to be a commercial necessity. It is the invaluable weapon with which every man who is striving for success must be equipped. Business demands men who can write and talk straight from the shoulder, and straight

to the point, without making mistakes in grammar, punctuation, pronunciation, spelling, and without using weak over-used words. *Business demands such men and is paying for them.*

The difference between weak, incorrect English, and crisp, vigorous English is the difference between the high stool and the mahogany desk. When one stops to consider that by actual test the average man in business is 61 per cent. efficient in the vital points of English the need for a method of teaching correct English is apparent.

After twenty years of scientific research and study Mr. Sherwin Cody, perhaps the best-known teacher of practical English in the country, has perfected his amazing "100 per cent. Self-Correcting System" and places it at your disposal.

## Only 15 Minutes a Day

This astonishing invention upsets all the old standards of teaching. By careful analysis Mr. Cody discovered all the faults embodied in the old methods and has remedied them. Useless rules, hard to remember, impractical definitions, lengthy uninteresting exercises have all been cast aside. The time usually required for a comprehensive study of English has

been cut down by several hundred per cent. *Fifteen minutes spare time each day, gives you a command of language that enables you to compete with men who have spent years in school and college studying for this key to social and business success. You need no longer work under the terrible handicap of poor English—Mr. Cody's great invention places Language Power within your reach.*

## The 100% Self-Correcting Method

On October 15th, 1918, Mr. Cody was granted a patent on his unique device. He went to great corporations and examined the employees and talked with the employers. He examined the methods in use in schools. From the data thus acquired, he has built his entire system. He has worked on the basis that good English can be taught only by *making the student form the "Habit" of correctness.* The 100 per cent. Self-Correcting system accomplishes this with most astounding effectiveness. It seems almost like magic. You write your lesson, whatever it may be, spelling, punctuation, grammar, letter writing, etc., in the space provided, then you see underneath just how Mr. Cody would correct it. You mark your errors, and try the same lesson later to see how many errors you have overcome. You see at a glance where you have improved. *You know at every step just where you stand.* It is as if Mr. Cody stood at your elbow every minute to correct and help you. Progress is unbelievably rapid. *In recent tests students of Mr. Cody's method improved more in five weeks than students of other methods did in two years.* And the wonderful part about it all is that only fifteen minutes of your spare time each day are necessary.

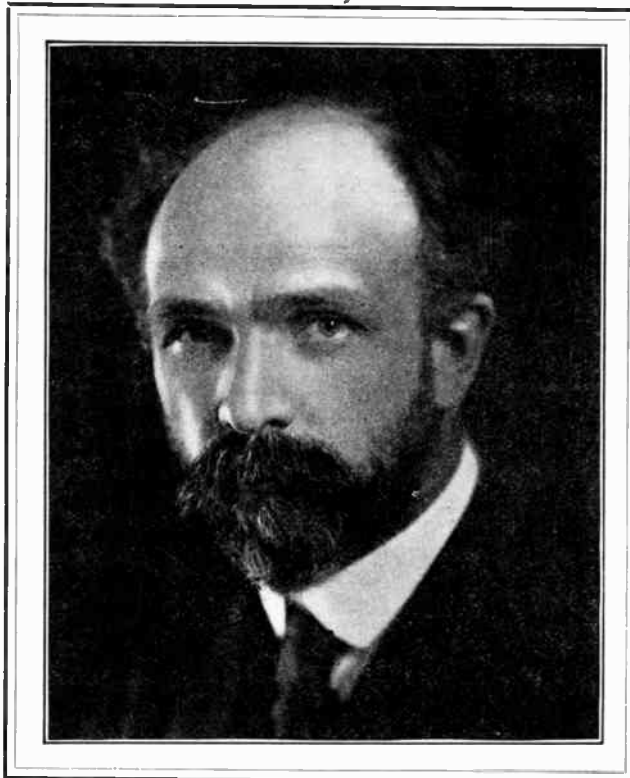

## Good English in Business

A well-known millionaire once said, "I know of no ability more valuable to the business man than the ability to speak and write good English." He knew what he was talking about—Language Power wins every time. All business is a game of buying and selling. Everyone has something to sell, whether it be buttons or brains. What you are selling makes no difference—you cannot be a good trader unless you tell others what you have in a way that will make them want to buy it. You must convince the buyer that what you have to sell is worth more to him than the money he is paying for it. Words are the weapons with which you fight your everyday battles. It is the man who uses these weapons that achieves success. The man who by the correctness and energy of his language can sway men's minds at will is the man who gains recognition and position. *He is the man who comes out on top.* Vigorous language, whether written or spoken, is the force that gets things done, it is the force that makes friends and holds them, it is the force that carries men up the road to success.

## Good English Is An Investment

The words you use are an advertisement of yourself and your worth. Spoken and written they are the sure index of your character. The use of ordinary words makes people regard you in an ordinary light; to appear at your best, you must use the best language possible. It is by their language that men are judged more than by any other characteristic. The use of precise, epigrammatic, hard-hitting words is the indication of a self-confident, independent, mentally alert man. Remember, people are watching you every minute. The impression you make depends on what you say and how you say it. The impression you make on other people can either be your greatest asset or your gravest liability.

## A New Booklet Free

Mr. Cody has written a new book of immense interest. In it he explains his 100 per cent. Self-Correcting Method, shows how and why it was evolved, and gives the results it has produced. He defines Language Power and shows you how you can acquire it in fifteen minutes of fascinating study a day, and why you should acquire it. If you want to get ahead, this book will be a revelation to you.

*Write to-day.* Every day you put it off means an actual loss to you. Don't needlessly handicap yourself by using poor English. Detach the coupon below and mail it at once, or just write a postal card, but do it now.

## SHERWIN CODY SCHOOL OF ENGLISH 258 News Bldg. Rochester, N. Y.

Sherwin Cody School of English,  
258 News Bldg., Rochester, N. Y.

Please send me at once New Free Book explaining about the "100 per cent. Self-Correcting" Course in English.

Name .....

Address .....

City .....

State .....

### Course a Great Help

"I cannot too highly recommend it, and I would advise any young persons who are compelled to leave school at an early age to take this course. They will be greatly benefited by the lessons in Composition, Spelling, and the reading of good literature. I consider the time and money well spent." —Paul R. Snyder, Saugerties, N. Y.

### Most Interesting Device for Self-Education

"Your 100 per cent. Self-Correcting Course in English Language is the finest and most interesting device for self-education I have ever tried.

"The system of checking up written work is absolutely infallible for showing up errors, and the student can immediately start in to correct his weak points, for these lessons will show him exactly what they are." —G. Fry, Baltimore, Md.

### No Others That Compare With Yours

"I am quite familiar with your works and honestly I do not believe there are any other publications in the field that can begin to compare with yours, along the line of plain, simple English composition. — how to make people talk in a straightforward way on paper." — Walter D. Moody, formerly Manager Chicago Association of Commerce, Chicago, Illinois.

### No Method Equal To Yours

"I hope you will be very successful in placing your 100 per cent. Self-Correcting Course in English in the hands of a large number of young business people. It would be a splendid thing if it could be studied carefully by an equal number of older people.

"The ability to use the English language correctly is a fine asset for anyone, and especially those who are engaged in business.

"I do not believe there is anything in which the usual business worker is so deficient as in the power of expression. I know of no method at all equal to this by which that power can be enlarged." —C. R. Hebble, Executive Secretary, Cincinnati Chamber of Commerce, Cincinnati, Ohio.



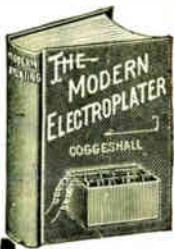

# HENLEY'S New Practical Books



## MOTOR BOATS AND BOAT MOTORS

By Victor W. Pagé, and A. Clark Leich. (6 x 9.) 524 pages. 372 illustrations. Cloth. Price \$4.00.

Indispensable for owners, users, repairmen or operators of motor boats and marine engines.

## SHOP PRACTICE FOR HOME MECHANICS

By Raymond Francis Yates. (6 x 9.) 324 pages, 309 illus. Cloth. Price \$3.00.

Deals with small tools and machines such as those employed about the home shop.

## STARTING, LIGHTING AND IGNITION SYSTEMS

By Victor W. Pagé. 815 pages. 492 specially made engravings. 1920 Edition, Revised and Enlarged. Price \$3.00.

A practical treatise on latest automobile starting, lighting and ignition system practice. Over 200 wiring diagrams are shown in both technical and nontechnical forms. Complete data is given for locating troubles in all systems, the various steps being considered in a logical way for those without expert electrical knowledge. All ignition systems receive full consideration, starting with the simplest battery and coil forms found on early cars to the modern short-contact timer and magneto methods used with the latest eight and twelve-cylinder motors.

## ABRASIVES AND ABRASIVE WHEELS

By Fred B. Jacobs. 340 pages, 200 illustrations. Price \$3.00.

A new book for everyone interested in abrasives or grinding. A careful reading of the book will not only make mechanics better able to use abrasives intelligently, but it will also tell the shop superintendent of many short cuts and efficiency-increasing kinks. The economic advantage in using large grinding wheels are fully explained, together with many other things that will tend to give the superintendent or workman a keen insight into abrasive engineering.

## HENLEY'S TWENTIETH CENTURY BOOK OF RECIPES, FORMULAS AND PROCESSES

Edited by Gardner D. Hiscox. 1920 edition. Cloth binding. Price \$4.00.

The most valuable technochemical formulæ book published, including over 10,000 selected scientific, chemical, technological and practical recipes and processes. This book of 800 pages is the most complete book of recipes ever published, giving thousands of recipes for the manufacture of valuable articles for everyday use. Hints, helps, practical ideas and secret processes are revealed within its pages. It covers every branch of the useful arts and tells thousands of ways of making money and is just the book everyone should have at his command.

## LIQUID AIR AND THE LIQUEFACTION OF GASES

By T. O'Connor Sloane. 400 pages fully illustrated. (1920.) Price \$3.00.

The third revised edition of this book has just been issued. Much new material is added to it; and the all-important uses of liquid air and gas processes in modern industry, in the production especially of nitrogen compounds, are described. The book gives the history of the theory, discovery, and manufacture of Liquid Air, and contains an illustrated description of all the experiments that have excited the wonder of audiences all over the country. It shows how liquid air, like water, is carried hundreds of miles and is handled in open buckets.

## MODERN ELECTROPLATING

By Kenneth M. Coggeshall. 350 pages, 142 illustrations. Price \$3.00.

Anyone interested in practical plating and metal finishing will find this book a valuable guide and complete manual of the art.

## EXPERIMENTAL WIRELESS STATIONS

By P. E. Edelman, E. E. (5 x 7) 390 pages, 167 illus. Cloth. Price \$2.50.

Answers every question—clears up mysteries of things radio, you have often wondered about.

## THE MODEL T FORD CAR, ITS CONSTRUCTION, OPERATION AND REPAIR, INCLUDING THE FORDSON FARM TRACTOR, F. A. LIGHTING AND STARTING SYSTEM, FORD MOTOR TRUCK

By Victor W. Pagé. 410 pages, 153 illustrations, 2 large folding plates. Price \$2.00.

This is the most complete and practical instruction book ever published on the Ford car and Fordson tractor. To the 1920 Revised Edition matter has been added on the Ford Truck and Tractor Conversion Sets and Genuine Fordson Tractor. All parts are described. All repair processes illustrated and fully explained. Written so all can understand—no theory, no guesswork. New Edition.

## MODEL MAKING

By Raymond Francis Yates. 400 pages, 301 illustrations. Price \$3.00.

A new book for the mechanic and model maker. This is the first book of its kind to be published in this country and all those interested in model engineering should have a copy. The first eight chapters are devoted to such subjects as Silver Soldering, Heat Treatment of Steel, Lathe Work, Pattern Making, Grinding, etc. The remaining twenty-four chapters describe the construction of various models such as rapid fire naval guns, speed boats, model steam engines, turbines, etc.

## ELECTRICIAN'S HANDY BOOK

By Prof. T. O'Connor Sloane. 840 pages, 600 engravings, handsomely bound in cloth. 1920 edition. Price \$4.00.

This work has just been revised and much enlarged. It is intended for the practical electrician who has to make things go. The entire field of electricity is covered within its pages. It is a work of the most modern practice, written in a clear, comprehensive manner, and covers the subject thoroughly, beginning at the A B C of the subject, and gradually takes you to the more advanced branches of the science. It teaches you just what you should know about electricity. A practical work for the practical man.

## WESTINGHOUSE E. T. AIR-BRAKE INSTRUCTION POCKET-BOOK CATECHISM

By Wm. W. Wood, Air-Brake Instructor. Cloth. 1920 edition. Price \$2.50.

A practical work containing examination questions and answers on the E. T. Equipment. Covering what the E. T. Brake is. How it should be operated. What to do when defective. Not a question can be asked of the engineman up for promotion on either the No. 5 or the No. 6 E. T. equipment that is not asked and answered in the book. If you want to thoroughly understand the E. T. equipment get a copy of this book. It covers every detail. Makes air-brake troubles and examinations easy. Fully illustrated with colored plates, showing various pressures.

*These Are the Books You Should Procure*

All Up-to-date and Reliable

Any of these books sent prepaid on receipt of price. FREE—1920 Catalogue of Practical Books—Send for a Copy

**The Norman W. Henley Publishing Co.**

2 WEST 45th ST., NEW YORK

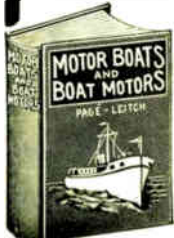

# Everything New About Shop Work!

## Examine Them Free

The sixth edition of Modern Shop Practice is now off the press. Let us send you the six volumes for seven days' free examination—not a penny in advance. See how 27 mechanical engineers, designers, and specialists in shop methods have given you the benefit of their vast experience. Read what they say about production, metallurgy, welding, tool making, tool design, die making, metal stamping, foundry work, forging, pattern making, mechanical and machine drawing, speed lathes, planers, metal drillers, grinders, milling machines, stamping machines, die presses, etc. Then after free examination, send the books back unless you are convinced they will raise your pay.

## Jump Ahead

The more you know about machine shop practice, the more money you will earn. Don't depend on your hands alone to earn your pay. Make your head work for you. Equip yourself with knowledge that designs machinery, that does the big work. These six massive volumes tell everything you want to know about every phase of shop work. Written in clear, non-technical language.

## Only 7 Cents a Day

These six magnificent volumes are flexibly bound in American Morocco, gold stamped. Contains 2300 pages, 2500 illustrations, photographs, drawings, explanatory diagrams, tables, etc. Up-to-date labor saving methods that big manufacturers have spent thousands of dollars to learn. Facts that you can use in your every day work at once. Examine the books free. Then if satisfied, pay for them at rate of 7c a day.

## No Money in Advance

Not a cent in advance. See the books in your own home first. Read them for seven whole days before you decide. Make no deposit—assume no obligation. If you are not more than satisfied—send them back and you won't owe a cent. If you are sure they will raise your pay—send only \$2.80 within seven days and then \$2 a month until the special introductory price of \$24.80 has been paid. (Regular price \$30.) With each set we give you Free a year's Consulting Membership in the American Technical Society. (Worth \$12.) Mail coupon for the books now. Send no money.

**AMERICAN TECHNICAL SOCIETY**  
Dept. M-35c CHICAGO, U. S. A.

AMERICAN TECHNICAL SOCIETY  
Dept. M-35c, CHICAGO, U. S. A.

Please send me the six-volume set of "Modern Shop Practice" for seven days' examination, shipping charges collect. If I decide to buy, I will send \$2.80 within seven days and balance at \$2 a month until \$24.80 has been paid. Then you will send me a receipt showing that the set of books and the Consulting Membership are mine, and fully paid for. If I think I can get along without the books, I will return them at your expense after seven days.

Name.....

Address.....

Reference.....



### 6 Great Volumes

Flexibly bound in American Morocco, gold stamped, six thick volumes, 2,300 pages, 2,500 photographs, drawings, tables and other explanatory illustrations.

### Double Your Earnings

Machinists, tool-makers, designers, pattern-makers, foundrymen, production experts are everywhere in demand. There are big positions and steady work for "Top Notch" Master these practical shop books, written by 27 experts, and double or treble your pay.

**Partial List of Contents**  
Shop Work, Shop Knives, Gear Cutting, Turret Lathes, Sewing Machines, Manufacturing Shop Management, Metallurgy, Welding, Die Making, Metal Stamping, Tool Making, Punch and Die Work, Malting, Foundry Practice, Pattern Making, Moulding Practice, Mechanical Drawing, Machine Drawing and Design, Automobile Shop Work.