

# C O N T E N T S

VOL. 9

JULY, 1920

NO. 4

COMMON CAUSES OF AUTOMOBILE NOISES— PART 1 .....	297
<i>By Victor W. Pagé, M. S. A. E.</i>	
MODERN PRECISION MEASUREMENTS.....	300
<i>By Harry A. Mount</i>	
ELECTRONS AND THE CONSTITUTION OF THE CHEMICAL ATOM .....	303
<i>By Prof. T. O'Connor Sloane</i>	
JET PROPULSION FOR MOTOR BOATS.....	305
HEAT TREATING ALLOY STEELS—PART 3.....	306
<i>By Victor W. Pagé, M. S. A. E.</i>	
DOMESTIC ILLUMINATING ENGINEERING.....	309
<i>By Harry A. Mount</i>	
A COMPRESSED AIR DRIVEN MONOPLANE.....	310
<i>By H. C. Ellis</i>	
HOW TO MAKE A COMPRESSED AIR MOTOR....	312
<i>By V. Davenport</i>	
A SIX-CYLINDER AIR MOTOR.....	314
<i>By A. Bohaboj</i>	
MODEL STEAM ENGINE AND BOILER CONSTRUCTION—PART 1.....	315
<i>By W. A. Helm</i>	
GAS HEATED SOLDERING COPPER.....	317
SWITCHES AND CUT OUTS.....	318
<i>By Prof. T. O'Connor Sloane</i>	
A MINIATURE RAILROAD SYSTEM.....	320
SHOP PRACTICE .....	321
Air Pressure Device for the Transfer of Oil— Protecting Molten Metal from Oxidation—Practical Oil Drill—Adapter for Surface Gauge— Hardening Small Carbon Steel Tools—Special Tool Holder—Using Cross-cut Saw as Try Square —Chart for Power Transmitted by Leather Belts —Quick Setting Machine Vise.	
NAPIER'S RODS AND THEIR USE.....	323
<i>By Prof. T. O'Connor Sloane</i>	
THE EVERYDAY MOTORIST.....	324
HOW TO TEST ENGINES FOR HORSEPOWER....	326
<i>By Adrian Van Muffing, M. S. A. E.</i>	
EXTRUDED METAL .....	327
UNIFLOW STEAM ENGINE—PICKLING AND CLEANING CASTINGS .....	329
ELECTRICAL PROGRESS DIGEST.....	330
SPECIAL APPLIANCES FOR EXPEDITING AUTOMOBILE REPAIRING .....	332
<i>By Victor W. Pagé, M. S. A. E.</i>	
BURNING PULVERIZED FUEL.....	335
AVIATION BRIEFS .....	336
London and Paris Aerial Passenger Service—The "Mosquito" and "Sport" Farman Airplanes—Fast Hydro-Aeroplane—Commercial Transport in China.	
MANUAL ARTS AND CRAFTS.....	338
<i>By Charles E. Muller, M. A. E.</i>	
Combination Hall Tree—Mission Style Hall Seat	
PHOTOGRAPH PROJECTOR MADE FROM CAMERA.	340
<i>By L. B. Robbins</i>	
EVERYDAY SCIENCE NOTES.....	342
TWO-STEP AUDIO FREQUENCY AMPLIFIER....	344
<i>By M. B. Sleeper</i>	
THE RADIO DEPARTMENT.....	347
RADIO EQUIPMENT FOR SMALL BOATS.....	348
TAPPING SINGLE LAYER INDUCTANCES.....	351
NEW RADIO APPARATUS.....	352
KNOBS FOR RADIO EQUIPMENT.....	353
A SIMPLE METHOD OF MEASURING INDUCTANCES OF LOW FREQUENCIES.....	354
THE BUREAU OF STANDARDS RADIO CLASSIFICATION .....	356
SEMI-LUMINOUS PAINT .....	366
BOOK REVIEW .....	381

# EVERYDAY ENGINEERING MAGAZINE



2 West 45th Street

New York City

A Dependable, Instructive Digest of Current Mechanical,  
Scientific, Automotive and Radio Progress.

*Managing Editor* VICTOR W. PAGÉ      *Science Editor* PROF. T. O'CONNOR SLOANE      *Radio Editor* M. B. SLEEPER  
*Contributing Editors*

L. M. CLEMENT  
*Radio Engineering*

CHAS. E. MULLER  
*Manual Arts and Crafts*

*Advertising Manager*  
STEPHEN ROBERTS

*Branch Advertising Office*  
SEARS & IRVING, Peoples Gas Building, Chicago, Ill.

Published Monthly by  
EVERYDAY MECHANICS COMPANY, Inc.  
New York, N. Y.

Entered as second-class matter November 20, 1915, at the post office at New York, N. Y., under the Act of March 3, 1879.

Subscription price \$2.00 a year in the United States and possessions; Canada, \$2.25; Foreign, \$2.50 a year.

Copyright, 1920, by Everyday Mechanics Co., Inc.

## The Age of Precision

THIS is truly the age of precision. We find the importance of precision measurements recognized just as much in practical mechanics as in theoretical science. In this issue the reader will find two articles which deal with the division of units we formerly thought minimum values in the field of mechanics and chemistry, to still more minute quantities, some of which are so small as to be hardly understood by the average human mind.

FOR some time past, mechanics and makers of precision instruments have believed that working to one-tenth of one-thousandth of an inch was the practical commercial limit as the most delicate mechanical measuring machine was capable of indicating, with reasonable accuracy, no lower unit than one hundredth of a thousandth part of an inch. New methods of measurement have now made it possible for men of ordinary attainments to measure variations as small as one-millionth part of an inch, and experts to measure accurately to the twentieth of a millionth of an inch.

THE chemist of former times could never get below the atom, so it was considered the smallest possible division of matter; it was held that two or more atoms formed a molecule, and that as an atom could not exist alone, molecules were the smallest unit of independently existing matter, and a molecule was built up of atoms. While the atom and molecule remain the working units of chemistry, the theory of the last few years considers the atom as a very large unit of matter, and as described in a very interesting article in this issue, a new unit of matter is now used by scientific men.

A CORPUSCLE termed the electron that is estimated as being less than one hundredth of a thousandth part of the diameter of an atom, is being seriously considered and talked of by Scientists. The size of an electron may be understood to be exceedingly minute, when an estimate made by a competent authority, who gives a value of one-fortieth of a millionth of an inch as the diameter of an atom, is properly grasped by the mind, a difficult feat for most of us.

# Get Bigger Pay through ELECTRICITY

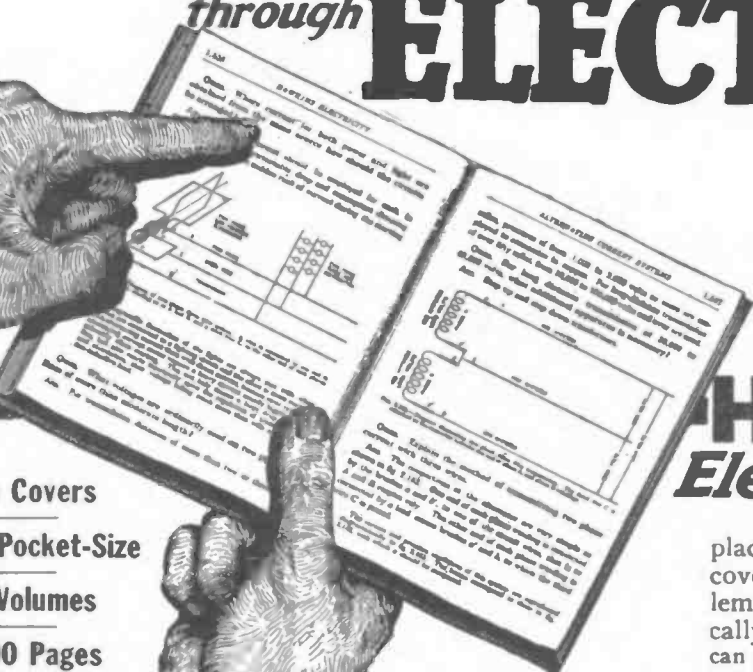

by using your set of **HAWKINS Electrical Guides Every Day.** They tell you just what you need to know.

## HAWKINS Electrical Guides

- Flexible Covers
- Handy Pocket-Size
- 10 Volumes
- 3500 Pages
- 4700 Pictures

**\$1 a NUMBER**  
**\$1 a MONTH**

place electricity at your fingers' ends. They cover every subject, principle, theory, problem, trouble, and way of doing things electrically. Every subject is indexed so that you can turn right to it. They are a study course and a reference guide in one, written in plain every day language—no wasted words—only what you need to know—full of up-to-the-minute electrical knowledge. The guides are a complete course in electrical engineering.

They will help you in every detail of the day's work. You can't ask an electrical question that Hawkins Guides can't give you help on.

### The **WHOLE SET** sent **FREE** for your inspection

The books are small enough to slip into your coat pocket—handsomely bound in flexible black covers.

You can carry each volume with you until you have mastered its contents. 3,500 pages of actual information and 4,700 illustrations. Once you see these books and put them into actual use you will never again want to be without them. Try it at our expense.

### TO EARN MORE—LEARN MORE

It will cost you nothing to receive these books—to look them over—ask them all the questions you can think of—use them in your work—study them—pick up some information that will increase your earning ability. We will ship you the entire set of 10 volumes entirely **FREE**.

This is a sign of our confidence in the guides. Pure gold does not object to being tested. Keep them for seven days and if you do not decide that you can't get along without them, return them to us and owe us nothing.

When you decide to keep them you only have to pay \$1.00 down and remit the balance of \$9.00 on the easy payment of \$1.00 a month till paid for.

Use the coupon to get the books. It will pay you many times over.

#### What Users Say:

**Become a Superintendent**

Hawkins Guides are worth double their price. I have been able to secure higher pay and a better position with their aid.

K. W. Monard,  
Supt. Erskine Light & Power Plant,  
Erskine, Minn.

**\$5,000 Saved**

The ten dollars I invested in Hawkins Electrical Guides netted the company by whom I am employed somewhere around \$5,000.

The knowledge gained from your books enabled me to save a transformer house, whereas a year ago I should have thought myself in great danger and have run.

Use this letter as you please as I am truly thankful for having the little wonders.

A. L. Foster, Ophar, Colo.  
Handy to Carry  
The great beauty of them is that you can carry them in your pocket. That suits me for I never want to be without them.

F. S. Collins,  
Richardson Engineering Co., Hartford, Conn.

**THEO. AUDEL & CO.**  
72 Fifth Ave., New York, N. Y.

THIS COUPON BRINGS THE GUIDES

**SEND NO MONEY**

THEO. AUDEL & COMPANY  
72 Fifth Avenue, N. Y.

Please submit me for examination Hawkins Electrical Guides (price \$1 each). Ship at once, prepaid, the 10 numbers. If satisfactory I agree to send you \$1 within seven days and to further mail you \$1 each month until paid.

Signature .....  
Occupation .....  
Employed by .....  
Residence .....  
Reference ..... July

#### READ THIS PARTIAL LIST OF CONTENTS

No. 1 Contains 348 pages, 388 illustrations. Electrical signs and symbols—static and current electricity—primary cells—conductors and insulators—resistance and conductivity—magnetism—induction coils—dynamo principles—classes of dynamos—armatures—windings—commutation—brushes, etc.

No. 2 Contains 348 pages, 394 illustrations. Motor principles—armature reaction—motor starting—calculations—brake horsepower—selection and installation of dynamos and motors—galvanometers—standard cells—current measurement—resistance measurement—voltmeters—wattmeters—wathour meters—operation of dynamos—operation of motors, etc.

No. 3 Contains 300 pages, 423 illustrations. Distribution systems—wires and wire calculations—inside, outside and underground wiring—sign flashers—lightning protection—rectifiers—storage battery systems, etc.

No. 4 Contains 270 pages, 379 illustrations. Alternating current principles—alternating current diagrams—the power factor—alternator principles—alternator construction—windings, etc.

No. 5 Contains 320 pages, 614 illustrations. A. C. Motors—synchronous and induction motor principles—A. C. commutator motors—induction motors—transformers; losses; construction, connections; tests—converters, etc.

No. 6 Contains 293 pages, 472 illustrations. Alternating current systems—switching devices—current breakers—relays—lightning protector apparatus—regulating devices—synchronous condensers—indicating devices—meters—power factor indicators—wave form measurement—switch boards, etc.

No. 7 Contains 315 pages, 379 illustrations. Alternating current, wiring power stations—turbines; pictures—etc. engine ignition—erection, testing, running, care and repair—telephones, etc.

No. 8 Contains 332 pages, 436 illustrations. Telegraph—simultaneous telegraphy and telephony—wireless—electrolysis bells—electric lighting—photometry, etc.

No. 9 Contains 322 pages, 627 illustrations. Electric railways—electric locomotives—car lighting—rolley car operation—miscellaneous applications—motors; pictures—gas engine ignition—automobile self-starters and lighting systems, electric vehicles, etc.

No. 10 Contains 513 pages, 599 illustrations. Elevators—cranes—pumps—air compressors—electric heating—electric welding—soldering and brazing—industrial electrolysis—electro-plating—electro—therapeutics—X-rays, etc.

Also a complete 126 page ready reference index of the complete library. This index has been planned to render easily accessible all the vast information contained in the 10 electrical guides. There are over 13,500 cross references. You find what you want to know instantly

**SEND NO MONEY- USE THE COUPON**

Please mention **EVERYDAY ENGINEERING MAGAZINE**

# LEARN WIRELESS AT HOME QUICKLY AND EASILY BY MARVELOUS NEW METHOD

A combination course in Wireless Telegraphy and Telephony perfected by the National Radio Institute that will fit you in a few months for a position paying \$200 or more a month to start.

Future success assured our graduates. Hundreds of attractive and interesting positions in Commercial Radio Service on Land, Merchant Marine, Railroads, Radio Supply Factories and Laboratories, Lake and Ocean Steamship Lines, Telegraphy Companies, and Aerial Mail Service always ready to be filled. Because of the efficiency of our graduates, they are given first choice, and positions are guaranteed to those who complete the course and secure a license.

### Big Money in Wireless Work

Few professions offer the opportunities found in Radio. Any young man with ambition and energy can soon be qualified for exceptional positions by taking our course in Wireless. Your first position will pay you the equivalent of \$200 or more a month—\$125 in salary, plus living expenses, which by a conservative estimate we place at \$100 a month.

There are exceptional chances for rapid promotion to Radio Mechanic, Electrician, Government Inspector, Radio Aid, and Radio Engineer. One of our recent graduates is getting \$6,000 a year.

No previous knowledge of Wireless or electricity is necessary to take our course. Our course is easy and comprehensive, and with the help of our Natrometer, you can master Wireless in a marvelously short time—right in your own home, the National Radio Institute way, in your spare time!

### Travel Around the World—Your Expenses Paid

If you are eager to travel, anxious to visit foreign countries, and increase your knowledge of world affairs, Wireless offers you the biggest chance you will ever have. You travel on shipboard with an officer's rating, living the life of an officer, eating at the captain's table, and mingling with the passengers. All without one cent's expense to you!

If you prefer to locate permanently at or near your own home, Wireless again offers the opportunity, for you may secure an equally attractive position at one of the many land stations, with Radio companies, Steamship companies, or Commercial houses.

Regardless of how big your desires and plans for your future, Wireless is always in the foreground, offering advantageous and attractive opportunities. Look into it and plan your life accordingly.

### This Fine Natrometer Given To You

This wonderful Natrometer automatically sends you Wireless messages as though coming from a radio station thousands of miles away. It is a complete improved sending and receiving set, embodying the same type of instruments as used by the United States Bureau of Navigation in testing applicants for official license. Made especially and exclusively for National Radio Institute students.

### Get Your Instructions From Washington—Center of All National Wireless Activities

The National Radio Institute was established in 1914, and was the first in America to successfully teach Wireless by mail. It is established in the heart of national interests—in Washington, the home of the United States Shipping Board—center of all official Wireless activities—and the home of the United States Department of Commerce (Radio Department) which passes upon every first grade government license granted in America, and also issues all permits to erect and operate radio stations.

Our location in the nation's capital, together with the high standing of our school and instructors, and our close communication with government officials connected with Wireless activities, naturally places us in the position of giving our students the very best instruction obtainable. We are also able to be of the utmost help in assisting them secure high type positions paying substantial salaries.

### Special Privileges to National Radio Institute Students

- Students of the National Radio Institute receive the following:
- Complete combination course in Wireless Telegraphy and Telephony—
- Special post-graduate course at our large Washington school, if desired—
- Five text books, one hand book, forty-six special lessons and eighteen personal examinations—
- Large handsome diploma suitable for framing—
- Complete automatic Natrometer outfit and carrying case—
- Personal help in securing wireless position and endorsement of Institute officials.

### Send For Free Booklet

We have prepared a book telling you all you want to know about Wireless and the future it offers you. Startling facts you are interested in are freely discussed. It tells how, during the past six years, we have helped hundreds of ambitious men and women and how we will help you. Send the coupon today or write to the

**NATIONAL RADIO INSTITUTE**  
 America's First and Foremost  
 Established 1914—Dept. 244,  
 14th and U Streets, N. W.,  
 Washington, D. C.

**NATIONAL RADIO INSTITUTE,**  
 Dept. 244, 14th & U Streets, N. W.,  
 Washington, D. C.

Send me your free book, "Wireless the Opportunity of Today," telling me about the opportunities in Wireless, your Famous Home Study course in Wireless Telegraphy and Telephony, your post-graduate course, and your special Wireless instrument offer.

Name .....

Age ..... Address .....

City ..... State .....

Please mention EVERYDAY ENGINEERING MAGAZINE





# HENLEY'S New Practical Books



## MOTOR BOATS AND BOAT MOTORS

By Victor W. Pagé, and A. Clark Leich. (6 x 9.) 524 pages. 372 illustrations. Cloth. Price \$4.00.

Indispensable for owners, users, repairmen or operators of motor boats and marine engines.

## SHOP PRACTICE FOR HOME MECHANICS

By Raymond Francis Yates. (6 x 9.) 324 pages, 309 illus. Cloth. Price \$3.00.

Deals with small tools and machines such as those employed about the home shop.

## STARTING, LIGHTING AND IGNITION SYSTEMS

By Victor W. Pagé. 815 pages. 492 specially made engravings. 1920 Edition, Revised and Enlarged. Price \$3.00.

A practical treatise on latest automobile starting, lighting and ignition system practice. Over 200 wiring diagrams are shown in both technical and nontechnical forms. Complete data is given for locating troubles in all systems, the various steps being considered in a logical way for those without expert electrical knowledge. All ignition systems receive full consideration, starting with the simplest battery and coil forms found on early cars to the modern short-contact timer and magneto methods used with the latest eight and twelve-cylinder motors.

## ABRASIVES AND ABRASIVE WHEELS

By Fred B. Jacobs. 340 pages, 200 illustrations. Price \$3.00.

A new book for everyone interested in abrasives or grinding. A careful reading of the book will not only make mechanics better able to use abrasives intelligently, but it will also tell the shop superintendent of many short cuts and efficiency-increasing kinks. The economic advantage in using large grinding wheels are fully explained, together with many other things that will tend to give the superintendent or workman a keen insight into abrasive engineering.

## HENLEY'S TWENTIETH CENTURY BOOK OF RECIPES, FORMULAS AND PROCESSES

Edited by Gardner D. Hiscox. 1920 edition. Cloth binding. Price \$4.00.

The most valuable technochemical formulae book published, including over 10,000 selected scientific, chemical, technological and practical recipes and processes. This book of 800 pages is the most complete book of recipes ever published, giving thousands of recipes for the manufacture of valuable articles for everyday use. Hints, helps, practical ideas and secret processes are revealed within its pages. It covers every branch of the useful arts and tells thousands of ways of making money and is just the book everyone should have at this command.

## LIQUID AIR AND THE LIQUEFACTION OF GASES

By T. O'Connor Sloane. 400 pages fully illustrated. (1920.) Price \$3.00.

The third revised edition of this book has just been issued. Much new material is added to it; and the all-important uses of liquid air and gas processes in modern industry, in the production especially of nitrogen compounds, are described. The book gives the history of the theory, discovery, and manufacture of Liquid Air, and contains an illustrated description of all the experiments that have excited the wonder of audiences all over the country. It shows how liquid air, like water, is carried hundreds of miles and is handled in open buckets.

## MODERN ELECTROPLATING

By Kenneth M. Coggeshall. 350 pages, 142 illustrations. Price \$3.00.

Anyone interested in practical plating and metal finishing will find this book a valuable guide and complete manual of the art.

## EXPERIMENTAL WIRELESS STATIONS

By P. E. Edelman, E. E. (5 x 7) 390 pages, 167 illus. Cloth. Price \$2.50.

Answers every question—clears up mysteries of things radio, you have often wondered about.

## THE MODEL T FORD CAR, ITS CONSTRUCTION, OPERATION AND REPAIR, INCLUDING THE FORDSON FARM TRACTOR, F. A. LIGHTING AND STARTING SYSTEM, FORD MOTOR TRUCK

By Victor W. Pagé. 410 pages, 153 illustrations, 2 large folding plates. Price \$2.00.

This is the most complete and practical instruction book ever published on the Ford car and Fordson tractor. To the 1920 Revised Edition matter has been added on the Ford Truck and Tractor Conversion Sets and Genuine Fordson Tractor. All parts are described. All repair processes illustrated and fully explained. Written so all can understand—no theory, no guesswork. New Edition.

## MODEL MAKING

By Raymond Francis Yates. 400 pages, 301 illustrations. Price \$3.00.

A new book for the mechanic and model maker. This is the first book of its kind to be published in this country and all those interested in model engineering should have a copy. The first eight chapters are devoted to such subjects as Silver Soldering, Heat Treatment of Steel, Lathe Work, Pattern Making, Grinding, etc. The remaining twenty-four chapters describe the construction of various models such as rapid fire naval guns, speed boats, model steam engines, turbines, etc.

## ELECTRICIAN'S HANDY BOOK

By Prof. T. O'Connor Sloane. 840 pages, 600 engravings, handsomely bound in cloth. 1920 edition. Price \$4.00.

This work has just been revised and much enlarged. It is intended for the practical electrician who has to make things go. The entire field of electricity is covered within its pages. It is a work of the most modern practice, written in a clear, comprehensive manner, and covers the subject thoroughly, beginning at the A B C of the subject, and gradually takes you to the more advanced branches of the science. It teaches you just what you should know about electricity. A practical work for the practical man.

## WESTINGHOUSE E. T. AIR-BRAKE INSTRUCTION POCKET-BOOK CATECHISM

By Wm. W. Wood, Air-Brake Instructor. Cloth. 1920 edition. Price \$2.50.

A practical work containing examination questions and answers on the E. T. Equipment. Covering what the E. T. Brake is. How it should be operated. What to do when defective. Not a question can be asked of the engineer up for promotion on either the No. 5 or the No. 6 E. T. equipment that is not asked and answered in the book. If you want to thoroughly understand the E. T. equipment get a copy of this book. It covers every detail. Makes air-brake troubles and examinations easy. Fully illustrated with colored plates, showing various pressures.



*These Are the Books You Should Procure*

All Up-to-date and Reliable

Any of these books sent prepaid on receipt of price. FREE—1920 Catalogue of Practical Books—Send for a Copy

**The Norman W. Henley Publishing Co.**

2 WEST 45th ST., NEW YORK

Please mention EVERYDAY ENGINEERING MAGAZINE





# Use One of These Libraries 10 DAYS FREE

**Now Is the Time to Get Ready for Bigger Pay** Industrial America is teeming and throbbing with the greatest activity in its history. Every day hundreds of men in small positions are raised to bigger responsibilities and bigger pay. A search is being made everywhere for men who have the necessary training to assume these new responsibilities.

**A McGraw-Hill Home Study Course Will Prepare You Quickly** The McGraw-Hill Home Study Courses are founded on actual work as it is done in the great fields of engineering which they cover. No space is wasted with higher mathematics and theory. Only facts, written so that you can understand them. About one hundred thousand men are now using them as a daily guide. They are equally valuable to the expert and the beginner.

## Not One Cent in Advance Small Monthly Payments If You Are Satisfied

No matter what your age is, where you are located, or how limited your means, you can succeed through one of the McGraw-Hill Home Study Courses. Everyone contains a complete education on the subject covered. No matter how much you might pay for books or courses you cannot acquire knowledge that will advance you more rapidly and surely than a McGraw-Hill Home Study Course.



### Power Plant Library

Power plant practice complete, including mathematics, boilers, engines, electricity, turbines and refrigeration. Now the most used engineers' library in existence. Has enabled thousands of men to pass the most rigid examinations. 2,500 pages, 1,500 illustrations. Eight handsome volumes, bound in the tough T pattern of cloth, as durable as leather. Price \$16, payable \$2.00 per month.

### Factory Management

A set of books written by leading authorities, to help men fit themselves to take complete charge of the shop or factory. Covers industrial organization, administration, purchasing, manufacturing costs and accounts, engineering of shops, factories and power plants. 6 volumes, 2,300 pages, fully illustrated. Bound in semi-flexible karatol. Price \$20, payable \$2 in ten days and \$3 per month.

### Croft Library of Practical Electricity

Without question of more practical value than anything of the kind ever attempted in the world of electricity. Enables you to know electricity as experts know it. Mathematics, practical electricity, electrical machinery, central stations, wiring for light and power, wiring of finished buildings, illumination. 8 flexible volumes, pocket size, 3,000 pages. Price \$20, payable \$2 in 10 days and \$3 per month.

### Iron and Steel Library

The high positions in the great iron and steel world are now attainable through this library, which is written by authorities actually engaged in this work. Metallurgy, foundry work, blast furnaces construction, operation and products, refractories. A complete iron and steel library. Seven volumes, over 3,000 pages. Fully illustrated. Price complete \$24, payable \$3 per month.

### Machine Shop Library

Machine shop practice complete. Written by eight practical men, well known in the machine shop world. Now the standard in America. No other set of books on the subject ever equalled it in popularity. Mathematics, drawing and design, composition and heat treatment of steel gears, tool work, grinding, jigs and fixtures, screw machines, dies, etc. 9 volumes, 3,000 pages. Price \$20, payable \$2 in 10 days and \$3 per month.

### Metal Mining Library

Herein is brought together in nine flexibly-bound volumes the very meat of metal mining practice in America. Examinations, principles of mining, timbering, thousands of working details, ore dressing, surveying, accounting, costs. All the information you need to reach the high positions in the mining world. The most intricate problems solved by plain words and illustrations. Price \$24, payable \$3 per month.

### Coal Mining Library

Coal mining and colliery practice complete, including outside and inside work—both mechanics and engineering. Of assistance to every man in the business, from the lowest paid man to the operator. It is now looked upon as a necessity, and as containing the secrets of success in coal mining. 8 volumes, 3,000 pages, 1,700 illustrations. Price \$20, payable \$2 in 10 days and \$3 per month.

### Radcliffe's Electricity

A three-volume compact set of books on the practical side of electricity. In question-and-answer form, for quick reference. This course is somewhat condensed, and will be found of special value to those interested in electricity as used in power plants. 700 pages of facts, illustrated and carefully indexed. Price \$6, payable \$1 per month.



**Any Library Shipped on Ten Days' Trial—  
At Our Expense. Merely Return the Coupon**

Look at the illustrations of the libraries at the left and right of this page. Then refer to the coupon, check the library you want, fill out the blank spaces carefully and return to us. After receiving the books, go over them carefully. Keep them ten full days. See how much knowledge you can gain from them within ten days. If then you decide you cannot afford to be without them, send us the small monthly payments called for. If on the other hand you do not want them, return at our expense. But pay no charges. We bear shipping expenses both ways.

Pay only  
**\$1 to \$3**  
per  
month  
if you are  
satisfied

## Free Examination Coupon

McGraw-Hill Book Co., Inc., 239 W. 39th St., N. Y.  
Gentlemen: Send for ten days' free inspection the library I have checked below:

- Croft's Electricity, \$20—payable \$3 per month.
- Machine Shop Library, \$20—payable \$3 per month.
- Iron and Steel Library, \$24—payable \$3 per month.
- Mining Library, \$24—payable \$3 per month.
- Coal Mining Library, \$20—payable \$3 per month.
- Power Plant Library, \$16—payable \$2 per month.
- Factory Management, \$20—payable \$3 per month.
- Radcliffe's Electricity, \$6—payable \$1 per month.

If satisfactory I will send first payment in ten days and the same amount each month until paid. If not wanted I will return the books at your expense.

Signature .....

Residence address .....

City and State .....

Your employer .....

His address .....

Your occupation .....

ED 7-20

Please mention EVERYDAY ENGINEERING MAGAZINE

# A SPECIAL OFFER TO OUR READERS

ANY ONE OF THESE BOOKS WILL BE SENT FREE FOR EACH NEW OR RENEWAL SUBSCRIPTION

**HOME MECHANIC'S WORKSHOP COMPANION**



TELLS HOW TO DO MANY USEFUL ELECTRICAL AND MECHANICAL THINGS INCLUDING NUMEROUS SHOP KINKS

By **ANDREW JACKSON JR.**

①

EVERYDAY ENGINEERING SERIES  
NORMAN W. HENLEY PUBLISHING CO  
1 WEST 45TH STREET, NEW YORK

**For the Handy Man in the Home or Shop**

There has always been a demand for a hand book of mechanical instruction that would help the average everyday man to do the many small jobs of repair work that are found around the home and shop.

**HINTS AND TIPS FOR AUTOMOBILISTS**



NEEPLY SAVES HOURS OF CARE AND OPERATION ALSO LOCATES AND REMEDIES MOST COMMON TROUBLES

By **VECTOR W PAGE**

②

EVERYDAY ENGINEERING SERIES  
NORMAN W. HENLEY PUBLISHING CO  
1 WEST 45TH STREET, NEW YORK

**For the Automobile Owner or Driver**

The book is ideal for the busy man or woman who wants to know about car operation and upkeep because of the economies possible when an automobile is intelligently operated. It contains many money saving hints.

**HOW TO MAKE & USE A SMALL CHEMICAL LABORATORY**



AN INTRODUCTION TO THE STUDY OF INORGANIC CHEMISTRY WITH DIRECTIONS FOR THE CONSTRUCTION OF A SMALL LABORATORY

By **RAYMOND FRANKS YATES**

③

EVERYDAY ENGINEERING SERIES  
NORMAN W. HENLEY PUBLISHING CO  
1 WEST 45TH STREET, NEW YORK

**For the Student Chemist and Experimenter**

This book gives all the necessary information for a well-grounded understanding of chemistry. It will not only be a help, but an inspiration to study further into this fascinating realm of science.

**SOLDERING & BRAZING**



A USEFUL HANDBOOK FOR MECHANICS

By **RAYMOND FRANCIS YATES**

④

EVERYDAY ENGINEERING SERIES  
NORMAN W. HENLEY PUBLISHING CO  
1 WEST 45TH STREET, NEW YORK

**For the Mechanic and Model Maker**

This treatise gives all the necessary "kinks" that will enable one to accomplish successful soldering. If a mechanic has not succeeded in his soldering, this book may tell him just what he needs to produce good work.

**RADIO HOOK-UPS**



A BOOK OF THE MOST ADVANCED CIRCUITS OF RECEIVERS, AMPLIFIERS AND TRANSMITTERS FOR BATTERY AND UNBATTERY WAVE WORK

By **M. S. SLEEPER**

⑤

EVERYDAY ENGINEERING SERIES  
NORMAN W. HENLEY PUBLISHING CO  
1 WEST 45TH STREET, NEW YORK

**For the Radio Experimenter and Amateur**

In this book, the best circuits for different instruments and various purposes have been carefully selected and grouped together. The result is a comprehensive summary of radio circuit diagrams for every purpose.

A special feature of this book is the explanations which accompany each circuit, giving construction or operating details.

**ALL** of these Books are written in Simple Non-technical Language and contain Information of Real Value on Subjects of Timely Interest.

**TRY TO SEND US FOUR NEW SUBSCRIBERS— WITH YOUR OWN— SO WE CAN SEND YOU THE SET OF SIX BOOKS**

Fill Out the Special Blank Below  
Check Off the Title Desired and Mail with Your Remittance

*Special Circular Describing These Books Sent on Request*

**The Experience and Knowledge of Experts Condensed and Simplified for the Handy Man—the Mechanic and the Radio Experimenter.**

**DESIGN DATA FOR RADIO TRANSMITTERS & RECEIVERS**



SIMPLE METHODS FOR DESIGNING APPLIANCES ACCORDING TO APPROVED AND ACCEPTED PRACTICE

By **M. S. SLEEPER**

⑥

EVERYDAY ENGINEERING SERIES  
NORMAN W. HENLEY PUBLISHING CO  
1 WEST 45TH STREET, NEW YORK

**For the Radio Engineer and Student**

In Design Data, radio experimenters are given such information, readily accessible, as to make it possible for them to have modern and highly efficient equipment and to get the best possible results from the instruments they make or buy.

## EVERYDAY ENGINEERING MAGAZINE

2 WEST 45TH STREET NEW YORK CITY

You may enter my subscription to EVERYDAY ENGINEERING MAGAZINE

for ..... years at \$2.00 per year (Canada, \$2.25; foreign, \$2.50). Please let this start with the ..... issue. I enclose \$....., and  
(Date of issue)

according to your special offer send me copy of book checked off.

Name .....

Street .....

City .....

State .....

**TEAR OFF AND MAIL THIS NOW**

EVERYDAY ENGINEERING SERIES OF HANDBOOKS  
Check off title desired here

1	HOME MECHANIC'S WORKSHOP COMPANION	
2	HINTS AND TIPS FOR AUTOMOBILISTS	
3	HOW TO MAKE AND USE A SMALL CHEMICAL LABORATORY	
4	SOLDERING AND BRAZING	
5	RADIO HOOK-UPS	
6	DESIGN DATA FOR RADIO TRANSMITTERS AND RECEIVERS	

Please mention EVERYDAY ENGINEERING MAGAZINE

# Health-Strength-Beauty Thru

# Renulife VIOLET RAY Treatments at Home

A recognized scientific effective means of handling your own case is afforded by the RENULIFE VIOLET RAY HIGH FREQUENCY GENERATOR. It is so designed and made that anyone can apply the wonderful corrective, upbuilding forces of the VIOLET RAY. This pleasant POWERFUL form of electricity has done and is doing wonders in relieving and eliminating pain and suffering. You owe it to yourself to investigate—find out the facts. Get our new booklet explaining the nature of the Violet Ray—its uses, benefits, and applications—send the coupon below at once.

### WHAT USERS SAY

"The Renulife Violet Ray High Frequency Generator is superior in efficiency because of its perfect character and control of current, compactness and perfect insulation. The smallness and lightness of Electrode holder is also a great advantage." "The doctor told me that the trouble was hardening of the arteries. I would not be without it for all the money in the world." "I cannot recommend it too highly." "I have been using mine now for a week for Sciatica and I am highly pleased with results." "I think it is one of the best little machines that was ever invented." "I have used it with excellent results for the restoration of hair and stiff and sore rheumatic finger joints." "Am well pleased with the Generator, and the kind treatment received from your Company." "My Generator has stopped my neuritis." "Every house should have a Renulife Violet Ray High Frequency Generator for the treatment of Neuralgia; Neuritis; Sore Throat; Kernels in Neck; Cramps; Headache; Stiff Neck Muscular Soreness; Rheumatism; Paralysis—in short, pain of all kinds."—M. D.

"I have been much relieved by the use of your Violet Ray Generator."

"It is fine for insomnia."

"I find it such a help in nervousness."

"I would not part with it for five times the price. It is sure a little wonder."

"I am more than pleased with the Generator, the whole family are using it."

THIS TYPE of Violet Ray instrument makes possible a light, convenient handle and permits large efficient units to be used contained in hand-some case.

### OUR NEW BOOK

JUST OUT. This latest edition explains in detail, with many illustrations, the uses and benefits of Violet Ray. You should have one. Free for the asking.

SEND FOR BOOK!

### THOUSANDS OF VOLTS

No Shock—No Harm—Simply Great Benefits

Current from your light socket is transformed into the most powerful, effective purifying Health and Beauty giving agency; yet as painless and pleasant as a ray of sunshine. Made safe for use in any home, on infant or weakest invalid. Attacks the deep seated source of diseases, at the same time relieving the aches and pains which may be this annoying symptoms. Learn how this modern form of electricity—The Violet Ray—so acceptable to the human body actually saturates the whole system with invigorating life-laden forces, bringing back normal conditions. You may treat the local area but results are not confined to that part alone—the blood, nerves, tissues are revitalized, toned and restored.

Send for the Booklet—full of information—that tells the story so you can understand it.

### Natures Own Aid

What is the strange relation between electricity and life? Some declare electricity is life. We do not know. But life cells do welcome and respond marvelously to electricity in the form of Violet Rays. It works with nature to restore where many other methods fail. It treats fundamentally and therefore is specified by physicians for a wide range of ailments—for rheumatism, neuritis, nerve and blood disorders—etc., etc.—both chronic and acute. See the list on coupon and ask for full particulars. Blood is brought to area treated—enriched and purified—assimilation and digestion improved—functions restored to normal. Combines the benefits of electricity, vibration, exercise, stimulation, and oxidation. Get the information as to what you may expect from the Violet Ray. Its astonishing low price places it within the reach of all. The Trial Plan proves its value, in actual use. Receive full information by return mail.

### Renulife Electric Co., Inc.

1907 Marquette Building, Detroit, Mich.  
Chicago Office, Room 410, 123 West Madison



Treat Your Own Face and Scalp as well as Specialists



Strengthens—Revitalizes—Builds up



Pain and Ache Eradicator—Without Equal



For Catarrh, Throat, Lungs—also Aemia

### LOWEST PRICED Efficient VIOLET RAYS

Several Models for Home and Professional Use



High Class Sales Distributors Write for Proposition

OZONE Labels—Does

### COUPON FOR BOOK and Special Information

RENULIFE ELECTRIC CO., 1907 Marquette Bldg., Detroit, Mich.

Please send without obligation, your book "Health," explaining Violet Ray treatments with Renulife Generators, also give full particulars as to its application for ailments checked below.

### TREATS SUCCESSFULLY

- .. Abscesses
- .. Anemia
- .. Asthma
- .. Arteriosclerosis
- .. Baldness
- .. Blackheads
- .. Brain Fog
- .. Bronchitis
- .. Bunions
- .. Bruises
- .. Cataract
- .. Colic
- .. Chills
- .. Dandruff
- .. Deafness and Ear Infections
- .. Eczema
- .. Solarized Prostate
- .. Facial Neuralgia
- .. Falling Hair
- .. Female Complaints
- .. Goitre
- .. Haemorrhoids
- .. Hay Fever
- .. Infantile Paralysis
- .. Inflammation
- .. Insomnia
- .. Lame
- .. Locomotor Ataxia
- .. Lombago
- .. Nervous Affections
- .. Neuritis
- .. Obesity
- .. Pain in Abdomen and Chest
- .. Paralysis
- .. Piles
- .. Purpura
- .. Pyorrhea
- .. Rheumatism
- .. Scars
- .. Sciatica
- .. Skin Diseases
- .. Sore Throat and Throat Diseases
- .. Sprains
- .. Toothache
- .. Weak Eyes
- .. Wrinkles
- .. Warts and Moles

Name .....

Address .....

Please mention EVERYDAY ENGINEERING MAGAZINE

# Man alive— Listen!

You can smoke Camels  
till the cows come home  
without tiring your taste!

**C**AMELS bring to you every joy you ever looked for in a cigarette! They are so new to your taste, so delightful in their mellow mildness and flavor, and so refreshing, you will marvel that so much enjoyment could be put into a cigarette!

Camels quality is as unusual as Camels expert blend of choice Turkish and choice Domestic tobaccos *which you will prefer to either kind of tobacco smoked straight!* No matter how liberally you smoke, Camels never will tire your taste!

You will marvel at Camels smooth "body". And, your delight will also be keen when you realize Camels leave no unpleasant cigaretty aftertaste nor unpleasant cigaretty odor!

For your own personal proof, compare Camels with any cigarette in the world at any price.



# Camel CIGARETTES

*Camels are sold everywhere in scientifically sealed packages of 20 cigarettes for 20 cents; or ten packages (200 cigarettes) in a glassine-paper-covered carton. We strongly recommend this carton for the home or office supply or when you travel.*

R. J. REYNOLDS TOBACCO CO.

Winston-Salem, N. C.

Please mention EVERYDAY ENGINEERING MAGAZINE



**PRACTICAL MECHANICS  
FOR EVERYDAY MEN**

**EVERYDAY  
ENGINEERING  
MAGAZINE**

**IT TELLS YOU HOW TO  
MAKE AND DO THINGS**

VOLUME 9

JULY, 1920

NUMBER 4

# Common Causes of Automobile Noises

*A Simplified Exposition for the Man Who Runs His Own Car  
Describing What Various Noises in an Automobile  
Are Due To and How To Eliminate Them*

By Victor W. Page, M. S. A. E.

**O**NE of the most annoying conditions experienced in motor-ing is noisy operation. The first year a car is used, providing that due care has been taken in regularly screwing down the multitude of grease cups provided, the motorist will not be annoyed by noise. But after the car has been operated for a season or two, no matter how well it has been taken care of, it will develop a series of rattles and squeaks when it is driven over roads that are not of the best. Some really important noises are due to relatively unimportant parts, so that a driver may be unnecessarily worried by a loud and reoccurring noise when it can be easily fixed by the application of a few drops of oil at the right place.

Automobile noises may be divided into four classes, i.e., those due to the engine, those resulting from wear in the power transmission system, from depreciation in the running gear, and lastly, those due to looseness in the body and auxiliary parts. A number of illustrations which accompany this article have been prepared to bring out in an easily understandable way the various points about an automobile that should be inspected in event of noisy operation. When locating noises, the proper thing to do is to go over the car systematically and inspect all of the points that are apt to be noisy unless properly adjusted and oiled.

### Body Noise

Among the most annoying of the common noises are the various squeaks and creaking sounds which are usually caused by the various parts of the body or auxiliary members. Most of the body squeaks result from two pieces rubbing together which should be in fixed relation. When a car is first

needed to produce a pronounced squeaking or creaking noise.

The remedy is a very simple one. If the felt strips are battered down to such a point that the sills can come in contact with the frame at different points, the old pads should be removed and new ones substituted for them. If, however, they are not flattened down very much, a simple tightening of all the body retention bolts is all that will be necessary to hold the parts firmly together.

### Squeaking Doors

Another common trouble in a body, especially if it is a closed body, is squeaking doors. Sometimes the metal members of the door lock may rub against each other, the door hinges may be dry or the material of which the door is composed may have changed in form sufficiently so that the door no longer fits the door frame accurately. Wherever metal parts come in contact, the squeaking

can soon be prevented by applying a few drops of oil at the right places. If the door squeaks and rattles because it is loose in the frame, various expedients, such as installing small leaf springs made from brass strips or clock springs so that they will take up the space between the door and the frame when the door is closed or small pads of rubber which may be cut from an old inner tube may be placed between the door and the body.

Another point about the body that is

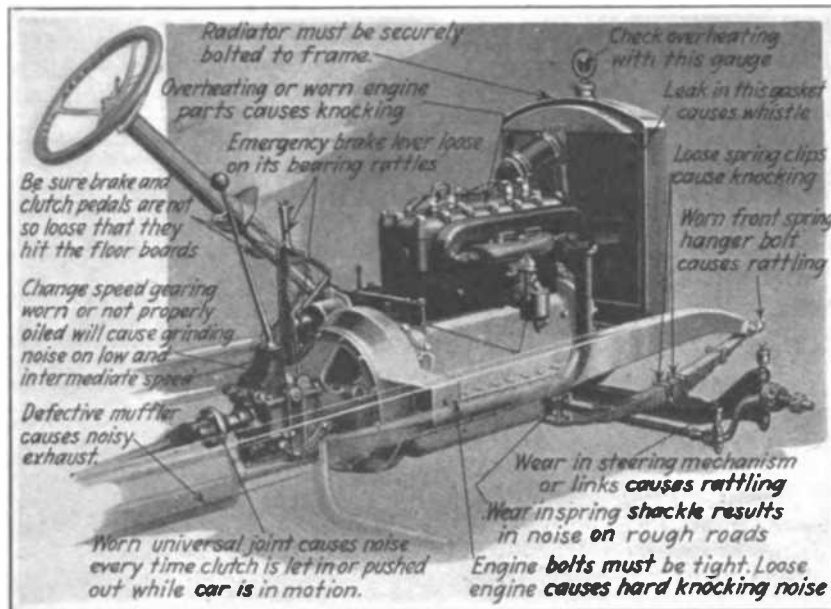

Front end of typical motor car showing sources of noise

built, the manufacturers interpose strips of felt or leather between the body sills and the frame side members. After a time this material flattens out or beds down and the sills of the body will rub on the dry leather or other padding or parts of the body may come in contact with the metal frame. When the body-retaining bolts are loose, a slight movement of the body is permitted every time a car goes around a corner or whenever it is run over rough roads. This slight movement is all that is

apt to squeak is the windshield. Whenever this causes noise, it is usually because the nuts on the windshield supporting posts are loose. These are placed under the cowl in almost all cars and as they are out of sight, they are apt to be out of mind. It is usually

or aprons can be prevented is to prevent the cause by strengthening the unsupported portions with strips of metal or wood securely riveted or bolted to the offending members and to the frame or supporting brackets.

Another cause of rattle that is not

it is not long before there is a slight loosening which will cause noise. Tighten them with pliers or a wrench to make sure they will not loosen.

### Engine Noise

Considering the power plant as a source of noise, various articles that have been published in EVERYDAY ENGINEERING MAGAZINE have outlined what these noises may be caused by. As a general rule, knocking is due to over-heating or excessive carbon deposits, if it is not produced by worn bearings or other mechanical parts. Knocking due to carbon can be readily prevented by eliminating the cause, and as most engines are now made with detachable cylinder heads, there is no real reason for not cleaning them out as frequently as may be necessary. Of course, knocking due to worn bearings can only be prevented by properly taking up the looseness. Knocking due to over-heating can be prevented by making sure that there is an ample supply of the proper grade of lubricating oil in the engine, that the fan-driving belt is tight, that the radiator is cleaned and none of the hose connections buckled to prevent proper flow of water, that the water pump is circulating the cooling liquid and that the radiator is kept properly filled with water.

In connection with lubrication the point that should be carefully looked after is to see that the oil pump is circulating oil through the system. In

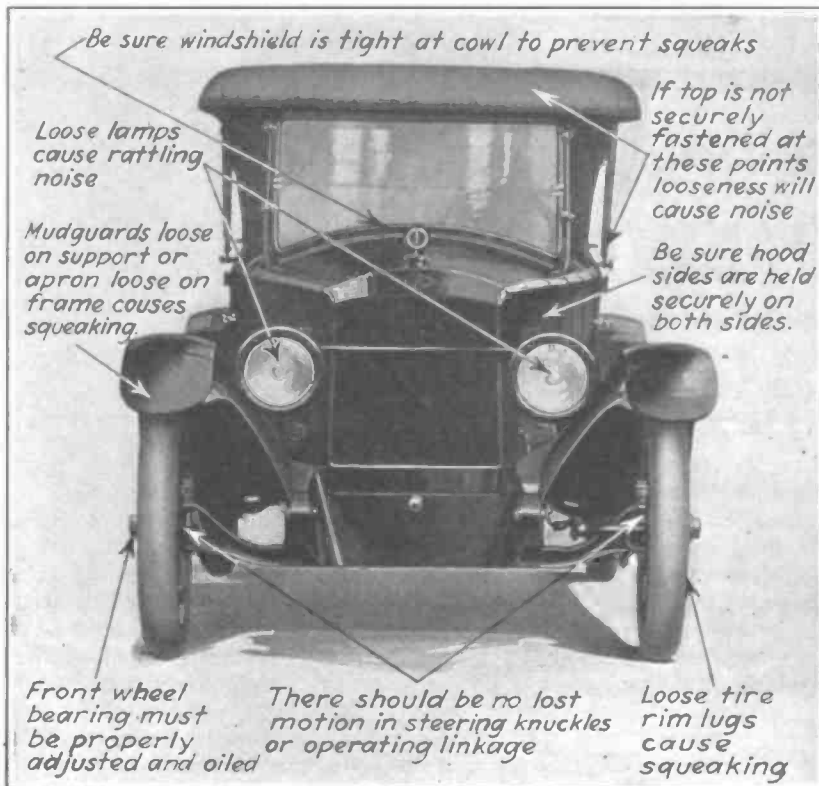

Front view of automobile showing points needing inspection in looking for noise

difficult to tighten them up with ordinary wrenches, so socket wrenches should be used to make sure that the nuts are screwed up tightly against the rubber washers and also that the windshield supporting posts are drawn tightly into their sockets or against the rubber washers at their base on top of the cowl.

Other parts that can cause intermittent noise are the mudguards and side aprons. If the mudguards or their supporting aprons are loose on the body, a rattling noise will result, whereas if the apron-retaining screws are loose where they go through the frame channel members, it is possible for the apron to move against the frame and cause a squeak. On some moderate priced and most cheap cars, the metal of which the fenders and apron are made is apt to be of a light gauge and as the metal is thin, there will be a certain amount of vibration because the parts may not be supported for considerable distances. The metal acting as a diaphragm produces a constant drumming or rattling noise, which in the case of a four-cylinder car keeps time with the running of the engine and vibrates in unison with the motor at certain critical speeds. The only way noise due to light gauge fenders

often located is the loosening of the points of support of the body at the body braces, also loose motor retention bolts and lost motion at the ball ends of the windshield support posts to which the front bow of the top is held by wing nuts or thumb-screws. Usually these are tightened with the fingers and

most of the modern engines, the pump must work continuously so that all parts will receive the proper amount of oil. If the pump is not working properly, the oil container in the engine base might be full of the proper grade of oil and yet it would not be circulating to the bearing points.

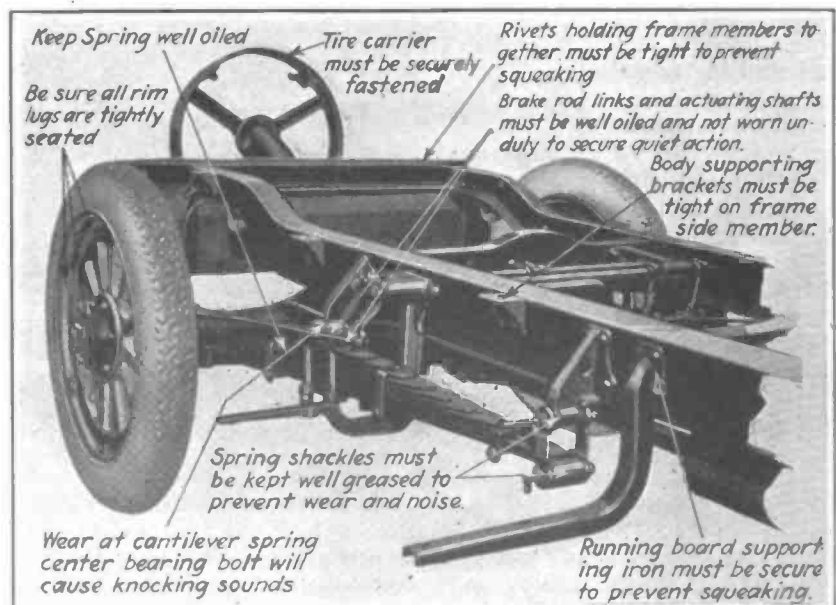

Rear end of modern automobile chassis showing frame parts to be looked over

**Transmission System Noise**

The transmission system is not apt to make any noise when the car is operated on the direct drive or high speed position unless there is considerable wear in the transmission bearings or an imperfect adjustment at the rear axle. When running on low and intermediate speeds most cars will produce noise because of the amount of power transmitted by gears, but this can be reduced to a minimum by filling the gear case with adequate quantities of the proper gear case lubricant.

When the universal joints are worn, one will note a rattling noise every time that the clutch is applied or released, and one will also notice a pronounced rattling if the engine does not run regularly. This is because the lost motion between the parts of the universal joints will be the first taken up and then the parts become loose again under the fluctuations of power delivery. If the engine runs steadily after the looseness is taken up by the initial application of power, the parts will remain in contact as long as the torque is uniform and there will be no noise.

**Dry Bearings Squeak**

A squeaking noise is sometimes produced by a dry clutch spigot bearing if a cone clutch is used and a dry or worn clutch throw-out bearing on any type of clutch may cause noise. This will be in the form of a squeaking that

or rollers is broken or if a race ring is cracked.

A grinding noise in the back axle indicates a poor adjustment of the driving gears and may be due to the gears meshing too deeply or not meshing deeply enough. The only way one can prevent rear axle noise is to make sure that the driving gears are in good condition, that they are properly adjusted and that there is plenty of grease in the differential housing.

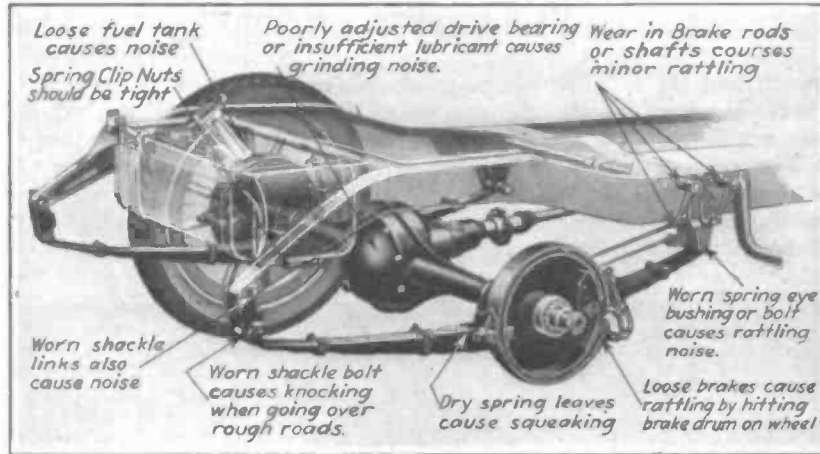

Points in the transmission system and rear suspension that rattle when worn

will be noticed only when the clutch is held out with the foot pedal. If the bearings on either the main or the countershaft of the gear box are worn or broken, there will be a certain amount of rattling noise all the while that the car is being driven. Practically all ball or roller bearings will cause a clicking noise which reoccurs at regular intervals if one of the balls

**Chassis Parts Cause Most Noise**

The various parts of the automobile chassis are the most common cause of noise, as any looseness in the multitude of links and shackles will cause a rattle. Starting with the front end of the car, the first thing to do is to see that the lamps and lamp-supporting brackets are secure. Another point to inspect is the lamp glass or lens which sometimes become loose in their frames and make a rattling noise all the time the car is operated because of engine vibration. This can be easily prevented by putting packing material, usually in the form of felt (Continued on page 370)

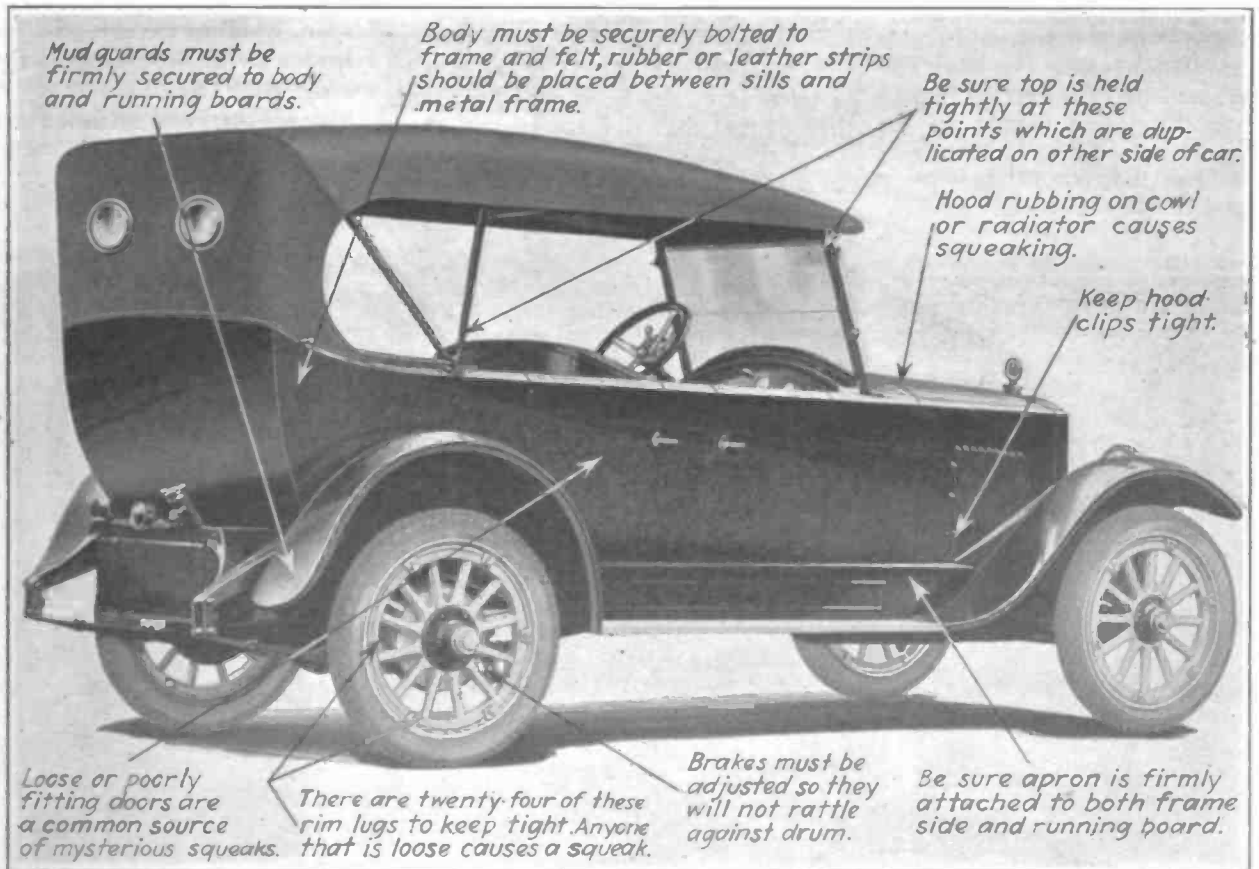

Three-quarter rear view of late model automobile showing parts of body and running gear that contribute their quota to a noisy car

# Modern Precision Measurements

*A Brief and Concise Exposition of the Latest Means of Measuring Minute Distances and the Refinement of Measuring Appliances From the Prehistoric Measuring Stick to Modern Precision Apparatus*

By Harry A. Mount

**T**HE art of measurement had its beginning so far back in dim antiquity that we do not know just where it originated. The earliest peoples of which we have record used crude measuring instruments and built their houses and measured distances by more or less crude standards. Undoubtedly, the first measuring instruments were nothing more than sticks or stones cut or broken to a common length. In fact, notched sticks have been taken from excavations of ancient sites and these appear to have been the crude ancestors of our yardsticks.

Just as the necessity for a standard of measurement grew as the ancestors of our race first learned to build houses and boats, so the measuring instrument itself has been made more and more accurate and better systems of measurement developed until today we are able to measure with absolute precision distances so small that the average human mind cannot conceive them. At the same time we are able to measure distances so great that our earth seems a puny speck in comparison.

The simplest of measuring instruments, the measuring stick, or "cubit rod" had its origin way back before the dawn of history. Even Noah laid out his ark in cubits. But it is a far cry from the ancient measuring stick to the precision measuring instruments of to-

day with which it is possible to measure with absolute accuracy so tiny a distance as a twenty-millionth of an inch—a twentieth part of a millionth—a distance so small as to be beyond the average understanding.

house-fly should alight on the tip of the rod, the fly's weight would bend the rod just a millionth of an inch! An ordinary human hair would have to be divided into about three thousand equal parts to get pieces a millionth of an inch in thickness. But you or I, equipped with modern apparatus, and given a few minutes instruction, could measure the thickness of that infinitesimal piece of hair very accurately.

## *Early Measurements Derived from Body*

It is interesting to note that our present English system of measurement was derived directly

from the dimensions of the human body. The earliest known systems of measurement were built something like this: digit, the width of a finger; palm or handbreadth, width of the palm; span, width of the extended hand; foot, length of the foot; cubit, length of the arm; pace, length of a step; fathom, distance between extended arms. For longer distances, a day's journey served as a convenient gauge.

But as the need for some sort of

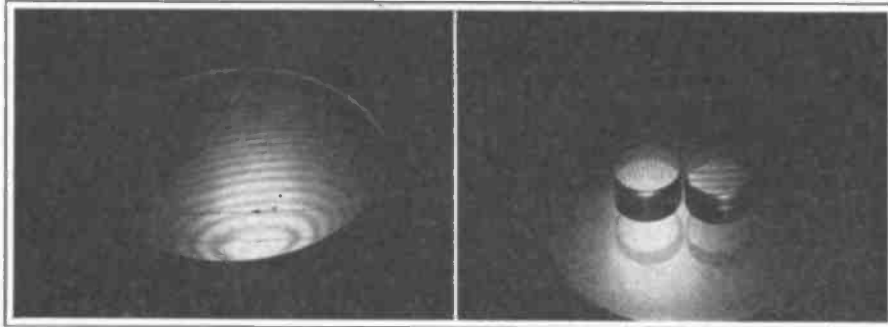

*Photographs taken to show interference bands used in measuring by light waves*

To give an understandable idea of just how far a millionth of an inch is, a scientist of the Bureau of Standards has figured that if a rod of tool steel, one-half inch in diameter were clamped in a vise, so that the free end projected twelve inches; and that if an ordinary

*The yardstick of the housewife need not be accurate to less than one-sixteenth of an inch. A skilled machinist can work to the hundredth of an inch with caliper and steel scale. Micrometer calipers will measure to one-tenth of a thousandth of an inch*





standards of measurement grew, rude measuring devices were invented. At first these were simply notched sticks. Probably one of the oldest existing measuring instruments is a notched stick taken from a very ancient Egyptian tomb by excavators for the Metropolitan Museum of Art. Later forms of Egyptian "cubit rods" which have been found were made of stone and fairly accurately divided.

It is probable stone measuring rods

self, has kept pace step by step with our ability to measure distances accurately.

*Accurate Measurement a Recent Development*

It has been only within very recent years that accurate measurement was an everyday matter. Old mechanics remember the day when men who could fit parts, such as bearings, accurately, received higher pay than his fellow

as making the micrometers themselves, dividing engines are used which are accurate within a hundred-thousandth of an inch. But the human element of uncertainty enters so largely into such fine measurements that in at least one big shop where accurate measurements are required, it is the practice to have three workmen make the measurement and then to average the results.

*Use of Light Waves*

Then came the interferometer method of measurement, developed by our Bureau of Standards during the war. The length of a wave of light is used both as a standard of measurement and in making the actual measurement. The length of that light wave never varies. It is the same at the North Pole as at the Equator. The new method determines with absolute precision variations of a millionth of an inch and the human element is entirely eliminated. With extreme care variations of a twenty-millionth part can be noted.

But what of it? What difference can it possibly make to you and me if a few scientists have gotten together and figured out a way to measure a millionth of an inch? It means, first of all, that we have progressed a long way from yardstick days. Not that we will ever measure the garden fence or lay the kitchen linoleum to a millionth of an inch. But we will have better and more enduring sewing machines,



*Precision measuring machine will measure to one-hundredth part of a thousandth of an inch*

were used in constructing the pyramids. The great pyramid of Ghizeh, built 4000 years B. C., seems to be accurately constructed and it stands today as a record of the system of measurement used by the ancients. In fact, the Anglo-Saxon system of measurement was derived directly from its dimensions. But until very recent times the dimensions of the human body were used as standards of measurement. In England, as late as the reign of Henry I, the English yard was the length of the sovereign's arm. The custom also prevailed in other countries and since kings were not cast all in the same mould there was great confusion as to standards of measurement which varied with the physical peculiarities of the reigning monarch.

Later standards of measurement, as the need for uniformity and accuracy grew and better measuring instruments were made, were fractional lengths of the earth's diameter and the arc of a pendulum. Other attempts to set invariable standards were made by finely engraving two parallel lines on metal bars. But as soon as measuring instruments of sufficient accuracy were made, it was found that these standards varied under different temperatures or other conditions. The advancement of science, and indeed of civilization it-

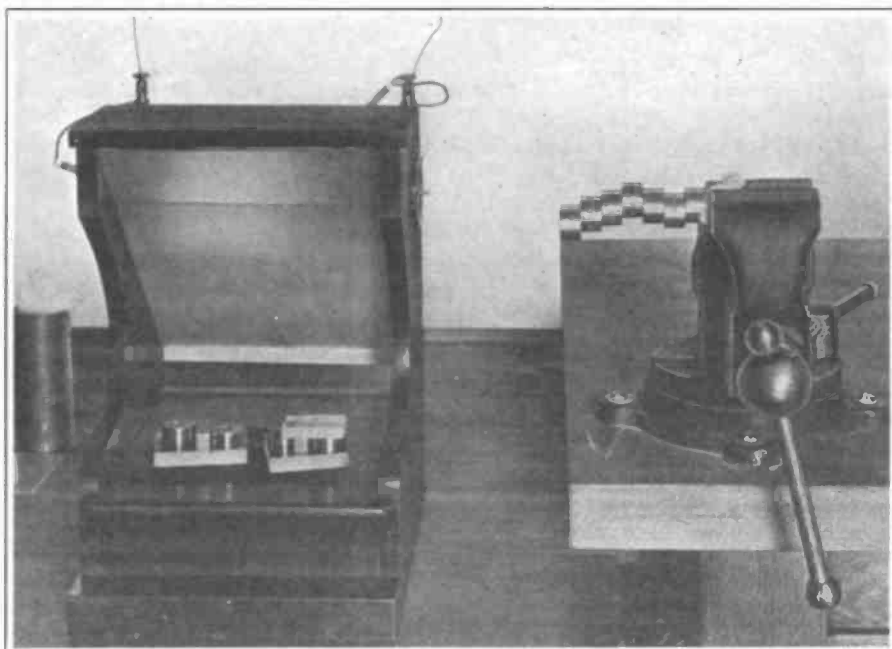

*At the left, the simple apparatus used in measuring by light waves is shown. The group of gauge buttons at the right have such accurately finished surfaces they adhere together with force enough to support their own weight*

workmen and he closely guarded the secret of his ability. His was almost a separate trade. Then came the micrometer caliper and today very accurate machine shop work is regularly done to a ten-thousandth of an inch. In the most accurate machine work, such

better bicycles, longer-lived automobiles and more reliable airplanes because accuracy in the fabrication of their components insures all of the desirable qualities.

The micrometer gauge is not to be discarded. But micrometers get out of

adjustment. As they are used, the measuring faces wear away and they have to be readjusted. So it is with all other types of accurate gauges used in machine shop practice, and accurate standards are necessary to reset them when worn.

Heretofore we have used gauge blocks that were very expensive and accurate to about a hundred-thousandth of an inch in making the corrections. Now we have available gauge blocks that cost less than a tenth as much and are accurate to a millionth of an inch. This means that we will have more uniformly accurate measuring tools and consequently a more uniform product. This is extremely important in quantity production where

come plainly visible. These bands are caused by the interference of light waves reflected from the lower surface of the glass with those reflected from the surface of the steel. It has been determined that the dark bands are caused by a quenching of the light, due to the two sets of waves getting "out of step" when one set crosses the air gap between the glass and the steel.

It has been further determined that these interference bands occur at every half wavelength of light, so that each band represents a variation of a hundred-thousandth of an inch in the steel surface. If the bands are straight and parallel it indicates the surface is perfectly flat. If the bands are curved, they indicate minute hills and valleys

monochromatic light, or light of one wavelength or color.

The light source is a conveniently arranged box containing a tungsten filament lamp. There is provided a special selenium diffusing lens, which cuts out all the wavelengths of the violet, blue, green, orange and yellow light and allows only a very definite red wavelength to pass. A monochromatic light is used because if more than one wavelength of light is allowed to fall on the object being gauged, the interference bands are double and it is more difficult to interpret them. A monochromatic light produces single interference bands, which are sharply defined as alternate light and dark spaces.

The wavelength of this red light is approximately a fifty-thousandth of an inch. The interference bands, however, occur at every half wavelength or every hundred-thousandth of an inch. Thus the unit of measurement is a hundred-thousandth. It is possible, however, to gauge a tenth of that distance with the eye, so that measurements of a millionth of an inch can be made with great accuracy. Finer measurements require more precise methods, but the same equipment may be used.

As an instance of how the apparatus is used, suppose we are testing a steel surface for flatness. Any one of the optical glass flats is pressed in close contact with the surface, so that all the air possible is expelled. If the surface is perfectly flat no interference bands will be observed. But if there is a depression in the surface, at the point where the depression begins there will be a tiny wedge of air between the glass and the steel surface. A light wave coming from the box will penetrate the glass and part of it will be reflected to the eye from the *under* or inside surface of the glass. Another part of the same wave will cross the tiny air gap and be reflected to the eye from the surface of the steel. But in crossing the air gap the two parts of the wave get "out of step" so that in reaching the eye they actually collide or interfere with each other and the eye sees these interferences as dark spots, or rather fails to see anything at these points. Thus, not only can we observe that there is a depression in the steel, but we can determine just how much of a depression by counting the interference bands.

Just what takes place is illustrated in the accompanying drawing, although on a greatly exaggerated scale.

In comparing the length of two gauges, or the diameters of two plug gauges or ball bearings, the two objects are placed between two of the glasses and the observer looks down through the two glasses. In this case the under surface of the top glass acts as one reflecting surface, as before, and

(Continued on page 313)

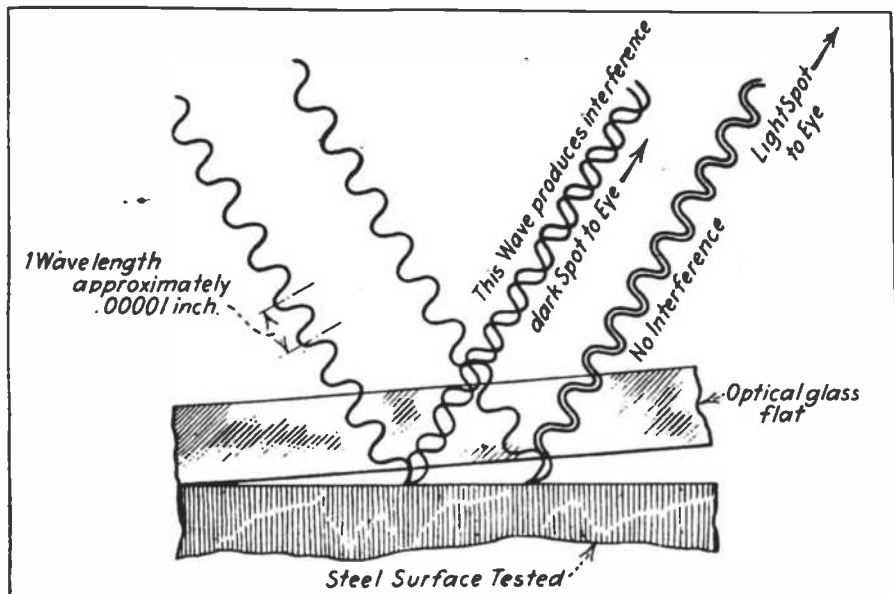

Exaggerated drawing showing how light waves can be used in measuring flatness of surfaces

pieces made in one department have to fit those made in another, and where spare and replacement parts have to be procured from factories thousands of miles away from the ultimate consumer of their product. But just how is it possible to measure a millionth of an inch? The method is not complicated. Briefly it is this:

#### Measuring a Millionth of an Inch

It is known that the waves of sodium light, produced by burning common salt in a flame, are one fifty-thousandth of an inch in length. We need not worry about how that was discovered. Suffice to say that it is a fact and that the length of the light wave is always the same.

Suppose we wish to test a steel surface for flatness. A simple piece of clear glass, ground on one side so that the surface is optically flat, is the only tool required. The steel is placed under the sodium light and the glass is pressed in close contact. Immediately a series of alternately dark and light "interference bands" varying in number and contour with the surface be-

in the steel surface, just as the lines on a contour map represent hills and valleys.

In measuring the length of a piece of steel, the piece to be tested is placed on a perfectly flat surface beside another piece of known length. The glass is placed across the two and by observing the interference bands it is possible to tell whether the two pieces are of exactly the same length, or how much they are at variance. By the use of an instrument called an interferometer, which operates on the same principle, the calculations can be reduced to so small a quantity as a twentieth of a millionth of an inch: So far the most practical application of the method has been in the making of precision gauges.

#### Outfit for Shop Use

A Boston concern has just placed on the market a complete outfit intended for shop use in inspecting flat surfaces and for length measurements by the interference of light waves. The outfit consists of two working optical glass flats, one master flat, and a source of

# Electrons and the Constitution of the Chemical Atom

By Prof. T. O'Connor Sloane

CENTURIES before the dawn of modern experimental science the ultimate constitution of matter was a subject of speculation and theory. The conception of the atom was formed, as a minute indivisible particle of matter and every substance was held to be composed of such minute and impenetrable particles. In the early days of the last century chemistry was formulated. The word atom acquired a new meaning, the conception of the molecule built up of atoms was evolved and the molecule came nearer the old time atom of the philosophers than did the new atom of the chemist. What might for instance, under the old theories be called an atom of water was now called a molecule of water; in a general way it was assumed that an atom could not exist alone, that it must be combined with one or more other atoms building up molecules. The conception of the chemical elements was formed, and the universe, or as much of it as man could get at, was found to consist of marvelously few elements. Another change has come; the atom no longer is accepted as the smallest possible division of matter, but is considered as a compound structure of varying numbers of parts, some atoms containing more parts than others, so that the atom is compound in structure and is made up of components, originally called corpuscles.

In olden times alchemists had made their living by persuading men of property and rank to back up their efforts, alleged or sincere, to convert the base metals into gold. Some of the alchemists were probably honest, but many were imposters. After the modern chemist had found that the world of matter consisted of less than a hundred elements, he began wondering whether there might not be an ultimate substance, out of which the elements were composed. If such were the case the transmutation of metals might not be impossible after all. This original of all matter, whose existence was not even hinted at by any known property of the elements, was termed protyle—the first stuff, from the Greek. The word, atom, from the same language means, indivisible; molecule, from the Latin, means little mass. The old scholastic philosophers had all sorts of views about matter. Some practically said, that it did not exist; this is about what Bishop Berkley's subjective idealism amounted to.

Priestly and Lavoisier are generally

considered the founders of the modern science of chemistry by their work on oxygen and on the theory of combustion. Soon the idea was grasped, that chemistry was a quantitative science, and that the composition of compounds must be determined and stated by weight. This was an immense stride in the right direction; the use of the chemist's balance, the subjection of compounds and elements to the criterion of proportion by weight, the devising of methods for the quantitative analysis of substances, making the quantitative composition the all important thing in the study of a substance, all these lie at the foundation of modern chemistry. The theory, that matter was all made up of compounds of a few original inalterable substances was formed, the substances were called elements, and it was found, by the application of the chemist's balance, that the elements united in very simple ratios as regards the weights entering into combination with each other. It was found that water was composed of one part of hydrogen and eight parts of oxygen; hydrogen was the lightest substance known, and one part of no other element entered into combination with eight parts of oxygen, it was always a greater weight. As water was taken to be a combination of an atom of hydrogen with an atom of oxygen, its gravimetric composition, which means its composition by weight, was supposed to give the relative weights of the atoms of hydrogen and oxygen; that of hydrogen, the lightest element known, was taken as the base of the atomic weights, and was put at unity, or one, which gave the weight of the atom of oxygen as eight. From time to time new or rather unknown elements were discovered and added to the list; their atomic weights were determined on the basis of the composition of water given above, and each such discovery was a triumph of the comparatively new science.

Then the law that the molecules in the gaseous state all occupy the same volume was formulated and accepted, and this forced a modification. A single instance will suffice to show just what kind of changes were involved. The volumetric composition of water, when its constituents were in the gaseous state, and in those times they were only known as permanent gases, is one volume of oxygen to two volumes of hydrogen. Water is readily decomposed by electrolysis, many of our readers have done it as an interesting

experiment, and when water is so decomposed and the gases are separately collected in two tubes, the hydrogen in one and the oxygen in the other, it will be found that the hydrogen measures twice as much as the oxygen. Therefore by the last law to form water, twice as many molecules of hydrogen would be needed as of oxygen. Molecules of elements are supposed to contain as a rule the same number each of atoms; therefore the water molecule should contain two atoms of hydrogen and one of oxygen, and its formula should be  $H_2O$  and not  $HO$ . Yet up to the year 1870 and even later many chemists wrote the formula of water as  $HO$ . But a few years earlier it was always so written. It was about the year 1868, that Columbia College, as it was then called, announced, that the new system of chemistry should be accepted and used in its scientific courses. In the old system the symbol or formula of water was, as we have seen,  $HO$ . Sulphuric acid was expressed as  $HO, SO_3$ , calcium chloride as  $Ca Cl$ . and so on; for many compounds formulas differing from the accepted ones of the present time were used.

In these days the expressions "old system" and "new system" are never heard; fifty years ago they were in constant use. As a matter of historical interest a few of the old system formulas are given here with their translations into the new system.

	<i>Old System</i>	<i>New System</i>
Water . . . . .	$HO$	$H_2O$
Sulphuric acid . . . . .	$HO, SO_3$	$H_2SO_4$
Calcium carbonate . . . . .	$CaO, CO_2$	$CaCO_3$
Calcium chloride . . . . .	$Ca Cl$	$Ca Cl_2$
Nitric acid . . . . .	$HO, NO_3$	$HNO_3$
Barium hydrate . . . . .	$BaO, HO$	$Ba(OH)_2$

The first theorizing about atoms referred to the physical atom, which is the chemical molecule. Various attempts were made to get an approximate picture of its shape. The smoke ring, often produced by smokers, and sometimes seen in great perfection formed at the smoke stack of a locomotive, shows the motions of the eddies of air. These rings collide and rebound, but never pass through each other. They are impenetrable by one another and are elastic. They have been cited as possibly somewhat like molecules.

The chemist in former times could never get below the atom, so it was

considered the smallest possible division of matter; it was held, that two or more atoms formed a molecule and that an atom could not exist alone, so that molecules were the smallest unit of independently existing matter, and a molecule was built up of atoms.

We have seen that two parts by weight of hydrogen combine with sixteen parts of oxygen. As the atomic weight of oxygen is sixteen, this tells us that two atoms of hydrogen combine with one of oxygen. Hydrogen is assigned a valency of one, and is called a monad. As two atoms are required to saturate one atom of oxygen, the latter element is called a dyad, meaning that it has a valency of two. The atomic weight of carbon is twelve and as many as four parts by weight of hydrogen can combine with twelve parts of carbon; this is the same as saying

as it were with another bond. Thus the atoms of hydrogen, barium, triad nitrogen, carbon, pentad nitrogen and hexad sulphur may be written thus:



But atoms under this theory have to unite and form molecules so as to saturate their bonds. The molecules of the same elements would then be represented thus:



The formulas of compounds must provide for the saturation of bond by bond, and to illustrate the principle the formulas, on the bond system, of water, of sulphuric acid and of benzol follow.

Each of these formulas tells its story

And now while the atom and molecule remain the working units of chemistry, while the old stoichiometrical rule of three calculations are good and valid as ever, the theory in the last few years has had great developments, a sort of protyle seems to have made its appearance, the atom is considered a very large unit of matter, comparatively speaking, and the impenetrability of the atom is quite disposed of. A new unit of matter, the corpuscule, appears on the scene; it is smaller than the atom, perhaps not a hundred thousandth part of the diameter of an atom, and the atom is made up of a few of these corpuscules so distributed, that the atom is far more void than substance, and an atom resembles a solar system, with corpuscules for sun and planets. Just as a body can move between sun and planets without hitting any of them, so can a corpuscule presumably move through the void space of an atom with freedom.

For the working system of chemistry the bond method is perfectly good and valid, but the phenomena of radiation have exacted a new conception of the atom and the electron and nucleus constitution is now the accepted one, subject undoubtedly to change and modification as more work is done on the abstruse subject.

If a number of similarly electrified corpuscules were placed near each other they would tend to fly apart and separate. If some force is conceived which overcomes their mutual repulsion and holds them in greater or less propinquity, the modern idea of the constitution of the atom is reached. The present accepted theory it may be said is, that the force holding the corpuscules together is located in a central body, whose electrical charge is the opposite of that of the other corpuscules. The central body is called the nucleus, and the mass of the atom is supposed to be concentrated in it. The surrounding corpuscules are called electrons, each is charged with exactly the same charge of negative electricity, and this charge is the natural unit of electric charge. The nucleus carries a positive charge equal to the sum of the negative charges of the surrounding electrons.

If a number of common needles are strongly magnetized, and each one is thrust through a cork and floated in a basin of water, as shown in the cut, similar poles being upward, they will repel each other. They may be taken as representing negatively charged electrons or corpuscules. Then if a magnet pole of opposite sign is held above them it will draw them together and they will take a symmetrical arrangement. The magnet represents the positively charged nucleus.

(To Be Continued)

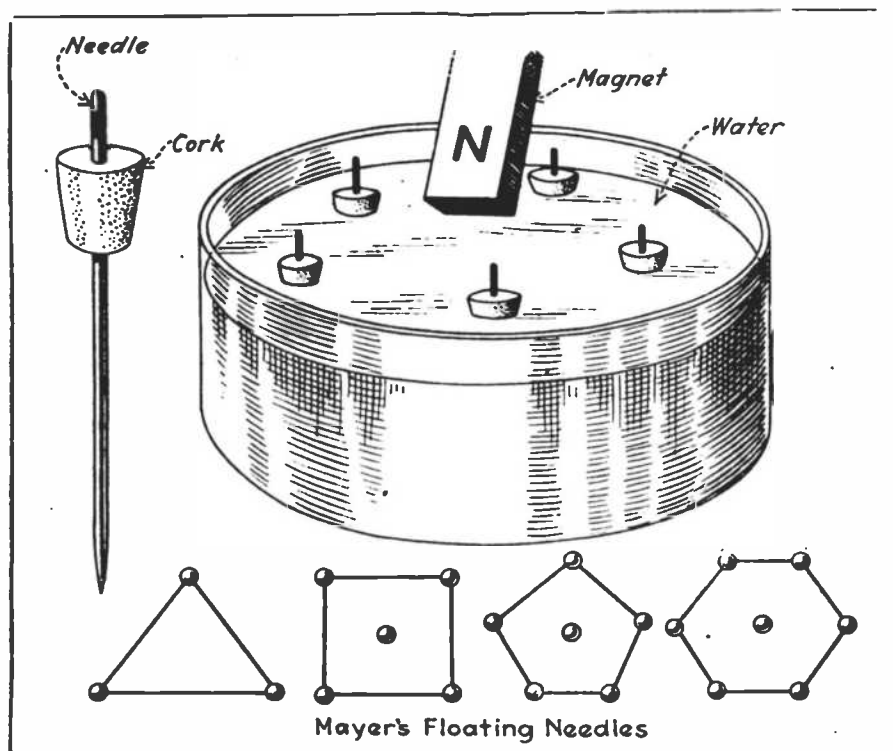

that four atoms of hydrogen can combine with one atom of carbon. Therefore carbon is an element whose atom can combine with four atoms of the monad hydrogen, which gives it a valency of four, and it is called a tetrad. The possible valencies of atoms run from one to eight, some possess more than a single valency; they are called monads, dyads, triads, tetrads, pentads, hexads, heptads and octads, terms derived from the Greek language, and indicating in the order written successive valencies from one to eight. Later it will appear that the number eight enters into the theory of atomic constitution very specifically.

In the bond system the valency of atoms was referred to the possession by each atom of unsaturated bonds, each bond representing a valency of one. A bond was saturated by joining hands

but there is not the least idea that they represent the shape or appearance of the molecule.

If an atom is separated by any operation from a molecule it immediately unites itself to another atom or group

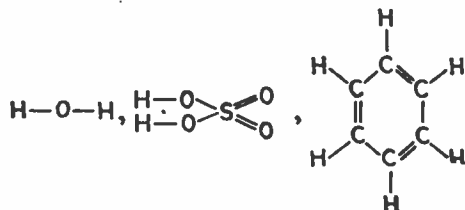

of atoms so as to become a part of a molecule. There is no known limit to the number of atoms which can form a molecule, the molecules of organic substances seem to have the capacity of containing more atoms than inorganic compounds can contain.



**JET PROPULSION FOR MOTOR BOATS**

ONE of the earliest methods for propelling boats and which was also employed in a suggestion for the first steam engine is a reaction motor in which a jet of water or steam impinges upon the air or water as the case may be, the resulting reaction serving to propel whatever the jet is fastened to in a

They are not only used for propelling the craft, but inasmuch as the direction of the discharge openings or nozzles may be changed by a steering wheel which revolves the pump casing to which the nozzles are attached, they also serve to steer the boat. The rudder is thus dispensed with and the inventor claims that the hull may be as easily controlled as with the usual form of rudder. It is claimed that this system

**FORMULA FOR WHITE BRASS**  
**A** GOOD white brass can be made as follows: Melt 20 lbs. of zinc and add 3 lbs. of copper in the form of thin sheet, wire or other easily dissolved material. Heat the zinc until the copper has been dissolved and then add gradually 12 lbs. of zinc, making a total of 32 lbs. To this add 63 lbs. of tin and 2 lbs. of phosphor tin. The mixture should be thoroughly stirred.

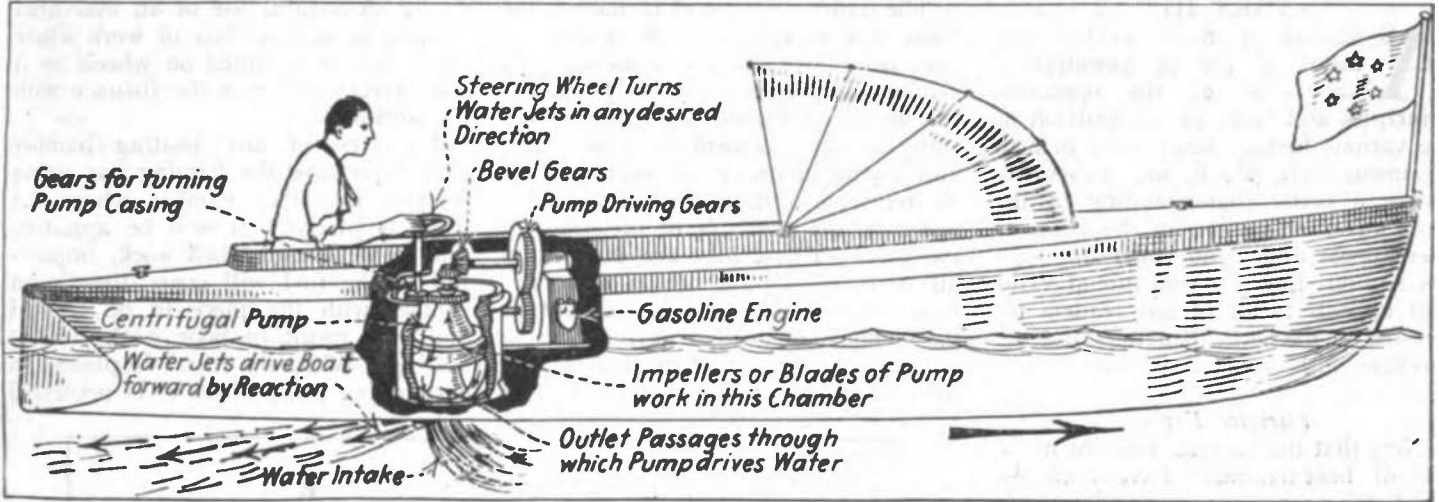

English scheme for jet propulsion applied to small motor boats

direction opposite to that of the jet.

This scheme has been suggested from time to time for the propulsion of ships and only recently we find an inventor backed by the resources of the French Government working out a blast engine for the propulsion of airplanes by a reaction system. We illustrate herewith a new scheme which has been suggested by an English inventor for utilizing hydraulic jets for propelling small boats. While the scheme is not as simple as the conventional propeller and its efficiency may be questioned until its value has been demonstrated by actual tests, the idea is a novel one as worked and should be interesting because it is a modern variation of an idea that is as old as Science and Mechanics. The propelling unit consists of a gasoline engine which drives a powerful centrifugal pump. Inasmuch as the crank shaft of the engine has a horizontal axis and the pump shaft is on a vertical axis, it is necessary to use considerable gearing, which no doubt contributes its quota to the loss of efficiency.

In the scheme suggested by the English inventor the impeller shaft is driven by bevel gearing. The water is drawn in through a suction intake and after being whirled around at high velocity it is discharged through water nozzles placed on the pump casing somewhat back of the center of buoyancy of the hull. The reason these jets must be placed either in back or ahead of the center of buoyancy is because the jets perform a dual function.

is particularly valuable for use in boats intended for shallow water.

The details of the propelling mechanism are clearly shown in sketch, but no reports are available to indicate if the scheme is an efficient one. It would seem that the inventor neglected to work out his scheme as fully as he might have by overlooking the fact that a gasoline engine would operate just as well with its crank shaft vertically placed as it will with its crank shaft horizontal. If there is any merit to the device, it would seem that the use of a five or seven-cylinder radial engine horizontally placed in relation to the mechanism with a centrifugal pump attached directly to the crank shaft and having no gears to transmit power would be considerably more efficient than the scheme outlined.

**LUBRICANTS FOR BICYCLES**

**O**IL used for lubricating bicycles is commonly made of sperm oil and vaseline, mixed, 3 parts of the former to 1 part of the latter by weight.

The sticks of hard lubricant that are rubbed on bicycle chains for lubricating purposes are made by melting some tallow, stirring in graphite until it is thick enough so as to have it set solid when cold. While it is still fluid it is poured into moulds of any desired character. A mixture that does not solidify and that must be applied with a brush consists of vaseline to which enough graphite is added to stiffen it again to the desired degree.

**ONE-MAN HAND TRUCK**

ONE of the disadvantages of the usual form of hand truck is that it often takes two men to load it, as one must steady the truck while the other assists in placing the boxes or barrels on the carrying platform. A new hand truck has been introduced to save the labor of one man and is shown in the accompanying illustration. This is



One-man hand truck

equipped with a special crate rest on the wheel guides that may be adjusted to various vertical and horizontal positions. To load a hand truck of this design, the operator seizes the case or box with an adjustable steel hook and this bolts back on the hand truck, the retaining hook insuring that the crate will rest properly on the truck.

# Heat Treating Alloy Steels

*A Series of Simplified Articles Detailing the Various Methods of Heat Treating Modern Alloy Steels. This Instalment Explains the Various Types of Furnaces Used in Hardening, Carburizing and Tempering*

By Victor W. Pagé, M. S. A. E.

## PART III

AS suitable furnaces to heat the metal in are so essential, a knowledge of the operating principles and types of construction of the various furnace forms used in heat treatment will enable the student to secure a better understanding of the more advanced articles of the series as they appear and at the same time such descriptions have an educational value that appeals to all of our readers interested in mechanical matters and not familiar with furnace construction.

### Furnace Forms

Now that the various different methods of heat-treatment have been defined, the next point to consider is the design and construction of the furnaces used in heating steel for carburizing it or heating preparatory to hardening. While a large number of designs of furnaces are offered, they may be classified in a few types. One method of classifying is by the class of fuel used in producing the heat. Some furnaces are adapted for using solid fuel, such as coal or coke, others are fitted with suitable burners to derive their heat from the combination of illuminating or other gases and air, while still others have burners adapted for liquid fuel, such as crude oil. Another group derive their heat from electricity instead of gas combustion.

### Three Main Furnace Types

The general construction of a furnace and the principle it follows is independent of the type of fuel used to a certain degree, but there are three main types of furnaces employed in the heat-treatment of steel, these being classified according to the way in which the heat is applied. A furnace may be under-fired, that is the fire may be below the chamber in which the work is placed; it may be over-fired, in which the heating medium is burned above the hearth on which the work is placed, or it may be heating-chamber fired, in which case the work is placed directly in the combustion chamber. Then again, there are types of furnaces that may really be considered as heating the work indirectly because the desired temperature of the steel is produced by immersing it in baths of molten metal, or putting it in a muffle surrounded by electrically heated metal wire coils.

The under-fire type of furnace is the form that is most suitable when one does not desire the gas resulting from combustion to strike directly against the work. A number of different designs and arrangements of combustion and heating chambers are built, but for the most part, the flue arrangement is based on the principle of breaking up the gases so that they are directed to all parts of the furnace to distribute heat evenly. The amount of heat in the combustion portion of the furnace is generally greater than that in the work chamber or hearth.

A natural use of an over-fired furnace is in that class of work where the hearth is mounted on wheels so it can be removed from the furnace with the work.

Furnaces of the heating-chamber fired type have the flaming gas going directly into the chamber where the work is placed. It will be apparent that in treating finished work, impurities in the fuel will come directly in contact with the piece to be treated and may result in poor work due to scaling. When the metal is placed in carburizing pots, where it is protected

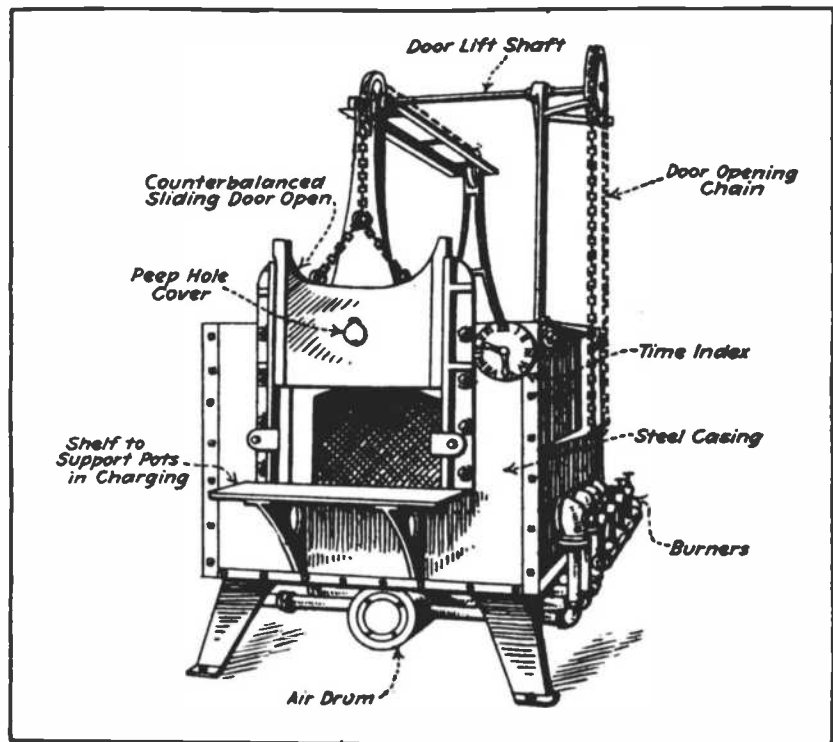

Typical steel-encased gas-heated furnace suitable for hardening or carburizing

The over-fired type of furnace is that in which the combustion chamber is placed above the heating chamber and the hot gases are conveyed to the latter through a series of openings made in the arch. The burning gases are discharged from the bottom of the hearth in the over-fired furnace. This type is not nearly as effective as the under-fired furnace because a natural law is defied. The tendency of heated gas is always to rise because it is lighter than gas of lower temperature. In an over-fired furnace, the heat must be exhausted by means of some form of blower or flue arrangement that produces extra

from the direct action of the burning gases by packing it in carburizing material and with luted top covers, such furnaces are found to give very good results. They are also suitable for annealing pieces that are afterwards machined. It will be evident that in a heating-chamber fired furnace, work will scale much more than in the form where the steel does not come in contact with the heating medium.

A muffle type of furnace is one in which the heating chamber is completely protected from the flame or hot gases. A furnace of this type is well adapted for heating finished pieces such

as dies and tools preparatory to hardening. The niceties of furnace design and construction require considerably more space than is available in a series of this nature and any reader who is interested in building a furnace can

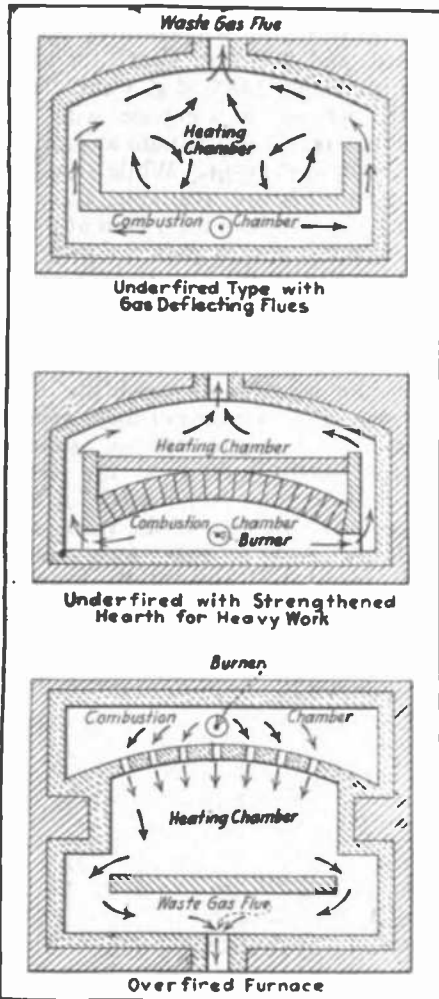

Diagrams outlining various systems of furnace construction

find special works on the subject that will go just as deeply into detail as he may consider necessary.

**Materials Used in Furnaces**

The materials employed in furnaces are heat-resisting brick for combustion chambers which are surrounded with various heat insulating materials, such as asbestos, magnesia and various types of composition, insulating bricks. The exterior of the furnace is made of ordinary building brick and if the furnaces are large or to be operated continually, the external walls are usually braced by angle or channel iron members arranged both horizontally and vertically and held together by tie-rods. The smaller, portable furnaces which may be purchased ready made from dealers in such material, usually have cast iron sides and front and are lined with heat-resisting material. In their simplest form, they are simply cast iron boxes lined with fire brick having openings for burners and flues for gas disposal.

**Automatic Furnaces**

When a large amount of work is to be handled, it is sometimes possible to use automatic furnaces which are equipped with special mechanism for carrying the work through them and dropping it into the bath. Special rotary hardening furnaces have been used in many manufacturing establishments for hardening screws, nuts, pins and washers and steel balls used in ball bearings that are not intended for extremely high grade work. The trouble with a rotary hardening furnace in which the work is fed through by means of a large screw-thread machined in the furnace shell or formed in the heat-resisting lining, is that the pieces passing through the furnace do not always go through at the same time or at the same speed. This results in some of the pieces being heated more than others and does not produce uniform work as some pieces will be quenched at too low a heat and others at temperatures that are too high.

**Lead Pot Furnace**

A lead pot furnace is the type in which molten metal is heated in a large metal tank or crucible which has a combustion chamber around and under it. These are often employed for heating work of which only certain portions are to be hardened. Lead pot furnaces are also used for tempering as various kinds of alloys of metal will become molten at different heats and in this way it is possible to obtain various temperatures by altering the proportions of the alloy that is to be melted as the writer has previously pointed out. A marked advantage of the lead pot furnace is that it will hold its temperature, in as much as the heat at which the molten metal is, does not fluctuate as much as in those types where the door must be frequently opened and closed to remove and in-

sert the work. A lead pot furnace is really a muffle furnace in which the usual refractory fire brick muffle is replaced by a metal pot or special crucible. It has the same advantage that the muffle furnace has in that the gases can not come directly in contact with the work.

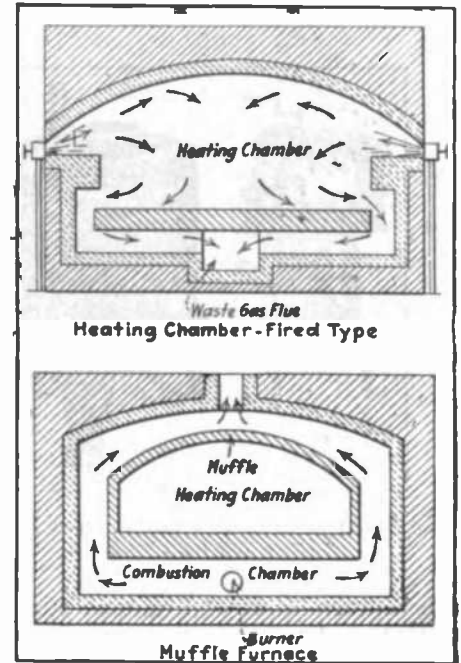

Diagrams showing difference between heating chamber fired and muffle furnaces

**Advantages of Gas Burners**

Most heat-treating furnaces now have either gas or fuel oil burners as it is much easier to regulate the flame when gas or oil vapor is burned than it is by using solid fuel and it is also possible to obtain higher temperatures. For very accurate work, such as in laboratory tests, furnaces heated by electrical resistance coils are generally used as their temperature can be controlled within very narrow limits by regulating the current flow. When crude oil is

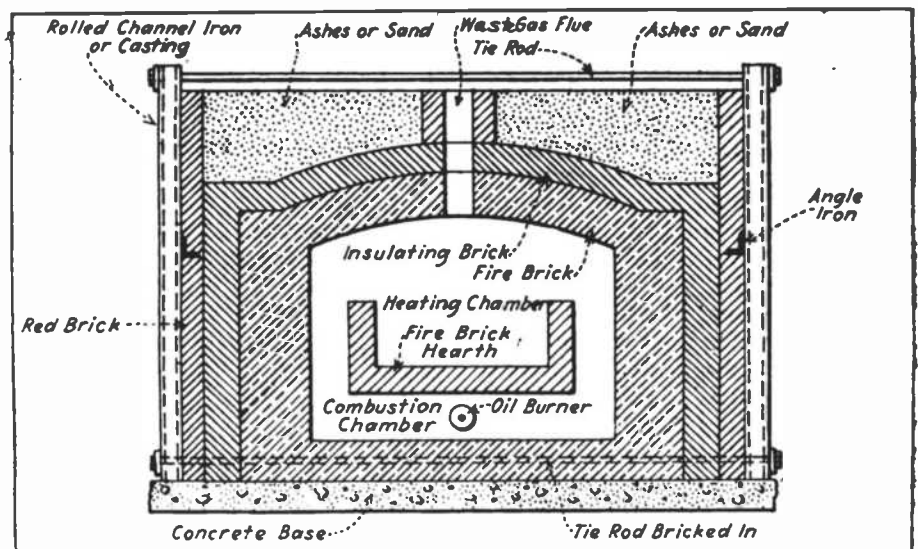

Sectional view of underfired furnace for heat-treating steel, showing materials used in construction of different parts

used for fuel, the burner is a simple type having a regulating valve to control the amount of oil sprayed into the air stream which is supplied by some form of blower. The air passes through an external tube while the liquid fuel is passed through an inner concentric tube. In some form of burners, both the air and liquid fuel may be controlled. The fuel oil is usually pumped

porting and adjacent turns are spaced by insulators of a special refractory compound set in the furnace wall. The construction of the unit is such that it may be easily removed from the front of the furnace. The terminal studs which pass through the furnace wall are insulated from the walls by means of heavy porcelain bushings.

(To be continued)

## THERMO-ELECTRIC PYROMETERS

THE question of a really satisfactory base-metal couple still remains to be solved. While it is quite true there are a good many base-metal couples on the market which are suited for the comparatively low temperatures up to 800 deg. and 900 deg. Cent., for temperatures above 1,000 deg. Cent. there is still nothing to compare with Le Chatelier's original platinum and platinum rhodium element. While supplies of these metals are available, there is nothing serious about this; even at present prices this couple pays for itself in the regularity of the heat-treated products. The fact is, however, that platinum is becoming more and more scarce, the price continually rises, and it is within the bounds of possibility that there may not be enough of these metals available for pyrometry—a serious prospect, having in view the large amounts which are being used for this purpose. Dr. Burgess of the Bureau of Standards, asserts that base-metal couples are being successfully applied in America. There are a number of

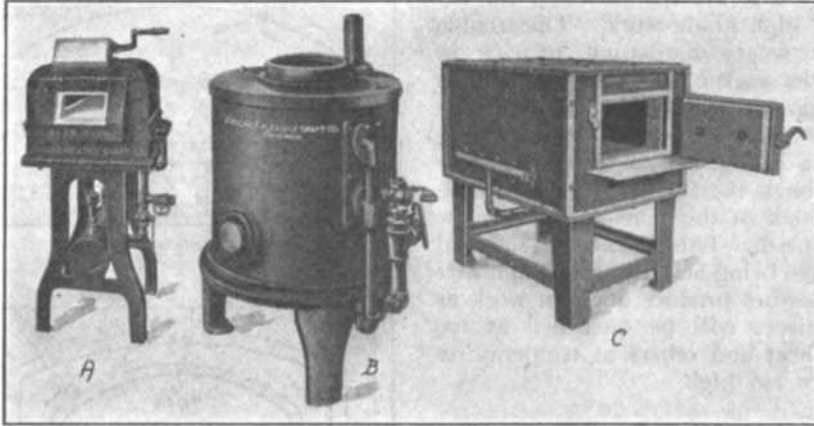

Examples of heat treating furnaces. A—Hardening furnace. B—Lead pot furnace for tempering. C—Carburising or case hardening muffle

to the burners from underground storage tanks. Practically the same form of burner is utilized when manufactured gas is used instead of liquid fuel except that the area of the gas passage must of course be larger than that of the passage of a crude oil burner.

### Electric Resistance Furnace

Any type, style or size of combustion furnace where the temperature does not exceed 980 degrees C. (1,800 degrees F.) can be made in the ribbon wound type electric furnace. In general, where high quality product is required, the electric furnace will show a saving in cost per finished piece. Some of the more specific examples of applications in which it is highly desirable to have uniform heating characteristics and accurate temperature control of the electric furnace are: hardening and drawing furnaces for high carbon and alloy steels, drawing furnaces for high speed steel, annealing furnaces for certain alloy steels, special grades of malleable iron, cold rolled strip steel for deep stamping, etc. Annealing furnaces for copper, aluminum, brass and other non-ferrous alloys can also be of the electrically heated types.

The accompanying illustration shows a horizontal semi-cylindrical furnace. The refractory brick lining is backed up with heat insulating brick and the whole is encased in a sheet steel jacket. The heating unit consists of a heavy nichrome ribbon wound on edge in such a manner that the successive convolutions form an arch which extends the full length of the heating chamber and gives a perfectly uniform distribution of heat. The ribbon is self-sup-

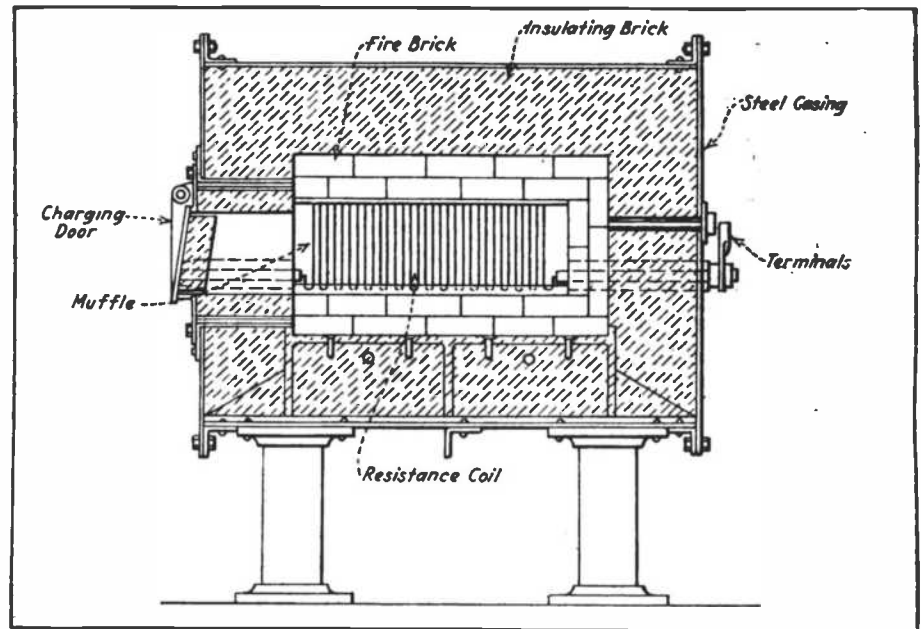

Diagram showing construction of electrically-heated resistance furnace

## LOCOMOTIVES IN GREAT BRITAIN

THE number of locomotives available for traffic on the 16 principal railways in Great Britain in June, 1919, was 17,743, a decrease of 1,186 as compared with the number available in 1913; 429 Government locomotives have been loaned to the companies, and strenuous efforts are being made to reduce the number awaiting repair and to increase the rate of construction of new locomotives.

quite excellent pyrometers on the market described as portable pyrometers. One is well advised, however, to take as little advantage of their portability as possible; there should be an instrument for each furnace or group of furnaces. Moving these delicate instruments about the works, to say the least, does them no good, and further, the calibration varies with the surroundings and the leveling. Unless the instruments are handled carefully and by experienced men, there is always the danger of setting them down too hard and disturbing the adjustment.



## DOMESTIC ILLUMINATING ENGINEERING

A LITTLE simple "illuminating engineering" applied to your door and window screens will make them serve the double purpose of protecting the interior of your home from the prying eyes of inquisitive folk, as well as from the inroads of flies and mosquitoes. One has simply to paint the screens white to make them "peep-proof". The accompanying photograph illustrates the principle. The picture was taken through an ordinary wire screen, half of which was painted white and half black. It will be noted that the black screen interferes very little with vision through it. The white screen, on the other hand, effectively conceals the room behind it.

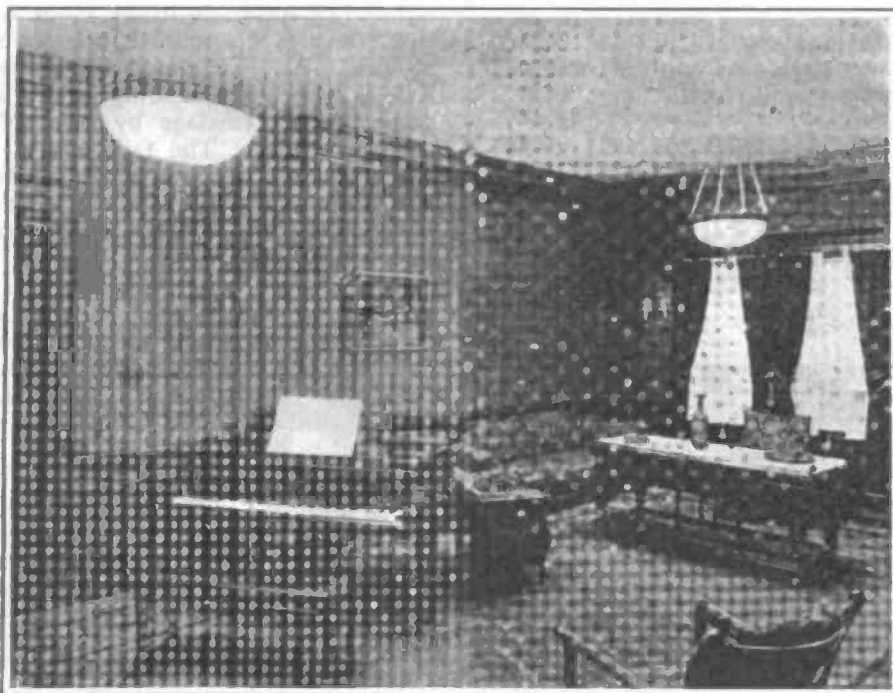

Photograph showing relative visibility through white and black screen mesh

The explanation is simple. The screen was only a few feet in front of the camera and is "out of focus". Nearly all of the light falling on the white wires is reflected and is seen as a blur of light. The intersecting white wires form a screen of white light which interferes with light coming between the wires and destroys good vision. The black wires, on the other hand, absorb most of the light which strikes them and there is no interference with light coming between the wires. Vision is good through it. The effect is the same to the eye as to the camera. To a person standing near a screen and looking through it, the wires are "out of focus" and the white wires offer even better resistance to vision than to the searching eye of the camera.

A white screen can be depended on for this purpose only in the daytime, however, since at night the observer outside has no reflected rays to contend

with, while persons inside the room will have difficulty in seeing out because of reflected light from lamps.

Vision from the inside of the house can be rendered better at all times by painting the inside of the screen black, while the outside remains white. This would seem to be the ideal screen, because even in daytime some reflected light from the interior of the room would interfere partially with vision out. The best plan in making a screen of this kind is to secure a screen which already has on it a coat of black enamel, and then to paint one side white. In doing this a small brush should be used, carrying as little paint as possible. It is well to have the paint thick. If these precautions are observed no trouble will be experienced from the

paint running through the mesh and coating both sides of the wire. A little more patience is required, but the results justify it.—HARRY A. MOUNT.

Hard rubber or ebonite, which is essentially a vegetable substance, if rubbed with a woolen cloth or with a piece of fur becomes charged with negative electricity. It is due to the contact of animal and vegetable substance, but if half of the piece of ebonite is rubbed with quick lime and then the piece is rubbed with the cloth or the fur the untreated portion will be negatively electrified as before, while that portion which has been rubbed with lime will become positively electrified, and this property will last for five or six months, gradually fading away until the lime-rubbed portion becomes quite inactive to rubbing with the cloth or fur.

## MEASURING HEAT VARIATION IN GAS ENGINE CYLINDERS

EXPERIMENTS described in *Engineering* show that the temperature at the inner surface of a small gas engine cylinder is about 240 degrees C; and the cyclical variation is usually less than 10 degrees C. The steady conditions of low temperature at the wall surface are maintained by the jacket-water, although the explosion of the gaseous mixture produces very great changes of temperature close to the walls of the combustion chamber.

This variation has not hitherto been measured for a complete cycle owing to the difficulties which occur in measuring the highest temperature of the explosion. In order to obtain the cyclical variation near the walls, a couple was made of an alloy of 10 per cent iridium and platinum, with a pure platinum wire, and this was secured in a metal plug so that it projected  $\frac{1}{4}$  inch into the cylinder. On light loads and weak mixtures the cycle remained unbroken, but near full load the platinum wire melted.

Couples made from 10 per cent alloys of iridium and rhodium with platinum were afterward used, having an electromotive force  $E$  above 500 degrees C. given by  $E = -174 + 7.6075 T - 0.00167 T^2$ , where  $T$  is the temperature centigrade. The junctions were rolled down to five or six ten-thousandths of an inch thickness and inserted at a depth of  $\frac{1}{2}$  inch from the cylinder wall.

These couples were able to withstand the highest temperatures near the walls, and they were not melted except during abnormal explosions. Measurements of the cyclical variations showed a variation of  $E. M. F.$  lying between 1.56 and 7.83 millivolts with an average cold junction temperature of 30 degrees C. The temperature variation corresponding to these values ranges between 250 degrees C. and 1,700 degrees C.

## HOW LOCOMOTIVES HAVE INCREASED IN POWER

THE lubrication of the main journal of the modern locomotive calls for careful consideration, both because of increased weights and exacting demands in service. A passenger type of fifteen years ago, with a tractive force of 16,000 pounds, could handle a light train between Chicago and New York in about thirty hours. Today the same service requires a locomotive of 300,000 pounds, with a tractive force of 30,000 pounds, capable of hauling the heavy all-steel train in twenty hours at all seasons and always without delays. In like manner freight locomotives have developed from a tractive force of 25,000 pounds to the Mallet articulated compounds, with tractive force of 100,000 pounds, weighing 450,000 pounds.

# A Compressed Air Driven Monoplane

*The Main Features of an Interesting and Simple Monoplane Using a Compressed Air Power Plant That Has Made Successful Flights*

By H. C. Ellis

**T**HERE is a growing interest on the part of model engineers in compressed air motors and model airplanes suitable for use in connection with them. The writer has recently completed a simple monoplane design that has made successful flights and that is not so complicated but what any amateur mechanic can build it without much trouble. If the enthusiast does not have shop facilities sufficiently complete to build the engine or tank, these may be secured from makers of model supplies, so the simpler work, such as wing construction and assembling the parts can be done by anyone possessing even a limited tool equipment.

While the machine illustrated is a monoplane, there is no reason why the experimenter cannot build other types of multiplanes, using the same power plant and air tank. Inasmuch as wing construction has been described in articles previously published in EVERYDAY ENGINEERING MAGAZINE detailing various rubber motor-propelled types, only the main points of construction will be considered in this article.

### Details of Motor

The motor is of the three-cylinder rotary type,  $\frac{3}{8}$ -in. bore and  $\frac{3}{8}$ -in. stroke. The cylinders are turned from

a solid piece of steel and have a small flange at the bottom so they may be bolted to the crankcase. The crankcase is entirely of aluminum. Pistons are of aluminum and are lapped into the cylinders to insure a perfect fit. Connecting rods are of bronze. It is not easy for the average reader to build these motors and will cost less in the end to purchase same from a model

*For some time past, our mail has indicated that there was more than the usual amount of interest in model airplanes driven by compressed air motors. The model plane and engines described on this and following pages should be of particular interest to the more advanced airplane model enthusiasts who have graduated from the rubber motor driven types of construction.—THE EDITOR.*

supply house specializing on such product, though instructions detailed enough for building several types are given in this issue of EVERYDAY ENGINEERING MAGAZINE.

### Main Planes and Landing Gear

The ribs of the main planes are the solid web type. They may be made of  $\frac{1}{16}$ -in. spruce or of Balsa and are

assembled on the wing spars and held in place by gluing. Twelve ribs are used in each wing. The curved wing tips are made of reed. The front spar is  $\frac{1}{8}$ -in. by  $\frac{1}{4}$ -in. section, rear spar  $\frac{1}{8}$ -in. by  $\frac{3}{16}$ -in. section, spruce. The entering and trailing edges are  $\frac{1}{8}$ -in. reed. Planes are covered with bamboo paper to which three coats of dope are applied. The landing gear is made of two V type strut assemblies and is constructed of spruce  $\frac{3}{8}$ -in. by  $\frac{1}{2}$ -in. section which is streamlined to lessen resistance. A  $\frac{1}{8}$ -in. round section steel axle is used. The landing gear is attached to the fuselage by small aluminum fittings. The tail skid is of  $\frac{1}{8}$ -in. reed bound and glued in place and is similar to the tail skids that were used for a time on the early Bleriot monoplanes.

The pylon for the bracing wires is also of reed, bent to shape and attached to the longeron members with a binding of fine wire. The bracing wires, which may be provided with light model turnbuckles if one desires, are attached to light aluminum fittings attached to one of the wing ribs. The flying wires are attached to the landing gear struts, the landing wires are secured to the pylon. The wing spars terminate into round aluminum or brass tubes which project about  $1\frac{1}{2}$  ins.

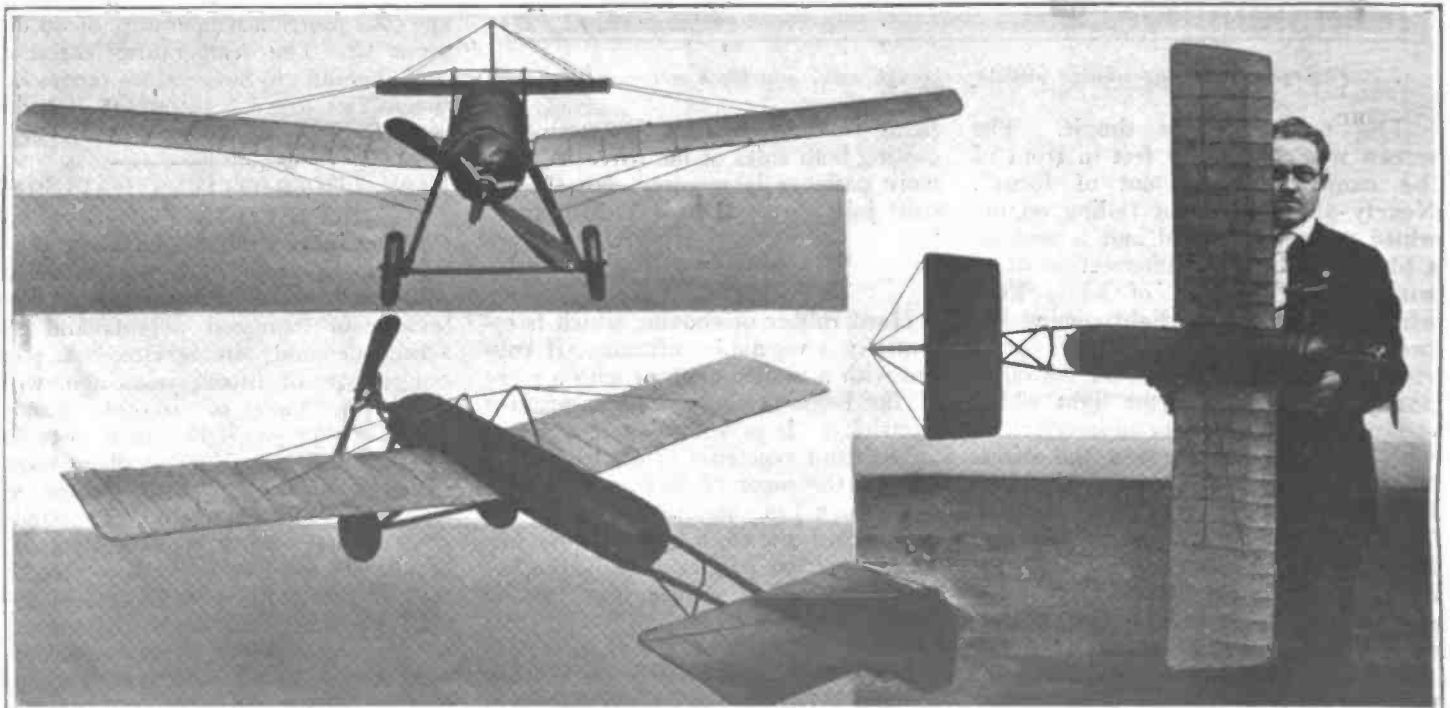

Front, three-quarter rear and top views of compressed air monoplane using a three-cylinder motor. The plan view shows the large size of this machine and how everything is built around the air tank

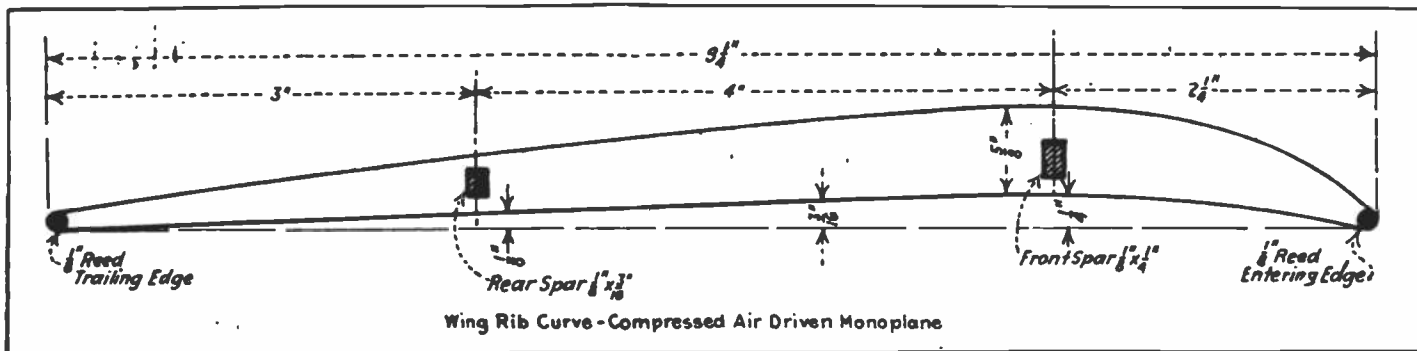

from the wing inner ends and which are inserted into sockets of tubing brazed or soldered in the air tank at the proper points. These tubes go entirely through the tank, and are carefully soldered at their ends to minimize leakage.

**Tank and Fuselage**

The tank is constructed of 30 gauge sheet bronze in strips of suitable size. The bronze is wrapped around a suit-

which all parts are fastened. They are 1/4-in by 5/16-in. at their greatest cross section, which is situated 22 inches from the nose of the model, from which point they taper to 3/16-in. by 1/4-in. at the ends. The longerons are united at the rear by gluing and binding. The tank is fixed by bronze distance pieces soldered to it. The ends of these are bent to the form of the longeron and then soldered to hold them in place. The general design of

**FIRE-PROOF FABRIC ON GERMAN AIRPLANE**

A PORTION of the airplanes that were surrendered to the Allies at the conclusion of the Armistice by the German Air Service have been received in this country and are distributed to the various flying fields so that the features of construction could be studied and various experiments could be carried out with different machines. During recent tests at Kelly Field,

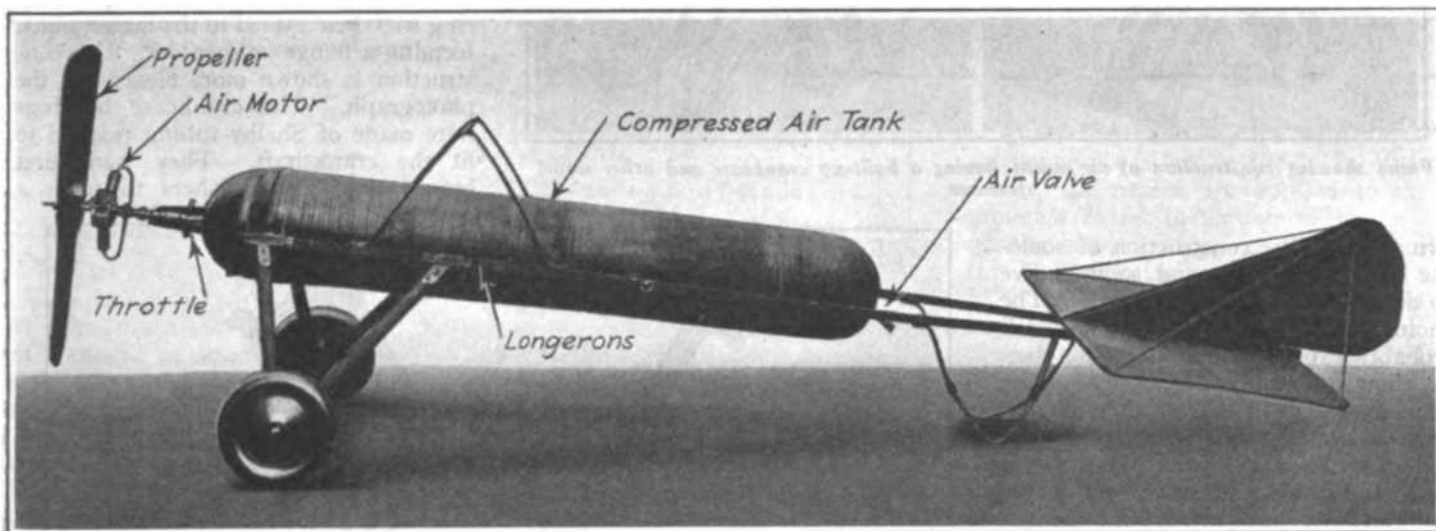

Side view of compressed air monoplane after wings are removed to show how air tank forms the basis of the entire fuselage

able mandrel to form the tank body, lapping the edges about 1/2 in. Hold the material in place with small rivets and solder the seams. After soldering the metal should be trimmed off to receive the ends. Wrap the tank with light gauge steel piano wire, making the wraps about 1/8-in. apart as a reinforcement. The wires should then be soldered at several points to keep it in position. The caps or ends are spun of steel of the same gauge as the bronze and are carefully riveted and soldered to the cylinder. Light tie rods are sometimes used, being placed longitudinally through the tank to help in holding the ends. An ordinary bicycle tire valve is carefully soldered in one end and the throttle and motor shaft in the other end.

Two longerons of spruce attached to and in connection with the tank form the two side members of the fuselage which carries the motor at the front end and empennage at the rear and to

the machine is clearly shown in accompanying illustrations and some idea of its size can also be obtained. The principal specifications follow:

**COMPRESSED AIR-DRIVEN MONOPLANE**

- Span .....56 ins.
- Chord .....9 1/4 ins.
- Length over all..... 50 ins.
- Propeller..12 ins. diam., 25 ins. pitch
- Tank.....4 ins. diam., length 24 ins.
- Wheels......4 ins. diam.
- Stabilizer......8 by 18 ins.
- Pressure .....150 pounds
- Weight .....30 ounces
- Distance of flight with 150 pounds pressure .....400 feet
- Wing area......462.5 sq. ins.
- Loading......15 sq. ins. per ounce
- Dihedral ......5 degrees
- Incidence ......4 degrees

Texas, it was found that the Fokker airplane was covered with fire-proof fabric. Even when the material with which the wings were covered was exposed to the hot flames from a blow torch the fire did not spread even after holes had been burned through the fabric, which required a great deal of time. Recent experiments made in this country with fire prevention materials indicated that by the use of wing coverings of fire-resisting material of non-inflammable dope, that the accidents which have been so common in the past due to a plane catching fire in the air, would be practically eliminated.

The Aviation Committee of the Aero Club of France has now approved the regulations for the Louis Bleriot Safety Prize. The prize of 100,000 francs will be awarded to the competitor, who under certain conditions makes the lowest vertical speed in descending from a height of 500 meters and lands in a circle of 50 meters in diameter.

# How To Make A Compressed Air Motor

*Details of an Interesting and Powerful Model Airplane Power Plant Built With a Minimum of Lathe Work*

By V. Davenport

I HAVE always held that a description of anything of this sort should be short and general in its nature as any real model engineer generally wants to follow out a few ideas of his

## *Crankcase Made of Sheet Metal*

The crankcase can perhaps best be described by the use of a sketch, which is given at Fig. 1. A strip of rather

of the crankcase is taken and the groove for the cylinder and the hole for the bolts laid out and drilled before bending to shape. A true hexagon should be cut from a block of wood to insure a true crankcase, as it serves as a pattern and the case is made by bending the strip of metal around it. The ends of the strip were butted together, riveted and brazed.

The sides or end plates of the crankcase were made from sheet aluminum cut to the shape of the crankcase proper. The flanges were made by taking a piece of the same material and cutting to the inside diameter of the hexagon, then cutting out the middle of it so as to leave a ring. This ring was then riveted to the larger plate, forming a flange or shoulder. The construction is shown more clearly in the photograph. The crankcase bearings were made of Shelby tubing reamed to fit the crankshaft. They were first brazed onto thin washers to form a

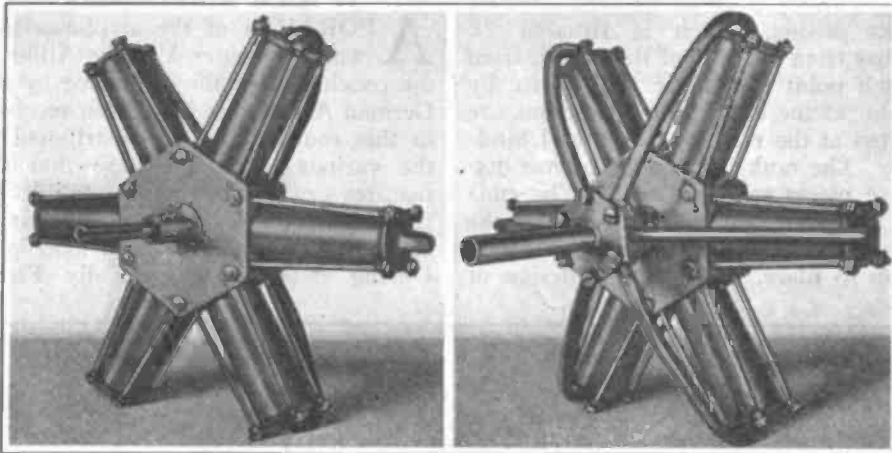

*Views showing construction of air motor having a built-up crankcase and other novel features*

own, even in the construction of someone else's apparatus, and so will give no dimensions or lengthy details. The photographs with this article will probably explain the construction better than a lengthy description. The main idea I want to bring out is that the only lathe work was the pistons and distributing valve. All the rest was hand work and easily obtainable material was used throughout the engine.

## *Reamed Tubing for Cylinders*

The cylinders were made from Shelby seamless steel tubing. They were first cut to slightly over length, and then a wooden block with a hole the same size as the outside diameter as the tubing was made so as to hold the tubing in a vise while it was reamed. To get a good finish the tubing was reamed three times. First with a roughing reamer, then with a standard size 15/16-in. reamer. It was finished with a 15/16-in. expansion reamer, expanded to a little over its ordinary size. The outside of the cylinders were polished by inserting a bolt, about a half inch longer than the cylinders in the chuck of a hand drill and slipping the cylinders over this and letting the conical end of the chuck extend into the tubing, a nut and washer on the other end holding them in place. The hand drill was placed in a vise and strips of emery cloth used for the polishing.

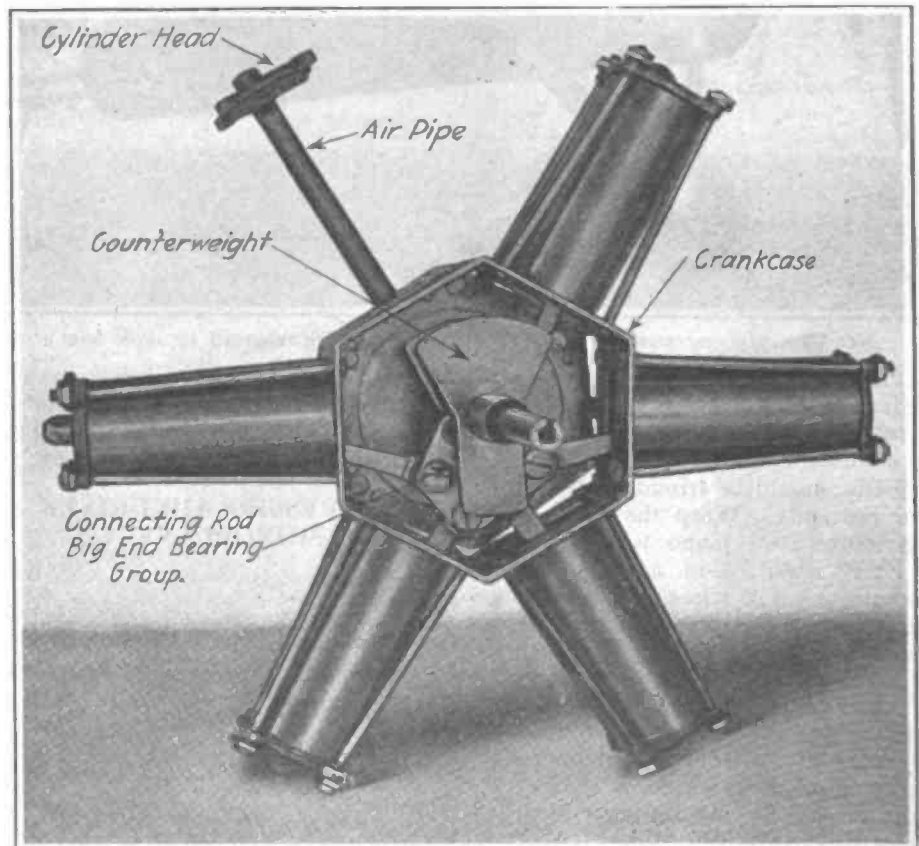

*View of crankcase interior of Davenport motor shows counterbalanced crankshaft and method of grouping connecting rod big ends*

thin steel, 1/16-in. is thick enough, equal to the width of crankcase wanted and in length equal to the perimeter

flange. This flange was then riveted to the crankcase. The bearings were finished the same as the cylinders.



**Built-up Crankshaft**

On account of the construction of the connecting rods the crankshaft was made in two pieces and bolted together by means of the crankpin, similar in construction to that of a motorcycle.

apart. The connecting rod big end assembly is very much the same as used on the Gnome aviation engine, consisting of one master rod and five auxiliary rods.

The cylinder heads were made the same as the crankcase was, except that

ing is copper and all joints are silver soldered. No doubt but the reader can considerably lighten the weight. The engine weighed 20 ounces as made and delivered a maximum of about three horsepower on two hundred pounds of air.

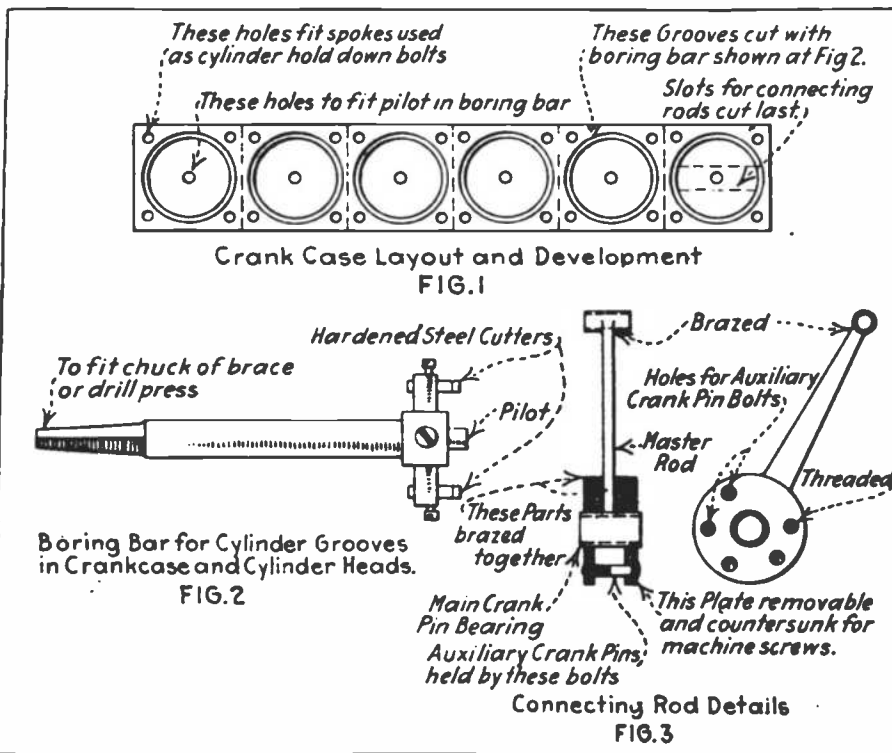

Fig. 1—Development of crankcase. Fig. 2—Special cutter for cylinder heads and crankcase. Fig. 3—Connecting rod details showing master rod

The crankpin itself is brazed to the propeller end of the crankshaft, making the end of the crankshaft that takes the strain one solid piece.

The connecting rod bearings and crankpin bearings were made from the rollers and roller sleeves from a motorcycle chain, and brazed to the connecting rods. Afterwards they were reamed to fit the crank and connecting rod pins. A jig was used for the brazing operation to make sure that the sleeves would be the same distance

they were made of brass. They were first drilled, the grooves cut, and then filed to shape. They can be made as separate pieces or as one piece and cut apart.

The cylinder retaining bolts were made of spokes from an aeroplane wheel, the reason being that the heads on these are straight and not at right angles, as with bicycle spokes. The crankcase sides are held by bolts running clear through. The rotary valve is of the ordinary construction. Tub-

**MODERN PRECISION MEASUREMENTS**

(Continued from page 302)

the other reflecting surface is the top surface of the under glass. If there is any difference in the thickness of the objects being compared the air space between the two glasses is again wedge-shaped, although the wedge is much wider. But the result is the same and not only can a difference in thickness be detected, but the difference determined within a millionth of an inch by counting the interference lines. By using a standard of known accuracy and comparing other parts to it, measurements can be rapidly made with the apparatus. A different procedure is necessary for other measuring operations, but the basic principle of determining distance from the interference bands is used throughout.

Quartz and flint are the mineralogical names for silica or silex. In other words, the names are applied to the minerals found in nature. Flint is a quartz with a sharp, conchoidal fracture, but chemically the same. Silica is the chemical name for quartz and flint. It is oxide of silicon. Silex is the old chemical name and is not used in modern chemical treatises. The name silica has replaced it. Therefore, quartz, silex, flint and silica are the same chemically, when ground into powder. But in masses, the quartz and flint have a slightly different appearance. Quartz is the name applied to a general class of materials of different colors but of the same chemical composition. Flint is really a variety of quartz, but this is not generally known.

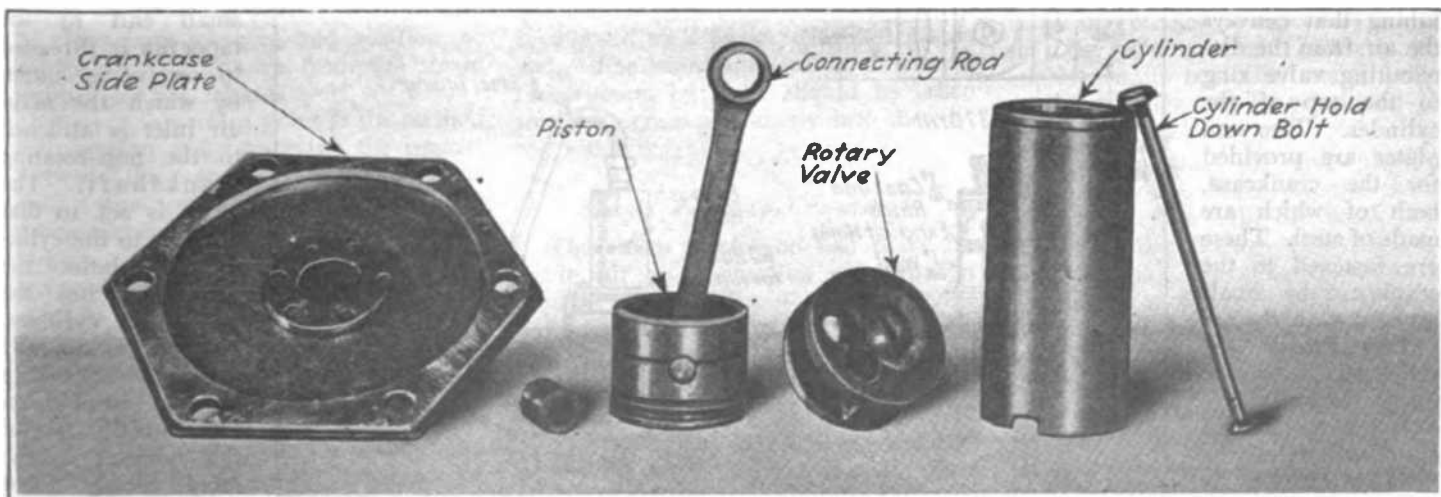

Group of parts of Davenport air motor. Note built-up crankcase side plate and method of using wire spoke as cylinder hold-down bolt

# A Six Cylinder Air Motor

By A. Bohaboj

**T**HE motor described is a six-cylinder form that has been used successfully on various types of model aircraft, including helicopters that have raised themselves and the weight of the motor, though they do not lift the source of compressed air. The illustrations and drawing show the details of construction clearly enough so that any experimenter of average ability and owning a small lathe should have no difficulty in building the engine.

The cylinders are machined from a solid steel bar and are  $\frac{1}{2}$ -in. bore and stroke and are machined to the dimensions indicated. The piston is made of cast iron and also uses  $\frac{1}{16}$ -in. section cast iron rings. The crankcase is made of aluminum and is machined from a hexagon of that material  $1\frac{3}{4}$  ins. across the flats and finished  $15/16$  of an inch wide.

Of course, sufficient stock must be allowed for finishing the sides so it is well to have the aluminum piece at least one inch thick. The internal dimensions need not be held very accurately, the aluminum piece being bored out so that there will be ample room for the crank pin and connecting rods to swing around as the cylinders and crankcase revolve. The boss on top of the cylinder is machined with a 10-32 thread and a simple coupling nut fitted thereto. This serves to hold the  $\frac{1}{8}$ -in. steel tubing that conveys the air from the distributing valve ring to the top of the cylinder. Two end plates are provided for the crankcase, both of which are made of steel. These are fastened to the crankcase by small screws and are turned from the solid stock to the forms shown.

A flange is formed on the base of the cylinder which is afterwards cut off at the sides and the

base is drilled with two No. 2-56 screws which hold the cylinder in place on the crankcase. A hole is drilled with a No. 37 drill through the boss on top of the cylinder for the air intake and a series of holes are drilled around the cylinder about midway of its length so that they are uncovered when the piston reaches the end of its stroke. These serve as passages for the exhaust compressed air. The connecting rods are light rectangular sec-

tion members machined out of sheet brass of any desired gauge. As considerable space is allowed inside the piston interior, the rods are assembled all in a line on the crank pin and some will be off center as relates to the cylinder center line.

The construction of the crankshaft, which also serves as an air distributing valve, can be readily ascertained. A No. 6 standard taper pin is used, this being carefully fitted to the end plate which is reamed with a standard No. 6 taper reamer. The rear end plate of the engine is machined from a piece of steel and has a ring turned on it which is drilled through with a series of holes that are intended to communicate with the air supply hole in the crankshaft. These holes are drilled to correspond to the center line of the cylinders and are tapped with a 10-32 thread for the coupling nut.

The crank pin is a piece of stock threaded at one end to fit into the crank web. It is held firmly in place by a small nut and is drilled at the end with a No. 60 hole for a pin that keeps the connecting rods from working off of the shaft. The web is made of a piece of sheet steel and has a square hole filed in it to fit a corresponding square portion that is filed at the big end of the taper pin. When this square projection is burred over, the crank web is firmly retained by the riveted metal. The small end of the taper pin is threaded to receive a union by which the main air inlet is attached to the non-rotating crankshaft. The valve is set so that air goes to the cylinders just before the piston reaches the top of the cylinder.

There is actually very little clearance between the piston top and the top of the cylinder as the more closely fitted  
(Continued on page 379)

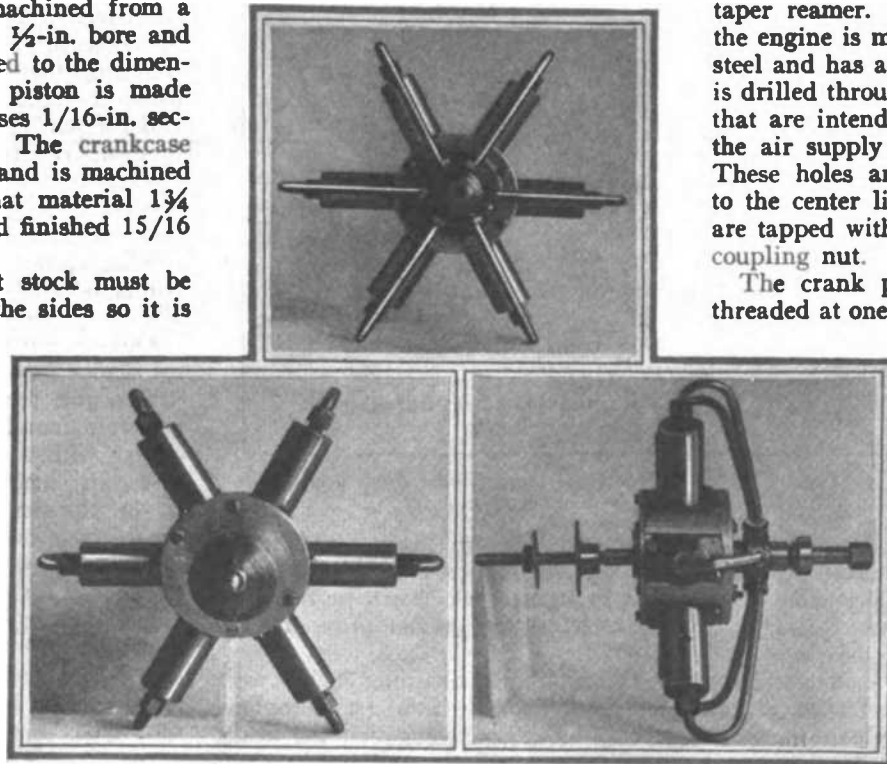

Front, rear and side views of the Bohaboj six-cylinder compressed air motor for model airplanes

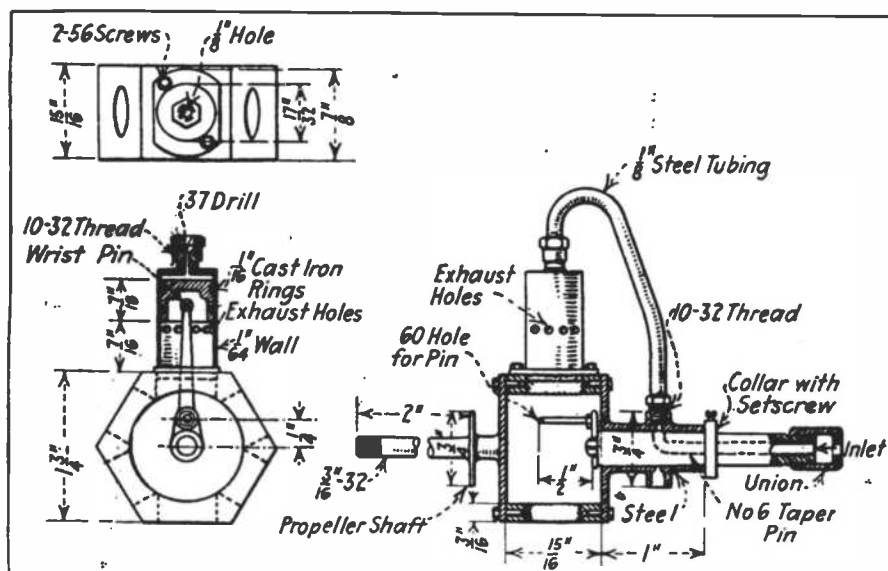

Design drawing showing main details of Bohaboj motor. Attention is directed to the simple air distributing valve and crankshaft construction

# Model Steam Engine and Boiler Construction

By W. A. Helm

## PART I

### SMALL OSCILLATING CYLINDER ENGINE

**A**LTHOUGH the following article will be of more interest to beginners than to older readers and more experienced model engineers I feel it fills an existing demand. The readers of EVERYDAY ENGINEERING increase with every issue and many of the boys who have been in the services during the war have returned to their old pastime of making models. So I feel justified in starting from the very beginning and gradually working up to the more complicated engines and locomotives. I shall begin with the oscillating type of steam engine as the simplest form. Before starting with the actual construction it will be necessary to say a few words as to the operating principles of those engines.

#### Steam Distribution

The steam is distributed by a port. A single port is drilled into the cylinder (see Figs. 1 and 2), the outer face of which slides over the ports in the steam block, the latter being stationary, also forms the pivot bearing for the cylinder (see Fig. 4). The setting of the ports depends on the size of the cylinder and the extent of the oscillation. The amplitude of the latter is regulated by the length of the stroke and that of the piston rod. The diagram at Fig. 3 shows how to set out the ports in a single acting oscillating engine. The width of the ports is not less than 1/6th of the cylinder bore. According to this rule, the ports for a cylinder of 3/8 in. diameter are 1/16 in. In setting out the ports on the steam block we must take care that they are sufficiently far apart to allow the port in the cylinder to clear both when in mid position, so as to prevent leakage from the steam supply to the exhaust port.

A very important point is the method of pivoting and preserving the contact between the port faces. The writer has found the spring contact the best and recommends it as the only satisfactory device. In selecting the spring it is necessary to be very careful as the tension of the latter must be sufficient to overcome the opposing steam pressure, which is tending to force the port faces apart. This force is equal to the pressure of the steam multiplied by the area of the port. On the other hand the tension of the spring must not be too great, as the resulting friction will seriously reduce the efficiency and speed of the engine.

Keeping the above facts in mind, let us now get to the actual construction of a single acting oscillating engine of 3/8 in. bore and 5/8 in. stroke. We begin with the cylinder, the dimensions and components of which you find in Figs. 1, 2 and 5. For the benefit of the readers who may prefer to build up their own cylinder in preference to purchasing the castings in the rough or half finished, full size details of the various parts are given in Fig. 5.

#### How Cylinder Is Made

The cylinder barrel can be made from a piece of solid drawn brass tubing with a bore of 3/8 in. inside diameter. By passing a 3/8 in. parallel reamer through the piece of tubing the bore can be trued up to the required diameter. Having done this, file the ends of the tube square until it is exactly 1 21/32 in. long. Then bell mouth the lower end so that there is no difficulty in placing the piston into position after it has been packed.

The top cap can be made out of a solid piece of brass and permanently soldered on, together with a block 3/16 in. thick drilled and tapped for the pivot pin. A 1/16 in. hole should be drilled through the interior of the cylinder, and the block should be recessed so that only the port face and the strip below the pivot pin make contact with the steam block. To show up the parts which form the bearing surfaces I have shaded the rubbing portions. The bottom cap of the cylinder may be made to fit tightly, or may be secured by a drop of solder. It should be provided with two or three vent holes. The piston shown is a long one with two grooves for packing or piston rings. It is screwed to a 1/8 in. diameter piston rod. The crankpin end is of simple construction but care should be taken to fit the crankpin snugly into the piston rod.

#### Simple Built-up Crankshaft

The steam block and bed plate are made out of one casting as shown in Figs. 4 and 6. Fig. 4 shows how the cylinder is secured to the steam block. The drawing speaks for itself and it is not necessary for me to describe how to finish it. The crankshaft is very simple. A piece of 3/32 in. diameter mild steel rod will be required. This should be 1 5/8 in. long, after the ends have been filed square. Place this in the bearing space which has been

drilled and afterward carefully smoothed with a reamer. The reamer used is a 3/32 in. expansion type. Then attach the flywheel on one side and the crankpin on the opposite side as indicated. So much for the construction of the engine proper.

#### HOW TO MAKE THE BOILER

A steam engine cannot run without a boiler to provide steam, so I have decided to describe a suitable boiler for each engine. The boiler described is of the stationary type and is perhaps the most efficient to drive a small oscillating engine, as the latter is seldom worked at a greater pressure than twenty or thirty lbs. I might suggest here to the prospective builder to take great care in building the boiler, as it is also of ideal construction to keep on hand for trying new engines as built.

To make this boiler take a piece of solid drawn copper tubing 3 ins. in diameter and 9 1/4 ins. long (see Fig. 1 of the plate giving the boiler details), the thickness of the wall being about 3/64th in. The end plates may be made out of a casting (see Fig. 2), or out of sheet brass turned or filed circular to make a tight fit inside the tube. If the latter method is employed cut two strips of copper 1/4 in. by 1/16 in. and about 9 1/4 ins. long and fit them accurately into the barrel of the boiler about 1/8 in. from each end, then rivet fast. Put the end plates in against those rings and flange the projecting rim of the tube, by lightly tapping with a hammer (see Fig. 3), the ends of the tube having been previously annealed. The first method of using a casting has the advantage of being by far the easiest way, and so I recommend this method as especially adapted to those who have not had any great experience in building model boilers, as the castings can be purchased at a very small cost.

Before putting the end plates in place, drill two holes through the top of the boiler to hold the brass bosses for the boiler fittings (see Fig. 4 of boiler plans). The latter shows the dimensions of the boss. The same size is employed for both the safety valve and the steam pipe. Before soldering the end plates and bosses into place it is necessary to scrape and clean the surfaces coming in contact so that the silver solder will be sure to run all around the joint. Through the front plate of the boiler drill two holes for the water gauge. Through the front

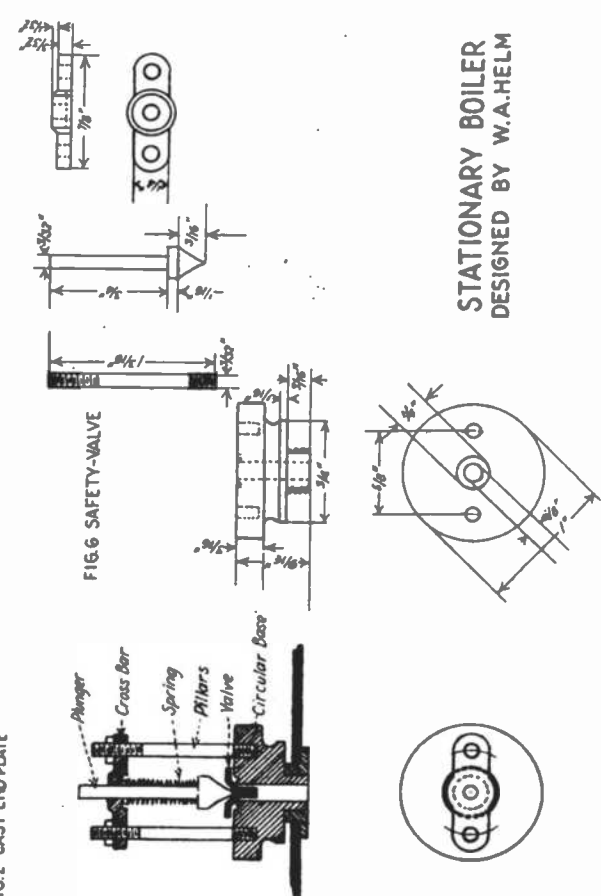
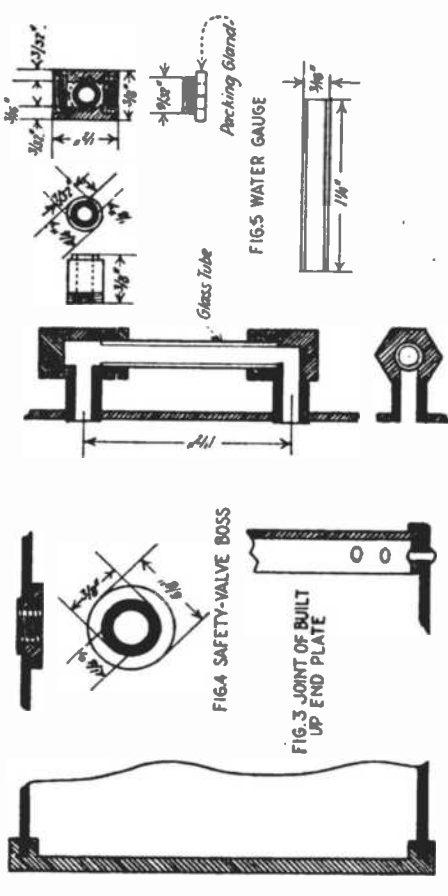
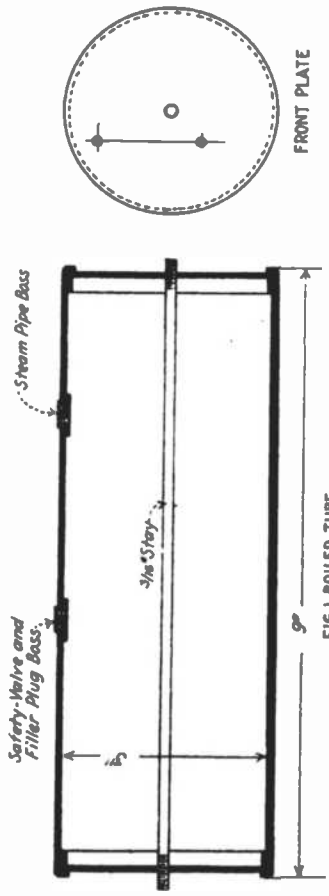

STATIONARY BOILER  
DESIGNED BY W.A.HELM

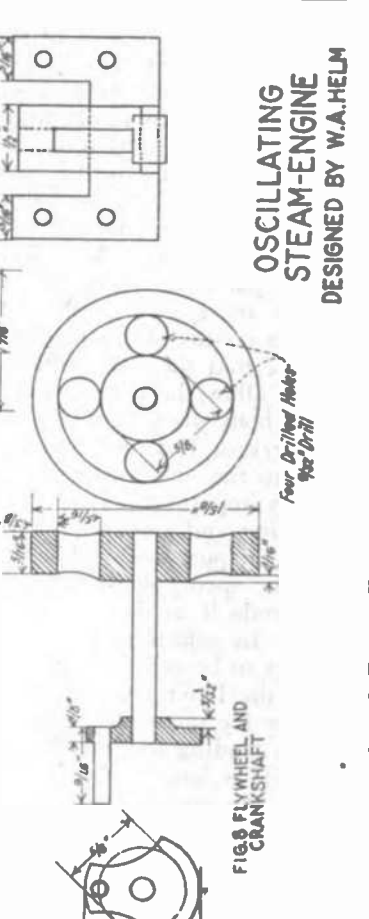
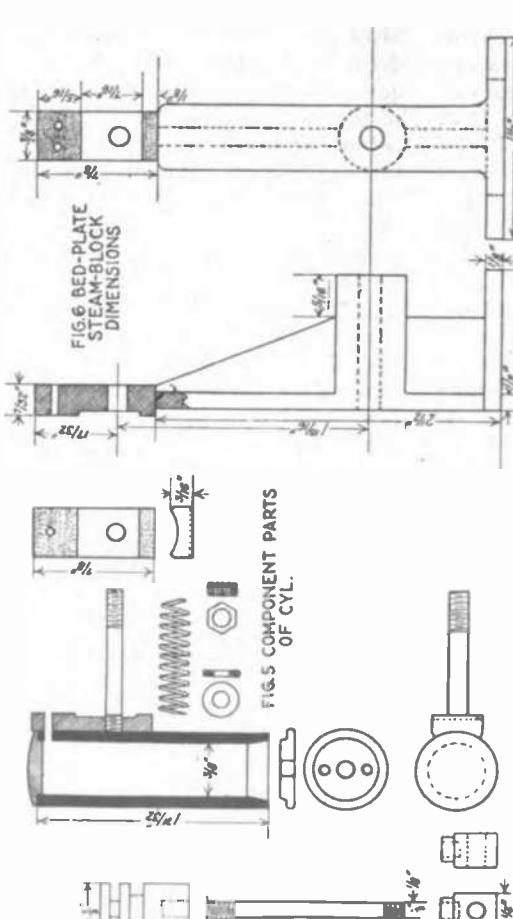
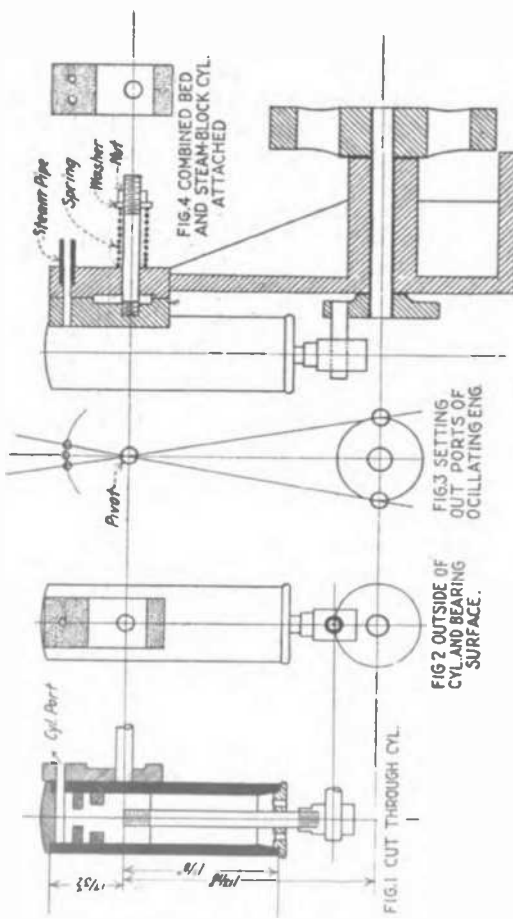

OSCILLATING  
STEAM-ENGINE  
DESIGNED BY W.A.HELM



and rear plate centers, drill a 3/16 in. hole in each for stay bolts.

After having completed the work on the boiler tube and the bosses, the end plates are soldered into place. We take the fittings in hand. They consist of a safety valve, filler plug, water gauge and steam pipe, the latter being equipped with a union cock to turn off the steam. As the efficiency of a model boiler is somewhat dependent upon its fittings it is good business to pay close attention to the making of them.

We start with the safety valve. The circular base of the latter also forms the filler plug. It is turned out of a solid brass bar of 1 in. diameter to the dimensions given in Fig. 5. The cross bar is also turned out of a solid piece of brass. The pillars and plunger are turned out of a mild steel rod. The valve itself is turned out of steel, tempered and carefully ground in. Care should be taken, when turning the valve, that the point of contact between the plunger and valve is below the seating surface of the latter.

The next fitting in importance is the water gauge as indicated in Fig. 6. It is a plain gauge without cocks and can be easily turned out of a 3/8 in. diameter hexagonal brass rod. The nipple into the boiler is silver soldered into the rod. The top fitting is open and has a cap for the insertion of the glass. The maker should be very careful in lining the top and bottom fitting up to the center of the glass, before inserting the latter.

These instructions should be sufficient to keep the reader busy over to the next article, when I shall finish the description of the boiler and shall advance to the next step in model steam engine construction.

HOW NAMES ORIGINATE

MANY persons are puzzled to understand what the terms of "fourpenny," "sixpenny" and "tenpenny" mean as applied to nails. "Fourpenny" means four pounds to the thousand nails, or "sixpenny" means six pounds to the thousand nails, and so on. It is an old English term, and meant at first "ten pound" nails (the thousands being understood), but the old English clipped it to "tenpun" and from that it degenerated until "penny" was substituted for "pounds." A "monkey wrench" is not so named because it is a handy thing to monkey with, or for any kindred reason. "Monkey" is not its name at all, but "Moncky." Charles Moncky, the inventor of it, sold his patent for \$2,000 and invested the money in a house in Brooklyn.

GAS HEATING SOLDERING COPPER

ONE of the deficiencies of the ordinary form of soldering iron or copper is that considerable time is taken up

to heat the iron and that it cools rapidly when it is removed from the source of heat and used in soldering. Of course, this can be eliminated to some extent by using two irons, one being heated while the other is used. Electrically heated soldering coppers are marketed and have many advantages for different varieties of work such as carried on by various manufacturing firms. In some cases, the gas heated copper bit such as illustrated may be

the various parts comprising the assembly. The gas is conveyed to the device by flexible, metal gas tubing. Even if illuminating gas is not available, hydro-carbon gas may be used if the burner design is modified somewhat so that the orifice through which the gas issues is controlled by a screw valve. In this case, if this modification is made, the flexible gas tube may be connected to a suitable container in which the gasoline is under air

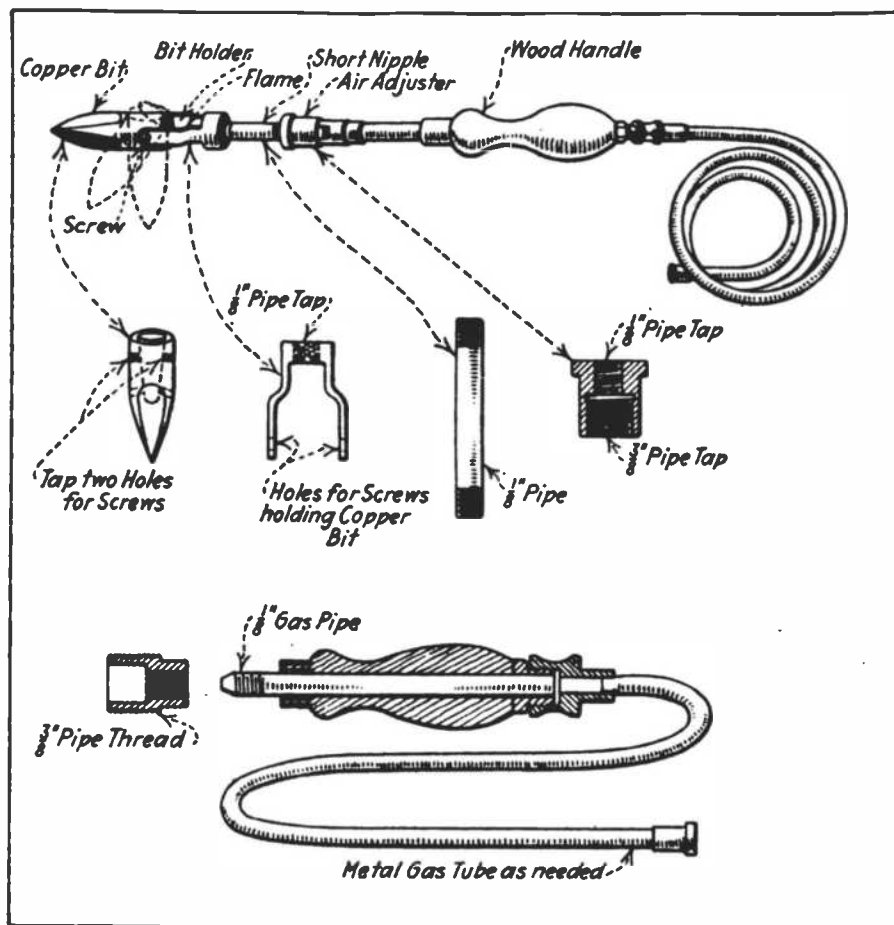

Details of gas-heated soldering copper

used advantageously. The soldering copper is carried by a simple forked member that screws on to the end of a piece of pipe which in turn is attached to an adjustable fitting that forms part of the Bunsen burner. In fact, this fitting has an air control for the burner. The pipe passing through the handle has its end blocked and is drilled so as to allow only the proper quantity of gas to pass through. The air adjuster carries a nipple that forms the burner and the flame issuing from its end, which is the usual hot, blue, Bunsen flame impinges against the copper and in a hole formed in its interior so that this is kept heated at all times that the burner is lighted. The adjustable bit support makes it possible to place it in various positions for different classes of work.

The construction of the device is clearly shown in a sectional view as are

pressure and the device will function on the same principle as a brazing torch. Modifications of this design will readily suggest themselves to the experimental engineer.

BELL METAL

THE best bell metal is composed of 78 parts of copper and 22 of tin. The use of silver in the manufacture of bells is purely imaginary. The idea grew out of a practice at the casting of church-bells when pieces of silver were supposed to be mixed with the bell metal. The foundrymen had other uses for the pieces of silver and contrived means for the silver pieces to fall through the grate bars into the ashpit. Nearly all bell makers have their own methods for determining the tone of a bell from a certain size.

# Switches and Cut-Outs

## Overload and Underload; Electro-Magnetic, Centrifugal and Film Circuit Breakers

By Prof. T. O'Connor Sloane

**C**UT-OUTS and switches may be entirely hand or mechanically operated, or the action of the electromagnet or other electric device may be utilized in their operation. There are a number of constructions of switch, in which centrifugal force is the controlling factor. When one of this type is applied to a motor, the latter will not start when merely connected to the circuit; the centrifugal switch must be closed and kept so by centrifugal action. Often the starting in such a case is done by hand, the rapid turning of the motor armature closing the switch.

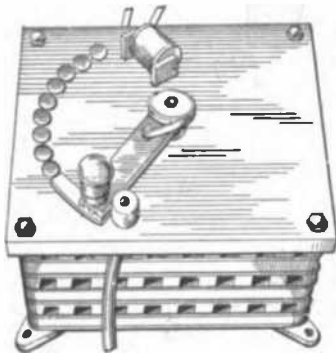

Fig. 1. Starting box

The cut-outs, which will be first described use electromagnetic action for their operation. The starting box whose appearance is familiar to all is an example of this type. It is used on direct current circuits for starting motors. If the full potential of a circuit were connected to a stationary motor with no resistance intervening, the armature would pass so strong a current in the absence of all counter-electromotive force, that it would be heated and perhaps permanently injured. Referring to the cuts, Fig. 1 and 2, it will be seen how this cause of accident or damage is avoided. The switch handle passes over a series of studs one by one. As it touches the first one, a number of resistances in series, one for each stud are interposed between the active lead and the motor. The armature begins to rotate under the effect of a reduced current. As the switch bar passes to the next stud it cuts out one resistance coil, and the armature now in motion receives more potential. This goes on as the switch is moved until all the coils are cut out, and the armature protects itself by counter electromotive force due to its own rotation. When

the switch handle or bar reaches its final position, it is held there by the electromagnet, from which a spring

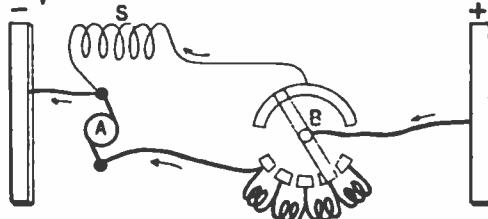

Fig. 2. Starting box connections

tends to separate it and to pull it back to its original inactive position, cutting off the current completely. Suppose that by any accident or incident the current is cut off; the electromagnet ceases to act, the switch bar flies back, and if the current is turned on at any other point, the motor circuit remains open and the motor does not start. It has to be started just as before, with the successive reduction of resistance, so as to protect the armature from burning out.

This is an example of a no-load or protective cut-out. If the motor circuit stayed closed, and the circuit was opened and closed, the closing would bring the full potential to bear on the armature and perhaps would burn it out. It is obvious, that, while this device is primarily or usually a no-load circuit breaker, the magnet and spring could be so adjusted as to make it an underload instrument, one which would open the circuit if it fell below a certain potential.

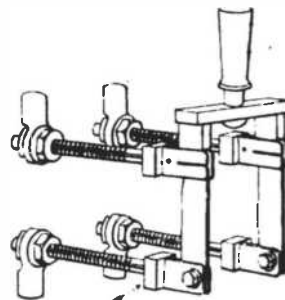

Fig. 3. Knife switch

This is also, as illustrated, an example of a flat bar switch. The knife-bar switch is the more approved construction for heavy currents, and to make the sequence complete a simple two-pole knife-switch is shown in the cut, Fig. 3. The construction is familiar to all; the only point to be made is,

that, except in particular circumstances, the switch should open downwards. Then as far as gravity is concerned it tends to stay open, and to that extent there is no danger of an accidental closing. If placed in the other position, the handle might fall and close the switch when not desired. The position is a safeguard against accidental closing.

The next cut, Fig. 4, shows an underload knife-switch cut-out. When the handle, H, is pushed up the circuit is closed and current passes. At M is an electromagnet. The bell-crank lever on the handle, H, is pulled back by the operator when the switch is to be closed.

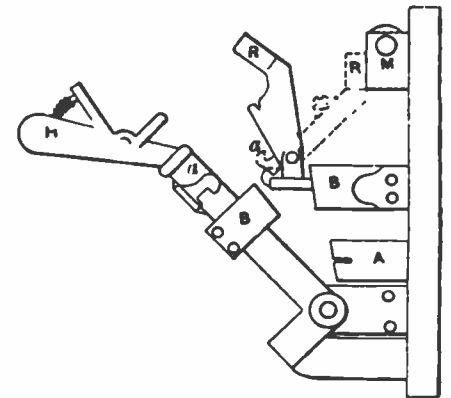

Fig. 4. Underload cut-out

As the handle is pushed up, the projecting end of this lever pushes the pivoted bar, R, into the position shown by the dotted lines. At the end, R, there is an armature, which is attracted by the magnet, M. The catch, *a*, engages in this position of R, with the corresponding catch on H, also indicated by *a*. The current is now passing. But if the current ceases or grows weak, the magnet will not have power enough to hold R, which is drawn away by a spring, omitted in the cut. The bar, R, will fly back the catch, *a*, will be released, the bar, H, will fall back and the current will be completely cut off and the circuit will be broken. The minimum load required to keep the circuit open is determined by the relative strength of spring and magnet.

There are double contacts in this switch. B, B, are carbon contacts and A is a metallic one. The carbon contacts are the last to open and the first to close. This protects the metal contacts from injurious sparking and arcing, although the metal contacts are the real working contacts.

The overload cut-out is designed to open a circuit when too strong a current is beginning to pass. It protects apparatus directly from burning out. One form is shown in Fig. 5. This is a knife-bar switch, with an auxiliary carbon contact above the metal one. In the position shown in full lines the carbon contacts at the top of the swinging bar are seen in contact with each other. Below them the metal contacts are in engagement. If the handle, seen

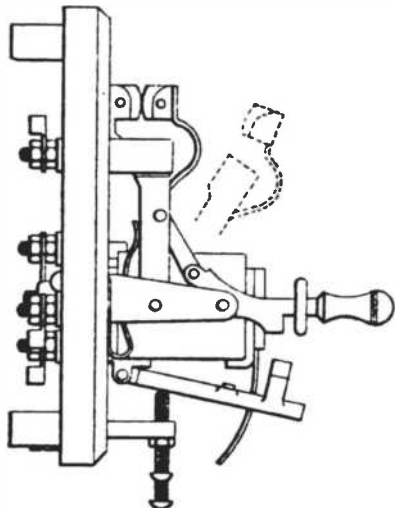

Fig. 5. Overload circuit breaker

projecting to the right, is pushed upwards the switch-bar will be thrown into the position shown in dotted lines and both carbon and metal contacts will be opened. This can be done by hand, but to introduce the feature of

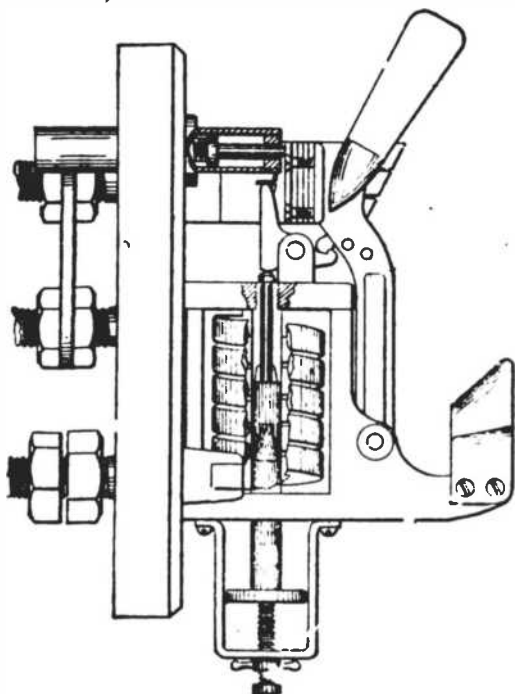
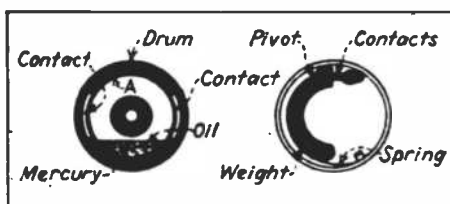

Fig. 6. I. T. E. overload cut-out

automatic overload opening, an electromagnet is placed back of the handle bar as shown, and below it is a pivoted armature. If too strong a current passes, the armature will be drawn up, it will strike the handle and drive it up so as to break the contacts.

Another form is shown in Fig. 6. The pivoted handle in its vertical position as shown closes the switch against the pressure of a spring, which presses against a bar, which in its turn presses against the switch-bar at its upper end. A low resistance solenoid coil is shown, cut away in the drawing to show the plunger within it. The entire current goes through this coil. The switch-bar is held in position against the pressure of the spring, just spoken of, by a catch, just above the solenoid. When too much current starts to pass, the solenoid draws up its plunger armature, driving up the rod seen on top of the plunger, and releasing the catch. The horizontal plunger actuated by the spring just spoken of pushes the switch-bar back and the contact is broken.

There is another type of switch depending for its action on centrifugal force. Several examples are given below.



Figs. 7 and 8. Centrifugal switches

The next cut, Fig. 7, shows a switch in which mercury thrown out from the center by centrifugal force forms a sort of ring around the inner perimeter of a drum. There is a contact plate on each side of the drum and the mercury when the motor is in action makes an electrical connection between the two. The case, A, of the drum is of insulating material.

In the next cut, Fig. 8, a curved arm is pivoted at the point as shown; near the pivot are the contacts also clearly indicated. The distant end of the switch-bar is weighted and is held by a spring in such a position as to keep the contacts separated when the motor is not in action. The switch in question is carried on the end of the motor shaft or in other position where it will rotate when the motor does. It will be understood that the actuating current of the motor passes through the switch. When therefore the current is turned on, none can pass because the switch is open. But if closed for an instant by hand or otherwise the motor will start into action and the weighted end of the switch-bar will swing outwards under the effect of centrifugal force, the contact points will come together and the motor will go on indefinitely. If it is a small motor all that is necessary to stop it is to check its rotation by hand; the switch will be opened by the spring and the current will be cut off.

The film cut-out, Fig. 9, is simply

a pair of contacts held apart by a piece of thin paper. It is to be used in parallel with a lamp in a series circuit. If the lamp filament should break down it would put out all the lamps on the

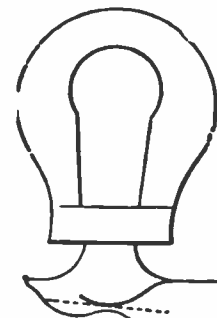

Fig. 9. Film cut-out

circuit. But if such an accident did occur there would be a sudden rise of potential, enough to make a spark, which would pierce the film and restore the connection. Of course the resistance of the lamp would be lost, but the series of lamps would be relighted instantly as the film would be perforated.

#### WHAT IS DRY ROT?

THE term "dry rot," the Forest Products Laboratory finds, is applied by many persons to any decay which is found in wood in a comparatively dry situation. Thus loosely used the term actually includes all decay in wood, since wood kept sufficiently wet cannot decay. In the more limited sense in which pathologists use the term, "dry rot" applies only to the work of a certain house fungus called *Merulius lachrymans*. This fungus gains its distinction from the fact that it is frequently found growing in timbers without any apparent moisture supply; in reality it does not grow without moisture and is as powerless as any other fungus to infect thoroughly dry wood. Given moist wood in which to germinate, it is able to make its way a surprisingly long distance in dry timbers, drawing the water it needs from the moist wood through a conduit system of slender, minutely-porous strands.

Wood in the typical advanced stage of dry rot is shrunken, yellow to brown in color, and filled with radial and longitudinal shrinkage cracks, roughly forming cubes. In many instances these cracks are filled with a white felty mass, the interwoven strands of the fungus. The decayed wood is so brittle and friable that it can easily be crushed into powder. The dry rot fungus is active in nearly every region of this country, in Canada, and in Europe. It is very destructive to factory and house timbers and to logs in storage. Coniferous or soft woods are more commonly infected by it than hardwoods.

# Miniature Railroad System

**W**HEN a man who has been active in business decides to retire and enjoy the peaceful routine of farm life, it is often necessary for him to interest himself in other things besides farm work in order to keep busy enough to satisfy his longing for action. A former New York broker, Mr. W. Cecil Gage, found that he had considerable time on his hands so he spent this spare time in building a miniature railroad, views of which are presented herewith. The materials for its construction were obtained by demolishing an unused hen-house, 250 feet long, which provided enough wood to not only build the railroad rolling stock, but also the track. Practically everything about this road is built of wood, the rails being made of 2" x 4" timbers, and even the locomotive being built largely of this material. Special passenger cars and freight cars have been built entirely of wood and the miniature railroad operates much the same as its larger prototype. The locomotive is driven by a four-horsepower gas engine which drives a counter shaft supported by regular shafting hangers, and this in turn transmits power to the traction wheels by means of a drive chain of the conventional pattern.

Plenty of room is provided in the engine room for the engineer, and the passenger cars will carry two people with ease and comfort. The interesting point about this railroad is that it was built entirely by a man who normally

a hobby and a source of pleasure and recreation.

The construction of the entire system called for considerably more skill than possessed by the average man and the installation of the engine and ef-

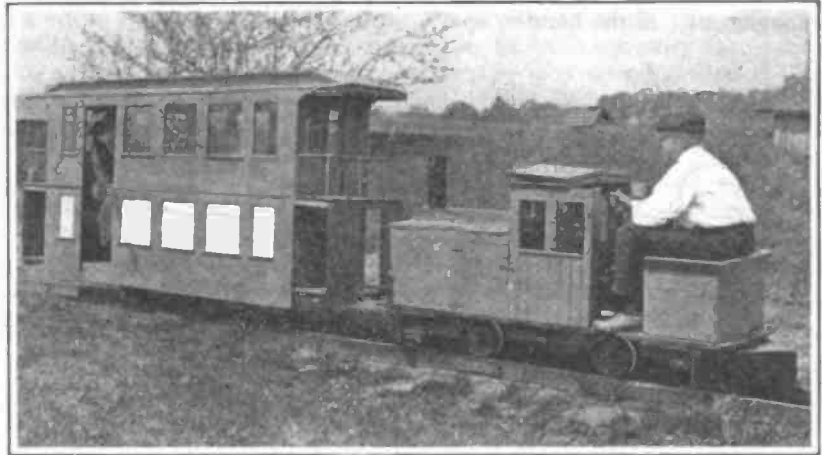

*The double-deck passenger car seats two people*

was engaged in a business that did not give him any opportunity to develop latent mechanical talent. He also claims that many men who are working in the professions and in merchandizing find in mechanical handiwork at once

effective utilization of its power in the compact and realistic-looking locomotive evidently required more than an elementary knowledge of mechanical principles. The false boiler top of the locomotive covers the power plant.

*The view below shows the locomotive power plant which is a single horizontal cylinder hopper cooled gasoline engine driving a countershaft, this in turn driving an axle by a chain*

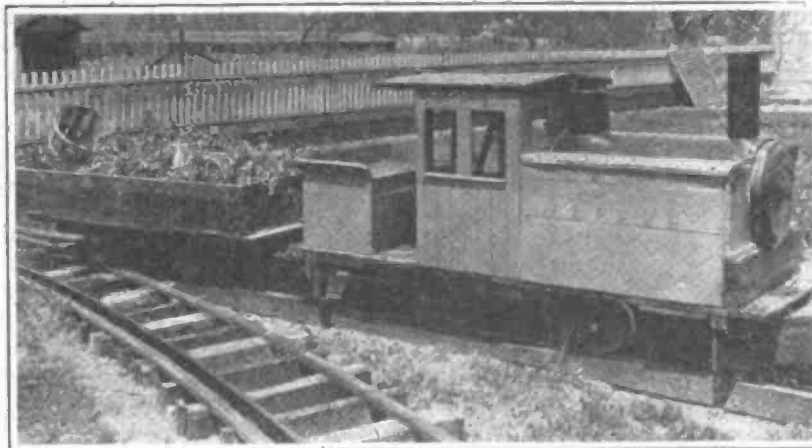

*The locomotive attached to a freight car full of produce is shown at left. The engineer, as seen below, seems to be a fair load for the tender and can reach the controls in the cab easily*

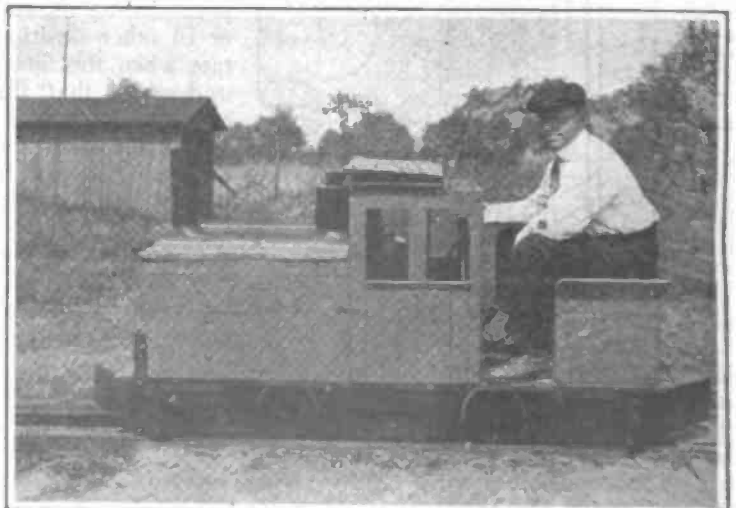
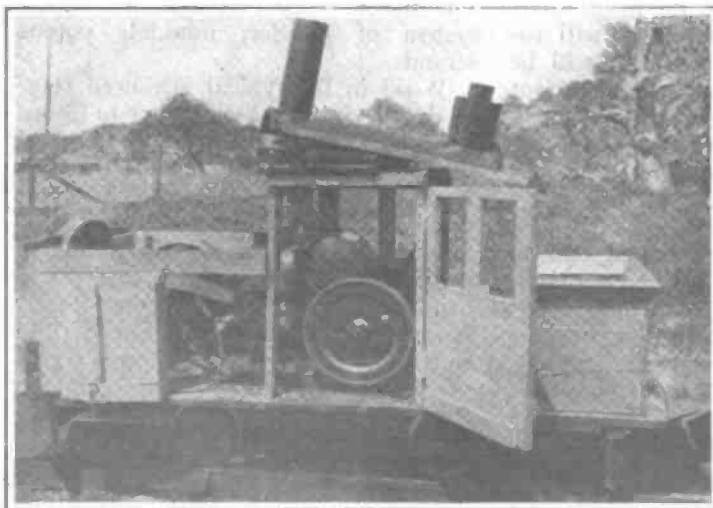





# SHOP PRACTICE

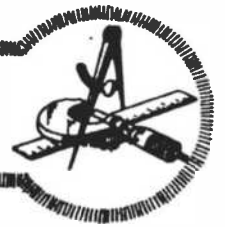

## AIR PRESSURE DEVICE FOR THE TRANSFER OF OIL

THE illustration shows a handy means of removing oil or other liquids from barrels or other closed containers for transmission to permanent shop tanks or elsewhere. It is essentially a home-made device of the class so numerous in railroad shops where a supply of air at suitable pressure is

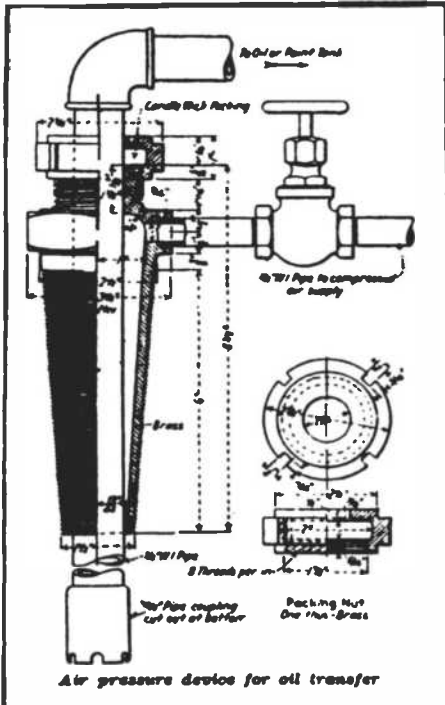

Details of air pressure device for transferring oil from barrel to storage tanks

always available, and the dimensioned drawing is reproduced from the *Railway Mechanical Engineer*. It comprises a long, finely threaded taper plug, with diameters ranging from 1½ to 2½ in., which may be screwed into any ordinary bunghole, or, if more convenient, into a hole in the barrel head. The oil delivery pipe which is long enough to reach the bottom of the barrel slides in a stuffing box which makes a practically air tight joint. When a barrel is to be emptied the plug is screwed into the bunghole, a small air hose is connected to the pipe at the side and connection is also made from the delivery pipe to the point where the oil or other liquid is to be deposited. A slight opening of the air valve admits pressure above the body of liquid and it is driven up the delivery pipe with any permissible rapidity.

## PROTECTING MOLTEN METAL FROM OXIDATION

A DIFFICULTY in melting alloys and some metals is the oxidation of the metal, whereby serious loss of material occurs. To meet this difficulty the *Technische Blatt* says it is a common practice to fill the container with a neutral gas so as to effect the fusion in a neutral atmosphere. But the usual arrangements allow the neutral gas to escape, its place being taken by air from the surrounding atmosphere. As a consequence, some oxidation still occurs. An invention, patented in Germany, remedies this effect. The container in which the metal is melted is constructed to be closed air-tight, and put in communication with a compressed air-cylinder filled with nitrogen. The gas, under a pressure of 60 to 70 atmospheres, may be led into the container through a reducing valve.

## PRACTICAL OIL DRILL

A MASSACHUSETTS firm has brought out the oil drill illustrated which is intended to remedy some of the troubles which have been noted by using those forms of oil drills in which the oil conductors are soldered to the drill. The old-style drill with an inserted tube sometimes gives trouble

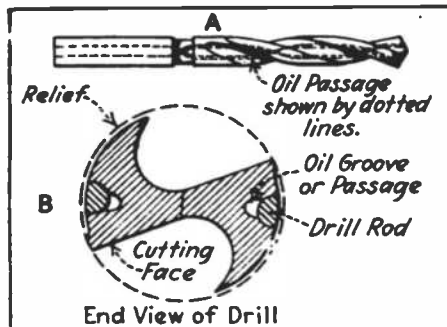

How a practical oil drill is made

through the loosening of the tube or this may bend and break. The oil conductor may also be bent and the flow interrupted. The new oil drill is made by forming an oil channel in the drill itself, by milling a groove in the body of the drill and dovetailing a piece of rod into the upper portion of this groove. When the process is complete the piece of drill rod can never come loose and for all practical purposes a solid oil drill is produced that is said to be free from trouble.

## ADAPTER FOR SURFACE GAUGE

A SURFACE gauge is a handy tool around a lathe and similar machinery, but it is not always an easy matter to clamp this securely to the carriage or tool. The accompanying illustration shows an adapter that should be very useful.

The adapter is made the same size as the regular surface gauge except that a collar is turned or brazed on its lower end. This collar may be easily

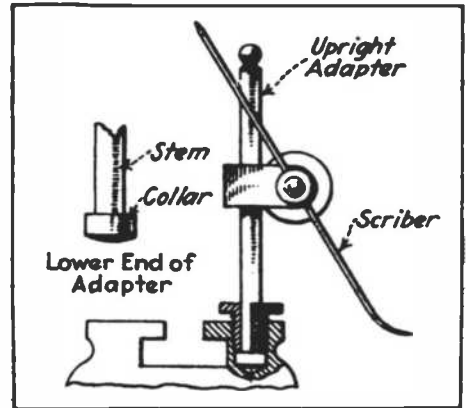

Adapter for surface gauge

formed by heating the lower end of the rod to the proper temperature and by upsetting it to form an enlargement which can afterward be machined down to required size. A special hollow nut that fits in the hole drilled into the tool slide and which is placed at any convenient part is a good fit on the surface gauge standard and when it is screwed into place the collar will be held firmly against the bottom of the hole. In using a surface gauge this is removed and the clamp and pointer are moved on the adapter to any desired point.

Various modifications for this device will suggest themselves. The lower end of the adapter column may be threaded or it may be a simple piece of straight stock that will clamp by a split, tapered nut, which closes in against the rod when it is screwed down into the hole.

## HARDENING SMALL CARBON STEEL TOOLS

SPECIAL care must be taken in the tempering of small tools of carbon steel. A small gas furnace, inclosed with a chamber for the heating of the tools, is desirable but a coal or coke fire properly banked is satisfactory. The fire must be burned down to a bed

of live coals, and it is best to insert a section of tubing into the fire to protect the tools from the direct blast. The quenching heat may be determined accurately by instruments, but where these are not available, the use of a magnet no longer has an attraction for the steel being heated at the part in the fire, the proper point for quenching may be determined by permitting the steel to remain in the fire a few minutes longer. The point at which the magnet ceases to attract is about 1,425° F., and the best heat for tempering is 10° above that temperature.

Tools cracked and damaged in the hardening process frequently result from the failure to relieve the strain on the steel after quenching, and the moment that it has cooled sufficiently to harden. While still grasping the tool in the cooling bath, the instant that the tremor from the sudden plunge stops, the piece should be withdrawn quickly, and permitted to cool in the open air. The steel will still be too hot to hold in the hand. This is only necessary, of course, when the steel is not to be drawn to temper on the original heating.—*American Blacksmith.*

**SPECIAL TOOL HOLDER**

THE special tool holder shown is of English design and possesses many features which enable one to describe it as both a handy and substantial tool. As the illustration shows, it takes 3/16th in. cutters of square section; the holder shank being 1/2 in. x 7/16th in., and 5 inches overall. The cutter is 3/8 in. above the level of the top slide; and the drop head, fitting flush and

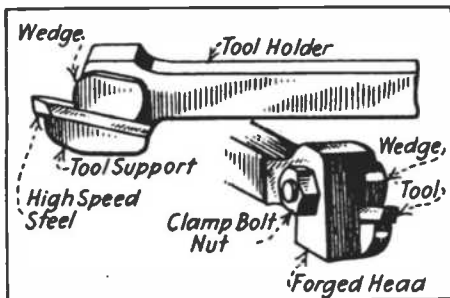

*Special lathe tool holder*

square to the edge of the slide rest, takes the "thrust" of the cut, preventing all vibration of the cutter. The head is also "off set," which enables a cut to be taken close up to the chuck or face-plate. A side or facing cutter can

also be used in the holder. The long bearing surface of the clamp permits the cutter to be held at an angle for recessing. It is only made in one size and is being marketed, with one high-speed cutter and spanner wrench to fit the clamp nut. Extra cutters of high-speed steel ground to various shapes may be easily inserted in the holder and can be made by the workman without any trouble from the special high-speed tool bits that can be secured from dealers in machinery supplies.

**USING A CROSS-CUT SAW AS A TRY-SQUARE**

A USEFUL kink for the handy man is shown in the illustration, as it demonstrates how a saw can be used to draw a line perfectly square across a board. The saw is held vertical with its back resting on the board and is

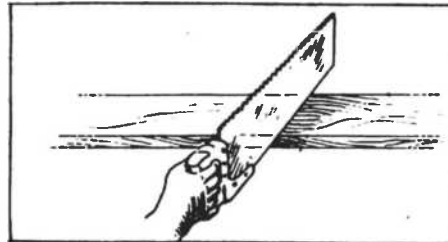

*Using saw as try-square*

turned one way or the other until the reflection of the edge in the bright blade is exactly in a line with the edge of the board in front of the saw blade. The saw now is exactly square with the edge and a pencil or scriber can be used to mark the place for the cut. If the saw is rusted it will not work so nicely because the reflection will be dimmed.

**CHART FOR POWER TRANSMITTED BY LEATHER BELTS**

THE accompanying chart may be used to determine the width of a single leather belt necessary to transmit any ordinary amount of power, the horsepower that will be transmitted by a single belt running at a given speed, or the speed at which a belt may run in order to transmit a given power. For example, to determine the power that will be transmitted by a single belt 7 inches wide running at a speed of 5000 ft. per minute, locate the point 7 and 5000 in the lower graduated line and then find the point midway between them. This point will be found at 44 h. p. on the upper graduated line. The dividing may be done with a rule, or

a pair of dividers, or by folding a piece of paper.

Should it be necessary to transmit 44 h. p. by means of a belt traveling at a speed of 5000 ft. per minute, the width of single belt required may be found by measuring the distance between 44 h. p. and 5000 and then measuring an equal distance to the left of the 44 h. p. point. In this case it will be found that a 7-in. belt is sufficient. In a similar way the belt speed can be determined where the belt width and horsepower are known. This chart is based on the well known rule of thumb: A single leather belt, 1 in. wide, running at a speed of 800 feet per minute will transmit one horsepower.—*Machinery.*

**QUICK SETTING MACHINE VISE**

THE vise we illustrate is an English one. The movable jaw of the vise is the inner one, the reverse of the usual practice. The vise-screw end enters the hole in the movable jaw. A plate is riveted to the back of the jaw which, when dropped, covers the hole. To force the movable jaw forward, this plate must be dropped. To open the vise, all that is necessary is to turn the screw back a quarter of a turn. The plate is then swung upwards, exposing the hole and the jaw can be pushed back by hand. When the work is replaced between the jaws, the movable jaw is pushed forward until it is in

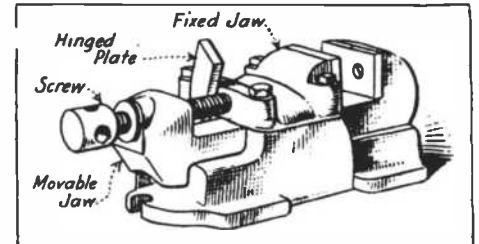

*Quick setting machine vise*

contact with the work. The plate is dropped down and a quarter turn of the screw locks the work fast. It is evident that, where a number of pieces of the same size are to be worked in the vise, there will be a great saving of time in its use.

It is often an object to have a source of illumination truly reproducing daylight for comparing colors and perhaps for other purposes. Considerable attention has been excited by the Shermingham daylight reflector, which is simply a reflector covered with little squares of different colored papers, which are so selected as to give a true daylight effect.

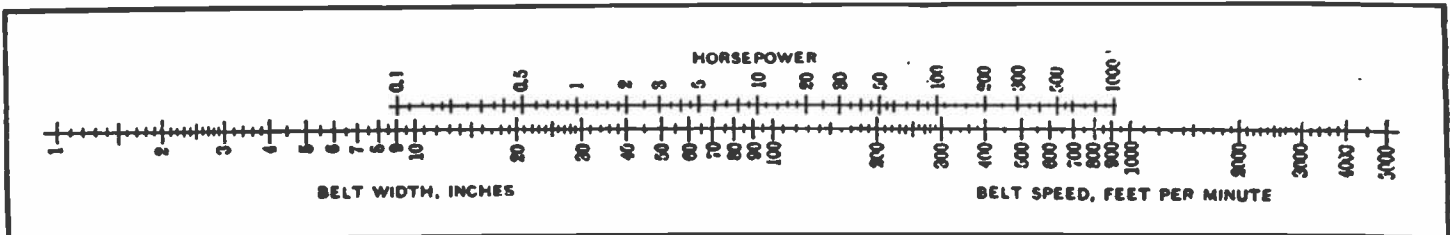

*Chart for power transmitted by leather belts*

# Napier's Rods and their Use

By Prof. T. O'Connor Sloane

**J**OHAN NAPIER of Merchiston, Scotland, born 1550, died 1617, is distinguished for all time as the inventor of logarithms. This is a capital claim to distinction for it is hard to say how trigonometry calculations could be performed in any reasonable time and without the aid of absolutely unwieldy tables, were it not for the conciseness of logarithmic methods. For years the discovery of a method of determining the longitude at sea was an unsolved problem, and was in the class with perpetual motion and the squaring of the circle. The mechanical solution came from the production of the chronometer. But to use the chronometer a calculation in spherical trigonometry has to be made for every observation. Two or more such observations are taken in a normal day at sea; the navigator has to solve a spherical triangle morning and afternoon and often at other times, in the evening when twilight enables him to see the stars and to distinguish the horizon. In the routine of navigating a ship Napier's great invention, logarithms, are in constant use to bring the ship across the ocean and into port.

We illustrate one of his inventions, on which he set great store, although now it is nearly forgotten, Napier's Rods or Bones. They are designed to facilitate multiplication. They are strips of bone, ivory, wood or even heavy cardboard. They may be from a quarter to half an inch wide, and about ten times as long as wide. Each one takes care of one of the multiplications of the multiplication table; two times up to twice nine, three times up to three times nine and so for the rest. As shown in the cut, each rod is divided into squares, and a diagonal line is drawn from corner to corner of each square, from the upper right-hand to the lower left-hand corner. At the top of each rod is placed the number by which the nine units are multiplied on that particular rod. Then in the upper divided square and below the diagonal line is placed the unit multiplied.

This is taken as "one times" the number at the head of the rod. In the next lower square is placed "two times" the same number and then "three times" and so down the rod in the successive squares. When numbers are reached which contains tens, such as 24, 36 and the others of two digits, the unit figure is placed below the diagonal and the tens figure above it. As many of such rods as needed are to be made, in general terms the more the better. Then there must be a master rod, which contains in its nine squares, the upper one being empty, the nine digits in

their regular order. A very convenient accessory is a board or tablet of wood or heavy pasteboard. A strip of the thickness of the rods is glued along its bottom, and another one at right angles to this at the left side and on the strip

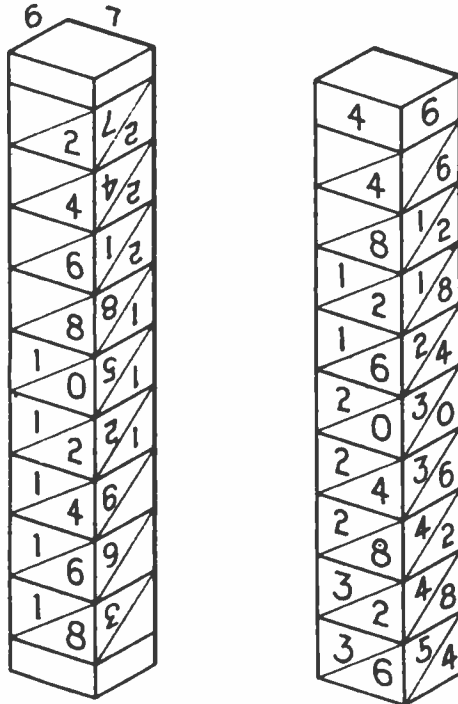

How square rods were numbered

at the side is glued the master strip, with the bottom of its lowest square exactly even with the top of the bottom strip.

To use the rods such are selected as are headed by the numbers of the multiplicand. They are put on the board as shown in the cut in proper order. Suppose they are to be multiplied by 7. The horizontal row of squares on a line with the seven square of the master rod contains the products of the digits of the multiplicand by 7. Suppose the number to be multiplied, the multiplicand is 37564. For the right hand figure of the product put down the unit figure of the square of the rod headed by 4, which square is opposite the number 7 of the master rod. This figure is 8. For the next figure add the tens figure of the same square, which figure is 2, placed above the diagonal as explained, to the unit figure of the square on the immediate left, which figure is 2, the unit figure of 42. This square is on the next rod, the one headed by 6. Adding these figures gives 4, the second figure of the product, which is 4. In this way we follow along the horizontal row, adding tens of the right-hand squares to units of the left-hand adjoining squares. 4 added to 5 gives 9, the next figure of the product. Sometimes there is one to carry. Thus in the particular multiplication we are supposed to be doing, after the addition of 4 to 5 comes the

(Continued on page 360)

	5	2	6	6	4
1	5	2	6	6	4
2	10	4	12	12	8
3	15	6	18	18	12
4	20	8	24	24	16
5	25	10	30	30	20
6	30	12	36	36	24
7	35	14	42	42	28
8	40	16	48	48	32
9	45	18	54	54	36

Arrangement of Napier's rods on a supporting frame for doing multiplication

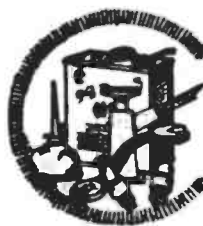

# EVERYDAY MOTORIST

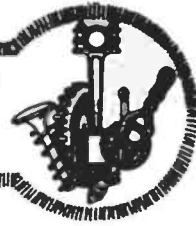

## MOTOR TRUCK FOR RAILS

**T**HE increasing interest of railroad heads in the use of motor trucks to facilitate freight and passenger transportation on short hauls is evidenced in the recent addition of motor

and baggage weighing 5 tons. When not pulling a trailer the round trip of 32 miles is made on 6 gallons of gasoline. At one point on its route the truck climbs a seven per cent grade with full load. It is operated continu-

ously and petition the railroads will add motor trucks to their transportation system in an effort to get all possible business, rather than see it go into outside hands. The motor truck of the type illustrated would seem to be specially well adapted to short lines that cannot be operated profitably with steam or electric power.

## NEW GERMAN ELECTRIC AUTOMOBILE

**O**NE of the late developments in Germany is the small automobile which is illustrated herewith and which has been developed to meet a need for urban transportation that exists on the part of a large portion of the public which cannot afford to pay the very high prices now asked for automobiles of conventional construction. This car is credited to Rudolph Slaby, son of the well-known Professor and wireless telegraph expert of Germany. The machinery in the car is extremely simple, as is the case with all electric vehicles. A person with little or no instruction can operate it because the current is supplied from batteries and is regulated by a simple controller and transmitted to the electric driving motor by simple wiring. It is claimed that the batteries supply current for four hours operation without recharging. The maximum speed of the car is 17½ miles per hour and the vehicle is so small that a garage not much larger than a dog house will accommodate it.

Because of the absence of the usual intricate propelling and speed changing machinery of the ordinary light car,

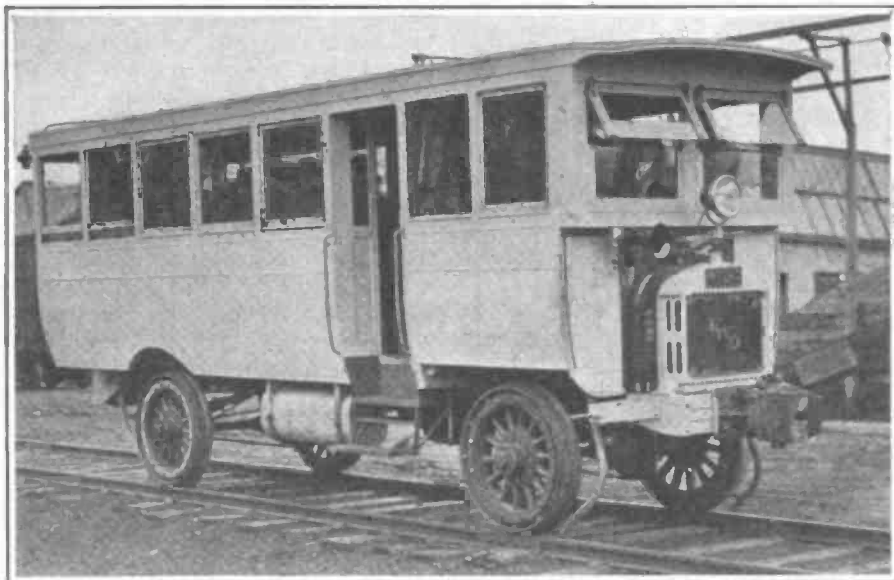

*Motor truck fitted with flanged wheels for short railroad lines*

lines by several roads. Prominent among these is the Palatine, Lake Zurich and Wauconda Railroad, which is using a 3-ton truck, equipped with flanged wheels and passenger body on its 16-mile track from Wauconda to Palatine, Illinois. The truck, which has a capacity to care for 30 passengers, also hauls a trailer loaded with freight

ously from morning until night.

Whether or not the railroads, with their return to private ownership will universally adopt the motor truck as an aid to their freight and passenger hauls is a question that is at present uppermost in the minds of truck manufacturers. It is the opinion of some that with a resumption of the old time com-

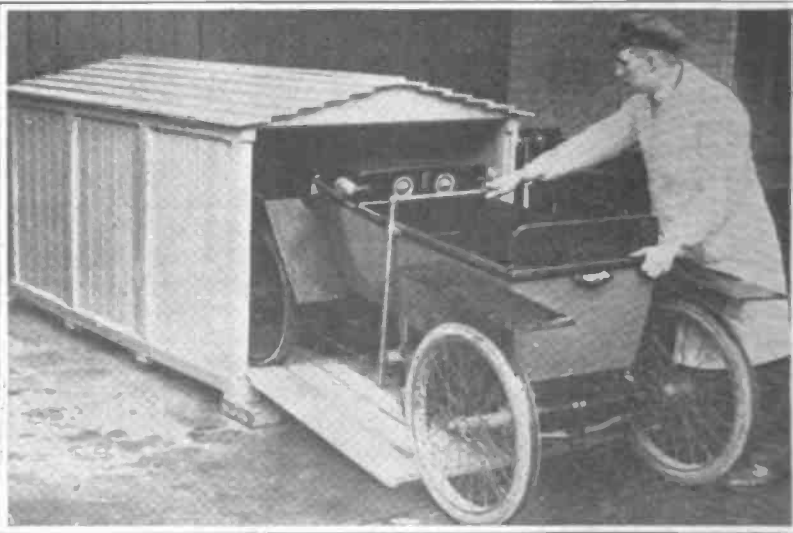
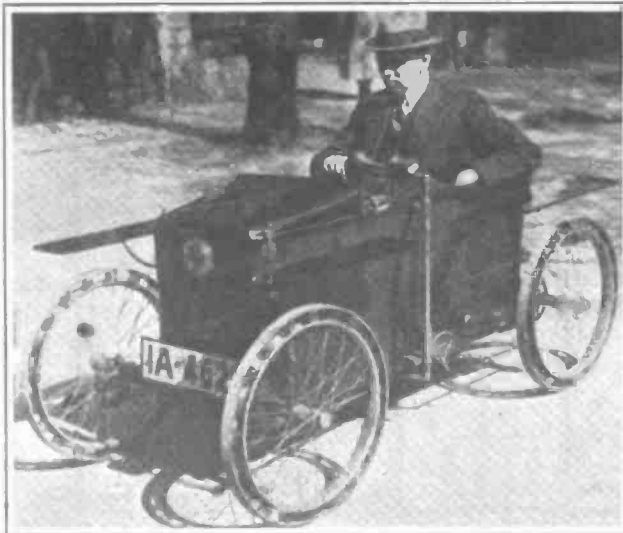

*The illustration at the left shows a small electric automobile of German design suited for one person. Attention is directed to the steel spring and leather tire substitute for the usual pneumatic form shown at the left. The small size of the garage needed is clearly shown at the right*



there is ample room for an adult in the small vehicle body. Steering is by a simple tiller carried at one side of the driver's seat, a method that was used in this country for many years in connection with electric vehicle control, and that is still found on a few types.

**MOWING LAWNS BY POWER**

**M**UCH of the mechanical progress in industry has been due to the limited capacity of the human being for work and also the fact that the average person does not enjoy exhausting himself in doing work that can just as well be done by machinery. This has re-

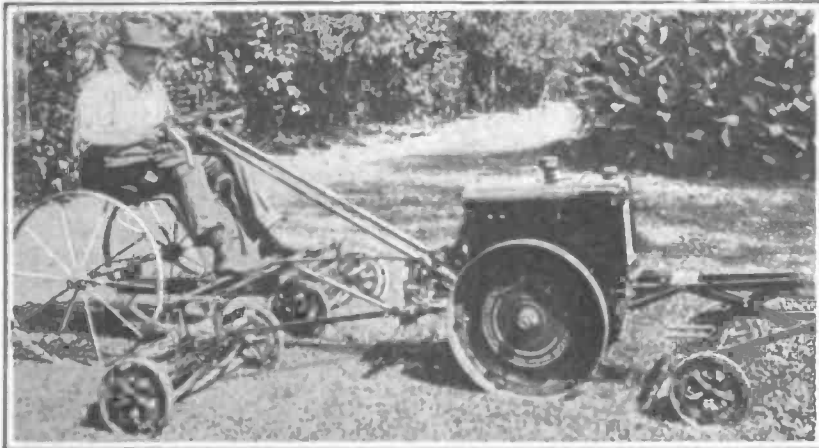

*How a garden tractor can be used for operating three lawn mowers and cutting a wide swath*

sulted in the development of various interesting forms of labor-saving machinery in our shops and factories. It is only in recent years that machinery has been applied generally to outdoor work, especially in doing relatively light work. The accompanying illustration shows a new garden tractor which is used for many odd jobs about the small farm and can be employed for cultivating and other garden work. The addition of the lawn mower mechanism to the garden tractor makes it suitable for mowing lawns with much less physical exertion on the part of the operator than the usual method and also makes it possible to do considerably more work in a given time than can be done with either hand operated or horse-drawn lawn mowers.

The other power mower shown is the invention of Admiral Sir Percy Scott, a well-known British seaman, and is very simple in design and construction. Power is furnished in this case by a small air-cooled engine, similar in construction to the types used on motorcycles. In deference to the vogue of the "Motor Scooter" which is being widely used in England, the new machine has been called "The Lawn Mower Scooter." While conventional types of power driven lawn mowers may be obtained in this country at low cost, those of our readers who are interested in making their own mechanical appliances can get ideas of value from the two types of power lawn mowers illustrated.

**STEEL DISK WHEELS POPULAR**

**T**HERE is a growing tendency on the part of motorists to favor the pressed steel disk wheel and increasing numbers of fine cars are being equipped with traction and support members of this type. The wheel used for passenger cars is a single disk type, being dished for strength. In most designs the thickness of the metal is greater at the center than at the rim, thus proportioning the section to the strain coming upon it. A cast-steel master hub is fastened to the axle, and the steel disk is attached to this by four easily re-

**PRODUCER GAS FOR MOTOR VEHICLES**

**A**BRITISH committee in a report on the use of gas as an automotive fuel enumerates three possible systems of making gas from plant carried on the vehicle itself, and, in the case of one of these, drawings are given of the arrangements. Such plants, it is stated, can be made to work automatically, after the necessary attention of lighting up. Their fuel cost, with coke at \$9 a ton or anthracite at \$11 a ton, is equivalent to gasoline at 8.6 cents per U. S. gallon. One hundredweight of coke or anthracite will, on the average, do the same work on the road as 5 or 6 gallons of gasoline, and the weight of generator and accessories for a 30-b. hp. engine is about 220 lbs.

The risk of escape of unburned carbon monoxide gas from a suction gas producer on a motor vehicle is not such as to call for special precautions, except when the vehicle is at rest within a closed structure with the fire still burning in the producer. The water feed to a portable suction gas producer can be so adjusted as to increase the calorific value of the issuing gases by as much as 50 per cent on a consumption of water, falling as low as 25 per

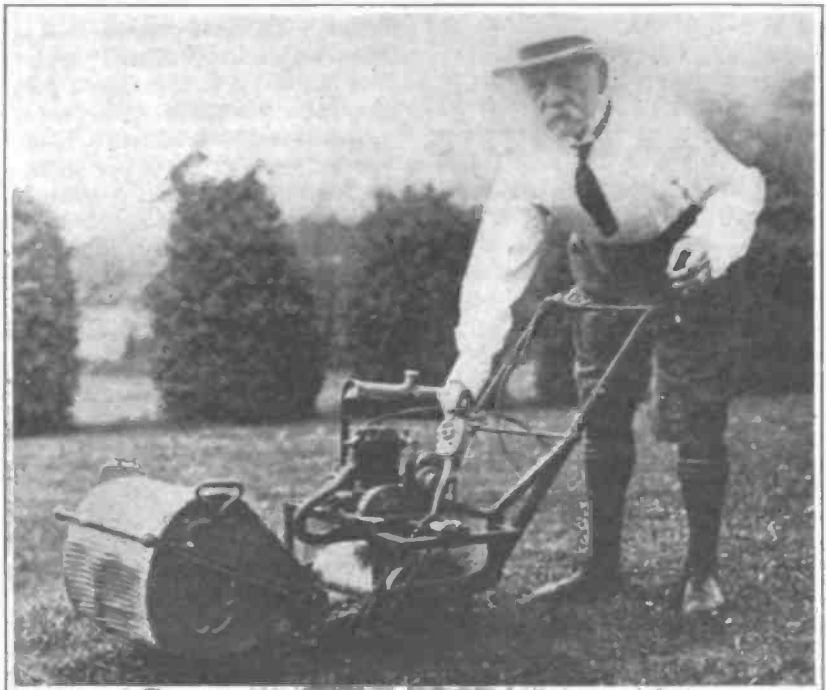

*Admiral Sir Percy Scott, a retired British seaman, has invented a simple lawn mower and roller propelled by a motorcycle engine*

movable nuts which screw on studs in the permanent hub flange. The disk wheel is as easily removed as any other type and is stronger and more easily washed than the conventional wood or wire spoked forms.

During warm weather, be sure to watch the lubrication and cooling systems. Keep fan belt tight, radiator filled with water and be sure to use the proper grade of oil.

cent by weight of the simultaneous combustion of coke or anthracite. In an ordinary motor vehicle engine, unaltered structurally as regards the compression space, the power-yield, on the basis of 100 for gasoline, may on the average be taken as 91 for town gas of 450 B.t.u. gross per cubic foot, 97 for suction-producer gas (partly hydrogenated with water gas) of 210 B.t.u. and 82 for suction-producer gas of 140 B.t.u. heating value.

# How to Test Engines for Horsepower

By Adrian Van Muffing, M.S.A.E.

IT is often desirable, or even necessary, to know exactly how many horsepower a certain motor develops, as in the case of automobile or marine motors that have been "fixed up" with a view to increase the power output for some reason or other. The usual (and easiest) way is to send the motor to some established testing station or to a concern which is known to have the necessary outfit for the purpose. This method is very expensive. Unless the power is unusually large, however, such tests can be quite accurately performed by anyone who is able to rig up a suitable stand, and who commands the most elementary notions of mechanics. The

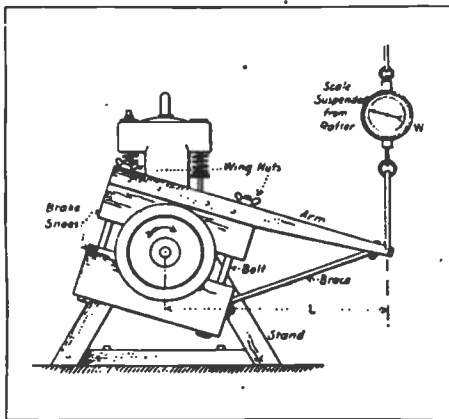

Simple Prony brake

purpose of this article is to show how such tests can be performed with comparative ease and little expense.

As nearly everyone knows, a horsepower is defined as being equivalent to 33,000 foot pounds per minute—that is to say, the work done in lifting a 33,000 pound weight one foot (or 33 pounds 1000 feet, or 330 pounds 100 feet, etc.) in one minute. The problem of finding the horsepower of a given unit then resolves itself to this: Find out how many pounds it will lift and how many feet per minute. Multiplying the two values together will give us the number of foot pounds (Ft. Lbs.). Dividing the result by 33,000 will give us the H.P. There are three ways of finding the foot pounds developed.

## Prony Brake Test Simple

The first is the familiar "Prony brake test." The motor is firmly mounted upon a stand, which should preferably be bolted on to the floor, or at least be heavily weighted to avoid tipping over. If the motor is provided with a moderate size flywheel this may conveniently be used, but if it is very large, a pulley should be fitted for the brake shoes to press against.

The shoes are made of hard wood,

cut out on a band saw so as to encircle at least 9/10 of the circumference of the flywheel. Two long bolts are then mounted so as to pass through the shoes and permit tightening up of the brake while the motor is running so as to apply the load gradually as the speed is increased. Wing nuts are excellent for this purpose.

One of the shoes has attached to it a strong arm of wood or metal, so placed that it will not bend, and which is about four feet long. The line between the shaft center and the point at which the scale is attached must always be horizontal, or nearly so, and is made to exert a pressure upon a pair of scales either of the platform type or an ordinary spring balance suspended from a rafter. A revolution counter of any suitable form completes the outfit.

The method of performing the actual test is as follows: The motor is first started and allowed to "warm up" at moderate speed, with the shoes completely released. When everything is ready pressure is gradually applied upon the brake by tightening the wing nuts while the throttle is gradually opened. (A little practice will be necessary to avoid "racing" or a sudden slowing down.) This must go on until the motor has attained its proper speed, which is most conveniently found by using the counter for a period of 10 seconds at the time, 150 revolutions being equivalent to 900 R.P.M., 166 to 1000 R.P.M., 200 to 1200 R.P.M., and so on. It is best to take short readings to avoid overheating the brake. When the motor is running at its rated speed (say 1200 R.P.M.) with throttle wide open, the actual test is made by measuring the number of pounds registered at the scale. Having this, we are through, and can proceed to calculate the H.P. of our motor.

What we must look for first is the actual distance that the end of the arm would have traveled if it had been left free to swing. If the end was four feet from the center of the flywheel, the circumference would obviously have been  $2 \times 4 \times 3.14 = 25.12$  feet.

In one minute it would have covered 1200 times that distance or

$$25.12 \times 1200 = 30,144 \text{ ft.}$$

This is the distance through which the registered pull acted during one minute. Let us say for example that the scale was found to indicate 46. pounds. Then the number of foot pounds is given by  $30144 \times 46 = 1,386,624$  foot pounds, which divided by 33,000 = 42.02 horsepower.

It will generally be found more convenient to write all the factors involved

in a formula as follows:

$$\text{H.P.} = \frac{2 \times L \times 3.14 \times W \times \text{R.P.M.}}{33,000}$$

in which L is the length of the arm in feet and W the weight shown by the scale.

During this test it will be found that the brake will heat up quite considerably. As this heat means a waste of power in the form of friction, it is evident that the test by this method is not entirely accurate. It should be noted, however, that as the power thus wasted is generated by the motor, and is not shown on the scale, the result will indicate a horsepower somewhat lower than the one actually developed. The error is thus on the safe side. To avoid undue heating the brake shoes are sometimes lined with asbestos cloth or brake lining. If the arm has a tendency to

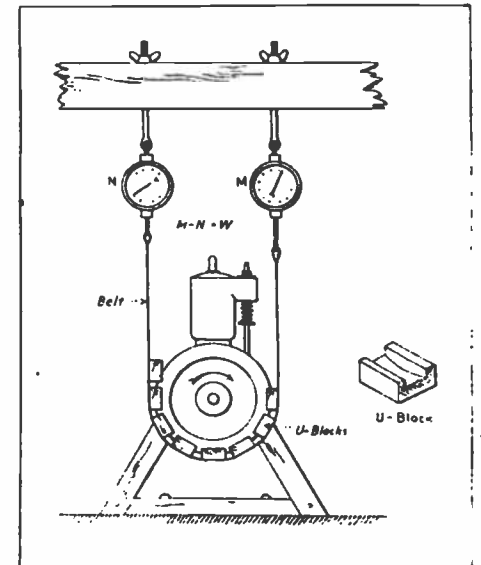

Modified Prony brake

"chatter," that is, vibrates too much to permit an accurate reading, a few drops of kerosene will generally obviate the trouble.

## Modified Prony Brake

The second testing method is a modification of the prony brake, and is sometimes more convenient, especially when the flywheel is large. It requires two pairs of scales and a long leather belt which passes around the flywheel, and is attached by each end to the scale. These are suspended from a roof rafter so as to allow the tension to be adjusted by means of wing nuts as before. Before the test is made the latter are drawn up until the tension of both legs of the belt is equal, say 50 pounds. The motor is started according to the procedure outlined above. It is obvious that the friction along the belt will increase the pull on one side while relaxing it on the

other. The total force is then indicated by the *difference* between the pulls on the two scales. This will be  $W$  in the formula, which can be applied just as before, excepting of course that the radius of the pulley now represents the arm, and consequently the value of  $L = \text{Diameter of the pulley}$ .

It may be found that the belt shows a tendency to slip off during the test. This can be obviated by interposing a number of small wooden blocks cut to a shallow U shape between the pulley and the belt, and screwed or riveted to the latter, the pulley being made to run in the channel of the U formed by the blocks.

be. But as the strength and dimensions of the club should be calculated, and as its use involves considerable danger (they have been known to fly apart and kill some innocent bystander), it is perhaps best to use a brake similar in construction to that described above, but now, of course, firmly bolted to the stand.

The test is performed in exactly the same manner as in the case of the prony brake, and the same formula can be applied,  $L$  being the length of the arm measure from the center of suspension of the cradle. If the arm is placed on the side of the cradle, which tends to go *downward*, the best way to measure the

because you don't pull on it, and it does not get hard because it retains its softening temperature during the extruding.

For lead extrusion the necessary outfit consists of a multiple plunger pump, a hydraulic accumulator for storing water under high pressure, and a hydraulic press with attachments. Briefly, these attachments consist of a heavy steel cylinder with a die-holding arrangement mounted on one end, the other end being adapted as to inside diameter, so as to form a close fit to the plunger or ram of the hydraulic press. In extruding lead wire a large piece of lead is put into this cylinder and the press started. Lead wire will flow continuously from the hole in the die until the ram reaches the end of its stroke. Naturally, some lead is left at the bottom of the cylinder, but the ram is withdrawn, another piece of lead put into the cylinder, and the ram started in again. Here is the interesting thing. During these two strokes of the ram there occurs no break in the lead wire; it is impossible to tell where the metal in the first piece of lead stops and that in the second piece begins.

In producing lead pipe a long arbor is used, the point of which enters the die in such a way as to make the orifice through which the lead must flow ring-shaped, or to be exact, shaped like a cross-section of the pipe.

Recognizing the possibilities of such a process, it was not long before experiments were tried, with the end in view of making brass rod, and wire by the extrusion process. Difficulties at once arose. It was found that to get any results at all the metal must be quite hot during the extruding; it was found that hydraulic machinery of great power was necessary; it was found that the dies suitable for lead extrusion would not stand up under the heat. However, these difficulties have been overcome and there are now a number of firms who sell extruded brass rod. One of the good features of this process is the practicability of extruding the brass through odd-shaped dies, to give a certain cross-section, very expensive to get by ordinary methods.

In discussing this process, it is interesting to note how interdependent all processes are on something else. Without the gas engine we would not have the automobile or the aeroplane; without the railroads we could not have big cities; without the powerful hydraulic press we could not extrude brass.—*Scoville Bulletin*.

The growth of trees has been registered by encircling the tree with an expansible ring, whose expansion operates an index, which records the movements on a revolving cylinder, thus making a graphic chart. The movement is multiplied by suitable gearing so relatively slight changes are magnified and made evident.

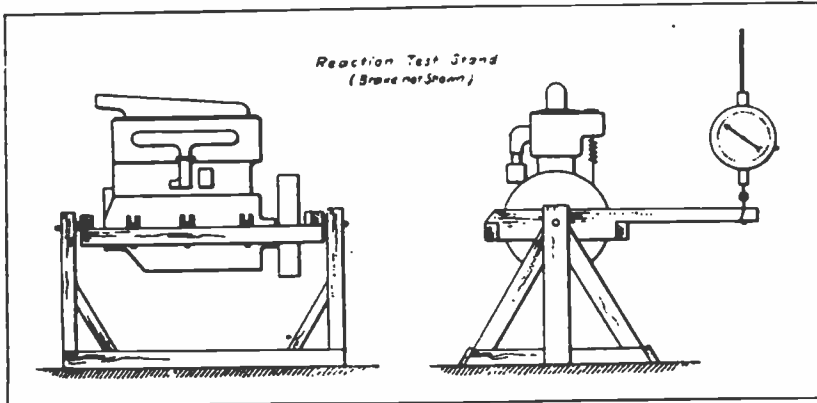

Reaction method of testing horsepower

### Torque Reaction Test

A better method by far, which requires a somewhat higher initial outlay but gives much more accurate results on account of eliminating all friction losses is known as the rocking cradle, or "torque reaction" test. It is based upon the fact that the reaction or "torque" of a motor is exactly equal to the motive force, and hence we get the same result whether we measure the turning force of the flywheel or the force which tend to rotate the motor around the shaft in the opposite direction. In order to be able to do this we must mount the motor in a cradle (of strong wood or iron), which is suspended into a framework so that it will rock along a line corresponding to the crankshaft of the motor. It will take a little ingenuity to suspend the motor in just that way, and it is most easily done by large ball bearings, which can freely pass over the crankshaft at both ends. When this cannot be done the suspension should be just below the crankshaft and as close to that as possible. This cradle is equipped with an arm attached to a pair of scales as before, with which the torque can be measured.

Next, the motor must be provided with a resistance, which may consist of a strong wooden club made up of laminations glued together and very carefully balanced and attached to the crankshaft as an aerial propeller would

torque will be to suspend a known weight from its end, which can be increased or decreased until the arm remains perfectly horizontal, with the motor running at the required speed and under load. When many tests are to be made on different motors a simple calculation will enable one to calibrate the length of the arm so that the horsepower can be read off directly by the number of pounds necessary to balance the cradle.

### EXTRUDED METAL

**M**ETAL wire and rod made by the extrusion process is coming more and more into common use, so that a little information about what the process is should be welcome. Wire and rod have been made for many years by the drawing process, in which the metal is pulled through dies, gradually reducing its diameter or shape. Volume of production by this process was limited, first by the fact that attempts to reduce the diameter of the wire too much at one draught resulted in pulling the metal apart; and second, by the fact that the frequent annealings necessary to soften the wire consumed time.

By the extrusion process, the metal is pushed through the die while quite hot. Thus are overcome at once the two limiting conditions mentioned in wire drawing; the wire cannot break

# Largest American Airplane

## *Some Interesting Details of a Large Three-Motored Design for Commercial Work*

**T**HE L. W. F. Owl is announced by its makers as being the largest freighter in America and one of the largest yet built. It was originally designed for the aerial mail service. It has a wing spread of 105 ft., being of biplane construction and an overall length of nearly 54 ft. The design is of the twin fuselage and center nacelle type. Three 400 hp. Liberty engines are used for power, one being mounted in each of the noses of the fuselages and nacelle. The machine loaded was designed to weigh ten tons and has a mail carrying capacity of 3000 lbs. on long distance flights or double that amount on shorter trips.

The crew and controls are located in the central nacelle while the two fuselages, constructed of laminated wood, carrying part of the fuel supply and the freight. Four persons comprise the crew, these being two pilots, a radio operator and a mechanic. At the maximum speed of 110 m.p.h., it is able to remain in the air for 10 hrs. or sixteen hours at a lower speed. Climbing ability with full load is claimed if only two of its engines are operative and it is designed to land at a speed

of 56 m.p.h., which is reasonable.

Among the distinctive features of the machine are the monocoque fuselage and nacelle, the intercommunicating phones, the fuel and the fire extinguisher systems. The wing construction is of the usual truss type and consists of three upper and three lower panels of 11 ft. chord and equal spans with a gap of 11 ft. Each wing is equipped with balanced interchangeable ailerons. Ribs are built up first and then slipped over the beams, which are built up of four pieces, forming a hollow box section. The top and bottom of the box spar are of spruce and the sides of birch. The internal wire bracing is double, of No. 8 solid piano wire and 3/16-in. hard cable. All external wire fittings are applied directly to the beams and project through the covering.

The fuselages and nacelle are supported between the upper and lower planes on tubular struts thoroughly streamlined. Each engine drives a tractor propeller. The main load and crew are carried in the nacelle while each fuselage carries its complete motor plant and has a small auxiliary compartment for extra cargo. Each power

plant is complete within its respective fuselage or nacelle and consists of a 12-cylinder Liberty engine equipped with Splittdorf ignition, electric starters and compression release. The radiators are above the motors, directly in the blast of the propeller and equipped with individual shutter controls.

The tail is of the biplane type, attached to the rear end of the two fuselages. It consists of two double cambered horizontal stabilizer planes superimposed, with elevators attached and a fin on the top of each fuselage followed by a balanced rudder. A third balanced rudder is installed midway between the two. The landing gear is of the six-wheel, two-axle type, with the outer two wheels side by side directly under the center of each fuselage and the other two wheels spaced equally between. The landing gear which is extremely well built is so placed that when landing the center of gravity falls sufficiently far back of the wheels to prevent any tendency to nose over. The great weight of the machine calls for shock absorbers of very large capacity, these being carried in streamline housings.

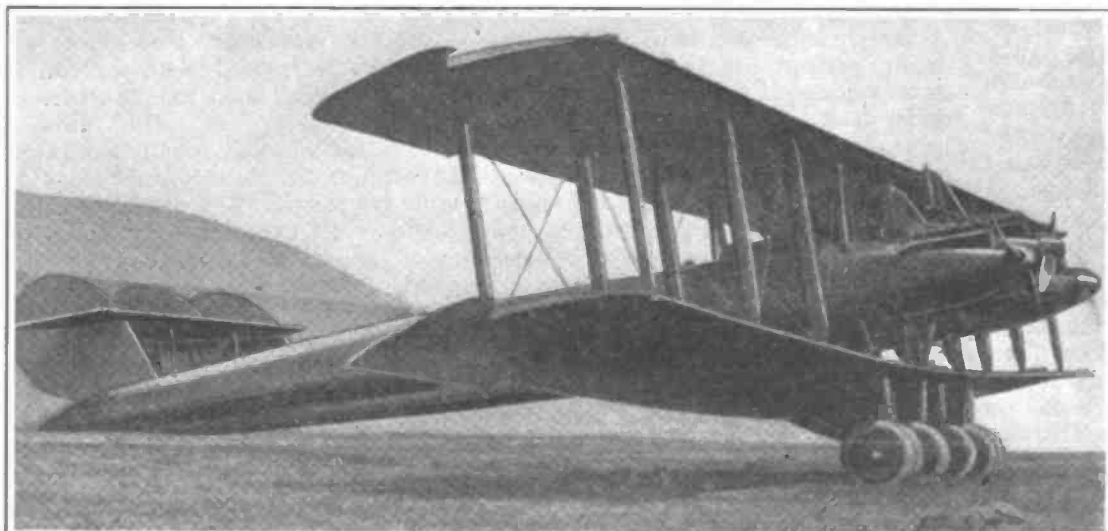

*The L. W. F. Owl is a double fuselage type biplane powered with three Liberty 12-cylinder engines driving tractor screws. It was intended for freight-carrying purposes, but has been taken over by the Army authorities for military use*

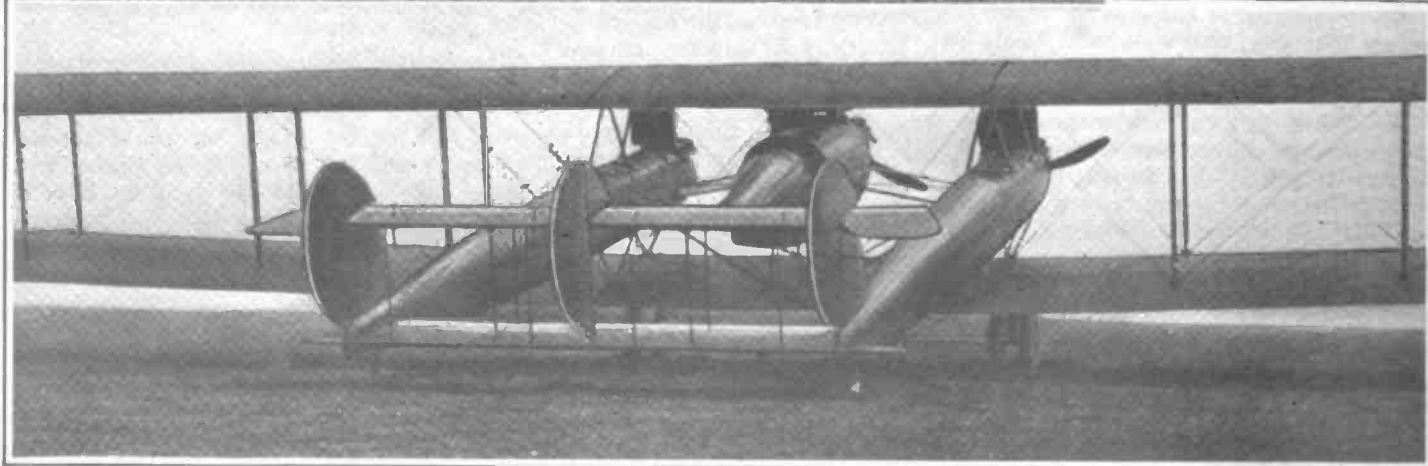



## THE UNIFLOW STEAM ENGINE

**T**HIS type of engine was described in a recent paper by Mr. Henry Billing, before the Manchester Association of Engineers, in England. It is a single cylinder engine, the steam actuating which, when it does move, moves in the same direction and in its expansion back of the piston may be taken as moving also in the same direction. The piston of this engine in total length is about 10 per cent less than the length of stroke and the cylinder itself is a little over double the stroke in length. Each end of the cylinder is provided with an inlet valve, which must be of rapid opening and closing action. Around the center of the cylinder, with its walls forming an external ring, is a steam conduit communicating with the exhaust. This

The Uniflow engine condenses less steam inside the cylinder than does a compound engine, because the temperature of the walls of the cylinder is kept hot. The exhaust ports are open only a fraction of the time given in a compound engine, and it is precisely this loss by internal condensation which has been a source of bad economy in steam engine practice. The engine has more or less definite limitations. Thorough condensation is needed so there must be plenty of condensing water and the direction of rotation must be continuous. The author of the paper says that for reversing engines, such as those used on steam windlasses, other types of engines are usually to be preferred. He states that he is at work on a very large engine, one of 60 inches diameter of cylinder and of six feet stroke.

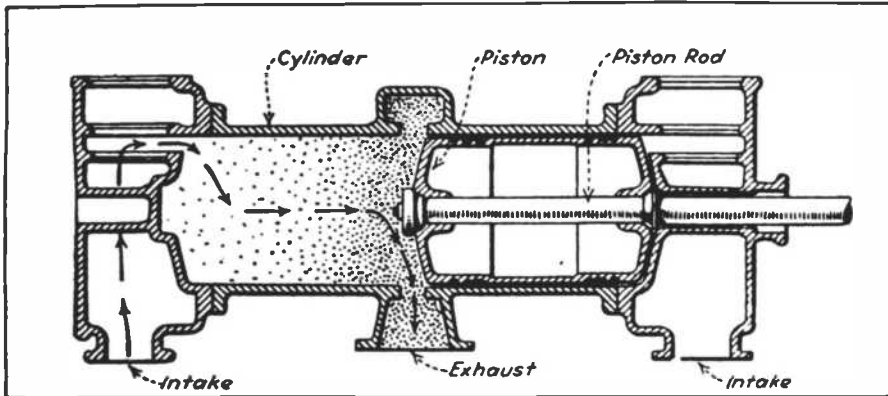

Construction of Uniflow steam engine cylinder

conduit communicates with the interior of the cylinder by steam ports.

As the piston travels back and forth it uncovers these ports at the end of each stroke and they remain open for about one-tenth of the stroke. This feature is clear from the diagram of the cylinder and piston. There the arrow shows the course of the steam on the left end passing out into the exhaust. Referring still to the cut it will be seen that as the piston begins its return stroke the ports will be closed and no more steam can escape from that side of the piston. The piston now completes its stroke. The inlet valve on the left side stays closed while that on the right closes before the completion of the piston stroke, not only to give expansion but to close the steam inlet before the central ports are opened. As the piston completes its stroke it uncovers the central exhaust ports this time on its right end and the greater part of the steam which has actuated it rushes out through the exhaust.

In each stroke a certain amount of steam remains in the idle end of the cylinder and this is compressed by the piston forced against it. The action of the exhaust port is quite comparable to that of the auxiliary outlet port sometimes used in internal combustion engines of the four-cycle type.

## GAS MASKS IN PULP AND PAPER MILLS

**G**AS masks of a nose-breathing type with canisters containing special chemicals are used in the digester house of the Forest Products Laboratory to give protection against sulphur dioxide. These masks enable the operator to make repairs under conditions otherwise unbearable and soon pay for themselves in time saved. Masks of this type are reported by the Bureau of Mines to hold up against a 5 per cent concentration of sulphur dioxide for about 15 minutes. When it is realized that 5 parts of sulphur dioxide to one million parts of air can readily be detected, and that at a concentration of 150 parts of sulphur dioxide to one million parts of air the air becomes unbreathable, some idea can be gained of the life of a canister even under adverse mill conditions. In addition to their use in the sulphite mill, these masks are of great assistance in the bleach room, where they are worn continuously during the mixing of the bleach liquor. Aside from monetary considerations, the increased comfort and safety of the workmen is sufficient argument in favor of the addition of gas masks to the regular mill equipment of up-to-date plants.

## PICKLING AND CLEANING CASTINGS

**I**RON castings that require machining must have the scale and sand removed. The common practice for doing this is to subject the castings to what is known as a "Pickling Bath." Iron castings are usually pickled with sulphuric acid and hydrofluoric acid, the former being commonly used. The pickling solution is usually made up of 1 part sulphuric acid to 10 parts of water. When the scale is loose the castings should be washed in hot water and if the castings are small it is well to immerse them in a soda solution for a short time, to thoroughly neutralize any acid. Hydrofluoric acid is usually sold in three grades. The first contains 30%, the second 48%, and the third 52% acid, the balance of the solution being water. The 30% solution is what is usually employed for pickling castings and 1 gallon should be mixed with 20 to 25 gallons of water. Hydrofluoric acid does not act upon iron appreciably but it does dissolve black oxide of iron and sand and dissolves them. The castings pickled in sulphuric acid solution have a dull or black surface. Those pickled in hydrofluoric acid have a whiter and silvery appearance. The castings pickled with hydrofluoric acid have a much smoother surface and for that reason whenever parts are to be polished or nickel plated, the hydrofluoric acid is used. The hydrofluoric acid bath is always used cold but must be kept up above the freezing point. The workman should always use rubber gloves when handling hydrofluoric acid, and if any is dropped or splashed on the skin, it should be washed off promptly with water and diluted ammonia.

Brass castings may be cleaned by mixing 3 parts of sulphuric acid and 2 parts of nitric acid by weight and add to 1 quart of the mixture about a handful of common table salt. While this mixture is frequently used without being diluted with water, it must be handled with care, as it will attack the human skin. This pickling solution must be kept in an earthen-ware crock. Hydrofluoric acid must be kept in a lead carboy but diluted acid may be kept in wooden tubs or vats. Hydrofluoric acid must not be kept in glass bottles, because it will eat glass, but in rubber bottles.

The peeling of lacquer is usually caused by the imperfect cleaning of the metal surface before lacquering, although it may be caused by the use of a lacquer not adapted for the purpose. Lacquers containing "gums," in addition to the regular pyroxylin base, hold more tenaciously, although not as tough as a straight pyroxylin lacquer.

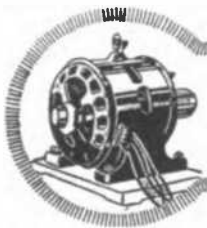

# ELECTRICAL PROGRESS DIGEST

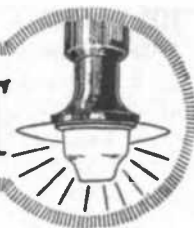

## METERING DIRECT CURRENT

An interesting system of metering heavy direct current involves the use of soft iron cores surrounding the electric conductor. Each core is a ring or rectangle and they are operated in pairs; on each one of the cores wire coils are wound which connect to an alternating current ammeter. An alternating current is passed through these

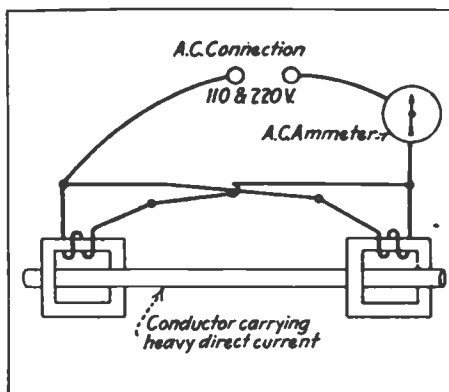

Metering heavy direct current

coils and through the ammeter. If no current is passing in the main electric conductor, the coils choke back practically all the alternating current. If current is passed through the main line, which threads the coils, the cores become magnetized, passing lines of force, and the choking effect of the cores and coils on the subsidiary alternating current is decreased. Therefore, as more and more current passes through the main line more current in exact proportion thereto is recorded or registered by the ammeter on the alternating current line. The alternating current is very small, of course, compared to the main current so that a small instrument can be used to measure a current of great intensity.

## HAVANA CENTRAL STATION TO DOUBLE POWER-PLANT CAPACITY

ON account of a rapid growth of load and the possibility of a still further growth in the next few years, the Havana (Cuba) Electric Railway Light & Power Company has just ordered two 25,000 kw. Westinghouse steam turbine-generators to double the plant rating. At present there are, in this plant, three 12,500 kw. generators supplying a combined railway and power load. In the original installation, space had been provided for only one

additional unit, but now that the load has become so great it was thought necessary to increase the capacity still more. Consequently the two 25,000 kw. units were ordered, one to be installed in the space available, and the other to replace one of the 12,500 kw. units. By this means it is unnecessary to extend the power plant buildings. However, the 12,500 kw. unit is in perfect operating condition and will probably be utilized elsewhere.

The first unit will be installed and will be in operation in 1921 and the second one will be on the line in 1922. The units are to be designed to operate at 185 lbs. pressure, 150 deg. superheat and 28 in. vacuum. In addition, arrangements have been made to operate this equipment at higher pressure and superheats if desired at a later time. To go with these turbine-generators, Westinghouse-Le Blanc 56,000 sq. ft. surface condensers and Le Blanc air and circulating water pumps have also been ordered. Each condenser will have two circulating pumps and divided water boxes so that one-half of the condenser may be cleaned while the other half is in operation. This station, which is the largest in Cuba, is modern in every respect and has an operating economy which is comparable with some of the best plants in the United States. The average fuel consumption is less than 2 lbs. of coal per kw. hr. notwithstanding that the plant has a low load factor. This economy is due to the excellent operation and maintenance afforded by the management and operating engineers of the plant.

## WATER POWER IN ITALY

ITALY'S lack of coal is often cited as a handicap to the industries of the country, but, in view of the water-power available for producing electricity, coal may largely be dispensed with. The Fiat motor works, which are said to be the largest in Europe, employ no coal whatsoever for driving machinery, being supplied with electricity generated by water-power in the Alps. Even the steel works and forges are operated entirely by electricity. The hydro-electric generating plant is situated on the Cenischia River, and by large extensions to the plant, and by increasing the size of the natural lake on the top of Mont Cenis, it is estimated that a current of 200,000,000 kilowatts will shortly be available.

## MULTIPLE CONNECTION SWITCH

THE switch illustrated in our cut is designed to prevent more than a certain amount of current being taken from a connection. A series of plugs are provided, each of which has its fuse, which blows out with an excess of current. The set of plugs and fuses are to be enclosed in a locked box. The

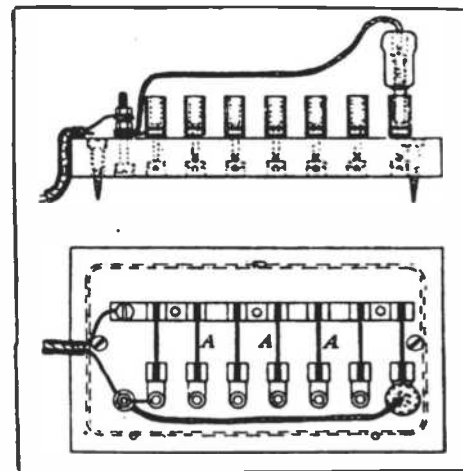

Multiple connection switch

person using the system can only take as much current as the particular fuse appertaining to the plug will pass without blowing. Should more current be required, the proper person must be notified, who will unlock the box and effect the desired connection. The inventor considers it adapted especially to such service as that of a hotel room.

## AN 11,000-VOLT SUBMARINE CABLE

FROM the Teknisk Ukeblad, we learn that a Swedish firm has supplied two high-tension cables for the Skars power station near Kristiansund, in Norway. Each cable is nearly two miles long and weighs 52 tons. It has a sectional area of copper wire of 350 square millimeters in three separate conductors. These are insulated with impregnated paper and compressed to form a cylindrical cable, wound with impregnated paper and surrounded with a 3/32-in. thick lead tube. This is further strengthened with impregnated jute, galvanized steel wire, and a final coat of impregnated jute. The diameter of the finished cable is 2 1/2 inches. This cable was tested in the factory with a pressure of 40,000 volts, and when placed in position it will again be tested to a pressure of 25,000 volts.

### VACUUM REGULATION OF X-RAY TUBES

A VACUUM tube subjected to constant or long prolonged discharges, as in X-ray practise, acquires a higher vacuum with time; it is said to become "hard"; this increases its penetrative power but reduces its actinic power, it does not work well in photographing objects, and is inferior from the standpoint of radiography. Now good radiographic power is what is demanded in modern X-ray work, so means have to be provided to add gas to a hard tube when it becomes unsatisfactory in photographic power and quality.

In Fig. 1 is shown the Bauer valve, by which the operator can admit gas. The bent tube seen in the interior of the larger tube contains mercury; in the small outlet tube attached to its left-hand limb at the center is a plug of porous substance, which may be carbon. Air can make its way through it but mercury cannot. To admit air so as to diminish the vacuum, air is pumped in by hand through the jet or nipple seen at the top of the larger tube; this depresses the mercury in the left-hand limb of the manometer tube, for this is what the inner tube really is; the porous plug is exposed and air slowly enters into the X-ray tube, which is connected to the lateral nipple of the large tube. When enough has entered the pressure is released and the mercury rises and once more covers the plug and the air is cut off.

In Fig. 2 is shown an automatic valve for doing the same thing and on the same lines. In it the mercury in the manometer tube is acted on by pressure of the gas or air in the bulb, A. At E is the porous plug; if the air in the bulb is heated the mercury sinks from C to D or thereabouts, the plug is exposed and the air slowly enters through the nipple, B, into the X-ray tube. If the heat in A is reduced the mercury rises and shuts off the plug so that no more can enter. Fig. 3 shows the connections in the case of a Coolidge tube. The valve is in parallel with the tube: as the tube grows hard its resistance increases, more current goes through the bulb, A, and the gas is heated. As the tube gets softer its resistance diminishes, less current goes through A and the gas in the bulb cools, the mercury rises again and shuts off the plug. This valve is the subject of a recent British patent.

On the west coast of Norway, a region familiar to North Cape tourists, efforts are being made to introduce wireless telephone lines. Norway has long depended on its telephone system for this region, where there is no railway communication whatever, and where much of her population is distributed.

Domestic electric heaters for boiling water and similar functions have had their efficiency examined. The radiant hot plate heater is about 40% efficient and the enclosed hot plate system is slightly inferior to this, but for high efficiency the self-contained kettle with its own resistance coil shows double the efficiency or more of the best of the others. As high as 95% efficiency has been credited to it.

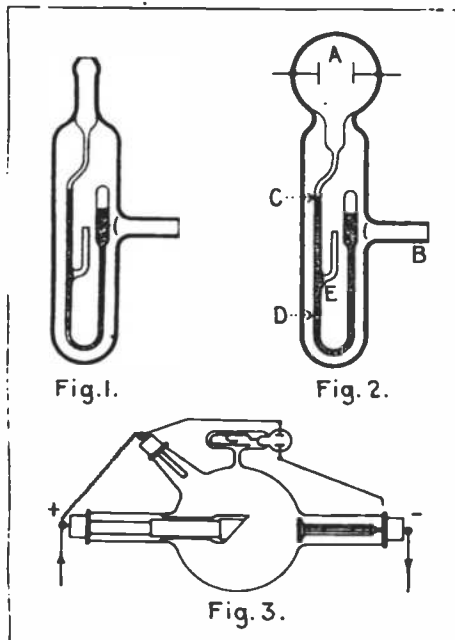

Vacuum regulation of X-Ray tubes

### ELECTRIC SHEARS

ELECTRIC shears are on the market driven by a motor which rotates at the rate of 9,000 revolutions per minute. One of the blades is stationary and the other vibrates at 9,000 oscillations

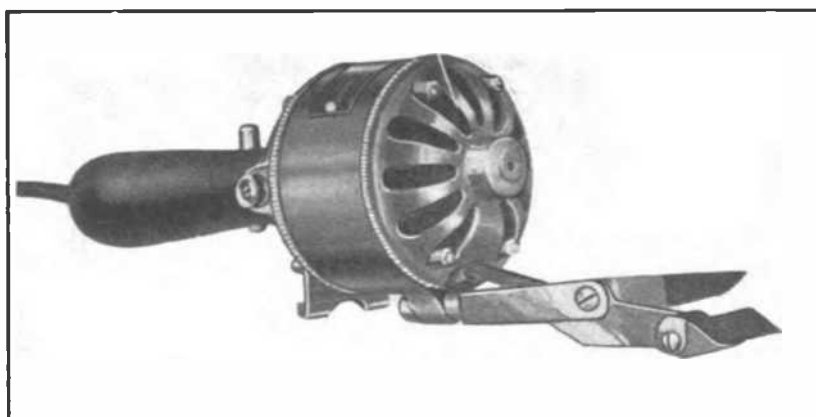

New Sperry electric shears

to the minute. Its amplitude of motion is only one-sixteenth of an inch, which is a great element of safety for the operator. It will cut the finest or the coarsest fabric, and on account of the small amplitude of motion, it cannot cut the operator's hand or finger. Cloth to be cut must be pushed down toward the hinge of the shears.

### A NEW ELECTRIC VEHICLE

SOME time ago Dr. Charles P. Steinmetz, whose name is so well known, announced the consummation of his many years of study and experimentation in electric vehicles in the form of a light-weight electric truck. The new vehicle is distinguished from the conventional types by the method of motor control, which gives compound characteristics to the motor by a storage cell floating on the field circuit. The result of this control is claimed to be speed maintenance, quick starting, power saving in the field at large currents and the feature of regeneration both on down grades and on stopping. The field and armature of the motor revolve in opposite directions, each driving one of the car wheels. In this way motor weight is saved, the differential is eliminated and the truck is as a result simpler and more compact.

In England one of the London Companies has put upon the market a portable electric rivet heater. It works on the principle of the electric welder with its transformer. The rivets to be heated are placed between spring-adjusted jaws completing a secondary circuit. Two minor features are that the heat is produced primarily in the central axis of the rivets and the point of the rivet which is the part to be expanded receives the greatest heat because the resistance is greatest there and because the greater mass of metal in the head keeps that from getting so hot. The effect of this is to put the heat where it belongs at the end of the rivet, to keep the head cool and to prevent scaling of the surface. A 3/4 in. rivet can be heated in 20 seconds or less to higher

temperature than is desirable. In normal operation a 23 kilowatt machine will appreciate such rivets up to riveting heat in 10 seconds and a British thermal unit will heat 19 such rivets. At English rates this figures out 10c a hundred rivets. The primary circuit is broken when the rivet is removed from the jaws.

# Special Appliances for Expediting Automobile Repair Processes

*A Description of Some of the Tools and Devices Developed to Aid the Automobile Repairman by Reducing Time and Labor Required to Do Work Efficiently*

By Victor W. Pagé, M. S. A. E.

THE production of enormous quantities of popular priced automobiles has created a new industry and that is the production of special tools, jigs and fixtures for making repair work easier on such makes of cars as are sold in quantities. In the early days the repairman was forced to make his own special fixtures because none were obtainable on the market and it was not often a profitable thing to do because it was seldom that enough automobiles of one make would be received for repairs to warrant the expenditure of money and labor. Now conditions are changed and so many cars of certain popular makes such as the Ford and the Overland are used in even small communities that almost any service station is justified in stocking certain fixtures.

Even the smallest shop should include valve head and valve seat reamers, valve grinding tools, bushing extractors, gear pullers and other devices of that kind. Shops of greater pretensions can now obtain engine supporting stands, special cylinder boring tools, rebabbiting jigs, piston chucks and vises, connecting rods, aligning and rebabbiting fixtures and numerous others that reduce labor and repair costs and yet that can be procured at much lower cost than they could make the devices

in their own shops because they are the product of manufacturers specializing on such tools and appliances.

The Ekern motor stand illustrated herewith is one of the handiest devices

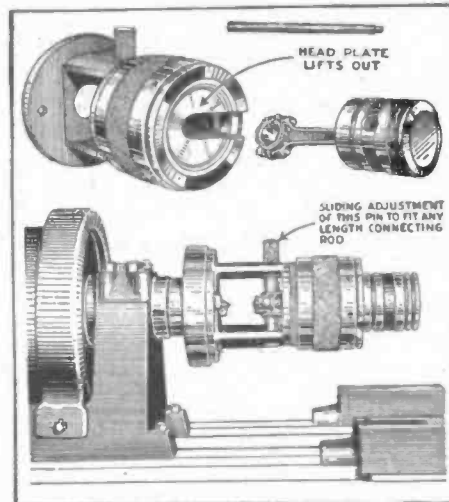

Special lathe chuck for turning piston ring grooves

of its kind for use in shops and garages doing Ford car work. The Ford motor, when taken from a car, can be fastened to the stand by the two cap screws which screw into the side of the motor where the water inlet connection is fastened. The stand is so constructed that

the part screwed to the motor will revolve in the clamp on the stand and can be locked by tightening the lock-screw, which will hold the motor in any position or angle desired to suit workman. It is provided with two large trays 22"x24" for convenience, where the workman can place his tools, motor and axle parts. The stand is mounted on three 4-inch diameter wheels. The rear castor wheel is so constructed that by pulling the plunger lock the castor will swing up off of the floor and the stand will then rest firmly on its legs. By kicking the castor lever down the stand will go back on its wheels and lock automatically.

The work bench is also equipped with a machinist's vise, which has a 3-inch jaw with a 4-inch opening which will handle any work required in overhauling a Ford motor or axle, also other kinds of work that will suggest itself to the repairman. The work bench and engine stand is 36 inches high and takes 27x42 inches floor space, it weighs but 120 pounds and can be moved from one part of the shop to the other or used on the road as part of the equipment of an emergency repair car.

## Useful Spanner Wrenches

There are various points in an auto-

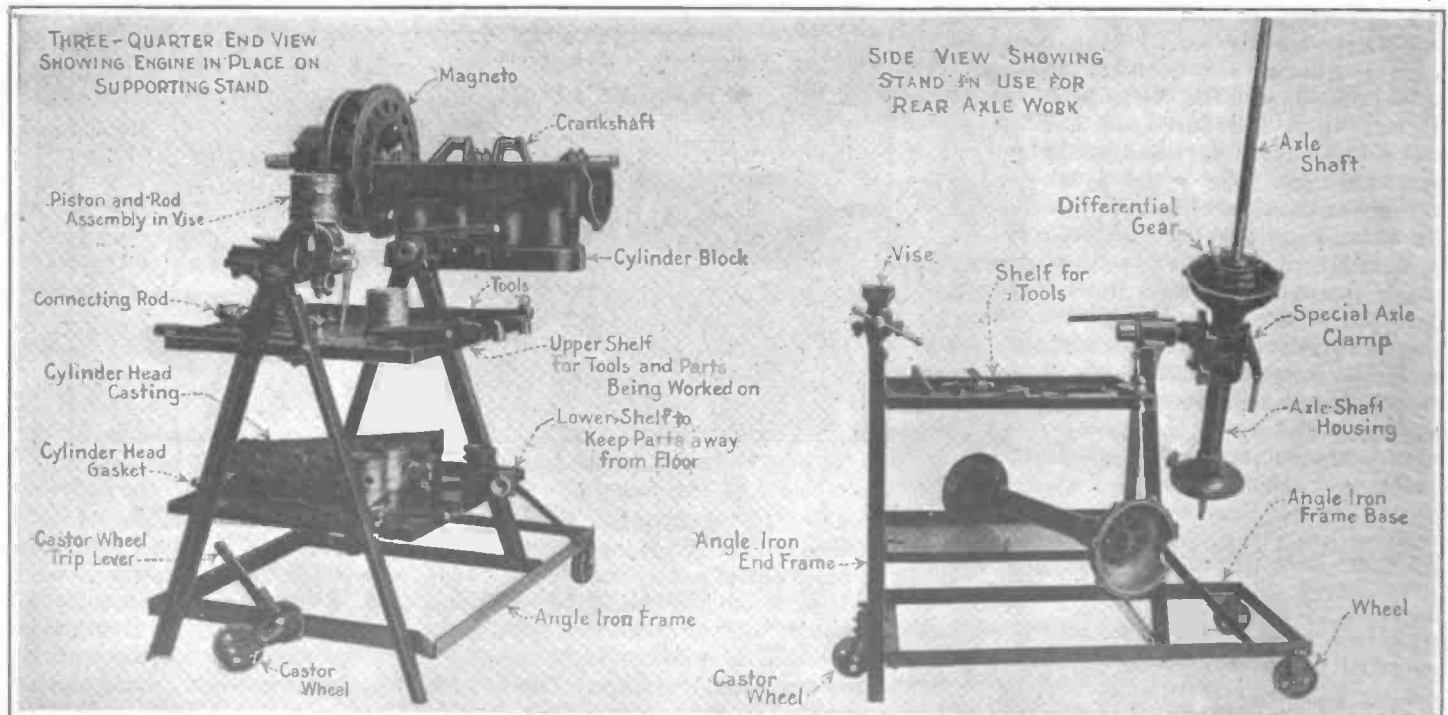

Ekern special stand and workbench facilitates work on Ford engines and rear axles by holding parts securely in any desired position



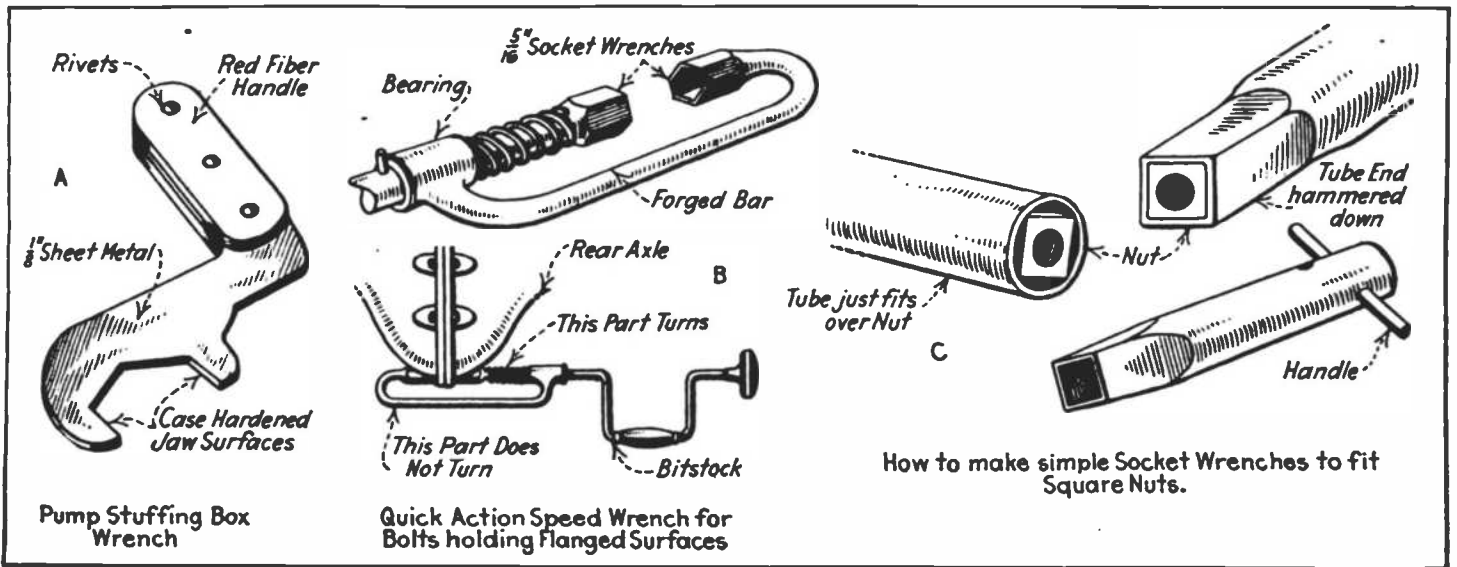

Special wrenches that are easily made by the automobile repairman make it possible to remove stubborn bolts and nuts with ease

mobile or gasoline engine that cannot be reached handily with the usual form of adjustable spanner wrenches. One of these points is the packing nut on the water pump which is generally hard to reach and which is so large as to require a special wrench. The simple wrench shown at A in the accompanying illustration may be made by any one handy with tools by cutting a piece of 1/8th inch thick sheet steel to the desired shape, then carefully fitting the jaws so that they will be the exact size of the nut on the stuffing box, by filing. After the wrench is completed the jaws should be case hardened. The handle is made by riveting two pieces of fiber to the bent portion or off-set of the wrench.

When a number of nuts are to be removed from a point where the bolt heads must be held from turning, as those holding the lower portion of the engine crank case to the upper part of it or keeping a differential housing together the speed wrench shown at D is a very useful fitting that can be made by any repair-man and will save its small cost on a single job. It will readily assemble or disassemble, any flanged parts held together by a series of bolts because it holds the head of the bolt from turning while the nut is unscrewed or replaced. A socket wrench is brazed or welded to the shank of a cheap bit stock or a simple bar of steel may be bent to perform the same functions, and a handle placed on the end as a hand grip. The wrench that holds the bolt head from turning is welded to the end of a forged bar shaped something like a hack saw frame and having a bearing at the end opposite the head of the wrench to receive the extension from the bit stock. A spring is used between the head of the movable socket wrench and the bearing on the forged bar carrying the fixed socket wrench.

This may be made as strong as desired and is intended to hold the wrench

firmly in place on the nut. A stop-pin may be placed in the bit stock if desired to keep the movable wrench from backing out too far. When it is desired to move the wrench from one bolt to another the spring is compressed by pulling back on the bit stock and the wrench may be readily withdrawn and moved to a new bolt. If the movable socket is made long enough it will hold several nuts forming a magazine that need not be emptied each time a nut is removed from its bolt. The general

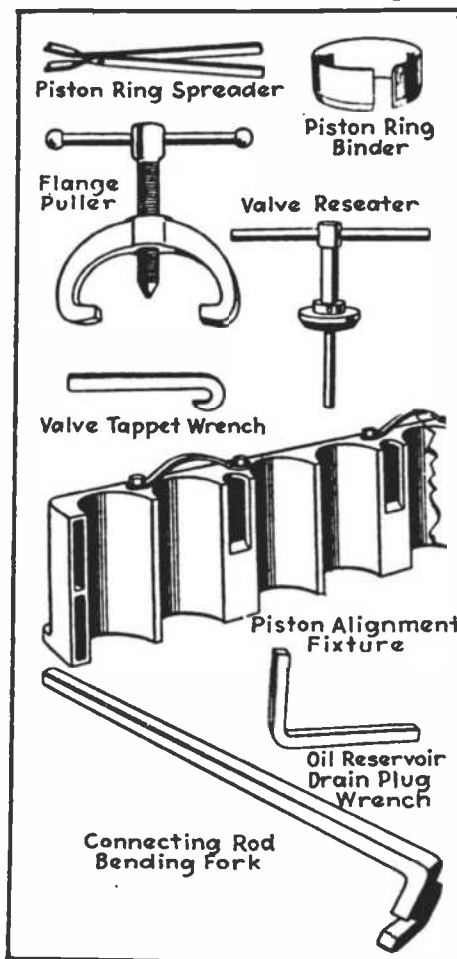

Special tools for Hudson cars may be modified for work on other makes

construction is clearly shown and the design can be duplicated by one possessing even a modicum of mechanical skill.

To fabricate a socket wrench is not difficult as the simple socket wrenches to fit square or hexagon nuts may be readily made as shown in the accompanying illustration. With that method it is necessary to secure a piece of seamless pipe or tubing of a size just large enough to go over the nut. For example, if a 3/4 inch square nut is to be removed, the wrench must be made from tubing having at least 3/4 inch inside diameter. The end of the tube, when heated to a red heat is placed over the nut and then hammered down on each facet, so that the tube end is hammered down and shaped to fit the nut at the same time. If a deeper wrench is desired, a piece of hexagon or square rod of the proper size may be used as a mandrel to form the required length of socket. Seamless steel tubing is the best material to use and after the wrench is made it may be well to case harden the formed end. The tube is cut to any desired length, six inches being the average for ordinary work and a 1/4 inch or 5/16 inch hole is drilled 1/2 inch from the top end of the pipe through which a short piece of iron or steel rod of the proper size may be inserted as a handle.

In the case of a hexagon wrench three holes are usually drilled through the end to correspond with the facets of the nut, one being placed below the other in the handle end of the tube. For a square wrench, it is only necessary to drill two holes, these being at right angles to each other as indicated.

**How Automobile Factories Help**

It is remarkable how the various automobile factories now co-operate with the repair-man in giving service to the owners of their cars. Some of the special tools furnished by the Hudson Motor Car Co. and described in a

special pamphlet are intended primarily for work on the Super-Six but there is no reason why modifications of these tools should not prove valuable to repairers of other makes of cars. These tools are shown in accompanying illustrations and a brief recapitulation of their use follows:

#### *Piston-Ring Spreader*

This is a convenient tool used to install or take out piston rings and its use will prevent chance of breaking the ring or burring the edges. It may be used on any car.

#### *Piston-Ring Binder*

This device is used for compressing rings into the cylinder. It is placed about the piston and rings and the piston is pushed into the cylinder. The binder remains with its lower edge on the top edge of the cylinder, and, of course, drops off when the piston is completely inserted.

#### *Spicer Universal Companion-Flange Puller*

This puller facilitates the removal of companion flanges on any Spicer universal, which flange is forced onto the gearset mainshaft and rear-axle pinion shaft to insure a perfect fit.

#### *Valve-Tappet Adjusting Wrench*

The wrench is designed to hook the tappet from the back. The design of the wrench gives more strength than is found in the conventional type. It is particularly applicable to the Hudson because of the lack of clearance between the valve tappet and the tappet-guide clamp.

#### *Valve-Reseating Tool*

The tool illustrated is easy to operate and is valuable in truing up the valve seats after the motor has seen considerable service.

#### *Piston Alignment Fixture*

This device consists of a standard cylinder block cut in half. To use, it is bolted to the crank case and gives an efficient means of lining up the pistons in reassembling a motor.

#### *Connecting-Rod Bending Fork*

This may be used in conjunction with the piston alignment fixture for lining up pistons. The slot is slipped over the arm of the connecting-rod and the leverage is sufficient to bend the rod any desired amount.

#### *Oil Reservoir Drain Plug Wrench*

This wrench is made of ordinary stock of cold-rolled square steel and is used to remove oil reservoir drain plugs.

#### *Valve Lifter*

This lifter is forged out of machine steel. It is equipped with a slip ring so that, if necessary, the valve spring may be held in a compressed position.

It may be used in practically any motor with valves on its side.

#### *Cylinder-Plate and Generator-Screw Driver*

A powerful driver has many uses in any repair shop. The one illustrated is designed particularly for use on valve covers and generator-field coils, but may be put to a number of other uses where good leverage is required.

#### *Radiator Outlet Hose Clamp*

This simple tool greatly assists in getting the hose line started back onto the water pump when installing a demountable radiator.

#### *Carburetor Packing Nut Wrench*

Gasoline mileage is often reduced because of leakage around the feed regu-

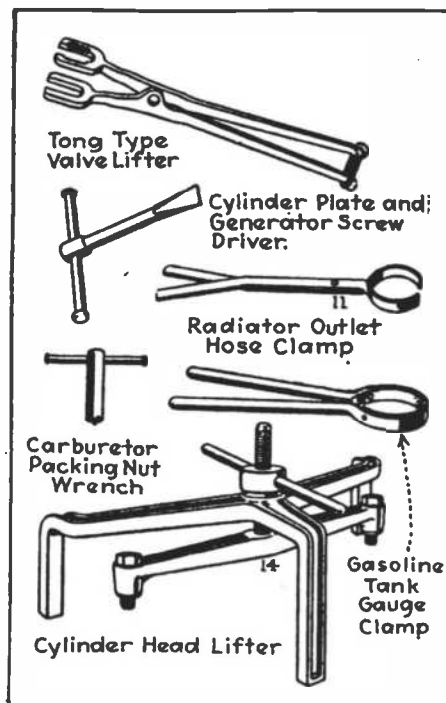

*Tools that make hard jobs easier*

lator of a carburetor. Tightening the gland forces the packing closer around the adjusting sleeve and prevents leaks. This wrench is made for that purpose.

#### *Gasoline-Tank Gauge Clamp Wrench*

Tank gasoline gauges are often held in position by a knurled cap which is tightened securely in place at the factory. Such a tool as the one illustrated is required to remove it.

#### *Cylinder-Head Lifter*

In removing a cylinder head it is often the case that some of the studs bind. Necessary variation of manufacturing limits create this condition. The removal of the head may be greatly facilitated by the use of lifter such as the one illustrated.

#### *Piston Chuck*

After an internal combustion engine has run for a period of six months to a year, depending upon the amount of use it has received, the piston rings will wear the ring grooves in the piston, so that it is necessary to true the ring grooves, eliminate the shoulders formed at their base and to fit new piston rings to secure maximum engine power and to keep the engine from pumping oil. The ordinary method of doing this by taking the piston off of the connecting rod and chucking it in a lathe, is of course, a practical method but one that requires considerable time, as the piston must be removed from the rods before they are placed in the chuck and afterwards re-assembled when the job is completed.

The new piston chuck illustrated makes it necessary to remove the wrist pin and connecting rod from the piston, as it may be chucked in the special fitting with these parts in place. Another advantage is that trouble from cracking the piston, as some times occurs when the ordinary form of lathe chuck is used, is prevented. The construction of this device and the method of using it can be readily ascertained by referring to the clear illustration herewith.

The desirability of having repair work done only in shops where time-saving fixtures are used must be apparent, as the experienced motorist realizes that he is not paying for wasted time when special tools are employed on his work. It may take a certain class of repairman several hours to drive a gear from a shaft, often with serious consequences to both members. The real mechanic uses a special gear puller that accomplishes the work in one-quarter the time and without danger of damaging the parts.

The manufacture of brass in Germany was first introduced in 1550 by Erasmus Ebener, an artist of Nurnberg, who prepared it by fusing copper with the so-called tutia formacem, or furnace cadmia. First made in England in 1781 by James Emerson according to one authority, but according to another it is stated that Queen Elizabeth granted a patent to William Humphrey to search and mine for calamine for making all sorts of battery wares, cast works and wire of latten, in 1565.

Babbitt metal is named for Isaac Babbitt, who was the first to use a soft metal alloy in bearings. He patented the use of soft metals in bearings in 1839, and claimed no particular mixture, but recommended one of 50 parts of tin, 5 parts of antimony, and 1 part of copper. This mixture is somewhat softer than is now used.

# Burning Pulverized Fuel

ONE of the claims made for the Diesel engine was that it would be run by dust, the dust being finely pulverized fuel. Within the last few years dust explosions in flour mills have occurred. The fine dust and flour produced in the mills mixing with the air would form an explosive mixture, and if ignited by any chance would blow the building to pieces. Pulverization of materials in technology has greatly developed in recent times. It is done on an enormous scale in the Portland cement industry and the engineer no longer regards the reduction of an

coal respectively. Many experiments have been made in the utilizing of the pulverized coal and the results have been gradually getting better and better and now it seems as if a good measure of success has been attained. The great point is to have the coal reduced to a dust and to have it dry. The illustration shows its use in an upright boiler.

The coal from the bunker descends to a combined pulverizer and blower. This reduces most of the coal to dust and the draft of air rises from it into a dust separating chamber. In this chamber all the coal over a certain size

water-tubes first, through an economizer where much of the residual heat is imparted to the steam in the steam chamber at the top of the boiler, and the hot exhaust goes on its way to the stack, passing through a tubular air heater immediately below the stack. This hot air is what supplies the combined pulverizer and blower with air.

At the bottom of the boiler there is a superheater and on the left of the boiler the steam pipe will be seen leading into the superheater at its top. The superheated steam leaves the superheater at its base on the right of the boiler as shown in the cut. When we remember the enormous heaps of culm, which hitherto were supposed to be valueless but can be cheaply pulverized and purified so as to give an excellent fuel in dust form, the importance of this development will be recognized by all. It is not only in boiler practice that such fuel has been used, but in metallurgical furnaces its use has been quite successful and it marks an important step in advanced engineering.

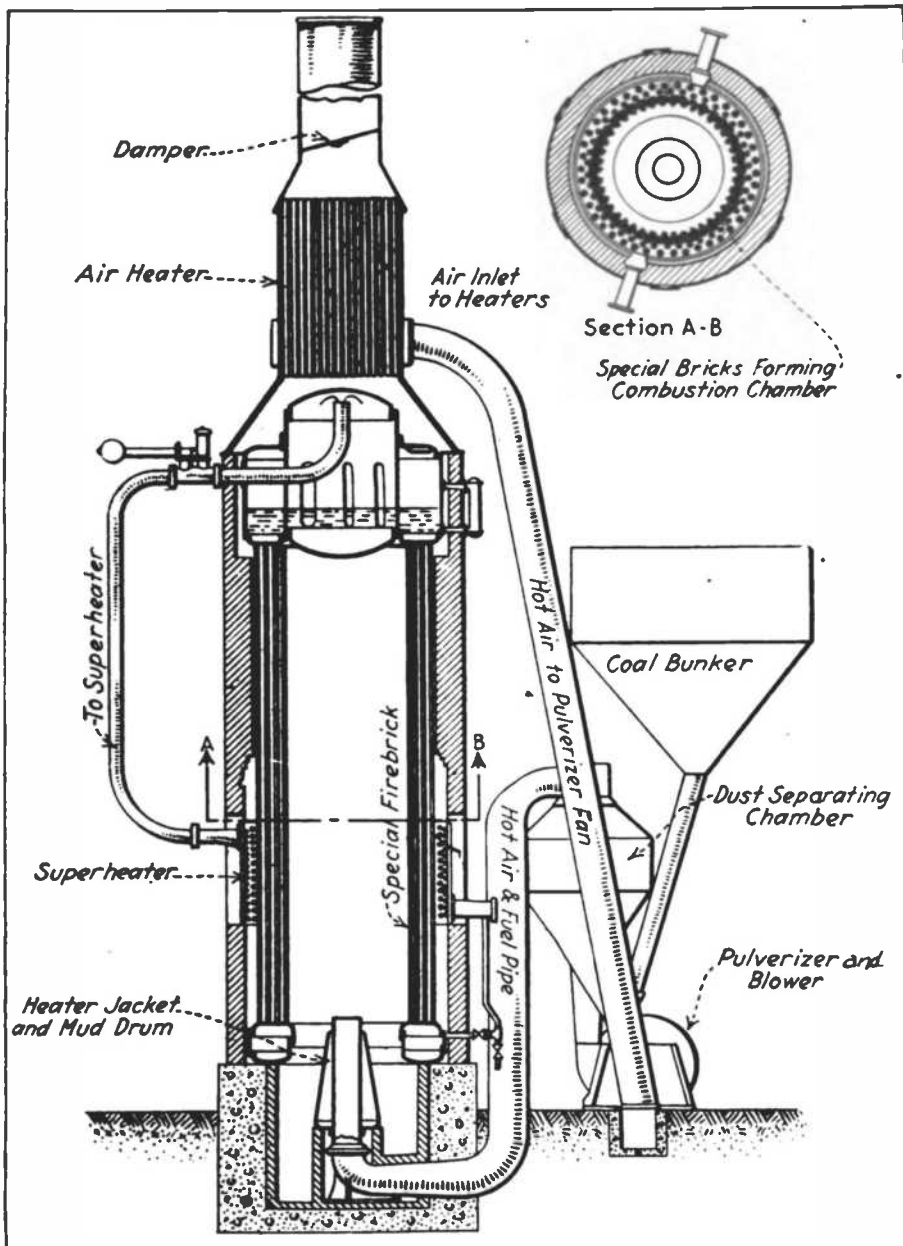

Boiler and accessories for burning pulverized fuel

ore or other substances to a fine product as difficult. The flotation process used for concentrating ores involving the use of a mixture of oil and water, and the purely mechanical flotation process for purifying coal involve the previous pulverization of the ores or

is caught and falls back into the pulverizer to be again ground up. The dust goes on with the blast and enters the bottom of the furnace, where as it issues from the nozzle it may be considered as virtually a Bunsen burner flame. The flames pass up between the

## OUTLINE DRAWINGS ON GLASS SLIDES

THE stereopticon is now so largely used at technical and popular lectures that a simple method of making line drawing slides to exhibit various forms of mechanism and present tubular matter may be of interest. All that are needed are some ground glass squares of the required size, these being ground on one side only; a drawing is made with a hard lead pencil on the ground surface and when the outline is finished properly, a coat of varnish is spread over the ground surface, which at once converts it into a clear glass with a fixed drawing upon it.

## CADMIUM-LEAD SOLDER

Laboratory tests, together with manufacturing experience, point to a composition of 80 per cent lead, 10 per cent tin and 10 per cent cadmium as being practical for many of the purposes for which solder is required. This solder has been tried in the manufacture of tin cans, on roofing materials and for electrical joints with encouraging results in all cases. A test has also been made of it in the manufacture of automobile radiators with most satisfactory results.

The tensile strength of the cadmium solder is about the same as that of 40-60 solder, but the ductility is approximately twice that of the ordinary solders. The point of complete liquation is only slightly less than that of solders of the ordinary composition, while the range of solidification is considerably greater. Because of the predominance of lead in the cadmium solder, the price of it is relatively low.—*Metallurgical and Chemical Engineering.*

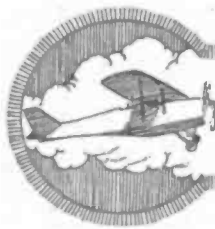

# AVIATION BRIEFS

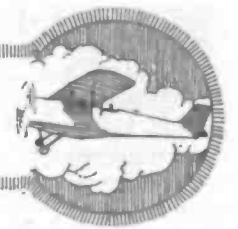

## LONDON AND PARIS AERIAL PASSENGER SERVICE

**T**HE progress of commercial aviation is more evident in Europe than it is in America because the Europeans were more familiar with work done by aircraft in the late war than we are here and there is greater interest in aviation on the part of the public.



*Luxuriously appointed interior of Vickers-Vimy airplane cabin*

People who were used to seeing enemy aircraft over their cities as was the case in London and Paris, really recognize the fact that this method of transportation is a practical one and that it enables one to cover long distances in much less time than any other known means. A well-known concern of London has recently instituted a new Aerial Passenger Service between London and Paris by purchasing a

number of large Vickers-Vimy airplanes as illustrated, to start the service with. These planes provide accommodations for eleven passengers in a palatial and comfortable cabin and also have a carrying space capable of carrying a half ton of baggage or other express matter. The details of the airplane are clearly shown and the in-

terior of the cabin and the way it is fitted up can be readily ascertained from the clear photographs.

## THE "MOSQUITO" AND "SPORT" FARMAN AIRPLANES

**I**N a recent issue we mentioned briefly the small Farman monoplane called the "Mosquito." We have received further advices and are now able to complete the specification of the little plane

and are also giving the particulars of the other French sport machine built by H. & M. Farman and designated the "Sport Farman."

Specifications of the "Mosquito":

Span, 5 meters (15.4 feet).

Speed, 110 kilometers (68.3 miles).

Useful load, 130 kilograms (286.1 lbs.)

Weight (machine empty), 240 kilograms (528.5 lbs.).

Engine, 30 h.p., A. B. C.

The sport Farman is a biplane and is said to be one of the most practical and handiest small planes ever built for the man who wants to fly safely, economically and regularly.

The specifications are:

Span, 7 meters (21.9 feet).

Length, 6 meters (18.2 feet).

Maximum speed, 130-140 kilometers an hour (80-87 miles).

Motor, Rhone 40 h.p.

Useful load, 200 kilograms (440 lbs.).

Weight (empty), 400 kilograms (881 lbs.).

Landing speed, 60 kilometers (37 miles).

Chord, 1.5 meter (4.8 feet).

Total area, 20 square meters (215 sq. ft.)

It can be seen from the illustrations herewith that it is the product of engineers and practical flyers who have flown, studied aerodynamics, and built airplanes ever since the early days of aviation. The "Sport Farman" is as practical in its field and serviceable as any motor-cycle or car. The little biplane is primarily a "bus" that will fly not only in the hands of a few experts but of anyone who can fly and land an ordinary training plane. It will, however, do many things the training

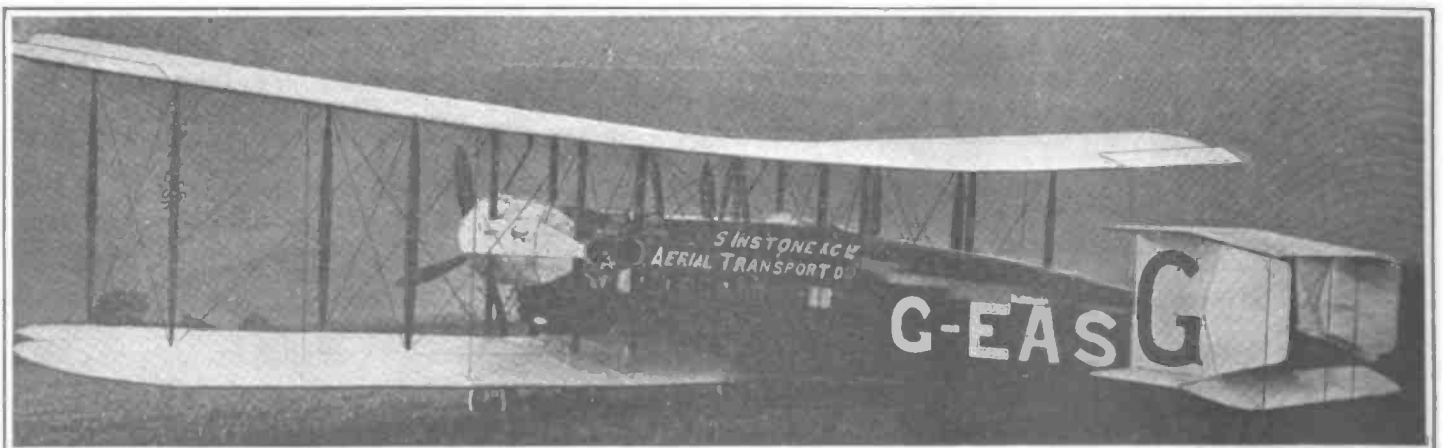

*Type of airplane used in London and Paris aerial passenger service. This is a Vickers-Vimy model*



planes cannot do; for instance, it will land in and get out of fields impossible for any airplane that lands at speeds of over 60 kilometers per hour (37 miles). It burns much less gas than the average plane; as the actual cost of gasoline to fly a kilometer is 13 centimes, or about 2 3/5 cents. It does not

for the wheel landing gear and the provision of out-board wing supporting floats, but it is the same in general construction as the Curtiss Wasp, which established altitude records until these were broken by Major Schroeder of the Army Air Service. The former record of a seaplane was 126 miles

COMMERCIAL TRANSPORT IN CHINA

AN air mail service has just been inaugurated between Peking and Tientsin with Handley-Page biplanes and in the initial flight mails and passengers were carried, one of the latter being Mr. B. F. Alston, the British Minister to China. The Macao Aerial Transport Co. is shortly starting a flying-boat service between Hong-Kong, Macao and Canton, and via Swatow, Amoy and Foochow to Shanghai. Curtiss H-16 type flying-boats fitted with two 330 h.p. naval type low-compression Liberty engines will be used. Beyond the fact that permission has to be obtained from the Rebel Government in Canton the service seems to be in a fair way towards success. The Hong-Kong Government seems to be typically conservative in its views, and in one case it took three weeks to get permission for one machine to fly at Hong-Kong, and then it had to be towed outside the three-mile limit.

The little Henri Potez biplane, type VIII, which was exhibited at the last Paris Aero Show and which was remarkable for the 50-h.p. Potez air-cooled engines, set with the crankshaft at right angles to the line of flight and a four-wheeled undercarriage, has been flown at Le Bourget, France, by M. Douchet. Seven flights were made, the results of which gave every satisfaction, the machine, on landing, pulling up after a run of about ten meters.

At the formal meeting of the Pan-American Aeronautical Congress at At-

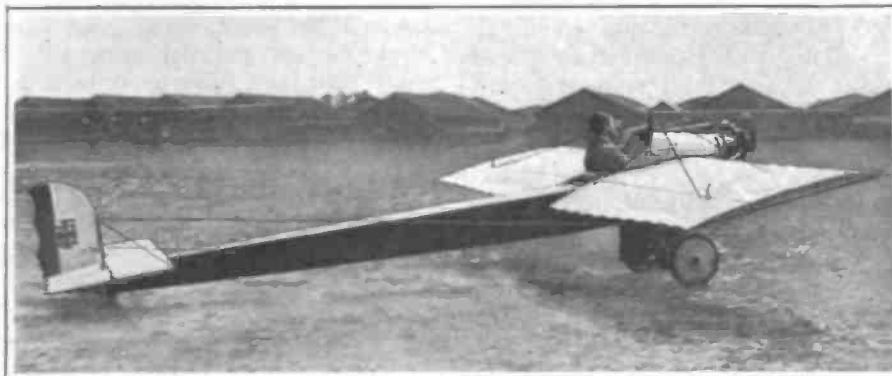

Two popular Farman airplanes. The "Sport" model is shown in upper view and the "Mosquito" below it

require a large crew of trained and high-salaried mechanics. The owner of a "Sport Farman" can line it up, operate it, and keep it in commission himself. The price of this machine is 13,000 francs or about \$2,600 at normal exchange.

Many people have been awaiting the small airplane of low horsepower, which shall be economical to operate and maintain. These enthusiasts have found the call of the air irresistible; they will fly this year and henceforth, just as in past seasons they played polo or tennis or rode to hounds or owned motor-boats and racing cars. And it is a most encouraging sign for the future of Aviation!—E. H. Lémonon, Paris.

FAST HYDRO-AEROPLANE

THE accompanying illustration is that of the Curtiss Wasp, which was recently piloted by Roland Rohlfs and which established a new world's record for seaplanes in recent Navy trials held at Rockaway, Long Island, by travelling at the rate of 138 miles per hour in its test flights. The machine is the usual triplane construction with the exception of the substitution of a float



Record-breaking hydro-aeroplane of Curtiss design owned by U. S. Navy

per hour, so it will be apparent that this triplane design is not only very efficient but that it gives promise of great speed because of the clean-cut fuselage which is stream-lined to the point where it offers a minimum of resistance.

During the period September 2, 1919, to May 15, 1920, the Handley-Page Continental Service (in conjunction with Cie. Messageries Aériennes) carried 1,413 passengers, 79,317 lbs. of freight and traveled 104,297 miles.

lantic City on May 20th, a statement made by Mr. Burleson, the U. S. Postmaster-General, was read. It was claimed that the air mail service had proved itself economical both as regards cost and time. In the first year of its working 193,000 lbs. of letters were carried, while in the year which ended on May 20, 538,734 lbs. were carried.

As a protest against lack of Government interest in domestic airplane production the Curtiss interests have closed their Buffalo plant.



# MANUAL ARTS AND CRAFTS

PROJECTS FOR THE SCHOOL, HOME OR SHOP



**COMBINATION HALL TREE PROJECT No. 5** is a very easily made and convenient Hall Tree, a combination of hat and coat rack, umbrella and cane stand and electric lamp. It exemplifies the simplest form of construction of slats and blocking. Omitting the lamp and umbrella features, it is very useful as a costumer. It can be modified to suit most any material and has been built by the ungraded class in our elementary department. This form of construction we also use in smaller models, that will be submitted in subsequent issues. It is very popular with the graduating classes in the elementary schools. Sewing basket stands, smoking sets and tabourets are made of this construction.

It is customary to proceed in the order as arranged in the bill of materials, however, this and the dimensions may be varied to suit one's convenience. The slats A are selected for figure or grains, they should be 2 to 3 inches wide, by approximately six feet in

length. Chestnut, cypress, redwood, white wood and most of the hard woods make excellent material for these projects. Their width is  $\frac{1}{4}$  to  $\frac{1}{2}$  inch less than the block E.

The spreader rails B should be of the same material but may be anything as they are very little in evidence. They should be the same width as the slats. They may be omitted if a smaller project is made by substituting a drop pan shelf D of sufficient dimensions. They may be half lapped as shown at B or one member may act as a cleat across the grain of the shelf D, butt joining the component pieces to the cleat. The ends are beveled to suit the slats. This is easily marked by spreading the slats to their respective positions and holding the spreaders in position to scribe the line where they meet. It is fastened in place by four  $1\frac{1}{2}$  inch No. 12 blued round-head wood screws.

The umbrella ring C may be made in two semi-circular pieces, and then glued, as shown, or may be made as

shown in the alternative piece. The holes in this last-mentioned part must be 2 inches or larger and may be bored with an expansive bit. For appearance sake they are made with a fret-turning or keyhole saw, larger than necessary. It is secured in position just the same as C.

The fixture block E may be any convenient material with the corners slightly chamfered, the ends are cut pyramid shape, but left at least  $\frac{1}{2}$  inch square on top and bottom to allow for the  $\frac{3}{8}$ -inch hole that is bored with an auger bit. Carefully locate the center on each end, bore one-half way through the piece, using great care to hold the bit parallel with all four faces then bore from opposite end. It is not absolutely essential that the holes meet accurately, but it is excellent practice and it will insure that the fixture will set plumb if the  $\frac{1}{8}$ -inch pipe nipple that is driven in the hole is true. The extension wire is threaded through this hole and nipple, then fastened to the socket. Anyone selling these fix-

**COMBINATION HALL TREE**  
**ELECTRIC LAMP, HAT, COAT, CANE, UMBRELLA RACK**  
 Designed For The Amateur By C.E. MULLER, M.A.P.  
 MANUAL TRAINING INSTRUCTOR, P.S. 5, MAN. NYC.

**BILL OF MATERIALS**

A	4	SLATS	2 1/2	60	CHESTNUT OR WHITE WOOD
B	2	SPREADER RAILS	22	22	
C	2	UMBRELLA RING	8	11	
D	1	DRIP SHELF	14	14	
E	1	FIXTURE BLOCK	2 1/2	14	
F	4	HOOKS	See Sketch		
G	1	BRASS PIPE NIPPLE	3" TO 4" LONG		
H	1	ELECT. BULB			
J	1	" " SOCKET	a 1 1/2 NO. 12 R.H.W.S.		
K	1	SHADE & FRAME	b 2 1/2 NO. 10 " " "		
L	1	RUBBER DRIP MAT	c 1 1/2 NO. 14 F.H.W.S.		

ALL DIMENSIONS ARE EXPRESSED IN INCHES

tures should be able to give the proper instructions for this installation. The wire frame K is made of any convenient flat 1/16 x 1/2 or 3/16-inch round wire, the ends are clamped between the block E and the slats.

Assemble A to E, fasten each slat with three 1 1/2-inch No. 12 blued, round-head wood screws then spring out the slats to fasten D in position, slide C into place. This location is determined by the natural bend of the material. The graceful curve of the slats must be maintained by adjusting the position of C until it does not distort this curve.

The clothes hooks may be purchased

**MISSION STYLE HALL SEAT**

**PROJECT No. 6** is a mission style settee designed for the front hall or porch. The rails may be mortised or dowelled with 3/8-inch dowel pins to the posts. If mortised add 2 inches to the lengths of D, E, F, G, H and J. If mortises are used allow 1/4 inch to 3/8 inch for each shoulder in the width and 1/8 inch on each side for the thickness, thus a tenon for a 3/4 x 3-inch rail would be 1/2 x 2 1/4 inches to 2 1/2 inches wide by 1 inch long. If dowels are used their centers would be 1/2 inch — 1 1/2 inches and 2 1/2 inches from the edge of a 3-inch rail. A 2-inch rail would only have two 3/8-inch dowels whose centers would be 3/8 inch from

used, stop chamfers will add to the effect. Stop chamfers may also be used on all corners and if carefully done always repay for the extra amount of work. Learn to gauge these chamfers with a pencil held in the hand using the nail of the second finger as a guide. Always slide the finger away from the body, this will avoid running slivers into the finger tips. The secret of stop chamfering is to have them uniform, small rather than large (approx. 45 degrees), and allow sufficient margin at the ends, remembering you can always take more off, if desired, but all your regrets will never add to that which is taken off if too much wood is removed.

**HALL SEAT WITH LEATHER SEAT**  
SCALE IN INCHES  
Designed By C.E. MULLER MAC  
MANUAL TRAINING INSTRUCTOR NYC  
NO ALL DIMENSIONS IN INCHES EXCEPT AS NOTED

BILL OF MATERIAL				
4	POSTS	1 1/2	X 1 1/2	X 2'-6" A
1	SEAT	1 1/2	X 14 1/2	X 2'-8 1/2" B
2	BOTTOM	1 1/2	X 14 1/2	X 2'-10 1/2" C
2	RAILS	1 1/2	X 2	X 2'-8 1/2" D
2	RAILS	1 1/2	X 2	X 12 1/2" E
2	RAILS	1 1/2	X 3	X 2'-8 1/2" F
2	RAILS	1 1/2	X 3	X 2'-10 1/2" G
2	RAILS	1 1/2	X 3	X 12 1/2" H
4	SLATS	1 1/2	X 5	X 9 1/2" I
7	SLATS	1 1/2	X 2 1/2	X 9 1/2" J
8	CLEATS	1 1/2	X 1	X 2" K

*Note: See Note on page 338 for details on mortising and tenoning.*

*ADD 2 INCHES TO THE LENGTHS OF P, E, F, G, H, J FOR TENONS*

in great variety. Brass hooks with porcelain tips may be purchased at 15 cents each. They are decorated with considerable engraving and contrast very strikingly with a dark-stained wood. The hooks may be made of ash, oak, maple or even white wood if the grain is parallel to the pins; that is, the straight cut would be 60 degrees to the fibers. They are fastened by two 2 1/2-inch No. 10 blued, round-head wood screws, as indicated at B. Stain and varnish as per directions for projects in the May and June issues of EVERYDAY ENGINEERING MAGAZINE.

each edge in width. In the rails marked G four dowels in each end would suffice for two tenons 2 inches wide, 1 inch from the edge would be sufficient. The rails marked D and E may be omitted if desired, the rails G and J would suffice.

The slats K or L are housed into the rails 1/2 inch deep at each end their full thickness. The slats K may be made in two pieces, which will avoid the necessity of fret sawing, the design may be varied to suit one's fancy. A method described in the previous issue of a series of holes and saw cuts may be used. If the slats outlined at L are

The posts A are laid out to the figures as shown in the front view. The mortises are cut to dimensions given in the paragraph on tenons. The mortises when made by hand are always cut first, the tenons always pared to fit the mortises. All parts should be assembled and fitted together temporarily to be sure that everything is correct before gluing.

Assemble and glue the K or L slats to the back rails F and B B, then add the rear posts to these rails, inserting G and D. Be sure to square the posts with the rails. Let this remain in the clamps until the glue sets from three

to twelve hours according to the glue used and the weather conditions. Now proceed with the front, glue G and D rails to the front posts. After the glue is set the front section is glued to the rear section.

The bottom is then fitted in and 8 cleat blocks are glued in the corners as indicated at M. The blocks may also be fastened in with flat head wood screws, especially if the furniture is to be used in damp climates. The seat is then hinged with three  $1\frac{1}{2}$ " x  $1\frac{1}{2}$ " brass butts as indicated in the perspective. A leather seat may be added to this following the suggestions for the mission chair in the June edition. Sofa pillows could be substituted for the leather seat and would add a cosy and artistic touch. This seat is hinged to permit the interior to be used as a receptacle for rubbers, etc. It should be stained and varnished or painted to correspond with the general color scheme of its surroundings.

### PHOTOGRAPH PROJECTOR MADE FROM A CAMERA

By L. B. Robbins

**T**HOSE who take Kodak pictures must have a camera to do it with and that same camera, if of the focusing type, can be used to project the prints to greatly enlarged proportions upon a white screen, exactly as a magic lantern operates. The construction of such a projector is simple and inexpensive and will afford hours of amusement for the builder and friends after vacation is over and the negatives all printed. Mounted or unmounted prints can be used as well as postcards or magazine clippings and small objects.

No definite dimensions are given because of the many sizes of cameras that are used. But by referring to the sketches, some idea of the proportions of the projector can be gained and one built accordingly to fit your own camera. Allowance is made in this device for altering the distances between picture and light and light and lens so that focusing can be regulated to suit the various sized pictures used. The box must be considerably larger than the camera and all joints well closed to prevent escape of light and the entire inside painted a dull black. This can be accomplished by mixing lamp-black, turpentine and dryer to a thin consistency.

We will suppose that the box has been chosen or built and you are ready to fit it up to accommodate the camera. It is arranged so the top will be wider than the height as the majority of views are taken the horizontal way of the film.

First, cut a hole in the front of the box somewhat larger than the camera

lens through which the image can be projected. Cut it circular and in the center of the end. Now measure the length of the camera from the end of the drop to the back and mark a distance about 1 in. longer than that from the lens hole in the box. This is the location of the first of a series of wooden uprights nailed to each side of the box, inside, and exactly opposite each other so to form runs 1 in. wide. Three or four cleats each side will give sufficient number of runs for focusing the camera from the light. Be sure the cleats are nailed in perpendicular and in true relation with each other so that the runs are even and will hold the camera partition vertical and at right angles to the sides of the box. Make them of  $\frac{1}{2}$  in. thick wood 1 in. wide.

The camera partition is made of a single piece of soft wood just a trifle thinner than the distance between the cleats just mentioned and the same outside dimensions as the inside of the box. This must be made so it will fit closely in the runs and keep any light from being admitted to the front section of the box. Remove the back of the camera and measure the opening over which the film passes and cut an opening the same size in the center of the camera partition. Then nail a strip of wood the thickness of the camera body beneath the opening to set the camera on and one upright each side of the opening which will just accommodate the camera between them horizontally. To each of the uprights fasten two spring buttons of brass. These will serve to hold the camera in position close to the partition and can be released at will. A gasket of felt between the back of the camera and the edge of the opening will help to exclude light at this joint.

Next comes the lamp base, made to slide between the last upright cleat and the back of the box. This is made of a single piece of board somewhat narrower than the aforementioned space and nearly as long as the inside width of the box. A horizontal cleat nailed to each side of the box will act as a guide to hold the base in position. Place a light spiral spring near each end of the base, between it and the end of box and a large screw-eye down through the center of the base which will engage with the bottom of the box when screwed down far enough. The springs will always tend to keep the base against the upright cleats but it can be pressed back if desired and held in position by means of the screw-eye sticking into the bottom of box.

Mount a 60-watt electric bulb near each end of the base around which are placed curved tin reflectors as shown. Care must be taken to arrange the reflectors so that no light is allowed to shine directly from the bulbs into the opening in the camera partition. Care

should be taken to direct all rays possible to the back of the box, which can only be done by experiment. When the proper position of the reflectors is reached, fasten them to the base with tacks through several little lugs cut in the bottom edge. Wire the bulbs in parallel and connect to a regulation lamp cord which passes out through a small hole in the back of the box.

Now cut a rectangular hole in the back of the box slightly larger than the camera partition opening and place small overlapping battens completely around it on the inside. Fit in a snug fitting door hinged along the bottom. Small runs of tin, to accommodate the prints and pictures are tacked vertically to the inside of this door as shown in detail. Place a knob outside the door for opening and closing. Be sure and make a snug fit to exclude all light.

To allow the operator to make adjustments, arrange the entire top of the box to swing up. This can be done by hinging it at the front edge and hooking it at the rear when down in position. Then by swinging it up, the camera partition can be changed into different runs as needed and the position of the lights altered. The perspective sketch shows how the projector looks when assembled. As before stated, it is normally arranged to project pictures with the long way horizontal. To project one taken vertically, simply place it in position and tip the projector over on its side.

The distance for prints from the holder to the opening in camera partition is from 3 to 5 ins., depending on their size. This can be altered by moving the partition back or forward in the runs and the distance of the lights can be changed at the same time. Then the focusing of the image upon the screen is done with the rack and pinion regulating the lens of camera. Once set for one size of print it will not have to be changed. To operate, first set the print in the slides, shut the door and turn on lights. Then focus as directed. If the lights shine directly upon print it will be seen in all detail upon the screen greatly enlarged. When door is opened to change prints much of the heat generated by the lights will escape. Set prints in holder upside down.

### TREATING CONCRETE

**E**XPERIMENTS continue with various methods for treating the surfaces of concrete floors, principally with a view to preventing excessive dusting. Chemical hardeners appear to be the most efficient. Such compounds as magnesium fluosilicate, sodium silicate, and zinc sulfate, give fairly satisfactory results. Aluminum sulfate treatment has given a floor which, after nine months, still remains in satisfactory condition.



### PHOTOGRAPH PROJECTOR MADE FROM CAMERA L.B. Robbins

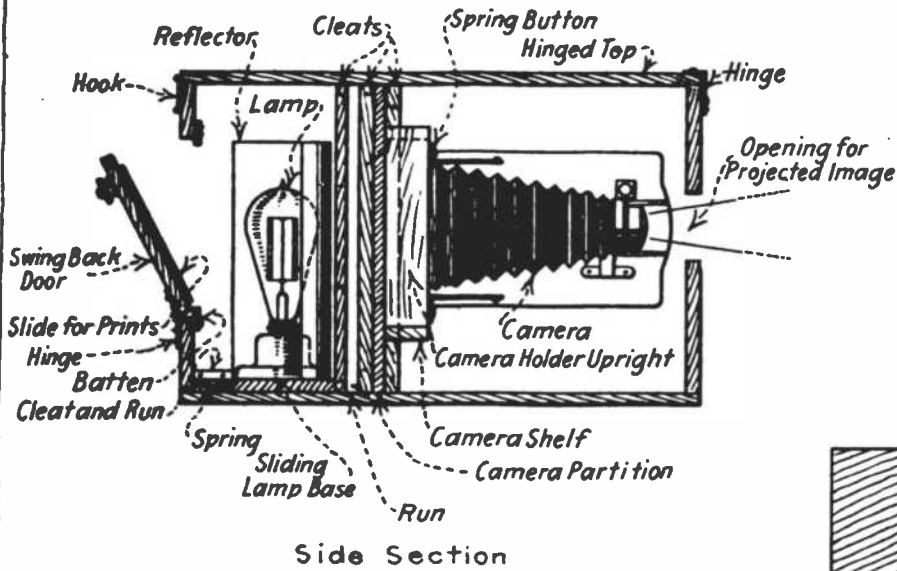

Side Section

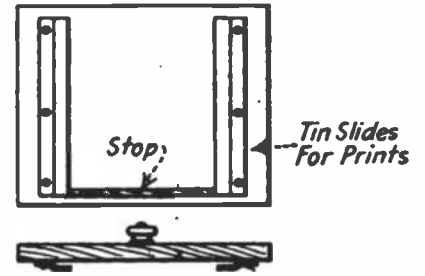

Detail of Swing Back Door

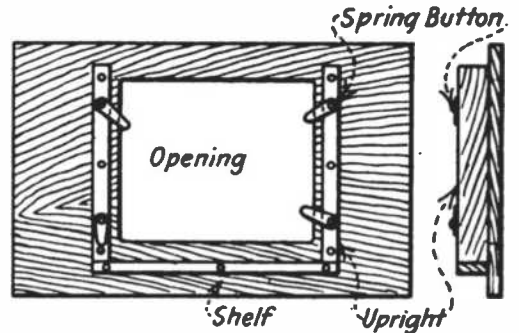

Detail of Camera Partition

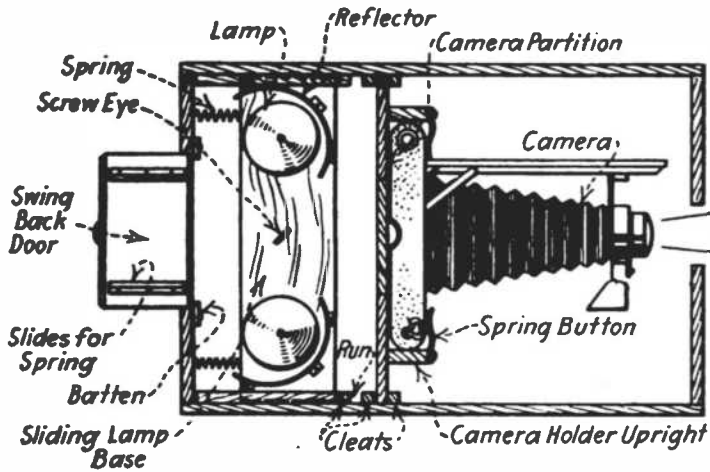

Top Section



Detail of Spring Button

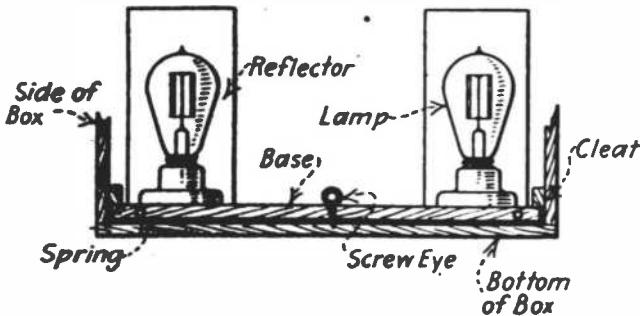

Detail of Sliding Base

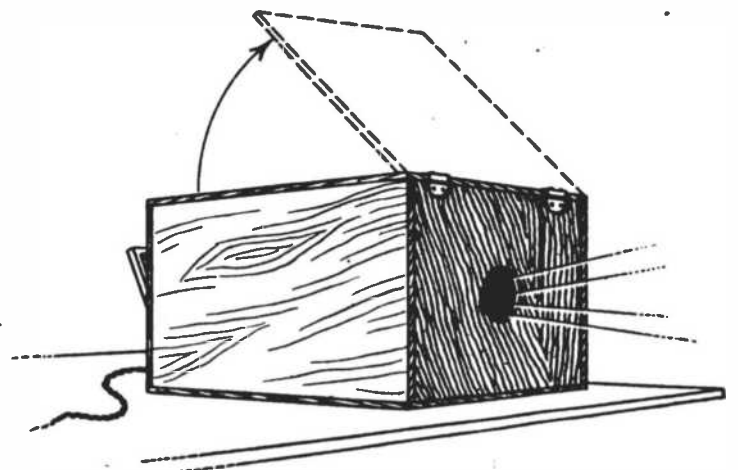

General Perspective

# EVERYDAY SCIENCE NOTES

BY PROF. T. O'CONOR SLOANE

## ROTATING ELECTRIC FURNACE

THE electric furnace, which is shown in the cut, is of the tipping class; the pivot on which it turns in the tipping process is seen at the front corner of the base-plate. At the rear of the furnace is the tipping mechanism of standard type. At the rear end, M, the body is carried by a pivot in the axial line. In front the neck of the furnace rests on a saddle with rollers, K. The outlet, D, is provided with a cover, F, to prevent loss of charge in the rotating of the furnace. From time to time, as may

Germany, during the war, had extensive experience in substitutions. They formerly used one-quarter of the world's copper and a large proportion of the aluminum. As far as possible copper was replaced by steel. Aluminum was replaced by zinc and it is said that motors even were wound with it. Iron was galvanized by exposure to vaporized zinc. This produces no perceptible increase in thickness so that it can be used for screws without danger of filling the thread. Cadmium was a substitute for tin in solder. Ferrosilicon was used for heavy resistance work, especially in electric cookers and to replace nickel.

The tarry residue from the distillation of petroleum as a fuel possesses a higher calorific value than that of coal; one part of the residue is equal to nearly twice its weight of the solid fuel. It presents difficulties in utilization as a fuel as it is liable to burn out the fire box of a boiler; this trouble is overcome to some extent by the use of brick lining. The fire brick get hot and this in itself is a good feature, as tending to maintain the combustion, while also protecting the shell of the furnace. Enough air must be supplied to prevent the formation of smoke and also to prevent the deposition of coke upon the nozzle of the burner. There is also some liability to corrosive action on the tubes and flues of a boiler in which it is used.

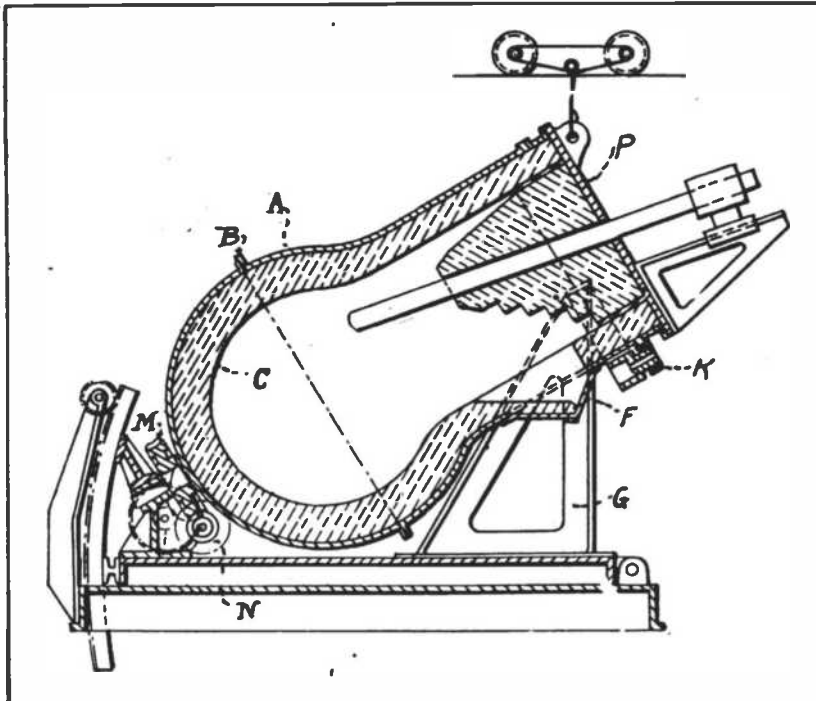

Rotating electric furnace

appear desirable, the furnace is rotated about its axis. This rotation is effected by the helical gear, M, and N, the front support, which is the saddle already mentioned on the top of the standard, G, holding the neck of the furnace in position during the turning. The effect of the turning is to protect the lining to some extent by preventing injurious localization of heat. Economy is also supposed to be produced by the absorption of the heat of the lining by the charge as it comes in contact with the hot lining in all parts of the interior.

Volcanoes in the island of Java have a very destructive form of eruption called "lahars." In periods of inaction the crater fills with water, forming a lake; when the volcano starts into activity, the first effect is to heat the water to the boiling point; the hot water then overflows the crater wall, making crevices in its sides, and, carrying mud and rocks with it, destroys life and everything it encounters. In one instance the crater was a lake containing some fifty millions of cubic yards of water. The eruption came, the hot water cut an outlet for itself in the side of the crater, poured down the mountain and killed fifty thousand people, devastating a region fifteen by twenty miles in area.

In electric apparatus cotton was replaced by paper, and artificial cellulose silk for the natural product. Enamel was used as an insulator. Bakelized paper was used for mica. Resinous gums were found in the great forests on the Baltic and elsewhere. To economize in the use of India rubber impregnated paper was employed and mixtures of mineral substances with sulphur and other substances took the place of hard rubber. The above, of course, is only a very small proportion of the substitutions.

Chloropicrine, one of the poisonous gases used in the war, is cited as a good insecticide and rat killer. It is especially recommended for use on ships, on which the rats are apt to be most troublesome and difficult to get rid of.

The atmosphere has been found to follow one law near the surface of the earth and another at high elevation. On the surface of the earth the highest temperature is found at the equator and the coldest or lowest temperature at the equator. But at high altitudes the low temperatures are over the equator and the highest temperatures are over the polar regions.

Italy and France are both much exercised over the fuel situation; Italy is electrifying her railroads and after eight years' work on the problem will effect a saving of one and a half millions of tons per annum. The power stations are to be placed along the slopes of the Appennines and will utilize turf and lignite, for Italy has no coal mines. In France the utilization of what they call white, green and blue coal is actively debated. White coal is the water power derived from glaciers and snow-clad mountains, as the water streams down the mountain sides, the name suggesting its origin. Green coal is the power from rivers; extensive installations on the rivers of France are already planned for early attack by the engineers. Blue coal describes the utilization of tidal power. The rise of the tide in France is so great that it is particularly available, and the utilization of its rise by advanced constructions in the way of tidal mills will do much to help along the cause.

The best course for aircraft to take in strong wind to reach a given place in a shortest time has been investigated by a German scientist, who finds that the curved course is generally the best.

In the winter of 1915-1916 over 100 inches of snow fell in the inland regions of New England and only a little less on the coast. The conclusion has been reached that the old-time New England winters of exceptional severity were no more numerous than at present, while it is believed, however, that the famous winters of 1716-1717, 1786-1787 were worse than any of recent times.

The sensibility of the human eye to the most favorable conditions has been tried, and it is found that the light of a candle at 27 kilometers distance is the extreme limit of the optic range. The calculation is made that the human eye is affected by  $1.25 \times 10^9$  erg per second, which is one and one-quarter billionths of the energy unit.

The very ingenious suggestion for a scale of purity of chemicals and other materials has been proposed in Germany. One part of impurity in ten is to be called the first grade, one particle in a hundred is the second grade, one particle in 1,000 is the third grade, and so on, as far as desired. It will be seen that each grade gives the numerical value of the exponent of the power of ten expressing the impurity. The first grade is  $10^1$ , the second grade will be  $10^2$ , the third grade  $10^3$ , and the author feels that, when  $10^6$  or the one-millionth of impurity, constituting the sixth grade is reached, it is safe to stop.

### VISCOSITY METER

THIS instrument, for which very accurate results are claimed, is simplicity itself. A cup with a handle and a ball fitting the same are the essential elements. Three symmetrically placed projections, about one-thousandth of an inch high, prevent absolute contact of ball and cup. To use it the cup has some of the oil to be tested placed in it and the ball is placed in the cup. There must be enough oil to fill the channel surrounding the edge of the cup after the ball is in place. After five or ten seconds' application of firm pressure by the hand of the operator, the cup with the ball in it is inverted, and the time required for the ball to fall out is taken. The time required is directly proportional to the viscosity of the oil. The action of the in-

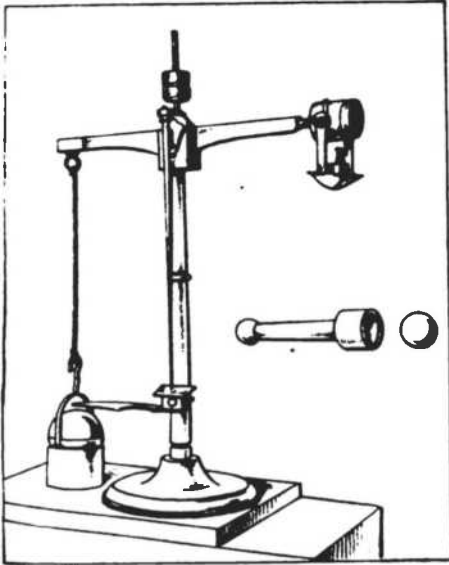

Viscosity meter

strument depends on the rate at which the oil film thickens, and the excess of oil in the channel ensures accurate action of this factor. Another way of using the instrument is to totally immerse the ball in a vessel of oil and to lower the cup over it, taking care to trap no air. After the same pressing for five or ten seconds, the time required for the ball to drop, when the cup is raised, is taken and gives the relative viscosity. For oils of low viscosity the balance arrangement shown in the cup is used. As just described the entire weight of the ball is the detaching force, but with the balance this force can be adjusted by weights in the pan, so that any desired fraction of the weight may come into action. One-tenth or one-twentieth or other fraction of the weight of the ball may be brought into action to detach it and break up the film. The viscosity figure is the quotient of the time in seconds divided by the constant of the instrument. The handle is insulated so that the heat of the hand will not affect the results.

To protect against mosquitos a French authority recommends cattle, who will monopolize the bites. Our readers will remember that footprints of cattle in wet ground, forming receptacles for water, have been recognized as an element in breeding mosquitos. The protection of fish who will eat larvae is recommended, and it is claimed that duck weed, a familiar water plant, will kill the larvae of the anopheles mosquito.

Currents of electricity passed through the earth from a generator or battery have been used with considerable success in investigating the geology of the ground. A fault has been thus detected in strata and stratifications have been followed out quite in detail and with considerable accuracy.

In England the methods of fixing the taxation of motor-cars has had a definite effect on the size and type of their engines, the object being to get power without incurring a heavy tax as a penalty. It is considered that a moderate speed engine is the lightest on account of its low inertia, the latter varying with the square of the speed. Taxing on a basis of the piston area has led to the adoption of small bore, long stroke engine cylinders, resulting in a heavy engine. The cars themselves are heavy and hard on the roads. In former times the ship duties used to have the effect of causing the shape of ships to be governed by considerations of avoiding the full extent of the tax, and it is said, that very bad models resulted from these efforts.

Ambidexterity is discussed in one of our contemporaries. Some years ago the novelist, Charles Reade, came out strongly in behalf of teaching children to use both hands indifferently. Our contemporary takes the ground that it is not advisable to take any special pains to teach it, as most ambidextrous work is not symmetrical, one hand having to do quite a different operation from the other. Rowing a boat is one exception where ambidexterity applies.

In the latest battle cruisers building in England it is hoped to get the weight of engine, boilers and water contents of the same down to 74 pounds per shaft horse-power. In destroyers, where every effort is made to reduce the weight, this figure has been reduced in some instances to 32 pounds. It is the use of the high speed engine and of the turbine, which, of course, is also a high-speed motor, that the weight has been so reduced.

Some of our photographic readers will be interested in trying the following printing process. A non-pigmented gelatine coated paper, such as a carbon double transfer process paper, is used. It is sensitized by a solution of one part of potassium bichromate in a hundred parts of water with a little over one-half part of copper sulphate (900 c.c. water; potassium bichromate 9 grams; copper sulphate 5 grams). The solution is applied with a sponge or brush. It is quite non-sensitive while wet. It is dried in the dark room and is printed until the half lights show. As long as it is dry, exposure to light must be carefully avoided. It is washed copiously until all the yellow disappears. By using a 1% solution of pyrogallol with 5 drops of acetic acid to the ounce, a sepia colored development can be obtained. Equal parts of pyrogallol and of pyrocatechine in 200 parts of water with 2 parts of tartaric acid and about  $\frac{1}{4}$  of the volume of a 10% solution of alum gives another color similar to that of everyday photographs. To get a purple tint a 1% solution of metaquinone or metol with half the quantity of gallic acid may be used.

An English concern is introducing rules graduated in what they call octaval notation for the fractions of an inch. An inverted degree mark separates the octaval notation on its right from the regular notation in inches on its left. The left hand or first figure of octaval notation indicates eighths, the next figure indicates 64ths, the next figure indicates 512ths and so on each figure indicating the next highest power of eighths as a dependent of a fraction. Thus,  $0.234$  would indicate  $\frac{2}{8} + \frac{3}{64} + \frac{4}{512}$  of an inch.

In Australia there is great trouble due to lack of standardization in the engineering world. There are eight different specifications for cement used by the railroad and public works. There are twenty different voltages at which electric power and light are supplied. It is considered that the starting of industrial manufacturing concerns in Australia is impeded by this course.

### GEAR WHEEL WITH REPLACEABLE RIM

THE cut shows very clearly the construction of this gear wheel whose rim on which the teeth are carried is made in two parts, each with a dovetailed rib around its inner periphery. This rib or projection slips into a corresponding groove on the periphery of the central portion of the wheel. The wheel

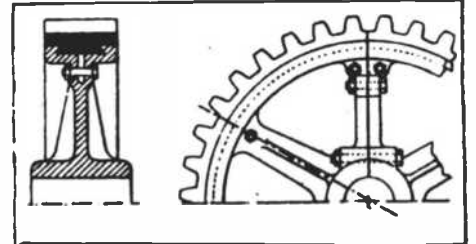

Gear wheel with replaceable rim

is also made in two halves. Thus the toothed sectors can be slid on and off, and are secured by transverse screws. This construction makes the replacing of broken teeth a simple matter. The broken or imperfect segment is taken off and a new one put on, without the necessity of making a new wheel or of sending the entire wheel off to the shop for repairs.

The rebuilding of the cities of France in the devastated region is receiving a great deal of attention and has created a new term for the study of methods of reconstruction of cities, "urbanism." The determination is not to neglect considerations of aestheticism, and the right angles of the streets of Philadelphia have been cited in France, as something to be avoided.

Bricks made from a mixture of finely ground and incinerated clay have been tried in France. The clay is treated to a heat of 925 to 1,200 deg. C., in a rotating furnace. The clay is wet down to slake any lime, which may be present, is dried and mixed with the cement. The mixture is wet down again, and made into bricks in a press, which are allowed to dry slowly.

In Alsace petroleum is produced to a not inconsiderable extent. As far as the explorations have gone it is concluded that fifty thousand tons a year can be produced for the next fifty years. Since 1813 some 2,500 wells have been sunk. It comes from depths of 100 to 700 yards. It is often impounded in subterranean galleries, and is pumped therefrom. It leaves the oil-bearing sands with some difficulty.

A famous meteorological station in British India records one of the heaviest annual rainfalls in the world—10.81 meters, about 33 feet per annum. But this is exceeded in the Sandwich Islands; there in one year a precipitation of 14.27 meters was recorded, only a little less than fifty feet. The greatest rainfall in one day was 81 centimeters, about 32 inches. A curious thing in the same place is that only ten miles may separate places of abnormally heavy and of so little precipitation. Thus one station reports an annual fall of over thirty feet of rain; ten miles distant another station reports about four and a half feet precipitation. In another instance stations four miles apart report annual falls of about thirty feet at one and less than five feet at the other.

The British Navy is the largest single user in the world of non-ferrous metals. They have been having endless trouble with corrosion of the condenser tubes. Of course in this case almost inevitably brass or copper comes in contact with iron or steel so as to establish a galvanic couple with the liability of rapid corrosion of the iron.



# RADIO

## TELEPHONE AND TELEGRAPH APPARATUS

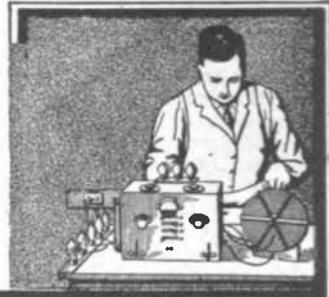

### Two-Step Audio Frequency Amplifier

*An amplifier, designed for maximum simplicity and minimum expense, for experimental work*

By M. B. Sleeper

**T**HE amplifier, to many experimenters, represents a more difficult problem than it really is, though there are important points which must not be overlooked. The two-step type, described in this article, was built in EVERYDAY's laboratory so that experimenters might see what can be done in the way of an efficient instrument, designed to fit the financial resources and the shop equipment of the average radio man.

Given the elements of an amplifier, the tubes and sockets, transformers,

forth over the set there is sure to be trouble from howling because of the feed-back effects which will occur between the grid and plate circuits. On some equipment, elaborate precautions are taken with grounded shields between the steps, but no trouble was experienced in this set.

The criticism may be made that biasing resistances, transformer condensers, and other details have been omitted. The answer is simply that this set worked as well as a manufactured amplifier which was equipped with those

that the clock-wise direction is used, in standard practice, for increasing whatever is controlled. No pointers were used as, for this purpose, they are not essential and only add to the work.

On the rear, as can be seen from Figs. 2 and 3, are the instruments which make up the completed amplifier.

#### TELEPHONE JACKS

Practically all amplifiers are equipped with telephone jacks instead of binding posts. They permit a quick

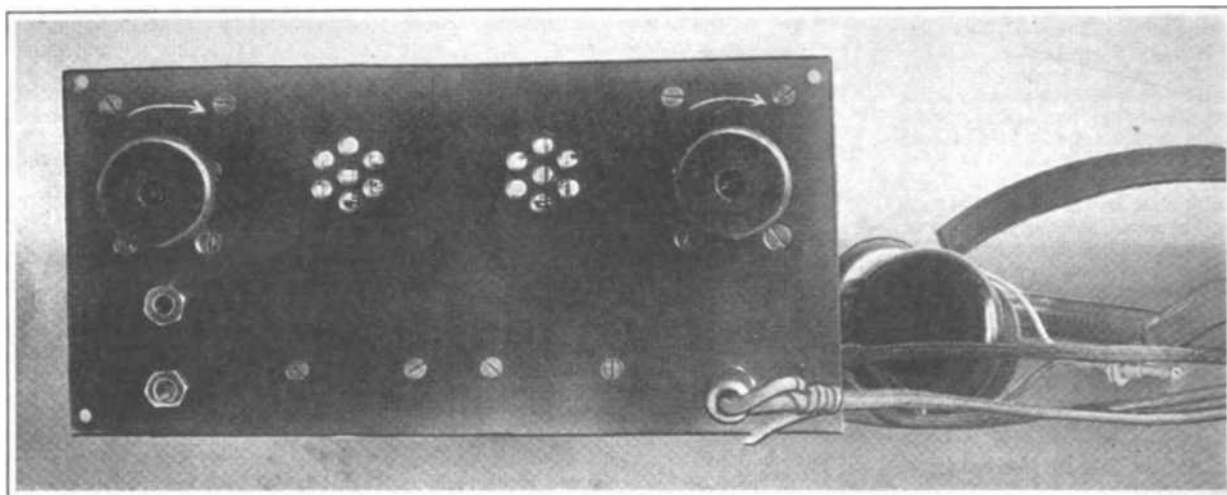

Fig. 1. On the front of the panel are the rheostat controls, jacks for detector, first step and second step of amplification, and observation windows for the filaments

rheostats, and jacks, there are almost as many ways of arranging them as there are constructors. In the drafting room, a designer must justify every part of his layout. If experimenters would put themselves to this test, making themselves show a reason for each step they take as they plan an instrument, they would be surprised in the improvement both in the appearance and results of their apparatus. The mere fact that a thing "fits" does not justify its place in the design.

Particularly in planning an amplifier, the circuit must be considered and given an equal weight with the other factors. If leads are run back and

things, and cost more than six times as much as it did to make this one.

#### GENERAL DESIGN

Fig. 1 shows the front of the panel, on which are the rheostats, jacks, and observation windows. The upper jack, of the double circuit type, allows the telephones to be inserted directly in the plate circuit of the detector. The lower jack, at the left, is for the first step, and the third, at the right, is for the second step. A bakelite panel, 5 by 10 by  $\frac{1}{8}$  in., was used for the panel.

Arrows above the rheostat handles indicate the direction of turning for increased resistance. It should be noted

change from one step to another, and can be used to change circuits which would otherwise require elaborate switches.

The jacks used for this set are of the Federal type. The detector jack is of the double circuit construction, as shown in Fig. 7. Both the first and second steps are closed circuit types, although it is better to use an open circuit jack for the second step. Then, though the filament of the second tube is lighted, no plate current will be consumed by that tube when only the first step is being used.

Because a  $\frac{1}{8}$ -in. panel was used, a little trouble was experienced in mount-



ing the jacks. This was overcome by making the holes in the panel only large enough to take the threaded portions of the front nuts, instead of the regular way with the hexagonal parts flush with the panel. This can be seen from the side views, Fig. 3.

**RHEOSTATS**

Half a dozen different kinds of rheostats were tried and found unsatisfactory before the type finally adopted was worked out. Rheostats are expensive and most of them take up considerable space on the panel. This design, shown in Figs. 3 and 5, is very simple and fitted in nicely with the other instruments.

First, two pieces of 1/8-in. bakelite were cut to a size of 1 3/4 by 1 in. Then the head of an 8-32 iron screw was cut off, leaving the threaded part 1 in. long. Next, the bakelite was put in a vise, and the screw hammered down on the four corners of the piece. This made a series of regular depressions in the bakelite, in which No. 24 Advance wire was wound.

The mounting posts were cut from 3/16-in. square brass rod, threaded with 6-32 tap for the screws through the panel, and drilled for the screws which hold the resistance units to the posts.

the rheostats. Looking at them from the front, the resistance windings are open at the right, and connected to the filament circuits at the left.

**AUDIO FREQUENCY TRANSFORMERS**

Federal transformers were selected for this set, because of their small size and

**TUBE SOCKET MOUNTING**

In Fig. 3, the audion sockets can be seen, and Figs. 5 and 6 show the mounting panel. The sockets themselves were made of 1 5/16-in. lengths of brass tubing 1 3/8 ins. inside diameter. Short lengths of threaded rod, soldered to the tubes, were used to hold

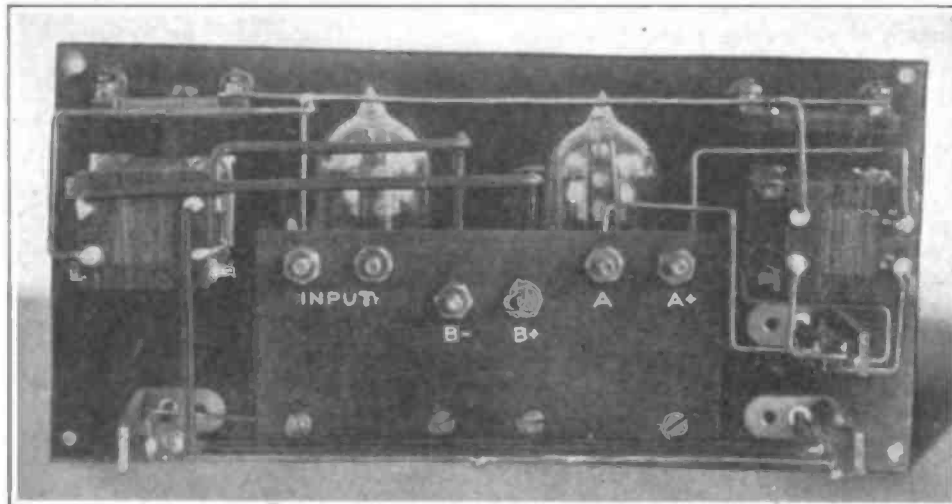

Fig. 2. Rear view, showing the terminals for outside connections, carried on a separate bakelite panel

high efficiency. Still, they were too large to mount directly on the panel without too much crowding. Accordingly, eight pieces, 3/4 in. long, were cut of 1/4- by 3/16-in. brass tubing,

them down on the mounting panel. A bakelite panel 1/8-in. thick, 5 ins. long and 2 1/2 ins. wide, was cut out for the socket mounting. In this piece were drilled the holes for the audion

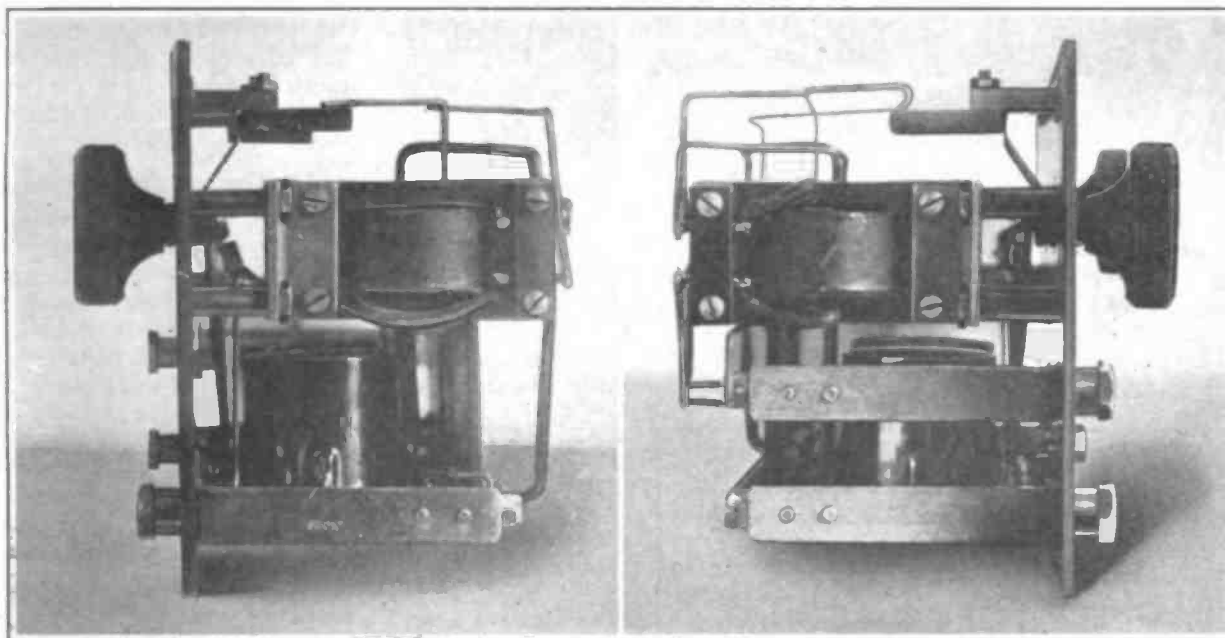

Fig. 3. The methods of mounting the transformers and jacks are shown in these end views

The centers of the rheostat handles are just 1 1/4 ins. below the centers of the supporting posts. This made it possible to use the upper transformer supports as stops for the rheostat contact arms. The contact arms are just short enough so that they clear the resistance element supporting posts, and pass on to the unwound portions of the small bakelite pieces, opening the filament circuits.

Flexible leads from the contact arms provide connections to those sides of

These pieces, put on 8-32 machine screws, act as spacers to hold the transformers back from the panel. This gives the necessary room, under the transformers, for the shafts of the rheostat controls.

Also, the binding posts of the transformers are made even with the terminals of the jacks, an advantage in wiring. The four posts hold the transformer as rigidly as if it were directly on the panel.

contact pins, socket mounting rods, and contact spring screws. Experimenters who use manufactured audion sockets can readily change the arrangement of the panel without departing from the general idea.

To hold the socket panel to the main panel, four brass angles were made from 3/8- by 1/16-in. strip. Four more were made at the same time to hold the rear connection panel. When holes must be drilled in parts of this sort, it is always advisable to drill them

before bending, to make the work easier. These angles are held by the same screws which hold the contact springs, as illustrated in Fig. 6.

Connections to the contact springs were soldered to the heads of the screws on the upper side of the panel. This made the wiring easier than it would have been to connect at the bottom, though it called for clever manipulation of the soldering iron.

**CONNECTION PANEL**

Another 1/8-in. bakelite panel, 5 by 2 1/2 ins., was used for the connections. As explained before, it is held by brass angles to the socket mounting panel. Three sets of terminals are provided for connections to the input, or plate circuit of the detector, and the A and B batteries.

The terminal screws are slightly staggered so that the wires will not interfere with each other. Lacking an engraving machine, the letters were

**WIRING**  
One of the easiest ways to spoil the appearance of an instrument is to wire

the wires cut and bent in sharp angles. This process takes a little extra time, but it is well spent.

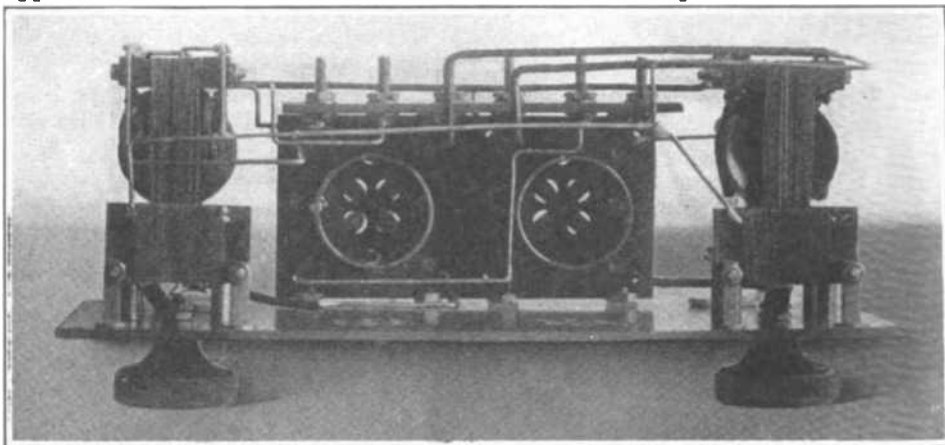

Fig. 5. Notice the construction of the rheostats and the way in which they are supported. The posts which hold the transformers also act as stops for the rheostat contact arms

it in a slipshod manner. Good wiring adds greatly to the looks of any apparatus. For this amplifier, No. 14

A word of warning:—To judge from the work of some experimenters, the prevalent idea is that a joint must have an ounce of solder to insure a perfect connection. As a matter of fact, a drop is as good as a pound, and looks far better.

Where it was necessary to run two wires close together, Empire tubing was slipped over the wire. This was not done throughout, however, because it was not necessary, and Empire tubing is expensive.

Fig. 7 gives the amplifier circuit. While it looks simple, there are numerous chances to make mistakes. It is much easier to have the wiring right the first time than to have to hunt trouble and make changes.

**USE OF THE AMPLIFIER**

To use this amplifier with an audion detector, it is only necessary to connect the plate to the input terminal which is joined to the transformer post marked P 2, and the positive terminal of the detector B battery to the P 1 (Concluded on page 358)

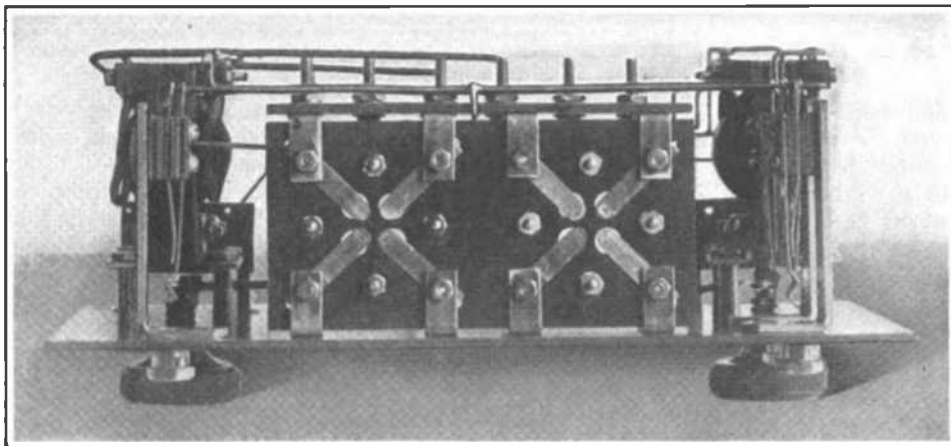

Fig. 6. This view shows the brass angles which carry the tube panel and rear connection panel

simply scratched deeply and filled with white lead. Paraffin and zinc oxide are easier to handle, but are apt to melt out if the bakelite is heated while the connections are being soldered.

bare copper wire was used. The wire was first cut to 12-in. lengths, and rolled straight between two boards. Then, as each connection was made, the distances were carefully measured, and

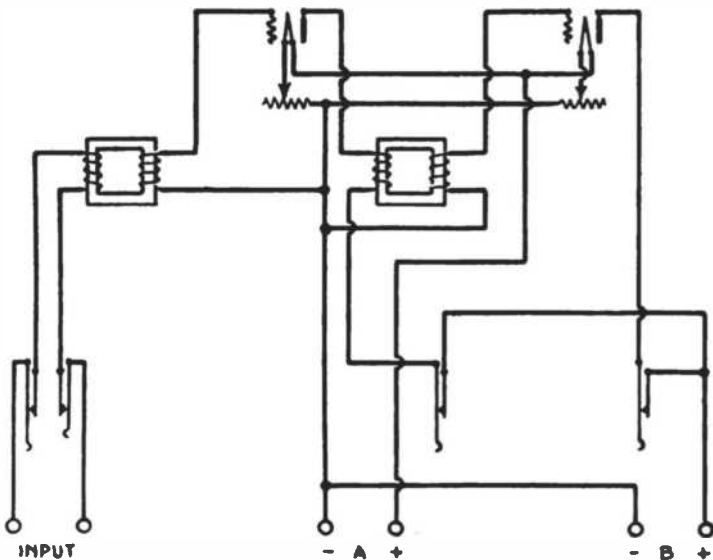

Fig. 7. Diagram of connections for the two-step amplifier

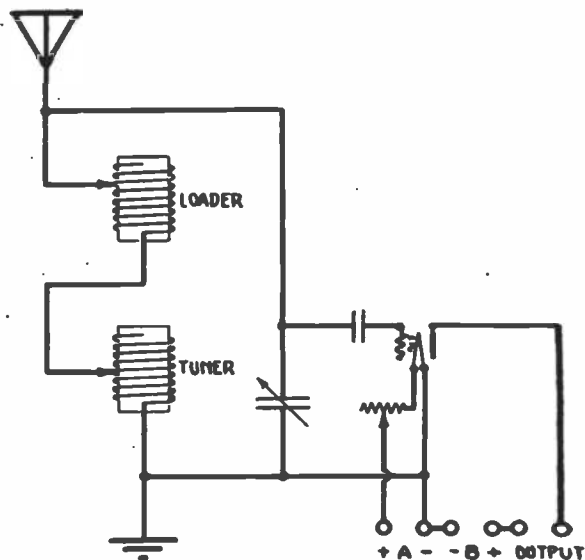

Fig. 8. Wiring of the receiver, previously described, with the amplifier

## The Radio Department

### *A Discussion of Current Topics of Interest to Manufacturers and Experimenters.*

"WHAT are you doing this summer?" is a seasonable question from one radio experimenter to another. Perhaps the static and fading have discouraged you in favor of cooler pursuits than groping through the X's for the signals which are just too faint to hear. Again, you may have found the laboratory too warm, or the heat of the soldering iron, perhaps, has consumed your ardor for radio work in the summer time.

The manufacturers would like to have radio a less seasonable business. As matters stand now, the sales during the months of June, July and August average, according to some reports, as low as ten per cent of the average monthly business in November, December, January and February.

To help equalize sales and production the year round, experimenters should do all they can to buy in the summer for their winter needs. The average radio man does not realize what a load is put upon the manufacturers by the winter peak.

Considering first the interests of the experimenters themselves, this peak is largely responsible for slow deliveries at a time when radio activities are at their height. The only way to overcome this difficulty is for the manufacturers and dealers to take the chance of overstocking, and tying up large amounts of money, hazardous undertakings in these times.

To meet the winter load, materials and supplies must be purchased from two or four months in advance. If the manufacturers play safe in ordering, they are quite apt to find themselves caught by January without materials and no prospect of getting them in time to meet the complaints of their customers whose work is held up really because of their own short-sightedness.

A few facts about the supply market will give experimenters an idea of the manufacturers' problem. Machine screws and nuts are almost impossible to buy, in some cases because material is hard to get, and, again, the demand exceeds the supply to the extent that many machine screw companies refuse to accept orders. Magnet wire is even harder to buy, particularly that requiring silk insulation. Copper, scarce enough, is easier to get than silk, a large part of which comes from Italy. Bakelite and wooden cases take two, three, or even four months to get, according to the nature and quantity of the order. Freight shipments complicate matters still further, and add one to three months to the date of delivery.

Summing up these facts, it is obvi-

ously important for experimenters to buy now if they want to have the things they will need for the winter's work. Help the manufacturers and dealers to smooth out the peak load.

THE commercial application of aircraft, tho it has made slow progress, has made good in the transportation of mail. In this connection much is being done to increase the factor of safety by the use of radio. It is now possible to guide a machine through the fog to the landing field, but, at the present stage of development, the radio operator in the airplane cannot determine his position over the field with sufficient accuracy to enable the pilot to bring the machine when the mist is so dense that the ground cannot be seen from a height of three or four hundred feet.

What is needed now is some sort of a radio barrage to surround the field, or some means by which the pilot or radio operator can tell when the machine is directly over the landing field. Knowing this, it would be comparatively safe for an airplane to descend within a short distance of the earth without risking a collision with smokestacks or church steeples.

Mail planes can now travel through fogs which obscure the earth, being guided by the radio compass. When the supplementary device is brought out by means of which planes can be brought down safely, the mail and other aerial service will be much more extensively used.

DID you ever stop to think of the efficiency of the telephone receiver? Offhand, what would you imagine to be the ratio of the energy in the useful sound to the electrical energy in the magnet?

W. Hahnemann and H. Hecht have found that, at frequencies between 500 and 1,000 cycles, the efficiency of a sensitive receiver is from 0.1 to 1.0 per cent. There seems to be no likelihood that anyone will soon bring out an instrument to supplant the telephone receiver, but these figures certainly show an opportunity for improvement. The sensitiveness of the ear can be appreciated when it is realized that the sensation of sound can be produced by a fraction of the infinitesimal energy picked up by the radio antenna.

THERE will be several articles in the August issue of EVERYDAY which will appeal particularly to experimenters. One is a description of a new inductance, similar in form, but entirely different in the method of

winding from the ordinary concentrated coils. In addition there will be tables and other data concerning the use and design of receiving inductances.

Many unusual features are incorporated in the Uni-control receiver, built by the Wireless Improvement Company, which will be described next month. Detailed photographs and circuits will be given.

The article on loop antennas, promised for this month, will be published in the August number. There are many design features about loop antennas which are not understood or appreciated by the experimenters. This may account for their unpopularity, tho, properly built and used, they give excellent results. These points will be covered in the coming article.

In addition, there will be other articles on the construction of apparatus, both for sending and receiving.

---

## BOOK REVIEWS

---

THE HOW AND WHY OF RADIO APPARATUS. By H. W. Secor. 160 pages. Illustration. 9½ in. by 6 in. Cloth bound. Published by the Experimenting Publishing Co., New York City.

This book, made up largely of material which has been published in the *Electrical Experimenter Magazine*, is in a way a review of the various kinds of instruments employed for various purposes in radio transmitting and receiving.

While there is a great deal of instructive material in this book, it appears that perhaps too much space has been given to apparatus now obsolete, a failing which is shared by the large majority of books of radio work. While such material has a very important place, the radio experimenter demands new material, forgetting the old as soon as it has become common knowledge.

In the first five chapters, induction coils, transformers, transmitting condensers and inductances, and spark gaps are described and their operation explained. The following five chapters are devoted to receiving apparatus and include a discussion of mechanical and vacuum tube amplifiers.

The remainder of the book takes up the measurement of wavelength and decrement, construction of radio antennas and the calculation of inductances.

There are, in this book, many points of interest to both beginners and advanced students.

SUPER RANGE RECEIVER. By M. B. Sleeper. An illustrated pamphlet, 8½ by 11 ins. Published by the General Apparatus Co., New York City.

This pamphlet gives detailed scale drawings for the construction of an F. range audion receiver for 6,000 to 20,000 meters, either damped or undamped waves.

(Continued on page 358)

# Radio Equipment for Small Boats

*The Advantages and Use of Radio Apparatus on Motor Boats and Yachts. The Direction Finder is also discussed*

**T**HERE are, in general, two classes of men who own motor boats and small yachts—one class has the conviction that nothing should be installed unless it is absolutely essential; the other class is comprised of men who want everything which adds to convenience or safety. Both classes fight shy of radio.

Although wireless equipment, even on a boat which makes trips of considerable length, may not come under the heading of necessities, it certainly belongs among the devices of safety and comfort. The reason that radio is used on so few boats and yachts is probably because of the technical understanding which appears, to the uninformed, to be required for the operation of a transmitter and receiver.

The technical part should not trouble any man who has enough of an electrical and mechanical sense to master the circuits and appliances of boat engines. As for the telegraph code, the pleasure and interest in operating a radio set is a sufficient incentive for learning quickly the use of the dots and dashes.

Of course, no one can form an accurate opinion regarding the utility of a radio installation on his particular craft until he knows something about the apparatus and its use.

The boat owner whose son has a radio station at home can, by means

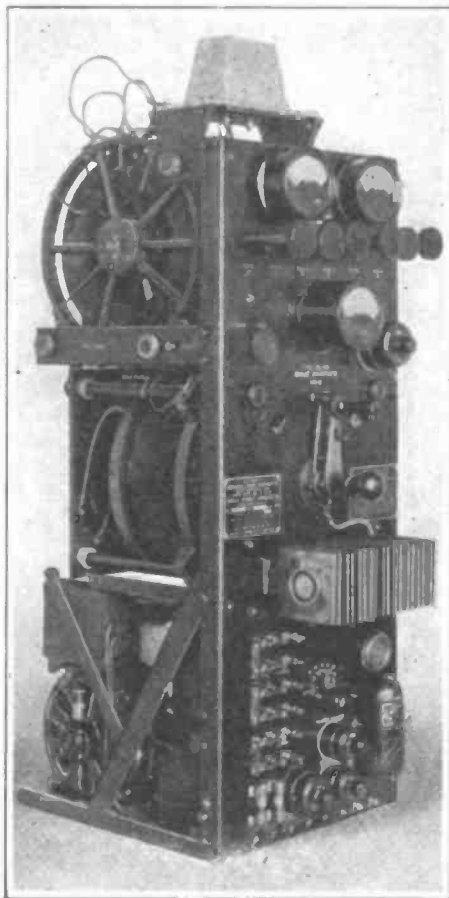

Fig. 4. A 200-watt set, operating on storage batteries or ship's mains, from the Wireless Specialty Company

of the wireless, keep in touch with affairs which require his attention but not his presence. Messages can be sent through commercial and government stations which are dotted along the coast. These are augmented by the great number of experimental stations where the owners are always glad to receive and relay messages without charge. There are so many radio installations now that a boat within transmitting range of land can almost invariably reach one station or another.

Of still greater and more general application is the use of radio as a safety device. The statements regarding communication with the land stations show the ease with which a boat in distress can obtain assistance. International radio regulations require ship and commercial land stations to maintain a receiving watch on 600 meters. The 200-meter experimental wavelength is near enough to 600 meters that private stations are generally in tune for the calling wave.

Another feature, comparatively new, is the direction finding stations which are located at certain light houses, and others, operated by the Navy, at the harbors. Near any of these points it is only necessary for a vessel to request a bearing report, and, by triangulation between two or more compass stations, the ship is located and informed of its

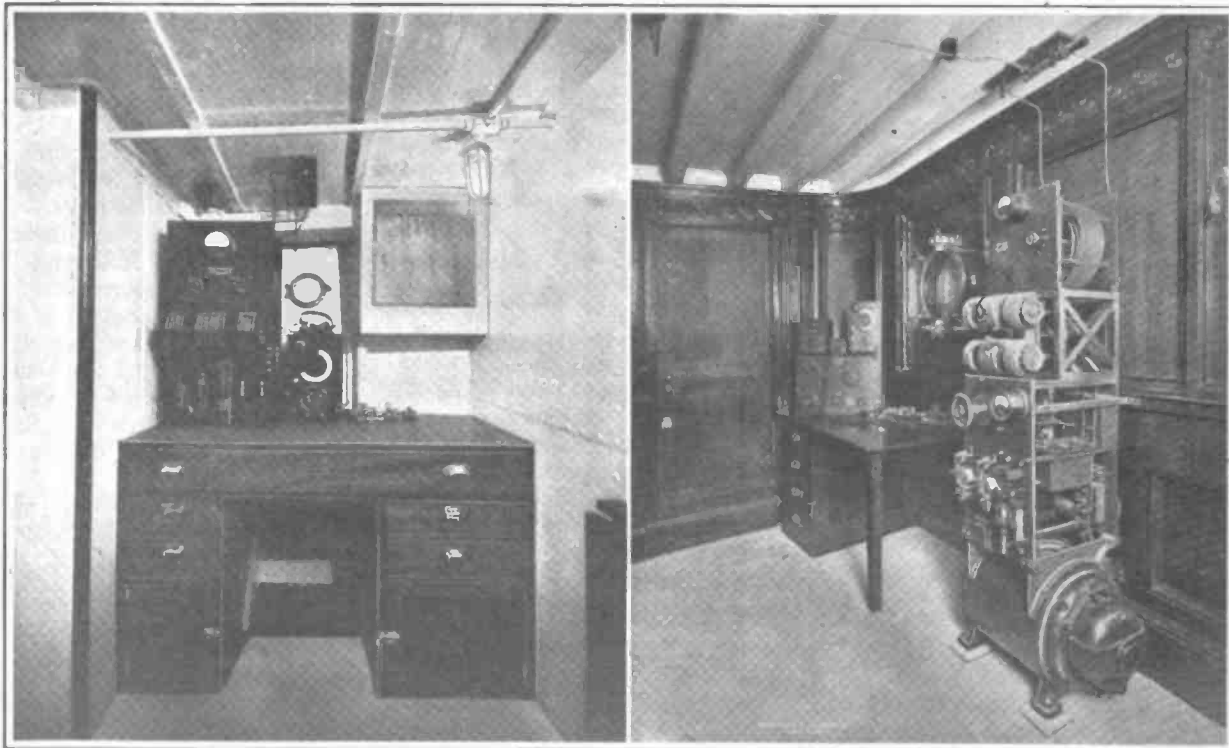

Fig. 1. Two Cutting and Washington installations for small boats. The set at the left operates on  $\frac{1}{2}$  h. w., and that at the right, 2 h. w. This type of equipment, because of its simplicity, is well adapted for use by inexperienced operators



position. If a direction finder is installed on the boat, the operator can obtain his own bearings on any land station.

Several types of transmitting and receiving sets are shown in the illustrations which accompany this article. These are typical examples, though there are many variations in design, size and power.

Fig. 1 shows two installations of Cutting and Washington equipment, the one at the left on a Russian submarine chaser, and at the right on the *Noma*, a more spacious craft.

The sub chaser set is made up of the transmitting panel, at the left, and the receiver, at the right. On the table are the detector and telegraph key, and overhead, a lightning switch. Power for the transmitter is supplied by a motor generator, not in view.

A set of this type is suitable for 45 to 50 ft. boats or larger craft. The motor-generator, operating on 110 volts d. c., draws 1,500 watts from the line, and delivers somewhat more than 500 watts, 500 cycles alternating current, to the transmitter. When no generating system has been installed already, a small engine, coupled directly to an a. c. generator, can be furnished.

The transmitting range of the Cutting and Washington  $\frac{1}{2}$  k. w. set, when used with the necessarily small antenna of a 50 ft. craft, is normally between 75 and 100 miles, although much greater distances can be covered when a very sensitive receiving set is employed at the land station. On larger yachts, where higher and longer antennas can

be put up, the transmitting range is considerably increased.

There are several advantages in this type of set. No transformer is employed to step up the voltage. Conse-

quently, there is no danger of injury from high potentials. The usual open spark gap is not used, but instead, a closed type which is practically silent in operation.

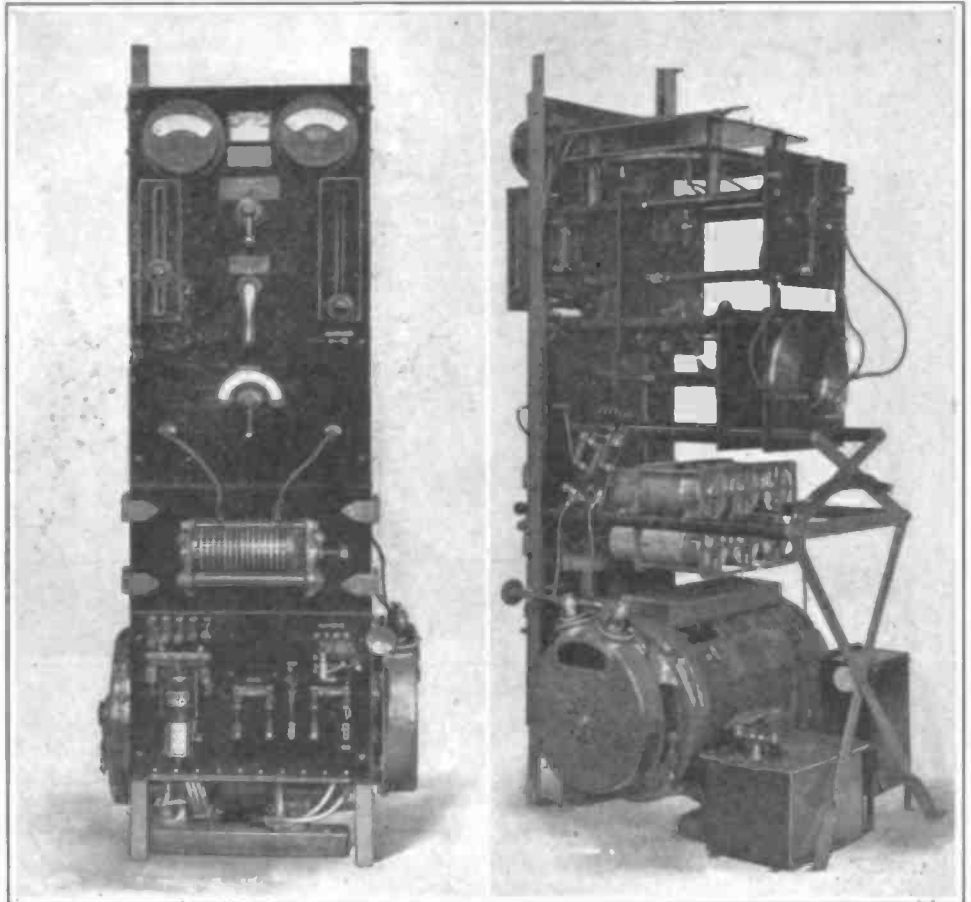

Fig. 6. Larger boats can accommodate 2-k.w. installation such as this Radio Corporation equipment

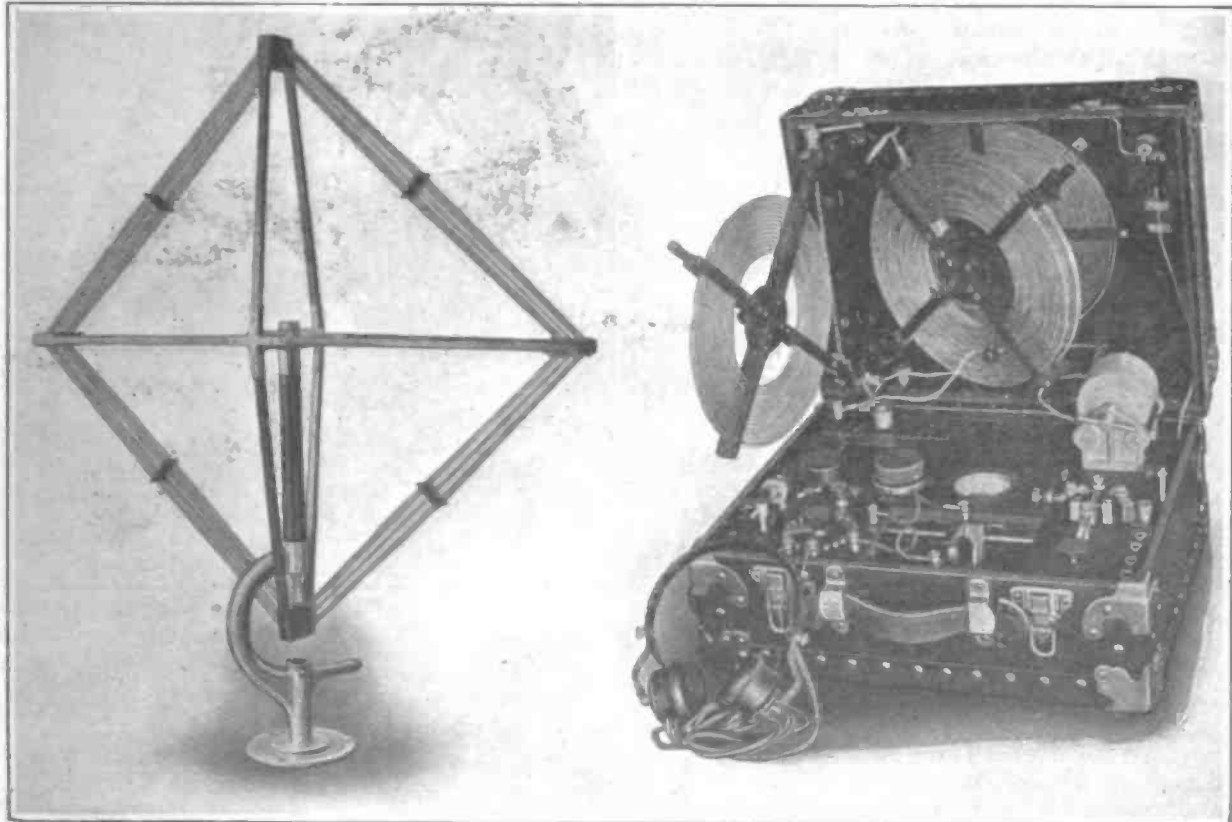

Fig. 2. At the left, a radio pelorus or direction finding loop. Right, a portable 250-watt transmitter and receiver for motor boats and yachts

For longer distance communication, the 2 k. w. equipment, at the right of Fig. 1, is designed. With it a more complete receiver is furnished, capable of operation over a wide range of wavelengths. Communication over several

Another type of transmitter which can be used for small craft, although it is designed primarily as an auxiliary for large sets, is shown in Fig. 4. The input of this set is only 200 watts, permitting it to be run from the ship's

receiver represents the most advanced design. The efficiency of the tuning circuits and the advantage gained by the vacuum tubes, make possible the reception of signals over very great distances, depending, of course, upon the power of the transmitter and the size of the receiving antenna.

On the top of the case are the telephones and a crystal detector for emergency use. Wavelengths from 150 to 6,800 meters can be received with this set.

Only slight modifications are required to make the set just described suitable for loop reception, or radio compass work. For this purpose, a loop antenna or radio pelorus, Fig. 2, is employed. A small compass is secured to the axis of the loop, near the handle.

To determine the direction from which signals are being sent, the pelorus is rotated until the signals are of maximum intensity. Then the compass indicates the direction of their origin. Such an equipment is of great advantage, particularly on larger yachts which must be piloted with great care in fogs. Some ships have gone for days without making any other observations than those obtained by the radio pelorus. Again, this apparatus makes it possible to enter a harbor when, otherwise, it would be necessary to stand outside until the fog lifted.

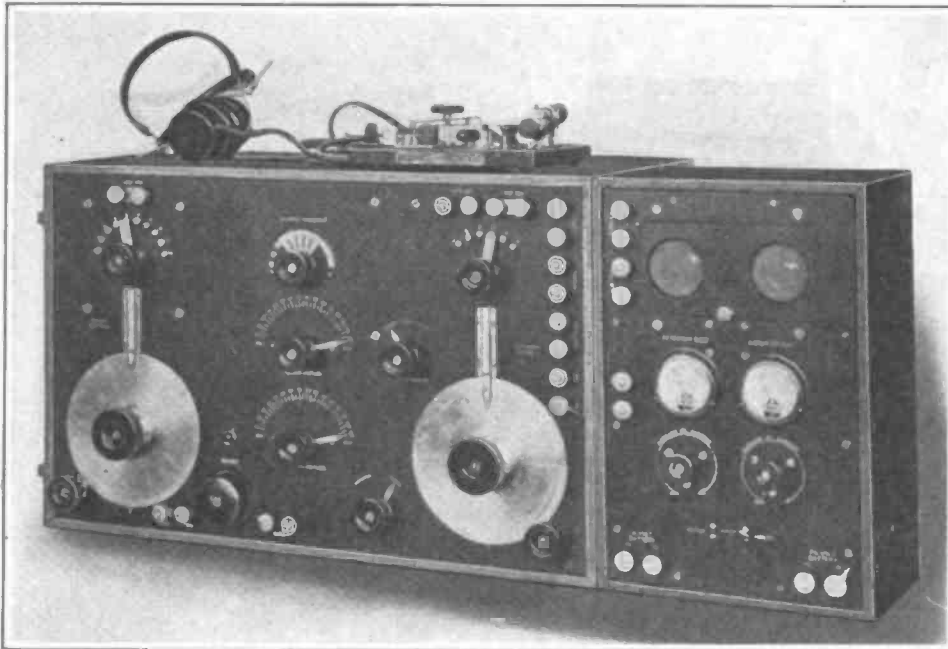

Fig. 5. A receiver of great selectivity and sensitivity, suitable for ship work

hundred miles can be carried on with a suitably equipped land station.

Fig. 2, at the right, illustrates a 250-watt portable transmitter and receiver, built by the Wireless Specialty Apparatus Company. The overall dimensions of the case, when closed, are 17½ by 15 by 10 ins., with a weight of 55 lbs., making it an excellent outfit for small boats. All the necessary apparatus, with the exception of the generator, are mounted in the case. The U. S. Navy has used many of these sets for landing parties, where communication back to the ship was necessary.

Power can be supplied from a motor-generator, a belted generator, a combination gas engine and generator, or a hand-operated generator, delivering 500-cycle a.c. current to the set. The engine driven outfit is shown in Fig. 3. A gasoline engine unit, complete in itself, is provided. The engine is of the single cylinder, four-cycle type, mounted on a portable oak frame. This unit weighs 130 lbs., while the portable hand-driven generator weighs only 77 lbs.

An antenna of the usual type can be used on shipboard, or a portable, umbrella type if, for any reason, the apparatus is to be carried ashore.

No switch is needed on the set to change from transmitting to receiving as there is an automatic control on the telegraph key. When the key is up, in the normal position, the receiving set is connected. Pressing the key to send, changes the circuit to the transmitter.

current or storage batteries if desired.

The dimensions over all are 44 by 19 by 15 ins. and the weight 210 lbs. All the controls are at the front of the

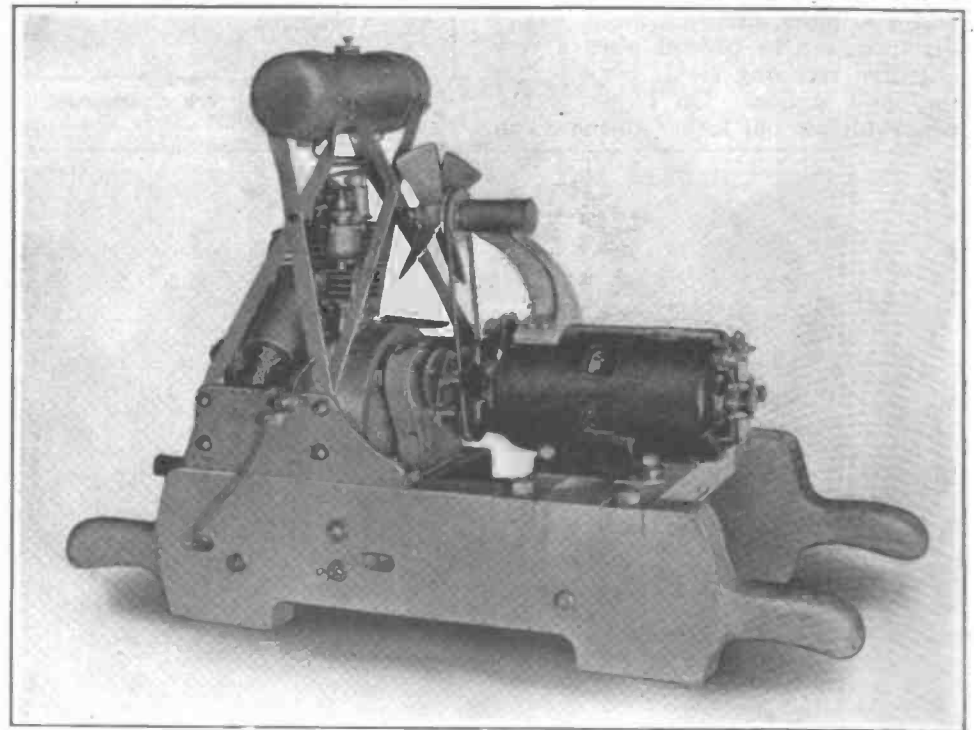

Fig. 3. The Wireless Specialty generator unit can be used on boats not equipped to furnish current for a radio transmitter

panel, so that the set can be installed in a corner or other convenient place where it will occupy a minimum of useful space.

In Fig. 5, a Wireless Specialty receiving set, equipped with an audion and one-step amplifier is shown. This

A 2-k.w. transmitter, manufactured by the Radio Corporation of America, is illustrated in Fig. 6. This is a commercial type set, transmitting at 500 cycles with a quench spark gap or synchronous rotary spark gap. The  
(Continued on page 358)



### A PORTABLE RECEIVER

**A**N excellent receiver, suitable for those who want an inexpensive radio set and one which can be easily operated, is shown below. The set, of the single circuit type, is made by the Esbro Company.

When the cover is closed, the box measures approximately 9 ins. long, 7 ins. wide and 6 ins. high, a convenient size for carrying. On the panel are the test buzzer and push button, inductance switch, and galena detector.

The detector construction is quite interesting, for it is simple and at the same time designed for universal adjustment. The vertical post is in two parts. A machine screw is threaded tightly into the lower section. This part is counterbored half way, and a spring put over the screw and fitted into the counterbore. The upper part is also threaded and counterbored. When the detector is assembled, the upper part carrying the contact rod and wire, is threaded onto the screw. Then the concealed spring maintains a tension on the upper section sufficient to hold it wherever it is set.

Two binding posts are provided at the front for a telegraph key by means of which the test buzzer can be operated for code practice. The buzzer battery is mounted beneath the panel. All the instruments are mounted above and below the panel, according to standard practice. By unfastening six

screws, the set can be removed from the box.

With an antenna of 0.003 mfd., this set tunes from 200 to 2,500 meters, making it useful as a time signal re-

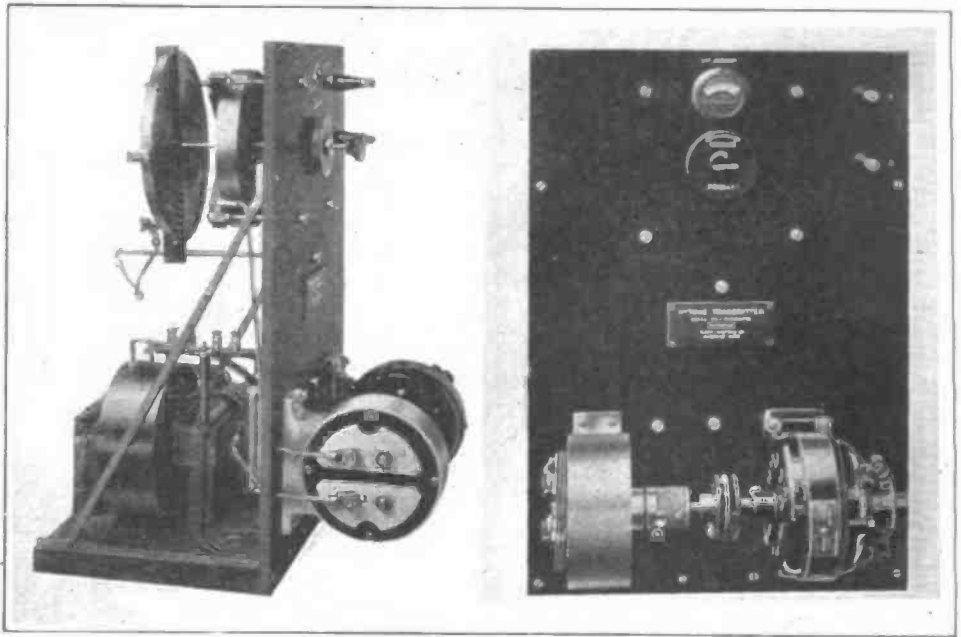

ceiver, as well as for amateur and commercial short wave reception.

### A NEW HYTONE TRANSMITTER

**E**XPERIMENTERS will welcome the introduction of a new type of  $\frac{1}{2}$  k. w. transmitter equipped with the Clapp-Eastham Hytone gap.

rated in this transmitter.

The  $\frac{1}{2}$  in. bakelite panel is 24 ins. high and 16 ins. long. At the top are the antenna and ground terminals, set in heavy bushings, antenna radiation meter, and controls for the oscillation transformer coupling and primary inductance. The secondary inductance is varied by a clip. On the lower part of the panel is the Hytone gap, redesigned for this set, and the driving motor.

Behind the panel are the other instruments. Bakelite strips are used to support the nickel-plated ribbon of the oscillation transformer. Five turns are provided in the primary and 10 in the secondary. Connections are made with heavy copper braid. Insurance against condenser trouble is obtained by the use of a Dubilier mica condenser.

The output of the transmitter is approximately 5 amperes in a 10-ohm antenna, giving 250 watts.

### PRESS DISPATCHES FROM NAUEN

**R**ADIO press dispatches are sent out daily from the high-powered station at Nauen, Germany, on the following program:

At 9,400 meters, undamped waves, at 2.30 P. M., and 9.00 P. M., Greenwich time. After each series on undamped waves, the dispatches are repeated on damped waves at 4,700 meters for stations not equipped to receive undamped signals.

Experimenters should have no difficulty in copying Nauen if they have a two-step amplifier. Many stations along the Atlantic coast are able to hear Nauen when they are using only an audion detector.





# Knobs for Radio Equipment

*Some side lights on knob design, with a very interesting conclusion*

By Douglas Rigney

**I**N prehistoric days there lived a cave-man. Smaller than his fellows, he was in constant terror of the heavy-handed tactics of his neighbors. One day, pursued by the chief bully of his village, he attempted to climb a tree, only to have the branch which he grasped snap off in his hand. Preservation is the first law of Nature,

and in obedience to that law our midget cave-man attempted to ward off the giant, and in so doing tapped the giant on the head with the branch of the tree. What astonishment was his, to see his brawny opponent sink to the earth and lose forthwith all interest in the proceedings. Thus came into being man's first weapon—the club.

Your city policeman carries a club, but its relation to our cave-man's truncheon represents generation upon generation of improvement. The cave-man's weapon was a log, which hurt his hand almost as much as it did his opponent's head. The patrolman's billy is a balanced, smoothed piece of seasoned ash, which fits his hand like a glove. Nor is it alone in weapons that we find the ingenuity of man has improved his implements. From the common ax-handle to the finest dental instrument, tools used manually are made to fit the hand.

Let us now glance at the instruments used in the latest and newest art—Radio. Behold, what a horrible collection of misfits are the knobs which at present adorn radio apparatus. Built after the general pattern of a door-knob, they are excellent things to grasp. One may hold them with the grip of death. But let the operator after having finally tuned in a C. W. station attempt to release his grip on the knob! Alas, his fingers have not the fine co-ordination of a Paderewski, and one of them is sure to give a final spas-

modic push to the knob—and the whistling C. W. fades.

It may be that the neglect of mechanical design in amateur radio apparatus is due to the persistent and pernicious theory that the amateur revels in "junk", that he is supremely pleased with a collection of wires and coils, held together by the grace of

dial are moulded in one piece, and on the back of the latter a groove is cut, in which a stop is fitted, to limit the swing of the dial. Imagine the action of a cone-clutch, with the fingers and knob forming the engaging members, and you have the theory of the new Grebe knob.

Consider also the appearance of this knob, as compared with those formerly in use. Just as the cave-man finally learned to smooth the knots and bark from his club, so this new design has eliminated the bumps and unsightly warts which ordinarily form part of knob design. A slightly knurled surface is the only non-slip device needed with this type of knob. Pressure, easily applied and relieved, does the rest. A glance at the picture of the CR-3 receiver, shown with the new knobs attached, will give a good idea of the improved appearance of apparatus using symmetrical dials and knobs. Observe that the switch handles and binding posts have been made to conform in design to the knobs, adding to the general effect.

These knobs are to be made standard Grebe equipment in the near future, and if the testimony of the few people who have used them is to be credited, they should prove very popular. They are made for the modern amateur, who desires apparatus in which efficiency of

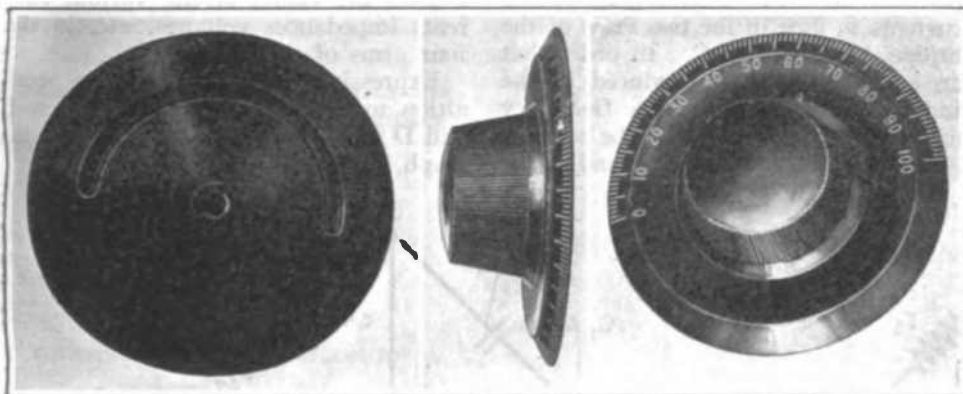

*Views of the Grebe dials, showing the details of the new design*

Providence. Surely the modern experimenter in radio has outgrown such superstitions. Such, at least, is the belief of A. H. Grebe & Co., Inc., in whose factory has been developed the new type of knob, illustrated herewith.

Moulded of bakelite, these knobs are fashioned in the form of a truncated



*The CR-3, fitted with the new scales and knobs*

cone. One does not grasp them with the strength of the fingers so much as by the pressure of the weight of the arm. By exerting this pressure, a firm grip may be secured and when it is desired to release the knob, the operator must merely draw back his arm, leaving the adjustment exactly as he desires it. In addition, the knob and its

operation and beauty of design are given their proper values.

Be sure to read in The Radio Department, page 347, about the radio manufacturers, and their problems. If you expect them to make your problems theirs, you must make their problems yours.

# A Simple Method of Measuring Inductances at Low Frequencies

*Any Experimenter Can Make His Own Inductance Bridge by Following the Instructions Given in This Article*

By V. Lynde Freeman

**I**N the work shop of the experimenter as well as in the larger laboratories, it is often desirable to have at hand a quick and reliable means of measuring small inductances. By a simple modification of the Owen Alternating Current Inductance Bridge such an instrument becomes available for the measurement of inductance values usually met with in radio telegraphy. As will be seen later, by the proper choice of the constants of the bridge, one can be so constructed that the value

two fixed capacities,  $C_1$  and  $C_2$ , the fixed resistance  $r_1$ , the two variable resistances  $r_2$  and  $R$ , and the inductance to be measured  $L$ . The alternating electromotive force is applied to the bridge through the transformer  $T$  to the points  $A$  and  $C$ . This voltage causes currents to flow in the two arms of the bridge  $ABC$  and  $ADC$ . In order that an audible signal be produced in the indicating instrument, the frequency of the supply current should be between 300 and 1,000 cycles per second.

ance, or resistance is equal to the current flowing through it multiplied by its numerical value, we can calculate the voltage across each of the arms of the bridge in terms of its constants and the currents through these arms. Table 1 gives the values of the various currents impedances voltages, etc. in the four arms of the bridge.

Expressing algebraically the condition to give zero voltage between  $B$  and  $D$  as mentioned in the above paragraph, we have:—

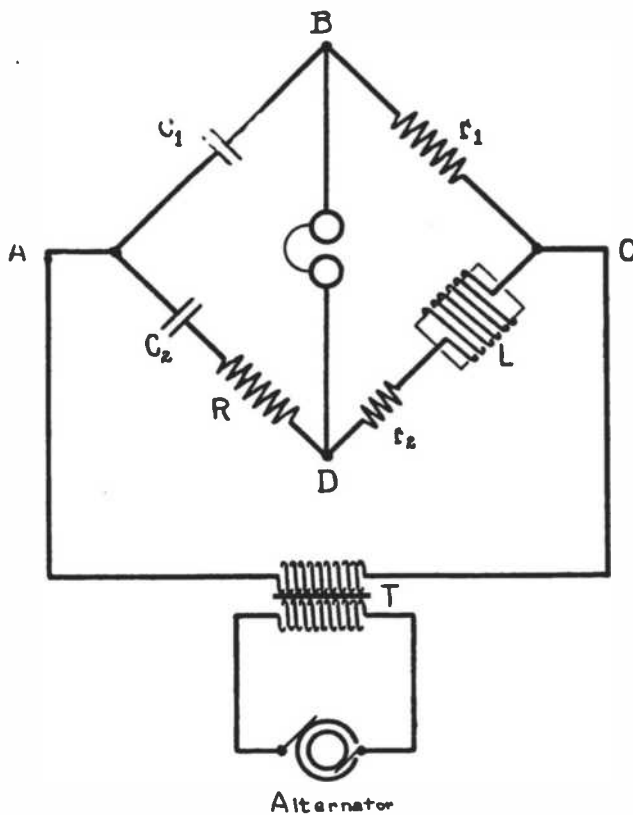

Fig. 1. The general circuit employed for measuring inductance

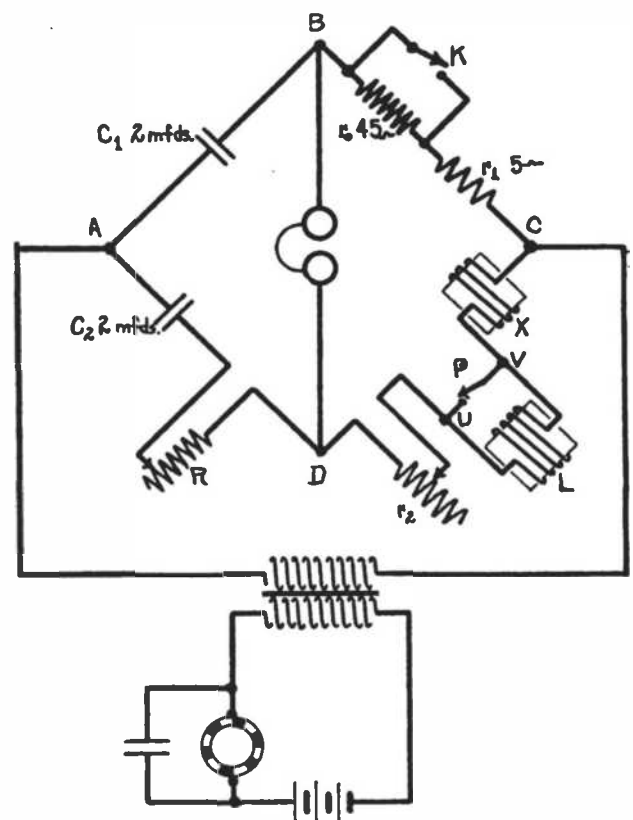

Fig. 2. Diagram of the complete inductance bridge

of inductance of millihenries is given by the value of resistance in tens of ohms necessary to balance the bridge.

The inductance values determined by this method are of course the low frequency values. For single layer or two layer banked winding coils or other coils of low distributed capacity, the high and low frequency inductances do not differ greatly.

Before describing a laboratory type of bridge it may be well to go into the theory of its operation.

### THEORY OF OPERATION

A schematic diagram of this bridge is shown in Fig. 1 and consists of the

When the resistances  $R$  and  $r_2$  are adjusted until the current from  $B$  to  $D$  through the telephone receivers is zero, the bridge is said to be balanced and obviously the current  $i_2$  in  $AB$  is equal to the current in  $BC$ . Similarly, the current  $i_1$  in  $AD$  is equal to the current in  $DC$ . Since the current through the telephones is zero the voltage  $BD$  is equal to zero.

In order that this condition obtains the ratio of voltage across  $AB$  to the voltage across  $BC$  must be equal to the ratio of the voltage across  $AD$  to the voltage across  $DC$ .

Since the voltage across an imped-

$$\frac{\text{Voltage AB}}{\text{Voltage BC}} = \frac{\text{Voltage AD}}{\text{Voltage DC}} \dots (1)$$

Upon substituting the values from Table 1 and solving the equations we find that

$$L = r_1 RC_1 \dots (4)$$

$$\frac{r_2}{C_1} = \frac{r_1}{C_2} \dots (5)$$

For those readers who are interested in the way at which these results were obtained the following is given:

Substituting the values of voltage across the various arms from Table 1 in Equation (1) it becomes

$$\frac{-j \frac{i_1}{\omega C_1}}{i_1 r_1} = \frac{i_2 \left( R - j \frac{1}{\omega C_2} \right)}{i_2 (r_2 + j \omega L)} \quad (2)$$

$$\text{or } \frac{-j \frac{1}{\omega C_1}}{r_1} = \frac{R - j \frac{1}{\omega C_2}}{r_2 + j \omega L}$$

Clearing fractions

$$-j \frac{r_2}{C_1 \omega} - j^2 \frac{\omega L}{C_1 \omega} = r_1 R - j \frac{r_1}{\omega C_2}$$

Since  $j = \sqrt{-1}$  ..... (3)  
and  $j^2 = -1$

$$-j \frac{r_2}{\omega C_1} + \frac{\omega L}{\omega C_1} = r_1 R - j \frac{r_1}{\omega C_2}$$

Equating the real terms to reals and the imaginary terms to imaginary, those containing  $j$ , we have:

$$\frac{L}{C_1} = r_1 R$$

$$-j \frac{r_2}{\omega C_1} = j \frac{r_1}{\omega C_2}$$

Upon simplification this reduces to

$$L = r_1 R C_1 \quad \dots \dots (4)$$

$$\text{and } \frac{r_2}{C_1} = \frac{r_1}{C_2} \quad \dots \dots (5)$$

As we can see from (4) the inductance varies directly with the resistance  $R$  if  $r_1$  and  $C_1$  are constant.

Since (4) and (5) are independent of frequency the operation of the bridge is more or less independent of the wave form of the applied electromotive force. For this reason a buzzer or an induction coil can be used to supply the indicating current to the bridge.

**DESCRIPTION OF A TYPE OF BUZZER FOR USE IN THE LABORATORY**

Fig. 2 is a diagram of a bridge similar to the one described but modified to admit of better accuracy of opera-

tion. The switch  $k$  short circuits the resistance  $r_0$  and is used as a means for direct reading in a sense in that the changing the range of the bridge as will be described later.

In order that the bridge may be value of inductance in millihenries is very closely equal to the resistance of  $R$  in terms of ohms, we must choose the constants in the following way. This numerical example of course is but one of the possible solutions but a bridge based on these results has been made up and found to give very good results.

**CALCULATION OF CONSTANTS**

Let us assume the following values of the constants with the switch  $k$  open:

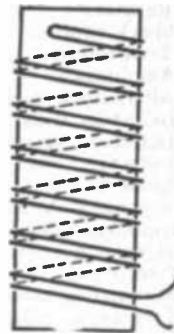

Fig. 3. Winding for a non-inductive resistance

$$C_2 = 2 \text{ microfarads} = 0.000002 \text{ farads}$$

$$C_2 = C_1$$

$$R = 10 \text{ ohms}$$

$$L = 1 \text{ millihenry} = 0.001 \text{ henry}$$

Let  $x$  be so small that it may be neglected except as explained later.

Substitution of these values in (4) gives us at once the value of  $(r_0 + r_1)$   
 $(r_0 + r_1) \times 10 \times 0.000002 = 0.001$

henry or 1 millihenry

from which  $(r_0 + r_1) = 50 \text{ ohms}$ .

It may be convenient to measure inductances of smaller values so we may determine the value of this resistance in arm BC of the bridge so that 1 milli-

henry as before is balanced by 100 ohms at  $L$ . In this case the value resistance can be calculated as above.

$$r_1 \times 100 \times 0.000002 = 0.001$$

henry or 1 millihenry

$$r_1 = 5 \text{ ohms}$$

The switch  $k$  as seen from the figure is arranged so that when it is open the resistance in BC is 50 ohms and when closed the resistance is 5 ohms. This gives a greater range for measurements as explained later on in this article.

**SOURCE OF VOLTAGE**

The alternating or pulsating voltage for supplying the bridge may be obtained from an alternator or a small medical induction coil, the primary of which is connected in series with an interrupter. A commutator having a number of segments and driven by a small motor can be used also. The condenser shown in Fig. 2 is to reduce the sparking of the contacts. The number of interruptions of the circuit per revolution of the commutator multiplied by the revolutions of the motor per second should be at least equal to five hundred for good operation.

**OTHER APPARATUS USED**

Ordinary paper condensers similar to those used by the telephone companies of proper capacity can be used for  $C_1$  and  $C_2$ . If it is impossible to obtain the desired size of condenser the values of  $r_1$  and  $r_0$  can be recalculated as explained above.

The resistances  $r_1$ ,  $r_2$ ,  $r_0$ , and  $R$  should be non-inductive and they can be made up easily from small insulated Advance resistance wire.

This wire is mentioned as its resistance varies only slightly with temperature. Fig. 3 shows the manner of winding this wire upon a wooden mandril so that it will be essentially non-inductive. The wire is adjusted to the proper length for the desired resistance before it is wound up. Each of these units is dipped in paraffin to protect them from moisture. Resistance boxes can be made up from .1, 1., 10. and 100 ohm units of this type and mounted in boxes.

**CORRECTION FACTORS**

In order to compensate for the distributed capacities in the bridge a small inductance is connected in the arm DC of the bridge at  $x$ . The inductance is very small and consists of a few turns of wire on a core about 2 in. in diameter. Upon closing the switch P and applying the voltage to the points AC of the bridge, the two resistances are adjusted until minimum sound is heard in the telephones. The value of  $R$  needed for balancing the bridge is a correction factor  $R_0$  which must be subtracted from subsequent readings of  $R$  taken on an inductance to be measured.

TABLE 1

Let  $\omega = 2 \pi f$        $\omega = \text{angular velocity}$        $J = \text{vector operator}$   
 $j = \sqrt{-1}$        $f = \text{frequency of the supply current}$

Bridge Arm	Current	Impedance	Impedance expressed in the vector notation	Voltage expressed in the vector notation
AB	$i_1$	$\frac{1}{\omega C_1}$	$0 - j \frac{1}{\omega C_1}$	$-j \frac{i_1}{\omega C_1}$
BC	$i_1$	$r_1$	$r_1 + J 0$	$r_1 i_1$
AD	$i_2$	$\sqrt{R^2 - \left(\frac{1}{C_2 \omega}\right)^2}$	$R - J \frac{1}{C_2 \omega}$	$i_2 \left( R - j \frac{1}{C_2 \omega} \right)$
DC	$i_2$	$\sqrt{r_2^2 + \omega^2 L^2}$	$r_2 + J \omega L$	$i_2 (r_2 + j \omega L)$

Note—For a more complete treatment of the above, refer to Radio Telegraphy by J. Mills, Chapter I.

# The Bureau of Standards Radio Classification

*The System Used by the Bureau of Standards  
to Classify Information on Radio Subjects*

## CLASSIFICATION OF RADIO SUBJECTS

- A. Radio Wave Phenomena**  
 A 1. Electromagnetic theory  
 A 2. Radiation and absorption  
 A 3. Transmission phenomena  
 A 4. Atmospheric  
 A 5. Directional properties  
 A 6. Waves on wires
- B. Antennas**  
 B 1. Elevated (condenser) antennas  
 B 2. Ground and underground antennas  
 B 3. Special types of antennas  
 B 4. Coil Aerials  
 B 5. Directive antennas  
 B 6. Direction finders  
 B 7. Ground connections  
 B 8. Constants of antennas  
 B 9. Artificial antennas
- C. Electron tubes**  
 C 1. Electron emission  
 C 2. Ionization phenomena  
 C 3. Properties of electron tubes  
 C 4. Electron tube generators  
 C 5. Electron tube detectors  
 C 6. Amplifiers  
 C 7. Radiotelephony with electron tubes  
 C 8. Regulator tubes  
 C 9. Modulators  
 C 10. Heterodyne  
 C 11. Applications to radio measurements  
 C 12. General.
- D. Radio Measurements**  
 D 1. Wave length  
 D 2. Capacity  
 D 3. Dielectric Constant  
 D 4. Inductance  
 D 5. Resistance  
 D 6. Decrement  
 D 7. Phase difference (Power loss)  
 D 8. Current  
 D 9. Voltage  
 D 10. Signal intensity  
 D 11. Cathode-ray oscillograph  
 D 12. Direction of waves  
 D 13. General
- E. Properties of Materials**  
 E 1. Insulating Materials  
 E 2. Electrolytes  
 E 3. Magnetic Materials  
 E 4. Conductors
- F. Radio Theory**  
 F 1. Simple radio circuits  
 F 2. Coupled circuits  
 F 3. Resonance  
 F 4. Damping  
 F 5. Harmonics  
 F 6. Modulation  
 F 7. Beats  
 F 8. High-frequency resistance  
 F 9. Inductance  
 F 10. Capacity  
 F 11. Negative resistance  
 F 12. Rectification  
 F 13. Short Waves
- G. Radio Research**  
 G 1. Suggested subjects  
 G 2. Programs  
 G 3. Personnel
- H. Radio Instruction**  
 H 1. Military  
 H 2. Commercial  
 H 3. Courses of study  
 H 4. Schools
- I. Miscellaneous Radio Apparatus and Methods**  
 I 1. Transmitting sets  
 I 2. Arcs  
 I 3. Receiving sets  
 I 4. High voltage generators  
 I 5. Large current generators  
 I 6. Inductors  
 I 7. Condensers  
 I 8. Resistors  
 I 9. Spark gaps  
 I 10. Transformers  
 I 11. Amplifiers  
 I 12. Alternators, high-frequency  
 I 13. Induction coils  
 I 14. Detectors, crystal  
 I 15. Detectors, miscellaneous  
 I 16. Buzzers  
 I 17. Recording devices  
 I 18. Automatic devices  
 I 19. Telephone receivers  
 I 20. Interrupters  
 I 21. Modulating methods  
 I 22. Frequency changers  
 I 23. Protective devices  
 I 24. Rectifiers  
 I 25. Electric filters  
 I 26. Shielding and grounding  
 I 27. Laboratories  
 I 28. Manufacture  
 I 29. Impulse excitation  
 I 30. Switchboards
- J. Radio Communication and Applications**  
 J 1. High power  
 J 2. Continuous waves  
 J 3. Radiotelephony  
 J 4. Aircraft  
 J 5. Submarine  
 J 6. Navigation  
 J 7. Radio beacons  
 J 8. Commercial  
 J 9. Private  
 J 10. Traffic  
 J 11. Press  
 J 12. Stations  
 J 13. Installation  
 J 14. Operating  
 J 15. Interference  
 J 16. Railroad  
 J 17. Forestry  
 J 18. Mining  
 J 19. Military  
 J 20. Naval  
 J 21. Amateur  
 J 22. Time Signals  
 J 23. Standard wave transmission  
 J 24. Photographs—Transmission of  
 J 25. Induction signalling  
 J 26. Ground telegraphy  
 J 27. Buzzerphone  
 J 28. Furnaces  
 J 29. Wired wireless  
 J 30. Duplex systems  
 J 31. Codes  
 J 32. Secrecy systems  
 J 33. Wave length assignment  
 J 34. Radio control system  
 J 35. Tree telegraphy  
 J 36. Historical  
 J 37. National developments
- K. Radio Miscellaneous**  
 K 1. Bibliographies  
 K 2. Patents  
 K 3. Symbols  
 K 4. Terminology  
 K 5. Standardization (rules)  
 K 6. Legislation and regulation  
 K 7. Engineering precautions  
 K 8. Towers  
 K 9. Graphical methods  
 K 10. Tables  
 K 11. Biographical  
 K 12. Non-technical  
 K 13. Societies  
 K 14. Reports of meetings  
 K 15. Design  
 K 16. Miscellaneous  
 K 17. Specifications
- L. Electrical Subjects Related to Radio**  
 L 1. Motor generators  
 L 2. Switches  
 L 3. Telephony  
 L 4. Batteries, primary  
 L 5. Batteries, secondary  
 L 6. Battery-charging devices  
 L 7. Thermophones  
 L 8. Generators  
 L 9. Relays  
 L 10. Transformers  
 L 11. Oscillographs  
 L 12. Galvanometers  
 L 13. Reactance Coils  
 L 14. Ammeters  
 L 15. Voltmeters  
 L 16. Electro-dynamometers  
 L 17. Piezoelectric phenomena  
 L 18. Submarine cable  
 L 19. Frequency meters  
 L 20. Wave form analysis  
 L 21. Telegraphy  
 L 22. Bridges  
 L 23. Mercury vapor tubes  
 L 24. X-Ray tubes  
 L 25. Miscellaneous
- M. Miscellaneous**  
 M 1. Visual signalling  
 M 2. Airplane mail service  
 M 3. Lightning  
 M 4. Photoelectric Phenomena  
 M 5. Vacuum apparatus  
 M 6. Mathematics  
 M 7. Mechanics  
 M 8. Sound  
 M 9. Heat  
 M 10. Light  
 M 11. Chemistry  
 M 12. Infra-red signalling  
 M 13. Submarine signalling

## INDEX TO CLASSIFICATION

- Abacs—see Graphical methods (K-9)  
 Aircraft (J-4) see also Transmitting (I-1)  
 and Receiving Apparatus (I-3)  
 Airplane—see Aircraft (J-4)  
 Airplane Mail Service (M-2)  
 Alternators, high-frequency (I-12)  
 Amateur (J-21)  
 Ammeters (L-14)  
 Ammeters—Radio. See Current Measure-  
 ment (D-7)  
 Amplifiers (electron tube) (C-6)  
 Amplifiers (miscellaneous) (I-11)  
 Antennas (B)  
 Apparatus—miscellaneous radio (I)  
 Applications—radio (J)  
 Applications of Electron tubes to Radio  
 Measurements (C-11)  
 Arcs (I-2)  
 Artificial antennas (B-9)  
 Atmospheric (A-4)



- Audibility—see (A-4) Signal Intensity (D-10)  
 Audions—see Electron Tubes (C)  
 Autodyne—see Beats (F-7)  
 Automatic devices (I-18)  
 Balloon—see Aircraft (J-4)  
 Battery-charging devices (L-6)  
 Batteries, primary (L-4)  
 Batteries, secondary (L-5)  
 Beats (F-7)  
 Bibliographies (K-1)  
 Biographical (K-11)  
 Braun tube—see Cathode-Ray Oscillograph (D-11)  
 Bridges (L-22)  
 Buzzerphone (J-27)  
 Buzzers (I-16)  
 Capacitive coupling—see Coupled Circuits (F-2)  
 Capacity—measurement (D-2)  
 Capacity—theory (F-10)  
 Cathode-ray oscillograph (D-11)  
 Cathode-ray tube—see Cathode-Ray Oscillograph (D-11)  
 Chemistry (M-11)  
 Codes (J-31)  
 Coil Aerials (B-4)—see also Direction Finders (B-6)  
   Induction Signalling (J-25)  
 Coils—properties of—see Inductors (I-6)  
 Commercial radio instruction (H-2)  
 Commercial radio communication (J-8)  
 Constants of antennas (B-8)  
 Condensers (I-7)  
 Conductors (E-4)  
 Continuous waves (J-2)—see also Electron Tubes (C) Arcs (I-2) Alternators (I-12)  
 Corona—see Electrical Subjects—Miscellaneous (L-25)  
 Courses of study (H-3)  
 Coupled circuits (F-2)  
 Current measurement (Radio) (D-8)  
 Damped waves—see Spark Gaps (I-9)  
 Damping—theory (F-4)  
 Decrement (D-6)  
 Decimeters—see Decrement (D-6)  
 Design (K-15)  
 Detectors, crystal (I-14)  
 Detectors—Electron Tube (C-5)  
 Detectors, miscellaneous (I-15) see also Negative Resistance Theory (F-11)  
 Dielectric constant—measurement (D-3)  
 Dielectric loss—see Phase Difference (D-7)  
 Direction finders (B-6) see also Coil Aerials (B-4) Radio beacons (J-6)  
 Direction finding—see Aircraft (J-4) Direction Finders (B-6) Directional Properties (A-5)  
 Direction of waves—Measurement (D-12)  
 Directional properties of radio waves (A-5)  
 Directive antennas (B-5)  
 Dischargers—see Spark Gaps (I-9)  
 Duplex systems (J-30)  
 Eclipse phenomena—see Transmission Phenomena (A-3)  
 Eithoven—see Galvanometers (L-12) Recording devices (I-17)  
 Electrical filters (I-25)  
 Electrodynamometers (L-16)  
 Electrolytes (E-2)  
 Electromagnetic theory (A-1)  
 Electron emission (C-1)  
 Electron relays—see Electron Tubes—Amplifiers (C-6)  
 Electron tube detectors (C-5)  
 Electron tube generators (C-4)  
 Electron tubes (C)  
 Elevated (condenser) antenna (B-1)  
 Engineering precautions (K-7)  
 Filters—electrical (I-25)  
 Fog Signalling—see Radio Beacons (J-7)  
 Forestry (J-17)  
 Frequency changers (I-22)  
 Frequency (Measurement)—see Radio Measurements—Wave Length (D)  
 Frequency meters (L-19)  
 Fullerphone—see Buzzerphone (J-27)  
 Furnaces (High-frequency) (J-28)  
 Galvanometers (L-12)  
 Gaps—see Spark (I-9) Arc (I-2)  
 Generators (L-8)  
 Graphical methods (K-9)  
 Ground connections (B-7)  
 Ground telegraphy (J-26)  
 Ground and underground antennas (B-2)  
 Harmonic analysis—see Wave-form analysis (L-20)  
 Harmonics (F-5)  
 Heat (M-9)  
 Heterodyne (C-10) see also Beats (F-7)  
 High-frequency alternators (I-12)  
 High-frequency oscillograph—see Cathode-Ray Oscillograph (D-11)  
 High-frequency resistance (F-8)  
 High power radio communication (J-1), see also Stations (J-12)  
 High-speed traffic—see Automatic Devices (I-18)  
 High voltage generators (I-4), see also Rectifiers (I-24)  
 Historical (J-36)  
 Hot-Wire instruments—see Current Measurement (D-7)  
 Impulse excitation (I-29)  
 Incendiary radio—see Engineering Precautions (K-7)  
 Inductance—Measurement (D-4)  
 Inductance—Theory (F-9)  
 Induction coils (I-13)  
 Induction signalling (J-25)  
 Inductive coupling—see Coupled Circuits (F-2)  
 Inductors (I-6)  
 Infra-red signalling (M-12)  
 Installation (J-13)  
 Instruction—Radio (H)  
 Insulating materials (E-1), see also Phase Difference (D-7)  
 Interference (J-15)  
 Interrupters (I-20)  
 Ionization Phenomena (C-2)  
 Kenotrons—see Electron Tubes (C)  
 Laboratories (I-27)  
 Lamps—see Electron Tubes (C)  
 Large current generators (I-5)  
 Legislation and regulation (K-6)  
 Light (M-10)  
 Lightning (M-3)  
 Longitude determination by radio—see Time signals (J-20)  
 Loops—see Coil Aerials (B-4) and Direction Finders (B-6)  
 Magnetic materials (E-3)  
 Manufacture (I-28)  
 Mathematics (M-6)  
 Measurements—Radio (D)  
 Mechanics (M-7)  
 Mercury vapor tubes (L-23)  
 Meteorology—see Atmospherics (A-4)  
 Methods—Miscellaneous radio (I)  
 Military radio communication (J-19)  
 Military radio instruction (H-1), see also Military Radio Communication (J-19)  
 Mining (J-18)  
 Miscellaneous—Radio (K-16)  
 Miscellaneous electrical subjects (L-25)  
 Modulating methods (I-21)  
 Modulation—Theory (F-6)  
 Modulation—see also Radiotelephony (J-3) and (C-7)  
 Modulators—Electron tube (C-9)  
 Motor generators (L-1)  
 National developments—(radio) (J-37)  
 Naval radio communication (J-20)  
 Navigation—Radio applications to (J-6), see also Submarine Radio (J-5)  
 Negative resistance—Theory (F-11)  
 Nomograms—see Graphical Methods (K-9)  
 Non-technical radio (K-12)  
 Operating (J-14)  
 Oscillation transformers—see Transformers (I-10)  
 Oscillographs (L-11)  
 Quenched gaps—see Spark Gaps (I-9)  
 Patents (K-2)  
 Personnel (G-2)  
 Phase difference (power loss) (D-7)  
 Photoelectric phenomena (M-4)  
 Photographs—Transmission of (J-24)  
 Piezoelectric phenomena (L-17)  
 Plotrons—see Electron Tubes (C)  
 Power loss—see Phase Difference (D-7)  
 Power tubes—see Electron Tubes—Generators (C-4)  
 Press traffic (J-11)  
 Private Radio Communication (J-9)  
 Programs (Research) (G-2)  
 Propagation—see Transmission Phenomena (A-3)  
 Properties of electron tubes (C-3)  
 Properties of materials (E), see also Radio Measurements (D)  
 Protective devices (I-23)  
 Radiation and reception (A-2)  
 Radiation—see also Transmission Phenomena (A-3)  
 Radio beacons (J-7), see also Direction Finders (B-6)  
 Radio control system (J-34)  
 Radiotelephony (J-3)  
 Radiotelephony with electron tubes (C-7)  
 Railroad radio communication (J-16)  
 Reactance coils (L-13)  
 Received signals—see Signal Intensity (D-10)  
 Receiving sets (I-3)  
 Recording devices (I-17)  
 Rectification (F-12)  
 Rectifiers (I-24), see also Photoelectric Phenomena (M-4), Electron Tubes (C), Detectors, Miscellaneous (I-15)  
 Regulator tubes (C-8)  
 Relays (L-9)  
 Reports of meetings (K-14)  
 Research—Radio (G)  
 Resistance measurement (D-5)  
 Resistors (I-8)  
 Resonance (F-3)  
 Resonance transformers—see Transformers (I-10)  
 Rotary gaps—see Spark Gaps (I-9)  
 Safety—see Engineering Precautions (K-7)  
 Schools (radio) (H-4)  
 Secrecy systems—Radio (J-32)  
 Shielding and Grounding (I-26)  
 Short waves (F-13)  
 Signal Corps—see Military Radio (J-19)  
 Signal intensity measurement (D-10)  
 Simple radio circuits (F-1)  
 Societies—Radio (K-13)  
 Sound (M-8), see also Signal Intensity Measurement (D-10)  
 Spark gaps (I-9)  
 Special types of antennas (B-3)  
 Specifications (K-17)  
 Standard wave transmission (J-23)  
 Standardization (K-5)  
 Static—see Atmospherics (A-4)  
 Stations (J-12)  
 Strays—see Atmospherics (A-4)  
 Submarine—Radio communication (J-5)  
 Submarine cable (L-18)  
 Submarine signalling (M-13)  
 Suggested subjects for research (G-1)  
 Switchboards—Radio (I-30)  
 Switches (L-2)  
 Symbols—Radio (K-3)  
 Tables (K-10)  
 Telegraphy (L-21)  
 Telephone receivers (I-19)  
 Telephony (wire) (L-3)  
 Terminology radio (K-4)  
 Theory—Radio (F)  
 Thermal ammeters—see Current measurement (D-7)  
 Thermionic tubes—see Electron Tubes (C)  
 Thermocouples—see Current Measurements (D-8)  
 Thermoclements—see Current Measurements (D-8)  
 Thermophones (L-7)  
 Time Signals (J-22)  
 Towers—Radio (K-8)

- Traffic (J-10)
- Traffic regulations—see Legislation (K-6)
- Transformers (commercial) (L-10)
- Transformers (radio) (I-10)
- Transmission phenomena (A-3)
- Transmitting apparatus—see Stations (J-12)
- Transmitting sets (I-1), see also Electron Tube Generators (C-4)
- Tree telegraphy (J-36)
- Triodes—see Electron Tubes (C)
- Tropical radio—see Interference (J-15)
- Tubes—see Electron Tubes (C)
- Tuning—see Resonance (F-3)
- Ultraudions—see Electron Tubes (C)
- Undamped waves—see Continuous Waves (J-2), Electron Tubes (C), Arcs (I-2), Alternators (I-12)
- Vacuum tubes—see Electron Tubes (C)
- Vacuum apparatus (M-5)
- Valves—see Electron Tubes (C)
- Vibration galvanometers—see Galvanometers (L-12)
- Visual signalling (M-1)
- Voltage measurement (D-9)
- Voltmeters (L-15)
- Wave form analysis (L-20)
- Wave length measurement (D-1)
- Wave length assignment (J-33)
- Wave phenomena—Radio (A)
- Waves on wires (A-6)
- Wired wireless (J-29)
- X-Ray tubes (L-24)

THE foregoing classification and index, published through the courtesy of Dr. S. W. Stratton, Director of the Bureau of Standards, offers very considerable advantages to those who keep a file of notes and articles, or a directory of publications in which radio articles have appeared.

Dr. Stratton has stated that this is not a final classification, and has asked for suggestions on any subjects or methods by which it can be made more complete. In its present form, however, it serves admirably the needs of engineers and experimenters.

There are two methods of using the classification. One is to purchase a standard Irving-Pitt loose-leaf binder which takes 8½- by 11-in. paper. Heavy cardboard sheets, bearing the classification letters, will serve for the main divisions. Then clippings can be pasted or fastened with rubber cement to sheets bearing the subdivision numbers. This system has the disadvantages of being cumbersome, and requiring the cutting of the publications.

A better way is to keep the publications intact, and simply note the name, date, and page on a card arranged in a small index.

### RADIO EQUIPMENT FOR SMALL BOATS

(Continued from page 350)

former is mounted at the front on the small center panel. The rotary gap is carried on the shaft of the motor generator. Insulated terminals and the phase adjusting handle can be seen in the side view.

Any one of three wavelengths, 300, 450 or 600 meters, can be selected by

the handle at the front of the upper panel. A set of this sort is generally used on such boats as can accommodate an operator, or where one of the crew is capable of handling the radio apparatus.

### BOOK REVIEW

(Continued from page 347)

The set is of the standardized panel type so designed as to simplify to the greatest extent the work of building a long wave receiver.

The particular value of this pamphlet lies in the fact that specific directions are given on the condensers and inductances so that the set can be depended upon to operate over its rated range of wavelengths at maximum efficiency. With a set of this type and a single wire 300 ft. long, European stations have been copied clearly at New York, without the use of an amplifier.

### TWO STEP AUDIO FREQUENCY AMPLIFIER

(Continued from page 346)

side of the transformer. The detector B battery is left in circuit, as no provision is made on the amplifier to supply the detector plate potential.

A quick adjustment of the amplifier rheostats puts the set in operation, after the detector has been adjusted. Oftentimes the operation is improved by changing tubes, for, though they are designed to have similar characteristics, vacuum tubes do vary.

This amplifier can be used with the radio frequency amplifier described in the March, 1920, issue of EVERYDAY ENGINEERING. The audio frequency amplifier is simply inserted in the detector circuit. With this combination, signals which can be barely heard with only a detector, come in so loudly that the phones cannot be kept on the ears.

Fig. 8 gives a wiring diagram of the amplifier used with the audion receiver described in the March, 1920, issue.

### A SIMPLE METHOD OF MEASURING INDUCTANCE AT LOW FREQUENCIES

(Continued from page 355)

#### METHOD OF PROCEDURE

1. Determine the correction factor  $R_c$  as explained under corrections.
2. Calibration of the bridge.

Connect a standard inductance of known value across the terminals UV and readjust the resistances R and  $r_2$  until minimum sound is heard in the receivers.

Subtract from the value of R obtained to produce balance the correction factor  $R_c$ . To obtain the multiplying factor M of the bridge divide the value of inductance in millihenrys by the result obtained above.

Inductance in millihenrys

$$R - R_c$$

This factor is approximately .1 when the switch k is open and .01 when it is closed.

#### MEASUREMENT OF AN UNKNOWN INDUCTANCE

1. Obtain the value of the correction factor  $R_c$  and the multiplying constant of the bridge M as explained above.

2. Connect the inductance to be measured to the terminals U and V of the bridge and readjust R and  $r_2$  until a balance is obtained.

The unknown inductance is then calculated in the following way.

L in millihenrys =  $M (R_c - R_c)$  where  $R_c$  is the value of R for balance when L unknown is connected.

A numerical example may help to illustrate the method. Suppose  $R_c = 2$  ohms. Let switch K be open. Connect a 1 millihenry coil to the terminals of the bridge and suppose the value of R = 13 ohms. The multiplying constant of the bridge is then:

$$1 \text{ millihenry} \quad 1$$

$$M = \frac{1}{13-2} = \frac{1}{11} = .091$$

Suppose now that when the unknown inductance is connected to U and V and the resistance R necessary to balance the bridge is 75 ohms, the inductance can be calculated as follows:

$$L = .091 (75-2) = 6.64 \text{ millihenry}$$

In the April 7th issue of *The Aeroplane*, under the heading "On American Credulity" is suggested (by an American paper) the transmission of power to an aeroplane in flight by "wireless."

Suppose two power-transmitting stations are 10 miles apart, a machine can only be five miles from the source of power, so the wireless power-wave that reaches the machine would have proceeded through space five miles, not direct to the aeroplane but in every direction. That is, the power-wave reaching the machine would be part of huge wave in the form of a sphere five miles in radius (for of course wireless waves travel through the earth as well as the atmosphere) having a total area of 8,758,000,000 sq. ft.

If we assume the aerial on the machine covers 10 sq. ft. the energy derived by the

receiving apparatus will be only  $\frac{10}{875,800,000}$  of the total transmitted from the source, or only 0.000,000,114 per cent. If the machine requires a constant 400 h.p. the total transmitted power will have to be 350,320,000,000 h.p.

I think this will show what possibilities this system has!—G. GORDON DENNOON.

**MAKING WOOD FIRE RESISTANT WITH PAINT**

**F**IRE retardent paints are the most practical means so far discovered by the Forest Products Laboratory by which small amounts of wood can economically be made fire resistant. The only other known methods of decreasing the inflammability of wood are to keep it wet, or to inject into it certain chemicals under pressure. These methods, though more effective than painting, are usually either impracticable or too expensive to be considered.

Ordinary calcimine or whitewash has proved in tests to be as fire resistant as any paint covering tried. It is cheap and convenient to use. Although it will not prevent the burning of wood exposed continuously to a high heat, a good coat of calcimine on wood will decrease the danger of a blaze spreading from burning cigarettes, sparks, matches, and similar small sources of fire. Calcimine is, of course, more effective for inside than for outside use.

For exterior use numerous patented fire retardent paints are available. An effective outdoor paint which has been developed at the Forest Products Laboratory consists of linseed oil, zinc borate, and chrome green. This paint has maintained its fire-resisting properties through more than three years of exposure to the weather.

**RUST PROOFING**

**T**HERE is a constant demand for cheap, simple treatments of iron and steel which will give uniform coatings which are rust-proof. Sherardizing and galvanizing are well known, as is also the Bower-Barff process, which produces a surface composed mainly of Fe<sub>3</sub>O<sub>4</sub>. To this list may be added the recently improved phosphatic coatings which seem to be cheaper than the other processes and to give a uniformity of coating that is much in its favor.

The processing solution is composed of phosphoric acid, iron phosphate and manganese dioxide. The bath must be used under controlled conditions and is kept in constant circulation. The articles are immersed for from one to two and a half hours at a temperature of 210-212 degrees F. The treatment is considered finished when the evolution of gas ceases, whereupon the work is dried and dipped in a paraffine oil mixture and afterwards set upon pans or racks to drain. The materials treated are said to be resistant to rust and stand exposure very satisfactorily. The process is particularly adapted for the treatment of tools, motor parts, typewriter parts, and other similar pieces which should be rustproof and at the same time attractive in appearance.—*Scientific American*.

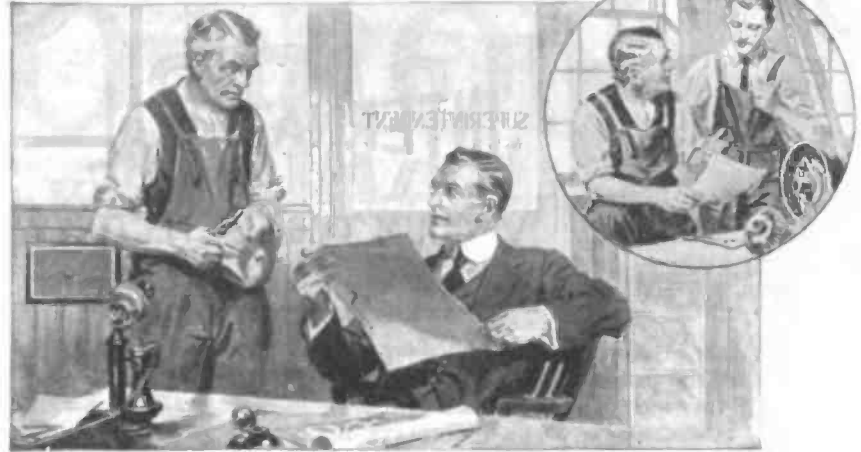

**“You’ve Gone Way Past Me, Jim”**

“Today good old Wright came to my office. All day the boys had been dropping in to congratulate me on my promotion. But with Wright it was different.

“When I had to give up school to go to work I came to the plant seeking any kind of a job—I was just a young fellow without much thought about responsibilities. They put me on the payroll and turned me over to Wright, an assistant foreman then as now. He took a kindly interest in me from the first. ‘Do well the job that’s given you, lad,’ he said, ‘and in time you’ll win out.’

“Well, I did my best at my routine work, but I soon realized that if ever I was going to get ahead I must not only do my work well, but prepare for something better. So I wrote to Scranton and found I could get exactly the course I needed to learn our business. I took it up and began studying an hour or two each evening.

“Why, in just a little while my work took on a whole new meaning. Wright began giving me the most particular jobs—and asking my advice. And there came, also, an increase in pay. Next thing I knew I was made assistant foreman of a new department. I kept right on studying because I could see results and each day I was applying what I learned. Then there was a change and I was promoted to foreman—at good money, too.

“And now the first big goal is reached—I am superintendent, with an income that means independence, comforts and enjoyments at home—all those things that make life worth living.

“Wright is still at the same job, an example of the tragedy of lack of training. What a truth he spoke when he said today, ‘You’ve gone way past me, Jim—and you deserve to.’ Heads win—every time!”

Yes, it’s simply a question of training. Your hands can’t earn the money you need, but your head can if you give it a chance.

The International Correspondence Schools have helped more than two million men and women to win promotion, to earn more money, to know the joy of getting ahead in business and in life.

Isn’t it about time to find out what they can do for you?

You, too, can have the position you want in the work of your choice, with an income that will make possible money in the bank, a home of your own, the comforts and luxuries you would like to provide your family. No matter what your age, your occupation, your education, or your means—you can do it!

All we ask is the chance to prove it—without obligation on your part or a penny of cost. That’s fair, isn’t it? Then mark and mail this coupon.

**INTERNATIONAL CORRESPONDENCE SCHOOLS**  
Box 6088R, SCRANTON, PA.

Explain, without obligating me, how I can qualify for the position, or in the subject, before which I mark X.

- |  |  |
|--|--|
| <input type="checkbox"/> ELECTRICAL ENGINEER       | <input type="checkbox"/> MECHANICAL ENGINEER       |
| <input type="checkbox"/> Electrician               | <input type="checkbox"/> SALESMANSHIP              |
| <input type="checkbox"/> Electric Wiring           | <input type="checkbox"/> ADVERTISING MAN           |
| <input type="checkbox"/> Electric Lighting         | <input type="checkbox"/> Show Card Writer          |
| <input type="checkbox"/> Electric Car Running      | <input type="checkbox"/> Outdoor Sign Painter      |
| <input type="checkbox"/> Heavy Electric Traction   | <input type="checkbox"/> RAILROADS                 |
| <input type="checkbox"/> Electrical Draftsman      | <input type="checkbox"/> ILLUSTRATOR               |
| <input type="checkbox"/> Electric Machine Designer | <input type="checkbox"/> DESIGNER                  |
| <input type="checkbox"/> Telegraph Expert          | <input type="checkbox"/> BUSINESS MANAGEMENT       |
| <input type="checkbox"/> Practical Telegraphy      | <input type="checkbox"/> Private Secretary         |
| <input type="checkbox"/> MECHANICAL ENGINEER       | <input type="checkbox"/> BOOKKEEPER                |
| <input type="checkbox"/> Mechanical Draftsman      | <input type="checkbox"/> Stenographer and Typist   |
| <input type="checkbox"/> Toolmaker                 | <input type="checkbox"/> Cert. Pub. Accountant     |
| <input type="checkbox"/> Ship Draftsman            | <input type="checkbox"/> Traffic Management        |
| <input type="checkbox"/> Machine Shop Practice     | <input type="checkbox"/> Commercial Law            |
| <input type="checkbox"/> Gas Engineer              | <input type="checkbox"/> GOOD ENGLISH              |
| <input type="checkbox"/> CIVIL ENGINEER            | <input type="checkbox"/> Common School Subjects    |
| <input type="checkbox"/> Surveying and Mapping     | <input type="checkbox"/> CIVIL SERVICE             |
| <input type="checkbox"/> FIRE FOREST OR HIGH       | <input type="checkbox"/> Railway Mail Clerk        |
| <input type="checkbox"/> ARCHITECT                 | <input type="checkbox"/> STATIONARY ENGINEER       |
| <input type="checkbox"/> Architectural Draftsman   | <input type="checkbox"/> Textile Designer or Supt. |
| <input type="checkbox"/> PLUMBING AND HEATING      | <input type="checkbox"/> AGRICULTURE               |
| <input type="checkbox"/> Sheet Metal Worker        | <input type="checkbox"/> Poultry Raising           |
| <input type="checkbox"/> Navigator                 | <input type="checkbox"/> Automobiles               |

Name \_\_\_\_\_ 7-2010  
 Present Occupation \_\_\_\_\_  
 Street and No. \_\_\_\_\_  
 City \_\_\_\_\_ State \_\_\_\_\_

**WIRELESS MANUAL**

We make a charge of 25c for it issuing a coupon receipt redeemable on a purchase of \$5 or more.

No. K-12  
Ready May 25

You cannot get satisfaction from wireless instruments unless they are absolutely perfect. The slightest imperfection in construction destroys their efficiency. We catalog and offer for sale wireless apparatus of the highest quality, guaranteed to be mechanically and electrically perfect. Get a copy of our complete wireless catalog and order all of your radio material from one source of supply and save trouble. Our 180 page combined Manual and Catalog illustrates and accurately describes the uses of standard radio instruments.

**MANHATTAN ELECTRICAL SUPPLY CO., INC.**  
 New York—17 Park Place  
 Chicago—114 So. Wells St.  
 St. Louis—1106 Pine St.  
 San Francisco—604 Mission St.

**NAPIER'S RODS AND THEIR USE**

(Continued from page 323)

addition of 3 to 9. It can all be seen in the cut. This gives 12. The 2 is put down as the fourth figure of the answer and the 1 is carried to the next addition, giving 1 and 4 and 1 to be added, making 6, the fifth number of the answer. The last or left-hand number of the product is 2. There is no addition for the left hand number; often there is 1 to be added to it from the preceding addition, which may have given 1 to carry.

The rods were sometimes made square and the four sides used for different sets of multiplications. It was his practise with four-sided rods to put the alternate sides in reverse; this is shown in the cut. The rods were very popular in old times; at the tercentenary of Sir Charles Napier, which was celebrated in Edinburgh a few years ago, a number of sets were exhibited, which had come down from former days. On square rods the numbers were so selected that the sum of the index numbers on alternate faces were equal. The sequence of numbers on the four faces of the rods ran as follows: 9, 8, 0, 1; 7, 9, 2, 0; 6, 9, 3, 0; 3, 4, 6, 5 and so on. They ran ten to the set, and a typical size was 2½ inches long and 3/16 inch square.

When square rods with reversed figures are used, the top index figure has to be omitted, and only nine squares put on each rod.

**TO MAKE A HOLE IN GLASS**

**MAKE** a circle of clay or cement rather larger than the intended hole; pour some kerosene into the cup thus formed, ignite it, place the plate upon a moderately hard support, and with a stick rather smaller than the hole required, and a hammer, strike a rather sharp blow. This will leave a rough-edged hole, which may be smoothed with a file. Cold water is said to answer even better than a blow.

While phosphorus is an excellent ingredient in bronzes if used properly, it can likewise become harmful if not employed in the right manner. Too much phosphorus in the copper and tin bronzes (without zinc in them) will cause the tin to separate in hard "tin-spots." When zinc is present in the bronzes, a very small amount of phosphorus only can be employed. A large amount causes blowholes. The amount of phosphorus to use is as follows: When no zinc is present, about 0.25 per cent. When zinc is present, from 0.01 to 0.02 per cent.



# RADIO INTERNATIONAL RADIO

## VACUUM TUBE DETECTOR or SINGLE STAGE AMPLIFIER

Single tube Detector and Amplifier Units are among the most useful of the Interchangeable panel instruments in the International Experimental Apparatus Line.

READY FOR IMMEDIATE DELIVERY

**AUDION DETECTOR RTD-102-A . . . . . \$15.00**

**SINGLE STAGE AMPLIFIER RTA-104-A. \$26.00**

F. O. B. NEW YORK CITY

Write to Department 21 for our new FREE six-page catalogue.

**International Radio Telegraph Company**  
326 BROADWAY NEW YORK CITY

**We're Prompt!**

You don't have to wait from three weeks to three months, for the apparatus you order. On everything except apparatus specially constructed to order, you'll have the benefit of

**Shipment Guaranteed Within Twenty-Four Hours**

**Audions and Amplifiers**

- Audion Control ..\$22
- Without bulb or B batteries:—
- 1 Step Amplifier
- Without Detector..\$28
- With Detector ...\$33
- 2 Step Amplifier
- Without Detector..\$45
- With Detector ...\$50

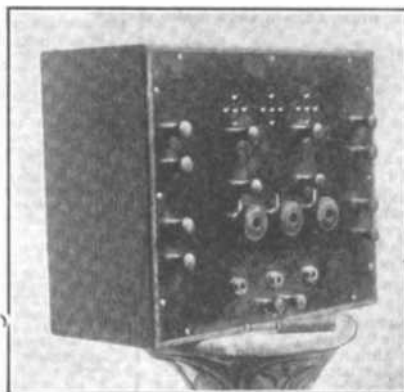

**10-Ampere  
Reco Key**

Mounted on Italian marble base, with solid silver bar contact points, finished in brushed brass or nickel. Absolutely no side play in this Key. A great big special at \$6.50 postpaid.

If you want a bright, snappy, monthly bulletin that means something; send us 6c in stamps. **NEW!** An Adaptor for Tubular Bulbs—fits any socket; is rugged—simple and 100 per cent. efficient, and positively vibration-proof—immediate Delivery **\$1.50**

Radisco Agents for the South  
**C. D. BLAIR**  
P. O. B. 859  
Richmond, Va.

**The Radio Engineering Co.**  
Baltimore, Md.

614  
North Calvert  
Street

**PRACTICALLY ANYTHING A RADIO MAN WANTS IS SOLD AT THE STORE OF THE American Electro Technical Appliance Company**

HERE ARE SOME OF THE INSTRUMENTS KEPT IN STOCK  
Filament Ammeters for Radio work, made by Reiler-Smith, 0-1, 0-2 Amperes. List Price, \$8.20 **SPECIAL \$6.00**

- |  |  |
|--|--|
| <p>Loose Couplers, \$5.00, \$10.00, \$15.00, \$19.00.</p> <p>Tuning Coils, 4,000 Meters, \$4.75; 1,250 Meters, \$3.50.</p> <p>Murdock Variable Condensers, .001 MFD, \$4.75; .0005, \$3.75.</p> <p>DeForest Variable Condensers Always On Hand.</p> <p>Fixed Condensers, .002 MFD, 70c; .003, 90c.</p> <p>Oscillation Transformer (Murdock Type), \$5.00.</p> <p>Lightning Switch, 600 V.-100 AMP., \$8.94.</p> <p>Switch Points 3/16"x3/16", Threaded Shank with Nut, 3c Ea.</p> <p>Switch Points, 3/16"x3/16" with Machine Screw, 20c Per Doz.</p> | <p>White Metal Dials, 3", 50c.</p> <p>Blinding Posts, 9c, 10c, 12c and 20c.</p> <p>Paragon Rheostats, \$1.75.</p> <p>DeForest Rheostats, \$1.00.</p> <p>All the Wireless Press Books.</p> <p>Marconi VT Bulbs, \$7.00; Socket for Same, \$1.50.</p> <p>Murdock VT Socket, \$1.00; DeForest Type, \$1.50.</p> <p>Western Electric Phones, \$12.00.</p> <p>Complete Stock of DeForest, Murdock and Grebe Manufacture.</p> <p>Loads of Other Apparatus on Hand.</p> |
|--|--|
- AMERICAN ELECTRO TECHNICAL APPLIANCE COMPANY**  
DEPT. EM, 235 FULTON STREET NEW YORK CITY

Please mention EVERYDAY ENGINEERING MAGAZINE

# AUDIOTRON

*The Original Tubular Vacuum Detector, Amplifier, Oscillator*

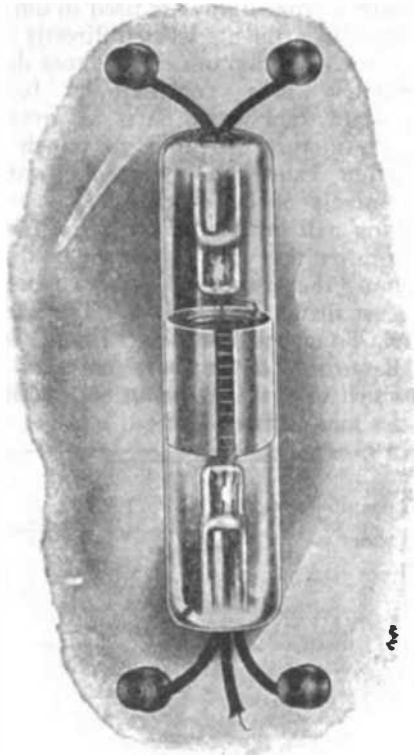

## NOW FREE FROM ALL RESTRICTIONS

*Dealers and Amateurs!—*

AUDIOTRONS, recognized as the most sensitive detectors ever produced, are now offered for amateur and experimental uses in radio communication without any restrictions whatever. They are no longer limited to audio frequency and can now be used as detectors and oscillators as well as amplifiers.

All patent questions also have been definitely settled. AUDIOTRON is the first and only amateur vacuum tube licensed under Fleming. Vacuum tube patents are basic and have been sustained by the Federal Courts.

Be sure to get genuine AUDIOTRONS. They outclass any other form of detector and are absolutely free from all legal restrictions or difficulties. These new uses make it even more necessary to insist on the genuine. You can always tell a real AUDIOTRON by the name stamped plainly on the glass.

Insist on the name AUDIOTRON on every tube you purchase! Fully guaranteed by the AUDIOTRON Mfg. Co. (Read the guaranty below.)

## Your last chance for an AUDIOTRON <sup>double filament</sup> DETECTOR

Manufacturing reasons make it impossible to continue the present hand made AUDIOTRON.

This type has a double filament of special thorium tungsten and the operating life is over 2,000 hours. No special socket is required. The electrical and mechanical dimensions result in a heavy plate current and corresponding signal strength. Plate voltage under 40.

The few thousand that will still be produced, however, will be of the same standard of excellence that has characterized every AUDIOTRON. Already recognized as the most sensitive detector on the market, these few that still remain, with all restrictions on amateur use lifted,

are undoubtedly the greatest opportunity ever offered to amateur radio operators.

See your dealer at once or order direct. Be sure to benefit by this last opportunity to secure a hand made super-sensitive double filament AUDIOTRON Detector, Amplifier, Oscillator.

**\$6.00 each**

**No Increase in price**

The AUDIOTRON Exclusive Guaranty: Each and every AUDIOTRON is guaranteed to arrive in good condition and to prove fully satisfactory. Replacement of unsatisfactory tubes will be made free of charge.

**AUDIOTRON MFG. COMPANY**

(Successors to the AUDIOTRON Sales Co.)

Dept. V      Lick Bldg.      San Francisco, California

**Dealers—**  
Get in touch with the AudioTron Mfg. Co. at once. We will give you full information about settlement of all patent difficulties. You will also be interested in our new proposition for wide awake dealers.  
After the present supply is exhausted, new types of AudioTron, manufactured entirely by machinery, will be offered for sale. Our extensive advertising during the Fall will establish definitely the superiority of the AudioTron and will create new sales for you. Be sure to take advantage of our full co-operation at once. Prepare to cash in on the AudioTron reputation, established since 1916.  
Write us today for full details.



# NEW RADIO PRODUCTS and PERSONAL SERVICE

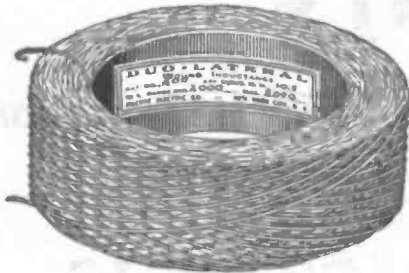

In endeavoring to give personal service to our ever growing clientele, we realize that new and more modern products make for the betterment and improvement of radio work and to this end we offer you the latest scientific achievement in radio

## DUO LATERAL WOUND COILS

made in several different sizes covering every wavelength, these coils have staggered winding and a lower natural period, lower high frequency resistance, very low distributed capacity, lower D. C. resistance and higher self inductance, which makes it an ideal part of any set and superior to all other coils for amateur work.

Radio Engineers have made extensive tests of these coils and give them their highest recommendations.

### ORDER BY CATALOG NUMBER AS LISTED

Catalog Number	Working Wavelength Range in Meters	Inductance in Millihenries	List Price Each Unmounted
25	130 to 250	.045 .045	\$ .90
35	180 to 450	.075 .073	1.00
50	250 to 700	.156 .15	1.10
75	400 to 900	.36 .34	1.20
100	500 to 1400	.66 .57	1.30
150	600 to 2000	1.40 1.35	1.40
200	1000 to 2500	2.50 2.30	1.50
250	1200 to 3500	4.2 4.	1.60
300	1500 to 4500	6.25 6.1	1.80
400	2000 to 5000	10.62 10.2	2.00
500	3000 to 6000	17.6 17.3	2.20
600	4000 to 10000	25.0 22.0	2.50
750	5000 to 12000	38.0 35.3	2.70
1000	6000 to 15000	72.8 68.3	2.90
1250	10000 to 20000	116.6 112.3	3.50
1500	15000 to 25000	171.5 162.2	4.00

We also carry a large stock of high grade electrical apparatus, including a very complete line of heating appliances.

You have our most courteous invitation to spend a few moments in our spacious show rooms and look over our complete stock. We will gladly show you any instrument or part you may desire to examine. It will be a revelation to you, besides it is part of our service.

OUR WORD OF HONOR TO YOU IS  
OUR GUARANTEE. LET US PROVE IT.

Write Dept. F6 for literature and price lists

## CONTINENTAL RADIO AND ELECTRIC CORP.

J. DiBlasi, Secy.  
6 Warren Street

J. Stantley, Treas.  
New York

## SUMMER CONSTRUCTION

of that new radio set should incorporate new, efficient and inexpensive improvements. "ARRANBEE JACKS AND PLUGS" accomplish such a purpose.

Use "ARRANBEE JACKS AND PLUGS" for cutting in additional headsets; on receiving or audion control panels in place of binding posts; for miniature experimental board for conveniently variable vacuum tube or other circuits, and for hundreds of other practical uses.

"ARRANBEE JACKS AND PLUGS" mean a new era in construction of future radio instruments. Go to your dealer NOW and ask him for them. He will get them for you if you want them. Made by the makers of the famous "STANDARD VT BATTERY."

"ARRANBEE JACKS AND PLUGS," nickel plated, \$1.50 per dozen.

RICHTER & BYRNE, Manufacturers

198 Roebing Street, Brooklyn, N. Y.

PACENT ELECTRIC CO., Inc., SOLE EASTERN AGENTS, 150 NASSAU ST., NEW YORK CITY.



Should you know of a worthy young man desirous of obtaining a good technical education and making a good future for himself refer him to our announcement on page 379 of this number.

Please mention EVERYDAY ENGINEERING MAGAZINE

## SIMPLE APPLIANCE SAVES LAMPS

By A. A. Michaud

HUNDREDS of shop managers and plant office managers are apt to overlook the largest and most important expense factor entering into lighting costs and by drawing their attention to it, they will eliminate the underlying cause and in consequence, lower the lighting bill considerably. This applies to hundreds of cases where powerful electric drop-lights are used in offices or shop departments located directly below a machine shop or other factory department, where considerable banging around, moving of parts in process of manufacture, trucking, or punch press action, causes the floor to vibrate excessively or jar quickly. The sudden bang will invariably break the filament or sever the wire in the lamp, directly under the disturbance, and a new lamp must then take its place. The filament of Tungsten lamps are more fragile than those of ordinary carbon lamps, which are rapidly being superseded by the more efficient type.

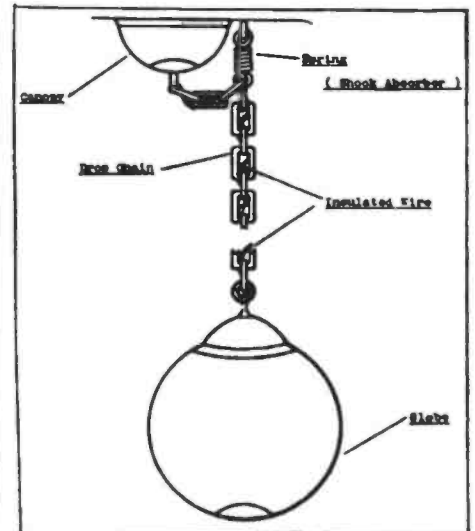

Spring suspension to save fragile lamps

An office using 40 250-volt, 200-watt lamps, and located under a machine shop (where only light parts were being manufactured) came under the writer's observation, and it developed that a daily average of four lamps were replaced at a cost of \$1.75 each, or a total daily expense in that department alone of \$7.00. As this daily loss was continued for a long time in an office with only 40 lights, located under a machine shop making light parts, the reader will appreciate the great saving to a company having many large offices and shops that come directly under departments making heavy parts, and the unnecessary expense incurred in some cases must amount to thousands of dollars annually. In fact, inasmuch as the bad lamps are usually replaced by the electrician or assistant before or after office hours—there being nearly adequate light during the day from nearby

lights not coming directly under the cause of destruction—this unnecessary expense is not likely to come under the observation of a responsible person. And, again, it is hardly necessary to mention the inconvenience sometimes felt when there is no light at all at a time when it is most needed, as in the case of sudden darkness brought about by an impending storm, or at a time when night work is required, in the offices that use very little artificial light during the day.

The accompanying drawing shows the practical remedy that was adopted several months ago by the concern using only 40 large drop lights in their offices, and the worth while saving has proved its practicability, and at the present time the lights in the shop are being equipped with these springs.

**BRUSH AND GAGE COMBINATION**

A CONCERN in Springfield, Mass., has brought out the gage illustrated herewith. The brush serves to clean the dirt from the hole to be gaged, and it is claimed that, thus equipped, the life of the gage is lengthened by not coming in contact with a hole charged with gritty substances. The bristles

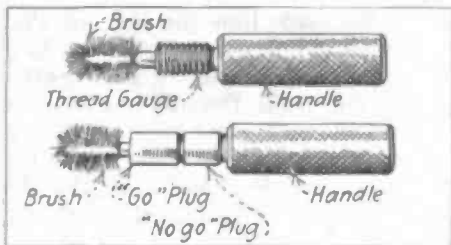

Brush and gage combination

are of slightly varying lengths so that when the brush is used in connection with a thread gage they tend to clean out the thread at both top and bottom. As plug gages are usually finished to limits of 1/10,000 of an inch with highly polished surfaces, the importance of inserting the gage into clean holes is important as it reduces the time needed for checking and refinishing due to wear from grit.

**DIE STOCK FOR SMALL DIES**

IN various classes of automobile and electrical work and also in machinery making, it is necessary to thread small screws or studs that cannot be removed from the place in which they are screwed very easily and which would be difficult to handle with the ordinary form of "T" handle die stock.

The tool illustrated is made by turning down a piece of steel to the size required to handle standard small, round dies. The shank of the device is a piece of pipe or tube, a 3/8-in. gas pipe being used in some cases, and this

(Continued on page 364)

**THE NEW  
A. R. Co Variable Condenser**

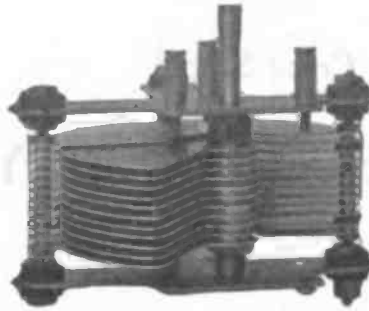

We offer Radio Men something out of the ordinary in variable condensers. This new model is a step ahead of its rivals in that the plates are made of aluminum and heavier than those found in the average condensers. The rotary plates are rounded at one end, not the usual semi-circular type, thus affording a straight line capacity, which is a very valuable feature in Wave Meter work. The zero capacity in an instrument of this type is considerably lower than that of usual condensers.

Shaft on which rotary plates are mounted is carefully machined from tool steel. Instrument can be quickly mounted in case or behind panel. Made in two capacities, furnished unmounted only, with or without dial of fine black moulded composition and bakelite knob. Backed up by Radisco guaranteed quality of workmanship and low price.

Capacity	Unmounted	With Dial & Knob
.0005 mf.	\$5.00	\$6.00
.001 mf.	6.25	7.25

Shipping weight 2 pounds.

Prices quoted do not include carrying charges to Pacific Coast or duty paid for Canadian use.

RADISCO AGENTS carry only apparatus of proven merit. Look for the Radisco trade mark on all parts you buy and be sure of getting efficient apparatus.

Below are listed a few of the reliable firms who carry the RADISCO COILS, Better "B" Batteries and are our Agents for all other standard apparatus of merit.

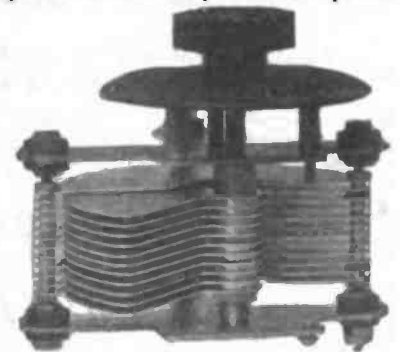

**COMMUNICATE YOUR WANTS TO THEM.**

- ALBANY, N. Y.  
E. L. Long,  
21 Magnolia Terrace
- ATLANTIC CITY, N. J.  
Independent Radio Supply Co.,  
118 So. New Jersey Ave.
- BALTIMORE, MD.  
Radio Engineering Co.,  
614 North Calvert St.
- BEINVILLE, QUEBEC, CAN.  
Canadian Radio Mfg. Co.
- BOSTON, MASS.  
Atlantic Radio Co.,  
88 Broad Street
- BROOKLYN, N. Y.  
Kelly & Phillips Electric Co.,  
312 Flatbush Ave.
- BRONX, NEW YORK  
Amateur Wireless Equipment Co.,  
1390 Prospect Ave.
- CHICAGO, ILL.  
Chicago Radio Laboratories,  
1316 Carmen Ave.
- EUREKA, PEORIA, ILLINOIS  
Klaus Radio Co.
- KANSAS CITY, MO.  
McCreary Radio Supply,  
4th and Delaware Streets
- LOS ANGELES, CALIF.  
The Wireless Shop,  
511 West Washington St.
- MONTREAL, CAN.  
J. B. Miller,  
1600 Hutchinson St.
- McKEESPORT, PA.  
K. & L. Electric Co.,  
427 Olive Street
- NEW ORLEANS, LA.  
L. A. Ross,  
121 Camp Street
- NEWARK, N. J.  
A. H. Corwin & Co.,  
4 West Park Street.
- NEWCASTLE, PA.  
Pennsylvania Wireless Mfg. Co.,  
507 Florence Ave. "8HA"
- PHILADELPHIA, PA.  
Philadelphia School of Wireless Telegraphy,  
Broad and Cherry Streets.
- PROVIDENCE, R. I.  
Rhode Island Elec. Equip. Co.,  
45 Washington Street.
- PITTSBURG, PA.  
Radio Electric Co.,  
3807 Fifth Ave.
- SEATTLE, WASH.  
Northwest Radio Service Co.,  
1801 Sixth Ave.
- SCRANTON, PA.  
Shotton Radio Mfg. Co.,  
P. O. Box 3,  
Branch 8 Kingsbury St.,  
Jamestown, N. Y.
- SPRINGFIELD, MASS.  
Electric Service Co.,  
585 Armory Street
- TORONTO, ONT., CAN.  
The Vimy Supply Co.,  
585 College Street.
- WASHINGTON, D. C.  
National Radio Supply Co.,  
808 Ninth Street, N. W.
- WICHITA, KAN.  
The Cosradio Co.,  
1725 Fairmount Ave.

If none of the above agencies are in your vicinity, communicate with  
**RADIO DISTRIBUTING COMPANY - Newark, New Jersey**

# ATTENTION AMATEURS

The only practical adapter

Price \$1.50

## RADISCO AGENCY

We make up sets to specifications



Made by the  
**AMATEUR WIRELESS EQUIPMENT CO.**

1390 Prospect Ave., Bronx, N. Y.

Catalogue sent on receipt of 10c, which may be deducted from first order.



Dealers write for proposition

## "Sparks" says:

### "Lasting Satisfaction"

is measured to a great extent by the initial quality of the radio apparatus you purchase.

Our high grade line of Standard-make Commercial and Amateur Radio equipment embodies the latest ideas in design and workmanship which assure you of lasting satisfaction under all operating conditions.

### Our Specialty

is rendering you such Service that you may always know your interests will be looked after as to Quality and price.

Call on us when in town. Your wants will be Quickly and Satisfactorily looked after.

Our latest catalog is yours for 10 cents to cover postage. Write for it today.



"Quality Radio Apparatus and service"

**The International Electric Co.**

Eugene Dynner, President  
226-A Fulton Street New York, N. Y., U. S. A.

## PRECISION AUDION CONTROL UNITS

TYPE AU-1	DETECTOR PANEL	.....	\$24.00
TYPE AU-1X	DETECTOR PANEL (For Tubular Audions)	.....	\$27.50
TYPE AU-3	TWO STAGE AMPLIFIER	.....	\$57.50
TYPE AU-4	TWO STAGE AMPLIFIER WITH DETECTOR	.....	\$67.50

Standard, compact instruments, mounted on dull grained finished Bakelite panels, tubes behind the panels. All types one size, measuring 7 $\frac{1}{8}$ " by 8 $\frac{3}{8}$ " and fitted in standard interchangeable cases measuring 4 $\frac{1}{4}$ " by 7 $\frac{3}{8}$ " by 8 $\frac{3}{8}$ " hand rubbed mission finish, and provided with hinged cover permitting inspection and tube renewals.

All instruments arranged to be used with regenerative circuits and sold without tubes or plate batteries.

**J. EDW. BROADBELT, JR.**

Maker of PRECISION RADIO EQUIPMENT

553 E. Thirty-eighth Street

Baltimore, Md.

## BE SURE AND ORDER YOUR COPY

OF EVERYDAY ENGINEERING MAGAZINE FOR AUGUST NOW TO INSURE GETTING IT

pipe is provided with a wooden or metal handle. A pin through the handle is used to secure that member to the shank and care should be taken in driving the pins at both ends of the tool so that they will be put to one side of the hole. This will hold the shank from turning just as securely as though they were driven right through the tube

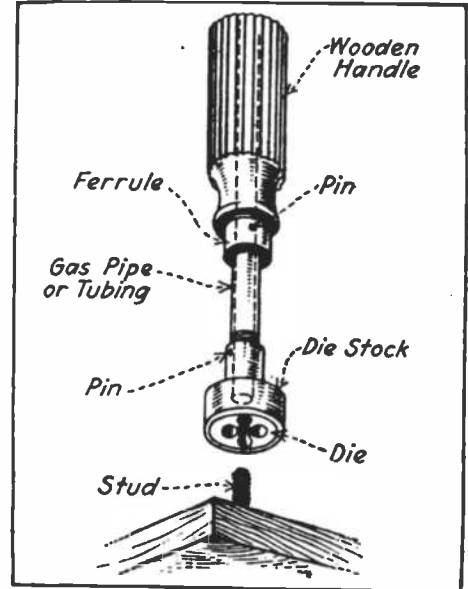

Die stock for small dies

and at the same time the bore of that member is not restricted so that long studs may be threaded. The central hole is cut right through the handle and it will be evident that very long threaded pieces may be made as the rod will pass into the handle as the die feeds down. The various uses of such a tool will suggest themselves to mechanical men.

### HANDY OILER FOR TOOLS

**M**ANY workmen and mechanics allow their tools to rust because of the bother of oiling up a rag and rubbing the tools over every time they leave them. To be continually fussing with an oil-can and an oily rag is more or less inconvenient so here is a little kink to relieve the situation.

Procure a small tin with a cover similar to a salve box. Then cut a strip of felt or heavy flannel just a little wider than the depth of the box and coil the strip of cloth inside until the box is completely filled. Press the layers together and squeeze in as much of the cloth as is necessary to make a compact mass.

Then saturate this felt-filled box with machine oil. When in the proper condition it will remind one of an ink-pad. Then when a tool is to be oiled simply remove the box cover and draw the tool over the oily padding as much as necessary and the job is done without soiling the hands. Replace cover on box when not in use to keep out the dust.—L. B. Robbins.

# The G. A. Standardized Condenser

GIVES THAT DEGREE OF PRIDE AND SATISFACTION YOU EXPECT FROM AN EXPENSIVE INSTRUMENT

While designed as a precision laboratory instrument, the G. A. STANDARDIZED CONDENSERS are invariably the choice of those who require maximum efficiency in receiving sets or vacuum tube transmitters.

Under actual comparison with condensers having moulded composition insulation, the signal strength and sharpness of tuning of a receiver is greater with the G. A. STANDARDIZED CONDENSERS. In vacuum tube transmitters, the radiation is increased as much as 20%, due to the perfect insulation of the Bakelite end plates. The capacity ratio of G. A. condensers is higher than that of any other make. The condenser can be mounted by securing the upper end plate to the panel. Radisco or similar dials can be used.

**SPECIFICATIONS:**—Small size, 0.00001 to 0.000585 mfd., 29 plates, height over shaft, 3 1/4 in. Large size, 0.000015 to 0.00115 mfd., 59 plates, height over shaft, 6 1/4 in. 3/16 in. shaft protrudes 1 in., threaded for 6/32 screw. End plates 1/4 in. Bakelite 3 1/4 in. diam.  
**PRICE:**—Small size, \$8.85, wt. 2 lbs. Large size, \$13.65, wt. 4 lbs. Calibration curve for either size, \$0.50.

Send 3c stamp for the G. A. Bulletin of Radio and Model Supplies

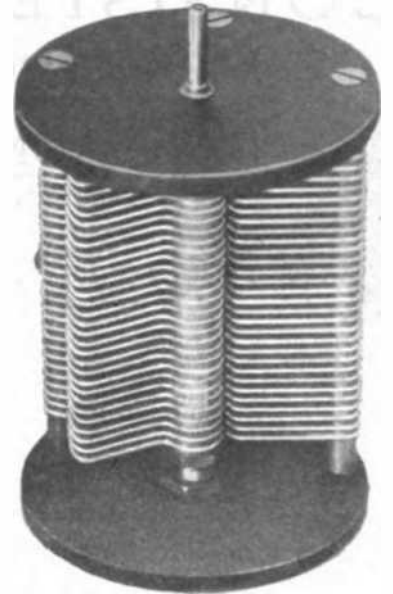

BUY YOUR SUPPLIES AT THE G. A. STORE



OPEN UNTIL NINE O'CLOCK EVERY EVENING

THE GENERAL APPARATUS COMPANY

4310-A Broadway at 183rd St.

New York City

## O, What a Pal

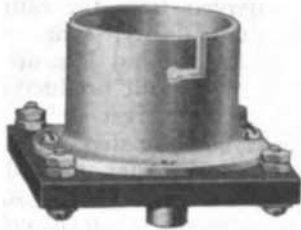

was Mary, but say boy, do you know an up-to-the-minute radio installation is SOME pal too?

We manufacture high grade apparatus only.

Here is a good value—The Ace V.T. Socket—with grid leak at \$1.50 each. Better buy Ace equipment than be sorry you did not. Ask your dealer.

**The Precision Equipment Company**

2437 Gilbert Ave., Dept. B,

Cincinnati, Ohio

# Federal Radio Accessories

Are the Recognized STANDARDS for Their Respective Uses.

**BULLETIN 102 W.A.**

Gives full description. Besides it contains valuable information on

**AMPLIFICATION of Radio Signals**

Send 6c in Stamps today and receive this Bulletin.

**FEDERAL TELEPHONE AND TELEGRAPH CO.**

1756 Elmwood Avenue  
BUFFALO, N. Y.

## REWINDING A. C. MOTORS

And all methods for connecting and reconnecting are clearly shown in the **ELECTRICAL WORKERS FRIEND**. 66 diagrams with detailed explanations solving every rewinding and reconnecting problem. Electricians and Experimenters will find this book exactly what the name implies "The Electrical Workers Friend." Price \$4.00 Cash with order or (C.O.D.—U.S.A. only).

HENRY F. BOSSHART  
P. O. Box 68 Homewood Sta. Pittsburgh, Penna.

Recognized as the largest and best



INCORPORATED

Send ten cents for descriptive catalogue to  
Dept. E, 900-902 Penna. Ave., N. W.,  
Washington, D. C.

## PACENT ELECTRIC COMPANY

Builders and specialists in Electrical, Radio and Laboratory equipment.

SALES AGENTS

for

DUBILIER CONDENSERS,  
DUO-LATERAL COILS,  
GREBE APPARATUS,  
MAGNAVOX PRODUCTS,  
RAWSON METERS,  
STANDARD VT BATTERIES,  
and other first class equipment.

Telephone Beekman 8810

150 NASSAU STREET, NEW YORK CITY

Subscribe to Everyday Engineering Magazine Now And You Will Be Sure to Get Every Issue. See Special Offer On Page 294—Books Given Away Free.

Please mention EVERYDAY ENGINEERING MAGAZINE

# CONSISTENT RESULTS



## Testimonials

### ACME 250

Boston—New York

"To 1DQ:

"Your sign come in great here OM. Am 25 miles north of New York City. I only wish you could exchange places for a night. All the thirteen messages received OK.

\*Delivered the No. 1 by phone this A. M. Mrs. P—— was glad to receive it.

"I radiate only three amps now. Set isn't tuned up good at all. Expect to get six amps very soon and maybe then you will not have any trouble in getting me. (It's 180 miles.)

"I know Boston pretty well OM. Was up there for a year with the United Fruit Co.'s Ships. "73" to all. Tell LAE I hear him but QRM bad from New York City." NAME ON REQUEST.

(I AE Uses an ACME TRANSFORMER)

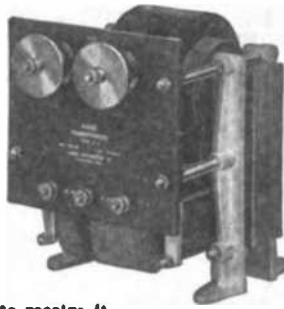

### ACME 1/2 KW—1100 MILES

"I have now used the Acme 1/2 KW Transformer for about five months. During that period I have worked the following stations outside of my district in spite of the bad conditions that exist in New England and in spite of the fact that I am in the heart of a fairly large city.

2BB 2BM 2BN 2DA 2JU 2KX 2TF 2XH 3CC 3CB 3CC 3DR 3DV 3DY 3EN 3EV 3JQ.

These are the stations actually worked and I have received numerous cards from all distances up to 1100 miles. The record being Capleville, Tenn., just 1100 miles, where I was copied QSA with single audiotron bulb and loose coupler." NAME ON REQUEST.

### ACME 1 KW—1700 MILES

St. Louis, Mo.  
"The following relay message received from the "K———" after working him several times while he was near Panama. Speaks mighty well for the 1 KW ACME TRANSFORMER.

"Letter received through Hicks. Will be in Gulf of Mexico 22nd. Listen for you 9 P. M. nightly. YOU STRONG OFF PANAMA. Write upon return to New York."

NAME ON REQUEST.

BULLETINS ON REQUEST

## ACME APPARATUS COMPANY

24 Windsor Street Cambridge 39, Mass.  
TRANSFORMER AND RADIO ENGINEERS AND MANUFACTURERS

# To the Radio Engineer Radio Manufacturer Radio Amateur

You cannot afford to do without the  
**PROCEEDINGS OF THE INSTITUTE OF RADIO ENGINEERS**

In it, you will find all the latest information on **Transmitters, Receivers, Bulbs, Radio Telephony, Elimination of Strays,** and every other important radio topic.

Subscription per year { \$9.00 (in U. S.)  
9.60 (abroad)

Address

Secretary,

**INSTITUTE OF RADIO ENGINEERS**  
COLLEGE OF THE CITY OF NEW YORK

## SEMI-LUMINOUS PAINT

SOON after the discovery of radium by the Curies in 1898 certain fluorescent and phosphorescent mineral compounds were found to be so sensitive to the radio activity of this element that they show luminescence when only brought near it, actual contact being unnecessary. A fine quality of zinc sulphid known as Sidot's blende proved to be the most responsive, says W. S. Andrews in the *General Electric Review*. Sir William Crookes by the invention of his ingenious spintharoscope brought this phenomenon of radio-active luminescence prominently before the public eye. This device consists of a dark chamber enclosing a disk of cardboard that is coated with zinc sulphid. A small wire is fixed above the disk so that one end of it is very close to the sulphid but not touching it and a microscopic speck of salt of radium is attached to this end of the wire. When this combination is observed through a magnifying lens of proper power, the zinc sulphid is seen to be perpetually scintillating with innumerable little stars in the vicinity of the radium. This remarkable appearance is caused by the alpha rays that are discharged from the radium with tremendous velocity, some of which bombard the sulphid like atomic cannon balls, every hit producing a flash of light on the target.

A next obvious step was to mix a very minute amount of radium salt with finely powdered zinc sulphid so that it might be combined with a suitable adhesive and used as a self-luminous paint. For a long time this paint was looked upon only as an interesting scientific curiosity, but during recent years it has been applied in various useful ways to make small objects constantly visible in the dark. For example, it is now used extensively on the hands and dials of watches and clocks, making it easy to tell the time in total darkness; also on the pointers of aeroplane and prismatic compasses and other instruments. One of its most recent and convenient applications is on electric switch buttons, drop chain sockets, etc., thereby guiding a person directly to the switch in a dark room.

### Phosphorescent Paint.

This radio-active self-luminous paint must not be confounded with an article that has been on the market for many years under the name of "Balmain's luminous paint," which was invented by Professor Balmain, of the London University, about the year 1875. The base of the Balmain paint is a special preparation of phosphorescent calcium sulphid, and it requires the excitation of a strong light to make it shine. It absorbs the luminous radiation and then emits it again as a soft phosphorescent

(Continued on page 368)

**Arnold** Loose Couplers  
Combination Loose Coupler Parts and accessories.  
Send 4c stamp for literature which is sure to interest you.  
J. F. ARNOLD 2082 Lexington Av., N.Y. Established 1910

**RADIO APPARATUS**  
on the  
**INSTALLMENT PLAN**  
Full particulars and the RYA BULLETIN each month sent on receipt of ten cents—stamp or coin.  
**J. DONALD VANDERCOOK**  
LOMBARD Box 443 ILLINOIS

Please mention EVERYDAY ENGINEERING MAGAZINE



# "THE ATLANTIC RADIO COMPANY VARIABLE CONDENSER"

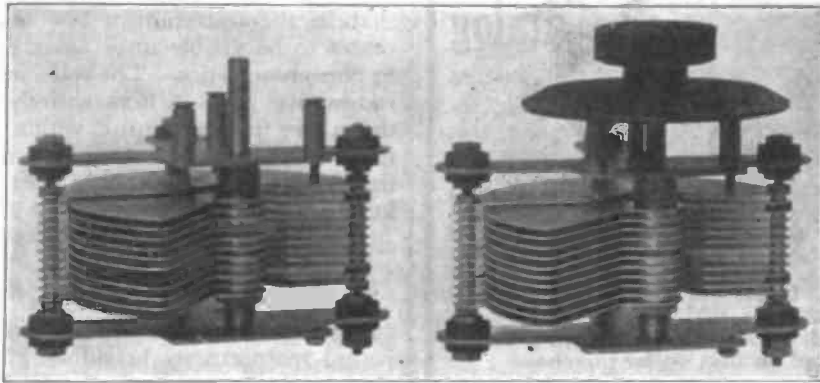

THE "ARCO" VARIABLE CONDENSER, illustrated above, is made in two capacities—.0005 Mfd. and .001 Mfd.

The rotary plates are rounded on one end, affording a straight-line capacity — a valuable feature in wave meter work. The condenser is furnished unmounted only, but with the addition of Dial and Knob, if

desired. Dial is of moulded composition, scale in white—0-100 reading. Bakelite Knob. We can guarantee this condenser in every way as to quality, reliability and satisfaction. The low price is decidedly an innovation.

Capacity	PRICES:	
.0005 Mfd.	Unmounted	With Dial and Knob
.001 Mfd.	\$5.00	\$6.00
	6.25	7.25

"BULLETIN 14"—describing and illustrating the best in RADIO EQUIPMENT will be mailed upon receipt of 10 cents in stamps. This amount may be deducted on your first order of \$1.00 or over.

## ATLANTIC RADIO CO., Inc.

New England Distributors "Radiaco" Products

88 BROAD STREET

BOSTON 9, MASS.



## A More Comprehensive WICONY SERVICE

The Radio Art has long known *Wicony* to stand for *perfection* as applied to Navy, Army and Commercial radio apparatus.

The Radio Art will now know *Wicony* to stand for *perfection* as applied to specially designed amateur and experimental radio apparatus.

*Radio Dealers, amateurs and experimenters* have been freely consulted. Therefore, this new service is really yours—outlined by men who would consider the matter from *your point of view*.

*Watch for further announcements in Radio periodicals.*

DEALERS: It will pay you to write us now.

### WIRELESS IMPROVEMENT COMPANY

Radio Engineers, Manufacturers and Distributors.

47-B West Street

New York City

"ASK ANYONE WHO HAS USED IT"

**What Our Patrons Say:**  
 "You manufacture a brand of phones that surpass all of equal price and most of higher price."  
 (Name on Request.)

### Brandes Wireless Headset



Superior, 2000 ohms, 87

**TRIAL OFFER** Test out Brandes Wireless Receivers against any other make. Test them for sensitivity, clearness and distance. If within ten days you're not only satisfied but enthusiastic over them—back comes your money without a question. Prove for yourself the fine quality, the "matched tone." The two diaphragms, toned exactly alike, strengthen the signals and prevent blurring. Used by many U. S. Government experts and experts abroad; by colleges and technical schools; and by professionals and amateurs everywhere.

SEND 4c FOR CATALOG M

**C. BRANDES** 32 Union Square, Room 822, New York, INC.

WIRELESS RECEIVER SPECIALISTS

# RADIO APPARATUS

Distributors of reliable Radio apparatus for experimenters in every branch of the Radio field!

"Pittsco"  
The sign  
of  
service.



"Remember" We carry an immense stock.

## Honey-Comb Coils

LITZENDRAHT WIRE.	(While they last.)		
LL-75	830-1030 meters	.....	\$1.60
LL-100	450-1460 "	.....	\$1.70
LL-150	660-2200 "	.....	\$2.00
LL-200	930-2850 "	.....	\$2.10
LL-250	1300-4000 "	.....	\$2.30
LL-300	1550-4800 "	.....	\$2.50
LL-400	2050-6300 "	.....	\$2.80
LL-600	4000-12000 "	.....	\$3.00
LL-750	5000-15000 "	.....	\$3.20
LL-1000	6200-19000 "	.....	\$3.50
LL-1250	7000-21000 "	.....	\$3.90

Note:—These are the genuine DeForest litz coils.

## Transmitting Condensers

(Dubbler)

Type	Watts	Cap	Price
D-100	250	.007	\$19.00
D-101	500	.007	\$30.00
D-102	1000	.007	\$45.00
D-103	1000 Spec.	.007	\$50.00
D-150	For C. W. or spark coil transmitters.	.0024 MF., 8000 volts	\$ 5.00

## F. D. Pitts Co. Boston, Mass. Transmitting Transformers

(New Type Acme)

Acme	250 Watt mounted	.....	\$16.00
"	250 " unmounted	.....	\$13.00
"	500 " mounted	.....	\$22.00
"	500 " unmounted	.....	\$18.00
"	1000 " mounted	.....	\$33.00
"	1000 " unmounted	.....	\$28.00

## F. D. Pitts Co. Boston, Mass. Continuous Wave, Power Transformers

(For Wireless Telephone)

Acme	200 Watt C. W. Power trans.	unmounted	.....	\$16.00
"	200 " C. W. Power trans.	mounted	.....	\$20.00
"	50 " C. W. Power trans.	mounted	.....	\$15.00
"	50 " C. W. Power trans.	unmounted	.....	\$12.00

## F. D. Pitts Co. Boston, Mass. Modulation Transformers

(For Wireless Telephone)

Acme	A-3 unmounted	.....	\$4.50
"	A-3 semi-mounted	.....	\$5.00
"	A-3 mounted	.....	\$7.00

## F. D. Pitts Co. Boston, Mass. Quenched Gaps

Amrad	G-1 1/2 K. W. type	.....	\$29.75
"	G-2 1/2 K. W. type	.....	\$18.85
"	G-3 1/2 K. W. type	.....	\$13.50

## F. D. Pitts Co. Boston, Mass.

Important! Every article sent to any part of the U. S. A. Postage prepaid. We want your business. Send 6 cents in stamps for new catalog.

**F. D. PITTS CO., Inc.**  
12 Park Square Dept. F.  
BOSTON, MASS., U. S. A.



# DUCK'S No. 14 264 Pages Electrical and Wireless Catalog

JUST OFF THE PRESS

176 Pages of Wireless Instruments

Any radio amateur will tell you there is no catalog to take its place, and that it is a *Beacon Light* to guide you in the selection of your apparatus.

THIS UNRIVALLED CATALOG MAILED TO ANYONE UPON RECEIPT OF 12c IN STAMPS OR COIN, which may be deducted on first dollar purchase.

Great cost of catalog and low prices prohibit distribution otherwise

## What This Big Catalog Contains

175 pp. Wireless Apparatus for Commercial and Experimental use;	42 pp. Motors and Dynamos.
10 pp. Raw Material;	3 pp. Flashlights;
2 pp. Transformers;	2 pp. Medical Batteries;
9 pp. Auto and Stg. Batteries;	3 pp. Ammeters and Voltmeters;
8 pp. Telegraph Instruments;	30 pp. Electrical and Mechanical Books.

## THE WILLIAM B. DUCK CO.

244-246 Superior Street, Toledo, Ohio

# BURGESS "B" BATTERIES

SEVERAL SIZES FOR SPECIAL WORK



SEND FOR CATALOGUE  
**BURGESS BATTERY COMPANY**

HARRIS TRUST BLDG.-CHICAGO, ILL.

# "POROX"

"Trade Mark"

High grade Batteries made up in single transparent Celluloid and Pyralin cells for model and radio work.

Special Batteries made to order also duplicating of foreign batteries.

Prices on request.

ALBERT MULLER

8758 Queens Boulevard  
Jamaica, Long Island, N. Y.

## SEMI-LUMINOUS PAINT

(Continued from page 366)

glow which gradually fades away, so that in the course of a few hours it ceases to be visible until again excited to phosphorescence. The self-luminous radi-active paint differs entirely from the above in containing within itself its own exciting power, so that it continues to shine indefinitely even when kept in perpetual darkness.

### Life of Radium.

The question is sometimes asked, "How long will the self-luminous compound maintain its brightness?" According to recent research the "half-period" decay of radium is 1750 years. Based on this assumption, and taking for example one gram of radium to start with, one-half of this will disappear by spontaneous decomposition in 1750 years, leaving half a gram. During the next period of 1750 years one-half of this remainder will disappear, leaving one-quarter gram, and so on. It is thus evident that, for all practical purposes, the life of the radium content may be considered unlimited. Not so, however, with the zinc sulphid, the quality of which in itself is subject to considerable variation according to its purity and the method of its preparation. There appears to be a certain amount of luminous quality locked up, so to speak, in the zinc sulphid. This quantum of light-producing ability may be liberated and used up quickly and with high intensity by strong excitation, or slowly and with a lower intensity by a weaker excitation. Therefore, assuming the use of a uniform quality of zinc sulphid, the useful life of a very bright self-luminous compound will naturally be shorter than that of a compound showing a weaker luminescence will depend on the percentage of radium element mixed with the zinc sulphid.

### Factors Determining Life of Luminous Paint.

An incandescent lamp may be taken as a familiar illustration of this argument. We may compare the voltage used on the lamp to the radium, and the filament to the zinc sulphid. We all know that an incandescent lamp operated at a voltage well below normal has a very long life and, vice versa, when it is operated at a voltage much higher than normal its life is short. These results are practically parallel with the results which obtain in connection with self-luminous paint. The normal voltage for an incandescent lamp is arbitrarily described by conditions under which it will produce a satisfactory light for a reasonable number of hours, and these same conditions may be applied to the consideration of a proper degree of brightness for self-

luminous radium-zinc compounds. If a compound containing, say 100 micrograms of radium element per gram of zinc sulphid has a useful life of 20 years, it is reasonable to infer that by doubling the radium content the luminescence will be increased about twofold; but the useful life will be halved, or reduced to 10 years.

The satisfactory luminescent intensity of a radio-compound will depend largely on the purpose for which it is used, this is also involving the area of the luminous surface employed, so that no fixed standard of light per unit of surface can be adopted. For army and navy purposes the United States Government calls for a guarantee on self-luminous paint that it shall maintain an undiminished luminosity for 2 years.

It is well known that the phenomenon of radio-activity is not confined to radium. A product of thorium, known as radio-thorium, is intensely radio-active, but it has a much shorter life than radium, its half period of existence being estimated at only 3 or 4 years. Meso-thorium, from which radio-thorium is evolved, is a by-product of the incandescent gas mantle industry and on account of its relative cheapness as compared with radium it is now being used extensively either by itself or combined with radium in the production of self-luminous paints.

**UNITED STATES AND THE WORLD**

The United States has only 6 per cent of the population of the world and only 7 per cent of the land, yet it produces:

- 20 per cent of the World's supply of Gold,
- 25 per cent of the World's supply of Wheat,
- 40 per cent of the World's supply of Iron and Steel,
- 40 per cent of the World's supply of Lead,
- 40 per cent of the World's supply of Silver,
- 50 per cent of the World's supply of Zinc,
- 52 per cent of the World's supply of Coal,
- 60 per cent of the World's supply of Cotton,
- 60 per cent of the World's supply of Copper,
- 60 per cent of the World's supply of Aluminum,
- 66 per cent of the World's supply of Oil,
- 75 per cent of the World's supply of Corn,
- 85 per cent of the World's supply of Automobiles.



3 inch dial only 75c. With knob \$1.30 Postpaid  
 3 3/8 inch dial only \$1.00. With knob \$1.70 Postpaid

**A More Improved INDICATING DIAL**

This new dial made of same quality and workmanship as our famous smaller one, is marketed to fulfill the demand for a dial to fit the standard 1/4 inch Shaft. Made of black polished composition with radial lines and figures accurately engraved and filled with brilliant white. Diameter is 3 3/8 inches, and 3/16 inches thick. Bevelled edge. Knob has set screw to clamp shaft of instrument.

Moorhead Electron Relay New Style.....\$6.00  
 Moorhead V.T. Amplifier..... 7.00  
 Moorhead Extra Hard V.T..... 7.50

Shipping weight 1 pound. Guaranteed. Licensed under Fleming and De Forest Patents.

**OUR NEW CATALOG** now ready for distribution contains 24 snappy pages of news and descriptions of all standard Radio parts, including the above indicating dial.

Sent anywhere upon receipt of 10c.

For sale at all Radisco Agencies and by  
**A. H. CORWIN & CO.**

4 West Park Street

Newark, N. J.



1/2 KW. PANEL TYPE HYTONE TRANSMITTER. PRICE \$250.00

**CAN YOU AFFORD TO EXPERIMENT**

with apparatus without an established reputation?

**OUR PRODUCTS**

Have earned an enviable reputation for reliability during 13 years of continuous manufacture.

**OUR LINE**

is most complete and is carried by most good dealers.

**OUR CATALOG**

will be mailed for 6c stamps and our prices are most reasonable—quality considered.

**Clapp Eastham Co.**

131 Main Street, Cambridge, Mass.

**WILCOX ROTARY GAP**

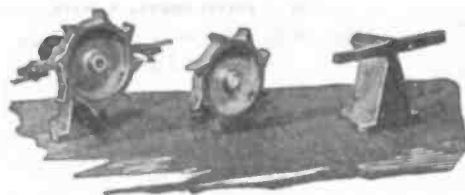

Belt-driven Well quenched  
 Solid balanced rotor Short leading spark  
 Large steel shaft Clear tone  
 Long brass bearing High Efficiency

**COMPLETE \$10.00**  
 Postpaid

The WILCOX LABORATORIES Inc.  
 Lansing Dept. D Michigan

**LEARN WIRELESS TELEGRAPHY**

*Fascinating and Educational Work—Big Salaries—Prepare Now*  
 The United States Shipping Board is making heavy demands upon us for Dodge-trained wireless operators. Travel all over the world, secure, free, unsurpassed living accommodations and earn a big salary.  
**We Also Teach Morse (Wire) Telegraphy and Railway Accounting**  
 School established 45 years. Endorsed by wireless, railway and telegraph officials. Low rates. Students can earn living expenses while attending school. **Catalog Free. Write Today**  
 Dodge's Telegraph and Wireless Institute 33rd St. Valparaiso, Indiana

Please mention EVERYDAY ENGINEERING MAGAZINE

DEFOREST

## An Inexpensive Radio Receiving Set for Amateurs

FOR the beginner in Radio work, this DeForest Simplified Radio Receiving Station offers the easiest and least expensive way to secure accurate, efficient and expertly designed apparatus of usual DeForest superior quality. The set is complete; Aerial and Ground connections, "Honey Comb" Tuning Coils, Crystal Detector, Tuning Condenser, Head Telephones, all necessary wire, insulators, back-board, base mounting, etc. Full instructions for installing and operating accompany the apparatus. The beginner can secure no better apparatus and with this set will gain practical knowledge and experience.

Our booklet, "How to Set Up an Amateur Radio Receiving Station" explains this and other sets and gives much information for the Amateur. Sent postpaid for 10 cents a copy.

### DE FOREST RADIO TEL. AND TEL. CO.

Inventors and Manufacturers of High Grade Radio Apparatus  
1415 Sedgwick Avenue, New York City  
Lee DeForest, Inc., 415 Market St., San Francisco  
Western Distributors

DEFOREST

### A NEW DETECTOR

That can either be used as a Panel Unit, as advocated by this magazine or "on the table," and only one knob is used for Position and Pressure. Instantly adjustable to any spot on the crystal. Price includes tested gals. Base 5 lbs. by 2 1/2 ins. \$2.50. Base 5 ins. by 5 ins. 1 cups \$3.00.

Just write for information and list

THE BARWICK RADIO SUPPLY CO.  
69 Britannia Ave. Hamilton, Ont., Can.

## YOUR FUTURE IS ON THE SEAS



Be a Ship Officer

### Join America's Mighty Merchant Marine

Hundreds of first, second and third mates, masters and captains are needed by the big shipping companies and America's great merchant marine.

Salaries up to \$412 per month and living expenses.

Ships flying the American flag pay the biggest salaries of any in the entire world.

Learn Navigation at Home or on Board Ship. Captain Warren Sheppard's Course on Ocean Coast and Lakes Navigation is now ready. It is a life time of practice placed before you for quick mastery. Captain Sheppard was instructor for the United States Shipping Board during the war. All of his students received licenses—from third mate to master. Not one failed. He offers this same sure method to you at a very low price. You cannot fail.

Valuable Booklet FREE

Fill out the coupon below and return to us. A 50-page booklet telling how you may become a ship officer at a big salary will be sent you free. Don't delay. Officers urgently needed.

FREE COUPON

World Technical Institute  
Dept. 102 Fuller Bldg., Jersey City, N. J.

Gentlemen:—Send to me free booklet, "Your Future is on the Seven Seas." (Write Plainly)

Name .....  
Address .....

### No Seals - No Secrets —BUT SERVICE!

Inspection of the interior of any Radio apparatus bearing the mark:



reveals design and workmanship fully in keeping with its outward appearance.

GREBE RADIO apparatus is licensed under the original Armstrong and Marconi patents.

Our guarantee is absolute and unconditional. Each instrument must give satisfactory service. Our interest in the purchaser does not terminate with the sale.

Ask your dealer to show you our line of super-grade apparatus.

A. H. GREBE & CO., Inc.  
71 Van Wyck Blvd., Richmond Hill, N. Y.

Send for  
**HALCUN**  
Radio Catalogue  
Full Line of  
Amateur Requirements  
**Halcun Radio Co.**  
San Francisco, Calif.  
Formerly Haller Cunningham  
Elec. Co.

### RADIO MEN

THE Mutual Purchasers Association will save you money on all WIRELESS APPARATUS

Write Dept. E10 for details.

Mutual Purchasers Association  
2-4 Stone Street, New York

### COMMON CAUSES OF AUTO-MOBILE NOISE

(Continued from page 299)

strips or candle wicking between the lamp glass and its metal frame.

The points where the lamp brackets attach to the frame should be inspected to make sure that the bolts or rivets which hold these are tight. Then test the radiator retention bolts to see that this is firmly held against the pads upon which it rests on the frame. See that the fan bearings are not worn unduly and that all the fan blades are tight, because a loose fan blade striking the radiator will not only cause considerable noise but will ultimately wear through the radiator cooling section and permit loss of water.

If the cooling fan operates on plain bearings, care should be taken that these bearings are well lubricated as an annoying squeak will develop if they are dry. It will be evident that if the radiator holding bolts or those which hold the engine in place on the frame are loose, that every time the car runs over a rough pavement, noise will result because a comparatively heavy piece of machinery will be moved up and down to take up the play caused by the loose retention bolts. This movement may be only a small fraction of an inch, yet the noise it will produce will be large in proportion to the slight degree of movement permitted. If either the gear case or the engine base is not securely bolted, a pronounced pounding noise will be noticed that will be intermittent in character, and will be considerably more noticeable when the car is operated over rough roads.

(To be continued)

### PRODUCING ALCOHOL FROM WOOD

THE first step in the process of obtaining alcohol from wood is digestion at a pressure of 115 lb. for fifteen minutes in dilute sulphuric acid. The cooked wood is transferred to a series of cylindrical cells so connected that water may be passed through them in rotation. From these cells an extract called "acid juice" is obtained which holds in solution practically all the sugar mixed with other water-soluble ingredients. This liquid is neutralized, either with high-grade limestone or slaked lime. Calcium sulphate is produced, which requires about twelve hours for settling. The clear juice is drawn off and cooled to about 88 deg. Fahr., yeast added, and the fermentation carried in the usual way. The juice must be slightly acid, as ordinary yeasts do not operate well in alkaline solutions. By distillation the alcohol is obtained, and may be readily refined.

Please mention EVERYDAY ENGINEERING MAGAZINE



**EFFECT OF OILS ON STRENGTH OF GLUES IN PLYWOOD**

**P**LYWOOD may be used near machinery and tanks with little likelihood of being dangerously weakened by the action of oil or gasoline on the glue joints. This fact is evident from a test lately completed at the Forest Products Laboratory. Plywood panels glued with animal, vegetable, blood albumin, and casein glues were immersed for nearly a year in engine oil and gasoline. At regular intervals specimens were removed from the liquids and tested for joint strength. All the glues weakened somewhat during the early part of the test, the animal and vegetable glues more than the casein and blood albumin glues. The total loss of strength in any case, however, was small enough to be negligible under most conditions of service. A glue shear strength of 100 to 125 pounds per square inch is considered sufficient for practically any purpose for which plywood is used. Only in two or three instances did the strength of the casein and blood albumin glues fall below 150 pounds per square inch. Engine oil, castor oil, and gasoline seemed to have practically the same effect on the glue joints. During the 45 weeks' test, the wood absorbed 60 per cent of its original weight in engine oil and 70 per cent of its original weight in gasoline. The absorption of these oils did not cause any noticeable swelling of the wood.

**HOW TO DETECT PAPER IN SHOES**

**T**HE substitution of paper for leather in shoes is so well done, that it is impossible to tell from ordinary observation whether paper is used in the shoe or not. Even experienced shoe buyers find it difficult to tell and usually rely on the statement of the manufacturer. The *Scientific American* outlines a simple test that is usually effective in determining whether or not a shoe is all leather. If paper is used, it is usually in the upper sections of the heel. If the point of a pocket knife is pressed on this part of the shoe, with the width of the blade parallel with the layer, it will readily sink in if the heel is of paper, but leather will resist quite heavy pressure from the knife. If paper is found here, it is good evidence that it has been used elsewhere in the shoe. Another test is to bend the counter inward. If it is of leather, it will at once spring back into shape, but if paper or fiber is used the counter will remain bent. A similar test can be applied to the toes of the shoe. If the box is pressed in, it is so resilient that it will spring back if of leather, but will remain permanently dented if made of paper.

# LEARN DRAFTING

## At Home—In Spare Time as you would in actual practice

Get into this constructive branch of industry where big salaries are paid. No previous training is necessary to become a capable draftsman with the help of the Columbia School of Drafting. You can master the practical lessons of our famous home study course, at home, in spare time. You will be personally coached and instructed, by mail, by Roy C. Clafin, president of the school, whose long experience as a draftsman and teacher, especially qualifies him to give you the training you need to become a successful Draftsman.

### Become a Specialist

We not only give you thorough and practical training in Mechanical Drafting, teaching you to make actual drawings as you would in any drafting room, but the additional benefit of a post-graduate course in some special branch of drafting. A big field of opportunity is thus opened to you as a trained specialist in this profession.

Draftsmen are needed in greater numbers, and receive better salaries than ever before.

### Draftsmen Get \$35 to \$100 a Week

Because of the importance of his work the draftsman is paid a big salary and is always in line for advancement. The draftsman's pay is from \$35 to \$100 a week. A knowledge of drafting is the stepping stone to big technical positions in the industrial field paying as high as \$50,000 a year.

### How "Columbia" Students Succeed

Students of the Columbia School of Drafting often secure positions at \$2,000 or more a year to start before completing the course. Hundreds of men and women with "Columbia" training are now making good with big concerns all over the country. Many more are needed for splendid positions now open. Here is what "Columbia" training is doing for some of our graduates: Laurence Johnston, over \$5,000 a year; George Murray, \$45 a week to start; G. Tangorra, \$2,800 a year; A. L. Gash, \$140 a month to start; W. S. Burfoot, \$150 a month to start; T. R. Brown, \$2,860 a year; R. Fowkes, \$3,700 a year. These are only a few of a great number of similar cases.

### This Complete Drafting Equipment Furnished

to students of our school. The instruments are of standard American make of the best quality, fully guaranteed, and become your property on completion of the course. Every instrument needed for the course is included.



### Big Concerns Employ "Columbia" Graduates

The best concerns in America employ Columbia graduates in their drafting departments because of the thorough practical training we give which enables them to step right into important drafting positions. Our diploma is the entering wedge into big drafting rooms everywhere. As a Columbia graduate you are recognized as an experienced draftsman, not as a mere apprentice. Why be satisfied with a grinding, underpaid position when there are hundreds of promising positions open to you in the big field of Drafting. We are called upon to place trained draftsmen more rapidly than we can produce them.

### Send This Coupon Today

Let us tell you the fascinating story of Drafting and how you can master this lucrative profession of big salaries and steady advancement through our help. Write today to

### COLUMBIA SCHOOL OF DRAFTING

Roy C. Clafin, President  
Dept. 1146, 14th & T Sts., N. W., Washington, D. C.

### COLUMBIA SCHOOL OF DRAFTING

Roy C. Clafin, President  
Dept. 1146, 14th & T Sts., N. W., Washington, D. C.

I am interested in your practical training in Mechanical Drafting. Please send me Free, your illustrated book of particulars, lesson plans, terms, etc. I am also interested in the special post-graduate course checked below: (Mechanical Drafting, or Machine Drafting is the foundation course and is complete in itself.)

- Architectural Drafting.....
- Automobile Drafting.....
- Electrical Drafting.....
- Aeroplane Drafting.....
- Special Machinery Drafting.....
- Sheet Metal Drafting.....
- Structural Drafting.....
- Highway Drafting.....
- Patent Drafting.....
- Topographical Drafting.....
- Ship Drafting.....
- Statistical Drafting.....
- Radio Drafting.....
- Automotive Drafting.....
- Hydrographic Drafting.....
- Machine Design.....
- Tool Design.....
- Shop Mathematics.....
- Builders' Course.....

Name.....  
Age..... Address.....  
City..... State.....

Please mention EVERYDAY ENGINEERING MAGAZINE



# THE RADIO REVIEW

A MONTHLY  
RECORD OF  
SCIENTIFIC  
PROGRESS IN  
RADIO  
TELEGRAPHY AND  
TELEPHONY

*Monthly - Half-a-Crown*

Single copies, post free 2s.  
9d. Annual Subscription,  
post paid, 30/- post free.

THE RADIO REVIEW,  
a new monthly magazine,  
devoted entirely to the  
technical side of radio  
communication.

Edited by Professor G.  
W. O. HOWE, D.Sc.,  
M.I.E.E., assisted by  
PHILIP R. COURSEY,  
B.Sc. A.M.I.E.E.

THE RADIO REVIEW  
is the Authoritative Jour-  
nal of Wireless Research.  
Contributions from the  
pens of the World's lead-  
ing Radio Scientists will  
be a special exclusive  
feature.

Editorial and Publishing Offices  
12-13, HENRIETTA STREET  
LONDON, W.C. 2

## WHAT BAKELITE IS

**B**AKELITE is a cellulose substi-  
tute which derived its name from  
the inventor, Dr. L. H. Bakeland, of  
Yonkers, United States of America,  
who patented, in 1904 (Pat. No.  
942699), the following process:

Equal weights of phenol (carbolic  
acid) and formaldehyde (formalin)  
are warmed together with an alkali,  
the latter acting as condensing agent.  
After cooling, the mixture forms two  
layers, a lower one, which is an im-  
mediate condensation product, and an  
upper layer, consisting of an aqueous  
solution. The latter is poured off, and  
the lower part of the mixture heated  
above 100 deg. C., which causes the  
formation of a third product, consisting  
of a spongy porous mass; but, as in  
this state, it would not be suitable for  
many purposes, the last phase of the  
process, which produces the third state  
of mixture, is conducted in a closed  
vessel (autoclave), at a temperature of  
130-150 deg. C., under a pressure of  
from 50-100 lb. per square inch, the  
result of the pressure being a solid,  
compact, non-porous mass, very simi-  
lar to the best celluloid. The specific  
gravity of the finished product is 1.25,  
the mass itself forms a material which  
is not elastic, but a first-class insulator  
of heat and electricity. The price of  
Bakelite is lower than best celluloid,  
casein and hard rubber. Of course,  
the above procedure covers the princi-  
pal points of the process, which is actu-  
ally carried out under varied condi-  
tions, the condensing agents employed  
are chosen from the groups of inor-  
ganic and organic acids, ammonia, am-  
monium carbonate, caustic alkali, al-  
kali carbonate, calcium, strontium or  
calcium hydrate, anilin or pyrodin be-  
ing also used.

To remove the water formed during  
condensation a water-soluble hygro-  
scopic salt, such as sodium or calcium  
chlorid, is added during the main  
phase of the process.

To produce very clear or colorless  
condensation products of phenola and  
aldehyde from the condensation prod-  
uct, which contains the coloring mat-  
ter, the latter is extracted by means of  
ether and other related solvents (Pat.  
No. 233395). The condensation proc-  
ess with application of solvents, is car-  
ried out as follows: Firstly, the con-  
densation produces a liquid material  
(at ordinary temperature), this is solu-  
ble in alcohol, acetone or other similar  
solvent; secondly, further heating pro-  
duces an intermediate product, which  
is insoluble in the above solvents, but  
which can be transformed into a horn-  
like mass by stopping the heating at a  
certain temperature; while, thirdly, a  
continued heating finally produces a  
mass which is not fusible. This final  
mass has remarkable properties; for

instance, it is not attacked by boiling  
acids or alkaline solutions; only con-  
densed sulphuric acid decomposes  
Bakelite at boiling temperature.  
Through treating wood, paper, or card-  
condensation product, these materials  
may be covered with a lacquer-like  
surface.

Bakelite is used in large quantities  
for manufacturing billiard balls, han-  
dles, buttons, and almost any other  
article which was formerly made from  
celluloid only and is widely employed  
in electrical work as an insulating sub-  
stance.

## LIGHT CREOSOTE OILS IN WOOD PRESERVATION

**L**IGHT creosote oils properly in-  
jected into wood apparently will  
prevent decay until the wood wears  
out or until it checks so badly that the  
untreated portions are exposed. Such  
is the indication of service records col-  
lected by the Forest Products Lab-  
oratory on railway ties and telegraph  
poles preserved with low boiling creos-  
otes. Creosotes used in ties from 25  
to 50 years ago were for the most part  
oils having 50 per cent or more dis-  
tilling below 235°C., with a residue  
not to exceed 25 per cent at 315°C.  
The ties so treated lasted from 15 to  
20 years, and failure was traceable in  
most cases to mechanical wear, such  
as rail cutting and spike killing. In  
no case was failure found to be the  
fault of the preservative.

Of 1558 telegraph poles in the Mont-  
gomery-New Orleans line, which were  
pressure-treated with a light creosote  
oil, 1049 poles were still sound after  
16 years. In 91 per cent of the cases  
of decay, the fungi had entered the  
wood through checks and shakes. Rep-  
resentative sections in the Norfolk-  
Washington line showed that after 17  
years service, of the 1614 poles in-  
spected, 1469 were sound, 92 decayed  
at the top, and 105 decayed at the  
ground line. The decay at the top  
was caused chiefly by cutting off the  
poles. In those decayed at the ground  
line, the causes of failure, as deter-  
mined in 88 per cent of the cases, were  
checks or shakes. Here again as in  
the ties, the preservative outlasted the  
mechanical life of the wood.

Unless some other factor than pro-  
tection from decay is considered im-  
portant, therefore, there is apparently  
no need to specify high boiling oils.  
The important point is that any coal  
tar creosote which is not extremely low  
boiling or extremely high boiling will  
satisfactorily prevent decay, and in the  
selection of an oil, factors such as  
price, penetrability, and convenience in  
handling should receive greater con-  
sideration than moderate differences in  
volatility.

## SCHNOTER'S SUSPENSORIES



**YOU** can enjoy perfect  
comfort and freedom.  
Schnoter's Suspensories  
and Jock Straps have  
gained their wide-spread  
popularity by quality,  
wear, fit and low price.

If your druggist does not carry Schnoter's,  
Accept No Substitutes. Sent direct upon re-  
ceipt of \$1.00.  
Send for booklet of other styles and prices.

**J. C. SCHNOTER CO.**  
828 SIXTH AVE. Dept. (B) N. Y. CITY

Please mention EVERYDAY ENGINEERING MAGAZINE

**FLEXIBLE SPOUT OILER**

**T**HE ordinary form of hand oiler cannot be used for oiling all parts of machinery because the oil holes are sometimes placed at points inaccessible for the regular spout. Various forms of spouts may be used but even these sometimes are found wanting in reaching certain locations. A flexible spout oiler that can be easily made by any one capable of using a soldering iron

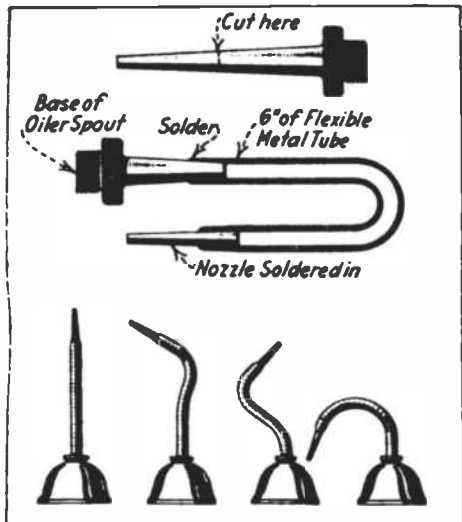

*Flexible spout oiler*

and hack saw is illustrated in the accompanying cut. The spout of the ordinary oil can is cut in two pieces and these pieces are soldered in a suitable length of flexible metal tubing of which various makes that are quite practical are now marketed. The new spout, which is composed of the two parts of the old spout soldered into the flexible tube can be bent into a variety of shapes as indicated, and it is possible to inject oil to points that formerly would be neglected because so hard to reach.

Magnesium is used in the manufacture of sound copper castings, because of its ability to decompose the gases formed by the copper in melt-gases formed by the copper in melting. The principal gas thus formed, carbon monoxide is attacked by the magnesium, forming two solids, carbon and magnesium oxide. By the use of magnesium, therefore, in small amounts, the production of blow-holes in the casting is eliminated.

In the Book Exodus, Moses is described as making a bitter spring potable by throwing into it the branch of a tree. This particular spring or well, it is thought, has possibly been identified and on analysis its water has been found to contain calcium sulphate in solution. If into it there were thrown branches of vegetation containing oxalates, the lime salt would be precipitated and the water would be thereby purified; this, it is thought, may have been what occurred during the days of the Pentateuch.

*The foreman says*

"I suppose it's because I used them myself when I was at the bench, but it does seem as though the best men in the shop have a preference for Starrett Tools.

"Of course, most of them sort of got into the habit of relying on Starrett for fine work when they were apprentices and journeymen.

"Speaking of apprentices — that little red book there, 'The Starrett Book for Machinists' Apprentices,' has saved me more time and helped more young fellows to learn how to do things right than anything else in the shop.

"When a young lad asks me how to do this or that, I usually tell him or show him, and then ask him if he has one of those books. I've noticed that as soon as he gets one of them he doesn't have half so many questions to ask.

"Starrett gets out another book, 'The Machinists' Data Book,' that's just about as big a help to the experienced machinist. It's got all the tables and formulas and so on that he ever needs, and it isn't cluttered up with a lot of engineers' stuff that he doesn't use.

"Yes, I bought one of each of the books down at the hardware store, as soon as they came out. They cost me seventy-five cents each, but they're worth it."

**The L. S. STARRETT COMPANY**  
THE WORLD'S GREATEST TOOLMAKERS  
Manufacturers of Hack Saws Uneexcelled  
**ATHOL, MASS.**

Machinists the world over have put their faith in the accuracy of Starrett Tools for thirty-nine years. Write for illustrated Catalog No. 21 "MB."



43-288



**Starrett Tools**



**Richardson's Polyphase Slide Rule**



has the regular A, B, C and D scales; also a CI or Polyphase Scale, Logarithm, Sine and Tangent Scales. All graduations are printed on white coated steel from engine divided plates. These Scales are accurate and will retain their accuracy indefinitely. They are not affected by acids, alkalis, water or grease. Length of rule 16". A 100 page Instruction Book, which teaches all there is to know about slide rules, is sent with each order.

Price of the Richardson's Polyphase Slide Rule, in case, with a 100-page Instruction Book, \$3.00.

An ideal slide rule. It is low priced and an equal to any other rule in appearance, accuracy and durability. Be convinced. Your money will be promptly refunded if you are not satisfied.

Send for our 60 page catalogue of supplies. It describes rules ranging from 60c to \$10 each. Instructions in Logarithms and Trigonometry free with every catalogue.  
**GILSON SLIDE RULE CO., Niles, Mich.**

**AMBITIOUS YOUNG MEN**

**WHO WANT A COLLEGE EDUCATION CAN READ OUR ANNOUNCEMENT ON PAGE 379 TO ADVANTAGE**

**S T U R D Y**

THAT'S WHAT YOU'LL SAY when you see this new handy Utility Chest. Built with a solid oak frame, and joints that are not dovetailed, but lock-cornered for extra strength. This chest is a sturdy keeper of tools; bang-proof, knock-proof, and weather-proof. Auto-mechanic, electrician, lineman, will find the

right house for his tools in this

**UNION Utility Chest**

Note tray that lifts with cover, yet fits snugly when cover is closed. Strong handle, hinges, hardware.

Write for Catalog

prices and name of nearest dealer. Sold on

"Satisfaction or Money-Back" guarantee. Write for special offer.

**UNION TOOL CHEST**

CO., Inc., 34 Mill St., Rochester, N.Y.



**UNION**  
TOOL CHESTS

**FOR SALE**

Two cell Electro-Medical-Battery, with polished plate base and nickel-plated parts in handsome hardwood box 9 x 8 x 6 inches; contains two metal handles, foot-plate, sponge electrode, pair 3 feet cords and 32 page book of suggestions and instructions for treating various diseases with faradic currents of electricity; absolutely new. Price \$10.50. Shipping weight, 13 lbs.

**JOSEPH F. MATIS**

316 East 89th St.

New York City

## This is not a Real Machine but a Wading River 4-Foot Scale Model NC-4

With a Wading River outfit, you, too, can build this perfect exhibition and experimental model. It is equipped with complete controls, dummy Lib-



erty Engine, Paragon Propellers—every detail a perfect reproduction of the original. It is easy to build with Wading River parts.

### BUILD AND FLY A MODEL NIEUPORT SCOUT BIPLANE

You can make it from our complete unassembled outfit. What this builder says stands good with all others who build this perfect model.

Feb. 9, 1919.  
Have had fine success with my Nieuport Biplane. It has flown 181 feet.  
E. Waterhouse, 521 W. Mo. St., El Paso, Texas.

### SET OF 11 SCALE DRAWINGS OF BEST KNOWN MACHINES FOR \$1.50

This set includes the Nieuport monoplane, Bleriot, Curtiss Hydroplane, Antonette, Langley Tandem, German Taube, Deperdussin, Wright biplane, White Racer, White Flyer, and Champion Racer. Send \$2 for our latest catalogue containing illustrations of models of Curtiss J.N. & B., B.P.A.D. Scout, De Havilland 4, Caproni Biplane, Handley Page, Sopwith Triplane and others.

### WADING RIVER MANUFACTURING CO.

672-D Broadway Brooklyn, N. Y.

## ADVANCED ENGINEERING

IN some of our contemporaries which aim to popularize science by detailing fanciful schemes, we find many queer things discussed with an apparent seriousness that must mislead the non-technical readers into expecting great advancement in science and engineering that really cannot take place because natural and established laws are defied. Our English contemporary, *The Aeroplane*, discusses one of these so-called discoveries in an amusing vein and the discussion may be of interest to some of our readers who have lately taken us to task and accused us of ultra-conservatism.

This accusation was made because we have not published articles on messages to Mars, negative gravity, wireless transmission of large quantities of power and other advanced engineering topics that are so far in advance that they are way ahead of the knowledge of our technical staff, who are all of the "show me" kind and apt to give more credit to an actual accomplishment of practical value than to problematical and spectacular discoveries of the future that have not yet materialized. The matter would be amusing if it were not for the fact that really serious and dependable mechanical and scientific publications are apt to be judged by those examples of radical thought and "yellow" scientific journalism that issue from the presses in such large quantities and that are considered to be representative American publications by our foreign contemporaries.

*The Aeroplane*, under the heading "On American Credulity" goes on to say: "In one of these curious, popular scientific magazines which America has produced in such large quantities, there is quite a long discussion on the possibilities of the electrically-driven aeroplane. This is based upon the opinions of two gentlemen, both of them sufficiently well known by name and reputation in American aviation circles to assure their ideas being taken for what they are worth. One is a not inconspicuous member of the Aero Club of America, and the other, is known to fame as the creator of one of America's most amazing achievements in the field of aeroplane construction. Both of these 'experts' agree that the electrically-driven aeroplane is a possibility.

"The scheme is that electrical generators are to be driven by petrol engines installed in the central body of the proposed aircraft. The power thus generated is to be then distributed to a number of electro-motors disposed in convenient positions about the machine, each driving an airscrew. One expert suggests that there are other obvious ways of electrically driving an aeroplane. One is to carry storage batteries

## Compressed Air Motors



THE new and improved method of propelling your model aeroplane. Manufactured of the finest materials. Workmanship guaranteed. Special repellers for the above motors. Send stamp for descriptive circular of these wonderful motors. We manufacture everything for the model aeroplane builder. Give us a trial and be convinced.

### HEC AEROPLANE CO.

22 East 49th St. New York City

## NOW YOU CAN FLY!

A REAL AEROPLANE AT LOW COST

### THE DELERAY D-5 SPORT PLANE

Wing Span 18 ft. Speed 35-45 m.p.h.  
Planned by men with 4 years' experience in designing successful U. S. Government aircraft.  
Equipped with 15 H.P. engine (practical engineering made it possible for this biplane to be flown with only 9 H.P.) Use your own motorcycle engine if you wish.  
Send \$5.00 for complete set of 18 large detailed blueprints, actual duplicates of our shop drawings, showing exactly how each part is made and fitted.

### DELERAY AIRCRAFT WORKS

AEROPLANES ENGINES PARTS  
FREEPORT, LONG ISLAND, N. Y.

### Don't Scrap Aluminum Parts

Save them with 80-LUMINUM. New, great welding solder, stronger than aluminum, perfect substitute for acetone, welding—M. time and cost. Use gasless torch or soldering iron. No flux required. Booklet on request. Sample bar \$1.00. Used and endorsed by United States Army and Navy. British Munitions Board and leading aeronautics and motor truck companies.

80-LUMINUM MANUFACTURING CO. New York  
1790 Broadway

## Umakem Airplanes

Umakem D. J. N. 4 can be made complete for \$10.00. \$5 from Umakem No. 11 (Curtis 250 cc. motor included).  
Umakem Flying Airplane for sale. Numerous demanded. Profile etc. Completed plane sells at \$18 and can be made in 8 hours from Umakem No. 11 set. Ask about our 40 Umakem sets for making airplanes. Tools, news, work benches and practical work cutting and milling lathe.

W. R. PATRICK, Inc., Dept. 17, Umakem Bldg., 127 9th Ave., N. Y.

## What Every Mechanic Should Thoroughly Know

This book points out the stumbling blocks for mechanics to avoid in acquiring a complete understanding, as well as to show you HOW TO GO AT the reading of a blue print drawing.

Every phase of the service subjects is gone into in detail, so that any average man can master with but little study. Every point is clearly brought out with sufficient details to describe each of the actual blue print drawings presented. In fact, the illustrations are practically self-explanatory.

Every mechanic needs this book, he will experience in mechanics limited or long. Read the following comment from a man who passes on from 58 to 566 blue prints a day:

"I never thought there was so much to know in the reading of a blue print drawing."  
WM. F. CONWAY, Planning Dept. Mgr.

D. S. RUBINER, Gen'l. Mch. Shop, Dept. for a copy to-day, before you forget. YOUR CATALOGUE FREE. YOUR MONEY REFUNDED IF NOT SATISFIED.

PRICE—Retail price U. S. \$2.00, Canada, \$3.15; Foreign, \$5.25.  
169 pages—Size 8 x 7 1/2 inches. 228 Illustrations.  
Handsomely bound in cloth.

EDUCATIONAL INSTITUTE, 138 Rowland Bldg., Detroit, Michigan



EDUCATIONAL INSTITUTE

Please mention EVERYDAY ENGINEERING MAGAZINE

supplying power to the motors, another is to transfer electrical energy by a kind of trolley dependent from the machine and running on supply lines laid over the route. A further possibility which he suggests is that of transmitting energy by wireless to the aeroplane.

"The petrol-electric system is, however, regarded as the most practicable. The great constancy of power and the beautiful control of the screws which can thus be obtained are among the advantages claimed for this system, and it is stated that 'one thing is certain—with this arrangement of gasoline-electric propulsion we know it will work.'

"The beautiful simplicity of the idea is quite apparent when one considers that the machine, which is described, is to be provided with two petrol engines, each of 3,200 h.p., two generators, each of 3,000 h.p., and electric motors of undefined numbers, but of the same aggregate output. If we assume that America can now produce aero-engines of 3,000 h.p., each with a weight of three pounds per h.p., it seems a little unnecessary to add to that a further electrical plant of twice that output and weighing certainly not less than 25 lb. per h.p. Even American aeroplane designers have not yet succeeded in building satisfactory aeroplanes with power plants weighing over 50 lb. per h.p."

Needless to say, the curious, popular scientific magazine describing such advanced aeronautical engineering was not EVERYDAY ENGINEERING MAGAZINE.

The factories in the occupied regions of Germany along the Rhine, have been visited with a view to ascertain what the enemy did in the production of chemical products.

Rubber was made from acetone which was reduced by aluminum and hydroxyl to pinacone. Water was removed from its molecule by distillation under pressure. The distillate was then heated to 600° C. four to six months and the resulting product was a synthetic rubber which was used for tires and other purposes.

Gas mask charcoal was made from pinewood. Small pieces were soaked for at least thirty minutes in hydrochloric acid with a little zinc chloric. They were then carbonized in a long muffle at a cherry red heat for six or eight hours. The charcoal was then washed with hydrochloric acid until only a very little zinc was left. It was then washed with water drained, dried in vacuo at 70° to 80° C. and sifted free from dust. Our readers will remember, how, during the war, fruit pits were industriously collected for making gas mask charcoal.

# Let Government Tests Save You Gasoline!

**Sparko-Gap Will Make Your Engine 37 Per Cent Better, Save Its Cost in Gasoline, or We Refund Your Money.**

Let us prove to you, on your own car, that Sparko-Gaps make your motor 37 per cent better and save 10 to 35 per cent in gasoline. See why they end spark plug troubles and see why they were used as standard equipment on all French airplanes. Check the U. S. Government tests on your own car.

We don't want you to send us a single penny now. Just fill in and mail the attached coupon and we will send you a SPARKO-GAP for each cylinder of your car. Try them on your car for 30 days. Try them on the foulest, sootiest, oiliest spark plug you can find. Try them on a cracked plug or try them on your best plug. You be the judge. If Sparko-Gaps don't give you a smoother-running car, if they don't save half their cost in gasoline bills during the month, send them back and you won't be out one cent.

**If Sparko-Gaps Do Not End Your Spark Plug Troubles—If They Do Not Make Your Motor Run Smoother, Easier, Better—If They Do Not Save 10% to 35% Gasoline, Send Them Back.**

## The Sparko-Gap Is the Wireless Quenched Gap

The Sparko-Gap is not a new idea, but an old idea applied in an ingenious new way, made necessary by the fierce competition of war. The Sparko-Gap principle has been used for years in wireless telegraphy to give twice the radius to sending outfits.

The Sparko-Gap condenses current—develops a hotter, fatter, surer spark. It sends the electric current through the spark plug in one intense spark instead of in many weaker oscillations.

The Sparko-Gap explodes 100% of gas and fires even fouled plugs. The intense spark insures 100% explosion and saves from 10% to 35% in gasoline. It stops carbon formation. It lessens the necessity for gear shifting. It fires plugs under all conditions, when fouled by oil or carbon—even when the porcelain is cracked. No miss fires—more snap—quicker pick-up.

The Sparko-Gap shows a visible spark. You can see how each cylinder is firing and so locate ignition trouble quickly. The Sparko-Gap is easy to adjust. There are no holes to bore, no attachments. All you have to do is to screw one little thumb nut on top of your spark plug. Just as if you were making a spark plug connection.

Professor A. Pross, Professor of Electrical Engineering of Berkeley, California, watched Sparko-Gaps working on U. S. subchasers, Liberty airplane engines, Liberty truck engines, and popular commercial motors in Government Laboratories at Washington. He states that the Sparko-Gap will fire plugs in conditions two hundred and fifty times as difficult as will an ordinary ignition system without them; so that plugs will fire no matter how dirty they are, and even with broken porcelain.

## DON'T SEND A PENNY

Remember, you don't send a single penny now. Just mail the coupon and tell us the make of your car and the number of cylinders. Don't bother to write a check or money order now. Simply pay the postman \$1.50 for each Sparko-Gap when they arrive. Then try them for 30 days on your car. If they do not make your car noticeably better, send them back and every penny you paid will be refunded. End your spark plug troubles now forever. Mail the coupon now. You can't begin too early to get more power out of your motor and more mileage out of your gas.

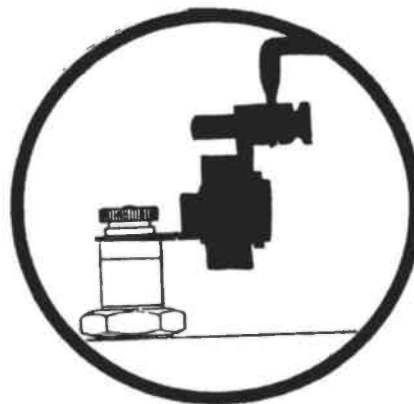

### SPARKO-GAP COMPANY

Dept. 10 54 West 39th St. New York City

Dealers—take advantage of our advertising. We back you up on above offer. Send for proposition.

### TRY THEM AT OUR RISK

SPARKO-GAP CO.  
54 W. 39th St., Dept. 10, New York City

Send me ..... Sparko-Gaps on 30 days' trial (one for each cylinder). I will pay postman \$1.50 each on arrival. It is understood that if I am not more than pleased you will refund my money in full.

My Name .....

Street .....

City..... State.....

Name of Car..... E. E.-1-30

## Telegraph Pictures

BY ELECTRICITY  
A complete set of two machines of this marvelous equipment for only \$19.50. Instructive, mystifying and useful. This picture of President Wilson was telegraphed by these machines. Picture telegraphing is the coming vocation. Write today.  
L. I. LEISHMAN CO., Dept. L, Ogden, Utah



## Mathematics Made Easy

The AreaScope—the Combination Triangle with a Brain—will multiply, divide, square percentages and proportions, solve all problems in trigonometry and geometry, draw symmetrical figures, pie arcs, etc. Superior to any slide rule. Simple to operate. Also includes A TRANS-PARENT TRIANGLE, PROTRACTOR and DIVERGENT RULER. Used at Columbia University, West Point, U. S. Aeronautic Schools, etc. Only \$1.50 postpaid. Order today before you forget.  
Dept. U, L. J. LEISHMAN CO., Ogden, Utah



Please mention EVERYDAY ENGINEERING MAGAZINE

# Become a Chief Electrician



CHIEF ELECTRICIANS ARE SCARCE, THOUSANDS ARE IN DEMAND. WHY NOT PREPARE NOW? YOU ARE CAPABLE OF EARNING

**\$60 to \$125 a week**

AS ONE OF THE LEADING CONSULTING ENGINEERS OF THE EAST I know exactly how to train men for positions of this kind. It is my SUCCESSFUL METHOD OF HOME STUDY COMBINED WITH MY OWN PERSONAL ATTENTION THAT HAS PUT HUNDREDS OF MY GRADUATES IN PROMINENT ELECTRICAL POSITIONS THROUGHOUT THE COUNTRY.

Apply immediately for my SPECIAL OFFER of this month.

H. K. BLATCHLEY & CO.: CONSULTING ENGINEERS. Liberty Building, 182 Temple St., New Haven, Conn. Kindly send me full particulars of your Home Study Course.

Name ..... Address .....

\$1.00 per Tire allowed if you bring us this Ad

## GOODYEAR

SERVICE STATION

(At Jamaica and Far Rockaway)

LET US QUOTE YOU

any tire made. We stock:—

- always **GOODYEAR**
- we **PENNSYLVANIA**
- EST **GOODRICH**
- we **GLOBE**
- EST **McCLAREN**
- we **HORSE SHOE RACINE**
- EST **NORWALK-CORD**
- we **MARTIN-CORD**
- EST **KELLY-SPRINGFIELD**
- we **(At New York)**
- EST **UNITED STATES, etc.**

Supplies AT COST to tire patrons. IT WILL PAY YOU to trade with:—

JAMAICA TIRE & RUBBER CO., INC.

- 1 West 48th Street.....New York
- Midway and Flushing Avenues.....Jamaica, N. Y.
- 10 Central Avenue.....Far Rockaway, N. Y.
- East Main Street.....Patchogue, N. Y.

"Largest, because we serve best"

## SAVE MONEY!

A High Grade

INNER TUBE FREE

6000 MILES Guarantee

Economy Reconstructed Tires made by our new special process are guaranteed to give good service because the best materials are used in their construction. Our tires are guaranteed for 6,000 miles and we give a FIRST quality inner tube free with every tire ordered from us. Our tires are reinforced with extra plies of fabric making them strong so they resist punctures and blowouts.

LINER IS FURNISHED WITH EACH CASING AT NO EXTRA COST. THESE PRICES INCLUDE CASING, RELINER AND TUBE.

2x3	\$7.15	3x4	\$11.00	4x4 1/2	\$13.15
2x3 1/2	8.25	3x4 1/2	11.25	3x4 1/2	13.50
2x3 3/4	9.00	3x4 3/4	11.75	3x5	14.50
11x4	10.10	8x4 1/2	12.25	3 7/8x5	14.50
12x4	10.45	3 1/2x4 1/2	12.90		

As with your order whether a straight side or other, plain or non-skid tread. Send a deposit \$3 for each casing ordered. Balance C. O. D. subject to examination. 1% discount if full amount sent with order. References furnished if desired.

UNITED ECONOMY TIRE CO.

West 48th Street New York City

## MakeM Club

You send \$5 for instructions. designs, blueprints then you MakeM Money running MakeM Community Shops or your own MakeM Club with the \$5 outfit. You make Bleriot, Curtiss, Spad and other Flying Planes, Sewing Machines, Stationary Bikes, Boat Trunks, Arts (Swords, Wagons, War Tanks, Toys, Dogs, Birds, Squirrels, Monarchs, Rabbits, etc.), Tents, Giraffes, Ostriches, Numbers, Letters, 100 Animals, Doll Furniture and Doll Houses. Prices below buy all their toys and everything new for Christmas. Get MakeM shop started quick and join MakeM Money.

PRICE, Inc., Dept. 17 Umacke Bldg., 127 6th Ave., N. Y.

# WANTED

Want ads for thousands of trained Automobile Repairmen are appearing in all the papers all over the Country. New Garages and Shops are badly needed everywhere. If you are earning less than \$30 a week—YOU SHOULD LEARN THIS TRADE.

**You Can Earn \$150 to \$400 a Month**

Come to this school and learn. We teach by actual practice on all kinds of cars. A few weeks time learning will fit you for a position in a garage, service station, or you can start in business for yourself. (No colored enrollments solicited.)

WRITE FOR FURTHER PARTICULARS

DO IT TODAY SEND IN COUPON

BUFFALO AUTO SCHOOL, No. E.E.I. 463-471 Connecticut St., Buffalo, N. Y. Please send me full particulars of your complete Automobile Course.

Name..... Age.....

Street or R. F. D.....

City..... State.....

## SHIP BY TRUCK

Motor Cartage.

One to Five-ton Trucks.

Hauls made to any point in United States and Canada.

Rates by hour, day or contract.

W. H. SQUIRES

1561 Woodward Avenue  
Detroit, Mich.

## You Can Save \$50.00

By recovering your old top from yourself. We make these covers to fit all makes and models of cars. Any person that can drive a car can put it on. We furnish instructions. Roof and quarters sewed together with rear curtain, fasteners, welts and tacks. All complete. Give us the name, year and model number of your car and we will send you our catalogue with samples and quote you exact price.

**\$8.93 and up** Parcel Post Paid

LIBERTY TOP & TIRE CO., Dept. E3, Cincinnati, O.

## TESTING LUBRICATING OILS FOR ACIDS

THAT a small quantity of fatty acid in oil renders it unfit for lubricating purposes is too well known to need repeating, but how to ascertain its presence, before irreparable injury has been done is a more difficult problem. The following is a simple method of testing for acids, namely, its action upon suboxide of copper or red oxide. If the red oxide is not at hand, the copper scale or ash of the coppersmith may be employed as it contains this suboxide. Either of these substances is placed in a white glass vessel, and covered with the oil to be treated. If the latter contains a trace of acid, or any resinous acid from rosin oil, with which it may have been adulterated, the oil soon turns green and that too nearest the copper scales. A gentle heat hastens the reaction, which in the cold, requires from 15 to 30 minutes. The test is extremely delicate, and cannot result in any doubt or error to those who use it for the first time. An oil which is not turned green by the copper scale can unhesitatingly be pronounced absolutely free from acid. If there be but little acid present the green color is fainter, by more acid, intenser, and if rosin has been added it is bluish. The chemical reaction is this: The free vegetable and fatty acids separated the sub-oxides into oxide and metallic copper; the former then combines with the acids to form greenish blue salt that dissolves more or less in the oil and imparts its color to it. The oxide of copper does not answer as well as the sub-oxide.

## TEST GAS IN TUNNELS

ONE of the problems that has developed in connection with the construction of the proposed vehicular tunnel under the Hudson River between New York and New Jersey, which will be 9000 feet long, with an estimated number of 2000 passenger cars and trucks passing through per hour during the rush periods is the amount of poisonous gas emitted by this long line of machines. This is now an unknown quantity and must be determined before the construction can be undertaken, so that provisions for proper ventilation may be made.

To carry on experiments with a view to ascertaining the amount of carbon monoxide, which is the deadly gas discharged by automobiles, that is likely to be emitted, the United States Bureau of Mines has just requested an appropriation of \$100,000 from Congress. And at the same time Yale University, New Haven, Conn., will construct an experimental tunnel and cooperatively attempt to determine whether the amount of poisonous gases given off by automobiles would be detrimental to life or endanger it in a long tunnel.

Please mention EVERYDAY ENGINEERING MAGAZINE



**GIANT ENGLISH SEAPLANE**

ACCORDING to *Flugsport*, a German aviation paper, a gigantic seaplane is under construction at the Barrow, England, works of Vickers, Ltd. In its general outline the machine is a long hull flying boat, with overhanging biplane wings. Only approximate dimensions are available at this time, but the span is given as 300 ft., the overall length as 200 ft., the overall height as 42 ft., and the wing chord as 27 ft. The power plant is fitted in four independent engine nacelles between the planes, each nacelle carrying two Rolls-Royce Condor 600 hp. engines "end on" and driving a tractor and four pushers, and the total horsepower is 4,800. It is estimated that the machine will be able to fly with full load on two-thirds engine power. The framework of the boat and of the planes is entirely constructed of duralumin, while the planking of the hull is made of Consuta, a special plywood sewn with copper wire, which was developed by Messrs. Saunders, the well-known yacht builders. The boat is fitted with two decks and is extensively furnished with passenger accommodations, there being sixteen two-berth cabins and a dining room in which in case of emergency thirteen more passengers can be accommodated. With forty-five passengers, the cruising endurance of the flying boat is estimated at 1,400 statute miles. The designed full speed is 110 m.p.h.

**A NEW FOKKER MACHINE**

THE new Fokker machine is constructed for commercial flying purposes. The wings are made on the principle well known in Fokker's other designs, that is to say, without stay-wires. The wings are 60 centimeters thick in the middle and are not covered with fabric, but with three-ply wood. The wing span is 16.1 meters, the length of the machine being 11.55 meters. It travels at a speed of 170 kilometers per hour with a motor of 185 h.p.

This indicates, we were told, an immense saving in gasoline and oil, and includes the advantage of light weight in the motor and also great saving in cost price as well as in use. The aeroplane itself weighs 1,200 kg. and when fully loaded 1,900 kg. With a full cargo it is calculated to reach a height of 4,000 meters in 45 minutes.

There is a closed cabin for four persons, the pilot and mechanic being comfortably seated in front of the cabin, and their seats are so arranged that small adjustments to the motor can easily be carried out while in flight. The motor is by the Bavarian Motor Works at Munich and is of the newest type. It is provided with an arrangement by which it develops its full power if desired at a height of 4,000 meters.

**"ALSOP-ALL-SPARK"**

Make your plugs last indefinitely

May Be Attached to Any Four-cylinder Car

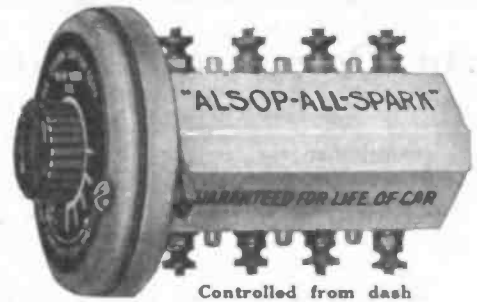

Controlled from dash

**THIS WONDERFUL DEVICE**

Insures a Hot Spark  
Fires Old Carbon-choked  
Plugs

Develops Greater Power  
Eliminates all Spark-Plug  
Troubles

Increases Gasoline Mileage

Puts new "Pep" in your car

The installation of the "Alsop-All-Spark" increases efficiency and insures continued driving when plugs crack or become dead.

Price 4 cylinder Type with Money Back Guarantee **\$7.50**

Write for descriptive literature NOW.

**ALL-SPARK IGNITION CO., Inc.**  
13 Water Street, Dept. E, New York

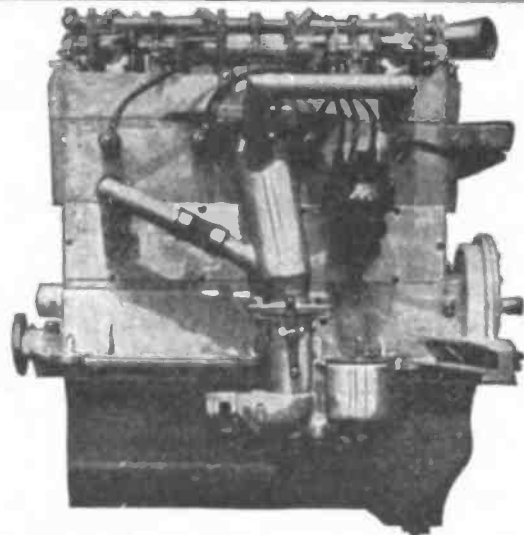

**"ACE" MOTORS**

Are Powerful, Light, Reliable and Economical

Weight 126 Pounds

Forty B. H. P.

These motors embody all the features of engineering that an extensive series of tests proved necessary, and are the product of ripe judgment of practical airmen. The ideal power plant for the man building his own plane.

Descriptive Literature on Request.

**HORACE KEANE**

*Aero Planes*

Sales Office  
280 Madison Ave.  
New York



INC.

Factory  
North Beach  
Long Island

**AMAZING OPPORTUNITIES**  
in the **Airplane Industry**

Right now is your opportunity to get into the greatest industry the World has ever known. Thousands of new positions opening up everywhere in this attractive new field. Never before have ambitious men had such a glorious chance. Send Coupon at once—find out how our wonderful Course in Practical Aeronautics will give you the knowledge to enter this new field. Learn at home by mail during your spare time.

**Prepare NOW**  
for these positions  
Aeronautical Engineer  
Aeronautical Instructor  
Aeronautical Contractor  
Aeroplane Repairman  
Aeroplane Mechanic  
Aeroplane Inspector  
Aeroplane Salesman  
Aeroplane Assembler  
Aeroplane Builder

**Enormous Demand for Men—Big Pay**  
If you know Practical Aeronautics, some big Airplane Corporation will want you. Unheard of Salaries are being paid trained men. Act at once. The pioneers are going to reap the big rewards. Automobile history, railroad history, movie history will repeat itself in Aviation.  
**Special Offer NOW—Send Coupon**  
Send the Coupon at once for full particulars of our remarkable new book "Opportunities in the Airplane Industry." No obligation. Be sure to tear off and mail coupon today.  
**AMERICAN SCHOOL OF AVIATION**  
431 S. Dearborn St. Dept. 7488 Chicago

**FREE BOOK COUPON**

American School of Aviation  
431 S. Dearborn St., Chicago  
Dept. 7488  
Gentlemen: Please send me full particulars of your remarkable offer, also your new big book "Opportunities in the Airplane Industry." I assume no obligation.

Name.....  
Address.....

## An Open Letter to the Model Engineers of America

Gentlemen:—

We trust you will excuse us in writing a letter directly to you, but we feel that we have something to tell you which will be to your advantage. We know that amateurs often find a difficulty in getting supplies, as the majority of firms do not bother with these small things. We do. We are prepared to quote prices for anything you may want in carrying on your pastime of making models. We specialize in model ship fittings, castings, patterns, model boilers and boiler fittings. We also have made arrangements to supply you with all the castings in the rough or partly finished to construct the engines and boilers described in this magazine by Wm. A. Helms.

Write us what you want and we will supply you. Until the amount of business justifies a store we take orders by mail only, and guarantee a prompt delivery. Hoping for your support, we are

Sincerely yours,

THE AMERICAN MODEL SALES & MFG. CO.  
601 Broadway, Telephone Spring 3337  
NEW YORK CITY.

## “Richards’ Made”

Complete Construction Sets from which you can build successful sailing Models. Circular tells the rest. Send for it.

WM. RICHARDS  
747 Tremont Ave. New York City

## OH—Just What I Wanted Real Model Racing Yachts Sails Faster Than You Can Walk

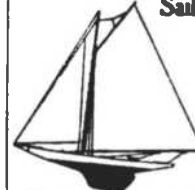

Sport for men and boys. Construction Set—complete—30 in. long, with Rigging, Fittings and HEAVY LEAD KEEL, ready to assemble. 5 screws, 20 brads and Yacht is built. Also same Model finished ready to sail. Send 25 cents and your dealer's name and address for book "Model Yacht Sailing," just printed, giving full instructions of the Sport; How to sail, rig, nautical terms, etc., etc.

New York Model Boat & Mfg. Corporation  
Dept. EM, 18 Broadway New York City

## MODEL ELECTRIC MOTOR YOU

can build this working model. All parts furnished complete with Blue Prints. No Extras required. \$2.00. Blue Prints only 25c.

A. F. CASSEL  
52 W. 130th Street, New York City

## DRAFTING

Inventions and Ideas Developed!

Mechanical, Electrical, Patent Office and Engineering Drawings of Every Description. COMPETENT DRAFTSMEN AT YOUR SERVICE

A. G. HAGSTROM  
116 Nassau St. New York City  
Telephone Beekman 4580

## Your Prospective Customers

are listed in our Catalog of 99% guaranteed Mailing Lists. It also contains vital suggestions how to advertise and sell profitably by mail. Counts and prices given on 9000 different national Lists, covering all classes; for instance, Farmers, Noodle Mfrs., Hardware Dirs., Zinc Mines, etc. This valuable reference book free. Write for it.

Send Them Sales Letters  
You can produce sales or inquiries with personal letters. Many concerns all over U. S. are profitably using Sales Letters we write. Send for free instructive booklet, "Value of Sales Letters."

ROSS-GOULD  
Mailing Lists St. Louis

## Mechanical Drafting

EXPERT SERVICE—REASONABLE  
INQUIRIES INVITED  
E. W. HEANEY & CO.

2105 Monterey Avenue New York City  
Telephone Fordham 6249

## Umakem Lathe You make a

High-grade Screw Cutting and Milling Lathe from Umakem outfit No. 15 which includes all Castings and 15 detail blueprints. Complete outfit \$35. Mean following dimensions: Length over all 2 ft. 11 in.; Bore, 1 1/2 in.; Approximate weight, 165 lbs. Dimensions of working surface of milling table, 6 in. by 6 in. This lathe has been designed to meet the wants of Model Makers who require a tool capable of very varied and accurate work. It is self-acting and Screw Cutting. With it all plain Milling work can be done, as well as making it easy to do a great many boring jobs otherwise very difficult. Address W. R. PRICE, Inc., Dept. 17, Umakem Bldg., 127 5th Ave., N. Y.

## MODEL AIRPLANE ENGINES

3 Cylinder Rotary Compressed Air Engines.

3/8 in. bore, 1/2 in. stroke  
1/2 in. bore, 3/4 in. stroke  
5/8 in. bore, 3/4 in. stroke

6 Cylinder rotary steam engines, steel cylinders, tobis bronze pistons, aluminum crank case.

3/8 in. bore, 1/2 in. stroke

Send stamp for descriptive circular.

MODEL MACHINE SHOP CO.  
415 East 71st St. New York City

## 6 INCH BENCH LATHE

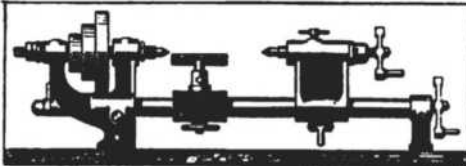

### Model Shop Equipment

Castings or finished machine. Shop tools and supplies. Designs for Model Boats. Drawings of U. S. Destroyer. Ready for immediate shipment. Stamp for catalog.

Hahn Mfg. Co., 584 Elm St., Arlington, N. J.



Small Steam Engines & Boilers, Gas & Gasoline Engines 1/2 H.P. and Up, Tanks, Pumps, Model Makers' Supplies. Get our big Catalogue, sent Postpaid for 15c (coin preferred) or Stamp. Refunded first order. 192 Pages, over 200 illustrations.

MODERN ENGINE & SUPPLY CO.  
364 Menadneck Bldg., Chicago, Ill.

Speed Lathe \$7 Complete Swing 7 in. 2 1/2 in. metal bed Head has a three step cone. Spindle is hollow. Centers are No. 1 Morse taper shank. Tail stock has a screw feed spindle and No. 1 Morse taper shank center. Spur counter is furnished for wood turning. Bearings are of high grade bearing metal and are adjustable to wear. Feet is adjustable to all positions. Lathe is complete at the above price. Larger bed \$1.00 per additional foot.

M. & J. SPECIALTY CO.  
282 S. Park St., Pontiac, Mich.

## A Necessity for Every Shop

"The Samson No. 3 Bench Punch," with a powerful leverage of 24 to 1, is intended for work beyond the capacity of the "Samson Hand Punch," and will punch holes from 1/4 to 3/8 in. in soft metal up to 12 Gauge. Extra sets punches and dies size 3/16, 1/4, 5/16, and 3/8 in. easily inserted and removed, (maximum punching capacity 3/16 in. through 12 gauge soft metal.)

Equipped with 3-16-inch Punch and Die unless otherwise specified. F.O.B. Factory



Price \$15.00

Catalog of Complete Line Sent on Request.

The Machine Appliance Corporation  
351 Jay Street, Dept. Eng. BROOKLYN, N. Y.

## For Gillette Blades Use The Big Four Stripper



A few turns and one operation gives perfect cutting edge. Makes old blades new and new blades better.

Guaranteed to give satisfaction or money refunded. Nothing to lose and everything to gain in comfort.

Every blade should be stripped before using, watch the barber, he knows. Sent postpaid \$2.00 anywhere in the United States for

BREZAL, Inc., Distributors  
Fifth Ave. and 21st St. New York City

## ALUMINUM CAN BE SOLDERED with

SUPREME BRAND ALUMINUM SOLDER  
FLOWS AT 500° FAHRENHEIT  
REQUIRES NO FLUX

Used by General Electric Company, Worthington Pump Company, Hale & Kilburn Company, Bethlehem Shipbuilding Corp., National Lead Company, and hundreds of other manufacturers and repair shops.

Instructions for using with each bar.  
Price \$3.00 per Pound in Half Pound Bars.  
Send Fifty Cents for 1-Ounce Sample Bar.

VANDAM SPECIALTY COMPANY  
Grand Central Palace, Dept. EE, New York City

Please mention EVERYDAY ENGINEERING MAGAZINE



**"You'll Have to Have An Auto-Wheel to Keep Up."**

It's the coaster wagon that real fellows have. Genuine Roller-Bearings make the ride smoother. The Auto-Wheel glides up to the finish line—leading all the others. Has steel tires and axles and a low racing body. Auto-Wheel wagons are well built. Not just rattle-traps, but high-grade, substantial, heavy-duty wagons. Carry 1,000 pounds. Material carefully selected, put together right.



**Two Models—Take Your Pick.** Auto-Wheel Coaster—the old standard and stand-by. Just as good for coasting as for hauling.



Auto-Wheel Convertible Roadster is the newest thing in wagons. Sides can fold up or down (on durable pivots.) If you want a roadster just swing sides up. For errand wagon fold sides down to form box-wagon.



**Auto-Wheel Owners Are Club Members.**

Write for details. Send names of three coaster dealers, mentioning which ones carry the Auto-Wheel. We'll put you on the mailing list of Auto-Wheel "Spokesmen." Tell about our big PRIZE CONTESTS.

**The Buffalo Sled Co.,**  
180 Schenck St., N. Tonawanda, N. Y.  
In Canada: Preston, Ont.

**A SIX-CYLINDER AIR MOTOR**

*(Continued from page 314)*

the pistons are to the top, the more effective travel or stroke is obtained. Care should be taken that the pistons do not hit the cylinder tops, as the engine will not rotate and the light connecting rods may be bent. The front plate of the crank case is machined from steel or brass and carries a flange by which the propeller is driven. This engine will swing a twenty-inch diameter two-blade screw, having a pitch of approximately 30 to 36 inches without any difficulty and operates well on an average air pressure of about one hundred pounds. Obviously, the more air pressure supplied, the higher the rate of revolutions and the greater the power output will be. The motor will work on any air pressure that the usual type of airplane model air reservoir or tank will carry. A simple collar with a small set screw is used to keep the taper valve seat tight.

After assembly, the engine should be run on a lathe or drill press, by holding the cylinders from turning and rotating the crankshaft by catching it in a chuck, supplying plenty of oil and lapping in so that all parts will be a good fit before the engine is used. This running-in process makes for an easy running and well fitted engine and one that will require a minimum consumption of air.

**TyCOS-**

Those who take their work most seriously are most likely to be found using Tycos Temperature Instruments—Indicating, Recording and Controlling.

Among Tycos Products are:

- Indicating Thermometers
- Recording Thermometers
- Controlling Thermometers
- Pyrometers
- Pressure Gauges
- Time Controls
- Hygrometers
- Hydrometers
- Barometers
- Vacuum Gauges
- Thermographs
- Oil Testing Instruments
- Laboratory Glassware
- Compasses
- Household Thermometers
- Altimeters
- Actinometers

Let us know your particular requirements. Literature mailed upon request.

(HH-4)

**Taylor Instrument Companies**  
ROCHESTER, N. Y.  
There's a Tycos and Taylor Thermometer for every purpose.

# Are You Going to Give Up a College Education

## BECAUSE YOU CAN'T AFFORD IT?

Will you allow yourself to go through life handicapped by the lack of technical education, knowing that you can never attain the success that would have been yours if you had gone to college?

**NO!**

If you have the stuff in you of which success is made you need not think of the cost of going to college, for EVERYDAY ENGINEERING MAGAZINE will pay your expenses at any University, College, Trade School or Correspondence School in the United States.

### *Everyday Engineering Will Finance Your Education*

in return for all or a portion of your spare time. It may seem too good to be true, but it is no less a fact—Four years at college with all the opportunities of learning, with the social life, which, in itself, is of tremendous importance in the life of every man.

To make arrangements for starting this coming fall, write immediately to the "Circulation Department", EVERYDAY ENGINEERING MAGAZINE, stating the name of the University to which you want to go, the course you are desirous of taking and the approximate cost for the scholastic year.

Here is your chance. It is up to you to take this opportunity now.

**EVERYDAY ENGINEERING MAGAZINE**

**2 West 45th Street**

**New York City, N. Y.**

Please mention EVERYDAY ENGINEERING MAGAZINE

# Useful Books on Mechanical Subjects

## Electro-Deposition of Metals

By George Langbein  
and  
William T. Brannt

The new eighth edition of this volume, which has been completely revised, considerably enlarged and entirely reset, is now ready. It is a complete and comprehensive treatise, written from a scientific as well as practical standpoint and especially intended for the practical workman, wherein he can find advice and information regarding the objects to be plated while in the bath as well as before and after electroplating. This volume is the foremost book on the subject in the English language and covers electroplating and galvanoplastic operations, the deposition of metals by the contact and immersion processes, the coloring of metals, lacquering, and the methods of grinding and polishing as well as descriptions of the voltaic cells, dynamo-electric machines, thermopiles, and of the materials and processes used in every department of the art. Particular attention has been paid to all important innovations, and it has been endeavored to include all of the latest practical methods of plating, as well as the most recent machinery and apparatus. It is a ready book of reference and a practical guide to the workshop. Octavo, 875 Pages, 185 Illustrations.

Price \$7.50

## Complete Practical Machinist

By Joshua Rose

One of the best-known books on machine shop work, now in its twentieth edition, and written for the practical workman in the language of the workshop. It gives full practical instructions on the use of all kinds of metal-working tools, both hand and machine, and tells how the work should be properly done. It covers lathe work, vise work, drills and drilling, taps and dies, hardening and tempering, the making and use of tools, tool grinding, marking out work, machine tools, etc. Throughout the entire classic the explanations are as clean-cut as the tools they describe, and the earnest mechanic or machinist seeking greater efficiency will be helped toward using both head and hands to better advantage. No machinist's library is complete without this volume.

547 Pages. 432 Illustrations

Price \$3.00

## Metal Worker's Handy-Book of Receipts and Processes

By William T. Brannt

This volume is a valuable work of reference and instruction for all engaged in the working of metals. It is a collection of formulas and practical manipulations for the working of all the metals and alloys including the decoration and beautifying of articles manufactured from them. The utmost pains have been taken to insure the accuracy and efficiency of the recipes so that with ordinary care as to quantities and manipulation the results may be implicitly relied upon.

It treats on alloys and amalgams; hardening, tempering, annealing; bronzing and coloring; casting and founding; cements; cleansing, grinding, pickling, polishing; decorating, enameling, engraving, etching; electroplating, brasing, coppering, galvanizing, gilding, nickeling, silvering, tinning, etc.; fluxes and lutes, lacquers, paints and varnishes; solders and soldering; welding and welding compounds. To the new edition has been added several new chapters on die-casting, thermite and oxyacetylene welding, etc.

582 Pages. 82 Illustrations

Price \$3.00

Send for our new 48-page descriptive catalogue mailed free on request.

**HENRY CAREY BAIRD & CO., Inc.**

Publishers of Mechanical  
and Industrial Books

2 West 45th Street, New York, N. Y.

## DETERMINING OIL FILM PRESSURE

CLAIMS have been made that under the heavy demands on journals and the necessity of keeping them in cool running condition, a properly compounded grease is safer in operation than by the use of oil, no matter how carefully the latter may be applied. From the experiments of Beauchamp Tower, a British engineer, the "film of oil" theory was established. The instant that this film is broken and metal

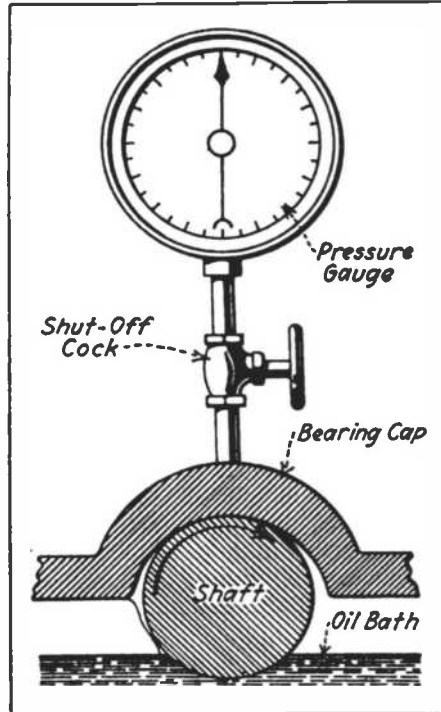

Apparatus for determining oil film pressure

touched metal, all laws of lubrication failed. Mr. Tower's experiments also show that there is a best lubricant for every class of service, ranging from the heavy oils and greases, with high viscosity or "body" for great pressures, and low velocity of rubbing, to the light spindle oils for low pressures and high velocities. Good judgment based on experience is the best guide in the selection of the proper oil for each service.

The results of some of Mr. Tower's experiments are interesting. In the accompanying drawing is shown a simple device showing the pressure on the oil or grease film in a journal box. A hole was drilled in the cap of the box for the purpose of applying oil at that point. It was found that oil would not enter there, and a bath was applied below the box, inserting a wood plug in the hole. But this was always forced out by the oil. Mr. Tower then connected a pressure gauge and found that while the pressure on the journal was 100 lbs. per square inch, the pressure gauge recorded an oil pressure of over 200 lbs. per square inch. Apparently

the journal with oil adhering to its surface serves as a pump constantly lifting oil to the top. The adhesion of the oil to the surface made it possible for the pressure at the center to reach this very high point. The importance to be attached to this is that journal boxes should be constructed so as to admit of the pumping of the lubricant up the side to the top. It is readily concluded that if an ample supply of lubricant can be maintained between rubbing surfaces of fluid pressure twice as great as the unit pressure on the journal, there need be no concern as to the failure of the film separating the metals.

## STUDY OF ENGINE TESTS

THE National Advisory Committee for Aeronautics, Washington, has just issued Report No. 46, "A Study of Airplane Engine Tests." It embodies deductions drawn from results of many tests made upon one engine in the altitude library of the Bureau of Standards.

Three major variables are considered; namely, speed, altitude and power, as well as other variables, such as best distribution, friction losses, carburetion, etc.

The work shows that:

Power varies approximately with the density of the air, decreasing with altitude. The heat supplied in the fuel should be proportioned to the density of the air, up to nearly 15,000 feet altitude, above this altitude a richer mixture should be supplied. The thermal efficiency based on brake power is a variable, but when based on the indicated power it is nearly a constant for all speeds and altitudes. The sensible heat in the exhaust varies somewhat, but is closely related to the heat rejected on the theoretical (Otto) cycle. The pounds of fuel per B. H.P. per hour is constant up to nearly 15,000 feet altitude, but increases at the higher altitudes as a richer mixture is required. When fuel consumption is based on B. H.P. it steadily rises with decrease of density owing to the effect of a nearly constant friction loss at a given speed.

In the production of nitric acid from Chile saltpetre, acid sodium sulphate has been a waste product. Recent experiments in melting with silica and other substances used by the glassmaker have resulted in the production of a clear greenish glass with a saving of over one-half the sulphur in the salt. If charcoal is added, some of the sulphur may be recovered as such, being reduced from the sulphate. It has long seemed as if silica, which may be common sand, could be used as an acid to expel other acids from their combinations. At high temperatures practically no acid can resist it.

Please mention EVERYDAY ENGINEERING MAGAZINE



# NEW BOOKS

**MOTOR BOATS AND BOAT MOTORS.** Design, Construction, Operation and Repair. By Victor W. Page, M. S. A. E. and A. Clark Leitch, N. A. 524 pages, 6 in. by 9 in. 372 illustrations. The Norman W. Henley Publishing Company, New York City.

This is a brand new book on motor boats and should be of value to everyone interested in boats or engines. It considers every phase of motor boating, as it considers all details of modern hulls and marine motors, deals exhaustively with boat design and construction, design and installation of all types of marine engines and gives expert advice on boat and engine maintenance and repair. Not only is boat construction fully treated, but every needed dimension is given for building from complete yet simple plans, and construction is considered step by step. Everything from the selection of the lumber and laying out the boat molds to the finish of the completed craft is outlined in detail. The boats described have been built by the author and the plans are right. The book has also a special chapter on seaplanes and flying boats and includes complete working drawings for boat builders, giving full instructions for building boats ranging from a general utility 16-foot model to a 25-foot raised cabin cruiser from tested designs. It is divided into two parts and is practically two books in one binding. Part 1 deals with the hull and fittings. Part 2, the Power Plant and its auxiliaries. It is the most complete book on motor boating we have examined to date.

**THE ELECTRICIAN'S HANDY BOOK.** By T. O'Connor Sloane, Ph. D. 823 pages. 593 illustrations. Flexible cloth binding. 6 1/2 in. by 4 1/2 in. Published by the Norman W. Henley Publishing Co., New York.

The Electrician's Handy Book has rapidly won its place in electrical literature and has already had a large clientele of readers. We note with interest this new edition which, while including the original matter of the book, has by extensive additions been made thoroughly up to date. It has filled a unique place in the literature of the science and the additions with their numerous illustrations operate to maintain its very high standard. The entire field of electricity is covered by the text, and the numerous illustrations, by their great clearness, facilitate its clear descriptions of electrical theory, operations and apparatus.

The book has a very full table of contents and is thoroughly indexed. Its very clear and systematic paragraphing make quick reference very easy.



# NEW MOTORS

FACTORY GUARANTEED  
ALL SIZES  
PROMPT DELIVERY

**Charging Generators**  
Suitable for all lighting. Battery Charging and Power Requirements.

8 v., 10 amp. . .	\$19.50
15 v., 10 amp. . .	\$26.50
40 v., 6 amp. . .	\$31.50
110 v., 2 1/2 amp. . .	\$31.50
110 v., 5 amp. . .	\$52.50
40 v., 12 amp. . .	\$52.50
110 v., 9 1/2 amp. . .	\$67.50
40 v., 25 amp. . .	\$67.50
110 v., 18 amp. . .	\$116.50
40 v., 50 amp. . .	\$116.50
110 v., 26 amp. . .	\$156.50
110 v., 50 amp. . .	\$238.50
Moving Picture Art Generator 88 v., 10 a.	\$116.50

**Polyphase Motors**

9 and 3 phase, A. C., 220 v., 60-1750 R. P. M. Complete with base and pulley.	
1/2 H. P. . .	\$46.50
1 H. P. . .	\$66.50
2 H. P. . .	\$86.50
3 H. P. . .	\$98.50
5 H. P. . .	\$116.50
1 H. P. Special Grinding and Buffing Motor . . .	\$106.50

**Direct Current Motors**

110 or 220 volts, D. C., shunt wound, 1750 R. P. M. With base pulley and starting box.	
1/4 H. P. Washing Machine Motor . . .	\$28.50
1/4 H. P., 27 v. Washing Machine Motor . . .	\$28.50
1/2 H. P. . . . .	\$58.50
1 H. P. . . . .	\$82.50
2 H. P. . . . .	\$124.50
3 H. P. . . . .	\$142.50
5 H. P. . . . .	\$218.50

**Single Phase Motors**

110-220 volts, A. C., 60 cycle, 1750 R. P. M. with pulley	
1/4 H. P., 22 v. induction Washing Machine Motor . . .	\$28.50
1/4 H. P., 110 v. grinding table motor . . .	\$28.50
1/2 H. P. induction, full load start . . .	\$46.50
1/2 H. P., repulsion induction For compressor service . . .	\$54.50
1 H. P. repulsion induction, Special Charge Motor . . .	\$74.50
2 H. P. repulsion induction 250 sliding base . . .	\$126.50
3 H. P. repulsion induction with sliding base . . .	\$146.50
5 H. P. repulsion induction with sliding base . . .	\$188.50

WRITE FOR CATALOG. BARGAINS IN MOTORS AND GENERATORS

**1/4 H. P.** 110 volts  
SPECIAL  
S. P., 1750 R. P. M.  
Complete, cord, plug and pulley

**WASHING MACHINE MOTORS**  
Available for repairing small Commercial, 6 office Washers, 220 v. Washers, Etc.  
\$26.50 Each

**SHOPPING TERMS:** 25% deposit required on all orders. Balance C. O. D. by Express. Slight freight with Bill of Lading attached by freight.

CHAS. W. JOHNSTON, Box 10, West End, Pittsburgh, Pa.

## Discover Your Talents

What Are You Best Fitted For?

Personal, Mental and Vocational analysis, by Dr. B. S. George, M.A., Ph.D., former U. S. Army expert. Will help you know your mind and what you are best fitted for. Complete course of tests and analysis, with 1,500 vocations classified, will be mailed to you on approval. Send \$3.00 for the course postpaid. If it is not satisfactory return it in five days and we will refund your money. Address

**The Vocational Guidance Institute**  
2285 Broadway, New York City

**CLEARTONE PHONOGRAPHS**  
\$4.00 to \$200.00 Retail

Our Sundry Dept. offers Needles 25c per thousand, in lots of 500,000. Motors \$1.25 to \$14.75 each. Tone Arms and Reproducer \$1.50 to \$8.75 per set. Main Springs \$60 to \$90 each. Records, Needles, Beahm's Paths and Parts at reasonable prices. Write for our 84-page catalogue, the only one of its kind in America, illustrating 25 different styles of Talking Machines and over 500 different Phonographic Parts. **LUCKY 13 PHONOGRAPH COMPANY** Export Dept. 4624, E. 12th St., N. Y., U.S.A.



## Umakem Outfit

No. 3 includes 10 good tools, designs, 3 ply wood, hardware, mechanical parts and everything to make a \$20 Toy Circus set including Animal Wagon and Circus Wagon each drawn by two large jointed animals with Clown Riders 10 Wild and Domestic Animals, kicking and jumping Donkeys with riders and other Circus Things. This set is a red hot Money Maker and several people can work with Umakem No. 3 at the same time. Fine for families, toy clubs and schools. Send \$10 for this set. Dealer: buy Christmas toys now. **W. R. PRICE, Inc., Dept. 17, Umakem Bldg., 127 9th Ave., N.Y.**

## Earn \$35 to \$100 a Week

**BECOME A PROFESSIONAL PHOTOGRAPHER**  
Big opportunities NOW. Qualify for this fascinating profession. Three months' course covers all branches:  
MOTION PICTURE—COMMERCIAL—PORTRAITURE  
Cameras and Materials furnished free  
Practical instruction; modern equipment. Day or evening classes; easy terms. The School of Recognized Superiority. Call or write for complete catalog No. 20.

**N. Y. INSTITUTE OF PHOTOGRAPHY**  
141 W. 36th St., N. Y. 508 State St., Bklyn.

## You Can Make Big Profits

Charging Auto Storage Batteries  
\$100 to \$300 Profit Every Month

Start Now making BIG PROFITS. HB Equipment most dependable on the market—no repairs, no burn-outs, no expensive renewals—pays biggest profits with least expense—economical to operate, never wears out. It costs only 10c to 15c each to charge batteries the HB way—customer pays 75c to \$2.00. You get those profits!

An HB Battery Charger for Every Size Battery Business



Small Cash Payment Puts Any HB Charger in Your Garage—Choose the Size You Need

Mark a cross (X) on picture of HB Charger you need—then tear out and mail this ad. All you need is the small cash payment—you have almost a year to pay balance on easy monthly terms. Your HB Profits will do it—easily. Sold on 10 days trial under HB Absolute Money-Back Guarantee. You run no risk. Write TODAY for information.

**HOBART BROTHERS COMPANY**  
Box EE-77 TROY, OHIO  
Successful Manufacturers Since 1893

## \$110 A Month To Start As Railway Traffic Inspector

ONE HUNDRED MONTHS spare time study will equip you for responsible position with a good salary from the start. Railway Traffic Inspectors advance rapidly—they work right with railway officials who are constantly seeking capable men. A pleasant position—you become broad-minded—you travel and see country, expenses paid. S.B.T.I. instruction is very interesting—it's easily assimilated. We arrange for position; no age limit. Those who started studying a few months ago fill positions today, and they're on the road to still further advancement, so write immediately for Booklet D 48 before you turn this page. Standard Business Training Institute, Buffalo N.Y.

WE ARRANGE FOR A POSITION

Please mention EVERYDAY ENGINEERING MAGAZINE



BOOK REVIEW

**PROSPECTOR'S FIELD BOOK AND GUIDE.** By H. S. Osborn. Ninth Edition. Revised and enlarged by M. W. Van Bernewitz. 400 pages, 4 5/8 by 7 3/8 inches. Pocket-book style. Illustrated. Henry Carey Baird & Co., Inc., New York.

"Some idea of the scope of the ninth edition may be gained from the fact that a spirited introduction emphasizes the necessity of prospectors receiving some technical training. The chapter on preliminary instruction covers the fundamentals of a study of the earth's crust. Then follow discussions on practical mineralogy, crystallography, the value of the blowpipe in prospecting, surveying and chemical tests in the field. Separate chapters are given to the precious and base metals, also to the non-metallic minerals. A general rearrangement has been made, and the metals or minerals found in association are considered together.

The chapter on the non-ferrous or alloy group of minerals is entirely new, being the best information available. The section on oil has been expanded, while the subject of oil-shale is new. A new and little known, yet successful method of prospecting for gold, is included, while surficial indications for copper receive full attention. The chapter on gems in the previous edition has been rewritten and condensed on that subject, but to it has been added matters concerning gemstones used for industrial purposes, such as abrasives. A general chapter covers many useful minerals and salts, the old matter being amplified and brought up to date.

An important guide and suggestive aid throughout the new book are the many brief descriptions of ore deposits of all minerals occurring in scattered parts of the world. These have been abstracted carefully, and tell how certain minerals may be expected to be found. No other prospector's book contains this class of information. Another special feature is the lists of outfits, prices and manipulation of the apparatus. In the appendix will be found numbers of useful tables, an explanation of the unit system of buying and selling ores, and a complete glossary of mining and mineralogical terms.

The conclusion has been reached that copper is an advantageous constituent of steel. Two samples are cited. One contained 0.86 per cent. of copper and the other .030 per cent. copper. The first sample is better under all conditions with a higher yield-point, higher ultimate stress and greater reduction on area with a slightly lower value for elongation. Under the Brinell and Shore tests and the Charpy impact test the sample with the larger percentage of copper was the harder. In its general effects copper in steel is comparable to nickel which has been used so much in the last few decades of metallurgical practice.

# PATENTS

**To the Man with an Idea**

I offer a comprehensive, experienced, efficient service for his prompt, legal protection and the development of his proposition.

Send sketch, or model, and description, for advice as to cost, search through prior United States patents, etc. Preliminary advice gladly furnished without charge.

My experience, and familiarity with various arts, frequently enable me to accurately advise clients as to probable patentability before they go to any expense.

Booklet of valuable information and form for properly disclosing your idea, free on request. Write today.

**RICHARD B. OWEN**  
PATENT LAWYER  
144 Owen Building, Washington, D. C.

## PATENTS

Before disclosing your invention to anyone, send for blank form, "Evidence of Conception," to be signed and witnessed. Form and information concerning patents FREE.

**LANCASTER AND ALLWINE**  
225 O'Quay Building, Washington, D.C.  
Originators of the form "Evidence of Conception"

**WILLIAM C. LINTON**  
Consulting Engineer and Patent Attorney  
"Inventor's Adviser" mailed free on request. Gives full information as to Patents, Trade Marks and Their Cost.

Offices  
364 University St. Montreal, Canada      920 F St., N. W. Washington, D. C.

**Competent Patent Service**  
By a Former Examining Official of the U. S. Patent Office

**NORMAN T. WHITAKER**  
Lawyer and Engineer  
580 Whitaker Bldg. Washington, D. C.  
Branch Office, 87 Nassau St., New York City  
INQUIRIES INVITED

## Free Book on PATENTS

Contains valuable information and advice to inventors on securing Patents. Send model or sketch of your invention for Free Opinion of its patentable nature. Prompt service. 20 years experience. Write today

TALBERT & TALBERT 4150 TALBERT BLDG., Washington, D.C.

# CELLULOID

SHEETING, PRINTING, MOLDING,  
TURNING, DIE CUTTING  
EXPERIMENTAL WORK, ETC.

**NAPIER BROWNING CO.**  
105 W. 40th St.      NEW YORK CITY

# WILLIAM VOGEL

INVENTIONS DEVELOPED  
MODELS, EXPERIMENTS  
Absolute Secrecy Guaranteed  
CONSULTATION

Phone Barclay 9134      96 Warren Street  
New York City

# PRINCE ALBERT

*the national joy smoke*

Our exclusive patented process cuts out bite and parch.

You can be quickly cured, if you

# STAMMER

Send 10 cents coin or stamps for 76-page book on Stammering and Stuttering. "Its Cause and Cure." It tells how I cured myself after stammering for 20 years.

Benjamin N. Began, 910 Began Bldg., Indianapolis

# THE Wireless World

The Official Organ of the Wireless Society of London

Commencing with April 3d, will be published fortnightly in order to adequately deal with the increasing amount of Wireless Experimental and Research Work.

Full of Practical hints and useful information for Wireless Amateurs.

Extensive reports of the Wireless Societies of Great Britain.

**Annual Subscription 17s, Post Free**  
Single Copies 9d, Post Free

To be entirely up-to-date in your knowledge of Wireless you must be a subscriber to The Wireless World.

To the Publisher,  
The Wireless World,  
12-13 Henrietta St.,  
London, WC2, England.

Please enter me as a subscriber to the Wireless World for the period . . . . . to . . . . . for which I enclose . . . . .

Name . . . . .

Address . . . . .

Please write distinctly.

Please mention EVERYDAY ENGINEERING MAGAZINE

# BURGESS ELECTRICAL HAND-BOOK

(called THE BURGESS BLUE BOOK, originally in blue-print form)  
**SHORT CUTS AND TIME SAVERS**

Prepared in pocket size especially for practical men and those taking up the study of electricity. Contains drawings and diagrams of electrical machinery—over 200 formulas for calculation and problems worked out showing how formulas are used. From the personal note book of Yorke Burgess while on all different kinds of electrical work covering a period of nearly a quarter of a century.

Electrical laws, formulas, methods of calculation, etc. Simplified and made easy to understand and remember. Easy to apply in practical work. Many valuable stunts not to be found in any other book. Of value to any electrical man, whether Technical Graduate, Electrical Engineer, Student or Practical Man.

Electricians all over the world are sending for this book. The most complete and valuable book of its kind published. Nothing else like it. If you have never seen this book it is impossible for you to realize what you have missed.

**Price \$1.00**

Send dollar bill, money order or check. You take no chance—money back ANY TIME if not satisfactory.

**THE BURGESS COMPANY**  
 Consulting Electrical Engineers  
 YORKE BURGESS, President

Engineering Division (Department 108) 750 E. 42nd Street,  
 CHICAGO, ILLINOIS, U. S. A.

## Professional Assistance and Consultation

We solicit the patronage of inventors and will give prompt, confidential service in the perfection of ideas. Complete drawings and plans prepared. Specialists in steam and gas engine appliances.

Correspondence Invited.

*Let Us Know Your Problem*

**Bell & Hoyt**

366 Madison Ave. New York, N. Y.

# DRAFTING



## Learn at Home!

Employers everywhere are looking for skilled draftsmen. They are offering splendid salaries, and good positions are always open.

No line offers greater opportunity for advancement. Drafting itself not only commands good pay, but it is the first step toward success in Mechanical or Structural Engineering or Architecture.

There is an easy delightful way in which you can learn right at home in spare time. For 29 years the International Correspondence Schools have been giving men and women just the training they need for success in Drafting and more than 200 other subjects. Hundreds of thousands have stepped into good positions through I. C. S. help but never were opportunities so great as now.

Let the I. C. S. help you. Choose the work you like best in the coupon below, then mark and mail it today. This doesn't obligate you in the least and it will bring you information that may start you on a successful career. This is your chance. Don't let it slip by. Mark and mail this coupon now.

—YEAR OUT HERE—  
**INTERNATIONAL CORRESPONDENCE SCHOOLS**  
 BOX #087a, SCRANTON, PA.

Explain, without obligating me, how I can qualify for the position, or in the subject, before which I mark X.

- |  |  |
|--|--|
| <input type="checkbox"/> ELECTRICAL ENGINEER<br><input type="checkbox"/> Electrician<br><input type="checkbox"/> Electric Wiring<br><input type="checkbox"/> Electric Lighting<br><input type="checkbox"/> Electric Car Running<br><input type="checkbox"/> Heavy Electric Traction<br><input type="checkbox"/> Electrical Draftsman<br><input type="checkbox"/> Electric Machine Designer<br><input type="checkbox"/> Telegraph Expert<br><input type="checkbox"/> Practical Telephony<br><input type="checkbox"/> MECHANICAL ENGINEER<br><input type="checkbox"/> Mechanical Draftsman<br><input type="checkbox"/> Ship Draftsman<br><input type="checkbox"/> Machine Shop Practices<br><input type="checkbox"/> Toolmaker<br><input type="checkbox"/> Gas Engineer<br><input type="checkbox"/> CIVIL ENGINEER<br><input type="checkbox"/> Surveying and Mapping<br><input type="checkbox"/> WINE, FUR, OR ENGR' ARCHITECT<br><input type="checkbox"/> Architectural Draftsman<br><input type="checkbox"/> PLUMBING AND HEATING<br><input type="checkbox"/> Sheet Metal Worker<br><input type="checkbox"/> Navigator | <input type="checkbox"/> CHEMICAL ENGINEER<br><input type="checkbox"/> SALESMANSHIP<br><input type="checkbox"/> ADVERTISING MAN<br><input type="checkbox"/> Window Trimmer<br><input type="checkbox"/> Show Card Writer<br><input type="checkbox"/> Outdoor Sign Painter<br><input type="checkbox"/> RAILROADER<br><input type="checkbox"/> ILLUSTRATOR<br><input type="checkbox"/> DESIGNER<br><input type="checkbox"/> BUSINESS MANAGEMENT<br><input type="checkbox"/> Private Secretary<br><input type="checkbox"/> BOOKKEEPER<br><input type="checkbox"/> Stenographer and Typist<br><input type="checkbox"/> Cert. Pub. Accountant<br><input type="checkbox"/> Traffic Management<br><input type="checkbox"/> Commercial Law<br><input type="checkbox"/> GOOD ENGLISH<br><input type="checkbox"/> STATIONARY ENGINEER<br><input type="checkbox"/> CIVIL ENGINEER<br><input type="checkbox"/> Railway Mail Clerk<br><input type="checkbox"/> Textile Operator or Supt.<br><input type="checkbox"/> AGRICULTURE <input type="checkbox"/> Spanish<br><input type="checkbox"/> Poultry Raising <input type="checkbox"/> French<br><input type="checkbox"/> Automobiles <input type="checkbox"/> Italian |
|--|--|

Name \_\_\_\_\_ 7-20-10  
 Present Occupation \_\_\_\_\_  
 Street and No. \_\_\_\_\_  
 City \_\_\_\_\_ State \_\_\_\_\_

## TWO GOOD BOOKS

### Model Engineering

By Henry Greenly  
 407 pages, 809 illustrations, cloth  
 Price \$3 postpaid

### Model Making

By Raymond Francis Yates  
 400 pages, 301 illustrations, cloth  
 Price \$3 postpaid

A postcard puts you on our mailing list.

**SWANSON BROS.**

Technical Book Service  
 186 No. La Salle St., Chicago, Ill.

## ATTENTION! PRACTICAL BOOKS FOR PRACTICAL MEN

Get our set of 18 Books on Machine Shop Practice. Contents: Gearing, Mathematical Tables, Shop Arithmetic for the Machinist, Drawing, Screw Cutting, Screws and Bolts, Milling Machine Tables, Strength of Materials and other information. Machine work. Price \$3.25 per set prepaid. One set of 9 Books on Electricity. Contents: Dynamos, Motors, Electric Railways, Transmission of Power, Electric Lighting, Telegraph and Telephone, Electro Plating, Armature and Magnet Winding, Wiring Diagrams, etc. Price per set \$5.00 prepaid. Automobile Guide. Price \$1.60. Dykes Automobile and Gasoline Engine Encyclopedia. Price \$6.40. Power Wagon Reference Book for 1920 and Power Wagon Magazine, both for \$5.00. Storage Batteries Book 75c. Automobile Road Maps of every state in the Union, 35c each state. Send money orders or stamps.  
**UNION TECHNICAL BOOK CO.**  
 4020 McPherson Avenue, St. Louis, Mo., U. S. A.

## Barometrical Determination of Heights

A practical method of barometrical levelling and hypsometry. By F. J. B. Cordero. Second edition, revised and enlarged, 6 x 4 in., limp cloth, 50 cents.

## Buchanan's Tables of Squares

Containing the square of every foot, inch, and sixteenth of an inch between one-sixteenth of an inch and fifty feet. These tables will be found to be of great value to all classes of Engineers, \$1.25.

## French Measure and English Equivalents

By John Brook. Giving equivalents in inches and decimals of an inch and inches and fractions of an inch (to the nearest 64th + or -) or from 1 to 1000 millimetres, and 1 to 100 metres, and table of fractional parts of an inch with corresponding decimals. 80 pages, 4 x 3 ins., limp cloth, 40 cents, net.

## Metrical Tables

By Sir Gullford G. Molesworth.  
 Fourth Edition, Revised and Enlarged  
 VIII + 95 pages, 5 x 3 in., limp cloth,  
 75 cents, net.

**SPON & CHAMBERLAIN**  
 120E Liberty St. New York

**EASY to LEARN at HOME**

# ELECTRICITY

**TAUGHT BY A PRACTICAL MAN**

This Home Study Course, based on the years of practical experience of Yorke Burgess, who gives personal attention to each student, has placed hundreds of men and boys in better positions. Beginners get employment after taking the Burgess course a short while—over 85% of students now engaged in electrical work.

**FOR BEGINNERS and EXPERIENCED MEN**  
 What You Should Learn and The Way You Should Learn It

Why the Burgess method is best for you—Read what L. E. Watkins, R. E. E., of Brooklyn, Mass., one of the foremost Electrical Engineers in the U. S. and a pioneer in electric railway work, writes of the Burgess school: "It is indeed good that there has been established a school of Electricity on so practical lines. Free From The Perils of the general run of correspondence schools."  
 You TAKE NO CHANCE—no confidence are we of your success that YOUR PAYMENTS CEASE IF YOU ARE NOT SATISFIED—EASY TO LEARN—EASY TO PAY FOR. Apparatus, instruments, materials, etc., are included in the course. Mr. Burgess has just issued a new 48 page book, "ELECTRICITY," that every person interested in electricity employed in any branch of electrical work should have. Contains valuable information and scores of letters from men and boys who are making a success by the Burgess method.

# ELECTRICITY

**TAUGHT BY A PRACTICAL MAN**

SEND for this Remarkable Book N-8 IT COSTS YOU NOTHING

**BURGESS ELECTRICAL SCHOOL**  
 YORKE BURGESS, Supt.  
 151 E. 42nd St., Chicago, Illinois

# CLASSIFIED ADVERTISING COLUMNS

HAVE YOU ANYTHING TO BUY, SELL OR EXCHANGE?

Automobile owners, mechanics, model makers, motor boat owners, radio and electrical experimenters and students read these classified columns every month, looking for advertisements of things they need. Are you telling them what you have? The cost is but 7c a word; about 7 words per line. Advertisements should reach us by the first of the month to insure proper classification.

## Agents Wanted

**MAKE \$30.00 NEXT SATURDAY.** Speederator for Ford's selling like wildfire. Used by Ford Motor officials. Makes any Ford run like a Packard. Stops stalling and bucking. Put on quick—Instant satisfaction. No holes to bore. Sell ten to twelve a day easy. Splendid profits and exclusive territory. Write quick for information. Address Perrin Co., 1047 Hayward Bldg., Detroit, Mich.

**AGENTS MAKING \$200 WEEKLY** selling Bull Dog Inner Tires. Double life of three, eliminate blowout and punctures. Big repeater. Wonderful opportunity to establish independent, permanent, growing business. Write at once. Eastern Auto Specialty Co., Dept. 8, Utica, N. Y.

**WANTED**—Men with Ford cars to work home territory or travel; earn \$10 to \$25 daily. Write for particulars. Barrett Motor Starter Mfg. Co., 1777 Broadway, New York City.

## Automobile Accessories

**VULCANIZE RUBBER** without heat or tools. Whirlwind muller to every Auto Owner. Further particulars free. Muscatine Agency, #403, Muscatine, Iowa.

**STORAGE BATTERIES FOR AUTOMOBILES.** We furnish all parts and moulds for making them. Sample Plate 40c. Foreign Countries 50c. Windsor Specialty Co., 8419 Windsor Ave., Chicago, Ill.

## Aviation

**CONSULTING AERONAUTICAL AND AUTOMOTIVE ENGINEERS.** Inventions analyzed and developed—Designs prepared. Tests. Expert advice. Van Manning & Marx, City College, New York.

## Books

**BOOKS DELIVERED FREE.** Write today for Illustrated Guide to the Latest Books. Wesley Mills Co., Dept. A, 500 Fifth Avenue, New York, N. Y.

## Business Opportunities

**FREE information** regarding large earnings. Raising Canaries for pastime. Birdland, Lynchburg, Virginia.

**SUBSTANTIAL Manufacturing corporation** wants capable men to establish branch and manage salesmen. \$300 to \$1,500 necessary. Will allow expenses to Baltimore as explained. Address, Treasurer, 416 N. Howard St., Baltimore, Md.

**WILL YOU HELP**—financially—to place the best Lock-Nut on the market? (Cheap, needs little additional machinery to manufacture, simple and positive.) How many shares at \$1.00 each will you buy, subject to when, as and if needed? Bolsh J. Lockner, 134 West 49th St., N. Y.

**AMBITIOUS MEN**—Grasp this opportunity to make money. You can make \$5.00 to \$10.00 every day in your spare time at home. Not a cheap scheme, agency or soliciting proposition, but substantial business plans. Investigate this today. Address, Business, Box 175, Fredonia, N. Y.

**START a business of your own.** 34 plans, \$1.00. Joel Tillberg, Proctor, Vermont.

## Cameras

**SEND favorite negative** and 50 cents for a beautifully mounted enlargement, guaranteed to please you or your money refunded by return mail. Western Portrait Co., 3118 Kendall St., Chicago, Ill.

## Chemicals

**EXPERIMENTAL LABORATORIES** fully equipped—\$11.00 to \$100.00. Payment Plan or Cash. Descriptions and actual photographs free. Write Dept. E-27, Lions Scientific Institute, "Laboratory Outfitters," Mt. Olive, Pittsburgh, Pa.

## Electrical

**INSTANTANEOUS Hot Water Heater**, attachable any faucet, valuable hospitals, physicians, and dentists' offices, barbers, and home use. Retail \$40. Dealers \$45. Victor O. Ford Company, 250 West 54th St., New York.

## Ford Owners

**FORDS RUN 34 MILES** per gallon with our 1920 carburetors. Use cheapest gasoline or half kerosene. Start easy any weather. Increased power. Styles for all motors. Runs slow in high gear. Attach yourself. Big profits for agents. Money back guarantee, 30 days' trial. Air-Friction Carburetor Company, 600 Madison St., Dayton, Ohio.

**FORD SPEED-POWER EQUIPMENT** stocked; 4 Speed Forward Auxiliary Transmissions, Doubles Pulling power, increases speed 40 or 20%; 16 Valve Overhead Cylinder head; speed carburetors; camshaft, piston rings; light pistons, crankshaft counterbalances; high tension magnets; underslung fixtures; speed power bevel gears; foot accelerators; steering wheels; wirewheels; disc wheels; metal wheel discs; Ford Fire Chemical Hook and Ladder 15'-30' Double Universal Wheelbase Extension; 1 1/2-ton Side Spring Additional Frame Work Units; Complete Line 1 1/2-ton Shaft-Chain Drive Units; Racing Body; Complete Racing Cars \$500.-\$1750. B. V. Ford Speed-Power Equipment Manufacturers, 250 West 54th St., New York.

## Formulas

**EXPERT CHEMIST** will furnish Formulas, Processes and Trade Secrets. All lines. Lists free. W. L. Cummings, Ph.D., 232-230 Gordon Ave., Syracuse, N. Y.

## For Sale

**PAINTS:** Before you buy paint, secure list heavy-bodied damp-resisting high grade oil paints; brick, cement, stucco, wood; low prices, prompt shipments, careful attention, orders large or small. The many repeat orders received due to quality, service and fair dealing speak for themselves. Dept. 51, Martinek Paint Co., 406 Lexington Ave., N. Y. C.

**THE REGULATION POLICE WHISTLE** is the highest quality and loudest sounding whistle made. Can be heard four blocks and instantly attracts every policeman within that distance. Sent postpaid on receipt of 50c. (Special prices to Police Departments). Sharpe Mfg. Co., Paterson, N. J.

**POLICE KEYS** are the best and most convenient for household use. Used by 20,000 pleased customers. Assortment of four different sizes sent postpaid on receipt of 40c. Stamps accepted. Sharpe Mfg. Co., Paterson, N. J.

**FOR SALE**—Flying Boat without motor \$1950.00 f.o.b. or with an 80 H.P. "Roberts" \$2400.00. R. L. Walls, General Delivery, Cleveland, Ohio.

**MOTOR BOAT POWER PLANT COMPLETE**—Four Cylinder, Fifteen H.P. Motor; Rear Starter; Magneto and Carburetor; Clutch and Reverse Gear; Enclosed Type; Spicer Universal Joint. Must sacrifice. Practically New. Price \$100.00 F.O.B. New York. Box 10, Everyday Engineering Magazine.

**CALIFORNIA FARMS FOR SALE.** Write for list. E. R. Waite, Shawnee, Oklahoma.

## Guinea Pigs

**WANTED 5,000 baby guinea pigs** 3 to 4 weeks old 60c each. Who will raise them for us? Breeding stock supplied at moderate prices. Western Reserve Animal Industries, Drawer B, Station E, Cleveland, Ohio.

## Help Wanted

**FIREMEN, BRAKEMEN, BAGGAGEMEN,** \$140-\$200. Colored Porters by Railroads everywhere. Experience unnecessary. 898 N. Bureau, East St. Louis, Ill.

**WRITE for newspapers and magazines.** Big pay. Experience unnecessary, details free. Press Reporting Syndicate, 534 St. Louis.

## Instruction

**INSTRUCTION, Drafting, Practical Courses;** Instruction free; Small Material cost. Write Cincinnati Industrial Training School, 2335 Kemper Lane, Cincinnati, Ohio.

## Inventors

**INVENTORS**—Write for our free illustrated guide book and Evidence of Conception. Blank, Send model or sketch and description of invention for our opinion of its patentable nature free. Highest References. Prompt Service. Reasonable Terms. VICTOR J. EVANS & CO., 148 Ninth, Washington, D. C.

## Male Help Wanted

**SALESMEN—City or Traveling.** Experience unnecessary. Send for list of lines and full particulars. Prepare in spare time to earn the big salaries—\$3,500 to \$10,000 a year. Employment services rendered members. National Salesmen's Training Association. Dept. 157-E, Chicago, Ill.

**DETECTIVES EARN BIG MONEY.** Travel, unusual opportunity. Write Johnson's Detective Correspondence School, Desk 17, 321 Sheldon Ave., Grand Rapids, Mich.

**DETECTIVES EARN BIG MONEY.** Excellent opportunity. Travel. Experience unnecessary. We train you. Particulars free. Write, American Detective System, 1908 Broadway, N. Y.

**RAILWAY TRAFFIC INSPECTORS** earn from \$110 to \$200 per month and expenses. Travel if desired. Unlimited advancement. No age limit. We train you. Positions furnished under guarantee. Write for Booklet CM-26. Standard Business Training Institute, Buffalo, N. Y.

## Miscellaneous

**MULTIGRAPHS, Addressographs, Duplicators, Sealers, Folders,** Less than half price. Guaranteed one year. Pruitt Company, 112-D, North La Salle, Chicago, Ill.

**SALES LETTERS** written by Jacobus. The Man who takes the Doubts out of Advertising. \$5.50 each. Three \$10.00. Jacobus Advertising Service, 1073 Sanford Ave., Irvington, N. J.

**WANT Goodell Pratt Lathes,** with Sawtable. Pray, 103 Heath, Somerville, Mass.

## Motion Picture Plays & Supplies

**\$25-\$500 PAID ANYONE** for ideas, suggestions suitable for photoplays. Experience unnecessary; complete outline Free. Producers League, 530, St. Louis, Mo.

**PHOTOPLAYS WANTED.** Big prices paid. You can write them. We show you how. Free particulars. Rex Publishers, Box 175A-10 and 175A-11, Chicago, Ill.

## Motorcycles

**USED AND REBUILT** Indians, Excelsiors, Harley's, Overhauled and tested by experts. Guaranteed and shipped on approval. We save you big money. We furnish Bank References. Send Stamp for Free List. Floyd Clymer, Dept. 3, "Largest Motorcycle Dealer in Western America," Denver, Colorado.

**\$25.00 UP, GUARANTEED REBUILT MOTORCYCLES.** Henderson, Excelsior, Indian, Harley-Davidson, Bicycles, \$5.00 up. Tires and accessories at wholesale. Illustrated bulletin A free. Ash Motor Corporation, 162 N. Clinton Ave., Rochester, N. Y.

## Opportunities

**AUTOMOBILE OWNERS' FRIEND,** labor, money saver \$1 guaranteed. Kautch Sales Co., Stockton, Cal.

## Patents

**PATENTS**—Herbert Jenner, Patent Attorney and Mechanical Expert, 623 F St., Washington, D. C. If report if a patent can be had and its exact cost. Send for circular.

**PATENTS.** Over 70 years' practice; all communications strictly confidential; handbook on patents free on request; special facilities for office consultations. Munn & Co., Patent Attorneys, 641 Woolworth Building, New York. 625 F Street, Washington; Tower Building, Chicago; Hobart Bldg., 582 Market Street, San Francisco, Calif.

**PATENTS** in all matters pertaining to invention consult National Institute of Inventors, 118 Fulton St., New York City, having three thousand members. Booklet free.

**PATENT WHAT YOU INVENT.** It may be valuable. Write us. No attorney's fee until patent is allowed. Estab. 1882. "Inventor's Guide" Free. Franklin H. Hough, 810 Loan & Trust Bldg., Washington, D. C.

**DON'T** lose your rights to patent protection. Before disclosing your invention to anyone send for blank form "Evidence of Conception" to be signed and witnessed. Form and information concerning patents free. Lancaster and Allwine, 237 Ouray Building, Washington, D. C. Originators of Form of "Evidence of Conception."

**"INVENTORS RECORD" AND "BULLETIN"** sent without charge. My free blank form for disclosing your invention simplifies procedure. Send sketch or description for preliminary advice. Wm. H. Mulligan, Registered Attorney, 354 Woodward Building, Washington, D. C.

**PATENTS**—Free in installments. Frank T. Fuller, formerly Lieutenant, Engineers, Washington, D. C.

**PATENTS**—Prompt, personal, efficient service by an attorney-at-law, skilled in all branches of Patent Practice. Over 13 years' actual experience; full information upon request. B. P. Fishburne, 323 McMill Bldg., Washington, D. C.

## Phonographs

**BUILD YOUR OWN PHONOGRAPH**—Big saving. We furnish parts and cabinets. Write today for free instructions. Associated Phonograph Supply Co., Dept. V, Cincinnati, Ohio.

## Photo Developing

**MAIL US 25c** with any size film for development and six velvet prints. Or send six negatives any size and 20c for six prints. Or send 40c for one 8 x 10 mounted enlargement. Prompt, perfect service. Roanoke Photo Finishing Co., 283 Bell Ave., Roanoke, Va.

## Short Stories Wanted

**SHORT STORIES, Poems, Plays, Etc.,** are wanted for publication. Literary Bureau, 166 Hannibal, Mo.

## Stammering

**ST-BYU-Y-T-TERING** and Stammering cured at home. Instructive booklet free. Walter McDonald, 103 Potomac Bank Building, Washington, D. C.

## Stamps

**APPROVAL 60% discount.** References please. Stamps bought. Lang, 1423-J 59th, Cicero, Illinois.

**HAVE YOU SEEN THE STAMP HERALD?** Finest monthly stamp paper published. Subscription 50c a year, 3 months trial for 10c. Stamp Herald Publishing Co., Dept. E, Indianapolis, Ind.

**STAMPS FREE**—60 all different for the names of two collectors and to postage. 30 Sweden stamps 10c. 20 Denmark stamps 10c. Toledo Stamp Co., Toledo, Ohio. U. S. A.

## Telegraphy

**TELEGRAPHY** (both Morse and Wireless) and Railway accounting, taught quickly. Tremendous demand. Big salaries. Great opportunities. Oldest and largest school; established 46 years. All expense less—can earn large part. Catalogue free. Dodge's Institute, P St., Valparaiso, Indiana.

## Toys

**AMERICAN MADE TOYS NEEDED.** Homeworkers on small scale and Manufacturers on large scale wanted to manufacture Toy Soldiers, Army, Navy, Machines, Cannons, War Ships, Indians, Cow-boys, Wild Animals, Whistlers and other toys and novelties. Greatest chance for industrial people to have an independent business. Enormous demand gives an unlimited field and great future all over the United States, Canada and foreign countries. Experience or tools not necessary. Hundred and more made complete per hour. Casting forms, complete outfit from \$3.00 up. We buy these goods all year paying fixed prices. For painted foods we offer attractive prices. Contracts made with reliable parties. We have connections all over the United States and goods made with these Casting forms are badly needed by all wholesale and retail dealers on account of the scarcity in these lines. Greatest opportunity are offered manufacturers of American Made Toys. A strictly business proposition and no one need apply unless he means business. In this case write for booklet and information, furnished free. Toy Soldier Mfg. Co., 32 Union Square, New York City.

## Typewriter Ribbons

**TYPEWRITER RIBBONS,** all typewriters, 50c. Abbott Typewriter Company, 35 East 23rd St., New York.

## Watches

**EXPERT WATCH REPAIRING,** prices moderate. Include return postage when sending watches. Workmanship guaranteed. Henry Dietrich, Watchmaker, Hamler, Ohio.

## Wireless

**WIRELESS PARTS, PROMPT DELIVERY.** Standard 1 1/2" style knee-lever complete 35c. Switch points with screw 25c dozen. State panel thickness. Novotny Electric, Charlotte, N. C.

Please mention EVERYDAY ENGINEERING MAGAZINE