

JULY 3, 1980

**SPECIAL REPORT: DEVELOPMENT SYSTEMS LINK LAB, FACTORY AND FIELD/134**

Communications interfaces spearhead IBM office-automation drive/95

Two chips turn telephone into data terminal/124



FOUR DOLLARS A MCGRAW-HILL PUBLICATION

# Electronics®

**PUTTING  
A FAST  
FINISH  
ON  
CUSTOM  
LOGIC**



146A 080324 60106 M106  
CS OSBORNE - JR  
PERIPHICON  
BOX 32  
BEAVERTON OR 97075

# Why Assemble, Mount and Calibrate a Pot and Dial...

When you can simply insert a Knobpot<sup>®</sup> potentiometer into your panel?

No assembly, no calibration... saves you time and money with no hassle. Knobpot potentiometers are integrally designed 10-turn wirewound pot/dial components that are preassembled and prephased at the factory. Attractive, rugged and accurate, they're easy to install, require less front panel space than most dials alone, and are available with either digital or clockface readouts. A recent product upgrade provides improved reliability, positive lens retention and smoother rotational torque. Four different models to fit your front panel needs:

	Digital Readout		Clockface Readout	
	3610	3650	3600	3640
Diameter	1 1/8"	1 1/4"	1 1/8"	1 1/4"
Standard Resistance Range (Ohms)	100-100K	100-500K	100-100K	100-500K
Resistance Tolerance	±5%	±3%	±5%	±3%
Repeatability (Voltage Ratio)	0.1%	±0.05%	0.1%	±0.05%
Power Rating (25 °C)	1.5w	2.5w	1.5w	2.5w
Rotational Life (Revolutions)	50,000	100,000	100,000	100,000
Mounting Style	Snap-in	Recessed Cup	Bushing	Bushing

Save time... save money... save space. Specify Knobpot potentiometers – built only by Bourns. They're in stock now at your local Bourns distributor and available for immediate installation. Call your local Bourns representative or distributor for more information and for your new 52 page PP-1 Precision Potentiometer catalog.

PRECISIONS DIVISION, BOURNS, INC., 1200 Columbia Avenue, Riverside, CA 92507.  
Ph: 714 781-5122 TWX: 910 332-1252.

European Headquarters: Bourns AG, Zugerstrasse 74 6340 Baar, Switzerland. Ph: 042 33 33 33. Telex: 78722.



The last word in resistive components  
**BOURNS**<sup>®</sup>



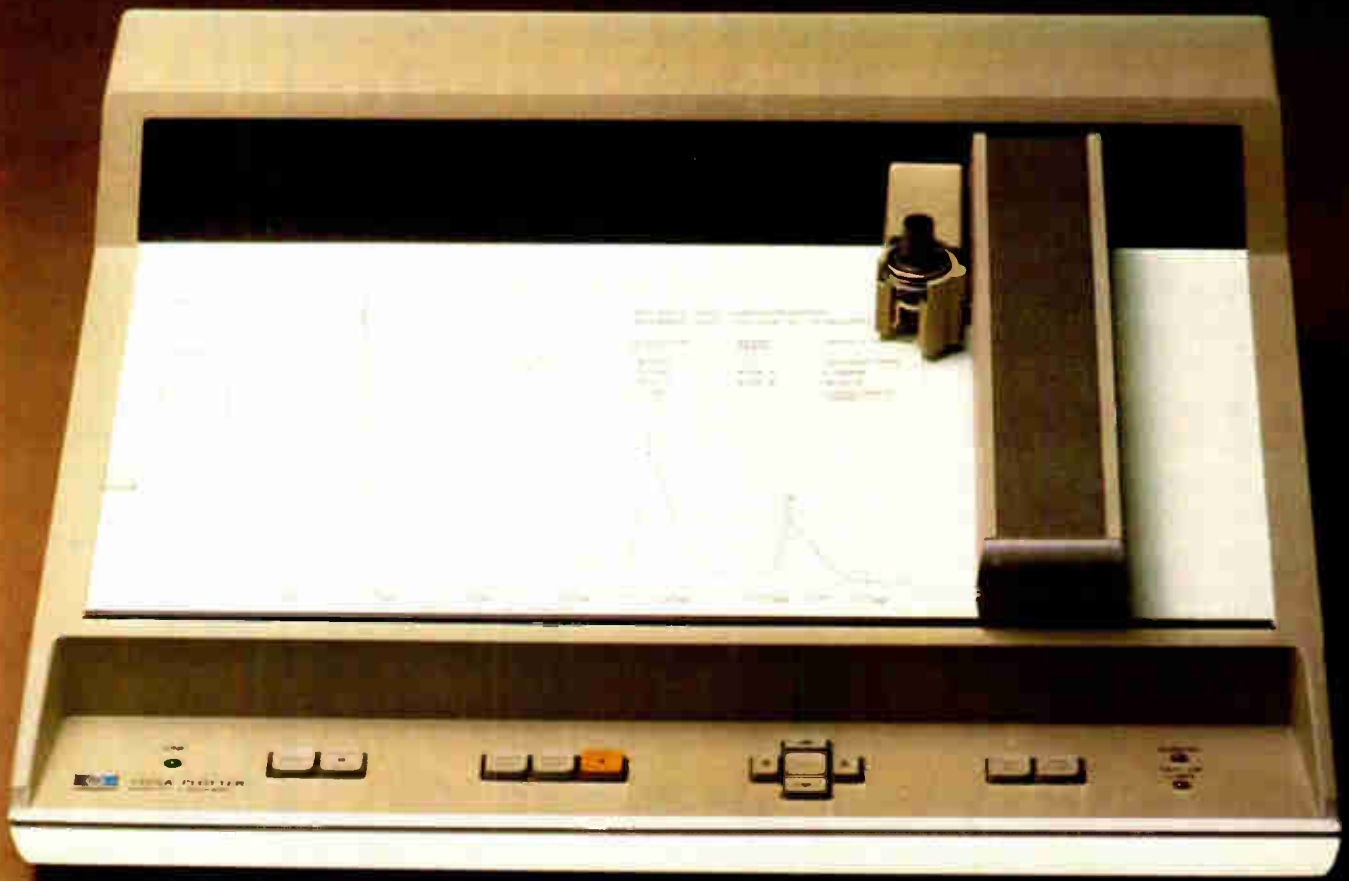

## Now OEM's can draw high quality graphics even when the bottom line is price.

Graphics gives you the best way to analyze and communicate data. But cost has been keeping it out of the picture for many OEM systems. That's why Hewlett-Packard is offering the new Model 7225A Graphics Plotter.

The price: \$1913 (domestic USA price with 17602A general purpose "personality" module), in quantities of five. With further OEM discounts from there.



Plug-in "personality modules" customize the plotter for you.

HP's versatile 7225A converts the output of processor based systems into high quality charts and graphs in any size up to 8½ x 11" (A4). A wide selection of plug-in "personality modules" lets you adapt the plotter to suit your needs. Different modules determine interface hardware, language, and capabilities such as internal character sets, axis generation, labeling and scaling.

Simple linear stepping motors eliminate many moving parts to assure reliability. Visually smooth, high resolution ink lines of any length and angle are generated, requiring only end point data.

And you give your customers the confidence of Hewlett-Packard's worldwide service network.

So if you want high quality graphics but you draw the line at price, look into the Model 7225A Graphics Plotter. For a detailed 24-page OEM brochure, contact Greg Diehl at Hewlett-Packard 16399 West Bernardo Drive, San Diego, CA 92127; (714) 487-4100.

11901



**HEWLETT  
PACKARD**

# Let Mini-Circuits' RF TRANSFORMERS Do Your Matching!

10 kHz — 800 MHz

...from \$2.95

(Actual size)



**Models T, TH (Plastic case)**  
(0.300" sq. x 0.230" high)

(Actual size)



**Model TMO (Metal case)**  
(.500" L x .230" W x .255" H)

DC ISOLATED PRIMARY & SECONDARY



Model No.	Imped. ratio	Freq. (MHz)	Price (10-49)
T1-1	1	.15-400	\$2.95
TMO1-1	1	.15-400	\$4.95
● T1-1H	1	8-300	\$4.95
T1.5-1	1.5	.1-300	\$3.95
TMO1.5-1	1.5	.1-300	\$6.75
T2.5-6	2.5	.01-100	\$3.95
TMO2.5-6	2.5	.01-100	\$6.45
T4-6	4	.02-200	\$3.95
TMO4-6	4	.02-200	\$6.45
T9-1	9	.15-200	\$3.45
TMO9-1	9	.15-200	\$6.45
● T9-1H	9	2-90	\$5.45
T16-1	16	.3-120	\$3.95
TMO16-1	16	.3-120	\$6.45
● T16-1H	16	7-85	\$5.95

CENTER-TAPPED DC ISOLATED PRIMARY & SECONDARY



Model No.	Imped. ratio	Freq. (MHz)	Price (10-49)
T1-1T	1	.05-200	\$3.95
TMO1-1T	1	.05-200	\$6.45
T2-1T	2	.07-200	\$4.25
TMO2-1T	2	.07-200	\$6.75
T2.5-6T	2.5	.01-100	\$4.25
TMO2.5-6T	2.5	.01-100	\$6.75
T3-1T	3	.05-250	\$3.95
TMO3-1T	3	.05-250	\$6.45
T4-1	4	.2-350	\$2.95
TMO4-1	4	.2-350	\$4.95
● T4-1H	4	8-350	\$4.95
T5-1T	5	.3-300	\$4.25
TMO5-1T	5	.3-300	\$6.75
T13-1T	13	.3-120	\$4.25
TMO13-1T	13	.3-120	\$6.75

● Up to 100mA DC without saturation

UNBALANCED PRIMARY & SECONDARY



Model No.	Imped. ratio	Freq. (MHz)	Price (10-49)
T2-1	2	.025-600	\$3.45
TMO2-1	2	.025-600	\$5.95
T3-1	3	.5-800	\$4.25
TMO3-1	3	.5-800	\$6.95
T4-2	4	.2-600	\$3.45
TMO4-2	4	.2-600	\$5.95
T8-1	8	.15-250	\$3.45
TMO8-1	3	.15-250	\$5.95
T14-1	14	.2-150	\$4.25
TMO14-1	14	.2-150	\$6.75

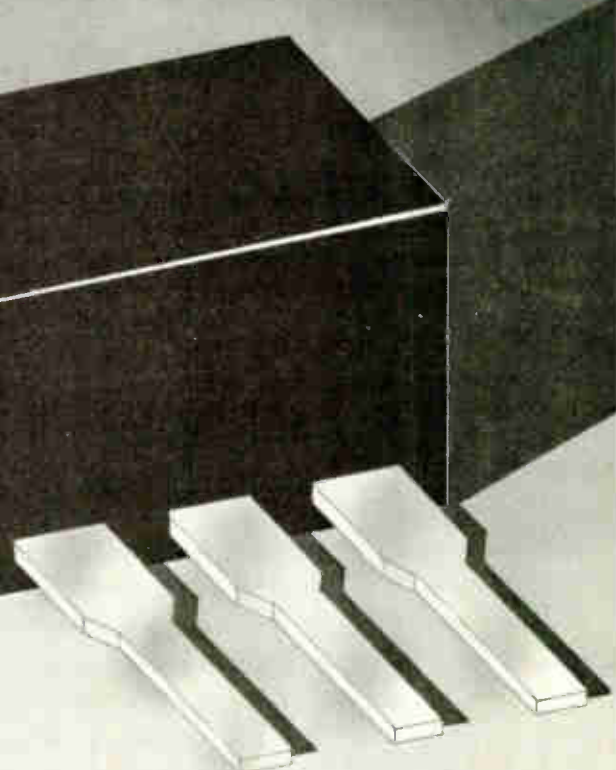

It's easy to transform impedance and reduce VSWR.

Choose from 40 models, 12.5 to 800 ohms, 10 kHz to 800 MHz, ultra-low distortion (H models) balanced, unbalanced and center-tapped . . . immediate delivery . . . at prices that can't be matched, starting at \$ 2.95

World's largest manufacturer of Double-Balanced Mixers

**Mini-Circuits**  
MINI-CIRCUITS LABORATORY  
A Division of Scientific Components Corp.

FOR ADDITIONAL INFORMATION, COMPLETE SPECIFICATIONS, AND PERFORMANCE CURVES, REFER TO 1979-80 MICROWAVES' PRODUCT DATA DIRECTORY pgs. 161 to 368 or 1979 EEM 2770 to 2974.

2625 East 14th Street Bklyn, New York 11235 (212) 769-0200  
Domestic and International Telex 125460 International Telex 620156

42/new/B



## 119 Technical Articles

### SOLID STATE

**CAD pits semicustom chips against standard slices, 119**

### COMMUNICATIONS

**Making a data terminal out of the Touch-Tone telephone, 124**

### SPECIAL REPORT

**Development system nets: the last link in automated manufacturing, 134**

### MICROCOMPUTERS

**N-MOS hurls 4-bit family into 8-bit orbit, 145**

### COMPONENTS

**Isolator stretches the bandwidth of two-transformer design, 151**

DESIGNER'S CASEBOOK: 130

ENGINEER'S NOTEBOOK: 162

---

## 43 Electronics Review

SOLID STATE: IC generates phoneme-based speech, 43

Laser annealing expands polysilicon's horizons, 44

Polysilicon crunch moves further off, 44

PACKAGING: Space-saving chip-carriers stepping into production role, 45

COMPONENTS: Power MOS FET design elongates p region for faster switching, 46

Switching power supply shrinks by using MOS FETs, 46

BUSINESS SYSTEMS: Joint computer design fights obsolescence, 48

SOLID STATE: Toshiba starts IC production in U. S., 50

PRODUCTION: Process tweak speeds additive plating of printed-circuit boards, 50

INFORMATION PROCESSING: Standards group plays Ethernet down, 52

SOFTWARE: Pascal popularizer turns to DOD's Ada, 54

COMMUNICATIONS: Bell installs a long-wavelength fiber-optic system, 59

CONSUMER: Zenith designs teletext hardware, 59

## 95 Probing the News

WORD PROCESSING: IBM ups the ante for its competitors, 95

CONSUMER: Hand-held computers brighten a generally gloomy show, 99

DATA COMMUNICATIONS: Can software do the data-encryption job? 102

CAREERS: R&D unites companies, colleges, 104

GOVERNMENT: Federal policies stall IC startups, 108

## 175 New Products

IN THE SPOTLIGHT: 16-K RAM accesses in 70 ns, 175

SOFTWARE: Concurrent Pascal reaches chip level, 183

INSTRUMENTS: Active filter has dc to audio uses, 194

POWER SUPPLIES: Dc-dc units fit in 24-pin DIPs, 206

COMPUTERS: Mainframe vies with IBM 4300, 210

DATA ACQUISITION: 8-bit converter has 16 pins, 214

INDUSTRIAL: Tape system aids minicomputers, 218

MATERIALS: 222

## Departments

Highlights, 4

Publisher's letter, 6

Readers' comments, 8

News update, 12

People, 14

Editorial, 24

In my opinion, 26

Meetings, 32

Electronics newsletter, 39

Washington newsletter, 65

International newsletter, 173

Engineer's newsletter, 76

Products newsletter, 225

## Services

Reprints available, 208

Employment opportunities, 226

Reader service card, 239

## 73 Electronics International

JAPAN: Magnetic field breeds Skylab-like semiconductors, 83

CANADA: Signal processor to pick up SOSs via satellite system, 84

WEST GERMANY: Optical-character-recognition scanner applies for supermarket job, 86

Lamp aids analysis of still purer alloys, 88

ITALY: Microcomputer net is ultimate thermostat, 88

EDITOR-IN-CHIEF: Samuel Weber

## MANAGING EDITORS

*Technical:* Raymond P. Capece,  
Alfred Rosenblatt  
*News:* Gerald M. Walker  
*International:* Arthur Erikson

ASSISTANT MANAGING EDITORS: Howard Wolff,  
Margaret Eastman

SENIOR EDITOR: Ray Connolly

ART DIRECTOR: Fred Sklenar

ASSOCIATE EDITOR: Benjamin A. Mason

## DEPARTMENT EDITORS

*Aerospace/Military:* Ray Connolly  
*Circuit Design:* Vincent Biancomano  
*Communications & Microwave:*  
Harvey J. Hindin  
*Components:* Roger Allan  
*Computers & Peripherals:* Anthony Durniak  
*Industrial/Consumer:* Gil Bassak  
*Test, Measurement & Control:*  
Richard W. Comerford  
*New Products:* Alan Serchuk,  
Ana Bishop  
*Packaging & Production:* Jerry Lyman  
*Solid State:* John G. Posa

CHIEF COPY EDITOR: Margaret Eastman

COPY EDITORS: Mike Robinson,  
Charlotte Wiggers, Jeremy Young

ART: Charles D. Ciatto, *Associate Director*  
Paula Piazza, *Assistant Director*

EDITORIAL SECRETARIES: Maryann Tusa,  
Alan Kleinberger, Dawn Ramsay

EDITORIAL ASSISTANT: Marilyn B. Steinberg

## REGIONAL EDITORS

*New York:* Pamela Hamilton (212) 997-2666  
*Boston:* James B. Brinton,  
Linda Lowe (617) 262-1160  
*Chicago:* Larry Marion (312) 751-3805  
*Dallas:* Wesley R. Iversen (214) 742-1747  
*Los Angeles:* Larry Waller (213) 487-1160  
*Palo Alto:* Bruce LeBoss, *Manager*  
Martin Marshall, *Computers & Instruments*  
(415) 968-2712  
*Washington:* Ray Connolly (202) 624-7592  
*Frankfurt:* John Gosch 72-5566  
*London:* Kevin Smith 493-1451  
*Paris:* Arthur Erikson,  
Kenneth Dreyfack 720-20-70  
*Tokyo:* Charles Cohen 581-9816

## McGRAW-HILL WORLD NEWS

*Editor:* Michael Johnson  
*Brussels:* James Smith  
*Millan:* Jeff Ryser

*Moscow:* Peter Hann  
*Stockholm:* Robert Skole  
*Tokyo:* Robert Neff

PUBLISHER: Paul W. Reiss

GENERAL MANAGER, DIRECT MARKETING  
OPERATIONS: Horace T. Howland

CIRCULATION MANAGER: Herbert A. Hunter

RESEARCH MANAGER: Margery D. Sholes

PROMOTION MANAGER: Jane De Court

MARKETING ADMINISTRATION MANAGER:  
Frances M. Vallone

BOOKS & SPECIAL PROJECTS MANAGER:  
Janet Eyler

SERVICE REVENUE SPECIALIST:  
Penny Reitman

## Cover: CAD puts a fast finish on semicustom C-MOS logic, 119

Coming rapidly into favor for applications requiring more than 1,000 or so copies of a digital circuit are large-scale master-slice chips that can be customized in three months or less by computer-aided design of the final metalization layer. Master slices are made with several technologies, but at present complementary MOS offers a compelling combination of speed, packing density, and low power consumption.

Cover illustration is by Art Director Fred Sklenar.

## Intelligent terminal in briefcase arrives amid consumer unease, 99

The hand-held stand-alone central processor with keyboard, liquid-crystal display, and 500 bytes of user memory mates with a modem, memory modules, tape drive, and printer—and it all fits in one briefcase, a complete intelligent terminal aimed at traveling businessmen. At the generally downbeat Chicago consumer electronics show, personal computer makers say they feel no threat from the intriguing Japanese entry.

## Chip set detects and decodes data from remote telephone, 124

A dual-tone multiple-frequency receiver on two ICs makes it possible for a microcomputer system to receive data or control commands from a Touch-Tone telephone anywhere. The chips will first be used in phone systems, but may control processors in the home or office of the future.

## Nets will link management, design, production, testing, and field, 134

Networks designed for microprocessor development systems are beginning to spread throughout the increasingly automated process of manufacturing electronic products, according to this forward-looking special report. Access to shared central files, including design specifications and tools for management, simulation, and testing, should help a company get a bug-free product to market faster and then help support it once in service.

## 15-kHz bandwidth comes to stable and linear isolation method, 151

Of the most widely used methods of electrically isolating analog signals, amplifier designs using two transformers are noted for their low drift and high linearity, but have taken a back seat in terms of bandwidth. Now a wideband two-transformer isolator makes this technique useful in motor-control, medical, and other applications.

## ... and in the next issue

A special report on data converters . . . packaging integrated circuits to prevent static-discharge damage . . . a special version of a one-chip microcomputer solves tough test problems . . . three-chip partitioning of mini-computer-emulating processor allows microstore expansion.

July 3, 1980 Volume 53, Number 15 101,124 copies of this issue printed

Electronics (ISSN 0013-5070). Published every other Thursday with an additional issue this April by McGraw-Hill, Inc. Founder: James H. McGraw, 1860-1948. Publication office: 1221 Avenue of the Americas, N.Y., N.Y. 10020, second class postage paid at New York, N.Y., and additional mailing offices.

Executive, editorial, circulation and advertising addresses: Electronics, McGraw-Hill Building, 1221 Avenue of the Americas, New York, N.Y. 10020. Telephone: (212) 597-1221. Teletype: 12-7950 TWX 710-581-4879. Cable address: MCGRAW HILL N E W Y O R K.

Subscriptions limited to professional persons with active responsibility in electronics technology. No subscriptions accepted without complete identification of subscriber name, title or job function, company or organization, and product manufactured or services performed. Based on information supplied, the publisher reserves the right to reject non-qualified requests. Subscription rates: in the United States and possessions \$18 one year, \$31 two years, \$46 three years; company addressed and company libraries \$23 one year, \$41 two years, \$58 three years; APO/FPO addressed \$35 one year only; Canada and Mexico \$19 one year, \$32 two years, \$47 three years; Europe \$50 one year, \$85 two years, \$115 three years; Japan, Israel and Brazil \$70 one year, \$115 two years, \$165 three years; Australia and New Zealand \$95 one year, \$170 two years, \$240 three years, including air freight; all other countries \$50 one year, \$85 two years, \$125 three years. Limited quota of subscriptions available at higher-than-basic rate for persons allied to field served. Check with publisher for these rates. Single copies: \$4.00; special Anniversary issue: \$9.00 each. Please allow four to eight weeks for shipment.

Officers of McGraw-Hill Publications Company: Paul F. McPherson, President; Executive Vice Presidents: James E. Boddorf, Gene W. Simpson; Group Vice President: Daniel A. McMillan; Senior Vice President-Editorial: Ralph R. Schatz; Vice Presidents: Kemp Anderson, Business

Systems Development; Stephen C. Croft, Manufacturing; Robert B. Doll, Circulation; James E. Hackett, Controller; William H. Hammond, Communications; Eric B. Harr, Planning and Development; John W. Patten, Sales; Edward E. Schirmer, International.

Officers of the Corporation: Harold W. McGraw, Jr., President, Chief Executive Officer, and Chairman of the Board; Robert N. Landes, Senior Vice President and Secretary; Ralph J. Webb, Treasurer.

Title registered in U.S. Patent Office; Copyright© 1980 by McGraw-Hill, Inc. All rights reserved. The contents of this publication may not be reproduced in whole or in part without the consent of copyright owner.

Where necessary, permission is granted by the copyright owner for libraries and others registered with the Copyright Clearance Center (CCC), P.O. Box 8891, Boston, MA 02114, to photocopy any article herein for the base fee of \$0.50 per copy of the article plus \$0.25 per page. Payment should be sent directly to the CCC. Copying done for other than personal or internal reference use without the express permission of McGraw-Hill is prohibited. Requests for special permission or bulk orders should be addressed to the publisher. ISSN 0013-5070/80\$0.50+.25.

Subscribers: The publisher, upon written request to our New York office from any subscriber, agrees to refund that part of the subscription price applying to copies not yet mailed. Please send change-of-address notices or complaints to Fulfillment Manager; subscription orders to Circulation Manager, Electronics, at address below. Change-of-address notices should provide old as well as new address, including zip codes. Attach address label from recent issue. Allow one month for change to become effective. Subscriber Service: call (800) 448-8110, 9 a.m. to 4 p.m. EST.

Postmaster: Please send form 3579 to Fulfillment Manager, Electronics, P.O. Box 430, Hightstown, N.J. 08520.



# Hotline to your PDP-11



## Able deals a powerful data-communications hand

We've moved well into data communications and already have a fist full of cards that sell for less than the competition but do a lot more. They all will save you space, power, bus loading and money while giving better performance, reliability, flexibility, and convenience. Take a look at the facts, then decide for yourself.

**DMAX/16<sup>™</sup>**  
(16-LINE DN11 REPLACEMENT)  
**INSTALLS IN:** <half> DN11 space. **DATA RATES:** All standard baud rates plus 19.2K baud and one user programmable rate (16 baud rates). **PROCESSING ADVANTAGES:** Word transfers (in lieu of byte DMA) cut processing overhead by half. **OPERATING MODES:** Full or half duplex with full modem control via DM-16 option. **CAPACITY:** Up to 256 lines on a single PDP-11 at 2 bus loads per 16-lines.

**QUADRASYNC/B<sup>™</sup>**  
(4-LINE DN11 REPLACEMENT EIA)  
**INSTALLS IN:** 1 SPC slot, 4 lines at 1 bus load. **DATA RATES:** 7 selectable rates for any of the 4 lines (150-9600). **ELECTRICAL:** EIA standard RS232C (Modem control not supported). **VECTOR ADDRESS SELECTION:** Vector and address values to be set on boundaries of 00s to 40s. 16 continuous word address for Vector or Address.

**QUADRASYNC/C<sup>™</sup>**  
(4-LINE DN11 REPLACEMENT CL)  
**INSTALLS IN:** 1 SPC slot, 4 lines at 1 bus load. **DATA RATES:** 7 selectable rates for any of the 4 lines (150-9600). **ELECTRICAL:** 20MA current loop (Send : Receive). **VECTOR/ADDRESS SELECTION:** Vector and address values to be set on boundaries of 00s to 40s. 16 continuous word address for Vector or Address.

**QUADRASYNC/E<sup>™</sup>**  
(4-LINE DN11-E REPLACEMENT)  
**INSTALLS IN:** 1 SPC slot, 4 lines at 1 bus load. **DATA RATES:** 7 selectable rates for any of the 4 lines (150-9600). **ELECTRICAL:** EIA standard RS232C with modem control. **VECTOR ADDRESS SELECTION:** 16 continuous word address for Vector or Address—starting values selected on any boundary.

**QUADRACALL<sup>™</sup>**  
(4-LINE DN11 REPLACEMENT)  
**INSTALLS IN:** 1 SPC slot, 4 lines at 1 bus load. **PERFORMANCE:** Interfaces up to 4 Bell 801 ACU's with Umbus for autodial link-ups. **INPUT/OUTPUT:** 5-input signals from ACU are handled by EIA RS-232 receivers. 6-output signals are transmitted using EIA RS232 drivers. **VECTOR ADDRESS SELECTION:** Allows selection of device address and vector by use of pencil switches.

**DV/16**  
(8, 16, 24 or 32-LINE DV11 REPLACEMENT)  
**INSTALLS IN:** <half> DV11 space providing byte protocol handling for sync/async communications such as DEC DDMCP, IBM BISYNC, etc. **OPERATING ADVANTAGE:** User may mix sync and async lines in combinations of 4 or 8 lines by on-board switch selection with modem control. Fully software compatible with all DV11 performance features.

Along with our powerful communication package and world-wide product support we have a complete selection of cache buffer memories, Fastbus memories, DMA interfaces, PDP-11 bus repeaters and LSI Q-bus adaptors. Write for details. You'll find out why our customers consider us the leader among manufacturers of PDP enhancements.

Able Computer, 1751 Langley Avenue, Irvine, California 92714.  
(714) 979-7030.  
TWX 910-595-1729. **Able, the computer experts**

PDP, LSI, UNIBUS, FASTBUS are registered trademarks of Digital Equipment Corporation.

**Now...  
the only  
RF power  
amplifier you  
may ever need.**

**The new ENI 550L  
delivers 50W, 1.5-400 MHz.**



This single unit is so incredibly versatile it can replace several you may be using now. And you may never need another. It's an extremely broadband high power, solid state, Class A linear amplifier. It's rated at 50W from 1.5-400 MHz. But it can provide 100 Watts from 1.5-220 MHz. All you need with the 550L is any standard signal or sweep generator and you've got the ultimate in linear power for such applications as RFI/EMI testing, NMR, RF Transmission, ultrasonics and more.

And, like all ENI power amplifiers, the 550L features unconditional stability, instantaneous failsafe provisions, and absolute protection from overloads and transients.

The 550L represents the pinnacle in RF power versatility. There's nothing like it commercially available anywhere! And it may be the only RF power amplifier you ever need.

For more information, a demonstration, or a full line catalog, please contact us at ENI, 3000 Winton Road South, Rochester, NY 14623. Call 716/473-6900, or telex 97-8283 ENI ROC.

**ENI**



**The advanced  
design line of  
power amplifiers**

**F**or Joseph Kroeger, a period between jobs back in 1974 may turn out to have been highly important to his future work. It was then that he participated in the development of a gate array as a favor for a friend who was the president of International Microcircuits Inc. in Santa Clara, Calif.

That array turned out to be IMI's first master-slice device. Kroeger thereafter went to work for Advanced Micro Devices and had nothing to do with master-slice technology until this year, when he moved to International Microcircuits as applications manager. In the cover article starting on page 119, Kroeger and Orhan Tozun, design engineering manager for IMI, describe the trade-offs involved in applying these semi-custom integrated circuits.

What changes have taken place since Kroeger first became involved with master-slice technology? "The differences are like night and day," he states.

First, all layouts are done by computer instead of by hand. Second, the number of products and their applications is much broader now. Third, the technology has advanced in density and performance. And fourth, market acceptance has increased dramatically.

Market acceptance, however, is a two-edged sword, Kroeger has learned. Besides suppliers like IMI that specialize in master-slice products, the large semiconductor houses have entered the market. And master-slice users have added a new factor with in-house production.

"It's not clear yet which one of these sources will dominate," he observes. "What is clear is that master-slice devices are a new choice in tools to solve problems."

Key to its success is that users can select a process technology, be it n-channel MOS, complementary-MOS, or integrated injection logic, that is best for a specific application. "Another factor that has helped master-slice acceptance," Kroeger quips, "is that IBM has blessed it."

And there has been a good deal of conjecture about the factory of the future. But what of the engineer's bench of the future?

The answer to this question appears in the special report on microprocessor development systems (p. 134). "Out of the present single and multi-user systems have evolved supernetworks involving as many as 64 or more users of a development system," comments instruments editor Dick Comerford. "These networks are going to change the nature of the way engineers will work."

Dick draws a picture that includes today's independent, or stand-alone, emulators, various networking schemes, and low-cost development systems. They point to a future in which the designer is freed of mundane paperwork, similar to what the office of the future promises.

"I used to think of this concept as blue sky, but it really is going to happen; the elements are already in place," he observes. It's going to happen simply because the software and hardware problems involved are too huge to attack in any other way, Dick adds.

Along the way there will be changes in the industry. For one, the issue of dedicated versus universal development systems should fade. Users armed with support software will be able to transform so-called dedicated systems to handle a variety of microprocessors. In addition, instrument companies will have available truly universal systems that are software-configurable.

Another change, already apparent, will be the homogenization of companies. Semiconductor companies will look not only like computer companies, but also like instrument producers. Instrument firms will resemble computer companies. And computer companies will look like instrument firms and semiconductor producers.

**T**here has been considerable discussion of the office of the future.



# smart power for ATE!

PROGRAMMABLE POWER FOR YOUR AUTOMATIC TEST EQUIPMENT

## KEPCO series **ATE** power supplies

- programmable from IEEE-488 bus with Kepco digital interfaces
- automatic crossover voltage and current stabilization
- 0.001% stabilization (load effect)
- 0.0005% stabilization (source effect)
- programmable over-voltage crowbar with flag
- fast programming capability
- five groups, 50 Watts to 1000 Watts



50 & 100 WATT MODELS

250 WATT MODEL

**KEPCO**® For complete specifications, write Dept. COF-14

KEPCO, INC. • 131-38 SANFORD AVENUE • FLUSHING, N.Y. 11352 U.S.A. • (212) 461-7000 • TWX #710-582-2631 • Cable: KEPCOPOWER NEWYORK

Circle 7 on reader service card

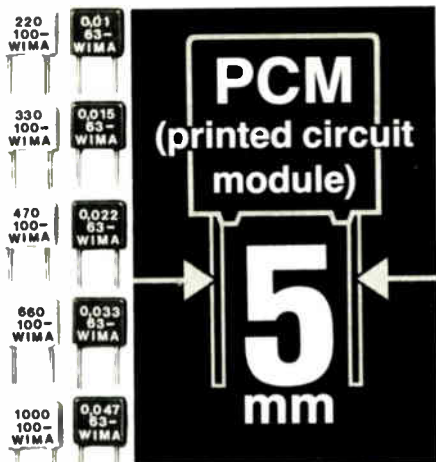

## Complete ranges from 220 pF to 1.0 $\mu$ F

WIMA were first with 5 mm pcm plastic film capacitors – miniature components designed for semiconductor technology.

WIMA plastic film capacitors show greater reliability and should be preferred to other types.

The uniform lead spacing of 5 mm for the complete capacitance range is ideal for automatic component insertion.

WIMA have always been in the forefront of plastic film capacitor technology.



FKP 2: 220 pF to 0.01  $\mu$ F: D.F.  $2-4 \times 10^{-4}$   
 FKZ 2: 220 pF to 0.01  $\mu$ F: D.F.  $1-2 \times 10^{-3}$   
 FKS 2: 1000 pF to 0.015  $\mu$ F: D.F.  $5-6 \times 10^{-3}$   
 MKS 2: 0.01  $\mu$ F to 1.0  $\mu$ F: D.F.  $5-8 \times 10^{-3}$   
 (Typical values at 1000 Hz)

### WILHELM WESTERMANN

Spezialvertrieb elektronischer Bauelemente  
 P.O. Box 2345 · D-6800 Mannheim 1  
 Fed. Rep. of Germany

U.S. Sales Offices:  
 THE INTERNATIONAL GROUP INC.  
 North Dearman Street · P.O. Box 23  
 Irvington · New York 10533 · (914) 591-8822

TAW ELECTRONICS CO.  
 4215 W. Burbank Blvd., Burbank  
 California 91505 · (213) 846-3911

## Readers' comments

### New evaluation criteria

To the Editor: I believe that in focusing so heavily on the benchmark tables that constitute a very small portion of my article, "How a 16-bit microprocessor makes it in an 8-bit world" [Sept. 27, 1979, p. 122], Mr. Locke, in his letter to the editor on page 8 of the June 19 issue, has either completely missed or fails to agree with the reasons behind the 6809's software efficiency and reliability. The "tidy instruction set of the 6809" may well save thousands of dollars in development, test, and repair costs, even in minimal micro-computer systems.

The 6809's ability to efficiently (and uniquely among 8-bit micro-computers) handle relocatable and modular code makes code more reusable in multiple system designs and, therefore, more inherently reliable for multiple uses. Additionally, modules may be independently and more thoroughly tested.

Microprocessor users may not previously have ranked software efficiency and reliability as number one on their list of evaluation criteria, but as more microprocessor-based systems are used, software-induced failures and their cost of repair may indeed make believers of previous skeptics. (How quickly we forget the lessons learned by our forefathers in the mainframe and minicomputer industry.)

Mr. Locke is completely correct in advising that a thorough analysis be executed whenever possible prior to selecting a particular processor. I further agree that a complete analysis is not always economically possible or necessary. However, to discount instruction set efficiency and programming ease as "niceties" of dubious benefit is shortsighted and misleading.

Benchmarks by themselves are insufficient selection criteria and are often used to skew one's thinking regarding certain processors. It certainly was not my intention to do this, and in fact, the benchmarks used were obtained from copies of a public presentation made by Motorola on the 6809. It is my understanding that these benchmarks were pro-

duced by Motorola to evaluate the instruction-set efficiency of the 6809 during its development to ensure completeness, and not for "marketing purposes."

I submit that whether the 6809 is x% better or worse than other high-performance 8- and 16-bit processors in any or all applications is a subject of infinite debate. The key point is that the 6809 is an excellent machine whose structure is unique among 8-bit processors in that it attacks and reduces the cost of software development and maintenance. It is my belief that Mr. Locke has mistakenly overlooked the tremendously vital importance of this issue to users.

Mitch Gooze  
 American Microsystems Inc.  
 Santa Clara, Calif.

### Speaking faster

To the Editor: "Speech I/O is making itself heard" [May 22, p. 95] contains one small error. It is certainly true that enlightenment on the new voice technology by coverage like this has been sorely needed. However, the article erroneously cites Interstate Electronics voice products with a 1.5-to-2-second delay in response time. That kind of "delay" would be totally unacceptable to a user.

The actual response time of our voice recognition module is in fact approximately 130 milliseconds, 190 ms, or 250 ms, depending upon opted vocabulary size of 40, 70, or 100 words, respectively. The 1.5 to 2 seconds more correctly approximate our maximum word length or duration of recognizable utterance.

Carl J. Wilkie  
 Interstate Electronics Corp.  
 Anaheim, Calif.

### Correction

The Electronics Newsletter story on page 33 of the June 5 issue about American Liquid Xtal Chemical's liquid-crystal-display development incorrectly credits Jim Ferguson (whose name was misspelled with a "u") with holding patents on dynamic scattering LCDs instead of twisted nematic LCDs.



IMMEDIATE  
DELIVERY

# The Silent Commander.

## 743 KSR

### Keyboard Send-Receive Data Terminal

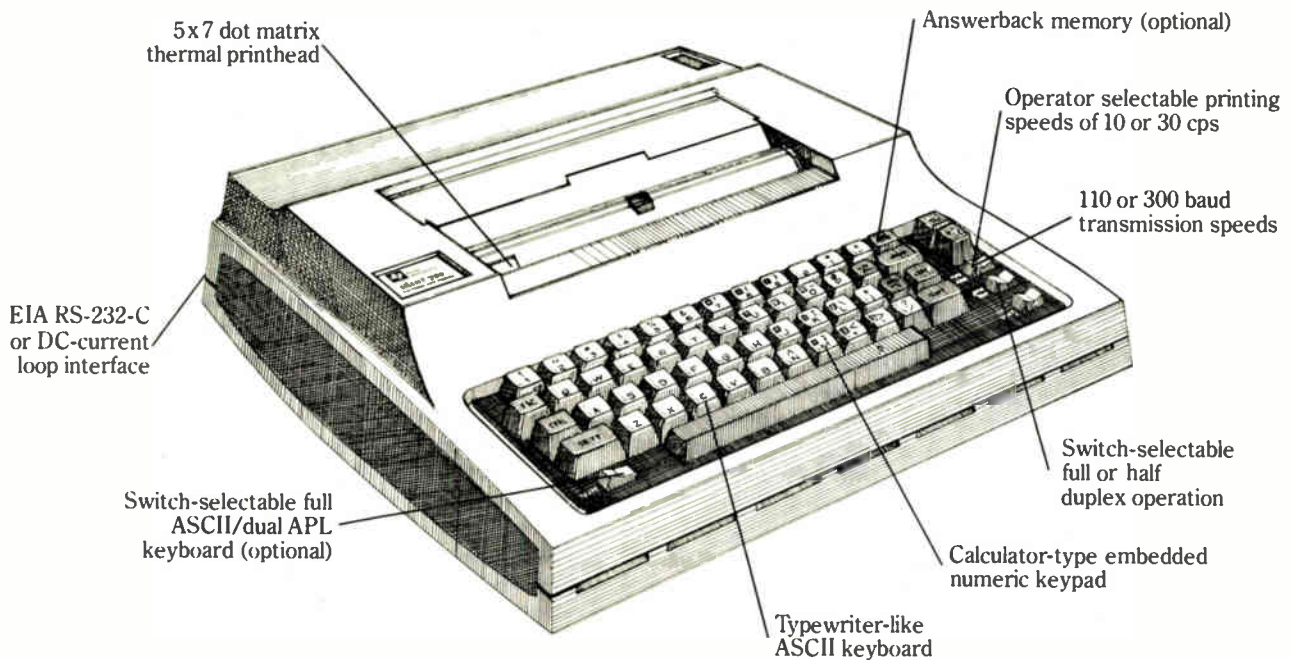

TI's *Silent 700*\* Model 743 KSR Data Terminal can help you take command of your data entry application needs today. The compact 743 offers a variety of easy-to-use standard features and options, and is an ideal input/output console. And with virtually silent thermal printing, the low-cost 743 leads the way for efficiency and reliability. The field-proven 743 is also available as a Receive-Only model.

With either 743, you can depend on high-quality *Silent 700* performance.

TI is dedicated to producing quality, innovative products like the 743 KSR Data Terminal. TI's hundreds of thousands of data terminals shipped worldwide are backed by the technology and reliability that come from 50 years of experience, and are supported by our worldwide organization of factory-trained sales and service representatives.

For more information on the 743 terminals, contact the TI sales office nearest you or write Texas Instruments Incorporated, P.O. Box 1444, M/S 7784, Houston, Texas 77001, or phone (713) 937-2016. In Europe, write Texas Instruments Incorporated, M/S 74, B.P. 5, Villeneuve-Loubet, 06270, France.



\*Trademark of Texas Instruments \*Service Mark of Texas Instruments Copyright ©1980. Texas Instruments Incorporated

# TEXAS INSTRUMENTS

We put computing within everyone's reach.

Circle 9 on reader service card

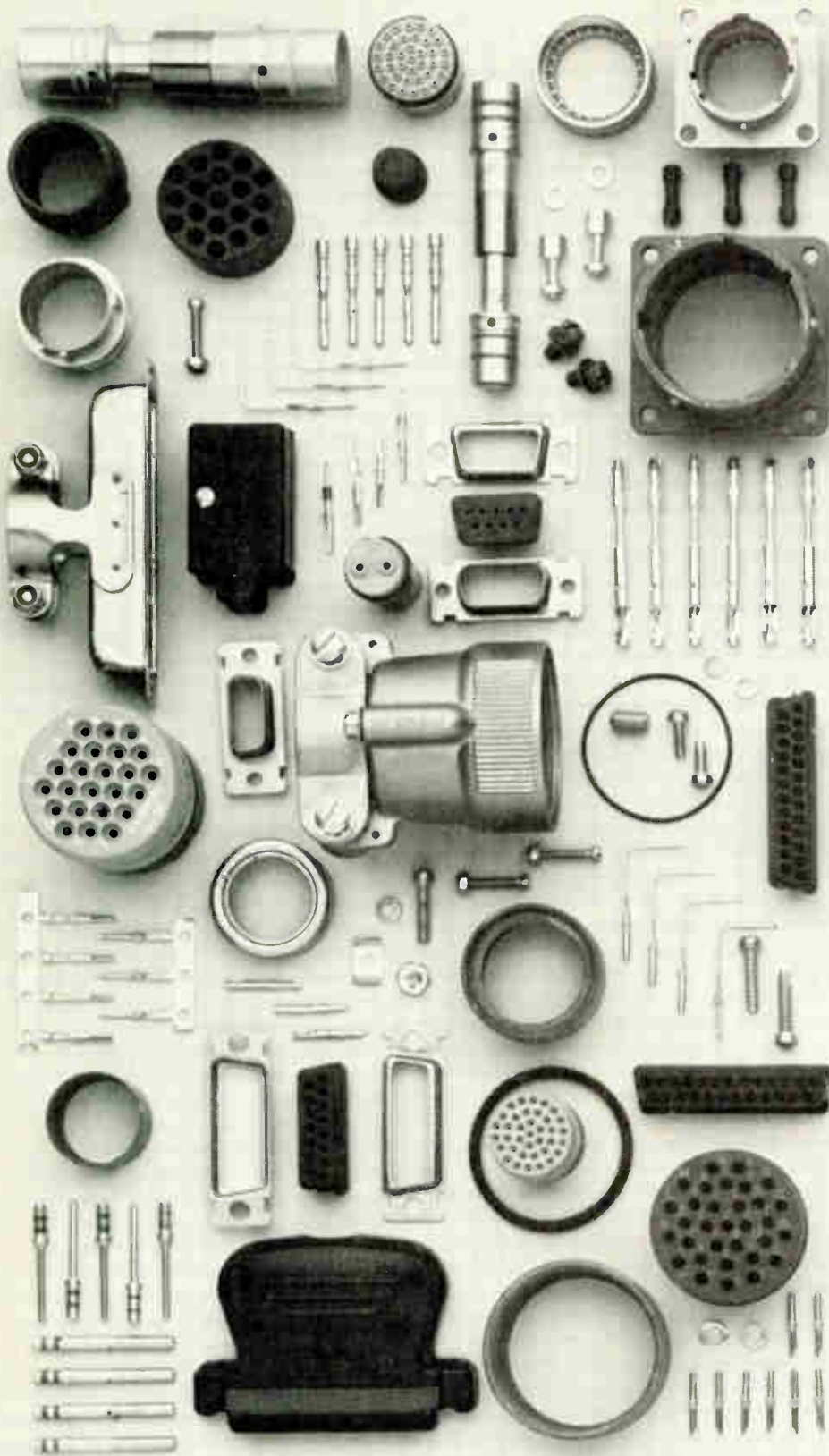

**MADE  
FRESH DAILY.  
ONLY AT YOUR  
CANNON  
DISTRIBUTOR.**

**ARIZONA**  
TIME ELECTRONICS/ARIZONA INC  
Tempe AZ  
Phone 602/967-2000  
**CALIFORNIA**  
KIERULFF ELECTRONICS INC  
Los Angeles, CA  
Phone 213/725 0325 714/636-1030  
WYLE DISTRIBUTION GROUP  
El Segundo, CA  
Phone 213/322-8100

RICHEY ELECTRONICS INC  
Sun Valley, CA  
Phone 213/875-2862 768-3800  
TIME ELECTRONICS WEST INC  
Torrance, CA  
Phone 213/320-0880  
TIME ELECTRONICS NOR/CAL  
Mountain View, CA  
Phone 415/965 8000

**COLORADO**  
ARROW ELECTRONICS INC  
Denver, CO  
Phone 303/758-4585  
**FLORIDA**  
TIME ELECTRONICS FLORIDA INC  
Ft Lauderdale, FL  
Phone 305/974-4800  
**GEORGIA**  
ELECTRO AIR CORP  
Atlanta, GA  
Phone 404/351-3545

**ILLINOIS**  
HALL MARK ELECTRONICS CORP  
Bensenville, IL  
Phone 312/860 3800  
**INDIANA**  
GENESIS ELECTRONICS  
South Bend, IN  
Phone 219/267-2811  
**MASSACHUSETTS**  
TIME ELECTRONICS NEW ENGLAND  
Woburn, MA  
Phone 617/935-8080



A Cannon® Authorized Plug Specialist (CAPS®) is totally unlike any other distributor. Because he stocks both component and sub-assembly inventories, then assembles finished connectors to give you unprecedented buying flexibility. It's a unique value-added service that lets you get the connector that fits your exact requirements. Usually faster and at very competitive prices.

You can get a full range of military and commercial circular connectors, rack and panel, D Subminiature, IDC, microminiature, Sure-Seal™ and UBC (for PC boards) connectors. All produced on a local level. With quality backed by our 2-step Q.A. program.

So when you need timely delivery with quality you can count on, call your CAPS distributor. He'll be happy to make up a fresh batch of connectors to fit your exact requirements.

## CANNON ITT

You can always connect with Cannon.

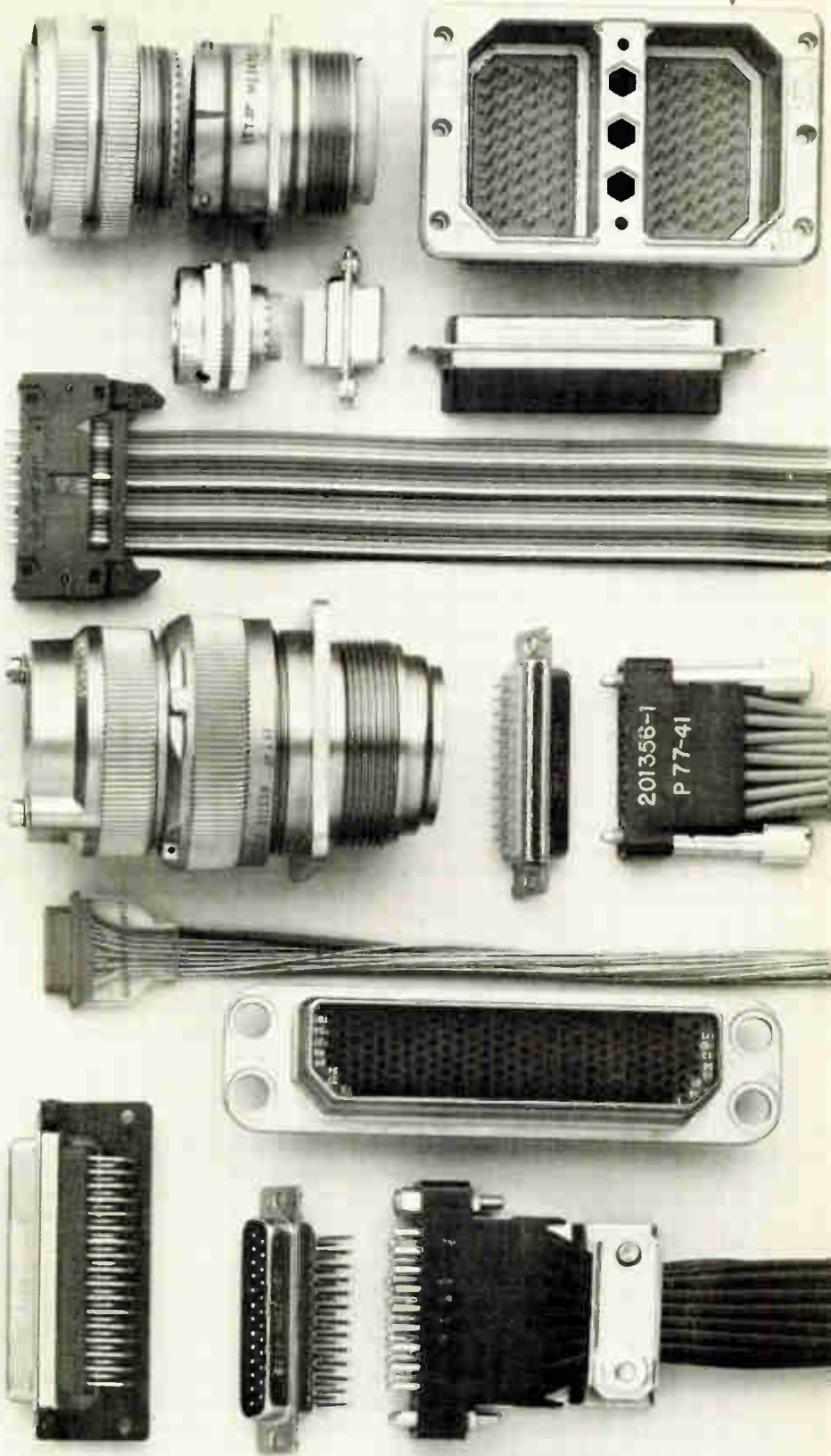

**MISSOURI**  
TIME ELECTRONICS/MID WEST  
St. Louis, MO  
Phone: 314/391-6444

**NEW YORK**  
A S I, PROGRESS ELECTRONICS CO. INC.  
Plainville, LI, NY  
Phone: 516/433-1700

**SUMMIT DISTRIBUTORS INC.**  
Buffalo, NY  
Phone: 716/884-3450

**TIME ELECTRONIC SALES**  
Hempstead, LI, NY  
Phone: 516/273-0100

**NORTH CAROLINA**  
ARROW ELECTRONICS, INC.  
Winston-Salem, NC  
Phone: 919/721-1661

**OHIO**  
ARROW ELECTRONICS, INC.  
Centerville, OH  
Phone: 513/435-5563

**PENNSYLVANIA**  
TIME ELECTRONICS/MID ATLANTIC  
Clifton Heights, PA (Philadelphia)  
Phone: 215/622-2500

**PHILADELPHIA ELECTRONICS INC.**  
Philadelphia, PA  
Phone: 215/568-7400

**TEXAS**  
HALL MARK ELECTRONICS CORP.  
Dallas, TX  
Phone: 214/234-7300

**HARRISON EQUIPMENT CO. INC.**  
Houston, TX  
Phone: 713/652-4700

**WASHINGTON**  
KIERULFF ELECTRONICS INC.  
Tukwila, WA  
Phone: 206/575-4420

ATTN: 8080 and  
Z-80 Programmers

# Software Problems?

Discover XYBASIC™—The language  
for measurement and control.

- Configure stand-alone systems that appear at the touch of a button with ROM Basic. Now you can keep both XYBASIC and your XYBASIC program in ROM.
- Versions available for SBC/80, CP/M, ISIS-II, INTELLEC 8 MOD80, and MDS-800 operating systems. There's even a version that lets you patch for your I/O.
- Unique control features and powerful debugging commands make XYBASIC ideal for control, process and lab applications.
- Specific OEM problems? We'll customize XYBASIC to your application.

Let it help you create process control programs for 8080-based computers in as little as one-tenth the time it used to take!

## Who is using XYBASIC now?

Control Data Corp. for testing 16K RAM chips

Disneyland for ride monitoring

Boeing for certifying 747's

GTE Sylvania, Magnavox and RCA for automatic testing of TV chassis

Bendix for quality control of electronic components

Northwestern University for laboratory experiment control... and many, many more!

## Find out how XYBASIC can help you

Mail coupon below or CALL COLLECT:  
(312) 472-6659 Ask for Robert Swartz

Mark Williams Company  
1430 Wrightwood Ave., Chicago, Illinois 60614

I'm interested!  
Please send comprehensive brochure.

Name Title \_\_\_\_\_

Company \_\_\_\_\_

Address \_\_\_\_\_

City \_\_\_\_\_ State \_\_\_\_\_ Zip \_\_\_\_\_

Country \_\_\_\_\_

Phone \_\_\_\_\_

E 1

## News update

■ At least one U. S. conglomerate is ready to step wholeheartedly into semiconductor technology research. United Technologies Corp. is establishing a microelectronics applied research laboratory with a primary focus on very large-scale integrated circuitry and associated applications.

The Colorado Springs, Colo., lab will employ nearly 100 persons to start, 50 of them engineers, says Peter L. Scott, executive vice president in charge of the Hartford, Conn., firm's Electronics Group. The hiring thrust will be in software programmers, integrated-circuit designers, and physicists.

**Research.** The main focus will be VLSI custom circuits and computer-aided design techniques, and advanced software technology will also be explored, Scott says. Another possibility is work in technologies for very high-speed ICs.

The lab will function as part of the Electronics Group, falling under the purview of L. J. Sevin, chairman and chief executive officer of Mostek Corp. Last fall, United Technologies acquired Mostek, the Carrollton, Texas, semiconductor maker and then established the Electronics Group [*Electronics*, April 10, p. 88].

"The main thrust of the laboratory will not be toward the other operating companies" of the conglomerate, such as Otis Elevator, Carrier Corp., and the Pratt and Whitney division, says Scott, noting, however, that it will provide CAD capabilities for all of United Technologies.

Moreover, there are plenty of units within the Electronics Group that will have a direct claim on the lab's work. Besides Mostek, some are a Telecommunications Products division, the entire Automotive Group, the Hamilton Standard division, and the Essex Controls division, as well as Norden Systems, which Scott (p. 14) led before formation of the Electronics Group.

Over the next two years, capital and operating funds will amount to about \$20 million. A major investment will be a 40,000-square-foot facility; until that is finished late next year, the lab will operate in leased space. **-Pamela Hamilton**





Thumb a wheel  push a button  flick a lever 

# CHERRY'S GOT YOUR NUMBER

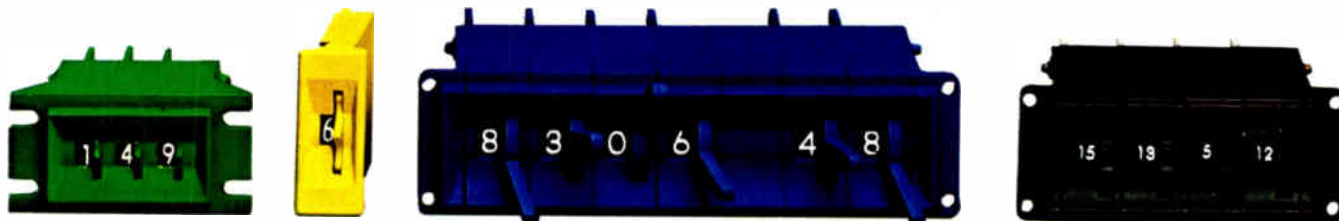
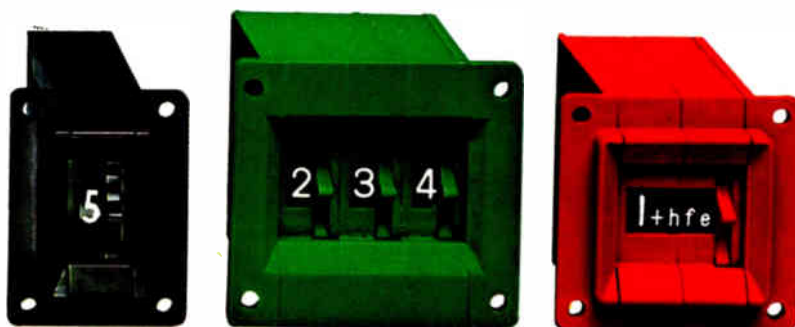

Take your pick from this colorful crop of remarkably versatile Cherry multi-position switches. All are light, tough, rugged. All can be used for both low level switching and encoding, yet consume no power. They read out their settings at all times. They offer basic choices like legend...lighted or non-lighted...dustproof models, too. In either standard black or extra-cost color.

- Choice of code: Dozens of standards. Specials, too.
- Choice of actuation: Thumbwheel, Leverwheel or button-indexed Pushwheel.
- Choice of mounting: Back

of panel, front mount or snap-in. • Choice of termination: PC board with parallel rows of holes, F-pins, J-pins... plus card-edge connectors. • Choice of size: From burly industrial size measuring 2.125" overall height right on down in size thru standard, miniature and .945" high subminiature...to sub-subminiature Pushwheels just .591" high.

All these choices in these hot numbers from Cherry. Just call...write...or TWX for complete catalog.



## MULTI-POSITION SWITCHES

**CHERRY ELECTRICAL PRODUCTS CORP.** 3608 Sunset Avenue, Waukegan, IL 60085 • 312/689-7700 • TWX 910/235-1572  
 Our worldwide affiliates and phone numbers: Cherry Semiconductor Corp., Cranston, RI, U.S.A., 401 483 8000 • Cherry Mikroschalter GmbH, Auerbach, Germany, 09 843 181 • Cherry Electrical Products Ltd., Sandridge (Herts) England, 44 727 32231 • Cherro Brasil Industria E Comercio Ltda., Sao Paulo, Brazil, 011 248 4343 • Hirose Cherry Precision Co., Ltd., Kawasaki, Japan, 044 933 3511

Circle 13 on reader service card

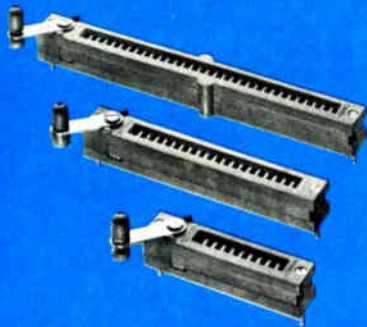

## ZIP STRIP® Test Sockets

**Highly versatile Textool zero insertion pressure sockets allow "custom" installations for testing most in-line devices.**

Textool's versatile ZIP STRIP sockets make it possible to "customize" socket installations for zero insertion pressure (ZIP) testing of most in-line devices with 100" spaced leads, regardless of spacing between rows (.300" minimum).

Two ZIP STRIP sockets may be placed on any convenient centers, or several socket locking levers may be ganged together for easy mass testing of devices. Since all ZIP STRIP models feature zero insertion pressure, expensive and highly sophisticated circuits may be safely tested without fear of mechanical damage to the package.

Simple mechanical action plus a thoughtful system of ramps and bevels to guide device leads into the contacts allow a device literally to be dropped loosely, and with a simple flick of a locking lever be ready to operate with exceptionally good electrical contacts. A quick release of the locking lever lets a device be extracted with zero pressure being exerted on the leads by the socket contacts.

When ganged in an array, ZIP STRIP sockets easily accept dozens of devices and secure them with a single locking lever. Upending the array and releasing the lever unloads the devices since there is no contact pressure to retain them in the socket.

ZIP STRIP sockets are available in strips for 10, 20 and 32 leads on .100" spacing.

**Detailed technical information on the complete line of Textool's zero insertion pressure sockets is available on request.**

**Textool Products Department  
Electronic Products Division/3M**  
1410 W. Pioneer Dr., Irving, TX 75061  
214/259-2676



## People

### Larsen reconstructing opto house for GI

Joining General Instrument Corp.'s Optoelectronics division as director of research and development, a new post, Ted Larsen can't help but get a feeling of *déjà vu*. Much as when he designed and rebuilt a home from an old, burned-down California adobe, Larsen is now pulling together and rebuilding the materials and optoelectronics product development activities from fragments GI acquired from Monsanto Co. last summer.

Formerly Monsanto's optoelectronics-device and III-V-materials operations, the Palo Alto, Calif., division "had a good product line, but the technology and business were neglected once Monsanto knew they were going to sell it," says the 45-year-old Larsen. Further complicating the situation, he adds, "most of their R&D effort was concentrated in the St. Peters, Mo., area," and the majority of personnel involved with that activity have accepted other posts with Monsanto.

He is no stranger to the optoelectronics field. The holder of a bachelor's degree in industrial engineering and a master's in metallurgy, both from the University of California at Berkeley, Larsen in 1962 began a 15-year period with Hewlett-Packard Co. at a time when its LED activity was just a novelty and mostly centered around Government-contract work. A three-year leave from HP to earn a doctorate in materials science from Stanford University left him "really into electronics and hooked by optoelectronics," says Larsen. He eventually was responsible for both materials development and manufacturing in HP's Optoelectronics division.

Larsen is stimulated by GI's enthusiasm about the optoelectronics business. "It has a strong commitment to furthering the development of the technology and the business," he says. What's more, he adds, "I believe it's heading to become the No. 1 supplier in the field." His part in reaching that goal is to build strong product-development groups



**Enthusiasm.** Larsen is stimulated by GI's commitment to the optoelectronics business.

"to support the marketing department's and customers' needs" and "reestablish a materials research activity."

Additionally, Larsen aims to exploit opportunities in GI's existing light-emitting-diode display and lamp business, as well as increase its efforts in intelligent displays. "There also are several business areas, such as fiber-optics, among others, that I want to expand into. That will force us to look into new materials, such as aluminum gallium arsenide, for higher radiance and laser-type devices," he explains.

### Scott adds the touch of the entrepreneur

If Peter L. Scott is anything, he is an entrepreneur. With that mind-set he will head United Technologies Corp.'s newest grouping—the Electronics Group—and steer it toward the leading edge of technology.

Scott, 53, has been with the Hartford, Conn.-based conglomerate since 1975, first as president of its Norden Systems subsidiary and, since late last year, as executive vice president in charge of the Electronics Group. In December, he was elected to the board of directors.

Despite this impressive collection of titles, Scott still views himself as an innovator—one who "must bring the critical [electronic] mass of the



# PDP11/23<sup>®</sup> ARRAY PROCESSOR SYSTEM



**FIRSTAR<sup>™</sup>**  
**PDP11<sup>®</sup>** **FPS<sup>®</sup>**

**FIRST COMPUTER CORPORATION INTRODUCES A NEW CONCEPT IN COST EFFECTIVE HIGH-SPEED ARITHMETIC PROCESSING SYSTEMS**

First Computer Corporation, one of the world's largest System integrators, has married Digital Equipment Corporation's advanced PDP-11/23 Computer Systems with the new Floating Point System's FPS-100 Arithmetic Processor. This complete packaged Array Processor System provides the power to tackle tough computational problems which were previously the domain of the "Super Computers".

**SUPER COMPUTER COMPUTATIONAL SPEED**

The FPS-100 is capable of up to eight million floating point operations per second with an effective throughput of up to forty million operations per second.

**PROVEN ARCHITECTURE + REAL-TIME ENHANCEMENTS = UNBEATABLE PERFORMANCE**

The FPS-100 is based on the proven parallel pipeline architecture of the FPS AP-120B. New enhancements such as extensive Real-Time capabilities provide maximum computational efficiency with a minimum host computer interaction. The cost-performance of the New FIRSTAR System is unbeatable in the universe.

**EXTENSIVE DEVELOPMENT SOFTWARE - SAVES PROGRAMMING COST**

With every FIRSTAR System you can select from an extensive library of easy to use software consisting of an Assembler, Debugger, Simulator, Utilities, Math Libraries, Signal Processing Libraries, Image Processing Libraries, and Host Executives. It's easy to start using your FIRSTAR System quickly.

**NEW SUPER-100 MULTI-TASKING REAL-TIME SUPERVISOR**

This new Real-Time Supervisor permits the execution of multiple Real-Time tasks on a priority basis. SUPER-100 can virtually place the FPS-100 in a stand-alone multi-tasking mode for the processing of multiple streams of input data with a minimum of host computer dependency.

**CHOICE OF DEC HOST COMPUTER OPERATING SYSTEMS**

Select the Digital Equipment Corporation Operating System which best matches your application needs. FIRSTAR is available with either the RT-11 Real-Time Executive or the RSX-11M Resource-Sharing Executive. All Operating Systems are fully supported by Digital.

**INSTALLATION AND FIELD SERVICE WORLDWIDE BY DEC AND FPS**

FIRSTAR Systems are jointly installed and maintained by DEC's and FPS's own Field Service Organizations. No third party maintenance to worry about.

\*Registered trademark of Floating Point Systems, Inc.

**First**<sup>™</sup>

**computer corporation**

corporate square / 3325 north east avenue / westmont, illinois, 60550 / (312) 920-1050

**TWX NUMBER 910-651-1916**

\*Trademark First Computer Corporation

\*Registered trademark of Digital Equipment Corporation

**AP-1**

Circle 15 on reader service card

**WHY STRUGGLE WITH CAGE ASSEMBLY?  
VECTOR-PAK DOES IT FOR YOU  
COMPLETELY ASSEMBLED-READY TO USE**

40 STANDARD CAGE AND  
MODULE COMBINATIONS  
SPECIALS TO ORDER

OFF THE SHELF



\$146.15  
COMPLETE

**EFP MODULE CAGES**

**Discrete Card Guide Cages** -- Aluminum or plastic. 4-way adjustable connect-or struts. 6 sizes off the shelf.

**Cardmount Cage Assemblies** -- Cards mount in 4 std. widths of L panels; 11 off-the-shelf cages; 13 module sizes.



CCK-13 Type \$41.32 (1-9)



CCM13 \$99.55 (1-9)



CCK3 \$39.62 (1-9)



CA87HP156 \$42.56 (1-9)

**Continuous Card Guide Cages**--Alum. plate style has 106, .077" wide card grooves, .150" ctrs. 4 sizes off-the-shelf.

**Multi-use Cage Kits**--Maximum flexibility, supplied unassembled in 4 different models to house cards and/or modules.

**FOR EXPERT ASSISTANCE FROM THE PACKAGING PROFESSIONALS**

**Vector Electronic Company**

12460 Gladstone Ave.  
Sylmar, CA 91342

CALL TOLL FREE 800-423-5659  
ON YOUR PACKAGING PROBLEMS.

If not stocked by your distributor order direct.

Prices subject to change without notice. 721079

Circle 16 on reader service card

**FREE**

**Brochure describes Electronics editorial reprints, services, books...**

- More than 70 article reprints in 15 subject categories
- Handy wall charts
- Custom-made reprint services
- Books especially for Electronics' readers
- Convenient postage-paid order cards



For your free copy, circle #275 on the reader service card.

**People**



**By twos.** Scott's goal for UTC's Electronics Group is to double its size in five years.

company together." His background is full of business startups. Receiving a degree from Ohio State University in 1949, he went on to found Hermetic Seal Transformer Co., Garland, Texas, in 1952. He merged this company with Dresser Industries in 1957. In 1963 he "retired" at the age of 36, only to return to the business world a year later to start Scott Electronics Corp. in Orlando, Fla. That company, a maker of magnetic components and subsystems, eventually became a subsidiary of Electronic Communications Inc., St. Petersburg, Fla.

**Builders.** "I built two businesses. I know what entrepreneurial spirit is," he says, emphasizing the long rein he plans to give Mostek Corp., the technological pivot in UTC's Electronics Group [*Electronics*, April 10, p. 88].

Scott is prepared to enlarge the \$2.5 billion group quickly—doubling its size in five years as he did with Norden. "The growth curve of the group may well exceed the overall growth of UTC as a whole," he predicts.

Fueling that growth will not be easy. Scott has established a separate research and development center in Colorado to provide advanced technological support for the group (see p. 12). He is also very concerned about the engineer shortage.

"One important challenge has been the people problem," he says. "UTC has grown through acquisition in the past. But can it do so effectively in the future without enough people?" he asks. □



Fluke Portable Test Instruments

# “What if we...”



*What if we added calculating and programming capabilities to a versatile new 5½-digit multimeter?*

# You'd call it a fast, easy way DMM. We call it the Fluke

**Exclusive Portable Test Instrument Packaging** lets you stack-and-latch the 8860A with other PTI Instruments from Fluke, including counters, thermometers and printers.

**5½-digits of resolution** with function annunciators. Two extra 7-segment LED's display program steps, exponentials, error messages and results of limits testing.

**Advanced math functions** include offset, hi/lo limits testing, peak-to-peak mode, and dcV and ohms zero.

**With 0.01% basic dc accuracy**, 8860A measures True RMS volts (ac or ac + dc), 2 or 4 terminal ohms. Safety features include internal four-terminal ohms and guard shorting links and recessed input jacks.

**Calculating controller option** uses RPN logic, is fast and easy to operate.

**Control section** lets technician call up prestored programs from memory cartridges without the keyboard attached. REM ("remote") switches unit to calculating controller operation.

**Standard features** include autoranging, switchable filter, selectable sample rates, and rear BNC trigger.

**Interchangeable non-volatile memory cartridges** for convenient program storage.

**Excellent value** as a stand-alone or system instrument: basic 8860A DMM \$1395; calculating controller option \$550; extra memory cartridges \$50 each; IEEE-488 interface option \$295 (U.S. prices only).



## Fast-Response Coupon

IN THE U.S. AND NON-EUROPEAN COUNTRIES:

John Fluke Mfg. Co., Inc.  
P.O. Box 43210 MS #2B  
Mountlake Terrace, WA 98043  
(206) 774-2481  
Telex: 152862

IN EUROPE:

Fluke (Holland) B.V.  
P.O. Box 5053  
5004 EB Tilburg,  
The Netherlands  
(013) 673 973 Tlx: 52237

- Please send me complete 8860A specifications and applications literature.
- I have to see this computing multimeter for myself. Please have a salesman call.

Name

Title  Mail Stop

Company

Address

City  State  Zip

Telephone (  )  Ext.

For technical data circle no. 19



# to program a 8860A Digital Multimeter.

*"Our customers asked for a powerful, computing multimeter. We designed just that... a precision benchtop DMM with an optional calculating controller that transforms it into an incredibly intelligent stand-alone measurement system."*



Our product designers are proud of the new Fluke 8860A, and rightly so: this unique computing multimeter system represents a significant advance in test and measurement technology.

Because it combines the analog measuring precision of a 5½-digit multimeter with a calculating controller option, the 8860A allows you to manipulate measurements as easily as you manipulate math with a programmable calculator, developing software for your specific application.

The 8860A concept provides a unique solution to some very challenging measurement problems: a system as practical as it is powerful.

## **Programmable power goes to work for you.**

Use the 8860A's math and programming capabilities to perform statistical analyses. Convert and directly display the output of transducers measuring temperature, pressure, power and other physical events. With powerful software that can both configure and command the DMM, the 8860A will make measurements, execute mathematical operations and branch on conditionals to subroutines.

The keyboard included with the 8860A's calculating controller option works just like any RPN programmable scientific calculator, and can be detached from the multimeter when not being used for program development. An inexpensive IEEE-488 option is also available for full function/range programming of the 8860A.

## **"Tell me more!"**

As a stand-alone system or in an IEEE-488 configuration, the 8860A allows you to automate a wide range of tedious, time-consuming procedures to streamline your applications today, and open new worlds of opportunity for tomorrow. For more information call toll free 800-426-0361; use the coupon; or contact your Fluke sales office or representative.



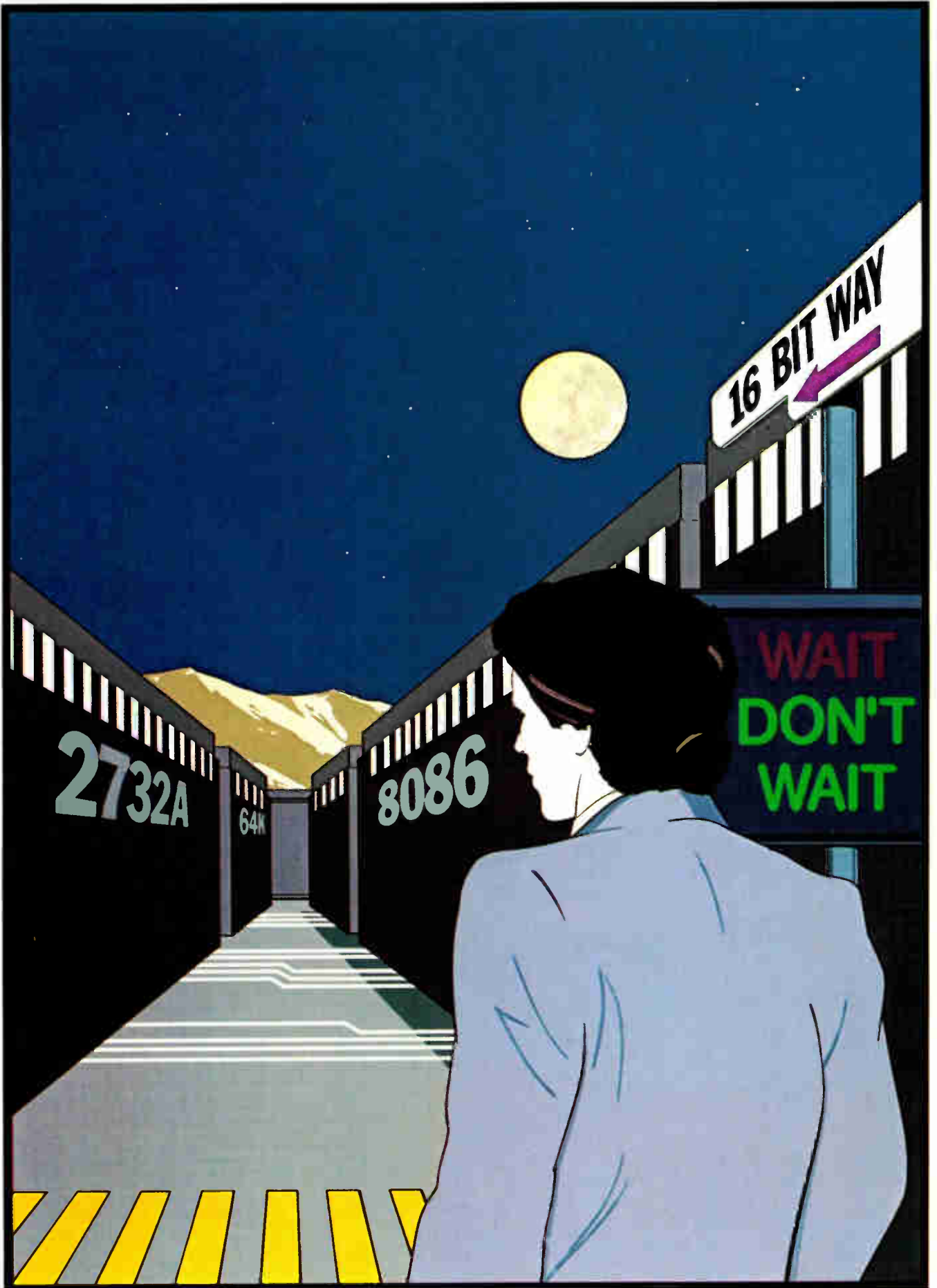



# No Waiting

## Introducing the Intel® 2732A EPROM. Now you can design 16-bit microcomputer systems without delays.

Now get all the performance you're paying for from your microprocessor designs with Intel's new 2732A EPROM. For 16-bit microprocessor systems, 2732A EPROMs deliver both the high speed (250ns) and high density (32K) solution. No other 32K EPROM on the market comes close.

### No speed limit

Other EPROMs require one, two, even three wait states to work with today's high speed microprocessors. Not Intel's 2732A EPROM. It's fast enough to keep up with any of them.

So now, at last, you can utilize the full potential of your microprocessor. In fact, when you use 2732As, you're designing a system that can run 25% faster.

And with a 32K bit density, you're not losing valuable board space to memory chips.

### The HMOS\*-E generation

By designing with the 2732A today, you're actually designing with the standard of tomorrow. The 2732A is a product of Intel's proven, reliable fourth generation EPROM technology, HMOS-E, and the first to come in a family of dense, high speed EPROMs.

HMOS-E technology means that we'll be able to incorporate

high performance features, like increased density, into future EPROMs, without affecting their speed or power characteristics. The 2732A is your first step towards a degree of flexibility in memory design never before available.

### JEDEC approved pinout

You can start designing for tomorrow now because the 2732A's pinout conforms to the approved JEDEC committee standard for byte-wide memories from 16K bits to 256K bits. So you can upgrade from a 2732A without changing your design or board layout. And you won't have to sacrifice features like 2-line control—a must in high-speed memories for avoiding bus contention problems.

### Proven Intel reliability

Like all our EPROMs, your 2732As are put through rigid quality control tests to insure they'll retain their programs and programmability for years to come.

And like all Intel products, the 2732A is backed with our traditional field support and technical documentation. Which means, if needed, you always have a source for technical information and design help to speed development along.

So whether you're designing a system around one of the new 16-bit microprocessors, like our 8086, designing in a high performance 8-bit processor, or upgrad-

ing an existing design, *don't wait*. For a cost effective, reliable, and total EPROM solution, with a no-compromise growth path, your best choice is the 2732A.

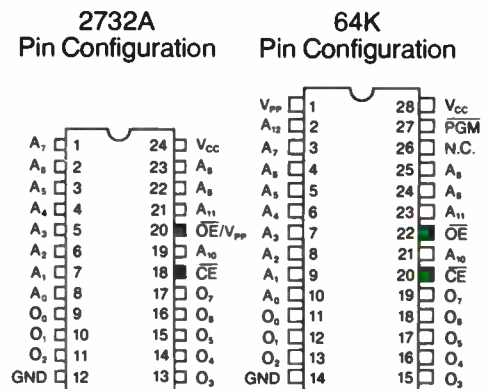

The 24-pin 2732A pinout conforms to the 28-pin JEDEC committee approved design for byte-wide memories. By using 28-pin sockets, there's no need for delays in upgrading to the 64K, 128K, or 256K EPROMs of the future.

Why add any unnecessary delays? To order now, or for more information—contact your local Intel distributor or sales office. Or, write Intel Corporation, Literature Department, 3065 Bowers Avenue, Santa Clara, California 95051. Or call (408) 987-8080.

\*HMOS is a patented Intel process.

## intel delivers solutions.

Europe: Intel International, Brussels, Belgium.  
Japan: Intel Japan, Tokyo. United States and Canadian distributors: Alliance, Almac/Strom, Arrow Electronics, Avnet Electronics, Component Specialties, Hamilton/Avnet, Hamilton/Electro Sales, Harvey, Industrial Components, Pioneer, L.A. Varah, Wyle Distribution Group, Zentronics.

---

## NEC NEWSCOPE

---

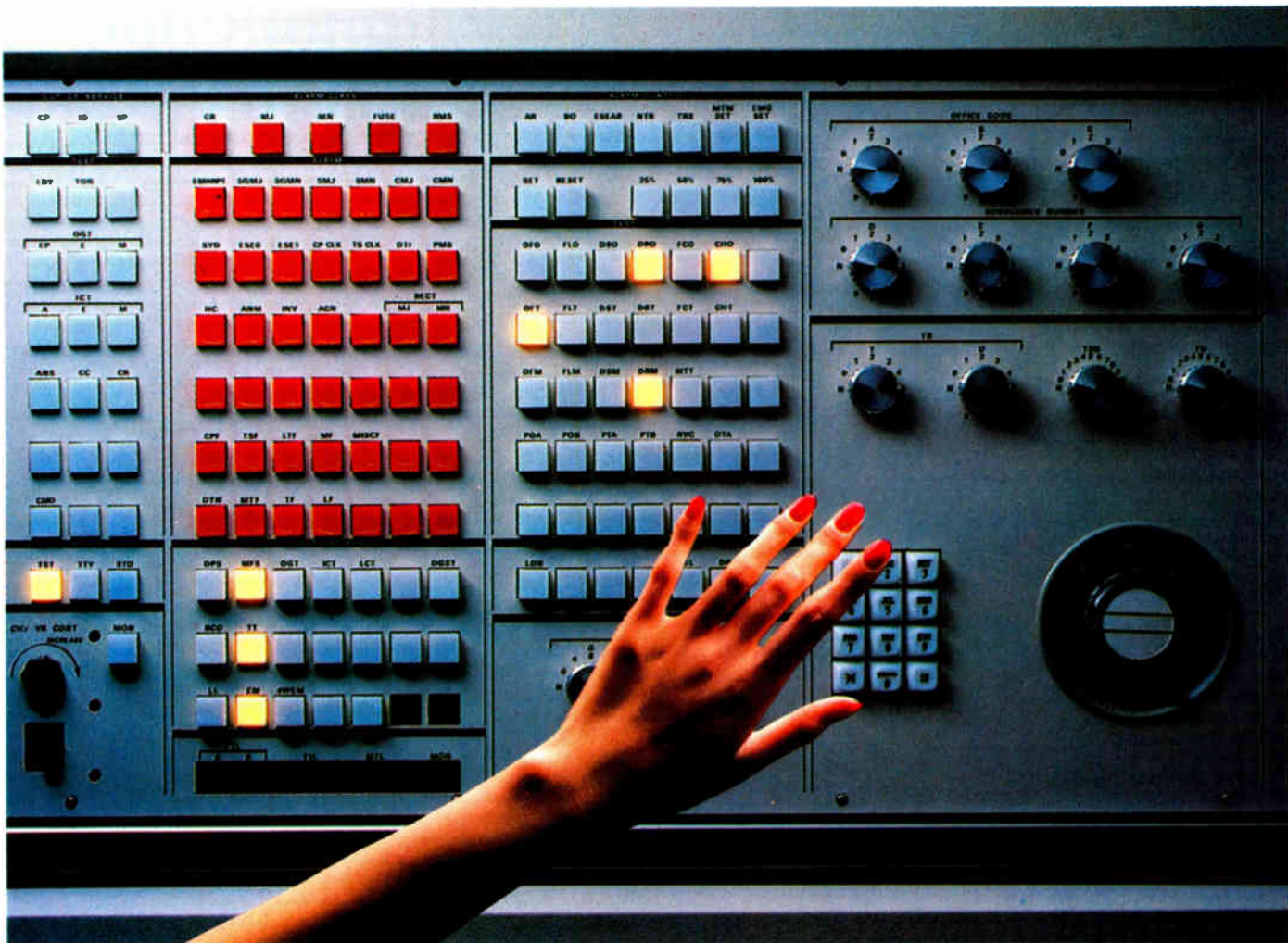

---

### PUERTO RICO SWITCHES TO "TIME MACHINE" ESS

---

**P**uerto Rico will modernize its telephone services by installing one of the world's most advanced digital switching systems: the NEAX61.

By the end of 1981, at least 17 NEAX61 systems will be working for the Puerto Rico Telephone Company (PRTC). Some of the systems will

replace existing equipment, and the rest will be installed at new exchange offices throughout the country to provide service for a total of about 55,000 lines.

Another NEAX61 will be installed in Caguas by the Puerto Rico Communications Authority. The system will serve

about 17,000 lines in more than 16 nearby cities through remote switching units.

NEAX61 is one of the most advanced digital switching systems currently available for central office use. Also called the "Time Machine", it can be used as a local/remote switch to handle up to 100,000 subscriber lines. NEC has already received orders for more than 300 NEAX61 systems from countries around the world. A dozen systems are already in service.



---

TV TRANSMITTERS  
AND EARTH STATIONS  
FOR THAILAND

---

The Bangkok Broadcasting & Television Co., Ltd. has placed an order with NEC for nine 10KW television transmitters and 10 small satellite communications earth station systems. A mobile satellite communications earth station system is also included in the order. The NEC equipment will help Thailand establish a nationwide television network.

The television transmitters and nine earth station systems will be installed in such important cities as Chiangmai in the north, Nakhon Ratchasima in the central region, Ubon in the east and six other cities throughout the country. One complete transmit-receive system will be set up in Bangkok. The Bangkok earth station will send television signals (both sound and picture) to the provincial earth stations for rebroadcasting in local cities.

The entire system will be completed by September. But the stations in



Bangkok and Chiangmai went into operation in December 1979, only 3.5 months after the contract was signed, and just in time to broadcast an important national athletic meet.

---

SYSTEM 500  
COMPUTERS COUNT  
INDONESIANS

---

Two large-scale NEC System 500 computers will be on the job when Indonesia begins its national census this year. Under the contract with the Central Bureau of Statistics of Indonesia, NEC will also supply terminal units, power supply equipment and



air-conditioning facilities.

In addition to helping with the census, the computer systems will handle other administrative tasks.

The NEC computer series, ranging from the giant System 900 to much smaller models, is designed to meet the general information processing needs of big corporations and small businesses alike. The System 500 features advanced hardware, software and system architecture. It is data-base oriented and especially suited for a communications network.

---

NEW ONE-CHIP MICROCOMPUTER  
HITS MARKET

---

NEC recently unveiled a new single-chip 8 bit microcomputer, the  $\mu$ COM-87 ( $\mu$ PD7801G).

The  $\mu$ COM-87 incorporates a 4K byte ROM, 128 byte RAM, timer, serial interface, I/O ports, etc., all on a single chip.

The memory capacity of the new one-chip microcomputer is up to 4 times larger than the capacities of conventional 8 bit single chips.  $\mu$ COM-87 can address large capacity external memories (up to 60K bytes) directly and freely regardless of program or data memories.

The new one-chip product is further equipped with a high-speed serial interface for easy multiprocessor con-

figuration, as well as a total of 140 instructions with various addressing modes. It has dual accumulators and general register sets which handle interruption processing 10 times faster than a single set of registers.

Because of its outstanding system expandability and programming flexibility,  $\mu$ COM-87 can be used in POS systems and numerous office machines; it is also well-suited for measurement control with multi-

chip configurations and distributed processing in building management and automatic metering.

NEC offers software (PDA-80/800 and INTELLEC SERIES-II) and hardware (EVAKIT-87) supports as well.



Circle 23 on reader service card

**NEC**

Nippon Electric Co., Ltd.  
P.O.Box 1, Takanawa, Tokyo, Japan.

## Where will the teachers come from?

One ironic result of the current shortfall in electronics engineers being produced by U. S. universities [*Electronics*, June 19, p. 91] is that it may impair the ability of schools to turn out EEs in the future. As potential employers bid the price for new graduates ever higher, even those with a strong inclination to stay to teach will be unable to resist starting salaries equal to those paid professors with doctorates. The electronics industries are, in effect, eating their young.

One answer should come from industry itself in the form of permanent endowments or long-term research projects to help raise engineering instructors' compensation scales

## Time to start thinking of a people's computer

Is the siren song of success luring the manufacturers of personal computers along a dangerous course, one that leads to high technology rather than to consumer convenience? Yes, says Raymond E. Kassar. As chairman and chief executive officer of Atari Inc., the Warner Communications subsidiary and itself a computer maker, he maintains that "the personal computer industry has unintentionally cowed the public—and retailers, too—with its prideful promotion of truly amazing technology." This approach goes right over the heads of the great majority that composes the mass market, he says. "Every time we make our products more complicated to use or understand, millions of people decide to postpone a possible purchase. 'Not for me,' they say, 'too many knobs, dials, and manuals.'"

Kassar also says that his study of consumer trends shows that three quarters of the women in the U. S. will be part of the work force by 1990 and that the manufacturers should consider this when marketing their machines. Make them in a wide range of colors, he says, much as IBM does with its typewriters;

nearer to those of their counterparts in industry. Companies could also provide both students and teachers with valuable work experience and vital knowledge by an interchange between the classroom and the design and production facilities. It is encouraging to note that such partnerships have already been going on and are on the increase (see p. 102).

If engineers are going to remain on campus to gain advanced degrees and teach, there must be incentives to keep them there. Electronics companies need engineers working for the future in the classroom as much as they need them working now at the design table.

coordinate them with furniture and fabric, along the lines adopted by Ohio Scientific for its low-end computers. "It's past time for the industry to shed its former clothes and appeal to the consumer in consumer fashion," Kassar insists.

The executive is also irked by the attitude that pervaded the recent Summer Consumer Electronics Show (see p. 99): that the market for personal computers will continue to include only the hobbyist and the small business. The belief that those two elements will be the leading-edge consumers for some time is regressive, Kassar says.

The latest events support his views. The rush to market the new personal models, triggered by the drive to seek expansion through lower prices, could be a classic example of a hardware wheel-spinning exercise. The new so-called hand-held units that were the talk of the consumer show could go the way of quadraphonic sound if makers fail to provide consumer-oriented hardware design and software packages. And the increasingly sophisticated business purchaser and hobbyist will not be around to pick up the slack this time.





## PROM manufacturers care what programmer you use.

**Every domestic PROM manufacturer evaluates our programmers, so you get PROMs programmed exactly to vendors' specs.**

Our U.L. listed Series 90 PROM programmer consists of interchangeable plug-in PROM personality modules and a control unit. To keep the system current and to insure programming reliability, we constantly work with the engineering departments of all domestic PROM manufacturers. They inform us of important new programming algorithms and PROM technologies. Thus, as new PROMs come along or as old PROMs change their algorithms, we can quickly develop a

new PROM personality module or modify an existing one. We routinely submit each module to the PROM manufacturer to evaluate our design and test our programming. We have secured vendor approval on modules for practically every PROM currently in use.

We have modules for specific PROMs, for whole PROM families and for gang programming 8 PROMs simultaneously. We also have a generic module for MMI PALs.

### **Backed by a 2-year warranty.**

Based on the field-proven reliability of 5,000 PROM programmers and 10,000 personality modules, we

provide a 1-year parts and labor warranty on modules and a 2-year parts and labor warranty on control units.

### **Learn more from our 96-page PROM User's Guide.**

A definitive work including cross reference charts on PROMs and other programmable devices. Call or write Pro-Log Corporation, 2411 Garden Road, Monterey, CA 93940, phone (408) 372-4593.

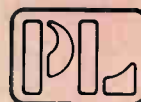

**PRO-LOG**  
CORPORATION

**Microprocessors at your fingertips.**

Circle 25 on reader service card

### Small companies need help to export

Melvin H. Damon, *president, Electronic Navigation Industries Inc., Rochester, N. Y.*

Export expansion, economists agree, is vital to the reversal of the United States' trade deficit. Although the U. S. Department of Commerce has sponsored seminars and counseling sessions extolling the advantages of the export business and the extent to which exporting can create new jobs and generate income, the concept has been hard to sell to small and medium-sized companies.

Many of the larger, more sophisticated electronics companies already in the export business fully appreciate the advantages of exporting. Since they have marketing, legal, financial, and tax accounting staffs to administer their export business, large companies can reap maximum profits from exports.

Small businesses, on the other hand, have generally not gone after export sales. Their activities usually center on the domestic market, and they tend to concentrate on what they understand best. The complexities of administering and financing exports tend to mask the intrinsic advantages of international business. Preoccupation with trade red tape rather than export opportunities further discourages small and medium-sized firms from entering foreign markets. Too often these companies look at exporting as an alternative only when domestic sales are lagging.

The most severe disincentive for many high-technology electronics firms considering the export market is the cumbersome and time-consuming administrative procedures required under Government export regulations. Because exporting from the U. S. is a privilege granted by the Government, a company must obtain a General Export License for all exports, and for many of its individual products a Validated Export License. The regulations may require getting an import certificate from the overseas customer, applying for the appropriate Validated License from the U. S. Department of Commerce through varying degrees of approval, and often requesting a Final Destination Verification Certificate.

To overcome this tangle of red tape, the Federal government should give immediate attention to:

- Updating the categorization schedule of products under existing Export Control Regulations. The present schedule, based on obsolete control

criteria, often requires various forms of Validated Licenses rather than the more convenient General License. The current schedule does not reflect the state of the commercial product-design art.

- Defining which products actually involve "militarily critical technology." Current export controls seem to be imposed more for political reasons than for the protection of U. S. technology. There is a serious question whether the restrictions should apply to commercial-grade products other than those in the computer or semiconductor industries [*Electronics*, Jan. 17, p. 26].

- Revising the Validated License Regulations to allow American manufacturers to compete internationally. Currently, other countries distribute and export similar commercial products unrestricted, penalizing the U. S. manufacturer in the international marketplace. The requirement that noncritical, commercially available products have COCOM review prior to shipment into Eastern European countries is a time-consuming, unnecessary encumbrance.

- Establishing a recourse procedure whereby small businesses can request relief from Validated Licensing Requirements predicated on historical trade relationships with other countries, the state of the art in competitive technology, the commercial nature of the product(s), or accepted practices of other countries exporting similar or competitive products.

For those companies—large or small—that have made the commitment to exporting, the present Export Control Regulations serve only as an impediment. Yet U. S. companies can expand their total volume of business via exporting in spite of these Government restrictions.

However, truly significant export expansion depends on a more positive and aggressive attitude by industry and Government. Constructive modification of the present red tape could be initiated by those companies already experienced in exporting. Such an effort might reduce export disincentives for large companies, and smaller companies could reap the benefits of increased export business.

---

*Electronics will periodically invite the expression of outside views on issues of importance to the electronics industries.*



# Meet HP's new System 45C color graphics computing center. It plugs into the wall--not into another computer.



*Engineering Design*

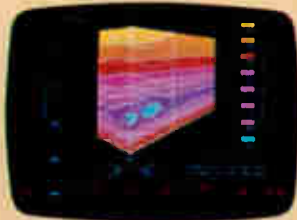

*Scientific Research  
and Analysis*



*Complex Data  
Presentation*



*Management Graphics*

Imagine what you could do with a powerful, easy to use graphics system that sits on your desk and is not dependent on another computer. A desktop computer that combines outstanding color graphics and the computational power to handle complex problems. All built into a compact, functionally-integrated unit, and all under your own individual control.

Based on HP's proven Series 45 desktop computers, System 45C is much more than a display. It's a color graphics processing system with significant computational abilities. You get to your solutions faster through new developments in graphics language extensions to BASIC.

High resolution and 4913 bright, crisp colors give you a realistic, lifelike display of your design. A light pen lets you work interactively with color images.

Solving tough problems with an outstanding color graphics system, up to 449K bytes of user-available read/write memory, and high-performance I/O is a rewarding experience when it's done the HP desktop system way — under your total control, and at your own pace. To learn more about the graphics capabilities of HP desktop computers, and to request literature or a demonstration of the new System 45C, please turn the page.

400/2

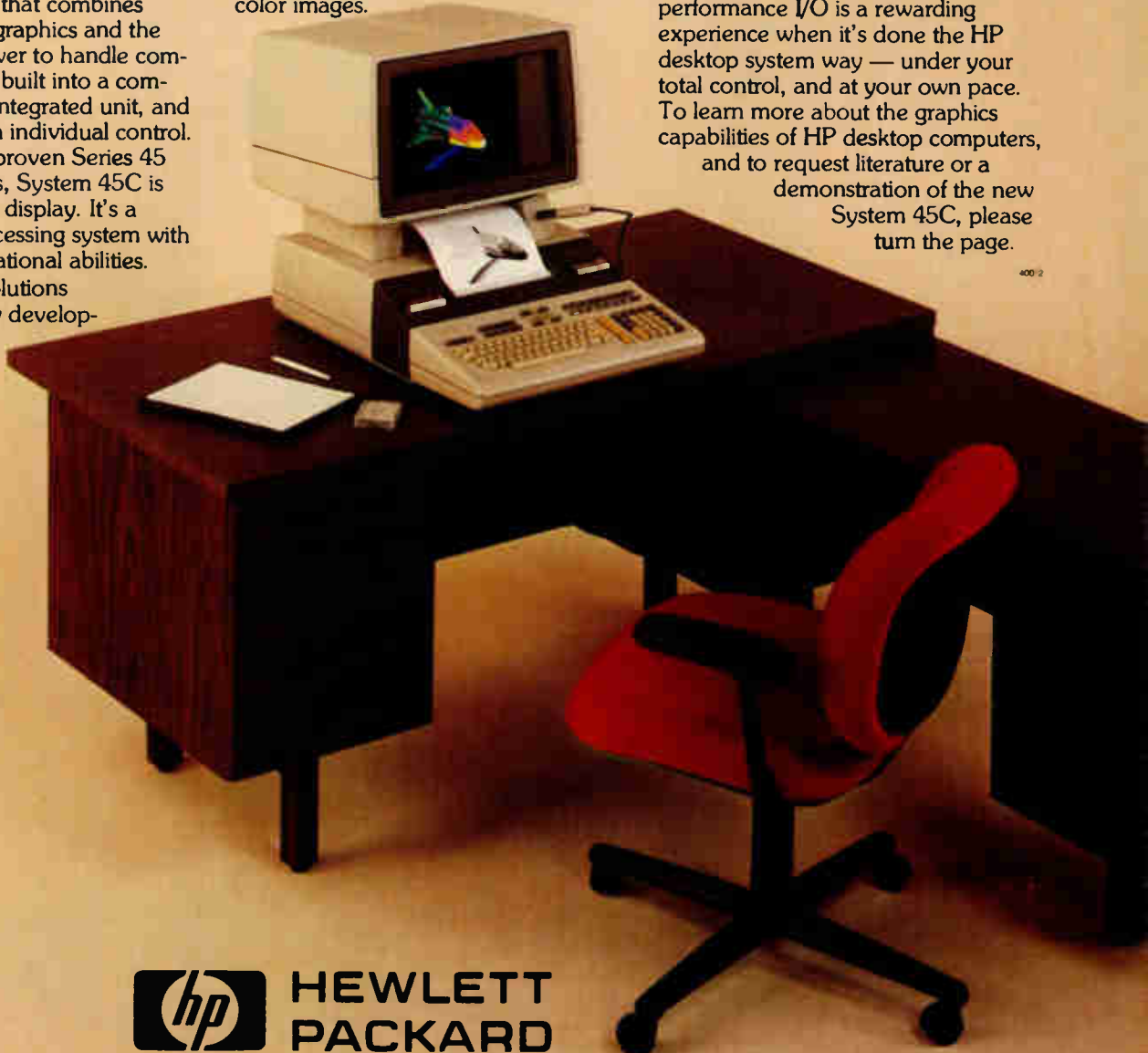

**HEWLETT  
PACKARD**

# Scientists and engineers computer systems powerful

## Why?

### *The Power of HP Graphics.*

Today's Hewlett-Packard desktop systems offer an impressive array of powerful graphics capabilities to help you analyze data more thoroughly and solve complex problems more quickly. With both full-color and monochromatic displays, and a broad range of HP input, output and storage peripherals, it's easy to tailor a graphics system to match your needs. And, you'll realize benefits that reach well beyond the power of display graphics. HP systems today give you powerful computing capabilities with user-available memory to 449K bytes, high-performance I/O, data base management and mass memory options to 120M bytes. Whether you're computing, optimizing a design or acquiring data from instruments, HP graphics systems put big computer power under your individual control.

### *An Interactive System.*

Your data can be entered in a number of ways. You can use the desktop computer's interactive keyboard. Or, if you're



working with drawings, photographs, maps and other graphic material, the HP Digitizer enables you to transfer this data to the computer. System 45C's Light Pen provides a natural way to let you move and construct objects on the system's CRT screen.

*Results the Way You Want Them.* Your HP graphics system will let you

choose the way you want your results presented. You can display your solutions on the desktop computer's CRT screen, and the image can be dumped onto the



# find today's desktop graphics tools.

desktop's built-in printer. Your output can be in the form of color plots or overhead color transparencies, made by an HP four color plotter. These can be useful in group presentations. Printed results, including letter

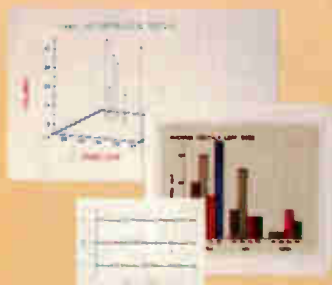

quality output, can also be obtained from HP printers. When your system is assembled to give you the graphic results you want, HP's high-performance language and industry standard I/O will ensure smooth interaction among all the components.

## Advanced Graphics Language.

To simplify your development of computational graphics, we've formulated a graphics language extension of HP Enhanced BASIC. With up to 70 commands, our graphics language eliminates numerous statements and hours of programming, letting you quickly manipulate monochromatic and color images from simple charts and diagrams to complex geometrical figures.

## Extended Capabilities.

The power and versatility of your desktop system can be extended through two new HP capabilities. Data Comm allows desktops to communicate with larger mainframes in High Speed Asynchronous or Bisynchronous modes. With this capacity, the desktop becomes a very powerful and fully integrated work station in a large computer system. Technical Data Base Management provides HP's award-winning IMAGE facilities that let you access information in the system without writing applications programs. DBM also includes a powerful adaptation of the QUERY inquiry program.

## A Choice — and Two New Systems.

We build a broad range of desktop computers, with one just right for your graphics applications. The new System 45C offers powerful color graphics and up to 449K bytes of computational power.



System 45B provides monochromatic graphics (including 3-D) and large read/write memory capacity. The new HP-85 is a modestly priced professional desktop computer with integrated graphics, CRT and printer. All three of these systems can be used with HP peripherals.

## A Growth Path.

As your needs expand, HP desktop computers can communicate with the HP 1000 family of real-time computer systems over data links. For dedicated graphics applications that require a multi-user, multi-terminal system, the HP 1000 Model 45 includes a graphics terminal and versatile graphics/1000 software. The multi-programming power of an HP 1000 can be teamed with the graphics devices described above, and can also control up to four full-color graphics display systems.



**For more information.** Call 800-821-3777, extension 303, toll-free day or night (Alaska and Hawaii included). In Missouri, call 800-892-7655, extension 303. Or write 3404 E. Harmony Road, Fort Collins, Colorado 80525.

**For a demonstration.** Call the HP regional office nearest you: East 201/265-5000; West 213/970-7500; Midwest 312/255-9800; South 404/955-1500; Canada 416/678-9430.



**HEWLETT  
PACKARD**



# The world's broadest +5 is available in volume

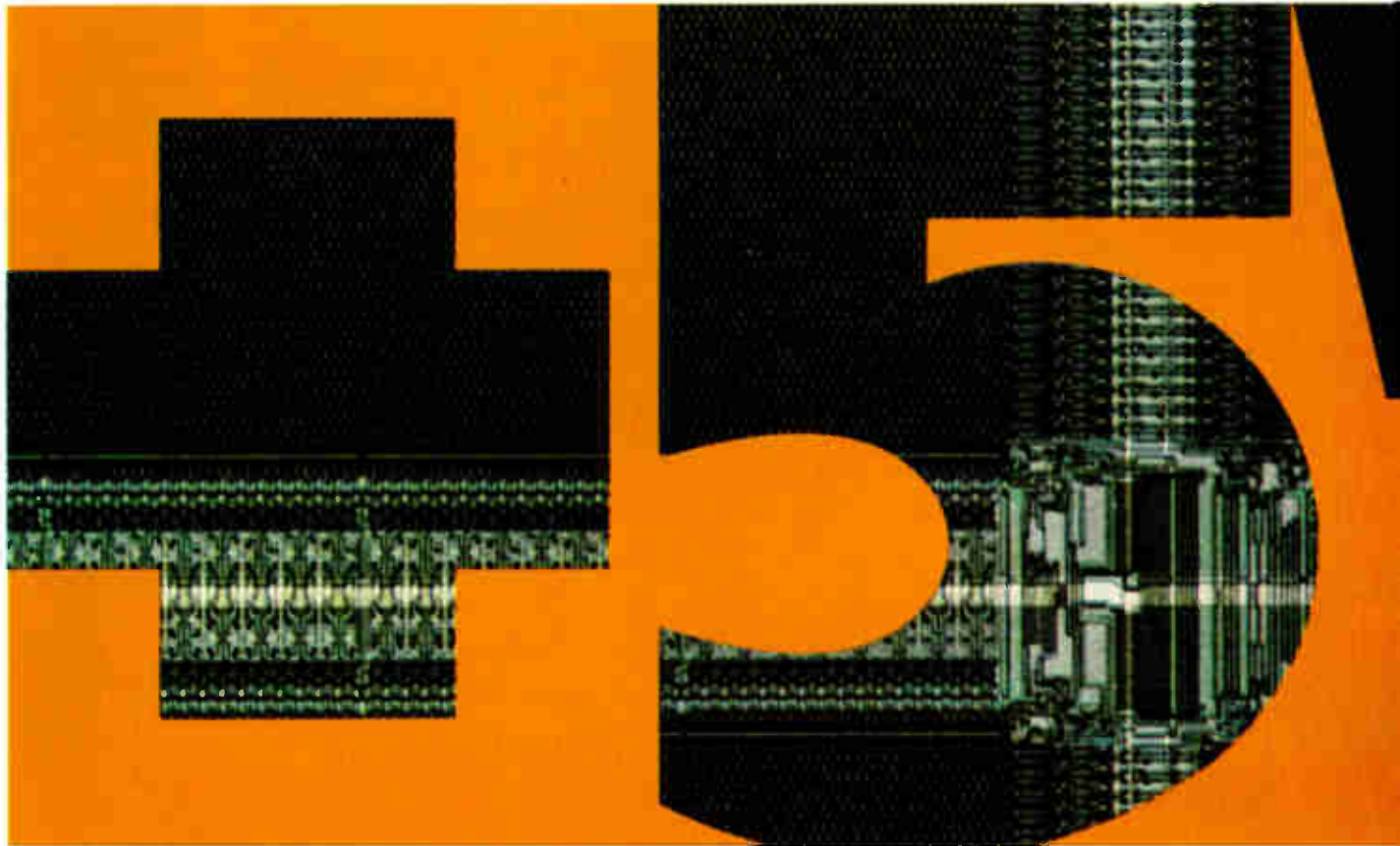

## The industry's most complete single +5 V supply dynamic RAM family

Density	Device	Self/Auto Refresh	Power Supply	Access times (ns)
64K 64K	MCM6664 MCM6665	✓ —	+5 V. $\pm 10\%$	150. 200
32K 32K	MCM6632 MCM6633	✓ —	+5 V. $\pm 10\%$	150. 200
16K 16K	MCM4516 MCM4517	✓ —	+5 V. $\pm 10\%$	120. 150. 200



# V dynamic RAM family today, from Motorola.

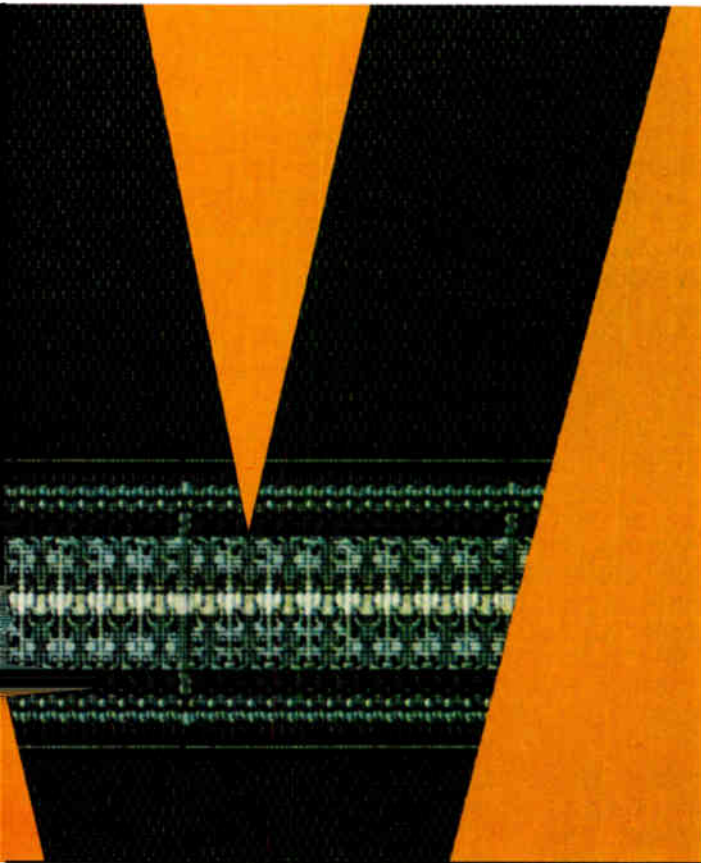

For the first time, a complete family of single-supply +5 V dynamic RAMs from 16K through 64K is available in production quantities. You can get them now, from Motorola.

The dynamic RAM family leaders are the 64Ks. These "memories of the future" are available *today* from Motorola, and from authorized Motorola distributors.

The single-supply 16K RAMs also are available now in production quantities from the factory and distributors. Completing this family of totally upward-compatible 16-pin RAMs are the +5 V 32Ks, for intermediate memory system densities between 16K and 64K. They're also available now direct from the factory.

The entire family uses industry-standard pinouts and has the high speed and low power you expect from our HMOS technology. Systems designed with our 16K RAM can double or quadruple their memory capacity as demand warrants by simply plugging in our 32K or 64K family members.

## The pin that refreshes

Motorola's +5 V 64K RAM was the first in volume production. Now, two versions are available. The original MCM6664 has the leadership Pin 1 self-refresh and auto-refresh functions. The MCM6665, without Pin 1 refresh, is now also in volume production.

Our 16K and 32K single-supply dynamic RAMs are designed with and without Pin 1 refresh, too. The 32K MCM6632 (with Pin 1 refresh) and MCM6633 (without) are both in production, as is the 16K MCM4517 (without). The 16K with Pin 1 refresh, MCM4516, will be available later this year.

Not only is Motorola first with the broad line of fully-pin-compatible 16K - 64K +5 V dynamic RAMs, but first with 16K - 64K +5 V families of fully pin-compatible 24-pin ROMs and EPROMs as well. Look to Motorola leadership in MOS Memories for designing

V <sub>CC</sub> Supply Current-Max Active/Standby mA*	Price* 100/pc.
50/5	\$124.00 113.00
50/5	62.00 56.65
23/2.5	18.00 15.00



\* 64K and 32K  
- 200ns ceramic.  
16K  
- 150ns plastic

Innovative systems through silicon.



**MOTOROLA INC.**

# Carborundum noninductive ceramic power resistors solve tough problems.

Carborundum makes three types of noninductive ceramic resistors that can solve tough resistance problems, save money and space.

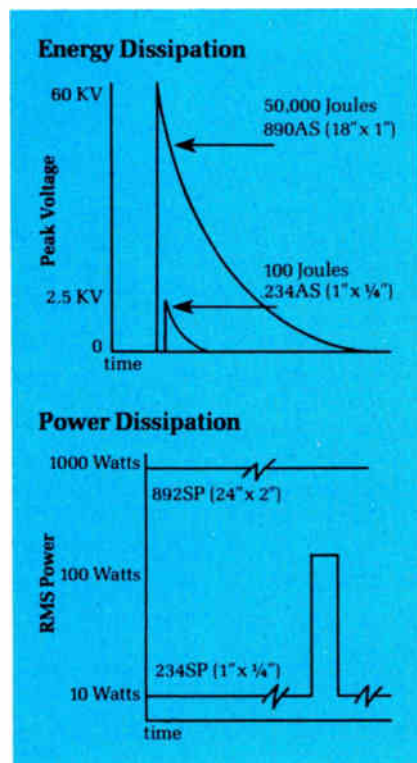

Regardless of the pulse shape, we have the resistor. Our Type SP handles large amounts of power from 60 cycles to many megahertz. Type AS can absorb huge amounts of energy while maintaining its noninductive properties at high voltages. Type A solves high resistance problems in high voltage situations.

For more information on ceramic power resistors and our broad line of thermistors and varistors, contact: The Carborundum Company, Graphite Products Division, Electronic Components Marketing, P. O. Box 339, Niagara Falls, New York 14302. Telephone: 716-278-2521.

**CARBORUNDUM**



A Kennecott Company

32 Circle 32 on reader service card

## Meetings

**Third International Conference on Hot Carriers in Semiconductors**, Université des Sciences et Techniques du Languedoc (Centre d'Etudes d'Electronique des Solides, 34060 Montpellier, France), Montpellier, July 7-10.

**International Microcomputer Application Conference (IMAC '80)**, Japan Electric Industrial Development Association (3-5-8 Shiba Koen, Minato-ku, Tokyo 105), Noky Building, Tokyo, July 8-10.

**Siggraph '80—Seventh Annual Conference on Computer Graphics and Interactive Techniques**, Association for Computing Machinery (Siggraph '80, P. O. Box 88203, Seattle, Wash. 98188), Olympic and Park Hilton Hotels, Seattle, July 14-18.

**Annual Conference on Nuclear and Space Radiation Effects**, IEEE *et al.*, Cornell University, Ithaca, N. Y., July 15-18.

**Electromagnetic Interference Metrology Seminar**, National Bureau of Standards (M. Gerald Arthur, EMI/Radiation Hazards Group, Electromagnetic Fields Division, NBS, Boulder, Colo. 80303), NBS, Gaithersburg, Md., July 22-24.

**1980 Microcomputer Show**, Online Conferences (Cleveland Road, Uxbridge JB8 2DD, England), Wembley Conference Center, London, July 22-24.

**Second Telecommunications Conference**, IEEE (Umid Nejib, Engineering Department, Wilkes College, Wilkes-Barre, Pa. 18766), Best Western Motel, Wilkes-Barre, July 28-31.

**SPIE's 24th International Symposium and Instrument Display**, Society of Photo-Optical Instrumentation Engineers (Box 10, Bellingham, Wash. 98225), Town and Country Hotel, San Diego, Calif., July 28-Aug. 1.

**23rd Midwest Symposium on Circuits and Systems**, University of Toledo (A. R. Thorbjornsen, Electric

Engineering Department, University of Toledo, Toledo, Ohio 43606), Toledo, Aug. 4-5.

**Fifth Annual Conference on Innovation and Regulatory Issues and Technical Seminar on Solar Energy and Energy Conservation**, National Bureau of Standards (Sandra A. Berry, B-226, Building Technology, NBS, Washington, D. C. 20234), Plaza Cosmopolitan Hotel, Denver, Colo., Aug. 6.

**1980 Joint Automatic Control Conference**, IEEE, Instrument Society of America, *et al.*, Sheraton-Palace Hotel, San Francisco, Aug. 12-15.

**Electronics/China 80**, U. S.-China Trade Consultants Inc. (Clapp & Poliak Inc., P. O. Box 277, Princeton Junction, N. J. 08550), Canton, China, Aug. 14-24.

**International High-Fidelity Trade Fair with Festival**, Nowea (D-4000 Düsseldorf 30, P. O. Box 320203, West Germany), Fairgrounds, Düsseldorf, Aug. 22-28.

**First Annual Hewlett-Packard 1000 International Users Group Conference** (Glen A. Mortensen, Intermountain Technologies Inc., P. O. Box 1604, Idaho Falls, Idaho 83401), San Jose Hyatt House, San Jose, Calif., Aug. 25-27.

**The 12th Conference on Solid-State Devices**, The Japan Society of Applied Physics (3-5-8 Shiba Koen, Minato-ku, Tokyo 105), Tokyo Chamber of Commerce & Industry Building, Aug. 25-27.

**10th Symposium on Electromagnetic Theory**, Verband Deutscher Elektrotechniker (D-6000 Frankfurt 70, Stresemannallee 21, West Germany), Munich Technical University, Aug. 26-29.

**The 15th International Conference on the Physics of Semiconductors**, Physical Society of Japan (3-5-8 Shiba Koen, Minato-ku, Tokyo 105), Kyoto International Conference Hall, Kyoto, Sept. 1-5.



## The starting point:

### Our new A/D converters.

To convert the analog world to digital, use either of our new A/D converters. Both are CMOS devices requiring only a single +5 volt power supply. Power dissipation is a low 1.5mW typical.

The MK50808 is an 8-bit successive approximation A/D converter. This 28-pin device has microprocessor-compatible control logic and an 8-channel input analog multiplexer. The MK50816 A/D converter is a 40-pin cir-

cuit with the same logic as the MK50808, but features an expandable 16-channel analog multiplexer.

Both A/D converters use a series resistor ladder approach that guarantees monotonicity and no missing codes and allows both ratiometric and fixed-reference measurements. With these devices, external zero and full-scale adjustments are unnecessary and an absolute accuracy of  $\leq 1$ LSB, including quantizing error, is provided. Operating temperature range versions of

0° to +70°C or -40°C to +85°C are available.

Maximum conversion time for both converters is a fast 110 microseconds. They also feature latched TTL-compatible 3-state outputs with true bus-driving capability for direct interface to the host microprocessor. Conversion can be continuous or controlled, and either an external clock or the on-chip oscillator may be used.

Low power, minimal temperature dependence, and excellent long-term accuracy/repeatability make these

converters ideally suited for machine and industrial control applications.

### Make the connection with a new serial control unit.

Now that all the signals are digital, connect them to the new MK14007 SCU1™ serial control unit. Designed for both monitoring and control systems, this 40-pin circuit performs 19 pre-programmed I/O tasks received from a host computer via a half-duplex

serial link. Commands include bit input and bit output; byte input and byte output; set, clear, and toggle selected pins; interface to A/D or D/A converters or to a 3½ digit digital panel meter (with data outputs); and monitor input pins for a specific bit pattern.

The SCU1 also provides for programmable remote I/O functions through its 16 I/O pins. The chip contains a complete communications processor capable of generating and receiving messages. Results of commands executed can be echoed back to the host computer.

You can use, and individually address, up to 255 SCUs in your network using only a single communications channel. Handshaking pins allow it to interface to the central controller over twisted pair lines, R.F. communications link, modems, or fiber optic cable. Plus error-resistant data link protocol. Power is a low 275mW (typ.), and the SCU1 requires only a single +5 volt power supply.

Low cost and easy implementation make the SCU1 an

excellent choice for microprocessor-based, distributed processing systems where remote intelligence is required.

### Cross the finish line with your choice of Z80-based controllers.

Next, run your communications link back to your control system one of two ways.

Buy the Mostek MD Series of STD-Z80 BUS expandable microcomputer boards. Based on the Z80 microprocessor, this compact board series has fully assembled, fully debugged and fully warranted

hardware. Plus comprehensive software support highlighted by the Matrix™ development system.

Or, if it's cost-effective, design your own control system using our MK3880 family of Z80 microcomputers. Then configure a simple and upward compatible memory array with our family of BYTEWYDE memories.

Whatever way you go, all the components, including the A/D converters and the SCU1, are available now from your Mostek distributor.

# MOSTEK.

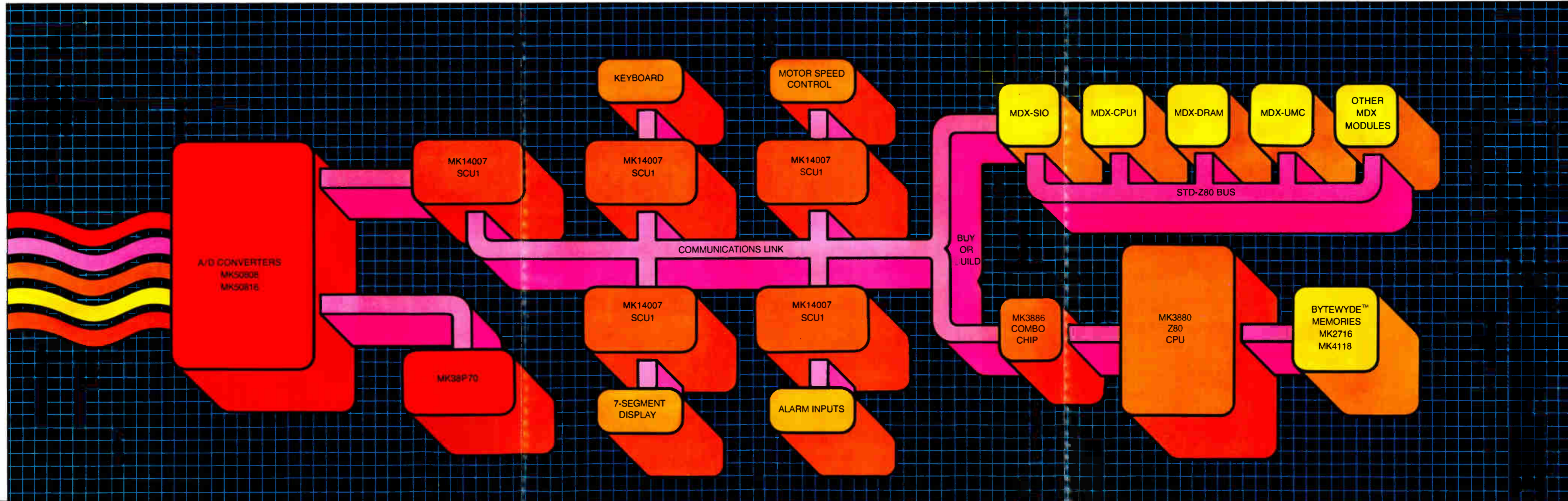







# Electronics newsletter

---

## **Chrysler schedules electronic odometer for '81 Imperials**

Chrysler Corp. will introduce an electronic odometer on its 1981 Imperial luxury car as part of a standard electronic instrument module. Ford Motor Co. and General Motors Corp. already have electronic instrumentation on certain luxury cars, but **the Imperial's odometer is believed to be the first in the industry.** Mileage data will be processed in one of the two Motorola 6801 microprocessors in the module. The random-access memory in the 6801 will store the mileage up to 6.2 miles (10 km), then dump it in a nonvolatile metal-nitride-oxide-semiconductor memory chip. The Highland Park, Mich., auto maker estimates that the MNOS memory can retain data for as long as 10 years without power when new and for at least one year even after the equivalent of 200,000 miles. **In addition to customer appeal, Chrysler figures the electronic unit is one way to achieve a virtually tamper-proof odometer.** Federal regulations require such a device in 1982 model-year cars.

## **Mount St. Helens gumming up some semiconductor works**

From the areas surrounding angry Mount St. Helens in Washington come reports that the settling volcanic ash is creating a nuisance for semiconductor manufacturers. Intel Corp., for instance, **temporarily shut down its Aloha, Ore., wafer fabrication facility because of high impurity levels.** Though it is back on line, Intel is taking "extreme precautions" by vacuuming off clean-room employees. Also, National Semiconductor Corp. is curtailing construction of a similar plant in Vancouver, Wash.—not because of contamination, but because prospective personnel are now reluctant to move into that area. In addition, volcanic ash has disrupted automated outdoor bank tellers in the area [*Electronics*, June 19, p. 55].

## **More protection ordered by Pentagon from static discharges**

Those polyethylene bags used to protect electrostatic-sensitive components during their in-plant travels will no longer do for shipping them for use in Government projects. A new standard from the Department of Defense, DOD Standard 1686, "Electrostatic Discharge Control Program for Protection of Electronic and Electrical Parts, Assemblies and Equipment," in effect puts an end to the practice. It specifies that **all such parts and equipment must have an additional conductive wrap** around the antistatic material to block external electrostatic discharges.

## **Use of automation by managers seen saving \$100 billion**

If managers and other professionals fully use automated office tools, a savings of over \$100 billion can be achieved by 1985, says a study recently concluded by Booz, Allen & Hamilton Inc. The New York consulting firm points out that **a white-collar worker's productivity can be increased by as much as 15% by 1985** with a time savings equivalent of 15% or more of operating income before taxes for the types of business organization surveyed. If such businesses move aggressively, says the study, a time savings of more than 9% annually is possible within 24 months.

## **Intel cuts 8-bit 8088 prices by 60%**

In what insiders term a major effort to capture the 8-bit market, Intel Corp. has dropped the price of its 8088 microprocessor by 60% at all quantity levels. The 5-MHz chip, which has the 8-bit data interface of the 8085 microprocessor and the instruction set of the 16-bit 8086 microprocessor, **will be priced closer to the 8-bit than to the 16-bit part.** In quantities of 100, the price of the 8088 drops from \$78 to \$31.90, and



# Electronics newsletter

---

single-unit pricing drops from \$93.60 to \$38.25. These prices are still not as low as the \$11.25 (100-unit quantities) tag on the popular 8085, but Santa Clara, Calif.-based Intel expects that the 1-megabyte direct addressability of the 8088, compared with the 65-kilobyte addressability of the 8085, will make the 8088 the choice for upgrading 8-bit systems.

## Radio-control chips being readied by TI for toy applications

Look for Texas Instruments Inc. to jump into low-cost radio control circuits used in remote-control toys. TI's Advanced Circuits department in Sherman, Texas, is believed to be readying a two-channel integrated-injection-logic receiver circuit known as the SN76609 that will work with the company's six-channel I<sup>2</sup>L transmitter chip, the SN76605. **In 500,000-unit quantities, the two are expected to sell for about \$2.50 per set, or about half the cost of other TI transmitter-receiver pairs.** TI is believed to be pursuing sales that could lead to volume production in time for the 1981 Christmas buying season.

## Researchers unveil high-resolution Josephson Squids

Researchers at International Business Machines Corp.'s Thomas J. Watson Research Center in Yorktown Heights, N. Y., last week announced fabrication of all-niobium, thin-film superconducting quantum-interference devices, termed Squids, using the Josephson-nanobridge technology announced a half year ago [*Electronics*, Jan. 3, p. 41]. Measurement of the noise properties of the devices demonstrates their intrinsic energy resolution to be about three times Planck's constant, the lowest value yet attained. Squids are being used in geophysical studies of gravitational waves to find ways to predict earthquakes and are being studied for use in medicine for noninvasive examination.

## Utility applies microprocessor control to save energy

Toledo Edison Co. in Toledo, Ohio, has installed a motor drive for its giant, 3,500-hp flue-gas fans, whose speeds are varied by adjusting the frequency of the voltage applied to the motor windings. Built around an 8080 microprocessor, the control is the first solid-state variable-frequency drive installed by a utility, says Westinghouse Industry Products Co., Buffalo, N. Y., the drive system's designer. Heretofore, utilities kept fan motors turning at a constant high speed and restricted the flue-gas flow from coal-fired boilers by mechanical vents. Part of a \$53 million upgrade, the motor and drive cost \$1.5 million. **The power company expects to save up to 30% of the cost of energizing four fans, or about 16 million kw-hr per year.** The drive system, which controls power-carrying thyristors, is fed information that determines how fast to draw out the flue gas. The ac frequency driving the synchronous motors is then optimized.

## Addenda

In a move aimed at reducing overseas refrigerated shipping costs to a growing number of offshore assemblers, Morton Chemical Co. has broken ground on a \$3 million factory in Singapore that will produce its Novolac B-type epoxy molding compound widely used by the semiconductor industry for plastic packaging. **The new plant will boost the Woodstock, Ill., firm's production capacity for the epoxy by some 20%.** . . . Intel Corp.'s Aloha, Ore., operation is starting to ship samples of 16-K static random-access memories using its new high-density double-polysilicon HMOS II process [*Electronics*, Nov. 22, 1979, p. 40].

# What's the difference between BASIC and Pascal?

COMPARE THESE APPROACHES TO DRAWING A CIRCLE

## in BASIC

"This is easy..."

```
100 MOVE R,0
110 FOR T=0 TO 360 STEP 25
120 DRAW R*cos(T), R*sin(T)
130 NEXT T
```

"Oops, didn't quite meet ..."

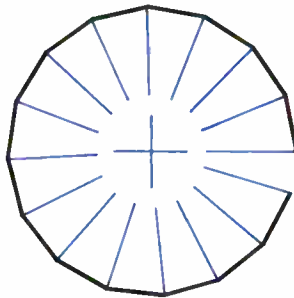

... but that's easy to fix."

```
100 MOVE R,0
110 FOR T=0 TO 360 STEP 25
120 DRAW R*cos(T), R*sin(T)
130 NEXT T
```

"Oh, now it closes ...  
in fact, it overlaps."

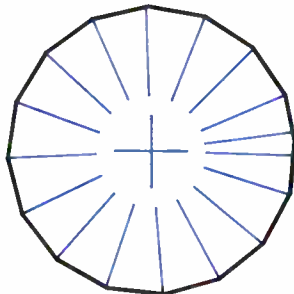

Programming by trial and error

## in Pascal

"The simplest circle drawn with line segments is a regular polygon..."

```
procedure Circle (X, Y, Radius: real);
const Sides = 16; Pi = 3.14159265;
var N: integer; Theta: real;
begin
  Move (X+Radius,Y);
  for N: = 1 to Sides do begin
    Theta := 2 * Pi * (N/Sides);
    Draw (Radius * cos (Theta) + X,
          Radius * sin (Theta) + Y);
  end;
end;
```

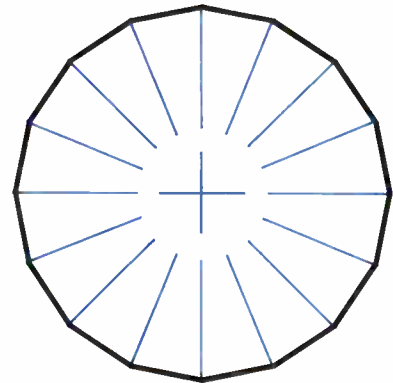

Programming by design

## GET IT RIGHT THE FIRST TIME

### INTERNATIONAL DISTRIBUTORS

Australia: Sydney  
Network Computer Services  
290-3677

Canada: Vancouver  
Valley Software  
(604) 291-0651

England: London  
Real Time Products  
01-588-0667

Japan: Tokyo  
Rikei Corporation  
03-345-1411

If you like the feel of precision tools, give us a call or return this coupon. EST

# Oregon Software

2340 SW Canyon Road • Portland, Oregon 97201  
(503) 226-7760 • TWX 910-464-4779

Name \_\_\_\_\_

Firm \_\_\_\_\_

Address \_\_\_\_\_

City \_\_\_\_\_

State \_\_\_\_\_ Zip \_\_\_\_\_



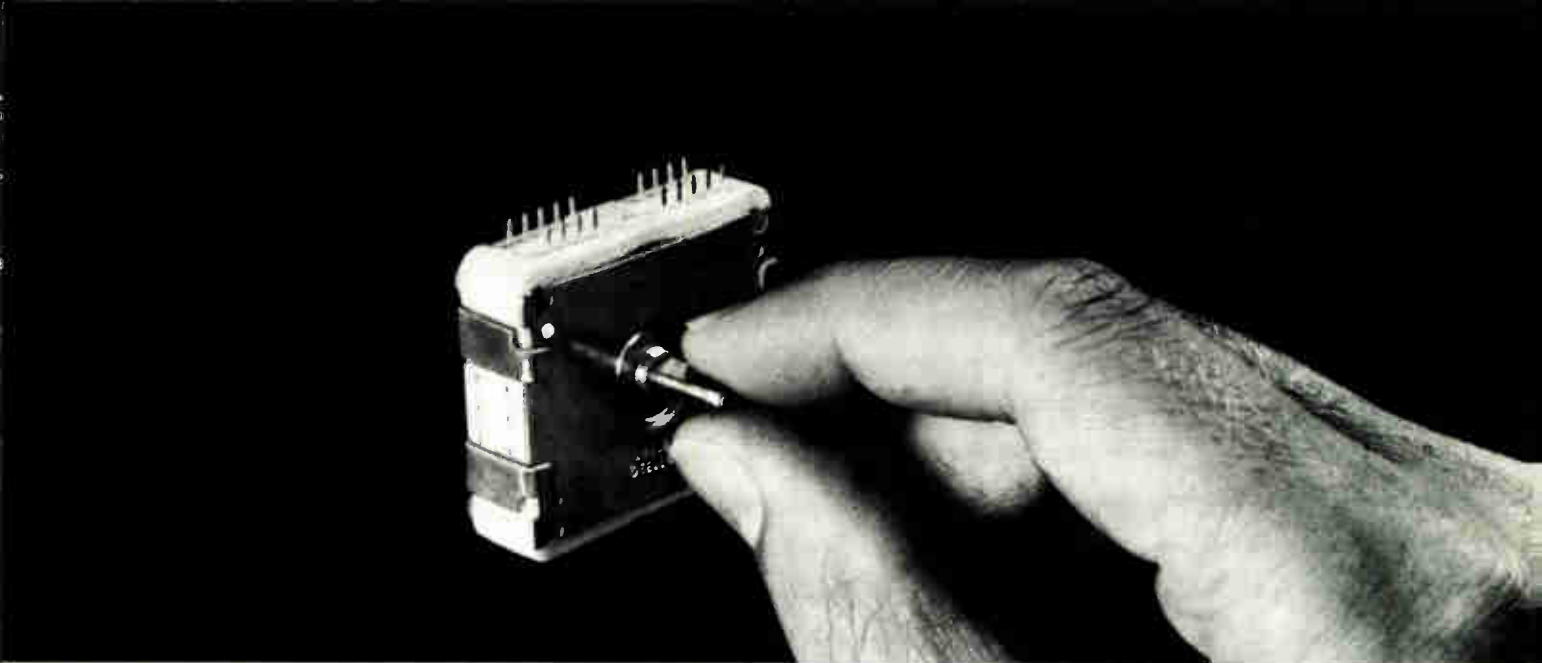

## New twist on an old idea sets new accuracy standards in digital logic switching.

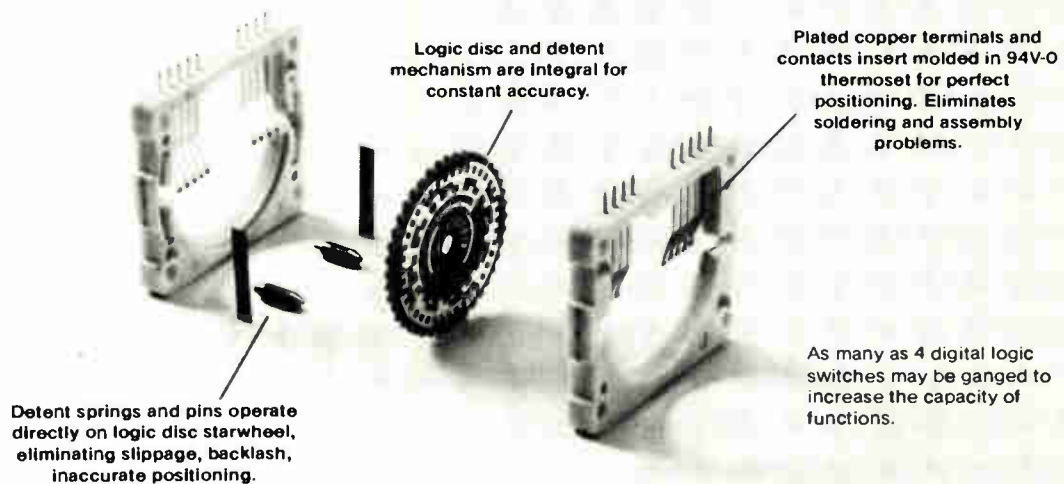

CTS Series 230 digital rotary switches assure accuracy in two important areas. First, contacts are insert molded securely in thermoset modules... not soldered or clipped in place. The one-piece molded design eliminates the mechanical shifting of contacts/terminations. And second, the detent mechanism is part of the logic disc for foolproof positioning.

Engineering imagination is just about the only limiting factor in using this problem solving switch. 40 detent positions are standard, but up to 50 are optional. And units may be ganged to increase the number of functions. Logic disc codes are anything

you can devise using a maximum 8 level truth table per switch section.

While one side of the logic disc is programmed for switching functions, the other side can have a 7 segment code to operate LED's or LCD's. And at a cost of about \$2, a CTS digital logic switch may well be an answer in search of a problem.

For technical information, circle the Reader Number. Or for a free 7 digit readout sample, write on your letterhead and indicate the use you contemplate for a CTS digital logic switch. Write CTS of Elkhart, Inc., 1142 West Beardsley Avenue, Elkhart, IN 46514. (219) 295-3575.

**CTS CORPORATION**  
ELKHART, INDIANA



## Phoneme-based speech chip needs less memory

by Gil Bassak, Industrial/Consumer Editor

Votrax converts its boards into C-MOS synthesizer that turns 70 to 100 b/s into an unlimited vocabulary

Not to be outdone by semiconductor makers' integrating speech synthesis circuitry onto silicon, the Votrax division of Federal Screw Works has announced a single-chip synthesizer that may leave the others speechless. The Troy, Mich., firm, a pioneer in phoneme-based board-level synthesizers, has packed the major features of its line—including unlimited vocabulary and minimal memory requirements—onto the SC-01 chip.

Unlike competitive parts from Texas Instruments and National Semiconductor, the new offering requires neither a human speaker nor the chip supplier to assist in generating the vocabulary. In competing devices, messages are reconstituted from previously spoken and analyzed words.

**Phonemes.** Rather, the Votrax synthesizer relies on phonemes, the most basic of speech sounds, stored as 6-bit words in a separate memory chip. The speech IC contains the circuits for selecting the phonemes and connecting them to generate words and sounds.

An important adjunct to the chip is a stand-alone development system (see photograph) with which a user develops the words to be generated. The system contains the general rules of speech used to formulate the phoneme sequence.

It converts the sequence into the digital code to be stored in the mem-



**Speak up.** Votrax's 6502-based development system converts typed words and phrases directly into spoken ones. Its algorithm simulates the rules for pronunciation.

ory chip. A user types a sentence or phrase into the development system, which breaks each word into phonemes and then into the code.

In some applications, the synthesizer chip itself can independently access the phonemes stored in memory. A microprocessor may be needed if the reproduced phrases reach a certain complexity—for example, if the words to be spoken go beyond a relatively simple phrase or sentence or choices among different possibilities must be made.

Shown at the recent Consumer Electronics Show in Chicago, the large-scale integrated circuit was designed for Votrax by Silicon Systems Inc., a Tustin, Calif., firm specializing in custom ICs for the telecommunications industry. Implementing the chip in complementary-MOS, Silicon Systems has produced a 155-mil-square part that functions typically at 7 milliamperes over a wide range of supply voltages.

Housed in a 22-pin dual in-line package, the SC-01 requires data rates of only 70 to 100 bits per sec-

ond, compared with at least 900 to 1,200 b/s required by other single and multichip synthesizers. Thus its speech program fills much less memory space.

One reason Silicon Systems was chosen as chip developer is its expertise in switched-capacitor filtering [*Electronics*, Feb. 15, 1979, p. 105] for realizing low-frequency analog filters on silicon. Phoneme-based synthesizer ICs are primarily analog.

**The script.** An original-equipment manufacturer can produce his own programs with the CDS1 development system, a \$10,000 investment. It processes English sentences and phrases entered on the keyboard by means of an algorithm that determines which of 45 phonemes, 16 durations, and 3 pauses best duplicate the phrases.

The OEM's programmer can modify the sequence for better sound. Then the sequence is stored in read-only memory for access by the synthesizer chip.

By varying the rate of the on-board clock, the OEM can produce



## Electronics review

electronic sounds beyond the range of speech, making the SC-01 appealing for toys and games. At \$12 apiece in quantities, the chip should be popular in consumer applications.

Though Votrax is silent about interested OEMs, some feedback may be heard from potential users. For example, Intelligent Systems Corp., the Norcross, Ga., maker of small business systems, is designing a voice-synthesis peripheral based on the SC-01. "You'll see a lot of products with it at the next Consumer Electronics Show," predicts David M. Deans, vice president of marketing for intelligent systems.

### Solid state

## Polysilicon bids to fill substrate role

A new wave of processing techniques, including laser annealing and advanced trimming methods, may give a burst of versatility to polysilicon. They expand the material's horizons to include serving as substrates for integrated circuits, notably three-dimensional and large-area ICs, and as high-accuracy resistors for analog applications.

Such uses were discussed at the 38th annual Device Research Conference, held late last month at Cornell University in Ithaca, N. Y. Also

a hot topic was a transistor made of amorphous silicon.

Polysilicon is already in use at the device level, heavily doped with impurities for gates and interconnections in MOS components and lightly doped for high-resistance loads in static memories. Researchers are using laser annealing to enlarge its grain size [*Electronics*, March 1, 1979, p. 88] so that it can substitute for expensive single-crystal silicon as the starting material for integrated-circuit fabrication.

**Combo.** Unlike the single-crystal material, polysilicon can be deposited atop insulating silicon dioxide. This cheaper insulating substrate could be used where IC makers are taking such expensive routes as combining sapphire with single-crystal silicon.

Polysilicon plus silicon dioxide could lead to true three-dimensional structures, as Texas Instruments Inc. has already demonstrated (see photograph). Another possibility with laser-annealed polysilicon would be very large chips: since its transistors do not rely on the regularity of single-crystal material, the problem of crystal imperfections or dislocations vanishes.

At the conference, Cornell and Stanford universities reported using laser-annealed polysilicon to fabricate metal-semiconductor field-effect transistors with gate lengths of 1 micrometer. The researchers say

## Polysilicon crunch moves further off

Prospects for a shortfall in the bulk polysilicon that is turned into single-crystal silicon for semiconductor fabrication are easing this summer, says industry consultant Daniel J. Rose. The improved outlook is due to increased availability of the trichlorosilane ( $\text{SiCl}_3\text{H}$ ) essential to polysilicon production, says the president of Rose Associates, Los Altos, Calif.

In high demand for many uses, the chemical is in stepped-up production at its major supplier, Union Carbide Corp. Thus all users—including polysilicon makers—can turn out more products, says Rose. The chemical is basic to the formation of the raw material from which polysilicon is made.

Early this year, Rose had predicted that between August and September semiconductor makers' demand for polysilicon would outstrip production [*Electronics*, Feb. 14, p. 45]. That crunch is moving further off, he says, but it is still coming in the long run. "There are still no plans for new startups of polysilicon plants," he notes.

Another factor bearing on polysilicon's supply-and-demand balance is perceptible softness in orders from chip makers. However, Rose and other observers see this as a short-term glitch.

-Larry Waller

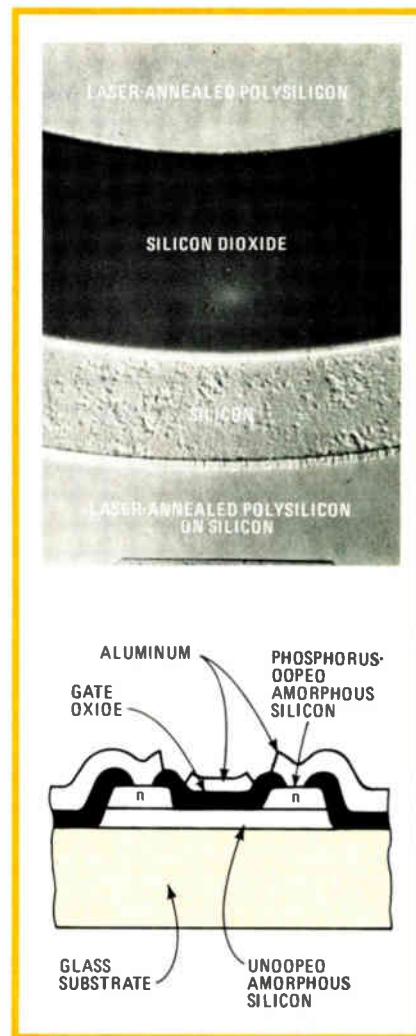

**Glassy.** When chips are fabricated of laser-annealed polysilicon on silicon dioxide, three-dimensional structures are possible (top). Another possible material under investigation for fabrication of integrated circuits is amorphous silicon (bottom).

MES FETs are suitable for both analog and digital circuits and "in novel structures such as multilevel integrated circuits."

National Semiconductor Corp. of Santa Clara, Calif., and the Advanced Research and Applications Corp. of Sunnyvale, Calif., are using a continuous-wave argon laser to activate previously implanted source and drain areas as well as to lower the resistance of polysilicon gates and resistors. This laser activation of polysilicon devices replaces high-temperature annealing, so fabrication requires no raising of wafer

temperatures beyond that needed for polysilicon deposition: 650°C.

Beyond laser-annealed polysilicon on a silicon dioxide substrate comes amorphous silicon, which can be applied directly to any kind of glass substrate. Researchers from the Tokyo Institute of Technology reported at the conference on fabricating an amorphous-silicon thin-film transistor (see figure) with an on-off current ratio of more than  $10^5:1$ . "To the best of our knowledge, this is the first amorphous silicon FET integrated transistor," they say.

Like polysilicon, large amorphous silicon transistors are not sensitive to crystal imperfections and dislocations. The Tokyo Institute researchers feel, therefore, that amorphous ICs are likely to serve as controllers and drivers in large-area displays.

**Electric trim.** Yet another use for polysilicon is as resistors in analog applications, where high accuracy is needed. To achieve that accuracy, researchers at the Musashino Electrical Communication Laboratory of the Nippon Telegraph and Telephone Public Corp. reported trimming these resistors electrically.

Their approach forgoes expensive laser trimming equipment, although it can only decrease resistance, so the values must be made high and then trimmed. However, the researchers say that the values can be trimmed as much as 50%, and "accuracies better than  $\pm 0.01\%$  can be easily obtained." Indeed, they have built a monolithic 14-bit digital-to-analog converter with nonlinearities held to less than  $1/2$  of a least significant bit.

In the trimming scheme, high current pulses of  $10^6$  amperes per square centimeter are shot through the polysilicon, heavily doped with  $10^{20}$  atoms of impurities per cubic centimeter. The researchers say the high current melts the boundary layers between grains, and in the subsequent recrystallization, impurity atoms concentrate at the boundaries to enhance conduction. However, it would appear that the current pulses effectively anneal the polysilicon—much like laser annealing does, but without the laser. —John G. Posa

## Packaging

### Chip-carriers stepping onto production line

Ceramic chip-carriers are moving out of the category of a next-generation packaging technique into use in both commercial and military applications. As this space-saving alternative to dual in-line packages gains in popularity, new chip-carrier structures are being developed.

"By the end of the decade, most of the packaging needs for integrated circuits will be met by chip-carriers," says John Stafford, supervisor of chip-carrier and discrete device packaging development at Bell Laboratories, Murray Hill, N. J. He was keynote speaker at a technical session at the recent Nepcon '80 East in New York, where papers from Digital Equipment Corp., Bell Labs, and RCA Corp.'s Missile and Surface Radar division described:

- Leadless chip-carriers on special sockets and ceramic motherboards for insertion into printed-circuit boards on production lines.
- Mixed chip-carriers and DIPs on pc boards.
- Dual-cavity chip-carriers and motherboards, doubling densities.

Chip-carriers are not only smaller than DIPs; they have their input/output pads on 40-to-50-mil centers, whereas the larger packages use 100-mil centers for I/O pins. For example, an equivalent chip-carrier takes up a third less space than a 68-pin DIP.

**In the future.** Even so, a board that will contain all large-scale and very large-scale ICs will need pad spacings of 20 to 25 mils to shrink the package size for these chips with their high I/O counts. Another development that may be in the works is direct soldering of chip-carriers to standard pc boards; now the leadless carriers must be inserted into a socket or motherboard.

But there is no waiting at DEC, where the carriers are in use in volume, says George Northover, senior engineer in applied manufacturing

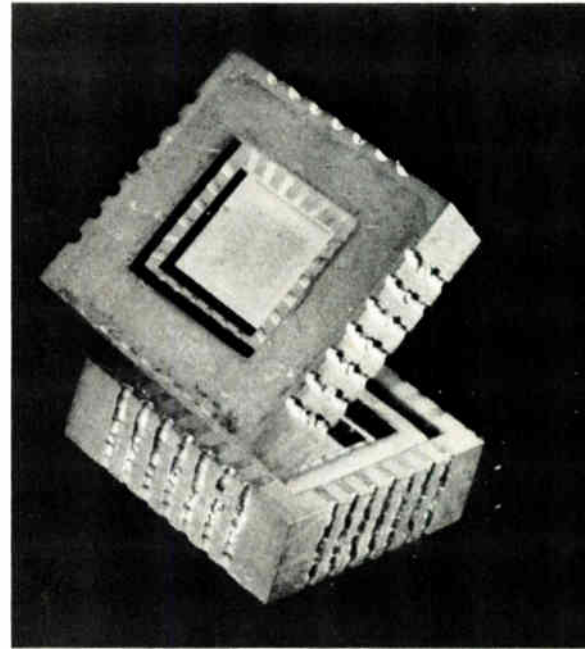

**Duplex housing.** An experimental chip-carrier developed at Bell Laboratories has cavities on both sides for active or passive integrated circuits, offering doubled chip densities on LSI- or VLSI-packaged pc boards.

technology at the Maynard, Mass., firm. "Any device with over 40 pins is now considered fair game for a chip-carrier," he says.

One approach, in a board for a computer peripheral, uses a chip-carrier in a custom socket from Amp Inc. of Harrisburg, Pa. The carrier has 50-mil spacing on its I/O pads, but the socket has solder tails on DIP-standard 100-mil centers. Thus both packages can be mixed on a single board.

**Motherboard.** DEC is also using small, leaded multilayer ceramic motherboards, onto which the carriers are reflow-soldered. One package contains a microprocessor chip and its read-only memory on a seven-layer 40-lead motherboard only 0.6 in. wide.

Another application is a side in-line package. The SIP contains four interconnected 16-K random-access memories plus capacitor ICs. It is mounted upright, occupying even less area than the motherboards with their DIP-sized footprint.

Bell Labs sees mixing chip-carriers and DIPs as an important near-term requirement, and so it is pushing ahead with its multiple intercon-

nection package, which is a small pc board onto which a chip-carrier in a socket mounts. The MIP's leads are on 100-mil centers.

**Dual cavities.** Another development at which Stafford says Bell is looking is an experimental carrier with chip cavities on both top and bottom (see photograph, p. 45). This arrangement allows two internally interconnected chips to fit where one went before.

For complex military applications, RCA's Missile and Surface Radar division has successfully fabricated

large ceramic motherboards with arrays of chip-carriers on both top and bottom. Each side is interconnected to the other by Berg edge pins.

The chip-carriers contain both single LSI chips and multichip hybrids. The packaging density of 25 chips per square inch of the double load approaches that of chips wire-bonded to substrates, the highest density packaging method, says Ron Kolc, unit manager of advanced technology at the Moorestown, N. J., operation.

-Jerry Lyman

---

## Components

---

### Planar geometry of power MOS FET lowers its resistance to fast switching

Aiming for fast-switching high-voltage power MOS field-effect transistors, Intersil Inc. has refined the vertical double-diffused process, achieving a structure with a bigger p region than other D-MOS processes give. The resulting MOS FETs boast substantially lower on-resistance and hence an order of magnitude improvement in switching time, says the Cupertino, Calif., company.

As the overhead view of the gate pattern in the photograph indicates, the underlying p regions are long running lines, rather than hexagons as in other vertical D-MOS parts. (The small hexagons in the photo are

simply the source contacts.) "It is a structure that yields a large periphery from which to inject current and results in the lowest on-resistance and highest current density, thus the best efficiency, for a given device size and breakdown voltage," says Jerry Zis, director of analog and power products marketing.

Z-MOS. The structure, named Z-MOS for no particular reason, "eliminates even more of the problems" associated with V-groove power FETs than Intersil's own U-groove modification, says Zis. Both v-MOS and vertical D-MOS structures are strong contenders in the race to overtake bipolar transistors in power applications [*Electronics*, May 22, p. 143].

As well as depending on the larger p region, current density is improved by substituting the essentially linear circuit patterns for the space-eating hexagons. "If we chose to engineer our device spec-for-spec equivalent to [a competitive D-MOS] device at any voltage breakdown level, the Z-MOS chip would be 20% to 25% smaller in area," says Tony Grant, product marketing manager.

Also, the Z-MOS structure has a lower gate capacitance than other D-MOS structures, Zis claims, "which affects the way the device is driven and reduces the cost of circuitry needed to drive it." The parts

will switch much faster than other vertical D-MOS offerings—10 versus 100 nanoseconds, typically, according to the company.

Intersil's product plans are still in the making, so the company is not ready as yet to release specifications. However, the company may target the 2.25-to-2.5-ampere range first, figuring on voltage breakdowns of 450 volts.

**Planar.** Similarly, pricing is far from set, but a density improvement of 20% should translate into a comparable yield improvement. Another cost benefit should be the planar structure resulting from the new Intersil process.

"It eliminates many problems associated with the V-groove structure," Zis says. As well as requiring fewer masking steps, "you don't have to make a V groove in each mask," he adds. "This provides better control of the process, since it is very tough to control the etching rate for each V groove."

When Intersil decided to enter the power MOS FET field, it developed its U-groove process to alleviate breakdown problems that occur with the sharp-pointed V structures. It plans to continue to use it in the near term for parts with breakdown voltages of 100 V or less, where Z-MOS's density improvement is much less dramatic.

-Bruce LeBoss and Roger Allan

---

### Power MOS FETs shrink switcher

The coming second generation of switching power supplies is in the works, featuring power MOS field-effect transistors to reduce size and weight, increase reliability, and improve response to line variations. In the vanguard is Hewlett-Packard Co.'s New Jersey division, which is introducing a series of supplies that use power MOS FET technology to switch at 200 kilohertz.

This operating frequency is about 10 times that of the best of present switching power supplies, which use bipolar switching transistors. However, the new line will be somewhat

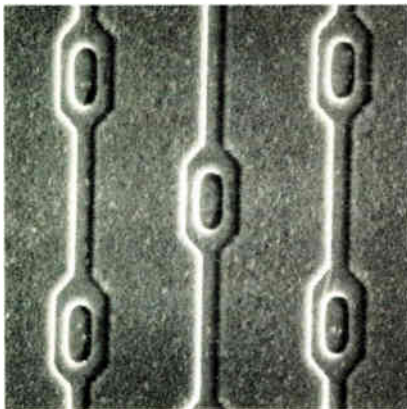

**Long.** Intersil's double-diffused process for power MOS field-effect transistors uses elongated p regions for low on-resistance and high current density.



# ETCH IT YOUR WAY,

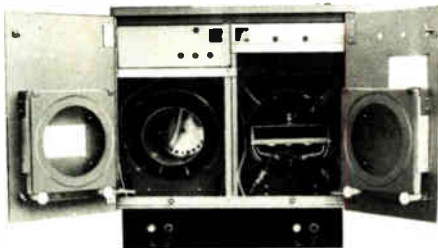
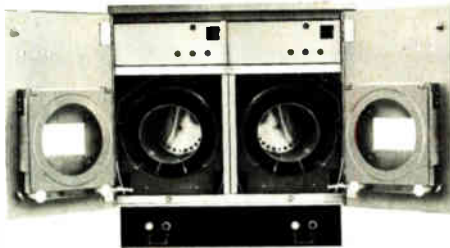
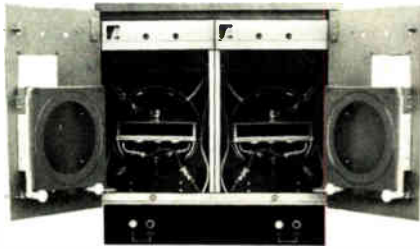

# PLANAR, BARREL, OR BOTH.

- High throughput
  - Automatic process controls
  - Independent chamber operation
  - Floating mode
  - Water-cooled substrates
  - Reactive ion and conventional planar etching
  - Four "process diagnosis" accessories
- Now you can "mix" or "match" the planar and barrel chambers in an LFE 1002 Dry Plasma System to meet your particular etching and stripping process requirements exactly. And it's like getting two systems for the price of one. Whatever your choice, 1002 provides very high throughput of the selective etching of polysilicon or silicon nitride. Floating mode achieves exceptional wafer-to-wafer uniformity— **better than  $\pm 0.1 \mu$  line width control**. A separate control console is supplied with each system. Available accessories include an automatic laser endpoint detector, a photoresist endpoint detector, a plasma preheat probe, and a capacitance manometer. For more information, contact LFE Corporation, 1601 Trapelo Road, Waltham, MA 02154. Telephone: 617-890-2000; TWX: 710-324-0681.

*Continuing to bring tomorrow's plasma technology today...*



**CORPORATION**

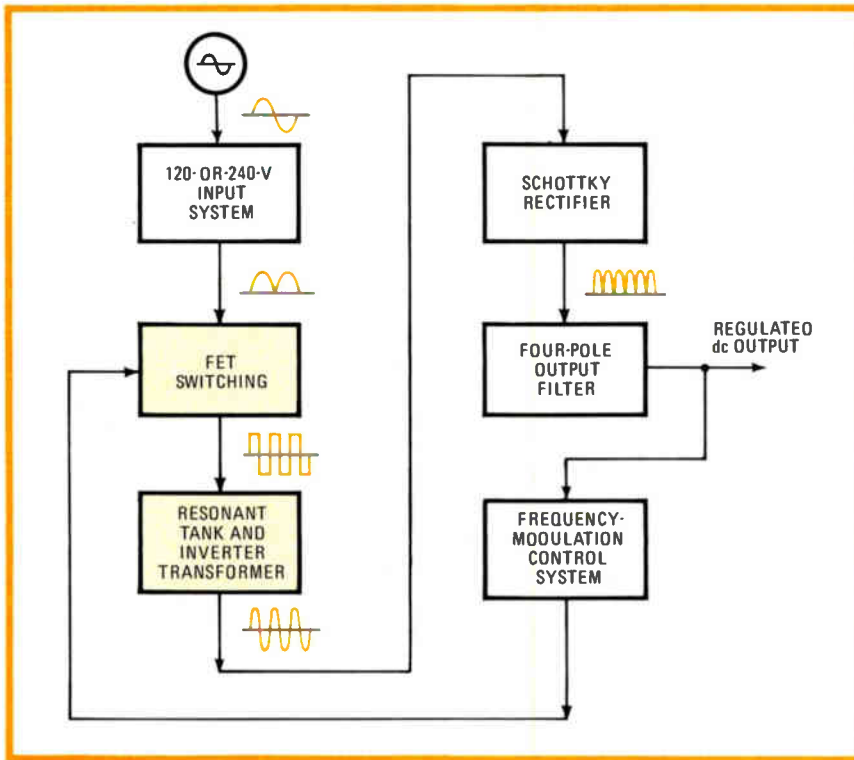

**Combo.** HP's new line of switching power supplies uses power MOS FETs and a resonant tank and inverter transformer that convert square waves into sine waves.

square wave generated by the MOS FET switching devices into sine waves (see figure). "The unique advantage of sine waves is that they have no edges and thus are much easier to filter or shield against than square waves and their associated sharp rise times," observes Paul Bailey, an HP section manager. By eliminating the sharp peaks, the sine-wave conversion circuit largely accounts for the reduced radio-frequency and electromagnetic interference, he adds.

Withal, MOS FET switching power supplies are likely to take a while to flower. The time is not ripe yet, says Robert J. Boschert, president of Boschert Inc., a leading power supply manufacturer.

"Operating at higher frequencies—up around 200 kilocycles—requires component expertise that isn't available now," he says. "Markets where cost isn't a factor will be using power FET supplies first, but it will be three to five years before the commercial or computer marketplace takes advantage of them," he adds.

-Pamela Hamilton

more expensive—a single output 50-watt modular unit will sell for \$154 in quantity, whereas the first-generation switchers sell for between \$50 and \$90.

Plus, HP can point to a distinct advantage in size and weight, which may well appeal to manufacturers making compact computers, peripherals, and instruments. A single-output supply weighs a mere 1 pound and measures 7.1 by 5 by 1.0 inches, whereas a typical bipolar switching supply of that size would weigh 2 to 2.5 lb.

What's more, the company is specifying a mean time between failures of 100,000 hours, compared with about 60,000 hours for the first-generation switchers. The line also will meet the stringent European VDE requirements for radio-frequency and electromagnetic interference.

Faster response is another plus with power MOS FETs. "You have a wider safe-operating area; you can handle larger instantaneous power levels," notes Bruce D. Rosenthal, power MOS operations manager at Intersil Inc. "The FETs have high

current gain and fast switching, as well as a free reverse diode." MOS FET devices have this diode inherently; in earlier switching supplies it could add \$10 to the cost of the circuitry, he explains.

The reduced parts count in the new line contributes to the reliability. "A single-output switching power supply that uses transistors has an average of 100 to 120 components," says Dilip Amin, project manager at HP's Rockaway, N. J., facility. "We have used about 20% fewer components." HP has not settled on a single supplier for the MOS FETs as yet. All of these devices will be designed to HP's specifications, however.

Also, the first-generation operating frequency of 20 kilohertz or less requires relatively large filter capacitors. HP can use high-density capacitors with the same equivalent-series resistance and inductance. Also, it winds its own transformers with small-diameter 50-strand wire, giving a compact unit that still can handle the high switching frequency.

Moreover, the resonant tank and inverter transformer changes the

## Business systems

### Joint computer design fights obsolescence

The new kid on the block in the computer systems game, Zenith Data Systems Corp., is teaming up with a university heavyweight in computer sciences, the Massachusetts Institute of Technology, to bring an MIT-designed machine to market. The design, from MIT's Laboratory for Computer Science in Cambridge, Mass., aims for a machine that shrugs off obsolescence.

The basic concept is about four years old, says Michael L. Dertouzos, head of the lab, but no computer maker would take on the job of developing the machine for a (1980) \$30,000 retail price. Finally the Heath subsidiary of Schlumberger Ltd. took it on—and when Zenith Radio Corp. bought Heath and restructured its own Data Systems sub-

# Kontron's Programmer Saves You Time and Money...

MPP 80S Field Service Programmers  
Only \$1995

We'll save you money from the very start. Why? Because we program following the PROM manufacturers specification . . . and we have approvals to prove it! No more lost bits in the field and expensive field service because of poor programming. Also, if you have to go to the field to update software, our MPP 80S goes with you. It is no larger than a briefcase.

Kontron's MPP 80S programmer is:

- Easy to operate
- Utilize RS232C interface
- Can be computer and remotely operated
- Have 17 data formats
- Offer auto baud and polarity select via key board
- Can be easily interfaced to IC handlers
- PROM manufacturer approved
- $\mu$ P controlled (Z80)<sup>TM</sup>
- Have standard UV lamp
- Full data manipulation

Now, Kontron offers a new EPROM gang programming module with interchangeable identifiers. Program and check via pass/fail Led's all popular EPROMS: 8 at a time.



Write to:  
Kontron Electric  
700 South Claremont Street  
San Mateo, California 94402  
(415) 348-7295  
Outside Calif. (800) 227-6854

**NEW**

PROM PROGRAMMERS:

## PROM PROGRAMMERS:

Sales  
Offices

**ARIZONA** Macdonald Associates  
Tel: 602-958-1848  
**NO. CALIFORNIA** Kontron Electric, Inc.  
Tel: 415-348-7295  
**SO. CALIFORNIA** Obinger Associates  
Tel: 213-439-0760

**COLORADO** Essler Sales & Service  
Tel: 303-794-1779  
**FLORIDA** Synergetics  
Tel: 813-586-5331  
**HAWAII** Aloha Associates  
Tel: 808-941-1574  
**ILLINOIS** Dot Tronics  
Tel: 312-581-0292  
**INDIANA** Lotan Green of Indiana  
Tel: 317-283-9827

**MARYLAND** Bytech Associates  
Tel: 301-667-1591  
**MASSACHUSETTS** Support Electronics  
Tel: 617-835-3530  
**MISSOURI** Kecco  
Tel: 314-576-4111  
**NEW JERSEY** JMR Sales  
Tel: 201-727-5335  
**NEW MEXICO** Tri-Tronics  
Tel: 505-266-7951

**NEW YORK** L-Mar Associates  
Tel: 716-328-3240  
**OHIO** Micro Sales Corporation  
Tel: 513-433-4171  
**OREGON** Westcon, Inc.  
Tel: 503-283-0132  
**TEXAS** Data Scientific  
Tel: 512-733-3073  
**CANADA** Duncan Instruments, Ltd.  
Tel: 416-742-8888



Circle #49 for Literature

Circle #231 for Demonstration

Visit our Booth at WESCON 101



## **Toshiba starts IC production in U. S.**

Silicon Valley has a new integrated-circuit manufacturer: Toshiba Semiconductor (USA) Inc. Its n-channel-MOS facility in Sunnyvale, Calif., acquired in April when Japan's Toshiba Corp., took over Maruman Integrated Circuits Inc. is already turning out 4114-type 4-K static random-access memories and 4116-type 16-K dynamic RAMs. Another Japanese company, Nippon Electric Corp., earlier bought IC maker Electronic Arrays Inc., and Fujitsu is building a RAM fabrication plant in San Diego. Hitachi and Mitsubishi are known to be considering American manufacturing bases.

In the fourth quarter, production will begin on a 16-K static RAM using a high-performance MOS process. Also coming then will be Toshiba's versions of Intel's 2147 4-K static RAM and 8049 microcomputer.

The \$9 billion parent corporation last year shipped to the U. S. \$20 million of its \$600 million semiconductor production. "We expect Toshiba's semiconductor sales in the U. S. to total about \$50 to \$60 million, with about 30% coming from Sunnyvale," says Randall Crume, director of marketing for memory and microcomputer products at Toshiba America, which is the separate marketing arm of the parent. "In 1981, we expect our semiconductor sales here to be about \$100 million, with 70% of that" coming from the California facility, he reports.

**-Martin Marshall**

subsidiary, Nu was ready to compete [*Electronics*, June 19, p. 36].

The Chicago subsidiary of Zenith has delivered 10 engineering prototypes to the lab and is shooting for production prototypes of Nu-type machines by year-end and first deliveries in 1981.

**Power.** Dertouzos' original concept was for a super-powerful personal computer that could be linked together in a distributed processing system in which no one machine would exercise control. Thus the microprocessor-based Nu has hefty processing power.

"Using a Nu would be something like working with a multi-hundred-thousand-dollar timesharing system, but with the convenience of having one's own data base at hand, of being able to dedicate the machine to experimental use in the lab, and of never having to wait in a queue," says Dertouzos. "Nu could give equivalent and possibly faster computation, offer network communication, electronic mail, word processing, and shared data bases where appropriate—but without dependence on large remote mainframes."

The machine has a multiplexed data bus that can handle 32 data and 32 address bits. Thus it can take full advantage of the 16-bit MC68000 microprocessor's addressing capabilities: 16-bit data and 24-bit address.

What's more, the extra width of the data bus will permit upgrading of the machine once more powerful microprocessors come along. "We want to ride the wave of microprocessor development," says Dertouzos. The bus is an example of the emphasis on avoiding obsolescence in the design—an effort much of which he attributes to Stephen A. Ward, an MIT professor of electrical engineering and computer science, and graduate student Christopher J. Terman.

Also important in the scheme to sidestep obsolescence is the operating system, called Trix. Though effective in single-user applications, it also is designed for networks of interconnected Nu machines. It uses a stream-communications approach, allowing uniform, transparent access to both local and remote files, programs, machines, and services.

**C language.** Trix is written in the high-level C language [*Electronics*, May 8, p. 129] and therefore can be translated rapidly should a Nu machine acquire a different processor. "The only major task is to rewrite the code generator for the compiler, then to recompile the existing software," Ward says. "The whole operation might take about a man-month." Dertouzos notes that MIT already has built Nu systems with the Intel 8086 and the Zilog

Z8000, as well as with the 68000.

The Trix operating system may use a little more memory than one written in machine language, but with today's low memory costs, that is almost irrelevant. The engineering prototypes will support as much as 8 megabytes of random-access main memory and 20 megabytes of disk memory. Although aimed at single-user applications, they include a 5-to-10-megabit-per-second serial interface for networking, as well as an RS-232-C port for slower digital communications.

Freedom from obsolescence also means applications flexibility, which appeals to Zenith Data Systems. Its president, Edward J. Roberts [*Electronics*, March 13, p. 14] envisions a series of Nu-based machines with varying amounts of memory, and possibly with less powerful microprocessors, priced from \$50,000 downward: he even talks of personal computing as a target.

"The machine seems to have the characteristics needed to break into the market," says small-computer expert Norman Zimbel of Arthur D. Little Inc. "Now we should watch for some creative marketing from Zenith—perhaps a combination of traditional and mass-marketing approaches, plus some flexible pricing."

**-James B. Brinton**

---

## **Production**

---

### **Faster bath refines additive plating**

The coming generation of multilayer printed-circuit boards will make rigorous demands on plating processes, requiring deeper holes and finer lines on tighter grids. PCK Technology sees an opening that will give additive plating processes the long-sought chance to augment subtractive plating, and so it has come up with an improved additive process.

Laden with very large-scale integrated circuits mounted on small chip-carriers featuring tightly packed input/output pins, the new pc boards will have plating require-

# Designing Digital LED or Laser 0.1–50Mb/s Fiber Optics?

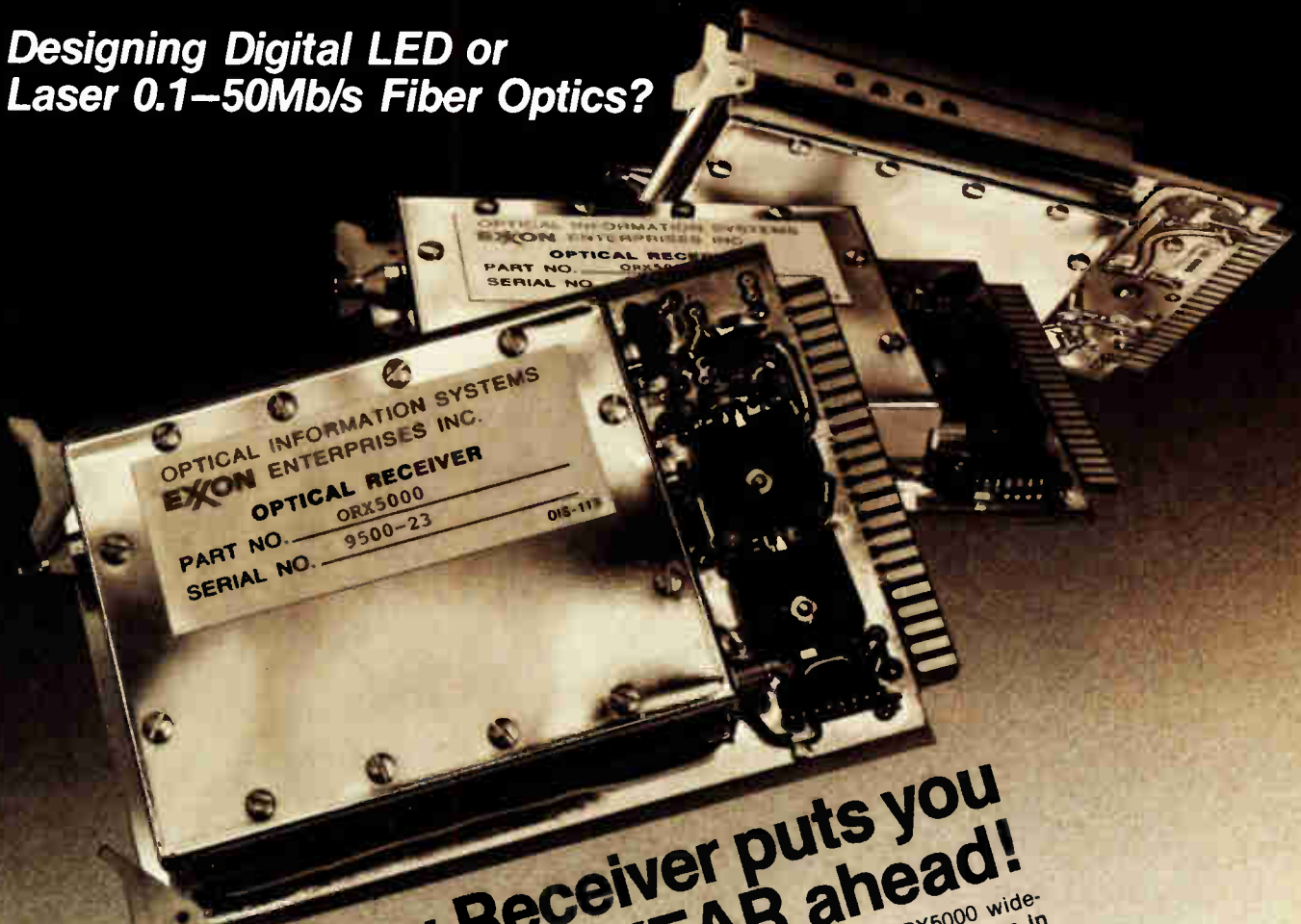

## This new Receiver puts you a MILE and a YEAR ahead!

Yes, even with an error rate better than  $10^{-9}$ , this new OIS Series ORX5000 wide-band TTL receiver gives you far more link length than any conventional design in its price class. Think kilometers, not hundreds of meters... even with LED sources.

The same engineering staff that developed our state-of-the-art 275Mb/s ECL transmitters and 150Mb/s ECL receivers has created this lower-cost, medium-speed TTL design, and equipped it with every one of the special OIS circuit features that anticipate—and respond to—the system constraints of modern link design. Considered together, they could easily save you a man-year or more of engineering. Check them:

- Operates from the simplest low-cost unregulated power supply — all regulation required is on board, for all voltage levels. Transient protection? Also on board.
- Prevents reverse-voltage burnout — protection is built in.
- Blocks conducted interference — efficient, high-frequency EMI filtering, plus photo-diode bias-decoupling filters, all included, all thoroughly field proven.
- Provides an ancillary analog output (as well as balanced, complementary digital line-driver outputs). This is invaluable for sophisticated clock-recovery systems.
- Prevents detector drift with temperature (in APD models), providing automatic, built-in bias-current compensation.
- Provides enough line-driver power for reasonable lengths of output-pulse distribution, on low-impedance coax lines.
- Provides EMI-tight electromagnetic and electrostatic shielding, for high S/N integrity in high-intensity noise environments.

...and there's more. OIS in-depth applications-engineering experience, available promptly and responsively. OIS technological leadership, in semiconductor lasers, laser transmitters, receivers, and systems philosophy. OIS quality — unsurpassed. OIS resources. And our exclusive commitment to mass-producible fiber-optics communications hardware.

Need immediate action? Call our Applications Engineering "hot line" at (914) 592-6800. Or use the inquiry number for prompt response.

**OIS**  
OPTICAL INFORMATION SYSTEMS  
350 Executive Boulevard,  
Elmsford, New York 10523





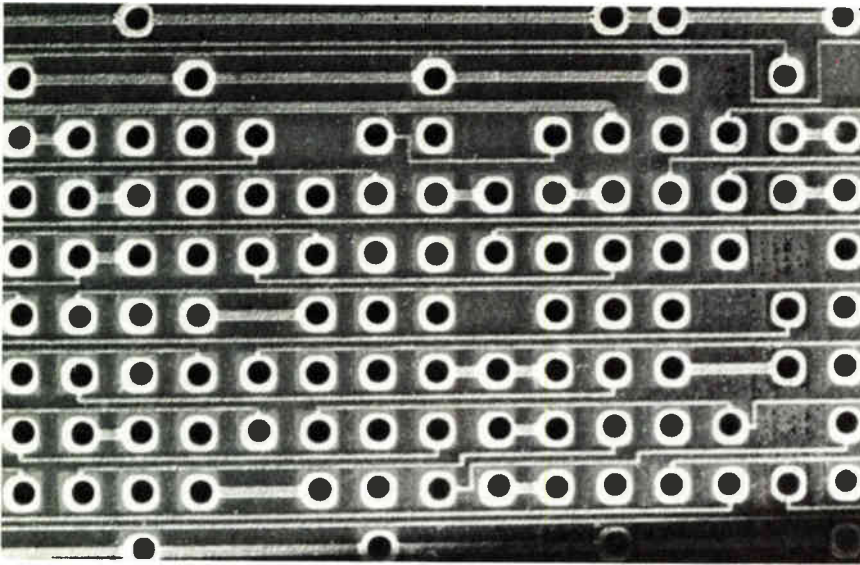

**Tight fit.** PCK Technology's new CC-5 additive process can plate extremely fine details, such as these 5-mil lines and spaces (shown at 100× magnification, left).

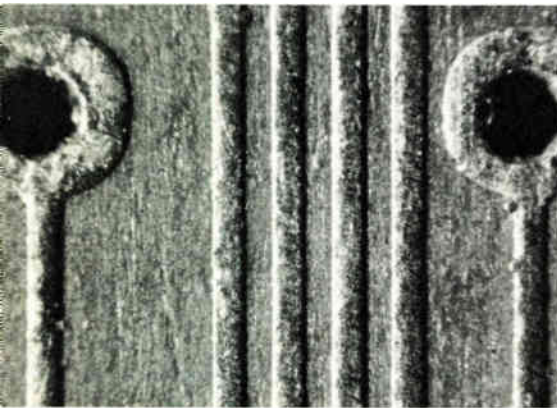

processes can uniformly plate a matrix of tiny via holes that have an aspect ratio of board thickness to hole diameter of as high as 10:1—a typical figure for a multilayer board.

The division already has made two-sided sample boards, both sides carrying 5-mil lines and spaces on a 50-mil grid suitable for the footprint pattern of chip-carriers. The currently used dual in-line packages need holes on 100-mil centers.

**Changes.** The processing steps are basically the same in CC-5 and CC-4, but PCK Technology has developed a faster-acting chemical solution for the plating bath. CC-5 uses a different complexing agent to keep the copper dissolved in the highly alkaline plating solution. It permits faster removal of the copper during plating.

Also, CC-5 works with a dry film resist, laminated onto the board, whereas CC-4 used a liquid screenable resist. Because of the inherently better resolution, 'dry film resists permit plating of finer lines.

Already, boards designed for an array of chip-carriers are moving into applications that present plating problems. For example, the Kollmorgen division is using its CC-5 process to plate some 20,000 vias, 20 mils in diameter and on 50-mil cen-

ments beyond the capabilities of subtractive etching, which tends to undercut fine lines and to plate deep holes unevenly. Additive processes overcome these hurdles; unfortunately, they have been excruciatingly slow and so have garnered only a small portion of the plating market.

**Faster.** PCK Technology, which is a division of Kollmorgen Corp., has refined its process so that it now takes 5 hours to plate 1 ounce of copper instead of the 12 to 20 it once took. "This factor alone could eliminate the use of second shifts, cutting labor costs considerably," says Howard Hansen, manager of applications engineering for the Glenn Cove, N. Y., operation.

What's more, the new CC-5 process can put down 5-mil lines and spaces to a  $\pm 1$ -mil tolerance, whereas the 15-year-old CC-4 process is hard to push below 10 mils. Both

ters on a 12-by-18-inch, 11-layer board that is 0.11 in. thick, which represents an aspect ratio of 5.5:1.

The prospective customer, a large computer manufacturer, subtractively etches the inner layers, laminates them together, and drills the interconnecting vias. Although its pc-board facility is capable of exceedingly complex work, it cannot electroplate the matrix of tiny, deep holes satisfactorily. So it shipped boards to PCK Technology, which demonstrated it could plate the high-aspect through holes. -Jerry Lyman

## Information processing

### Standards group plays Ethernet down

Touted as a standard for local data-communications networks, Ethernet is finding the going rough at the hands of a working group developing such a norm for the Institute of Electrical and Electronics Engineers. "There are substantial differences between the committee's drafted functional requirements for a standard and the present Ethernet conception as put forth by its developers," Xerox Corp., Digital Equipment Corp., and Intel Corp., says the Local Network Standards Committee in an interim report.

The proposed digital packet switching network [*Electronics*, June 5, p. 89] is under consideration, says committee chairman Maris Graube of Tektronix Inc. in Beaverton, Ore. But there are several areas where his group sees problems.

**Problems.** For one, the committee wants the standard to include the modulator-demodulator and the interface between the user's equipment and the modem that gives access to the network. "If this is done, the user need only replace the modem to convert a signal-transmission technology like coaxial cable into fiber-optic, infrared, or some combination," says Graube. Ethernet is a coaxial network only and is dependent on a specific modulation technique.

The handshaking procedures and

**I care about your business. That's why I put a tough guarantee on every instrument.**

Good service and dependable delivery are important to me, because they are important to you. That's why I've put a tough guarantee on every instrument. Either we live up to our guarantee or you get 25% of your first month's rental fee back for that unit.

**Here's what I promise:**

1. The instrument will arrive on the day we say it will.
2. It will work properly, be calibrated and have everything you need right down to the operator's manual.

**Choose from the industry's largest pool of general purpose test instruments.**

USIR stocks more than a thousand models of instruments from more than one hundred leading manufacturers. We add more every day as new instruments are introduced. No one else offers you this much to choose from.

**See what a difference caring makes.**

Systems and computers don't solve your test and measurement problems. People do. At USIR we have people who are willing to try just a little harder to get you the instrument you need, when you need it. In short, we care.

Call or write for a complete 92-page, illustrated catalog today.  
2121 S. El Camino Real,  
San Mateo, California,  
94403, (415) 574-6006



**United States  
Instrument Rentals, Inc.**

**US**

A U.S. Leasing Company

Circle 53 on reader service card

**"GET THE TEST INSTRUMENTS YOU WANT.  
ON TIME. OR GET MONEY BACK."**

*—Anthony Schiavo, President.*





various error checks as insurance against signal loss are also problems. Graube feels that Ethernet's use of its own protocol rather than a standard such as HDLC makes it difficult to realize these safeguards.

"Error correction in Ethernet is handled by user software in yet unspecified ways," he says. "This allows each device to be on its own, creating incompatibilities."

Graube also reports that his committee [*Electronics*, March 27, p. 40] feels that a local net should follow what the International Standards Organization calls the open systems interconnection reference. This standard assigns a list of tasks to the network, and Ethernet "does not appear to follow it," he says.

By summer's end, he hopes the committee will "come up with a system that will satisfy perhaps 70% of all possible local network requirements." With backing from three heavyweights that span the electronics industries, Ethernet may gain some *de facto* acceptance, but that will not influence his group, he says emphatically. **-Harvey J. Hindin**

---

## Software

---

### Pascal popularizer turns to DOD's Ada

By the end of August, the Department of Defense will announce the final definition of its Ada high-level language. Already the language is spurring much controversy, but one noted software expert thinks DOD is on the right track.

Programmers favoring lean, streamlined languages are saying that Ada is huge and overdone because it includes operating system features. But DOD has special needs; for example, it would like all input, output, and runtime software to be in Ada for maximum uniformity among its myriad of computers.

Adding such facilities later requires extensions, notes Kenneth L. Bowles, director of the Institute for Information Systems at the University of California. His past work has

## News briefs

### Rockwell putting 1-Mb bubbles on boards

Rockwell Inc.'s long-promised 1-megabit bubble-memory chip will be ready sometime next month, as part of single-board memory systems. However, the boards, which include all control circuitry, are being offered now with Rockwell's 256-K bubble memory. Initially the RMS family includes a 32-kilobyte board with a single 256-K memory and a 64-kilobyte board. Designated RMS 121 and 122, they sell in single quantities for \$1,800 and \$2,100. Boards using 1-megabit bubbles, the 128-kilobyte RMS 141, and the 256-kilobyte 142 will cost \$3,200 and \$5,350. Each 6-by-9.75-inch board has a 100-kilohertz field rate and is compatible with 6500- and 6800-bus development systems. Communication rates between the host and memory boards depend on the number of parts: average data rate for the RMS 122 two-memory board, for example, is 22 kilobytes per second after access.

### Indian firm buys rights to Lear Siegler mini

Appearing soon on the Indian subcontinent will be Lear Siegler's VDP-1000 minicomputer line, discontinued by the company last July. The rights to the line have been bought by International Power Company of Madras, which currently markets Data General minicomputers. Lear Siegler will manufacture the VDP-1000s, which are compatible with Data General Nova 1200s, until the end of the year. The Indian firm currently manufactures power systems, as well as creating applications software for the Data General systems it sells. It is one of only three firms in India that market computers, primarily because of restrictive import licensing regulations. Its computers, the first to be manufactured there, will not be subject to these restrictions.

### Signetics shrinks packages for analog ICs

Signetics Corp. has put 13 of its analog integrated circuits into single in-line packages about one-quarter the size of conventional dual in-line packages, or 0.188 by 0.196 by 0.053 inch. The 13 circuits initially available in the S.O. (small outline) package include comparators, single and dual operational amplifiers, encoders and decoders for radio control systems, and precision voltage regulators. By the end of 1980, Signetics plans to have another 12 standard ICs available in SIPs, costing about 30% more than their DIP counterparts. The S.O. package is small enough to be used in hybrid modules in place of naked chips, and Signetics will perform both ac and dc tests on the parts, whereas it is set up to perform ac tests only on bare integrated circuits.

### RCA Corp. drops president . . .

RCA Corp. president Maurice R. Valente is out after six months on the job, allegedly for inadequate performance. Chairman and chief executive officer Edgar H. Griffiths is replacing him with a five-member Office of the Chairman that includes William C. Hittenger, executive vice president for research and engineering; Roy H. Pollack, executive vice president for government and commercial systems; Julius Koppelman, executive vice president for the communications operations; Frank A. Olsen, president and chief executive officer of Hertz; and George H. Fuchs, executive vice president for industrial relations. Valente had been an executive vice president at International Telephone & Telegraph Corp., where he was a contender for the giant company's top spot.

### . . . Changes, too, at RCA Solid State and Motorola Semiconductor

At RCA's Solid State division, in Somerville, N. J., Carm Santoro will head engineering, manufacturing, and marketing, coming from American Microsystems Inc., where he was senior vice president in charge of microprocessors, memory, and communications products. At the Motorola Semiconductor Group, Pasquale A. Pistorio has resigned as head of the Phoenix-based International division to take the presidency of SGS-ATES, a leading semiconductor maker in his native Italy. An 18-year Motorola veteran, Gary L. Tooker, is taking his place.

# NATIONAL ANTHEM

SEMICONDUCTOR NEWS FROM THE PRACTICAL WIZARDS OF SILICON VALLEY.

## National takes the RAM market head on.

HIGH PERFORMANCE RAMs FROM A HIGH PERFORMANCE SOURCE.

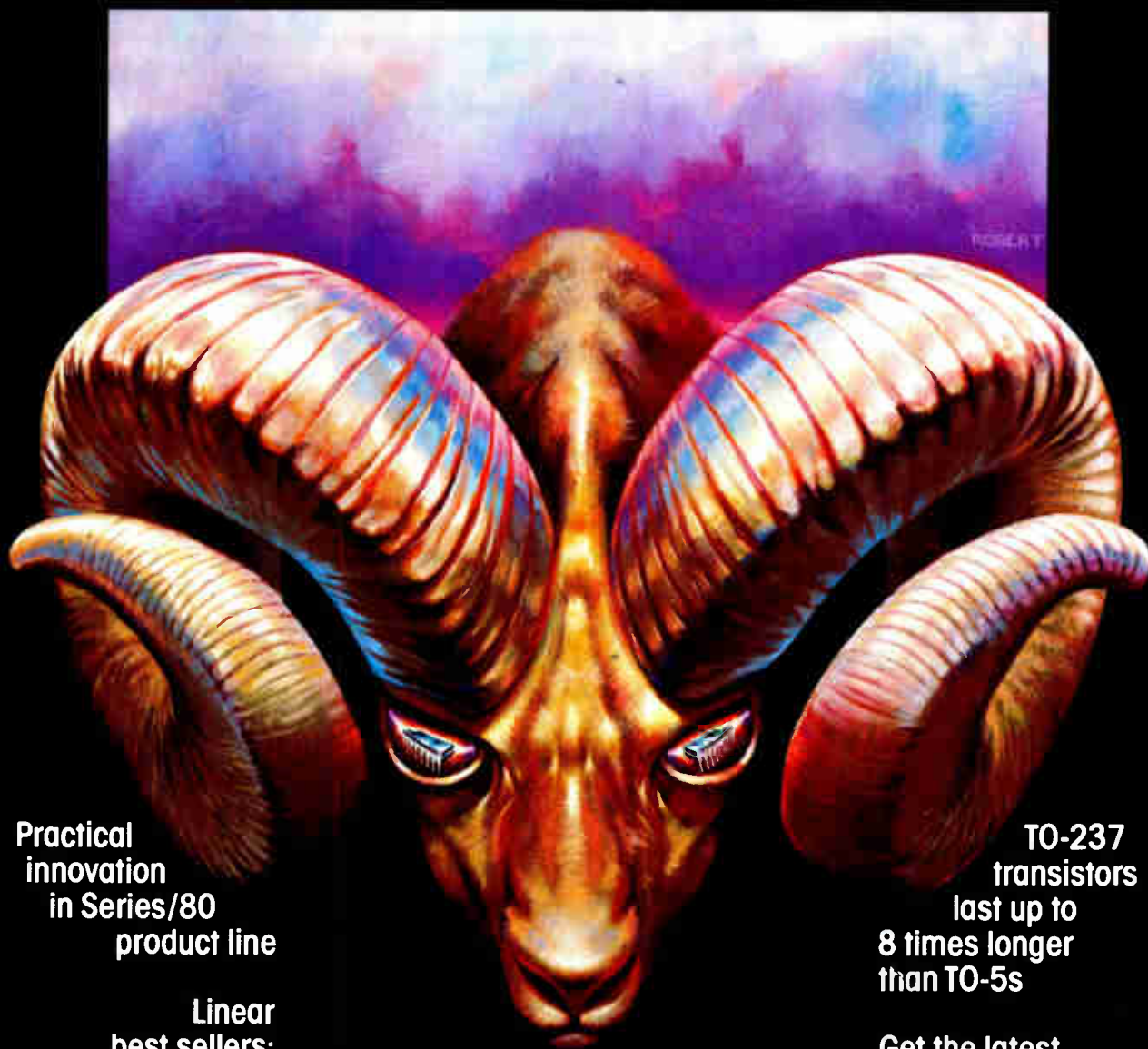

Practical  
innovation  
in Series/80  
product line

Linear  
best sellers:  
see National  
Archives

TO-237  
transistors  
last up to  
8 times longer  
than TO-5s

Get the latest  
from the National  
Archives

Data Acquisition   Logic   Transistors   Hybrids   Linear   Interface   Bubble Memory  
RAMs/ROMs/PROMs   Transducers   Displays   Custom Circuits   Optoelectronics  
Memory Boards   Microprocessors   Development Systems   Microcomputers   Modules



# NATIONAL ANTHEM

## Draw from the industry's largest selection of microcomputer boards.

**National offers the broadest line of practical Series/80 board level computer products that feature functional design, reliable operation and easy availability.**

When it comes to selecting board level computer products, it never pays to gamble on boards that don't easily lend themselves to practical application.

This is precisely why National offers over 75 MULTIBUS™ compatible Series/80 products. Because the Practical Wizards believe that no product should have to be forced into an application.

And although many customers come to National for plug-compatible replacements for Intel SBC products, their Series/80 BLC line is hardly just a second source supply.

In fact, a full two-thirds of their Series/80 Family is made up of proprietary products, including CPUs, memories, controllers, ana-

log and digital I/Os, peripheral controllers, rack-mounted systems, a full complement of card cages, power supplies, cables and other accessories.

And each one features high reliability, functionality of design, and the longest warranty coverage in the business.

**Setting a good example.** The depth and range of the Series/80 product line can best be illustrated by examining just a few of its members.

The BLC-8222 Double Density Floppy Disc Controller can handle up to four dual or single-sided drives (either standard or mini). It features CRC error checking with programmed re-try, user definable sector sizes and switch selectable base addresses that allow multiple controller systems.

The BLC-8737 Analog I/O board with 12-bit resolution makes each input and output channel appear to be a RAM address. On-board logic eliminates the need for the

system CPU to drive the analog circuitry through its conversions. Its 16 single-ended (8 differential) input channels are easily expandable to twice that capacity.

The BLC-8715 Intelligent Analog I/O board was specifically designed for industrial and process control systems. This new product offloads all of the analog data processing and many of the control functions normally performed by the host CPU.

And in doing so, the CPU may then devote more of its valuable resources to the rest of the control system.

Be sure to check this issue's National Archives coupon for free literature on these and all of the practical Series/80 products from National Semiconductor.

With the strength of the industry's broadest selection to choose from, you can't go wrong.

MULTIBUS is a trademark of Intel Corporation

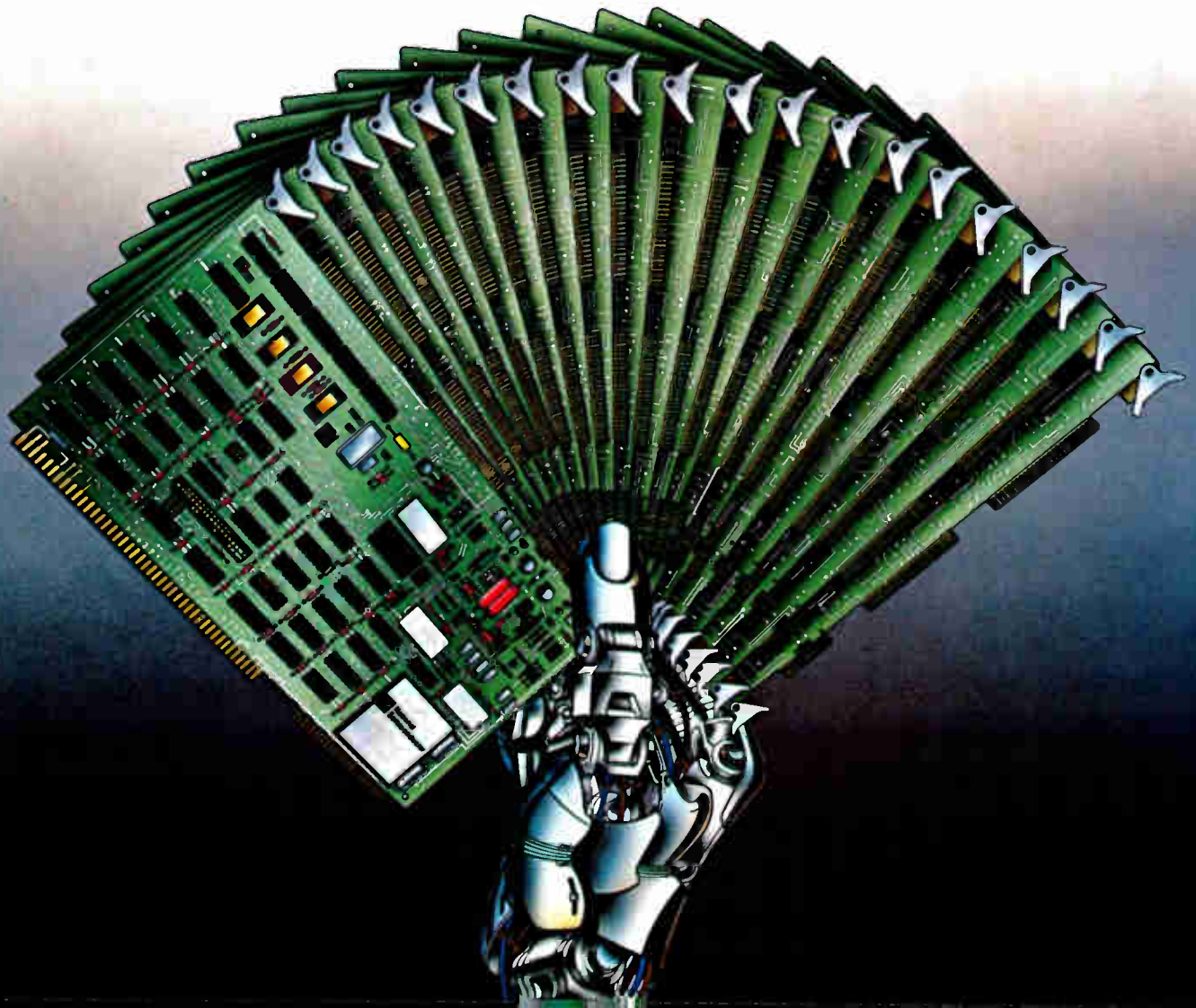

# National's TO-237 puts heat on ice.

**TO-237 transistors run cooler to last eight times longer than metal cans. Yet they cost 40% less.**

The Practical Wizards from National Semiconductor are offering a refreshing alternative to the TO-5 and TO-39 transistors: the pin-compatible TO-237.<sup>†</sup>

The TO-237 transistor—encased in National's patented Epoxy B\* plastic—runs so much cooler that it can last eight times longer than the metal cans. As if that wasn't enough, National has priced it 40% less than the short-lived competition.

The key to the TO-237's cool disposition is an exclusive combination of the Epoxy B used in conjunction with an efficient heat dissipating thermal tab. The result, as shown in the graph, is a reliable workhorse component that can last 8 times longer than the cans (at 0.5W dissipation).

**National sorts them out.** The TO-237s

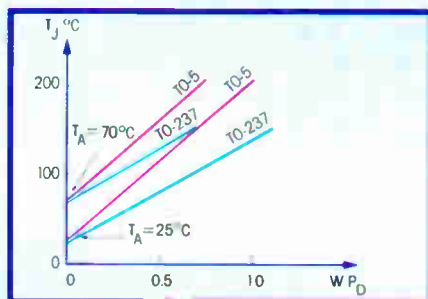

JUNCTION TEMPERATURES TO-237 vs. TO-5

are currently available off-the-shelf in 65 standard part types and pin configurations. However, should a special selection be required, National would be more than willing to supply it.

This kind of design and production versatility comes from over 20 years in the

transistor business. So it's no surprise that only National can offer this cool, low-cost alternative to metal can transistors.

**The cooling trend continues.** The Epoxy B TO-237s have already proven overwhelmingly successful in many diverse yet demanding applications: TV, automotive, photography, computer, telecommunications, and more.

Each and every one of these applications has been made more reliable thanks to practical wizardry as applied to transistors.

For additional information about the low-cost Epoxy B transistors, be sure to check this issue's National Archives coupon or contact your local distributor or National sales rep.

The Epoxy B TO-237. Proving once again that practicality will prevail.

\*U.S. Patent Number 3838094

†NSC originally applied for JEDEC package registration (1979)



NORMAN



# National takes the RAM market head on.

**Only National has the technical expertise and manufacturing muscle to produce the industry's most popular high performance RAMs.**

It takes a great deal of manufacturing and technical know-how to satisfy the ever-increasing demand for static and dynamic RAMs. And National Semiconductor has a lot of both.

In fact, National offers the most popular line of high performance MOS RAMs in the business.

Having just stepped up their production capacity even further, National is able to ship more parts in one month than most suppliers can ship in six. At volumes like these, you can be sure that their prices are competitive.

**Vastly superior test facilities.** Between the production and shipment of each RAM order come National's high-caliber test procedures.

In addition to their use of conventional component level electrical testing from wafers to tested packages, many dynamic RAM customers request National's unique MST™ (Memory Systems Test) program.\*

MST eliminates or greatly reduces your own requirements for internal testing. So your incoming test, board test, and system rework costs are substantially reduced. Because MST parts have already been debugged in a 9 megabyte memory system.

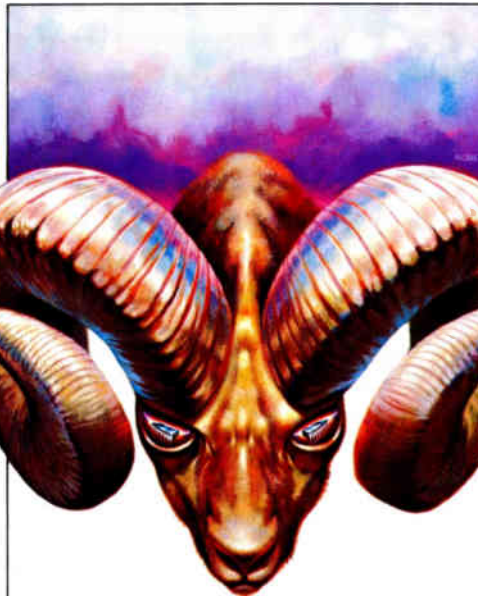

**The future looks even brighter.** In the months to come, National's MOS RAM product line will grow even broader. They will soon add new low-power X MOS™ static RAMs and new dynamic RAMs incorporating their exclusive TRI-POLY™ process.\*

The new TRI-POLY RAMs will feature (among other things) improved refresh characteristics and a high immunity to soft errors.

To find out just how competitive National really is, contact your local distributor or NSC sales rep.

Between their technical expertise, their high volume production capacity and their high-quality RAMs, it's easy to see that the Practical Wizards are taking the RAM market head on. 

\*Patent pending.  
†Production in 2-4 months  
††Production in 1981  
MST, X MOS, and TRI-POLY are the trademarks of National Semiconductor Corporation.

## RAM SUMMARY TABLE

STATIC RAMS		
Part Number	T <sub>AA</sub> (ns)	Organization
MM2114	200-450	1K x 4
MM5257	250-450	4K x 1
NMC2114A†	120-250	1K x 4
NMC5257A†	120-250	4K x 1
NMC2141†	120-250	4K x 1
NMC2142†	120-250	1K x 4
NMC2147	45-70	4K x 1
NMC2147H†	35	4K x 1
NMC2148†	55-70	1K x 4
DYNAMIC RAMS		
Part Number	T <sub>AA</sub> (ns)	Organization
MM5280	200-270	4K x 1
MM5298	150-250	8K x 1
MM5290	120-250	16K x 1
NMC5295††	80-150	16K x 1
NMC4164††	120-250	64K x 1

## What's new from the National Archives?

- 006  Special Functions Data Book (\$6.00)
- 035  Additional Series/80 Information
- 036  Optoelectronics Handbook (\$3.00)
- 037  Additional STARPLEX and ISE Information
- 042  Additional TO-237 Information
- 043  Memory Data Book (\$6.00)

- 044  1980 Linear Data Book only (\$6.00)\*      qty. \_\_\_\_\_
  - 045  1980 Data Book Package (4 books; \$20.00)\*      qty. \_\_\_\_\_
  - 047  1980 Linear/Data Acquisition Data Book Package (2 books; \$10.00)\*      qty. \_\_\_\_\_
- TOTAL \$ \_\_\_\_\_

\*Special offer: prices effective until September 1, 1980

For desired information, mail coupon to:  
National Semiconductor Corporation  
2900 Semiconductor Drive  
Mail Stop 16250  
Santa Clara, California 95051

In Europe, mail coupon to:  
National Semiconductor GmbH  
Industriestrasse 10  
D-8080 Fürstentfeldbruck  
West Germany

Enclose check or money order based upon appropriate currency. Make checks payable to National Semiconductor. Allow 4-6 weeks for delivery.

NAME \_\_\_\_\_ TITLE \_\_\_\_\_  
COMPANY \_\_\_\_\_ PHONE \_\_\_\_\_  
ADDRESS \_\_\_\_\_  
CITY \_\_\_\_\_ STATE \_\_\_\_\_ ZIP \_\_\_\_\_

 **National Semiconductor**  
The Practical Wizards  
of Silicon Valley

## Electronics review

popularized Pascal, the language base for Ada.

Bowles notes that extensions to Pascal have evoked heated debates [*Electronics*, Feb. 15, 1979, p. 96]. "Once a programming language is standardized and in widespread use, it is most difficult to standardize extensions to that language for new uses," he says.

Turn. Thus he is turning his attention from his UCSD Pascal to Ada. With the help of students and colleagues, he intends to implement "a large and very usable subset" for microcomputers, possibly starting general distribution within a year.

His compiler will generate pseudo-code, the same p-code generated by the UCSD Pascal compiler. Users already geared up for UCSD Pascal execution should be able to make a quick switch to Bowles's Ada.

He anticipates an Ada programming style like that associated with the high-level languages Forth and Lisp. Instead of bulky, complex operating systems, software modules will, in effect, plug into a smaller operating system kernel.

If Pascal supports modular programming, Ada improves on it, because among the operating facilities that DOD will want incorporated are independent packages of related routines and data objects. Such packages ease the writing of large programs by several programmers.

Also, Ada will support concurrent

programming by keeping tasks synchronous through a scheme of rendezvous points. Exception handling will be more structured than in Pascal, with error-recovery blocks of code for runtime infractions.

Several hundred companies competing for DOD computer-related business are clearly interested in Ada, Bowles says. Semiconductor makers like Texas Instruments and Intel are watching the language carefully, too. Indeed, Intel's coming iAPX 432 32-bit microprocessor will be designed to recognize many of Ada's data structures and command statements [*Electronics*, Feb. 28, p. 89].

-John G. Posa

## Consumer

### Zenith has designs on teletext hardware

Aware of the sprouting of video information systems around the U.S., Zenith Radio Corp. is mounting a design effort on the hardware for teletext services. Last month the Chicago company showed off its first hardware—encoding and decoding units needed by TV broadcasters who want to transmit the alphanumeric and graphic data in the vertical blanking interval of their signals.

Zenith demonstrated its Virtex units at the recent Chicago Spring

### Bell installs long-wavelength fiber system

An existing fiber-optics system for carrying telephone conversations in Sacramento, Calif., has been converted into the world's first long-wavelength system and is now in operation. The 1.3-micrometer system is an attempt "to see how longer-wavelength systems function in a real environment," says John Singleton of the Bell Laboratories Digital Lines department in North Andover, Mass.

The 2.7-mile system formerly worked at 0.83  $\mu\text{m}$ , but the longer-wavelength light energy meets less resistance as it propagates through the fibers. The lowered attenuation makes possible less sensitive detectors and fewer amplifiers in a long-distance connection.

The new system is powered by light-emitting diodes that feed data into the fibers at 12.6 megabits a second. It is a double-heterostructure emitter with an external lens to improve optical coupling into the fiber. Bell chose an LED over a laser diode because of greater reliability, wider operating temperature range, and simplified packaging requirements. The receiver is an indium gallium arsenide p-i-n diode.

-Harvey J. Hindin

# Nobody else has LSI-11 and LSI-11/2 cards like these.

Our digital cards are loaded with unique features such as the ability to use I/O lines as either inputs or outputs in increments of eight, up to 64 TTL inputs or outputs interfaced directly to the LSI-11 bus, the ability to detect contact closures on discrete input lines, and discrete latched outputs with the capability to drive high current incandescent lamps.

The Bus Repeater Card accommodates more devices than the basic bus can handle. The Bus Translator Card allows LSI-11 peripherals to operate with a Unibus CPU.

Both high level and low level analog cards are available with features like direct thermocouple digitizing, 250V CM isolation, six gain codes, up to 64 channels, and program control interface ... to mention just a few.

ADAC Corporation,  
70 Tower Office Park,  
Woburn, MA 01801  
(617) 935-6668.

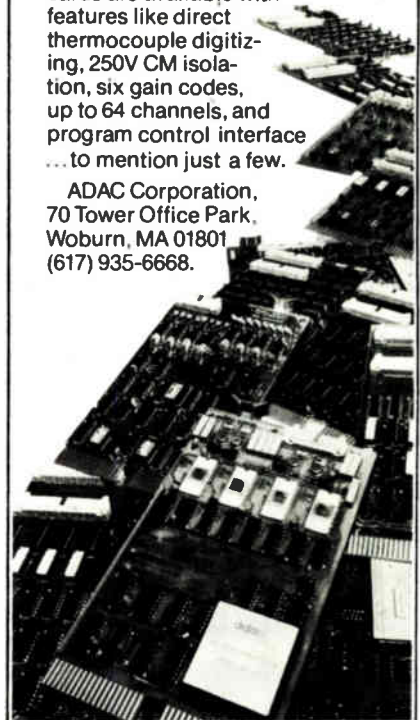

GSA Contract Group 66  
**adac**  
corporation



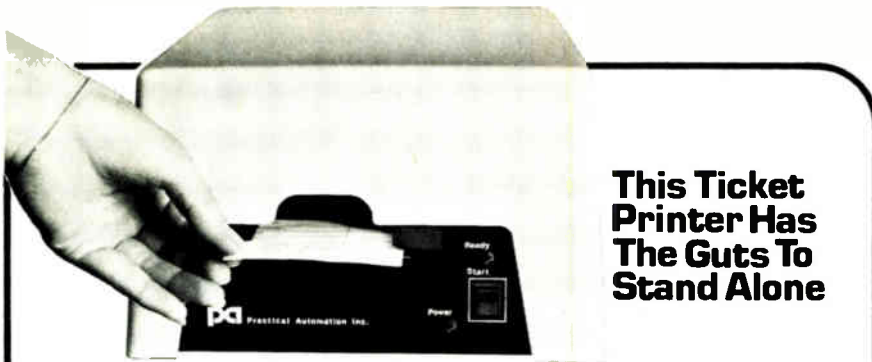

## This Ticket Printer Has The Guts To Stand Alone

Inside its free standing case, our PK-970 alphanumeric printer teams an advanced microprocessor-based controller and power supply, our long life dot matrix print head, and stepper motor that controls ticket advance, 6 lines to the inch or .110, and positioning until the message is complete. The result: a versatile standalone workhorse that can print both analog and digital data on the same card for special applications from lab to weigh station to manufacturing process control.

Print standard or enhanced characters on single-sheet cards or multi-part tickets, with or without ribbon mechanism. Program it for 30, 37 or 49 character line lengths and character density of 10, 12.4 or 16.5 characters/inch. And count on that integral controller to accept parallel, or serial data to meet your system's needs. For details write or call today.



**PRACTICAL  
AUTOMATION, INC.**

Trap Falls Road, Shelton, Conn. 06484/Tel: (203) 929-5381

Circle 60 on reader service card

Conference on Consumer Electronics. The company is aiming its first units at cable TV stations, which would use the composite video data to modulate a radio-frequency carrier they send to customers on a blank TV channel.

Already Southern Satellite Co. a Tulsa, Okla., specialized common carrier supplying services and hardware to cable-TV operators, is planning a test run of Virtext. The encoder places the data on a signal going up to a satellite; the decoder removes it at the ground station and converts it to composite video.

**Entry.** The Chicago demonstration is "our entry into the viewdata and teletext business we'll be in within a few years," says William Thomas, a senior engineer in Zenith's advanced development department in Glenview, Ill. Viewdata information services distribute data interactively to TV sets over telephone lines. Teletext is a one-way, over-the-air broadcast system that also could go out over cable. Both services are of British origin.

"We're using technology available today for broadcast equipment," Thomas says. "As engineers, we've been frustrated with everyone talking about teletext and not doing it."

Thomas readily concedes that the Virtext equipment, at \$1,500 per box, can only be afforded by broadcasters. However, it is "the first step in the evolution [of teletext] into the mass market," he explains. For Southern Satellite, the equipment allows any of 800 pages to be selected and displays up to 40 characters on 20 lines.

**Circuitry.** Thomas points out that the Virtext units operate according to standards developed by the British for their teletext system but modified for the 525-line U. S. TV system. Zenith is using custom circuits supplied by Signetics Corp., which, in turn, were based on designs developed in Britain by Mullard Ltd., a fellow affiliate under the corporate umbrella of the worldwide conglomerate Philips Gloeilampenfabrieken of the Netherlands.

"Signetics has been able to supply us with the level of integrated cir-

HERE IS THE THIRD EDITION OF THE UNIQUE RAC DATABOOK WHICH PORTRAYS IN DEPTH THE RELIABILITY EXPERIENCE OF DISCRETE SEMICONDUCTOR DEVICES AS RECORDED IN GOVERNMENT AND INDUSTRY PROGRAMS. WE THINK THAT THE COMPREHENSIVENESS, CURRENCY AND USEFULNESS OF THE ANALYZED DATA IT CONTAINS ARE UNEQUALLED BY ANY OTHER PUBLICATION AVAILABLE TO THE PUBLIC.



## TRANSISTOR/DIODE DATA, 1979/80

- Failure rates, screens, stresses, failure modes and mechanisms.
- Data representing several billion part-hours of operation in 32 different systems.
- Over 400 pages—fully indexed.
- Thousands of detailed data entries, scores of data summaries on transistors, diodes, thyristors, and optoelectronics.
- Experienced failure rates vs MIL-HBK-217C predictions.
- Ordering No. DSR-3 • \$60 per copy, (\$70 non-U.S.) prepaid

**RAC**



**Reliability Analysis Center**

RADC/RBRAC • Griffiss AFB, NY 13441 • Tel. (315) 330-4151; Autovon: 587-4151

RAC is a DoD Information Analysis Center Operated by IIT Research Institute

# Optimize microelectronic interconnections at all levels!

With this information-packed resource covering all the techniques, materials, and procedures you need most...

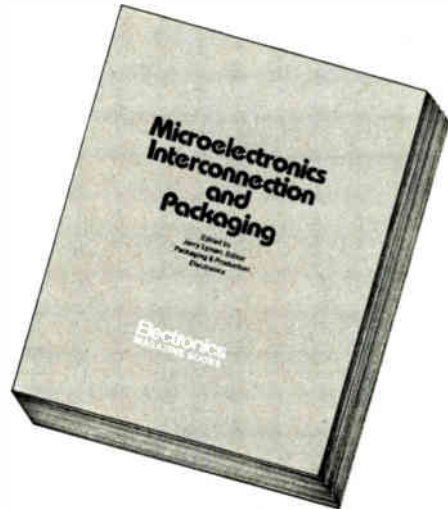

## Microelectronics Interconnection and Packaging

edited by Jerry Lyman, Packaging and Production Editor of *Electronics Magazine* 318 pages, \$12.95

Stop searching through dozens of resources for the answers to your most pressing microelectronic design questions. Start discovering the most efficient and effective methods—directly applicable to your own projects—when you turn to this authoritative reference. Articles drawn from recent issues of *Electronics* highlight everything you need to know about...

- all forms of IC lithography • plasma etching (dry processing)
- breadboards • a new and potentially important substrate, porcelainized steel • polymer thick films • the cause and cure of "hook" in pc substrates • pc substrate types • effects of nuclear radiation on various IC logic families • chip and film carriers • in-circuit testing (digital and analog) • automatic testing of backplanes and pc boards • and more.

### Take a look at just this sampling of on-the-job problems you'll solve quickly.

- You have to choose a low-cost, high-density assembly method for consumer circuits. Don't make a decision until you've checked the sections on the modified thick-film approach on porcelainized steel and polymer thick films on standard plastic pc substrates.
- Should you buy an e-beam lithography system for 2µm geometries on production IC chips? You won't when you've read about a system that works just as well at one-fourth the price!
- You need to wire electronic equipment for a long-life space mission. Read the section on stitch-wired nickel conductors before you act!

### Contents

#### 1. Lithography and Processing for Integrated Circuits.

*Techniques and equipment for putting down micron-sized circuit details on silicon wafers.*

#### 2. Thick- and Thin-Film Hybrids.

*Manufacturing techniques, materials and substrates. Plus how to form hybrid passive components.*

#### 3. Printed Circuit Board Technology.

*Rigid and flexible printed circuits, including materials, plating methods, and breadboards.*

#### 4. Automatic Wiring Technology.

*Competitors of the multilayer pc.*

#### 5. IC Packages and Connectors.

*All methods of packaging IC chips from the DIP to the bare chip, including extensive attention to the new beam tape and chip carriers.*

#### 6. Environmental Factors Affecting Interconnections and Packages.

*Coping with the effects of thermal, vibration, and radiation conditions.*

#### 7. Computer Aided Design.

*For pc boards and IC masks.*

#### 8. Automatic Testing of Interconnections and Packages.

*Computer checks for the high-density boards.*

Order today, and don't forget the other valuable books listed in the coupon below.

**Electronics Magazine Books**  
P.O. Box 669, Hightstown, NJ 08520  
(609) 448-1700, ext. 5494



If after my 10-day free-trial examination I am not fully satisfied I understand that my payment will be refunded.

Payment enclosed  Bill firm  Bill me

Charge to my credit card:

American Express  Diners Club  
 Visa  Master Charge\*

Acct. No. \_\_\_\_\_ Date Exp. \_\_\_\_\_

\*On Master Charge only, first numbers above name \_\_\_\_\_

Name \_\_\_\_\_ Title \_\_\_\_\_

Company \_\_\_\_\_

Street \_\_\_\_\_

City \_\_\_\_\_ State \_\_\_\_\_ Zip \_\_\_\_\_

Signature \_\_\_\_\_

No. of Copies	Title	Price
_____	Microprocessors	\$ 8.95
_____	Applying Microprocessors	\$ 9.95
_____	Large Scale Integration	\$ 9.95
_____	Basics of Data Communications	\$12.95
_____	Circuits for Electronics Engineers	\$15.95
_____	Design Techniques for Electronics Engineers	\$15.95
_____	Memory Design: Microcomputers to Mainframes	\$12.95
_____	Personal Computing: Hardware and Software Basics	\$11.95
_____	Microelectronics Interconnection and Packaging	\$12.95

Discounts of 40% on orders of 10 or more copies of each book.



# When Clear Displays Count

You can count on Ferranti-Packard's electromagnetic 7-Segment display module to give you the electronic compatibility you need plus the reliability and visibility your customers demand.

Performance-proven for over 5 years, the simple design and construction, backed by Ferranti-Packard research and engineering, gives you the combination of reliability, visibility and flexibility that no other read-out component can match.

When you design an electronic read-out system, Ferranti-Packard display modules will help you do it better. It's clearly the display module you should consider. See the difference for yourself, write or call us and we'll prove it.

**When clear displays count—  
Specify Ferranti-Packard.**



Circle 62 on reader service card



**compass**  
microsystems

## 6500 USERS



We offer the most complete line of 6500 support tools available — both hardware and software. Our CSB family of single board computers get your project running quickly. The DAIM floppy disk system turns your AIM 65 into a serious development system. The DB/65 provides the debug system you have been looking for. Cross assemblers are available for many popular computers plus CSL/65 — the high level language for the 6500 family.

224 SE 16th St. P.O. BOX 687 AMES, IA 50010 (515) 232-8187

62 Circle 234 on reader service card

## Electronics review

cuitry we care to deal with," Thomas says. "We have gotten circuits from others but they have been less well developed—more like breadboards," he adds. "The designs are evolving, but Mullard's 525-line timing-chain chip, for example, reduces chip count appreciably."

Other set makers besides Zenith are paying attention to teletext. For example, RCA is investigating its applicability to the TV sets it makes and to its broadcasting, international communications, and cablevision supply companies. It has announced no hardware, however.

**Demonstration.** Zenith used a pair of color TV sets in its conference demonstration. One TV set received the teletext signal at its antenna terminals. The other had the signal applied at its color controls, bypassing the radio-frequency section, a scheme that could be used if the TV set were built to accept teletext.

Before teletext is offered over the air in the U. S., broadcasters must agree on a standard system. The Electronic Industries Association is expected to draft such a standard this summer.

Zenith used for its data base some 25 pages of information stored in the memory of an H89 personal computer, of the line acquired when it bought Heath Co., the electronic kit maker, from Schlumberger Ltd. last year. Pages of information were first encoded onto a cable TV signal, then decoded by the Virtext equipment, and played on the TV sets.

**First order.** The company will be supplying 20 of its Virtext decoders to Southern Satellite for use at satellite ground stations servicing cable-TV operators. The division of Atlanta-based Satellite Syndicated Systems Inc. will test the decoders in helping distribute Reuters, United Press International, and possibly the Dow-Jones news wires, says Southern Satellite engineering vice president Gary Stanton.

He adds that Southern Satellite also is evaluating decoding units made by Scientific-Atlanta Inc. of Atlanta. He anticipates "a much larger order [for the decoders] in the near future."  
—Alfred Rosenblatt

Electronics/July 3, 1980

Unless money is no object, Wavetek's new Model 859 Programmable Pulse Generator is obviously the way to go. First of all, the under-\$8,000 price is for single channel operation. Our dual-channel version is priced about the same as other single-channel instruments!

Either way, the Model 859 is a high-performance, GPIB-compatible instrument for bench or ATE applications. You can program frequencies from 0.5 Hz to 50 MHz, pulse widths from

10 nanoseconds to 1 second, delays to 1 second, transition times from 5 nanoseconds to 25 milliseconds, and output levels up to 20 volts. For repetitive testing, you can store and recall up to 25 setups (which eliminates the need for a controller).

Besides economy, the key features of the 859 are accuracy and quality. Timing accuracy, for example, is 2%. And the microprocessor-assisted programming gives you pulse fidelity like you've never seen before.

Getting back to price: the money you save with the 859 will probably cover most of your software costs. But don't take our word for it. Call us and arrange a complete demonstration of the Model 859, and find out what pulse quality and value are really about. Wavetek, 9045 Balboa Avenue, P.O. Box 651, San Diego, CA 92112. Tel. (714) 279-2200. TWX 910-335-2007.

**WAVETEK®**

Circle #63 for Demonstration  
Circle #233 for Literature



**Some \$11,000  
programmable pulse generators  
perform as well as this one.**

**Unfortunately for them,  
this one sells for under  
\$8,000.**





# SAMTEC "SUDDEN SERVICE" as it appears\* to our customers



## \* Actual retouched photo

Of course this is a considerable exaggeration of SAMTEC's service facilities. But, even though our air fleet is strictly imagination, our devotion to "old fashioned" trouble-free service keeps customers coming back for more. The reason? SAMTEC cares about your order as much as you do. Catalogs, samples, quotations go out the same day we get them. Your order is usually on its way to you within 36 hours after we receive it. And trained expeditors follow-thru so that you know how the shipment went out and when to expect delivery.

Call or write today for our new catalogs—  
 complete with all specs and ordering data.

Get SAMTEC's "old fashioned service" with your next order.

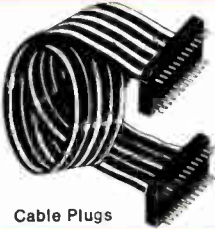
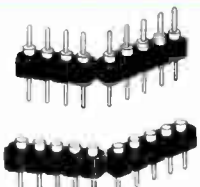
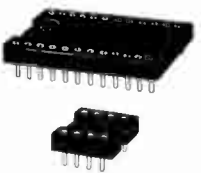
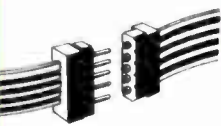

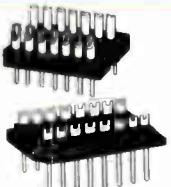
 <p>Cable Plugs</p>	 <p>Socket/Terminal Strips</p>	 <p>DIP Sockets</p>	 <p>Cable Strip Connectors</p>	 <p>TO Sockets</p>	 <p>Adaptors</p>
---	---	--	--	---	---

© 1980, Samtec, Inc.



## ELECTRONIC HARDWARE

810 PROGRESS BOULEVARD, NEW ALBANY, INDIANA 47150

(812) 944-6733

Circle 64 on reader service card

## **Pressure rising for telecommunications rewrite by Congress . . .**

Odds against final passage of compromise legislation to reduce regulation and increase competition in U. S. telecommunications are increasing daily, but so is the pushing and shoving by diverse Government and industry interests as Congress moves closer to its adjournment target late this month. Although positions on specific legislative provisions vary, the White House is pressing hard for passage, using the Commerce Department's National Telecommunications and Information Administration to lead the effort. Also pressing are leaders of American Telephone & Telegraph Co., IBM Corp., and the just-formed Coalition for Telecommunications Reform Legislation. The coalition is made up so far of eight organizations, including three large independent telephone companies, two communications labor unions, and three trade associations. Aligned against aspects of the amended bills—the House's H. R. 6121 and the Senate's S.2827—is a host of smaller telecommunications interests that fear that the bills will lead to dominance of emerging markets by a diversified AT&T.

## **. . . with rules for competition and antitrust key issues**

As Act 2 of the legislative melodrama closed at the end of June, key issues are American Telephone & Telegraph Co.'s competitive participation in new markets through a fully separated subsidiary and the prescribed transition period for its creation. **The House compromise calls for any AT&T subsidiary to perform all of its own final assemblies within 4 years after enactment of the law, sets a limit of 5 years for transfer of applied research (although use of Bell Laboratories' basic research could continue indefinitely), and allows 7 years for transfer of all subassembly manufacturing and 10 years for components.**

Opponents of the plan, like the Computer and Communications Industry Association, say the timetable "should be reduced to half its present length, or the Federal Communications Commission should be given the power to shorten the transition consistent with its own assessment of feasibility." The CCIA and others also contend that public hearings on the subsidiary compromise have never been held **and that the FCC is not equipped in any event to monitor AT&T's compliance with the transition requirements.**

## **NASA begins tests of small airport traffic system**

First operational tests of an automated pilot-advisory system (APAS) for use at small airports without air-traffic control systems will be conducted by the National Aeronautics and Space Administration. They will take place during July at Virginia's Manassas Municipal Airport. The prototype will use **computer-generated voice messages broadcast on an assigned vhf wavelength** to advise pilots every 20 seconds of area traffic, as well as radar and weather updates every two minutes.

## **Guided munitions using VHSIC will lead U. S. programs**

Precision-guided munitions using third-generation target seekers are the key to future U. S. weapons systems, says William J. Perry, under secretary of defense for research and engineering. High-technology programs like the triservice effort on very high-speed integrated circuits (VHSIC) will continue to drive U. S. weapons development, Perry noted in an ad lib presentation keynoting the Armed Forces Communications and Electronics Association annual convention at the end of June in Washing-



ton, D. C. Perry warned that U. S. efforts to upgrade the quality as well as add weapons to its inventory should not be misconstrued to mean a deemphasis of electronics and other high technologies.

## **Domsat demand could exceed orbital space . . .**

The U. S. will run out of orbital slots for domestic communications satellites unless the Federal Communications Commission requires that applicants use the "best available technology" to provide more channels and larger satellite antennas that permit greater reuse of frequencies. That warning to the FCC from the Ford Aerospace & Communications Corp. cites an amazing growth pattern in domestic communications satellite demand. **It "will be far in excess of the capacity in orbit" proposed by the 21 applications now before the commission,** not including the needs of Canada and a number of South American nations that must use the same orbits for their planned domestic systems. The Detroit-based Ford unit reminded the commission that given the 2,750-lb payload limit of currently available Delta-class launch vehicles, plus the three-year time lag between application approval and operational availability of a communications satellite with its minimum seven-year lifetime, any system approvals this year "would result in the U. S. having in orbit in 1990 essentially first-generation spacecraft representing 1975 technology."

## **. . . but upgrading for channel reuse may make room**

Ford Aerospace proposes two solutions to the orbital space problem. For the long term, the company urges the FCC to examine the International Telecommunications Satellite Organization's Intelsat V spacecraft and its ability to reuse the available frequency "by simultaneously having spatial separation of beams with the cross-polarization techniques currently used in first-generation spacecraft." By using larger satellite antennas with 8-ft diameters, "it is possible to have beams that not only cover the U. S., but also to have beams separately illuminating the East Coast and West Coast," and thus **simultaneously reusing the C band frequencies up to three times.** U. S. Atlas Centaur rockets—whose 4,800-lb payload capacity is nearly double that of the Delta class—will launch Intelsat V and could also be used to launch similar high-capacity U. S. domestic satellites after 1983, with 3,000-MHz bandwidths equally split between the C band and the K band. **This capacity would be triple the available bandwidth that can be orbited in a Delta class vehicle.** Though Atlas Centaur launch costs of \$43 million to \$45 million are 15% higher than for Delta class rockets, its greater payload reduces the orbital costs per pound by 30%, Ford Aerospace contends. For temporary relief of orbital overcrowding, the company says the FCC should consider adding a "handful" of additional orbital locations by studying the feasibility of reducing satellite separations from 4° to 3°.

## **Congress warns Japan to cut U. S. trade surplus**

Projecting a 1981 U. S. trade deficit with Japan of \$16 billion led by electronics, automobiles, and steel, 70 congressmen have introduced a joint resolution calling on Japan to help reduce the surplus. **The forecast 1981 deficit—one third of the \$47 billion total for all of the 1970s—is expected to grow even larger in years to come,** the congressmen said, producing a situation that is "intolerable and unacceptable and threatens the future" of trade relations with Japan.

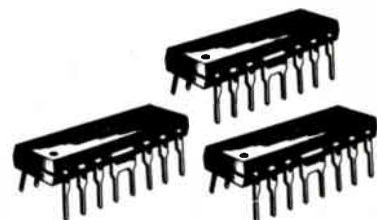

## Solve design problems simply with 1.5 Amp Interface ICs for Negative Supply Applications.

You can use Sprague Electric's new Series UDN-2840B 1.5 amp monolithic quad power drivers in three basic versions to solve your circuit needs for (1) sink applications, (2) source applications, and (3) com-

bination sink-and-source applications.

You can get this versatile IC family with either 5V logic compatibility or 12-15V MOS compatibility. Make your choice from these six types:

TYPE	I <sub>OUT</sub>	V <sub>OUT(OFF)</sub>	OUTPUTS	V <sub>SUPPLY (TYP)</sub>	COMPATIBILITY	TYPICAL APPLICATIONS
UDN-2841B	1.5 A	-50 V	Sink (4)	0 V to 5 V	5 V Logic	electrosensitive printer interface
UDN-2842B	1.5 A	-50 V	Sink (4)	0 V to 12 V	PMOS, CMOS	
UDN-2843B	-1.5 A	-50 V	Source (4)	5 V	5 V Logic	solenoid, LED, or relay drive
UDN-2844B	-1.5 A	-50 V	Source (4)	5 V to 12 V	PMOS, CMOS	
UDN-2845B	1.5 A/-1.5 A	-50 V	Sink (2) Source (2)	5 V	5 V Logic	bridge motor drives
UDN-2846B	1.5 A/-1.5 A	-50 V	Sink (2) Source (2)	5 V	PMOS, CMOS	

All Series UDN-2840B power driver ICs include input current limiting, level translation, and sufficient amplification to operate high current Darlington out-

puts. The Sprague-originated 16-lead webbed dual in-line package is used for maximum power dissipation.

For application engineering assistance on these or other interface circuits, standard or custom, write or call Paul Emerald, Semiconductor Division, Sprague Electric Co., 115 Northeast Cutoff, Worcester, Mass. 01606. Telephone 617/853-5000.

For Engineering Bulletin 29314 and a 'Quick Guide to Interface Circuits', write to: Technical Literature Service, Sprague Electric Company, 35 Marshall Street, North Adams, Mass. 01247.

For the name of your nearest Sprague Semiconductor Distributor, write or call Sprague Products Company Division, North Adams, Mass. 01247. Telephone 413/664-4481.

### FOR FAST INFORMATION, CALL YOUR NEAREST SPRAGUE SALES OFFICE:

ALABAMA, Sprague Electric Co., 205/883-0520 • ARIZONA, Sprague Electric Co., 602/244-0154; 602/966-7233 • CALIFORNIA, Sprague Electric Co., 213/649-2600; 714/549-9913; R. D. Miner Co., 714/421-5586; Wm. J. Purdy Co., 415/347-7701 • COLORADO, Wm. J. Purdy Co., 303/777-1411 • CONNECTICUT, Sprague Electric Co. 203/261-2551; Ray Perron & Co., Inc., 203/268-9631; 203/673-4825 • DIST. OF COLUMBIA, Sprague Electric Co. (Govt. sales only), 202/337-7820 • FLORIDA, Sprague Electric Co., 305/831-3636 • ILLINOIS, Sprague Electric Co., 312/296-6620 • INDIANA, Sprague Electric Co., 317/253-4247 • MARYLAND, Sprague Electric Co. 301/792-7657 • MASSACHUSETTS, Sprague Electric Co., 617/899-9100; 413/664-4411; Ray Perron & Co., Inc., 617/969-8100 • MICHIGAN, Sprague Electric Co. 517/787-3934 • MINNESOTA, HMR, Inc., 612/831-7400 • MISSOURI, Sprague Electric Co., 314/781-2420 • NEW HAMPSHIRE, Ray Perron & Co., Inc., 603/742-2321 • NEW JERSEY, Sprague Electric Co., 201/696-8200; 609/795-2299; Trinkle Sales Inc., 609/795-4200 • NEW MEXICO, Wm. J. Purdy Co., 505/266-7959 • NEW YORK, Sprague Electric Co., 516/234-8700; 914/834-4439; 315/437-7311; Wm. Ruff, Inc., 914/834-8555; Paston-Hunter Co., Inc., 315/437-2843 • NORTH CAROLINA, Electronic Marketing Associates, 919/722-5151 • OHIO, Sprague Electric Co., 513/866-2170; Electronic Salesmasters, Inc., 800/362-2616 • PENNSYLVANIA, Sprague Electric Co., 215/467-5252; Trinkle Sales Inc., 215/922-2080 • SOUTH CAROLINA, Electronic Marketing Associates, 803/233-4637 • TEXAS, Sprague Electric Co., 214/235-1256 • VIRGINIA, Sprague Electric Co., 703/463-9161 • WASHINGTON, Sprague Electric Co., 206/632-7761 • CANADA, Sprague Electric of Canada, Ltd., 416/766-6123 or 613/238-2542



a subsidiary of **GK Technologies**  
Incorporated

Circle 67 on reader service card







## How First Boston completed the largest leveraged buy-out ever done.

Early this year, Fibic Corporation, a company formed by The First Boston Corporation, purchased all of the assets of Congoleum Corporation, a major, publicly owned, diversified industrial company. The proceeds were distributed to the public stockholders of Congoleum.

The transaction was remarkable not only for its size—approximately \$450 million—but also for its innovation. The capital for the purchase was raised through a financing involving only 13 institutional and commercial bank participants. First Boston encouraged investment by committing its own capital to the equity portion of the financing.

The marshaling of expertise in diverse areas was the key to the success of this creative financing. It is characteristic of First Boston. We are involved in every phase of investment banking, every day. Abilities interact. Communication among disciplines leads to insight. Innovation follows.

Our willingness to assume risk is also important. With a strong permanent equity capital position, First Boston executes insights. We make knowledge work. We can put it to work for you.

Start First Boston thinking about your investment banking needs. Call on professionals like these five people in our headquarters in New York: (from left) Tony Grassi, Sophie Bell, and Tom Cassidy, all of Corporate Finance; Art Nagle, Direct Placements; and Ted Stolberg, Mergers and Acquisitions. Phone: (212) 825-2000.



**First Boston**  
Thinking capital





# WE WROTE THE BOOK.

## YOURS FOR THE ASKING.

Answers to timing, counting and display driving problems. Answers from Intersil. Single-chip answers. Answers in low power CMOS. In fact, answers in MAXCMOS™, Intersil's proprietary CMOS process.

## DOZENS OF ANSWERS.

Whether you're planning timer / counter / display functions for a micro-processor-based or hard-wired system, we think you'll find an Intersil chip that does the job.

## SYSTEMS ON A CHIP.

While they were thinking circuits, we were thinking systems. Systems on a single chip that replace up to 20 TTL packages. That means you can design systems faster, use less real estate, and gain the reliability that's inherent not only in lower component count...but in low power CMOS operation.

## DISPLAY IT YOUR WAY.

Intersil's display drivers drive LED, LCD and Vacuum fluorescent displays. Displays up to 1" in height. And, you can cascade displays to 32 or more digits.

## COUNT IT YOUR WAY.

Count units, period, frequency or time interval. With Intersil's advanced monolithic low power MAXCMOS™ counters.

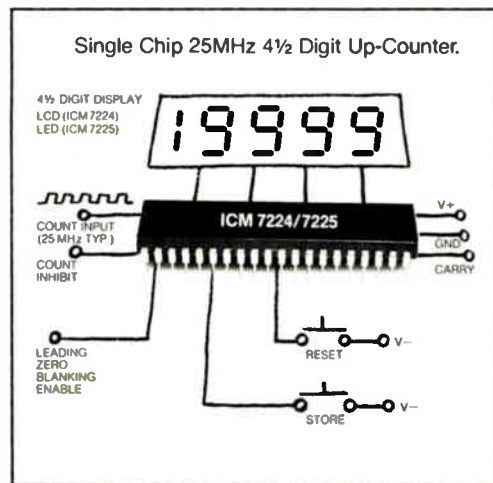

## TIME IT YOUR WAY.

Time events from microseconds to months. Intersil offers devices that feature user programmability or offer fixed outputs utilizing a stable quartz crystal time base.

## FREE ANSWERS.

The Timers, Counters, Display Drivers Applications Handbook is yours. Free. From any Intersil Sales Office, Intersil Franchised Distributor, or simply by returning the coupon below. We wrote "The Book." For you.

# INTERSIL

Analog Products — Low Power  
We've got the answers  
10710 No. Tantau Ave., Cupertino, CA 95014  
Tel: (408) 996-5000 TWX: 910-338-0171  
(800) 538-7930 (outside California)

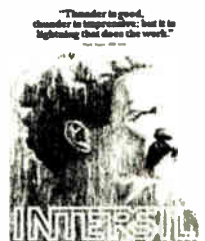

Gentlemen,  
Send me "The Book." I need monolithic answers in  
\_\_\_\_\_ timing, \_\_\_\_\_ counting, \_\_\_\_\_ display driving applications.  
\_\_\_\_\_ Send me your Mark Twain poster.

Name \_\_\_\_\_

Company \_\_\_\_\_

Address \_\_\_\_\_

City \_\_\_\_\_ State \_\_\_\_\_ Zip \_\_\_\_\_



# GENERAL PURPOSE HF ...at its BEST!

## The WJ-8718 General Purpose HF Receiver



### FEATURES:

- Frequency Range  
5 kHz-30 MHz
- Four Switch-Selectable  
Tuning Speeds
- 10 Hz Tuning Resolution
- AM, FM, and CW Reception  
Modes
- Tunable Synthesized BFO  
 $\pm 8$  kHz
- Seven-Digit LED Frequency  
Readout
- AC Power Interrupt Memory
- Low Phase-Noise  
Synthesizers
- High Dynamic Range
- Five IF Bandwidths

### OPTIONS:

- Remote Control Compatible  
with IEEE and EIA Standards
- ISB, LSB, USB Module
- Sub-octave Preselector
- 1 Hz Tuning and Display

Watkins-Johnson's cost-effective WJ-8718 represents the latest technological advances in HF receivers. Since its introduction in 1977, over 1,000 WJ-8718's have been produced and delivered . . . How's that for proven delivery capability? Call or write to obtain specifications, price, and delivery.

*Do you want to be a member of our industry-leading team? If so, write our Personnel Dept., or call collect (301) 948-7555 for career opportunity information.*

700 Quince Orchard Road, Gaithersburg, MD 20760.



WATKINS-JOHNSON

Watkins-Johnson—U.S.A.: • California, San Jose (408) 262-1411; El Segundo (213) 640-1980 • Georgia, Atlanta (404) 458-9907 • District of Columbia, Gaithersburg, MD (301) 948-7550 • Massachusetts, Lexington (617) 861-1580 • Ohio, Fairborn (513) 426-8303 • Pennsylvania, Haverford (215) 896-5854 • Texas, Dallas (214) 234-5396 • United Kingdom: Shirley Ave., Windsor, Berkshire SL4 5JU • Tel: Windsor 69241 • Cable: WJUKW-WINDSOR • Telex: 847578 • Germany, Federal Republic of: Manzingerweg 7, 8000 Muenchen 60 • Tel: (089) 836011 • Cable: WJDBM-MUENCHEN • Telex: 529401 • Italy: Piazza G. Marconi, 25 00144 Roma-EUR • Tel: 59 45 54 • Cable: WJROM-I • Telex: 612278

Circle 72 on reader service card

## International newsletter

---

### **Hitachi markets all-solid-state color TV camera**

For the first time ever, a color television camera using solid-state area sensors for image pickup is available off the shelf for industrial and commercial applications. For the device's three sensor arrays, manufacturer Hitachi Ltd. has preferred MOS technology to the charge-coupled devices used in other manufacturers' prototype cameras, on the grounds that the drop in CCD transfer efficiency in dim light downgrades a camera's sensitivity. In addition, the area of each picture element in the MOS sensor array is larger for a given image size, making for higher sensitivity.

The color camera, which sells in Japan for \$11,600, is manufactured by Hitachi subsidiary Hitachi Denshi Ltd. Each sensor has 320 pixels horizontally by 244 vertically in an 8.8-by-6.6-mm (346-by-260-mil) area—the same size as the target of a 2/3-inch-diameter vidicon. To get a resolution of 400 TV lines horizontally and 350 vertically, **the green sensor is offset by half the pixel pitch from the blue and red sensors**, which are aligned with each other. The sensors are also for sale separately.

### **European chip makers gear up for huge new telephone market**

Semiconductor manufacturers in Europe are jockeying for position in the huge markets they see coming in the microprocessor-equipped telephones being developed by European telephone administrations (PTTs). In the next few months, both the French subsidiary of Motorola Inc.'s Semiconductor Group and the Italian subsidiary of Texas Instruments Inc. plan to announce **speech-processing bipolar circuits, complete with on-chip amplifiers, that will be placed in the telephone handset itself** and be usable with electret or electrodynamic microphones. Motorola and RTC—La Radiotechnique Compélec, a subsidiary of the Netherlands' Philips group, have each received contracts from the French PTT to develop speech circuits. Since the PTT specifications have not yet been set officially, Motorola apparently intends to modify its circuit to meet them after the circuit has been introduced. RTC, on the other hand, is waiting for the PTT specs before completing circuit development.

### **Telefunken supplies efficient I-f transmitters to the Netherlands**

West Berlin-based AEG-Telefunken has installed in the Netherlands an intermediate-frequency transmitting station it claims is the world's most modern, thanks mostly to its use of the Pantel technique. Pantel stands for pulse-duration anode modulation system Telefunken [*Electronics*, Jan. 20, 1977, p. 56 or 6E]. The station's two 600-kw Pantel transmitters are 1% to 10% more efficient than two conventional transmitters of equal rating—in continuous operation, **each consumes up to 1 million kw-h less energy a year**. Moreover, the Pantel technique, together with extensive equipment transistorization, makes only two high-output tubes necessary. Finally, an antenna that sends out ground waves undisturbed by reflected sky waves blankets the Netherlands with virtually fade-free signals.

### **ICL targets high-growth market in multilayer boards**

Add a newcomer to the list of all too scarce suppliers of high-technology multilayer printed-circuit boards. Britain's International Computers Ltd. is cashing in on its in-house expertise with a new operation—ICL Logicl原因, based on a specially built \$12 million plant in Plymouth Grove, Manchester. ICL reckons to be at the leading edge of the technology, as its 2900 series consists of **22-layer motherboards with 6-mil line widths and spacings**. The multilayer sector of the pc board market, for all its smallness



now, is in ICL's opinion one of the fastest growing because it is driven by the increasing density of integrated circuitry. In 1979, for example, multilayer boards accounted for 14% of a total European market worth \$1,084 million. By 1984, these figures are expected to rise to 19% of a market worth \$1,483 million.

## **CCITT agrees on International viewdata standards**

With a judgment befitting Solomon, the International Consultative Committee on Telephony and Telegraphy **has adopted the British Prestel system and the viewdata version of the French Teletext system as alternative viewdata standards**, with compatibility between them achieved through the use of international gateway exchanges. Another result of the CCITT session held June 9-12 in Montreal was prospective standards for second- and third-generation viewdata systems now in development that need much less memory.

## **Canada proposes to use spectrum in un-WARC-like ways**

The Canadian government's Department of Communications has released its proposals for a "Canadian Table of Frequency Allocations." This spectrum usage chart is based on the results of both the 1979 World Administrative Radio Conference and Canadian needs, which in some cases differ from WARC recommendations. **All manufacturers of radio equipment for the Canadian market are invited to comment on the two-volume document.**

## **Siemens adds four computers to popular 7.500 series**

To cover a broader customer and performance spectrum, Munich's Siemens AG is adding four new models to the 7.500 computer series it announced only 14 months ago. The 7.536 is intended for the medium-performance range in office applications, the three others—the 7.551, 7.561, and 7.571—for use mainly in computer centers. The compact construction of the new machines is due in large part to Siemens' extensive use of its own 64-K memories, **their performance to highly integrated emitter-coupled-logic components working in the subnanosecond range** and also of the company's own construction.

Siemens has already installed or received orders for some 1,100 of the first three models in the 7.500 series. Deliveries of the four new models will start in October of next year. The largest system, the 7.571, is 35 times as powerful as the smallest, the 7.521.

## **Addenda**

A research team at the Federal Institute of Technology in Zurich, Switzerland, has found that operators of video display terminals complain not only of eyestrain and blurred or double vision but also of **back pains, rheumatic-type disease, and other ailments traceable to their constrained posture.** It suggests redesign of the apparatus. . . . IBM Japan Ltd. will become **the second U. S. firm to manufacture semiconductors in Japan.** Its initial product will be random-access memories, which it will be turning out in large numbers in 1983. . . . In a move to **strengthen its position in the data-processing field,** AEG-Telefunken of West Berlin has paid \$3.5 million for a 10% share of the U.S. computer firm Ontel. Corp in Woodbury, N. Y., a producer of display-based computer systems.

# Fastest Op Amp.

**Signetics' NE5539 spans 1.2GHz and slews at 600V/ $\mu$ sec.**

Signetics' NE5539 brings you hybrid performance, "DC to daylight"—at monolithic prices.

It's the industry's fastest monolithic op amp. Unmatched speed with superior bandwidth makes it your one choice for demanding uses in wideband video and data acquisition systems.

Use it anywhere your design calls for a 600V/ $\mu$ sec slew rate with a 1.2GHz gain/bandwidth product. And where you're after a full-power closed-loop bandwidth of 48 MHz.

Suddenly systems design is simpler. The NE5539's great speed and bandwidth help you reduce parts count, while an emitter-follower design gives you true differential high input impedance.

This op amp is already making color video systems more reliable. And it's being specified for coaxial cable drivers, pulse amplifiers, RF oscillators, and A-D/D-A converter systems.

It's a natural for *fast* sample-and-hold circuitry.

Our NE5539 is just the latest addition to Signetics' growing family of high performance linears. For harsh system environments, specify our SE5539.

It brings you NE5539 performance *qualified* to MIL-STD 883B.

For the lowest noise duals, specify one of our silent partners. Our 5532 really shines at 6nV/ $\sqrt{\text{Hz}}$ , and our 5533 brings it home at 4.5nV/ $\sqrt{\text{Hz}}$ .

Find out how you can put Signetics' advanced linear technology to work in your system. Contact your nearby Signetics sales office or distributor for full details.

Or, write *Signetics Corp.*, 811 East Arques Ave., P.O. Box 409, Sunnyvale, CA 94086, (408) 739-7700.

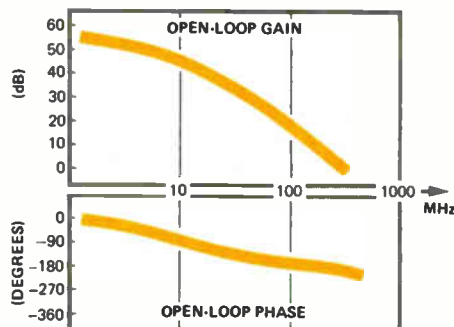
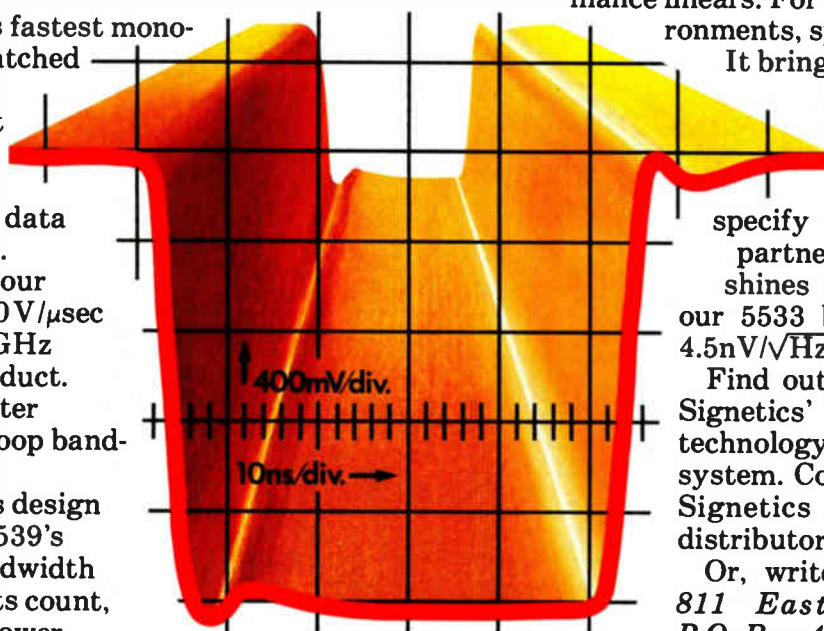

## Signetics

a subsidiary of U.S. Philips Corporation

**Multiple Technologies from 8 Divisions:**  
Analog, Bipolar Memory, Bipolar LSI, MOS Memory, MOS Microprocessor, Logic, Military, Automotive/Telecom

To: Signetics Publication Services, 811 E. Arques Ave., MS 27, P. O. Box 409, Sunnyvale, CA 94086 <sup>E73</sup>

( ) Rush complete specs on the industry's fastest op amp.

My application is: \_\_\_\_\_

Name \_\_\_\_\_ Title \_\_\_\_\_

Company \_\_\_\_\_ Division \_\_\_\_\_

Address \_\_\_\_\_ MS \_\_\_\_\_

City \_\_\_\_\_ State \_\_\_\_\_ Zip \_\_\_\_\_

Please have an op amp specialist phone me at once at:

( ) \_\_\_\_\_ ext. \_\_\_\_\_



Hail the latest star of the 8-bit wars: our new S68045 CRT Controller.

AMI's stellar engineers have created this dazzling device for use with the S6800 MPU (or any other 8 or 16-bit microprocessor). Just plug it in and take control of the CRT in intelligent terminals, word process-

ing and information display systems.

AMI made it pin-compatible with the MC6845 and SY6545. But outflanked the competition by adding programming ability in the shape of two on-board ROMs.

With the only exclusively MOS mask-programmed device, we can

help you fight back against high-priced controllers. And AMI's people cut costs without sacrificing flexibility. You can light up your screens with two sets of parameters, such as character sizes and widths, 50 or 60 Hz refresh rates, and cursor format.

So give your MPU complete

# AMI's S6800 Family welcomes

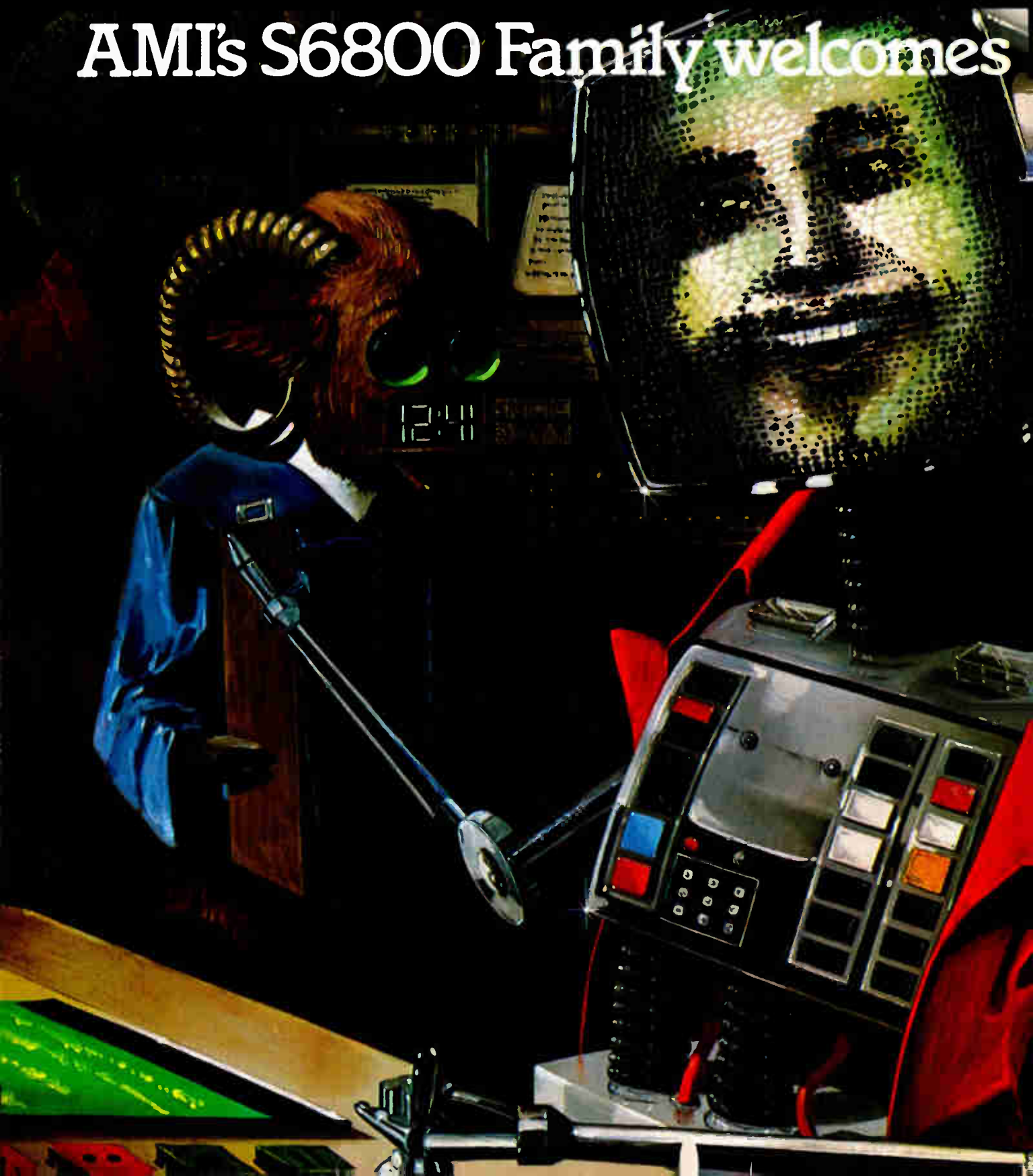

mastery over its CRT with our lean, efficient controller. Check your nearest AMI distributor for details. Or get in touch with us at AMI S6800 Marketing, 3800 Homestead Road, Santa Clara CA 95051. Phone (408) 246-0330.

This is one new interface with real star quality.

# a bright new interface.



## The AMI S6800's all-star cast.

### MPUs

S6800	1.0 MHz MPU
S68A00	1.5 MHz MPU
S68B00	2.0 MHz MPU
S68H00	2.5 MHz MPU
S6801*	Single Chip MCU with Clock
S6801E*	Single Chip MCU with External Clock
S6802	MPU with on-board Clock and RAM
S6803*	Single Chip MCU without RAM and/or ROM
S6805	Low Cost Single Chip MCU
S6808	MPU with on-board Clock
S6809	Enhanced MPU/on-board Clock
S6809E*	Enhanced MPU/External Clock Input

### PERIPHERALS

S1602/S8868	UART
S2350	USRT
S6821	} Peripheral Interface Adapter (PIA)
S68A21	
S68B21	
S68H21	
S6840	High Speed PIA
S68A40	} Programmable Timer Module (PTM)
S68B40	
S68045	CRT Controller
S68047	Video Display Generator (VDG)
S68488	IEEE 488 Bus Adapter
S6850	} ACIA
S68A50	
S68B50	
S6852	} Synchronous Serial Data Adapter
S68A52	
S68B52	
S6854	} Advanced Data Link Controller
S68A54	
S68B54	
S6894	Data Encryption Unit

### MEMORIES

S6810	} 128 x 8 Static RAM
S68A10	
S68B10	
S6831	16K Static ROM
S68332	32K Static ROM
S6834	4K EPROM
S68364*	64K Static ROM
S6846	16K ROM with on-board I/O and Timer

\*Consult factory for availability

**AMI**  
AMERICAN MICROSYSTEMS, INC.

Circle 77 on reader service card







# Managing the unmanageable: 57 tons of engineering data-- cataloged, collated, cross-indexed and cross-referenced for you.

## That's *processed* information.

Any number of companies would like to help you with your information processing.

But only Information Handling Services provides you *processed* information . . . engineering data that's already been cataloged, collated, cross-indexed and cross-referenced for you. So that when you need one important catalog page, Industry Standard, Mil Spec or Government Spec, you can get it. Faster than with any comparable system in the world.

In other words, what you get from Information Handling Services isn't hardware that helps process data.

It's processed engineering data, presented in a useful, usable form.

### **The most comprehensive engineering data base in the world.**

We've been gathering and distributing engineering data for over twenty years. In the industrial area alone, we currently have over 23,000 different manufacturers' catalogs. Plus the most comprehensive collection of Military Specs in the world. Along with 90% of the world's most important Industry Standards. In fact, our total data base now incorporates more than 8,000,000 pages of technical information.

### **Fast, easy access.**

Even more important, we've organized all this information into a system that delivers fast access. All you do is identify the product in which you're interested. Our unique Locator Index then directs you to the catalogs you need, to all appropriate Industry Codes and Standards, to Government and Military Specifications, even to International Standards. In minutes.

### **One thousand people working for you.**

Information Handling Services does a better job of providing you with *processed* information, because we originated Visual Search Microfilm Files (VSMF). Today, our engineers spend tens of thousands of manhours each year simply organizing and cataloging technical data, to make it easier for you to use. For that matter, we have more than 1100 employees now producing a wide variety of information services ranging from manufacturers' catalogs to Military Specifications and Standards, and from an Industry Standards service to Federal Documents, including the Code of Federal Regulations.

### **Interested?**

Find out for yourself the difference between information processing and *processed* information. We have a complete information package that will give you more details, and that can help you determine which of our many information services might best relate to your work. Just write: Dept. 480, 15 Inverness Way East, Englewood, CO 80150. Or call (toll free) 1-800-821-2280, ext. 301 (in Missouri, call 1-800-892-7655, ext. 301.)

**Not information processing,  
but *processed* information.**



**Information Handling Services**

An Indian Head Company

Circle 79 on reader service card



# Catch a dedicated or multiplexed bus...

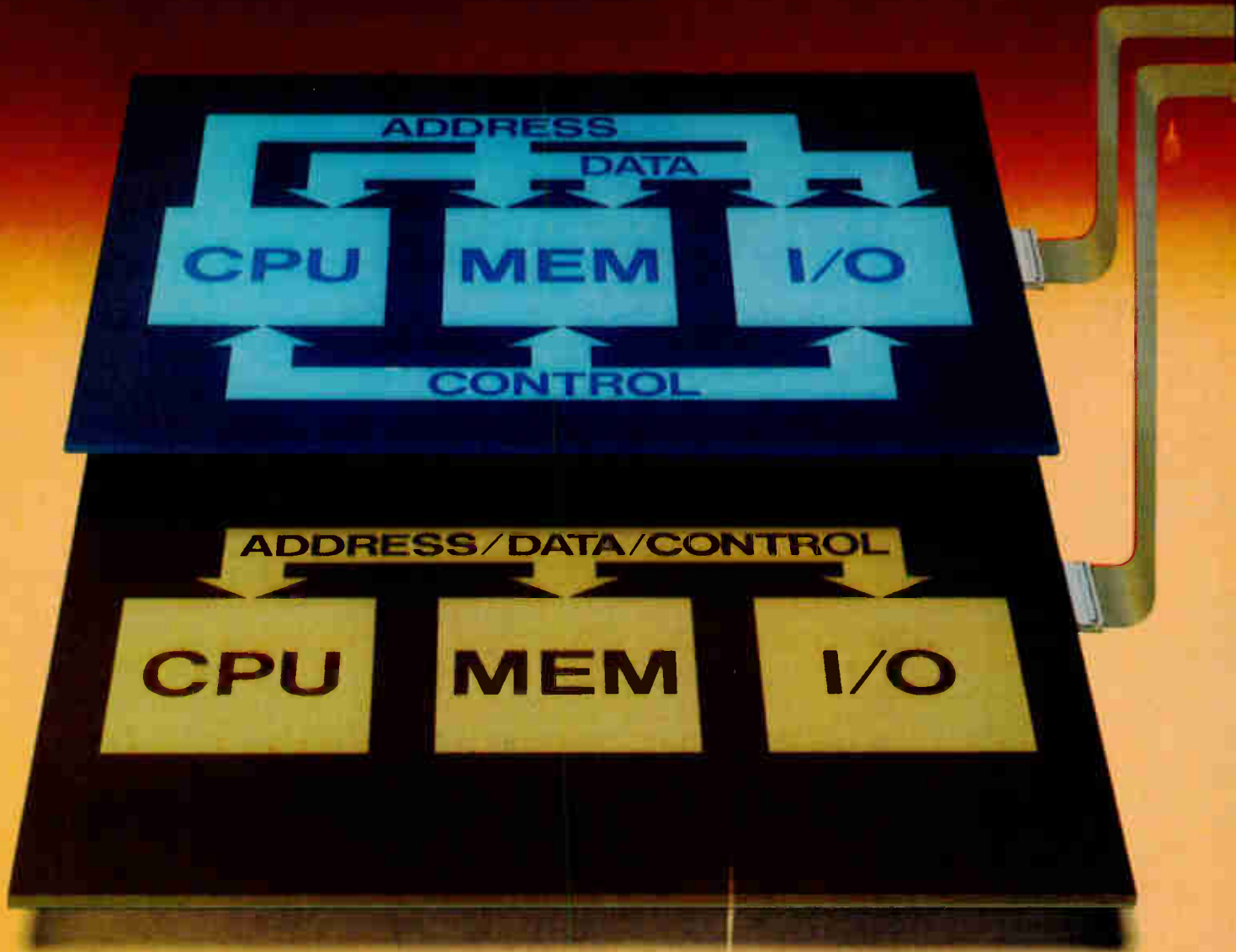

# and leave the analyzing to HP's 1610B.



If you're working with mini- or micro-based systems, you'll find that HP's 1610B is a very efficient dedicated-bus logic state analyzer.

But unlike other analyzers, the HP 1610B can also handle multiplexed-bus analysis just as effectively. The reason? Because with multiplexed buses, addresses and data appear at different times on the same lines. And first-generation logic analyzers, with their single-clock design, simply cannot demultiplex these correctly.

One popular solution to this problem has been to build a two-clock sequential acquisition system into a single package. While this approach will separate out address and read/write functions, it is still inferior to the 1610B. Why? Because this is still not true demultiplexing, in that this technique cannot correct for the real-time differential between the capture of address information and the capture of read/write data.

This means address and data information can be interleaved in the display. It requires the operator to interpret read or write functions. And it means that triggering may occur on false address/data combinations. In other words, it complicates analysis and may lead to false conclusions.

In comparison, the HP 1610B incorporates not two — but three clocks — plus a buffered memory to deliver true demultiplexing. In short, the 1610B can independently monitor addresses, plus read and write data, to demultiplex in real time for efficient and accurate analysis.

So with the 1610B, addresses and corresponding data are displayed as a single line of information, for easy comparison with your original programs. And you're sure that if you trigger on an address-data combination, the data is present at that address at that specific point in the program.

#### **Other important capabilities.**

In addition, the HP 1610B delivers other capabilities required for efficient state flow analysis of both bus structures. It will store information on a qualified basis, to permit selective editing. Which means you don't have to sort through unnecessary data. And it makes functional measurements, such as time

interval analysis, on the state flow, which speeds analysis and troubleshooting.

#### **Flexibility for the future.**

Because the 1610B is a 32-bit analyzer with user-selected parameters, and a variety of options, you can use it with both mini and micro based systems, including 8-bit microprocessors such as the Motorola 6800 and the Intel 8085, as well as the newer 16-bit microprocessors such as the Z8000. And, of course, it includes HP's popular menu program format that speeds set-ups and analysis.

#### **An economical solution to microprocessor-based systems analysis.**

Another good answer to the problem of microprocessor demultiplexing is the 1611A Logic State Analyzer, with HP's general-purpose module. This module incorporates a seven-clock system that allows multiplexed information on common bus structures to be latched into 1611A inputs at the appropriate time for display. If you're already using an HP 1611A, you'll



find this module to be both an effective and cost-efficient solution.

#### **For complete details.**

The HP 1610B is priced at \$12,500,\* while the 1611A (including the general-purpose module) is \$6,000.\* For more information on these, and for an application note on state analysis of multiplexed microprocessors, write: Hewlett-Packard, 1507 Page Mill Road, Palo Alto, CA 94304. Or call the HP regional office nearest you: East (201) 265-5000, West (213) 970-7500, Midwest (312) 255-9800, South (404) 944-1500, Canada (416) 678-9430.

\*Domestic U.S.A. price only



**HEWLETT  
PACKARD**



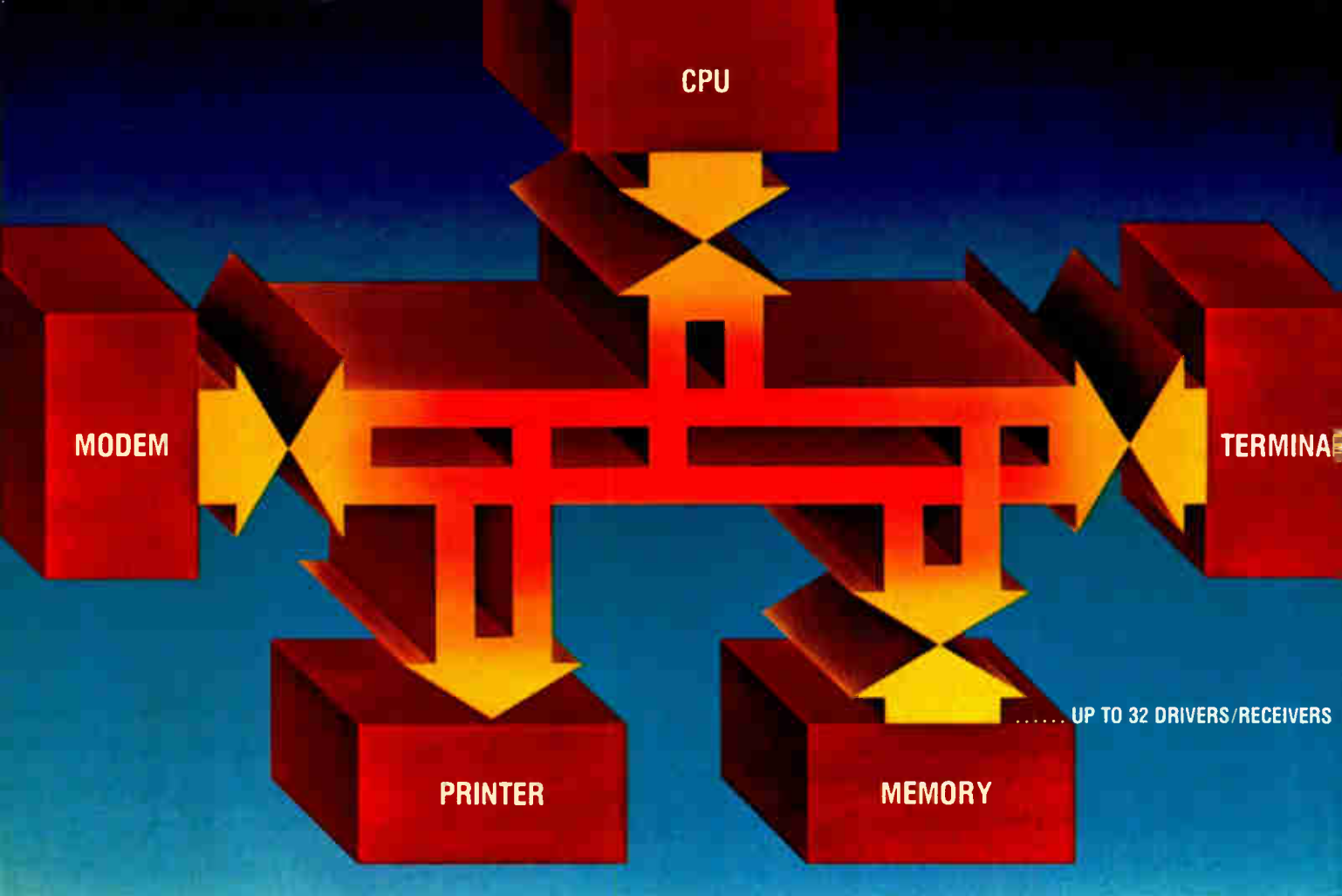

UP TO 32 DRIVERS/RECEIVERS

*More linear firsts from TI . . .*

## RS422 drivers/receivers. For balanced multipoint communication.

Introducing four new interface ICs. Two quad drivers. Two quad receivers. The first interface devices to be designed specifically for balanced multipoint data bus transmission, and meet EIA-RS422 standard.

All of these devices feature broad positive and negative common mode range, operate from a single 5-V supply, have 3-state outputs and very low power requirements.

And, all of these devices are pin-compatible with popular RS422 devices second-sourced by TI, including AM26LS31/32A and MC3487/86.

Up to 32 driver/receiver pairs on a common bus. Another first. A significant innovation that provides an interface for balanced transmission of serial binary information between a host computer and various types of peripheral equipment. Like an input ter-

minal. Or a printer. At data rates up to 10M bits-per-second. Over distances as great as 4 thousand feet.

**Significant features of SN75172/SN75174 drivers** include high output impedance in the third state, over +12 to -7 volts common mode range with power on or off and up to 60 mA output drive capability.

Contention protection, for the case where two or more drivers are simultaneously enabled, is provided by positive and negative current limiting and thermal shutdown circuitry. Maximum standby power is a low 53 mW per channel.

**Receiver circuits SN75173/SN75175**, which meet RS423 as well as RS422, feature +/-200 mV input sensitivity over a common mode range of +12 to -12 V. There's also 50 mV of hysteresis

for increased noise immunity and 12 K ohms minimum input impedance.

These unique characteristics make the driver/receiver pairs ideally suited for party line applications in noisy environments.

Operating from 0 to 70°C, all four new devices are offered in a 16-pin plastic or ceramic DIP.

The 100-piece price for drivers SN75172/SN75174 in the plastic package is \$3.02\*. For receivers SN75173/75175, \$2.23\*.

**Samples are available now** at your nearest authorized TI distributor or local field sales office. For more detailed information, send for our free brochure. Write to Texas Instruments Incorporated, P.O. Box 225012, M/S 308, Dallas, Texas 75265.



**TEXAS INSTRUMENTS**  
INCORPORATED

\*U.S. prices, subject to change without notice.  
© 1980 Texas Instruments Incorporated

Circle 82 on reader service card

82165

## Magnetic field breeds Skylab-like semiconductors

by Charles Cohen, Tokyo bureau manager

By eliminating convection currents in silicon melt, Sony enhances crystal uniformity, chip yields

By fabricating its own silicon ingots, as it did many years ago, Sony Corp. is obtaining wafers that are more uniform, have fewer defects, and warp less during processing than those it has been buying. The decrease in warping especially is credited with increasing the yield of a 4,200-gate television-tuner circuit control from 40% to 70%.

What the company calls a magnetic-field Czochralski process is responsible for these improvements. Although the mechanisms involved are quite different, the results Sony has obtained on earth with silicon are similar to those gotten in Skylab experiments on growing indium antimonide in a weightless environment.

In the conventional Czochralski approach, a seed crystal is immersed in molten silicon heated to about 1,420°C and then rotated while being lifted to grow an ingot of single-crystal silicon. In the Sony method, a strong transverse magnetic field of about 2,000 gauss is used to suppress convection currents in the melt. The silicon then has a smooth surface with a temperature constant to within 0.1°C near the surface and a very low dissolved oxygen content of near optimum value, all of which contribute to growth of a uniform crystal with a low defect density. The low oxygen content further eliminates most warpage and distortion during device fabrication.

(Complete elimination of oxygen is undesirable, though—the optimum range is said to be between 6 and 15 parts per million.)

Molten silicon has a very low resistivity of about  $8 \times 10^{-5}$  ohm-centimeters. The strong magnetic field suppresses motion by inducing in the silicon a current with a force that opposes the original motion in accordance with Lenz's law, so the melt's viscosity increases greatly.

**The status quo.** Normally, convection currents in the crucible agitate its surface, and the temperature near the surface varies erratically by several degrees. The convection currents also accelerate the chemical reaction between the melt and its silica crucible, causing oxygen to dissolve in the molten silicon. Ingots grown under these conditions have striations caused by the irregular growing conditions and segregation of impurities together with defects caused by an excessive amount of oxygen (see figure).

Sony researchers say that wafers

from their new ingots have more uniform resistivity, giving more uniform and stable threshold voltages in MOS transistors. The sharp decrease in crystal defects cuts noise in circuits with low operating currents, including charge-coupled-device image sensors for television cameras, which have many fewer white spots than usual when fabricated on these wafers. Reduction in warping and

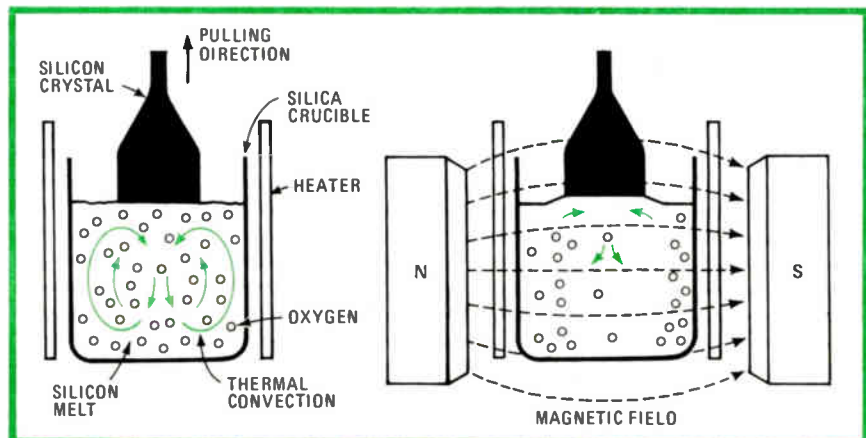
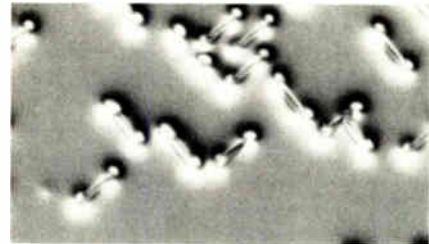

**Crystal clear.** Photos show how oxygen-caused defects vanish when magnetic field (below right) counters convection currents that beset silicon melt in normal Czochralski process.



distortion of course improves the resolution in photolithographic processes, resulting in a higher yield for a given mask set and permitting denser circuits to be made.

The new process shows promise for other applications that Sony has yet to investigate in depth. It will probably be suitable for producing high-resistivity, 150- $\Omega$ -cm ingots for use in thyristors and similar products. Such ingots are usually grown by the floating zone process, as the maximum resistivity for the Czochralski process is usually only 50  $\Omega$ -cm. Furthermore, the stable surface of the melt should be ideal for the lateral growth of ribbons for use in solar cells.

Sony sources say that the electricity consumed by the magnet is about the same as that used by the graphite heaters that hold the melt. Each consumes electricity to the tune of about 2% of the cost of the finished ingots, so the use of the magnets adds about only 2% to the process's running cost.

### Canada

## Signal processor to pick up SOSs

Survivors of an airplane crash or shipwreck may still die if the arrival of help is delayed—as it often is, since even those passenger aircraft or lifeboats that carry emergency locator transmitters (ELTs) can send out only short-range, line-of-sight distress signals.

Soon, however, a sophisticated signal processor made by Canadian Astronautics Ltd. of Ottawa, Ontario, will be deciphering some of those faint signals. It forms part of a project, sponsored by Canada, the U. S., and France, to launch a search and rescue satellite (Sarsat) system capable of spotting marine and aviation distress signals anywhere in the world. However, an experimental system, which is scheduled to go into operation in 1982, will at first limit itself to locating airplane crashes in the U. S. and Canada.

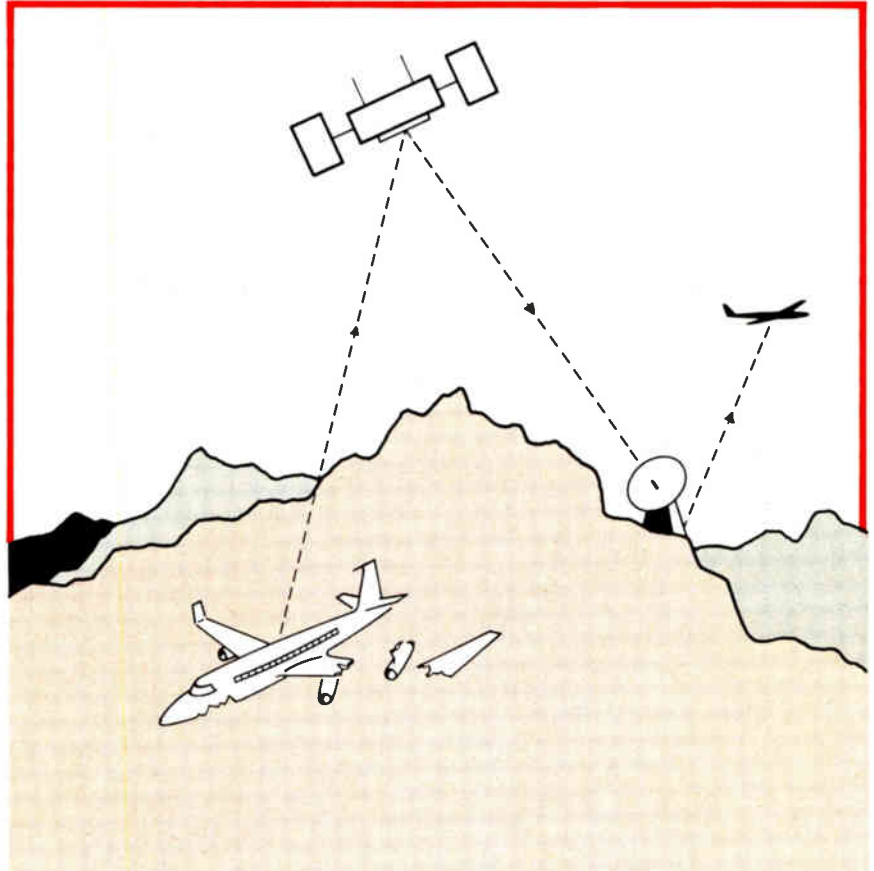

**To the rescue.** Signal processor in Sarsat ground station will have to detect feeble signals from transmitter not designed for satellite use for retransmission to search plane.

Radio receivers and transmitters on low-altitude polar-orbiting satellites will bounce the signals from the scene of an emergency to a ground receiving station every six hours (see figure). Situated in that ground station, the processor will calculate the location of the emergency from the doppler frequency shift of the distress signals as the satellite passes over the ELT. Tests and simulations have shown that the Sarsat system should be able to delimit emergencies to within 20 kilometers—accurate enough to permit search aircraft to home in on the scene.

**Obstacles.** Canadian Astronautics' president Jim Taylor says the processor has to cope with low signal-to-noise ratios and interference: "Even after three years of research we cannot provide all the answers to these problems. The processor has to handle both 121.5- and 243-megahertz distress signals with a high false-alarm rate. Furthermore, to

locate the downed airplane accurately, it must measure frequency with a precision of 0.001% while handling 10 signals simultaneously in a narrow bandwidth."

The signal processor is controlled by a Hewlett-Packard HP 1000F computer and a Floating Point Systems AT120B array processor. "We need as much sophistication as we can get, not only because of the stringent specifications but also because of the unknowns in this new system," Taylor says. These unknowns include error-inducing frequency shifts due to the ionosphere. "The antenna noise temperature the ground station will see is not well known either," he adds.

**Noncoherent.** Poor ELT waveforms are yet another problem for the processor. Relatively inexpensive devices, ELTs are supposed to generate a square-wave-modulated carrier with well-determined mathematical characteristics. In fact, says Taylor,

# YOU KNOW THE LARGEST ELECTRONIC COMPANIES IN THE WORLD. DO YOU KNOW ISKRA?

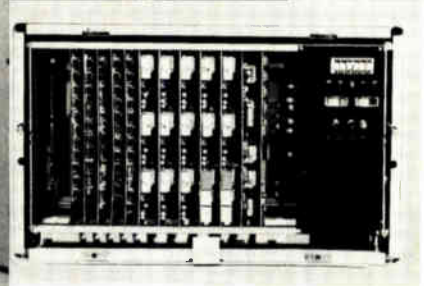
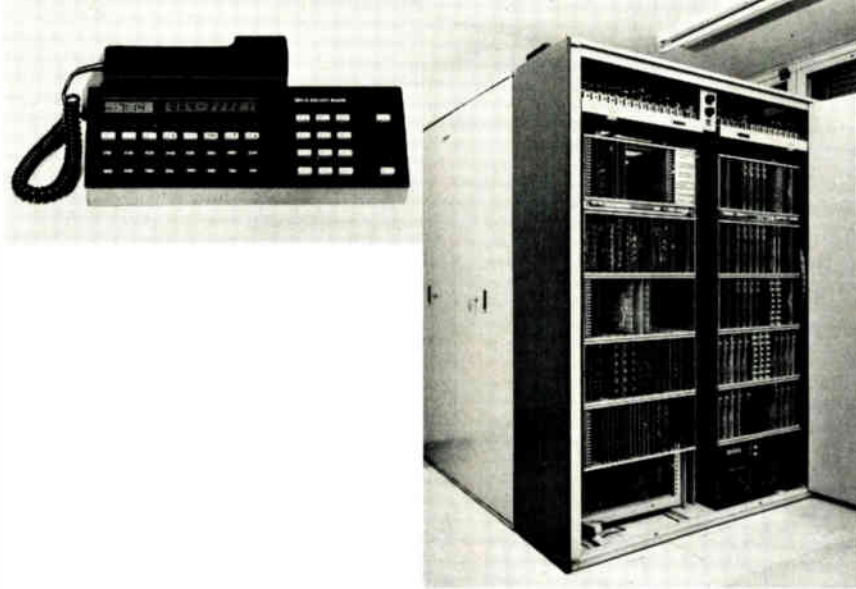

Iskra group has some 29,000 employees including 2,000 research and development engineers in 81 factories, research, marketing and other organizations, and the most up-to-date technologies to work with. With a total turnover of 1.294 billion dollars last year, it has been classified among 16 largest manufacturers of electronic products in Europe.

In its development, Iskra is oriented towards tomorrow's activities which go far beyond the traditional limits of electromechanics and extend to the widest application of electronics with priority being given to the promotion of the development of computers, communications, automation, microelectronics, optoelectronics and engineering activities. All to ensure that every project we handle comes within schedule and budget requirements and meets performance and client expectations.

Iskra has 24 trading companies, representative offices and production plants in 18 countries all over the world. In the period 1974-1979, Iskra's exports increased by 153% reaching 120 million dollars in 1979. In 1980, the total turnover is expected to be 1.486 billions of dollars and the export figure approximately 145 million dollars.

For more information call or write:

Iskra Commerce, Trg revolucije 3, 61001 Ljubljana, Yugoslavia, Telephone-international: + 38 61 324 261; Telex: 31 356 yu iskexp  
 USA: Iskra Electronics Inc., 8 Greenfield Road, Syosset, N.Y. 11791, Tel.: (516) 364 2616—Germany: Iskra Elektronik, GmbH, Furtbachstrasse 2b, 7000 Stuttgart 1, Tel.: (711) 60 30 61—CEFRA, GmbH, Ungererstrasse 40, 8000 München 40, Tel.: 39 20 61—Italy: Iskra Elettronica Italiana, S.r.l., Piazza de Angeli 3, 20 146 Milano, Tel.: 49 80 036—France: Iskra France, 354, rue Lecourbe, 75015 Paris, Tel.: 554 04 27—United Kingdom: Iskra Limited, Surrey CR 3 2 HT, Redlands, Coulsdon, Tel.: 66 87 141—Switzerland: Iskra Electronics AG, Stalden 11, CH 4500 Solothurn, Tel.: (065) 22 81 22—Czechoslovakia: Iskra, Lazarska 5, 11000 Prague, Tel.: 20 27 71—Poland: Iskra, Swietokrzyska 36 m 15, Warsaw, Tel.: 20 12 53—Germany DR: Iskra, Hermann-Maternstrasse 46, 104 Berlin, Tel.: 28 28 322—Rumania: Iskra, Str. Visarion nr. 6, Bucharest, Tel.: 50 26 75—U.S.S.R.: Iskra, Mosfilmovskaja 42, Moscow, Tel.: 147 84 03—Egypt: Iskra, 34 Adly Street, Cairo, Tel.: 74 76 95—Iran: Iskra Teheran, 9th Street No. 6, Maydan Sanai, Teheran, Tel.: 82 67 65—Turkey: Iskra Istanbul, Yenicarsi Biltex Han No. 40, Galatasaray, Tel.: 44 75 00—Venezuela: Eurocommerce S.A., Apartado 68901, Altamira, Caracas, Tel.: 72 88 21.



## Iskra

Circle 85 on reader service card



"it's really a noncoherent carrier signal, and we also have harmonics and incidental frequency modulation to worry about."

Canadian Astronautics has already delivered a prototype processor and is negotiating with the National Aeronautics and Space Administration to provide equipment in the U. S. It will also build a complete ground station near Ottawa under a \$1.5 million contract from the Canadian government's Department of National Defense and Department of Communications.

-Harvey J. Hindin

---

### West Germany

---

## OCR scanner applies for supermarket job

The bar codes that leer incomprehensibly at customers from many packages in today's supermarkets and department stores might start to disappear if a fast new optical-character-recognition scanner from West Germany's Scantron GmbH catches on. Early next year the small Frankfurt company will field-test a number of scanners capable of reading an alphanumeric price and identification label whatever its position in relation to the machine—upside down, skewed, or right way up.

Till now only point-of-sales readers using bar codes have enjoyed this independence of label angle. It has lent them a turn of speed denied to OCR readers, which have required the cashier at a check-out counter to stop and align every item before scanning its label with a wand from left to right. But bar-code approaches have their drawbacks. Besides being baffling to human readers, the code takes up a lot of space on the package and is also expensive to print, since the bar thicknesses and spacings must be maintained to close tolerances.

**Fast.** Scantron's new microprocessor-based scanner combines advantages of both approaches and should therefore have a big impact on retail operations, according to general

manager Hans Scholze. It processes a 22-character label in less than a second, faster than a cashier can slap packages down onto its reading field (see photograph).

However, U. S. and European bar-code experts note that a package cannot be swept past the field but must sit still in it, even if only momentarily. They also say the label can be read at an angle from the horizontal plane of no more than 8°.

**TV resemblance.** For proprietary reasons, Scantron and the unit's developer, the Frankfurt-based Battelle Institute, will discuss the scanning technique used only in general terms. According to Klaus Wevelsiep, head of the Battelle team that developed it, Alpha 1 scans rather like a television camera. At the check-out counter, the cashier puts the article label side down on a reading field, 5 inches in diameter. Though the present scanner handles labels with two lines of up to 11 OCR-A or OCR-B characters, future versions, including those to be field-tested next year, will be able to handle up to three lines of 14 characters.

Below these lines is a standard black and white pattern of three lines. From it, an 8-bit microcom-

puter in the scanner deduces the label's position relative to the reading field and then calculates the coordinate points of the first character in the top information line.

Next, Alpha 1 scans each line character by character, producing a high-resolution pattern of closely spaced black and white dots. The signals representing this pattern are temporarily stored in a solid-state buffer memory. Any dots due to specks of dirt on the label are recognized as erroneous and ignored in the subsequent decoding step.

**The secret.** Using a special algorithm, the decoder analyzes the distribution of light and dark dots and classifies them into groups. A certain sequence of dots corresponds to a certain character. If the scanner detects a character that has been willfully altered—possibly in an attempt to change the price—the reading process stops and an acoustical and optical alarm is given.

Significantly, the Alpha 1 recognizes, stores, and processes a multiple-line dot pattern. This, Wevelsiep says, enables it to read characters printed in the OCR-A, the OCR-B, or any other font. Conventional OCR scanners such as check readers rec-



**Quick study.** TV-camera-like scanner uses 8-bit microcomputer to read 22-character label in less than a second. The goal is to topple bar-code-based systems.

# 300 NANOSECOND VOLTAGE DAC

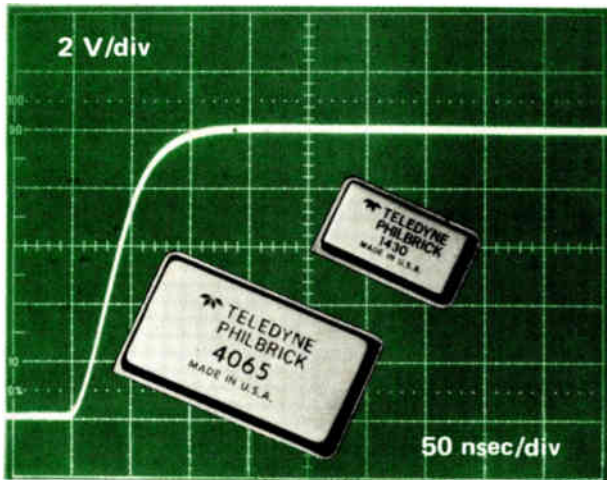

## True 12-Bit D To A Conversion

... is achieved by combining our 4065 current DAC and our 1430 fet operational amplifier. The result is a 12-bit hybrid voltage DAC system with a voltage settling of under 300 nsec to 0.01%. In addition, these units offer operation from  $-55^{\circ}\text{C}$  to  $+125^{\circ}\text{C}$  and the high reliability that is inherent in MIL-STD-883 screening.



DATA CONVERTERS, V/F/V CONVERTERS, LINEARS, NONLINEARS, POWER SUPPLIES  
Allied Drive at Route 128, Dedham, Massachusetts 02026  
Tel: (617) 329-1600 TWX: (710) 348-6726 Telex: 92-4439

Circle 87 on reader service card

## THE ZENDEX "MULTIBUS\* DEBUGGING AID" Model ZX-906 BUS DISPLAY

The Model ZX-906 is designed for use in MDS, SBC or other MULTIBUS-compatible systems. Features 20-Bit Address and 16-Bit Data Hexadecimal Display. Selectors set display for Latch of Memory, I/O and R/W cycles.

Can be set to Latch, On-The-Fly, Data Sent or Read from a particular port or memory address. Single Stepper Circuits provide or allow program stepping and display.

Four LEDs tell you, visually, whether the Master CPU is in Memory Read/Write or I/O Read/Write cycle. Power requirements 5 volts only.

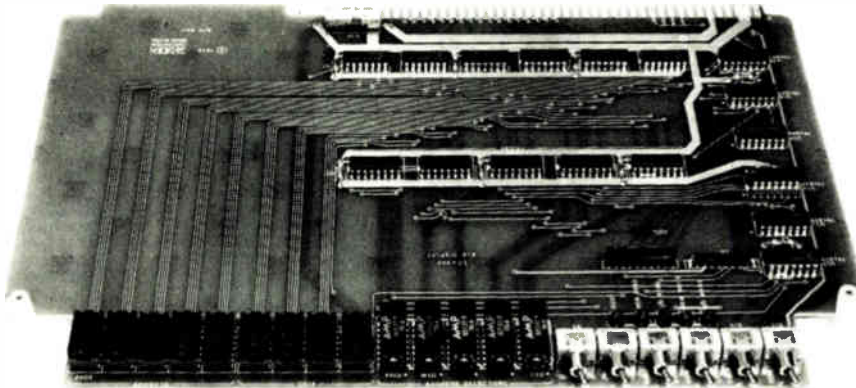

Made in Dublin, † by ...

**Zendex**  
corporation

† 6398 Dougherty Road, #32, Dublin, CA 94566

• (415) 829-1284

\*TM INTEL CORP.



# Have an EMI/RFI PROBLEM?

Let ERIE help  
with an efficient,  
cost effective  
solution.



The world leader in EMI/RFI Filter design and manufacturing offers you complete filtering support . . . from initial design consultation through final testing of the completed filter product.

ERIE does it all! Application assistance, custom design, prototype and high volume production . . . all available from one facility. With our complete performance and environmental test capability, ERIE is your best source for solving EMI/RFI problems.

For 25 years and thousands of designs, ERIE has developed cost efficient solutions in the following EMI/RFI applications:

MILITARY ELECTRONIC SYSTEMS  
HI-REL/AEROSPACE APPLICATIONS  
MEDICAL & TEST INSTRUMENTATION  
INDUSTRIAL SYSTEMS

Write for our complete catalog . . . EMI Filters. Or call 613-392-2581.

# ERIE

ERIE TECHNOLOGICAL PRODUCTS, LTD.  
Trenton, Ontario, Canada  
613-392-2581

## Electronics International

ognize only one-line patterns and can read only one type of character.

The Alpha 1 scanner may be used either on or off line. The decoded output, which is the ASCII representation of the characters, can be fed into any device with a standardized computer interface for inventory control or further processing. It can also be applied to a magnetic-tape cassette.

As all components are off the shelf, commercial units will be priced somewhere between an OCR hand-held scanner and a laser-based bar-code reader. Scholze reports that initial reaction from supermarkets has been highly favorable. He also notes that trade associations are beginning to question the merits of the long-established bar code.

As for other applications for the OCR omnidirectional scanning technique, Scholze expects there to be many, including production and material-flow control and document reading at banks and similar institutions.

-John Gosch

## Lamp aids analysis of still purer alloys

The nickel content of an alloy containing 80% of the metal by weight has been determined to within  $\pm 0.24\%$  by a new West German approach to optical-emission spectroscopy. Other, more complex approaches yield roughly  $\pm 2\%$  errors in analyzing the composition of metallic alloys, whose purity is crucial in advanced semiconductor technologies like Josephson junctions.

The key to Vacuumschmelze GmbH's development is a novel light source—a magnetic-field glow-discharge lamp. The firm is a Siemens subsidiary based in Hanau, near Frankfurt.

In conventional optical-emission spectroanalysis, a small sample of the material is placed in an electric arc or spark chamber, where it is evaporated and excited into emitting light. However, errors are introduced into the subsequent spectral analysis by background radiation.

Also, the melting process can lead to variable rates of material removal and hence to variable results from analysis to analysis.

Vacuumschmelze's lamp is a modification of one it developed a few years ago. As Werner Grimm, its principal inventor, explains it, a cavity in the fist-sized lamp is mounted flush with the polished surface of the material to be analyzed. The material then becomes the lamp's cathode. The space between it and the anode, 0.2 mm away, is evacuated and then filled with a noble gas, like argon, at very low pressure.

**Very cool.** When an acceleration voltage of 800 to 1,200 volts at 80 to 120 milliamperes is applied, a process akin to cathode sputtering spins off minute amounts of the cathode material. The resulting glow light is an optically thin luminous plasma with an ion temperature of only a few hundred kelvin. The absence of any traceable background radiation reduces the error to  $\pm 0.7\%$ .

Using a permanent magnet to act as the anode helps shrink this error to  $\pm 0.3\%$ . The axially magnetized ring-shaped anode, 40 mm in outer diameter, 8 mm in inner diameter, and 15 mm thick, forces the free electrons in the plasma to collide with more of the plasma's atoms. Also contributing to this error reduction is an electrode that protrudes into the plasma and has a positive potential vis-à-vis the anode, further accelerating the electrons.

With this twofold increase in electron current comes an increase in light intensity. This increase in turn translates into a constant material removal rate, which eliminates the need to repeat analyses.

-J. G.

## Italy

## Microcomputer net is ultimate thermostat

Staggering fuel bills and government energy-conservation edicts have prompted many householders in Italy to turn down their thermostats. Further help in kicking the overheat-

# LCD DRIVERS

FOCUS HUGHES EXPERIENCE ON YOUR PROGRAM.

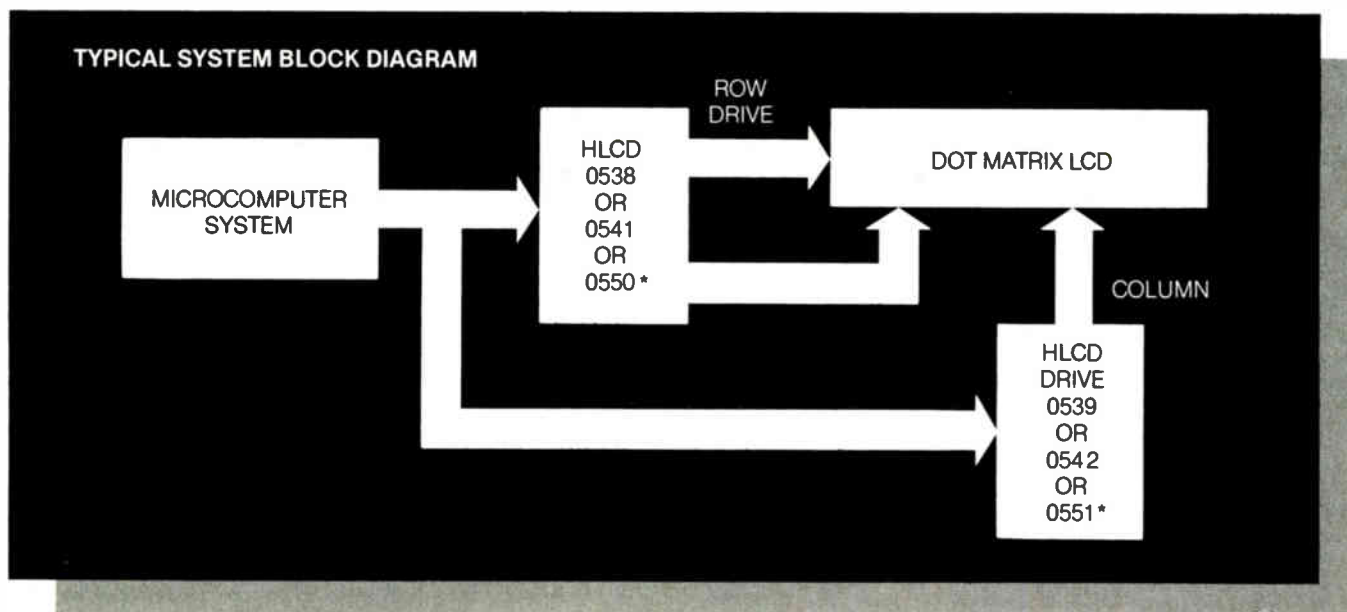

As the first source in LCD Drivers, Hughes-Solid State Products delivers millions of Drivers for products ranging from complex computer chess games to digital volt meters. Hughes standard products drive multiplexed arrays and custom displays, as well as 7 segment numerics. The Drivers are all CMOS and include oscillators, precision voltage dividers, and dual rank latches. Naturally, these circuits are cascadable and microcomputer compatible.

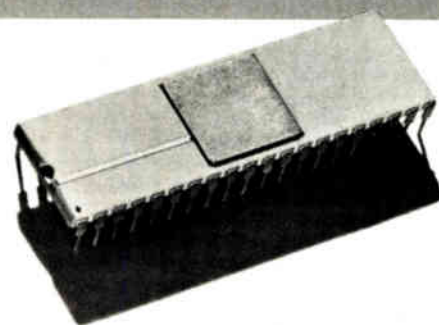

For more information on the only complete line of LCD Drivers, call or write:

**HUGHES**  
HUGHES AIRCRAFT COMPANY  
 SOLID STATE PRODUCTS DIVISION

500 Superior Avenue, D80  
 Newport Beach, California 92663  
 (800) 854-3515 or (714) 759-2942

Circle 89 on reader service card

DRIVER	CAPABILITY
HLCD 0550/1 *	Up to 32 characters, 5 x 7 Dot Matrix. Includes character encode and refresh
HLCD 0541/2 } HLCD 0538/9 }	5 x 7 Dot Matrix or 8 row array with arbitrary number of columns, serial or parallel input
HLCD 0540	Up to 32 x 32 array, 2 circuits required
HLCD 0548	Up to 16 x 16 array
HLCD 0438A	Any LCD, multiplexed or parallel drive, regardless of size
HLCD 0437	4 digit, 7 segment

\*3Q, 1980



ing habit is on the way from the Consorzio per lo Sviluppo dell'Elettronica e L'Automazione (CSEA), a research and development association that groups together 23 small electronics and automation companies from the Piedmont region around Turin. CSEA's contribution: a network of microcomputers that con-

trol the heat in apartment and office buildings room by room through links to a central processor that controls the building's boiler.

According to general manager Giovanni Papa, the network can cut heating costs by some 40% on the average for buildings in climates like northern Italy's. He says the savings

would be enough to amortize over three years the cost of the system—something like \$700 per household. However, microprocessor-based heat-control systems announced last summer in the U.S. [*Electronics*, Aug. 16, p. 48], intended for residential systems and costing much less, have failed to catch on, notes one U.S. company in the field.

CSEA has tried out a pilot version of its system, which is built around Intel 8085 single-chip microcomputers backed by 4 kilobytes of out-boarded read-only memory. *Il caldo robot* (the heat robot), as CSEA calls it at present, "learns" people's heating habits and tries to improve them.

**Mechanics.** Each household has its own microcomputer, which controls radiators in up to seven different rooms, individually or collectively. The householder uses a simple control panel to program "comfort" settings daily for each room and for each hour of the day, as well as to signal if there will be no one around. From this data the local microcomputer develops control signals for three-way valves that regulate the hot-water supply to the radiators, comparing the calculated temperatures with the actual temperature fed to it by a sensor in the room.

If the householder finds a room uncomfortable, he tells the microcomputer. If he doesn't, the system drops the room's temperature every hour until he orders more heat. The microcomputer keeps track of this interplay and thus "learns" his heating habits. The local computer also estimates the heat needed by the household over the hour ahead and compares it with the average consumption throughout the building, figured by the system's central processor—a minicomputer in the pilot system, a microcomputer eventually. The results are displayed on the local panel to show the household how it compares with its neighbors.

Papa has found attentive ears at the state-owned oil company AGIP Spa, which will participate in a field trial starting in September in Turin. He expects the eventual market to run to between 300,000 and 400,000 units.

-Arthur Erikson

# Disk Memory Power Supplies

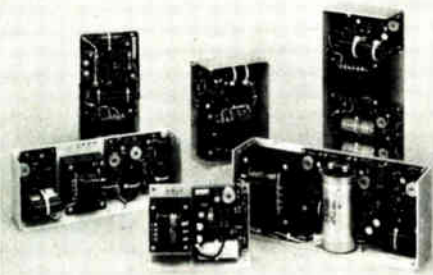

Power-One, a leading supplier to the Disk Drive Industry, now offers a complete line of power supplies for FLOPPY DISK and new WINCHESTER FIXED DISK applications.

Call or Write for our New Catalog.

### WINCHESTER FIXED DISK

SHUGART - CENTURY - MICROPOLIS are just a few drives powered by this new universal model. Powers (1) Winchester drive plus controller circuitry.

1st Output	2nd Output	3rd Output	Model	Price (1-9)
+ 5V @ .9A	- 5V or - 12V @ .8A	+ 24V @ .7A / 4.5A PK	CP384	\$120.00

### FLOPPY DISK - 5 1/4" MEDIA

BASF - SHUGART - PERTEC - SIEMENS plus all other popular 5 1/4" media drives.

1st Output	2nd Output	Model	Price (1-9)
+ 5V @ .5A / .7A PK	+ 12V @ .9A / 1.8A PK	CP340	\$ 44.95
+ 5V @ 2A	+ 12V @ 4A	CP323	\$ 74.95

CP323 powers up to (4) drives simultaneously.

### FLOPPY DISK - 8" MEDIA

SHUGART - PERSCI - CDC - WANGCO plus many other single and multiple drive applications.

1st Output	2nd Output	3rd Output	Model	Price (1-9)
+ 5V @ 1A	- 5V @ .5A	+ 24V @ 1.5A / 1.7A PK	CP205	\$ 69.95
+ 5V @ 2.5A	- 5V @ .5A	+ 24V @ 3A / 3.4A PK	CP206	\$ 91.95
+ 5V @ 3A	- 5V @ .6A	+ 24V @ 5A / 6A PK	CP162	\$120.00
+ 5V @ 1.7A / 2.2A PK	- 5V @ .15A / .2A PK	+ 24V @ .2A / 3A PK	CP272A	\$ 91.95
+ 5V @ 2A	+ 12V @ .4A	- 12V @ .4A	HTAA-16W	\$ 49.95

CP272A powers Persci Drives (includes unregulated 7 - 10V @ 1.2A / 10A PK). HTAA-16W powers Persci controller.



Power One Drive • Camarillo, CA 93010 • (805) 484-2806 • TWX 910-336-1297  
Eastern Regional Headquarters • (518) 399-9200

---

---

**There is only one  
high performance  
VLSI computer  
solution.**

**Intel delivers it.**

---

---



---

---

# Architecture for hi



---

**How Intel's 8086 microsystem, with its powerful structured architecture, helps designers meet the complex performance requirements of the '80s.**

---

You need more than a CPU alone to meet the performance requirements of the '80s, because today's success lies in powerful new, structured approaches to system design. By logically segmenting and distributing system functions, structured design allows greatly increased throughput—and shorter design cycles. For example, with the 8086 family, using classical mainframe multiprocessing techniques, you can achieve I/O bandwidths of from 2 to 20 megabytes per second. That's at least 10 times wider than other systems. The object code for the 8086 family is 30% denser than the code for any other microcomputer available today. And, using our 8087 co-processor, you'll be able to perform 64-bit floating point arithmetic in less than 15 microseconds, surpassing existing systems by factors of 10 to 1000.

Intel's 8086 microsystem is the only 16-bit solution designed specifically to accommodate efficient multiprocessing schemes. What's more, only the 8086 is supported today by the VLSI building blocks you need to implement these high powered multiprocessing designs. Intel's new HMOS\* 8089 I/O processor, for example, can increase through-

---

---

# gher performance.

put by a full order of magnitude in I/O intensive designs. And look to Intel for high-integration co-processors, such as 8087 numerical data processors. They're to help you increase performance in multi-processing systems using our 8086 CPU. Or, for even faster processing, use our new 8086-2. It's the 8MHz CPU, available today, that delivers the top price/performance of any 16-bit microprocessor. Count on Intel for optimum price/performance in the future, too, as we add memory management and protection, and software modules in silicon.

Intel lets you implement powerful designs in an 8-bit format, too, with our 8088. The 8088 is hardware compatible with your 8-bit designs and software compatible with our 8086, to help you get tomorrow's performance in your system today.

You'll find other ways to unburden your CPU and increase throughput with Intel's 5 data communication peripherals, 7 device controllers, 6 slave processors, and 8 system interface circuits—all compatible with the industry standard Multibus™ bus. For high performance program memory, choose from Intel's 16K and 32K EPROMs, including our new high speed 2732A. Intel also delivers the world's largest selection of 5-volt static and dynamic RAMs,

including our new 16K 2118 Dynamic RAM.

## New fluency in high level languages

The trend toward structured high level languages is one more reason to choose Intel's 8086 system solution. Of all the 16-bit microcomputers, only the architecture of the 8086 is made to let designers work effectively in high level languages and achieve fastest possible system through-

put with them. Because the 8086 is memory based, it allows up to 30% shorter high level language object programs and correspondingly faster instruction fetching. And Intel lets you match your language precisely to your task with Pascal, PL/M, our ASM86 macroassembler, and ASM89 assembler. You'll get even more flexibility in the future with Intel's FORTRAN and COBOL.

## Development tools for higher performance

To help designers shorten design cycles and save development costs in the '80s, Intel delivers a full complement of structured software and hardware development tools. Our revolutionary new RMX/86™ multi-tasking operating system, for example, puts you months closer to market with complete file

manipulation, task scheduling, and interrupt capabilities. And since this software package is here today, you can start developing your applications software immediately.

To improve the performance and productivity of your entire development team, use Intel's Intellec® Microcomputer Development System and our ICE-86™ and ICE-88™ In-Circuit Emulators. They're the fastest tools available for developing and debugging 16-bit microcomputer systems. For even faster time to market, get Intel's already tested and debugged iSBC86/12A™ single board computer.

## Meeting the demands of a new decade today

Everything you need to improve performance, reduce complexity, and speed your time to market is here from Intel today. For more information on our complete 8086 VLSI system solution, mail us the coupon on the other side of this page.

\*HMO is a patented Intel process.

intel delivers solutions.

Europe Intel International, Brussels, Belgium.  
Japan Intel Japan, Tokyo, United States and Canadian distributors: Alliance, AImac/Stroum, Arrow Electronics, Avnet Electronics, Component Specialties, Hamilton/Avnet, Hamilton Electro Sales, Harvey, Industrial Components, Pioneer, L. A. Varah, Wyle Distribution Group, Zentronics.

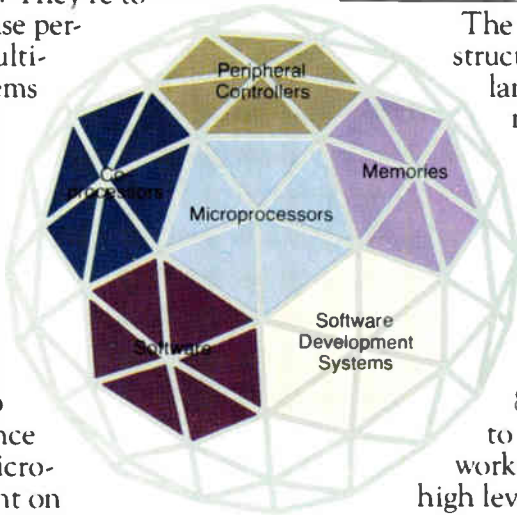

## Intel Structured System

# Your first step toward higher performance

## How to get more information on 8086 VLSI system solutions.

To find out more about our solutions, fill out the information

requested below and send it to Intel Corporation, Literature Department, 3065 Bowers Avenue, Santa Clara, CA 95051. Indicate what your particular interests are, including workshops, and we'll make sure you get the appropriate material. If you don't have a pair

of scissors handy, give us a call at 408/734-8102 (Literature Department) and we'll rush the material out to you. Or call your local Intel distributor.

Intel wants to help you meet the performance requirements of the '80s. It all starts right here.

Name \_\_\_\_\_

Title \_\_\_\_\_

Company \_\_\_\_\_

Division \_\_\_\_\_

Address \_\_\_\_\_

City, State, ZIP \_\_\_\_\_

I have an immediate requirement, please telephone me at ( \_\_\_\_\_ ) \_\_\_\_\_

I need additional information.

Please put the letter corresponding to your yearly requirements in the line to the left of those products of interest.

w for 1-10 per year  
x for 11-99 per year  
y for 99-999 per year  
z for over 1,000 per year

A 16-bit Microprocessors

B 8-bit Microprocessors

C Single-Chip  
Microcontrollers

D Peripheral Controllers

E RAMS

F EPROMS

G Bubbles

H Single Board Computers

I Development Systems

J Debug Tools

K High-Level Languages

( \_\_\_\_\_ )  
Indicate languages

L Macroassembler

M Operating Systems  
(RMX/86™)

N Telecom Products

O Military Products

P Workshops



## IBM ups word-processing ante

Industry giant will aggressively price its Displaywriter as low as \$7,895 and hints at communications interface software to come

by Anthony Durniak, Computers & Peripherals Editor

The company that essentially created the word-processing market almost 16 years ago only to see it slip away, International Business Machines Corp., has a message for its competitors and customers: it will be aggressively competitive once more.

Although its original Magcard Typewriter was innovative, IBM lost ground to a host of competitors (led by Wang Laboratories Inc. and Lanier Business Products Inc.) that based their text-editing systems on cathode-ray-tube terminals. IBM's most recent attempt to stem the tide—the three-year-old Office System/6—was unsuccessful. In fact, some considered IBM “the laughing-stock of the industry,” in the words of William Becklean, securities analyst with Bache Halsey Stuart Shields Inc.'s technology group in Boston.

But now the company's Office Products division has unveiled the Displaywriter, a stand-alone, CRT-based, microprocessor-driven word processor whose price starts at only \$7,895—the lowest in the industry. Clearly, “it's a whole new ball game,” says Amy Wohl, a long-time industry watcher and president of Advanced Office Concepts Corp., Bala Cynwyd, Pa.

Even more significant, however, are the hints IBM gave of what its lineup will be for the rest of the office-of-the-future ball game. Although the Franklin Lakes, N. J.-based Office Products division has been its flagship in this area, confusion arose over which IBM division would handle such products when the General Systems division added its 5520 Administrative System and the Data Processing division

introduced its 3730 Distributed Office Communications System [*Electronics*, Nov. 22, 1979, p. 92].

**Troika approach.** In an unusual “statement of direction” made at the same time the Displaywriter was announced on June 17, the corporation said the three divisions will continue to offer such products and refine their offerings in order to provide “a variety of solutions.” And in a statement bordering on preannouncement, Chauncey I. Bartholet, director of market requirements planning for IBM's corporate marketing department, said the company plans to provide communications “to support the integration of these

products into single, coherent enterprise-wide solutions.”

No one corporate marketing executive will be responsible for coordinating the efforts of the three divisions, he says. Instead, the corporation will depend on the three divisions to “cooperate” in deciding which products are best for a particular customer's problems.

Rather than make the current office products from the three divisions completely compatible with identical instruction sets, data formats, and file structures, the key to their interfacing will be communications, Bartholet says. A new “document interchange architecture,” as

### Spreading the word

Communications is also the underpinnings of a new product from another heavyweight in the office automation market—the Vydec Inc. portion of Exxon Information Systems. Unveiled at the International Word Processing Association's Syntopian show last week, the Florham Park, N. J., firm's new Network System is a communications controller that lets the company's model 1400, 1800, 2000, and 4000 word processors tie to intelligent typewriters from sister Exxon affiliate Qyx and any other word- or data-processing gear that uses a Teletype-compatible asynchronous communications interface.

Based on the Z80A microprocessor from another Exxon affiliate, Zilog Inc., the unit also allows the attached word processors to share up to 75 megabytes of disk storage to create an electronic file cabinet and to send messages in an elementary electronic mail system. The Network controllers will be available in two versions: the S-200 model, which has either a 50- or 75-megabyte disk, will cost between \$20,000 and \$36,000 and will be shipped starting in February; the smaller S-100 controller, with 10 or 20 megabytes of disk storage, will be out in May and sell for between \$10,500 and \$24,000.

The unit obviously provides room for growth—Vydec says the multiprogramming operating system supports virtual addressing capable of accessing up to 16 megabytes of disk memory and is written in Pascal for easy upgrading. Like IBM, which stated that it will provide communications to integrate the parts of its office equipment, Exxon is not pulling its punches. Vydec specifically calls the Network “another step toward advancing the integration of the Exxon Information Systems product line.”

## Probing the news

yet not formally named, is being designed to handle the interfacing task without displacing IBM's current data communications structure as spelled out in its Systems Network Architecture (SNA). Protocol translation and emulation of current terminal protocols will be the key to this architecture.

For example, although asynchronous and Binary Synchronous Communications are the only two communications protocols announced for the Displaywriter, the company said that in the future it will offer for it the Synchronous Data Link Control (SDLC) protocol that is central to SNA. In addition, it will offer the same protocol that is used on the model 3270 data terminals, thus allowing the Displaywriter to access files stored on a System/370 mainframe computer.

Although this capability is still several years away—even elementary communications on the Displaywriter will not be available until August 1981—IBM is obviously notifying its customers and many competitors that it will permit and assist the integration of its word- and data-

processing equipment into a single network that can handle additional tasks like electronic mail.

**Ease of use.** If the Displaywriter is any indication, those future IBM systems will be nothing to sneeze at. Taking to heart criticisms of its earlier products, IBM started from the ground up and paid a lot of attention to human engineering aspects—an increasingly important design criterion in office systems [*Electronics*, March 27, p. 102].

As a result, the display is the largest ever offered by the Office Products division—25 lines—and it tilts and swivels for operator comfort. The difficult-to-learn command codes that characterized the earlier IBM machines are gone. Special-function keys and English-language prompts on the display now help step the operator through the tasks.

A unique feature is its spelling verification function that can check the spelling of some 50,000 words using a proprietary algorithm rather than a lookup table scheme. In addition, the user can add up to 500 specialized words to a dictionary.

To keep the costs down IBM used many off-the-shelf components. The unit is based on Intel's 16-bit 8086 microprocessor and can handle from

160 to 224 kilobytes of random-access-memory—all consisting of 16-K chips purchased from a number of outside vendors.

IBM purchases the monitors from Matsushita Electric Industrial Co.'s Panasonic subsidiary, although it now manufactures its own daisy-wheel printers for the first time. One 284-kilobyte, 8-inch diskette is also included in the system, with a second one optional.

First deliveries of the Displaywriter, which ranges in price up to almost \$10,000, are slated for January. Many in the industry are confident that the schedule gives them plenty of time to respond—if a response is necessary.

**A late 'replacement.'** "It would have been a much stronger product if it came out two years ago," says John Cunningham, executive vice president at Wang, in Lowell, Mass., adding that it does not change his company's product plans or pricing. Despite IBM's statement of direction, he feels "it's just a typewriter replacement and still the approach of a typewriter company. If IBM is to be competitive, its Office Products division must become more of a systems company."

Other vendors, examining the product for the first time at last week's Syntopian, the eighth annual convention of the International Word Processing Association in Minneapolis, said they were similarly unimpressed.

"We're not surprised," says Joe Eichberger, vice president of planning for Raytheon's Lexitron Corp. subsidiary in Chatsworth, Calif. Although he wouldn't specify how his company would respond, he concedes that "it would be naive to say we didn't have any reaction."

Tom Quinn, director of marketing for Micom Data Systems Ltd. of Montreal, says, "Pricing looks great for them, but what it does is more important." Like many others, he feels the IBM system's features are not unique.

Despite the competitors' confidence, analyst Wohl expects the Displaywriter's prices to force some "rearrangements" in the industry. And from now on, "one has to take IBM a lot more seriously in office automation," she says. □



**Wordsmith.** Displaywriter, with its desktop display, printers, and diskette storage, checks the spelling of 50,000 different words.



# See SCOUT save.

SCOUT™ has a red light. It does not mean what you think. The red light says one of SCOUT's boards does not feel well.

Will this make you sad because your minicomputer can't play anymore?

Will the expensive repairman take a long time to get it fixed?

No no, silly. Since SCOUT's ISOLITE™

showed you which card is bad, all you do is pull it out and put in a spare 6.25" x 8.3" card.

What fun! Now SCOUT can run and play again. And save you a lot of jack.

Save SCOUT, save.

Save on service costs. Save on system costs.

Save on 16-bit minicomputer performance. SCOUT starts at less than \$1000 for a CPU, I/O, 32K Byte RAM and card cage.

Isn't saving fun? Save SCOUT, save.

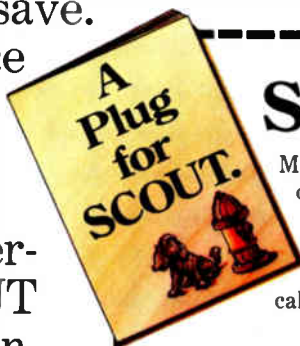
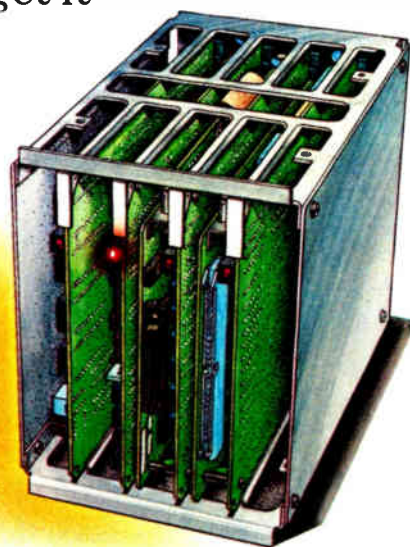

## See SCOUT save.

Money. Time. And end user aggravation. Plus other ways to save in our how-to-save-on-maintenance primer, *A Plug for SCOUT*. Get your free copy with this coupon and a business card. Or, for immediate information call 714/833-8830, Ext. 455.

Name \_\_\_\_\_ Title \_\_\_\_\_

Company \_\_\_\_\_

Address \_\_\_\_\_

City \_\_\_\_\_ State \_\_\_\_\_ Zip \_\_\_\_\_



**ComputerAutomation**

NAKED MINI® Division

*Where OEM's come first.*

18651 Von Karman, Irvine, CA 92713

SCOUT and ISOLITE are registered trademarks of Computer Automation Inc.



# CMOS/LSI LIQUID CRYSTAL DISPLAY DRIVERS

# EASY DRIVER

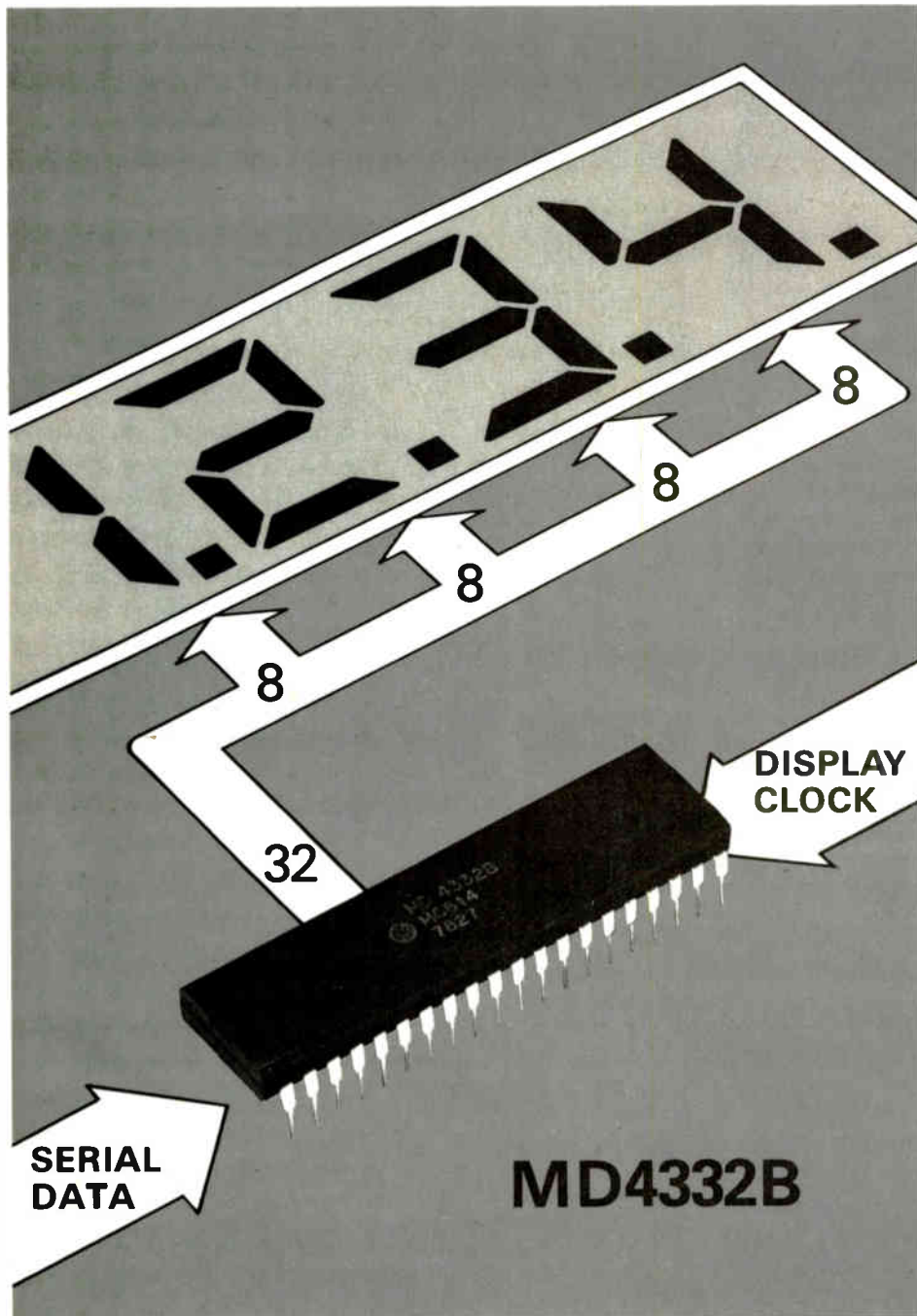

Until now you've needed an assortment of drivers, gates and buffers for your LCD Displays. That's all over. Mitel Semiconductor has designed a series of single chip CMOS LCD drivers. The MD4330B family: an easy, practical complement to your elegant, practical design.

The CMOS, MD4330B and MD4332B are 30 and 32 bit, Static Shift Registers. Each circuit can directly drive 30 or 32 LCD Segments. For example the MD4332B will drive two 16 segment characters. True and complementing output buffer control provides direct A.C. drive to the LCD. A single output pin allows cascading of devices for driving displays with a large number of characters.

#### MD4330B, and MD4332B Common Features:

- 1 $\mu$ A Low Power CMOS
- 3 to 15 volt Single Supply
- Waveshaping Clock Input
- 3MHz High Speed Shift Register
- 40 Pin Dual-In-Line package

Mitel also offers the following additional display drivers for a variety of applications:

#### Type

- MD 4055B BCD to 7 segment, Level shifting and output clock LCD driver
- MD 4056B Latched BCD to 7 segment, Level shifting LCD driver
- MD 4311B Latched Hexadecimal to 7 segment, high current, Common Anode LED display drivers
- MD 4511B Latched BCD to 7 segment, high current, Common Anode LED display driver
- MD 4368B Hexadecimal to 7 segment, high current, Common Anode LED display driver. Pin for pin with 9368, TTL.

All of the above circuits are available from stock.

For further information and data please contact your nearest Mitel office.



## MITEL SEMICONDUCTOR

United States: 1735 Jefferson Davis Highway, Suite 1009, Arlington, Virginia, U.S.A. 22202. Telephone (703) 243-1600  
1223 Westchester Pike, Havertown, Pennsylvania, U.S.A. 19083. Telephone (215) 449-5556.  
2321 Morena Blvd., Suite M, San Diego, California, U.S.A. 92110. Telephone (714) 276-3421.

Canada: P.O. Box 13089, Kanata, Ottawa, Ontario, Canada K2K 1X3. Telephone (613) 592-2122, Telex: 053-4596, TWX: 610-562-8529.

18 Airport Blvd., Bromont, Quebec, Canada J0E 1L0. Telephone (514) 534-2321, Telex: 05-267474.

Europe: Hamilton Road, Slough, Berkshire, England SL1 4QY. Telephone 0753-36137, 0753-36138, Telex: 847730  
Fredericiagade 16, Suite 309, 1310 Copenhagen K, Denmark. Telephone (01) 119302, Telex: 27246

Asia: TST P.O. Box 98577, Kowloon, Hong Kong, Telex: 64235-Mitel HX

Circle 98 on reader service card

Consumer electronics

# Hand-held computers star at CES

Portable terminals are expected to find a market among businessmen who need data while traveling, but not in the consumer sector

by Larry Marion, Chicago bureau manager

A new generation of personal computers, portable or hand-held models that retail for a fraction of the cost of desktop models, was the bright light that shone through a dismal economic picture at the Summer Consumer Electronics Show in Chicago last month. Upgraded language translators or entirely new designs that cost little more than the translators, the forthcoming \$200-and-up models excited buyers from the traditional audio shops looking for new and profitable products to shore up weak sales and marginal income from home and car stereo and video appliances. However, despite the new low prices, the business community is the only marketplace in sight.

Low-cost computing power is the only common denominator among the portable electronic terminals from Quasar, Panasonic, Nixdorf, Sinclair, Commodore, and Sharp—companies that showed prototypes or production hardware to the thinner than expected crowds at the CES. Each is expected initially to attract businessmen who need an intelligent terminal while traveling, but not the mass-market consumer.

Existing leaders in the personal computer market do not feel threatened by the prices, and the long-feared onslaught of Japanese computers seems years away. The development of software for the American market will prove too difficult for Oriental programmers to master in the next few years, explains Sy Lipper, president of APF Electronics Inc., New York: "It's not like producing a calculator; you need to understand American thinking."

Support for the concept that the new hand-held units do not compete

with desktop models—they cost less and have limited displays of perhaps 16 characters, compared with the cathode-ray-tube displays used with the desktop types; memory capacity is considerably less; and they lack a typewriter-sized keyboard—comes from an established personal computer maker now entering the portable field. Commodore International Ltd. showed engineering prototypes of a new "Minipet" or "Micropet," with the name depending on which employee was giving the demonstration. Each of the three prototypes contained a snap-action solid-state keyboard with a typewriterlike arrangement of the letters, a separate numerical keypad, and the 6502 microprocessor already used in the Norristown, Pa., company's popular line of Pet desktop computers.

The new low-cost version will retail for \$199, but will display only black and white images on the home television set; the color version is targeted at about \$299, depending on the amount of read-only and ran-

dom-access memory. Retailers are due to get them next year. A Commodore source says that the production models will contain 4 to 16 kilobytes of RAM and less than 12 of ROM with Basic, and a liquid-crystal display may be included to supplement the TV capability. The company has a \$500 target for a system with a cassette tape player for mass storage and a printer.

**Another road.** That type of marketing package is not on a collision course with the computer terminal now marketed by Nixdorf Computer Personal Systems Inc. of Burlington, Mass., which is based on a language translator first developed by Lexicon Corp. of Miami, Fla. [*Electronics*, Dec. 7, 1978, p. 50]. For one thing, the Nixdorf communications unit is not portable. For another, it is tailored to the needs of the hobbyist for use in the home. In contrast, Commodore's type is designed to accompany the businessman on his or her travels. Nixdorf and Lexicon already have a modem and an RS-



**Handy data.** This is the central processor for Panasonic's hand-held computer. Peripherals are packed in an attaché case. ROM capacity is about 40,000 words, RAM is 73 kilobytes.



## Probing the news

232 interface ready and are working on a printer and additional memory modules.

Explains Michael Levy, Lexicon president, "We're going to see hand-held computers used more and more by big companies with a large sales force. A salesman with access to his company's computer could sit at a customer's facility and get things like the exact status of an order, inventory situation, or price quotes." The recently announced Quasar and Panasonic units come in specially designed attache cases to facilitate that type of use, as well as with higher prices because of the additional RAM, ROM, and higher-performance features [*Electronics*, June 19, 1980, p. 46]. They also offer a modem and an acoustic coupler.

As usual with a new class of product, though, there is little agreement about priorities and even less standardization. For, example, a modem and communications interface is not a high priority for developers of the \$200 Sinclair ZX80 hand-held computer introduced earlier this year in Great Britain, says Nigel Searle, executive vice president of Sinclair Research Ltd., Cambridge [*Electronics*, Feb. 14, p. 80]. The Z80-based unit with a membrane keyboard is designed as an intelligent terminal

for a stand-alone application, he says, and additional peripherals and software are on his wish list.

**Eyeing the masses.** Overall, the new hand-helds and the desktop personal computers are still trying to hit the mass market. Several joint ventures by retailers and personal computer companies are growing. In one, Ohio Scientific Inc., Aurora, Ohio, will expand its role with retailing giant Montgomery Ward & Co. The St. Paul, Minn., Ward's experiment with the low end of the Ohio Scientific line will grow to about 100 stores nationwide by year-end because the Minnesota computer store generated five times the average revenue per square foot, claims Charity Cheiky, Ohio Scientific president.

Ward, Ohio Scientific, and franchised dealers around the country have established a unique agreement that may provide the elusive key to selling high technology in the mass market—Ohio Scientific's dealers will operate the majority of Ward's computer stores, providing the expertise and stable staff resources that are lacking at the typical mass merchandiser.

Meanwhile, other personal computer makers showed expanded software libraries and peripheral lineups to broaden their appeal to the ultimate consumer, the mass market buyer. While marketers at Atari, Mattel, and elsewhere say they are

satisfied with their slow but steady progress down the learning curve, they are also groping for a magical combination of price, hardware, software, and promotion that will expand their potential beyond the hobbyist and small-business markets.

But for the hand-held machines really to prosper, comments one knowledgeable person in the field who asks not to be identified, further developments in semiconductor technology are required. That expert ticks off such items as more memory, elimination of the attache case holding the computer's memory and acoustic coupler and the like, and longer operation—say, up to eight hours—between battery changes.

**Games fade.** On other fronts, even the shiniest consumer electronics product loses some of its luster in a recession, and the troubled economic climate has taken its toll of the truly spectacular growth of hand-held electronic games. Instead of doubling retail sales in 1980 compared with 1979, hand-held sports, strategy, and self-improvement games will be lucky to achieve a 50% boost to \$750 million at retail, concede some manufacturers' officials, with a few optimists insisting that the \$1 billion target is possible.

The slower growth results from an embarrassing excess of inventory for some products from some manufacturers after last Christmas, which led to discounting and dumping early in 1980 and strained relations between retailers and manufacturers. Retailers blamed manufacturers for proliferating games and then threatening shortages, and manufacturers faulted retailers for overordering. This situation was in marked contrast to the shortage that prevailed during the 1978 holiday selling season.

The smaller game makers are easing out of the most competitive segment, sports games, and into the more family-oriented strategy games. Now that the demand "for anything with the word 'electronic' on the box and light-emitting diodes inside" has diminished, notes one manufacturer, a broader array of nonduplicative products should help calm the electronic toy industry into a more orderly growth pattern. □



**Shown off.** Atari's line includes, clockwise from lower right, modem, microcomputer, thermal printer, interface module, program recorder, impact printer, dual disk drive, disk drive.



# The logic of logic analysis

DOLCH introduces the world's first 48-channel logic analyzer



Trace it all, and fast . . .

If you're switching from 8 to 16 bit microprocessors, make sure your logic analyzer can support the move. An adequate number of input channels is the prime prerequisite for 16-bit-uP testing.

Dolch's LAM 4850 is not only the record holder with 48 input channels, it offers you even more of the world's first features such as 3 level simultaneous clocking to untangle multiplexed bus signals or "trigger tracing" that lets you examine nested program execution in real time.

It's features include:

- 1024 bits recording and reference memory per channel
- sampling rates DC to 50 MHz
- 5 ns glitch capability
- 4 level sequential triggering
- binary, hex, octal, ASCII and mnemonics display
- 16-channel x 2048 timing display
- IEEE interface (optional)

Visit our Booth at WESCON 101

**dli** **DOLCH**  
LOGIC INSTRUMENTS

In the United States contact:  
Kontron Electronic Inc.,  
700 South Claremont Street,  
San Mateo, California 94402



Data communications

# Can software do encryption job?

In the face of standards agency's recognition of hardware only and objections of chip makers, versions are appearing

by Deborah Williams, McGraw-Hill Publications Co., and Harvey J. Hindin, Communications & Microwave Editor

When the National Bureau of Standards published its data encryption standard (DES) three years ago, it stated that only hardware implementations would be certified. Although there was nothing in the algorithm precluding it, software was considered too slow, difficult to validate, and subject to unauthorized modification. So hardware manufacturers took advantage of the opportunity to develop special DES chips.

But undaunted by the lack of NBS blessing, software experts continued to work on their versions and the results are coming in. For example, Richard Gumpertz, an associate in

the computer science department at Carnegie-Mellon University in Pittsburgh, has implemented a DES program for a variety of computers that gives results as good as or better than those of existing hardware.

Not everyone is happy with this development. First, there is an ongoing controversy over why the NBS did not certify software in the first place; also, hardware manufacturers question software's security and decry its impact on their market. On the bright side, industry experts agree that fast software will expand the sluggish encryption market itself [*Electronics*, June 5, p. 96].

Not against software per se, the NBS "uses software for DES testing," says Dennis Branstad, director of NBS computer security there. He adds that "it's not impossible that the bureau would consider a DES for software."

**Why the delay?** The NBS originally estimated that the software implementation of a standard 64-bit data block would take 30 to 200 microseconds. That is the equivalent of a data rate of 0.3 to 2.0 kilobits per second, which is not at all suitable for high-speed communications or computer links. But Gumpertz determined that one of the reasons a programmed

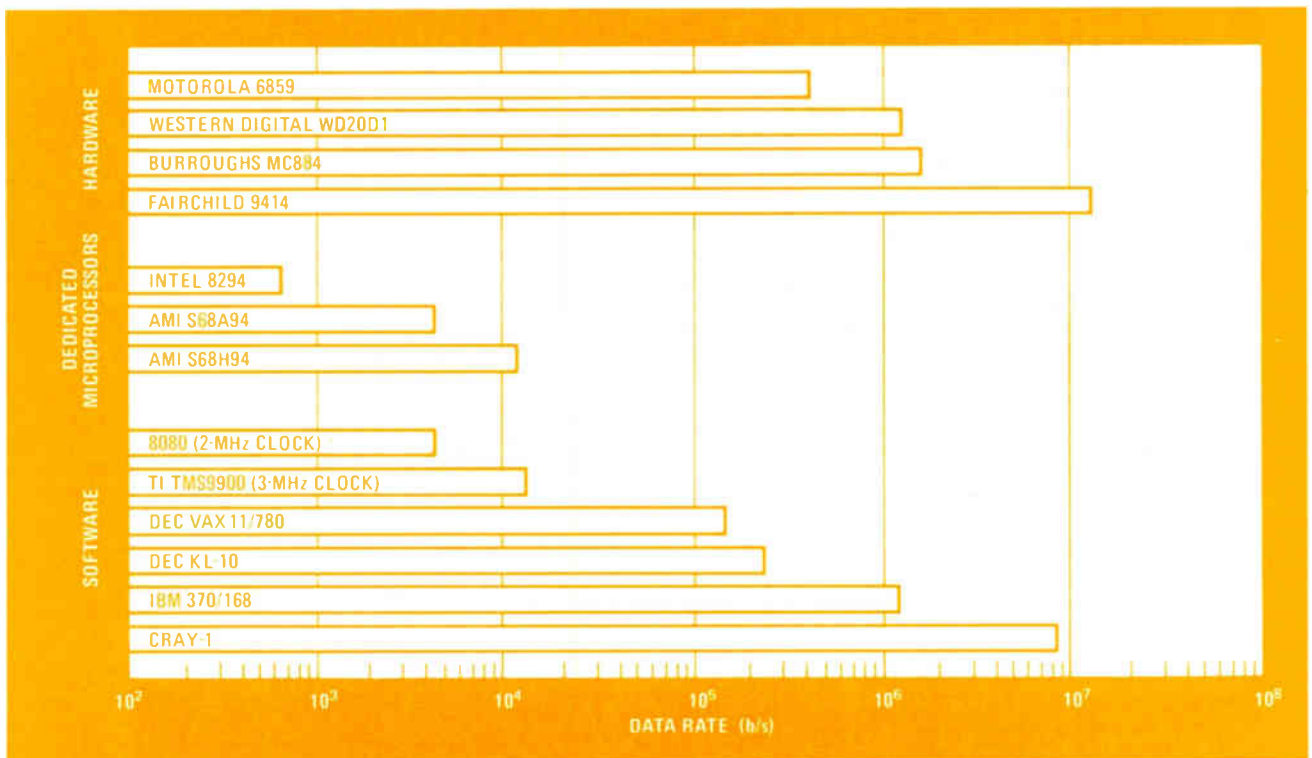

**Fast approaches.** Gumpertz's program yields throughputs in the popular block-cipher mode that are on a par with hardware speeds (compare bottom six bars with top seven). The time to get data to and from the computer is not included in the calculation, nor are computer interrupts.

implementation is slow is that the typical computer is not equipped with the right data paths for the necessary DES algorithm manipulations.

Making fast software harder to develop are the initial and final permutation steps in the algorithm. These two mathematical manipulations, difficult to implement in software, greatly increase a program's execution time. Gumpertz suggests that they were included in the DES both to ease some hardware designs and to discourage software.

The algorithm's 16 internal expansion cycles, each of which requires eight arithmetic manipulations, present another obstacle. For Gumpertz this was the principal bottleneck to a fast program and took up more than half the execution time. "The instruction sets of typical computers do not offer much assistance in implementing the expansion operations," he explains.

Gumpertz's program finally overcame all these obstacles without needing much computer space. Only 150 bytes are required for the data, and 2.5 kilobytes are needed for the program. "The program does not take up much space because most of the time is spent doing the same thing over and over," he says. "Furthermore, few temporary locations are needed for intermediate results," he concludes.

**Same difference.** For Steven Kent, too, software is the way to go. Asked to compare his approach with Gumpertz's, the research assistant at the Massachusetts Institute of Technology in Cambridge, Mass., says that his group's program does not combine operations in the same way nor does it have the problem with the expansion cycles.

"Our timing is fairly compatible with Gumpertz's but our implementation doesn't have the same combination of operations. I assure you that the expansion steps don't have to be a limitation to a fast DES. Gumpertz is doing it just one way of the many possible," he says. Kent's group sold an IBM System/370 program to a mainframe manufacturer for \$10,000, but he says that similar versions could be sold for less.

In contrast to Gumpertz and Kent, Herbert Bright, president of

Computation Planning Inc. in Bethesda, Md., has been marketing software-encryption systems since 1975. His \$4,700 Desqik package does the algorithm at 38 kilobytes per second on machines in the Amdahl 470V/6 class. He says business in the first four months of 1980 was better than for the last four and a half years, although he will not give figures.

Of course, some of Gumpertz's assumptions are challenged by the hardware people. Says Ken Cohen, security product line manager at Western Digital Corp. of Newport Beach, Calif., "I think Gumpertz has demonstrated that it is possible to write an efficient DES program, but I question how fast some of the subroutines—particularly in the Cray-1—would be in an interrupt environment. In the real world, that machine has to be doing things such as collecting data from a communications line or a disk, decrypting it, and passing it off to an applications program. What happens to the speed of the algorithm in that environment, what happens when encryption is fighting for priority in the stack of jobs to be run and the processor is handling many input/output interrupts?"

**Occasional.** Cohen also questions the enormous cost of running a machine when inexpensive hardware is available. Gumpertz acknowledges that it may not be fair to compare the \$10 million Cray to a chip. But he suggests that a general-purpose processor would be more economical if encryption is not often used.

The occasional-use problem is only one of several reasons to consider software in the first place. Perhaps more important, according to Gumpertz, the appropriate interfacing circuitry may not be available.

Gumpertz adds that once software encryption is installed, it can be used on data other than that being transmitted or received over one particular channel. "This flexibility can be very useful. Consider, for example, data on a magnetic tape. Even if there is already DES hardware on site, it probably has been wired into the communications system and so cannot be used for this purpose. On the other hand, a subroutine can trivially be used to massage data before writing it on tape," he says. □

# Im agi na tion

is just one of our advantages. Others are reliability, versatility and combat-proven use.

We offer you custom-designed electronic equipment and systems for military microwave communications (command, control, data) and power.

Try us for communications systems

- airborne and other military power supplies and converters
- pulse radar altimeters
- proximity fuzes for artillery and mortars.

**Tell us what you need.**

 **telkooor** LTD  
electronics industries

Marketing Manager  
P.O.B. 76, Petah Tikva, Israel  
Tel. 03—903661-3,  
Telex: 341993 MAAC IL.

A subsidiary of Koor Electric & Electronics Ltd



Careers

# R&D unites companies, colleges

Industry's investments in research partnerships pays off in form of more qualified personnel and in technological advances

by Pamela Hamilton, New York bureau manager

Electronics companies are turning increasingly to the campus for aid in research needed to solve technological problems. At the same time, they are responding to a need on the part of the universities to convince graduates to stay on for advanced training by providing the wherewithal for hands-on experience with the expensive equipment used in such areas as semiconductor processing, computer-aided design, and software development.

Underscoring the effort is a picture of a set of industries having a difficult time locating quality professionals and having to spend a good deal of money on recruiting those that are available [*Electronics*, June 19, p. 91]. Technology is advancing at such a rapid rate that the demand for experienced, knowledgeable practitioners far outstrips the supply. Not only that, but engineers with a few years in the field have to replenish their technological skills more frequently than ever before. Finally, high-technology innovation is no longer the private picnic ground of U.S. companies, and research and development centers need economic bolstering and infusions of fresh ideas and people.

Companies have begun to address these problems by supplying funds for research projects, grants for graduate fellowships, and monies for capital equipment. Such programs may involve many companies interested in consolidating their resources for basic research or a single firm concerned about a particular product. The funding for projects varies from a few thousand dollars to several million; schools receiving these funds may be small local institutions

or larger centers of learning with a wider following.

**Resource pooling.** The California Institute of Technology in Pasadena has organized a program to explore very large-scale integrated-circuit design and development. Begun in 1978, the Silicon Structures Program has a budget of slightly more than \$250,000 per year, with funding from seven companies each contributing \$100,000. The remaining \$500,000 or so goes for equipment and the use of campus facilities. The participating companies are IBM, Digital Equipment Corp., Honeywell, Xerox, Intel, Burroughs, and Hewlett-Packard.

The Center for Microelectronics and Information Sciences at the University of Minnesota in Minneapolis is another joint endeavor, although more recently started [*Electronics*, April 24, p. 98]. The industrial participants so far are Control Data Corp. and Honeywell

Inc., each contributing about \$2 million. "We're all in the same boat. If we could combine our efforts via university-based research and development, we'd all benefit," explains Wallace W. Lindemann, vice president of the computer components division of CDC.

**Back to school.** Starting this fall, the Massachusetts Institute of Technology will be offering a graduate course with the title, "Program Development Workshop." Stanley Rich, an adjunct professor, is heading the program.

The workshop is organized so that industry comes to MIT with a specific problem in mind and then students from the engineering department work on it for a semester or possibly longer. "We essentially function as an R&D center for a company," says Rich. Four students will be assigned to each task: one to oversee the pertinent competitive and legal literature, one to develop quantitative specifications, and two to do the actual technical work. Nine companies have been selected to participate so far. The chair Rich holds has been endowed with \$1 million by Bernard M. Gordon of Analogic Corp.; the companies pay nothing except incurred expenses but must supply any capital equipment.

At Rensselaer Polytechnic Institute, Troy, N. Y., General Electric, Boeing, and General Motors provided about \$1 million in seed money last year to start the Center for Manufacturing Productivity and Technology Transfer. "The center was established to influence students to go into manufacturing areas," notes Christopher W. Le Maistre, associate director. Companies are



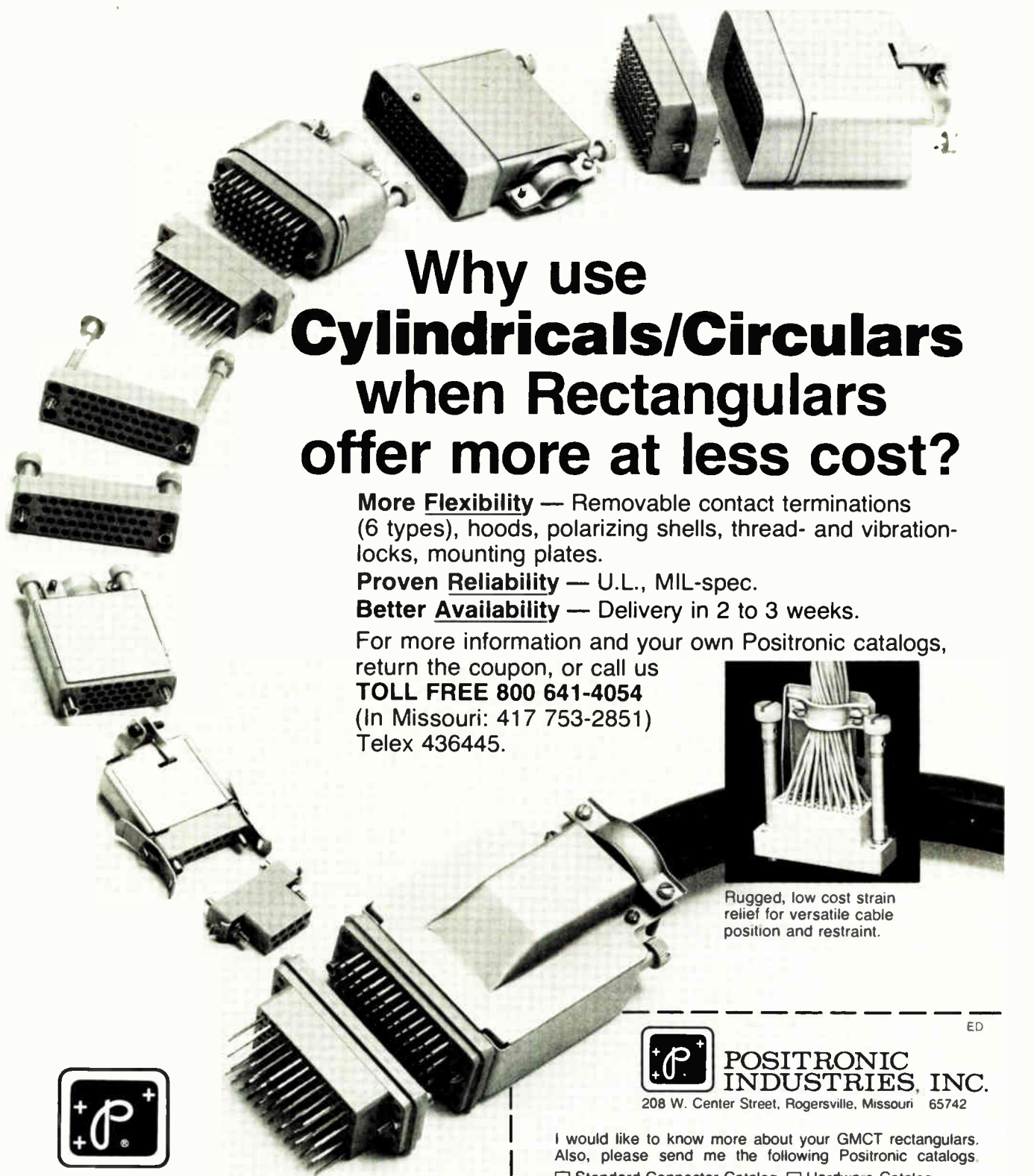

# Why use Cylindricals/Circulars when Rectangulars offer more at less cost?

**More Flexibility** — Removable contact terminations (6 types), hoods, polarizing shells, thread- and vibration-locks, mounting plates.

**Proven Reliability** — U.L., MIL-spec.

**Better Availability** — Delivery in 2 to 3 weeks.

For more information and your own Positronic catalogs, return the coupon, or call us

**TOLL FREE 800 641-4054**

(In Missouri: 417 753-2851)

Telex 436445.

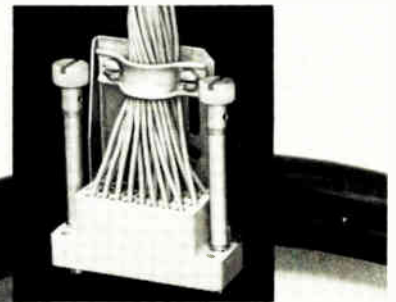

Rugged, low cost strain relief for versatile cable position and restraint.



**POSITRONIC  
INDUSTRIES, INC.**

208 W. Center Street, Rogersville, Missouri 65742

If the coupon to the right is missing,  
please write, or call us TOLL FREE.



**POSITRONIC  
INDUSTRIES, INC.**

208 W. Center Street, Rogersville, Missouri 65742

ED

I would like to know more about your GMCT rectangulars. Also, please send me the following Positronic catalogs.

- Standard Connector Catalog  Hardware Catalog  
 Subminiature-D Connector Catalog

Name \_\_\_\_\_ Title \_\_\_\_\_

Company \_\_\_\_\_

Address \_\_\_\_\_

City/State/Zip \_\_\_\_\_

Area Code \_\_\_\_\_ Phone \_\_\_\_\_



**For IN-STOCK,  
Interchangeable\* DPM's  
Call the Gralex HOT LINE  
516-694-3600 x300.**

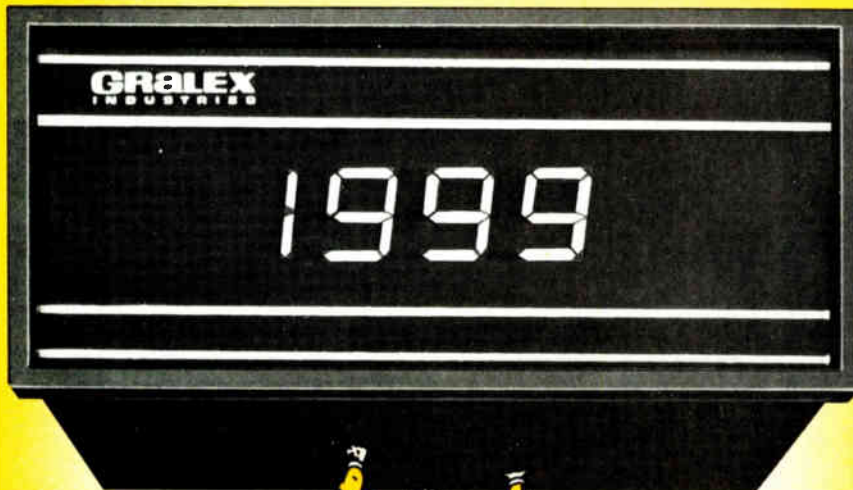

Gralex Model 38-2 bipolar, 3½ digit DPMs are in stock at one of our worldwide local distributors for fast delivery to satisfy your immediate needs.



The unit features LSI circuits, 0.6" LED readouts, BCD and ratiometric options, floating differential input and a NEMA case.

CALL x300 for delivery information and x215 for applications assistance...or send for specification sheets.

\*Pin for pin interchangeable with Weston Models 2461, 2462, 2463 & 2464.

**GRALEX**  
INDUSTRIES

A GENERAL MICROWAVE DIVISION  
155 MARINE ST., FARMINGDALE, N.Y. 11735  
TEL. 516-694-3600 • TWX 510-224-6406

Circle 106 on reader service card

**Probing the news**

charged for the work the center does—solving applications problems mainly, says Le Maistre. That charge is based on the number of students and project engineers working on the problem.

**One on one.** There are a variety of grants, fellowships, and research projects funded by individual companies, and the number is growing daily. For example, a recently announced agreement between the State University of New York at Stony Brook and General Instrument Corp., Hicksville, N. Y., provides annual, renewable funding for a graduate fellowship and research funding for a professor in VLSI system architecture. This year GI will give a total of \$30,000 to the Long Island school. The semiconductor maker also plans to donate wafer-processing, chip-assembly, and test equipment.

Rockwell International Corp. has been working with the University of Texas at Arlington for several years, with very pleasing results, according to Herbert E. Welch, multiplex and switching system department manager at Rockwell's Collins Telecommunications Systems division in Dallas. He has worked as an adjunct professor at the school, as well as helped to set up a research program in signal processing. Grants for the project have varied between \$40,000 and \$100,000 annually since 1976, including, recently, a minicomputer. Welch estimates that the work done at the university increases the effectiveness of Rockwell's research dollars by about 4 or 5 to 1.

Texas Instruments Inc. and the University of Illinois at Champaign-Urbana are collaborating on research in field-effect transistors, with TI providing fine-line lithography equipment and the university supplying a crystal growth capability. The project, begun in January, is supported by a three-year, \$400,000 grant from the Air Force Office of Scientific Research. The university and TI wrote the grant proposal together, but the grant money is used solely for the school's part of the project; TI is paying on its own for its participation. □

**NEW 1980 Electronics Buyers' Guide**

The only book of its kind in the field. If you haven't got it, you're not in the market.

To insure prompt delivery enclose your check with this coupon.

Yes, please send me \_\_\_\_\_ copies of 1980 EBG.

I've enclosed \$30 per copy delivered in USA or Canada. Address: EBG, 1221 Avenue of the Americas, New York, N.Y. 10020.

I've enclosed \$52 for air delivery elsewhere. Address: EBG, Shoppenhangers Road, Maidenhead, Berkshire S16, 2Q1 England.

Name \_\_\_\_\_

Company \_\_\_\_\_

Street \_\_\_\_\_

City \_\_\_\_\_

State \_\_\_\_\_ Zip \_\_\_\_\_ Country \_\_\_\_\_





**ComputerAutomation**  
Industrial Products Division

**TERADYNE**



**GenRad**

WHICH  
OF THE TOP 3  
TESTER COMPANIES  
IS THE BEST BET  
FOR SOLVING  
YOUR TESTER  
PROBLEMS?

No two problems are ever quite the same. So it follows that no one solution can ever be the best solution.

Which explains why there's a "big three" to start with. And why smart buyers get bids and presentations from all three.

Of course, the plain truth is that you really can't lose, no matter which one of the top three tester companies you go with; it's simply a matter of how much you're going to win.

Because even though all three "solutions" are known quantities

with proven performance, there are significant differences. In technology. Product modularity. And upward compatibility. In the software approach. In the ongoing support package.

And some of those differences can make a difference to you.

Which is why you owe it to yourself to talk to all of the top three tester companies.

And besides, if you don't get the complete picture, you just won't know what you've been missing...

Contact Computer Automation, Industrial Products Division, 2181 Dupont Dr., Irvine, California 92713, (714) 833-8830.

***For productivity...today and tomorrow.***

U.S. regional offices in Santa Clara, CA (408) 727-6800; Bensenville, IL (312) 860-1830; Bloomfield, NJ (201) 338-8870. District Offices in Newport Beach, CA; Boston, MA; Raleigh, NC; Dayton, OH; Dallas, TX. In Europe: CAI Ltd., Rickmansworth, Herts., England 011-449-237-7121. Offices in Frankfurt, Germany and Rue Fourny, France.

Circle 107 on reader service card

Government

# Federal policies stall IC startups

Study says Washington's practices can influence for the worse more than just funding and innovation

by James B. Brinton, Boston bureau manager

Electronics executives regularly call for reforms of Government policy, pleas that often are shrugged off as "business wanting a larger share of the pie." But now there is a study of the semiconductor industry that shows Government policy affecting only the financial side of business but its innovative climate as well. The study also finds that some seemingly innocent policies can have unexpected indirect effects.

From Charles River Associates Inc. of Boston, the study is based on original research and interviews with key semiconductor executives. Completed late in May for the Department of Commerce's Environmental Technology Incentives Program, its goal is to give policy makers a guide to the effects on innovation of future policy decisions.

CRA vice president Robert J.

Larner and senior research associate Robert W. Wilson headed the group that put the inch-thick document together. And though not yet released to the public, it has already triggered so much interest that the Lexington Books division of D. C. Heath Co. will publish it this fall in slightly revised form.

The study focuses on the semiconductor industry in general and the integrated circuit segment in particular. This is because of the industry's rapid growth and evolution, the high rate of both incremental and major innovation in the business, and Government's role in the industry's early years, often credited with getting it off the ground.

Titled "Innovation, Competition, and Government Policy in the Semiconductor Industry," the work includes a compressed history of the IC

business, evaluations of market forces and the learning curve and their combined effect on pricing and growth, and other background.

The study identifies six major policy areas that impact the IC business: procurement, funding and grants, antitrust policy, trade policy, tax policies, and manpower policies. Of these, the first three affect the industry directly, though to different degrees in different firms.

One important aspect of all Government policy, according to the study, is the manner in which it changes over time. The use of semiconductors by the military and National Aeronautics and Space Administration was "extremely important" in the 1950s and 1960s, especially in the years following the invention of the IC.

During the middle sixties Government demand fell off as a proportion of the market. Though NASA and the military remained involved in new technology development, commercial markets became the prime lure to new firms. At the same time, while Government incentive declined, there were at least no new anti-incentive Government policies.

**Changed attitudes.** A third period, beginning in the late '60s and running to the present, is characterized by growing industry unhappiness with tax and trade policies. Some of this has been spurred by foreign competition and the aid given by other governments to their semiconductor industries. Where industry and Government were once cordial, though, they now tend to be adversaries, often falling out over a policy area that gave the industry what may have been its biggest boost,

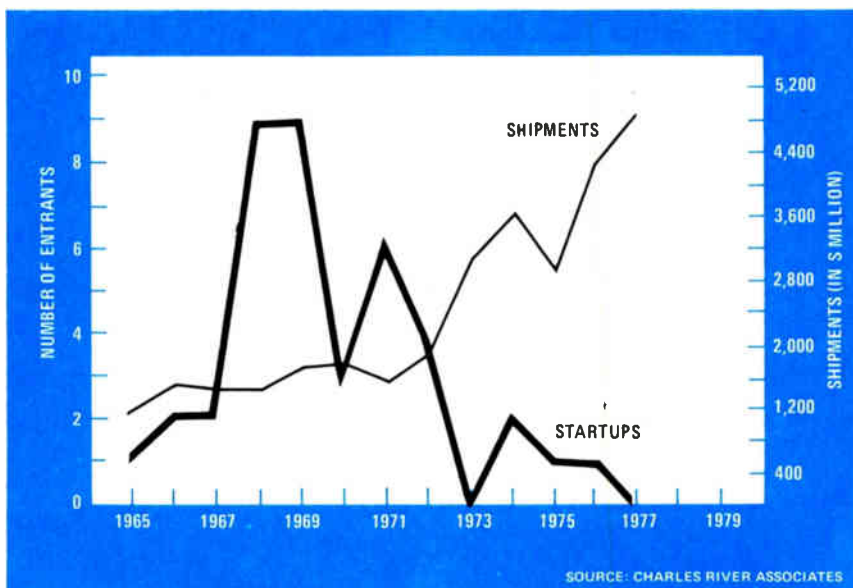

**More out, fewer in.** A track of production and new-company startups in the semiconductor business since 1965 shows that as the industry turned out more parts, fewer firms entered.







# THEY WENT THATAWAY. ...TRANSIENTS, that is!

And you'll know when and how long. In a hard copy printout.

Source or load transients are identified in an instant with Programmed Power's Model 3500 Power Line Disturbance Monitor and its transient direction and polarity detection option. Another option prints out the transient duration in microseconds.

Other options, nine in all, include 50-441Hz line monitoring; DC bus monitoring simultaneously with AC line; undervoltage or overvoltage duration in milliseconds with outputs for remote data logging.

The most versatile line monitor around.

Fast deliveries.

We also make award-winning Frequency Converters and UPS.

For more information, contact:



Power Line Disturbance Monitor



**Franklin Electric**

Programmed Power Division

995 Benicia Ave., Sunnyvale, CA 94086, (408) 245-8900, Telex: 357-405

Circle 110 on reader service card

## For discriminating players!

Send distortion to the bar with our classic model 2283F monolithic crystal discriminator. At 10.7 MHz, you can get 1% total harmonic distortion and up to 800 mV of recovered audio when used with CA 3089E quadrature detector. Model 2378F offers the same action at 21.4 MHz. Bear off a note and we'll send you the complete specs to your home board.

**The standard in monolithic crystal filters.**

EXCELLENCE  
ACROSS THE BOARD

**Pi**

**Piezo Technology Inc.**  
2525 Shader Rd., Orlando, FL 32804  
(305) 298-2000

110 Circle 236 on reader service card

## Probing the news

antitrust policy and enforcement.

Antitrust policy was a factor in two periods. The first was marked by the Justice Department's 1956 suit against AT&T and the resulting consent decree that kept Bell Laboratories and Western Electric out of the semiconductor merchant market. Antitrust policy now has reemerged as an issue as U.S. firms call for fewer restrictions to help them compete with large Japanese and European conglomerates.

Tax policy has had its greatest effect in recent years, according to the study, which refers to the investment tax credit and its effect on capital investment; the tax treatment of stock options and the resulting effect on the availability and risk attitudes of key executives; the different ways of writing off research and development costs; treatment of foreign earned income; and, possibly most important, taxation of capital gains. The last two areas directly affect investment strategies.

Government manpower policies also go beyond the obvious effects of such agencies as the Occupational Safety and Health Administration. According to the study, the supply of qualified engineers fluctuates directly with the amount of Government research funding of universities.

**Options and incentives.** The importance of such major innovations as the planar process is so great that the study suggests stimulating the careers of the inventive by offering capital gains and stock-option incentives and portable patents.

Not that today's situation is impossible. What the study calls the relatively laissez-faire U.S. system has aided innovation by making it financially attractive, and by minimizing legal barriers to market entry and personal mobility. That said, the report notes that some recent trends, for example in tax law, are harmful and should be tempered. "To promote . . . good international performance by U.S. firms," says the report, "Federal policy should put domestic firms on an equal footing with foreign ones in terms of capital availability and R&D incentives and support." □

# SURPRISE!



## HP's New Fiber Optic System is Guaranteed to 1 km.

HP's new 1 km fiber optic system is a complete, point-to-point data link, capable of transmitting any pattern of digital information, from dc to 10 Mbaud, up to 1000 metres. At the heart of this new system is our HFBR-1002 Transmitter. It can directly replace the currently used HFBR-1001 (100-metre) Transmitter to give you full 1 km capability.

In addition, "Cable by the Metre" is available to meet your special requirements. Now you can order cable in one-metre increments, at \$2\*/metre plus connector installation.

HP's fully specified and guaranteed systems are the result of extensive testing totalling over 1.6 million hours. We also give you applications assistance.

In quantities of 100, the HFBR-1002 Transmitter sells for \$235\* and the HFBR-2001 receiver sells for \$150\*. For off-the-shelf delivery, or for more information about HP's fiber optic capability, contact your nearest HP components franchised distributor. In the U.S. contact Hall-Mark, Hamilton/Avnet, Pioneer Standard, Schweber, Wilshire or the Wyle Distribution Group (Liberty/Elmar). In Canada, call Hamilton/Avnet or Zentronics, Ltd.





# THE 8-BIT DAC HAS F

## THE WORLD'S MOST COMPLETE 8-BIT DAC HAS EVERYTHING.

Our new AD558 DACPORT™ is the first 8-bit IC digital-to-analog converter that can interface directly between a data bus and the analog

world with no additional components. It's a complete DAC, including input latches, a precision voltage reference and a calibrated voltage output, all on a single monolithic chip. And it's fast: it settles to  $\pm\frac{1}{2}$  LSB in 1  $\mu$ S max. It even runs on a single +5 to +15 volt supply, so it can use whatever supply your  $\mu$ P uses.

## THE FIRST DAC DESIGNED FOR DESIGNERS.

Our DACPORT is so complete, you just plug it in. That's it. No external components, like input latches, voltage reference, or output op amps are needed. And no adjustments either. It's laser-trimmed at the wafer stage, eliminating any need for external adjustments for offset and gain. Its calibration

**JUST PLUG IT IN!**





# FINALLY COME TO THIS.

**THIS.**



Complete and comprehensive,  
we've got the world's  
easiest-to-use DAC.

**NOT THIS.**



accuracy is guaranteed over the full operating temperature range to within  $\pm 1$  LSB, both at full scale and at zero. And all versions are monotonic over temperature.

The DACPORT can just as easily be used without a  $\mu$ P and still offer extraordinary value because of its completeness, factory calibration, and single supply operation. It's the ideal 8-bit DAC for both digital and analog designers.

## IT'S "COMPLETE" FOR ONLY \$5.95.

Our plastic packaged AD558JN, with a relative accuracy error of  $\pm 1/2$  LSB max, is priced in 100's at only \$5.95. Several performance grades of the AD558 are available in a her-

metically-sealed ceramic package. And processing to MIL-STD-883, Class B, can be provided.

If you're looking for a full performing, complete, reliable, no-external-components-required 8-bit DAC, you've found it with our AD558 DACPORT. For more information on this revolutionary, evolutionary 8-bit DACPORT, get in touch with Doug Grant or Don Travers at (617) 935-5565, or write Analog Devices, Inc., P.O. Box 280, Norwood, MA 02062.



## WAY OUT IN FRONT.

# Now, HP lets you make FDM carrier one programmable

0.1 Hz frequency resolution means precise frequency setability over the full 50 Hz to 32.5 MHz range.  $\pm 2$  dB level accuracy allows measurements with .01 dB resolution all the way down to -80 dBm.

Optional Transmission Impairments Measurements allow you to quickly troubleshoot voice channel problems using phase jitter, noise-with-tone, signal-to-noise-with-tone-ratio, and single level impulse noise, all with one instrument.

Level accuracy is  $\pm 0.05$  dB at full output at 10 kHz with  $\pm 0.1$  dB flatness to 20.9 MHz, and you can sweep the full band with  $\pm 15$  dB leveling.

Amplitude blanking allows testing of operational FDM systems without disturbing adjacent channels while the frequency is changed.

The new Hewlett-Packard Level Measuring Set brings outstanding measurement convenience, precision and automatic control to the design, manufacture, installation and maintenance of Frequency Division Multiplex systems. It consists of two new instruments: the HP 3586A/B Selective Level Meter, and the HP 3336A/B Synthesizer/Level Generator. The A versions are compatible with CCITT requirements, while the B versions are compatible with North American (Bell) standards. In addition, C versions are available for general purpose wave analysis and frequency synthesis applications.

Precise frequency and level measurements are provided by

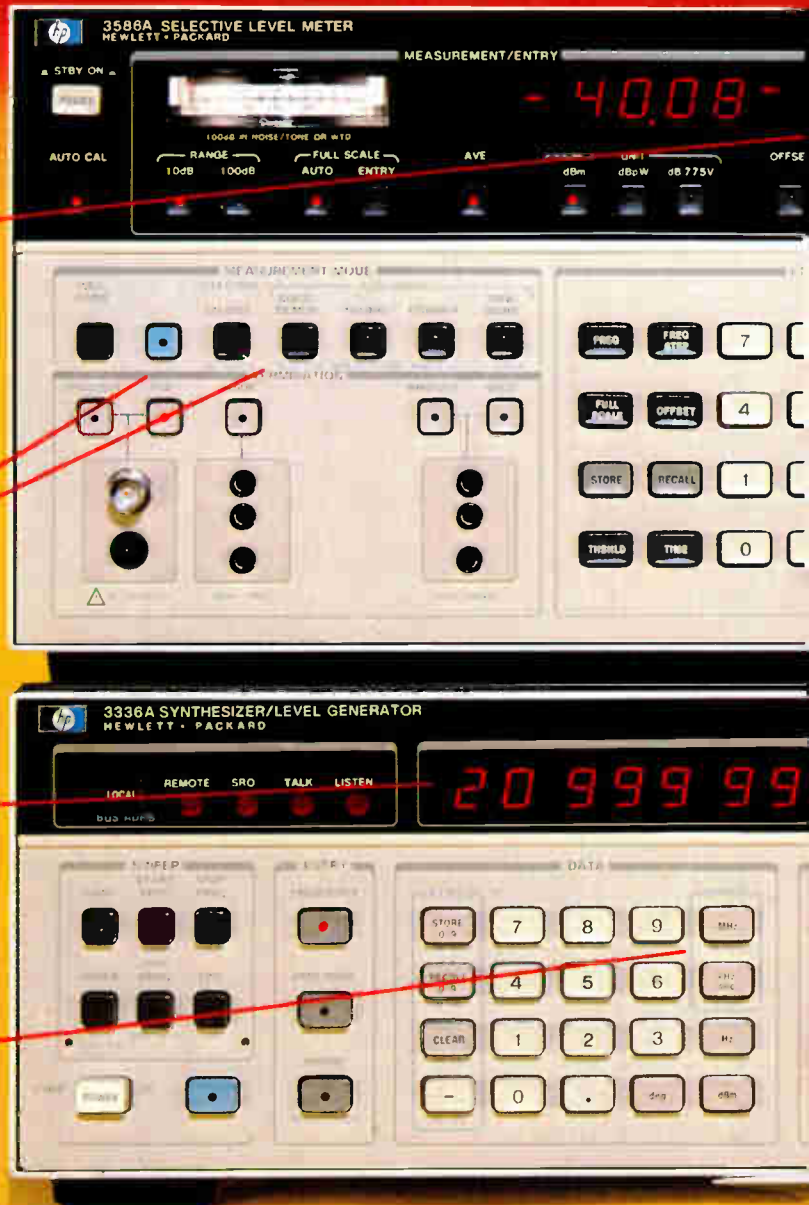

the HP 3586A/B Selective Level Meter. In addition to delivering 0.1 Hz resolution over the full 50 Hz - 32.5 MHz range, the Selective Level Meter lets you make measurements at both FDM voice channel and carrier frequency with one instrument. And, when you select the optional Transmission Impairments Measurements feature, you enjoy a new versatility in FDM system troubleshooting.

The new HP 3336A/B Synthesizer/Level Generator offers extremely stable, accurate signals with harmonics more than 50 dB down, and phase noise 70 dB down in a 3 kHz band. As a precision companion source, the Synthesizer can be

# and voice frequency tests with Level Measuring Set.



Frequency Counter lets you measure a frequency precisely, then tune to it with one keystroke, eliminating the need for "rocking" the tuning control to peak the signal.

HP-IB control is standard on both instruments, allowing all functions to be remotely programmed for automated testing.

Use the 3586A/B as a "tunable channel bank filter" with shape factors up to 1.2 and 75 dB adjacent channel rejection.

Optional Noise Weighting Filter permits direct Psophometric or C-message weighted noise measurements. Or use the standard equivalent weighted noise filters supplied.

Manual tuning with selectable resolution lets you change frequency, amplitude and other functions in desired steps.

set to automatically track the frequency of the Selective Level Meter. Or you can use it for stand-alone frequency synthesis applications.

Through HP-IB, the Level Measuring Set is fully programmable. A computing controller such as one of HP's 9800 Series permits automatic operation to reduce manufacturing time and to lower maintenance costs through automated testing.

Prices are \$9,200\* for the 3586A/B (\$475\* for Transmission Impairments Measurements option) and \$4,100\* for the 3336A/B. For full information, write to Hewlett-Packard, 1507 Page Mill Road, Palo Alto, CA 94304. Or call the HP regional

office nearest you: East (201) 265-5000, West (213) 970-7500, Midwest (312) 255-9800, South (404) 955-1500, Canada (416) 678-9430.

\*Domestic U.S.A. price only.

099-54



Circle 115 on reader service card



**At Penn State's Hershey Medical Center, they needed a sensor that would last a lifetime.**

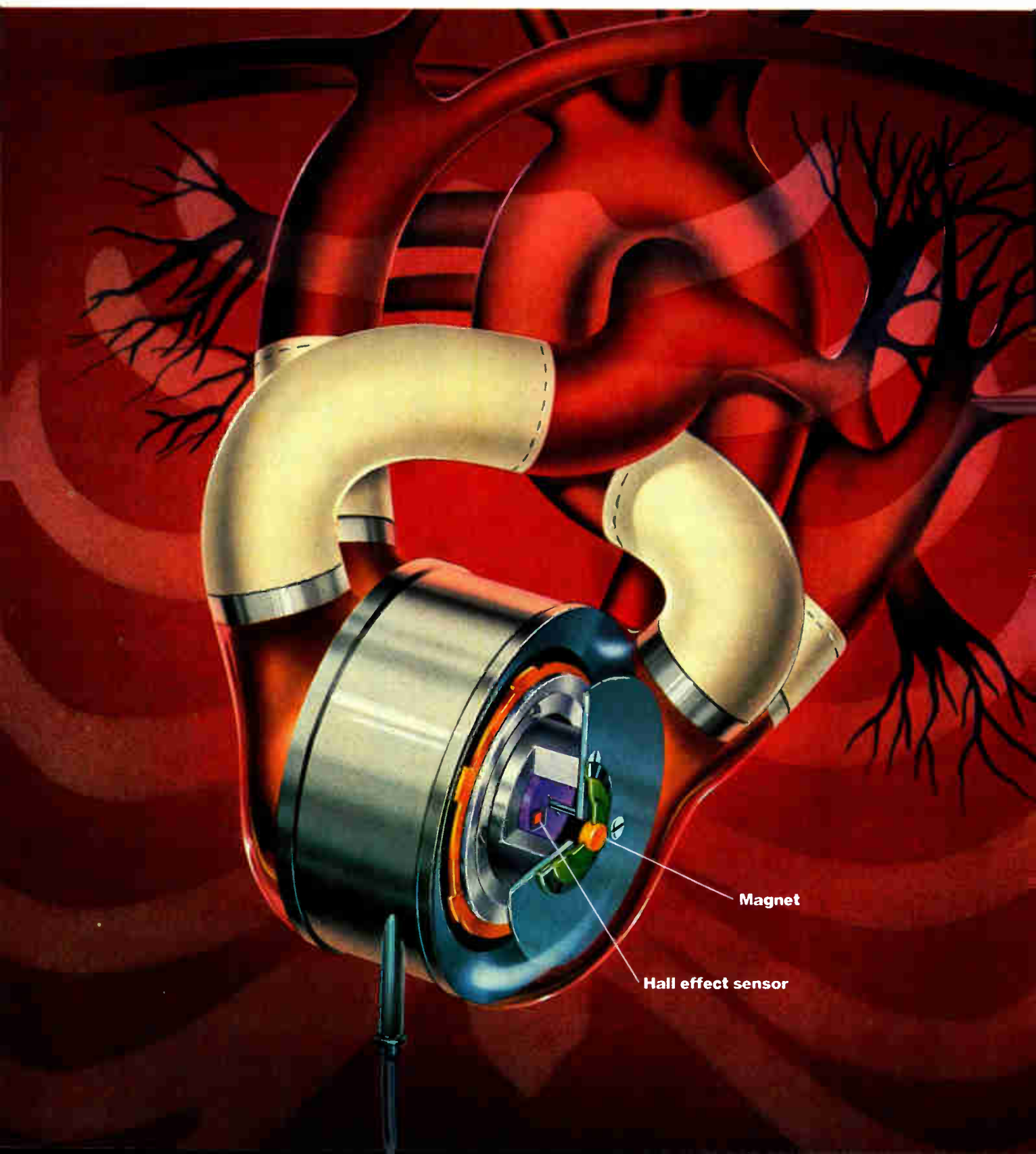

Magnet

Hall effect sensor

Until recently, the artificial heart was only a dream of modern medicine. A few medical pioneers at The Milton S. Hershey Medical Center of The Pennsylvania State University have made it a reality.

The first news came in 1977, when a mother of four underwent open heart surgery to replace a damaged heart valve. A heart/lung machine kept her alive during the operation. But after surgery, her heart failed, and specialists agreed she would die if removed from the machine.

Then they tried a small, experimental heart assist pump that today is controlled by our solid state Hall effect position sensor. It kept her alive for the eight days it took her to recover.

And yet, that pump is only part of what it takes to make a totally artificial heart.

Unlike the assist pump, the artificial heart is implanted inside the chest. So it has to be compact, and controllable. It must be made of materials that don't react with the body. And it has to beat without producing excessive heat.

Today the artificial heart is still experimental. But medical experts believe we have helped them solve one of their problems.

We gave them a heartbeat.

One of our Hall effect position sensors fit the requirements of Hershey's design. It controls the filling and emptying of plastic sacks that duplicate the natural motion of a healthy heart.

Already, a number of calves have been kept alive over 100 days. So far, one of our sensors has actuated over 18 million times in experiments at Hershey without a single failure.

And this is only the beginning.

Eventually, the artificial heart will be perfected for humans. Which means our sensor will operate about eighty times a minute. 115,000 times a day. 42 million times each year.

Working with customers early in their design process nearly always results in a better product. For them, and for us. That's one of the reasons why we have the widest variety of switches and sensors in the world. And, if we don't already have one that solves your problem, chances are we can design a solution together.

For information about how we can bring your project to life, write MICRO SWITCH, The Sensor Consultants. Freeport, Illinois 61032. Or call 815-235-6600.

MICRO SWITCH products are available worldwide through Honeywell International.

**MICRO SWITCH**  
a Honeywell Division



## Norplex® multilayer materials make your ideas work.

Norplex base materials can help put your circuitry concepts into working order. Our product philosophy is to develop laminates and prepregs needed for today's generation of multilayer interconnections.

We stress the involvement of our advanced engineering groups in the design of all multilayer materials. Using segregated production facilities, specially-designed impregnation treaters and sophisticated laminating press lines, Norplex combines top-grade materials into superior multilayer laminates. We also maintain a vigorous program for survey and evaluation of new technologies.

The excellent dimensional stability of Norplex laminates is demonstrated by proper registration of layers after lamination. Laminate integrity is also maintained

throughout board fabrication.

Norplex prepregs are characterized by consistent resin flow and rheology. Conductor encapsulation and void expulsion results in superior resistance to thermal degradation. Precision thickness tolerances and controlled electrical properties also contribute to high production yields and consistent performance in the application.

So, if you've got a multilayer application to be transformed from design to working reality, talk with the man who can help make it happen: your Norplex Technical Representative.

Norplex Division, UOP Inc., La Crosse, WI. European Headquarters: Wipperfürth, West Germany. Pacific Headquarters: Kowloon, Hong Kong.

**Norplex® laminates  
by uop**



One of The Signal Companies





Technical articles

# CAD pits semicustom chips against standard slices

---

Master-slice circuits such as gate arrays benefit from automatic placement and routing programs; advanced C-MOS process gives speed at low power

---

by Joseph H. Kroeger and Orhan N. Tozun, *International Microcircuits Inc., Santa Clara, Calif.*

□ Modern computer-aided design algorithms are increasingly clever at placing and interconnecting electronic circuit components. It will be some time before such programs allow the speedy design of fully custom integrated circuits, but, because of CAD, master-slice devices—semicustom chips like gate arrays that are programmed with a final metalization layer—can now be prepared in a matter of weeks.

Helped by the speed and density attainable through advanced wafer processing, the influence of these circuits is broadening as they become competitive with standard chips in some applications and with custom chips in others. This trend is evident in IBM's use of master slices in some of its new computers and Amdahl's use of them in its large machines. The reason: they can be produced with less than one tenth the design effort expended on a fully custom component and still be unique, with the low power usage and package count and the increased reliability of a highly integrated solution.

Not to be confused with other semicustom compo-

nents, gate arrays differ in several ways from programmable array logic (PAL) chips and programmable logic arrays (PLAs). Although all three are based upon standard arrays that are hard-programmed for a particular application, they are differently customized. PALS and PLAs are usually personalized after production and packaging by blowing fuses, whereas master-slice gate-array circuits are customized during manufacture, in the patterning of their final metalization layer.

PAL-type products are excellent solutions in many applications, as evidenced by their significant market. But because of their large fuses—and the circuitry needed to access and burn those fuses—PALS and PLAs are typically limited to low and medium-scale densities of a few hundred gates per chip or less. Master-slice circuits, on the other hand, are achieving large-scale densities of 2,000 gates per chip and beyond.

Various technologies are being used to make master slices, including emitter-coupled logic, TTL, integrated injection logic (I<sup>2</sup>L), n-channel MOS, and complementary

MOS. Each has its unique set of tradeoffs.

A combination of low power, high density, and high speed has been difficult to achieve in the past. However, a new master-slice family implemented in a high performance, oxide-isolated C-MOS process originated at Mitel Semiconductor and called ISO-C-MOS has broken previous density and performance barriers. The low-power MasterMOS series from International Microcircuits currently has circuit densities of up to 2,000 gates per chip and gate delays of 5 nanoseconds, with densities greater than 3,500 gates per chip planned.

Even master-slice circuits of modest size and performance are increasing their penetration as application-tailored solutions. This is in part because they are amenable to computer-aided design techniques. The fast turnaround made possible by CAD and the automated manufacturing of the circuits is one of the justifications IBM cites for its internal use of such devices.

In his keynote address at the recent Comcon conference, IBM's vice president Erich Bloch stated that multiple-purpose master-slice components are one way of attacking the problem of proliferating part numbers that is becoming acute as integration continues. In contrast, thousands of different functions can be produced from a single base master-slice circuit.

### Multipurpose VLSI

A digital master-slice circuit generally contains a pre-specified configuration of uncommitted transistors that is personalized for a specific application through a final metal interconnection layer (Fig. 1). In addition, the chip may have predefined power and ground buses, crossover patterns, input and output cells, and interfacing pads. The metal layer connects the transistors to

**1. Three steps.** The design of a master slice usually begins with a schematic (a). Then gates and flip-flops are used to represent the circuit (b). Finally, these gates and flip-flops are realized in hardware by interconnecting uncommitted transistors in the array (c).

form gates, flip-flops, counters, buffers, and so on.

Besides the use of CAD in defining final metalization, master-slice circuits also exhibit shorter production cycles because the wafers can be preprocessed right up to the final layer. Thus, total turnaround time for this type of master slice—from the logic schematic to working prototype parts—is usually in the range of 8 to 12 weeks, compared with 60 weeks or more for a fully custom version of the same LSI circuit.

Master-slice circuits in a variety of technologies are available from several manufacturers. In addition to International Microcircuits, companies such as Texas Instruments, Exar, Interdesign, RCA, Motorola, Signetics, Fairchild, and others are now offering them. With this much diversity, a designer usually has no trouble finding the most appropriate technology and master-slice

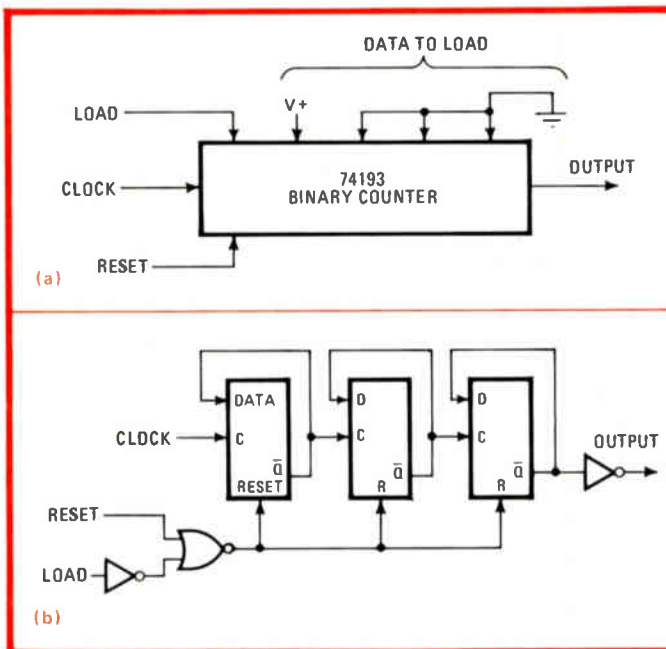



design for the requirements of the application at hand.

In all fairness, the circuits are not the answer to all logic problems. Whether they are the best approach for an application depends upon various design criteria and production volumes, so a comparison is often made between them and medium-scale integrated TTL chips, fully custom ICs, and microprocessors.

### Competitive approaches

With the speed of master-slice circuits on the rise, the edge once held by low-power-Schottky (LS) TTL in MSI form is diminishing. In fact, LS TTL gate arrays will outperform standard TTL MSI packages in both speed and density. PAL circuits also compete here. A typical TTL master slice, for example, can operate at up to 40 megahertz, with gate delays on the order of 5 to 10 nano-

seconds. And circuit densities of up to 1,200 gates per chip can be achieved. Discrete SSI and MSI TTL designs tend to have lower operating speeds, many more packages, and higher power dissipation.

Furthermore, with C-MOS technology, up to 2,000 gates are available (see Table 1), with operating speeds ranging up to 30 MHz and gate delays in the 5-ns range. This means that a single C-MOS master slice can replace more than 200 small-scale integrated and MSI TTL chips (using 18 gates per device as an average density for TTL). The number of printed-circuit board interconnections is reduced by two orders of magnitude, and the required area is reduced even more. Furthermore, since power consumption is only 20 microwatts per gate with C-MOS, this master slice consumes roughly two orders of magnitude less power as well. With fewer interconnec-

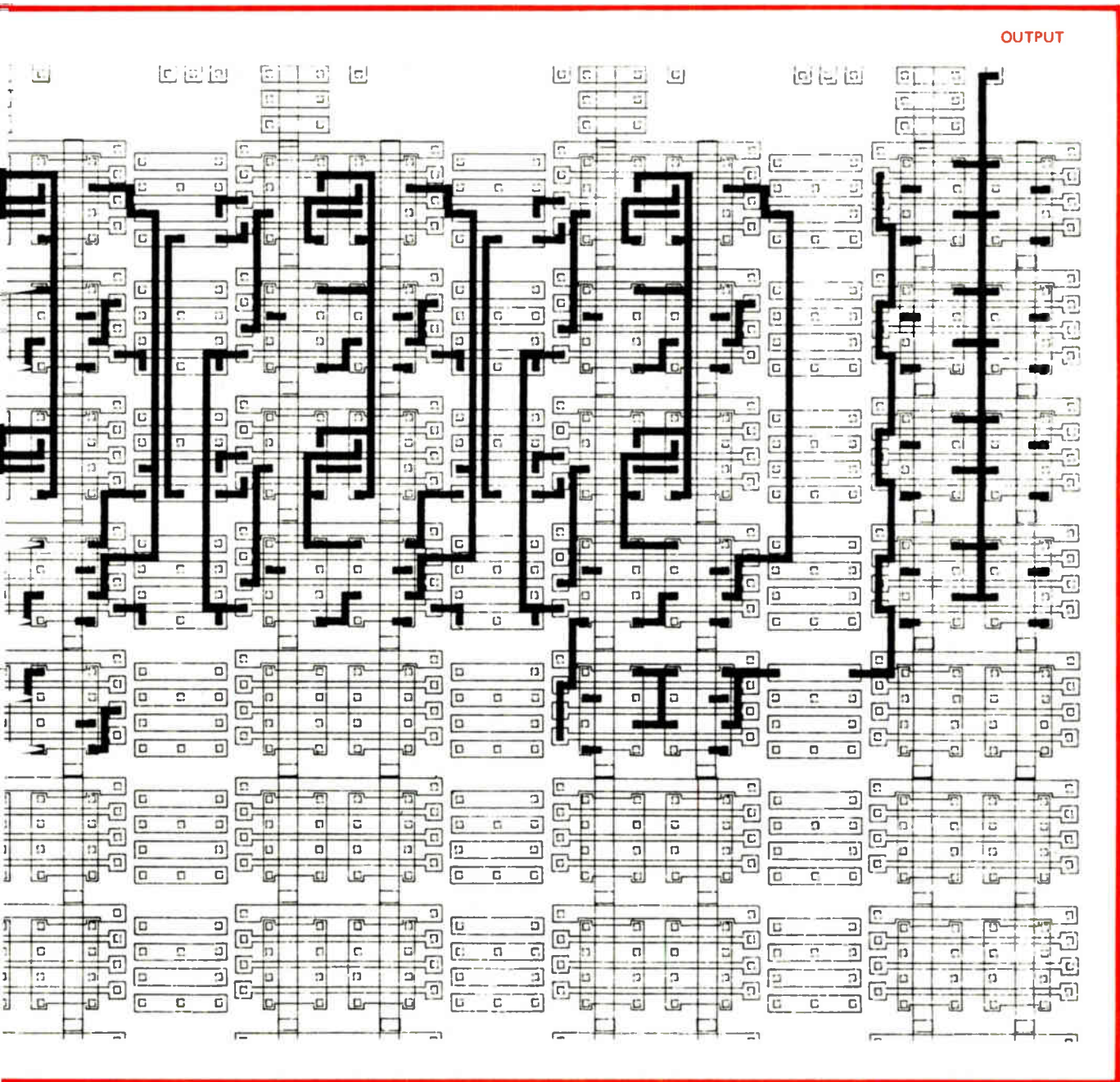



**TABLE 1: TECHNOLOGY CHARACTERISTICS OF SOME CURRENT MASTER-SLICE PRODUCTS**

Feature	Complementary MOS	Integrated injection logic	TTL	n-channel MOS
Density (gates per chip)	~2,000	~1,000	~1,200	~1,000
Gate delay, average internal (ns)	<5	<15	<10	<15
Power per gate, average internal (mW)	~0.02	~0.25	~2	~0.25
Toggle rates (MHz)	~30	~10	~40	~8
Output drive, low-power Schottky TTL loads	~4	~10	~30	~8

tions and far less power, reliability is also significantly improved. Finally, another advantage of a single integrated circuit—compared with a discrete implementation—is that it helps the designer conceal a unique circuit from competitors.

The volume of identical master-slice circuits ordered and the number of types of logic elements that they displace also figures into bottom-line cost effectiveness. If, for example, a circuit design requires less than about half a dozen SSI or MSI parts to implement, then substituting a master slice brings little improvement in cost or packaging. This is because a six-package design usually has less than about 100 active gates (though there are exceptions to this example in situations where space is of prime importance).

The total number of production parts may be a determining cost factor because commercially available master slices carry an initial development fee. For each specific application, these initial development costs plus the recurring costs, divided by the production volume, should first be roughly determined.

The development cost for typical master-slice circuits of reasonable density is usually in the range of \$10,000 to \$50,000. Similarly, development of the PC board that accompanies an MSI design is also expensive. Yet production costs are invariably less than those for producing a board full of discrete TTL logic, involving insertion, board, testing, and inventory expenses, among others.

### A case in point

A dedicated controller circuit was implemented using standard LS TTL, a typical digital master-slice circuit, and a custom chip. As shown in Table 2, the LS TTL design requires 50 packages, whereas the master-slice approach uses a single 1,000-gate chip—again, based on an average TTL circuit density of about 18 gates per chip. The TTL design uses up about 50 square inches of circuit board areas based on an average of 1 in.<sup>2</sup> per TTL package. The 1,000-gate master slice and the custom circuit consume about 2 in.<sup>2</sup> each.

Development time for the master slice is approximately 14 weeks from logic diagram to working prototypes, during which time the TTL layout is translated into a metalization pattern to produce the first prototype parts. The development time for the LS TTL design is similar and includes layout and debugging of the PC board plus the manufacture of the first boards. Incorporating

**TABLE 2: IMPLEMENTATION COMPARISON**

	Small- or medium-scale integrated logic	Master slice	Full custom
Chip count	50	1 (1,000 gates)	1 (850 gates)
Gate count usage	95%	85%	100%
Board area	50 in. <sup>2</sup>	2 in. <sup>2</sup>	2 in. <sup>2</sup>
Development costs	\$10,000–\$20,000	\$20,000–\$30,000	\$50,000–\$100,000
Component costs	\$40–\$75	\$20–\$90	\$15–\$90
Testing and assembly	\$20–\$50	\$4–\$10	\$4–\$12
Development time	10–16 weeks	10–16 weeks	9–12 months
Total cost per board for run of:			
250	\$180	\$200	—
2,500	\$100	\$ 90	\$120
25,000	\$ 80	\$ 50	\$ 60
250,000	\$ 65	\$ 30	\$ 30
2.5 million	—	\$ 25	\$ 20

rating minor design modifications also usually requires about two to three weeks in each case.

Development costs generally will be somewhat lower for the TTL design than for the master slice. The custom IC consumes more time and money, but it is a smaller chip with an ultimately higher yield. As such, it should also have a lower recurring component cost at high volumes. The decreased power consumption, distribution, and decoupling costs of C-MOS are not reflected in the table.

Production costs—both recurring and nonrecurring—decrease more slowly for the MSI design as volume levels rise; in this case, total MSI production costs are lowest only at the lowest volumes. Master slices serve a wide range of intermediate volumes efficiently and only at the very highest production runs does the full custom approach prove viable. These results are summarized in Fig. 2, which is intended to convey general relationships only; specific crossover points and values will vary from application to application.

### Master slice vs microprocessor

Programmed through software, microprocessors do not usually compete directly with TTL, master-slice, or fully custom solutions. In many cases, however, a master-slice circuit or extra TTL is used to boost the performance of a microprocessor or to interface it with some specialized portion of the system. Here the device may let the processor enter into application areas that it would otherwise be incapable of handling alone.

Sometimes, depending upon the amount of auxiliary circuitry and the type of application, a master-slice circuit will perform all the necessary functions to replace a microprocessor altogether. In such cases, though, the flexibility that comes from software-programmed logic is surrendered. What is gained is added performance and often a lower chip count. For some functions in software, the performance gain can be quite significant—from one to two orders of magnitude.

Another advantage over microprocessors is the elimination of the software development cycle. Whereas a master-slice circuit may take 14 weeks to go from the

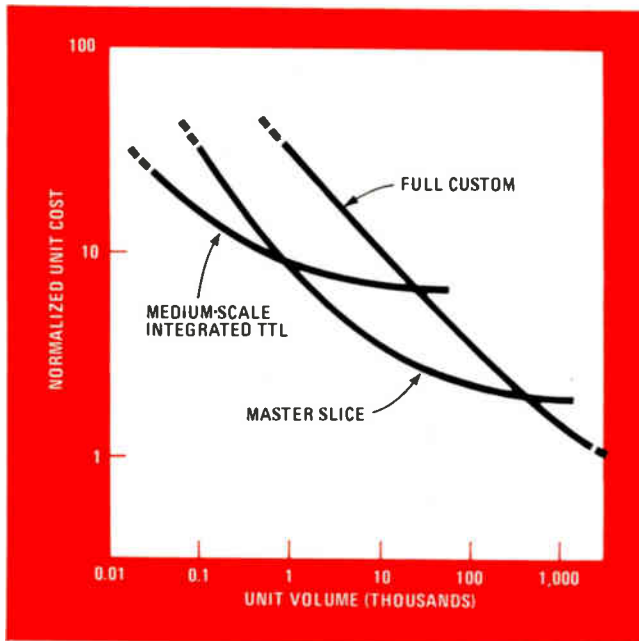

**2. Crossovers.** For volumes below about 1,000 units, discrete TTL is probably the best approach. For intermediate volumes, the master slice offers the lowest unit cost. At the highest volumes, fully custom chips dominate. The ultimate choice depends upon the application.

definition phase to the working prototypes stage, software debugging and system integration problems can push even a simple microprocessor development cycle out to several months.

### Selecting a master slice

Before deciding on a particular master slice, a designer should study a logic diagram and product definition. The required density can be estimated from the logic diagram and the product definition will indicate the performance required. These density and performance criteria, in conjunction with the I/O pin count, will help determine the optimum master-slice technology.

Each technology has its strong and weak points, as outlined back in Table 1. C-MOS technology is the clear leader at present. It can provide packing densities of up to 2,000 gates, 30-MHz toggle rates, and inherent low power consumption. The fan-out of IMI's C-MOS is, however, limited to a few LS TTL loads.

Faster gate arrays are possible with TTL, especially when output drive is an important consideration. However, the speed is attained at the expense of power consumption, which can approach eight times that of C-MOS and more. The power dissipation of TTL tends to limit densities to around 1,200 gates.

### Pros and cons

$I^2L$  consumes more power than C-MOS, but less than TTL. Its output drive is attractive, but it is slower than either silicon-gate C-MOS or TTL. It does have some advantages in applications that require both linear and digital circuitry on the same chip. New  $I^2L$  products with higher densities are scheduled for introduction soon.

N-channel MOS has potentially the highest density, but this fact has not yet been exploited for commercial

master slices. Its output drive and power dissipation are both moderate, but its tolerance of supply-voltage variations is not nearly as great as C-MOS's.

To benefit most from the technology selected, the layout of the master slice must be efficient. Many factors may influence overall efficiency, including transistors per cell, cell area, cell contact access, cell performance, wiring channels between cells, accessibility and availability of underpasses, I/O buffers and pads, power busing, internal buffers, and CAD-adaptable grids. A master slice designed for general-purpose logic functions is a complex optimization of these and other issues.

In some cases, the tradeoff is clear; for example, more wiring channels ease interconnection but decrease the chip's transistor density. An increase in the number of I/O pads increases the die size for a given array, but many applications need an abundance of interface pins. One of IBM's master-slice circuits used in its 4300 computer, for example, has 132 I/O pads for a 704-gate array. The use of standard packages may sometimes also limit the number of available pins.

### From logic to master slice

Once a suitable base master slice is selected, the design of the final layer of metal interconnection is undertaken, usually by the supplier. Admittedly, because of each master slice's unique design rules, the final metal patterning process may seem like a black art. Fortunately, CAD systems can now off-load much of this work.

With a CAD system, the digital master-slice design process becomes much more efficient. The interconnection of commonly used functions—such as many types of flip-flops, various gates and gate combinations, counters, and decoders—are stored in a function library. Proceeding on a schematic, the designer calls up logic functions on a cathode-ray-tube terminal. Each function initially appears as a shaded block that is used to further generate an overall placement plan at a magnification of around 20 to 50 times. Interconnection algorithms help the designer with both placement and with the routing of wires between blocks.

Using rules that force wiring into preassigned channels removes a lot of the drudgery of checking. Much of the manual wiring, final design details, and layout checks are performed on the screen at a magnification of 1,000 times or more, with each transistor, wiring path, and contact visible. The CRT screen becomes a movable window through which any portion of the chip can be viewed at any desired resolution. A hard-copy plot may also be generated to show the whole chip or any section.

Finally, a detailed check is made against the input logic diagram. Once the design is complete and correct, the CAD system produces a pattern-generator tape, which produces the final photomasks.

A CAD system can reduce development time for a master-slice design in several ways. For instance, each logic function need not be redesigned every time it is used as each has already been confirmed, checked, and characterized. Also, manual pattern generation—using Mylar tape, for instance—is unnecessary, so a 200-gate master-slice circuit that once took a week or more to complete can now be made in a few hours with CAD. □



# Making a data terminal out of the Touch-Tone telephone

A two-chip dual-tone multiple-frequency receiver plus some other logic can turn the phone into a low-cost remote controller or data-entry system

by Robert A. Broomfield, Thomas Foxall, and Patrick Beirne, *Mitel Semiconductor Inc., Kanata, Ottawa*

□ Touch-Tone keypads, by now an international standard for entry into the worldwide telephone network, also make data communications possible wherever there is a telephone. Essential to this use is the dual-tone multiple-frequency receiver, which processes the two discrete frequencies generated whenever one of the keypad's push buttons is pressed.

Although one- and several-chip approaches to a DTMF receiver already exist, a two-chip version is now being introduced for the first time. Aided by a few external components, this Mitel design—separate filter and decoder chips designated the MT8865 and MT8860, respectively—affords an optimum tradeoff between cost-effectiveness and flexibility.

Like the other chips, the MT8865/8860 offers both the classic telephone functions and many important new ones. It can be used to construct a single-ended or differential DTMF receiver, update older rotary-dial phones by means of tone-to-pulse conversion, and create a call restrictor in an individual telephone or a private branch exchange. But more significantly, it will in the future also serve in many remote control and remote data-entry systems. Examples are the remote control of test, measurement, and industrial equipment and eventually, in the office or home of the future, the remote

control of home appliances, alarm systems, and unattended message recorders.

Today DTMF receivers have only a small share of this market. But their potential in the data-communications area is limited only by a designer's imagination.

## A proper combination

The MT8865 DTMF analog bandsplit filter consists of two bandpass filters plus zero-crossing detectors for the front-end functions of bandsplitting, dial-tone rejection, and limiting. The MT8860 DTMF digital decoder detects and decodes the tones (Fig. 1a). External components tailor the chips for different applications.

A DTMF signal received by the MT8865 is the conventional combination of two tones from the eight frequencies the keypad can generate (Fig. 1b). If there were no additional restrictions, this scheme would allow 28 different tone combinations. But DTMF signaling rules split the tones into two groups of four and restrict the combinations to one tone from each group, limiting the number of possible combinations to 16.

Since it is known that one frequency component lies in the low group of 691 to 941 hertz and the other in the high group of 1,209 to 1,633 Hz, the original tones can be extracted by two fixed bandpass filters, each designed

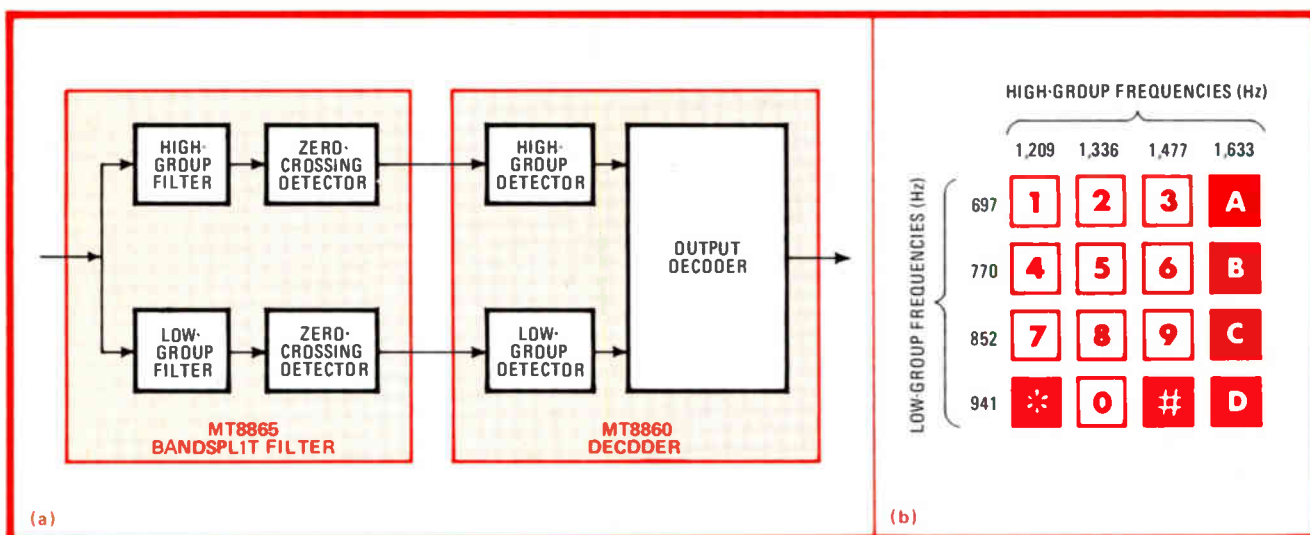

**1. Pick a pair.** The Mitel MT8865/8860 dual-tone multiple-frequency receiver chip set (a) decodes the symbols transmitted by a standard three- or four-by-four keypad. The inhibit pin on the 8860 decoder disables detection of the tone pairs generated by the shaded keys (b).

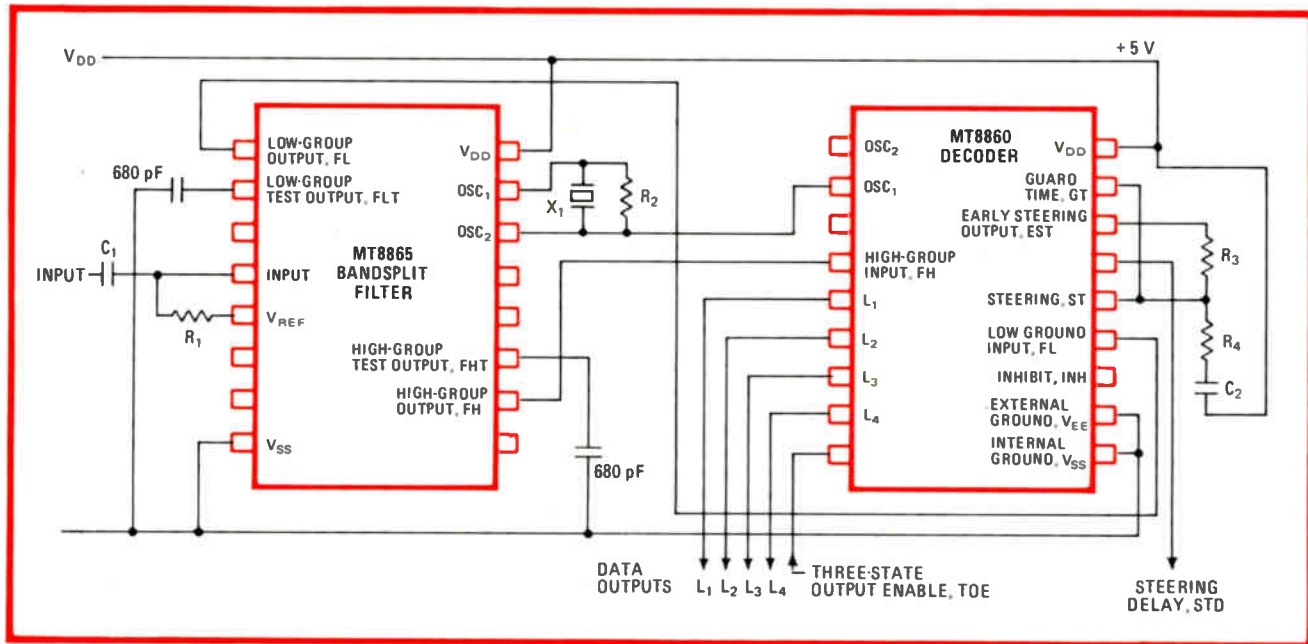

**2. Single-ended.** A basic DTMF receiver may be set up so that both chips are controlled by one 5-volt supply and one external crystal. The minimum component circuit is suitable for application to single-ended devices and requires few external components.

to pass one range only. The two outputs obtained are relatively pure tones, separately limited to produce digital signals or square waves having the same frequencies as the originating tones. Digital counting algorithms are employed to determine the frequency of the received tones accurately. Each group is checked individually for the presence of a DTMF frequency, and when both groups detect a valid tone for a minimum time duration, the circuit decodes the digit that was transmitted.

This detection method is possible only because of the restricted signaling format employed. DTMF receivers that must detect any two out of a number of possible tones are more complicated since they cannot use a simple bandsplit filter to separate the incoming tones.

### Inside the filter

The bandsplit filter chip consists of bandpass filters, which split the incoming signals into their component frequencies, and comparator circuitry, to square up the resulting waveforms. It employs switched-capacitor circuit techniques implemented in Mitel's ISO<sup>2</sup>-CMOS (double-polysilicon oxide-isolated complementary-MOS) technology. A high-speed, dense, C-MOS process with a linear circuit capability, it is ideal for mixed analog and digital circuits like this filter.

The filter's electrical specifications are more than adequate for the DTMF job. The bandpass ripple is less than 0.75 decibel and intergroup rejection is better than 37 dB. As a bonus, both filters have a notch at 440 Hz to aid in dial-tone rejection. The gain of the filters in the passbands is unity, and comparator levels have been set to ensure 30 dB of dynamic range.

Both the high-group filters and the low-group filters are sixth-order switched-capacitor designs, whose accuracy is a function only of the capacitance ratios and the system clock frequency. Since both of these parameters are well controlled, the filters can be realized very accu-

rately without the need to resort to trimming.

Each sixth-order bandpass filter has three biquad sections. A leapfrog design minimizes filter sensitivity to switched-capacitor sampling-coefficient errors. On the final filter output, this sampling is done at 127.8 kilohertz—a rate that is compatible with the 64-kHz input sampling rate of the digital decoder.

### A crucial element

The most critical filter component is the operational amplifier. The bandsplit chip contains 16 of these—14 in the filters and 2 as output buffers. They are C-MOS designs consisting of two gain stages and a buffer stage to drive a 9-picofarad compensation capacitor that uses the two polysilicon levels of ISO<sup>2</sup>-CMOS for its plates. The low gate-drain capacitance of the ISO<sup>2</sup>-CMOS process ensures that all secondary poles are high enough in frequency not to interact with the dominant pole of this compensation capacitor.

The MT8860 decoder detects and decodes all 16 standard DTMF pairs and discriminates accurately between adjacent frequencies in both high and low groups in the presence of noise and normal voice signals.

It is this ability to function in the presence of noise that makes the 8860 superior to earlier digital detectors, which were simple period counters and depended on passive or discrete active filters to separate the DTMF signal into its constituent tones. The frequency of the tones could then be determined by measuring the time between their zero crossings. This simple technique works very well on pure single-frequency tones in the absence of noise. However, in typical applications, such ideal conditions are not met and more sophisticated algorithms must be used.

Noise originates from a variety of sources. After the DTMF signal has been processed by the bandsplit filter, the time of any given period is affected by jitter from





## What's the twist?

DTMF receiver technology has its own jargon. Words and phrases such as talk-off, twist, signal-to-noise ratio, and dynamic range either are unique to DTMF receivers or do not have the normal definition.

**Talk-off** occurs when the DTMF receiver detects a tone falsely because speech or other background signals simulate and are received as DTMF tones. This parameter is difficult to measure in an absolute manner as an infinite number of tone simulations can occur. The most successful approach is the use of a standard test tape designed to contain as many near-valid tones and speech-simulated tones as practical. The most widely used standard in North America is the Mitel test tape. Fewer than 10 hits from the tape is considered very good talk-off performance.

**Twist** is a measure of the difference in amplitude of the two received tones. Positive twist implies that the low-group tone has a larger amplitude than the high-group

tone. This is the usual case in DTMF operation since higher frequencies are attenuated by the telephone transmission lines. Negative twist is due to preemphasis of the generated high group tone that has not been normalized by transmission-line attenuation.

**Signal-to-noise ratio** applies only to the incoming signal and is the measure of a receiver's ability to detect a valid DTMF signal in the presence of its surrounding noise. (The noise level of the receiver itself is included in its noise figure specification.)

**The dynamic range** of a receiver is a measure of the range in DTMF signal amplitude that will be detected by the receiver. This is not a measure of the dynamic range of the receiver circuitry, but rather a value that is determined by setting its comparator inputs at an appropriate threshold level. The finite thresholds prevent the comparators from switching on noise or very low-level signals.

are driven from a single inexpensive crystal (Fig. 2).

The circuit takes about 30 milliseconds to receive a number. This time-to-receive is the sum of the digital detection time and the guard time. The guard time is a safety factor that prevents signal interference; it is under the control of the user and determined by the external component values (the resistors and capacitors in Fig. 2). In contrast, the user has no control over the digital detection time, as it is determined by the device's digital algorithm. It is not constant, however, but is dependent upon the state of the algorithm at the time when the tone is first applied, which tone is received, and the purity of the incoming tone.

Increasing the guard time tends to improve talk-off performance but degrades the S/N ratio of the incoming signal. It also increases the time to receive. For the circuit shown, a dynamic range of 30 dB, a twist of  $\pm 10$  dB and a S/N ratio of 14 dB is obtained with readily available external resistors and capacitors. These specifications are adequate for most applications. To meet the more stringent noise requirements in mobile radio applications, the time-to-receive guard time is reduced to acquire the signal faster, and the time to signal dropout is extended to prevent distortion. An S/N ratio of 12 dB can be achieved in this way.

The data outputs  $L_1$ - $L_4$  of the MT8860 are three-state and are controlled by the three-state output enable (TOE) signal. When  $L_1$ - $L_4$  are connected to a data bus, TOE may be controlled by external circuitry or connected directly to the steering delay pin. The latter automatically enables the four outputs whenever a tone is received. In either case STD can be used to flag external circuitry to indicate that a character has been received. The STD output goes high 12 microseconds after the data has been latched into the output buffer.

Where it is desirable to receive only the characters available on a rotary-dial telephone, taking the inhibit line to a logic high inhibits detection of the additional DTMF characters (Fig. 1b). This also improves talk-off by reducing the number of detectable tones.

The basic DTMF receiver can form the heart of a toll-call restrictor. This device, not a new concept, is

manufactured in the most cost-effective manner with the Mitel two-chip receiver.

A toll-call restrictor prevents the making of unauthorized calls, usually by restricting the telephone's use to local or internal private-branch-exchange calls. This is typically done by obstructing calls to numbers starting with 0 or 1 (Fig. 3). In PBX systems having an access digit for outside lines, the restrictor may have to check the second rather than the first digit of a dialed number. If it is necessary to check digits other than the first or second, this is also readily done by modifying a digit counter designed to be unaffected by subsequently transmitted or received DTMF tones.

The aim of this system is to detect denied tones as quickly as possible. To this end the guard time of the receiver is reduced. The resulting degradation in talk-off is of no concern, as the receiver is active only during transmission of the first one or two digits of outgoing calls and inactive on incoming calls.

System operation is straightforward. The tone receiver is connected across the telephone line using a differential amplifier. It is both enabled and disabled by flip-flop  $FF_1$ , which monitors call status using inputs from the loop detector, incoming-and-outgoing-call  $FF_5$ , and the digit-counter  $FF_3$  and  $FF_4$ . When a call comes in to the telephone, ringing is detected and the system plays no part in call connection. When an outgoing call is made, the loop detector activates the receiver during the relevant digit periods.

When a valid call is made, the system disables itself until the next call. If an invalid call is attempted, the denial decode logic detects the digit 0 or 1 in the relevant digit position. This causes call denial  $FF_2$  to activate the relay and in this way break the telephone's connection with the exchange.

### Remote data links

Useful as the toll restrictor is, the chip pair has far more significance in the long run for the home and office of the future, for it can be used to set up remote data links to control microprocessors at the call recipient's site. A basic circuit to implement these remote control

and remote data-entry systems is a DTMF-to-microprocessor interface. This interface can take information from the sender's DTMF keypad through either a direct link or a centrally or distributed switched communications network.

For this purpose, the keypad may be used to send coded data. The set of characters and commands sent from a standard DTMF telephone may be as simple as the 12 characters printed on the buttons. However, many other coding schemes can be implemented for specific applications. In fact, a two-digit coding scheme can easily send the entire ASCII character set.

It should also be noted that in a distributed (as opposed to a central) switching system, several pieces of receiving equipment are accessed one at a time over the same land line or radio channel. Here a DTMF receiver serves a dual purpose. As well as receiving and decoding transmitted data, it also switches the data with the aid of selective call logic. Each receiving interface on the link receives all the DTMF tones sent and decodes them while looking for its own unique access number. There is no limit to the number length so long as the selective call logic is suitably designed. A receiver decoding its own number causes a confirmation tone to be sent back to the transmitter. It then sets itself up to read subsequent tones as data. This system of switching is becoming increasingly popular as a method of selective calling of mobile, portable, and hand-held radios.

All the systems described operate only in a simplex mode with manual input. But they do not have to—given a suitable DTMF interface, the sender can be provided with a full keyboard or 16-digit hexadecimal keyboard. Furthermore, high-speed half-duplex transmission from precoded data is possible with extra DTMF interfaces.

#### A microprocessor interface

The tone receiver readily serves as the basis of an inexpensive data-communications device. For example, a microprocessor may be remotely accessed directly from either a 16- or a 12-button pad with only the tone receiver as interface (Fig. 4). The control input/output port of the microprocessor that is used to interface with the receiver depends on the complexity of the other devices controlled.

The microprocessor is programmed to enable and check the output of the receiver latch periodically. This is set by the rising edge of the STD signal when a tone is received. If a logic high is detected on the latch output, the TOE input signal of the tone receiver is enabled and the receiver output code word is read from the data bus. TOE is then disabled and the latch is reset with an address line.

This DTMF microprocessor interface is a very basic device, but it can easily be expanded into a more useful system—for instance, a DTMF receiver interface for handling a set of up to 100 data characters and 10 command characters. The commands give the user direct control over a number of functions at the receiver without involving the main processor to which it is sending data.

In this system all 10 system commands start with \*. Each of the 100 characters sent consists of two DTMF digits (using the ASCII code mentioned earlier) and is

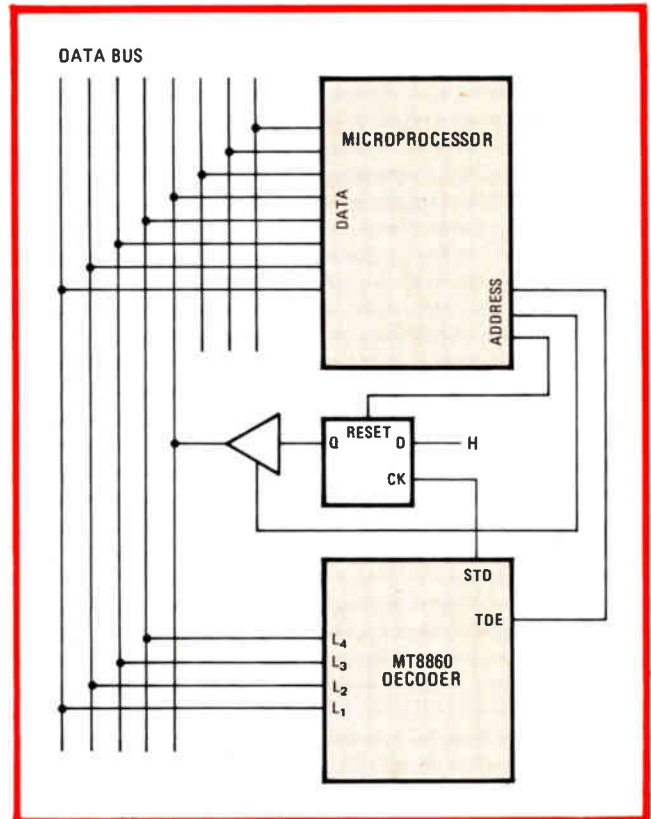

**4. Data communication.** A DTMF receiver functions as part of an interface to a microprocessor at the call recipient's site. As the processor interprets the transmitted data, it provides a remote data entry capability for operating equipment or receiving data.

separated from the next character by a single-space digit #. To the user the function of the # key is similar to that of CR on a data terminal except that it is employed after every character instead of just at the end of a line. The only essential control command is CLEAR DOWN, or \*1, which is used to break the connection. In this system a typical data entry from a salesman might be "Sold 22 items of product type 6 at \$15.00." Abbreviated to S22 P6 \$15, this is sent in the code as:

28#02#02#25#06#50#01#00#\*1.

Variations on the code may be used to introduce error checking. Furthermore, if a suitable timing structure is built into the receiver and timing constraints are placed on the user, the # key may be eliminated, increasing the sending rate by as much as 50%.

#### Coding scheme

A circuit for receiving alphanumeric information transmitted by means of such a coding scheme is shown in Fig. 5. It employs only 2 of the 10 possible system commands, namely LINE CLEAR DOWN, to sign off at the end of a call, and CANCEL LAST ENTRY, to delete an incorrectly entered character. When decoded, the # tone indicates that the data entered is valid. Incorrectly entered data must be canceled before this character is sent. The # digit also sets the input control circuitry ready to receive a new character. The control characters themselves operate directly and are not followed by #.

The output interface is an 8-bit parallel data word

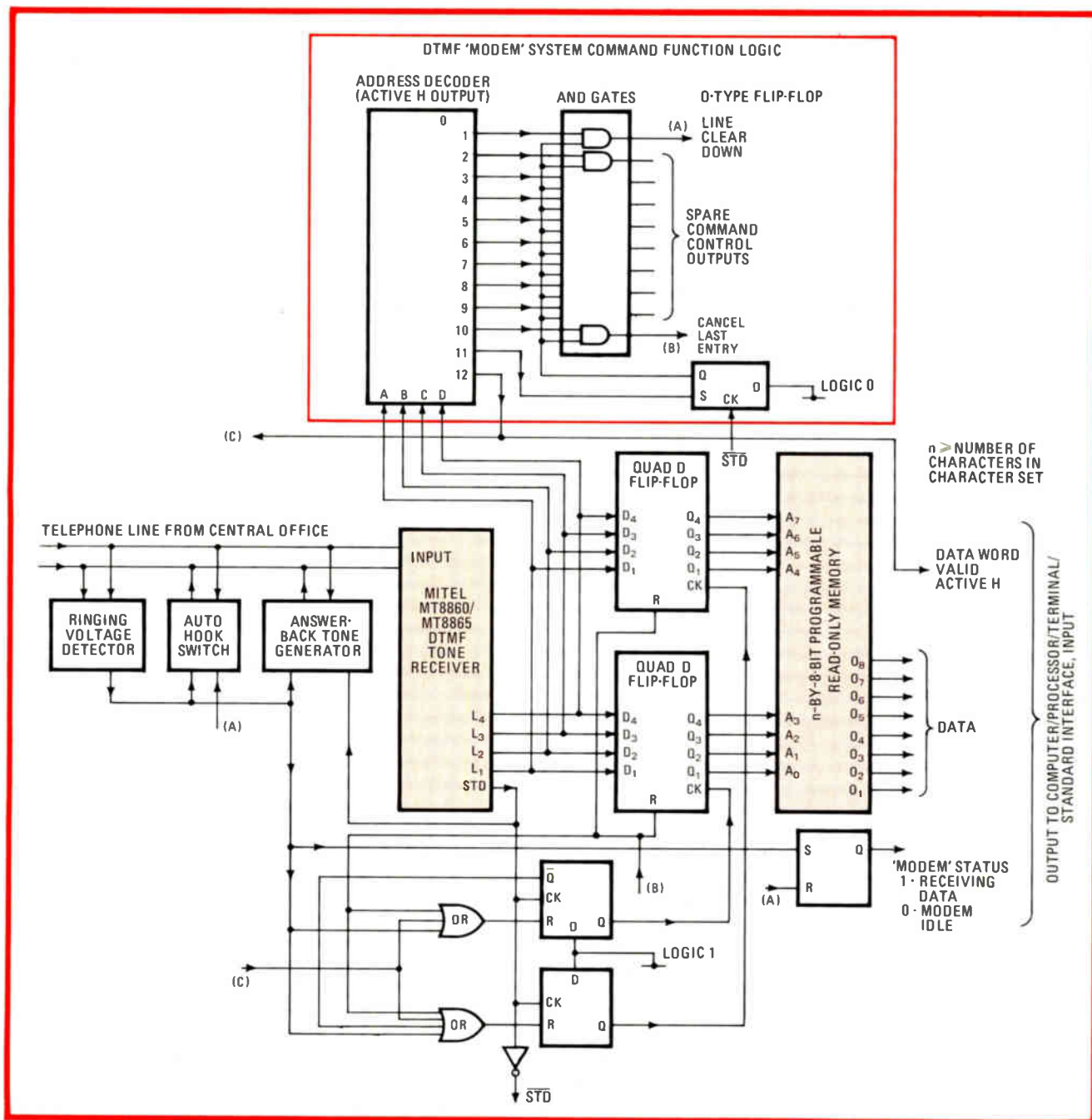

**5. On the receiving end.** A DTMF receiver, control logic, and a programmable read-only memory are all that is required to accept remotely generated alphanumeric data sent from a standard DTMF telephone keypad to a recipient's terminal or microprocessor. If an existing microprocessor is used in conjunction with some additional software, it is possible to eliminate a lot of the circuit hardware.

that drives into a data bus buffer or input register of the computer or microprocessor terminal. It also sets two flag outputs that indicate the operating status of the receiver and when a new valid character is presented at the data output.

The ring detector, the hook switch, and the answer-back tone generator detect, accept, and confirm incoming calls. Each subsequent DTMF digit is decoded by the tone receiver into a 4-bit word. The 4-bit words corresponding to two successive digits are assembled in the quad latches to form an 8-bit word. This word serves as the read-only-memory address and causes the appro-

appropriate ASCII code to appear at the ROM output. The subsequent # digit decoded by the tone receiver and address decoder supplies the data-word-valid flag to the output interface. It also causes the digit sequence counters (FF<sub>1</sub> and FF<sub>2</sub>) to be reset, so that they are ready for the next two digits.

The data output code of the programmable ROM can be whatever the subsequent processing equipment needs. If ASCII is required, then only 7 of the 8 bits are necessary. If retransmission through a different data-transmission system is needed, the eighth bit can be programmed to provide a parity bit. □



## One-chip voltage splitter conserves battery power

by David Bingham  
Intersil Inc., Cupertino, Calif.

Positive and negative supply voltages of equal magnitude are usually secured in a battery or other low-power floating-source arrangements by establishing system ground at half the source potential by means of a simple voltage divider. But this scheme more often than not consumes excessive power. Modifying Intersil's ICL7660 positive-to-negative voltage converter to work as a voltage divider, however, will increase the power-conversion efficiency to as high as 98% at an output current of 10 milliamperes.

The conventional voltage divider circuit shown in (a) uses two resistors and a unity-gain operational-amplifier buffer. While this circuit can function at relatively low power, depending upon the op amp used and the value of R, it will suffer from an inherently low power efficiency if the load should be connected between system ground and either V<sup>+</sup> or V<sup>-</sup>. In such cases, the current flowing through the load will always be the same as that drawn from the battery, and thus the maximum efficiency can never be greater than 50%.

The ICL7660 can be made to simulate a divide-by-2 voltage converter by simply grounding pin 5 (normally the V<sup>-</sup> lead) and using the normally grounded lead at pin 3 as the output, as shown in (b). The voltage distribution on the chip will be unchanged, since pin 3 is midway between V<sup>+</sup> and V<sup>-</sup>, as before. And no power is lost in heating up any resistance, as the ICL7660 operates in the switched-capacitor (charge-transfer) mode to derive the output voltage.

With this configuration, an open-circuit output voltage equal to V/2 ± 0.1% is achieved. The output impedance is 13 ohms for a supply voltage of 9 v and 0.1 mA < I<sub>out</sub> < 80 mA, or 17 ohms for V = 6 v and an output current in the same general range.

Because the ICL7660 can source only an output current reliably, difficulty may be encountered if the load is connected between pins 3 and 8 of the device. To ensure startup for current-sinking applications, a 1-MΩ resistor is placed between pin 6 and ground. This step guarantees that there will always be some voltage across the on-chip oscillator and the control circuitry.

As for circuit performance (c), conversion efficiency will be no lower than 80% for V = 6 v and 0.5 mA < I<sub>out</sub> < 80 mA. In equation form:

$$\eta = (V_{out} I_{out} / V + I) 100$$

where I<sub>out</sub> is the magnitude of the output current, regardless of sign. □

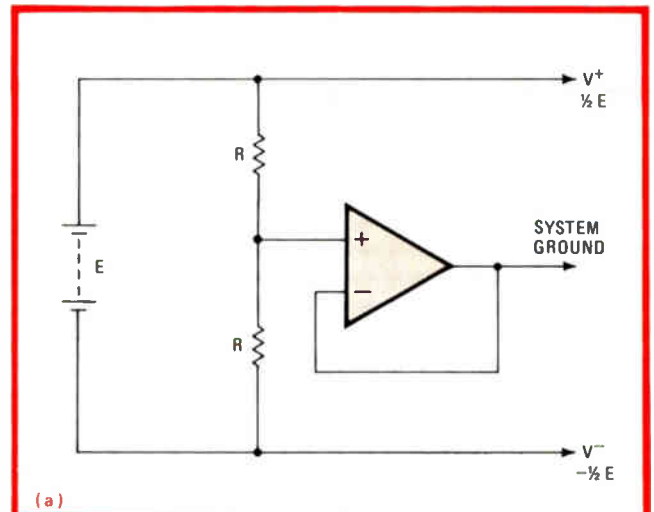

(a)

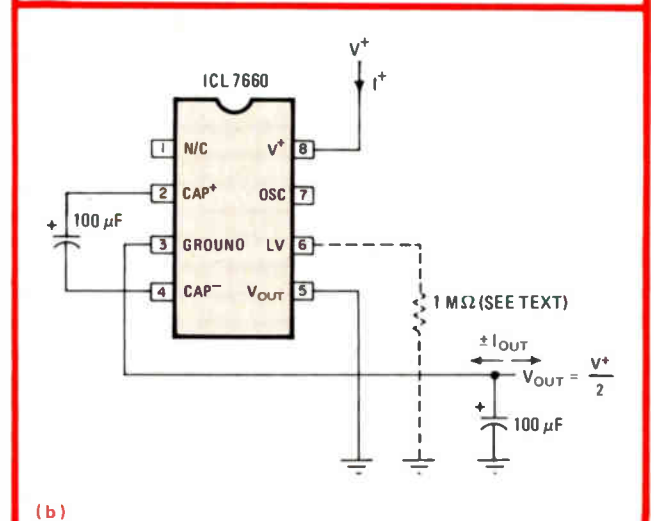

(b)

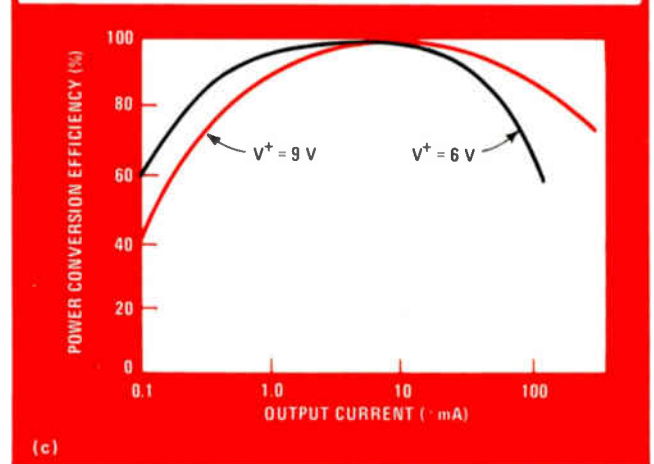

(c)

**Efficient.** Simple resistive voltage divider (a) dissipates excessive power and thus is ordinarily not suited to providing positive and negative supply voltages from floating source. Suitably wired ICL7660 converter (b) provides the function without power loss, yielding conversion efficiencies (c) approaching 98%.

# Bilateral speaker networks form switchless intercom

by Frank Kasparec  
St. Poelten, Austria

Only one transducer—a dynamic loudspeaker—is required at each station of this intercom to permit transfer of audio information in both directions simultaneously. Having no need for push-to-talk switches, the circuit is less costly and less bulky than conventional transceiver units. Undesired acoustic distortion normally encountered in this type of transmission system is eliminated by using a simple phase-compensation network.

As described for the receiver portion of the unit, audio signals at the input are converted into their acoustical equivalent,  $S_1$ , by the speaker after passing through the RC network made up of  $C_1$  and resistors  $R_3$  to  $R_7$ , which is required to offset the frequency-dependent phase shift created by the speaker's inductance. When properly set, potentiometer  $R_6$  also cancels the feedback (talkback) voltage appearing at the noninverting input of the 741 differential amplifier, which is normally used to amplify the electrical equivalent of the acoustic vibrations,  $S_2$ , hitting the cone of the speaker in the transmit mode.

As expected, the compensation network responds similarly to voltages emanating from the speaker's coil, acting to minimize phase distortion at  $V_{out}$ . In this case, however, input signals to the differential amplifier are in the millivolt range. The 741 op amp provides a gain of  $R_9/R_8$  and thus the needed amplification at  $V_{out}$ . Note that in most cases a power stage will be required following the 741 op amp to energize a loudspeaker.

The design of the phase-shift network, although easy, must be done with care if acoustic feedback is to be reduced to a minimum. The phase differences as seen by the differential amplifier must be canceled, and thus  $(R_1 + R_2)/Z_1 = Z_{C1}/(R_3 + R_4/2)$ , where  $Z_1 = j\omega L_1$ ,  $Z_{C1}$  is the reactance of capacitor  $C_1$ , and  $L_1$  is the speaker's inductance. It is also assumed that  $R_2$  is approximately equal to  $R_1$ , and  $R_3$  and  $R_4$  are much smaller than  $R_5$ – $R_7$ . For the general purpose speaker,  $R_1$  will be about 4 or 8 ohms. The above equation reduces to  $(R_1 + R_2)(R_3 + R_4/2) = L_1/C_1$ . At the same time, for direct current balance at the output of the op amp,  $R_2/R_1 = (R_7 + R_6/2)/(R_5 + R_6/2)$ .

To determine the element values in the phase-compensation network, and to estimate the frequency response of the unit, it is necessary to measure both the loudspeaker's dc resistance and its inductance. The best way to find the dc resistance is to use a digital ohmmeter. To determine coil inductance, it is necessary to apply an audio signal (preferably at  $f = 1$  kHz) to the loudspeaker, as shown in the inset, and to measure  $A$ , the ratio of the root-mean-square output voltage to the rms input voltage. The coil inductance is then given by:

$$L_1 = [R_1^2 - A^2(R_1 + R_2)^2 / 4\pi^2 f^2 (A^2 - 1)]^{1/2}$$

Rearranging the equation:

$$A = [R_1^2 + 4\pi^2 f^2 L^2 / (R_1 + R_2)^2 + 4\pi^2 f^2 L^2]^{1/2}$$

and it can be seen that the speaker response tends toward a high-pass characteristic. Because  $L_1$  is generally negligible, the frequency response is largely flat over the audio range.

Adjustment of the circuit is simple.  $R_4$  is initially set to null the output of the differential amp under no-signal conditions. A square wave is then applied at  $V_{in}$  and  $R_6$  set to minimize  $V_{out}$ . □

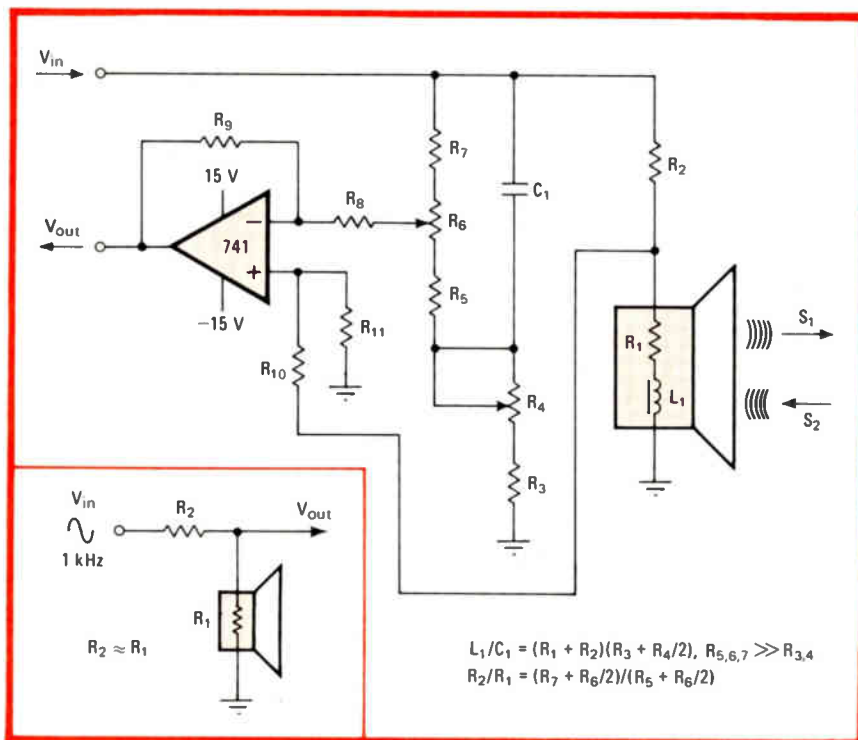

**Double duty.** One-transducer intercom station using dynamic loudspeaker minimizes cost and bulk of conventional units. Compensation network  $(R_3$ – $R_7)C_1$  reduces phase distortion created by speaker. Speaker inductance may be easily measured (see inset) in order to set component values in compensation network.

# A UNIQUE CHOICE OF DATA ACQUISITION SYSTEMS FOR THE LSI-11/2 AND 11/23. NOW FROM ADAC.

When it comes to data acquisition systems, there is nothing quite like the ADAC System 1000 and the new System 2000.

Both systems can operate as low cost peripheral expanders to any UNIBUS computer. When incorporating a DEC LSI-11/2 or 11/23 microcomputer the systems operate as stand alone control systems or as remote intelligent terminals.

The compact System 2000 is built to hold 13 half quad cards. If you need greater capacity, slave units can be utilized or you can go to the larger System 1000 which accommodates any combination of 11 quad size cards or 22 half quad size cards. Both systems can be bench top or rack mounted and have a universal power supply that can support up to 256 kilobytes of memory.

The real heart of both System 1000 and System 2000 is their incredible number of analog, digital, serial I/O, clock, bus and CPU/memory cards. Functional analog cards communicate directly with thermocouples, load cells, strain gauges, isolation amplifiers,

transmitters and strip chart recorders to name a few. Discrete cards communicate with switch contacts, relays, thumb wheel switches, pumps, motors and other devices. All cards can be purchased as separate items.

A single System 1000 can be supplied with up to 700 high level analog input channels, or 128 analog low level input channels, or 700 digital I/O functions. A typical System 2000 contains a CPU, 64 kilobytes of memory, floppy disc controller, 16 channel A/D, 4 channel D/A, 32 TTL I/O lines, two serial I/O ports plus room for another six cards of your choice.

Another nice thing about both systems is their prices. They start at \$995 for the System 2000 and \$1550 for the System 1000. So you can choose the combination of price and capability that's just right for your application. Contact ADAC for full details.

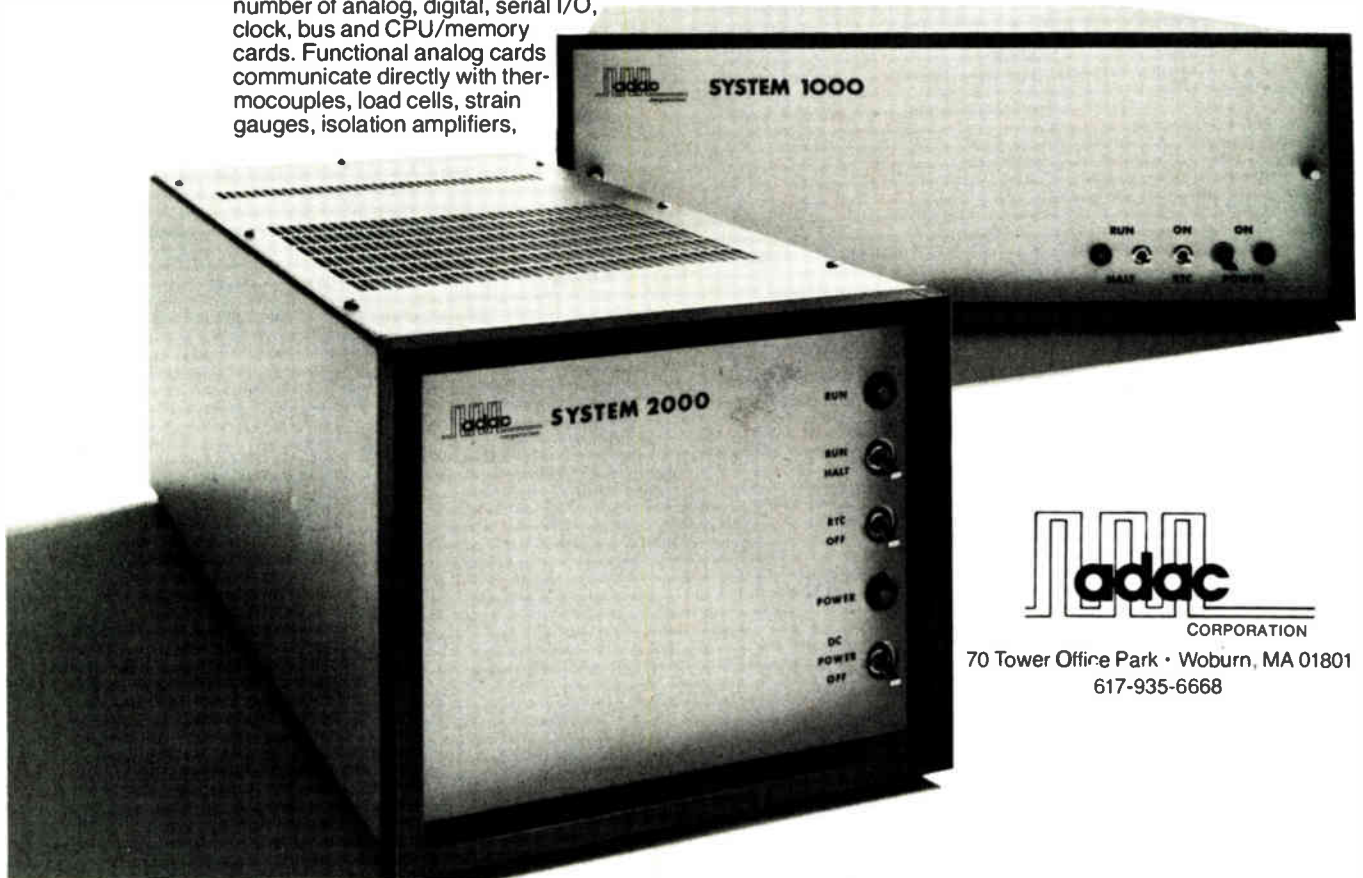

70 Tower Office Park • Woburn, MA 01801  
617-935-6668



# Switched V-f converter linearizes analog multiplier

by Kamil Kraus  
Rokycany, Czechoslovakia

This analog voltage multiplier provides a degree of linearity not attainable with circuits that use rudimentary voltage-to-frequency converters. And when modified, it is a more versatile analog divider than the circuit proposed by Kumar<sup>1</sup>, which finds the quotient for only one fixed reference voltage because of the way its current source is configured. The much improved performance is achieved with a one-chip unit designed specifically for V-f conversion duties, and a simple but accurate switched-capacitor arrangement to do the actual multiplication.

The product of two voltages is found by utilizing the TL604 single-pole, double-throw switches, thereby sampling input voltage  $V_2$  periodically and placing a corresponding charge on capacitor  $C_u$ . The average current that flows to charge  $C_u$  during these intervals will thus be proportional to  $V_2$ ,  $C_u$ , and the sampling frequency, which is a function of input  $V_1$ . The equivalent resistance corresponding to the average current that flows will therefore be  $R_{eq} = k/C_u f$ , where  $k$  is a constant and  $f$  is the sampling frequency. Assuming a high sampling fre-

quency, a pure resistance equal to  $R_{eq}$  may be considered to be in series between the output of the switch and the inverting input of the TL071 operational amplifier, as shown.

Thus the output voltage  $V_{out}$  may be expressed as some function of  $V_2$  multiplied by the switching function, or, more clearly, as  $V_{out} = -V_2(R_2/R_{eq}) = -V_2 R_2 C_u f / k$ , where the sampling frequency, on the order of 50 to 500 kHz for  $0 < V_1 < 25$  v, is generated by the V-f converter. But the sampling frequency is given by  $f = V_1 / 2R_1 C k_1$ , and so  $V_{out} = V_1 V_2 R_2 C_u / R_1 C k_1$ , which is proportional to  $-V_1 V_2$  (constant  $k_1$  is introduced by the VCO).

If the output circuit is modified slightly (see inset), the circuit will function as a divider. Then,  $V_{out} = V_2(R_{eq}/R_2) = R_2 V_2 k / C_u R_1 C_1 k_1 \sim -V_2 / V_1$ . □

## References

1. Umesh Kumar, "Improved analog divider finds large-signal quotients," *Electronics*, Dec. 6, 1979, p. 135.

Designer's casebook is a regular feature in *Electronics*. We invite readers to submit original and unpublished circuit ideas and solutions to design problems. Explain briefly but thoroughly the circuit's operating principle and purpose. We'll pay \$50 for each item published.

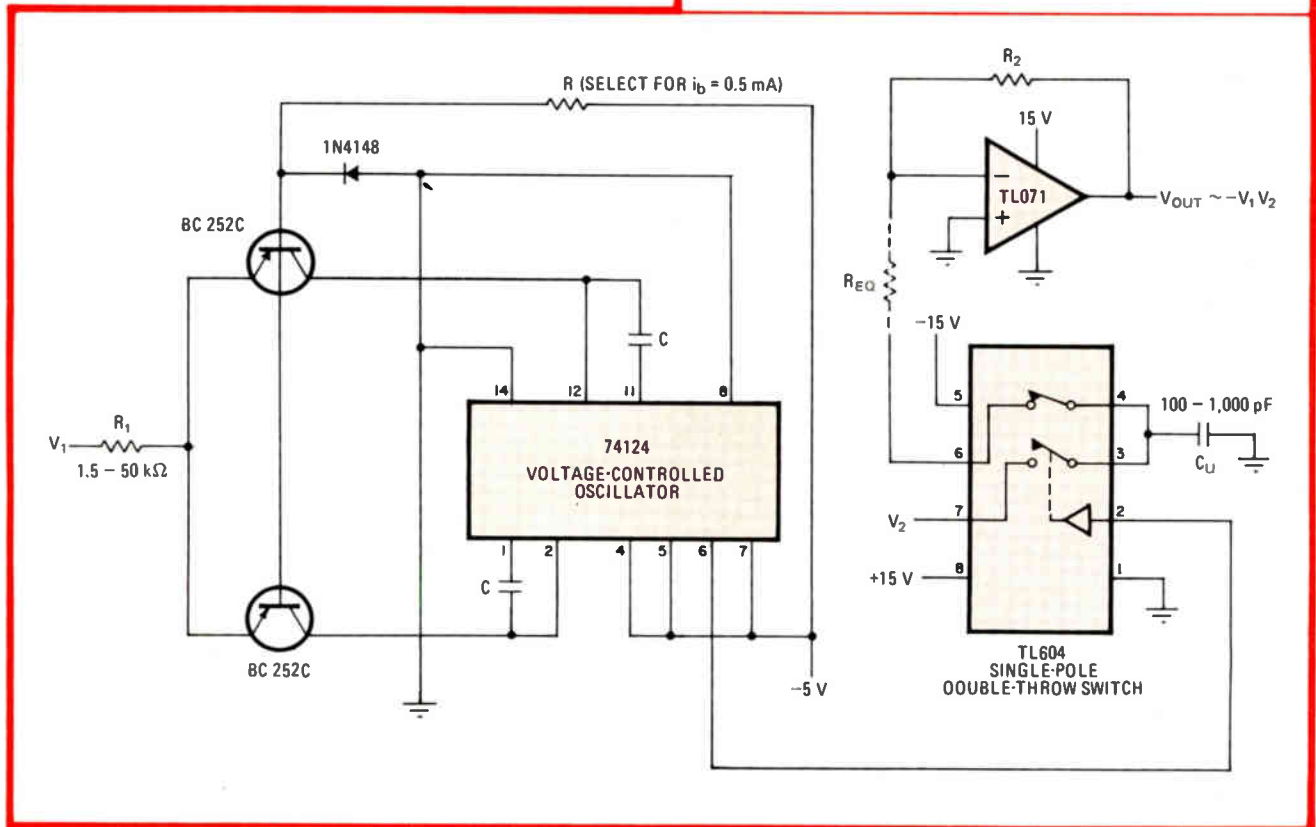
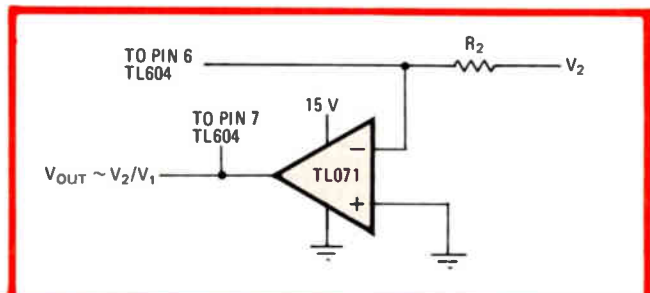

**Mathematics.** One-chip V-f converter and switched capacitor arrangement provided by solid-state switches yield excellent linearity and wide-range voltage-handling performance in an analog multiplier. Interchanging  $R_{eq}$  and  $R_2$  by modifying output circuit slightly (see inset), where  $R_{eq}$  represents the average current flowing in capacitor  $C_u$  during sampling period, converts unit into two-input analog divider.

## Development system networks: the last

Reaching outward from stand-alone and multi-user systems, networks of software and hardware development tools will pull factory, office, and field together

by Richard W. Comerford, *Test, Measurement & Control Editor*

□ Watch the microprocessor development system. It is starting to integrate the diverse elements of modern electronic production, pushing upward to link factory, front office, and field support, sending forth new roots into engineering facilities.

Less than two years ago, a development system was an expensive box that stood on the bench and dealt primarily with software and its interface with hardware via emulation—aspects of design foreign to most engineers. But in late summer of 1978 [*Electronics*, Aug. 17, 1978, p. 88], two iconoclastic independents, Paul Page and Bruce Gladstone of what was then Futuredata Computer Corp. in Los Angeles, Calif., pointed manufacturers in a new direction. By introducing the first network of development systems to rely on a distributed-processing scheme, they changed the thinking of industry, pushing it toward a design solution in which the sharing of resources is becoming paramount.

Hewlett-Packard Co. was next. Last September, its Colorado Springs division introduced the first part of its development solution. Also a distributed processing system, HP's network was based on a minicomputer and had greater storage at its hub: hard disks able to store up to an astonishing 960 megabytes of information. Motorola, Intel, E-H International, and others are also planning to provide networks that will tie together their existing and future development system products. All have gotten the message that development systems are going to have to do more work, both in design and production, if the microprocessor revolution is to keep spreading (Fig. 1).

### First, multiple users

These multi-user systems are only the first step toward the larger networks that will tightly link the design, production, and support process for both hardware and software. One such system, the ECL-3211 from Emulogic Corp. of Westwood, Mass., is already about to make its appearance. Expandable to 64 software or emulation stations, the PDP-11-based system can be tied to large time-sharing networks and can emulate 8-, 16-, or 32-bit processors simultaneously at speeds to 30 MHz.

Even the first multi-user systems will permit their manufacturers to offer more sophisticated software tools. Not only will these tools let both tyro and pro program with greater ease, but they will also improve management of the entire product-building process.

Software tools will not be the only additions to the development system networks. Along with them will come tools to improve hardware-software integration, ones which permit interactive emulation of two or more processors (as Intel's Multi-ICE and Philips GmbH's PM4421 do) and provide greater stimulus and measurement capability. This latter element in what will be this decade's productivity solution has already been seen, not in development systems, but in the System 5000.

Introduced in the late summer of 1979 by Paratronics Inc. of San Jose, Calif. [*Electronics*, Aug. 30, 1979, p. 41], the 5000 was the first commercial virtual instrument—meaning one that could easily be adapted to suit a wide variety of measurement needs. Changing the System 5000's software and its analog front-end card turns it into a number of different instruments: logic analyzer, waveform generator, spectrum analyzer, voltmeter. The hardware-software integration tools that will be added to the development network will be built

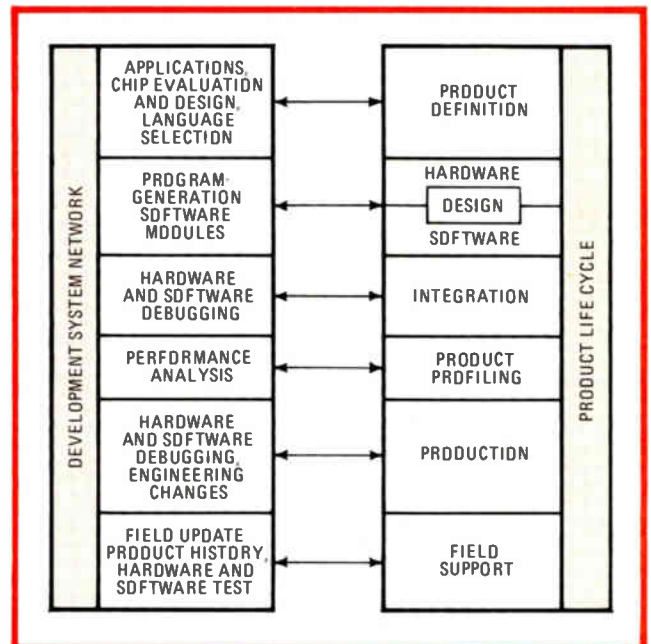

**1. Tightly coupled.** Networks growing out of multi-user development systems will pull together the various elements in a product's life cycle. Forcing this solution will be the need for more economical use of information and manpower in all stages.

# link in automated manufacturing

around this virtual instrument concept. Along with emulation and logic analysis, they will provide signal sources to fully exercise the product being built.

Pushing the development system to do more is the microprocessor which first gave it birth. There are virtually no new products that have not felt the processor's impact. Sam Lee, product manager at HP's Colorado Springs division, says that "my company will have no new instruments that do not contain microprocessors." Many other manufacturers say the same.

Even in those companies most familiar with digital designs, the shift to microprocessor-based design is far from painless. Aside from the fact that already crowded benches have to make room for more tools, the staff now has to become knowledgeable in software. F. Taylor Scanlon, manager of microprocessor-support products engineering at Motorola Inc.'s MOS Integrated Circuits division in Mesa, Ariz., acknowledges the importance of this new aspect of engineering when he says, "I'm not hiring any engineers unless they have a software background." And such people are not easy to come by.

## Top-down design

One clear impact of the microprocessor can be seen in the way products are now being designed. Effective design can begin only at the top, with plans made as to which functions will be implemented in hardware and which in software before a single joint is soldered. The design team then branches into hardware and software groups, which trade bits of software and chunks of hardware. Typically, the software group has complete command of the development systems at this point, while the hardware group relies heavily on logic analyzers. The two groups reconverge at the battle of final integration.

It is at this point that the joint hardware-software capabilities of the development system prove critical. "I don't care if your hardware guy says that the hardware is all working and your software guy says ditto for software," says Motorola's Scanlon. "Comes that magical morning when you plug in the microprocessor and turn on the power—and it doesn't work—you are probably in bad shape."

Even software designers who prefer to work on time-sharing terminals realize that this is an area where development systems can prove their worth. Gomer Thomas, a project leader and software designer at John

Fluke Manufacturing Co., Mountlake Terrace, Wash., notes that "the only time I've had difficulties that couldn't be easily solved using software debugging tools was when it wasn't clear whether the software or hardware was acting up."

Bruce Farley and Charles H. House of HP have also remarked on problems infesting the hardware-software integration phase of design [*Electronics*, Sept. 13, 1979, p. 141, and Feb. 28, 1980, p. 143]. But House also notes that the war is not over once that battle is won: equally critical are the production and field-support phases. The company that is able not only to get its new widget out the door fastest but also to offer cradle-to-grave support should have a decisive edge on those who cannot.

Indeed, the development system is already moving into the production arena. Jeff Krawitz, sales representative with Advanced Micro Devices Inc., in Horsham, Pa., notes a shift toward people using development systems as test stations for hardware troubleshooting both in design

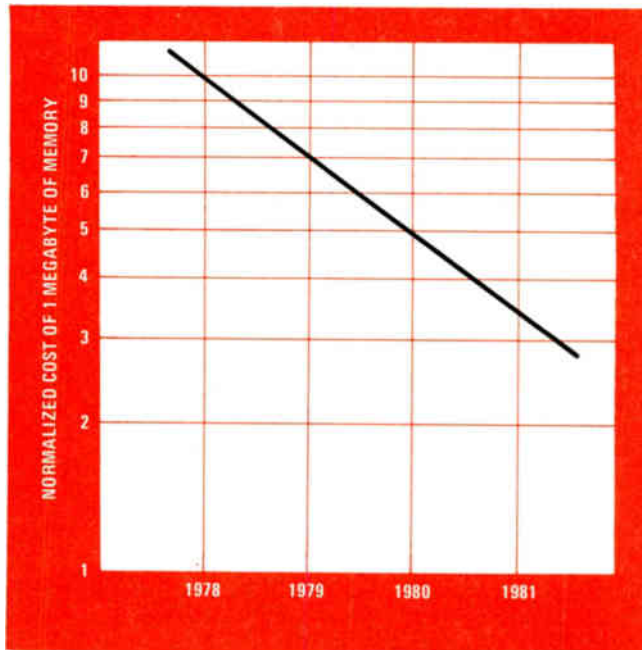

**2. Free resource.** Hewlett-Packard is banking on the continuing decline in the cost of memory, a phenomenon it sees occurring at a rate of 30% per year. It expects the cost of other high-technology devices to undergo similar cost drops.



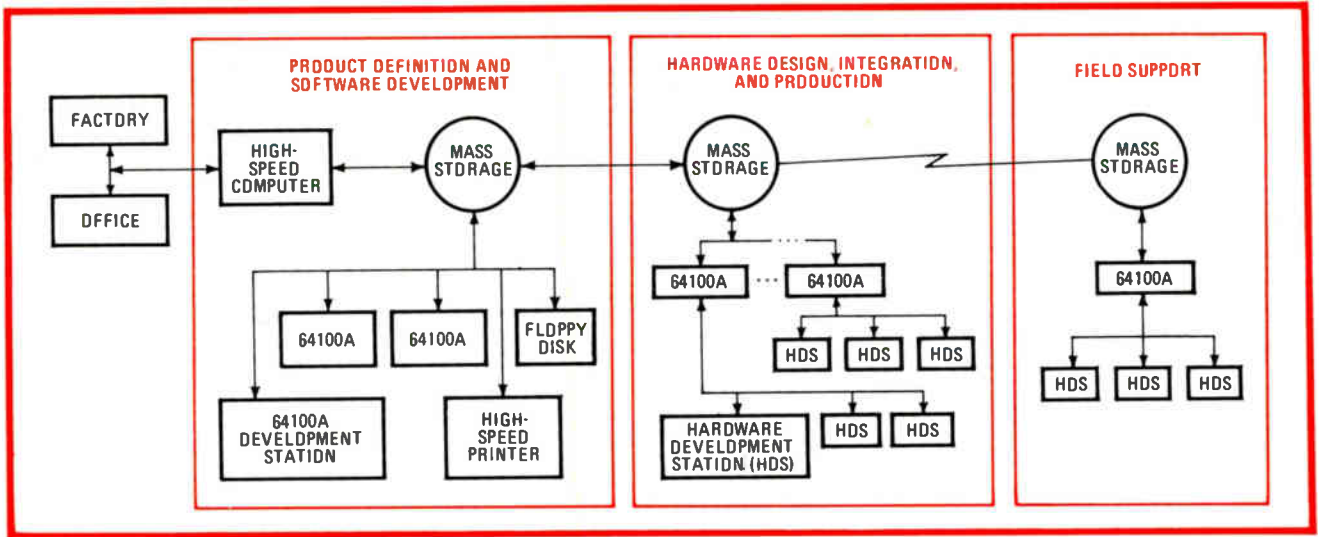

**3. Spreading a net.** Use of mass storage to form extensive archives is key to the HP approach, which will probably take on a form similar to that in its automated factory, like the one shown. The high-speed HP computer will perform number crunching and file reformatting.

and production. The philosophy behind this move is simple: if a fairly specialized unit is used in developing a product, it makes sense to use that same piece of gear to debug the product in production.

But even as the development system takes on new work in production, its traditional design duties are being redefined and extended to handle exasperating problems like the unnecessary duplication of effort. For example, in debugging a design, the engineers often solve the same software and hardware problems that later pop up again. But these early efforts are often lost to the production and field support people, either because the engineer who found it has moved on, or because the solution has been buried in a ream of other documentation. The job of keeping archives will fall to development systems.

Software compounds this difficulty, for engineers working together on a project must share files, and deciphering one another's code can be extremely hard if it is not fully documented. Further, parts of overall programs (hardware drivers, for example) can appear in identical or very similar form in a number of product programs. Unless these pieces can be used in other programs, the same programming effort must be paid for again and again and again.

### Management tools

The answer to these software problems lies in the provision of good project management aids. One such aid is the equivalent of a general-purpose chip like an analog-to-digital converter. For software, that equivalent is an application program provided in read-only memory for, say, translating thermocouple inputs into Celsius temperatures. By using prepackaged programs, with thorough documentation, a project manager can reduce the risk and time it takes to bring his product to market.

Project management problems are now being experienced in designs based on large-scale integration; the advent of very large-scale integration in commercial products will magnify them at least tenfold. Programs for the powerful VLSI processors can be extremely large,

requiring massive workspace and storage. And with VLSI designs, widespread application will demand a certain amount of custom chip tailoring for all but the highest-volume applications.

To create a successful VLSI-based product, a designer will have to communicate with corporate or sales offices to determine what opportunities really exist, at what volume, and at what price. He will then have to know the specifications and options of the latest master VLSI chips. Once he has decided on the customization of gate arrays and on-chip ROM, he will have to give that information to the semiconductor fabrication facility as quickly as possible to get the best position for his final product in the market. This demands data communication at a level of efficiency that only an integrated network can provide.

### Networks abound

Engineers have been dreaming about such integration for such a long time that they are almost used to passing off such things as "blue sky." That such an integration is now truly about to take place is evident in many ways. Witness the recent cooperative announcement by office copier giant Xerox Corp., minicomputer titan Digital Equipment Corp., and semiconductor colossus Intel Corp. of the general-purpose Ethernet. Witness the host of office systems networks from Wang and others. Witness the factory networks from Fairchild, Teradyne, Eaton's Macrodata, and most recently, GenRad. Upon that new high-speed network, GRnet, president Bill Thurston has frankly announced his intention to build the "factory of the future." This year and the next, the semiconductor and instrument companies will be vying to build the bench of the future.

The first elements—multi-user systems with shared storage resources—of most supernetworks will be in place by the end of the year. There are two immediate reasons for providing them: users need more storage, to develop not only 16-bit processors but 8-bit ones as well, and sharing resources will make the cost per station lower and hence the systems more attractive. But the

## “But I can't afford a network”

While microprocessor development networks will undoubtedly provide the means for users with many different applications to develop products based on 16- and 32-bit microprocessors, they cannot fill the bill for the user who just wants to get a simple design based on a single 8- or 4-bit processor up and running. For the latter, the initial answer must contain the key words “low cost.”

Putting those key words in the answer depends upon what the potential designer already has in his shop. If he or she is starting from scratch, there are a number of low-cost systems on or coming to the market that may satisfy his or her needs, and there are even development techniques that eschew hardware altogether. On the other hand, if there is a minicomputer already available for time sharing, a combination of inexpensive software and hardware tools may be the right approach.

For those starting from scratch, the Microsystem Designer series 1000 of Millennium Systems, Cupertino, Calif., is one of the least expensive ways to get moving. Priced at \$1,300 to \$1,650 depending on which processor is being supported (the unit also supports 16-bit processors such as the 8086 and the Z8000), it allows a designer to write programs using a hexadecimal keypad and try them out on his or her target system, which can be put on an integral breadboard. Programs can then be stored on an external tape cassette.

For users who intend to do a bit more programming and feel they would like a more powerful tool, there's the EXORset from Motorola. Priced around \$6,000, the unit provides software development capability for the 6809 microprocessor on which it is based. The EXORset has two minifloppy-disk drives built in for program storage and additional EXORcisor cards can be added to its internal bus to expand its capabilities. Graphics capability and a Basic interpreter are built in, and it comes with a powerful editor along with other software.

Another system for users who would like to work with the 6809 microprocessor will be brought to market on Sept. 1 by Smoke Signal Broadcasting Inc. of Westlake Village, Calif. The \$6,750 system (shown below) includes two floppy-disk drives for double-density, double-sided, 8-inch disks and a software package that provides Basic and UCSD Pascal, a text editor, a debugging package, a macro assembler, and an MDOS conversion package,

among others. Also included is an electrically programmable read-only memory (E-PROM) programmer so that users can move programs to the target system.

Other companies offering low-cost systems include Cromemco, Fairchild, Mostek, Mupro, RCA, and Rockwell. Intel is at present working on a very low-cost system that will permit both software development and emulation.

ProLog Corp. of Monterey, Calif., feels that, for 8-bit processors at least, all that hardware is unnecessary. The company teaches a course enabling even unsophisticated users to write programs in a structured way by hand. The result is software that can run on the company's or the user's own STD-bus-compatible modules—software that is well documented and understandable by a test technician, according to the company. The only cost to the user is that of the course itself (\$400) and that of a PROM programmer (from ProLog, around \$2,000).

Would-be microprocessor system designers who have access to a time-shared system in house can use it if they obtain cross compilers or cross assemblers from one of the software houses addressing that market. Among that number are the Boston Systems Office, Systems Kontakt Inc. in Bedford, Mass., Sierra Digital Systems in Reno, Nev., Microtec in Sunnyvale, Calif., and many others. The software packages run from around \$1,000 to \$4,000.

Once the programs have been written, they can be downloaded to a PROM programmer and thus tried out on the target system. Another way of trying out the program, one with greater flexibility and visibility, is the stand-alone in-circuit emulator. Programs can also be downloaded into these units and then run in the target system, but with the added advantage that operation of the target processor being emulated can be observed.

The Microsystem Designer can be used as an in-circuit emulator too. But for higher-speed emulation, Millennium offers the Microsystem Emulator Series 2000, which operates at speeds up to 6 MHz and costs between \$5,500 and \$6,000 depending on the processor being emulated. The unit is also capable of operating under direct-memory-access conditions found in some processors. The Microsystem Analyzer can also be used as an emulator and field tester. For this unit, the company has recently introduced a guided probe to speed troubleshooting.

Tektronix offers the 8001 for emulating a wide variety of processors. Configured to support an 8080A, it costs about \$9,000 and permits emulation with the program in the emulator alone, the target system alone, or part in the emulator and part in the target system. Thus software can migrate to the target system.

E-H International recently entered the stand-alone emulator market [*Electronics*, March 13, 1980, p. 168] with the model 800 which is priced at \$5,895 and which currently supports one of three processors for that price. The unit can easily be carried into the production arena.

Applied Microsystems Corp. of Kirkland, Wash., also offers a stand-alone emulator for five different processors. With a price ranging from \$2,495 to \$2,895, it emulates the target processor using memory within the system. For an extra \$950, 8 K of RAM can be added to the emulator so that it may be downloaded via an RS-232-C port.

Latest to enter the stand-alone emulator market is Zilog with its ZSCAN 8000 [*Electronics*, June 5, 1980, p. 42]. Priced at \$4,500, the unit has two RS-232-C ports and is capable of emulating the Z8001 or Z8002.



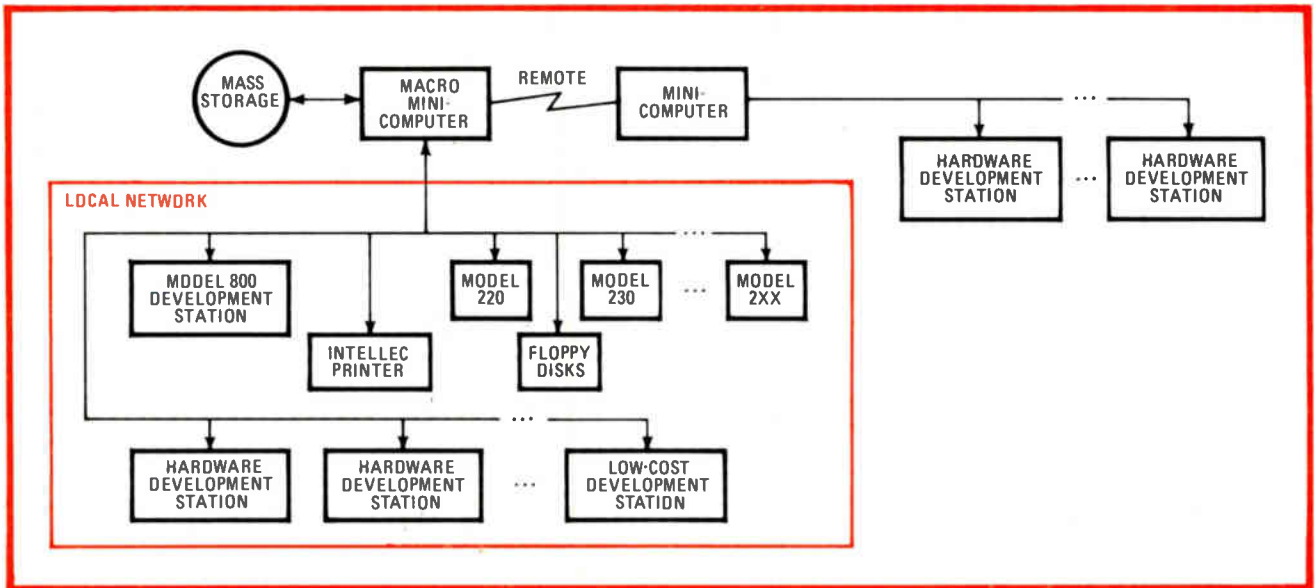

4. **Through the Ether.** Intel's involvement with Ethernet will result in a packet-switching development network like the one above, for which the company will develop separate emulator-instrument hardware tools whose capabilities will rely on the net's 10-megabit/s speed.

multi-user system will also allow manufacturers to begin introducing more software tools, since they need greater storage from which to operate. Further, the way in which the manufacturers choose to configure the data base has implications for the coming large nets.

How much storage should be shared by multiple users is open to debate. According to Sam Lee, part of HP's rationale is that, compared to other development costs, "memory is free." He points to the cost-per-megabyte curve (Fig. 2), which he expects to drop at about 30% per year, and sees its cost as offset by the value of providing massive archival storage.

Motorola, Intel, and GenRad/Futuredata take issue with HP's view. "We find that a little bit difficult [to accept], with customers already complaining about the high cost of these systems," says Motorola's Scanlon. His company's network, which will become available in the last quarter of this year, will provide 16 megabytes each of fixed and removable storage. It can optionally be expanded by another 32 megabytes.

James P. Lally, Intel Corp.'s development system general manager, feels that the rule of thumb most people are currently employing—2 to 10 megabytes per station—is appropriate. The Santa Clara, Calif., company's disk- and file-sharing system, D/FSS [*Electronics*, May 22, 1980 p. 39], will let up to eight Intel development systems share any of its existing hard- and Winchester-type disk drives. But providing a data base of several hundred megabytes "is insane," he says. "The key is not having a massive data base, the key is having the program management tools to control it."

Gladstone of Futuredata, now in Culver City, Calif., and a division of GenRad, also does not see a need for a grand centralized base; his eight-user network will not go much beyond its present 70-megabyte limit. "I think that when it gets to managing 900-megabyte disk drives, high-speed line printers, and all the things you need for a large data base, there are people who do a lot better job of it now than we could," he says, adding that some are

already GenRad original-equipment manufacturers.

HP has approached the problem with a linked-list structure—similarly to that of UNIX, the Bell Telephone System's C-based operating system. With a linked-list structure, files are stored in random sectors on the disk depending on which are open, as opposed to on consecutive sectors. Sectors to be used for files are pulled from a "free" list that the linked-list system keeps automatically. Thus the user does not have to look for consecutive disk sectors each time he wishes to open a file.

In the file catalogue, only a file's first and last sector addresses are kept. The address of preceding and following sectors are encoded with the data stored in each sector, and the controller reads those addresses before pulling the next sector. "What this means," explains Lee, "is that you trade off a little access speed for the ability to have disk space managed automatically."

### Computer tie-in

Minicomputer access to automatically managed large files is key to the supernetwork architecture that HP is planning. A distributed processing scheme much like that which HP has already installed in its IC facility [*Electronics* June 5, 1980, p. 151], it will form the link between such factories and the electronic office (Fig. 3). The massive file structure will make possible dynamic access to and global transmission of design specifications, integrated-circuit artwork, masks for read-only memory, programmable-logic-array equations, test procedures, and other information that will be needed, particularly for VLSI circuit design.

The individual minicomputer development stations now in place are tied together with an IEEE-488 bus operating at 150 kilobytes per second. The distance between present stations will be lengthened with fiber optics, letting each minicomputer govern other devices. The multiple-bus architecture of the present station will permit this.

Intel's Lally sees the common data base as a prerequi-



site for efficiently providing management tools and archival program storage. But even for program archiving, the amount of storage needed can be minimized. "You don't want to 'archive' numerous versions of the source modules," he claims, "you want to archive the smaller edit modules that let you get there, and you want to do it automatically so it's transparent to the user."

Providing these tools for compact storage will enable Intel's coming network to employ its present disks. Rather than tie into a single large data base, Intel will most likely make use of its recent agreements with DEC and Xerox to provide an Ethernet of development systems, transferring data between systems at a 10-megabit/s rate in addressed packets (Fig. 4).

From that distributed data base, Intel plans to let users support a wide variety of, say, operating system programs. If a remote user wants to diagnose a product in the field, he will be able to call up the OS version used in that product with a build-type command, one that automatically reconstructs that OS version and gives him a trace of changes to it since it was originally conceived. "Those things have to be done automatically—when you have 10 or 15 people in different physical locations working on the same application, the communication problem is just massive," Lally explains.

### **32-bit computer**

Motorola's Scanlon, like Lally, sees management tools as the driving force behind development system growth. But whereas Lally does not feel that the cost-per-station issue is as important as it is now made out to be, Scanlon claims his strategy is "to try and amortize the cost of a large system at a central site while giving full development capabilities at remote sites—capabilities far beyond what could fit into a remote site."

At the hub of Motorola's network (Fig. 5) will be EXORmacs. Significantly, the "macs" in EXORmacs stands for the company's advanced computer system. Around this computer system, Motorola will build a time-shared system with which EXORterm terminals and other stations will communicate for program development. With a 32-bit bus structure, Scanlon sees the unit as being around for at least eight years. As Motorola evolves new processors, they may actually first appear in the development systems, giving the system the power to work on new chips in cloning fashion.

It might be thought that GenRad/Futuredata, which brought distributed processing to development systems, would be unlikely to go to a time-shared system. But in actuality, its present stations, based on 8-bit processors, will become terminals communicating with a large computer like the DEC PDP-11/70 (Fig. 6). Such a system would bear a strong resemblance to a GRnet-based system network [*Electronics*, June 5, 1980, p. 169].

That time-sharing is an extremely viable means of development is borne out by a number of software engineers who swear by it. "If you look at a system to support software alone," says Fluke's Thomas, "you find that the various development systems are generally much less efficient than our time-sharing system. The development system is very slow at assembly and printing." A number of companies supply cross-assemblers and cross-

linkers that run on Digital Equipment Corp.'s PDP-11/75, for example. For people with in-house computer systems, those products can let them develop software for a fraction of the cost of a development system. But while this admirably addresses the problems of software development, it does not attack the real-world integration of hardware and software.

### **That magic morning**

The transition from development system to board is the most critical part of the product development cycle. There are two major ways of easing it at present: simulation, in which the interaction of the software with the processor is simulated by a computer model; and emulation, in which a processor plugged into the board emulates the performance of the target processor in such a way that its actions can be observed. Simulation routines are provided by the same people who offer cross-assemblers and cross-compilers, while emulators are supplied by development system manufacturers and others.

Simulation can be a valuable tool. Long before the first chip is cast in silicon, its specifications are generally known and simulation programs can be written. Thus it is possible to write and test programs to some degree beforehand. For those who must of necessity stay far in advance of semiconductor production, simulation is the only answer.

But perhaps the biggest drawback of simulation is that it relies on ideal operating conditions and hence falls short of providing a true picture of the real world in which the program is run. Simulation programs require a very powerful computer, such as an IBM System 370/168, and although programmers at Boston Systems Office indicate that multiple-processor simulations are possible, coupling such needs with VLSI will make simulation untenable here, as it also will be for automated testing.

### **Enter the emulator**

Emulators, on the other hand, offer the user a look at how his software will work in a real environment—the ultimate thing he wishes to know. And while they are generally available only after the actual processor being emulated has been produced, for most users the time difference is inconsequential. Any delay can be spent in building hardware and writing software independently and in testing chunks of software by downloading to a programmable ROM.

Emulators are generally classified as in-system or stand-alone. An in-system emulator is one that resides in the development system mainframe (perhaps sharing its resources), whereas the stand-alone emulator is housed in a separate chassis. The in-system emulator generally ties up the development system resource; software development can not be done while it is running an emulation. Stand-alone emulators, however, work independently of the development system and are often portable.

The term stand-alone is to some degree a misnomer. While such units can be used without any additional hardware, to get a detailed look at what is happening in the emulation processor the user generally needs a cathode-ray tube terminal of some sort. The stand-alone

emulator was pioneered by Millennium Systems Inc., Cupertino, Calif., in its Microsystem products. Today, units are available from Tektronix Inc., Beaverton, Ore. (8001); Applied Microsystems Corp., Kirkland, Wash. (EM 184); E-H International Inc., San Jose, Calif. (Microsupport Standalone); and most recently, Zilog Inc., Cupertino, Calif. (ZSCAN 8000).

### Breaking away

In the near future, the modular emulator will fully come into its own. Already, the emulator has been coupled with a logic-state analyzer that looks at the address and data links of the emulation processor and, in some instances, at external circuit points as well.

Those development system manufacturers who do not already have separate emulation units will soon have them. HP, for example, will take its emulator out of the 64000 and place it in a separate chassis, at the same time enlarging the emulator memory so that the larger programs used by 16-bit processors can be more easily emulated. This new chassis will also accept more than one emulator at a time.

Motorola will also provide a modular multi-emulator called a hardware development system station, which it will begin delivering in the second quarter of 1981. The unit will work with an EXORterm; its emulation programs will download from EXORmacs via RS-232-C serial lines.

GenRad/Futuredata made allowance for stand-alone operation in the design of its slave emulator system. At present, the company provides the coding scheme to be used for communicating with its emulator, and users could program a smart terminal to communicate with it. Although GenRad/Futuredata does not yet support that mode of operation, it seems likely that some software houses will. Intel, too, will most likely put its Multi-ICE in a separate chassis that communicates with its development network.

The reason for this move on the part of industry is not

solely to let emulators be carried into production separately. In addition to reducing system cost by sharing resources, the modular emulator allows them to provide better systems for the processes of both design and production, like the System 5000.

The logic analyzer is now closely tied to the emulator, as it was in Intel's short-lived  $\mu$ -Scope. The protean analyzer will grow, providing additional channels for observing not only the processor but other points on the board. What's more, other instruments needed to stimulate the board will be added to the emulator box in card form (Fig. 7). Signal generators, able to provide the analog signals needed to fully emulate the in-system operation of hybrid a-d boards, for example, will be added so that their response can be controlled and triggered by the system CPU along with the emulator.

On digital boards, word generators will perform a similar function. Then, too, low-frequency digital oscilloscopes will also be put in the box so that actual signal waveforms can be observed. This will bring Motorola, Intel, and other semiconductor companies into strong competition with HP, Tektronix, E-H International, and other traditional instrument manufacturers, as all of them try to grab sizable shares in that virtual-instrument market.

Such devices will not be stand-alone units. They will tie into the nets so that software in the form of both programs to be emulated and operating systems that call into play the various items needed can be downloaded to the box. These units will therefore not only be used in the local network inside the engineering facility, but will work in the field via remote links. The same tools will then both make and fix a system.

Motorola's development system philosophy—creating boards for its development systems that later end up as chips—has important implications for the future of instrumentation. Putting instruments into silicon will allow them to be built directly into a system, so that remote diagnosis can become an economic reality. It is

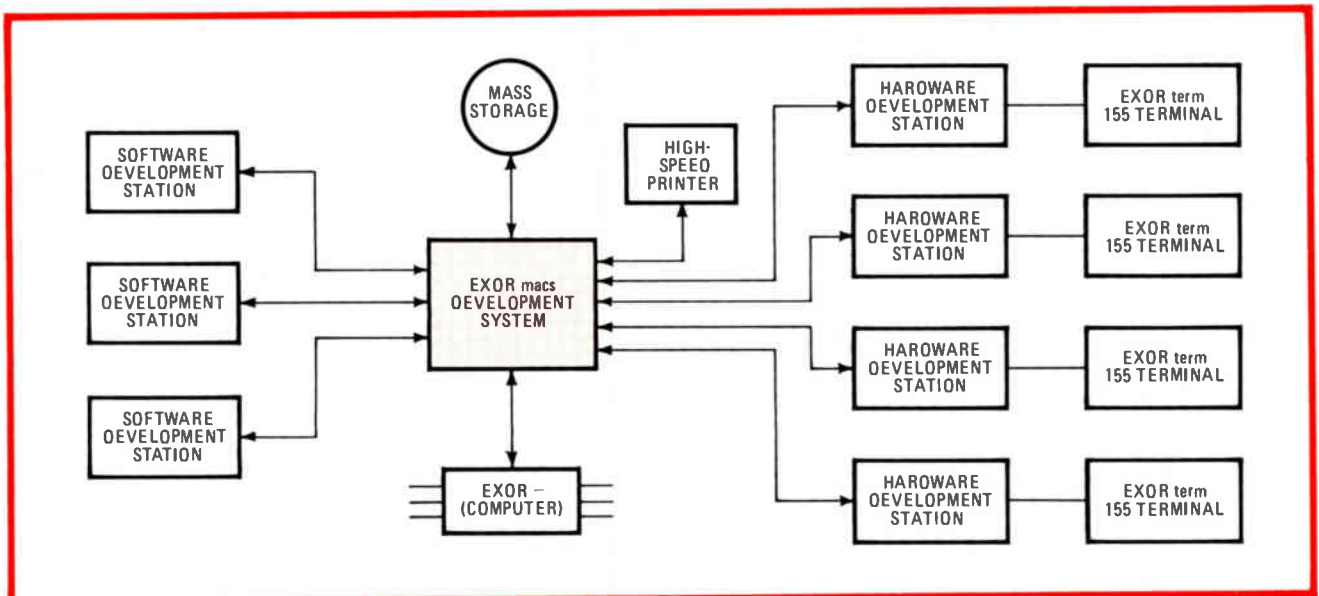

**5. Distributed time sharing.** The EXORmacs system provides a development environment which several programmers can share interactively with hardware developers. Hardware development stations, which may be remotely located, will rely on the host for powerful software tools.

no wonder then that instrument houses such as Fluke, HP, and Tektronix are busily engaged in building massive, captive IC facilities and introducing new "instruments" that can more accurately be described as dedicated computers.

While busily working on these new hardware tools, the development system manufacturers are also going full blast molding new software tools. These tools will require the Winchester-type and hard-disk storage that is being installed at present. While such storage systems may initially seem expensive, the tools that they permit will ultimately reduce the truly expensive aspect of microprocessor-based design: software development. In addition, they will put capabilities in the hardware development stations that could not otherwise be realized.

By the end of this decade, every engineer will be a programmer—not that everyone will have to learn an obscure language, but the programming tools will become so sophisticated that by typing out simple sentences in a logical, structured way on an ASCII keyboard, people will in essence be writing programs. This is the only way in which the microprocessor revolution will in fact succeed.

The push to that goal started with the Pascal language, which is already available for a number of systems. It should be remembered that Niklaus Wirth's original reason for designing it was so that programming could be taught to those unfamiliar with it. Most manufacturers are turning to the International Standards Organization's standard version of that language, one that more closely resembles the version Wirth originally developed.

The major benefit of Pascal is that it lets programs be generated quickly and inexpensively. Pascal's block-structured format forces the programmer to write programs in such a way as to permit his work to be incorporated with that of others. Thus several novices can write code that can be easily linked to form a large program, reducing the time and experience needed to generate the large programs that more sophisticated microprocessors will use.

But despite this benefit, Pascal has its drawbacks. For

one thing, there are a variety of Pascal dialects that do not go together without some effort on the part of a knowledgeable programmer. This, to some degree, defeats the benefits of using Pascal; still, that defect can be overcome within a company that adopts a single dialect as a company standard. Thus the program modules that are generated within a single company can always be linked.

Further, sticking with one version of the language will be particularly valuable if that version is supported by a major semiconductor manufacturer. Motorola, for example, is writing all its ISO-based Pascal programs so that they will ultimately be storable in ROM. In this way, they will be able to supply customers with software in silicon, greatly reducing the purchaser's programming expense and program management overhead. Eventually, such programs will be delivered on the processing chip itself, as opposed to being stored in separate ROMs.

From a hardware perspective, another drawback to Pascal is its inefficiency. A program written in Pascal generally takes up much more space than one written in, say, an assembly language. It also takes much more time to run, particularly if it requires an in-system interpreter. Like many development system makers, however, HP's Lee sees Pascal as "an essential element in future microprocessor designs" and is currently working on overcoming those drawbacks.

### Improving Pascal, adding C and Ada

While the code space that Pascal requires cannot be greatly reduced, the constantly dropping cost of semiconductor memories may make objections to it in this area less strenuous, particularly when traded off against the cost of programming in an assembly language. Still, when vast amounts of memory are involved, any reduction in memory space will mean dollars saved and less expensive end products, advantages always of importance to manufacturers. These applications will require a high-level language much closer to assembly language, such as Intel's PL/M or Zilog's PLZ/ASM.

But the speed with which Pascal programs can be run is already increasing. HP is introducing a two-pass Pascal compiler that produces object code, so that an interpreter is not needed in the system. Further, the code can be disassembled to an assembly-like language that software mavens can bit-pick to maximize the efficiency of the most heavily used parts of the program. Unfortunately, this has the consequence of defeating the transportability of that segment of code.

Despite its drawbacks, Pascal will definitely be an important part of the development process. It will teach novices structured programming techniques and it will provide the first portable applications modules for the program bank.

The programming language invented at Bell Laboratories, C, is another structured high-level language that many experienced programmers have come to prefer. It has already been adopted by GenRad and Fluke as their standard programming language and, since no one has yet fiddled with it, it is a *de facto* standard language. Fluke's Thomas has found that his assembled C programs take up only 1.1 to 1.2 times the space required

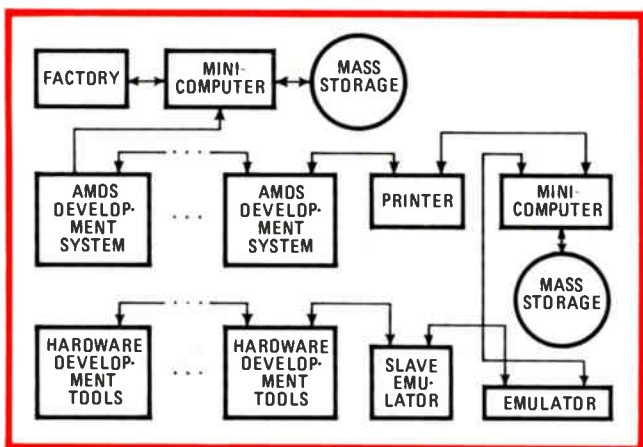

**6. Chain of developments.** The recently announced GRnet will serve GenRad/Futuredata's development plans as its transmission speed rises from the first-round 40-kilobit/s rate. Minicomputer will serve similar function to the 2290 currently used in the factory net.



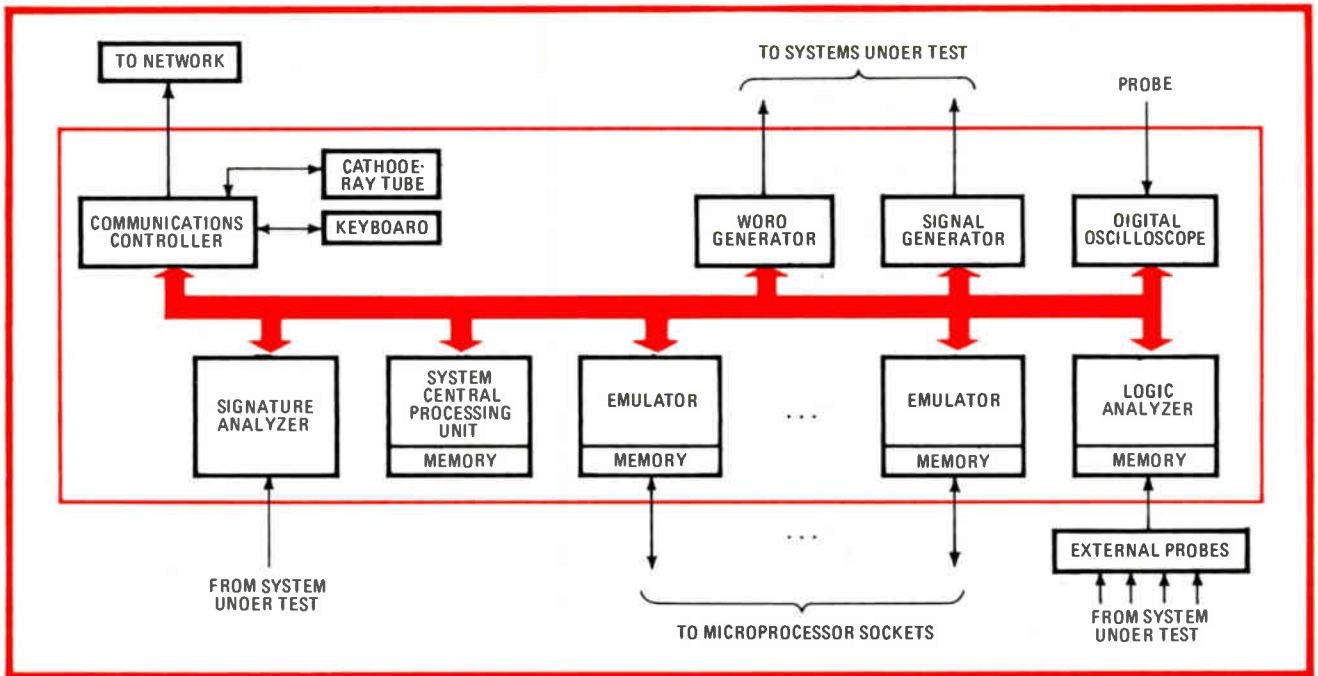

**7. Virtuosity.** Hardware development tools will become card cages into which a number of instrument cards can be slipped. Sharing CRT and keyboard, the units will work interactively under the CPU's control. For field use, only the emulators and signature analyzer may be needed.

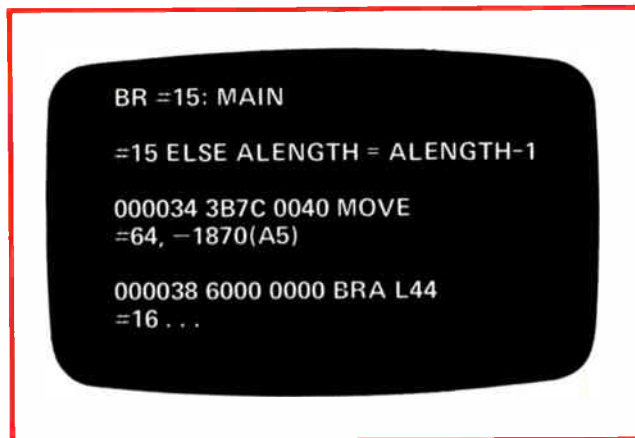

**8. Symbolic debugging.** Rather than concern himself with assembly coding, a hardware engineer will enter a breakpoint in high-level language by listing the source program line and name. Here, the trace is given in Pascal, with assembly code below.

for assembly. With Pascal, he has found that figure to be 3 to 4 times greater than assembly.

Beyond C is the new Department of Defense language, Ada, which is under investigation by a number of companies, including GenRad/Futuredata, Fairchild, and Intel. Although the first compilers for the language will not be ready for a year and they will probably be massive, the language is structured, has a broad vocabulary, and will have the force of the joint services behind it. Considering the address capability of a 16-bit microprocessor, its size may not present a major problem and even with its size, subsets of the language tailored to the individual areas will arise. So by early 1982 the language will find its way into development systems.

Aside from the languages that will be offered, the operating systems for the development systems will

become more friendly. HP's syntax-driven soft-key system is an excellent example of what this friendliness can mean to users. By presenting the user with a set of choices whose variety is controlled by the operating system, it allows a novice to start programming quickly. The same feature will also let the user configure HP's coming hardware station for the factory or field test.

#### Profiles, too

Testing the performance of these computer-based products will also become a major aspect of development. Profiling of performance can already be done with logic analyzers, and HP, Motorola, and others will support this evaluation with their hardware station logic analyzers and software.

The application of software to the hardware/software debug process is where the development systems will excel. Tied to an extensive net, the hardware station will be able to rely on a massive data base, distributed or centralized, from which to obtain information in a more understandable form.

Motorola, for one, will provide symbolic debugging that will bring high-level languages down to the hardware level (Fig. 8). Thus, the operator at a remote station will be able to enter logic analysis breakpoints at, say, line 15 of a program called MAIN. The remote station will then ask the host computer for an absolute address.

Another of Motorola's management tools is the memory-mapping capability it will provide. Essentially, there will be three memory maps: one for the system, one for the applications software as it is being written, and one in the hardware station that directs the emulator to either of those two maps or to system firmware. Thus, software can migrate through the development system to the target system as its generation progresses. □

# There's no body like our new

# 300x 300x

The new AO STEREOSTAR<sup>3/4</sup> Zoom "T" microscope features the "T" zoom body with coaxial illumination and photo capabilities. It may be just what you need to boost output in your production, assembly or inspection department.

The Zoom "T" gives you a constant 4" of working room. It has a 1x - 6x magnification range, and with auxiliary lenses and eyepieces it offers a total range of 5x - 300x. Magnification can be conveniently changed with controls on both sides of the body. No matter what magnification you're working with, you get crisp, sharp image definition.

Modular in construction, the Zoom "T" can be ordered with or without the coaxial illuminator. In fact, any accessory can be simply added at any time. However, if you're working with highly reflective opaque surfaces, coaxial illumination is invaluable because it gives contrast without hot spots, glare, reflections or shadows.

We invite you to compare the new AO STEREOSTAR Zoom "T" microscope, feature by feature, with any other competitive microscope.

We're confident you'll immediately see that it offers the outstanding value in its field. See your AO dealer or representative for a demonstration. Or write for a detailed brochure  
American Optical,  
Scientific Instrument  
Division, Box 123,  
Buffalo, NY 14240.

**AO**  
American  
Optical

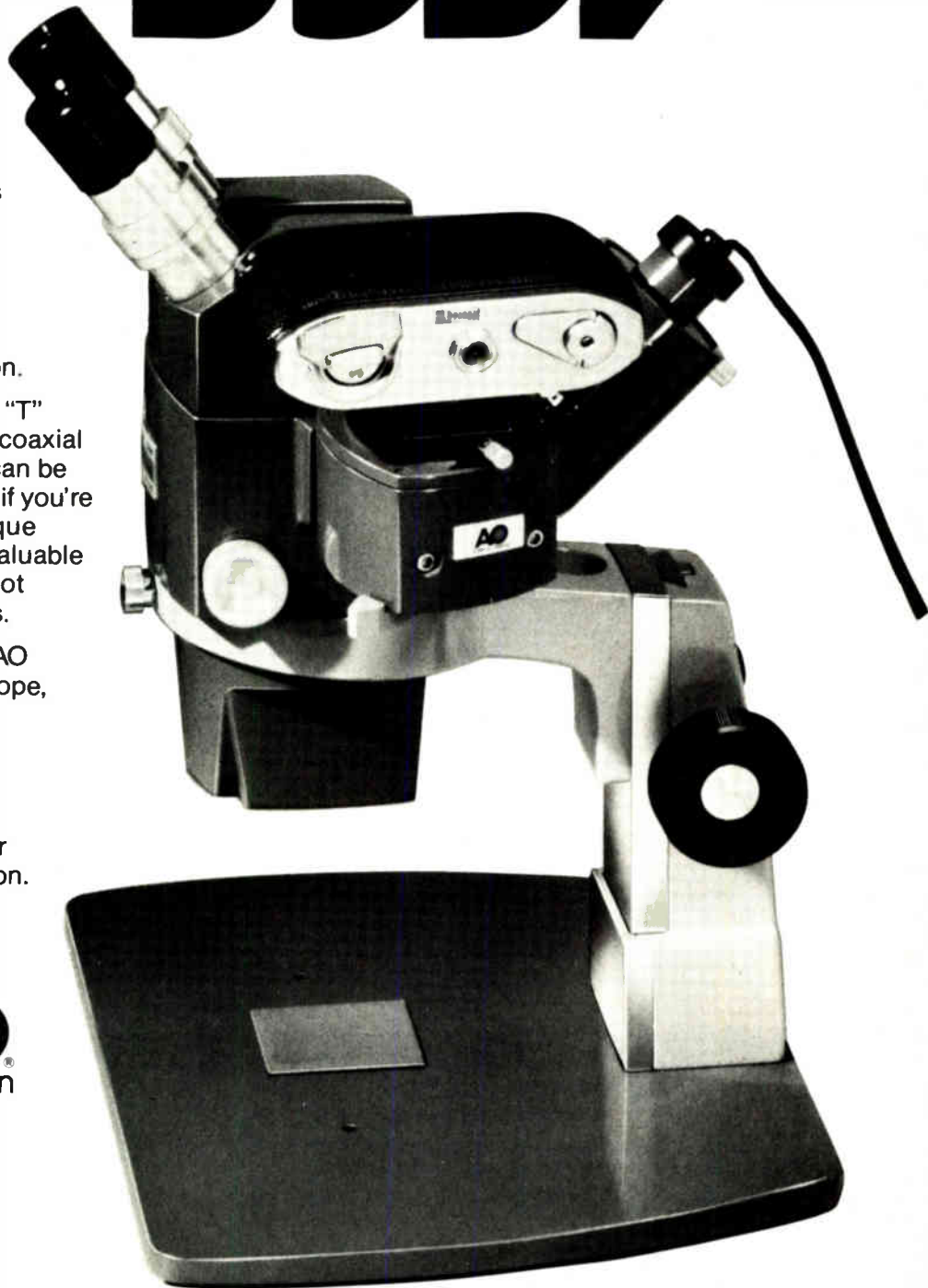

# TRANSISTOR SOCKETS

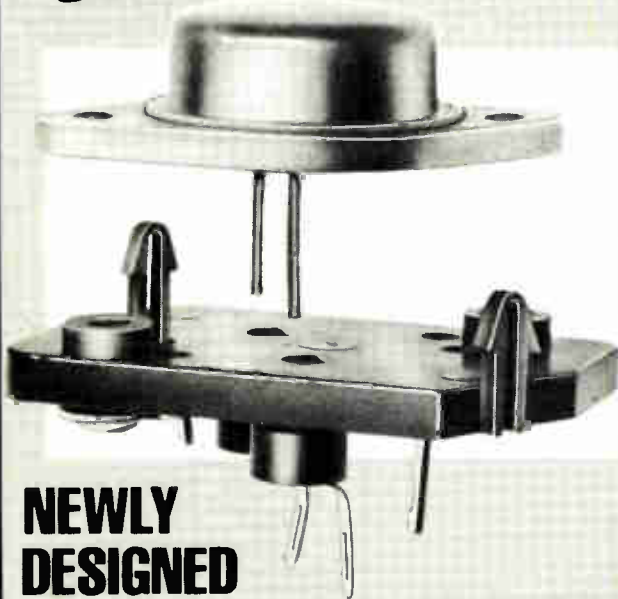

## NEWLY DESIGNED SNAP-IN SOCKETS FOR TO-3 & TO-66



*The most complete line of transistor sockets and mica insulators in the industry. Our sockets are designed for the TO-3 and TO-66 transistors. Available from stock. Introducing our latest design in printed circuit sockets plus an extensive line of snap-in sockets. Sockets are available in the latest UL approved materials.*

NEW FREE CATALOG ON REQUEST



### KEYSTONE

ELECTRONICS CORP.

TWX 710-581-2861 CABLE-KEYELCO

49 BLEECKER STREET, NEW YORK, N.Y. 10012 212-475-4600

# CAMBION IC PACKAGING PACKAGED!

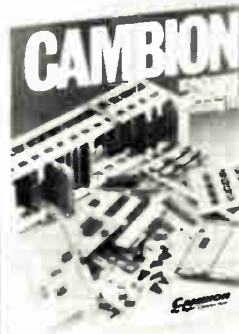

*Catalog 131—68 pages chock full of Cambion IC Sockets, breadboards, Cambi-cards®, card files, integrated sockets, panels, interfacing hardware, power planes, power supplies, power and ground systems, and other extremely useful products to answer all of your IC Packaging requirements from loading the PC board to stacking the system! Cost efficiently. Get the Catalog and Connect with Cambion at over 100 distributor locations! Cambridge Thermionic Corp., 445 Concord Avenue, Cambridge, MA 02238, Tel: (617) 491-5400, Telex: 92-1480, TWX: (710) 320-6399.*

**CAMBION®**  
*The Right Connection.*

Circle 239 on reader service card

## ELEVAM DISCHARGE TUBES FOR RELAYS AND SERGE ABSORBER

Introducing a new surge absorber in a low cost.

● CHARACTERISTICS

- (1) The stable character is always kept on avoiding at, being influenced by the environmental conditions.
- (2) Even if this type that has an advantage of gas discharge phenomena gets shocked and shocked a little later on, it is durable and renewable, however, a semi-conductor isn't.
- (3) Being able to know how the conditions go visibly.
- (4) For customers, this can be varied with their usage.

● FEATURES

Lamp Type	Starting Voltage (vac)	External Resistance (K-ohms)	Normal Current (mA)	Outline and Dimensions (%)	
				overall length	diameter
SA-80	70-90	33	1.6	20	6.5
SA-140	130-150	75	1.0	25	6.5
SA-200	160-240	100	1.7	20	6.5
SA-300	250-350	150	1.6	20	6.5
SA-350	350-400	150	2.0	20	6.5

● MAIN PRODUCTS

Glow Lamps,  
Color Light,  
Xenon Flash Tube,  
Black Light, and  
UV-Light.

ELEVAM ELECTRONIC TUBE CO., LTD.

«For further information.»

NO, 17-8, 2-chome, chuo, ota-ku, Tokyo, Japan.  
Telephone (03)774-1231 Telex : 246-8855 ELEVAM.



# N-MOS hurls 4-bit family into 8-bit orbit

Single-chip microcomputers feature fast operation, a serial I/O port, and a built-in counter-timer

by Eijiro Toyoda, *Matsushita Electronics Corp., Kyoto, Japan*,  
and Takashi Sakao and Kazuaki Mayumi, *Matsushita Electric Industrial Co., Osaka, Japan*

□ Single-chip microcomputers are being used increasingly as machine controllers and in consumer products, where cost considerations generally call for 4-bit machines. In many of these applications, however, 4-bit performance is barely adequate, especially as these devices all are made with p-channel or complementary-MOS technology and most have architectures and instruction sets geared to use in calculators and cash registers. With next-generation consumer products in the offing, there is clearly a need for greater performance, but 8-bit

machines are still too expensive.

Fitting neatly into this slot, which promises to grow into a veritable domain, is the MN1500 family. These 4-bit single-chip microcomputers, bus-oriented devices with a general-purpose architecture (Fig. 1), offer close to 8-bit performance. Fabricated using n-channel technology, the devices are fast, executing instructions in either 2 or 4 microseconds. Some of the 124 instructions perform 8-bit operations, combining several simple instructions into one. In addition, one feature, a serial

**1. N-MOS.** The MN1500 series of 4-bit microcomputers is fabricated with 4- $\mu$ m lines and enhanced-depletion-mode n-channel MOS technology. The die is 0.21 by 0.20 inch and contains up to 256 by 4 bits of RAM and 4,096 by 8 bits of ROM.

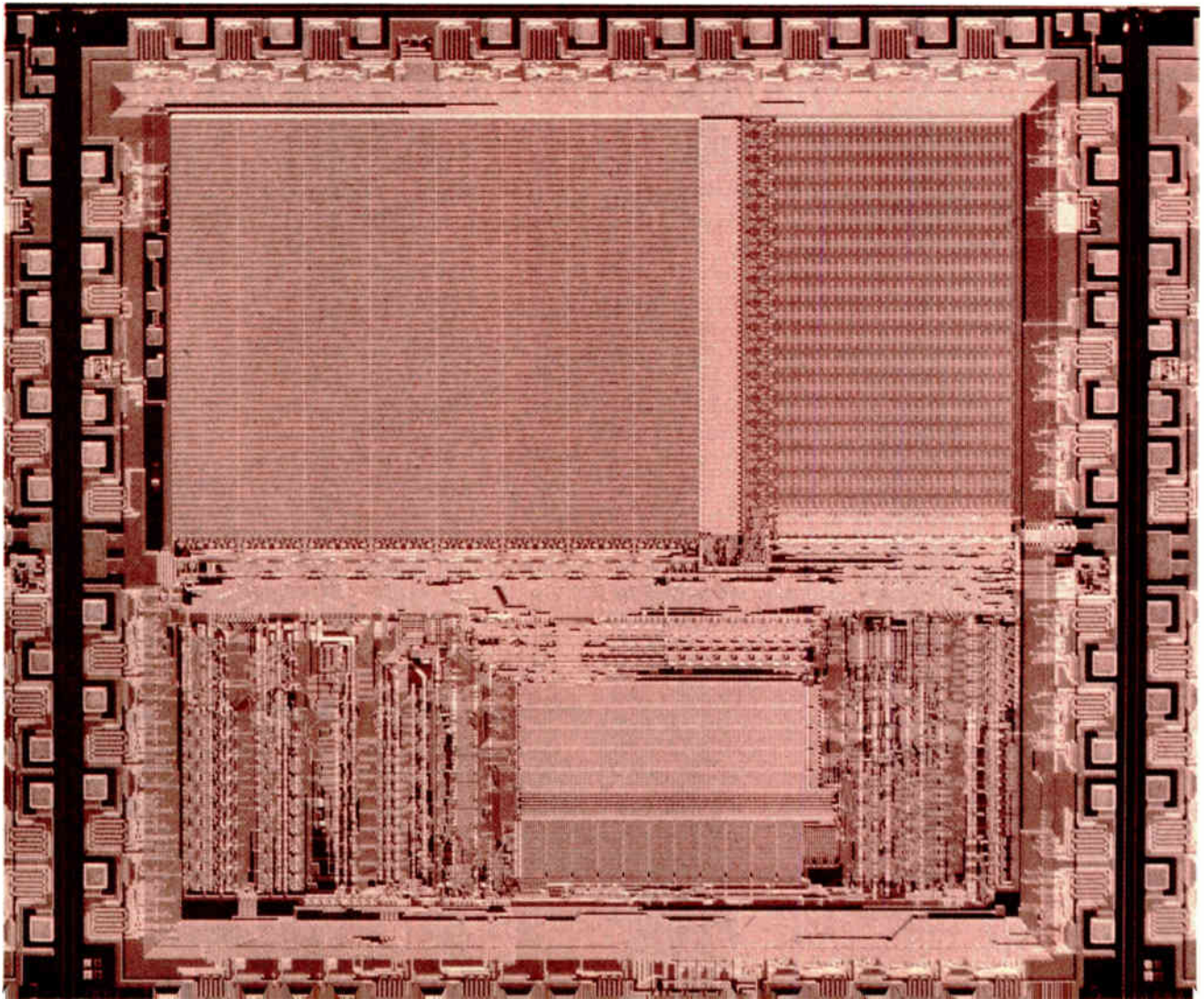

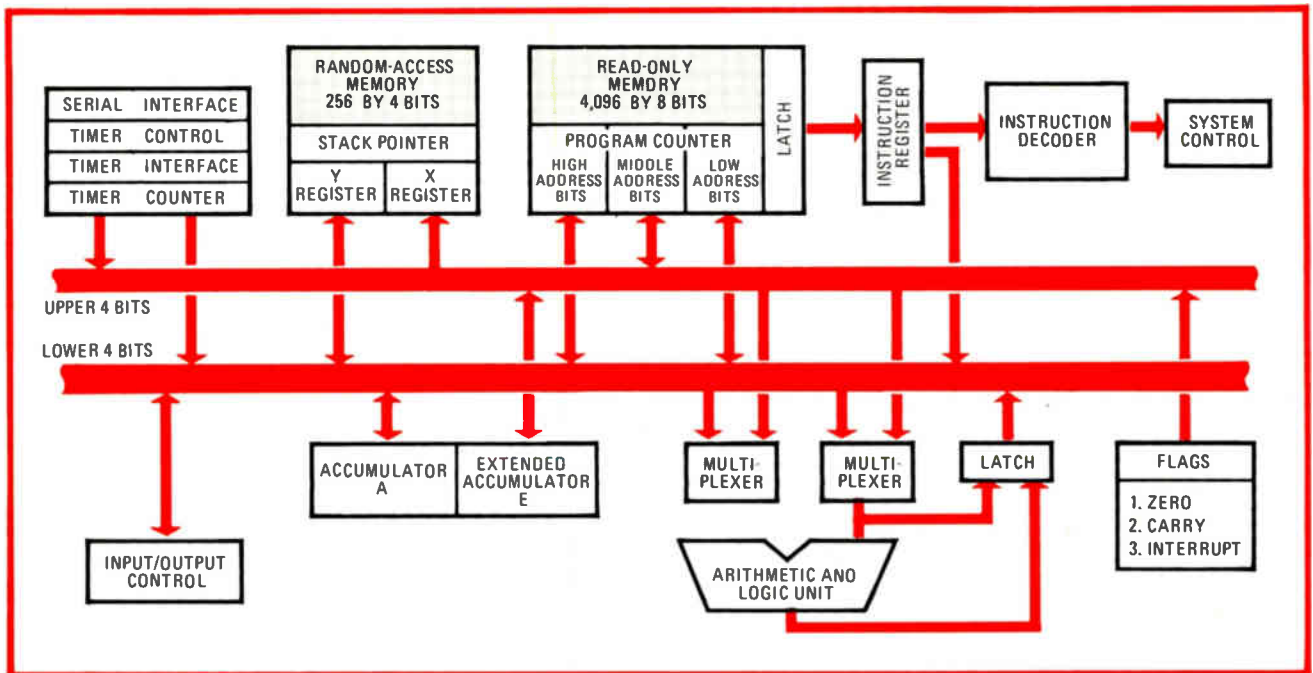

**2. Two-by-four.** Two 4-bit buses in the MN1500 microcomputer family allow 8-bit data transfers in a single, 2-microsecond machine cycle. Overall performance is enhanced by built-in features such as a serial input/output port and a counter-timer.

input/output port, is unique to 4-bit machines.

Five chips make up the microcomputer series. One, the MN1599, is used for program development, and the other four differ merely in memory size and in the number of I/O ports.

### Architecture

The MN1500 is organized to handle 8-bit data. Figure 2 shows the block diagram of the series. The MN1542 and the MN1562 have a ROM capacity of 2,048 8-bit words and 152 4-bit nibbles of random-access memory. The MN1562 has 12 4-bit I/O ports and is housed in a 64-pin package, compared with 6 ports for the 40-pin MN1542. The other two members of the family, the MN1544 and MN1564, are distinguished by the same respective differences in package and port capacity. These two, however, have increased memory: 4 kilobytes of ROM and 256 nibbles of RAM.

Two 4-bit data buses allow 8-bit data transfers in one machine cycle, as well as 4-bit arithmetic and logical operations.

### Technology

The series is fabricated using 4-micrometer n-channel Locos silicon-gate enhanced-depletion-mode MOS technology (Locos stands for local oxidation of silicon, a process originally developed by Philips). This technology was chosen for its high speed and high level of integration. A previous series, the MN1400 single-chip 4-bit microcomputers, was developed in 1977 using 6- $\mu\text{m}$  technology. Along with the greater speed and higher integration, several process improvements distinguish the newer family of chips. To reduce the short-channel effect and prevent punch-through, arsenic ion implantation is used for the source and drain diffusion, controlling junction depth to less than 0.7  $\mu\text{m}$ . Channel doping is also

used, and an oxide-passivation process diminishes breaks in the aluminum metalization. Contact-window self-aligned diffusion is used to increase the junction depth under contact windows in order to prevent current leakage caused by the aluminum-silicon alloy.

Figure 3 shows the RAM cell in the MN1400 series and that in the MN1500. The latter is designed using 4- $\mu\text{m}$  lines, resulting in a 33% shrinkage in size. The overall chip size of 0.21 by 0.20 inch (5.4 by 5.16 millimeters) is achieved by optimizing the arrangement of functions and circuit connections, yet the MN1544 contains about 50,000 devices. ROM writing, which is done with a contact-window mask, contributes to short production lead times.

### Timing

Instructions are executed in either one or two machine cycles. Each machine cycle consists of four clock cycles. Using a 4-megahertz clock fixes the machine cycle at 2 microseconds, so that the execution time for instructions is either 2 or 4  $\mu\text{s}$ . Some instructions can read out of and write into RAM within one machine cycle. A four-phase dynamic circuit to generate overlapping machine cycles reduces the number of gates and keeps power dissipation at a moderate level for the family's relatively high operating speed.

There are several options available for supplying the system clock. These include a simple capacitor-resistor network or a crystal-controlled source.

### Program counter and ROM

The program counter (PC) consists of an 8-bit binary counter for the lower-order bits and a 4-bit register for the higher bits, organizing ROM into 16 pages of 256 words each. Thus the MN1500 can execute up to 4 kilobytes of program instructions and data from its ROM.



For program development, the MN1599 evaluator chip is available, as noted. It contains no ROM and uses a memory-bank flip-flop bit added to the 12-bit program counter to access 8,192 bytes of memory, all of it external. Once the program is developed with the MN1599 and stripped of development aids, it should be possible to reduce it from the original working 8 kilobytes of memory to the 4 kilobytes or less required to fit on the actual production chips.

### Read/write memory

The series is available with either 256 or 152 4-bit nibbles of RAM. A memory map is shown in Fig. 4. When instructions call for 8 bits of data, for instance, in a stack operation, RAM is accessed in 8-bit bytes. The low order of the address is designated by the lower 4 bits of the address, and the upper address by the adjacent 4 bits. For example, the stack, which is located at the highest addresses in RAM, contains 32 8-bit locations to store the machine status during calls, interrupts, and push instructions. The 32 bytes of RAM are formed by joining adjacent 4-bit nibbles into pairs between RAM addresses  $CO_{16}$  to  $FF_{16}$ . Although they are assigned to the stack, these bytes can be accessed the same way as the remaining RAM area.

Using the stack, 16 levels of subroutines can be nested. In addition, there are three special-purpose nibbles in the very beginning of the RAM address space. They can be used as temporary registers to store the contents of the E, X, and Y registers, when necessary, to reduce the overall program size. Call instructions and interrupt service routines both follow the same procedure with regard to the operation of the stack.

One of the status conditions held in the stack is the LIFF (load-immediate flip-flop) bit. The LIFF is a flag

that remembers whether the previous instruction is a load-immediate instruction, which loads 4 bits of immediate data into the A register. With the load-immediate flag set, succeeding load-immediate instructions are processed as no operation; that is, only the first of a series of contiguous load-immediate instructions is executed.

Finally, a separate power supply pin, VDDM, can be used to supply power to the RAM independent of the other circuits of the microcomputer, allowing the RAM data to be preserved when the main supply of power is interrupted. The control pin, HLDM, is used to retain the RAM data.

Four 4-bit registers (E, A, X, and Y) and one 8-bit register, the stack pointer, are provided. The A register is an accumulator, the E register extends the accumulator for 8-bit operations, and the X and Y registers form the high and low address halves of the RAM pointer, respectively. Each register may also be used for general purposes. Zero and carry flags are also maintained and are affected by logical and transfer operations.

### The I/O ports

The input and output circuits are quasi-bidirectional; that is, different I/O ports have varying degrees of flexibility and handshaking ability. Four-bit and 8-bit data transfers can be handled by the entire I/O system, but only 4 data bits can be masked at a time. The  $P_0$  and  $P_1$  I/O ports strobe an output device with a separate line; the other ports do not. Four I/O ports can be indirectly addressed by the Y register, and an output pulse can be issued, under program control, from all the ports. The user can choose the I/O port best suited to the application. Table 1 summarizes the I/O port organization.

There are four interrupt modes. Two, labeled SIRQ (system interrupt request) and IRQ (interrupt request),

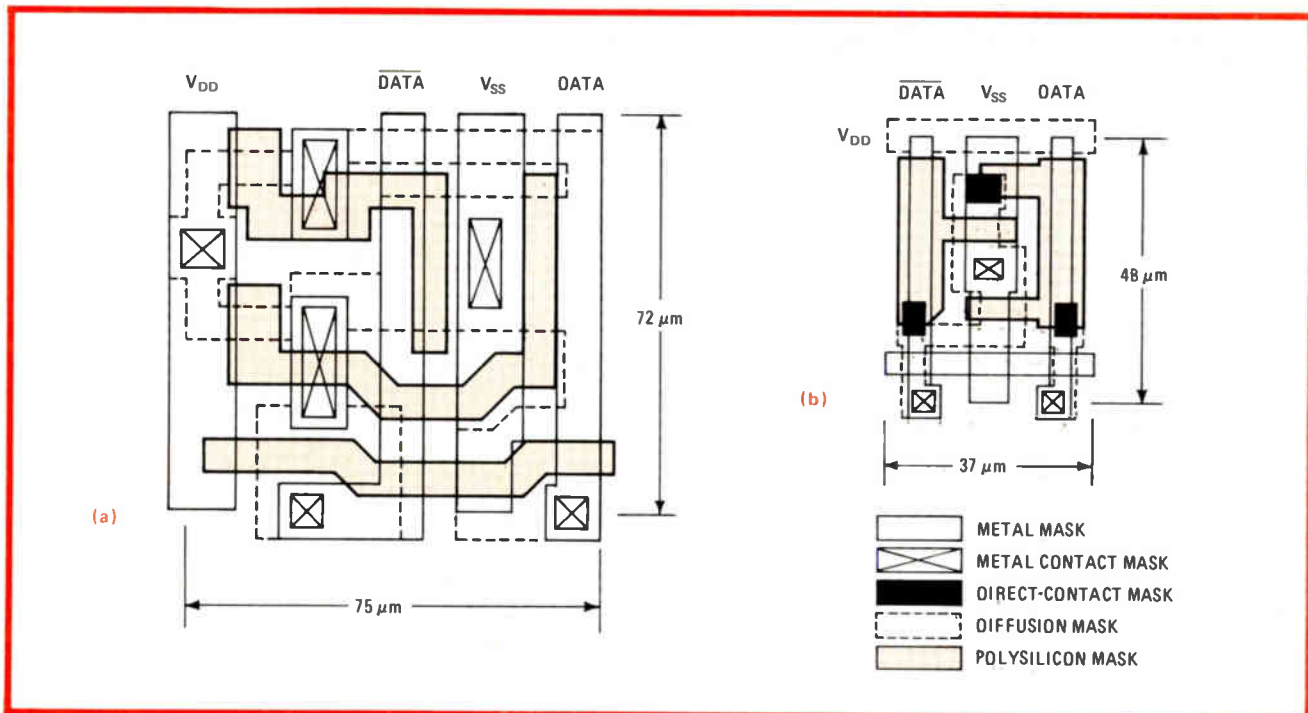

**3. Cell size.** By reducing the line width of the MN1400's memory cell (a) from 6 to 4 μm for the MN1500 (b) and reconfiguring the basic circuit, 33% of the cell size was shaved. The MN1544 member of the family contains about 50,000 transistors.



are external, and the latter is maskable. The other two, TCIRQ and SBRQ (timer-counter and serial-buffer interrupt request, respectively), are generated internally, the first by the built-in timer-counter and the other from the serial interface. Both are controllable in software. In addition, the MN1599 has a special, highest-priority-level interrupt, MIRQ (monitor interrupt request), which is used for program development.

TABLE 1: HOW THE MN1500's INPUT/OUTPUT PORTS ARE ORGANIZED

Port address	MN1542 MN1544 MN1562 MN1564			MN1562 MN1564 only
	P <sub>0</sub> , P <sub>1</sub>	P <sub>2</sub> , P <sub>3</sub>	P <sub>4</sub> , P <sub>5</sub>	P <sub>6</sub> - P <sub>8</sub>
Output pulse	●	●	●	●
Discrete output addressed by Y register	●	●		
Output strobed by separate line	●			

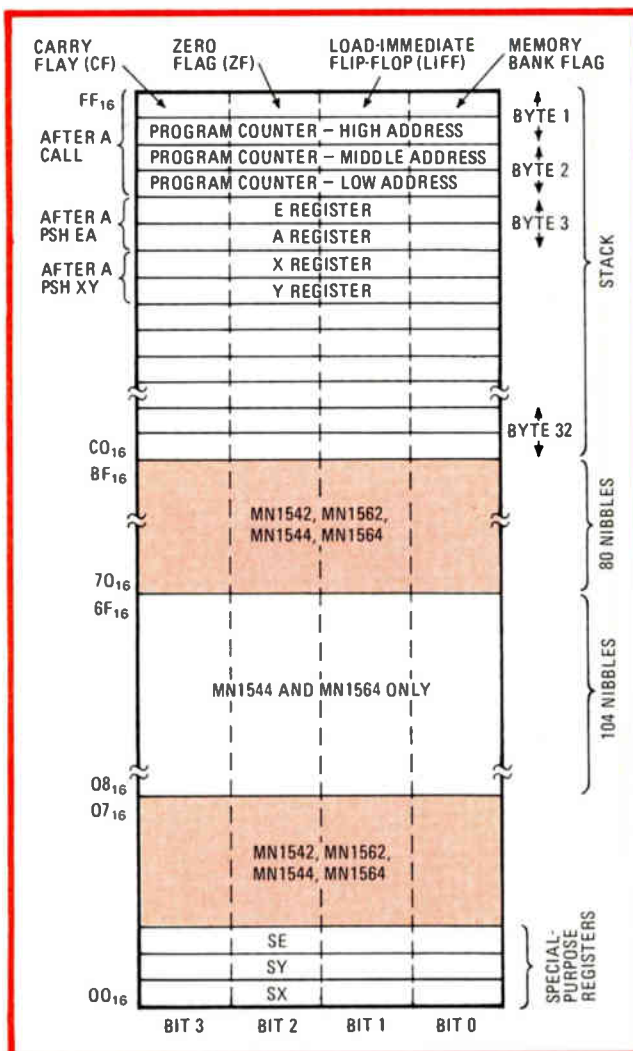

**4. RAM Space.** Although the RAM space of the MN1500 is organized in 4-bit nibbles, stack operations are organized to read and write 8-bit bytes of data, as are some other instructions. All memory locations, however, can be addressed as a 4-bit nibble if necessary.

A hardware priority encoder assigns the starting address of each interrupt and fixes the priority levels. Table 2 shows the interrupt priority levels and the starting address assigned to each interrupt request.

### The timer-counter

The timer-counter consists of three 8-bit registers: the control register (TC), the buffer register (TB), and a binary counter (BC). Not shown, but part of the timer-counter, is a 7-bit prescaler. The time-counter performs three functions—internal timing, external-event counting, and pulse-width measurement.

Two pins operate with the timer-counter. They are TCI, the counter input, and TCO, which serves as an 8-bit overflow indicator.

The instruction set contains 124 entries, divided into four categories. These categories are data-transfer instructions, I/O instructions, arithmetic and logical instructions, and control and transfer instructions.

### Instructions

An instruction may occupy 1 or 2 bytes in ROM. A single-byte instruction is executed in either one or two machine cycles, whereas all 2-byte instructions require two machine cycles. By including a number of complex instructions—ones that would otherwise require a string of simpler instructions—program memory space is conserved. For example, conventional 4-bit microcomputers often use a programmable logic array (PLA) to generate the segment signals to drive the output display. The MN1500 series instead has an 8-bit lookup table instruction (RTDBL) that is addressed by the 8-bit register pair EA. This instruction expands the range of output characters beyond those a PLA can offer. The RTDBL instruction can also be used to implement a fast multiplication table.

The MN1500 has several operating modes that allow for quick self-testing. The RAM-test, ROM-test, and jamming modes are all equal in weight to the user's execution mode. The RAM-test mode provides the internal processing that allows direct RAM reading and writing through ports 0 and 1 without the use of the regular instruction set, that is, using hardware only in a time-division mode. The ROM-test mode permits hardware control to read out the contents of the ROM in successive memory locations to check that the memory is correctly written. Finally, the so-called jamming mode permits all instructions to be executed through signals applied to ports 0 and 1.

The chip is initialized in one of two ways. The first is via a manual reset pin on chip. However, a low-voltage detector circuit will automatically sense when the supply voltage falls below 3.5 volts. At that moment, the processor defaults to the initialization state. In this condition, the manual reset pin also goes low, indicating the cause of the interruption.

### Interfacing

The MN1500 series communicates with the outside world serially through an interface intended for system expansion, as well as for serial communication.

Either an internal or an external clock will drive the

TABLE 2: HOW THE MN1500's INTERRUPTS ARE ORGANIZED

Priority level	Interrupt		Starting address of service routine			
	Function	Mnemonic	Bank	Program counter		
Highest ↑	Monitor	MIRQ	1	0	0	0
	System (nonmaskable)	SIRQ	0	0	0	8 <sub>16</sub>
	System (maskable)	IRQ	0	0	0	A <sub>16</sub>
	Timer-counter	TCIRQ	0	0	0	C <sub>16</sub>
Lowest	Serial bus	SBIRQ	0	0	0	E <sub>16</sub>

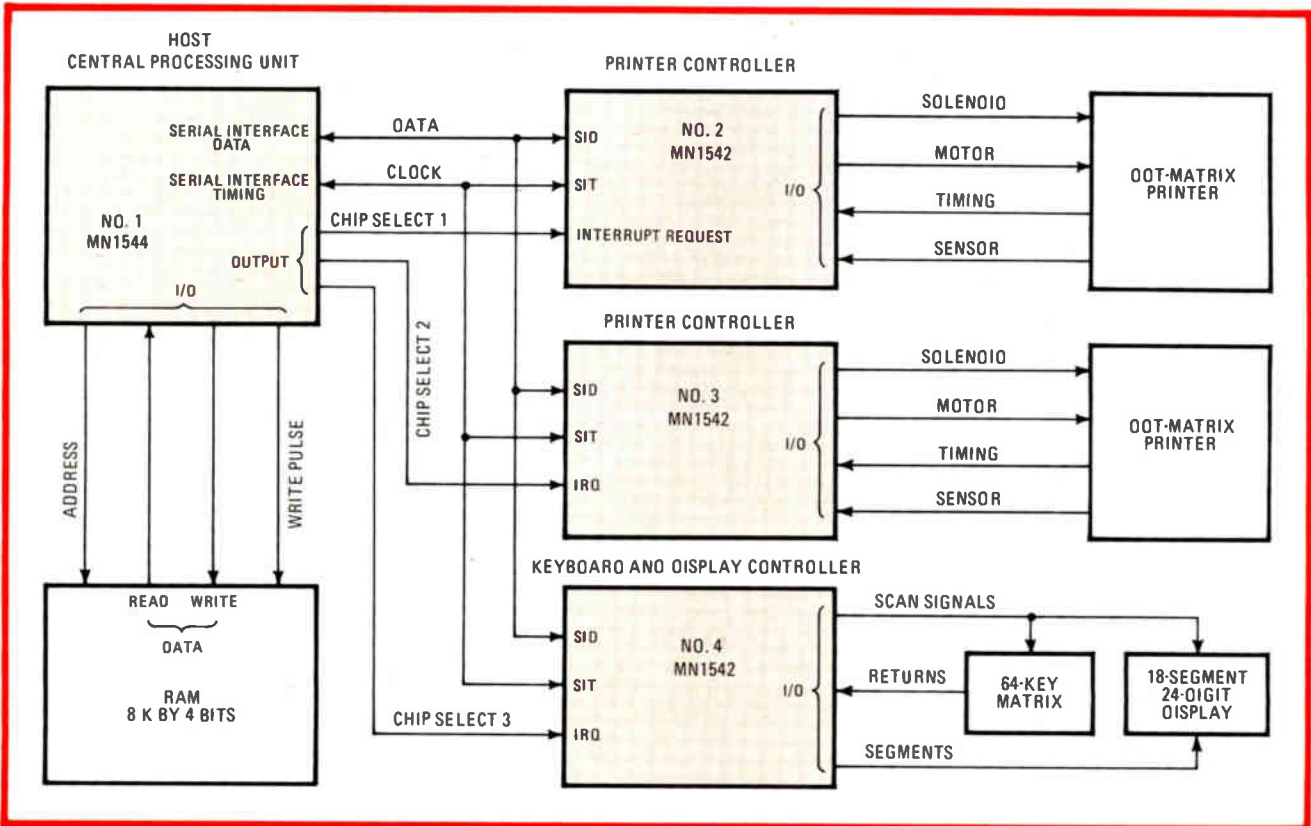

**5. Division of Labor.** The need for external components in this cash register system is minimized by separating the various control functions and by taking advantage of the built-in serial I/O and interrupt capability of the MN1500 microcomputer family.

serial transmission to and from the chip so that at the 2- $\mu$ s instruction rate an 8-bit word can be transmitted in 16  $\mu$ s. Selection of the timing signal source is done in software.

The two pins on the device that affect serial communication are SID, the serial interface data line, and SIT, the serial interface timing signal.

### Cashing in

The cash register system shown in Fig. 5 serves as a good example of some of the advantages of the MN1500 series. Using the serial interface and interrupt functions of the family facilitates this application.

Four separate chips are put to work. The MN1544, with 4 kilobytes of on-board ROM and a 256-byte RAM, acts as the main controller and external RAM controller. Three MN1542s, with 2 kilobytes of ROM and 152 bytes of RAM each, control the dot printing and the keyboard

and display functions.

Instructions and data transfer between the main controller chip and the peripheral controllers uses the 8-bit serial capability and the interrupt functions with no additional circuitry. Data communication between chips is initiated by the external interrupt, IRQ, and terminated by an end-of-transmission command. Clock and data lines are common to all the processors.

Using multiple processors to implement this system results in several benefits. Dividing up the functions across separate chips simplifies the programming task for each processor. Since the power to control the sequence of events is assigned to each processor, the amount of additional hardware required to perform the control function is less than if one central processor were used. Finally, the distribution of the functions into programmable processors eases the task of extending or modifying the system. □

# CARD READERS' DIGEST

C. Itoh offers you a complete line of magnetic card readers. Speeds from 3.9 IPS up to 59 IPS and points in-between. Models that can read, write, read after write, read/write, in single or multi-channel configurations. Naturally, with the encoding to match your standards (including ABA, IATA and Track 3).

You can also have your pick of slide or insert card readers. Models built to perform flawlessly indoors or outside. Compact machines designed to do a lot of speed reading (300,000 card passes in the life of one of our readers is about average).

So if you're looking for the one source that has card reader selection down to a science, look no further. Contact us for our MCR/SRD series catalog, the digest that covers your subject, at any speed you want.

## C. ITOH ELECTRONICS, INC.

5301 Beethoven Street, Los Angeles, CA 90066  
(213) 390-7778; Telex: (WU)65-2451  
666 Third Avenue, New York, NY 10017  
(212) 682-0420; Telex: (WU)12-5059

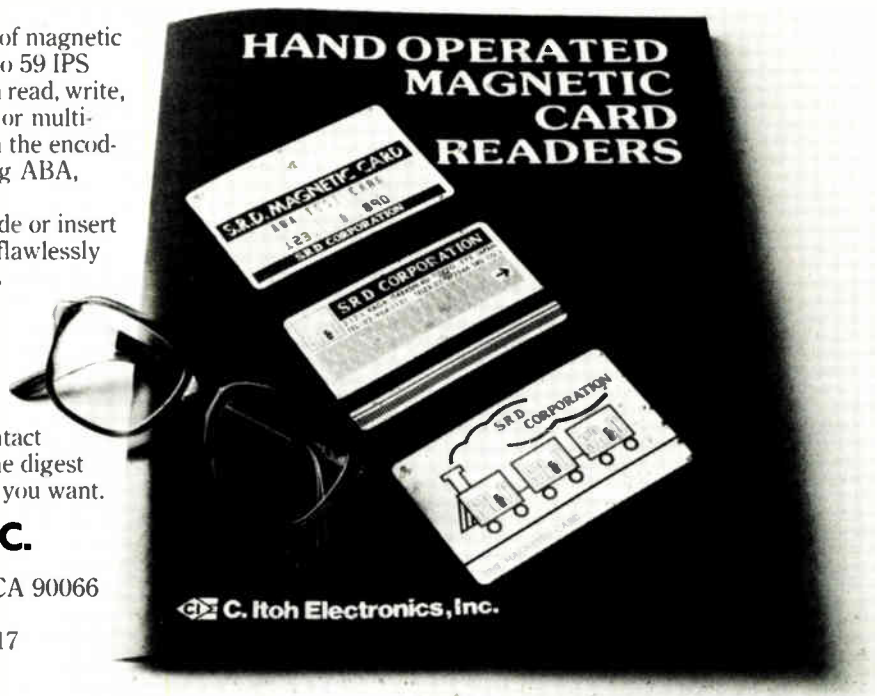

Circle 150 on reader service card

## THE QUALITY OF THESE PROGRAMMERS HAVE CONVINCED OVER 2,000 BUYERS WORLD-WIDE

The compact, completely portable Gang EPROM Programmer PKW-8000 with its own built-in power supply and automatic self-check functions is in a class by itself. It is only 1/4 the size its nearest competitor (15" X 12.40" X 2.24") and, of course, the software select units are standard.

Also a standout is the PKW-5000, a smart, easily portable EPROM Programmer which, like the PKW-8000, reflects true quality and unsurpassed performance. Both of these fine machines are complete in themselves and require nothing extra.

Either machine is available free of charge for an in-house evaluation.

Convince yourself! Write or phone for complete information.



## WESCON PRODUCTS, INC.

525 University Ave., Suite 705, Palo Alto, CA 94301, Telephone (415) 327-4051 TELEX 345549

Available: DENMARK-Semicap, Gammel Kongevej 1485, DK-1850 Copenhagen V Tel: (01)22 15 10 FINLAND-Nabla Elektroniikka Oy, Espoo, 10 Tel: 90-46 28 29 FRANCE-A K Electronique, 75015 Paris Tel: (1) 575. 53. 53 ITALY-Elind, 20063 Cernusco, Milan Tel: (02) 9 041 319-9 (043 983 NETHERLANDS-Aurienna Netherland BV, 5611 CC Eindhoven Tel: (40-44447) SWITZERLAND-Altrac, AG CH-8953 Dietikon Tel: 01/741 46 44 WEST GERMANY-Electronica Gmb H, 2000 Hamburg 11 JAPAN-Intertek, Inc., 7-2-8, Nishi-Shinjuku-ku, Tokyo, 160 Japan Tel: (03) 363-6649



# Isolator stretches the bandwidth of two-transformer designs

Stable and linear isolation-amplifier approach now suits many applications in which analog signals up to 15 kHz must be handled, such as motor control

by Bill Morong, Analog Devices Inc., Norwood, Mass.

□ The list of applications requiring the isolation of analog signal sources from data-processing circuitry is a long one and growing. These diverse applications place widely varying demands on the isolation scheme used, so it is not surprising that many different isolation techniques have been developed to meet those demands.

Transformer and optical isolation methods are two of the most common routes taken. Two-transformer isolators, though outstanding in terms of linearity and stability of gain and offset, are generally shorter on bandwidth

than single-transformer or optical isolator designs. The arrival of a wideband two-transformer amplitude-modulated isolation amplifier, the model 289, opens up a number of formerly impractical applications to the two-transformer technique.

Any application in which low-level analog signals must be detected in the presence of high common-mode voltages requires isolation; circuits in which ground-loop currents can introduce large errors in the signal being measured are also candidates. Proper isolation allows the

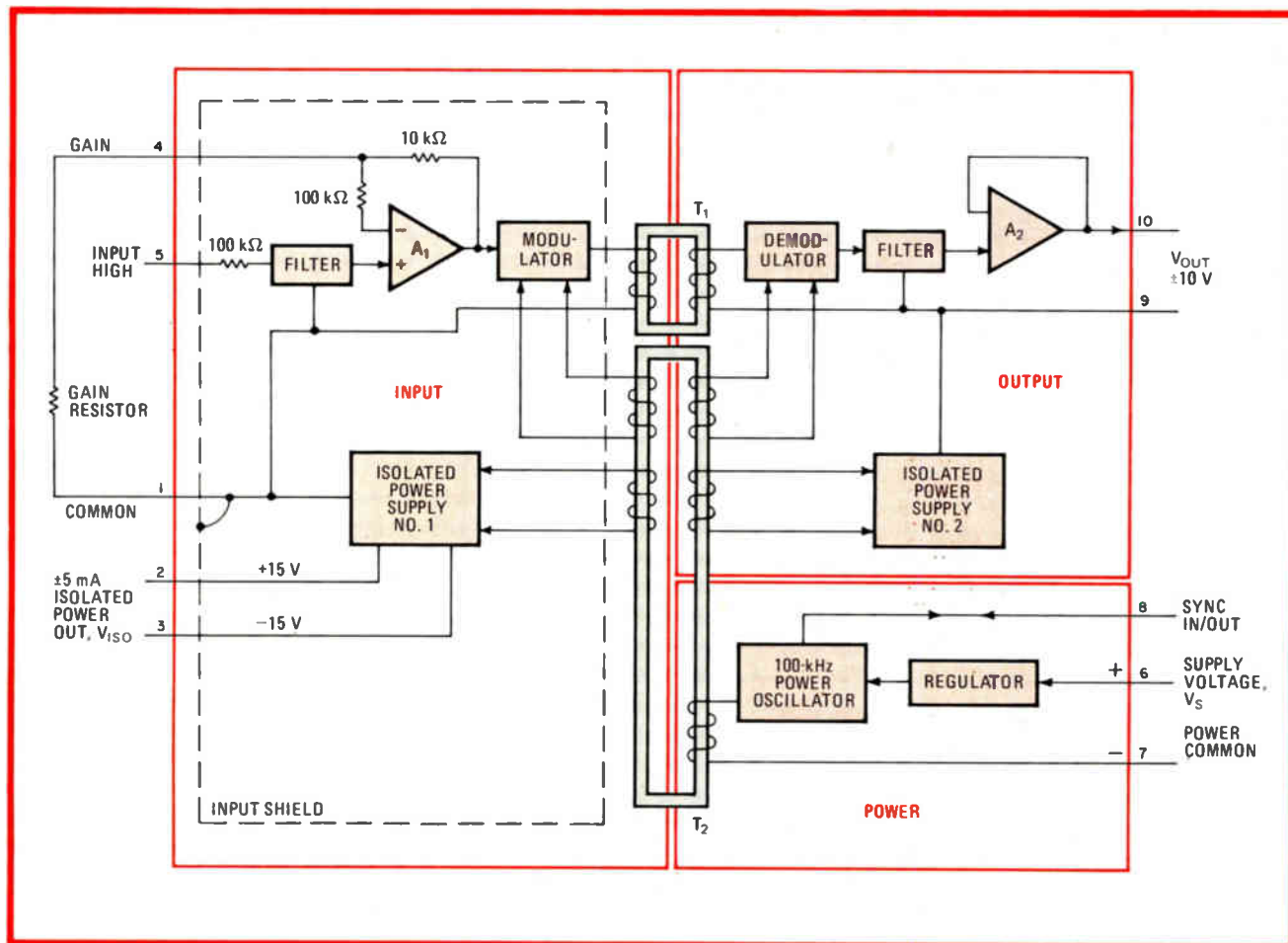

1. Isolated. A favorable cost-performance compromise between optically coupled and single-transformer isolation amplifiers is achieved by the wideband two-transformer model 289 isolation amplifier. It owes much of its high performance to its input and power isolation schemes.

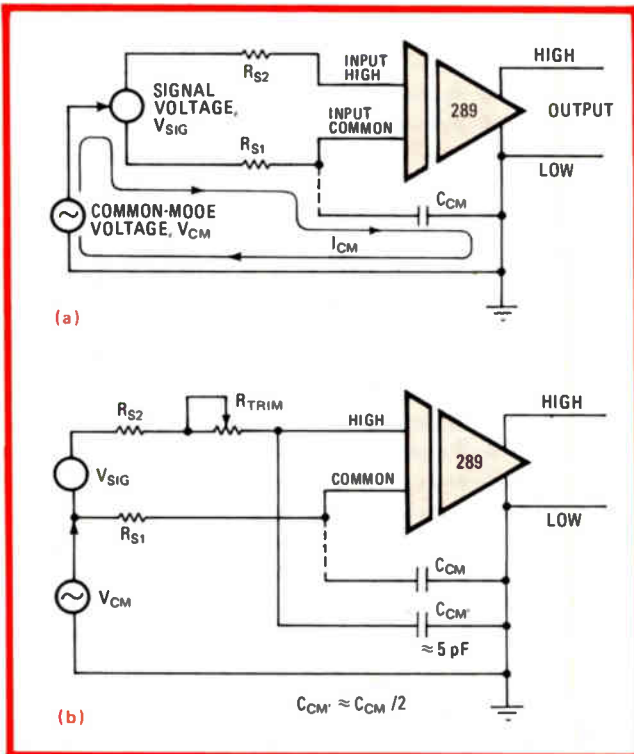

**2. Common-mode.** Finite capacitance across an isolation amplifier's isolation barrier limits common-mode rejection (a). Adding capacitor  $C_{CM'}$  and resistor  $R_{TRIM}$  as in (b) causes the common-mode voltage across  $R_{S2}$  to cancel the common-mode voltage across  $R_{S1}$ .

transmission of a signal across a nonconducting barrier without a galvanic or electrical connection.

Of the wide variety of isolation techniques now in use, optical and magnetic isolation schemes are by far the most common in all but highly specialized applications. A knowledge of their strengths and weaknesses is important for a designer faced with isolation problems.

A typical transformer-coupled isolation amplifier incorporates an oscillator to generate the carrier signal. The isolation amplifier's input modulates this carrier. The input signal can be any frequency within the pass-band of the isolation amplifier—including dc. The modulated carrier is passed through a signal transformer and demodulated, where a replica of the input signal is reconstructed at the isolation amplifier's output port.

### The second transformer

Transformer-coupled isolation amplifiers often contain a second transformer that makes the unmodulated carrier signal available on both sides of the isolation barrier. This unmodulated carrier signal is used to facilitate modulation and demodulation and to generate dc power to energize the isolation amplifier's input or output circuitry. It can sometimes be used for powering external circuits.

Two-transformer isolation amplifiers have been available for a long time and are convenient to use. They feature input-offset drifts of a few microvolts per °C, gain-temperature coefficients under 50 parts per million per °C, and gain nonlinearities of less than 0.01%. Long-

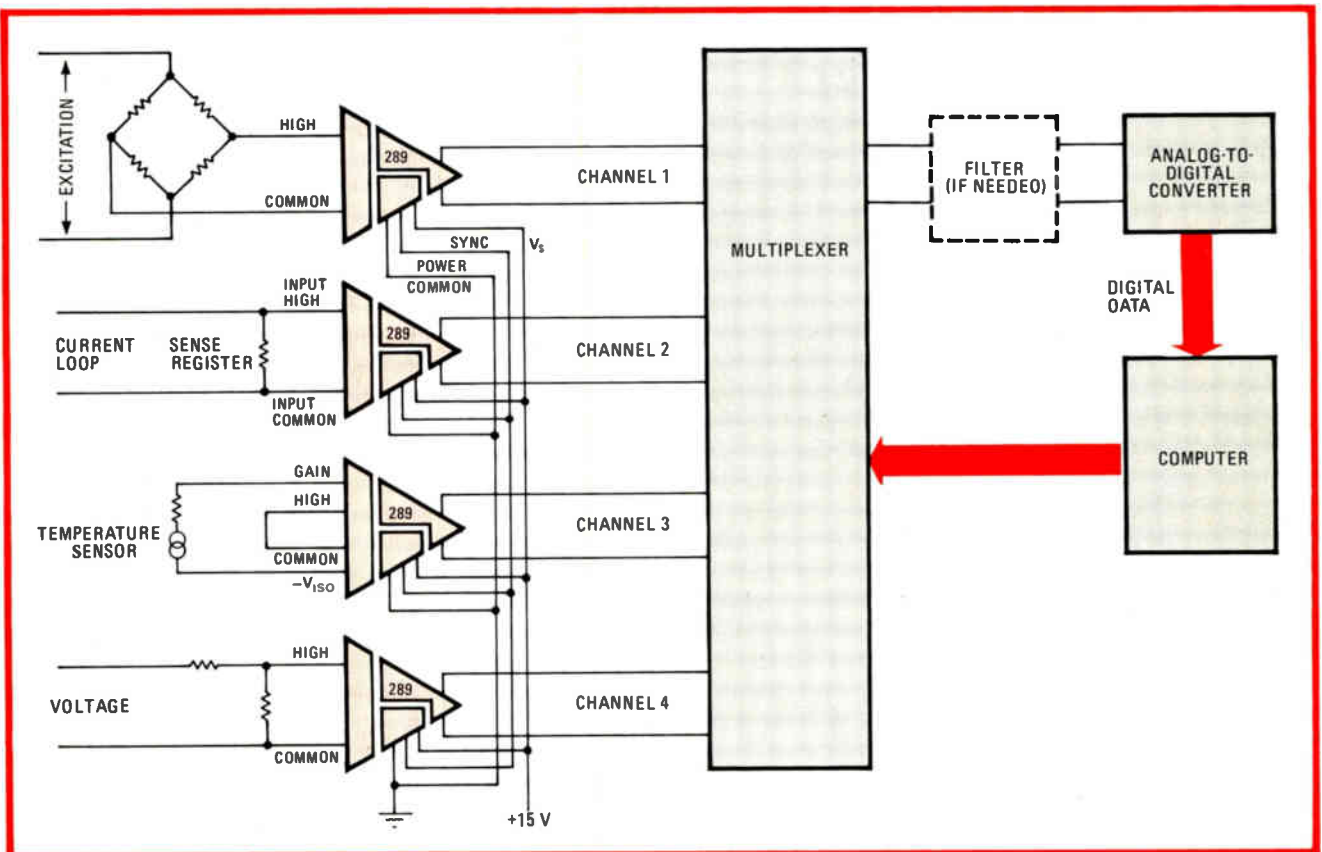

**3. Process control.** A two-transformer isolation amplifier is sufficiently linear to isolate floating transducers from computerized process-control equipment. The analog-to-digital converter used must be monotonic to guard against instability in closed-loop systems.





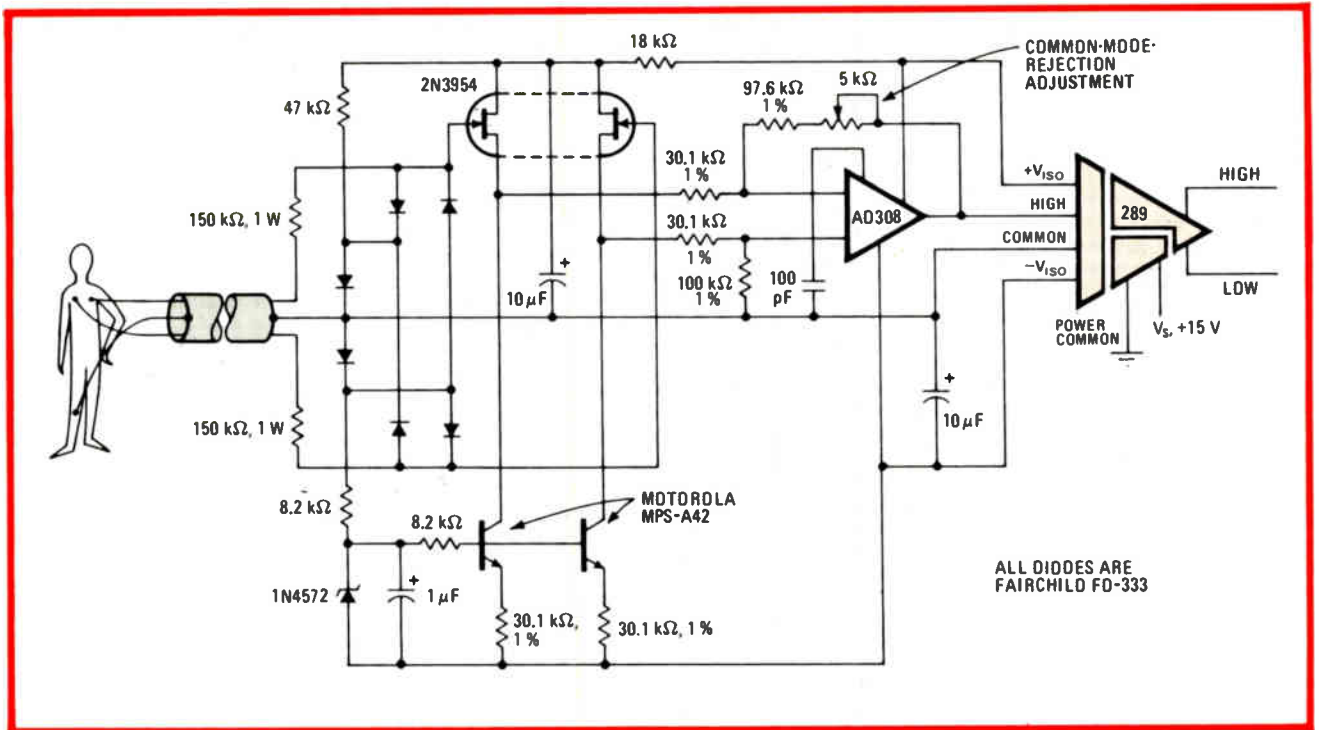

**5. Patient isolation.** Although many isolation amplifiers are used in electrocardiograph patient-lead isolation, few have the bandwidth for applications like electromyography and pacemaker-pulse analysis—but the 289 is wideband enough for these medical uses.

the former method are as good, if not better. Moreover, offset-voltage changes with temperature are by far the lowest with the two-transformer design.

The presence of a carrier signal in a transformer-coupled isolation amplifier inevitably leads to a carrier-ripple component in the isolation-amplifier's output. As the bandwidth of an isolation amplifier becomes a larger fraction of its carrier frequency, ripple becomes more difficult to control. Despite this fact, the 289 isolation amplifier produces less ripple than many other transformer-coupled isolation amplifiers having much less bandwidth. This low ripple level means less need for output filtering.

### Holding down ripple

To keep power-supply ripple from modulating the isolation-amplifier's carrier signal, voltage regulators should be used. Some isolation amplifiers have built-in regulators, not only to eliminate power-supply ripple effects, but also prevent carrier-frequency spikes from being broadcast to the rest of the system via the isolation amplifier's power terminal.

Another potential problem is that of output loading. For many isolation amplifiers with unbuffered output impedances of 1,000 ohms or more, the use of low-impedance loads can lead to large gain errors. The use of external output buffering is recommended in such cases. Of course, those isolation amplifiers with internal output buffering eliminate the need to do so.

Three-port isolation amplifiers are easier to apply than two-port ones, since the latter have their power-supply and output-port returns through a common terminal. But even three-port ones are not all of the same construction and thus offer differing degrees of isolation

between output and power ports. For example, some three-port isolation amplifiers have their power-supply and output ports connected by a capacitor. The capacitor permits carrier current to pass but blocks dc, allowing moderate levels of output common-mode voltages. However, the carrier signal's return through external circuits can introduce ripple currents into those external circuits.

True three-port isolation amplifiers like the model 289 have galvanically isolated ports between which neither ac nor dc can flow. Their outputs can be connected to common-mode voltages of either polarity, within the output common-mode voltage range of the isolator.

Certain precautions must be observed when applying isolation amplifiers. The most obvious is that the circuit in which the isolation amplifier is used must be wired in such a manner that the amplifier's isolation properties are not lost. This means that adequate spacing must be provided between input and output circuits.

### Maximizing common-mode rejection

The conversion of common-mode signals into normal-mode ones at the input to an isolation amplifier limits the common-mode rejection of the amplifier to some finite value. A certain amount of capacitance exists between circuitry on either side of the isolation barrier, and it causes a common-mode current to flow when a common-mode voltage is applied across the barrier (Fig. 2a). This common-mode current is proportional to the applied voltage of the common-mode signal, its frequency, and the barrier capacitance.

For most isolation amplifiers, the common input terminal forms a more direct path for the common-mode current caused by the barrier capacitance than the high input terminal, so most of the common-mode current

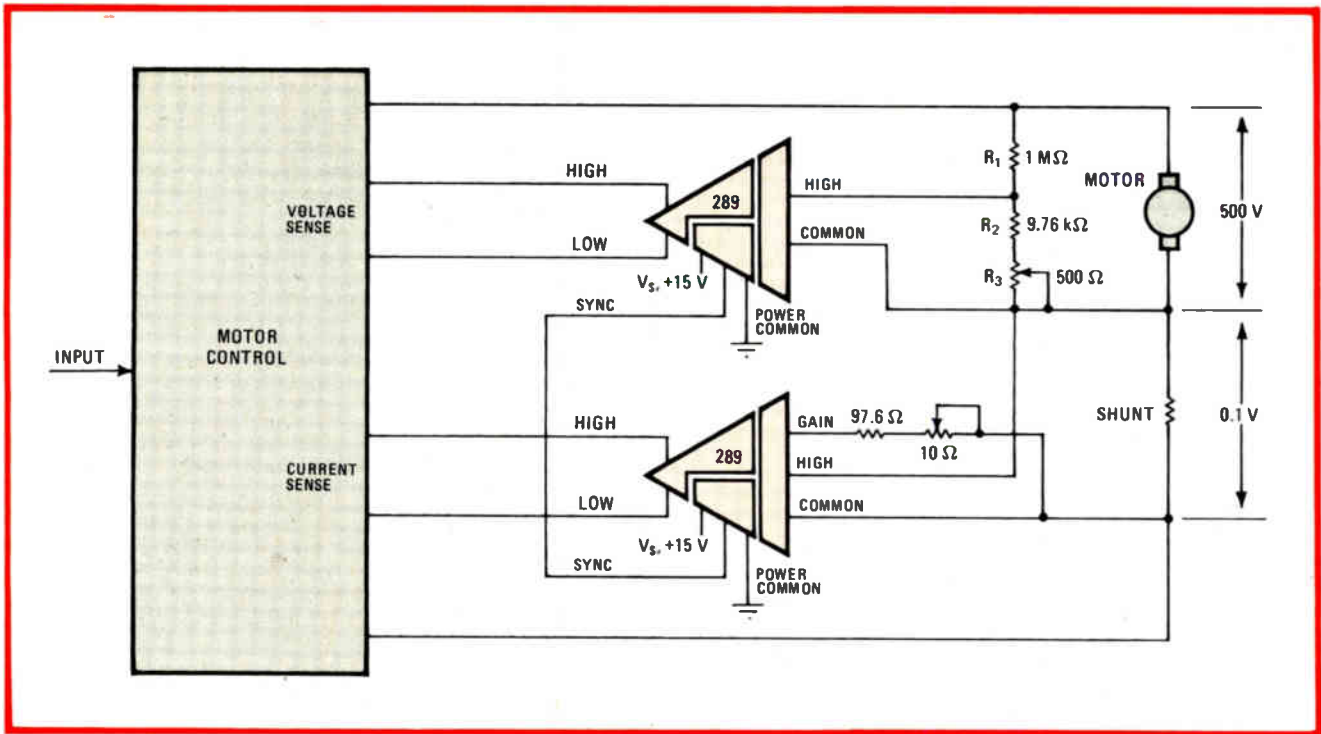

**6. Motor control.** The 289 isolation amplifier has sufficient bandwidth and low enough phase shift to be used in motor and ac load-control applications. Two isolators are used, one to sense motor current and another to feed armature-voltage information to the controller.

flows through the common input terminal. If a normal-mode signal source with two equal output resistors is connected to an isolation amplifier as shown in Fig. 2a, a common-mode-induced normal-mode signal appears in series with the signal source and is treated by the system as a normal-mode signal.

One way to minimize the effects of common-mode currents is to interpose a shield in the isolation barrier to intercept common-mode currents and divert them around the input-source resistance. Another method is to employ a differential input stage ahead of the isolation amplifier. These techniques, however, may be limited for those cases where physical space is at a premium and little room is available for shields or additional input stages. In such cases, common-mode rejection can be maximized by minimizing the capacitance value across the isolation barrier.

For applications in which the source resistance is known and is relatively constant, large common-mode-rejection improvements can be obtained at little extra cost using the circuit of Fig. 2b. Adding capacitor  $C_{CM}$  causes more common-mode current to flow in  $R_{S2}$  and  $R_{TRIM}$ . The proper adjustment of  $R_{TRIM}$  can develop a voltage in series with the high input terminal that can cancel the common-mode-induced voltage across  $R_{S1}$ . The penalty for this approach is a small increase in common-mode current (about 0.25 microampere at 117 volts, 60 hertz).  $C_{CM}$  must be capable of withstanding the full common-mode voltage across the isolation amplifier.

Using a lengthy cable to connect a high-impedance device to the input of an isolator exacerbates the problem of converting common-mode signals into normal-mode ones and opposes the cancellation obtained in

Fig. 2b. The use of a long cable between signal source and isolation amplifier should therefore be avoided.

When data must be acquired from floating transducers for computerized process-control systems, a two-transformer isolation amplifier like the model 289 may be used for potential differences or to interrupt ground loops among transducers or between transducers and local ground levels (Fig. 3).

### In process control

Since the isolation amplifier and the analog-to-digital converter are likely to be included in a large feedback loop, the converter must be monotonic and isolation must be sufficiently linear not to induce non-monotonic behavior. Lack of monotonicity can cause instability in the feedback loop.

In using the circuit of Fig. 3, it is desirable that the isolation amplifiers be protected against differential input overloads. Otherwise, miswiring the amplifiers to the ac power line can cause them to fail. Furthermore, the isolation amplifiers should be synchronized to avoid errors caused by beat-frequency signals generated by the mixing of the amplifiers' individual carrier frequencies. The connection of the synchronization terminals in Fig. 3 achieves this purpose. This circuit suffices for common-mode voltages up to 2,500 v peak, ac or dc.

In a data-acquisition system in which multiple transducers are powered by a single supply and the voltage level of that supply is sufficiently low that a multiplexer can handle all of the transducers' voltages, a lone isolation amplifier and a multiplexer can be used (Fig. 4). In the past, such a configuration has not been generally possible because of the speed limitations of the isolation amplifiers available. The model 289 isolation amplifier,

## A comparison of error budgets

A comparison of error budgets for the three most common analog isolation schemes—two-transformer designs such as the model 289, optically coupled hybrid amplifiers, and single-transformer amplifiers—shows clearly the first technique's advantages over the other two. The following calculations are based on the summary of major specifications listed in the table. For the sake of brevity, only major error sources are treated. Calculations are for a circuit with unity gain, with an output of 10 volts full scale ( $\pm 5$  V). Operation is at  $25^\circ\text{C} \pm 25^\circ\text{C}$ , and it is assumed that initial gain and offset errors are trimmed out.

A gain temperature coefficient of  $0.005\%/^\circ\text{C}$  multiplied by a  $25^\circ\text{C}$  span yields 0.125% of full scale for the dual-transformer scheme (listed first in the table). Next, input and output offset voltages as a function of temperature,  $\pm 10$  and  $+50$  microvolts/ $^\circ\text{C}$  yield  $1,500 \mu\text{V}$ , which is 0.015% of the 10-V full-scale output. The new error sum is now 0.125% (gain temperature coefficient) plus 0.015% (offset voltage), which equals 0.14%. Add to this gain nonlinearity of 0.01%, and the total error becomes 0.15% of full scale.

The gain temperature coefficient of the second design, with optical coupling, is the same as that of the dual-transformer scheme—0.125% for a  $25^\circ\text{C}$  span. The  $455\text{-}\mu\text{V}/^\circ\text{C}$  offset voltage multiplied by  $25^\circ\text{C}$  yields  $11,375 \mu\text{V}$ , which is 0.114% of 10 V. When the linearity error of 0.05% of full scale is added, the total ( $0.125\% + 0.114\% + 0.05\%$ ) is 0.289%.

For the third, single-transformer design, the gain tem-

perature coefficient of  $0.006\%/^\circ\text{C}$  multiplied by a  $25^\circ\text{C}$  span yields 0.15% of full scale. The  $525\text{-}\mu\text{V}/^\circ\text{C}$  offset voltage multiplied by  $25^\circ\text{C}$  yields  $13,125 \mu\text{V}$ , which is 0.13% of 10 V. When the linearity error of 0.05% of full scale is added, the total ( $0.15\% + 0.13\% + 0.05\%$ ) comes to 0.33%.

For gains other than unity, the calculations become more complicated. The stability of user-supplied gain resistors can affect the amplifier's gain stability, so the effects of these must be included. (This is also true at unity gain for isolation amplifiers in which gain is set to unity by user-supplied resistors.) At different levels of isolation-amplifier gain, offset drift varies, further complicating error-budget calculations. For example, the first isolation scheme has less total offset drift below a gain of 80 than the second. Above a gain of 80, the second scheme has less total offset drift than the first. And the third, the single-transformer design, has more offset drift at all levels of gain than the other two.

Other complicating factors include errors caused by input-difference current and by noise. For applications involving low source resistance, these errors are small enough to be negligible. If, however, it becomes necessary to add resistors in series with the input of an isolation amplifier for differential-overload protection, these errors may become large enough to merit consideration. Because the input structures of different isolation amplifiers vary greatly, including these errors in the above calculations is very difficult if not impossible.

PERFORMANCE COMPARISON OF THREE ISOLATION AMPLIFIER TYPES

Isolator type	Small-signal bandwidth (kHz)	Maximum gain nonlinearity (percentage of full scale)	Maximum gain temperature coefficient (percentage of full scale/ $^\circ\text{C}$ )	Maximum offset-voltage temperature coefficient ( $\mu\text{V}/^\circ\text{C}$ , $G = \text{gain}$ )
Two-transformer plastic module	15	0.01	0.005	$\pm 10 \pm 50 / G$
Optically coupled hybrid	15	0.05	0.005	$\pm 5 \pm 450 / G$
Single-transformer hybrid	30	0.05	0.006	$\pm 25 \pm 500 / G$

however, has a sufficiently short settling time to make its use practical in this circuit.

The approach shown in Fig. 4 is useful when the voltage difference between any two terminals of the transducers does not exceed 30 v. A limitation of this circuit is that, though the input of the isolation amplifier is protected against ac power-line voltages, the amplifier's power terminals as well as the multiplexer are not.

Addressing of the multiplexer in Fig. 4 is binary, with an enable signal being provided for the selection of the signal-source circuit. Digital signals are optically isolated. For several groups of transducers, several circuits may be used as in Fig. 4, in which case the isolation amplifiers are synchronized for operation. And if several transducers share the same common terminal, that terminal can be attached to the input common of the isolator, halving the number of switching elements.

In wideband vibration analysis, a strain gage may be bonded to a mechanical member that is subject to stress. Strain produced in the mechanical member is transmitted to the strain gage. Since the gage must be intimately connected to the mechanical member, it may be desirable to isolate its output. For cases in which the frequencies of interest extend much beyond a few hundred hertz, a wideband isolation amplifier like the model 289 can be used. The use of variable filters at the isolation amplifier's output stage makes it possible to view on an oscilloscope particular frequency spectra.

### Medical applications

The 289 is useful in medical applications such as patient isolation. Although many isolation amplifiers are used in electrocardiograph patient-lead isolation, few have the bandwidth necessary for use in electro-



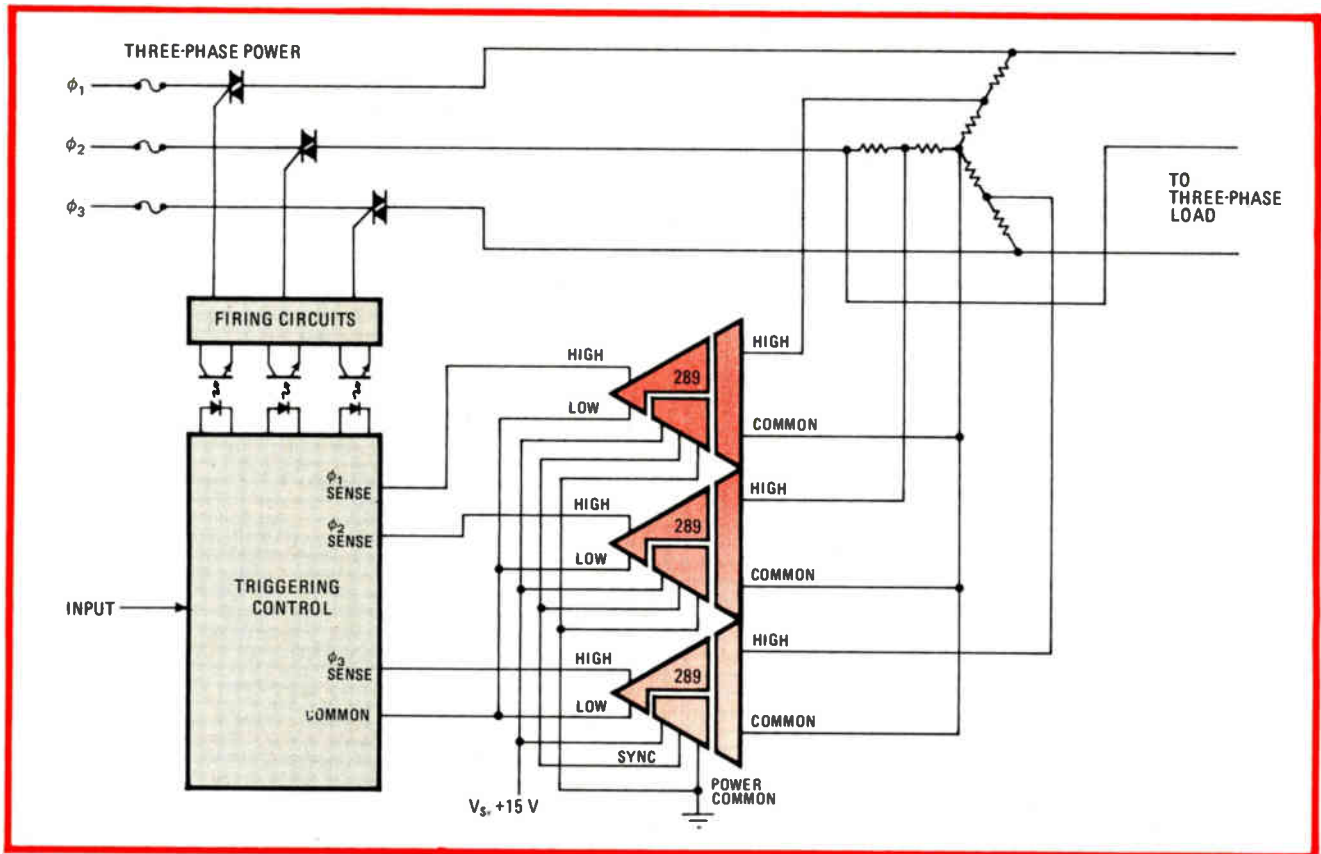

**7. Three-phase.** Three dual-transformer isolation amplifiers can be used in a control circuit for a three-phase ac load. Each amplifier senses a line's voltage, produces a replica of the waveform sensed, and provides this replica waveform to the trigger-control circuit.

myography or for the analysis of pacemaker pulses.

The circuit of Fig. 5 is useful for such applications. A differential amplifier is connected to the isolation amplifier's input. This allows the 289's common input to be connected to the patient so that the patient's common-mode voltage drives the amplifier. A balanced input structure reduces the normal-mode noise that is converted from common-mode noise.

The circuit's FET inputs allow the use of large-value input-protection resistors without affecting noise performance. These input resistors, along with the clamping diodes, protect the isolation amplifier's input structure from defibrillator pulses and protect the patient from fault currents that can develop in the event of the failure of a preamplifier component.

The differential input of Fig. 5 is converted into a single-ended input suitable for use by the isolation amplifier. The gain stage used for this conversion does not make use of unduly high impedance values, thus minimizing noise generation. The input diode should be of a low-leakage type and must not be light-sensitive lest photocurrents be generated in the input structure.

In any patient-lead isolation application, wiring on the patient's side of the isolation amplifier is as critical as the isolation properties of the amplifier itself. Since this wiring is an extension of the patient's vulnerable area, its proper selection is critical. For example, some cables produce copious noise when flexed, thus ruining the otherwise noise-free performance of an isolation system. Cable length can also be a problem. A few tens of feet of

patient cable along a concrete floor can entirely bypass the capacitive isolation of the amplifier.

For motor and ac load control, the use of two-transformer-coupled isolation amplifiers has not usually been possible because of such amplifiers' bandwidth limitations. Thus optically coupled isolation amplifiers equipped with floating power sources to energize their input amplifiers have been used. The two-transformer design used in the model 289 makes it possible to use transformer-coupled isolation amplifiers for motor and ac load-control applications. This amplifier possesses sufficient bandwidth and low enough phase shift to make its use practical in such applications.

### Faithful replication

Figure 6 shows two dual-transformer isolation amplifiers sensing the armature voltage and current of a motor. Faithful replicas of the waveforms of these variables are delivered to the motor control. Isolation amplifier  $A_1$  operates at unity gain from divider  $R_1$ - $R_3$  to deliver an output that is 1/100 of the armature voltage. Isolation amplifier  $A_2$  operates at a gain of 100 to deliver a voltage that is 100 times that developed across the current-sensing resistor.

Figure 7 shows three dual-transformer isolation amplifiers sensing the voltages on the three lines of a three-phase ac load. The Y network divides the voltages of the three phases and creates a neutral for the input commons of the isolation amplifiers. The output of each isolation amplifier is a faithful replica of the waveform

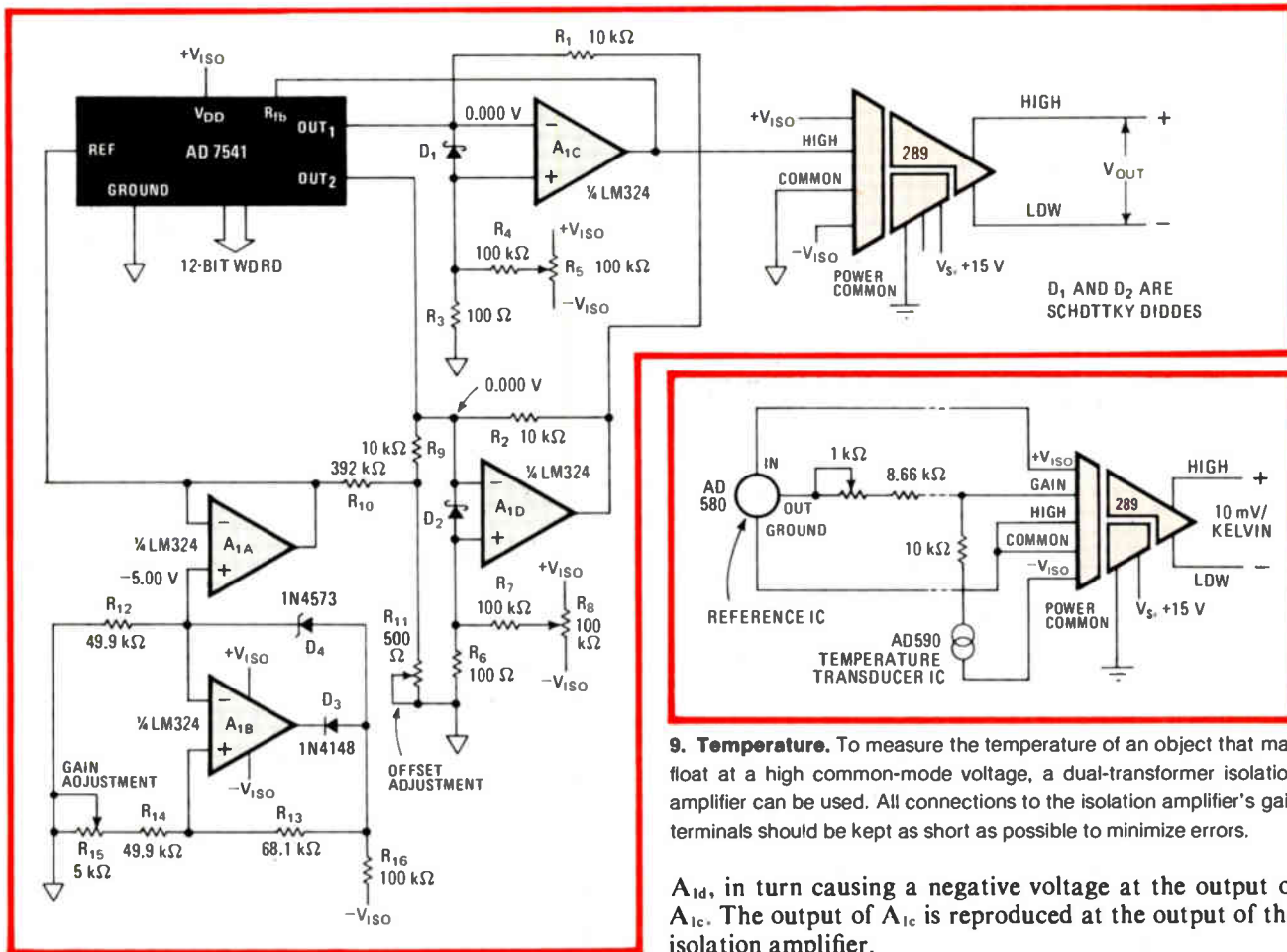

**8. Converter.** The 289 two-transformer isolation amplifier can be used to isolate the output of a 12-bit digital-to-analog converter. Resistors  $R_5$  and  $R_6$  should be adjusted to produce less than 0.5 millivolt at both d-a converter outputs for this circuit to work properly.

of the phase that it senses. The isolation-amplifier outputs provide the feedback necessary for the trigger control to correctly fire the triacs. These same outputs could also be fed to root-mean-square-to-dc converters in similar ac load-control applications.

A note of caution on the use of the circuit of Fig. 7: since transformer-coupled isolation amplifiers are susceptible to applied magnetic fields, it is best to place them outside the leakage fields of motors, transformers and other sources of magnetic interference. If this is not done, these magnetic fields can modulate the signals passing through the isolation amplifiers.

Figure 8 shows a dual-transformer isolation amplifier providing a 12-bit d-a converter with isolated output-voltage capability. A buffered -5-v reference voltage is provided to the converter by amplifiers  $A_{1a}$  and  $A_{1b}$  and their associated circuitry. The fractional value of a digital-word input to the converter causes a proportional fraction of the d-a converter current to flow in the converter's  $OUT_1$  output terminal. The remaining converter current flows into the converter's  $OUT_2$  terminal. Current flowing into  $OUT_1$  causes a positive voltage at the output of amplifier  $A_{1c}$ . Current flowing into  $OUT_2$  of the converter causes a positive voltage at the output of

**9. Temperature.** To measure the temperature of an object that may float at a high common-mode voltage, a dual-transformer isolation amplifier can be used. All connections to the isolation amplifier's gain terminals should be kept as short as possible to minimize errors.

$A_{1d}$ , in turn causing a negative voltage at the output of  $A_{1c}$ . The output of  $A_{1c}$  is reproduced at the output of the isolation amplifier.

For the circuit of Fig. 8 to work properly, resistors  $R_5$  and  $R_6$  must be adjusted to produce less than 0.5 millivolt at both d-a converter outputs. Resistor  $R_{15}$  can be used for gain adjustment, while resistor  $R_{11}$  can be used to adjust the output offset between an input binary code of 100000000000 and one of 0. Circuit operation is bipolar with a  $\pm 5$ -v swing.

### Measuring floating temperatures

A dual-transformer isolation amplifier like the 289 may be used in applications where it is necessary to measure the temperature of an object that may float at a high common-mode voltage, as shown in Fig. 9. The isolation amplifier provides a ground-referenced output.

In the circuit of Fig. 9, the temperature sensor sinks a current of -1 microampere per kelvin. This current flows from the gain terminal of the isolation amplifier, developing across the amplifier's internal feedback resistor a voltage of +10 millivolts/K. This voltage appears at the isolation amplifier's output.

For an output of 10 mV/ $^{\circ}$ C, the circuitry shown with a dotted connection can be used. A current of +273  $\mu$ A is sourced through the 8.66-kilohm resistor and the 1-k $\Omega$  potentiometer, canceling the temperature-sensor current at 0 $^{\circ}$ C (273 K). This results in 0 mV at the amplifier output at 0 $^{\circ}$ C.

For proper operation of the circuit in Fig. 9, all connections to the isolation amplifier's gain terminals should be kept as short as possible.  $\square$

# One small word about computers.

# Osborne

The Leader in Microcomputer Books

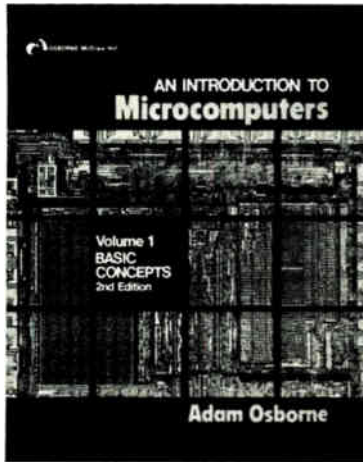

## The World's Best Selling Microcomputer Text REVISED!

**An Introduction to Microcomputers:  
Vol. 1, Basic Concepts, 2nd Ed.**  
by Adam Osborne

Since this book first appeared in 1976 more than 200,000 copies in four different languages have been sold, making it the best selling book on microprocessors ever written. Now it has been completely revised to reflect changes in this dynamic field. Basic Concepts, 2nd edition contains the most current information on microprocessor fundamentals to be found in any publication. #34-9 \$12.50

Also in the **Introduction to Microcomputers** series:

**Volume 0 — The Beginner's Book**  
by Adam Osborne

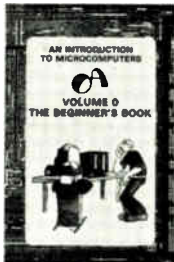

This book introduces computer logic and terminology to the complete beginner in the field of microcomputers. Numerous illustrations and photographs combine with clear, easy-to-follow text to provide an elementary but broad-based background. #26-8 \$7.95

**Volume 2 — Some Real Microprocessors**  
by Adam Osborne et al.

This unique reference provides objective descriptions of virtually every microprocessor on the market today. Lets you know what's available, how they work (or don't work), and how to use them. Loose-leaf. Binders and yearly updates (six issues) sold separately.

Vol. 2 book, 1978 ed.           \*15-2 \$25.00  
Vol. 2 binder                   \*16-0 \$ 5.00  
Vol. 2 1978/79 updates       \*97 \$25.00

Combined update subscriptions can be purchased for both Volumes 2 and 3, a total of twelve update issues. #99 \$40.00

**Volume 3 — Some Real Support Devices**  
by Jerry Kane et al.

Same objective, in-depth coverage as Volume 2, but applied to support devices: memory, data converters, data communication devices, direct memory access controllers, busses, and much more. Loose-leaf. Binders and yearly updates (six issues) sold separately.

Vol. 3 book, 1978 ed.           \*18-7 \$15.00  
Vol. 3 binder                   \*19-5 \$ 5.00  
Vol. 3 1978/79 updates       \*98 \$25.00

## Order Form

Book No.	Price	Quantity	Amount
#			
#			
#			
#			

Calif. residents add 6% sales tax.  
S. F. BART residents add 6-1/2% sales tax.  
No tax on update subscriptions.

**SHIPPING** (Shipping for large orders to be arranged)  
All foreign orders \$4.00 per item for air mail  
No charge in the U. S. on update subscriptions  
\$.75 per item 4th class in the U. S. (allow 3-4 weeks)  
\$1.25 per item UPS in the U. S. (allow 10 days)  
\$2.50 per item special rush shipment by air in the U. S.

For faster shipment or credit card, phone (415) 548-2805

Subtotal

California residents tax

Shipping

TOTAL

Name: \_\_\_\_\_  
Address: \_\_\_\_\_  
City: \_\_\_\_\_ State: \_\_\_\_\_  
ZIP: \_\_\_\_\_ Phone: \_\_\_\_\_

 **OSBORNE/McGraw-Hill**

630 Bancroft Way, Dept. E20  
Berkeley, CA 94710  
(415) 548-2805  
TWX 910-366-7277



S1104



# Whodunit?

## Radar & Radio Communications IC Handbook



 **Plessey**  
Semiconductors

Forget the cloak and dagger.  
Don't bother to question the butler  
or the upstairs maid.

The perpetrator of this micro-  
electronic masterpiece is as plain as the  
Plessey logo on the front cover.

### Take the mystery out of specifying IC's for radar and radio systems applications.

Plessey makes a complete array  
of complex "function block" IC's for  
radar signal processing and radio  
communications.

And you can read about all of them

in the just-published, 450-plus-page  
RADAR & RADIO COMMUNICA-  
TIONS IC HANDBOOK. It's chock-full  
of applications notes and design tips,  
a "cookbook" for all you high frequency  
fans that will simplify your designs,  
increase reliability, improve per-  
formance and lower your system cost.

**PLESSEY IC'S FOR RADAR I.F.'S**

**Wideband Amplifiers for Successive Detection Log Strips**

- SL521 30 to 60 MHz center frequency, 12 dB gain.
- SL523 Dual SL521 (series).
- SL1521 120 to 160 MHz center frequency, 12 dB gain.
- SL1522 Dual SL1521 (parallel).
- SL1523 Dual SL1521 (series).

**Low Phase Shift Amplifiers**

- SL531 True log I.F. amplifier, 10-200 MHz,  $\pm 0.5^\circ/10$  dB max phase shift.
- SL532 400 MHz bandwidth limiting amplifier,  $1^\circ$  phase shift max. when overdriven 12 dB.

**Linear Amplifiers**

- SL550 125 MHz bandwidth, 40 dB gain, 25 dB swept gain control range, 1.8 dB noise figure, interfaces to microwave mixers.
- SL1550 320 MHz bandwidth version of SL550.
- SL560 300 MHz bandwidth, 10 to 40 dB gain, 1.8 dB noise figure drives 50 ohm loads, low power consumption.

**Video Amplifiers and Detectors**

- SL510 Detector (DC to 100 MHz) and video amplifier (DC to 24 MHz) may be used separately, 11 dB incremental gain 28 dB dynamic range.
- SL511 Similar to SL510 with DC to 14 MHz video amplifier, 16 dB incremental gain.
- SL541 High accuracy op amp configuration, 175 V/ $\mu$ s slew rate 50 ns settling time, stable 70 dB gain, 50 ns recovery from overload.

**"Must reading for every radar systems buff..."**

Whether you're working with radar and ECM, weapons control or navigation and guidance systems, you'll quickly surmise that Plessey IC's are a simpler, less expensive, more flexible alternative to whatever you're now using for any I.F. strip up to 160 MHz.

The handbook abounds with examples of Plessey's Radar IC prowess.

A case in point is the Plessey SL531 True Log Amplifier. A six stage log strip requires a minimum of external components (one capacitor, one resistor per stage), yet has a bandwidth of 500 MHz, a dynamic range of 70 dB and has a phase shift of only  $\pm 3^\circ$  over its entire range.

As with most other Plessey devices, it operates over the full MIL-temp range and is available screened to MIL-STD-883.

This thriller goes on for page after page with more of the same—highly integrated function blocks that are on the leading edge of technology without pushing the ragged edge of capability. You'll just have to get your copy of the HANDBOOK for the rest of the details.

**"I couldn't put it down. The only mystery was why I hadn't tuned Plessey into my radio communications systems before now..."**

Even the most casual reader will appreciate the benefits of devices such as the Plessey SL600 Series (hermetic) and SL1600 Series (plastic DIP).

Even more exciting is the Plessey SL6000 Series. It extends the Plessey IC "building block" concept even further, with devices that permit higher levels of integration, lower power consumption and provide exceptional performance.

The HANDBOOK is full of gems in silicon, but one example should suffice. The Plessey SL6600 is a monolithic IC that contains a complete IF amplifier, detector, phase locked loop and squelch control. Power consumption is a meager 1.5 mA at 6V, S/N ratio is 50 dB, dynamic range is 120 dB and THD is just 1.3% for 5 kHz peak deviation. The SL6600 can be used at I.F. frequencies up to 50 MHz, with deviations up to 10 kHz.

Plessey's comprehensive line of radio communications function block IC's is cutting costs, increasing reli-

ability and reducing system size in applications that range from commercial communications to military manpack radios. Read all about it in the HANDBOOK.

**PLESSEY RADIO IC'S**

**Amplifiers**

- SL610 SL1610 140 MHz bandwidth, 20 dB gain, 50 dB AGC range, low 4 dB N.F., low distortion.
- SL611 SL1611 100 MHz bandwidth, 26 dB gain, sim. to SL610.
- SL612 SL1612 15 MHz bandwidth, 34 dB gain, 70 dB AGC range, 20 mW power consumption.
- SL613 145 MHz bandwidth, 12 dB gain, limiting amp/detector.

**Mixers**

- SL640 SL1640 Double balanced modulator eliminates diode rings up to 75 MHz, standby power 75 mW typical.

**Detectors and AGC Generators**

- SL620 SL1620 AGC with VOGAD (Voice Operated Gain Adjusting Device).
- SL621 SL1621 AGC from detected audio.
- SL623 SL1623 AM SSB detector and AGC from carrier.
- SL1625 AM detector and AGC from carrier.
- SL624 AM/FM/SSB/CW detector with audio amplifier.

**Audio Amplifiers**

- SL622 Microphone amp. with VOGAD and sidetone amp.
- SL630 SL1630 250 mW microphone/headphone amplifier.

**I.F. Amplifiers/Detectors**

- SL6600 FM double conversions with PLL detector.
- SL6640 FM single conversion, audio stage (10.7 MHz).
- SL6650 FM single conversion (10.7 MHz).
- SL6690 FM single conversion, low power for pagers (455 kHz).
- SL6700 AM double conversion.

**Audio Amplifiers**

- SL6270 Microphone amplifier with AGC.
- SL6290 SL6270 with speech clipper, buffer and relay driver.
- SL6310 Switchable audio amplifier (400 mW/9V/8 ohms).
- SL6440 High-level mixer.

**The \$4 solution.**

It's elementary, dear reader.

If you're involved in the design of systems for radar signal processing or radio communications, the new Plessey RADAR & RADIO COMMUNICATIONS IC HANDBOOK should be at the very top of your current reading list.

Even if our Handbook unravels but one small systems solution for you, it will have been well worth the \$4 (postage paid) purchase price.

For your copy, just write Plessey Semiconductors, 1641 Kaiser Avenue, Irvine, CA 92714. Telephone (714) 540-9979.

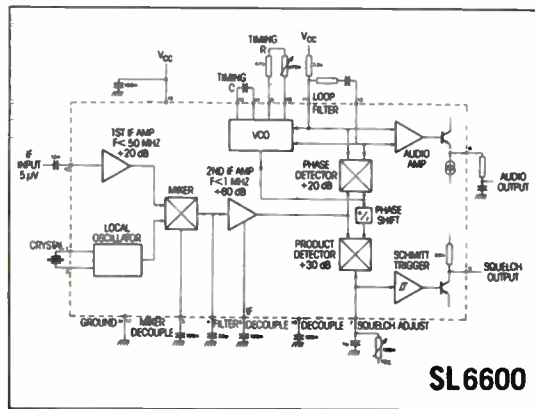

Plessey's radio IC prowess at work. The SL 6600 is a masterful monolithic IC that contains a complete I.F. amp, detector, PLL and squelch control. Power consumption is exceptionally low. Performance is exceptionally high (Reprinted from RADAR & RADIO COMMUNICATIONS IC HANDBOOK).

**Plesseydunit.**

## PROM comparator monitors digital window limits

by Noel A. Sivertson  
Storage Technology Corp., Louisville, Colo.

In much of today's automated test equipment, analog data is digitized and measured against some standard or specification by means of a microprocessor-based system. But what if a microprocessor is not available or there is no strong need to use one? Then a relatively simple digital window comparator built with fuse-link programmable read-only memories can be used to check the data in hardware, as shown here.

The general scheme is shown in (a), where 1,024-word-by-4-bit PROMs are used to test four decades of binary-coded decimal data against some arbitrary upper and lower limits. Line  $A_0$  on all devices is the cascaded error input, needed to generate the error signal at the output if the programmed data stored in any PROM is exceeded or is below its minimum specified value, as the case may be. The state of  $A_1$  determines whether the comparison is to be made against the upper or lower limit. Address bus  $A_2$ - $A_5$  calls out one of a maximum of 16 specified test conditions. Lines  $A_6$ - $A_9$  accept the input data.

An example of how the circuit is both programmed and configured to monitor a given data window is given in (b), where the input BCD data is expected to fall within 1393 and 1505. As shown in the lower-limit determinant map, the hundreds digit PROM,  $P_2$ , deter-

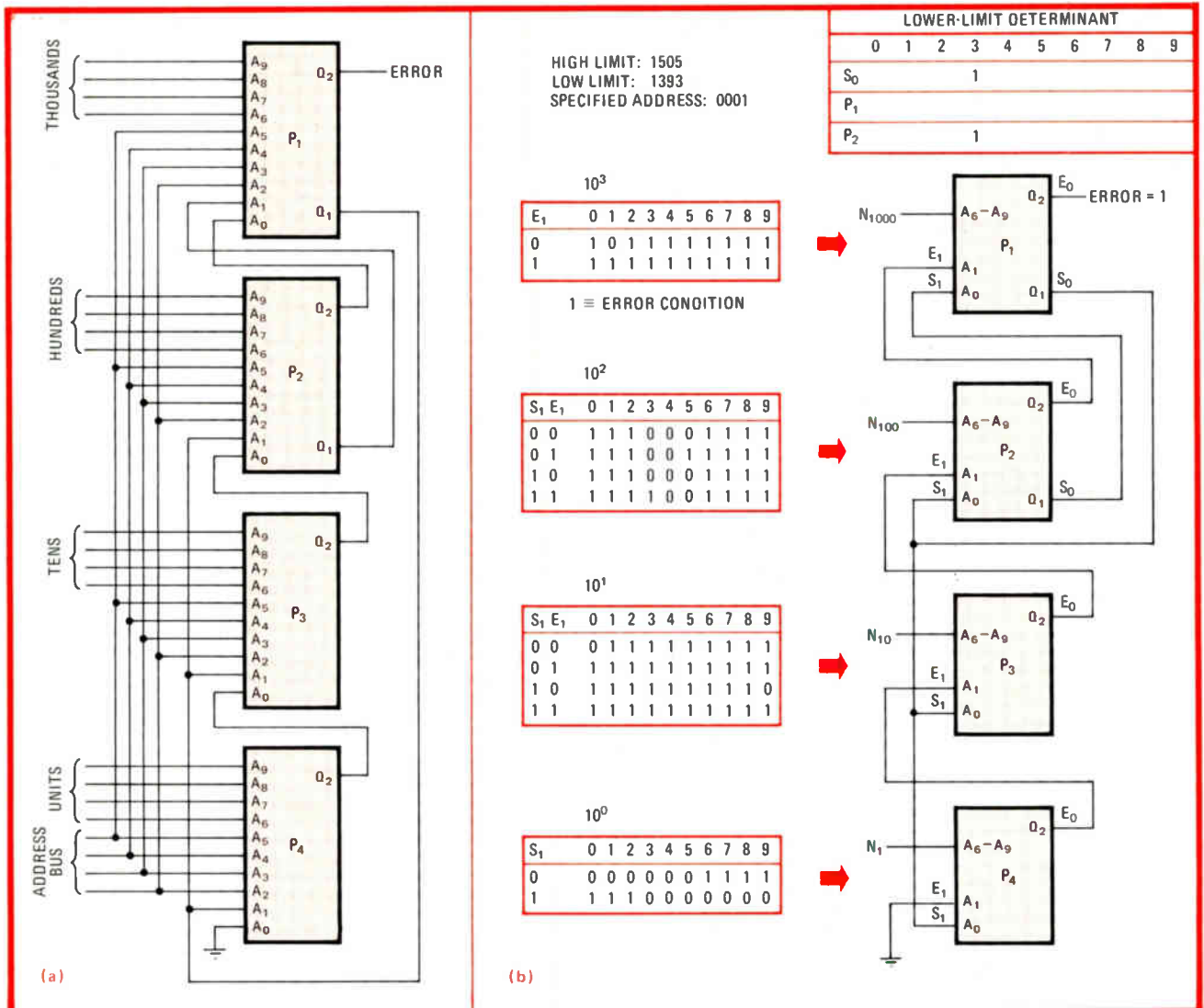

**Logical endpoints.** PROMs comprise four-decade window comparator (a), useful for checking upper and lower limits of binary-coded decimal data without the need for software. Example (b) describes design of typical automatic test circuit in detail.



mines if the measurement is made for the high or low limit. If the hundreds digit is a 3, for example, as in 1,393,  $S_0$  of  $P_2$  will go high, pass through  $S_1$  of  $P_1$ , and appear at its  $S_0$  output. This action will enable  $S_1$  of  $P_2$ ,  $P_3$ , and  $P_4$ . Thus each PROM will examine its data input against the lower limit at address 0001.

Conversely, if the hundreds digit is a 5, as in 1,505,  $S_0$  of  $P_2$  will remain low, as will  $S_1$  of  $P_2$ ,  $P_3$ , and  $P_4$ . Consequently, the PROMs will compare the data input against the high limit programmed for address 0001. Tabulation of an error map for each PROM, as shown, aids the user in attaining the desired output at each PROM's  $Q_1$  and  $Q_2$  output, so that programming for the desired window may be set in a minimum of time. As seen, the condition of both  $S_1$  and  $E_1$  must be known in the middle two PROMs in order to determine if the

corresponding input number falls into one of three categories, including that of equaling the specified limit.

If the high- or low-determinant digit occurs in the thousands input (2,700  $\rightarrow$  3,700, for instance), then  $S_0$  of  $P_1$  responds to its own data input rather than to the data at  $S_1$ . Here,  $S_0$  of  $P_2$  is programmed to remain low.

If the data entered does not fall within the preset window, an error signal is generated at the corresponding PROM's  $E_0$  output and carried to the PROM of the next most significant digit. Thus, the data-bit window is reduced by one for the high-limit measurement or increased by one for the low-limit measurement, depending on the status of its corresponding  $S_1$  signal.  $\square$

Engineer's notebook is a regular feature in *Electronics*. We invite readers to submit original design shortcuts, calculation aids, measurement and test techniques, and other ideas for saving engineering time or cost. We'll pay \$50 for each item published.

## Cyclic redundancy routine tracks data-stream errors

by William W. Pfeifer  
Tektronix Inc., Components Division, Beaverton, Ore.

Detecting bit errors in a serial data stream by performing a cyclic redundancy check, this M6800 routine runs more quickly than the one proposed by S. V. Alekar<sup>1</sup> and is more reliable as well. Virtually any type of bit error can be detected.

The program's function is the same as Alekar's, wherein a 16-bit data stream polynomial is divided by a standard CRC polynomial, including the CRC-16, CRC-16 reverse, CRC-CCITT, and CRC-CCITT reverse specifications. The generated check word is then appended to the data stream during transmission. During reception, the incoming data stream is again divided by the same CRC polynomial. For error-free data, the check word should be zero.

Unfortunately, however, Alekar's routine does not often yield the proper check word because the program combines the check word and the CRC polynomial via an exclusive-OR operation at locations 2010 and 2012, independently of the carry generated. But the carry is the exclusive-OR result of combining the most significant bits of the check word and the data byte; the exclusive-OR operation should therefore be carried out only when the carry is set. Consequently, the correct check word cannot usually be generated by the Alekar program except for a handful of types of data errors.

Although it is simple enough to modify Alekar's program to perform the exclusive-OR operation at the proper time, better results are obtained from the program shown in the table. It will be executed in an average of only 400 machine cycles. In contrast, Alekar's routine would require more than 500 cycles in order to run flawlessly.

The hexadecimal codes corresponding to the polynomial standard to be generated are loaded at locations HPLY and LPLY, as in the original program, and they have the same values. For the CRC-16 standard, 80<sub>H</sub> is entered into HPLY and 05<sub>H</sub> into LPLY; for CRC-16 reverse, 40<sub>H</sub>

M6800 CRC ALGORITHM				
Location	Label	Op code	Operand	Comments
2000		LDA	A #0B	
2002		STA	A CNT	Store an B in the counter.
2005	LOOP	CLR	A	
2006		ASL	DATA	Left-shift data byte, most significant bit in carry.
2009		ROR	A	Carry bit into MSB of register A.
200A		EOR	A HCHK	Exclusive-OR check word with data MSB.
200D		LDA	A LCHK	
2010		ASL	B	Left-shift check word, MSB in carry.
2011		ROL	A	
2012		BCC	NOTEOR	Check carry.
2014		EOR	A HPLY	Exclusive-OR with polynomial.
2017		EOR	B LPLY	
201A	NOTEOR	STA	A HCHK	Store check word.
201D		STA	B LCHK	
2020		DEC	CNT	Decrement counter.
2023		BNE	LOOP	Done?
2025		RTS		
2026	CNT	RMB	1	Loop counter.
2027	HPLY	RMB	1	Upper byte of polynomial.
2028	LPLY	RMB	1	
2029	HCHK	RMB	1	Upper byte of check word.
202A	LCHK	RMB	1	
202B	DATA	RMB	1	Data byte.

# EASY, CLEAN AND EFFICIENT TIMING CHART PREPARATION

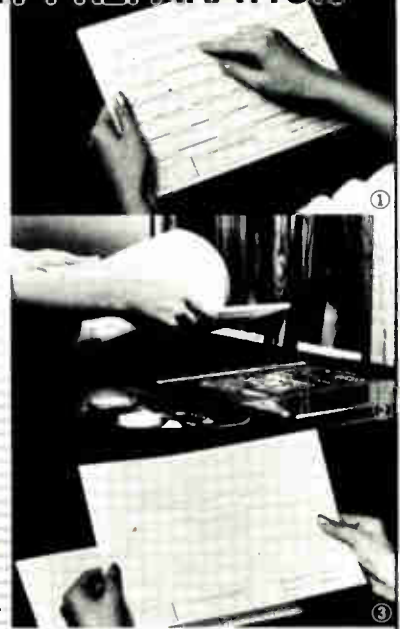

Enquiries for distributorship are welcome.

PAT. PEND.

How often have you had a basket full of crumpled paper or your table covered with eraser shreds because you had to rewrite your timing charts many times before it was just right? No more of such mess now because Xebec Trading Corporation has brought out the Logic Scale, which is just a simple A4-size plastic board with 320 sliders arranged in eight horizontal rows. These sliders can be moved vertically between two click-stop positions representing the two logic levels. All you need do for preparing your timing charts is to move the sliders in each row to represent the waveforms in your circuit and after you have fully checked your design just go to your office copying machine and take a copy for your files. A quick glance at the photograph will tell you more than all the description we could write here.

Material: ABS Plastic Dimensions: 297W x 210H x 7T mm

## XEBEC TRADING CORP.

No. 21-12, 4-Chome, Kasuya, Setagaya-ku, Tokyo, 157 Japan.  
 CABLE: XEBEC JAPAN  
 TELEX: 2324788 XEBEC J.  
 TELEPHONE: (03)307-5641

Circle 164 on reader service card

## Robert Bosch announces a new Mini-Giant built to help resist moisture, dust and galloping inflation

Here's a new 30-amp, 12 VDC plug-in relay engineered to do the job better than ever. Yet it's available at or below our 1979 price. The secret is in the housing of rigid polyamide plastic.

Robert Bosch engineers chose this tough, impact-resistant plastic to replace traditional galvanized steel as the housing material. That helps explain the savings—in production costs for us, purchase price for you.

The relay is protected by a seamless housing. Neither moisture nor dust can easily penetrate. The bottom of the unit is vented with a single hole to avoid heat buildup. But for extra heavy-duty, outdoor applications, even this vent can be closed with a Teflon plug that filters out foreign matter while allowing air to circulate.



PCB Relay  
0.56 cu. in.

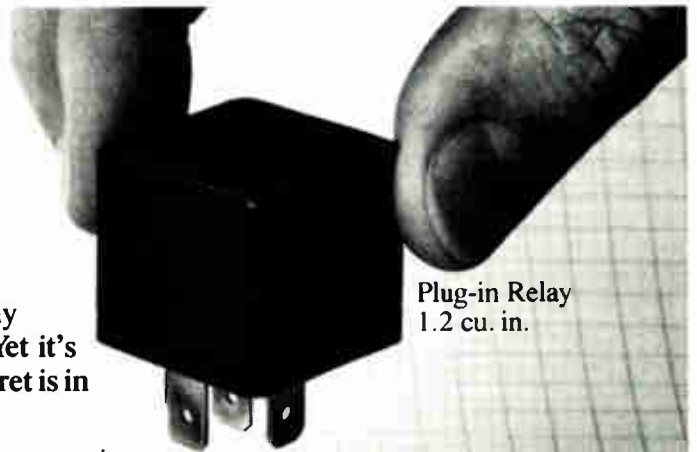

Plug-in Relay  
1.2 cu. in.

For free specifications on the full line of Mini-Giant relays, both plug-in and PCB, write:

Robert Bosch Corporation  
 Dept. O/PGE 4  
 2800 So. 25th Avenue  
 Broadview, IL 60153  
 or phone Dave Robson,  
 (312) 865-5459

# ROBERT BOSCH

©1980 Robert Bosch Corporation

and  $03_H$ , respectively; for CRC-CCITT,  $10_H$  and  $21_H$ , respectively; and for CRC-CCITT reverse,  $08_H$  and  $11_H$ , respectively. The data byte being transferred is stored in location DATA, and the higher and lower bytes of the

check word are stored in locations HCHK and LCHK, respectively. □

#### References

1. "M6800 program performs cyclic redundancy checks." *Electronics*, Dec. 6, 1979, p. 167.

## Optical generator traces scope-mounted masks

by E. Chandan and Agarwal Anant, *Department of Electrical Engineering, Indian Institute of Technology, Madras, India*

Using a photoresistor encased in the aluminum hood of an oscilloscope for adjusting the position of the scope beam in the vertical axis, this function generator reproduces almost any waveform by electrically tracing out the pattern of the waveshape's defining cut-out mask that is mounted on the scope's face. It eliminates the need for expensive digital systems of the kind often employed for arbitrary waveform generation in biomedical and other applications below 500 hertz.

The photoresistor should be placed snugly in the scope's hood in such a way that light from all parts of the scope screen is directly incident upon it, as shown in (a). The black paper cut-out of the required waveshape is then taped on the screen.

The sensing circuit (b) monitors the screen illumination and adjusts the scanning beam to fall at the upper boundaries of the mask. Suppose the instantaneous loca-

tion of the beam is at point  $P_1$ . The photoresistor will be intensely illuminated and assume a low resistance of perhaps only a few hundred ohms. Therefore, the noninverting input of the 741 operational amplifier will go negative, and its output will also of course move to a corresponding negative voltage.

The output of the 741, which represents the generator output, drives the Y input of the scope, so that the beam will be forced to move to a low point on the vertical axis. The beam will tend to fall below the upper boundaries of the mask in most instances, at point  $P_2$ . Consequently, the photoresistance will rise to several megohms, causing the voltage at the noninverting junction of the 741 to move positive and to force the beam upward.

Because of the aforementioned feedback, the beam attempts to rest at  $P_3$ , where  $R_1 = R_2$ . Of course, the beam traverses the X axis from left to right at the same time, and so the circuit will try to position the beam along the mask's boundaries, thereby generating an output voltage conforming to the cutout.

Occasionally, the gain of the 741 stage ( $1 + R_3/R_4$ ) needed for the vertical displacements desired for a given scope may cause the scanning beam to oscillate to an unacceptable degree. If the output of the 741 is taken after a low-pass filter (port B), the problem will be eliminated entirely. □

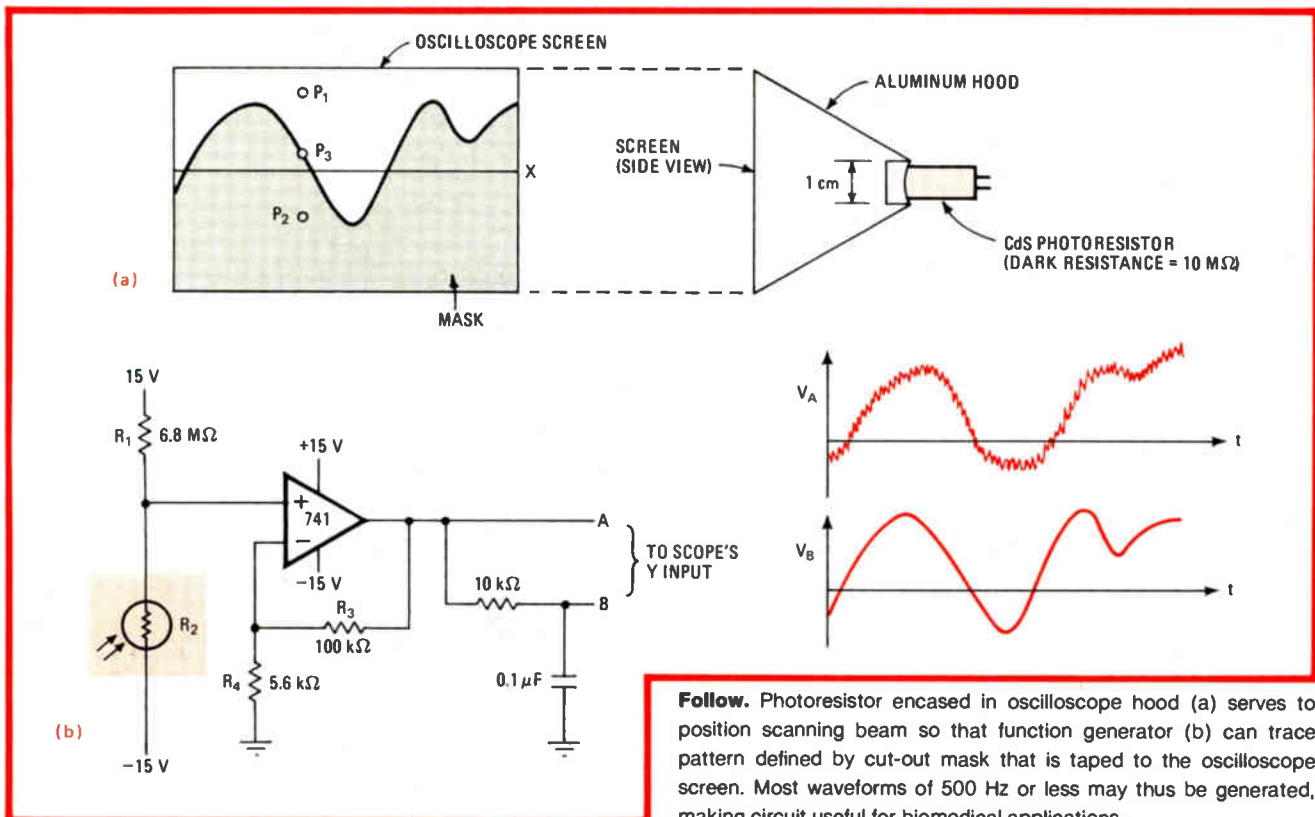

**Follow.** Photoresistor encased in oscilloscope hood (a) serves to position scanning beam so that function generator (b) can trace pattern defined by cut-out mask that is taped to the oscilloscope screen. Most waveforms of 500 Hz or less may thus be generated, making circuit useful for biomedical applications.



## Floppy disks stay on track

The industrywide problem of accurately calibrating head-to-track alignment, particularly as it affects the field interchangeability of flexible diskettes, has moved one step closer to solution with a new technique for producing alignment disks developed jointly by Dymek Corp., Santa Clara, Calif., and Micropolis Corp., Chatsworth, Calif. Dymek claims that the accuracies attained in its disks are the first to yield fully satisfactory tolerances for all its 96- and 100-track/in. floppy-disk drives. **A maximum variation in radial alignment of only  $\pm 0.3$  mil was measured in alignment disks produced primarily for 48 tracks/in.,** Dymek reports.

Dymek is currently offering alignment disks for 48-, 96-, and 100-track/in. diskettes in 5 $\frac{1}{4}$ - and 8-in. formats, both single- and double-sided. Micropolis has certified models designed for its 5 $\frac{1}{4}$ -in. floppies for 96 and 100 tracks/in. Alignment disks for Micropolis 96- and 100-track/in. products are available from Dymek at \$28 for single-sided and \$56 for double-sided models. For more information, contact Duane Meulners at Dymek, 2589 Scott Blvd., Santa Clara, Calif. 95050.

## Trifet op amp cuts noise in data converters

Those who have replaced the popular AD536 with the higher-bandwidth AD536A in their rms-to-dc converters and who have noticed a larger offset may be seeing the root-mean-square value of the wideband noise from the preamplifier that drives it, as mentioned in the Potpourri section of Analog Dialogue, Vol. 14, No. 1, published by Analog Devices Inc., Norwood, Mass. The solution is to use a lower-noise preamp stage, such as the company's new AD544 Trifet operational amplifier, **a monolithic device made with ion-implanted field-effect transistors and laser-trimmed thin-film resistors.** It features a maximum bias current of 25 pA, a maximum offset voltage of 0.5 mV, 5  $\mu\text{V}/^\circ\text{C}$  drift, an 8-V/ $\mu\text{s}$  minimum slewing rate, and a 3- $\mu\text{s}$  settling time to within 0.01%. Combined with its high gain (50,000 minimum), low quiescent current (2.5 mA maximum), and 2- $\mu\text{V}$  peak-to-peak noise (0.1 to 10 Hz), it is ideal for use with digital-to-analog converters and portable equipment. Price varies from \$2.50 for the J version to \$11.50 for the S.

## ICs may be as good as their gold

The reliability of integrated circuits may be affected by the gold market, cautions Integrated Circuits Engineering to its consulting clients. **Problems associated with subsequent metal substitutions, process changes, or thinner gold plating may result in the wake of soaring gold prices,** the Scottsdale, Ariz., firm says. One such problem is expected to be manifested on Cerdip packages, where use of a glass-frit die attachment might lead to chip fractures during extreme temperature cycling. ICE advises circuit buyers to switch to plastic or chip-carrier devices if possible.

## Micropower op amp boasts notable specs

Circuit designers will hail the availability of Precision Monolithics' Op-420, a bipolar, highly accurate quad operational amplifier for micropower applications. The Santa Clara, Calif., firm's amp boasts **a power drain so low that one T134 mercury battery can power it continuously for more than six months.** Supply voltages of as low as +3 or  $\pm 1.5$  V can be used; the supply current is a maximum of 0.25 mA at  $\pm 15$  V. Other key characteristics include a maximum offset voltage of 3.5 mV and a typical common-mode rejection ratio of 83 dB. Contact PMI's Tom Schwartz at (408) 246-9222.

-Vincent Biancomano

# Itron Advanced Alphanumerics. They'll put your readouts upfront.

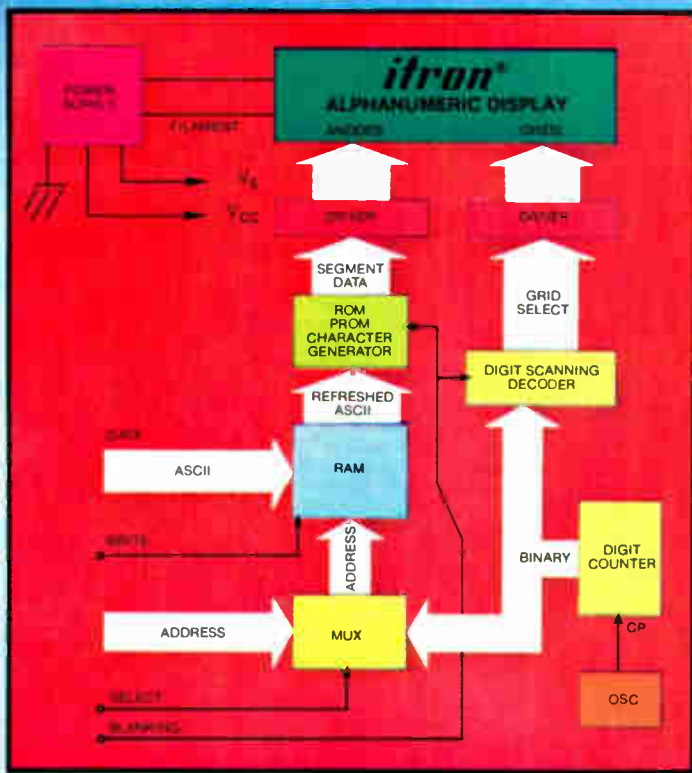
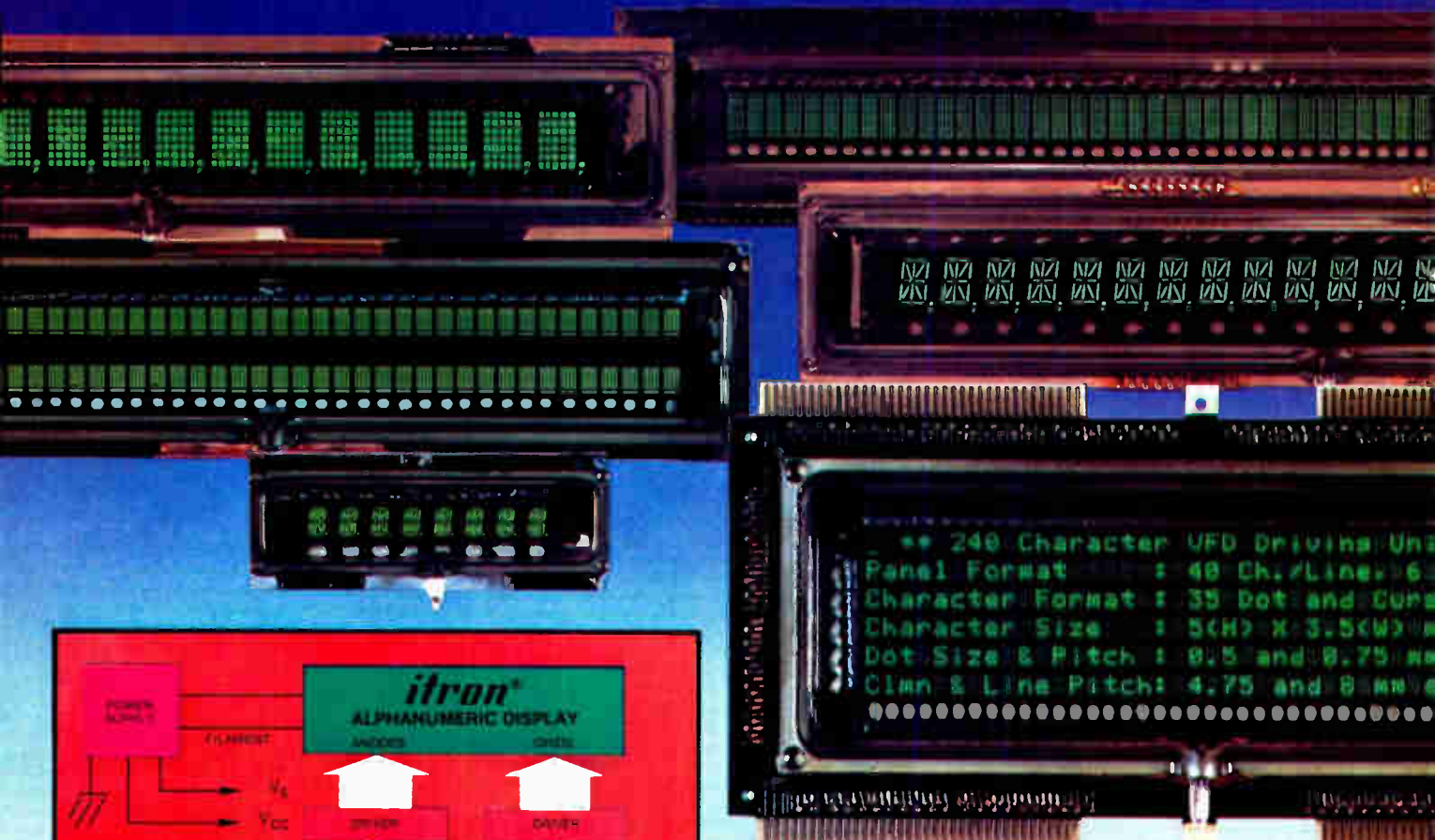

#### INTERNATIONAL REPRESENTATIVES

WEST GERMANY: Neumuller GmbH, Eschonstr. 2, 8021, Taufkirchen, Munich. Phone: 089/6118-245. Telex: 522106.

FRANCE: Europavia France, 5 Avenue Leon Harmel 92167 Antony Cedex. Phone: 666-21-10. Telex: 42204381.

UNITED KINGDOM: ITT Meridian, West Road, Harlow, Essex CM20 2BP. Phone: 0279-35351. Telex: 817202.

SWEDEN: AB Nordqvist & Berg, Box 9145 S-10272, Stockholm. Phone: 08-690400. Telex: 10407.

DENMARK: E. V. Johansen Elektronik A-S, Tritagade 15-2200, Copenhagen. Phone: 01/839022. Telex: 16522.

HONG KONG: Phone: 5-232420. TAIPEI: Phone: 351-0293.

With Itron's evolutionary 14-segment and dot matrix alphanumeric displays, your readout designs are sure to be front-runners everytime. They're offered in a wide selection of character heights from 5 mm to 15 mm, and character counts that range from an 8-character 14-segment mini-package dot array, all the way up to the unique 240 character, 5 x 7 dot matrix (6 line x 40 characters/line) plug-in panel—and even 5 x 12 dot matrices for upper/lower case fonts.

Their long-term field-proven reliability, even under severe environments, further enhance their desirability for most every application where bright, easy-to-read legibility (even at a distance and under high ambient light), wide viewing angles and flat-glass simple-to-mount packages—plus low voltage and low current-drain are paramount. So, since brevity is called for, contact us to find out all the particulars on how to put your readout designs in the forefront with Itron's Advanced Alphanumerics.

**itron**<sup>®</sup>  
FLUORESCENT DISPLAYS  
Patented and Manufactured by  
ISE ELECTRONICS CORP.

#### NORITAKE ELECTRONICS, INC.

EASTERN OFFICE: 41 Madison Avenue, New York, NY 10010 • (212) 481-3440 • Telex: 12-5469

CENTRAL OFFICE: 16250 Northland Drive, Southfield, MI 48075 • (313) 569-0088

WESTERN OFFICE: 22410 Hawthorne Boulevard, Torrance, CA 90505 • (213) 373-6704 • Telex: 67-4910

#### NORITAKE COMPANY, LIMITED

JAPAN: 1-1, Noritake-Shinmachi, Nishiku, Nagoya-Shi • (052) 562-0336 • Telex: J59738

EUROPE: Burotel Belgium SA, Rue de la Presse 3-5, 1000 Bruxelles • (02) 217-83-60 • Telex: 4626962



# Announcing the HP 1000 Separate I/O processors let the

Our new HP 1000 L-Series is designed to give you outstanding processing performance—even in the most demanding applications.

The reason is our innovative distributed intelligence architecture. Each I/O interface has its own processor—made with our exclusive SOS LSI process—and its own direct memory channel. Which means each interface can control and monitor data transfers—without interrupting the central processor.

So the CPU can concentrate on its main job of computation.

And you get faster response, higher throughput and superior system performance.

But what's really surprising about the L-Series is that you get all this performance at prices

that start as low as \$1968 for our starter set.† Or \$15,510 for a complete disc-based system.††

## Nobody makes processors like we do.

The key to the HP-1000 L-Series' impressive new architecture is our own Silicon-On-Sapphire technology. SOS lets us make CPU and I/O chips with extremely high circuit density, low power consumption, high processing speeds and high reliability—at a very low cost.

It's this combination of high performance and low cost that make the L-Series appropriate for the whole range of OEM and industrial appli-

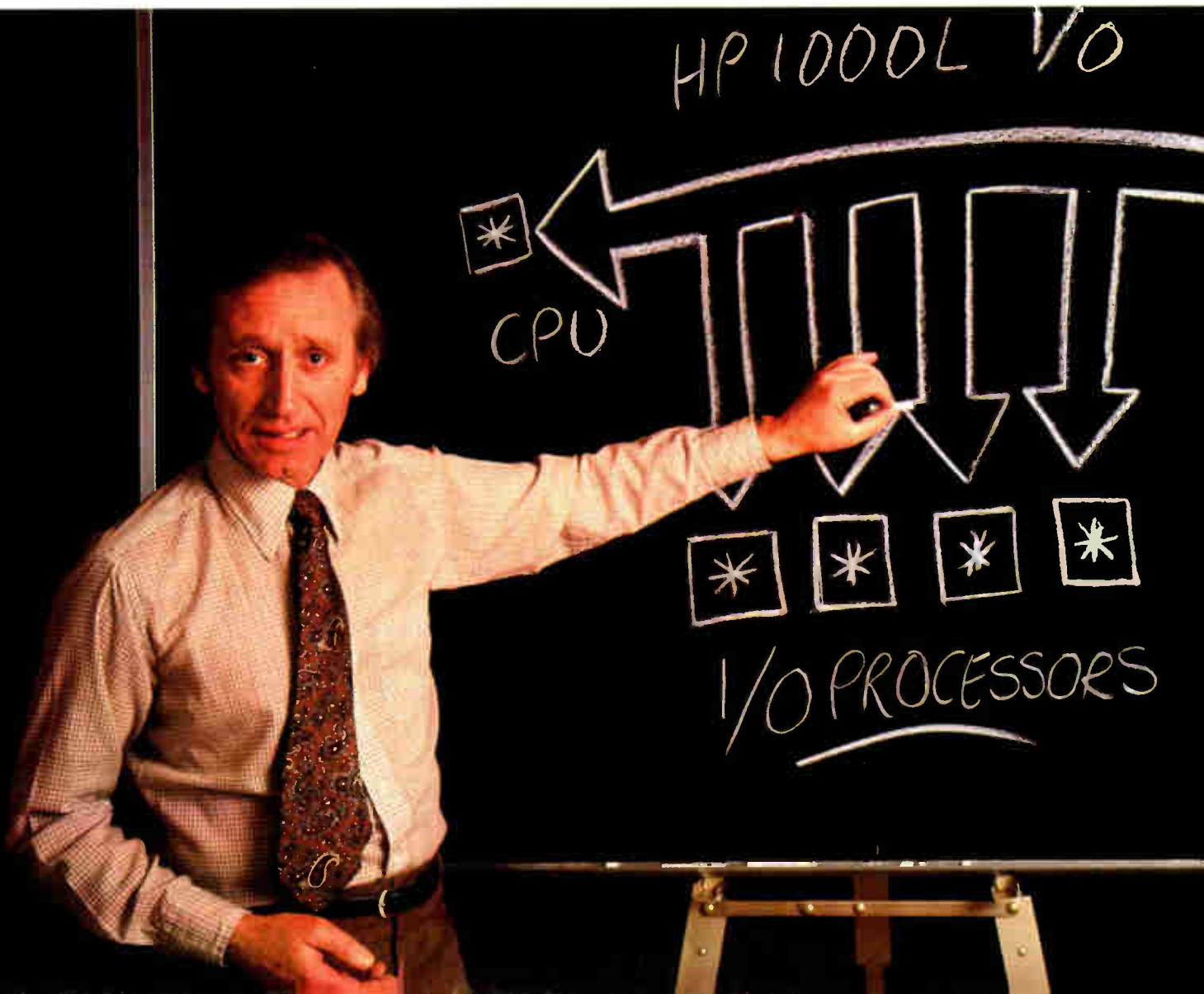



# L-Series Computer. CPU concentrate on computation.

cations — including data management, process control and instrumentation.

And to insure you can get the exact configuration you need for your specific application, the L-Series is available in a wide choice of board, box and system packages.

The HP 1000 L-Series is a fully compatible member of our high performance HP 1000 family. Which means you can move up to a larger computer—all the way to our powerful F-Series — as your application grows.

It also means you can use any HP 1000 computer—and its sophisticated program development tools—to design programs for the L-Series.

## The reliability is built in.

Like all HP computers, the HP 1000 L-Series is designed to give you outstanding reliability. Reliability that's significantly enhanced by our SOS technology — processor boards have fewer active parts, so

† Starter Set: CPU, 64KB memory, one I/O board.  
†† Disc-Based System: HP's new 12MB Winchester disc drive and 2621 display console.  
(U.S. OEM prices in quantities of 100)



From  
**\$1968**

fewer things can go wrong. In addition, the L-Series has its own self-test programs and diagnostics.

And, of course, the L-Series is backed by our full range of support and documentation services—including our worldwide service network.

For more information or a hands-on demonstration of our high performance, low cost L-Series, contact your nearest HP sales office listed in the White Pages or write to: Roger Ueltzen, Dept. 673, 11000 Wolfe Road, Cupertino, CA 95014.



**HEWLETT  
PACKARD**

1976



1977

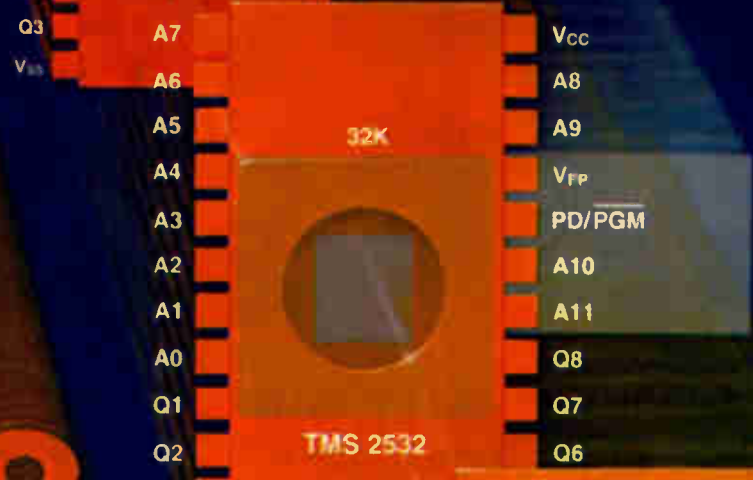

1978



1979



# 64K EPROMs from Texas Instruments. Defining the future. Ready today.

EPROMs regularly double in density — 128K devices are inevitable. By factoring TI's new 64K EPROM into your plans today, you can pave the way for these greater densities and minimize system redesign.

Because the new TMS2564 comes in a 600-mil, 28-pin, dual-in-line package. Plug compatible with that anticipated for the 128K EPROMs ... and ROMs. When the time comes to upgrade, you'll be able to substitute one for the other.

## Outstanding compatibility

In the meantime, the TMS2564 EPROM allows you a great deal of latitude. For maximum compatibility with present devices, its JEDEC-approved pinout is derived

from the industry-standard 24-pin 64K ROM supplied by eight sources.

On the new TMS2564, pins 26 and 28 are reserved for the 5-V supply. With a supply trace to pin 26, both 24- and 28-pin devices can be used

with no jumpering. If you choose, you can even use smaller EPROMs without compatibility problems. And upgrading from the TMS2532 32K EPROM is a snap.

## Low power

The TMS2564 offers you the lowest power per bit in the industry ... only 13  $\mu$ W max active. A must for high reliability and low system operating costs.

## Widest choice

Adding the TMS2564 to our fast-growing EPROM family gives you a choice unmatched in the marketplace. All members are available in 600-mil packages with industry-compatible pinouts. All share the reliable production-proven TI EPROM technology.

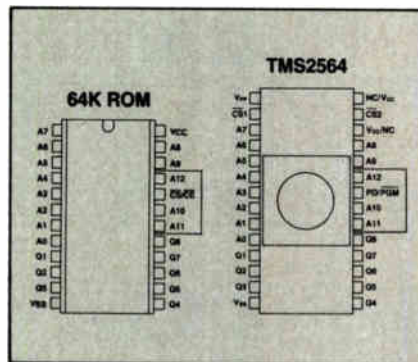

## PACESETTING EPROMs FROM TI

Device	Description	Power Supply	Typical Power (0°C)		Access Time
			Operating	Standby	
TMS2564	64K	5 V	400 mW	50 mW	450 ns
TMS25L32	32K	5 V	325 mW	50 mW	450 ns
TMS2532	32K	5 V	400 mW	50 mW	450 ns
TMS2516-35	16K	5 V	285 mW	50 mW	350 ns
TMS2516	16K	5 V	285 mW	50 mW	450 ns
TMS2508-25	8K	5 V	250 mW	50 mW	250 ns
TMS2508-30	8K	5 V	250 mW	50 mW	300 ns
TMS2716	16K	+12, $\pm$ 5 V	315 mW	—	450 ns
TMS27L08	8K	+12, $\pm$ 5 V	245 mW	—	450 ns
TMS2708	8K	+12, $\pm$ 5 V	690 mW	—	450 ns
TMS2708-35	8K	+12, $\pm$ 5 V	690 mW	—	350 ns

## Here now

TI's TMS2564 has been in production since mid-1979. No need to wait — place your order today for the industry's first 64K EPROM, from the industry's first supplier of 16K and 32K EPROMs. Check your nearby TI sales office or authorized distributor. Or write Texas Instruments, P.O. Box 1443, M/S 6965, Houston, Texas 77001.



TEXAS INSTRUMENTS  
INCORPORATED



Critical factors in selecting a microprocessor development system . . .

# Evaluating emulator transparency.





Today's microprocessor development systems are more sophisticated than ever. If you select the right one, it can make your job easier and help speed the development process. But to choose such a system requires more than just a knowledge that it's compatible with your microprocessor.

### True transparency?

The first contribution of any microprocessor development system is in the area of software development. Beyond this, it must provide a RAM environment, downloading capability and run controls. That's where emulation comes in. Ideally, the development system should be totally transparent to your target processor. However, complete transparency is prohibitively expensive. Thus some compromises must be made.

### Some criteria.

How can you judge how close a particular development system actually comes to true transparency? We think there are three important criteria: How emulator control is isolated from the user system; the RAM environment; and the speed of real-time emulation.

### A better answer to interrupts.

With many systems, when you wish to take control of the processor to initialize a program counter to a particular value, interrogate a register, or single step through a program, the target processor must be interrupted via an interrupt line. In contrast, HP's 64000 Logic Development System 8-bit emulators incorporate a different architectural philosophy.

Instead of calling for an interrupt, they achieve functional transparency through the use of bank switched background memory where all emulator control programs reside. As a result, no interrupt lines are used and no processor address space is occupied by emulator control programs.

### Advanced Emulation Architecture

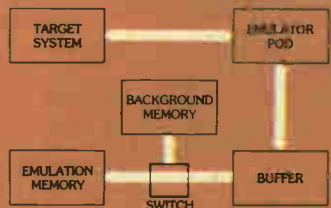

### All the memory you're paying for.

Another way in which HP steps closer to true transparency is in RAM environment. While other systems may have memory that can be accessed by both the host and target processors, the HP 64000 separates the host and target processors, buses and memory. The host processor executes the monitor program, operating system and application pro-

gram, and manages the system options and I/O. It executes out of its own 64k memory in conjunction with a choice of 12 to 120 Mbyte hard disc, which functions as a virtual memory and provides mass storage.

This means you get the use of all available emulation memory . . . and you have no contention problems. What's more, the 64000 architecture lets you do other tasks while emulation is in progress. For example, you can modify emulation memory while your processor is executing a program.

### The meaning of real time.

How close a system will run to real-time is a function of memory chips and system architecture. The HP 64000 uses high-speed memory chips and microprocessors which impose fewer artificial speed limitations. Since both the host and target processors each have their own dedicated memory and buses, there's never a contention problem; and in most applications your system runs at operating speed with no wait-states. And the 64000's optional internal analyzer gives you a real-time, transparent view of target processor bus activity to help you spot problems that show up when your system operates at speed.

### Independent Bus and Memory Structure

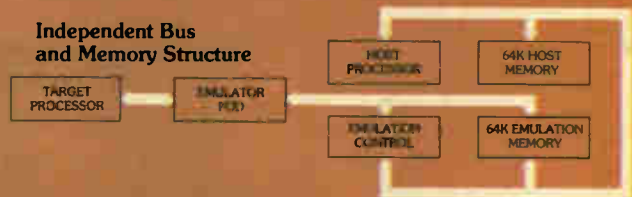

### Other important differences.

The HP 64000 (\$23,500\* for the basic system including emulator plus 8K of emulation memory) offers other important advantages. It uses a universal, rather than a dedicated approach, so that you can use it with most of today's popular microprocessors. Its directed syntax utilizes "soft keys" that speed learning and simplify operation. HP's shared peripherals approach means that a common data base can serve up to six development stations for team software development. And its user-oriented display editor speeds both editing and debugging.

Find out how close to true transparency a development system can come. For a copy of the HP 64000 brochure, write to Hewlett-Packard, 1507 Page Mill Road, Palo Alto, CA 94304. Or call the HP regional office nearest you: East (201) 265-5000, West (213) 970-7500, Midwest (312) 255-9800, South (404) 955-1500, Canada (416) 678-9430.

\*Domestic U.S.A. price only



**HEWLETT  
PACKARD**



# If Ben Experimented Today, He Could Rent Any One Of 18,000 Test Instruments From General Electric.

Short of a kite and a key, a broad selection of the most wanted test instruments is available—like lightning!—from a GE Rental Shop near you. Biddle Megger Testers. Hewlett-Packard Signal Generators. Honeywell Oscillographs and Plug-in Amplifiers. Scopes from Tektronix. Recorders from Gould Brush and Esterline Angus...and many more. So, whether you need a single scope, specialized instrumentation, a complex measurement system or application assistance, renting from GE is a breeze!



All rental instruments are maintained in tip-top shape, thoroughly checked and calibrated before each shipment. And it's on the way to you fast, normally the same day you call.

For your FREE RENTAL CATALOG call collect to the inventory center nearest you;  Los Angeles, CA (213) 642-5350  Atlanta,

GA (404) 457-5563  Chicago, IL (312) 854-2994  Detroit, MI (313) 285-6700  Schenectady, NY (518) 385-2195  New York City (201) 227-7900  Houston, TX (713) 672-3570. Or call (518) 372-9900.

---

Quick-rental instruments  
**GENERAL ELECTRIC COMPANY**  
Building 4, Room 210, 1 River Road  
Schenectady, NY 12345

---

**GENERAL**  **ELECTRIC**



# 16-K RAM accesses in 70 ns

Chip is fastest 2-K-by-8-bit MOS static memory available; future versions will access in 55 ns

by Wesley R. Iversen, Dallas bureau manager

A number of MOS manufacturers have introduced 4-K MOS static random-access memory devices in the gathering race to fill functions previously needing bipolar parts to meet speed specifications. But now Mostek Corp. has increased the pace by introducing a 16-K MOS static part that also addresses the high-speed MOS microprocessor market.

To be available late this month in sample quantities, the MK4802 will be offered initially with premium access times specified as low as 70 ns. That is not yet as fast as the 55-ns times offered by the popular 4-K 2147 static device, let alone the 35-ns speeds achieved by the 2147H, built by Intel with its HMOS II process. But the 2-k-by-8-bit 4802 will be significantly faster than anything currently available on the market at the 16-K level, points out Harry Margulis, a memory products marketing and applications manager. And within six months following the projected beginning of volume production in late September, Margulis expects that learning-curve process improvements will allow the part to be offered in a 55-ns version.

A number of manufacturers, including Texas Instruments, Hitachi, Oki, Nippon Electric Co., Harris Semiconductor Products, Inmos and Intel now produce or plan to produce a 16-K MOS static device. And though some may use complementary-MOS techniques to drive power dissipation to levels below those offered by the Mostek device, competitive 2-k-by-8-bit devices on which data sheets are currently available are aimed primarily at microprocessor systems with longer access times than those pegged for

the 4802—typically in the 120-to-200-ns range or higher, Mostek officials note.

The 4802's speed is attributable largely to the use of Mostek's scaled Poly 5 n-channel MOS process technology. Compared with the firm's earlier Poly R process, which produces minimum geometries of about 5  $\mu\text{m}$ , minimum channel lengths on the 4802 are reduced to between 2.5 and 3  $\mu\text{m}$  using scaled Poly 5. This enables 16,384 six-element static cells and more to fit on a 35,748-mil<sup>2</sup> die.

Another factor in the speed of the 4802 involves its relatively elongated 331-by-108-mil layout. The chip was designed with an eye toward complete data-sheet compatibility with the Texas company's high-speed 1-k-by-8-bit sister static memory—the MK4801 [*Electronics*, Sept. 27, 1970, p. 131], says Michael L. Bolan, strategic marketing manager for memory products. That part, currently available in sample quantities, is housed on a 106-by-182-mil die and is laid out as two arrays of 128 by 32 bits separated by a bar of

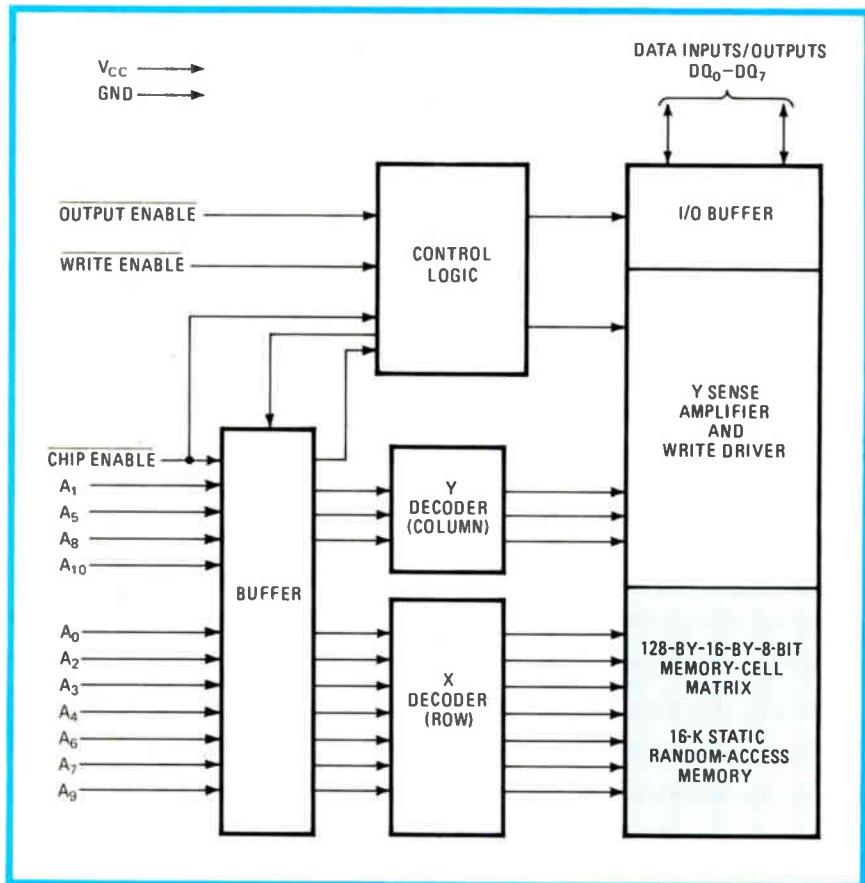



# LARGEST RADAR INVENTORY IN THE WORLD

## SYSTEMS & SPARES

AN/ALT-6-7-8  
AN-APG-33  
AN/APG-51  
AN/APN-69  
AN/APN-102  
AN/APN-169  
AN/APQ-50  
AN/APQ-55  
AN/APQ-20  
AN/APQ-31A  
AN/APQ-42-45  
AN/APQ-64  
AN/ASB-4/9  
AN/CPS-6B  
AN/CPS-9  
AN/DPN-32  
AN/FPS-6-8  
AN/FPS-14-18  
AN/FPS-20-75  
AN/FRC-39  
AN/FRT-15  
AN/GPA-30  
AN/GPA-126  
AN/MPQ-4A-10  
AN/MPQ-29  
AN/MPS-19  
AN/MPX-7  
AN/MSQ-1A  
AN/SPA-4A  
AN/SPA-8  
AN/SPN-5  
AN/SPS-5B  
AN/SPS-6C  
AN/SRW-4C  
AN/TPN-12/17  
AN/TPS-1D,E  
AN/TPS-10D  
AN/TPS-28  
AN/TPS-34B  
AN/TPS-37  
AN/TPX-21  
AN/UPA-25-35  
AN/UPX-4-6  
AN/UPX-14  
HIPAR  
MK-25  
Nike Ajax  
Nike Hercules  
SCR-584

## AUTOTRACK ANTENNA SCR-584 RADAR SYSTEM

360 deg AZ 210 deg EL, 1 mil. accuracy. Missile vel. accel. and slew rates. Amplidyne control. Handle up to 20 ft. dish. Compl. control chassis. ALSO in stock 10 cm. van mounted rad. system. Conical scan. PPI. 6 ft. dish. 300 pg. instr. bk. on radar. \$50.

## RF SOURCES

17-27 KHz 200 W CW  
125-450 KHz 4 KW CW  
2-30 MHz 3 KW CW  
4-21 MHz 40 KW CW  
24-350 MHz 100 W CW  
80-240 MHz 500 W 2-5 uS  
175-225 MHz 300 KW 1, 20 uS  
200-2000 MHz 40 W CW  
210-225 MHz 1 MW 5 uS  
385-575 MHz 1.5 KW CW  
400-700 MHz 1 KW .03 DC  
950-1500 MHz 1 KW .06 DC  
900-1040 MHz 5-10 KW .006 DC  
1.2-1.35 GHz 500 KW 2 uS  
1.5-9.0 GHz 150 W CW  
3.2-3.3 GHz 10 KW .002 DC  
2.7-2.9 GHz 1 MW 1 uS  
3.1-3.5 GHz 1 MW 1.3 uS  
2.7-2.9 GHz 5 MW 2-3 uS  
4.4-5.0 GHz 1 KW CW  
5.4-5.9 GHz 5 MW .001 DC  
6 GHz 1 MW 1 uS  
6.2-6.6 GHz 200 KW .37 uS  
8.5-11 GHz 200 W CW  
9.375 GHz 40 KW 5-1-2 uS  
8.5-9.6 GHz 250 KW .0013 DC  
15.5-17.5 GHz 135 KW .33-1-3 uS  
24 GHz 40 KW .15 uS  
35 GHz 50 KW .1 uS

## MODULATORS

25 KW 5.5 KV 4.5 A; .0025 DC  
144 KW 12 KV 12 A; .001 DC  
250 KW 16 KV 16 A; .002 DC  
405 KW 20 KV 20 A; .1 DC  
500 KW 22 KV 28 A; .001 DC  
1 MW 25 KV 40 A; .002 DC  
3 MW 50 KV 60 A; .30 uS  
10 MW 76 KV 135 A; .001 DC  
66 MW 160 KV 400 A; .00

## TRACKING SYSTEMS

K BAND MONOPULSE 40 KW E-34  
X BAND NIKE AJAX/HERCULES  
X BAND HI-RES MONOPULSE MOD IV  
X BAND GCA PAR II  
X BAND FIRE CONTROL 250 KW M-33  
X BAND MOBILE 40 KW AN/MPQ-29  
X BAND BEACON 100 W AN/DPN-62  
S BAND 10' DISH 500 KW AN/MPQ-18  
S BAND 250 KW AN/MPQ-10A  
S BAND 250 KW AN/MPS-9  
X BAND HAWK MPO-34  
X BAND HAWK MPO-33  
C BAND 1.5 MW MPS-19(C)  
S BAND 14' DISH PRELORT

## SEARCH SYSTEMS

KU BAND AIRBORNE 135 KW B-58  
X BAND WEATHER 250 KW AN/CPS-9  
X BAND WEATHER 40 KW AN/SPN-5  
X BAND 7 KW AN/TPS-21  
X BAND CW DOPPLER AN/PPS-9/12  
X BAND HGT FDR 1 MW TPS-37  
C BAND 285 KW AN/SPS-5B/D  
S BAND HGT FINDER 5 MW AN/FPS-6  
S BAND COHERENT 1 MW AN/FPS-18  
S BAND 1 MW NIKE AJAX/HERC  
L BAND 40' ANT 500 KW AN/FPS-75  
L BAND 500 KW AN/TPS-1D/GSS-1  
UHF 1 MW HELIHUT TPS-28

## C BAND TRACKER

Pwr: 1.5 MW Range: 250 miles  
Recv: param Display 5" "A" scopes.  
10' dish w/linear or circ. polarization.

## NIKE HERCULES SPARES/MAINTENANCE

Over 10,000 major components in stock w/repairs and overhaul facilities incl: SHOP 1 & 2 MAINTENANCE VANS.

SEND FOR FREE 24 PAGE CATALOG



**Radio Research Instrument Co., Inc.**

2 Lake Avenue Ext., Danbury, CT 06810  
(203) 792-6666 • Telex 962444

## New products

row decoders running down the middle of the chip.

In organizing the 4802, Mostek designers have essentially laid two 4801s end to end, creating a part consisting of two 256-by-32-bit arrays divided down the middle by row decoders. This approach enables the speed of the 4802 to match that of the 4801, since the polysilicon row lines running the width of the arrays do not have to be lengthened. The higher-resistivity polysilicon lines cannot be extended without significant increases in propagation delays. The bit lines running the length of the 4802 are of relatively low-resistivity metal, so that the longer 4802's performance is not degraded as is that of the 4801.

Like the 4801, the 4802 is an internally clocked device using what Mostek calls an "address-activated technique" to limit power dissipation. By turning on sense amplifiers and certain circuit nodes only when needed, this technique limits the chip's power dissipation to 300 mw typically and 625 mw maximum and at the same time provides fully static performance.

The 4802 requires a single 5-v power supply for operation and uses an on-chip substrate-bias pump to counteract negative voltage under-shooting at the system level. The part will be offered in a 24-pin package with a Jedec-approved pinout that will enable upward pin-for-pin compatibility with the 4801.

Like the 4801, the 4802 will initially be offered in a 70-ns version designated the 4802-70 and a 90-ns version designated the 4802-90. Slower, 120- and 200-ns versions designated -1 and -3 will also be supplied. In 100-piece lots, the 4802-70 will sell for \$150.80 each in plastic. The -90, -1, and -3 versions will go for \$115.10, \$65.50, and \$56.50, respectively.

Mostek officials expect the slower 4802 parts to be used with slower microprocessors and in other wide-word applications where speed is not particularly needed.

Mostek, P.O. Box 169, 1215 West Crosby Rd., Carrollton, Texas 75006. Phone Ron Gandy at (214) 323-6216 [338]

Circle 176 on reader service card

# We're in Complete Control

## Signal Processing

- Accepts process signals 4-20, 1-5, etc.
- Displays and/or controls Temperature Pressure 4424 Level Speed



## Digital Control

- Unique internal digital control
- Control with signal conditioning
- Adjustable setpoints
- Plug-in display 4424-K



## Digital Measurement

- 3 1/2 digits, 0.1% accuracy
- The only 1" high display
- AC ranges available
- UL recognized (Model 4424) 4443



For additional information, circle the Reader Service Number or contact

LFE Corporation, 1601 Trapelo Road, Waltham, Mass. 02154 617-890-2000  
In Canada: Lisle-Matrix Ltd., Toronto



176 Circle 240 on reader service card

Electronics/July 3, 1980

# 308 DATA ANALYZER

## Big power in a small package.

The 308 operates in four modes: parallel state, parallel timing, serial state and signature analysis.

### The 308 Data Analyzer. From Tektronix.



The new 308 Data Analyzer packs an impressive array of logic analysis capabilities inside its trim, 8 pound (3.6 kg) frame. For instance, it operates in the serial and signature modes as well as parallel state and timing. And samples both synchronously and asynchronously up to 20 MHz. With a variable voltage threshold that covers all logic families in addition to TTL.

Two separate memories, acquisition and reference, allow automatic data comparisons. If there's no data difference, the sampling process is repeated until a discrepancy appears. And the acquisition memory can be automatically searched for any given word.

Word recognition can be up to 25 bits and includes an external output to trigger other instruments. And the trigger itself can be delayed up to 65,535 clock pulses past the trigger point. The 308 features a latch mode (5 ns), a memory "window" to let you closely examine portions of the memory and state tables which are displayed in binary, hex and octal.

The 308 Data Analyzer, from Tektronix. Performance? Uniquely versatile. Size? Conveniently compact. Price? Exceptionally reasonable.

If you're interested, contact your local Tektronix field office, or write us at:

**U.S.A.**  
Tektronix, Inc.  
P.O. Box 1700  
Beaverton, OR 97075  
Phone: 503/644-0161  
Telex: 910-467-8708  
Cable: TEKTRONIX

**Africa, Europe  
Middle East**  
Tektronix Int'l. Inc.  
European Marketing Center  
Postbox 827  
1180 AV Amstelveen  
The Netherlands  
Telex: 18312

**Asia, Australia, Canada, Central &  
South America, Japan**  
Tektronix, Inc.  
America's/Pacific  
P.O. Box 500  
Beaverton, OR 97077  
Telex: 910-467-8708  
Cable: TEKTRONIX

**Tektronix**  
COMMITTED TO EXCELLENCE

For immediate action, dial our toll free automatic answering service 1-800-547-1512



# MOTOROLA HELPS SEAT

Every day, around the world, over a million and a half people make, unmake and change airline seat reservations, some for this evening, some for two weeks from Tuesday, some for as long as a year in advance.

It all depends on computers, of course, but a computer is merely a storehouse for information. To use the information, computers must be able to talk to each other, and to remote terminals miles away, within seconds.

## **ELECTRONIC CONVERSATIONS.**

Such digital dialogue is called

data communications; and in countries around the world, more than half of all airline reservations are now being made through equipment from Codex, the data communications arm of Motorola.

A complete Codex data communications system comprises three key technological tools. First, modems, which translate computer data into signals that can travel over ordinary telephone wires, undersea cables and satellite links.

Second, network processors, which can squeeze the signals from as many as 124 lines through a single telephone wire, without losing the integrity of any one of them.

Finally, network manage-

ment and control equipment, whose job is to supervise, correct and report on the operation of the whole communications network.

Codex has made major contributions to data communications technology, helping improve the reliability, cutting the operating cost, and in some instances quadrupling the speed of data transmission.

## **APPLICATIONS ABOUND IN OUR COMMUNICATIONS-INTENSIVE WORLD.**

Fast, dependable real-time data communication is indispensable to an airlines reservation system—or to any communications-intensive industry. For instance, it helps get the very





# 800,000 PEOPLE A DAY.

latest currency exchange information within seconds from places as remote as London and Sydney and Hong Kong. It helps directory-assistance operators in the Los Angeles area handle ten times as many inquiries as they once could. It helps keep stock-market quotations current for brokers; even makes computer time-sharing less expensive by slicing seconds finer.

These electronic miracles are merely representative of what Motorola products are doing every day.

## **A TOTALLY ELECTRONIC INVOLVEMENT.**

From its beginning as a pioneer

in car radios, and later as an innovator in television sets for the home (a product we no longer make or market here at all), Motorola has become one of the world's largest manufacturers devoted exclusively to electronics.

Today, we make hundreds of models of two-way radios, and we're also one of the foremost designers of standard and custom semi-conductors. And with products like the Codex 6000 family of communications processors, and the Motorola MC68000



*A microcomputer, drawn larger than life.*

microprocessor, we are in the leading edge of electronic innovation.

That innovative strength has enabled us to develop systems that can make a home more energy-efficient. Systems that help keep the news new at news services. Systems that transmit color photographs from the depths of space.

And, of course, complete data communications systems that help computers share their information to benefit you.



## **MOTOROLA**

### **Making electronics history.**

Circle 179 on reader service card



For further information, write Public Affairs Office, Corporate Offices, Motorola, Inc., 1303 E. Algonquin Road, Schaumburg, Illinois 60196.

Codex, Motorola and  are registered trademarks.

All airline reservation data are estimated based on 1978 industry figures.

# The problem in big board testing is finding the problem.

**Introducing the FF323.  
The first digital in-circuit  
test system that can test  
up to 2400 points and pin-  
point the problem right  
down to the component.**



Building faults into large, digital PC boards is inevitable. And the bigger the board the more chance of faults. Simple shorts, opens, misorientation and misinsertion cause most. But chip faults, such as stuck at one or zero, IC power loss or functional failure can all occur at final test. Until now, finding faults like these was like finding a needle in a haystack.

The new FF323 from Fairchild has changed all that. It's a digital in-circuit test system with 2400 points – more than twice the capacity of any other system. It not only tells you where the fault is, but what the fault is.

It can test a broad range of SSI, MSI and LSI device types, and it can isolate faults on highly complex PCBs. It can handle microprocessors, peripheral chips, bit slices, RAMs, ROMs, shift registers, UARTs, as well as the full range of small and medium scale ICs

in technologies like CMOS, NMOS, SOS, TTL and DTL. The FF323 can even pinpoint the analog component problems on your digital boards.

**You save time, labor,  
money and headaches.**

The FF323's testing capability delivers complete and precise fault isolation in seconds – not hours. A 100 chip board can be tested in 100 seconds. And the FF323 delivers yields of 95% and better at final test. Fairchild's in-circuit testing strategy safely isolates catastrophic faults, before power-up testing begins so costly ICs won't be unnecessarily destroyed. And our patented digital testing technique insures comprehensive, functional interrogation of ICs.

**You do more testing, less  
programming.**

FF323 software helps you solve the problems of development costs and turnaround. You get up to speed quickly and stay there with the world's most comprehensive IC testing library. Our FAULTS automatic program generator gets new board testing programs on line in weeks instead of months. And the BASIC editor makes program changes problem free so you respond immediately to engineering changes.

Look closer, and you'll find our software short and simple. CHIPS, the LSI test compiler, allows fast test routine generation. Real time datalogging and analysis helps you keep track of component and board faults. And our foreground/

background programming option gives you optimum CPU use with concurrent program execution.

**Only Fairchild can offer all  
the big board testing you  
need.**

FF323's flexibility lets you choose a system configuration to suit your application. Choose from either 1200 or 2400 system point capacity – just plug in 32 point switching modules as you need them. Our range of computer and peripheral options lets you select a well balanced data management subsystem. An instrumentation option is also available and Fairchild's Thinline® fixturing system lets you choose from a wide variety of fixtures, fixture kits and two universal designs.

With Fairchild, you'll also get all the applications engineering, training, service and support you need to keep testing without interruption.

For more information on the FF323, contact your nearest Fairchild Test Systems sales office. Or write Fairchild Test Systems Group, 299 Old Niskayuna Rd., Latham, N.Y. 12110. Tel. (518) 783-3600.

**FAIRCHILD**

A Schlumberger Company

**The  
first family  
of ATE.**







The foremost solution  
to high volume, custom-design switch panels...

# Monopanel Touch Switches *from* **CENTRALAB**



Designers of switch panels for today's newest products — from appliances to instrumentation — are turning to Monopanel touch switches for custom designs that incorporate all the circuitry, switching function and graphics they require. Centralab, the industry's most complete touch switch facility, offers a choice of film-base or rigid panels.

Recognized for over 50 years as experts in switch technology, Centralab is a singular source of help for custom switch graphics and quality, high volume switch production capabilities. Monopanel is the answer to your high density switching needs. Batch processing enables us to economically produce as many as 748 switches on a master panel that's only 11" x 17". Monopanel is a complete switch package that's thin, light, durable and 100% tested. More than 10 million failure-free switching cycles attest to its long operational life.

Add the touch of innovation to your product. Call your Centralab Representative for a demonstration, application help or information on prototyping panels, or write Centralab, Inc., a North American Philips Company, 5855 N. Glen Park Road, P.O. Box 2032, Milwaukee, Wisconsin 53201.

# CENTRALAB REPRESENTATIVES

- |  |  |
|--|--|
| <b>AL</b> Huntsville<br>CARTWRIGHT & BEAN<br>☎ (205) 533-3509  | <b>NY</b> Albany<br>REAGAN/COMPAR<br>☎ (518) 489-7408<br>Endwell<br>REAGAN/COMPAR<br>☎ (607) 723-8743<br>Fairport<br>REAGAN/COMPAR<br>☎ (716) 271-2230<br>Great Neck<br>CENTRALAB<br>☎ (516) 466-6570<br>New Hartford<br>REAGAN/COMPAR<br>☎ (315) 732-3775 |
| <b>AZ</b> Phoenix<br>CLEMICK-NEENAN<br>☎ (602) 279-7649  | <b>NC</b> Charlotte<br>CARTWRIGHT & BEAN<br>☎ (704) 377-5673<br>Raleigh<br>CARTWRIGHT & BEAN<br>☎ (919) 781-6560   |
| <b>CA</b> Palo Alto<br>BROOKS TECH. GROUP<br>☎ (415) 328-3232<br>San Diego<br>CLEMICK-NEENAN<br>☎ (714) 268-8540<br>Sherman Oaks<br>CLEMICK-NEENAN<br>☎ (213) 990-3150<br>Tustin<br>CLEMICK-NEENAN<br>☎ (714) 547-0966 | <b>OH</b> Brecksville<br>CENTRALAB<br>☎ (216) 526-1205<br>Worthington<br>CENTRALAB<br>☎ (614) 888-2150   |
| <b>CO</b> Evergreen<br>CENTRALAB<br>☎ (303) 674-1092   | <b>OR</b> Beaverton<br>CENTRALAB<br>☎ (503) 643-5516   |
| <b>CT</b> Meriden<br>CENTRALAB<br>☎ (203) 235-0766   | <b>PA</b> Narberth<br>BRESSON ASSOC.<br>☎ (215) 664-6460   |
| <b>FL</b> Ft. Lauderdale<br>CARTWRIGHT & BEAN<br>☎ (305) 735-4900<br>Orlando<br>CARTWRIGHT & BEAN<br>☎ (305) 422-4531  | <b>TN</b> Knoxville<br>CARTWRIGHT & BEAN<br>☎ (615) 693-7450<br>Memphis<br>CARTWRIGHT & BEAN<br>☎ (901) 276-4442   |
| <b>GA</b> Atlanta<br>CARTWRIGHT & BEAN<br>☎ (404) 233-2939   | <b>TX</b> Austin<br>CENTRALAB<br>☎ (512) 454-9529<br>El Paso<br>CENTRALAB<br>☎ (915) 779-3961<br>Farmers Branch<br>CENTRALAB<br>☎ (214) 243-8791   |
| <b>HI</b> Honolulu<br>DOUGHERTY ENT.<br>☎ (808) 847-4144   | <b>VA</b> Lynchburg<br>BRESSON ASSOC.<br>☎ (215) 664-6460  |
| <b>IA</b> Cedar Rapids<br>JERRY VRBIK CO.<br>☎ (319) 366-8733  | <b>WA</b> Bellevue<br>CENTRALAB<br>☎ (206) 454-7754  |
| <b>IL</b> Des Plaines<br>CENTRALAB<br>☎ (312) 827-4487   | <b>WI</b> Milwaukee<br>CENTRALAB<br>☎ (414) 228-2122   |
| <b>IN</b> Indianapolis<br>LES M. DeVOE CO.<br>☎ (317) 842-3245   | <b>PUERTO RICO</b><br>Hato-Rey<br>M. ANDERSON CO.<br>☎ (809) 751-2026  |
| <b>KS</b> Shawnee Mission<br>LOWELL-KANGAS<br>☎ (913) 631-3515   | <b>CANADA</b><br>B.C. North Vancouver<br>ARWIN TECH SALES<br>☎ (604) 980-4346  |
| <b>LA</b> Metairie<br>CARTWRIGHT & BEAN<br>☎ (504) 835-6220  | <b>ONT</b> Ajax<br>McHUGH ELEC.<br>☎ (416) 683-1540  |
| <b>MA</b> Needham<br>CENTRALAB<br>☎ (617) 444-4781   | <b>QUE</b> Ste. Dorothee Laval<br>HARNETT ENT.<br>☎ (514) 689-4184   |
| <b>MO</b> Columbia<br>BRESSON ASSOC.<br>☎ (215) 664-6460   |  |
| <b>MI</b> Lathrup Village<br>CENTRALAB<br>☎ (313) 559-9095<br>St. Joseph<br>CENTRALAB<br>☎ (616) 983-0233  |  |
| <b>MN</b> Minneapolis<br>CENTRALAB<br>☎ (612) 831-5212   |  |
| <b>MD</b> St. Louis<br>LOWELL-KANGAS<br>☎ (314) 821-4050   |  |
| <b>MS</b> Jackson<br>CARTWRIGHT & BEAN<br>☎ (601) 981-1368   |  |

## New products

### Software

# Concurrent Pascal reaches chip level

## High-level microprocessor language does concurrent, real-time programming

Until recently, when a concurrent software system was needed to synchronize the use and sharing of microcomputer resources, it was written in assembly language. Typically, although such systems can synchronize tasks in real time, they cannot ensure freedom from error when protecting data and managing devices.

A new high-level language for concurrent, real-time programming—Micro Concurrent Pascal (mCP)—handles events and synchronizes tasks as they occur and in addition enforces data protection and resource management via its own language design and implementation, not via the programmer. The developer of the language, Enertec

Inc., says that mCP is, in fact, "the only high-level language not tied to a single microprocessor that provides concurrency extensions for microprocessor execution."

**Modules.** Micro Concurrent Pascal uses data-monitoring, device-monitoring, and process modules. The processes execute code, while calling data and device monitors to access data or devices. The data monitors contain both the data and all the routines that operate on that data. The device monitors permit input and output devices to be managed directly from the language. Further, the two types of monitor enforce the mutual exclusion of processes: no other process may access a monitor that is already inhabited by a process being executed.

Since mCP descends from Pascal, it offers most of the benefits of this popular language. It also offers the following for programming microcomputer systems: separate data types for 8- and 16-bit integers to allow efficient data storage, language constructs that permit direct hardware addressing and direct bit manipulation, a drop to assembly-language capability for time-critical routines, string-manipulation routines, as

## A Pascal compiler for the HP 64000

A series of Pascal compilers for the Hewlett-Packard 64000 logic development systems uses a two-pass compilation process to translate source-language files directly into relocatable modules that can be linked to other Pascal or assembly-language modules to produce object files. The first pass, or parser segment, generates a machine-independent intermediate data structure. The second pass, or code-emitter segment, generates target-processor object code. These files can then be loaded into the emulator facility of the HP 64000 for testing in the microprocessor environment. The first of the compiler series, product number 64810A, compiles to 8080 and 8085 object code and sells for \$2,000. It can be delivered immediately.

A major advantage of the two-pass approach is that additional processors are supported by generating new code emitters for the processor-independent parsers. Another benefit for the user of Pascal/64000 is that it enhances program debugging. Tight coupling between the source code and the actual debugging process on the target system enables table information and source-program line numbers to be passed to the emulator and logic analyzer. In addition, the user may transparently exit emulation and leave the running target system undisturbed while he edits the Pascal source file, compiles, and relinks. Users may request an equivalent assembly-language listing of the object code for code optimization and debugging. To enhance portability, source-code statements that deviate from the proposed ANSI standard are automatically identified upon user request. Contact Hewlett-Packard Co., 1501 Page Mill Rd., Palo Alto, Calif. 94304 [342]

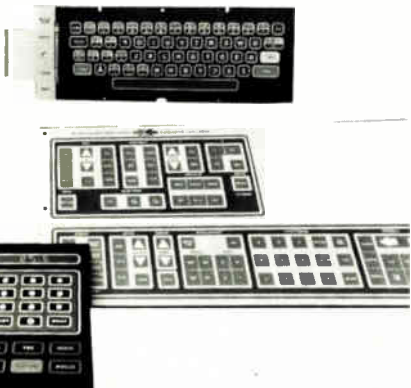



# OUR SCHOTTKY DELIVERY RUNS CIRCLES AROUND THE COMPETITION.



## UNITRODE SCHOTTKY RECTIFIERS

Introducing Unitrode's DO-4 and TO-3 Schottkys—with the same fast delivery as our DO-5.

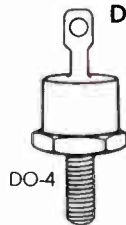

When it comes to delivering SD41, center-tap SD241, or any other power Schottkys, Unitrode leaves the others at the starting gate. Because we're making deliveries on time. Every time. Just

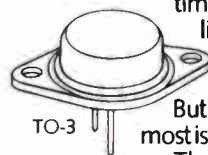

like we're doing with our SD51 Schottkys.

But what we deliver most is performance.

The DO-4 and TO-3 are rated up to 50V at 150°C

and 40A. With specs like 175°C operating junction temperature and forward voltage drops of .55V max. at 125°C.

All this, with the kind of reliability you've come to expect from Unitrode.

For a sample, contact your nearest Unitrode representative or distributor listed next to this ad. Try them out, and find out what we mean by running circles around the competition.

Unitrode Corporation,  
5 Forbes Rd., Lexington, MA  
02173.



**UNITRODE**

## Unitrode Representatives:

AL: Conley & Assoc., Inc. 205-882-0316 AZ: Fred Board Assoc., Inc. 602-994-9388 CA: I2 Inc. 408-988-3400, Great American Rep Company 714-832-8113, Great American Rep Company 213-990-4870, SR Electronics (San Diego) 714-560-8330 CO: Component Sales, Inc. 303-759-1666 CT: Kanan Assoc. 203-743-1812 FL: Conley & Assoc., Inc. (Oviedo) 305-365-3283, Conley & Assoc., Inc. (Boca Raton) 305-395-6108, Conley & Assoc., Inc. 813-885-7658 GA: Conley & Assoc., Inc. 404-447-6992 IL: Carlson Electronic Sales Co. 312-956-8240 IN: Carlson Electronic Sales Co. 317-842-3740 IA: Carlson Electronic Sales Co. 319-377-6341 KS: Rush & West Assoc. 913-764-2700 MD: New Era Sales, Inc. 301-768-6666 MA: Kanan Assoc. 617-944-8484 MI: Millmore Sales, Inc. 313-349-0260, Millmore Sales, Inc. 616-942-9721 MN: Electronic Innovators 612-835-0303 MO: Rush & West Assoc. 314-394-7271 NJ: Lorac Sales, Inc. 201-492-1050 NM: Reptonix, Ltd. 505-881-8001 NY: Lorac Sales, Inc. 516-681-8746, Reagan/Compar Albany, Inc. 518-489-7408, Reagan/Compar Albany, Inc. 315-732-3775, Reagan/Compar Albany, Inc. 716-271-2230, Reagan/Compar Albany, Inc. 607-723-8743 OH: Baehr, Greenleaf & Assoc., Inc. (Cincinnati) 513-891-3826, Baehr, Greenleaf & Assoc., Inc. 513-293-1102, Baehr, Greenleaf & Assoc., Inc. 216-221-9030, Baehr, Greenleaf & Assoc., Inc. 614-486-4046 OR: Vantage Corp. 503-297-1714 PA: GCM Assoc. 215-233-4600, Bacon Electronic Sales 814-796-2381 TX: Sundance Sales, Inc. 214-699-0451, Sundance Sales, Inc. 512-250-0320 UT: Component Sales, Inc. 801-484-4222 WA: Vantage Corp. 206-455-3460 WI: Carlson Electronic Sales Co. 414-476-2790 CANADA: Kaytronics Limited 514-487-3434, Kaytronics Limited 416-669-2262, Kaytronics Limited 403-276-9844

## Unitrode Distributors:

AL: Hall-Mark/Huntsville 205-837-8700 AZ: Kierulff Electronics (Phoenix) 602-243-4101, Wyle Distr. Group (Phoenix) 602-249-2232 CA: Wyle Distr. Group 408-727-2500, Kierulff Electronics 415-968-6292, Capacitor Sales 408-734-3020, Components Plus 408-732-0990, Components Plus 714-754-0471, Kierulff Electronics 213-725-0325, Kierulff Electronics (San Diego) 714-278-2112, Wyle Distr. Group 213-322-8100, Kierulff Electronics (Tustin) 714-731-5711, Wyle Distr. Group (Irvine) 714-641-1600, Wyle Distr. Group (San Diego) 714-565-9171, Arrow Electronics, Inc. 408-739-3011 CO: Wyle Distr. Group 303-289-4631, Kierulff Electronics 303-371-6500, Bell Industries Elec. Dist. Div. 303-424-1985 CT: Arrow Electronics, Inc. 203-265-7741, Lionex Corp. 617-272-9400 FL: Hall-Mark/Orlando 305-855-4020, Pioneer/Florida 305-859-3600, Kierulff Electronics 813-576-1966, Hall-Mark/Miami 305-971-9280, Arrow Electronics, Inc. (Palm Bay) 305-725-1480, Arrow Electronics, Inc. (Ft. Lauderdale) 305-776-7790 GA: Arrow Electronics, Inc. 404-449-8252 IL: Kierulff Electronics 312-640-0200, RM Electronics 312-932-5150, Hall-Mark/Chicago 312-860-3823 IN: Pioneer/Indiana 317-849-7300, RM Electronics 317-247-9701 KS: Hall-Mark/Kansas City 913-888-4747 MD: Arrow Electronics, Inc. 301-247-5200, Hall-Mark/Baltimore 301-796-9300 MA: Arrow Electronics, Inc. 617-933-8130, Lionex Corp. 617-272-9400, Kierulff Electronics 617-667-8331 MI: Pioneer/Michigan 313-525-1800, RM Electronics 616-531-9300 MN: Arrow Electronics, Inc. 612-830-1800, Hall-Mark/Minneapolis 612-884-9056, Industrial Components, Inc. 612-831-2666, Kierulff Electronics 612-835-4388 MO: Hall-Mark/St. Louis 314-291-5350 NH: Arrow Electronics, Inc. 603-668-6968 NJ: Kierulff Electronics 201-575-6750, Arrow Electronics, Inc. 201-797-5800, Arrow Electronics, Inc. 215-928-1800, 609-235-1900 NM: Bell Industries Elec. Dist. Div. 505-292-2700 NY: Components Plus 516-231-9200, Lionex Corp. 516-921-4414, Arrow Electronics, Inc. 516-231-1000, Arrow Electronics, Inc. 315-652-1000, Arrow Electronics, Inc. 716-275-0300 NC: Arrow Electronics, Inc. 800-334-0421, Hammond Electronics, Inc. (Greensboro) 919-275-6391, Hall-Mark/Raleigh 919-832-4465 OH: Pioneer/Cleveland 216-587-3600, Hall-Mark/Columbus 614-846-1882, Pioneer/Dayton 513-236-9900 OK: Hall-Mark/Tulsa 405-835-8458 PA: Arrow Electronics, Inc. 412-351-4000, Pioneer/Pittsburgh 412-782-2300, Hall-Mark/Philadelphia (Cherry Hill) 609-424-0880 TX: Hall-Mark/Dallas 214-234-7300, Components Plus 214-783-6060, Hall-Mark/Houston 713-781-6100, Lenert Co., Inc. 713-225-1465, Hall-Mark/Austin 512-837-2814, Arrow Electronics, Inc. (Stafford) 713-491-4100, Arrow Electronics, Inc. 214-386-7500 UT: Bell Industries Elec. Dist. Div. 801-972-6969, Kierulff Electronics 801-973-6913 WA: Kierulff Electronics 206-575-4420, Shannon, Ltd. 206-763-0545, 503-643-5754, Wyle Distr. Group 206-453-8300 WS: Taylor Electric Co. 414-241-4321, Hall-Mark/Milwaukee 414-761-3000, Kierulff Electronics 414-784-8160 CANADA: Future Electronics, Inc. 514-735-5775, Future Electronics, Inc. 416-663-5563, Future Electronics, Inc. 613-820-9471, Future Electronics, Inc. 604-438-5545

## New products

well as hexadecimal constants.

The new language permits the writing of complete real-time operating systems, including all device drivers. It assists and promotes modular software design and at the same time makes programs easily divisible among programmers working on the same project. Since mCP has self-documenting code, the programs are easily modified, maintained, and upgraded.

Two pieces of software implement Micro Concurrent Pascal: a compiler and an interpreter kernel. An mCP program is first compiled into mCP pseudocode, then the p-code is interpreted with the kernel acting as the program executive to perform process switching, process synchronization, and interrupt vectoring. The interpreter kernels can be written for any microprocessor.

The license for mCP compiler source code is \$5,000. In a ready-to-run configuration (with an object code precompiled by Enertec under a specified operating system), the primary site license is \$1,200. The source license of a single interpreter is \$750, and no additional licensing is required to distribute executable programs created by the compiler or the object code of any interpreter. Support is provided for one year and includes access to upgrades for a small service charge.

Enertec Inc., 19 Jenkins Ave., Lansdale, Pa. 10446. Phone (215) 362-0966 [341]

## Software generates faster tests for LSI, VLSI circuits

A new version of Lasar test-generation software—Lasar 5.1—allows faster, easier, and more accurate programming for the testing requirements of boards containing large-scale and very large-scale integrated circuits. The new version makes it possible to produce test patterns that can be run on boards that operate on three-state buses.

The program capacity of Lasar has been increased to handle more than 8,000 board-level circuit nodes and 512 board input and 512 board

output pins. Also, the number of component types available from the system library has more than doubled. As a convenience, programmers will be able to identify circuit nodes with symbolic names and to use longer names for component types. Special data-compression techniques are employed to reduce the size of the final test program by a factor of four when compared with the earlier version of Lasar. Lasar 5.1 can reveal potential bus conflicts on boards—such state and activity conflicts as result from lack of initialization or from out-of-phase clocks. Software licensing cost is \$150,000 for the first installation. Delivery is immediate.

Teradyne Inc., 183 Essex St., Boston, Mass. 02111. Phone (617) 482-2700 [343]

## Interpreter runs standard Basic under UNIX on PDP-11s

For PDP-11 users who run the UNIX time-sharing system and who have not been able to run or develop programs written in standard Basic, Human Computing Resources has developed HCR/Basic. This implementation of Basic conforms to ANSI standard X3.60-1978. In addition to the ANSI-required features, HCR/Basic has block-structured multiline functions. It also offers full string support, random and sequential access-file support, and the ability to execute UNIX commands under program control. It also has an on-line help facility. HCR/Basic is available for a one-time license fee of \$1,350, which includes complete source code and documentation.

Human Computing Resources Corp., 10 Mary St., Toronto, Ontario M4Y 1P9, Canada. Phone Mike Tilson at (416) 922-1937 [344]

## Cobol-74 compiler is written in Pascal

A Cobol-74 compiler written in the Pascal language conforms to the ANSI X3.25-1974 standard. The Co-



**UNITRODE**

# THE BRIDGE

IEEE 488-1975  
INSTRUMENT BUS TO RS232C ADAPTER



The FI BRIDGE will permit the transfer of data between the GP-IB and RS232C interfaced instruments. Fully buffered I/O is offered as a standard feature. The Bridge will link terminals or printers to measurement systems with a minimum of change to system software or hardware.

**\$795.00** U.S. (F.O.B. Ottawa)



FOUNDATION ELECTRONIC INSTRUMENTS INC.  
1794 Courtwood Cres., Ottawa, Ont. K2C 2B5  
(613) 226-4000

Circle 186 on reader service card

Dealer inquiries invited

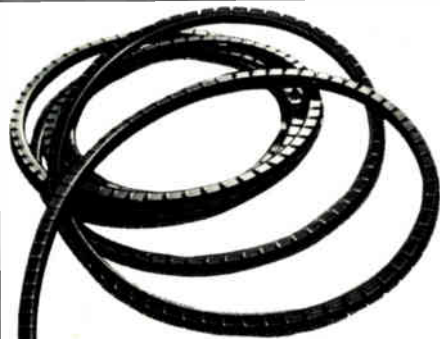

## NYLON GROMMETING

Make your own grommets to fit any size or shape opening with Weckesser Type 6/6 Nylon Grommeting. Extruded grommeting available in 25 and 50 foot lengths, five standard sizes to fit panel thicknesses from .052" to .250".

Also available in molded flexible strips, 12-3/4" long. All available in black or natural.

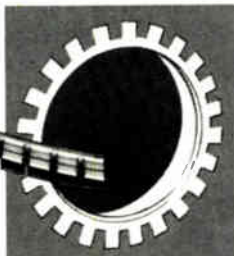

**Weckesser COMPANY, Inc.**

4444 West Irving Park Road • Chicago, Illinois 60641 • 312/282-8626

186

Circle 244 on reader service card

## New products

bol nucleus and nine functional modules conform to full Level 2 standards. The modules perform table handling, sequential input and output, relative I/O, indexed I/O, sort and merge functions, segmentation, library handling, debugging, and interprogram communication. The compiler has a multipass design structure and object-code generation for standard Cobol statements.

The compiler can be modified easily once the Cobol 80 standard is finalized, says the manufacturer, because the back end of the product can be replaced with minimum effort, permitting the compiler to generate a different set of relocatable code. The Cobol-74 compiler has a base price of \$230,000, which includes manuals, source programs, and personnel training; the Pascal version is available at no additional cost. The product will be available in late 1980.

Advanced Computer Techniques Corp., 437 Madison Ave., New York, N. Y. 10022. Phone (212) 421-4688 [345]

## TRS-80 and Apple II get critical-path scheduling

Project Schedule Analysis/L (PSA/L) is a cassette-based introduction to computer-aided scheduling for the TRS-80 Level II and Apple II computers with floating-point Basic and at least 16 kilobytes of memory. The software package uses critical-path scheduling techniques. It computes schedules for each job within a project, showing how early each job can be started and how early it can be finished, as well as the latest each can be started, finished, and still meet a project deadline set by the user. Schedules also show how long jobs can be delayed without affecting other jobs. Data can be stored on tape for later analysis, and results can be displayed on a video monitor or printed.

For \$25, a user will receive the program cassette and user manual.

Express Marketing, P. O. Box 1736/ELM, Poulso, Wash. 98370. Phone (206) 779-9508 [347]

Electronics/July 3, 1980



# FEAR OF FLYING?

## THE OLD "SEAT-OF-THE-PANTS" FLYING CAPACITOR MULTIPLEXER.

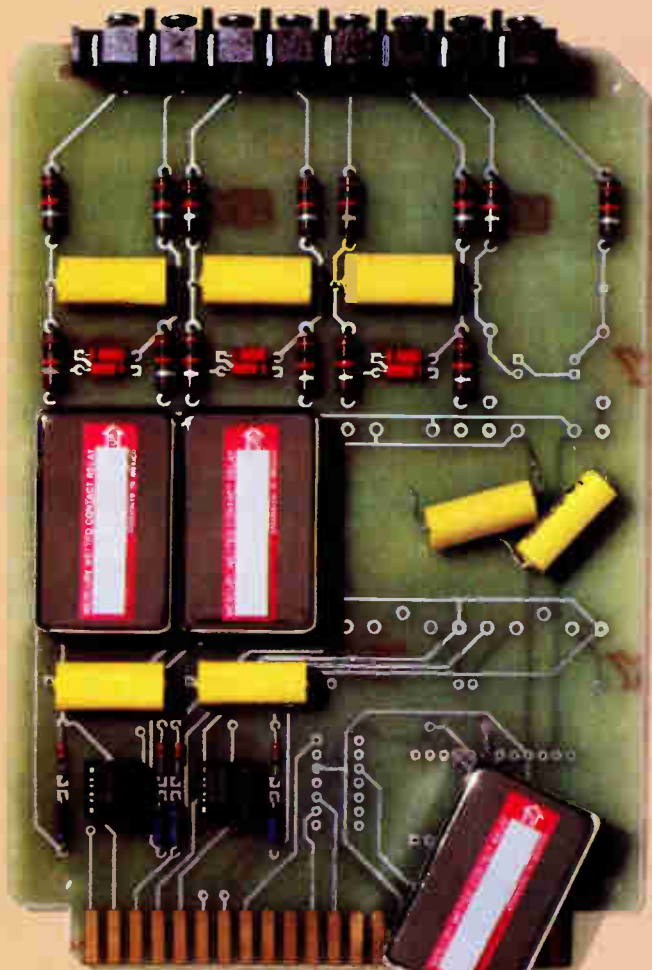

The good old flying cap mux may well be a thing of the past. Its reed relays can make it unreliable and economically hard to maintain. Its thermal drift is high, noise rejection is low, and scanning speed is slow. Its common mode rejection suffers and isolation can be a problem. Why take chances with a do-it-yourself thermocouple multiplexer, when we've done it all for you?

## THE NEW SOLID STATE, ISOLATED, THERMOCOUPLE /- MILLIVOLT MULTIPLEXER.

 ANALOG  
DEVICES

# 2B54

FOUR CHANNEL ISOLATED  
THERMOCOUPLE/mV CONDITIONER

MADE IN U.S.A.

The new 4-channel 2B54 was specifically designed as a high-performance, versatile and reliable alternative to the standard flying cap mux.

The 2B54 provides outstanding low drift, high noise rejection, high throughput, and 1000 V isolation. If you're looking for a low cost, high performance alternative to the good old flying cap mux, read on:

### Specifications:

Low Drift:  $\pm 1 \mu\text{V}/^\circ\text{C}$   
(Max, 2B54B)  
Amplification: To 1000 V/V  
Isolation:  $\pm 1000\text{V}$  dc  
(chan/chan/ground)  
Common Mode Rejection:  
156dB @ 60 Hz

Filtering:  $-55\text{dB}$  @ 60 Hz  
Multiplexing:  
400 channels/sec  
Open Input Detection  
Low Cost: \$36/chan  
(2B54A, 100's)  
And Solid State Reliability!

## OUR NEW 2B55 AND 2B56 ARE TWO OTHER GREAT WAYS TO GO.

If your application is high level signals (from  $\pm 50$  mV to  $\pm 5\text{V}$  or 4-20 mA), use our new 2B55. If you need cold junction compensation, our new 2B56 can be used directly with our 2B54.

For more information, call Robert Butler at (617) 329-4700 or write Analog Devices, Box 280, Norwood, MA 02062.

 ANALOG  
DEVICES

## WAY OUT IN FRONT.

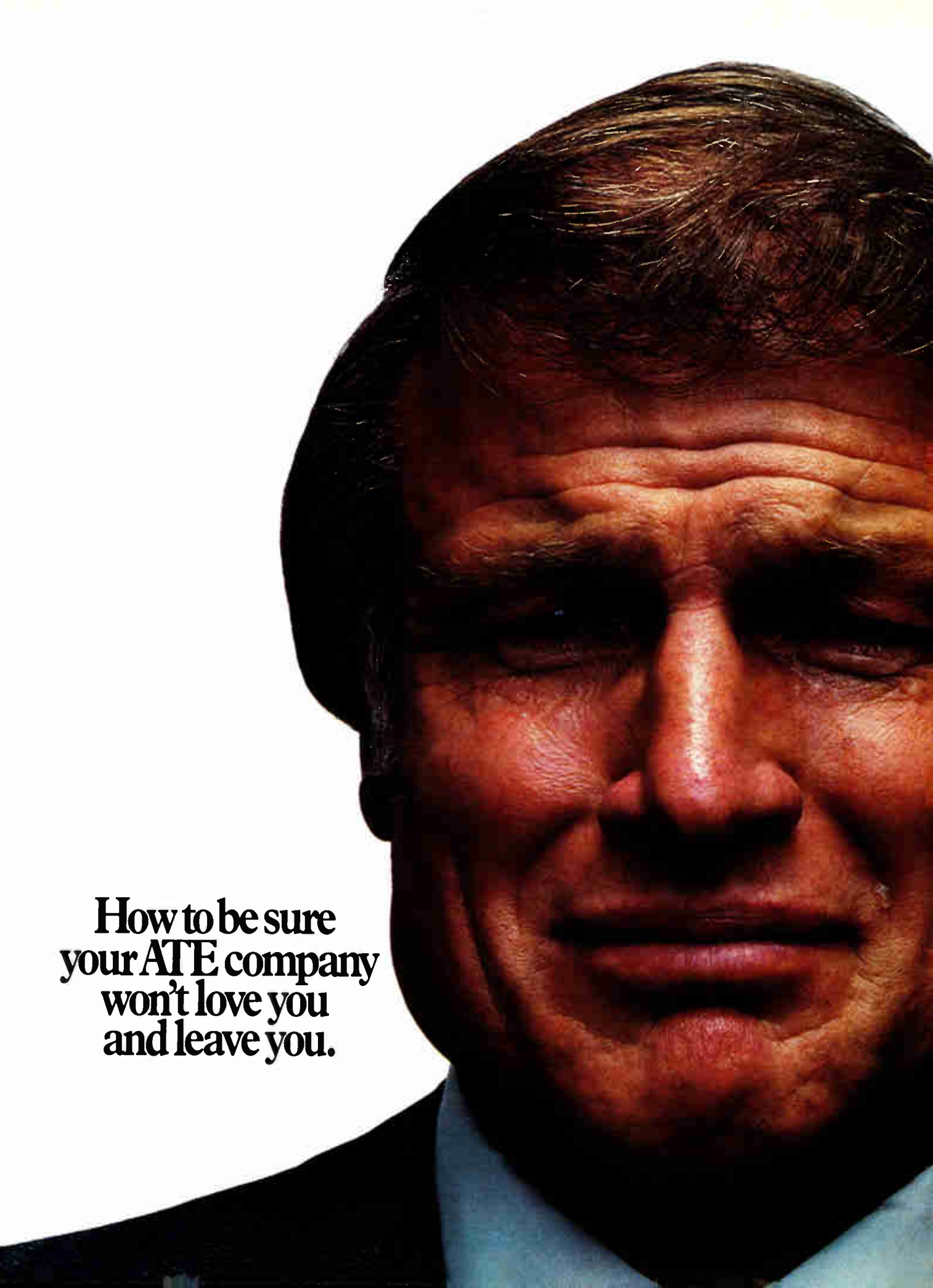

**How to be sure  
your ATE company  
won't love you  
and leave you.**

The last thing you want to do is fall for a sweet-talking ATE company, and find yourself left without any visible means of support.

That won't happen if your ATE company is GenRad. That's because no other company offers you as many different levels of support.

First, you'll meet our Product Specialist. He'll take a close look at your operation and analyze your needs.

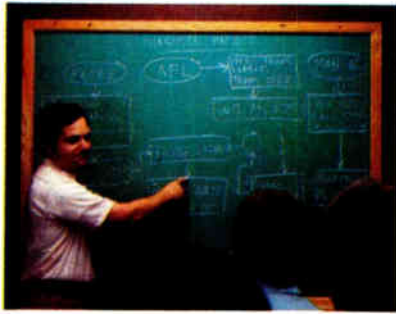

GenRad Applications Engineers work closely with your test system engineers to develop the most effective solutions to your testing problems.

Then you'll meet our Applications and Software Engineers. Their job is to fine-tune both hardware and software to your specific application.

And as your needs change, our Software Support Group is always there to help. Generating software device models and application notes, and working with you on debugging and enhancements. Just give them a call whenever you need them.

GenRad also has a lot of other people you can call on. For instance, our Training Specialists will make sure every one of your programmers understands their new system inside and out.

And our Programming Services Group, made up of full-time applications specialists, can off-load your programmers whenever you need help.

If a problem does occur, we can have a Field Service Specialist right there and solving any problem within hours of your call.

We even help you solve problems *before* they develop by putting you in touch with one of our User Groups.



GenRad User Groups meet often to discuss common concerns and share ideas. One user may already have an answer to a testing problem you're working on.

People like you who own and use GenRad equipment. In many cases, you'll be able to benefit from the experience of someone who's had a testing problem similar to yours.

Altogether, GenRad offers you eight different levels of support. No other ATE company even comes close.

That's something to think about before you let an ATE company get close to you.

For details on our complete ATE line—from product development to field testing—write GenRad, Concord, MA 01742.



GenRad's Programming Services Group is always ready to off-load your programmers whenever you need help.



# GenRad

Put our leadership to the test.

Circle 189 on reader service card





# HITACHI QUALITY

Expanding  
the Limits of  
Excellence  
in Semiconductor  
Design



# HITACHI

Hitachi America, Ltd., Electronic Devices Sales and Service Division  
707 West Algonquin Road, Arlington Heights, IL 60005 (312) 593-7660 TLX 20-6825

Symbol of Semiconductor Quality, Worldwide

Circle 191 on reader service card

# 6 questions the V. may ask you about



## **Are bubbles supported by reputable companies?**

Bubble technology is out of the lab and into the marketplace. Eight major semiconductor companies have committed to bubble production by 1981 and six of them are shipping products now.

Rockwell International is the only bubble producer to have arranged two second source suppliers.



## **Are bubble memories competitive with other memories?**

Bubble memories fill the price/access-time gap between RAMs and some electromechanical memory media. Based on cost-of-ownership, bubble memory pricing is attractive in many applications today.

Within two years, bubble memory costs are expected to be less than 15 millicents per bit in production quantities.

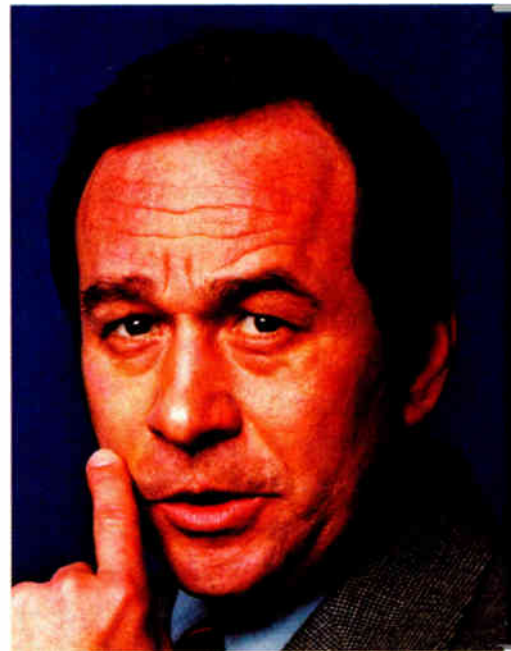

## **What industries have started using bubbles?**

Bubble memories have already been designed into industrial controls, terminals, business data systems, instrumentation, telecommunications systems and computers.

Rockwell International has shipped its bubble memory products to 175 companies in these market segments.

**Micro  
Power**



# P. of Engineering bubble memories.



## What bubble products are available now?

Another company has a 92K bit device in production, and Rockwell International is in production of a 256K bit device. Two other companies are now sampling their 256K bit devices. Three companies have announced megabit devices.

Rockwell devices are also available on memory board systems.



## What kinds of applications are best suited for bubbles?

Applications where modularity in 32K byte increments up to 8M bytes is required; where electronic equipment must withstand unclean conditions; where size or packaging flexibility is important; where memories must operate for long periods without maintenance; where non volatile, solid state data storage is mandatory.

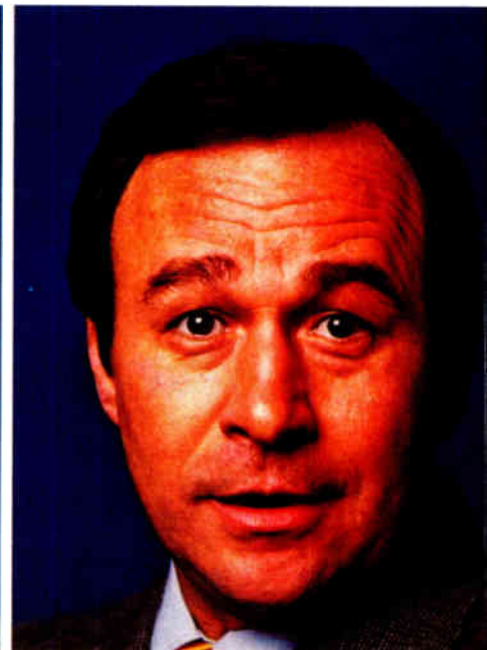

## How about support circuits for bubble memories?

Most bubble memory manufacturers have committed to the production availability of LSI support circuits by the end of 1980. Rockwell International will have all support circuits and they will be alternate sourced. They will interface with the major microprocessor buses.

To learn more, ask Rockwell. Rockwell International, Bubble Memory Products, Electronic Devices Div., P.O. Box 3669, RC-55 Anaheim, CA 92803. (714) 632-3729.



**Rockwell International**

...where science gets down to business

Circle 193 on reader service card

**Instruments**

---

**Active filter has  
dc to audio uses**

---

Unit offers resolution  
to 0.3% of full scale, bypass,  
and choice of gain and input

---

Frequency Devices Inc., long a maker of active filter circuits for original equipment, is entering the test equipment field with a low-cost benchtop active filter having features rarely found even on more costly units. The model 901F—aimed at dc through audio-frequency applications—is an eight-pole, Butterworth low-pass active filter with selectable corner frequencies. Measured at their 3-dB points, these frequencies range from 0.1 Hz to 29.9 kHz and are selected using four rotary switches. Resolution is 0.3% of full scale, or about 100 Hz at the high end of the 901F's range. The stability of a selected corner frequency is typically 0.01%/°C.

Costing only \$299, the instrument includes such features as a three-position gain switch offering unity, +10-dB, and +20-dB gains; a choice of single-ended, differential- and grounded-input operation; and a bypass switch.

These are functions that engineers have long been resigned to providing from spare parts breadboarded together in the midst of an experiment. A simple thing like a bypass switch that cuts the filters out of the circuit can mean the difference between taking data in seconds and lengthy frustration. The 901F's "frustration coefficient" is further reduced by the buffer amplifier that comes into play when the bypass function is engaged; the amplifier maintains a 50-ohm output impedance despite the nature of the circuitry at the 901F input.

Grounded-input operation is especially important in dc and near-dc applications as it allows operators to use a front-panel 10-turn potentiometer to trim out the 901F's dc input-offset voltage, thus removing a source of possible error.

Nor should gain contribute to experimental error. The 901F's gain accuracy is specified as  $\pm 0.02$  dB and is claimed stable to within  $\pm 0.02\%$ . In contrast, the meters used to measure audio- and low-frequency amplitude usually are hard-pressed to maintain 0.1-dB accuracy, making the 901F about one-tenth the error source the equipment frequently used with it is.

For \$100, users can add a nickel-cadmium battery pack with internal charger. Besides making the 901F portable, it also makes it immune to line voltage noise and especially interruptions—a must when servic-

ing equipment with independent power. Further, using the battery option in the lab removes a key source of electromagnetic noise from sensitive experiments; it is common for engineers to spend hours changing the polarity of ac-line plugs and engaging and disengaging chassis grounds in order to cut noise and remove ground loops. The 901F's freedom from the ac-line should reduce that problem.

The unit's internal noise is rated at 225 mV rms for ac-line operation, but falls to 6 mV rms in the battery mode. The battery pack's advantage for low-noise lab use is obvious.

Nor should the 901F load down the equipment at its input. Its input impedance is 1 M $\Omega$  in the single-ended mode and 2 M $\Omega$  in the differential mode; shunt capacitance is 47 pF in both cases.

Maximum safe input voltage for the 901F is  $\pm 15$  V continuous over a full power-bandwidth of dc to 800 kHz. Its rated output is 10 V peak to peak at a continuous 100 mA into a 50- $\Omega$  load.

The unit is small—3.5 by 8.5 by 9.3 in.—and weighs 3.5 lb in its ac-powered version and 4.5 lb with a battery pack.

The 901F is available wired either for 105-to-125-v or 210-to-250-v operation, both at 50-to-60-Hz line frequencies.

Delivery takes six to eight weeks. Frequency Devices Inc., 25 Locust St., Haverhill, Mass. 01830. Call William Morse, applications engineer, at (617) 374-0761 [351]



---

**Subsystems adapt analyzer  
for bus-carried serial data**

A pair of subsystems added to Gould's K100-D logic analyzer adapts it for serial data analysis of communications signals carried on the RS-232 or the Consultative Committee of International Telephony and Telegraphy's V.24 signal bus; the IEEE-488 general-purpose instrument bus; and up to eight optional signal sources.

With the K100-D/RS-232 subsys-





*Bendix—We pioneered connector technology. Our Pygmy connectors introduced practical, miniature design and became the world's most copied connector family. Our JT series connectors provided more contacts in less space. And our LJT series were the first 'scoop-proof' connectors that helped prevent blind mating contact damage.*

*Bendix—We've set milestones. Our multipin cylindrical miniature and sub-miniature connectors became national standards. Our Bristle Brush connector brought about a practical solution to the problem of mating and unmating high contact count printed circuit boards with a low mating force connector. And our square cut RF connectors made 30 second assembly a reality.*

*Bendix—We do more than just look to the future. We lead the way. The Bendix Corporation Electrical Components Division  
Sidney, N. Y. 13838  
607/563-5315.*

**We speak connectors.**



Circle 195 on reader service card



# Instant Access to All American and International

## Data Communications Standards

Presents all 89 relevant data communications standards promulgated by:

- CCITT • ISO
- ANSI • EIA • FTSC

Plus... descriptions of each of the standards groups  
And... relational charts of similar interfacing standards produced by each group



1133 pages  
Edited by  
Harold C. Folts  
and  
Harry R. Karp

Order today using this coupon!

Return coupon to:  
Data Communications Standards  
P.O. Box 669  
Hightstown, New Jersey 08520

Send me \_\_\_\_\_ copy (copies) of **DATA COMMUNICATIONS STANDARDS** (099782-9) on a 10-day money-back guarantee. I understand that if I am not absolutely satisfied, I may return the book(s) within ten days at no further obligation. Otherwise, McGraw-Hill will bill me \$165, for each copy, plus applicable sales tax, shipping and handling charges.

- Check enclosed
- Bill me
- Bill my company
- Company purchase order #



**SAVE MONEY!** Enclose payment in full, plus local sales tax, and McGraw-Hill pays all regular shipping and handling charges. Ten-day money-back guarantee still applies.

Name \_\_\_\_\_  
Title \_\_\_\_\_  
Company \_\_\_\_\_  
Address \_\_\_\_\_  
City \_\_\_\_\_ State \_\_\_\_\_ Zip \_\_\_\_\_

This offer subject to acceptance by McGraw-Hill ELT

### New products

tem pod, the analyzer can be triggered by serial data and can record all six RS-232 inputs—transmitted data, received data, request to send, clear to send, data set ready, and data terminal ready status lines. These signals may be monitored dynamically at up to 19.2 kilobauds internally or 625 kilobauds externally throughout transmit-and-receive transactions of 1,024 data words.

With the K100-D/488 GPIB adapter, signals from eight data input/output lines and eight management and handshaking lines are recorded. Through the K100-D, the company believes this to be one of the few analyzers able to analyze a bus's operation as well as operate on it. Microprocessor-based, it has clock rates to 100 MHz for 10-ns resolution and 5-ns glitch capture, records up to 1,024 words of test data, operates in time and data domains, and includes two memories and a selection of triggering and display modes.

The price for the RS-232 pod is \$1,000 and the 488 adapter is \$600. Both have a 90-day delivery.

Gould Inc., Biomation Division, 4600 Old Ironsides Dr., Santa Clara, Calif. 95050. Phone (408) 988-6800 [353]

### Guarded integrating DMM provides 10-nV resolution

Designed for bench or systems use, the model 3456A is a microprocessor-based, fully guarded integrating digital multimeter. Full-scale dc ranges from 0.1 v to 1,000 v are provided. Selectable integration time (up to 100 power line cycles) and settling time allow the operator to choose anywhere from 270 readings/second or one every 15 minutes. Also selectable is a resolution of 100 nV at 48 readings/s (6½ digits) to 10 µV at 270 readings/second (3½ or 4½ digits).

The integration technique features program memory and reading store to ensure that the first reading is correct every time. With 100-nV sensitivity, accuracy in the 10-v range is to ±0.0008%, plus two counts over

24 hours at 23° C, ±1° C.

Four full-scale, true-rms ac voltage ranges have up to 10 readings/second over a 20-Hz-to-250-kHz frequency range with 1-µV resolution (six digits). Best accuracy is to within 0.05%. Crest factor is greater than 7 at full scale.

Compensating for resistance inaccuracies due to thermally produced offset voltages in the circuit under test, the 3456A resistance range is from 1 mΩ to 1.2 GΩ, using two- or four-wire connections.

There are no options available for the model 3456A digital multimeter; it costs \$3,500.

Hewlett-Packard Co., 1507 Page Mill Rd., Palo Alto, Calif. 94304 [354]

### Bus interface transfers at 500 kilobytes/s

Providing a direct-memory-access interface from the Digital Equipment Corp. PDP-11 to the IEEE-488 instrumentation bus, the GPIB11-2 gives transfer rates of up to 500 kilobytes/second for three-state operation and up to 250 kilobytes/s for open-collector operation.

The handshaking speed is software-programmable, with high-speed operation controlled by circuitry that automatically holds the Unibus for a burst of 16 bytes before releasing it to higher priority after each byte transfer.

Support software includes drivers, utilities, and an interactive control program. A 4-meter-long cable with a general-purpose interface-bus connector on the outboard end can connect as many as 14 instruments on a single interface.

Available from stock, the GPIB11-2 costs \$1,995.

National Instruments Corp., 8900 Shoal Creek, Austin, Texas 78758 [355]

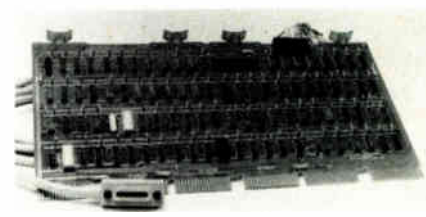

# Improve heat dissipation with Berg's free-standing Tri-Socket™

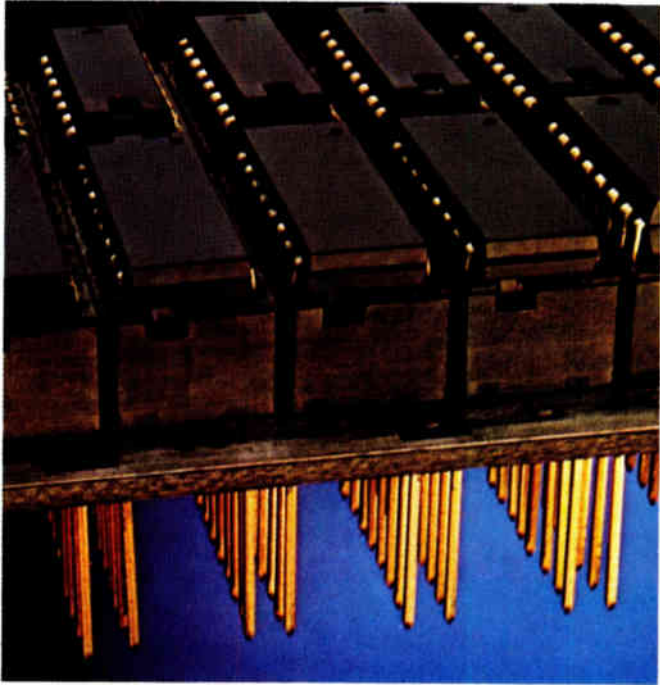

Densely populated boards with plastic sockets run hot.

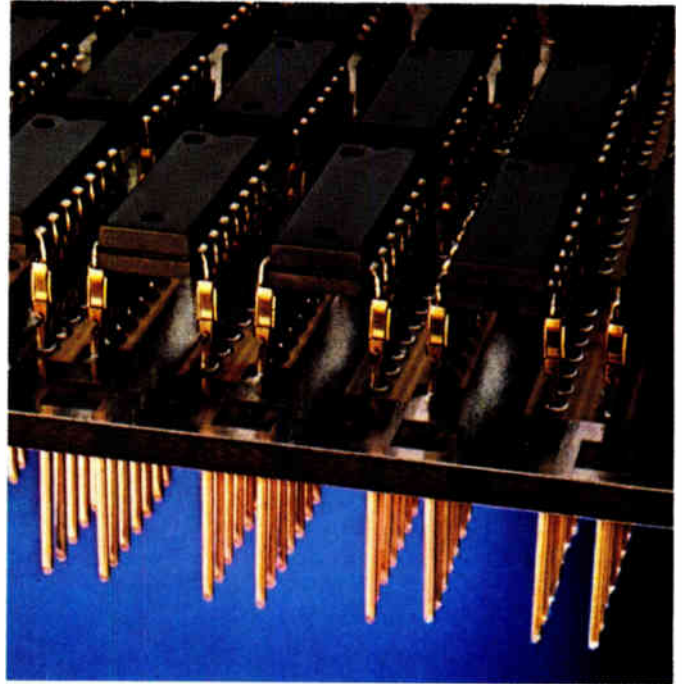

Boards with free-standing Tri-Socket provide better thermal management.

Your IC's run cooler...your components last longer...because the Tri-Socket connector eliminates the plastic shroud and exposes the entire surface of your IC's to air. Tops. Sides. And bottoms. The result: longer component life.

You save space from IC to IC. In fact, they can be as close as 0.100 inch, permitting maximum board density.

Compliant design permits use in wide range of hole sizes...from 0.036 inch to 0.042 inch. This permits use of less expensive PC boards. And the versatile "Tri-Socket" accepts IC leads of either "edge-bite" or "side-bite" type.

Production goes smoother, too. For one thing, a "Tri-Socket" solders easily

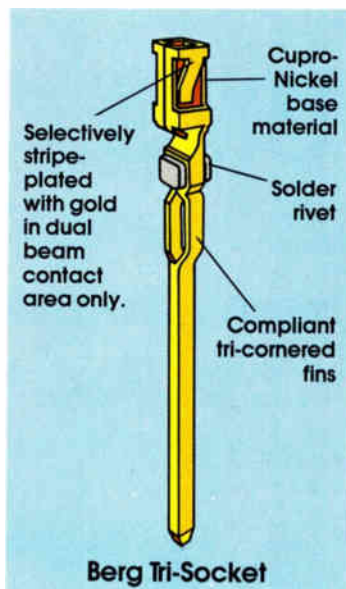

to the board. A solder rivet, precisely positioned above the pins, is ready for mass reflow. No need for hand soldering. When reflowed, the solder forms a reliable 360 degree fillet on each pin at the top and bottom of the board interface. What's more, you can automatically insert these sockets at rates up to 18,000 per hour on a Berg computerized x-y staking machine.

Write for literature. The Du Pont Company, Berg Electronics Division, New Cumberland, Pennsylvania, 17070, Telephone (717) 938-6711. In Europe: 's-Hertogenbosch, Netherlands, Telephone: (31) 73-215255.

Innovations for Electronics

## Berg Electronics

030 6/4/80

Electronics / July 3, 1980







Circle 197 on reader service card

197

# SUPER HIGH POWER OUTPUT IR EMITTERS

Xciton's Super High Output IR Emitters and Materials, constructed from Gallium Aluminum Arsenide, emit at 880 nm. These devices deliver typically twice the optical power of present commercial state of the art, and provide significantly improved coupling efficiency to Si Phototransistors.

PACKAGE STYLE	XCITON PART TYPE	Po, MIN mW @ 20 mA	FWD VOLT TYP @ mA	BEAM ANGLE NOMINAL	PACKAGE STYLE	
					Plastic Emitters	TO-46 Hermetic Metal Can
PLASTIC PACKAGES	XC-880-A, XC-881-A XC-880-B, XC-881-B XC-880-C, XC-881-C XC-880-D, XC-881-D	1 2 3.2 5	1.3 @ 20	24°, 50°	 T-1	 T-1 1/2
	XC-1288-A XC-1288-B XC-1288-C XC-1288-D	1 2 3.2 5	1.3 @ 20	40°	XC-1288 Series	XC-880 Series XC-881 Series
MIN mW @ 100 mA						
TO-46	XC-88-PA, XC-88-FA XC-88-PB, XC-88-FB XC-88-PC, XC-88-FC XC-88-PD, XC-88-FD	7 9 10.5 12	1.6 @ 100	15°, 65°		
	XC-99-30 XC-99-50	30 mW/sr @ 100 50 mW/sr @ 100	1.6 @ 100	15°	XC-88-F Series	XC-88-P Series XC-99 Series
						
<p>Xciton Corporation Shaker Park, 5 Hemlock Street Latham, New York 12110 (518) 783-7726, TWX: 710-444-4962</p>						

Circle 249 on reader service card

## THINK BAUSCH & LOMB QUALITY

Since 1959, when StereoZoom® Microscopes were first introduced, more electronic assembly, packaging, and inspection operations have put StereoZoom® Microscopes to work for them than any other instruments of their kind.

The reasons all relate to Bausch & Lomb quality. Like human-engineered design that has been use-tested for over twenty years for operator convenience. World famous Bausch & Lomb optics that have enabled production lines to increase thruput without sacrificing quality. And a dedicated effort to listen to you, our customer, that has produced such quality innovations as patented coaxial illumination, the high performance StereoZoom 7 Microscope; and now, tungsten-halogen illumination.

This constant attention to your quality needs has made us industry's first choice. Call or write today for detailed catalog, applications assistance, or a personal demonstration.

**Precision. Value. Performance. Three good reasons to . . .  
THINK BAUSCH & LOMB QUALITY.**

**BAUSCH & LOMB** 

Scientific Optical Products Division

Rochester, New York 14602 USA

716-338-6000, TWX 510-253-6189 TELEX 97-8231, CABLE: Bausch & Lomb



Circle 247 on reader service card

Consult Yellow Pages  
under "Microscopes"



# ENLIGHTENMENT

ADVANCED OPTOELECTRONIC PRODUCTS

## How to add 55% more display to a 0.3" package



Now you can upgrade to our new 0.4" display without changing your 0.3" pin configurations.

Larger, brighter LED digits add sales appeal to any device or instrument using displays. That's exactly what General Instrument's 0.4" display can do for your product.

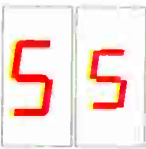

And the highly legible sculptured font improves aesthetics even further.

The Big 4 comes in 4 colors. These new seven segment displays are designed for high brightness, high contrast, and are available in:

- Green (MAN4500 Series)
- Orange (Hi-efficiency red, MAN4600 Series)
- Red (MAN4700 Series)
- Yellow (MAN4800 Series)

They're available in common anode or common cathode and overflow models.

And like all General Instrument displays, the new 0.4" digit offers low power consumption and solid state reliability for a longer operational life.

**Write or call today.**

For more technical data or pricing information, contact General Instrument, Optoelectronics Division (formerly Monsanto Optoelectronics), 3400 Hillview Avenue, Palo Alto, California 94304. Telephone: (415) 493-0400.



# GENERAL INSTRUMENT

Circle 199 on reader service card

# You either have it,

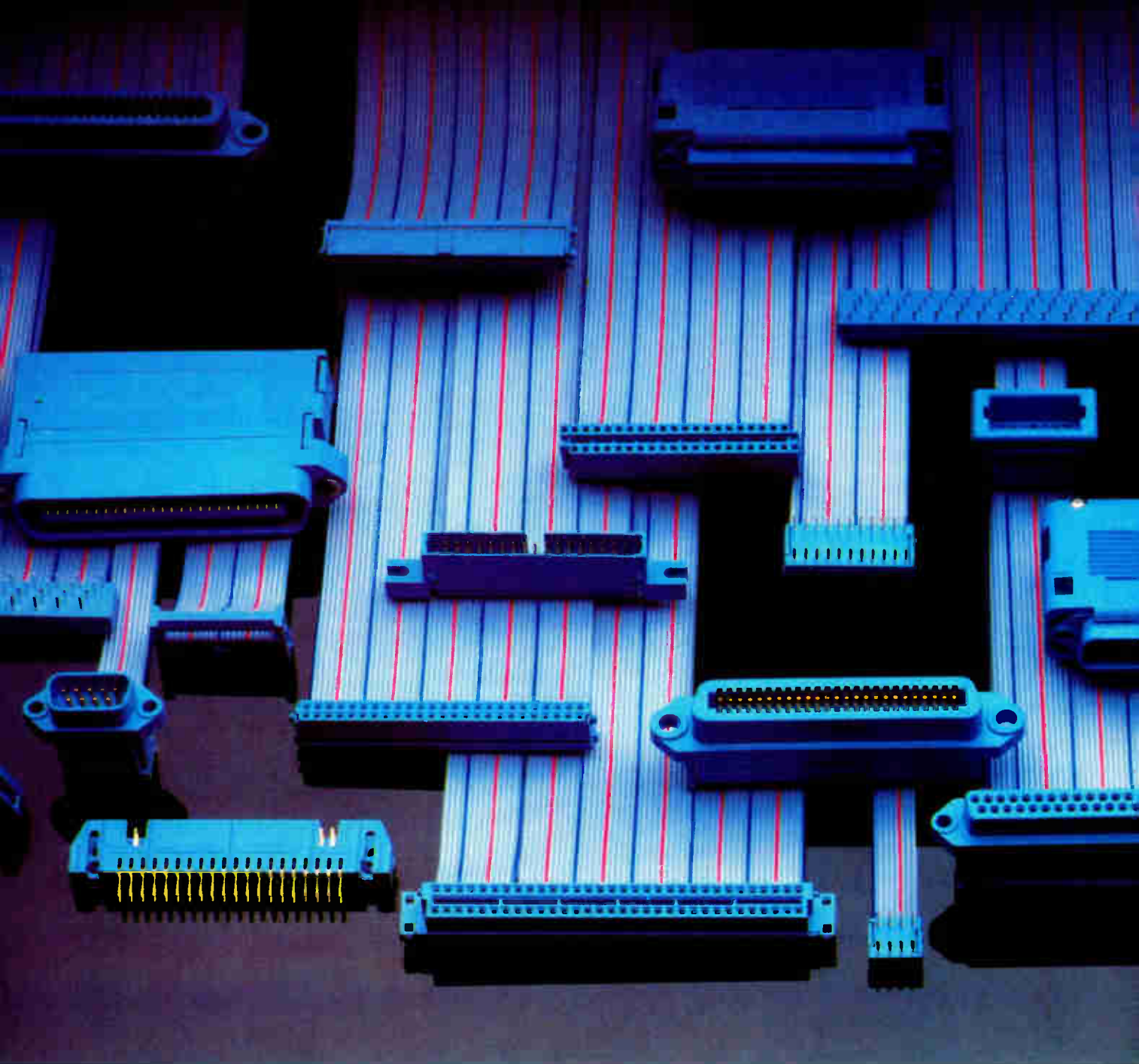

**INTERNATIONAL OFFICES:** AUSTRALIA, Dee Why West N S W, (02) 938-3199 AUSTRIA, WEST GERMANY, Dreieich, 06103-8-2021 CANADA, Ontario, Quebec, (416) 661-2761 ENGLAND, Luton, (0582) 597-271 JAPAN, Tokyo, 03-354-9661 MEXICO, (905) 562-2643 SINGAPORE, (65) 283-4244 SOUTH AFRICA, Benrose, 61-46451 SPAIN, Barcelona, (34) 3-3002252 SCANDINAVIA, Uplands Vasby Sweden, 0760-86140

# or you don't.

**We've got the  
broadest line  
of mass termination  
connectors, flat cable  
and tooling.**

Industry standard Blue Macs<sup>®</sup> connectors for input-output applications. Connectors that can be soldered to boards. Back panel connectors for boards or cabinets. Connectors for dual in-line plug configurations. Connectors for board-to-board applications. Daisy chain applications. And many more!

A complete line of standard and jacketed Blue Macs<sup>®</sup> cables for intra or inter cabinet wiring, cables for high flex life application, and a variety of cable structures for EMI and RFI protection requirements.

The industry's largest package of IDC mass termination hand tools, some with interchangeable dies, manual bench presses and pneumatic tooling.

So give us a call for complete information. Or send for our FREE 116-page catalog.

When your needs involve any kind of mass-assembled flat cable/connector system, contact the company that has it all.

**T&B / Ansley**  
The mass termination company.

T&B/Ansley Corporation  
Subsidiary of Thomas & Betts Corporation  
3208 Humboldt St.  
Los Angeles, CA 90031

TEL. (213) 223-2331  
TELEX 68-6109  
TWX 910-321-3938

Stocked and sold through  
authorized T&B/Ansley distributors.

Circle 201 on reader service card



**Brand-Rex: The state-of-the-art company in electronic packaging, connector and circuit assemblies and systems.**

At Brand-Rex, we make it our business to be on the growing edge of technology.

That's why we've moved aggressively to electronic packaging, connector and circuit assemblies and systems. That's why we took our wire and cable manufacturing know-how into electronics and telecommunications over a decade ago. A move that has created a company

of more than \$200 million in sales with 8 divisions covering the entire spectrum of the interconnection marketplace. At Brand-Rex we connect genius with common sense. Imagination with experience. Blue Sky product planning with down-to-earth business know-how.

At Brand-Rex we don't just ride the waves of progress into the future. We make the waves.

That's what it means to be a state-of-the-art company.

**Abbott & Company**, Marion, Ohio. Producer of electrical interconnect-

ing assemblies, harnesses, cord sets, plugs and inserts for the consumer appliance and related industries. Three plants in Ohio and one in Tennessee.

**Electronic & Industrial Cable Division**, Willimantic, Connecticut. Wire and cable for the business machine, utility, military, and industrial process industries. Also, extruded electrical insulating materials. Additional plants are located in Manchester, Connecticut and Glenrothes, Fife, Scotland (Brand-Rex Ltd.).  
**Garry Manufacturing Company**,

## SOME RIDE THE WAVES OF



Multi-layer double-sided and flexible circuit boards are manufactured by General Circuits, Inc



IC Pluggable Packaging Assemblies and Accessories from Garry Manufacturing Co



Toll Management, Key Station, Coin Telephone and Central Office Equipment from Teltronics



Pyle-National's C-Line connector designed for the Marine cargo handling industry



New Brunswick, New Jersey. Manufactures a variety of electronic interconnection devices, including integrated circuit logic panels, sockets and related accessories. Also operates a plant in Pennsylvania and at two locations in Switzerland.

**General Circuits, Inc.**, Rochester, New York. Manufactures multi-layered, double-sided and flexible printed circuits for the computer and telecommunications markets.

**Nonotuck Manufacturing Company**, South Hadley, Massachusetts. Fabri-

cates uninsulated copper and copper alloy wire.

**Pyle National Company**, Chicago, Illinois. Specializes in commercial and military connectors for aircraft, missile, industrial, railroad and general purpose applications. Has subsidiaries in Mississauga, Ontario, Canada, and Nottingham, England.

**Telecommunications Cable Division**, Willimantic, Connecticut. Producers of a broad line of telephone wire and cable products, including fiber optic cables, at plants located in Asheville, North Carolina, and

Siloam Springs, Arkansas.

**Teltronics, Inc.**, Lakeland Florida. Supplier of a wide range of telecommunications products, including central office, pay station and key system line units, toll restriction devices, and test equipment for the telephone and aerospace industries.

## **BRAND-REX**

BRAND-REX COMPANY, A PART OF AKZONIS INC

Willimantic, Connecticut 06226  
Phone: 203/423-7771

# **PROGRESS. OTHERS MAKE THEM.**



**BRAND-REX.  
THE STATE-OF-THE-ART-COMPANY.**

# Multiply your micro capabilities with

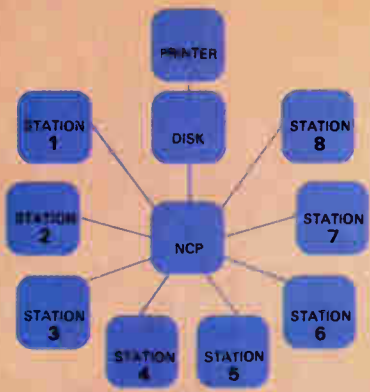

2301 Series multi-station networks share disk and printer with up to eight stations. Each station is universal and may be ordered with the software and/or hardware capabilities required.

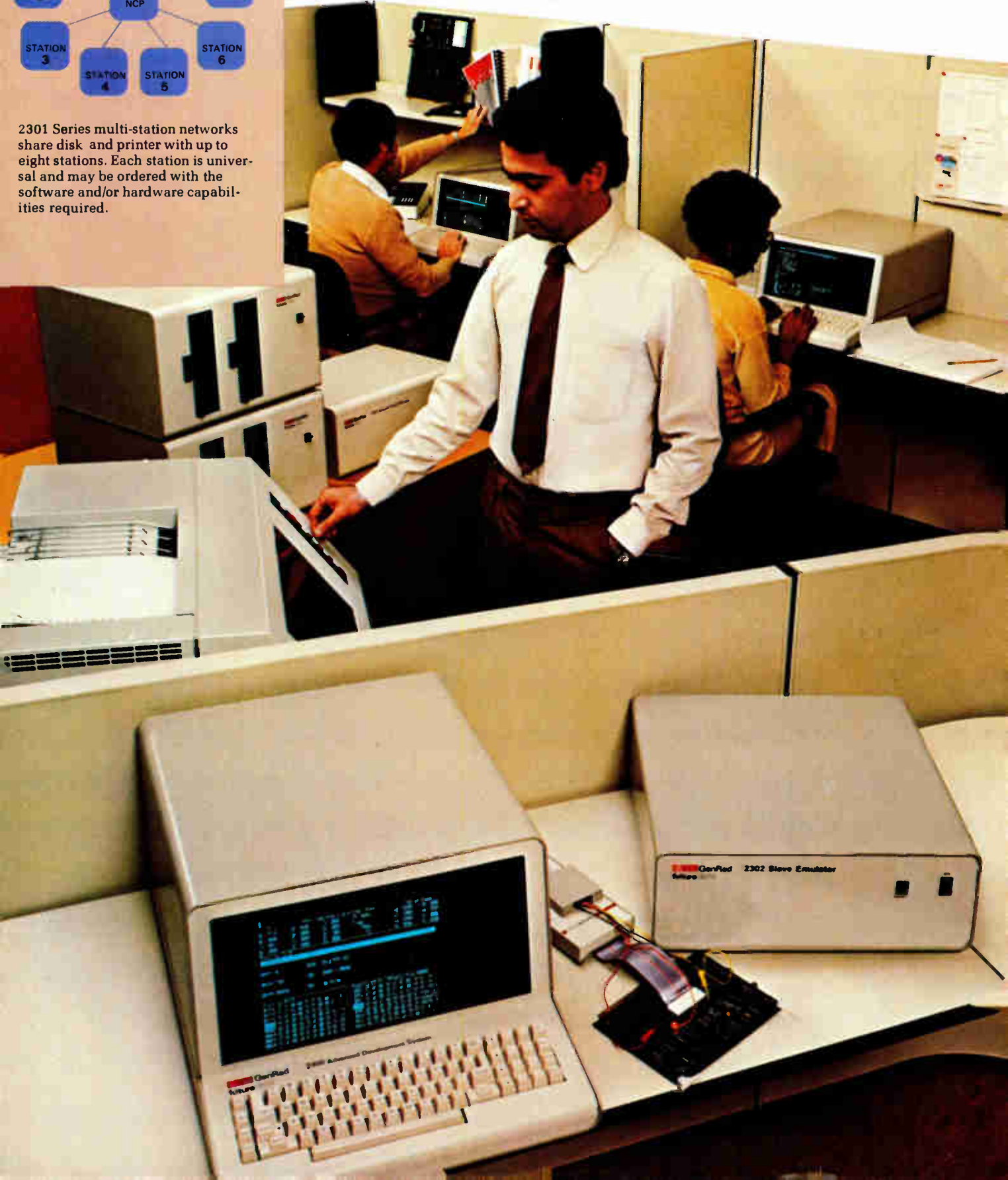



# processor based design our universal network

**ADVANCE YOUR SMART-PRODUCT DEVELOPMENT PROGRAMS**—Our universal, multi-user development system network is the most cost-effective means of implementing a multi-station, microprocessor-based design facility. It's also the most versatile and productive solution to smart-product design.

**MORE SUPPORT FOR MORE CHIPS FOR MANY USERS**—Our network stations already support all of the most popular microprocessors. Our unique slave emulation system permits us to add support for new chips faster than anyone else. With eight stations tied into our network you can stop paying designers to wait in line. All eight can be developing products simultaneously with different chips.

**MULTI-PROCESSOR EMULATION**—Our slave emulation system provides transparent, non-stop, full-speed emulation to 10 MHz. And, it's the only system that allows simultaneous emulation of many different processors. Up to eight emulators can be tied into one network station. Our transparent in-circuit emulation and logic analysis take all the guesswork out of processor evaluation and design, even for products using several different chips.

**SHARE AND SAVE**—By sharing costly and under-utilized resources (disks, printers, slave emulators, design aids and software), a network system lowers your cost-per-station dramatically. Without trade-offs! Each user has his own CPU, CRT and keyboard. The same powerful software supplied with our stand-alone development systems is provided to each network station. Each station can be equipped with any combination of software and/or hardware capabilities you require, including local disk storage.

**SPEED UP YOUR PROGRAMMING**—With our interactive, high-speed CRT, complete operating system software, and assembly and high-level language programming capabilities, things happen fast—sometimes instantaneously. Now available with highly block-structured PASCAL compilers, our system can cut your programming time by 50% or more.

**RELY ON THE LEADER**—We started delivering network systems over one year ago. For a complete understanding of how these cost-effective systems can multiply your capabilities, contact one of our worldwide sales and service offices today.

 **GenRad**  
futuredata

GenRad/Futuredata  
5730 Buckingham Parkway  
Culver City, CA 90230  
(213) 641-7200. TWX: 910-328-7202.

GenRad/Futuredata universal development systems –  
expanding your world of microprocessor-based design.



8086  
8085  
8080  
z8000  
z80  
68000  
6809  
6802  
6801  
6800  
6502  
1802  
3870

## New products

Power supplies

### Dc-dc converters fit in 24-pin DIPs

Small size, broad output selection, low cost mark power device series

A family of dc-dc power converters is making its debut in a small way: 24-pin dual in-line packages, slightly larger than standard but measuring only 1.25 by 0.6 by 0.4 in., house the DCR series of regulated converters and the DCU unregulated series from Intronic. Selling for less than \$35, the converters can plug into a board, near the component they supply, thanks to their modest size. A wide selection of single and dual outputs, from inputs of either 5 v or 12 v, adapts both series to the individual power needs of analog as well as digital circuits on boards containing both. The result will be greater ease and flexibility for printed-circuit board designers, says the Newton, Mass., firm.

As on-card power sources, both converters can bias operational amplifiers, digital-to-analog and a-d converters, integrated circuits, microprocessors, and RS-232 loop drivers. All members of both series have 300 v of input/output isolation and 10-M $\Omega$  minimum impedance.

The DCR series consists of eight single-polarity models; customers may select from among those with outputs of 5 v, 9 v, 12 v, or 15 v and five models with dual-polarity outputs of  $\pm 5$  v,  $\pm 12$  v, or  $\pm 15$  v. All models have outputs regulated to  $\pm 0.3\%$ , no load to full load. Their current ratings vary according to output voltage and range from  $\pm 65$  mA to  $\pm 100$  mA.

Dual-output DCR converters have a load regulation of less than 45 mV from no load to 80 mA and line regulation of  $\pm 45$  mV; their output noise is a maximum of 30 mV peak to peak. Single-output units have a less than 150-mV load regulation from no load to full load,  $\pm 30$  mV line regulation, and a maximum of 100 mV peak-to-peak noise. Output voltage tolerance of all DCR models is  $\pm 5\%$  of rated output voltage.

The DCU series consists of three single-polarity units with 5-v or 10-v outputs between 100 mA and 200 mA and four dual-polarity models with outputs of  $\pm 12$  v or  $\pm 15$  v between 65 mA and 80 mA. Output voltage tolerance is  $\pm 10\%$  of output, and noise is 50-mV root mean square over a bandwidth of 20 Hz to 20 MHz.

The temperature coefficient of all DCR series converters is  $\pm 0.015\%$  of rated output/ $^{\circ}\text{C}$ ; temperature coefficient of DCU models is  $\pm 0.6\%$  of output. Both series operate over a temperature range of  $-25^{\circ}$  to  $+70^{\circ}\text{C}$ . All 5-v-input models of either series accept between 4.75 v

and 5.25 v dc and input currents of up to 400 mA. The 12-v-input models accept from 10.8 v to 13.2 v dc and up to 200 mA of current. Both series use current limiting to protect against short circuits.

Single-output DCR models and all DCU models cost \$29.95, and dual-output DCR converters cost \$34.95, in lots of one to nine. Delivery is from stock to four weeks.

Intronic Inc., 57 Chapel St., Newton, Mass. 02158. Phone (617) 332-7350 [401]

### Triple power supply for CRT test set sells for \$2,750

The model CRT-30—three highly regulated power supplies in one unit—has three independent ten-turn dials that provide the fine adjustment of anode outputs from 0 to 30 kv at 2 mA, focus outputs from 0 to 10 kv at 1 mA, and grid outputs

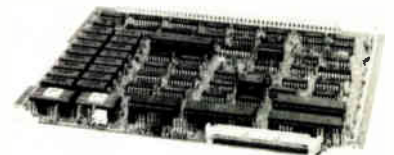

from 0 to 1 kv at 1 mA. Ripple (peak to peak) and line and load regulation each reach a maximum of 0.01% of full scale, making the CRT-30 useful for testing of cathode-ray tubes.

It sells for \$2,750. Delivery takes four weeks.

Bertan Associates Inc., 3 Aerial Way, Syosset, N.Y. 11791. Phone (516) 433-3110 [404]

### 30-W open-frame switcher sells for \$83

Selling for only \$83 each, the ES-D series of open-frame switching regulated power supplies has an output power of 6 A at 5 v dc. A monolithic chip containing all regulation, modulation, and protective circuitry allows a 20% parts reduction and a 50,000-hr mean time between fail-

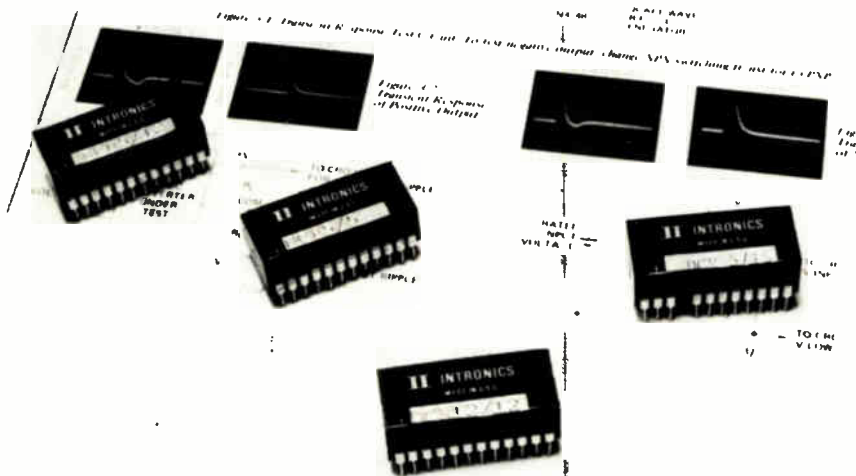





# New Pressure Transducer Catalog

If you measure pressure, you'll want this condensed catalog. It describes a wide range of pressure transducers and related instruments. All units are built to exacting quality standards for reliable, trouble-free operation in the toughest environments. And at prices you have to like. Send for catalog of stock models.



**DATA INSTRUMENTS INC.**

4 Hartwell Place, Lexington, Mass. 02173  
617-861-7450 TWX 710-326-0672

Circle 208 on reader service card

## New products



ures. Line and load regulation are 0.2% each, and ripple and noise are less than 50 mV peak to peak. The efficiency of the ES-D units varies from 70% to 84%.

The units operate from a dual ac input of 85 to 132 v ac and 170 to 264 v ac at 47 to 63 Hz. The supply features protection against brown-out, overvoltage, overload, short circuit, reverse polarity, and soft start, as well as a remote-sensing capability. The D series has a holdup time of 16 ms after loss of ac power. Outputs for the units are 5 v at 6 A, 12 v at 3 A, 15 v at 2.4 A, 24 v at 1.5 A, 28 v at 1.3 A, and 36 v at 1 A. They are all adjustable to within 10% and meet Underwriters Laboratories and Canadian Standards Association requirements.

Power/Mate Corp., 514 South River St.,  
Hackensack, N. J. 07601 [403]

## Floppy-disk supply provides 5 outputs

The FD508 power supply provides five voltage outputs for operating any dual floppy-disk drive. The five outputs are: +5 v dc (with overvoltage protection) at 25 A; +12 v dc (with overvoltage protection) at 4 A; -5 v dc at 1.25 A; -12 v dc at 1 A, and +24 v dc at 1.5 A continuous or 3.4 A surge. Operating on 115 or 230 v ac  $\pm$  10%, 50 or 60 Hz, the FD508 provides a power OK signal with positive and negative logic outputs and a line time clock output, all with 800-ns rise times. Line and load regulation are each 0.1% for positive outputs and 1% for negative outputs. The supplies sell for \$297.50 each in quantities of one to nine.

CEI Corp., P. O. Box 501, Grenier Industrial  
Park, Londonderry, N. H. 03053 [406]

# FREE

## Brochure describes Electronics editorial reprints, services, books...

- More than 70 article reprints in 15 subject categories
- Handy wall charts
- Custom-made reprint services
- Books especially for **Electronics'** readers
- Convenient postage-paid order cards

For your free copy, circle #275 on  
the reader service card.

For faster response, write directly to  
**Electronics Reprints**, P.O. Box 669,  
Hightstown, NJ 08520, or call  
(609) 448-1700, ext. 5494.



# Why the switch is on to film capacitor filters.

(30-80% higher SPS efficiency.)

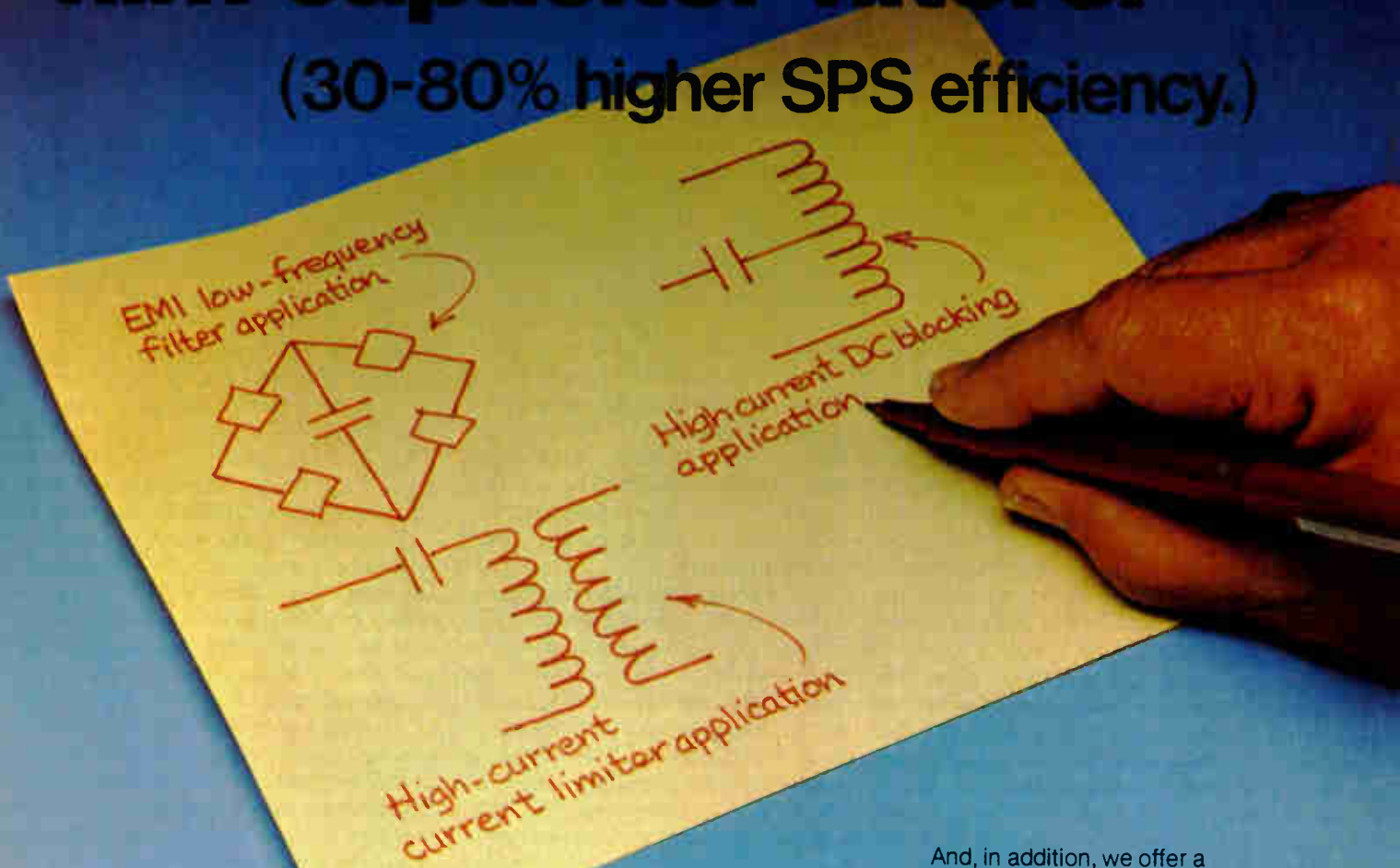

For switching power supplies the evidence is conclusive. Where a filter capacitance of 50 mfd or less will do, metallized polypropylene (film) capacitors far surpass electrolytics in impedance characteristics.

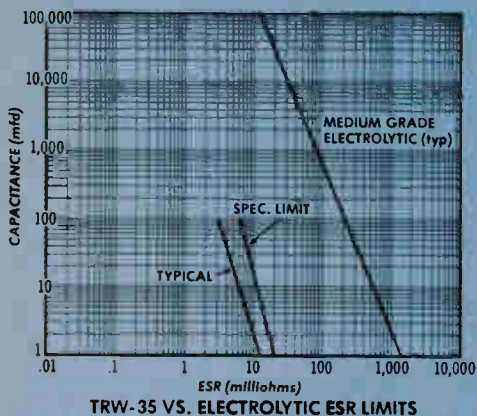

Here's why:

At resonance, ESR for a film capacitor is less than *one-tenth* that of an electrolytic. The film's

capacitance won't dwindle at higher switching rate frequencies, so you can design with a lower value cap.

With a constant 2 amp ripple current, a film cap will cut  $I^2R$  losses—by orders of magnitude. Its current-carrying capacity is greater, so paralleling is usually not required. And ripple voltages are significantly less.

Film caps can be round or flat—you gain design versatility. And weight reduction: 16 grams/cu. in. vs. 26 for electrolytics. The bottom line: maximum current, minimum size and minimum loss.

At TRW, we're past pioneering a superior concept. We're delivering a buttoned-down product: the TRW-35 film capacitor is available now for input/output filtering in your state-of-the-art SPS design.

And, in addition, we offer a complete custom film package for your specific needs in the 40KHz and above SPS range.

Get the evidence in hand—send for the TRW-35 data sheet. And we'll provide you a reprint of the technical article that triggered the switch to a new SPS technology.

**Send in coupon or call us at (308) 284-3611.**

<b>TRW Capacitors</b>	
An Electronic Components Division of TRW Inc 301 W. "O" Street, Ogallala, Nebraska 69153	
Please send data on your <b>SPS Capacitors</b> .	
Name _____	
Company _____	
Div/Dept _____	Mail Code _____
Address _____	
City _____	
State _____	Zip _____

E-7



Computers &amp; peripherals

## Mainframe vies with IBM's 4300

---

4331-type machine uses commercial chips to offer more power at lower cost

---

Claiming 20% more computing power and a 20% lower price tag than the IBM 4331 group 2 machines, Magnuson Computer Systems Inc., of San Jose, Calif., unveiled its M80/31 mainframe late last month. The M80/31 is the sixth Magnuson mainframe in the 4300 class, and it is the first response among plug-compatible mainframe manufacturers to IBM's announcement of the group 2 machines in May [*Electronics*, May 22, p. 48].

In its basic configuration, the M80/31 comes with 1 megabyte of main memory, and it can be upgraded to 8 megabytes in 1-megabyte increments. Also standard in the basic configuration are a byte channel with a throughput of between 36 and 500 kilobytes per second and two block channels with a 2.5-megabyte/s throughput. Three additional block channels are available as options.

The M80/31 is most directly comparable with an IBM 4331 group 2 system when built around a console,

1 megabyte of main memory, one byte channel, and two block channels. In this configuration, it is priced at \$135,000, compared with \$166,176 for the IBM system. According to Magnuson president Joseph L. Hitt, the firm "uses exactly the same criteria to measure performance as IBM uses, and under those circumstances the M80/31 has at least 20% more computing power." The average instruction execution rate for the M80/31 using IBM's criteria is 0.45 million instructions per second (MIPS). MIPS, a parameter that measures the pure number-crunching ability of the mainframe's central processing unit, does not tell the full story, however. A computer must also be judged by how swiftly it executes input/output-intensive operations, and in that category Hitt claims superiority.

**Software support.** Like the company's other offerings, the M80/31 will directly run software written under such IBM operating systems as the current DOS, OS/VS1, and VM370, as well as the new DOS/VSE. "In addition, we support the MVS [multiple virtual storage] operating system on the M80/31," Hitt notes. "No 4331 system does that." In addition to the hardware, Magnuson also provides full software support for DOS and DOS/VS, both of which are no longer supported by IBM. Magnuson also supports all versions, or releases, of OS/VS1 and VM370, though IBM supports only release 7 OS/VS1 and release 6 VM370.

Magnuson's software capability has also been aided recently by the unbundling of software by Amdahl Corp. of Sunnyvale, Calif. Hitt claims that Amdahl's system extension package runs directly on Magnuson systems and is the primary software package from Amdahl that can help a Magnuson system.

A prime feature offered by IBM's 4331 group 2 announcement was the availability of an 8-kilobyte cache memory, a feature which the M80/31 expands. The M80/31 can support up to 16 kilobytes of cache memory and between 48 kilobytes and 256 kilobytes of user-accessible control storage.

Unlike IBM, Magnuson does not orchestrate its mainframes around custom integrated circuits. Instead, the company relies upon a bus-oriented structure and commercially available ICs. "That way we can upgrade a system one board at a time as new IC technology becomes available," notes Carl Amdahl, Magnuson's executive vice president of technology. This approach also allows Magnuson to move the M80/31 to market faster—within 30 days after receipt of order.

Magnuson Computer Systems Inc., 2902 Orchard Park Way, San Jose, Calif. Phone (408) 946-8100 [361]

---

## Rugged hard-disk drive daisy-chains to floppies

A rugged 9-in. hard-disk drive that almost meets military standards, the model 301D-FE is aimed at industrial control, mobile, and military applications. What's more, the drive is totally compatible with systems that use Shugart 850- and 851-type floppy drives, so it can be daisy-chained or used alone. In its floppy-disk emulation mode, the 301D-FE has a buffered bit-transfer rate of 2 megabits/s.

Various versions of the drive have capacities that range from 0.5 megabyte to 8 megabytes, and all are built to withstand up to 10 g of physical shock within the temperature range of 0° to 55°C. Special versions, with

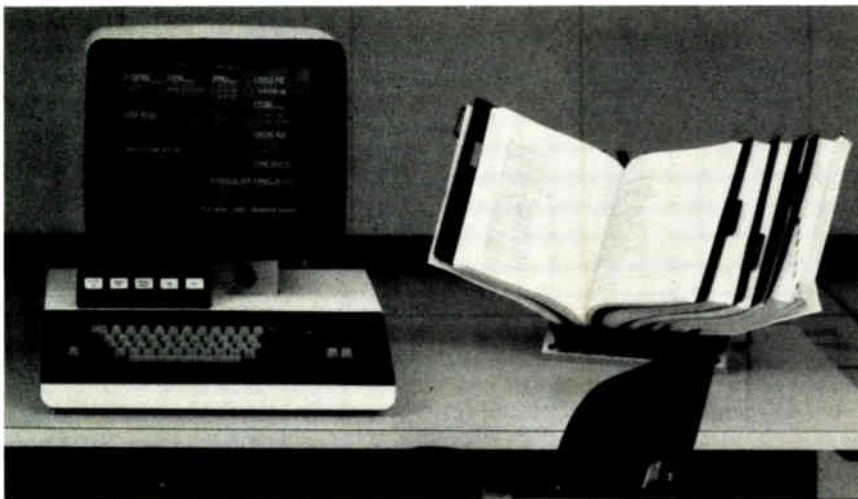



# THE DATA I/O SYSTEM 19 PROGRAMMER: SAVES ENGINEERS TIME. SAVES DEVELOPMENT SYSTEM TIME.



**Data I/O's System 19 Programmer frees your microprocessor development system for more important tasks.** Here's an example:

An engineer is building six prototypes for a new microprocessor based product. If each unit has eight 2708 PROMs, it will take more than an hour to program those 48 PROMs—one at a time—on the development system.

That's time and money wasted.

Instead of tying up the development system to program PROMs, the engineer could simply download the information into the System 19's RAM and free the development system for more creative tasks.

That's time and money saved.

**System 19 interfaces more easily with more development systems than any other programmer, and accommodates 16 bit microprocessor data too!**

System 19 is intelligent. It can communicate using RS232C or 20mA current loop with a variety of formats without the need for intermediaries like paper tape.

And Data I/O makes interfacing easy because we supply application notes explaining exactly how to do it.

System 19 can transmit and receive data formatted in: Binary, DEC Binary, ASCII-BNPF, ASCII-BFLF, ASCII-B10F, 5-level BNPF, Spectrum, ASCII-Hex, ASCII Octal, RCA Cosmac, Fairchild Fairbug, MOS Technology, Motorola Exorciser, Intel Intellec 8/MDS, Signetics Absolute Object and Tektronix Hexadecimal.

**System 19 is a valuable editing tool.** Instead of waiting for development system time to refine a program, an engineer can also edit the program using the System 19 keyboard.

**The System 19 modular concept keeps it state of the art.** The System 19 is designed around a standard mainframe and plug-in modules:

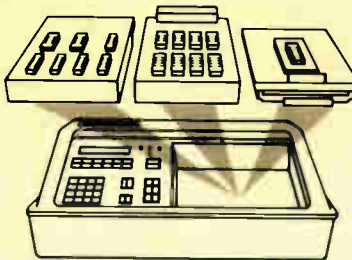

—UniPak: a single, seven socket module that programs more than 200 different bipolar and MOS PROMs and gives you design and purchasing freedom for evaluating new devices and developing second sources.

—Individual PROM Programming Paks: for generic PROM families.

—Individual Logic Programming Paks: for devices such as FPLAs and PALs.

—Gang Module: programs up to eight MOS devices at once.

**Let us show you the future.**

The Data I/O System 19 is available now. To make arrangements for a demonstration or to get your free copy of this valuable 32-page book, circle reader service

number or

contact

Data I/O,

P.O. Box 308,

Issaquah, WA 98027. Phone

206/455-3990 or TOLL FREE

800/426-9016.

## DATA I/O

Circle 211 on reader service card



# CHRISTIE High Current DC Power Supplies



**Symbolic of time-tested reliability.**

- DC current from 40 to 1500 amps
- Voltages to 280 VDC

Write for latest detailed catalog or call toll free for application assistance.



SINCE 1929  
**CHRISTIE**  
ELECTRIC CORP.

20665R MANHATTAN PLACE  
TORRANCE, CALIFORNIA 90501  
(213) 320-0808  
TWX 910-349-6260  
(800) 421-2955

Circle 212 on reader service card

**Etablissement Public des Eaux de Fiegh  
Damascus, Syria  
Prequalification of Contractors  
Contract C—Communications Subsystem  
Damascus Water Supply  
USAID Financed**

Qualified telecommunications contractors are requested to submit prequalification data for equipment supply and installation services for Contract C—Communications Subsystem for central water dispatching system, part of expansion of the Damascus water system. Eligibility for prequalification is limited to U.S. firms, joint ventures of U.S. firms, or joint ventures of U.S. and Syrian firms. The contract will be made up of unit price components, as furnished and installed, with price variation provisions, and will include furnishing, installing and starting up a communications system to connect components of the dispatching system. Work includes approximately 25,000 meters of cable in a water supply tunnel; UHF radio equipment, including antennas, at 35 locations throughout the system; cable runs; telephone channels; a repeater station; and a training program for EPEF personnel. These quantities and descriptions are provided as an indication of the scope of the project, are approximate, and are subject to change. U.S. goods and services will be provided under A.I.D. Loan 276-K-010 and firms will be paid in U.S. dollars and Syrian currency. Prequalification questionnaires and additional information may be obtained from: **Eng. M. Eida Hourtada, President Director General, Etablissement Public des Eaux de Fiegh (EPEF), Rue El Nassr, Damascus, Syria; Telex: 11312 SY; Cables: FIGEDAM; OR R. W. Caswell, Gilbert Associates, Inc., P. O. Box 1498, Reading, PA 19603; Phone: 215-775-2600; Telex: 902260.** The completed questionnaire shall be returned to EPEF postmarked no later than Aug 18, 1980. A prequalified bidders list will be established by EPEF following receipt of qualifying information. Prequalified firms wishing to submit bids may be required to visit the country and the site of the work before submitting bids.

## New products

a different bearing, operate between  $-30^{\circ}$  and  $+70^{\circ}\text{C}$ , which surpasses MIL-STD-E-16400, Class 4 requirements for an operating temperature of  $-10^{\circ}$  to  $+62^{\circ}\text{C}$ . The 301D-FE, however, does not withstand the salt-spray test required by that same standard. Nevertheless, for industrial applications where these qualities are not needed, the unit's \$3,465 price for a 3.1-megabyte drive—or \$4,065 for a 6.2-megabyte drive—holds its own.

The drive uses up to eight parallel flying heads that share a common ceramic slider unit, itself positioned by a stepper motor. Its recording medium, an aluminum disk with nickel-cobalt plating and a tin-nickel protective coating, is similar to those used on older head/track drives. Also, the flying heads land when the disk's rotational speed is reduced to 450 rpm on shut-down, thus eliminating the need for head-retraction mechanisms. Delivery of the drives takes six to eight weeks.

Disk Memory Technology Inc., Box 19814, Portland, Ore. 97219. Phone (503) 643-6383 [362]

## 32-bit single-board computer has features of larger CPU

A single-board 32-bit computer—Concept/32—includes such features available in larger machines as a 16-megabyte mapped memory management system, instruction look-ahead, and floating-point arithmetic instructions. The minicomputer, which can be expanded to contain 1 megabyte of directly addressable memory in its 15-in. chassis, can be mounted onto any standard 19-in. rack.

Concept/32's integrated memory module combines 256 bytes of error-checking and -correcting (ECC) MOS memory. An input/output processor module within the minicomputer has 16 device controller subchannels, four external priority interrupts, an interval timer, a real-time clock, and an operator's console interface. Through a mapped programming executive, the computer is compatible with all System 32

series computers. A memory-resident version of the MPX operating system can be loaded from magnetic tapes or floppy disks. The single-chassis configuration is priced at \$25,000 and can be delivered within 90 days.

Systems Engineering Laboratories Inc., P. O. Box 9148, Ft. Lauderdale, Fla. 33310. Phone Paul T. Haller at (305) 587-2900 [363]

## \$3,000 speech-recognition unit fits RS-232 terminals

A speech-recognition unit that is priced at about \$3,000 interfaces with all RS-232-C terminals. The model 7000 allows users to enter information directly into computers without typing, but it also allows the use of a keyboard alternatively or simultaneously. A spectrum analyzer in the unit uses digital filtering and pattern-matching techniques to analyze audio input. The output is automatically transferred to the computer in standard ASCII format.

The unit can be trained to recognize up to 64 words or phrases, each up to three seconds in length. It is compatible with all common programming languages, such as Fortran, Cobol, Pascal, and Basic. It can be retrained to accept different voices. The 7000 comes in a stand-



alone cabinet, but a single-board version is available for the original-equipment manufacturer. Both versions include a noise-canceling microphone in a headset. An auxiliary input accepts telephone, tape recorder, or other high-level inputs.

Heuristics Inc., 1285 Hammerwood Ave., Sunnyvale, Calif. 94086. Phone (408) 734-8532 [364]





# ROEDERSTEIN specialized and worldwide in electronics

## CAPACITORS

polyester, polycarbonate and polypropylene capacitors in foil/foil versions and metalized, aluminum-electrolyte capacitors, tantalum capacitors with liquid electrolyte, tantalum capacitors with solid semiconductor electrolyte, ceramic capacitors.

## RESISTORS

carbon-film resistors, metal-film resistors, metal-oxide film resistors, precision wirewound resistors, potentiometers.

## OTHER PRODUCTS

interference suppression devices, voltage multipliers, thick-film devices (thick-film hybrid circuits, resistor networks, high-valued resistors), semiconductors and micro-computer learning aids.

The range of application for ROEDERSTEIN components encompasses the whole entertainment electronics spectrum, household appliance and industrial electronics, communications, measuring and control, office equipment and computers, medical electronics, and the aerospace electronics sector. We can supply components that meet MIL, CECC and GfW specifications.

We will send you a condensed catalogue upon request. If you need specific information a detailed catalogue is available.

# FIRMENGRUPPE ROEDERSTEIN

D-8300 LANDSHUT · FEDERAL REPUBLIC OF GERMANY · TELEX 0 58 335 (erola)

Circle 213 on reader service card



Data acquisition

## 16-pin DIP houses 8-bit converter

---

Single-channel C-MOS integrated circuit uses successive approximation

---

The latest entry in Mostek's emerging family of analog-to-digital converters is designed for low-cost microprocessor applications where multichannel converter input capabilities are not required.

The MK5168 is a single-channel 8-bit device fabricated using the same low-power complementary-MOS technology employed for the firm's initial a-d converters—the MK50808 and MK50816 [*Electronics*, March 27, p. 237]. Unlike the earlier 8- and 16-channel input devices, however, which are pin-compatible renditions of parts built by National Semiconductor Corp., the 5168 is housed in a 16-pin package that Mostek officials believe to

be unique for a monolithic C-MOS successive-approximation a-d unit. Other single-channel C-MOS 8-bit devices are usually housed in 18- or 20-pin packages.

Except for an external precision reference that is generally required for all C-MOS a-d converters, the 5168 requires no off-chip support circuitry. The part operates either under microprocessor control with a maximum conversion time of 110  $\mu$ s or in a stand-alone mode using an internal clock that pushes conversion time up to about 200  $\mu$ s. No zero or full-scale adjustment is required, and the absolute accuracy is specified as  $\pm 1$  least significant bit. (Absolute accuracy is defined as the difference between the actual input voltage and the full-scale weighted equivalent of the binary output code, including quantizing and all other errors.) The part requires a single 5-v power supply for operation, and power dissipation is pegged at a maximum of 1.65 mW with no load.

In housing the 5168 in a 16-pin package, the company sacrificed ratiometric-conversion capability to accommodate a variable-input voltage span. The 5168's input voltage

span is fixed at 0 to 5 v, but Mostek industrial products marketing manager, Jim Garrett, notes that most applications typically apply signal-processing circuitry that can meet the 0-to-5-v span requirement in front of the a-d converter.

Advantages of the 16-pin approach include board-space savings compared with the heftier 18- and 20-pin parts, Garrett says. Designed with a particular eye to industrial control and other applications in which only a single transducer is to be monitored, the 5168 will be offered only in a plastic-packaged industrial-grade version ( $-40^{\circ}$  to  $+85^{\circ}$ C) and priced at \$6.15 each in 500-unit quantities. The single-unit price is \$9.15. Samples are scheduled to be available in September.

Mostek Corp., 1215 W. Crosby Rd., Carrollton, Texas 75006 [381]

---

## \$6,680 microcomputer offers hardware, software flexibility

By using the well-established STD microcomputer bus structure, the C2000 network data-acquisition microcomputer offers hardware flexibility. In addition, the \$6,680 unit uses any of the software available for Digital Research Inc.'s CP/M disk operating system. Use of the STD bus allows the C2000 to expand its basic desktop configuration with such options as extra disk drives, a telecommunications modem, software for polling data-loggers, and the use of cathode-ray tubes, printers, and nine-track tape drives.

Included in the C2000's basic price are two Shugart 8-in. drives, the CP/M operating system, Microsoft's Extended Basic interpreter, a Z80 microprocessor with 48 kilobytes of random-access memory (expandable to 56 kilobytes), three serial RS-232 input/output ports, and a switching power supply. The floppy-disk drives offer 600 kilobytes of mass storage. Other software accompanying the C2000 includes a text editor, as well as utilities for cassette read/write and memory testing based on a 2-kilobyte read-only

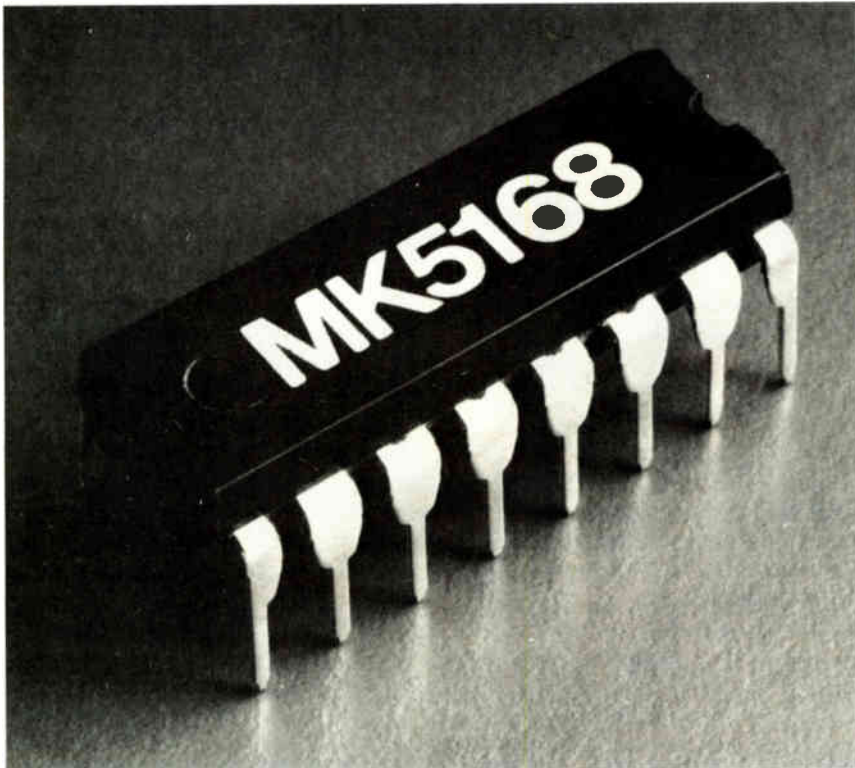



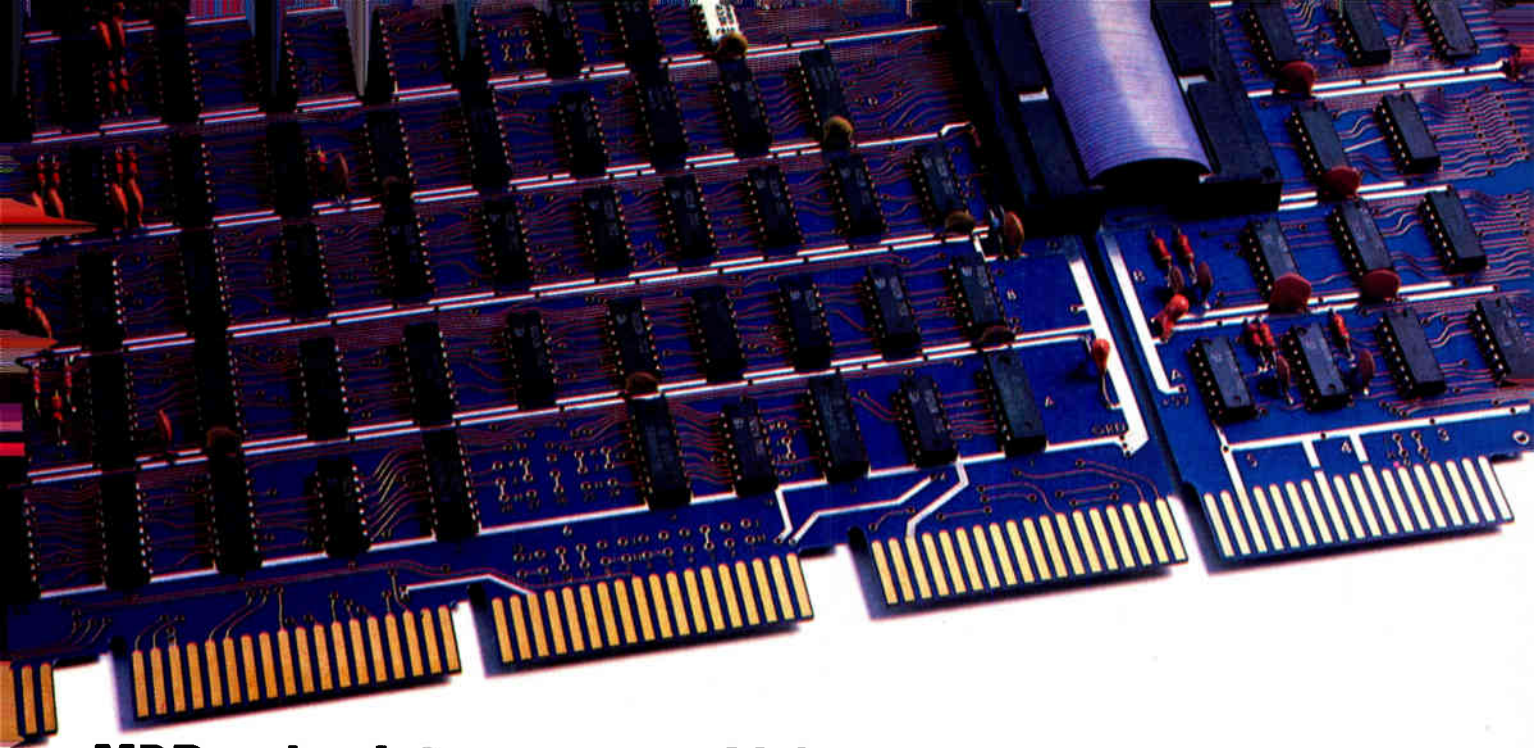

**MDB makes Interprocessor Links with speeds of 500 KHz/sec. for distances up to 3,000 feet.**

# Imagine what else we can do!

Hook 'em up. Networks of PDP\*-11, VAX\*-11/780 and (never possible before) LSI\*-11/2 and 11/23. Name your configuration, even PDP to LSI or LSI to LSI, — MDB interprocessor links will provide high speed DMA (parallel) data transmission at speeds as high as 500 K words/sec. For extra long line applications MDB's PDP-11 to PDP-11 boards are equipped with differential drivers and receivers for high speed operation up to 3,000 feet. The security of optically isolated receivers is standard on all boards for LSI and available for PDP & VAX models. Optical isolation provides AC/DC circuit and ground loop isolation at distances up to 1,000 feet. All this performance is compactly housed on MDB's small size boards—a hex for PDP models and quad for LSI. And you get the convenience of complete DEC DA11B software compatibility.

Imagine even more. Because MDB manufactures the most complete line of interface products available for DEC, Data General, P-E and IBM Series One computers. We make boards for H-P and Intel too. Like our line printer controllers—we offer more than 100 printer/computer combinations. Our communications interfaces range in performance from plain vanilla to plain incredible and all MDB foundation modules require only one

card slot. We've got PROM memories that let you program ROM on the board and multiplexors that allow mix and match of 20 milliamp and EIA.

All MDB products are warranted for a full year. Most can be delivered in 30 days or less and you can buy them under GSA contract #GS-00C-01960. What else can we do—for you?

**MDB** 1995 N. Batavia Street  
SYSTEMS INC. Orange, California 92665  
714-998-6900  
TWX: 910-593-1339

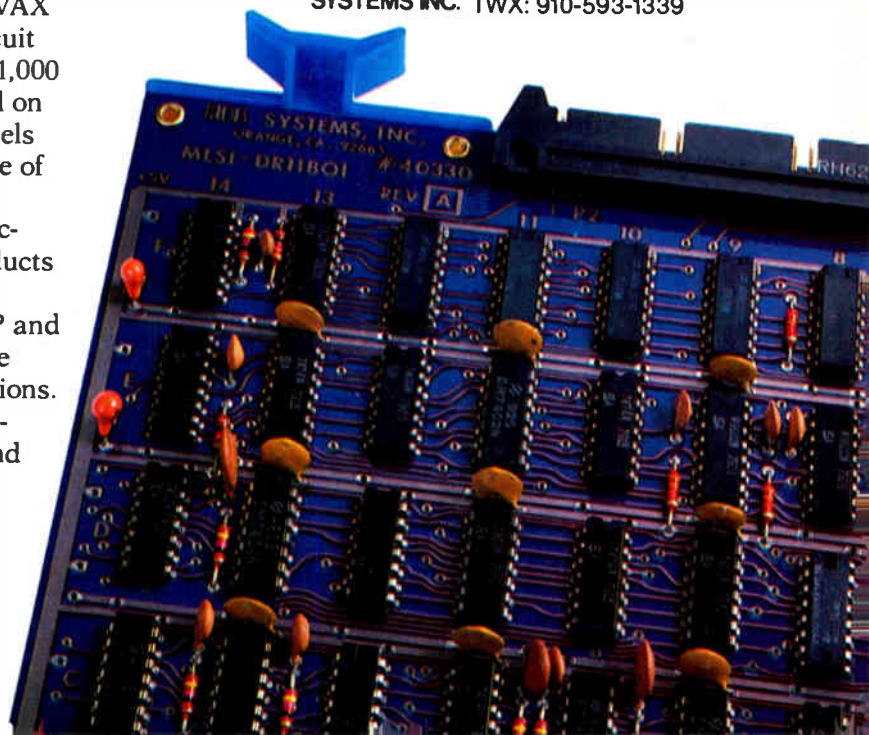

\*Trademark Digital Equipment Corporation.

Circle 226 for LSI, 227 for PDP, 228 for DG,  
229 for PE, 230 for IBM.

# The NEW Electronics Buyers' Guide is now available!

Completely new listings of catalogs, new phone numbers, new addresses, new manufacturers, sales reps, and distributors! The total market in a book—four directories in one!



**The only book of its kind in the field.**

**If you haven't got it, you're not in the market.**

**To insure prompt delivery enclose your check with the coupon now.**

Yes, please send me \_\_\_\_\_ copies of 1980 EBG.

I've enclosed \$30 per copy delivered in USA or Canada. Address: EBG, 1221 Avenue of the Americas, New York, N.Y. 10020.

I've enclosed \$52 for air delivery elsewhere. Address: EBG, Shoppenhangers Road, Maidenhead, Berkshire S16, 2Q1 England.

Name \_\_\_\_\_

Company \_\_\_\_\_

Street \_\_\_\_\_

City \_\_\_\_\_

State \_\_\_\_\_

Zip \_\_\_\_\_

Country \_\_\_\_\_

## New products

memory and extended Basic interpreter. A cabinet, extra power supply, motherboard, and fan are available to original-equipment manufacturers for \$1,250.

Campbell Scientific Inc., P. O. Box 551, Logan, Utah 84321. Phone (801) 753-2342 [385]

### 10-bit d-a converter comes on monolithic chip

A digital-to-analog converter built as a monolithic integrated circuit contains all the elements required for d-a conversion, offering 10-bit resolution and accuracy to  $\pm 0.1\%$ . The NE5020 includes such necessary features as a voltage reference, application resistors, output-summing amplifiers, databus-compatible latches, and an input buffer amplifier. The matched application resistors allow scaling of either unipolar (0-to-10-v) or bipolar ( $\pm 5$ -v) output values. The low-loading latches, adjustable logic thresholds, and addressing capability permit direct interfacing with most microprocessor and logic-controlled systems. The settling time for the unit is 5  $\mu$ s; monotonicity is guaranteed over its full operating temperature range, which is 0° to 70°C.

The NE5020 comes in a 24-pin dual in-line package. When ordered in quantities of 100 units, each IC sells for \$12 in a plastic package and for \$14 in ceramic. The converters are available from stock.

Signetics Corp., 811 East Arques Ave., P. O. Box 409, Sunnyvale, Calif. 94086. Phone (408) 739-7700 [384]

### Eight-channel d-a system is compatible with PDP-11

A single-board, eight-channel, 12-bit digital-to-analog converter system features full backplane and software compatibility with Digital Equipment Corp.'s PDP-11 minicomputers and Unibus. The model DT1716 is mounted on a quad-sized board. Each of its independent channels

operates under PDP-11 program control and includes a 16-bit data-input register; the base address is jumper-selectable.

The system comes with either voltage- or current-output d-a converters. The voltage-output version can be wired to deliver a unipolar output of 10 v at 10 mA full scale for straight binary input codes or a bipolar full-scale output of  $\pm 10$  v at  $\pm 10$  mA for either offset binary or 2's complement digital input codes. The current-output converter versions deliver 4 to 20 mA in response to straight binary digital codes.

In either version, the converter features linearity to within 0.02% of full scale and a differential linearity to within  $\frac{1}{2}$  least significant bit, with settling time for a full-scale unipolar step of 35  $\mu$ s. The \$1,695 converter system is available from stock, and the price includes appropriate software diagnostics.

Data Translation Inc., 4 Strathmore Rd., Natick, Mass. 01760. [386]

### \$4,500 data-logger has display, keypad, printer

Depending on the configuration, a calculating data-logger—the Auto-data Ten/5—is priced from \$4,500. The unit comes with a 32-character alphanumeric display, a 56-character keypad, and a printer. Twenty user-programmable MX + B scaling functions provide true engineering units. When an optional Mini-Mathpack software package is added, the Ten/5 can calculate point difference, data averaging over time, digital averaging of a group of measurement channels, and square root. It can also add, subtract, multiply, and divide.

The basic unit includes an alarm package with three alarm modes, four set points per channel, an individually assignable deadband, and the ability to put out the alarm in English. Delivery of the Ten/5 is set for 60 to 90 days.

Acurex Corp., 485 Clyde Ave., Mountain View, Calif. 94042. Phone (415) 964-3200 [387]



# POLYSULFONE PCB SUBSTRATE GIVES

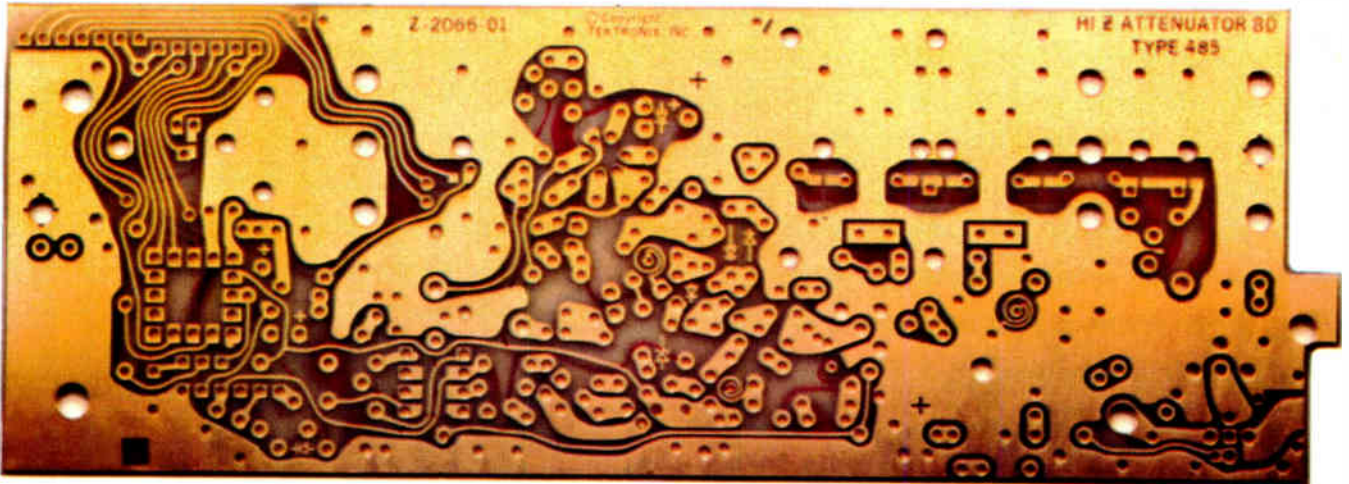

## PERFORMANCE CLOSE TO PTFE/GLASS,

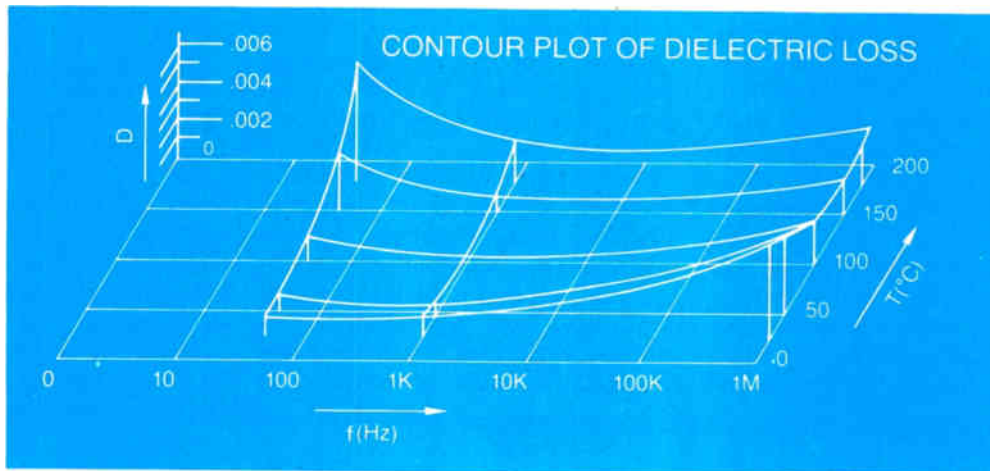

## AT A PRICE CLOSER TO EPOXY/GLASS

When you're looking for high performance in PCB's—particularly in high frequency applications—a polysulfone substrate can give it to you at far less cost than PTFE/glass. Polysulfone has excellent electricals: low dielectric constant and low dissipation factor for low loss (see graph). It withstands hand and wave soldering (500°F. bath for 5 seconds).

Polysulfone can be easily extruded for PCB substrate, and easily drilled. Copper-clad laminate of polysulfone has good peel strength and low z axis expansion. It can be processed by subtractive, semi-additive and fully additive processes. (Copper-clad sheet is available from Norplex.)

You can also  *mold*  polysulfone for PCB's with standoffs, holes of all sizes, and in almost any shape—to save finishing and machining time.

And cost is modest. Tektronix saved \$120,000 annually by switching from polyphenylene oxide to extruded UDEL® Polysulfone.

For full data on UDEL Polysulfone for PCB and other electric/electronic applications, use the coupon below or the reader service card.

UNION CARBIDE CORPORATION  
Engineering Polymers, Dept. PE 7-80  
270 Park Avenue, New York, NY 10017

I'd like to get high performance in PCB's at lower cost. Please send me bulletin on UDEL® Polysulfone.

Name \_\_\_\_\_ Title \_\_\_\_\_  
Company \_\_\_\_\_  
Street \_\_\_\_\_  
City \_\_\_\_\_  
State \_\_\_\_\_ Zip \_\_\_\_\_ Phone \_\_\_\_\_

UDEL® is a registered trademark of Union Carbide Corporation.

**PEOPLE PLANNING THE FUTURE.**



Engineering Polymers

Circle 217 on reader service card

Industrial

## Tape system aids minicomputers

A cartridge tape unit provides an economical disk-store alternative

For industrial and laboratory data logging, program loading, and similar applications, disk stores can be inappropriate or too costly. Thus ADAC Corp.'s new 2000TU cartridge tape system should interest cost-conscious minicomputer users, especially those with Digital Equipment Corp. hardware; the 2000TU is directly compatible with DEC's PDP-11/03 and -11/23, as well as with the LSI-11 and -11/2.

The firm's 2000TU is supported by DEC's TU-58 tape-store software and is compatible with the RT-11 operating system used with several LSI and PDP series minicomputers. Thus, a purchaser can simply add a 2000TU to an existing system and

start using it.

The 2000TU is complete. Offered for benchtop installation or rack-mounting and in single- or dual-cartridge models, it is packaged with interface control circuitry and a power supply. The controller is based on an 8085 microprocessor, which manages all motor and tape-head control, read-write electronics, and much of the host-peripheral communication.

Servo-regulated speed and direction circuits are controlled by the microprocessor, using signals from the tape and tachometer readouts for reference. These power the cartridge-drive motors. Further, current-limit sensing in the motors protects the tape if it should bind; an "anti-runaway" timer halts the tape during winding or searching operations if the feeding spool stops, preventing breakage.

Firmware control for the microprocessor resides in a 2-kilobyte read-only memory that also is partitioned to act as data-buffer memory.

Data storage is block-oriented, much like some disk systems and similar to DECTape. Each cartridge stores 262 kilobytes of data in 512-

byte blocks; a two-drive 2000TU thus has a 524-kilobyte capacity.

The drives read at 30 in./s and search at 60 in./s. This searching speed, plus the fact that data is requested by block address, makes for fairly fast data retrieval. Since the system need not search an entire length of tape to find a file every time a request is made, access time is faster, falling to a typical 9.3 s. The worst-case access time is 28 s.

The host computer and controlling microprocessor communicate through what is called a radial-serial protocol, which formats byte sequences into the data and command packets. This simple formatting method makes for high-level, host-peripheral interaction at a relatively low cost.

Communication between the 2000TU and its host is via a full-duplex, four-wire asynchronous link with selectable throughputs of 150 bauds to 38.4 kilobauds. Users can also select send and receive rates conforming to the Electronic Industries Association's RS-232 and RS-423 standards.

Though already back-ordered, the 2000TU's delivery time is quoted as 45 to 60 days. A single-drive, benchtop unit costs \$1,195, and a dual-drive benchtop store is priced at \$1,395; add \$180 for rack-mounted versions.

The ADAC Corp., 70 Tower Office Park, Woburn, Mass. 01801 Phone: (617) 935-6668 [371]

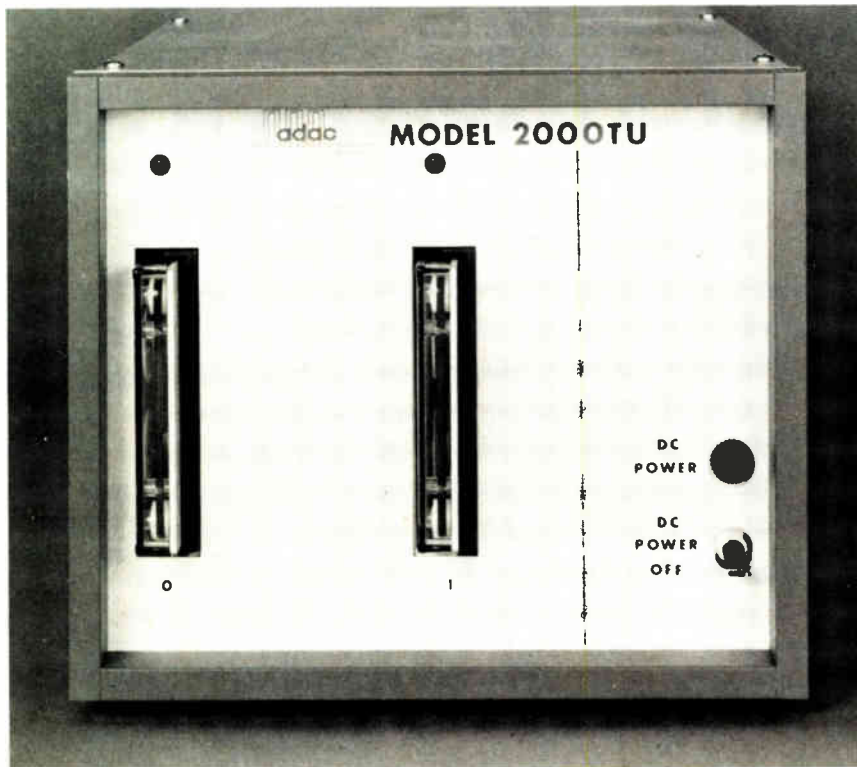

## Signal averager computes simultaneously or concurrently

The model SA-02A signal averager can convert, factor, equate, formulate, continuously average, or perform any other arithmetic or algebraic computation using the input signal as an operand. And it does so concurrently or simultaneously within the sampling period. The concept of process measurement and control using arithmetic predictions within the time constants of the process variable is not new, but it is difficult to implement. The manufacturer



# New AIRPAX linear actuators give your designs a better break.

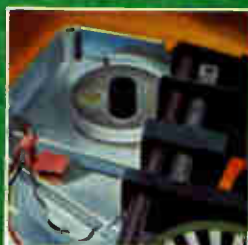

Control critical linear movements digitally.



Introducing AIRPAX digitally stepped linear actuators for precise, positive control of linear movements. Now you can get accurate positioning with resolution in steps of 0.001" to 0.004" per pulse. Linear force from 15 oz. to 19 lbs. Strokes from 1/2" up to 3" or more.

New AIRPAX linear actuators can be operated by a microprocessor to provide the finesse you need for computer peripherals, medical instrumentation, precision valve operation, HVAC systems, automotive carburetor controls or other applications with critical linear motion requirements. Besides affording extreme accuracy, these linear actuators reduce the number and complexity of components required. You will simplify your systems and reduce overall costs. Unipolar drive is standard; bipolar drive can be specified for increased force.

Write for free linear actuator catalog. We'll point you in the right direction; you take it from there. AIRPAX/North American Phillips Controls Corp., Cheshire Industrial Park, Cheshire, CT 06410. Phone (203) 272-0001.

## AIRPAX

Linear Motion and Control Division

Cheshire Division

Circle 218 on Reader Service Card



The source for...  
**DEFENSE ELECTRONIC  
 PRODUCTS AND SERVICES**  
 U.S. Suppliers  
 1980

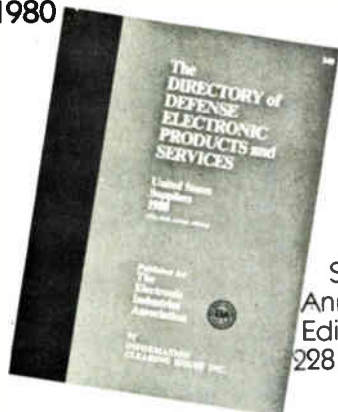

Sixth  
 Annual  
 Edition  
 228 pp.  
 \$40

The only technical sourcebook of its kind, covering more than 40 categories of U.S. defense products and services.

Sixty major U.S. suppliers provide detailed specifications and some 300 illustrations in such categories as...

- Command and control • Communications, including data communications • Displays • EW
- Fire control • Maintenance services • Navigation • Radar
- Recorders • Systems engineering • Telemetry • Test equipment and instruments
- Training aids and simulators
- Plus...cross-index and five appendices.

**Order your copy today!**

**The Directory of Defense  
 Electronic Products and  
 Services, 1980**

Electronics Magazine  
 1221 Ave. of the Americas  
 New York, NY 10020 USA  
 Please ship \_\_\_\_\_ copies of  
 "The Directory of Defense  
 Electronic Products and  
 Services, 1980" at \$40 each,  
 postage and handling included.  
 Non-U.S. orders add \$14 for  
 air shipment.  
 Payment must accompany order,  
 checks payable to **Electronics**.

\_\_\_\_\_  
 Name/title

\_\_\_\_\_  
 Company/organization

\_\_\_\_\_  
 Address

\_\_\_\_\_  
 City/postal code/state/country

**New products**

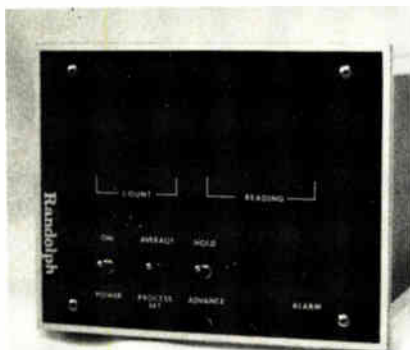

**Pocket-sized thermometer  
 has 34 thermocouple probes**

A pocket-sized digital thermometer comes with more than 34 interchangeable fast-response, type K thermocouple probes. The system measures the temperature of surfaces, liquids, powders, and gases over a range of 0° to 1,370°C. It is available with either light-emitting-diode or liquid-crystal displays and has a resolution of 1°C and an accuracy of  $\pm 0.3\% \pm 1$  digit. The system sells for \$395 and delivery time is two weeks.

Wahl International Ltd., 5750 Hannum Ave.,  
 Culver City, Calif. 90230. Phone (213) 641-  
 6931 [375]

**Solid state I/O modules  
 provide 4,000-V rms isolation**

A series of 12 solid-state input/output modules provides a photo-isolated, 4,000-v root-mean-square, noise-free interface that links microprocessors, programmable controllers, and other computerized controls to industrial systems. Of the 12 modules, six have a built-in buffered input that simplifies interfacing with low-level TTL circuits. The buffered output modules are available in both inverting and noninverting types. The 3.5-A output modules run approximately 20 degrees cooler than conventional units. The derated maximum output of 3.5 A is 0.0545 A/°C above 45°C. The modules' voltage outputs are 60 v dc and 120 and 240 v ac. A 30% hysteresis factor blocks most transient signals.

Housed in color-coded molded cases measuring 1.7 by 1.25 by 0.6 in., a row of 24 modules can be mounted in a standard 19-in. relay rack. A straight-line pin arrangement facilitates printed-circuit board mounting. The series 6 modules range from \$7 to \$10 each in quantities of 100 or more.

Crydom division of International Rectifier,  
 1521 E. Grand Ave., El Segundo, Calif.  
 90245. Phone (213) 322-4987 [376]

believes this instrument will ease the use of the concept.

The instrument can be used for pollution monitoring. By simply inserting a programmable chip, the SA-02A performs the measurement conversion equations for sulphur dioxide, nitrogen oxides, and mixed fuels, concurrently with each measurement. The instrument's front panel has a seven-digit light-emitting-diode display. The signal averager sells for \$2,785 and delivery is from stock to 12 weeks.

E. A. Randolph & Associates, P. O. Box  
 15432, Baton Rouge, La. 70895. Phone  
 (504) 924-6206 [373]

**Servo controller IC does  
 time-division multiplexing**

The ZN419CE monolithic integrated circuit is a low-priced servo controller that requires few external components and performs time-division multiplexing. Selling for only \$2.20 each in lots of 1,000 and \$3.25 each in lots of 100, the device can be used for both consumer and industrial remote-control applications, such as model cars and airplanes.

Mounted in a 14-pin dual in-line package, the device has such features as low power consumption (typically a 7-mA quiescent current drain with a 4.8-v supply), high-current complementary output drive, Schmitt trigger input shaping, and on-chip precision voltage regulators. Delivery of the ZN419CE takes from four to eight weeks.

Ferranti Electric Inc., Semiconductor Products,  
 87 Modular Ave., Commack, N. Y.  
 11725. Phone (516) 543-0200 [374]



## WITH OUR MODEL 101, TAPE MANAGEMENT AND CALIBRATION ARE FAST AND EASY, TOO.

Here's the instrumentation portable so self-contained, it even has its own  $\mu$ P. And all the calibration equipment you'll ever need, built right in.

And at the touch of a button, the Model 101 automatically checks itself and tells you what, if anything, needs adjustment.

Honeywell's  $\mu$ P-controlled Model 101 boasts such automatic tape management and data handling features as programmable selective track recording, shuttle, transport sequencing, and preamble.

Remote control? Get any of three popular



Calibrate in half the time with only a screwdriver or tweaking tool.

computer-compatible interfaces: the RS-232C, the RS-449, or the IEEE 488.

The Model 101 comes with long-life solid ferrite heads, shock-isolated deck, eight tape speeds—from 15/16 to 120 ips—and large reel capacity for up to 32 hours of recording. Up to 32 data channels—wideband or intermediate band.

Compare the Model 101 with your present tape system and see what a difference the  $\mu$ P makes. Want more? Contact Darrell Petersen, Honeywell Test Instruments Division, Box 5227, Denver, Colorado 80217. Phone 303/771-4700.

**WE'LL SHOW YOU A BETTER WAY.**

# Honeywell

## New products/materials

A series of epoxide adhesives has a wide range of specifications that makes it useful for industrial, structural, and electrical bonding applications. Intended for the end user, the AR 1001-4 series has a tensile strength of 3.0 by 104 psi and a flexural strength of 5.1 by 104 psi. The materials exhibit good thermal properties, passing the thermal shock specification of MIL-I-16923 and having a thermal conductivity of 3.0 BTU/hr/ft<sup>2</sup>/°F/in. The adhesives also have an Izod impact of 4.0 ft-lb/in. Bond strength of the materials at 25°C ranges from 750 psi to where the substrate fails before bond failure. The materials can be cured for 24 hr at room temperature, ½ to 1 hr at 150 to 160°F, and 15 to 30 min at 200 to 220°F.

Prices for the series are \$12.84, \$16.05, \$21.40, and \$69.95 per kit in



1-lb, 2-lb, 4-lb, and 16-lb quantities. The materials are also available in 5-gallon pails and 55-gallon drums. Formulated Resins Inc., P. O. Box 508, Greenville, R. I. 02828 [476]

A potting material—an organic-inorganic cross-linked polymer—has a



heat distribution point of 300°C. Aremco-Cast 554 can be cured at a low temperature of 105°C, which is an advantage when potting temperature sensitive components. The material can be thinned with MEX or acetone and filled with ceramic fillers such as alumina. Typical applications for the potting material include potting high-temperature transformers, thick-film hybrid circuits, and bonding radomes. The material is available from stock at \$225 a gallon, the minimum order.

Aremco Products Inc., P. O. Box 429, Ossining, N. Y. 10562 [477]

A heat-sink compound for mounting components, including semiconductors, transistors, diodes, and rectifiers, exhibits no particle migration or fluid separation. The EFD #70 heat-sink silicone-free material has  $16.7 \times 10^{-4}$  calories/cm<sup>2</sup>/°C/s/cm thermal conductivity and a 220 v/mil dielectric strength over a -50° to +200°C operating temperature range. Meeting Western Electric specification

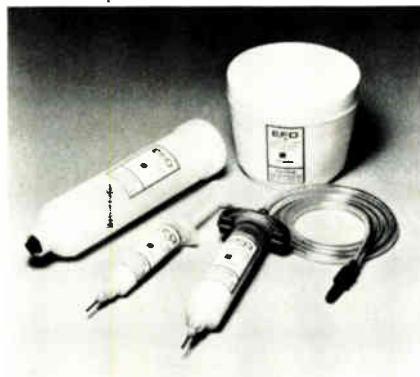

KS21343, the synthetic, metal-oxide-filled ester-based grease is rated at 0.09% maximum bleed and 0.6% maximum evaporation at 200°C for 24 hrs. Shelf life of the material is 24 months at 24°C. The heat-sink compound sells for \$9.54 each (10-49 barrels) for a 75-gram, 30-cc barrel.

Electron Fusion Devices Inc., 977 Waterman Ave., East Providence, R. I. 02914 [478]

An electrically conductive coating that can be applied and cured at room temperature exhibits good adhesion to such substrates as injec-

tion-molded polycarbonate, polystyrene, and ABS without crazing or degrading the plastic. X-Coat 210-X has a cured resistance of 0.5Ω/sq at a thickness of 2 to 3 mils. Since the material contains no silver or other precious metals, the manufacturer suggests that it be used in business machines to shield against radio-frequency interference and in plastic automotive components where electrical conductivity is required for rf suppression. The material is available in volume for \$75 per gallon, or less than 30¢ per ft<sup>2</sup>.

Electro-Kinetic Systems Inc., 1000 Herald Square, Aston, Pa. 19014 [479]

A high-temperature sealant can be used at temperatures up to 1,400°F. Aremco-Coat 567 consists of a silicone binder, glass frits, and a ceramic base. It adheres well to ceramic and metals and is used as a moisture sealant for porous ceramic insulation like the alumina, silica, and magnesium oxide used in heating elements, thermocouples, and thermometers. The silicone in the 567 material acts as a moisture barrier to 700°F; above that temperature the glass frits melt, maintaining the integrity of the seal up to 1,400°F. The sealant is available from stock in pints (\$30), quarts (\$45), and gallons (\$85)

Aremco Products Inc., P. O. Box 429, Ossining, N. Y. 10562 [480]

Vulcanized strip gasketing—a combination of silicone rubber with knitted metal mesh—shields against electromagnetic interference. The Combo Seal strip gasketing does not separate, thus retaining its structural integrity as well as its flexibility in corona- and ozone-laden atmospheres, moisture, and steam, as well as after prolonged weathering and aging. The material has a shielding effectiveness of up to 90 dB, between 10 kHz and 1 GHz, and under 20-psi pressure. It has a specific gravity of  $1.13 \pm 0.03$ . The gasketing offers a peel strength of 3 lb per linear in. and meets the specification for silicone rubber: MIL-R-5847, Class II, Grade 50.

Metex Corp., 970 Durham Rd., Edison, N. J. 08817 [475]



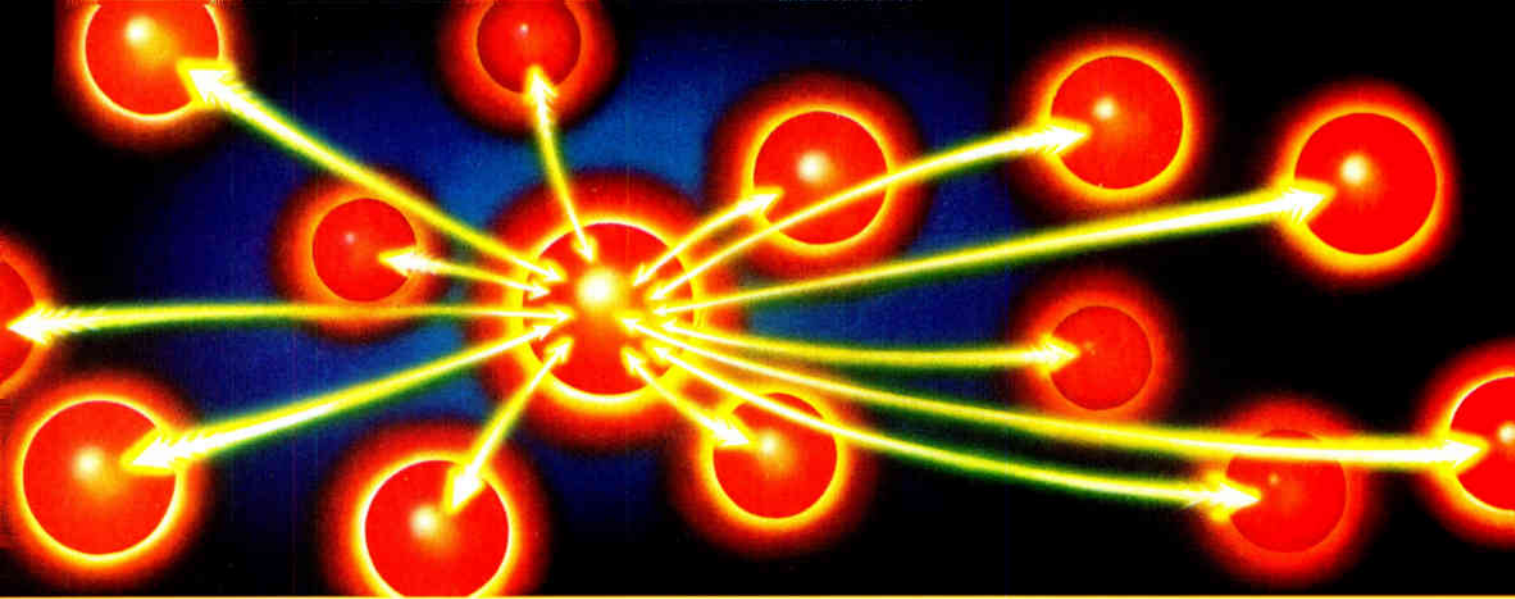

# Managing to cover all bases.

Expansion. Diversification. Acquisition. Growth. As a business becomes more complex, its information management needs expand exponentially. The more locations involved, for example, the greater the need for centralized control of intercity communications.

Many corporations seeking ways to increase productivity, while controlling communications costs at all locations, are converting to Bell's Dimension® PBX.

With Electronic Tandem Switching, it provides an integrated system with over 150 customized management and control capabilities. Its stored programs bring cost-saving features to the network, add time-saving functions to existing telephones. Long distance calls automatically take the least expensive routes. Calls that encounter busy signals are redialed electronically. Detailed calling records facilitate the allocation of charges. And each company as well as each of its locations can modify its own system without calling in Bell installers.

We have applied such advances for some of America's leading businesses, integrating many divisions, plants, warehouses and service centers into one total system.

That's our business—applying a knowledge of networks and advanced communications to the specialized information management needs of your business.

It's a process that starts with a call to your Bell System Account Executive.

## The knowledge business



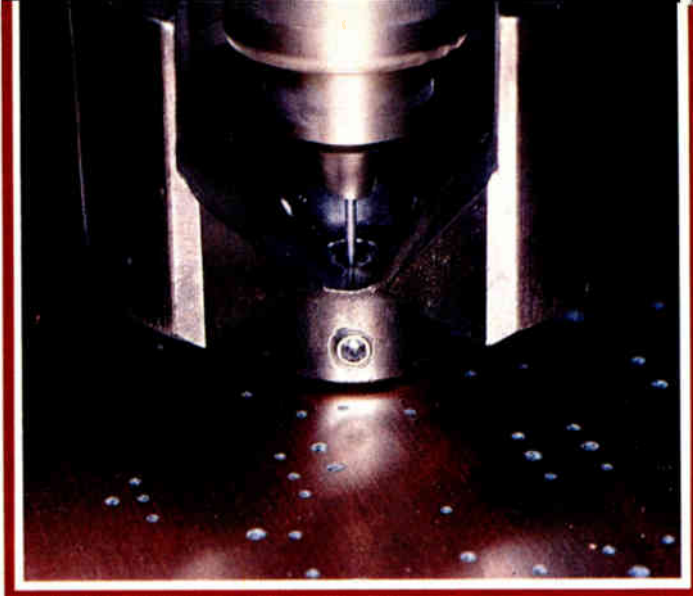

# THE HOLE TRUTH

## New GE Engineered FR-4. An advanced laminate designed to reduce drilling abrasion, improve thru-hole quality, and lower processing costs.

Now there's a PC board laminate with even better processing qualities than conventional FR-4. It's the new *Engineered* FR-4 epoxy-woven glass laminate from General Electric.

You can process Engineered FR-4 in exactly the same way as conventional FR-4, and tests by PC manufacturers have shown that you can enjoy improved yields and substantial productivity benefits.

The key to these benefits is a GE discovery: an exclusive epoxy adhesion promoter that greatly enhances the 3-D bonding of the epoxy resin to itself, and to the woven glass layers. The resulting uniform matrix gives the laminate much greater integrity than possible before.

As a result you can expect greater thermal shock resistance and reduced tendency toward delamination during processing. But the

opportunity for cost reduction is greatest in the drilling and plating-thru operations. Less abrasion encountered during drilling means reduced heat generation and longer drill life. This is illustrated in the 260X photomicrographs below. Note differences in tip sharpness and wear.

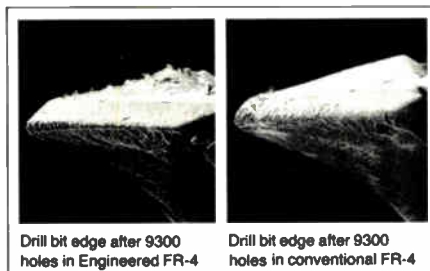

Drill bit edge after 9300 holes in Engineered FR-4

Drill bit edge after 9300 holes in conventional FR-4

Because there is less drilling abrasion and less heat generated, the quality of thru-holes is greatly improved. With Engineered FR-4, there is less resin smear, rifling, void

formation; and fewer torn glass bundles. This in turn provides a superior, more uniform surface for electroless copper plating.

New Engineered FR-4 is the first of a series of technology-oriented PC laminates designed to keep you ahead of today's application requirements. And it's now being produced at our high-capacity plant at Coshocton, Ohio. The unique GE Laminate Technical Center is located there, too, with sophisticated R&D instrumentation devoted to solving your PC processing problems.

See the hole truth for yourself. Contact us for a detailed brochure, and to arrange a trial run of new Engineered FR-4 at your facility. General Electric Company, Laminated and Insulating Materials Business Department, Box EL-7, Coshocton, Ohio 43812.

**GE LAMINATES: THE DIFFERENCE IS TECHNOLOGY**

**GENERAL**  **ELECTRIC**

### **Mostek accepts customer codes for 8-K-by-8-bit ROM**

Mostek Corp., Carrollton, Texas, is accepting customer codes for the MK37000, an 8-K-8-bit read-only memory. Housed in a 28-pin package, the device will be **pin-compatible with the company's forthcoming 64-K erasable programmable ROM**—the MK2764—which is expected later this year. The 37000 was built using Mostek's 5- $\mu$ m n-MOS Poly R process. It is essentially a repinned version of the company's 24-pin 64-K ROM, the MK36000, but contains an output-enable control not found on the earlier part. A 300-ns version is available already, priced at \$19.60 each in 1,000-unit quantities.

### **Sanders gets into raster-scan displays**

Sanders Associates Inc., Nashua, N. H., is venturing out of its stroke and refresh display technology into raster scanning with its newest high-resolution graphics display system. Thanks to a low-cost semiconductor memory, the new display—Graphic 8—retains the high resolution offered by stroke and refresh displays (it has a maximum resolution of 1,024 by 1,024 pixels) while attaining the high refresh speeds of raster-scan techniques—in this case, 60 Hz without interrupting the display. **The Graphic 8 can display up to 256 colors on its 19-in. screen.** A built-in bipolar bit-slice processor supports distributed networking, and software packages allow graphics programming independent of a host computer, as well as independent test routines. The system, which will be ready for delivery by the first quarter of 1981, includes a controller, serial RS-232-C interface, keyboard, and display monitor for less than \$23,000.

### **IBM offers Cobol compiler for System/38 computers**

International Business Machines Corp.'s General Systems division in Atlanta has a System/38 Cobol compiler that incorporates ANSI 1974 Level 2 functions. The program, available in May 1981 for a monthly license charge of \$140, **operates with the System/38's Control Program Facility operating system.** The program consists of a compiler that can perform syntax checking in batch mode and in interactive mode using the system's Source Entry Utility. A sort and merge utility is also available, and System/38 Cobol users may use communications under Systems Network Architecture with the Synchronous Data Link Control protocol.

### **Nixdorf portable computer converts to data terminal**

A communications module from Nixdorf Computer Corp., Burlington, Mass., transforms the company's LK-3000 hand-held personal computer into a portable data terminal. With the new unit, **the system will be able to access real-time data from remote locations.** The LK-2010 module, which uses a standard RS-232-C interface, communicates with any computer using an acoustic coupler over telephone lines. It operates at 110 or 300 b/s with self-contained protocol software such as for Teletype and the TRS-80. Together, the computer and module sell for \$335.

### **Chromatics color terminals get CP/M, increased memory**

Chromatics Inc. of Atlanta is offering CP/M operating software and up to 96 kilobytes of user memory as options on all its microprocessor-based color graphics computers. The memory option will **add 64 kilobytes to the amount of user memory currently available on Chromatics systems.** It will be priced at \$1,500 per 32-kilobyte increment. The CP/M option, already used in the recently introduced model 3999 high-resolution terminal [*Electronics*, May 22, p. 174], will cost \$350.



# Classified section FOR ENGINEERING/TECHNICAL EMPLOYMENT OPPORTUNITIES



**WE'RE BRIDGING THE GAP IN VOICE & DATA TELECOMMUNICATIONS AT GTE LENKURT IN DENVER.**

GTE Lenkurt, a leader in the field of telecommunications, invites you to join us at our new location in Denver, Colorado. This unique opportunity exists for individuals who can contribute to the establishment of our product lines, and to the development of this new division. Products including voice signaling, data transmission/distribution, and terminating telecommunications equipment require innovative designs using the latest state-of-the-art technology for both electronic and packaging design. Some of the openings currently available include:

**Engineering Technology Manager**  
MSEE or its equivalent and minimum 5 years electronics experience in supervisory capacity. Telecommunications and CAD experience preferred.

**Manufacturing Engineering Manager**  
BSME or BSIE or its equivalent and 7 years

manufacturing/industrial experience including 5 years as manager.

**Instrumentation Manager**  
MSEE or its equivalent and 7 years experience in engineering development and manufacturing support for instrumentation with minimum 3 years in supervisory capacity.

For immediate consideration on these positions and other positions available, please forward your resume, including salary history to:

**Ms. Charlotte Delinger**  
GTE Lenkurt, Inc.  
876 Ventura Street  
Aurora, Colorado 80011  
An Affirmative Action Employer M/F/H/V

**GTE Lenkurt Incorporated**  
**GTE** Communications Transmission Systems

## Your Ultimate Choice

### TELEPHONE ENGINEER

Salary Area \$30,000

A leading integrated oil company is seeking an electrical engineer to furnish technical support in all aspects of the company's telecommunications equipment, including consultation services for overseas projects. Significant experience in telecommunications is the key to this challenging opportunity which is accompanied by a profit sharing plan and other outstanding benefits.

For further information, please contact our Engineering Specialists, Glen Bixler or Bill McDaniel at (713) 943-2860.

ALL FEES ASSUMED BY COMPANIES

*M. David Lowe*  
PERSONNEL SERVICES

435 Houston Natural Gas Building  
1200 Travis  
(713) 943-2860  
Houston, Texas 77002

### ELECTRONICS ENGINEERS

If you are an engineer looking for upward career mobility, call us. We specialize in electronics/aerospace nationwide. All fees assumed by our clients. Submit resume in professional confidence to: Jim Crumpley/Gayle Smart

**Dorsey Love & Associates, Inc.**  
P.O. Box 4387 G.S.  
Springfield, Mo. 65804

Our nationwide search firm would like to confidentially represent you to the most prestigious, progressive companies in the U.S. Many different on-going projects for the experienced Engineer.

MICRO PROCESSORS    ANALOG  
SOFTWARE                SEMI-CONDUCTORS  
HARDWARE                DIGITAL  
COMMUNICATIONS

Salary \$18-45K. Affiliates in all major cities.



**PENTAD**  
Darryl Lustig  
3315 Algonquin Road  
Rolling Meadows, IL 60008  
(312) 259-8696

### ELECTRONICS SPECIALIST

To repair and maintain in-plant minicomputer systems. B.S. degree or 2 years technical schooling and a minimum of 2 years experience are required. Familiarity with general automation, interdata or DEC equipment is a plus. Our maintenance responsibilities include disk drives, CRTs and various special purpose electronic devices. Assistance and training are provided. No travel, component level repair, and design opportunities make this position a step above field engineering. Send complete resume and salary requirements to:

**P-2572, Electronics**  
Classified Advertising Dept.  
P.O. Box 900, N.Y., N.Y. 10020

### ENGINEERS

- Design
- Avionics
- Systems
- Test
- Communication
- Digital
- Analog
- Micro Processing

Our specialty is placing engineers with electronic and agricultural machinery companies. Engineering positions available anywhere in the United States. Companies pay for interview, relocation and fees.

Send resume to  
**ALPS PERSONNEL INC.**  
235 S. Maitland Ave., Suite 113  
Maitland, Fla. 32751 Ph. (305) 628-2577



# TIRED OF BEING BOXED IN? FORD AEROSPACE AND COMMUNICATIONS CORPORATION HAS SPACE FOR YOU!

Ford Aerospace & Communications Corporation, a leader in space information systems, has room for talented people, like you, who want limitless challenges. Since 1963, Ford Aerospace has been instrumental in all phases of ground-based support systems that have helped man and machine share information across the far reaches of space. We were the principal company responsible for the development, design, manufacture of equipment, installation, and continued maintenance and operation of NASA's Johnson Space Center Mission Control Center.

Our challenges continue with exciting programs like the redesign of the Mission Control Center to support the Space Shuttle—the transportation system of tomorrow. We're developing the Payload Operations Control Center "POCC" to monitor the many experiments that will be performed on the Shuttle.

These programs are part of the career opportunities at Ford Aerospace. Currently we have openings for the following professionals:

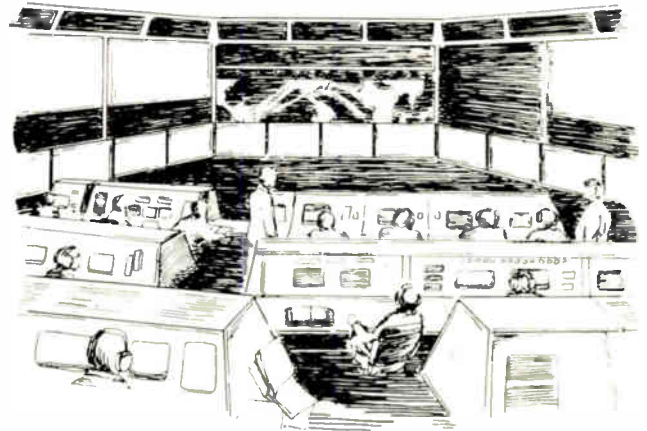

**Digital Design Engineers**

**Systems Engineers**

**Engineering Designers**

**Mission Planning Analysts**

We offer competitive salaries, an outstanding benefits package, and the convenience of living in the Clear Lake area, just 25 miles southeast of downtown Houston. If you want the challenges of space, or just want more space to advance your career, CALL COLLECT, John Brown (713) 488-2119 or (713) 486-6228, or Ted Sarno, (713) 486-6219 or send resume in confidence to Ford Aerospace & Communications Corporation, P.O. Box 58487, Dept. AJH, Houston, Texas 77058. We are an equal opportunity employer, m/f.

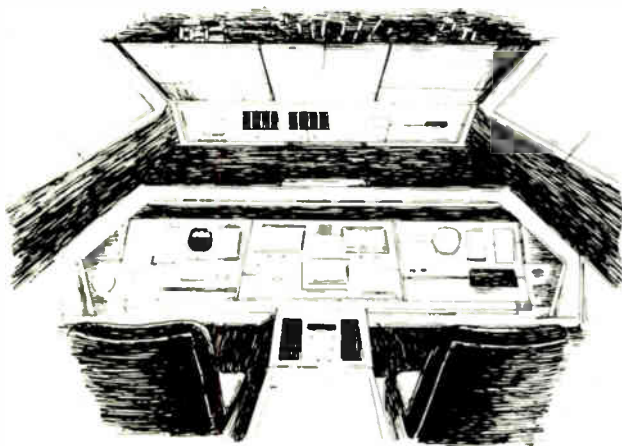

**Ford Aerospace &  
Communications Corporation**

Space Information Systems Operation

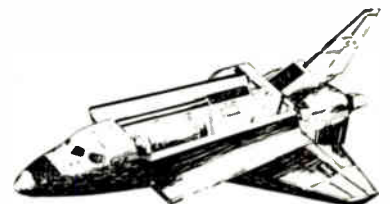

# There's Only One Way at STC... UP!

You seek a secure future with a stable organization offering a challenging work environment and exceptional growth potential. Combine that with the opportunity to live and work at the very base of the magnificent Colorado Rockies and to enjoy the summer and winter recreation these mountains provide, and you'll find yourself at STC. Currently we have openings for the following:

## ENGINEERS

- **Systems**
- **Test**
- **Quality**
- **Industrial**
- **Manufacturing**
- **Process**  
(PCB drilling, lamination, or semiconductor)
- **Development ELECTRICAL**  
(preferably with a background in I.C. design, read/write, semiconductor, thin film, tape or disk).
- **MECHANICAL**  
(servo, packaging, special tooling, tape or disk experience).

## TECHNICIANS

- **Engineering**
- **Manufacturing**
- **Quality**
- **SEM Equipment**
- **SC Process**
- **Electro/Mechanical**
- **HVAC**

## DESIGNERS/DRAFTSPERSONS

(Electro/Mechanical)

## PROGRAMMERS/ SYSTEMS ANALYSTS

(Both business & engineering oriented)

If you are the type of person who likes to see your ideas impact the industry, we want to hear from you. We offer an excellent compensation package including health & insurance benefits, stock purchase plan and more. For consideration please submit your resume in confidence to Mr. Bob Williams, STORAGE TECHNOLOGY CORPORATION, MD#29, E6/19, 2270 South 88th Street, Louisville, Colorado 80027, or call TOLL FREE 800-525-2940, Ext. 3169. We are an equal opportunity employer.



**STORAGE  
TECHNOLOGY  
CORPORATION**

## SIEMENS

### Colorado Opportunities

You will like our suburban location just 15 miles north of Denver where you can enjoy plenty of excellent hunting, fishing and skiing locations.

We are the world's fifth largest producer of electronic equipment and components and the fastest growing power semiconductor manufacturer in North America. We have immediate openings for Senior Application Engineer, Process/Product Engineers and Development Engineer.

### POWER MOSFET PROGRAM SENIOR APPLICATIONS ENGINEER

Experienced in switch mode circuitry plus transistor applications with a BSEE or equivalent required. Key member of Siemens SIPMOS program with responsibility for North American customer support and applications coordination with Siemens in Munich, Germany.

### PROCESS/PRODUCT ENGINEERS

To sustain yields and make process improvements on high power diodes and SCR's during an aggressive plant expansion. The successful candidates will have experience in one or more of the following areas: Wafer fabrication, assembly soldering, brazing, welding, final test, diffusion, metalization, junction contouring and surface passivation. Requires a BS Degree in Engineering or a related physical science, or equivalent experience, and a thorough understanding of process variables and their influence upon final device characteristics.

### DEVELOPMENT ENGINEER

Position encompasses a wide variety of duties with emphasis in developing materials, methods and processes for the semiconductor market. Experience in diffusion, alloying, and soldering is required. Experience in processing for glass passivation, plasma etching, schottky diode processes and photolithography is desirable.

Due to our aggressive plant expansion program we anticipate the need to recruit management, engineering and technical support positions. We offer excellent salary and benefit program which includes life, medical, dental and retirement plan. If you would like to join a team of skilled professionals who enjoy the technical support of a parent company such as Siemens, send work experience and salary requirements to the Employment Manager.

# Sitronix

A member of the Siemens Group

800 Hoyt Street

Broomfield, CO 80020

Equal Opportunity/Affirmative Action Employer

## ATTENTION ELECTRONIC ENGINEERS!!!

<b>Electronic Design Engineers</b>	<b>24-36K</b>
<b>Design Engineers (Digital)</b>	<b>25-35K</b>
<b>Analog Design Engineers</b>	<b>-25-35K</b>
<b>Systems Design Engineers</b>	<b>-28-35K</b>
<b>Electrical Design Engineers</b>	<b>-24-40K</b>
<b>Instrumentation Design Engineers</b>	<b>-25-40K</b>
<b>Test/Design Engineers</b>	<b>-24-35K</b>

Our clients are aerospace and electronic firms who pay our fees for locating engineers. For more information, send note or resume to Al Madsen, C.E.C.

### CORPORATE PERSONNEL CONSULTANTS, INC.

5950 Fairview Road  
Two Fairview Plaza, Suite 608  
Charlotte, North Carolina 28210  
(704) 554-1800



## MICROELECTRONICS ENGINEERS

# NCR has key openings at its LSI/VLSI R&D facility in Colorado Springs

If you prefer challenges to stop-and-go commuting, the NCR/Microelectronics operations for MOS wafer fabrication and assembly has openings you should investigate at once. You'll be joining a mature microelectronics organization that has established three full-scale multi-million dollar production facilities.

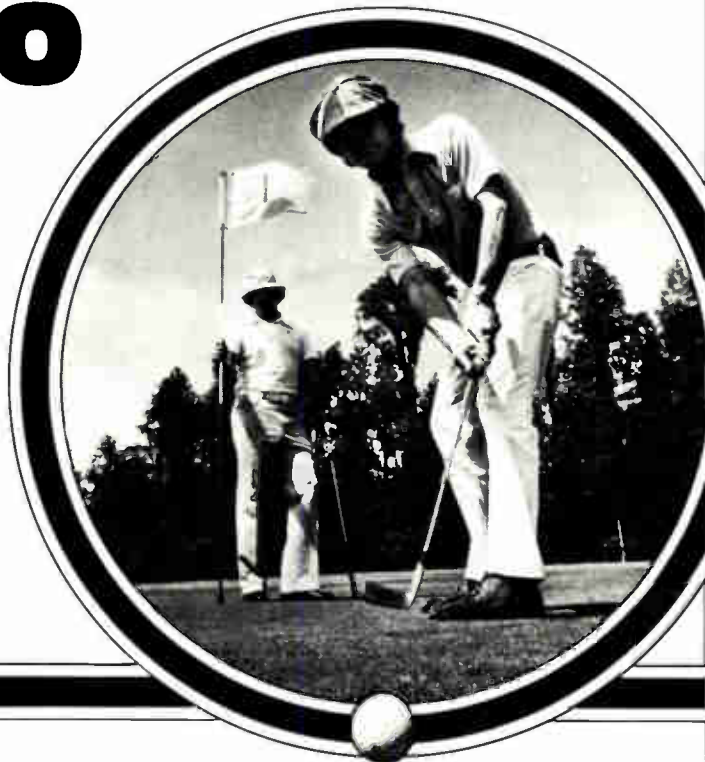

*We have immediate openings for:*

### **MOS/VLSI Circuit Design Engineer**

Project responsibilities in MOS/VLSI memory or logic circuit design in short channel NMOS or CMOS. Project responsibilities will be for full VLSI circuit designs from conception and customer interface to release to production. Candidate should be BSEE with a minimum of 2 to 5 years MOS circuit design experience with attendant processing knowledge and an understanding of its relationship to circuit design.

### **Product Engineers**

Set up and maintain interdivisional liaison to assist in test and evaluation of custom products. Develop internal specifications, analyze failures and recommend corrective action as required. Requires Bachelors' degree and 2-3 years related experience.

### **Diffusion Process Engineer**

Expertise must span all areas of diffusion processing—oxidation, boron and phosphorous diffusion, LPCVD systems.

### **Reliability and Failure Analysis Engineer**

BSEE and a minimum of 3-years experience in IC semiconductor analysis preferred. Will be responsible for the generation of statistical data on reliability IC's, life testing, failure analysis, and FA laboratory. Should have experience in management reporting techniques.

### **Photo Resist Engineer**

3-5 years in MOS photolithography, and experience in negative and positive resist systems, proximity/projection printing techniques and plasma etching.

### **Device Modeling**

Requires experience in process, device or circuit modeling, using computer simulation. Prefer a degree combination of electrical and solid state physics.

Modeling will be used to assist in the development of new devices, process and the enhancement of circuit performance.

• • •

Our Colorado Springs facility is an hours' drive South of Denver—located in one of the finest living environments in the U.S.

To investigate these exciting LSI/VLSI R&D opportunities first hand, send your resume and salary history in confidence to: Ms. Sue Grierson, Personnel Resources, Dept. 78K, NCR Corporation, Microelectronics, 2850 North El Paso Street, Colorado Springs, Colorado 80907.

# NCR

Complete Computer Systems

An Equal Opportunity Employer

ENGINEERS

# Expanded career opportunities are at your fingertips

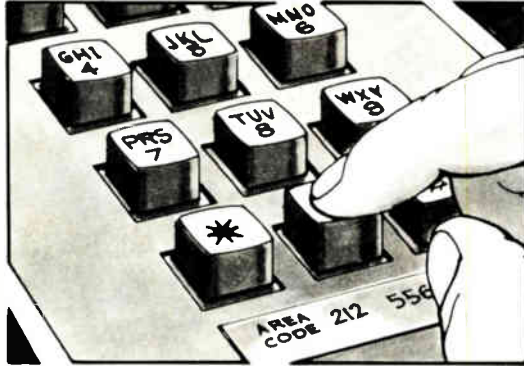

## call 800-321-6980

(In Ohio 800-362-6120)

**Talk to Tom O'Brien  
about your skills and background for,  
positions such as...**

**Software Engineers** Capitalize on your Comp. Sci. or related degree and apply your software experience – assembly languages, PASCAL, FORTRAN. Utilize our VAX 11/780 DEC 11/34 or TEKTRONIX Development Systems to support your designs.

**Hardware/Firmware Design Engineers** Design NC and PC systems employing advanced digital techniques. Degree and 2+ years experience desired. Your involvement would include design verification using VAX 11/780, DEC 11/34 or TEKTRONIX Development Systems.

**Application Engineers** Define customer control system requirements, prepare proposals and assist new product planning.

**Product/Marketing Engineers** Research and identify product opportunities based on industry requirements utilizing your degree and 2+ years of electronics or industrial experience.

These are opportunities with a future.

We are a dynamic part of an international corporation employing over 17,000 people. Our products apply "leading edge" computer and microprocessor technology that increases productivity for all types of industry.

**Our careers are challenging and rewarding...**

**Let's Talk About It – Call Today:** or if you prefer, send your resume to:



## ALLEN-BRADLEY

747 Alpha Drive  
Highland Heights, Ohio 44143

An Equal Opportunity Employer M F

### SOUTH & SOUTHWEST POSITIONS

Engineering and Management positions throughout the South, Southwest and U.S. Employers pay all fees. Send resume in confidence to: Bob Hogue. *personnel consultant*

*SouthWest Technical*

P.O. Box 33070,  
San Antonio, Texas 78233

### POSITIONS VACANT

**Electronics Engineer**—with rapidly growing R&D firm. \$29K-\$45K, B.S. plus several years experience and a background preferably in digital signal processing and/or microprocessor electronics. Will be responsible for the development of new digital signal processing to use with electro-optical sensors. Will involve the development of signal processing electronics for use with IR focal plane arrays to provide both readout and responsivity nonuniformity correction. Also will be involved in the development of signal processing for clutter rejection and automatic target identification for both IR search and track sensors and electro-optic missile seekers. Some microprocessor software experience is desired. This person will interface with exploratory development hardware efforts in his/her area of expertise. Contact: Dr. Mahaffey or Mr. Biosca at 301-927-4980 or send resume to: Sachs/Freeman Associates, 5809 Annapolis Rd., Suite 512, Bladenburg, MD 20710.

**Electrical Engineer/Instructor.** Qualifications: Electrical Engineer, Bachelor's Degree, Master's Degree preferred. Three years of applied experience in the design or application of engineering principles on electronic equipment or equal. Solid state and computer background as they relate to the communications field is desirable. Salary Range: depending upon training and experience. To apply send resume, transcripts and salary requirements in confidence to: Edward R. Maclosky, Director of Personnel, Springfield Technical Community College, One Armory Square, Springfield, MA 01105. An Equal Opportunity Employer.

**Computer Software Designers** needed immediately. Salaries to \$40,000. Computers and microprocessors. Fee paid. CAPA, 808 Downtowner Blvd., Suite G, Mobile, AL 33609.

### FACULTY POSITIONS VACANT

**Faculty Positions in Electrical Engineering Technology** Undergraduate teaching positions in electrical engineering technology available on August 16, 1980 in Tuscaloosa, Alabama at The University of Alabama. Teaching duties will be in the area of circuits and electronics and one or more of the following areas: power, controls, communications, digital electronics. Master's degree or equivalent and at least one degree in EE or EET desirable. Some recent relevant industrial experience required. Some teaching experience desirable. P.E. registration desirable. Although positions are tenure track, applications are desired from those wishing a temporary appointment for all or part of the 1980-81 academic year. Applicants should send a complete resume to: Dr. John D. Antrim, Director, Engineering Technology Programs, The University of Alabama, P.O. Box 1941, University, AL 35486. An EO/AA employer.

# A world of opportunity for tomorrow-minded Electronic Engineers at Martin Marietta Aerospace in Denver



You'll find a career with Martin Marietta secure, challenging and rewarding. Today, you could be working on any number of long-term projects including the Space Shuttle, Missile X, and in areas such as command and information systems, spacecraft, launch vehicles and solar energy.

And working in our Denver facility, adjacent to the Rocky Mountains, means you'll have every opportunity to enjoy a wide array of recreational activities, as well as educational and cultural facilities that rival any metropolitan area.

We have the following selective openings:

## **Ground Support Electronics Design Engineers and Power Systems Design Engineers**

### **Instrumentation Engineers**

A number of engineers are needed who have a BSEE and experience with a variety of transducers including strain gauges, accelerometers, position, acoustic, vibration, pressure and temperature instrumentation. Specific related design experience to process transducer signals should include analog signal conditioning, high rate digitizing, and high speed recording techniques. Specific tasks will include Instrumentation Subsystem design, requirements definition, interface definition, and vendor coordination. Commercial instrumentation experience is acceptable.

### **Ground Digital Systems Engineers**

A number of engineers are needed who have a BSEE. Background should include experience with ground digital equipment and test operations. Specific tasks should include system architecture design, requirements definition, test planning analysis and interface definition. Systems typically involve computers and associated peripheral equipment including displays, control consoles, RF equipment and power equipment.

### **Power Systems Engineers**

Requires BSEE or MSEE with five to ten years experience or equivalent in the design of power systems including the use of solar arrays, secondary batteries and complex distribution and power conditioning hardware. Good background in power management and power systems analysis is desirable.

### **Power Distribution & Cabling Engineers**

Requires experience in both electrical and schematic drafting as well as equipment and wire harness installation.

### **Power Conditioning Design Engineers**

BSEE or MSEE required. Requires at least 5 years experience in the design of power supplies, battery chargers and regulators.

### **High Voltage Power Supply Design Engineers**

BSEE or MSEE required. Experience in the design of power supplies ranging from 2KV to 30KV with both low and high power outputs.

### **Photovoltaics**

BSEE or MSEE required. At least 5 years experience in Photovoltaic related areas required.

### **Electrical Materials and Process Engineer**

BS degree or equivalent experience. Responsibilities include the evaluation, development, selection and application of materials and processes for aerospace electronic hardware. Engineers for all M&P disciplines including the following: Fiber Optics, High Voltage, and Organic Coatings & Encapsulants.

### **Communication Systems Engineers**

Will prepare specifications at the system and subsystem level for procurement by government agency. This position available at a government site in Maryland.

If interested please send your resume in complete confidence to: Martin Marietta Aerospace, Personnel Department, P.O. Box 179, Mail #D-6310, Denver, CO 80201.

An Affirmative Action Employer  
actively seeking the Handicapped and Veterans

**MARTIN MARIETTA**



# PROCESS ENGINEER

**Here's a chance  
to Pioneer  
Electronic Display  
Systems with  
NCR in  
Colorado  
Springs.**

NCR Microelectronics is not only a leading developer and producer of LSI/MOS devices and deeply engaged in developing the full potentialities of VLSI, but is also involved in the development and manufacturer of plasma display systems.

We have an important ground floor opportunity for a creative engineer to work with a small group of professionals in a developing technology. Background must include experience in thick film screen printing, screen making, and screen parameters and techniques. Must have 3 to 5 years manufacturing experience and BS degree in Physics, Chemistry or Engineering.

Our location is as stimulating as the work we're doing. Colorado Springs, just 40 miles south of Denver, offers one of the finest, 4-season living environments in the U.S.

Please send confidential resume and salary history to, or call **COLLECT Ms. Sue Grlerson, (303) 471-8440, NCR Corporation, Dept. 78P, 4750 Edison Avenue, Colorado Springs, Colorado 80915.**

# NCR

Complete Computer Systems



## COLORADO OPPORTUNITIES FOR ENGINEERS

Ball Aerospace Systems, a division of the Ball Corporation, is located in Boulder, Colorado - a community nestled in the foothills of the majestic Rocky Mountains. We are a leader in the development of space science instrumentation, electro-optics, antennas, military electronics, satellite systems and subsystems.

We are looking for top quality professionals who want to grow with a progressive aerospace organization

- ELECTRICAL ENGINEERS
- MECHANICAL ENGINEERS
- QUALITY ENGINEERS
- ANTENNA ENGINEERS

We offer excellent salary and benefits, including medical, dental and life insurance, a stock purchase plan, and four (4) weeks vacation

For more information about outstanding career opportunities, contact

### Aerospace Systems Division

Employee Relations Department  
P.O. Box 1062  
Boulder, Colorado 80306  
(303) 441-4111

An Equal Opportunity Employer M/F

# Inventors

We are looking for individuals who will take creative risks with conductive polymer materials. Expand upon your educational background (BS, MS, or PhD) or Industrial experience as an Electrical Engineer or Physicist. You should be able to function in an environment which will professionally challenge your best efforts. If you feel confident about your ability to:

- **Create New Products**
- **Develop Electronic Devices, or**
- **Research Unique Polymer Materials,**

**we can offer you an exciting future.**

Explore this opportunity to excel in a high-technology company with RAYCHEM... the International Leader in the field of irradiated polymers and specialty metals. Positions include Project Leaders, Staff, and Assistant Staff depending upon your motivation and capabilities. Write directly to me describing your abilities and preferences. Please include your resume and references.

**Dr. Steve Jacobs**  
**Raychem Corporation**  
**300 Constitution Drive**  
**Menlo Park, CA 94025**

We are proud to be an equal opportunity employer.

# Raychem

## ELECTRICAL ENGINEER

EG & G/Kirtland Operations currently has an opening for Electrical Engineer. This individual will research, design and develop electronic instrumentation and equipment. Work will involve both analog and digital electronic designs. Much of the work will concern optical effects and devices and will be a good opportunity to learn optics. This individual will supervise and conduct experiments, record and evaluate results and assist in preparation of work proposals. Send resumes to:

Elaine Mitchell  
Personnel Administrator  
EG & G/Kirtland Operations  
P.O. Box 4339  
Station A  
Albuquerque, NM 87196

---

### POSITIONS VACANT

---

The Department of Electrical Engineering of Gonzaga University invites applications for a tenure track position at the Assistant Professor level. Desired areas of expertise are: electromagnetic fields, communications and solid state electronics. A Ph.D. and some practical experience are desirable. Send resume to: W.P. Ilgen, Dean, School of Engineering, Gonzaga University, Spokane, WA 99258. An equal opportunity/affirmative action employer.

---

### EMPLOYMENT SERVICES

---

Electronic engineering growth positions with clients located nationally. Our service is enhanced by the fact that I am an EE with 20 years in industry and over 10 years in placing professionals on an employer fee paid basis. Send your resume to Joe Torcassi, Director, J. Anthony & Associates, PO Drawer AD, Lynchburg, OH 45142. 513/364-2305.

---

### RESUMES

---

Resumes—Complete instructions and examples; \$4. Consultants, Box 567—J. Bergenfield, N.J. 07621.

# Phoenix

## Growth Opportunities for Engineers

Sperry Flight Systems is an industry leader in the design, development and manufacture of state-of-the-art flight instruments and controls for aircraft and space flight applications. Join us in one of the nation's fastest growing high-technology centers, and benefit from the expansion of our business!

## Control Systems Engineers

Your duties will include hardware/software design trade-offs; specification design including guidance, navigation, and control algorithm development; systems integration and installation; flight test and customer liaison. Experience in hardware and software design is required.

## Software Development Engineers

Your duties will include design, test, and integration of real-time operational software with emphasis on modular and structured programming techniques. Experience in assembly language and PASCAL and/or JOVIAL is desirable.

## Circuit Design Engineers

You'll be designing circuits using state-of-the-art technologies. Experience in analog and digital circuit design is required. Knowledge of microprocessor application is useful.

## Join Us!

We offer industry-competitive salary, a complete benefits program, and outstanding opportunities for professional growth. To be considered, send your resume and salary history, in complete confidence, to Jim Kenyon.



P. O. Box 21111  
Phoenix, Arizona 85036

We're an Equal Opportunity Employer.

U.S. citizenship or permanent resident status required.

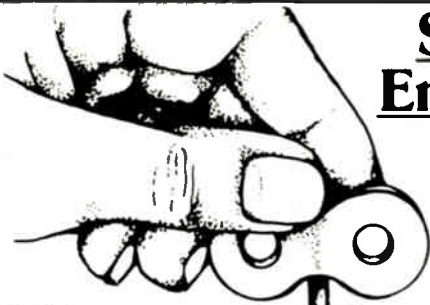

## Software Engineers.

# You wind you up. We turn you on.

Coulter Electronics is a world leader in medical electronics and instrumentation. An innovator in precision products related to health care and hematological functions.

The technology involved—and the diversified application problems—require constant upgrading in **software design and engineering.**

Obviously, we can't rely on yesterday's technology.

We need engineers with a grasp on tomorrow. Professionals who care about contributing to a project totally—from concept through implementation.

Which is why from day one at Coulter Electronics, **you're highly visible.** You're contributing. You're recognized.

We turn you loose. We turn you on. Expecting excellence because we have a tradition of engineering excellence.

Right now, we need **Software Engineers with micro-processor/mini-computer experience for our top-down design, structured programming environment.**

This is your chance to utilize your degree in Math, Computer Science, or Electrical Engineering—and your process control experience.

This is your chance to grow.

Send in your resume and salary history to: **Mr. Pete Chylko, Employment Manager, Dept. E, P.O. Box 5-2794, Miami, Florida 33152.**

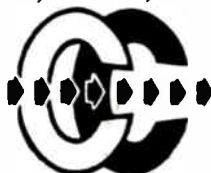

**COULTER ELECTRONICS, INC.**  
**INNOVATING A VITAL TECHNOLOGY.**

An Equal Opportunity Employer M/F

# Harness Systems Marketing Applications Manager

Apply your well developed technical skills and 3-5 years experience with wire harness products (preferably in the Interconnect field) to adapting our unique technology to the growing Interconnect Marketplace.

You will evaluate new harness systems opportunities (both technically and economically), work directly with customers integrating Raychem's wire products to specific needs, coordinate product design and development to meet customer requirements, and be involved in long term planning for specific harness problems. BSEE (or equivalent) preferred; working knowledge of current military vehicle wiring, EMC and/or connector Mil Specs a plus!

RAYCHEM TODAY has a technology expanded to include conductive polymer systems, heat recoverable metals, cross linked polymer chemistry, new specialty polymers and adhesive systems. Our commitment to maintain a leadership position in our field is demonstrated by our 25% annual compounded growth rate since 1957.

FOR IMMEDIATE CONSIDERATION, Contact Dennis E. Mitchell, (415) 561-5755, or send your resume to Mr. Mitchell at Raychem, 300 Constitution Drive, Menlo Park, CA 94025. An equal opportunity employer.

# Raychem

## ENGINEERS

**ELECTRONICS ENGINEERS, \$60,000.** Choice entry level to management positions immediately available in Pennsylvania & national locations. Reply in strict confidence to J. G. Weir, President, WEIR PERSONNEL SERVICES, 535 Court St., Reading, PA 19603 (215/376-8486).

**ELECTRONICS ENGINEERS, \$18,000-\$40,000.** Nationwide positions in digital, analog, microprocessor, microwave & instrumentation technology. For immediate confidential response, send resume w/ salary history to Glenn English, President, GLENN ENGLISH AGENCY, 7840 Mission Center Ct., San Diego, CA 92108 (714/291-9220).

**ELECTRONICS ENGINEERS, \$18,000-\$40,000.** Suburban New Jersey & nationwide. Numerous choice positions in co's utilizing the latest State-of-Art methods & equipment. Reply in confidence to James E. Mann, VP/Eng., ARTHUR PERSONNEL, Suite Y6, 8 Forest Avenue, Caldwell, NJ 07006 (201/226-4555).

**DESIGN ENGINEERS to \$38K.** Central Penna. & nationwide. Design connectors/terminals, microprocessors & controls. Reply in confidence to Z. A. Gonglewski, MECK ASSOC. PERSONNEL, 1517 Cedar Cliff, Camp Hill, PA 17011 (717/761-4777).

**npc** NATIONAL PERSONNEL CONSULTANTS

**ENGINEERS**  
SEND YOUR CREDENTIALS TODAY!  
TRANSITION to your new CAREER OBJECTIVES using TSC's nationwide employment search resources.  
TRANSITION SEARCH CONSULTANTS  
2697 International Parkway, Suite 203,  
Virginia Beach, Virginia 23452  
804-427-3700

## ENGINEERS

South & West Colorado

★ Mechanical

★ Electrical

★ Civil

★ Environmental

- Contracts • Design •
- Plant Operations •
- Forecasting & Rates • Planning •
- Construction • Analysis • Safety •

Colorado-Ute Electric Association is a rapidly growing generation and transmission utility serving Western and Southern halves of the State of Colorado. Currently two 400 megawatt units are being constructed and bids are being accepted on the third unit. At the present time we have 4 coal-fired stations, 2 hydros, over 50 substations and over 1,000 miles of transmission lines.

Degreed Engineers are being sought for transmission, substation and plant design, maintenance and planning.

We offer excellent benefits and promotional possibilities. Salaries commensurate with education and experience.

Send resume to:  
Dept. JVJ

**COLORADO-UTE  
ELECTRIC  
ASSN., INC.**

P.O. Box 1149  
Montrose, CO 81401

An Equal Opportunity Employer M/F



# Computer Hardware Professionals

Our clients, highly successful manufacturers and OEMs of Computer Systems, Electronic Systems, and Peripherals, have immediate openings for Hardware Development Professionals to work on FUTURE SYSTEMS PROJECTS. Such projects include COMPUTER ARCHITECTURE, DATA COMMUNICATIONS, PERIPHERAL DEVELOPMENT, and POWER SUPPLY DESIGN. Specific openings currently exist at Senior and Intermediate levels for:

**COMPUTER ARCHITECTS** — Definition and development of Micro- Mini-computer systems.

**POWER SUPPLY DESIGN ENGINEERS** — Switching regulators for Off-Line Power supplies. Experience in High Frequency P.W.M. techniques and AC Power Distribution would be desirable.

**MICROPROCESSOR DESIGN ENGINEERS** — Design/Development of state-of-the-art Microprocessor based systems and interfaces. Experience on any Microprocessor acceptable.

**LSI DESIGN DEVELOPMENT** — Numerous positions with local systems oriented firms in LSI technology development.

**CPU DESIGN ENGINEERS** — BSEE/BSCS and/or experience in the design of Digital Computers or Microprocessor systems. Requires an understanding of Software, i.e. ASSEMBLY, FORTRAN, or PL-1.

**DIGITAL LOGIC AND CIRCUIT DESIGN ENGINEERS** — Logic and Circuit design plus a familiarity with TTL, CMOS, LSI/VLSI, etc.

**ANALOG DESIGNERS** — 30 to 40 megahertz Phase Lock loop experience. Experience with 80 megahertz power drivers and DC motors.

**PCB DESIGNERS** — With CAD experience.

**COMMUNICATIONS SYSTEMS DEVELOPERS** — Experience with store and forward message switching, Network Data Link Control, and/or PBX and EPX Systems.

Compensation on all positions ranges from low 20's to low 40's, based upon experience. Client companies are equal opportunity/affirmative action employers, provide excellent benefits, and assume all fees.

Qualified applicants will receive IMMEDIATE RESPONSE and are invited to contact: Don Bateman, in strict confidence, at (617) 861-1020. Or submit current resume to him for review. For those who find it inconvenient to call during working hours, our office will be open until 7:30 p.m.

Contact: Don Bateman

**RK Robert Kleven and Co., Inc.**  
INDUSTRIAL RELATIONS MANAGEMENT CONSULTANTS

Three Fletcher Avenue, Lexington, Massachusetts 02173  
Telephone (617) 861-1020

Member  
Massachusetts Professional Placement Consultants  
National Computer Associates  
(Office Nationwide)  
Representing Equal Opportunity Employers M F



## MAKE YOUR HOME NEAR THE MOUNTAINS WITH Hewlett-Packard

We offer you the opportunity for a challenging career with one of the foremost electronics companies and the opportunity to enjoy a small community atmosphere.

The Loveland Instrument Division of Hewlett-Packard develops and manufactures state-of-the-art measurement instrumentation in the fields of: voltmeters, circuit board test, signal analyzers and signal sources. As a fast-growing company, new or recent graduates benefit from our philosophy of promoting managers from within our company. Presently we have career opportunities in research and development, manufacturing, and quality assurance.

**ELECTRICAL ENGINEER:** With minimum Bachelor's degree and up to 5 years experience in one of the following to work in R & D:

- Analog/Digital circuit design
- Signal processing
- Software development

**COMPONENT ASSURANCE ENGINEER:** With knowledge of the theory, design, fabrication, application and physics of failure of a wide range of electronic components, person will define failure mechanisms and appropriate stress tests, analyze test results physically and statistically.

**PRODUCTION ENGINEER:** With minimum Bachelor's degree in electrical or mechanical engineering and up to 5 years experience. Will provide technical support for manufacturing including problem solving and optimization.

If you'd like to spend your future with a dynamic, growing electronics company and experience the joys of small-town living, send your resume to: HEWLETT-PACKARD COMPANY, Department 205, P.O. Box 301, Loveland, CO 80537.

Equal Opportunity Employer Dedicated to Affirmative Action.



**HEWLETT  
PACKARD**

# SUPPORT ENGINEERS

**AUTOMATIC TEST EQUIPMENT  
—(HARDWARE & SOFTWARE)  
RELIABILITY**

**COMPONENTS  
QUALITY**

Your expertise is desperately needed by many of our clients located throughout the country. RCI is a Cincinnati based technical search firm. Although Cincinnati is our base, we are national in scope, for we travel throughout the U.S. recruiting and interviewing prospective candidates for our client companies.

Should you be interested in exploring new opportunities, send a resume or a brief description of your background.

Manny Rao

**RCI**

213 W. 9th Street Rm. A  
Cincinnati, Ohio 45202  
513/579-1513

## Engineers

- Design
- Development
- Project
- Software

**\$20,000-\$50,000**

Riddick Associates Engineering Division specializes in placement of electrical and electronics engineers with top companies in the Southeast and throughout the U.S. We provide advice on careers, resumes and interviews for a position tailored to your skills. Client companies pay all fees. For details call or send resume in strict confidence to Phil Riddick, President.

**Riddick Associates, Ltd.**  
9 Koger Executive Center  
Norfolk, VA 23502  
Area 804-461-3994

## S.W. & SUNBELT

- System EE's
- Design EE's
- Product EE's
- Software
- Design ME's
- Communications

**\$20,000 to \$50,000**  
100% Fee Paid

Specializing in placing technical people with data acquisition and peripheral equipment manufacturers located across southern U.S. Send complete resume, salary history and geographic preferences to:

**J. Robert Thompson Companies, Inc.**  
Management & Employment Consultants  
2200 West Loop South, Suite 800  
Houston, Texas 77027 713/627-1940

## GREATER TEXAS POSITIONS

Engineering and related management openings throughout the Southwest. Top clients paying all fees and relocation expenses. Send resume in confidence to: Alan Myler.

**KEY SEARCH**  
P.O. Box 38271  
Dallas, TX 75238

# Data Communications Books.

Recent rapid growth in the use of data communications means more and more people are finding themselves working with the technology. If you are one of them, these books have been published for you.

## McGraw-Hill's Compilation of Data Communications Standards

Presents all 89 user-relevant data communications standards promulgated by Consultative Committee for International Telephone and Telegraph (CCITT), International Organization for Standardization (ISO), American National Standards Institute (ANSI), Electronic Industries Association (EIA), and Federal Telecommunications Standards Committee (FTSC). Also includes descriptions of the standards organizations, plus relational charts of similar interfacing standards produced by different groups. Edited by Harold C. Folts and Harry R. Karp. 1133 pp., clothbound, \$165.

## Data Communications Procurement Manual

The most authoritative and current information you need to turn data communications procurement into a smoothly running, cost-effective operation. Includes sample solicitation clauses and forms, specification checklists on 38 devices, and 8 useful appendixes. By Gilbert Held. 150 pp., clothbound, \$24.50

## Practical Applications of Data Communications: A User's Guide

Articles from *Data Communications* magazine cover architecture and protocols, data-link performance, distributed data processing, software, data security, testing and diagnostics, communication processors, and digitized-voice and data-plus-voice. 424 pp., paperback, \$13.95



## Basics of Data Communications

This compilation of essential articles from *Data Communications* magazine includes chapters on terminals, acoustic couplers and modems, communications processors, networking, channel performance, data-link controls, network diagnostics, interfaces, and regulations and policy. 303 pp., paperback, \$12.95

Order today, using this coupon!

Electronics Magazine Books  
P. O. Box 669  
Hightstown, NJ 08520  
Tel. (609) 448-1700, ext. 5494



Please send me ...

\_\_\_\_\_ copies of *Data Communications Standards* @ \$165.

\_\_\_\_\_ copies of *Data Communications Procurement Manual* @ \$24.50

\_\_\_\_\_ copies of *Practical Applications of Data Communications* @ \$13.95

\_\_\_\_\_ copies of *Basics of Data Communications* @ \$12.95

Name \_\_\_\_\_

Title \_\_\_\_\_

Company \_\_\_\_\_

Street/P.O. address \_\_\_\_\_

City/state/zip \_\_\_\_\_

Payment enclosed (payment must accompany orders under \$25)  
 Bill me  Bill my company

Ten-day money-back guarantee applies on all books.

EL

Able Computer Technology	5	‡ CTS Corporation	42	Intel Special Products Division	20,21
ADAC	59,132	Data Instruments	208	‡ Intersil	70,71
* AEG Telefunken	9E	Data I/O Corporation	211	■ Iskra Commerce Marketing	85
■ Airpax / Cheshire Division	219	* Ducati Elettrotecnica Microfared	16E	* Italtel / SIT	174
* Altos Computer Systems	191	■ Electronic Navigation Industries	6	C. Itoh	150
American Microsystems, Inc.	76,77	Elevam Electronic Tube Co., Ltd.	144	■ ITT Cannon Electric	10,11
■ American Optical Scientific Instrument Div.	143	■ Erie Technological Products	88	* Iwatsu Electric Company, Ltd.	12E
American Telephone & Telegraph	223	Fairchild Test Systems	180,181	■ Kepco, Inc.	7
Analog Devices	112,113,187	■ Ferranti-Packard, Ltd.	62	■ Keystone Electronics	144
Anslay (Thomas & Betts)	200,201	First Boston	68,69	Kontron Electronics, Inc.	49,101
* Avantek	105	■ First Computer Corporation	15	■ LFE Corporation	47,176
Beusch & Lomb Scientific Optical Products	198	John Fluke Manufacturing Company	17,18,19	MDS Systems, Inc.	215
■ Bendix Electrical Components Division	195	Foundation Electronic Instruments, Inc.	186	■ Microswitch Division of Honeywell	116,117
Berg Electronics	197	* GEC M-O Valve	14E	■ Mini-Circuits Laboratory	2
Robert Bosch Corporation	164	‡ General Electric Instrument Rental Division	174	Mitel Semiconductor, Inc.	98
■ Bourns, Inc.	2C	General Electric Insulating Materials	224	Mostek Corporation	33-38
Brand Rex	202,203	General Instrument Opto Electronics Division	199	‡ Motorola Corporate	178,179
* Branson / IPC	13E	■ Genrad, Inc.	188,189	Motorola Semiconductor Products	30,31
Cambion	144	GenRad / Futuredata	204,205	■ National Semiconductor	55-58
The Carborundum Company	32	Gilbert	212	Nippon Electric Company, Ltd.	22,23
‡ Centralab Electronics Division	182,183	■ Gralex Industries	106	* Norma Mebtechnik GmbH	2E,3E
■ Cherry Electrical Products	13	■ Hewlett Packard	1,27,28,29,80,81, 109,111,114,115,168, 169,172,173	Noritake Electronics, Inc.	167
Christie Electric	212	‡ Hitachi America, Ltd.	190,191	Norplex Division UOP, Inc.	118
■ Clairex Electronics	4C	■ Honeywell TID	221	Optical Information Systems	51
■ Compas Microsystems	62	Hughes Aircraft Co., Solid State Products	89	■ Opto 22	3C
Computer Automation, Inc., Industrial Products Division	103	Information Handling Services	78,79	Oregon Software	41
Computer Automation, Inc., Naked Mini Division	97	Intel MPO	91-94	Osborne & Associates, Inc.	159



• Philips Elcoma	15E	Textool Products Department Electronic Div.	14
• Philips T & M	1E	TRW Capacitors	209
■ Piezo Technology	110	Union Carbide Corporation	207
Plessey Semiconductor	160,161	Union Carbide Corporation UPOL	217
‡ Positronic Industries	105	Unitrode Corporation	184,185
Power One, Inc.	90	‡ US Instrument Rentals	53
Practical Automation	60	Vector Electronics	16
Programmed Power, Div. Franklin Electric Co.	110	• Wandel un Goltermann	53
Pro-Log	25	Watkins-Johnson Company	72
RAC Reliability Analysis Center	60	■ Wavetek San Diego	63
■ Radio Research Instrument Company	176	Weckesser Company, Inc.	186
• Rapid Recall	5E	Wes-Con Products, Inc.	150
Rockwell Microelectronics Device Division	192,193	Wilhelm Westermann	8
Ernst Roederstein GmbH	213	Mark Williams Company	12
Semtec	64	Xebec Company, Ltd.	164
• SEPA S.p.A.	4E	Xciton	198
• Shell	42	Zendex Corporation	87
• Siemens AG	11E,70		
Signetics Corporation	75		
• Solartron	178,179		
Sprague Electric	67		
• TEAC Corporation	10E		
Tektronix	177		
Teledyne Philbrick	87		
• Telefongyar	6E		
Tel-Koor, Ltd.	103		
Texas Instruments, Inc. (Digital Systems Div.)	9	■ For more information of complete product line see advertisement in the latest Electronics Buyers Guide	
Texas Instruments Semiconductor	82,170,171	• Advertisers in Electronics International	
		‡ Advertisers in Electronics domestic edition	

### Classified and employment advertising

F. J. Eberle, Manager 212-997-2557

Allen-Bradley Co	230
Alps Personnel, Inc	226
Ball Aerospace	232
Colorado Ute	234
Corporate Personnel Cons	228
Coulter Electronics, Inc	234
Dorsey Love & Assoc	226
E G & G Kirtland Operations	233
Ford Aerospace Comm., Corp	227
GTE Lenkurt Inc	226
Hewlett Packard	235
Key Search	235
Kleven & Co, Robert	235
Low David M. Personnel Services	226
Martin Marietta Aerospace	231
National Personnel Consultants Inc	234
NCR Corporation	229,232
Perint	226
Raychem Corp	232,234
RCI-Executive Search Consult	235
Riddick Associates Ltd	235
Sitronix	228
Southwest Technical	230
Sperry Airlight	233
Storage Technology Corp	228
Thompson Robert J.	235
Transition Search	234

### Advertising Sales Staff

**Advertising sales manager:** Norman Rosen  
3200 Wilshire Blvd., South Tower  
Los Angeles Calif. 90010 [213] 487-1160

### Market managers:

*Components:* William Boyle, Rochester, N.Y.  
*Computers & Peripherals:* Frank Mitchell, Boston  
*Test & Measurement:* Don Farris, San Francisco  
*Semiconductors:* Norman Rosen, Los Angeles

**Atlanta, Ga. 30309:** Peter Stien  
100 Colony Square, 1175 Peachtree St., N.E.  
[404] 892-2868  
**Boston, Mass. 02118:** Frank Mitchell  
607 Boylston St., [617] 262-1160  
**Cleveland, Ohio 44113:** William J. Boyle  
[716] 248-5620  
**Fort Lauderdale, Fla. 33306:** Peter Stien  
3000 N.E. 30th Place, Suite #400  
[305] 563-9111  
**New York, N.Y. 10020**  
1221 Avenue of the Americas  
John Gallie [212] 997-3616  
Matthew T. Reseska [212] 997-3617  
**Philadelphia, Pa. 19102:** Matthew T. Reseska  
Three Parkway, [212] 997-3617  
**Pittsburgh, Pa. 15222:** Matthew T. Reseska  
4 Gateway Center, [212] 997-3617  
**Rochester, N.Y. 14534:** William J. Boyle  
Powder Mill Office Park, 1163 Pittsford-Victor Rd.,  
Pittsford, N.Y. 14534 [716] 248-5620  
**Chicago, Ill. 60611**  
645 North Michigan Avenue  
Jack Anderson [312] 751-3739  
Robert M. Denmead [312] 751-3738  
**Detroit, Michigan 48202:** Jack Anderson  
1400 Fisher Bldg., [313] 873-7410  
**Costa Mesa, Calif. 92626:** Edward E. Callahan  
3001 Red Hill Ave. Bldg. #1 Suite 222  
[714] 557-6292  
**Dallas, Texas 75201:** John J. Uphues  
2001 Bryan Tower, Suite 1070  
[214] 742-1747  
**Denver, Colo. 80203:** Harry B. Doyle, Jr.  
655 Broadway, Suite 325  
[303] 825-6731  
**Houston, Texas 77002:** John J. Uphues  
601 Jefferson Street, Dresser Tower  
[713] 659-8381  
**Los Angeles, Calif. 90010:** Chuck Crowe  
3200 Wilshire Blvd., South Tower  
[213] 487-1160  
**San Francisco, Calif. 94111:** Don Farris,  
Larry Goldstein, 425 Battery Street,  
[415] 362-4600

**Paris:** Michael Sales  
17 Rue-Georges Bizet, 75116 Paris, France  
Tel: 720-16-80  
**United Kingdom:** Simon Smith  
34 Dover Street, London W1  
Tel: 01-493-1451  
**Scandinavia:** Andrew Karnig and Assoc.  
and Simon Smith  
Kungsholmsgatan 10  
112 27 Stockholm, Sweden  
Tel: 08 51 68 70 Telex: 179 51  
**Milan:** Ferruccio Silvera  
1 via Baracchini, Italy  
Phone 86-90-656

**Brussels:**  
23 Chaussee de Wavre  
Brussels 1040, Belgium  
Tel: 513-73-95  
**Frankfurt/Main:** Fritz Krusebecker  
Liebigstrasse 27c, Germany  
Phone 72 01 81

**Tokyo:** Akio Saijo, McGraw-Hill  
Publications Overseas Corporation,  
Kasumigaseki Building 2-5, 3-chome,  
Kasumigaseki, Chiyoda-Ku, Tokyo, Japan  
[581] 9811

### Business Department

**Thomas M. Egan**  
Production Director  
[212] 997-3140  
**Carol Gallagher**  
Production Manager  
[212] 997-2045  
**Betty Preis**  
Production Manager Domestic  
[212] 997-2908  
**Thomas Kazich**  
Production Manager Related Products  
[212] 997-2044  
**Karen Walpole**  
Production Assistant  
[212] 997-2843  
**Frances Vellone**  
Reader Service Manager  
[212] 997-6057

### Electronics Buyers' Guide

**H.T. Howland**, General Manager  
[212] 997-6642  
**Regina Hera**, Directory Manager  
[212] 997-2544

### Classified and Employment Advertising

**Frank Eberle**, Manager  
[212] 997-2557

# ADDRESSABLE I/O SYSTEMS FROM OPTO 22



(PB 16S1)

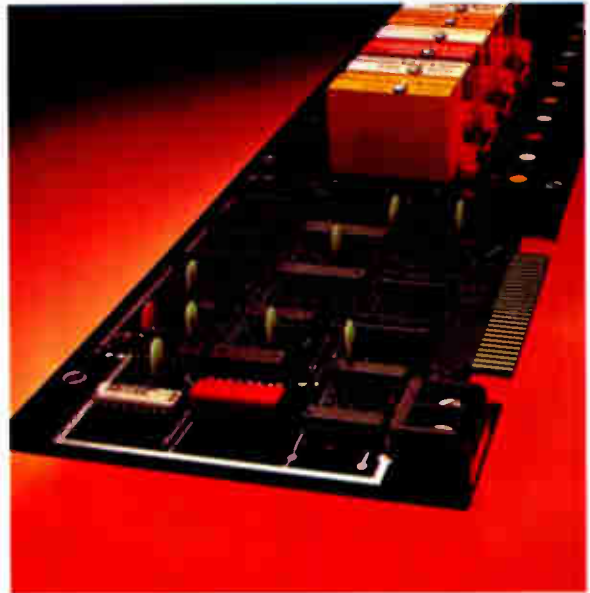

(PB 16P1)

Huntington Beach, California . . . Opto 22, originators of the industry standard I/O system, announces the second generation in I/O Systems in both serial and parallel configurations.

#### **SERIAL ADDRESSABLE RACK (PB 16S1)**

Communication with multiple input/output stations.  
32 station address capability per serial loop.  
Up to 16 power I/O modules per station.

Switch selectable baud rate.

Opto 22 provided firmware includes message protocol, event counter, self test, watch dog timer and more.

Plug in modules provide choice of:

1. 20 Ma Current Loop.

2. RS 422 Balanced Differential Drivers and Receivers.
3. Optically Coupled Drivers and Receivers.
4. RS 232

#### **PARALLEL ADDRESSABLE RACK (PB 16P1)**

Bidirectional Communication with input or output modules.

64 station address capability.

Up to 16 Power Input/Output modules per station.

50 Conductor Daisy-Chain cable connects all racks to host controller.

On-board station address select switch.

15272 Relay Circle, Huntington Beach, CA 92649  
(714) 892-3313

Another Opto 22 product available for immediate shipment.



# PHOTOTRANSISTORS & PHOTODARLINGTONS

• Clear Epoxy Packages • Less than 50 cents

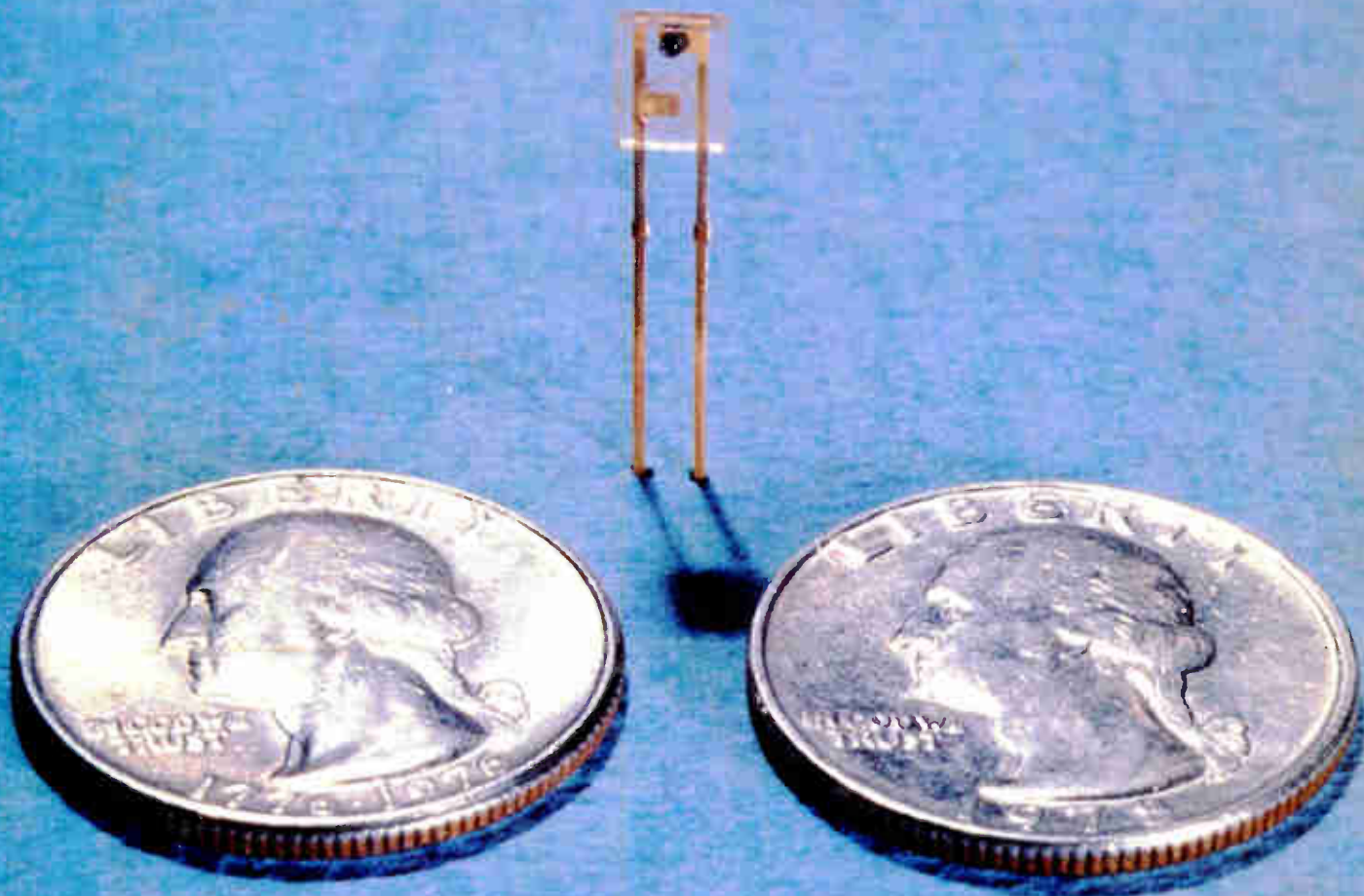

The CLT 4000 series of phototransistors and the CLR 4180 photodarlington utilize lead frame construction for direct soldering into circuit boards or socket mounting and are molded in clear epoxy packages... and the price is less than 50 cents each in production

quantities.

This design includes a molded lens over the transistor to control angular response. All units have guaranteed light sensitivity and are spectrally compatible with the Clairex CLED 400 IR Emitter. The CLR 4180 offers particularly high

sensitivity at low irradiance levels of 0.1 mW/cm<sup>2</sup> and 1.0 mW/cm<sup>2</sup>.

For specific details call 914-664-8602 or write Clairex Electronics, 560 South Third Avenue, Mount Vernon, New York 10550.

## CLAIREX ELECTRONICS

A Division of Clairex Corporation

Circle 302 on reader service card